

TM 5-6675-316-14-1

TECHNICAL MANUAL

OPERATOR'S, ORGANIZATIONAL, DIRECT
SUPPORT AND GENERAL SUPPORT
MAINTENANCE MANUAL

TOPOGRAPHIC SUPPORT SYSTEM
DRAFTING SUPPORT SECTION
MODEL ADC-TSS-4
NSN: 6675-01-105-5754

This manual, together with TM 5-6675-316-14-2, supersedes TM 5-6675-316-14,
20 June 1983.

HEADQUARTERS, DEPARTMENT OF THE ARMY

7 JUNE 1985

CHANGE }
No. 2 }

HEADQUARTERS
DEPARTMENT OF THE ARMY
WASHINGTON, D. C., 14 April 1988

Operator's, Organizational, Direct Support and
General Support Maintenance Manual

TOPOGRAPHIC SUPPORT SYSTEM
DRAFTING SUPPORT SECTION
MODEL ADC-TSS-4
NSN : 6675-01-105-5754

TM 5-6675-316-14-1, 7 June 1985, is changed as follows:

1. Remove and insert pages as indicated below. New or changed text material is indicated by a vertical bar in the margin. An illustration change is indicated by a miniature pointing hand.

Remove pages

Insert pages

1-19 and 1-20

1-19 and 1-20

2. Retain this sheet in front of manual for reference purposes.

By Order of the Secretary of the Army:

CARL E. VUONO
General, United States Army
Chief of Staff

Official:

R.L. DILWORTH
Brigadier General, United States Army
The Adjutant General

DISTRIBUTION:

To be distributed in accordance with DA Form 12-25A, Operator, Unit, Direct Support and General Support Maintenance requirements for Topographic Support System, Drafting Support Section (ADC-TSS-4).

CHANGE }
No. 1 }

HEADQUARTERS
DEPARTMENT OF THE ARMY
WASHINGTON, D.C., 19 September 1986

Operator's, Organizational, Direct Support and
General Support Maintenance Manual

TOPOGRAPHIC SUPPORT SYSTEM
DRAFTING SUPPORT SECTION
MODEL ADC-TSS-4
NSN: 6675-01-105-5754

TM 5-6675-316-14-1, 7 June 1985, is changed as follows:

1. Remove and insert pages as indicated below. New or changed text material is indicated by a vertical bar in the margin. An illustration change is indicated by a miniature pointing hand.

Remove pages

i/ii
1-13 and 1-14
1-55 and 1-56
1-61 through 1-64
1-71 and 1-72
1-95 and 1-96
1-99 and 1-100
2-61 and 2-62
2-81 and 2-82
2-163 and 2-164
2-179 and 2-180
2-183 and 2-184
2-203 and 2-204
2-297 and 2-298
2-323 and 2-324

Insert pages

i/ii
1-13 and 1-14
1-55 and 1-56
1-61 through 1-64
1-71 and 1-72
1-95 and 1-96
1-99 and 1-100
2-61 and 2-62
2-81 and 2-82
2-163 and 2-164
2-179 and 2-180
2-183 and 2-184
2-203 and 2-204
2-297 and 2-298
2-323 and 2-324

2. Retain this sheet in front of manual for reference purposes.

By Order of the Secretary of the Army:

Official:

R. L. DILWORTH
Brigadier General, United States Army
The Adjutant General

JOHN A. WICKHAM, JR.
General, United States Army
Chief of Staff

DISTRIBUTION:

To be distributed in accordance with DA Form 12-25A, Operator's, Organizational, Direct Support and General Support Maintenance requirements for Topographic Support System, Drafting Support Section (ADC-TSS-4).

WARNING

HIGH VOLTAGE is used in this equipment. DEATH ON CONTACT or severe injury may result if personnel fail to observe safety precautions.

Do not be misled by the term LOW VOLTAGE. Low voltage can cause serious injury or death.

Test procedures requiring the operator or maintenance personnel to investigate equipment or restore casualties with interlocks disconnected or covers removed may result in DEATH ON CONTACT if personnel fail to observe safety precautions.

Voltages in switches and circuit breaker panels may result in DEATH ON CONTACT if personnel fail to observe safety precautions.

Failure to ground the section or equipment may result in DEATH ON CONTACT if personnel fail to observe safety procedures.

For Artificial Respiration refer to FM 21-11.

WARNING

Dry cleaning solvent, P-D-680, used to clean parts is potentially dangerous to personnel and property. Avoid repeated and prolonged skin contact. Wear solvent-impermeable gloves and eye/face protective equipment when using solvent. Do not use near open flame or excessive heat. Flash point of solvent is 100° F to 138° F (38° C to 59° C).

WARNING

Rotating and spinning equipment may snag loose clothing, hair or jewelry resulting in SEVERE PERSONNEL INJURY.

WARNING

Attempting to move overweight or top heavy equipment that is unsecured may result in SEVERE PERSONNEL INJURY. Always have sufficient personnel and equipment to accomplish the task.

INTRODUCTION

This manual is divided into two volumes:

Volume 1, TM 5-6675-316-14-1 consists of Chapters 1 and 2.

Volume 2, TM 5-6675-316-14-2 consists of Chapters 3 through 12, Appendixes A through E, Glossary and Index.

The Appendixes, Glossary and Index in Volume 2 are applicable to both volumes.

TECHNICAL MANUAL

NO. 5-6675-316-14-1

HEADQUARTERS
DEPARTMENT OF THE ARMY
WASHINGTON, D. C., 7 June 1985

Operator, Organizational, Direct Support and
General Support Maintenance Manual

TOPOGRAPHIC SUPPORT SYSTEM
DRAFTING SUPPORT SECTION
MODEL ADC-TSS-4
NSN: 6675-01-105-5754

REPORTING ERRORS AND RECOMMENDING IMPROVEMENTS

You can help improve this manual. If you find any mistake or if you know of away to improve the procedures, please let us know. Mail your letter, DA Form 2028 (Recommended Changes to Publications and Blank Forms), or DA Form 2028-2 located in the back of this manual direct to: Commander, U.S. Army Troop Support Command, ATTN: AMSTR-MCTS, 4300 Goodfellow Boulevard, St. Louis, M063120- 1798. A reply will be furnished directly to you.

TABLE OF CONTENTS

	Page
CHAPTER 1	DRAFTING SUPPORT SECTION 1-1
Section I	Introduction 1-1
Section II	Operating Instructions 1-11
Section III	Operator Maintenance 1-45
Section IV	Organizational Maintenance 1-53
Section V	Direct/General Support Maintenance 1-88
CHAPTER 2	COMPOSING MACHINE 2-1
Section I	Introduction 2-1
Section II	Operating Instructions 2-74
Section III	Operator Maintenance 2-134
Section IV	Organizational Maintenance 2-140
Section V	Direct/General Support Maintenance 2-189

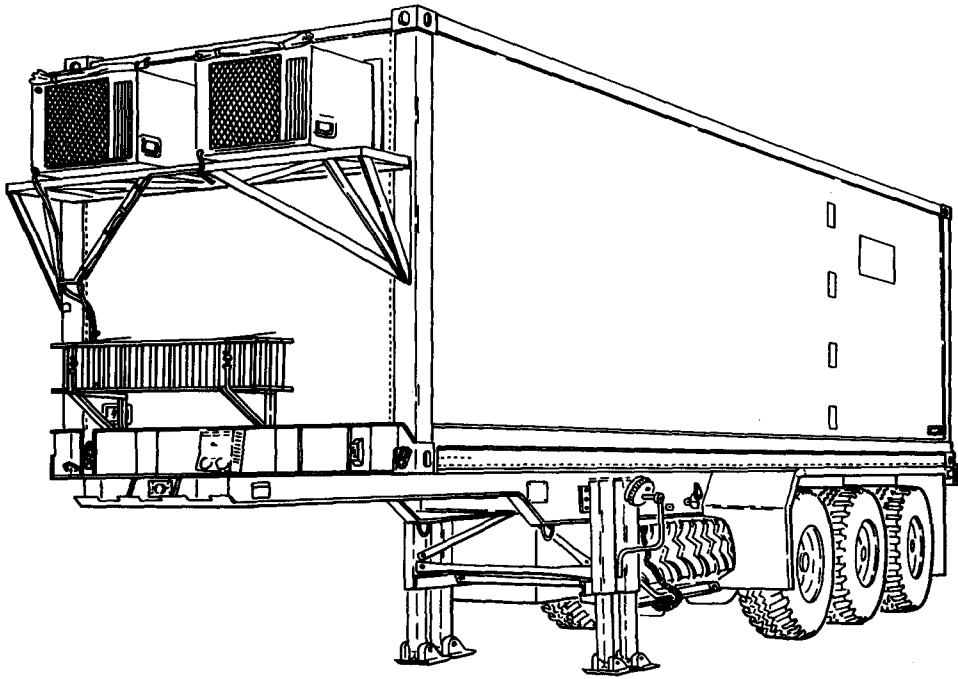

CHAPTER 1

DRAFTING SUPPORT SECTION

Section I INTRODUCTION

1-1. GENERAL INFORMATION.

1-1.1 Scope. This manual contains operating and maintenance instructions for the ADC-TSS-04, Drafting Support Section, Topographic Support System (TSS). The purpose of the Drafting Support Section is to provide cartographic products to other TSS sections. The trailer chassis is covered in TM 5-2330-305-14, Operator, Organizational, Direct Support and General Support Maintenance Manual, Topographic Support System, Chassis, Semi trailer, ISO Container Transporter. Repair parts and special tools are listed in TM 5-6675-316-24P, Organizational, Direct Support, and General Support Maintenance Repair Parts and Special Tools List, Drafting Support Section, Topographic Support System. Lubrication instructions are contained in LO 5-6675-316-12, Lubrication Order, Drafting Support Section, Topographic Support System. All authorized equipment, supplies, and their locations for transport are shown in Location and Description of Major Components of this manual.

1-1.2 Purpose of Equipment. To provide a transportable facility for production of set type; analysis of topographic products; production of precision drawings, grids, and masks; and pin registration.

1-1.3 Maintenance Forms and Records. Department of the Army forms and procedures used for equipment maintenance will be those prescribed by DA Pam 738-750, The Army Maintenance Management System (TAMMS).

1-1.4 Reporting Equipment Improvements (EIR's). If the Drafting Support Section needs improvement, let us know. Send us an EIR. You, the user, are the only one who can tell us what you do not like about your equipment. Let us know why you do not like the design or performance. Put it on an SF 368 (Quality Deficiency Report). Mail it to us at: U.S. Army Troop Support Command, ATTN: AMSTR-QX, 4300 Goodfellow Blvd, St Louis, MO 63120-1798. We will send you a reply.

1-1.5 Destruction of Material to Prevent Enemy Use. For information on destruction of material to prevent enemy use, refer to TM 750-244-3, Procedures for Destruction of Equipment to Prevent Enemy Use.

1-1.6 Preparation for Storage or Shipment.

- a. Perform your preparation for movement procedures.
- b. For administrative storage of equipment, refer to TM 740-90-1.

The chapters of this manual describe special shipping instructions for major components located in the section.

d. In the event this equipment must be removed from the section for repair or replacement, contact your battalion for packing and shipping instructions.

1-2. EQUIPMENT DESCRIPTION.

1-2.1 Equipment Characteristics, Capabilities, and Features.

- a. Air and sea transportable.
- b. Transportable cross-country capability when mounted on trailer chassis.
- c. Controlled internal environment.

1-2.2 Special Considerations.

Site must permit section to be leveled within $\pm 2^\circ$, be well drained, and provide adequate overhead concealment. Wooded areas and other obstacles must not impede movement of transporters.

- b. Dispersal of topographic sections is limited to the length of electric power transmission cable available for unit generators.

During site selection, avoid overhead power transmission lines to prevent danger from electric shock or electromagnetic interference.

- d. Power is normally supplied by 60 kW generators. Commercial electric power should be used if it is compatible and available.

Cross-country capability of sections and transporters is limited. Relocation should be accomplished over hard-surfaced, all-weather roads whenever possible.

1-2.3 Location and Description of Major Components.

a. Roadside Exterior.

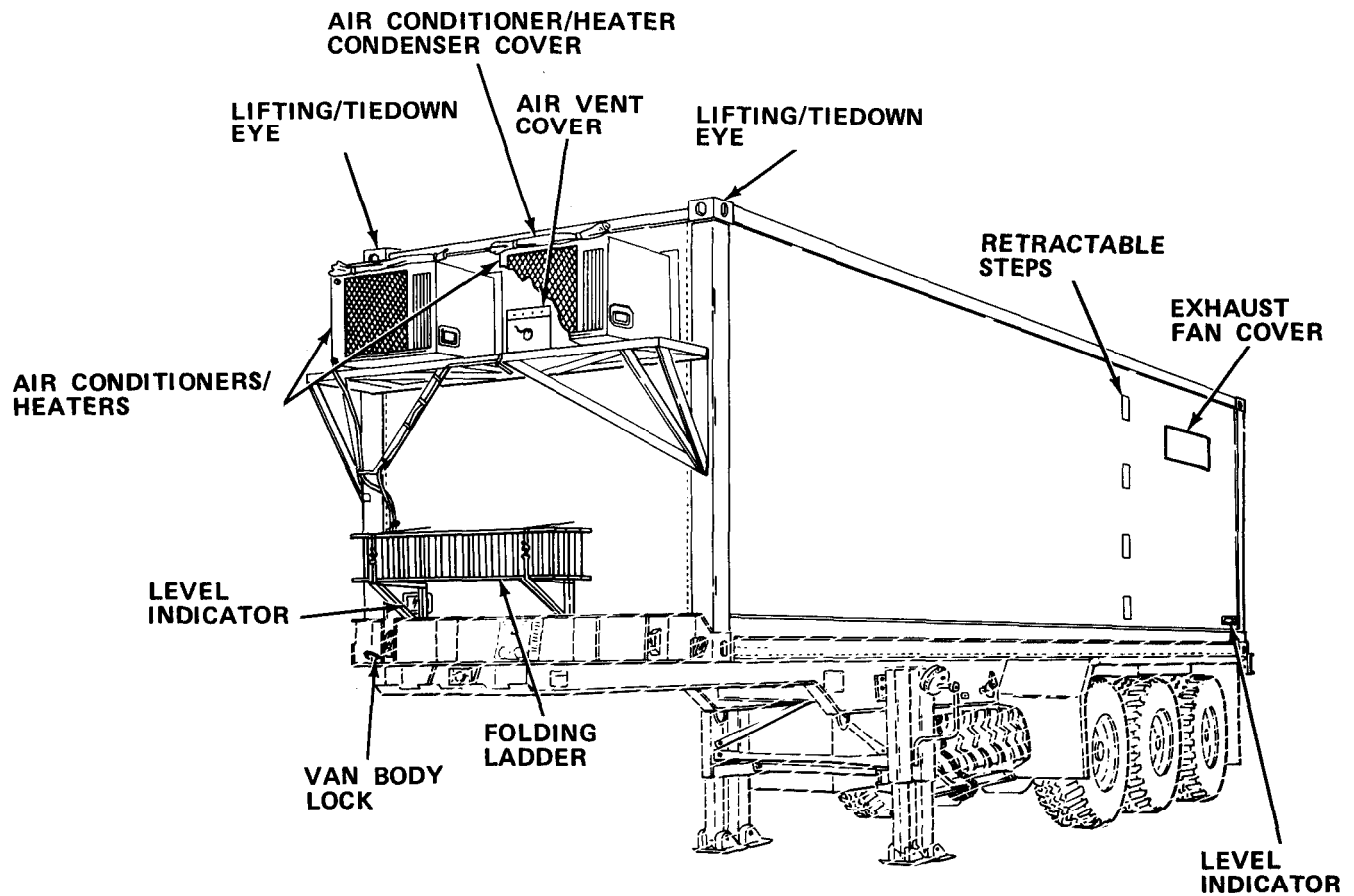

VAN BODY LOCK . Locks van body to trailer chassis.

AIR CONDITIONERS/HEATERS. Two air conditioner/heater units for internal environmental control .

LIFTING/TIEDOWN EYES. Attachment point for lifting or tying down van body.

AIR CONDITIONER/HEATER CONDENSER COVERS. Covers air conditioner/heater condenser to prevent water/air entering air conditioner/heater unit when in transport or storage.

AIR VENT COVER. Covers air vent opening.

RETRACTABLE STEPS . Provide access to roof.

EXHAUST FAN COVER. Covers exhaust fan opening.

LEVEL INDICATORS. Indicate van body inclination.

FOLDING LADDER. Allows access to air conditioners and top of van.

b. Curbside Exterior.

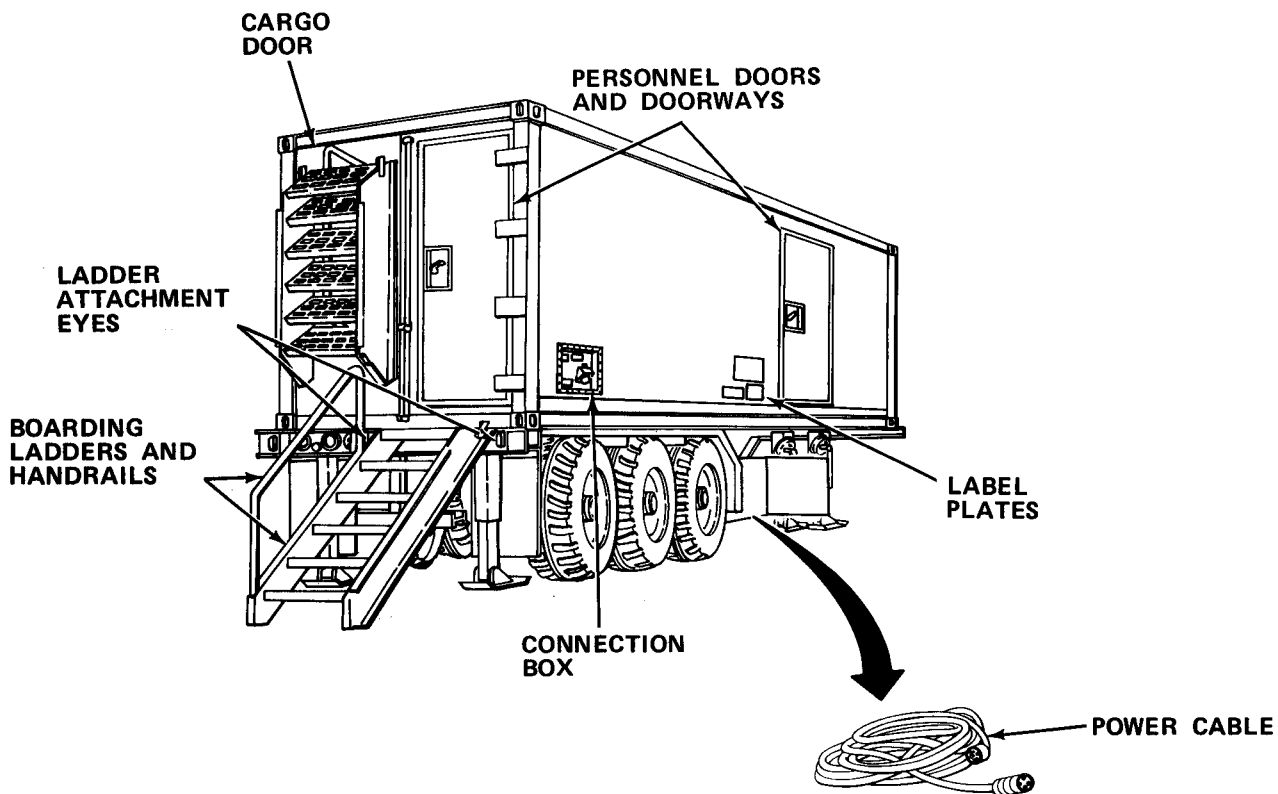

CARGO DOOR. Access for equipment removal / installation.

PERSONNEL DOORS. Doors are 35.75 in. (90.8 cm) wide by 86 in. (218.4 cm) high.

PERSONNEL DOORWAYS. Doorways are 30.75 in. (78.1 cm) wide by 78.5 in. (199.4 cm) high.

LABEL PLATES. Provide weight/moment data.

POWER CABLE. Power cable is in 50 ft (15.2 m) sections. (Stored in trailer chassis storage box.)

CONNECTION BOX. Contains terminals for ground cable, power cables, and telephone lines.

LADDER ATTACHMENT EYES. Attachment points for boarding ladder.

BOARDING LADDERS AND HANDRAILS. Provide access to van body.

c. Interior.

PERSONNEL DOOR. Weatherproof, fitted with blackout switch.

BLACKOUT SWITCH. Turns ceiling lights off when activated.

FIRE EXTINGUISHER. Dry chemical fire extinguisher.

FIRST AID KIT. Limited first aid supplies.

CARGO DOOR. Access for equipment removal/installation.

TRANSFORMER. Isolation transformer that provides constant voltage for composing machine.

WALL STORAGE CABINET. Storage.

FLUORESCENT CEILING LAMP. White, two-level (high/low) overhead light.

EXHAUST FAN. Provides ventilation. Fitted with lightproof louvers and weatherproof cover.

TELETYPE. Component of drafting machine.

BLACKOUT DOME LIGHT. Red-lensed, white-lensed 12 V ac light actuated when blackout switch operates, or from external power.

DRAFTING/MEASURING MACHINE. Automatic drafting and measuring device.

MAGNIFIER LAMP. Provides illumination and magnification for light table work station.

SPLIT STAGE LIGHT TABLE. Contains two illuminated surfaces and movable mounting assembly for stereoscopic analysis.

WASTEPAPER BASKET. Storage for transport.

FILING CABINET. Storage.

AIR CONDITIONERS/HEATERS. Internal environmental control.

EMERGENCY LIGHTS. Battery-powered lighting actuated by power failure.

AIR VENT. Permits filtered make-up air to enter van body.

FIRE EXTINGUISHER. Dry chemical fire extinguisher.

STORAGE CABINET. Storage

FOLDING CHAIR. Storage for transport.

CORKBOARD. Vertical display board.

PIN REGISTER BOARD. Aligns overlays and graphics.

PAPER RACK. Storage for roll paper.

CIRCUIT BREAKER PANEL. Circuit breakers with phase test indicator.

SAFETY SWITCH. Main power safety disconnect switch.

GROUND ROD. Electrical ground for section.

RIFLE RACK. Weapon storage.

CHAIR. Storage for transport.

BLACKOUT CURTAIN. Lightproof cover for personnel door.

MAP AND PLAN FILING CABINET. Storage for maps/topographic products.

ZOOM STEREOSCOPE. Storage for transport.

VACUUM CLEANER. Cleaning equipment.

TOOL KITS.

TIEDOWNS. Stored inside storage cabinet when not in use.

DRAFTING, SCRIBING/TRACING TABLE. Illuminated tracing board. Turns over for drafting board.

DRAFTING CHAIR. Adjustable height chair.

TELEPHONE JACK. Communication terminal.

SEALING MACHINE. Used for applying adhesive wax.

COMPOSING MACHINE. Phototypesetting machine transfers characters displayed on CRT to photographic paper cassette for processing in separate section.

1-2.4 Equipment Data - ISO Container (Unmounted).

Dimensions	
Length	33.66 ft (10.26 m)
Width	8 ft (2.44 m)
Height	8 ft (2.44 m)
Cubage	2038 ft ³ (57.7 m ³)
Connections	
Telephones	One telephone (three-post) connection
Power	20.8 kW. One 120/208 V, three-phase, four-wire connection and one 12 V dc connection
Ground	Ground lug
Air Conditioner/Heater (Two Units)	
Cooling	18,000 Btu/hr (5274 W) Each
Heating	14,300 Btu/hr (4190 W) (Max) each
Power Requirements	208 V, 60 Hz, three-phase
Exhaust Fan	289 ft ³ /min (8.18 m ³ /min)
Air Vent	289 ft ³ /min (8.18 m ³ /min)
Weight	
Gross (Container and Chassis)	24,970 lbs (11,323.90 kg)
Tare (Container Only)	13,530 lbs (6135.86 kg)

1-3. TECHNICAL PRINCIPLES OF OPERATION,

1-3.1 General. The operation of major components located within the van are explained in the appropriate chapter for that equipment.

1-3.2 Electrical System.

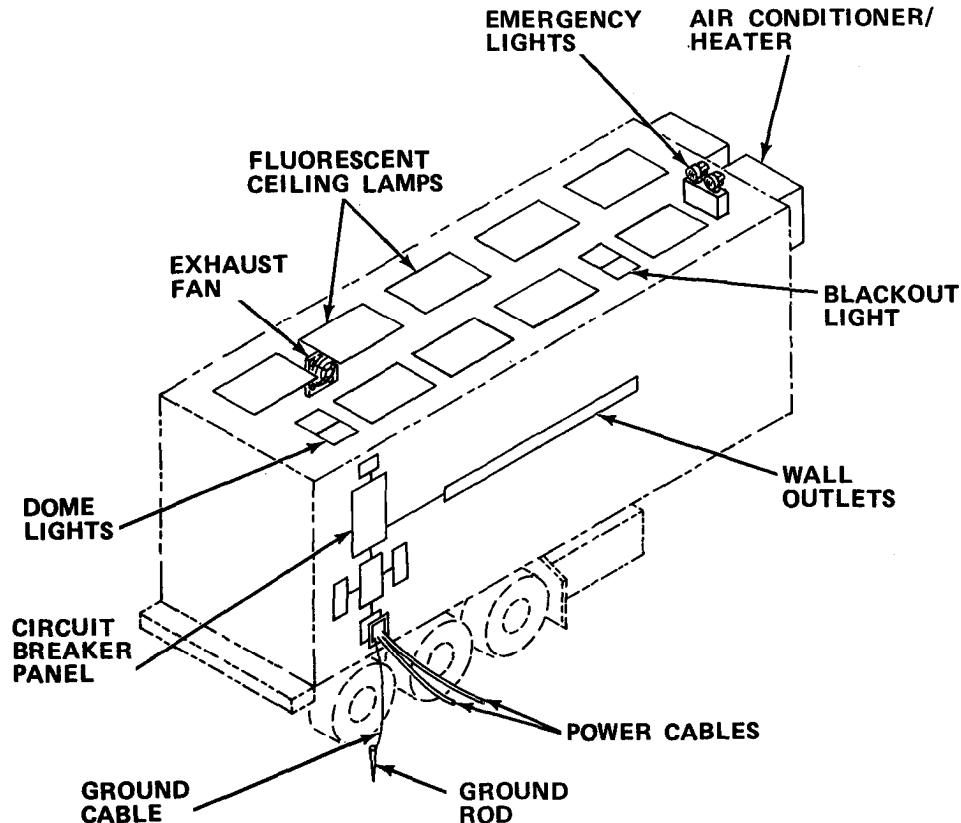

GROUND ROD. Used to ground van body.

GROUND CABLE. Used with ground rod.

CIRCUIT BREAKER PANEL. Contains voltage indicator, phase monitor, and circuit breakers.

DOME LIGHTS. White-lensed, 12 V dc lights powered from external source. Separately switched and fused.

EXHAUST FAN. Plug-in fan. Separately fused.

FLUORESCENT CEILING LAMPS. Two-level (high/low) overhead lights with blackout override switches.

EMERGENCY LIGHTS. Battery powered. Activated by power loss.

TM 5-6675-316-14

AIR CONDITIONER/HEATER. Air conditioner and electrical heater powered by three-phase, 208 V, 30 amp current.

BLACKOUT LIGHTS. Red-lensed, 12 V ac lights actuated when blackout switch operates.

WALL OUTLETS. Provide grounded outlets for portable or plug-in equipment.

POWER CABLES. Power input (120/208 V ac and 12 V dc).

1-3.3 Wiring Diagram. A foldout wiring diagram is provided at the end of this manual.

1-3.4 Ventilation System.

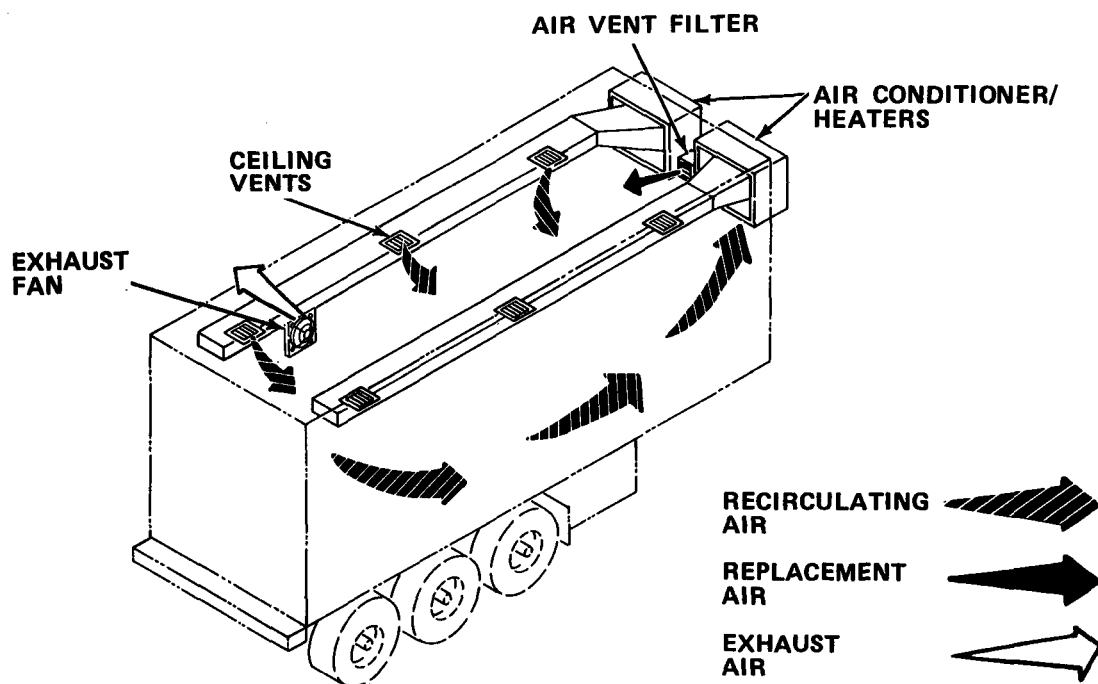

Exhaust fan exhausts air. Replacement air flows into the section through the air vent filter. Recirculating air is filtered as it enters the air conditioners/heaters. From the air conditioners/heaters, it flows through the ceiling vents and into the section.

NOTE

Detailed description of air conditioner/heater operation is contained in TM 5-4120-367-14, Operator, Organizational, Direct Support, and General Support Maintenance Manual, Air Conditioner, Horizontal, Compact, 18,000 Btu/hr Cooling, and TM 5-4120-367-24P, Organizational, Direct Support, and General Support Maintenance Repair Parts and Special Tools List (Including Depot Maintenance Repair) for Air Conditioner, Horizontal, Compact, 18,000 Btu/hr (5274W).

Section II OPERATING INSTRUCTIONS

1-4. DESCRIPTION AND USE OF OPERATOR'S CONTROLS AND INDICATORS.

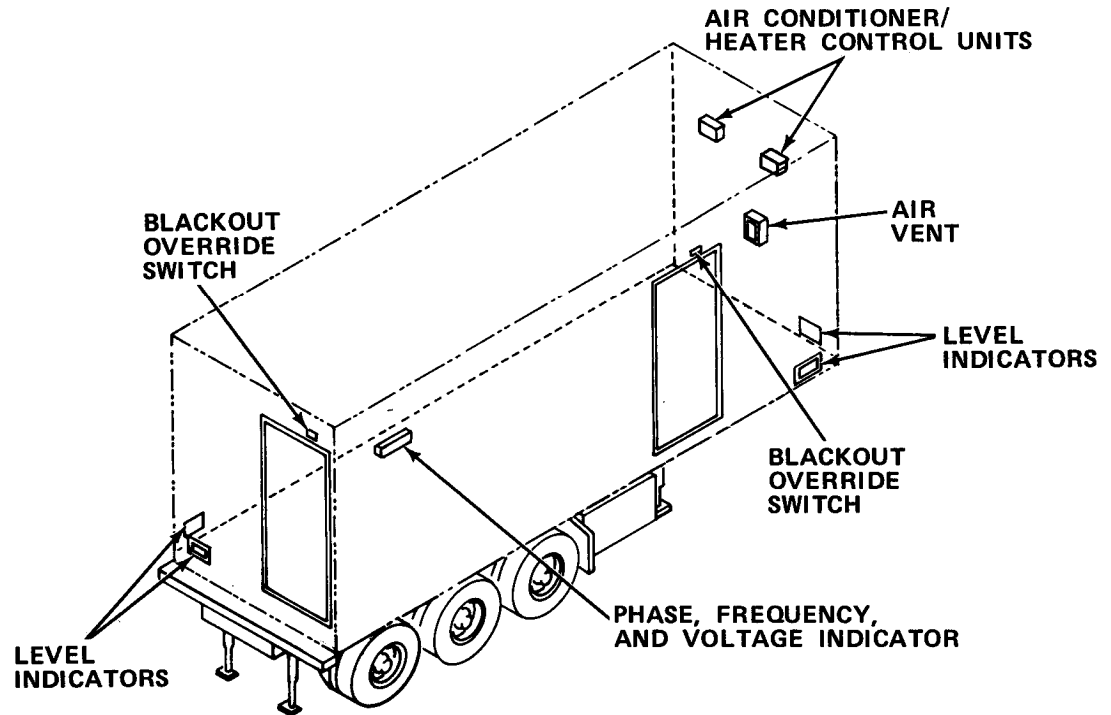

Control or Indicator	Function
Blackout Override Switches	Turn off illumination when doors are opened.
Air Vent	Permits make-up air to enter as required.
Air Conditioner/Heater Control Units	Permit selection of air conditioner or heater mode of operation and temperature.
Phase, Frequency, and Voltage Indicator	Monitors electrical power, phase, frequency, and voltage.
Level Indicators	Used to level section.

1-5. OPERATOR PREVENTIVE MAINTENANCE CHECKS AND SERVICES.

Before You Operate. Always keep in mind the WARNINGS and CAUTIONS. Perform your before (B) PMCS.

b. While You Operate. Always keep in mind the WARNINGS and CAUTIONS. Perform your during (D) PMCS.

c. After You Operate. Be sure to perform your after (A) PMCS.

d. If Your Equipment Fails to Operate. Troubleshoot with proper equipment. Report any deficiencies using the proper forms. See DA Pam 738-750.

1-5.1 PMCS Procedures.

PMCS are designed to keep the equipment in good working condition by performing periodic service tasks.

b. Service intervals provide you, the operator, with time schedules that determine when to perform specified service tasks.

c. The "Equipment is Not Ready/Available If" column is used for identification of conditions that make the equipment not ready/available for readiness reporting purposes or denies use of the equipment until corrective maintenance is performed.

d. If your equipment fails to operate after PMCS is performed, immediately report this condition to your supervisor.

e. Perform weekly as well as before operation if. You are the assigned operator and have not operated the item since the last weekly or if you are operating the item for the first time.

f. Item number column. Item numbers are assigned in chronological ascending sequence regardless of interval designation. These numbers are used for your "TM Number" column on DA Form 2404, Equipment Inspection and Maintenance Worksheet in recording results of PMCS.

Interval columns. This column determines the time period designated to perform your PMCS.

h. Item to be inspected and procedures column. This column lists functional groups and their respective assemblies and subassemblies as shown in the Maintenance Allocation Chart (Appendix B). The appropriate check or service procedure follows the specific item to be inspected.

i. Equipment is not ready/available if: column. This column indicates the reason or cause why your equipment is not ready/available able to perform its primary mission.

j. List of tools and materials required for PMCS is as follows:

Item	Quantity
Wire Brush	1 ea
6 in. Adjustable Wrench	1 ea
Flat Tip Screwdriver	1 ea
Vacuum Cleaner	1 ea
Cheesecloth (Item 6, Appendix E)	ar
General Purpose Detergent (Item 9, Appendix E)	ar
Paint (Items 17, 17A and 17B Appendix E)	ar
Paint Brushes	ar

Table 1-1. OPERATOR PREVENTIVE MAINTENANCE CHECKS AND SERVICES - Cont

B - Before
D - During
A - After

W - Weekly
M - Monthly
Q - Quarterly

AN - Annually
S - Semiannually
BI - Biennially

(Number) - Hundreds of Hours

ITEM NO.	INTERVAL	ITEM TO BE INSPECTED PROCEDURE	For Readiness Reporting, Equipment Is Not Ready/ Available If:
1	B	<p><u>VAN BODY - Cont</u></p> <p><u>Inspect Exterior - Cont</u></p> <p style="text-align: center;"><u>WARNING</u></p> <p>To prevent death or serious injury, do not handle or clean power cable or connectors when cable is connected to power source.</p> <p>3. Inspect power cable assembly for dirt, or damaged connectors.</p> <p>a. Wipe cable insulation with clean, dry cloth to remove dirt.</p> <p>b. Clean corrosion from terminals.</p> <div style="text-align: center;">  </div>	Connector damaged.

Table 1-1. OPERATOR PREVENTIVE MAINTENANCE CHECKS

AND SERVICES - Cont

B - Before
D - During
A - After

W - Weekly
M - Monthly
Q - Quarterly

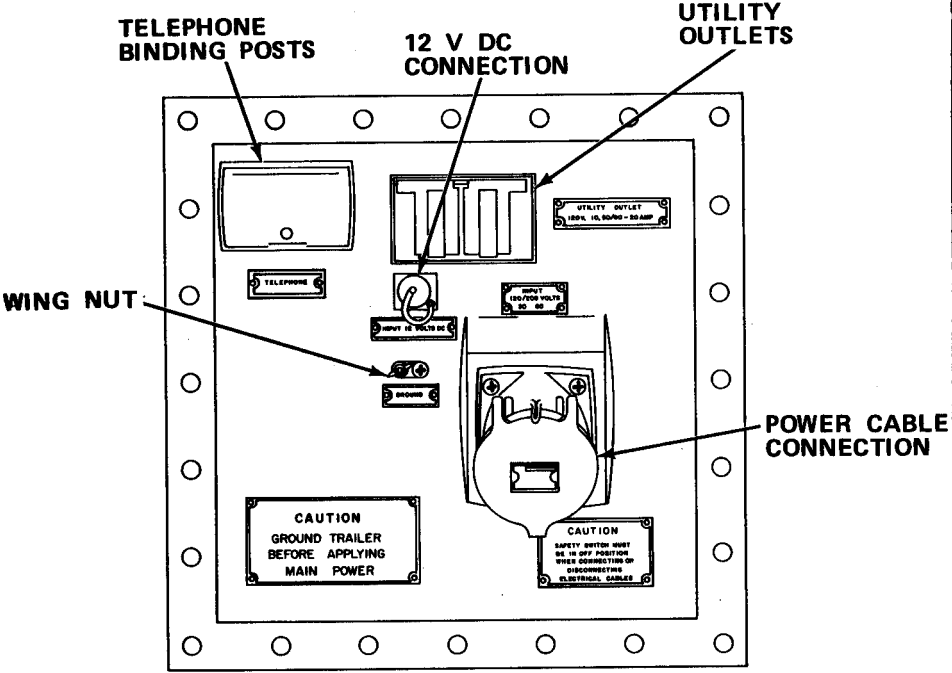
AN - Annually
S - Semiannually
BI - Biennially

(Number) - Hundreds of Hours

ITEM NO.	INTERVAL	ITEM TO BE INSPECTED PROCEDURE	For Readiness Reporting, Equipment Is Not Ready/ Available If:
1	B/W B/W	<p><u>VAN BODY - Cont</u></p> <p><u>Inspect Exterior - Cont</u></p> <p>4. Inspect power entry panel for accumulated dirt, water, or corrosion. Clean power entry panel.</p> <p>5. Inspect power entry panel to be sure any unused receptacles are covered.</p> 	Missing covers.

Table 1-1. OPERATOR PREVENTIVE MAINTENANCE CHECKS AND SERVICES - Cont

B - Before
D - During
A - After

W - Weekly
M - Monthly
Q - Quarterly

AN - Annually
S - Semiannually
BI - Biennially

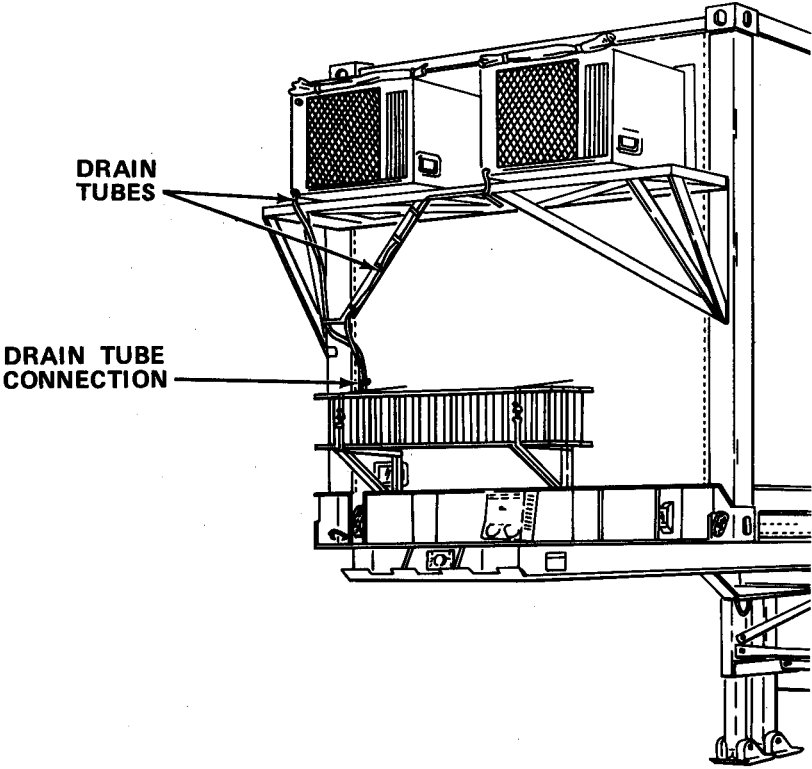
(Number) - Hundreds of Hours

ITEM NO.	INTERVAL	ITEM TO BE INSPECTED PROCEDURE	For Readiness Reporting, Equipment Is Not Ready/ Available If:
<u>VAN BODY - Cont</u>			
1	B/W	<p data-bbox="337 576 701 612"><u>Inspect Exterior - Cont</u></p> <p data-bbox="354 640 1170 768">6. Inspect air conditioner/heater drain tube to be sure tube is positioned as shown. Check for breaks and crimps in hose and check connections for damage or leakage.</p>  <p data-bbox="1040 863 1198 910">EXHAUST FAN COVER</p> <p data-bbox="984 1442 1154 1489">AIR VENT COVER</p>	
	B/W	<p data-bbox="354 1736 1235 1864">7. Inspect exhaust fan cover and air vent covers to be sure they are not blocked or clogged. Clean as required. Clean screen with vacuum cleaner as necessary.</p>	

Table 1-1. OPERATOR PREVENTIVE MAINTENANCE CHECKS AND SERVICES - Cont

B - Before
 D - During
 A - After

W - Weekly
 M - Monthly
 Q - Quarterly

AN - Annually
 S - Semiannually
 BI - Biennially

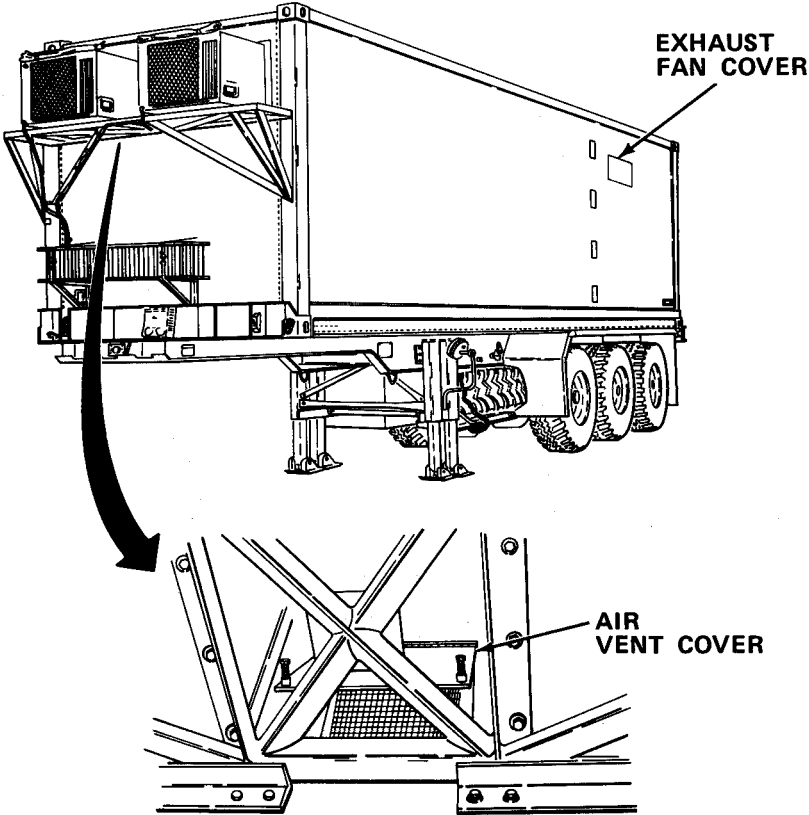
(Number) - Hundreds of Hours

ITEM NO.	INTERVAL	ITEM TO BE INSPECTED PROCEDURE	For Readiness Reporting, Equipment Is Not Ready/ Available If:
<u>VAN BODY - Cont</u>			
1	B/D/A Q W Q	<u>Inspect Exterior - Cont</u> 10. Inspect front and rear van body locks to be sure locks are fully engaged. 11. Inspect gaskets on personnel doors for leaks or damage. 11.1 Inspect hinges for proper placement of hinge pins. 12. Clean and paint blistered, pitted, or flaking areas and bare metal spots in accordance with instructions contained in TM 43-0139, Painting Instructions for Field Use.	Lock dis-engaged. Missing hinge pins.
2	B/D W W D W D B/M/A	<u>Inspect Interior.</u> 1. Test emergency lights by pressing test button. 2. Inspect power cords and cables to be sure wires are not kinked, cut, or cracked. 3. Inspect plug connectors to be sure all plug connectors are tight and firmly seated. Tighten if necessary. 4. Inspect for burned out light bulbs and fluorescent lamps. Replace as required. 5. Inspect walls, ceiling, and floor for holes, open seams, or signs of seepage or leaks. 6. Check storage cabinets for broken hinges, latches, and locks. 7. Inspect fire extinguishers. Be sure security seals are not broken.	Emergency lights do not light. Wires or cables are cracked or cut. Leaks are present. Hinge, latch, or lock is broken. Fire extinguisher is missing or seals are broken.

Table 1-1. OPERATOR PREVENTIVE MAINTENANCE CHECKS AND SERVICES - Cont

B - Before
D - During
A - After

W - Weekly
M - Monthly
Q - Quarterly

AN - Annually
S - Semiannually
BI - Biennially

(Number) - Hundreds of Hours

ITEM NO.	INTERVAL	ITEM TO BE INSPECTED PROCEDURE	For Readiness Reporting, Equipment Is Not Ready/ Available If:
2	Q	<p><u>VAN BODY - Cont</u></p> <p><u>Inspect Interior - Cont</u></p> <p>8. Inspect circuit breaker panel.</p> <p style="text-align: center;">NOTE</p> <p>Inspection is to be conducted on a not-to-interfere basis with work being conducted. Individual equipment will be inspected as directed by the appropriate chapter of this manual.</p> <div style="text-align: center;"> </div> <p>a. Set main circuit breaker to ON.</p> <p>b. Set each circuit breaker to OFF, then ON.</p>	Circuit breaker is defective.

Table 1-1. OPERATOR PREVENTIVE MAINTENANCE CHECKS AND SERVICES - Cont

B - Before
D - During
A - After

W - Weekly
M - Monthly
Q - Quarterly

AN - Annually
S - Semiannually
BI - Biennially

(Number) - Hundreds of Hours

ITEM NO.	INTERVAL	ITEM TO BE INSPECTED	PROCEDURE	For Readiness Reporting, Equipment Is Not Ready/ Available If:
2		<p><u>VAN BODY - Cont</u></p> <p><u>Inspect Interior - Cont</u></p> <p>b. Dry vertical and horizontal painted surfaces with clean cloth.</p> <p>c. Vacuum interior of section to remove dirt and waste. Pay particular attention to work stations.</p>	<p>S 11. Inspect first aid kit.</p>	

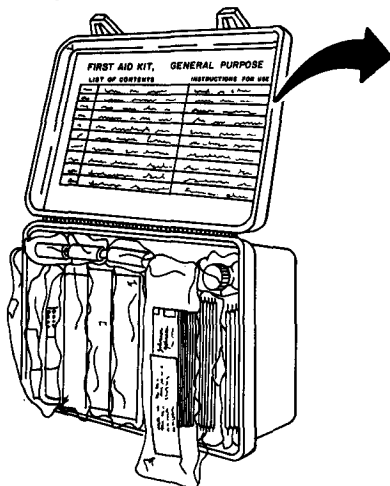

FIRST AID KIT, GENERAL PURPOSE		
LIST OF CONTENTS	INSTRUCTIONS FOR USE	
3 ROLLS	ADHESIVE TAPE, SURGICAL, 1"X1 1/2" YARDS	USE FOR MINOR CUTS AND CLOTHING REPAIR
18 EACH	BANDAGE, ADHESIVE, 5"X3"	MINOR CUTS, AS REQUIRED
2 EACH	BANDAGE, GAUZE, COMPRESSED, CAMOUFLAGED, 3"X6 YARDS	CUT IN LENGTHS AS REQUIRED FOR BANDAGE INJURIES
1 EACH	BANDAGE, MUSLIN, COMPRESSED, CAMOUFLAGED, 37X37X62 INCH	USE FOR SLING
1 PKG	BLADE, SURGICAL PREPARATION RAZOR, STRAIGHT, SINGLE EDGE, 5/8"	SHAVING HAIR AND OPENING WOUNDS AS REQUIRED
1 PKG	COMPRESS AND BANDAGE, CAMOUFLAGED, 2"X2", 4x	FOR WOUNDS
3 EACH	DRESSING, FIRST AID, FIELD, 4X7 INCHES	FOR LARGE WOUNDS, EXCESSIVE BLEEDING
1 EACH	FIRST AID KIT, EYE DRESSING	FOR EYE WOUNDS, SEE INSTRUCTIONS
1 PKG	GAUZE, PETROLATUM, 3"X36", 3x	FOR BURNS, APPLY PAD OVER BURN
1 BTL	POVIDONE, IODINE SOLUTION, W OUNCE	AS DISINFECTANT AND CLEANSER OF CUTS AND WOUNDS, APPLY BEFORE BANDAGING
1 EACH	AMMONIA INHALANTS	CRUSH INHALANT BETWEEN FINGERS. HOLD A FEW INCHES FROM NOSE. HOLD CLOSER AS AMMONIA GETS WEAKER. WHEN TOO WEAK, USE FRESH INHALANT.
1 EACH	INSTRUCTION BOOKLET AND FIRST AID EXPLANATIONS	

- Remove first aid kit from bracket.
- Remove contents.
- Inspect container for damage.
- Inspect contents for damage. Then use checklist to inventory contents.
- Replace damaged or missing items.
- Repack kit.
- Reinstall kit.

Table 1-1. OPERATOR PREVENTIVE MAINTENANCE CHECKS AND SERVICES - Cont

B - Before W - Weekly AN - Annually (Number) - Hundreds of Hours
 D - During M - Monthly S - Semiannually
 A - After Q - Quarterly BI - Biennially

ITEM NO.	IN-TERVAL	ITEM TO BE INSPECTED PROCEDURE	For Readiness Reporting, Equipment Is Not Ready/ Available If:
2	B/W	<p><u>VAN BODY - Cont</u></p> <p><u>Inspect Interior - Cont</u></p> <p>12. Inspect blackout curtains.</p> <p> a. Inspect blackout curtains and valances for tears, missing hooks, or broken eyelets.</p> <p> b. Inspect nylon hook and pile tape on curtain and wall for security of attachment.</p>	Curtains damaged.
3	B	<p><u>Inspect Air Conditioner/Heater.</u> Refer to TM 5-4120-367-14 for preventive maintenance checks and services.</p>	
4	M	<p><u>Service Power Cable.</u></p> <p style="text-align: center;"><u>WARNING</u></p> <p>Electrical shock hazard. Power cable must be de-energized before servicing. Death or serious injury may occur from failure to observe this safety precaution.</p> <p>1. Turn off safety switch.</p> <p>2. Disconnect cable from power entry panel.</p> <p>3. Wrap any cuts or abrasions in cable with electrical insulation tape.</p> <p style="text-align: center;"><u>NOTE</u></p> <p>Check to be sure cable does not endanger personnel.</p> <p>4. Reconnect power cable to entry panel.</p>	

1.6. OPERATION UNDER USUAL CONDITIONS. Operation of the Drafting Support Section consists of activation of power after the section has been located at the operation site and 12 V dc power disconnected.

1-6.1 Preparation for Use.

- a. Procedures for Leveling.

CAUTION

Trailer-mounted section must be on surface that is approximately level to avoid unnecessary stress or twisting of chassis when-section is-leveled.

NOTE

- Snow or ice should be removed from under leveling foot plate before attempting to level section.
- Sand, soft ground, or mud requires that shoring or scrap material be placed under leveling foot plate to increase surface area and prevent sinking into surface.
- Be sure that air suspension is deflated as indicated in TM 5-2330-305-14.

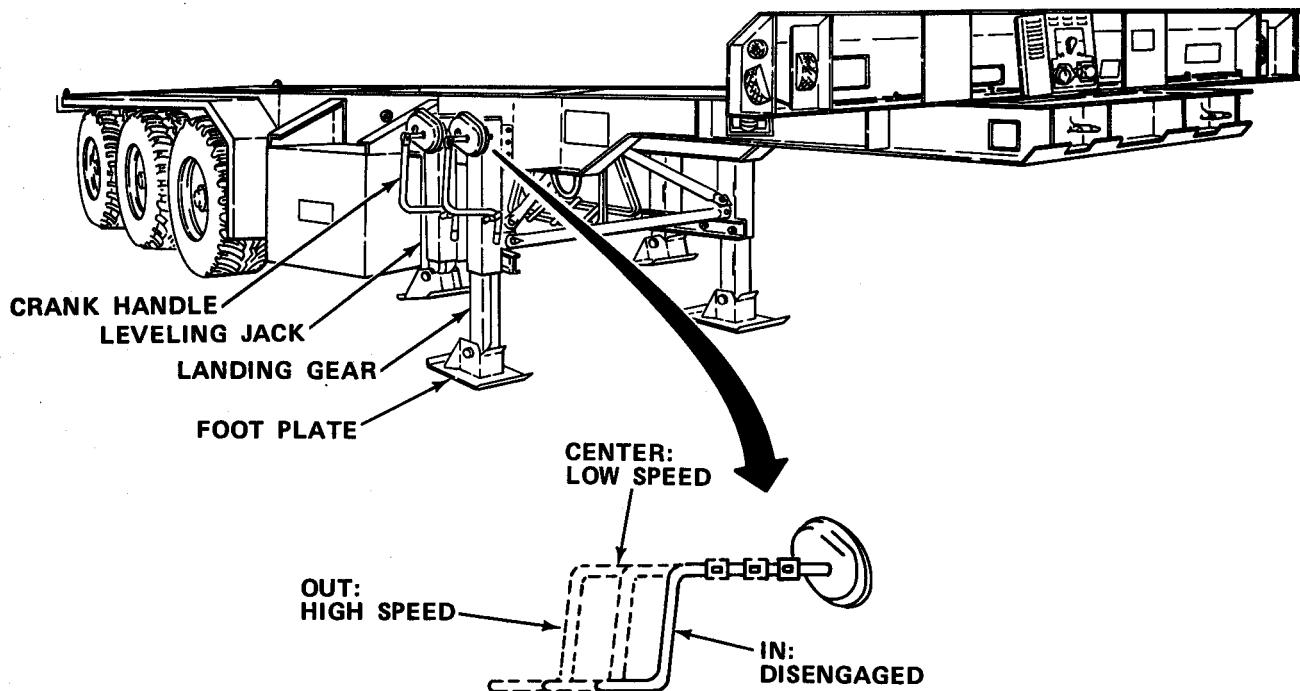

- (1) Deflate air suspension in accordance with TM 5-2330-305-14.

(2) Approximately level trailer chassis by raising or lowering landing gear.

(3) Move handle from secured location and swing out.

(4) Pull crank handle on each leveling jack all the way out and engage. There are two positions when handle is engaged. Fully out is high speed. Partially out is low speed.

(5) Lower each leveling jack by turning crank to right at high speed until foot plate just contacts ground.

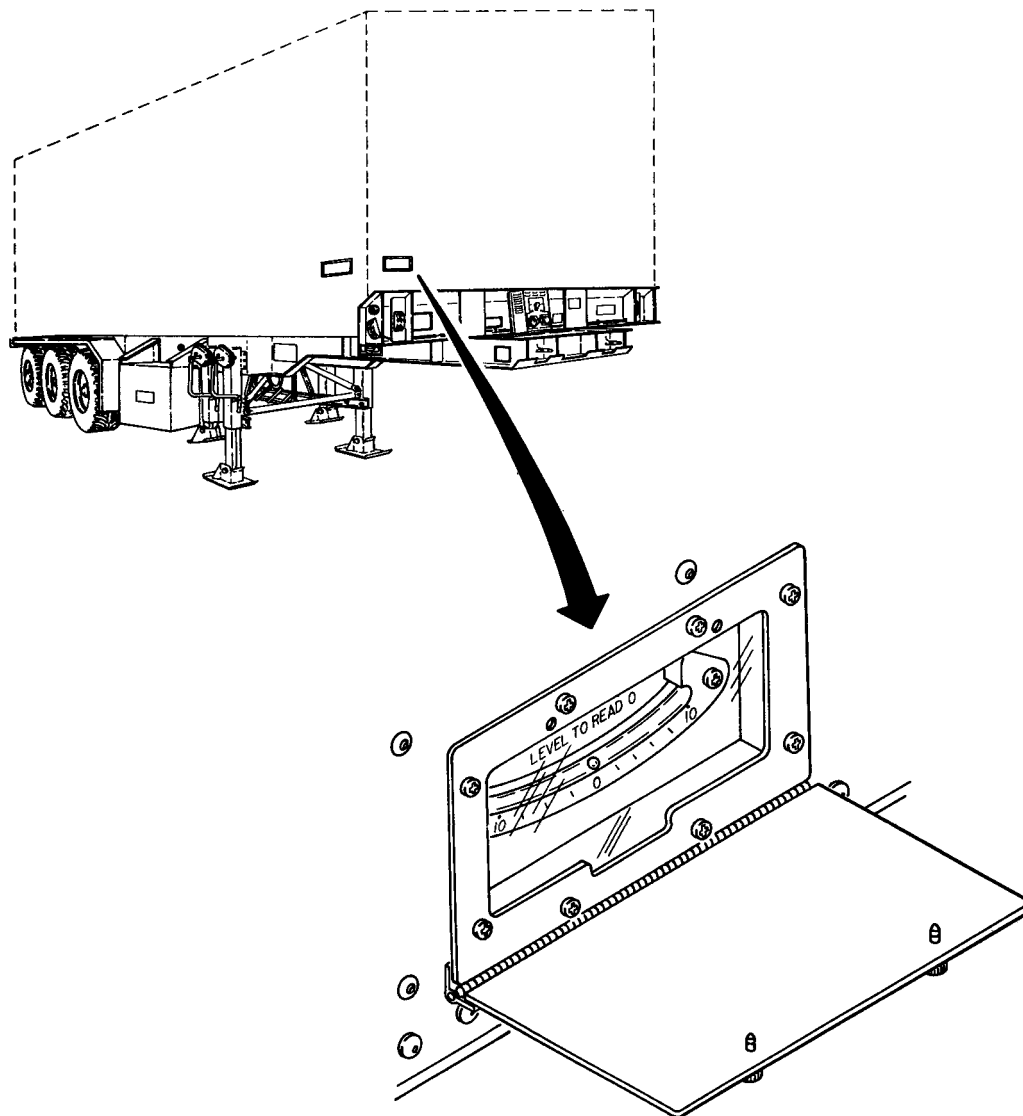

(6) Station personnel to have a clear view of level indicators at both front and rear of section.

(7) Observe level indicators to determine which end and side must be raised.

CAUTION

Do not attempt to level section by lifting at diagonal corners, or frame will be twisted.

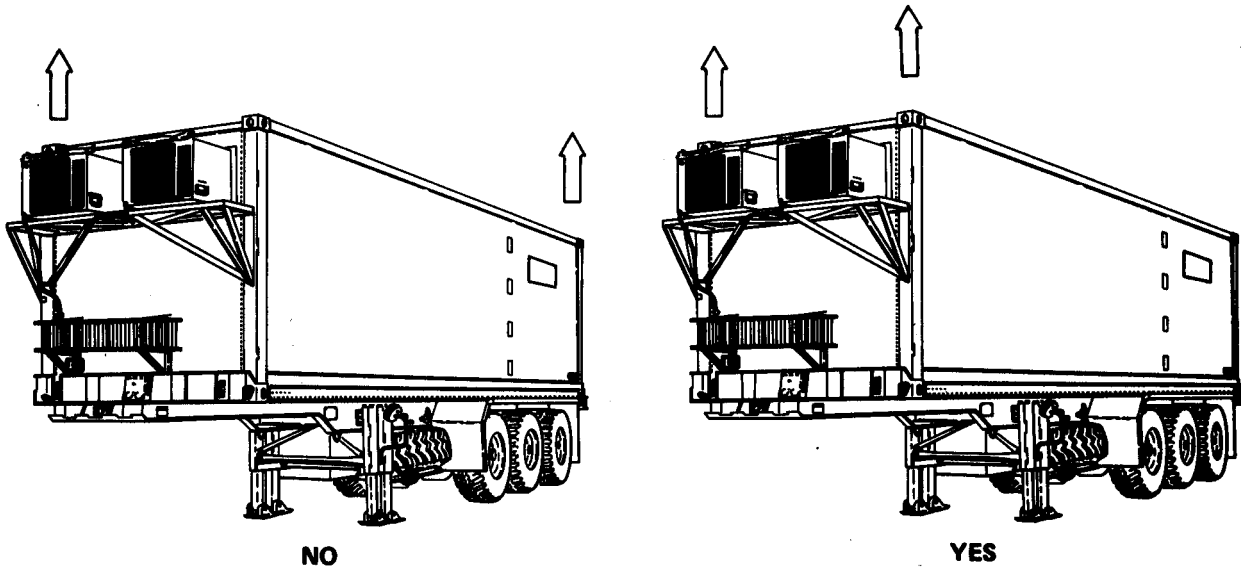

(8) Raise low end by extending both leveling jacks at low end. Use low speed.

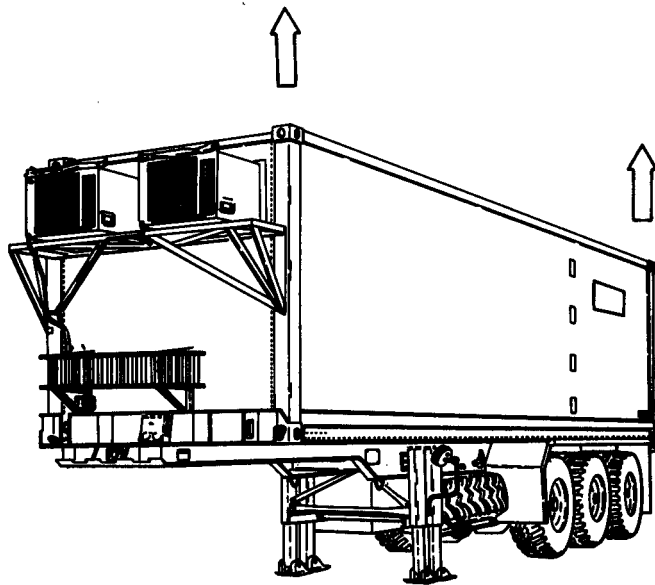

(9) Raise low side by extending both leveling jacks at low side.

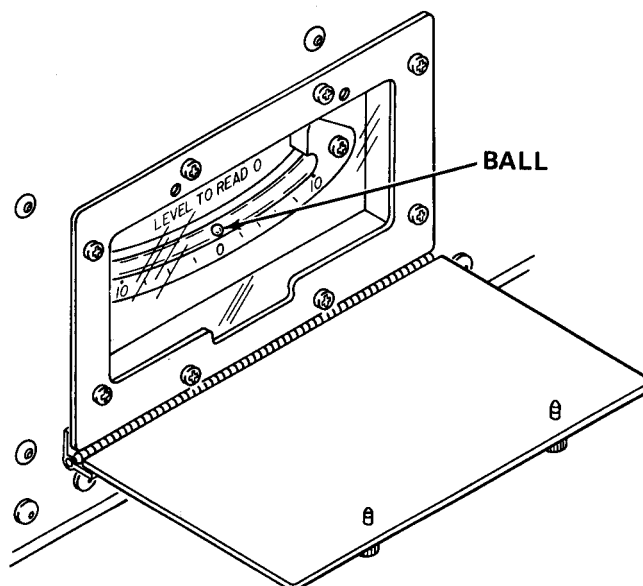

NOTE

Be sure ball is centered on all four level indicators $\pm 2^\circ$.

(10) Pull leveling crank handles away from trailer chassis, and lower crank handle to stowed position.

b. Procedures To Activate Section.

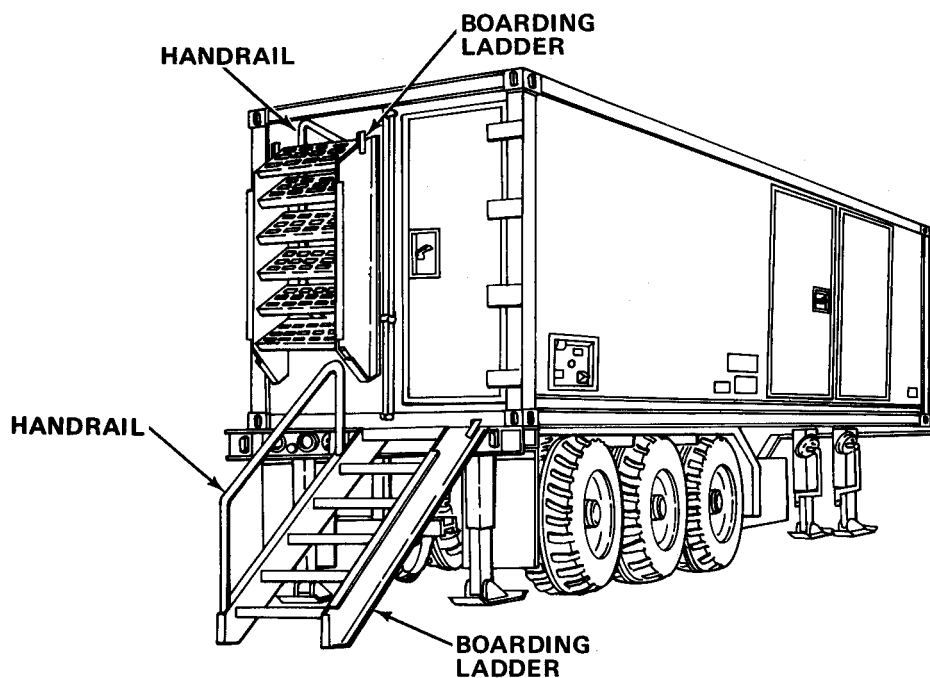

(1) Remove boarding ladders and handrails from rear of section.

(2) Remove handrails from ladders.

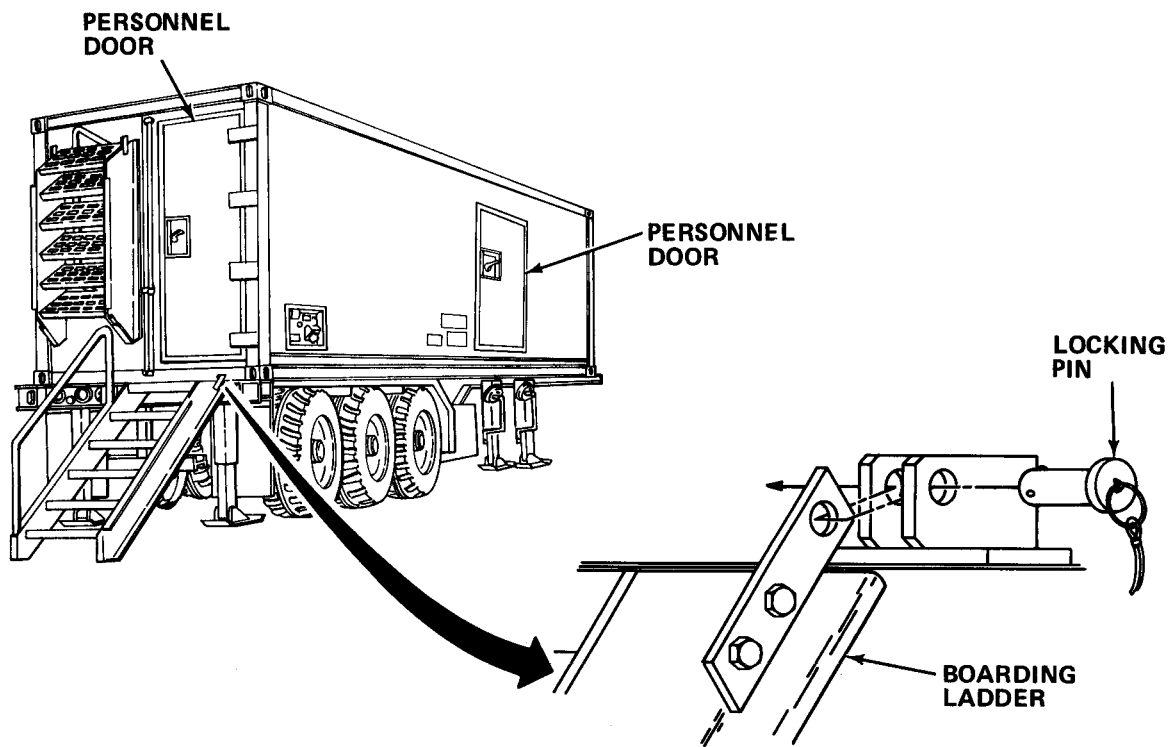

(3) Mount ladders at personnel doors and secure with locking pins.

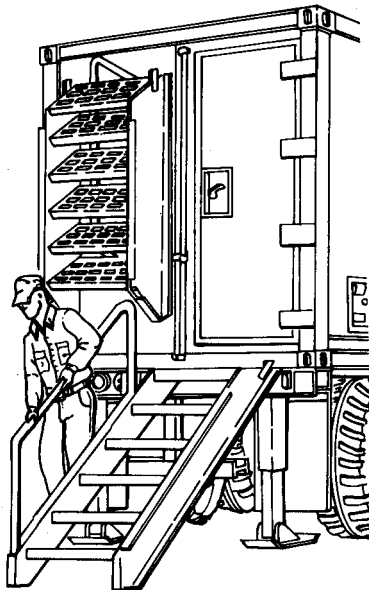

(4) Mount one handrail on each ladder.

(5) Enter section and be sure safety switch, main circuit breaker, and all equipment power supply switches are off.

WARNING

Death or serious injury may result from connecting power cable to section before grounding.

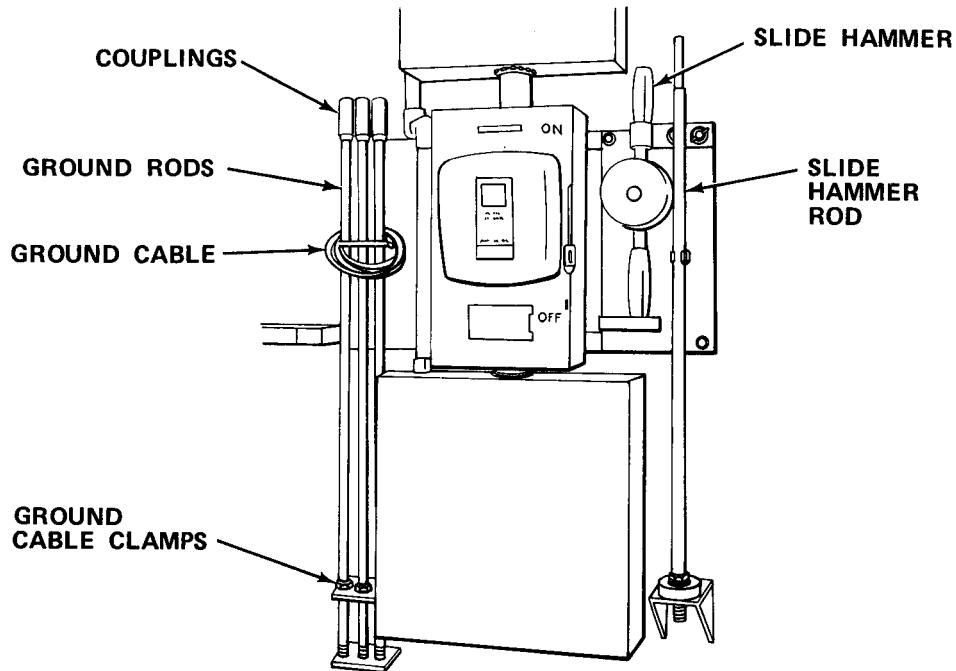

(6) Remove ground rod, slide hammer, and ground cable from section.

NOTE

- Apply a thin film of grease to threaded ends of rods before driving into ground. This will permit easy disassembly upon removal from ground.
- Bottom ground rod must be numbered or identified so that it will always be the first rod driven into the ground.
- These instructions supplement TC 11-6, Grounding Techniques.

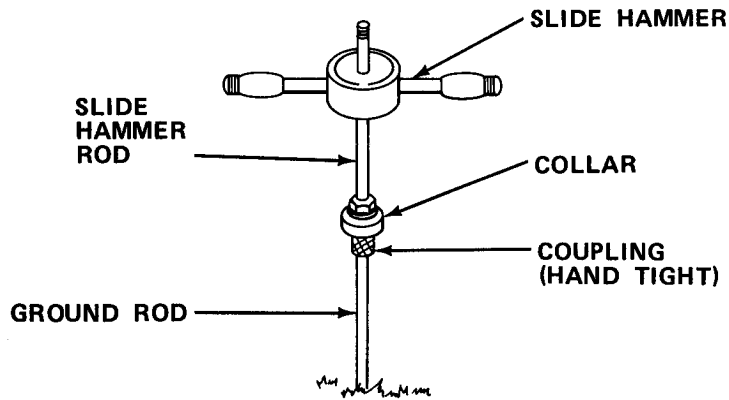

(7) Select an area as close to power entry panel as possible to install ground rod. Then assemble the first ground rod and coupling to the side hammer rod.

CAUTION

Do not allow ground rod to rotate when removing the slide hammer rod. Rods must be kept screwed together to make a good electrical ground.

NOTE

Before driving ground rod be certain that rods meet inside coupling. Be sure collar is handtight against coupling.

(8) Place slide hammer on hammer rod end, and drive ground rod into ground. Remove slide hammer rod. Attach slide hammer rod to a new section of ground rod, and repeat procedure until only 12 in. (30.5 cm) of the third rod is above ground.

(9) Remove slide hammer and hammer rod, and place in section.

(10) Secure ground cable clamp and ground cable to ground rod.

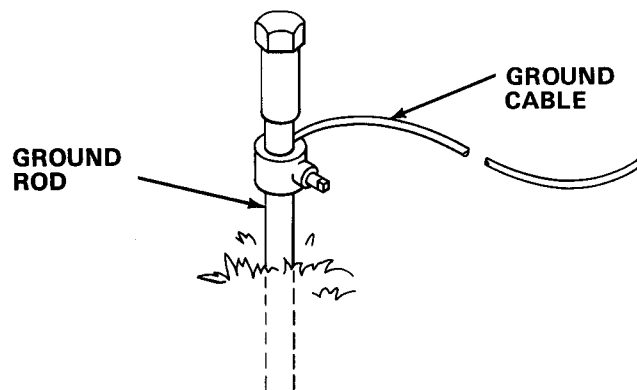

WARNING

To prevent death or serious injury, do not handle or clean power cable or connectors when cable is connected to power source.

NOTE

The section must be properly grounded before power is connected. If it is not possible to drive the three sections of ground rod fully into ground, the rods may each be driven into the ground separately and connected in series. If it is impossible to drive a ground rod, a suitable alternative ground must be found; such as a buried metal water-pipe. See TC 11-6, Grounding Techniques for additional instructions.

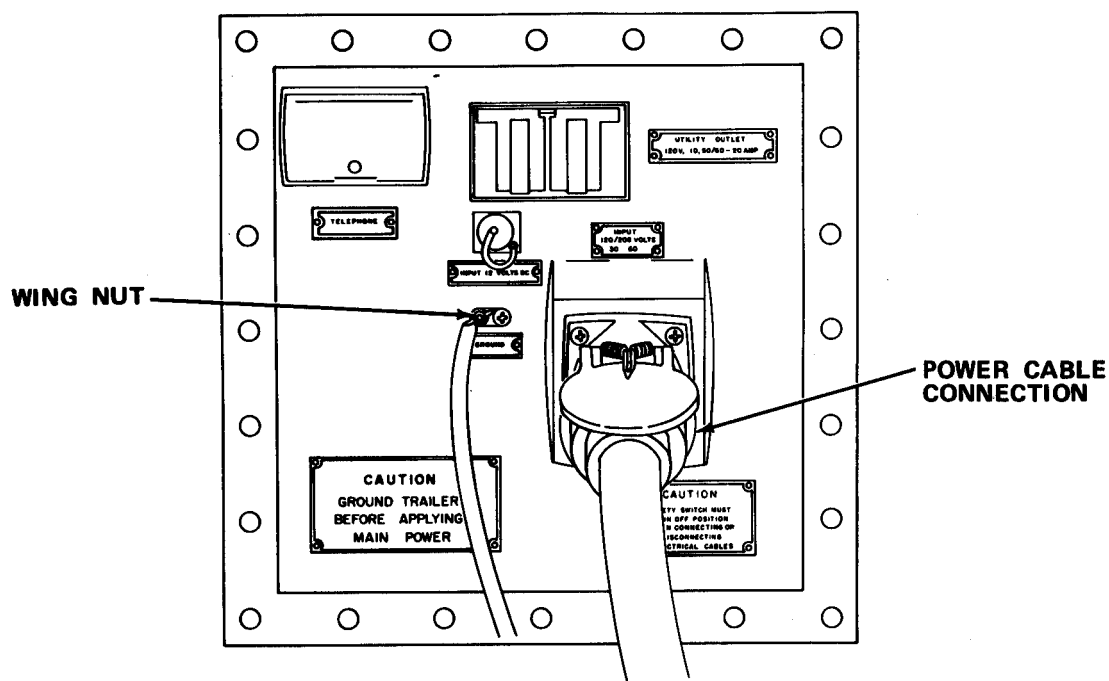

(11) Connect ground cable to ground lug with wing nut.

CAUTION

Be sure safety switch is off before connecting power cable to avoid equipment damage.

(12) Firmly connect the power cable to the power receptacle.

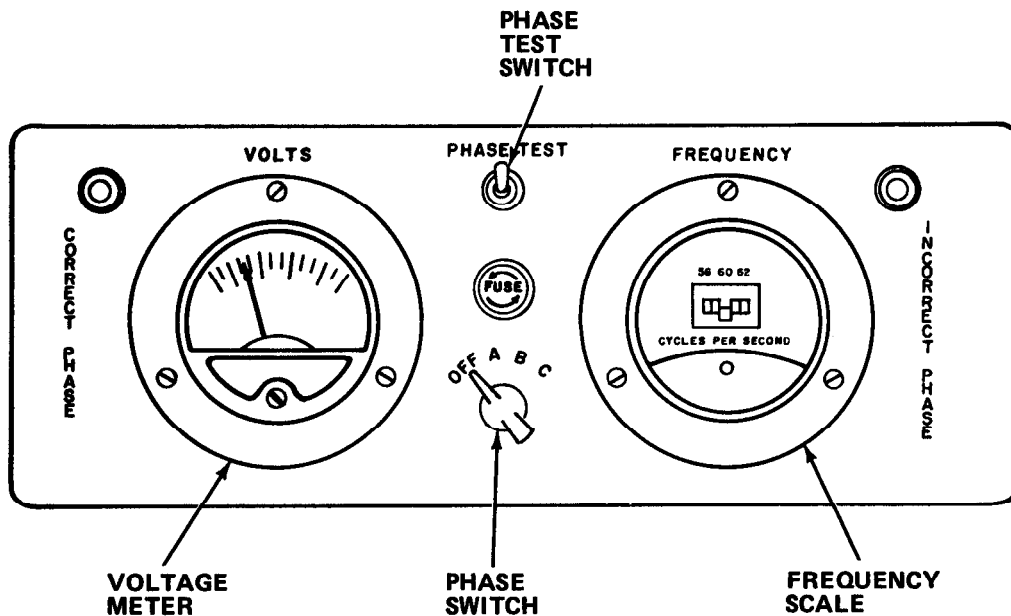

(13) Turn on safety switch.

CAUTION

Do not energize section if incorrect phase lamp lights. Damage to equipment may result.

(14) Check voltage and frequency as follows:

- (a) Push phase test switch. Observe correct phase lamp lights.
- (b) Turn phase switch to A.

CAUTION

Voltage must be between 110 and 120, and frequency must be at 60 ± 1 Hz on each leg before turning on main circuit breaker or damage to equipment may result.

- (c) Read voltage on meter.
- (d) Read frequency on scale.
- (e) Repeat for positions B and C on phase switch.

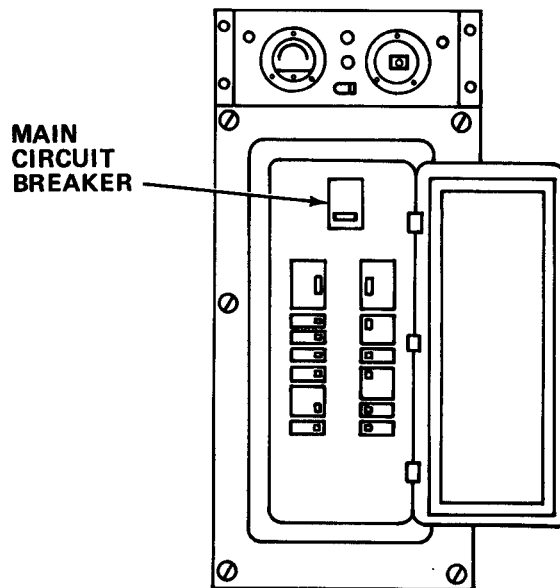

(15) Set main circuit breaker ON.

NOTE

This step must be accomplished if section is placed in operation in darkness, fog, mist, or under blackout conditions.

(16) Close blackout curtains, if required.

(17) Turn on circuit breakers in following order:

- (a) Individual lighting.
- (b) Curbside and roadside air conditioners/heaters.
- (c) Curbside and roadside receptacles.

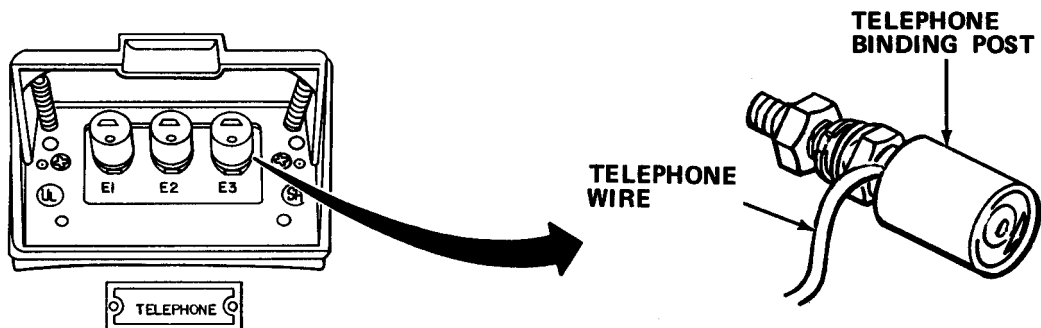

(18) Connect telephone lines to corresponding interior binding posts.

- (19) Check blackout switches.
- (20) Plug in emergency lighting and turn switch to READY.
- (21) Fully deflate air shocks until composing machine, split-stage light table, and drafting and measuring machine rests on top of air shocks.

1-6.2 Preparation for Movement.

- a. Inventory equipment and supplies.

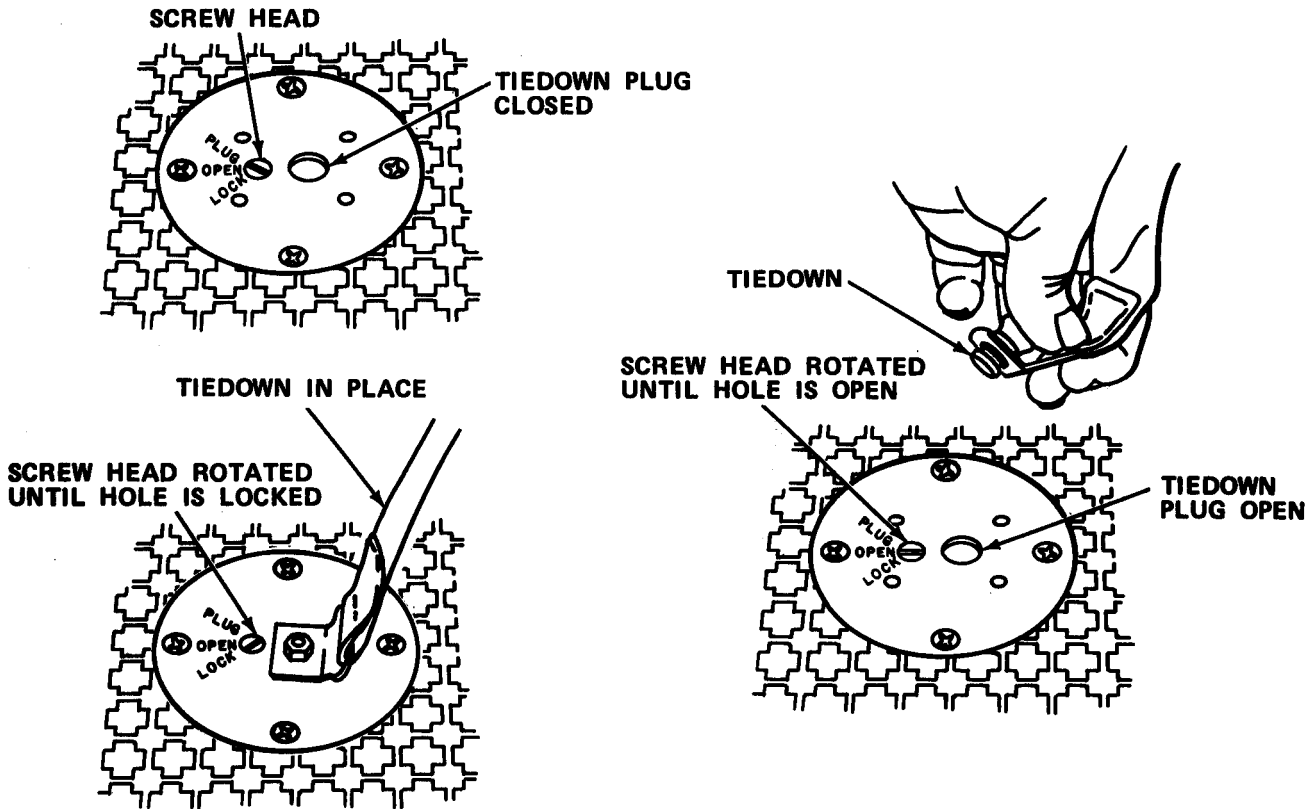

- b. Install tiedowns in tiedown sockets.
- c. Secure authorized equipment in proper containers or as specified by appropriate chapters.
- d. Secure straps and remove slack from tiedowns.
- e. Inflate shock absorbers.
 - (1) Remove all valve caps.

CAUTION

To prevent damage to equipment or air shocks during transportation, inflate air shocks correctly. Do not exceed 90 psi (620 kPa) for the composing machine, and drafting and measuring machine. Do not exceed 70 psi (483 kPa) for the split-stage light table.

- (2) Connect air hose to valve.

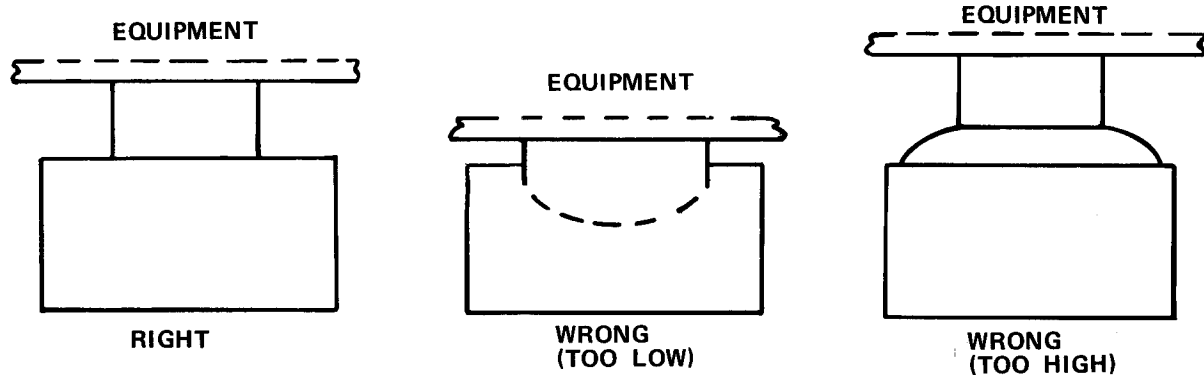

- (3) Inflate each mount until top of diaphragm is level as shown.

- (4) Reinstall valve caps.

WARNING

Death or serious injury may occur if power cable is disconnected while power is on.

- f. Turn equipment switches OFF.
- g. Turn main circuit breaker OFF.
- h. Turn safety switch OFF.
- i. Have power cable disconnected at power supply end. Then disconnect power cable from receptacle. Put cable in storage box on-trailer chassis.
- j. Turn emergency light switch OFF.
- k. Disconnect telephone cables from power entry panel.

CAUTION

To prevent loss of rod or thread damage, do not allow ground rod to rotate and unscrew when removing the slide hammer rod.

1. Remove ground rod with slide hammer, and put ground rods, couplings, and slide hammer inside section. Clean threads on each ground rod before storing.

NOTE

Be certain exhaust fan and air vent doors are securely closed.

- m. Reinspect section interior for loose equipment and close all vents.
- n. Close section. Secure and lock all personnel doors and cargo door.

NOTE

Be sure air conditioner/heater covers are down and secured.

- o. Remove handrails from boarding ladders.
- p. Remove boarding ladders and insert handrails into back of ladders.
- q. Secure ladders to back of section.
- r. Fully extend landing gear.
- s. Retract leveling jacks.
- t. Visually inspect van exterior to be sure all equipment and covers are **secured.**

1-6.3 Operating Instructions on Decals and Instruction Plates.

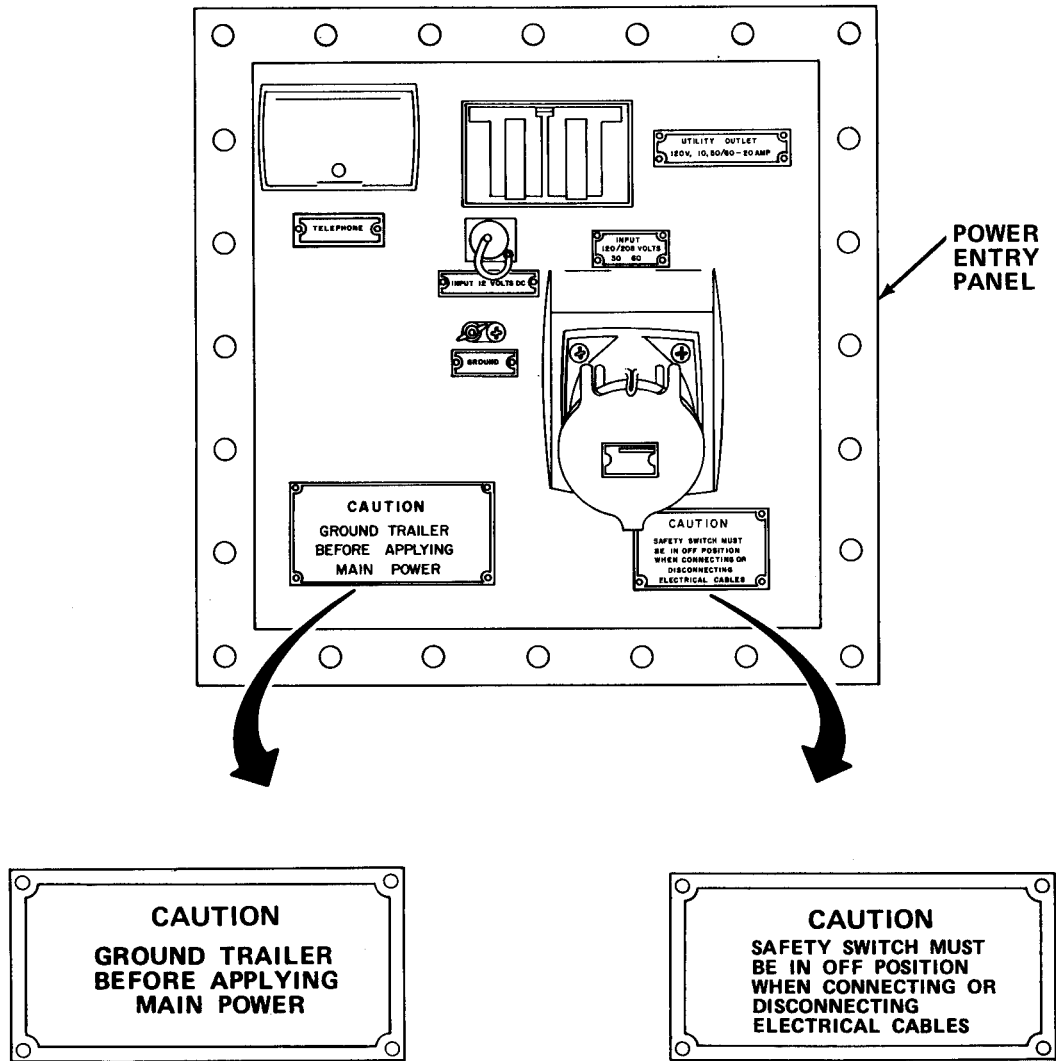

CAUTION
FOR SAFE OPERATION
SEE TM FOR PROPER
INTERNAL AND EXTERNAL
GROUNDING

**CAUTION TO START UNIT ON "COOL"
MODE AT 0°F AMBIENT
JUMPER LACO SWITCH (S-5)**

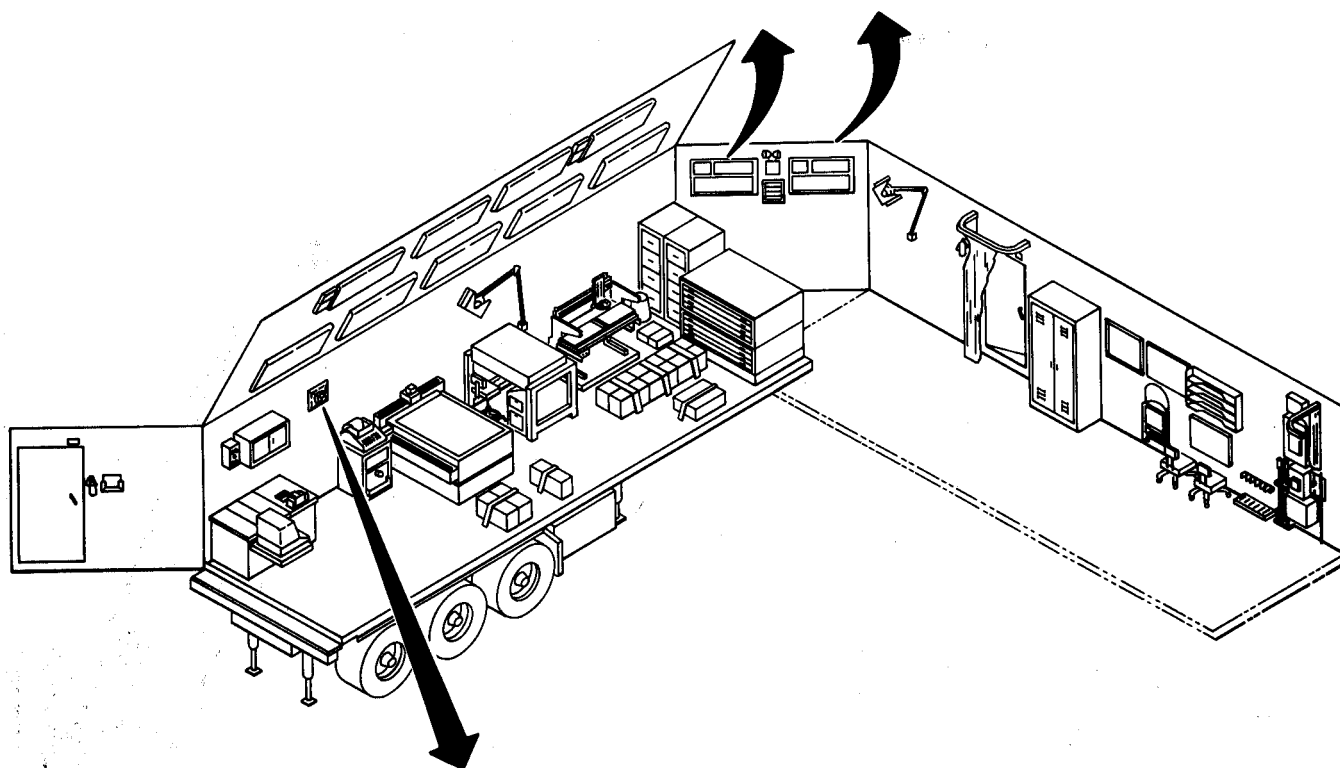

CAUTION
OPEN OUTSIDE VENT BEFORE
OPERATING FAN

CAUTION
EMERGENCY LIGHT SWITCH
MUST BE IN THE OFF POSITION
WHEN ELECTRICAL POWER
IS INTENTIONALLY DISCONNECTED

SWITCH MUST BE IN THE READY
POSITION FOR NORMAL EMERGENCY
LIGHT OPERATION

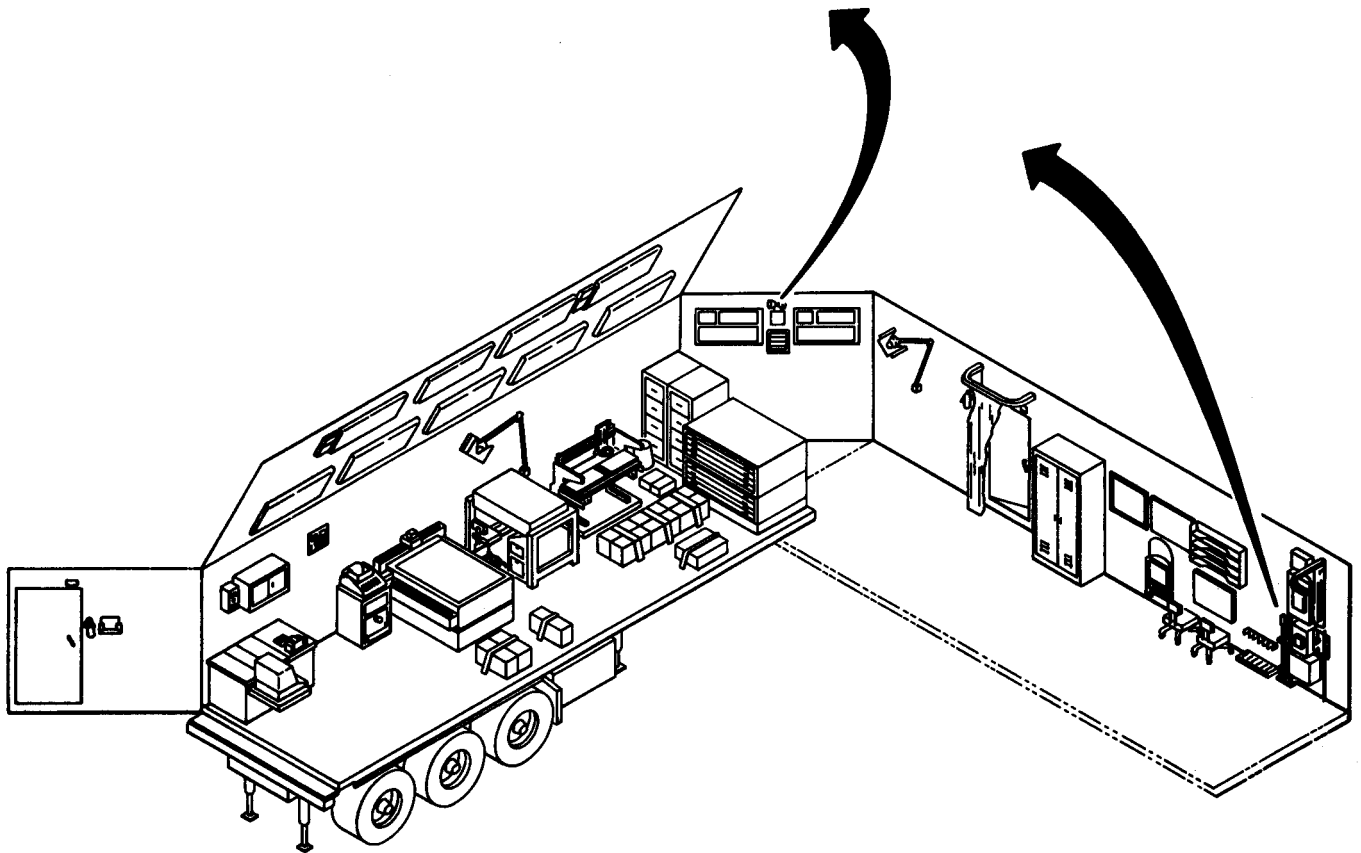

CAUTION
OPEN OUTSIDE FLAPS
PRIOR
TO OPERATING AIR COND

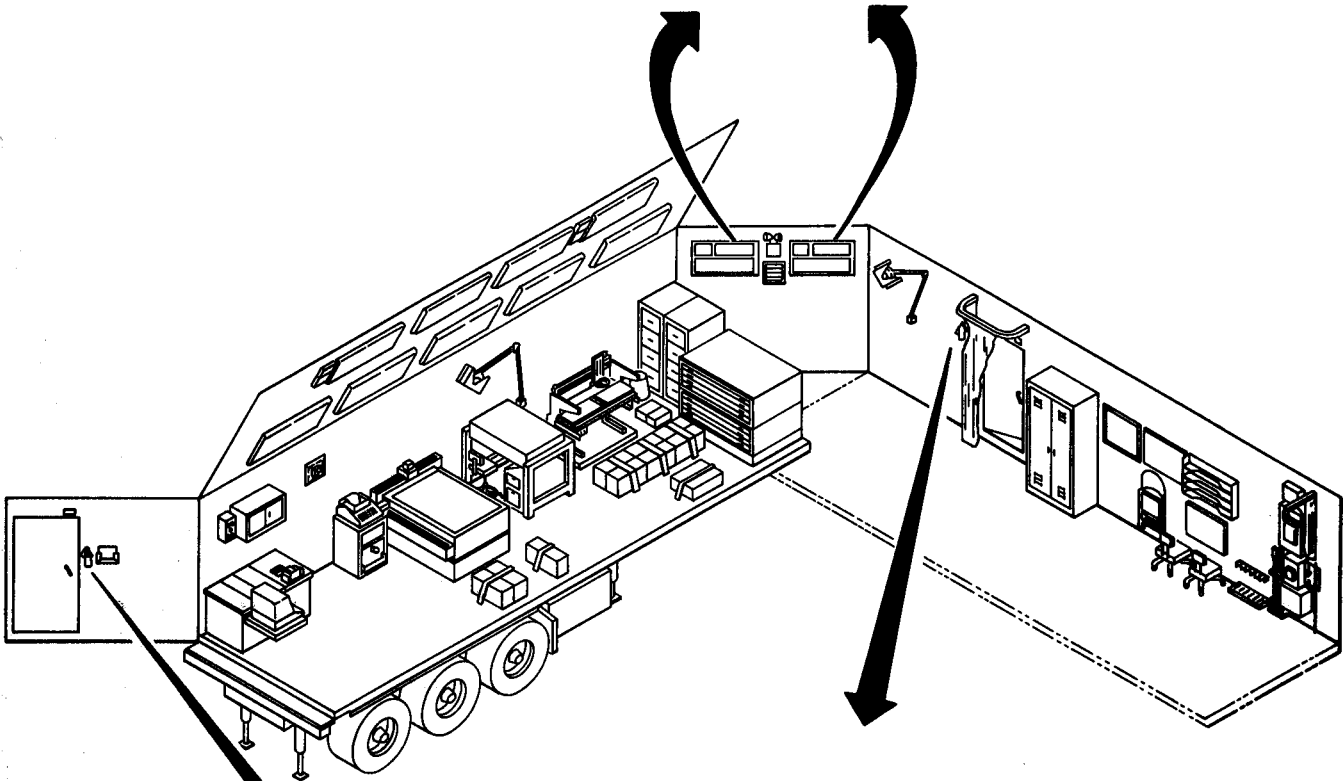

TO OPERATE

1. PULL RING PIN
2. POINT HORN CLOSE TO BASE OF FIRE
3. DEPRESS TRIGGER FOR DISCHARGE AND KEEP BASE OF FLAMES COVERED
4. AVOID BREATHING OF SMOKE
5. REMOVE VALVE AND HORN ASSEMBLY AND DISCARD USED CYLINDER

EXTINGUISHER, FIRE, CF₃BR, 2 3/4 LB

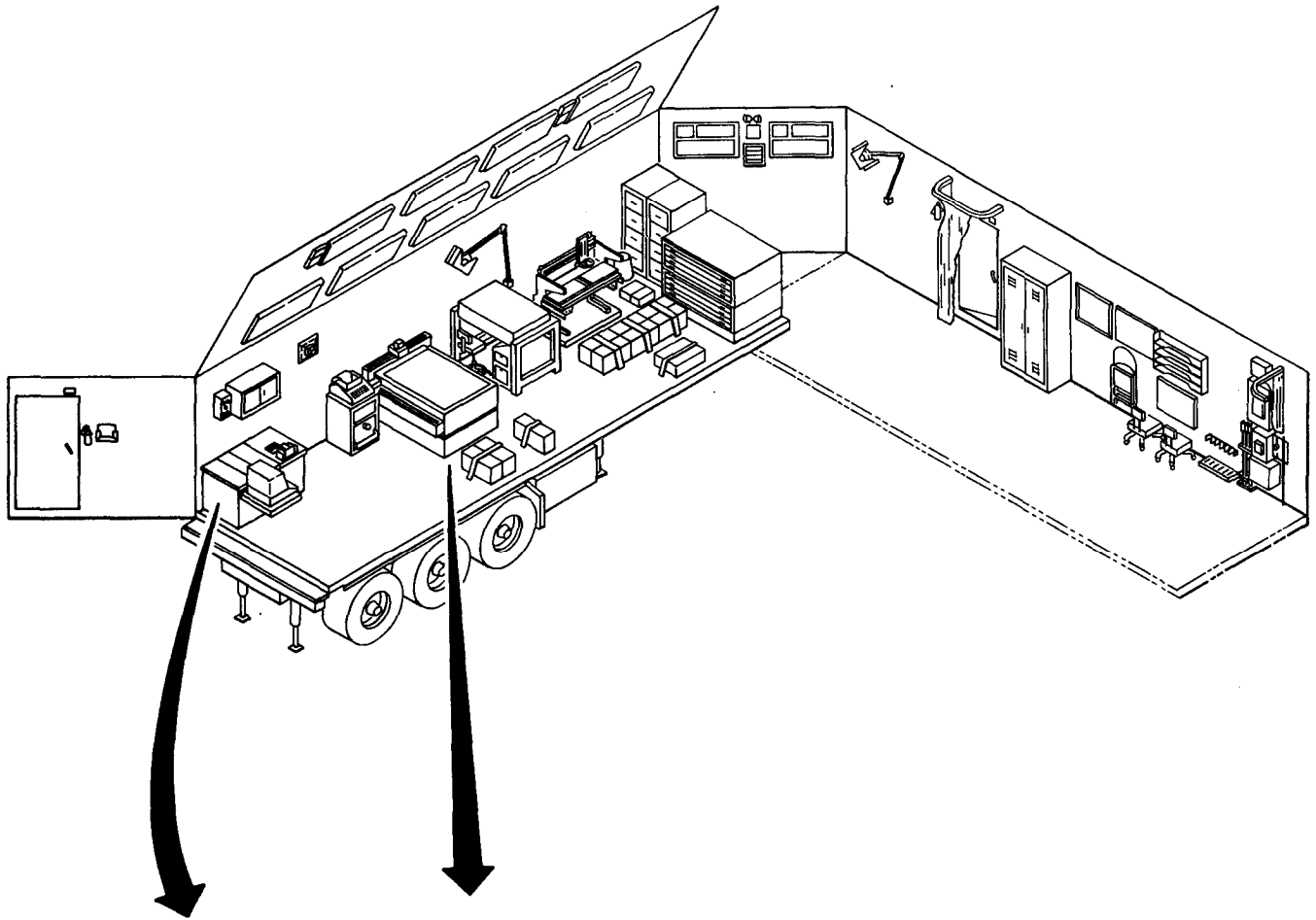

LOAD MUST BE PLACED ATOP MOUNT BEFORE INFLATING.
MAXIMUM INFLATION PRESSURES MUST NOT BE EXCEEDED.
MOUNT MUST BE DEFLATED BEFORE REMOVAL OF LOAD.

BARRY STABL-LEVL SLM-6
LOAD RATING: 150 to 600 LBS.
MAX. INFLATION 90 P.S.I.

EQUIPMENT LOAD ON MOUNT MUST BE WITHIN LOAD RATING.
EQUIPMENT MOUNTING SURFACE MUST BE, OR ADAPTED TO BE FLAT
AND OF SIZE TO COVER ENTIRE OUTSIDE DIAMETER OF MOUNT.

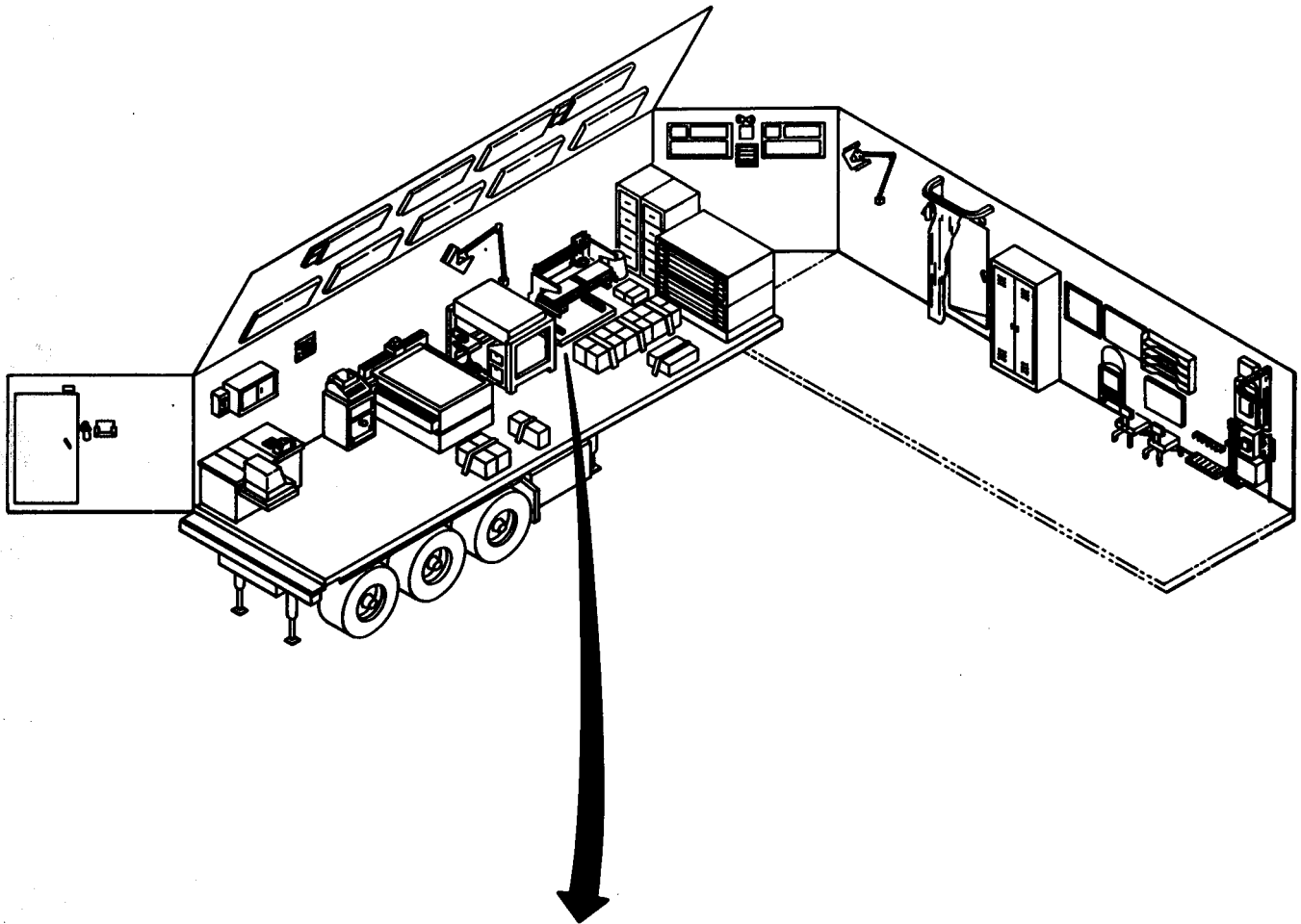

**LOAD MUST BE PLACED ATOP MOUNT BEFORE INFLATING.
MAXIMUM INFLATION PRESSURES MUST NOT BE EXCEEDED.
MOUNT MUST BE DEFLATED BEFORE REMOVAL OF LOAD.**

**BARRY STABL-LEVL SLM-3
LOAD RATING: 75 TO 300 LBS.
MAX. INFLATION 70 P.S.I.**

**EQUIPMENT LOAD ON MOUNT MUST BE WITHIN LOAD RATING.
EQUIPMENT MOUNTING SURFACE MUST BE, OR ADAPTED TO BE FLAT
AND OF SIZE TO COVER ENTIRE OUTSIDE DIAMETER OF MOUNT.**

1-7. OPERATION UNDER UNUSUAL CONDITIONS.**NOTE**

Damage to container permitting light leaks, water, or dirt entry must be temporarily repaired using available material on hand. Maintenance personnel will conduct permanent repairs; however, crew must maintain operational capability of section.

1-7.1 Operation in High Wind or Storm Conditions.

- a. Relocate section if trees or structures present hazard.

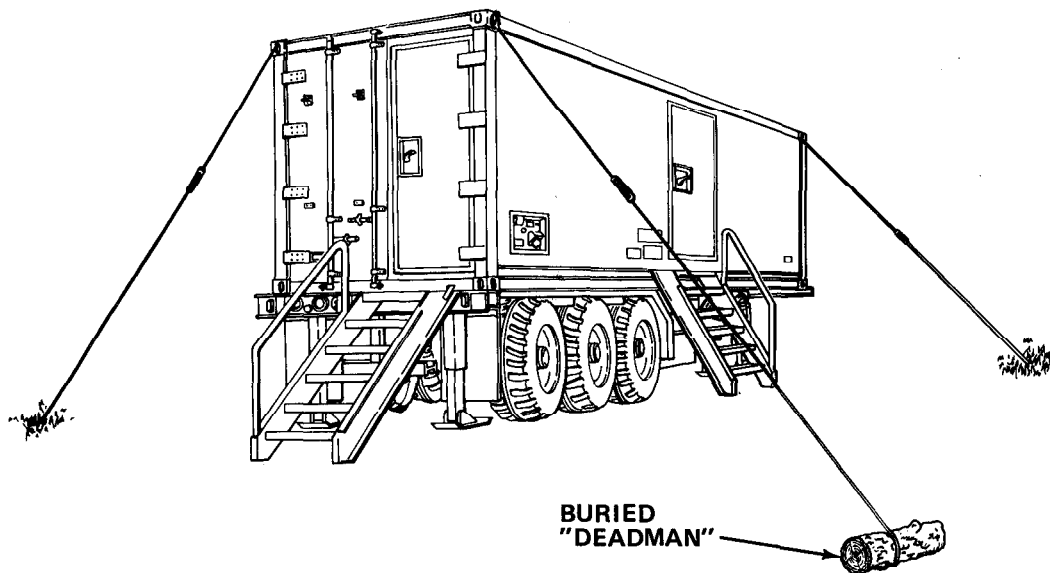
SUGGESTED METHOD OF ANCHORING THE SECTION IN HIGH WINDS

- b. Secure section corners at lifting eyes to deadmen or substantial objects.
- c. Remove all loose objects from area.

1-7.2 Operation in Cold Weather.

- a. The operation of the internal equipment is performed within environmentally controlled conditions; however, in extreme cold, the main power supply cable and grounding cable, will become hard, brittle, and difficult to handle. Be careful when connecting or disconnecting the cables so that kinks and unnecessary loops will not result in permanent damage.

b. Make certain that connections and cable receptacles on the outside of the section are free of frost, snow, and ice.

c. When section heaters are not operating or when the section is being transported, liquid consumable supplies may freeze, break their containers, then melt, and ruin equipment or documents. Store these items in an area to prevent equipment and document damage.

1-7.3 Operation in Extreme Heat. The operation of the internal equipment is performed within environmentally controlled conditions; however, during transportation or when air conditioning units are not operating, consumable supplies may suffer reduced shelf life, and internal components may have accelerated deterioration of gaskets, seals, or insulation.

1-7.4 Operation in Tropical Conditions. Fungi, mildew, or mold will form on and in equipment, documents, and supplies if internal environmental control equipment is not operating and outside heat and humidity are allowed to enter the section.

1-7.5 Operation in Desert Conditions. Dust, grit, and sand will ruin supplies, equipment, and documents. Extreme care must be taken to prevent dust, grit, and sand from entering the section. Air filters will be changed whenever airflow is restricted, and cleaning of section interior must be conducted more frequently than specified by PMCS schedules.

1-7.6 Emergency Procedures. There are no specific emergency procedures for operation of the section.

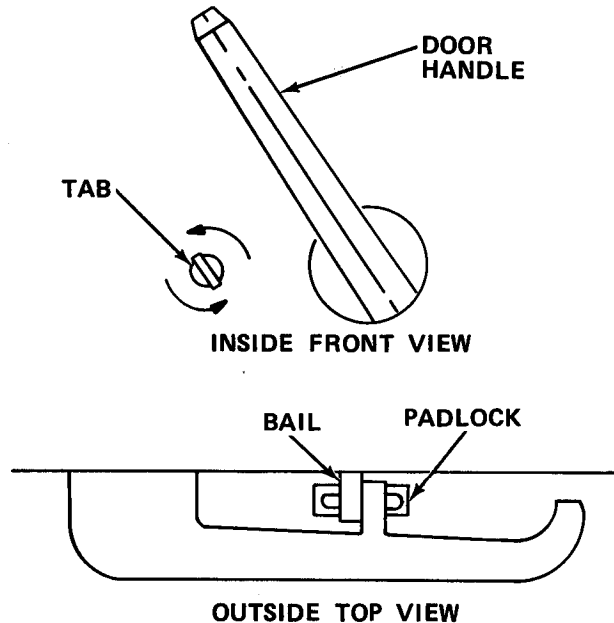

1-7.7 Emergency Means of Exit. In the event personnel are locked in the section, the tab may be turned to the left until the bail on the padlock falls free. The door handle is now free to turn.

Section III OPERATOR MAINTENANCE

1-8. LUBRICATION INSTRUCTIONS.

a. Lubrication instructions for the Drafting Support Section are contained in LO 5-6675-316-12, Lubrication Order, Drafting Support Section, Topographic Support System. The intervals and man-hours specified in the Lubrication Order are based on normal operations. During inactive periods, lubrication periods may be extended with adequate preservation.

b. Topographic equipment and all optical equipment require special care in lubrication. When a specified lubricant is called for, substitutions are not authorized. Minimum amounts of lubricant are to be used and all excess lubricant is to be immediately removed. Spray lubricants must not be used in the vicinity of optical equipment unless optics are completely protected. No lubricant is to be applied unless a thorough cleaning is conducted first to remove dirt, dust, or abrasive material.

c. Be sure that you refer to the appropriate chapter before any equipment is stored after use, that the temperature has stabilized, and that lubrication required after use is accomplished.

1-9. TROUBLESHOOTING PROCEDURES.

a. The table lists the common malfunctions which you may find during operation or maintenance of the Drafting Support Section, or its components. You should perform the test/inspections and corrective actions in the order listed.

b. This manual cannot list all malfunctions that may **occur**, nor all test or inspections and corrective actions. If a malfunction is not listed or is not corrected by listed corrective actions, notify your supervisor.

Table 1-2. TROUBLESHOOTING

MALFUNCTION	TEST OR INSPECTION	CORRECTIVE ACTION
-------------	--------------------	-------------------

1. NO ELECTRICAL POWER TO SECTION.

WARNING

Death or serious injury may result. Do not perform any electrical maintenance or make electrical connections or disconnections at main power receptacle when power cable is energized.

Step 1. Observe voltage and frequency for phases A, B, and C. Read $115 \pm 5V, 60 \pm 1 \text{ Hz}$.

- (a) If voltage and frequency are correct, proceed to step 2.
- (b) If voltage and frequency are incorrect, notify power supply supervisor.

CAUTION

Do not energize section if voltage or frequency is not correct. Damage to equipment may result.

Step 2. Press phase test switch on power panel for A, B, and C.

- (a) If phases A, B, and C are correct, proceed to step 3.
- (b) If incorrect phase lamp lights, notify power supply supervisor.

CAUTION

Do not energize section if incorrect phase lamp lights. Damage to equipment may result.

Step 3. Check safety switch position.

- (a) If safety switch is ON, proceed to step 4.
- (b) If safety switch is OFF, turn ON.

Table 1-2. TROUBLESHOOTING - Cont

MALFUNCTION	TEST OR INSPECTION	CORRECTIVE ACTION
1. NO ELECTRICAL POWER TO SECTION - Cont	Step 4. Check main circuit breaker position.	<ul style="list-style-type: none"> (a) If circuit breaker is ON, refer to direct/general support maintenance. (b) If circuit breaker is OFF, turn ON. (c) If circuit breaker trips repeatedly, notify power supply supervisor.
2. NO ELECTRICAL POWER TO EQUIPMENT.	Step 1. Check equipment power switch.	<ul style="list-style-type: none"> (a) If power switch is ON, proceed to step 2. (b) If power switch is OFF, turn ON.
	Step 2. Check power cord.	<ul style="list-style-type: none"> (a) If power cord is plugged in, proceed to step 3. (b) If power cord is unplugged, plug in.
	Step 3. Inspect circuit breaker panel for breakers in OFF position.	<ul style="list-style-type: none"> (a) If all circuit breakers are ON, refer to direct/general support maintenance. (b) If any circuit breakers are OFF, turn ON.

Table 1-2. TROUBLESHOOTING - Cont

MALFUNCTION

TEST OR INSPECTION

CORRECTIVE ACTION

3. BLACKOUT SWITCH DOES NOT OPERATE.

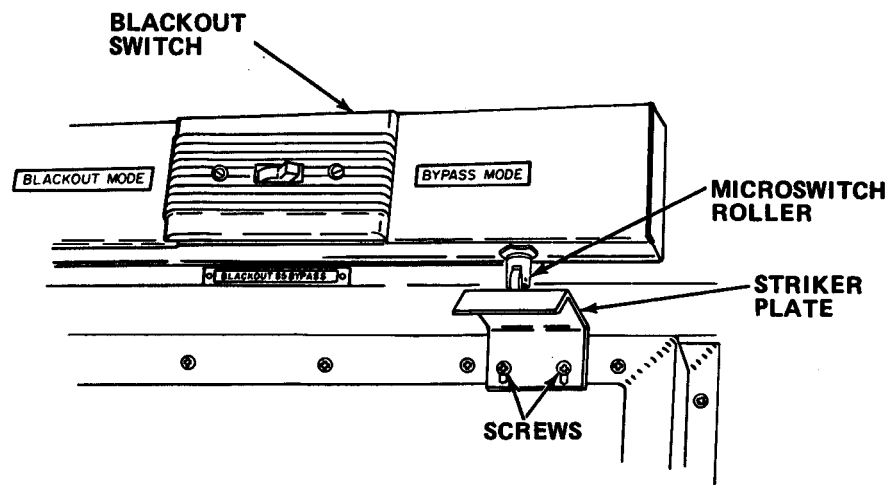

Step 1. Check blackout switch position.

- (a) If switch is ON, proceed to step 2.
- (b) If switch is OFF, reset switch to BLACKOUT.

Step 2. Check to see that striker plate contacts roller on microswitch.

- (a) Loosen screws, and move plate up or down until microswitch operates.
- (b) If blackout switch still fails to operate, refer to organizational maintenance.

1-10. MAINTENANCE PROCEDURES.

This section contains instructions covering operator maintenance functions for the Drafting Support Section. Personnel required are listed only if the task requires more than one.

b. After completing each maintenance procedure, perform operational check to be sure that equipment is properly functioning.

I N D E X

PROCEDURE	PARAGRAPH
Repl ace Fl uorescent Lamp	1-10. 1
Servi ce Venti lati on Ducts	1-10. 2
Repl ace Bl ackout/Dome Li ght	1-10. 3



1-10.1 Replace Fluorescent Lamp

MOS: 81C, Cartographer

TOOLS: None

SUPPLIES: Fluorescent Lamp

WARNING

Death or serious injury may result if power is left on while servicing

- a. Turn switch OFF.

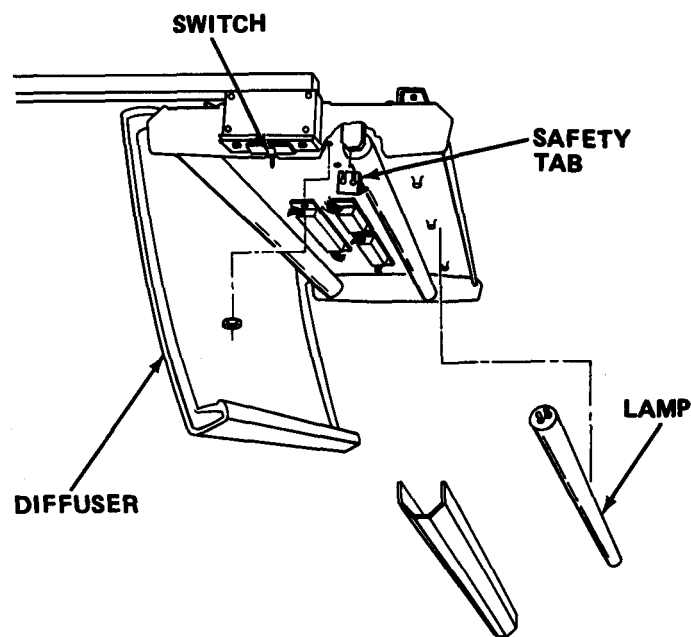

- b. Gently pull diffuser from light bracket, and place diffuser out of the way to prevent damage.
- c. Remove safety tab from lamp socket.
- d. Rotate defective lamp until prongs are free from slot and remove.
- e. Insert new lamp prongs into slot and rotate 90 degrees.
- f. Reinstall safety tab into lamp socket.
- g. Reinstall diffuser.
- h. Turn power ON.

1-10.2 Service Ventilation Ducts.

MOS : 81C, Cartographer

TOOLS: Vacuum Cleaner
Flat Tip Screwdriver

SUPPLIES: None

- a. Cover equipment to prevent dust from entering equipment.
- b. Close all doors and cabinets.
- c. Remove any documents or other work that may be damaged by dirt/dust.
- d. Turn off air conditioner/heater.

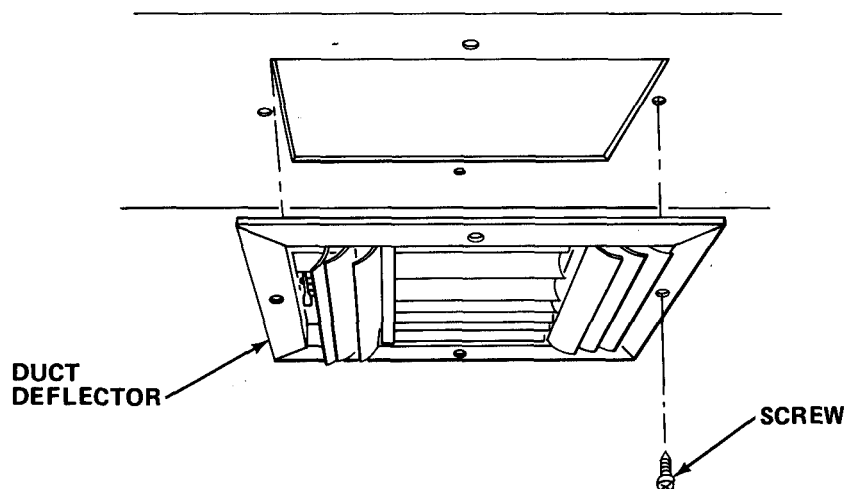

- e. Remove four screws from each ventilation duct deflector.
- f. Remove all duct deflectors.
- g. Vacuum dirt or dust from deflector louvers.
- h. Insert vacuum cleaner probe into ventilation duct at each deflector hole, and vacuum as far as probe will reach.
- i. Reinstall deflectors and secure with four screws.
- j. Turn on air conditioner/heater.
- k. Vacuum any dislodged dirt or dust from interior of section.
- l. Remove covers for operation.

1-10.3 Replace Blackout/Dome Light.

MOS: 81C, Cartographer

TOOLS: None

SUPPLIES: Lamp (12 V)
Silicone Spray (Item 25, Appendix E)

NOTE

Blackout light and dome light are sealed units. No bulb replacement is possible. Complete light must be replaced.

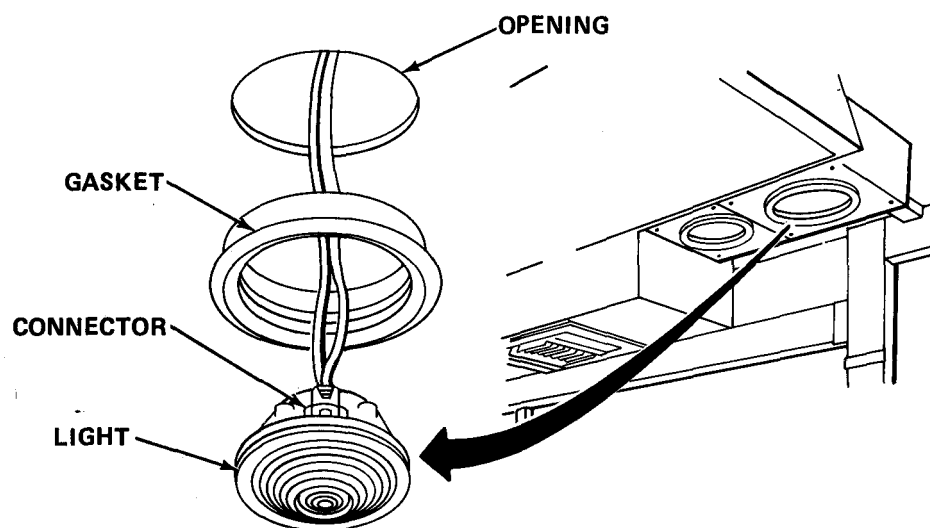

- a. Push light and gasket up into opening.
- b. Tilt and remove light and gasket from opening.
- c. Disconnect defective light from connector.
- d. Connect new light to connector.
- e. Reinstall gasket in opening.

NOTE

The use of silicone spray on the gasket will help to position light.

- f. Position light in gasket and push in.

Section IV ORGANIZATIONAL MAINTENANCE

1-11. LUBRICATION INSTRUCTIONS. This equipment does not require lubrication at this level of maintenance.

1-12. REPAIR PARTS, SPECIAL TOOLS; TEST, MEASUREMENT, AND DIAGNOSTIC EQUIPMENT (TMDE); AND SUPPORT EQUIPMENT.

1-12.1 Common Tools and Equipment. For authorized common tools and equipment, refer to the Modified Table of Organization and Equipment (MTOE) applicable to your unit.

1-12.2 Special Tools; Test, Measurement, and Diagnostic Equipment; and Support Equipment. Special Tools, TMDE, and Support Equipment is listed in the applicable repair parts and special tools list and in Appendix B of this manual.

1-12.3 Repair Parts. Repair parts for this equipment are listed in the Repair Parts and Special Tools List, TM 5-6675-316-24P covering organizational maintenance for this equipment.

1-13. SERVICE UPON RECEIPT.

NOTE

The section may be received mounted on a chassis, or as a van body for mounting on an available transporter, or on site. Inspection of the chassis is covered in TM 5-2330-305-14. Inspection of the air conditioner/heater is covered in TM 5-4120-367-14.

1-13.1 Checking Unpacked Equipment.

Inspect the equipment for damage incurred during shipment. If the equipment has been damaged, report the damage on DD Form 6, Packing Improvement Report.

(1) Visually inspect the section exterior starting at the rear to cover rear, curbside, roadside, front, top, and bottom. Inspect for damage, tears, breaks or corrosion.

(2) Enter section and inspect for broken equipment, tool boxes, chairs, or equipment loose and not secured.

(3) Close doors and vents to determine if light leaks exist.

(4) Inspect doors for damage, torn or rotted seals, and tightness of closure.

(5) Inspect interior for evidence of water damage, fungi, mildew or corrosion.

(6) Report damage or discrepancies in accordance with AR 735-11 and AR 735-11-2.

- b. Check the equipment against the packing list to see if shipment is complete.

Report all discrepancies in accordance with the instructions of DA Pam 738-750.

(1) Inventory section against Components of End Item and Basic Issue Items Lists (Appendix C).

(2) Inventory expendable supplies contained in section as shown in Appendix E.

(3) Conduct operational checks on equipment in accordance with the chapters in this manual when operators are available and power can be safely provided to the van body.

- c. Check to see whether the equipment has been modified.

1-14. ORGANIZATIONAL PREVENTIVE MAINTENANCE CHECKS AND SERVICES.

PMCS are designed to keep the equipment in good working condition by performing certain tests, inspections, and services. The intervals provide you, the organizational technician, with time schedules that determine when to perform specified tasks.

b. Item number column. Item numbers are assigned in chronological ascending sequence regardless of interval designation. These numbers are used for your "TM Number" column on DA Form 2404, Equipment Inspection and Maintenance Worksheet, in recording the results of PMCS.

Interval columns. This column determines the time period designated to perform your PMCS.

d. Item to be inspected and Procedures column. This column lists functional groups and their respective assemblies and subassemblies as shown in the Maintenance Allocation Chart (Appendix B). The appropriate check or service procedure follows the specific item to be inspected.

Preventive maintenance checks and services for the air conditioners/heaters are contained in TM 5-4120-367-14.

f. List of tools and materials required for PMCS is as follows:

<u>Item</u>	<u>Quantity</u>
Vacuum Cleaner	1 ea
8 in. Adjustable Wrench	1 ea
Cross Tip Screwdriver	1 ea
Flat Tip Screwdriver	1 ea
Spring Scale	1 ea
Padlock	1 ea
Flashlight	1 ea

Table 1-3. ORGANIZATIONAL PREVENTIVE MAINTENANCE CHECKS AND SERVICES

B - Before W - Weekly AN - Annually (Number) - Hundreds of Hours
 D - During M - Monthly S - Semiannually
 A - After Q - Quarterly Bl - Biennially

ITEM NO.	INTERVAL	ITEM TO BE INSPECTED PROCEDURE
<u>VAN BODY</u>		
1	M	<u>Service Air Conditioner/Heater.</u> Refer to TM 5-4120-367-14 for preventive maintenance checks and services.
2	M	<p data-bbox="294 700 683 734"><u>Service Lighting System.</u></p> <div data-bbox="294 734 1321 1276"> </div> <p data-bbox="677 1319 826 1361" style="text-align: center;"><u>WARNING</u></p> <p data-bbox="404 1393 1115 1585">Do not open circuit breaker panel or service electrical connections, cables or switches until main power is off, and voltage meter confirms circuit is not energized. Death may result from failure to observe these safety precautions.</p> <ol data-bbox="305 1606 1247 1868" style="list-style-type: none"> 1. Turn off main circuit breaker. Turn off safety switch. 2. Padlock safety switch. 3. Tighten all loose screws, bolts, and clamps. 4. Check which switches, switch plate outlets, receptacles, and posts require repair.

Table 1-3. ORGANIZATIONAL PREVENTIVE MAINTENANCE CHECKS AND SERVICES - Cont

B - Before
D - During
A - After

W - Weekly
M - Monthly
Q - Quarterly

AN - Annually
S - Semiannually
BI - Biennially

(Number) - Hundreds of Hours

ITEM NO.	INTERVAL	ITEM TO BE INSPECTED	PROCEDURE
<u>VAN BODY - Cont</u>			
2	M	<u>Service Lighting System - Cont</u>	5. Check for loose screws and nuts on ceiling, console lights, circuit breaker panels, and conduits. 6. Remove padlock. 7. Turn on main circuit breaker and safety switch.
3	M	<u>Service Air Vent.</u>	 <ol style="list-style-type: none"> 1. Remove screws from front of grille. 2. Remove front grille. 3. Using vacuum cleaner, clean screens on side doors. Vacuum inside of air vent. 4. Reinstall grille and secure with screws.

Table 1-3. ORGANIZATIONAL PREVENTIVE MAINTENANCE CHECKS AND SERVICES - Cont

B - Before
D - During
A - After

W - Weekly
M - Monthly
Q - Quarterly

AN - Annually
S - Semiannually
BI - Biennially

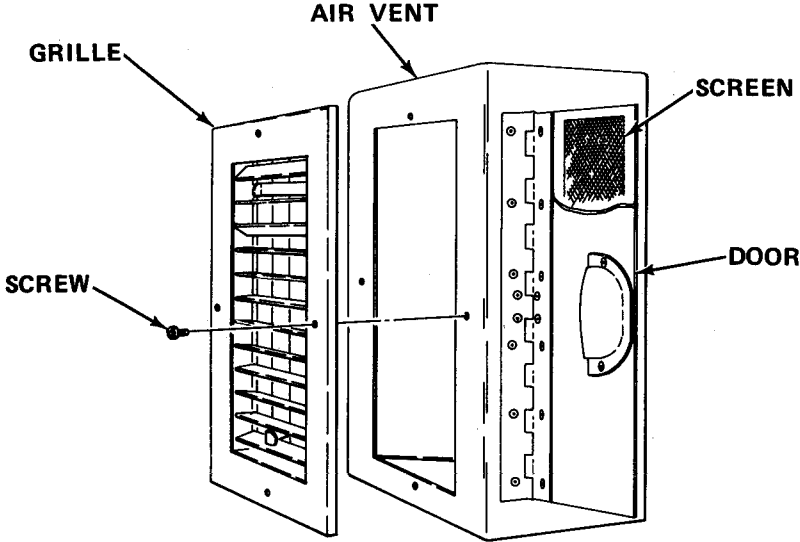
(Number) - Hundreds of Hours

ITEM NO.	INTERVAL	ITEM TO BE INSPECTED PROCEDURE
4	M	<u>VAN BODY - Cont</u>
		<p data-bbox="305 597 718 634"><u>Inspect Fire Extinguisher.</u></p> <div data-bbox="355 719 1362 1319"> </div> <ol data-bbox="305 1389 1181 1681" style="list-style-type: none"> 1. Remove from mounting bracket. Check free movement of bracket. 2. Inspect nozzle and adapter assembly for damage. 3. Inspect seal. Be sure it is not broken. 4. Weigh cylinder. Replace if gross weight has decreased by 6 oz (170 g) or more.

1-15. ORGANIZATIONAL TROUBLESHOOTING PROCEDURES.

a. Organizational troubleshooting procedures cover the most common malfunctions **that** may be repaired at the organizational level. Repair or adjustment requiring specialized equipment is not authorized unless such equipment is available. Troubleshooting procedures used by the operator should be conducted in addition to the organizational troubleshooting procedures.

b. This manual cannot list all the possible malfunctions or every possible test/inspection and corrective action. If a malfunction is not listed or corrected by a listed corrective action, notify your supervisor.

For unidentified malfunctions, use the facing schematic or the foldout located at the end of this manual for further fault analysis.

d. If any component of the Drafting Support Section does not power up when turned on, verify that 120 V ac is present at the receptacle. If voltage is not present, plug equipment into receptacle with power available and proceed with equipment troubleshooting. Perform no-power troubleshooting procedures for dead receptacle (Table 1-4).

Table 1-4. ORGANIZATIONAL TROUBLESHOOTING

MALFUNCTION
TEST OR INSPECTION
CORRECTIVE ACTION

WARNING

Electrical shock hazard. Be sure power is off when checking continuity at troubleshooting points. Death or serious injury could result from failure to do so.

1. FLUORESCENT CEILING LAMP IS INOPERATIVE.

Step 1. Check for continuity of fluorescent lamp switch.

(a) If continuity exists, proceed to step 2.

(b) If continuity does not exist, replace switch (paragraph (1-16.3)).

Table 1.4. ORGANIZATIONAL TROUBLESHOOTING - Cont

MALFUNCTION	TEST OR INSPECTION	CORRECTIVE ACTION
1. FLUORESCENT CEILING LAMP IS INOPERATIVE - Cent	Step 2. Check for continuity of lamp ballast.	(a) If continuity exists, proceed to step 3. (b) If continuity does not exist, replace lamp ballast (paragraph 1-16.1).
	Step 3. Check for shorts in RF Filter.	Replace RF filter (paragraph 1-16.2).
2. EXHAUST FAN IS INOPERATIVE.	Check on/off switch for continuity.	(a) If continuity exists, replace fan (paragraph 1-16.9). (b) If continuity does not exist, replace switch (paragraph 1-16-4).
3. EMERGENCY LIGHTS ARE INOPERATIVE.	Press in test indicator.	If lamps do not light, replace emergency light assembly (paragraph 1-16.11).
4. NO POWER TO EQUIPMENT.	Step 1. Check circuit breaker ON/OFF position.	(a) If circuit breaker is ON, proceed to step 2. (b) If circuit breaker is OFF, turn ON. (c) If circuit breaker trips repeatedly, notify power supply supervisor.

Table 1-4. ORGANIZATIONAL TROUBLESHOOTING - Cont

MALFUNCTION	TEST OR INSPECTION	CORRECTIVE ACTION
4. NO POWER TO EQUIPMENT - Cont	Step 2. Check circuit breaker input for 120 V ac.	(a) If input voltage is present, proceed to step 3. (b) If input voltage is not present, refer to direct/general support maintenance for repair or replacement of defective wiring.
	Step 3. Check circuit breaker output for 120 V ac.	(a) If output voltage is present, proceed to step 4. (b) If output voltage is not present, refer to direct/general support maintenance for circuit breaker replacement (paragraph 1-20.5).
	Step 4. Remove receptacle and check for 120 V ac input.	(a) If present, replace receptacle (paragraph 1-16.6). (b) If not present, refer to direct/general support maintenance for repair or replacement of defective wiring.

1-16. MAINTENANCE PROCEDURES.

This section contains instructions covering organizational maintenance functions for the Drafting Support Section. Personnel required are listed only if the task requires more than one.

b. After completing each maintenance procedure, perform operational check to be sure that equipment is properly functioning.

INDEX

PROCEDURE	PARAGRAPH
Replace Fluorescent Lamp Ballast	1-16.1
Replace Radio Frequency (RF) Filter	1-16.2

INDEX - Cont

PROCEDURE	PARAGRAPH
Replace Fluorescent Lamp Switch	1-16.3
Replace On/Off Switch	1-16.4
Replace Blackout/Dome Light Microswitch	1-16.5
Replace Receptacle	1-16.6
Replace Wire Molding	1-16.7
Repair Telephone Binding Post Assembly	1-16.8
Replace Exhaust Fan.	1-16.9
Replace Exhaust Fan Cover.	1-16.10
Replace Emergency Light Assembly	1-16.11
Repair Blackout Curtain	1-16.12
Repair Van Body Skin (Temporary)	1-16.13
Replace Tiedown Socket	1-16.14
Repair Level Indicator	1-16.15
Replace Air Vent Screen	1-16.16
Replace Air Vent Cover	1-16.17
Repair Personnel Ladder	1-16.18
1-16.1 <u>Replace Fluorescent Lamp Ballast</u>	

MOS: 83FJ6, Reproduction Equipment Repairer

41B, Topographic Instrument Repair Specialist

TOOLS: Flat Tip Screwdriver
 1/4 in. Wrench
 1/4 in. Drive Socket Set
 Scribe

SUPPLIES: Lamp Ballast
 Wire Ties

WARNING

Death or serious injury may occur unless overhead light circuit breaker and main circuit breaker are turned off before working on light fixture.

- a. Turn off overhead light circuit breaker and main circuit breaker.
- b. Remove diffuser from light fixture.
- c. Remove safety tabs and lamps. Place in diffuser.
- d. Squeeze light wiring guard and remove.
- e. Remove wire ties as required.

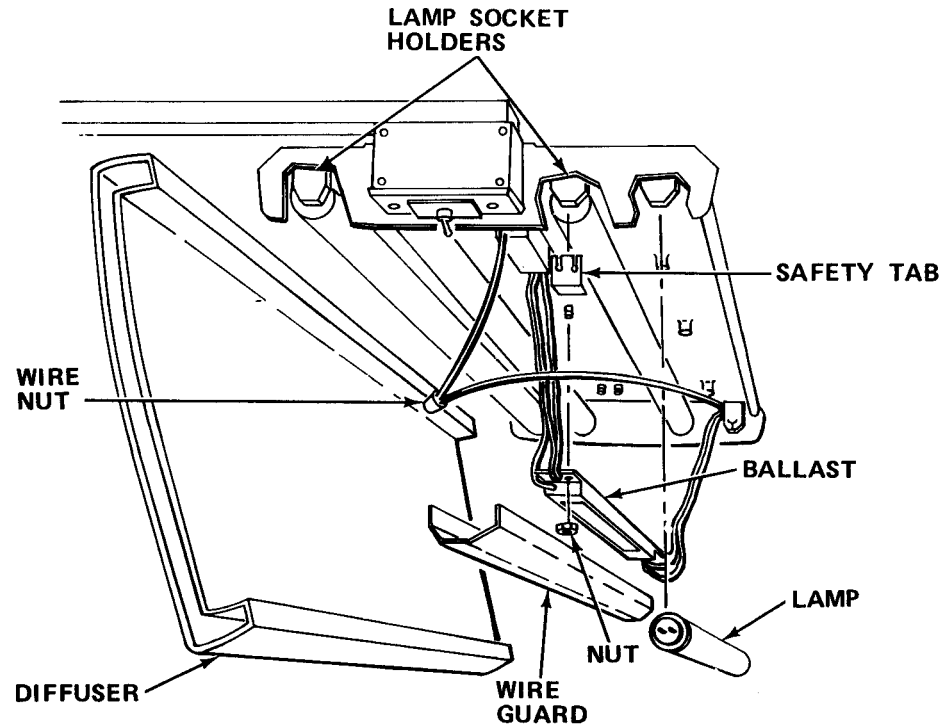

- f. Tag wires from ballast for reference.
- g. Disconnect ballast wire from wire nut connection.
- h. Pry out lamp socket holder with flat tip screwdriver.
- i. Using scribe, depress wire clips and disconnect ballast wiring.
- j. Remove nut and defective ballast.
- k. Install new ballast and connect wires to corresponding lamp socket holders.
- l. Secure with nut.
- m. Reconnect ballast wire to wire nut connection.
- n. Remove tags.
- o. Install new wire ties.

NOTE

Be sure wires are free of kinks and do not interfere with placement of wire guard.

- p. Reinstall wire guard.
- q. Reinstall lamp and safety tabs.
- r. Reinstall diffuser.
- s. Turn on overhead light circuit breaker and main circuit breaker.

1-16.2 Replace Radio Frequency (RF) Filter.

MOS: 83FJ6, Reproduction Equipment Repairer

41B, Topographic Instrument Repair Specialist

TOOLS: Flat Tip Screwdriver
1/4 in. Wrench
1/4 in. Drive Socket Set

SUPPLIES: RF Filter
Wire Ties

WARNING

Death or serious injury may occur unless overhead light switch is turned OFF before working on light fixture.

- a. Turn overhead light switch OFF.
- b. Remove diffuser from light fixture.
- c. Remove safety tabs and lamps. Place in diffuser.
- d. Squeeze light wiring guard and remove.
- e. Remove wire ties as required.

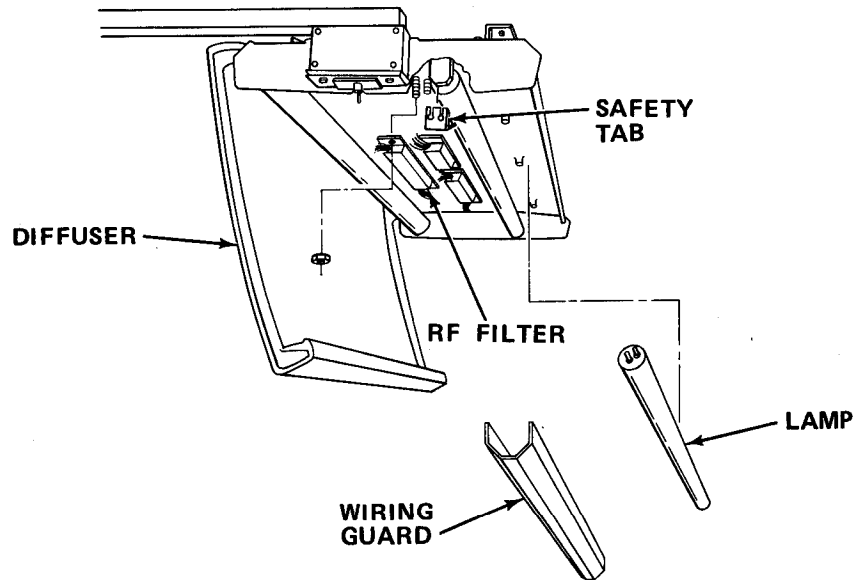

- f. Tag wires to filter.
- g. Remove wire nuts and disconnect filter wires.
- h. Remove nuts and defective filter.
- i. Install new filter. Secure with nuts.
- j. Reconnect filter wires and secure with wire nuts.
- k. Remove tags.
- l. Install new wire ties.

NOTE

Be sure wires are free of kinks and do not interfere with placement of wire guard.

- m. Reinstall wire guard.
- n. Reinstall lamps and safety tabs.
- o. Reinstall diffuser.
- p. Turn on light switch.

1-16.3 Replace Fluorescent Lamp Switch.

MOS: 83FJ6, Reproduction Equipment Repairer

41B, Topographic Instrument Repair Specialist

TOOLS : Flat Tip Screwdriver
Needle Nose Pliers
Flashlight

SUPPLIES: Switch Assembly

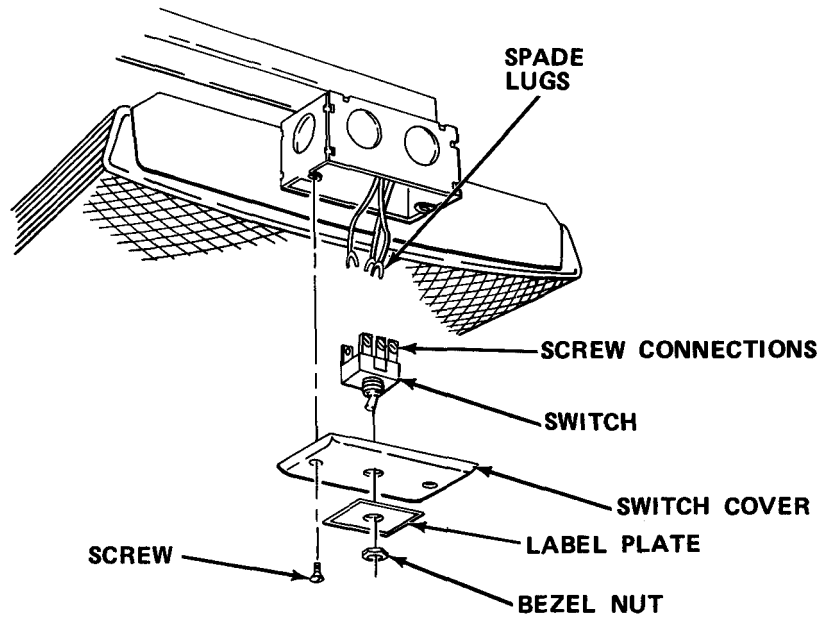

WARNING

Death or serious injury may occur if lighting circuit breaker is not turned off before working on lamp assembly.

NOTE

Alternate lighting is required to perform this task.

- a. Turn circuit breaker OFF.
- b. Remove bezel nut.
- c. Note notch in label plate and remove label plate.
- d. Loosen screws.

NOTE

Note position of cover and reinstall as noted.

- e. Remove cover plate.
- f. Tag and disconnect wires from defective switch.
- g. Install new switch and connect wires.
- h. Insert switch through cover plate and label plate.

NOTE

Be sure label plate is in same direction as when removed. Secure with bezel nut.

- i. Align cover plate with holes and secure with screws.
- j. Turn circuit breaker ON.

1-16.4 Replace On/Off Switch

MOS : 83FJ6, Reproduction Equipment Repairer

41B, Topographic Instrument Repair Specialist

TOOLS : Flat Tip Screwdriver

SUPPLIES: Switch

WARNING

Death or serious injury may occur if switch circuit breaker is not turned off before working on switch.

- a. Turn off appropriate circuit breaker.

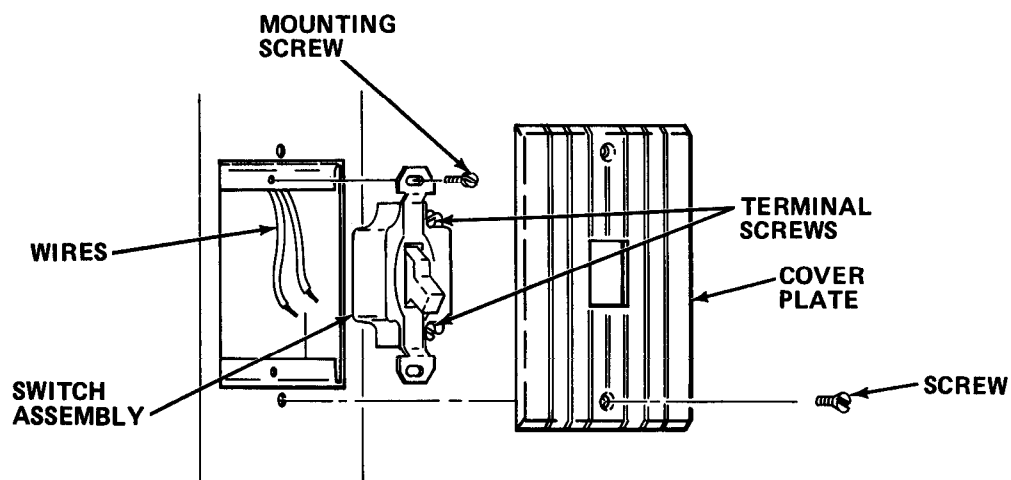

- b. Remove screws.
- c. Remove cover plate.
- d. Remove mounting screws.
- e. Pull switch assembly from wire guide to gain access to wires.
- f. Loosen terminal screws; then disconnect wires.
- g. Install new switch.
- h. Reconnect wires.
- i. Guide switch into wire guide, aligning holes.

NOTE

Be sure wires are not kinked or strained.

- j. Reinstall mounting screws.
- k. Reinstall cover plate and secure with screws.
- l. Turn on switch circuit breaker.

1-16.5 Replace Blackout/Dome Light Microswitch.

MOS: 83FJ6, Reproduction Equipment Repairer
or
41B, Topographic Instrument Repair Specialist

TOOLS: Flat Tip Screwdriver
6 in. Adjustable Wrench

SUPPLIES: Microswitch

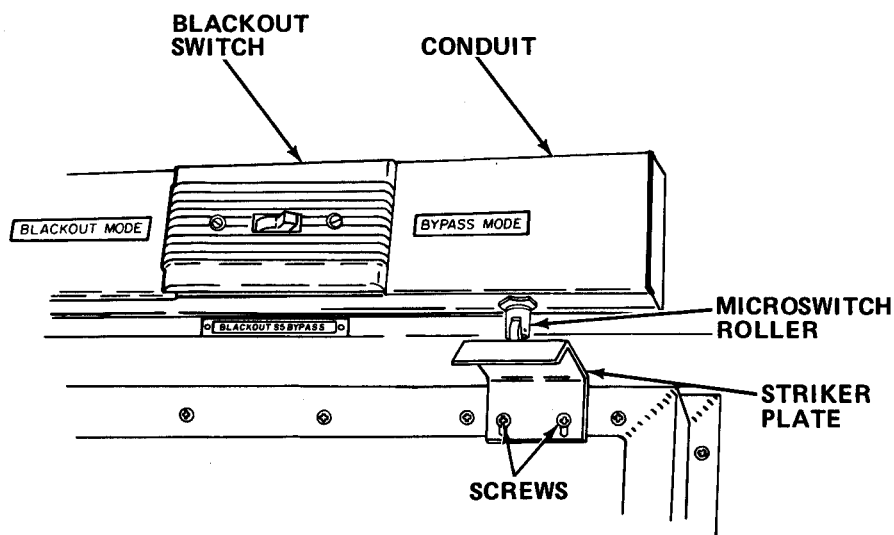
**WARNING**

Death or serious injury may occur from electrical shock unless power is off before servicing.

- a. Turn off blackout/dome light circuit breaker.
- b. Remove conduit cover.
- c. Remove nut and pull out switch to expose wiring.
- d. Disconnect wires from defective switch.
- e. Connect wires to new switch.
- f. Install switch and secure with nut.
- g. Adjust striker plate until plate contacts rollers.
- h. Reinstall conduit cover.
- i. Turn on circuit breaker.

1-16.6 Replace Receptacle.

MOS: **83FJ6**, Reproduction Equipment Repairer

41B, Topographic Instrument Repair Specialist

TOOLS : Flat Tip Screwdriver

SUPPLIES: Receptacle

WARNING

Death or serious injury may occur if receptacle circuit breaker is not turned off before working on receptacle.

- a. Turn off receptacle circuit breaker.

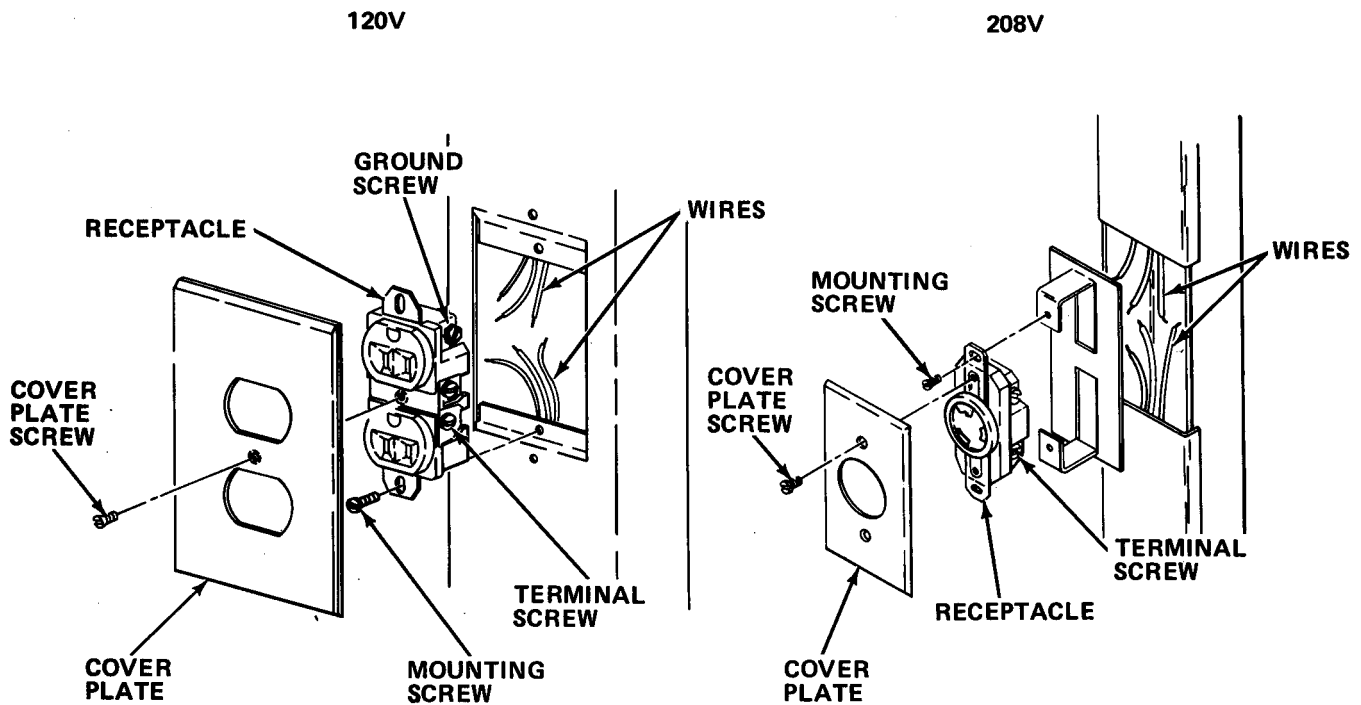

- b. Remove cover plate screws.
- c. Remove cover plate.
- d. Remove mounting screws.
- e. Withdraw receptacle to gain access to wires.

- f. Loosen terminal screws and ground screw. Then disconnect wires.
- g. Reconnect wires. Connect green (ground) wire first.
- h. Install new receptacle.
- i. Guide receptacle into wire guide.

NOTE

Be sure wires are not kinked or strained.

- j. Secure receptacle with screws.
- k. Reinstall cover plate. Secure with screws.
- l. Turn on receptacle circuit breaker.

1-16.7 Replace Wire Molding.

MOS: 83FJ6, Reproduction Equipment Repairer

41B, Topographic Instrument Reps Specialist

TOOLS: Flat Tip Screwdriver

Hacksaw

Flashlight

DELETED

Paint Brush

Multimeter

Drill and Bits

File

Machinist Rule

SUPPLIES: Paint (Item 18, Appendix E)

Cheesecloth (Item 6, Appendix E)

Conduit Base

Conduit Cover

Padlock

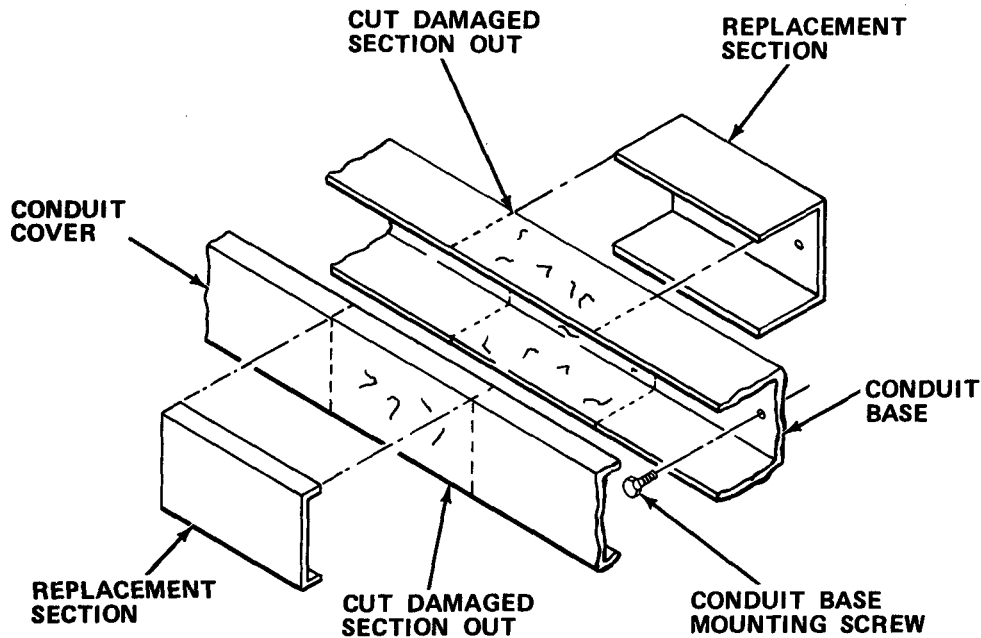

WARNING

Death or serious injury may occur from failure to turn off and padlock safety switch before repairing molding.

NOTE

Alternate lighting is required to perform this task.

- a. Turn off and padlock safety switch.
- b. Remove conduit cover.
- c. Inspect wires for damage.

NOTE

Refer to direct support maintenance for wiring repair if necessary.

- d. Loosen wiring and carefully pull it from the entire base section.
- e. Remove screws and base from wall.
- f. Mark and measure damaged area on molding. Record measurement.
- g. Cut damaged area from molding.
- h. Cut section from new molding to the length recorded in step f.
- i. Using damaged area as a template, mark mounting holes on new piece.
- j. With a number 25 drill bit, drill holes in new molding.
- k. With file, remove all burred edges.
- l. Paint base section as required.
- m. Reinstall conduit base on wall with screws.
- n. Carefully place wiring back in conduit base.
- o. Reinstall cover on base.
- p. Test wiring for continuity between power wires and conduit. If there is continuity, determine and correct grounding fault.
- q. Test wiring with power on.

1-16.8 Repair Telephone Binding Post Assembly.

MOS: 83FJ6, Reproduction Equipment Repairer
or
41B, Topographic Instrument Repair Specialist

TOOLS: Cross Tip Screwdriver
1/2 in. Combination Wrench

SUPPLIES: Binding Post Box
Binding Posts

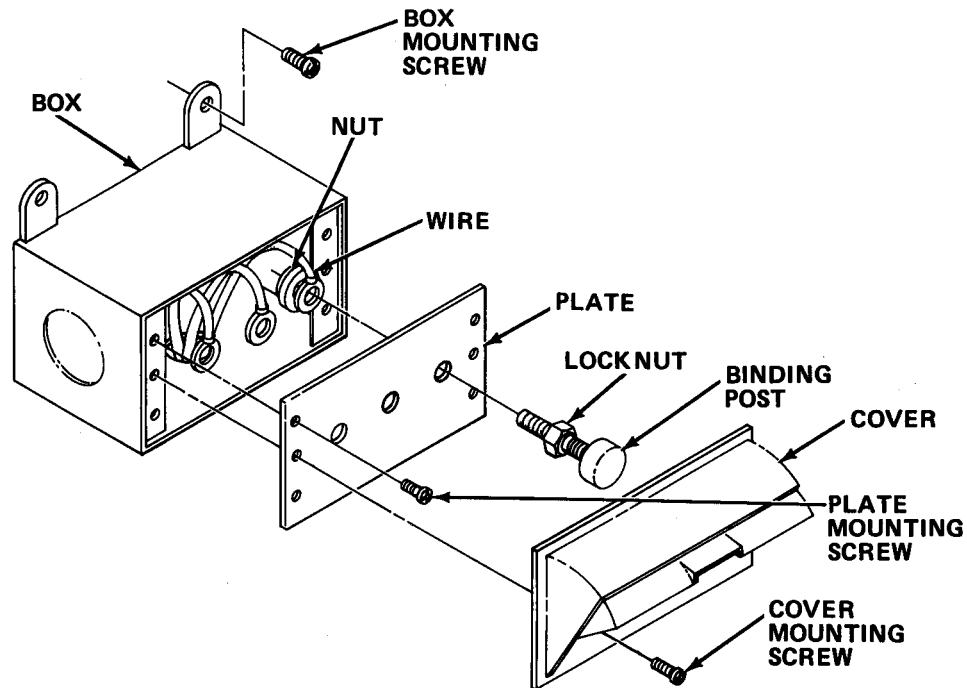

- a. Remove cover mounting screws. Remove cover.
- b. Remove plate mounting screws to gain access to back of plate.
- c. Tag wires for identification
- d. Remove nuts and wires from binding riding posts.
- e. If required, remove box mounting screws and replace box.
- f. Replace any defective binding posts. Secure wires to new posts and remove tags.
- g. Reinstall box assembly and plate, and secure plate with screws.
- h. Secure cover with screws.

1-16.9 Replace Exhaust Fan.

MOS: 83FJ6, Reproduction Equipment Repairer
 or
 41B, Topographic Instrument Repair Specialist

TOOLS: Flat Tip Screwdriver
 Cross Tip Screwdriver
 Wire Cutters

SUPPLIES: Fan Assembly
 Wire Nuts
 Power Cord

WARNING

Death or serious injury may occur if power is left on. Turn fan switch OFF and unplug power cord before working on exhaust fan.

- a. Unplug power cord.

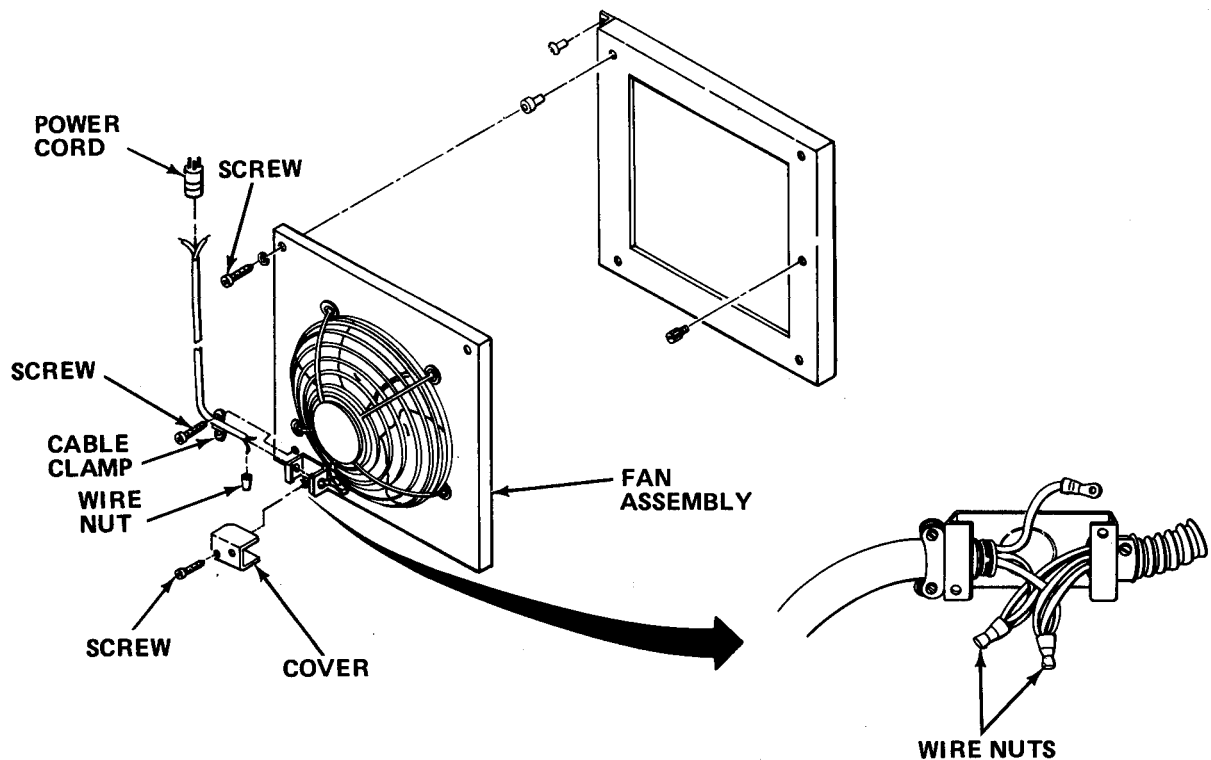

- b. Remove screws and place fan assembly on work surface.
- c. Loosen screws on cable clamp.
- d. Remove screws and cover.
- e. Tag wires and cut wire nuts from wires.

- f. Remove power cord from defective fan assembly.
- g. Install new fan.
- h. Install new power cord.
- i. Connect wires with wire nuts and remove tags.
- j. Tighten cable clamp screws.
- k. Reinstall cover. Secure with screws.
- l. Reinstall fan assembly. Secure with screws.
- m. Plug in power cord.

1-16.10 Replace Exhaust Fan Cover.

MOS: 83FJ6, Reproduction Equipment Repairer
or
41B, Topographic Instrument Repair Specialist

TOOLS : Drill and Bits
Pop Rivet Gun
Scraper

SUPPLIES: Pop Rivets
Exhaust Fan Cover
Gasket
Solvent P-D-680 (Item 24, Appendix E)
Adhesive (Item 1, Appendix E)
Cheesecloth (Item 6, Appendix E)
Impermeable Gloves
Goggles

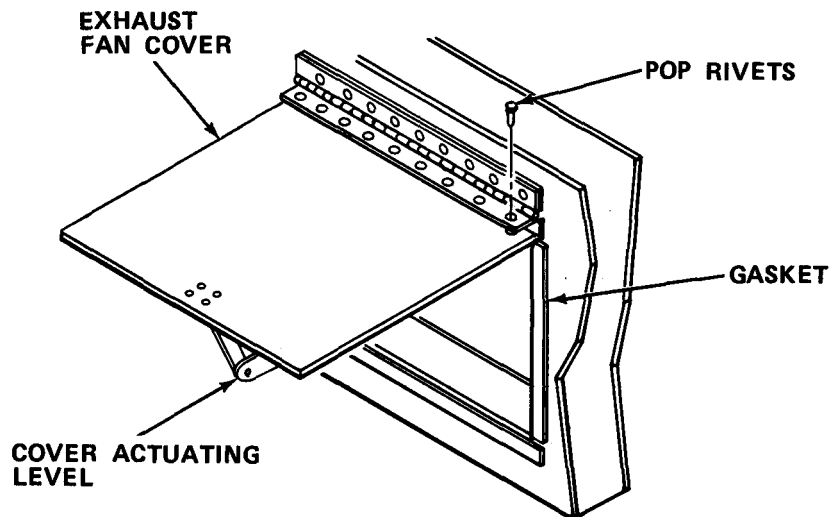

- a. Drill pop rivets from hinged cover to remove vent cover.
- b. Remove defective cover and transfer mounting hardware to new cover.

WARNING

Dry cleaning solvent, P-D-680, used to clean parts is potentially dangerous to personnel and property. Avoid repeated and prolonged skin contact. Wear solvent-impermeable gloves and eye/face protective equipment when using solvent. Do not use near open flame or excessive heat. Flash point of solvent is 100° F to 138° F (38° C to 59° C).

- c. Scrape gasket off van body and clean area with solvent P-D-680.
- d. Secure new gasket to van body with adhesive.
- e. Align fan cover and pop rivet to hinge.
- f. Test cover for tightness of closure.

1-16.11 Replace Emergency Light Assembly.

MOS: 83FJ6, Reproduction Equipment Repairer
or
41B, Topographic Instrument Repair Specialist

TOOLS: Cross Tip Screwdriver
Flat Tip Screwdriver

SUPPLIES: Emergency Light Assembly

WARNING

Death or serious injury may occur if power cord is not unplugged before servicing light.

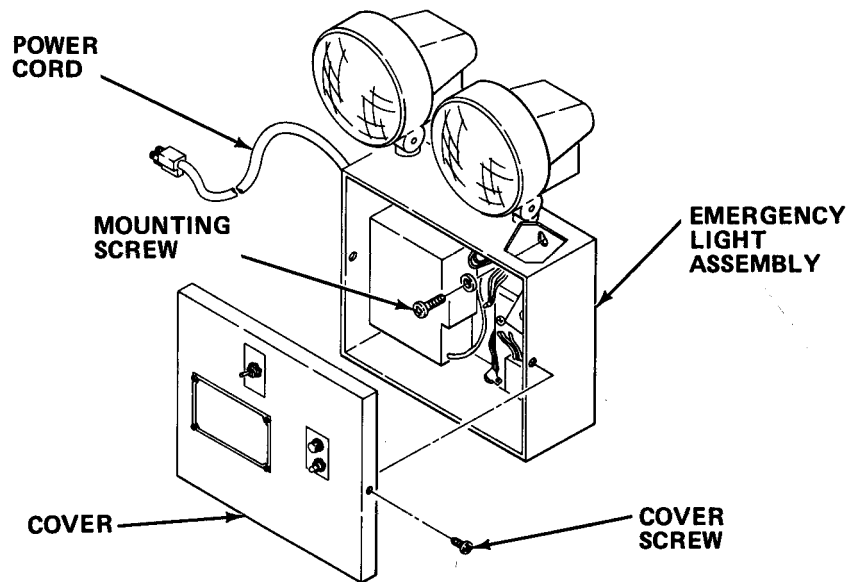

- a. Unplug power cord.
- b. Remove cover screws. Move cover out of way.
- c. Remove mounting screws.
- d. Remove emergency light assembly.
- e. Install new emergency light assembly. Secure with screws.
- f. Secure cover with screws.
- g. Plug in power cord.

1-16.12 Repair Blackout Curtain.

MOS: 83FJ6, Reproduction Equipment Repairer

41B, Topographic Instrument Repair Specialist

TOOLS: Cross Tip Screwdriver

SUPPLIES: Hooks
Valance
Curtain
Nylon Hook and Pile Tape
Adhesive (Item 1, Appendix E)

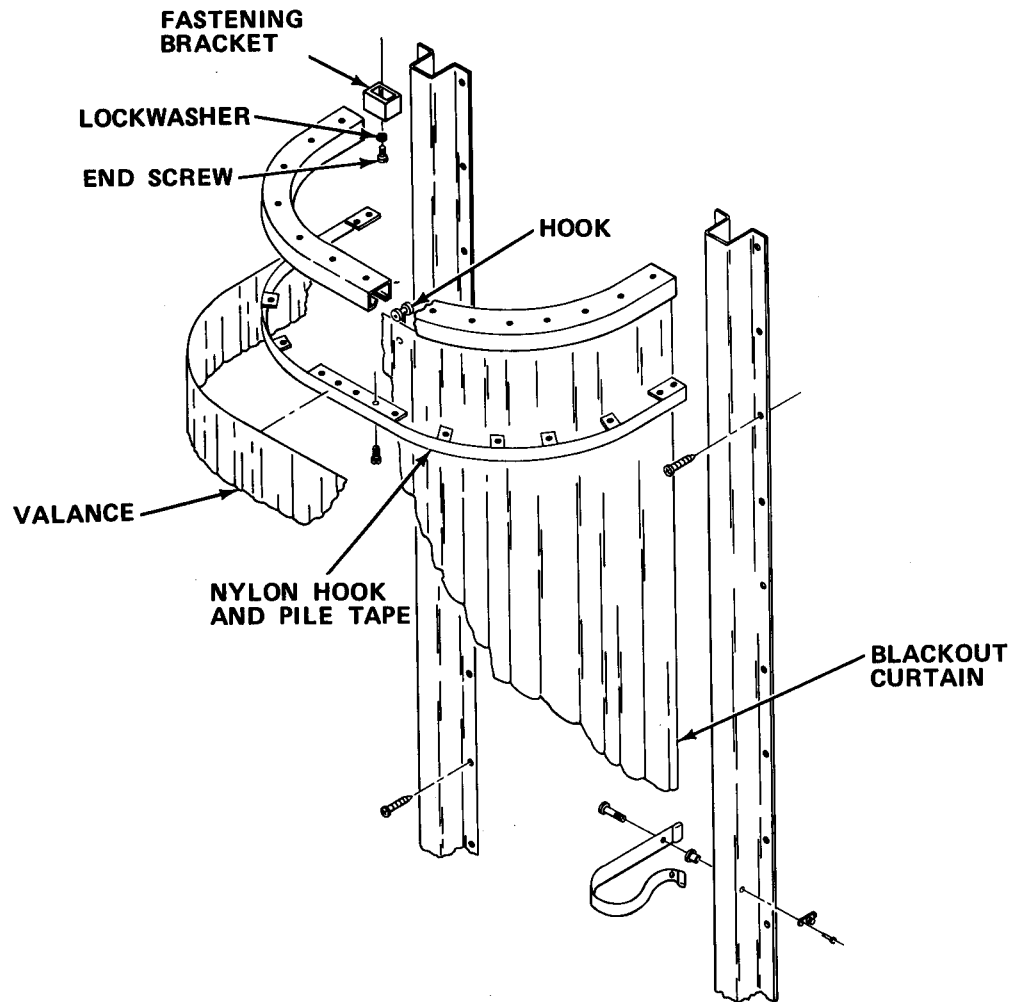

- a. Remove curtain from hooks.
- b. Pull curtain and valance from nylon hook and pile tape.
- c. Remove end screw, lockwasher, and fastening bracket from ceiling.
- d. Replace damaged hooks.

- e. Reinstall fastening bracket with hooks. Fasten with end screw and lockwasher.
- f. Glue loose nylon hook and pile tape to wall or bracket. Replace tape if worn out.
- g. Hook curtain to bracket.
- h. Attach valance.
- i. Check curtain for free movement.

1-16.13 Repair Van Body Skin (Temporary).

MOS: 52C, Utilities Equipment Repairer

TOOLS: Pliers
Ball Peen Hammer
Scissors or Utility Knife

SUPPLIES: Cloth Duct Sealing Tape (Item 27, Appendix E)
Silicone Sealant (Item 22, Appendix E)
Spray foam (Item 26, Appendix E)
Cheesecloth, (Item 6, Appendix E)

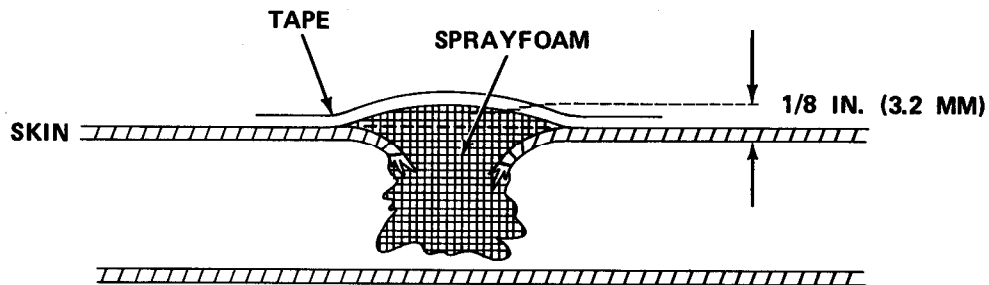

- a. Bend broken edges of punctured skin inward into puncture hole. Do not attempt to remove fragments of skin by bending or pulling outward. Bend skin inward only enough to put broken edges below surface of unbroken skin.
- b. Remove any loose fragments of foam which are not now held in place by bent broken skin. Removing small pieces of foam or dust is more important than removing chunks.
- c. Using cloth slightly dampened with water, wipe area around puncture to remove any dirt or mud and wipe dry.

- d. Inject sprayfoam into puncture. Mound sprayfoam to about 1/8 in. (3.2 mm) above surface of unbroken skin. Apply bead of sealant about 1/4 in. (6.4 mm) wide over all cuts in skin leading out from puncture. Do not smooth out sealant.
- e. Plan how puncture is to be covered with tape before applying any tape. Length and width of tape, number of tape strips, overlapping, and how tape is applied will affect sealing capability of repair. Each piece of tape should extend about 1-1/2 in. (3.81 cm) beyond sealant it will cover. If this will require more than one strip of tape, tape should overlap about 1/2 in. (12.7 mm). **If** three or more strips of tape are required, center strip should be applied first.
- f. Holding tape taut, apply it perpendicular to panel skin. Do not apply with rolling motion either end-to-end or center-to-ends. Do not rub each strip in place individually. Apply all strips lightly with proper overlap and rub into place.
- g. If necessary, damaged tape can be replaced; however, it should be removed with careful peeling motion to avoid damage to sealant. If sealant also peels back, new sealant should be applied. Complete removal of old sealant is not necessary. Permanent repair by direct support, or higher category of maintenance, should be made as soon as possible.

1-16.14 Replace Tiedown Socket.

MOS: 83FJ6, Reproduction Equipment Repairer

41B, Topographic Instrument Repair Specialist

TOOLS: Cross Tip Screwdriver
Flat Tip Screwdriver

SUPPLIES: Tiedown Socket

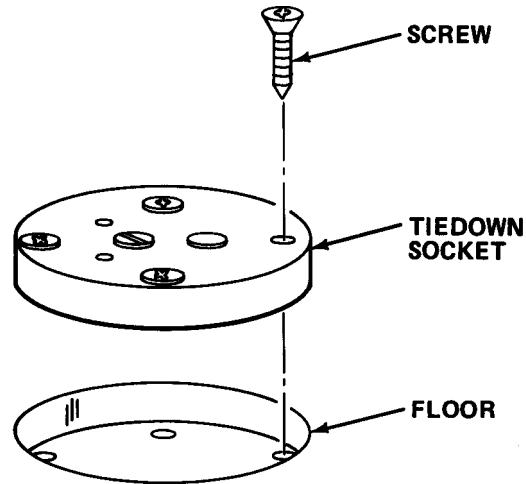

- a. Remove screws from tiedown socket.
- b. Pry defective socket from floor.
- c.** Install new tiedown socket. Rotate new tiedown socket enough to avoid installing screws in old screw holes.
- d. Reinstall screws.

1-16.15 Repair Level Indicator.

MOS: 83FJ6, Reproduction Equipment Repairer

41B, Topographic Instrument Repair Specialist

TOOLS : Carpenter's Level
 Cross Tip Screwdriver
 Knife, TL-29

SUPPLIES: Level Indicator
 Gasket

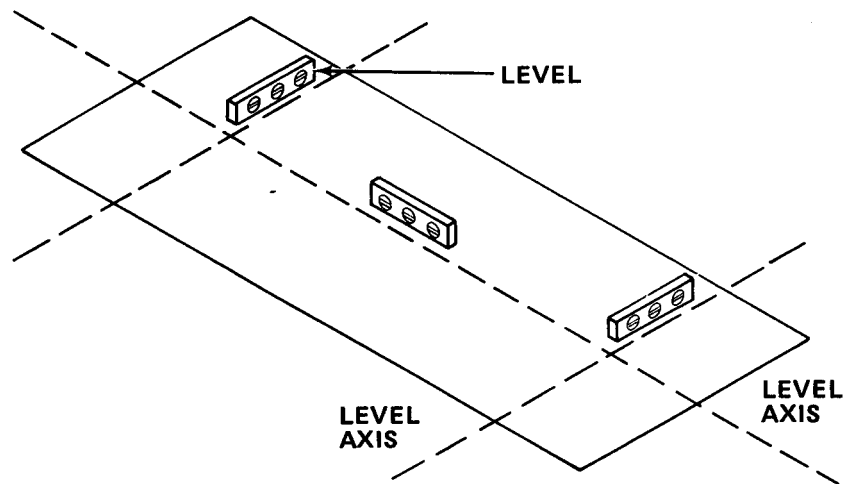

- a. Level section using level indicators. Then confirm section is level by using carpenter's level on floor inside section.
- b. Adjust section leveling jacks until section is level as indicated by carpenter's alignment level at front-rear and left-right at each end as shown in illustration.

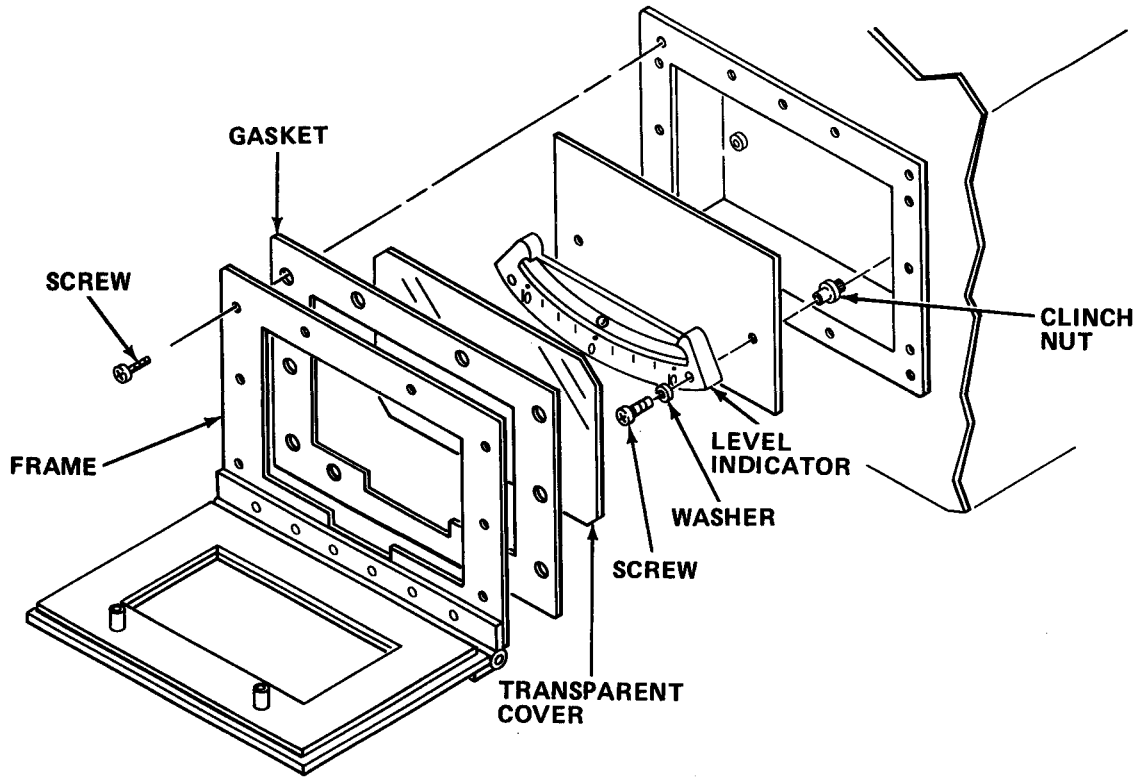

- c. Loosen knurled screws and move cover away from level assembly.
- d. Remove screws and washers to release frame and gasket.
- e. Remove transparent cover.
- f. Remove screws and washers to remove level indicator.
Replace level assembly and secure with screws and washers.
- h. Reinstall transparent cover.
- i. Install new gasket.
Reinstall frame and secure with screws and washers.

1-16.16 Replace Air Vent Screen.

MOS: 83FJ6, Reproduction Equipment Repairer

41B, Topographic Instrument Repair Specialist

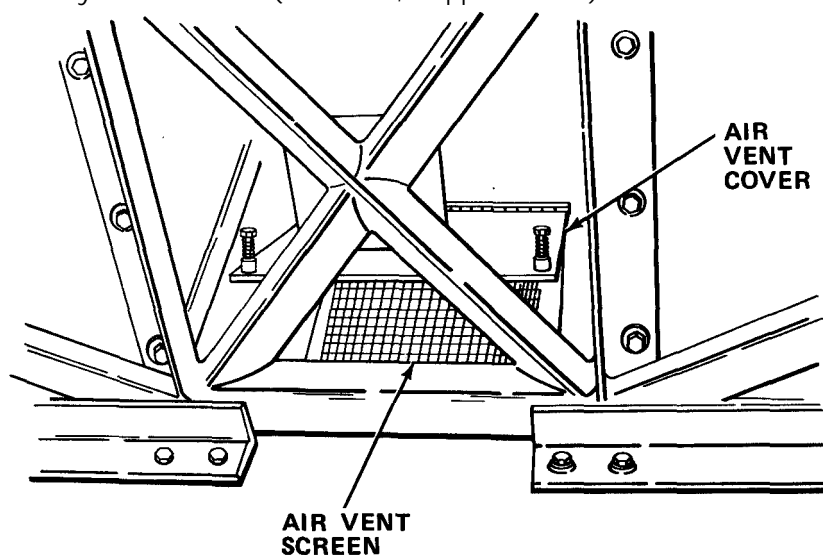
TOOLS: Cross Tip Screwdriver
ScissorsSUPPLIES: Rubber Adhesive (Item 1, Appendix E)
Nylon Screen (Item 21, Appendix E)

- a. Raise access cover and remove screws holding screen frame to section.
- b. Remove screen and frame.
- c.** Clean all old screen material and adhesive from frame.
- d. Cut new screen material to size and attach to frame with adhesive.
- e. Reinstall frame to section and secure with screws. Lower cover.

1-16.17 Replace Air Vent Cover.

MOS: 83FJ6, Reproduction Equipment Repairer

41B, Topographic Instrument Repair Specialist

TOOLS: Drill and Bits
Pop Rivet Gun

SUPPLIES: Vent Cover
Pop Rivets

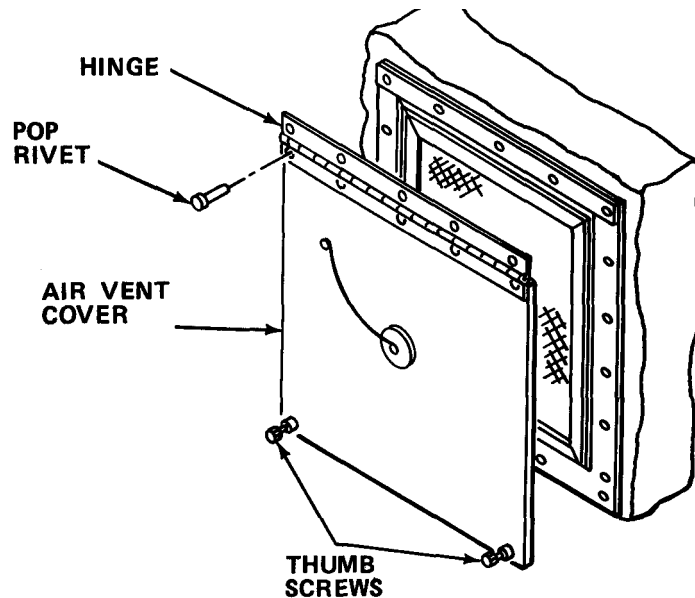

- a. Loosen thumb screws.
- b. Drill pop rivets from hinge. Remove air vent cover.
- c. Align holes and pop rivet new air vent cover to section.
- d. Tighten thumbscrews.

1-16.18 Repair Personnel Ladder.

MOS: 83FJ6, Reproduction Equipment Repairer

TOOLS: Drill and Bits
Pop Rivet Gun
9/16 in. Combination Wrench
8 in. Adjustable Wrench

SUPPLIES: Cable Assembly
Quick Release Pins
Pop Rivets
Mounting Brackets

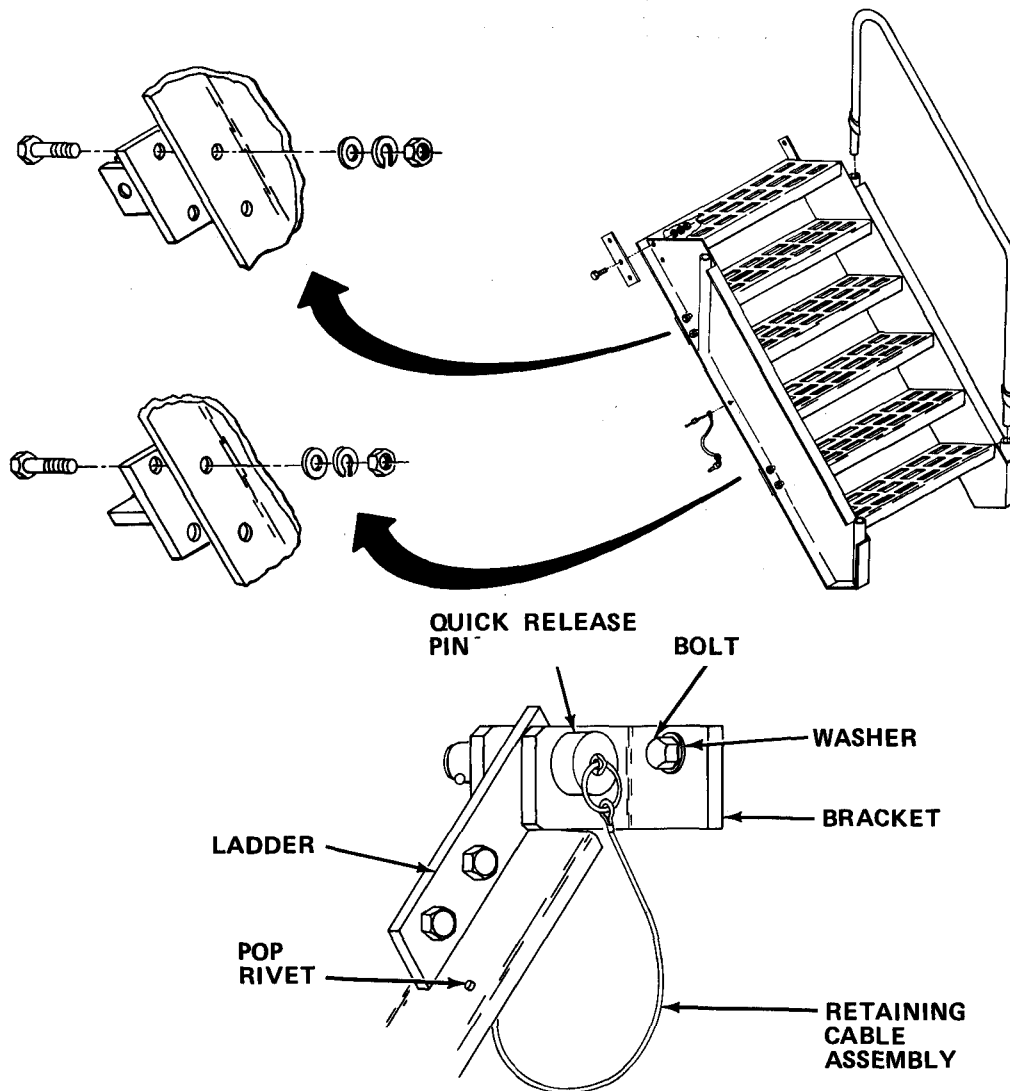

- a. Remove ladder from mounting bracket.
- b. Remove bolts, washers, and nuts securing damaged mounting brackets to ladder.
- c. Remove damaged cable assembly from ladder by drilling out rivet.
- d. Reinstall or install new mounting brackets. Secure with bolts, washers, and nuts.
- e. Rivet new cable assembly to ladder.

NOTE

Be sure ladder mounting brackets fit section on rear door and under personnel doors.

- f. Reinstall ladder on mounting bracket.

1-17. PREPARATION FOR STORAGE OR SHIPMENT.

a. Section may be stored or shipped either mounted on trailer chassis or unmounted. Preparation of trailer chassis is covered in TM 5-2330-305-14 and should be referred to when trailer-mounted section is prepared for storage and shipment. TM 5-4120-367-14 must be reviewed for instructions covering air conditioner/heater.

b. Remove consumable supplies that have limited shelf life or broken seals. Replace missing items and be sure that all remaining consumable supplies are at authorized levels. Be sure all major components are operational.

c. Remove all unauthorized or personal equipment from, section.

d. Move all classified material or sensitive data to proper storage. Complete all accountability and/or transfer of documents.

e. Refer to Preparation for Movement (paragraph 1-6.2) and follow applicable steps and any additional steps directed by proper authority.

Section V DIRECT/GENERAL SUPPORT MAINTENANCE

1-18. REPAIR PARTS, SPECIAL TOOLS; TEST, MEASUREMENT, AND DIAGNOSTIC EQUIPMENT (TMDE); AND SUPPORT EQUIPMENT.

1-18.1 Common Tools and Equipment. For authorized common tools and equipment, refer to the Modified Table of Organization and Equipment (MTOE) applicable to your unit.

1-18.2 Special Tools; Test, Measurement, and Diagnostic Equipment; and Support Equipment. Special Tools, TMDE, and Support Equipment is listed in the applicable repair parts and special tools list and in Appendix B of this manual.

1-18.3 Repair Parts. Repair parts are listed and illustrated in the Repair Parts and Special Tools List, TM 5-6675-316-24P covering direct/general support maintenance for this equipment.

1-18.4 Electrical System. Direct/general support level of maintenance for the repair of the section's electrical system will consist of electrical wiring repair using standard electrical wiring repair procedures.

1-19. DIRECT/GENERAL SUPPORT TROUBLESHOOTING PROCEDURES.

a. Direct/general support troubleshooting procedures cover the most common malfunctions that may be repaired at the direct/general support level. Repair or adjustment requiring specialized equipment is not authorized unless such equipment is available. Troubleshooting procedures used by lower level maintenance should be conducted in addition to the direct/general support troubleshooting procedures.

b. This manual cannot list all the possible malfunctions or every possible test/inspection and corrective action. If a malfunction is not listed or corrected by a listed corrective action, notify your supervisor.

For unidentified malfunctions, use the facing schematic or the foldout located at the end of this manual for further fault analysis.

Table 1-5. DIRECT/GENERAL SUPPORT TROUBLESHOOTING

MALFUNCTION	TEST OR INSPECTION	CORRECTIVE ACTION
1. PERSONNEL/CARGO DOORS DO NOT CLOSE COMPLETELY.	Step 1. Check that latch rollers rotate freely. Step 2. Check to see if latch rods are bent. Step 3. Check to see if door gasket is torn or broken.	Replace latches (paragraph 1-20.2). Replace latch rods (paragraph 1-20.2). Replace door gasket (paragraph 1-20.3).
2. PERSONNEL/CARGO DOORS DO NOT LATCH PROPERLY.	Check door latch for missing or damaged components.	Replace door latch (paragraph 1-20.2).
3. AIR OR WATER ENTERS SECTION AROUND DOOR.	Check to see if door gasket is worn or broken.	Replace door gasket (paragraph 1-20.3).

Table 1-5. DIRECT/GENERAL SUPPORT TROUBLESHOOTING - Cont

MALFUNCTION

TEST OR INSPECTION

CORRECTIVE ACTION

4. RECEPTACLES DO NOT OPERATE BUT CIRCUIT BREAKERS ARE ON.

WARNING

Turn off main circuit breaker before inspecting or servicing circuit breakers or receptacles. Failure to do so may result in death or serious injury.

Step 1. Check to see if power cable is firmly connected to power entry panel.

Connect power cable.

Step 2. Check to see if voltage meter and frequency scale and INCORRECT PHASE or CORRECT PHASE lamp indicate necessary power.

Notify your supervisor for service of power supply at source.

5. CIRCUIT BREAKERS TRIP CONTINUALLY.

WARNING

Turn off and padlock safety switch before inspecting or servicing circuit breakers or receptacles. Failure to do so may result in death or serious injury.

Step 1. Check to see if receptacles are overloaded.

Reconnect equipment to different receptacles.

Step 2. Check to see if receptacles are damaged.

Replace receptacles (paragraph 1-16.6).

1-20. MAINTENANCE PROCEDURES.

a. This section contains instructions covering direct/general support maintenance functions for the Drafting Support Section. Personnel required are listed only if the task requires more than one.

b. After completing each maintenance procedure, perform operational check to be sure that equipment is properly functioning.

INDEX

PROCEDURE	PARAGRAPH
Repair Personnel Door Handle	1-20.1
Replace Cargo Door Latch Assembly	1-20.2
Replace Personnel /Cargo Door Gasket	1-20.3
Replace Personnel /Cargo Door	1-20.4
Replace Circuit Breaker	1-20.5
Repair Floor Covering	1-20.6
Repair Van Body Skin (Permanent)	1-20.7
Replace Air Conditioner/Heater	1-20.8
Replace Air Conditioner Support Bracket	1-20.9
Replace Ventilation Duct	1-20.10

1-20.1 Repair Personnel Door Handle.

MOS: 63W, Wheel Vehicle Repairer

TOOLS: Cross Tip Screwdriver
Needle Nose Pliers
15/16 in. Combination Wrench
Hammer
Center Punch
1/8 in. Hex Head Key Wrench

SUPPLIES: O-Ring Washer
Sleeve
Roll Pin
Personnel Door Handle
Cheesecloth (Item 6, Appendix E)
Oil, Lubricating, General Purpose (Item 15, Appendix E)
Hand Oiler
Cotter Pin

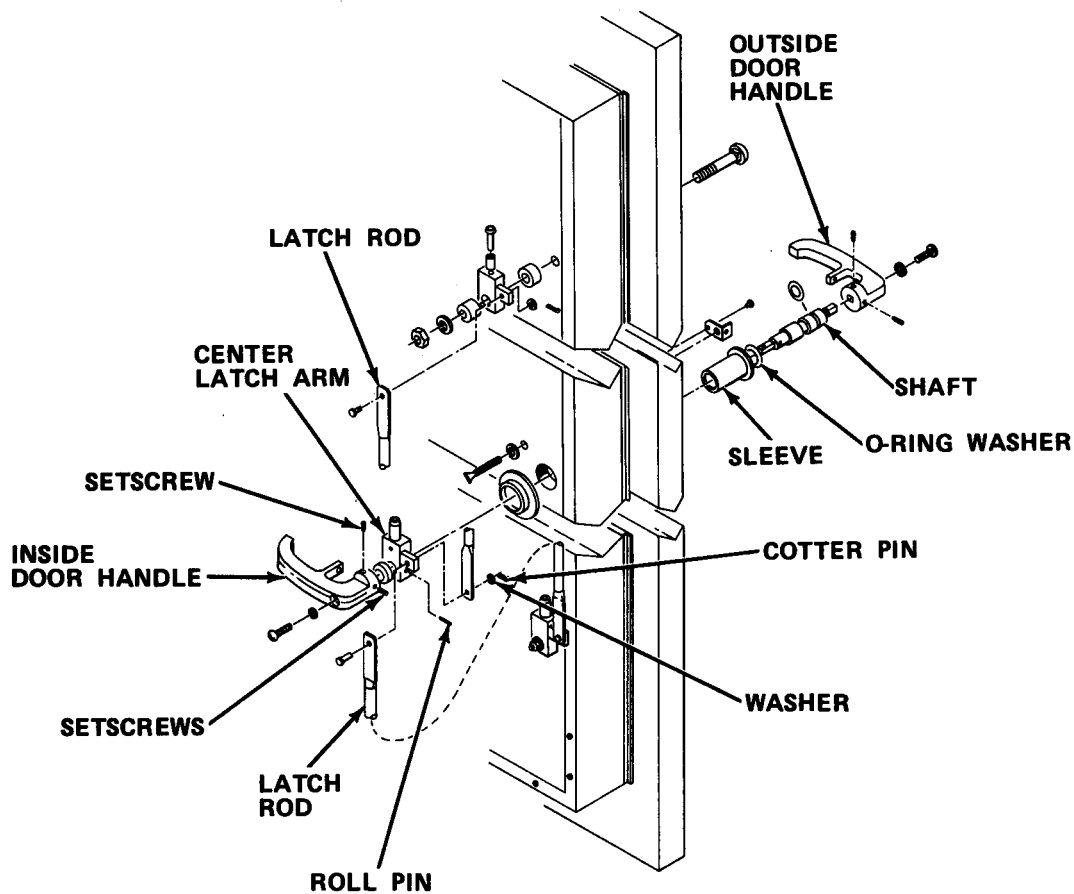

- a. Loosen screw and socket head setscrews. Remove defective inside door handle.

- b. Remove cotter pin and pins from center latch arm assembly.
- c. Move latch rods out of way.
- d. Punch roll pin from center latch arm assembly and pull latch arm assembly from shaft.
- e. Withdraw latch and defective outside door handle.
- f. Inspect all components for wear.
- g.** Replace worn O-ring washer and sleeve.
- h. Replace other worn components as needed.
- i. Reinstall shaft and new outside door handle.
- j. Aline center latch arm assembly on shaft. Secure with new roll pin.
- k. Aline latch rods. Attach to latch arms with pins, washers, and new cotter pin.
- l.** Reinstall new inside door handle.
- m. Lightly oil all moving parts. Wipe up surplus oil.

1-20.2 Replace Cargo Door Latch Assembly.

MOS: 63W, Wheel Vehicle Repairer

TOOLS: 9/16 in. Combination Wrench

SUPPLIES: Cargo Door Latch Assembly

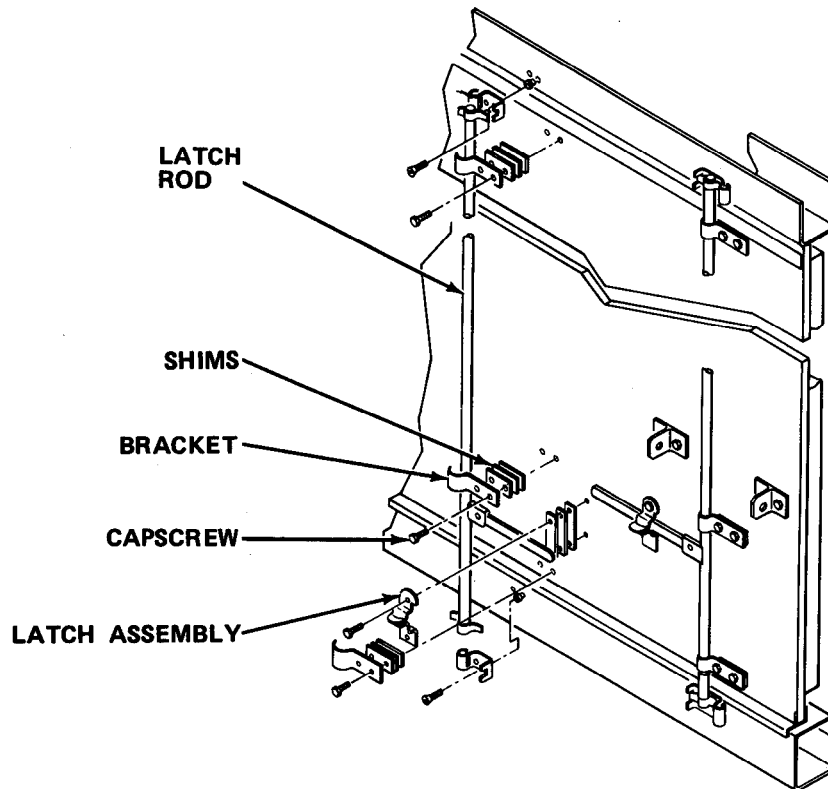

- a. Unlock latch.
- b. Remove capscrews and washers from brackets. Remove brackets and shims.
- c. Remove defective latch assembly and latch rod.
- d. Install new latch assembly and latch rod.
- e. Reinstall shims, brackets, washers, and capscrews.
- f. Check movement of latch rod and latch assembly. Lock latch.

1-20.3 Replace Personnel/Cargo Door Gasket.

MOS: 63W, Wheel Vehicle Repairer

TOOLS: Knife

SUPPLIES: Vinyl Gasket
 Adhesive (Item 1, Appendix E)
 Solvent P-D-680 (Item 24, Appendix E)
 Impermeable Gloves
 Goggles

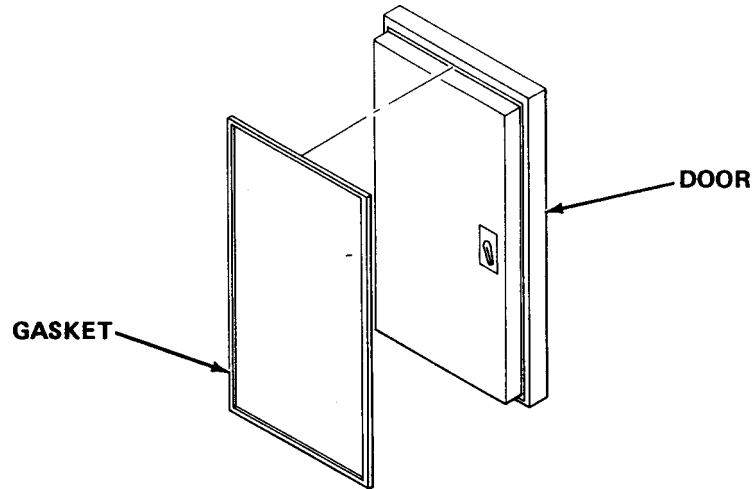

- a. Open door completely and secure in open position.

WARNING

Dry cleaning solvent, P-D-680, used to clean parts is potentially dangerous to personnel and property. Avoid repeated and prolonged skin contact. Wear solvent-impermeable gloves and eye/face protective equipment when using solvent. Do not use near open flame or excessive heat. Flash point of solvent is 100° F to 138° F (38° C to 59° C).

- b. Remove defective gasket by prying gasket from door. Scrape traces of gasket and adhesive from door. Wash with solvent P-D-680.
- c. Coat gasket area on door with adhesive.
- d. Firmly press new gasket onto door.
- e. Wipe excess adhesive from gasket.
- f. Close door and wipe excess adhesive from door and frame.
- g. Allow adhesive to dry before using door.

1-20.4 Replace Personnel /Cargo Doors.

MOS: 63W, Wheel Vehicle Repairer

PERSONNEL: Two persons are required to perform this procedure.

TOOLS : Pop Rivet Gun
Electric Drill and Bits
Hoist
3/4 in. Combination Wrench
Paint Brush

SUPPLIES: Personnel /Cargo Door
Pop Rivets
Vinyl Gasket
Paint (Items 17, 17A and 17B Appendix E)
Paint (Item 18, Appendix E)
Adhesive (Item 1, Appendix E)
Cheesecloth (Item 6, Appendix E)

WARNING

To prevent personal injury or equipment damage, do not attempt to remove doors unless suitable lifting equipment and hoist are available.

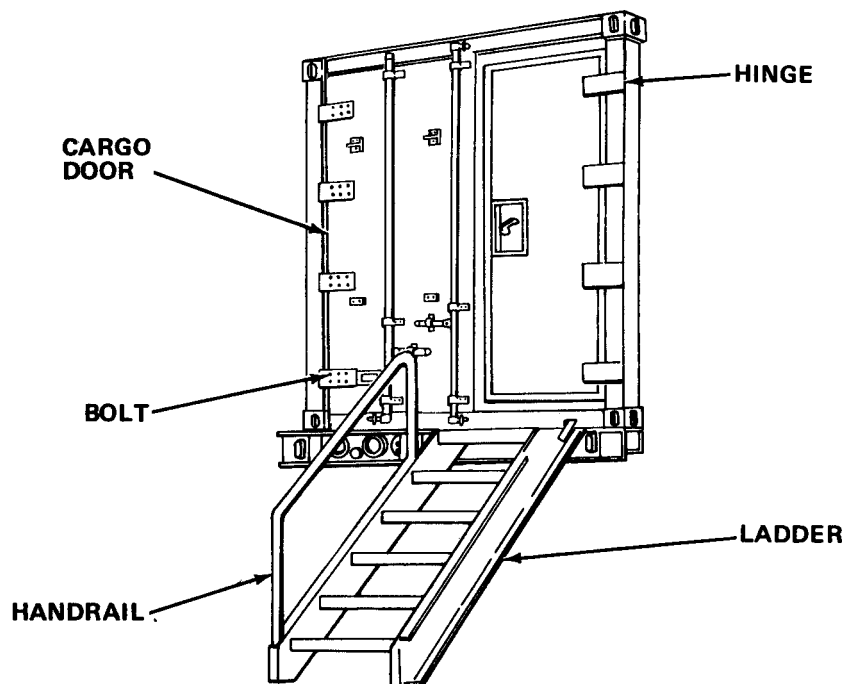

- a. Remove handrails and ladders if rear cargo door is to be replaced.

- b. Unlock and open door to be replaced.

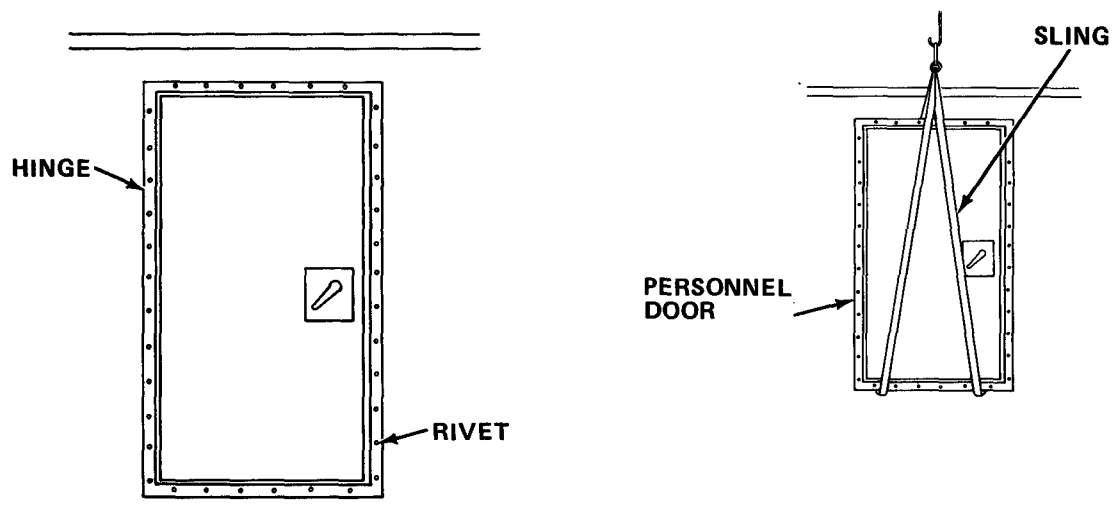

- c. Place sling around door and put a slight strain on hoist to remove weight from hinges.
- d. Remove bolts from hinges on rear personnel door. On side personnel door, drill out pop rivets from hinge. Remove hinges from door.
- e. Remove damaged door using hoist.
- f. Install new door using hoist.
- g. Reinstall hinges on rear personnel door. Secure with bolts. Reinstall hinges on side personnel door. Secure with pop rivets.
- h. Remove sling from door.
- i. Install new gaskets on door after it is mounted (paragraph 1-20.3).
- j. Repaint as needed.
- k. Close and lock door.

1-20.5 Replace Circuit Breaker.

MOS: 35E, Special Electronic Devices Repairer

TOOLS : Flat Tip Screwdriver
Multimeter

SUPPLIES: Circuit Breaker

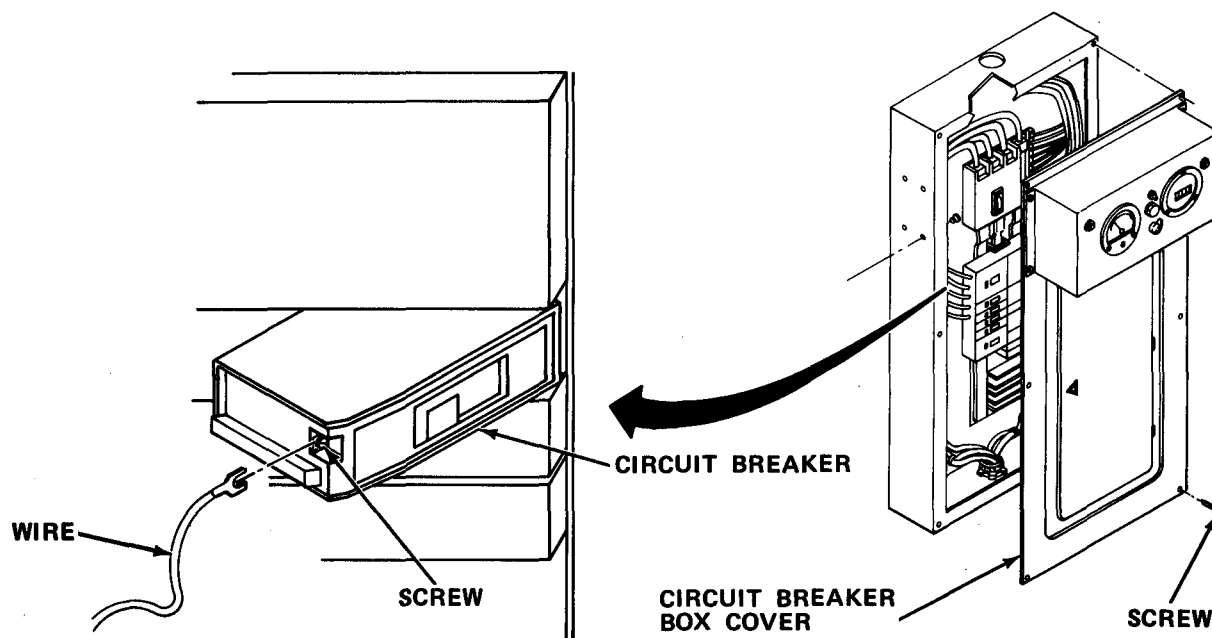

WARNING

Turn off and padlock safety switch. Turn off all individual circuit breakers before inspecting or servicing circuit breakers. Failure to do so may result in death or serious injury.

- a. Turn off, and padlock safety switch. Turn off individual circuit breakers.
- b. Remove circuit breaker box cover.
- c. Use multimeter to make sure voltage is not present.
- d. Remove defective circuit breaker by pushing and snapping out of place.
- e. Tag and remove wires from defective circuit breaker.
- f. Pull circuit breaker from panel.
- g. Reconnect wires to new circuit breaker. Secure wires with screws.

- h. Install new circuit breaker by pushing and snapping into place.
- i. Reinstall circuit breaker box cover.
- j. Remove padlock and turn on safety switch and individual circuit breakers.

1-20.6 Repair Floor Covering.

MOS : 52C, Utilities Equipment Repairer

TOOLS : Utility Knife
 Cross Tip Screwdriver
 Scraper
 Straightedge

SUPPLIES: Vinyl Floor Covering
 Epoxy Resin (Item 20, Appendix E)
 Floor Patch (Item 10, Appendix E)
 Cheesecloth (Item 6, Appendix E)
 Adhesive (Item 2, Appendix E)

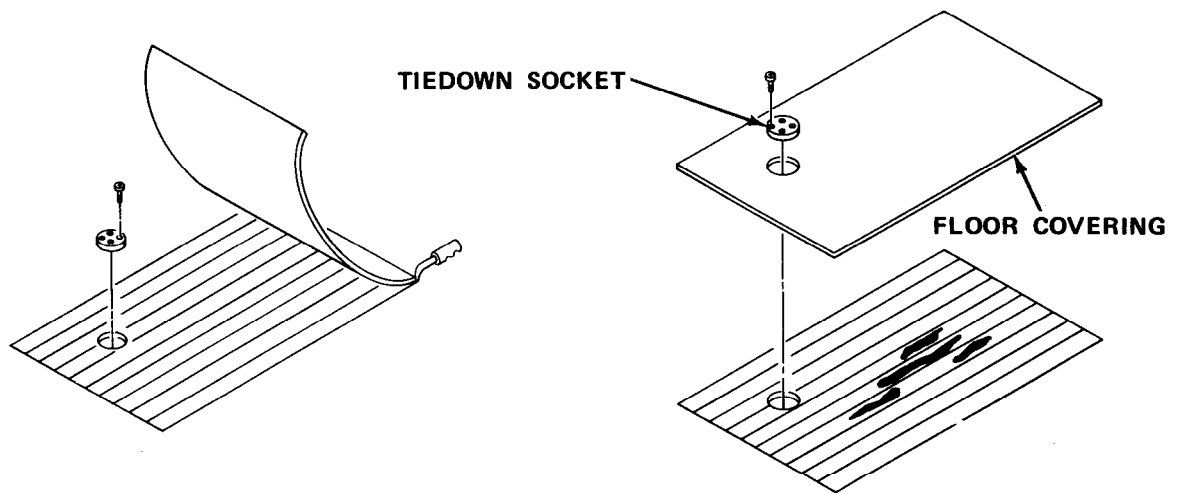

- a. Cut a rectangular area from damaged floor covering.
- b. Remove tiedown socket. Remove damaged floor covering.
- c. Cut new floor covering to fit. Apply adhesive to floor. Press down new floor covering.
- d. Reinstall tiedown socket.

1-20.7 Repair Van Body Skin (Permanent).

MOS: 63W, Wheel Vehicle Repairer

TOOLS : **Pod** Rivet Gun
Electric Drill and Bits
Paint Brush

SUPPLIES: **Pod** Rivets
Sprayfoam (Item 26, Appendix E)
Silicone Sealant (Item 22, Appendix E)
Sheet Metal
Paint (Items 17, 17A and 17B Appendix E)
Cheesecloth (Item 6, Appendix E)

- a. Bend broken edges of skin inward into puncture hole. Do not attempt to remove fragments of skin by bending or pulling out.
- b. Remove any loose fragments of foam.
- c. Use cloth dampened with water to clean area around puncture. Wipe dry.
- d. Inject sprayfoam into puncture. Fill to 1/8 in. (3.2 mm) above surface of unbroken skin. Apply sealant to cracks leading to puncture.

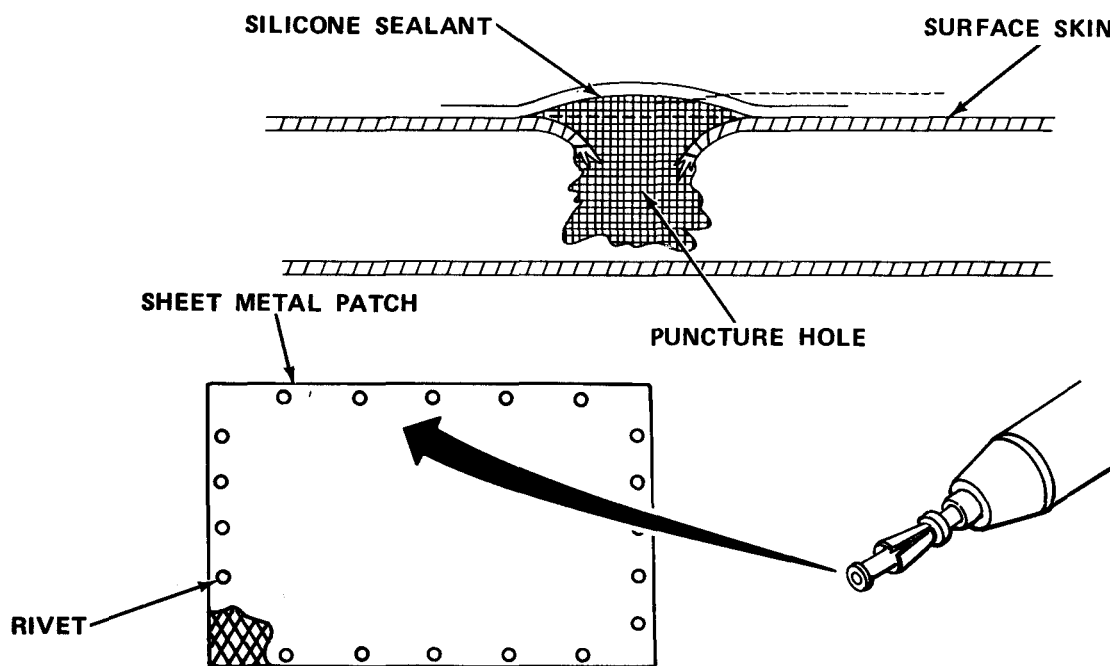

- e. Prepare sheet metal patch large enough to cover damaged area with overlap.

- f. Place patch over damaged area and mark all around edges of patch.
- g. Drill holes 1 in. (25.4 mm) apart.
- h. Apply sealant to edges of patch.
- i. Apply patch to van body.
- j. Install pop rivets beginning at center of each side. Rivets should be placed 1 in. (25.4 mm) apart.
- k. Paint as needed.

1-20.8 Replace Air Conditioner/Heater.

MOS: 63W, Wheel Vehicle Repairer

PERSONNEL: Two persons are required to perform this procedure.

TOOLS: Cross Tip Screwdriver
Lifting Equipment
8 in. Adjustable Wrench
7/16 in. Combination Wrench

SUPPLIES: Air Conditioner/Heater
Solvent P-D-680 (Item 24, Appendix E)
Gasket
Silicone Sealant (Item 22, Appendix E)
Adhesive (Item 1, Appendix E)

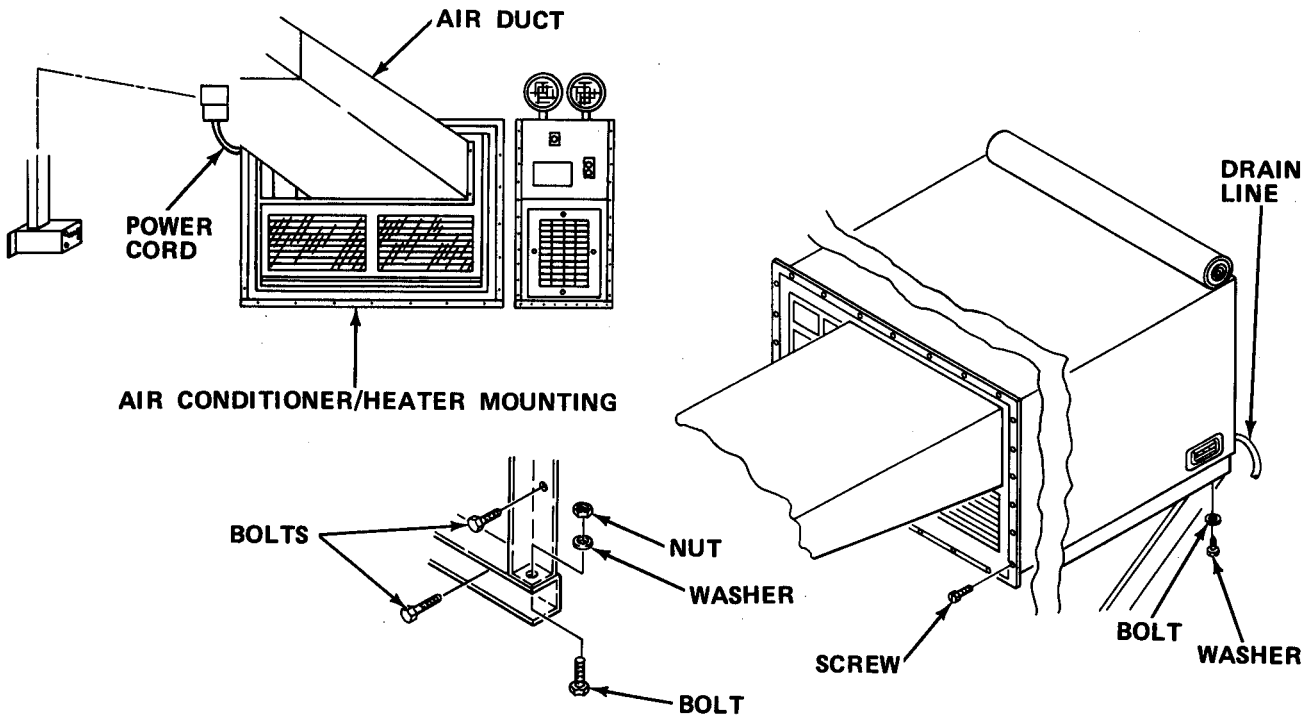

WARNING

- Use hoist or proper lifting equipment to replace air conditioner/heater. Failure to do so may result in death or serious injury.
- Turn off air conditioner/heater circuit breaker and unplug power cord. Failure to do so may result in death or serious injury.
 - a. Turn off air conditioner/heater circuit breaker. Unplug or disconnect power cord as appropriate.

- b. Remove screws holding air duct to air conditioner/heater.
- c. Remove nut, washer, and screw from each corner of air conditioner/heater mounting. Remove screws securing mounting to van wall.
- d. Disconnect drain line from air conditioner/heater.
- e. Attach sling to lifting handles. Raise hoist enough to remove slack from sling.
- f. Remove mounting bolts and washers.
- g. Slide out air conditioner until other lifting handles are free. Attach sling to handles.
- h. Raise defective air conditioner/heater with hoist until unit is free from brackets and section.
- i. Place air conditioner/heater on flat-bed truck or pallet.

WARNING

Dry cleaning solvent, P-D-680, used to clean parts is potentially dangerous to personnel and property. Avoid repeated and prolonged skin contact. Wear solvent-impermeable gloves and eye/face protective equipment when using solvent. Do not use near open flame or excessive heat. Flash point of solvent is 100° F to 138° F (38°C to 59° C).

- d. Clean sealant from opening using dry cleaning solvent P-D-680.
- k. Remove damaged gasket and replace with new gasket.
- l. Raise air conditioner/heater until it rests on air conditioner/heater brackets.
- m. Remove two sling hooks as unit is eased into hole until grille touches duct.
- n. Remove remaining sling.
- o. Reinstall washers and mounting bolts.
- p. Reconnect drain lines.
- q. Reinstall screws securing air conditioner/heater mounting to section wall. Reinstall screw, washer, and nut to each corner of mounting.
- r. Reinstall screws securing air duct to air conditioner/heater.
- s. Reconnect or plug in power cord. Turn on air conditioner/heater circuit breaker.

1-20.9 Replace Air Conditioner Support Bracket.

MOS: 63W, Wheel Vehicle Repairer

PERSONNEL: Two persons are required to perform this procedure.

TOOLS: 9/16 in. Combination Wrench
Lifting Equipment
Knife, TL-29

SUPPLIES: Air Conditioner Support Bracket
Drain Tube Ties

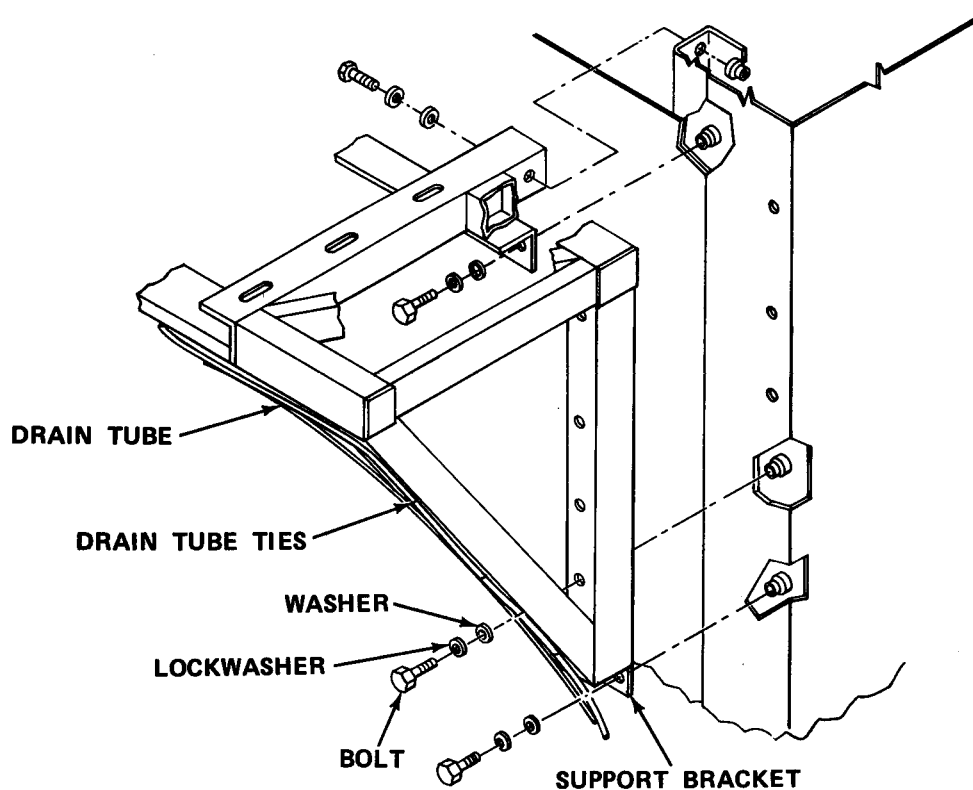

WARNING

Serious injury to personnel or damage to equipment may occur unless two or more personnel are used to remove and replace air conditioner/heater because of weight and balance of air conditioner/heater.

- a. Remove air conditioner/heater (paragraph 1-20.8).
- b. Cut drain tube ties, and remove drain tube from support bracket.
- c. Remove bolts, lockwashers, and washers securing support bracket.

- d. Remove defective support bracket.
- e. Install new support bracket. Secure to van with bolts, lockwashers, and washers.
- f. Reinstall drain tube on support bracket, and secure with new ties.
- g.** Reinstall air conditioner/heater (paragraph 1-20.8).

1-20.10 Replace Ventilation Duct.

MOS: 52C, Utilities Equipment Repairer

TOOLS: Hacksaw
Electric Drill and Bits
Ball Peen Hammer
Pop Rivet Gun
Paint Brush
Cross Tip Screwdriver

SUPPLIES: Sealant (Item 22, Appendix E)
Wood Block
Pop Rivets
Paint (Item 18, Appendix E)
Cheesecloth (Item 6, Appendix E)
Salvaged Ventilation Duct

- a. Turn off air conditioner/heater so air will not blow through duct.

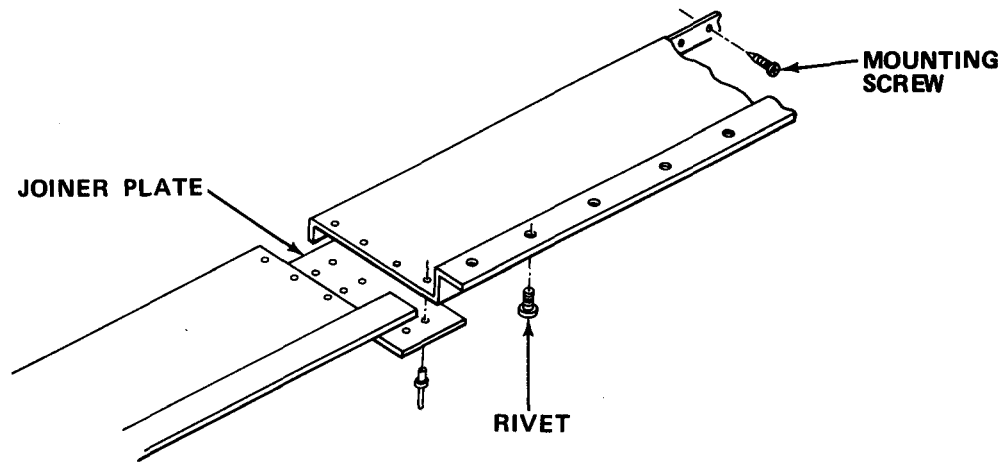

- b. Drill rivets from damaged section of duct. Remove joiner plates.
- c. Remove mounting screws to remove damaged sections of duct.
- d. Straighten remaining sections of duct at edges using hammer and wood block.
- e. Place sealant on mounting edges.
- f. Install new duct section cut from salvaged duct. Secure with screws.
- g. Reinstall joiner plates. Install rivets to secure.
- h. Paint as necessary.
- i. Turn on air conditioner/heater.

TM 5-6675-316-14

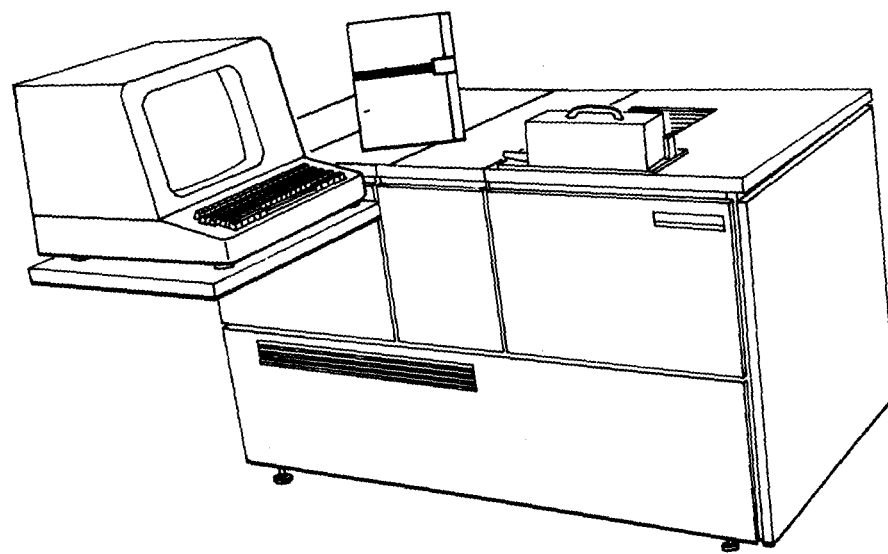

CHAPTER 2

COMPOSING MACHINE

Section I INTRODUCTION

2-1. GENERAL INFORMATION.2-1.1 Scope.

a. Model Number and Equipment Name. Model AM 3510 Direct Entry Phototypesetting Composing Machine.

b. Purpose of Equipment. To produce professional quality, camera-ready composition.

2-1.2 Reference Information.

a. List of Abbreviations

ACL	Accumulated Leading
BDE	BUS DRIVER ENABLE
CE	CHIP ENABLE
CHEQ	CHARACTER EQUALITY
CLK	Clock
COMP	Comparator
CPU	Central Processing Unit
CRRDY	Carriage Ready
D/A	Digital to Analog
DTATRK	Data Track
DSCCL	Disc Clear
FCH	FETCH CONTROL
FEQ	FONT EQUALITY
FF	Flip Flop
FLXD	Flex Data

FP	Flash Pulse
I/O	Input/Output
LVC	Low Voltage Control
MASCLK	Master Clock
MP	Missing Pulse
PC	Printed Circuit
PROM	Programmable Read Only Memory
RAM	Random Access Memory
ROM	Read Only Memory
R/W	Read/Write
SEDG+MP	SINGLE-EDGE PLUS MISSING PULSE
R	Register
SPDREF	Speed Reference
STBEDG	Strobe Edge
STBTRK	STROBE TRACK
STD	Strobe Data Track
TDLY	Time Delay
WDTHALW	WIDTH ALLOWED
WRT	Write

b. Glossary.

Center Command	Copy is centered between left and right margins.
Cursor	Rectangular block of light which indicates point at which action takes place on monitor screen.
EM Space	Fixed space 18 units wide.
EN Space	Fixed space 9 units wide.

Fit	Overall appearance of word. On some of larger type sizes, it may be necessary to remove some of white space to improve readability of word.
Flush Left	Copy is set flush against left margin.
Flush Right	Copy is set flush against right margin.
Font	Disc which contains more than one style of printing type.
Justified Copy	All lines of type are same length so that there are even margins on left- and right-hand sides.
Leading.	Spacing between lines of type. (Pronounced as for the metal, lead).
Mortise.	Method of removing white space between characters to improve their fit.
Overwrite/Overstrike	Positioning cursor over character and replacing it with next character keyboarded.
Pica	Measurement of type size, approximately 1/6 in.
Point.	Measurement of type size. (There are 12 points to 1 pica. A point on Composing Machine = 0.01384 in.)
Primary Leading	Instruction given to composing machine which will determine primary spacing between lines of type.
Quadding	Setting flush left, right or center.
Secondary Leading	Additional leading function available for use between paragraphs, after headings or at other times which require spacing different from primary leading.

Set Solid	When leading space, measured in points, is same as type size.
Super Shift	Method of accessing additional 26 characters available on type disc.
White Space	Space built into type design so that characters do not touch .

2-2. EQUIPMENT DESCRIPTION.

2-2.1 Equipment Characteristics, Capabilities, and Features.

- a. Color-coded, light-touch keyboard.
- b. Unrestricted type style mixing.
- c.** Monitor screen, 11 in. X **8 in. (27.94 cm X 20.32 cm)**, with green characters on black background.
- d. Keyboard-selected type size, 5-1/2 to 74 points.
- e. Four type styles or special symbols on each type disc.
- f. Type disc changeable in 10 sec.
- g.** Line length of 45 picas.
- h. Automatic letter spacing.
- i. Automatic hyphenless justification.
- j.** Automatic flush left, right, and center.

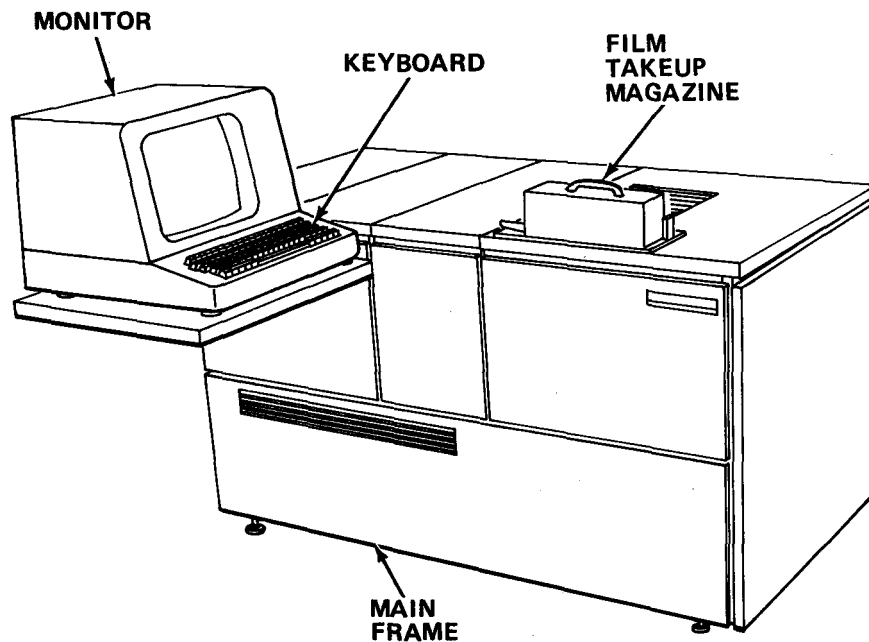
2-2.3 Location and Description of Major Components.

MONITOR. Contains **11** in. X 8 in. (27.94 cm x 20.32 cm) CRT and associated power supplies.

KEYBOARD. Alphanumeric and control, 83-key keyboard provides manual input to system.

FILM TAKE-UP MAGAZINE. Holds exposed film. Magazine is removable.

MAINFRAME. Houses optical unit, computer stack, film magazine, and power supplies.

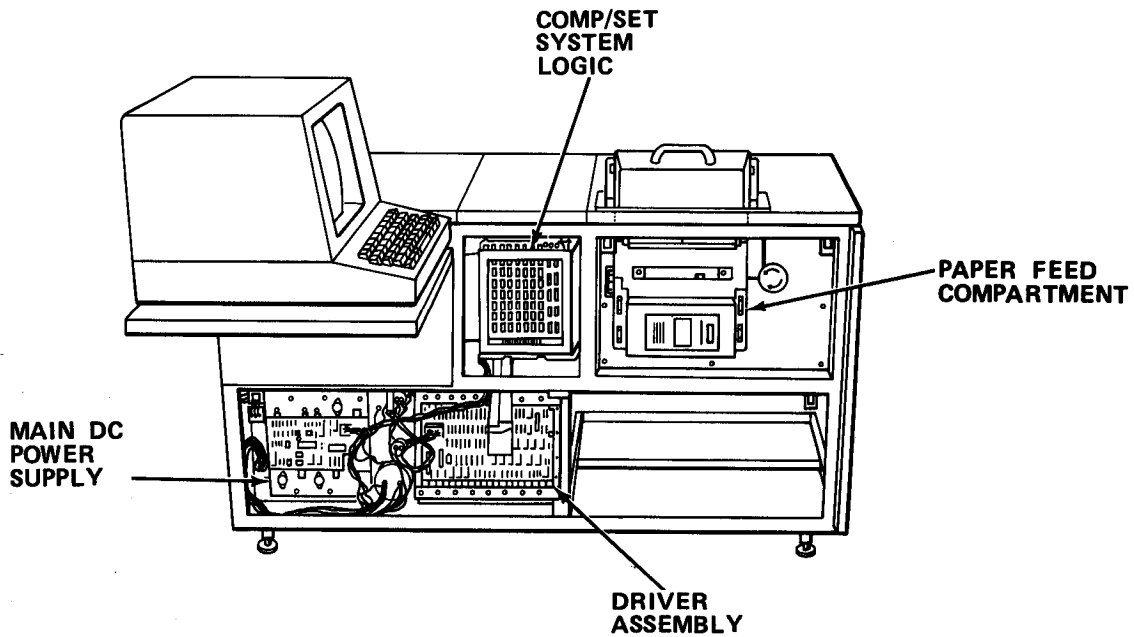

COMP/SET SYSTEM LOGIC. Fourteen-position PC card file houses applications program and ten interface boards.

PAPER FEED COMPARTMENT. Contains photosensitive paper supply, drive rollers, and shutter mechanism.

MAIN DC POWER SUPPLY. Provides six dc output voltages with variety of current capabilities.

DRIVER ASSEMBLY. Receives logic levels from motherboard assembly and drives optical system electromechanics.

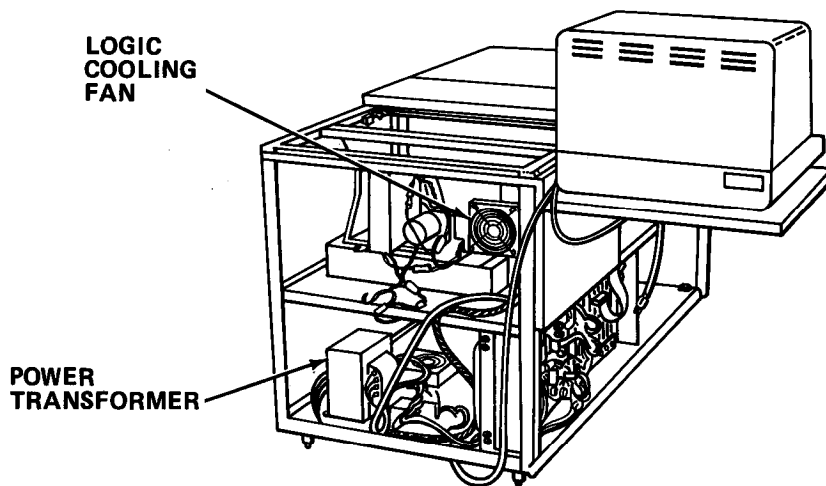

LOGIC COOLING FAN. Provides forced-air cooling for logic system.

POWER TRANSFORMER. Main transformer converts supply voltage to those required by unit.

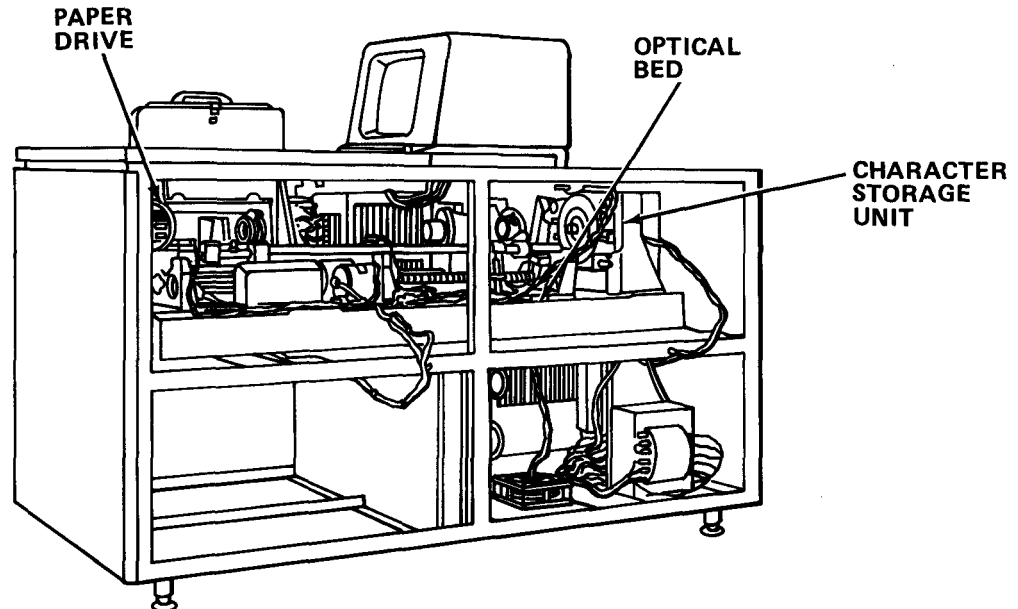

PAPER DRIVE. Stepper motor advances photosensitive paper.

OPTICAL BED. Main casting provides bed for optical assembly.

CHARACTER STORAGE UNIT. Houses xenon flash unit, font disc drive and optical detector assembly.

2-2.3 Equipment Data.

Power Requirements	115 V, 60 Hz, 7.5 amps used with constant voltage transformer.
Video Display	11.0 x 8.0 in. (27.9 x 20.3 cm); displays 14-point green characters on black background.
Keyboard	83 keys, typewriter-oriented, color-coded
Type Size	5-1/2 to 74 point range; selected by keyboard function.
Line Length	Maximum of 45 picas in all type sizes.

TM 5-6675-316-14

Type Styles	Four type styles on each font disc; 448 characters per disc; all selectable by keyboard.
Leading	Primary, secondary, and add-lead; From 0-99 1/2 points; selectable by keyboard.
Justification	Automatic hyphenless justification or manual end of line; automatic flush left, right, and center
Word Space Control	Minimum and maximum allowable justifying word space value; selectable from keyboard.
Letter Spacing	Automatic insertion of letter spacing as required; maximum value programmed from keyboard.
Dimensions	
Height	39-1/2 in. (100.3 cm)
Width	43 in. (109.2 cm)
Depth	51 in. (129.5 cm)
Weight	485 lbs (220 kg)

2-3. TECHNICAL PRINCIPLES OF OPERATION.

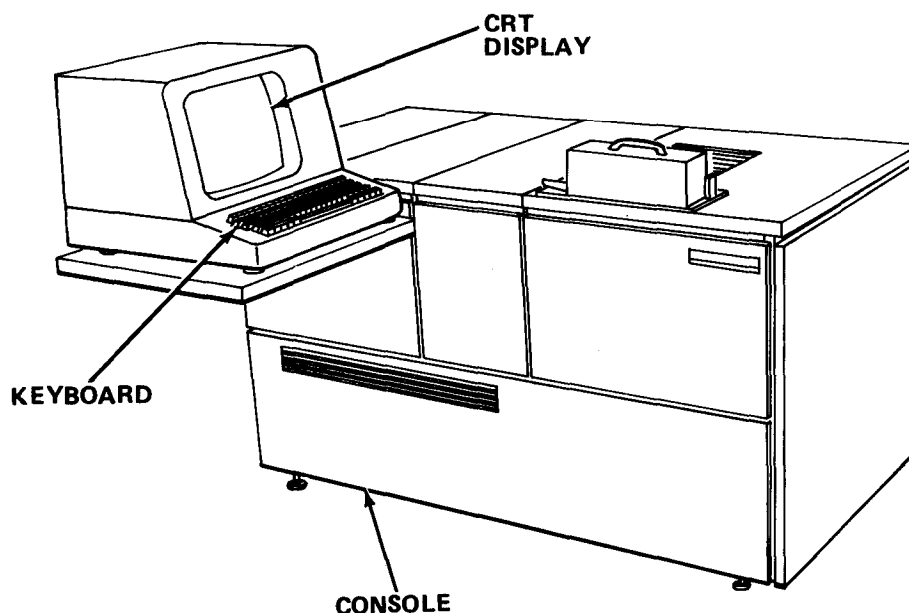

2-3.1 General. The composing machine is a keyboard operated phototypesetter. It consists of a keyboard with CRT display and console containing the photo unit. From one type disc, 74 point sizes are available in four type faces. These are all accessible from the keyboard. Format information such as type font, size, line length, line remainder and leading are all clearly indicated on the CRT.

The selected characters are instantly visible on the CRT display upon keystroking. These can easily be changed or corrected as desired, before printing. When a line is completed, it is automatically set by the photo unit while the next line is being keyboarded.

The microprocessor, housed in the mainframe, performs the following functions:

- a. Handling all input control and alphanumeric keystrokes whenever they occur.
- b. Loading the character generator memory, to be capable of displaying the keystrokes on the CRT.
- c. Reading a stored character width code from the character disc.
- d. Calculating functions related to point size and line length.
- e. Commanding the various stepping motors to the proper positions.

f. Flashing a particular character.

(1) When the keyboard is operated, the output data is automatically stored in a buffer memory by the keyboard interface logic. The microprocessor processes the functional data, and the font character information is read from the disc, which is then stored in the display memory. The display memory supplies this data to the character generator logic which processes it for presentation on the CRT.

(2) When an end-of-the-line decision is detected, the program transfers data from the lower half of the screen to the top. At the same time, it begins to process data sequentially from the display memory, passing instructions to the various phototypesetter functions which will set the characters on the film. As the film is advanced, it is stored in a take-up cassette mounted on top of the console. When the required copy has been set, the film is advanced into the take-up cassette and then cut off. The take-up cassette can then be removed and taken to the processing machine.

2-3.2 Detailed.

a. Photo unit.

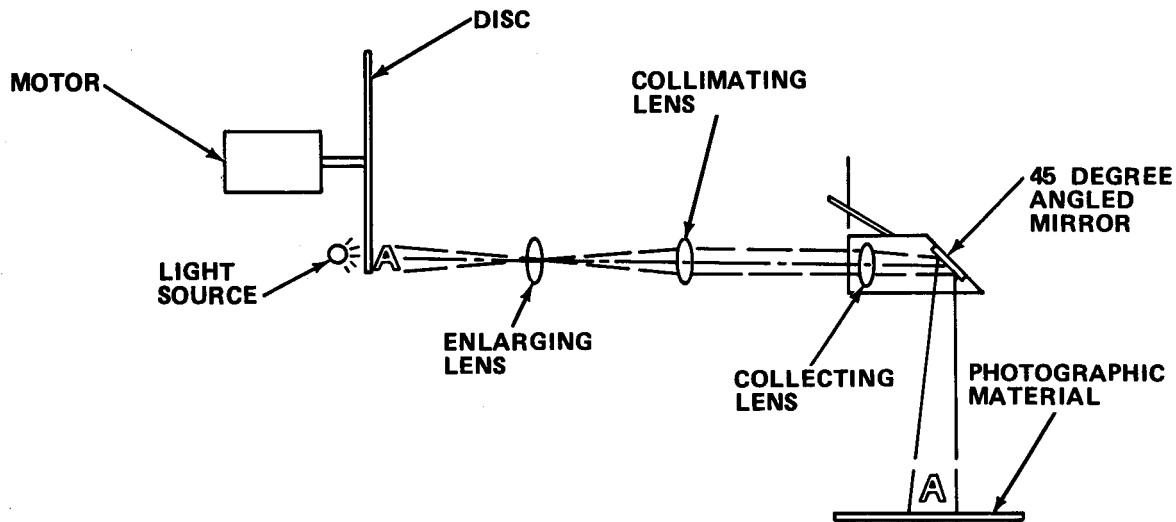

(1) The photo unit is basically a camera which exposes images from a motor driven disc through a lens system and onto photographic material. The disc contains four rows of characters, with information and timing information. The light source flashes when triggered by the timing information and illuminates only the required character. The image of this character then passes through an enlarging lens, a collimating lens, collecting lens, 45-degree angled mirror and onto the-photographic material. By moving the collecting lens assembly backward and forward, lines of type can be formed. The photographic material is moved at the end of each line in preparation for the next.

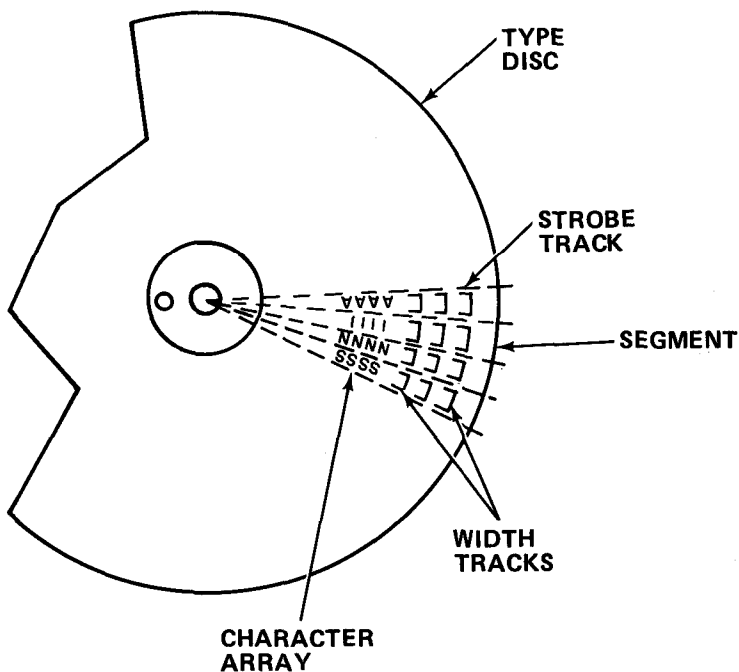

(2) The type disc is a circular piece of film, 5.375 in. (13.650 cm) in diameter and approximately 0.007 in. (0.177 mm) thick. The material is a stable polyester plastic, coated with a high resolution emulsion.

(3) The character array contains four tracks of characters, each in a different font style; there are 112 positions in each track. Tracks are numbered 1 to 4, from the center to the edge of the disc. Total character capacity of the disc is 448. The same alphanumeric character appears in tracks 1, 2, 3 and 4 for each segment. The outer edge of the disc has three data tracks, a strobe track, and two width tracks.

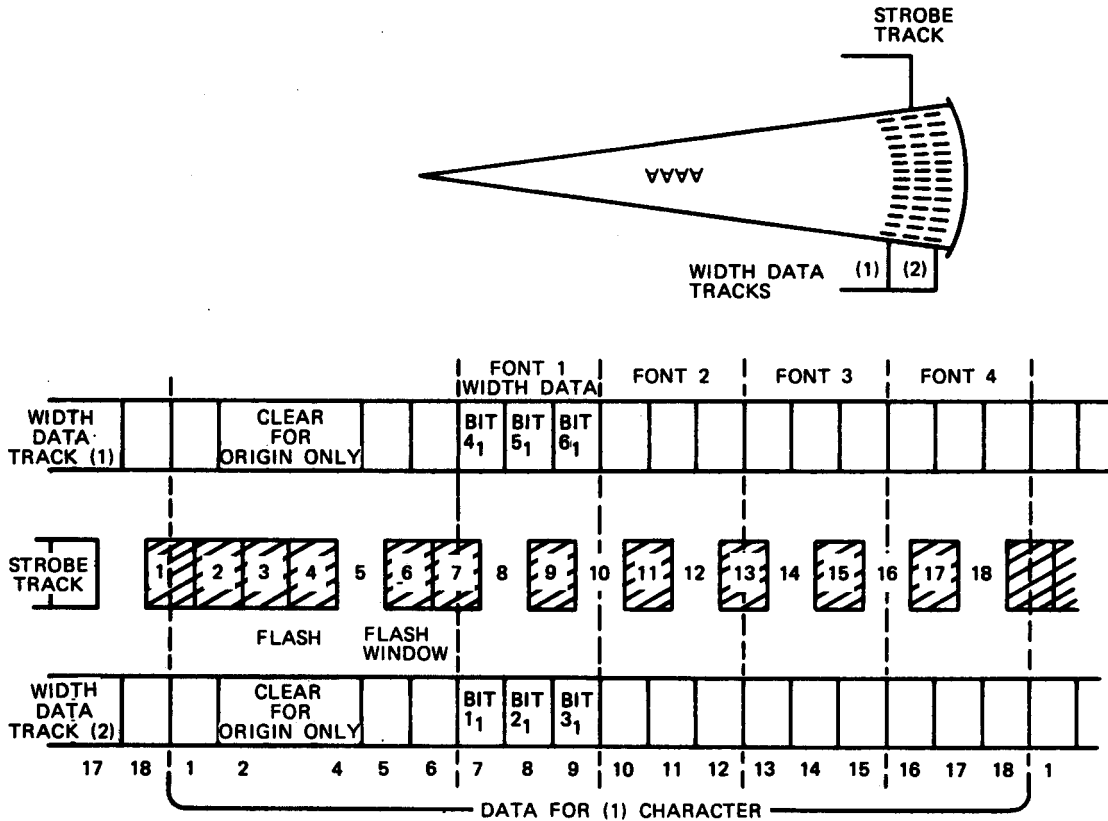

(4) Each data track character segment consists of 18 bits represented by either transparent or non-transparent adjoining lines. The first six bits relate to the strobe track, and each succeeding set of three bits relate to a character in one of the four fonts. Since there are two tracks of width information, each character has six data bits. The width codes per character represent five data bits (0 to 31) and a parity bit. The data bits will be translated in the photo unit to character unit widths as **shown on the following page.**

dB = Data Bit
 W = Character Unit Width

dB-W	dB-W	dB-W	dB-W
0-0	8-5.5	16-9.5	24-14
1-1	9-6	17-10	25-15
2-2	10-6.5	18-10.5	26-16
3-3	11-7	19-11	27-17
4-3.5	12-7.5	20-11.5	28-18
5-4	13-8	21-12	29-19
6-4.5	14-8.5	22-12.5	30-20
7-5	15-9	23-13	31-21

(5) The data and timing tracks are divided into 112 segments, as are the alphanumeric. Each data segment is divided into 18 parts which are bits of information. These bits are approximately 0.0008 in. (0.020 mm) in width, and are either transparent (clear) or non-transparent (black).

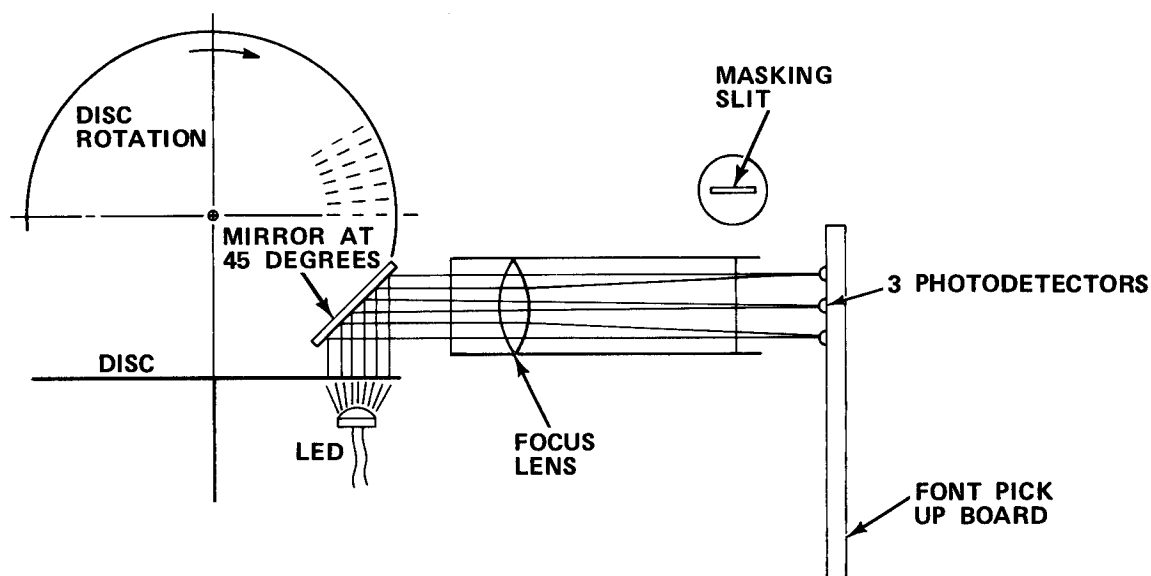

(6) Located at the outside perimeter of the disc is a detector assembly which picks up data from the tracks on the edge of the disc. The detector assembly consists of a large light emitting diode, approximately 1/4 in. (6.35 mm) in diameter, which projects infrared light across the three tracks, through the disc and onto a 45-degree mirror where the light is turned through 90 degrees. A small lens focuses the beam of light through a slit mounted on the font pickup lens tube. Three photodetectors are mounted in line with the slit, and each corresponds to a data track on the disc. With the disc in rotation, pulse patterns representative of the three data tracks are developed and detected by the photodetectors. The three pulse trains are then converted by the font interface logic into binary data which is representative of the data encoded on the three tracks of the disc.

(7) To expose an individual character, the program determines at which point in the font disc rotation the xenon flash will fire. The xenon flash freezes the selected character and projects it through the lens system and onto the film.

(8) A font change is accomplished by moving the whole disc laterally so that the adjacent character is positioned opposite the flash window. The track data detection system moves with the disc assembly.

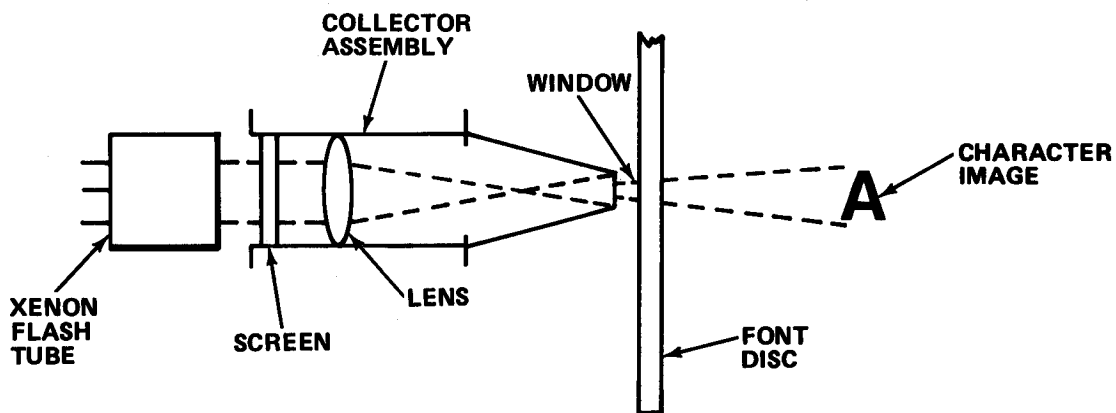

(9) The xenon flash tube is fed by a high voltage potential from the flash power supply. The resulting 0.080 in. (2.032 mm) long arc passes into the collector assembly where it is diffused by the screen. The lens focuses the bright spot through the window onto the font disc. The character image is then projected.

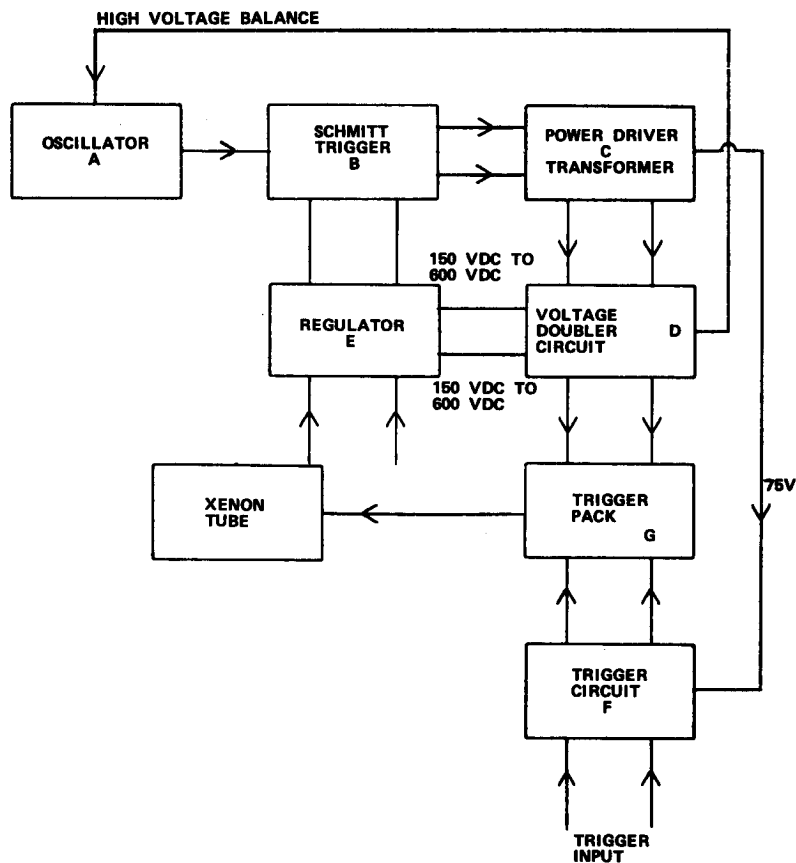

SCHMITT TRIGGER OUTPUT

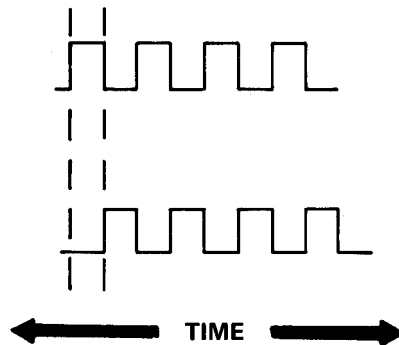

(10) To supply the high voltage required to fire the xenon flash tube, an oscillator (A) produces a triangular wave shape which the Schmitt Trigger (B) divides into alternating pulses displaced in time from one another.

(11) These pulses are applied alternately through the power drivers to the 30:1 transformer at 50 V (C), producing a high voltage alternating wave. This high voltage is fed to the rectifiers and filter capacitors of the voltage doubler circuit (D). The voltage doubler circuit provides charging voltage (75 V) for the trigger pack capacitor and control feedback to the regulator (E). The regulator determines the triggering point (in B) and, therefore, the width of the pulses going to the power drivers.

(12) When the high voltage capacitors are fully charged (approximately 1500 V), the regulator moves the triggering point beyond the peak of the oscillator output, stopping the pulse output and the production of high voltage. Production is resumed when the voltage across the capacitors falls below the level set by the regulator.

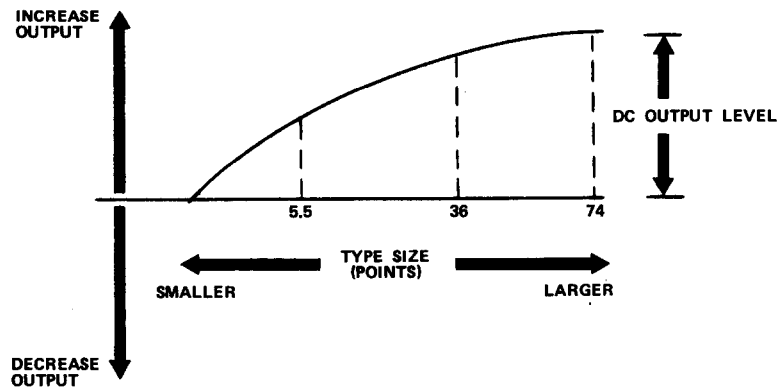

(13) The trigger circuit (F) contains a capacitor, an SCR, and a trigger transformer. When the trigger pulse comes in, and fires the SCR, the capacitor discharges through the primary of a winding inside the trigger pack (G) firing the xenon tube. Each selected type size requires a different flash intensity to ensure correct exposure density. Larger type requires higher intensity and vice-versa. The microprocessor program determines the flash value for each type size, and a digital-to-analog converter converts this information into a current.

(14) The flash intensity current is fed to the regulator circuit where it controls the output level of the dc high voltage supply to the xenon flash tube.

(15) As previously explained, each font disc contains four rows of type, each in different styles. To access all four rows of type it is necessary to move the whole font disc laterally so that an adjacent character image track will be positioned in the exposure window of the light source.

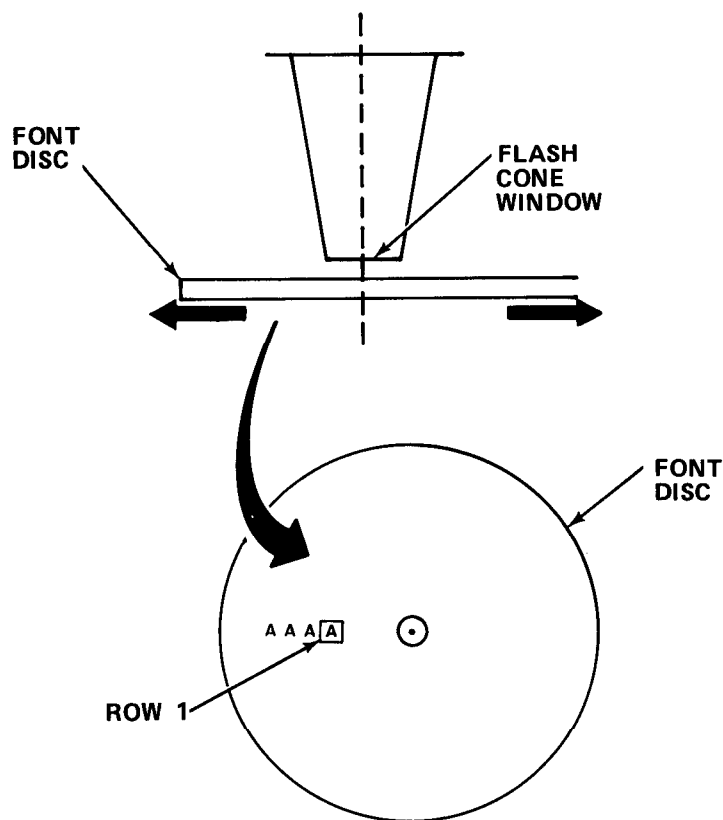

(16) The font disc is moved laterally by a stepping motor which is controlled by the microprocessor. In this case, the flash cone window is opposite row 1 of the type. To access rows 2, 3 and 4, the font disc would be moved to the right.

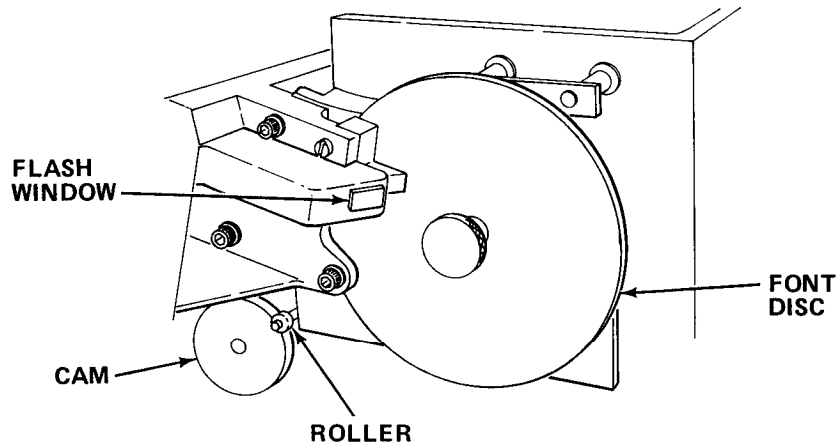

(17) The mechanical movement of the font disc is accomplished by changing the position of the cam. This laterally moves the roller and the font disc. The flash window remains stationary. Once the selected character has been illuminated, the image passes through the optical system where it is magnified as determined by keyboard size selection, and the values stored in the microprocessor program.

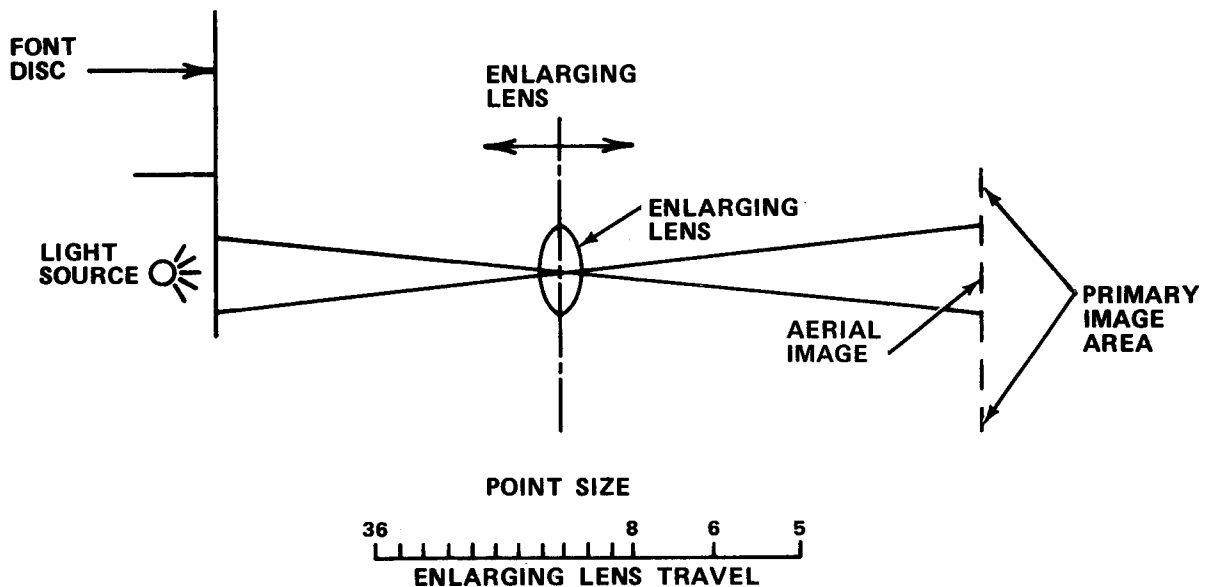

(18) The illuminated character image is projected into the enlarging lens. The position of this lens from the font disc determines the final image size, in this case from 5.5 to 74 points. The enlarging lens is moved backward and forward on a carriage driven by a helix screw and stepping motor. The microprocessor program determines the position of the lens by feeding information on the required number of motor steps via the driver board to the stepping motor. By moving the lens closer to the font disc, the aerial image increases in size. By moving the lens away from the font disc, the image gets smaller. This increase and decrease in size can be translated into point size as shown. The image formed is known as the primary image, and is from 5.5 to 74 points in size.

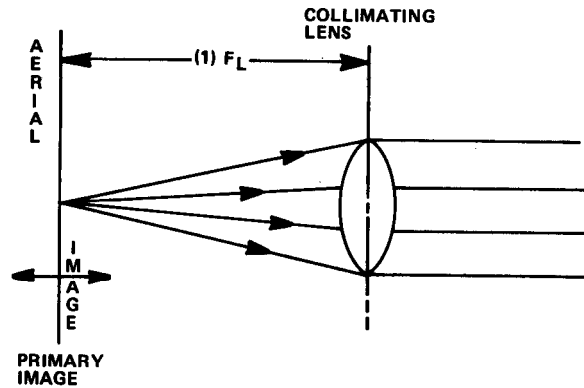

(19) Mounted in the same plane is another movable lens, the collimator lens. This lens is always kept one focal length away from the aerial image produced by the enlarging lens. This means that the image leaving the collimator lens will be projected as parallel light. The collimator lens is moved backward and forward on a carriage driven by a helix screw and stepping motor. As in the case of the enlarging lens, the microprocessor program determines the position of the lens by feeding information on the required number of steps via the driver board to the stepping motor. The combined movements of the enlarging and collimator lenses, as determined by the values stored in the program, produce point sizes from 5.5 to 74.

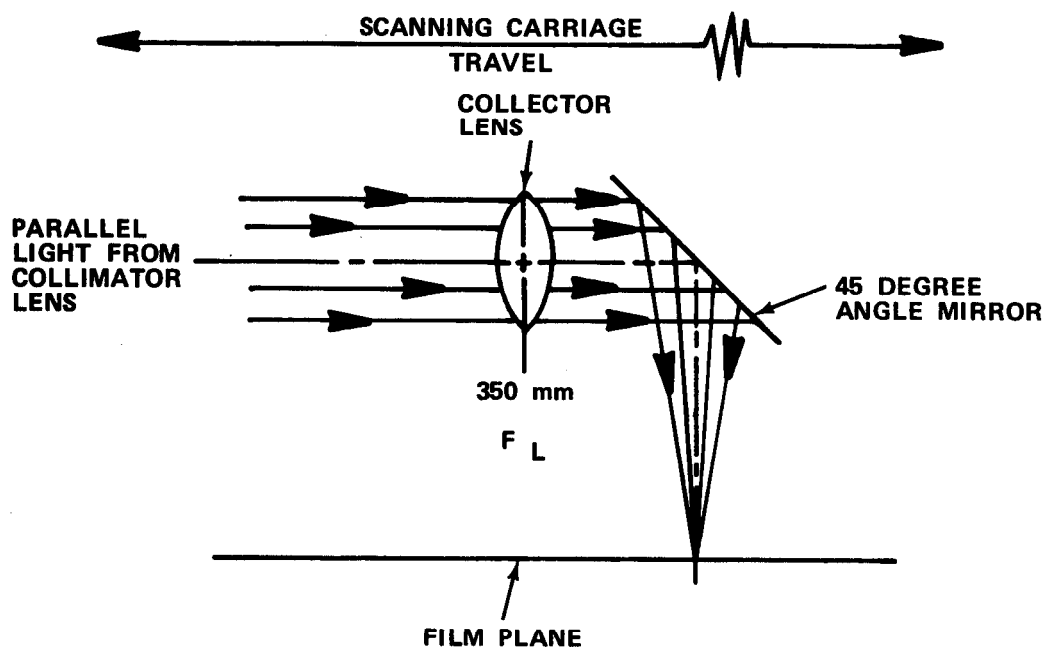

(20) The parallel light from the collimator lens passes along the optical plane into the collector lens. This lens has a focal length distance of 350 mm, which is the optical distance between this lens and the film plane. The image is turned through 90 degrees by the 45-degree angle mirror and onto the film plane. The collector lens is mounted on a carriage parallel to the film plane. This carriage moves along wayrods driven by a stepping motor/cable arrangement.

$$\text{Number of Motor Steps} = \frac{(\text{Absolute Character Width}) \times (\text{Point Size})}{3}$$

3

(21) The horizontal distance that the scanning carriage will move is determined by the main program using the formula above. In this manner, correct spacing for specific character width is maintained. (Character width is obtained from the disc track for each character.)

b. Film feed and magazine system.

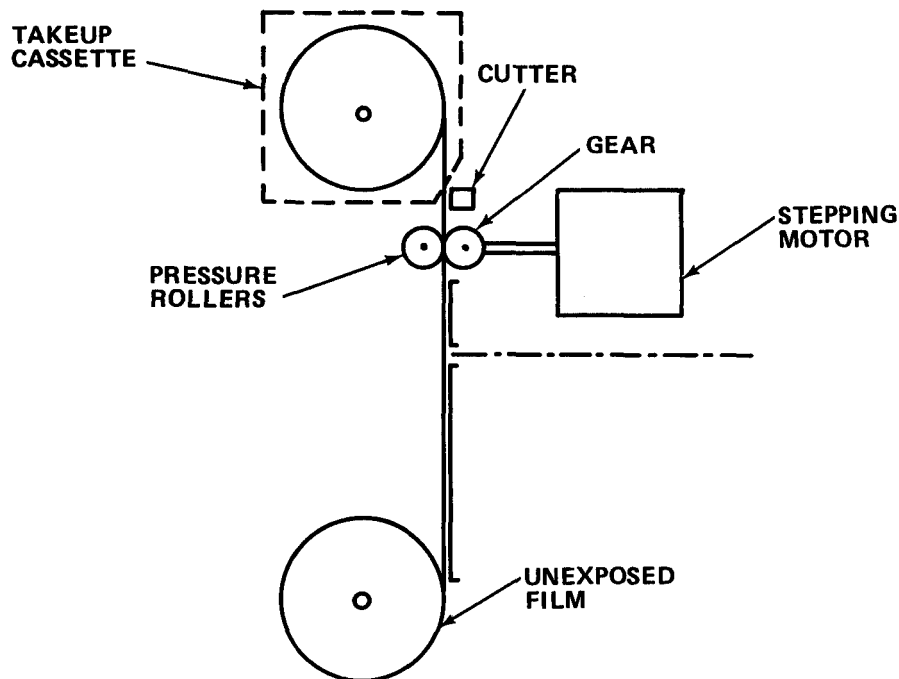

(1) Vertical spacing between lines of exposed copy is accomplished by advancing the exposed film upward as each line of type is exposed. The unexposed film is stored in a lightproof container in the film feed magazine. Film is pulled from the storage container by the pressure rollers. The stepping motor is gear-coupled to the pressure rollers, which drives the film past the cutter and into the take-up cassette.

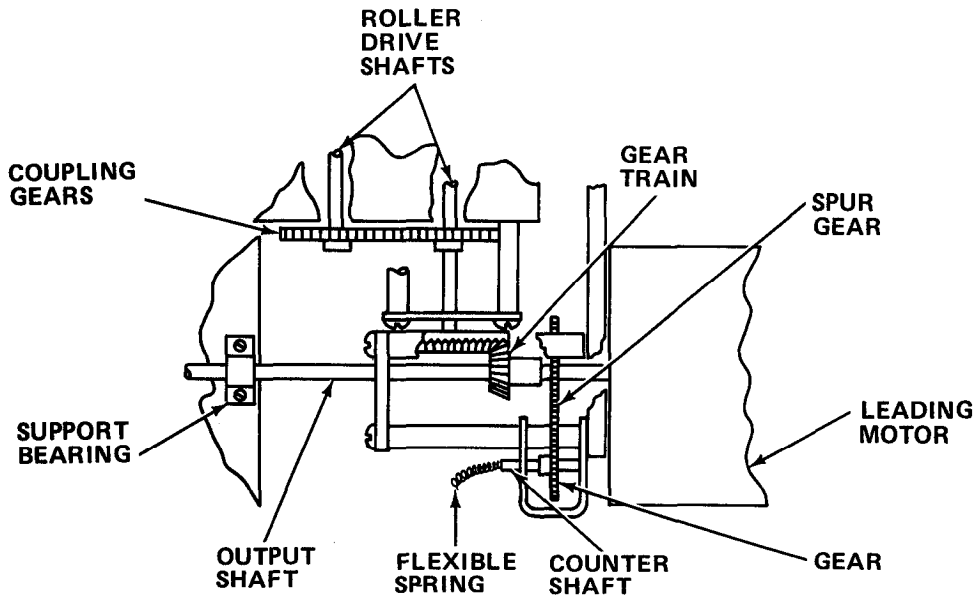

(2) The film drive or leading motor has a long output shaft. The shaft is extended through the support bearing to a knob which is used for manual film advance. The spur gear rotates with the main shaft, turning the gear. This gear is fixed to the counter shaft. The rotation is transferred via the flexible spring to a mechanical digital display which shows the quantity of film that has been used. The roller drive is taken through the 90-degree gear train to two coupling gears and to the roller drive shafts. The stepping motor operates in 0.007 in. (0.177 mm) steps, as controlled via the main program.

(3) Four constant current Darlington driver circuits supply the four leading motor coils to step the motor. The drivers are controlled by signals from the LVC (Low Voltage Control) stepper board, a fifth signal is used to switch the current to the coils from full to half when the motor is not stepping.

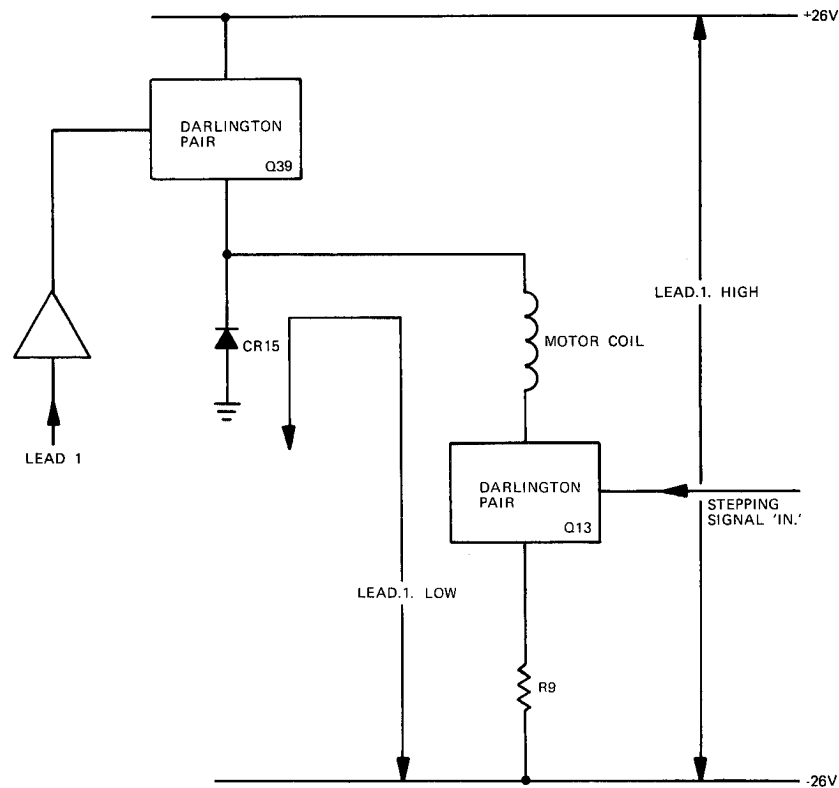

(4) A single Darlington driver circuit associated with each of the four coils allows current to flow in one direction through the motor coil, the current either flows to ground via a diode CR15 or to +26 V via Q39, depending on whether Lead 1 is high or low.

(a) When Lead 1 is biased high and a stepping signal is received at Darlington Q13, then Q39 is on. This allows full current to flow from the -26 V supply through emitter resistor R9 to Q13 which is also on, through the motor coil and Q39 to the +26 V supply.

(b) When Lead 1 is biased low, Darlington Q39 is off and the motor coil return is through diode CR15 to ground. This allows only half of the current to flow through the motor coil.

(c) The current in each motor coil remains the same regardless of temperature or motor impedance, the base of each Darlington being clamped to a reference voltage.

(d) Constant current regulation is achieved in this manner: Emitter resistor R9 provides negative current feedback which changes the bias of Darlington Q13 according to the current drawn by the motor coil. Current in the coil can be measured by sensing the voltage drop across emitter resistor R9.

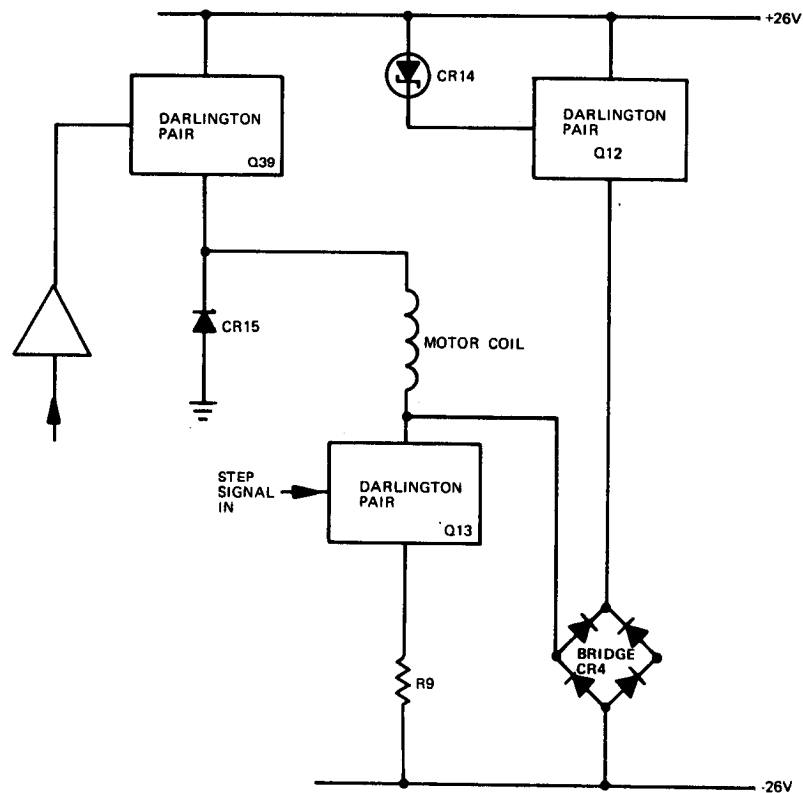

(5) When the current in the coil is turned off, the collapsing field will induce transients. These are shunted back into the -26 V supply by diode CR4, zener diode CR14 and Darlington Q12. Each motor coil is driven with the same basic circuit so the program provides four signals in sequence to drive the stepping motor, and the film is advanced the requisite number of steps upward at the completion of each line of type.

c. Variator or enlarging lens drive system. The variator or enlarging lens moves backward and forward on a carriage driven by a helix screw and stepping motor. The main program determines the position of the lens by feeding information on the requisite number of motor steps.

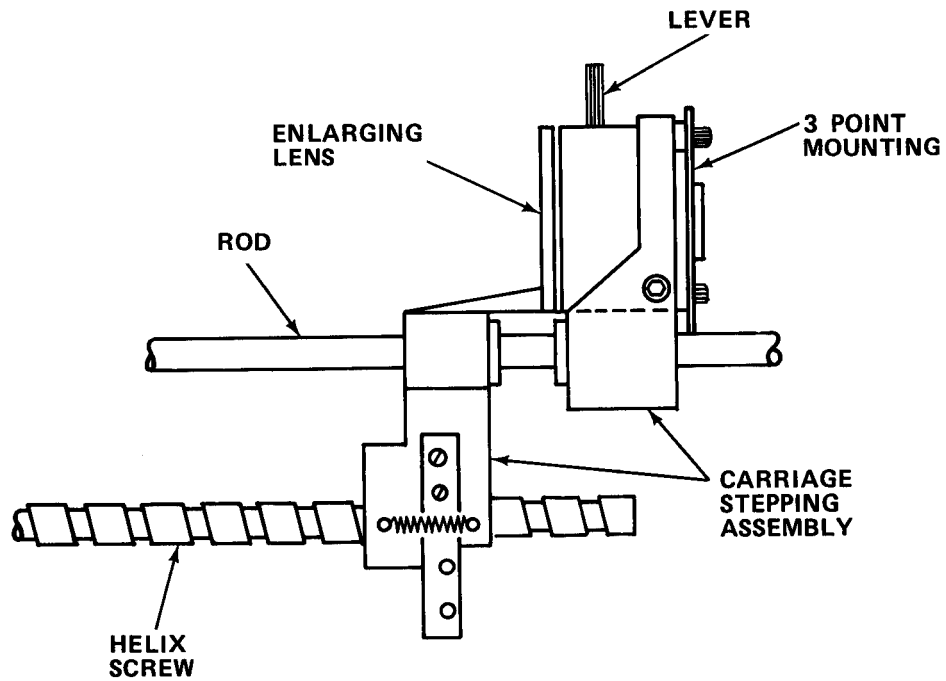

(1) The variator or enlarging lens is mounted on the carriage stepping assembly by a three-point mounting. This lens is also fitted with a variable aperture, controlled by a lever. The carriage stepping assembly is located on two rods which are fixed parallel to the optical plane. Movement, both forward and backward, is accomplished by rotation of the helix screw.

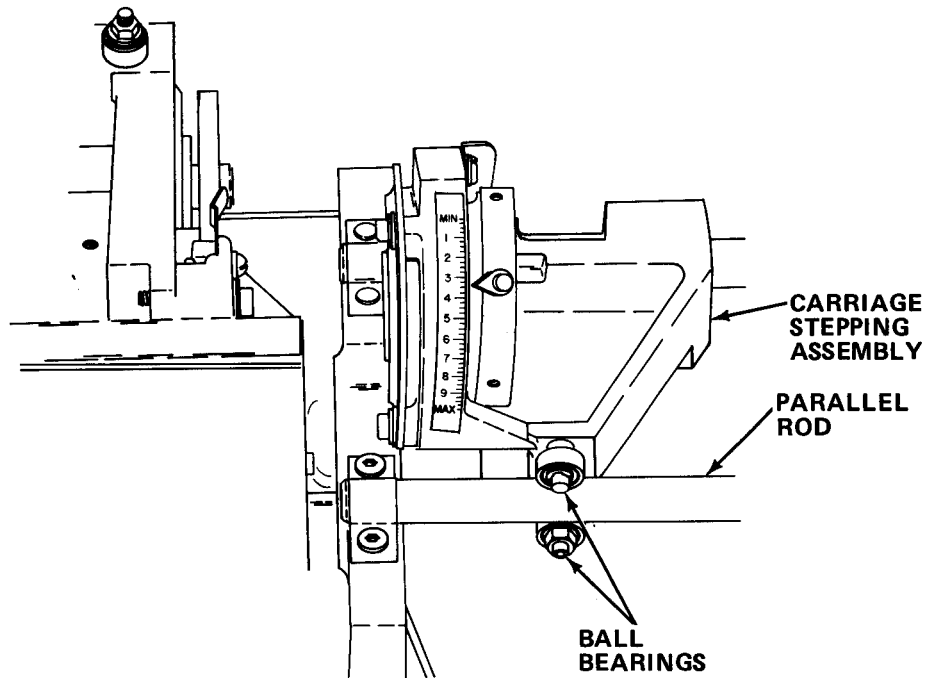

(2) On one side, the parallel rod passes through precision bearings fixed to the carriage stepping assembly. On the other side, two ball bearings rest on the upper and lower surfaces of the second parallel rod, preventing any rotational movement of the carriage stepping assembly as it is driven by the helix screw.

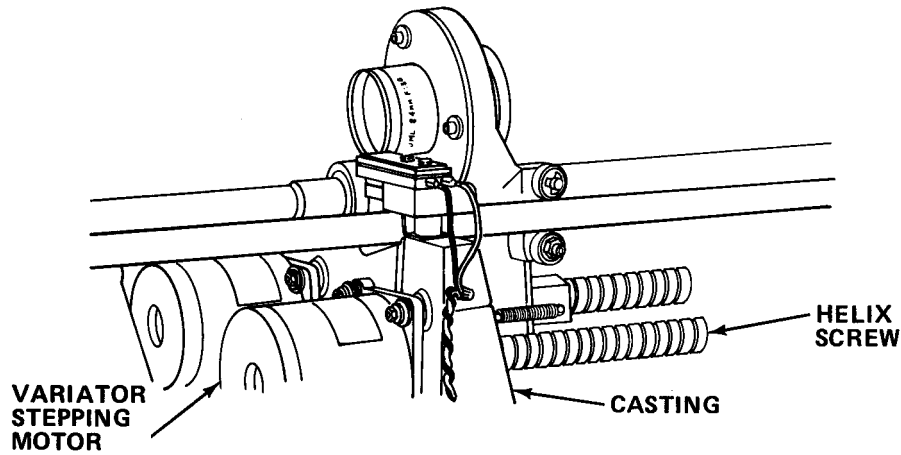

(3) The helix screw is rotated by the variator stepping motor, the motor being mounted horizontally in a casting approximately midway along the optical plane. The motor shaft is coupled to the helix screw by a taper pin.

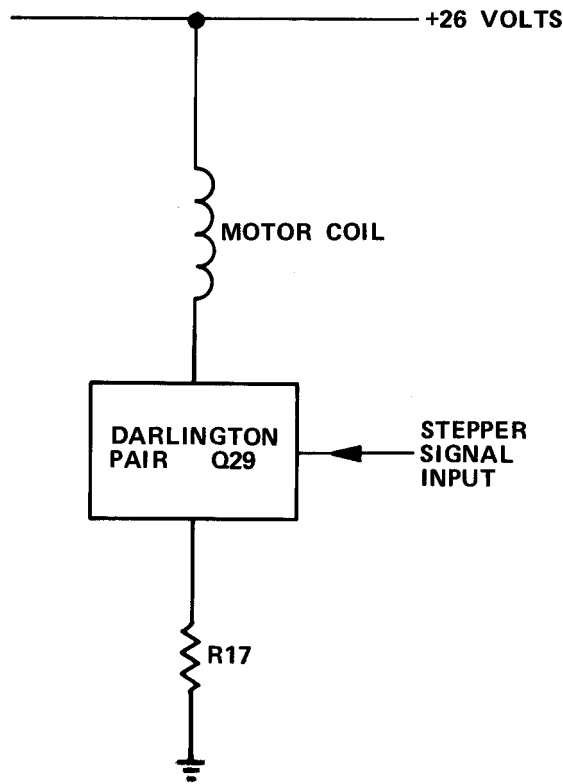

(4) Four constant current Darlington driver circuits supply the four variator motor coils used to step the motor. Sequential signals are supplied by the LVC stepper board.

(a) When the stepper signal input is high, the Darlington pair Q29 is on. This allows current to flow from ground supply through emitter resistor R17, Darlington pair Q29, and the motor coil to the +26 V supply. With the stepper signal input low, the Darlington pair Q29 is biased off and no current flows.

(b) With the Darlington pair Q29 on, current flows through emitter resistor R17. As the current flow increases, the voltage drop across emitter resistor R17 increases, reducing the forward bias on the Darlington pair Q29 and the current passing through the motor coil. This effectively contracts the coil current. Current flowing in the motor coil can be measured by sensing the voltage drop across the emitter resistor R17.

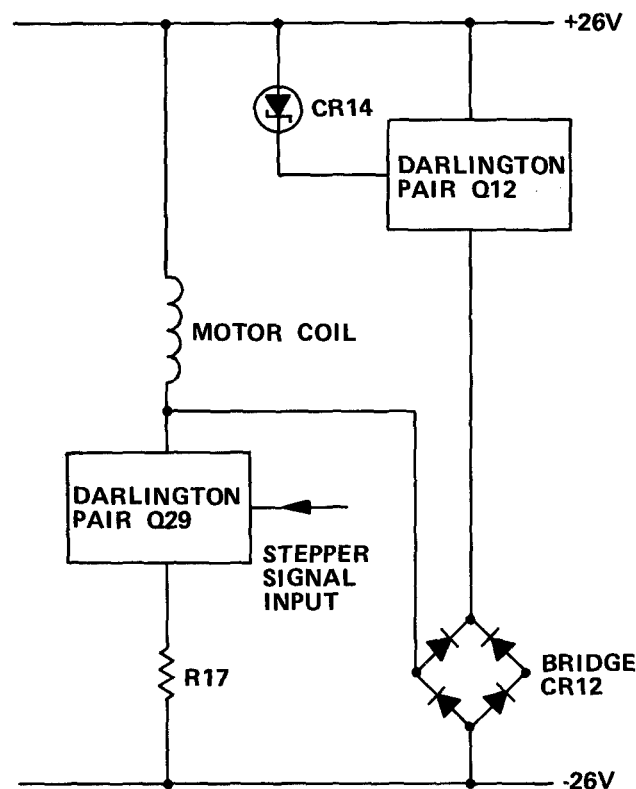

(5) When the current through the motor coil is turned off, the collapsing magnetic field around the coil induces voltage transients which could damage the Darlington Q29. Diodes in the bridge CR12 bypass the voltage spike directly to the -26 V supply, and indirectly to the +26 V supply via Q12 and zener diode CR14.

d. Collimator lens drive system. The collimator lens moves backward and forward on a carriage driven by a helix screw and stepping motor. The main program determines the position of the lens by feeding information on the number of steps required. This lens of 105 mm focal length intercepts the aerial image of the character as projected by the variator or enlarging lens. It is always positioned to maintain a distance of one focal length (105 mm) away from the aerial image. If the collimator lens sees the primary image at this distance as its object source, then the image leaving the lens will be as parallel rays of light.

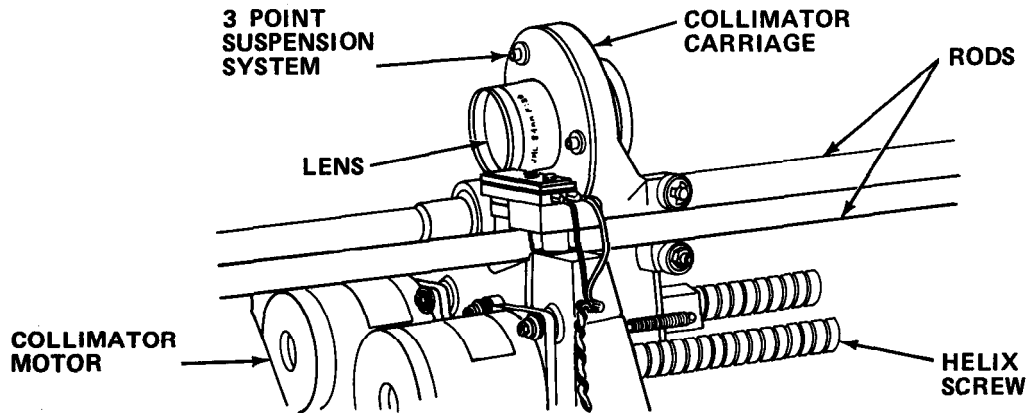

(1) The lens is mounted in a three-point suspension system on the collimator carriage. The carriage runs on two rods which are parallel to the optical plane. A helix screw drives the carriage backward and forward to maintain the 105 mm relationship with the variator lens.

(a) On one side, the parallel rod passes through precision bearings on the carriage. On the other side, two carriage-mounted ball bearings located on top and bottom of the parallel rod prevent any rotational movement of the carriage stepping assembly as it is driven by the helix screw.

(b) The collimator lens helix screw is rotated by the collimator stepping motor. The motor is mounted horizontally alongside the variator stepping motor, both motors being mounted in a casting approximately halfway along the optical plane. The stepping motor shaft is coupled to the helix screw by a taper pin.

(c) Four constant current Darlington driver circuits supply the four collimator motor coils to drive the stepping motor. The drivers are controlled by sequential signals from the LVC stepper board.

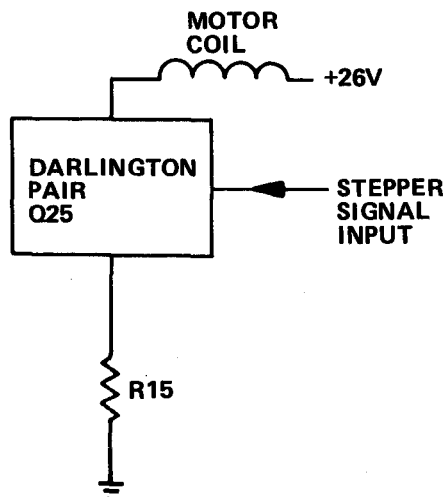

(2) When the stepper signal input is high, the Darlington pair Q25 is biased on. This allows current to flow from ground through emitter resistor R15 and through the motor coil to the +26 V supply.

(a) With the stepper signal input low, the Darlington pair Q25 is biased off and no current flows.

(b) With the Darlington pair Q25 on, current flows through R15 and, as current flow increases, the voltage drop across R15 increases, reducing the forward bias on the Darlington pair Q25 and the current flowing through the motor coil. This effectively controls the coil current.

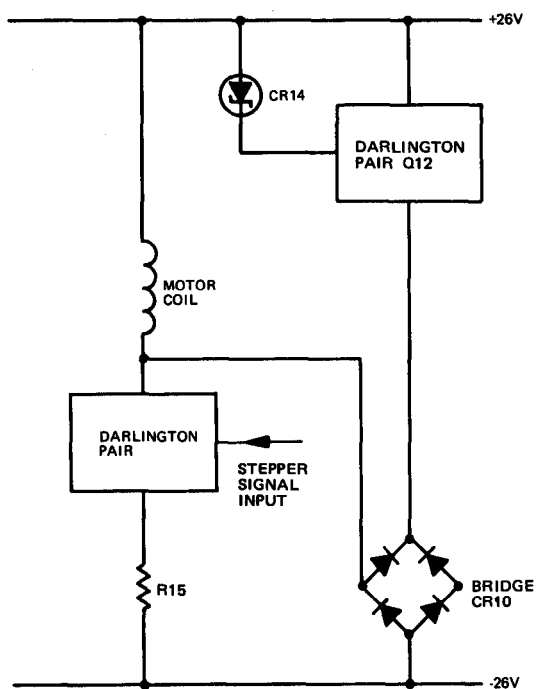

(3) When the current in the motor coil is turned off, the collapsing magnetic field around the coil induces voltage transients which could damage the Darlington Q25. Diodes in the bridge CR10 bypass the spike directly to the -26 V supply and indirectly to the +26 V supply via Q12 and zener diode CR14.

e. Row shift.

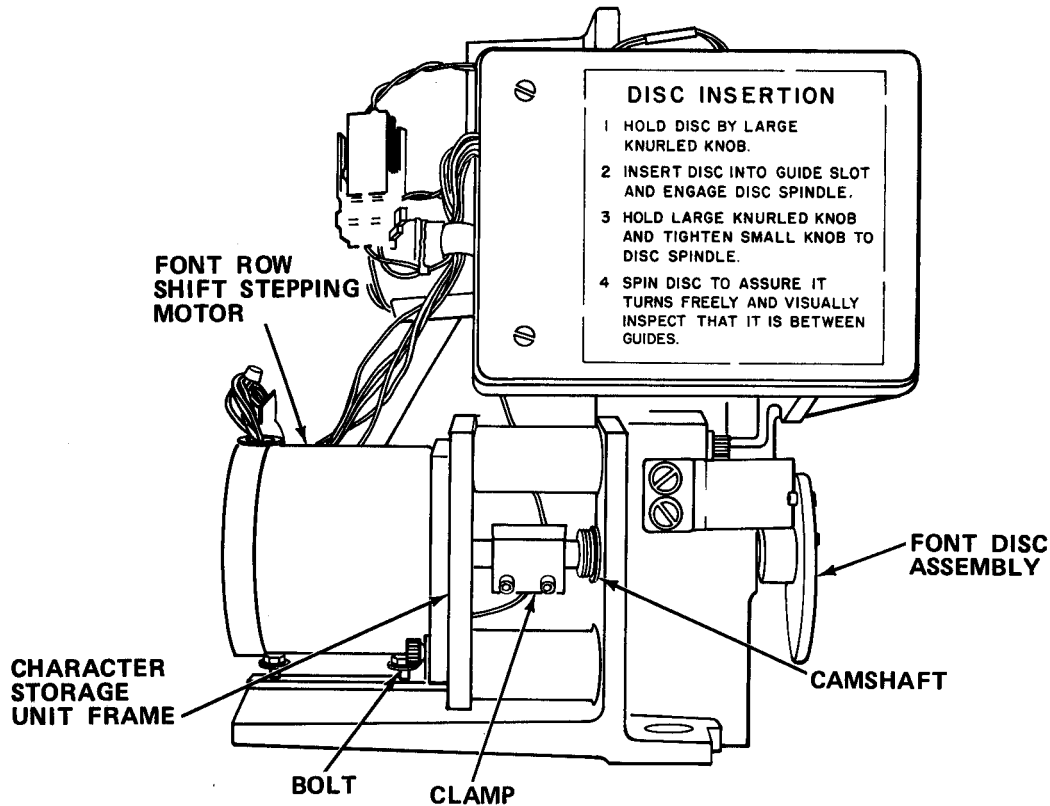

(1) The font row shift stepping motor is bolted onto the character storage unit frame. It is coupled to the camshaft by a simple clamp. **To change the row of** type required, the whole font disc assembly is moved laterally across the optical plane, placing the selected type in front of the flash windows.

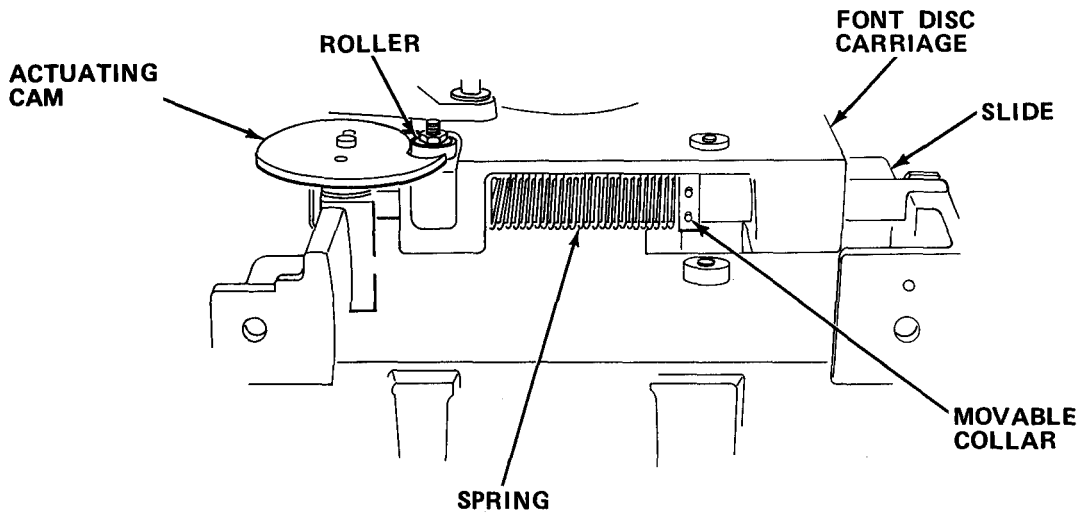

(2) The actuating cam is rotated by the stepping motor and bears upon the roller. This moves the font disc carriage along the slide against the spring. A movable collar provides adjustment of the spring tension.

(3) Four constant current Darlington driver circuits supply the four row shift motor coils to drive the stepping motor. The drivers are controlled by sequential signals from the digital analog (D/A) stepper board.

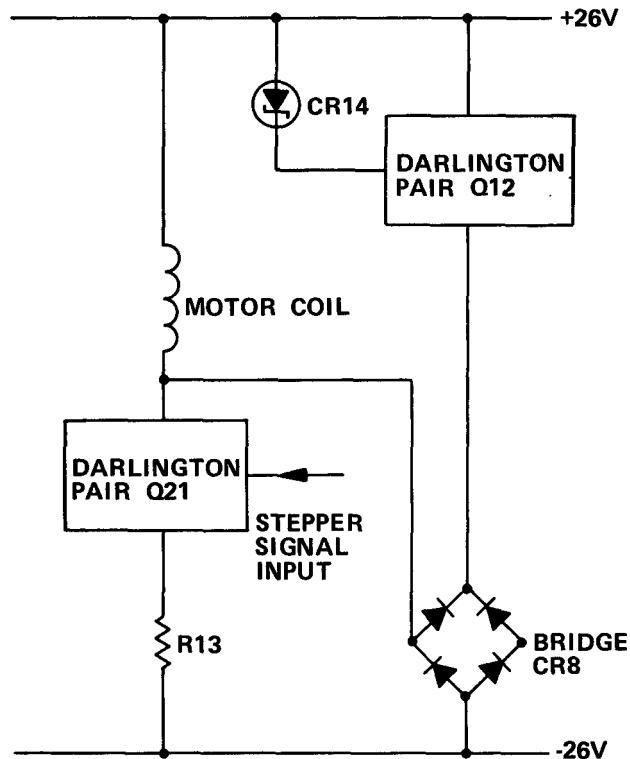

(4) When the current in the motor coil is turned off, the collapsing magnetic field around the coil induces voltage transients which could damage the Darlington Q21. Diodes in the bridge CR10 bypass the spike directly to the -26 V supply and indirectly to the +26V supply via Q12 and zener diode CR14.

f. Carriage stepping assembly. The collector lens and mirror assemblies are mounted on a carriage which moves parallel to the paper plane. The carriage moves along wayrods driven by a stepping motor/cable arrangement.

(1) When the stepper signal #1 is high, the Darlington pair Q7 is biased on. This allows current to flow from ground through emitter resistor R6 and the motor coil to the +26 V supply. When stepper signal #2 is high, the Darlington pair Q6 is biased on. This allows current to flow from the -26 V supply through emitter resistor R5 through the motor coil to ground.

(2) When the stepper signal input is low, the Darlington pair Q6, Q7 is biased off and no current flows.

(3) With the Darlington pair Q6 or Q7 on, current flows through R5 or R6 and, as current flow increases, the voltage drop across R5 or R6 increases, reducing the forward bias on the Darlington pair Q13 and the current flowing through the motor coil. This effectively controls the coil current.

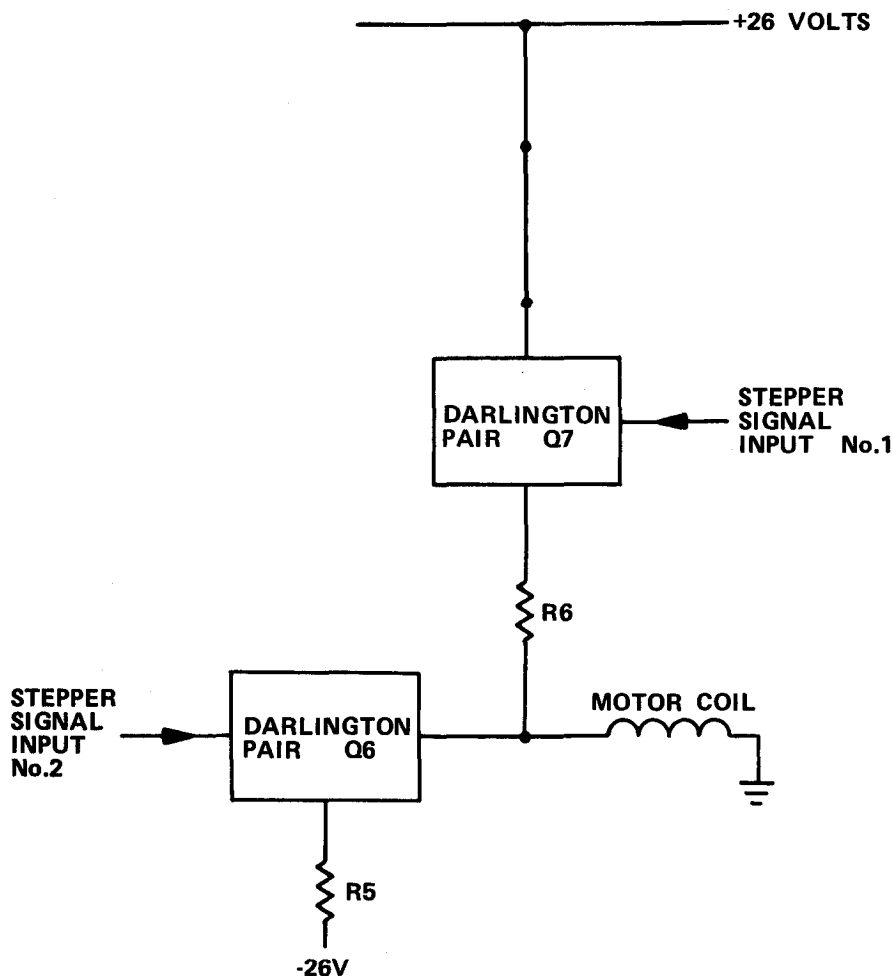

(4) The main program and carriage escapement board J12 determines the position of the carriage assembly by feeding information on the required number of motor steps to the driver board, where pairs of Darlington driver circuits, associated with each of the five motor coils, enable current to flow in either direction in each coil.

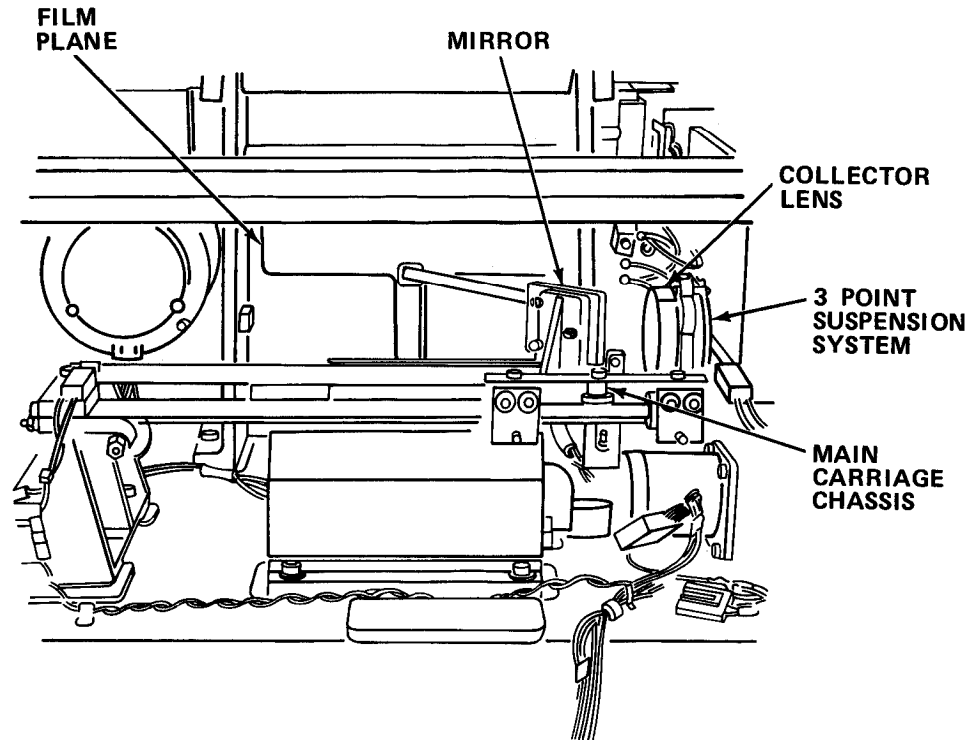

(5) The collector lens is mounted in a three-point suspension system which is part of the main carriage chassis. The image from the collector lens is turned through 90 degrees by a mirror where it falls onto the film plane.

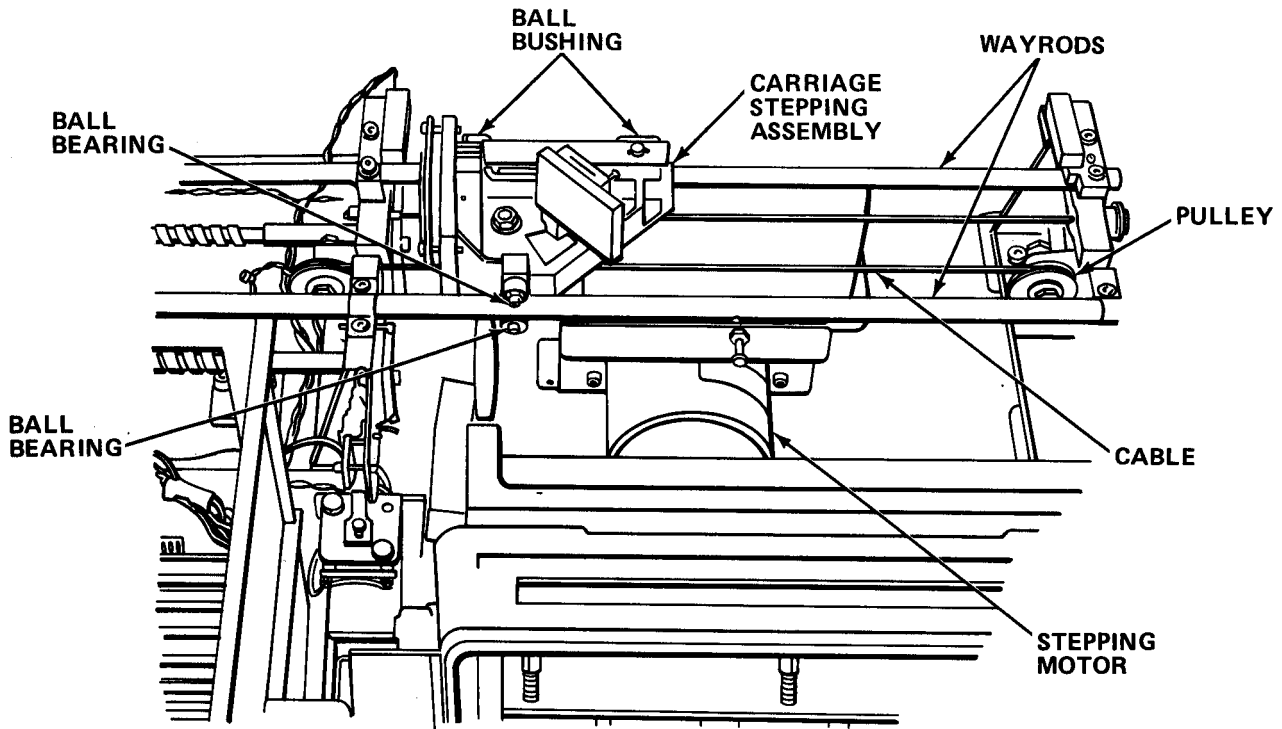

(6) The complete carriage stepping assembly travels parallel to the film plane along two wayrods. A tandem arrangement of two linear ball bushings and a set of ball bearings guide the carriage on the wayrods. The carriage is moved by a stepping motor, cable, and pulley arrangement.

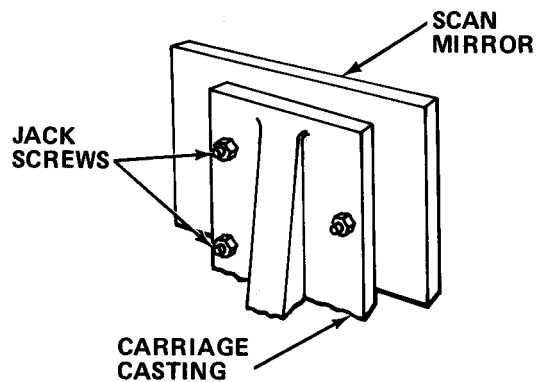

(7) The 45-degree scan mirror is attached to the carriage casting with an elastic type adhesive which allows canting of the mirror to obtain perpendicularity. The canting is obtained with three jack screws through the carriage butting into the back of the mirror. Once adjustment has been made, epoxy is applied to the mirror mounting. Field adjustment is not normally required.

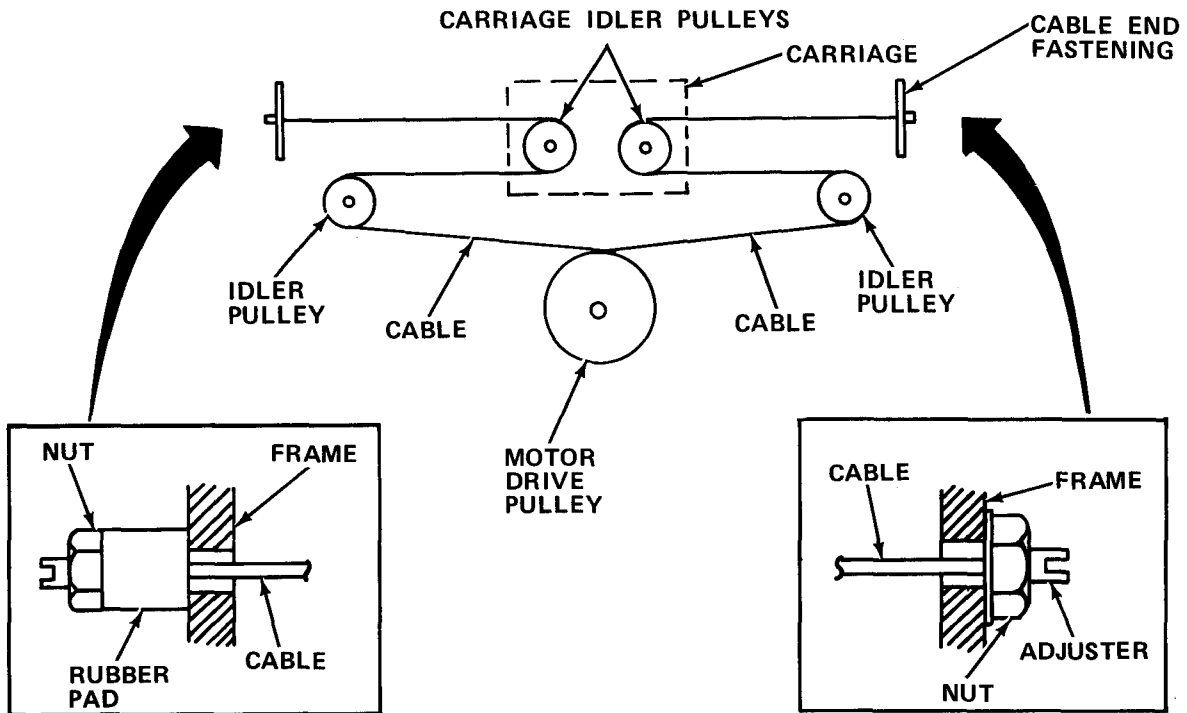

(8) The carriage stepping motor carries a double-grooved motor drive pulley. Around this is wrapped the tensioned carriage drive cable. When the motor is stepped, horizontal movement is accomplished as the cable winds and unwinds from the drive pulley. Idler pulleys transmit this to the carriage stepping assembly, which is stepped along the wayrods. Correct tension of the drive cable is given by compressing the rubber pad.

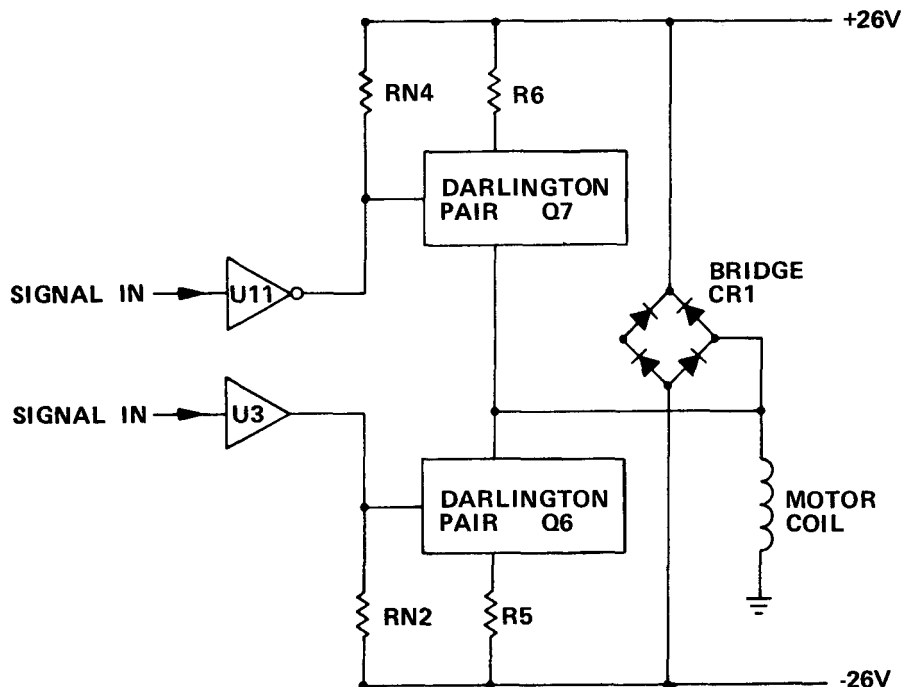

(9) Carriage escapement board J12 supplies 10 signals to control the carriage stepping motor. These 10 signals control 10 constant current Darlington driver circuits which supply current to the five motor coils to step the motor.

(a) Pairs of Darlington driver circuits associated with each of the five motor coils enable current to flow in either direction through the motor coil.

(b) When a signal is applied to U11, and it is high, it turns on the Darlington pair Q7. This allows current flow from ground through motor coil, Darlington pair Q7 and emitter resistor R6 to the +26 V supply. When the input signal is low, the Darlington pair Q7 is biased off and no current flow takes place.

(c) When signal input is applied to U3, Darlington pair Q6 is turned on. This allows current flow from the -26 V supply, through R5 and the Darlington pair Q6 to the motor coil. When the input signal goes low, the Darlington pair Q6 is biased off and no current flow takes place.

(d) The current in the motor coils is regulated to 1.35 amps, regardless of the temperature or motor impedance. When current flows through R5 or R6, a voltage is developed across the resistance. If current tries to rise above the preset level of 1.35 amps, the voltage drop across the resistors will increase. This will reduce the forward bias on the Darlington. This in turn reduces the current passing through the motor coil. Current in the circuit can, therefore, be measured by the voltage drop across R5, R6. It should equal 1.35 V, as $R5 \text{ and } 6 = 1 \text{ ohm}$.

(e) When the Darlington is biased off, the resulting collapse of the magnetic field around the motor coil can give rise to voltage transients which could damage the Darlington. Bridge rectifier CR1 bypasses the voltage spike back to the +26 V and -26 V supplies. The other driver circuit pairs are identical to the one described.

g. Disc drive.

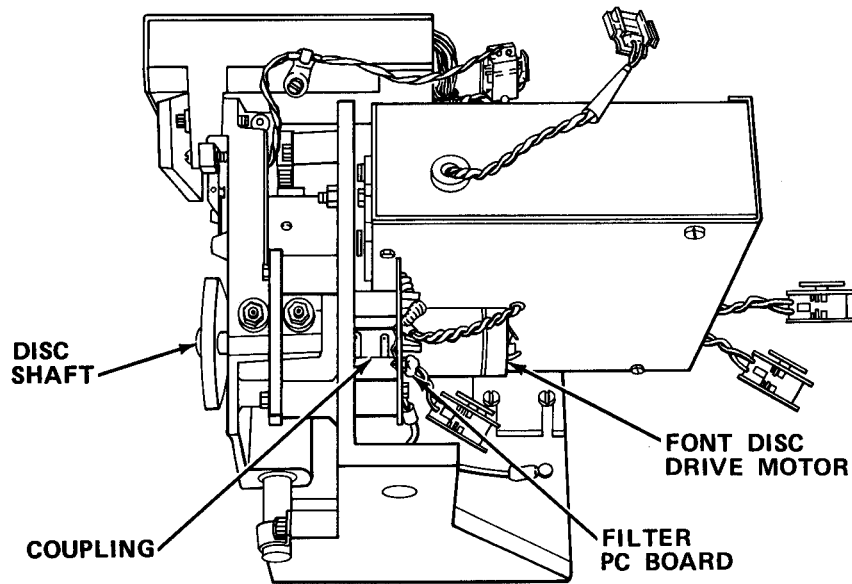

(1) The font disc drive motor is mounted on the character storage disc chassis, a noise filter PC board also being part of the same assembly. The font disc drive is transmitted via a coupling to the disc shaft. The font disc is fitted onto the disc shaft and secured by a threaded knob assembly which is an integral part of the font disc.

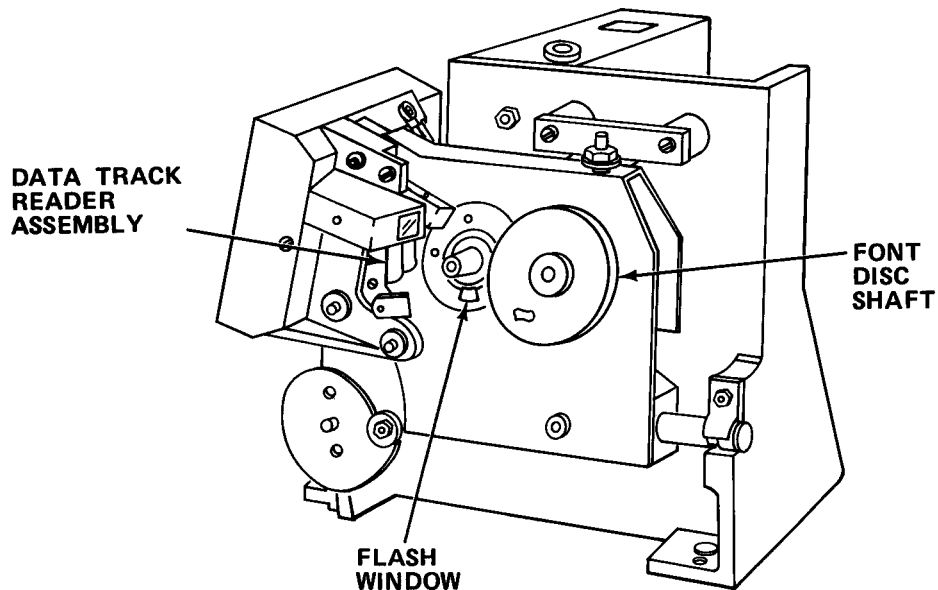

(2) The font disc shaft projects through to the front of the character storage unit, its location being such that the disc is in perfect alignment with the flash window and data track reader assembly. A +26 V supply for the disc drive motor comes from the driver board.

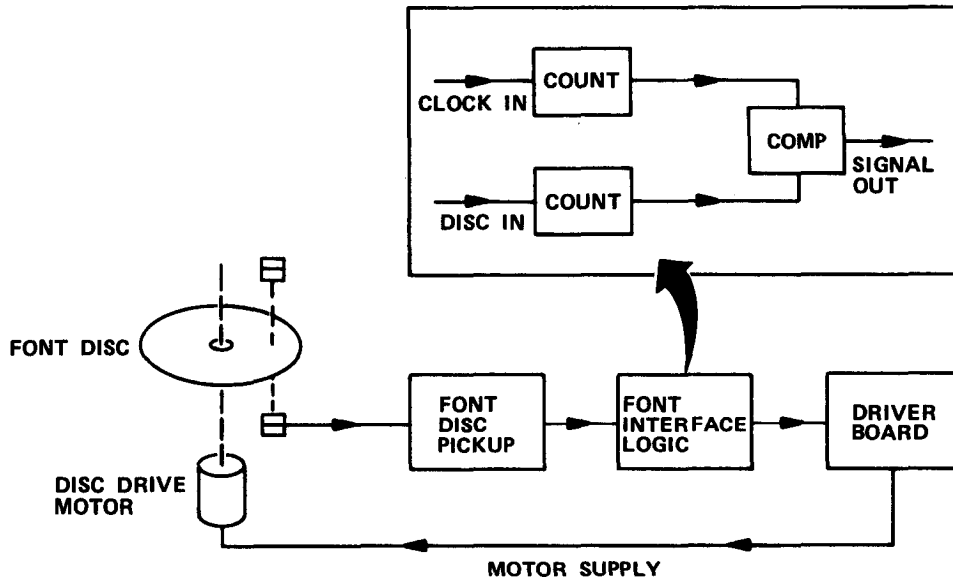

(3) As the font disc rotates, the amplified signal picked up from the strobe track is passed to the font interface logic board. Here the signal is compared with a reference frequency generated by a master clock circuit. The difference of these two frequencies is passed to the driver board, which modifies the supply to the font drive motor until the two frequencies are identical.

h. Shutter solenoid. The film magazine assembly houses a shutter unit which shuts off the magazine, and unexposed film from exposure to light when the covers or doors of the main optical section are opened.

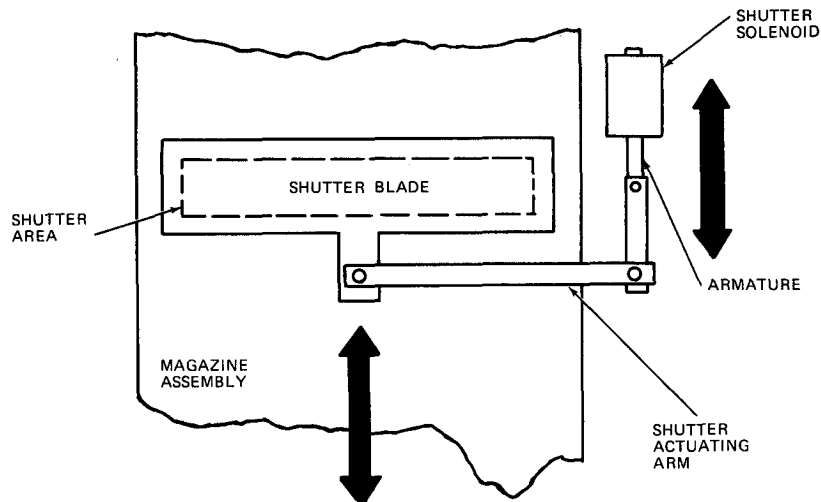

(1) The shutter solenoid is connected to the actuating arm by a downlink attached to the solenoid armature. The blade moves downward to uncover the shutter area, and is held down by a 300 mA holding current. When the cover interlock switch is deactivated, the blade is closed, sealing off the film from exposure to light. The shutter solenoid receives its operating voltage of 26 V from the driver board, controlled by the font interface III board.

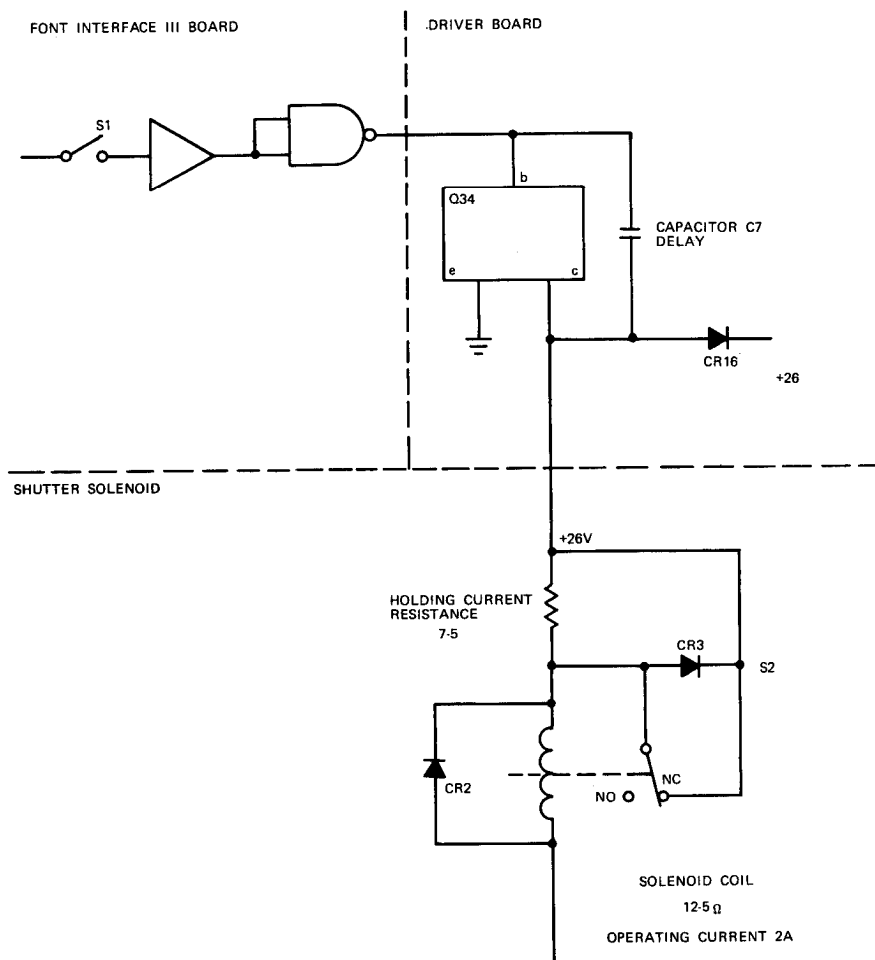

(2) When the composing machine covers are closed, the optical assembly is lightproof, interlock switch S1 is actuated and initiates a high, which turns on Darlington Q34. Shutter solenoid switch S2 is in the normally closed position, and allows the full 26 V to pass through the solenoid operating coil. This activates the shutter. With the shutter fully open, S2 opens and the operating current passes through the 7.5 ohms holding resistance dropping from the full 2 amps operating to 300 mA holding current. When the shutter solenoid is deenergized, any induced voltage transients are shunted away from the Darlington Q34 by diodes CR2, CR3 and part of bridge CR16. Delay capacitor C7 is across Darlington Q34 to slow the switching and suppress transient noise.

i. Input/monitor unit.

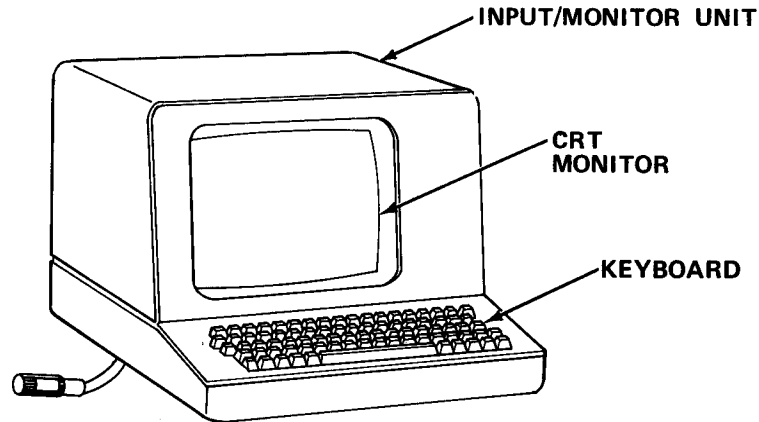

The input/monitor unit is made up of an 83-element keyboard and 12.00 in. (30.48 cm) CRT monitor. This unit is mounted on a small extension table off the main equipment, connection being made via a multiway cable.

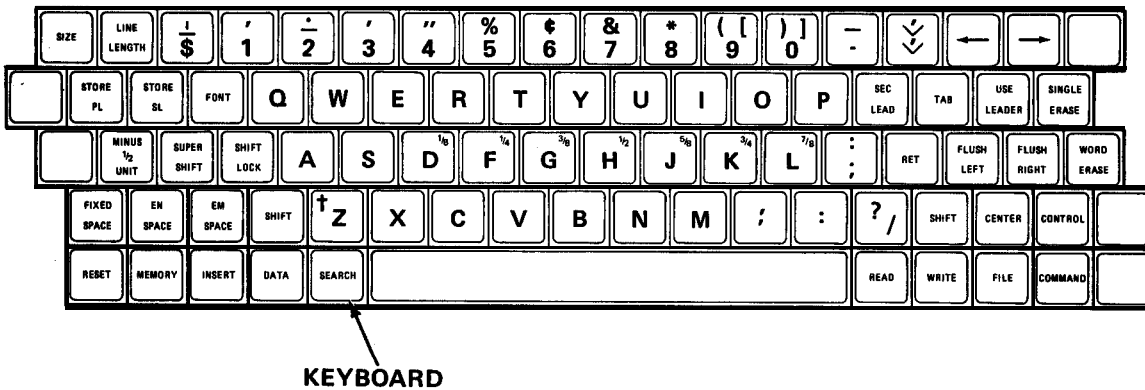

(1) The keyboard is an MOS encoding keyboard with 83 encoded keys. Each key station uses a Hall effect solid-state switch. Upon depression of a key the keyboard generates the appropriate 8-bit code and a keyboard strobe pulse which appears on the output lines of the keyboard. The 8-bit code is then stored in a buffer memory that is part of a 1K display memory located on the character generator board. The output code generated by the keyboard remains on the output lines of the keyboard until another key is depressed.

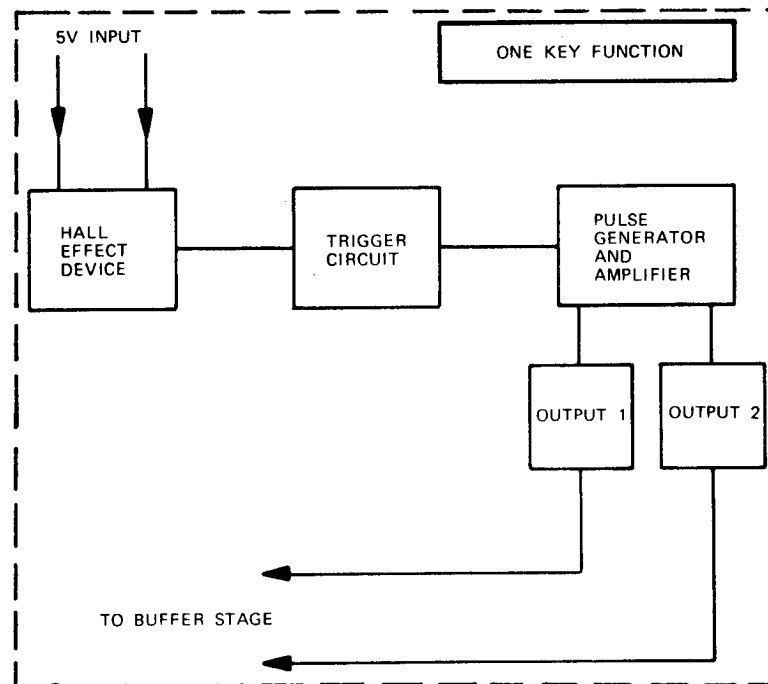

(2) The Hall effect device is a transducer which changes its characteristics under the influence of a changing magnetic field. In the keyboard, the device is operated by magnetic material mounted in the key. Depression of the key activates the device which then switches the trigger circuit which holds the pulse generator on. The resultant 8-bit code, which is unique to the key depressed, will remain on-line until another key is depressed which resets the trigger circuit.

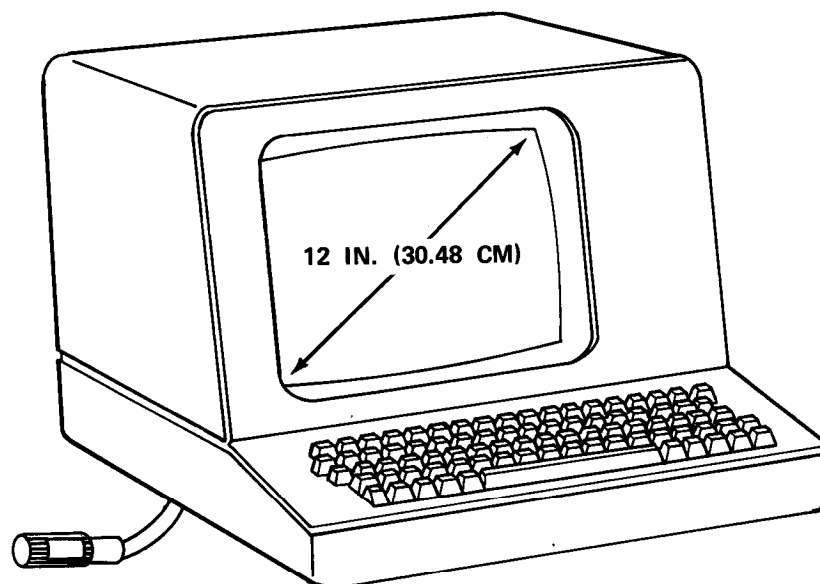

(3) To produce a visual representation of the characters and functional data input to the phototypesetter, character shapes and associated symbols are displayed on a 12 in. (30.5 cm) monitor screen.

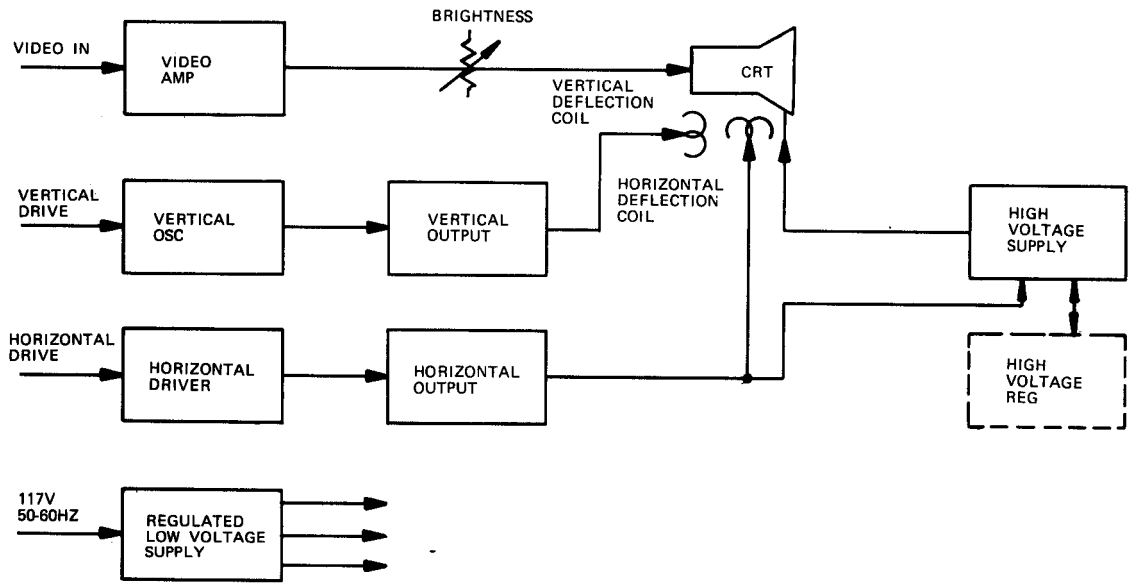

(a) The monitor unit is all solid-state (with the exception of the picture tube), and the power supplies are regulated to ensure a stable display. The picture tube consists of a basic CRT mounted in the monitor cabinet, and positioned to provide easy viewing for the keyboard operator.

(b) The display of video information is achieved by modulation of the beam brightness in synchronization with the sweep of each horizontal scan line. This information would be passed into the video amp as VIDEO IN. The vertical and horizontal drivers generate the raster scan.

(c) The regulated low voltage power supply converts the 120 V, 50/60 Hz input into the various low voltage dc regulated supplies as required for those circuits other than the high voltage supply.

(d) All these circuits are housed in the input/monitor unit.

CHARACTER MATRIX BLOCK

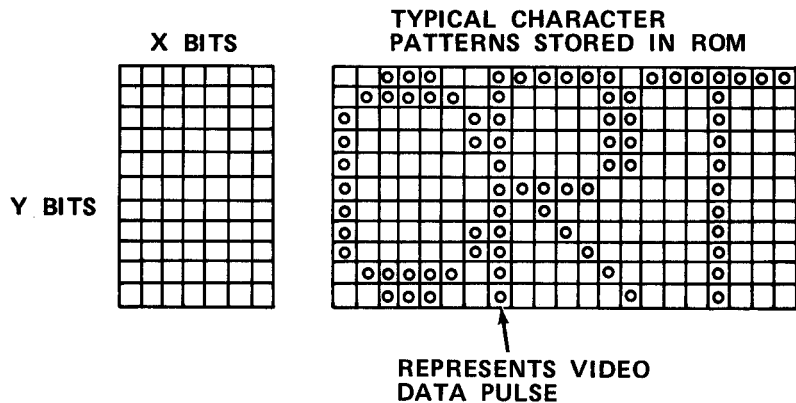

(e) The character shapes are formed on the screen by video dot patterns which make up the character shapes. The video patterns are stored in a ROM accessed by the character generator logic. Each different pattern is stored in an address block which is X bits wide, and Y bits high, forming a matrix.

(f) Data bits are stored in the matrix block in locations representing the physical shapes of the characters or symbols.

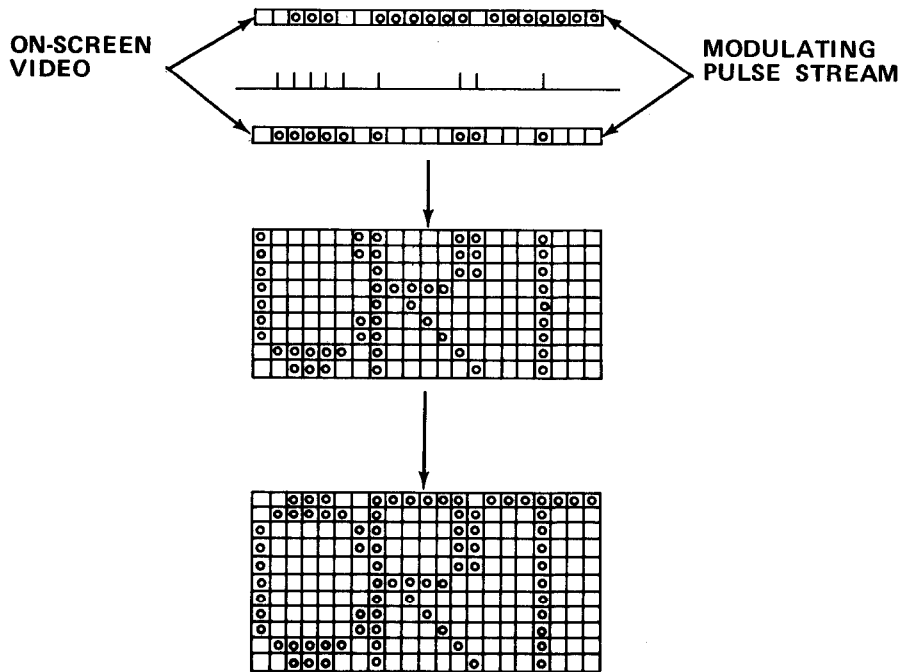

(g) When a character key is depressed, a modulating pulse stream is generated which is fed into the video amp in sequence with the sweep of the horizontal scan line. Each spike on the modulating pulse stream produces a bright spot on the CRT. As each succeeding line is scanned, the video pulse stream changes, finally producing the complete character. The sequence takes place over the full width of the number of characters selected in each line of print, up to the maximum of 64 characters per line.

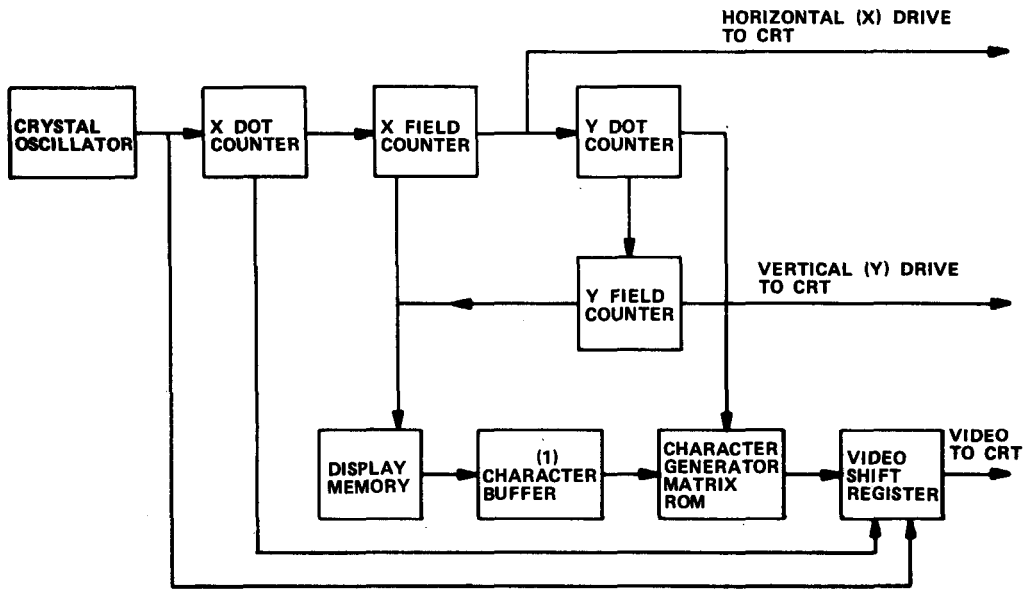

(h) The address locations in the display memory describe the X- and Y-coordinates relating to the monitor screen. The characters appearing on the first line of the screen would be stored in the first 64 locations of the display memory as an 8-bit code.

(i) The crystal oscillator provides the main timing control of the display system, each cycle of the oscillator representing one dot on the screen. The X-dot counter divides the output of the oscillator by the number of pulses designated for the width of the character matrix block plus one dot on either side of the matrix for spacing.

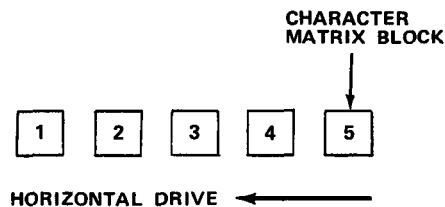

(j) The X-field counter counts the number of character matrix blocks on a line. As each character is completed, the X-dot counter increments the X-field counter by one. When the character count matches the selected count, the X-field counter generates a horizontal drive signal.

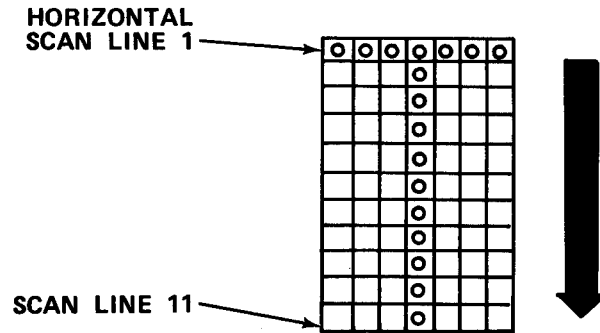

(k) The Y-dot counter counts the horizontal scan lines in a character row.

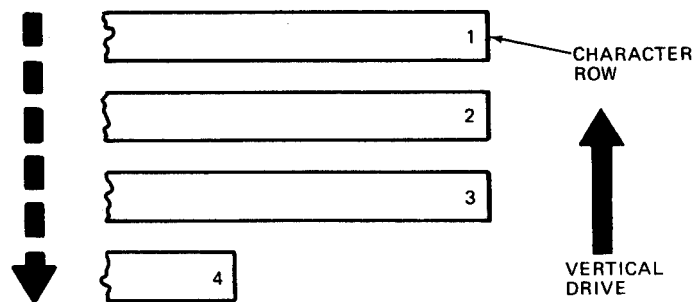

(1) The Y-field counter counts the character rows on the screen. As the number of scan lines is completed, the Y-dot counter increments the Y-field counter by one. When the row count is satisfied, the Y-field counter generates a vertical drive signal.

(4) The display memory receives information from the computer, and stores the characters to be displayed on the screen. It also gets addressing information from the X and Y field counters. This information determines the position on the screen that the next character will be displayed. The next required character is fed to the character data buffer. This buffer stores the next character information while other data is fed into the display memory, and the character generator matrix ROM processes the last character.

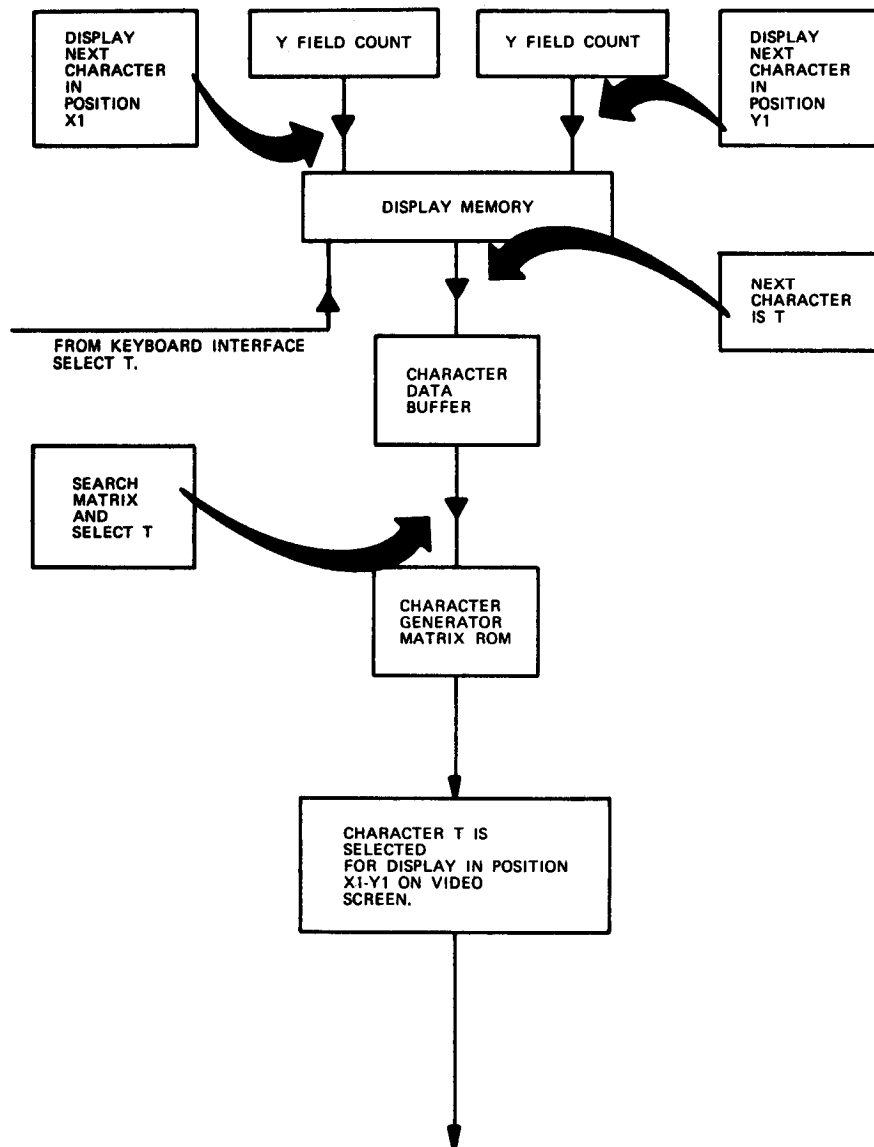

(5) The character generator matrix ROM stores all the character shapes in a matrix-format. The character data buffer tells the character generator which matrix block to select for the next required character. The generator ROM also has an input from the Y-dot counter which selects a horizontal slice of the selected block. The output of the generator ROM is, therefore, a dot pattern representing one slice of the character.

Microprocessor mainframe. There are positions for a total of 14 cards. Positions J1 thru J8 are reserved for the program boards, and are bused together allowing board placements in any of the first eight positions.

(1) Positions J9 thru J14 have designated positions for the interface boards.

(2) Position J9 holds the character generator board. This board generates the video signals for display on the monitor. These symbols, when displayed, will be representative of the characters and symbols received as input from the keyboard.

(3) In addition to the video signals, the board generates horizontal and vertical sync signals for the monitor drive circuits.

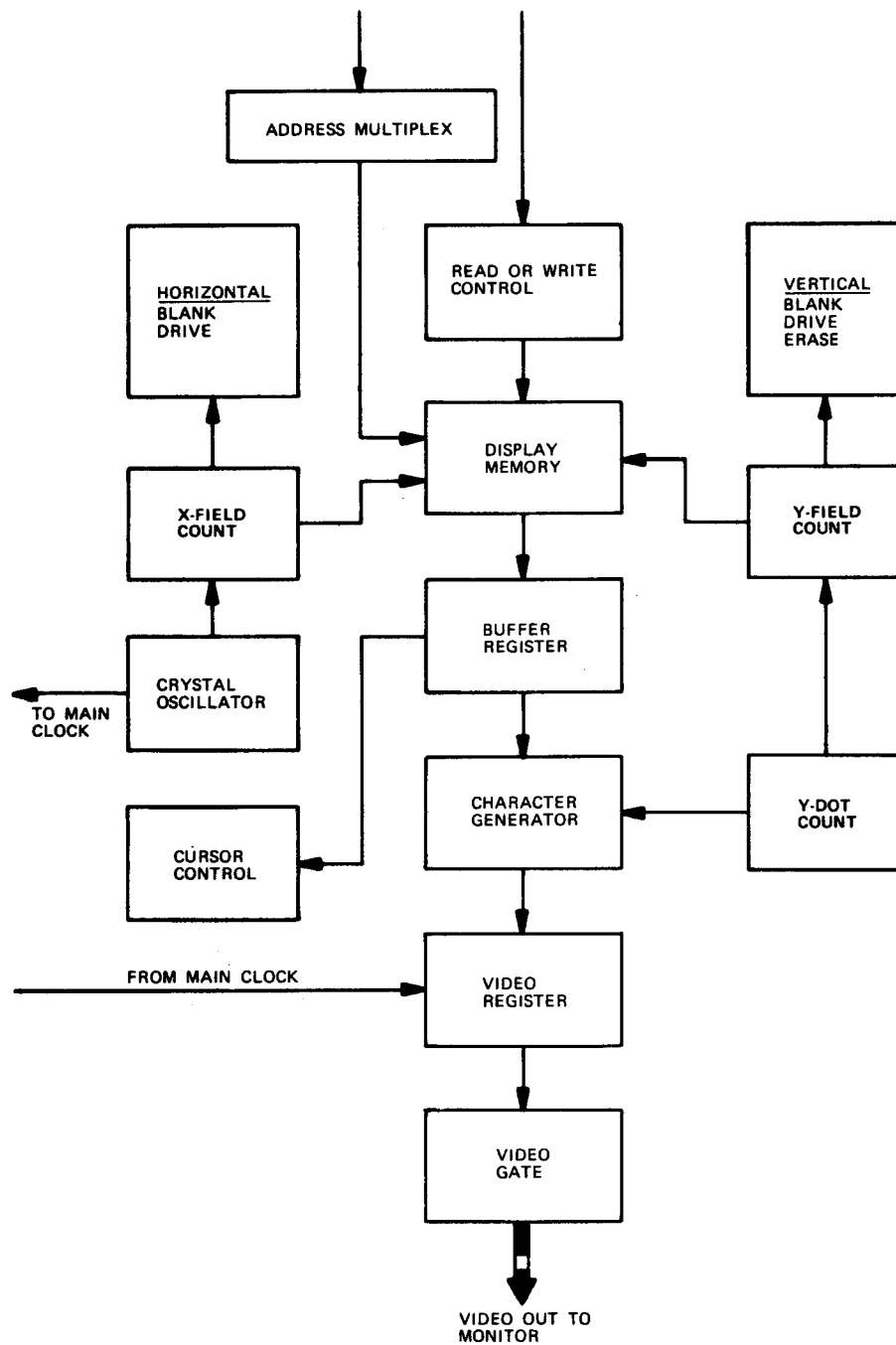

(4) Incorporated on the character generator board is a 1K x 8-bit RAM memory known as the display memory. This memory has 640 locations which store the character data displayed on the screen. The remaining storage space is used by the main program as work space with 16 of these locations allocated as keyboard buffer.

(5) The character symbols are stored in special ROM called the character generator. It contains 128 symbols arranged in character blocks, any one of which can be selected by the code information stored in the display memory. The character generator presents data for one horizontal slice of the selected symbol. By successive selection of these slices, the entire character or symbol is built up.

(6) As a function of the character generator logic, each complete character block is located to a specific X- and Y-coordinate on the screen which designates an address location in the display memory.

(7) The display memory can, therefore, reach into the character generator ROM, select-a-specific character or symbol and position it in a precise location on the monitor screen.

The display memory has three main functions:

(a) Stores, in code form, symbols/characters to be displayed by the monitor.

(b) Used as a program work area.

(c) Used as a keyboard buffer.

(8) Characters and symbols are stored in this 1K x 8-bit memory as if it were an extra part of the main program. The memory is interfaced with the main program via the data and address registers. These are located on the keyboard interface III board.

(9) Address information enters the keyboard interface 111 board via the address multiplexer where it is passed to the display memory. At the same time, data is received via the read/write control. The read/write control only allows data to be written into the memory while the horizontal display is blank. This prevents streaking or smearing of the monitor image. The display memory also accepts inputs from the X- and Y-field counters. This information determines the position on the screen and the instant in time that the next character is to be displayed.

(10) The next character, once selected and its display position is determined, is fed into and stored by the character buffer. The character keystrokes are held in the seven-word buffer to be processed as required. As this seven-word buffer is being used, a second buffer is collecting input information. The cursor control also receives its signal from the buffer register and, when a command is received, the cursor control will invert the output of the video register.

(11) The character generator ROM requires three voltages, +5 V, -3 V and +12 V, in addition to the ground. Two of these, -3 V and +12 V, are not available from the main power supply so they are produced on the character generator board.

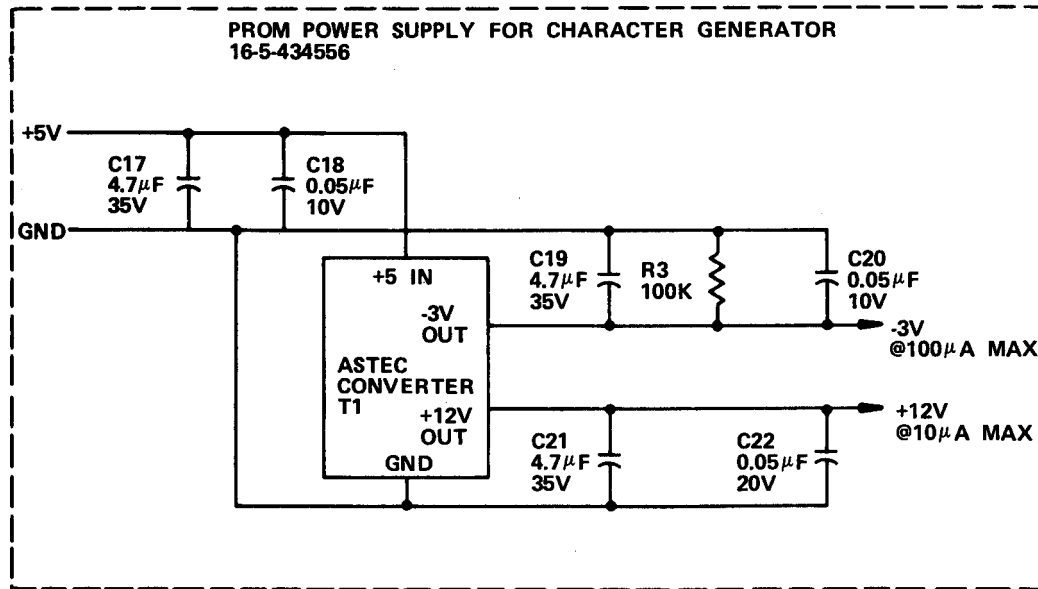

(12) A commercial dc/dc converter produces the primary supply of -3 V and +12 V at 100 µA and 10 µA respectively.

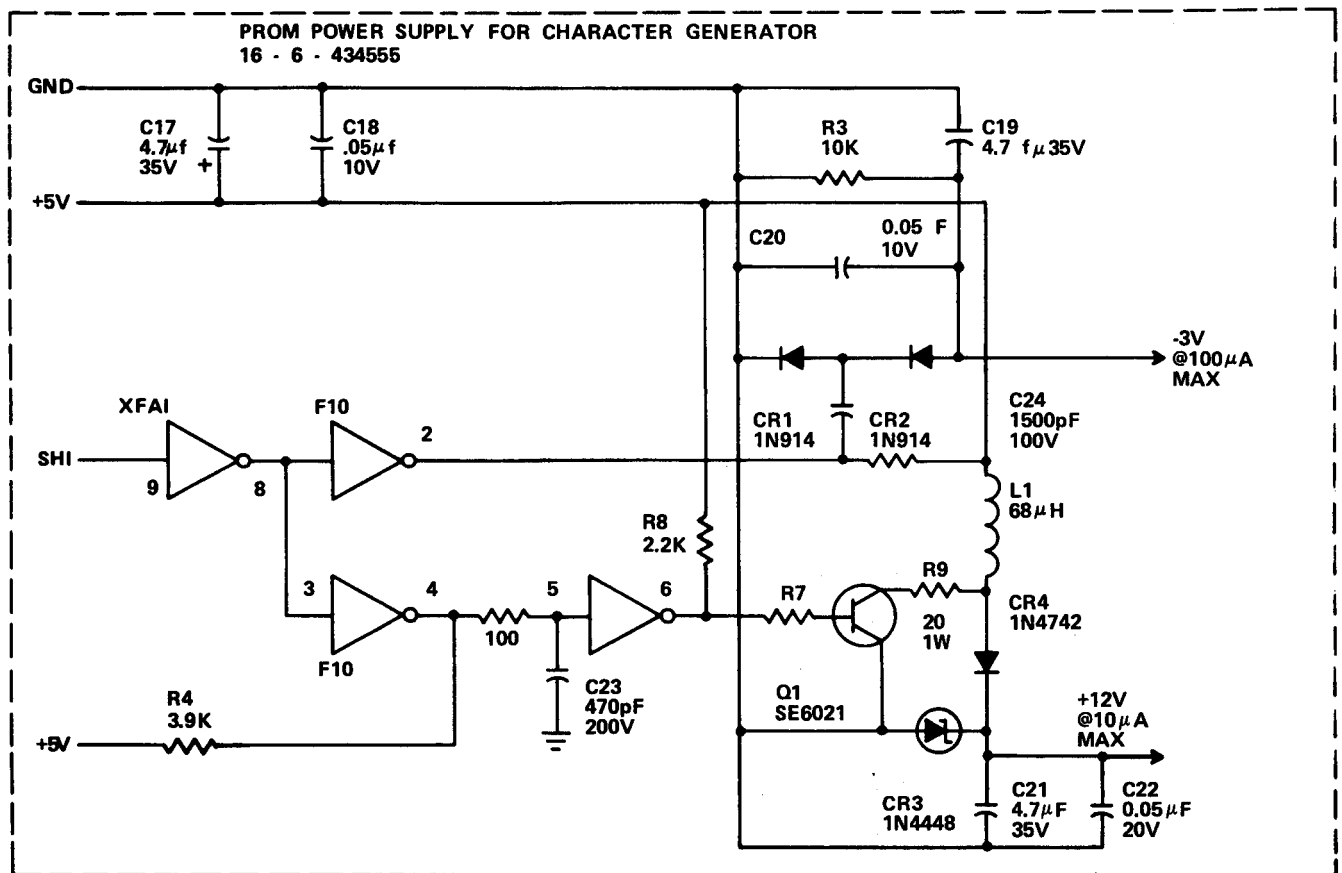

(13) A secondary or backup supply is co-located with the primary source. It uses the same input and output components as the primary.

k. 8K X 8-bit RAM board.

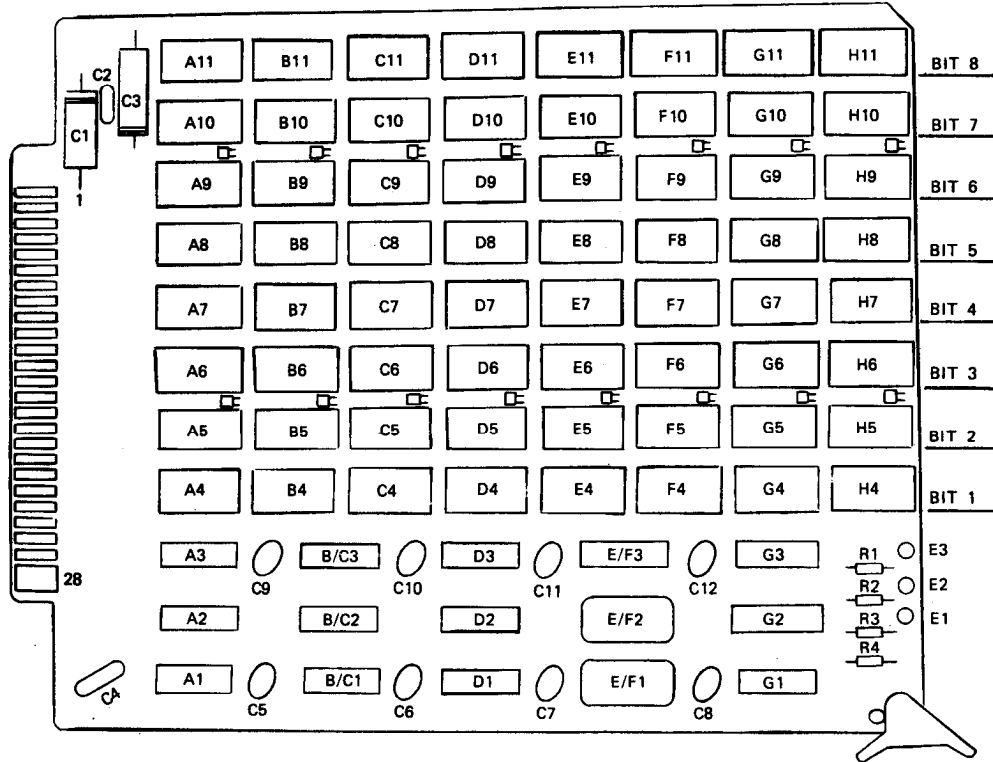

	E/F1	E/F2	E/F1	E/F2	E/F1	E/F2	E/F1	E/F2
6	ON	*	ON	*	ON	*	ON	*
5	*	*	*	*	ON	*	ON	*
4	*	ON	ON	ON	*	ON	ON	ON
3	*	ON	*	ON	*	ON	*	ON
2	*	ON	*	ON	*	ON	*	ON

* INDICATES OFF (SWITCH POSITIONS 1,7,8 ARE OFF)

(1) The RAM memory is used for program and data storage. The board size of 8K can be reduced in **1K** increments down to a 1K board size. The board uses low-powered static 1K X 1-bit RAMs with faster memory speeds. Also, the read/write function can be disabled, allowing two memories to share the same address. All RAMs are organized by bits in columns and by **1K** increments in rows. The first 1K of memory is in row A; the second 1K, in row B. Bit 1 is in column 4; bit 2, in column 5. The 1K of memory and bit designations are etched on the board.

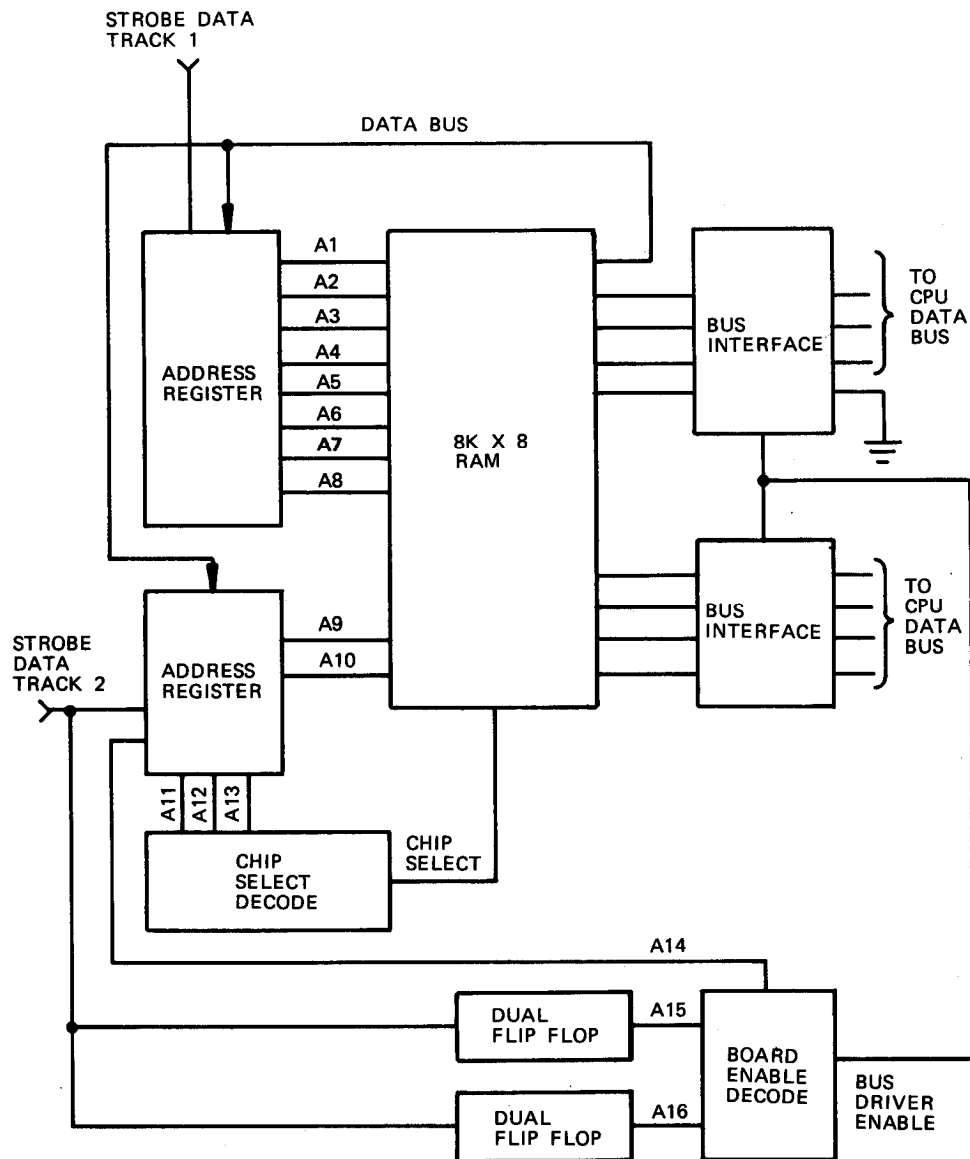

(2) The address register holds the address in memory to be accessed. The address register is enabled by inputs Strobe Data Track (SDT) 1 and 2. The address outputs A1 thru A10 drive the 8K RAM. Address lines A11 thru A16 are used for chip select decoder and board enable decoder. Two bus transceivers interface the 8K RAM to the CPU data bus. The high-speed transceivers are continuously enabled, and the bus drivers are gated on by the BDE signal only when data is called for from this board.

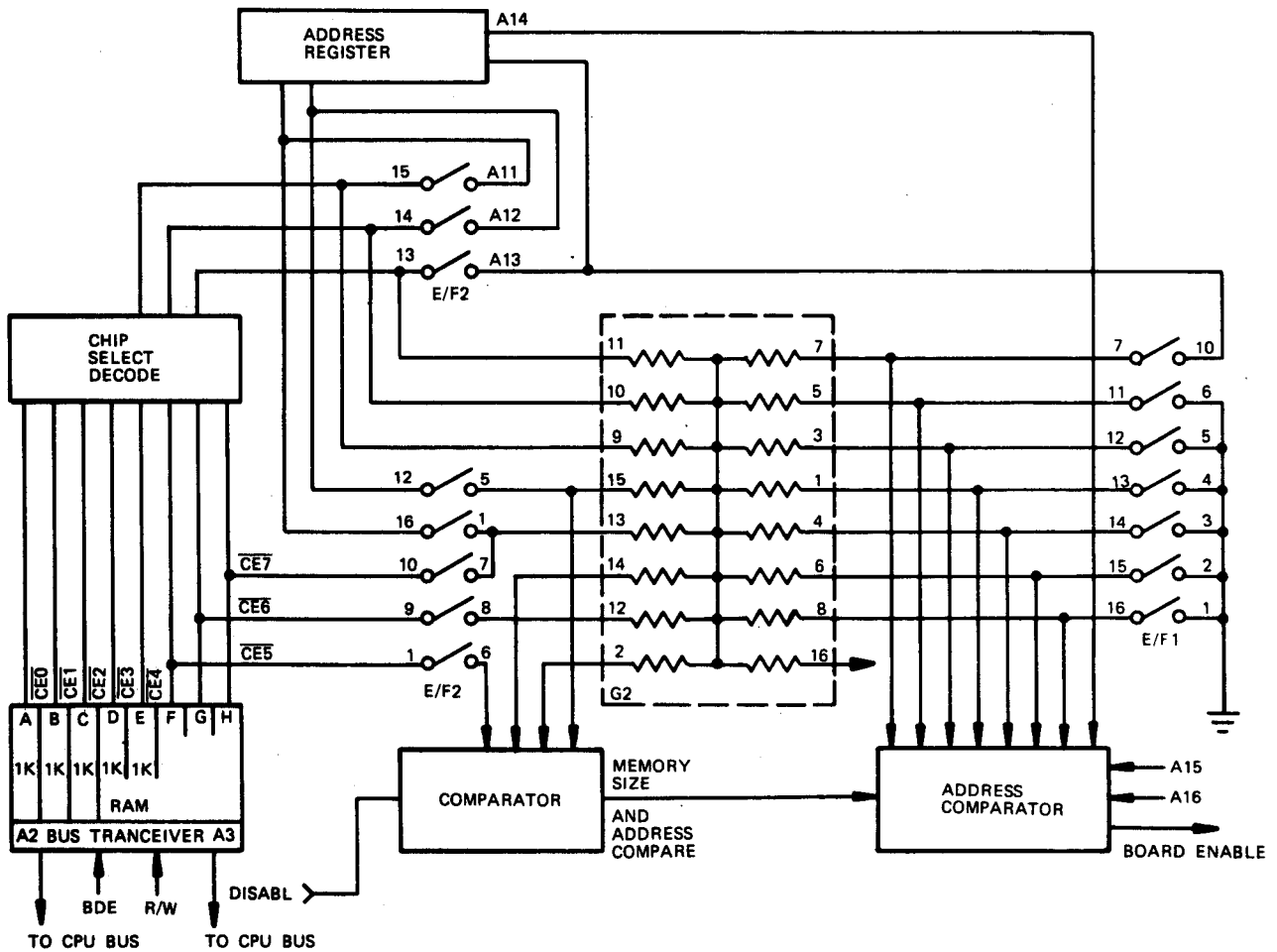

(3) Address lines A11, A12 and A13 are routed to the chip select decoder via switch E/F2. There they are decoded into chip select 1ines (CE0 thru CE7) to enable a single row of RAMs (1K x 8-bit). Memory size is determined by the settings of switches E/F1-7 and E/F2. Address lines A11, A12 and A13 are decoded by chip select decoder to enable 1K of RAM memory. For memory sizes smaller than 8K, various combinations of A11, A12, A13 and CE5, CE6, H7 are compared at the comparator. The output of the comparator is used to enable or disable the address comparator. When address lines A11, A12 and A13 are not used for enabling RAMs, they are used as part of the BOARD ENABLE. These signals are connected to memory size and address comparators through E/F2-1 (A11), E/F2-5 (A12), and E/F1-7 (A13) where they are compared to E/F1-1 (A11), E/F1-2 (A12) and E/F1-3 (A13). The remaining address decode switches E/F1-4, E/F1-5 and E/F1-6 are compared directly to A14, A15 and A16.

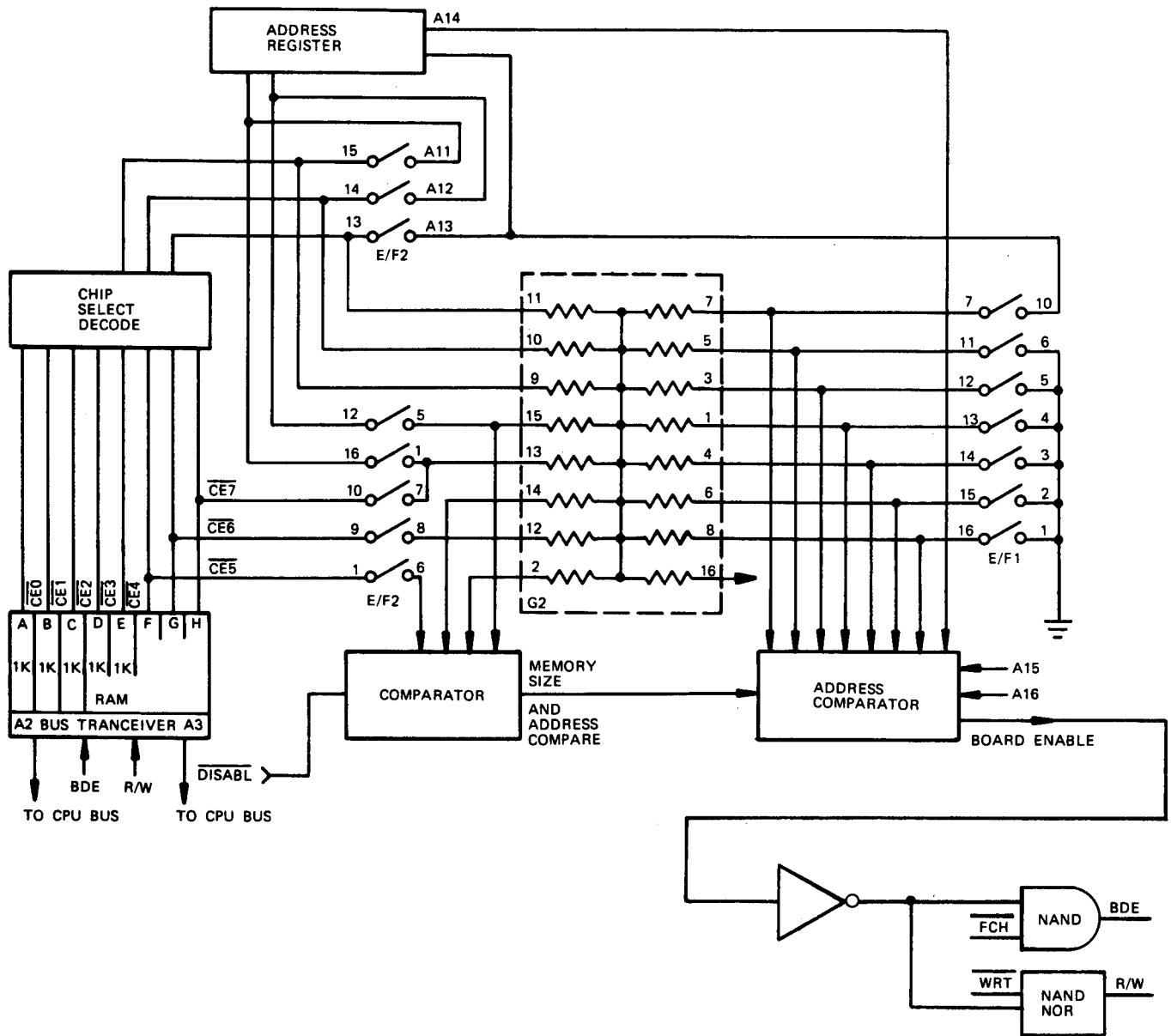

(4) One final input to the comparators is DISABL for board disable function. The board can be enabled only for the proper addresses, provided DISABL is high. When WRT is low, R/W goes low if the board is enabled to write into memory. Chip Enable (CE0 through CE7) on the RAM prevents the common R/W signal from writing into more than the 1K selected. The bus transceivers (A2 and A3) output RAM data to the CPU bus when BDE is present. When FCH is low and BOARD ENABLE is high, BDE is high.

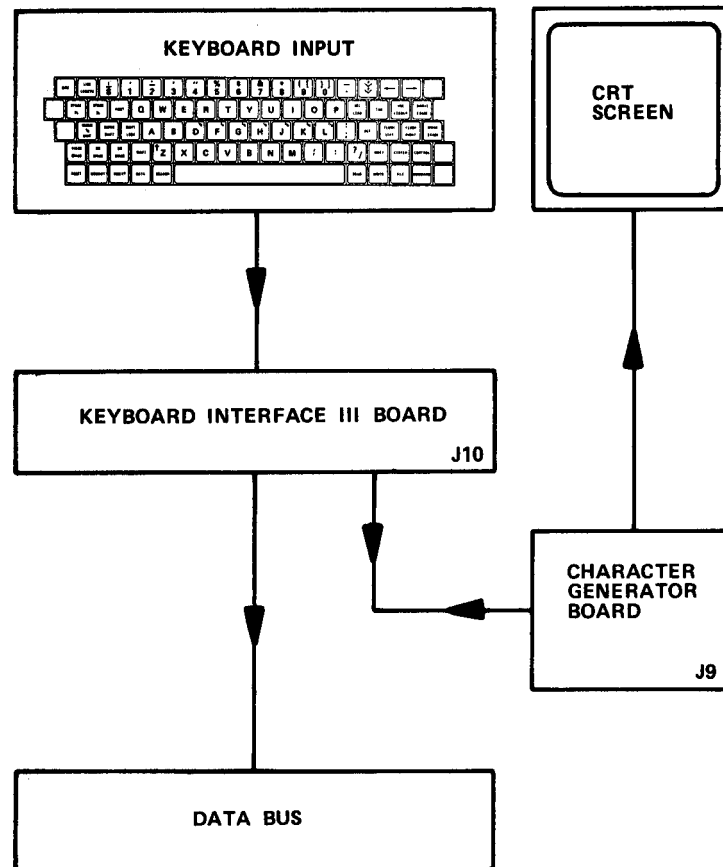

1. Keyboard interface III board J10. Holds the keyboard interface III board which interfaces between the keyboard, data bus and character generator board. Total control of the character display is achieved via this board. The keyboard interface III board contains all the circuits necessary to feed keystrokes in code format into the character generator's display memory. It consists of the following circuits:

- Cursor Speed Counter
- Data Multiplexer
- Roll Control Circuit
- Keyboard Counter/Load Register

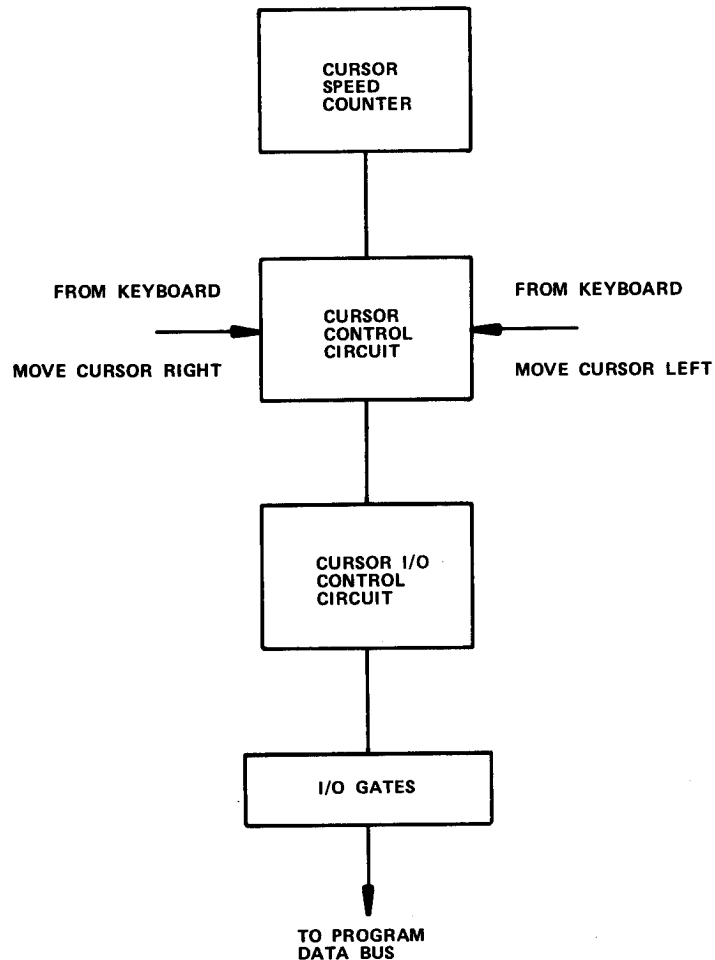

(1) Cursor speed counter. The operator controls cursor movements from the keyboard. Two keys are provided for this purpose. Depressing one key causes the cursor to move toward the right of the monitor screen. The other key moves the cursor to the left. Single keystrokes move the cursor one character block; however, if the key is held down, the cursor speed counter moves the cursor at a steady rate until the key is released.

As the cursor speed counter controls the speed of movement, the cursor control circuit makes these commands available to the data bus. The output of the cursor control circuit is a level signal generated by either key. Holding the key down for more than 300 msec causes the cursor speed counter to generate a 30 Hz pulse, and this is fed into the data bus via the cursor control circuit I/O gates.

(2) Data multiplexer. The data multiplexer takes data from the standard program interface, and keyboard data from the keyboard. This data is then selected and transferred to the character generator board. The erase circuit operates when the four bottom lines on the monitor are transferred to the top. Prior to this taking place, the erase circuit erases the top four lines. While this is taking place, the ERASE input to the data multiplexer disables both inputs, and outputs all zeros to the display memory, to clear the memory.

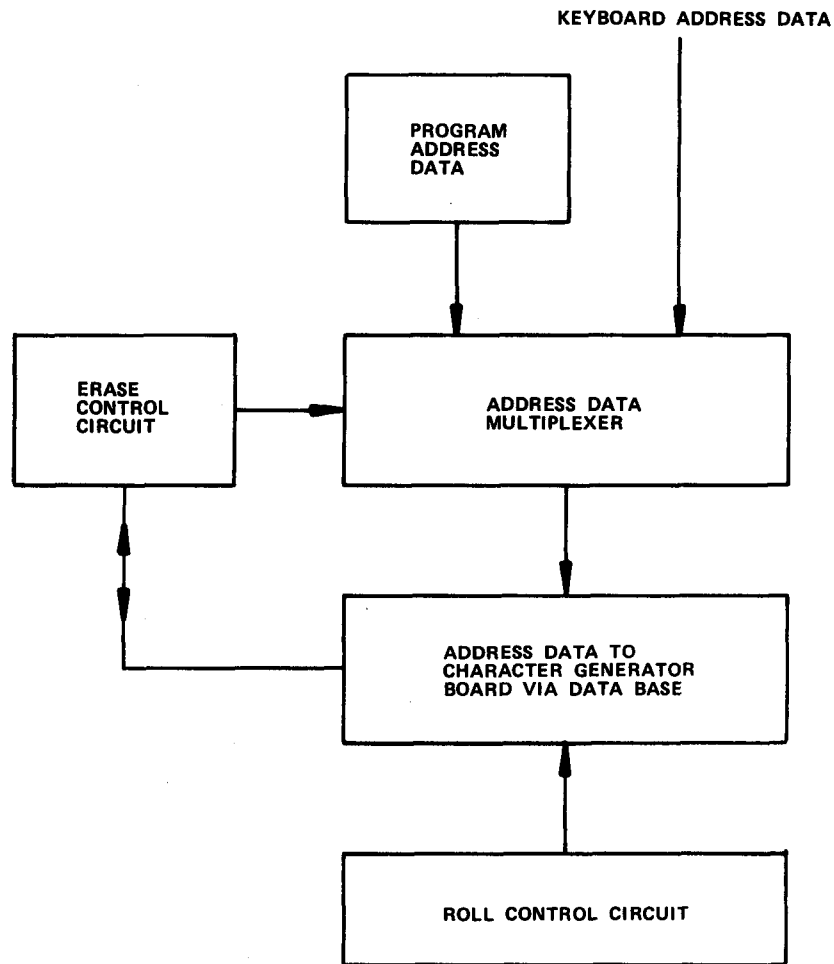

ERASE is initiated by a command from the character generator board. It is terminated by another command from the same board. This END ERASE signal is generated on the character generator board after the fourth line has been erased.

(3) Roll control circuit. The roll control circuit causes the bottom four lines on the monitor to be transferred to the top four lines, and the top four lines, which have just been erased, to the bottom four lines. This is achieved by modifying the Y-field addressing to the display memory. The roll control circuits generate the ROLL signal and transmit it to the character generator board. This signal initiates the address modification. The address remains modified until the next ROLL command is received when it returns to its unmodified mode.

Note that the data has not been moved; only the sequence of displaying the information.

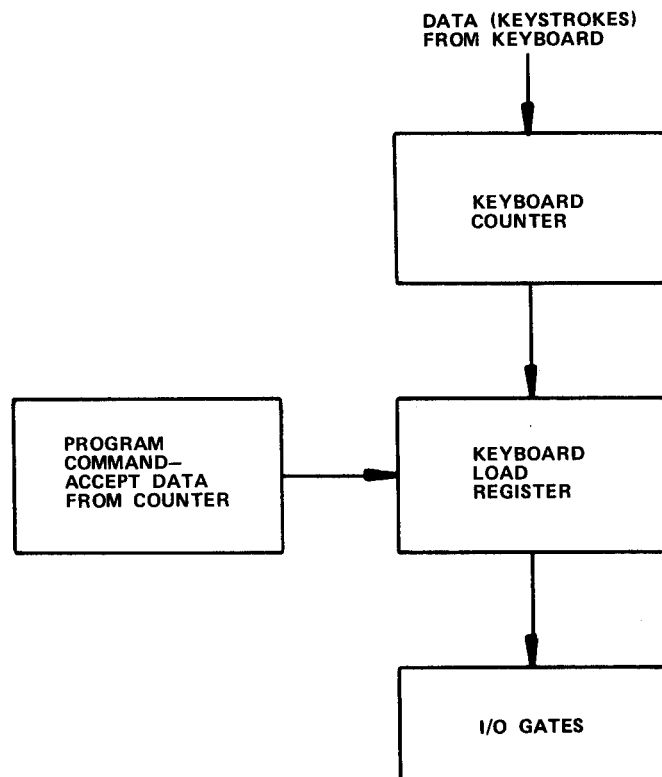

(4) Keyboard counter/load register. The keyboard counter just counts key-strokes. These are transferred into the keyboard load register when the register receives an accept command from the program. This data is then passed via the I/O gates to the data bus. The program then goes to the keyboard buffer in the display memory, pulls out the character code stored there and displays it on the CRT screen. The program only selects those codes contained in the keyboard load register which acts as a buffer. There are two buffers; while the program takes character codes out of one, the operator can continue typing and loading information into the other.

m. D/A stepper board **J11**. The board is divided into the following functions:

Program Interface

Flash Intensity Control

Clock Interface

Row Shift Stepping Control

(1) Program interface. Acts as a four-register storage with associated buffers. Received information is buffered and then placed on the data bus.

(2) Flash intensity control. This circuit controls the intensity of the flash as a function of type size. Character width information is received from the main program and stored in the register. The information is then loaded into the

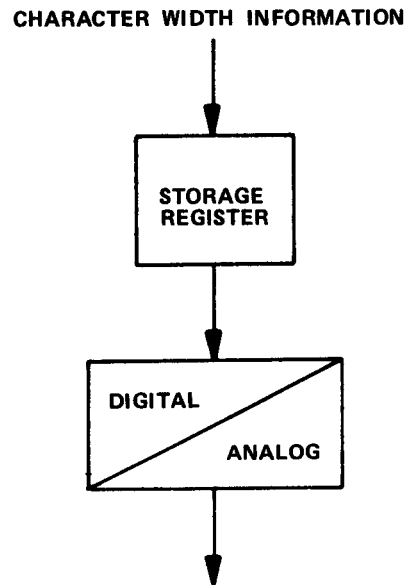

D/A converter and a voltage proportional to the character width is produced. This voltage is then passed to the flash power supply where it is used to control the intensity of the flash; the larger the voltage, the greater the intensity of the flash.

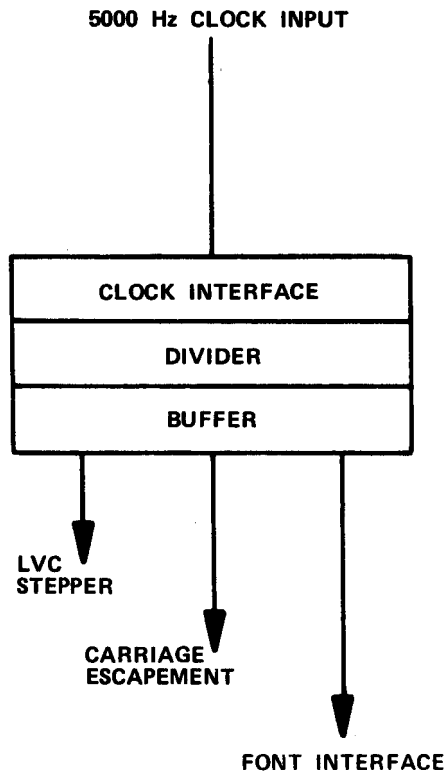

(3) Clock interface. The clock interface on the board receives a 500 kHz signal from the program bus. The clock signal is counted down by a four-stage counter to obtain the various frequencies required to drive all the stepping motors. The outputs are buffered and then bused via the motherboard to the LVC stepper, carriage escapement and font interface boards.

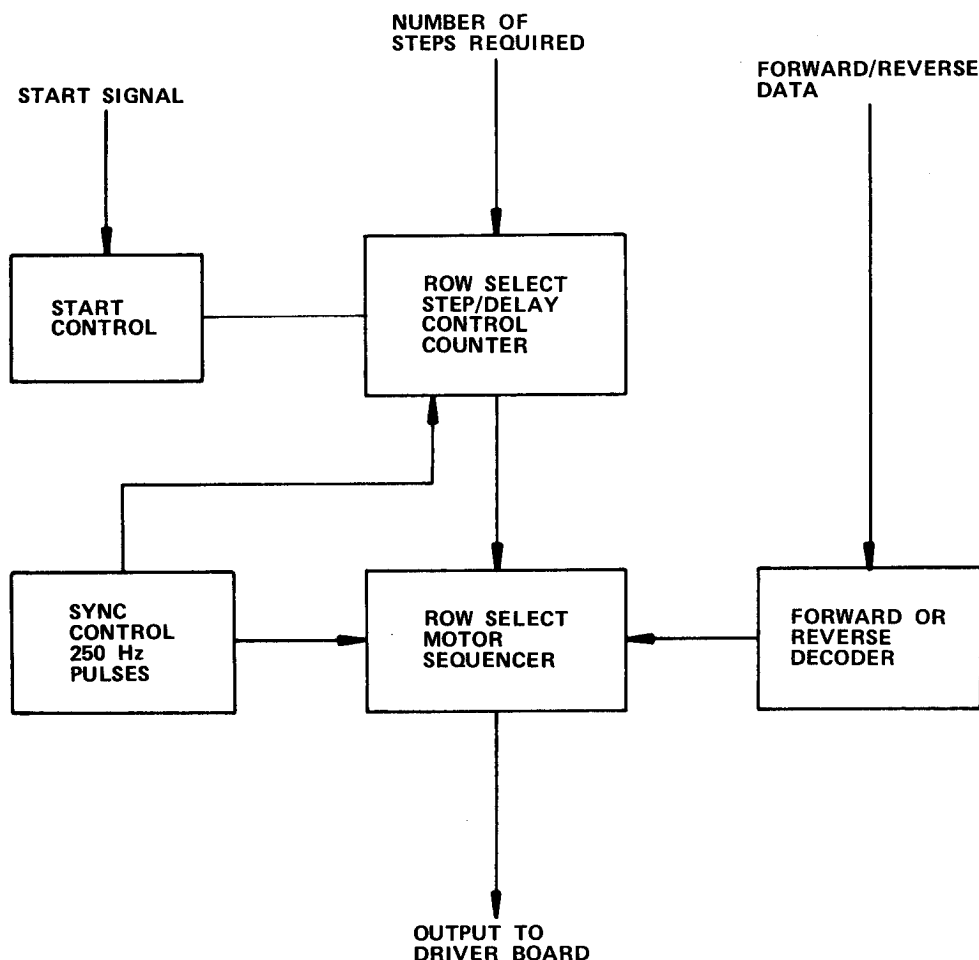

(4) Row shift stepping control. This circuit controls the complete sequence required to change fonts by moving the font disc. The main program determines the number of steps that the font disc stepping motor will be required to take. This information is passed to the row select step/delay control counter. The direction in which the move is to be made is decoded and fed to the row select motor sequencer. When a START command is received by the START CONTROL, it removes a HOLD signal from the row select step/delay control counter and, at the same time, the sync control is enabled. The system is now in a stepping mode. The 250 Hz pulse starts the row select motor sequencer, and the row select step/delay control counter begins to decrement the value originally set by the program instruction. The output pulses to the driver board will terminate only when the input pulses to the row select motor sequencer end. Input pulses continue until the row select step/delay control counter is empty. At this point, it resets the step/delay control counter, in turn resetting the sync control, stopping the stepping sequence.

The row select step/delay control counter now begins to count up the 1 kHz input, every pulse into the counter representing 1 msec. When the counter reaches 64 (64 msec), the step/delay control counter resets, terminating all stepping and delay counting activity. The resetting of the system, after the 64 millisecond delay, removes an INHIBIT signal to the program which allows the next sequence of operations to begin.

LVC stepper board J14. This board contains logic circuits which control the following functions:

- Variator or Enlarging Lens Control
- Collimator Lens Control
- Leading Motor Control
- Clock Interface
- Power On Reset

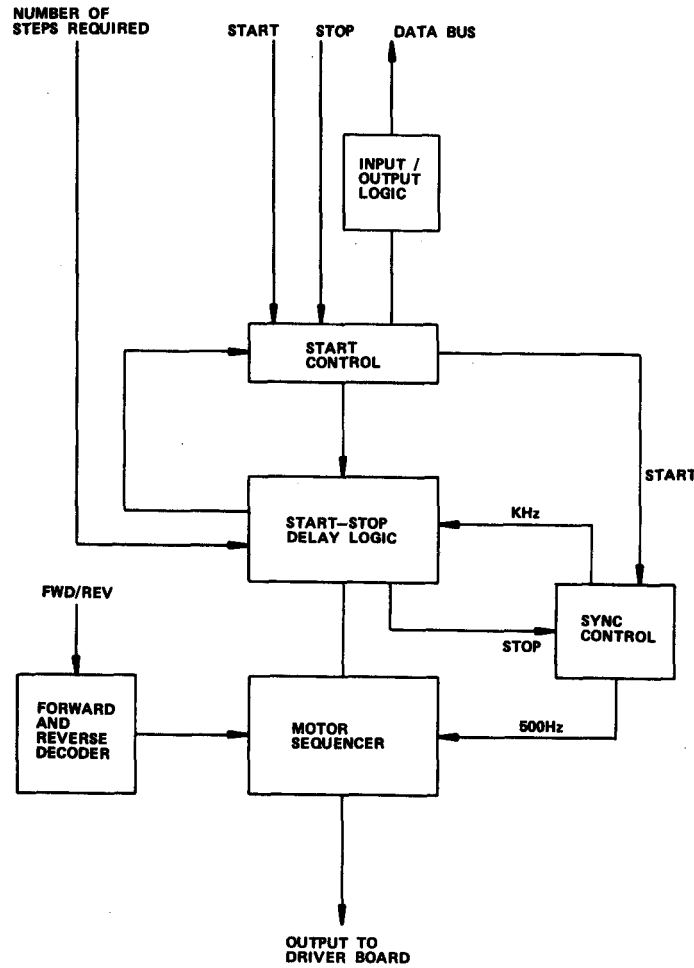

(1) Variator or enlarging lens control. This circuit operates in a similar fashion to the font row shift control. The start control circuit initializes the sequence of events when a START command is received from the program. The amount of movement, or number of motor steps required, already has been passed to the start-stop-step-delay logic. The START control releases an INHIBIT signal to the start-stop-step-delay control placing it in the stepping mode. At the same time, the sync control is enabled allowing 500 Hz pulses to be fed to the motor sequencer. The direction in which the lens is to move was passed from the program in code to the FORWARD/REVERSE DECODE logic, and from there to the motor sequencer. The motor sequencer now commences to output drive signals to the motor via the main driver board.

Each time that the motor steps, the total step count, as set by the program, is decreased by one. As the last pulse is reached, the start-stop-delay logic inhibits further pulse action by stopping the sync control. At this point, the stop-start-delay logic goes into the delay mode, and begins to count the 1 kHz pulse output of the sync control. When the required delay is reached (1 pulse = 1 msec), the logic generates a DELAY COMPLETE pulse, and places the entire logic block into a WAIT condition. The START CONTROL logic informs the program of this condition via the INPUT/OUTPUTj logic and the data bus. Other information passed via the INPUT/OUTPUT logic covers the condition of the collimator and leading motors.

(2) Collimator lens control. This is nearly identical to the preceding control description, the only difference being the functional description of the STOP and START commands from the program.

(3) Leading motor. This circuit is similar to the VARIATOR and COLLIMATOR circuits; there are two differences:

(a) Power to the leading motor is not shut off at the end of the STEP/DELAY sequence. At the completion of movement, the driver board holds 50-percent power to the motor coils. This ensures that the film or paper maintains its position.

(b) The leading motor mechanism has a film out switch which passes this information to the program via the data bus.

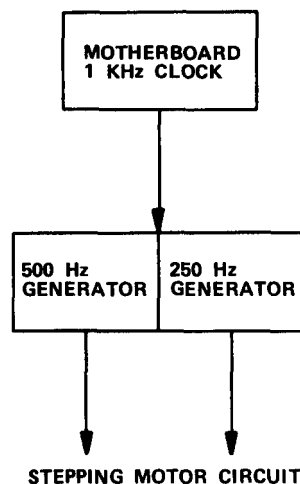

(4) Clock interface. This circuit takes the 1 kHz clock output from the motherboard and generates the 500 and 250 Hz signals required for the stepping motor circuits.

(5) Power on reset. This circuit determines whether an interrupt has been caused by power turn-on or by RESET key depression. This allows the program to determine if RAM data must be reloaded.

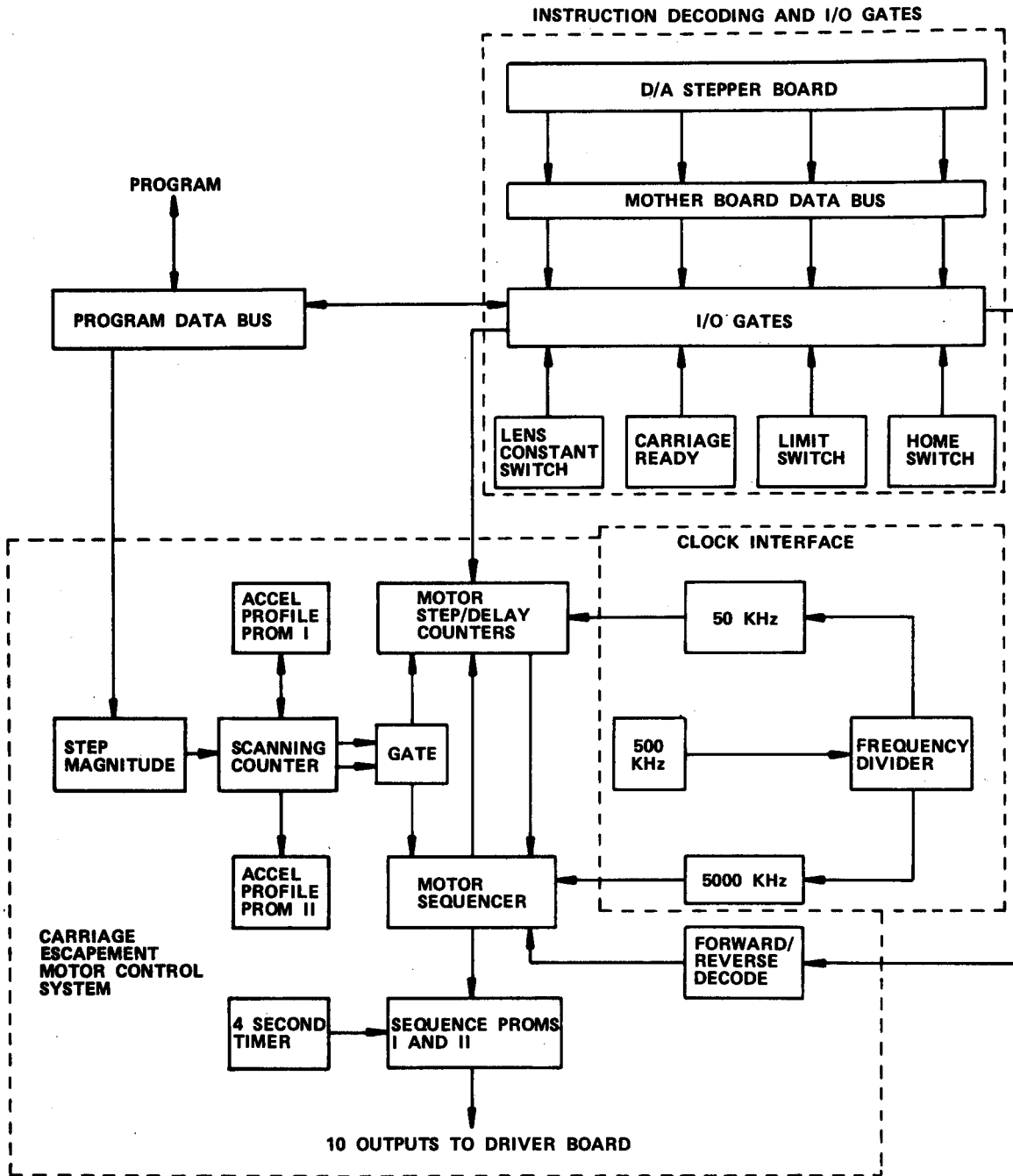

0. Carriage escapement board J12. Can be divided into four main operational groups:

Clock Interface

Instruction Decoding and I/O Gates

Lens Constant Switches

Carriage Escapement Motor Control System

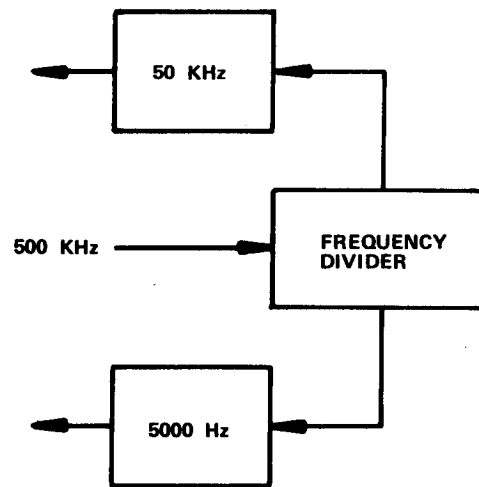

(1) **Clock interface.** Consists of two main parts: the 500 kHz clock and the frequency divider. The frequency divider counts the 500 kHz clock down to the 50 kHz clock output and the 5000 Hz output. These clocks are used to step the carriage motor and carriage setting delay.

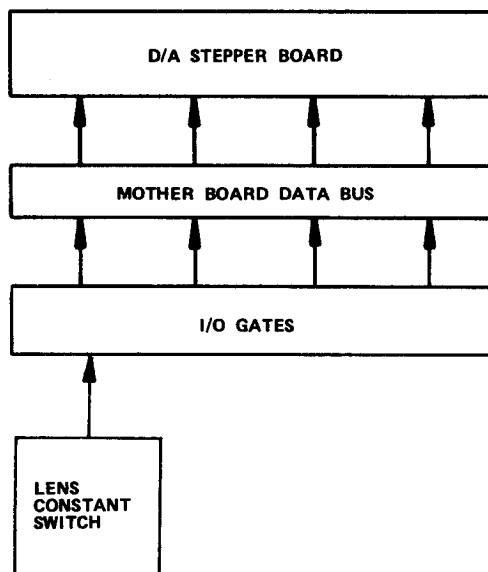

(2) Instruction decoding and I/O gates. The main information required to move the carriage escapement stepper motor is received from the D/A stepper board via the motherboard bus. These signals are decoded, and then serve to load the carriage steps. In addition to the number of carriage steps required, the delay settle time is set. This function has two modes: the normal mode and the proof mode.

(a) In the normal mode, the amount of time between carriage commands is 10 msec (setting delay).

(b) In the proof mode, this time is reduced to 3.3 sec. This reduction is achieved by a command to the motor step/delay counter to reduce delay. When the latter mode is selected, the composing machine will operate at higher speed but with a loss of copy quality.

(3) Lens constant switches. Because the optical systems between composing machines cannot be identical due to differences in the lens tolerances, the positions of the variator and collimator lenses in the optical path will vary slightly between machines. Each optical system, therefore, requires correction constants to alter the position of the lenses in the system to produce correct size and focus of the characters. The correction constants are stored in two 8-bit switches mounted on this board, the 16 individual rocker switches are placed in the ON or OFF position depending upon the correction factor required. As these settings are unique to each composing machine, they are recorded on a chart which is located in the photo unit. The information from each switch is read by the program via the instruction decoding and I/O gates and the data bus.

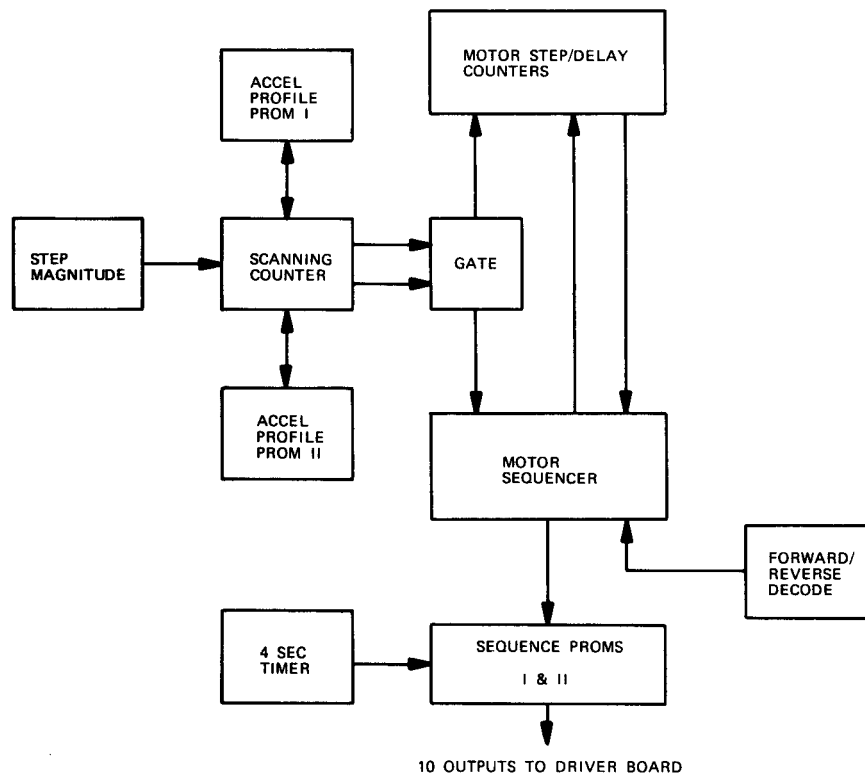

(4) Carriage escapement motor control system. Is the main part of this board, and is similar in operation to the other stepper motor control boards. The number of motor steps required to move the carriage the correct distance are fed into the motor step/delay counters from the program via the D/A stepper board, motherboard data bus and the instruction decoding and I/O gates. At the same time, the normal or proof mode and the FORWARD/REVERSE commands are processed, together with an instruction to the step magnitude circuit indicating that more or less than 32 steps are required.

(a) The stepping motor, used to control the escapement carriage, is capable of stepping at 5000 steps/see but it is not capable of starting or accurately stopping at this rate. To overcome this problem, the stepping rate is increased and decreased relatively slowly when starting and stopping the stepping motor.

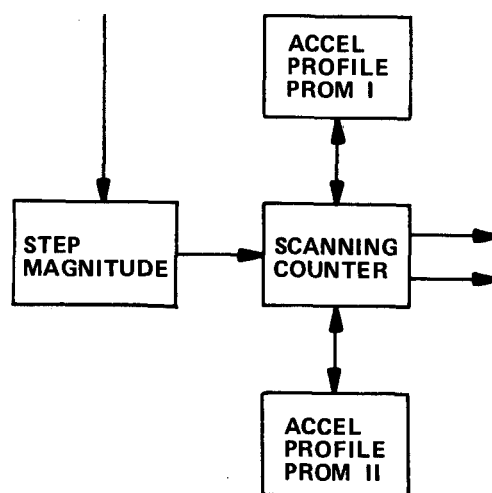

(b) The profiles of stepping acceleration and deceleration are stored in two PROMS. The step profiles are generated by testing the stepping motor under given loads.

(c) The step profiles are different depending upon the number of steps to be taken. Each PROM contains 16 different step profiles. PROM I covers steps 1 thru 15 and PROM II from 16 thru 32. For a given number of steps, the scanning counters select the correct profile and output the step pulses according to that profile.

(d) The step pulses generated by the step profiles are fed to the motor sequencer and motor step/delay counters via a gate. The motor step/delay counters count down as the motor sequences steps. This continues until the total number of step pulses have been outputted to the motor sequencer, and the counters are at the zero count. The setting delay mode is activated at the zero count and, when it is completed, the carriage escapement motor control is ready for another series of steps.

(e) The selection of the correct step profiles depends upon the step count. If the total step count is 32 steps or lower, the scanning counter will be loaded with the starting address of the appropriate PROM step profile. The counter scans through the PROM, and outputs the steps to the motor sequencer and the motor step/delay counters via the gate.

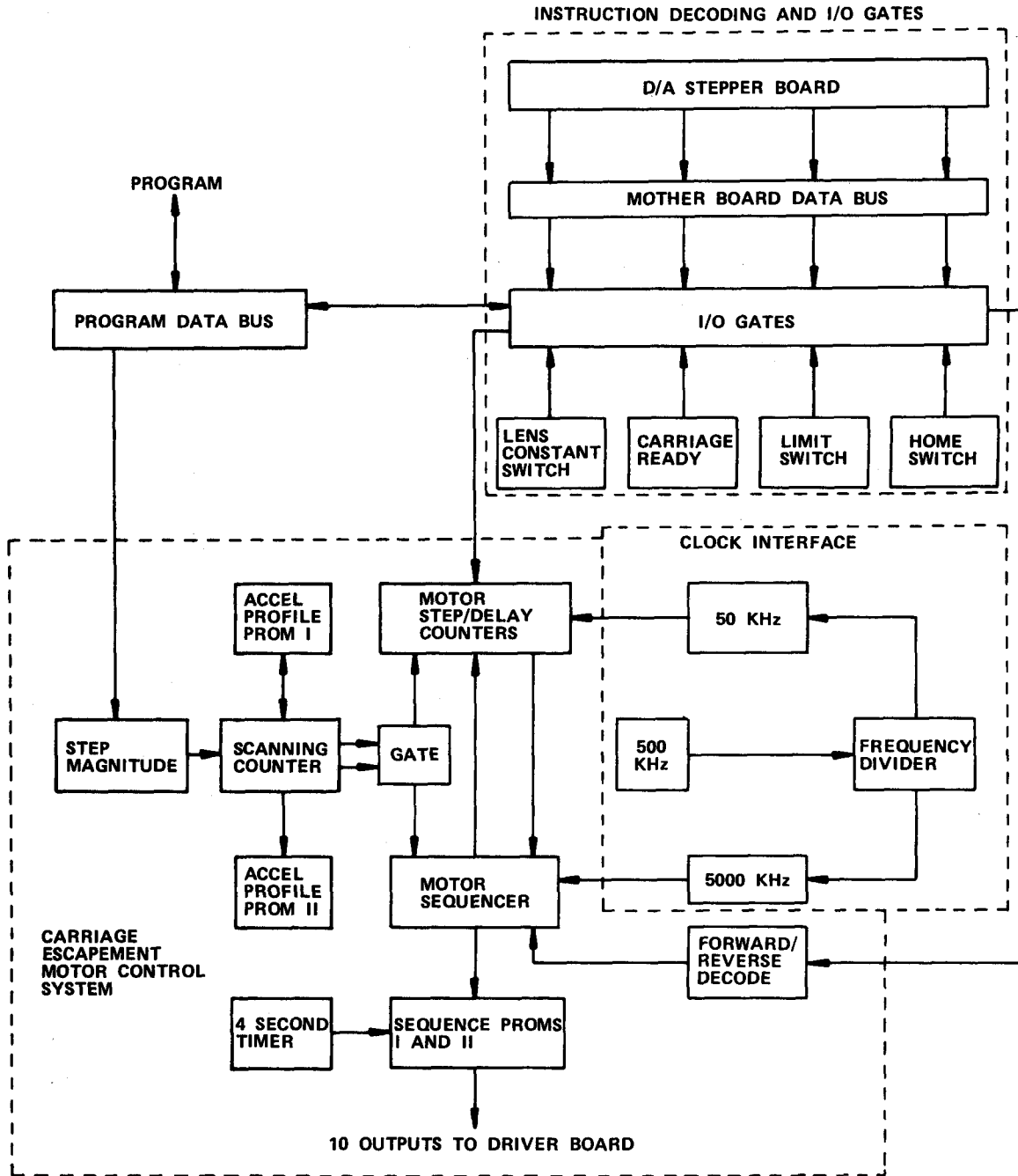

(f) If the total step count is more than 32, the motor step/delay counters are set to the 32-step profile. First this step profile delivers 16 acceleration steps to both the motor step/delay counters and motor sequencer. At the completion of the 16 acceleration pulses, the 5000 Hz signal is applied to the motor step/delay counters and motor sequencer. The motor is now running at 5000 steps/see with the motor step/delay counters counting down at the same rate. When only 16 steps are remaining, the deceleration sequence begins. The 5000 Hz pulse is shut down, and the scanning counter accesses the deceleration profile from the PROM. At the completion of the 16 deceleration steps, the zero condition in the counter starts the delay sequencer and stops the stepping action.

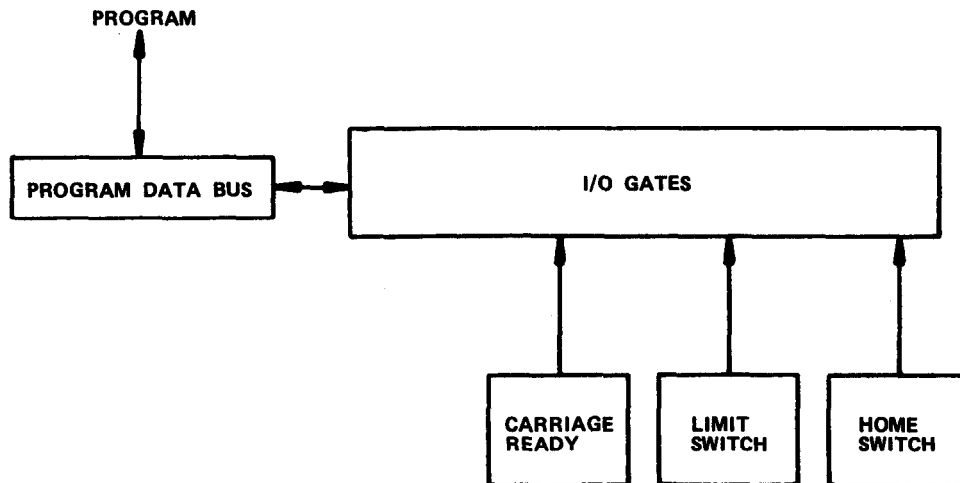

(g) The escapement carriage has a limit switch and a home switch, both of which are gated with a forward and reverse flip-flop. The output of these gates is a stop stepping signal which indicates that the escapement carriage has hit one of the limit switches. The CARRIAGE READY signal allows the escapement carriage to move away from a struck limit switch. All these signals are passed through the I/O gates to the program data bus.

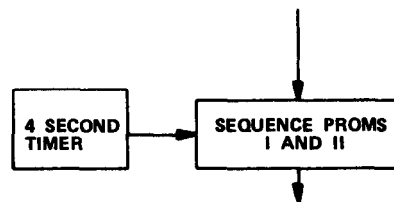

The final circuit on this board is the power shutoff to the carriage escapement motor. When the timer detects that the motor has not been given instructions to move for approximately 4 see, it shuts off the enable signal of the two sequencing PROMS . This removes power from the carriage escapement motor.

Font interface board III J13. Performs the operations required for proper character selection from the character disc, width data and FLASH logic.

(1) Disc speed control uses the 5 MHz master clock (MASCLK) which is gated through a divide-by-3 counter (counter 1). The output of counter 1 sets the range of speeds available. The output of counter 1 divided by counter 2. The output of counter 2 is controlled by counter 4. The 5B07 signal loads FLXD1 thru FLXD4 into counter 4. This enables counter 4 to change the divisor of counter 2. The output of counter 2 is applied to counter 3. The output of counter 3 is a reference frequency used to control the speed of the disc (SPDREF). SPDREF is applied to Nand gates 2 and 3. The amplified signal from the strobe track on the character disc is sent to the Font Interface Board III. This STBTRK signal is fed into amplifiers 1 and 2, then to Nand gate 1 via JK flip-flops 1 and 2. The output of Nand gate 1 is a 200 ns pulse for every dark-to-clear transition on the disc. This output is fed to JK flip-flop 3. JK flip-flop 3's output is fed to Nand gates 2 and 4 and Register 1. The outputs of Nand gates 2; 3, 4 and 5 are compared with STBEDG and the difference of the two frequencies controls the output of register 1. This changes the disc speed until both frequencies are identical.

(2) Width select data on the strobe track on the font disc contains 112 sectors. Each sector is divided into 18 parts. The first 4 parts are opaque, the 5th clear, 6th and 7th opaque and the last 11 alternate in a black-and-white pattern.

The circuit that detects three consecutive dark divisions is called MP counter 5. MP counter 5 generates an output pulse after 1-3/4 dark divisions have been detected. Therefore, a pulse will be generated at the beginning of each sector. The other opaque divisions of the sector are too short to allow MP counter 5 to output a pulse. Each transition and missing pulse is detected by FF1, 2 and 6 from the STBTRK signal. The output of FF2 produces a signal called SEDG+MP. This represents every transition plus the MP. The pulses go through a divide-by-3 counter (counter 1). Each pulse output represents one-font. These pulses are fed to counter 2 which keeps track of the font position. MP counter 5 is kept in a preset condition as long as the strobe track is clear. When a dark division appears, MP counter 5 is released. MP counter 5 is preset by the next clear position through FF3 via counter 2. When three dark divisions are detected, counter 2 will overflow and generate the MP. This disc is designed so that DTATRK1 is opaque for 111 positions around the disc adjacent to the MP. DTATRK1 is clear for only one sector. Gating MP and DTATRK1 generates an origin pulse. The origin pulse is generated when the first character position approaches the character flash window. When this occurs, counters 4 and 3 are preset to 1. Gating the MP with inverted DTATRK signal will produce three pulses. These pulses cause counters 3 and 4 to keep track of the disc position. The outputs of disc position counters 3 and 4 and font position counter 2 go into comparators (COMP) 1, 2 and 3. The other inputs to the comparators are font position register R3 and disc position registers R4 and R5. The registers are loaded with I/O instructions 5B04 and 5D04 (the disc position and font of the character whose width is being requested). When the disc is in position to be read, two signals, CHEQ and FEQ are generated. When signal 5D04 is present, it sets FF4. FF5 output (WDTHALW) goes high on the next MP. The following signals are required to allow data to be loaded into registers R1 and R2: FEQ, SEDG+MP, WDTHALW and CLK. The output of Nand gate N4 produces properly timed and clocked signals relative to the data-tracked signal so that data is properly loaded into the width registers (R1 and R2). The width registers hold width data until 4704 Input Instruction (147) width of character from the program processes the information.

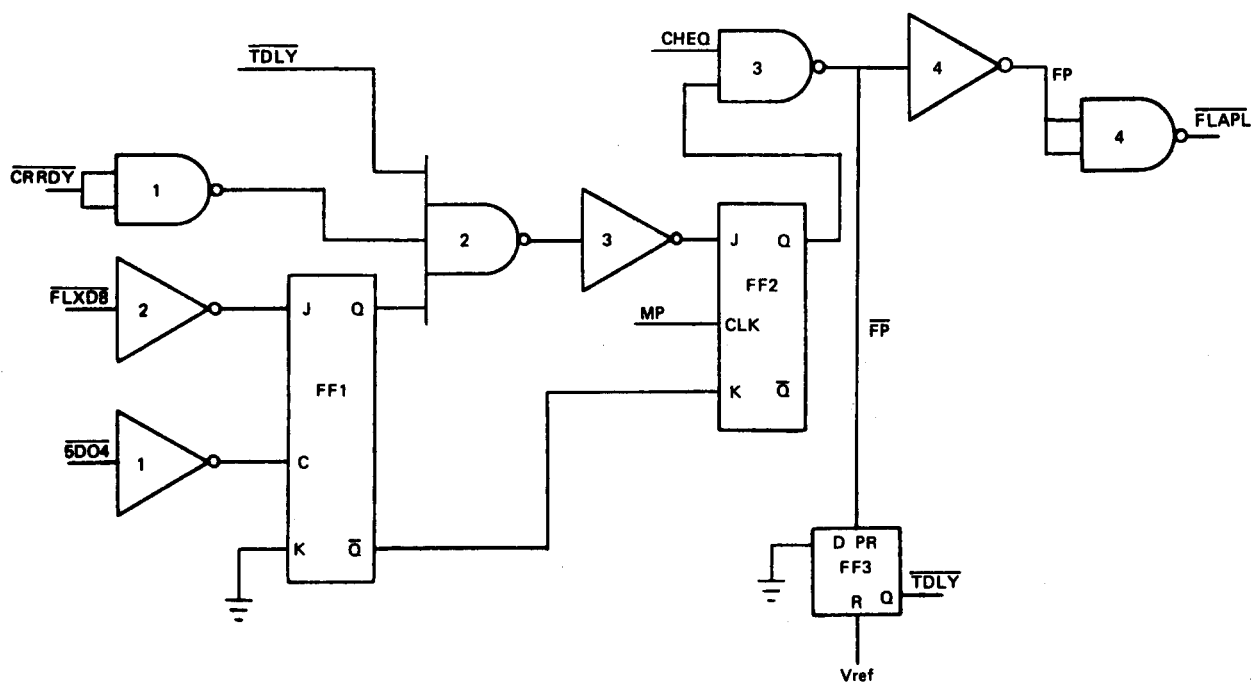

(3) Flash control circuit. To initiate a flash, three conditions must be satisfied:

Carriage must be low (CRRDY).

Flash Power Supply must be low (TDLY).

5D04 and FLXD8 signals must be low.

When these conditions are met, flip-flop F2 will set on the next MP signal. Nand gate 3 requires two high inputs, CHEQ and flip-flop F2. This **all**ows a flash pulse on the first dark part to clear transition after the MP. The $FP = 0$ signal sets flip-flop F3. This starts a 16 msec time delay (TDLY) = 0 to allow the flash power supply capacitors to recharge.

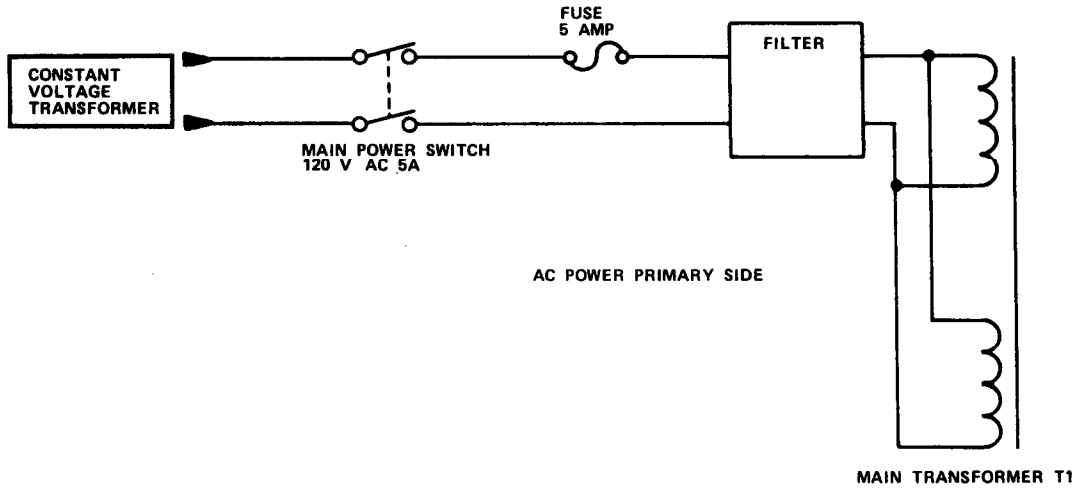

q. AC distribution system. Begins with the supply to the primary side of the main power transformer. Power is supplied through a double-pole switch, an 8 amp fuse and a noise filter to the primary windings of the transformer. Both the switch and fuse are accessible to the operator. The 120 V supply is taken from a normal grounded, single-phase outlet with a rating of at least 10 amps. The constant voltage transformer uses an input from 95-130 V, 60 Hz to provide a constant 120 V, 60 Hz.

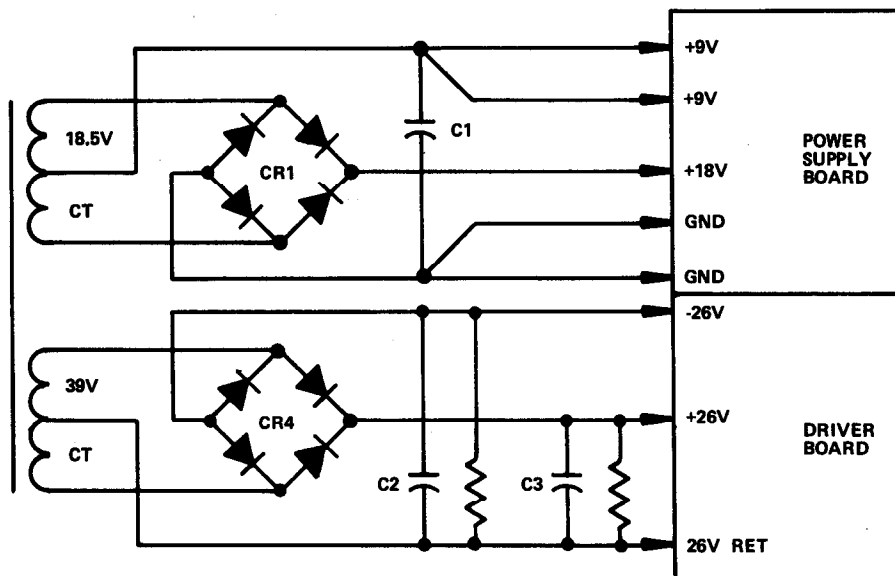

The 18.5 V ac center-tapped winding feeds bridge rectifier CR1 which produces +18 V and +9 V. Smoothing is provided by a capacitor C1. Both the 18 V and 9 V supplies go to the +5 V regulator on the power supply board. The 39 V ac center-tapped winding feeds bridge rectifier CR4, which produces +26 V, -26 V and provides a 26 V return. Filtering is provided by capacitors C2 and C3. Both the positive and negative 26 V supplies go to the driver board.

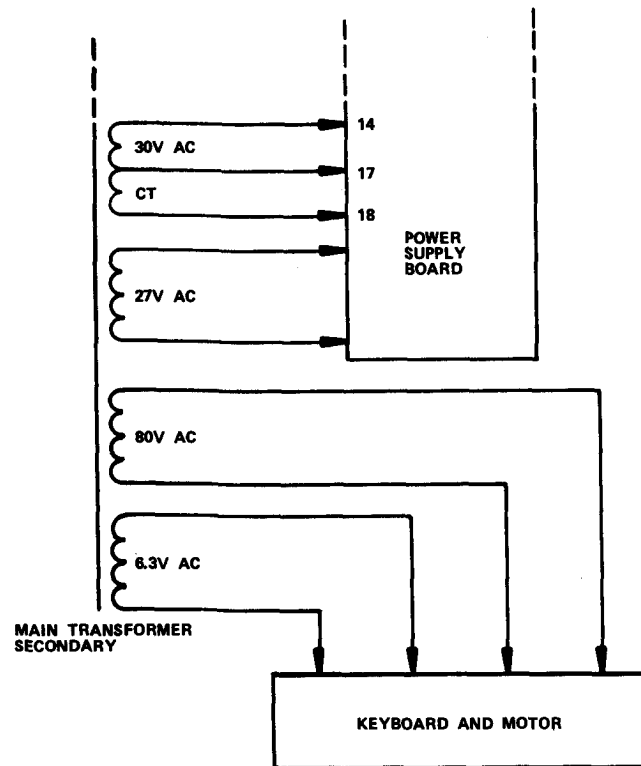

Four secondary windings supply ac power to the power supply board and the input/monitor unit. The 30 V ac center-tapped winding supplies power to the +12, -12, -9 and -5 V regulators on the power supply board, the 27 V ac winding going to the +24 V regulated supply circuit also on the power supply board.

The input/monitor unit receives two ac supplies: 80 V ac, which is used to supply the monitor with all its power requirements, and 6.3 V ac, which is used specifically to power the heating filament of the CRT.

The main dc power supply can be divided into three sections:

- Terminal Regulators
- High-Current, +5 V Supply
- +24 V Circuitry

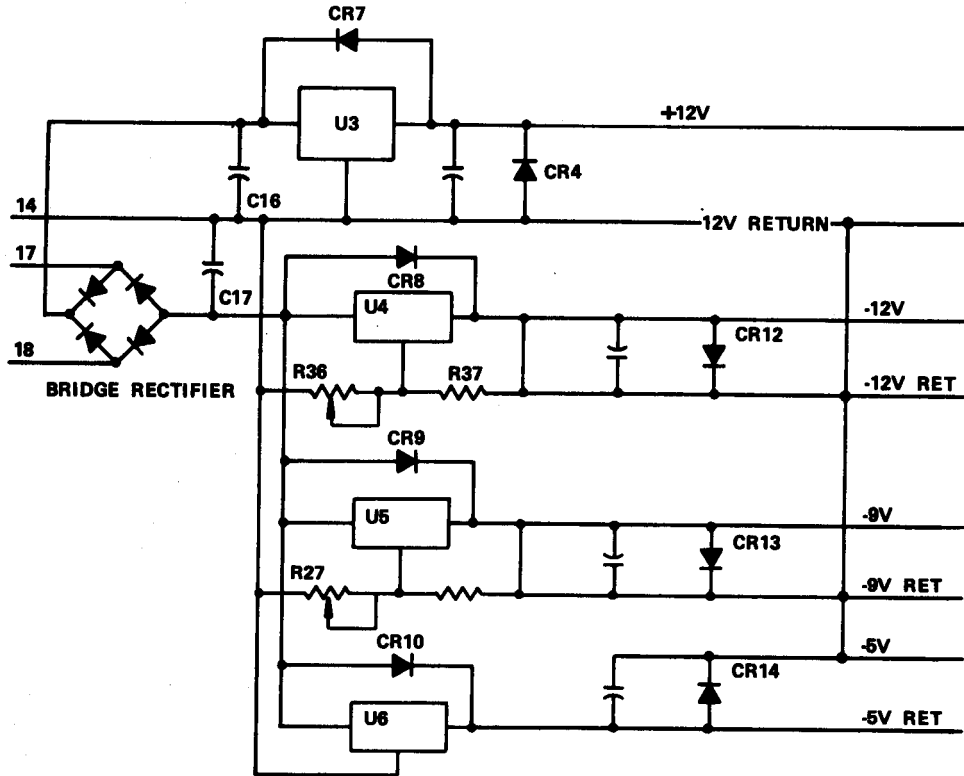

(1) Terminal regulators. U3, U4 and U6 use an unregulated ac supply from a 30 V ac center-tapped secondary winding on the main power transformer. This ac voltage is rectified by the bridge rectifier and filtered by capacitors C16 and C17. Regulators U3, U4 and U6 convert this unregulated dc voltage to fixed dc voltages according to the output specifications. The unregulated dc input does in fact provide a minimum of 13 V under full-load conditions. Regulator U4 is provided with an adjustable resistor-trimmer network R36-R37 to set the output at -12 V. Diodes CR7 through CR14, between the input, output and return lines, protect the regulators from reverse voltages that may be caused by external system faults or transient conditions.

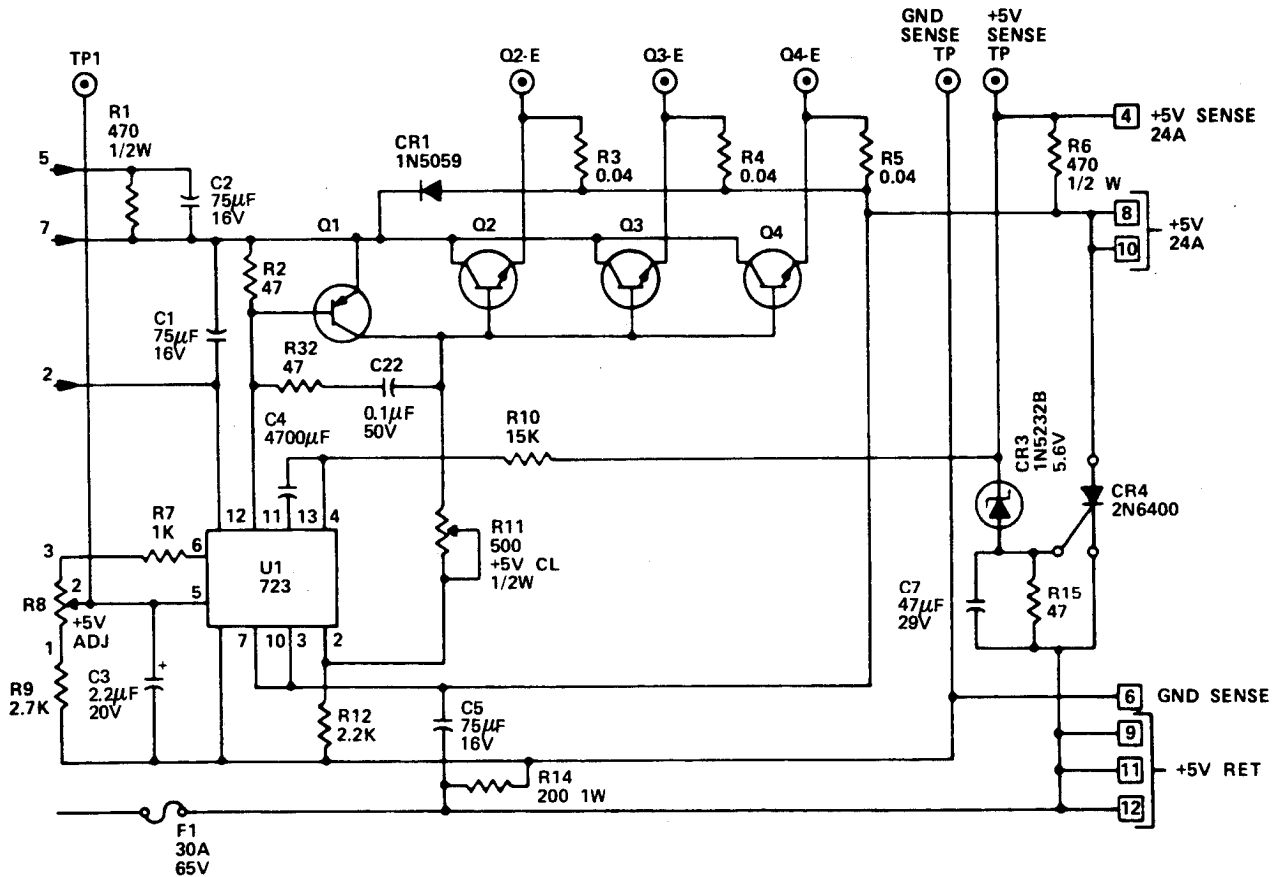

(2) High current +5 V supply. The main high power supply provides +5 V at 24 amps with overvoltage protection and current limiting. The +5 V regulator gets the unregulated dc voltages from pins 5 and 7 for the high-current section and pin 2 for regulator U1.

(a) Regulator U1 compares the main +5 V output voltage with a reference voltage and drives pass transistor Q1 through emitter-follower Q4 so that the two voltages are equal. Regulator U1 is referenced to both the +5 V output and the ground (grid) sense terminals. These are tied directly to the load and bypass any losses in the winding.

(b) Pin 6 on regulator U1 provides a +7.15 reference voltage which is divided by R7-R9. Trimmer R8 allows an adjustment range from +4.6 to +5.4 V on regulator U1, pin 5. Regulator U1 drives the output so that the voltage on pin 4 equals that of pin 5. Since pin 4 is tied to the +5 V sense lines, and in turn to the LOAD, then the load voltage will equal the voltage set on pin 5.

(c) Regulator U1 is also used in the current-seeking mode. Pin 11 seeks a current proportional to the output demand. This current is sensed by the base of pass transistor Q1, and its collector current drives the bases of emitter-followers Q2, Q3 and Q4. The emitters of these transistors are tied together through 0.04 ohm resistors to ensure current sharing.

(d) The 0.04 ohm resistors are printed circuit t-type and are located under the heat sink extrusion. For current limiting, the voltage between the collector of pass transistor Q1 and the +5 V output terminal is sensed. This sets a bias voltage on regulator U1, pin 2 with respect to U1, pin 3.

(e) Trimmer R11 is adjusted so that there is 650 mV between pins 2 and 3 when the output current is at the desired maximum. If the output load is increased, then the voltage will decrease and the output current will also fall. With a full short-circuit across the output, the current will be about 30 percent of the maximum. Resistors R6 and R14 are provided for protection in the event of a break in one of the sense lines. They limit the output voltage to a level which will not damage the external system. With both sense lines disconnected, the output voltage will be approximately 1 V above set value.

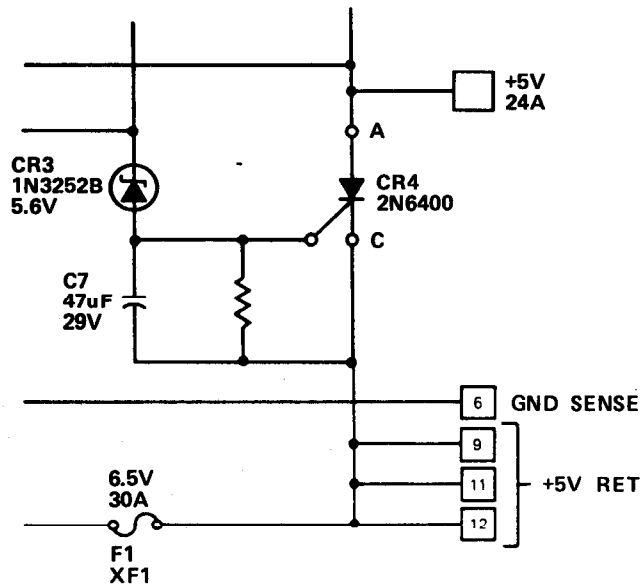

(f) Should a major failure occur, the full unregulated voltage (+10 V) will attempt to reach the output terminals. At approximately +5.6 V, zener diode CR3 will conduct current to the gate of SCR-CR4 and trigger it. This shorts the output terminals, and blows fuse F1 as the current-limiting circuit is ineffective in this situation.

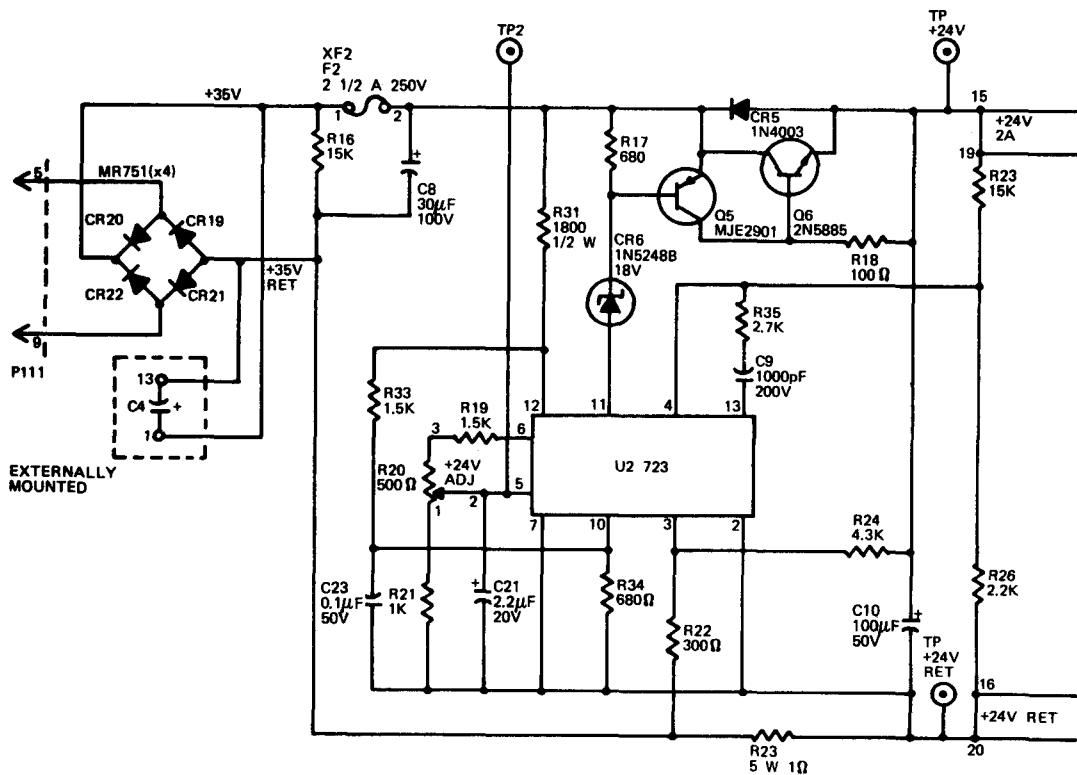

(3) +24 V circuitry. The +24 V circuitry is similar in configuration to the +5 V supply but it supplies less current and has no overvoltage protection.

(a) The ac is supplied by a 27 V secondary winding on the main power transformer and is rectified by bridge rectifiers CR19, 20, 21 and 22. Filtering is provided by C4, which is mounted remote from the main board.

(b) The unregulated voltage is divided by R31, R33 and R34. This powers regulator U2.

(c) Reference voltage is provided at pin 6 from voltage dividers R19, R20 and R21. Trimmer R20 provides a range from +2.4 to +3.6 V on pin 5. The output voltage then equals $ER_{20} (ER_{25} + ER_{26}) / ER_{26}$. With the output voltage set to +24 V, pin 5 voltage is about +3.1 V.

(d) Pin 11 seeks a current proportional to the output demand. This current flows to ground through pin 10 and R34 and is sensed by the base of Q5, which drives the base of emitter-follower Q6. Resistors R22 and R24 bias pin 3 so that with 650 mV between pins 2 and 3, the output current is 2.4 amps. Any increase in output load will cause the output current to be limited. A direct short will result in only 650 mA at the output.

Section II OPERATING INSTRUCTIONS

2-4. DESCRIPTION AND USE OF OPERATOR'S CONTROLS AND INDICATORS.

Control or Indicator	Function
----------------------	----------

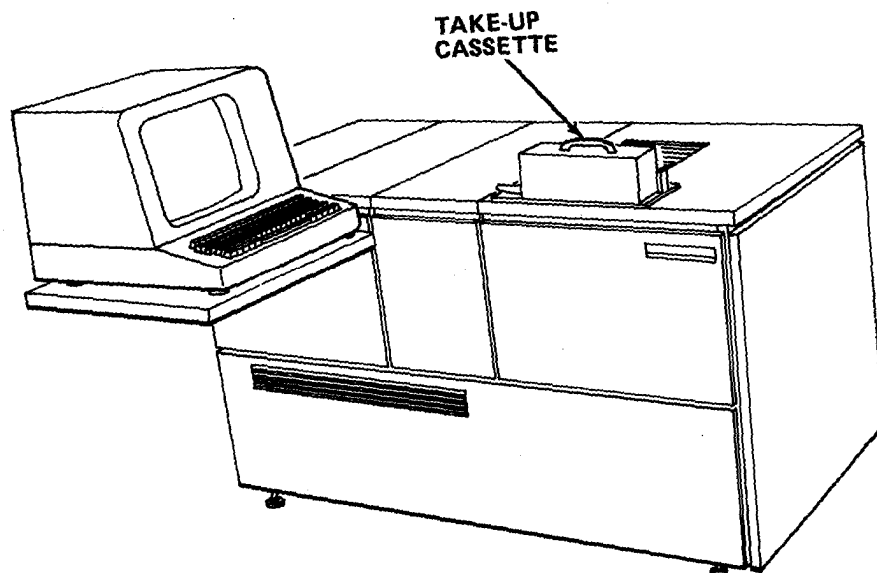

Take-Up Cassette

Holds exposed photographic paper.

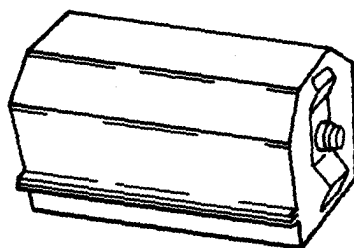

SUPPLY PAPER CASSETTE

Supply Paper Cassette

Contains 150 ft of unexposed photographic paper.

Control or Indicator

Function

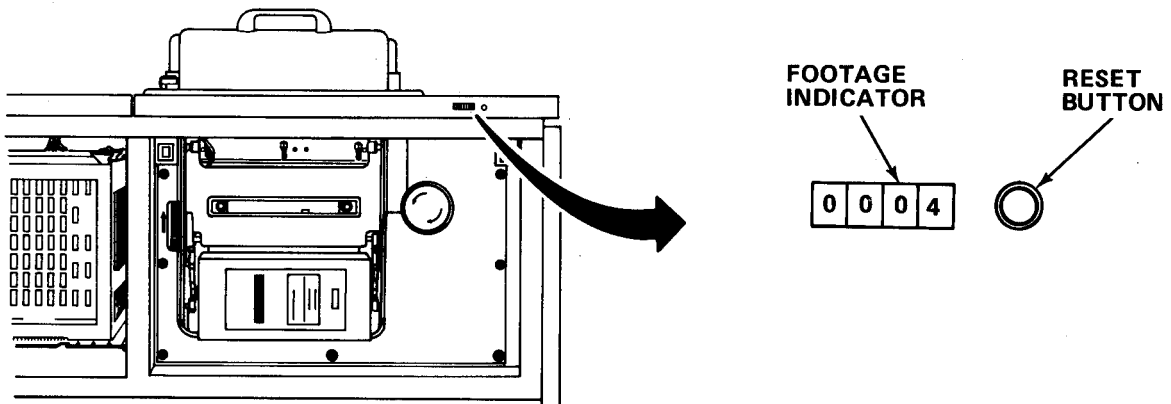

Footage Indicator

Shows total amount of paper used in feet and tenths of feet.

Reset Button

Resets footage indicator when new supply cassette is installed.

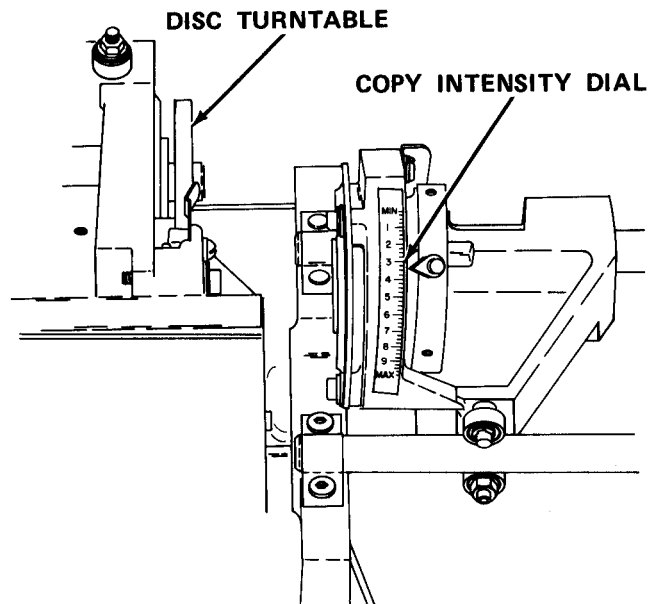

Copy Intensity Dial

Controls lightness or darkness of copy being set photographically.

Disc Turntable

Located in console type-setter. Houses disc.

Control or Indicator

Function

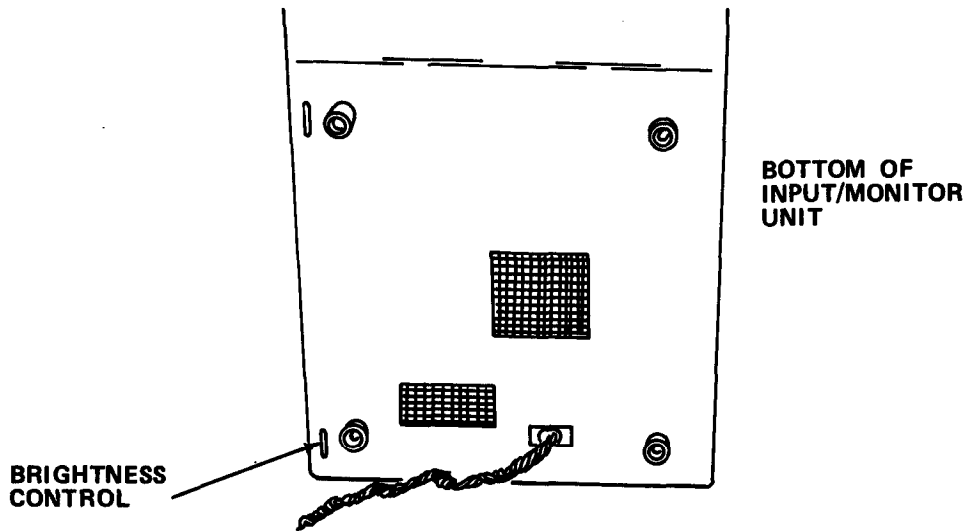

Brightness Control

Located on underside of screen cabinet. Controls brightness of image on screen.

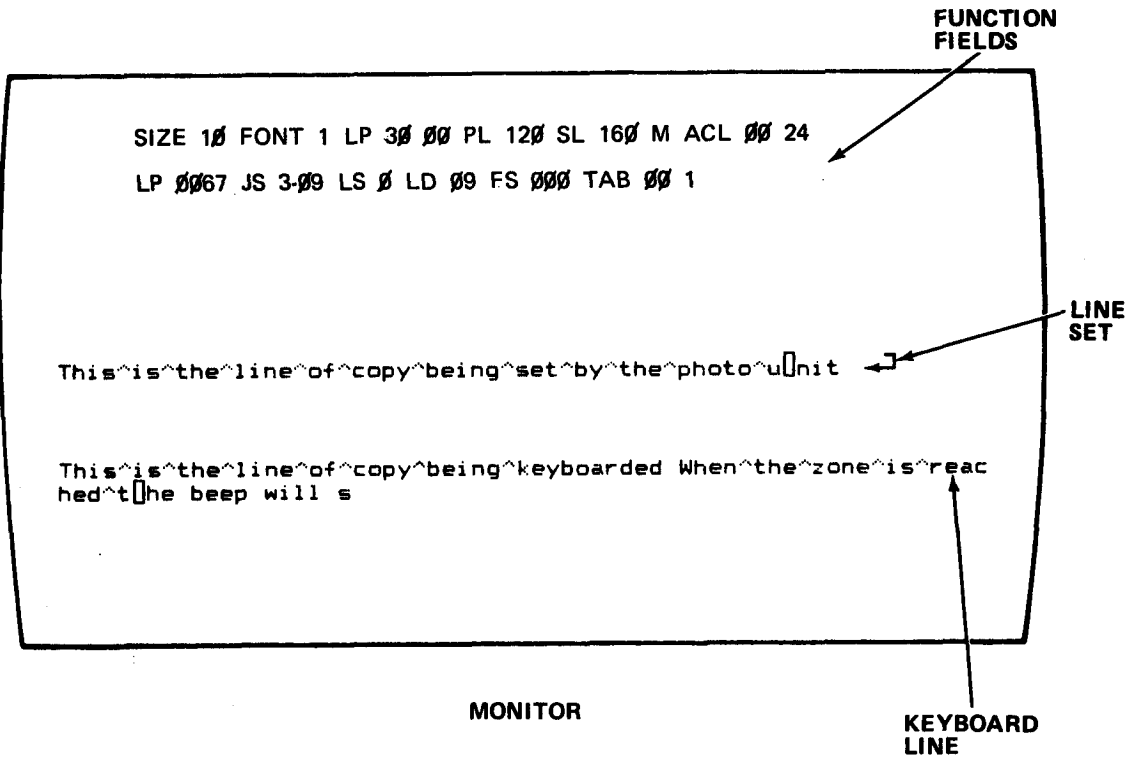

Control or Indicator	Function
Function Field	Five areas are functions (commands) that must be entered in composing machine before keyboarding job.
Line Set	Displays line being set by photo unit.
Keyboard Line	Displays line being keyboarded.

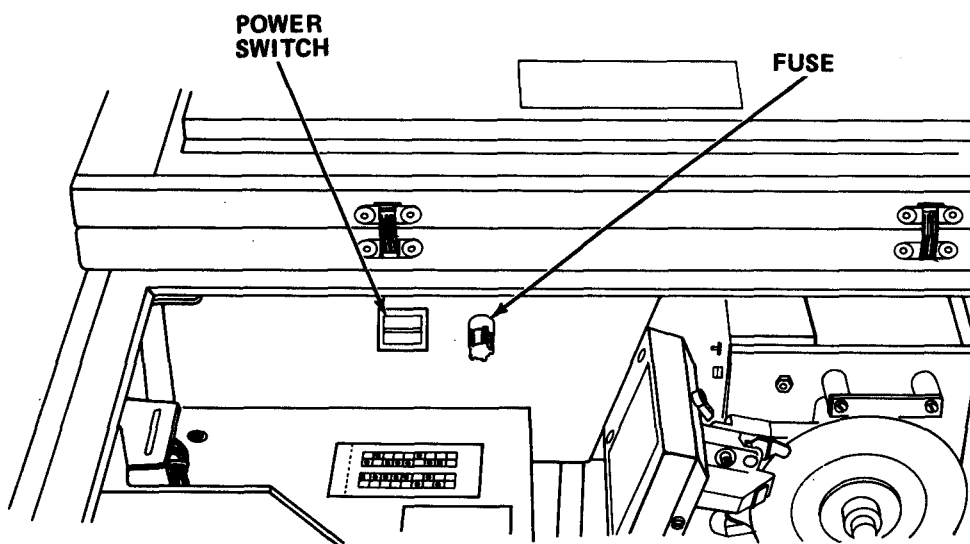

Fuse	8 amp fuse current overload protection.
Power Switch	Applies primary power to composing machine.

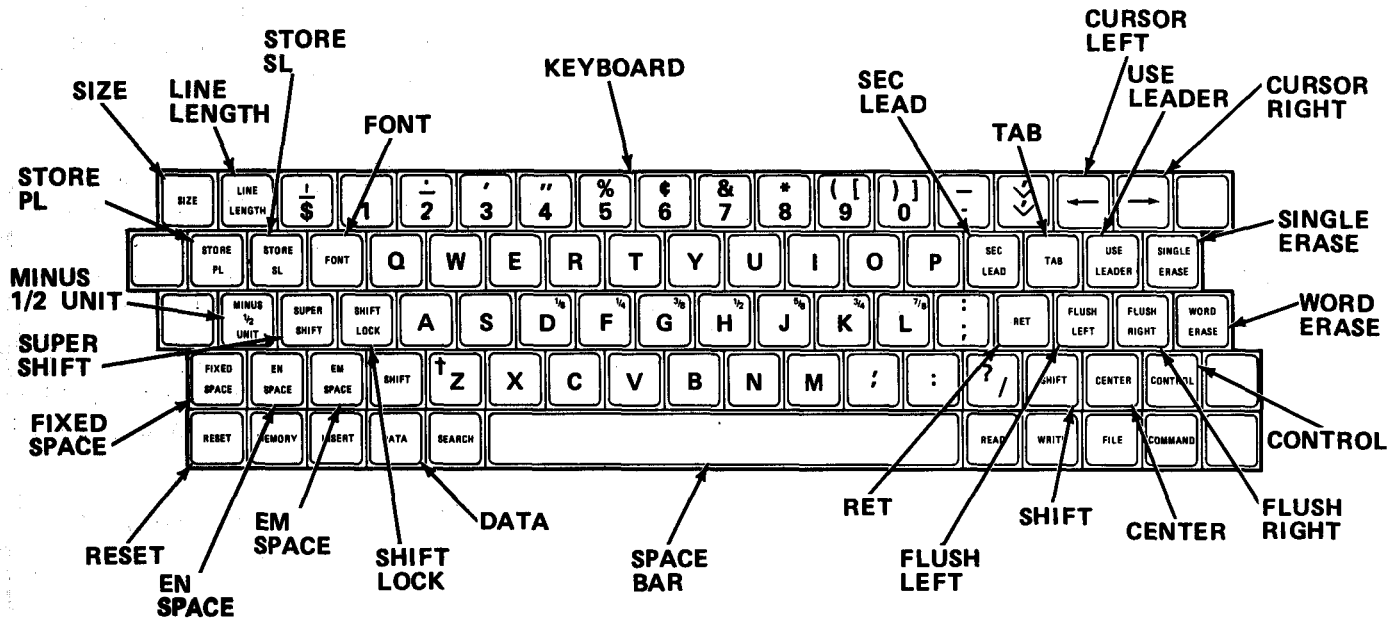

SEC LEAD (SL)

Additional leading function for use between paragraphs, after headings or any other time value is needed which is different from stored primary leading value.

TAB

Used in manual mode for columns. Column length is expressed in picas.

Cursor Left/Right

Used to control direction of cursor movement.

USE LEADER

Prints dots, dashes or ruled lines between copy when depressed.

SINGLE ERASE

When depressed, erases last keyboarded character on line.

WORD ERASE

Erases last keyboarded word.

Control or Indicator	Function
CONTROL	Used in conjunction with other dedicated and non-dedicated keys to store and access functions.
CENTER	Centers copy between left and right margins.
FLUSH RIGHT	Positions copy to right of line measure.
SHIFT	Upper case command tells typesetter all characters that follow are to be upper case.
FLUSH LEFT	Positions copy to left of line measure.
RET	When depressed, typesetter advances paper amount stored as primary leading value.
Space Bar	Moves typesetter to right.
DATA	Used to store and recall programmable data segments. Up to 99 data storage segments available. Used with CONTROL key.
SHIFT LOCK	Locks SHIFT key to upper case.
EM SPACE (Mutt)	Width: 18 units. Widest standard fixed space used for indents, such as beginning of paragraph.
EN SPACE (Nutt)	Width: 9 units. Used in combination with EM SPACE for varied indents. Can be used to create larger word space.

Control or Indicator	Function
RESET	Reloads program. Used to begin operation of system and also to clear system of stored memory.
FIXED SPACE	Access fixed space value in units, maximum 999.
SUPER SHIFT	Used for small caps, special characters, symbols or superior numbers. When depressed, SS appears on CRT. To release, press SUPER SHIFT.
MINUS 1/2 UNIT	Removes 1/2 unit back space between any two characters. Generally employed when using larger point sizes.
STORE PL (Store Primary Leading)	Used to control amount of space between lines.
SIZE	Expressed in points. Measurement of size of letter.
LINE LENGTH	Distance between left and right margins expresses in picas and points.
STORE SL (Store Secondary Leading)	Leading function which can be used between paragraphs, after headings or any other time value is needed which is different from stored primary leading value.
FONT	Contains complete alphabet, A-Z, in upper and lower case, numbers, punctuation and symbols. Each disc contains four fonts: FONT 1: Generally lighter medium-faced characters.

Control or Indicator	Function
FONT - Cont	<p>FONT 2: Italic characters of same type style.</p> <p>FONT 3: Boldface characters.</p> <p>FONT 4: Varies. Has matching or contrasting type style.</p>
Keyboard	Contains complete alphabet, numbers, punctuation and symbols.

2.5 OPERATOR PREVENTIVE **MAINTENANCE** CHECKS AND SERVICES.

Before You Operate. Always keep in mind the WARNINGS and CAUTIONS. Perform you; before (B) PMCS.

b. While You Operate. Always keep in mind the WARNINGS and CAUTIONS. Perform your during (D) PMCS.

c. After You Operate. Be sure to perform your after (A) PMCS.

d. **If Your Equipment Fails to Operate.** Troubleshoot with proper equipment. Report any deficiencies using the proper forms. See DA Pam 738-750.

2-5.1 PMCS Procedures.

a. PMCS are designed to keep the equipment in good working condition by performing periodic service tasks.

b. Service intervals provide you, the operator, with time schedules that determine when to perform specified service tasks.

c. The "Equipment is Not Ready/Available If" column is used for identification of conditions that make the equipment not ready/available for readiness reporting purposes or denies use of the equipment until corrective maintenance is performed.

d. If your equipment fails to operate after PMCS is performed, immediately report this condition to your supervisor.

Perform weekly as well as before operation if you are the assigned operator and have not operated the item since the last weekly or if you are operating the item for the first time.

TM 5-6675-316-14

f. Item number column. Item numbers are assigned in chronological ascending sequence regardless of interval designation. These numbers are used for your "TM Number" Column on DA Form 2404, Equipment Inspection and Maintenance Worksheet in recording results of PMCS.

Interval columns. This column determines the time period designated to perform your PMCS.

h. Item to be inspected and procedures column. This column lists functional groups and their respective assemblies and subassemblies as shown in the Maintenance Allocation Chart (Appendix B). The appropriate check or service procedure follows the specific item to be inspected.

i. Equipment is not ready/available if: column. This column indicates the reason or cause why your equipment is not ready/available to perform its primary mission.

j. List of tools and materials required for PMCS is as follows:

<u>Item</u>	<u>Quantity</u>
Vacuum Cleaner	1 ea
Cheesecloth (Item 6, Appendix E)	ar
Camel Hair Lens Brush	1 ea
Pail	1 ea
Liquid Detergent (Item 9, Appendix E)	ar
Naphtha (Item 14, Appendix E)	ar
Cotton Pads (Item 7, Appendix E)	ar

Table 2-1. OPERATOR PREVENTIVE MAINTENANCE CHECKS AND SERVICES

NOTE

If the equipment must be kept in continuous operation, check and service only those items that can safely be checked and serviced without disturbing operation. Make the complete checks and services when the equipment can be shut down.

B - Before
D - During
A - After

W - Weekly
M - Monthly
Q - Quarterly

AN - Annually
S - Semiannually
Bi - Biennially

(Number) - Hundreds of Hours

ITEM NO.	INTERVAL	ITEM TO BE INSPECTED PROCEDURE	For Readiness Reporting, Equipment Is Not Ready/ Available If:
1	B	<p>COMPOSING MACHINE</p> <p><u>Inspect Composing Machine.</u></p>  <p>1. Be sure copy aid is on composing machine.</p>	

Table 2-1. OPERATOR PREVENTIVE MAINTENANCE CHECKS AND SERVICES - Cont

B - Before
D - During
A - After

W - Weekly
M - Monthly
Q - Quarterly

AN - Annually
S - Semiannually
BI - Biennially

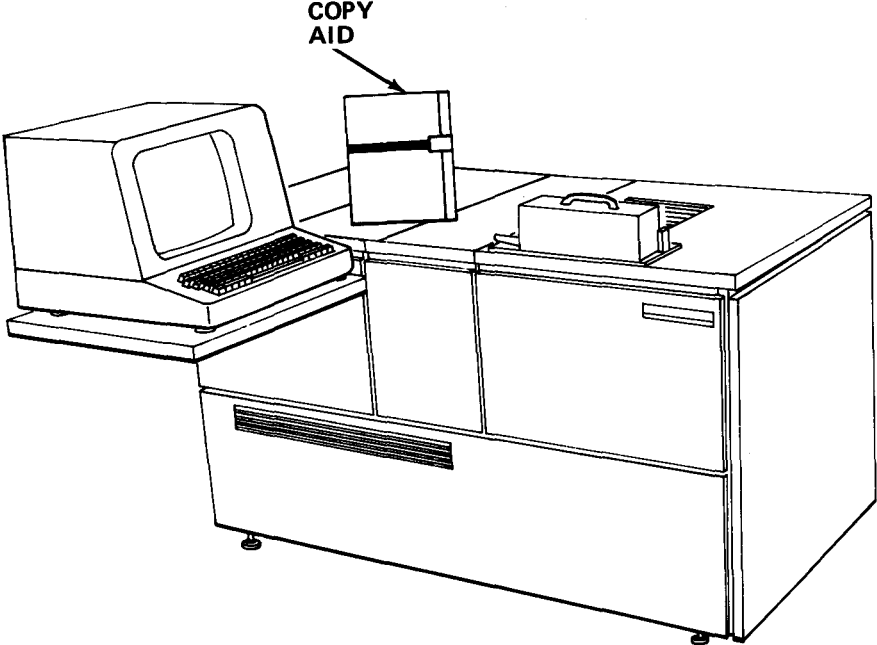
(Number) - Hundreds of Hours

ITEM NO.	INTERVAL	ITEM TO BE INSPECTED PROCEDURE	For Readiness Reporting, Equipment Is Not Ready/ Available If:
1	B	<p><u>COMPOSING MACHINE - Cont</u></p> <p><u>Inspect Composing Machine - Cont</u></p>  <p style="text-align: center;">CONSTANT VOLTAGE TRANSFORMER</p> <ol style="list-style-type: none"> 2. Trace power cord to constant voltage transformer. 3. Check that connections to constant voltage transformer are tight. 4. Inspect power cord for cuts, worn spots and frayed insulation.  <ol style="list-style-type: none"> 5. Check that input/monitor unit cable is connected to typesetter jack. 	<p>Power cord is defective.</p> <p>Input monitor unit cable is disconnected.</p>

Table 2-1. OPERATOR PREVENTIVE MAINTENANCE CHECKS AND SERVICES - Cont

B - Before W - Weekly AN - Annually (Number) - Hundreds of Hours
 D - During M - Monthly S - Semiannually
 A - After Q - Quarterly BI - Biennially

ITEM NO.	INTERVAL	ITEM TO BE INSPECTED PROCEDURE	For Readiness Reporting, Equipment Is Not Ready/ Available If:
2	B	<p><u>COMPOSING MACHINE - Cont</u></p> <p><u>Clean Font Film Guides.</u></p>  <p>1. Remove top left panel.</p>	

Table 2-1. OPERATOR PREVENTIVE MAINTENANCE CHECKS AND SERVICES - Cont

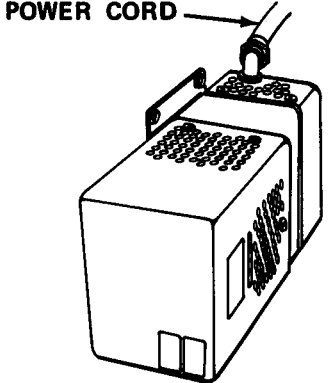
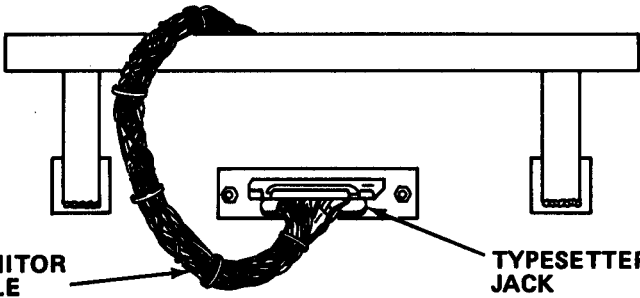
B - Before
D - During
A - After

W - Weekly
M - Monthly
Q - Quarterly

AN - Annually
S - Semiannually
BI - Biennially

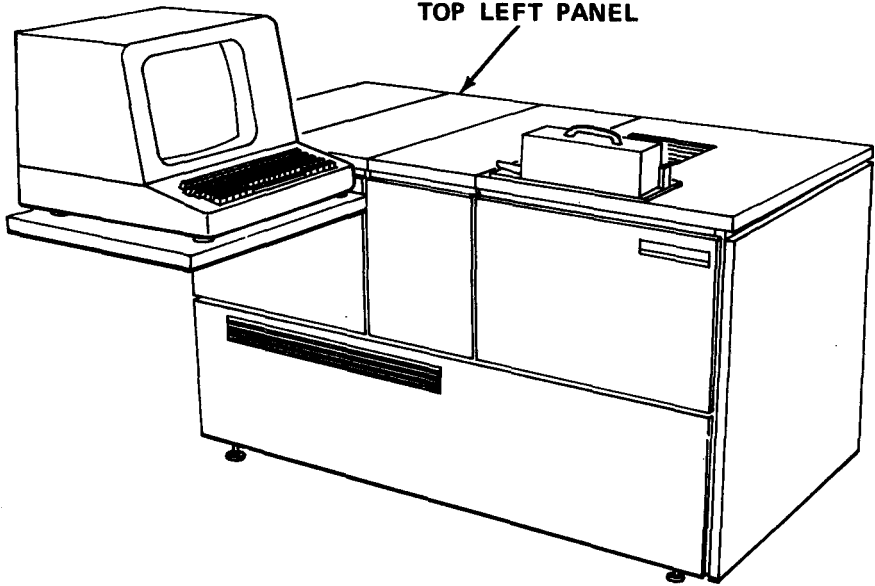
(Number) - Hundreds of Hours

ITEM NO.	INTERVAL	ITE- For Readiness Reporting. Equipment Is Not Ready/ Available If:	INSPECTED	PROCEDURE
2	B	<u>CLOSING MACHINE - Cont</u>		<u>Clean Font Film Guides - Cont</u>
 <p>The diagram shows a top-down view of a typewriter. A line points from the label 'POWER SWITCH' to a switch on the left side of the machine's frame. Another line points from the label 'FONT FILM GUIDES' to a circular inset that shows a magnified view of the internal mechanism where the font film guides are located.</p>				
<ol style="list-style-type: none"> 2. Check that power switch is off. 3. Check that there is no disc installed. 4. Use vacuum cleaner to remove dust and lint from font film guides. 5. Replace top left panel. 				
				Font film guides remain dirty.

Table 2-1. OPERATOR PREVENTIVE MAINTENANCE CHECKS AND SERVICES - Cont

B - Before
 D - During
 A - After

W - Weekly
 M - Monthly
 Q - Quarterly

AN - Annually
 S - Semiannu
 BI - Biennially

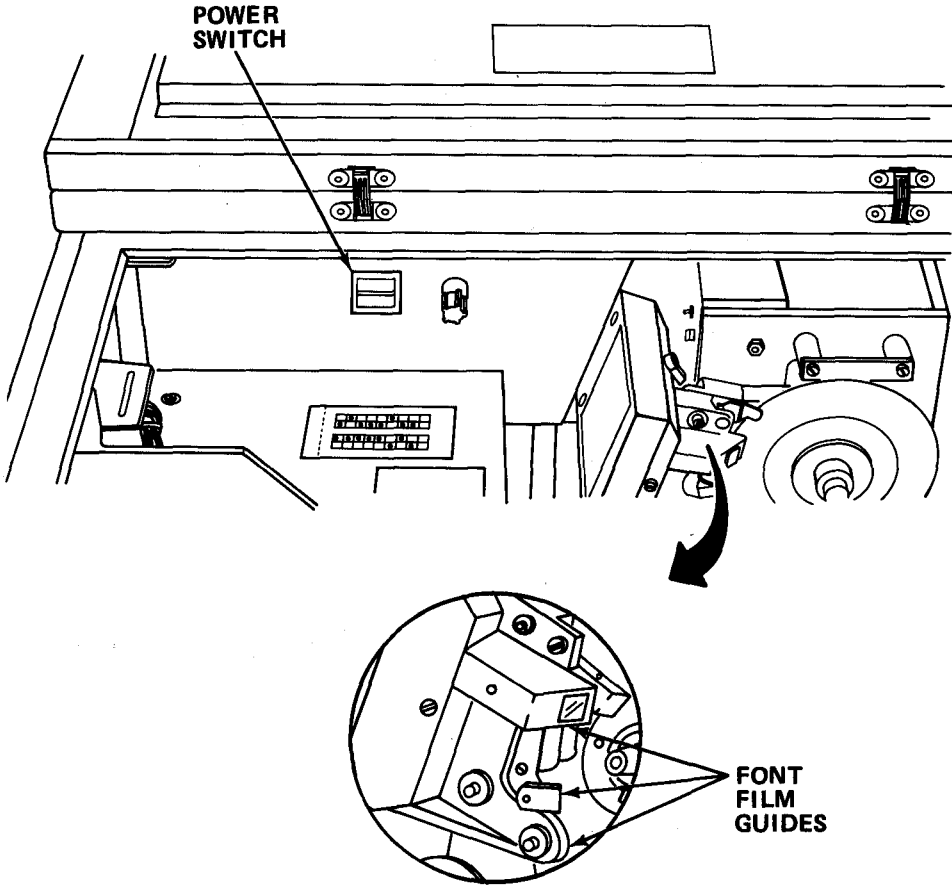
ITEM NO.	INTERVAL	ITEM TO BE INSPECTED PROCEDURE
3	W	<p><u>COMPOSING MACHINE - Cont</u></p> <p><u>Clean Composing Machine.</u></p>  <p>1. Remove copy aid.</p> <p>2. Use cheesecloth moistened with detergent and water to wipe top left panel and side panels.</p> <p>3. Use dry cheesecloth to dry top left panel and side panels.</p> <p>4. Grasp take-up cassette and pull gently upward to remove.</p> <p>5. Use camel hair brush to remove loose dust and dirt around paper take-up area.</p>

Table 2-1. OPERATOR PREVENTIVE MAINTENANCE CHECKS AND SERVICES - Cont

B - Before
D - During
A - After

W - Weekly
M - Monthly
Q - Quarterly

AN - Annually
S - Semiannually
BI - Biennially

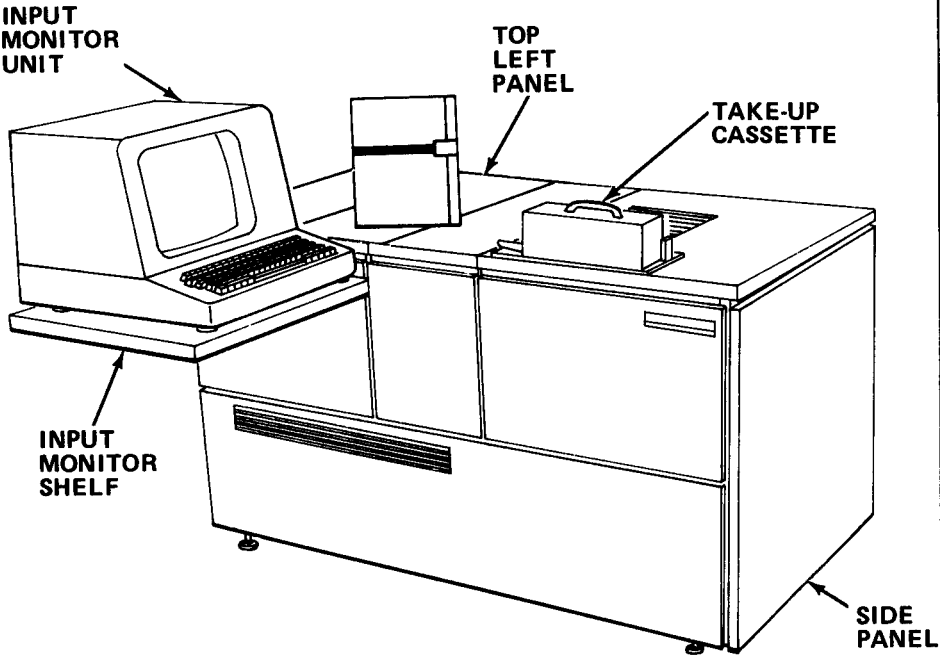
(Number) - Hundreds of Hours

ITEM NO.	INTER-VAL	ITEM TO BE INSPECTED PROCEDURE	For Readiness Reporting, Equipment Is Not Ready/ Available If:
3	W	<p><u>COMPOSING MACHINE - Cont</u></p> <p><u>Clean Composing Machine - Cont</u></p> <ol style="list-style-type: none"> 6. Use vacuum cleaner to remove any dust and dirt in take-up cassette area. 7. Replace take-up cassette. 8. Grasp input/monitor unit and place on top left panel. 9. Use cheesecloth moistened with water and detergent to clean input/monitor unit shelf. 10. Dry input/monitor unit shelf with dry cheesecloth. <div data-bbox="462 1106 1153 1500" style="text-align: center;"> <p>The diagram shows a rectangular input/monitor unit. It has a CRT display on the front face. Below the display is a keyboard. A cable is connected to the bottom left of the unit. Labels with arrows point to the 'INPUT MONITOR UNIT' (the top part), 'CRT DISPLAY' (the screen), and 'KEYBOARD' (the bottom part).</p> </div> <ol style="list-style-type: none"> 11. Use cheesecloth moistened with detergent and water to wipe exterior of input/monitor unit. 	

Table 2-1. OPERATOR PREVENTIVE MAINTENANCE CHECKS AND SERVICES - Cent

B - Before
D - During
A - After

W - Weekly
M - Monthly
Q - Quarterly

AN - Annually
S - Semiannually
BI - Biennially

(Number) - Hundreds of Hours

ITEM NO.	INTERVAL	ITEM TO BE INSPECTED PROCEDURE	For Readiness Reporting, Equipment Is Not Ready/ Available If:
3	W	<p><u>COMPOSING MACHINE - Cont</u></p> <p><u>Clean Composing Machine - Cont</u></p> <p>12. Dry exterior of input/monitor unit with dry cheesecloth.</p> <p>13. Use camel hair brush to clean CRT display.</p> <p>14. Wipe CRT display with dry cheesecloth.</p> <p>15. Use camel hair brush to remove dust and dirt from keyboard.</p> <p>16. Use vacuum cleaner to remove dust and dirt from corners and between keys on keyboard.</p> <p>17. Place input/monitor unit on input/monitor unit shelf.</p> <p>18. Place copy aid on top left panel.</p> <p>19. Remove rear and side panels.</p> <p>20. Vacuum interior of composing machine.</p> <p>21. Use camel hair brush to get to hard-to-reach places.</p> <p>22. Replace rear and side panels.</p>	<p>Moisture remains inside the equipment. Input monitor unit is dropped.</p>

Table 2-1. OPERATOR PREVENTIVE MAINTENANCE CHECKS AND SERVICES - Cont

B - Before
D - During
A - After

W - Weekly
M - Monthly
Q - Quarterly

AN - Annually
S - Semiannually
BI - Biennially

(Number) - Hundreds of Hours

ITEM NO.	INTERVAL	ITEM TO BE INSPECTED PROCEDURE	For Readiness Reporting, Equipment Is Not Ready/ Available If:
4	M	<p><u>COMPOSING MACHINE - Cont</u></p> <p><u>Clean Font Disc.</u></p>  <p>1. Place all discs in convenient location.</p> 	

Table 2-1. OPERATOR PREVENTIVE MAINTENANCE CHECKS AND SERVICES - Cont

B - Before W - Weekly AN - Annually (Number) - Hundreds of Hours
 D - During M - Monthly S - Semiannually
 A - After Q - Quarterly BI - Biennially

ITEM NO.	INTERVAL	ITEM TO BE INSPECTED PROCEDURE	For Readiness Reporting, Equipment Is Not Ready/ Available If:
4	M	<p><u>COMPOSING MACHINE - Cont</u></p> <p><u>Clean Font Disc - Cont</u></p> <p style="text-align: center;"><u>CAUTION</u></p> <p>Handle disc with extreme care. Do not set disc on unclean or rough surface or surface covered with plastic. Damage to disc can occur. Use only naphtha for cleaning disc.</p> <ol style="list-style-type: none"> 2. Open cover. 3. Grasp knurled knob and remove disc from box. 4. Dampen cotton pad with naphtha. 5. Gently wipe surfaces of disc. 6. Gently place disc on smooth clean surface. 7. Use vacuum cleaner to clean interior of box. 8. Grasp knurled knob and lower disc in its box. Then latch box. 9. Store box in designated location. 10. Repeat steps (2) through (9) for remaining discs. 	<p>Font disc is scratched.</p>

Table 2-1. OPERATOR PREVENTIVE MAINTENANCE CHECKS AND SERVICES - Cont

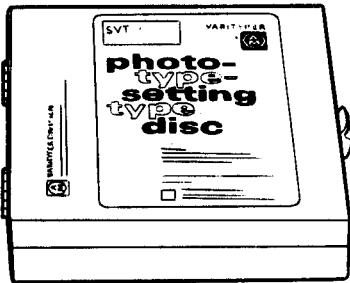
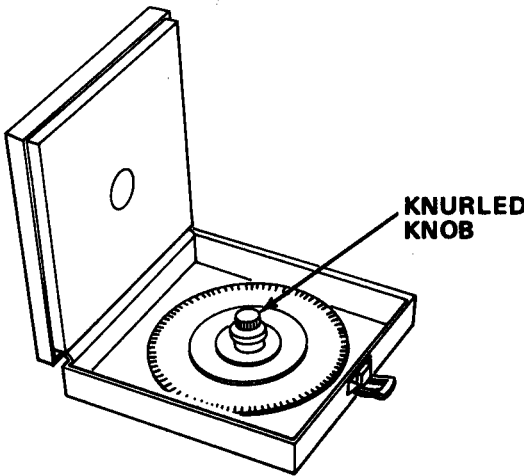
B - Before
D - During
A - After

W - Weekly
M - Monthly
Q - Quarterly

AN - Annually
S - Semiannually
BI - Biennially

(Number) - Hundreds of Hours

ITEM NO.	INTERVAL	ITEM TO BE INSPECTED PROCEDURE	For Readiness Reporting, Equipment Is Not Ready/ Available If:
5	M	<p><u>COMPOSING MACHINE - Cont</u></p> <p><u>Clean Paper Magazine.</u></p>  <ol style="list-style-type: none"> 1. Remove copy aid. 2. Remove top left panel. 3. Depress paper cutoff handle. 4. Grasp take-up cassette and pull upward gently. 5. Turn off all white lights. 6. Pull up on small lever at top right corner to open front panel. 	<p>Paper magazine is not light tight.</p>

Table 2-1. OPERATOR PREVENTIVE MAINTENANCE CHECKS AND SERVICES - Cont

B - Before
D - During
A - After

W - Weekly
M - Monthly
Q - Quarterly

AN - Annually
S - Semiannually
BI - Biennially

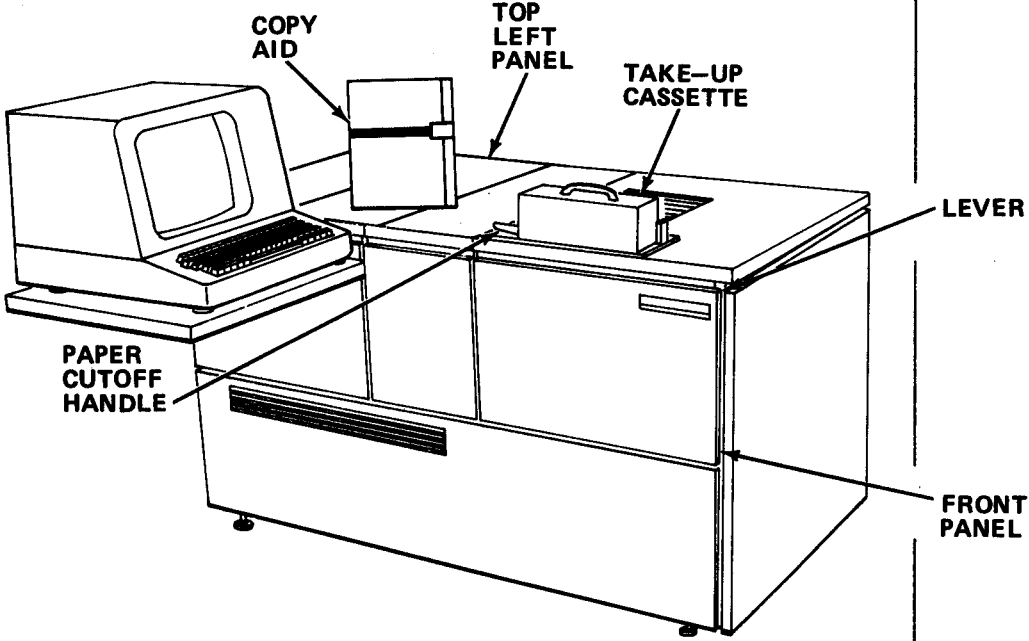
(Number) - Hundreds of Hours

ITEM NO.	INTERVAL	ITEM TO BE INSPECTED PROCEDURE	For Readiness Reporting, Equipment Is Not Ready/ Available If:
5	M	<p><u>COMPOSING MACHINE - Cont</u></p> <p><u>Clean Paper Magazine - Cont</u></p>  <p>7. Check that power switch is OFF.</p>	

Table 2-1. OPERATOR PREVENTIVE MAINTENANCE CHECKS AND SERVICES - Cont

B - Before
D - During
A - After

W - Weekly
M - Monthly
Q - Quarterly

AN - Annually
S - Semiannually
BI - Biennially

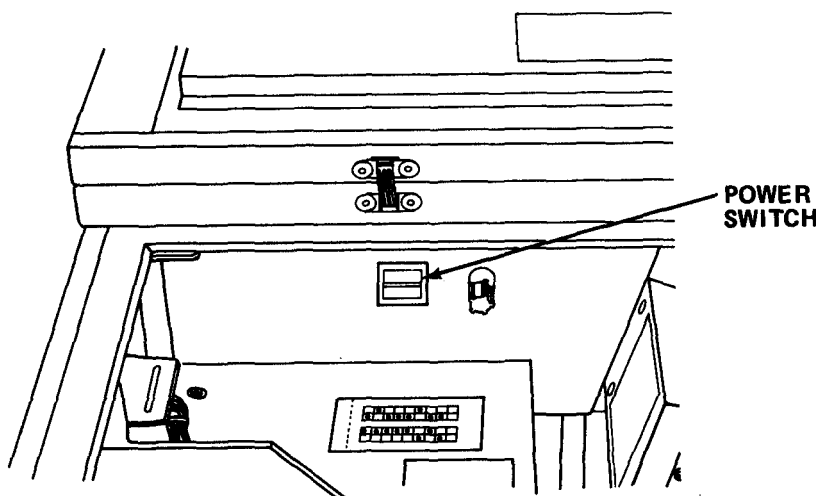
(Number) - Hundreds of Hours

ITEM NO.	INTERVAL	ITEM TO BE INSPECTED	PROCEDURE	For Readiness Reporting, Equipment Is Not Ready/ Available If:
COMPOSING MACHINE - Cont				
5	M	<u>Clean Paper Magazine - Cont</u>		
			<ol style="list-style-type: none"> 8. Raise cassette so that knobs on each end of box clear slots. 9. Turn knob left until photographic material is clear of composing machine. 10. Place photographic material in dark metal storage cabinet with cassette facing away from light. 11. Turn on normal lights. 	

Table 2-1. OPERATOR PREVENTIVE MAINTENANCE CHECKS AND SERVICES - Cont

B - Before
D - During
A - After

W - Weekly
M - Monthly
Q - Quarterly

AN - Annually
S - Semiannually
BI - Biennially

(Number) - Hundreds of Hours

ITEM NO.	IN-TER-VAL	ITEM TO BE INSPECTED PROCEDURE	For Readiness Reporting, Equipment Is Not Ready/ Available If:
5	M	<p><u>COMPOSING MACHINE - Cont</u></p> <p><u>Clean Paper Magazine - Cont</u></p>  <p>12. Depress two latches.</p> <p>13. Raise gate.</p>	

Table 2-1. OPERATOR PREVENTIVE MAINTENANCE CHECKS AND SERVICES - Cont

B - Before
D - During
A - After

W - Weekly
M - Monthly
Q - Quarterly

AN - Annually
S - Semiannually
BI - Biennially

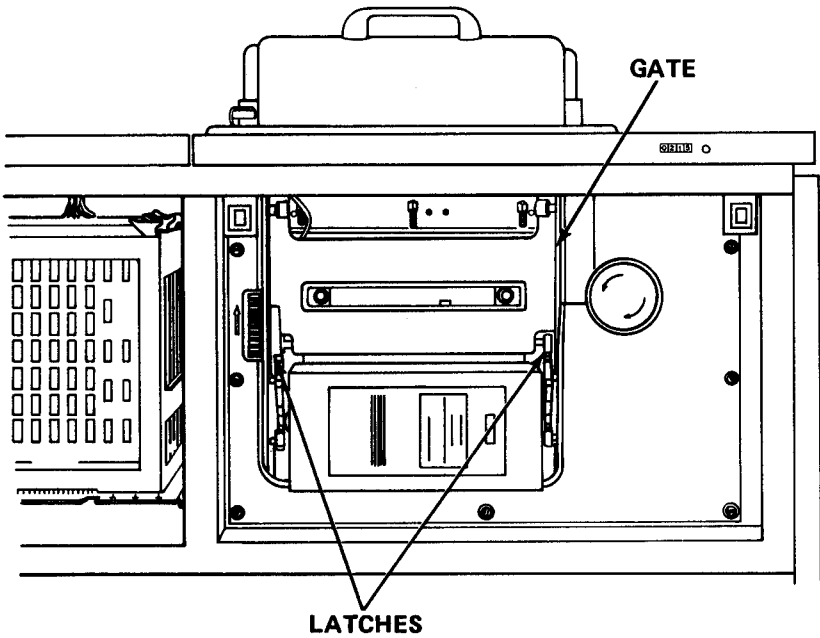
(Number) - Hundreds of Hours

ITEM NO.	INTERVAL	ITEM TO BE INSPECTED PROCEDURE	For Readiness Reporting, Equipment Is Not Ready/ Available If:
5	M	<p><u>COMPOSING MACHINE - Cont</u></p> <p><u>Clean Paper Magazine - Cont</u></p>  <p>14. Use camel hair brush to remove lint and dust from interior of magazine.</p> <p>15. Use vacuum cleaner to remove any remaining dust and lint.</p> <p>16. Lower gate until it is locked securely on two latches.</p> <p>17. Remove used photographic material from metal storage locker.</p>	

Table 2-1. OPERATOR PREVENTIVE MAINTENANCE CHECKS AND SERVICES - Cont

B - Before
D - During
A - After

W - Weekly
M - Monthly
Q - Quarterly

AN - Annually
S - Semiannually
BI - Biennially

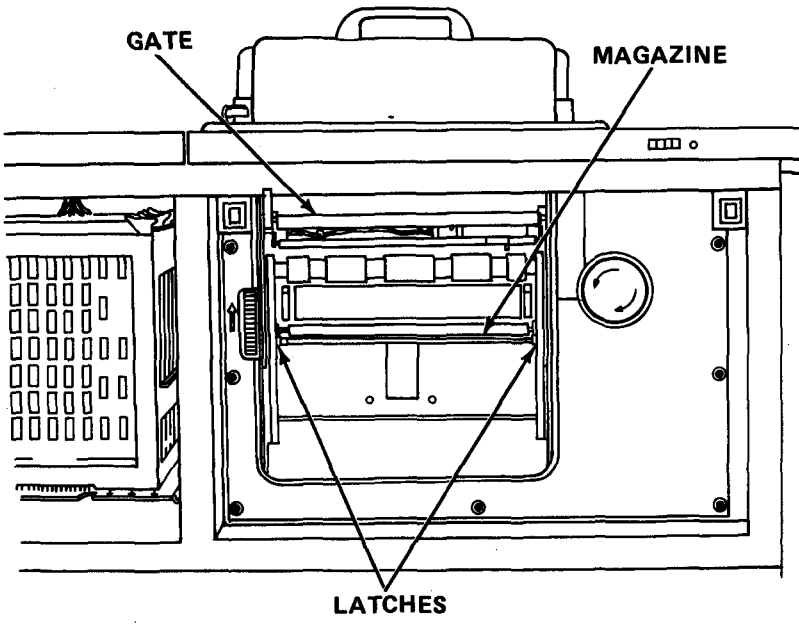
(Number) - Hundreds of Hours

ITEM NO.	INTERVAL	ITEM TO BE INSPECTED PROCEDURE	For Readiness Reporting, Equipment Is Not Ready/ Available If:
5	M	<p><u>COMPOSING MACHINE - Cont</u></p> <p><u>Clean Paper Magazine - Cont</u></p>  <p>18. Insert edge of paper or film behind first roller behind box.</p> <p>19. Be sure knobs on cassette fit into slots.</p> <p>20. Push cover down.</p> <p>21. Roll thumb dial 5 to 6 times.</p> <p>22. Pull up on locking latch.</p> <p>23. Turn paper feed knob right. If thumb dial starts to turn, paper/film is loaded correctly.</p>	

Table 2-1. OPERATOR PREVENTIVE MAINTENANCE CHECKS AND SERVICES - Cont

B - Before
D - During
A - After

W - Weekly
M - Monthly
Q - Quarterly

AN - Annually
S - Semiannually
BI - Biennially

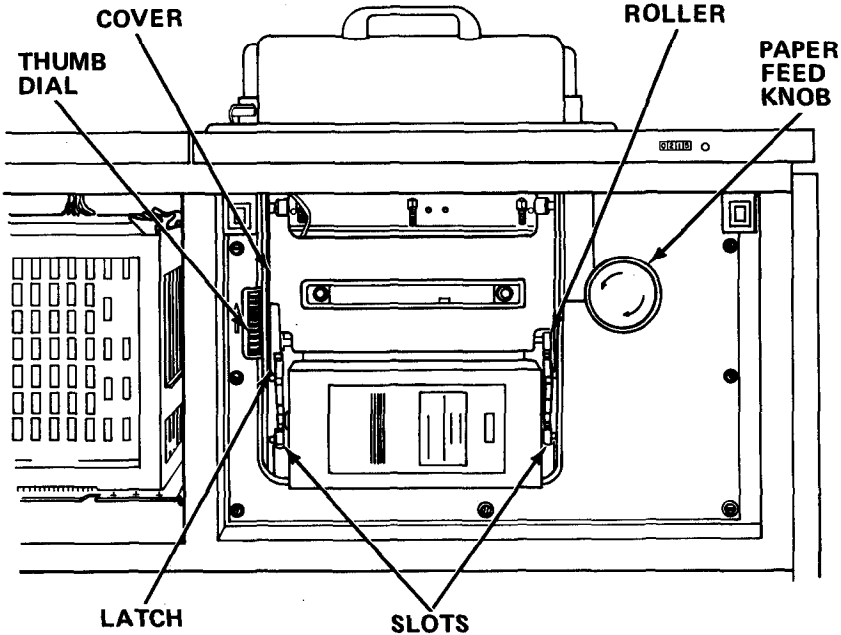
(Number) - Hundreds of Hours

ITEM NO.	INTERVAL	ITEM TO BE INSPECTED PROCEDURE	For Readiness Reporting, Equipment Is Not Ready/ Available If:
5	M	<p><u>COMPOSING MACHINE - Cont</u></p> <p><u>Clean Paper Magazine - Cont</u></p>  <p>24. Turn power switch to ON. Close side panel.</p>	

Table 2-1. OPERATOR PREVENTIVE MAINTENANCE CHECKS AND SERVICES - Cont

B - Before
D - During
A - After

W - Weekly
M - Monthly
Q - Quarterly

AN - Annually
S - Semiannually
BI - Biennially

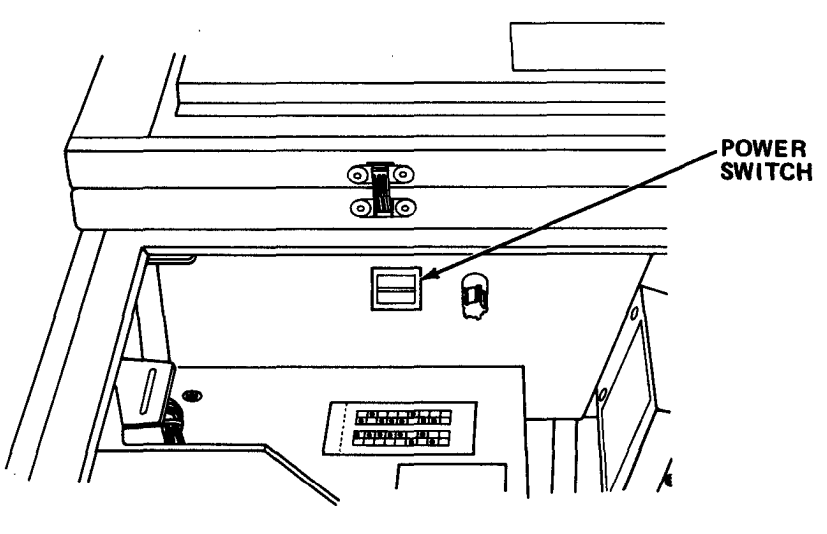
(Number) - Hundreds of Hours

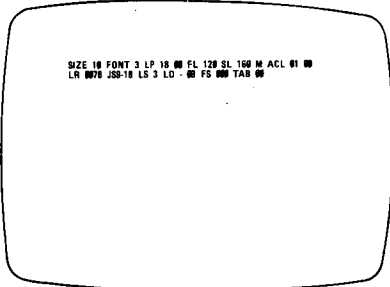
ITEM NO.	INTERVAL	ITEM TO BE INSPECTED PROCEDURE	For Readiness Reporting, Equipment Is Not Ready/ Available If:
5	M	<p><u>COMPOSING MACHINE - Cont</u></p> <p><u>Clean Paper Magazine - Cont</u></p> 	

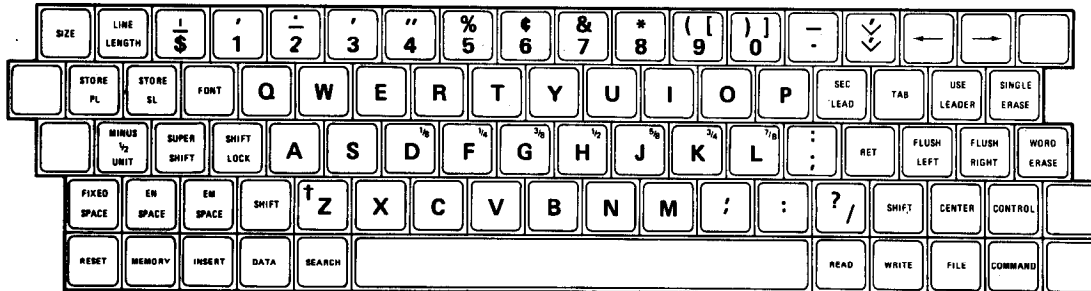

25. Press RESET and DATA, and fill in function fields.
26. Press CONTROL and e.

Table 2-1. OPERATOR PREVENTIVE MAINTENANCE CHECKS AND SERVICES - Cont

B - Before
D - During
A - After

W - Weekly
M - Monthly
Q - Quarterly

AN - Annually
S - Semiannually
BI - Biennially

(Number) - Hundreds of Hours

ITEM NO.	INTERVAL	ITEM TO BE INSPECTED PROCEDURE	For Readiness Reporting, Equipment Is Not Ready/ Available If:
5	M	<p><u>COMPOSING MACHINE - Cont</u></p> <p><u>Clean Paper Magazine - Cont</u></p>  <p style="text-align: center;">CAUTION</p> <p>Press paper cutoff handle only once to prevent paper/film jam.</p> <ol style="list-style-type: none"> 27. Press paper cutoff handle and discard exposed paper. 28. Replace take-up cassette. 29. Place power switch to OFF. 30. Replace top left panel and copy aid. 	

Table 2-1. OPERATOR PREVENTIVE MAINTENANCE CHECKS AND SERVICES - Cont

B - Before
D - During
A - After

W - Weekly
M - Monthly
Q - Quarterly

AN - Annually
S - Semiannually
BI - Biennially

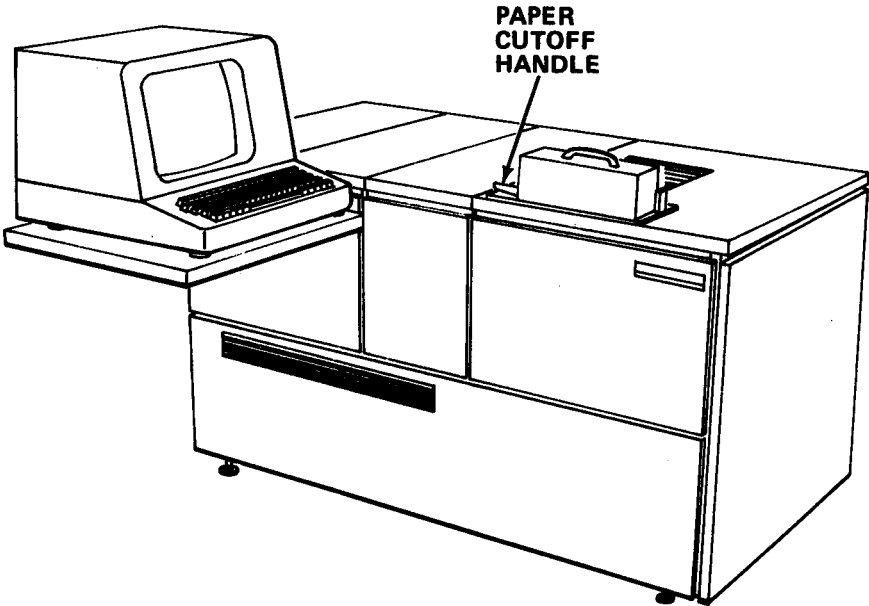
(Number) - Hundreds of Hours

ITEM NO.	INTERVAL	ITEM TO BE INSPECTED PROCEDURE	For Readiness Reporting, Equipment Is Not Ready/ Available If:
6	M	<p><u>COMPOSING MACHINE - Cont</u></p> <p><u>Clean Cassette Assembly.</u></p> <ol style="list-style-type: none"> 1. Remove take-up cassettes from storage containers. 2. Place take-up cassettes in convenient location. <div data-bbox="574 783 954 1072" data-label="Image"> </div> <p style="text-align: center;">NOTE</p> <p>Be sure all take-up cassettes are empty. Do not remove take-up cassette from composing machine.</p> <ol style="list-style-type: none"> 3. Release two latches on take-up cassette and separate cover from base. 	

Table 2-1. OPERATOR PREVENTIVE MAINTENANCE CHECKS AND SERVICES - Cont

B - Before
D - During
A - After

W - Weekly
M - Monthly
Q - Quarterly

AN - Annually
S - Semiannually
BI - Biennially

(Number) - Hundreds of Hours

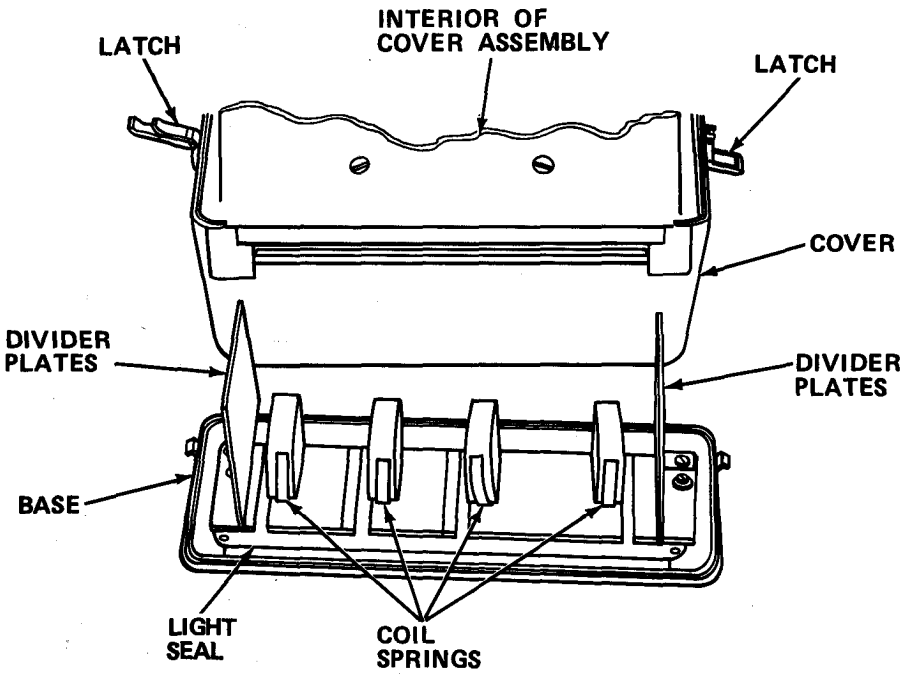
ITEM NO.	INTERVAL	ITEM TO BE INSPECTED PROCEDURE	For Readiness Reporting, Equipment Is Not Ready/ Available If:
6	M	<p><u>COMPOSING MACHINE - Cont</u></p> <p><u>Clean Cassette Assembly - Cont</u></p>  <p>4. Use cheesecloth to wipe coil springs, divider plates, light seal and interior of cover assembly.</p> <p>5. Attach cover to base.</p> <p>6. Secure two latches.</p> <p>7. Wipe exterior of take-up cassette with cheesecloth moistened with water.</p> <p>8. Repeat steps 3. through 7. with remaining take-up cassettes.</p> <p>9. Store take-up cassettes.</p>	

2-6. OPERATION UNDER USUAL CONDITIONS.

2-6.1 Assembly and Preparation For Use.

- a. Install Disc.

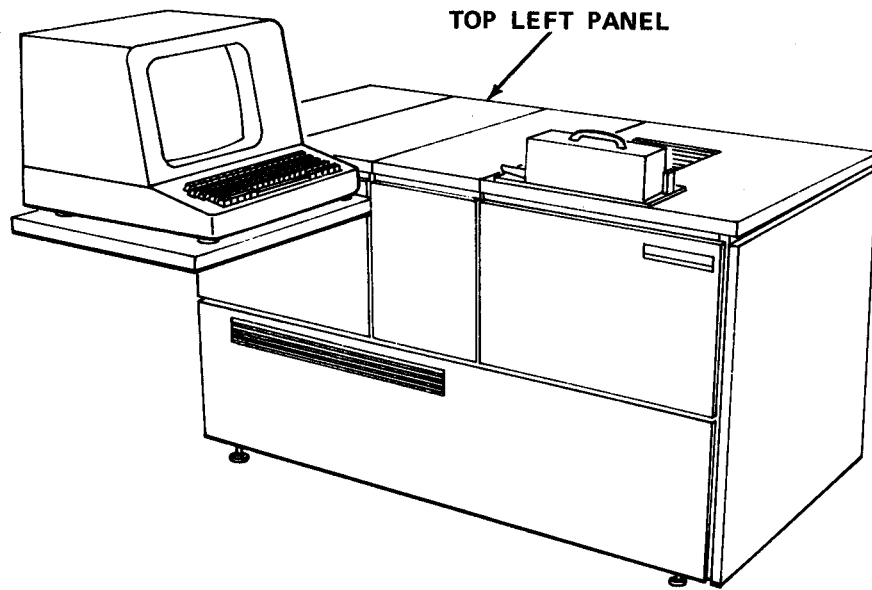

- (1) Raise top left panel on typesetter.

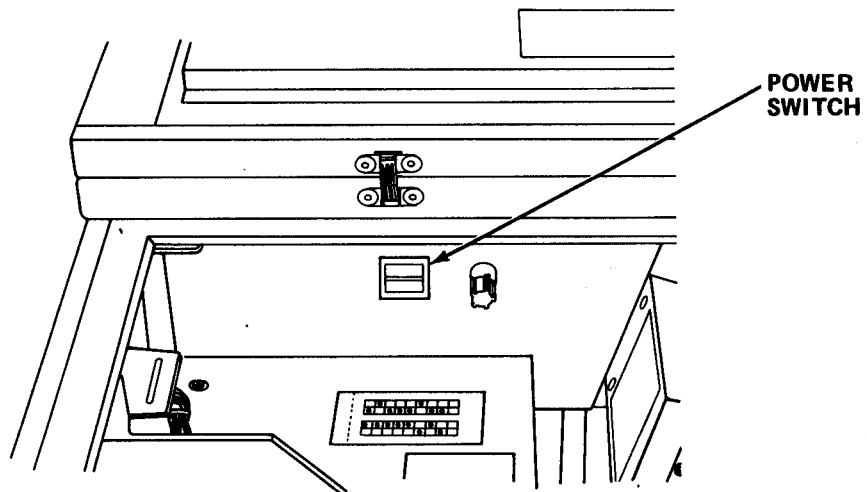

- (2) Be sure power switch is OFF.

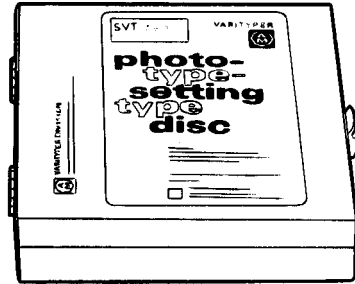

- (3) Select proper disc for job.
- (4) Open disc box.

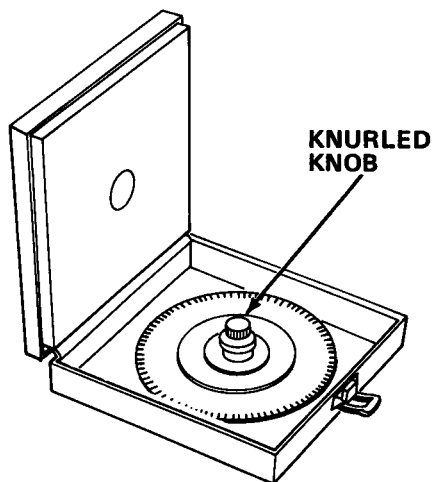

CAUTION

Do not touch disc. Do not lay disc on any surface. Damage to disc could result.

- (5) Grasp knurled knob and remove disc from box.

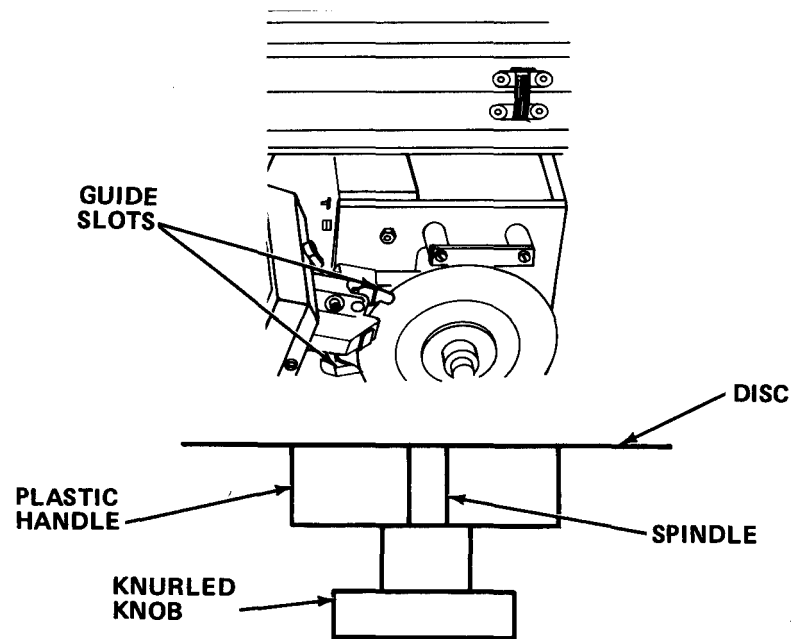

- (6) Insert disc into guide slots and engage disc spindle.
- (7) Hold plastic handle and tighten knurled knob to disc spindle.
- (8) Spin disc to assure it spins freely.
- (9) Inspect visually to be sure disc is between guides.

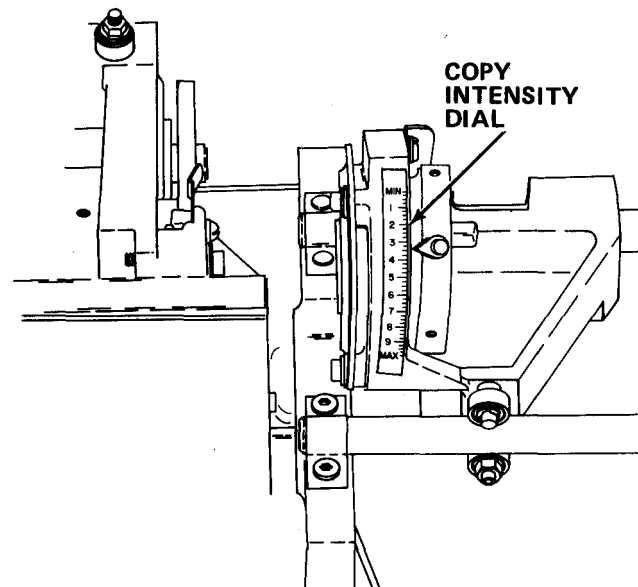

NOTE

If this is first time the system has been used, set copy intensity dial to 2. Select a higher number to darken.

- b. Set copy intensity dial to desired setting.

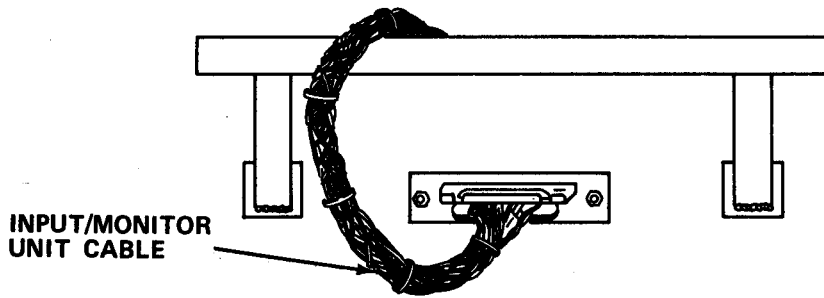

Check that input/monitor unit cable is connected to connector beneath input/monitor unit shelf.

- d. Selection and installation of film cassette.

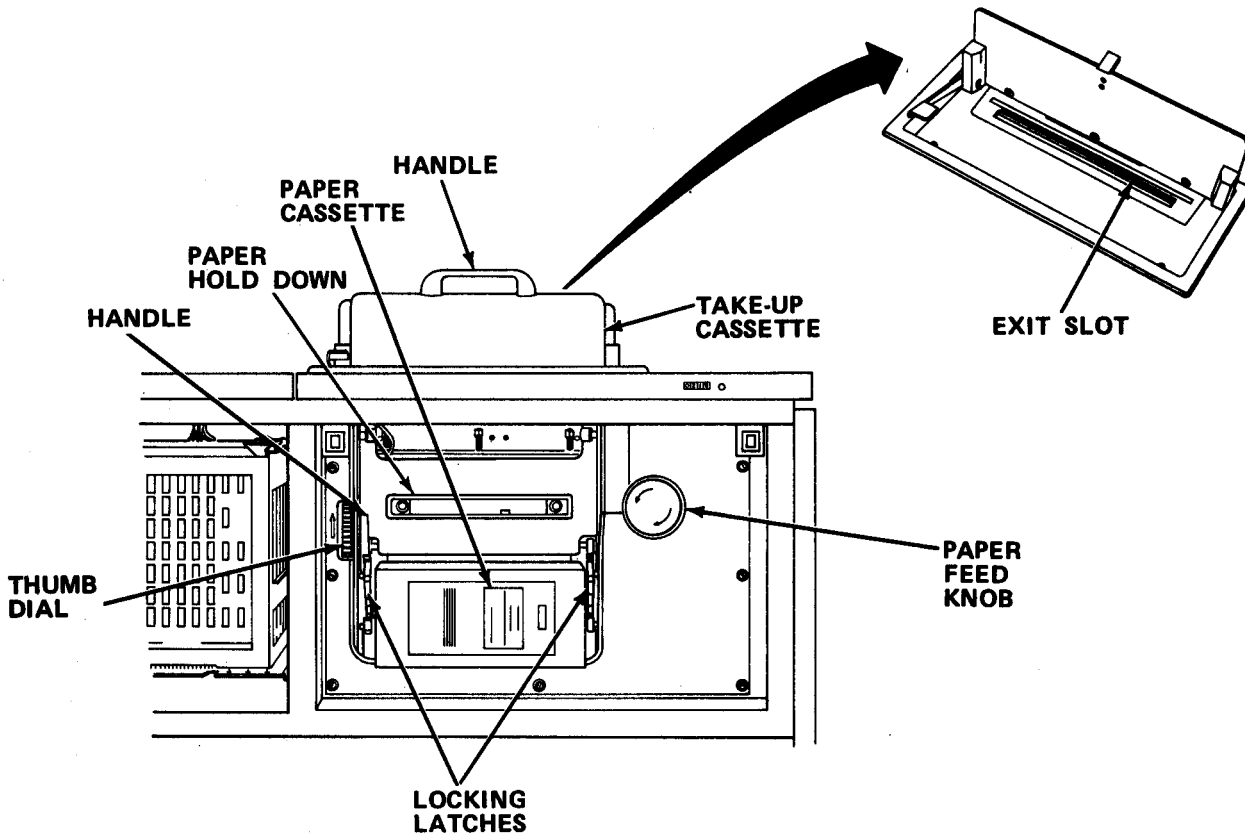

(1) Select desired cassette and pull 1.25 to 1.75 in. (3.18 to 4.45 cm) of paper from cassette.

(2) Cut edges to all low for easy feeding into rollers.

- (3) Open front cover.
- (4) Move handle down.
- (5) Depress locking latch, raise paper holddown and hold in position.
- (6) Install film cassette and close paper holddown.
- (7) Turn up thumb dial 5 to 6 times.
- (8) Move locking latch up.
- (9) Turn paper feed knob left until paper is visible through exit slot located in cover shroud.
- (10) Close front panel door.

NOTE

Be sure that flat side of cassette faces rear.

- (11) Install take-up cassette in space provided.

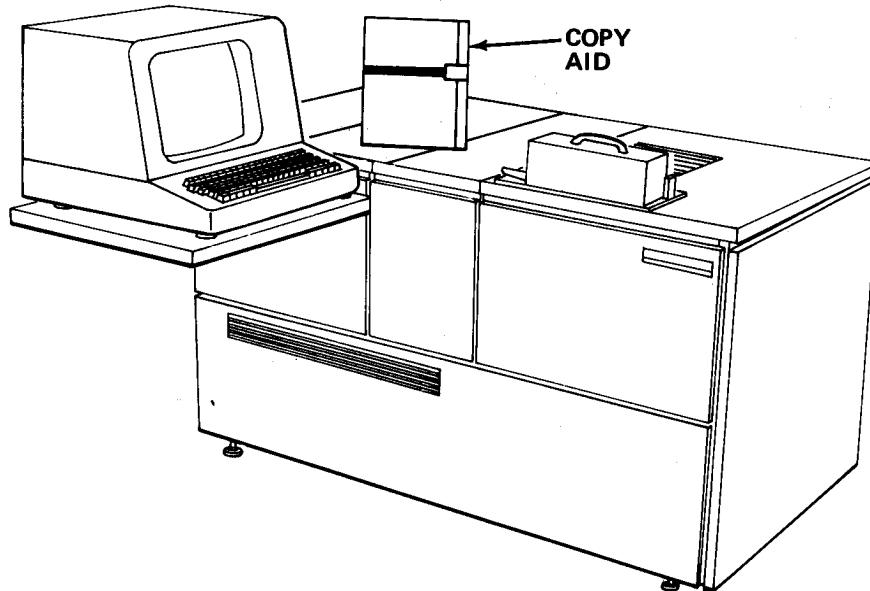

- e. Place copy aid in position so that original can be read.

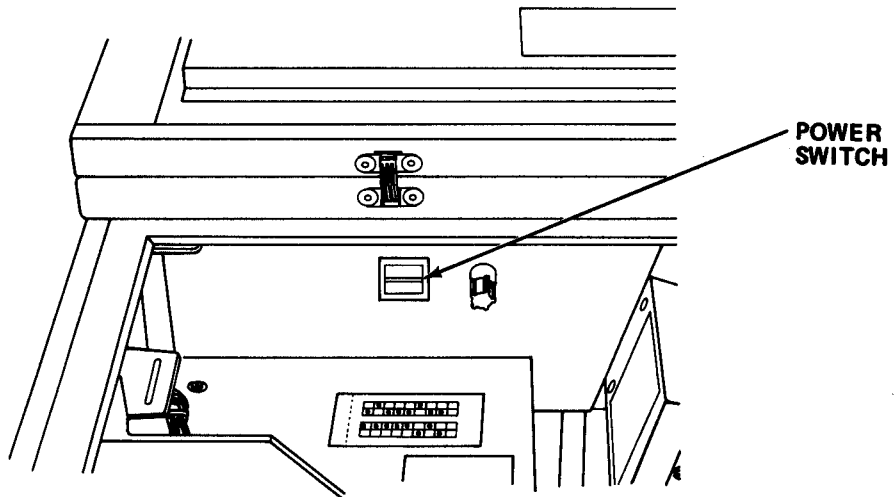

f. Turn on power switch.

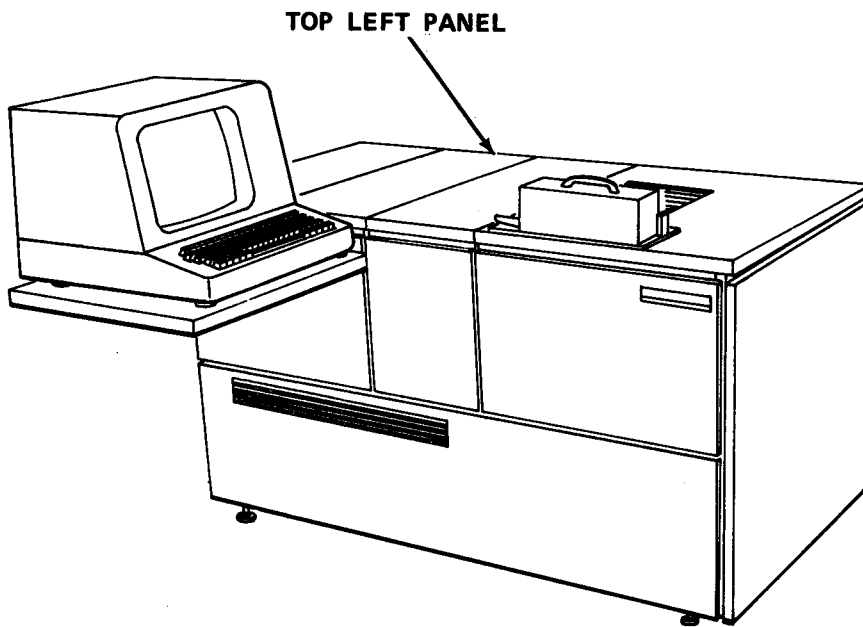

g. Close top left panel.

2-6.2 Operating Procedures.

a. Preliminary procedures.

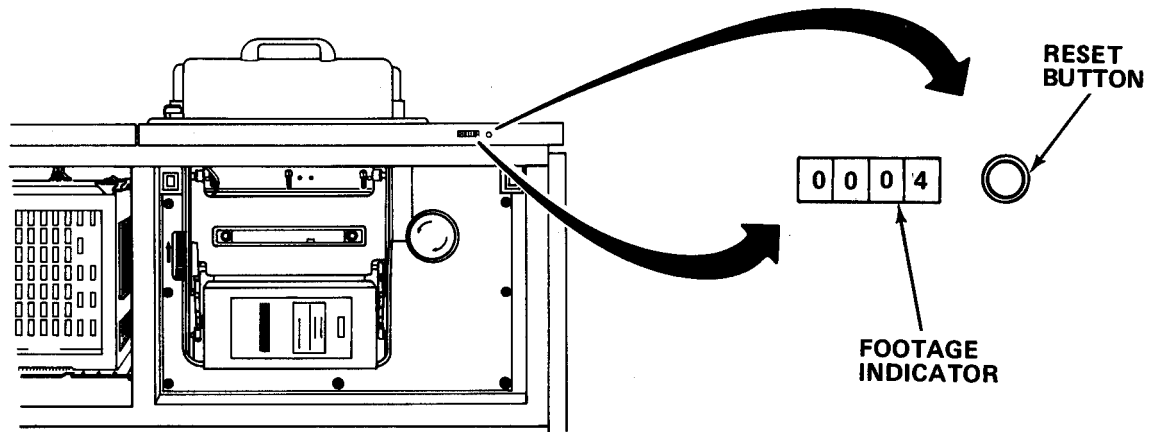

0. (1) Press recessed footage counter button with pencil tip to reset counter to

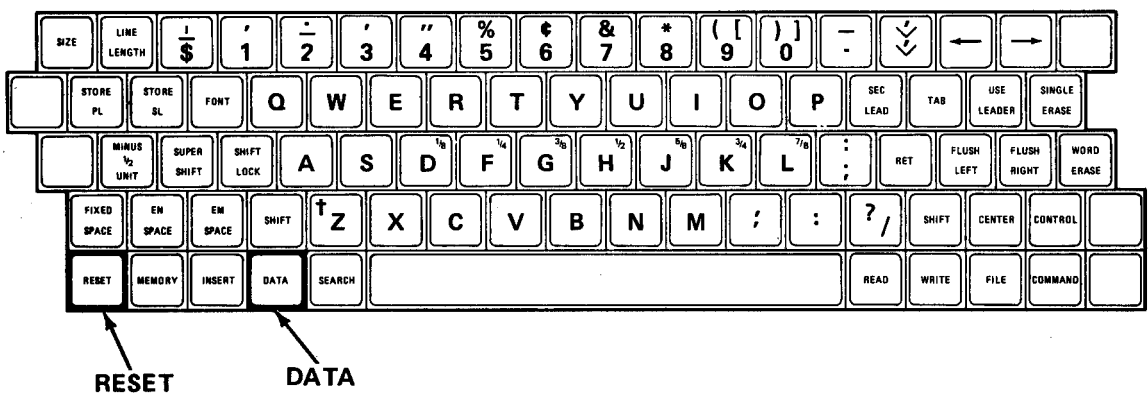

(2) Press RESET and DATA.

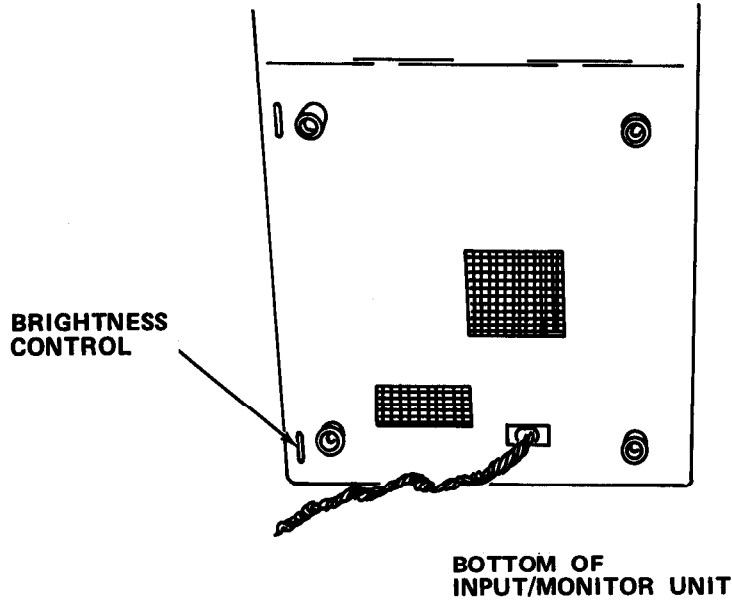

(3) Adjust brightness control for desired image.

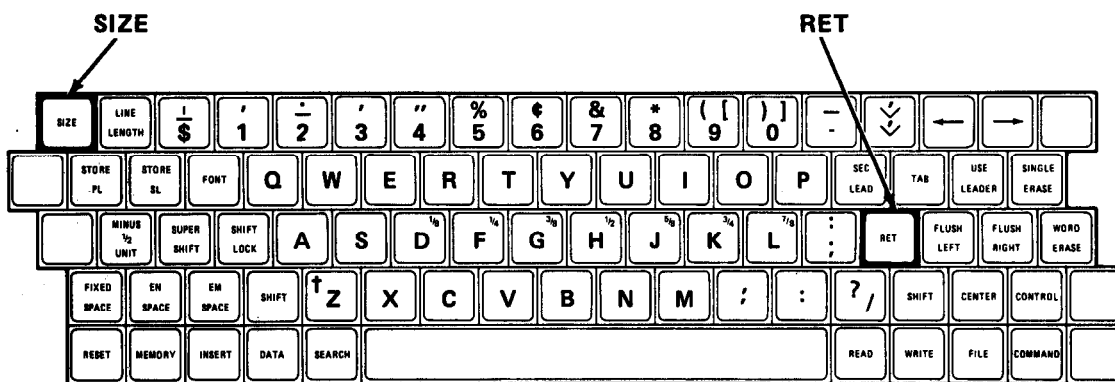
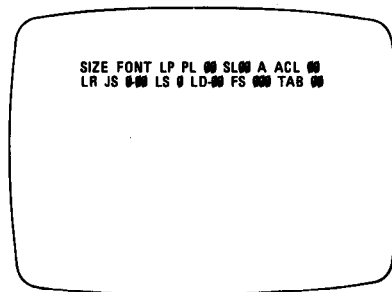

b. Set type size.

NOTE

- Function field entries will be displayed in function field and typing line.
- Type sizes available are: 5.5, 6, 7, 8, 8.5, 9, 10 and 11 thru 74 except 55.

SIZE	1	∅	= SIZE 1∅
SIZE	∅	6	= SIZE 6
SIZE	9	5	= SIZE 9½
SIZE	7	4	= SIZE 74

- (1) Press SIZE followed by two digits.
- (2) Point size is recorded in function field and displayed on typing line.

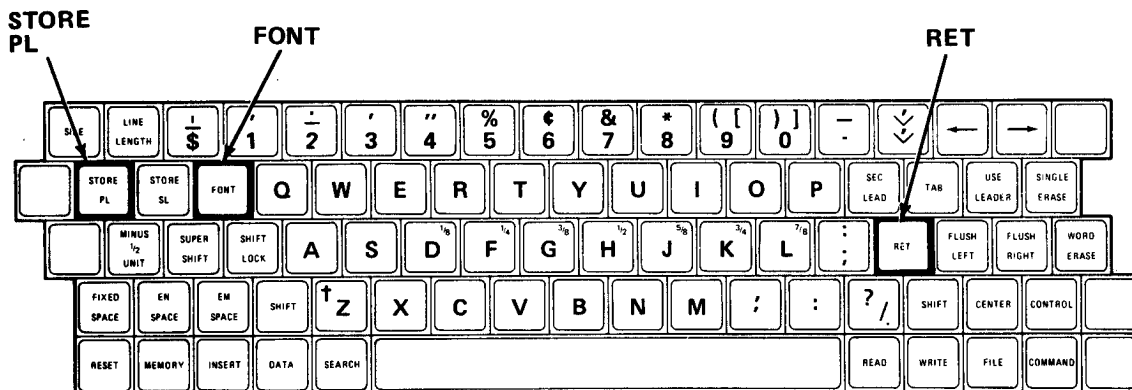
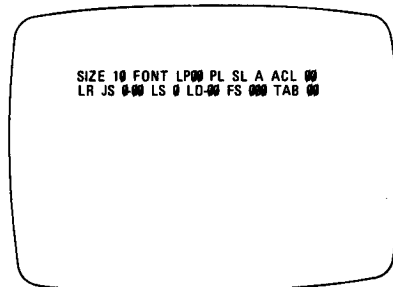

c. Set type style.

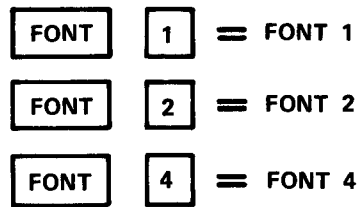

(1) Press FONT followed by one digit for type style.

NOTE

Digital entries will be displayed on function field and typing line.

d. Set line length.

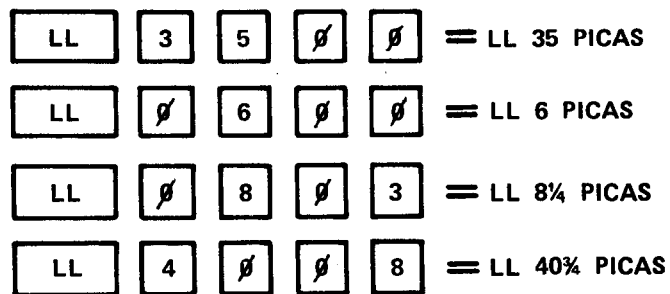

(1) Press LINE LENGTH.

NOTE

Maximum line length is 45 picas for all point sizes.

12 points = 1 pica
72 points = 1 in.
6 pica = 1 in.

Point on Comp/Set = 0.01384 in.

(2) Press four digits for line length in picas.

e. Set primary leading.

(1) Press STORE PL key.

NOTE

First two numbers equal full points and third equals 1/2-point leading. Enter 0 if 1/2-point leading is not required. Only primary leading is displayed in function field.

(2) Press three digits.

f. Set secondary leading.

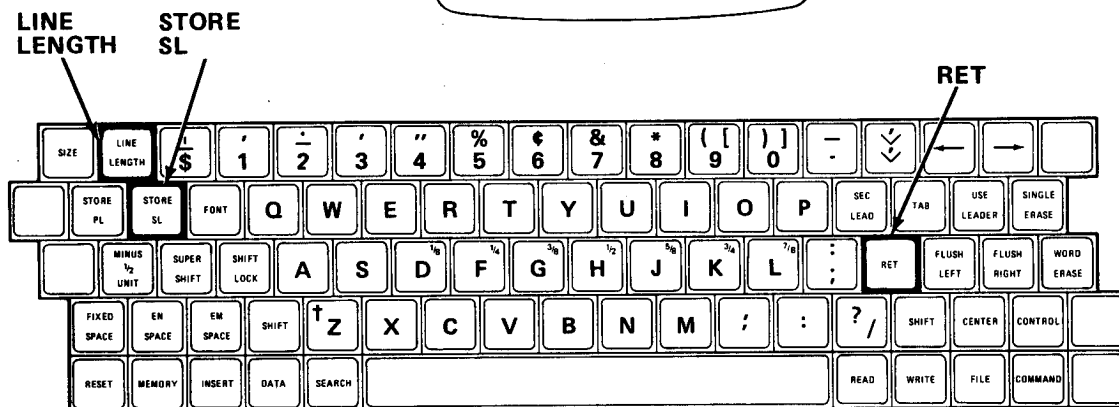
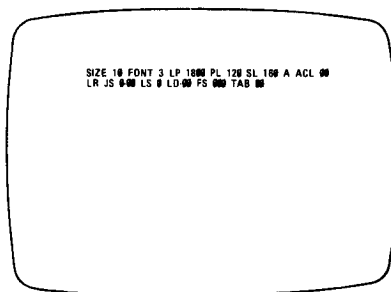

(1) Press STORE SL.

NOTE

First two digits equal full points. Third digit equals 1/2-point. Secondary leading is displayed in function field.

(2) Enter three digits.

(3) Press RET. Wait 5 sec.

g. Advance paper.

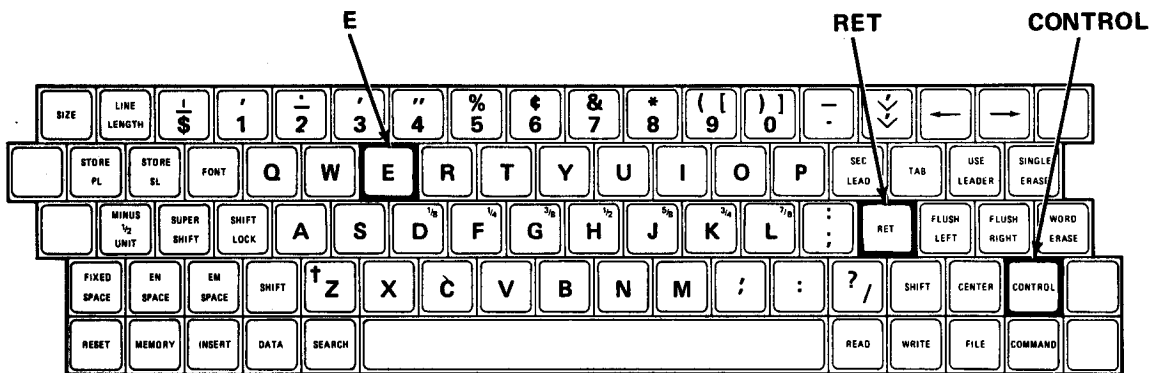
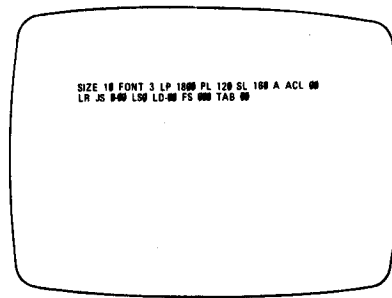

- (1) Press CONTROL and E.
- (2) Press RET.

h. Set tabs.

NOTE

Steps a. through f. must be completed first.

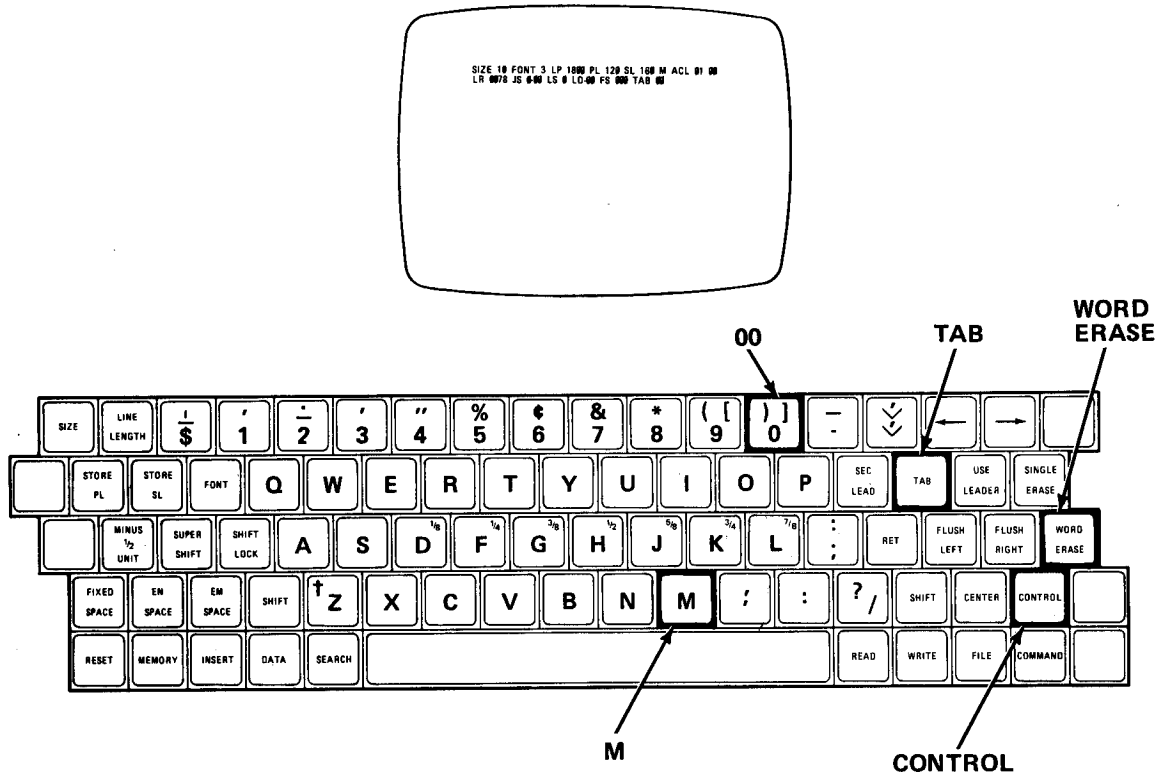

- (1) Press CONTROL and M.
- (2) Press CONTROL, TAB, 00 and WORD ERASE.

NOTE

Numbers 01-99 are available as tab numbers. Tab information should include:

- Size
- Font
- Line Length
- Flush left, center or right
- Indent left, right or both
- Repetitive characters or fixed spaces
- Primary leading
- Secondary leading

- (3) Store first tab by pressing CONTROL, TAB and two digits.

NOTE

- If error is made, press SINGLE ERASE.
- When you store tab information it is displayed on screen as you keyboard it.
- Marker is displayed by ACL.

(4) Type functions/characters to be stored.

(5) Press TAB if displayed information is correct.

(6) Repeat steps 3, 4, and 5 for each tab column.

(7) After storing tabs, press TAB to be sure information is correct.

(8) All information stored on TAB 01 will be displayed.

(9) To check information on other tabs, continue to press TAB.

(10) If tab information is correct, press RET. If tab has incorrect data, perform following steps.

(a) Press CONTROL, TAB and number (incorrect data).

(b) Type correct information.

(11) Press TAB.

(12) Press RET. Wait 5 sec.

i. Accessing tabs.

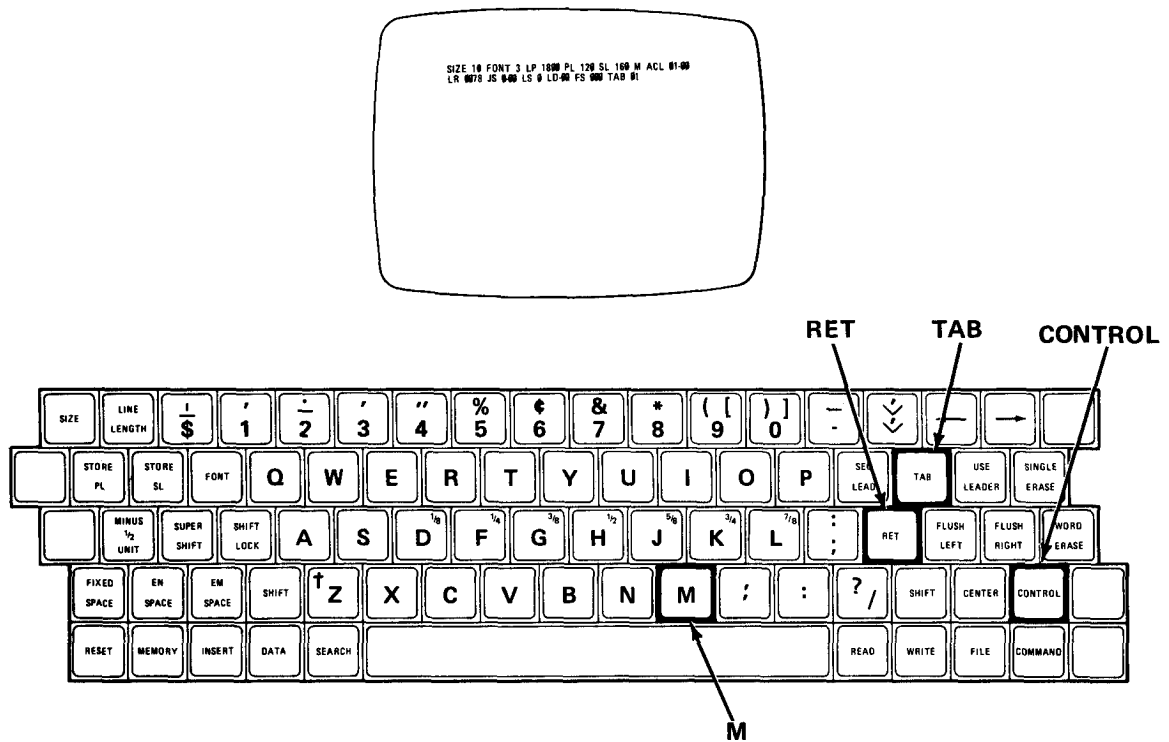

- (1) Press CONTROL and M.
- (2) Press TAB. Information stored in tab 01 is displayed.
- (3) Type text for tab 01 and press TAB.
- (4) Information displayed is for tab 02.
- (5) Type text for tab 02 and press TAB.
- (6) Repeat tab, text-tab operation until last tab.
- (7) After typing text for last tab, press RET. Wait 5 sec.

j. Override stored tab. The two following steps may independently be used to override stored tab.

- (1) Upon reaching tab position where override is to be made, type changes along with desired text.
- (2) Erase text or functions displayed for tab position.

k. Tab indexing.

(1) Check that you are in manual mode. (Press CONTROL and M.)

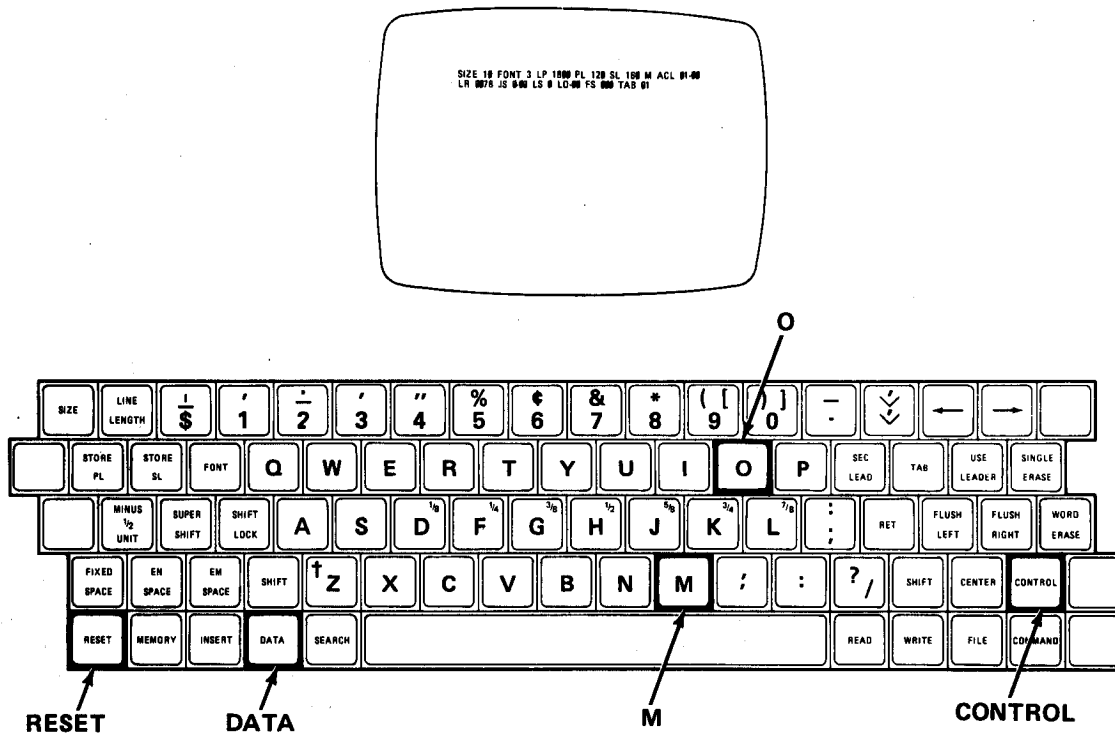

(2) Press CONTROL, o and tab number. Then press TAB.

(3) Typesetter starts tab job with information stored in selected tab.

(4) Starting position can be changed by pressing CONTROL, o, and appropriate two-digit tab number. Then press TAB.

1. Justification. There are two modes available with composing machine.

Automatic
Manual

(1) The automatic mode is always active when composing machine is turned on or if RESET and DATA are depressed.

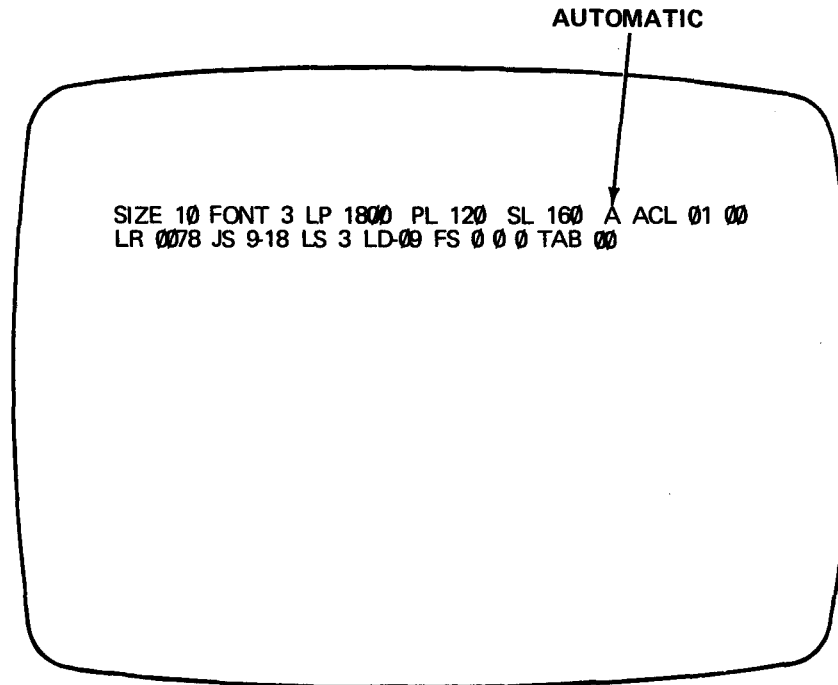

(a) An A in the function field indicates the automatic mode is active. The automatic mode decides where to end a justified line. As characters are keyboarded, character width is subtracted from the overall line length. When characters keyboarded exceed the line length, the composing machine automatically converts the last word space into a return and carries the word (overset) that would not fit on the line to the next line.

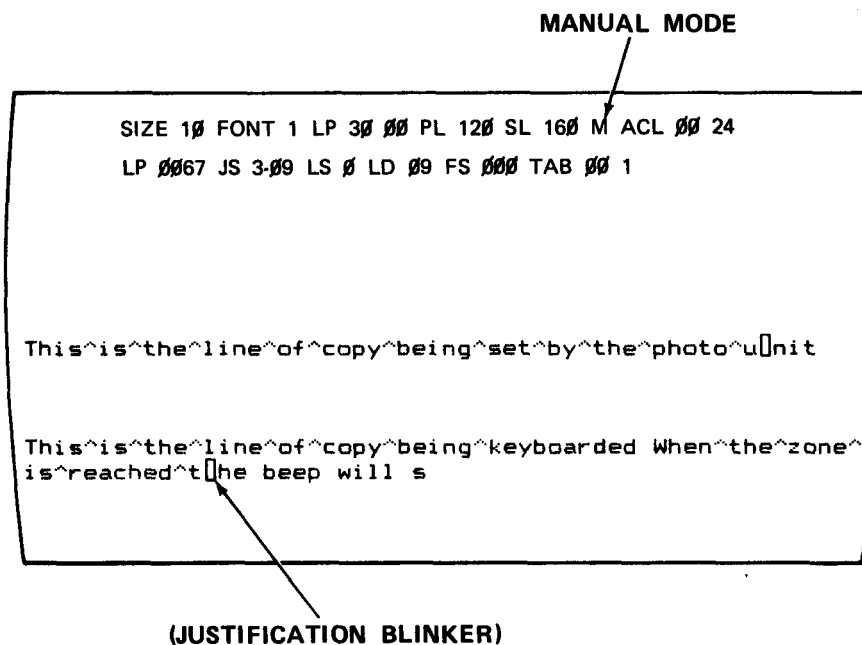

(b) If a word that overset the line is a long word and there is not a word space in the justification zone, the composing machine will switch to the manual mode, indicate an overset condition and wait for the operator to decide how to end the line. The operator can erase the overset word using WORD ERASE, retype part of the word until the justification blinker comes on and enter a hyphen/return at the appropriate point. When RET is entered, the composing machine goes back to the automatic mode. Another approach is to erase the entire line and either decrease minimum word space, increase maximum word space or use white space reduction or white space addition to enable the line to justify.

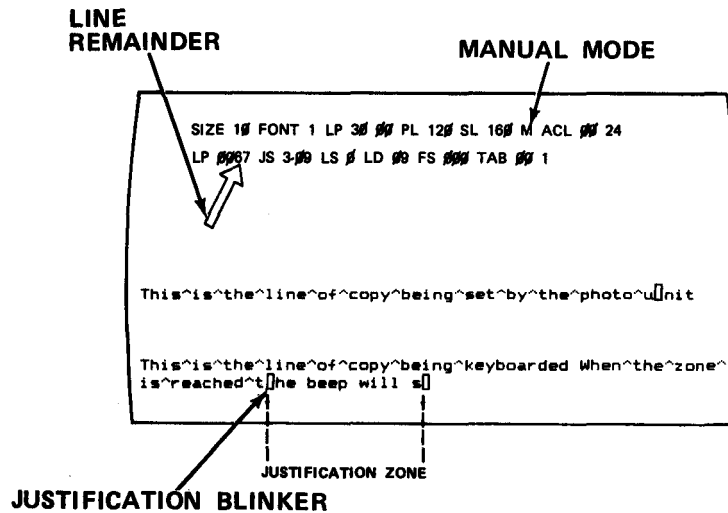

(2) In the manual mode, the operator decides when to end a line. When enough characters and word spaces have been entered on a line for the line to justify, a marker appears and a beep is sounded indicating the start of the justification zone. At the same time, the line remainder (LR) in the function field indicates the number of units remaining in the line. As you continue to keyboard, the LR counts down. When the remaining space is too small to enter the next word, enter a RET.

(3) The automatic mode is usually faster when producing justified copy. Because end-of-line decisions are made by the composing machine, the operator can concentrate on typing accuracy. The manual mode allows the operator to examine the line before allowing it to be set, thus, allowing complete control over how a line looks.

- m. Store data.

NOTE

- The following information concerns storing data. This, data can be text, text and function combinations, or just functions.
- Information that is repetitive in nature, such as logo, address block, or frequently used long name, can be stored.

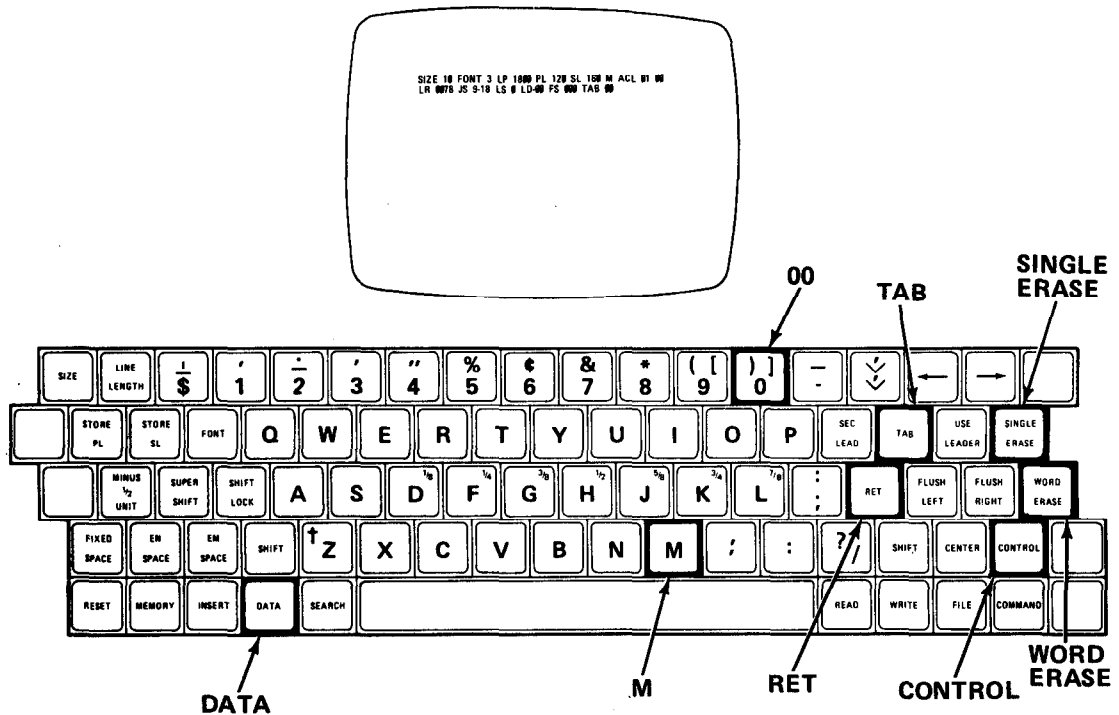

- (1) Press CONTROL and M.
- (2) Press CONTROL, TAB, 00 and WORD ERASE.
- (3) Press CONTROL, DATA and two digits (01-99) for data block address.

NOTE

You can type up to 251 characters in any data block. Data information should include:

- Size
- Font
- Line Length
- Primary Leading
- Secondary Leading

- (4) Type in information for that data block. Typed information will appear on typing line.
- (5) If there is error, press SINGLE ERASE and type in correct information.
- (6) Press DATA.
- (7) Store remaining data block by repeating steps (3) through (6).

- (8) As final check on data stored, press DATA and two digits to access data.
- (9) Data and functions will be displayed on screen.
- (10) Repeat step (8), if desired, to check all other data areas.
- (11) If information is correct, press RET. If there is error, perform following steps.
 - (a) Press CONTROL, DATA, and the block number with error.
 - (b) Retype information.
 - (c) If information is correct, press RET. Wait 5 sec.
- n. Access data.
 - (1) Check that you are in manual mode (CONTROL m).
 - (2) Press DATA and number of data memory.
 - (3) Information stored in data area is displayed on screen and automatically typeset according to specifications.
- o. Use stored data and stored tabs together.
 - (1) Press TAB until desired number is reached.
 - (2) Press DATA and desired data number.
- p. Changing disc.

NOTE

Disc can be changed between typeset lines, not between words.

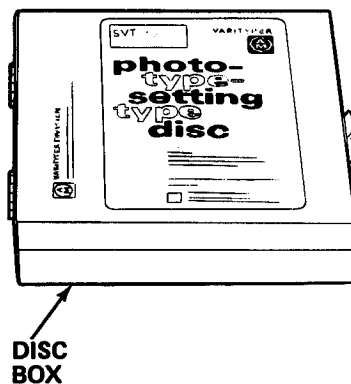

- (1) Place empty disc box in convenient location.

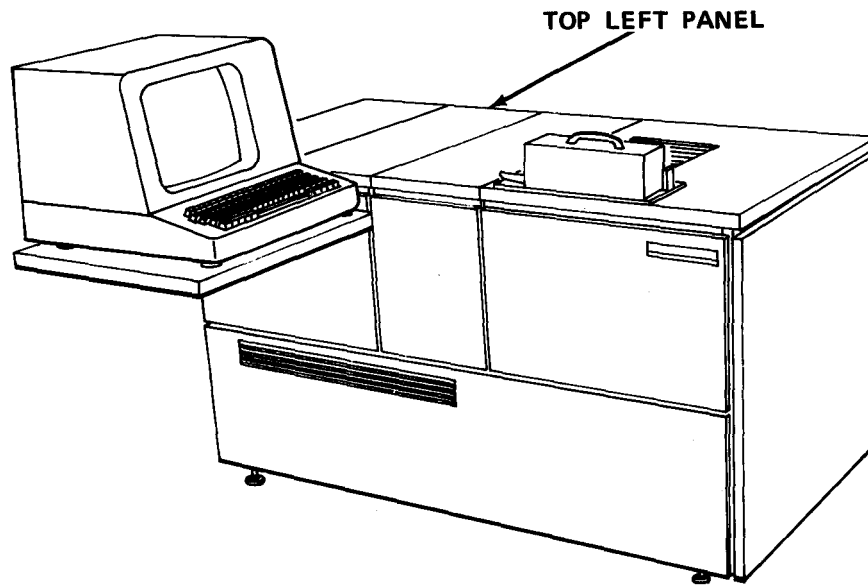

(2) Open top left panel.

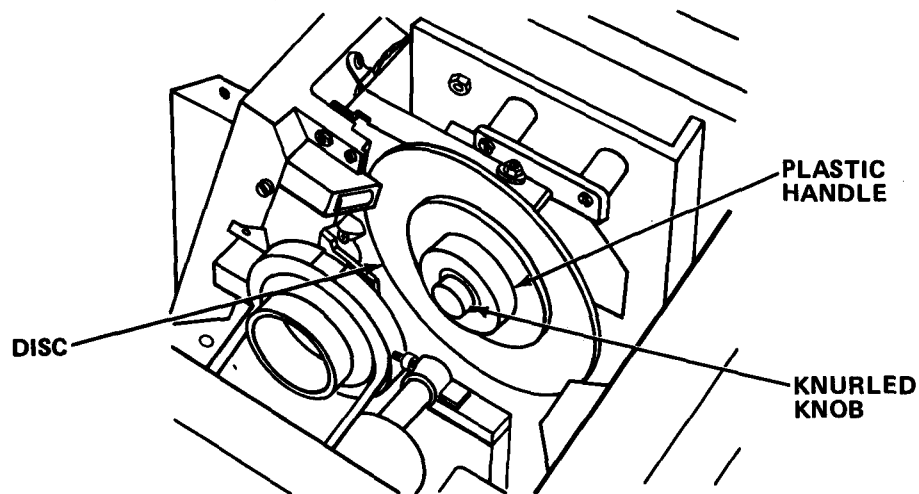

(3) Grasp plastic handle.

(4) Loosen knurled knob.

(5) Use knurled knob to slide disc to right and out.

(6) Place disc in empty box.

- (7) Place disc box in proper storage area.
- (8) Select proper disc.
- (9) Place disc box in convenient location.

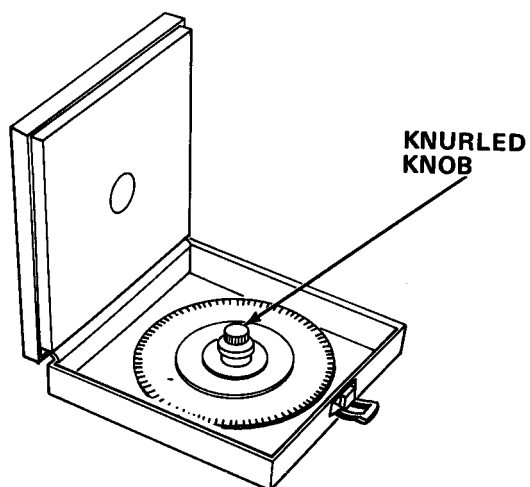

- (10) Open disc box.
- (11) Grasp disc by knurled knob and remove from box.

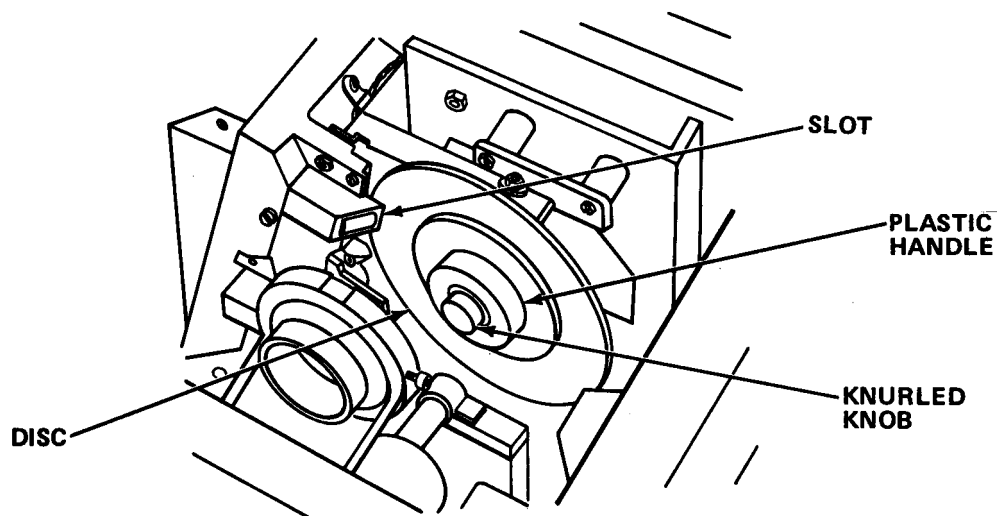

- (12) Grasp disc by plastic handle.
- (13) Insert left edge of disc into slot.

- (14) Tighten knurled knob.
- (15) Use knurled knob to spin disc. If it moves easily, it is installed correctly.
- (16) Close top left panel.
- (17) Close and latch empty disc box.
- (18) Stow empty disc box in proper storage area.

g. The following table lists all CONTROL key functions. If CONTROL is accidentally pressed, press CONTROL again to cancel-command.

Table 2-2. CONTROL FUNCTIONS

Function	Control = $\hat{\text{C}}$
Automatic mode	$\hat{\text{C}}$ a
Manual Mode	$\hat{\text{C}}$ m
Store New Disc Widths	$\hat{\text{C}}$ y
Line Length Flag - Pica/Points	$\hat{\text{C}}$ d 0 (LL####)
Line Length Flag - Units	$\hat{\text{C}}$ d 2 (LL ####)
Line Length Flag - Ciceros/Points	$\hat{\text{C}}$ d 1 (LL ####)
Minimum Word Space Change	$\hat{\text{C}}$ n #
Maximum Word Space Change	$\hat{\text{C}}$ x ##
Letter Space Change	$\hat{\text{C}}$ s #
White Space Addition	$\hat{\text{C}}$ f # (1/8S)
White Space Reduction	$\hat{\text{C}}$ r # (1/8S)
Store Leader Character	$\hat{\text{C}}$ USE LEADER (Character)
Leader Width Change	$\hat{\text{C}}$ w ##
Store Fixed Space	$\hat{\text{C}}$ FIXED SPACE ###
Single Fixed Space	$\hat{\text{C}}$ z #

Table 2-2. CONTROL FUNCTIONS - Cont

Function	Control = ^
Indent Left	^ FLUSH LEFT #####
Indent Right	^ FLUSH RIGHT #####
Indent Both	^ CENTER #####
Cancel indents	^ CENTER 0000
Repeat Line (Manual Mode Only)	^ RET
Add Lead	^ v
Reverse Carriage Sequence	^ MINUS 1/2 UNIT
End of Job	^ e
Cancel Line	^ c 1
Clear ACL	^ k
Paper Index (Film/RC)	^ p 0 (LL #####)
Paper Index (Standard)	^ p 1 (LL #####)
Insert Widths (Parity Error)	^ i ###
Reread Widths (Parity Error)	^ g

NOTE

The following procedure is used to prevent loss of stored data.

- r. Replace paper cassette with power on.

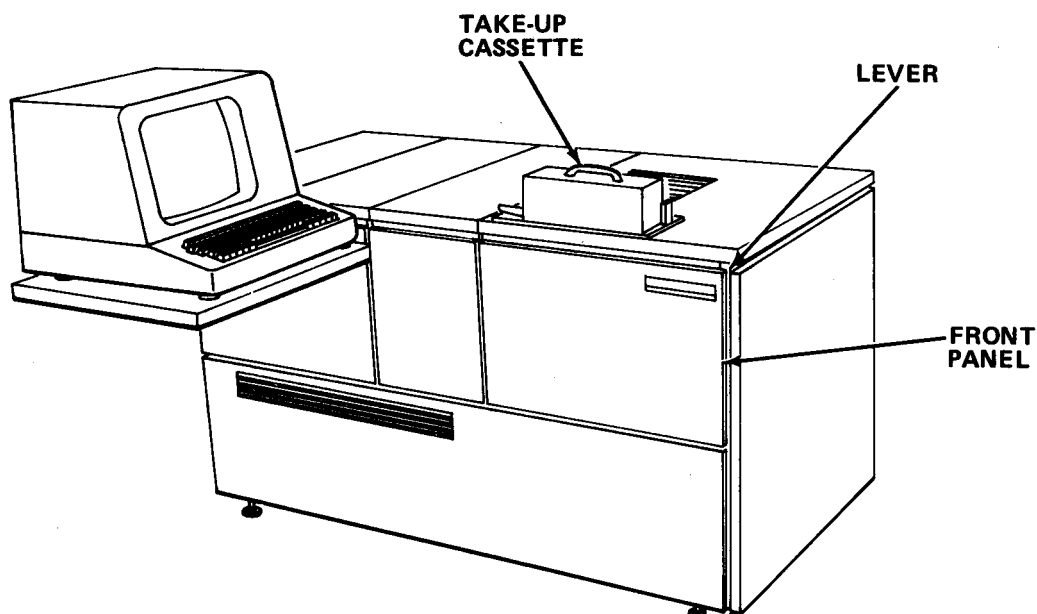

- (1) Grasp handle on take-up cassette and gently pull forward.
- (2) Pull small lever at top right corner.
- (3) Front panel will swing down.
- (4) Cut paper/film edge on new cassette to approximate y 2 to 3 in. (5.08 to 7.62 cm).

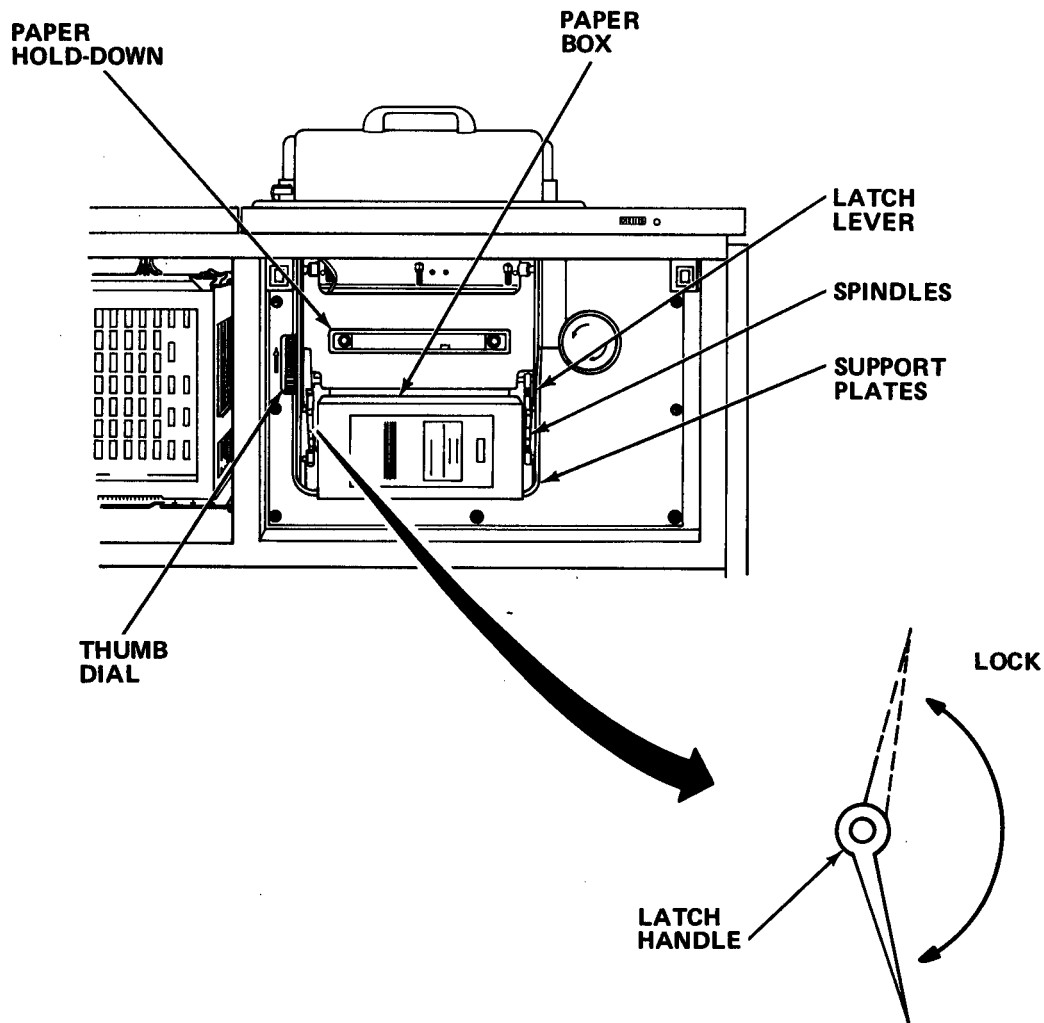

- (5) Rotate closing latch handle downward.
- (6) Press latch lever downward to release paper holddown.
- (7) Lift paper holddown to full open position and hold.
- (8) Insert paper box into magazine.
- (9) Be sure spindles are firmly seated in support plates.
- (10) Leading edge of paper should face up and sit on top of lower rear 0.5 in. (12.7 mm) roller.
- (11) Lower paper hold down and press closed.
- (12) Lock closing latch handle.
- (13) Rotate thumb dial 5 to 6 times.

(14) Close front panel.

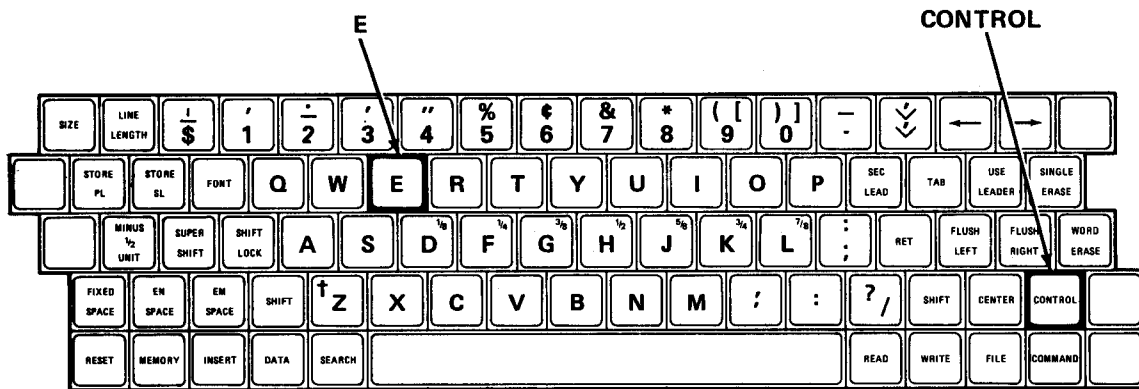

- (15) Press CONTROL and E.
- (16) Cut exposed paper and discard.
- (17) Replace take-up cassette.

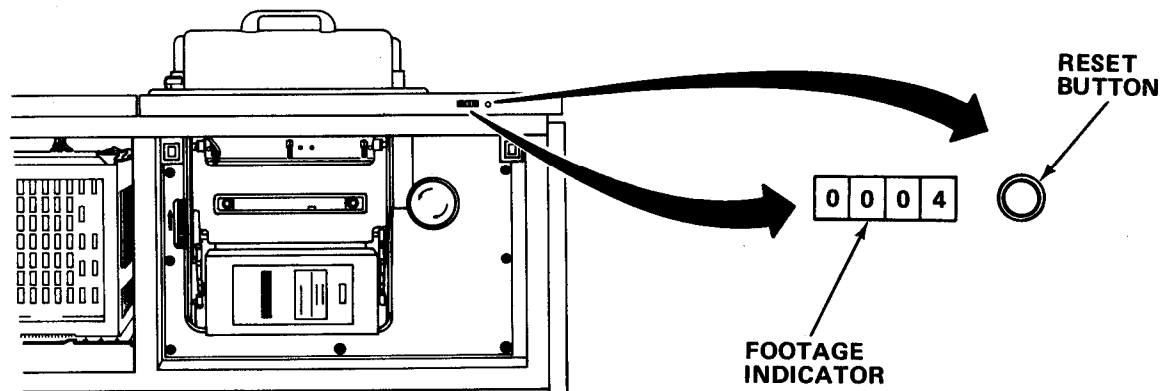

(18) Use pencil tip to depress recessed footage counter button to reset counter to 0.

S. Process procedures.

- (1) Press CONTROL and E.
- (2) Depress paper cutoff handle.
- (3) Grasp handle of take-up cassette and gently pull forward.

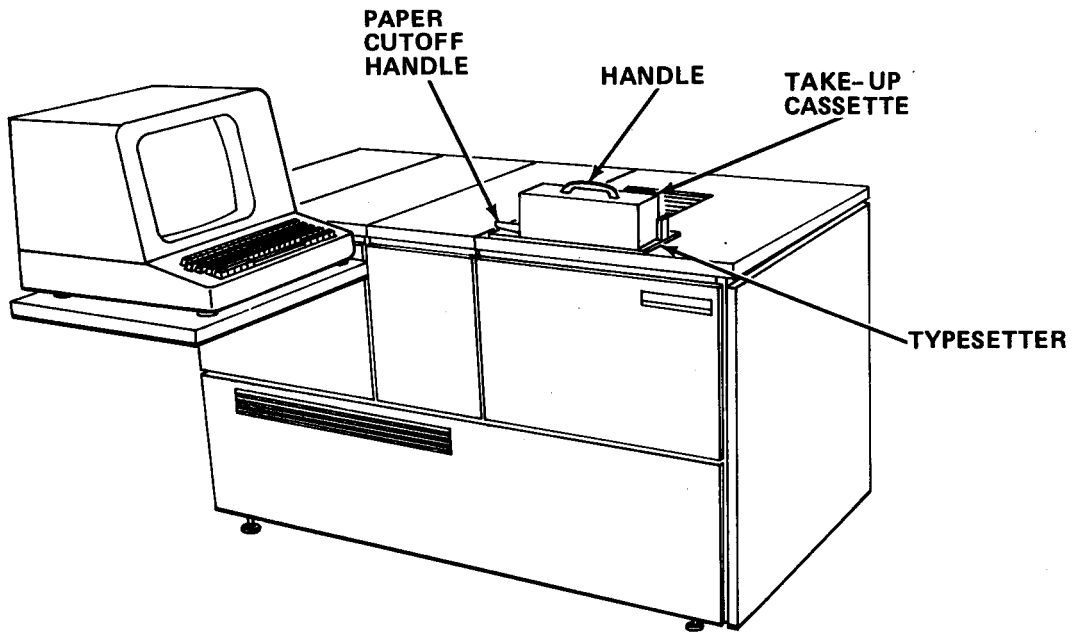

- (4) Pull approximately 1.00 in. (2.54 cm) of paper out of take-up cassette.
- (5) Take take-up cassette to area where it can be processed.
- (6) Install empty take-up cassette on typesetter.

2-6.3 Preparation for Movement.

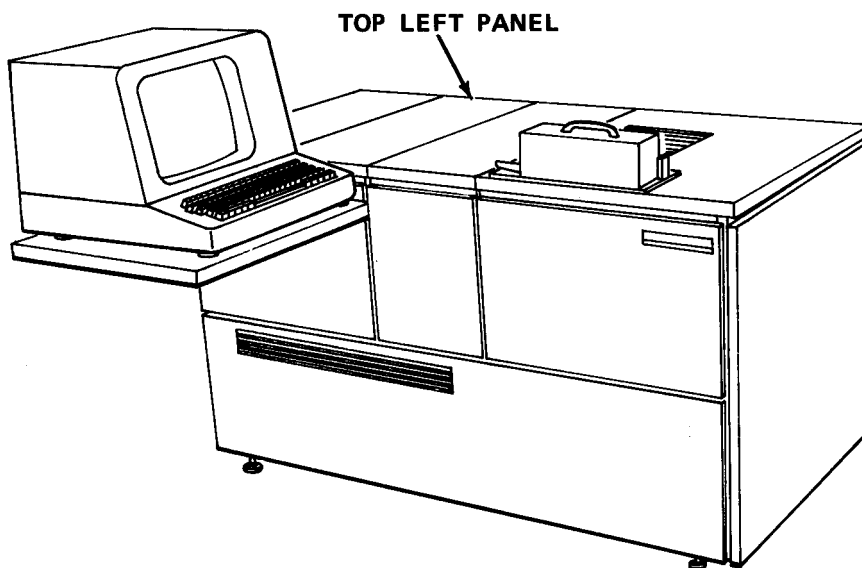

- a. Press CONTROL and E.
- b. Open top left panel.
- c. Place empty disc box in convenient location.

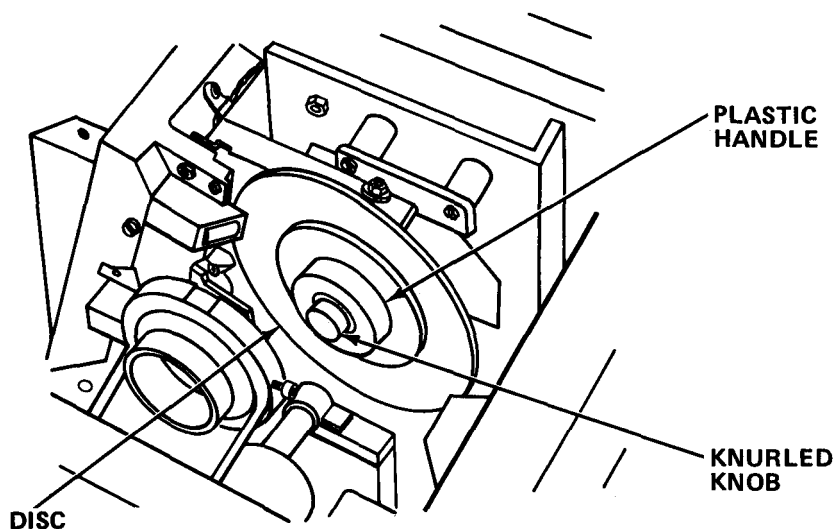

- d. Grasp plastic handle.
- e. Unscrew knurled knob.
- f. Use knurled knob to slide disc to right and out.
- g. Place disc in empty box.
- h. Place disc box in proper storage area.

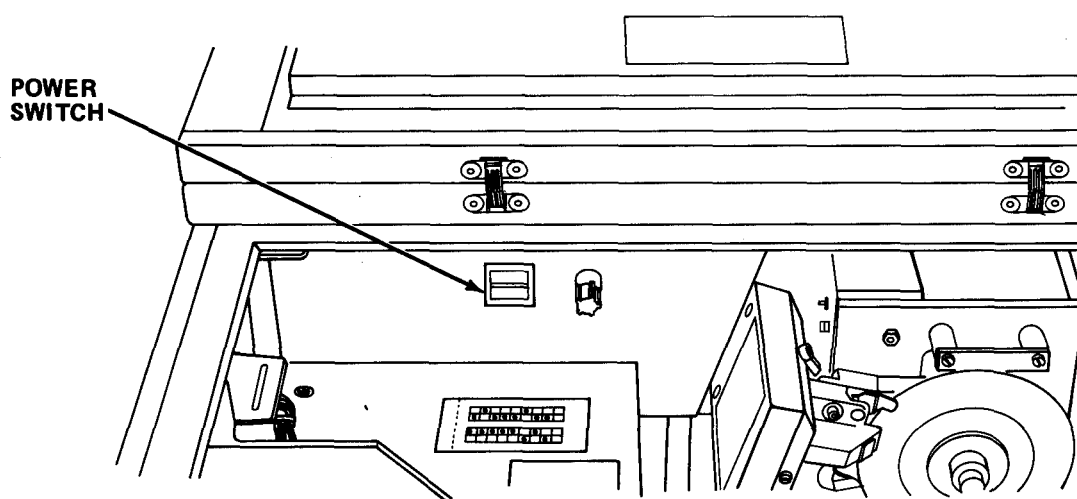

- i. Place power switch to OFF.
- j. Close top left panel.
- k. Store accessories.
- l. Secure strap across top of machine.
- m. Turn off circuit breaker.

2-6.4 Operating Instructions on Decals and Instruction Plates.

PAPER LOADING

1. CUT PAPER APPROXIMATELY 1¼" - 1½" FROM TOP OF MAGAZINE 1.
2. ROTATE CLOSING LATCH HANDLE 2 TO DOWNWARD POSITION.
3. PRESS LATCH LEVER 3 DOWNWARD TO RELEASE PAPER HOLD DOWN.
4. LIFT PAPER HOLD DOWN 4 TO FULL OPEN POSITION AND HOLD.
5. INSERT PAPER BOX INTO MAGAZINE.
 - A. INSURE THAT BOX SPINDLES 5 ARE FIRMLY SEATED IN SUPPORT PLATES.
 - B. LEAD EDGE OF PAPER SHOULD FACE UP AND SIT ON TOP OF LOWER (REAR) ¼ INCH DIA. ROLLER.
6. LOWER PAPER HOLD DOWN 4 AND PRESS CLOSED. CLOSING LATCH 2 MUST ENGAGE CAM SHAFT TO PREVENT REOPENING OF GATE.
7. ROTATE KNURLED THUMBWHEEL 6 IN DIRECTION OF ARROW AND VIEW PAPER AT EXIT SLOT.
8. ROTATE CLOSING LATCH 2 HANDLE UPWARD TO STOP POSITION.
9. SEE MANUAL FOR RECEIVING CASSETTE INSTRUCTIONS.

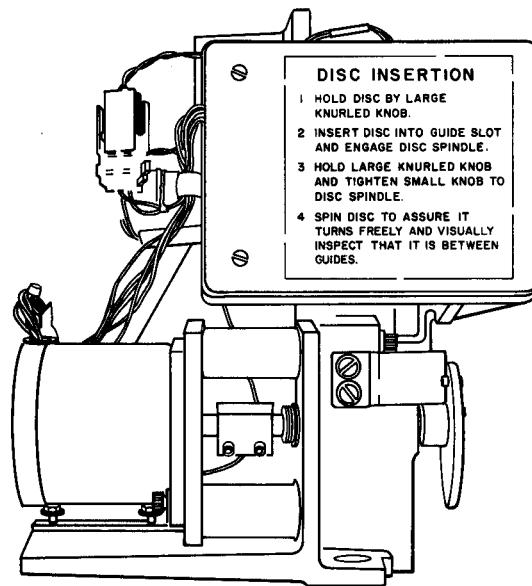
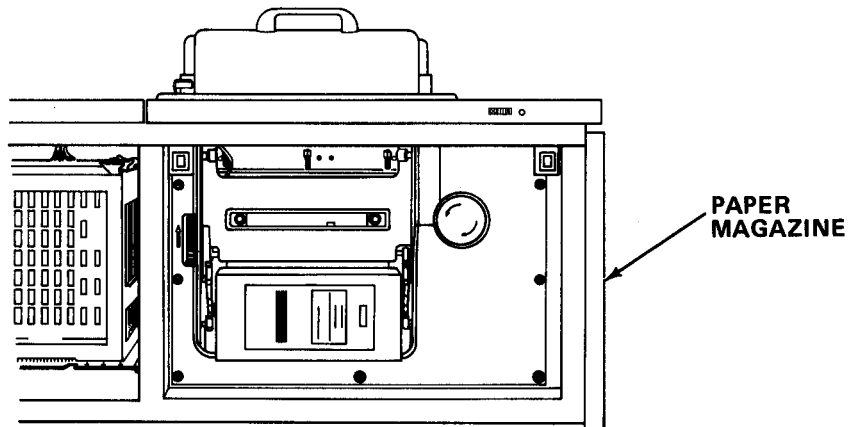

a. DISC INSERTION instructions are located under the top left panel near the power switch and turntable.

b. PAPER LOADING instructions are located on the front panel. These provide instructions for loading photographic paper.

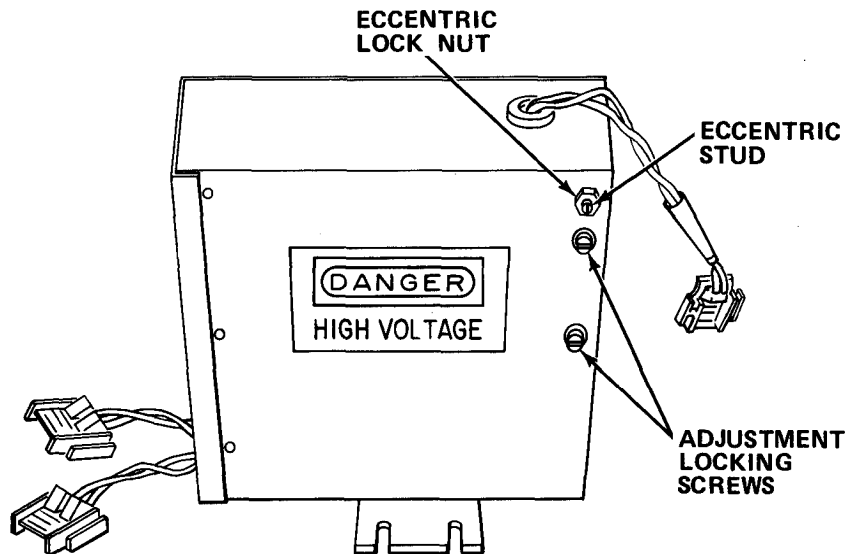

c. HIGH VOLTAGE warning located on side of flash power supply.

CAUTION

Do not operate machine without disc(s) in place. Close cover before operating machine.

d. CAUTION label located inside top left panel.

2-7. **OPERATION UNDER UNUSUAL CONDITIONS.** The composing machine is designed for operation only in a controlled environment.

Section III OPERATOR MAINTENANCE

2-8. LUBRICATION INSTRUCTIONS. This equipment does not require lubrication at this level of maintenance.

2-9. TROUBLESHOOTING PROCEDURES.

a. The table lists the common malfunctions you may find during operation or maintenance of the composing machine or its components. You should perform the test/inspections and corrective actions in the order listed.

b. This manual cannot list all malfunctions that may occur, nor all of the tests or inspections and corrective actions. If a malfunction is not listed or corrected by listed corrective actions, notify your supervisor.

Table 2-3. TROUBLESHOOTING

MALFUNCTION
TEST OR INSPECTION
CORRECTIVE ACTION
<p>1. MACHINE SOUNDS PROLONGED BEEP AND, AFTER TYPING A FEW CHARACTERS, KEYBOARD LOCKS .</p> <p>Check contents of paper cassette.</p> <p>Insert photographic paper and reset counter.</p>
<p>2. LINES ARE NOT PROPERLY JUSTIFIED.</p> <p>Step 1. Check if size or font changes entered after entering reverse carriage function.</p> <p>(a) If entries correctly made, proceed to step 2.</p> <p>(b) Enter size or font change prior to entering reverse carriage function.</p>

Table 2-3. TROUBLESHOOTING - Cont

MALFUNCTION	TEST OR INSPECTION	CORRECTIVE ACTION
2. LINES ARE NOT PROPERLY JUSTIFIED - Cont	Step 2. Check that corrections are entered on line after entering reverse carriage function.	<ul style="list-style-type: none"> (a) If corrections entered properly, proceed to step 3. (b) Make all corrections on line before entering reverse carriage function. (c) Cancel entire line and retype it correctly.
	Step 3. Check if justified space was attempted to be used within reverse carriage sequence.	<ul style="list-style-type: none"> (a) If entries were properly made, proceed to step 4. (b) If two or more words are typed, use fixed space between them. Fixed space of six units is desirable word space.
	Step 4. Check for runover left on typing line.	Clear last line and enter end-of-job command.
3. PROLONGED BEEP SOUNDS DO NOT STOP.	Check to see if internal composing machine temperature is too high for reliable operation.	<ul style="list-style-type: none"> (a) End job within one minute and turn off composing machine. (b) Notify direct/general support maintenance.
4. UNWANTED CHARACTERS ARE APPEARING ON DISPLAY AND RANDOM COMMANDS ARE BEING EXECUTED.	Check for unstable 120 V ac.	Notify direct/general support maintenance.

Table 2-3. TROUBLESHOOTING - Cont

MALFUNCTION	TEST OR INSPECTION	CORRECTIVE ACTION
5. LIGHT LEAKS ON PHOTOGRAPHIC PAPER.		
	Step 1. Check to see if power supply panel is properly closed.	
	(a) If closed, proceed to step 2.	
	(b) Close panel.	
	Step 2. Check if take-up cassette is properly mounted.	
		Ensure that take-up cassette is clipped tightly to back metal plate.
6. CURSOR WILL NOT MOVE DURING/AFTER COMMANDS.		
	Check for improper keyboarding of cursor commands.	
		Make certain command and correct number of digits are entered.
7. NO COMMANDS IN TAB/DATA STORAGE.		
	Check to see if upper case commands/digits used.	
		Use lower-case commands/digits.
8. FOOTAGE INDICATOR READING REMAINS CONSTANT.		
	Check to see if paper jam has occurred.	
		Clear paper jam.
9. DENSITY OF COPY IS LOW.		
	Check to see if lens is dirty.	
		Clean lens.

Table 2-3. TROUBLESHOOTING - Cont

MALFUNCTION	TEST OR INSPECTION	CORRECTIVE ACTION
10. FOCUS IS POOR.	Check for smudges on lens and mirror.	Clean lens and mirror.
11. FONT OR COMMAND IS DIFFERENT FROM KEYBOARDED INFORMATION.	Check for defective keyboard or key interface.	Refer to direct/general support maintenance.
12. CURSOR DISAPPEARS.	Check for open panel.	Close panel.
13. DISC STOPS SPINNING.	Check for open panel.	Close panel.
14. JAMMED KEYBOARD.	Check for open panel.	Close panel.
15. RANDOM ADDRESSES APPEAR IN ACL FIELD.	Check to see if disc is dirty.	Clean disc.

Table 2-3. TROUBLESHOOTING - Cont

MALFUNCTION	TEST OR INSPECTION	CORRECTIVE ACTION
-------------	--------------------	-------------------

16. NO POWER TO MACHINE.

Step 1. Check that power switch is in ON position.

(a) If power switch is on, proceed to step 2.

(b) Turn power switch on.

Step 2. Visually check main power fuse.

(a) Replace fuse if defective (paragraph 2-10. 1).

(b) If problem is not corrected, refer to direct/general support maintenance.

2-10. MAINTENANCE PROCEDURES.

This section contains instructions covering operator maintenance functions for the composing machine. Personnel are listed only if the task requires more than one.

b. After completing each maintenance procedure, perform operational check to be sure that equipment is properly functioning.

INDEX

PROCEDURES	PARAGRAPH
Replace Main Power Fuse.	2-10.1

2-10.1 Replace Main Power Fuse.

MOS: 81C, Cartographer

SUPPLIES: Fuse (8 amp, S1o-B1o)

WARNING

Death or serious injury may occur from electrical shock unless power is secured before servicing.

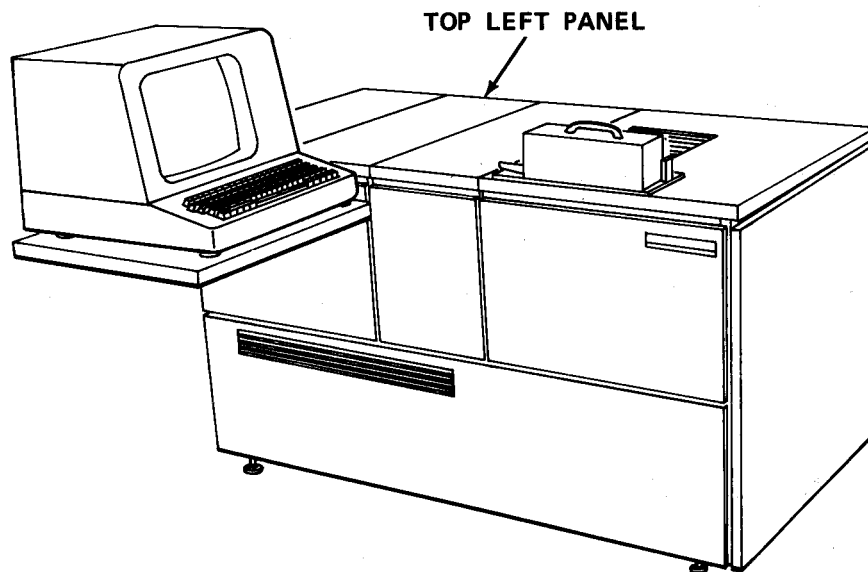

- a. Turn off circuit breaker.
- b. Raise top left panel.

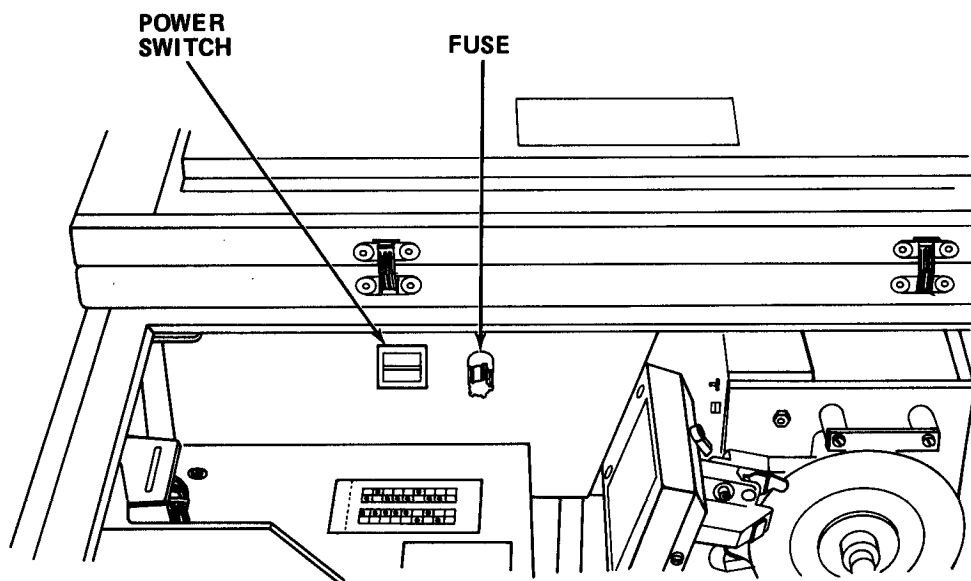

- c. Turn off power switch.
- d. Remove defective main power fuse.
- e. Install new main power fuse.
- f. Close top left panel.
- g. Turn on circuit breaker.

Section IV ORGANIZATIONAL MAINTENANCE

2-11. LUBRICATION INSTRUCTIONS.

NOTE

These lubrication instructions are mandatory.

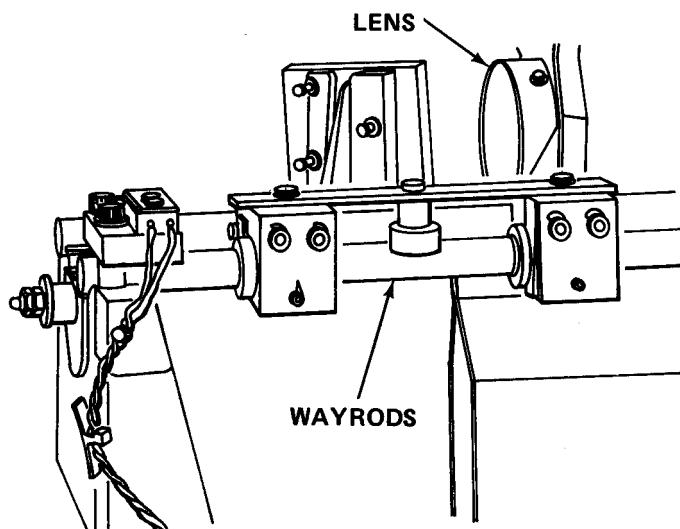

2-11.1 Lubricate Wayrods. Apply a thin coat of oil on wayrods with cheesecloth moistened with oil (Item 15, Appendix E) annually.

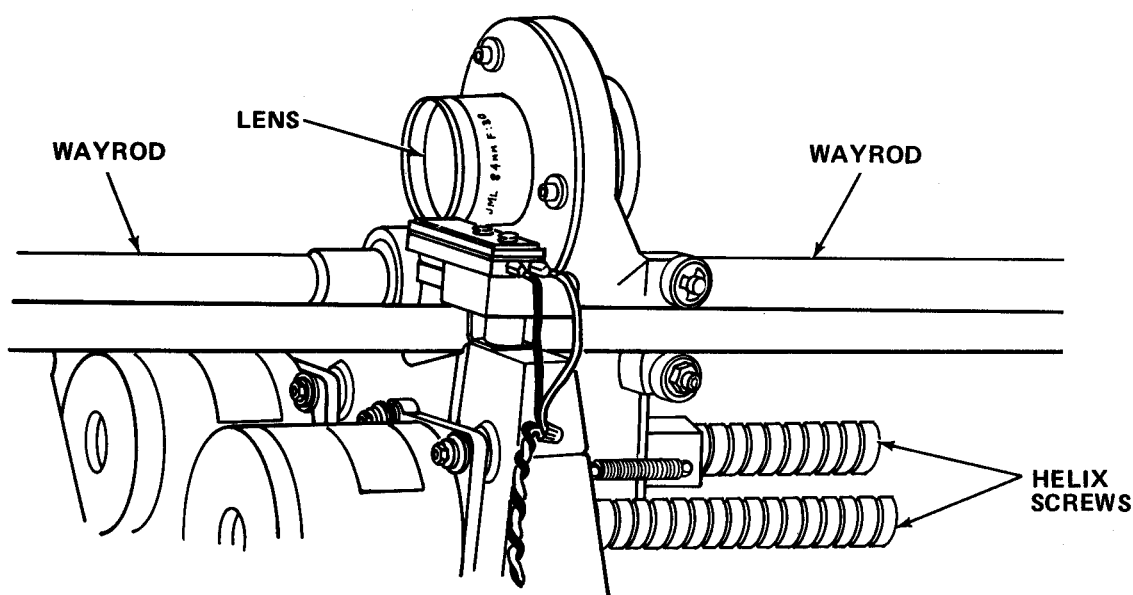

2-11.2 Lubricate Helix Screws. Lightly coat helix screws with versilube, (Item 30, Appendix E) annually.

2-12. REPAIR PARTS, SPECIAL TOOLS; TEST, MEASUREMENT, AND DIAGNOSTIC EQUIPMENT (TMDE); AND SUPPORT EQUIPMENT.

2-12.1 Common Tools and Equipment. For authorized common tools and equipment, refer to the Modified Table of Organization and Equipment (MTOE) applicable to your unit.

2-12.2 Special Tools: Test, Measurement, and Diagnostic Equipment; and Support Equipment. Special Tools, TMDE, and Support Equipment is listed in the applicable repair parts and special tools list and Appendix B of this manual.

2-12.3 Repair Parts. Repair parts for this equipment are listed and illustrated in the Repair Parts and Special Tools List TM 5-6675-316-24P covering organizational maintenance for this equipment.

2-13. SERVICE UPON RECEIPT.

2-13.1 Checking Unpacked Equipment.

a. Inspect the equipment for damage incurred during shipment. If the equipment has been damaged, report the damage on DD Form 6, Packing Improvement Report.

b. Check the equipment against the packing list to see if the shipment is complete. Report all discrepancies in accordance with the instructions of DA Pam 738-750.

c. Check to see whether the equipment has been modified.

2-14. ORGANIZATIONAL PREVENTIVE MAINTENANCE CHECKS AND SERVICES.

PMCS are designed to keep the equipment in good working condition by performing certain tests, inspections and services. The intervals provide you, the organizational technician, with time schedules that determine when to perform specified tasks.

b. Item number column. Item numbers are assigned in chronological ascending sequence regardless of interval designation. These numbers are used for your "TM Number" column on DA Form 2404, Equipment Inspection and Maintenance Worksheet, in recording the results of PMCS.

Interval columns. This column determines the time period designated to perform your PMCS.

d. Item to be inspected and procedures column. This column lists functional groups and their respective assemblies and subassemblies as shown in the Maintenance Allocation Chart (Appendix B). The appropriate check or service procedure follows the specific item to be inspected.

e. List of tools and materials required for PMCS is as follows:

<u>Item</u>	<u>Quantity</u>
Vacuum Cleaner	1 ea
Lens Brush	1 ea
Cheesecloth (Item 6, Appendix E)	ar
Flashlight	1 ea

Table 2-4. ORGANIZATIONAL PREVENTIVE MAINTENANCE CHECKS AND SERVICES

B - Before
D - During
A - After

W - Weekly
M - Monthly
Q - Quarterly

AN - Annually
S - Semiannually
BI - Biennially

(Number) - Hundreds of Hours

ITEM NO.	INTERVAL	ITEM TO BE INSPECTED PROCEDURE
1	AN	<p><u>COMPOSING MACHINE</u></p> <p><u>Clean and Inspect Scanning Carriage.</u></p>  <p>1. Remove copy aid. 2. Open top left panel.</p>

Table 2-4. ORGANIZATIONAL PREVENTIVE MAINTENANCE CHECKS AND SERVICES - Cont

B - Before
D - During
A - After

W - Weekly
M - Monthly
Q - Quarterly

AN - Annually
S - Semiannually
BI - Biennially

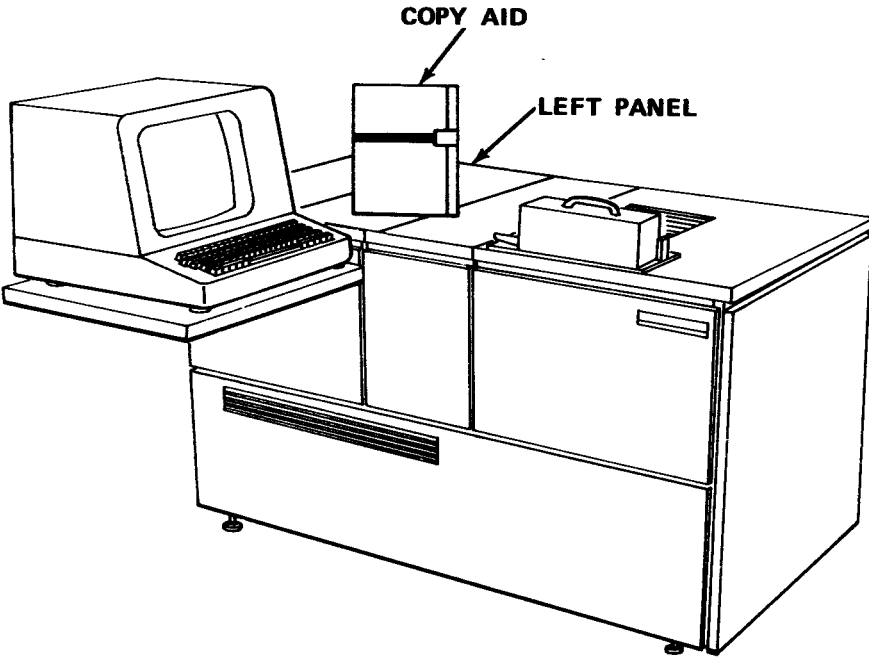
(Number) - Hundreds of Hours

ITEM NO.	INTERVAL	ITEM TO BE INSPECTED PROCEDURE
1	AN	<p><u>COMPOSING MACHINE - Cont</u></p> <p><u>Clean and Inspect Scanning Carriage - Cont</u></p>  <p style="text-align: center;"><u>WARNING</u></p> <p>Death or serious injury may occur from electrical shock unless power is turned off before servicing.</p> <p>3. Turn power switch OFF.</p>

Table 2-4. ORGANIZATIONAL PREVENTIVE MAINTENANCE CHECKS AND SERVICES - Cont

B - Before
D - During
A - After

W - Weekly
M - Monthly
Q - Quarterly

AN - Annually
S - Semiannually
BI - Biennially

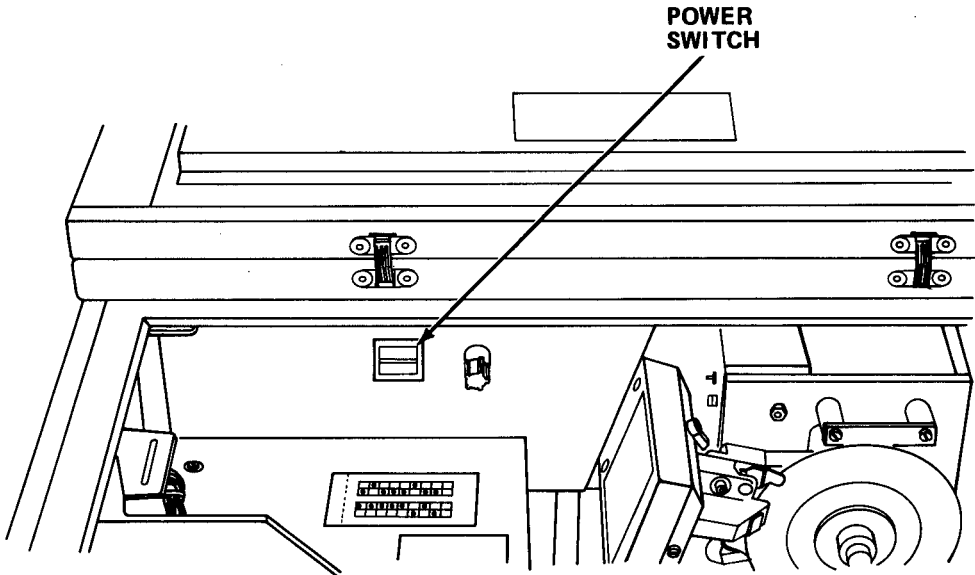
(Number) - Hundreds of Hours

ITEM NO.	INTERVAL	ITEM TO BE INSPECTED PROCEDURE
1	AN	<p><u>COMPOSING MACHINE - Cont</u></p> <p><u>Clean and Inspect Scanning Carriage - Cont</u></p>  <p style="text-align: center;">REAR PANEL REMOVED</p> <p>4. Remove rear panel.</p> <p style="text-align: center;"><u>CAUTION</u></p> <ul style="list-style-type: none"> ● To prevent damage to optical surfaces, do not wipe optical surfaces until dust and foreign matter have been removed. ● Do not touch optical surfaces with bare fingers.

Table 2-4. ORGANIZATIONAL PREVENTIVE MAINTENANCE CHECKS AND SERVICES - Cont

B - Before
D - During
A - After

W - Weekly
M - Monthly
Q - Quarterly

AN - Annually
S - Semiannually
BI - Biennially

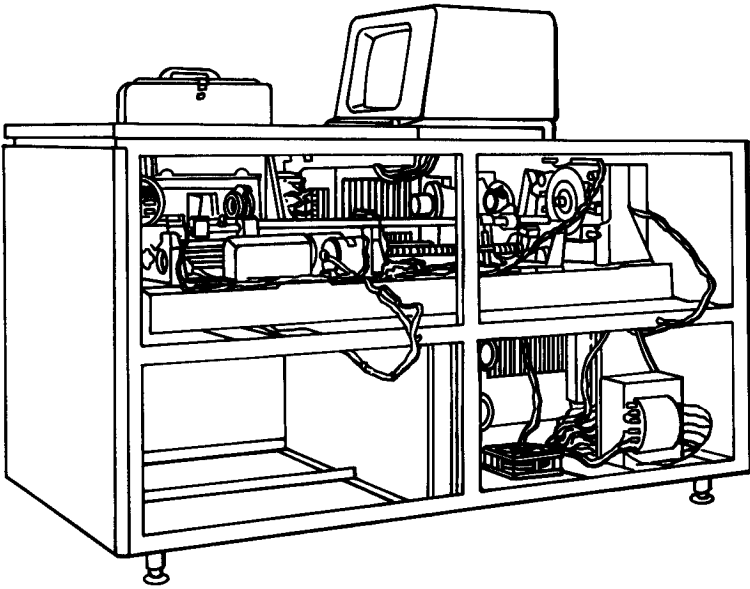
(Number) - Hundreds of Hours

ITEM NO.	INTERVAL	ITEM TO BE INSPECTED PROCEDURE
1	AN	<u>COMPOSING MACHINE - Cont</u>
		<p><u>Clean and Inspect Scanning Carriage - Cont</u></p>  <p>5. Use dry clean lens brush to dust off LED, scanning mirror, and lens.</p> <p>6. Inspect wires and components for burn marks, arcs, and burnt components.</p> <p>7. Replace rear panels.</p> <p>8. Close top left panel.</p> <p>9. Replace copy aid.</p>

Table 2-4. ORGANIZATIONAL PREVENTIVE MAINTENANCE CHECKS AND SERVICES - Cont

B - Before
D - During
A - After

W - Weekly
M - Monthly
Q - Quarterly

AN - Annually
S - Semiannually
BI - Biennially

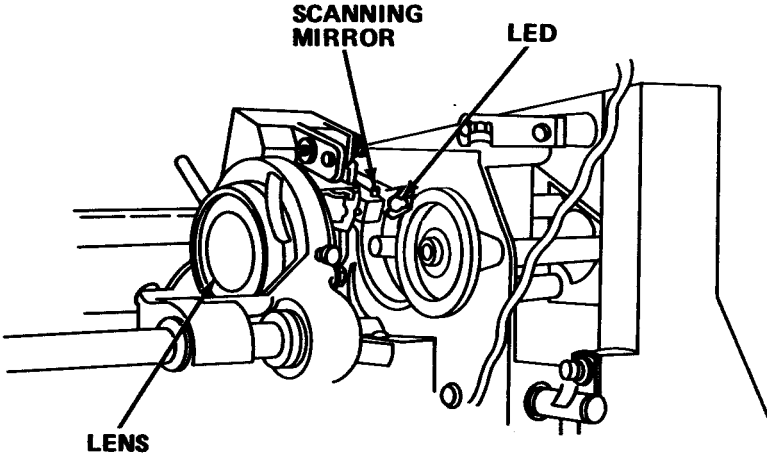
(Number) - Hundreds of Hours

ITEM NO.	INTERVAL	ITEM TO BE INSPECTED PROCEDURE
2	AN	<p><u>COMPOSING MACHINE - Cont</u></p> <p><u>Inspect Font Guides.</u></p> <div data-bbox="454 691 1323 1276" data-label="Image"> <p>The diagram shows a large, rectangular composing machine with a control console on the left side. The console includes a monitor and a keyboard. On the top surface of the main machine body, there is a rectangular panel. An arrow points from the text 'TOP LEFT PANEL' to this panel. The machine has a front panel with a horizontal slot and is supported by four small feet.</p> </div> <p>1. Open top left panel.</p>

Table 2-4. ORGANIZATIONAL PREVENTIVE MAINTENANCE CHECKS AND SERVICES - Cont

B - Before
D - During
A - After

W - Weekly
M - Monthly
Q - Quarterly

AN - Annually
S - Semiannually
BI - Biennially

(Number) - Hundreds of Hours

ITEM NO.	INTERVAL	ITEM TO BE INSPECTED PROCEDURE
2	AN	<p><u>COMPOSING MACHINE - Cont</u></p> <p><u>Inspect Font Guides - Cont</u></p>  <p style="text-align: center;"><u>WARNING</u></p> <p>Death or serious injury may occur from electrical shock unless power is turned off before servicing.</p> <p>2. Check that power switch is OFF.</p>

Table 2-4. ORGANIZATIONAL PREVENTIVE MAINTENANCE CHECKS AND SERVICES - Cont

B - Before
D - During
A - After

W - Weekly
M - Monthly
Q - Quarterly

AN - Annually
S - Semiannually
BI - Biennially

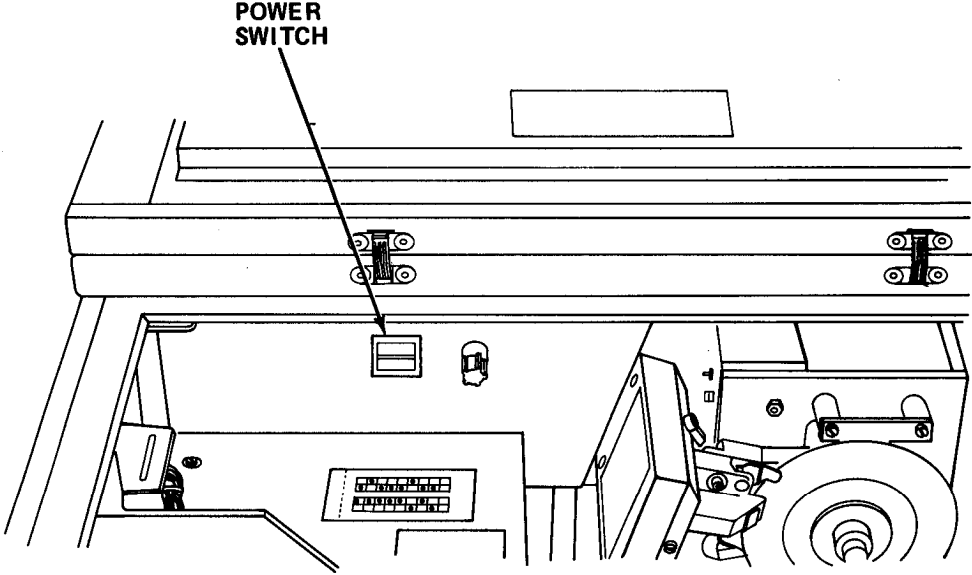
(Number) - Hundreds of Hours

ITEM NO.	INTERVAL	ITEM TO BE INSPECTED PROCEDURE
2	AN	<p><u>COMPOSING MACHINE - Cont</u></p> <p><u>Inspect Font Guides - Cont</u></p>  <p>REAR PANEL REMOVED</p> <p>3. Remove rear panels.</p>

Table 2-4. ORGANIZATIONAL PREVENTIVE MAINTENANCE CHECKS AND SERVICES - Cont

B - Before
D - During
A - After

W - Weekly
M - Monthly
Q - Quarterly

AN - Annually
S - Semiannually
BI - Biennially

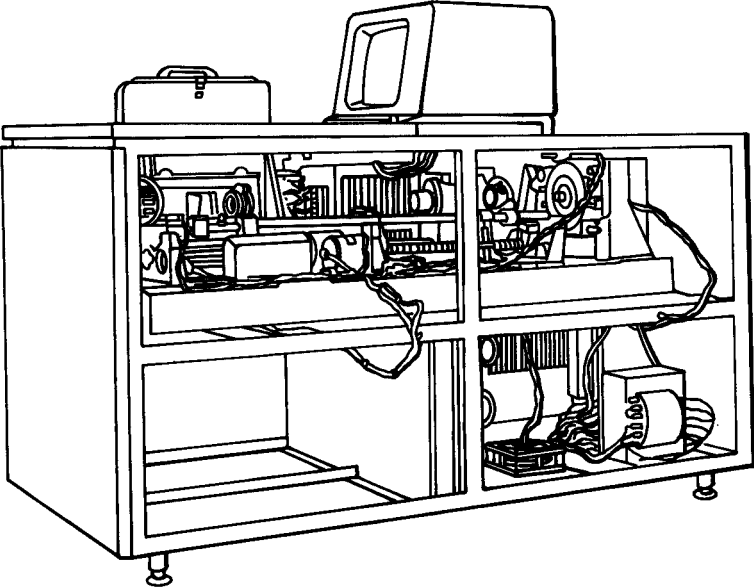
(Number) - Hundreds of Hours

ITEM NO.	IN-TER-VAL	ITEM TO BE INSPECTED	PROCEDURE
<u>COMPOSING MACHINE - Cont</u>			
2	AN	<u>Inspect Font Guides - Cont</u>	 <ol style="list-style-type: none"> <li data-bbox="310 1570 1027 1661">4. Inspect between font guides for excessive film lint. If lint is not found, proceed to step 9. <li data-bbox="310 1698 911 1730">5. Remove font guide mounting screws. <li data-bbox="310 1761 1117 1793">6. Use lens brush to remove lint from font guides. <li data-bbox="310 1825 1166 1857">7. Vacuum font guides to be sure all lint is removed.

Table 2-4. ORGANIZATIONAL PREVENTIVE MAINTENANCE CHECKS AND SERVICES - Cont

B - Before W - Weekly AN - Annually (Number) - Hundreds of Hours
 D - During M - Monthly S - Semiannually
 A - After Q - Quarterly BI - Biennially

ITEM NO.	INTERVAL	ITEM TO BE INSPECTED PROCEDURE
2	AN	<p><u>COMPOSING MACHINE - Cont</u></p> <p><u>Inspect Font Guides - Cont</u></p> <p>8. Reinstall font guide mounting screws.</p> <p>9. Replace rear panels.</p> <p>10. Remove left side panel.</p> <div data-bbox="508 840 1181 1383" style="text-align: center;"> <p style="text-align: center;">POWER SWITCH</p> </div> <p>11. Turn on power switch.</p>

Table 2-4. ORGANIZATIONAL PREVENTIVE MAINTENANCE CHECKS AND SERVICES - Cont

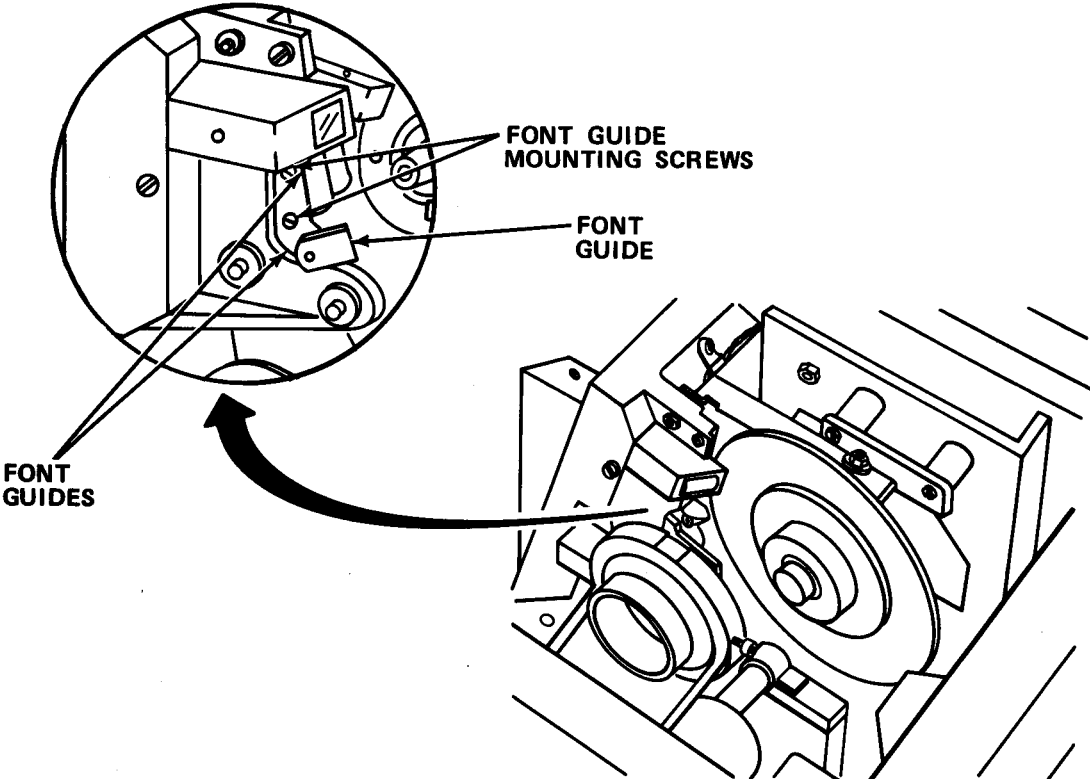
B - Before
D - During
A - After

W - Weekly
M - Monthly
Q - Quarterly

AN - Annually
S - Semiannually
BI - Biennially

(Number) - Hundreds of Hours

ITEM NO.	INTERVAL	ITEM TO BE INSPECTED PROCEDURE
2	AN	<p><u>COMPOSING MACHINE - Cont</u></p> <p><u>Inspect Font Guides - Cont</u></p> <div data-bbox="508 634 1240 1108" data-label="Image"> </div> <p>12. Check that fans operate.</p> <p>13. Turn off power switch.</p> <p>14. Reinstall left side and top left panels.</p>

2-15. ORGANIZATIONAL TROUBLESHOOTING PROCEDURES.

a. Organizational troubleshooting procedures cover the most common malfunctions that may be repaired at the organizational level. Repair or adjustment requiring specialized equipment is not authorized unless such equipment is available. Troubleshooting procedures used by the operator should be conducted in addition to the organizational troubleshooting procedures.

b. This manual cannot list all the possible malfunctions or every possible test/inspection and corrective action. If a malfunction is not listed or is not corrected by a listed corrective action, notify your supervisor.

c. For unidentified malfunctions, use the facing schematic or the foldout located at the end of this manual for further fault analysis.

NOTE

Sufficient data is not available for you to test or troubleshoot printed circuit boards. When associated wiring, ribbon cables, power cords and other related electrical components have been eliminated as possible faults, then the printed circuit boards must be substituted, one for one, until the fault is isolated.

Table 2-5, ORGANIZATIONAL TROUBLESHOOTING

MALFUNCTION
TEST OR INSPECTION
CORRECTIVE ACTION
1. GENERAL DENSITY OF COPY IS LOW. Check high voltage supply output to flash lamp. If incorrect, replace flash power supply (paragraph 2-16.9).

Table 2-5. ORGANIZATIONAL TROUBLESHOOTING - Cont

MALFUNCTION

TEST OR INSPECTION

CORRECTIVE ACTION

2. FOCUS IS GENERALLY POOR.

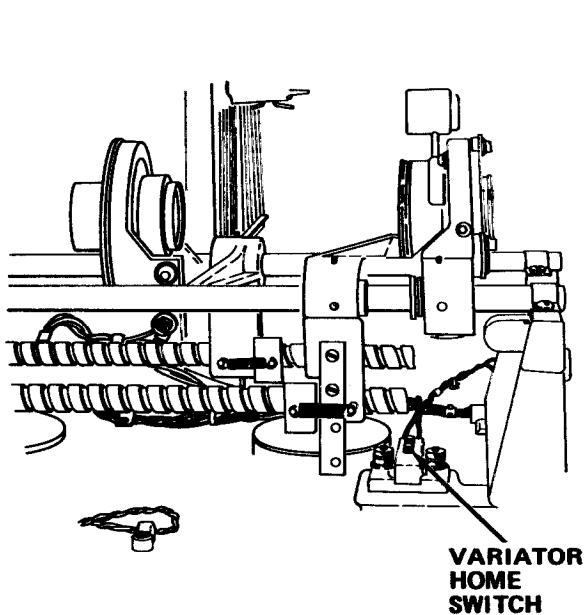

REAR OF COMPOSING MACHINE
REAR PANEL REMOVED

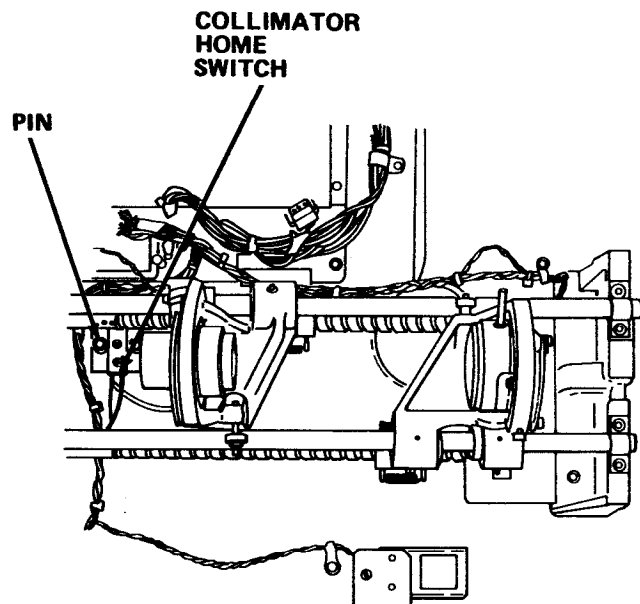

REAR OF COMPOSING MACHINE
REAR PANEL REMOVED

Step 1. Check that variator and collimator home switches are properly adjusted and make certain that they are against pin.

(a) If properly adjusted, proceed to step 2.

(b) Adjust switches.

Step 2. Check if lenses are secure in their mounts.

Tighten **lenses**.

Table 2-5. ORGANIZATIONAL TROUBLESHOOTING - Cont

MALFUNCTION**TEST OR INSPECTION****CORRECTIVE ACTION**

3. NO POWER.

- Step 1. Check for presence of 120 V ac output from constant voltage transformer at TB1.
- (a) If present, proceed to step 2.
 - (b) If not present, refer to direct/general support maintenance.
- Step 2. Check for presence of 120 V ac at input of line filter FL1.
- (a) If present, proceed to step 4.
 - (b) If not present, proceed to step 3.
- Step 3. Check fuse F1 for continuity.
- (a) If continuity is present, proceed to step 4.
 - (b) If not, replace fuse (paragraph 2-20. 1).
- Step 4. Check output of line filter FL1 for 120 V ac.
- (a) If present, proceed to step 5.
 - (b) If not, replace line filter (paragraph 2-16.1).
- Step 5. Check input of transformer T1 for 120 V ac.
- (a) If present, replace transformer (paragraph 2-16.2).
 - (b) If not present, refer to direct/general support maintenance.

4. NO VOLTAGES FROM POWER SUPPLY.

- Step 1. Check transformer for continuity.
- (a) If continuity exists, proceed to step 2.
 - (b) If defective, replace transformer (paragraph 2-16.2).

Table 2-5. ORGANIZATIONAL TROUBLESHOOTING - Cont

MALFUNCTION	TEST OR INSPECTION	CORRECTIVE ACTION
4. NO VOLTAGES FROM POWER SUPPLY - Cont	Step 2. Check driver power supply fuse for continuity.	(a) If continuity exists, proceed to step 3. (b) If defective, replace fuse (paragraph 2-16.7).
<u>WARNING</u>		
	High voltages that are capable of causing death may be stored in capacitor after power is removed. Be sure capacitor is discharged and reduced to zero volts.	
	Step 3. Check filter capacitors.	(a) If capacitor is defective, replace (paragraph 2-16.4). (b) Refer to direct/general support maintenance.
5. NO DISPLAY ON MONITOR.	Check continuity of monitor fuse f2.	Replace fuse (paragraph 2-16.6).
6. PROLONGED BEEP SOUNDS DO NOT STOP.	Internal temperature too high, check operation of fans.	Replace fans (paragraph 2-16.3).
7. NO SOUND FROM LOUDSPEAKER.	Check loudspeaker for continuity.	Replace loudspeaker (paragraph 2-16.5).

2-16. MAINTENANCE PROCEDURES.

This section contains instructions covering organizational maintenance functions for the composing machine. Personnel required are listed only if the task requires more than one.

b. After completing each maintenance procedure, perform operational check to be sure equipment is properly functioning.

INDEX

PROCEDURES	PARAGRAPH
Replace Line Filter	2-16.1
Replace Transformer	2-16.2
Replace Fan(s)	2-16.3
Replace Filter Capacitors	2-16.4
Replace Loudspeaker	2-16.5
Replace Input/Monitor Unit Fuse	2-16.6
Replace Driver Power Supply Fuses	2-16.7
Replace Flash Tube and Trigger Pac	2-16.8
Replace Flash Power Supply PC Board	2-16.9
Remove/Install Composing Machine	2-16.10

2-16.1 Replace Line Filter.

MOS: 35E, Special Electronic Devices Repairer

TOOLS : Flat Tip Screwdriver

SUPPLIES: Line Filter

WARNING

Death or serious injury may occur from electrical shock unless power is turned off before servicing.

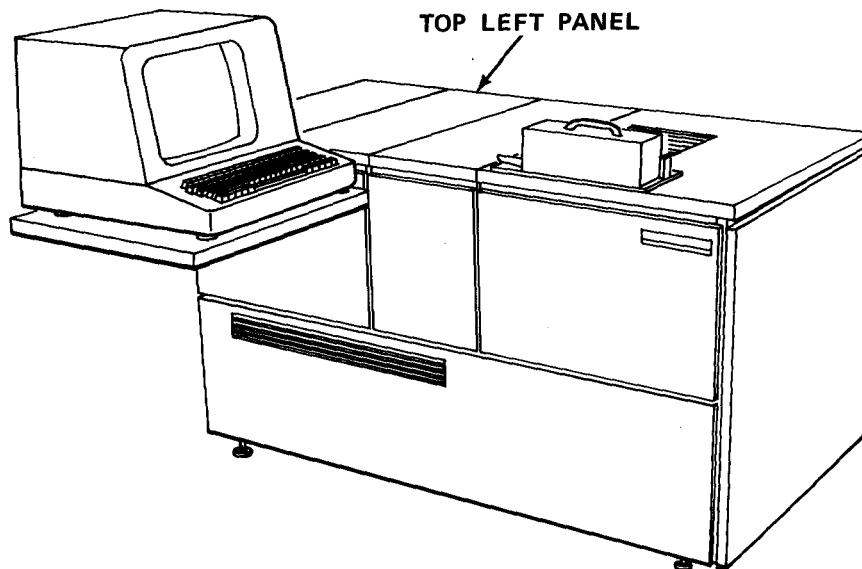

- a. Open top left panel.

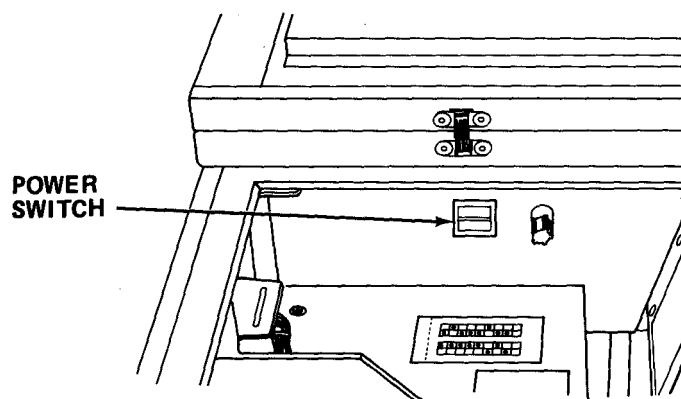

- b. Turn off power switch.

- c. Turn off circuit breaker.

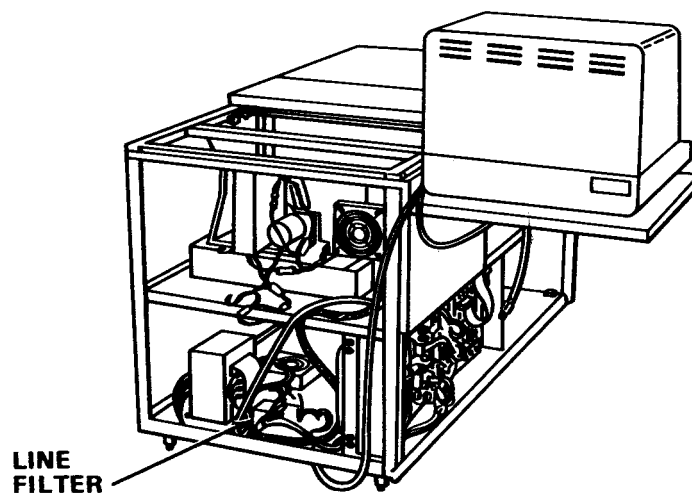

- d. Remove left **side** panel .

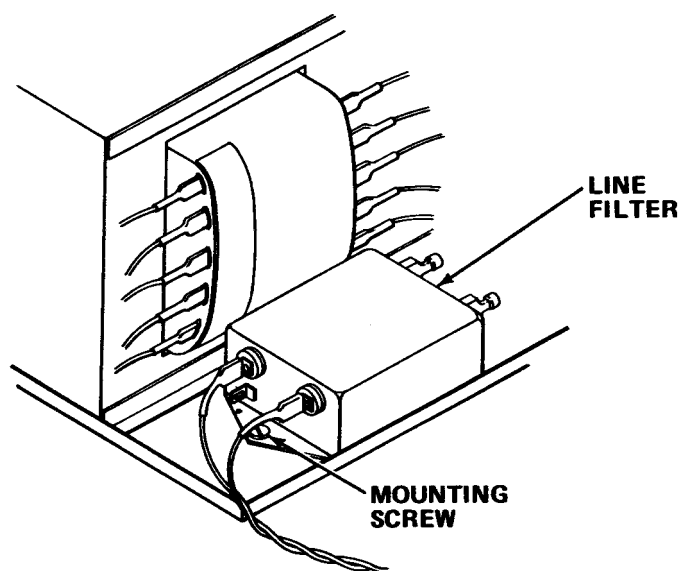

- e. Tag and disconnect line filter wires.
- f. Remove line filter mounting screws.
- g. Remove defective line filter.
- h. Install new line filter and secure with mounting screws.

- i. Reconnect line filter wires.
- j. Reinstall left side panel.
- k. Close top left panel.
- l. Turn on circuit breaker,
- m. Turn on power switch.

2-16.2 Replace Transformer.

MOS: 35E, Special Electronic Devices Repairer

PERSONNEL: Four persons are required to perform this procedure.

TOOLS : Flat Tip Screwdriver
3/16 in. Hex Head Key Wrench

SUPPLIES: Transformer

WARNING

Death or serious injury may occur from electrical shock unless power is turned off before servicing.

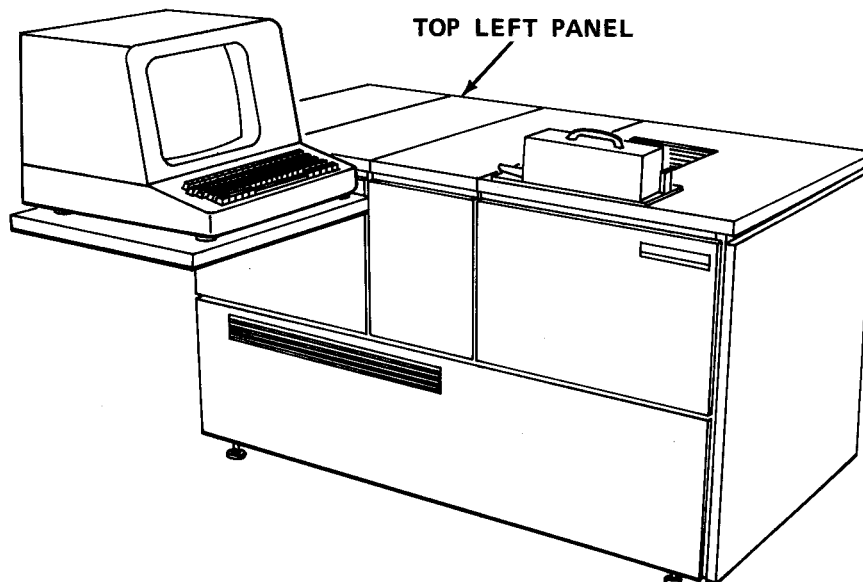

- a. Raise top left panel.

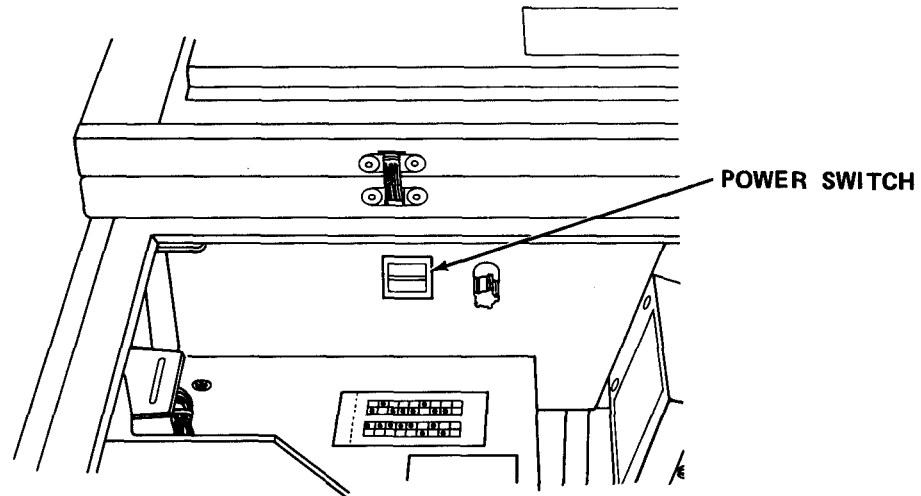

- b. Turn off power switch.
- c. Turn off circuit breaker.

WARNING

To avoid personal injury, four persons are required to move the composing machine. This equipment weighs 485 lbs (220kg).

- d. Move composing machine away from wall (paragraph 2-16.10).

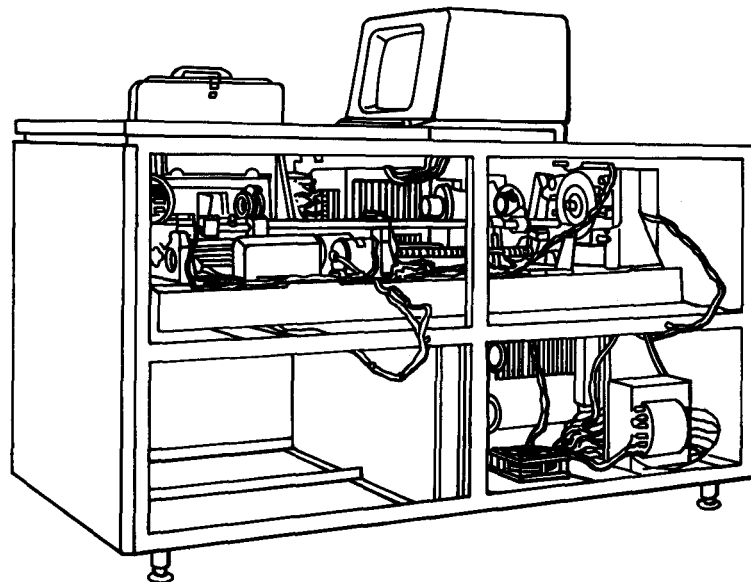

REAR PANEL REMOVED

- e. Remove left rear panel and left side panel.
- f. Tag and disconnect all transformer wires.

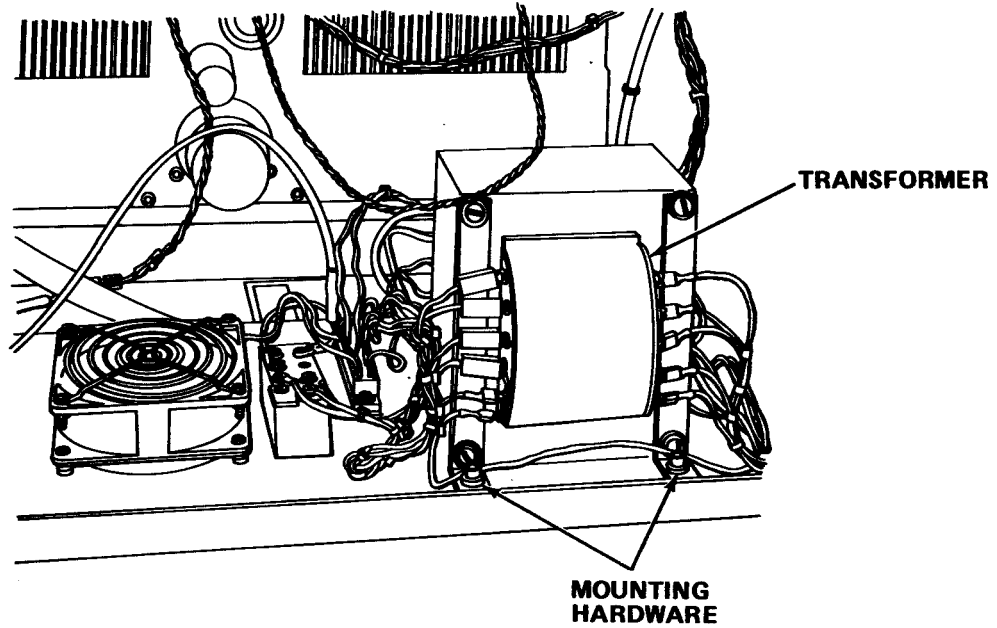

- g. Remove mounting hardware and defective transformer.

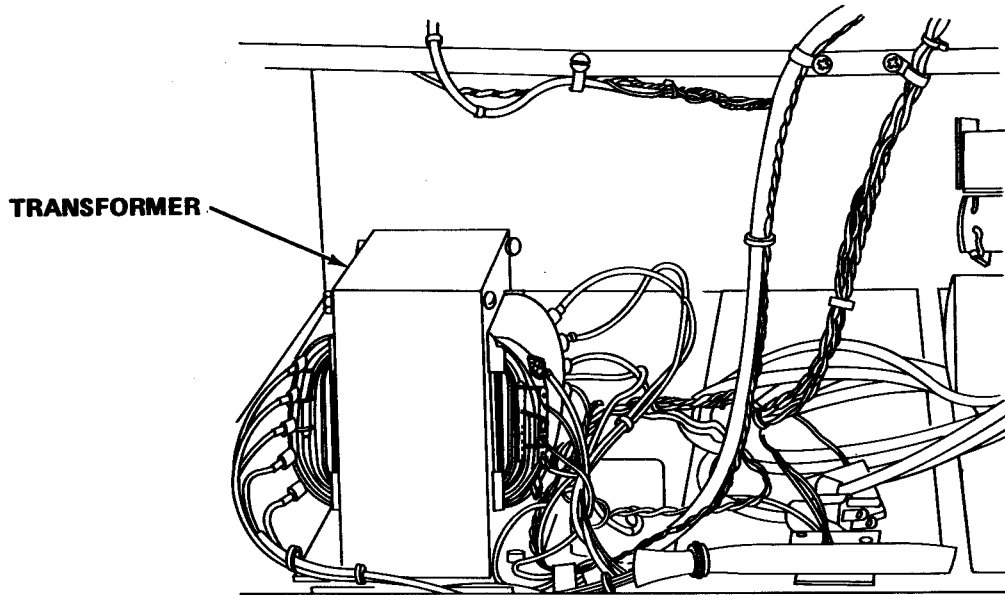

- h. Install new transformer.

- i. Secure with mounting hardware.
- j. Reconnect transformer wires.
- k. Install left side and left rear panels.
- l. Move composing machine back to wall and reinstall on mounts (paragraph 2-16.10).
- m. Close top left panel.
- n. Turn on circuit breaker.
- o. Turn on power switch.

2-16.3 Replace Fan(s)

MOS: 35E, Special Electronic Devices Repairer

TOOLS : Flat Tip Screwdriver
 5/16 in. Combination Wrench
 5/16 in., Socket ¼ in. Drive
 ¼ in. Ratchet

SUPPLIES: Fan(s)
 Fan Power Cord

WARNING

Death or serious injury may occur from electrical shock unless power is turned off before servicing.

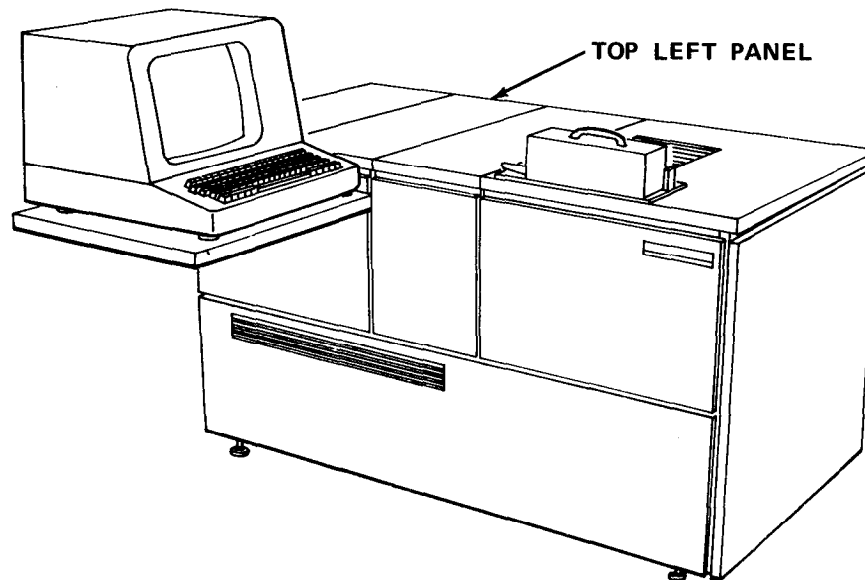

- a. Open top left panel .

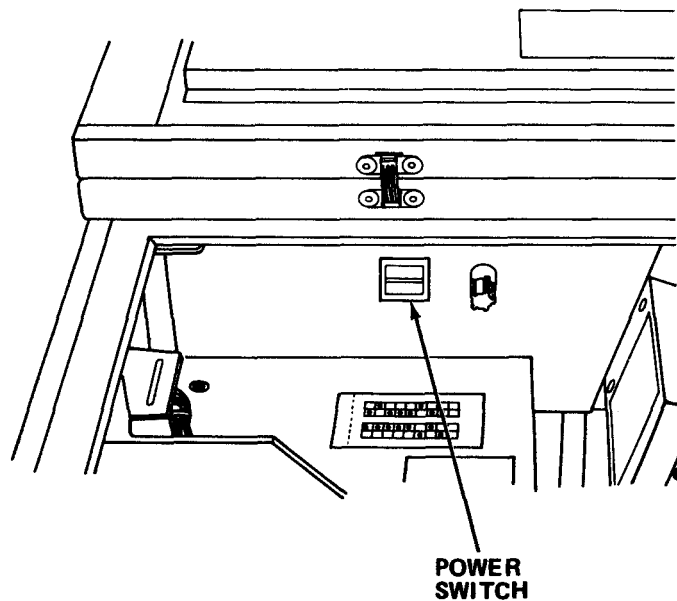

- b. Turnoff power switch.
- c. Turn off circuit breaker.

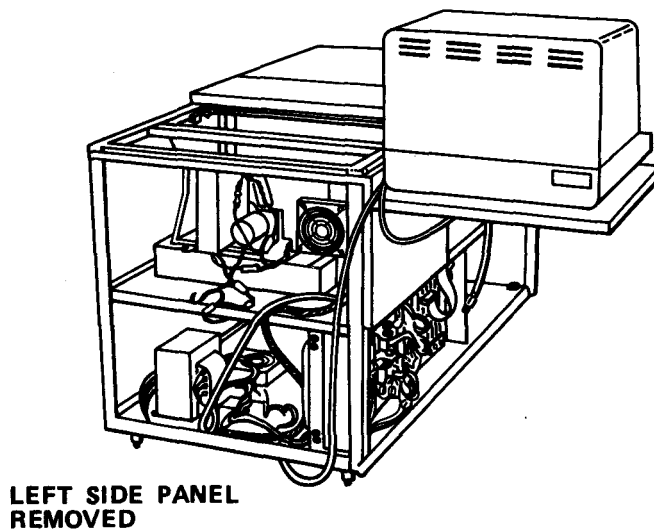

- d. Remove left side panel.

Use steps e. through j. for replacing microprocessor cooling fan; steps k. through p. for replacing power supply cooling fan.

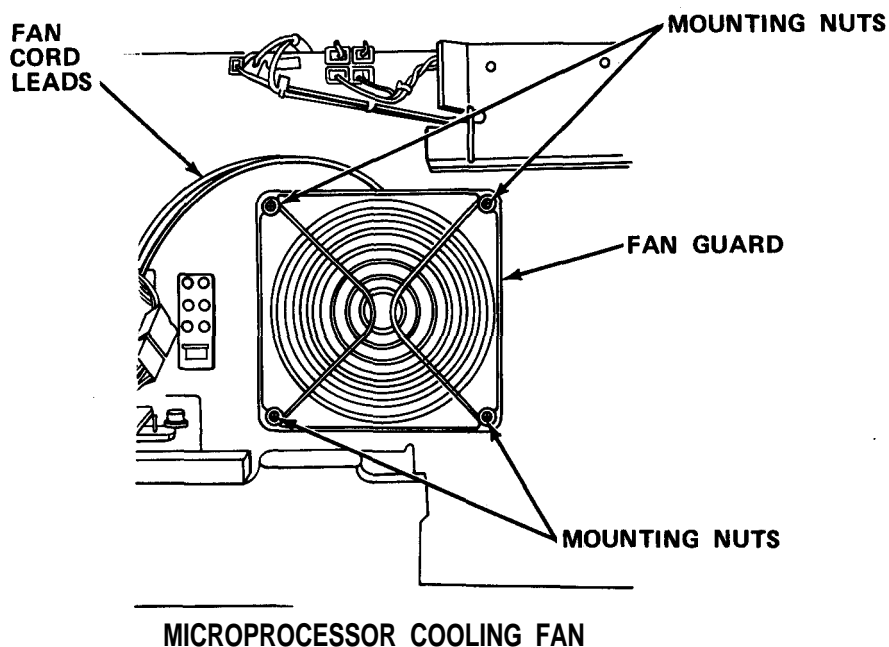

- e. Unplug microprocessor fan power cord.
- f. Remove fan mounting nuts, washers, lockwashers, and bolts.
- g. Remove fan assembly.
- h. Place new fan guard on fan.
- i. Mount fan assembly and secure with bolts, washers, lockwashers, and nuts.
- j. Plug in fan power cord.

NOTE

If power supply cooling fan is not to be replaced at this time, proceed to step q.

- k. Unplug power supply cooling fan power cord.

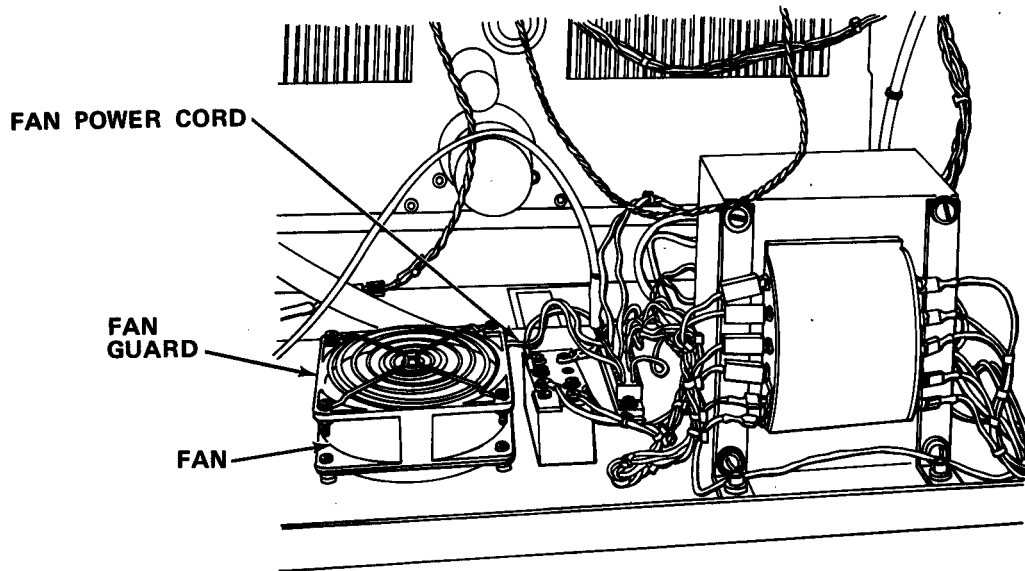

POWER SUPPLY COOLING FAN

- l.** Remove mounting nuts, washers, and lockwashers and defective fan assembly.
- m.** Remove screws, washers, lockwashers and fan guard from defective fan.
- n.** Install fan guard on new fan.
- o.** Reinstall fan assembly and secure with bolts, lockwashers, washers and nuts.
- p.** Plug in fan power cord.
- q.** Install left side panel.
- r.** Turn on circuit breaker.
- s.** Turn on power switch.
- t.** Close top left panel.

2-16.4 Replace Filter Capacitor.

MOS: 35E, Special Electronic Devices Repairer

TOOLS: Flat Tip Screwdriver
Flat Tip Captive Screwdriver

SUPPLIES: Filter Capacitor(s)

WARNING

Death or serious injury may occur from electrical shock unless power is turned off before servicing.

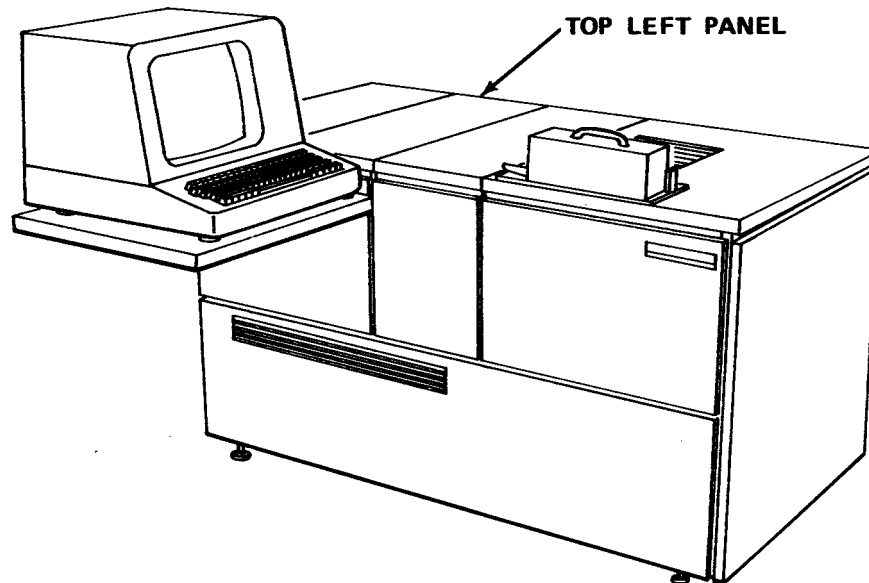

- a. Open top left panel.

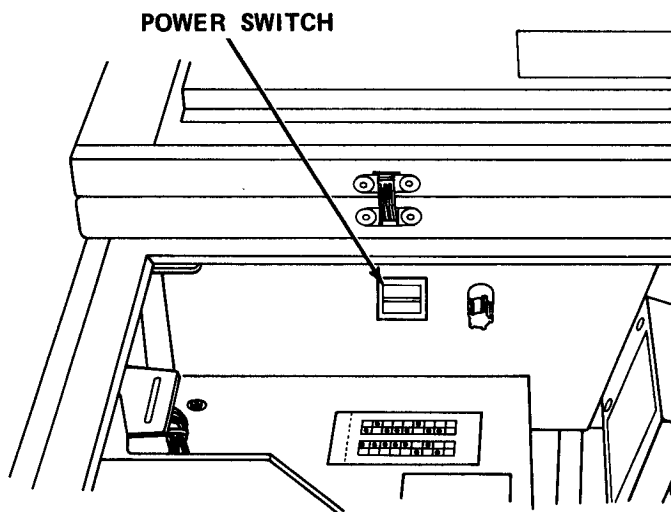

- b. Turn off power switch.
- c. Turn off circuit breaker.

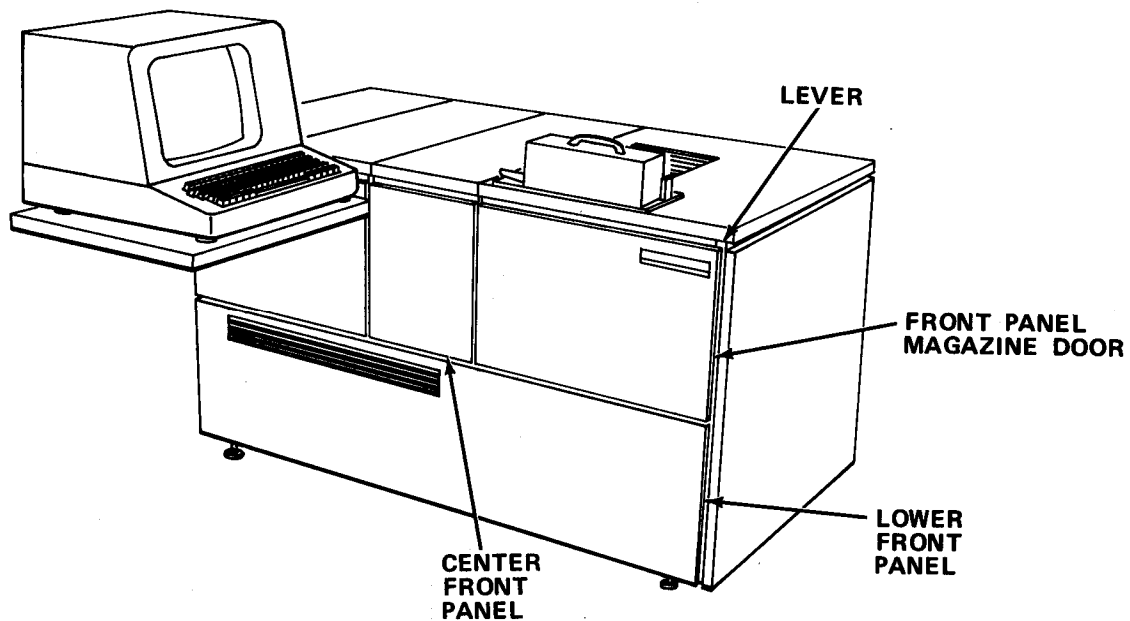

- d. Lift lever and open front panel magazine door.
- e. Remove one screw and center front panel.
- f. Lift and remove lower front panel.

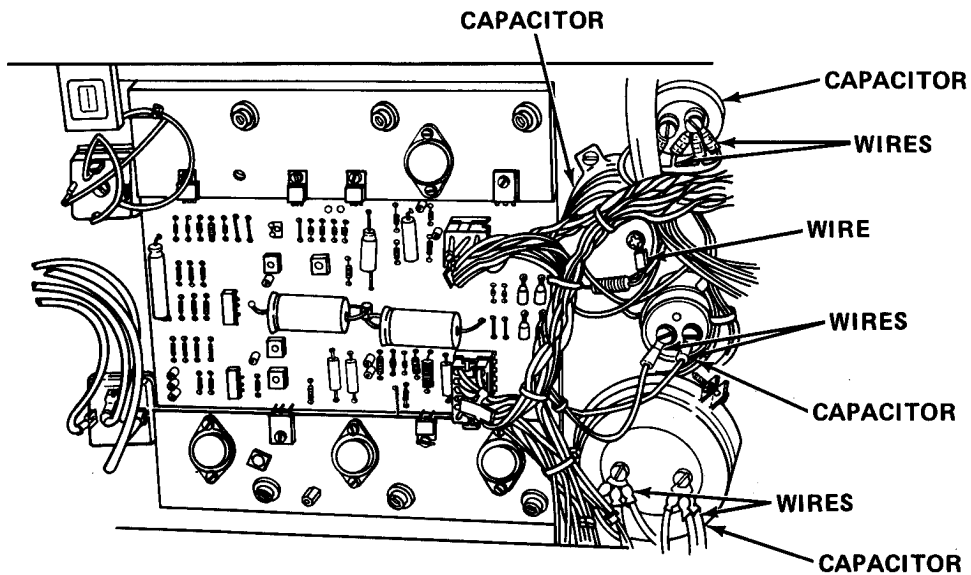
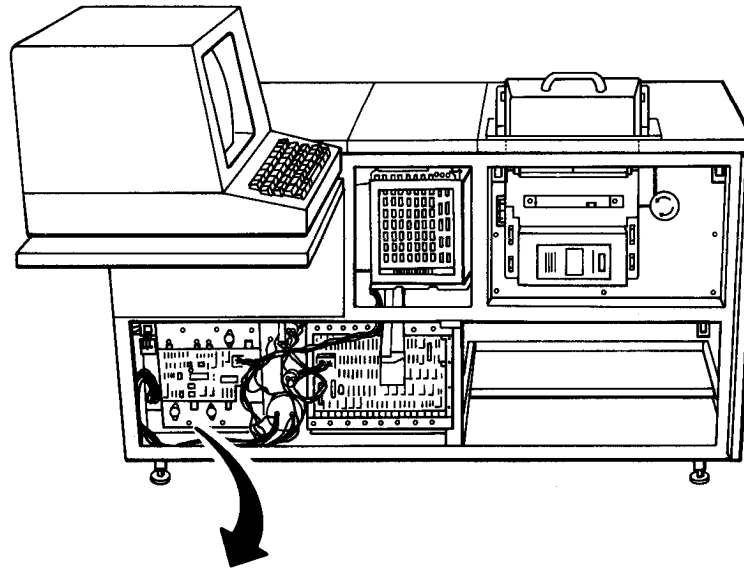

WARNING

High voltages that are capable of causing death may be stored in capacitor after power is removed. Be sure capacitor is discharged and reduced to zero volts.

NOTE

Tag all capacitor wires. Do not lose any components.

- g. Tag and remove wires from capacitor(s).

- h. Remove mounting screws and remove defective capacitor(s) with mounting bracket.
- i. Remove defective capacitor(s) from mounting bracket and install new capacitor(s) on mounting bracket.
- j. Install new capacitor(s) and mounting bracket.
- k. Tighten mounting screws.
- l. Connect wires to new capacitor(s).
- m. Reinstall lower front panel.
- n. Reinstall center front panel and secure with screw.
- o. Close front panel magazine door.
- p. Turn on circuit breaker.
- q. Turn on power switch.
- r. Close left top panel.

2-16.5 Replace Loudspeaker.

MOS: 35E, Special Electronic Devices Repairer

TOOLS: Flat Tip Screwdriver

SUPPLIES: Loudspeaker

WARNING

Death or serious injury may occur from electrical shock unless power is turned off before servicing.

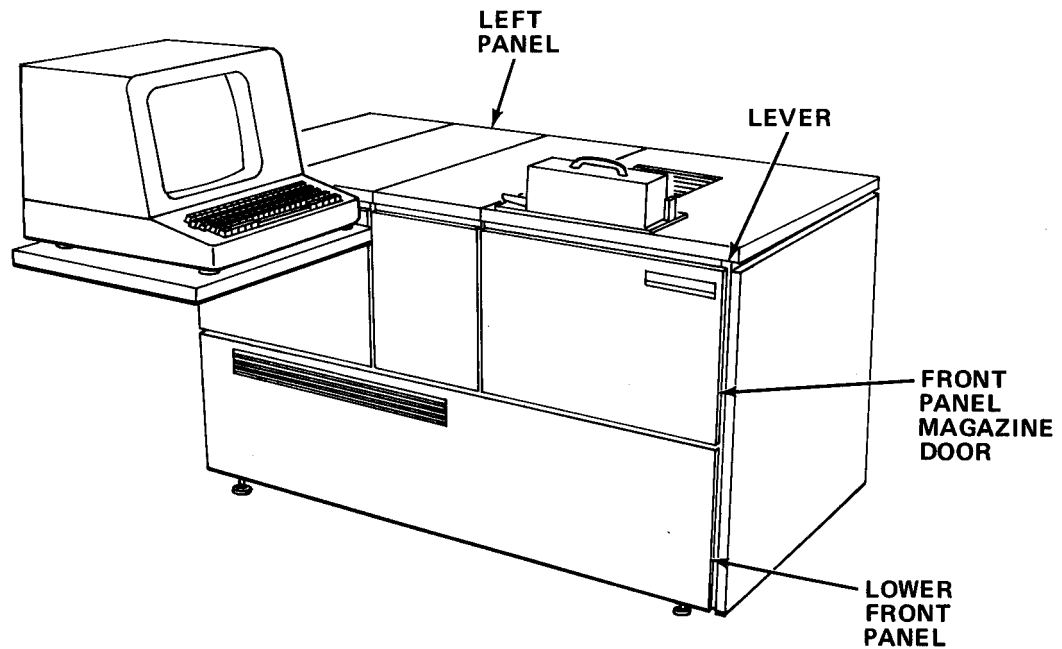

- a. Open top left panel.
- b. Turn off power switch.
- c. Turn off circuit breaker.
- d. Lift lever and open front panel magazine door.
- e. Remove screw and top center panel.
- f. Lift and remove lower front panel.

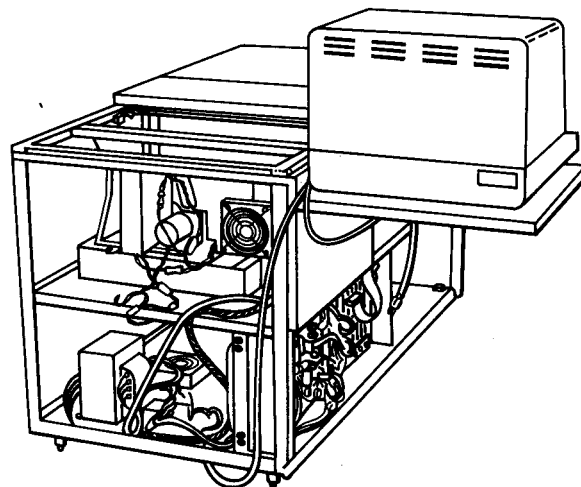

- g. Remove left side panel.

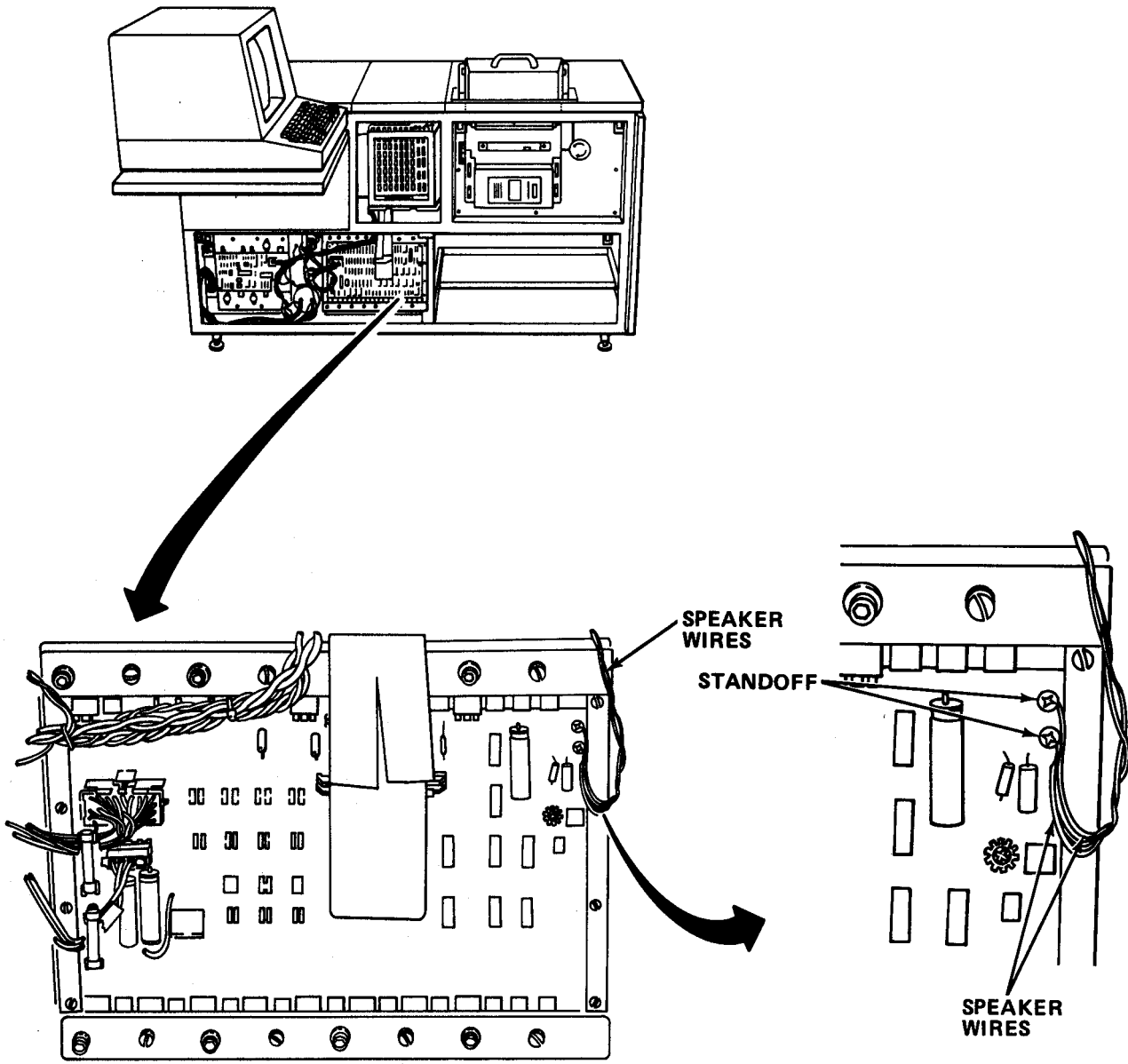

- h. Tag and disconnect loudspeaker wires.
- i. Move to left side of composing machine.

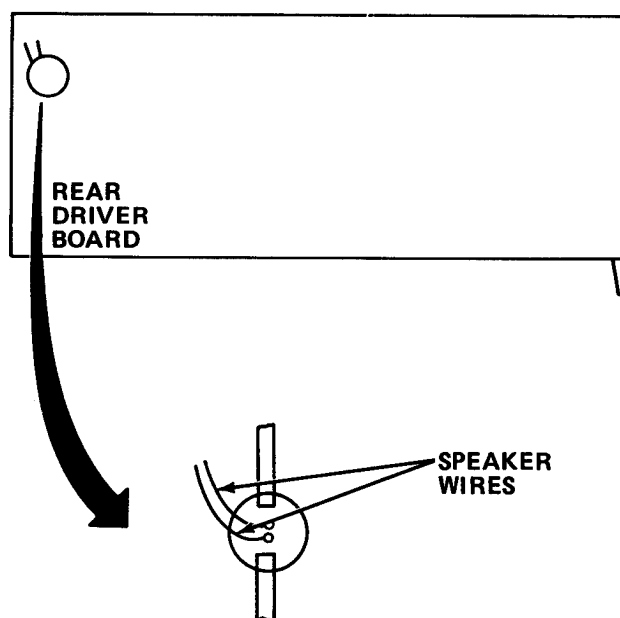

- j. Disconnect loudspeaker from its mounting base by sliding toward left of machine.
- k. Pull loudspeaker wires clear of driver supply board.
- l. Install new loudspeaker.
- m. Push wires through opening at left edge of driver supply board.
- n. Reconnect loudspeaker wires to driver supply board.
- o. Reinstall lower front panel.
- p. Reinstall left side panel.
- q. Reinstall top center panel and secure with screw.
- r. Close front panel magazine door.
- s. Turn on circuit breaker.
- t. Turn on power switch.
- u. Close top left panel.

2-16.6 Replace Input/Monitor Unit Fuse.

MOS: 35E, Special Electronic Devices Repairer

TOOLS: Flat Tip Screwdriver
Fuse Puller

SUPPLIES: Fuse (1 amp, Slo-Blow)

WARNING

Death or serious injury may occur from electrical shock unless power is turned off before servicing.

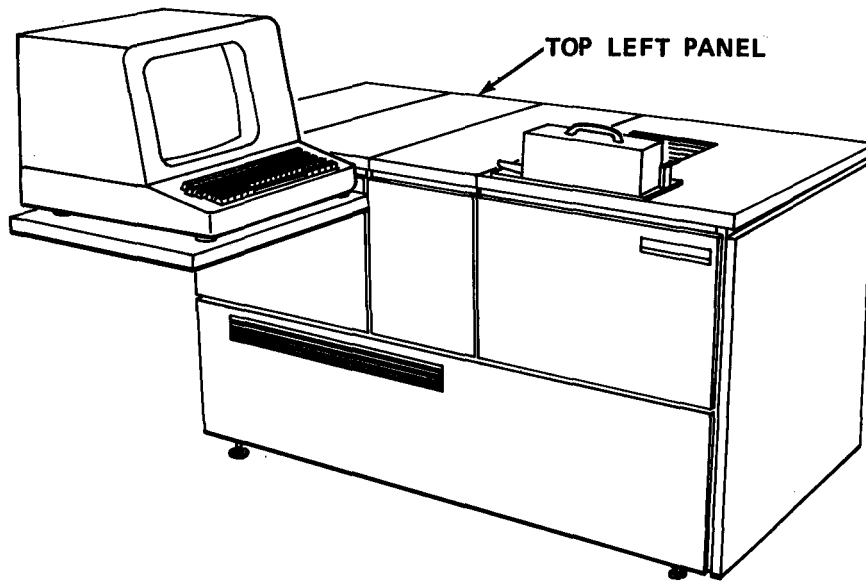

- a. Open top left panel.

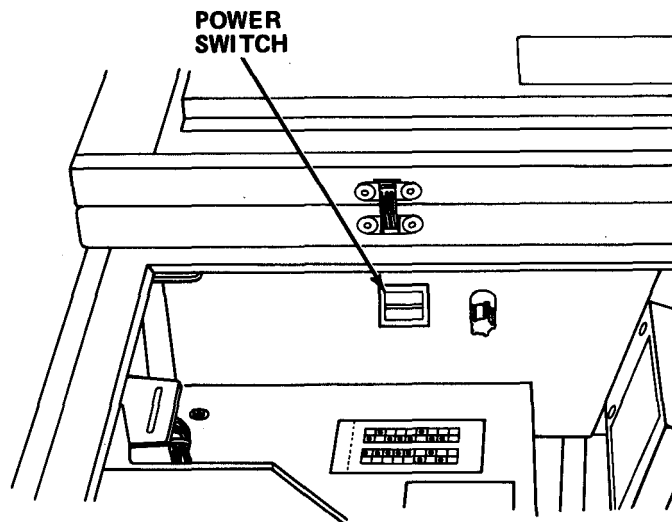

- b. Turn off power switch.
- c. Turn off circuit breaker.

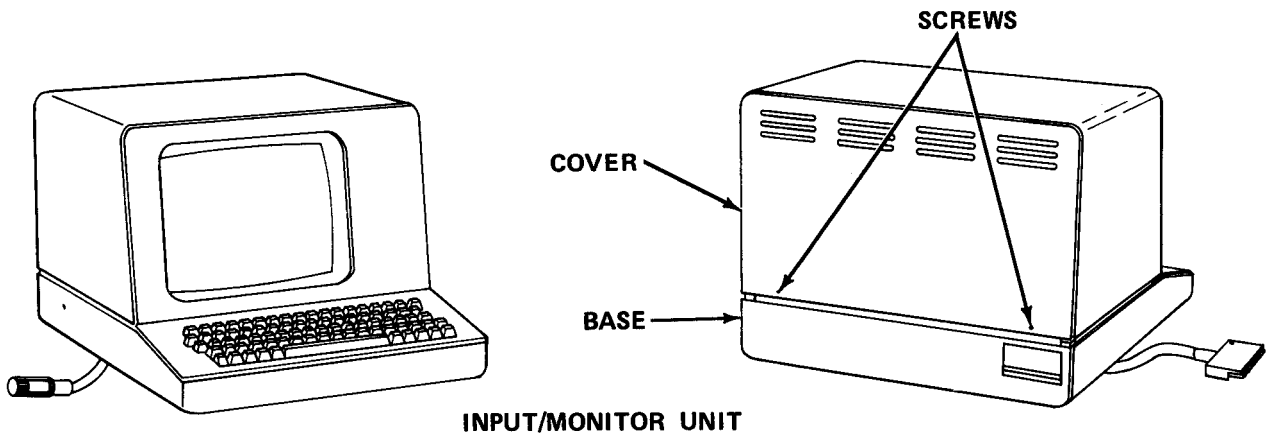

- d. Remove two screws from rear of input/monitor cover.
- e. Lift cover clear of base of input/monitor unit.

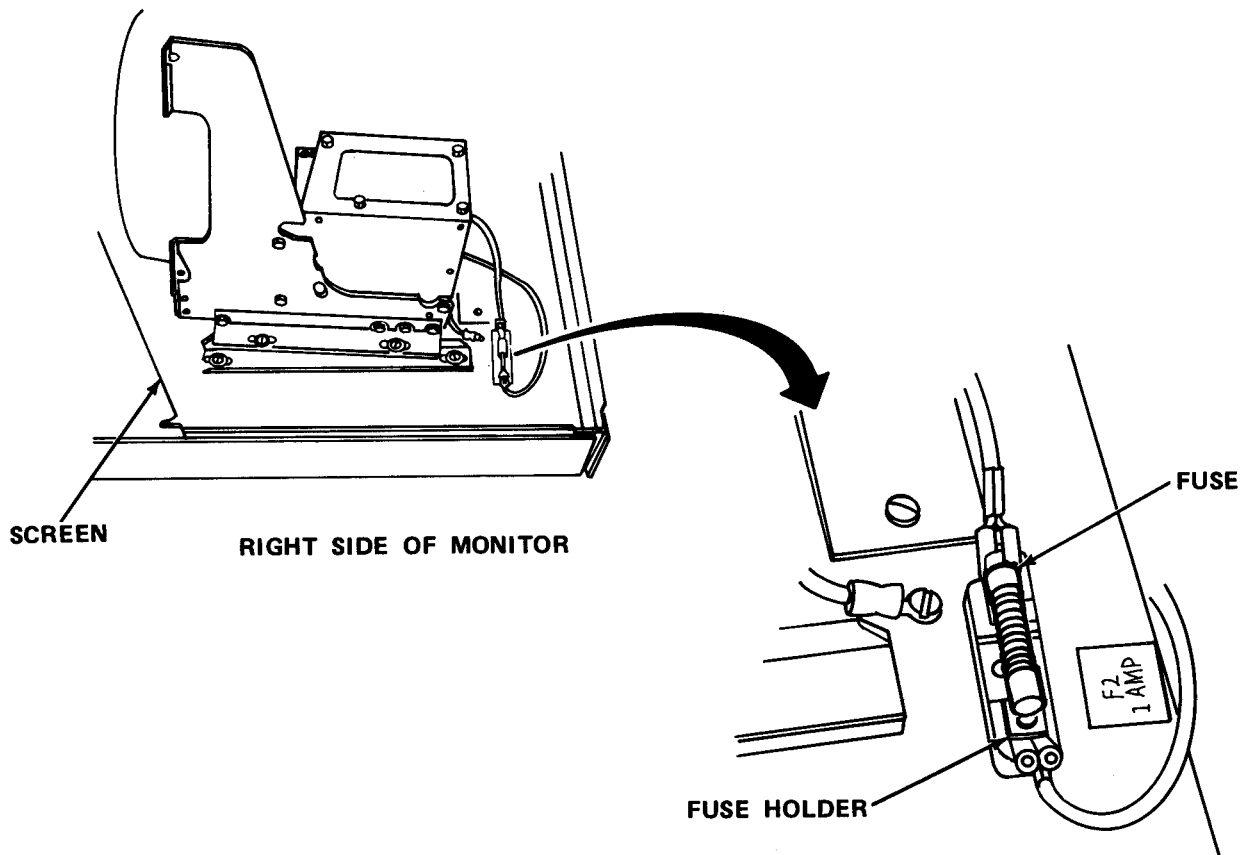

- f. Remove defective fuse from fuse holder.

- g. Install new fuse in fuse holder.
- h. Reinstall cover on base of input/monitor unit.
- i. Turn on circuit breaker.
- j. Turn on power switch.
- k. Close top left panel.

2-16.7 Replace Driver Power Supply Fuses.

MOS: 35E, Special Electronic Devices Repairer

TOOLS: Flat Tip Screwdriver
Fuse Puller

SUPPLIES: Fuse (6 amp Slo-Blow)
Fuse (10 amp)

WARNING

Death or serious injury may occur from electrical shock unless power is turned off before servicing.

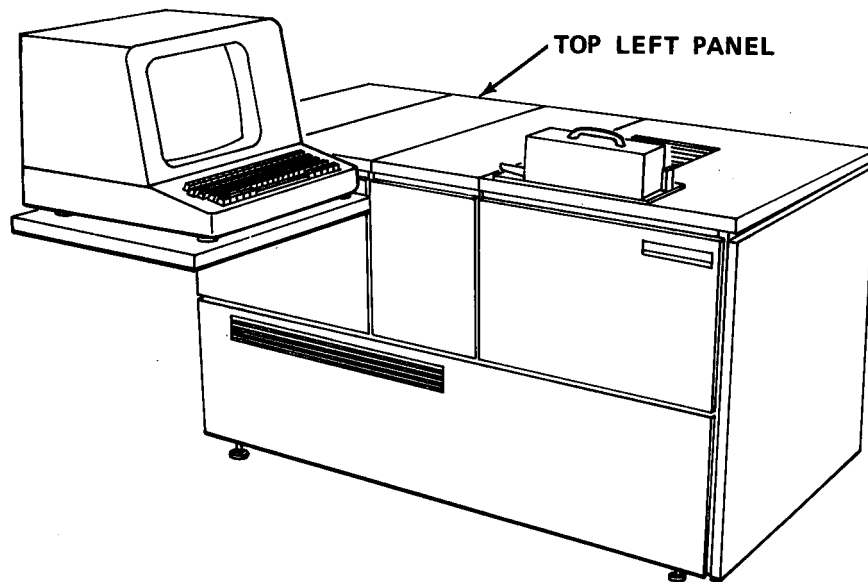

- a. Open top left panel.

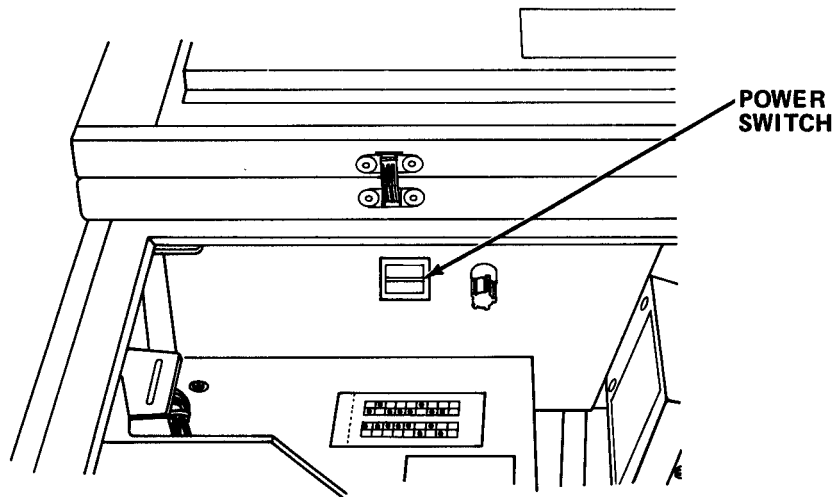

- b. Turn off power switch.
- c. Turn off circuit breaker.

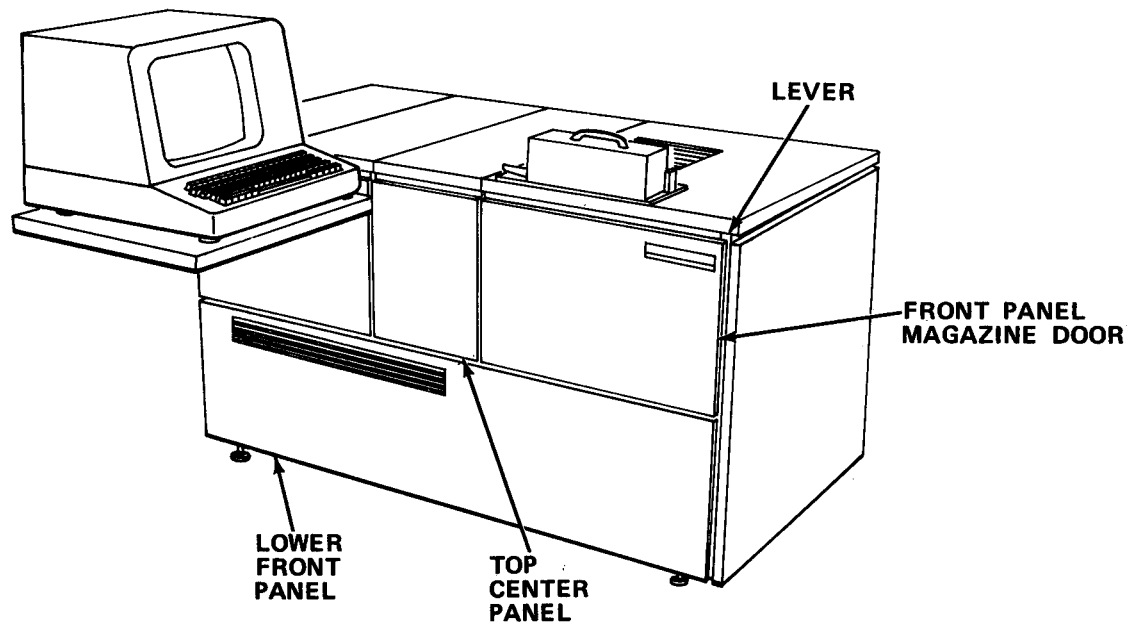

- d. Lift lever.
- e. Open front panel magazine door.
- f. Remove screw and top center panel.

- g. Remove lower front panel.

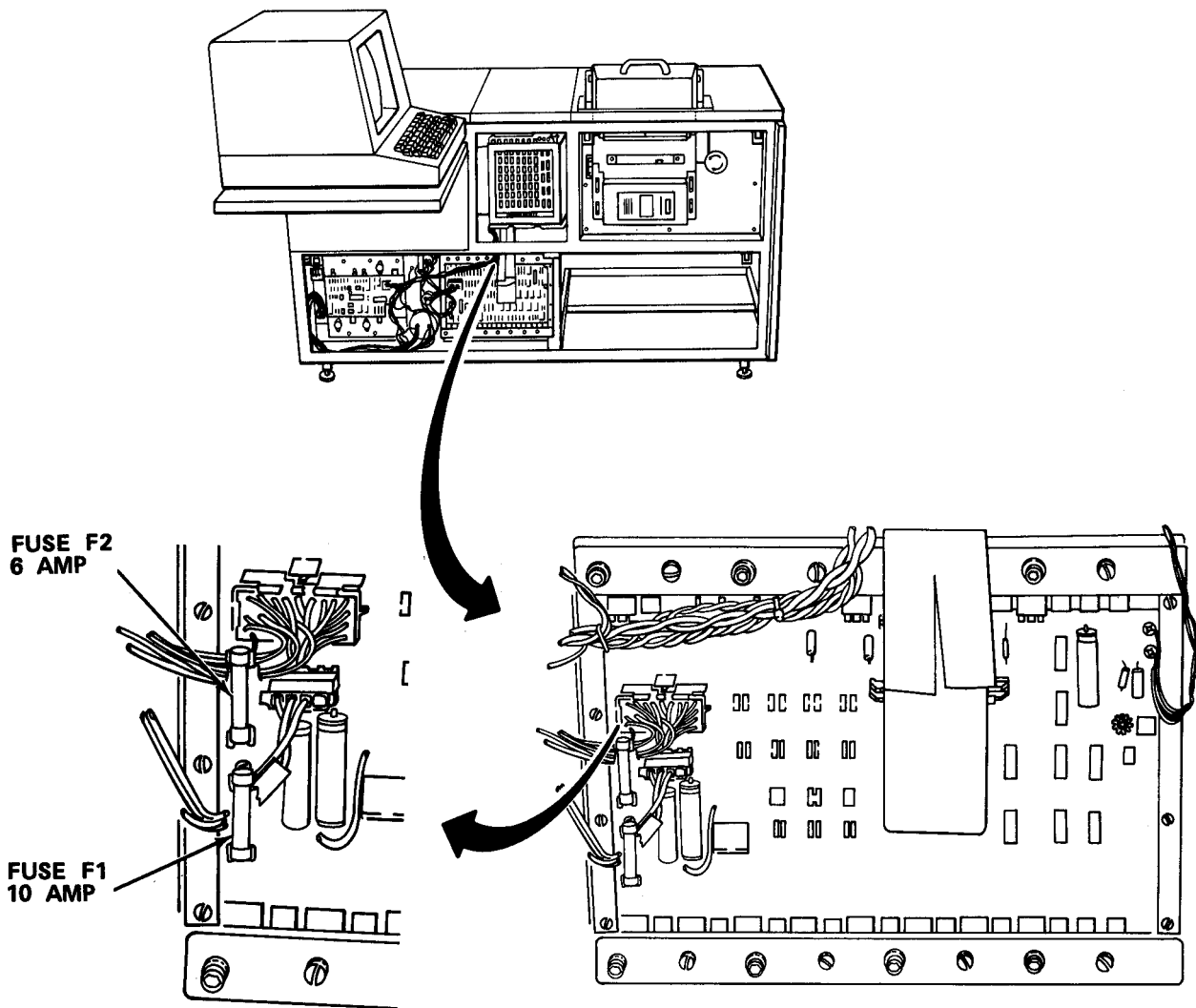

- h. Remove defective fuse F1 (10 amp).
- i. Install new fuse F1.
- j. Remove defective fuse F2 (6 amp).
- k. Install new fuse F2.
- l. Reinstall lower front panel.
- m. Reinstall top center panel and secure with screw.
- n. Close front panel magazine door.

- 0. Turn on circuit breaker.
- p. Turn on power switch.
- q. Close top left panel.

2-16.8 Replace Flash Tube and Trigger Pac.

MOS: 35E, Special Electronic Devices Repairer

TOOLS: Flat Tip Screwdriver 2 x 1/8 in.

1/4 in. Open End Wrench

1/4 in. Socket 1/4 in. Drive

1/4 in. Drive Ratchet

SUPPLIES: Flash Tube
Trigger Pac

WARNING

Death or serious injury may occur from electrical shock unless power is turned off before servicing.

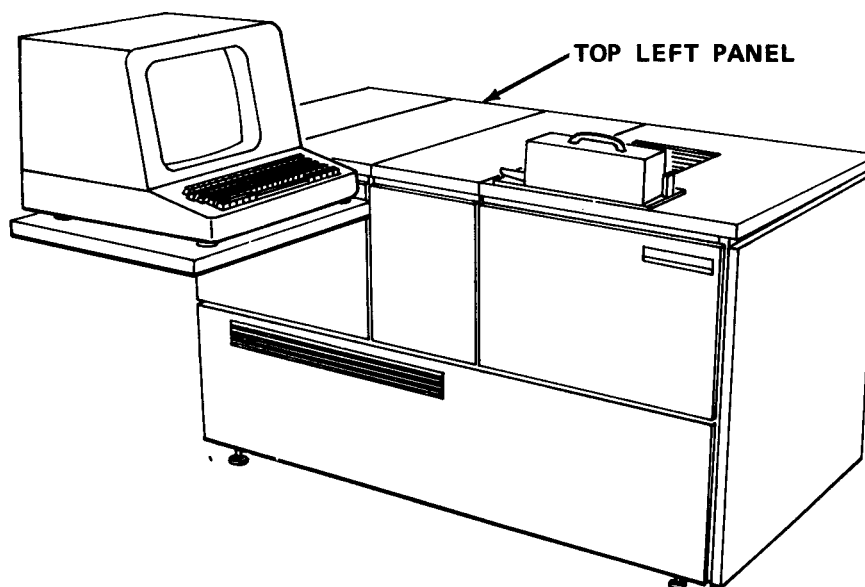

- a. Open top left panel.

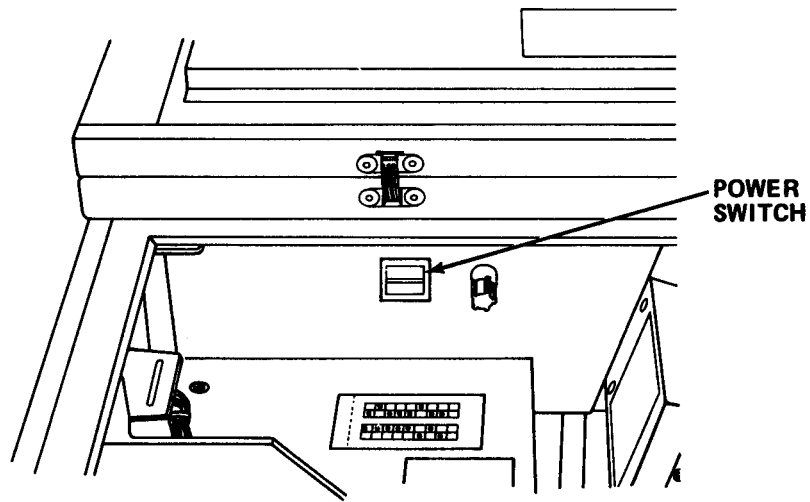

- b. Turn off power switch.
- c. Turn off circuit breaker.

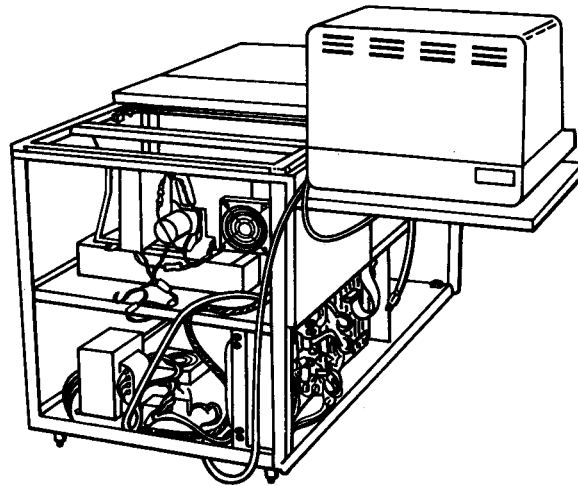

LEFT SIDE PANEL

- d. Remove left side panel.

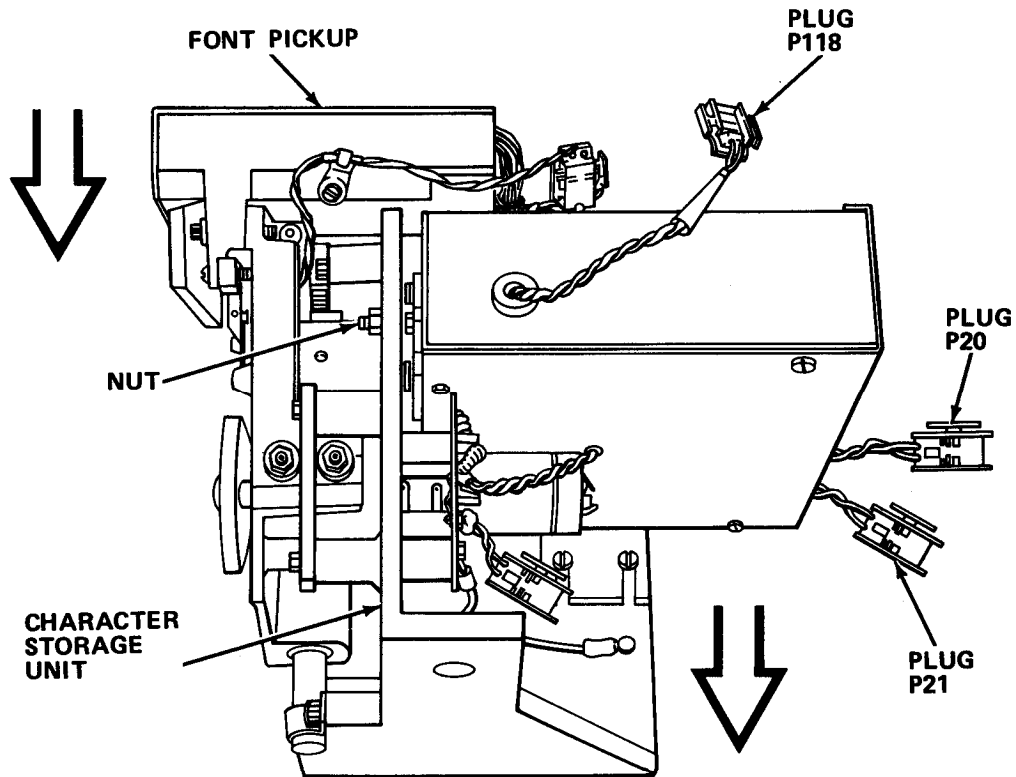

WARNING

High voltages that are capable of causing death may be stored in capacitor after power is removed. Be sure capacitor is discharged and reduced to zero volts.

- e. Disconnect plugs (P118, P20 and P21).
- f. Remove flat head screw at rear of flash power supply base.
- g. Loosen two small bolts at forward side of power supply base.
- h. Carefully slide character storage unit toward rear of machine while lifting gently on flash power supply.
- i. Remove flash power supply from character storage unit.
- j. Remove four screws and cover from flash power supply.

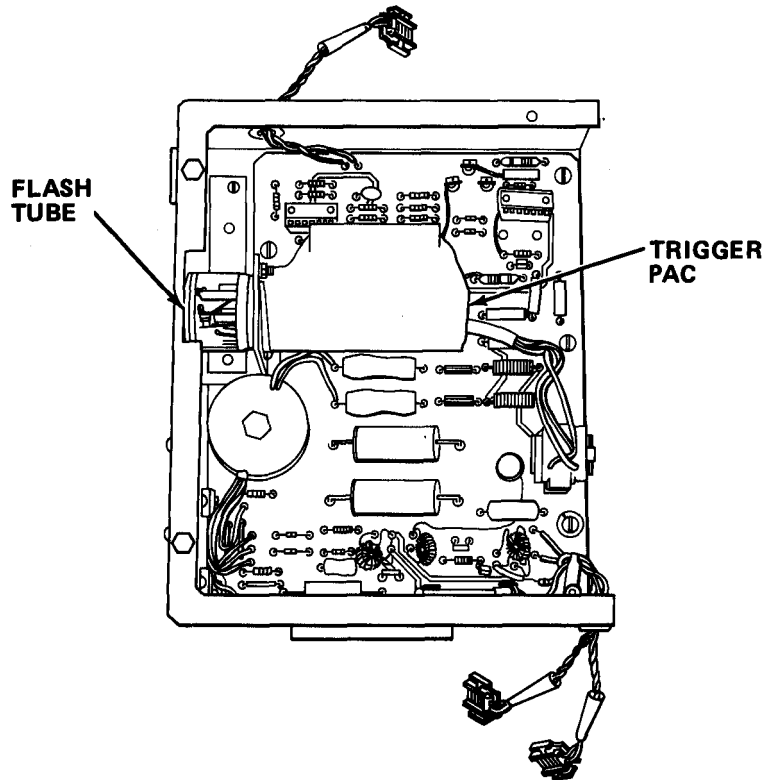

- k. Remove two screws from outside forward housing of flash power supply. Unplug and remove defective flash tube and trigger pac.
- l. Install new flash tube and trigger pac.
- m. Reinstall cover on flash power supply.
- n. Reattach flash power supply to character storage unit.
- o. Reconnect plugs.
- p. Reinstall left side panel.
- q. Turn on circuit breaker.
- r. Turn on power switch.
- s. Close top left panel.

2-16.9 Repair Flash Power Supply Assembly

MOS : 35E, Special Electronic Devices Repairer

TOOLS : Flat Tip Screwdriver
1/4 in. Open End Wrench
1/4 in. Drive, Socket Set

SUPPLIES: Flash Power Supply PC Board
Flash Tube
Trigger Pac

WARNING

Death or serious injury may occur from electrical shock unless power is turned off before servicing.

NOTE

This procedure is in a disassembly-assembly sequence. Disassemble the flash power supply only as far as necessary.

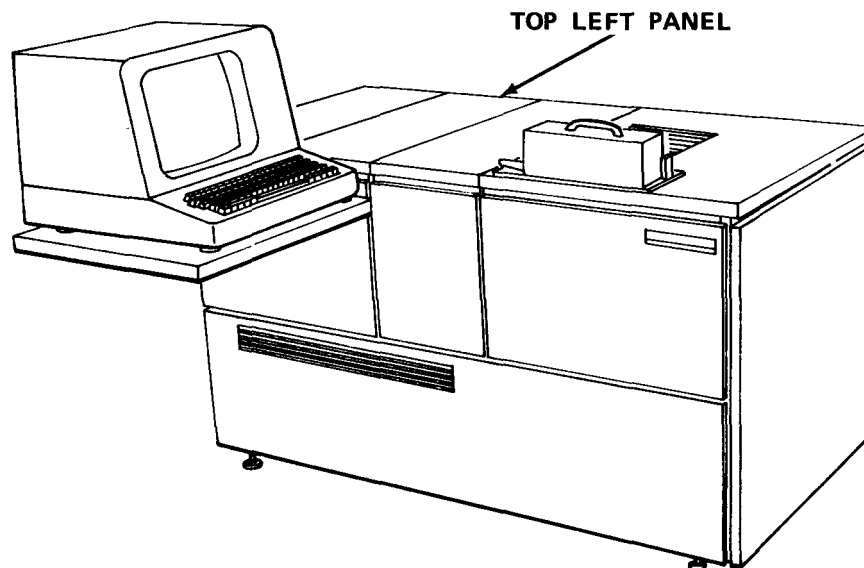

- a. Open top left panel.

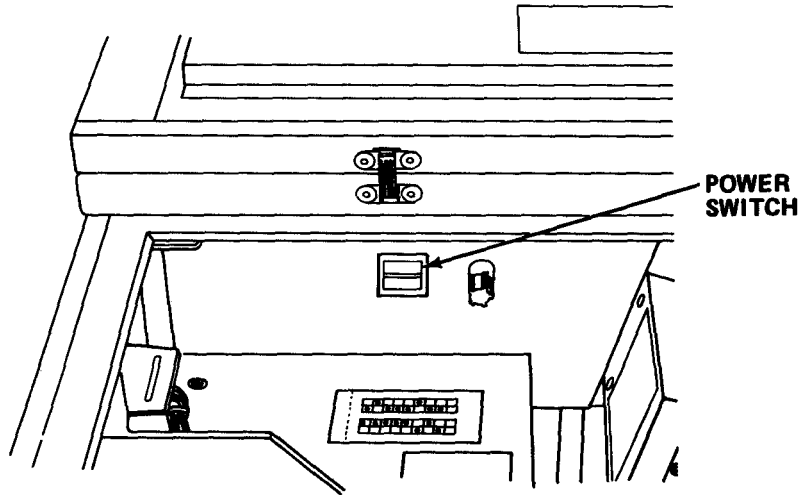

- b. Turn off power switch.
- c. Turn off circuit breaker.

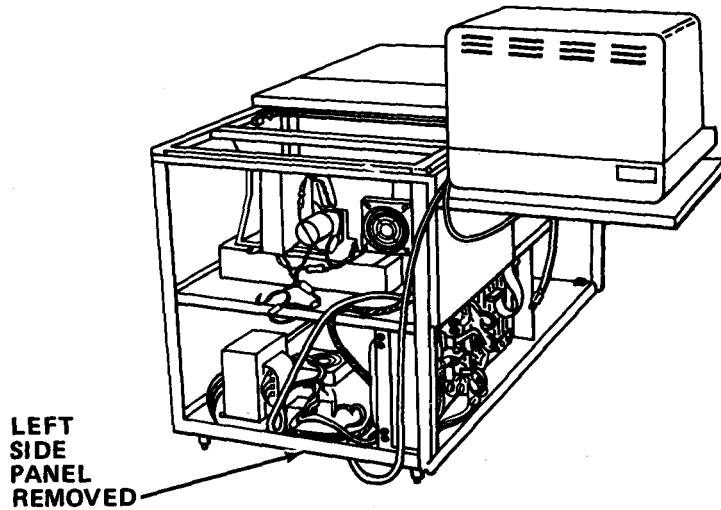

- d. Remove left side panel.

WARNING

High voltage capable of causing death may be stored in capacitor after power is removed. Be sure that capacitor is discharged and reduced to zero volts.

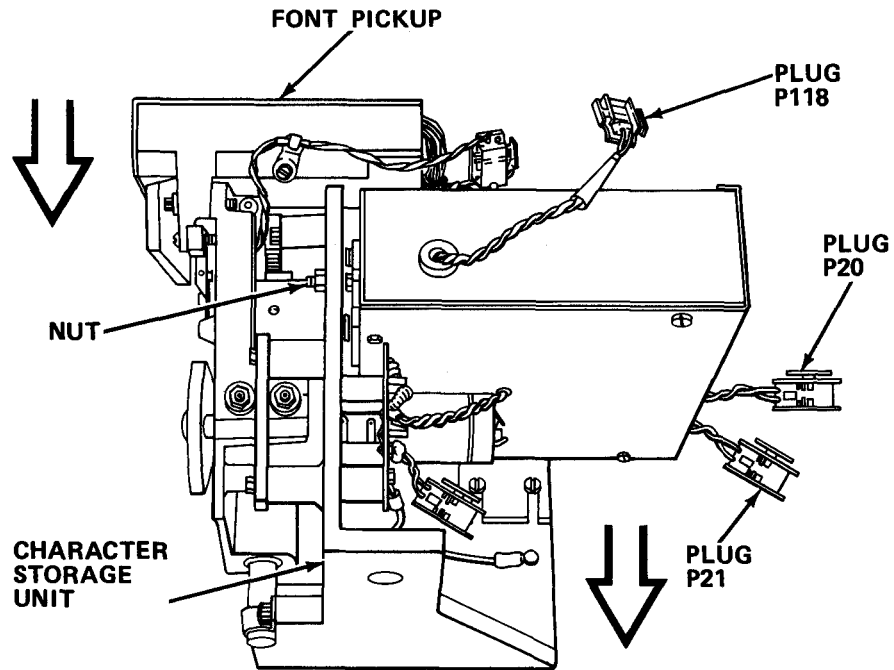

- e. Tag and disconnect three plugs (P20, P21 and P118).
- f. Remove screw at rear of assembly and loosen two mounting screws at front of assembly.
- g. Carefully slide character storage unit toward rear and remove from machine.
- h. Remove flash power supply from character storage unit.
- i. Loosen two screws and remove cover from assembly.

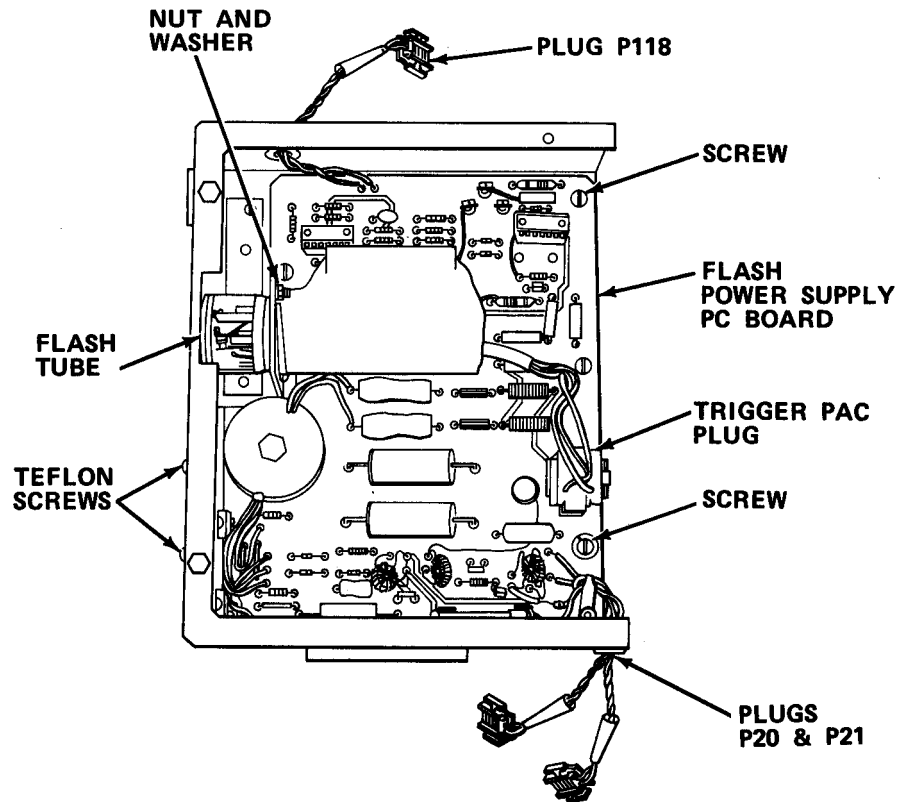

- j. Note position and disconnect trigger pac plug.
- k. Remove two screws and remove trigger pac and flash tube as a unit.
- l. Pull flash tube straight out from trigger pac and place mounting bracket aside.
- m. Pull P20 and P21 grommets from housing.
- n. Tag and disconnect P118 wires at board terminals.
- o. Remove mounting screws and PC board.
- p.** Inspect and replace defective parts.
- q.** Reconnect wires.
- r. Reinstall flash tube and trigger pac.
- s. Reinstall cover and flash power supply.
- t. Reconnect plugs.
- u. Reinstall rear side panel.

- v. Turn on circuit breaker.
- w. Turn on power switch.
- x. Close top left panel.

2-16.10 Remove/Install Composing Machine

MOS : 35E, Special Electronic Devices Repairer

PERSONNEL: Four persons are required to perform this task.

TOOLS : Flat Tip Screwdriver
7/16 in. Combination Wrench
3/4 in. Combination Wrench

SUPPLIES: Composing Machine

WARNING

Death or serious injury may occur from electrical shock unless power is turned off before servicing.

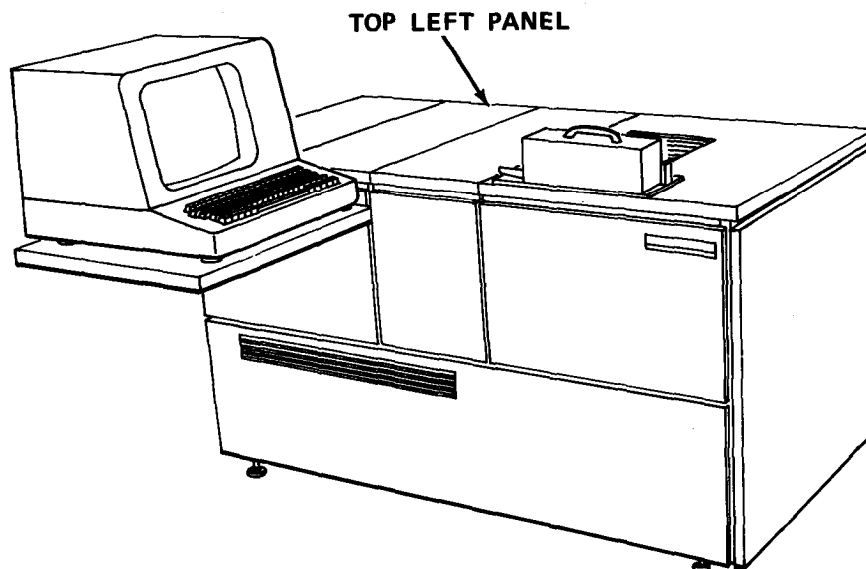

- a. Raise top left panel.
- b. Turn off power switch.
- c. Turn off circuit breaker.

- d. Close top left cover.
- e. Remove bolts, washers, and display screen.
- f. Remove bolts, washers, shelf, and bracket.
- g. Remove left panel.

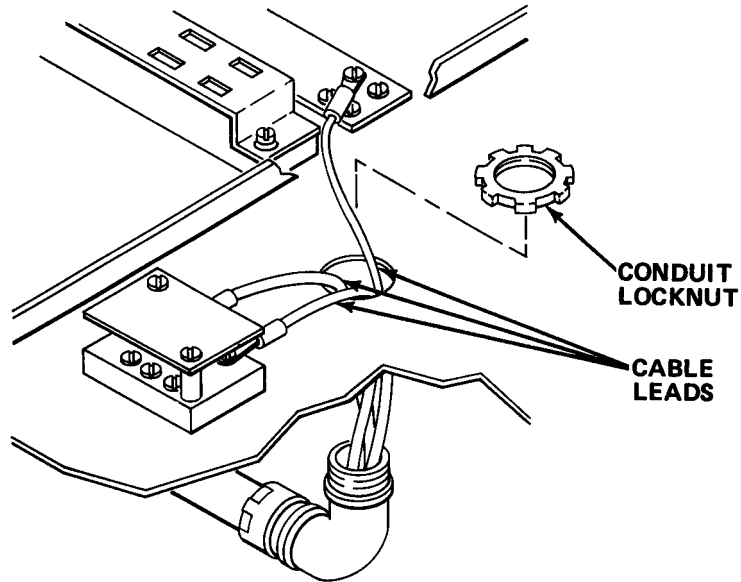

- h. Tag and disconnect power cable leads.
- i. Remove conduit locknut. Remove cable from composing machine and reinstall left panel.
- j. Remove shock mount center bolts.

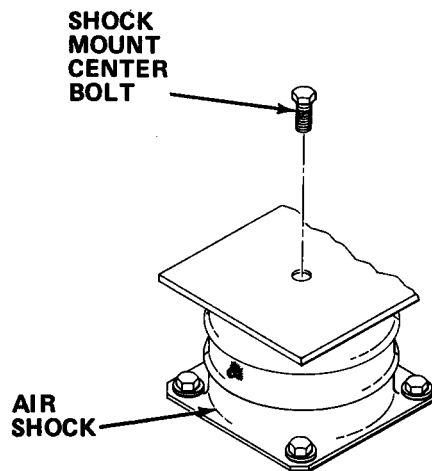

WARNING

To prevent personnel injury, four persons are needed to move this equipment. Composing machine weighs 485 lbs (220 kg).

- k. Lift composing machine from shock mounts and move to center of van.
- l. Remove defective composing machine from section with materials handling equipment.
- m. Position new composing machine over shock mounts and secure with shock mount center bolts.
- n. Remove left panel.
- o. Reinstall cable assembly. Reinstall and tighten conduit locknut.
- p. Reconnect cable leads. Turn on power switch.
- q. Reinstall top left panel.
- r. Reinstall display screen and secure with washers and bolts.
- s. Turn on circuit breaker.

2-17. PREPARATION FOR STORAGE OR SHIPMENT. Contact your battalion for packing and shipping instructions.

Section V DIRECT/GENERAL SUPPORT MAINTENANCE

2-18. REPAIR PARTS, SPECIAL TOOLS; TEST, MEASUREMENT, AND DIAGNOSTIC EQUIPMENT (TMDE); AND SUPPORT EQUIPMENT.

2-18.1 Common Tools and Equipment. For authorized common tools and equipment, refer to the Modified Table of Organization and Equipment (MTOE) applicable to your unit.

2-18.2 Special Tools; Test, Measurement, and Diagnostic Equipment; and Support Equipment. Special Tools, TMDE and Support Equipment required for the repair of this equipment are found in the repair parts and special tools list and Appendix B of this manual.

2-18.3 Repair Parts. Repair parts for this equipment are listed and illustrated in the Repair Parts and Special Tools List, TM 5-6675-316-24P covering direct/general support maintenance for this equipment.

2-19. DIRECT/GENERAL SUPPORT TROUBLESHOOTING PROCEDURES.

a. Direct/general support troubleshooting procedures cover the most common malfunctions that may be repaired at the direct/general support level. Repair or adjustment requiring specialized equipment is not authorized unless such equipment is available. Troubleshooting procedures used at lower levels should be conducted in addition to the direct/general support troubleshooting procedures.

b. This manual cannot list all the possible malfunctions or every possible test/inspection or corrective action. If a malfunction is not listed or is not corrected by a listed corrective action, notify **your supervisor**.

NOTE

Sufficient data is not available for you to test or troubleshoot printed circuit boards. When associated wiring, ribbon cables, power cords, and other related electrical components have been eliminated as possible faults, then the printed circuit boards must be substituted, one for one, until the fault is isolated.

Table 2-6. DIRECT/GENERAL SUPPORT TROUBLESHOOTING

MALFUNCTION	TEST OR INSPECTION	CORRECTIVE ACTION
1. GENERAL DENSITY OF COPY IS LOW.	Step 1. Check flash power supply intensity reference voltage. (a) If properly adjusted, proceed to step 2. (b) If out of tolerance, adjust voltage (paragraph 2-20.23).	Step 2. Check large size adjustment. Perform flash intensity large size adjustment (paragraph 2-20.23).
2. DENSITY DISTRIBUTION ACROSS CHARACTERS IS POOR.	Check lens tube alignment. Align lens tube (paragraph 2-20.24).	

Table 2-6. **DIRECT/GENERAL SUPPORT TROUBLESHOOTING - Cont**

MALFUNCTION	TEST OR INSPECTION	CORRECTIVE ACTION
3. CHARACTER DENSITY VARIES WITH POINT SIZE.	Check flash intensity reference and large size adjustment.	Adjust flash intensity and large size (paragraph 2-20.23).
4. FOCUS IS GENERALLY POOR.	Step 1. Check flash intensity reference and large size adjustment.	(a) If adjustment is correct, proceed to step 2. (b) If not correct, perform flash intensity and large size adjustment (paragraph 2-20.23).
	Step 2. Check optical focus switches on carriage escapement board against punch chart inside top left panel.	(a) If switch settings are correct, proceed to step 3. (b) If not correct, correct switch settings.
	Step 3. Check flash power supply reference and large size adjustments.	Adjust flash power supply reference and large size (paragraph 2-20.23).
5. NO POWER.	Step 1. Check output of constant voltage transformer.	(a) If present, repair wiring between TB2 and constant voltage transformer. (b) If not present, proceed to step 2.
	Step 2. Check input of constant voltage transformer.	(a) If not present, proceed to step 3. (b) If present, replace constant voltage transformer (paragraph 2-20.21).

Table 2-6. **DIRECT/GENERAL SUPPORT TROUBLESHOOTING - Cont**

MALFUNCTION

TEST OR INSPECTION

CORRECTIVE ACTION

5. NO POWER - Cont

Step 3. Check output voltage of circuit breaker in power panel.

(a) If present, repair wiring between circuit breaker and transformer.

(b) If not present, replace circuit breaker (paragraph 1-20.5).

6. VARIOUS VOLTAGES FROM POWER SUPPLY INCORRECT. ALL OTHER VOLTAGES ARE CORRECT.

Step 1. Check for output on pins 6, 7, and 8 of transformer T1.

(a) If present, proceed to step 2.

(b) If not present, replace transformer (paragraph 2-16.2).

Step 2. Check 18 V dc output.

(a) If present, proceed to step 3.

(b) If not present, replace CR1 (paragraph 2-20.6).

Step 3. Check wires from secondary of transformer to rectifier for continuity.

(a) If correct, proceed to step 4.

(b) If continuity does not exist, repair wiring.

Step 4. Check ground lead from CR1 to J110 for continuity.

(a) If continuity exists, proceed to step 5.

(b) If continuity does not exist, repair lead.

Step 5. Check for 26 V dc at output of CR4.

(a) If present, proceed to step 6.

(b) If not present, replace CR4.

Table 2-6. DIRECT/GENERAL SUPPORT TROUBLESHOOTING - Cont

MALFUNCTION	TEST OR INSPECTION	CORRECTIVE ACTION
6. VARIOUS VOLTAGES FROM POWER SUPPLY INCORRECT. ALL OTHER VOLTAGES ARE CORRECT - Cent		<p data-bbox="774 634 915 666" style="text-align: center;"><u>WARNING</u></p> <p data-bbox="261 700 1392 795">High voltage capable of causing death may be stored in capacitor after power is removed. Be sure capacitor is discharged and reduced to zero volts.</p> <p data-bbox="294 859 1009 895">Step 6. Check 9 V dc output at capacitor C1.</p> <p data-bbox="475 923 1058 959">If not present, replace capacitor C1.</p>
7. UNWANTED CHARACTERS ARE APPEARING ON DISPLAY AND RANDOM COMMANDS ARE BEING EXECUTED.		<p data-bbox="294 1115 1091 1151">Check constant voltage transformer for continuity.</p> <p data-bbox="475 1178 1108 1215">Replace transformer (paragraph 2-20.21).</p> <p data-bbox="824 1272 905 1304" style="text-align: center;">NOTE</p> <p data-bbox="261 1338 1410 1412">Adjust power supply voltages (paragraph 2-20.22) and perform diagnostic test (paragraph 2-20.1).</p>
8. INPUT DISPLAY IS FUZZY AND SLIGHTLY OUT OF FOCUS.		<p data-bbox="294 1534 819 1570">Check adjustment of display unit.</p> <p data-bbox="475 1598 1108 1634">Adjust display unit (paragraph 2-20.27).</p>

2-20. MAINTENANCE PROCEDURES.

This section contains instructions covering direct/general support maintenance functions for the composing machine. Personnel required are listed only if the task requires more than one.

b. After completing each maintenance procedure, perform operational check to be sure equipment is properly functioning.

INDEX

PROCEDURES	PARAGRAPH
Perform Diagnostic Test	2-20.1
Replace Carriage Escapement Board, LVC Board, Font Interface III Board, D/A and Stepper II Board, Keyboard and Interface III Board, and Character Generator S/A2 Board	2-20.2
Replace 8K X 8 RAM Board , 32K ROM/PROM Board, CPU Data Board, and CPU Control Board.	2-20.3
Replace Disc Track LED and Cable Assembly.	2-20.4
Replace Driver Supply Board	2-20.5
Replace Bridge Rectifier	2-20.6
Replace Power Supply.	2-20.7
Replace Stepping Motor...	2-20.8
Replace Shutter Assembly	2-20.9
Replace Carriage Cables	2-20.10
Replace Carriage Motor....	2-20.11
Replace Interlock Switch	2-20.12
Replace Row Shift Motor	2-20.13
Adjust Setting on Compatibility Switches	2-20.14
Replace Brightness Control	2-20.15
Replace Film Out Switch.	2-20.16
Replace Movable Knife	2-20.17
Replace Font Pickup PC Board	2-20.18
Replace Variator/Collimator Motor(s)	2-20.19

I N D E X - C o n t

PROCEDURES	PARAGRAPH
Repl ace Li mi t Swi tch (es)	2-20. 20
Repl ace Constant Vol tage Transformer	2-20. 21
Adj ust Power Supply Vol tages	2-20. 22
Adj ust Fl ash Intensi ty and Large Si ze	2-20. 23
Adj ust Fl ash Tube Verti cal and Hori zontal	2-20. 24
Al i ne Left Margi n	2-20. 25
Focus and Al i ne LED	2-20. 26
Adj ust Input/Moni tor Uni t Di spl ay.	2-20. 27
Adj ust Basel i ne	2-20. 28
Al i ne Margi n Between Poi nt Si zes	2-20. 29

2-20.1 Conduct Diagnostic Test.

MOS: 35E, Special Electronic Devices Repairer

SUPPLIES: Test Disc
Self-Diagnostic Board
Photographic Paper
US/Metric Rule (12 in.)

WARNING

Death or serious injury may occur from electrical shock unless power is turned off before servicing.

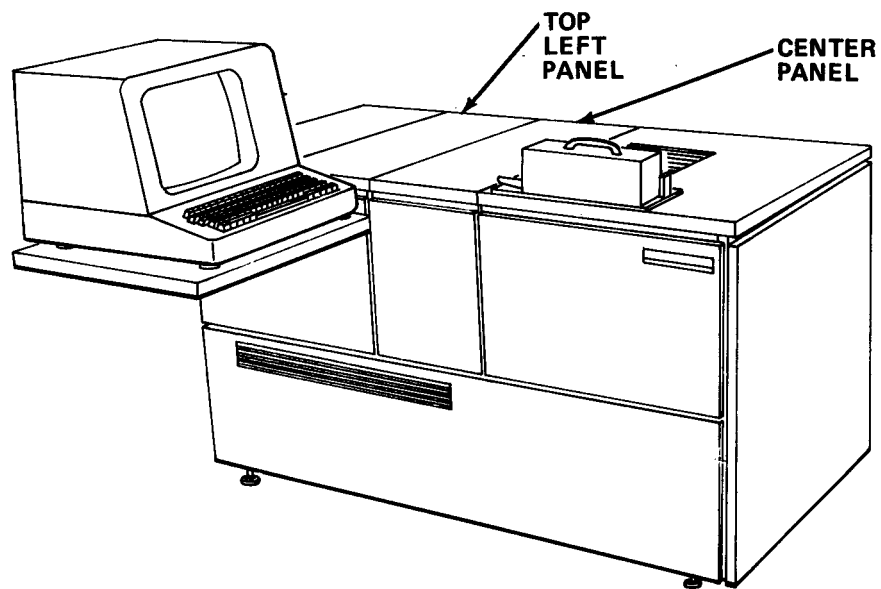

- a. Open top left panel.
- b. Remove center panel.

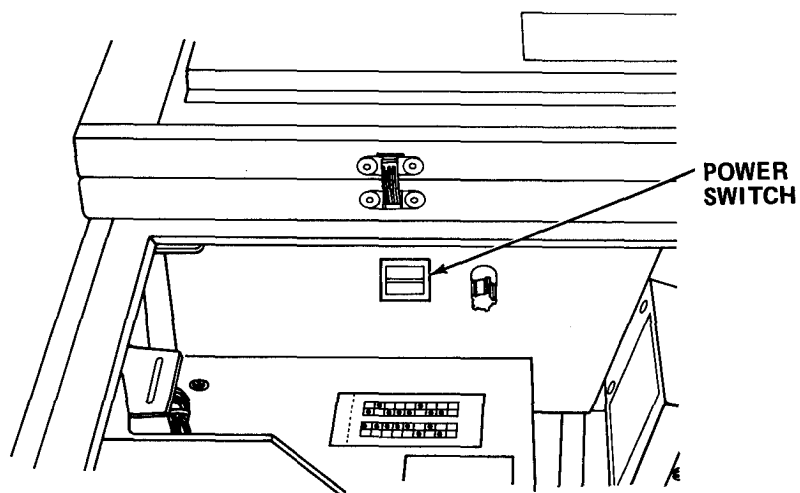

- c. Turn off power switch.
- d. Turn off circuit breaker.

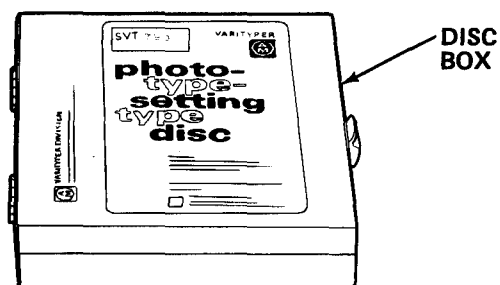

- e. Place disc box containing test disc in convenient location.
- f. Open disc box.

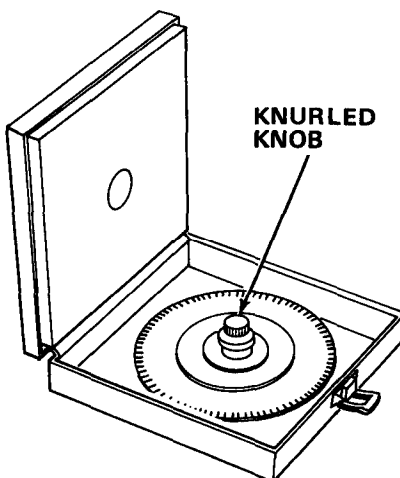

- g. Grasp knurled knob and remove disc from disc box.

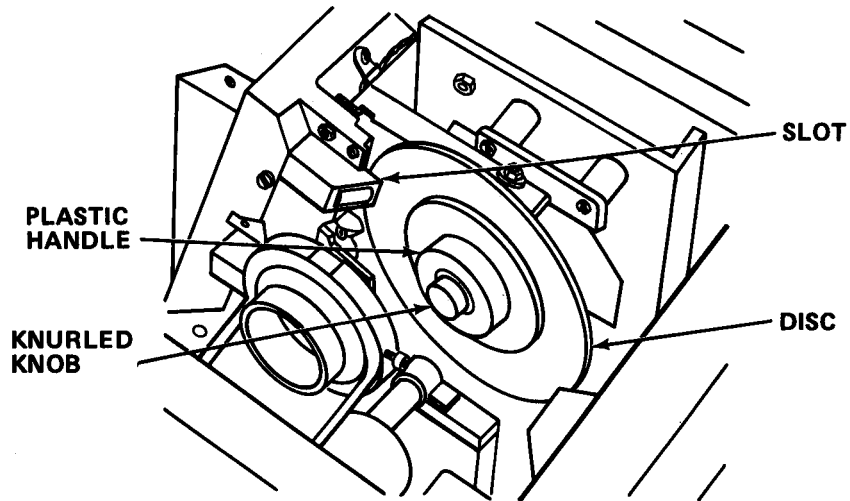

CAUTION

Do not touch disc with hands. Skin oils contaminate disc rendering it useless.

- h. Grasp plastic handle.
- i. Place left edge of disc into slot.
- j. While holding plastic handle, tighten knurled knob.
- k. Use plastic handle to spin disc. It should rotate easily.

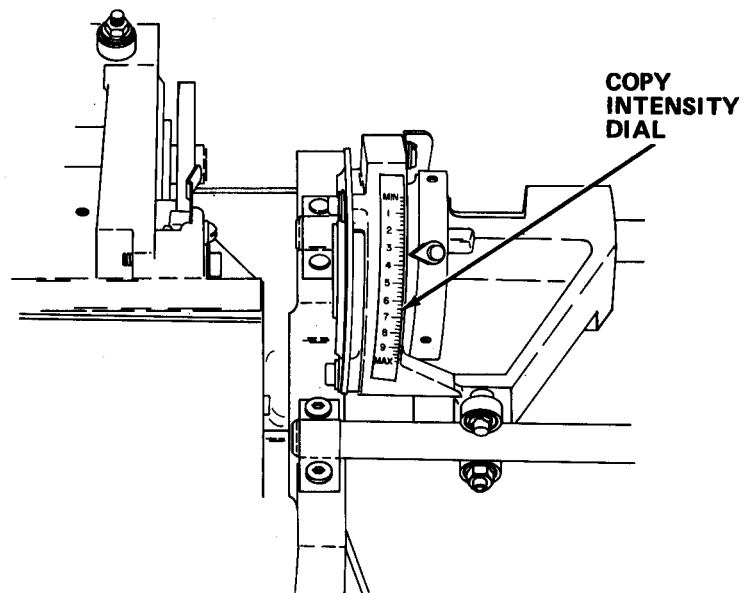

- 1. Set copy intensity dial to 2.

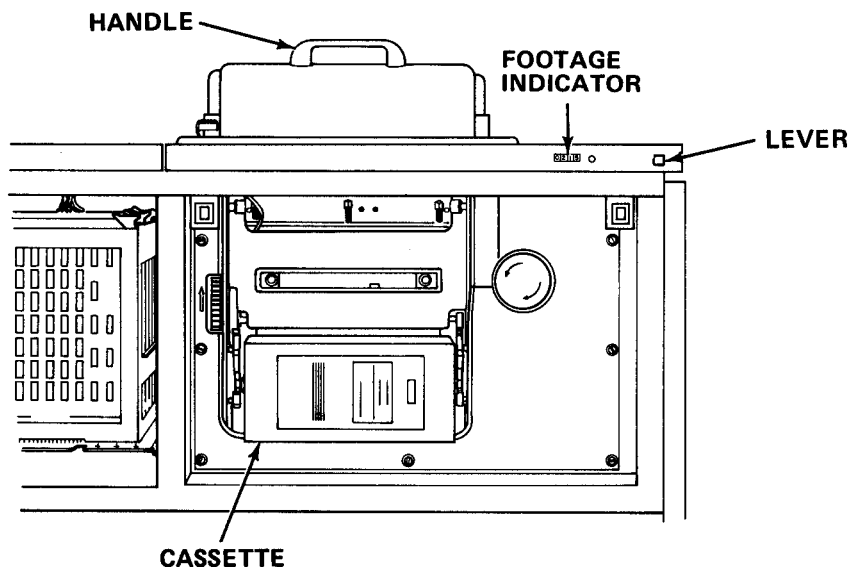

- m. Note footage indicator. If it reads less than 145 proceed to step w.
- n. Remove take-up cassette.
- o. Lower front panel.
- p. Remove and discard paper cassette.
- q. Cut paper edge on new cassette 2 to 3 in.

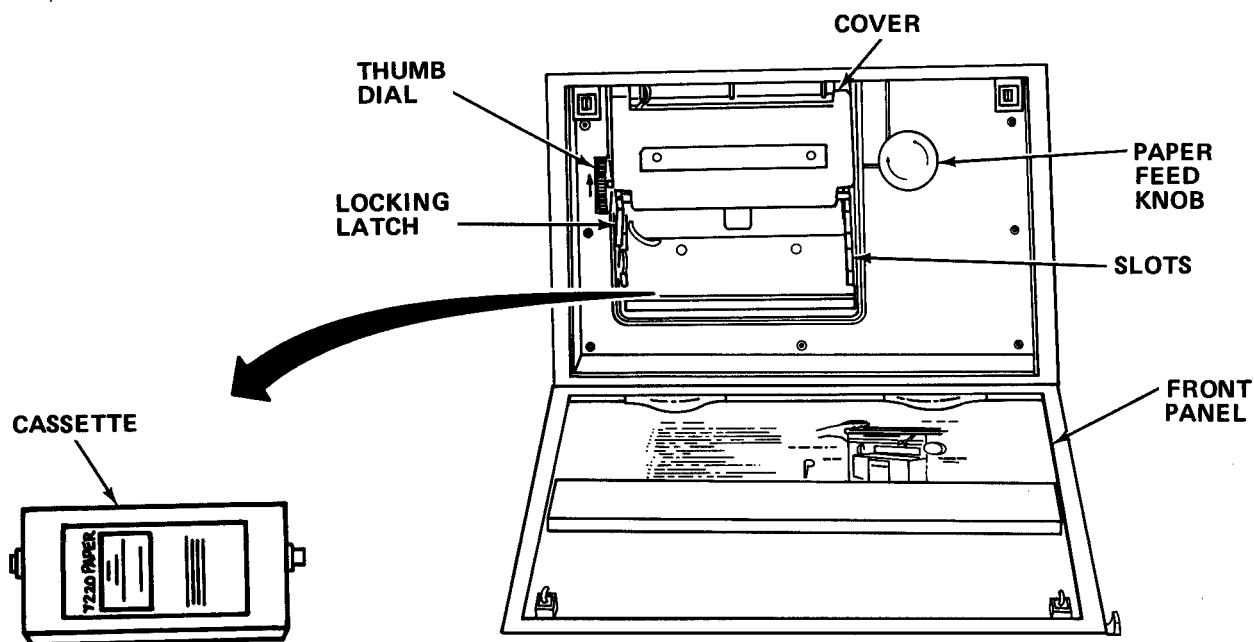

- r. Insert cassette into composing machine.

NOTE

Be sure that knobs of cassette fit into slots and that paper/film is behind first roller.

- s. Push cover down until it clicks.
- t. Rotate thumb dial upward 5 to 6 times.
- u. Pull up locking latch.
- v. Turn paper feed knob up. If thumb dial starts to turn, paper is loaded correctly.
- w. Close front panel.

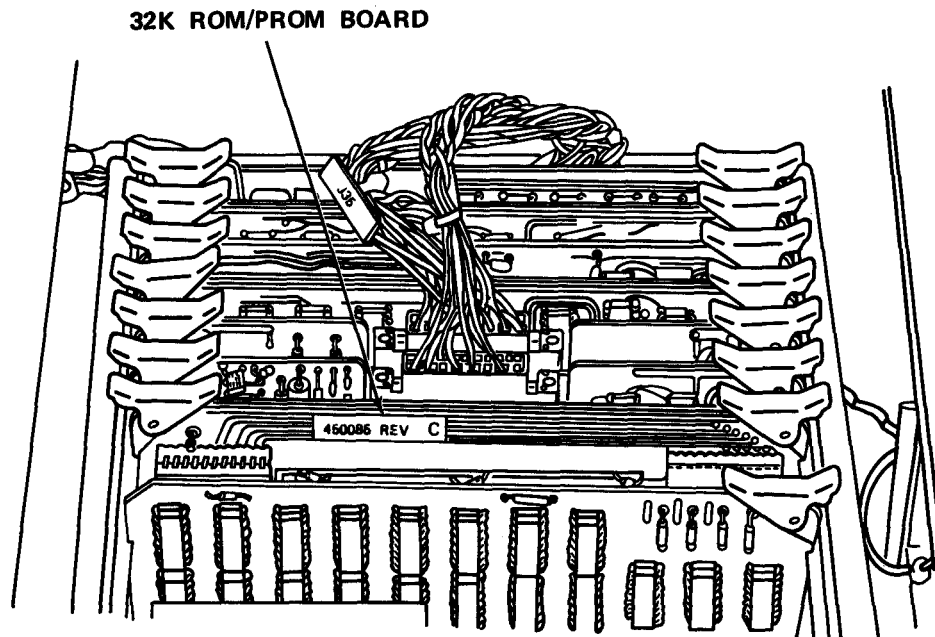

- x. Remove 32K ROM/PROM board.

SWITCH # 1

8	7	6	5	4	3	2	1	IS IMPLIED	
ON	OFF	OFF	OFF	OFF	OFF	OFF	OFF		
HEX 8				0				0	0

VALUE OF THE LOWEST RAM ADDRESS

SWITCH # 2

8	7	6	5	4	3	2	1	IS IMPLIED	
ON	OFF	OFF	ON	ON	ON	ON	ON		
HEX 9				F				F	F

VALUE OF THE HIGHEST RAM ADDRESS

SWITCH # 3

8	7	6	5	4	3	2	1
						CPU PROM MAIN PGM NOT PRESENT	PROM ON CPU
OFF	OFF	OFF	OFF	OFF	OFF	(YES-ON) NO-OFF	(YES-ON) NO-OFF

SWITCH # 4

8	7	6	5	4	3	2	1
		TURRETT	FLOPPY	PUNCH READER	MAX. POINT SIZE 74 POINT		MODEL COMP/SET
OFF	OFF	OFF	OFF	OFF	OFF	ON	ON

- y. Set switches on self-diagnostic board as shown.
- z. Install self-diagnostic board into any card cage slot.
- aa. Reinstall center panel.

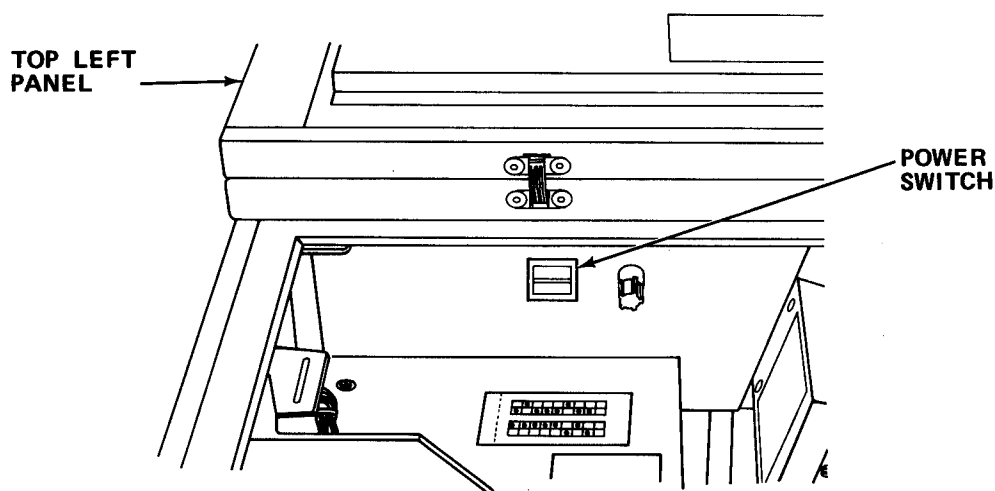









- ab. Turn on circuit breaker.

- ac. Turn on power switch.
- ad. Close top left panel.

NOTE

Tables 2-7 and 2-8 contain keyboarding information and test description required for performing diagnostic test.

Table 2-7. DIAGNOSTIC EXECUTION REQUIREMENTS

Key	Description
SHIFT/ 	Return to supervisor if in pause, or go to pause. Delete entry if in supervisor routine.
SPACE BAR	Allows 8 lines on screen to be filled with single character, only with character generator diagnostic.
SHIFT/ 	Continue test.
SHIFT / 	Answer of "NO" to question.
SHIFT / 	Answer of "YES" to question
	Response to  .
	Response to  .

NOTE





- After inserting the diagnostic ROM board, the diagnostic program may be executed by holding either cursor key down and then pressing the RESET key momentarily. At the sound of the beeper, the cursor key is released.
- When RESET is pressed, a series of tests automatically starts, and "SHIFT/  if desired, will appear after the completion of the hardware register test. If SHIFT/ is pressed, control goes directly to the supervisor, otherwise a 90% functional machine checkout will be performed before obtaining supervisor control. A double right arrow followed by a blinker will be displayed on the CRT, i.e.,  indicating the program is under supervisor control.
- It is recommended that SHIFT/ not be pressed when checking the machine for the first time.
- Supervisor Control: All commands are allowed via the keyboard or test panel. Data and/or instructions not understood by the supervisor will be answered with question marks "???". After two seconds, control reverts back to the supervisor.

Table 2-8. TEST DESCRIPTION

Test	Description
ROM Diagnostic Checksum Test:	<p>Performed automatically -- Upon pressing RESET. Performs a sequential summation of all data within the ROM memory and compares the total against a known checksum value. An error causes ERROR 98 to appear on the upper left portion of the CRT.</p> <p>No indication is given if the test passes successfully.</p>
Speaker Test:	<p>This is an audible test of the speaker. The speaker sounds for two seconds. An error is indicated by the absence of an audible tone.</p>
Screen Swap and Erase Test	<p>A screen swap or erase error is indicated by a continuous audible tone of two seconds on followed by 1/4 second off. An error indicates a problem in either the keyboard interface or character generator board.</p>

Table 2-8. TEST DESCRIPTION - Cont

Test	Description
Keyboard Buffer Swap Test	A keyboard buffer swap error is indicated by a continuous audible tone of two seconds on followed by two seconds off. An error indicates a problem in the keyboard interface board.
CPU PROM Checksum Test	Performs a sequential summation of all data within locations 0000 to 00FF. Includes locations 0005 and 0006 which contain the known checksum value. A comparison of the calculated total is then made against the known value. An error causes ERROR 97 to appear in the upper left portion of the screen.
CPU PROM Checksum Test - Cont	No indication is given if the test successfully passes. In the event there is no CPU PROM, the test checks the same locations in ROM which become an overlay of locations 0000 to 00FF. ERROR 98 appears if an error occurs.
Hardware Register Diagnostics	Verifies all working parts on the CPU board by performing an extensive pattern and sequence test. An error causes the buzzer to sound continuously. Two short bursts on followed by two seconds off. The error indication can be terminated only by pressing the keyboard RESET. An error indicates a problem in the CPU DATA or CPU CONTROL boards.
CPU PROM Checksum Test - Cont	No indication is given if the test successfully passes. Upon successful completion of hardware register diagnostics, the following message will be displayed on the screen.
	ENTER <input type="checkbox"/> is desired.
	If SHIFT/ <input type="checkbox"/> is entered from the keyboard, the diagnostic program will go to the supervisor mode and display on the screen, waiting test request entry from the keyboard.

Table 2-8. TEST DESCRIPTION - Cont

Test	Description
NOTE	
If SHIFT/← is not entered, the following tests are performed automatically: 1, 2, 3, 6, 7, 9, 10, 13, 15, 17, 18, and 25	
<u>Display Memory Diagnostics</u>	
Test 1: Functional Test	Verifies the IK display memory by performing a dynamic test pattern (up-down) and extended sequence test. The test in progress is visible on the screen.
	An error is indicated by a continuous buzzer tone. An error indicates a problem in the character generator board.
	Successful completion of the test returns program control to the supervisor routine, at which time ⇒□ will be displayed on the screen. Individual test can then be requested by appropriate test number.
<u>Carriage Diagnostics</u>	
Test 2: Functional Test	Upon initiating this test, primary message request that carriage be physically placed off its limits.
Test 3: Stepping Accuracy Test	This test accuracy and repeatability of carriage stepping assembly and home position (left limit) switch. If error occurs in functional or accuracy tests, program will automatically run tests 4 and 5, which will continue to cycle carriage back and forth until, SHIFT/← is entered from keyboard, returning program control to supervisor routine.
Test 4:	Cycles carriage 1500 steps (2 times) forward and reverse. Allow test to run for at least one minute.

Table 2-8. TEST DESCRIPTION - Cont

Test	Description
<u>Carriage Diagnostics - Cont</u>	
Test 5:	Cycles carriage 20 steps (150 times) forward and reverse. Allow test to run at least one minute.
<u>Variator Diagnostics</u>	
Test 6: Functional Test	Checks operation of variator lens drive system.
Test 7: Accuracy Test	Checks accuracy and repeatability of variator lens drive system with respect to its home switches.
Test 8:	Cycling test.
<u>Collimator Diagnostics</u>	
Test 9: Functional Test	Checks operation of collimator lens drive system.
Test 10: Accuracy Test	Check accuracy or repeatability of collimator lens drive system with respect to its home switch.
Test 11 : Cycling Test (Ping Pong)	This test is a diagnostic tool to aid in troubleshooting when errors are found in functional or accuracy tests.
<u>Lens Constant</u>	
Test 12: Visual Indication of Switch Status	Tests switches and associated wiring for possible shorts and/or opens.
<u>ROW Shift Diagnostic</u>	
Test 15: Functional Test	Checks operation of ROW shift circuit and mechanism.
	Timing errors are displayed on screen in the following format:
	04X ROW Ready ERROR X ROW Number in ERROR 049 ROW Never Ready

Table 2-8. TEST DESCRIPTION - Cont





Test	Description																																			
<u>ROW Shift Diagnostic - Cont</u>																																				
<p>The mechanism may be stopped at any position by pressing SHIFT/ . This puts you in pause condition. SHIFT/  continues ROW shift cycling. Pressing SHIFT/  when in pause causes control to return to supervisor routine.</p>																																				
<u>Disc and Detector Diagnostic</u>																																				
Test 17: Functional Test	<p>Upon selecting this test, flashing will begin if no errors are detected, accompanied by  to continue message. Indicated response will cause "Character Ready" or the ability to obtain width data for each of 112 characters in all four rows. Third part of this test reads and sense width code errors.</p> <p>Pauses on each ROW, to continue test press SHIFT/ .</p> <p>Errors are indicated on screen as follows: Disc position (POS) is in decimal, RQ - Required Hex and IS Hex for up to seven rows.</p>																																			
Test 17: Functional Test - Cont	<table border="0"> <tr> <td>POS</td> <td>RQ</td> <td>IS</td> <td>POS</td> <td>RQ</td> <td>IS</td> <td></td> </tr> <tr> <td>016</td> <td>0B</td> <td>0D</td> <td>----</td> <td>--</td> <td>--</td> <td></td> </tr> <tr> <td>034</td> <td>32</td> <td>34</td> <td>----</td> <td>--</td> <td>--</td> <td>(Repeat blank entries 5 more</td> </tr> <tr> <td>035</td> <td>33</td> <td>38</td> <td>----</td> <td>--</td> <td>--</td> <td>times)</td> </tr> <tr> <td>053</td> <td>14</td> <td>00</td> <td>----</td> <td>--</td> <td>--</td> <td></td> </tr> </table>	POS	RQ	IS	POS	RQ	IS		016	0B	0D	----	--	--		034	32	34	----	--	--	(Repeat blank entries 5 more	035	33	38	----	--	--	times)	053	14	00	----	--	--	
POS	RQ	IS	POS	RQ	IS																															
016	0B	0D	----	--	--																															
034	32	34	----	--	--	(Repeat blank entries 5 more																														
035	33	38	----	--	--	times)																														
053	14	00	----	--	--																															
Test 18: Disc Speed Test	<p>This test initially determines whether a disc is present, checks widths for parity and determines whether disc is four or six-row. Disc motor is then turned off and checked for zero speed (#0F).</p>																																			

Table 2-8. TEST DESCRIPTION - Cont

Test	Description								
<u>Disc and Detector Diagnostic - Cont</u>									
Test 18: Disc Speed Test - Cont	Next test phase examines disc at each speed (0-9, Four-row/0-B, six-row) to determine that speed has increased from previous speed and at approximately 1400 R/min, speed is accurate within 1 percent. Numbers are relative speed indication. Motor overspeed-#0E.								
<u>Disc Width Dump</u>									
Test 19: Functional Test	This test simultaneously dumps all 112 decimal codes from any disc in actual typesetter width. Parity errors (if any) are indicated by blinking cursors adjacent to width value. Half-units (when available) are displayed after integer width value.								
<u>Keyboard Diagnostic</u>									
Test 20: Functional Test	Upon initiating this test, "ENTER 7 KEYS WITHIN 8 SECONDS" is requested on the screen. Seven identical alphanumeric characters should be entered within time allotted. This phase of test is executed two times.								
	Next part of test enables check out of key switch codes for 78 key keyboards. Primary message indicates key number to be pressed. As appropriate keys are pressed, audible signal indicates the key entered was sensed correctly. Buzzer is not sounded. Errors are displayed on the screen in the following format.								
	<table border="0"> <tr> <td>KEY NO.</td> <td>REQ</td> <td>IS</td> <td>6 COLUMNS</td> </tr> <tr> <td>005</td> <td>2D</td> <td>2A</td> <td>7 ROWS</td> </tr> </table>	KEY NO.	REQ	IS	6 COLUMNS	005	2D	2A	7 ROWS
KEY NO.	REQ	IS	6 COLUMNS						
005	2D	2A	7 ROWS						
	The following keys are inactive: 66, 67, 69, 71, 72, 73, and 74. If pressed, they will result in errors.								

Table 2-8. TEST DESCRIPTION - Cont

Test	Description
<u>Keyboard Diagnostic - Cont</u>	
Test 20: Functional Test - Cent	<p>If key is not sensed, or if no key is entered within 5 sec, KEY XXX ENTERED NO <input type="checkbox"/> YES <input type="checkbox"/> message is displayed. NO triggers RE-ENTER KEY NO. XXX message.</p> <p>Enter appropriate key to continue with testing. YES <input type="checkbox"/> entered in response causes error message to be displayed. Test will continue automatically and is repeated for shift mode. When keyboard has been completely tested, PAUSE message will be displayed. For the purpose of this test, the two SHIFT keys, SHIFT LOCK and RESET are unnumbered.</p>
<u>Key Code Dump Diagnostic</u>	
Test 21: Key Code Dump Test	<p>This test allows visual verification of any desired key code.</p> <p>When first key is depressed, "CODE" message will appear accompanied by hex code corresponding to that key. Displayed code can then be checked against key code table to determine any errors.</p>
<u>Character Generator Diagnostic</u>	
Test 22: Functional Test	<p>This test provides the technician with means to make subjective visual judgments as to display performance character generator functions.</p> <p>Test sequences, through entire character program, fill lower 8 lines of screen with single character in ascending coded order. Images appear for approximately 2 sec, providing time to visually screen errors.</p>
Test 25: Memory Test	<p>Verifies all RAM by performing dynamic pattern test (up-down) and sequence test to extent as set on diagnostic status switches S1 and S2.</p>

Table 2-8. TEST DESCRIPTION - Cont

Test	Description
<u>Copy Quality Diagnostics</u>	
Test 26: Copy Quality	This test automatically performs tests 26 through 29 inclusive.
Test 27: Horizontal Spacing, Tip and Baseline	Evaluates escapement carriage and scanning mirror. Continuous horizontal line of connected dashes indicates stepping accuracy of escapement carriage. Setting of scanning mirror is analyzed by group of three interlocking images.
Test 28: Interfont Focus, Exposure, and Baseline	This test evaluates interfont focus, exposure and baseline. Copy produced is character "M" from fonts 1 and 4 mixed on same line. Each line is different size starting at 5.5 points through 74 points.
Test 29: Intersize Horizontal and Vertical Ruling.	Evaluates margin and baseline alignment between sizes. Bottom edge of 5.5 point character and bottom edge largest character (dash) should align. Likewise, left edge of 5.5 point character and left edge of largest character (vertical rule) should align.

ae. Run automatic sequence diagnostic.

(1) Press cursor left.

(2) Momentarily press reset.

(3) Allow automatic test sequence to run and observe test results.

(a) Test pass screen indication  .

(b) Test failure will be indicated by a test code #XXX. Check this number with failure code in table in specific test.

- af. Run diagnostic test in supervisor mode.
- (1) Press cursor left.
 - (2) Momentarily press reset.
 - (3) When "SHIFT ← if desired" is displayed on screen, quickly press SHIFT and cursor left.
 - (4) Select desired test by pressing test number and RET.
- ag. Test Display Memory.
- (1) Select test 1 (step af).

NOTE

An error indicates a problem in the character generator board.

- (a) → indicates test pass and return to supervisor control.
- (b) A continuous buzzer indicates an ERROR.

- ah. Test carriage diagnostics.
- (1) Select test 2 (step af).

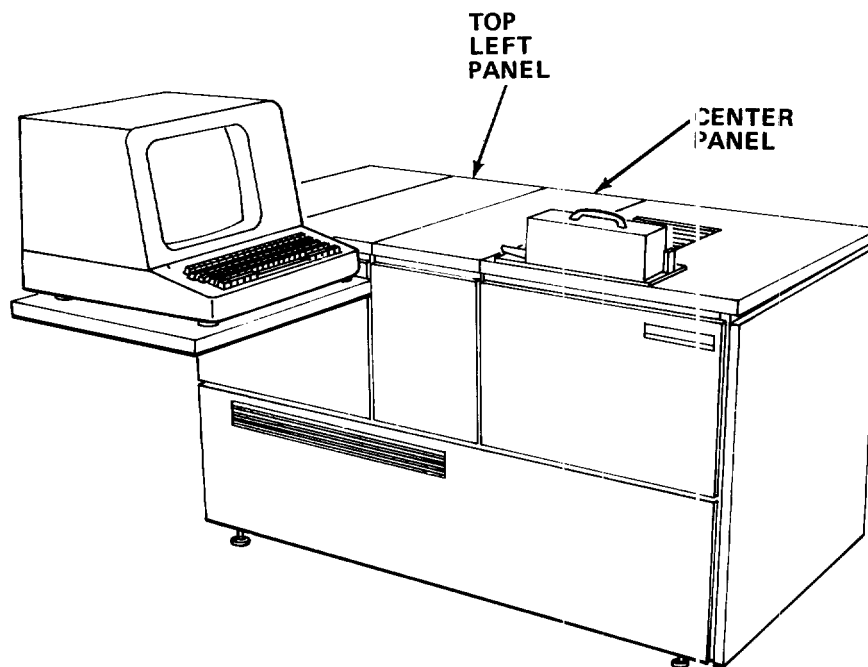

(2) Manually move carriage clear of limit switches when directed by

- (a) Raise top left panel.
- (b) Remove center panel.

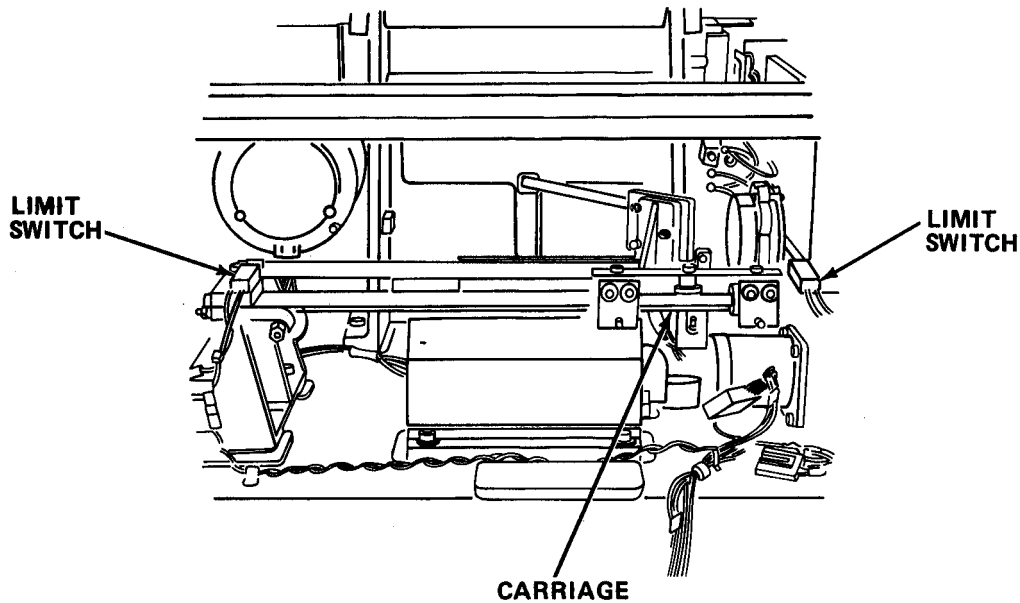

- (c) Slide carriage clear of limit switches.
- (d) Install center panel.
- (e) Lower top left panel.

NOTE

- If errors occur in functional or accuracy tests, program will automatically run tests 4 and 5, which will continue to cycle carriage back and forth until SHIFT/cursor left is entered from keyboard returning program control to supervisor routine.
- Test 4: Cycles carriage 1500 steps (2 times) forward and reverse. Allow to run for at least one minute.
- Test 5: Cycles carriage 20 steps (150 times) forward and reverse. Allow test to run for at least one minute.

(3) Press SHIFT/cursor right to continue test.

(4) Check display for errors (Table 2-9).

- (5) Select test three (step af).
- (6) Allow test to run for two minutes.
- (7) Check display for errors (Table 2-9).

Table 2-9. CARRIAGE TEST DIAGNOSTIC ERROR CODES

Code	Error
010	Carriage Ready Error
011	Left and Right Limit Switches Shorted
012	Right Limit Switch Shorted
013	Direction Error
014	Right Limit Switch Open
015	Carriage Moved in Wrong Direction
016	No Carriage Motion and/or Right and Left Limit Switches Shorted
017	Left Limit Switch Open
018	Carriage Accuracy Error
019	Left Limit Switch Shorted

NOTE

If tests four and five were conducted or errors were displayed that stopped a test in progress, all further tests must be keyboarded.

- ai. Test variator diagnostics.

NOTE

If there are errors in tests six or seven, test eight should be performed to aid in troubleshooting.

- (1) Select test six (step af).

- (2) Check display for errors (Table 2-10).
- (3) Select test seven (step af).
- (4) Check display for errors (Table 2-10).
- (5) **If** required, select test eight (step af).

Table 2-10. VARIATOR TEST DIAGNOSTIC ERROR CODES

Code	Error
020	Forward direction error
021	Home switch shorted and/or variator motion error
022	Home switch open and/or variator motion error
023	Variator ready error
024	Variator accuracy error

aj. Test collimator diagnostics.

NOTE

If errors are present in tests nine or ten, perform test **11** as an aid in troubleshooting. **If** none present, proceed to test 13.

- (1) Select test nine (step af).
- (2) Check display for errors (Table 2-11).
- (3) Select test ten (step af).
- (4) Check display for errors (Table 2-11).
- (5) **If** required, select test **11** (step af).

Table 2-11. COLLIMATOR TEST DIAGNOSTIC ERROR CODES

Code	Error
027	Forward direction error
028	Home switch shorted and/or motion error
029	Home switch open and/or motion error
030	Collimator ready error
031	Collimator accuracy error

ak. Test lens constant.

NOTE

Upon initiating this test, screen will display LENS CONSTANT TEST in function field, and data, such as shown in example in data field.

Example: In this example switch D6 has position 6 OFF and switch D5 has positions 8 and 4 OFF

SW D6	SW D5
ON 87 54321	765 321
OFF 6	8 4

- (1) Select test 12 (step af).
- (2) Check data on screen against data on punch chart.
 - (a) If data agrees, return to supervisor routine.
 - (b) If error exists, perform steps (3) through (14).

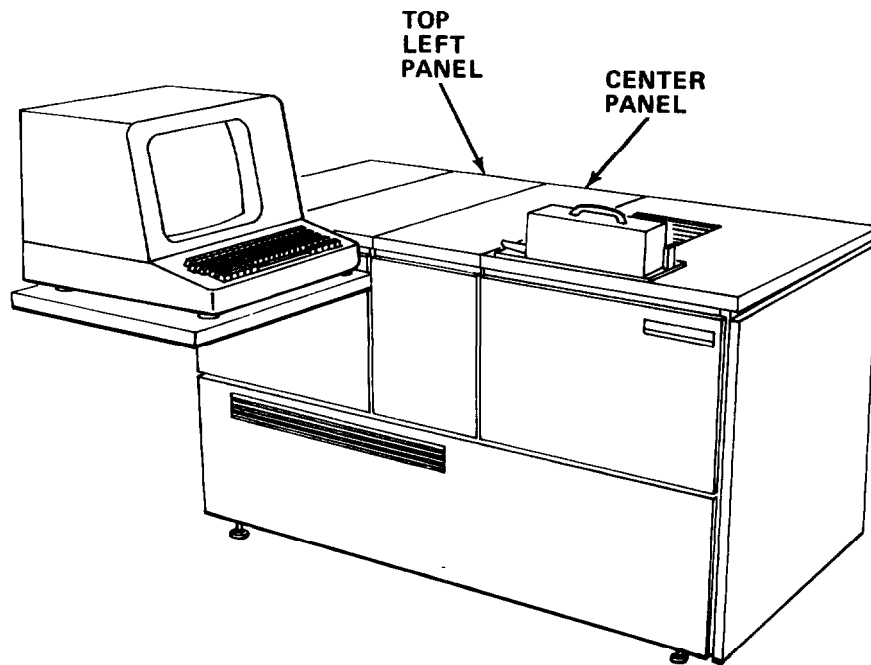

(3) Raise top left panel .

WARNING

Death or serious injury may occur from electrical shock unless power is turned off before servicing.

- (4) Turn off power switch.
- (5) Turn off circuit breaker.
- (6) Remove center panel.

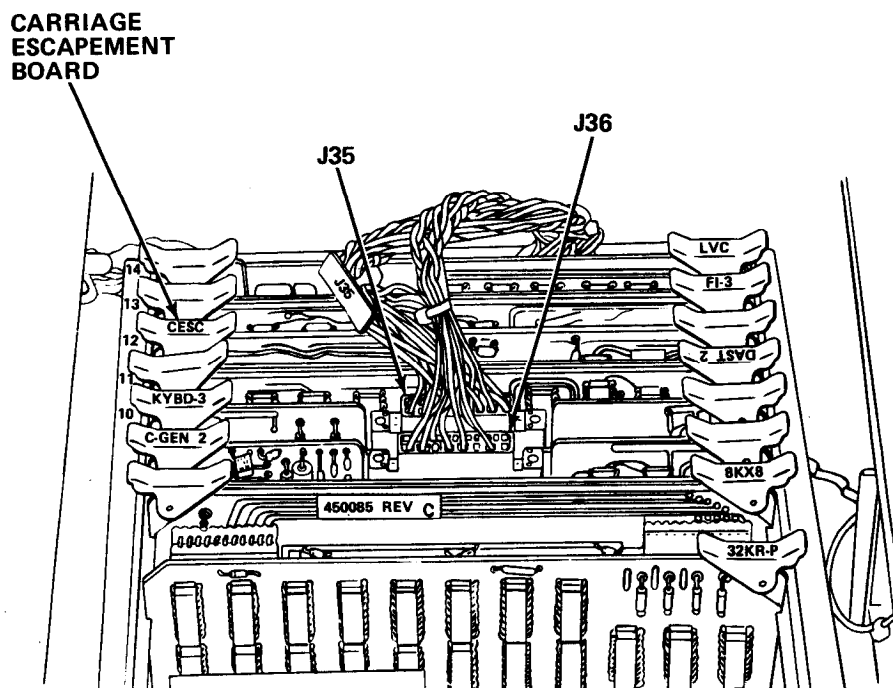

- (7) Remove carriage escapement board.
 - (8) Place switches D5 and D6 in positions shown on punch data card.
 - (9) Reinstall carriage escapement board.
 - (10)** Reinstall center panel.
 - (11)** Turn on circuit breaker.
 - (12) Turn on power switch.
 - (13) Close top left panel.
 - (14) Press SHIFT/cursor right. Switches will be reread automatically.
- a. Leading diagnostic test.
- (1) Check that paper magazine door is closed.
 - (2) Select test 13 (step af).
 - (3) When ENSURE NO PAPER is displayed, open paper magazine **door**.
 - (4)** Press SHIFT/cursor right to continue test.
 - (5) When LOAD PAPER is displayed, close paper magazine door.
 - (6) Press SHIFT/cursor right to continue test.

- (7) When CUT PAPER is displayed, cut paper.
- (8) Press SHIFT/cursor right.
- (9) When CUT PAPER is displayed, cut paper.
- (10) Measure length of paper. It should measure 10 inches (25.4 cm).

Table 2-12. LEADING TEST DIAGNOSTIC ERROR CODES

Code	Error
032	Paper out switch shorted
033	Paper out switch open
034	Leading ready error

- am. Test 14 is not applicable.
- an. Perform ROW shift diagnostic.

NOTE

- Timing errors are displayed on screen in the following format:
 - 04X ROW ready error
 - X ROW number in error
 - 049 ROW never ready
- The mechanism may be stopped at any position by pressing SHIFT/cursor left. This puts you in pause condition. SHIFT/cursor right continues ROW shift cycling. Pressing SHIFT/cursor left when in pause causes control to revert to supervisor routine.
 - (1) Select test 15 (step af).
 - (2) Check display for errors.
 - ao. Test 16 is not applicable.
 - ap. Perform disc and detector diagnostic test.

NOTE

- Upon selecting this test, flashing will begin if no errors are detected, accompanied by **[R]** to continue message.
- Errors are indicated on screen as follows: Disc position (POS) is in decimal, RQ - required hex and IS hex for up to seven rows.

POS	RQ	IS	POS	RQ	IS	
016	0B	0D	---	--	--	
034	32	34	---	--	--	(Repeat up to seven rows)
035	33	38	---	--	--	
053	14	00	---	--	--	

- (1) Select test 17 (step af).
- (2) Check display for errors.
- (3) If errors are found, press SHIFT/cursor right to continue test.

Disc and Detector Diagnostic Error Code

050 Character Ready Error

- aq. Perform disc speed test.

NOTE

After testing all usable speeds, motor is required to overspeed and check for turn-off. Successful test completion is followed by return to supervisor routine.

- (1) Select test 18 (step af).
- (2) Check display for errors.

Table 2-13. DISC SPEED DIAGNOSTIC ERROR CODES

Code	Error
103	Disc not at zero speed
104	Disc not turning
105	Disc read parity error
106	Disc not stable
107	Disc speed lower than previous speed
108	Disc not at correct speed
109	Disc did not stop on overspeed
110	Disc speed did not change

ar. Perform disc width dump test.

(1) Select test 19 (step af).

(2) Check display. Display format is as follows:

```

001      008      015      022 . . . . . 106
06-1/2  . . . . .
07      . . . . .
06      . . . . .
    
```

as. Perform keyboard diagnostic.

NOTE

Upon initiating this test ENTER 7 KEYS WITHIN 8 SECONDS is requested on the screen. Seven identical alphanumeric characters should be entered within time allotted. This phase of the test is executed twice.

(1) Select test 20.

(2) Make data entry when requested.

(3) Check display for errors.

Table 2-14. KEYBOARD DIAGNOSTIC ERROR CODES

Code	Error
051	Buffer swap error
052	Buffer error

NOTE

- Next part of test enables checkout of key switch codes for 78-key keyboards. Primary message indicates keyboard mode (SHIFT or unSHIFT). Second message indicates key number to be pressed. As appropriate keys are pressed, audible signal indicates the key entered was sensed correctly. Errors are displayed on screen in the following format.

KEY NO.	REQ	IS	6 COLUMNS
005	20	2A	7 ROWS

- The following keys are inactive 66, 67, 69, 71, 72, 73, and 74. If pressed, they will result in errors.
- If key is not sensed, or if no key is entered within 5 sec, KEY XXX ENTERED NO YES R message is displayed. NO and cursor left triggers RE-ENTER KEY NO XXX message.
- For the purpose of this test, the two SHIFT keys, SHIFT LOCK and RESET are not numbered.

(4) Enter appropriate to continue with testing.

(5) Enter YES to cause error message to be displayed.

(6) Continue with remainder of test.

at. Perform key code dump test.

(1) Select test 21 (step af).

(2) Press first key.

(a) Code message accompanied by hex code will appear on display.

(b) Check displayed code against key code table to determine errors.

(3) Continue with rest of keys to be checked.

- au. Perform character generator diagnostic test.
 - (1) Press SHIFT/cursor left.
 - (2) Press 22 and RET.
 - (3) Press SHIFT/cursor left (pause).
 - (4) Press space bar to obtain ENTER CODE NNN... display.
 - (5) Press up to three numbers and RET, keyboarded numbers will be displayed for 4 see, followed by PAUSE.
 - (6) Sequence may be repeated by repeating steps 3 through 5.
 - (7) Inspect CRT display for:
 - (a) Sharply focused characters.
 - (b) No tilt of characters.
 - (c) Full screen deflection.

- av. Perform general RAM test.
 - (1) Press 2, 5, and RETURN.
 - (2) Errors are displayed in middle left portion of screen. Error displayed is current error.
 - (3) Press SHIFT/cursor right to continue test.
 - (4) Error display is in the following format.
 - #### REQ XX IS YY
 - Where #### is hex location in error.
 - Where XX is hex required value.
 - Where YY is actual value found at that particular address.

NOTE

When test is completed, program control returns to the supervisor routine.

- aw. Perform copy quality diagnostic test.

NOTE

Selecting test 26 automatically includes the running of tests 27 through 29.

- (1) Select test 26.
- (2) Check display for errors.
 - ax. Turn off power switch.
 - ay. Remove self diagnostic board and reinstall 32K ROM/PROM Board.
 - az. Reinstall center panel.
 - ba. Place disc box in convenient location.
 - bb. Grasp plastic handle.
 - bc. Screw knurled knob left.
 - bd. Slide disc to right and out.
 - be. Place disc in disc box.
 - bf. Close top left panel.

2-20.2 Replace Carriage Escapement Board, LVC Board, Font Interface III Board, D/A and Stepper II Board, Keyboard and Interface III Board and Character Generator S/A 2 Board.

MOS: 35E, Special Electronic Devices Repairer

SUPPLIES: Carriage Escapement Board
LVC Board
Font Interface III Board
D/A and Stepper II Board
Keyboard Interface III Board
Character Generator S/A 2 Board

WARNING

Death or serious injury may occur from electrical shock unless power is turned off before servicing.

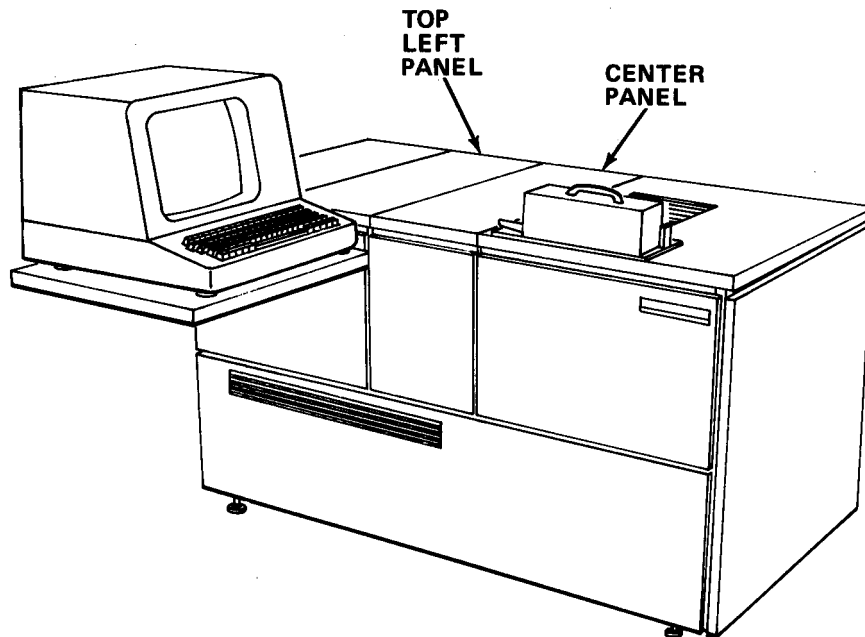

NOTE

These printed circuit boards must be in the illustrated positions at all times.

- a. Raise top left panel.
- b. Remove center panel.

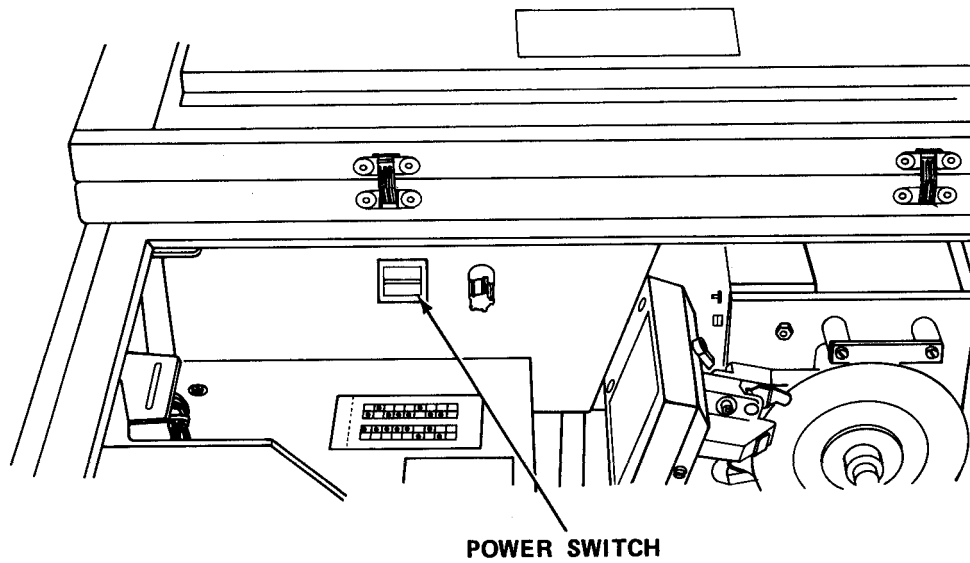

- c. Turn off power switch.
- d. Turn off circuit breaker.

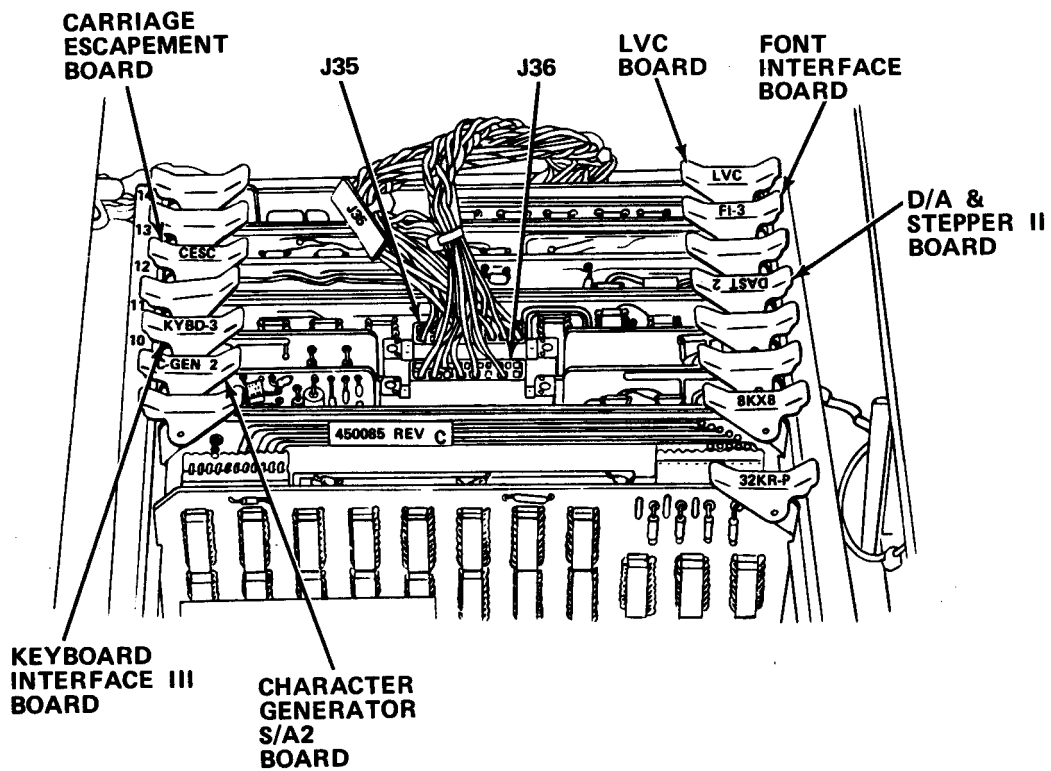

- e. Disconnect plugs J36 and J35.
- f. Grasp tabs and remove defective printed circuit board.

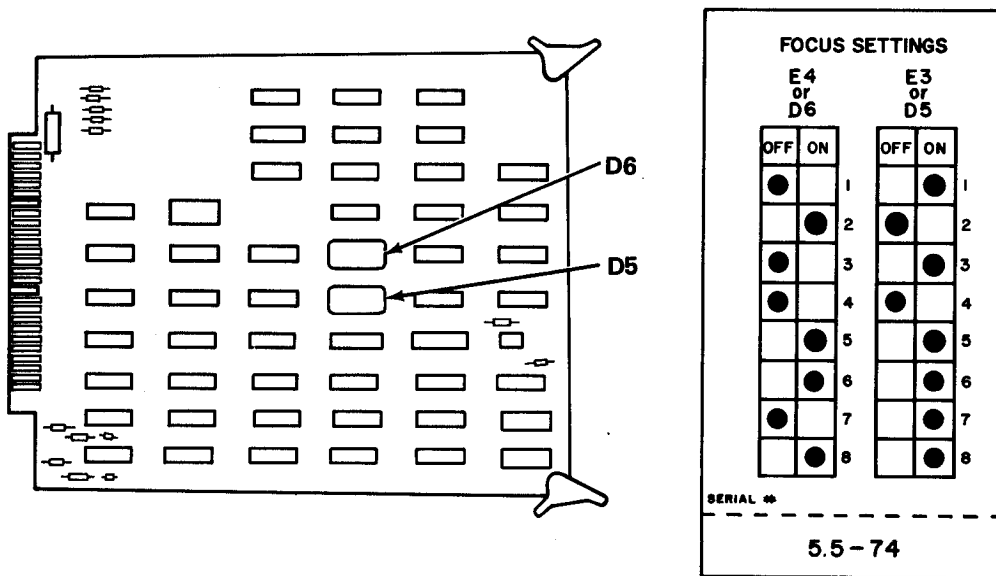

- g. If replacing the carriage escapement board, set switches D5 and D6 as shown on focus setting table.
- h. Install new printed circuit board.
- i. Reconnect plugs J36 and J35.
- j. Install center panel.
- k. Lower top left panel.
- l. Perform diagnostic test.

2-20.3 Replace 8K X 8 RAM Board, 32K ROM/PROM Board, CPU Data Board and CPU Control Board.

MOS : 35E, Special Electronic Devices Repairer

SUPPLIES: 8K X 8 RAM Board
32K ROM/PROM Board
CPU Data Board
CPU Control Board

WARNING

Death or serious injury may occur from electrical shock unless power is turned off before servicing.

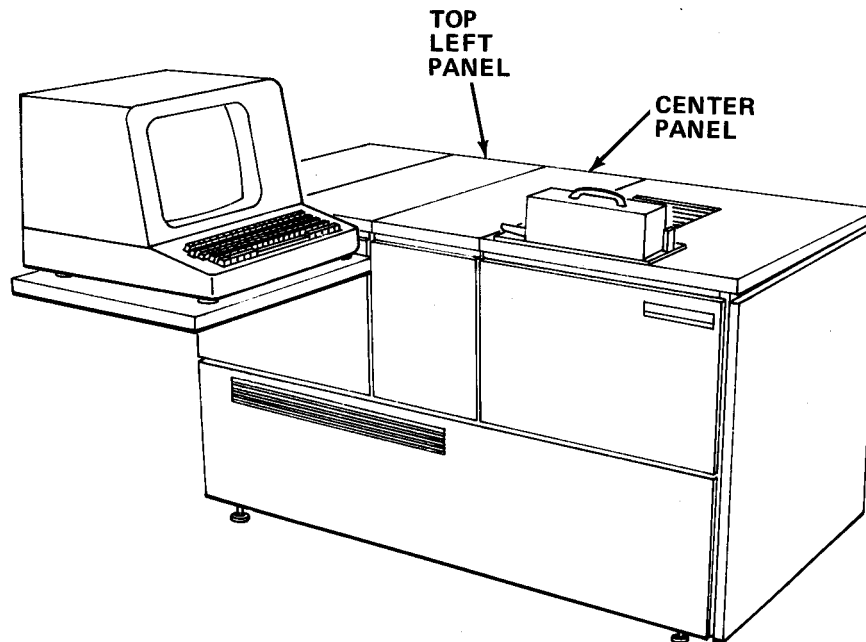

- a. Open top left panel.
- b. Remove center panel.

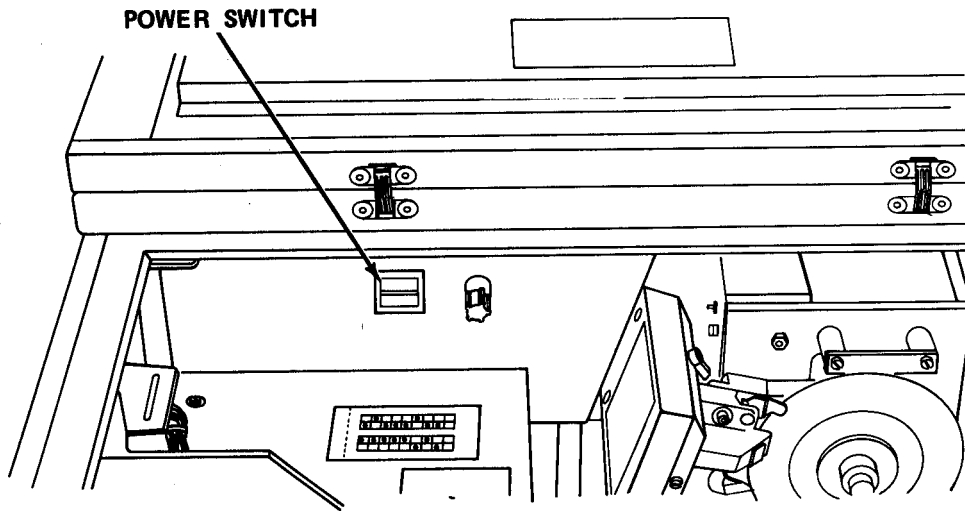

- c. Turn off power switch.
- d. Turn off circuit breaker.

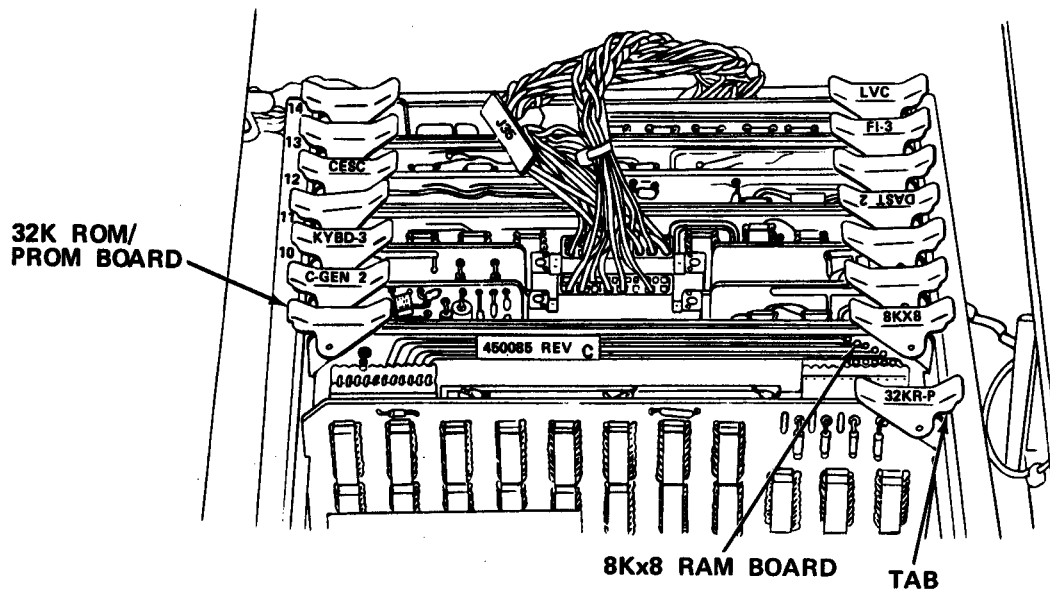

- e. Grasp tabs and lift out defective board.
- f. Install new board.
- g. Reinstall center panel.

- h. Turn on circuit breaker.
- i. Turn on power switch.
- j. Close top left panel.
- k. Perform diagnostic test.

2-20.4 Replace Disc Track LED and Cable Assembly.

MOS : 35E, Special Electronic Devices Repairer

TOOLS: .050 in. Hex Head Key Wrench
Flat Tip Screwdriver

SUPPLIES: Disc Track LED and Cable Assembly

WARNING

Death or serious injury may occur from electrical shock unless power is turned off before servicing.

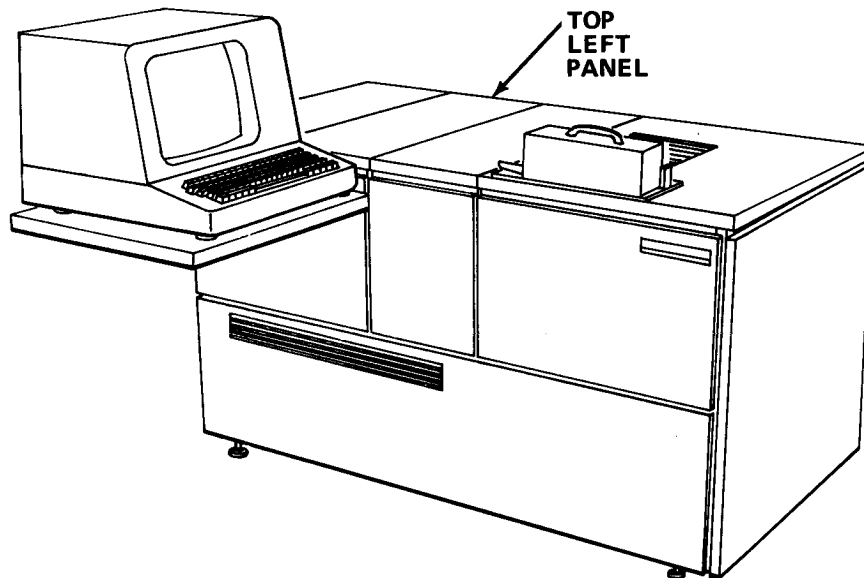

- a. Open top left panel.

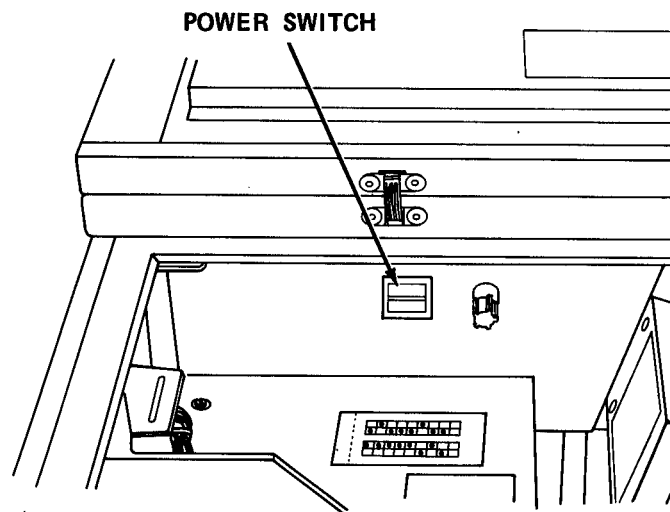

- b. Turn off power switch.
- c. Turn off circuit breaker.

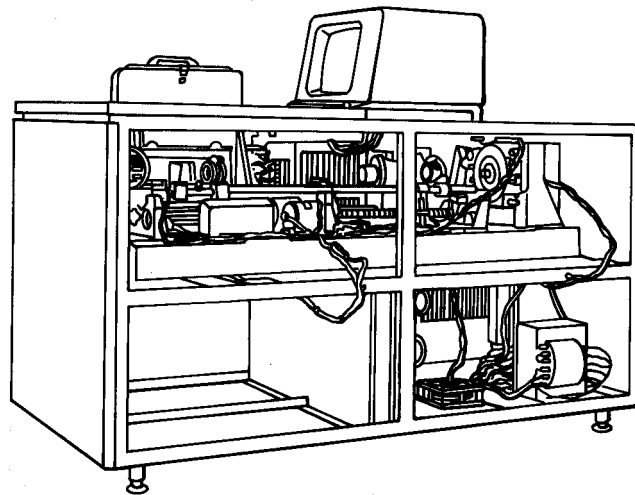

REAR PANEL REMOVED

- d. Remove front panel.

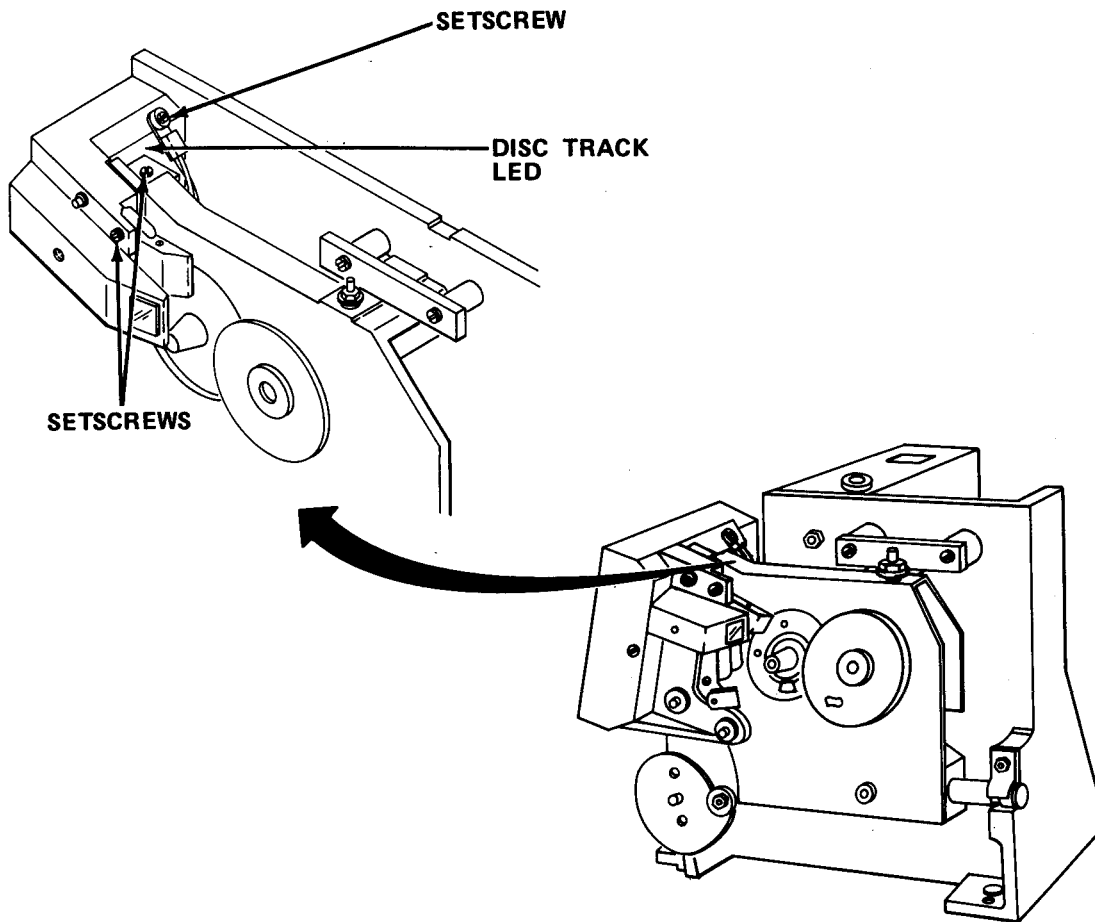

- e. Loosen setscrew on disc track LED.
- f. Remove mounting screws.
- g.** Slide front pickup unit to left.
- h. Remove defective disc guide, disc track LED, and cable by disconnecting P29.
- i. Install new disc track LED, disc guide, and cable.
- j. Reinstall mounting screws.
- k. Tighten disc track LED setscrew.
- l. Install front panel.
- m. Turn on circuit breaker.

- n. Turn on power switch.
- o. Close top left panel.
- p. Perform diagnostic test.

2-20.5 Replace Driver Supply Board.

MOS: 35E, Special Electronic Devices Repairer

TOOLS: 3/16 in. Hex Head Key Wrench
Flat Tip Screwdriver

SUPPLIES: Driver Supply Board

WARNING

Death or serious injury may occur from electrical shock unless power is turned off before servicing.

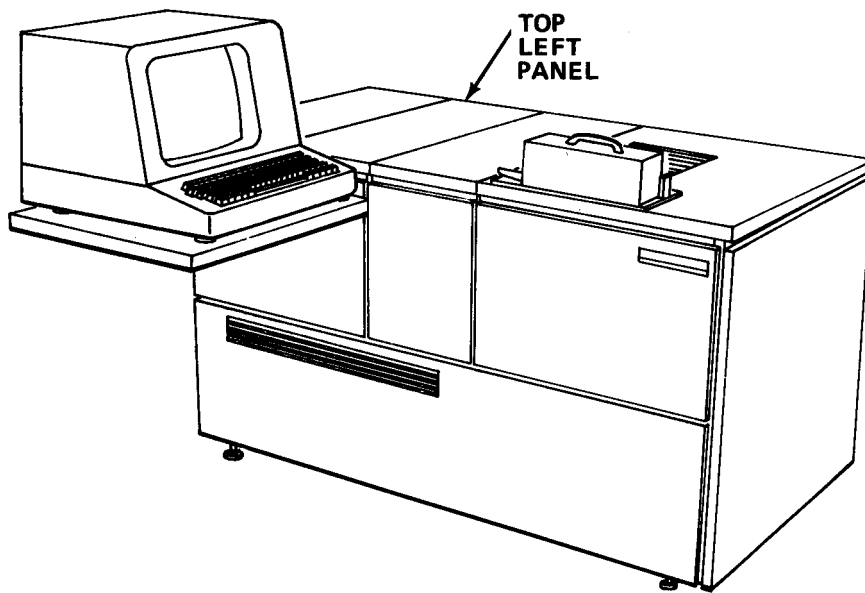

- a. Open top left panel.

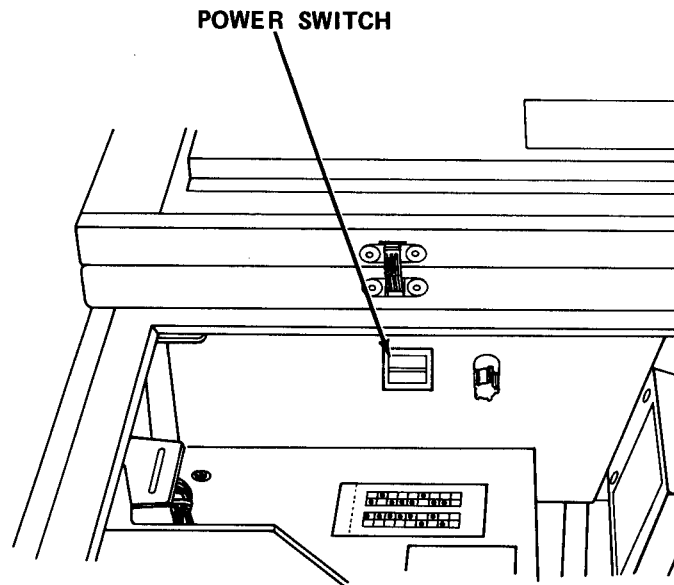

- b. Turn off power switch.
- c. Turn off circuit breaker.

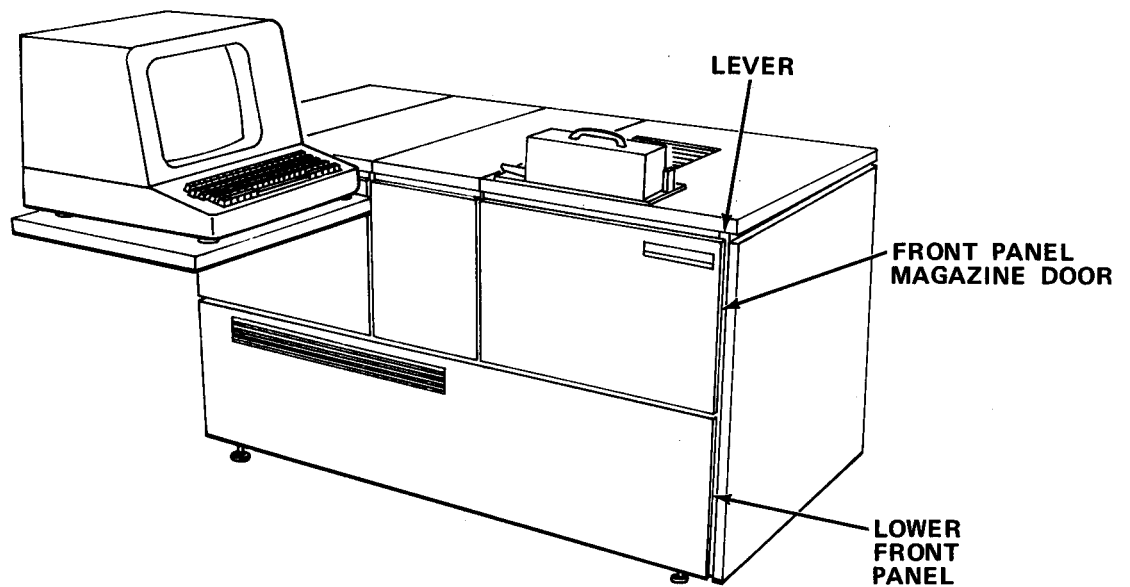

- d. Depress lever.
- e. Open front panel magazine door.
- f. Remove lower front panel.

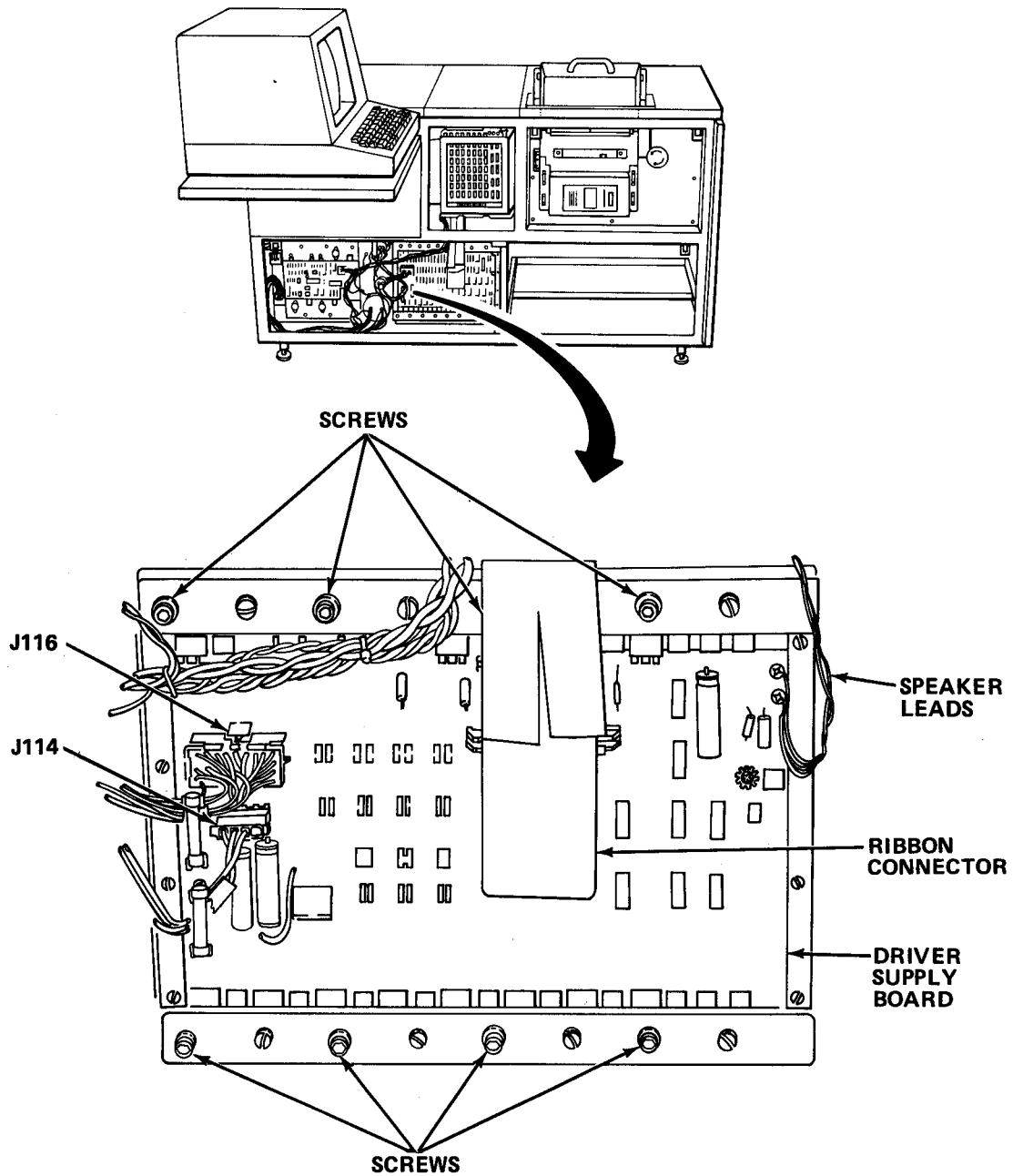

- g. Disconnect plugs J114, J116, speaker leads and ribbon connector.
- h. Remove 8 hex head mounting screws.
- i. Remove defective driver supply board.
- j. Install new driver supply board. Tighten mounting screws.
- k. Reconnect ribbon connector, speaker leads, plugs J116 and J114.
- l. Reinstall lower front panel.

- m. Close front panel magazine door.
- n. Turn on circuit breaker.
- o. Turn on power switch.
- p. Close top left panel.
- q. Perform diagnostic test.

2-20.6 ~~Replace Bridge Rectifier~~

MOS: 35E, Special Electronic Devices Repairer

TOOLS: Flat Tip Screwdriver

SUPPLIES: Bridge Rectifier

WARNING

Death or serious injury may occur from electrical shock unless power is turned off before servicing.

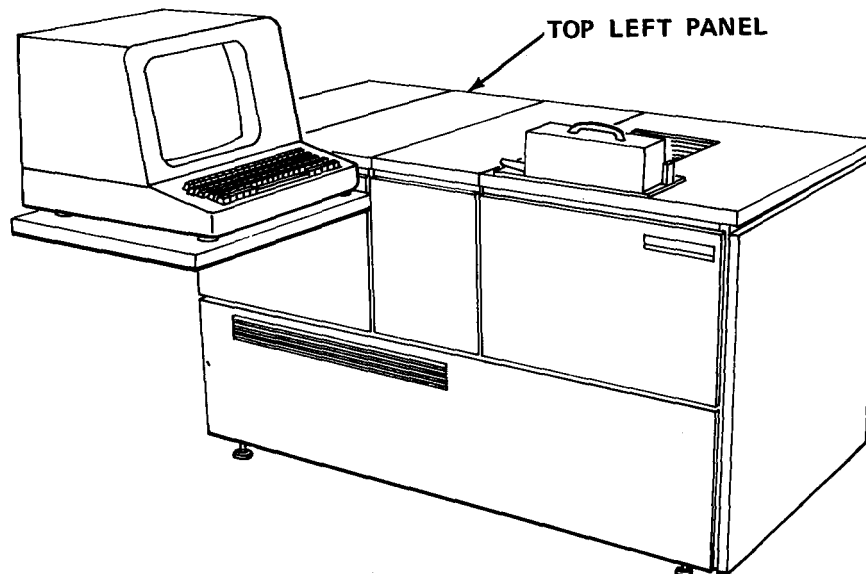

- a. Open top left panel.

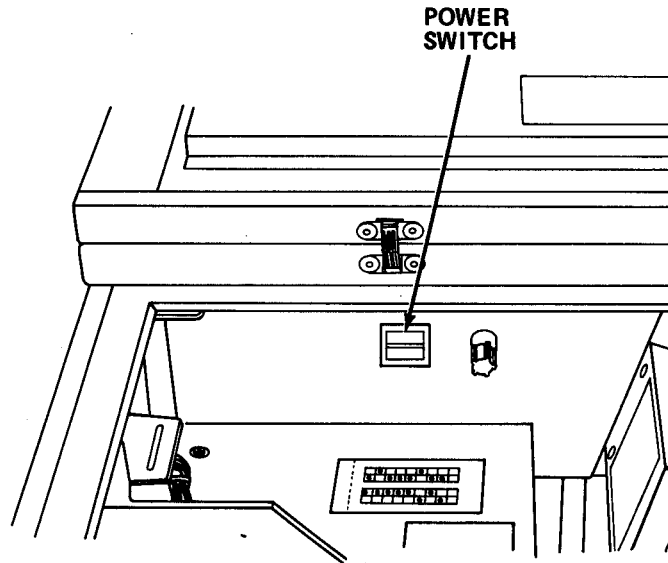

- b. Turn off power switch.
- c. Turn off circuit breaker.

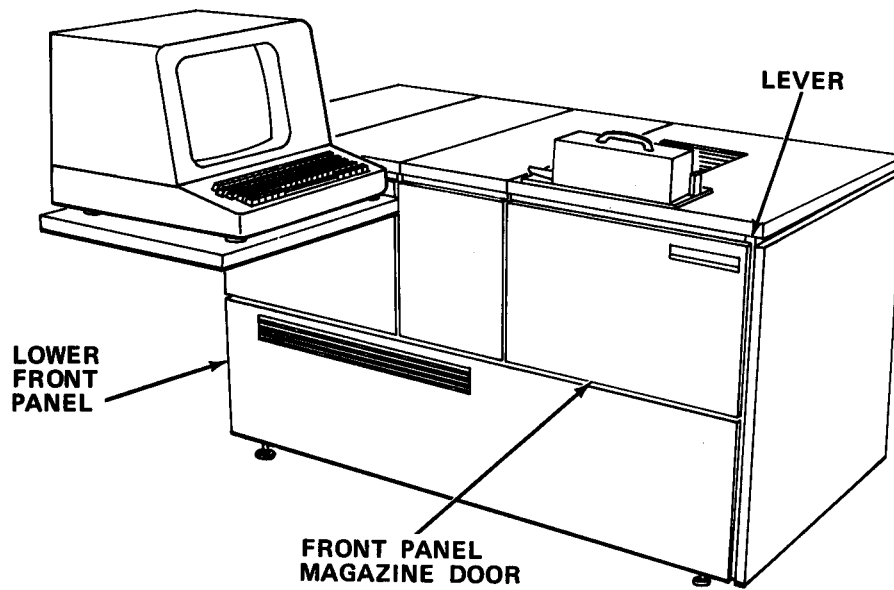

- d. Depress lever.
- e. Open front panel magazine door.
- f. Remove lower front panel.

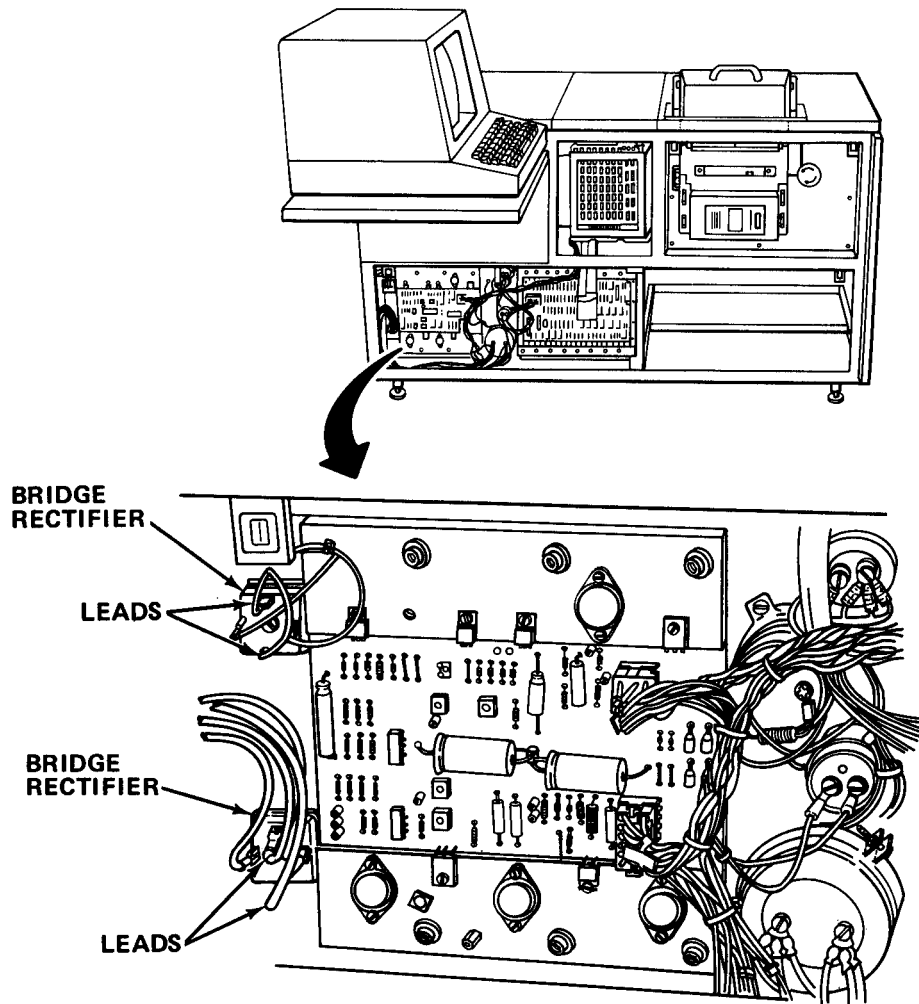

- g.** Tag and disconnect leads to bridge rectifier.
- h.** Remove defective bridge rectifier.
- i.** Install new bridge rectifier.
- j.** Attach leads to new bridge rectifier.
- k.** Reinstall lower front panel.
- l.** Turn on circuit breaker.
- m.** Turn on power switch.
- n.** Close front panel magazine door.
- o.** Close top left panel.
- p.** Perform diagnostic test.

2-20.7 Replace Power Supply.

MOS: 35E, Special Electronic Devices Repairer

TOOLS: Flat Tip Screwdriver
3/16 in. Hex Head Key Wrench

SUPPLIES: Power Supplies
Silicone Grease (Item 13, Appendix E)

WARNING

Death or serious injury may occur from electrical shock unless Power is turned off before servicing.

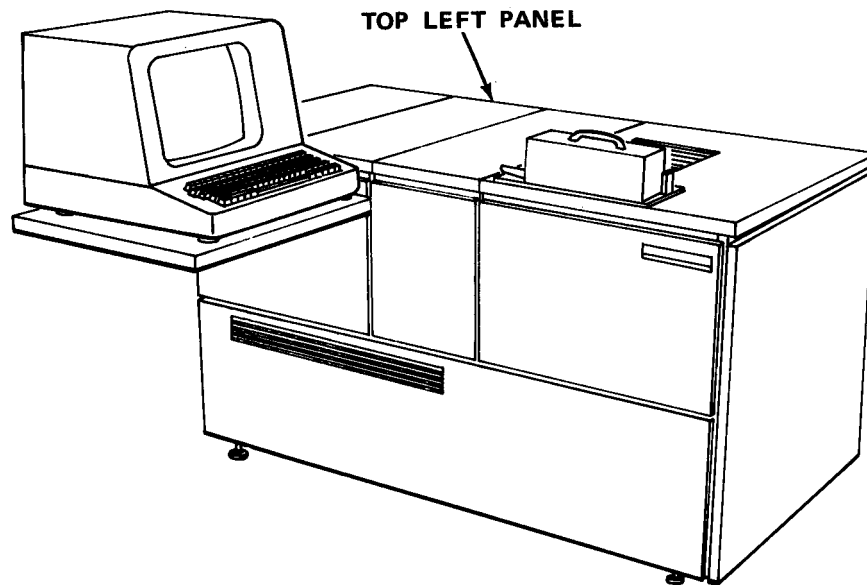

- a. Open top left panel.

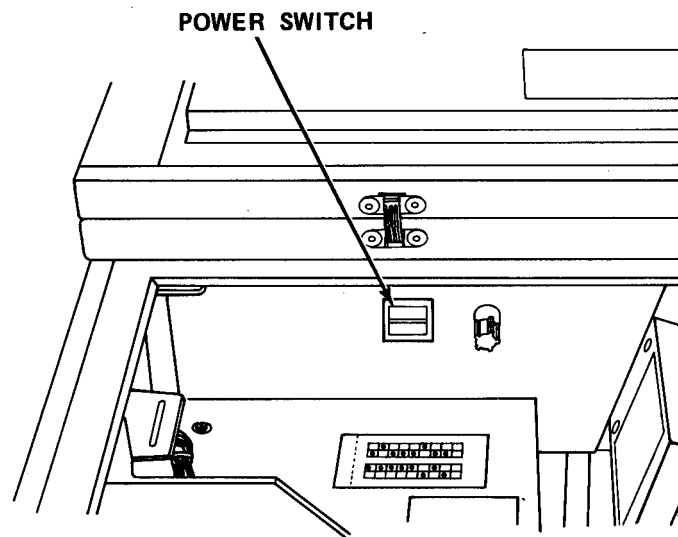

- b. Turn off power switch.
- c. Turn off circuit breaker.

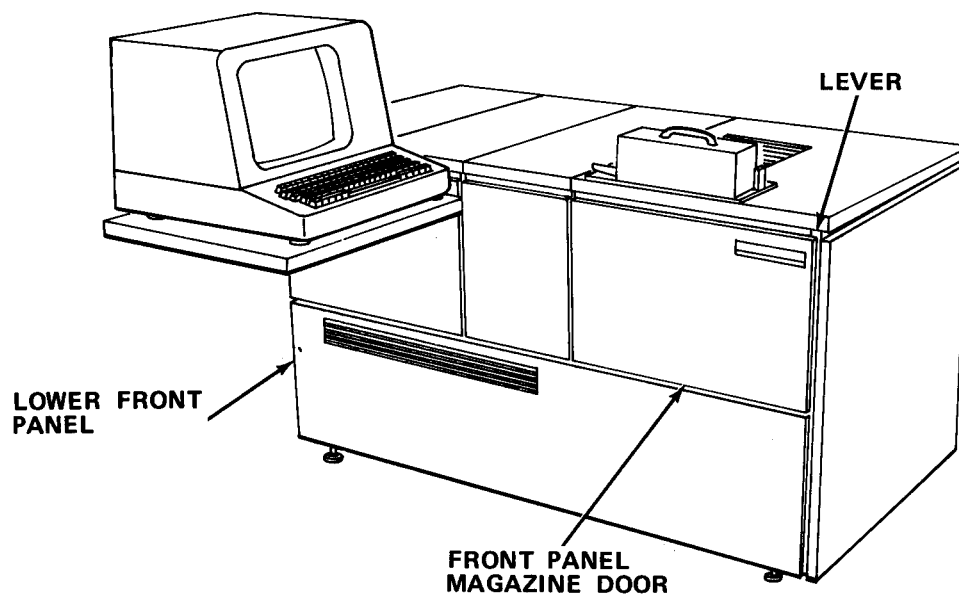

- d. Depress lever.
- e. Open front panel magazine door.
- f. Remove lower front panel.

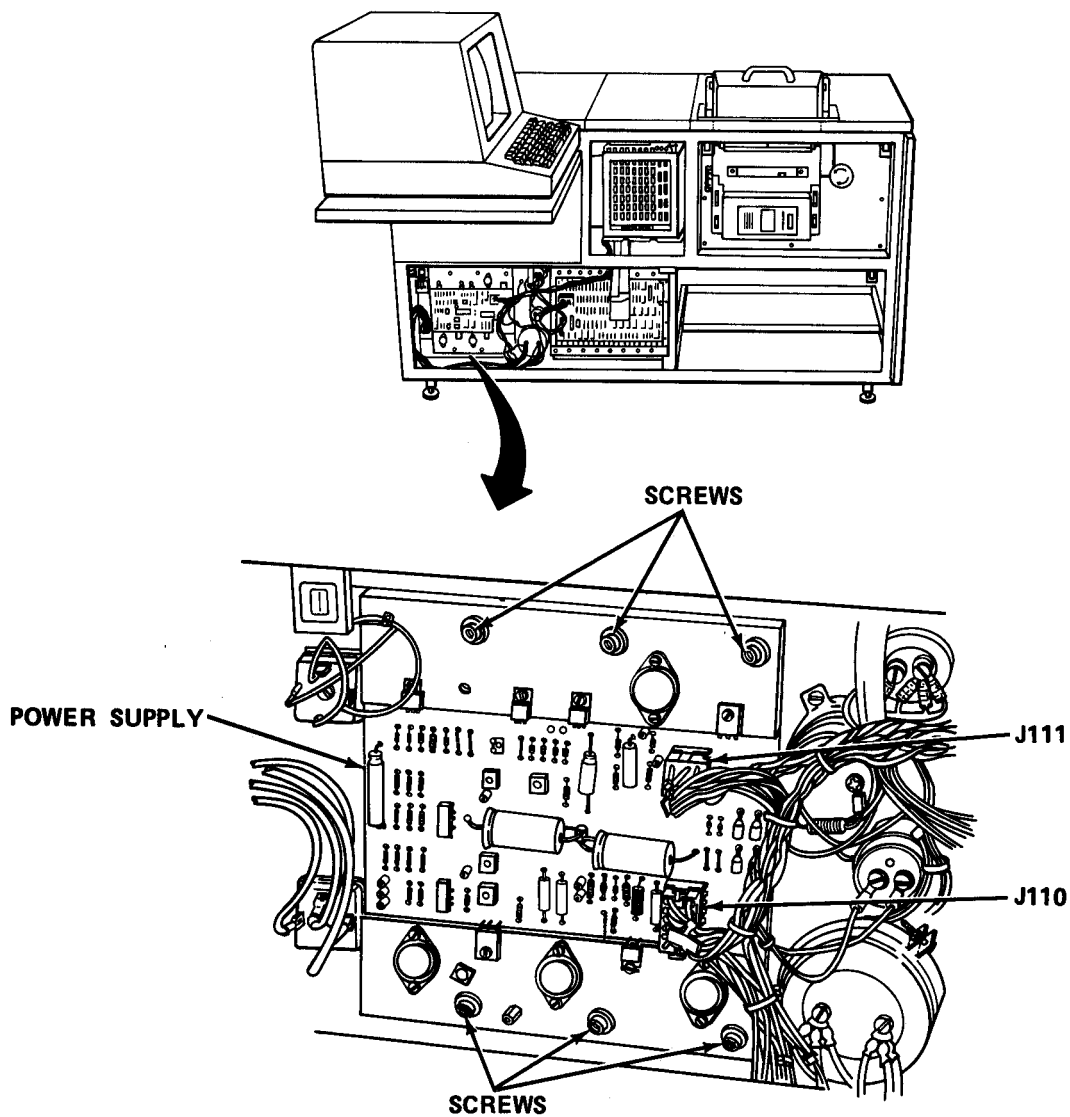

- g. Disconnect plugs J111 and J110
- h. Remove mounting screws.
- i. Remove defective power supply.
- j. Coat back of new power supply with silicone grease.
- k. Install new power supply and secure with mounting screws.
- l. Reconnect plugs J111 and J110.
- m. Turn on circuit breaker.
- n. Turn on power switch.
- o. Perform power supply adjustment (paragraph 2-20.23).

- p. Reinstall lower front panel.
- q. Close front panel magazine door.
- r. Close top left panel.
- s. Perform diagnostic test.

2-20.8 Replace Stepping Motor

MOS : 35E, Special Electronic Devices Repairer

TOOLS: Flat Tip Screwdriver
.050 in. Hex Head Key Wrench
5/32 in. Hex Head Key Wrench
1/4 in. Nut Driver

SUPPLIES: Motor

WARNING

Death or serious injury may occur from electrical shock unless power is turned off before servicing.

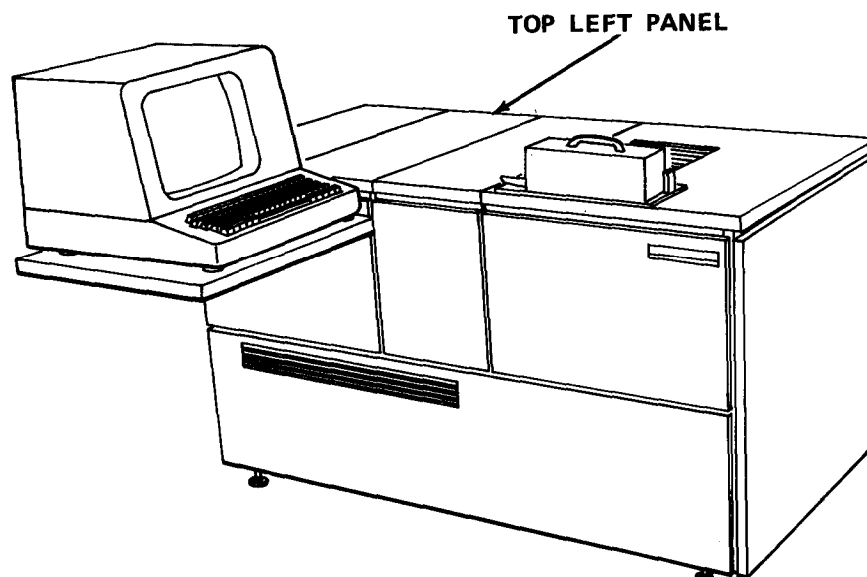

- a. Open top left panel.

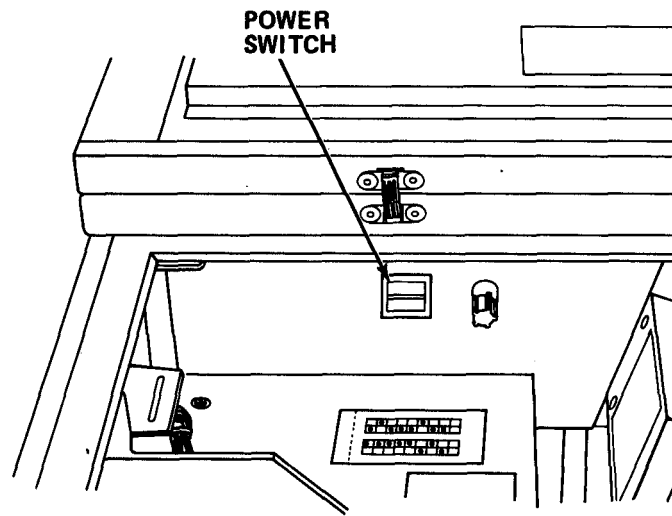

- b. Turn off power switch.
- c. Turn off circuit breaker.

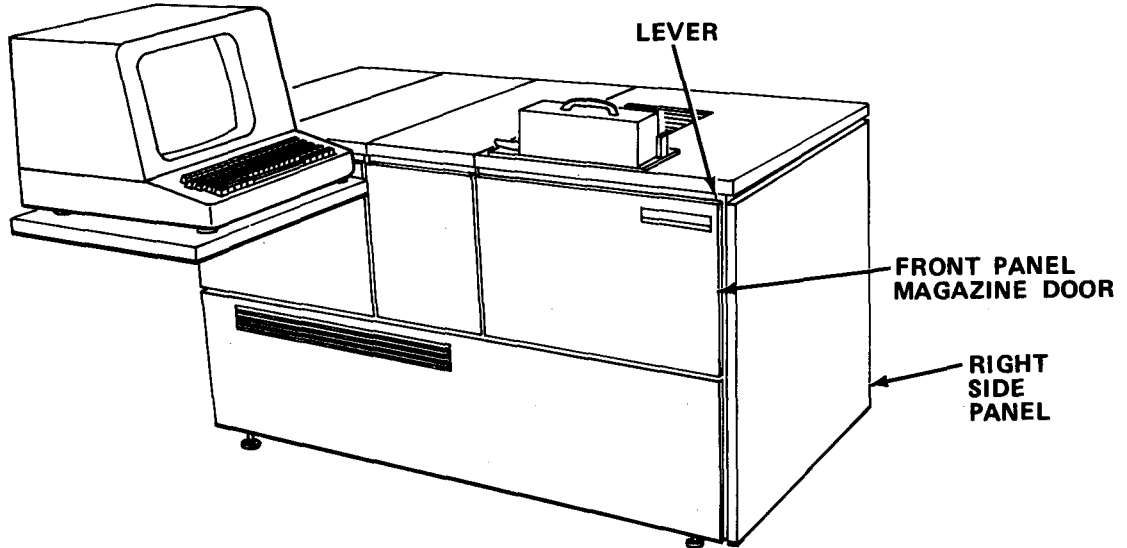

- d. Depress lever.
- e. Open front panel magazine door.
- f. Remove right side panel.

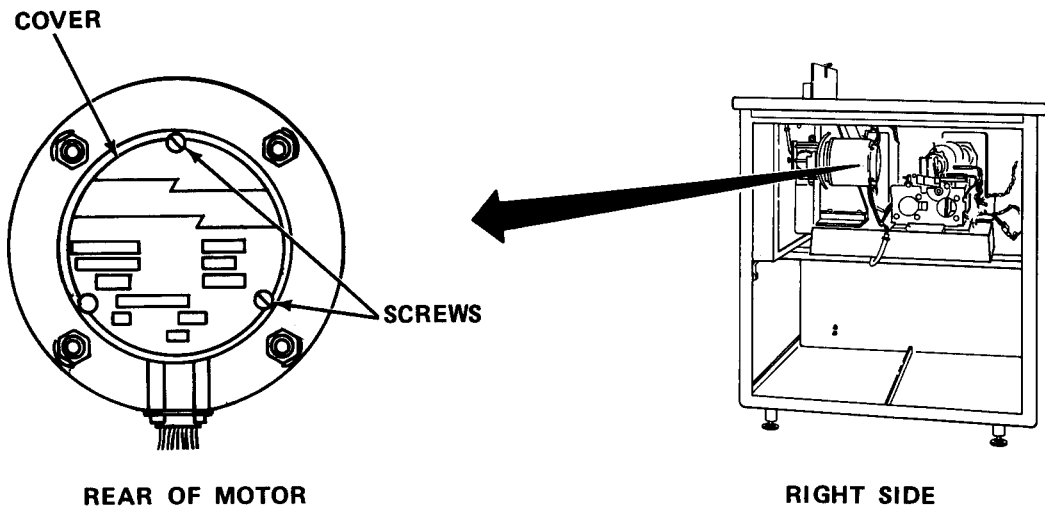

- g. Remove two screws from rear of stepping motor and remove cover.
- h. Tag and disconnect wires from motor.

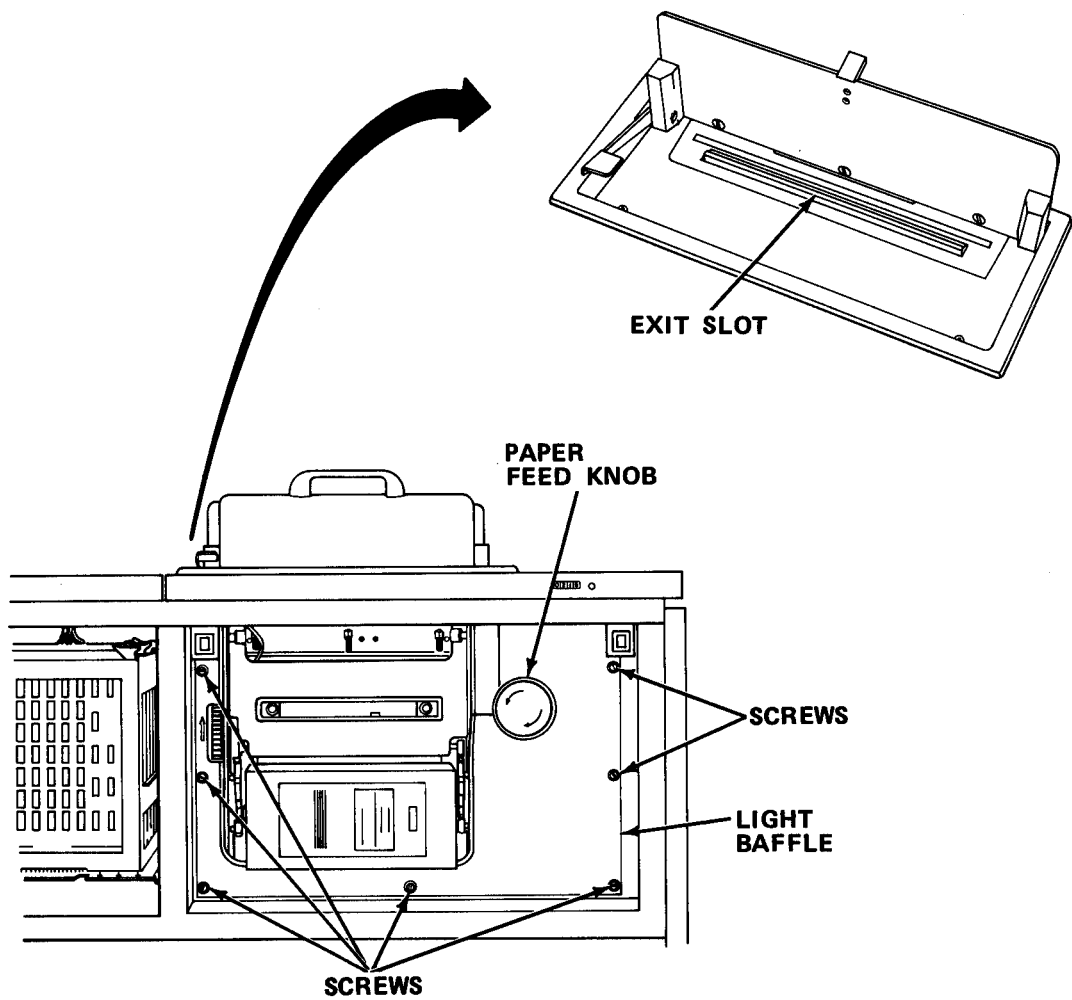

- i. Loosen knob shaft setscrew at motor and remove paper feed knob.
- j. Remove light baffle.

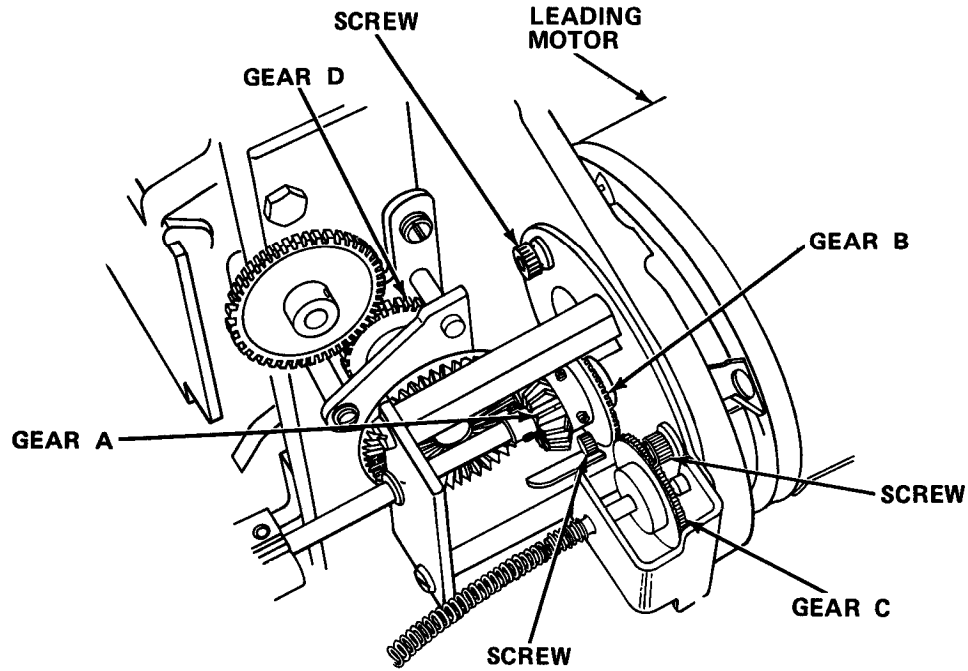

CAUTION

Handle stepping motor with two hands. Stepping motor is heavy. If motor is dropped, it will be damaged. Do not chip gear teeth or the gears will be damaged beyond repair.

- k. Remove three motor mounting screws.
- l. Remove defective stepping motor.
- m. Remove gears (A and B) from motor shaft.
- n. Install gears on new motor shaft but do not tighten setscrews.
- o. Install new motor and secure with mounting screws.
- p. Align gear B with gear C and ensure gear teeth mesh.
- q. Tighten setscrews on gear B,
- r. Align gear A with gear D and ensure gear teeth mesh.
- s. Tighten setscrews on gear A.
- t. Reconnect motor wires and replace cover.

- u. Reinstall light baffle.
- v. Reinstall paper feed advance knob and shaft and tighten setscrews.
- w. Close front panel magazine door.
- x. Reinstall right side panel.
- y. Close top left panel.
- z. Turn on circuit breaker.
- aa. Turn on power switch.
- ab. Perform diagnostic test.

2-20.9 Replace Shutter Assembly.

MOS : 35E, Special Electronic Devices Repairer

TOOLS: Flat Tip Screwdriver
Spring Clip Pliers

SUPPLIES: Switch
Solenoid

WARNING

Death or serious injury may occur from electrical shock unless power is turned off before servicing.

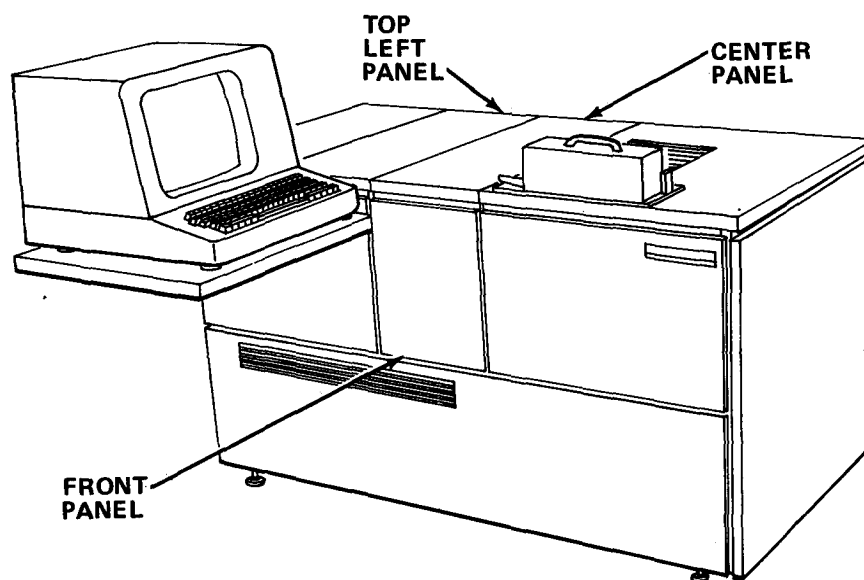

- a. Open top left panel.

- b. Remove center panel.
- c. Remove front panel.

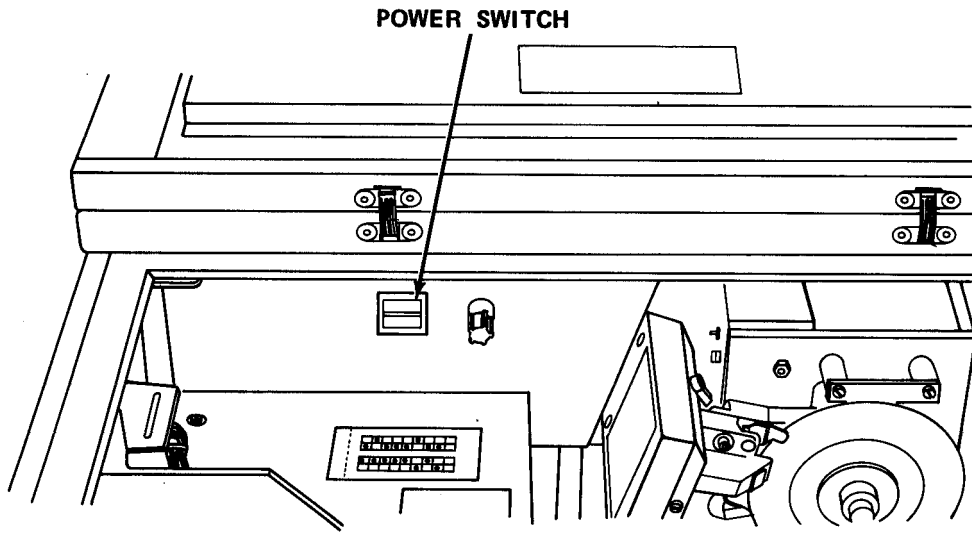

- d. Turn off power switch.
- e. Turn off circuit breaker.
- f. Tag and remove wires from switch.

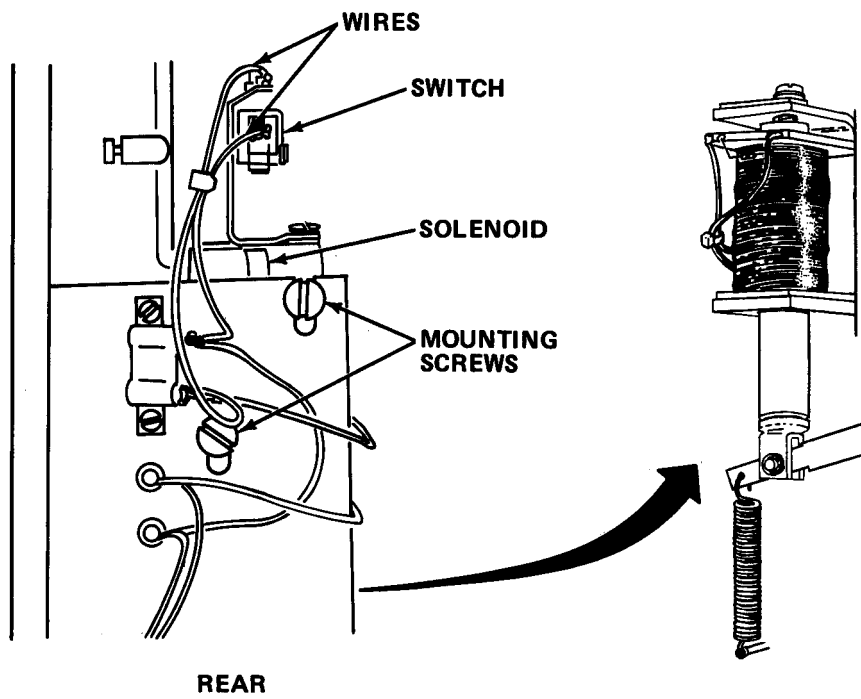

- g. Disconnect spring.

- h. Remove mounting screws from switch.
- i. Remove retaining clip and pin from solenoid shaft.
- j. Remove defective solenoid.
- k. Install new solenoid and secure with mounting screws.
- l. Reinstall pin and retaining clip.
- m. Connect wires to new solenoid.
- n. Reinstall front panel.
- o.** Reinstall center panel.
- p. Turn on circuit breaker.
- q.** Turn on power switch.
- r. Close top left panel.
- s. Perform diagnostic test.

2-20.10 Replace Carriage Cables.

MOS: 35E, Special Electronic Devices Repairer

PERSONNEL: Four persons are required to perform this procedure.

TOOLS : Flat Tip Screwdriver
3/8 in. Combination Wrench
3/8 in. Open End Offset Ignition Wrench
7/16 in. Combination Wrench
5/64 in. Hex Head Key Wrench
12 in. Rule

SUPPLIES: Carriage Cables
Electrical Hookup Wire

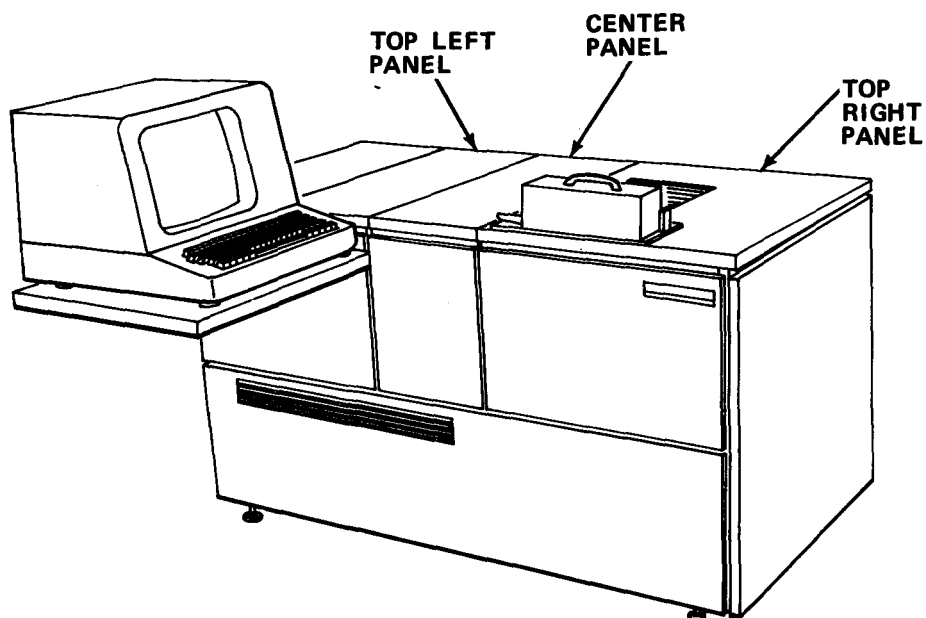

WARNING

Death or serious injury may occur from electrical shock unless power is turned off before servicing.

- a. Open top left panel.
- b. Remove center panel.

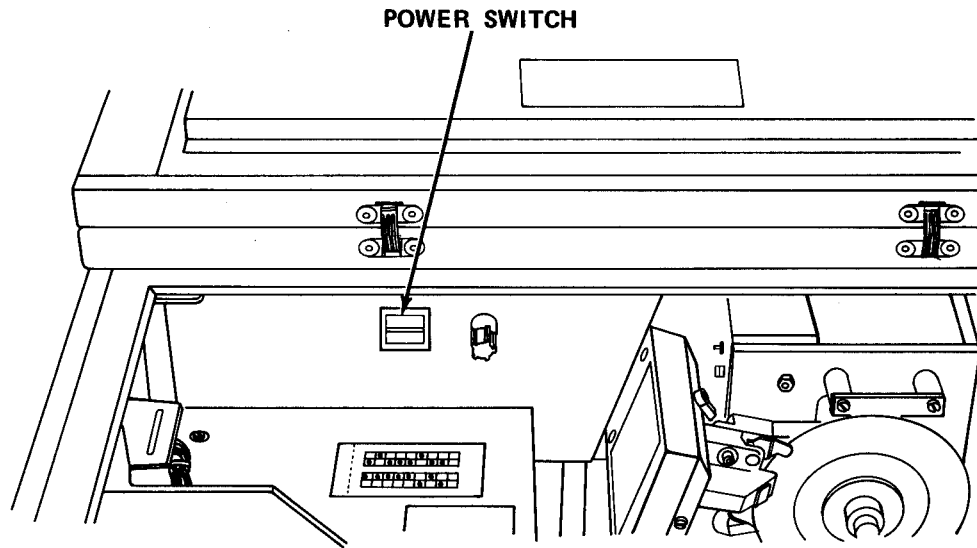

- c. Turn off power switch.
- d. Turn off circuit breaker.

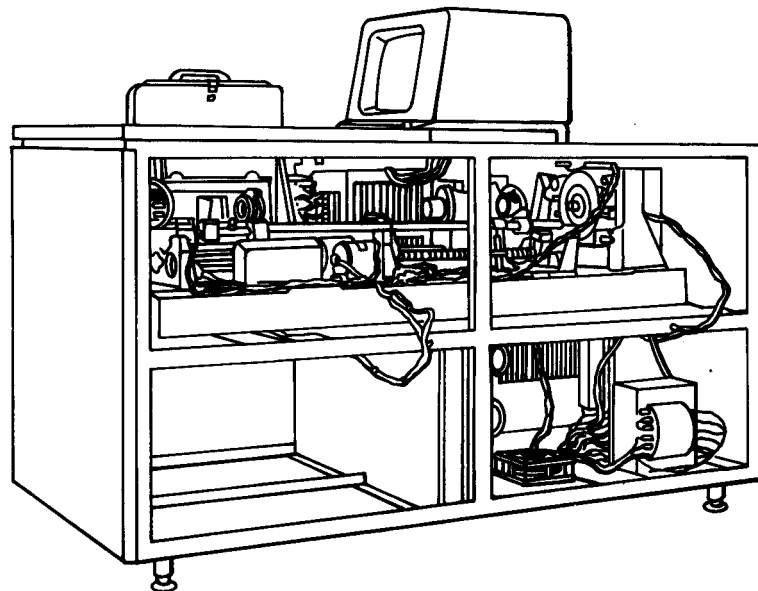

REAR PANEL REMOVED

- e. Remove cassette mounting bracket.
- f. Disconnect spring and remove top right panel.

WARNING

This procedure requires four persons. The composing machine weighs 485 pounds. Serious personnel injury may occur unless an adequate number of persons are used to move equipment.

- g. Move composing machine away from wall (paragraph 2-16.10).
- h. Remove rear panel.

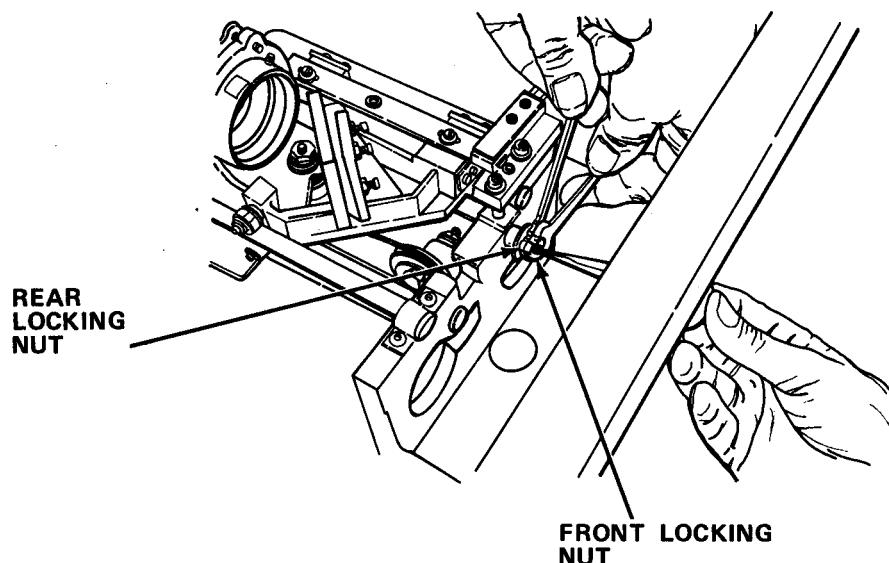

- i. Hold rear locking nut with thin 3/8 in. ignition wrench, while loosening front locking nut with standard 3/8 in. combination wrench.
- j. When front locking nut is loose, place screwdriver in slot on cable end connector and continue loosening front locking nut until free of connector.
- k. Repeat step j. above, and remove rear locking nut.
- l. Remove flat washer and compression baffle.

NOTE

Tension is now relieved from the carriage cables, and both cables are free to be threaded from machine.

- m. Remove defective carriage cables.

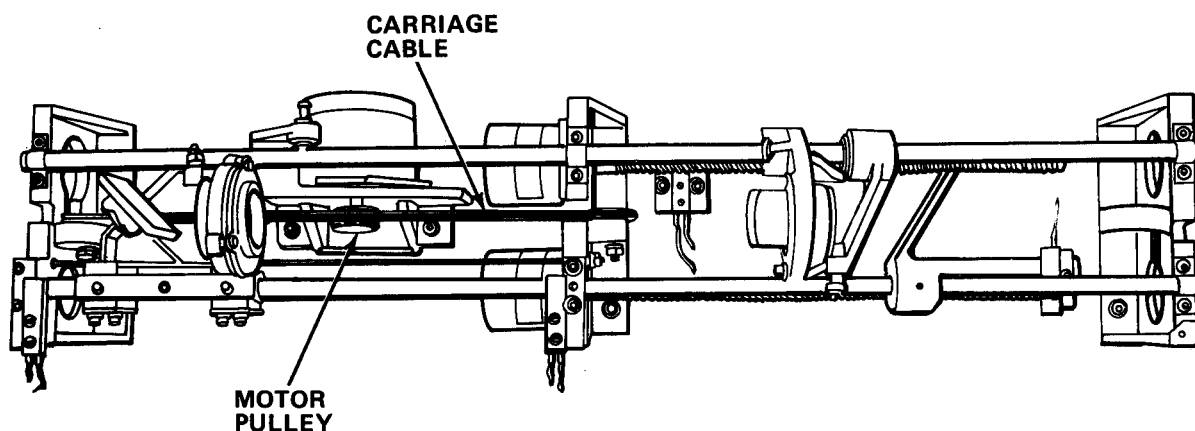

NOTE

The following is both the installation procedure and alignment procedure for the carriage cables.

- n. Insert bead end of first new carriage cable into rear slot of motor pulley.
- o. Wrap carriage cable left around motor pulley 6-1/2 turns.

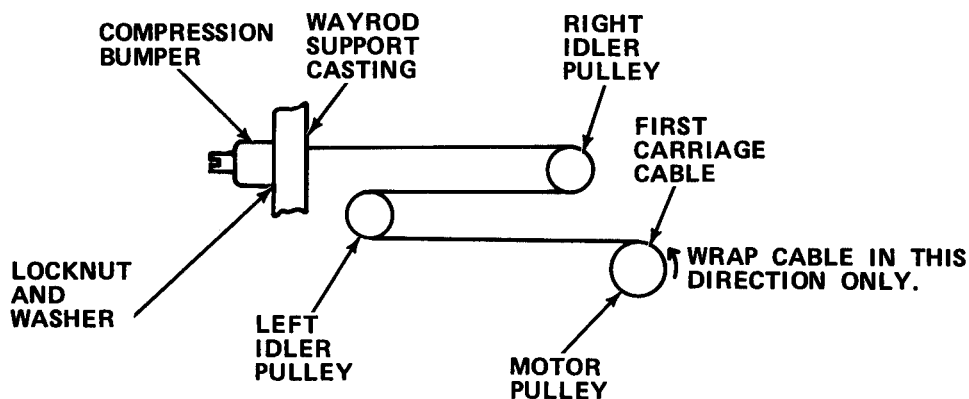

- p. Thread carriage cable from the bottom, through groove of left pulley, around the pulley to idler pulley upper groove, then to the wayrod support casting.
- q. Secure first carriage cable with compression baffle, flat washer and two locking nuts.
- r. Thread beaded end of second carriage cable into front slot of motor pulley.

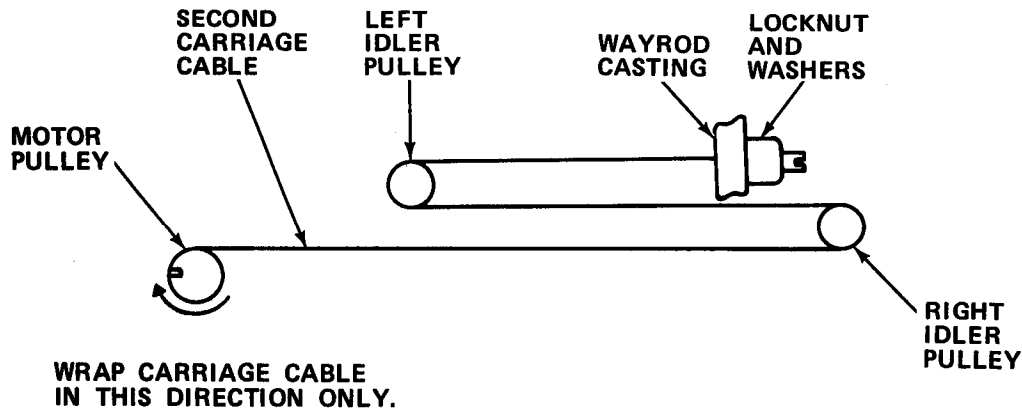

- s. Wrap carriage cable around motor pulley, to the right, 2-1/4 turns.
- t. Thread carriage cable from the bottom, through groove of right pulley, around pulley to idler pulley lower groove, then to wayrod support casting.
- u. Secure second carriage cable with flat washer and two locking nuts.
- v. Reinstall rear panel.
- w. Move composing machine back to wall (paragraph 2-16.10).
- x.** Reinstall top right cover and reconnect spring.
- y.** Reinstall cassette mounting bracket.
- z. Turn on circuit breaker.
- aa. Turn on power switch.
- ab. Reinstall center panel.
- ac. Close top left panel.
- ad. Perform diagnostic test.

2-20.11 Replace Carriage Motor.

MOS: 35E, Special Electronic Devices Repairer

PERSONNEL: Four persons are required to perform this procedure.

TOOLS: Flat Tip Screwdriver
3/8 in. Combination Wrench
3/8 in. Open End Offset Ignition Wrench
7/16 in. Combination Wrench
5/64 in. Hex Head Key Wrench
5/32 in. Hex Head Key Wrench
.050 in. Hex Head Key Wrench
1/4 in. Nut Driver

SUPPLIES: Carriage Motor
Carriage Cables

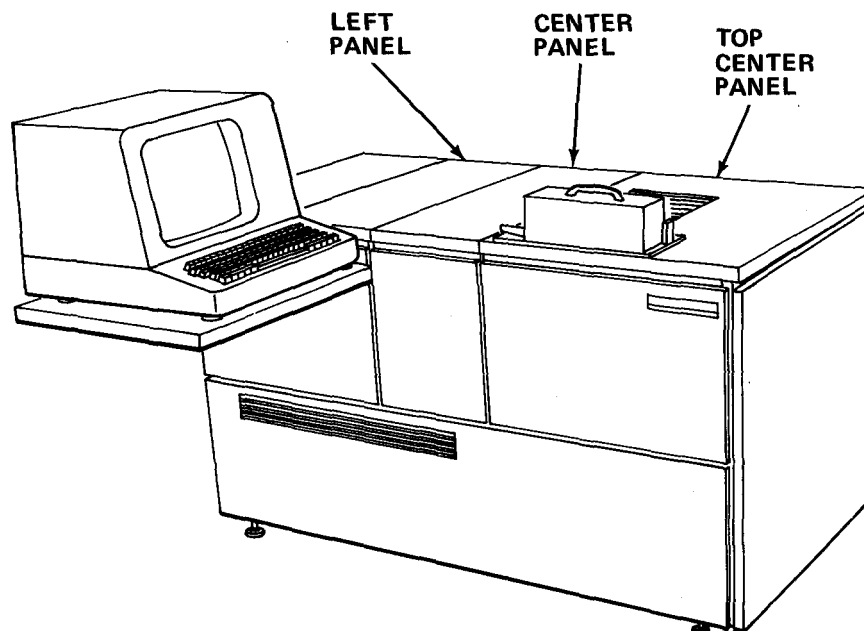

WARNING

Death or serious injury may occur from electrical shock unless power is secured before servicing.

- a. Open top left panel.

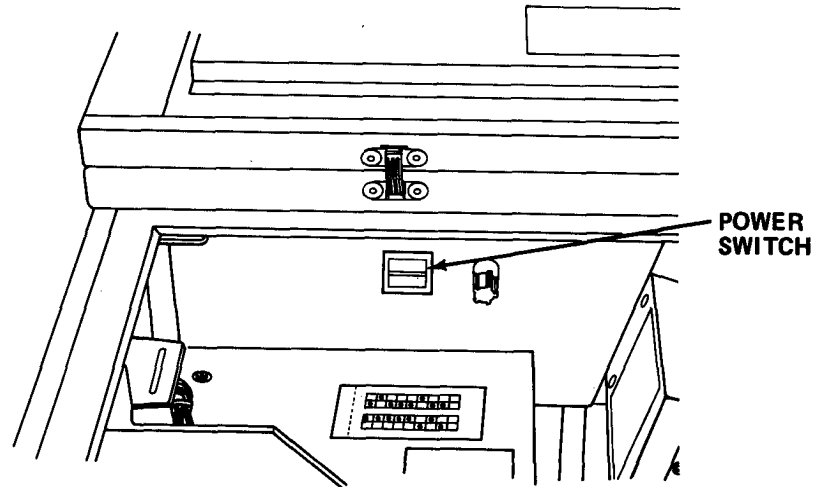

- b. Remove center panel.
- c. Turn off power switch.
- d. Turn off circuit breaker.
- e. Remove cassette mounting bracket.
- f. Disconnect spring and remove top right panel.

WARNING

This procedure requires four persons. The composing machine weighs 485 pounds. Serious personnel injury may occur unless an adequate number of persons are used to move equipment.

- g. Move composing machine away from wall (paragraph 2-16.10).
- h. Remove rear panel.
- i. Remove carriage cables (paragraph 2-20.10).

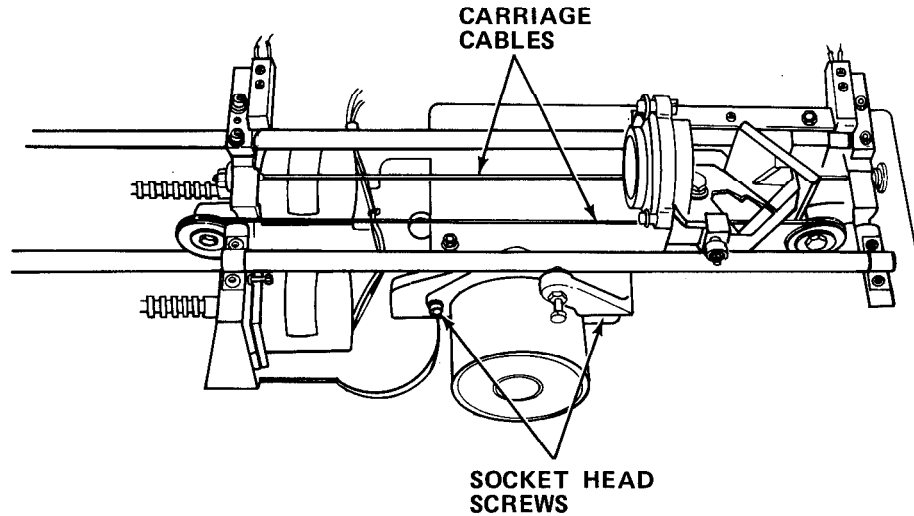

- j. Remove two socket head screws and defective carriage motor.
- k. Install new motor and secure with screws.

NOTE

When carriage motor is replaced, always install new carriage cables.

- l. Install new carriage cables (paragraph 2-20.10).
- m. Reinstall rear panel.
- n. Move composing machine back to wall (paragraph 2-16.10).
- o. Reinstall top right cover and reconnect spring.
- p. Reinstall cassette mounting bracket.
- q. Turn on circuit breaker.
- r. Turn on power switch.
- s. Reinstall center panel.
- t. Close top left panel.
- u. Perform diagnostic test.

2-20.12 Replace Interlock Switch.

MOS: 35E, Special Electronic Devices Repairer

PERSONNEL: Four persons are required to perform this procedure.

TOOLS: Flat Tip Screwdriver

SUPPLIES: Interlock Switch

WARNING

Death or serious injury may occur from electrical shock unless power is secured before servicing.

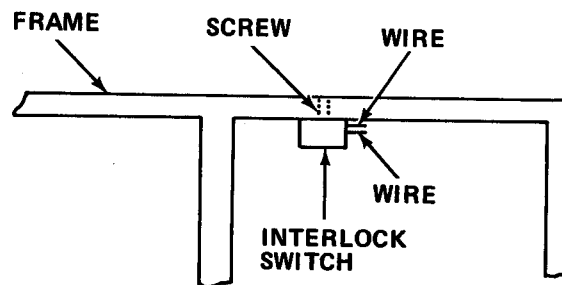
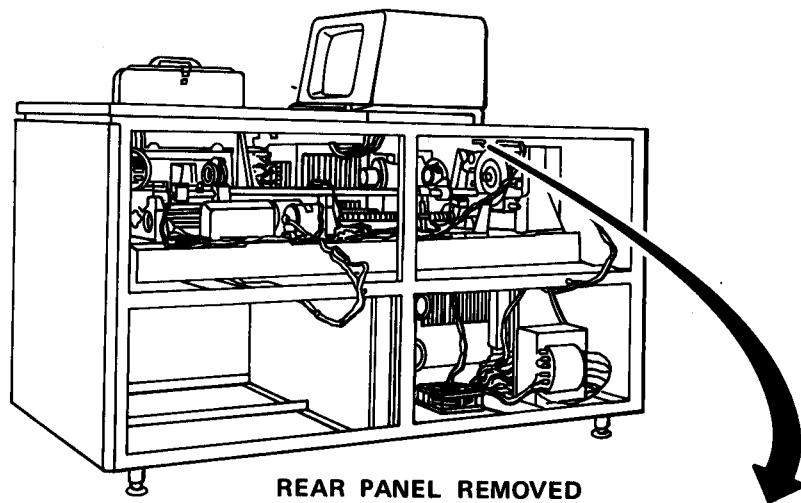

- a. Remove top left panel.
- b. Turn off power switch.
- c. Turn off circuit breaker.

WARNING

This procedure requires four persons. The composing machine weighs 485 pounds. Serious personnel injury may occur unless an adequate number of persons are used to move equipment.

- d. Move composing machine away from wall (paragraph 2-16.10).
- e. Remove rear panel.
- f. Tag and disconnect interlock switch wires.
- g. Remove switch mounting screw and remove defective interlock switch.
- h. Install new interlock switch and secure with screw.
- i. Connect interlock switch wires.
- j. Reinstall rear panel and close top left panel.
- k. Move machine back to wall (paragraph 2-16.10).
1. Perform diagnostic test.

2-20.13 Replace Row Shift Motor.

MOS: 35E, Special Electronic Devices Repairer

TOOLS: Flat Tip Screwdriver
7/64 in. Hex Head Key Wrench
1/8 in. Hex Head Key Wrench
9/64 in. Hex Head Key Wrench

SUPPLIES: Row Shift Motor

WARNING

Death or serious injury may occur from electrical shock unless power is secured before servicing.

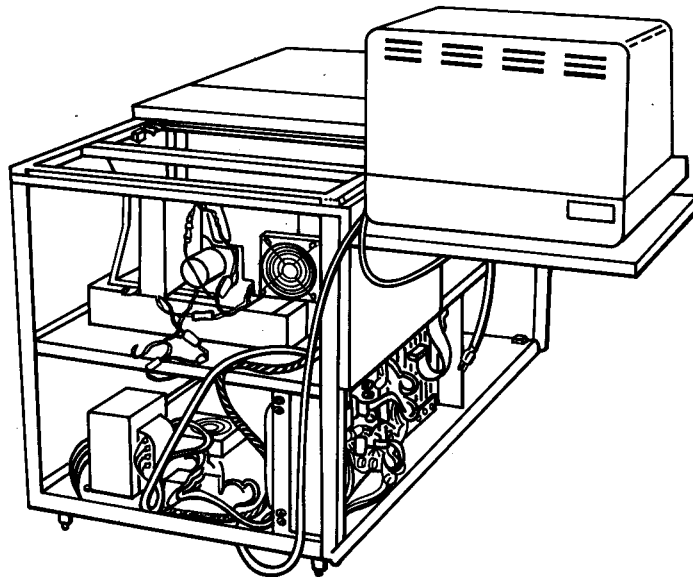

**LEFT SIDE
PANEL REMOVED**

- a. Turn off power switch.
- b. Turn off circuit breaker.
- c. Remove left side panel.

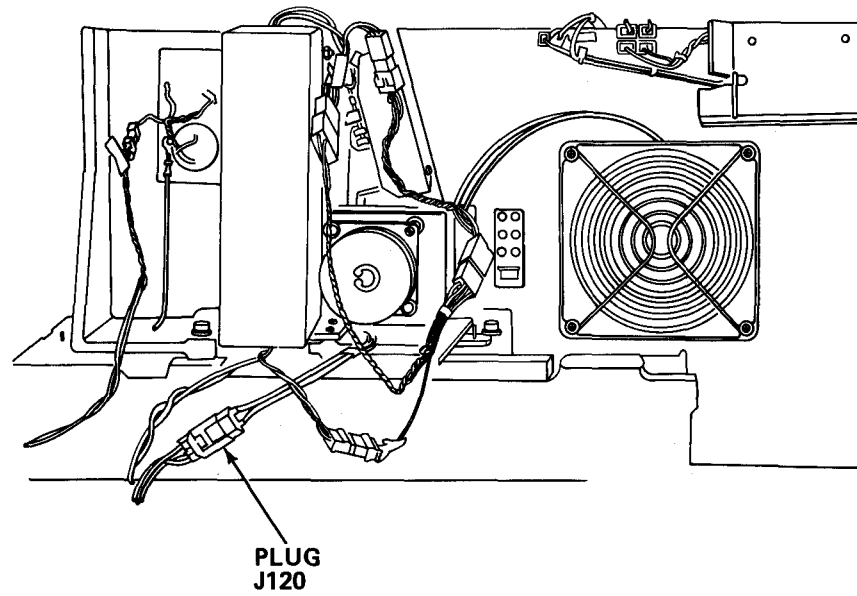

d. Disconnect plug J120.

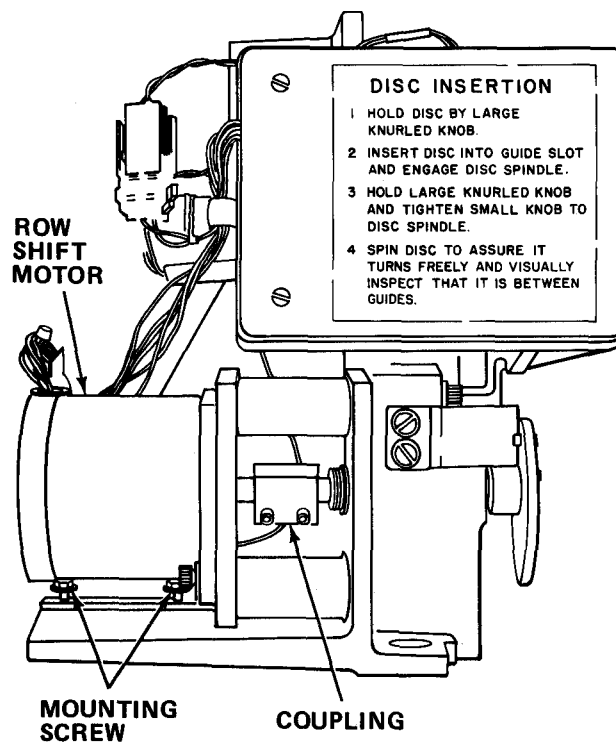

e. Loosen setscrews in coupling.

f. Remove mounting screws and defective row shift motor.

g. Install new row shift motor and secure with mounting screws.

- h. Slide coupling over motor shaft and tighten setscrews on coupling.
- i. Reconnect plug.

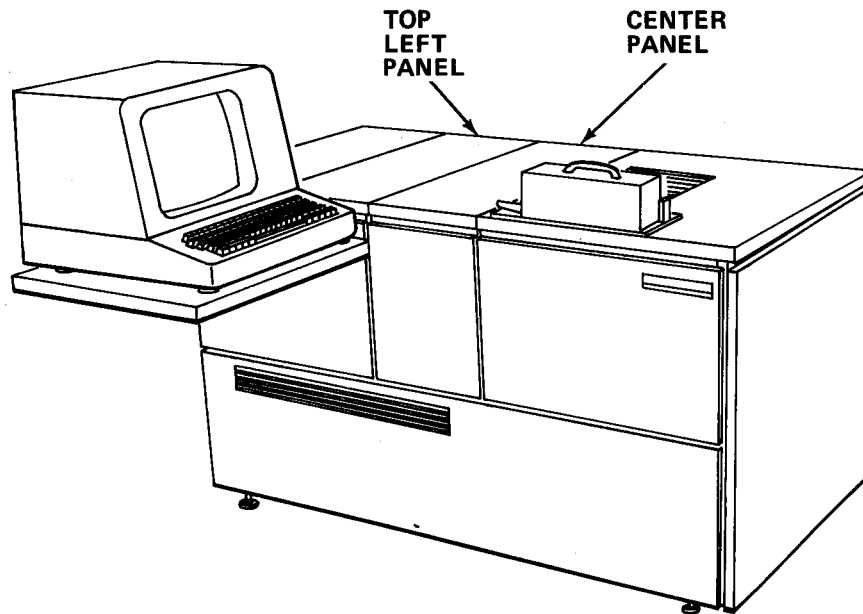

- j. Open top left panel.
- k. Place disc box in convenient location.
- l. Open disc box.

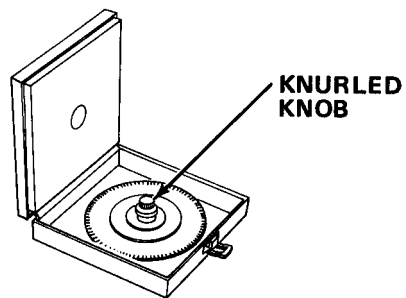

- m. Grasp knurled knob and remove disc from disc box.

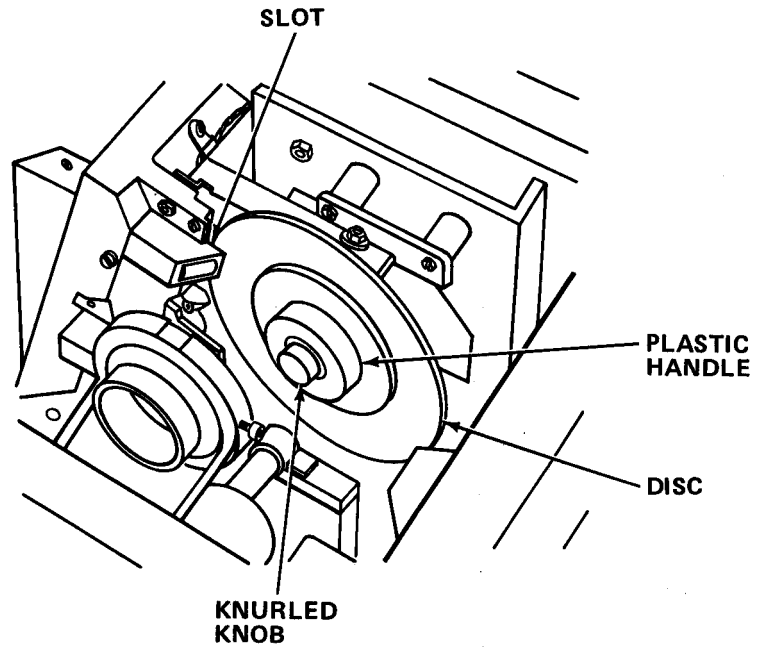

- n. Grasp plastic handle.
- o. Place left edge of disc into slot.
- p. While holding plastic handle, tighten knurled knob.
- q. Spin disc using plastic handle. It should rotate easily.

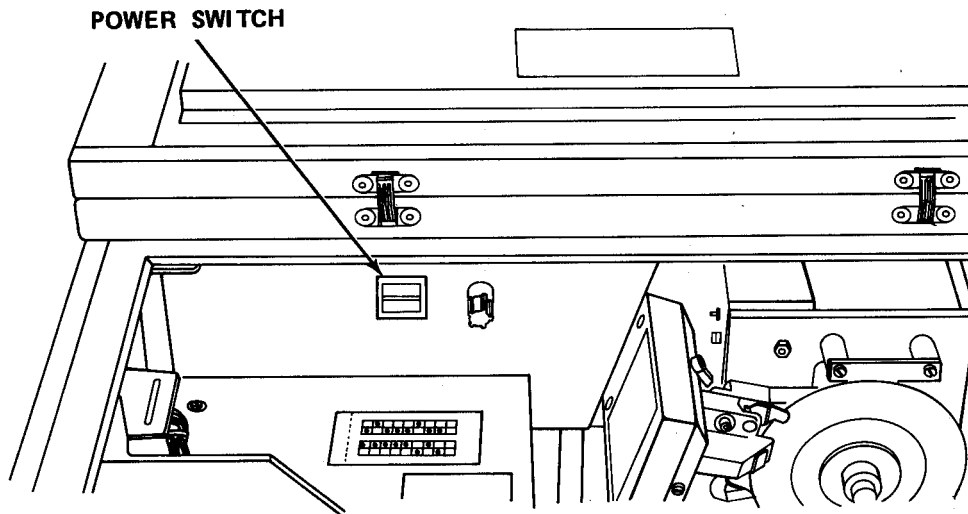

- s. Set power switch to ON. Close top left panel.

- t. Press RESET and DATA several times until distinct clicking sound is heard.

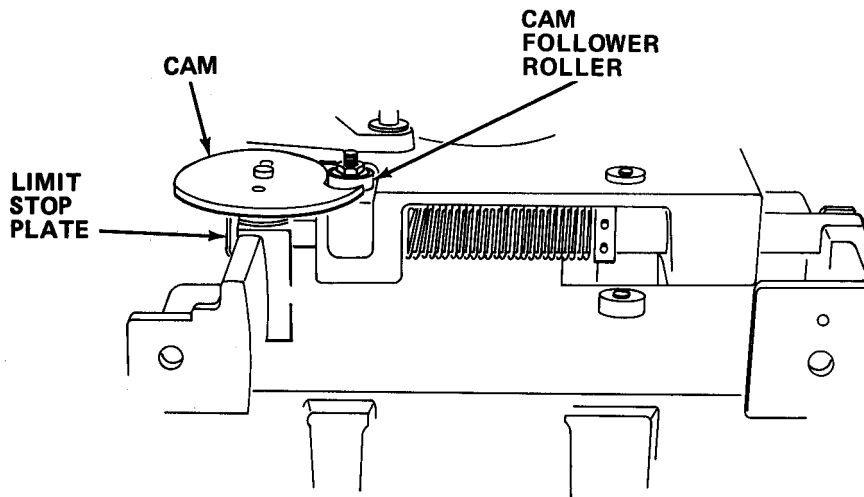

NOTE

Be sure cam follower roller is centered in dwell of cam. If adjustment is required, bend cam limit stop plate.

- u. Select FONT 1. Cam follower roller should be centered in dwell of cam.
- v. Repeat step u. for fonts 2, 3 and 4.
- w. Enter the following function field data: SIZE 6, LINE LENGTH 30, STORE PL 30, STORE SL 12 and FONT 1.
- x. Type the following: The quick brown fox jumps over the lazy dog.
- y. Change to FONT 2 and repeat step x.
- z. Change to FONT 3 and repeat step x.
- aa. Change to FONT 4 and repeat step x.
- ab. Press CONTROL and e (end of job).

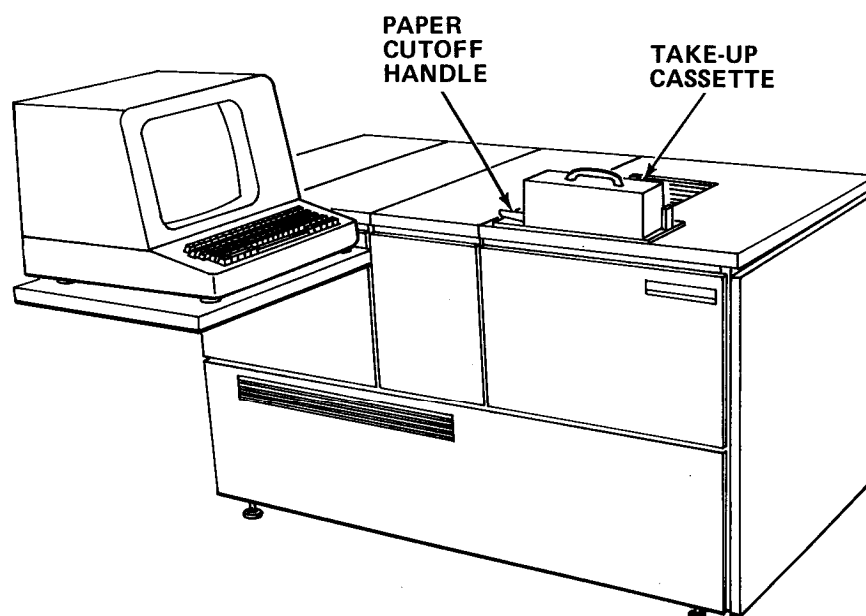

- ac. Depress paper cutoff handle.
- ad. Pull take-up cassette forward.
- ae. Develop image.
- af. Replace take-up cassette.

DOG

GOOD IMAGE

DOG

POOR IMAGE

- ag. Inspect copy for cutoffs on any font.
- ah. If fonts are incorrect, repeat steps t. through ag.
- ai. Open top left panel. Set power switch to OFF.
- aj. Remove disc and store.
- ak. Reinstall left side panel.
- al. Turn on circuit breaker.
- am. Turn on power switch.
- an. Close top left panel.
- ao. Perform diagnostic test.

2-20.14 Adjust Setting on Compatibility Switches.

MOS: 35E, Special Electronic Devices Repairer

TOOLS: Flat Tip Screwdriver

WARNING

Death or serious injury may occur from electrical shock unless power is secured before servicing.

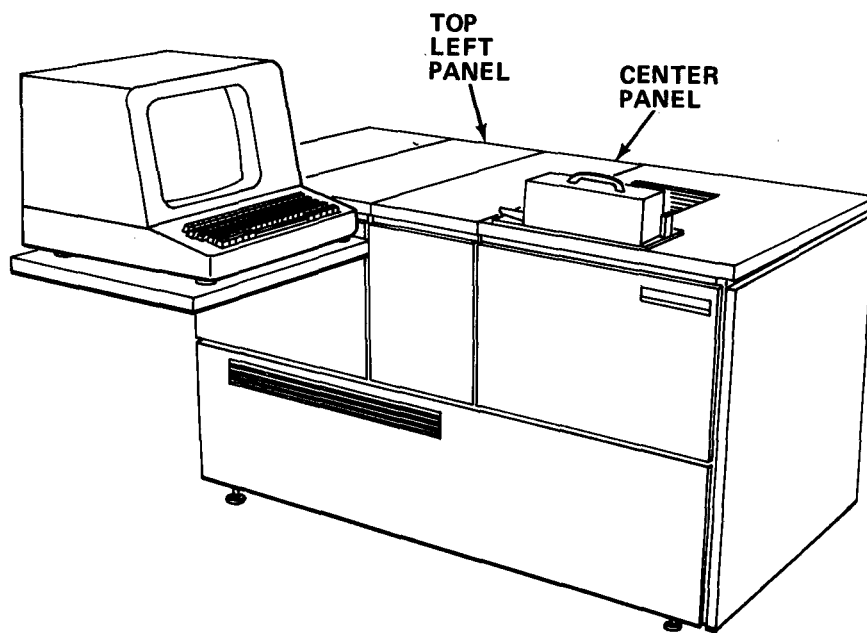

- a. Open top left panel.
- b. Remove center cover.

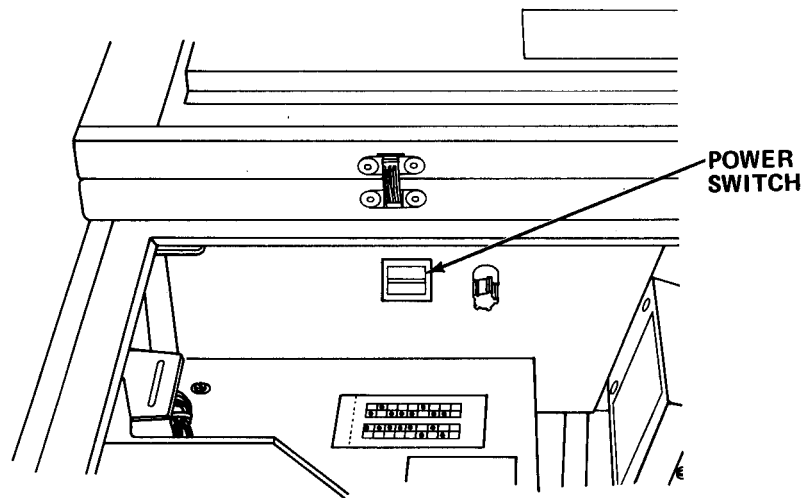

- c. Turn off power switch.
- d. Turn off circuit breaker.

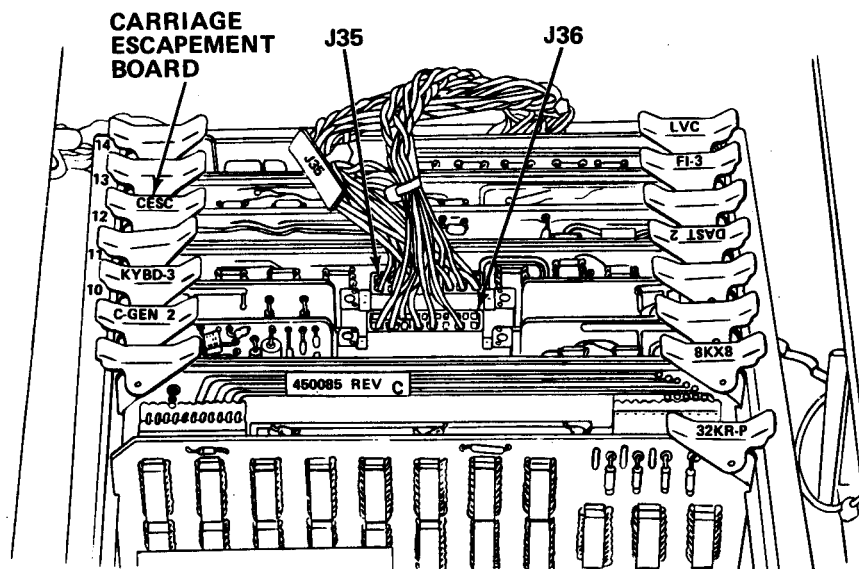

- e. Grasp tabs and remove carriage escapement board.

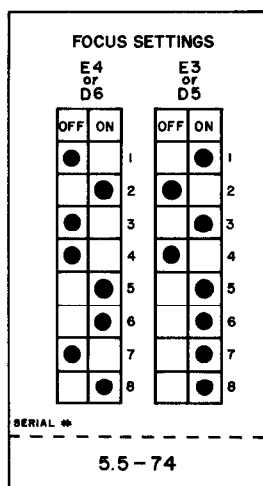
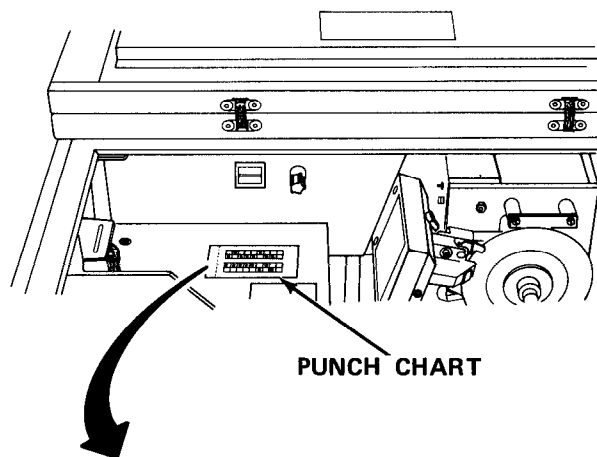

- f. Check position of switches D5 and D6 on carriage escapement against focus setting chart.
- g. Set switches D5 and D6 as indicated on focus setting chart.
- h. Reinstall carriage escapement board.
- i. Reinstall center panel.
- j. Turn on circuit breaker.
- k. Turn on power switch.
- l. Close top left panel.
- m. Perform diagnostic test.

2-20.15 Replace Brightness Control

MOS : 35E, Special Electronic Devices Repairer

TOOLS: Flat Tip Screwdriver
Soldering/Desoldering Set
.050 in. Hex Head Key Wrench
1/2 in. Combination WrenchSUPPLIES: Potentiometer
Solder (Item 23, Appendix E)**WARNING**

Death or serious injury may occur from electrical shock unless power is secured before servicing.

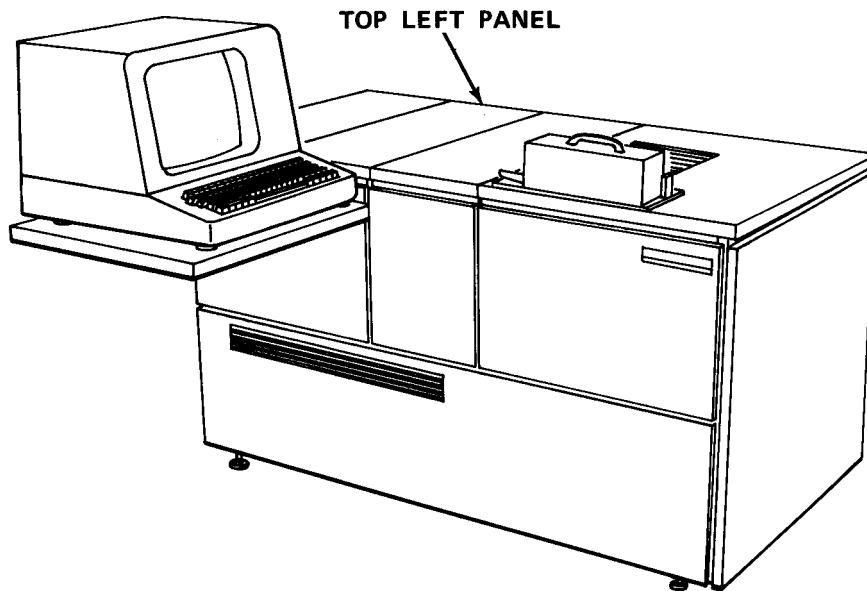

- a. Open top left panel.

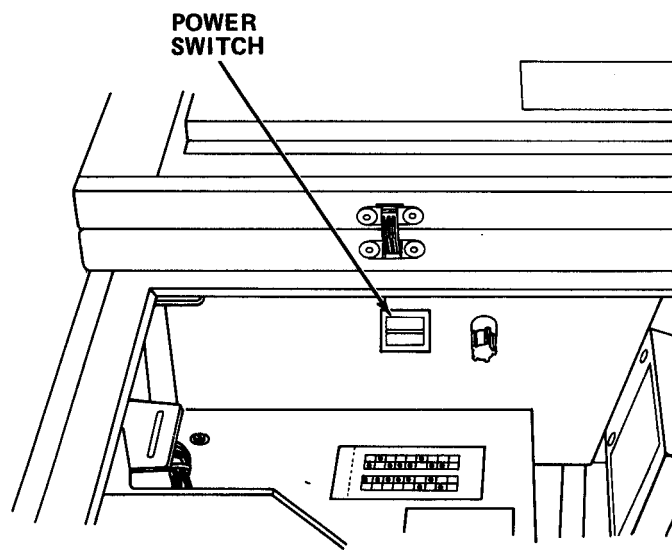

- b. Turn off power switch.
- c. Turn off circuit breaker.

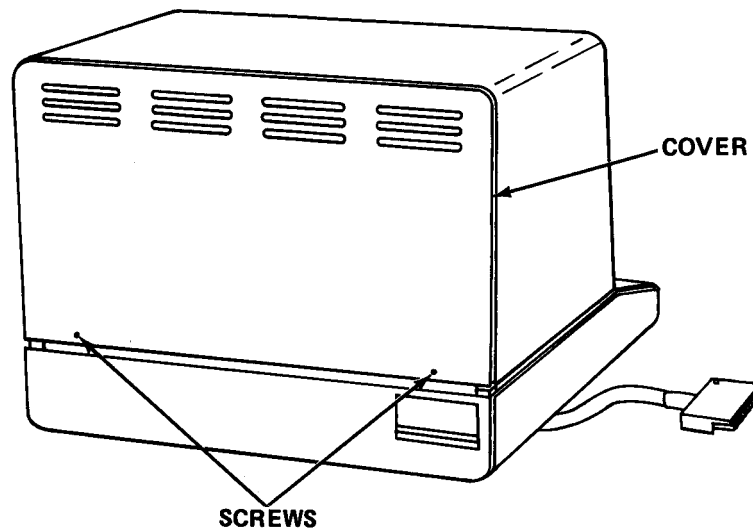

- d. Remove mounting screws from display monitor cover.
- e. Remove cover.

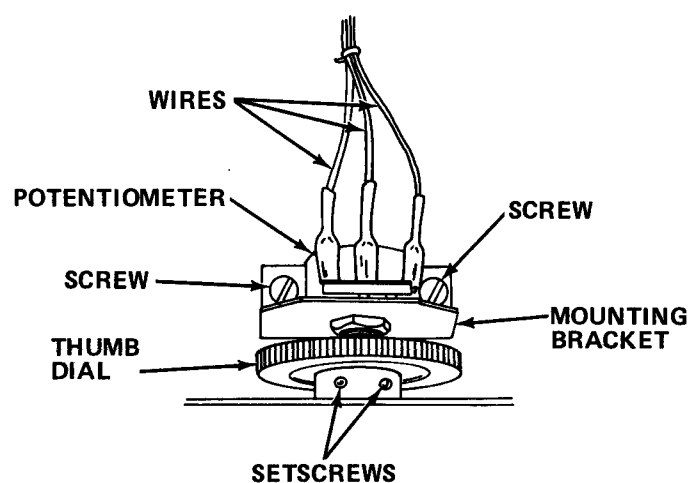

- f. Tag and desolder wires from potentiometer.
- g. Remove two screws.
- h. Remove locknut and raise mounting bracket.
- i. Loosen setscrews and remove thumb dial.
- j. Remove defective potentiometer.
- k. Install new potentiometer.
- l. Reinstall thumb dial and tighten setscrews. Reinstall retaining locknut.
- m. Reinstall mounting bracket with two screws.
- n. Reconnect wires.
- o. Reinstall cover.
- p. Turn on circuit breaker.
- q. Turn on power switch.
- r. Close top left panel.
- s. Perform diagnostic test.

2-20.16 Replace Film Out Switch.

MOS: 35E, Special Electronic Devices Repairer

TOOLS: Flat Tip Screwdriver

SUPPLIES: Switch

WARNING

Death or serious injury may occur from electrical shock unless power is secured before servicing.

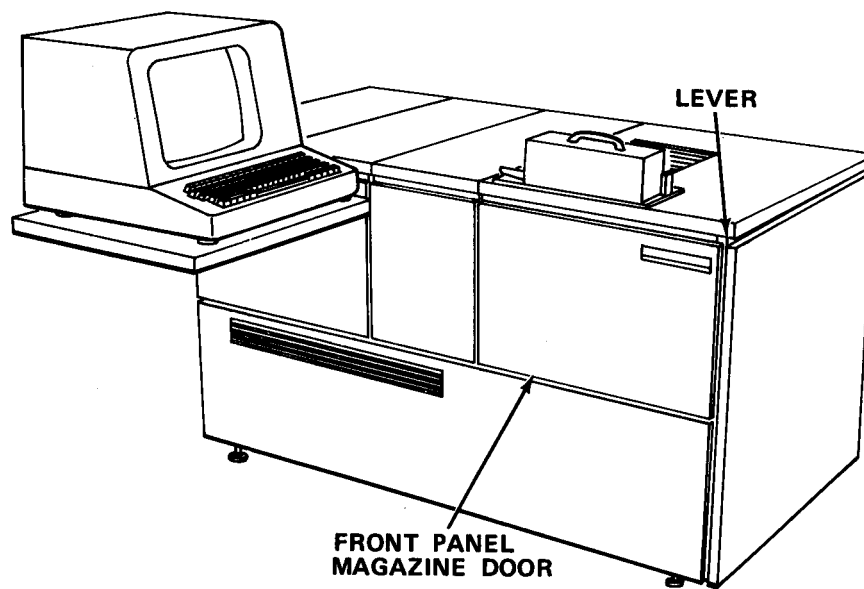

- a. Turn off power switch.
- b. Turn off circuit breaker.
- c. Depress lever.
- d. Open front panel magazine door.

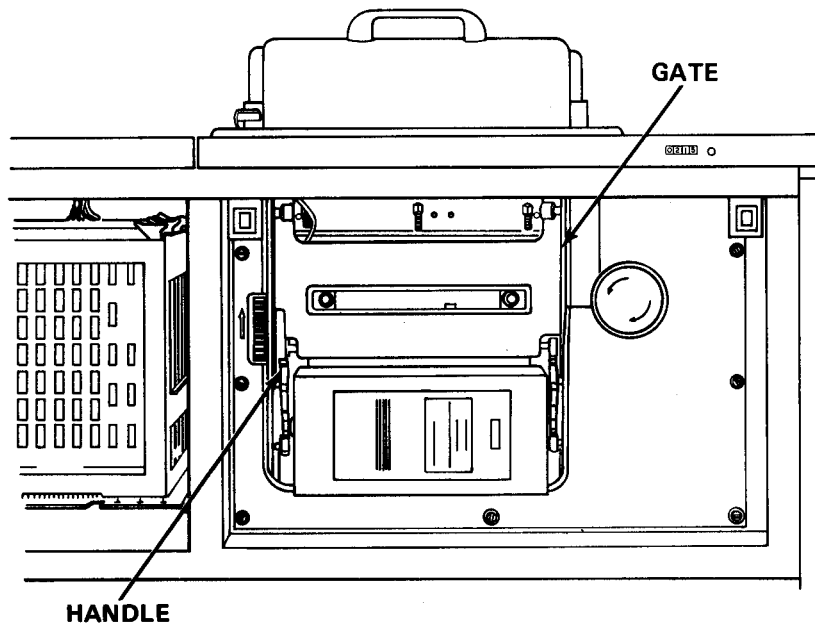

- e. Rotate handle upward.
- f. Raise gate until it locks in place.

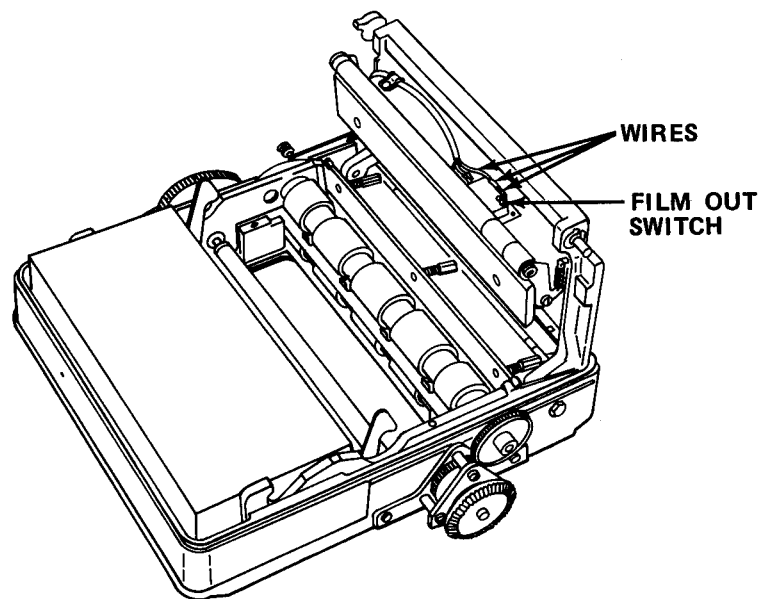

- g. Tag and remove three wires.
- h. Remove screws and defective film out switch.

- i. Install new film out switch.
- j. Reconnect wires.
- k. Lower gate.
- l. Rotate handle upward.
- m. Close front panel magazine door.
- n. Turn on circuit breaker.
- o. Turn on power switch.
- p.** Perform diagnostic test.

2-20.17 Replace Movable Knife.

MOS : 35E, Special Electronic Devices Repairer

TOOLS: Needle Nose Pliers
Spring clip Pliers
5/16 in. Combination Wrench
3/8 in. Combination Wrench
5/64 in. Hex Head Key Wrench
7/64 in. Hex Head Key Wrench
5/32 in. Hex Head Key Wrench
1/4 in. Nut Driver
5/32 in. Nut Driver
Flat Tip Screwdriver

SUPPLIES: Movable Knife

WARNING

Death or serious injury may occur from electrical shock unless power is secured before servicing.

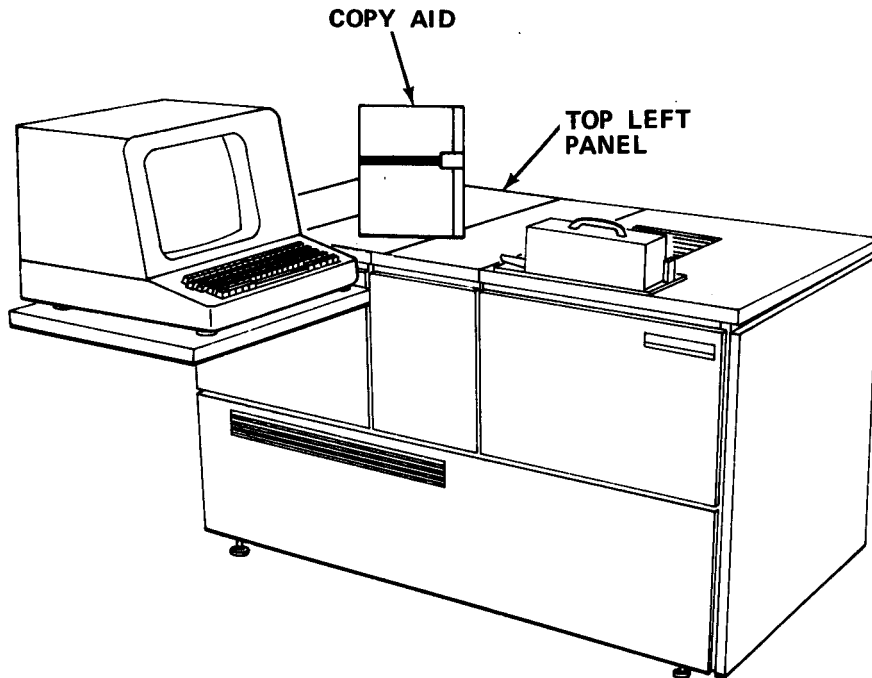

- a. Remove copy aid.
- b. Open top left panel.

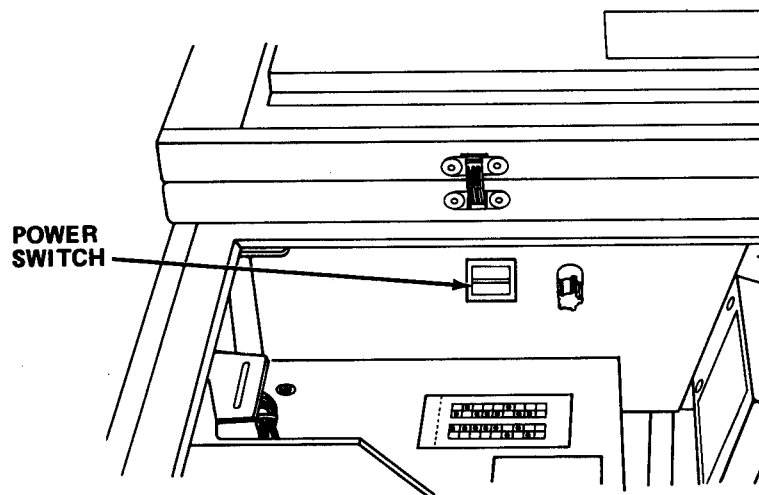

- c. Turn off power switch.
- d. Turn off circuit breaker.

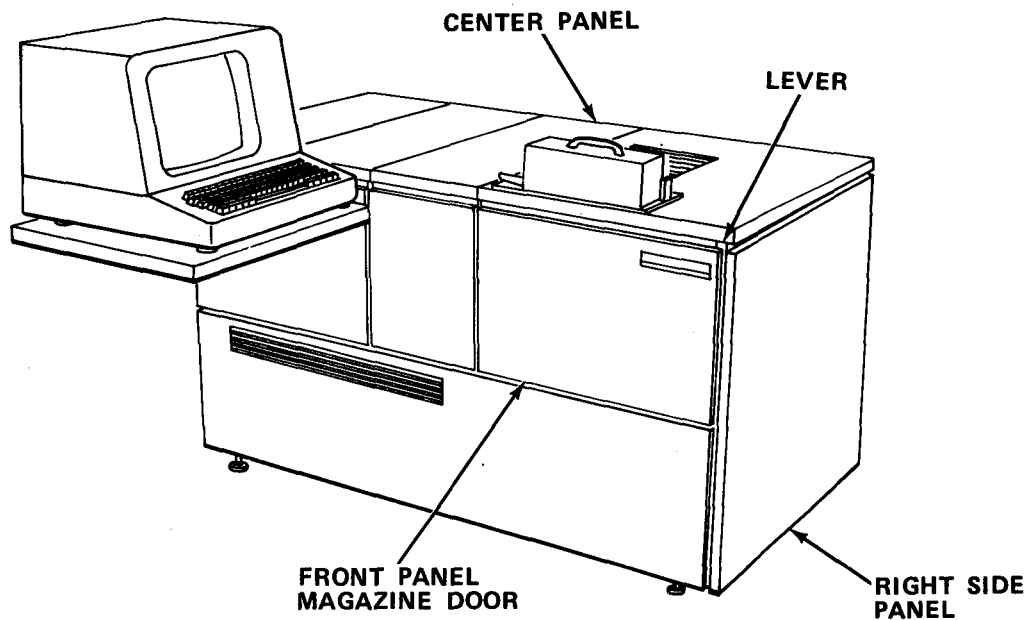

- e. Remove right side panel.
- f. Remove center panel.
- g. Depress lever.
- h. Open front panel magazine door.

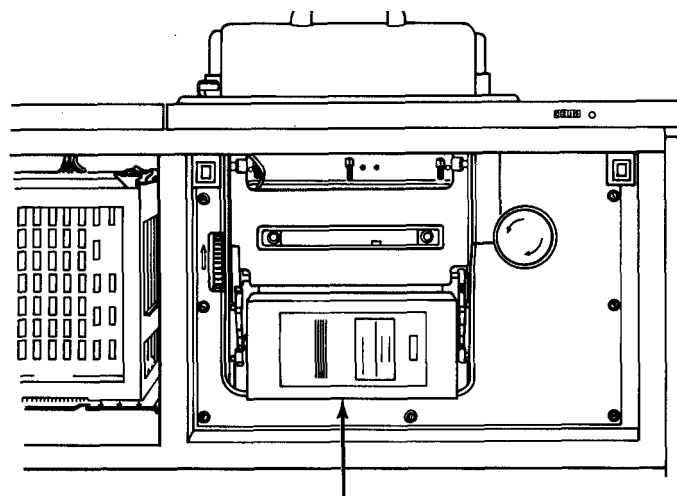

- i. Remove cassette.

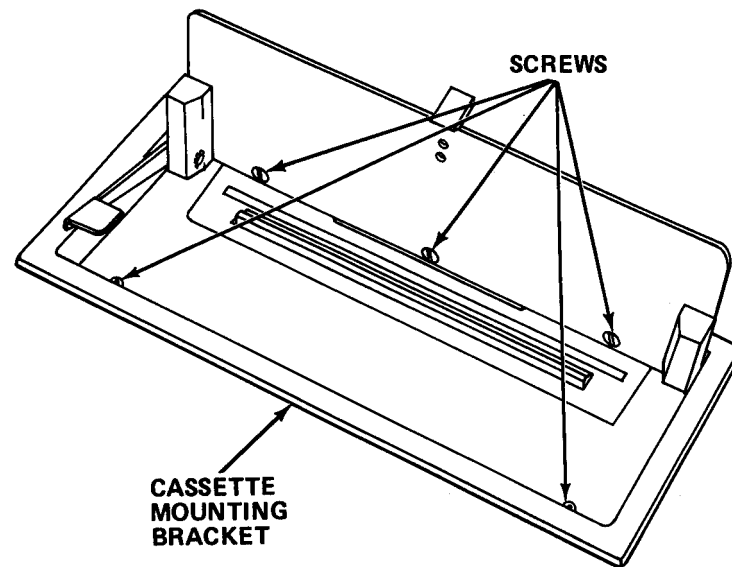

- j. Remove five screws from cassette mounting bracket.
- k. Remove cassette mounting bracket.

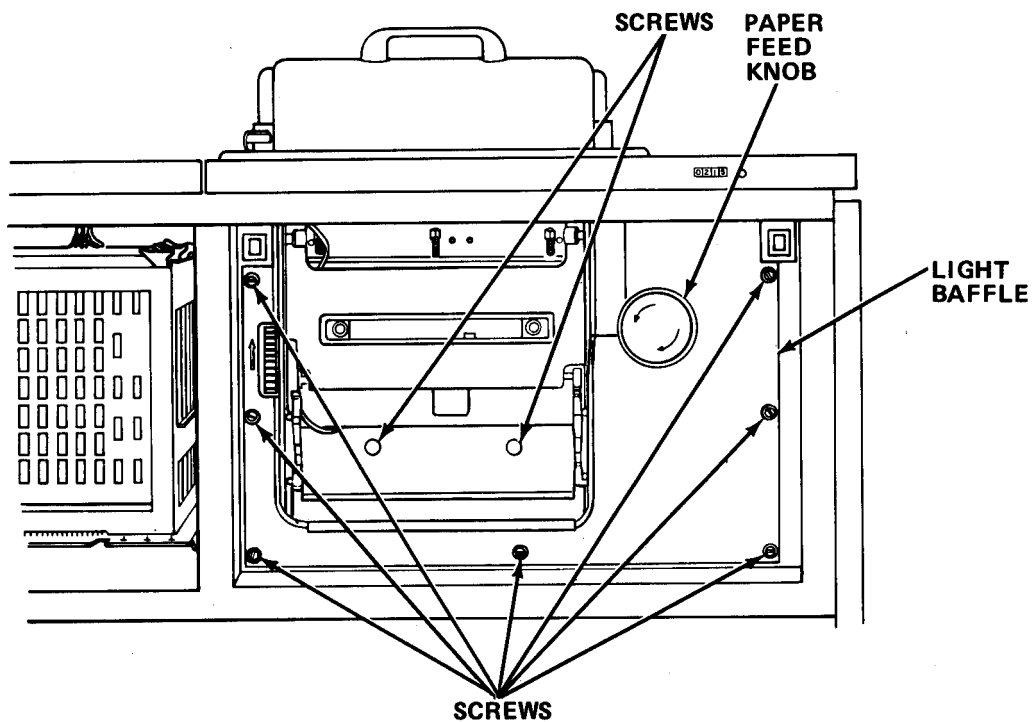

- l. Remove seven screws and paper feed knob.
- m. Remove seven screws from light baffle panel.
- n. Remove two screws from inside magazine.

NOTE

The two hex head screws located at rear of magazine secure magazine to frame bracket.

- o. Remove two hex head screws from upper rear of magazine,

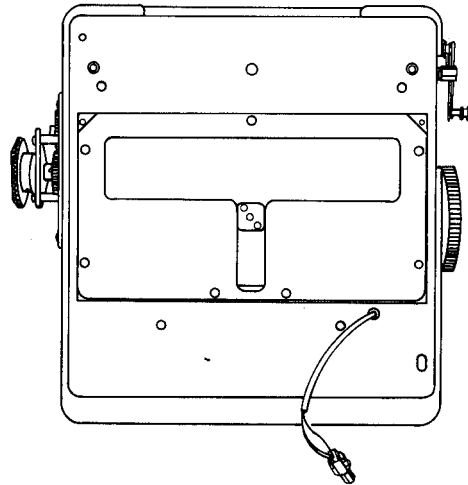

- p. Disconnect connector to shutter solenoid.
- q. Remove magazine from composing machine. Inspect magazine for damage and replace if necessary.

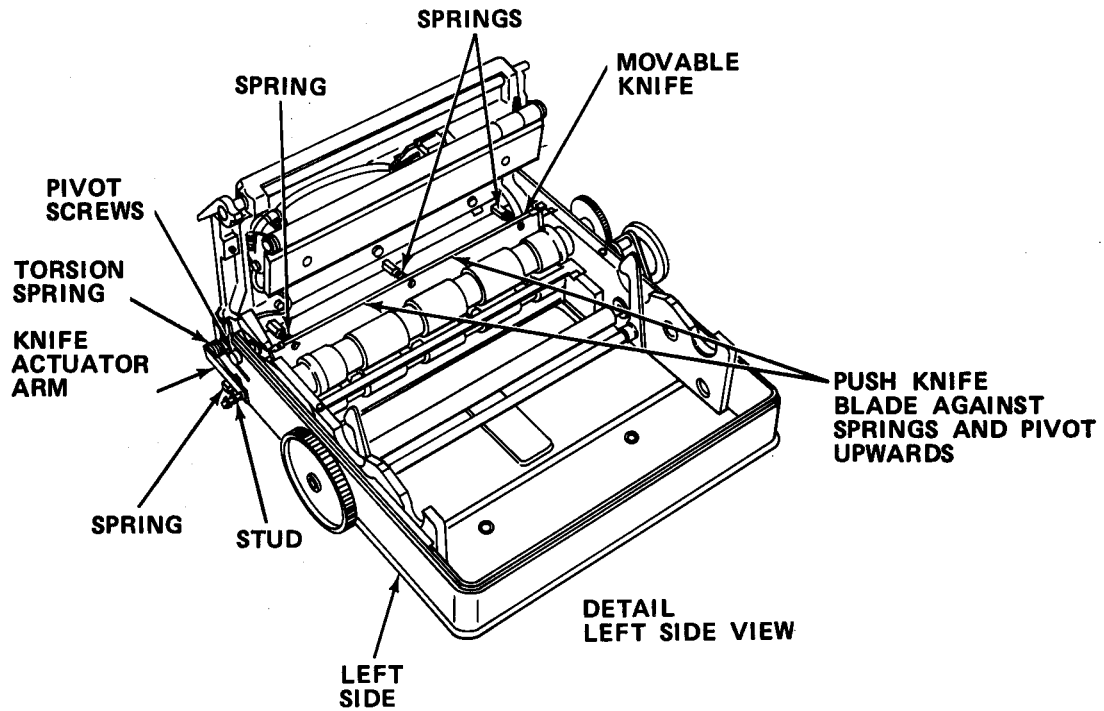

- r. Release torsion spring from knife actuator arm and stud on left side.

- s. Remove pivot screws.
- t. Open cassette assembly.
- u. Compress springs by pushing knife blade against springs. Then pivot knife upward.

NOTE

Black spring must be placed on right side. Do not lose springs and washers,

- v. Remove defective movable knife.
- w. Reinstall springs and washers.
- x. Install new movable knife.
- y. Reinstall pivot screws.
- z. Reinstall torsion spring on stud and knife actuator arm.
- aa. Reinstall magazine into composing machine.

NOTE

Be sure roll pins are in magazine frame. Be sure knife arm is behind flange.

- ab. Reconnect shutter solenoid and solenoid connector.
- ac. Reinstall two screws inside magazine.
- ad. Reinstall two hex head screws at rear of magazine.
- ae. Reinstall front panel and seven screws.
- af. Reinstall paper feed knob and tighten setscrews.

NOTE

Check gears for proper gear mesh.

- ag. Reinstall cassette mounting bracket with five screws.

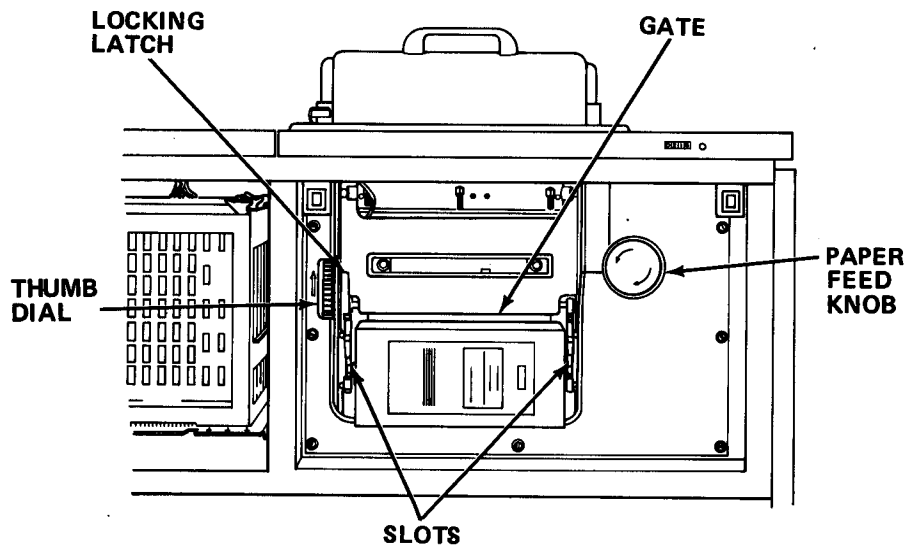

- ah. Hold cover up.
- ai. Insert cassette.

NOTE

Be sure knobson cassette fit in their slots.

- aj. Pull cover **down** until click is heard.
- ak. Rotate thumb dial 5 to 6 times.
- al. Pull up on locking latch.
- am. Turn paper feed knob upward. **If** thumb dial rotates, paper is loaded correctly.
- an. Close front panel magazine door.
- ao. Reinstall center panel.
- ap. Reinstall right side panel.
- aq. Reinstall top left panel.
- ar. Reinstall copy aid.
- as. Turn on circuit breaker.
- at. Turn on power switch.
- au. Perform diagnostic test.

2-20.18 Replace Font Pickup PC Board.

MOS : 35E, Special Electronic Devices Repairer

TOOLS : Flat Tip Screwdriver
1/4 in. Nutdriver
Soldering and Resoldering Set

SUPPLIES: Font Pickup PC Board
Solder (Item 23, Appendix E)

WARNING

Death or serious injury may occur from electrical shock unless power is secured before servicing.

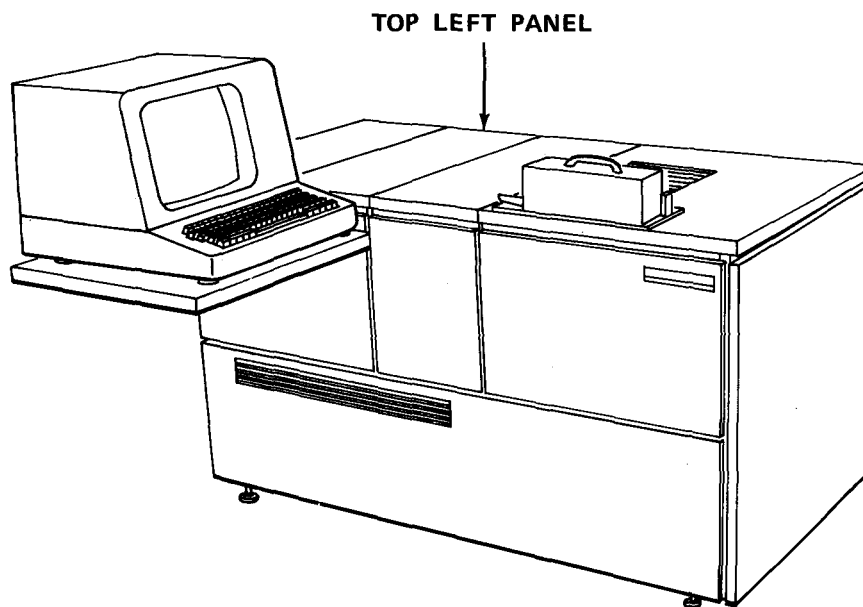

- a. Open top left panel.

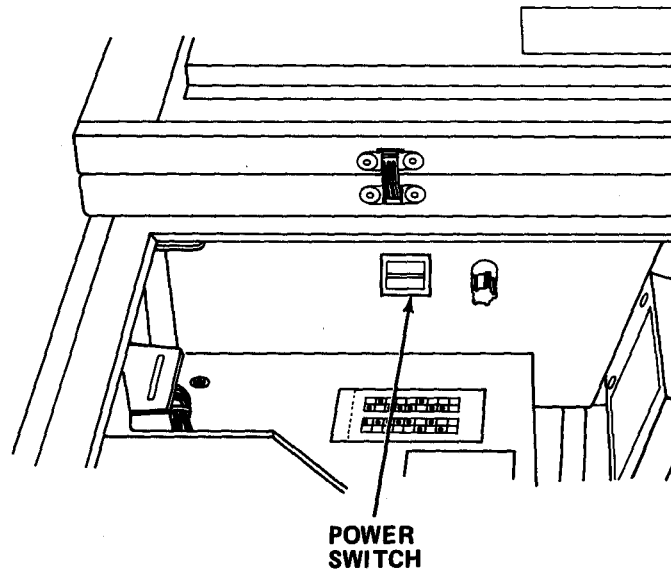

- b. Turn off power switch.
- c. Turn off circuit breaker.

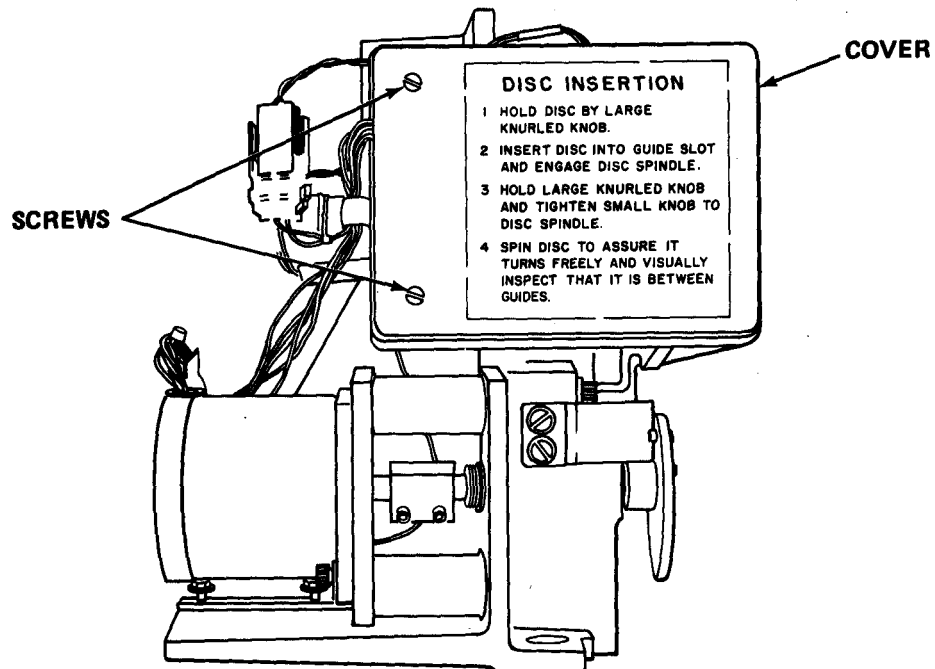

- d. Remove three screws and cover.

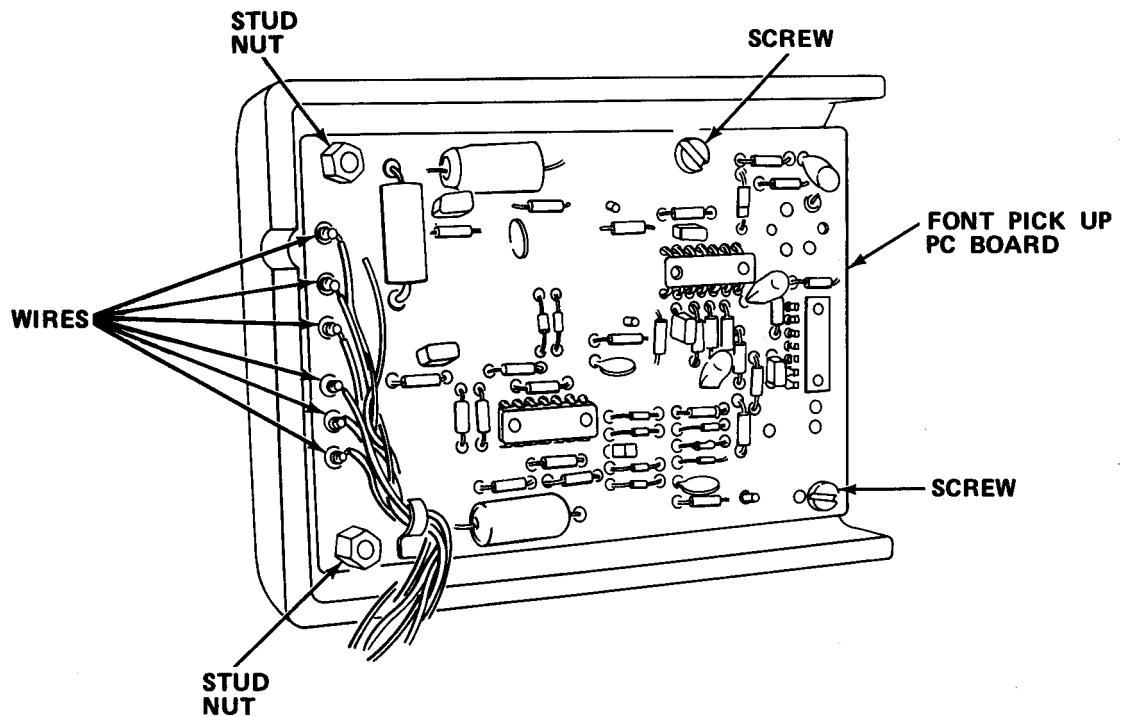

- e. Tag and desolder wires.
- f. Remove screws and stud nuts.
- g. Remove defective font pickup PC board.
- h. Install new font pickup PC board and secure with screws and stud nuts.
- i. Solder wires to new board.
- j. Reinstall cover and secure with screws.
- k. Turn on circuit breaker.
- l. Turn on power switch.
- m. Close top left panel.
- n. Perform diagnostic test.

TM 5-6675-316-14

2-20.19 Replace Variator/Collimator Motor(s).

MOS: 35E, Special Electronic Devices Repairer

TOOLS: Flat Tip Screwdriver
1/16 in. Hex Head Key Wrench
7/64 in. Hex Head Key Wrench

SUPPLIES: Variator Motor
Collimator Motor

WARNING

Death or serious injury may occur from electric shock unless power is secured before servicing.

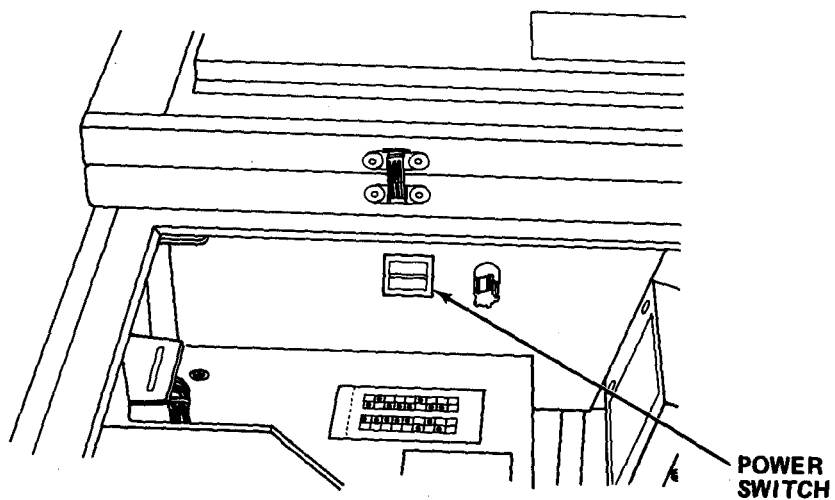

- a. Open top left panel.
- b. Turn off power switch.
- c. Turn off circuit breaker.

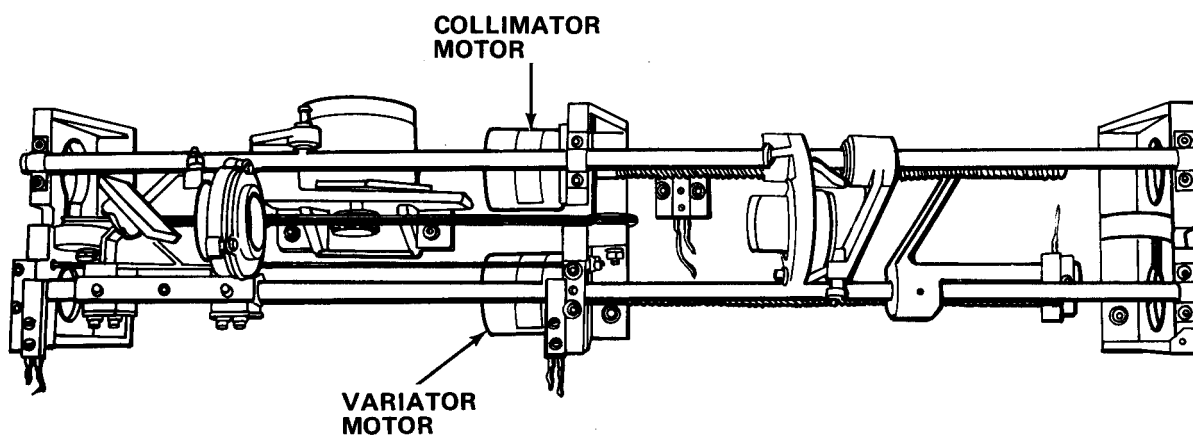

d. Remove cassette mounting bracket and right top panel.

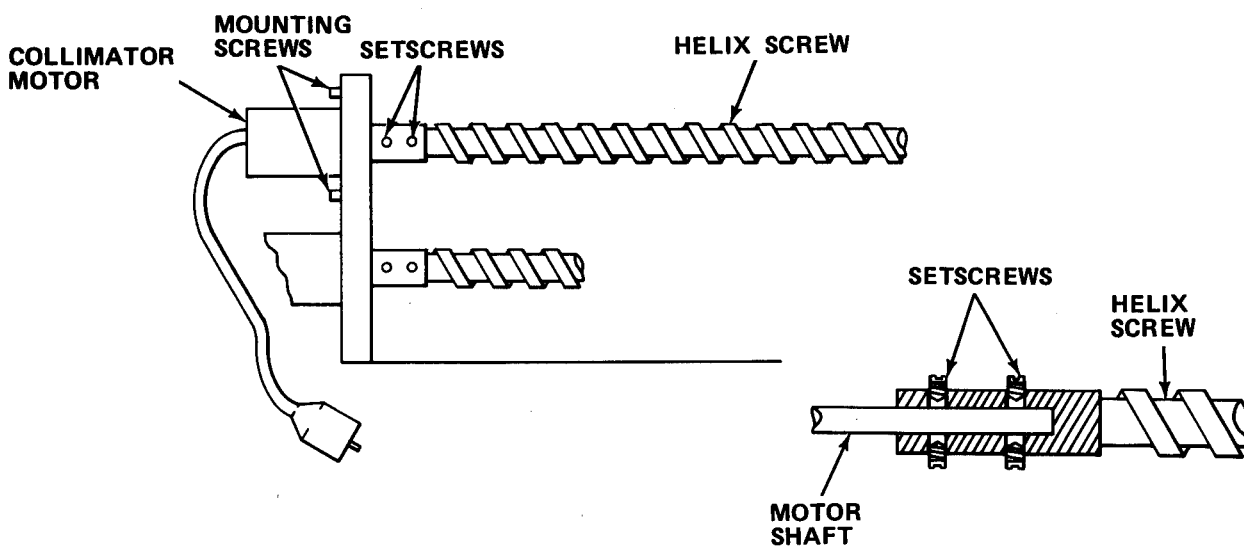

NOTE

Variator motor is one closest to you. Helix screw rotates easily by hand.

- e. Loosen two setscrews.
- f. Unplug P43, or J28 as necessary.
- g. Remove mounting screws. Then slide defective variator motor from mounting bracket.
- h. Loosen two remaining setscrews and remove motor shaft collar.
- i. Install shaft collar on new motor and tighten setscrews.
- j. Tighten remaining setscrews.

- k. Secure motor assembly with mounting screws.
- l. Reconnect P43, or J28 as necessary.
- m. Reinstall right top panel.
- n. Turn on circuit breaker.
- o. Turn on power switch.
- p. Close top left panel.
- q. Perform diagnostic test.

2-20.20 Replace Limit Switch(es).

MOS: 35E, Special Electronic Devices Repairer

TOOLS: Flat Tip Screwdriver
3/32 in. Hex Head Key-Wrench
5/16 in. Open End Wrench

SUPPLIES: Limit Switch(es)

WARNING

Death or serious injury may occur from electrical shock unless power is secured before servicing.

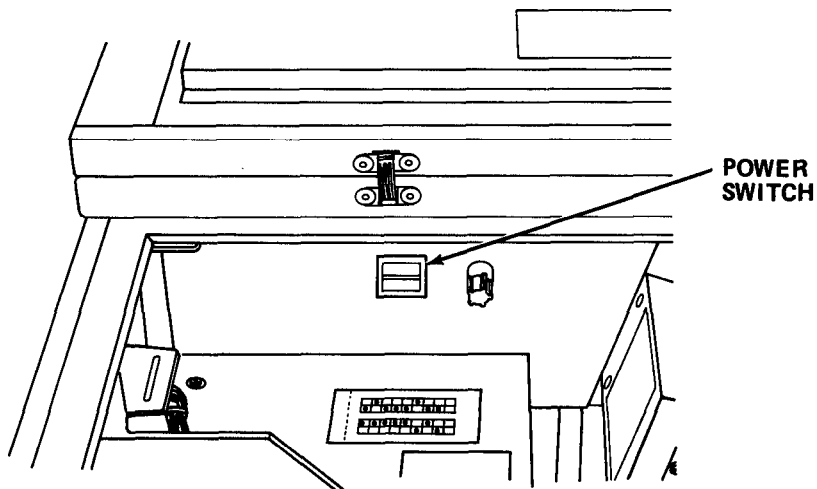

- a. Remove top left panel, center panel, cassette mounting bracket, and top right panel.

- b. Turn off power switch.
- c. Turn off circuit breaker.

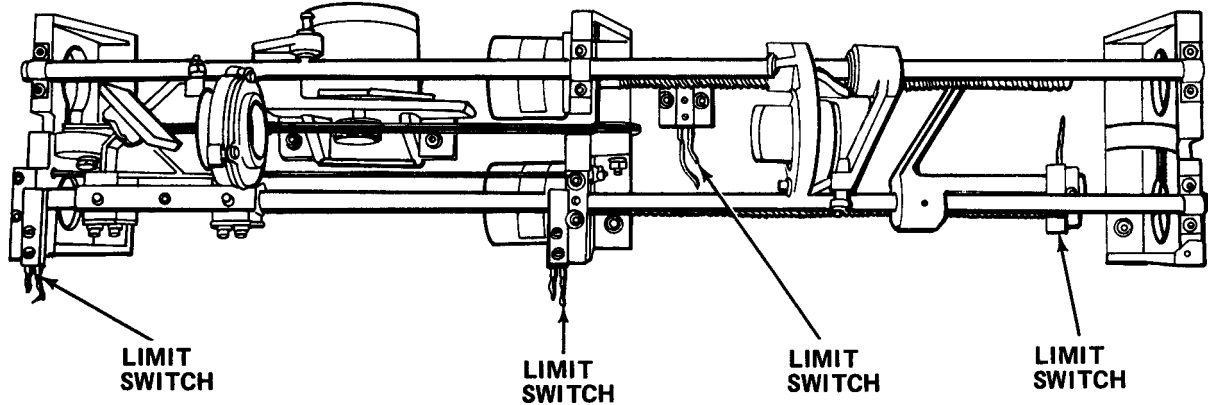

- d. Tag and disconnect wires from limit switch.
- e. Remove mounting screws, plate, and defective limit switch.
- f. Install new limit switch, plate, and secure with mounting screws.
- g. Connect wires.
- h. Reinstall top left panel, center panel and top right panel and cassette mounting bracket.
- i. Turn on circuit breaker.
- j. Turn on power switch.
- k. Close top left panel.
- l. Perform diagnostic test.

2-20.21 Replace Constant Voltage Transformer.

MOS: 35E, Special Electronic Devices Repairer

TOOLS: Cross Tip Screwdriver
Flat Tip Screwdriver
3/8 in. Combination Wrench
1/2 in. Combination Wrench
3/4 in. Combination Wrench
12 in. Adjustable Wrench

SUPPLIES: Constant Voltage Transformer

WARNING

Death or serious injury may occur from electrical shock unless power is secured before servicing.

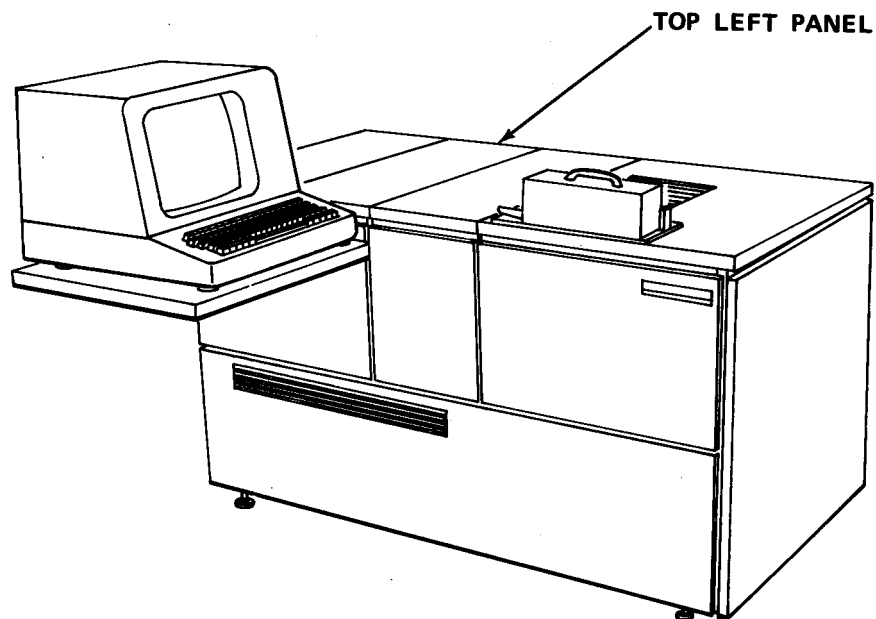

- a. Open top left panel.

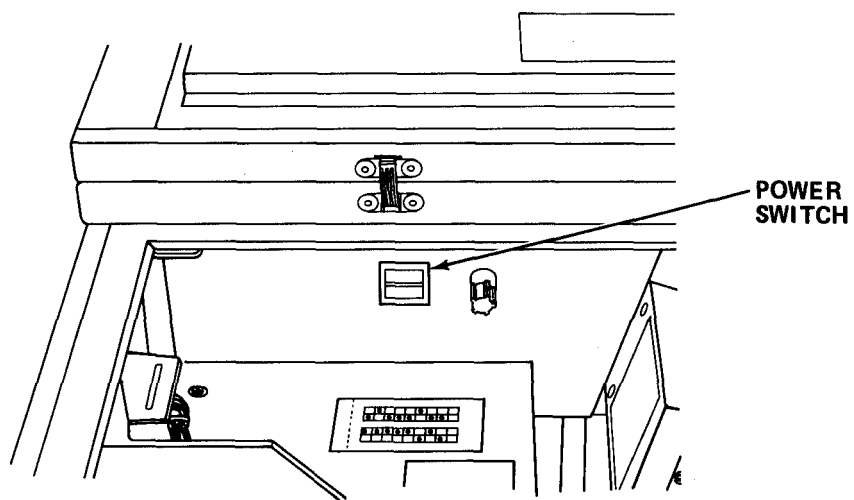

- b. Turn off power switch.
- c. Turn off circuit breaker.

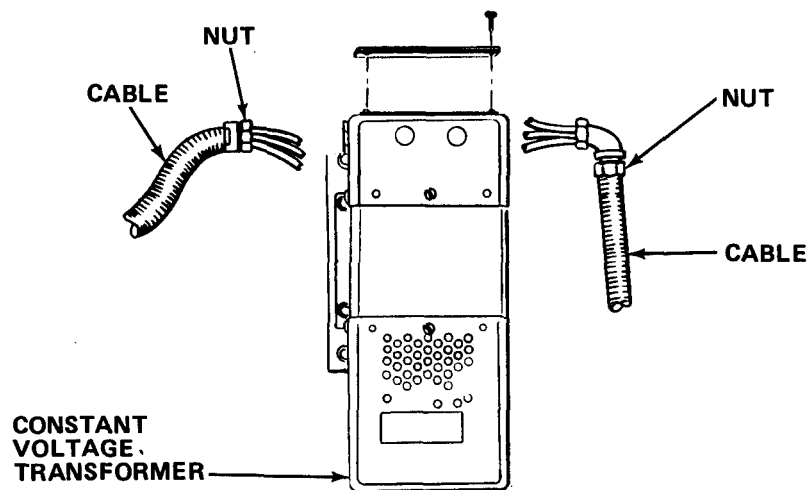

- d. Loosen conduit nuts.

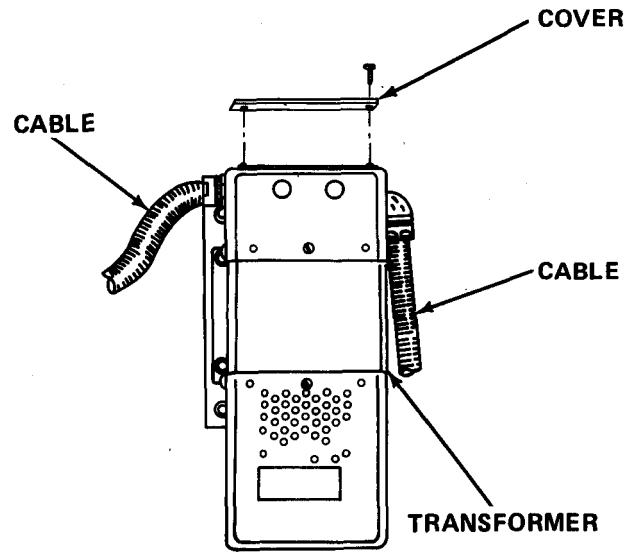

- e. Remove end cover.
- f. Tag and disconnect input/output wires from transformer.

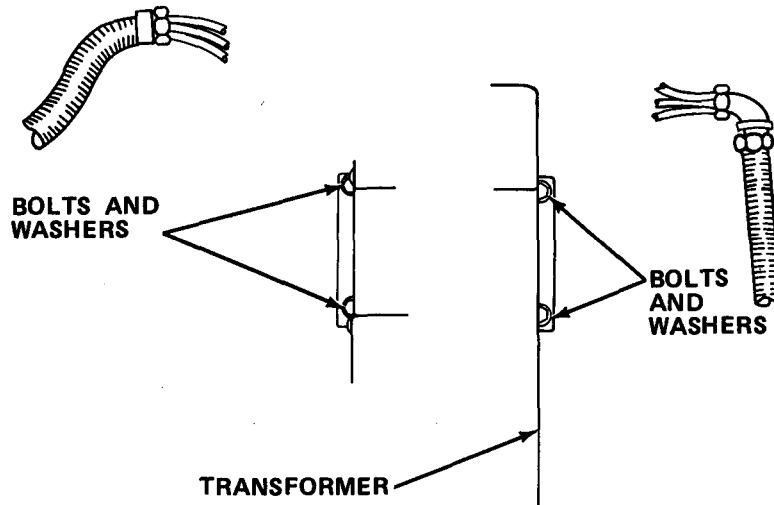

- g. Remove defective transformer and bracket from wall.
- h. Mount new transformer assembly on wall.
- i. Reconnect wiring.
- j. Reinstall end cover.
- k. Tighten conduit nuts.

- l. Turn on circuit breaker.
- m. Turn on power switch.
- n. Close top left panel.
- o. Perform diagnostic test.

2-20.22 Adjust Power Supply Voltages

MOS: 35E, Special Electronic Devices Repairer

TOOLS: Digital Multimeter
Jewelers Screwdriver Set

WARNING

Death or serious injury may occur from electrical shock unless power is secured before servicing.

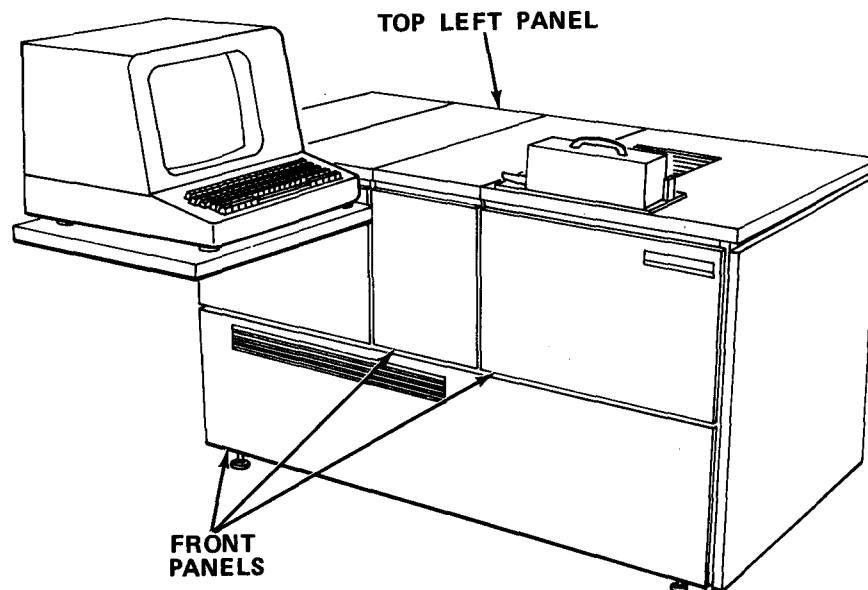

- a. Remove front panels.
- b. Open top left panel.

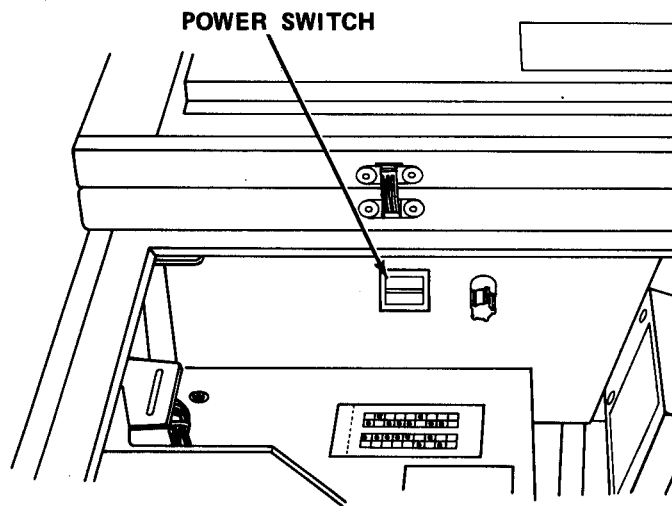

- c. Turn on power switch. Then wait 3 minutes.
- d. Set multimeter controls to measure +5 V.

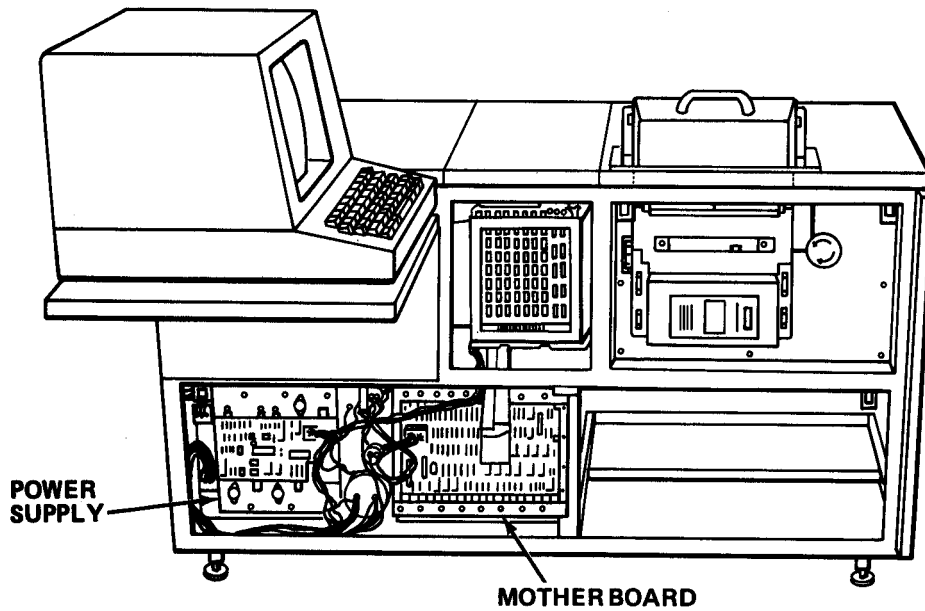

- e. Locate power supply and motherboard.

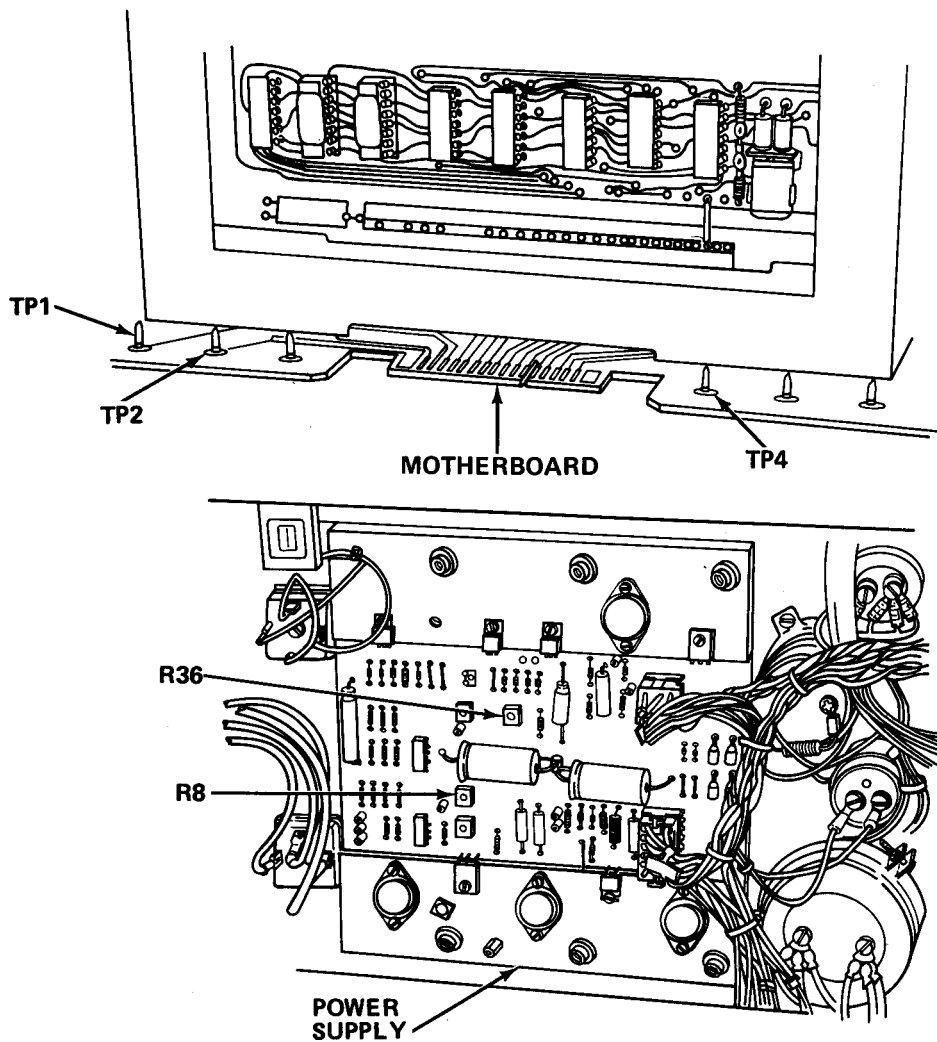

- f. Place negative lead on TP4; positive lead on TP2.
- g. Adjust R8 for $+5 \pm 0.01$ V.
- h. Remove positive lead from TP2 and negative lead from TP4.
- i. Set up multimeter to measure -12 V.
- j. Connect negative lead to TP4 and positive lead to TP1.
- k. Adjust R36 for -12 ± 0.01 V.
- l. Remove multimeter leads.
- m. Reinstall front panels.
- n. Place power switch to OFF.
- o. Reinstall top left panel.
- p. Perform diagnostic test.

2-20.23 Adjust Flash Intensity and Large Size.

MOS: 35E, Special Electronic Devices Repairer

TOOLS: Alinement Tool Kit
Pocket Knife
Test Disc
Digital Multimeter
Electrical Hookup Wire (2 ft)
Red Test Lead
Black Test Lead

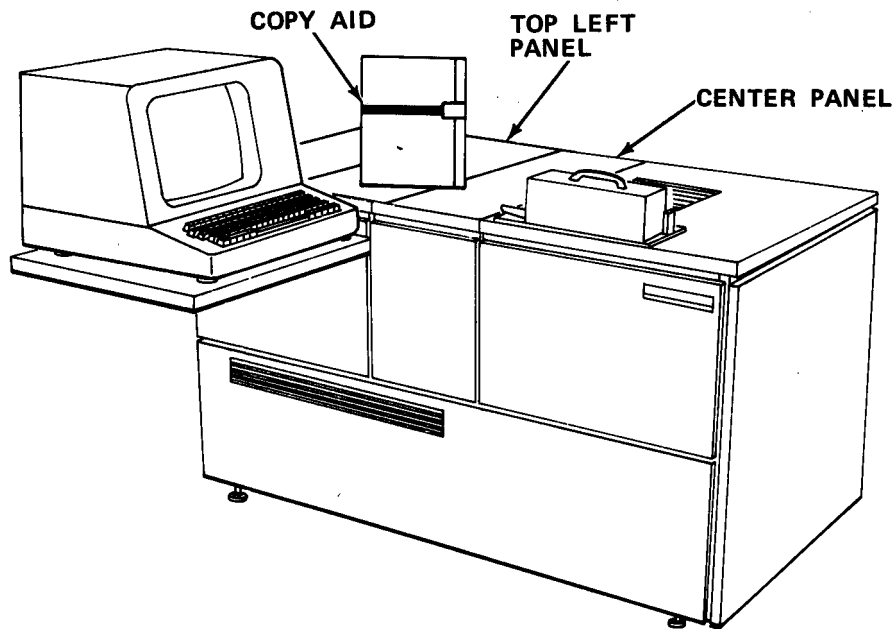

- a. Remove copy aid.
- b. Open top left panel.
- c. Remove center panel.

WARNING

Death or serious injury may occur from electrical shock unless power is secured before servicing.

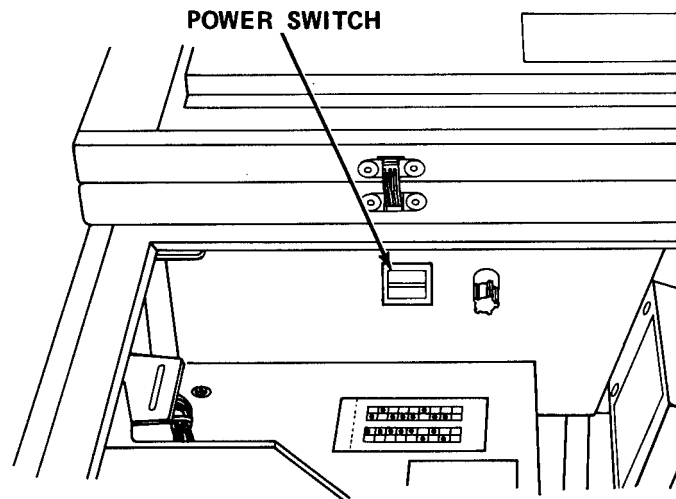

- d. Turn off power switch.
- e. Turn off circuit breaker.

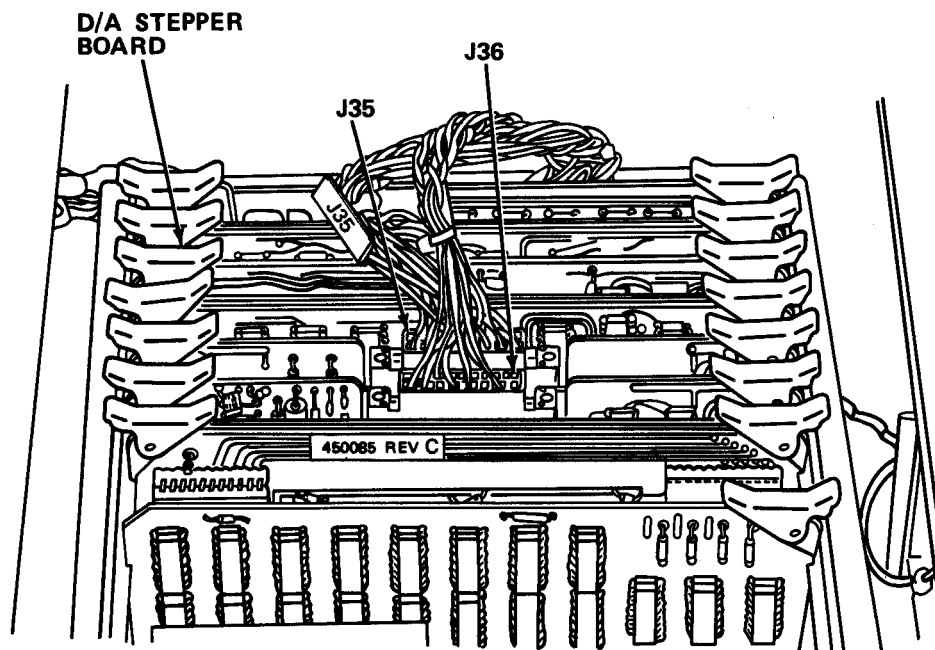

- f. Remove D/A stepper board.

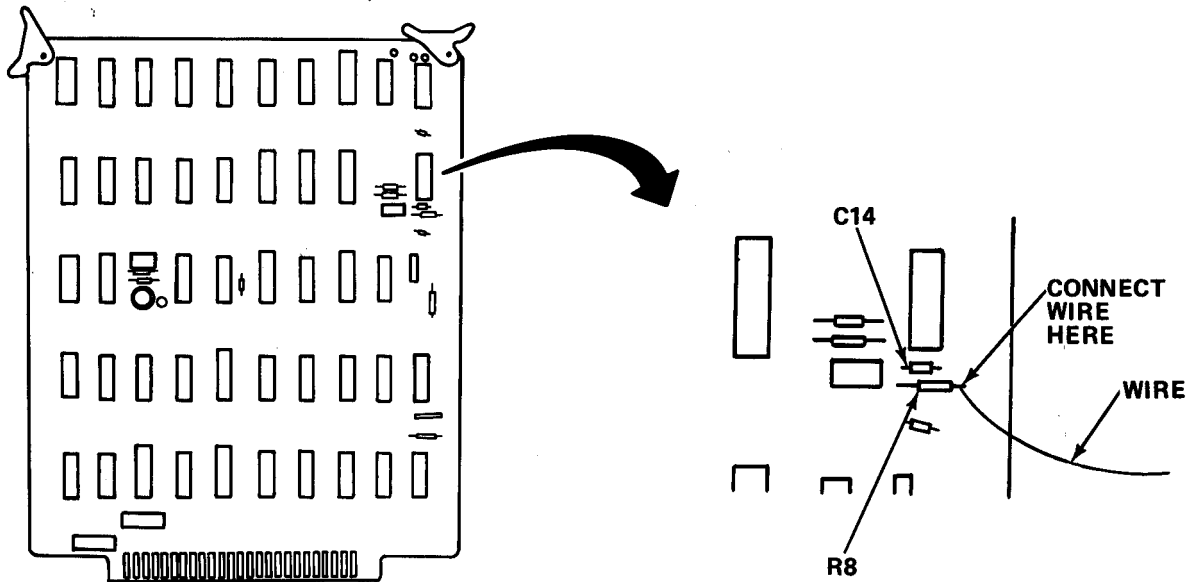

- g. Use piece of electrical hook-up wire and connect one end at junction of R8 and C14.
- h. Reinstall D/A stepper board.

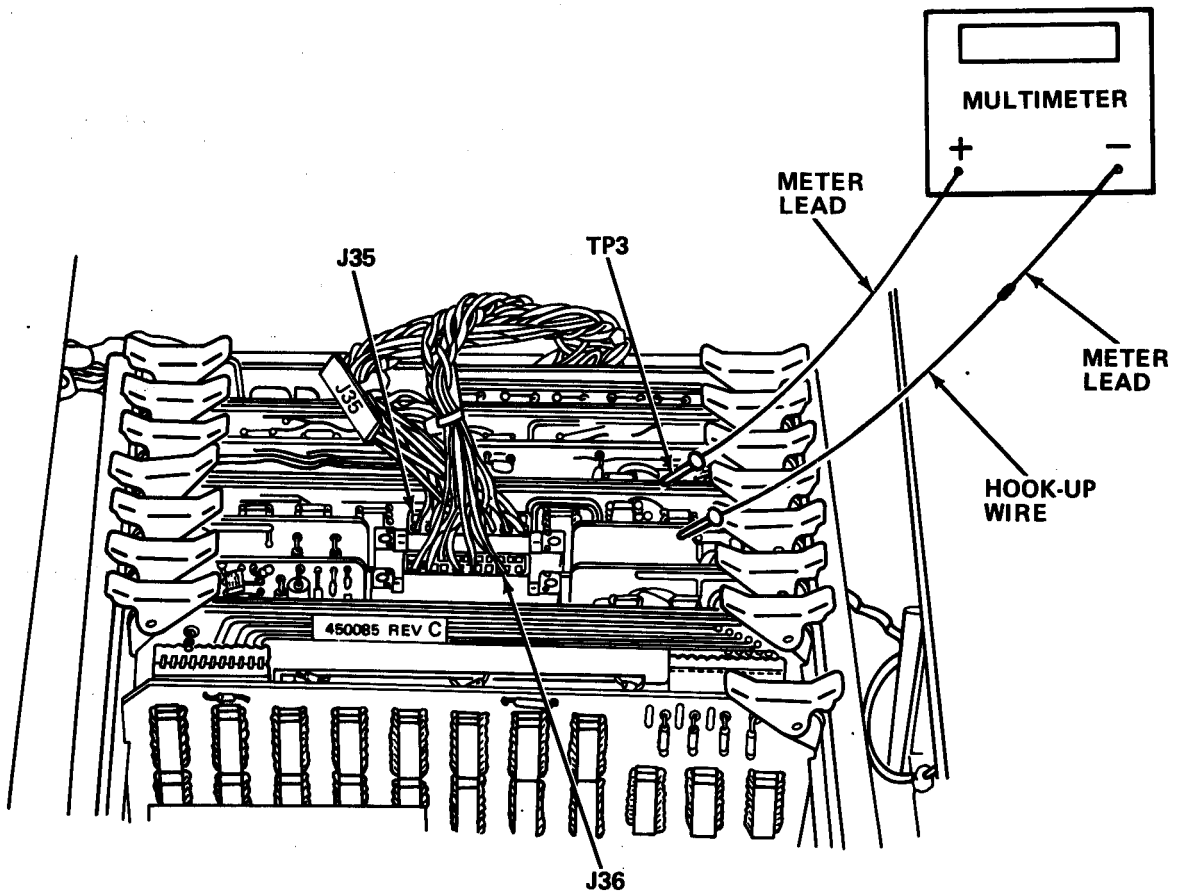

- i. Connect positive lead of multimeter to TP3 of D/A stepper board.

- j. Connect negative lead of multimeter to electrical hook-up wire.
- k. Set multimeter controls to indicate -9 V.

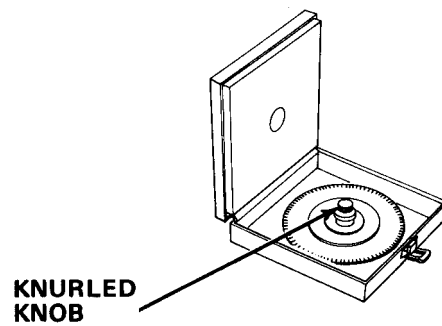

- l. Open box containing font pick-up test disc.
- m. Grasp knurled knob and remove from box.

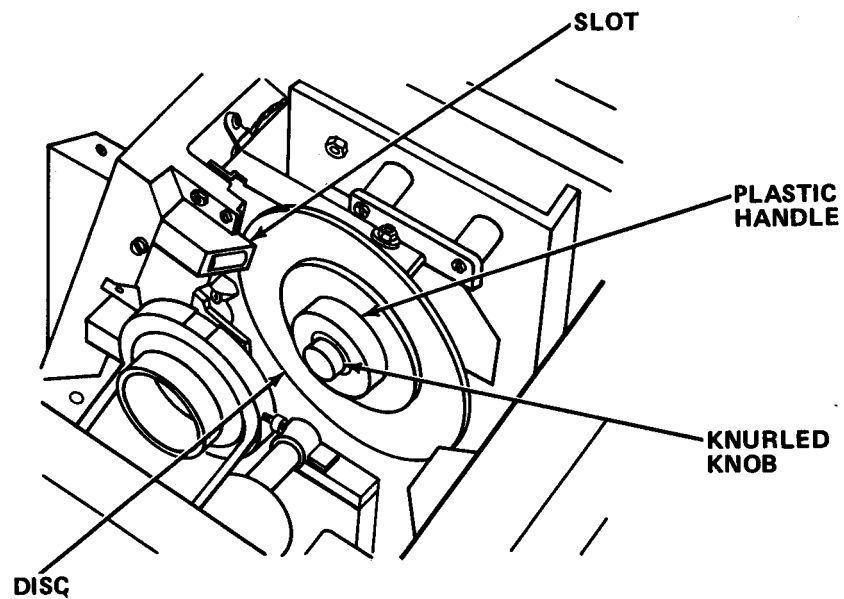

- n. Hold disc by plastic handle and place left edge of disc into slot.
- o. Tighten knurled knob.
- p. Spin disc slowly. If properly inserted, it will turn easily.

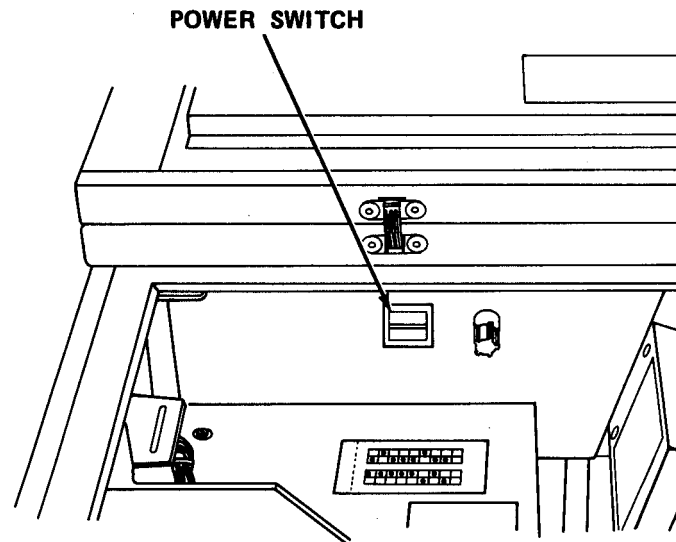

- q. Turn on circuit breaker.
- r. Set power switch to ON, then close top left panel.

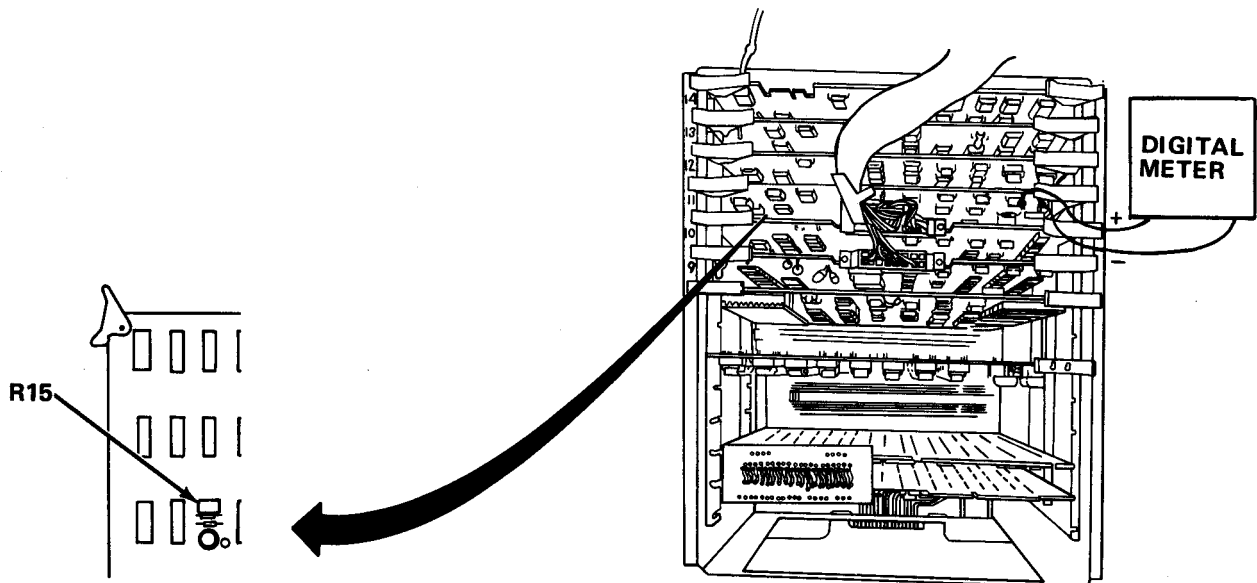

- s. Adjust R15 on D/A stepper board for multimeter indication of -9 ± 0.01 V.
- t. Open top left panel. Set power switch to OFF.

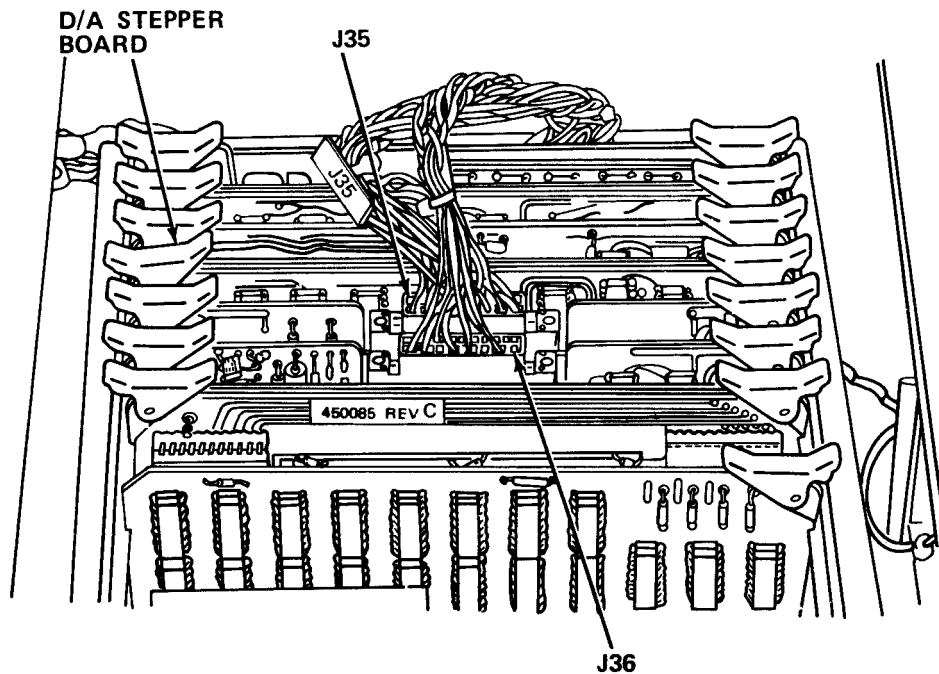

- u. Remove D/A stepper board.
- v. Remove electrical hook-up wire from junction C14 and R8.
- w. Reinstall D/A stepper board.

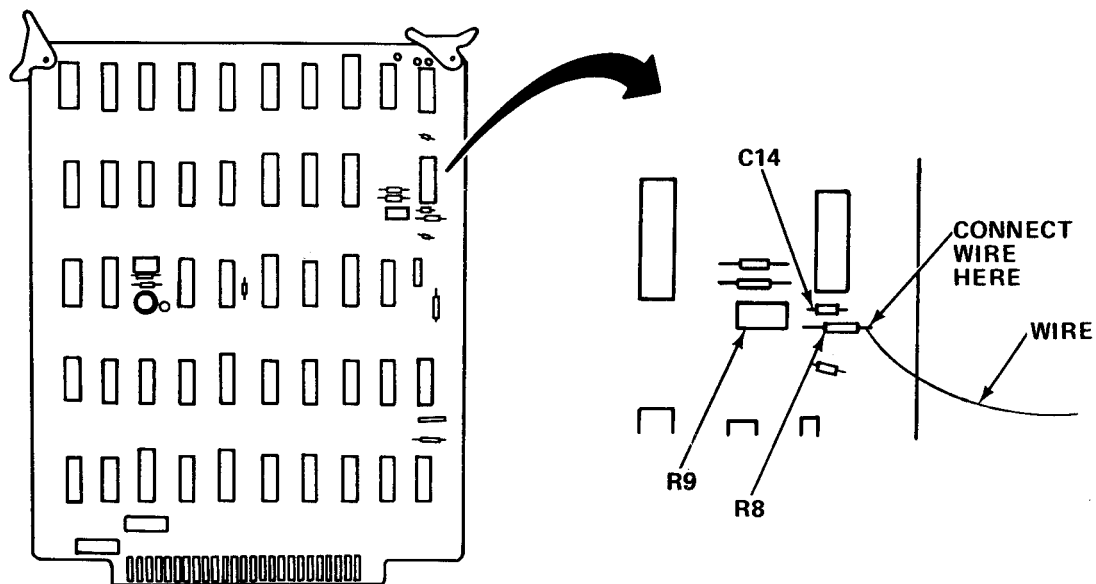

- x. Set multimeter to indicate 1.2 V dc.

- y. Connect black lead (-) to TP2 on D/A stepper board.
- z. Connect red lead (+) to TP1.
- aa. Open top left panel. Set power switch to ON. Then close top left panel.
- ab. Press RESET and DATA.
- ac. Press SIZE, 7 and 4, press LINE LENGTH 4500, PL 780, SL 780 and FONT 1.

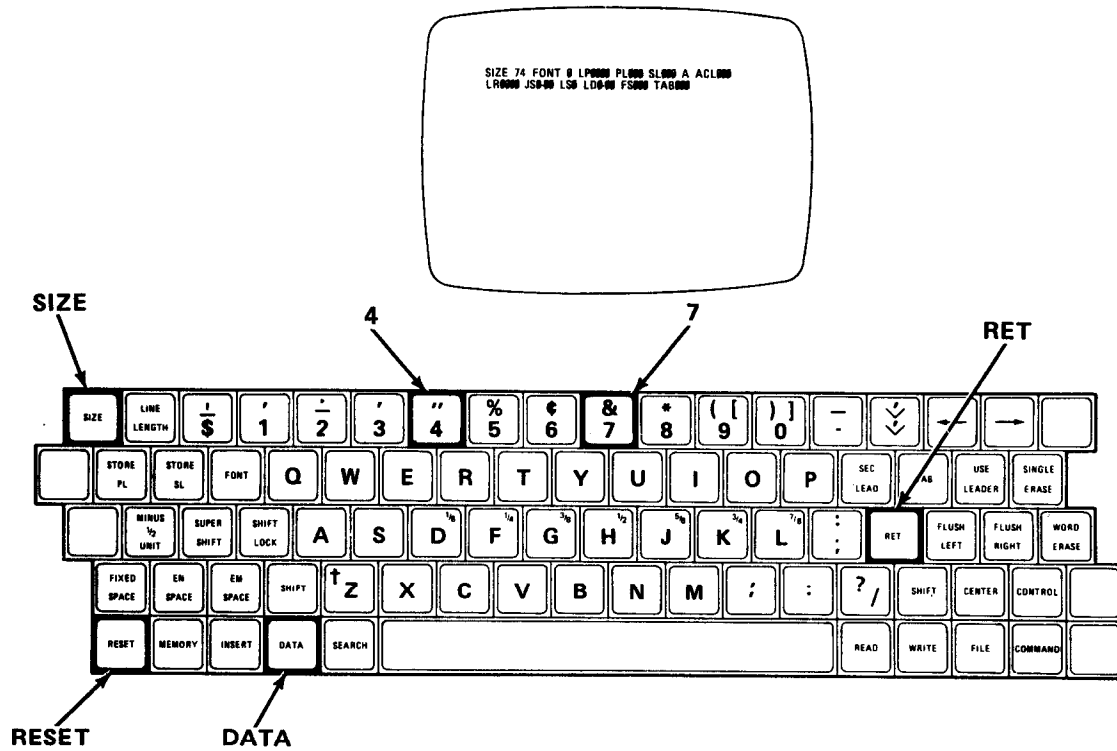

- ad. Press RET.
- ae. Adjust R9 for multimeter indication of 1.2 ± 0.01 V.
- af. Open top left panel. Turn off power switch.
- ag. Disconnect multimeter leads from TP1 and TP2.
- ah. Place empty disc box in convenient location.

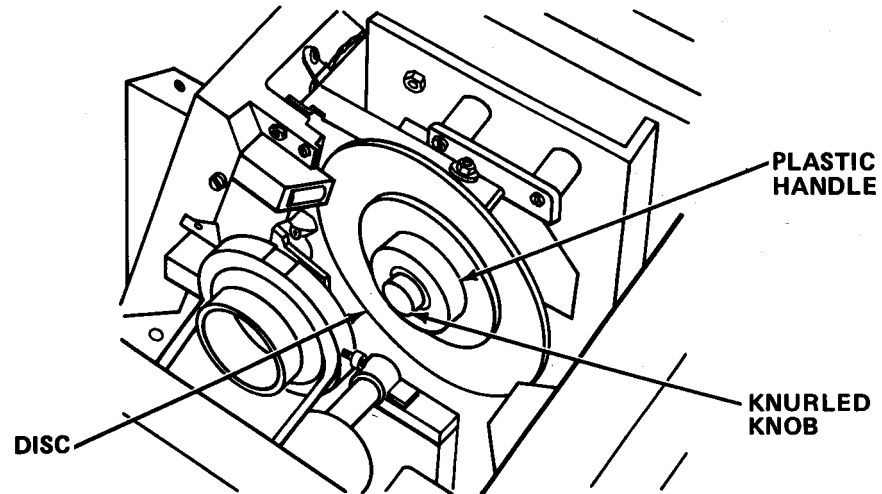

- ai. Grasp plastic handle.
- aj. Unscrew knurled knob.
- ak. Use knurled knob to slide disc to right and out.
- al. Place disc in empty box.
- am. Place disc box in proper storage area.

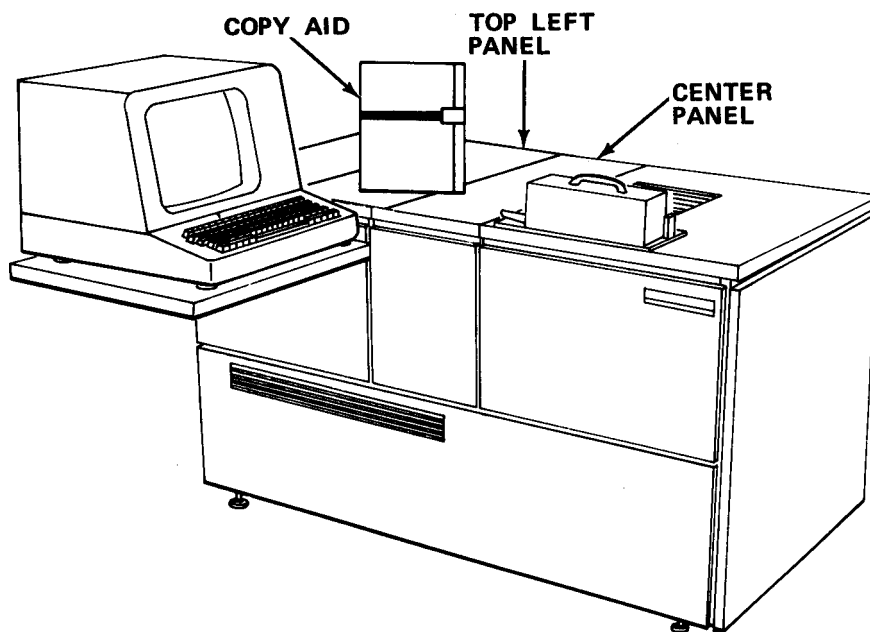

- an. Reinstall center panel.
- ao. Close top left panel.
- ap. Replace copy aid.
- aq. Perform diagnostic test.

2-20.24 Adjust Flash Tube Vertical and Horizontal.

MOS: 35E, Special Electronic Devices Repairer

TOOLS : Flat Tip Screwdriver
Test Disc

SUPPLIES: Photographic Paper

WARNING

Death or serious injury may occur from electrical shock unless power is secured before servicing.

NOTE

Procedure should be accomplished if character images are not evenly exposed from top to bottom or character images are not evenly exposed from left to right.

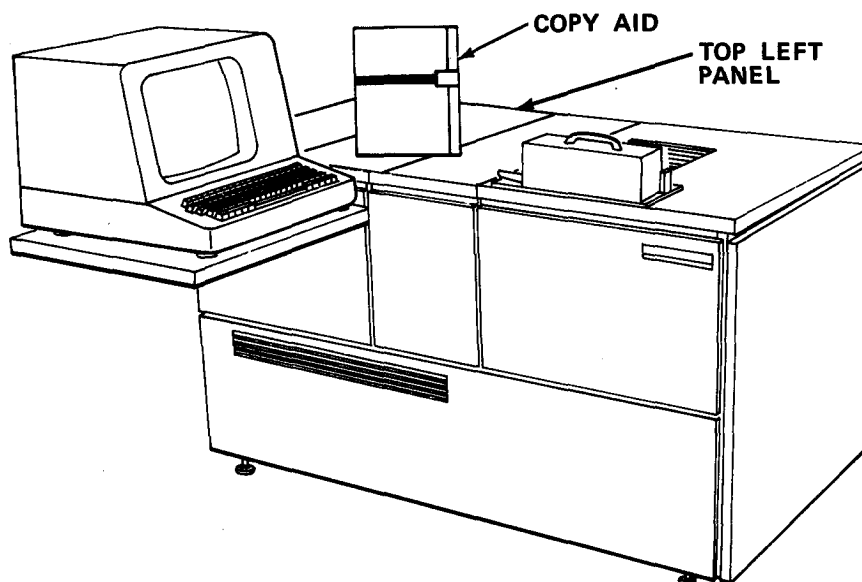

- a. Vertical Adjustment.
 - (1) Remove copy aid.
 - (2) Open top left panel.

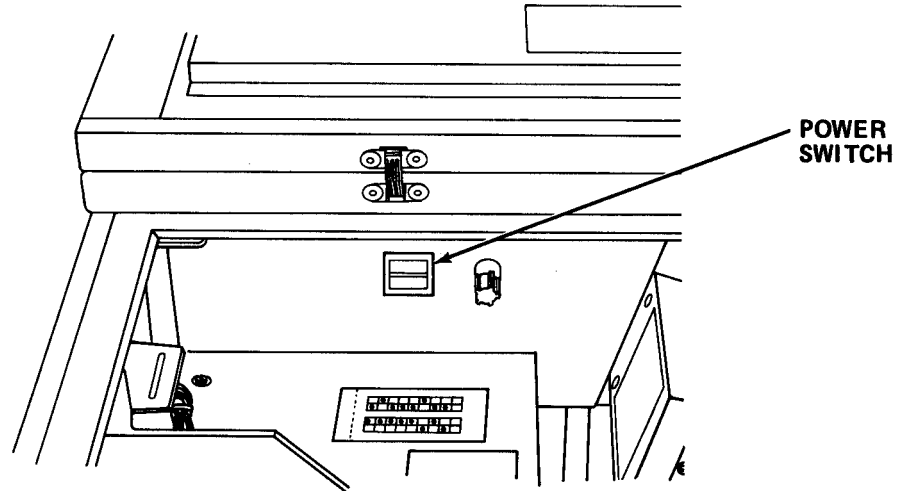

- (3) Turn off power switch.

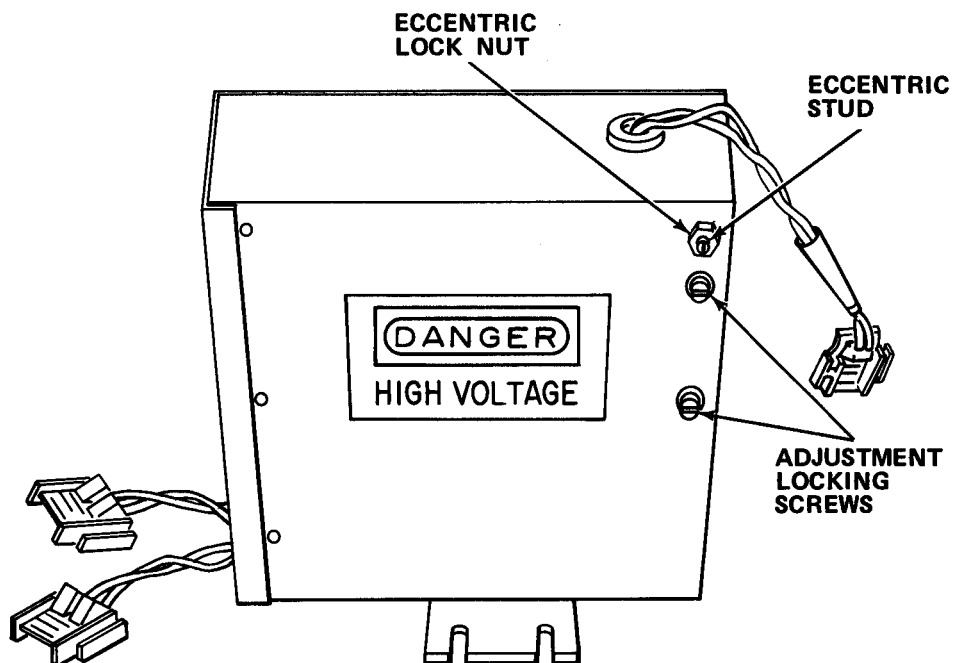

- (4) Loosen, but do not remove, two screws.
- (5) Remove flash power supply cover.

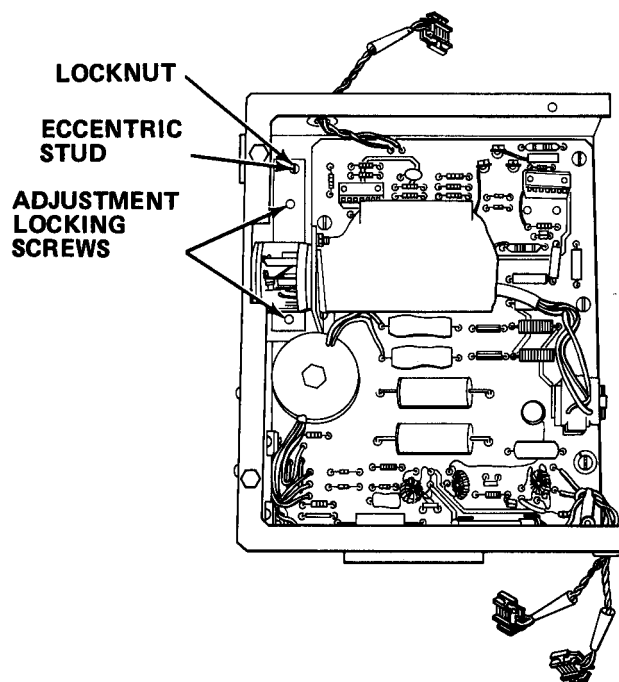

- (6) Loosen adjustment locking screws.
- (7) Loosen eccentric locknut.

NOTE

If tops of characters are light, lower flash tube socket. If bottom of characters are light, raise flash tube socket.

- (8) Adjust eccentric stud.
- (9) Tighten eccentric locknut while holding eccentric stud.
- (10) Tighten adjustment locking screws.

b. Horizontal Adjustment.

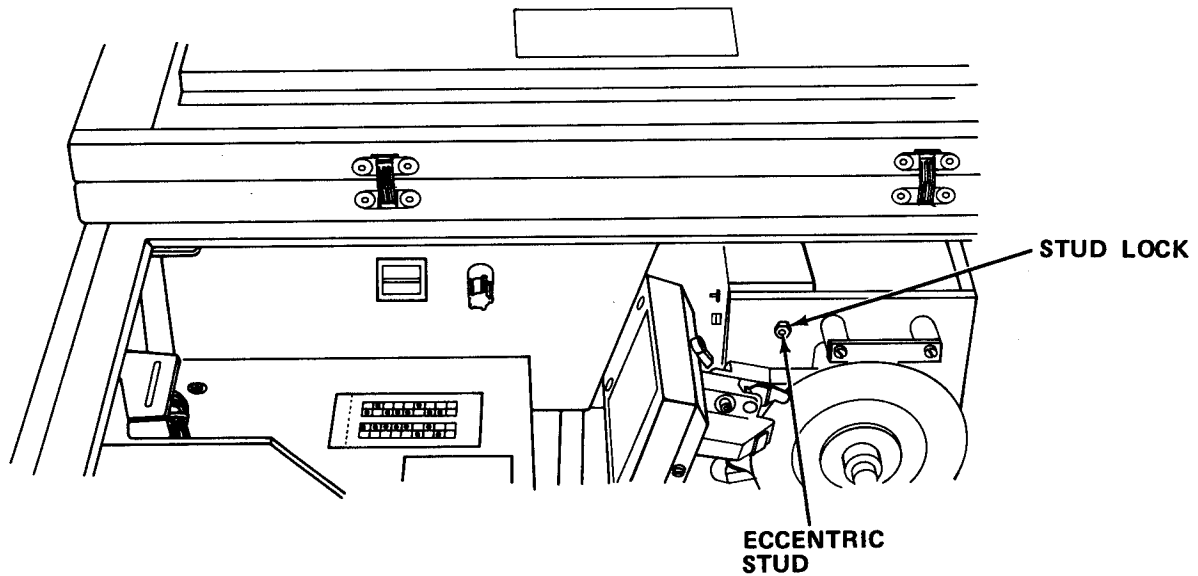

- (1) Loosen eccentric stud lock.

NOTE

If left side of characters are light, move power supply to right (toward disc). If right side of characters are light, move power supply to left (away from disc).

- (2) Adjust eccentric stud.
 - (3) Tighten eccentric stud lock while holding eccentric stud.
- c. Perform Diagnostic Test.

2-20.25 Align Left Margin

MOS: 35E, Special Electronic Devices Repairer

TOOLS: Flat Tip Screwdriver
12 inch Rule

WARNING

Death or serious injury may occur from electrical shock unless power is secured before servicing.

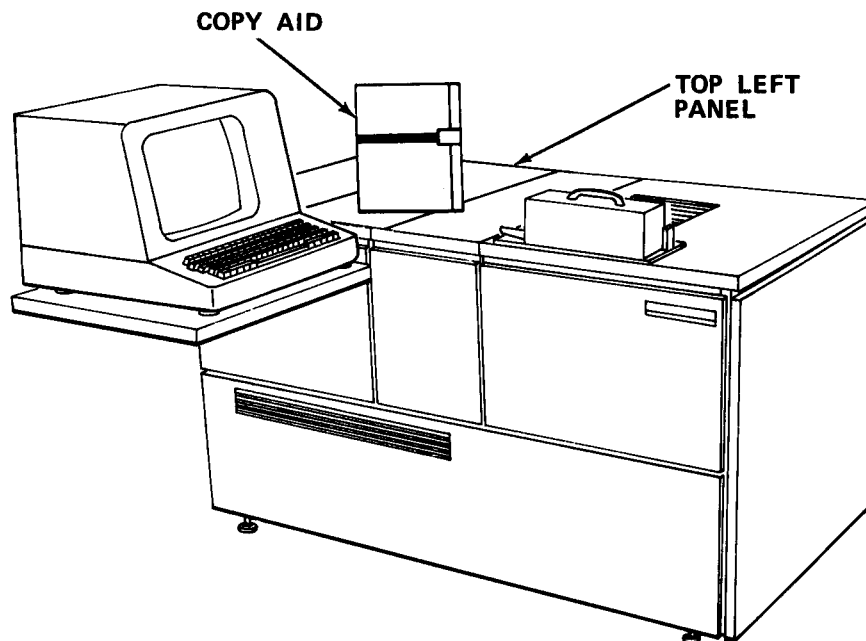

- a. Remove copy aid.
- b. Raise top left panel.

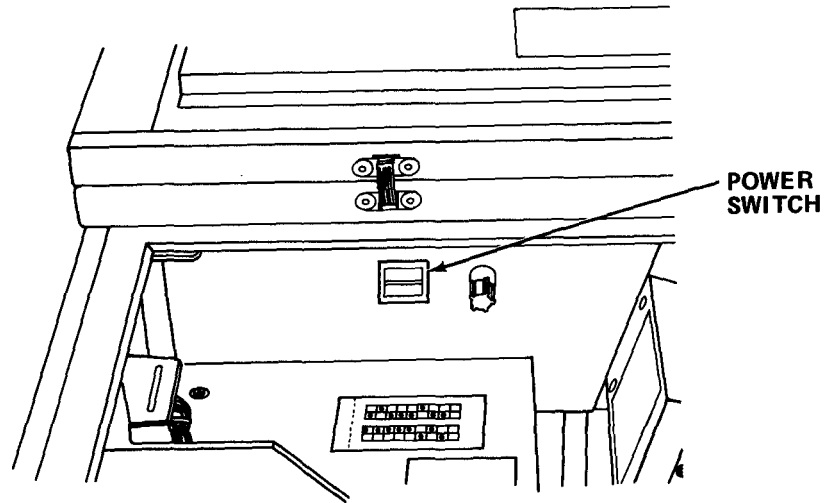

- c. Turn off power switch.
- d. Turn off circuit breaker.

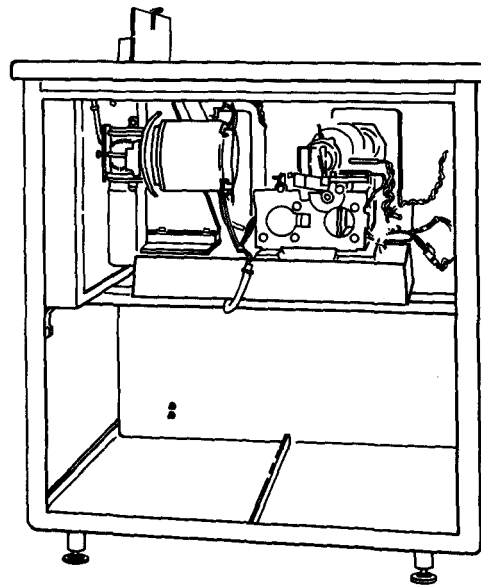

**RIGHT SIDE
PANEL
REMOVED**

- e. Remove right panel.
- f. Locate carriage escapement.

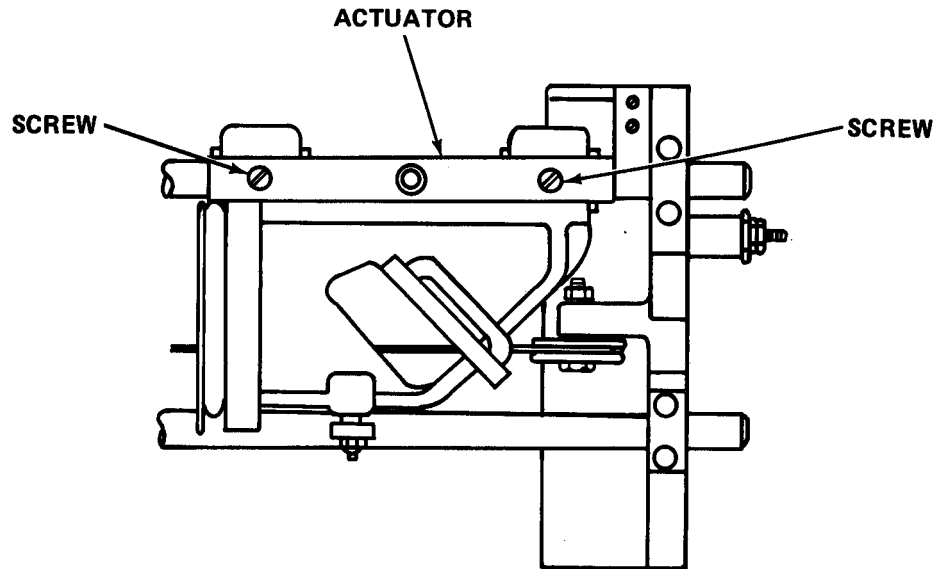

- g. Loosen two screws on actuator.
- h. Slide actuator to right or left approximately 0.25 in. (6.35 mm).
- i. Tighten two screws.
- j. Reinstall side panel.
- k. Turn on circuit breaker.
- l. Turn on power switch.
- m. Close top left panel.
- n. Reinstall copy aid.
- o. Perform diagnostic test.

2-20.26 Focus and Aline LED.

MOS: 35E, Special Electronic Devices Repairer

TOOLS: Oscilloscope, Dual Trace
10X Probe
Digital Multimeter
Test Disc
Flat Tip Screwdriver, 8 in. shaft
Flat Tip Screwdriver; 2 in. shaft
Universal Test Lead Kit
5/64 in. Hex Head Key Wrench

WARNING

Death or serious injury may occur from electrical shock unless power is secured before servicing.

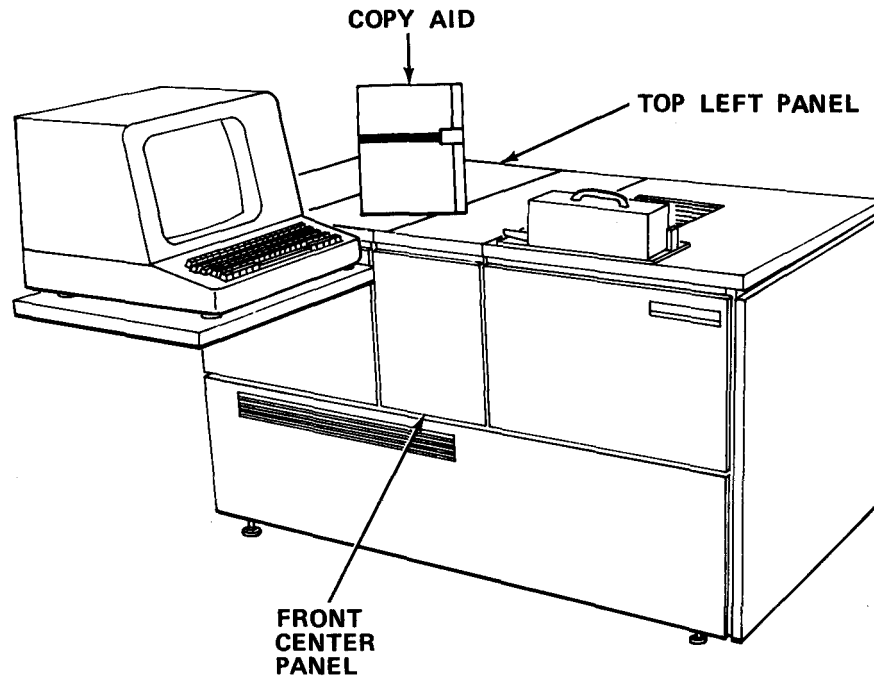

- a. Remove copy aid.
- b. Open and remove top left panel.
- c. Remove front center panel.

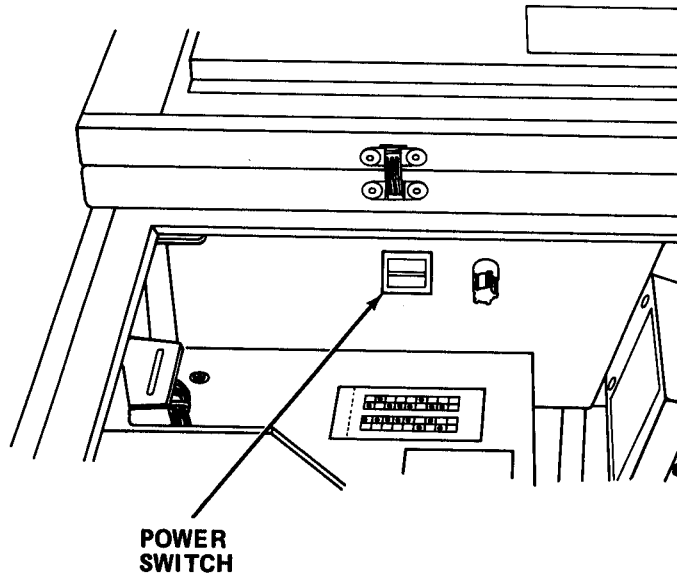

- d. Turn off power switch.
- e. Turn off circuit breaker.

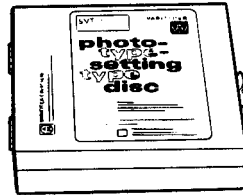

- f. Obtain disc box containing font alignment test disc.
- g. Open disc box.

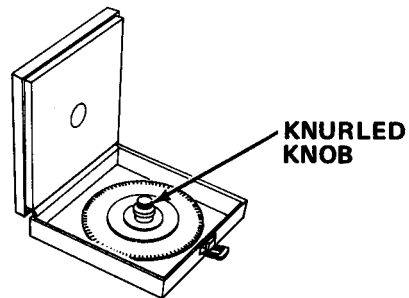

h. Grasp knurled knob and remove disc from box.

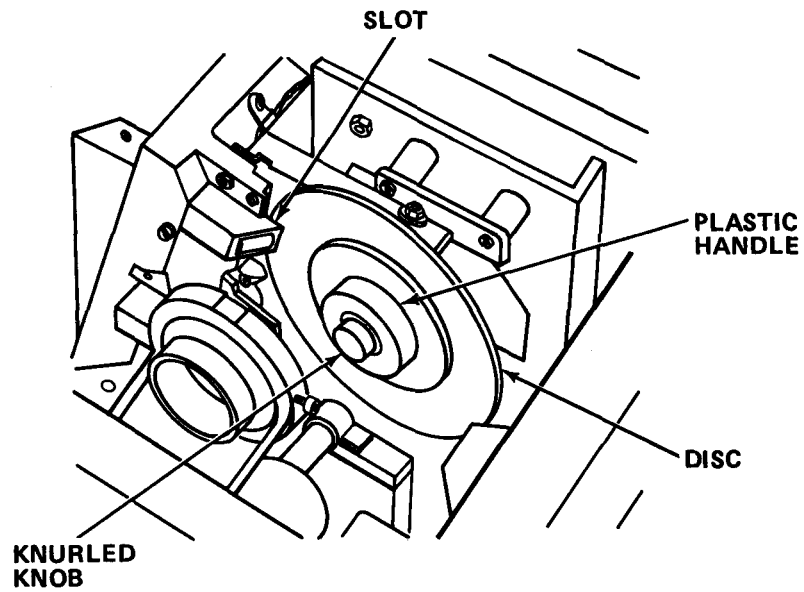

i. Hold disc by plastic handle. Place left edge of disc into slot.

j. Tighten knurled knob.

k. Use plastic handle to slowly spin disc. It should turn easily.

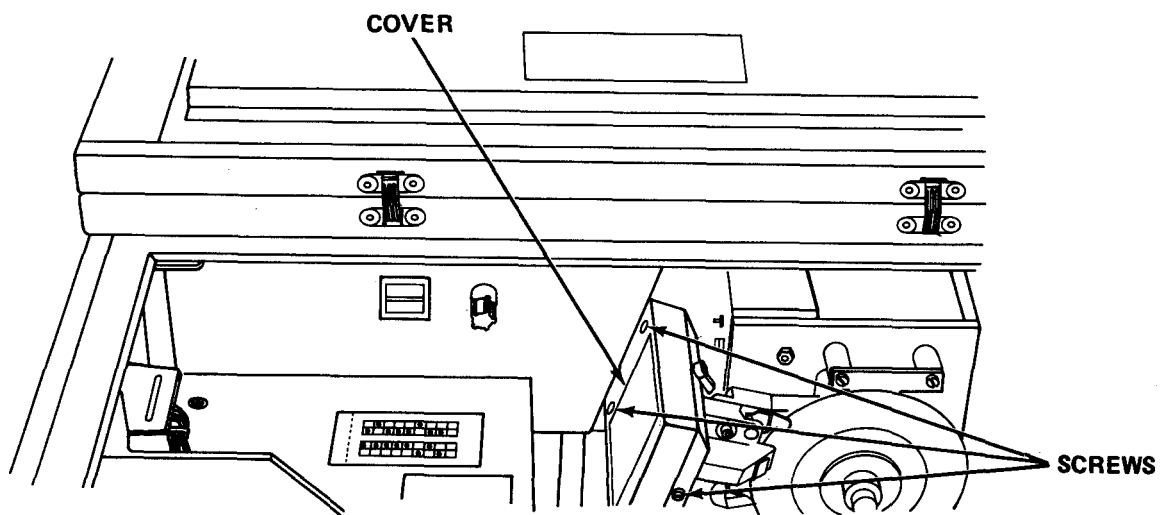

l. Remove three screws from front pick-up unit.

m. Remove cover.

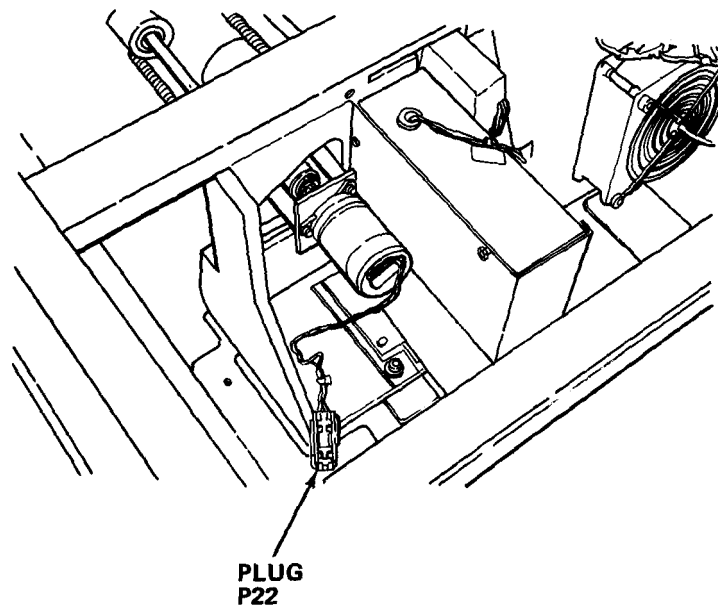

n. Disconnect plug P22.

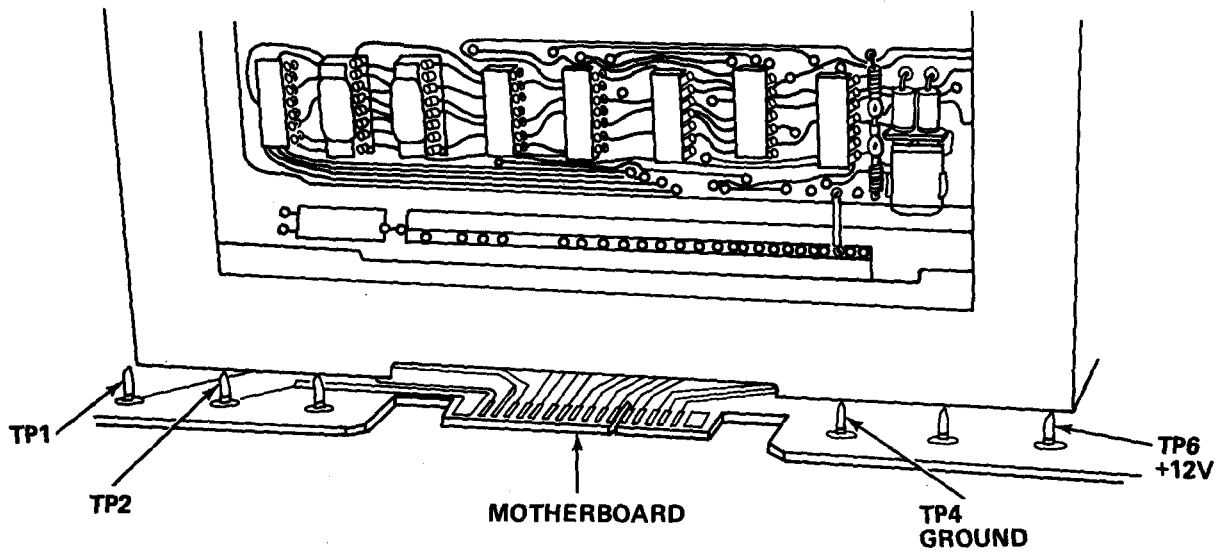

o. Connect lead from +12 V TP6 on motherboard to P22 orange lead.

p. Connect lead from ground TP4 on motherboard to P22 black lead.

q. Set up oscilloscope for dual-trace operation.

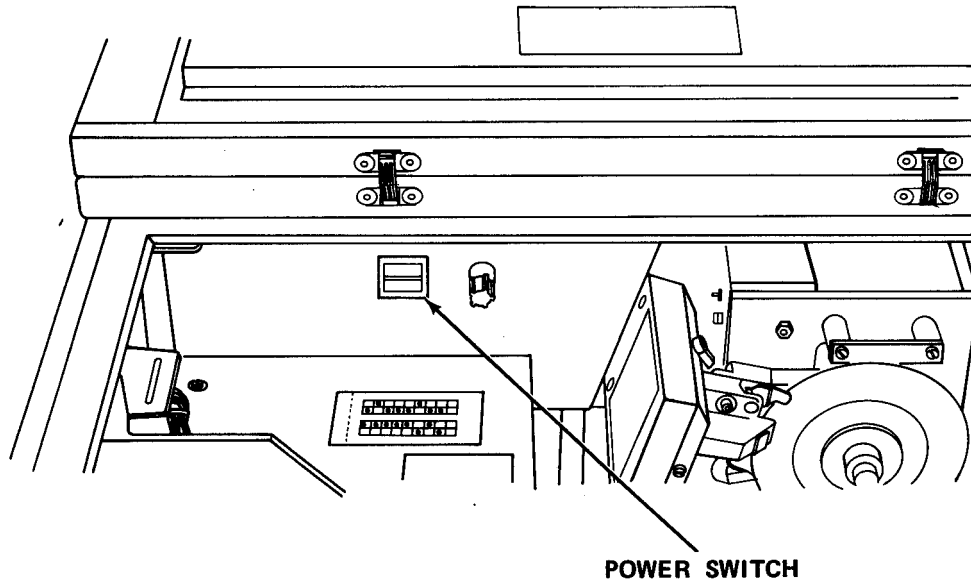

- r. Turn on circuit breaker.
- s. Turn on power switch.

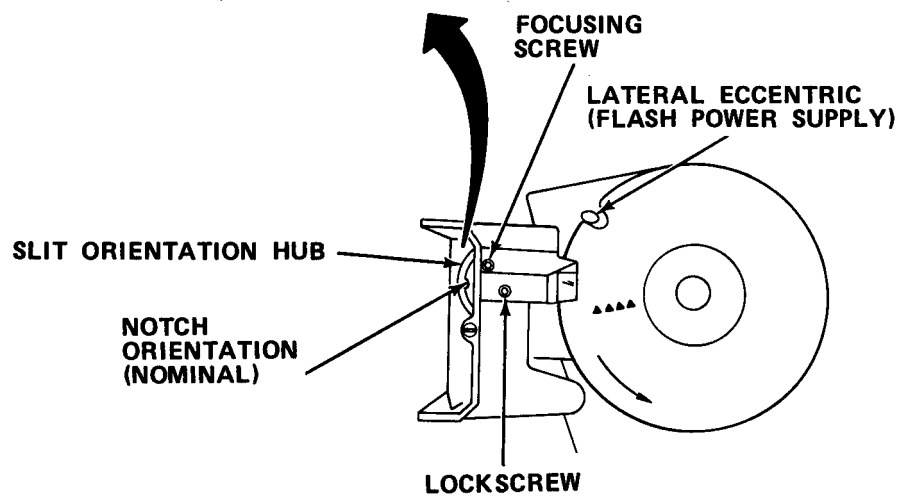
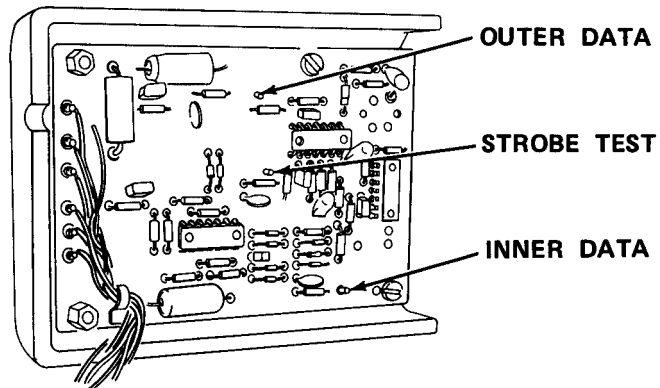

- t. Loosen lockscrew.
- u. Rotate slit orientation hub until reference mark is oriented as shown in above illustration.
- v. Loosen focus adjust screw.
- w. Push tube until hub meets casting.
- x. Attach oscilloscope probe to strobe test point on PC board.

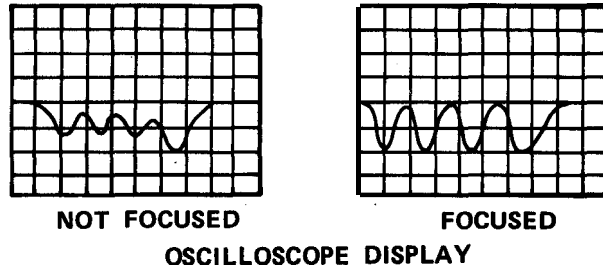

NOTE

Applying light pressure with finger on orientation hub will aid in focusing.

- y. Adjust focus screw until display is focused.
- z. Remove oscilloscope probe from strobe test point. Attach probe leads to inner and outer data test points.

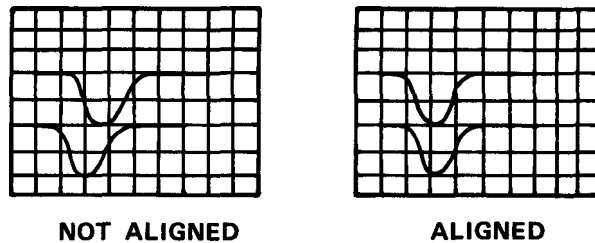

- aa. Rotate hub until two signals are aligned.
- ab. Tighten lockscrew.

NOTE

Minimum voltage amplitude is 2.5 V. Maximum variation between signals is 0.25 V.

Adjust amplitude using adjustment resistors on front pick up board.

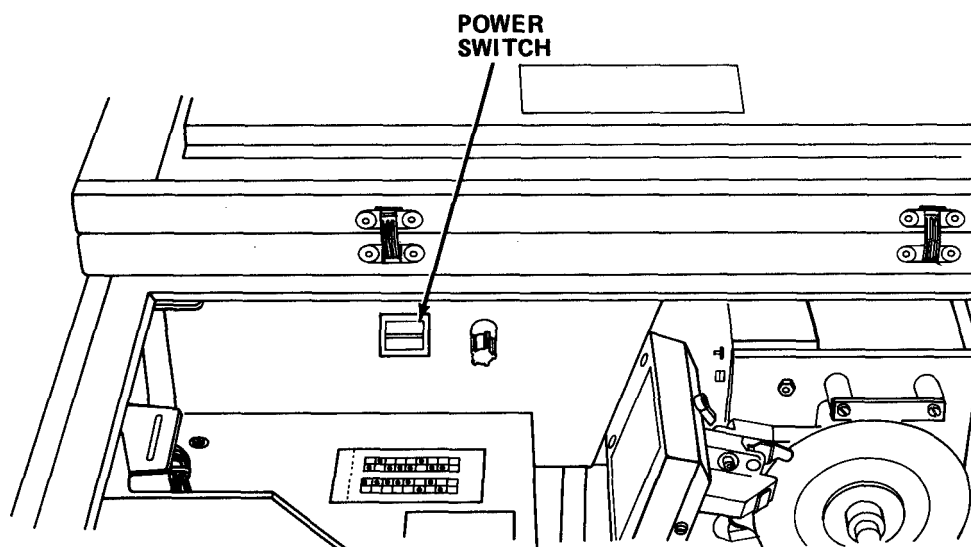

Set power switch to OFF.

Disconnect leads from P22 and motherboard.

Connect P22 to J22.

Reinstall front pick-up cover.

Remove front pick-up test disc.

Install center front panel.

Turn on main power switch.

Install and close top left panel.

Turn on circuit breaker.

Reinstall copy aid.

Perform diagnostic test.

2-20.27 Adjust Input/Monitor Unit Display.

MOS: 35E, Special Electronic Devices Repairer

TOOLS: Test Disc
Self Diagnostic Board
Digital Multimeter
Alignment Tool Kit
Electrical Clip

SUPPLIES: Rubber Floor Mat
Rubber Gloves
Mirror

WARNING

Death or serious injury may occur from electrical shock unless power is secured before servicing.

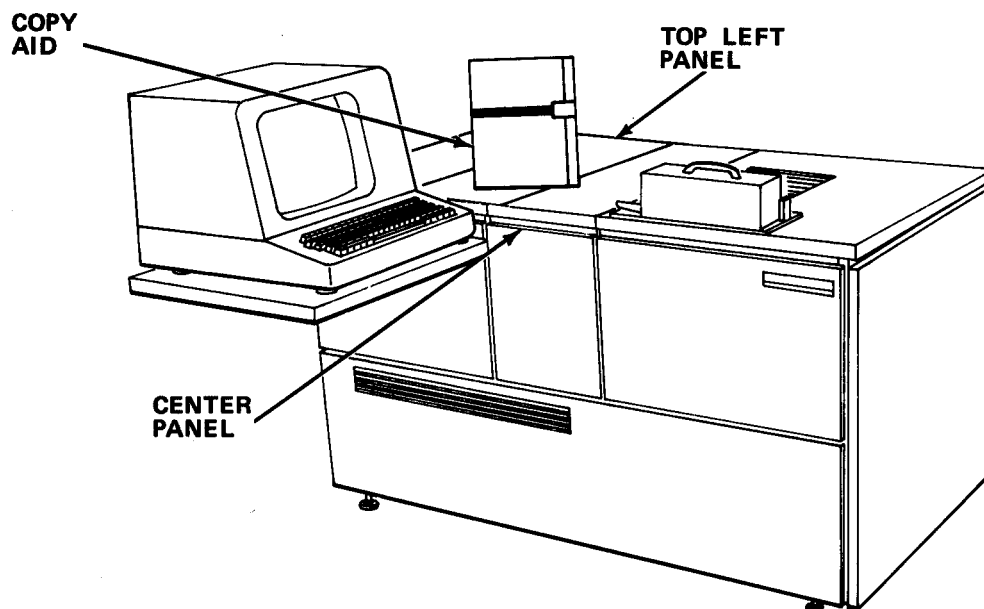

- a. Remove copy aid.
- b. Open top left panel and remove center panel.

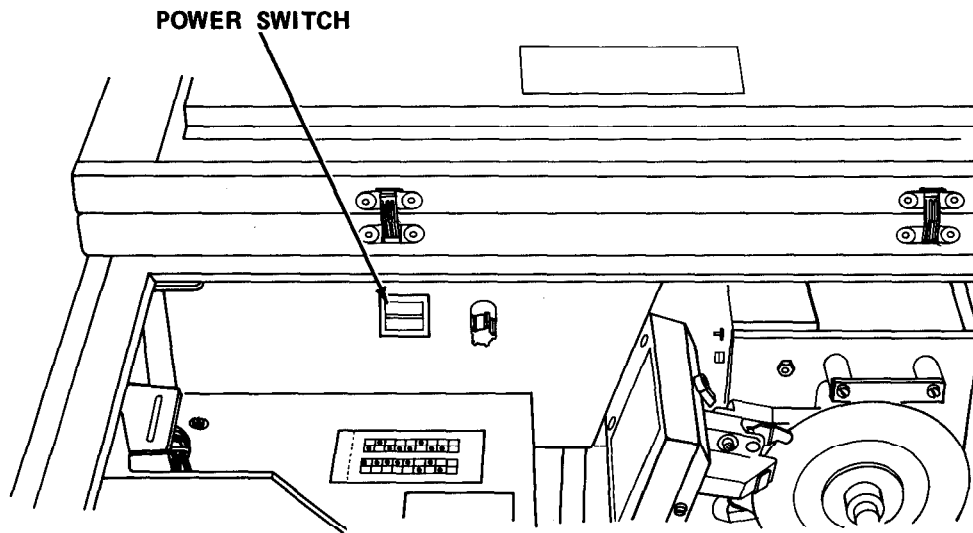

c. Turn off power switch.

SWITCH # 1

8	7	6	5	4	3	2	1	IS IMPLIED	
ON	OFF	OFF	OFF	OFF	OFF	OFF	OFF	0	0
HEX 8				0				0	0

VALUE OF THE LOWEST RAM ADDRESS

SWITCH # 2

8	7	6	5	4	3	2	1	IS IMPLIED	
ON	OFF	OFF	ON	ON	ON	ON	ON	F	F
HEX 9				F				F	F

VALUE OF THE HIGHEST RAM ADDRESS

SWITCH # 3

8	7	6	5	4	3	2	1
						CPU PROM MAIN PGM NOT PRESENT	PROM ON CPU
OFF	OFF	OFF	OFF	OFF	OFF	YES-ON NO-OFF	YES-ON NO-OFF

SWITCH # 4

8	7	6	5	4	3	2	1
		TURRETT	FLOPPY	PUNCH READER	MAX. POINT SIZE 74 POINT		MODEL COMP/SET
OFF	OFF	OFF	OFF	OFF	OFF	ON	ON

d. Set all switches according to machine configuration on diagnostic board. Then remove 32k ROM/PROM PC board.

- e. Insert diagnostic board into open bus socket.

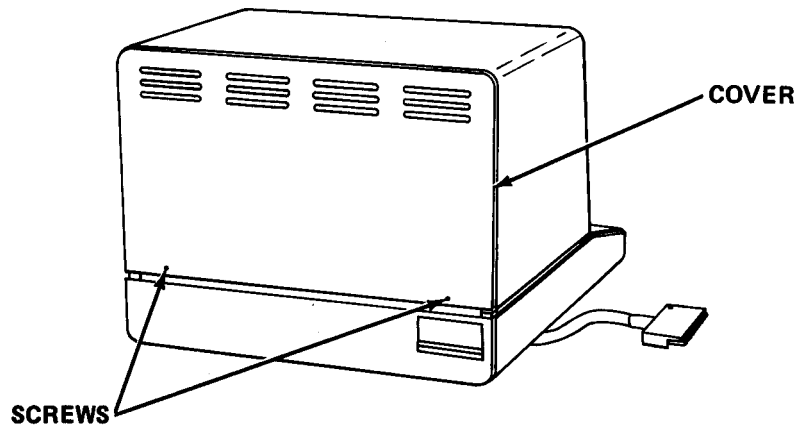

- f. Remove two screws.
- g. Lift cover clear of monitor.

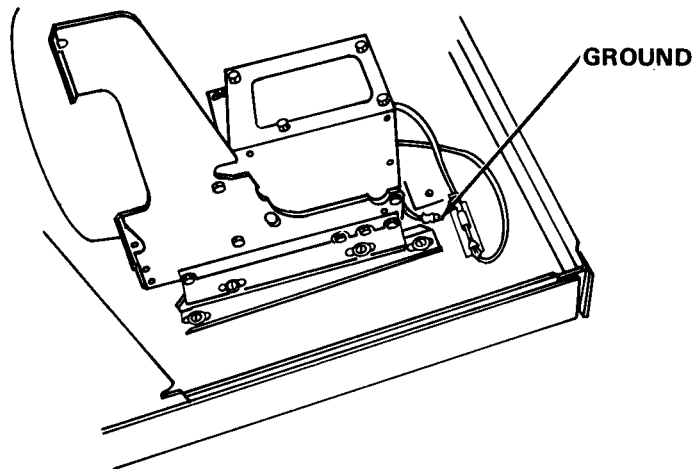

- h. Connect black lead of multimeter to ground (1).
- i. Connect red lead to emitter of Q150.

CAUTION

Be sure red lead does not touch base of Q10 and/or components. Damage to equipment may occur.

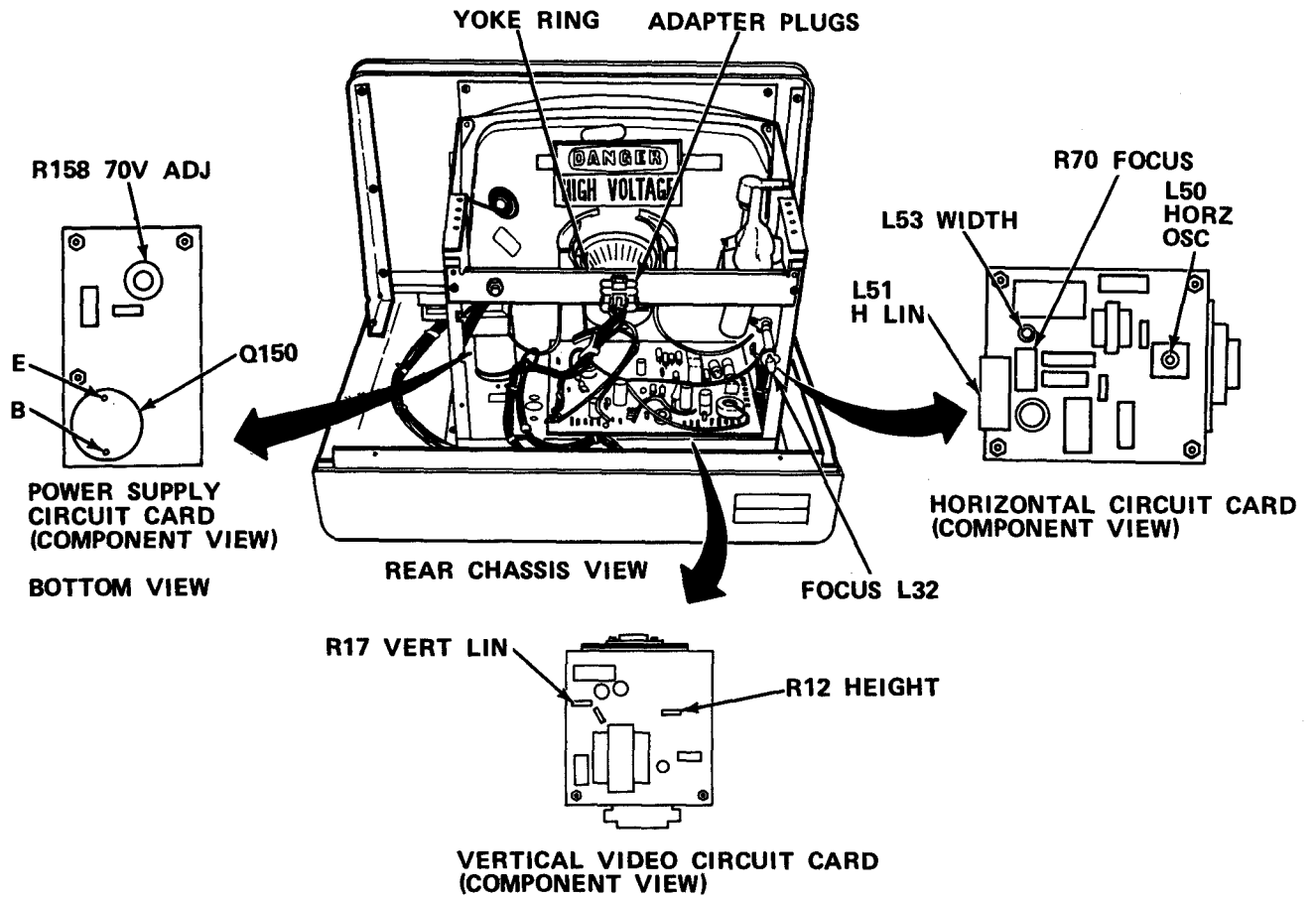

j. Set multimeter controls for indication of +70 V.

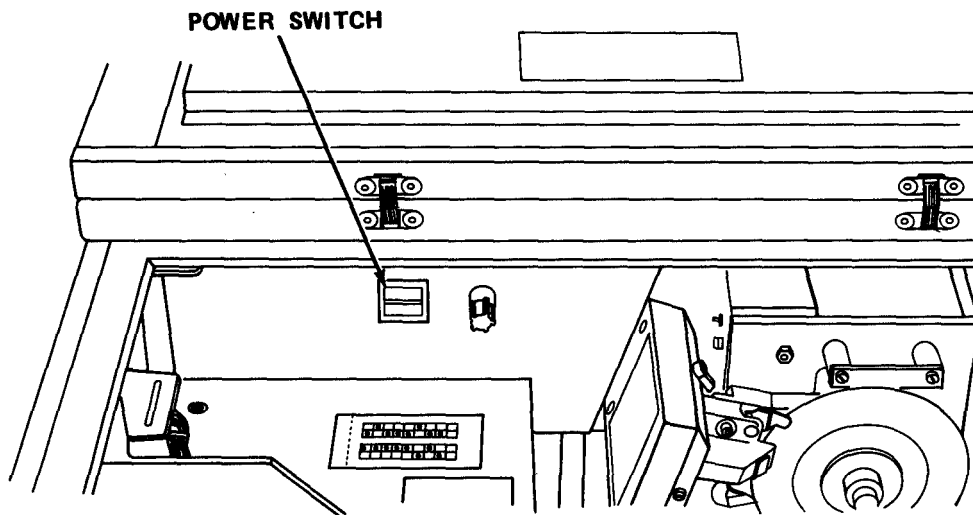

k. Turn on power switch.

NOTE

Allow ten minute warm-up.

- l. Place disc box containing test disc in convenient location.
- m. Open disc box.

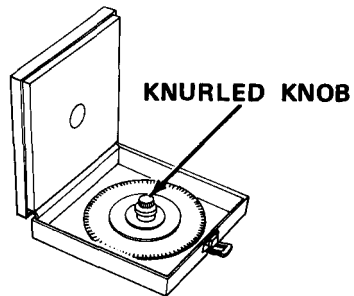

- n. Grasp knurled knob and remove disc from box.

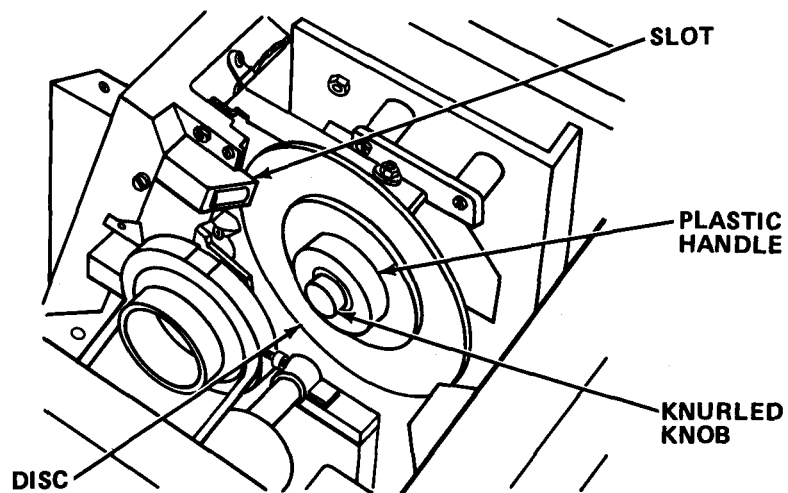

- o. Grasp disc by plastic handle. Place left edge of disc into slot.
- p. Tighten knurled knob.
- q. Replace top left and center panels.

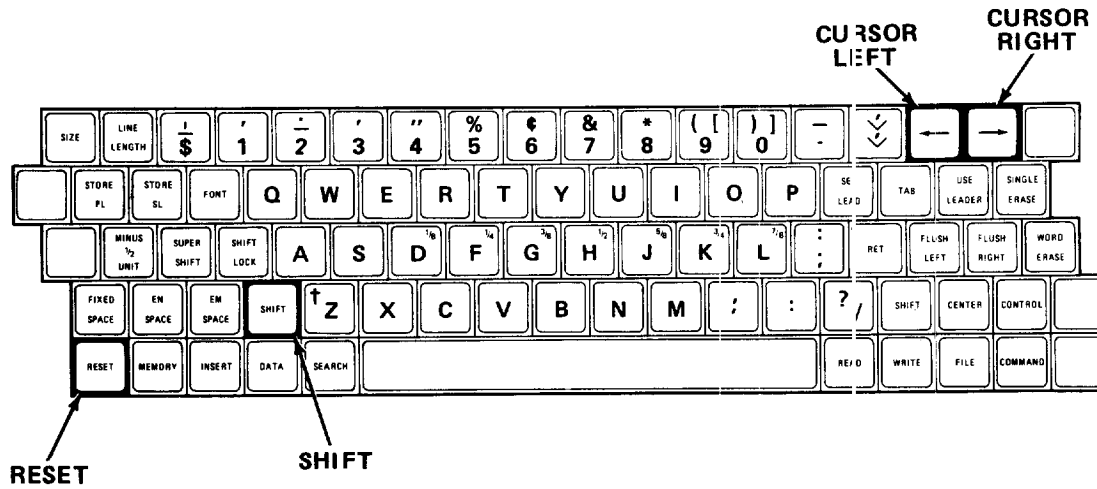
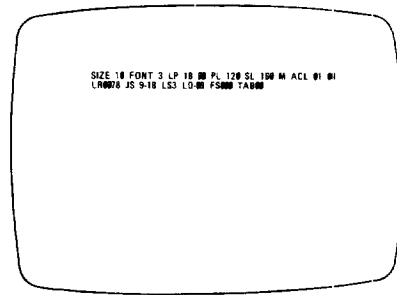

- r. Press cursor right key.
- s. Press RESET momentarily.

NOTE

Moni tor wi ll di spl ay: ENTER IS DESI RED

- t. Press SHIFT/cursor left key.

NOTE

Moni tor wi ll di spl ay ← .

- u. Enter 22.
- v. Depress SHIFT/cursor left key.

NOTE

Display will indicate eight lines of CRT characters for CRT alignment.

- w. Inspect display for out-of-focus characters.

WARNING

Death or serious injury may occur. Wear rubber gloves. Shock hazard is present. Use well-insulated, non-metallic tools. Use rubber mat on floor.

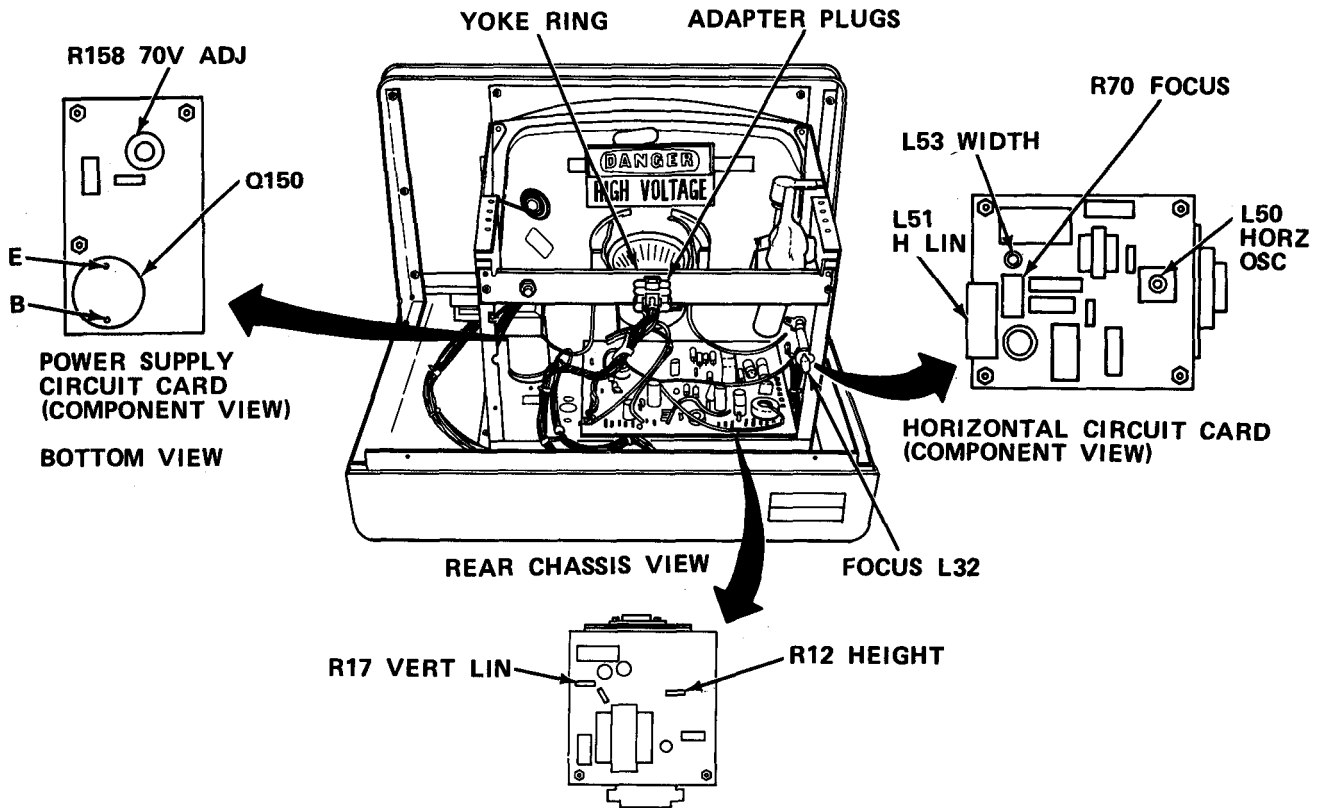

- x. Adjust R158 for multimeter indication of 70 V dc.
- y. Remove multimeter leads.
- z. Place mirror in front of display.
- aa. Position mirror so that you can view display from rear of monitor.
- ab. Adjust L50 for stable display.
- ac. Adjust L53 to produce 8.75 in. (222.25 mm) wide video display.

- ad. Adjust R12 to produce 5.75 in. (146.05 mm) high video display.
- ae. Adjust R17 to produce uniform character heights from top to bottom of screen.
- af. Adjust two centering tabs on CRT yoke to center raster display.
- ag. Adjust R70 for best focus in center of screen.
- ah. Adjust L52 for best focus at edges of screen.
- ai. Alternately adjust R70 and L52 for best focus.

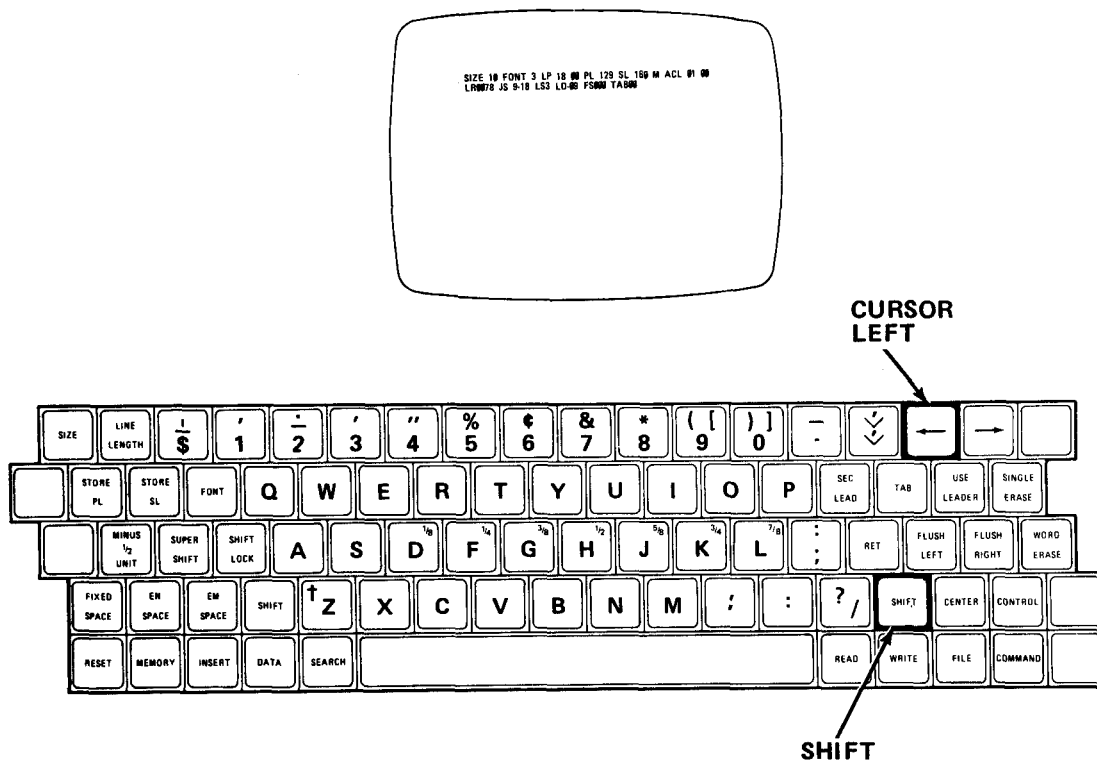

- aj. Press SHIFT/cursor left key.
- ak. Press SHIFT/cursor left key again.
- al. Open top left panel.
- am. Remove center panel.
- an. Set power switch to OFF.
- ao. Remove test disc.
- ap. Place test disc in disc box.
- aq. Remove diagnostic board. Reinstall 32k ROM/PROM PC board.

- ar. Reinstall cover on input/monitor unit.
- as. Reinstall center panel. Close top left panel.
- at. Reinstall copy aid.

2-20.28 Adjust Baseline.

MOS: 35E, Special Electronic Devices Repairer

TOOLS: 3/32 in. Hex Head Key Wrench
5/32 in. Hex Head Key Wrench
7/64 in. Hex Head Key Wrench

WARNING

Death or serious injury may occur from electrical shock unless power is secured before servicing.

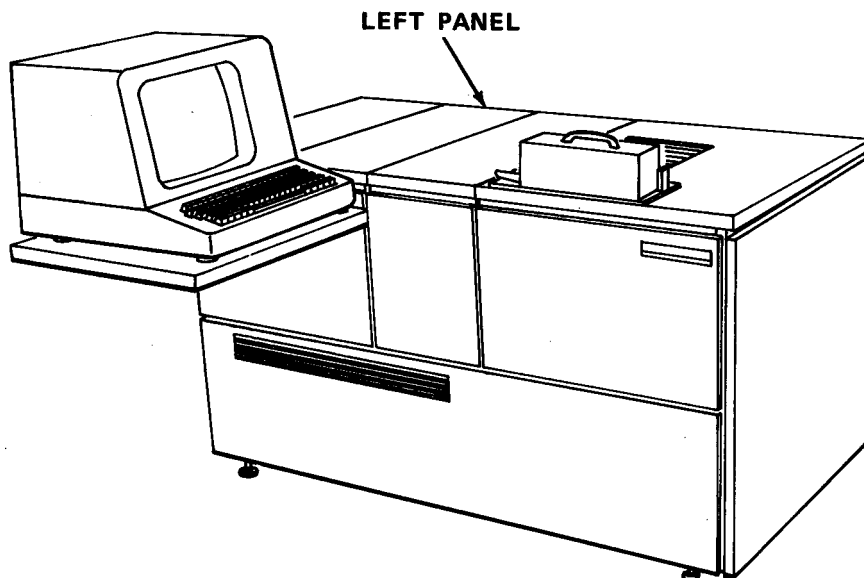

- a. Open top left panel.

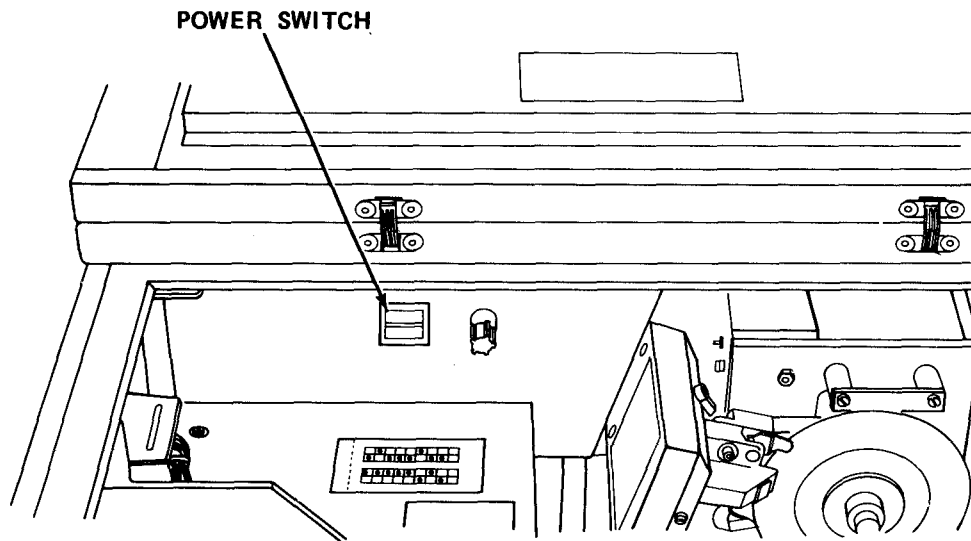

- b. Turn off power switch, then turn composing machine breaker OFF.
- c. Remove top left panel.
- d. If baselines between font 1 and font 4 are separated by more than 0.005 in. (0.127 mm), adjust mechanical timing.

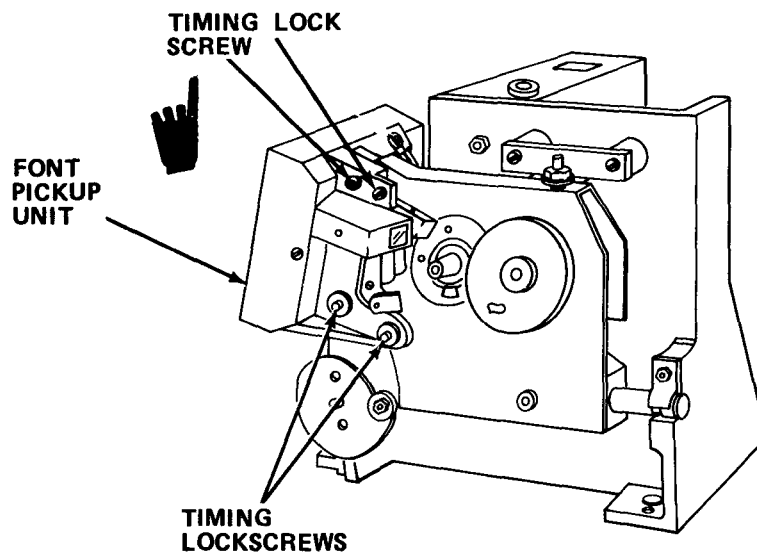

- (1) Loosen three timing lockscrews.

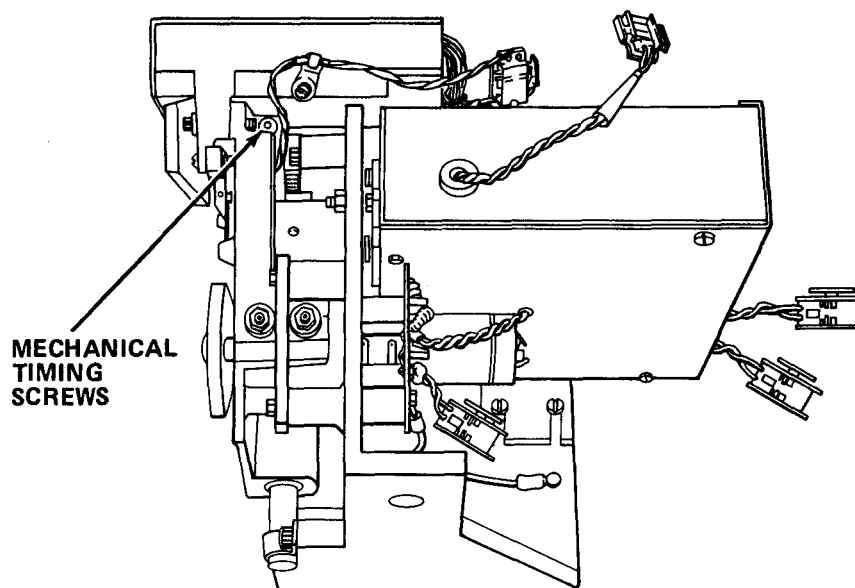

NOTE

20 degrees rotation of mechanical timing equals 0.005 in. at 36 point.

- (2) If font 4 "Z" is LOW, turn mechanical timing screw to the left.
- (3) If font 4 "Z" is HIGH, turn mechanical timing screw to the right.
- e. If baselines varies between characters of the same font and size, adjust as follows:
 - (1) Adjust scanning carriage linear bearings to zero clearance.
 - (2) Tighten wayrod hold down clamps.
- f. If baseline varies between characters of different point size, adjust variator lens vertically.
 - (1) Remove center panel.

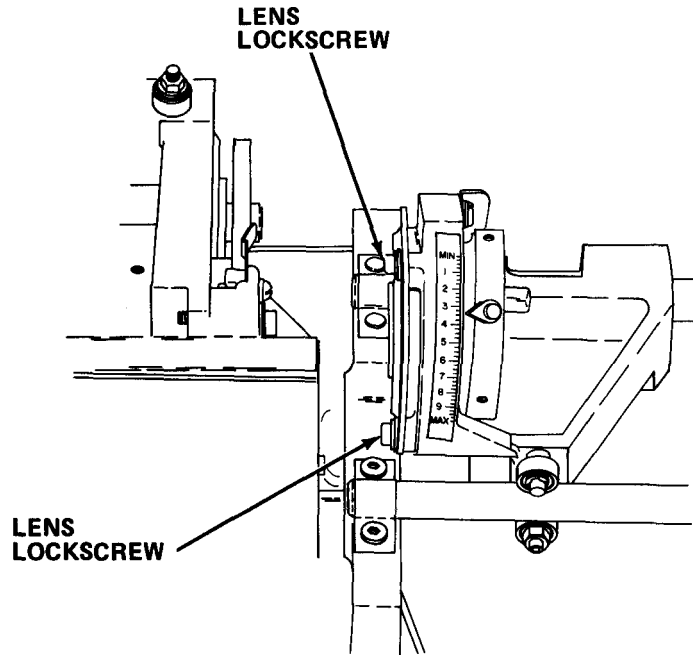

(2) Loosen three lens lock screws as the following conditions indicate.

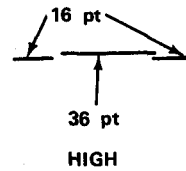
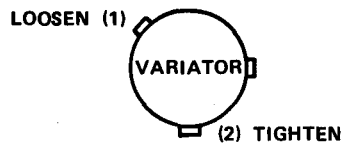
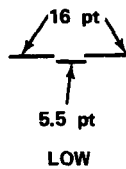

(a) If baselines continuously go higher with increasing point size, correct this condition by loosening uppermost lens adjustment setscrew slightly and tighten lower lens adjustment setscrew.

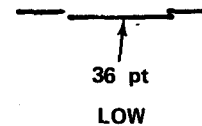
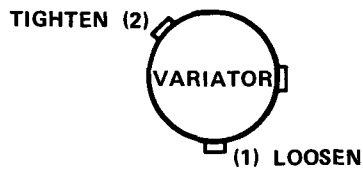
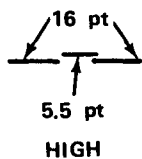

(b) If baselines continuously go lower with increasing point size, correct this condition by loosening the lower lens adjustment setscrew slightly and tighten the upper lens adjustment setscrew.

- g. Tighten lens lock screws.
- h. Reinstall top center panel and top left panel.
- i. Turn on circuit breaker, then turn on power switch.
- j. Perform diagnostic test.

2-20.29 Align Margin Between Point Sizes

MOS: 35E, Special Electronic Devices Repairer

TOOLS : 3/32 in. Hex Head Key Wrench
5/32 in. Hex Head Key Wrench
7/64 in. Hex Head Key Wrench

WARNING

Death or serious injury may occur from electrical shock unless power is secured before servicing.

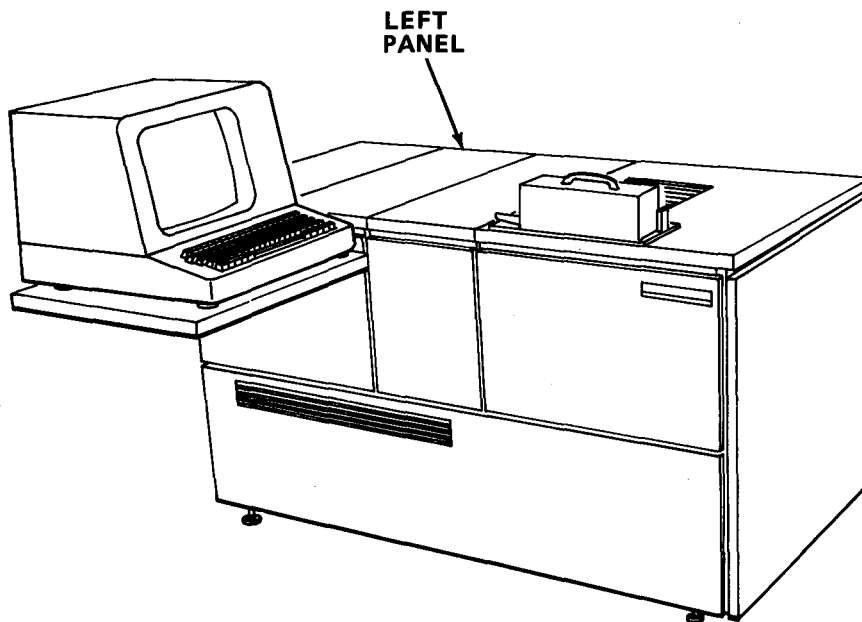

- a. Open top left panel.

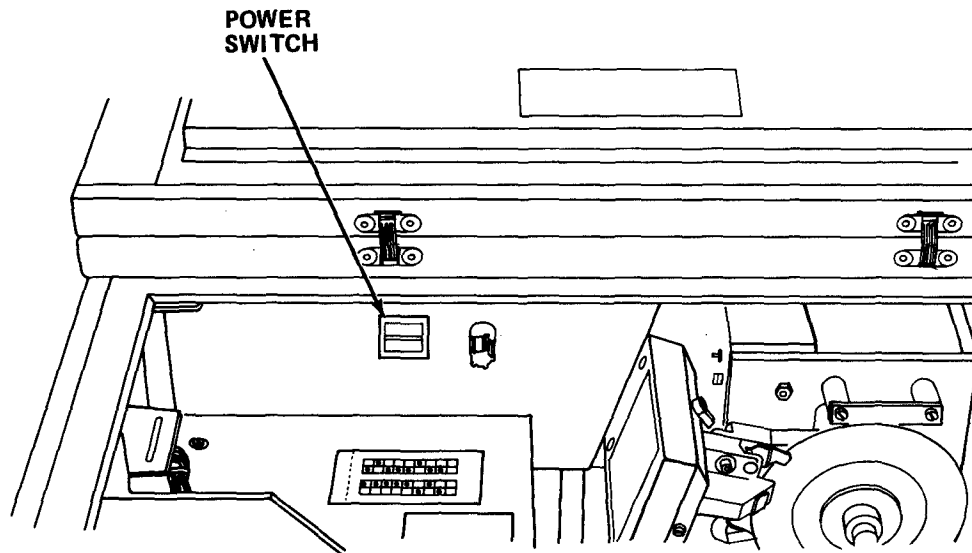

- b. Turn off power switch, then turn off composing machine breaker.
- c. Remove top left panel and center panel.
- d. **If** intersize vertical rules do not line up, make the following adjustments.

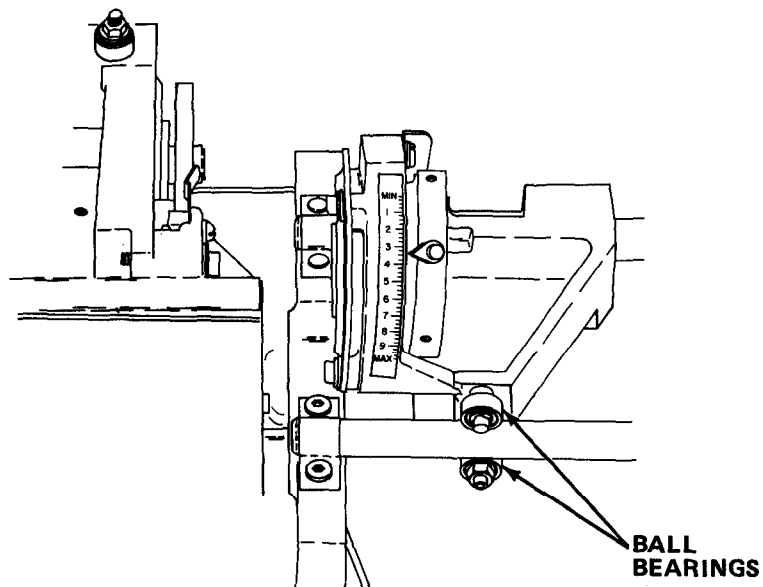

- (1) Adjust ball bearing shaft followers for zero clearance. They should be loose enough to rotate with the fingers.

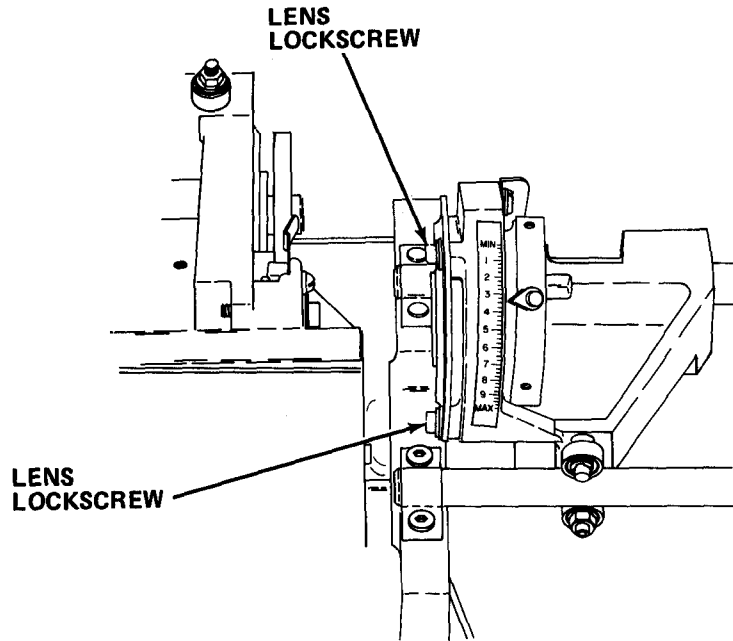

(2) Loosen lens lockscrews as the following conditions indicate:

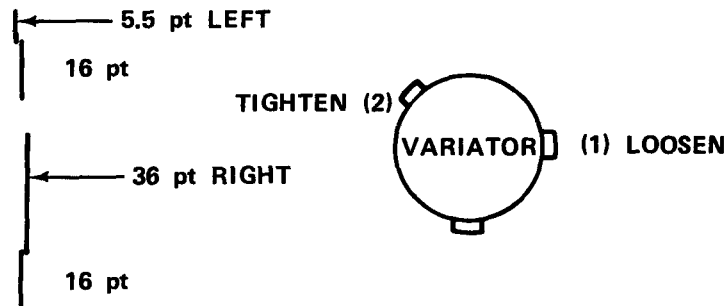

(a) If margin continuously goes right with increasing point size, correct this condition by loosening the side lens adjustment setscrews and tightening the topmost lines adjustment screw.

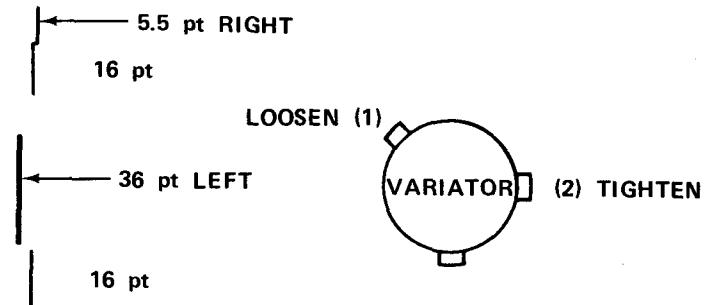

(b) If margin continuously goes left with increasing point size, correct this condition by loosening the upper lens adjustment setscrew and tightening the side adjustment screw.

- e. Tighten three lines lockscrews.
- f. Reinstall top center panel and top left panel.
- g.** Turn on circuit breaker, then turn on power switch.
- h. Close top left panel.
- i. Perform diagnostic test.

By Order of the Secretary of the Army:

JOHN A. WICKHAM, JR.
General, United States Army
Chief of Staff

Official:

DONALD J. DELANDRO
Brigadier General, United States Army
The Adjutant General

DISTRIBUTION:

To be distributed in accordance with DA Form 12-25A, Operator, Organizational, Direct Support and General Support Maintenance Requirements for Mapping Equipment.

RECOMMENDED CHANGES TO EQUIPMENT TECHNICAL PUBLICATIONS



SOMETHING WRONG WITH THIS PUBLICATION?

THEN... JOT DOWN THE DOPE ABOUT IT ON THIS FORM. CAREFULLY TEAR IT OUT. FOLD IT AND DROP IT IN THE MAIL!

FROM: (PRINT YOUR UNIT'S COMPLETE ADDRESS)

PFC JOHN DOE
COA, 3d ENGINEER BN
FT. LEONARDWOOD, MD 63108

DATE SENT

PUBLICATION NUMBER

TM 5-6675-316-14-1

PUBLICATION DATE

7 June 1985

PUBLICATION TITLE
Topographic Support System, Drafting Support Section

BE EXACT... PIN-POINT WHERE IT IS

PAGE NO.	PARA-GRAPH	FIGURE NO.	TABLE NO.
6	2-1 a		
B1		4-3	
125	line 20		

IN THIS SPACE TELL WHAT IS WRONG AND WHAT SHOULD BE DONE ABOUT IT:

In line 6 of paragraph 2-1a the manual states the engine has 6 cylinders. The engine on my set only has 4 cylinders. Change the manual to show 4 cylinders.

Callout 16 on figure 4-3 is pointing at a bolt. In key to figure 4-3, item 16 is called a shim - Please correct one or the other.

I ordered a gasket, item 19 on figure B-16 by NSN 2 910-05-762-3001. I got a gasket but it doesn't fit. Supply says I got what I ordered, so the NSN is wrong. Please give me a good NSN

PRINTED NAME, GRADE OR TITLE, AND TELEPHONE NUMBER

JOHN DOE, PFC (268) 317.7111

SIGN HERE:

JOHN DOE

DA FORM 1 JUL 79 2028-2

PREVIOUS EDITIONS ARE OBSOLETE.
DRSTS-M Overprint 1, 1 Nov 80

P.S.--IF YOUR OUTFIT WANTS TO KNOW ABOUT YOUR RECOMMENDATION MAKE A CARBON COPY OF THIS AND GIVE IT TO YOUR HEADQUARTERS.

TEAR ALONG PERFORATED LINE

FILL IN YOUR
UNIT'S ADDRESS

FOLD BACK

DEPARTMENT OF THE ARMY

OFFICIAL BUSINESS
PENALTY FOR PRIVATE USE \$300

POSTAGE AND FEES PAID
DEPARTMENT OF THE ARMY
DOD 314



COMMANDER
US ARMY TROOP SUPPORT COMMAND
ATTN: AMSTR-MPS
4300 GOODFELLOW BOULEVARD
ST. LOUIS, MO 63120-1798

TEAR ALONG PERFORATED LINE

RECOMMENDED CHANGES TO EQUIPMENT TECHNICAL PUBLICATIONS



SOMETHING WRONG WITH THIS PUBLICATION?

THEN... JOT DOWN THE DOPE ABOUT IT ON THIS FORM. CAREFULLY TEAR IT OUT, FOLD IT AND DROP IT IN THE MAIL!

FROM: (PRINT YOUR UNIT'S COMPLETE ADDRESS)

DATE SENT

PUBLICATION NUMBER

TM 5-6675-316-14-1

PUBLICATION DATE

7 June 1985

PUBLICATION TITLE

Topographic Support System, Drafting Support Section

BE EXACT... PIN-POINT WHERE IT IS

PAGE NO.	PARA-GRAPH	FIGURE NO.	TABLE NO.
----------	------------	------------	-----------

IN THIS SPACE TELL WHAT IS WRONG AND WHAT SHOULD BE DONE ABOUT IT:

TEAR ALONG PERFORATED LINE

PRINTED NAME, GRADE OR TITLE, AND TELEPHONE NUMBER

SIGN HERE:

DA FORM 2028-2
1 JUL 79

PREVIOUS EDITIONS ARE OBSOLETE.
DRSTS-M Overprint 2, 1 Nov 80.

P.S.--IF YOUR OUTFIT WANTS TO KNOW ABOUT YOUR RECOMMENDATION MAKE A CARBON COPY OF THIS AND GIVE IT TO YOUR HEADQUARTERS.

FILL IN YOUR
UNIT'S ADDRESS

FOLD BACK

DEPARTMENT OF THE ARMY

OFFICIAL BUSINESS
PENALTY FOR PRIVATE USE \$300

POSTAGE AND FEES PAID
DEPARTMENT OF THE ARMY
DOD 314



COMMANDER
US ARMY TROOP SUPPORT COMMAND
ATTN: AMSTR-MPS
4300 GOODFELLOW BOULEVARD
ST. LOUIS, MO 63120-1798

TEAR ALONG PERFORATED LINE

FILL IN YOUR
UNIT'S ADDRESS

FOLD BACK

DEPARTMENT OF THE ARMY

OFFICIAL BUSINESS
PENALTY FOR PRIVATE USE \$300

POSTAGE AND FEES PAID
DEPARTMENT OF THE ARMY
DOD 314



COMMANDER
US ARMY TROOP SUPPORT COMMAND
ATTN: AMSTR-MPS
4300 GOODFELLOW BOULEVARD
ST. LOUIS, MO 63120-1798

TEAR ALONG PERFORATED LINE

RECOMMENDED CHANGES TO EQUIPMENT TECHNICAL PUBLICATIONS



THEN... JOT DOWN THE DOPE ABOUT IT ON THIS FORM, CAREFULLY TEAR IT OUT, FOLD IT AND DROP IT IN THE MAIL!

SOMETHING WRONG WITH THIS PUBLICATION?

FROM: (PRINT YOUR UNIT'S COMPLETE ADDRESS)

DATE SENT

PUBLICATION NUMBER

TM 5-6675-316-14-1

PUBLICATION DATE

7 June 1985

PUBLICATION TITLE

Topographic Support System, Drafting Support Section

BE EXACT... PIN-POINT WHERE IT IS

PAGE NO	PARA-GRAPH	FIGURE NO	TABLE NO

IN THIS SPACE TELL WHAT IS WRONG AND WHAT SHOULD BE DONE ABOUT IT:

TEAR ALONG PERFORATED LINE

PRINTED NAME, GRADE OR TITLE, AND TELEPHONE NUMBER

SIGN HERE:

DA FORM 2028-2
1 JUL 79

PREVIOUS EDITIONS ARE OBSOLETE.
DRSTS-M Overprint 2, 1 Nov 80.

P.S.--IF YOUR OUTFIT WANTS TO KNOW ABOUT YOUR RECOMMENDATION MAKE A CARBON COPY OF THIS AND GIVE IT TO YOUR HEADQUARTERS.

FILL IN YOUR
UNIT'S ADDRESS

FOLD BACK

DEPARTMENT OF THE ARMY

OFFICIAL BUSINESS
PENALTY FOR PRIVATE USE \$300

POSTAGE AND FEES PAID
DEPARTMENT OF THE ARMY
DOD 314



COMMANDER
US ARMY TROOP SUPPORT COMMAND
ATTN: AMSTR-MPS
4300 GOODFELLOW BOULEVARD
ST. LOUIS, MO 63120-1798

TEAR ALONG PERFORATED LINE

The Metric System and Equivalents

Linear Measure

1 centimeter = 10 millimeters = .39 inch
 1 decimeter = 10 centimeters = 3.94 inches
 1 meter = 10 decimeters = 39.37 inches
 1 dekameter = 10 meters = 32.8 feet
 1 hectometer = 10 dekameters = 328.08 feet
 1 kilometer = 10 hectometers = 3,280.8 feet

Weights

1 centigram = 10 milligrams = .15 grain
 1 decigram = 10 centigrams = 1.54 grains
 1 gram = 10 decigrams = .035 ounce
 1 dekagram = 10 grams = .35 ounce
 1 hectogram = 10 dekagrams = 3.52 ounces
 1 kilogram = 10 hectograms = 2.2 pounds
 1 quintal = 100 kilograms = 220.46 pounds
 1 metric ton = 10 quintals = 1.1 short tons

Liquid Measure

1 centiliter = 10 milliliters = .34 fl. ounce
 1 deciliter = 10 centiliters = 3.38 fl. ounces
 1 liter = 10 deciliters = 33.81 fl. ounces
 1 dekaliter = 10 liters = 2.64 gallons
 1 hectoliter = 10 dekaliters = 26.42 gallons
 1 kiloliter = 10 hectoliters = 264.18 gallons

Square Measure

1 sq. centimeter = 100 sq. millimeters = .155 sq. inch
 1 sq. decimeter = 100 sq. centimeters = 15.5 sq. inches
 1 sq. meter (centare) = 100 sq. decimeters = 10.76 sq. feet
 1 sq. dekameter (are) = 100 sq. meters = 1,076.4 sq. feet
 1 sq. hectometer (hectare) = 100 sq. dekameters = 2.47 acres
 1 sq. kilometer = 100 sq. hectometers = .386 sq. mile

Cubic Measure

1 cu. centimeter = 1000 cu. millimeters = .06 cu. inch
 1 cu. decimeter = 1000 cu. centimeters = 61.02 cu. inches
 1 cu. meter = 1000 cu. decimeters = 35.31 cu. feet

Approximate Conversion Factors

To change	To	Multiply by	To change	To	Multiply by
inches	centimeters	2.540	ounce-inches	newton-meters	.007062
feet	meters	.305	centimeters	inches	.394
yards	meters	.914	meters	feet	3.280
miles	kilometers	1.609	meters	yards	1.094
square inches	square centimeters	6.451	kilometers	miles	.621
square feet	square meters	.093	square centimeters	square inches	.155
square yards	square meters	.836	square meters	square feet	10.764
square miles	square kilometers	2.590	square meters	square yards	1.196
acres	square hectometers	.405	square kilometers	square miles	.386
cubic feet	cubic meters	.028	square hectometers	acres	2.471
cubic yards	cubic meters	.765	cubic meters	cubic feet	35.315
fluid ounces	milliliters	29.573	cubic meters	cubic yards	1.308
pints	liters	.473	milliliters	fluid ounces	.034
quarts	liters	.946	liters	pints	2.113
gallons	liters	3.785	liters	quarts	1.057
ounces	grams	28.349	liters	gallons	.264
pounds	kilograms	.454	grams	ounces	.035
short tons	metric tons	.907	kilograms	pounds	2.205
pound-feet	newton-meters	1.356	metric tons	short tons	1.102
pound-inches	newton-meters	.11296			

Temperature (Exact)

°F	Fahrenheit temperature	5/9 (after subtracting 32)	Celsius temperature	°C
----	------------------------	----------------------------	---------------------	----

