

TM 11-6625-2578-12

TECHNICAL MANUAL

OPERATOR'S AND ORGANIZATIONAL MAINTENANCE MANUAL

RADIO TEST SET GROUP

OQ-60/USQ-46

HEADQUARTERS, DEPARTMENT OF THE ARMY

OCTOBER 1972

TECHNICAL MANUAL }
 No. 11-6625-2578-12 }

HEADQUARTERS
 DEPARTMENT OF THE ARMY
 WASHINGTON, D.C., 31 October 1972

OPERATOR'S AND ORGANIZATIONAL MAINTENANCE MANUAL
 RADIO TEST SET GROUP OQ-60/USQ-46

	Paragraph	Page
CHAPTER 1. INTRODUCTION		
Section I. General - - - - -	1-1	1-1
Section II. Description and Date - - - - -	1-4	1-2
CHAPTER 2. INSTALLATION AND INITIAL CHECKOUT		
CHAPTER 3. OPERATION		
Section I. Operators Controls, Metering and Connectors - - - - -	3-1	3-1
Section II. Operation - - - - -	3 - 2	3-2
CHAPTER 4. OPERATOR MAINTENANCE INSTRUCTIONS		
Section I. General Requirements - - - - -	4-1	4-1
Section II. Preventative Maintenance - - - - -	4-3	4-1
CHAPTER 5. ORGANIZATIONAL MAINTENANCE INSTRUCTIONS		
Section I. General - - - - -	5 - 1	5-1
Section II. Preventive Maintenance - - - - -	5-3	5-1
CHAPTER 6. SHIPMENT AND LIMITED STORAGE AND DEMOLITION TO PREVENT ENEMY USE		
Section I. Shipment and Limited Storage - - - - -	6-1	6-1
Section II. Demolition of Material to Prevent Enemy Use - - - - -	6-3	6-1
APPENDIX A. REFERENCES - - - - -		A-1
APPENDIX B. MAINTENANCE ALLOCATION - - - - -		B-1

CHAPTER 1 INTRODUCTION

Section I. GENERAL

1-1. Scope

This manual describes Radio Test Set Group OQ-60/USQ-46 (fig. 1-1) and includes instructions for installation, operation and organizational maintenance. The manual includes instructions for cleaning and inspecting the equipment and replacement of parts available at the organizational maintenance level.

1-2. Indexes of Publications

a. **DA Pam 310-4. Refer to the latest issue of DA Pam 310-4 for new additions, changes or additional publications pertaining to the equipment.**

b. DA Pam 310-7. Refer to DA Pam 310-7 for modification work orders (MWO's) pertaining to the equipment. DA Pam 310-7 lists all authorized Department of the Army modification work orders, identifying the type, model, series, and Federal stock number of the item to be modified; the number, date, and classification of the MWO; the category of maintenance authorized to perform the modification; and the man-hours required to apply the modification to each item.

1-3. Forms and Records

a. **Reports of Maintenance and Unsatisfactory Equipment.** Use equipment forms and records in accordance with instructions provided in TM 38-750.

b. Report of Packaging and Handling Deficiencies. Complete and forward DD Form 6 (Report of Packaging and Handling Deficiencies) as prescribed in AR 700-58 (Army), NAVSUP Publication 378 (Navy), AFM 71-4 (Air Force), and MCO P4030.29 (Marine Corps).

c. Discrepancy in Shipment Report (DISREP) (SF 361). Complete and forward Discrepancy in Shipment Report (DISREP) (SF 361) as prescribed in AR 55-38 (Army), NAVSUP Pub 459 (Navy), AFM 75-34 (Air Force), and MCO P4610.19 (Marine Corps).

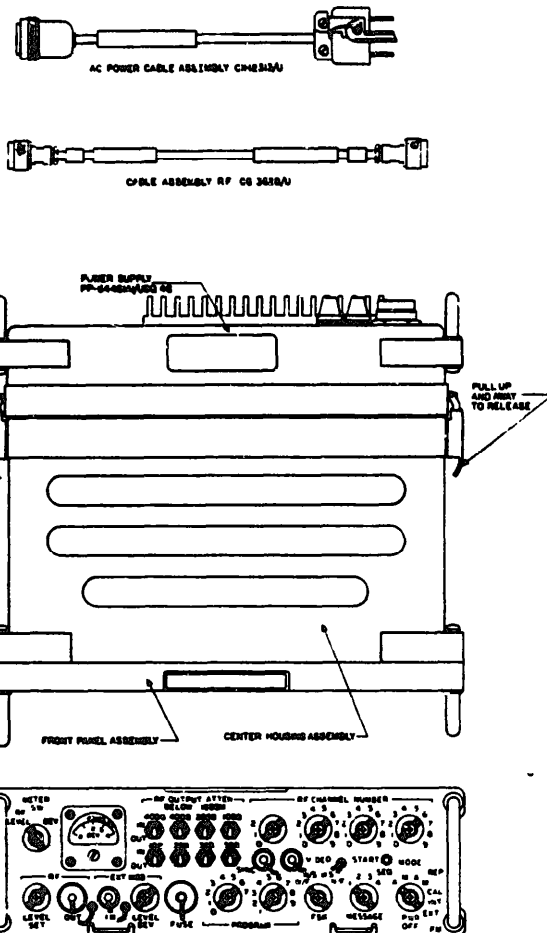

EL6625-2578-12-TM-1

Figure 1-1. Radio Test Set Group OQ-60/USQ-46.

d. Reporting of Equipment Manual Improvements. The reporting of errors, omissions, and recommendations for improving this publication by the individual user is encouraged. Reports should be submitted on DA Form 2028 (Recom-

mended Changes to Publications) and forward direct to Commander, U.S. Army Electronics Command, ATTN: AMSEL-MA-ML, Fort Monmouth, N.J. 07703.

Section II. DESCRIPTION AND DATA

1-4. Purpose and Use

Radio Test Set Group OQ-60/USQ-46 is a portable FM signal generating device. The OQ-60/USQ-46 generates signals which are used to test and evaluate the operational performance of RF Monitor Sets AN/USQ-46 and AN/USQ-46A. The OQ-60/USQ-46 is comprised of the Radio Test Set TS-2963/USQ-46 (hereinafter called the TS-2963/USQ-46), power supply PP-6446A/USQ-46, incompact AC power cable CX-12313/U, and an Rf output cable CG-3628/U. The OQ-60/USQ-46 generates signals which exercise all Rf channels and message formats that either Rf Monitor Set is capable of receiving and processing.

1-5. Technical Characteristics

a. Radio Test Set TS-2963/USQ-46.

Number of RF Channels: - 2700
 Message of Modulation Capability : All modulation characteristics for which the RF Monitor Set AN/USQ-46 is capable of receiving and processing.
 RF Output Level: - -10 dbm to -181 dbm
 Duty Cycle : - Continuous (100%)
 Warmup Time: - Within 5 seconds after application of power.

Tuneup Time: ----- Within 5 seconds after setting new output frequency.

Operating Temperature Range, Ground Environment: ----- +155°F to -40°F

CAUTION. EXPOSURE AT HIGH OPERATING TEMPERATURES SHOULD NOT EXCEED 4 HOURS AT ANY ONE TIME. EXPOSURE AT LOW OPERATING TEMPERATURES SHOULD NOT EXCEED 72 HOURS AT ANY ONE TIME. EXPOSURE AT HIGH STORAGE TEMPERATURES SHOULD NOT EXCEED 24 HOURS AT ANY ONE TIME.

Storage Temperature Range, Ground Environment: ----- +160°F to -65°F

b. Power Supply PP-6446A/USQ-46.

Power Output ----- +12 vdc (regulated) +27 vdc (unregulated).

Power Input ----- 100 to 132 vac, 50 to 60 or 400 Hz, single phase or +22 to +33 vdc.

Duty Cycle ----- Continuous
 Protection ----- Under/over input voltage, overload, and transient input voltage spikes.

1-6. Components and Dimensions

Components and dimensions of the Radio Test Set Group OQ-60/USQ-46 (fig. 1-1) are listed in chart 1-1.

Chart 1-1. Radio Test Set Group Components and Dimensions

FSN	Equipment	Length (in)	Width (in)	Height (in)	Weight (lb)
6625-176-5292	Radio Test Set TS 2963/USQ-46	12.25	18	4	25
5820-451-5498	Power Supply PP-6446A/USQ-46	3.4	18	4	8.0
5995-177-3699	AC Power Cable Assembly CX-12313/U	77.0	--	--	1.0
6625-177-4548	RF Cable Assembly CG-3628/U	48.0	--	--	--
	Operators Manual	--	--	--	--

1-7. Differences in Models

At the operator and organizational level, there are no operational differences in the Radio Test Group OQ-60/USQ-46. There are two power supplies available, a PP-6446/USQ-46 and a PP-6446A/USQ-46. Both units are functionally identical and are completely interchangeable.

1-8. Additional Equipment Required

Equipment	Purpose	Applicable Publication
Radio Frequency Monitor Set AN/USQ-46 or AN/USQ-46A.	To receive, decode, and display signals from the OQ-60/USQ46.	TM 11-5820-790-12
Power Supply Group OP-63/USQ46	To supply power required for operation of the AN/USQ-46 or AN/USQ-46A.	TM 11-5820-790-12
Signal Generator, AN/USM-264	Perform operational test on TS-2963/USQ-46.	TM 11-6625-1842-12
Oscilloscope, AN/USM-281A	Perform operational test on TS-2963/USQ-46.	TM 11-6625-1703-15
Frequency Counter, AN/USM-207	Perform operational test on TS-2963/USQ-46.	TM 11-6625-700-25
RMS Voltmeter, ME-318/U	Perform operational test on TS-2963/USQ-46.	TM 11-6625-1541-15
50-Ohm Load, DA-265/U	Perform operational test on TS-2963/USQ-46.	
RF Indicator, ID-1721/USQ-46	To decode and display signals from AN/USQ-46 or AN/USQ-46A.	

CHAPTER 2

INSTALLATION AND INITIAL CHECKOUT

2-1. Unpacking

The Radio Test Set Group OQ-60/USQ-46 may be packed in a wooden packing box or a cardboard shipping carton (fig. 2-1). Unpack the equipment carefully to prevent damage to the equipment.

2-2. Checking Unpacked Equipment

a. Inspect the equipment for damage that may have occurred during shipment. If the equipment has been damaged, complete and forward DD Form 6 (para 1-3b).

b. Check to see that the equipment is complete as listed on the packing slip. Report all discrepancies in accordance with TM 38-750. Equipment can be placed in service when a minor assembly

or part that does not affect proper functioning is missing.

NOTE

Current MWO's applicable to the equipment are listed in DA Pam 310-7.

c. Check to see if the equipment has been modified. If the equipment has been modified, the MWO number will appear on the front panel near the nomenclature plate. Insure that all MWO's current at the time the equipment is placed in use have been completed.

d. Check the latest issue of DA Pam 310-4 to insure that the applicable maintenance literature is current. Equipment issued by depot may have been in stock for some time and may contain superseded manuals.

2-3. Installation of Power Supply PP-6446A/USQ-46

Refer to figure 1-1 and proceed as follows to install the Power Supply on the Radio Test Set:

a. Place the TS-2963/USQ-46 face down on a level surface.

b. Position the PP-6446A/USQ-46 output power receptacle over the plug located on the TS-2963/USQ-46 center housing assembly, and press downward gently.

c. Fasten the two spring latches.

2-4. Installation of RF Cable Assembly CG-3628/U

a. Place the TS-2963/USQ-46 on a level surface with the front panel facing forward.

b. Connect either end of RF Cable Assembly CG-3628/U to the RF OUT connector of the TS-2963/USQ-46. Tighten the cable connector.

2-5. Installation of AC Power Cable Assembly CX-12313/U

a. Place Radio Test Set Group OQ-60/USQ-46

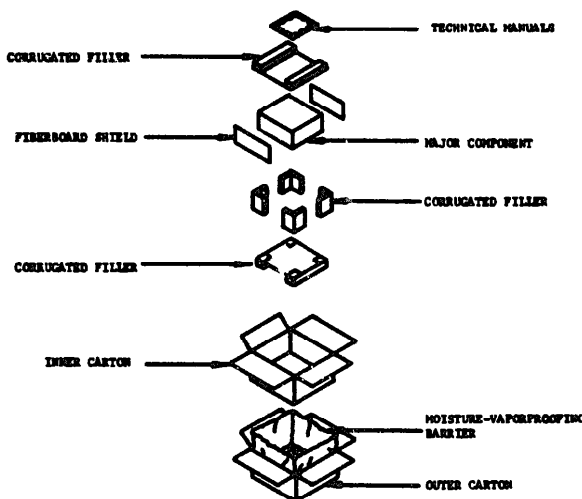

EL6625-2578-12-TM-2

Figure 2-1. Typical Packaging Diagram.

on a level surface with the PP-6446A/USQ-46 input power plug facing forward.

b. Position connector P1 of the AC power cable assembly CX-12313/U over the power supply input plug and press inward gently.

c. Twist the locking ring on P1 clockwise until locked in place.

2-6. Initial Adjustment of Equipment

To verify that the OQ-60/USQ-46 is operational, perform tests described in paragraphs 2-7 through 2-9. Check to ensure that the power supply, Rf cable assembly, and AC power cable assembly are properly installed (paragraph 2-3, 2-4 and 2-5) before performing the tests.

a. Connect a 50-ohm dummy load to the TS-2963/USQ-46 RF OUT connector.

b. Connect primary power to the PP-6446A/USQ-46 (refer to paragraph 1-b, power requirements).

c. Set the MODE switch to CAL.

d. Set the METER SW to RF LEVEL.

e. Set the FSK switch to W/F.

f. Set all the RF OUTPUT ATTEN switches to the OUT positions.

g. Adjust the RF LEVEL SET control to obtain meter deflection to the blue POWER SET line on the meter scale.

h. Set the MODE switch to INT.

i. Set the METER SW to DEV.

j. Adjust the EXT MOD LEVEL DEV control to obtain "3" indication on the meter.

k. Set the FSK switch to N/S, and verify that the meter indicates "1.5".

l. Set the FSK switch to W/S, and verify that the meter indicates "3."

m. Set the FSK switch to N/S, and verify that the meter indicates "1.5."

n. Set the MODE switch to PWR OFF, and verify that the meter indicates zero.

NOTE

If the Radio Test Set Group OQ-60/USQ-46 is not operational, proceed in accordance with paragraph 4-7.

2-7. External Modulation

a. Connect equipment as shown in figure 2-2 with the signal generator connected to the EXT MOD IN connector and the RF Monitor connected to the RF OUT connector of the TS-2963/USQ-46.

b. Set signal generator to 500 Hz.

c. Adjust the front panel EXT MOD LEVEL DEV control for maximum output. Adjust the signal generator output level to obtain an indication of ± 3 kHz on the TS-2963/USQ-46 front panel meter. The measurement noted on channel A of the oscilloscope must not exceed 5.5 volts peak-to-peak.

NOTE

Signal generator output must be kept at a constant amplitude during the frequency response check.

d. Adjust oscilloscope channel A to display a 500 Hz signal of 4 cm peak-to-peak. Measure frequency response of the external modulation circuit from 10 Hz to 2 kHz. The frequency response is measured on the true RMS voltmeter in terms of \pm dB from the 500 Hz reference and must remain within 2.5 dB from 10 Hz to 2 kHz.

2-8. Internal Modulation

a. Connect equipment as shown in figure 2-2 except, the signal generator, RMS voltmeter, and oscilloscope are not required. Connect pin T of the RF Monitor EXT DISPLAY connector to the frequency counter (use a 1:1 probe).

b. Set METER switch to DEV and MODE switch to INT.

c. A 1 kHz ± 300 Hz signal must be observed on the frequency counter.

d. Vary the front panel LEVEL DEV control and observe that the front panel meter indicates a ± 3 kHz deviation.

2-9. Frequency Accuracy

a. Connect equipment as shown in figure 2-2 except, the signal generator, RMS voltmeter, oscilloscope, and RF Monitor are not required. Connect the frequency counter to the RF OUT connector.

b. Set RF CHANNEL NUMBER switches for 2400, MODE switch to CAL, all RF OUTPUT ATTEN switches to OUT and MESSAGE switch to any position except 4. Set METER SW to RF

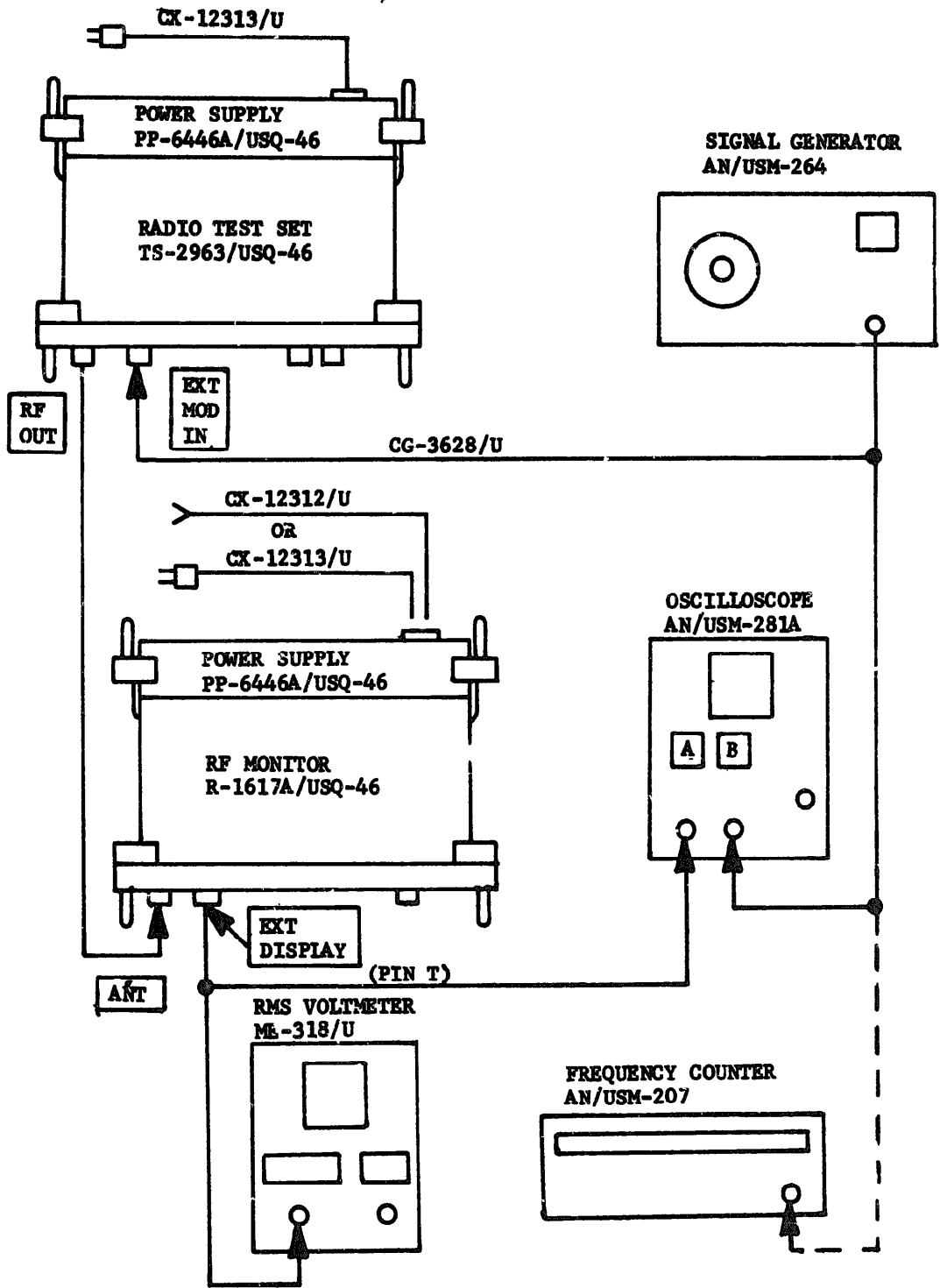

EL6625-2578-12-TM-4

Figure 2-2. Internal and External Modulation Test Setup.

LEVEL and adjust LEVEL SET control for the POWER SET indication on the meter.

c. Observe the frequency counter readout. This frequency must be 160.12500 **MHz ±801 Hz.**

d Repeat steps b and c, except set the RF CHANNEL NUMBER switches for 1045. The

output frequency must be 168.53125 MHz ±843 Hz.

e. Repeat steps b and c, except set the RF CHANNEL NUMBER switches for 2218. The output frequency must be 175.86250 MHz ±880 Hz.

CHAPTER 3 OPERATION

Section I. OPERATORS CONTROLS, METERING AND CONNECTORS

3-1. Controls, Metering and Connectors

Operators controls, indicating meter and connectors are located on the front panel assembly as shown in figure 3-1. Table 3-1 describes their function.

Table 3-1. Operators Controls, Metering and Connectors

Item	Function
METER SW	Selects the functions of the meter (RF LEVEL or DEV).
METER	Used in calibrating the RF output level or analog modulation characteristics (internal or external modulation source).
RF OUTPUT ATTEN BELOW -10 DBM switches	Adjust RF output level by switching a fixed attenuator system IN or OUT of output circuit.
RF CHANNEL NUMBER switches	Four rotating channel switches select the desired channel number. The left-most switch has positions 0 to 2 and se-

Table 3-1. Operators Controls, Metering and Connectors-Continued

Item	Function
RF LEVEL SET control	Adjusts the RF output level to the power set (calibrate) meter setting.
RF OUT connector	Provides RF signal output connection for RF cable assembly CG-3628/U.
SYNC connector	Provides external synchronization of test equipment.
EXT MOD IN connector	Input connection for external audio frequency sources for the purpose of external control of the modulation frequency.

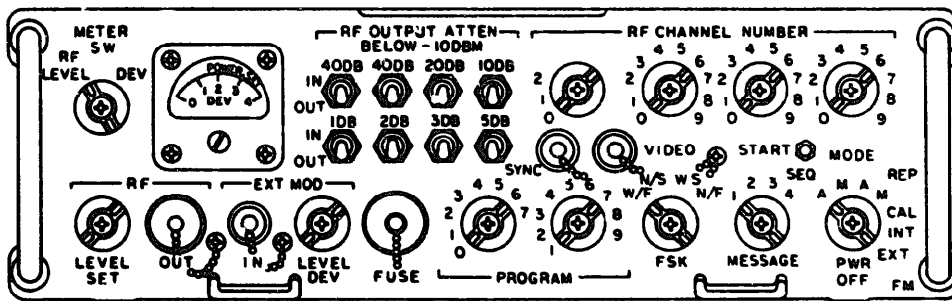

EL6625-2578-12-TM-3

Figure 3-1. Operators Controls, Metering and Connectors.

Table 3-1. Controls, Metering and Connectors--Continued

Item	Function
EXT MOD LEVEL DEV control	Adjusts audio frequency input from an external source to a level suitable for producing correct analog modulation. Also adjusts internal modulation level.
FUSE	Protects equipment from overloads. Always use 1-amp fuse when replacing.
NOTE. PROGRAM, FSK and MESSAGE switches are used in conjunction with each other to select all message structures that an RF Monitor Set AN/USQ-46 or AN/USQ-46A may receive and process.	
PROGRAM switches	Selects all message programs (1 through 71).
TSK switch	Selects analog and digital modulation characteristics of program.
MESSAGE switch	Selects message type utilized for program.
MODE switch	Selects the following test set operational modes:
PWR OFF	Disables power to the TS-2963/USQ-46.
EXT	Enables metering circuit for meter calibration when modulation is being provided by an external source.
INT	Enables metering circuit for meter calibration when mod-

Table 3-1. Operators Controls, Metering and Connectors--Continued

Item	Function
CAL	Enables metering circuit when modulation is being provided by the internal source.
REP-M	Enables metering circuit when calibrating RF output level.
REP-A	Enables generation of the selected program once each time the START switch is activated.
SEQ-A	Enables repetitive or continuous generation of the selected program when the START switch is activated.
SEQ-M	Enables sequential generation of the entire program compliment (1 through 71) with each activation of the START switch.
START switch	Enables sequential generation of the program compliment but only one program is generated for each activation of the START switch.
VIDEO connector	Activates program mode selected. Provides synchronised output signal used for signal tracing of manually programmed messages from test point to test point in the RF Monitor Set AN/USQ-46A.

Section II. OPERATION

3-2. General

a. The TS-2963/USQ-46 has four basic operating modes : REP A, REP M, SEQ A and SEQ M. The function of these modes are described in table 3-1. Any message type (1, 2, 3 or 4) and any program (1 through 71) may be selected for each of the operating modes.

b. Message types 1 and 4 correspond to short words (18 bits) which are processed and acted upon by the RF Monitor only. Types 2 and 3 correspond to long words (24 bits) which are processed and acted upon by both the RF Monitor and RF Indicator.

c. At present, all RF Monitors are wide-band receivers. Therefore, the TS-2963/USQ-46 FSK switch is always used in the W/S (wide-band slow bit-rate) or W/F (wide-band fast bit-rate) position. However, the TS-2963/USQ-46 does have the capability for testing a narrow-band RF Monitor (N/S and N/F positions of FSK switch).

3-3. Operating Procedure

a. Connect equipment as shown in figure 3-2. Perform initial checking and adjusting of equipment described in paragraph 2-6 prior to performing step b.

b. Set the AN/USQ-46 controls as follows:

CHANNEL	1045
POWER	ON
VOLUME	Maximum Clockwise
SQUELCH	Maximum Counterclockwise
DIM	Maximum Clockwise
BIT RATE	FAST

c. Set the TS-2963/USQ-46 controls as follows :

CHANNEL	1045
MODE	CAL
MESSAGE	
FSK	W/F
PROGRAM	01
METER	RF LEVEL

d. Adjust TS-2963/USQ-46 RF OUTPUT ATTEN switches and RF LEVEL SET for -90 dBm at the RF Monitor input (-80 dB of at-

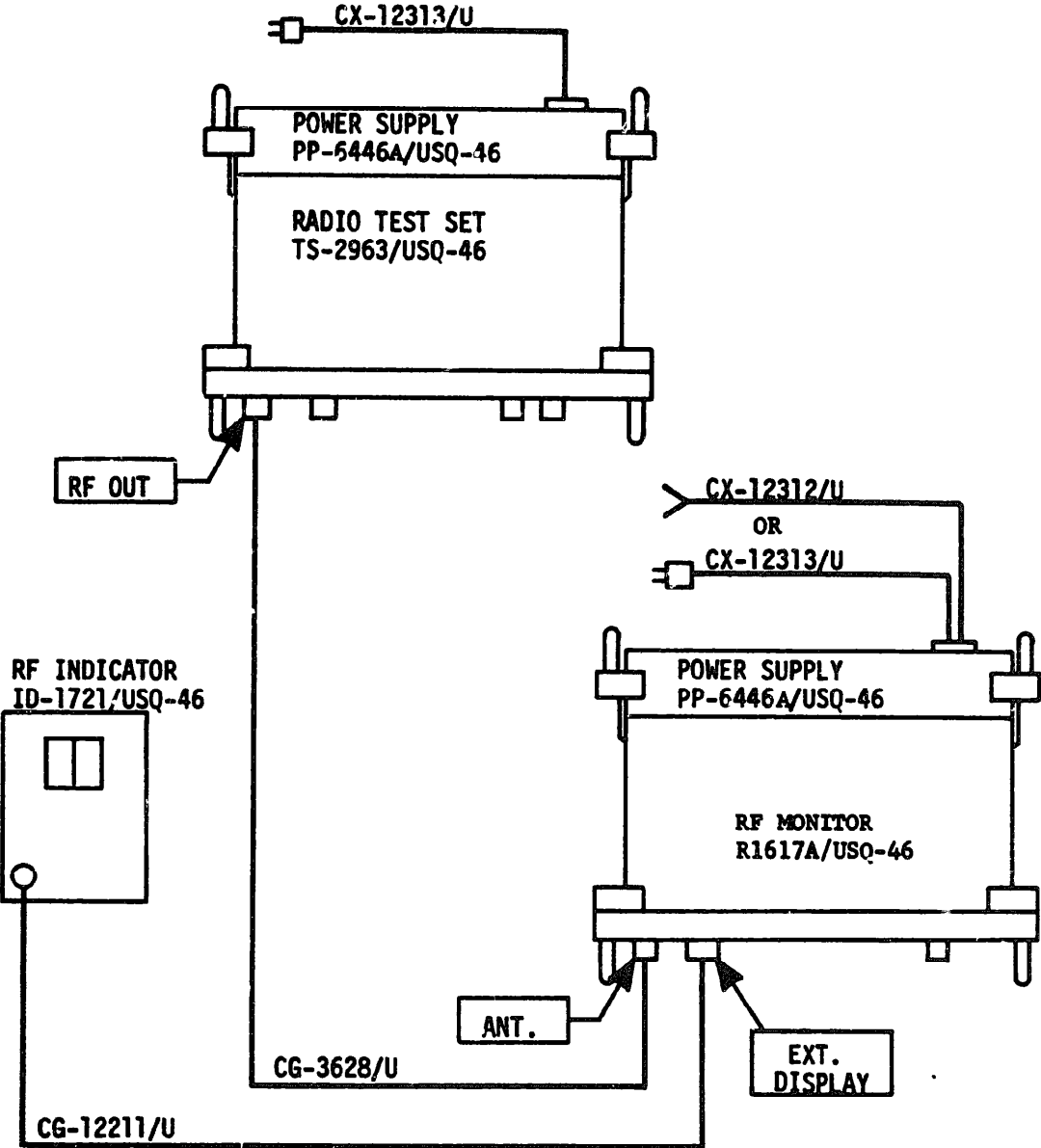

EL6625-2578-12-TM-5

Figure 3-2. Radio Test Set Group operational test setup.

tenuation switched in and meter adjusted for "POWER SET" mark).

e. Chart 3-1 lists various methods of generating message programs which are used to test an RF Monitor and an RF Indicator (ID-1731/USQ-46). Each method of chart 3-1 references a table (3-2 through 3-6) which defines the requirements of an operational RF Monitor and/or RF Indicator. The methods listed in Chart 3-1 exercise all functions of the TS-2963/USQ-46 which, in turn, exercises all functions of the RF Monitor and RF Indicator.

f. If the TS-2963/USQ-46 is being used to troubleshoot or test the RF Monitor, only those methods using message types 1 and 4 need be performed. If the RF Indicator is also being

tested, methods using message types 2 and 3 must also be performed.

g. Perform the operational tests listed in chart 3-1 and refer to tables 3-2 through 3-6 for the applicable test results.

h. The RF Monitor display results listed in tables 3-2 through 3-5 must meet an error rate of 0.4 percent or less when tested in SEQ-A mode. An error is defined as lamps lighting out of sequence or a lamp not lighting when it should. If an error is observed, the sequential display (SEQ-A mode) must be performed three more times to ensure that the error was random. If the same error is repeated or additional errors are noticed, the equipment is faulty and must be turned in for maintenance.

Chart 3-1. TS-2963/USQ-46 Operational Tests

METHOD	Mode	MESSAGE SW	FSK SW	PROGRAM SW	TEST RESULTS
1	SEQ-A	1	W/F	N/A	Table 3-2
2	SEQ-M	1	W/F	N/A	Table 3-2
3	REP-A	1	W/F	01	Table 3-2
4	REP-M	1	W/F	01	Table 3-2
5	SEQ-A	2	W/F	N/A	Table 3-3
6	SEQ-A	3	W/F	N/A	Table 3-2
7	REP-M	4	W/F	01	Table 3-6

NOTE:

(1) When MODE switch is in SEQ-A position, all programs (1 through 71) will be generated (in sequence) by pressing the START switch once. All programs will be regenerated by another press of the START switch. Each program is generated every second normally (greater than every 0.5 second, but not more than every 1.5 seconds).

(2) When MODE switch is in SEQ-M position, one program will be generated (in sequence) each time the START switch is pressed.

(3) When MODE switch is in REP-A position, the selected program (01 for example) will be generated and repeated every second normally (greater than 0.5 second but not more than every 1.5 seconds). Pressing the START switch again will stop the repeated generation of the selected program in this mode.

(4) When MODE switch is in REP-M position, the selected program (01 for example) will be generated each time the START switch is pressed.

(6) When MODE switch is in REP-M position and MESSAGE switch is position 4, a 1 kHz tone which lasts for 20 ± 2 seconds is provided after data word.

MESSAGE PROGRAM GENERATION

Table 3-2. Program Table, Message 1

Prog	RF Monitor AN/USQ-46		Indicator, RF ID-1721/USQ-46				
	Display	Audio	Msg IIA Lamp	Msg IIB Lamp	Event Count	Sensitivity	
						Real Time	Non-Real Time
1	1	Tone Burst	Off	Off	Off	Off	Off
through	through	↑	↑	↑	↑	↑	↑
9	9						
11	11						
through	through						
19	19						
21	21						
through	through						
29	29						
31	31						
through	through						
39	39						
41	41						
through	through						
49	49						
51	51						
through	through						
59	59						
61	61						
through	through						
69	69	↓	↓	↓	↓	↓	↓
71	71	Tone Burst	Off	Off	Off	Off	Off

MESSAGE PROGRAM GENERATION

Table 3-3. Program Table, Message 2

Prog	RF Monitor AN/USQ-46		Indicator, RF ID-1721/USQ-46				
	Display	Audio	Msg IIA Lamp	Msg IIB Lamp	Event Count	Sensitivity	
						Real Time	Non-Real Time
1	1	Tone Burst	On	Off	1	Off	Off
through	through	↑	↑	↑	through	↑	↑
9	9				9		
11	11				10		
through	through				through		
19	19				18		
21	21				19		
through	through				through		
29	29				27		
31	31				28		
through	through				through		
39	39				36		
41	41				37		
through	through				through		
49	49				45		
51	51				46		
through	through				through		
59	59				54		
61	61				55		
through	through				through		
69	69	↓	↓	↓	63	↓	↓
71	71	Tone Burst	On	Off	00	Off	Off

MESSAGE PROGRAM GENERATION

Table 3-4. Program Table, Message 3

Prog	RF Monitor AN/USQ-46		Indicator, RF ID-1721/USQ-46				
	Display	Audio	Mag IIA Lamp	Mag IIB Lamp	Event Count	Sensitivity	
						Real Time	Non-Real Time
1 through 9	1 through 9	Tone Burst	OFF	OFF	OFF		
11 through 19	11 through 19	↑	↑	↑	↑		
21	21					ⓐ	
22	22						
23	23					ⓐ	
24	24					ⓐ	
25	25						
26	26						
27	27					ⓑ	
28	28					ⓐ	
29	29						
31	31	Tone Burst	OFF	OFF	OFF		ⓐ
32 through 37	32 through 37	↑	↑	↑	↑		
38	38						ⓐ
39	39						
41	41						ⓐ
42	42						ⓐ
43	43						ⓐ
44	44						
45	45				OFF		ⓑ
46	46				On		ⓐ
47	47				↑		
48	48						ⓐ
49	49						
51 through 59	51 through 59	↓	↓	↓	↓		
61 through 69	61 through 69	↓	↓	↓	↓		
71	71	Tone Burst	OFF	On	OFF		

Note Circle with number in Real and Non-Real Time columns represent actual visual indication displayed on screen of RF Indicator

MESSAGE PROGRAM GENERATION

Table 3-5. Program Table, Message 4

Prog	RF Monitor AN/USQ-46		Indicator, RF ID-1721/USQ-46				
	Display	Audio	Mag IIA Lamp	Mag IIB Lamp	Event Count	Sensitivity	
						Real Time	Non-Real Time
1	1	Tone	Off	Off	Off	Off	Off
through	through	Burst	↑	↑	↑	↑	↑
9	9	20 ± 2 sec ana- log Mod- ulation in REP-M Mode only	↑	↑	↑	↑	↑
11	11						
through	through						
19	19						
21	21						
through	through						
29	29						
31	31						
through	through						
39	39						
41	41	↓	↓	↓	↓	↓	
through	through						
49	49						
51	51						
through	through						
59	59						
61	61						
through	through						
69	69						
71	71						

3-4. Shutdown Procedure

To shutdown the TS-2963/USQ-46 turn MODE switch to PWR OFF position.

CHAPTER 4

OPERATOR MAINTENANCE INSTRUCTIONS

Section I. GENERAL REQUIREMENTS

4-1. Scope of Operators Maintenance

Operator maintenance of the Radio Test Set Group is limited to the tasks listed below. If a repair requires corrective actions exceeding the extent of the listed tasks, replace the equipment with a shelf spare and route the defective equipment to the next higher maintenance category for further action.

a. Preventive maintenance (refer to paragraph 4-3).

- b. Cleaning (refer to paragraph 44).
- c. Troubleshooting (refer to paragraph 4-7).

4-2. Tools, Materials and Test Equipment Required

No test equipment or special tools are required to perform operator maintenance of the Radio Test Set Group. A lint free cloth (FSN 8305-170-5062) is needed for cleaning operations.

Section II. PREVENTATIVE MAINTENANCE

4-3. Operator Preventive Maintenance checks and Service Periods

Preventive maintenance checks and services of the equipment are required daily and weekly.

Paragraphs 4-4 and 4-5 specify the items to be inspected and serviced. If the equipment is being maintained in a standby condition, the daily (para 4-4) and weekly (para 4-5) checks and services should be accomplished at the same time.

4-4. Daily Preventive Maintenance Checks and Services

Sequence No.	Items to be checked or serviced	Inspection	Reference
1	Radio Test Set Group OQ-60/USQ-46	Check for completeness	Chapter 1.
2	TS-2963/USQ-46 and PP-6446A/USQ-46	Check that the equipment is clean, dry and free of grease or dirt.	Paragraph 4-6.
3	TS-2963/USQ-46 Controls	a. Check to see that controls work smoothly, are tight on their shafts, and do not bind. b. Check that meter is not cracked or that meter pointer is not bent and sticking.	a. Report to higher category of maintenance. b. Report to higher category of maintenance.

4-5. Weekly Preventative Maintenance Checks and Service

Sequence No.	Items to be checked or serviced	Inspection	Reference
1	RF Cable Assembly CG-3628/U and AC Power Cable Assembly CX-12313/U.	Inspect cable for chafed, cracked or frayed insulation.	Report to higher category of maintenance.
2	Radio Test Set Group OQ-60/USQ-46.	Check for bent or damaged connector pins. Check for bent connector shells.	Report to higher category of maintenance.

4-6. Cleaning

Inspect the exterior and interior surfaces of the Radio Test Set Group OQ-60/USQ-46. The exterior surfaces should be free of dust, dirt, grease, and fungus.

a. Remove dust and loose dirt with a clean, soft cloth (FSN 8305-170-5062).

WARNING

Prolonged breathing of cleaning compound is dangerous; make sure adequate ventilation is provided. Cleaning compound is flammable; Do not use near a flame. Avoid contact with the skin; wash off any that spills on the hands.

b. Remove grease, fungus, and ground-in dirt from the exterior of the Radio Test Set Group OQ-60/USQ-46, Use a damp cloth (not wet) with cleaning compound (FSN 7930-395-9542). If dirt is difficult to remove, use mild soap if necessary.

c. Remove dust or dirt from the jack and plugs with a brush.

4-7. General Troubleshooting Information

Troubleshooting the equipment is based on per-

forming the initial checkout and the operational test procedures contained in chapters 2 and 3. To troubleshoot the equipment, perform all functions of the initial checkout and operational test procedures until an abnormal condition is observed. When an abnormal condition is observed, refer to the troubleshooting chart (pars 4-8) and perform the corrective measures indicated. If the corrective measures indicated do not result in correction of the trouble, higher category maintenance is required

4-8. Operator Troubleshooting

a. If the equipment fails to operate properly, turn TS-2963/USQ-46 MODE switch to OFF and check the following items:

(1) TS-2963/USQ-46 fuse on front panel (fig. 3-1) or PP-6446A/USQ-46 fuses (fig. 4-1).

(2) Input power cable CX-12313/U for loose connection, broken or bent pins.

(3) PP-6446A/USQ input power connector (2A3J1) or output power connector (2J2) for broken or bent pins (fig. 4-1).

b. If the checks in a above do not locate the trouble, a higher category of maintenance is required.

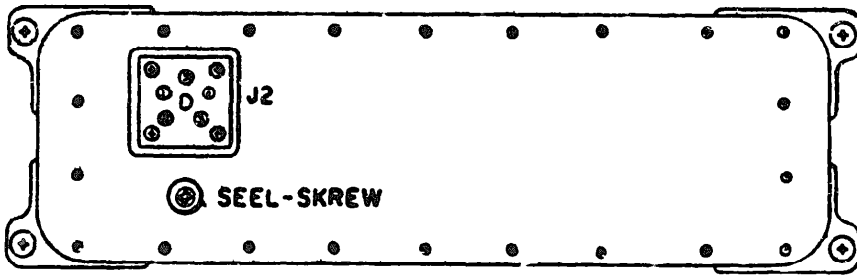
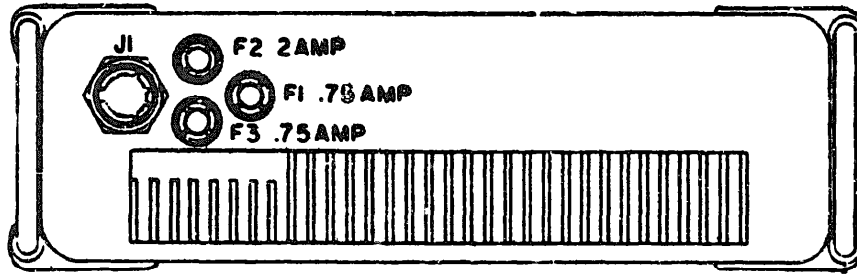

EL6625-2578-12-TM-6

Figure 4-1. Power Supply PP-6446A/USQ-46 External Component Locations.

CHAPTER 5

ORGANIZATIONAL MAINTENANCE INSTRUCTIONS

Section I. GENERAL

5-1. Scope of Organizational Maintenance

Paragraphs 6-2 through 5-8 cover organizational maintenance of the Radio Test Set Group OQ-60/USQ-46, including instructions for performing preventive maintenance accomplished by the organizational repairman.

5-2. Tools, Materials, and Test Equipment Required

a. A small screwdriver (FSN 5120-277-9491) is required to tighten knobs.

b. The following materials are required:

- (1) Cleaning compound (FSN 1930-395-9642).
- (2) Cleaning cloth (FSN 8305-170-5062).
- (3) Fine sandpaper.

c. The maintenance duties assigned to the organizational maintenance man do not require any test equipment.

Section II. PREVENTIVE MAINTENANCE

5-3. General

a. Preventive maintenance is the systematic care, inspection, and servicing of the equipment to maintain it in serviceable condition, prevent breakdowns, and assure maximum operational capability of all categories of maintenance concerned with the equipment and includes the inspection, testing, and repair that inspection and tests indicate would probably fail before the next scheduled periodic service. Preventive maintenance checks and services of the equipment at organizational maintenance are made at quarterly intervals unless otherwise directed by the commanding officer.

b. Maintenance forms and records to be used and maintained on the equipment are specified in TM 38-750.

5-4. Quarterly Preventive Maintenance

Quarterly preventive maintenance on the equip-

ment will be scheduled in accordance with the requirements of TM 33-760. All deficiencies or shortcomings will be recorded, and those not corrected during the inspection and service will be immediately reported to higher maintenance categories by forms and procedures specified in TM 38-750. Equipment deficiency that cannot be corrected by organizational maintenance should be deadlined in accordance with TM 38-750. Perform all the services listed in table 5-1 in the sequence listed. Whenever a normal condition or result is not observed, take corrective action in accordance with the paragraph or manual listed under the "References" column.

5-5. Operator Quarterly Preventive Maintenance Checks and Services

The operator performs the functions listed in table 5-1 on a quarterly schedule.

Table 5-1. Quarterly Preventive Maintenance Checks and Services

Sequence No.	Item to be Inspected	Procedure	References
1	Publications	<p>a. Insure all publications are complete and in usable condition.</p> <p>b. Insure all changes pertinent to the equipment are on hand.</p>	<p>a. App A.</p> <p>b. DA Pam 310-4.</p>

Table 5-1. Quarterly Preventive Maintenance Checks and Services-Continued

Sequence No.	Item to be Inspected	Procedure	References
2	Modification work orders ...	Check to see that all URGENT MWO's have been applied to the equipment and that all NORMAL MWO's have been scheduled.	DA Pam 310-7.
3	Operation	Perform the operational checks in chapter 3.	Chapter 3.
4	Housing surfaces	Clean and repaint visibly damaged surfaces as necessary.	Paragraph 5-7.

5-6. Repainting and Refinishing

If bare spots or corroded areas are present on the case, clean areas with materials listed in paragraph 5-2a and repaint or refinish in accordance with TB 746-10. Refer to SB 11-573 for information regarding paint to be used.

CAUTION

Use care to prevent paint from reaching connectors and connector threads.

5-7. Equipment Performance Check

a. General. The equipment performance check contains the required information to determine if the equipment is in working condition. If the corrective action listed does not repair the equip-

ment, troubleshooting by a higher category of maintenance is required. Record how the equipment performs on the appropriate form and what corrective measures were taken, as required by TM 38-750.

b. Procedure. Check the performance of the equipment by performing operator troubleshooting steps described in chapter 4.

5-8. Replacement of Parts

Parts replacement at the organizational maintenance level is limited to the replacement of fuses in the TS-2963/USQ-46 and PP-6446A/USQ-46 or replacement of major items such as the power supply, radio test set, and cable assemblies.

CHAPTER 6

SHIPMENT AND LIMITED STORAGE AND DEMOLITION TO PREVENT ENEMY USE

Section I. SHIPMENT AND LIMITED STORAGE

6-1. (U) Disassembly of Equipment

a. Disconnect the RF cable assembly CG-3628/U by reversing the installation instructions of Paragraph 2-4.

b. Disconnect the electrical, Power Cable assembly CX-12313/U by reversing the installation instructions of paragraph 2-5.

c. Remove the Power Supply PP-6446A/USQ-46 by reversing the installation instructions of Paragraph 2-3.

6-2. Repackaging for Shipment

Repackaging of the Radio Test Set Group for shipment or limited storage is normally performed at a packaging facility or by a repackaging team. If emergency packaging is required, select the materials from those listed in SB 38-100. Package the equipment in accordance with the original packaging (refer to paragraph 2-1) as nearly as possible, using available materials.

Section II. DEMOLITION OF MATERIEL TO PREVENT ENEMY USE

6-3. Authority for Demolition

Demolition of the equipment will be accomplished only upon the order of the commander. Use the destruction procedures in TM 750-244-2 to prevent further use of the equipment.

6-4. Priorities for Destruction

The following order of priority should be followed for demolition of equipment.

- a. Test Set, Radio _____ TS-2963/USQ-46
- b. Power Supply _____ PP-6446A/USQ-46
- c. Cable Assembly, RF _____ CG-3628/U
- d. Cable Assembly, Electrical,
Power _____ CX-12313/U

APPENDIX A

REFERENCES

Following is a list of applicable references available to the operator and organizational repairman of Radio Test Set Group OQ-60/USQ-46:

DA Pam 310-4	Index of Technical Manuals, Technical Bulletins, Supply Manuals (types 7, 8, and 9), Supply Bulletins, and Lubrication Orders.
DA Pam 310-7	U. S. Army Equipment Index of Modification Work Orders.
SB 11-578	Painting and Preservation Supplies Available for Field Use for Electronics Command Equipment.
SB 38-100	Preservation, Packaging and Packing Materials, Supplies, and Equipment Used by the Army.
TB 746-10	Field Instructions for Painting and Preserving Electronics Command Equipment.
TM 38-750	The Army Maintenance Management System (TAMMS).
TM 750-244-2	Procedures For Destruction of Electronics Materiel to Prevent Enemy Use (Electronics Command).

APPENDIX B

MAINTENANCE ALLOCATION

Section I. INTRODUCTION

B-1. General

This appendix provides a summary of the maintenance operations covered in the equipment literature. It authorizes categories of maintenance for specific maintenance functions on reparable items and components and the tools and equipment required to perform each function. This appendix may be used as an aid in planning maintenance operations.

B-2. Maintenance Functions

Maintenance functions will be limited to and defined as follows :

a. Inspect. To determine serviceability of an item by comparing its physical, mechanical, and electrical characteristics with established standards.

b. Test. To verify serviceability and to detect incipient electrical or mechanical failure by use of special equipment such as gages, meters, etc. This is accomplished with external test equipment and does not include operation of the equipment and operator type tests using internal meters or indicating devices.

c. Service. To clean, to preserve, to charge, and to add fuel, lubricants, cooling agents, and air. If it is desired that elements, such as painting and lubricating, be defined separately, they may be listed.

d. Adjust. To rectify to the extent necessary to bring into proper operating range.

e. **Align.** To adjust two or more components or assemblies of an electrical or mechanical system so that their functions are properly synchronized. **This does not include setting** the frequency control knob of radio receivers or transmitters to the desired frequency.

f. **Calibrate.** To determine the corrections to be made in the readings of instruments or test

equipment used in precise measurement. Consists of the comparison of two instruments, one of which is a certified standard of known accuracy, to detect and adjust any discrepancy in the accuracy of the instrument being compared with the certified standard.

g. Install. To set up for use in an operational environment such as an encampment, site, or vehicle.

h. Replace. To replace unserviceable items with serviceable like items.

i. Repair. To restore an item to serviceable condition through correction of a specific failure or unserviceable condition. This function includes, but is not limited to welding, grinding, riveting, straightening, and replacement of parts other than the trial and error replacement of running spare type items such as fuses, lamps, or electron tubes.

j. Overhaul. Normally, the highest degree of maintenance performed by the Army in order to minimize timework in process, is consistent with quality and economy of operation. It consists of that maintenance necessary to restore an item to completely serviceable condition as prescribed by maintenance standards in technical publications for each item of equipment. Overhaul normally does not return an item to like new, zero mileage, or zero hour condition.

k. Rebuild. The highest degree of materiel maintenance. It consists of restoring equipment as nearly as possible to new condition in accordance with original manufacturing standards. Rebuild is performed only when required by operational considerations or other paramount factors and then only at the depot maintenance category. Rebuild reduces to zero the hours or miles the equipment, or component thereof, has been in use.

l. Symbols. The uppercase letter placed in the

appropriate column indicates the lowest level at which that particular maintenance function is to be performed.

B-3. Explanation of Format

a. Column 1, group number. Column 1 lists group numbers, the purpose of which is to identify components, assemblies, subassemblies and modules with the next higher assembly.

b. Column 2, functional group. Column 2 lists the noun names of components, assemblies, subassemblies and modules on which maintenance is authorized.

c. Column 3, maintenance functions. Column 3 lists the maintenance category at which performance of the specific maintenance function is authorized. Authorization to perform a function at any category also includes authorization to perform that function at higher categories. The codes used represent the various maintenance categories as follows:

Code	Maintenance Category
C - - - - -	Operator/Crew
O - - - - -	Organizational Maintenance
F - - - - -	Direct Support Maintenance
H - - - - -	General Support Maintenance
D - - - - -	Depot Maintenance

d. Column 4, tools and test equipment. Column 4 specifies, by code, those tools and test equipment

required to perform the designated function. The numbers appearing in this column refer to specific tools and test equipment which are identified in table I.

e. Column 5, Remarks. Self-explanatory.

B-4. Explanation of Format of Table 1, Tool and Test Equipment Requirements

The columns in Table I, Tool and Test Equipment Requirements are as follows:

a. Tools and Equipment. The numbers in this column coincide with the numbers used in the tools and equipment column of the Maintenance Allocation Chart. The numbers indicate the applicable tool for the maintenance function.

b. Maintenance Category. The codes in this column indicate the, maintenance category normally allocated the facility.

c. Nomenclature. This column lists tools, test, and maintenance equipment required to perform the maintenance functions.

d. Federal Stock Number. This column lists the Federal stock number of the specific tool or test equipment.

e. Tool Number. Not used.

SECTION II MAINTENANCE ALLOCATION CHART

GROUP NUMBER	COMPONENT ASSEMBLY NOMENCLATURE	MAINTENANCE FUNCTIONS										TOOLS AND EQUIPMENT	REMARKS						
		INSPECT	TEST	SERVICE	ADJUST	ALIGN	CALIBRATE	INSTALL	REPLACE	REPAIR	OVERHAUL			REBUILD					
1A1	TEST SET GROUP, RADIO OQ-60/USQ-46	C	C					C	C							Visual Inspection Operation Test			
			F	F						F						1,3,4,6,8,10,11,13,14,21,23,26,35,37,40	Repair by replacement of modules. Note 1,3,5.		
				H		H	H										1,3,4,5,6,8,10,11,13,14,21,23,26,35,37,40,60,61,62	Note 1,3,5.	
				D		D	D					D	D				1 thru 62	Note 1,2,3,4,5.	
		TEST SET, RADIO TS-2963/USQ-46	C						C	C									
				F	F						F							1,3,4,6,8,10,11,13,14,21,23,26,35,37,40,45	Repair by replacement of modules. Note 1,3,5.
				H		H	H											1,3,4,5,6,8,10,11,13,14,21,22,23,35,37,40,60,61,62	Note 1,3,5.
			D		D	D						D	D				1 thru 62	Note 1,2,3,4,5.	
	FRONT PANEL MODULE ASSEMBLY	F	F					F	F									1,3,4,6,8,10,13,21,23,35,37,40	Repair by replacement of modules.
				H						H								1,3,4,5,6,10,14,35	

MAINTENANCE ALLOCATION CHART

GROUP NUMBER	COMPONENT ASSEMBLY NOMENCLATURE	MAINTENANCE FUNCTIONS											TOOLS AND EQUIPMENT	REMARKS		
		INSPECT	TEST	SERVICE	ADJUST	ALIGN	CALIBRATE	INSTALL	REPLACE	REPAIR	OVERHAUL	REBUILD				
1A1A1	VCKO MODULE	F						F	F						35	Visual
	VCKO CIRCUIT CARD		F												1,8,13,14,35	Go No Go utilizing test PTS on module. Note 1,3,5.
1A1A2	DETECTOR-OUTPUT MODULE		D		D										1,3,8,9,10,13,21,26,35,36,42	Depot facilities
		D													35	
		D		D			D	D	D						1,3,6,8,9,10,13,21,26,35,36,42	
	F		F												35	Visual
DETECTOR-OUTPUT CIRCUIT CARD			F												1,8,13,14	Go No Go utilizing test PTS on module. Note 1,3,5.
		H		H	H		H	H							1,3,4,5,6,10,14,26,33,35	Replacement of module. Requires align of set. Note 1,3,5.
		D		D	D					D					1,3,8,10(2req) 15 thru 18,20, 21,25,25(2req) 35,36,41	Note 2.
	D	D		D	D		D	D	D						1,3,8,10(2req) 15 thru 18,20, 21,25,26(2req) 35,36	Note 2.

MAINTENANCE ALLOCATION CHART

GROUP NUMBER	COMPONENT ASSEMBLY NOMENCLATURE	MAINTENANCE FUNCTIONS										TOOLS AND EQUIPMENT	REMARKS	
		INSPECT	TEST	SERVICE	ADJUST	ALIGN	CALIBRATE	INSTALL	REPLACE	REPAIR	OVERHAUL			REBUILD
1A1A3	LOOP FILTER/VCO MODULE	F	F					F	F				35	Visual
			D		D	D					D		1,8,13,14,35	Go No Go utilizing test PTS on module. Note 1,3,5.
	LOOP FILTER/VCO CIRCUIT		D		D	D		D	D	D			1,7,9(2 req), 10(4 req),13, 20,21,35,36	Note 2.
1A1A4	SYNTHESIZER/MIXER MODULE	F	F					F	F				35	Visual
			D		D						D		1,8,13,14,35	Go No Go utilizing test PTS on module. Note 1,3,5.
	SYNTHESIZER/MIXER CIRCUIT CARD		D		D			D	D	D			1,8,10,15(2 req),16thru18, 26,35,36	Note 4.
1A1A5	PROGRAMMABLE DIVIDER MODULE	F	F					F	F				35	Visual
			D								D		1,8,10,15(2 req),16thru18, 26,35,36	Note 4.
	PROGRAMMABLE DIVIDER CIRCUIT CARD		D					D	D	D			1,8,10,19,22, 35,36,42,48	Note 2.
			D					D	D	D			1,8,10,19,22, 35,36,42,48	Note 2.

MAINTENANCE ALLOCATION CHART

GROUP NUMBER	COMPONENT ASSEMBLY NOMENCLATURE	MAINTENANCE FUNCTIONS										TOOLS AND EQUIPMENT	REMARKS		
		INSPECT	TEST	SERVICE	ADJUST	ALIGN	CALIBRATE	INSTALL	REPLACE	REPAIR	OVERHAUL			REBUILD	
1A1A6	MODE CONTROL I MODULE	F						F	F					35	Visual
			F											1,8,13,14,35	Go No Go utilizing test PTS on module. Note 1,3,5.
	MODE CONTROL I CIRCUIT CARD		D								D			8,35,36,39	Note 5.
1A1A7	RF AMPLIFIER/MIXER MODULE	D	D					D	D	D				8,35,36,39	Note 5.
		F												35	Visual
			F											1,3,8,14	Go No Go utilizing test PTS on module. Note 1,3,5.
			H		H	H		H	H					1,3,4,5,6,10,14,33,35	Replacement of module requires align of set. Note 1,3,5.
			D		D	D					D			1,3,8,10,14 thru 19,21,26 (2 req), 33,35	Depot facilities
	RF AMPLIFIER/MIXER CIRCUIT CARD	D	D		D	D		D	D	D				1,3,8,10,14 thru 19,21,23,26 (2 req), 35	
1A1A8	MODE CONTROL II MODULE	F												35	Visual
			F					F	F					1,8,13,14,35	Go No Go utilizing test PTS on module. Note 1,3,5.
			D								D			8,35,36,39	Note 5.

MAINTENANCE ALLOCATION CHART

GROUP NUMBER	COMPONENT ASSEMBLY NOMENCLATURE	MAINTENANCE FUNCTIONS										TOOLS AND EQUIPMENT	REMARKS	
		INSPECT	TEST	SERVICE	ADJUST	ALIGN	CALIBRATE	INSTALL	REPLACE	REPAIR	OVERHAUL			REBUILD
1A1A8 (continued)	MODE CONTROL II CIRCUIT CARD	D						D	D	D			35	
			D										8,35,36,39	Note 5
1A1A9	WORD LENGTH GENERATOR MODULE	F											35	Visual
			F					F	F				1,8,13,14,35	Go No Go utilizing test PTS on module. Note 1,3,5
	WORD LENGTH GENERATOR CIRCUIT CARD		D										8,35,36,37,39	Note 5
		D	D					D	D	D			8,35,36,37,39	Note 5
1A1A10	REFERENCE GENERATOR MODULE	F											35	Visual
			F					F	F				1,8,13,14,35	Go No Go utilizing test PTS on module. Note 1,3,5
			D		D								1,3,8,10(3req) 14 thru 19, 28,35,36,41, 47	Note 2
	REFERENCE GENERATOR CIRCUIT CARD	D	D		D			D	D	D			1,3,8,10(3req) 14 thru 19, 28,35,36,41, 47	Note 2
1A1A11	MODE CONTROL III MODULE	F											35	Visual
			F					F	F				1,8,13,14,35	Go No Go utilizing test PTS on module. Note 1,3,5.
			D										8,35,36,39	Note 5

MAINTENANCE ALLOCATION CHART

GROUP NUMBER	COMPONENT ASSEMBLY NOMENCLATURE	MAINTENANCE FUNCTIONS										TOOLS AND EQUIPMENT	REMARKS	
		INSPECT	TEST	SERVICE	ADJUST	ALIGN	CALIBRATE	INSTALL	REPLACE	REPAIR	OVERHAUL			REBUILD
1A1A11 (continued)	MODE CONTROL III CIRCUIT CARD	D	D					D	D	D			8,35,36,39	Note 5
1A1A12	ENCODER I MODULE	F											35	Visual
			F				F	F					1,8,13,14,35	Go No Go utilizing test PTS on module. Note 1,3,5.
			D							D			8,35,36,39	Note 3 & 5
	ENCODER I CIRCUIT CARD	D	D				D	D	D				8,35,36,39	Note 3 & 5
1A1A13	ENCODING MATRIX MODULE	F											35	Visual
			F				F	F					1,8,13,14,35	Go No Go utilizing test PTS on module. Note 1,3,5.
			D							D			35,36,37	Note 1,3,5.
	ENCODING MATRIX CIRCUIT CARD	D	D				D	D	D				35,36,37	Note 1,3,5.
1A1A14	ENCODER II MODULE	F											35	Visual
			F				F	F					1,8,13,14,35	Go No Go utilizing test PTS on module. Note 1,3,5.
			D							D			8,35,36,39	Note 1,3,5.
	ENCODER II CIRCUIT CARD	D	D				D	D	D				8,35,36,39	Note 1,3,5.
1A1A15	SHIFT REGISTER MODULE	F											35	Visual
			F				F	F					1,8,13,14,35	Go No Go utilizing test PTS on module. Note 1,3,5.

TM 11-6625-2578-12
MAINTENANCE ALLOCATION CHART

GROUP NUMBER	COMPONENT ASSEMBLY NOMENCLATURE	MAINTENANCE FUNCTIONS										TOOLS AND EQUIPMENT	REMARKS	
		INSPECT	TEST	SERVICE	ADJUST	ALIGN	CALIBRATE	INSTALL	REPLACE	REPAIR	OVERHAUL			REBUILD
1A1A15	SHIFT REGISTER MODULE (continued)		D								D		8,35,36,39	Note 5.
	SHIFT REGISTER CIRCUIT CARD	D	D					D	D	D			8,35,36,39	Note 5.
1A1A16	TEMPERATURE COMPENSATED CRYSTAL OSCILLATOR	F											35	Visual
			F					F	F				1,8,13,14,35	Go No Go utilizing test leads on module. Note 1,3,5.
			D		D						D		1,8,10,23,28,35	Repair by adjusting
1A1A17	POWER SUPPLY/REGISTER	F											35	Visual
			F					F	F				1,8,10,13,14,21,35	Go No Go utilizing terminals on card in system.
			D								D		8,10,21,35,44,45,46	Depot facilities
1A1A18	FRONT PANEL SUBASSEMBLY	F	F								F		1,8,13,14,23,35	Repair limited to replacing switches, connectors, knobs, fuseholder, gasket, cable assembly.
			H		H	H					H		1,3,4,5,6,10,14,35	Repair by replacement of above plus attenuators, meter resistors. Replacement of attenuators, meter, variable resistors require alignment of set. Note 3 & 5.
1A1TB1	TERMINAL BOARD	F											35	Visual
			F					F	F	F			7,23,37,40	Repair by connecting broken wires. Note 3 & 5.

MAINTENANCE ALLOCATION CHART

GROUP NUMBER	COMPONENT ASSEMBLY NOMENCLATURE	MAINTENANCE FUNCTIONS										TOOLS AND EQUIPMENT	REMARKS	
		INSPECT	TEST	SERVICE	ADJUST	ALIGN	CALIBRATE	INSTALL	REPLACE	REPAIR	OVERHAUL			REBUILD
1A1TB2	TERMINAL BOARD	F						F	F	F			35	Visual
			F					F	F	F			7,23,37,40	Repair by connecting broken wires and replacement resistors. Note 3 & 5.
1A1TB3	TERMINAL BOARD	F						F	F	F			35	Visual
			F					F	F	F			7,23,37,40	Repair by connecting broken wires and replacement resistors. Note 3 & 5.
1A2	CENTER HOUSING	F								F			35	Visual
			F							F			23,35,37	Repair by replacing connectors, seals, etc. Note 5.
1W1	RADIO FREQUENCY CABLE ASSEMBLY CG-3628/U	F	F										23	Visual
			H		H			H	H	H			1,3,4,5,6,7,10,14,23,35	Replacement requires calibration of equipment. Note 3 & 5.
2	POWER SUPPLY PP-6446A/USQ-46	O	O					O	O	O			23	Operational test
			F							F			23,35	Replace connector 2J2 and cover gasket.
			H							H			8,10,11,12,21,23,24,35	Replace transformer T1, choke L1, capacitor C1 & C2 and repair component plate assembly.
			D										8,10,11,12,21,23,24,30,31,32,35,50 thru 59	

TM 11-6625-2578-12
 MAINTENANCE ALLOCATION CHART

GROUP NUMBER	COMPONENT ASSEMBLY NOMENCLATURE	MAINTENANCE FUNCTIONS										TOOLS AND EQUIPMENT	REMARKS		
		INSPECT	TEST	SERVICE	ADJUST	ALIGN	CALIBRATE	INSTALL	REPLACE	REPAIR	OVERHAUL			REBUILD	
247	ELECTRICAL POWER CABLE ASSEMBLY CX-12313/U	F							F	F	F			23,35	Visual Repair by replacing connector.

Nomenclature of End Item or Component

SECTION III - TOOL AND TEST EQUIPMENT REQUIREMENTS

Tool or Test Equipment Reference Code	Maintenance Category	Nomenclature	FSN	Tool Number
1	F,H,D	Digital Readout Electronic Counter AN/USM-207	6625-911-6368	
2	D	Signal Generator Marconi TF-2006*	NSN	
3	F,H,D	Electronic Voltmeter AN/URM-145	6625-973-3986	
4	H,D	Precision Attenuator, Stoddard 905B-40&60*	NSN	
5	H,D	Signal Generator AN/URM-70	6625-519-2104	
6	F,H,D	RMS Voltmeter ME-318/U*		
7	D	Test Oscillator SG-770/U	6625-073-7416	
8	F,H,D	Oscilloscope AN/USM-281A	6625-228-2201	
9	D	Pulse Generator, Data Pulse 110B*	NSN	2 Req
10	F,H,D	Power Supply PP-3940/G	6130-985-8136	4 Req at Depot 1 Req at F,H
11	F,H,D	Ammeter ME-65A/U	6625-985-5251	
12	H,D	Variable Power Transformer CN-16/U	5950-235-2086	
13	F,H,D	Electrical Dummy Load DA-265/U	5985-069-8820	
14	F,H,D	Spectrum Analyzer AN/UFM-84	6625-557-8262	
15	D	Signal Generator AN/USM-44A	6625-669-4031	2 Req
16	D	Sweep Generator AN/USM-203	6625-086-7165	
17	D	Variable Attenuator CN-796/U	5985-087-2547	
18	D	Detector DT-307/G	6625-876-3106	

Nomenclature of End Item or Component

SECTION III - TOOL AND TEST EQUIPMENT REQUIREMENTS

Tool or Test Equipment Reference Code	Maintenance Category	Nomenclature	FSN	Tool Number
19	D	Signal Generator SG-479/G	6625-819-0472	
20	H,D	Signal Generator SG-321/U	6625-674-7097	
21	F,H,D	Digital Voltmeter AN/GSM-64	6625-870-2264	
22	D	Signal Generator SG-299/U	6625-808-5584	
23	O,F,H,D	Multimeter TS-352B/U	6625-242-5023	
24	D	Decade Resistor ZM-16/U	6625-669-0266	
25	D	VSWR, Kit, Telonic TRK-1	6625-939-5473	
26	F,H,D	Signal Generator AN/USM-264	6625-935-4214	
27	D	100K Ohm Resistor RC07GF104J	5905-686-3129	2 Req
28	D	1 K Ohm Resistor RC05GF102J	5905-923-3534	2 Req
29	D	51 Ohm Resistor RC05GF510J	5905-683-7720	2 Req
30	D	Air Pressure Valve 0-3 lbs Whitey 1GSL4*	NSN	2 Req
31	D	Manometer Marion Inst Co.	6685-242-8420	
32	D	Adapter Resdel P/N 82231*	NSN	
33	D	Signal Generator, Marconi TF 2006*	NSN	
34	D	Tee, Union 400-3*	NSN	
35	F,H,D	Electronic Equipment Tool Kit TK-100/G	5180-605-0079	

Nomenclature of End Item or Component

TM 11-6625-2578-12

SECTION III - TOOL AND TEST EQUIPMENT REQUIREMENTS

Tool or Test Equipment Reference Code	Maintenance Category	Nomenclature	FSN	Tool Number
36	D	Printed Wiring Repair Kit MK-772/U	6625-912-0429	Fabrication instructions contained in TM
37	F,H,D	Power Extender Cable		
38	D	Resistor 3.5K Ohm, RWU352SP (Same as 1A1A8R2)		
39	D	Special Cable Assembly with Breadboard		
40	F,H,D	Head Set H-251	5965-043-3460	
41	D	2K Ohm Resistor RC05GF202J	5905-917-5524	
42	D	10K Ohm Resistor RC05GF103J	5905-922-7215	
43	D	10K Ohm Resistor Variable RWU-1031SP	5905-974-6388	
44	D	470 Ohm Resistor RC05GF471J	5905-792-4107	
45	D	62 Ohm Resistor RC05GF620J	5905-897-2164	
46	D	100 Ohm Resistor RC05GF101J	5905-948-2596	
47	D	0.01 uf Capacitor CK06BK103K	5910-847-7288	
48	D	0.47 uf Capacitor CP09AKB474K3	5910-688-2825	
49	D	150 pf Capacitor CM04ED151J		
50	D	50 Ohm 10% 25W Resistor	5905-539-4581	
51	D	175 Ohm 10% 25W Resistor	5905-198-5272	
52	D	25 Ohm 10% 225W Resistor	5905-195-2471	

SECTION III - TOOL AND TEST EQUIPMENT REQUIREMENTS

Tool or Test Equipment Reference Code	Maintenance Category	Nomenclature	FSN	Tool Number
53	D	125 Ohm 10% 50W	5905-193-2078	
54	D	15 Ohm 10% 25W Resistor	5905-192-1089	
55	D	Shutoff Valve Whitney No. 1RS4*	NSN	2 Req
56	D	Check Valve Napro No. 4C	NSN	
57	D	Vacuum Pump Neptune (DYNA) No. 4-K*	NSN	
58	D	Surge Tank Return Will No. 934 GROSS*	NSN	
59	B	Orifice Resdel Part No. 82232*	NSN	
60	H,D	Spectrum Analyser and Display HP-141S*	6625-450-7631	
61	H,D	Dual Trace Amplifier HP-1405A*	6625-937-3610	
62	H,D	Time Base HP-1422A*	6625-489-1299	
		* OR EQUIVALENT		

SECTION IV - REMARKS

Reference Code	Remarks
NOTES:	
1	Requires use of OD-45/USQ-46
2	Requires piece part selection
3	Requires use of AN/USQ-46
4	Requires Modules 1A1A10 and 1A1A16
5	Requires use of OQ-60/USQ-46

By Order of the Secretary of the Army:

CREIGHTON W. ABRAMS
General, *United States Army*
Chief of Staff

Official:

VERNE L. BOWERS
Major General, United States Army
The Adjutant General

Distribution:

Active Army:

USASA (1)
CofSptS (1)
ACSC-E (2)
USAMB (10)
AMC (1)
TECOM (3)
USARPAC (5)
1st LOGCOMD (5)
USACDC (10)
USACDCCEA (1)
USACDCCEA (Ft Huachuca) (1)

USARV (5)
Eighth USA (10)
SAAD (10)
TOAD (10)
Gen Dep (5)
Sig Sec, Gen Dep (8)
Sig Dep (12)
USAMERDC (2)
USAERDAA (2)
USAERDAW (2)
Sig FLDMS (2)

ARNG & USAR: None.

For explanation of abbreviations used, see AR 310-50.

END

8-1-83

DATE



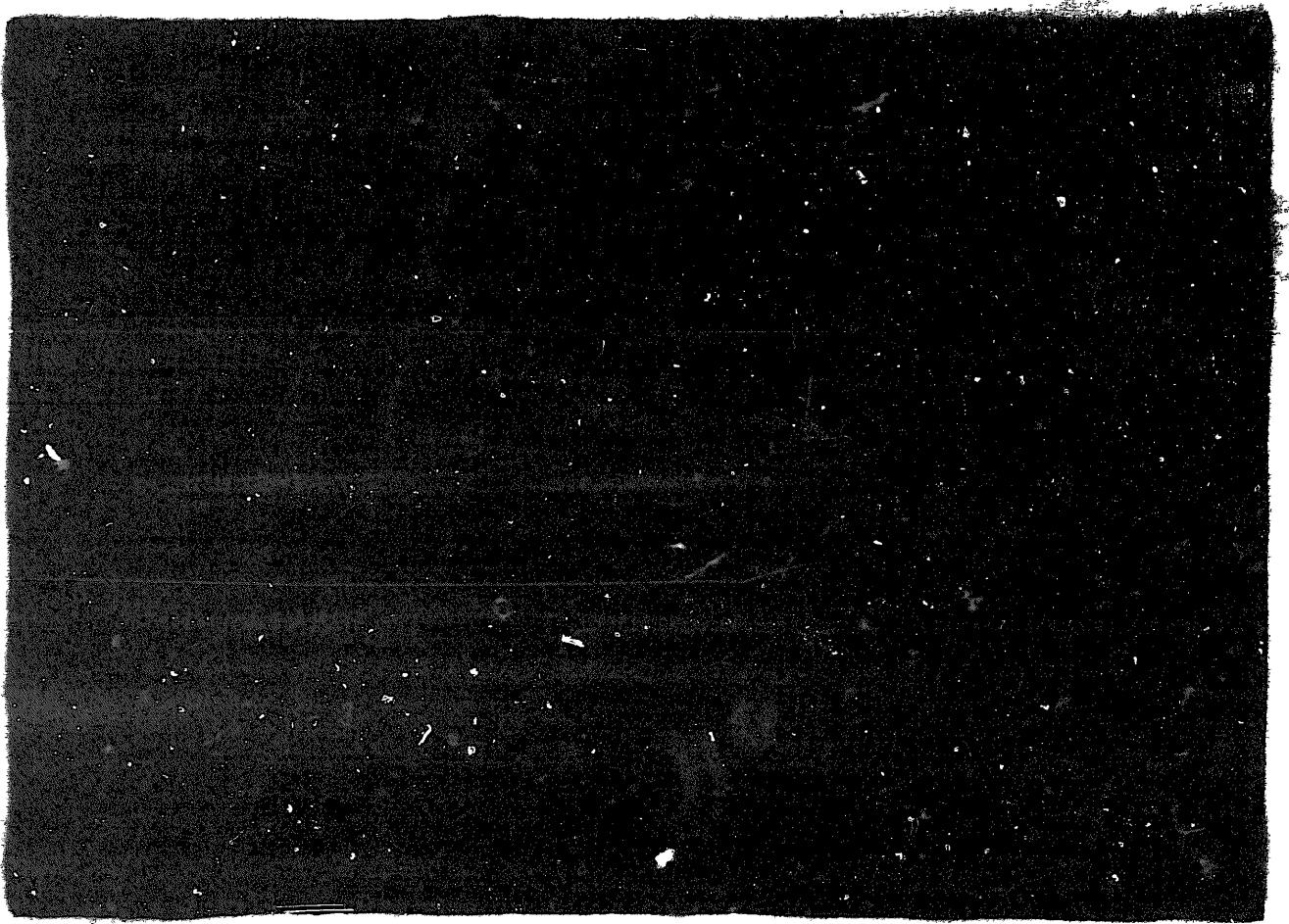

DEPARTMENT OF THE ARMY
MICROFORM
TEST TARGET

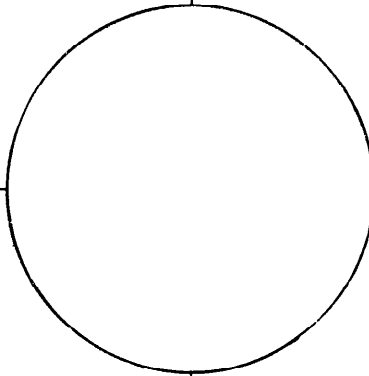
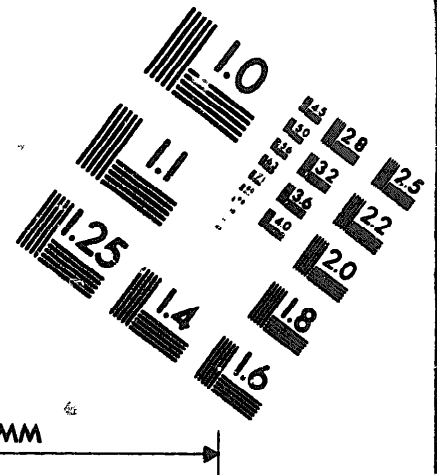
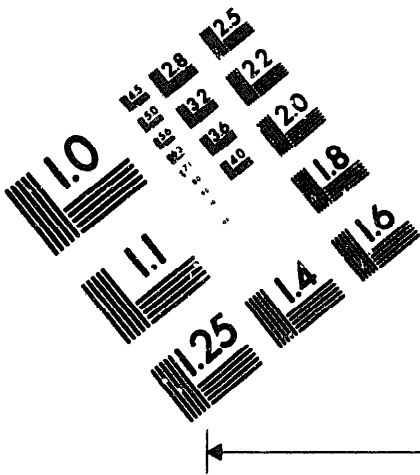

150 MM

10 mm (e= 81 mm)

ABCDEFGHIJKLMN OPQRSTUVWXYZ 1234567890
abcdefghijklmnopqrstuvwxyz \$%&' /%# 1/2 1/4 3/4 —+ x&@*

15 mm (e= 109 mm)

ABCDEFGHIJKLMN OPQRSTUVWXYZ 1234567890
abcdefghijklmnopqrstuvwxyz \$%&' /%# 1/2 1/4 3/4 —+ x&@*

20 mm (e= 137 mm)

ABCDEFGHIJKLMN OPQRSTUVWXYZ
abcdefghijklmnopqrstuvwxyz
1234567890 \$%&' /%# 1/2 1/4 3/4 —+ x&@*

2.5 mm (e= 1.77 mm)

ABCDEFGHIJKLMN OPQRSTUVWXYZ
abcdefghijklmnopqrstuvwxyz
1234567890 \$%&' /%# 1/2 1/4 3/4 —+ x&@*

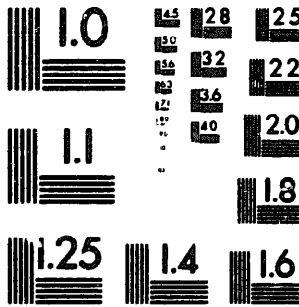

10 mm (e= 81 mm)

ABCDEFGHIJKLMN OPQRSTUVWXYZ 1234567890
abcdefghijklmnopqrstuvwxyz \$%&' /%# 1/2 1/4 3/4 —+ x&@*

15 mm (e= 109 mm)

ABCDEFGHIJKLMN OPQRSTUVWXYZ 1234567890
abcdefghijklmnopqrstuvwxyz \$%&' /%# 1/2 1/4 3/4 —+ x&@*

20 mm (e= 137 mm)

ABCDEFGHIJKLMN OPQRSTUVWXYZ
abcdefghijklmnopqrstuvwxyz
1234567890 \$%&' /%# 1/2 1/4 3/4 —+ x&@*

2.5 mm (e= 1.77 mm)

ABCDEFGHIJKLMN OPQRSTUVWXYZ
abcdefghijklmnopqrstuvwxyz
1234567890 \$%&' /%# 1/2 1/4 3/4 —+ x&@*



200 MM

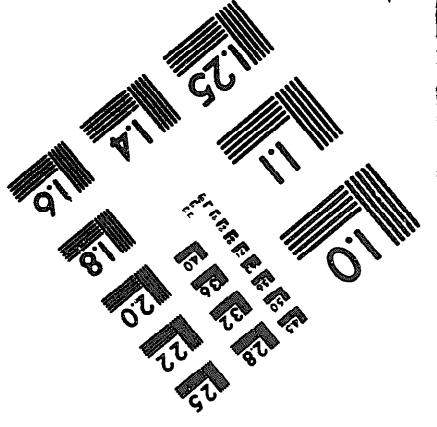
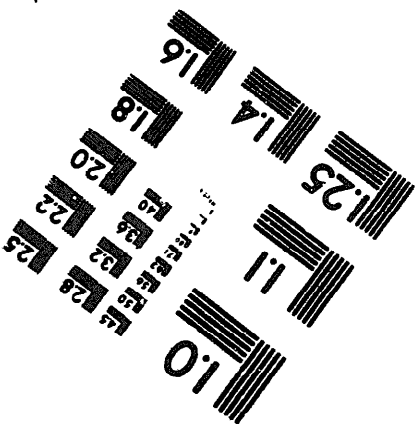

250 MM