

TM 5-9282

1/4 *U113*
12
TM
U.S. Dept. of Army

**WAR DEPARTMENT
MAINTENANCE MANUAL
AND PARTS CATALOG**

**POWER CONTROL UNIT, CABLE
OPERATING, REAR MOUNTED,
LE TOURNEAU MODEL R7**

R. G. LeTOURNEAU, INC.

PEORIA, ILL.

OCTOBER 9, 1943

WAR DEPARTMENT
Washington 25, D. C., (10/9/43)

TM 5-9282, Power Control Unit, Cable Operating,
Rear Mounted, LeTourneau Model R7, is published for
the information and guidance of all concerned.

(A.G. 300.7) 10/9/43)

BY ORDER OF THE SECRETARY OF WAR:

G. C. MARSHALL
Chief of Staff.

OFFICIAL:

J. A. ULIO,
Major General,
The Adjutant General.

POWER CONTROL UNIT, CABLE
OPERATING, REAR MOUNTED,
LE TOURNEAU MODEL R7

MANUFACTURED BY

R. G. LE TOURNEAU, INC.

PEORIA, ILL.

STOCKTON, CALIF.

FOR

CORPS OF ENGINEERS

TABLE OF CONTENTS

W113
T.M. 5-1282
L943
Frontispiece

Description of Power Control Unit..... Frontispiece

OPERATION SECTION

SECT. 1

Introduction.....	1
Cable and Cable Cutter.....	2
Cable Threading.....	2
Operation, including Safety Precautions.....	3
Functions of Power Control Unit.....	5
Specifications.....	6
Preparation for Initial Operation.....	6
Cut-away view of Unit showing points of Lubrication and Adjust- ment that can be taken care of by Operators.....	7
Operators Adjustments.....	8
Lubrication.....	14
Operation under Dusty, Muddy, Low Temperature and other Ab- normal Conditions.....	16
Preparation for Storage.....	16
Preparation for Export Shipment.....	16

REPAIR SECTION

SECT. 2

Care of Power Control Unit.....	1
Adjustments.....	1
Disassembling.....	11
Re-Assembling.....	20
Removing Power Control Unit from Tractor.....	25
Installing Power Control Unit on Tractor.....	26
Clutch and Brake Facings.....	28
Table of Clearances and Tolerances of Bearings and Adjustable Parts.....	32
Trouble Shooters Guide.....	33

PARTS CATALOG

SECT. 3

Case Cross-Section.....	1
Case Group (Exploded).....	2
Main Gear Driving Cone (Exploded).....	3
Brake Group (Exploded).....	4
Pinion Group.....	5
Cable Drum Group Cross-Section.....	6
Cable Drum (Exploded).....	7
Handles and Spline Shaft.....	8
Double-Deck Group.....	9
Spare Parts and Price Lists.....	10

M574570

INDEX

OPERATION SECTION

Brake Adjustment	8
Brake Shaft Bearing Adjustment	10
Cable and Cable Cutter	2
Cable Threading	2
Clutch Adjustment	11
Functions of Power Control Unit	5
Lubrication	14
Operation	3
Operation under Dusty, Muddy, Low Temperature and other Ab- normal Conditions	16
Points of Lubrication and Adjustment that can be taken care of by Operator	7
Preparation for Export Shipment	16
Preparation for Initial Operation	6
Preparation for Storage	16
Safety Precautions	3
Specifications	6

REPAIR SECTION

Assembling	20
Brake Facings	28
Cable Drum Bearing Adjustment	2
Clutch Facings	28
Disassembling	11
Double-Deck Sheave Housing Bearing Adjustment	10
Installing Power Control Unit on Tractor	26
Main Gear Bearing Adjustment	5
Pinion Bearing Adjustment	8
Re-Assembling	20
Removing Power Control Unit from Tractor	25
Table of Clearances and Tolerances of Bearings and Adjustable Parts	32
Trouble Shooters Guide	33

PARTS CATALOG

Brake Group (Exploded)	4
Cable Drum (Exploded)	7
Cable Drum Group Cross-Section	6
Case Cross-Section	1
Case Group (Exploded)	2
Double-Deck Group	9
Handles and Spline Shaft	8
Main Gear and Driving Cone (Exploded)	3
Pinion Group	5
Spare Parts and Price Lists	10 thru 13

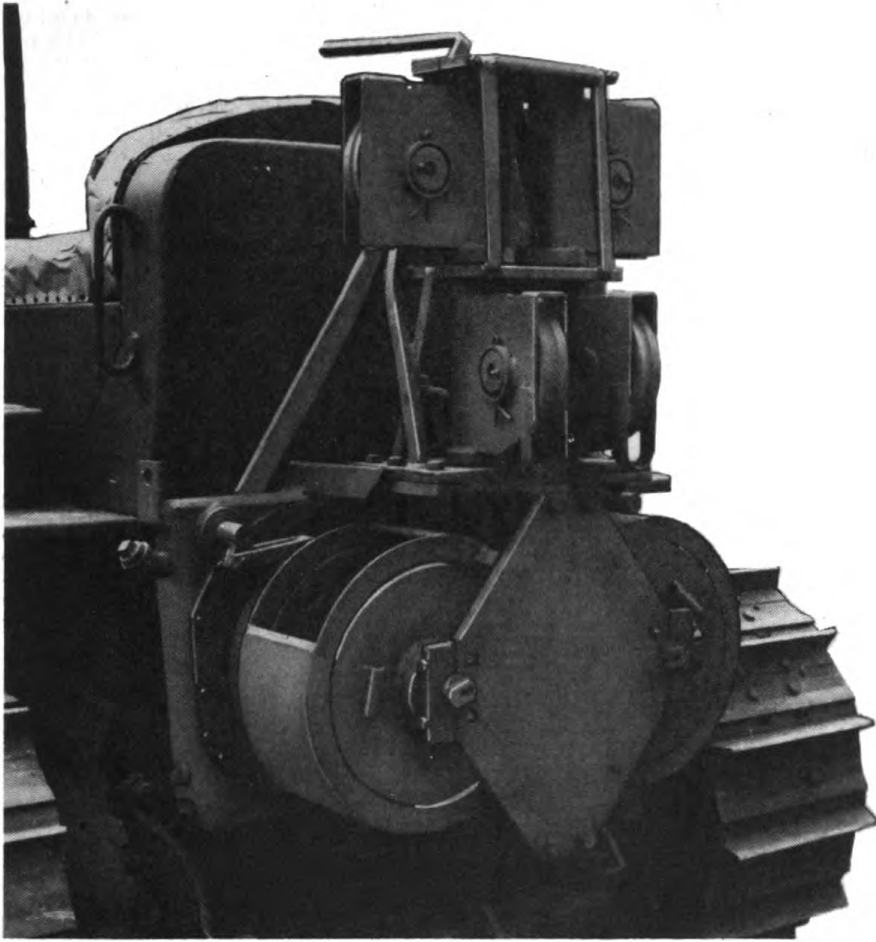

THE LeTOURNEAU MODEL "R" SERIES POWER CONTROL UNIT

The LeTourneau Power Control Unit is the "heart" of all LeTourneau earthmoving and construction equipment. Through its action, LeTourneau Scrapers, Dozers, Rooters, Cranes, etc., are given the power with which to do their work—through its quick, positive response to the movement of the control levers, the operator can accurately control and manipulate the working parts of this equipment.

LeTourneau Model "R" Series Power Control Units have two cable drums and are designed for mounting on the rear of Caterpillar Tractors. A take-off shaft, known as the "spline shaft," connects the Power Control Unit with the tractor upper transmission shaft, and through this connection the Power Control Unit is driven by the tractor engine.

Control cables (wire ropes) extend from the Power Control Unit cable drums to the equipment that is being operated by the Power Control Unit. Two control levers (one for each drum) extend up behind the tractor seat and are within easy reach of the operator. By movement of these control levers, the operator can at will cause the control cables to be either spooled on or unspooled off the cable drums, thereby operating the various working parts of the Scraper, Dozer, or other equipment being operated by the Power Control Unit.

SECT. 1

OPERATION SECTION



OPERATION SECTION

It has often been said that "No machine is better than the operator behind the controls."

This statement carries with it a great amount of truth and is especially true of equipment used in earthmoving.

Not only is the performance of the equipment dependant upon the skill with which the operator handles the operation, but also upon the every day maintenance performed by the operator.

Since the effectiveness of the equipment being operated by the Power Control Unit is to a large extent dependant upon the performance of the Unit, it is very important that the Power Control Unit be correctly operated and serviced.

On the following pages will be found the recommended procedures to be followed by the operator in operating and servicing the Power Control Unit.

CABLE

LeTourneau Model R Series Power Control Units are designed for use with Tournarope or other high quality wire rope meeting the following specifications:— 6 x 19 wire rope of Warrington construction with strand center, preformed, Langlay, and made from improved plow steel. It should be internally lubricated during the manufacturing process. (Similar cable of equal construction can be used without harmful results.)

For size of cable (diameter and length), refer to the Parts Catalog covering the particular piece of equipment being operated by the Power Control Unit.

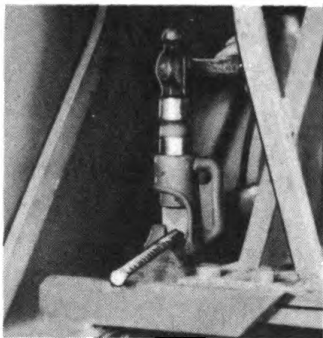

CABLE CUTTER

The purpose of the cable cutter, which is mounted on top of the Power Control Unit, is to cut cable, as illustrated.

Cutting speed and ease depend on the sharpness and accuracy of the blows, and a 4 or 5 pound hammer is of sufficient size.

CABLE THREADING

As a safety measure, cable threading, as outlined below, should not be attempted when the tractor engine is running with the flywheel clutch engaged.

To correctly thread the cable through the double-deck sheave assembly and onto either the right or left cable drum, first enter one end of the cable into the bottom of the lower sheave housing (A) and out through hole in rear of housing, pulling several feet of slack in the cable. Then insert cable back through hole in rear of housing (A) and up and over sheave housing (B), pulling cable up tight, and then down to cable drum (C). Then extend the end of the cable out through hole (D) in the cable drum flange, pulling a few feet of cable through the hole. Then insert the cable back through hole (E) and out through hole (F), not drawing cable tight through holes. Extend the end of the cable through loop (G), allowing approximately 1" of the cable to protrude from end of loop.

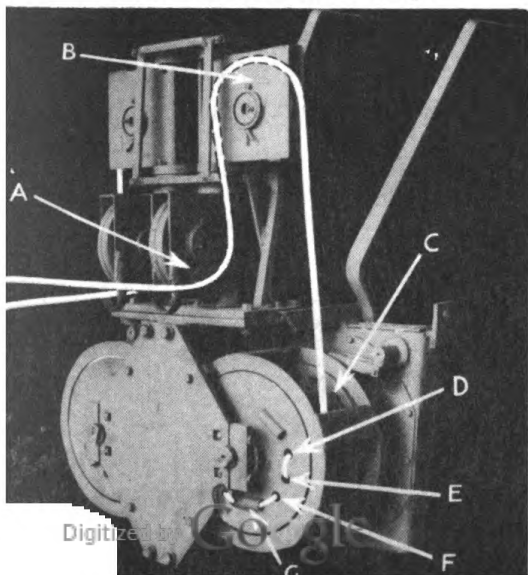

Hold the end of the cable in this position and pull all slack between loop (G) and hole (F) back through hole (F). Then pull all slack between holes (F) and (E) out through hole (E), and all slack between holes (E) and (D) back through hole (D), drawing the cable tight. Then, with the tractor motor idling and the flywheel clutch engaged, engage the Power Control Unit clutch and spool the slack cable evenly onto the cable drum.

OPERATION

The Power Control Unit is operated by moving the control levers, located behind the operator at the rear of the tractor. The right control lever operates the right cable drum and the left lever operates the left drum.

Each control lever is normally in neutral position. To engage the clutches and thereby spool cable onto the cable drums, move the left control lever to the right and the right control lever to the left, using a quick, full movement. To disengage the clutches and thereby stop the spooling of the cable onto the drums, allow the control levers to return to neutral position.

The brakes automatically release when the clutches are engaged and automatically take hold when the clutches are disengaged, with the control levers in neutral position. To release the brakes to permit free-spooling of the cables off the cable drums, move the left control lever to the left and the right control lever to the right. To stop the free-spooling of the cables, move the control levers back into neutral position, thereby allowing the brakes to take hold.

In order to avoid clutch and brake slippage and the resultant overheating of the Power Control Unit clutches and brakes, the operator should always fully engage and disengage the clutch with a quick, full movement of the control lever. Over-heating of the Power Control Unit from improper operation may cause the leather in the oil seals to harden and result in oil and grease leakage.

The extreme brake released position of the control lever is known as the "lock-out" position. When in this position, the brake is fully released and the cable drum can be turned in either direction by hand.

Instructions which pertain to the use of the Power Control Unit with Scrapers, Dozers, etc., will be found in the Manuals covering those machines.

SAFETY PRECAUTIONS

1. When operating the Power Control Unit, keep the hands free from the cable and working parts.
2. Do not use weak, frayed cable which might break when under tension.
3. Always lower Scraper or Dozer bowl to the ground before working on Power Control Unit. Do not work on Unit while tractor engine is running with the flywheel clutch engaged.

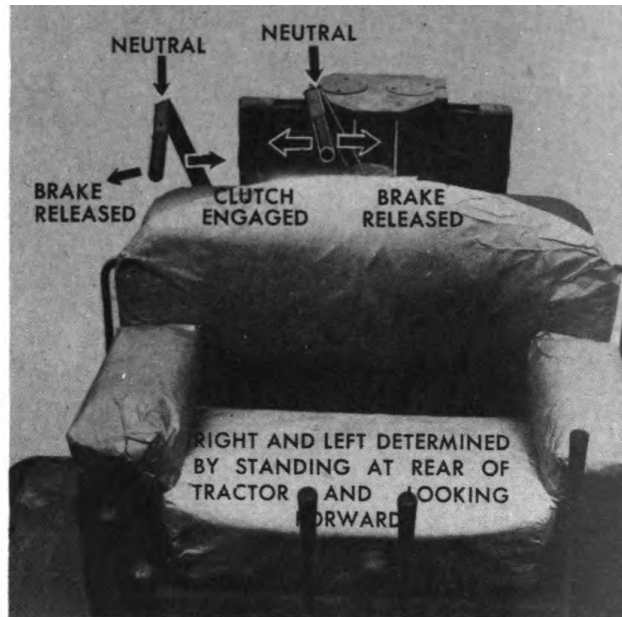

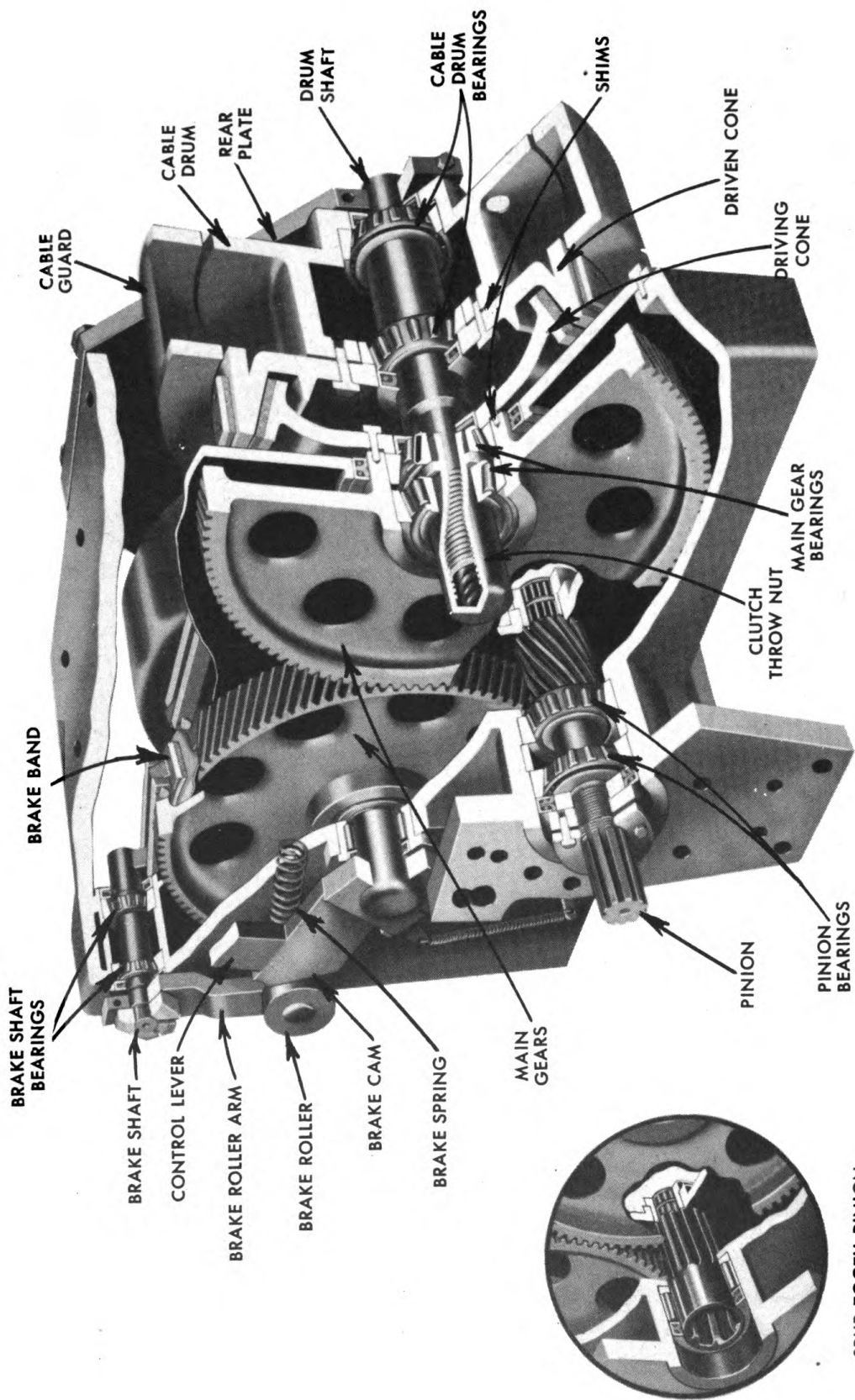

CUT-AWAY VIEW OF MODEL R POWER CONTROL UNIT

WORKING PRINCIPLE

Power Control Unit pinion (1) is connected with tractor upper transmission shaft by a splined connector shaft, known as "spline shaft." When tractor engine is running with flywheel clutch engaged, the engine turns upper transmission shaft, causing Power Control Unit pinion (1) to turn. Pinion then turns right main gear (2) which turns left main gear (3). Each main gear and driving cone (assembled as one unit) ride on bearings on clutch throw-nut (5) and (6), and turn constantly when tractor engine is running with flywheel clutch engaged.

The clutches are engaged by moving control levers. When moved to the left, control lever (4), clamped around throw-nut (5) at lower end, engages right clutch. Likewise, when moved to the right, a similar control lever (not shown in cut-away illustration) clamped around left throw nut (6), engages left clutch. (Inasmuch as both right and left clutch and cable drum assemblies are alike, only the left assembly shown in cut-away will be explained.) When left control lever (not shown) is moved to engage clutch, throw-nut (6) turns on drum shaft (7), advancing throw-nut to the rear on threads on shaft. Rotating main gear (3) and driving cone (8) are carried to rear with throw-nut, and driving cone (8) is brought into contact with driven cone (9), thereby engaging clutch. Driven cone (9) and cable drum (10) now turn, spooling cable onto drum.

To disengage clutch and thereby stop spooling of cable onto cable drum, the control lever is returned to its original neutral position. As the control lever is returned, clutch throw-nut (6) turns with lever, causing main gear and driving cone to be moved forward away from driven cone, thereby disengaging clutch. Cable drum (10) is held by the self energizing brake which takes hold when control lever is in neutral.

To release brake to permit unspooling of cable off cable drum, control lever is moved out of neutral position, in the direction opposite that used in engaging clutch. (Inasmuch as both right and left brake assemblies are alike, only right brake assembly will be explained.) By moving control lever to release brake, brake cam (11) at lower end of control lever, moves against brake roller (12), causing brake roller and lower end of roller arm (13) to be moved outward. This movement of brake roller arm (13), which is clamped to end of brake shaft (14), causes brake shaft to rotate. Rotation of brake shaft (14) causes linkage (15) connecting end of brake shaft with brake band (16) to raise band away from drum, thereby releasing Brake.

To re-engage brake, return control lever to neutral position.

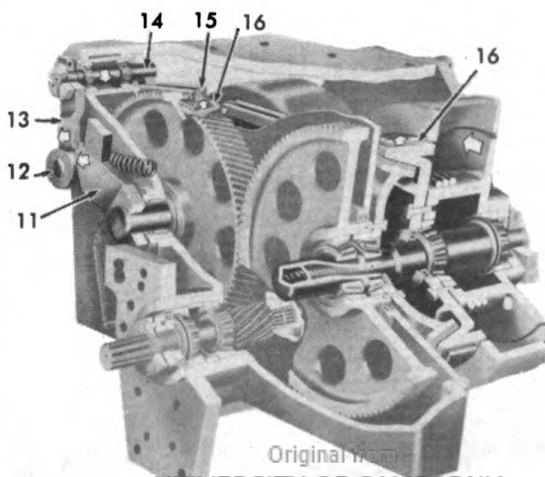
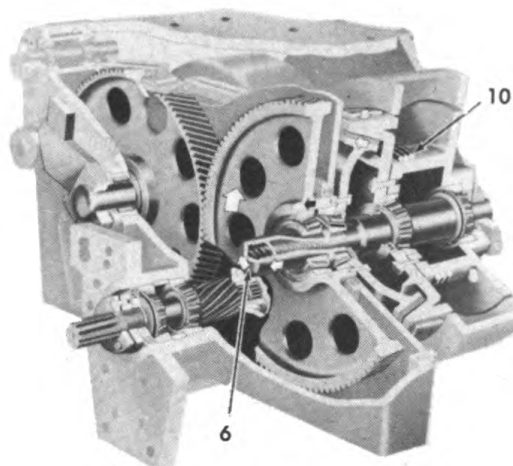
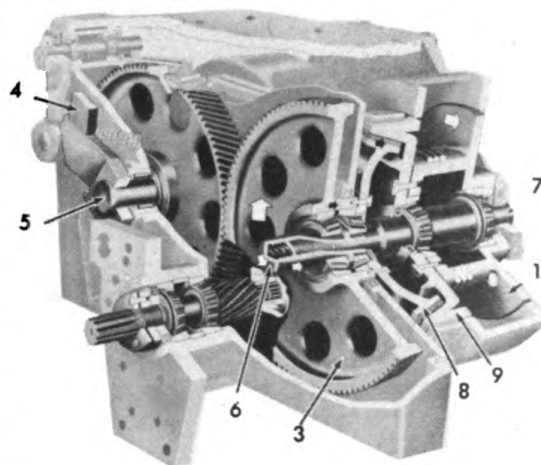
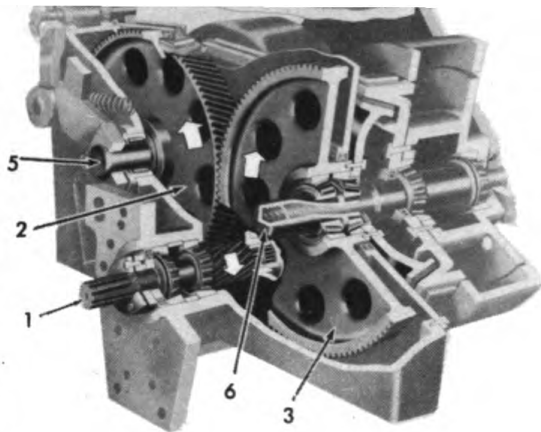

SPECIFICATIONS

MODEL....."R" Series Units

FOR USE WITH TRACTOR.....Caterpillar D6, D7, or D8

DRUMS:

Number and mounting.....Double—Rear
 Diameter..... $8\frac{5}{8}$ "
 Length..... $7\frac{5}{8}$ "
 Flange Diameter.....15"

OPERATION.....Mechanical from tractor gears

GEAR REDUCTION.....7.2:1

LINE PULL:

Bare Drum.....5,000 lbs.
 Full Drum.....Up to 3,100 lbs.

LINE SPEED:

Bare Drum (ft. per minute).....(D8)-298, (D7)-313, (D6)-440
 Full Drum (ft. per minute).....(D8)-484, (D7)-510, (D6)-713

CABLE CAPACITY, $\frac{1}{2}$ " CABLE.....225 ft.

WEIGHT.....Approx. 1,525 lb.

PREPARATION FOR INITIAL OPERATION

Before placing a newly delivered Power Control Unit in operation, check the following:

1. Make sure that the cork is removed from the breather hole in the oil fill plug.
2. Check oil level in the gear case. The oil should never be permitted to drop below the oil level plug.
3. Check the threading of the cable through the double-deck sheaves and onto the cable drums for correctness. (Refer to cable threading instructions on page 2 of Operation Section.)
4. Make sure brake bands are not "frozen" to driven cones, by moving control levers to lock-out position.
5. Check clutch and brake adjustments. (Refer to adjustment instructions on pages 8 and 11 of Operation Section.) Make any needed corrections.

BRAKE SHAFT BEARINGS

Check adjustment every 1,024 hours.
Hand packed with lubricant every 2,048 hours, usually by maintenance and repair men, rather than operators.

CLUTCH

Make adjustment when needed.

BRAKE ROLLER

Lubricate every 64 hours.

BRAKE

Check adjustment every 8 hours.

MAIN GEAR BEARINGS

Adjustment checked every 256 hours by maintenance and repair men.

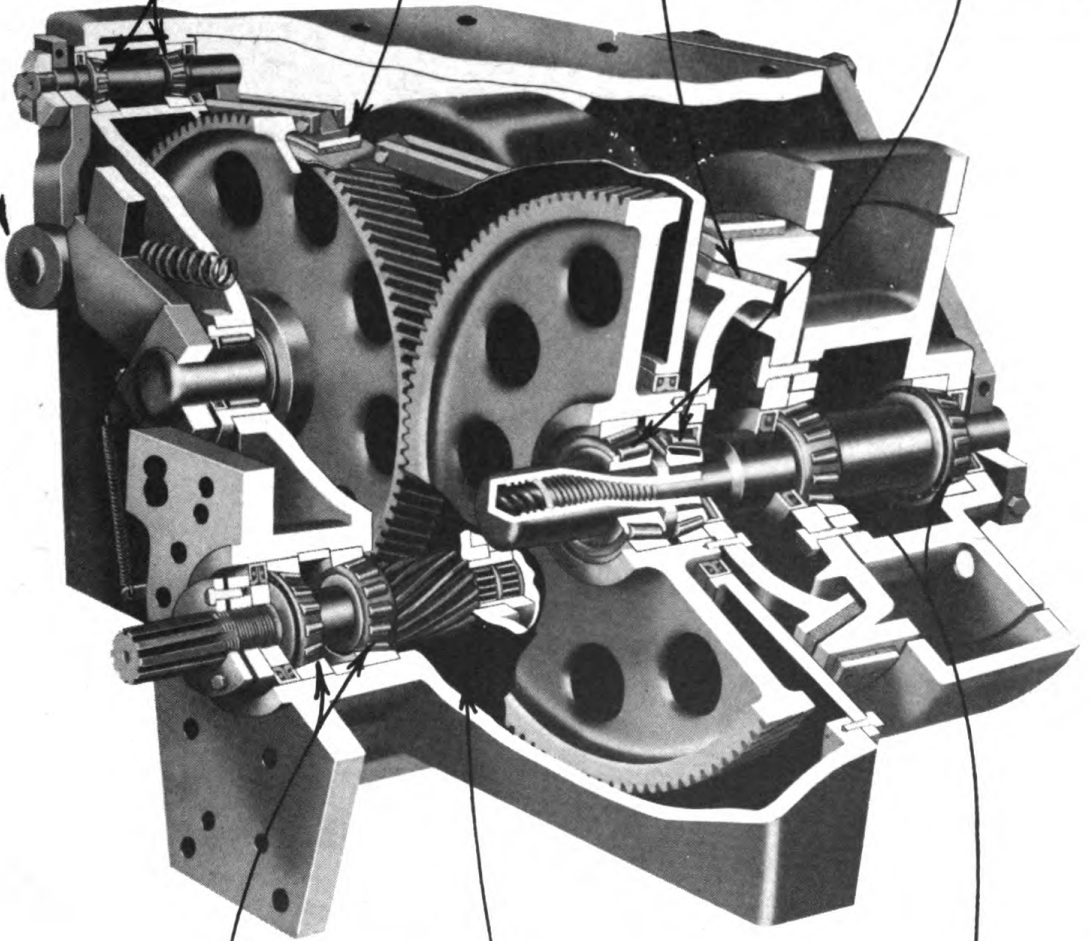

PINION BEARINGS

Adjustment checked every 512 hours by maintenance and repair men.
(Only on Model "R" Series Units having serial numbers ending with the suffix D or E.)

CABLE DRUM BEARINGS

Hand packed with lubricant every 1,024 hours, usually by maintenance and repair men, rather than operators.
Adjustment checked every 256 hours by maintenance and repair men.

GEAR CASE

Check oil level every 64 hours.
Change oil every 1,024 hours.

Cut-away view of Unit, showing points of lubrication and adjustment that can be taken care of by operator.

ADJUSTMENTS

The successful operation of the LeTourneau Power Control Unit is more dependent upon proper adjustment than any one other thing. If properly adjusted, the Unit should give trouble-free operation. However, if not in the correct adjustment, difficulty in its operation may result.

The clutch adjustments, brake adjustments, and brake shaft bearing adjustments can be made without disassembling the Unit, and can therefore be taken care of by the operator (refer to instructions which follow). The cable drum bearing adjustments, main gear bearing adjustments, and pinion bearing adjustment require partial disassembly of the Unit, and are therefore usually taken care of by maintenance and repair men. The double-deck sheave bearing adjustments are also usually taken care of by maintenance and repair men. (For instructions refer to Repair Section.)

BRAKE ADJUSTMENT

Occasional adjusting of the Power Control Unit brakes is necessary because of brake lining wear.

Check brake adjustment every 8 hours of operation. To check adjustment, follow the instructions below:

HOW TO CHECK ADJUSTMENT

With the control lever in neutral position, check the position of the brake roller against the brake cam.

The accompanying drawing illustrates the correct relative position of the brake roller against the cam when the control lever is in neutral position (with slack in cable).

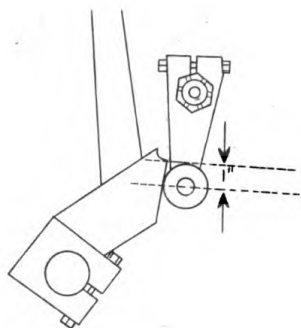

If the position of the roller against the cam is not approximately as illustrated, an adjustment should be made.

IF ADJUSTMENT IS INCORRECT

If the Unit should be operated with the brake roller not correctly positioned against the brake cam (refer to illustration above), the action of the brake cam against the roller will be affected and may cause the brake to not properly release.

Also, the tension of the brake spring will be affected, possibly resulting either in brake slippage or in more effort being required to disengage the brake than should be necessary.

HOW TO MAKE BRAKE ADJUSTMENTS

1. Loosen clamp bolt at upper end of brake roller arm. (The use of two wrenches may be necessary to prevent bolt from turning with nut.)

2. Place a wrench on rear end of brake shaft as illustrated and tighten brake band on drum by moving wrench away from center of Unit, using force. Hold the wrench in this position and move control lever in the direction required to bring brake roller into correct position against brake cam. (Approximately 1" down from lock-out position.)

3. With brake roller correctly positioned against brake cam, hold the control lever and tighten clamp bolt at upper end of brake roller arm. (*Caution*—If control lever is moved before bolt is tightened, the position of the brake roller against the brake cam may change, affecting the adjustment, and it will be necessary to repeat steps 2 and 3.) Give bolt final tightening by using two wrenches as in Step 1.

4. After completing Step 3, check the adjustment. The brake roller should be spaced approximately 1" down from lock-out position as illustrated. (This 1" dimension may be changed slightly in instances where it is necessary to change position of control lever to place lever within convenient reach of operator.)

Note—In adjusting the brakes, the position of the control levers are changed. Therefore, the clutch adjustment is also affected, and for this reason, each brake adjustment must be followed by an adjustment of the clutch.

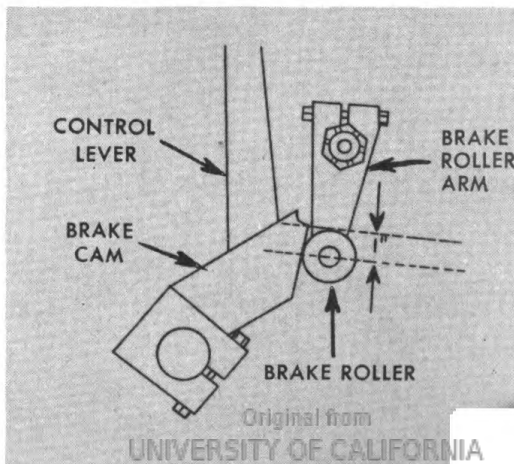
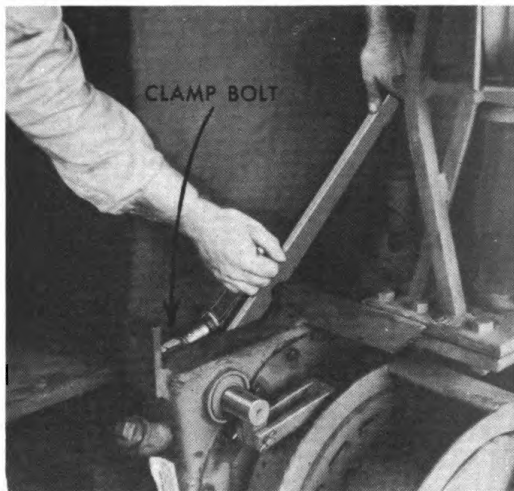
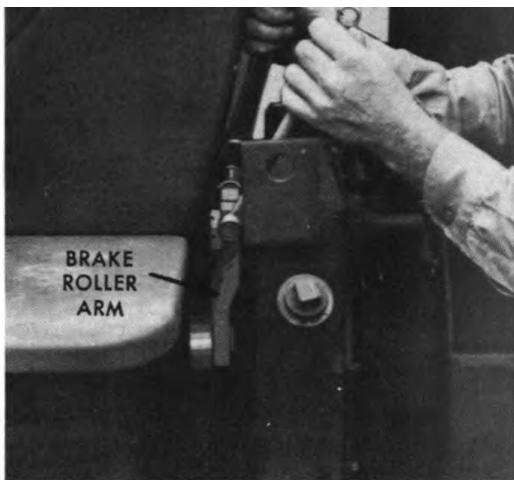

BRAKE SHAFT BEARING ADJUSTMENT

Since the brake shafts rotate only a part of a turn during operation, there is very little wear on the bearings. Therefore, the adjustment does not require frequent attention.

Check the brake shaft bearings for correct adjustment every 1,024 hours of operation or when brake slippage is experienced and cannot be traced to any other source.

HOW TO CHECK ADJUSTMENT

To check for bearing looseness, insert a pry bar or similar tool between brake roller and gear case, and by prying in and out, detect any end movement of shaft. If end movement is noticeable, the bearings are loose.

To check for bearing tightness, remove brake spring and disconnect brake band from brake shaft. Then rotate shaft by hand. If shaft does not turn freely, the bearings are adjusted too tight.

If bearings are adjusted either too tight or if there is noticeable looseness, an adjustment should be made.

IF ADJUSTMENT IS INCORRECT

If the Power Control Unit is operated with the bearings adjusted too tight, brake slippage may result. If the bearings are noticeably loose, the brake shaft and linkage will have excessive play, affecting the brake action, and the life of the bearings may be shortened.

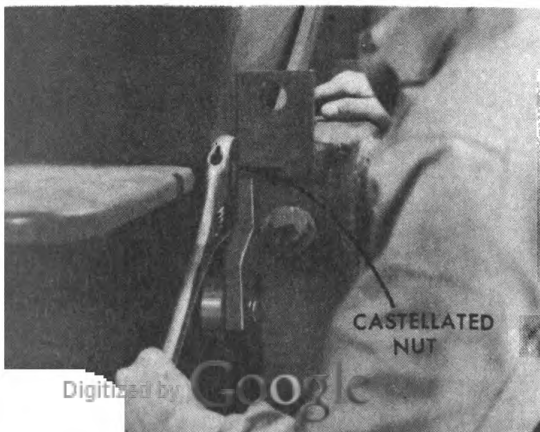

HOW TO MAKE ADJUSTMENT

To make adjustment, first remove brake spring. Then proceed as follows:

1. Loosen clamp bolt at upper end of roller arm. Then remove cotter pin from castellated nut at end of brake shaft.
2. To tighten the bearings, turn the castellated nut located at the upper end of the roller arm clockwise on brake shaft. To loosen the bearings, turn the nut counterclockwise.

The adjustment is correct when bearings are free rolling and without end play.

When correct adjustment is reached, reinstall cotter pin and tighten clamp bolt.

CLUTCH ADJUSTMENT

There is no set interval for checking the clutches for adjustment. Rather, the operation of the unit by the operator serves as a constant check on the adjustment.

If operating a Power Control Unit having an incorrectly adjusted clutch, the operator will have difficulty in making the Power Control Unit function properly, and there will be symptoms which will indicate to the operator that the clutch is incorrectly adjusted. These symptoms are: (1) Travel of control lever from neutral to the fully engaged position too great for efficient operation, (2) Clutch won't fully engage, (3) Clutch slippage, (4) Clutch won't release, (5) Clutch dragging, (6) Brake won't fully release, (7) Overheating as a result of the above.

If troubled by one or more of the above symptoms when operating the unit, it is an indication that the clutch is probably incorrectly adjusted and an adjustment should be made.

There are three factors which affect the clutch adjustment and which cause the symptoms listed above:

1. *Incorrect amount of clearance between driving cone and driven cone when control lever is in neutral.* This clearance regulates the distance the driving cone must travel to fully engage the driven cone. Since this clearance cannot be measured accurately without difficulty, it is usually thought of in terms of the distance the control lever travels between neutral and the fully engaged position. If the cones are spaced too far apart, the travel of the control lever from neutral to the fully engaged position will be so great that it will be difficult for the operator to efficiently operate the unit. If spaced too close, the driving cone may drag on the driven cone when the control lever is in neutral position. The clearance between the driving and driven cones is correct when the travel at the top of the control lever from the neutral to the fully engaged positions is approximately 12". (Slightly less for efficient Dozer operation.)
2. *Main gear incorrectly spaced inside gear case.* If spaced too far to the rear, the gear will strike rear side of gear case as control lever is moved to engage clutch, preventing the clutch from fully engaging. If spaced too far to the front, it will strike against front side of gear case as control lever is moved in the direction that releases the brake, preventing control lever from being moved into lock-out position, and possibly preventing the brake from fully releasing.
3. *Insufficient clearance between the brake cam and throw-nut bushing.* If there is insufficient clearance at this point, the brake cam will ride against the throw-nut bushing before the driving cone becomes fully engaged in the driven cone, thereby preventing the clutch from fully engaging. With the control lever in the fully engaged position there should be some clearance at this point.

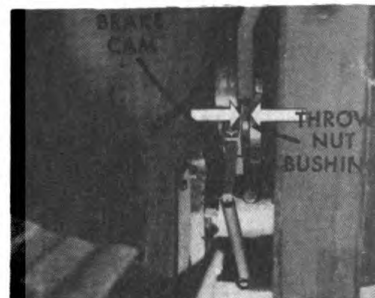
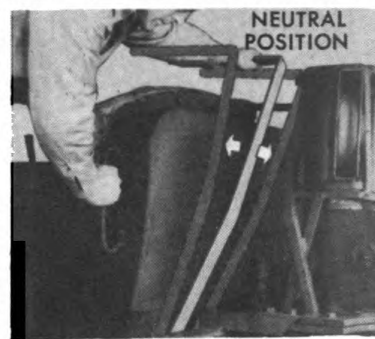
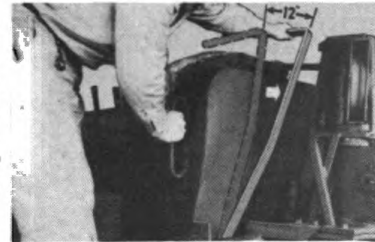

By making the clutch adjustment as outlined on the following pages, the three possible sources of trouble listed above will be corrected. If the same symptoms are present after making the adjustment, the difficulty is caused from some other source, and a different correction must be made. (Refer to Trouble Location Chart in Repair Section.)

HOW TO MAKE CLUTCH ADJUSTMENT

To adjust either clutch, first make sure that brake roller is correctly positioned against brake cam (refer to brake adjustment instructions on Page 8).

Then proceed as follows:

1. Move control lever into the lock-out position (extreme brake released position). Leave lever in this position and loosen drum shaft clamp bolts at rear end of drum shaft.
2. With control lever in lock-out position, turn drum shaft with a wrench, bringing the driving cone and driven cone together tight. (If adjusting the right clutch, turn the right shaft in a clockwise direction. If adjusting the left clutch, turn the left shaft in a counter-clockwise direction.)
3. Insert a pry bar between rear plate and cable drum and pry drum assembly toward the tractor as far as it will go.
4. Insert the bar between the driving cone and the gear case cover plate and pry the assembly in the opposite direction $\frac{1}{8}$ " to $\frac{3}{16}$ ". This will correctly space main gear inside gear case.

5. Place a wrench on end of drum shaft and move control lever from lock-out position, back to a point approximately 9" past neutral position, allowing the wrench to turn with drum shaft as control lever is moved. (If Unit is hot, 9" movement should be increased slightly due to expanded condition of driven cone.) The drum shaft will turn with the control lever in making this part of the adjustment. (The above 9" travel of control lever from neutral to fully engaged position will give approximately 12" travel of lever in actual operation after adjustment has been completed. This amount of travel will provide proper clearance between driving cone and driven cone when in neutral position.)
6. Hold the drum shaft from turning by holding the wrench stationary, and return the control lever to neutral position.
7. Then, without turning the drum shaft, clamp the drum shaft to the rear plate by tightening the drum shaft clamp bolts, turning them down evenly.
8. Fully engage clutch and check for clearance between brake cam and throw-nut bushing. There should be some clearance at this point. If there is no clearance, release clamp bolt from lower end of control lever and space lever farther out on clutch throw-nut, without changing the relative position of the lever. Then re-tighten clamp bolt.

Important:

The above steps in making the clutch adjustment must be made in the order given and no steps can be eliminated.

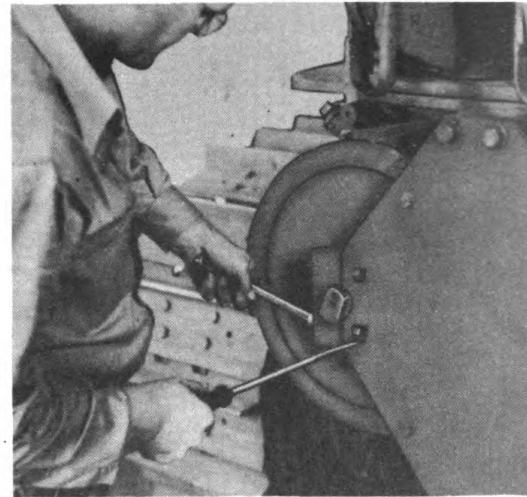
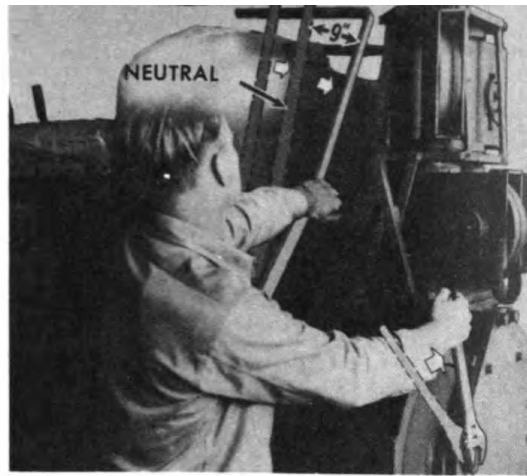

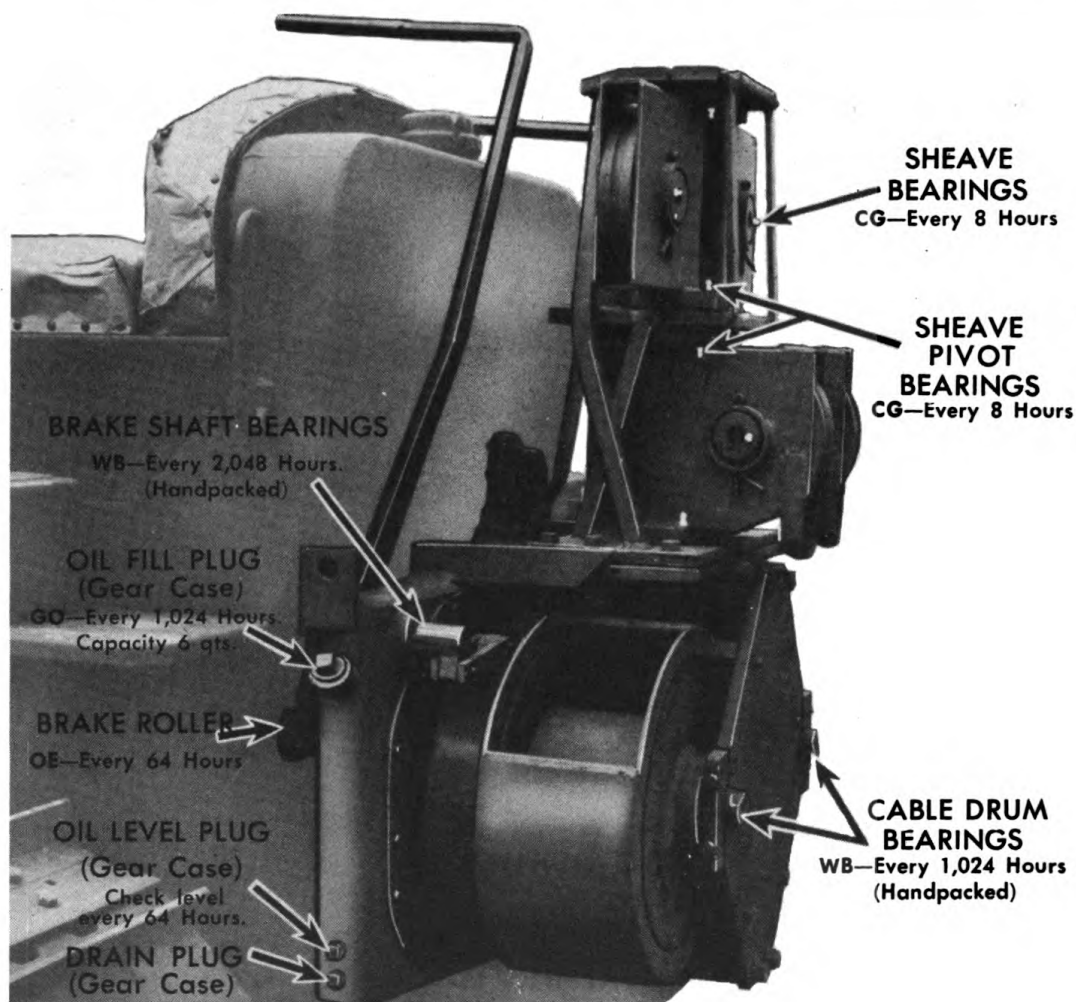

LUBRICATION

GEAR CASE

All gears, bearings, and working parts inside the Power Control Unit gear case receive lubrication by the "splash" system from the oil in the lower part of the case. The main gears dip in the oil when turning and the constant spray of oil resulting therefrom provides ample lubrication.

The oil should be kept up to the oil level plug (see illustration) at all times. Check oil level every 64 hours of operation.

Drain, flush, and refill up to oil level plug every 1024 hours of operation. Use GO-90 (lubricant, gear, universal, S.A.E. 90) in temperatures from $+90^{\circ}$ F. to $+32^{\circ}$ F., and GO-80 (lubricant, gear, universal, S.A.E. 80) in temperatures from $+32^{\circ}$ F. to 0° F. (For recommendations in temperatures above $+90^{\circ}$ F., refer to Engineer Field Service Bulletin L-1000-E. In temperatures below 0° F., refer to Engineer Field Service Bulletin L-1000-D).

CABLE DRUM BEARINGS

Hand-pack cable drum bearings with recommended lubricant every 1,024 hours of operation or when disassembled.

Use WB-2 (grease, general purpose, No. 2) in temperatures between +90° F. and 0° F. (For recommendations in temperatures above +90° F., refer to Engineer Field Service Bulletin L-1000-E. In temperatures below 0° F., refer to Engineer Field Service Bulletin L-1000-D).

Before hand-packing, remove old grease and wash grease chamber and bearings with kerosene and dry thoroughly. Then apply lubricating oil to bearings.

With the drum shaft removed from cable drum and bearing cones installed on shaft, apply grease to bearing cones, packing it around rollers and on ends of rollers.

Then reassemble cable drum assembly, leaving out two of the capscrews which secure the driven cone to the cable drum. Then, with the drum assembly standing on end, insert recommended grease through one of the capscrew holes, filling the drum only $\frac{2}{3}$ full of grease. In this operation, use a conventional pressure grease gun or any other suitable means of inserting the grease through the capscrew hole. Also, insert a measuring stick or wire down through the other capscrew hole to serve as a gauge in determining when the cable drum is $\frac{2}{3}$ full of grease.

For emergency lubrication, a drilled grease duct is provided in the drum shaft extending from the rear of the shaft to the grease chamber inside of the cable drum. In event an excessive amount of grease is lost around the cable drum oil seals and for some reason it is impractical to disassemble the unit until after a few more hours of operation have been completed, the bearings may be temporarily supplied with lubricant by removing the brass plug from the rear of the drum shaft and inserting a grease fitting in its place. Then inject enough grease through the grease fitting to replace that which was lost around the seals, using a conventional pressure grease gun.

As soon as possible thereafter, the cable drum assembly should be removed and disassembled to replace the leaky oil seals and the bearings should again be hand packed with grease and the drum filled $\frac{2}{3}$ full of recommended lubricant.

BRAKE SHAFT BEARINGS

Hand-pack brake shaft bearings with recommended lubricant every 2,048 hours of operation or when disassembled.

Use WB-2 (grease, general purpose, No. 2) in temperatures between +90° F. and 0° F. (For recommendations in temperatures above +90° F., refer to Engineer Field Service Bulletin L-1000-E. In temperatures below 0° F., refer to Engineer Field Service Bulletin, L-1000-D).

CONTINUED

BRAKE ROLLERS

Lubricate brake rollers with OE-10 (oil, engine, S.A.E. 10) or OE-30 (oil, engine, S.A.E.-30) every 64 hours of operation, using an oil can.

DOUBLE DECK SHEAVE BEARINGS

Lubricate the sheave bearings and sheave pivot bearings in the double-deck sheave assembly every 8 hours of operation using a conventional pressure grease gun.

Use CG-1 (grease, general purpose, No. 1) in temperatures from +90° F. to +32° F., and CG-O (grease, general purpose, No. 0) in temperatures from +32° F. to 0° F. (For lubrication instructions when operating in temperatures above +90° F., refer to Engineer Field Service Bulletin L-1000-E. In temperatures below 0° F., refer to Engineer Field Service Bulletin L-1000-D.)

Important—Do not over-lubricate bearings because of the danger of grease dropping onto the clutch and brake facings, resulting in clutch or brake slippage.

OPERATION UNDER DUSTY, MUDDY, LOW TEMPERATURE AND OTHER ABNORMAL CONDITIONS

Few special instructions are required for operating the Power Control Unit in dusty, muddy, low temperature and other abnormal conditions.

1. When operating in extreme dusty conditions, apply lubricant rather sparingly to the cable. The reason for this is that the particles of dust, when mixed with the lubricant on the cable, may become abrasive, acting similar to a cutting compound and damaging the cable.
2. When operating in extreme muddy conditions, try to keep the clutches, brakes, brake springs, and cable drums free of mud. Remove all mud from unit after completing a day's work.
3. In cold weather, always make sure brake band is not frozen to drum before starting operation by moving control lever into lock-out position, freeing band from drum.
4. Use lighter weight lubricants when operating in cold temperatures than when operating in warm temperatures. (Refer to lubrication instructions on page 14 of Operation Section.)

PREPARATION FOR STORAGE

For instructions covering the preparation of the Power Control Unit for storage, refer to Preventative Maintenance Manual—"Storage of Engineer Equipment," (latest revisions), published by Engineer Field Maintenance Office.

PREPARATION FOR EXPORT SHIPMENT

For instructions covering the preparation of the Power Control Unit for export shipment, refer to Export Manuals (latest revisions), published by Engineer Field Maintenance Office.

REPAIR SECTION

SECT. 2

REPAIR AND MAINTENANCE

The LeTourneau Model R Series Power Control Unit is a well designed, strongly built piece of equipment which, if properly serviced at the correct intervals, should give trouble-free operation.

CARE OF POWER CONTROL UNIT

WHEN POWER CONTROL UNIT IS DELIVERED:

Remove cork from breather hole in oil fill plug. Check all points of adjustment and make any necessary corrections.

Check oil level in gear case.

Check threading of cable on cable drums.

WHEN NEEDED:

Make clutch adjustments.

ONCE EVERY 8 HOURS:

Check brake adjustments.

Lubricate double deck sheave bearings.

ONCE EVERY 64 HOURS:

Check oil level in gear case.

Lubricate brake rollers.

ONCE EVERY 128 HOURS:

Check double deck sheave housing bearings.

ONCE EVERY 256 HOURS:

Check cable drum bearings.

Check main gear bearings.

ONCE EVERY 512 HOURS:

Check pinion bearings (Units having serial numbers ending with suffix D or E).

ONCE EVERY 1024 HOURS:

Check brake shaft bearing adjustment.

Change oil in gear case.

Hand-pack drum bearings with grease.

ONCE EVERY 2048 HOURS:

Hand-pack brake shaft bearings with grease.

LUBRICATION

For lubrication instructions, refer to Page 14 of Operation Section.

ADJUSTMENTS

CLUTCH, BRAKE AND BRAKE SHAFT BEARING ADJUSTMENTS:

The clutch adjustments, brake adjustments, and brake shaft bearing adjustments are of a type which can be made by the operator. For instructions, refer to Pages 8 through 13 of the Operation Section.

CABLE DRUM BEARING, MAIN GEAR BEARING, PINION BEARING, AND DOUBLE DECK SHEAVE BEARING ADJUSTMENTS:

The cable drum bearings, main gear bearings, pinion bearings, and the double deck sheave bearings are normally adjusted by maintenance and repair men, rather than operators.

Complete instructions as to how to check and make these adjustments will be found on the following pages.

CABLE DRUM BEARING ADJUSTMENT

Occasional adjusting of the cable drum bearings is necessary because of bearing wear.

Check the cable drum bearing adjustment every 256 hours of operation.

HOW TO CHECK ADJUSTMENT

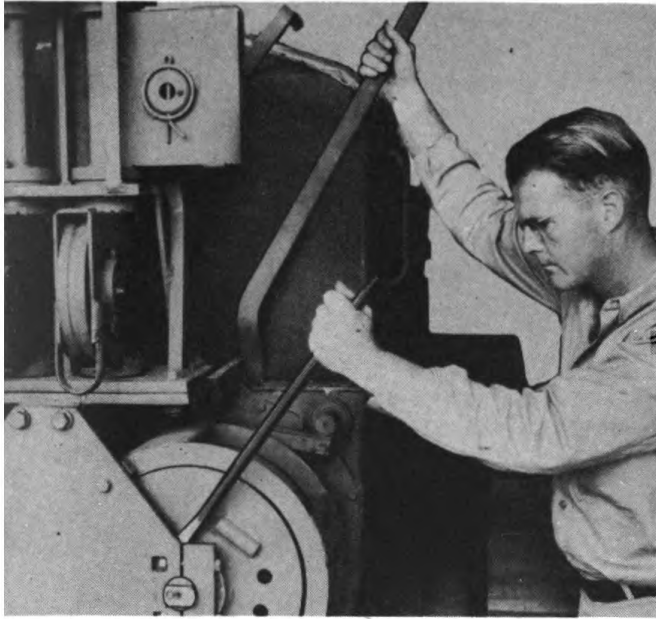

To check the adjustment, insert a pry bar between the rear plate and cable drum, and firmly engage and disengage the clutch while prying against cable drum with the bar. If the drum bearings are loose, the cable drum will move back and forth on the drum shaft, and the end of the bar will also move. The "feel" of this movement will be very noticeable to the one holding the end of the bar.

If movement is noticeable, the bearings are loose and an adjustment should be made.

For a more accurate check, clamp a dial indicator against cable drum, and repeat above operation, noticing end movement as recorded on indicator.

IF BEARINGS ARE LOOSE

If the unit should be operated with the bearings in either cable drum in a loose adjustment, the cable drum and clutch driven cone would assume an off-center position on the drum shaft and will be in misalignment with the clutch driving cone, as shown in the drawing, thus causing spongy, erratic clutch action. With loose bearings, the driven cone might move to the front or to the rear with the driving cone as the control lever is moved, thereby preventing proper releasing of the clutch, and causing the throw of the control lever to be increased, possibly resulting in the throw of the control lever being too great for efficient operation. It might also cause the driven cone to drag on the driving cone when the control lever is in neutral position, resulting in over-heating of the clutch, which in turn might cause oil seal leakage, due to hardening of the leather in the seals. Also, loose cable drum bearings might result in cable breakage, due to a delay in quick clutch disengagement.

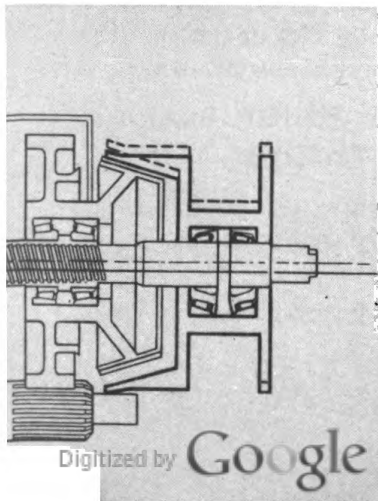

HOW TO MAKE ADJUSTMENT

To make cable drum bearing adjustment, first remove cable drum assembly from unit. (Refer to disassembly instructions on Page 11 of the Repair Section). Then proceed as follows:

1. With hammer and center punch, mark cable drum and driven cone at points illustrated in order to assure proper alignment when re-assembled.
2. Remove capscrews which secure driven cone to cable drum. Then slide driven cone off drum shaft, being careful not to damage oil seal.
3. Remove bearing adjusting shim (or shims) from between driven cone and cable drum to take up adjustment. (Shims are of two thicknesses, .004" and .007", in order to make possible a fine variation in adjustment.) Remove shims one at a time in making adjustment.

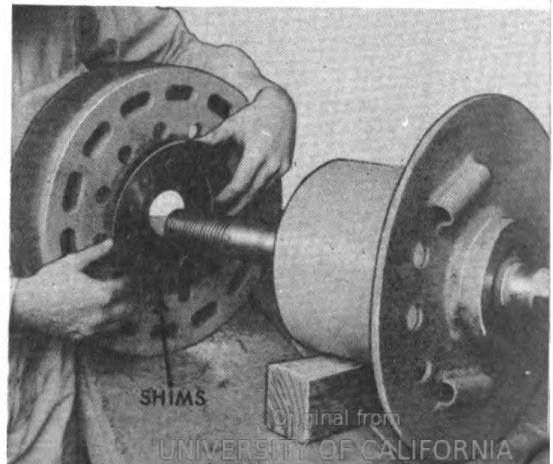
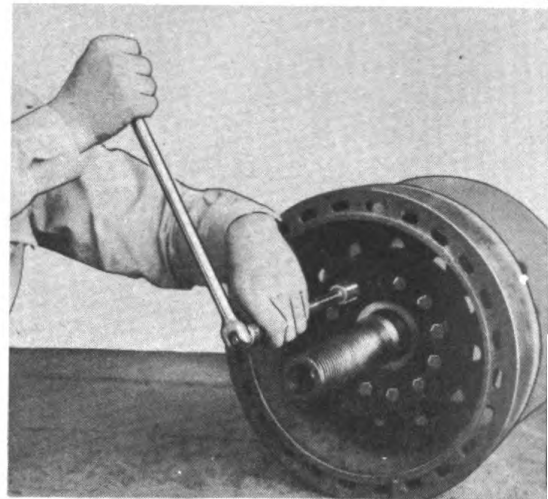
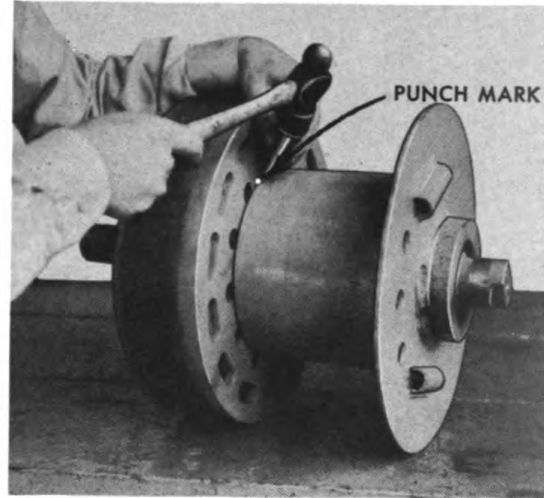
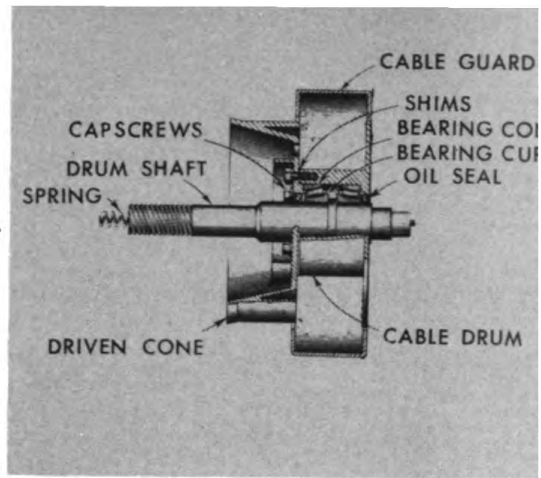

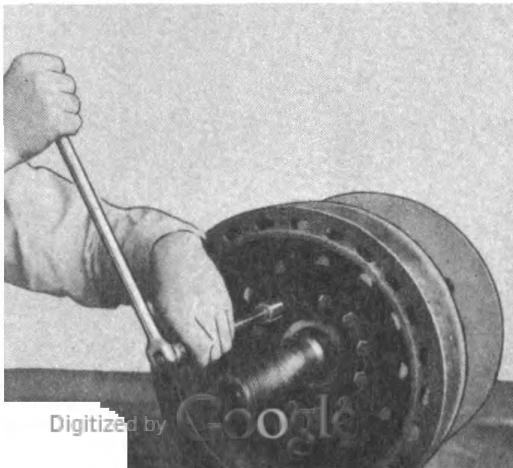
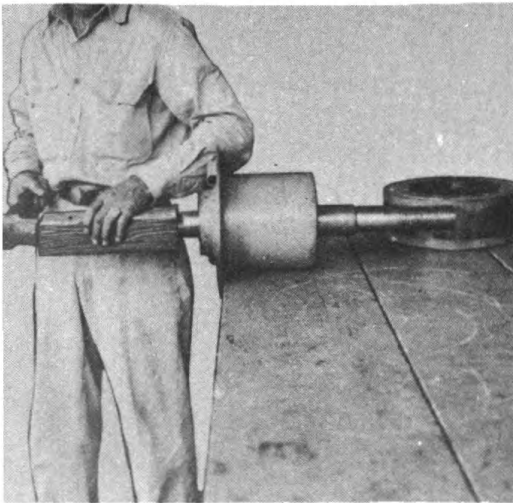
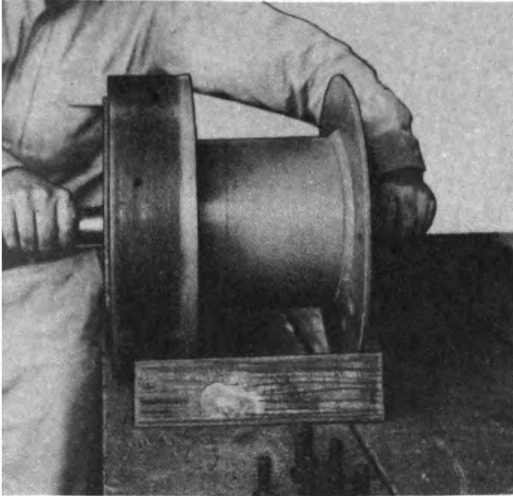
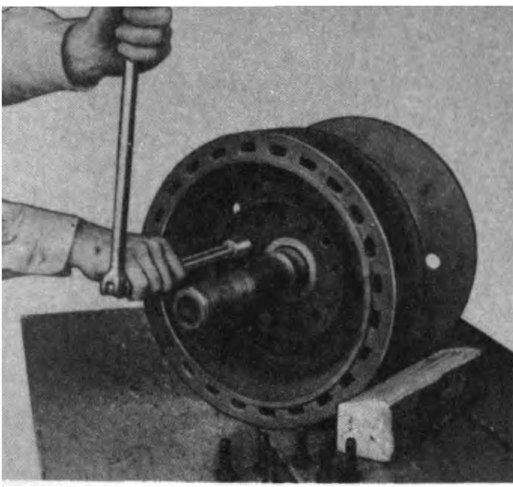

4. Reinstall driven cone on cable drum, lining up center punch marks on cone and drum. (This operation is done only to determine bearing tightness. Therefore, it is only necessary to install capscrews in every third capscrew hole. Do not use lockwashers in this operation due to damage to washers.) Turn capscrews up tight. If new oil seals are to be installed, leave them out until after the following test has been made.
5. Test adjustment by turning drum shaft in cable drum, using both hands. If adjustment is correct, there will be a definite drag on the drum shaft during this operation. Unless there is a noticeable drag on the drum shaft, the bearings are still loose and another shim must be removed. Repeat the above operation until the correct adjustment is reached.
6. In event the bearings are drawn up so tight in the above operation that the drum shaft cannot be turned by hand, it will be necessary to again remove the driven cone and then drive against the short end of the drum shaft, using a wooden block and sledge, thereby freeing the bearings. Then add one .004" shim and repeat operations 4 and 5.
7. When correct adjustment is reached, install capscrews and lockwashers in driven cone, drawing them up tight. If oil seals have been omitted or if release spring has been removed from end of drum shaft, install them in place. Then re-install drum assembly in unit.

Note—The cable drum bearings should be hand-packed with lubricant whenever the drum assembly is disassembled. This should therefore be done when making the above adjustment. (Refer to Page 15 of Operating Section.)

MAIN GEAR BEARING ADJUSTMENT

Occasional adjusting of the main gear bearings is necessary because of bearing wear. Check the main gear bearings for looseness every 256 hours of operation.

HOW TO CHECK ADJUSTMENT

1. Fully engage clutch, using considerable force on control lever. With clutch engaged, wedge driving cone tightly into driven cone by driving two chisels or wedges between driving cone and cover plate on opposite sides of cone.

2. If dial indicator is available, clamp indicator to unit with the contact point bearing against end of clutch throw nut at center. Move control lever slowly out of fully engaged position, back toward neutral, using little force. In other words, take up only the free travel of control lever. (Check to make sure driving cone is not moving in and out by placing finger between driving cone and cover plate, with which to feel any movement.) While moving control lever back and forth, check reading on indicator. If bearings are loose, throw nut will move in and out and indicator will show within approximately .002" amount bearings are loose. (As much as .002" of movement may not be due to loose bearings.)

3. If indicator is not available, fully engage clutch and drive wedges behind cone as in Step 1. Scribe a mark part way around clutch throw nut with a sharp tool such as a knife. (Mark should be right up against throw nut oil seal). Then move control lever, as in Step 2, while closely watching mark on throw nut. If bearings are loose, throw nut will move in and out and this movement will be visible to the eye when watching mark. The amount of movement determines extent to which bearings are loose.

If dial indicator shows an end movement of as much as .005" (Step 2), or if there is visible end movement of mark (Step 3), an adjustment should be made.

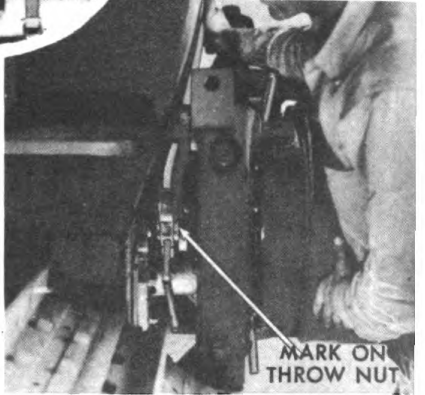
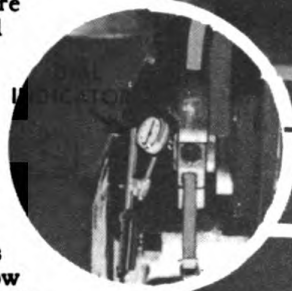
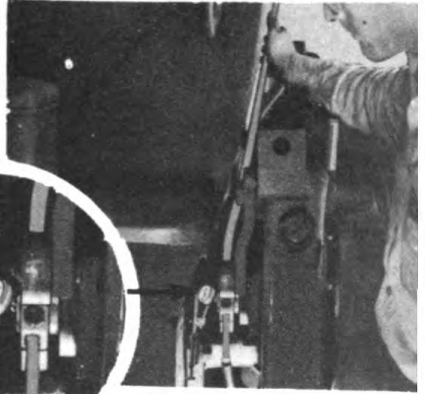

IF BEARINGS ARE LOOSE

If the Power Control Unit should be operated with the gear bearings in a loose adjustment, the driving cones may become misaligned with driven cones, thus causing spongy, erratic, clutch action. Also, the driving cones may "hang-up" in the driven cones when disengaging the clutches, resulting in cable breakage. In addition, the clutch cones may drag when in neutral position, resulting in over-heating of the unit. This in turn may cause oil seal failure.

HOW TO MAKE MAIN GEAR BEARING ADJUSTMENT

To make main gear bearing adjustments, first remove cable drum assembly from Unit. (Refer to disassembly instructions on page 11 of Repair Section.) Also remove neutral position spring from lower end of control lever. Then proceed as follows:

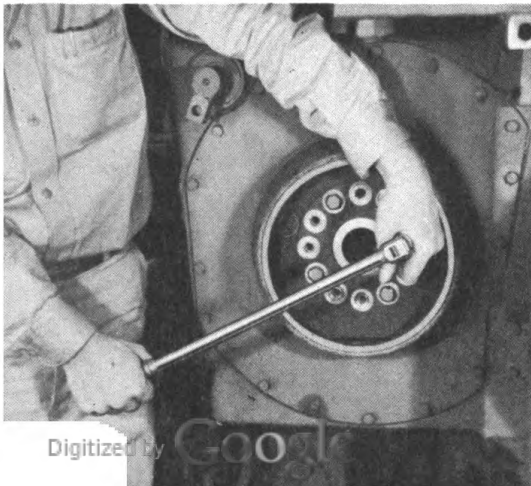
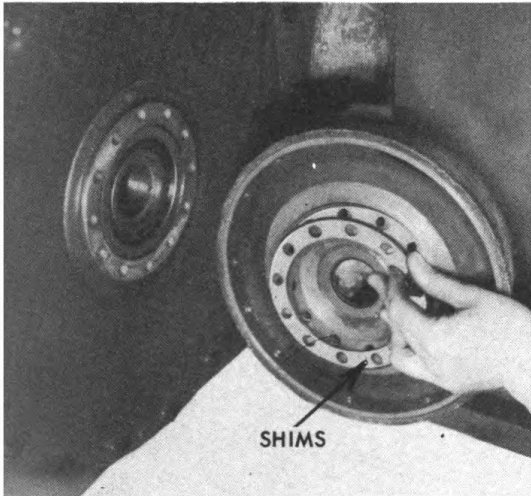
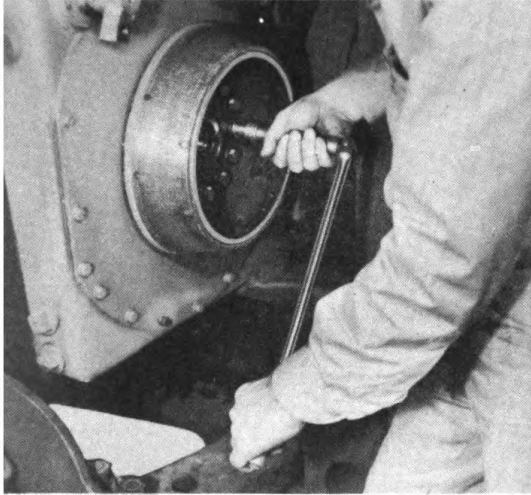

1. Feel amount of drag on clutch throw nut caused by oil seal. If Power Control Unit is mounted on tractor, this can be done by moving control lever back and forth by hand, with the control lever positioned as nearly erect as possible. Take hold of the control lever down close to the throw nut, as illustrated. If the Power Control Unit is removed from the tractor, the drag can best be felt by removing control lever from clutch throw nut and turning the throw nut by hand.
2. Remove capscrews which secure driving cone to hub of main gear. Then remove driving cone.
3. Remove bearing adjusting shim (or shims) from between driving cone and gear hub in order to take up adjustment. (Shims are of two thicknesses, .004" and .007", in order to make possible a fine variation in adjustment). Remove shims one at a time in making adjustment.
4. Reinstall driving cone on gear hub. (This operation is done only to determine bearing tightness. Therefore, it is only necessary to install capscrews in every third capscrew hole. Do not use lockwashers in this operation, due to damage to washers.) Turn capscrews up tight.

5. Check bearing tightness by feeling the drag on the throw-nut, as in Step 1. The bearings are correctly adjusted when all end play of the throw-nut in the gear hub has been eliminated, without the bearings causing a heavy drag on the throw-nut. (The drag may be slightly more than that caused by oil seals alone, as felt in Step. 1, but should not be great enough to cause a heavy drag on the control lever or to prevent the throw-nut from being turned with one hand if the control lever has been removed). In event the bearings are drawn up so tight in the above operation that there is a heavy drag on the throw-nut, it will be necessary to again remove the driving cone and then free the bearings as follows.
6. Move the main gear as far to the rear in the gear case as possible. Then insert a wood block between the front end of the clutch throw-nut and rear of tractor as illustrated (if Unit is mounted on tractor).
7. Then, with block inserted between throw-nut and tractor, drive against gear hub from the rear, using a wooden block and sledge, thereby freeing bearings. (*Caution*—Do not mar face of gear hub by driving directly against it with a hammer, sledge, punch, or other metal object.) If Power Control Unit is not mounted on tractor, drive against front end of throw-nut, rather than gear hub. Re-adjust bearings by adding one .004" shim and repeating operations 4 and 5.
8. When correct adjustment is reached, install capscrews and lock-washers in driving cone, drawing them up tight. Examine oil seal in hub of driving cone and replace if necessary. Then reinstall drum assembly, cable guards, and rear plate.

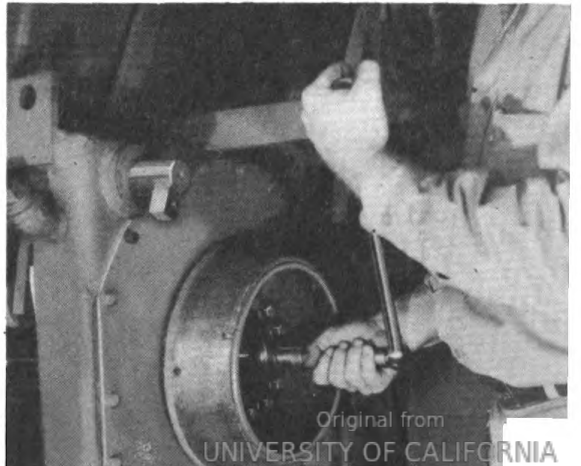

PINION BEARING ADJUSTMENT

(Only on Model "R" Series Units having serial numbers ending with the suffix D or E.)

Model "R" Series Power Control Units having serial numbers ending with the suffix D or E are equipped with helical gears and pinions.

Due to the end thrust that is thrown upon the pinion as a result of the use of helical gears, adjustable tapered roller bearings are used on the pinion shaft.

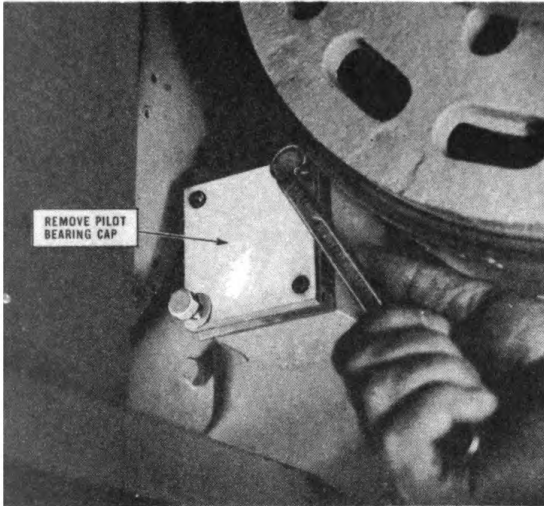

Occasional adjusting of the pinion bearings in these Units is necessary because of bearing wear.

Check the pinion bearing adjustment every 512 hours of operation.

HOW TO CHECK ADJUSTMENT

1. To check pinion bearings for looseness, first remove the pilot bearing cap from the Power Control Unit.

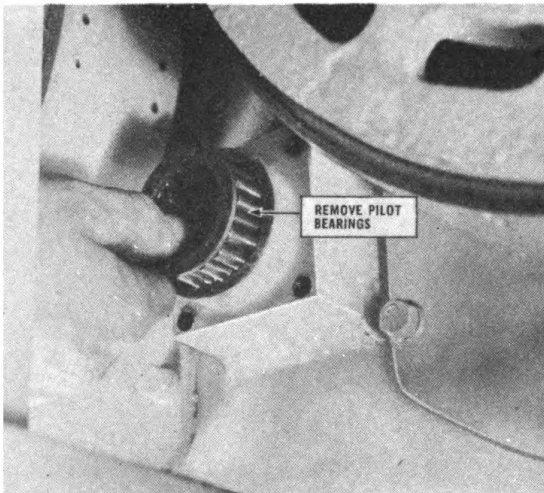

2. Slide pilot bearings off end of pinion. (There are two pilot bearings on end of pinion.)

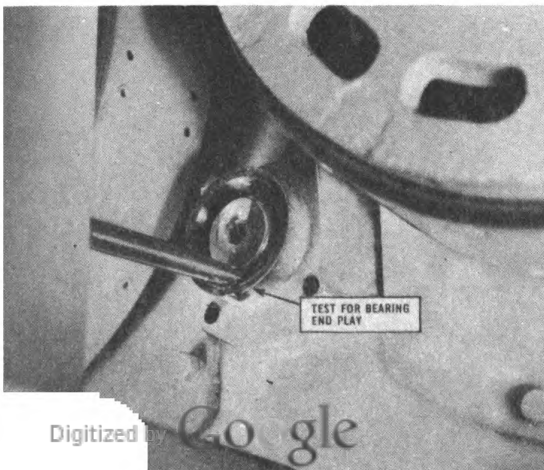

3. Pry lightly on end of pinion with a small bar, watching for movement of the pinion. If there is noticeable movement, the pinion bearings are too loose and an adjustment should be made. (The pinion bearings are correctly adjusted when they are .005" loose.)

HOW TO MAKE ADJUSTMENT

To adjust the pinion bearings, it is first necessary to remove the Power Control Unit from the tractor.

Then proceed as follows:

1. Remove capscrews which secure lock nut to bearing adjusting nut and turn lock nut off over end of pinion.
2. To tighten the bearings, turn the adjusting nut in a clockwise direction on the threads on front end of pinion. The bearings are correctly adjusted when there is .005" end play on end of pinion. Therefore, adjusting nut should only be turned up to the point where this amount of end play is received. With a dial indicator clamped to the Power Control Unit with the contact point bearing against end of pinion, it can be accurately determined when correct adjustment is reached by prying back and forth on pinion and reading the amount of end movement as recorded on indicator.
3. In event the bearings should be drawn up too tight when making adjustment, it will be necessary to back off adjusting nut and free bearings by driving against end of pinion, using a wooden block and sledge. Then repeat Step 2.

When the correct adjustment is reached, turn lock nut onto threads on pinion, leaving approximately $\frac{1}{8}$ " space between lock nut and adjusting nut. Then install and tighten capscrews through holes in lock nut and into holes in adjusting nut, thereby locking the adjustment.

Then re-install Power Control Unit on tractor.

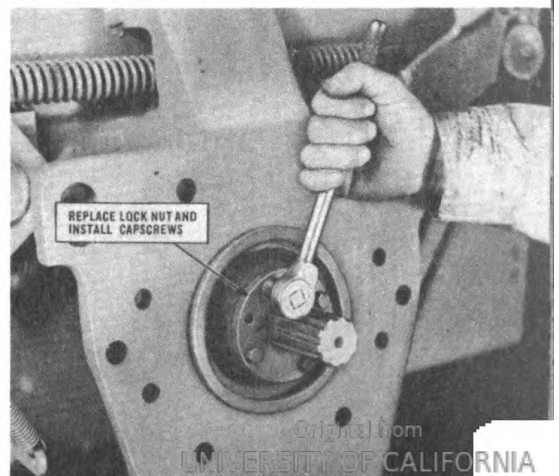
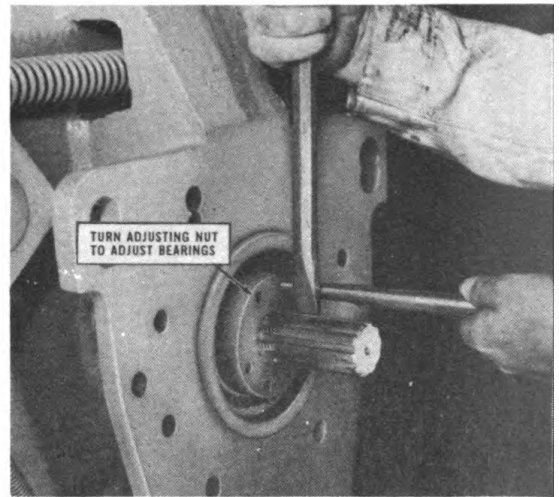
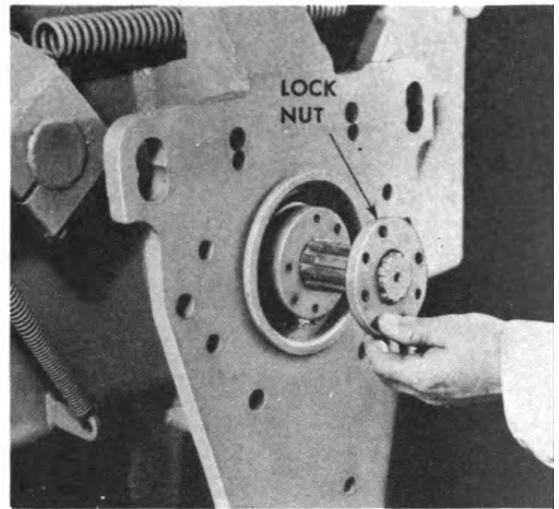
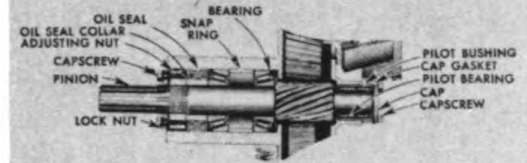

DOUBLE-DECK SHEAVE HOUSING BEARING ADJUSTMENT

There should be a slight drag on the double-deck sheave housing bearings at all times.

Check the adjustment every 128 hours of operation.

HOW TO CHECK ADJUSTMENT

To check the bearings for looseness, insert a pry bar between the bottom of each sheave housing and the sheave bracket, and pry up and down with the bar.

If in this operation up and down movement of the sheave housings is found, it is an indication that the bearings are loose and an adjustment should be made.

HOW TO MAKE ADJUSTMENT

To make the adjustment, first loosen the clamp bolt at the top of the double deck sheave bracket as illustrated.

Then, using a hammer and punch, turn the adjusting nut in a clockwise direction until a slight drag is felt when turning the sheave housings by hand. During this operation, tap on the sheave housings with a hammer to make sure that the take up in bearing adjustment is equally distributed to both the upper and lower housings.

When the correct adjustment is reached, re-tighten the clamp bolt at the top of the sheave bracket.

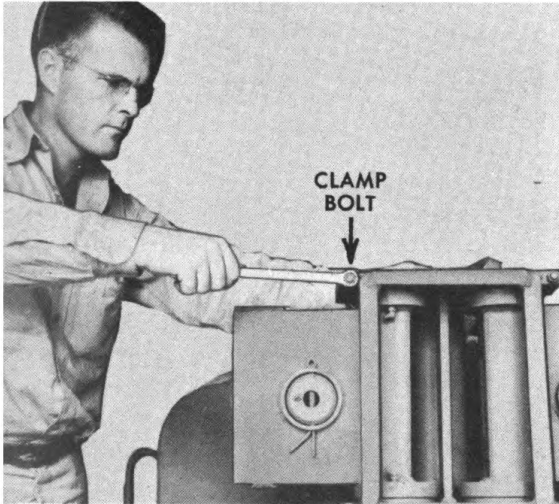
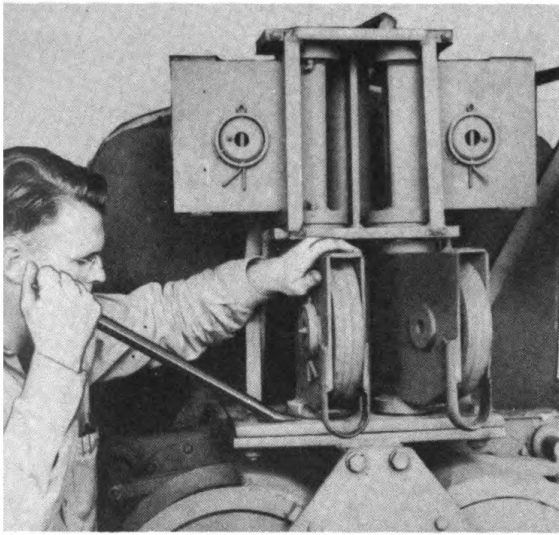
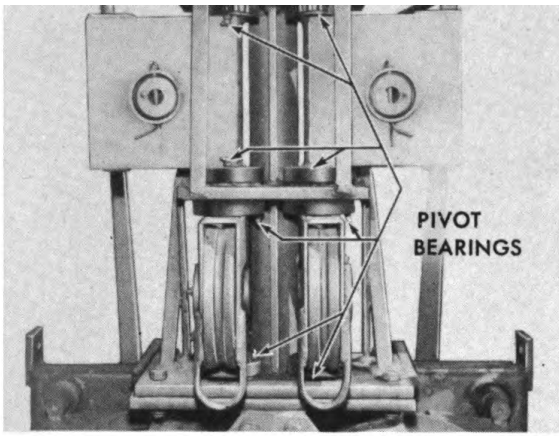

DISASSEMBLING

When disassembling a Power Control Unit to replace a worn part, install new clutch or brake facings, remove bearing adjusting shims, etc., the length of time that is consumed is quite often an important matter, especially if the disassembly results in other equipment being shut down during that period. Therefore the instructions which follow explain the quickest and easiest method of correctly removing and disassembling each assembly or group of related parts.

REMOVING CABLE DRUM ASSEMBLIES

The cable drum assemblies can be removed without removing the Power Control Unit from the tractor. To remove either the left or right cable drum assembly, first remove cable from cable drum. Then proceed as follows:

1. Loosen clamp blocks which clamp rear end of drum shafts to power control unit rear plate by loosening clamp bolts. Then remove capscrews (A) which secure rear plate to Power Control Unit.
2. Remove rear plate and cable guards as one unit by sliding them to the rear, off the ends of the drum shafts, as illustrated. Also remove brake band from drum that is to be removed. (Refer to instructions for removal of brake band on page 16 of Repair Section.
3. Remove either right or left cable drum assembly by turning drum shaft out of clutch throw-nut, using a wrench. Turn the left drum shaft clockwise and the right drum shaft counter-clockwise. In this operation it is necessary to support the cable drum as illustrated in order to prevent damaging the oil seal in the hub of the driving cone as the drum shaft passes through the seal.

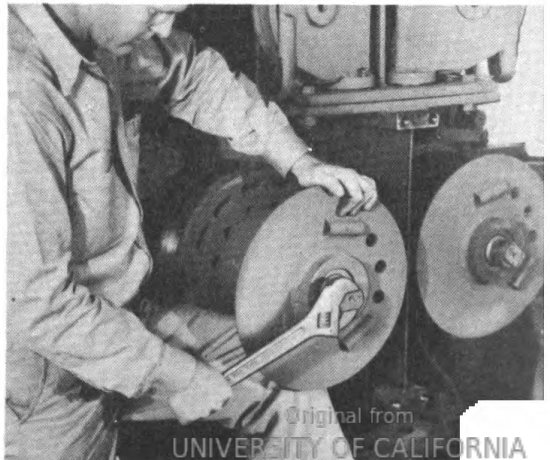
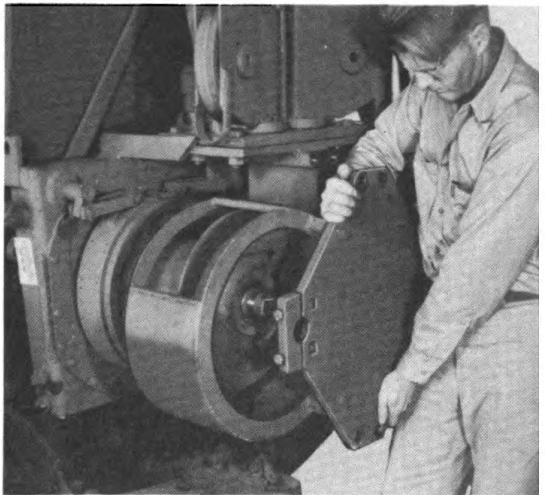
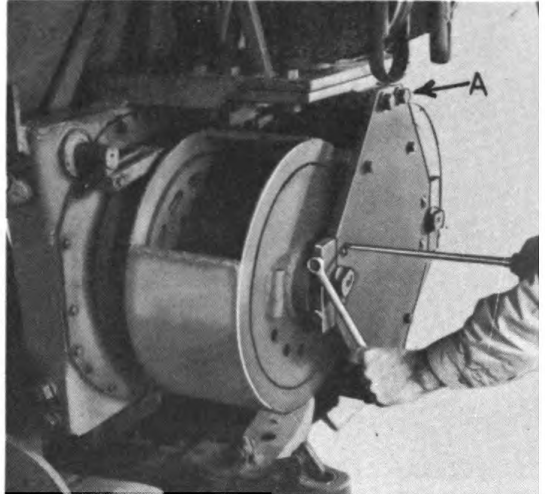

DISASSEMBLING CABLE DRUM ASSEMBLIES

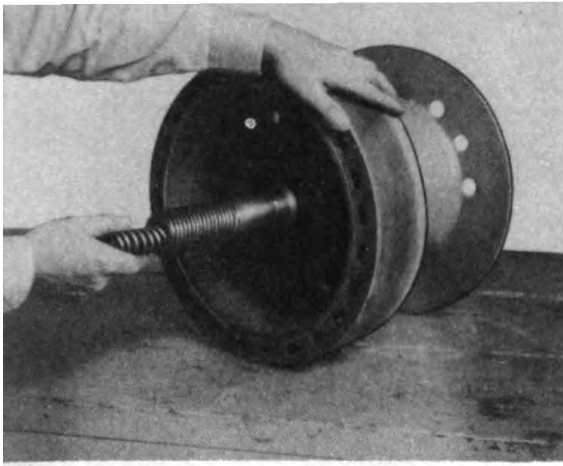

1. If spring at end of drum shaft is to be removed, pull it out of end of shaft.

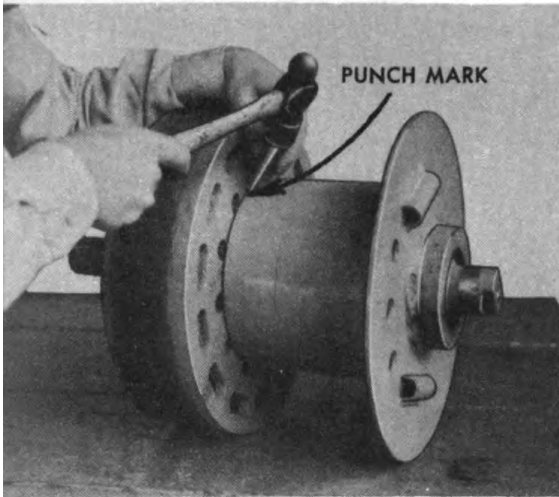

2. With hammer and punch, mark cable drum and driven cone at the points shown. This is done in order to assure proper alignment when reassembled.

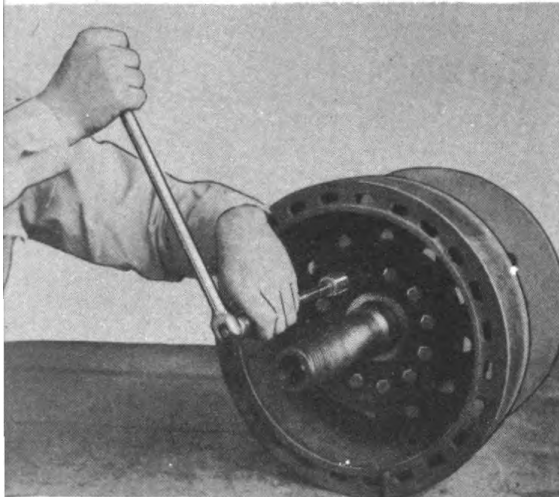

3. Remove capscrews which secure driven cone to cable drum. Then slide driven cone off over end of drum shaft, being careful not to damage hub oil seal.

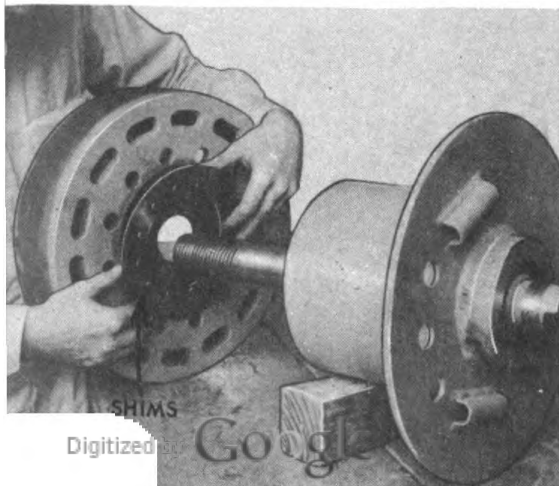

4. Remove bearing adjusting shims from between cable drum and driven cone. To avoid loss of shims, wire them together.

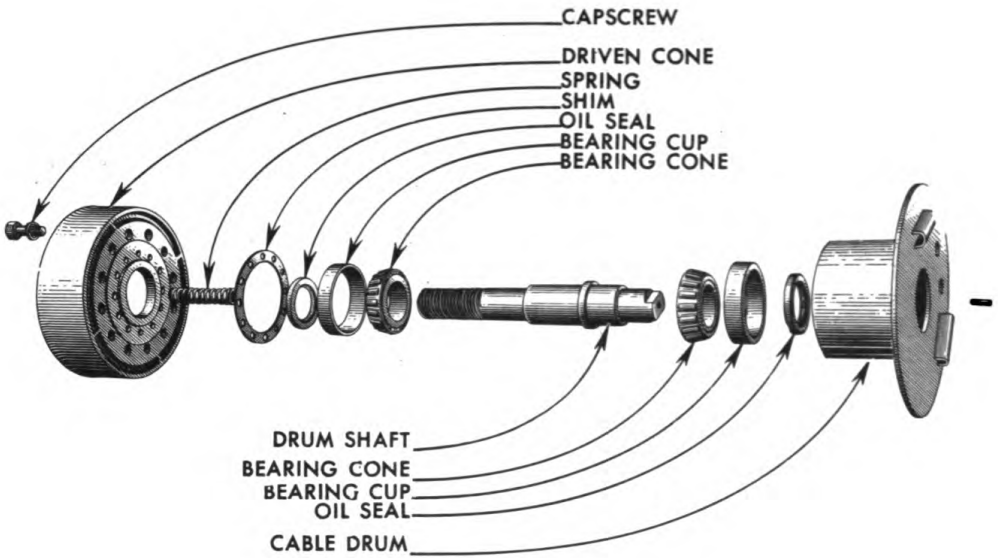

5. Remove drum shaft from cable drum by driving against short end of shaft, using a wood block and sledge. The bearing cup at opposite end of cable drum will be removed during this operation.

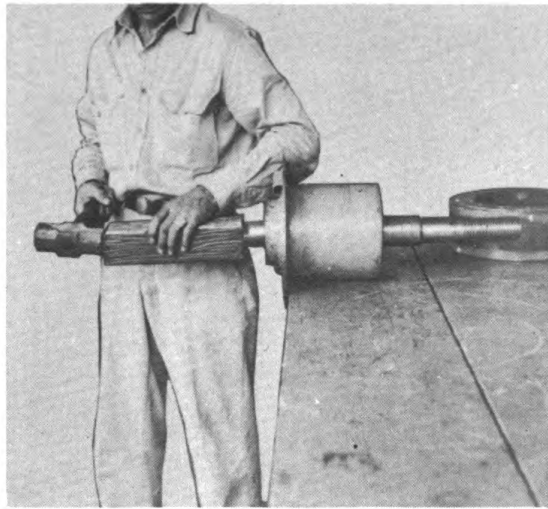

6. If bearing cones are to be replaced, drive or pull them off drum shaft. Also, the cable drum oil seal and the remaining bearing cup can be removed from the cable drum.

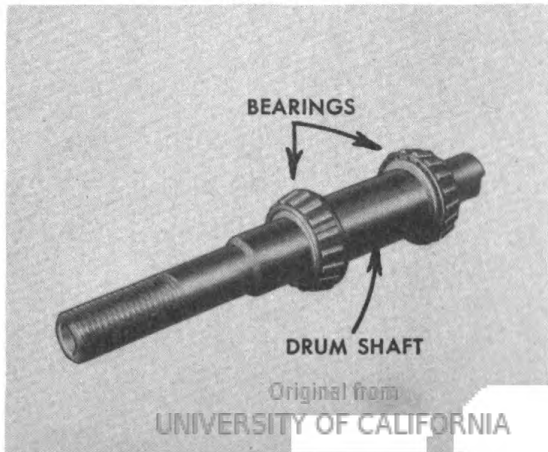

REMOVING MAIN GEAR AND DRIVING CONE ASSEMBLY

The main gear and driving cone assemblies can be removed without removing the Power Control Unit from the tractor. To remove either the left or right gear and cone assembly, follow the instructions below.

1. First remove cable drum assembly, as outlined in preceding instructions. Then remove driving cone by removing capscrews which secure it to hub of main gear. Remove bearing adjusting shims from back side of driving cone. (To avoid loss of shims, wire them together.) If driving cone oil seal is to be replaced, remove it from hub of driving cone.
2. To remove main gear, gear bearings, or clutch throw-nut, proceed by draining the oil from the gear case and removing capscrews which secure cover plate to gear case.
3. Strike cover plate a blow near center with a hammer, thereby breaking cover plate loose from gear case. Then pry cover plate away from gear case as illustrated, using a screw driver or similar tool. Care should be used to pry cover plate off evenly in order to avoid damaging oil seal and dowel pins. Remove oil seal from cover plate if it is to be replaced.
4. Loosen clamp bolt from lower end of control lever, thereby freeing control lever on clutch throw-nut. Then move the main gear as far to the rear in the gear case as possible and insert a wood block between the front end of the clutch throw nut and rear of tractor as illustrated (if Unit is mounted on tractor).

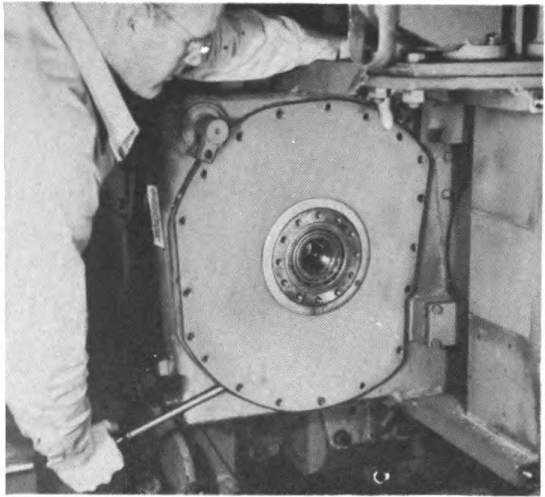
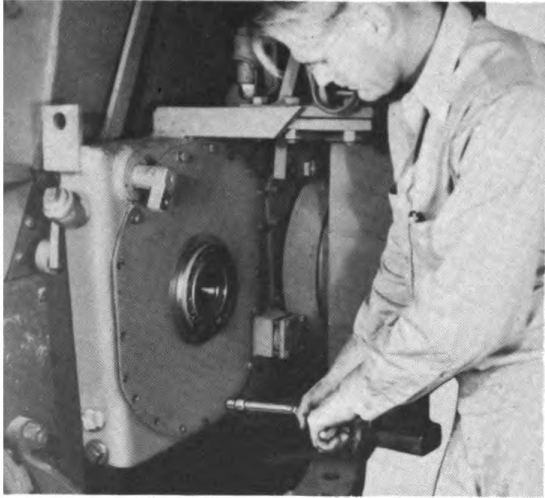
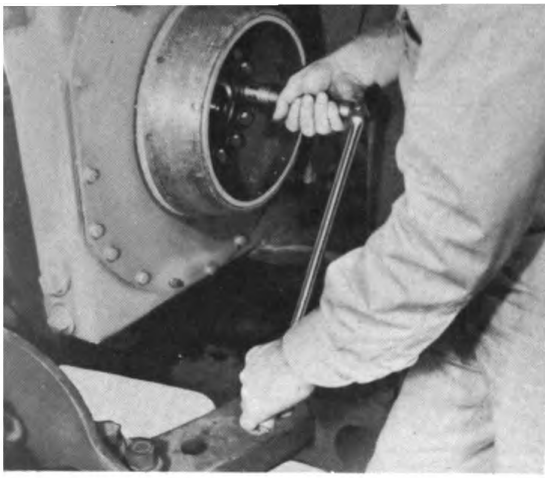

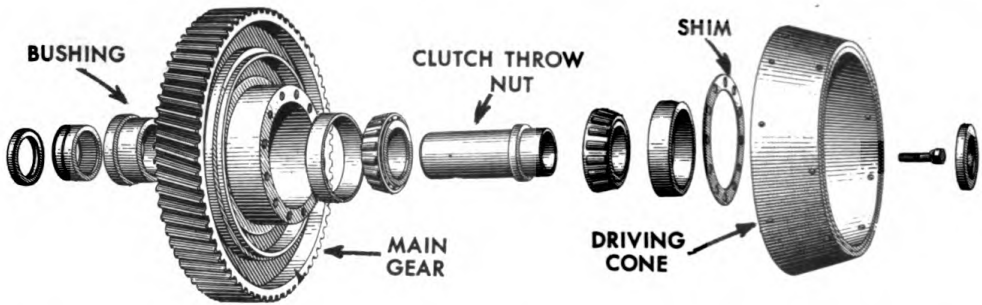

5. Then, with block inserted between throw nut and tractor, drive against gear hub from the rear, using a wooden block and sledge, thereby driving bearing cup out of rear side of main gear hub. (*Caution*—Do not mar face of gear hub by driving directly against it with a hammer, sledge, punch, or other metal object.) If Power Control Unit is not mounted on tractor, drive against front end of throw nut with block and sledge, rather than against gear hub.

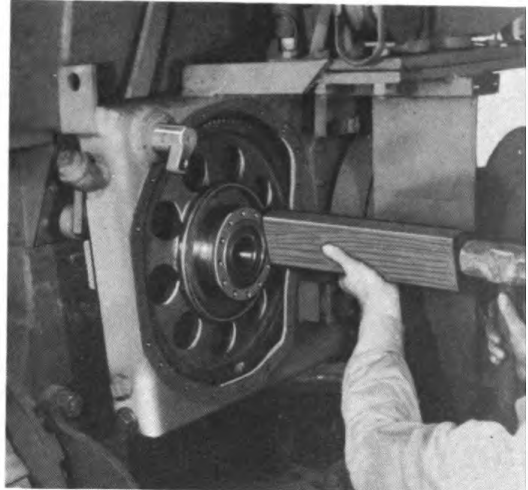

6. Slip control lever off front end of clutch throw nut and then lift throw nut and main gear bearings out of gear hub as one unit. If bearings are to be replaced, either drive or pull them off the throw nut.

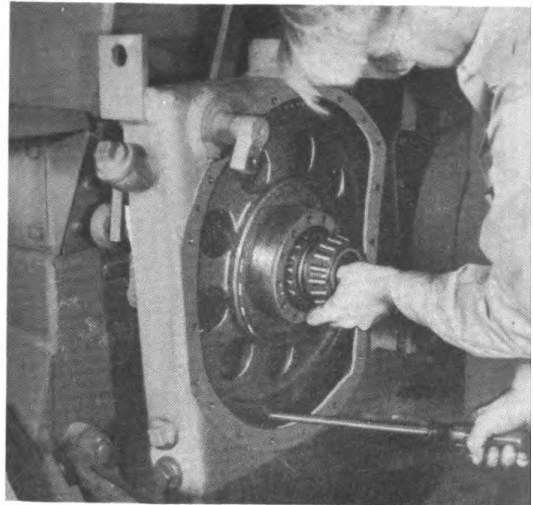

7. Lift main gear out of gear case through cover plate opening. If remaining bearing cup is to be removed, drive or pull it out of the gear hub. (*Note*—In event the gear will not pass through the cover plate opening on any particular Unit after completing Step 6, it will be necessary to also remove the throw nut from the remaining gear in the other side of the gear case before the removal of the gear can be effected.)



REMOVING BRAKE ASSEMBLIES

All parts of the brake assemblies can be removed without removing the Power Control Unit from the tractor.

1. Before removing any part of either the right or left brake assembly, it is usually advisable to first remove the brake spring.

2. To remove a brake band, first remove the rear plate and cable guards. (Refer to disassembly instructions on page 11 of Repair Section.) Then remove link pins which connect brake links with brake shaft and gear case, leaving brake links connected to brake band.

3. Slide brake band off over cable drum.

4. To remove a brake roller arm or brake shaft, it is not necessary that the brake band and cable guard first be removed. The first step in removing the roller arm is to release the clamp bolt at the upper end of the roller arm.

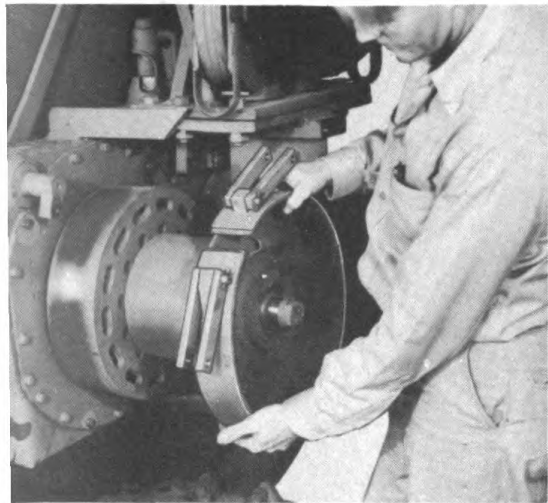
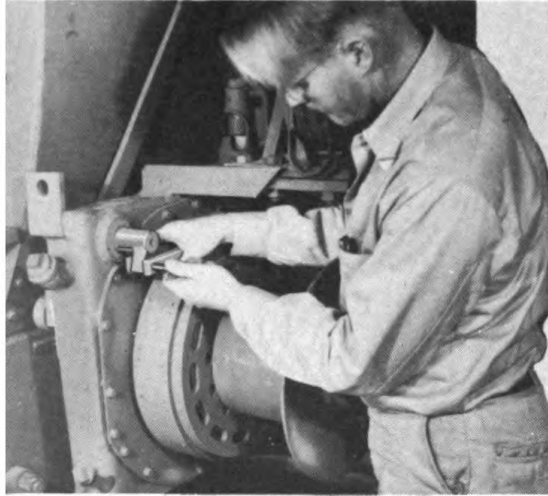
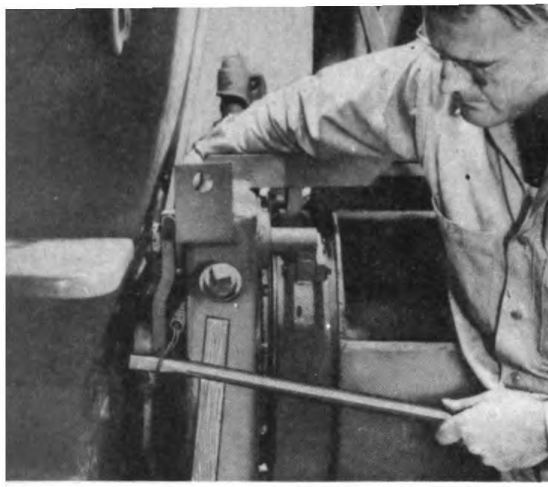

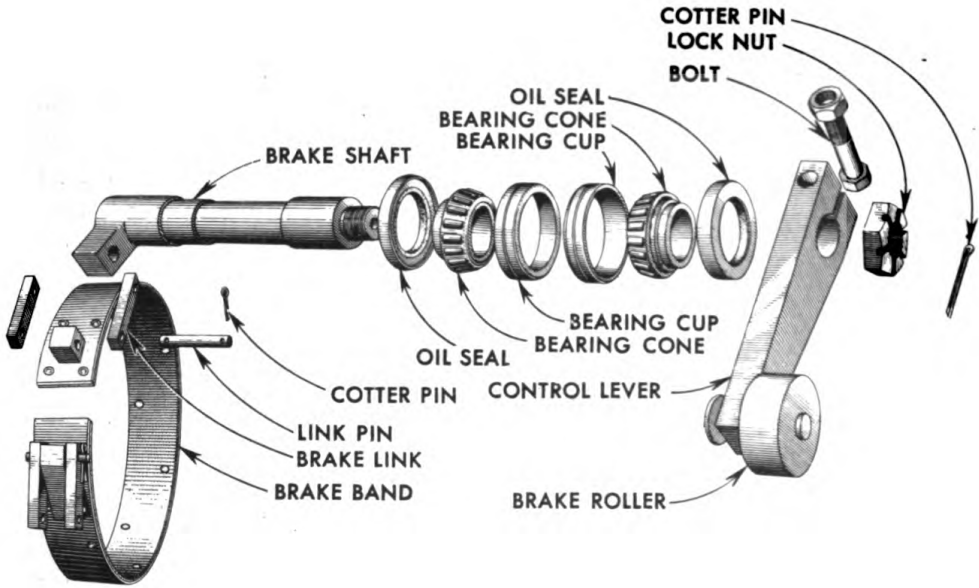

5. Remove the cotter pin and then turn castellated nut (A) off the end of the brake shaft. The roller arm can now be slipped off the front end of the brake shaft.

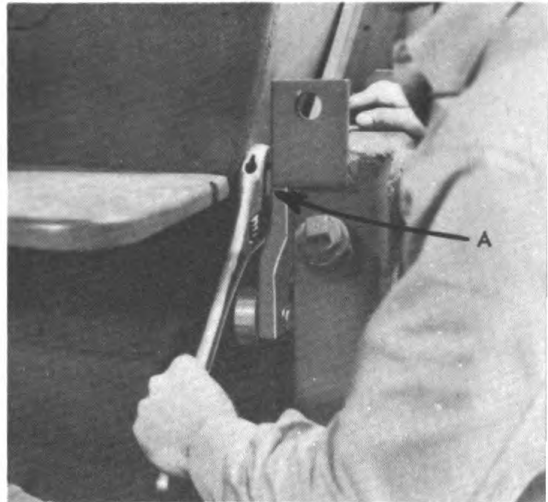

6. If the brake shaft is to be removed, pry it out of gear case, using a pry bar and wooden block as illustrated. The rear bearing cone and oil seal can then be removed from shaft and the front bearing cone and oil seal from housing. If bearing cups are to be removed, pull them out of housing.



REMOVING CLUTCH THROW-NUT BEARINGS, OIL SEALS AND BUSHINGS

The clutch throw-nut bearings, oil seals, and bushings can be removed without the Power Control Unit removed from the tractor

1. To remove clutch throw-nut bearing and oil seal from either side of the Unit, first remove throw-nut and main gear as outlined in previous instructions. Then drive bearing out of bushing from inside of gear case, using a hammer and wood block. The oil seal will be forced out of bushing ahead of bearing.
2. The clutch throw-nut bushing is pressed tightly into the gear case and very seldom requires replacing. However, if the inner bearing surface should become worn to the point that replacement is necessary, the bushing can be driven out of the gear case by using a steel punch and hammer or sledge.

REMOVING PINION

(All Model "R" Series Units except those having serial numbers ending with the suffix D or E.)

To remove the spur tooth pinion from one of the above units, first remove the Power Control Unit from the tractor. Then proceed as follows:

1. Drain the oil from the Power Control Unit gear case. Then remove the four capscrews from the pilot bearing cap and remove the cap and gasket.
2. Remove the pilot bearings from the end of the pinion and then drive against the pinion from the pilot end, forcing it out of the Power Control Unit gear case. Then remove the oil seal, remaining bearing, etc.

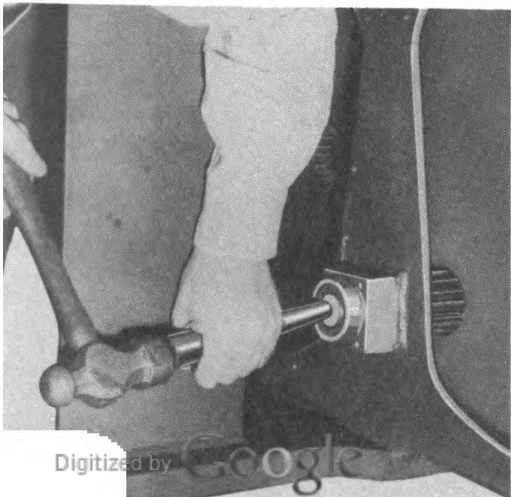
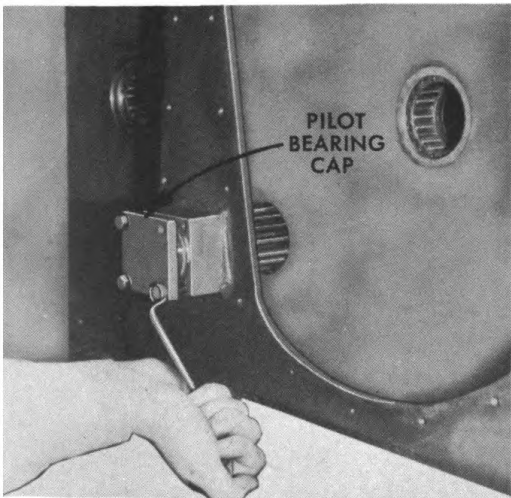
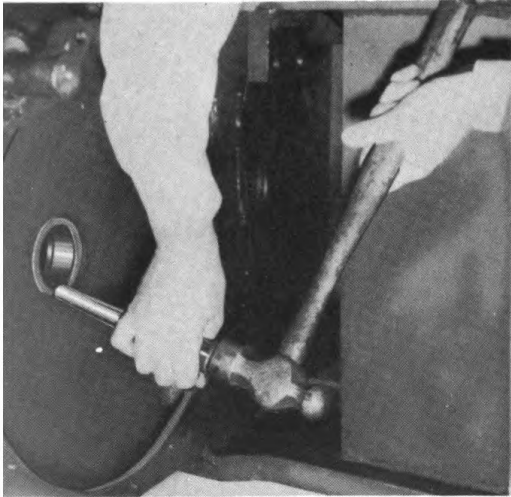
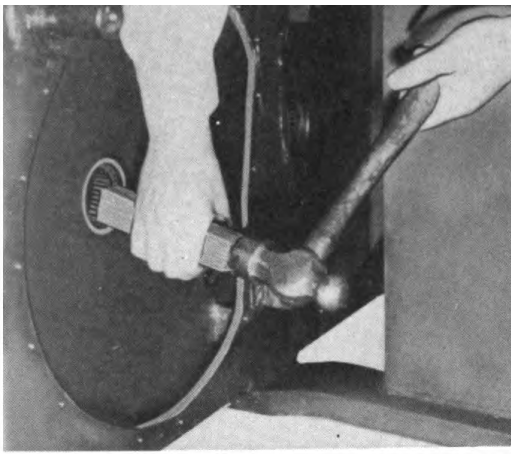

REMOVING PINION

(On Model "R" Series Power Control Units having serial numbers ending with the suffix D or E.)

All Model "R" Series Power Control Units having serial numbers ending with the suffix D or E are equipped with helical tooth gears and pinions. To remove a pinion from one of these Units, first remove the Power Control Unit from the tractor.

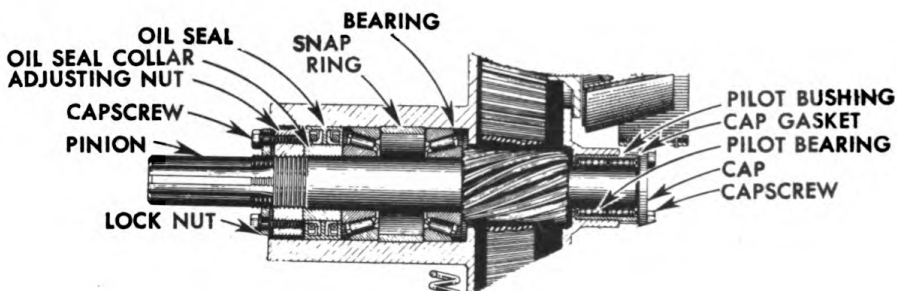

Drain the oil out of the Power Control Unit gear case. Then, with the pilot bearing cap and pilot bearings removed, force the pinion out of the gear case as follows:

1. Remove cable guards and rear plate. Also remove cable drum assembly from right side of Unit.
2. Install a steel plate on the back of the Power Control Unit, in the position normally occupied by the Power Control Unit rear plate. (The rear plate should not be used in the operations which follow because of the danger of bending or flexing the plate, thereby causing misalignment of cable drums when re-assembled.) Make use of the same capscrew holes when installing steel plate on back of Unit as is used to secure rear plate to Unit.
3. Insert a hydraulic jack between rear end of pinion and newly installed steel plate, with which to jack pinion forward, out of gear case.
4. Remove capscrews from Power Control Unit neck and remove lock nuts from capscrews. Then re-install capscrews in neck and turn them in far enough to raise snap ring up out of groove in which it sets.
5. Using the jack, start forcing the pinion forward. After the initial forward movement, snap ring will have passed the groove in which it sets and capscrews in neck should be backed out to avoid catching them on inner bearing cup as pinion is moved farther forward.
6. Force the pinion out the front of the gear case, using the jack.
7. By removing the capscrews from the lock nut, the adjusting nut and lock nut can be turned off the end of the pinion. The oil seal, oil seal collar, bearings and snap ring can then be removed from the pinion.

The pilot bushing is pressed tightly into the gear case. If it is to be replaced, it must be forced out of the case.

REASSEMBLY

INSPECTION OF PARTS

Before re-assembling the Power Control Unit, the following inspection and care of parts should be made:

1. Carefully examine oil seals before re-installing. Replace any oil seals which do not appear to be in good condition.
2. Make new oil seals pliable by soaking in light weight oil and by running a round object, such as the shank of a screw-driver or hammer handle, around the inner circumference of the seal, thus working the leather.
3. Replace all working parts that are worn excessively.
4. Examine bearings before re-installing. Use none that may have become Brinelled, pitted, or excessively worn.
5. Replace bearing cups when replacing bearing cones, and vice-versa.
6. Examine clutch and brake facings before re-installing driving cones or brake bands. Wash oil soaked woven facings with gasoline or naphtha. Roughen woven facings that have become glazed with a rasp. Make sure facings are tight on driving cone or brake band before reinstalling. If driving cone has been newly re-lined with metallic facing, the facing should be machined to a 15° taper to take off any high spots.
7. Replace brake spring if it has become stretched and lost its tension.
8. Keep all parts clean and free from foreign particles during assembly.

ASSEMBLING

The procedure for assembling the Power Control Unit is the reverse of that for disassembling the Unit. (Refer to Disassembling Instructions.)

If the pinion has been removed from the Power Control Unit, it must be re-installed before the Unit can be mounted on the tractor. However, the remainder of the parts of the Unit can be installed with the Unit either mounted or removed from the tractor.

The procedure which follows is for the assembling of parts on only one main gear, brake, and cable drum assembly. Since both the right and left assemblies are alike the same procedure can be used for assembling both.

The parts can be assembled in the following order:

PINION ASSEMBLY

(A) (*Spur Tooth Pinions*)

All Model "R" Series Power Control Units excepting those having serial numbers ending with the suffix D or E are equipped with spur

tooth gears and pinions. To install a pinion in one of these units proceed as follows:

Press or drive the bearing spacer (66) into front end of neck up tight against gear case. Also drive bearing race (67) into neck and up against bearing spacer. Then install pinion (69) through front end of neck and install bearing (67) over front end of pinion. Install pilot bearings (71) over end of pinion. Then install gasket and cap at rear end of pinion by inserting capscrews and lockwashers, tightening capscrews evenly. Press oil seal (68) into place on front end of pinion.

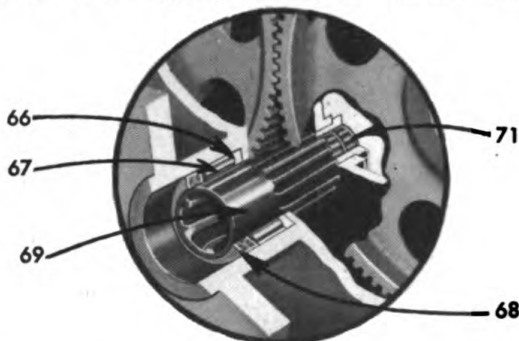

(B) (Helical Tooth Pinions) (Refer to illustration on page 23.)

All Model "R" Series Power Control Units having serial numbers ending with the suffix D or E are equipped with helical tooth gears and pinions. To install a pinion in one of these Units proceed as follows:

Press or drive bearing cone (62) up tight against teeth on pinion (28), if removed. Then insert pinion into gear case through front end of the Power Control Unit neck. Press or drive bearing cup (63) and snap ring (64) into place. Also press or drive bearing cup (32) and bearing cone (29) into place in neck. Then install oil seal collar (26) and oil seal (25) over front end of shaft, up against bearing cup. Install adjusting nut (31) onto threads on end of shaft and tighten nut to point where pinion shaft has .005" end play. (Refer to pinion bearing adjustment instructions on page 8 of the Repair Section.) Then turn lock nut (27) onto threads on pinion, leaving approximately $\frac{1}{8}$ " space between lock nut and adjusting nut. Install capscrews and lockwashers (30) and tighten capscrews through holes in lock nut and into holes in adjusting nut. Install pilot bearings (61) on rear end of pinion. When pinion bearing adjustment has been made install gasket and pilot bearing cap by inserting capscrews and lockwashers, tightening capscrews evenly.

BRAKE ASSEMBLY

Install bearing cone (10) and oil seal (3) onto rear end of brake shaft (9), if removed. Also press bearing cups (8 and 11) into front and rear ends of housing. Then insert brake shaft (9) through housing from the rear and install remaining bearing cone (7) and oil seal (6) over front

end of shaft, up against the bearing cup. (*Note:* During assembly, the brake shaft bearings should be handpacked with lubricant, as outlined in Lubrication Instructions on page 14 of the Operation Section.) Install clamp bolt and lockwasher (4) in upper end of brake roller arm (12) and install roller arm on end of brake shaft (9). Install castellated nut (5) onto threads on end of shaft and tighten nut to point where all end play of shaft is eliminated, but without drag on brake shaft bearings. Then install cotter pin in end of shaft, thereby locking nut (5), and tighten clamp bolt (4) in upper end of roller arm (12).

The brake band (35) is installed later during cable drum installation. Also, the brake spring (15) is usually installed later when the unit has been completely assembled.

CLUTCH THROW NUT BUSHING, BEARING, AND OIL SEAL

If throw-nut bushing (17) has been removed from gear case, press or drive replacement bushing into case. Insert bearing (21) inside bushing. Do not install oil seal (20) in bushing (17) until after main gear and driving cone assembly has been installed and the main gear bearing adjustment made.

MAIN GEAR AND DRIVING CONE ASSEMBLY

Press or drive bearing cones (52) onto clutch throw-nut (60), if removed. Also press bearing cup (57) into hub of main gear (37). Raise main gear into position in gear case. (If both main gears have been removed, place both in position in the gear case before installing either clutch throw-nut.) Insert throw-nut (60) into gear hub from rear, with end of throw-nut extending out through bearing (52). Slip control lever onto end of throw nut, not tightening clamp bolt until later. Install remaining bearing cup (49) in gear hub from rear, not drawing cup up tight against bearing cone until later. Press oil seal (56) into cover plate (58) with heavy leather cupped toward inner side of plate. Then install gasket and cover plate (58) in position, lining up dowel pin holes with dowel pins, and install capscrews and lockwashers (59). (Be careful not to damage or reverse leather in oil seal (56) when installing cover plate). Press oil seal (53) into hub of driving cone (55) with leather cupped toward front side of cone. Raise driving cone (55) into position against hub of main gear (37), inserting between the two the number of shims required to correctly adjust the main gear bearings (refer to main gear bearing adjustment instructions on page 6 of Repair Section) and install capscrews and lockwashers (54), turning them up tight. (When installing driving cone on gear hub, it is advisable to insert two $\frac{1}{2}$ " stud bolts in opposite capscrew holes in gear hub to serve similar to dowel pins, in order to assure proper alignment of the cone on the gear. The studs should be removed after the cone has been secured to the gear, and capscrews installed in their place. Use care

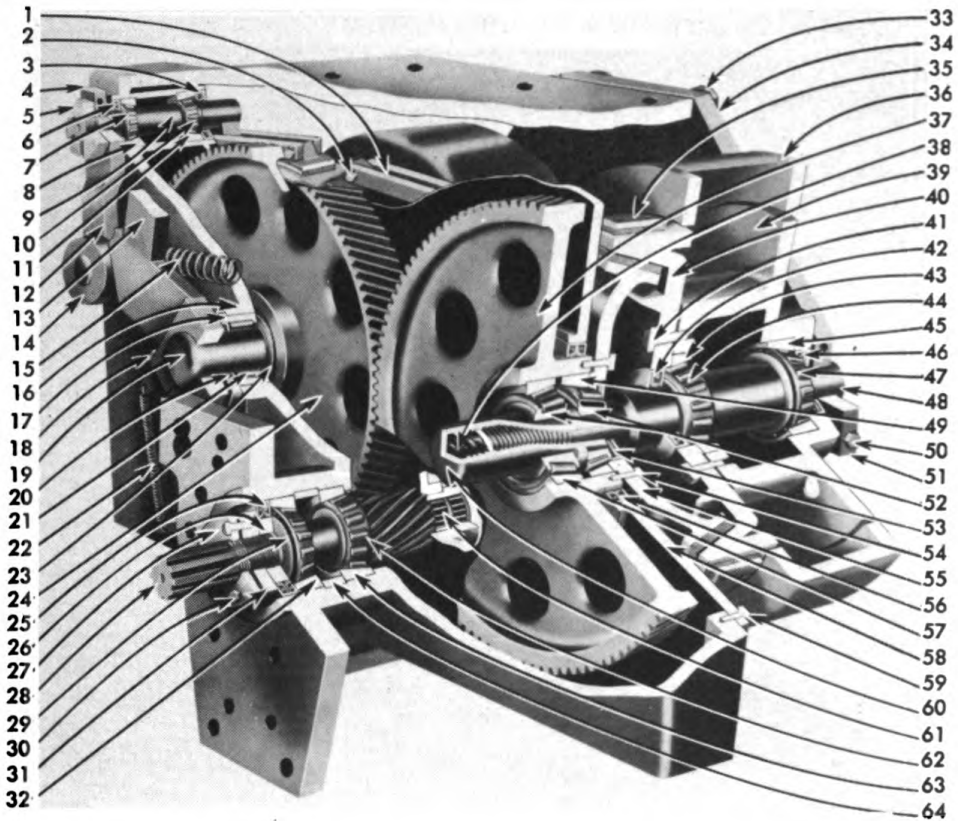

when installing the driving cone on the gear hub, to avoid peeling off a burr which might become deposited between the gear hub and cone and thereby cause misalignment). After the main gear bearing adjustment has been made, install oil seal (20), being careful not to damage or reverse leather in oil seal.

ASSEMBLING CABLE DRUM ASSEMBLY

Press bearing cones (44 and 47) onto drum shaft (48), if removed. Also press bearing cup (45) into rear end of cable drum (39). Insert drum shaft into cable drum from front end of drum and install remaining bearing cup (43) in cable drum from front end, not installing it tight against bearing cone until later. Place clutch driven cone (40) in position against cable drum (39) inserting between the two the number of shims required to correctly adjust the cable drum bearings (refer to cable drum bearing adjustment instructions on page 3 of Repair Section), and install capscrews and lockwashers (41), drawing them up tight. After cable drum bearing adjustment has been made install oil seal (42) in front end of cable drum and oil seal (46) in rear end of cable drum with leathers cupped inward, being careful not to damage or reverse leather in oil seals. (Note: During assembly, the cable drum bearings should be packed with lubricant, as outlined in Lubrication Instructions on page 14 of the Operation Section). Insert spring (38) in end of drum shaft (48).

INSTALLING CABLE DRUM ASSEMBLY

Raise drum assembly up to rear end of gear case and turn drum shaft (48) into clutch throw-nut (60) using a wrench on rear end of shaft. (Be very careful in this operation not to damage leather in oil seal (53) as threads on end of shaft pass through seal). Slide brake band (35) over cable drum and onto driven cone (40). Connect outer end of band with rear end of brake shaft (9) and inner end of band with lug on gear case by means of brake links (1) and pins (2). If the cable guard (36) has been removed from rear plate (34), reinstall by inserting capscrews and lockwashers. Install cable guard and rear plate as one unit by sliding over cable drum (39) and fasten rear plate to gear case by inserting capscrews and lockwashers (33) in top and bottom of rear plate. Then tighten cap (51) on drum shaft (48) by turning capscrews (50) tight into tapped holes in rear plate.

Tighten clamp bolt at lower end of control lever (13). Also make clutch and brake adjustments and lubricate unit before placing it in operation. (Refer to adjustment and lubrication instructions in Operation Section).

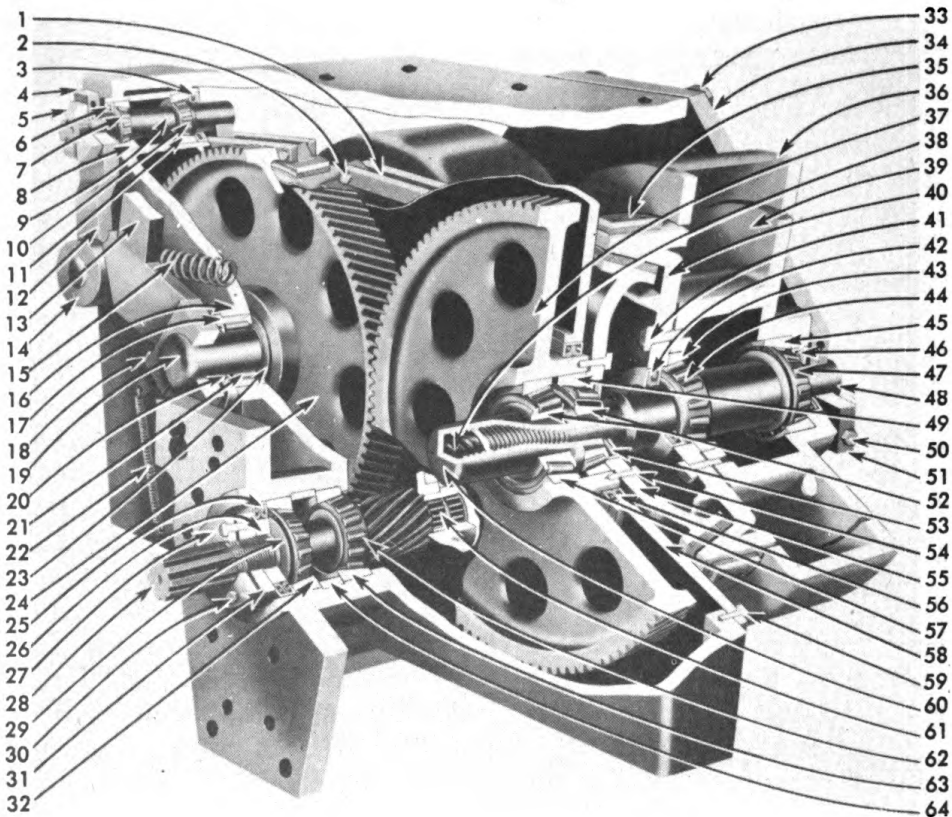

REMOVING POWER CONTROL UNIT FROM TRACTOR

1. To remove the Power Control Unit from the tractor, first connect a hoist chain to the Power Control Unit as illustrated, with which to support the Unit during removal.

2. With all the slack taken out of hoist chain, remove mounting cap-screws and hex nuts which secure Power Control Unit to rear of tractor.

3. Insert a pry bar between Power Control Unit face plate and rear of tractor, thereby prying Power Control Unit to the rear, away from tractor. Move the Power Control Unit to the rear far enough to permit the pinion to slide off the end of the spline shaft, and then lower the Power Control Unit to the floor or ground.

4. Complete the removal by pulling spline shaft to the rear, off the end of the tractor upper transmission shaft. If the tractor is to be operated without a Power Control Unit installed on the rear, install the inspection plate on the rear of the tractor. Also remove the two large studs from the rear of the tractor and install corks in the bolt holes to prevent oil leakage.

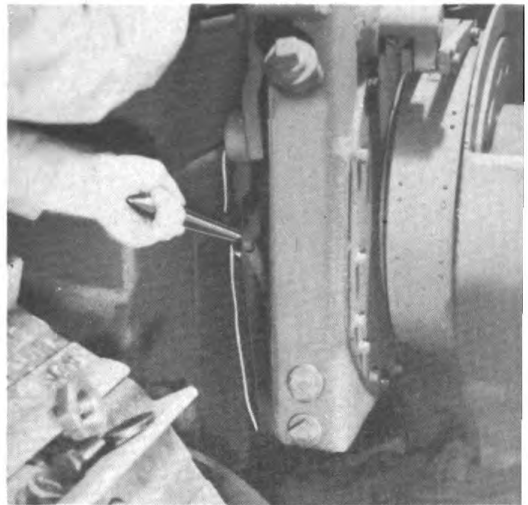
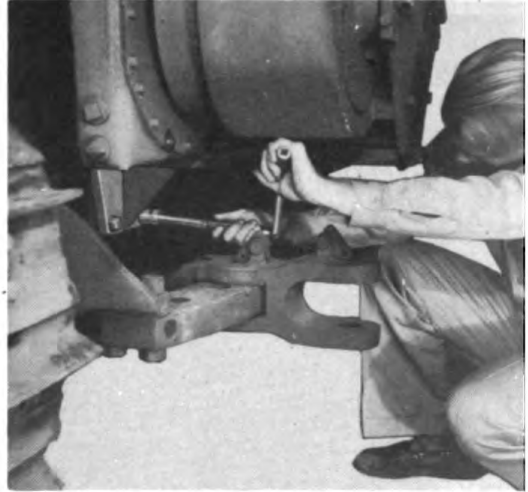
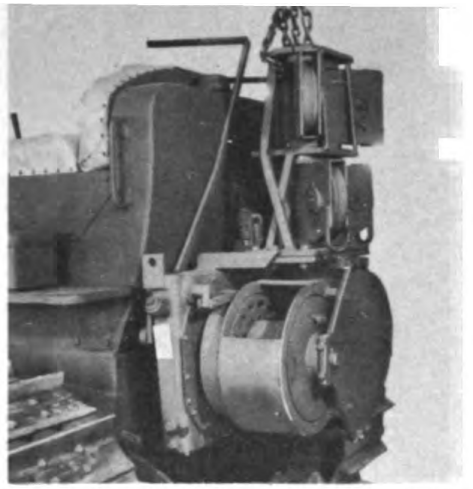

INSTALLING POWER CONTROL UNIT ON TRACTOR

1. To install a Model "R" Series Power Control Unit on a tractor, first remove the inspection plate from the rear of the tractor.
2. Remove the corks from the mounting bolt holes at the rear of the tractor. Install the stud bolts supplied with Power Control Unit in the bolt holes. (Units mounted on different sizes of tractors make use of different amounts of cap-screws and stud bolts.)
3. Examine recess in female ends of spline shaft and pinion and remove any wax or other foreign matter which might prevent the installation of spline shaft on pinion to full depth of recess. Test spline shaft for length by first inserting shaft through opening at rear of tractor and slipping it onto end of tractor upper transmission shaft, as far as it will go. (It is necessary to test spline shaft length because of variation in the relative position of tractor upper transmission shafts due to adjustment, etc.)
4. With Units having serial numbers with suffix D or E, measure distance from bottom of the recess in rear end of spline shaft to a line flush with rear of tractor case, using a straight edge and measuring stick as illustrated. With Units having serial numbers ending with a suffix other than D or E, spline shaft will project out beyond rear of tractor case, and a mark should be scribed on shaft flush with rear of tractor case.

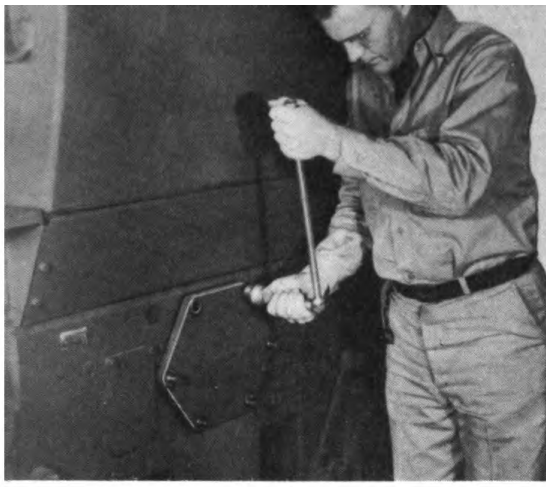

5. Place a straight edge across end of pinion (on Units having serial numbers ending with D or E) and measure distance from end of pinion to Power Control Unit face plate as illustrated. This distance should be at least $\frac{1}{8}$ " to $\frac{1}{4}$ " less than the distance measured in Step 4. On Units having serial numbers ending with letters other than D or E, remove the spline shaft from tractor and insert rear end of shaft in splined recess in end of pinion, as far as it will go. Place another mark on spline shaft, flush with face plate (not flush with boss ring). This mark should overlap the first mark on the spline shaft approximately $\frac{1}{8}$ " to $\frac{1}{4}$ ".

If spline shaft is too long, it will be necessary to cut off male end of pinion or spline shaft.

6. Install face plate gasket over studs on rear of tractor.
7. Attach a hoist chain to top of Power Control Unit as illustrated, and, with the spline shaft in place, raise Unit into position on rear of tractor.
8. Complete the installation by installing capscrews, hex nuts, and lockwashers which secure Power Control Unit to rear of tractor.

(Note—In mounting Units on Caterpillar D7 tractors, copper washers are used in place of lockwashers on the two stud bolts which are lowest in the bolt circle. This prevents oil seepage around stud bolts.)

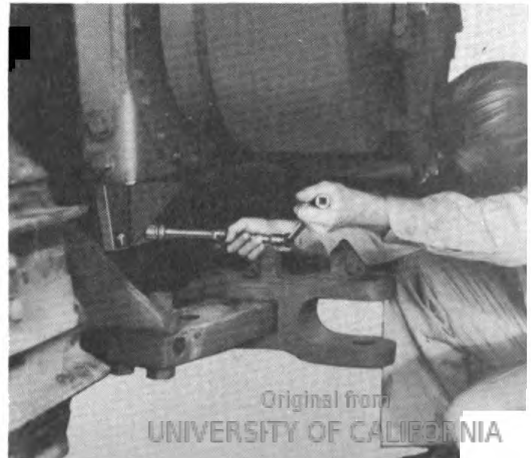
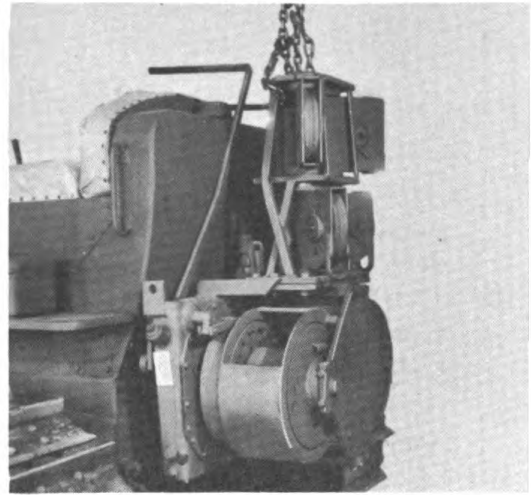
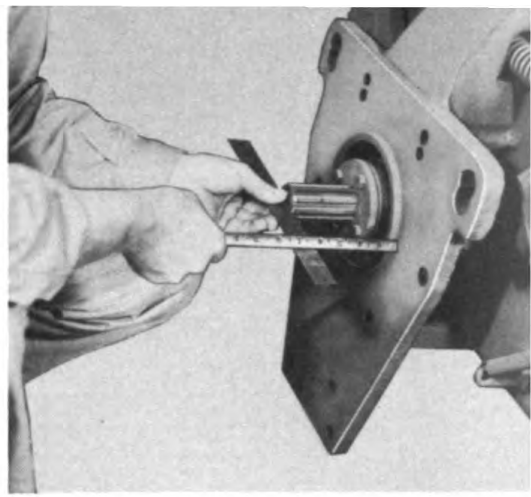

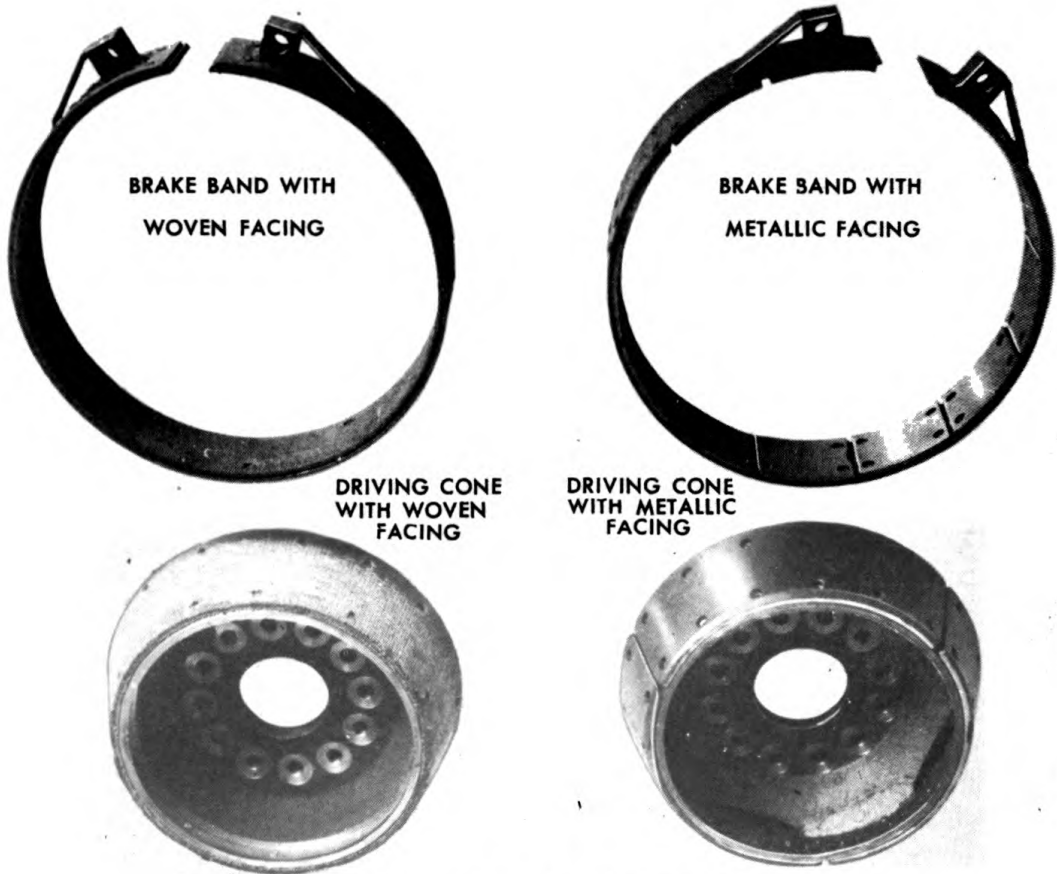

CLUTCH AND BRAKE FACINGS

TYPES OF FACINGS

LeTourneau Power Control Units may be equipped with either woven or metallic clutch and brake facings. Both types of facings used are of the highest grade, and both have a comparatively high co-efficient of friction. The metallic lining is especially resistant to wear, and ordinarily lasts somewhat longer than the woven lining.

CARE OF FACINGS

The clutch and brake facings usually require very little attention after having been properly installed. There are, however, a few things that can be done to the facings under certain conditions which help the operation of the Power Control Unit. There are also other practices which are sometimes resorted to which do not help the operation and which should be avoided, as discussed below.

(a) WOVEN FACINGS:

Woven facings must be kept free of oil if proper operation is to be expected. If oil or grease should leak onto the facings, the cause of this

oil leakage should be determined, and the necessary corrections should be made. Unless the clutch and the brake facings are too badly oil soaked, the oil can usually be removed from the facing by washing the facing in naphtha or gasoline.

Facings sometimes become glazed after they have become worn, and in a case of this kind, the surface of the facings may be roughened with a rasp to improve operation, and to prevent having to replace the lining before it has received its maximum amount of wear.

If the clutch or brake facings overheat during operation, do not pour water on them to cool them off. Instead, check the Unit and the operation to determine the cause of the overheating, and allow the lining to cool slowly by its contact with the air. Pouring cold water on a hot clutch will often cause the clutch cones to warp.

The most common causes of overheating of either the clutches or brakes are improper adjustment and slow engaging and disengaging of the clutch and brake by the operator.

(b) METALLIC FACINGS:

To obtain the maximum usefulness from metallic clutch and brake facings, a small amount of light weight oil, such as fuel oil, may be poured on them each day. This helps to keep the facings free from dust and other foreign particles, and makes for longer facing life.

(NOTE: It is recommended that if the clutch facings are metallic, the brake facings should also be metallic, and vice-versa. This is due to the fact that oil may be applied to one type facing but must not be applied to the other, and it is practically impossible to apply oil to either the clutch or brake facing without the oil also leaking onto the other.)

If either the clutch or brake should overheat during operation, do not pour cold water onto the facings to cool them off. Cold water applied to a hot clutch sometimes causes the clutch cones to warp. If overheating does occur, determine the cause, and make the necessary corrections. The most common causes of overheating of either the clutches or brakes are improper adjustment and slow engaging and disengaging of the clutch by the operator.



RELINING CLUTCH DRIVING CONES

(a) WOVEN CLUTCH FACINGS:

To install a new facing on a driving cone, remove the cone from the Power Control Unit. (Refer to disassembly instructions.) Remove the



worn facings and rivets from the cone. Proceed with the installation by heating the new facing either in hot water or in an oven, causing it to expand. Then place the facing on a bench with the smaller diameter on the bottom, or in an up-turned driven cone. Lower the unlined driving cone into the heated facing, making certain that the cone and facing are in perfect alignment with each other. Also, in doing this, line up the seam in the lining with the proper rivet holes in the cone, as illustrated.

Place the cone and facing under a press and force the cone tight into the facing. (If a press

is not available, other means of exerting heavy pressure on the cone may be used.) Make certain that the cone is not obstructed from being pressed extremely tight in the facing because of coming in contact with the bench during this operation. (Other methods of installing the facings are also sometimes used with fairly satisfactory results, such as hammering the facing tight onto the cone, etc.) Check to determine whether the facing is tight on the cone by striking around the surface of the facing with a hammer. If the facing is tight, a clear "ring" will be heard. Any points where the facing is not tight will show up by giving off a dull noise with no "ring". Drill or punch rivet holes into the facing, making them line up with the rivet holes in the cone. Counterbore each rivet hole to a depth not less than half the thickness of the facing, and not more than $2\frac{3}{8}$ the thickness of the facing, using a $\frac{3}{8}$ " counterbore. Then insert the rivets and rivet the facing to the cone.

Unless the facing is installed exceptionally tight on the cone, spongy clutch action may result. If the facing should be installed eccentric and out of alignment with the cone, clutch drag will occur and the clutch will overheat.

(b) METALLIC CLUTCH FACINGS:

Metallic clutch facings come in segments, shaped to fit the outer circumference of the driving cone, and with the rivet holes already drilled in them. To install the segments on the cone, merely line the holes in the segments up with the holes in the outer circumference of the cone, and rivet the facing to the cone. The rivets should be drawn down very tight in order to prevent the segments from breaking loose when the cone is placed in operation. Only steel rivets should be used.

If possible, the newly lined cones should be placed in a lathe and any high spots or irregularities in the thickness of the different segments machined off. (The facings should be machined to a 15 taper.)

If the clutch surface of the driven cone has worn rough or grooved, it may be advisable to either replace the cone or to machine a very thin cut off the surface of the cone. This machining should also be done on a 15 taper.

RE-LINING BRAKE BANDS**(a) WOVEN LINING:**

To re-line a brake band with woven lining, first remove the brake band from the Power Control Unit. (Refer to disassembly instructions.) Remove the worn lining and rivets from the brake band.

Extend the brake lining around the inner circumference of the brake band, and rivet one end of the lining to the band. Push the lining snug against the band with the hand, around the entire circumference of the band. Then move the lining back about $\frac{1}{4}$ " at the unriveted end, and install the rivets at this end of the band. A small hump will be formed by the lining at the center of the band with this procedure, which should be forced down, causing the lining to be pressed very tight against the brake band. Then install the remaining rivets.

To install the rivets, drill or punch the rivet holes in the lining, and counterbore these holes to a depth of not less than $\frac{1}{2}$ and not more than $2\frac{3}{4}$ the thickness of the lining to provide for the heads of the rivets. Use a $\frac{3}{8}$ " counterbore. Then install the rivets, cinching them down very tight.



(b) METALLIC LINING:

To reline a brake band with metallic lining, first remove the brake band from the Power Control Unit. (Refer to Disassembly Instructions.) Remove the worn segments and rivets from the brake band.

To install the new segments, place them in position on the inner circumference of the brake band, line the rivet holes in each segment up with the corresponding rivet holes in the brake band, and rivet the segments to the band, using steel rivets. Draw the rivets up very tight in order to prevent the segments from breaking loose when the brake band is placed in operation.

BRAKE SHAFT BEARINGS

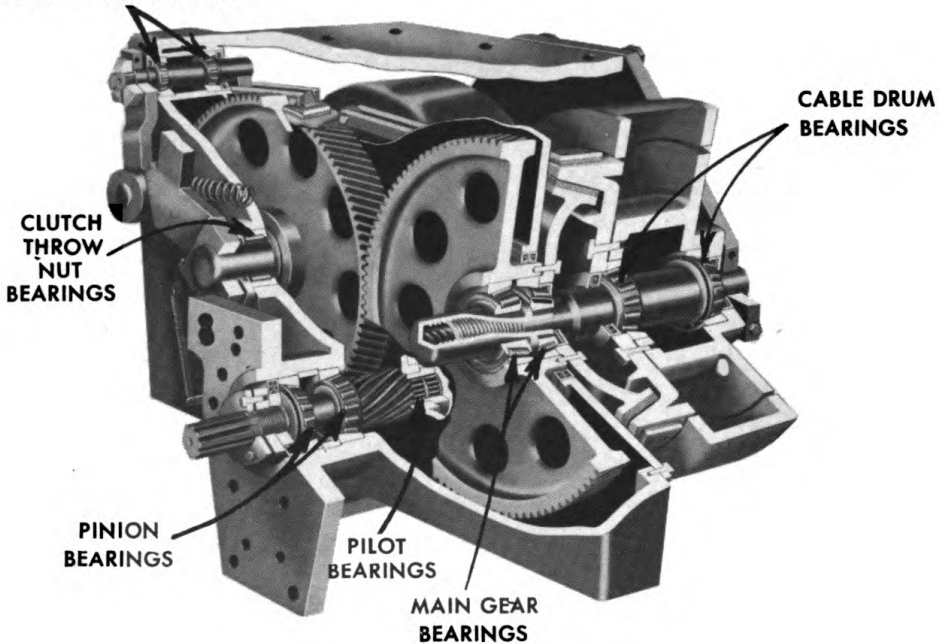

TABLE OF CLEARANCES AND TOLERANCES OF BEARINGS AND ADJUSTABLE PARTS

POINT OF ADJUSTMENT	CORRECT ADJUSTMENT	ALLOWABLE TOLERANCE
Main Gear Bearings	.002" pre-load	.000' to .003' pre-load
Cable Drum Bearings	.005" pre-load	.003' pre-load to .006" pre-load
Brake Shaft Bearings	.000"	.002" loose to .001" pre-load
Pinion Bearings (helical tooth pinion)	.005" loose	.003" loose to .010" loose
Pinion Bearings (spur tooth pinion)	non-adjustable	
Pinion Pilot Bearings	non-adjustable	
Clutch Throw Nut Bearings	non-adjustable	

TROUBLE SHOOTER'S GUIDE

CLUTCH SLIPPAGE

CAUSE	REMEDY
<i>Control lever installed too far to the rear on clutch throw-nut and therefore riding against throw-nut bushing as control lever is moved, preventing driving cone from fully engaging driven cone.</i>	Space control lever farther to the front on clutch throw-nut. (Refer to Step 8 of clutch adjustment.)
<i>Main gear incorrectly spaced inside gear case, thereby riding against back side of gear case when control lever is moved to engage clutch, preventing driving cone from fully engaging driven cone.</i>	Make clutch adjustment, correctly spacing main gear inside gear case.
<i>Oily or greasy clutch facing (woven facing only).</i>	Remove driving cone and either replace facing or wash facing with naphtha or gasoline. Also prevent further oil or grease from reaching clutch surfaces as follows:—Correct oil seal leakage, if present (refer to "Oil Seal Leakage" corrections.) Do not lubricate that portion of cable which wraps onto cable drum. Never apply oil to woven facings.
<i>Clutch facing installed eccentric on driving cone (woven facing) or high spots on facing not having been machined off (metallic facing), causing only a part of clutch facing to bear against driven cone when clutch is fully engaged.</i>	If woven facing, either remove facing and install it concentric on cone or machine surface or facing true with cone using a grinder. If metallic facing, machine off high spots.
<i>Worn out clutch facing.</i>	Either install new facing on driving cone or install a replacement lined driving cone.
<i>Smooth, glazed clutch facing.</i>	Remove driving cone and roughen clutch facing with a rasp.

CLUTCH WON'T RELEASE — CLUTCH DRAGGING

CAUSE	REMEDY
<i>Clutch adjustment incorrect, with travel of control lever from neutral to fully engaged position set at less than the recommended distance, thereby providing insufficient clearance between driving and driven cones when in neutral.</i>	Make clutch adjustment, correctly setting travel of control lever from neutral to fully engaged position.
<i>Main gear bearings in a loose adjustment, causing driving cone to drag on driven cone when control lever is in neutral position.</i>	Correctly adjust main gear bearings.
<i>Cable drum bearings in a loose adjustment, causing driven cone to drag on driving cone when control lever is in neutral position.</i>	Correctly adjust cable drum bearings.
<i>Clutch facing loose on driving cone, resulting in facing dragging on driven cone when control lever is in neutral.</i>	Remove driving cone and either re-install facing on driving cone or install new lined cone.
<i>Threads excessively worn on drum shaft or clutch throw-nut, resulting in full travel of control lever being required to take up play in threads instead of moving driving cone away from driven cone.</i>	Replace worn drum shaft or throw-nut.

TROUBLE SHOOTER'S GUIDE

CLUTCH WON'T ENGAGE

CAUSE	REMEDY
<i>Control lever installed too far to the rear on clutch throw-nut, therefore riding against throw-nut bushing as control lever is moved, preventing driving cone from fully engaging driven cone.</i>	Space control lever farther to the front on clutch throw-nut. (Refer to Step 8 of clutch adjustment.)
<i>Main gear incorrectly spaced inside gear case, thereby riding against back side of gear case when control lever is moved to engage the clutch, preventing driving cone from fully engaging driven cone.</i>	Make clutch adjustment, correctly spacing main gear inside gear case.
<i>Clutch incorrectly adjusted, causing excessive throw of control lever, possibly resulting in control lever striking seat before clutch becomes fully engaged.</i>	Adjust clutch, correctly setting distance of travel of control lever from neutral to the fully engaged position. (Refer to clutch adjustment instructions.)

CLUTCH WON'T HOLD ADJUSTMENT

CAUSE	REMEDY
<i>Clamp block at rear end of drum shaft insufficiently tightened, allowing drum shaft to turn.</i>	Re-adjust clutch and tighten clamp block on drum shaft by turning capscrews down tight, using force.
<i>Control lever not clamped tight on clutch throw-nut, allowing lever to slip on throw-nut.</i>	Clamp control lever tight on clutch throw-nut by turning clamp bolt up tight, using force. Then re-adjust clutch.
<i>Brake roller arm not clamped tight on brake shaft, allowing roller arm to slip on shaft.</i>	Re-adjust brake and tighten clamp bolt at upper end of roller arm, using force.

SPONGY CLUTCH

CAUSE	REMEDY
<i>Main gear bearings in a loose adjustment, allowing end play of driving cone on clutch throw-nut, and mis-alignment of driving cone with driven cone.</i>	Correctly adjust main gear bearings.
<i>Cable drum bearings in a loose adjustment, allowing end play of cable drum and driven cone on drum shaft and mis-alignment of driven cone with driving cone.</i>	Correctly adjust cable drum bearings.
<i>Clutch facing not tight on driving cone, thereby tending to "give" and become "spongy" when engaging and disengaging clutch.</i>	Remove driving cone and re-line or install a replacement lined cone.
<i>Clutch facing installed eccentric on driving cone, causing only a portion of facing to contact driven cone when engaging clutch, resulting in slippage until heavy force is applied on control lever, giving "spongy" action.</i>	Remove driving cone and machine surface of facing true with cone.

TROUBLE SHOOTER'S GUIDE

BRAKE SLIPPAGE

CAUSE	REMEDY
<i>Brake roller positioned too low against brake cam, causing lower end of roller arm to be positioned too far to the center thereby decreasing tension of brake spring.</i>	Make brake adjustment, correctly positioning brake roller against brake cam. (Refer to brake adjustment instructions.)
<i>Brake shaft bearings adjusted too tight, preventing free rotation of brake shaft and causing shaft to bind, sometimes holding brake band away from drum.</i>	Correctly adjust brake shaft bearings.
<i>Oily or greasy brake lining (woven lining only.)</i>	Remove brake band and either replace band or wash lining with naphtha or gasoline. Also prevent further oil or grease from reaching brake lining as follows:—If oil seals are leaking, correct leakage (refer to "Oil Seal Leakage" corrections.) Do not lubricate that portion of cable which wraps onto cable drum. Never apply oil to woven lining.
<i>Tension of brake spring decreased, due to old age or long period of operation.</i>	Replace brake spring.
<i>Mud, rocks or other obstacles lodged in brake spring or behind brake roller arms or linkage.</i>	Remove mud, rocks, or other obstructions.
<i>Worn out brake lining.</i>	Replace brake lining.
<i>Brake band improperly formed to fit drum, possibly through accident.</i>	Replace or re-shape brake band.

BRAKE WON'T RELEASE

CAUSE	REMEDY
<i>Brake roller positioned too high against brake cam, preventing cam from moving roller arm outward far enough to cause brake to release when control lever is moved.</i>	Make brake adjustment, correctly positioning brake roller against brake cam. (Refer to brake adjustment instructions.)
<i>Brake roller arm not clamped tight on brake shaft, allowing roller arm to slip on shaft.</i>	Correctly adjust brake and tighten clamp bolt at upper end of roller arm, using force.
<i>Main gear incorrectly spaced inside gear case, thereby riding against front side of gear case as control lever is moved to release brake, limiting travel of control lever and preventing brake from fully releasing.</i>	Make clutch adjustment, correctly spacing gear inside gear case.
<i>Brake band frozen to drum.</i>	Move control lever into lock-out position, freeing band from drum.

TROUBLE SHOOTER'S GUIDE

OVERHEATING

CAUSE	REMEDY
<i>Operator not engaging and disengaging clutch fully and quickly, causing short intervals of clutch slippage and overheating.</i>	Engage and disengage clutch with a quick, full movement of control lever.
<i>Brake slipping.</i>	Correct the cause for brake slippage. (Refer to "Brake Slippage" corrections.)
<i>Clutch slipping.</i>	Correct the cause for clutch slippage. (Refer to "Clutch Slippage" corrections.)
<i>Clutch dragging.</i>	Correct the cause for clutch dragging. (Refer to "Clutch Dragging" corrections.)

OIL SEAL LEAKAGE

CAUSE	REMEDY
<i>Power Control Unit overheating and thereby burning and hardening leather in oil seals.</i>	Correct cause for overheating (refer to "Overheating" chart above.) Also replace leaky oil seals.
<i>Cable drums filled more than $\frac{2}{3}$ full of grease (possibly by inserting grease through rear end of drum shaft with grease gun), causing grease to be forced out around seals as pressure is built up inside drum through heat of operation.</i>	Remove cable drum and pack only $\frac{2}{3}$ full of recommended lubricant. Also replace leaky oil seals. Lubricate through holes in drum shaft only in case of emergency.
<i>Lubricants may not be those which are recommended. Oils lighter than recommended may seep out under seals, while incorrect type grease may break down and become fluid from heat of operation.</i>	Remove incorrect lubricants and replace with lubricants which are recommended.
<i>Main gear bearings in a loose adjustment causing gear and driving cone to wobble, thereby whipping out leather in oil seals.</i>	Correctly adjust main bearings. Also replace leaky oil seals.
<i>Cable drum bearings in a loose adjustment, allowing cable drum to raise and lower on drum shaft each time load is raised and lowered, thereby working cable drum oil seals up and down on shaft, permitting grease to escape.</i>	Correctly adjust cable drum bearings. Also replace leaky oil seals.
<i>Oil seals damaged during assembly.</i>	Replace leaky oil seals, being careful not to damage replacement seals.
<i>Oil seals incorrectly installed during assembly, with leathers cupped outward, away from oil or grease chamber.</i>	Remove oil seals and install with leathers cupped inward, toward oil or grease chamber. Double leather oil seals should be installed with heavy leather facing inward.
<i>Breather hole in oil fill plug not open, causing a pressure to be built up inside the gear case, forcing oil out around the seals.</i>	Remove cork (or dirt) from breather hole in fill plug. Also replace leaky oil seals.
<i>Gear case filled with oil above the oil level plug.</i>	Lower oil level to oil level plug.

PARTS CATALOG

WARNING

SPARE PARTS can be supplied promptly and accurately only if positively identified by correct part number and correct part name.

FURNISH THIS INFORMATION ON ALL REQUISITIONS. WITHOUT FAIL, on all requisitions, give name of machine, name of manufacturer, model or size, manufacturer's serial number of each machine and subassemblies attached to machine, and components and accessories for which spare parts are required.

List spare parts for only one make or kind of machine on each requisition.

Requisitions must be double spaced to provide room for office notations when necessary.

SECT. 3

PREPARATION OF REQUISITIONS

Sample Copy for Use in the Preparation of Requisitions

Revisions in QMC Form 400 for requisitioning spare parts are confined to new column headings. Until new forms are available all organizations are to continue using the present form and either type or write in corrections indicated in column headings.

Under revised heading "Nomenclature and Unit" list the article and the unit (ea for each; lb for pound, etc.). Under heading "Authorized or Maximum Level" list the authorized depot stock levels or organizational allowances given in Part III of the Corps of Engineers Supply Catalog. The total number on hand for each item is listed under "On Hand". In column

headed "Due In" enter the total quantity previously requisitioned but not delivered. For "Initial" and "Replenishment" requisitions, the sum of "Required", "Due In", and "On Hand" should equal the "Authorized or Maximum Level".

On this page is shown a sample requisition on QMC Form No. 400 which conforms to the latest revisions. The marginal notes give instructions for preparing a requisition for spare parts for Engineer equipment. Additional information on this subject is contained in section AA-1 of Part III Engineer Supply Catalog, available from the Engineer Field Maintenance Office, P. O. Box 1679, Columbus, Ohio.

- State PERIOD designation by use of one of the following terms:
- (1) "INITIAL"—first requisition of authorized allowances.
 - (2) "REPLENISHMENT"—subsequent requisitions to maintain authorized allowances.
 - (3) "SPECIAL"—requisitions for necessary repairs not covered by allowances.

Type "SPARE PARTS" in upper right hand corner of requisition.

Give complete shipping instructions. Special instructions for packing, marking, routing, etc., should be given at the end of the requisition.

State proper nomenclature of machine, also make, model, machine serial number and U. S. A. registration number.

Prepare a separate requisition for each different machine.

State basis or authority and date delivery is required, immediately below description of machine.

Double space between items.

Group parts required under group headings as shown in manufacturers' parts catalogs (Technical Manuals).

State manufacturers' parts numbers and nomenclature descriptions accurately and completely. Do not use abbreviations.

(SAMPLE)

SPARE PARTS

REQUISITION

To: Engineer Field Maintenance Office No. of Sheets 1 Sheet No. 1
P. O. Box 1679, Columbus, Ohio
Requisition No. R-211-1-14 Date 6 October 1943 Period Special

sent to Engineer Property Officer, Pine Camp, NEW YORK

MARKED FOR: Supply Officer, 147th Engineer Regiment, Pine Camp, NEW YORK

Requisitioned By (show Signature, Rank, Organization, Destination if different from "sent to" include address):
Robert E. Roe
Robert E. Roe
Major, C.E.
Engineer Property Officer

Approved For the Commanding Officer:
John D. Doe
John D. Doe
Colonel, C.E.
Executive Officer

QMC NO.	SYMBOLIC NOMENCLATURE AND UNIT	APPROX. QUANTITY	ON HAND	REQUISITIONED	DUE IN	RECEIVED	APPROVED
PARTS FOR LeTOURNEAU MODEL R7 POWER CONTROL UNIT							
SERIAL NO. P-20000-R7C AND UP							
Basis: To complete second echelon Delivery requested by August 15, 1943							
<u>CASE GROUP</u>							
H-2807	GASKET	ea	-	0	0	2	
L-3705C	OIL SEAL	ea	-	0	0	2	
<u>DOUBLE DECKER GROUP</u>							
C-65	BRACKET STRUCTURE	ea	-	0	0	2	
<u>CABLE DRUM GROUP</u>							
E-4896	DRUM STRUCTURE	ea	-	0	0	3	
C-196	PLUG	ea	-	0	0	3	

*Nonexpendable items such as tools must be accounted for, when requisitioned, by a statement that they have been placed on REPORT OF SURVEY or STATEMENT OF CHARGES.

Emergency requisitions sent by telephone, telegraph or radio must always be confirmed immediately with requisition marked: "Confirming (state identifying data)."

633-G

PREPARATION OF REQUISITIONS

A Sample requisition in the correct form for submission by the Engineer Property Officer is shown on the opposite page.

THIS SHALL BE FOLLOWED IN MAKING OUT REQUISITIONS.

In order to eliminate duplication of work, Property Officers may authorize organizations to prepare requisitions in final form, leaving requisition number space blank for completion by Property Officer.

THE FOLLOWING RULES WILL BE OBSERVED CAREFULLY IN PREPARING REQUISITIONS FOR SPARE PARTS:

- a. Prepare a separate requisition for each different machine.
- b. Type "SPARE PARTS" in upper right hand corner of requisition form.
- c. State PERIOD designation by use of one of the following terms:
 - (1) "INITIAL"—first requisition of authorized allowances.
 - (2) "REPLENISHMENT"—subsequent requisitions to maintain authorized allowances.
 - (3) "SPECIAL"—requisitions for necessary repairs not covered by allowances.
- d. Give complete shipping instructions.
- e. State proper nomenclature of machine, and make, model, serial number and registration number.
- f. State basis or authority, and date delivery is required, immediately below description of machine.
- g. Group parts required under group headings as shown in manufacturers' parts catalogs.
- h. State manufacturers' parts numbers and nomenclature descriptions accurately and completely. Do not use abbreviations.
- i. Double space between items.
- j. Emergency requisitions sent by telephone, telegraph, or radio must always be confirmed immediately with requisition marked: "Confirming (state identifying data)".
- k. Nonexpendable items must be accounted for.

MODEL R7 POWER UNIT

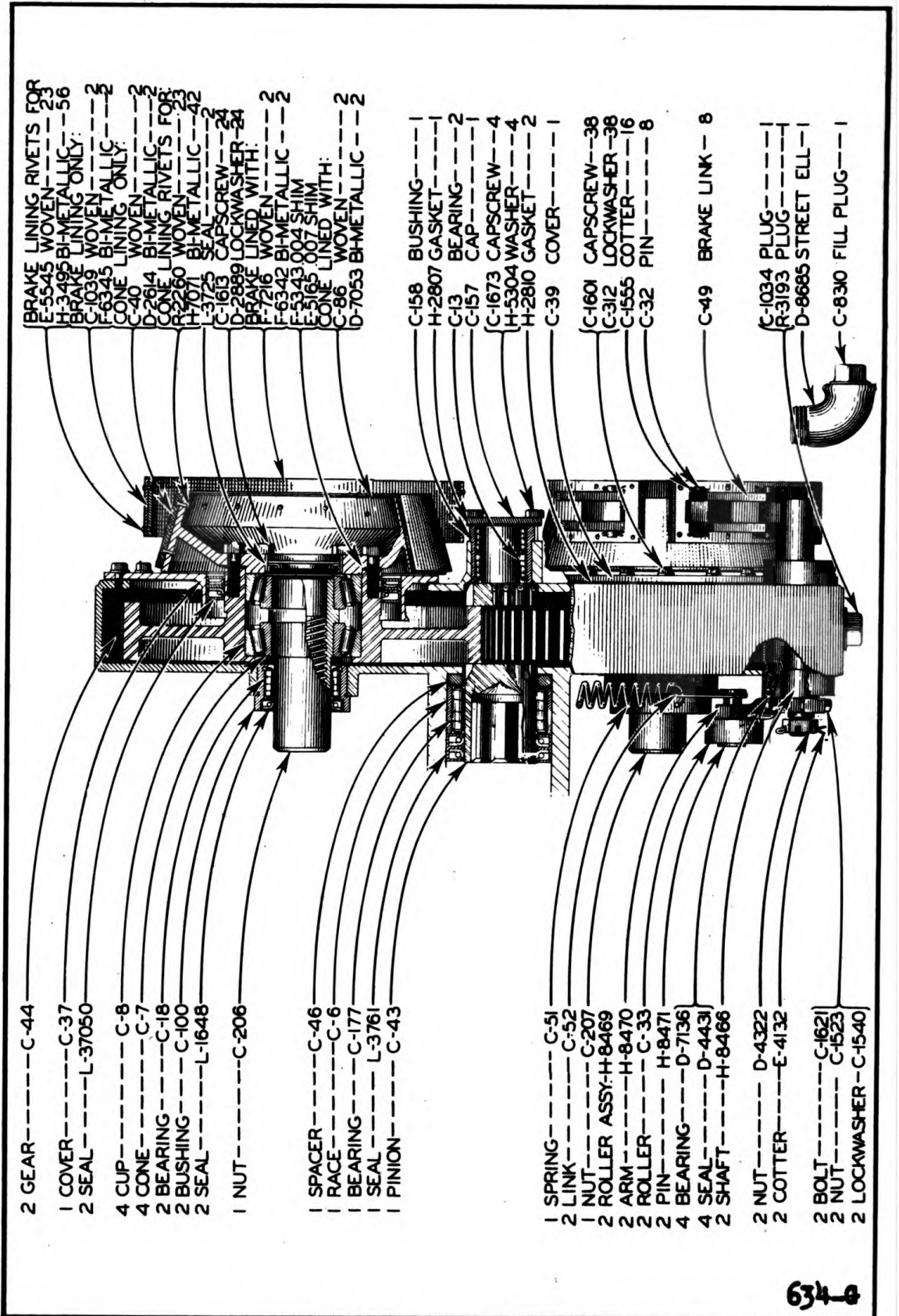

- 2 GEAR --- C-44
- 1 COVER --- C-37
- 2 SEAL --- L-37050
- 4 CUP --- C-8
- 4 CONE --- C-7
- 2 BEARING --- C-18
- 2 BUSHING --- C-100
- 2 SEAL --- L-1648
- 1 NUT --- C-206
- 1 SPACER --- C-46
- 1 RACE --- C-6
- 1 BEARING --- C-177
- 1 SEAL --- L-3761
- 1 PINION --- C-43
- BRAKE LINING RIVETS FOR E-5545 WOVEN --- 23
- H-3495 BI-METALLIC --- 56
- BRAKE LINING ONLY: C-1039 WOVEN --- 2
- F-6345 BI-METALLIC --- 2
- CONE LINING ONLY: C-40 WOVEN --- 2
- D-2614 BI-METALLIC --- 2
- CONE LINING RIVETS FOR R-2260 WOVEN --- 23
- H-7071 BI-METALLIC --- 42
- L-3775 SEAL --- 2
- C-1613 CAPSCREW --- 24
- D-2889 LOCKWASHER --- 24
- BRAKE LINING WITH: F-7216 WOVEN --- 2
- F-6342 BI-METALLIC --- 2
- F-5343 004 SHIM --- 1
- E-5165 007 SHIM --- 1
- CONE LINING WITH: C-86 WOVEN --- 2
- D-7053 BI-METALLIC --- 2

- 2 LINK --- C-51
- 1 NUT --- C-207
- 2 ROLLER ASSY --- H-8469
- 2 ARM --- H-8470
- 2 ROLLER --- C-33
- 2 PIN --- H-8471
- 4 BEARING --- D-7136
- 4 SEAL --- D-4431
- 2 SHAFT --- H-8466
- 2 NUT --- D-4322
- 2 COTTER --- E-4132
- 2 BOLT --- C-1621
- 2 NUT --- C-1523
- 2 LOCKWASHER --- C-1540

- C-158 BUSHING --- 1
- H-2807 GASKET --- 1
- C-13 BEARING --- 2
- C-157 CAP --- 1
- C-1673 CAPSCREW --- 4
- H-5304 WASHER --- 4
- H-2810 GASKET --- 2
- C-39 COVER --- 1
- C-1601 CAPSCREW --- 38
- C-312 LOCKWASHER --- 38
- C-1555 COTTER --- 16
- C-32 PIN --- 8
- C-49 BRAKE LINK --- 8
- C-1034 PLUG --- 1
- R-3193 PLUG --- 1
- D-8685 STREET ELL --- 1
- C-8310 FILL PLUG --- 1

6348

CASE CROSS SECTION

- H-8474 CASE
- H2807 GASKET
- C-157 CAP
- C-1673 CAPSCREW
- H-5304 LOCKWASHER
- H-2810 GASKET
- C-37 COVER
- C-39 COVER
- C-1601 CAPSCREW
- C-312 LOCKWASHER
- C-1644 CAPSCREW
- C-1542 LOCKWASHER

- 2 SEAL
- 1 GUARD
- 1 GUARD
- 4 CAPSCREW
- 2 CAP
- 4 NUT
- 1 PLATE
- 4 CAPSCREW
- 4 LOCKWASHER
- L-37050
- E-5046
- E-5071
- C-1687
- C-9
- C-1524
- R-857
- C-1615
- C-1540

CASE GROUP—EXPLODED

635-8

MODEL R7 POWER UNIT

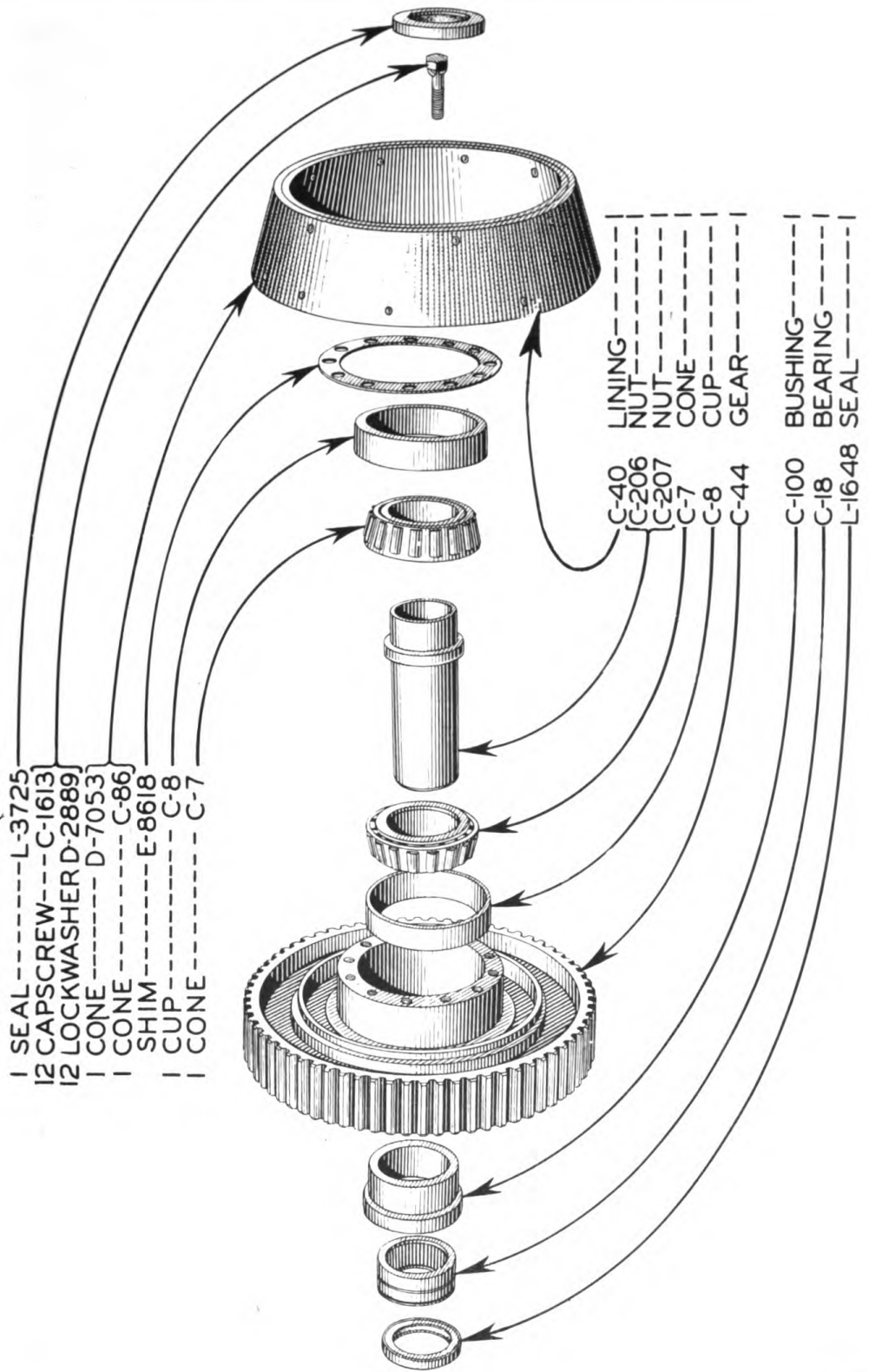

MAIN GEAR & DRIVING CONE-EXPLODED

636-G

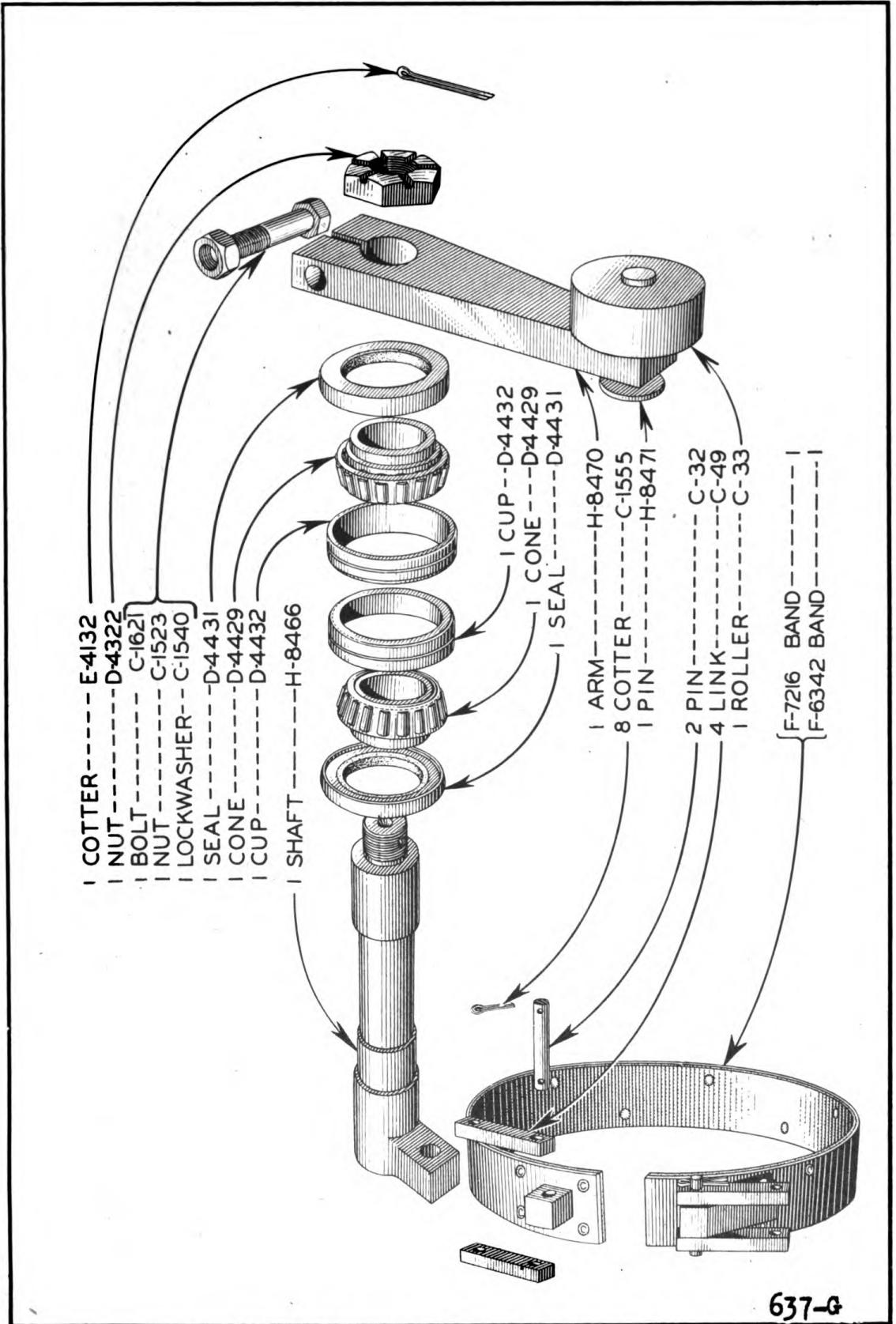

- 1 COTTER-----E-4132
- 1 NUT-----D-4322
- 1 BOLT-----C-1621
- 1 NUT-----C-1523
- 1 LOCKWASHER--C-1540
- 1 SEAL-----D-4431
- 1 CONE-----D-4429
- 1 CUP-----D-4432
- 1 SHAFT-----H-8466
- 1 CUP--D-4432
- 1 CONE--D-4429
- 1 SEAL--D-4431
- 1 ARM-----H-8470
- 8 COTTER--C-1555
- 1 PIN-----H-8471
- 2 PIN-----C-32
- 4 LINK-----C-49
- 1 ROLLER--C-33
- 1 F-7216 BAND-----
- 1 F-6342 BAND-----

TWO ASSEMBLIES REQUIRED

BRAKE SHAFT-EXPLODED

637-G

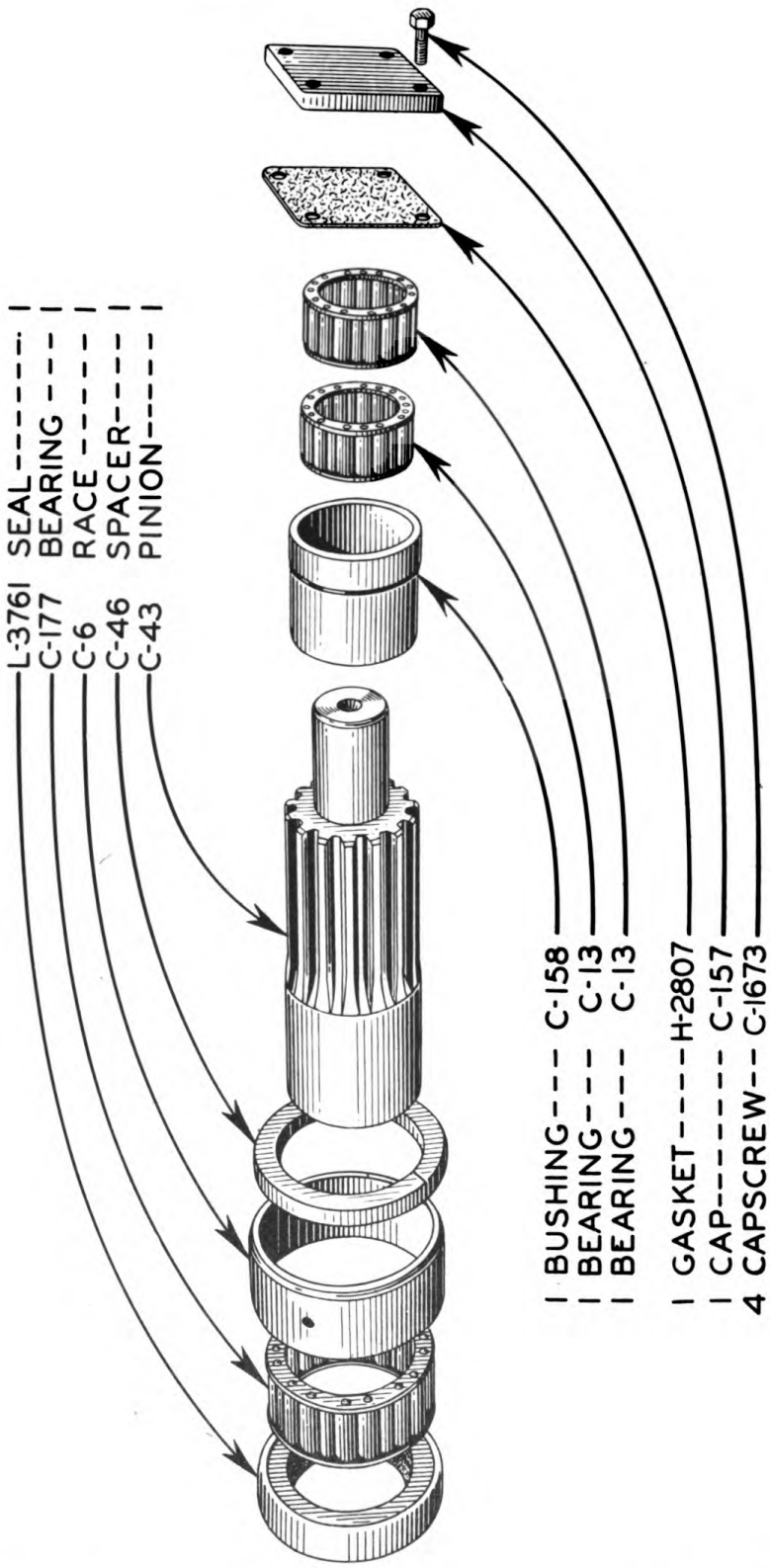

PINION ASSEMBLY-EXPLODED

638-G

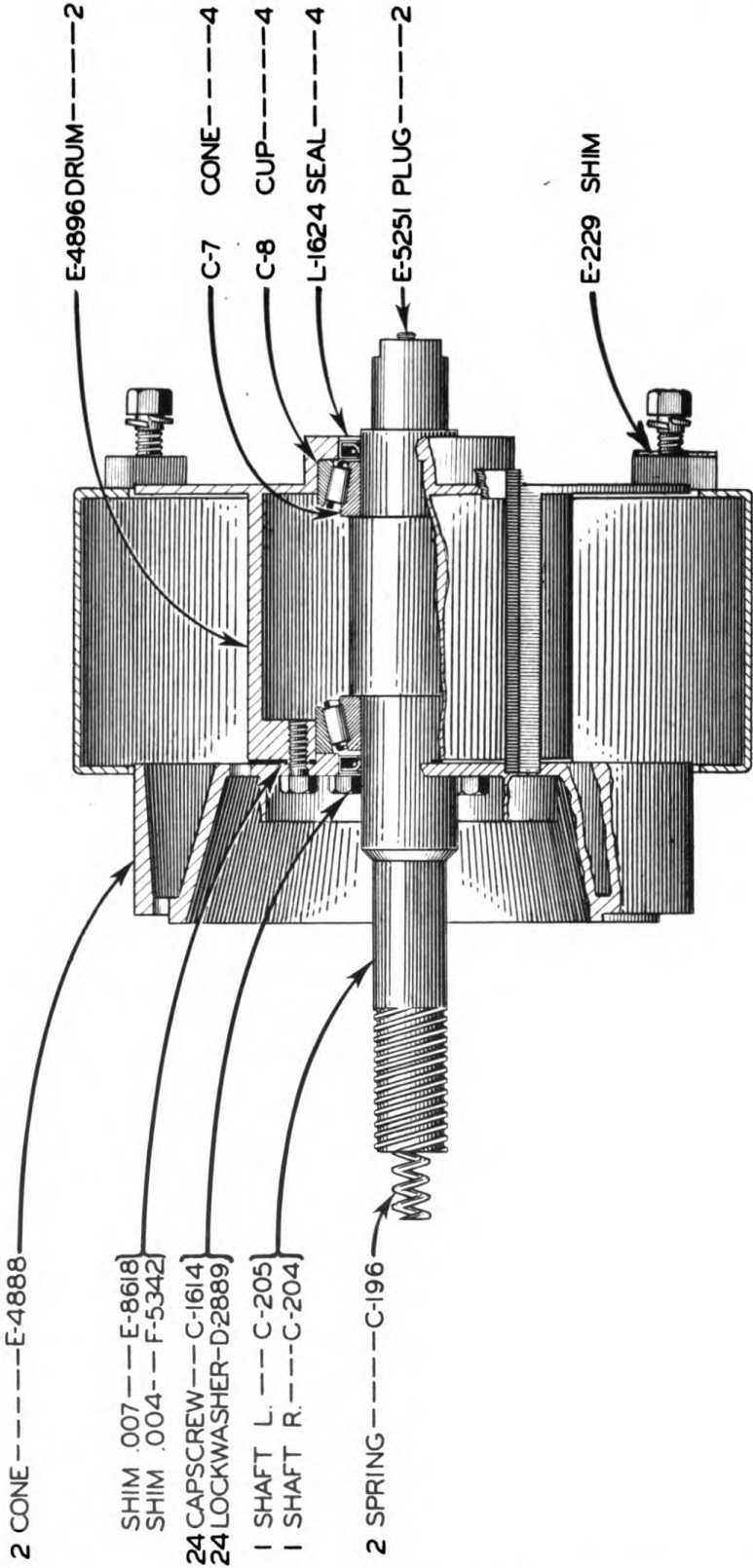

CABLE DRUM ASSEMBLY

639-G

- [C1614 CAPSCREW---I2
- [D2889 LOCKWASHER---I2
- E-4888 CONE-----I
- C196 SPRING-----I
- E8618 SHIM-----I
- L-1624 SEAL-----I
- C-8 CUP-----I
- C-7 CONE-----I

- I SHAFT-----C-205
- I SHAFT-----C-204
- I CONE-----C-7
- I CUP-----C-8
- I SEAL-----L-1624
- I DRUM-----E-4896
- I PLUG-----E-525I

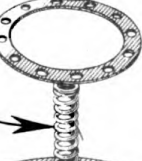
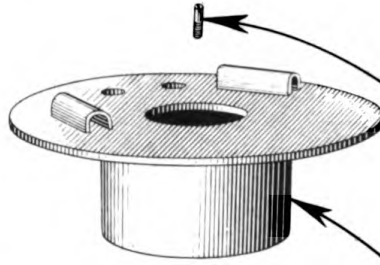

640-G

CABLE DRUM GROUP-EXPLODED

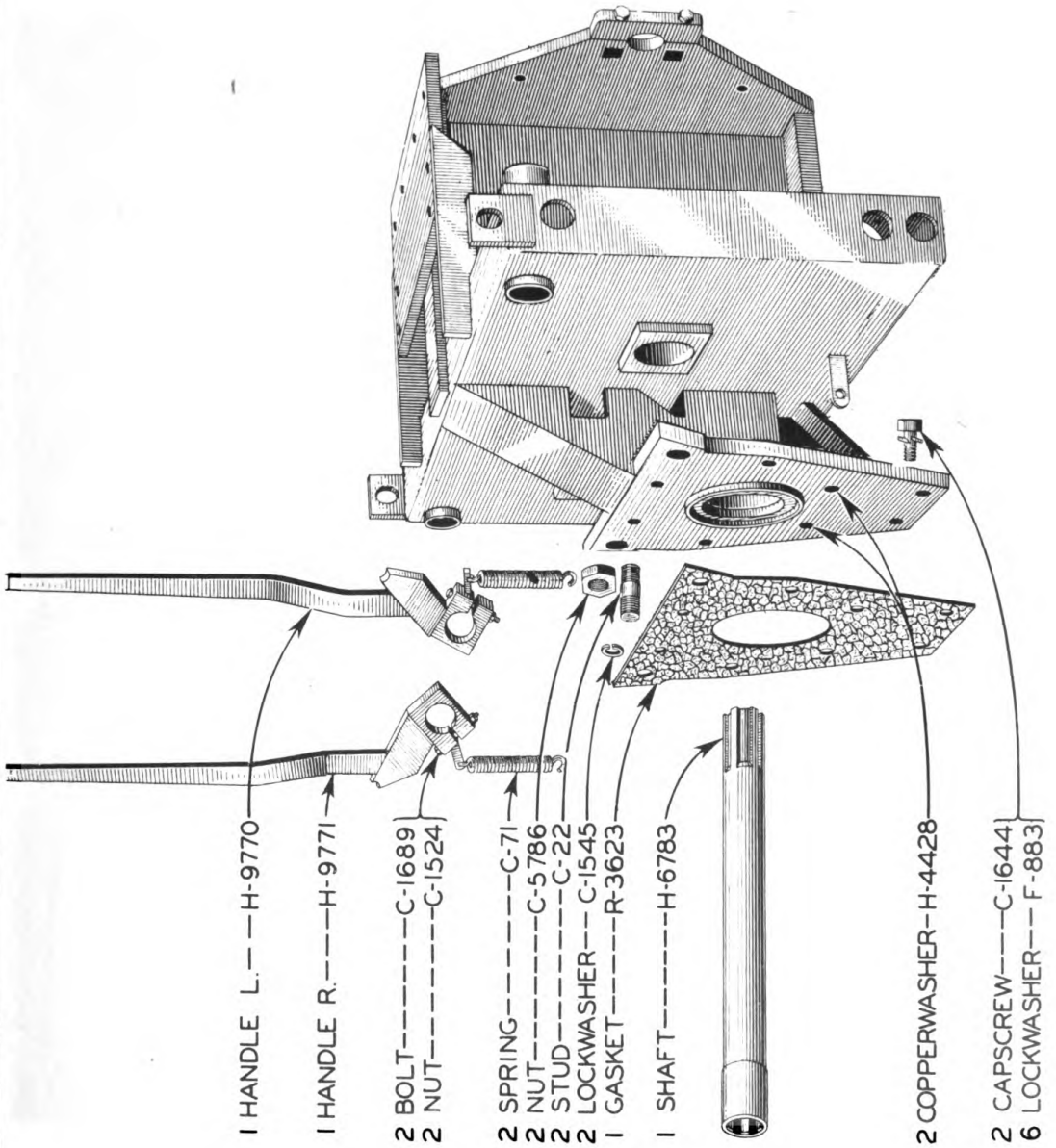

641-G

MISCELLANEOUS GROUP

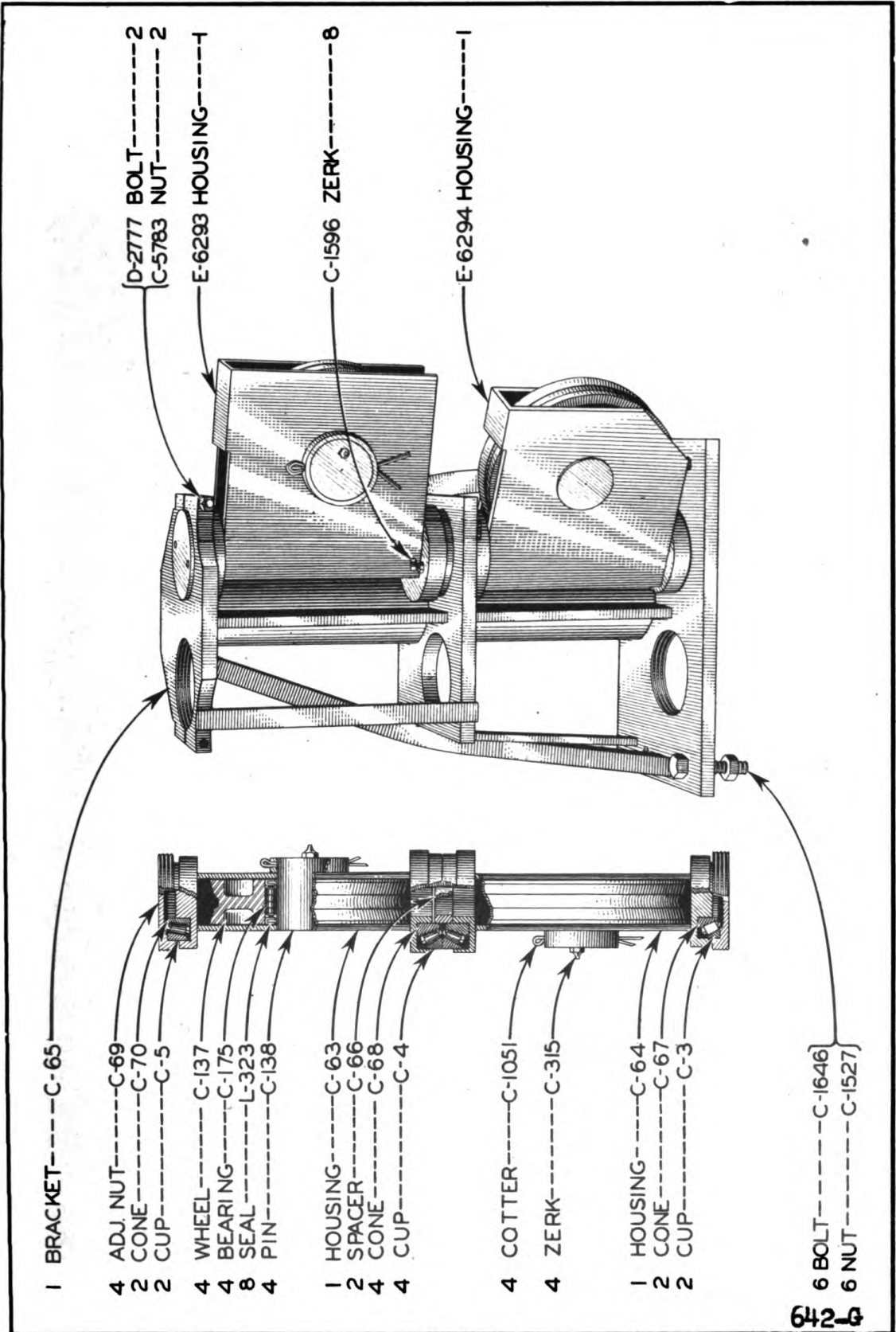

642-G

DOUBLE DECK ASSEMBLY

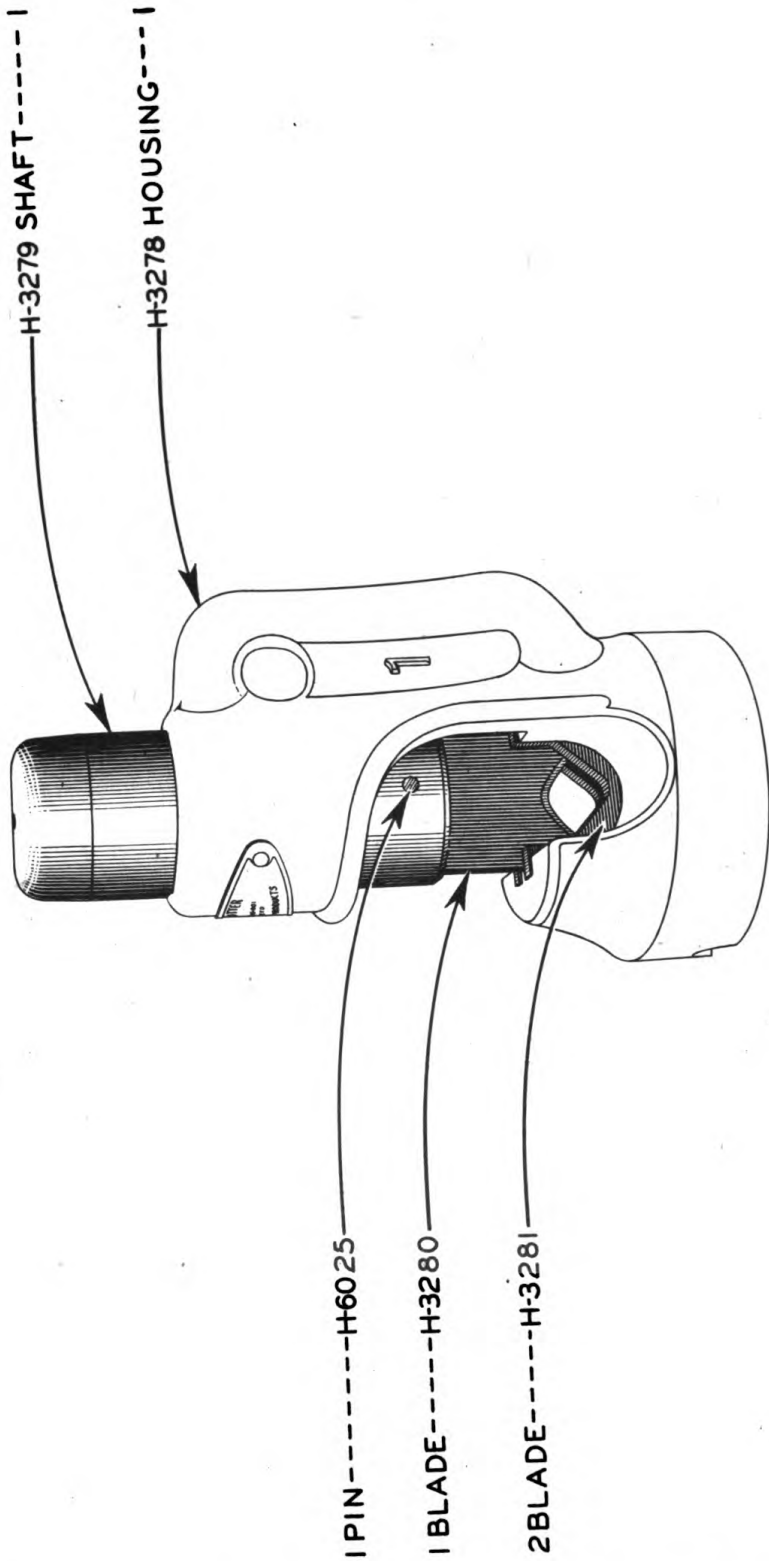

CABLE CUTTER GROUP

643-G

MODEL R7 POWER UNIT

11

(FOR USE WITH CATERPILLAR D7 TRACTOR,
SERIAL No. 7M-1 & UP)

PART No.	DESCRIPTION	PAGE	QTY.	WEIGHT		PRICE EACH
				Lbs.	Oz.	
C-3	CUP—TIMKEN (44348).....	9	2	..	8	.97
C-4	CUP—TIMKEN (55443).....	9	4	1	12	1.75
C-5	CUP—TIMKEN (414).....	9	2	..	12	1.07
C-6	BEARING (WOR-212).....	1, 5	1	1	8	3.29
C-7	CONE—TIMKEN (559).....	1, 3, 6, 7	8	2	10	3.95
C-8	CUP—TIMKEN (552-A).....	1, 3, 6, 7	8	1	10	2.55
C-9	CAP	2	2	2	..	1.30
C-13	BEARING—HYATT (RAW-206).....	1, 5	2	..	8	1.17
C-18	BEARING—HYATT (RA-210)	1, 3	2	..	12	1.71
C-22	STUD	8	2	1	..	.63
C-32	PIN	1, 4	825
C-33	ROLLER	1, 4	2	1	8	.74
C-37	COVER (Main Right)	1, 2	1	22	..	12.30
C-39	COVER (Main Left)	1, 2	1	22	..	12.30
C-40	LINING, CLUTCH (Woven or Molded).....	1, 3	2	2	4	5.56
C-43	PINION	1, 5	1	10	..	30.00
C-44	GEAR (Main).....	1, 3	2	74	..	59.85
C-46	WASHER	1, 5	1	..	14	.58
C-49	LINK—BRAKE	1, 4	8	..	12	.28
C-51	SPRING—BRAKE	1	1	1	12	1.69
C-52	LINK—SPRING	1	2	..	8,	.28
C-63	HOUSING (Top Left).....	9	1	20	..	11.25
C-64	HOUSING (Bottom Left).....	9	1	20	..	11.16
C-65	BRACKET	9	1	109	..	77.73
C-66	SEAL	9	276
C-67	CONE—TIMKEN (44150).....	9	2	1	..	2.15
C-68	CONE—TIMKEN (55200).....	9	4	1	4	2.85
C-69	NUT—TIMKEN (Adjusting).....	9	4	2	..	3.30
C-70	CONE—TIMKEN (418)	9	2	1	..	2.01
C-71	SPRING	8	2	..	6	.66
C-86	CONE (Driving) (Lined with Woven or Molded).....	1, 3	2	22	..	26.55
C-100	BUSHING	1, 3	2	2	..	2.80
C-137	WHEEL	9	4	15	..	5.28
C-138	PIN	9	4	6	..	2.65
C-157	CAP (Pilot)	1, 2, 5	1	..	14	.88
C-158	BUSHING (Pilot).....	1, 5	1	..	14	2.53
C-175	BEARING (Hyatt) (RA-212)	9	4	1	8	2.38
C-177	BEARING (Hyatt) RAW-212.....	1, 5	1	2	..	2.70
C-196	SPRING (Clutch).....	6, 7	2	..	4	.51
C-204	SHAFT—RIGHT	6, 7	1	27	..	24.18
C-205	SHAFT—LEFT	6, 7	1	27	..	24.18
C-206	NUT—RIGHT	1, 3	1	3	8	13.95
C-207	NUT—LEFT	1, 3	1	3	8	13.95
C-312	LOCKWASHER 3/8"	1, 2	3601
C-315	ZERK 1/8" STRAIGHT.....	9	406
C-1034	PLUG 1 1/4" PIPE.....	1	1	..	12	.17
C-1039	LINING—BRAKE (Woven or Molded).....	1, 4	2	2	12	4.07
C-1051	COTTER 3/8" x 5".....	9	4	..	4	.06
C-1523	NUT 1/2" NC HEX.....	1, 4	203
C-1524	NUT 1/2" NF HEX.....	2, 8	603
C-1527	NUT 3/4" NC HEX.....	9	605
C-1540	LOCKWASHER 1/2"	1, 2, 4	601
C-1542	LOCKWASHER 3/4"	2	403
C-1545	LOCKWASHER 1 1/4"	8	213
C-1555	COTTER 5/32" x 1"	1, 4	1601
C-1596	ZERK 60°	9	810
C-1601	CAPSCREW 3/8" x 3/4" NC.....	1, 2	3603

644-0

SPARE PARTS & PRICE LIST

MODEL R7 POWER UNIT

12

C-1613	CAPSCREW 1/2" x 1 1/4" NC.....	1, 3	2406
C-1614	CAPSCREW 1/2" x 1 1/2" NC.....	6, 7	2406
C-1615	CAPSCREW 1/2" x 1 3/4" NC.....	2	406
C-1621	CAPSCREW—1/2" x 3 1/4" NC.....	1, 4	211
C-1644	CAPSCREW 3/4" x 2" NC.....	2, 8	6	..	6	.17
C-1646	CAPSCREW 3/4" x 2 1/2" NC.....	9	6	..	8	.18
C-1673	CAPSCREW 3/8" x 1 3/4" NF.....	1, 2, 5	403
C-1687	CAPSCREW 1/2" x 3 1/2" NF.....	2	4	..	4	.12
C-1689	CAPSCREW 1/2" x 4" NF.....	8	2	..	4	.13
C-5783	NUT 7/16" NF HEX.....	9	203
C-5786	NUT 1 1/4" NC HEX JAM.....	8	2	..	6	.22
C-8310	PLUG 1 1/4" PIPE DRILLED.....	1	1	..	8	.23
D-2614	LINING CLUTCH (Bi-Metallic—Not Available for Duration).....	1	2	5	8	16.52
D-2777	BOLT 7/16" x 6" NF MACHINE.....	9	2	..	8	.11
D-2889	LOCKWASHER 1/2" SHAKEPROOF.....	1, 3, 6, 7	4801
D-4322	NUT.....	1, 4	2	..	8	.37
D-4429	CONE—TIMKEN (14139).....	4	4	..	8	1.27
D-4431	CLOSURE FELT.....	1, 4	4	..	4	.26
D-4432	CUP—TIMKEN (14274).....	4	4	..	2	.47
D-7053	CONE—DRIVING (Lined with Bi-Metallic—Not Available for Duration).....	1, 3	2	28	..	37.58
D-7134	BAND—BRAKE.....	4	2	5	8	9.89
D-7136	BEARING ASSEMBLY—TIMKEN (Includes D-4429 and D-4432).....	1	4	..	10	1.74
E-229	SHIM CABLE.....	610
E-670	STREET ELL 1 1/4".....	1	1	1	..	.38
E-4132	COTTER 1 1/2" x 2".....	1, 4	201
E-4888	CONE—DRIVEN.....	6, 7	2	40	..	46.25
E-4896	DRUM—CABLE.....	6, 7	2	50	..	37.00
E-5046	GUARD—RIGHT CABLE.....	2	1	26	..	10.40
E-5071	GUARD—LEFT CABLE.....	2	1	26	..	10.40
E-5165	SHIM.....	110
E-5251	PLUG 1/8" PIPE.....	6, 7	205
E-5545	RIVETS—BRAKE (For Woven Lining).....	1	2	c .78
E-6293	HOUSING—TOP RIGHT.....	9	1	20	..	11.25
E-6294	HOUSING—BOTTOM LEFT.....	9	1	20	..	11.25
E-8618	SHIM—DRUM.....	3, 6, 710
F-883	LOCKWASHER 3/4" SHAKEPROOF.....	8	603
F-5342	SHIM—DRUM .004.....	610
F-5343	SHIM—GEAR .004.....	110
F-6342	BAND—BRAKE (Lined with Bi-Metallic—Not Available for Duration).....	1	2	12	8	24.44
F-6345	LINING—BRAKE (Bi-Metallic—Not Available for Duration).....	1	2	7	..	15.81
F-7216	BAND—BRAKE (Lined with Woven or Molded).....	1	2	15	..	12.88
H-2807	GASKET.....	1, 2, 5	110
H-2810	GASKET.....	1, 2	280
H-3278	HOUSING.....	10	1
H-3279	SHAFT—CABLE.....	10	1	2	12	4.90
H-3280	BLADE—TOP CABLE.....	10	1	..	2	1.75
H-3281	BLADE—BOTTOM CABLE.....	10	2	..	2	1.50
H-3495	RIVET—BRAKE (For Bi-Metallic Lining).....	1	56	1.80
H-4428	WASHER 3/4".....	8	205
H-5304	LOCKWASHER 3/8" SHAKEPROOF.....	1, 2	401
H-6025	PIN.....	10	110
H-6783	SHAFT—SPLINE.....	8	1	24	..	35.00
H-7071	RIVET—CONE (For Bi-Metallic—Not Available for Duration).....	1	42	c 2.50

645-G

SPARE PARTS & PRICE LIST

MODEL R7 POWER UNIT

13

H-7071	RIVET (VeleTouch Lining).....	1	42	c	2.50
H-8466	SHAFT—BRAKE	1, 4	2	5	8		3.89
H-8469	ROLLER ASSEMBLY.....	1	2	5	..		2.84
H-8470	ARM	1, 4	2	3	..		1.30
H-8471	PIN	1, 4	2	..	8		.80
H-8474	CASE STRUCTURE.....	2	1	370	..		150.00
H-9770	HANDLE—LEFT	8	1	13	..		5.35
H-9771	HANDLE—RIGHT	8	1	18	..		5.45
R-857	PLATE—REAR	2	1	61	..		13.78
R-2260	RIVET—CONE (For Woven or Molded).....	1	23	c	.80
R-3193	PLUG 1¼".....	1	1	..	8		1.00
R-3623	GASKET	8	160
L-323	SEAL (Special).....	9	8	..	2		.50
L-1624	SEAL (354216).....	6, 7	4	..	4		.66
L-1648	SEAL (335212).....	1, 3	2	..	3		.60
L-3725	SEAL (Special).....	1, 3	2	..	3		.60
L-3761	SEAL (Special).....	1, 3	1	1	2		2.63
L-37050	SEAL (Special).....	1, 2	2	2	..		7.35

660-G

SPARE PARTS & PRICE LIST

MODEL R7 POWER UNIT

14

PART No.	DESCRIPTION	PAGE	QTY.	WEIGHT		PRICE EACH
				Lbs.	Oz.	
E-4283	DOUBLE DECK SHEAVE ASSEMBLY (Includes following)	9	1	300	..	167.50
C-3	CUP		2			
C-4	CUP		4			
C-5	CUP		2			
C-63	HOUSING		1			
C-64	HOUSING		1			
C-65	BRACKET		1			
C-66	SPACER		2			
C-67	CONE		2			
C-68	CONE		4			
C-69	ADJUSTING NUT		4			
C-70	CONE		2			
C-137	WHEEL		4			
C-138	PIN		4			
C-175	BEARING		4			
C-315	ZERK		4			
C-1051	COTTER		4			
C-1527	NUT		6			
C-1596	ZERK		8			
C-1646	BOLT		6			
C-5783	NUT		2			
D-2777	BOLT		2			
E-6293	HOUSING		1			
E-6294	HOUSING		1			
L-323	SEAL		8			
H-3150	CABLE CUTTER ASSEMBLY (Includes following)	10	1	8		10.70
H-3278	HOUSING		1			
H-3279	SHAFT		1			
H-3280	BLADE		1			
H-3281	BLADE		2			
H-6025	PIN		1			

674-B

LIST OF ASSEMBLIES

