

*468* *W113*  
*12*  
*1941*

**TM 9-1557**

*U.S. Dept of Army*

**WAR DEPARTMENT**

---

**TECHNICAL MANUAL**

**ORDNANCE MAINTENANCE**

**ELEVATION QUADRANT M1**

**October 20, 1941**

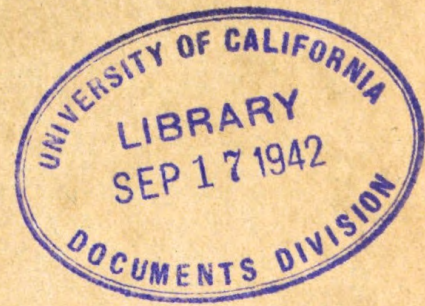

U113  
.2

TM 9-1557  
1-2

TM 9:1557

TECHNICAL MANUAL }  
No. 9-1557 }

1941

WAR DEPARTMENT,  
WASHINGTON, October 20, 1941.



ORDNANCE MAINTENANCE  
ELEVATION QUADRANT M1

Prepared under direction of the  
Chief of Ordnance

General .....	Paragraph	1
Description and operation .....		2
Inspection .....		3
Maintenance and repair .....		4
Care and preservation .....		5
APPENDIX. List of references .....	Page	15

1. **General.**—*a. Purpose.*—This manual is published primarily for the information and guidance of ordnance maintenance personnel.

*b. Scope.*—This manual supplements the Technical Manuals which are prepared for the using arm. It contains general descriptive matter and detailed instructions for maintenance and repair of the elevation quadrant by ordnance personnel. Figures which accompany the manual show the placement and method of fastening of each of the component parts of the elevation quadrant.

*c. References.*—The Appendix lists all Standard Nomenclature Lists and other publications pertaining to the elevation quadrant.

2. **Description and operation.**—*a. Description.*—(1) The elevation quadrant M1 is the elevation indicating element for use with the 8-inch gun railway mount M1 and with other railway and seacoast gun matériel which had formerly used the elevation quadrant M1917. The elevation quadrant M1 supersedes and replaces the elevation quadrant M1917 in all applications.

(2) The elevation quadrant is mounted on the right trunnion of the gun cradle and rotates with the gun in elevation. It forms part of the complete sighting system which includes a telescope mount and one or more telescopes for pointing the gun in azimuth. Sighting equipment for the 8-inch gun railway mount M1 includes elevation quadrant M1, telescope mount M20, and panoramic telescope M8.

M558657

(3) The elevation quadrant M1 consists principally of the elevation mechanism, cross leveling mechanism, bracket, and lighting system.

(4) The cross leveling knob (A179351, sec. D-D, fig. 5) at the lower left portion of the elevation quadrant positions the quadrant case (D43347, fig. 3) in a vertical plane. The cross level vial (A31314) indicates the true vertical position.

(5) The elevating knob (B138905, sec. C-C, fig. 4) operating through worm (B138902) and segment (C70184) positions the longitudinal level vial (A180819, sec. E-E, fig. 5) as required to determine elevation. Elevation indications in mils are shown on the elevation scale (coarse, 100-mil intervals) and micrometer (fine, 1-mil intervals).

(6) The bracket (D43246, fig. 3) is pinned and screwed to the right trunnion of the gun cradle. Rotation of the gun in elevation is imparted to the quadrant through the bracket and pivot.

(7) Electric power for illuminating the elevation quadrant is drawn from the main power source on the gun mount and is controlled by a toggle switch on the right under side of the quadrant case. A 2-conductor cable, 4 feet long, with plugs is furnished with the quadrant for connection from the main power source to the socket near the toggle switch. The lamp housings are cast integral with the quadrant castings. Removable lamp receptacles (sec. G-G, fig. 6) which screw into the lamp housings render the lamps accessible for replacement. Each lamp receptacle is locked by a headless screw (BCUX2CD). The electric lamps are Mazda, No. 51 type, bayonet base, single contact, 1 cp, 6 to 8 volts, 0.25 ampere.

*b. Operation.*—(1) To set off quadrant elevation, rotate elevating knob (B138905, sec. C-C, fig. 4) until the desired elevation is registered on the elevation scale (coarse, 100-mil intervals) and elevation micrometer (fine, 1-mil intervals). Elevate or depress the gun until the bubble in the longitudinal level is centered with respect to the graduations on its vial.

(2) Keep cross level bubble centered during the above operation so that a true vertical angle will be measured. The cross level bubble is centered by means of cross level knob (A179351, sec. D-D, fig. 5).

**3. Inspection.**—Inspection is for the purpose of determining the condition of the elevation quadrant, whether repairs or adjustments are required, and the remedies necessary to insure serviceability and proper functioning. The listing below will serve as a guide for inspection. Refer to assembled and sectioned views of the elevation quadrant for location of parts.

- | <i>Parts to be inspected</i>        | <i>Points to be observed</i>  |
|-------------------------------------|---|
| <p>a. Exposed mechanical parts.</p> | <p>a. Note general appearance and check for bent or missing parts. Scale and micrometer graduations and index lines should be clear and legible. The four mounting screws (BCAX2BD) and washers (BECX1R, sec. B-B, fig. 4) are part of the elevation quadrant and should be attached therewith.</p>   |
| <p>b. Elevating worm mechanism.</p> | <p>b. Elevating worm (B138902, sec. C-C, fig. 4) should operate smoothly without looseness or undue friction. Total rotation should be approximately <math>14\frac{3}{4}</math> turns with the rotation limits extending beyond the end graduations of the elevation scale (rotation limits are determined by stop rings (A179339 and A179338) assembled on the worm shaft).</p>      |
| <p>c. Cross leveling mechanism.</p> | <p>c. Cross leveling knob (A179351, sec. D-D, fig. 5) should operate smoothly without binding or excess friction. Compression spring (A179352, fig. 3) should function properly to take up lost motion. Adjustment of plugs on pivot (B139192, sec. B-B, fig. 4) should permit free motion between bracket (D43246, fig. 3) and case (D43347) with neither looseness nor binding.</p> |
| <p>d. Level vials.</p>              | <p>d. Level vials should not be broken and should be secure in their mountings. Level vial covers should operate properly.</p>  |
| <p>e. Illumination.</p>             | <p>e. Elevation scale, elevation micrometer, and level vials should be properly illuminated when illuminating system is connected to a 6-volt source.</p>   |

*Parts to be inspected*

f. Gaskets (B138908, fig. 3 and A179358, fig. 2).

*Points to be observed*

f. Gasketed joints under case cover assembly (C77745, fig. 3) and terminal cover (A179357, fig. 2) should be waterproof. Other sealed joints not provided with gaskets should likewise be waterproof.

**4. Maintenance and repair.**—*a. Tools.*—An optical repair kit containing the necessary tools, fixtures, cements, oils, etc., for use with coast artillery sighting and fire-control equipment is furnished to ordnance maintenance companies. A list of the items comprising the kit is pasted in the cover of the tool chest. Every item in the kit is designated by a number equivalent to the compartment number in the tool chest. The tools used with the elevation quadrant require no specific description as their uses are self-explanatory.

*b. Disassembly and assembly.*—(1) *Case pivot (B139192) and cross leveling screw mechanism.*—(a) Remove cross leveling knob (A179351, sec. D-D fig. 5, secured by nut (BBGX1E), which is secured by cotter pin (BFAX1DG). Unthread and remove cross leveling screw (A179348). Cross leveling screw pins (A179349 and A179350) and compression spring (A179352, fig. 3) are then readily accessible for removal.

(b) To remove case pivot (B139192, sec. B-B, fig. 4) remove cotter pin (BFAX1DT), plug (A179353), and disk (A179379) at each end of pivot. Remove clamping screw (BCAX1CF) in split portion of case. Extract the taper bushings (A179156) from each end of pivot and drive out pivot. Separate case (D43347, fig. 3) from bracket (D43246), exercising particular care to prevent damage to the mating surfaces.

(c) Clean and lubricate parts as described in paragraph 5b before reassembling. Reassemble in reverse order of disassembly and adjust as indicated below.

(d) Adjust taper bushings (A179156, sec. B-B, fig. 4) by means of plugs (A179353) to provide a snug fit at each end of pivot. Secure plugs by means of cotter pins (BFAX1DT).

(e) Adjust cross leveling screw nut (BBGX1E, sec. D-D, fig. 5) to take up lost motion under sleeve of cross leveling knob (A179351). Secure nut by means of cotter pin (BFAX1DG).

(2) *Elevating worm (B138902).*—(a) Remove elevating knob assembly (B139191, sec. C-C, fig. 4) secured by three cap screws (BCCX1AA) and washers (BEAX1H). Remove elevation micrometer (B138904).

(b) Loosen lock screw (BCGX3FE) in micrometer adapter retaining nut (A36061) and remove retaining nut. Remove micrometer adapter (A179331) which is keyed to worm shaft. Remove washers under micrometer adapter.

(c) Loosen screw (BCUX1FD, fig. 2) in wall of case and remove elevating worm plunger plug (A36245, sec. C-C, fig 4), spring (A36247), and plunger (A179340).

(d) Loosen headless flat-point screw (BCUX1FE) which locks ball cap (A179335) and headless dog-point screw (A179601) which locks ball socket (A179336). Unscrew ball cap. Pull out elevating worm with ball, ball socket, and stop rings.

(e) Clean and lubricate parts before reassembling as described in paragraph 5b. Lubricate felt washers very lightly with oil, lubricating, for aircraft instruments and machine guns. Reassemble in reverse order of disassembly and adjust as indicated below.

(f) Adjust stop rings (A179339) to limit motion of elevating worm properly. There are 17 of these stop rings, each with a protruding lug which meets the protruding lug of the neighboring ring. These rings are all free to rotate on the worm shaft except the first one, which engages a slot in a shoulder on the shaft. An eighteenth ring (A179338) is similar to the others, except that it is thicker and is pinned to the worm ball (B138903) which is locked in the housing. At the stop limits, the protruding lugs of all stop rings butt solidly together.

(g) Turn ball socket (A179336), using a stiff wire or similar tool, to bring locating notch under clamping screw hole and clamp ball socket. The projecting lug of the ball should be located in its socket in the upper part of the case. Tighten ball cap (A179335) to a snug fit on worm ball (B138903) and clamp ball cap.

(h) Adjust elevation micrometer (B138904) to read zero when elevation scale reads exactly zero.

(3) *Case cover assembly (C77745).*—(a) Remove level bracket assembly (C77746, fig. 3) secured by two cap screws (BCAX1CB, sec. E-E, fig. 5) and safety nut (BBSX2AB, fig. 3). Adjusting screws (A46233, sec. E-E, fig. 5) must be loosened, thereby disturbing adjustment of longitudinal level. If necessary to remove bracket entirely from elevation quadrant, unsolder electric wires at terminal assembly (B139001, sec. G-G, fig. 6); however, a sufficient length of wire is coiled in central recess to make removal unnecessary in most cases. Examine felt strip ( $\frac{3}{16}$  by  $\frac{3}{16}$  by 14, shellacked in groove) and replace if torn or otherwise unserviceable.

(b) Remove 15 flat-head screws (BCKX2CE, fig. 3) which secure case cover assembly (C77745) and gently pry cover free from case,

being careful not to injure gasket (B138908): Gasket will normally break free from case and remain attached to cover.

(c) Reassemble in reverse order of disassembly. Lubricate felt strip very lightly with oil, lubricating, for aircraft instruments and machine guns.

(4) *Elevating worm segment assembly.*—(a) Remove case cover assembly (C77745, *c* above) and elevating worm (B138902, *b* above).

(b) Remove index (A179360, fig. 2) secured by two screws (BCCX1AR) and washers (BEAX1H).

(c) Remove ball bearing lock nut (BBRX1AH, fig. 3) secured by washer (BEFX1AH).

(d) Pull out elevating worm segment (C70184) and ball bearings.

(e) Reassemble in reverse order of disassembly.

(5) *Longitudinal level vial (A180819).*—To replace longitudinal level vial (sec. E-E, fig. 5), remove plug (A179341) at each end of level vial cavity. Plugs are threaded in position and secured by pins ( $\frac{3}{32}$  by  $1\frac{3}{16}$ ). Pull out level vial tube (A179342). Clean out broken glass and old packing. Locate new level vial in level vial tube so that graduations are centered in proper opening and pack with calcined gypsum (plaster of paris) which has been mixed to medium consistency. After plaster has set, clean excess from surfaces. Remove a strip of silver and covering from under side of level vial to permit illumination. Reassemble level vial tube and replace plugs and pins.

(6) *Cross level vial (A31314).*—To replace cross level vial (fig. 3), remove level vial plug (A34057) at end of level vial cavity. Plug is threaded in position and secured by pin (BFDX3.1A). Loosen four headless screws (BCUX2CB) in end of level vial tube (A33994) and pull out level vial tube. Clean out broken glass and old packing. Locate new level vial in level vial tube so that graduations are centered in opening and pack with calcined gypsum (plaster of paris) which has been mixed to medium consistency. After plaster has set, clean excess from surfaces. Reassemble level vial tube and tighten the four headless screws. Replace level vial plug and its pin.

(7) *Lighting system.*—Removal of cover assembly (B139189, fig. 2) provides access to the electric wire terminals. The cover assembly is secured by six flat-head screws (BCKX2CE). The toggle switch and socket (A178646) are in series connection and are connected by flexible wires to terminal plates marked L1 and L2. The electric lamps are connected in parallel to these same terminal plates. Terminals (A45421, sec. K-K, fig. 6) are marked to correspond to the terminal plates. Wires are routed through clearance passages in the interior of the quadrant and are supported by clips where necessary. Wires

are set in sealing compound (knife grade gray Vulcatex cement, or equal) at points where there is possibility of entrance of water. When replacing electric lamps, loosen headless locking screw (BCUX2CD, sec. G-G) in rim of lamp receptacle before attempting to remove lamp receptacle. In reassembling, tighten locking screw to prevent loosening of lamp receptacle.

(8) *Lubrication when assembling.*—See paragraph 5b.

*c. Adjustment of level vials.*—(1) Adjustment of longitudinal level vial is performed with the elevation quadrant assembled on the gun. Adjustment of cross level vial is not required, as any error in elevation resulting from a possible inaccuracy of the cross level vial would be negligible.

(2) To verify the adjustment of the longitudinal level vial, elevate the axis of the bore to quadrant elevations corresponding to short, medium, and long range. Check the elevation quadrant readings against clinometer readings for each elevation. If an error exists, and if the error is constant for all elevations, adjustment is required as described below. However, if the error is not constant for all elevations, determine and correct the condition before proceeding with the adjustment.

(3) To adjust the longitudinal level vial, first level the gun by means of the clinometer. Do not disturb this setting until the adjustment is completed. Set elevation scale and micrometer to indicate zero elevation. Loosen two screws (BCAX1CB, sec. E-E, fig. 5) and nut (BBSX2AB, fig. 3) which clamp level bracket. Loosen two headless screws (sec. E-E, fig. 5) which clamp adjusting screws (A46233). By use of these adjusting screws, bring level bubble to central position. Tighten clamping screws, nut (BBSX2AB), and screws (BCAX1CB).

*d. Adjustment of elevation micrometer.*—The elevation micrometer (B138904, sec. C-C, fig. 4) should read zero when elevation scale reads exactly zero. To adjust micrometer, loosen three fillister head screws (BCCX1AA) which secure elevation worm knob and shift micrometer under knob until correct reading is obtained; then tighten screws which secure knob.

**5. Care and preservation.**—*a. Handling.*—(1) Care must be exercised to prevent bumping the level bracket or other parts of the elevation quadrant.

(2) Keep the level vials covered at all times when not in use.

(3) Do not attempt to force the rotation of knobs beyond the stop limits.

(4) Dissassembled parts should be thoroughly cleaned with solvent, dry cleaning, before lubrication and assembly.



*b. Lubrication instructions.*—(1) The elevation quadrant M1 should be lubricated on assembly with the following lubricants furnished by the ordnance department:

(a) Grease, special, low temperature.

(b) Oil, lubricating, for aircraft instruments and machine guns, U. S. Army Specification No. 2-27.

(2) Gears, ball bearings, and all other sliding surfaces should be lubricated with a thin film of grease.

(3) External contact surfaces should be lightly oiled.

(4) The exterior surfaces of the elevation quadrant should be kept free of dirt and also of any lubricant which might seep out from around moving parts. Wipe off all excess lubricant.

(5) Lubricants for fire-control instruments function also as rust preventives. It is important that they be applied carefully. Care should be taken not to overlubricate. Too much grease applied to delicate movements may cause stiffness of operation in cold weather.

ELEVATION QUADRANT M1

TM 9-1557

5

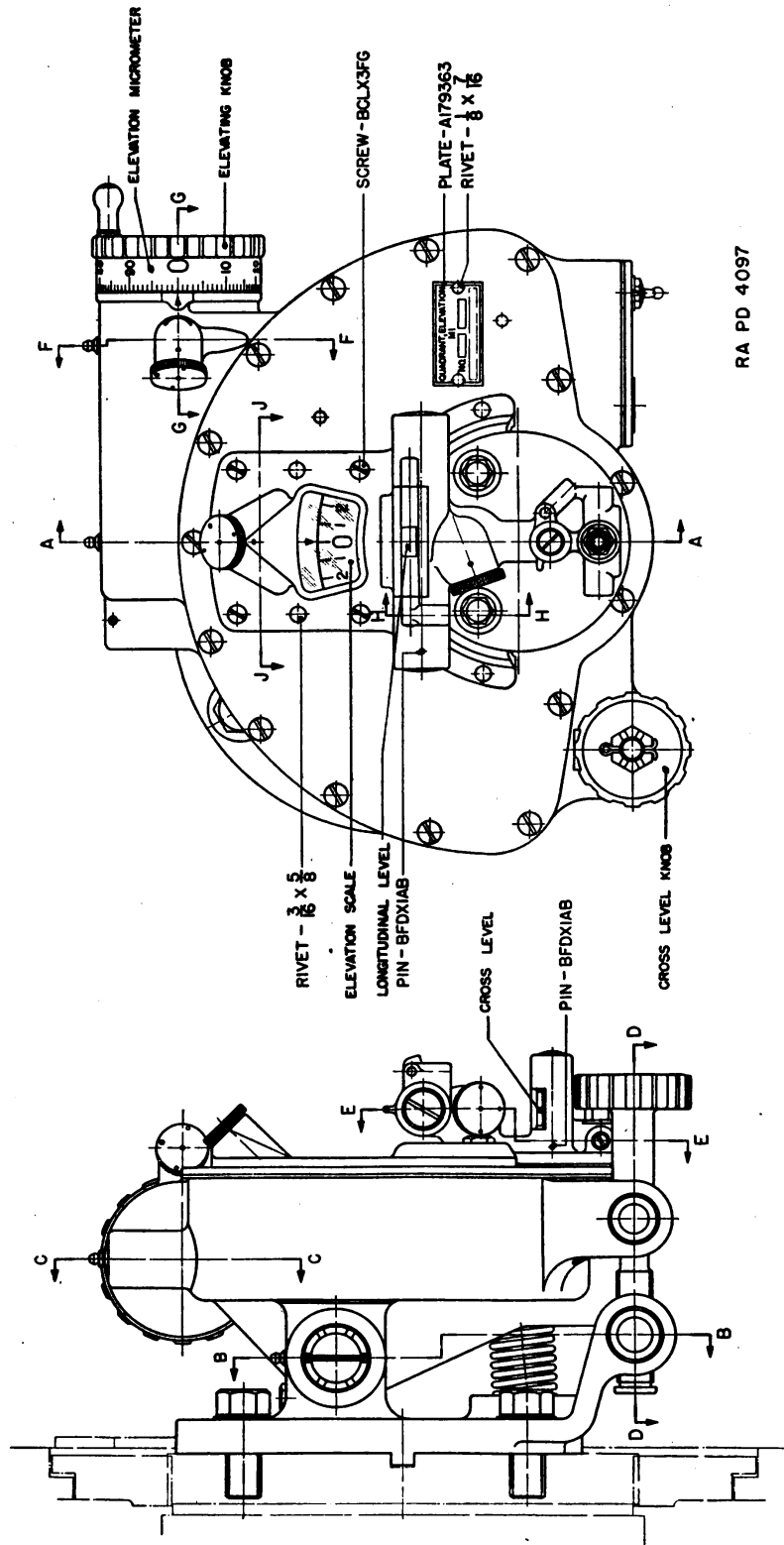

RA PD 4097

FIGURE 1.—Elevation quadrant M1—assembled views.

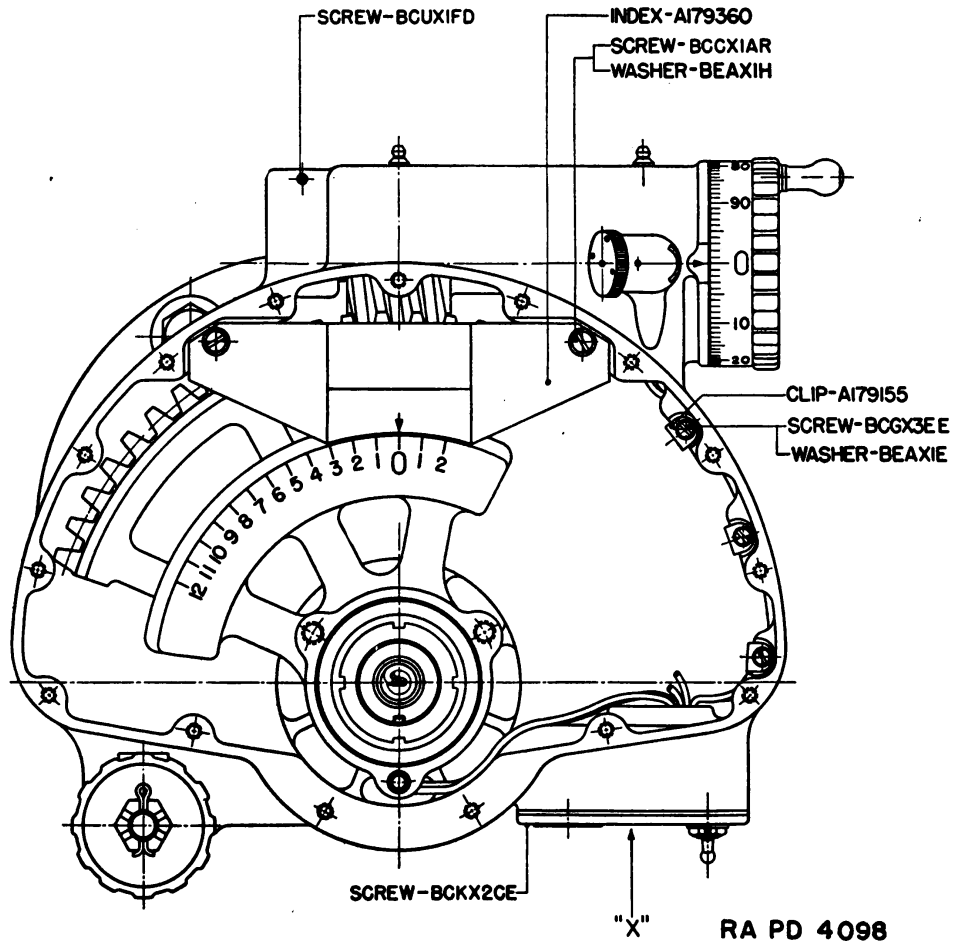
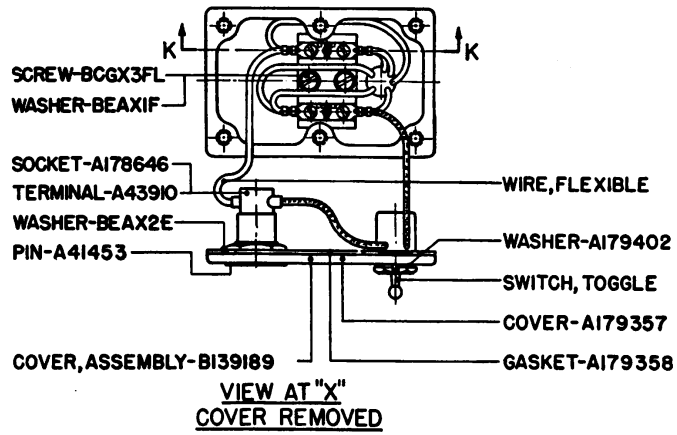
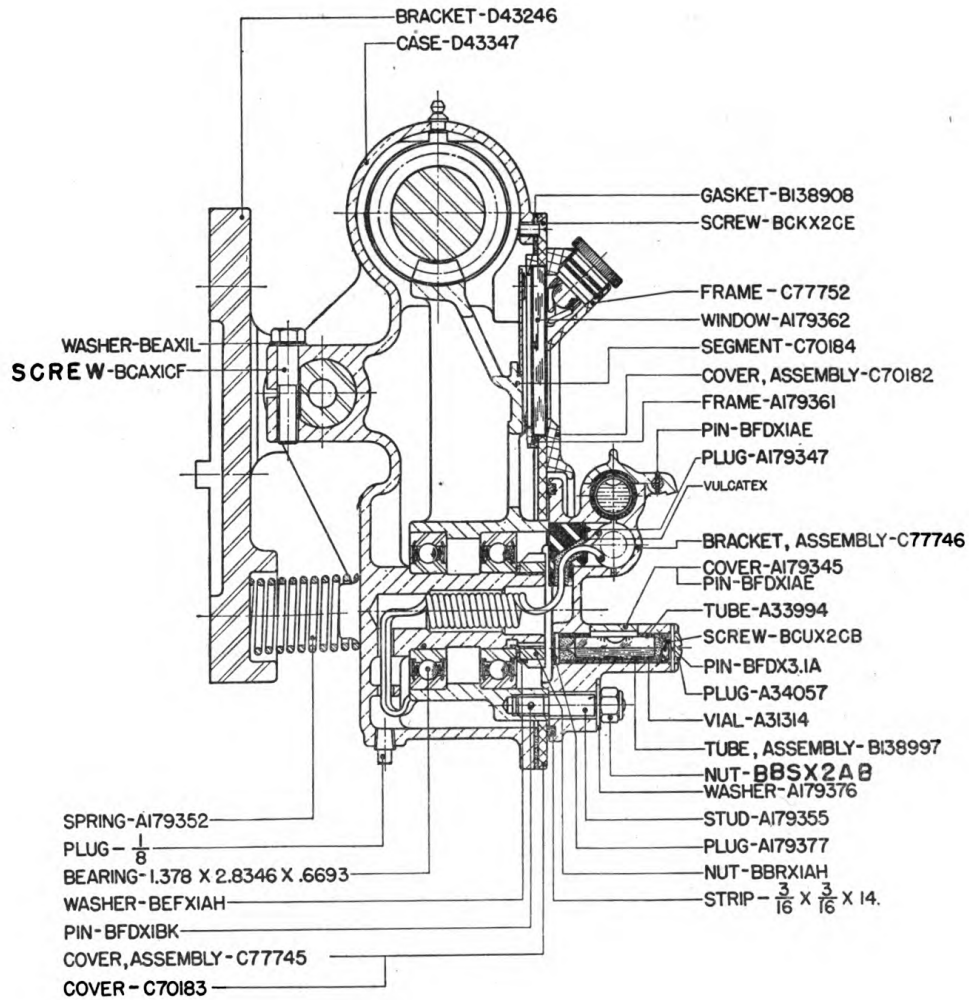

FIGURE 2.—Elevation quadrant M1—assembly views, covers removed.

ELEVATION QUADRANT M1



SECTION A-A

RA PD 4099

FIGURE 3.—Elevation quadrant M1—sectioned view A-A.

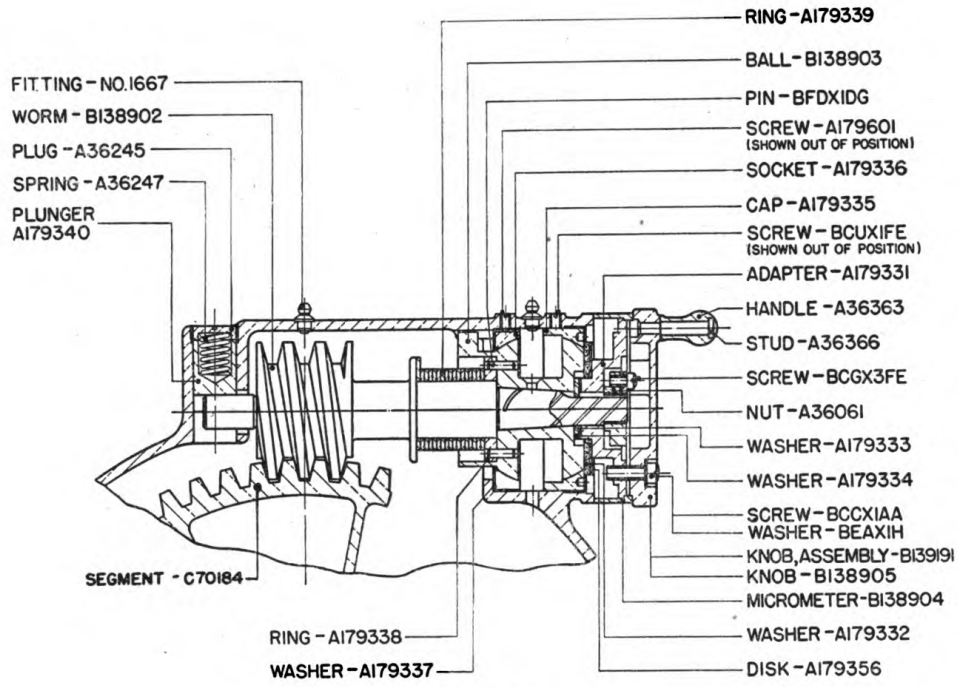

SECTION C-C

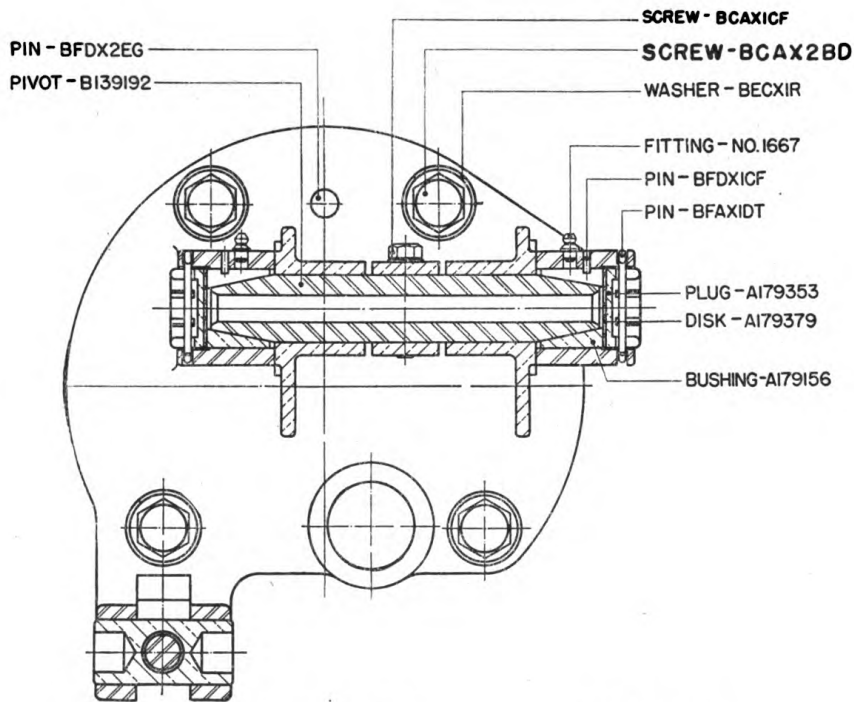

SECTION B-B

RA PD 4100

FIGURE 4.—Elevation quadrant M1—sectioned views B-B and C-C.

ELEVATION QUADRANT M1

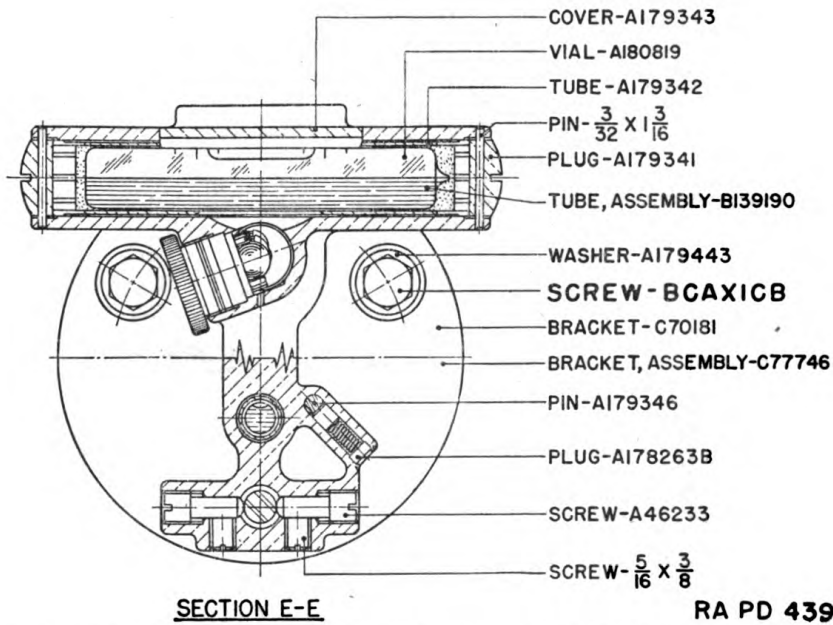
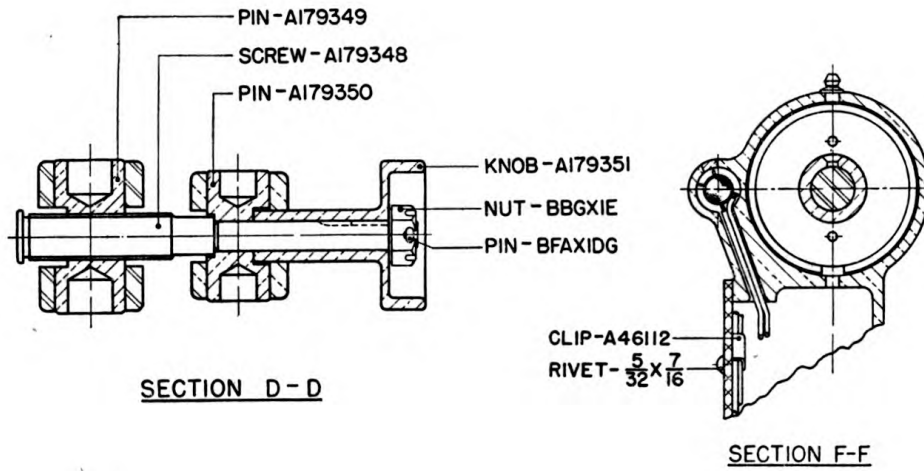

RA PD 4392

FIGURE 5.—Elevation quadrant M1—sectioned views D-D, E-E, and F-F.

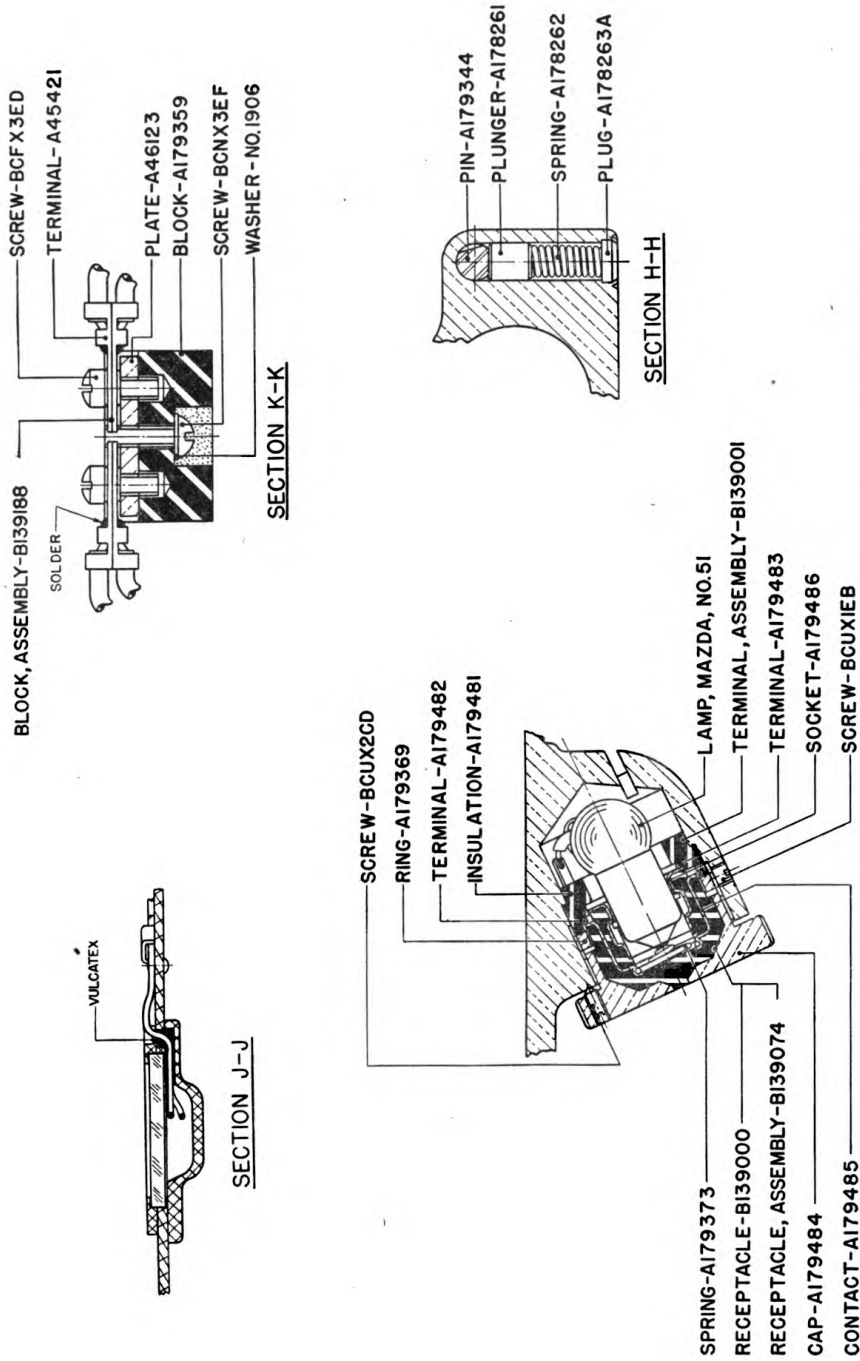

RA PD 4393

FIGURE 6.—Elevation quadrant M1—sectioned views G-G, H-H, J-J, and K-K.

APPENDIX

LIST OF REFERENCES

1. **Standard Nomenclature Lists.**  
 Mount, telescope, M20----- SNL F-186  
 Telescope, panoramic, M8----- SNL F-196  
 Quadrant, elevation, M1----- SNL F-204  
 Current Standard Nomenclature Lists  
 are as tabulated here. An up-to-  
 date list of SNL's is maintained as the  
 "Ordnance Publications for Supply  
 Index"----- (OPSI)
2. **Technical Manuals.**  
 Cleaning and preserving materials---- TM 9-850  
 Matériel inspection and repair----- TM 9-1100
3. **Field Manual.**  
 Seacoast artillery, fire control and  
 position finding----- FM 4-15
4. **Ordnance Field Service Bulletin.**  
 Lubrication instructions for fire-con-  
 trol instruments ----- OFSB 6-F-1  
 (tentative)

[A. G. 062.11 (10-20-41).]

BY ORDER OF THE SECRETARY OF WAR:

G. C. MARSHALL,  
*Chief of Staff.*

OFFICIAL:

E. S. ADAMS,  
*Major General,  
 The Adjutant General.*

DISTRIBUTION:

B 4(2) ; IR 4(2) ; Bn 9(2) ; IC 9(4).  
 (For explanation of symbols see FM 21-6.)



