

hd U113
12
TM
1941

TM 9-1685

WAR DEPARTMENT

U.S. Dept. of Army

TECHNICAL MANUAL



ORDNANCE MAINTENANCE

DEPRESSION POSITION FINDER

M1907

October 14, 1941

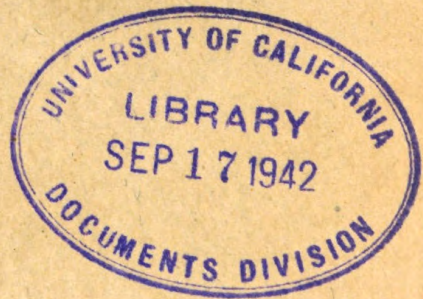

Doc well
yft
non are

U113
.2

TM 9-1685

1-2

TM 9:1685
1941

TECHNICAL MANUAL }
No. 9-1685

WAR DEPARTMENT,
WASHINGTON, October 14, 1941.



ORDNANCE MAINTENANCE

DEPRESSION POSITION FINDER M1907

Prepared under direction of the
Chief of Ordnance

	Paragraph
General.....	1
Description.....	2
Operation.....	3
Inspection.....	4
Maintenance and repair.....	5
Care and preservation.....	6
Spare parts and accessories.....	7
	Page
APPENDIX. List of references.....	27

1. **General.**—*a. Purpose.*—This manual is published primarily for the information and guidance of ordnance maintenance personnel.

b. Scope.—This manual supplements the Technical Manuals which are prepared for the using arm. It contains general descriptive matter and detailed instructions for the maintenance and repair of the instrument by ordnance personnel. Figures which accompany the manual show the placement and method of fastening of each of the component parts of the instrument.

c. References.—The appendix lists Standard Nomenclature Lists and other publications pertaining to this instrument.

2. **Description.**—*a. General.*—(1) The depression position finder M1907 is an instrument used for measuring from heights above sea level, the true horizontal range of an object on the surface of the sea and also the azimuth of the object from the azimuth reference line.

(2) The instrument consists essentially of a telescope, mount, and pedestal. The mount carries the telescope and contains suitable mechanisms for directing it. The mount is accurately leveled on the pedestal by three leveling screws. When the telescope is directed on the water line of a target the depression angle is measured mechanically, and the corresponding horizontal range, corrected for curvature of the earth and normal atmospheric refraction, is read directly on a range scale graduated in yards. A compensating mechanism corrects for tidal variations, abnormal atmospheric refraction, and for heights of instrument other than those for which the range scale is

M558708

calibrated. Azimuths are read directly from an azimuth scale and subscale.

(3) The depression position finder M1907 is superseded by the depression position finder M1.

(4) The instrument is built in several classes, designated alphabetically as listed below, to cover the varying needs of the service. The depression mechanism components and the range scale supplied determine the class of the instrument.

<i>Class</i>	<i>Height of emplacement above sea level (feet)</i>	<i>Range (yards)</i>
A.....	35 to 80.....	1,500 to 12,000.
B.....	60 to 145.....	1,500 to 12,000.
C.....	125 to 300.....	1,500 to 12,000.
D.....	280 to 690.....	1,500 to 12,000.
E.....	90 to 210.....	600 to 9,000.
F.....	165 to 400.....	600 to 9,000.
AA.....	25 to 60.....	1,000 to 6,000.
BM.....	60 to 145.....	1,500 to 15,000.
CM.....	125 to 300.....	1,500 to 20,000.
DD.....	160 to 400.....	1,000 to 6,000.
DM.....	280 to 800.....	1,500 to 20,000.
DM1.....	380 to 1,140.....	2,000 to 20,000.
DMM.....	280 to 800.....	1,500 to 20,000.
DMM1.....	380 to 1,025.....	2,000 to 20,000.
EE.....	300 to 750.....	1,000 to 6,000.
G.....	1,200 to 3,500.....	2,500 to 25,000.
H.....	280 to 760.....	5,000 to 30,000.
K.....	310 to 900.....	3,000 to 25,000.

b. Telescope.—(1) The telescope for depression position finder M1907 is shown in figures 1 to 4, inclusive.

(2) The telescope is furnished with two interchangeable eyepiece assemblies. The optical characteristics with the eyepieces furnished are as follows:

Magnification.....	15X.....	25X.
Field of view.....	3°.....	1°.
Diameter of exit pupil.....	0.20 inch.....	0.12 inch.
Effective focal length of objective.....	25 inches.....	25 inches.
Effective focal length of eyepiece.....	1.667 inches.....	1 inch.
Apparent field of view.....	45°.....	45°.

(3) The optical system includes an objective (A36637), two porro prisms (A36636), a reticle assembly, and eyepiece assembly (C44216 or C44217). The image produced is erect.

(4) The eyepiece is threaded into the eyepiece adapter (20A). Each eyepiece assembly contains an amber filter (A36635) assembled in a filter holder (20N). The knurled arm of the filter holder, used for adjustment, projects through the edge of the eyepiece cap.

(5) The reticle frame (20G, fig. 3) contains two fine platinum cross wires which locate the vertical and horizontal axes of the field of view. Electrical illumination is provided and a shutter sleeve (20B) controls the degree of illumination.

(6) The adjusting pinion knob (17K) controls the movement of the cross wires into the focal plane of the objective.

(7) The mask assembly (C44262, fig. 2) enables the observer to relax the eye that is not focused on the telescope. It is adjustable and can be set to suit the observer. The head should not be rested on the mask or any part of the telescope.

(8) The telescope is positioned on the mount by two telescope trunnions (5C, fig. 1) which are retained in the yoke by an accurately machined bar (18D, fig. 3). The bar is secured to the under side of the tube (9C) and rests on the pin (3B, fig. 9) in the head of the compensating screw. The optical axis of the telescope is parallel to the lower surface of the bar.

(9) The counterweight assembly (B129215, figs. 2 and 4) is adjustable for proper balance of the telescope. The sunshade (9F), although removable, should be kept in place when the telescope is in use, as its weight is necessary to secure the correct balance.

(10) The safety clip (18F, fig. 3) which is attached to the body tube bar (18D) hooks under the head of the compensating screw and prevents accidental lifting of the telescope.

c. Mount.—(1) The mount for depression position finder M1907 (figs. 1 and 5 to 10) supports the telescope and contains leveling, azimuth, and ranging mechanisms. Figure 10 refers only to the class G instrument which varies slightly from the general type in construction of the tangent screw assembly.

(2) The table (5A) which supports the gear case (2A5 for instruments Nos. 1-238 and 2RB for instruments Nos. 239 and up) containing the depression mechanism rides on the body (6B) bearing lightly on a circular track formed on the periphery of the body and also bearing on the table center (14L). A center screw (4H) permits adjustment to obtain minimum friction and minimum play on the circular track.

(3) The mount is positioned on the pedestal cap (4A) by the ball (4J) and ball cap (4Y, sec. D-D, fig. 7). Three leveling screws (6N, fig. 1) threaded through the lower portion of the body (6B, figs. 1 and 7) bear on the upper surface of the pedestal cap.

(4) The azimuth knob (17K, sec. E-E, fig. 7) rotates the table (5A, figs. 7 and 8) on the body. The table can be locked in any position by the table clamp knob (5D). Azimuth angles are ob-

tained by adding the indications, viewed through window (17C) of—

(a) The azimuth scale (14H) graduated at 10° -intervals, numbered from 0-35, the number coinciding or directly above the index mark being read.

(b) The azimuth subscale (14A) graduated at 1° -intervals, numbered from 0-9, indicated on some portion of the subscale vernier.

(c) The subscale vernier (14M) graduated at 0.01° -intervals, numbered from 0-100, read at the point where the subscale registers.

(5) Two level assemblies (figs. 1, 5, and 7) are mounted on the table (5A).

(6) The knurled sleeve on the rear tangent screw nut (figs. 6 and 10) operates the depression mechanism which controls the depression of the telescope for ranging. An internal gear train raises or lowers the front and rear tangent screw nuts simultaneously, inclining the telescope. The gear train also operates the range scale and the pointer which moves across the face of the range scale and indicates the range. A set of stop rings (13B) limits rotation of the tangent screw nut.

(7) The slide block (sec. K-K, fig. 9), carrying the compensating screw and pin (3B) can be moved along the tangent screw rail (3UA, fig. 6) to compensate for variations in the height of the instrument above sea level. The height scale lies in a recess in the tangent screw rail and is read at an index on the rear surface of the slide block. The adjusting screw (3H) operated by the knob (3K, fig. 5) provides a fine adjusting motion for the slideblock. Clamping thumbscrews (22T, fig. 9) and gibs secure the slide block and adjusting screw nut (3N) to the tangent screw rail.

(8) The compensating cam (fig. 6) operating through the compensating bar (sec. N-N, fig. 9) and rack (3NA, sec. L-L, fig. 9) drives the pinion (3V) which rotates the compensating screw (sec. K-K, fig. 9). The motion applies exact correction to compensate for differences in effect of curvature of the earth and normal refraction which exist at any height except the initial height, which is the height above the sea for which the range scale is computed. The thumb-screw (22G) clamps the compensating screw to the pinion, and when released permits independent motion between these parts for initial setting.

(9) The range scale, the azimuth scales, and the cross wires in the telescope are electrically illuminated. A portable lamp is furnished for illuminating the height scale. A snap switch (B16805, fig. 5) with binding posts is located on the table hub. The electrical equipment supplied with the instrument is described in paragraph 7.

d. Pedestal.—(1) The pedestal is a hollow column of cast iron having three feet and an accurately machined upper portion which receives the pedestal cap (4A, fig. 1).

(2) The pedestal cap (4A, figs. 1 and 7) is secured to the pedestal by three hexagon-head screws (22XA). The upper portion of the pedestal cap contains seats for the leveling ball (4J) and ball cap (4Y), and a copper-plated circular track for the leveling screw shoes (6M). A 0.5-inch diameter hole is provided to receive an adjusting pin for turning the cap on the pedestal head.

3. Operation.—*a. To set up instrument.*—(1) Bolt the pedestal securely to the floor or foundation. Provide three small blocks of wood about 1 inch thick and place them on the pedestal cap. Set the mount on the blocks and start the ball cap (4Y) into the threads in the pedestal cap. Screw the leveling screws (6N) through the tapped holes in the lower part of the body and into the leveling screw shoes (6M) to transfer the weight of the body from the wood blocks to the leveling screws. Remove the wood blocks, lower the mount, and screw down the ball cap, using the adjusting pin provided.

(2) To mount the telescope in the yoke (5F), adjust the trunnions (5C) to support the telescope, allowing free rotation with no side play. An open-end engineer's wrench is provided for the trunnion clamping screws. Adjust the counterweight assembly (B129215) until there is light but positive contact between the body tube bar and the compensating screw pin.

(3) Select a datum point of known azimuth. Turn the table by rotating the azimuth knob until the known azimuth is indicated on the azimuth dials, then clamp the table to the body of the instrument. Loosen the three pedestal cap screws (22XA, fig. 1). Insert the large adjusting pin in the hole in the side of the pedestal cap (4A) and turn the cap until the vertical cross line in the telescope coincides with the datum point. This procedure may disturb the level of the instrument. Level again and check by sighting on the datum point. Repeat until a correct setting is obtained, then tighten the three pedestal cap screws.

b. To level instrument.—All observations are made with the instrument accurately leveled. To level the instrument, set one of the levels parallel to two of the leveling screws and manipulate the leveling screws until the bubble in each level is central. At the final setting, each screw should be tight but not strained.

c. To focus telescope.—(1) Focus the eyepiece by screwing it in or out until the reticle cross wires appear in sharp focus.

(2) Focus the objective for elimination of parallax by turning the focusing pinion knob until the image of an object in the field of view shows no apparent motion relative to the cross wires as the eye is shifted slightly up or down or from side to side. This focusing varies to some extent for objects at greatly different ranges and for this reason should be repeated during normal operation.

d. To determine azimuth of target.—Azimuths are obtained by rotation of the table after the table clamping knob (5D) has been released. Final accurate setting should be made by means of the azimuth knob (17K). The azimuth is read on the azimuth scale (10° units), sub-scale (1° units), and vernier ($.01^\circ$ units) as described in paragraph 2c(4).

e. To determine range of target.—(1) Before determining ranges it is essential to calibrate the instrument in order to secure accurate results. Three operations are necessary for complete calibration, as described below:

(a) Determine the height of tide and the corresponding height of the instrument above sea level, which height is the initial height of the instrument in feet with the height of tide added or deducted. Set the slide block to the point on the height scale corresponding to the height of the instrument above sea level and clamp at this setting. Frequent check on tide should be made and the height corrected accordingly, as a small change in the height setting will affect the range.

(b) Direct the telescope in azimuth on a datum point of known range near the maximum working range of the instrument and rotate the knurled sleeve of the rear tangent screw nut until the known range of the datum point is indicated by the pointer on the range dial. If the horizontal cross wire in the telescope does not coincide with the water line of the datum point, unclamp the thumbscrew (22G) on the compensating screw and turn the compensating screw until coincidence is established. The thumbscrew should then be tightened. This operation is termed "initial setting."

(c) After obtaining the initial setting of the instrument, direct the telescope in azimuth on a datum point of known range near the minimum working range of the instrument, and turn the knurled sleeve of the rear tangent screw nut until the horizontal cross wire in the telescope coincides with the water line of the datum point. If atmospheric refraction is normal, the range indicated by the range dial will be in agreement with the known range of the datum point. When atmospheric refraction is above normal, indicated range will be less than the known range; when atmospheric refraction is below

normal, which is seldom the case, indicated range will be greater than known range. To make correction for abnormal refraction, two datum points, one at short range and the other at long range, must be used successively, and a slightly different position of the slide block determined which will enable the instrument to give correct ranges for the two datum points. This accomplished, readings at other ranges will be practically correct. The slide block should be moved toward the telescope trunnions for above normal refraction and away from the telescope trunnions for below normal refraction. The new position found will be only a very small distance from the true position indicated on the height scale. This small adjustment can be readily made by clamping the adjusting screw nut to the tangent screw rail and using the adjusting screw to move the slide block.

(2) To determine the range of a target, rotate the knurled sleeve on the rear tangent screw until the horizontal cross wire falls on the water line of the target. The range is then indicated by the pointer on the range dial.

4. Inspection.—Inspection is made for the purpose of determining the condition of the instrument, whether repairs or adjustments are required, and the remedies necessary to insure serviceability and proper functioning.

a. Telescope.

Parts to be inspected

(1) Exposed mechanical parts.

(2) Optical system.

(3) Eyepiece assembly.

Points to be observed

(1) Observe general appearance, smoothness of operation of eyepiece, focusing mechanism, mask, clamps, etc. The bar (18D) should be free of nicks and burs.

(2) Note if checks or frost patterns appear in the field of view. Such defects are evidence of loosening of the balsam used in cementing lenses and, if severe, require the return of the telescope to an arsenal for overhaul.

(3) Using the collimating telescope (No. 98, optical repair kit), focus the eyepiece for sharpness and definition of the reticle. If this condition is not obtained at approximately the midposition of the focusing range of the eyepiece, adjustment of the eyepiece may be required.

Parts to be inspected

(4) Reticle.

b. Mount.

(1) Exposed mechanical parts.

(2) Trunnions.

(3) Level vials.

(4) Rotation of table.

(5) Alinement of the instrument.

Points to be observed

(4) Test for vertical and horizontal positioning of the reticle cross wires by sighting on a vertical line, such as a plumb line, with the instrument level. Sight on a true horizontal line (horizon, etc.) or upon a distant point, traversing the instrument to move the point horizontally across the field of view to check the horizontal cross wire. If the wires are loose or broken the reticle should be replaced.

(1) Observe general appearance, smoothness of operation of knobs, leveling screws, thumbscrews, etc., through entire range. Graduations should be clearly legible.

(2) Lift the telescope slightly by the eyepiece end. Check for play or tightness between telescope bearings and trunnions. See that the trunnion set-screws are secure. The telescope body bar (18D) should be centrally located on the pin.

(3) See that the two level vials are secure in their housings and unbroken. Level the instrument and rotate the table slowly through 360°. If the bubbles do not remain centered, the levels require adjustment (see par. 5c).

(4) The table should rotate freely when the table clamp has been released and the azimuth knob (17K) is turned. Wobbling or excessive friction indicates that the center screw (4H, fig. 7) require adjustment (see par. 5c).

(5) With the instrument leveled and the telescope pointed at a plumb line, move the slide block and the knurled sleeve of the rear tangent screw nut over the entire range. If the vertical cross wire varies to the right or left of the

*Parts to be inspected**Points to be observed*

- plumb line the instrument is not in adjustment. The telescope may be incorrectly seated in the yoke. The safety clip (18F) may be bearing on the side of the compensating screw. The bar (18D) or the tangent screw rail (3UA) may be distorted.
- (6) Range mechanism. (6) The effect of wear and possible misalignment may be checked by leveling the instrument and sighting on known datum points representing the extremes of the range and intermediate known ranges. Observe whether the range stop located under the knurled head of the rear tangent screw nut permits motion through full range. If this is not the case the stop may be adjusted.
- (7) Tangent screw rail. (7) With the instrument level, check the tangent screw rail for horizontal operation through entire range, using a sensitive level.
- (8) Rack and shoe. (8) There should be no play between the rack (3NA) and the rack shoe (3P). There should be no play between the rack shoe (3P) and the slot of the compensating bar.
- (9) Cam. (9) The cam should be secure on its shaft and there should be no play between the compensating bar pin and the cam.
- (10) Illumination. (10) Check rheostats and sockets for electrical contact and mechanical connections. Test rheostat by turning knob and noting dimming and brightening of reticle lamp. Leads should have secure fittings and should not be frayed. (See par. 7.)
- c. Pedestal.*
Exposed mechanical parts. Observe general appearance, security of pedestal cap, etc.

5. **Maintenance and repair.**—*a. Tools.*—(1) *Optical repair kit for harbor defense.*—An optical repair kit containing the necessary tools, fixtures, cement, oils, etc., for use with this instrument is furnished to ordnance companies. A complete list of the items comprising the kit is contained in a blue print which is fastened in the cover of the chest. Every item in the kit is designated by a number equivalent to the compartment number. Most of the items as screw drivers, etc., require no description as their uses are self-explanatory. The collimating telescope (No. 98) which is furnished with the kit is an ordinary nonerecting type. It is adjusted for parallax by focusing the eyepiece on the cross wires and then removing parallax by turning the focusing nut to focus the objective. The magnifying power of the collimating telescope is 8.13X; the field of view is 3°.

(2) *Other tools.*—Other tools required for this instrument are included in paragraph 7.

b. Disassembly and assembly.—Disassembling of the instrument may be required for cleaning or repair. Repairs involving realignment, removal or replacement of optical parts, or other repairs which cannot be made with the facilities available will require that the instrument be turned in to the base shop or arsenal. Assembly may be made by reversing steps taken in disassembly except where indicated.

(1) *Telescope.*—To remove the telescope from the mount, slide back the trunnions (5C) secured by lock screws. Slide the telescope until the safety clip (18F) clears the compensating screw. It may be necessary to shift the slide block or to remove the safety clip. An engineer's open-end wrench is provided for the lock screws.

(a) *Eyepieces.*—To remove the eyepieces (C44216 or C44217) unscrew them from the adapter (20A).

(b) *Amber filter holder.*—To remove the amber filter holder (20N) unscrew the stud (22C, fig. 3).

(c) *Adjusting pinion.*—To withdraw the adjusting pinion (19B, fig. 3) remove the special fillister head screw (22D, fig. 2) and draw the adjusting pinion and knob (17K) out of the tube (9C). In reassembly, mesh pinion and rack carefully to avoid burring teeth.

(d) *Reticle.*—To remove the reticle frame (20G) mark the position of the eyepiece adapter (20A) on the prism housing cover (19G). Remove the five brass fillister head screws (22E) and the eyepiece adapter. Remove the four special adjusting screws (22X) and the reticle frame. (See *c* below.)

(e) *Special screws.*—The special screws (22DA) positioning the objective cell must not be adjusted or removed except at a base shop or arsenal.

(2) *Mount.*—The telescope should be removed before the mount is disassembled.

(a) *Slide block.*—To remove the slide block, loosen the adjusting screw nut (3N) and thumbscrews (22T) and slide the block until the rack shoe (3P) clears the compensating bar. Remove the rack and slide the block off the tangent screw rail (3UA).

(b) *Compensating bar.*—Remove the compensating bar, if necessary, after the rack and shoe have been disassembled. Withdraw the two special fillister head screws (22H, fig. 9) securing the compensating bar guide (3QA) to the compensating bar. Lift up the bar, disengaging it from the stud riveted on the compensating bar support.

(c) *Yoke.*—Remove the yoke retaining screw (22RA, fig. 1) and lift the yoke up.

(d) *Cam.*—Remove the cam (fig. 6) from the cam shaft (15A) after the compensating bar and pin have been removed. Remove the special fillister head screw (22R). By inserting a drift pin or similar tool in the slanting access hole, drive out the taper pin securing the cam to the cam shaft.

(e) *Gear case.*—Return the instrument to a base shop or arsenal for repairs involving disassembly of the gear case (2A5 for instruments Nos. 1-238 and 2RB for instruments Nos. 239 and up) or table (5A).

(f) *Azimuth knob assembly.*—Drive out the tapered pin (sec. E-E, fig. 7) and remove the knob (17K) from the pinion shaft (17L). Remove the five fillister head screws securing the gear case (17F) to the table (5A). Withdraw the intermediate traversing pinion (17M) after driving out the tapered pin which secures it to the shaft. Do not disassemble the traversing pinion gear (17G) from the traversing pinion (17H) except for replacement.

(g) *Table clamp assembly.*—Drive out the taper pin (sec. G-G, fig. 7) and unscrew the knob (5D) holding the special fillister head screw (22TA) with a screw driver. Unscrew the special fillister head screw, removing the table clamp shoe (5E).

(h) *Levels.*—To repair a level, remove the assembly (sec. E-E, fig. 7) from the table and disassemble by unscrewing the four special oval-flat head screws securing the plugs to the level vial tube. Pull out the plugs and remove any broken glass and old packing. Position the new vial (type T, A31321), center the graduations in the

opening, and pack level vial lightly with paper strips. Secure with calcined gypsum (plaster of paris) which has been mixed to medium consistency. Replace plugs and screws. After plaster has hardened, remove excess from surfaces. For adjustment after reassembly to table see *c* below.

(i) *Lamps*.—To replace a lamp, remove the receptacle adapter by pushing in and twisting to the left until free. Replacement lamps should be 2- to 3-candlepower, 34- to 38-volt, 0.20- to 0.34-ampere miniature lamps with short candelabra base.

c. Adjustment.—(1) *Levels*.—Level the instrument and observe the level bubbles as the instrument is rotated slowly in azimuth. If they remain centered, the levels are in correct adjustment. If one or both bubbles move, the following adjustment is to be made:

(a) Set the level to be adjusted parallel to any two of the leveling screws and level the instrument so that the bubble is centered.

(b) Turn the instrument 180° in azimuth.

(c) By means of the level adjusting nuts (16N, sec. F-F, fig. 7), return the level bubble *halfway* to its original central position. An adjusting pin is provided with the instrument to fit the pinholes in the adjusting nuts.

(d) Relevel the instrument, rotate it 180°, and again note the position of the bubbles. Repeat the operation, if necessary, until the best possible adjustment is obtained.

(2) *Azimuth mechanism*.—The azimuth indicating mechanism is in adjustment when the subscale moves freely, without backlash, and a graduation on the azimuth scale aligns exactly with its index as the zero of the subscale matches the zero of the subscale vernier. To remove backlash or to adjust the scale settings, loosen slightly the two clamping screws (22PA, figs. 8 and 5). Turn the eccentric (14G) with a screw driver, either to take up backlash or to disengage the pinion. Avoid excessive tightening of the eccentric. Then the special screw (22F) may be turned to align the subscale with the zero of the vernier when a graduation on the azimuth scale aligns exactly with its index. This screw is located under the large fillister head screw (22UA) which is removed for adjustment.

(3) *Table center*.—The table is supported at its outer edge by a circular track formed on the body and at its center by a shoulder on the table center (14L, sec. C-C, fig. 8, and sec. D-D, fig. 7). The center screw (4H) regulates the height of the center and the friction on the plate and is accessible after the yoke has been removed. If the center requires adjustment, remove the yoke and the three clamping screws (22WA, sec. D-D, fig. 7). Adjust the center screw, using

the T-handle socket wrench provided, until minimum friction and minimum play of the table on the body are obtained.

(4) *Range stop*.—The range stop may be adjusted, if necessary, to permit travel to the maximum or minimum range. Turn the knurled knob of the rear tangent screw nut as far as it will go in the desired direction. Hold the collar located below the stop ring housing (13A, fig. 6) to keep it from falling and loosen the three headless cone point screws (22U). The knurled knob may then be turned until the desired range is obtained. Tighten the three screws. If the knurled knob moves stiffly it indicates that one of the screws has been screwed in too far.

(5) *Reticle*.—If the reticle has been disturbed or replaced it should be adjusted as follows:

(a) Set fixture (No. 86, optical repair kit) or any other surface plate on pedestal (No. 85) and level with bench level (No. 73). Clamp the collimating telescope (No. 89), using suitable rings or guides, to the plate. Clamp the telescope M1907 to the plate, using the bar (18D) as reference surface.

(b) Lay off a target having a long vertical line and two horizontal cross lines spaced a distance equal to the difference in heights between the collimating telescope (No. 89) and the telescope M1907. Line the target up with a plumb line.

(c) Lay the collimating telescope on its line on the target and adjust the reticle of telescope M1907, using the special screws (22X) in slotted holes, until the horizontal cross wire coincides with its line on the target.

(d) Verify the vertical cross wire.

6. Care and preservation.—*a. Care in handling.*—(1) The instrument contains delicate and highly accurate mechanism and the telescope contains precise optical parts. Careful handling is imperative to avoid damage caused by unnecessary shocks, straining, etc.

(2) Avoid forcing the mechanism against the ring stops provided for limiting motion of tangent screws and range mechanisms (figs. 6 and 10).

(3) Avoid unnecessary motion of telescope between the safety clip (18F) and the pin in the compensating screw, which might cause injury to the contact surfaces.

(4) Leveling and clamping screws must not be tightened beyond a snug contact. Excessive wear of threads and other damage to parts is thereby avoided.

(5) When the instrument is not in use, protect it with the canvas cover provided. If removed from the pedestal, the telescope and

mount should be stored in the packing chests in which they are shipped.

b. Lubrication.—(1) Lubricants for fire control instruments function also as rust preventives. It is important that they be applied carefully. Care should be taken not to apply lubricants excessively.

(2) Only the following lubricants will be used in the servicing of this matériel:

Grease, special, low temperature.

Oil, lubricating, for aircraft instruments and machine guns (U. S. A. Spec. No. 2-27).

(3) Oil holes for the depression mechanism are plugged by the fillister head screws (22B, 22CA, and 22R, fig. 6) stamped "Oil." Remove the screws and apply a few drops of oil. (Screw 22CA is used with instruments having serial number 239 and higher, in place of screw 22B.)

(4) An oil hole, plugged by a knurled hand screw (22Q), permits lubrication of the circular track. Oil should be applied sparingly while the table is rotated completely in azimuth.

(5) Remove the yoke (5F) to oil the table center. (See par. 5b(2).) A small quantity of oil around the top of the center will work down to the shoulder bearings.

(6) To lubricate the compensating screw assembly (sec. K-K, fig. 9) remove the thumbscrew (22G) and apply a drop or two of oil to the compensating screw pinion. Apply a drop of oil to the joint between the compensating screw and the slide block.

(7) Apply a light film of grease to the trunnions before the telescope is assembled to the mount.

(8) A light film of oil should be applied daily to the exterior contact surfaces and exposed parts.

(9) When the instrument is to be out of use for some time, the tangent rail should be elevated to its highest position and the tangent screws covered with grease, then lowered to its bottom position. Leave the excess lubricant on the tops of the round nuts. When the instrument is to be used, wipe off the old lubricant and oil the screws thoroughly.

(10) Avoid lubricating parts of the telescope other than the counterweight assembly.

(11) Excess lubricants should be wiped off to prevent accumulation of dust and grit.

c. Optical parts.—(1) To obtain satisfactory vision, it is necessary to keep the exposed surfaces of the lenses and other parts clean

and dry. Corrosion and etching of the glass surfaces can thus be prevented or retarded.

(2) Moisture due to condensation may collect on the optical parts of the instrument when the temperature of the instrument is below that of the surrounding air. This may be removed by placing the instrument in a warm place. Heat from strongly concentrated sources should never be applied directly as it may cause unequal expansion of parts with resulting inaccuracies in observation.

(3) For dusting optical parts use only a clean brush, camel's-hair. For wiping, use only paper, tissue, for cleaning optical glass.

(4) To remove oil or grease from optical surfaces, apply ethyl alcohol with a clean camel's-hair brush and rub gently with clean tissue paper. If alcohol is not available, breathe on the glass and wipe off with clean tissue paper; repeat this operation several times until clean.

(5) To remove dust, brush the glass lightly with a clean camel's-hair brush and rap the brush against a hard body in order to knock out dust particles clinging to the hairs. Repeat until dust is removed.

(6) Do not wipe lenses or windows with the fingers.

(7) Polishing liquids or pastes are not to be used for polishing lenses or windows.

7. Spare parts and accessories.—a. Tools.—(1) A tool roll supplied with each instrument contains adjusting pins, screw drivers, and wrenches.

(2) In addition, an oiler, camel's-hair brush, and varnish brush are furnished.

(a) The camel's-hair brush is used for removing dust from the telescope lenses. The bristles should be kept clean and dry and should not be allowed to come in contact with oil or grease.

(b) The varnish brush is used for removing dust from the dry metal surfaces of the instrument. It is not to be used on optical parts.

*b. Packing chests for telescope and mount.—*Separate packing chests are provided for the telescope and mount. Both packing chests have internal blocking to prevent shifting of the parts when packed.

*a. Cover.—*A canvas cover is furnished for protection of the instrument when it is mounted but not in use.

d. Electrical equipment.—(1) Four candelabra lamp sockets wired in parallel provide illumination for the reticle, the range scale, the azimuth scale, and the portable lamp. They are connected to binding posts on the switch block assembly (7L) secured to the hub of the table.

(2) Electric power is supplied to the lamps from 110- or 220-volt mains. For 110-volt power an inclosed fuse contact is inserted in the line. For 220-volt power a combination fuse and resistor unit block is furnished. A rheostat for regulating current through the lamps is furnished with either combination and should be mounted on a wall or ceiling convenient to the observer. An 8-foot length of lamp cord is provided for connection between rheostat and switch block.

e. Spare parts.—The following spare parts are issued with each instrument:

2 cartridge fuses.

4 electric lamps.

1 reticle assembly, complete with retaining screws and washers.

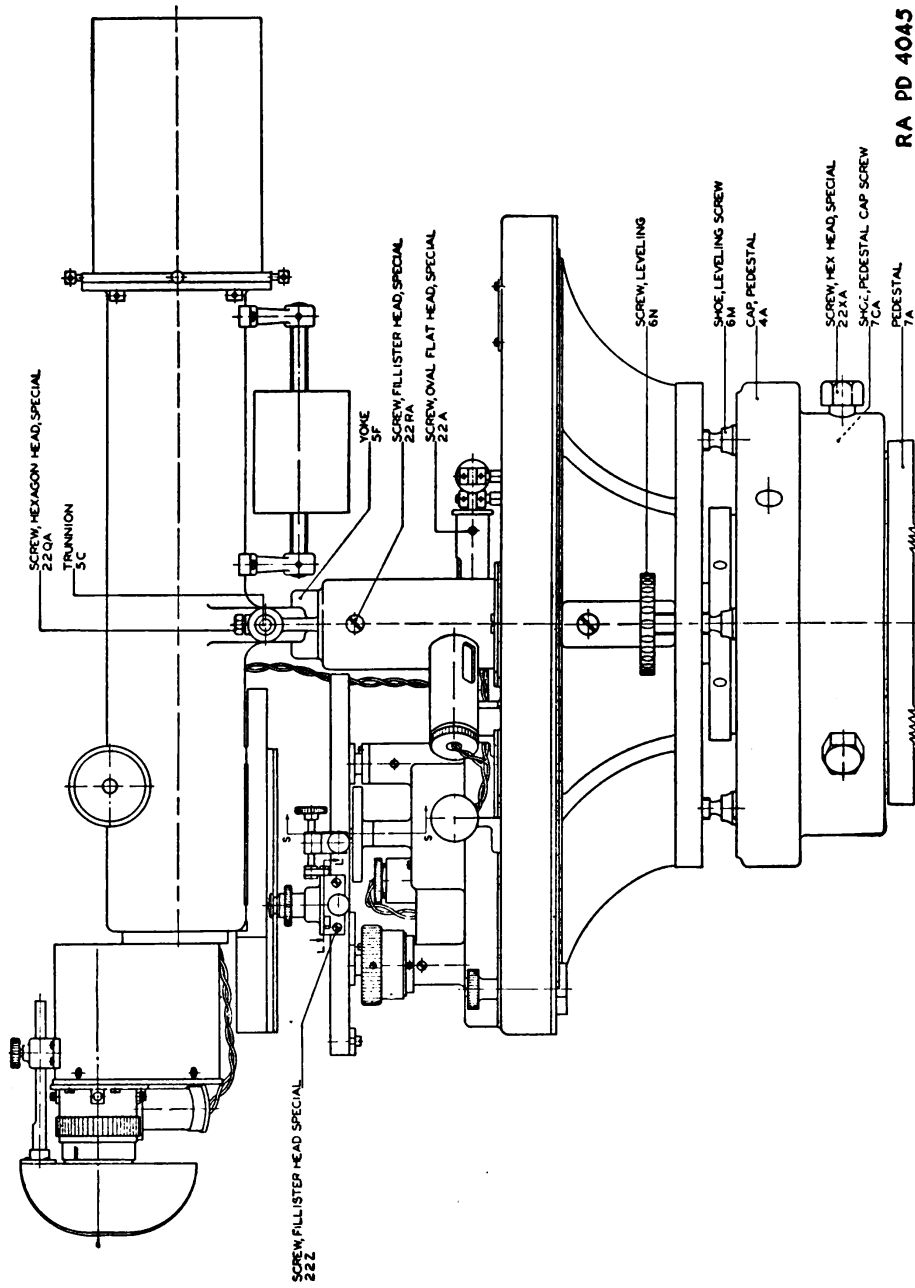

RA PD 4045

FIGURE 1.—Finder, depression position, M1907—assembled views.

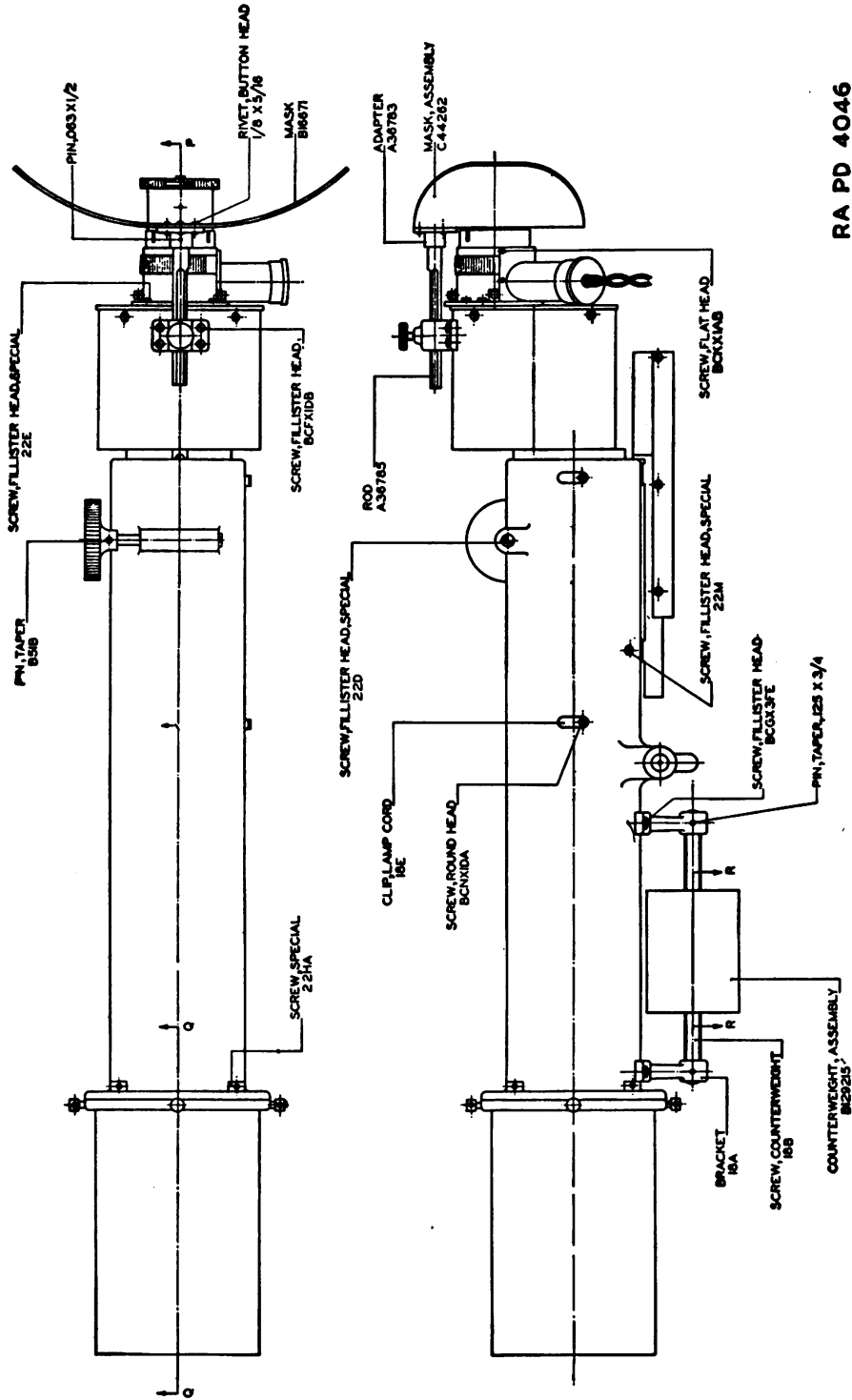

RA PD 4046

FIGURE 2.—Telescope, depression position finder, M1907—assembled views.

DEPRESSION POSITION FINDER M1907

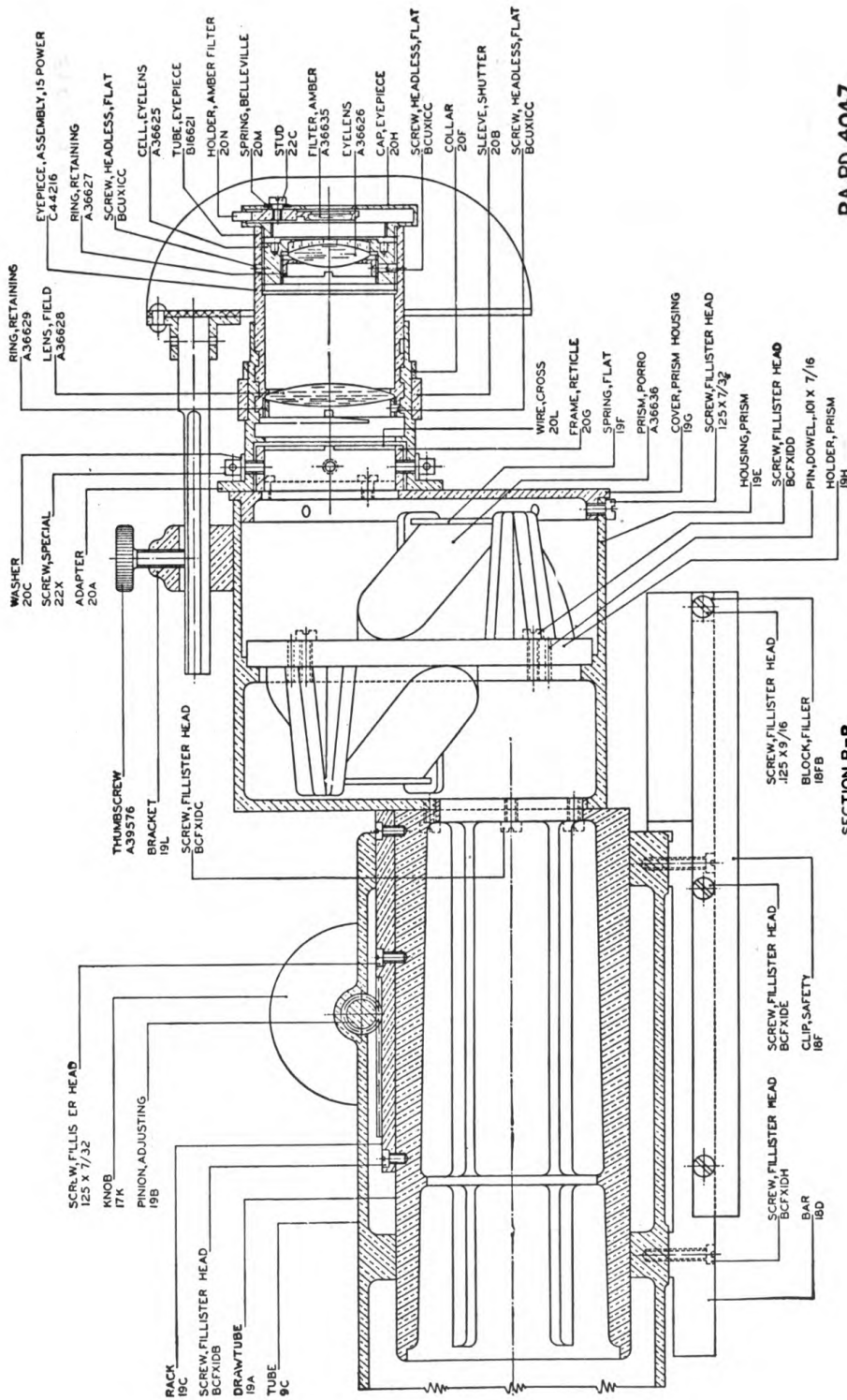

RA PD 4047

SECTION P-P

FIGURE 3.—Telescope, depression position finder, M1907—sectioned views.

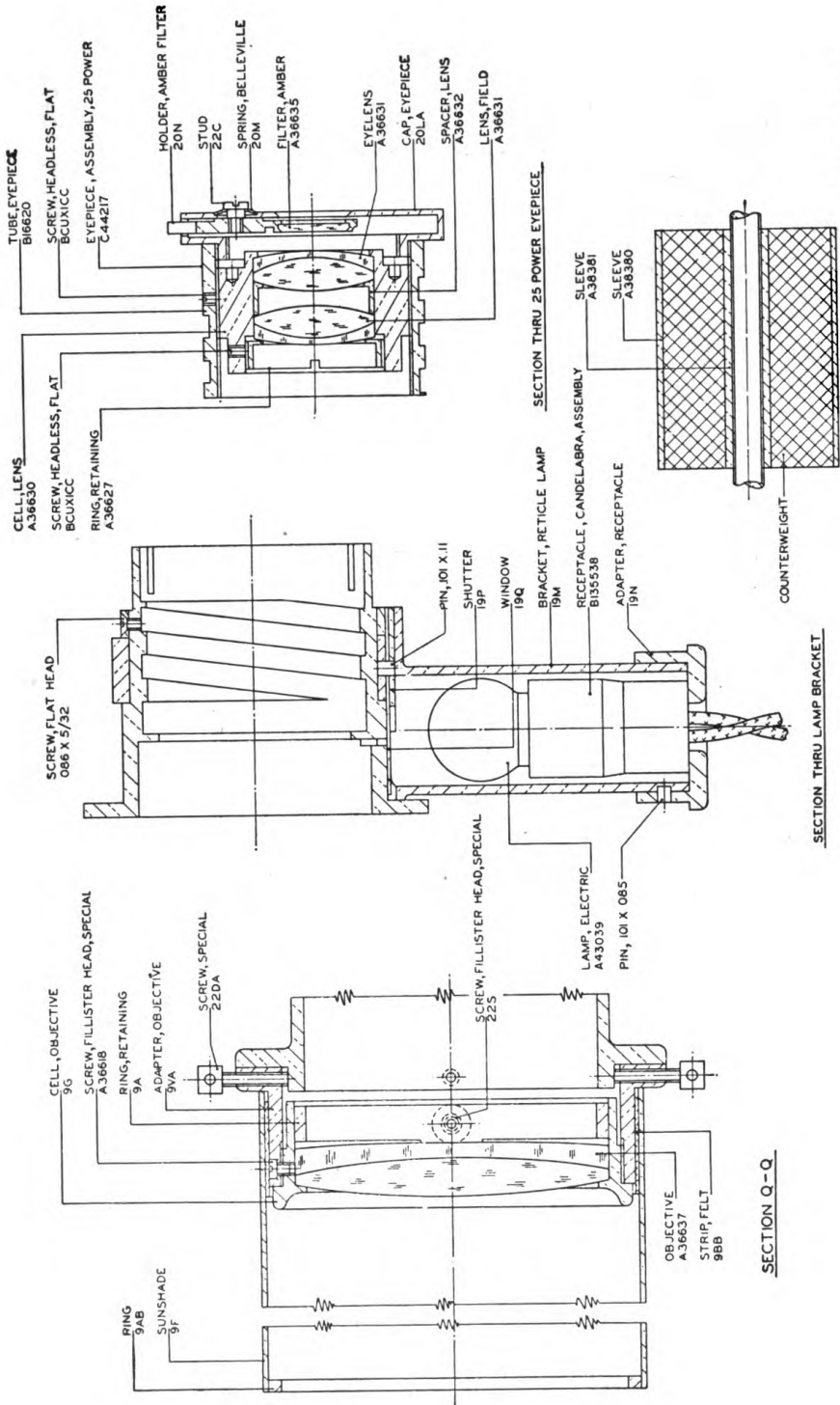

RA PD 4043

FIGURE 4.—Telescope, depression position finder, M1907—sectioned views.

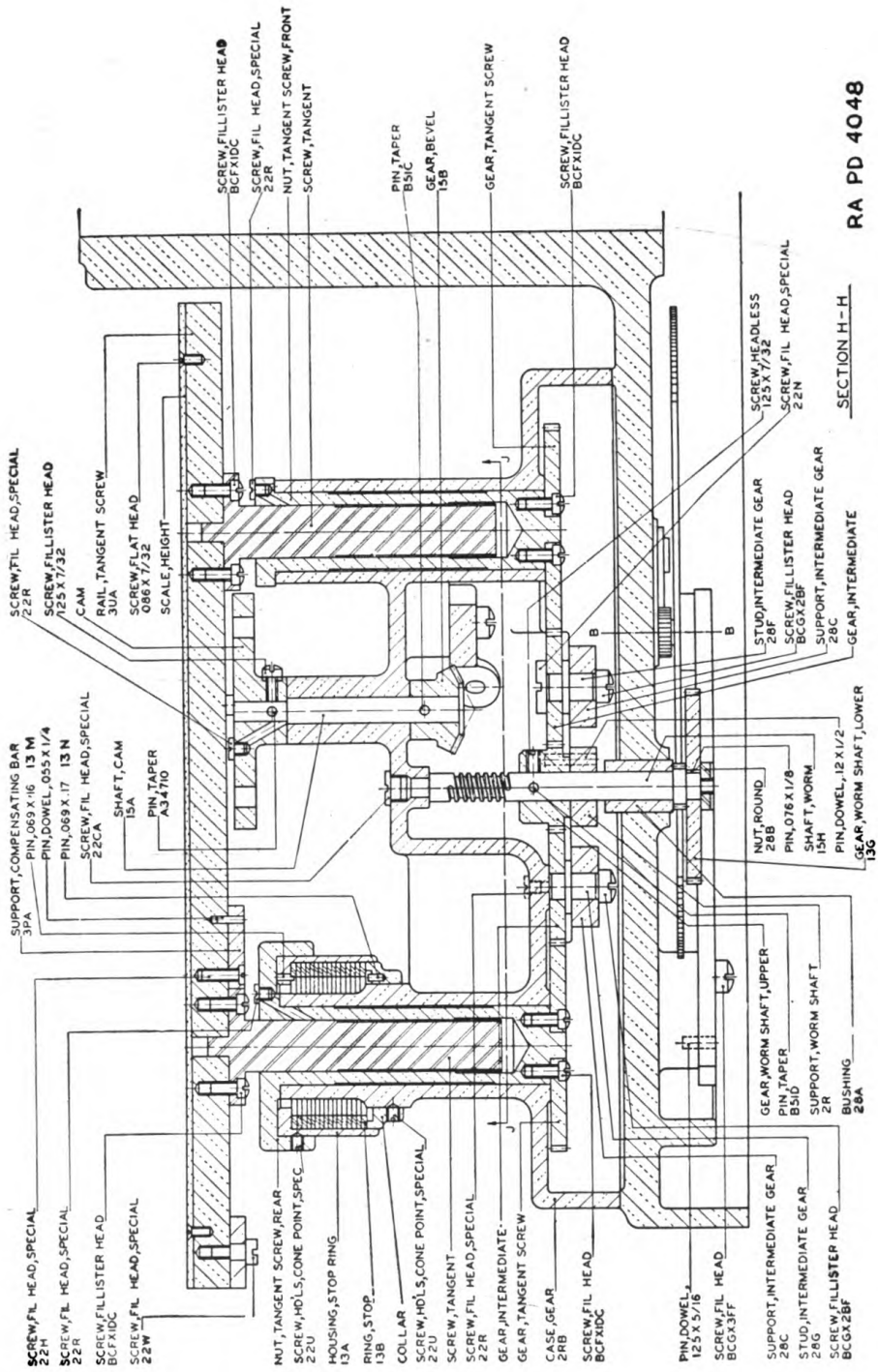

RA PD 4048

FIGURE 6.—Mount, depression position finder, M1907—sectioned views.

DEPRESSION POSITION FINDER M1907

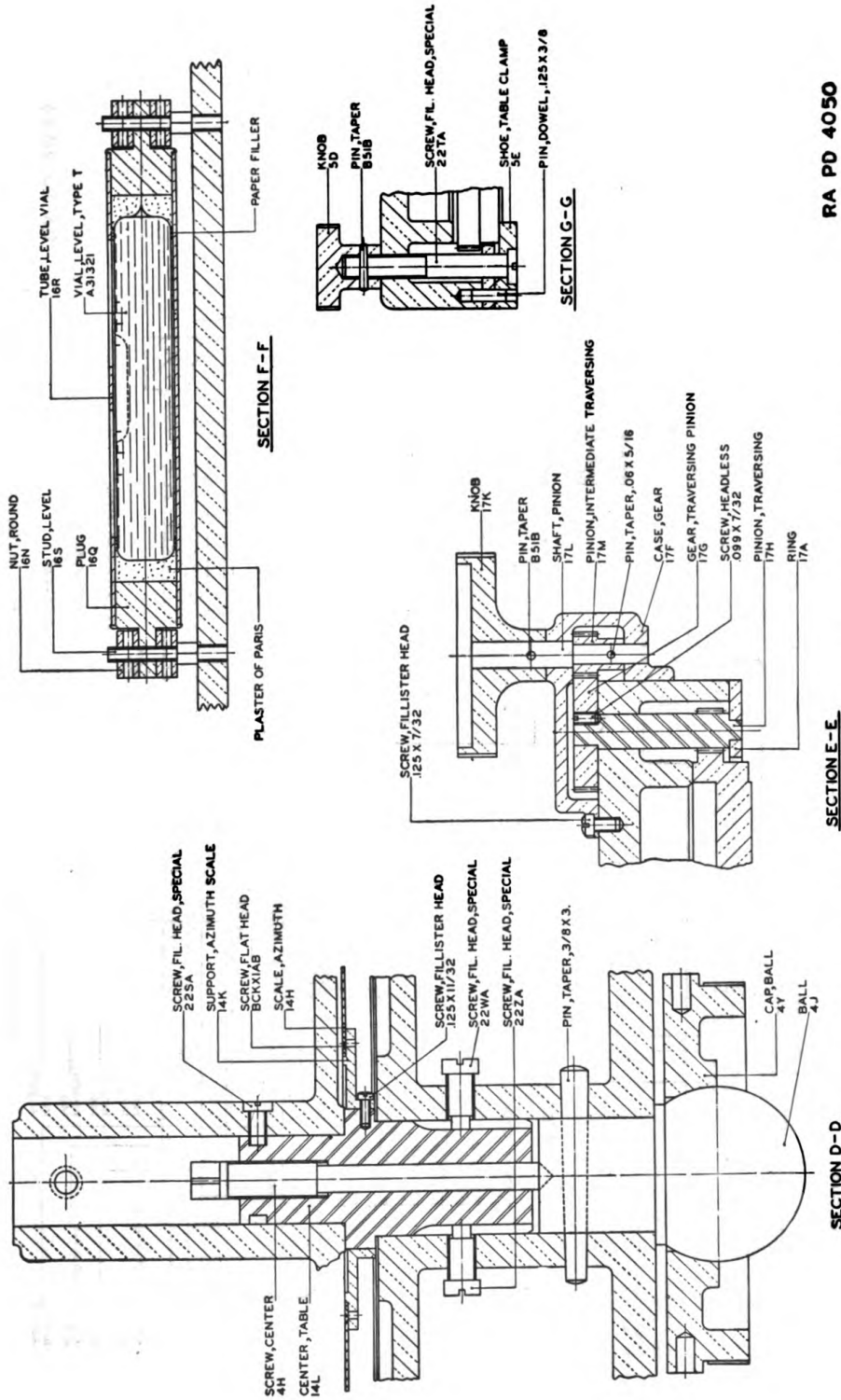

RA PD 4050

FIGURE 7.—Mount, depression position finder, M1907—sectioned views.

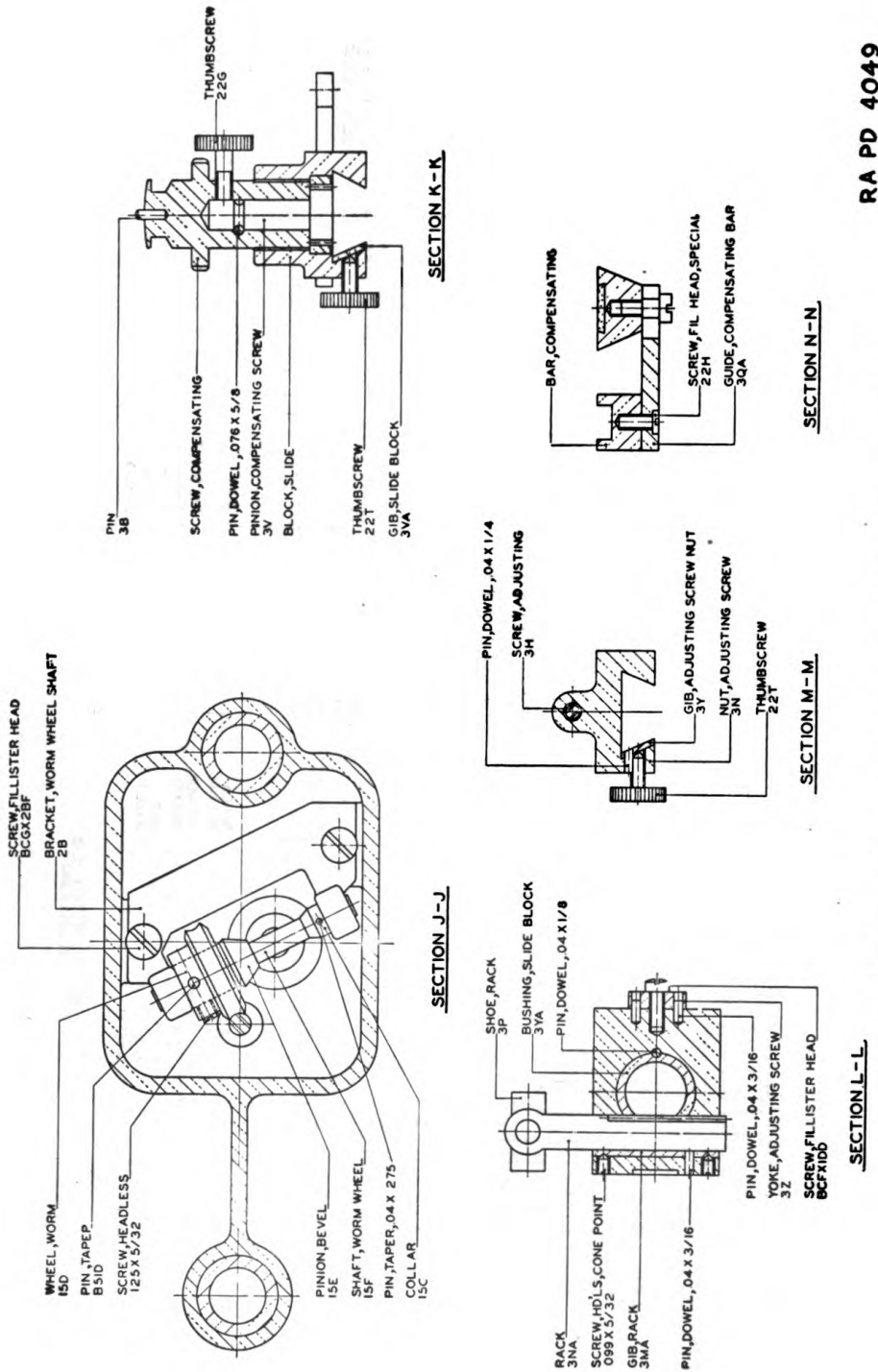

RA PD 4049

FIGURE 9.—Mount, depression position finder, M1907—sectioned views.

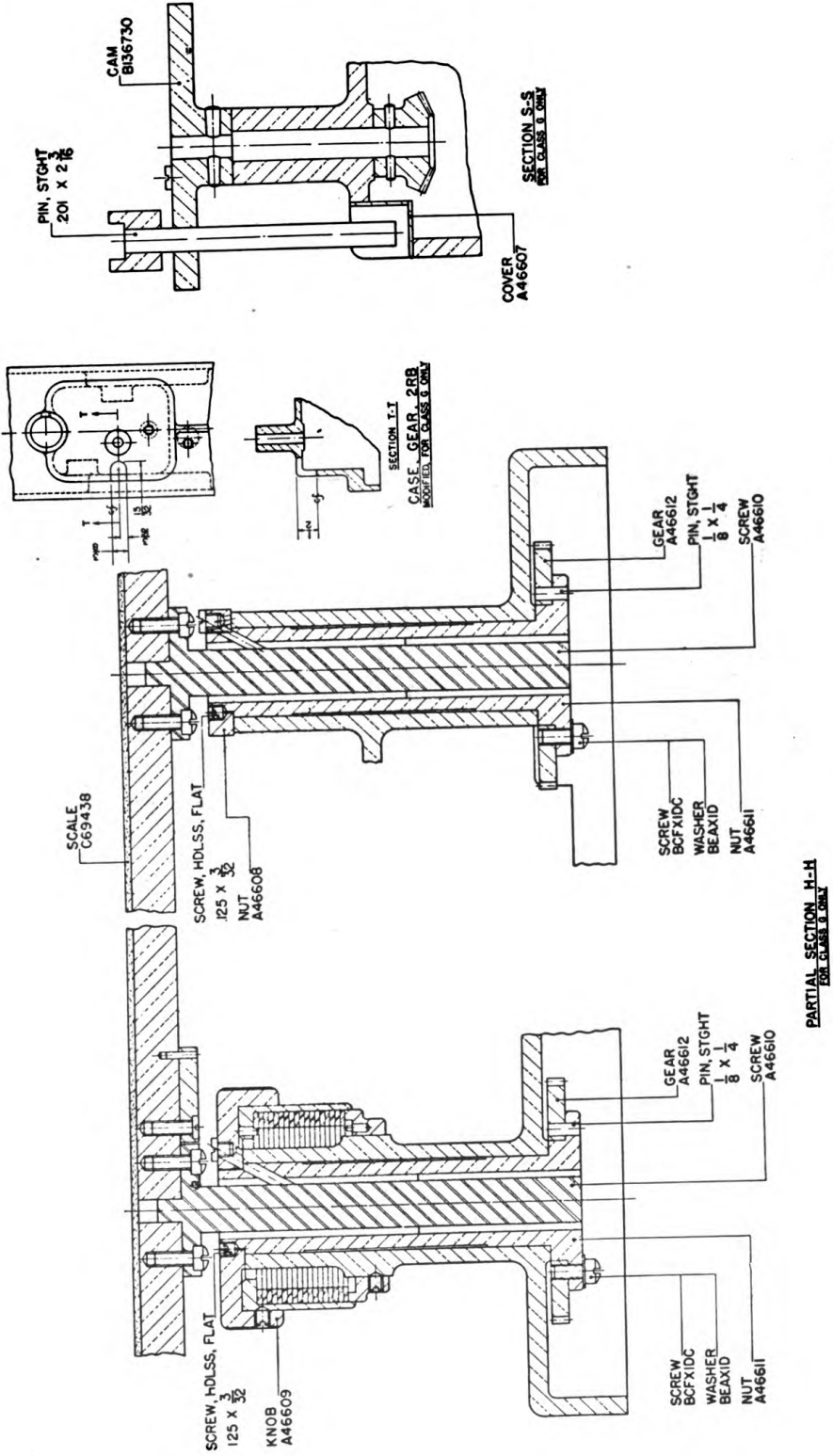

RA PD 4041

FIGURE 10.—Mount, depression position finder, M1907 (class G only)—sectioned views.

DEPRESSION POSITION FINDER M1907

APPENDIX

LIST OF REFERENCES

1. **Standard Nomenclature Lists.**

Finder, depression position, M1907----- SNL F-45.
 Optical repair kit for harbor defense----- SNL F-93.
 An up-to-date list of SNL's is maintained as the
 "Ordnance Publication for Supply Index"----- OPSI.

2. **Technical Manuals.**

Cleaning and preserving materials----- TM 9-850
 (now published as TR 1395-A)
 Matériel inspection and repair----- TM 9-1100.

3. **Field Manuals.**

Gunnery, seacoast artillery----- FM 4-10.
 Fire control and position finding, seacoast artillery_ FM 4-15.

[A. G. 062.11 (8-7-41).]

BY ORDER OF THE SECRETARY OF WAR:

G. C. MARSHALL,
Chief of Staff.

OFFICIAL:

E. S. ADAMS,
Major General,
The Adjutant General.

DISTRIBUTION:

B 4 (2); IR 4 (3); IBn 9 (2); IC 9 (4).
 (For explanation of symbols see FM 21-6.)

