

✓ 1/4 00 U113
12
TM
1943

TM11-605

WAR DEPARTMENT TECHNICAL MANUAL

U. S. Dept of Army

RADIO SETS

SCR-509-(*) AND SCR-510-(*)



WAR DEPARTMENT • 15 NOVEMBER 1943

RADIO SETS

SCR-509-(*) AND SCR-510-(*)

WAR DEPARTMENT '15 • NOVEMBER 1943

United States Government Printing Office

Washington : 1947

WAR DEPARTMENT,
Washington 25, D. C., 15 November 1943

TM 11-605, Radio Sets SCR-509-(*) and SCR-510-(*), is published for the information and guidance of all concerned.

[A.G. 300.7 (15-November-43)]

By Order of the Secretary of War:

G. C. MARSHALL,
Chief of Staff.

OFFICIAL:

J. A. ULIO,
*Major General,
The Adjutant General*

Bill
well
just
non line

DISTRIBUTION:

B6 (2); R2, 17 (2); IBn 2, 5, 11, 17 (2);

IC 2, 5, 6, 11, 17, 18 (3)

(For explanation of symbols, see FM 21-6)

II

TECHNICAL MANUAL

RADIO SETS SCR-509-(*) AND SCR-510-(*)

CHANGES }
No. 2 }DEPARTMENT OF THE ARMY
WASHINGTON 25, D. C., 24 November 1952

TM 11-605, 15 November 1943, is changed as follows:

Section I. DESCRIPTION

Note. (Added) Power Supply Unit PE-120-A is changed to Power Supply Unit PE-120-(*) wherever it appears in this manual.

1. General

This technical manual * * * the *radio set*. Throughout this manual Radio Receiver and Transmitter BC-620-(*) refers to Radio Receiver and Transmitter BC-620-A, -B, -F, -G, -H, and -J; Mounting FT-250-(*) refers to Mountings FT-250-A, FT-250-B, FT-250-C, FT-250-E, FT-250-F, FT-250-H, and FT-250-J; Case CS-79-(*) refers to Cases CS-79-A, CS-79-B, CS-79-C, CS-79-D, CS-79-E, CS-79-J, CS-79-K, CS-79-L, and CS-79-M; Mounting FT-317-(*) refers to Mountings FT-317-A, and FT-317-B; Plate Supply Unit PE-97-(*) refers to Plate Supply Units PE-97-A, PE-97-D, and PE-97-F; Antenna AN-45-(*) refers to Antennas AN-45-A, AN-45-B, AN-45-E, AN-45-F, and AN-45-G; Vibrator VB-1-(*) refers to Vibrators VB-1-A and VB-1-B; Vibrator VB-7-(*) refers to Vibrators VB-7-A and VB-7-B; and Capacitor CA-403-(*) refers to Capacitors CA-403-A and CA-403-B. These parts are * * * handset or microphone.

4. Description of Components

* * * * *
d. Case CS-79-(*). Case CS-79-(*) contains * * * catch clips provided. Case CS-79-N is a modification of Case CS-79-(*) and is electrically interchangeable with it. Case CS-79-N is capable of withstanding heavy rains. The following mechanical improvements have been incorporated. The cover is easily removable. Five catch clips have been added to hold down the cover securely to the gasket. The connector cable has been replaced by a receptacle mounted on the recessed portion of the front panel (fig. 3.1).

* * * * *
h. (Superseded). Plate Supply Unit PE-97-(*) and Power Supply Unit PE-120-(*).

- (1) Plate Supply Unit PE-97-(*) (issued only with Radio Sets SCR-510-A and SCR-510-B) is a vibrator-type power supply designed for connection to either a 6-volt or a 12-volt vehicular battery. Hooks and catch clips are provided for mounting the radio receiver and transmitter on top of, and securing them to, Plate Supply Unit PE-97-(*); the entire assembly may in turn be fastened to shock Mounting FT-250-(*) (fig. 2). This unit also may be mounted separately by using Mounting FT-317-(*). The plate supply is contained in a case with space provided for carrying Handset TS-13-(*); a coil of insulated Wire W-126, extension Cord CD-509; and also a spare Fuse FU-38, Vibrator VB-1-(*), and electrolytic Capacitor CA-403-(*). The vibrator and capacitor are of the plug-in type (fig. 5) for quick and easy replacement.
- (2) The inside cover of the power pack of Plate Supply Unit PE-97-(*) has a label which shows the correct change-over link connections that are required to adapt the unit for operation from either a 6-volt or a 12-volt vehicular battery (fig. 5).
- (3) Power Supply Unit PE-120-(*) is a vibrator-type power supply, designed for connection to 6-volt, 12-volt, or 24-volt vehicular batteries. Hooks and catch clips are provided on the power supply housing so that Radio Receiver and Transmitter BC-620-(*) can be mounted on top of, and secured to, Power Supply Unit PE-120-(*) or Mounting FT-317-(*). Power Supply Unit PE-120-(*) is contained in a metal case with space provided for a spare vibrator and spare fuses. The vibrators are of the plug-in type for quick and easy replacement.
- (4) Modification work order MWO SIG 11-605-7 covers the modification of Radio Receiver and Transmitters BC-620-A, -B, -F, and -G and Plate Supply Units PE-97-A and -D to provide improved filament voltage regulation. Radio Receiver and Transmitters BC-620-H and -J are not covered by this modification work order, since they were procured after its publication, nor do they contain the features of the modification. Therefore, the BC-620-H and BC-620-J are not to be used with the PE-97-(*). Instead, the BC-620-H and BC-620-J are to be used with Power Supply Unit PE-120-(*), which has self-contained filament voltage regulation. Power Supply Unit PE-120-(*) may be used with all models of the BC-620-(*). Power Supply Units PE-120-A, -B, and -C are all essentially the same and are interchangeable as units.

- (5) Externally, Power Supply Units PE-120-B and -C differ slightly from Power Supply Unit PE-120-A in appearance and in the manner in which the cover is secured to the case (fig. 3.1). The case cover for Power Supply Unit PE-120-B or -C is secured to the case with spring-loaded catches and is completely removable; the case cover for Power Supply Unit PE-120-A is hinged to the case and is not detachable. The eight-pin socket connector, SO2, is mounted in a recess in the side of the case of Power Supply Units PE-120-B and -C, instead of being connected to a cable extension as in Power Supply Unit PE-120-A.
 - (6) Functionally, Power Supply Unit PE-120-B or -C is interchangeable as a unit with Power Supply Unit PE-120-A. Because of the difference in the mounting of socket connector SO2, however, the interior chassis, which mounts the components of Power Supply Units PE-120-B and -C, cannot be installed in the case designed for Power Supply Unit PE-120-A, and the chassis of Power Supply Unit PE-120-A cannot be installed in the cases designed for Power Supply Units PE-120-B and -C.
 - (7) The types of all the resistors and some of the capacitors used in Power Supply Unit PE-120-C differ from the corresponding ones used on Power Supply Unit PE-120-A. All the resistors used in Power Supply Unit PE-120-C have been relocated (fig. 11.2). In Power Supply Unit PE-120-C, secondary buffer capacitor C5 has been changed from 5,000 $\mu\mu\text{f}$ to 6,000 $\mu\mu\text{f}$, and resistors R8 and R9 have been added in the receiver filament circuit. These minor differences do not alter the over-all operation of the unit.
- i.* (Superseded). *Radio Receiver and Transmitter BC-620-(*).*
- (1) The receiver and transmitter are on one chassis base. A channel switch is provided on the front panel of the unit to permit rapid changing to either of the two preset frequencies that are controlled by plug-in crystals.
 - (2) Clips are provided to fasten the receiver and transmitter unit to battery Case CS-79-(*), Plate Supply Unit PE-97-(*), Power Supply Unit PE-120-(*), or Mounting FT-250-(*).
 - (3) In Radio Receiver and Transmitters BC-620-G, -J, and -K, the output transformer has been changed to provide an extra impedance-matching tap to accommodate a 250-ohm load in addition to the 4,000-ohm load. A label located on the under side of the chassis indicates the manner in which the change of impedance is made. A metal tag is mounted near the

phone jack to indicate the impedance connection at the time the set left the factory. All impedance changes must be accompanied by a corresponding reversal of the tag.

- (4) The front panel of Radio Receiver and Transmitters BC-620-H, -J, and -K has been weatherproofed as follows:
 - (a) Hold-down catch clips at sides of front panel have been enlarged to distribute evenly the pressure exerted on the housing by the front panel.
 - (b) The indicating meter has been weatherproofed by the addition of a rubber gasket, a Plexiglas gasket, and a steel reinforcing backplate between the front panel and the meter. To replace the meter, remove the three nuts at the rear of the meter rim. The metering zero adjustment has been weatherproofed by the insertion of a bushing with a sealing plug to cover the adjustment hole. To zero-set the meter, unscrew the plug and proceed as usual.
 - (c) The shafts of the meter control switch, channel switch, and volume control have been weatherproofed further by substituting water-pump packing for the velutex gaskets. This packing is wrapped securely around the shaft and drawn tightly by means of a packing gland.
- (5) Modification work order MWO SIG 11-605-2 covers modification of the BC-620-(*) metering socket to permit presetting the tuning controls as an aid in tuning the transmitter. Modification work order MWO SIG 11-605-3 covers modification of the power cable leading from the BC-620-(*) to the power supply, to prevent power cable failure.
- (6) Modification work order MWO SIG 11-605-7 covers modification of Radio Receiver and Transmitters BC-620-A, -B, -F, and -G and Plate Supply Units PE-97-A and -D to provide improved filament voltage regulation. Radio Receiver and Transmitters BC-620-H and -J are not covered by this modification work order, since they were procured after its publication, nor do they contain the features of the modification. Therefore, the BC-620-H and BC-620-J must not be used with the PE-97-(*). Instead, the BC-620-H and BC-620-J must be used with Power Supply Unit PE-120-(*), which has self-contained filament voltage regulation. Power Supply Unit PE-120-(*) may be used with all models of the BC-620-(*).
- (7) Modification work under MWO SIG 11-605-8 covers modification of the SCR-509-(*) and the SCR-510-(*). Its purpose is to eliminate breakage of draw-pull catches and distortion of cases, by installing new draw-pull catches of increased

mechanical strength. Modification work order MWO SIG 11-605-10 covers modification of Radio Receiver and Transmitter BC-620-(*). Its purpose is to replace those fixed capacitors that have proved unsatisfactory because of moisture absorption.

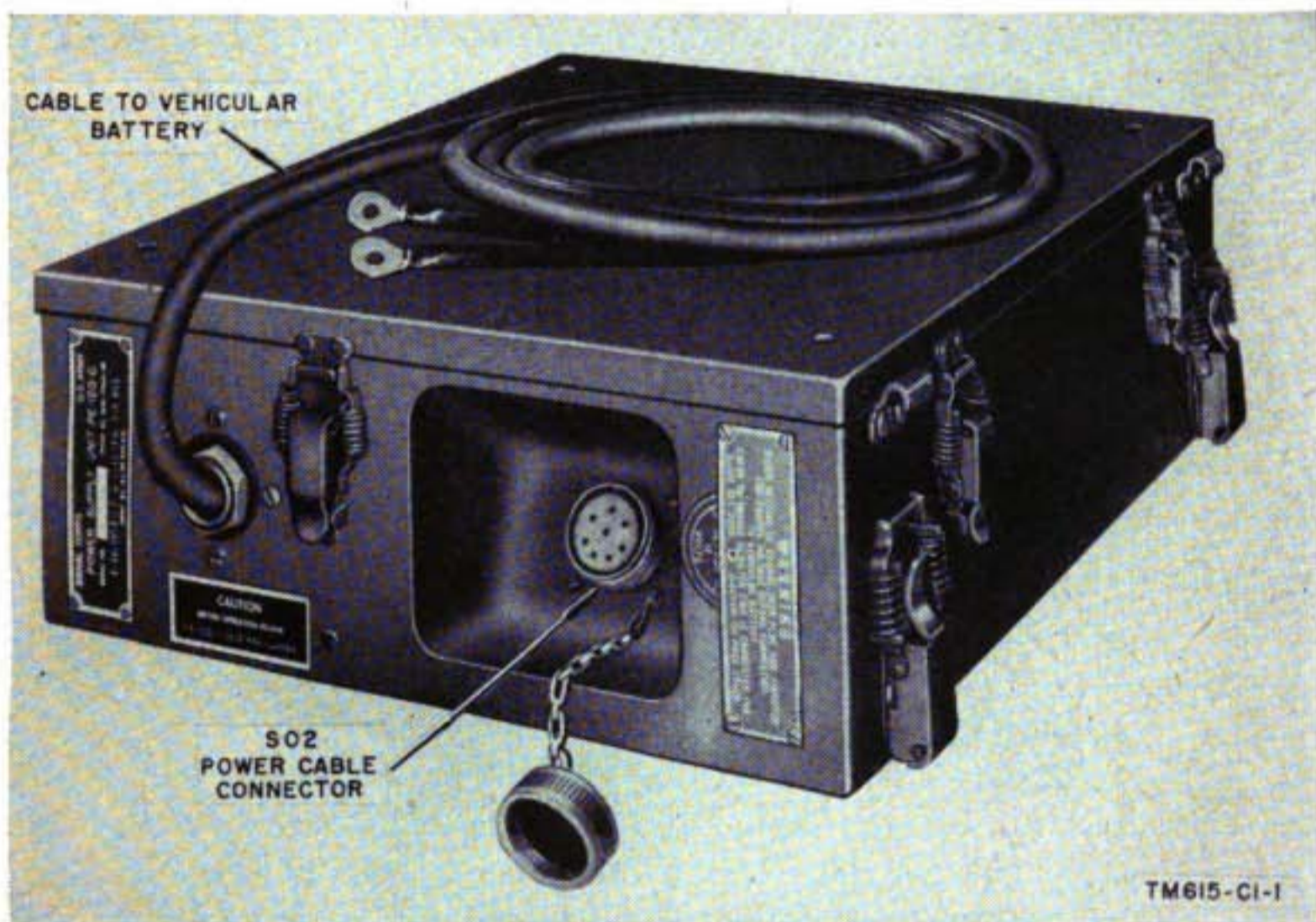

Figure 3.1 (Added) Power Supply Unit PE-120-C, exterior view.

6.1 Terminal Box TM-206-A

Added

a. General. Satisfactory operations will result only if this equipment is used with one of the following antenna systems:

- (1) Mast Base AB-15/GR, Mast Sections MS-117 and MS-118, and lead-in Wire W-128 (2 feet, 0 inch).
- (2) Mast Base MP-48 or MP-48-A, Mast Sections MS-52 and MS-53, and lead-in Wire W-128 (2 feet, 0 inch).
- (3) Mast Base AB-15/GR, Mast Sections MS-116, MS-117, and MS-118, and Cord CG-67/MRQ-2 (9 feet, 0 inch).
- (4) Mast Base MP-48 or MP-48-A, Mast Sections MS-51, MS-52, and MS-53, and CORD CD-1297 (9 feet, 0 inch).
- (5) Antenna AN-45-(*), mounted directly on terminal Box TM-206-A.

b. Purpose. Box TM-206-A is a waterproof terminal box designed to replace the antenna mounting block assembly mounted at the rear of Radio Receiver and Transmitter BC-620-(*). It is to be used with

Radio Sets SCR-509-(*) and SCR-510-(*) in installations where the radio set is located more than 2 feet from the mast base. In this type of installation, with Mast Base AB-15/GR, a 9-foot length of coaxial cable Cord CG-67/MRQ-2 is used. Mast Base MP-48 or MP-48-A may be used with a 9-foot length of coaxial cable Cord CD-1297. It also may be used as a mount for Antenna AN-45-(*), or, when the mast base is located within 1 foot of the radio set, it may be used with a 2-foot length of Wire W-128 connecting it to the mast base.

c. Description.

- (1) Box TM-206-A (figs. 6.1 and 6.2) is a terminal box approximately $2\frac{3}{4}$ inches square and $1\frac{1}{2}$ inches deep. On the top is a post for mounting Antenna AN-45-(*) and a binding post for connection of Wire W-128. On the bottom is a coaxial cable connector and a right-angle adapter. Inside the box are a change-over link and a capacitor connected between the link and the coaxial fitting. An instruction label is mounted inside the cover.
- (2) Cord CG-67/MRQ-2 consists of 9 feet of coaxial cable with a connector Plug PL-259 on each end. Cord CD-1297 consists of 9 feet of coaxial cable with a plug AN-3106-14-3ST on one end and a Plug PL-259 on the other.

Caution: Do not cut the cord furnished to another length. The tap settings shown on the inside of the cover of the terminal box are determined for a 9-foot coaxial cable and are not the proper settings for a cable of any other length.

d. Installation.

- (1) Remove the screws around the edges of the panel of Radio Receiver and Transmitter BC-620-(*) or unsnap the catches and slide out the chassis.
- (2) Remove the six double nuts and lockwashers from within the back of the case and remove the antenna junction box and mounting block.
- (3) Remove the four screws that fasten the cover of the terminal box. Remove the lockwashers and nuts from the six screws on the back of the terminal box. Insert the screws into the holes on the case of the radio set and fasten securely within the case with lockwashers and nuts.
- (4) Slide the chassis back into the case and fasten the panel screws or catches.
- (5) If the terminal box is to be used with coaxial cable connection, set the change-over link as shown in figure 6.2. If the box is to be used with Antenna AN-45-(*) or with 2 feet of lead-in wire to the mast base, set the change-over link as shown in

figure 6.1. Replace the cover of the terminal box and fasten with the four screws.

- (6) If the coaxial cable is to be connected vertically, remove the right-angle adapter from the coaxial cable connector. If the coaxial cable is to be connected horizontally, mount the right-angle adapter in the most convenient position.
- (7) Install the radio set, with terminal Box TM-206-A attached, and the mast base in the vehicle for which they are intended. Connect Cord CG-67/MRQ-2 between terminal Box TM-206-A and Mast Base AB-15/GR, or Cord CD-1297 between terminal Box TM-206-A and Mast Base MP-48 or MP-48-A.

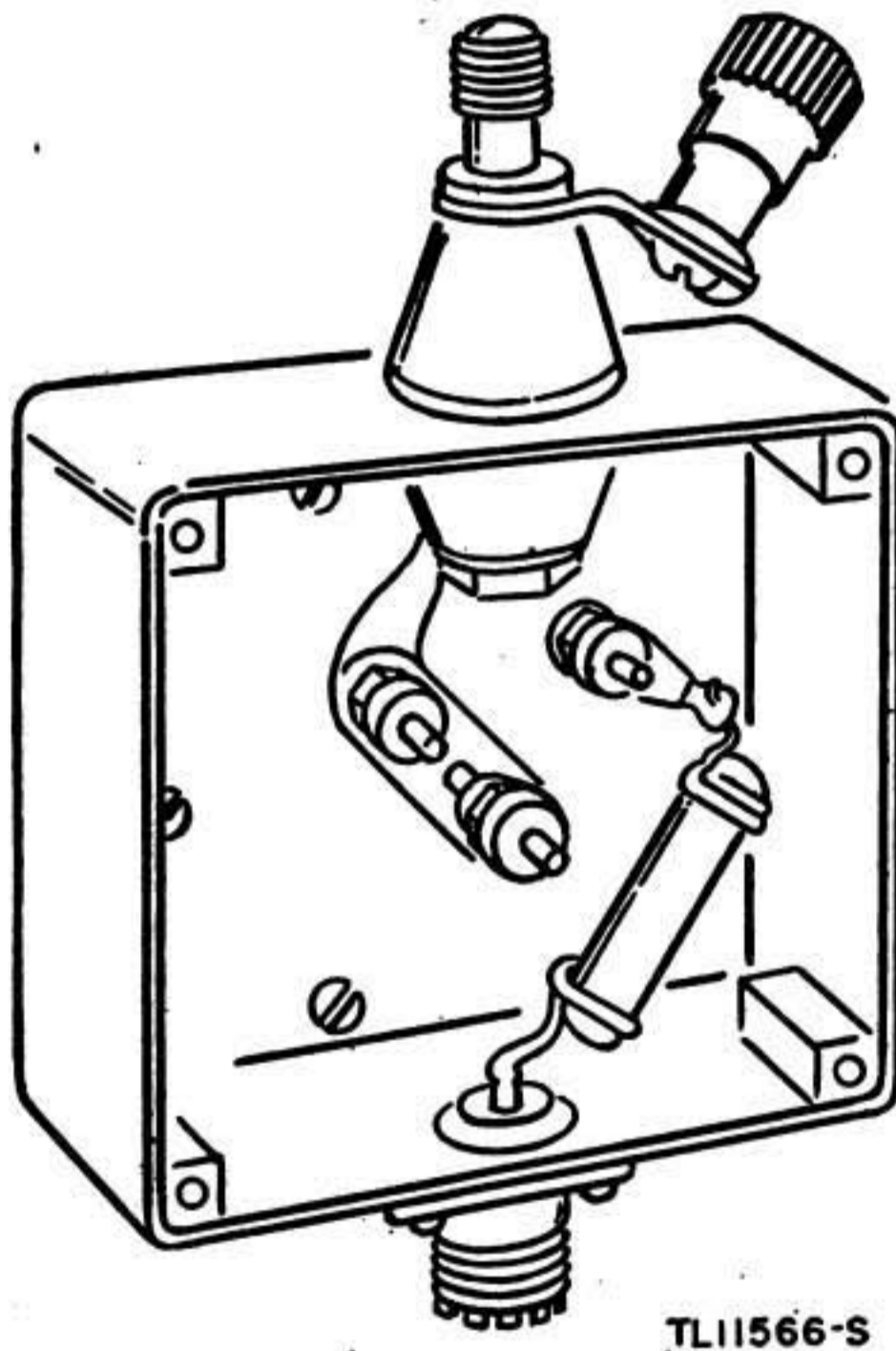

Figure 6.1 (Added) Terminal Box TM-206-A, cover removed, connection for Antenna AN-45-().*

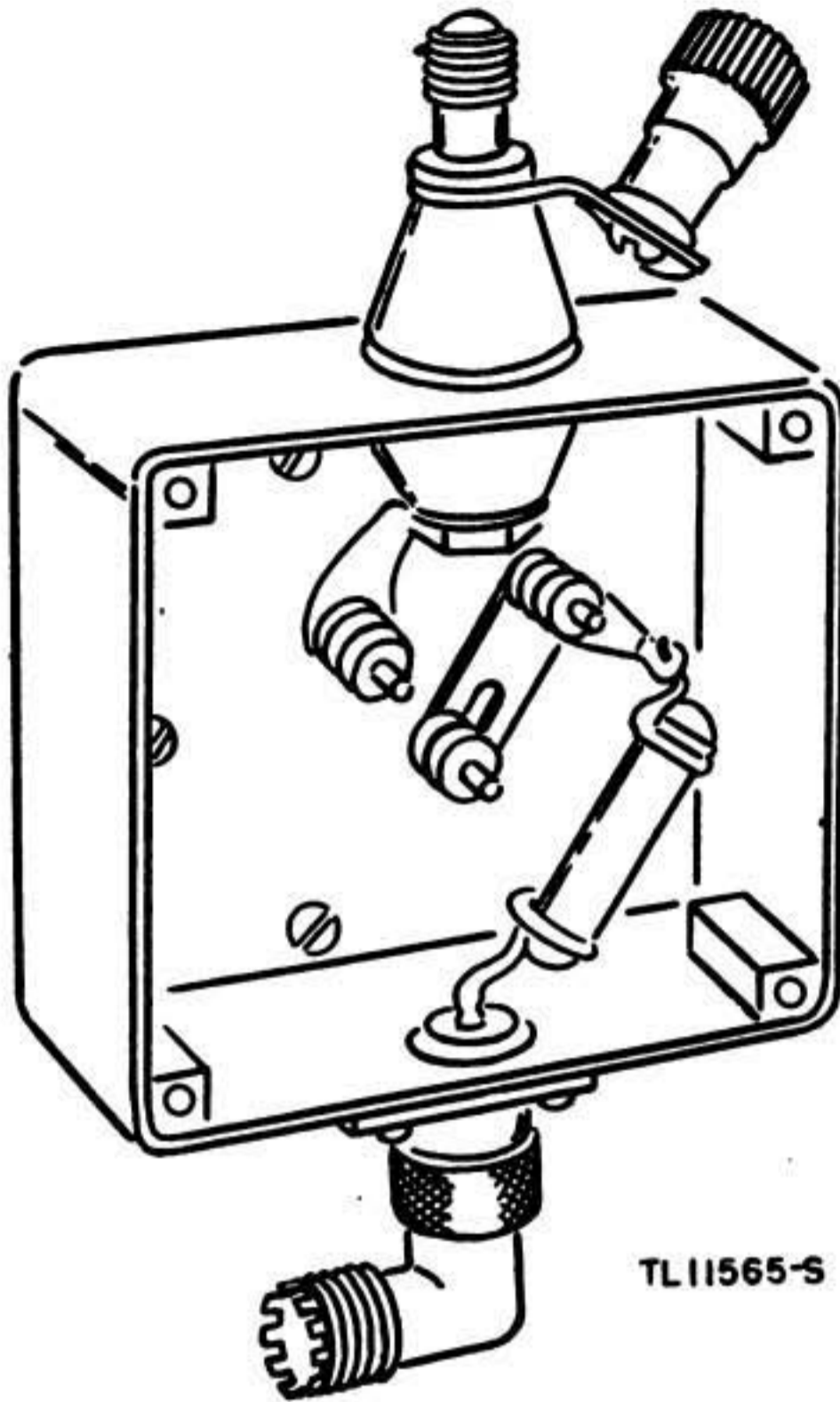

Figure 6.2 (Added) Terminal Box TM-206-A, cover removed, connection for coaxial cable.

7. Preparation for Use

* * * * *
 c. For vehicular operation * * * battery in use.

Note. (Added) Be sure that the correct vibrator is inserted in vibrator socket SO1, and that plug P1 is inserted correctly for the vehicular battery source before connecting Power Supply Unit PE-120-(*) to the vehicular battery. Use Vibrator VB-12-A for 6-volt, Vibrator VB-13-A for 12-volt, and Vibrator VB-11-A for 24-volt operation.

* * * * *

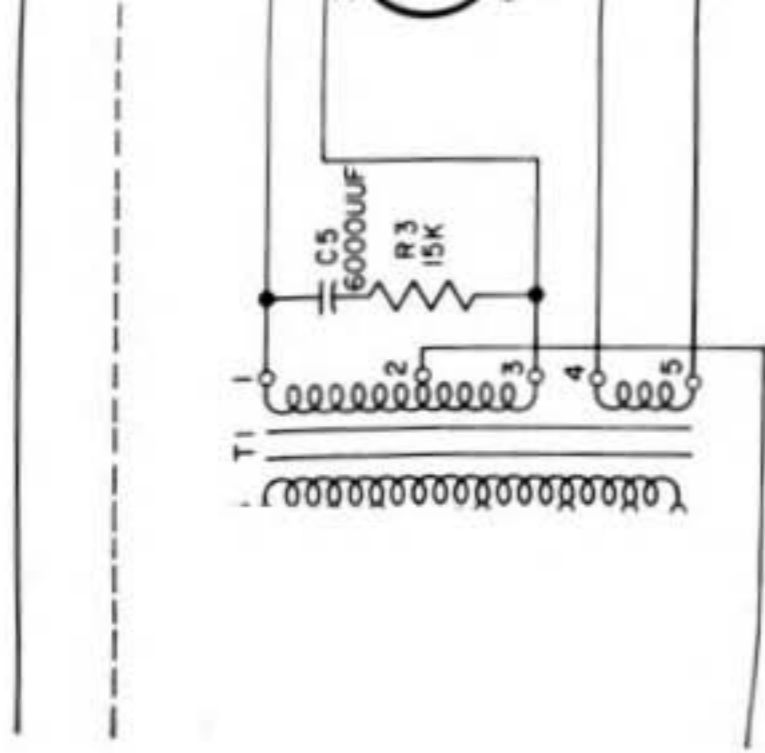
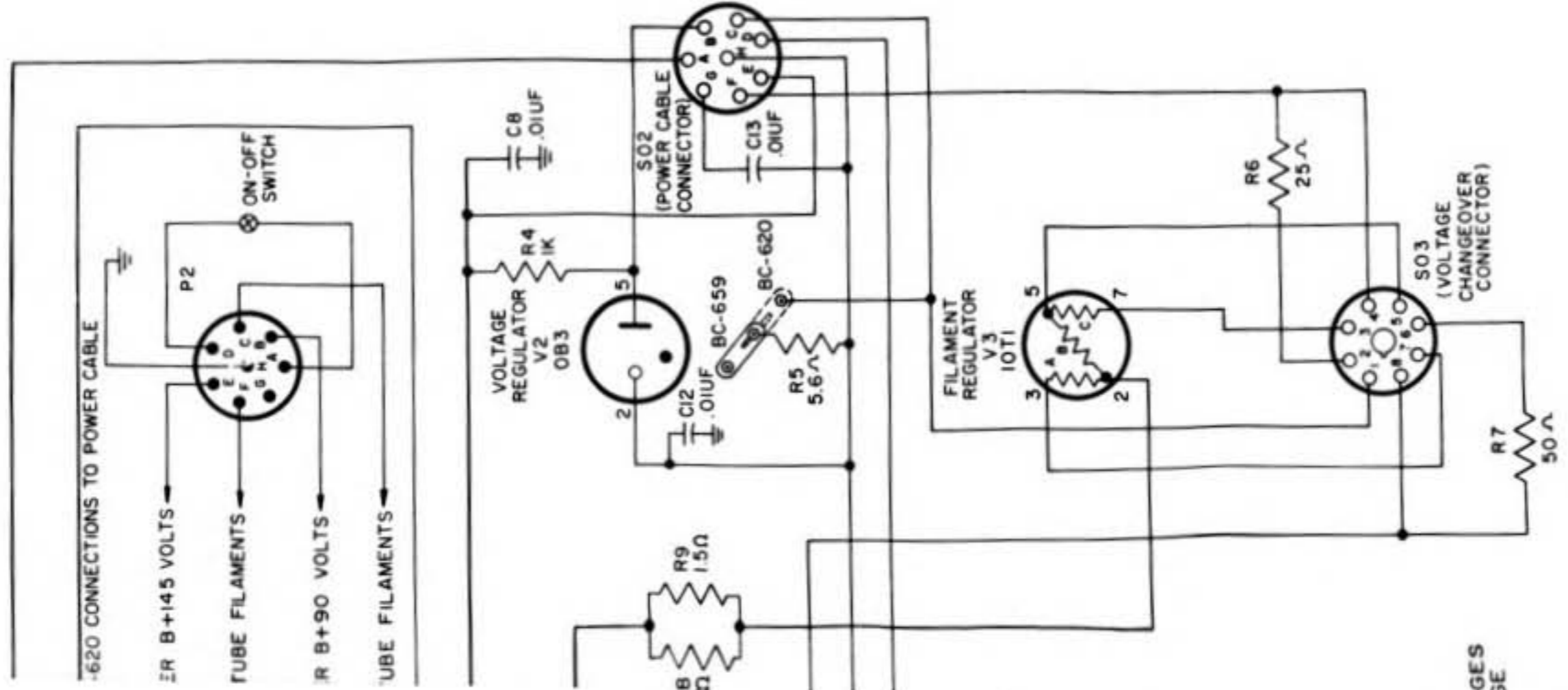

VIB2
VB-13-A
12 VOLT VIBRATOR

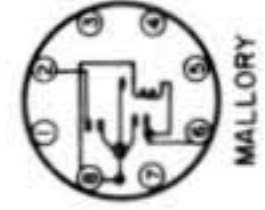
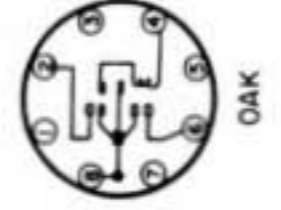

VIB1
VB-1
24 VOLT



CORRECT VIBRATOR
 AND BATTERY VOLTAGE
 BATTERY
 BATTERY / BATTERY

TM618-C1-3

30. Presetting Procedure Using Adapter M-394

- * * * * *
- c. The following steps * * * the microphone switch.
* * * * *
- (4) Tune A6 (B6) * * * approximate (chart) setting.

Note (Added) In order to maintain a fine adjustment in steps (3) and (4) above, it is recommended that the probe be inserted in pin jack No. 8 of the metering socket. Observe the meter for a slight dip at the maximum noise peak. The VOLUME control should be turned on fully.

- d. The following steps * * * while making adjustments.
(1) Insert probe in * * * on this peak.

Note (Added) If it is difficult to determine the correct dip, remove the first r-f amplifier tube V5 (VT-179) for this step only.

* * * * *

31. I-F and Discriminator Alinement

- * * * * *
- d. The following alinement * * * and Adapter M-394.
* * * * *
- (10) Turn set off (VOLUME control), set adapter OFF-ALINE-switch to OFF and remove 2.88-megacycle crystal. Replace the channel crystals in their proper sockets.

* * * * *

33.2. Corrective Measures and Maintenance Hints

* * * * *

d. (Added) The vibrator chassis of Power Supply Unit PE-120- (*) is insulated from the main chassis. If the main chassis is removed from the housing, be sure to use the same length screws when replacing it. Longer screws will ground the vibrator chassis to the main chassis.

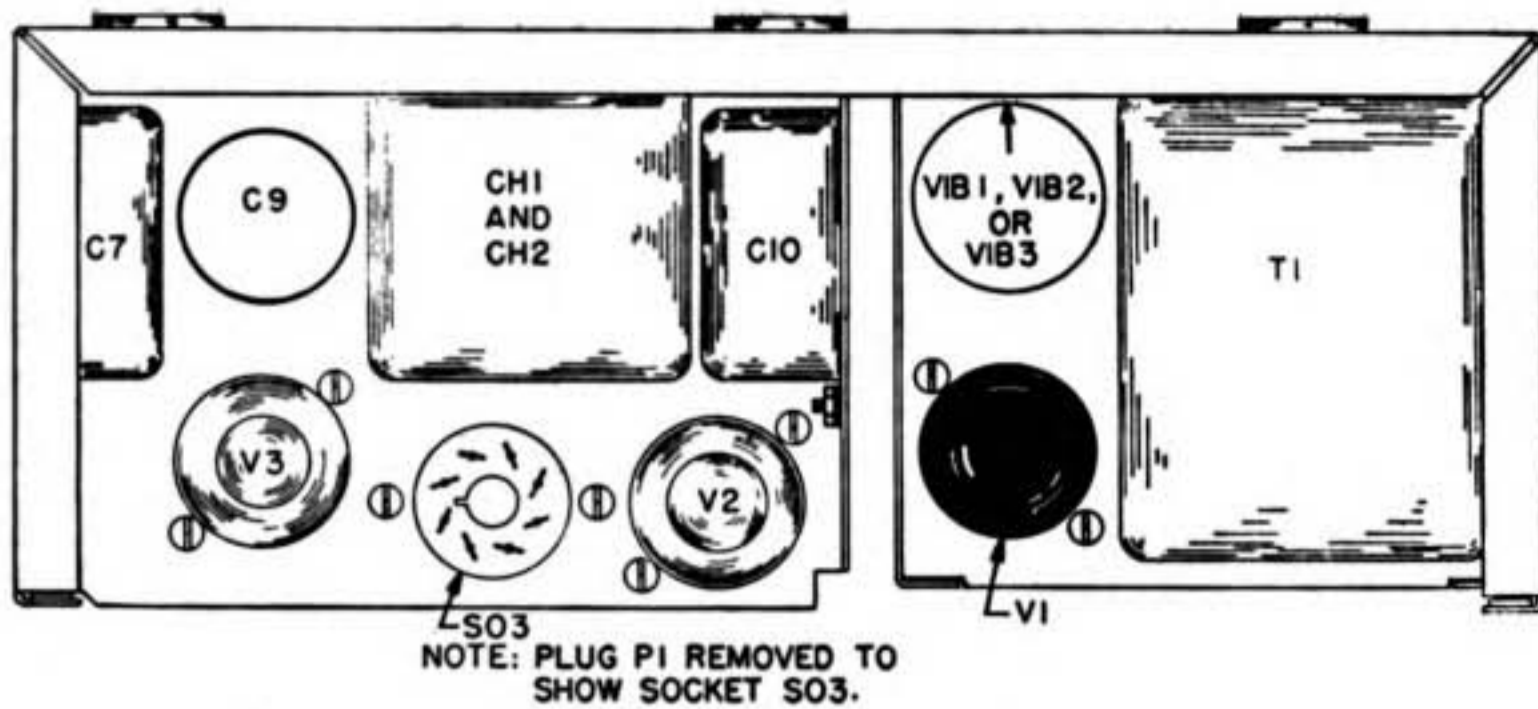
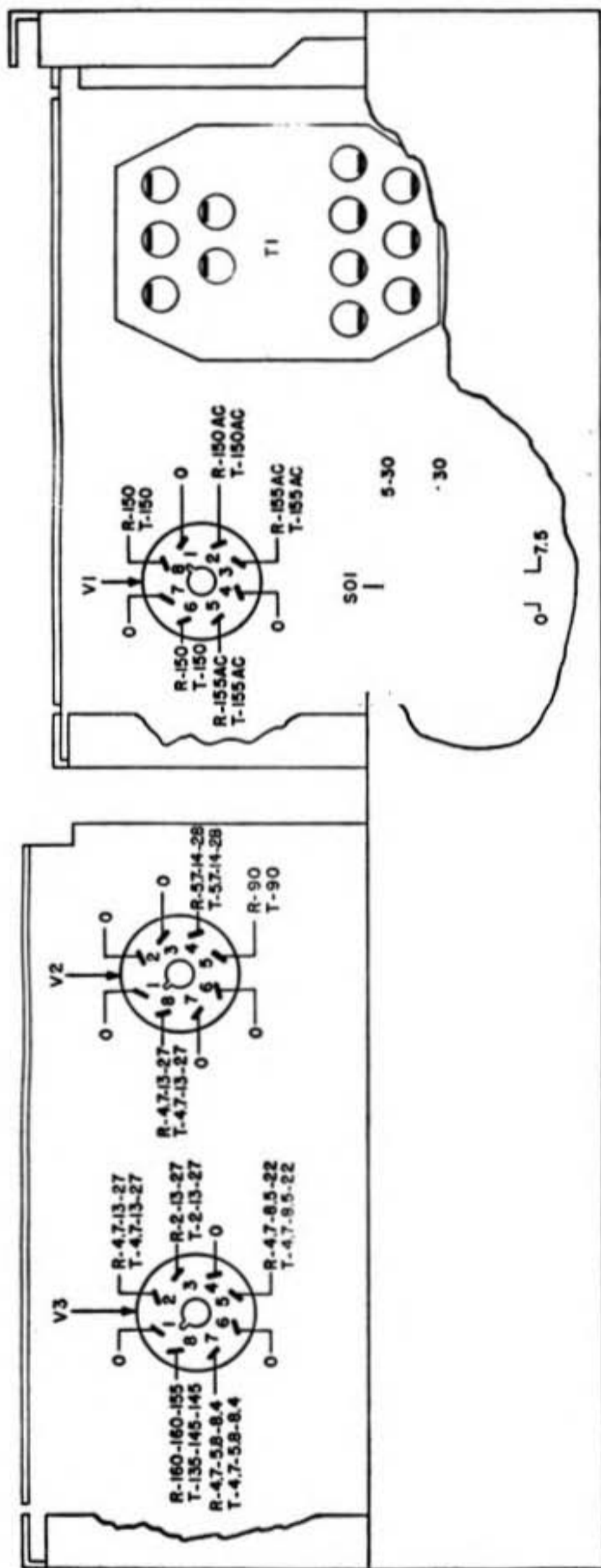

Figure 24.2 (Added) Power Supply Unit PE-120-C, side and top views with cover removed.



NOTE: VOLTAGE MEASUREMENTS MADE UNDER THE FOLLOWING CONDITIONS:

1. POWER SUPPLY UNIT PE-120-C CONNECTED TO RADIO RECEIVER AND TRANSMITTER BC-659-() WHICH IS KNOWN TO BE IN GOOD OPERATING CONDITION.
2. VOLTAGE INPUT TO POWER SUPPLY UNIT PE-120-C. CAUTION: SEE PAR. 27 BEFORE CONNECTING TO VEHICULAR BATTERY. WHERE THREE VALUES ARE GIVEN, THEY ARE FOR 6-12- AND 24-VOLT BATTERY INPUT, RESPECTIVELY. ALL VALUES SHOWN ARE NOMINAL.
3. R- WITH RADIO RECEIVER AND TRANSMITTER BC-659-() IN RECEIVE POSITION. T- WITH THE BC-659-() IN TRANSMIT POSITION.
4. VOLTAGES MEASURED WITH VACUUM TUBE VOLTMETER. ALL READINGS ARE D-C VOLTS EXCEPT WHERE INDICATED AS AC. ALL VOLTAGES MEASURED BETWEEN POINT INDICATED AND B-(BROWN LEAD).
5. WITH VOLTAGE REGULATOR V2, OB3, WORKING.
6. CURRENT DRAIN WITH 6-VOLT INPUT-3.0 AMPERES IN RECEIVE POSITION, 4.5 AMPERES IN TRANSMIT POSITION; WITH 12-VOLT INPUT-2.0 AMPERES IN RECEIVE POSITION, 2.75 AMPERES IN TRANSMIT POSITION; WITH 24-VOLT INPUT-1.5 AMPERES IN RECEIVE POSITION, 2.0 AMPERES IN TRANSMIT POSITION
7. ALL VALUES SHOWN ARE WITH 7.5-, 15-, AND 30-VOLT INPUT, WHICH SHOULD OCCUR WHEN 6-, 12-, AND 24-VOLT BATTERIES ARE FULLY CHARGED, OR WHEN THE GENERATOR OF VEHICLE IS OPERATING.

Figure 25.2 (Added) Power Supply Unit PE-120-C, voltage diagram.

TM615-C1-4

34.2. Maintenance Parts List for Radio Receiver and Transmitter BC-620-(*)

Ref symbol	Name of part and description	Function of part	Signal Corps stock No.
* C9	* * * 300 v d-c (working) CAPACITOR: fixed; mica; * * * CAPACITOR: fixed; ceramic; .005 μ f +80%, -20%, 300 v dc working (this capacitor is used in later models of the BC-620-(*), and is interchangeable with the old C9).	* *	* 3DA10-78 3DA5-24
* C65	* * * CAPACITOR: fixed, styramic paper; .01 μ f \pm 20%, 300 v dc working	* *	* 3D10-230
* C68	* * * CAPACITOR: fixed, molded paper; .005 μ f; 300 v dc working	* *	* 3DA5-134
SW11	SWITCH: same as SW10		
SW14	SWITCH: slide; Stackpole SS-3 DPDT		3Z9839
* T7	* * * TRANSFORMER C-62: output TRANSFORMER: a-f output; secondary tapped at 4000 ohms, 250 ohms, and 3 ohms (used in Radio Receiver and Transmitters BC-620-G and -J).	* *	* 2Z9662 2Z9632.223
* *	* * * *	* *	* *

34.2.1 Identification Table of Parts for Radio Receiver and Transmitter BC-620-H (Added)

Ref symbol	Name of part and description	Function of part	Signal Corps stock No.
	GASKET, meter: neoprene; $2\frac{13}{16}$ " dia o/a; $\frac{3}{32}$ " thk; openings for meter scale and zero reset; 3 mtg holes evenly spaced on 2.437" dia; Admiral #P616-125.	Weatherproofs meter front.....	2Z4868.135
	GASKET, rubber: black neoprene; $11\frac{15}{16}$ " lg x $6\frac{3}{16}$ " wd x $\frac{3}{32}$ " thk OD; $11\frac{3}{8}$ " lg x $6\frac{3}{16}$ " wd ID; Galvin #32B49774.	-----	2Z4868.95
	PACKING, fiber: graphite; $\frac{1}{8}$ " dia x 3" lg; Admiral #999-203-1.....	Weatherproofs control shaft.....	2Z6904-1
	PANEL, front: consists of panel, long catch clips, meter zero reset bushing and gaskets; Admiral #G2039.	-----	2Z6959-18
	PLATE, reinforcing: steel; 18 gage x $2\frac{13}{16}$ " dia o/a; cadmium-plated; 3 mtg holes spaced evenly on 2.437" dia and tapped #3-48 machine screw; openings for meter zero reset and for meter scale; Admiral #202-402.	Reinforces meter window.....	2Z7093-23
	PLUG ASSEMBLY, weatherproofing: consists of male plug w/ $\frac{5}{8}$ "-24 thread, $3\frac{1}{2}$ " lg stranded 000 safety chain, spring clip, neoprene gasket, brass retaining washer; Admiral #G2040.	-----	2Z3351-40
R41	RESISTOR, fixed: carbon; 3.3 ohms $\pm 10\%$; $\frac{1}{2}$ w; $\frac{3}{16}$ " lg x 0.218" dia; Eire #504.	V4 filament dropping.....	3Z5993-21
R44	RESISTOR, fixed: carbon; 180 ohms $\pm 10\%$; $\frac{1}{2}$ w; $\frac{3}{16}$ " lg x 0.218" dia; RC21AE181K.	V4, filament shunt.....	3RC21AE181K
R43	RESISTOR, fixed: carbon; 220 ohms $\pm 10\%$; $\frac{1}{2}$ w; $\frac{3}{16}$ " lg x 0.218" dia; RC20AE221K.	V3 Filament shunt.....	3RC20AE221K
	WASHER, cable: hard brass; $1\frac{1}{16}$ " OD x 0.031" thk x $\frac{3}{4}$ " ID; Admiral #P910-54.	Protects fiber washer.....	6L50122
	WINDOW, meter: Plexiglas; $2\frac{13}{16}$ " dia o/a x $\frac{1}{16}$ " thk; 3 mtg holes evenly spaced on 2.437" dia; openings for meter zero reset, $\frac{3}{16}$ " dia; Admiral #952-120.	Weatherproofs meter front.....	2ZA1352-51

34.3.1 Identification Table of Parts for Case CS-79-N (Added)

Ref symbol	Name of part and description	Function of part	Signal Corps stock No.
	CAP, plug: black rubber; $\frac{3}{8}$ " cable hole and 1" connector hole; $1\frac{1}{8}$ " dia x $1\frac{1}{2}$ " lg x $1\frac{1}{32}$ " h o/a; Galvin #37A30251.	Insulates connector terminals.....	2Z7104-27
	CATCH, clip: hold-down type; small; $1\frac{1}{2}$ " lg; steel; od finish; Galvin #55A53415.	-----	2Z1923-1
	CLIP, catch; hold-down type; hook-shaped; $\frac{7}{8}$ " lg x $\frac{9}{16}$ " wd x $\frac{1}{4}$ " thk; Galvin #55A53416.	-----	2Z2727-1
	CONNECTOR, female contact: $1\frac{1}{2}$ " sq x $1\frac{1}{2}$ " d; Amphenol #3102-20-7S.	-----	2Z8678.68
	GASKET, connector: neoprene; $1\frac{1}{16}$ " sq x $\frac{1}{16}$ " thk; $1\frac{1}{8}$ " dia hole for connector; 4 mtg holes 1 156" ctr; Admiral #P616-139.	Weather seal between case and connector.	2Z4868.133
	GASKET, panel: neoprene; black; $14\frac{3}{32}$ " lg x $11\frac{1}{16}$ " wd; Admiral #P616-138.	Water seal between housing and cover.	2Z4868.134

34.5.1 Identification Table for Parts for Power Supply Unit PE-120-B (Added)

Ref symbol	Name of part and description	Function of part	Signal Corps stock No.
	CAP, plug: black rubber; $\frac{3}{8}$ " cable hole and 1" connector hole; $1\frac{3}{8}$ " dia x $1\frac{1}{2}$ " lg x $1\frac{1}{32}$ " h o/a; Galvin #37A30251.	Insulates connector terminals.....	2Z7104-27
	CATCH, clip: hold-down type; small; $1\frac{1}{2}$ " lg; steel; od finish; Galvin #55A53415.	-----	2Z1923.1
	CLIP, catch: hold-down type; $\frac{7}{8}$ " lg x $\frac{9}{16}$ " wd x $\frac{1}{4}$ " thk; Galvin #55A53416.	-----	2Z2727-1
	CONNECTOR, female contact: 8 cont; $1\frac{1}{2}$ " sq x $1\frac{1}{2}$ " d; Amphenol #3102-20-7S.	-----	2Z8678.68
	GASKET, connector: neoprene; black; $1\frac{1}{16}$ " sq x $\frac{1}{16}$ " thk; $1\frac{1}{4}$ " dia hole for connector; 4 mtg holes 1.156" ctr; Admiral #P616-139.	Weather seal between case and connector.	2Z4868.133
	GASKET, panel: neoprene; black $14\frac{3}{32}$ " lg x 12" wd x $\frac{3}{32}$ " thk; hole $14\frac{3}{32}$ " lg x $11\frac{3}{16}$ " wd; Admiral #P616-138.	Water seal between housing and cover.	2Z4868.134

34.5.2 Identification Table of Parts for Power Unit PE-120-C (Added)

Note. The following is an identification table of parts for Power Supply Unit PE-120-C (Sig C stock No. 3H4496-120). The fact that a part is listed in this table is not sufficient basis for requisitioning the item. Requisitions must cite an authorized basis, such as a specific T/O & E, T/A, SIG 7 & 8, SIG 7-8-10, SIG 10, list of allowances of expendable material, or other authorized supply basis. The Department of the Army Supply Catalog applicable to the equipment covered in this change is SIG 7 PE-120. For an index of available supply catalogs in the Signal portion of the Department of the Army Supply Catalog, see the latest issue of SIG 1.

Ref symbol	Name of part and description	Function of part	Signal Corps stock No.
119	BOARD, terminal: bakelite; includes 1 term. and soldering lug.	Used as a tie point for leads-----	2Z770-1.34
121	BOARD, terminal: laminated bakelite; includes 4 solder-lug type term. 2" lg x 3/8" wd x 3/32" thk. BUS BAR: brass; rectangular; solid; 7/8" lg x 5/16" wd x 0.05" thk.	Provides attachment and transfer points for leads. Provides a means of changing the circuit connections so that the power supply unit may be used either with Radio Receiver and Transmitter BC-659 or Radio Receiver and Transmitter BC-620.	2Z9402.112 2Z558-71
102	CABLE, power: electrical; stranded; two #14 AWG and two #10 AWG cond; synthetic rubber insulated approx 10' lg o/a; Sig C type #CO-134. CABLE, power: electrical; stranded: 8 cond; six #20 AWG and two #14 AWG cond; approx 24" lg o/a.	Conducts energy from the battery to the power supply unit.	3E2134
C9	CAPACITOR, fixed: electrolytic; 1,100 μ f; 25 vdcw; JAN type CE41C112F.	Connects the output of the unit to the output receptacle. Filter for filament supply-----	2E2139 3DB1000-4
C1, C2	CAPACITOR, fixed: paper dielectric; 500,000 μ f \pm 20%; 200 vdcw.	Bypass r-f voltages to ground-----	3D9000.5-7
C3	CAPACITOR, fixed: paper dielectric; 1.0 μ f \pm 20%; 100 vdcw; JAN type CP54-B1EB105V.	Primary buffer capacitor for the transformer---	3DB1.184

TAAGO 1728B

C4, C6, C8, C11, C12, C13.	CAPACITOR, fixed: paper dielectric; 10,000 $\mu\mu\text{f}$ $\pm 20\%$; 300 vdcw; JAN type CN22A103M.	R-f bypass capacitors.....	3DA10-447
C5	CAPACITOR, fixed: paper dielectric; 6000 $\mu\mu\text{f}$ $\pm 10\%$; 1500 vdcw; JAN type CP28A1EH602K.	Secondary buffer capacitor for the transformer.	3DA5-129
C7, C10	CAPACITOR, fixed: paper dielectric; 2.0 μf $\pm 20\%$; 200 vdcw; JAN type CP53B1FC205V.	Filter capacitors.....	3DB2.207
RFC1	CHOKER, RF: nominal inductance 2.9 μh $\pm 20\%$ at 1000 cps.	Filters input to the vibrator and the transformer.	3C362-32
RFC2	CHOKER, RF: nominal inductance 120 μh at 1000 cps.	Filters output of the rectifier tube.....	3C362-33
RFC3	CHOKER, RF: nominal inductance 12.2 μh $\pm 20\%$ at 1000 cps.	Filters input to the receiver filament.....	3C362-3
CC1, CC2	CLAMP, electrical: aluminum; screw type; 1 $\frac{3}{4}$ " lg o/a.	Secure the input cable and the output lead.....	2Z1587-284
107	CLAMP, electrical: phosphor bronze, tin-plated; circular spring type; 2" lg o/a.	Secures the vibrator in place when not in use...	2Z2642.648
111	CLAMP, electrical: steel; spring type; 1 $\frac{7}{8}$ " lg o/a.....	Grounds the vibrator.....	2Z2642.648
S02	CONNECTOR, receptacle: 8 female contacts; polarized.	Receptacle for connecting the using equipment to output of the power supply unit.	2Z8678.68
	COVER, electrical connector, threaded cap; aluminum; 1 $\frac{1}{4}$ " dia x $\frac{3}{16}$ " thk.	Protects the output receptacle when the receptacle is not in use.	2Z1612
109	FASTENER, catch to case: steel; 1" lg o/a.....	Large strike for case catch; part of draw-type latch.	6Z1747-49
105	FASTENER, cover to base: draw type latch; steel..	Part of the catch clip assembly which secures the cover to the case.	6Z3810-49
106	FASTENER, cover to case; draw type latch; steel...	Part of the catch clip for securing the PE-120-C to shock Mounting FT-250.	6Z918-68
	FITTING, conduit: conduit coupling; threaded; $\frac{1}{2}$ " lg o/a.	Mounts the clamp securing the battery cable and the output cable.	6Z3421-1

Ref symbol	Name of part and description	Function of part	Signal Corps stock No.
F1	FUSE, cartridge: ferrule type; one-time; 6 amp, 250 v; instantaneous; nonindicating.	Protects the unit from damage caused by excessive input.	3Z2606.3
117	FUSEHOLDER: retainer type; accommodates 1 cartridge-type fuse.	Retains the fuse.....	3Z1939
	INSULATION, sleeving, electrical: flexible; transparent vinylite; 1.375" ID; 3 1/8" lg o/a.	Used to cover the electrolytic capacitor.....	3G2264
122	INSULATOR: washer, bakelite; round, flat; 1 1/2" dia.	Used as insulator for the electrolytic capacitor.	3G385-63
	INSULATOR: washer, bakelite; round, flat; 1/2" dia.	Insulates r-f choke RFC 1.....	3G385-64
110	LATCH RETAINER: keeper; spring steel.....	Secures the latch loop when the latch is not in use.	6Z3810-112
114	LUG, terminal: round tongue end type; copper; accommodates one #10 AWG and one #14 AWG wire.	Solder lug; connects input cable to battery terminals.	3Z12073-44.8
P1	PLUG, voltage changeover: 8 male contacts; octal retainer ring type plug w/marker.	Provides means of connecting circuits so that the equipment will produce the desired output from 6-volt, 12-volt, or 24-volt input.	2Z7118.34
CH1, CH2	REACTOR: sealed; dual sections; 3.5 hy, 75 ma and 0.01 hy, 950 ma.	Filter chokes.....	3C317-33
R1, R2	RESISTOR, fixed: composition; 820 ohms, ±10%; 1 w; JAN type RC30BF821K.	Buffer resistors for the primary of the transformer.	3RC30BF821K
R3	RESISTOR, fixed: composition; 15,000 ohms ±10%; 1/2 w; JAN type RC20BF153K.	Buffer resistor for the secondary of the transformer.	3RC20BF153K
R4	RESISTOR, fixed: WW; 1,000 ohms ±5%; 10 w; JAN type RW31.	Dropping resistor.....	3RW24320
R5	RESISTOR, fixed: WW; 5.6 ohms ±5%; 8 w; JAN type RW30G5R6.	Filament shunting.....	3RW10802
R6	RESISTOR, fixed: WW; 25 ohms ±5%; 8 w; JAN type RW30G250.	Transmitter filament series resistor.....	3RW14708

R7	RESISTOR, fixed: WW; 50 ohms $\pm 5\%$; 8 w; JAN type R-26.	Transmitter filament series resistor:-----	3RW16507
R8, R9	RESISTOR, fixed: WW; 1.5 ohms $\pm 10\%$; 1 w; type #RU4B1R5K.	Receiver filament dropping resistors:-----	3RU08005
V3	RESISTOR, thermal: ballast tube; octal; Amperite type #10T1.	Ballast tube; used to regulate filament volt-ages.	3Z6925-3.8
	RING, retainer: AN; connector; aluminum ring, spring steel speed nuts.	Retains output connector S02:-----	2Z7858-291
S01, S03	SOCKET, electron tube: octal; one-piece saddle mtg; 8 contacts; spec JAN-S-28.	Receptacles for vibrator, voltage change-over plug, and rectifier, voltage regulator and filament regulator tubes.	2Z8670.33
	STUFFING TUBE: feed-through type; straight; $1\frac{1}{8}$ " lg o/a.	Protects the battery lead while it passes through the case.	2Z3006-1
T1	TRANSFORMER, power: vibrator; sealed metal case; input, 6 v, 12 v, or 24 v; 4 to 5 amp, 3 to 3.5 amp, 2 to 2.5 amp; output 140 v, 115 cps; 60 ma.	Steps up voltage supplied by interrupter:-----	2Z9625-24
V2	TUBE, electron: diode, gas-filled; JAN type OB3:-----	Voltage regulator tube; maintains voltage constant.	2JOB3
V1	TUBE, electron: dual diode; JAN type 1005:-----	Rectifies the transformer output:-----	2T1005
VIB1	VIBRATOR, nonsynchronous: single reed; input 6 v dc, 4.53 amp; 115-cps output; Sig C type #VB-12().	Interrupter used with 6-volt d-c input:-----	3H6712
VIB2	VIBRATOR, nonsynchronous: single reed; input 12 v dc, 3.083 amp; 115-cps output; Sig C type #VB-13-().	Interrupter used with 12-volt d-c input:-----	3H6713
VIB3	VIBRATOR, nonsynchronous: single reed; input 24 v dc, 2.15 amp; 115-cps output; Sig C type #VB-11-().	Interrupter used with 24-volt d-c input:-----	3H6711

34.13 Identification Table of Parts for Terminal Box TM-206-A (Added)

Ref symbol	Name of part and description	Function of part	Signal Corps stock No.
	ADAPTER M-359		2Z299-359
	BINDING POST TM-145		3Z245
	CAPACITOR: 39 $\mu\mu\text{f}$ $\pm 5\%$; silver mica		3K2039032
	SOCKET SO-239		2Z8799-239
	GASKET: Buna S; $\frac{3}{32}$ " thk x $2\frac{1}{2}$ " x $2\frac{3}{4}$ ", with six screw holes and ctr hole $1\frac{1}{2}$ " x $1\frac{3}{4}$ ".		2Z4867.331
	INSULATOR: molded bakelite; cone-shaped; $1\frac{1}{4}$ " dia at base; $\frac{5}{8}$ " dia at top; $\frac{3}{4}$ " lg with 0.323 dia hole.		3G1836-18

[AG 300.7 (30 Oct 52)]

BY ORDER OF THE SECRETARY OF THE ARMY :

OFFICIAL :

WM. E. BERGIN
Major General, USA
The Adjutant General

J. LAWTON COLLINS
Chief of Staff, United States Army

DISTRIBUTION :

Active Army:

Tech Svc (1) ; Tech Svc Bd (1) ; AFF Bd (ea Svc Test Sec) (1) ; AFF (5) ; AA Comd (2) ; OS Maj Comd (5) ; Base Comd (5) ; Log Comd (5) ; A (20) ; MDW (5) ; CHQ (2) ; FT (2) ; Sch (5) except 11 (25) ; PMS & T 11 (1) ; Gen Dep (2) ; Dep 11 (20) except Sig Sec, Gen Dep (10) ; Tng Div (2) ; POE (10), OSD (2) ; Lab 11 (5) ; Mil Dist (3) ; 4th & 5th Ech Maint Shops 11 (3) ; Two (2) copies to each of the following T/O & E's: 9-500 AA through AC; 11-107; 11-127A; 11-128; 11-500, CA, CB, CC, CD; EA through ET; 11-587; 11-592; 11-597.

NG: Same as Active Army except one copy to each unit.

ORC: Same as Active Army except one copy to each unit.

For explanation of distribution formula, see SR 310-90-1.

TABLE OF CONTENTS

U113
2
TM 11:605
1943
★ ★

SECTION I. Description

	Page
Paragraph 1 General.....	1
2 Power Requirements.....	3
3 Radio Sets SCR-509-(*) and SCR-510-(*)— Components.....	4
4 Description of Components.....	10

II. Installation and Operation

5 Initial Procedure.....	16
6 Installation.....	16
7 Preparation for Use.....	20
8 Operation.....	21
9 Operating Precautions.....	27

III. Functioning of Parts

10 Receiver.....	28
11 Transmitter.....	30
12 Plate Supply Unit PE-97-(*).....	33
13 Case CS-79-(*).....	34

IV. Maintenance

14 Inspection.....	35
15 Battery Replacement.....	38
16 Cables and Connectors.....	39
17 Tube Replacement.....	39
18 Desiccator.....	40
19 Capacitors.....	40
20 Sockets and Coils.....	40
21 Miscellaneous Parts.....	40
22 Meter Protecting Fuse.....	41
23 Volume Control.....	41
24 Meter Switch.....	41

III

M574744

SECTION IV. Maintenance (Continued)

	Page
Paragraph 25 Normal Point to Point Resistance Values . . .	42
26 Plate Supply Unit PE-97-(*), Point to Point Resistance Values	48
27 Adapter M-394	50
28 Presetting, General	52
29 Presetting Procedure using I-107-(*).	56
30 Presetting Procedure using M-394	59
31 I-F and Discriminator Alignment	61
32 Neutralization	63
33 Operation Checks	64

V. Supplementary Data

34 Tabular List of Replaceable Parts	74
35 Manufacturers' Names and Addresses	128
36 RMA Color Code for Resistors and Capacitors	129

LIST OF ILLUSTRATIONS

Fig.	Page
1 Radio Receiver and Transmitter BC-620-(*), With Battery Case CS-79-(*).	1
2 Radio Receiver and Transmitter BC-620-(*), With Plate Supply Unit PE-97-(*), and Shock Mounting FT-250-(*).	2
3 Case CS-79-(*), Layout	12
4 Radio Receiver and Transmitter BC-620-(*), Rear View, Showing Antenna Terminal Connections	17
5 Plate Supply Unit PE-97-(*), Layout	18
6 Connector and Bondnut, Installation Detail	19
7 Radio Receiver and Transmitter BC-620-(*), Top View of Chassis	22
8 Vehicular Antenna Assembly	24
9 Tying Down Vehicular Antenna	25
10 Vehicular Antenna Assembly, Using Mast Bracket MP-54.	26
11 Plate Supply Unit PE-97-(*), Schematic Diagram	32
12 Radio Sets SCR-509-(*), and SCR-510-(*), Cording Diagram	36
13 Adapter M-394, Top View	50
14 Adapter M-394, Bottom View	50
15 Adapter M-394, Installed in Radio Receiver and Transmitter BC-620-(*).	51
16 Adapter M-394, Circuit Diagram	52

IV

Fig.	ILLUSTRATIONS (Continued)	Page
17	Radio Receiver and Transmitter BC-620-(*), Antenna Loading Coil Connection Detail.....	53
18	Radio Receiver and Transmitter BC-620-(*), Bottom View of Chassis.....	57
19	Pin View of Internal Battery Box Plug.....	64
20	Radio Receiver and Transmitter BC-620-(*), and Plate Supply Unit PE-97-(*), Tube Base Connections and Element Layout.....	66
21	Radio Receiver and Transmitter BC-620-(*), Vacuum Tube Specifications.....	67
22	Radio Receiver and Transmitter BC-620-(*), Channel Numbers and Crystal Frequencies.....	68
23	Radio Sets SCR-509-(*), and SCR-510-(*), Outline Dimensional Detail.....	69
24	Plate Supply Unit PE-97-(*), Parts Location Detail.....	70
25	Plate Supply Unit PE-97-(*), Voltage Diagram.....	71
26	Radio Receiver and Transmitter BC-620-(*), Tube Socket Voltage Diagram.....	72
27	Functional Diagram of Receiver of BC-620-(*).	135
28	Functional Diagram of Transmitter of BC-620-(*).	136
29A	Radio Receiver and Transmitter BC-620-(*), Schematic Diagram (Effective on Order Nos. 325-Chi.-42, 2495-Chi.-42, and on some early production sets on Order No. 6329-Phila.-43.)	137
29B	Radio Receiver and Transmitter BC-620-(*), Schematic Diagram. (Effective to Serial No. 860 on Order No. 19912-Phila.-43.)	138
29C	Radio Receiver and Transmitter BC-620-(*), Schematic Diagram. (Effective after Serial No. 860 on Order No. 19912-Phila.-43 and all sets on Order 32945-Phila.-43 and 32904-Phila.-43.)	139

SAFETY NOTICE

THERE IS NO DANGER OF AN ELECTRICAL SHOCK AT ANY POINT OF THIS SET WHEN IT IS IN OPERATION.

WHEN THE CHASSIS IS OUT OF THE CASE AND CONNECTED TO THE BATTERY, BE CAREFUL, AS HIGH VOLTAGES OF 90 AND 150 VOLTS ARE PRESENT AT MANY POINTS ON THE BOTTOM OF THE CHASSIS.

Do not remove the vibrator power pack cover, inside Plate Supply Unit PE-97-(*), (part of Radio Set SCR-510-(*),) except when the set is turned off or when the cable connector to the radio receiver and transmitter is disconnected. This removes the high voltage from exposed parts within the internal vibrator power pack.

DESTRUCTION NOTICE

- WHY** To prevent the enemy from using or salvaging this equipment for his benefit.
- WHEN** When ordered by your commander, or when you are in immediate danger of capture.
- HOW**
1. Smash—Use sledges, axes, hand-axes, pick-axes, hammers, crowbars, heavy tools, etc.
 2. Cut—Use axes, hand-axes, machete, etc.
 3. Burn—Use gasoline, kerosene, oil, flame-throwers, incendiary grenades, etc.
 4. Explosives—Use firearms, grenades, TNT, etc.
 5. Disposal—Bury in slit trenches, fox holes, other holes. Throw in streams. Scatter.
 6. **USE ANYTHING IMMEDIATELY AVAILABLE FOR DESTRUCTION OF THIS EQUIPMENT.**
- WHAT**
1. Smash—
 - a. Radio Receiver and Transmitter BC-620-(*) housing, front metering panel, tubes, tube sockets, coils and transformers.
 - b. Plate Supply Unit PE-97-(*) housing, tubes, tube sockets and transformers.
 - c. Case CS-79-(*) housing and batteries.
 2. Cut—
 - a. Cut all wiring in the units to make it impossible to be rewired.
 - b. Cut up Cord CD-509, Wire W-29, Wire W-126 and cord on handset.
 3. Bend and/or Break—
 - a. Mast Sections MS-52 and MS-53.
 - b. Antenna AN-45-(*)
 - c. Mounting FT-317-(*)
 - d. Mounting FT-250-(*)
 4. Burn—
 - a. Technical Manual TM 11-605.
 - b. All wiring in units and cords.
 5. Bury or Scatter—Any or all of the above pieces after breaking.

DESTROY EVERYTHING

SECTION I—DESCRIPTION

	Page
Par 1 General.....	1
2 Power Requirements.....	3
3 Radio Sets SCR-509-(*) and SCR-510-(*) Components.....	4
4 Description of Components.....	10

1. General.

This technical manual covers Radio Sets SCR-509-A, SCR-509-B, SCR-510-A and SCR-510-B. These sets differ from each other in certain minor circuit details and in the type and quantity of accessories. Throughout this manual where remarks are applicable to all sets, reference will be made to "the radio set". Basic components that are interchangeable with those bearing a different suffix letter are indicated by an asterisk in parenthesis (*). Where there are specific differences, as in operation, wiring or layout, each unit is described separately.



Figure 1. Radio Receiver and Transmitter BC-620-(*), With Battery Case CS-79-(*)

This Technical Manual supersedes TM-11-605 dated Aug. 12, 1942, July 14, and 1 Oct. 1943.

Radio Sets SCR-509-A, SCR-509-B, SCR-510-A and SCR-510-B contain a portable, low power, frequency modulated Radio Receiver and Transmitter BC-620-(*), for communication over a range of approximately 5 miles. The main components of the radio set are shown in Figures 1 and 2. The set may be operated from a stationary position, such as on the ground or on some other stationary support. It obtains its power from dry batteries. Radio Sets SCR-510-A and SCR-510-B may also be used in vehicular installations, obtaining power from the vehicular battery. Radio Sets SCR-510-A and SCR-510-B contain additional components necessary when used in vehic-



Figure 2. Radio Receiver and Transmitter BC-620-(*), With Plate Supply Unit PE-97-(*), and Shock Mounting FT-250-(*)

ular service. The frequency of Radio Receiver and Transmitter BC-620-(*) is crystal controlled for operation on any two of 80 different channels spaced 100 kilocycles apart, covering a range of 20.0 to 27.9 megacycles inclusive. Either of these two pre-set frequencies may be chosen by throwing the CHAN switch. The change from receiving to transmitting is made by pressing a button on the handset or microphone.

2. Power Requirements.

The power requirements for Radio Sets SCR-509-A, SCR-509-B, SCR-510-A and SCR-510-B are as follows:

a. Portable Operation.

(1) Receiving.

	<i>New Batteries</i>		<i>Old Batteries (End Point)</i>	
Rec. "A"	1.5 volts	.7 ampere	1.1 volts	.55 ampere
Rec. "B"	90 volts	25 milliamperes	66 volts	19 milliamperes

(2) Transmitting.

	<i>New Batteries</i>		<i>Old Batteries (End Point)</i>	
Rec. "A"	1.5 volts at	.7 ampere	1.1 volts at	.55 ampere
Rec. "B"	90 volts at	45 milliamperes	66 volts at	35 milliamperes
Trans. "A"	7.5 volts at	.3 ampere	5.5 volts at	.22 ampere
Trans. "B"	150 volts at	45 milliamperes	110 volts at	35 milliamperes

b. Vehicular Operation.

(1) 6.2 volts input

Receiving—2.8 amperes (Approx. 17.4 watts)

Transmitting—3.5 amperes (Approx. 21.7 watts)

(2) 12.4 volts input

Receiving—2.1 amperes (Approx. 21.0 watts)

Transmitting—2.9 amperes (Approx. 36.0 watts)

3. RADIO SETS SCR-509-(*) AND SCR-510-(*)—COMPONENTS

Signal Corps Stock Number	Quantity		ARTICLE	DIMENSIONS (Inches)					Unit Wt. (In Lbs.)
	SCR- 509-(*)	SCR- 510-(*)		Height	Width	Depth	Length	Diam- eter	
6Q349	1	1	Alignment Tool TL-150 or TL-207				5	$\frac{7}{8}$	
2A245-(*)	1	1	Antenna AN-45-(*)	(Collapsed)— (Extended)—	$17\frac{3}{16}$ $98\frac{1}{2}$	— —		$\frac{1}{2}$.63
3A39	6	2	Battery BA-39 (Transmitter)		$7\frac{1}{2}$	$6\frac{7}{16}$	$3\frac{3}{4}$		7.25
3A40	6	2	Battery BA-40 (Receiver)		$7\frac{3}{8}$	$5\frac{1}{4}$	$4\frac{1}{16}$		6.50
3A41	2	2	Battery BA-40 (For BC-620-(*))		$3\frac{1}{2}$	$2\frac{3}{8}$	$2\frac{1}{8}$.66
5C2806		*	Box TM-206 (Antenna Terminal)		$2\frac{9}{16}$	$2\frac{1}{4}$	$1\frac{1}{16}$		
	2	2	Bracket Assembly (For Power Cable)						
2Z6721-419		*	Bracket FT-419 (For FT-250-(*))		18	$1\frac{1}{2}$	$12\frac{15}{16}$		
2Z6721-420		*	Bracket FT-420 (For FT-250-(*))		18	$1\frac{1}{2}$	$11\frac{1}{16}$		
2Z6721-422		*	Bracket FT-422 (Brush Guard)		$13\frac{1}{4}$	$1\frac{1}{4}$	$1\frac{1}{4}$		
		*	Bracket (SC-A-8687)						
		*	Bracket (SC-A-8688)						
		*	Bracket FT-424 (For FT-250-(*))						
		*	Bracket (SC-A-8689)						
		*	Bracket FT-426						
		*	Bracket FT-428						

An asterisk in the column headed "Quantity" indicates that the item is issued in quantities authorized, depending upon the type of installation to be made.

3. RADIO SETS SCR-509-(*) AND SCR-510-(*)—COMPONENTS—(Continued)

Signal Corps Stock Number	Quantity		ARTICLE	DIMENSIONS (Inches)					Unit Wt. (In Lbs.)						
	SCR- 509-(*)	SCR- 510-(*)		Height	Width	Depth	Length	Diam- eter							
3B879-(*)	1		• Bracket (SC-A-7110)	4½	13¾	15¾			10.00						
2Z2651-423			• Bracket (SC-A-7111)												
2Z2654-424		1	Case CS-79-(*) (For Battery Power Supply)												
6Z3147-1		2	Clamp MC-423 (For MS-51)												
		2	Clamp MC-424 (For MS-52)												
			• Connector & Bondnut Appleton No.'s 61004 & BL-50 respectively										1¾	1¾	.25
3Z3147			• Connector & Bondnut Appleton No.'s 61007 & BL-50												
3E1307A-55			• Cord CD-307-A (65' long for HS-30-(*))												
3E1318A			• Cord CD-318-A (For Microphone T-30-(*) or T-45)											84	1.50
3E1509			• Cord CD-509 (For PE-120-(*))											96	
			• Cord CD-604 (For HS-30-(*))											10	
3E1636			• Cord CD-636 (Coaxial Antenna Lead)												
3E2218			• Cordage CO-218												
2Z3400-108			1							Cover BG-108 (For MP-48-A)	14	6½			
2Z3400-153		•	Cover BG-153 (For Radio Set)												
		2	Microphone Cover M-367 (For Microphone T-17), 1 in Use, 1 Spare												

TM 11-605

DESCRIPTION

Par. 3

3. RADIO SETS SCR-509-(*) AND SCR-510-(*)—COMPONENTS—(Continued)

Signal Corps Stock Number	Quantity		ARTICLE	DIMENSIONS (Inches)					Unit Wt. (In Lbs.)
	SCR- 509-(*)	SCR- 510-(*)		Height	Width	Depth	Length	Diam- eter	
2Z4643		2	Fitting (used with Rope RP-5), 1 in Use, 1 Spare						
2Z4648		*	Frame FM-43						
2B613-(*)	1	1	Handset TS-13-(*)	3 $\frac{1}{8}$	2 $\frac{1}{2}$		79 $\frac{1}{8}$		1.80
		*	Footman's Loop, No. 1165 1-inch, for Power Unit (North & Juad)						
		1	Hardware Kit: All screws, nuts, lockwashers, clamps, hooks, etc. in a heavy cloth bag marked "Contents: Hardware for Radio Set SCR-510-(*)"						
2B830-(*)		*	Headset HS-30						
		*	Installation Kit MC-450						
		*	Installation Kit MC-475						
			Includes: 4 Lord Shock Mounts No. 150, 1 Angle Frame $\frac{1}{8}$ " x 1" x 1"; 2 Steel Strap #11GA, 1" x 16"; 1 Tank Metal Pad 2 $\frac{1}{2}$ " x 3 $\frac{1}{2}$ " x $\frac{1}{4}$ "						
		1	Instructions, Installation, for Radio Sets SCR-509-(*) & SCR-510-(*)						

3. RADIO SETS SCR-509-(*) AND SCR-510-(*)—COMPONENTS—(CONTINUED)

Signal Corps Stock Number	Quantity		ARTICLE	DIMENSIONS (Inches)					Unit Wt. (In Lbs.)
	SCR- 509-(*)	SCR- 510-(*)		Height	Width	Depth	Length	Diam- eter	
3G586		2	Insulator (Used with Rope RP-5) 1 in Use, 1 Spare						
3G601		2	Insulator IN-86 (For Aux. Antenna)				3	1¼	
3G611		*	Insulator IN-121						
		*	Insulator IN-111						
		*	Interphone Control Box BC-606-(*) with attached hardware						
2A2088-48-A		1	Mast Base MP-48 or MP-48-A, (includes 6 ft. wire W-126)	15				3¾	11.25
2A2090-50		*	Mast Bracket MP-50	5	5¼	8			4.25
		*	Mast Base Bracket MP-60						
2A2090-54		*	Mast Base Bracket MP-54	11⅞	6	7½			6.25
2A2351		2	Mast Section MS-51, 1 in Use, 1 Spare						
2A2352		2	Mast Section MS-52, 1 in Use, 1 Spare	38½				4¼	.57
2A2353		2	Mast Section MS-53, 1 in Use, 1 Spare	38⅝				3½	.69
2B1617		1	Microphone T-17						
3B1645		1	Microphone T-30-(*) or T-45						
ZZ6721-250-(*)		*	Mounting FT-250-(*)	4½	11¼	20			11.50
ZZ6721-317-(*)		*	Mounting FT-317-(*)	20⅞	12	6⅞			12.50

TM 11-605

DESCRIPTION

Par. 3

An asterisk in the column headed "Quantity" indicates that the item is issued in quantities authorized, depending upon the type of installation to be made.

∞ 3. RADIO SETS SCR-509-(*) AND SCR-510-(*)—COMPONENTS—(Continued)

Signal Corps Stock Number	Quantity		ARTICLE	DIMENSIONS (Inches)					Unit Wt. (In Lbs.)
	SCR- 509-(*)	SCR- 510-(*)		Height	Width	Depth	Length	Diam- eter	
2Z7155		•	Plug PL-55 (Used with CO-218 and BC-606-(*))						
		•	Plug PL-68 (Used with CO-218 and BC-606-(*))						
		•	Mounting Strap ST-51 (For Power Unit)						
		•	Mounting Strap ST-52 (For Power Unit)						
2C5360-(*)	1	1	Radio Receiver and Transmitter BC-620-(*) Includes: 1 Fuse, Littelfuse #1007	6 $\frac{3}{4}$	13 $\frac{3}{16}$	14 $\frac{15}{16}$			27.20
2Z3543			80 Crystal Holders FT-243, 2 in Use, 78 Spares						
2J1LH4			2 tubes 1LH4 (VT-177), 1 in Use, 1 Spare						
2J1LC6			2 tubes 1LC6 (VT-178), 1 in Use, 1 Spare						
2J1LN5			7 tubes 1LN5 (VT-179), 4 in Use, 3 Spares						
2J1291			4 tubes 1291 (VT-128), 2 in Use, 2 Spares						
2J1294			2 tubes 1294 (VT-183), 1 in Use, 1 Spare						
2J1299			8 tubes 1299 (VT-185), 4 in Use, 4 Spares						
2Z7069-429		•	Reinforcing Plate FT-429 (For MP-50)		1 $\frac{1}{2}$	$\frac{3}{16}$	4 $\frac{1}{2}$		
2Z8056A		1	Roll BG-56-A (For Mast Sections)	45	9 $\frac{1}{4}$				1.50
		•	Support FT-418						
6C7926		15 feet	Rope RP-5						

3. RADIO SETS SCR-509-(*) AND SCR-510-(*)—COMPONENTS—(Continued)

Signal Corps Stock Number	Quantity		ARTICLE	DIMENSIONS (Inches)					Unit Wt. (In Lbs.)
	SCR- 509-(*)	SCR- 510-(*)		Height	Width	Depth	Length	Diam- eter	
2E9019A	2	2	Strap ST-19-A						
6D13038	2	2	TM 11-605, Technical Manual for Radio Sets SCR-509-(*) & SCR-510-(*)	8½	5½				
1B29	27 feet	27 feet	Wire W-29 (Auxiliary Antenna).				324		
1B-128		6 feet	Wire W-126 (issued with MP-48)						
		*	Plate (For BC-606-(*))						
3H4496-120-(*)		*†	Power Unit PE-120-(*) Includes: 2 fuses, 6 amp., -25V-3AG; 1 in Use, 1 Spare						
2Z9900.1			1 Regulator, Current, type 9-2-4 .Amperite						
2JVR9030		2	Tubes VR-90-30 (VT-184), 1 in Use, 1 Spare						
2J1005		2	Tubes QMG-159-(CK-1005) (VT-195), 1 in Use, 1 Spare						
		2	Vibrator , 1 in Use, 1 Spare VB-11 for 24-volt Vehicles VB-12 for 6-volt Vehicles VB-13 for 12-volt Vehicles						

*An asterisk in the column headed "Quantity" indicates that the item is issued in quantities authorized, depending upon the type of installation to be made.

†If Power Unit PE-120-(*) is not available Plate Supply Unit PE-97-(*), (which includes necessary tubes, and Vibrator VB-1, Capacitor CA-403-(*), Fuse FU-36, one each in use and one spare may be used.

4. Description of Components.

a. Alignment Tool TL-150.



ALIGNMENT TOOL TL-150

This is an insulated screwdriver used to make tuning adjustments when setting new channels or aligning Radio Receiver and Transmitter BC-620-(*). It is carried in CASE CS-79-(*).

b. Antenna.



ANTENNA AN-45-(*)

(1) Collapsible Antenna AN-45-(*) is provided for use with the radio receiver and transmitter when it is being operated as a portable unit. It may be quickly screwed to the antenna terminal which is located on the rear of the receiver and transmitter case. This antenna is stored in battery Case CS-79-(*). (See Figure 3.)

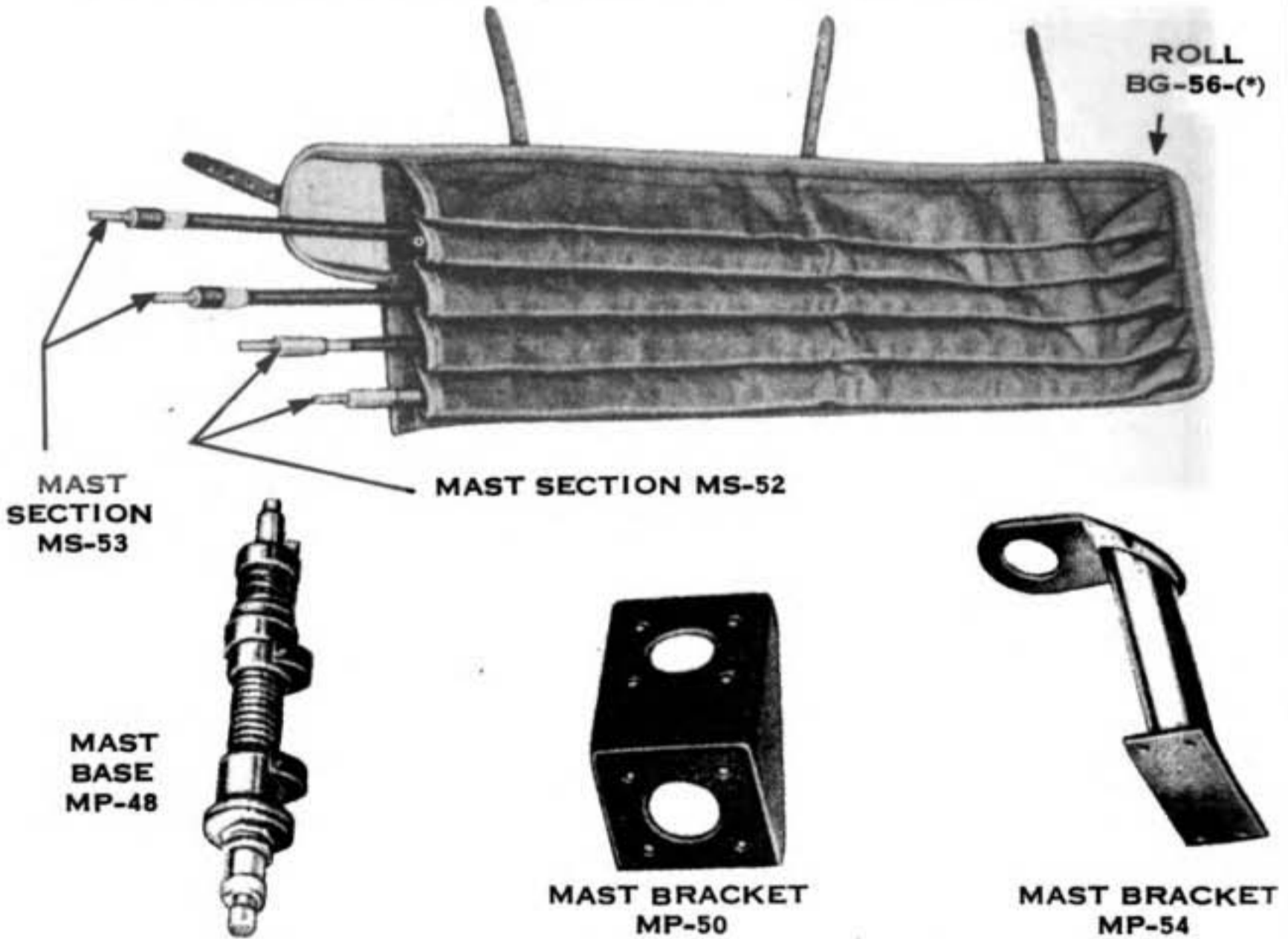

(2) For vehicular service, a sectional type mast antenna is provided. When not in service the sections are stored in Roll BG-56-(*). Mast Base MP-48-(*) is designed so that it will bend without



WIRE W-126

BAG
BG-108

breaking, and resume its upright position after the antenna hits any obstruction. Cover BG-108 is used to cover the mast base when not in use. Mast brackets are provided for mounting the base and mast to the vehicle. A wire lead-in or coaxial cable, is used to connect the antenna mast to the antenna terminal of the radio set.



WIRE W-29

(3) Where it is necessary to substitute a wire antenna for the mast, use a 27-foot length of antenna Wire W-29. Loop the uninsulated end of the wire around the antenna terminal and fasten it between the knurled nut and the square portion of the terminal. (See Figure 4.) *Be sure to remove all insulation from that portion of the wire which is to be secured under the nut.*

c. Mounting FT-250-().*

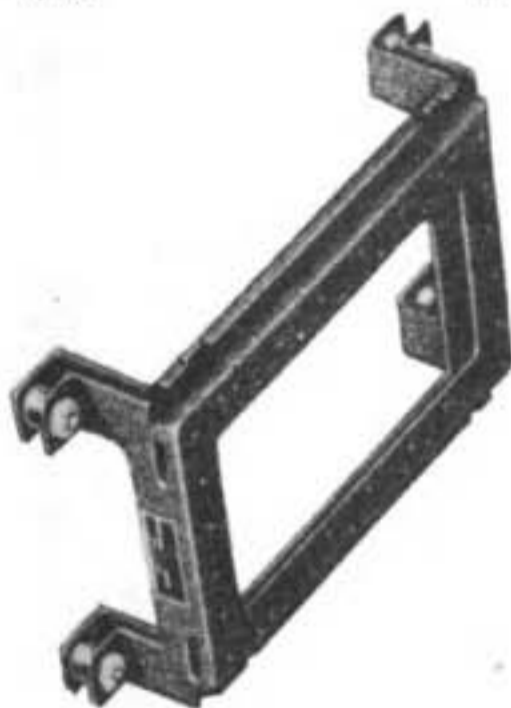

MOUNTING FT-250-(*)

The shock mounting is shown in Figure 2 with Radio Receiver and Transmitter BC-620-(*), and Plate Supply Unit PE-97-(*), in position. Holes are provided in the bottom cradle of Mounting FT-250-(*), for mounting to the vehicle with suitable screws or bolts. (Issued only with Radio Sets SCR-510-A and SCR-510-B).

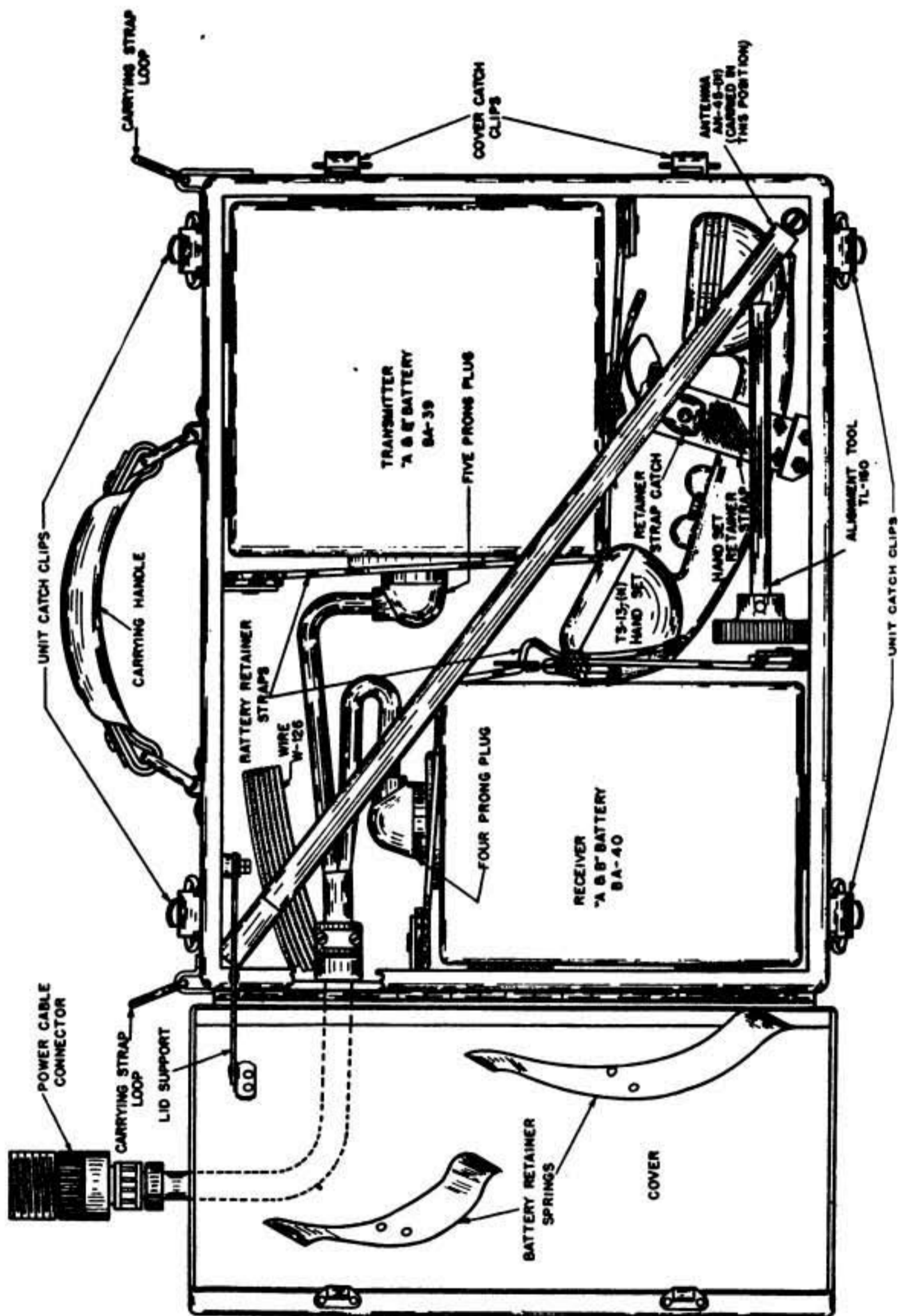

Figure 3. Case CS-79-(*), Layout

d. Case CS-79-().*

CASE CS-79-(*)

Case CS-79-(*), contains Batteries BA-39 and BA-40 that supply power for Radio Receiver and Transmitter BC-620-(*), for portable operation. The batteries are held securely in place with straps and space is provided for carrying the handset, alignment tool, antenna, and coil of insulated wire for use as an antenna. (See Figure 3.) Figure 1 illustrates Case CS-79-(*), and Radio Receiver and Transmitter BC-620-(*), fastened together with the catch clips provided.

e. Connector and Bondnut.

CONNECTOR AND BOND NUT

For vehicular installation the connector and bondnut are used to bring the "A" battery lead from Plate Supply Unit PE-97-(*), through a metal wall. See Figure 5 for installation details.

f. Cord CD-509.

CORD CD-509

An 8-foot extension cord, CD-509 is used to connect Radio Receiver and Transmitter BC-620-(*), to Plate Supply Unit PE-97-(*), when units must be mounted apart (8 feet maximum) from each other. (Issued only with Radio Sets SCR-510-A and SCR-510-B.)

g. *Mounting FT-317-(*)*.

MOUNTING FT-317-(*)

This shock mounting is used in installations that require mounting of Plate Supply Unit PE-97-(*) separately from Radio Receiver and Transmitter BC-620-(*). Holes are provided in the mounting so that it may be mounted to the vehicle with suitable screws or bolts. (Issued only with Radio Sets SCR-510-A and SCR-510-B.)

h. *Plate Supply Unit PE-97-(*)*.PLATE SUPPLY
PE-97-(*)

This is a vibrator type power supply and is designed for connection to either a 6-volt or 12-volt vehicular battery. Hooks and catch clips are provided for mounting the radio receiver and transmitter on top of, and secured to, Plate Supply Unit PE-97-(*), and the entire assembly may in turn be fastened to Shock Mounting FT-250-(*). This mounting is shown in Figure 2. This unit may also be mounted separately by using Mounting FT-317-(*). The plate

supply is contained in a case with space provided for carrying Handset TS-13-(*); a coil of insulated Wire W-126, extension Cord CD-509; and also a spare Fuse FU-38, Vibrator VB-1-(*), and electrolytic Capacitor CA-403-(*). The vibrator and capacitor are of the plug-in type for quick and easy replacement. (See Figure 5.) (Issued only with Radio Sets SCR-510-A and SCR-510-B.)

The inside cover of the power pack of Plate Supply Unit PE-97-(*), has a label which shows the correct change-over link connections that are required to adapt the unit for operation from either 6-volt or 12-volt vehicular battery. (See Figure 5.)

i. Radio Receiver and Transmitter BC-620-().*

The receiver and transmitter are on one chassis base. A channel switch is provided on the front panel of the unit to permit rapid changing to either of the two pre-set frequencies which are controlled by plug-in crystals.

Located on the front panel are the controls for turning the radio set ON or OFF, for testing battery voltages, for changing channels, for alignment check, and for regulating the radio receiver volume. Suitable jacks are located on the panel for connecting the telephone handset. (See Figures 1 and 2.)

A box for holding Battery BA-41 is mounted on the chassis near the front panel. (See Figure 7.)

Clips are provided to fasten the receiver and transmitter unit to battery Case CS-79-(*), Plate Supply Unit PE-97-(*), or Mounting FT-250-(*).

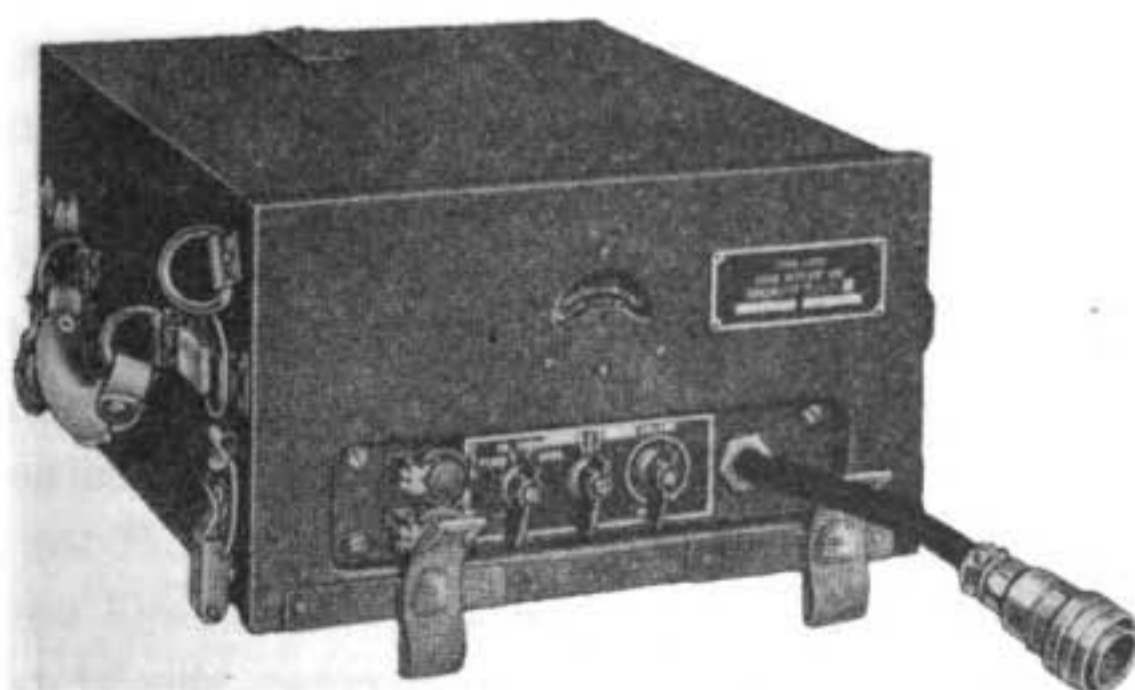

RADIO RECEIVER AND TRANSMITTER BC-620-(*)

SECTION II—INSTALLATION AND OPERATION

	Page
Par. 5 Initial Procedure.....	16
6 Installation.....	16
7 Preparation for Use.....	20
8 Operation.....	21
9 Operating Precautions.....	27

5. Initial Procedure.

Unpack the equipment carefully to prevent damage or loss of components. Also note the channels on which the receiver and transmitter are aligned. Radio Sets SCR-509-A, SCR-509-B, SCR-510-A, and SCR-510-B are aligned, and equipped with crystals for channels 10 and 55 during manufacture.

6. Installation.

Radio Sets SCR-509-A, SCR-509-B, SCR-510-A and SCR-510-B are shipped with all tubes in place but without batteries.

a. Radio Receiver and Transmitter BC-620-().*

To remove the receiver and transmitter chassis from the case, first remove the ten screws on the outer edge of the front panel. Pull forward on the panel, which is attached to the chassis. Remove the cover of the battery box located on the chassis near the front panel. (See Figure 7.)

Place Battery BA-41 in the box, being careful to engage the plug into the socket of the battery. Replace the cover. Check to see that all tubes are seated firmly in their sockets. **CAUTION: DO NOT INTERCHANGE CRYSTALS; DOING SO REQUIRES REALIGNMENT OF THE EQUIPMENT FOR NETTED COMMUNICATION.** Make sure that the two toggle switches SW₁₀ and SW₁₁ located near the left edge of the chassis are turned to ON. Slide the chassis back into position, making sure that the gasket is properly seated. Replace the ten screws, being careful not to cross the threads, and tighten securely. (All screws should be started before any one is tightened.)

Radio Receiver and Transmitter BC-620-F is fastened to its case by means of two catch clips, one on each side of front panel.

b. Portable.

Open battery case CS-79-(*) and install Batteries BA-39 and BA-40. (See Figure 3.) Tighten the webbed straps to hold the batteries securely. Place one telephone Handset TS-13-(*), Antenna AN-45-(*), and Alignment Tool TL-150 in position. (See Figure 3.) Also put in the coil of Wire W-29. Close the case and fasten the catch clips. The unit is now ready for service.

RADIO RECEIVER AND TRANSMITTER BC-620-(*)
REAR VIEW, SHOWING COLLAPSIBLE TELESCOPIC
ANTENNA AN-45-(*) IN POSITION.

RADIO RECEIVER AND TRANSMITTER BC-620-(*)
REAR VIEW, SHOWING HOW WIRE IS USED AS
ANTENNA OR CONNECTOR FOR EXTERNAL ANTENNA

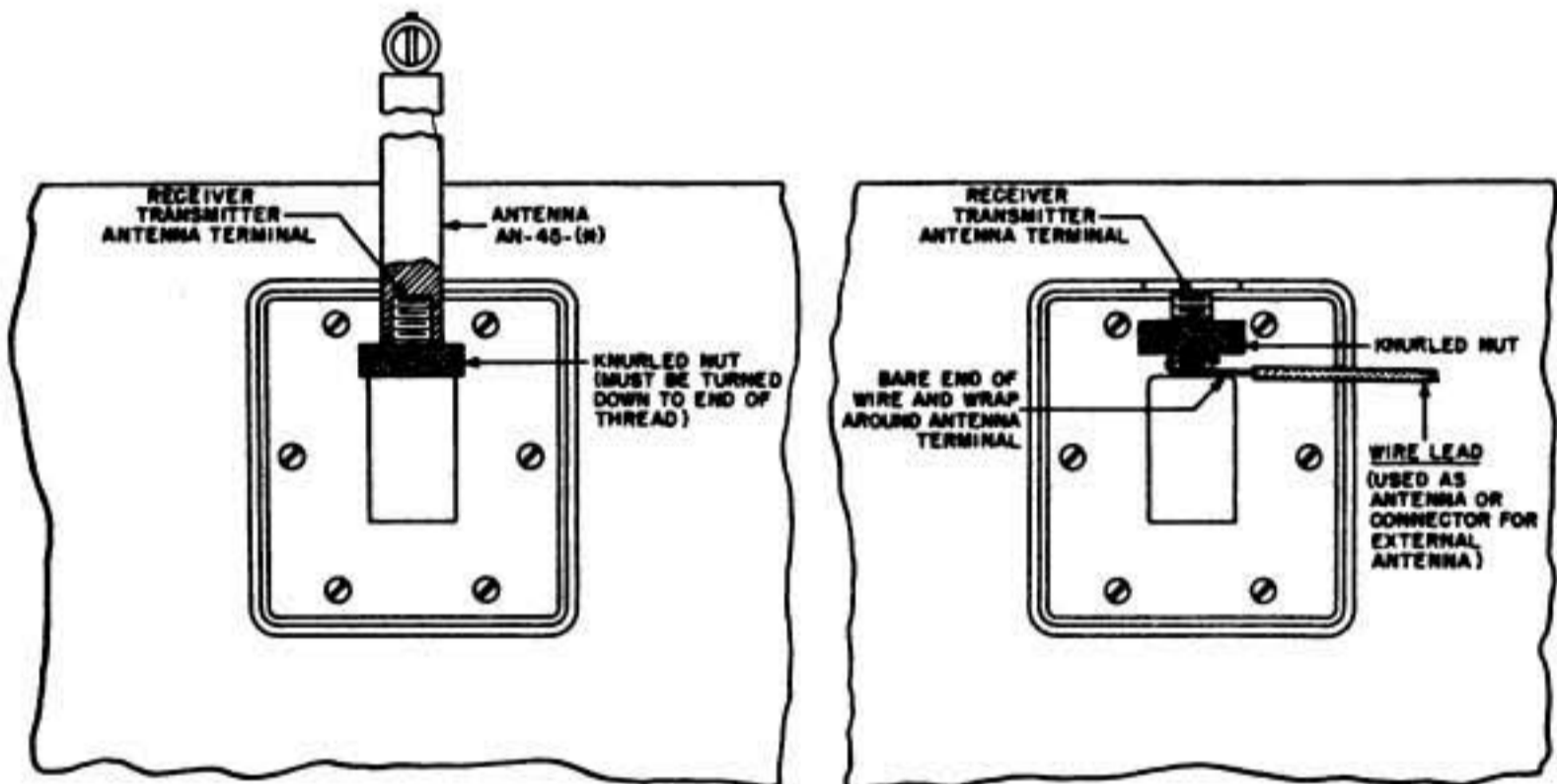

Figure 4. Radio Receiver and Transmitter BC-620-(*), Rear View, Showing Antenna Terminal Connections

c. Vehicular. (Radio Sets SCR-510-A and SCR-510-B.)

(1) Open Plate Supply Unit PE-97-(*), unscrew the six knurled nuts and remove the power pack cover. Figure 5 shows an interior view of the case. Check to see that Vibrator VB-1-(*), rectifier Tube VT-195, voltage regulator Tube VT-184, electrolytic Capacitor CA-403-(*), and Fuse FU-38, are properly installed in their respective receptacles. Also make sure that spare Vibrator VB-1-(*), electrolytic Capacitor CA-403-(*), and Fuse FU-38, are, likewise, in their respective clips.

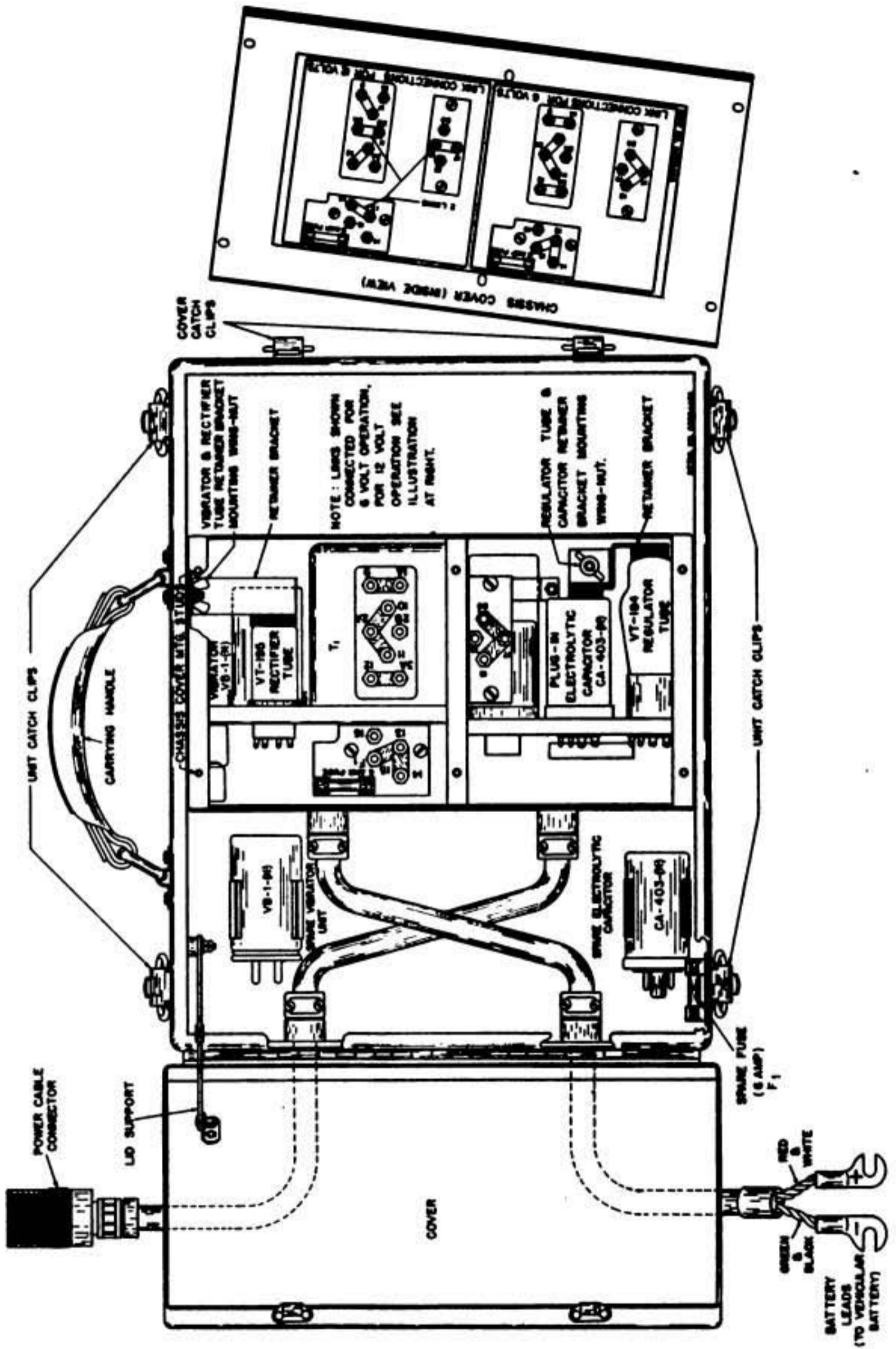

Figure 5. Plate Supply Unit PE-97-(*), Layout

IMPORTANT

MAKE SURE THAT THE VOLTAGE CHANGE-OVER LINKS ARE SET FOR THE VOLTAGE OF THE VEHICULAR BATTERY. If a 12-volt vehicular battery is used with a power unit with links set for 6-volts, damage is sure to result. The correct position is shown on the label on the power pack cover. Place Handset TS-13-(*) in one of the storage compartments of Plate Supply Unit PE-97-(*), located at each end of the case as shown in Figure 5.

(2) If possible install mounting FT-250-(*) so that an antenna lead-in 2 feet (\pm 1 in.) long may be used. Longer runs will require the use of Coaxial Cable CD-636 and Terminal Box TM-206. In selecting this location, allow sufficient space to mount Radio Receiver and Transmitter BC-620-(*) on top of Plate Supply Unit PE-97-(*). (See Figure 2.) If this cannot be done, Cord CD-509, supplied for the purpose, can be used to connect the power unit to the radio receiver and transmitter. When Plate Supply Unit PE-97-(*) is mounted separately from the receiver-transmitter unit, use Mounting FT-317-(*). Installation of Mounting FT-317-(*) will depend on the vehicle, therefore no specific instructions are given here.

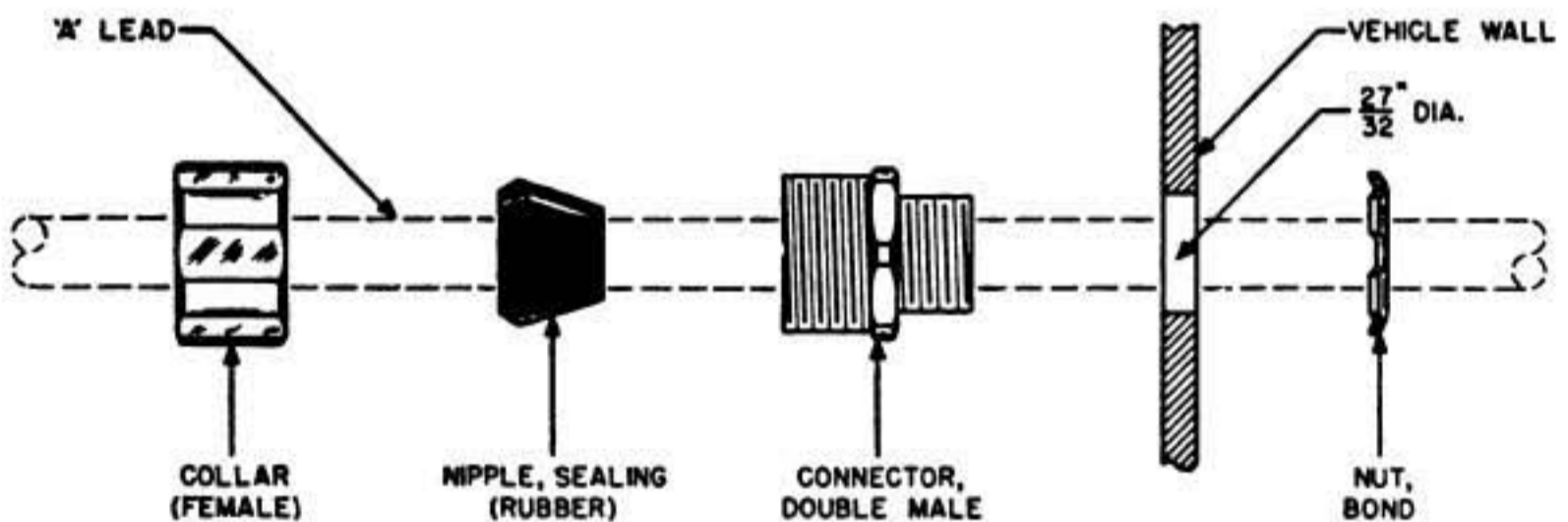

Figure 6. Connector and Bondnut, Installation Detail

(3) Radio Receiver and Transmitter BC-620-(*) should be mounted horizontally when the set is installed in $\frac{1}{4}$ -ton 4x4 truck. It may be mounted either horizontally or vertically in larger vehicles. If mounted vertically, only Radio Receiver and Transmitter BC-620-(*) can be installed in Mounting FT-250-(*). That is, Case CS-79-(*) or Plate Supply Unit PE-97-(*) should not be carried with the receiver and transmitter vertical. Select positions for the mast base, as well as for the shock mounting, before either of the two units is mounted in position. After the shock mounting is fastened

place Plate Supply Unit PE-97-(*), and Radio Receiver and Transmitter BC-620-(*) in position and fasten the catch clips. Connect the power cable plug of the radio receiver and transmitter to the corresponding receptacle of Plate Supply Unit PE-97-(*), making sure they are matched properly and screwed together securely. Connect the "A" battery leads to the vehicular storage battery. The terminals on the ends of this cable are marked (+) and (-). Be sure that the (+) terminal is connected to the positive side of the battery and the (-) terminal to the negative side of the battery. Route the cable so that it is out of the way and protected as much as possible. If it is necessary to pass cable through a wall, use the connector and bondnut. (See Figure 6.)

(4) Unpack the mast bracket and mount it on the vehicle, using suitable bolts or screws. Mount it in the position that is best suited to the limitations of the vehicle and to the mounting space requirements for the radio set. As indicated in Paragraph 6c(2), it is better to place it close enough to Mounting FT-250-(*) so that the length of the antenna connecting lead can be a 2-foot (\pm 1 in.) length of wire.

(5) Assemble Mast Base MP-48 to the mast base bracket. Connect the antenna terminal of the receiver and transmitter to the top terminal of the mast base. Use Wire W-126 (or W-128) 24 inches (\pm 1 in.) long, routed through the guides of the mast base. (See Figures 4, 8, and 10.) Be sure to remove the inner connector of MP-48 when using a wire lead-in, otherwise the range of the set will be reduced about 50 percent. In those installations where you need a lead-in longer than 24 inches (\pm 1 in.) *you must use Coaxial Cable CD-636 and Terminal Box TM-206.* Place mast base Cover BG-108 over the complete assembly.

7. Preparation for Use.

In preparing to operate Radio Sets SCR-509-A, SCR-510-A and SCR-510-B, be careful to select a suitable site for communication. Objects close to the antenna will absorb some of the radiated energy and reduce the range of communication. Any objects touching the antenna will seriously impair performance.

a. Make sure the antenna connections are clean and tight. Where insulated wire is used, strip off the insulation to assure good electrical contact to the antenna post or terminal. When using the collapsible antenna be sure it is extended fully.

b. In joining the power cable connectors, see that the key and keyway are together. Do not force the connectors together in any other position. Screw the ring clamp down securely to prevent disconnection during operation. See that the plugs make firm and positive connection to the batteries.

c. For vehicular operation, be sure the "A" battery cable connections to the vehicular battery are of correct polarity, and that the change-over links in the plate supply are all in the proper positions for the voltage of the vehicular battery in use.

d. Be sure that all batteries are of sufficient voltage to operate the radio set. (See Paragraph 2 and paragraph 9*d* (1).)

e. Keep the handset plug, jack contacts, and the battery plug prongs clean. Dirt or corrosion on these contacts may cause erratic operation.

8. Operation.

a. Portable.

(1) Place battery Case CS-79-(*) on the ground or other support. Open the case and remove Handset TS-13-(*), and Antenna AN-45-(*). See that the battery plugs are properly inserted into the batteries. Close the case cover and latch it. Place the radio receiver and transmitter on Case CS-79-(*) and fasten the two units together with catch clips. Join the cable connectors of the two units, placing the key in the keyway, and screw the fittings together securely. Extend Antenna AN-45-(*) to its full length and screw it to the antenna terminal on the rear of the radio receiver and transmitter case, first tightening down the knurled nut securely. (See Figure 4.) Insert the Handset TS-13-(*) plugs into the proper jacks on the radio receiver and transmitter panel. The set is now ready to operate.

(2) Turn the switch and volume control knob full ON (to the right.) Turn the meter switch to OPER. Turn the channel selector knob to the channel on which communication is to be made. Listen for the station with which communication is desired. Regulate volume to the desired level. To transmit, press the switch on the handset and speak clearly into the microphone. Release the switch when transmission is completed. To turn the radio set off, turn volume control knob to OFF, (to the left).

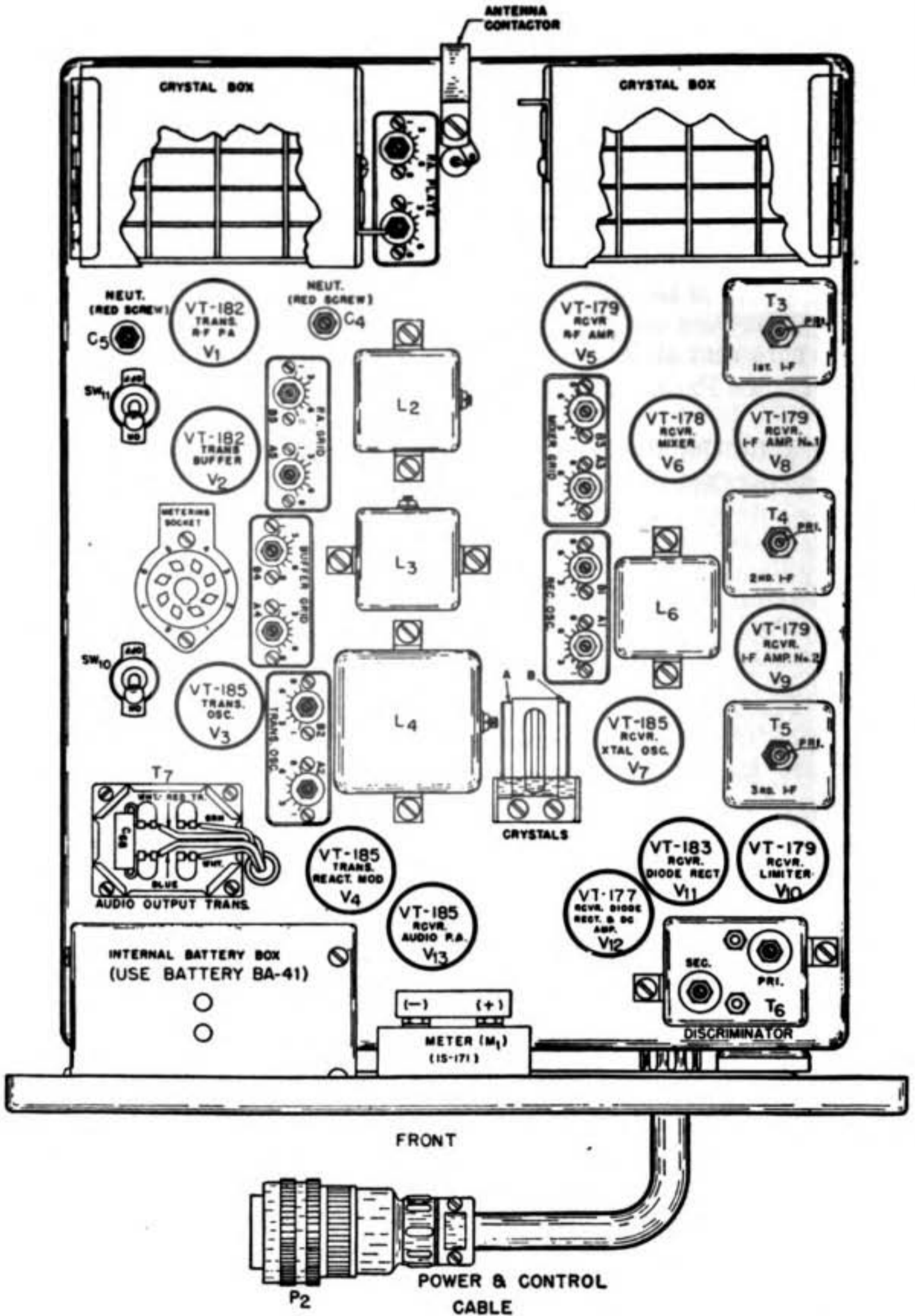

Figure 7. Radio Receiver and Transmitter BC-620-(*), Top View of Chassis

NOTE: The VOL knob controls only the receiver volume and has no effect on the output power of the transmitter.

b. Vehicular.

For vehicular operation of Radio Sets SCR-510-A and SCR-510-B:

(1) Remove Handset TS-13-(*) from Plate Supply Unit PE-97-(*) .

(2) Place the radio receiver and transmitter on the plate supply unit and fasten them with the catch clips to each other and to the mounting.

(3) Join the power and control cable connectors and screw them together securely.

(4) Check that the antenna wire lead-in (or coaxial cable) is properly connected.

(5) Plug Handset TS-13-(*) into the panel jacks.

(6) Remove Mast Sections MS-52 and MS-53 from Roll BG-56-(*) and assemble. Screw them together tightly, using a pair of gas pliers.

(7) In installations using coaxial cable, Mast Section MS-51 is added to MS-52 and MS-53. *Always use three mast sections when antenna of SCR-510-(*) is fed by a coaxial cable.*

(8) Wind several turns of friction tape, in a counter-clockwise direction, (to the left), tightly around junction of mast sections, to prevent unscrewing of mast sections under severe vibrating conditions. Use Clamps MC-423 and MC-424, if you have them, instead of tape.

(9) Remove Cover BG-108 and the protecting cap screw from the mast base, and screw in the assembled mast sections.

(10) The radio set is now ready to operate and the rest of the procedure is as described in Paragraph 8 *a* (2).

(11) *Tying Down the Antenna.*

It may be necessary, to attract as little attention as possible to your vehicle, or to avoid overhead obstructions when in motion, to

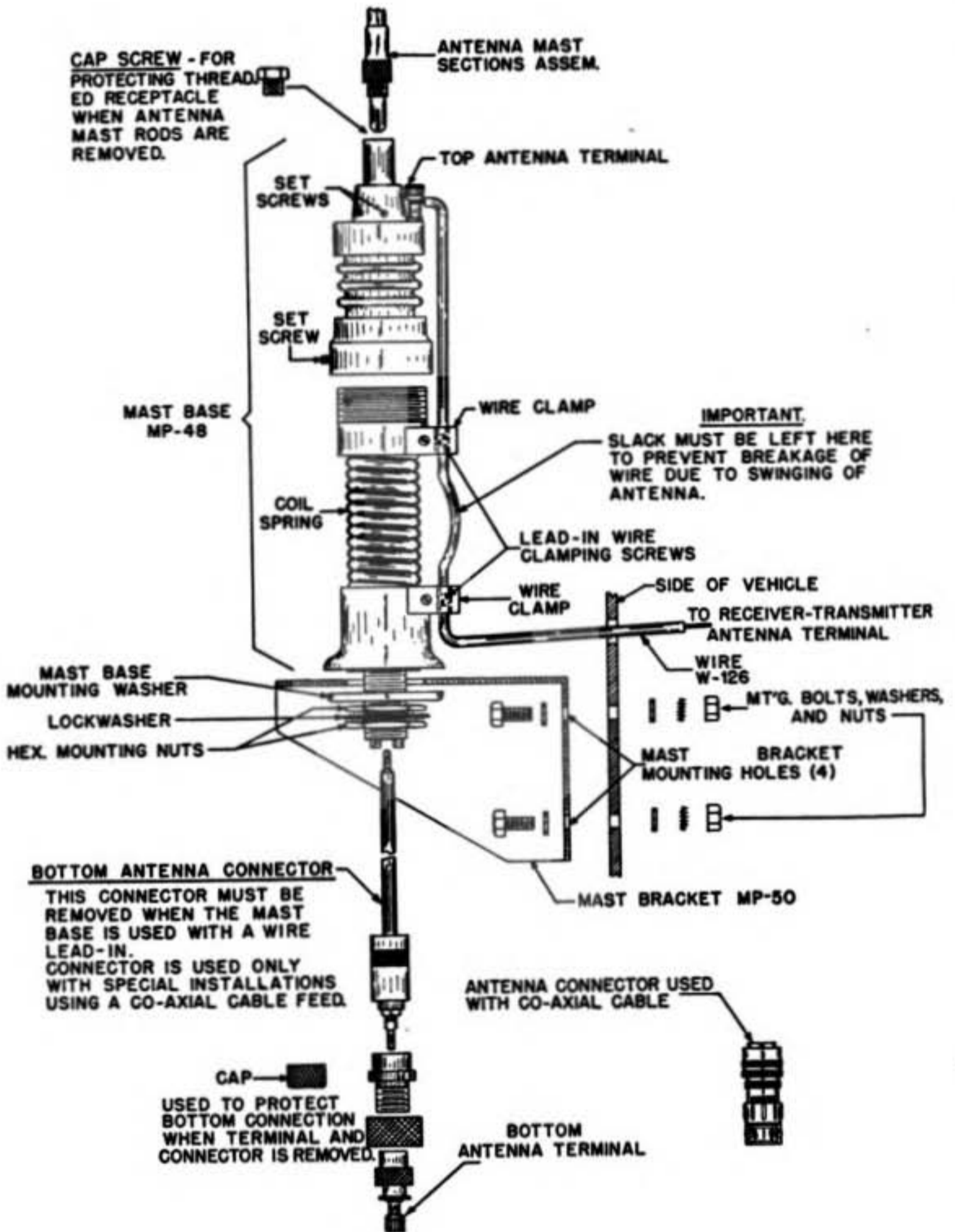

Figure 8. Vehicular Antenna Assembly

tie down the antenna. A metal fitting, a ceramic (porcelain) insulator, and at least 15 feet of Rope RP-5 are issued for use as the tie-down assembly. Proceed as follows:

(a) Cut $1\frac{1}{2}$ feet of rope from the 15-foot length. Tie one end securely through the $\frac{3}{8}$ -inch hole of the metal fitting and the other through one hole of the porcelain insulator. Attach the remaining rope through the other hole of the insulator and tie it securely.

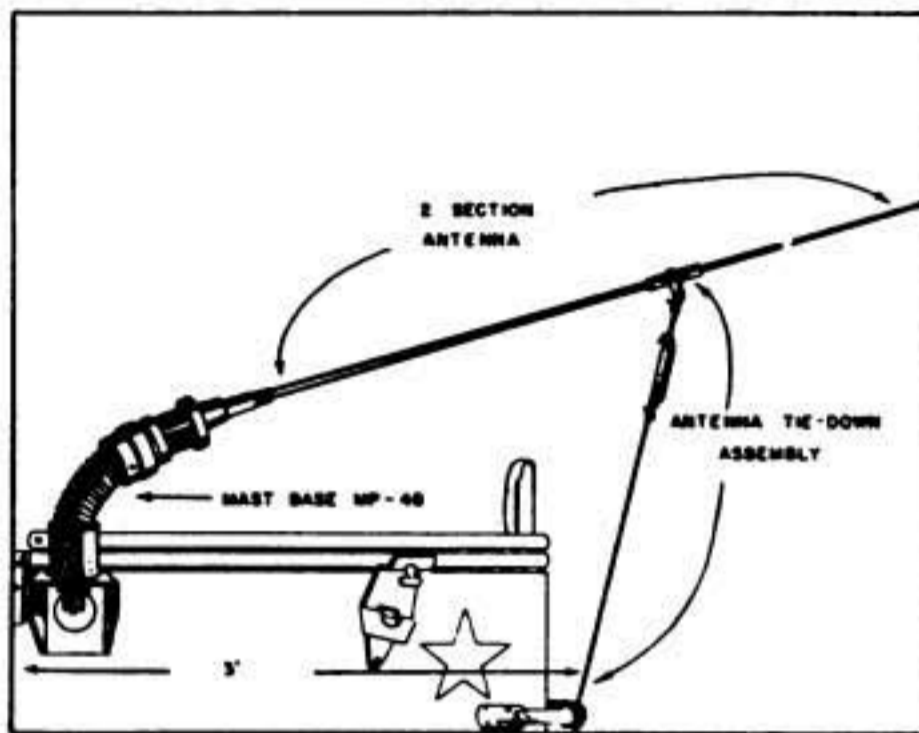

Figure 9. Tying Down Vehicular Antenna

(b) Slip the lower end (the threaded portion of the plug end) of Mast Section MS-52 through the $\frac{1}{2}$ -inch hole of the metal fitting and screw the mast section back into the top of the lower Mast Section MS-53. Pull the antenna down, by means of the rope, until it is nearly horizontal. Fasten the rope with a secure knot to a convenient point on the vehicle, approximately three feet from the mast base bracket.

(c) **CAUTION:** Remember that the frequencies used for FM transmission act very much like light. A good rule to remember is that FM signals cannot be relied upon to travel any farther than the distance you can see on a clear day *from the spot where you are operating*. This distance on flat terrain is usually to the horizon. Therefore select a site on top of a rise in ground. The higher the better. *Your signals will be louder and you'll send further when your antenna is vertical. So keep it that way, unless you want to reduce visibility of your vehicle. When your Antenna is tied down horizontally, remember you won't be able to send so far.* Keep this in mind. Don't expect your normal range. Plan accordingly.

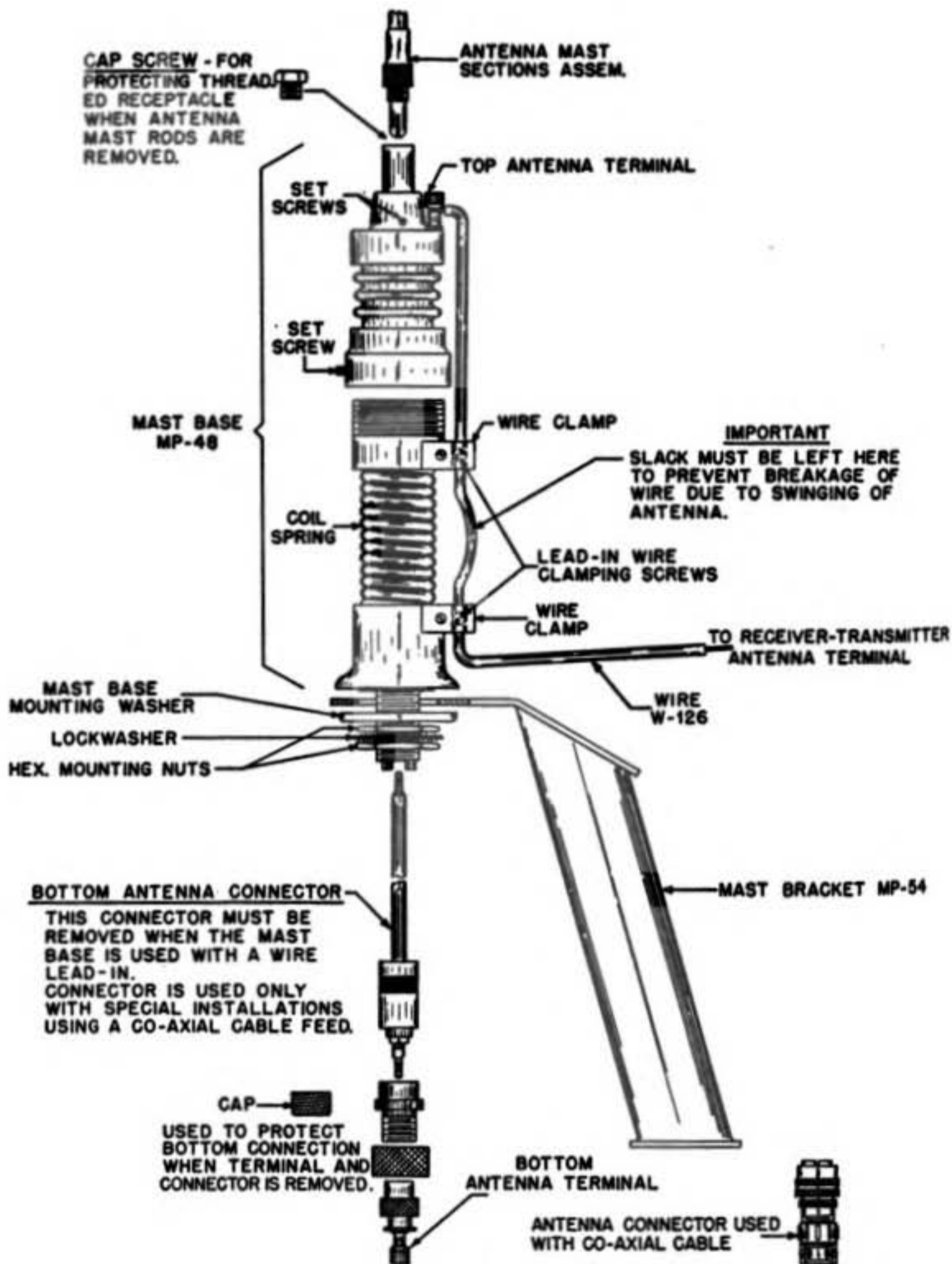

Figure 10. Vehicular Antenna Assembly, Using Mast Bracket MP-54

9. Operating Precautions.

a. Always turn the VOLUME control *on* far enough to the right to assure hearing the other station; turn it all the way *on* and when that station is heard, reduce the volume to the desired level. When communication is completed, turn the VOLUME knob to the left to OFF; a click will be heard when the switch is thrown. Do not leave the switch ON when the receiver is not in use. This causes unnecessary drain on the batteries.

b. Make sure the CHAN switch is turned to the correct channel, and is not set between stops.

c. With the meter switch at OPER, and the push-to-talk switch pressed, read the panel meter. This should read from 1.8 to 3.0 if the transmitter is functioning properly.

THESE PLACES ARE BAD FOR RADIO



VALLEYS

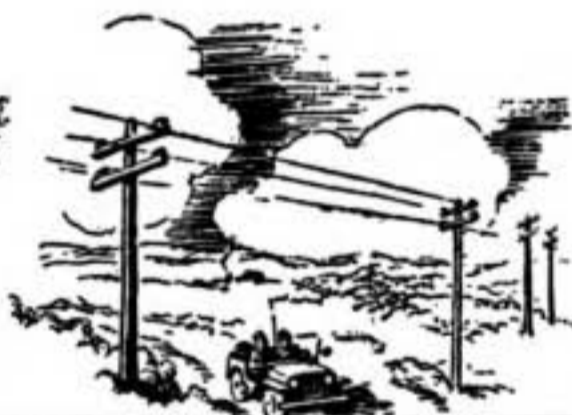

HIGH TENSION LINES

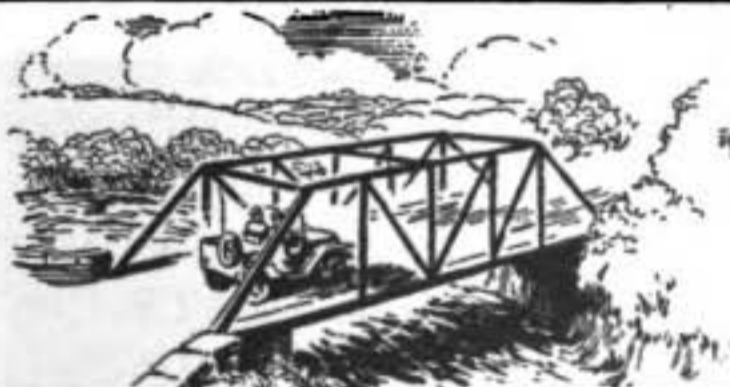

OVERHEAD STEEL BRIDGES



UNDERPASSES

But **THESE ARE GOOD**



GOOD

ON LEVEL GROUND



BETTER

SLIGHT RISE



BEST

BIG HILL

d. Check the condition of the batteries occasionally as follows:

(1) *Dry Battery Operation.*

Turn the meter control switch to PLATE, press the push-to-talk switch, and read the panel meter. A reading of less than 2 indicates a weak Battery BA-39. Turn the switch to FIL, and read the meter. Less than 2 shows a weak Battery BA-40. If voltages are low, install fresh Batteries BA-39 and BA-40, in Case CS-79-(*). The drain on internal Battery BA-41 is very low and its life approximates normal shelf life. Replace it about every 8 months. If the set is not being used for 24 hours or more, remove the plugs from Batteries BA-39 and BA-40. If the set is to be shipped or stored for 30 days or more, remove all dry batteries including internal Battery BA-41.

(2) *Vehicular Battery Operation, Radio Sets SCR-510-A and SCR-510-B.*

Turn the meter control switch to PLATE, press the push-to-talk switch, and read the panel meter. If it reads less than 2 (the luminous spot), it indicates a weak storage battery, or trouble in Plate Supply Unit PE-97-(*). Zero plate voltage may mean either a defective fuse, electrolytic Capacitor CA-403-(*), or Vibrator VB-1-(*). A spare of each of these is carried in the case of Plate Supply Unit PE-97-(*). To replace any of these, refer to Figure 5. Remove the cover of the vibrator pack to replace any of the above three parts. Replace the spare parts removed from the unit with new spares at the first opportunity. Turn the switch to FIL and read the meter. It should not be less than 2 (the luminous spot). A lower reading indicates low storage battery voltage, or failure of the vehicular battery.

SECTION III—FUNCTIONING OF PARTS

	Page
Par. 10 Receiver.....	28
11 Transmitter.....	30
12 Plate Supply Unit PE-97-(*).	33
13 Case CS-79-(*).	34

10. Receiver.

a. The receiver is a superheterodyne type with a crystal controlled oscillator, and designed for reception of frequency modulated signals. In addition to its normal function, the receiver provides automatic frequency control of the transmitter.

When used as a receiver, Radio Receiver and Transmitter BC-620-(*) uses the following tubes:

An r-f amplifier stage using Tube VT-179 (V_5).

A Pierce oscillator using Tube VT-185 (V_7).

A mixer stage using Tube VT-185 (V_6).

A two stage i-f amplifier using two Tubes VT-179 (V_8 and V_9).

A limiter stage using Tube VT-179 (V_{10}).

A discriminator circuit using Tube VT-183 (V_{11}), and the diode section of Tube VT-177 (V_{12}).

A d-c amplifier stage using Tube VT-185 (V_{12}).

An audio power amplifier stage using Tube VT-185 (V_{13}).
(See Figure 27.)

Two additional tubes are contained in Plate Supply Unit PE-97-(*), a voltage regulator, Tube VT-184, and a rectifier, Tube VT-195.

(1) When receiving, the signal is picked up by the antenna, and coupled to the control grid of the r-f amplifier, Tube VT-179 (V_5), from the power amplifier plate tank circuit through coupling capacitor C_{35} . In the r-f amplifier Tube VT-179 (V_5), the signal is amplified and coupled to the signal grid of the mixer, Tube VT-178 (V_6), through capacitor C_{36} . The third harmonic of the crystal oscillator is fed to the injector grid of the mixer tube. The set is so designed that the injected voltage on the mixer tube is always below the signal frequency of the receiver and is the third harmonic of the crystal fundamental. This crystal frequency can be calculated by subtracting the intermediate frequency from the signal frequency, and dividing the result by three.

(2) The oscillator, Tube VT-185 (V_7), and associated circuit components are shown in Figure 27.

(3) The output of the mixer Tube VT-178 (V_6), is an intermediate frequency equal to the signal frequency minus the third harmonic of the oscillator. This i-f signal is amplified by a two stage i-f amplifier composed of Tubes VT-179 (V_8) and VT-179 (V_9), and the i-f transformers T_3 , T_4 and T_5 . The output of the i-f stages is

coupled to the control grid of the limiter Tube VT-179 (V_{10}), through transformer T_5 . The grid voltage developed by a signal through this tube can be measured at pin number 3 of the metering socket, SO_1 . The limiter tube eliminates variations in the amplitude of the impressed signal. The output of the limiter tube practically at a constant level and with noise peaks reduced, is coupled to the discriminator circuit, through transformer T_6 . This includes the discriminator transformer T_6 , the diode, Tube VT-183 (V_{11}), the diode elements of Tube VT-177 (V_{12}), and associated resistor network.

(4) The diode rectifiers and the transformers T_6 are arranged in push-pull, and the output depends on the frequency of the i-f signal. If this signal is at 2880 kc, which is the nominal i-f of the receiver, the output voltages of the two diodes cancel, and no voltage appears between the cathode of Tube VT-183 (V_{11}) and ground. Should the frequency change, however, a voltage is developed between the cathode of Tube VT-183 (V_{11}) and ground, being positive when the frequency of the signal is lower, and negative when the frequency is higher, within the limits of the circuit. This voltage can be measured at pin No. 7 of the metering socket (SO_1).

(5) When a frequency-modulated signal is received, the voltage output of the diodes will vary as the frequency varies on both sides of nominal, and an audio signal is produced. This signal is amplified by the audio power amplifier Tube VT-185 (V_{13}) and coupled through the output transformer T_7 to the headphone jack J_2 , into which phones or handset can be connected.

(6) This discriminator voltage is also impressed on the grid of the d-c amplifier tube, which is the triode section of Tube VT-177 (V_{12}). The amplified voltage output of this tube is fed to the transmitter reactance modulator grid as is explained under Transmitter.

11. Transmitter.

a. The transmitter is designed for transmission of frequency modulated signals. When transmitting, Radio Receiver and Transmitter BC-620-(*) uses the following tubes:

A reactance modulator stage using Tube VT-185 (V_4).

An oscillator stage using Tube VT-185 (V_3).

A buffer stage using Tube VT-182 (V_2).

An r-f power amplifier stage using Tube VT-182 (V_1).

All tubes with the exception of Power Amplifier Tube VT-185 (V_{13}) in the receiver function with the d-c amplifier to stabilize the transmitter oscillator.

(1) The oscillator is designed for high frequency stability over a wide range of temperature. The oscillator frequency is determined by the Coil L_4 , Capacitor C_{22} , Capacitor C_{20} (or C_{21}) and the reactance modulator.

(2) The reactance modulator Tube VT-185 (V_4) affects the oscillator frequency by bringing about an increase or decrease in the grid bias of the modulator tube, (which is the sum of the voltage output of the receiver d-c amplifier and the audio voltage from the secondary of the microphone transformer (T_2),) making an effective change in the capacity of the oscillator tank circuit and thus a change in the transmitter frequency. An increase in bias brings about a higher transmitter frequency, and a decrease in bias produces a lower frequency.

A portion of the transmitter signal is fed into the receiver and since the receiver is crystal controlled, the transmitter frequency is corrected for any frequency change that appears at the receiver input, as long as the transmitter frequency remains within the range of control of the discriminator and d-c amplifier. Therefore, a bias produced by the d-c amplifier tends to hold the transmitter frequency constant and the bias voltage from the microphone through microphone transformer T_2 modulates the oscillator frequency of the transmitter at the voice frequency.

(3) The oscillator is of the type commonly known as an electron-coupled oscillator. Its plate circuit has high harmonic content. By coupling its plate output through capacitor C_{16} to the tuned circuit, (coil L_3 , capacitors C_{14} , C_{15} , and C_{12} (or C_{13}), tuned to the second harmonic of the oscillator fundamental frequency), enough voltage will be developed across the coil L_3 to excite the grids of the buffer-doubler tube V_2 (VT-182). This tube (V_2) is connected so that the grids are in push-pull, and the plates are in parallel, enabling it to function as a high efficiency doubler. The output of this doubler is coupled through capacitor C_{10} to the tuned circuit coil L_2 , capacitors C_8 and C_6 (or C_7). This circuit is tuned

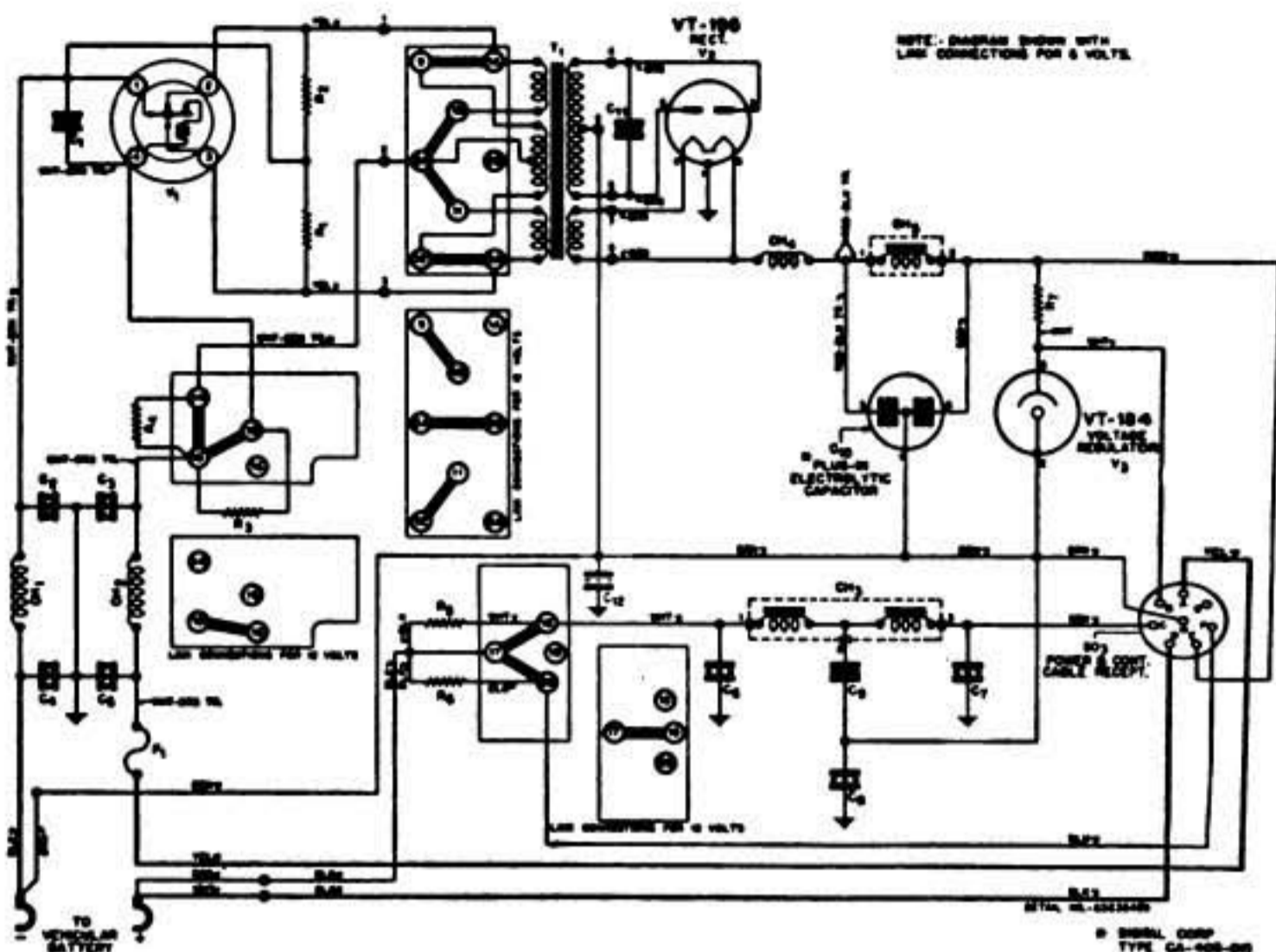

Figure 11A. Plate Supply Unit PE-97-(*) Schematic Diagram (Effective to Serial No. 675 on Order No. 19912-Phila.-43)

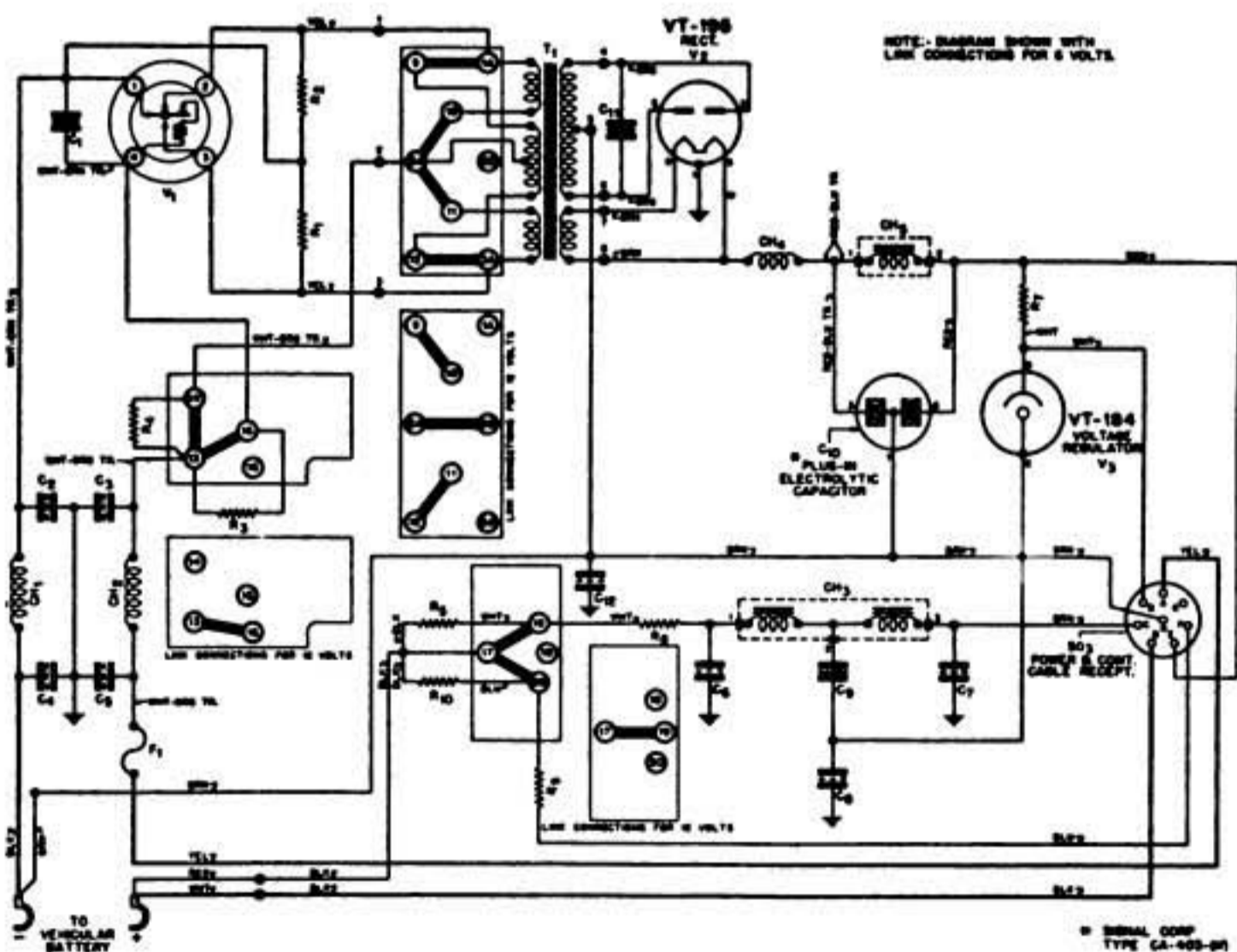

Figure 11B, Plate Supply Unit PE-97-(*) Schematic Diagram (Effective after Serial No. 675 on Order No. 19912-Phila.-43 and on all units on Order Nos. 32945-Phila.-43 and 32904-Phila.-43)

to twice the buffer-doubler input frequency (four times the oscillator frequency). The voltage developed across coil L_2 excites the grids of the power amplifier tube V_1 (VT-182) which is connected in a conventional neutralized push-pull circuit. The tuned plate circuit consists of the primary of T_1 and capacitor C_2 (or C_3), and is tuned to the same frequency as the grid circuit (four times oscillator frequency).

The antenna circuit consists of the tapped coil L_1 and the secondary of T_1 which is inductively coupled to the primary.

12. Plate Supply Unit PE-97-(*)

Plate Supply Unit PE-97-(*) is used to supply Radio Receiver and Transmitter BC-620-(*) with the correct operating voltage from a 6-volt or 12-volt vehicular battery. The schematic wiring diagram of Plate Supply Unit PE-97-(*) is shown in Figure 11.

a. The battery supply leads are about ten feet long. (See Figure 5.) Low voltage power to the vibrator transformer is controlled by switch SW_{12} and SW_{13} on back of the volume control in Radio Receiver and Transmitter BC-620-(*). The vibrator circuit is fused by Fuse F_1 . The positive and negative leads to the vibrator transformer are filtered with chokes CH_1 , CH_2 , and fixed capacitors C_2 , C_3 , C_4 and C_5 , to prevent hash from the vibrator plate rectifier units getting back into the vehicular battery leads.

b. Vibrator V_1 alternately applies the vehicular battery voltage to first one side and then the other of the primary of the vibrator transformer T_1 . The a-c voltage on the secondary of the vibrator transformer T_1 is applied to the rectifier, Tube VT-195. The secondary winding 7-8 applies a-c voltage to the filament 6-8 of the rectifier, Tube VT-195. The high voltage from the secondary 4-6 of the Transformer T_1 is applied to the rectifier plates 3 and 5. Paper capacitor C_{11} is a buffer capacitor which prevents radio frequency voltages from being generated in the rectifier tube, and at the same time tunes the secondary of the transformer T_1 to the correct operating frequency. This operating frequency, at which vibrator V_1 applies potential to the primary windings of T_1 , is determined by the mechanical resonance of the reed in the vibrator unit. The vibrator is actuated by a coil which has its own independent contact on the vibrating reed, as indicated in the schematic diagram. (See Figure 11.)

c. The d-c output of the rectifier, Tube VT-195 is applied through an r-f choke CH₄ to the "B" filter choke CH₅. The electrolytic filter capacitor C₁₀ contains two electrolytic capacitor units, which are connected to both sides of the "B" filter choke CH₅. The filtered d-c high voltage output from Plate Supply Unit PE-97-(*) appears at terminal No. 2 of choke CH₅ and is carried by the red wire to pin E of the power supply cable connector SO₃.

d. The receiver "B" voltage regulator, Tube VT-184, is contained in Plate Supply Unit PE-97-(*), and regulates the d-c voltage appearing at pin 5 of this tube. It is regulated to approximately 90 volts, and is carried to terminal B of Plate Supply Unit PE-97-(*) cable connector SO₃ by the white wire.

e. The receiver filament supply for Radio Receiver and Transmitter BC-620-(*) is obtained from Plate Supply Unit PE-97-(*) through the green wire connecting to terminal C of the plate supply unit cable connector SO₃. The hash and hum voltages that may occur across the vehicular battery terminals is filtered through filter chokes shown as CH₃. Hash capacitors are shown as C₆ and C₇, across choke CH₃. The hum filter capacitor is C₉. This is an electrolytic capacitor of approximately 1000 μ f. The connecting links across R₅ and R₆ are used to change from 6-volt to 12-volt vehicular batteries.

NOTE: After Serial No. 675 on order No. 19912-Phila.-43 and all units on orders Nos. 32945-Phila.-43 and 32904-Phila.-43, R₆ is replaced by R₁₀, and R₈ and R₉ are added.

f. The voltage change-over links, for changing the power transformer connections, are across the terminal posts indicated at the primary winding of the vibrator transformer (T₁) and across resistors R₃ and R₄. The positions shown for the connecting link are for 6-volt vehicular battery operation. These links are shifted for 12-volt operation as indicated by the insert diagrams in Figure 11, and also underneath the lid of the vibrator power pack inside of Plate Supply Unit PE-97-(*).

13. Case CS-79-(*).

Battery Case CS-79-(*) is shown in Figure 3. This unit permits Batteries BA-39 and BA-40, Handset TS-13-(*), Wire W-29, Alignment Tool TL-150, and Antenna AN-45-(*), to be installed within the case. A molded connector cable passes through the battery case. This has the battery plugs on the inside end and the cable connector at the outside end, to convey the battery voltages from Case

CS-79-(*) to Radio Receiver and Transmitter BC-620-(*). The wiring diagram of this cable and battery connector is shown in Figure 12.

Web belting, fastened to brackets in Case CS-79-(*) and two large springs fastened to the top lid, serve to maintain the batteries in their correct position within the case.

SECTION IV—MAINTENANCE

	Page
Par. 14 Inspection.....	35
15 Battery Replacement.....	38
16 Cables and Connectors.....	39
17 Tube Replacement.....	39
18 Desiccator.....	40
19 Capacitors.....	40
20 Sockets and Coils.....	40
21 Miscellaneous Parts.....	40
22 Meter Protecting Fuse.....	41
23 Volume Control.....	41
24 Meter Switch.....	41
25 Normal Point to Point Resistance Values.....	42
26 Plate Supply Unit PE-97-(*), Point to Point Resistance Values.....	48
27 Adapter M-394.....	50
28 Presetting, General.....	52
29 Presetting Procedure using I-107-(*).....	56
30 Presetting Procedure using M-394.....	59
31 I-F and Discriminator Alignment.....	61
32 Neutralization.....	63
33 Operation Checks.....	64

14. Inspection.

a. If Radio Receiver and Transmitter BC-620-(*) fails to operate, inspect for possible causes of failure.

(1) Make certain the meter control switch is at OPER and that the CHAN switch is definitely set at one channel or the other.

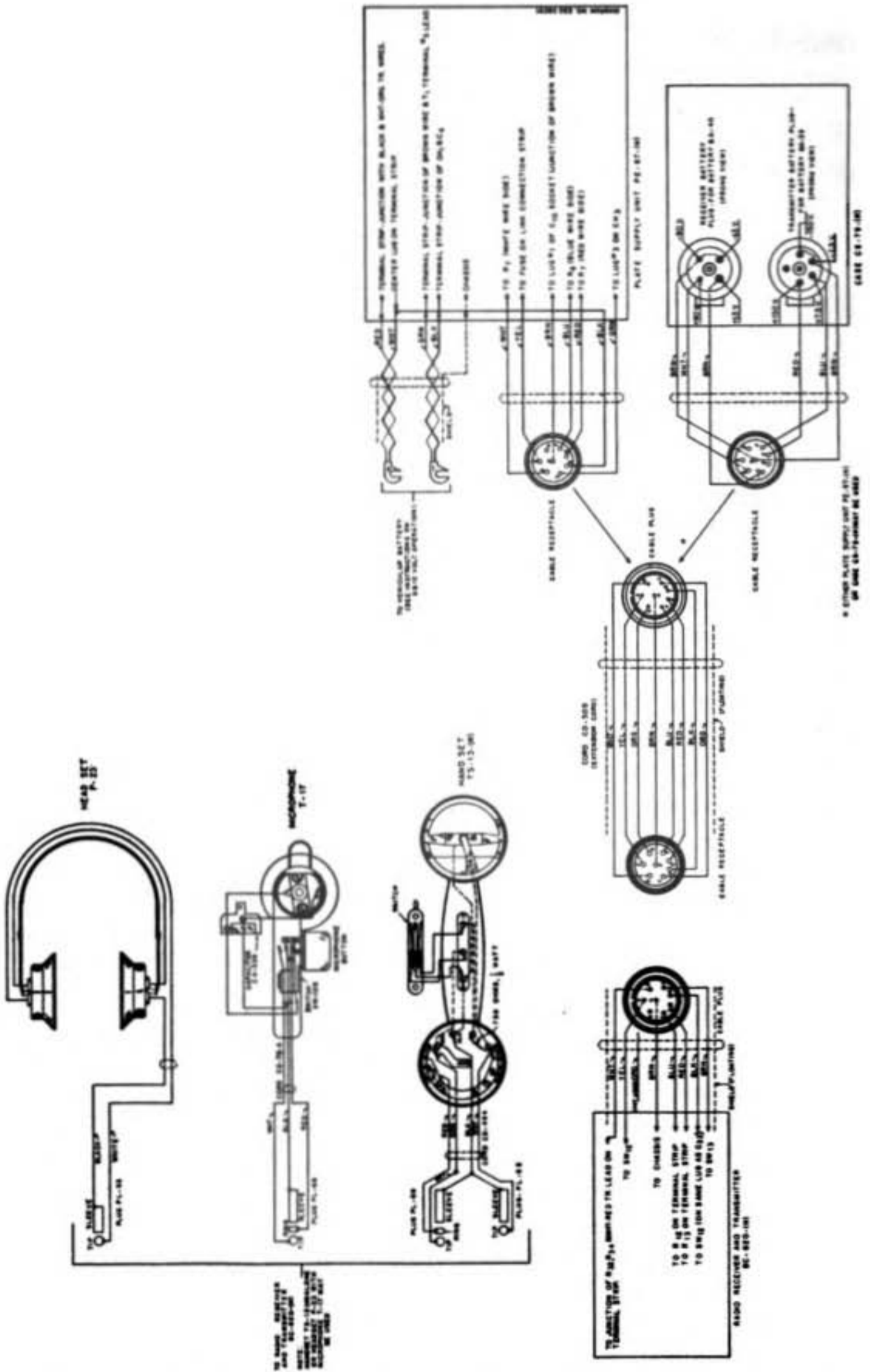

Figure 12. Radio Sets SCR-509-(*) and SCR-510-(*), Cording Diagram

(2) Make sure the microphone and phone plugs are properly inserted into their receptacles.

(3) Check the antenna terminal to make sure the telescopic antenna is installed properly, or that the antenna lead is firmly connected to the antenna terminal.

(4) Check to see that the antenna connector is connected to the mast terminal, (if a mast antenna is being used) and that the antenna is not being *grounded* or detuned by some other object coming in contact with it.

(5) Turn the meter control switch to PLATE and note the panel meter, which should read about 2 or more. If there is no reading, it indicates lack of "B" voltage.

(6) Turn the control to FIL and note the reading. This should also be about 2 or more. If there is no meter reading the filaments of the tubes in Radio Receiver and Transmitter BC-620-(*) are receiving no voltage.

(7) Check the connector plug and receptacle which join Radio Receiver and Transmitter BC-620-(*) to Plate Supply Unit PE-97-(*) or to Case CS-79-(*). Be sure both sections of the connector are pushed together securely to assure a good contact, and that they are tightly threaded.

b. Dry Battery Operation.

Check the condition of the batteries occasionally, as follows: Turn the meter control switch to PLATE, press the push-to-talk switch and read the panel meter. If it reads less than 2 (the luminous spot) it indicates a weak Battery BA-39. Turn the selector switch to FIL and read the meter. It should be not less than 2. If lower voltages are indicated, a fresh Battery BA-40 should be installed in Case CS-79-(*).

c. Vehicular Battery Operation.

(1) Open Plate Supply Unit PE-97-(*), and check to make sure that Fuse F₁ is intact, that Vibrator VB-1-(*), rectifier Tube VT-195, voltage regulator Tube VT-184, and plug-in electrolytic Capacitor CA-403-(*), are seated properly in their respective sockets, and making good contact.

(2) Check the position of the link connections on the power pack by comparing them to the drawing cemented to the inside of the plate supply unit cover, to make certain that they are in the proper position for the voltage of the vehicular battery.

(3) Turn the meter control switch to PLATE, press the push-to-talk switch and read the panel meter. If it reads less than 2 (the luminous spot) it indicates a weak vehicular battery, or trouble in Plate Supply Unit PE-97-(*). Zero plate voltage possibly indicates a defective fuse, defective Capacitor CA-403-(*), or defective Vibrator VB-1-(*).

(4) Located in Plate Supply Unit PE-97-(*) on the power pack chassis, are five items that may need replacement from time to time. These are Fuse F₁ (6 ampere), Vibrator VB-1-(*), rectifier Tube VT-195, voltage regulator Tube VT-184 and electrolytic Capacitor CA-403-(*). These can be identified in Figure 5. All of these items plug into suitable sockets or receptacles on the power pack, and in all cases, socket arrangements are such that no error can be made when inserting the replacement. Spares for all items except the rectifier Tube VT-195, and voltage regulator Tube VT-184, are carried in suitable clips right inside Plate Supply Unit PE-97-(*). Two spare rectifier Tubes VT-195, and voltage regulator Tubes VT-184, are supplied in the replacement tube kit. When defective, any of these components may be removed by pulling them from their sockets. The replacement should be inserted so that the pins line up properly with the socket holes, and it should be pushed down firmly to assure good contact.

NOTE: Vibrators VB-1-A and VB-7-C are interchangeable with Vibrator VB-1-B. Capacitor CA-403-B is interchangeable with Capacitor CA-403-A.

15. Battery Replacement.

a. When the receiver and transmitter batteries run down, as indicated by a reading of less than 2 on the panel meter, with the meter control switch either at PLATE or FIL:

(1) Replace the old batteries with fresh ones. Placing them in position as shown in Figure 3.

(2) Tighten the webbed straps securely.

(3) Insert the two battery plugs into the receptacles on the batteries, pushing firmly to make certain they make good connections.

b. There is an internal Battery BA-41, located in a small battery box that is mounted near the front panel inside Radio Receiver and Transmitter BC-620-(*) case. Negligible current is drawn from this battery and its life in the radio set is consequently the normal shelf life.

(1) Replace it with a fresh battery after about 8 months of use.

(2) In making replacement, insert the plug firmly into the battery socket to assure good contact, and replace the battery box cover.

16. Cables and Connectors.

Defective cables or connectors, such as open and short circuits, will stop operation of the radio set. These defects can be located with the voltohmmeter and the cording diagram. (See Figure 12.) If the fault is in the connector, it can generally be corrected by disassembling the connector and resoldering or wrapping tape around the wires to keep them separated. If the cable is defective, it is advisable to replace the cable.

To make any of the replacements or tests in the following paragraphs of this section, it will be necessary to remove Radio Receiver and Transmitter BC-620-() from the case. See Paragraph 6a Section II.*

17. Tube Replacement

a. To locate a defective tube, try tubes known to be good in each socket (one at a time). Do not replace any but defective tubes. When replacing tubes, be sure that the proper type of tube is used.

(1) First read the type number on the tube being removed from the socket and compare the new tube with the type number indicated for that socket. (See Figure 7.)

(2) To remove the old tube carefully rock or tilt it slightly (about $\frac{1}{8}$ inch) in the direction of the screw heads located in the chassis base at the bottom of the tube, and at the same time pull it firmly upward out of the socket. *Do this carefully or it may cause permanent damage to the socket contacts.*

(3) Insert the new tube so that the key in the tube-base lines up with the keyway in the tube socket and push firmly down until it locks in the socket.

(4) If the transmitter oscillator or transmitter reactance modulator-tubes are changed, check and if necessary realign the transmitter oscillator-tuning-capacitor, A2 B2 on both channels, as directed in Paragraph 29*d* or 30*d*. (See Figure. 7)

18. Desiccator.

Although Radio Receiver and Transmitter BC-620-(*) is sealed against moisture, a silica jell desiccator, enclosed in a spun glass bag, is used as an extra precaution to absorb any moisture which may collect in the radio. A portion of this bag is coated with cobalt chloride to serve as an indicator of the moisture content of the silica jell. The cobalt chloride indicator is visible through the perforations in the metal desiccator cover plate, when the radio receiver and transmitter chassis is removed from its case. A *blue* color indicates a *dry* desiccator; a *pink* color indicates a *moisture* saturated desiccator requiring regeneration.

To regenerate (dry) the desiccator, first remove it from the case and heat the desiccator bag in a circulating oven (about 300°F) for 1 hour. A temperature higher than 300°F. may be injurious to the silica jell. If a non-circulating type oven is used, a longer regeneration (drying) period will be necessary. As this operation normally cannot be performed in the field, the saturated desiccator should be turned in for replacement and repair.

19. Capacitors.

The metal encased by-pass capacitors are replaced by removing the mounting screw from the top of the chassis base, and unsoldering the leads. Other capacitors are held by their leads only.

20. Sockets and Coils.

Replacement of sockets and coils will present no problem, as they are held to the chassis base with machine screws, washers, and nuts.

21. Miscellaneous Parts.

The replacement of any other parts of Radio Receiver and Transmitter BC-620-(*) will not present any problem.

22. Meter Protecting Fuse.

In series with the transmitter "B" supply there is a $\frac{1}{2}$ ampere fuse F_2 which protects the meter when the metering switch is at OPER. If a short circuit occurs in any of the plus "B" circuits of the transmitter, this fuse will burn out, but the meter will not be damaged. If a good Battery BA-39 is plugged in, and no voltage can be measured at either terminal of Switch SW_{10} , it is likely that this fuse is burned out. Before replacing it, check the "B" circuit of the transmitter to locate and eliminate the short circuit which caused the fuse to burn out. (Resistor R_{13} is used instead of F_2 on Order Nos. 325-Chi.-42, 2495-Chi.-42, and on some early production sets on Order No. 6329-Phila.-43. Fuse F_2 is used on Order Nos. 8458-Phila.-43, 19912-Phila.-43, 32904-Phila.-43, 32945-Phila.-43, and some late production sets on Order No. 6329-Phila.-43.)

23. Volume Control.

To replace the volume control or meter switch, it will be necessary to remove the front panel. Remove the control levers from the meter control switch, the channel switch, and the volume control.

Remove the four screws in the corners of the recessed section of the front panel. Remove the leads from the meter. Loosen and remove the clamp holding the power cable, and push the cable in through the front panel to allow sufficient room between the front panel and the chassis base to remove and replace the various parts located directly behind the front panel.

Remove the leads from the PHONES and MIC jacks, or remove the jacks from the front panel, making sure to hold the jacks firmly from the back, as the mounting nuts have been punched to avoid the possibility of the jacks becoming loose.

Disconnect the volume control switch leads and with a $\frac{5}{8}$ -inch wrench remove the mounting nut. Install the new volume control connecting leads to the proper terminals. (See Figure 18.) Solder the leads carefully, replace the mounting nut securely, and assemble the front panel to the chassis base. Place the control levers in position, and tighten securely with the mounting screws, being sure to use the lockwashers. Pull the power cable out into position and place the locking clamp in position, tightening securely.

24. Meter Switch.

This replacement is made in the same manner as the volume control. Be sure the leads are connected to the proper terminals. (See Figure 18.)

25. Normal Point-to-Point Resistance Values.

a. Normal resistance values obtained by point-to-point measurements on Radio Receiver and Transmitter BC-620-(*) in a satisfactory condition, are indicated in the following charts. Use of these data in connection with similar measurements on faulty equipment, combined with a logical circuit analysis, will frequently disclose the source of trouble in an improperly operating or dead receiver and transmitter. The readings should be taken under the following conditions, and these must be followed exactly if comparison measurements on a faulty unit are to be of value.

(1) *Remove All Tubes.*

In addition to causing an incorrect reading, tube filaments can be burned out by the high ohmmeter current used in some ohmmeters.

(2) *Set Meter Switch at OPER.*

This position affords the meter the greatest degree of protection (prevents high ohmmeter current from flowing through meter) and prevents incorrect readings by removing the shunting effect.

(3) *Remove Battery BA-41.*

Besides providing false ohmmeter readings, the ohmmeter may be damaged by battery current.

(4) Turn the VOLUME knob control fully clockwise, (to the right). This turns the power switch on and the volume control to maximum.

(5) The channel switch may be at "A" or "B". Check that SW₁₀ and SW₁₁ are on.

(6) Both the microphone and headphone must be disconnected from set.

(7) All readings can be taken on the voltohmmeter unit of Signal Corps Test Set I-56-(*). The meter scale used should give the greatest usable deflection.

b. Power and control cable plug point-to-point resistance values.

All measurements made between plug pins and chassis. Pins on plug are identified by letters.

PIN NO.	RESISTANCE TO CHASSIS
A	Open Circuit
B	Open Circuit
C	Open Circuit
D	Open Circuit
E	Open Circuit
F	1 Megohm minimum (Depends on current leakage through electrolytic capacitor C ₃₁).
G	Open Circuit
H	0 Ohm

c. Internal battery plug (for Battery BA-41) resistance values.

All measurements made as indicated in chart below. Pins are identified by letters as shown. (See Figure 19.) The pin-identifying letters do not appear on the plug.

READING BETWEEN	RESISTANCE
Pin A and chassis	Open Circuit
Pin B and chassis	Open Circuit
Pin C and chassis	Open Circuit
Pin D and chassis	0 Ohm
Pin E and chassis	Open Circuit
Pin A and Pin B	1 Megohm

d. Socket terminal resistance values

(All measurements made between socket terminal and chassis.)

STAGE	TUBE	TUBE SOCKET PIN NOS							
		1	2	3	4	5	6	7	8
V ₁ Trans. r-f Pwr. Amp.	VT-182	*1 megohm minimum	Open Circuit	2800 Ohms	Open Circuit	2800 Ohms	Open Circuit	*1 megohm minimum
V ₂ Trans. Buffer	VT-182	Open Circuit	Open Circuit	22,000 Ohms	Open Circuit	22,000 Ohms	Open Circuit	Open Circuit
V ₃ Trans. Osc.	VT-185	Open Circuit	Open Circuit	Open Circuit	Open Circuit	Open Circuit	Open Circuit	Open Circuit
V ₄ Trans. React. Mod.	VT-185	Open Circuit	Open Circuit	Open Circuit	Open Circuit	Open Circuit	Open Circuit
V ₅ Rec'vr. r-f Amp.	VT-179	Open Circuit	Open Circuit	Open Circuit	0 Ohm	0 Ohm	1 megohm	Open Circuit	0 Ohm
V ₆ Rec'vr Mixer	VT-178	Open Circuit	Open Circuit	Open Circuit	270,000 Ohms	Open Circuit	0 Ohm	Open Circuit	0 Ohm
V ₇ Rec'vr. Xtal Osc.	VT-185	Open Circuit	Open Circuit	Open Circuit	Open Circuit	1.47 megohms	470,000 Ohms	0 Ohm
V ₈ Rec'vr. i-f Amp. No. 1	VT-179	Open Circuit	Open Circuit	Open Circuit	0 Ohm	0 Ohm	4.5 Ohms	0 Ohm

d. Socket terminal resistance values (cont.)

(All measurements made between socket terminal and chassis)

STAGE	TUBE	TUBE SOCKET PIN NOS.							
		1	2	3	4	5	6	7	8
V ₉ Rec'vr. i-f Amp. No. 2	VT-179	Open Circuit	Open Circuit	Open Circuit	0 Ohm	0 Ohm	4 Ohms	0 Ohm
V ₁₀ Rec'vr. Limiter	VT-179	Open Circuit	Open Circuit	Open Circuit	0 Ohm	0 Ohm	100,000 Ohms	Open Circuit	0 Ohm
V ₁₁ Rec'vr. Diode Rect.	VT-183	0 Ohm	270,000 Ohms	540,000 Ohms	Open Circuit
V ₁₂ Rec'vr. Diode Rect. & d-c Amp.	VT-183	Open Circuit	Open Circuit	Open Circuit	270,000 Ohms	540,000 Ohms	810,000 Ohms	Open Circuit	0 Ohm
V ₁₃ Rec'vr. a-f Pwr. Amp.	VT-185	Open Circuit	Open Circuit	Open Circuit	Open Circuit	Open Circuit	Open Circuit	0 Ohm
Metering Socket		1.47 Megohms	270,000 Ohms	1.1 Megohms	Open Circuit	22,000 Ohms	Open Circuit	540,000 Ohms

*Depends on current leakage through electrolytic capacitor C₃₁.

d. Socket terminal resistance values (cont.)

All measurements made between socket terminals and (—) negative battery lead.
Link connections set for 6- or 12-volt operation.

Socket		Socket Terminals							
		1	2	3	4	5	6	7	8
Rectifier	VT-195	Open Circuit	Open Circuit	60 ohms	55 ohms	Open Circuit	Open Circuit
Voltage Regulator	VT-184	0 ohm	Open Circuit
Vibrator	VB-1- (*) (V ₁)	0 ohm	100 ohms	100 ohms	*
Electrolytic Capacitor	CA-403 (C ₁₀)	0 ohm	Open Circuit	Open Circuit	Open Circuit

*With 6-volt connection—100 ohms; with 12-volt connection—120 ohms.

e. Normal choke, coil and transformer d-c resistance values.

	DESCRIPTION	D-C RESISTANCE
CH ₁	Choke, Low "L" R-F	.13 ohm
CH ₂	Choke, R-F	40 ohms
CH ₃	Choke, R-F	40 ohms
CH ₄	Choke, Low "L" R-F	.13 ohm
CH ₅	Choke, R-F	40 ohms
CH ₆	Choke, Microphone Hash	500 ohms
CH ₇	Choke, High "L" R-F	8 ohms
CH ₈	Choke, R-F	40 ohms
CH ₉	Choke, Filament	.13 ohm
L ₁	Coil & Shield, Antenna Loading*	
	1-8	.02 ohm
L ₂	Coil & Shield, P-A Grid*	
	1-2	.006 ohm
	1-3	2,700 ohms
	3-chassis	100 ohms
L ₃	Coil & Shield, Buffer Grid*	
	1-2	.039 ohm
	1-chassis	22,000 ohms
L ₄	Coil & Shield, Transmitter Oscillator*	
	4-1	.021 ohm
	4-2	.038 ohm
	4-3	.05 ohm
L ₅	Coil & Shield, Mixer Grid*	.019 ohm
L ₆	Coil & Shield, Receiver Oscillator*	
	1-2	.019 ohm
T ₁	Transformer, P-A Plate*	
	3-1	.010 ohm
	2-4	.003 ohm
	3-5	.010 ohm
T ₂	Transformer, Microphone	
	1-2	3 ohms
	3-4	2,600 ohms
T ₃	Transformer & Shield, 1st I-F*	
	1-2	4.5 ohms
	3-4	3.5 ohms
T ₄	Transformer & Shield, 2nd I-F*	
	1-2	4 ohms
	3-4	4 ohms

e. Normal choke, coil and transformer d-c resistance values (cont'd.)

	DESCRIPTION	D-C RESISTANCE
T ₅	Transformer & Shield, 3rd I-F*	
	1-3	3.5 ohms
	3-2	100,000 ohms
	3-6	1 megohm
T ₆	Transformer & Shield, Discriminator*	
	4-5	3.5 ohms
	1-2	2.5 ohms
	5-3	1.5 ohms
T ₇	Transformer, Output	
	5-4	1.5 ohms
	1-2	850 ohms
	3-4	1,200 ohms

Refer to Radio Receiver and Transmitter BC-620-() Chassis Bottom View and Schematic Diagram for location of terminals that are not marked on parts.

26. Plate Supply Unit PE-97-(*) Point-to-Point Resistance Values.

a. Normal resistance values obtained by point-to-point measurements on Plate Supply Unit PE-97-(*) are indicated in the following charts. Use of the data in connection with similar measurements on faulty equipment, combined with a logical circuit analysis, will disclose the source of trouble in an improperly operating or dead plate supply unit.

The readings were taken under the following conditions, and these must be followed exactly if comparison measurements on a faulty unit are to be of value.

- (1) Remove the rectifier, Tube VT-195, and voltage regulator Tube VT-184 from their sockets.
- (2) Remove Vibrator VB-1-(*) (V₁) from its socket.
- (3) Disconnect the power and control cable from Radio Receiver and transmitter BC-620-(*).
- (4) Disconnect the battery leads from the vehicular battery.

(5) The fuse F_1 should remain in the fuse clips.

(6) All measurements were made with the voltohmmeter unit of Signal Corps Test Set I-56-(*).

In general, ohmmeter readings will be more accurate when taken on the upper two-thirds of the scale, and wherever possible, the range should be chosen that will give indications in this area.

b. Power and control cable receptacle continuity measurements.

All measurements made between receptacle contact H and contact indicated.

Receptacle contacts are identified by letters.

RECEPTACLE CONTACT LETTER	RESISTANCE
A	100 ohms
B	*Open Circuit
C	*Open Circuit
D	*Open Circuit
E	Open Circuit
F	*Open Circuit
G	

*Use low ohmmeter range. If a reading is obtained, reverse test leads. If electrolytic capacitor is normal no reading will be obtained in one position of the test leads.

c. Normal choke and transformer d-c resistance values.

DESCRIPTION	D-C RESISTANCE
CH ₁ Choke, r-f	.03 ohm
CH ₂ Choke, r-f	.03 ohm
CH ₃ Choke, "A"	
1-2	3.5 ohms
2-3	3.5 ohms
CH ₄ Choke, r-f	42 ohms
CH ₅ Choke, "B" filter	138 ohms
T ₁ Transformer	
1A-10	.09 ohm
9-12	.19 ohm
2A-9 or 12	.098 ohm
3A-11	.104 ohm
7-8	.291 ohm
4-5	57 ohms
5-6	57 ohms

27. Adapter M-394.

a. Description.

(1) Adapter M-394 is issued for installation in those sets which do not include it as a factory installation.

(2) Adapter M-394 consists of a metal bracket on which is mounted a terminal block and a d.p.d.t., OFF-ALIGN, slide switch that is connected to a separate tube-socket-adapter-plug having a metering plug lead. The switch also is connected to the terminal block, and has two separate leads.

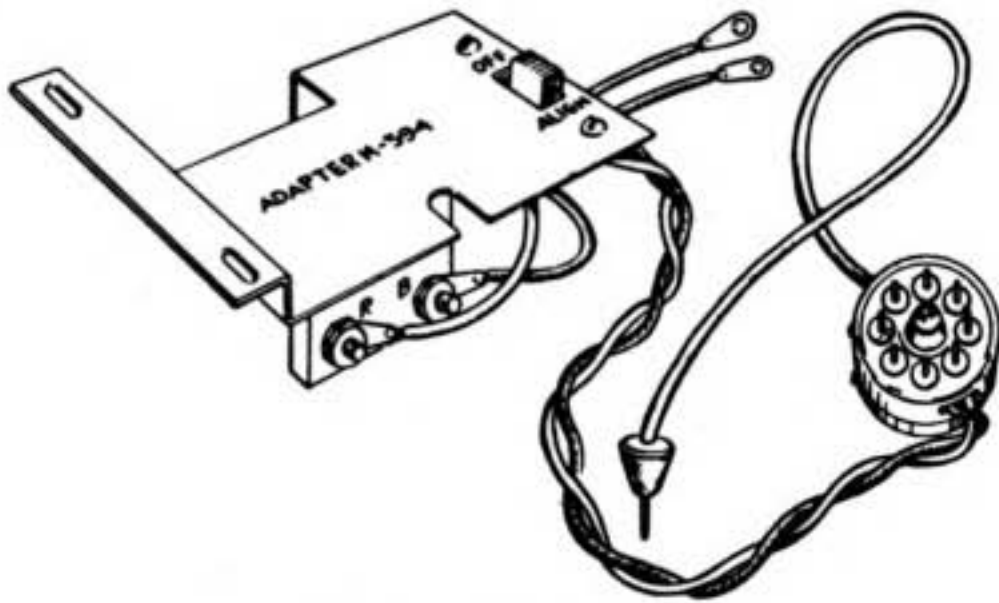

Figure 13. Adapter M-394, Top View

(3) The bracket of Adapter M-394 is designed for permanent installation in Radio Receiver and Transmitter BC-€20-(*). When it is installed, and the connections made properly, the adapter switch at ALIGN converts the receiver amplifier stage of the set into a vacuum-tube-voltmeter circuit utilizing the panel meter of the set.

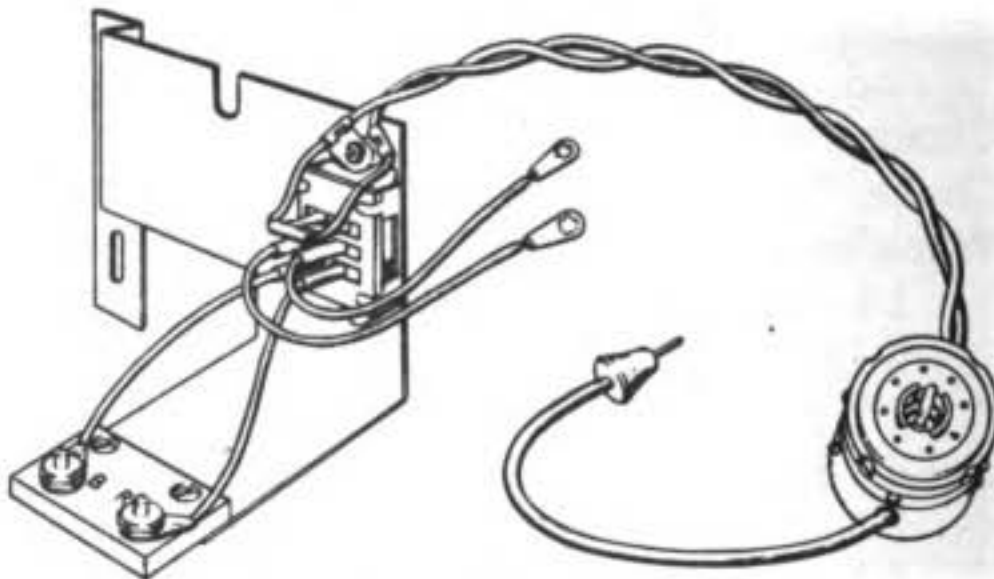

Figure 14. Adapter M-394, Bottom View

This permits the changing of channels as well as complete alignment of the set without using an external meter. With the adapter switch at OFF, Adapter M-394 does not interfere with the ordinary use of the set.

b. Installing Adapter M-394.

(1) Take receiver-transmitter from its case by removing all the screws around the edge of the panel and pulling the chassis forward.

NOTE: Radio Receiver and Transmitter BC-620-F is fastened to its case by means of two catch clips, one on each side of front panel.

(2) Use a 5/16" wrench (part of Maintenance Equipment ME-13-(*) or Maintenance Equipment ME-73), to disconnect the two leads attached to the panel meter of the set, and then connect these leads to terminals B and R of Adapter M-394, attaching the red lead to R.

(3) Take the two separate leads of Adapter M-394, and connect them to the meter terminals, attaching the red lead to the meter terminal nearest Transformer T₆.

(4) Remove the two screws from the edge of the top cover of the battery box that contains Battery BA-41, and mount the bracket of Adapter M-394 there, using the original screws.

(5) Remove the receiver power-amplifier Tube VT-185 from its socket and insert the adapter plug. Then insert the VT-185 tube in the adapter plug socket, as shown.

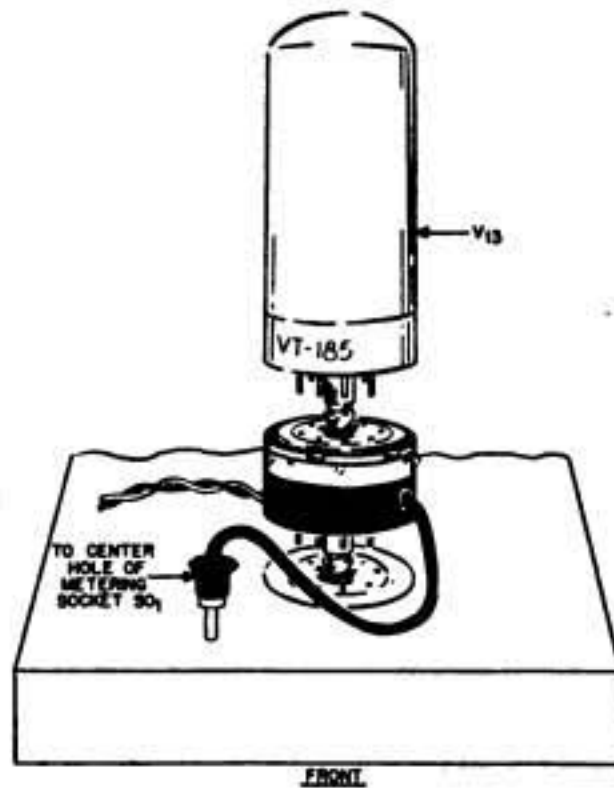

Figure 15. Adapter M-394, installed in Radio Receiver and Transmitter BC-620-(*).

(6) Insert the adapter metering plug in the center hole of the metering socket, and throw the adapter switch to OFF.

(7) Replace Radio Receiver and Transmitter BC-620-(*) in its case, being careful to see that the gasket is properly seated. Tighten the panel screws carefully to put uniform pressure on all screws and prevent leakage through the gasket.

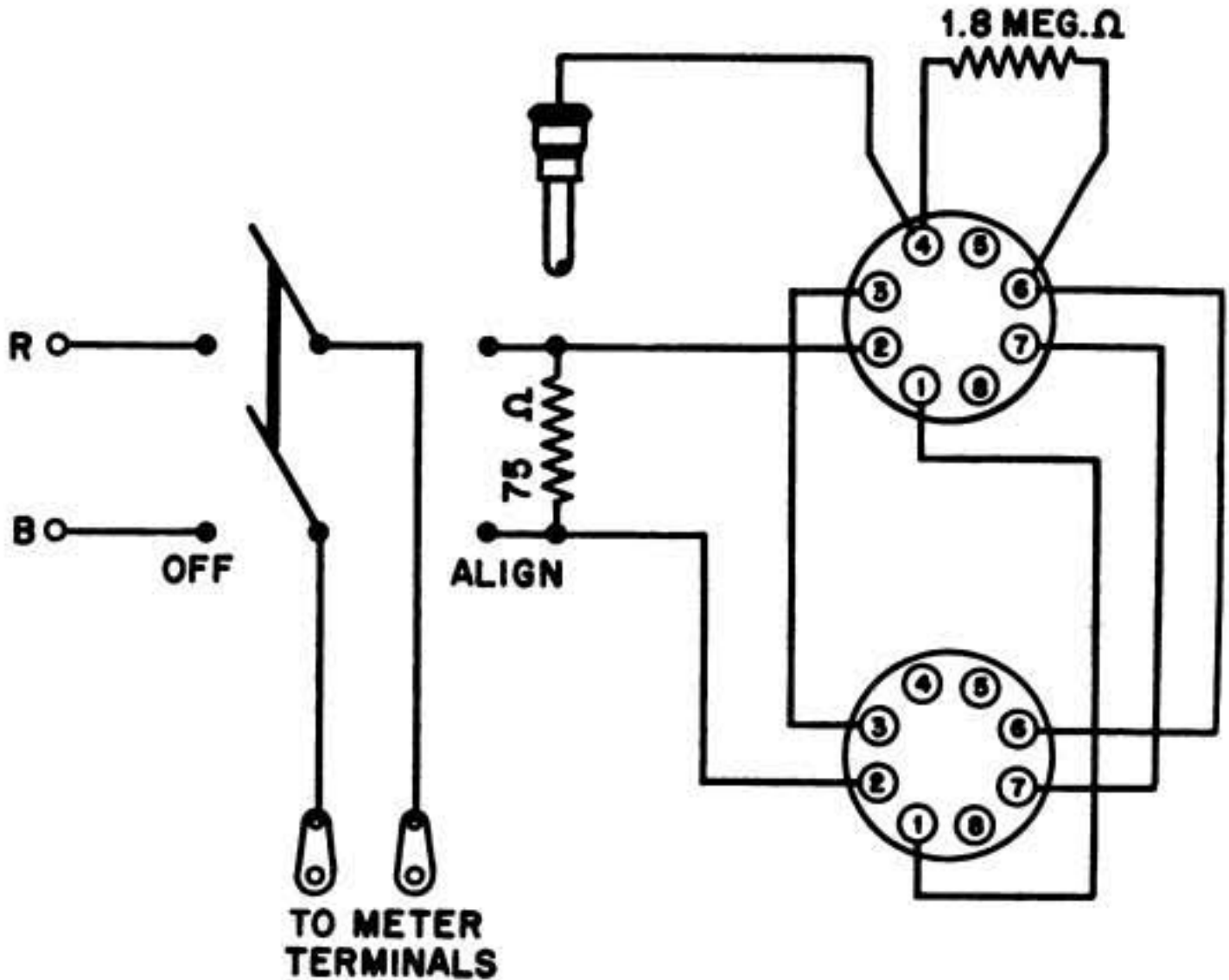

Figure 16. Adapter M-394. Circuit Diagram

28. Presetting, General.

a. Radio Receiver and Transmitter BC-620-(*) is designed to operate on any frequency within the range of 20.0 to 27.9 megacycles. The frequency of the transmitter and receiver is crystal-controlled for operation on any 2 of 80 different channels, spaced 100 kilocycles apart, within this range. Sets, when issued, are properly aligned and preset on the two frequencies marked on the container. With batteries and crystals installed, and proper connections made in accordance with Section II, the set should operate on these two frequencies. Check that the set operates properly before attempting to change the channel presettings.

b. Before placing the set in operation on any two assigned frequencies, it is necessary first to have the proper crystal for each assigned channel, and then to adjust (preset) properly the trimmer capacitors on the chassis to the assigned channels. These trimmers are arranged in six pairs, marked A1 (B1) to A6 (B6) on the chassis and are provided with dial cards. *ONLY these trimmers need to be adjusted when presetting channels. Do not disturb any other adjustments.*

c. While the adjustments described will probably seem difficult at first reading, after a few trials they will be found so simple that it is possible to completely preset this radio on two new frequencies within 10 minutes. Men assigned to this work must familiarize themselves thoroughly with the procedures, and practice constantly until they know it thoroughly. Most of the failures in these sets can be traced directly to carelessness in presetting. *Always check your work carefully.*

d. For convenience in distinguishing between the controls for the two channels, all of the controls for one channel are labeled "A", and all of the controls for the other are labeled "B". The channel selector switch marked CHAN, on the panel of Radio Receiver and Transmitter BC-620-(*), and the two positions in the crystal sockets on top of the chassis are also labeled "A" and "B".

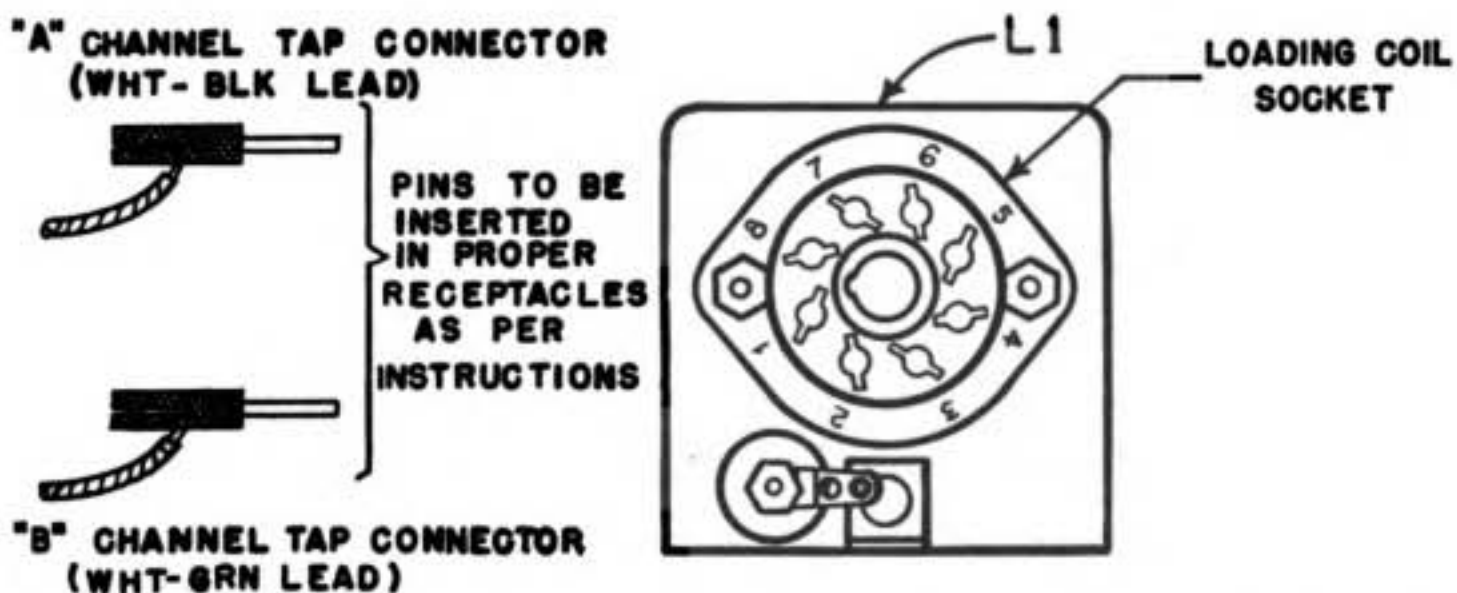

Figure 17 Radio Receiver and Transmitter BC-620-(*), Antenna Loading Coil Connection Detail

e. A metering socket is provided on the chassis of Radio Receiver and Transmitter BC-620-(*) for connecting a meter at various points in the circuit for alignment and test. The pin jacks on this socket are numbered from 1 to 8 and are connected to the various parts of the circuit so that when the common lead of an electronic voltmeter is connected to the *chassis (not the front panel)* of the set and the d-c probe of the electronic voltmeter is inserted into the pin jack indicated in the following table, the corresponding voltage is read on the electronic voltmeter:

Pin jack No. 1—Receiver oscillator grid voltage.

Pin jack No. 2—Receiver converter injection grid voltage.

Pin jack No. 3—Receiver limiter grid voltage.

Pin jack No. 4—Reactance modulator grid voltage (d-c amplifier output).

Pin jack No. 5—Transmitter buffer grid voltage.

Pin jack No. 6—Transmitter oscillator grid voltage.

Pin jack No. 7—Receiver discriminator output voltage.

Pin jack No. 8—Not connected.

f. The special items of test equipment required to preset channels are furnished in or issued with Maintenance Equipment ME-13-(*) and Alignment Equipment ME-73:

(1) An electronic voltmeter for measuring voltages at the metering socket, which may be:

(a) Voltohmmeter I-107-(*), part of ME-13-(*). Refer to TM 11-306.

(b) The panel meter of Radio Receiver and Transmitter BC-620-(*) in conjunction with Adapter M-394.

(c) Any other electronic voltmeter such as Hickock Model 202, RCA Voltohmyst, etc.

(2) Alignment Tool TL-150 or TL-207.

(3) Adapter RS-259.

(4) Other tools such as hex socket wrench, screw drivers, etc.

g. These steps in setting up equipment can be followed regardless of the type of electronic voltmeter you use. Additional steps, as necessary, are given under the presetting procedures in paragraphs 29 and 30.

(1) Remove the chassis of the radio receiver and transmitter from its case by removing all screws around the edge of the panel and pulling the chassis forward toward you.

NOTE: Radio Receiver and Transmitter BC-620-F is fastened to its case by means of two catch clips, one on each side of front panel.

(2) Set switches SW₁₀ and SW₁₁ to OFF. Set panel meter switch to CHECK.

(3) Insert the required crystals in the proper channel sockets. The metal name plates should face outward, away from each other. Plug in a handset.

(4) Set the locknuts on the trimmers A1 (B1) through A6 (B6) with Alignment Tool TL-207 (or other 5/16-inch wrench) for a fairly stiff "drag" on the trimmer adjusting shafts. *Do not tighten them so that trimmer shafts jam. Do not tighten locknuts further after presetting as further tightening tends to change the adjustment and may damage the capacitors.*

(5) Set each trimmer to its approximate setting and insert L₁ tap connector pins as shown in the following chart:

APPROXIMATE TRIMMER SETTINGS

Channel No.	A1 B1	A2 B2	A3 B3	A4 B4	A5 B5	A6 B6	*Positions of pins in L ₁
0-19	3.0	2.0	2.0	2.0	1.5	3.0	8
20-29	5.0	2.8	4.0	2.5	2.0	3.8	6
30-39	5.5	5.0	4.5	4.5	4.5	5.0	4
40-54	6.0	5.8	5.5	5.2	5.2	5.8	3
55-74	6.9	6.8	6.5	6.0	6.2	6.5	2
75-80	7.4	7.8	7.2	7.0	7.8	7.2	1

*Refer to figures 17 and 18.

NOTE: Red dots on the trimmer shafts indicate the side of the slot that should be toward the dial card. The width of the slot is about 1/10 of a division. In case the red dot has worn off, its proper location can be found by fully meshing the capacitor. The end of the slot near the C of the 0-6 scale is the end that should carry the red dot.

CAUTION: In adjusting the trimmers in the following operations they need not be turned very far from the approximate settings shown in this chart. If it does appear necessary to turn them far from these settings, it means that some adjustment has been incorrectly made, or that these capacitors are defective. Recheck your previous steps and examine the capacitors for misalignment of plates, or breakage.

(6) Check the condition of Battery BA-41 by means of an electronic voltmeter by inserting the probe in pin No. 4 of the metering socket. Replace the battery if the voltage is less than 20 volts.

(7) Connect Radio Receiver and Transmitter BC-620-(*) to its source of power by joining the two halves of the power and control cable connector. If Case CS-79-(*) is to be used, insert Adapter RS-259 (part of ME-13-(*) and ME-73) between Battery BA-39 and its plug. Adapter RS-259 places a 500-ohm resistor in series with the high voltage lead to protect the transmitter tubes while making adjustments. If Plate Supply Unit PE-97-(*) is to be used the adapter is not necessary because of the voltage regulation characteristics of this plate supply unit.

h. The procedure from this point depends upon the maintenance equipment you use. After presetting, it is strongly recommended that, *when tactical considerations will permit*, the set be put on the air and given an operating test to make sure that it has been tuned to the correct frequencies and is "getting out." Contact another set that you know is functioning properly on the same channels. Separate the two sets at least 300 to 500 yards.

29. Presetting Procedure Using Voltohmmeter I-107-(*) or Other Electronic Voltmeter.

a. Set up and calibrate voltohmmeter I-107-(*) as directed in TM 11-306. Connect the common lead alligator clip to the *chassis* (*not to the front panel*) of Radio Receiver and Transmitter BC-620-(*). The front panel, etc. are insulated from the chassis and you can't use them as a return.

b. Set panel meter switch to CHECK. Rotate VOLUME control fully clockwise (to the right). Set CHAN switch to A or B, whichever is to be the lower frequency channel. *Remember that the lower frequency channel must be preset first.*

c. The following steps preset the *receiver*. Do not press the microphone switch.

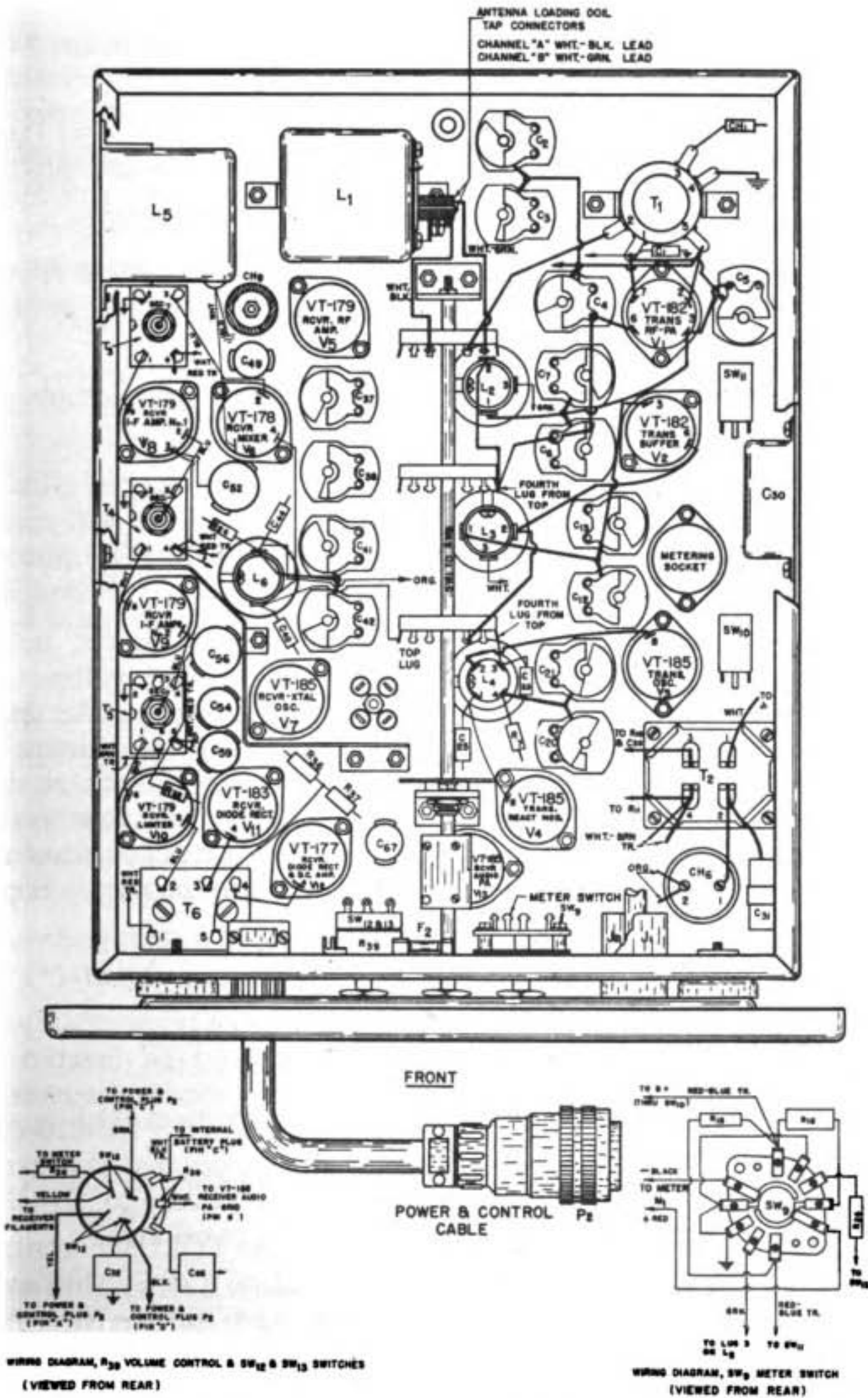

Figure 18. Radio Receiver and Transmitter BC-620-(*), Bottom View of Chassis

(1) To check crystal activity, insert the meter probe in pin jack No. 1 of metering socket. A meter reading of approximately -15 volts indicates a good crystal.

(2) Insert probe in pin jack No. 2 of metering socket, and tune A1 (or B1 if channel B is to be set first) for maximum meter reading.

(3) Tune A3 (B3) for maximum noise in the handset.

(4) Tune A6 (B6) for maximum noise in the handset. However, if the noise peak cannot be distinguished, leave A6 (B6) at the approximate (chart) setting.

d. The following steps preset the *transmitter*. Press the microphone switch *only* while making adjustments.

(1) Insert probe in pin jack No. 3 of metering socket. *Slowly* tune A2 (B2) about its approximate setting. You will see that more than one peak can be found. Choose the *highest* peak *near* the approximate setting and adjust A2 (B2) for maximum.

(2) Insert probe in pin jack No. 4 of metering socket, press microphone switch, and note the reading on the electronic voltmeter. Then *very carefully and slowly* make a *slight* readjustment of A2 (B2) in the direction that brings the meter reading to -6 volts. Listen in the handset while making this adjustment. If a rushing background noise comes up, A2 (B2) has been moved too far. Go back to step (1) and get back on the correct peak again. Check that it is now possible to hear your voice in the phones when speaking into the microphone.

(3) Insert probe in pin jack No. 5 of metering socket, and tune A4 (B4) for maximum meter reading.

(4) Check that the panel meter switch is at CHECK. The rest of these adjustments will be made using the panel meter.

(5) Set SW₁₀ to ON. Tune A5 (B5) for maximum reading on the panel meter.

(6) Set SW₁₁ to ON. Turn panel meter switch to OPER. QUICKLY tune A6 (B6) for MINIMUM on the panel meter.

CAUTION: Do not press microphone switch until you are all set to make the adjustment swiftly, as it is easy to ruin the power amplifier tube during this adjustment.

Note the setting of A6 (B6). If not still near the approximate (chart) setting, go back to step (1) and start over.

e. The lower frequency channel is now completely preset. Set SW₁₀ and SW₁₁ to OFF, panel meter switch to CHECK, and CHAN switch to the other channel. Preset this channel in the same manner, tuning the other set of trimmers.

f. Check that SW₁₀ and SW₁₁ are ON, restore the set to its case, and connect the antenna. Recheck A6 (B6) for minimum. There is a covered opening at the rear top of the case for this purpose. The panel meter should now read between 1.8 and 3 (OPER).

30. Presetting Procedure Using Adapter M-394.

a. Adapter M-394 converts the receiver power amplifier stage and panel meter into an electronic voltmeter. If Adapter M-394 is not already installed in the set, installation instructions can be found in paragraph 27. Before using the adapter for presetting it is necessary that its proper functioning be checked. Set the adapter switch to ALIGN, VOLUME control full on, and note the panel meter reading. Turn the VOLUME control all the way back to the left from full on, and note the change in the meter reading. If the change is more than one division, try other VT-185 tubes in the adapter socket (Radio Receiver and Transmitter BC-620-(*) has four) until one is found that is satisfactory. Normal tubes should satisfy this condition and should give a meter reading between 1.5 and 2.5. Next turn the VOLUME control full on. Note the meter reading with the probe free (held away from the set). Then ground the probe to the *chassis*, and if the meter reading does not increase at least five divisions a weak Tube VT-185, Battery BA-40 or BA-41 is the reason. Replace as necessary.

b. Set Adapter M-394 switch to ALIGN. Set the panel meter switch to CHECK. Rotate VOLUME control *fully* clockwise (to the right); Set CHAN switch to A or B, whichever is to be the lower frequency channel. *Remember that the lower frequency channel will be preset first.*

c. The following steps preset the *receiver*. Do not press the microphone switch.

(1) To check crystal activity, insert probe in pin jack No. 1 of metering socket. With VOLUME control fully clockwise (to the right), the meter reading should be approximately zero for good crystals.

(2) Insert probe in pin jack No. 2 of metering socket, and tune A1 (B1) for minimum on the meter.

(3) Tune A3 (B3) for maximum noise in the handset.

(4) Tune A6 (B6) for maximum noise in the handset. However, if the noise peak can't be found, leave A6 (B6) at the approximate (chart) setting.

d. The following steps preset the *transmitter*. Press the microphone switch only while making adjustments.

(1) Insert probe in pin jack No. 3 of metering socket. *Slowly* tune A2 (B2) about its approximate setting. You will find more than one peak. Choose the peak that will give the *minimum* reading on the meter and still be *near* the approximate setting. Tune A2 (B2) accurately for *minimum* on this peak.

(2) Before the next presetting step it is necessary to calibrate the meter. A Battery BA-41 that is known to be good *must* be in the set. Note the meter reading with the probe free (held away from the set). Then note the reading with the probe grounded to the *chassis*. Reduce the VOLUME control setting until the difference between the two readings is exactly $4\frac{1}{2}$ divisions. *Do not disturb the VOLUME control setting during the following operations.*

(3) Press microphone switch and note the reading with the probe free. Insert probe in pin jack No. 4 of metering socket. Then very carefully and slowly make a *slight* readjustment of A2 (B2) in the direction that brings the meter reading to *exactly one division* less than what it was with the probe free. Listen in the phones while making this adjustment. If a rushing background noise comes up A2 (B2) has been moved too far. Go back to step (1) and get back on the correct peak again. Check that it is now possible to hear the voice in the phones when speaking into the microphone.

(4) Insert probe in pin jack No. 5 of metering socket, and tune A4 (B4) for minimum on the meter.

(5) Set Adapter M-394 switch to OFF. Check that panel meter switch is at CHECK. The rest of these adjustments will be made using the panel meter in its normal circuits.

(6) Set SW₁₀ to ON. Tune A5 (B5) for maximum reading on the panel meter.

(7) Set SW₁₁ to ON. Turn panel meter switch to OPER. QUICKLY tune A6 (B6) for MINIMUM on the panel meter.

CAUTION: Don't press microphone switch until you are all set to make the adjustment swiftly as it is easy to ruin the power amplifier tube during this adjustment.

Note the setting of A6 (B6). If not still near the approximate (chart) setting, go back to step (1) and start over.

e. The lower frequency channel is now completely preset. Set SW₁₀ and SW₁₁ to OFF, panel meter switch to CHECK, and CHAN switch to the other channel. Preset this channel in the same manner, tuning the other set of trimmers.

f. Check that SW₁₀ and SW₁₁ are ON, restore the set to its case, and connect the antenna. Recheck A6 (B6) for minimum. There is a covered opening at the rear top of the case for this purpose. The panel meter should now read between 1.8 and 3 (OPER).

31. I-F and Discriminator Alignment.

WARNING: Only trained repair personnel in units furnished with the special items of equipment necessary, and authorized to perform such work, will adjust i-f and discriminator trimmers. Many sets turned in for repair are inoperative only because of unauthorized tampering with these trimmers. Don't deprive an outfit of a radio set when it is sorely needed. A radio set turned in for repairs means that some unit is without communication.

a. In addition to the equipment mentioned in paragraph 28*f*, a means of generating a signal at the intermediate frequency (2.88 megacycles) is required. Maintenance Equipment ME-13-(*) includes Oscillator VO-4-(*). Alignment Equipment ME-73 includes a 2.88-megacycle crystal that is used in the receiver oscillator circuit.

b. Set up equipment as in steps (1), (2), and (7) in paragraph 28*g*. Remove both crystals from the set.

c. The following alignment procedure using *Maintenance Equipment ME-13-(*)* is based on the use of Volt ohmmeter I-107-(*) as an indicator. However, any other available electronic voltmeter will serve equally well.

(1) Set up and calibrate Volt ohmmeter I-107-(*) as indicated in TM 11-306. Connect the common lead alligator clip to the *chassis* of Radio Receiver and Transmitter BC-620-(*).

(2) Set up Oscillator VO-4-(*) as indicated in TM 11-306 and set its switch to 2.88 megacycles. Turn ATTENUATION control clockwise (to the right) only enough to turn Oscillator VO-4-(*) on.

NOTE: During i-f alignment, reduce the output of Oscillator VO-4-() whenever possible, by turning the ATTENUATION control still further to the right. Work with as weak a signal as possible.*

(3) Turn Radio Receiver and Transmitter BC-620-(*) on (VOLUME control). Do not connect microphone.

(4) Connect the "hot" lead of Oscillator VO-4-(*) to pin No. 4 of the mixer tube V₆ (VT-178) (Figure 18).

(5) Insert probe in pin jack No. 3 of metering socket. Adjust secondary (bottom) and primary (top) of i-f transformers T₅, T₄, and T₃ in that order for maximum on the voltmeter. (Figures 7 and 18).

(6) Readjust primary and secondary of T₃, T₄, and T₅ in that order. I-f amplifier is now aligned.

(7) Insert probe in pin jack No. 7 of metering socket. Using full output of Oscillator VO-4-(*) and lowest range of voltmeter, adjust discriminator transformer T₆ secondary (Figure 7) for zero volts (*with alignment tool removed*).

(8) Connect the probe, with a 1-megohm resistor in series, to the junction of R₃₆ and R₃₇ (Figure 18). Adjust T₆ primary for maximum on the voltmeter.

(9) Check secondary of T₆ as in step (7) and readjust to zero if necessary. Discriminator is now aligned.

(10) Turn set off, disconnect test equipment, and replace crystals. Be sure crystals are inserted in the proper channel sockets.

(11) Check presetting adjustments for both channels.

d. The following alignment procedure uses Alignment Equipment ME-73 and Adapter M-394.

(1) Check for proper functioning of the adapter circuit as in paragraph 30a.

(2) Insert 2.88-megacycle crystal (part of ME-73) in either crystal socket and set CHAN switch accordingly. Set adapter switch to ALIGN.

(3) Rotate VOLUME control of Radio Receiver and Transmitter BC-620-(*) fully clockwise (to the right).

(4) Insert probe in pin jack No. 3 of metering socket. Adjust secondary (bottom) and primary (top) of i-f transformers T_5 , T_4 and T_3 in that order for minimum on the panel meter (Figures 7 and 18).

(5) Readjust primary and secondary of T_3 , T_4 , and T_5 in that order. I-f amplifier is now aligned.

(6) Note the panel meter reading with the probe grounded to the chassis. (VOLUME full on.) This is a zero voltage reading.

(7) Insert probe in pin jack No. 7 of metering socket. Adjust discriminator transformer T_6 secondary (Figure 7) until the meter indication is the same (*with alignment tool removed*) as in step (6).

(8) Connect the probe, with a short wire and 1-megohm resistor in series, to the junction of R_{36} and R_{37} (Figure 18). Adjust T_6 primary for minimum on panel meter.

(9) Check secondary of T_6 as in step (7) and readjust to zero volts if necessary. Discriminator is now aligned.

(10) Turn set off, set adapter switch to OFF, and remove 2.88-megacycle crystal. Replace the channel crystals in their proper sockets.

(11) Check presetting adjustments for both channels.

32. Neutralization.

a. Neutralization of the final power amplifier stage should not be necessary unless the original setting of the neutralizing capacitors has been accidentally changed. The adjustment screws are painted red on the top side of the chassis for identification. Do not move them unless it actually becomes necessary to re-neutralize the final power amplifier stage.

b. To check neutralization:

(1) Remove set from case. Turn panel meter switch to CHECK. Set SW_{11} to OFF and CHAN switch to A.

(2) Press microphone switch and tune A6 through its range, watching for a dip on the panel meter.

(3) Repeat steps (1) and (2) for channel B.

(4) If the dip is more than one division, the stage must be neutralized.

c. To neutralize:

- (1) Set CHAN switch to the higher frequency channel.
- (2) Adjust C_4 and C_5 (Figures 7 and 18) equally in small steps, checking between adjustments for dip as in *b(2)* above until the dip is less than one division. Settings of C_4 and C_5 must be kept approximately equal. Check by observing the mesh of the plates.
- (3) Check dip on the other channel. The same adjustment of C_4 and C_5 must serve for both channels.

d. Set SW_{11} to ON and panel meter switch to OPER. Restore set to its case.

33. Operation Checks.

The metering socket and panel meter of Radio Receiver and Transmitter BC-620-(*) afford excellent means of quickly checking the set for normal operation. The values given below should be considered nominal. On the higher frequency channels some voltages at the metering socket may be normally less than those shown. If readings are radically different from those given below, check the presetting adjustments and condition of batteries and tubes before investigating the circuit for faults.

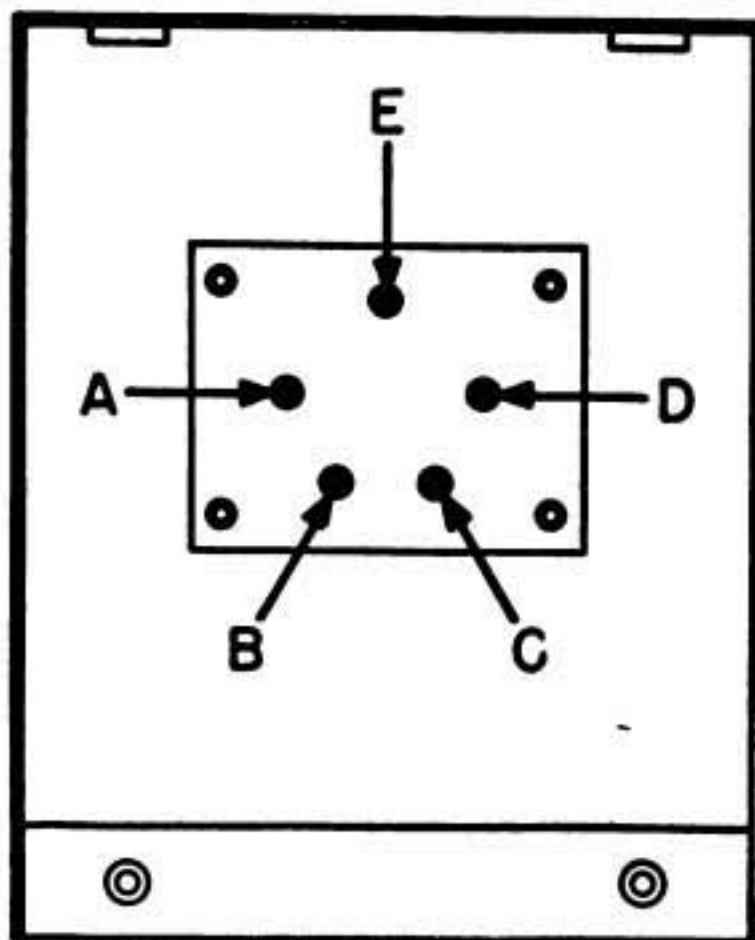

Figure 19. Pin View of Internal Battery Box Plug

a. Readings on panel meter

(transmit position)

SW Position	Reading	Remarks
FIL	2 or more
PLATE	2 or more
CHECK	1.5 or more
OPER	less than 1	Antenna disconnected
OPER	1.8 to 3	Antenna connected

b. Voltages at metering socket

(measured with an electronic voltmeter)

Pin Jack No.	Volts	Remarks
1	-15v or more	Receive position
2	- 4v or more	Receive position
4	-5.5 to -6v	Transmit position
5	-15v or more	Transmit position
6	- 8v or more	Transmit position

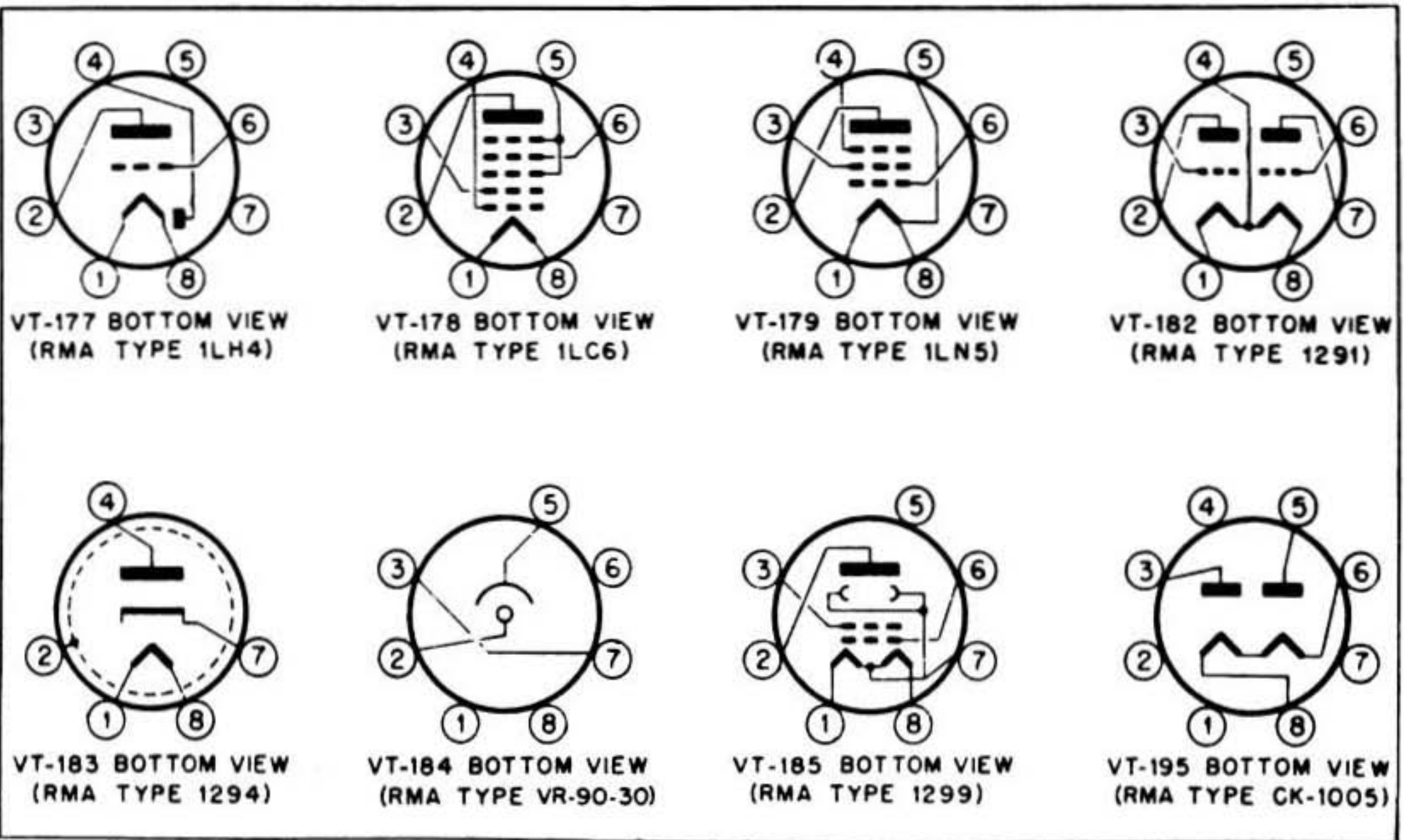

Figure 20. Radio Receiver and Transmitter BC-620-(*) and Plate Supply Unit PE-97-(*), Tube Base Connections and Element Layout

Signal Corps Tube Type No.	Compl. Comm. Type No.	No. Used	Use	Plate		Screen		Filament		Grid		Plate Resis. Meg. Ohms	Power Output MW	Amp. Factor	Mutual Cond. umho	Type
				Volts	Ma	Volts	Ma	Volts	Ma	Volts	Ma					
VT-177	1LH4	1	Diode & D.C. Amp.	90	.15			1.4	50	0	0	340		65	275	Diode High mu Triode
VT-178	1LC8	1	Converter	90	.75	35	.7	1.4	50	0	0	650			275	Penta Grid Converter
VT-179	1LN5	4	r.f. Amp. L.F. Amp Limiter	90	1.6	90	35	1.4	50	0	0	1.1			800	r.f. Amplifier Pentode
VT-182	1291	2	Buffer Doubler & Per. Amp.	180	15 per section			1.4	230	0	0		2.53 watts	21	1850	Hi-Frequency Double Triode
VT-183	1294	1	Diode Rectifier	10 RMS	5 Average			1.4	150							Cathode Hi-Frequency Diode
VT-184	VR 90-30	1 Used on PE-67-(*)	Voltage Regulator	90	10/30											Gaseous Diode Voltage Regulator
VT-185	1299	4	Revrr. Osc. Audio P. A. Trans. Osc. Rect. Mod.	90	9.5	90	1.6	1.4	230	-6	0	.006	270		2100	Beam Power Amplifier
VT-195	QMG 159 CK-1006	1 Used on PE-67-(*)	Rectifier	200	65			6.3	100							

Figure 21. Radio Receiver and Transmitter BC-620-(*), Vacuum Tube Specifications

RADIO RECEIVER AND TRANSMITTER BC-620-(*) CHANNEL NUMBERS AND CRYSTAL FREQUENCIES.

Channel No.	Crystal Fundamental Frequency	Receiver and Transmitter	Channel No.	Crystal Fundamental Frequency	Receiver and Transmitter
0	5706.7kc	20000kc	41	7073.3kc	24100kc
1	5740.0	20100	42	7106.7	24200
2	5773.3	20200	43	7140.0	24300
3	5806.7	20300	44	7173.3	24400
4	5840.0	20400	45	7206.7	24500
5	5873.3	20500	46	7240.0	24600
6	5906.7	20600	47	7273.3	24700
7	5940.0	20700	48	7306.7	24800
8	5973.3	20800	49	7340.0	24900
9	6006.7	20900	50	7373.3	25000
10	6040.0	21000	51	7406.7	25100
11	6073.3	21100	52	7440.0	25200
12	6106.7	21200	53	7473.3	25300
13	6140.0	21300	54	7506.7	25400
14	6173.3	21400	55	7540.0	25500
15	6206.7	21500	56	7573.3	25600
16	6240.0	21600	57	7606.7	25700
17	6273.3	21700	58	7640.0	25800
18	6306.7	21800	59	7673.3	25900
19	6340.0	21900	60	7706.7	26000
20	6373.3	22000	61	7740.0	26100
21	6406.7	22100	62	7773.3	26200
22	6440.0	22200	63	7806.7	26300
23	6473.3	22300	64	7840.0	26400
24	6506.7	22400	65	7873.3	26500
25	6540.0	22500	66	7906.7	26600
26	6573.3	22600	67	7940.0	26700
27	6606.7	22700	68	7973.3	26800
28	6640.0	22800	69	8006.7	26900
29	6673.3	22900	70	8040.0	27000
30	6706.7	23000	71	8073.3	27100
31	6740.0	23100	72	8106.7	27200
32	6773.3	23200	73	8140.0	27300
33	6806.7	23300	74	8173.3	27400
34	6840.0	23400	75	8206.7	27500
35	6873.3	23500	76	8240.0	27600
36	6906.7	23600	77	8273.3	27700
37	6940.0	23700	78	8306.7	27800
38	6973.3	23800	79	8340.0	27900
39	7006.7	23900			
40	7040.0	24000			

Figure 22. Radio Receiver and Transmitter BC-620-(*), Channel Numbers and Crystal Frequencies

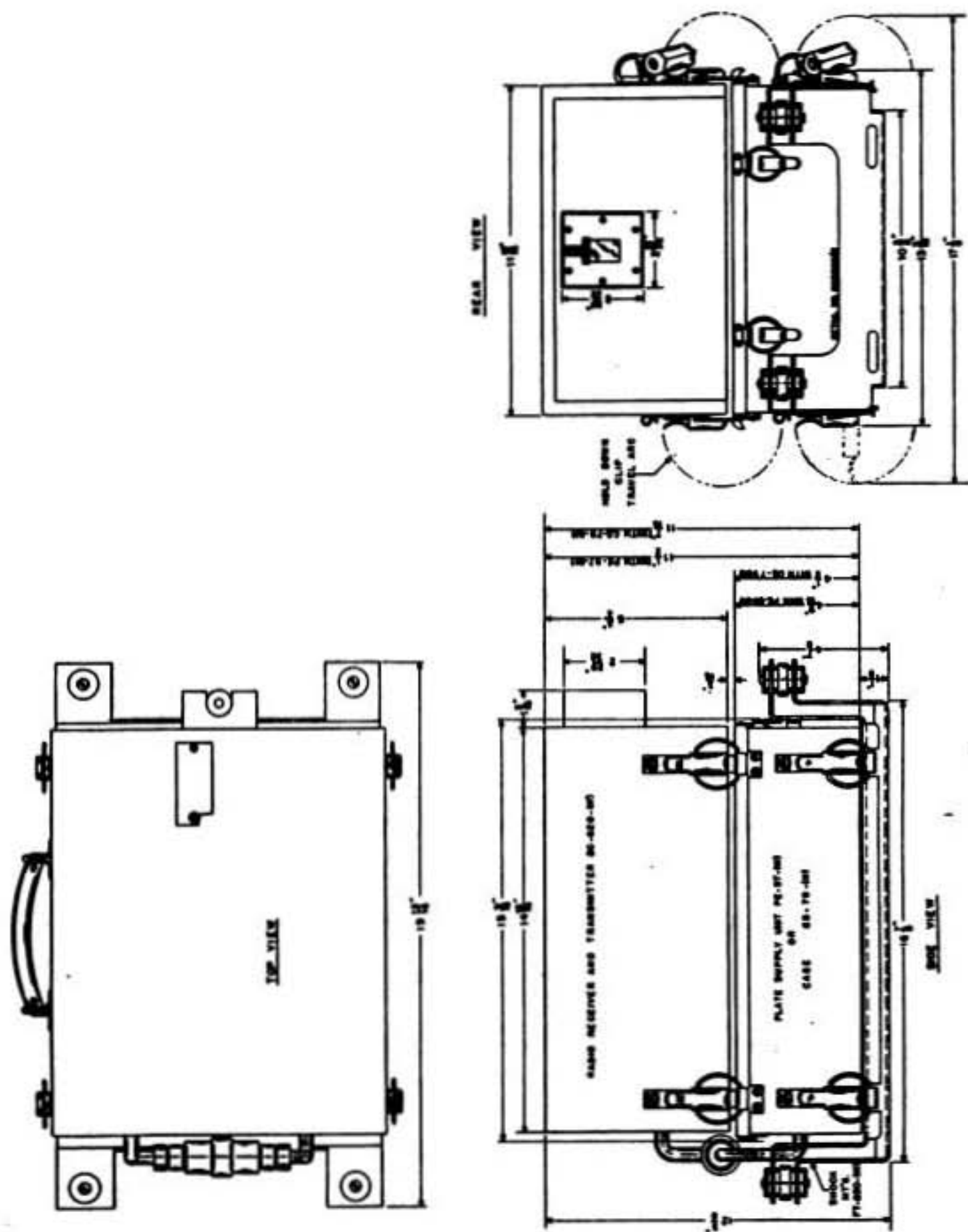

Figure 23. Radio Sets SCR-509-A, SCR-509-B, SCR-510-A and SCR-510-B Outline Dimensional Detail

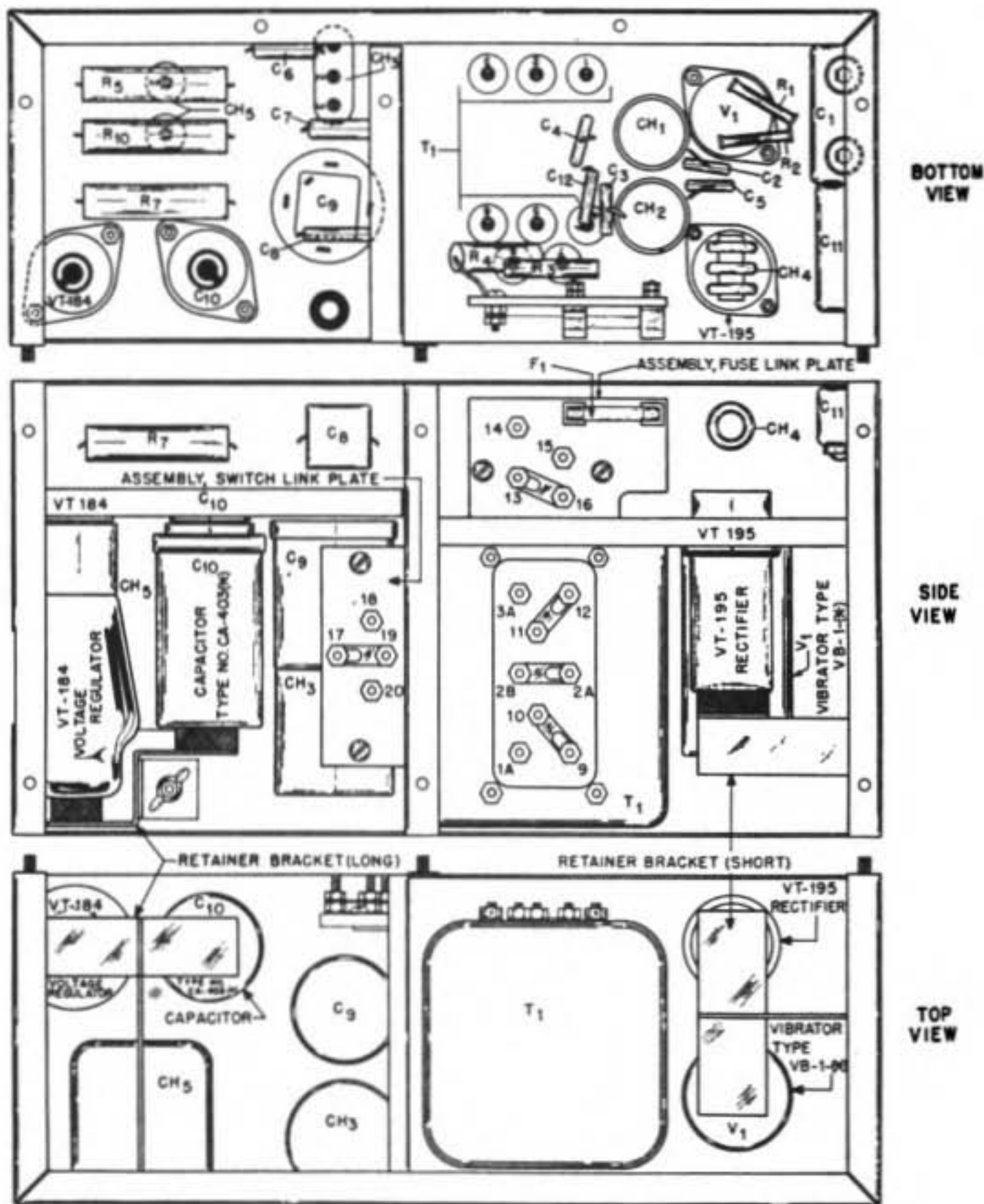

Figure 24. Plate Supply Unit PE-97-(*), Parts Location Detail

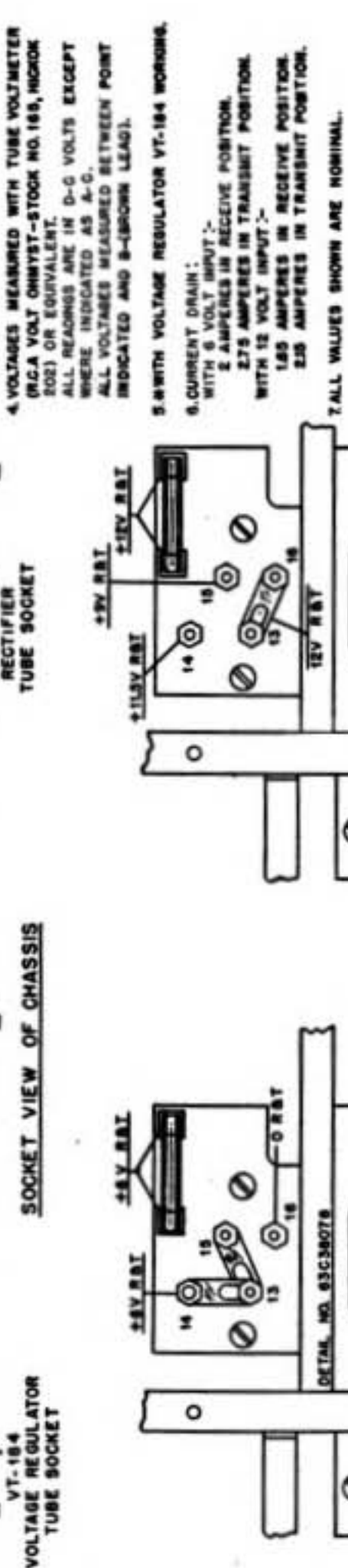
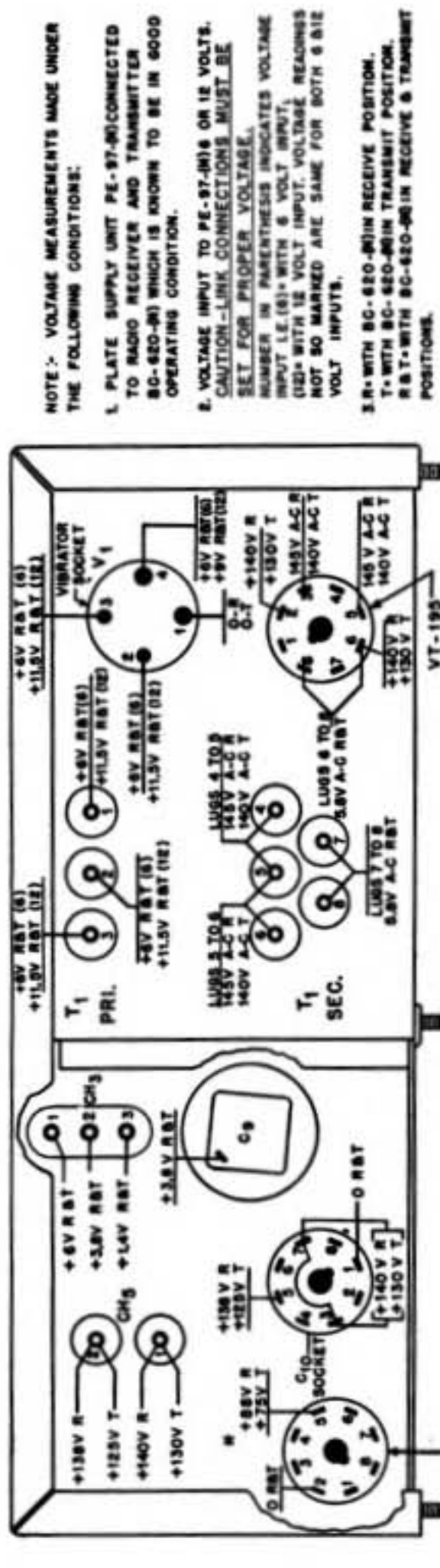
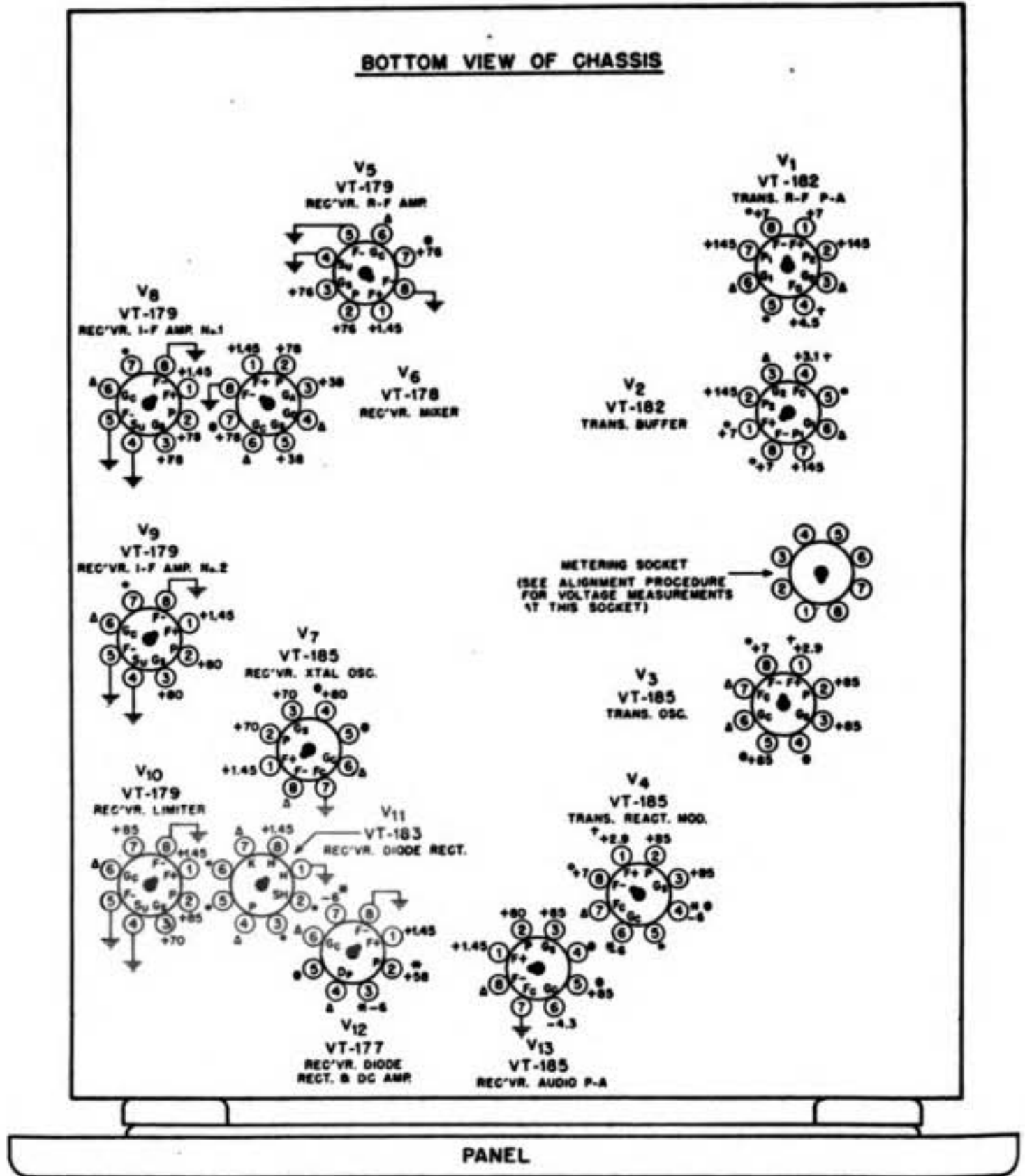

Figure 25. Plate Supply Unit PE-97-(*), Voltage Diagram

- NOTE:** VOLTAGE MEASUREMENTS MADE UNDER THE FOLLOWING CONDITIONS:
1. PLATE SUPPLY UNIT PE-97-(*), CONNECTED TO RADIO RECEIVER AND TRANSMITTER BC-620-8) WHICH IS KNOWN TO BE IN GOOD OPERATING CONDITION.
 2. VOLTAGE INPUT TO PE-97-(*), 6 OR 12 VOLTS. CAUTION—LINK CONNECTIONS MUST BE SET FOR PROPER VOLTAGE.
 3. NUMBER IN PARENTHESIS INDICATES VOLTAGE INPUT LE (6) WITH 6 VOLT INPUT, (12) WITH 12 VOLT INPUT. VOLTAGE READINGS NOT SO MARKED ARE SAME FOR BOTH 6 & 12 VOLT INPUTS.
 3. R WITH BC-620-8) IN RECEIVE POSITION.
T WITH BC-620-8) IN TRANSMIT POSITION.
R & T WITH BC-620-8) IN RECEIVE & TRANSMIT POSITIONS.
 4. VOLTAGES MEASURED WITH TUBE VOLTMETER (RCA VOLT OHMST—STOCK NO. 165, HOKOR 202) OR EQUIVALENT.
 - ALL READINGS ARE IN D-C VOLTS EXCEPT WHERE INDICATED AS A-C.
 - ALL VOLTAGES MEASURED BETWEEN POINT INDICATED AND 8-4BROWN LEAD).
 5. WITH VOLTAGE REGULATOR VT-184 WORKING.
 6. CURRENT DRAIN:
WITH 6 VOLT INPUT:—
2.75 AMPERES IN RECEIVE POSITION.
2.75 AMPERES IN TRANSMIT POSITION.
WITH 12 VOLT INPUT:—
1.85 AMPERES IN RECEIVE POSITION.
2.25 AMPERES IN TRANSMIT POSITION.
 7. ALL VALUES SHOWN ARE NOMINAL.



NOTE: - VOLTAGES MEASURED IN 'RECEIVE' POSITION, EXCEPT WHERE NOTED. ALL VOLTAGES MEASURED BETWEEN CHASSIS AND SOCKET TERMINAL INDICATED, VALUES ARE IN DC VOLTS.

VOLUME CONTROL FULL ON.
METER SWITCH ON 'OPERATE.'
CHANNEL SWITCH 'A' OR 'B'.

VOLTAGES SHOWN ARE OBTAINED BY USING FRESH BATTERIES.

VOLTAGES MEASURED WITH TUBE VOLTMETER (R.C.A. VOLT OHMYST, STOCK NO.-165) (HICKOK-202) OR EQUIVALENT.

Δ WITH ZERO DISCRIMINATOR VOLTS.
† WITH TRANSMITTER SWITCH ON
7 V. WITH TRANSMITTER SWITCH OFF.
* WITH TRANSMITTER SWITCH OFF.
• NO EXTERNAL CONNECTION.

Δ NOT MEASURED.
● SOCKET TERMINAL USED AS TIE OR DUMMY LUG ONLY. NO TUBE ELEMENT CONNECTS TO THIS LUG.

ALL VALUES SHOWN ARE NOMINAL.

Figure 26. Radio Receiver and Transmitter BC-620-(*). Tube Socket Voltage Diagram

SECTION V
SUPPLEMENTARY DATA

	Page
Par. 34 Tabular List of Replaceable Parts.....	74
35 Manufacturers' Names and Addresses.....	128
36 RMA Color Code for Resistors and Capacitors.....	129

34. TABULAR LIST of REPLACEABLE PARTS—a. RADIO RECEIVER & TRANSMITTER BC-620-(*)

Field Stock	Quantity		Ref. No.	Signal Corps Stock No.	Name of Part and Description	Function	Mfr. No. **	Contractor's Part and Drwg. No.
	Depot Stock	In Set						
2		1	C1	3D9010-25	Capacitor Fixed, ceramic; 10 μmf , $\pm 10\%$, Negative temperature coefficient: .0001 $\mu\text{mf}/\mu\text{mf}/^\circ\text{C}$. $\pm 15\%$, Color coded: red, brown, black, black, white. .460" long x .255" diameter. Centralab Type D.	Equalizing, T1.		21A31495
					or:		5	21A36330
1		1	C2	3D9035 V-4	Fixed, ceramic; 10 μmf , $\pm 10\%$, Negative temperature coefficient: -.00010 $\mu\text{mf}/\mu\text{mf}/^\circ\text{C}$. .375" long x .187" diameter. Muter Type F-10	Tuning, T1, Channel B.	1	19K29854
1		1	C3	3D9035V-2	Capacitor Variable, air; 35 μmf maximum. (Rotor wiper lug on right hand side.) —Special	Tuning, T1, Channel A.	1	19K29855
2		2	C4	3D9005 V-2	Capacitor Variable, air; 5 μmf , maximum. (Rotor wiper lug on left hand side.) —Special	Neutralizing V1	1	19B29853

				Also C ₅ .			
		C ₅		Capacitor Same as C ₄ .	Neutralizing V ₁ .		
2	2	C ₆	3D9050 V-30	Capacitor Variable, air; 50 $\mu\mu\text{f}$. maximum. (Rotor wiper lug on right hand side.) —Special	Tuning, L ₂ , Channel A.	1	19K29856
				Also C ₃₇ .			
2	2	C ₇	3D9050 V-29	Capacitor Variable, air; 50 $\mu\mu\text{f}$. maximum. (Rotor wiper lug on left hand side.) —Special	Tuning, L ₂ , Channel B.	1	19K29857
				Also C ₃₈ .			
	1	C ₈	3D9022-1	Capacitor Fixed, ceramic; 22 $\mu\mu\text{f}$, $\pm 5\%$, Negative temper- ature coefficient: .0001 $\mu\mu\text{f}/\mu\mu\text{f}/^\circ\text{C}$. $\pm 15\%$. Color coded: red, red, red, black, green. .460" long x .225" diameter. Centralab Type D.	Padding, L ₂	4	21A31494
				or:			
				Fixed, ceramic; 22 $\mu\mu\text{f}$, $\pm 5\%$, Negative tem- perature coefficient: $-.0001 \mu\mu\text{f}/\mu\mu\text{f}/^\circ\text{C}$. Coded: F-22. .625" long x .187" diameter. Muter Type F-22. Inside and Part of L ₂ .		5	21A36329

* List of Manufacturers' names and addresses follows Tabular List of Replaceable Parts.

76 34. TABULAR LIST of REPLACEABLE PARTS—a. RADIO RECEIVER & TRANSMITTER BC-620-(*) Cont.

Quantity		Ref. No.	Signal Corps Stock No.	Name of Part and Description	Function	Mfr. No. **	Contractor's Part and Drwg. No.
Field Stock	In Set						
		C9		Capacitor Same as C11 except inside and part of L2. or: Fixed, mica; .01 μ f. +14%, -6%, 300 w-v d-c. Color coded: brown, black, orange, blue, or- ange. $\frac{25}{64}$ " square x $\frac{1}{4}$ " thick. Aerovox 1467X (used in some sets).	Bias resistor by-pass, V1.	2	21B6609
6	3	C10	3DA1-48	Capacitor Fixed, mica; .001 μ f. +14%, -6%, 300 w-v d-c. Color coded: brown, black, red. $\frac{1}{16}$ " wide x $\frac{11}{64}$ " long x $\frac{11}{64}$ " depth. Aerovox 1468X. Cornell Dubilier 5LL. Mica- mold XOM. Also C36, C39.	Coupling V2 to V1.	2 3 20	21B6611
24	13	C11	3DA5-24	Capacitor Fixed, ceramic; .005 μ f. +80%, -20%, 300 w-v d-c. $1\frac{1}{16}$ " long x $\frac{5}{16}$ " diameter. —Special or:	Filament by-pass.	1	21A38631

				Fixed, paper; .005 μ f, +80%, -20%, 300 w-v d-c. $1\frac{1}{8}$ " long x $\frac{5}{8}$ " wide x $\frac{3}{32}$ " thick. —Special		1	8A38632
				or:			
				Fixed, mica; .005 μ f, +14%, -6%, 300 w-v d-c. Color coded: green, black, red, blue, orange. $\frac{35}{32}$ " square x $\frac{1}{4}$ " thick. Aerovox 1467X (use in some sets)		2	21B6610
				Also C ₉ , C ₁₇ , C ₁₈ , C ₂₅ , C ₂₆ , C ₃₂ , C ₃₄ , C ₄₃ , C ₄₄ , C ₄₅ , C ₄₇ , C ₆₀ .			
2	2	C ₁₂	3D9075V-1	Capacitor Variable, air; 75 μ μ f, maximum. (Rotor wiper lug on right hand side.) —Special	Tuning L ₃ , Channel A	1	19K29858
				Also C ₄₁ .			
2	2	C ₁₃	3D9075V-2	Capacitor Variable, air; 75 μ μ f, maximum. (Rotor wiper lug on left hand side.) —Special	Tuning L ₃ , Channel B	1	19K29859
				Also C ₄₂ .			

**List of Manufacturers' names and addresses follows Tabular List of Replaceable Parts.

34. TABULAR LIST of REPLACEABLE PARTS—**a. RADIO RECEIVER & TRANSMITTER BC-620-(*) Cont.**

Field Stock	Quantity		Ref. No.	Signal Corps Stock No.	Name of Part and Description	Function	Mfr. No. **	Contractor's Part and Drwg. No.
	Depot Stock	In Set						
		3	C ₁₄	3D9050-62	Capacitor Fixed, ceramic; 50 $\mu\mu\text{f}$, $\pm 5\%$. Negative temperature coefficient: $.0001 \mu\mu\text{f}/\mu\mu\text{f}/^\circ\text{C}$. $\pm 15\%$. Color coded: red, green, black, black, green. $.460''$ long x $.225''$ diameter. Centralab Type D. or: Fixed, ceramic; 50 $\mu\mu\text{f}$, $\pm 5\%$. Negative temperature coefficient: $-.0001 \mu\mu\text{f}/\mu\mu\text{f}/^\circ\text{C}$. $.750''$ long x $.250''$ diameter. Muter Type F-50. Inside and part of L ₃ . Also C ₁₅ , C ₇₂ .	Padding L ₃ .	4	21A31496
			C ₁₅		Capacitor Same as C ₁₄ . Inside and part of L ₃ .	Padding L ₃ .	5	21A36332
2		1	C ₁₆	3D9250-24	Capacitor Fixed, mica; 250 $\mu\mu\text{f}$, $+14\%$ -6% , 400 w-v d-c. Color coded: red, green, brown. $\frac{1}{16}''$ wide x $1\frac{1}{16}''$ long x $1\frac{1}{64}''$ depth.	Coupling V ₃ to V ₂ .	2 3	21B6613
			C ₁₇		Capacitor Same as C ₁₁ .	Screen grid by-pass, V ₂ .		

				or: Fixed, mica; .01 μ f, +14%, -6%, 300 w-v d-c. Color coded: brown, black, orange, blue. orange. $\frac{25}{32}$ " square x $\frac{1}{4}$ " thick. Aerovox 1467X (use in some sets).		2	21B6609
		C ₁₈		Capacitor Same as C ₁₁	Filament by-pass.		
				or: Fixed, mica; .01 μ f, +14%, -6%, 300 w-v d-c. Color coded: brown, black, orange, blue. orange. $\frac{25}{32}$ " square x $\frac{1}{4}$ " thick. Aerovox 1467X (Use in some sets.)		2	21B6609
2	1	C ₁₉	3D9050-35	Capacitor Fixed, mica; 50 μ μ f, +14% -6%, 400 w-v d-c. Color coded: green, black, black. $\frac{1}{16}$ " wide x $1\frac{1}{16}$ " long x $1\frac{1}{64}$ " depth.	Grid leak by-pass, V ₃ .	2 3	21B6614
1	1	C ₂₀	3D9140V-5	Capacitor Variable, air; 140 μ μ f. maximum. (Rotor wiper lug on right hand side.) —Special	Tuning, L ₄ , Channel A.	1	19K29862
1	1	C ₂₁	3D9140V-6	Capacitor Variable, air; 140 μ μ f. maximum. (Rotor wiper lug on left hand side.) —Special	Tuning, L ₄ , Channel B.	1	19K29863

**List of Manufacturers' names and addresses follows Tabular List of Replaceable Parts.

34. TABULAR LIST of REPLACEABLE PARTS—a. RADIO RECEIVER & TRANSMITTER BC-620-(*) Cont.

Quantity			Ref. No.	Signal Corps Stock No.	Name of Part and Description	Function	Mfr. No. **	Contractor's Part and Drwg. No.
Field Stock	Depot Stock	In Set						
		1	C ₂₂	3D9080-2	<p>Capacitor Fixed, ceramic; 80 $\mu\mu\text{f}$. $\pm 2\%$. Negative temperature coefficient: .0001 $\mu\mu\text{f}/\mu\mu\text{f}/^\circ\text{C}$, $\pm 10\%$. Color coded: red, gray, black, black, red. .860" long x .225" diameter. Centralab Type D.</p> <p>or:</p> <p>Fixed, ceramic; 80 $\mu\mu\text{f}$. $\pm 2\frac{1}{2}\%$. Temperature coefficient: -.00010 $\mu\mu\text{f}/\mu\mu\text{f}/^\circ\text{C}$. 1.078" long x .250" diameter. Muter Type F-80. Inside and part of L₄.</p>	Padding, L ₄ .	4	21A31497
2		1	C ₂₃	3DA1-81	<p>Capacitor Fixed, mica; .001 μf. $\pm 5\%$, 200 w-v d-c. Color coded: brown, black, red. $\frac{1}{16}$" wide x $1\frac{1}{16}$" long x $\frac{3}{16}$" depth.</p>	Coupling, V ₄ to V ₃ .	3	21B6615
			C ₂₅		<p>Capacitor Same as C₁₁.</p> <p>or:</p>	Filament by-pass.		

Par. 34 RADIO SETS SCR-509-(*) AND SCR-510-(*) TM 11-605

34. TABULAR LIST of REPLACEABLE PARTS—a. RADIO RECEIVER & TRANSMITTER BC-620-(*) Cont.

Quantity			Ref. No.	Signal Corps Stock No.	Name of Part and Description	Function	Mfr. No. **	Contractor's Part and Drwg. No.
Field Stock	Depot Stock	In Set						
2		1	C ₃₀	3D9005-20	Capacitor Fixed, paper; .5 μ f, \pm 20%, 200 w-v d-c. Shielded and oil filled. Mounting lugs attached. 2.125" centers with .187" diameter holes. —Special	Audio by-pass, T ₂ .	1	8A31231
2		1	C ₃₁	3DB25-12	Capacitor Electrolytic, strap mounting; 25 μ f. 25 w-v d-c. 1 $\frac{3}{16}$ " long x 1 $\frac{1}{16}$ " diameter. —Special	Microphone current filter.	1	23A31226
			C ₃₂		Capacitor Same as C ₁₁ . or: Fixed, mica; .01 μ f, +14%, -6%, 300 w-v d-c. Color coded: brown, black, orange, blue orange. $\frac{35}{32}$ " square x $\frac{1}{4}$ " thick. Acrovox 1467X (Used in some sets).	R-F by-pass	2	21B6609
			C ₃₃		Capacitor Same as C ₂₉ .	R-F by-pass, V ₃ , grid metering lead.		
			C ₃₄		Capacitor Same as C ₁₁ .	B+, r-f by-pass, V ₁ .		

Par. 34 RADIO SETS SCR-509-(*) AND SCR-510-(*) TM 11-605

C35	Capacitor Same as C28	Receiver antenna coupling.	
C36	Capacitor Same as C10.	Coupling, V5 to V6.	
C37	Capacitor Same as C6.	Tuning, L5 Channel B.	
C38	Capacitor Same as C7.	Tuning, L6, Channel A.	
C39	Capacitor Same as C10.	Crystal feed-back coupling.	
C40	Capacitor Fixed, mica; 25 μ f. \pm 5%, 300 w-v d-c. Color coded: red, green, black. $1\frac{1}{16}$ " long x $\frac{3}{16}$ " wide x $1\frac{1}{16}$ " thick. Aerovox Type 1469	Plate blocking, V7.	2 21B6618 3 22
C41	Capacitor Same as C12.	Tuning, L6, Channel B.	
C42	Capacitor Same as C13.	Tuning, L6, Channel A.	
C43	Capacitor Same as C11.	Screen grid by-pass, V7.	

88 **List of Manufacturers' names and addresses follows Tabular List of Replaceable Parts.

34. TABULAR LIST of REPLACEABLE PARTS—a. RADIO RECEIVER & TRANSMITTER BC-620-(*) Cont.

Quantity		Ref. No.	Signal Corps Stock No.	Name of Part and Description	Function	Mfr. No. **	Contractor's Part and Drwg. No.
Field Stock	In Set						
		C44		Capacitor Same as C11.	R-F by-pass, V7, output metering lead.		
		C45		Capacitor Same as C11. or: Fixed, mica; .01 μ f, +14%, -6%, 300 w-v d-c. Color coded: brown, black, orange, blue, orange. $\frac{5}{16}$ " square x $\frac{1}{4}$ " thick. Aerovox 1467X (used in some sets)	Screen and anode grids r-f by-pass, V6.	2	21B6609
	7	C46	3D9020-3	Capacitor Fixed, ceramic; 20 μ f, \pm 5%. Negative temperature coefficient: .0001 μ f/ μ f/ $^{\circ}$ C. \pm .00003 Color coded: red, red, black, black, green. .460" long x .225" diameter. or: Fixed, ceramic; 20 μ f, \pm 5%. Negative temperature coefficient -.0001. .625" long x .187" diameter. Muter Type F-20. Inside and part of T3. —Centralab Type D.	Padder, T3 primary.	4	21A31492
						5	21A36331

				Also C48, C51, C53, C55, C57, C71.			
		C47		Capacitor Same as C11	B+, r-f by-pass, V5, V6.		
				or			
				Fixed, mica; .01 μ f, +14%, -6%, 300 w-v d-c. Color coded: brown, black, orange, blue, orange. $\frac{3}{16}$ " square x $\frac{1}{4}$ " thick. Aerovox 1467X (used in some sets)		2	21B6609
		C48		Capacitor Same as C46. Inside and part of T3.	Padder, T3 secondary.		
6	3	C49	3DA130-1	Capacitor Fixed, paper; .13 μ f, \pm 20%, 100 w-v d-c. Overall dimensions $1\frac{1}{8}$ " long x $\frac{3}{16}$ " diameter. Shielded and oil filled, mounting bracket ex- truded and tapped 6-32, full thread —Special	Filament by-pass.	1	8A31212
		C50		Capacitor Same as C39.	R-F by-pass, V7, grid metering lead.		
		C51		Capacitor Same as C46. Except inside and part of T4.	Padder, T4 primary.		

34. TABULAR LIST of REPLACEABLE PARTS—a. RADIO RECEIVER & TRANSMITTER BC-620-(*) Cont.

Quantity			Ref. No.	Signal Corps Stock No.	Name of Part and Description	Function	Mfr. No. **	Contractor's Part and Drwg. No.
Field Stock	Depot Stock	In Set						
4		2	C52	3DA250-17	Capacitor Fixed, paper; .25 μ f. \pm 20%, 200 w-v d-c. (oil filled). $1\frac{1}{16}$ " long x $\frac{7}{8}$ " diameter. —Special Also C56.	B+, r-f by-pass, V8.	1	8A31207
			C53		Capacitor Same as C46. Except inside and part of T4.	Padder, T4 secondary.		
			C54		Capacitor Same as C49.	Filament by-pass.		
			C55		Capacitor Same as C46. Except inside and part of T5.	Padder, T5 primary.		
			C56		Capacitor Same as C52.	B+, r-f by-pass, V9.		
			C57		Capacitor Same as C46. Except inside and part of T5.	Padder, T5 secondary.		
		1	C58	3D9100-46	Capacitor Fixed, mica; 100 μ μ f, +14%, -6%, 400 w-v d-c. Color coded: brown, black, brown. $\frac{7}{16}$ " wide x $1\frac{1}{16}$ " long x $1\frac{1}{64}$ " depth. Inside and part of T5. Aerovox Type 1468X.	Bias resistor by-pass, V10.	2 3 20	21B6620

Par. 34 RADIO SETS SCR-509-(*) AND SCR-510-(*) TM 11-605

2	1	C ₅₉	3DA50-43	Capacitor Fixed, paper; .05 μ f, \pm 20%, 600 w-v d-c. (oil filled). 1 $\frac{1}{8}$ " long x $\frac{3}{8}$ " diameter. —Special	B+, r-f by-pass V ₁₀ .	1	8A31211
		C ₆₀		Capacitor Same as C ₁₁ . or: Fixed, mica; .01 μ f, +14%, -6%, 300 w-v d-c. Color coded: brown, black, orange, blue, orange. $\frac{3}{8}$ " square x $\frac{1}{4}$ " thick. Aerovox 1467X (used in some sets)	Screen grid by-pass, V ₁₀ .	2	21B6609
		C ₆₁	3D9060V	Capacitor Variable, air; 2 sections, 28 μ f, minimum, 60 μ f maximum each. (Part of C ₆₃). —Special (Used in some sets. Replaced by C ₆₉ and C ₇₁).	Tuning, T ₆ primary.	1	Part of 19B30267
		C ₆₂	3D9100-81	Capacitor Fixed, mica; 100 μ f, \pm 5%, 300 w-v d-c. Color coded: brown, black, brown. $\frac{1}{8}$ " wide x $\frac{1}{8}$ " long x $\frac{1}{4}$ " depth. Aerovox Type 1469. Inside and part of T ₆ .	T ₆ , Coupling.	2 3 20	21B6619
		C ₆₃		Capacitor Same as C ₆₁ . (Part of C ₆₁). (Used in some sets. Replaced by C ₇₀).	Tuning, T ₆ secondary.		

34. TABULAR LIST of REPLACEABLE PARTS—a. RADIO RECEIVER & TRANSMITTER BC-620-(*) Cont.

Quantity			Ref. No.	Signal Corps Stock No.	Name of Part and Description	Function	Mfr. No. **	Contractor's Part and Drwg. No.
Field Stock	Depot Stock	In Set						
		1	C64	3D9025-35	Capacitor Fixed, ceramic; 25 $\mu\mu\text{f}$, $\pm 5\%$. Negative temperature coefficient: $.00015 \mu\mu\text{f}/\mu\mu\text{f}/^{\circ}\text{C} \pm 15\%$. Color coded: orange, red, green, black, green. $.460''$ long x $.225''$ diameter Centralab Type D. (Used in some sets. Replaced by C72).	Padding, T ₆ secondary.	4	21A31493
2		1	C65		Capacitor Fixed, ceramic, $.01 \mu\text{f}$, 500 w-v d-c. $1\frac{1}{16}''$ long x $\frac{5}{16}''$ diameter. —Special or: Fixed, styramic paper; $.01 \mu\text{f}$, $\pm 20\%$, 300 w-v d-c. $1\frac{1}{16}''$ long x $\frac{5}{8}''$ wide x $\frac{1}{4}''$ thick. or: Fixed, molded paper; $.01 \mu\text{f}$, $\pm 20\%$, 300 w-v d-c. Color coded: brown, black, orange, orange, black. $1\frac{5}{16}''$ long x $\frac{5}{8}''$ wide x $\frac{1}{4}''$ thick.	Audio coupling. V ₁₁ to V ₁₃ .	5 1	21A83389
			C66		Capacitor Same as C29	Discriminator load by-pass	19 20	8A38299 8A38382

Par. 34

RADIO SETS SCR-509-(*) AND SCR-510-(*)

TM 11-605

2	1	C ₆₇		Capacitor Same as C ₄₉ .	Audio by-pass, V ₁₃ , control grid.	5	21A47005
		C ₆₈		Capacitor Fixed, silver ceramic; .005 μ f, 300 w-v d-c. 1 $\frac{1}{16}$ " long x $\frac{5}{16}$ " diameter.	Audio compensation.		
		C ₆₉		Capacitor Variable, air; 2 sections, 7.5 μ μ f minimum, 45 μ μ f maximum. (Part of C ₇₀). Inside and part of T ₆ . —Special (Used in most sets. See C ₆₁).	Tuning, T ₆ primary.		
4	2	C ₇₀		Capacitor Same as C ₆₉ , (Part of C ₆₉ .) Inside and part of T ₆ . (Used in most sets. See C ₆₃).	Tuning, T ₆ secondary.	1	24A31706
		C ₇₁	3D9020-14	Capacitor Same as C ₄₆ . Except inside and part of T ₆ . (Used in most sets. See C ₆₁).	Padding, T ₆ primary.		
		C ₇₂		Capacitor Same as C ₁₄ . Inside and part of T ₆ . (Used in most sets. See C ₆₄).	Padding, T ₆ secondary.		
		CH ₁	3C362	Choke, Low r-f Single layer solenoid; 45 turns No. 24 enam- eled wire. White wax dipped. (Inductance— 5.58 μ h at 4 megacycles). —Special (Also CH ₄).	Plate, V ₁ .		

**List of Manufacturers' names and addresses follows Tabular List of Replaceable Parts.

34. TABULAR LIST of REPLACEABLE PARTS—a. RADIO RECEIVER & TRANSMITTER BC-620-(*) Cont.

Quantity		Ref. No.	Signal Corps Stock No.	Name of Part and Description	Function	Mfr. No. **	Contractor's Part and Drwg. No.
Field Stock	In Set						
8	4	CH ₂	3C362-1	Choke, r-f 3 pie; 185 turns No. 38 single celanese wire per pie. White wax dipped. (Inductance—1.14 μh at 300 kilocycles). —Special (Also CH ₃ , CH ₅ , CH ₈ .)	Plate, V ₂ .	1	24A31705
		CH ₃		Choke, r-f Same as CH ₂ .	Plate, V ₃ .		
		CH ₄		Choke, Low r-f Same as CH ₁ .	Filament, V ₃ .		
		CH ₅		Choke, r-f Same as CH ₂ .	Plate, V ₄ .		
2	1	CH ₆	3C549	Choke, Microphone Hash Shielded; 500 ohm d-c resistance. (Inductance 1.3 henries at 60 cycles. —Special	Hash filter.	1	25A31206
2	1	CH ₇	3C362-12	Choke, High "L" r-f Single layer solenoid; 190 turns No. 36 plain enameled wire. White wax dipped. (Inductance—97 μh at 1000 kilocycles). —Special	Plate, V ₅	1	24A31707

	CHs	Choke, r-f Same as CH ₂ .	Plate, V ₇ .	
2	1	CH ₁ 3C362-13	1	Filament filter, receiver. 24A31726
100	1	F ₁ 3Z2595.6	11	Meter protector. 65X40217 (No. drwg.)
	1	J ₁ 2Z5572	1	Microphone plug receptacle 40A30454
	1	J ₂ 2Z5570	1	Headphone plug receptacle. 40A30453
1	1	L ₁ 2C5360A/ A4		Adjustable antenna. 24B30497

749368 O - 47 - 7

*List of Manufacturers names and addresses follows Tabular List of Replaceable Parts.

91

34. TABULAR LIST of REPLACEABLE PARTS—a. RADIO RECEIVER & TRANSMITTER BC-620-(*) Cont.

Quantity			Ref. No.	Signal Corps Stock No.	Name of Part and Description	Function	Mfr. No. **	Contractor's Part and Drwg. No.
Field Stock	Depot Stock	In Set						
1		1	L ₂	2C5360A/A5	Coil & Shield P.A. Grid 7 turns No. 18 solid tinned (bare) copper wire, space wound on 3/4" diameter form. Aluminum shield can. Includes C ₈ , C ₉ , R ₁ and R ₂ . —Special	V ₁ , grid tank coil.	1	24B30493
1		1	L ₃	2C5360A/A6	Coil & Shield, Buffer Grid 17 turns No. 20 solid tinned (bare) copper wire, space wound on 3/4" diameter form. Aluminum shield can. Includes C ₁₄ , C ₁₅ and R ₄ . —Special	V ₂ , grid tank coil.	1	24B30494
1		1	L ₄	2C5360/A7	Coil & Shield, Transmitter Oscillator 17 3/4 turns No. 22 solid tinned (bare) copper wire, space wound on ceramic form. Aluminum shield can. Includes C ₂₂ . —Special	Osc. V ₃ , tank coil.	1	24B30495
1		1	L ₅	2C5360A/A8	Coil & Shield, Mixer Grid 7 turns No. 18 solid tinned (bare) copper wire, space wound on 3/4" diameter form. Aluminum shield can. —Special	V ₆ , Control Grid tuning.	1	24B30352
1		1	L ₆	2C5360A/A9	Coil & Shield Receiver Oscillator 10 turns No. 18 solid tinned (bare) copper wire, space wound on 3/4" diameter form. Aluminum shield can —Special	V ₇ , Oscillator tank.	1	24B30491

1	1	M ₁	3F898	Meter 0-8 ma. Luminous pointer and mark on dial. 3.2 ohms internal resistance. —Special	Indicates: rec'vr. Fil. voltage; trans. plate voltage for V ₁ and V ₂ , and V ₁ grid and plate current.	1	59B30011
	1	P ₁	2Z7229	Plug 5 pin (on internal battery box) plug. Pins are $\frac{5}{8}$ " long. Insulated base in $1\frac{1}{2}$ " long x 1" wide x $\frac{1}{16}$ " thick. Cinch #M-50	Battery BA-41 connector.	10	28A30250
	1	P ₂	2A7229-1	Plug 8 pin connector, consisting of plug, clamp ring and back shield. Overall dimensions of complete assembly: $2\frac{3}{8}$ " long x $1\frac{5}{8}$ " diameter. —Special	Power and control cable plug.	1	28A30437
	1	R ₁	3Z6270-5	Resistor Fixed, carbon; 2700 ohms, $\pm 10\%$, $\frac{1}{2}$ watt, insulated. Inside and part of L ₂ . Erie Type 504 Ins., Stackpole Type MB- $\frac{1}{2}$ Ins. $\frac{1}{16}$ " long x .218" diameter. I.R.C. Type BT- $\frac{1}{2}$ Ins. $\frac{5}{8}$ " long x .187" diameter.	Grid bias, V ₁ .	8 12 21	6B5577
	1	R ₂	3Z6010-39	Resistor Fixed, carbon; 100 ohms, $\pm 5\%$, $\frac{1}{2}$ watt, insulated. Inside and part of L ₂ . Erie Type 504 Ins., Stackpole Type MB- $\frac{1}{2}$ Ins. $\frac{1}{16}$ " long x .218" diameter.	Meter shunt.	8 21	6B6408

**List of Manufacturers' names and addresses follows Tabular List of Replaceable Parts.

34. TABULAR LIST of REPLACEABLE PARTS—a. RADIO RECEIVER & TRANSMITTER BC-620-(*) Cont.

Quantity			Ref. No.	Signal Corps Stock No.	Name of Part and Description	Function	Mfr. No. **	Contractor's Part and Drwg. No.
Field Stock	Depot Stock	In Set						
8		2	R ₃	3Z6005A-6	Resistor Fixed, molded wire wound; 56 ohms $\pm 10\%$, $\frac{1}{2}$ watt, insulated. $\frac{5}{8}$ " long x $\frac{3}{16}$ " diameter. I.R.C. Type BW- $\frac{1}{2}$. or: Fixed, carbon; 56 ohms, $\pm 10\%$, $\frac{1}{2}$ watt, insulated. $\frac{1}{16}$ " long x .218" diameter. Erie Type 504 Ins., Stackpole Type MB- $\frac{1}{2}$ Ins. Also R ₄₂	Filament equalizing.	12	17K34116
			R ₄	3Z6622-2	Resistor Same as R ₂₀ . Except inside and part of L ₃ .	Grid bias, V ₂ .	8 21	6B5614
8		2	R ₅	3Z6627-1	Resistor Fixed, carbon; 27,000 ohms, $\pm 10\%$, $\frac{1}{2}$ watt, insulated. Erie Type 504 Ins., Stackpole Type MB- $\frac{1}{2}$ Ins. $\frac{1}{16}$ " long x .218" diameter. I.R.C Type BT- $\frac{1}{2}$ Ins. $\frac{5}{8}$ " long x .187" diam. Also R ₉ .	Grid leak, V ₃ .	8 12 21	6B6434

8	2	R ₆	3Z6330-1	Resistor Fixed, carbon; 3,300 ohms, $\pm 10\%$. $\frac{1}{2}$ watt, insulated. Erie Type 504 Ins., Stackpole Type MB- $\frac{1}{2}$ Ins. $\frac{1}{16}$ " long x .218" diameter. I.R.C. Type BT- $\frac{1}{2}$ Ins. $\frac{5}{8}$ " long x .187" diam. Also R ₂₅ .	B+, decoupling, V ₄ .	8 12 21	6B5581
4	1	R ₇	3Z6506-3	Resistor Fixed, carbon; 5,600 ohms, $\pm 10\%$. $\frac{1}{2}$ watt, insulated. Erie Type 504 Ins., Stackpole Type MB- $\frac{1}{2}$ Ins. $\frac{1}{16}$ " long x .218" diameter. I.R.C. Type BT- $\frac{1}{2}$ Ins. $\frac{5}{8}$ " long x .187" diam.	Osc. mod. phase shift.	8 12 21	6B6117
	1	R ₈	3Z6010-18	Resistor Fixed, wire-wound; 100 ohms, $\pm 10\%$. $\frac{1}{2}$ watt, insulated. I.R.C. Type BW- $\frac{1}{2}$. (replaced by R ₄₂ after number 860 on Order No. 19912-Phila-43).	Filament equalizing.	12	17K34117
		R ₉	3Z6627-1	Resistor Same as R ₅ .	R-F filter, V ₄ grid.		
8	6	R ₁₀	3Z6747-10	Resistor Fixed, carbon; 470,000 ohms, $\pm 10\%$. $\frac{1}{2}$ watt, insulated. Erie Type 504 Ins., Stackpole Type MB- $\frac{1}{2}$ Ins. $\frac{1}{16}$ " long x .218" diameter. I.R.C. Type BT- $\frac{1}{2}$ Ins. $\frac{5}{8}$ " long x .187" diam.	Voltage divider, T ₂ .	8 12 21	6B6377

**List of Manufacturers' names and addresses follows Tabular List of Replaceable Parts.

34. TABULAR LIST of REPLACEABLE PARTS—a. RADIO RECEIVER & TRANSMITTER BC-620-(*) Cont.

Field Stock	Quantity		Ref. No.	Signal Corps Stock No.	Name of Part and Description	Function	Mfr. No. **	Contractor's Part and Drwg. No.
	Depot Stock	In Set						
4		1	R ₁₁	3Z6656-1	<p>Also R₁₈, R₂₁, R₂₂, R₂₇, R₂₉.</p> <p>Resistor Fixed, carbon; 56,000 ohms. ±10%, ½ watt, insulated. Erie Type 504 Ins., Stackpole Type MB-½ Ins. ¼" long x .218" diameter. I.R.C. Type BT-½ Ins. ⅝" long x .187" diam.</p>	Voltage divider, T ₂ .	8 12 21	6B6378
		1	R ₁₂	3Z5992-1	<p>Resistor Fixed, wire-wound; 2.2 ohms, ±10%, ½ watt, insulated. ⅝" long x ⅜" diameter. I.R.C. Type BW-½.</p> <p>(Replaced by R₄₁ after Serial No. 860 on Order No. 19912-Phila-43.)</p>	Filament dropping.	61	17K34115
		1	R ₁₃	3Z6010-46	<p>Resistor Fixed, wire-wound; 100 ohms, ±10%, 1 watt insulated. 1¼" long x ¼" diameter. I.R.C. Type BW-1 (Used on some sets. Replaced by F₂).</p>	Meter protection.	61	17K31423

16	5	R ₁₄	3Z6801-36	Resistor Fixed, carbon; 1 megohm, ±10%, ½ watt, insulated. Erie Type 504 Ins., Stackpole Type MB-½ Ins. ⅜" long x .218" diameter. I.R.C. Type BT-½ Ins. ⅜" long x .187" diam. Also R ₁₇ , R ₁₉ , R ₃₀ , R ₃₃ .	Isolating, V _s grid metering lead.	8 12 21	6B6046			
4	1	R ₁₅	3Z5991-4	Resistor Fixed, wire-wound; 1 ohm, ±10%, ½ watt, insulated. ⅜" long x ⅜" diameter. I.R.C. Type BW-½. or: Fixed, carbon; 1 ohm, ±10%, ½ watt, insulated. ⅜" long x .218" diameter. Erie Type 504 Ins.	Meter shunt.	12	17K31449			
4	1	R ₁₆	3Z6620-65	Resistor Fixed, carbon; 20,000 ohms, ±5%, 1 watt, insulated. Erie Type 518 Ins., Stackpole Type MB-1 Ins. ⅜" long x .281" diameter.	Meter multiplier.	8 21	6B5616 6B5582			
		R ₁₇		Resistor Same as R ₁₄ .	Grid leak V _s .					

••List of Manufacturers' names and addresses follows Tabular List of Replaceable Parts.

34. TABULAR LIST of REPLACEABLE PARTS—a. RADIO RECEIVER & TRANSMITTER BC-620-(*) Cont.

Quantity			Ref. No.	Signal Corps Stock No.	Name of Part and Description	Function	Mfr. No. **	Contractor's Part and Drwg. No.
Field Stock	Depot Stock	In Set						
			R ₁₈		Resistor Same as R ₁₀ .	Control grid bias, V ₇ .		
			R ₁₉		Resistor Same as R ₁₄ .	Isolating V ₇ , grid metering lead.		
4		2	R ₂₀	3Z6622-2	Resistor Fixed, carbon; 22,000 ohms, ±10%, ½ watt, insulated. Erie Type 504 Ins., Stackpole Type MB-½ Ins. ¼" long x .218" diameter I.R.C. Type BT-½ Ins. ⅝" long x .187" diam. Also R ₄	Screen and anode grids voltage dropping, V ₆ .	8 12 21	6B6397
			R ₂₁		Resistor Same as R ₁₀ . Except inside and part of T ₃ .	Loading, T ₃ primary.		
			R ₂₂		Resistor Same as R ₁₀ . Except inside and part of T ₃ .	Loading, T ₃ secondary.		
16		4	R ₂₃	3Z6047	Resistor Fixed, carbon; 470 ohms, ±10%, ½ watt, Erie Type 504 Ins., Stackpole Type MB-½ Ins. ¼" long x .218" diameter. I R.C. Type BT-½ Ins. ⅝" long x .187" diam.	B+, decoupling, V ₅ and V ₆ .	8 12 21	6B6090

			Also R ₂₈ , R ₃₂ , R ₃₄ .					
	R ₃₄		Resistor Same as R ₃₆					Metering, V ₆ , injection grid bias.
	R ₂₈	3Z6330-1	Resistor Same as R ₆ .					V ₇ , B+ decoupling.
4	1	R ₃₆	3Z6020-7	Resistor Fixed, wire-wound; 200 ohms, ±5%, ½ watt, insulated. ⅝" long x ⅜" diameter. I.R.C. Type BW-½.			12	17A31417
			or:					
			Fixed, carbon; 200 ohms, ±5%, ½ watt, insulated. Erie Type 504 Ins., Stackpole Type MB-½ Ins.				8 21	6B5613
	R ₃₇		Resistor Same as R ₁₀ . Except inside and part of T ₄ .					Loading, T ₄ .
	R ₂₈		Resistor Same as R ₃₃					B+ decoupling, V ₈
	R ₂₉		Resistor Same as R ₁₀ . Except inside and part of T ₅ .					Loading, T ₅ .

••List of Manufacturers' names and addresses follows Tabular List of Replaceable Parts.

34. TABULAR LIST of REPLACEABLE PARTS—a. RADIO RECEIVER & TRANSMITTER BC-620-(*) Cont.

100

Quantity			Ref. No.	Signal Corps Stock No.	Name of Part and Description	Function	Mfr. No. **	Contractor's Part and Drwg. No.
Field Stock	Depot Stock	In Set						
			R30		Resistor Same as R14. Except inside and part of T8.	Isolating, V10, grid metering lead.		
			R31		Resistor Same as R33. Except inside and part of T8.	Grid bias, V10		
			R32		Resistor Same as R23	B+ decoupling, V9.		
8		3	R33	3Z4550	Resistor Fixed, carbon; 100,000 ohms, ±10%, ½ watt, insulated. Erie Type 504 Ins., Stackpole Type MB-½ Ins. ¼" long x .218" diameter. I R.C. Type BT-½ Ins. ⅝" long x .187" diam. Also R31, R40.	Screen grid dropping, V10.	8 12 21	6B6031
			R34		Resistor Same as R23.	B+ decoupling, V10.		
			R35		Resistor Same as R14.	Plate load, V12.		

16	4	R ₃₆	3Z6727	Resistor Fixed, carbon; 270,000 ohms, ±10%, ½ watt, insulated. Erie Type 504 Ins., Stackpole Type MB-½ Ins. ¼" long x .218" diameter. I.R.C. Type BT-½ Ins. ¼" long x 187" diam.	Discriminator load.	8 12 21	6B6414
				Also R ₃₄ , R ₃₇ , R ₃₈ .			
		R ₃₇		Resistor Same as R ₃₆ .	Discriminator load.		
		R ₃₈		Resistor Same as R ₃₆ .	Audio frequency filter V ₁₂ .		
2	1	R ₃₉	2Z7262.2	Potentiometer 1 megohm (also includes SW ₁₃ and SW ₁₃ on back). Overall dimensions including switches: 1¼" long x 1¼" diameter. Mounting bushing ¼" long, ⅜-32 thread. —Special	Volume control	1	18B31441
		R ₄₀	2Z4550	Resistor Same as R ₃₃ .	Loading, V ₅ plate choke.		
4	1	R ₄₁		Resistor Fixed, carbon; 3.3 ohms, ±10%, ½ watt, insulated. ¼" long x .218" diameter. Erie Type 504 Ins. (Replaced R ₁₃ after Serial No. 860 on Order No. 19912-Phila-43).	Filament droppng, V ₄ .	8	6B5680

••List of Manufacturers' names and addresses follows Tabular List of Replaceable Parts

102 34. TABULAR LIST of REPLACEABLE PARTS—a. RADIO RECEIVER & TRANSMITTER BC-620-(*) Cont.

Quantity		Ref. No.	Signal Corps Stock No.	Name of Part and Description	Function	Mfr. No. **	Contractor's Part and Drwg. No.
Field Stock	Depot Stock						
				or: Fixed, wire-wound; 3.3 ohms, = 10%, 1/2 watt, 5/8" long x 3/16" diameter I.R.C. Type BW-1/2.		12	17K47557
		R42		Resistor Same as R3. (Replaced R3 after Serial No. 860 on Order No. 19912-Phila-43).	Filament equalizing.		
4				Resistor Fixed, molded wire wound; 220 ohms, = 10%, 1/2 watt. 5/8" long x 3/16" diameter. I.R.C. Type BW-1/2.	Filament Shunt, V3.	12	17K47552
		R43		or: Fixed, carbon; 220 ohms, = 10%, 1/2 watt, insulated. 7/16" long x .218" diameter. Erie Type 504 Ins., Stackpole Type MB-1/2 Ins. 5/8" long x .187" diam. I.R.C. Type BT-1/2 Ins. (Added after Serial No. 860 on Order No. 19912-Phila-43)		8 12 21	6B6270

				Filament shunt, V ₄ .		
4	1	R ₄₄	Resistor Fixed, carbon; 180 ohms, ±10%, ½ watt, insulated. ⅞" long x .218" diameter. Erie Type 504 Ins.. Stackpole Type MB-½ Ins. or: Fixed, wire wound; 180 ohms, ±10%, ½ watt. Molded case. ⅞" long x ⅜" diameter. I.R.C. Type BW-½. (Added after Serial No. 860 on Order No. 19912-Phila-43).	8 21	17K47553	
20	1	SO ₁	Socket Octal, molded. Type 88-8TM.	Metering socket.	9A6799	
10	1	SO ₂	Socket 2 crystal receptacle. —Special	Crystal socket.	9A30451	
		SW ₁		Channel changing, ant. loading tape.		
		SW ₂		Channel changing, V ₁ plate.		
		SW ₃		Channel changing, V ₁ grid.		
		SW ₄	Switch, Channel Ganged; 3 section, 2 position. Complete switch	Channel changing, V ₂ grid.	40B30016	

*List of Manufacturers' names and addresses follows List of Replaceable Parts.

34. TABULAR LIST of REPLACEABLE PARTS—a. RADIO RECEIVER & TRANSMITTER BC-620-(*) Cont.

Quantity		Ref. No.	Signal Corps Stock No.	Name of Part and Description	Function	Mfr. No. **	Contractor's Part and Drwg. No.
Field Stock	Depot Stock						
2		SW 5	3Z9825-24	is 7 ¹⁵ / ₁₆ " long. Brass mounting bushing ³ / ₈ " long with ³ / ₈ -32 thread. Spring contacts are silver-plated. All metal parts are tin-plated. —Special	Channel changing, V ₃ grid. Channel changing, V ₆ grid. Channel changing, crystals.		
		SW 6	3Z9825-24				
		SW 7	3Z9825-24				
		SW 8	3Z9825-24		Channel changing, V ₆ Osc.		
1		SW 9	3Z9822-2	Switch Meter 2 pole, 4 position. Contacts silver plated. Spring brass. Mounting bushing ¹ / ₄ " long, ³ / ₈ -32 thread. —Special	Meter function selector.	1	40A30009
		SW 10	3Z9853-3	Switch, Toggle Single pole, single throw (Includes mounting nuts and indicator plate). Mounting bushing ¹⁵ / ₁₆ " long, ¹⁵ / ₁₆ -32 thread. Rating 3 amps. at 125 v. —Special Also SW 11.	Trans. buffer plate B+ switch.	1	40A30035
		SW 11	3Z9853-3	Switch, Toggle Same as SW 10	P.A. Plate B+ switch.	1	

		SW ₁₂ SW ₁₃	Part of R ₃₉	Switch Double pole, single throw (on back of volume control). Part of R ₃₉ .	Plate Supply Unit PE-97-A On-Off and Receiver filament On-Off.		Part of 18B31441
1	1	T ₁	2S9978-7	Transformer, P-A Plate Primary; 6½ turns No. 18 solid bare tinned copper wire. Secondary; ½ turn No. 18 stranded insulated r-f wire. —Special	P.A. Plate tank coil and ant. coupling.	1	24B31704
1	1	T ₂	2Z966A	Transformer, Microphone Transformer C-66-A (Signal Corps). —Special	Microphone input.	1	25A30575
1	1	T ₃	2C5360A/ T2	Transformer and Shield, 1st I-F Shielded transformer; variable iron core tuned. Includes C ₄₆ , C ₄₈ , R ₂₁ , and R ₂₂ . —Special	Interstage coupling.	1	24B30354
1	1	T ₄	2C5360A/ T3	Transformer and Shield, 2nd I-F. Shielded transformer; variable iron core tuned. Includes C ₅₁ , C ₅₃ , and R ₂₇ —Special	Interstage coupling.	1	24B30358
1	1	T ₅	2C5360A/ T4	Transformer and Shield, 3rd I-F Shielded transformer; variable iron core tuned. Includes C ₅₅ , C ₅₇ , C ₅₈ , R ₂₉ , R ₃₀ , and R ₃₁ . —Special	Interstage coupling.	1	24B30371
1	1	T ₆		Transformer and Shield, Discriminator Shielded transformer; variable air capacitor tuned. Includes C ₆₂ , C ₆₉ , C ₇₀ , C ₇₁ and C ₇₂ . —Special	Interstage coupling.	1	24B30391

**List of Manufacturer's names and addresses follows Tabular List of Replaceable Parts.

34. TABULAR LIST of REPLACEABLE PARTS—a. RADIO RECEIVER & TRANSMITTER BC-620-(*) Cont.

Quantity			Ref. No.	Signal Corps Stock No.	Name of Part and Description	Function	Mfr. No. **	Contractor's Part and Drwg. No.
Field Stock	Depot Stock	In Set						
1		1	T7	2C5360A/ T5 2Z9662	or: Shielded transformer; variable air capacitor tuned. Includes C ₆₁ , C ₆₂ , C ₆₃ , and C ₆₄ . (Used in some sets). Transformer, Output. Transformer C-62 (Signal Corps). —Special	Audio output.	1	25A31205
			V1	2T182	Tube VT-182—RMA Type 1291.	Trans. r-f Pwr. Amp.	16	
			V2	2T182	Tube VT-182—RMA Type 1291.	Trans. Buffer	16	
			V3	2T185	Tube VT-185—RMA Type 1299	Trans. Osc.	16	
			V4	2T185	Tube VT-185—RMA Type 1299.	Trans. React. Mod.	16	
			V5	2T179	Tube VT-179—RMA Type 1LN5.	Recvr. r-f Amp.	16	
			V6	2T178	Tube VT-178—RMA Type 1LC6.	Recvr. Mixer	16	
			V7	2T185	Tube VT-185—RMA Type 1299.	Recvr. Xtal. Osc.	16	
			V8	2T179	Tube VT-179—RMA Type 1LN5.	Recvr. i-f Amp. #1.	16	
			V9	2T179	Tube VT-179—RMA Type 1LN5.	Recvr. i-f Amp. #2	16	

	V ₁₀	2T179	Tube VT-179—RMA Type 1LN5.	Recvr. Limiter.	16	
	V ₁₁	2T183	Tube VT-183—RMA Type 1294	Recvr. Diode Rect.	16	
	V ₁₂	2T177	Tube VT-177—RMA Type 1LH4.	Recvr. Diode Rect. and d-c amp.	16	
	V ₁₃	2T185	Tube VT-185—Radio RMA Type 1299	Recvr. a-f Pwr Amp.	16	
1	P ₂	3Z1622	Assembly, Cable Connector Clamp. 8-pin plug connector with cable clamps only. —Special	Cable connector plug.	1	1X31629
1	100	2C5360A/ A ₃	Assembly, Battery Box Metal battery box with 5-pin plug and leads. —Special	Internal battery box and contact plug.	1	1X30505
1	101	2C5379A/ A1/1	Assembly Battery Box Cover and Spring Metal cover with battery retainer spring. —Special	Internal battery box cover.	1	1X31581
1	102	3Z1621	Assembly Cable and Connector (Complete) 8-pin plug connector with cable clamp; 12 inches of 8-conductor rubber covered cable mounting bushing. —Special	Cable and connector plug.	1	1B34394
1	103	2Z3405	Assembly, Cover and Gasket Rectangular metal cover with neoprene weath- erproofing gasket. Wrinkle olive drab finish. 3" x 1 $\frac{3}{8}$ ". —Special	Antenna tuning adjustment cover.	1	1X31299

**List of Manufacturers' names and addresses follows Tabular List of Replaceable Parts.

34. TABULAR LIST of REPLACEABLE PARTS—a. RADIO RECEIVER & TRANSMITTER BC-620-(*) Cont.

Quantity		Ref. No.	Signal Corps Stock No	Name of Part and Description	Function	Mfr. No. **	Contractor's Part and Drwg. No.
Field Stock	In Set						
	1	104	2Z2644-1	Assembly Crystal Box Crystal box with pads with separators for 20 crystals. —Special	Crystal box.	1	1X30502
	1	105	2Z2644	Assembly Crystal Clamp and Bracket Crystal clamp mounted on U-shaped bracket. —Special	Holds crystals in position.	1	1X30893
	1	106	2Z8868-3	Assembly, Spring and Bracket (LH). Spring bracket and chassis hold-down spring riveted together. —Special	Rear left-hand chassis hold-down.	1	1X31056
	1	107	2Z8868-4	Assembly Spring and Bracket (RH) Spring bracket and chassis hold-down spring riveted together. —Special	Rear right-hand chassis hold-down.	1	1X31057
	1	108	2A245A/B1	Block, Antenna Mounting Metal block with antenna mounting. Stud Thread: $\frac{5}{16}$ -18. —Special	Antenna mounting.	1	46A30002
	1	109	2A245A/B2	Box, Antenna Junction $2\frac{3}{8}$ " high, $2\frac{1}{8}$ " wide, and $1\frac{1}{8}$ " deep. Wrinkle olive drab finish. —Special	Antenna mounting block protector.	1	15B35285

1	110	ZZ1392	Bushing Control Shaft 3/16-28 outside thread. 1/16-20 inside tap. —Special	1	43A30242	Meter channel, and volume control shaft bushings.
4	111	ZZ2727-3	Catch Clip Large, 2 1/16" long. Smooth olive drab finish. —Special	1	55B31520	Clip for fastening unit to power supply of shock mounting.
4	112	ZZ2728	Clip, Loop Retainer Spring Steel, 5/8" wide, 2 3/8" long. 1/8" loop on one end. —Special	1	42A31561	Holds catch clip loop when not in use.
1	113	ZZ3293	Couplings and Inserts Molded phenolic, with metal inserts. For 1/4" shaft. Four 8-32 tapped holes for setscrews. —Special	1	67A30449	Couples knob shaft to channel switch.
2	114	ZZ3352	Cover, Jack Neoprene. 1" outside diameter. 1 1/8" long. —Special	1	37A34143	Weatherproofing cover for phone and microphone jacks.
1	115	6G251	Desiccator Silica jell moisture absorbing compound enclosed in a spun glass bag. —Special	1	1K31011	To absorb any moisture which may collect inside radio.
1	116	2C5360A/ E1	Escutcheon, Front Panel Aluminum etched, black paint filled. —Special	1	13B30072	Control knob escutcheon.

**List of Manufacturer's names and addresses follows Tabular List of Replaceable Parts.

34. TABULAR LIST of REPLACEABLE PARTS—a. RADIO RECEIVER & TRANSMITTER BC-620-(*) Cont.

Quantity		Ref. No.	Signal Corps Stock No.	Name of Part and Description	Function	Mfr. No. **	Contractor's Part and Drwg. No.
Field Stock	In Set						
	1	117	2A245A/G1	Gasket, Block Insulator Neoprene. 2 $\frac{3}{4}$ " by 2 $\frac{1}{2}$ " outside dimension. 1 $\frac{3}{4}$ " by 1 $\frac{1}{2}$ " inside dimension. —Special	Antenna insulator weatherproofing gasket.	1	37A30028
	1	118	2C5379A/G1	Gasket, Front Panel Neoprene, 6 $\frac{3}{4}$ " wide, 1 $\frac{1}{8}$ " long. —Special	Weatherproofing seal between front housing and panel.	1	37A30175
	1	119	2C5379A/G2	Gasket, Meter Neoprene. 2 $\frac{11}{16}$ " outside diameter, 2 $\frac{1}{16}$ " inside diameter. —Special	Weatherproofing seal between meter and panel.	1	37A30029
	1	120	2C5379A/G4	Gasket, Shaft Bushing Vellutex. $\frac{3}{4}$ " outside diameter; $\frac{9}{16}$ " inside diameter. —Special	Weatherproofing seal for meter, channel and control shaft bushing.	1	37K30068
	1	121	2Z4922-1	Handle Leather handle, complete with mounting screws. —Type #16	Carrying handle.	18	55B30177
	1	122	3G1838	Insulator, Antenna Mounting Block XXX phenolic plate; 2 $\frac{11}{16}$ " long, 2 $\frac{7}{16}$ " wide. —Special	Antenna mounting block insulator.	1	14A30005

1	3	123	ZZ5829	Knob, Control 1 $\frac{1}{8}$ " long. Smooth olive drab finish. —Special	1	Control knobs.	1	36A30265
	1	124	6L3505-18.2	Nut, Knurled $\frac{7}{8}$ " diameter, $\frac{1}{4}$ " thick; knurled. Thread: $\frac{5}{8}$ " x 18". —Special	1	Wire antenna or lead-in clamping nut.	1	2A30021
	1	125	6L3509-28	Nut, Shaft Bushing $\frac{3}{8}$ -28 thread, $\frac{3}{4}$ " hexagonal —Special	1	Mounts meter, chan- nel and volume con- trol shaft bushings.	1	2A31012
	1	126	ZZ7229-5	Plug, Socket Pin .097 pin size. Knurled body. —Special	1	Loading coil tap connector.	1	29A30030
	1	127	2C5379A/ P1	Post, Antenna Contactor Mounting $\frac{1}{2}$ " diameter, 1" long; XXX phenolic 8-32 tapped hole in both ends. —Special	1	Antenna contactor insulator and mount- ing.	1	46A30034
	1	128	2C5379-A/ R1	Rail, Chassis Insulating Molded phenolic L-shaped rail, with 4 brass mounting inserts. —Special	1	Chassis bottom guide and insulator.	1	14B30176
	6	129	6L4904- 10.20	Screw, Cap $\frac{1}{4}$ -20 thread, $\frac{5}{8}$ " long. White nickel plated. —Special	6	Antenna mounting block fastener and antenna contactor wiper.	1	3A30459
	3	130	6L7936	Screw, Control Shaft Packing $\frac{7}{8}$ -20 thread, .265" inside diameter. —Special	3	Holds control shaft weatherproofing packing in position.	1	3A30241

**List of Manufacturers' names and addresses follows Tabular List of Replaceable Parts.

112 34. TABULAR LIST of REPLACEABLE PARTS—a. RADIO RECEIVER & TRANSMITTER BC-620-(*) Cont.

Field Stock	Quantity		Ref. No.	Signal Corps Stock No.	Name of Part and Description	Function	Mfr. No. **	Contractor's Part and Drwg. No.
	Depot Stock	In Set						
		1	131	2Z1393	Shaft, Channel Switch 2 $\frac{5}{16}$ " long. 6-32 tapped hole in one end —Special	Channel Switch knob shaft.	1	47A35254
		13	132	2Z8637.1	Socket, Tube Molded-loctal Tan. —Type 69530	Tube Socket	10	9A30730
		1	133	2Z9476-5	Terminal Strip 5 insulated lugs; No. 1 and No. 7 mounting. $\frac{1}{2}$ " spacing. —Special	Tie point	1	31A31224
		1	134	2Z9476-2.1	Terminal Strip 2 insulated lugs; vertical mounting. $\frac{3}{8}$ " spacing. —Special	Tie point	1	31A31221
		1	135	2Z9476-2.2	Terminal Strip 2 insulated lugs; vertical mounting. $\frac{1}{2}$ " spacing. —Special	Tie point.	1	31A31223
		1	136	2Z9476-2	Terminal Strip 2 insulated lugs; center mounting. $\frac{3}{8}$ " spacing. —Special	Tie point.	1	31A31218
		1	137	2Z9477-2	Terminal Strip 1 insulated lug and one ground lug. $\frac{3}{8}$ " spacing. Special	Tie point.	1	31A31217

1	138	2Z9482	Terminal Strip 1 insulated lug; vertical mounting. $\frac{3}{8}$ " spacing. —Special	Tie point.	1	31A31215
1	139	2Z9477-3.1	Terminal Strip 2 insulated lugs and one ground lug. $\frac{1}{2}$ " spacing. —Special	Tie point.	1	31A31222
1	140	2Z9482-1	Terminal strip 1 insulated lug. —Special	Tie point.	1	31A31216
1	141	2Z9476-2.3	Terminal Strip 2 insulated lugs; horizontal mounting. $\frac{1}{2}$ " spacing. —Special	Tie point.	1	31A31219
2	142	6L50512	Washer, Insulated (Extruded) Fibre; $\frac{3}{4}$ " outside diameter, .390" inside diameter. —Special	Jack insulating washer.	1	14A35250
1	143	6L73400	Washer, Packing Neoprene; .250" inside diameter, .375" outside diameter. —Special	Control shaft packing.	1	37A30108
1	144	2A245A/WI	Wiper Antenna Phosphor bronze. —Special	Antenna contactor.	1	39A30010

**List of Manufacturers' names and addresses follows Tabular List of Replaceable Parts.

34. TABULAR LIST OF REPLACEABLE PARTS—b. PLATE SUPPLY UNIT PE-97-(*)—Cont.

Quantity			Ref. No.	Signal Corps Stock No.	Name of Part and Description	Function	Mfr. No. **	Contractor's Part and Drwg. No.
Field Stock	Depot Stock	In Set						
2		1	C ₁	3DA500-39	Capacitor Fixed, paper; .5 μ f, +14%, -6%, 200 w-v d-c Shielded and oil filled. Mounted by two lugs, 2.125" centers with .187" diameter holes. —Special	Vibrator by-pass.	1	8A31232
16		8	C ₂	3DA10-78	Capacitor Fixed, ceramic; .005 μ f, +80%, -20%, 300 w-v d-c. 1 $\frac{1}{16}$ " long x $\frac{5}{16}$ " diameter. —Special or: Fixed, molded paper; .005 μ f, +80%, -20%, 300 w-v d-c. 1 $\frac{1}{16}$ " long x $\frac{5}{8}$ " wide x $\frac{3}{16}$ " thick. —Special or: Fixed, molded paper; .005 μ f, +80%, -20%, 300 w-v d-c. $\frac{7}{8}$ " long x $\frac{9}{16}$ " wide. Color coded: green, black, red, orange. —Micamold Type 339. or:	By-pass.	5	21A38631
							1	8A38632
							20	8A41614

				Fixed, mica; .01 μ f, +14%, -6%, 300 w-v d-c. Color coded: brown, black, orange, blue, orange. $\frac{35}{64}$ " square x $\frac{1}{4}$ " thick. Aerovox 1467X (use in some sets). Also C ₃ , C ₄ , C ₅ , C ₆ , C ₇ , C ₈ , C ₁₂ .		2	21B6609
		C ₃		Capacitor—Same as C ₂ .	By-pass.		
		C ₄		Capacitor—Same as C ₂ .	By-pass		
		C ₅		Capacitor—Same as C ₂	By-pass.		
		C ₆		Capacitor—Same as C ₂	By-pass.		
		C ₇		Capacitor—Same as C ₂ .	By-pass.		
		C ₈		Capacitor—Same as C ₂	By-pass.		
2	1	C ₉	3DB1000-1	Capacitor Electrolytic; 1000 μ f, +150% -10%, 15 w-v d-c. Over-all length, $2\frac{11}{16}$ " x $1\frac{1}{16}$ " diameter. —Special	Filament filter.	1	23B31235
4	1	C ₁₀	3D403 3D403A	Capacitor, CA-403-(*), Electrolytic; 20 and 20 μ f, +150% -10%, 400 w-v d-c, plug-in type. —Special	B+ filter	1	23B31236

**List of Manufacturers' names and addresses follows Tabular List of Replaceable Parts.

34. TABULAR LIST OF REPLACEABLE PARTS—b. PLATE SUPPLY UNIT PE-97-(*)—Cont.

Field Stock	Quantity		Ref. No.	Signal Corps Stock No.	Name of Part and Description	Function	Mfr. No. **	Contractor's Part and Drwg. No.
	Depot Stock	In Set						
2		1	C ₁₁	3DA20-18	Capacitor Fixed, paper; .02 μ f, +14% -6%, 1600 w-v d-c, shielded, and oil filled 1 $\frac{19}{32}$ " long x $\frac{25}{32}$ " wide. Mounting lugs attached, 1.875" centers with .156" diameter holes. —Special	Secondary buffer, T ₁ .	1	8A31227
			C ₁₂		Capacitor—Same as C ₂ .	By-pass.		
4		2	CH ₁	3C362-3	Choke, R-F 35 turns No. 16 enamel copper wire. (Inductance: 12.2 μ h at 1000 cycles). —Special Also CH ₂ .	Hash filter.	1	24A31248
			CH ₂		Choke, R-F—Same as CH ₁ .	Hash filter.		
2		1	CH ₃	3C362-14	Choke, A Filter Two identical units mounted in can. Inductance: .055 henries minimum at 700 ma. Resistance: terminals 1 to 2 = 3.25 ohms; terminals 2 to 3 = 3.25 ohms. —Special	Filament filter.	1	25B31298
2		1	CH ₄	3C362-1	Choke, R-F 3 pie; 185 turns No. 38 single celanese wire	B+ R-F choke.	1	24A31705

2	1	CH _s	3C362-5	Choke, B+ Filter 6 henries at 80 ma.; resistance—150 ohms. —Special	B+ filter	1	25B31297			
10	1	F ₁		Fuse FU-38 6 ampere, 25 volt tubular; glass enclosed.	Short protection.	11	65K34075			
	1	SO _s	3E4300-1	Connector, Cable Receptacle 8 prong female cable connector. Type 97-5103-20L14-634S.	Cable connector.	15	9A30441			
8	2	R ₁	3Z6020-20	Resistor Fixed, carbon; 200 ohms, ±10%, 1 watt, not insulated. 1" long x .187" diameter. Globar Type 766-A.	Primary buffer, T ₁ .	7	6B6315			
				Also R ₂ .						
				Resistor—Same as R ₁ .	Primary buffer, T ₁ .					
4	1	R _s	3Z6002-12	Resistor Fixed, molded wire-wound; 20 ohms, ±10%, 1 watt. 1¼" long x ¼" diameter. I.R.C. Type BW-1. or Fixed, carbon; 20 ohms, ±10%, 1 watt, insulated. ¾" long x .281" diameter. Eric Type 518 Ins., Stackpole Type MB-1 Ins.	Vibrator regulating, V ₁ .	12	17A31422			
						8	6B5617			
						21				

*List of Manufacturers' names and addresses follows Tabular List of Replaceable Parts.

34. TABULAR LIST OF REPLACEABLE PARTS—b. PLATE SUPPLY UNIT PE-97-(*)—Cont.

Field Stock	Quantity		Ref No.	Signal Corps Stock No.	Name of Part and Description	Function	Mfr. No. **	Contractor's Part and Drwg No.
	Depot Stock	In Set						
4		1	R ₄	3Z5984	Resistor Fixed, wire-wound, .4 ohms, $\pm 5\%$, 5 watt, insulated. $1\frac{7}{32}$ " long x $1\frac{5}{32}$ " diameter. Koolohm.	Transformer regulating, T ₁ .	13	17A31431
4		1	R ₅	3Z5999	Resistor Fixed, wire-wound; 9.8 ohms, $\pm 5\%$, 10 watt, insulated. $1\frac{7}{32}$ " long x $1\frac{5}{32}$ " diameter. Koolohm.	Filament dropping (Rec'vr.)	13	17K40158
		1	R ₆	3Z6002B2	Resistor Fixed, wire-wound; 22 ohms, $\pm 5\%$, 10 watt insulated. $1\frac{7}{32}$ " long x $1\frac{5}{32}$ " diameter. Koolohm (R ₆ replaced by R ₁₀ after Serial No. 675 on Order No. 19912-Phila-43.)	Filament dropping (Trans.)	62	17K31433
4		1	R ₇	3Z6150-32	Resistor Fixed, wire-wound; 1500 ohms, $\pm 5\%$, 10 watts, insulated. $1\frac{7}{32}$ " long x $1\frac{5}{32}$ " diameter. Koolohm.	Regulating bleeder.	13	17K31434
4		1	R ₈		Resistor Fixed, wire-wound; .25 ohms, $\pm 5\%$, 5 watts Ceramic case. $1\frac{1}{32}$ " long x $\frac{1}{16}$ " diameter. —Special	Filament dropping (Rec'vr.)	1	17A47608

4	1	R ₉	(R ₈ , R ₉ added after serial No. 675 on Order No. 19912-Phila-43.) Resistor Fixed, wire-wound; .8 ohms, ±5%, 5 watts. Ceramic case 1 7/8" long x 3/8" diameter. —Special (R ₈ , R ₉ added after Serial No. 675 on Order No. 19912-Phila-43.)	Filament droppings (Trans.)	1	17K47609
4	1	R ₁₀	Resistor Fixed, wire-wound; 30 ohms, ±5%, 10 watts. Ceramic case. 1 7/8" long x 1 1/8" diameter. —Special (R ₁₀ replaces R ₉ after Serial No. 675 on Order No. 19912-Phila-43.)	Filament droppings (Trans.)	1	17K47606
2	1	T ₁	Transformer, Power and Links Power transformer with changeover links for 6 volt and 12 volt operation. —Special	Vibrator transformer	1	25B31296
4	1	V ₁	Vibrator 4 prong full-wave, non-synchronous. VB-1-A or B. Oak Type V-6160-17 x S.	Transformer primary current interrupter.	9	48A31519
		V ₂	Tube VT-195 Radio RMA Type CK-1005 (metal).	Rectifier.	14	
		V ₃	Tube VT-184 Radio RMA Type VR-90/30 (glass.)	Voltage regulator.	14	

*List of Manufacturers' names and addresses follows Tabular List of Replaceable Parts.

34. TABULAR LIST OF REPLACEABLE PARTS—b. PLATE SUPPLY UNIT PE-97-(*)—Cont.

Quantity			Ref. No.	Signal Corps Stock No.	Name of Part and Description	Function	Mfr. No. **	Contractor's Part and Drwg. No.
Field Stock	Depot Stock	In Set						
		1	SO ₃	3H4600-117C/C1	Assembly, Cable and Connector (Complete) 8-pin socket connector and 2 ft. 8-conductor cable. —Special	Cable and connector to Radio Receiver & Transmitter BC-620-(*).	1	1X31356
		1	200	3B4297A/C1	Assembly, Cable and Lugs (Complete) 10 ft. rubber covered 4-conductor cable. Lugs marked (-) and (+) on one end. —Special	Cable to vehicular battery.	1	1X31357
		1	201	3Z3255	Assembly, Fuse, Link Plate 2½" x 1½" phenolic plate with four terminals marked 13, 14, 15 and 16, two change-over links and fuse clips. —Special	Change-over link terminal board and fuse receptacle.	1	1X31353
		1	202	3Z2912	Assembly, Plate and Fuse Clips 1½" x 2¼" metal plate. Clips to hold 6 amp., 25 volt, tubular glass enclosed fuse. —Special	Spare fuse holder.	1	1X31448
		1	203	3H4600-117C/R2	Assembly, Retainer Bracket (Long) 3½" high, "L" shaped on one end, other end has bracket with two felt pads ¼" thick, ¾" square. —Special	Holds plug-in capacitor and Tube VT-184 in place.	1	1X31358

1	204	3H4600-117C/R3	Assembly, Retainer Bracket (Short) 2 $\frac{1}{8}$ " high, "L" shaped on one end, other end has bracket with two felt pads, $\frac{1}{4}$ " thick, $\frac{3}{4}$ " square. —Special	Holds vibrator and tube VT-195 in place.	1	1X31359
1	205	3Z3255-1	Assembly, Switch Link Plate 2 $\frac{3}{4}$ " x 1 $\frac{1}{16}$ " phenolic plate with four terminals marked 17, 18, 19 and 20, and two change-over links. —Special	Change-over link terminal board (Trans. & Rec'vr. filaments).	1	1X31352
4	206	2Z2727-3	Catch Clip Large. 2 $\frac{5}{16}$ " long. Smooth olive drab finish. —Special	Part of catch clip assembly for holding units together.	1	55B31520
2	207	2Z2727-1.1	Catch Clip Small, 1 $\frac{1}{2}$ " long. Smooth olive drab finish. —Special	Part of catch clip assembly for holding case cover closed.	1	55A31516
1	208	2Z2638	Clamp, Choke $\frac{1}{2}$ " width. Semi-circular ring. $\frac{3}{4}$ " radii. —Special	Holds "A" choke secure.	1	42A30929
1	209	2Z2637	Clamp, Vibrator and Capacitor "U" shaped, 1 $\frac{1}{4}$ " wide, 1 $\frac{3}{8}$ " high. —Special	Spare vibrator and capacitor holder.	1	42A30667
2	210	2Z2727-1	Clip, Hold-Down $\frac{9}{16}$ " long, $\frac{7}{8}$ " wide; $\frac{1}{8}$ " loop. Smooth olive drab finish. —Special	Part of catch clip assembly for holding case cover closed.	1	55K34338

**List of Manufacturers' names and addresses follows Tabular List of Replaceable Parts.

34. TABULAR LIST OF REPLACEABLE PARTS—b. PLATE SUPPLY UNIT PE-97-(*)—Cont.

Quantity			Ref. No.	Signal Corps Stock No.	Name of Part and Description	Function	Mfr. No. **	Contractor's Part and Drwg. No.
Field Stock	Depot Stock	In Set						
		4	211	2Z2727	Clip, Hold-Down 1 $\frac{1}{8}$ " long, 1" wide; $\frac{1}{4}$ " loop. Smooth olive drab finish. —Special	Part of catch clip assembly for holding units together.	1	55K31523
		6	212	2Z2728	Clip, Loop Retainer Spring steel, $\frac{5}{8}$ " wide, 2 $\frac{3}{8}$ " long. $\frac{1}{8}$ " loop on one end. —Special	Holds catch clip loop when it is not being used.	1	42A31561
		1	213	2Z2728.2	Clip, Vibrator 1 $\frac{3}{8}$ " diameter. Wipers $\frac{5}{8}$ " high. —Special	Grounding clip for vibrator.	1	42A4215
		1	214	3H4600-117C/C5	Cover, Chassis "U" shaped, 11 $\frac{1}{8}$ " long, 6" wide, 4 $\frac{1}{8}$ " high. —Special	Cover for chassis.	1	15C30932
		1	215	2Z4922-1	Handle Leather handle, complete with mounting screws. —Type #16	Carrying handle.	18	55B30177
		1	216	6L3408-32K	Nut, Knurled $\frac{3}{8}$ " round, knurled edge. 8-32 thread. —Special	Mounts chassis cover.	1	2A31225
		1	217	6L3820	Nut, Wing $\frac{1}{8}$ " high, $\frac{3}{8}$ " long, 8-32 thread. —Special	Holds tube, vibrator and capacitor retainer brackets in position.	1	2A30931

	1	218	2Z2728.3	Plate, Clip Spacer $\frac{5}{16}$ " brass, $\frac{3}{8}$ " x 1" with two .203" diameter holes. Smooth olive drab finish. —Special	Spacer for catch clip.	1	64A30082
30	2	219	2Z8654	Socket, Tube Octal, black phenolic. —Type 88-8TM	Tube and plug-in capacitor socket.	15	9A31229
10	1	220	2Z8654.1	Socket, Tube 4 prong, black phenolic. —Type MIP-4M	Vibrator socket.	15	9A31234
	1	221	2Z9476	Terminal Strip 3 insulated lugs. No. 1 and No. 4 mounting. $\frac{1}{2}$ " spacing. —Special	Tie point.	1	31A31279
	1	222	2Z9476-1	Terminal Strip 3 large insulated lugs. No. 2 mounting. $\frac{3}{8}$ " spacing. —Special	Tie point.	1	31A31549
	1	223	2Z9476-2	Terminal Strip 2 insulated lugs, center mounting. $\frac{3}{8}$ " spacing. —Special	Tie point.	1	31A31218
	1	224	2Z8654.3	Wafer, Electrolytic Phenolic, $1\frac{1}{16}$ " mounting centers. $\frac{1}{16}$ " thick. —Type A93423-1	Capacitor C ₉ , insulator and mounting wafer.	6	9A31245

**List of Manufacturers' names and addresses

shows Tabular List of Replaceable Parts.

34. TABULAR LIST OF REPLACEABLE PARTS—b. PLATE SUPPLY UNIT PE-97-(*)—Cont.

Quantity			Ref. No.	Signal Corps Stock No.	Name of Part and Description	Function	Mfr. No. **	Contractor's Part and Drwg. No.
Field Stock	Depot Stock	In Set						
		1	225		Terminal Strip 2 insulated lugs, on a $1\frac{7}{16}$ " long x $\frac{3}{8}$ " width x $\frac{3}{8}$ " canvas bakelite strip, wax impregnated. One mounting lug centered on strip for mounting.	Tie point.	10	31A38089
		1	300	3E1509	Assembly Cable and Connector (Complete) 8-pin socket shell and Y cable and battery plugs, housing bushing and gasket. —Special	Battery plate and filament supply cable connector, and plug.	1	1X31347
		1	301	3A39/1	Assembly, Battery Retainer Strap and Bracket (Long) $12\frac{5}{8}$ " long, 1" wide. Overlap on one end $1\frac{1}{8}$ ", other end has binder plate. Strap riveted to bracket. —Special	Long strap of assembly for holding Batteries BA-39 and BA-40 in position.	1	1X31345
		1	302	3A39/2	Assembly, Battery Retainer Strap and Bracket (Short) $4\frac{5}{8}$ " long, 1" wide. Overlap on one end $1\frac{1}{8}$ ", other end has buckle. Strap bracket riveted to strap. —Special	Short strap of assembly for holding Batteries BA-39 and BA-40 in position.	1	1X31346
		1	303	2B613A/H1	Assembly Handset Retainer Strap and Bracket 9" long, 1" wide, one male and one female snap. Binder plate on each end. Strap riveted to bracket. —Special	Holds headset secure in case.	1	1X31344

2	304	2Z2727-3	Catch Clip Small, 1 1/8" long. Smooth olive drab finish. —Special	1	55A31516	Part of catch clip assembly for holding case cover closed.
4	305	2Z2727-3	Catch Clip Large, 2 5/8" long. Smooth olive drab finish. —Special	1	55B31520	Part of catch clip assembly for holding units together.
2	306	2Z2727-4	Clip, Hold-Down 3/8" long, 7/8" wide; 1/8" loop. Smooth olive drab finish. —Special	1	55K34338	Part of catch clip assembly for holding case cover closed.
4	307	2Z2727	Clip, Hold-Down 1 1/8" long, 1" wide; 1/4" loop. Smooth olive drab finish. —Special	1	55K31523	Part of catch clip assembly for holding units together.
6	308	2Z2728	Clip, Loop Retainer Spring Steel. 5/8" wide, 2 3/8" long; 1/8" loop on one end. —Special	1	42A31561	Holds catch clip loop when it is not being used.
1	309	2Z3600-3	Cushion, Battery Sponge rubber 3/8" x 1 1/4" x 4". —Special	1	37A30923	Battery cushion.
1	310	2Z4922-1	Handle Leather handle, complete with mounting screws. —Type #16	18	55B30177	Carrying handle

125
**List of Manufacturers' names and addresses follows Tabular List of Replaceable Parts.

34. TABULAR LIST OF REPLACEABLE PARTS—b. PLATE SUPPLY UNIT PE-97-(*)—Cont.

Quantity			Ref. No.	Signal Corps Stock No.	Name of Part and Description	Function	Mfr. No. **	Contractor's Part and Drwg. No.
Field Stock	Depot Stock	In Set						
		1	311	2Z2728.3	Plate, Clip Spacer $\frac{5}{8}$ " brass, $\frac{3}{8}$ " x 1" with 2 holes .203" diameter. Smooth olive drab finish —Special	Spacer for catch clip.	1	64A30082
		1	312	2Z7229-2	Plug 4 prong, black phenolic. —Type 28-4	Plug for Battery BA-40.	17	28A30252
		1	313	2Z7229-3	Plug 5 prong, black phenolic. —Type 28-5	Plug for Battery BA-39.	17	28K30253
		1	314	2Z3097	Socket and Shell 8-pin socket enclosed in shell. Cable clamp included. —Type 97-5103-20L14-634S	Cable connector from Battery supply to Radio Receiver & Transmitter BC-620-(*).	15	9A30441
		4	400	2Z8503-1	Collar, Shock Mount Metal, $1\frac{3}{8}$ " dia., $\frac{1}{8}$ " width of outside rim. .171" diameter hole in center. Smooth olive drab finish. —Special	Washer between rubber shock mounts.	1	43A30027
		4	401	613108-32.5	Nut 8-32 tap $\frac{5}{16}$ " hexagon.	Used in shock mount assembly.	1	2S8371

4	402	2Z8503	Shock Mount Rubber 1" diameter, 3/4" high; held by metal plate 1 1/4" square. .166" diameter hole through center. Olive drab finish —Special	1	37A30084
4	403	6L6832.30	Screw 8-32 thread 1 7/8" long, round head.	1	3S8083
4	404	2Z8503-2	Washer, Shock Mount 1" diameter, .171" hole, .062" thick. Smooth olive drab finish. —Special	1	4A30264
			Fits between mounting bases to absorb shock.		
			Holds upper and lower mountings together.		
			Used in shock mounting assembly.		

••List of Manufacturers' names and addresses follows Tabular List of Replaceable Parts.

35. LIST OF MANUFACTURERS' NAMES AND ADDRESSES

<i>Mfr. No.</i>	<i>Name</i>	<i>Street Address</i>	<i>City</i>	<i>State</i>
1	Galvin Manufacturing Corporation . . .	4545 Augusta Blvd.	Chicago	Illinois
2	Aerovox Company		New Bedford	Massachusetts
3	Cornell Dubilier Company	1000 Hamilton	South Plainfield	New Jersey
4	Centralab	900 E. Keefe Avenue	Milwaukee	Wisconsin
5	Muter Company	1255 S. Michigan Avenue	Chicago	Illinois
6	P. R. Mallory Company		Indianapolis	Indiana
7	Carborundum Corporation	Global Division	Niagara Falls	New York
8	Erie Resistor Corporation	644 W. 12th Street	Erie	Pennsylvania
9	Oak Manufacturing Corporation		Crystal Lake	Illinois
10	Cinch Manufacturing Company	2339 W. Van Buren Street	Chicago	Illinois
11	Littelfuse Corporation	4757 N. Ravenswood	Chicago	Illinois
12	International Resistance Company	18 W. Chelton	Philadelphia	Pennsylvania
13	Sprague Spec. Company		North Adams	Massachusetts
14	Raytheon Product Corporation	445 Lake Shore Drive	Chicago	Illinois
15	American Phenolic	1830 S. 54th Street	Cicero	Illinois
16	Sylvania Radio Products		Emporium	Pennsylvania
17	H. H. Eby, Inc.	4700 Stenton Avenue	Philadelphia	Pennsylvania
18	Stalker Manufacturing Company	71-73 Murray	New York	New York
19	Dumont Electric Company	34-54 Hubert Street	New York	New York
20	Micamold Corporation	1087 Flushing Avenue	Brooklyn	New York
21	Stackpole Carbon Company	Elk County	St. Mary's	Pennsylvania
22	Sangamo Electric Company		Springfield	Illinois

36. RMA STANDARD COLOR CODE CHARTS

For Resistors

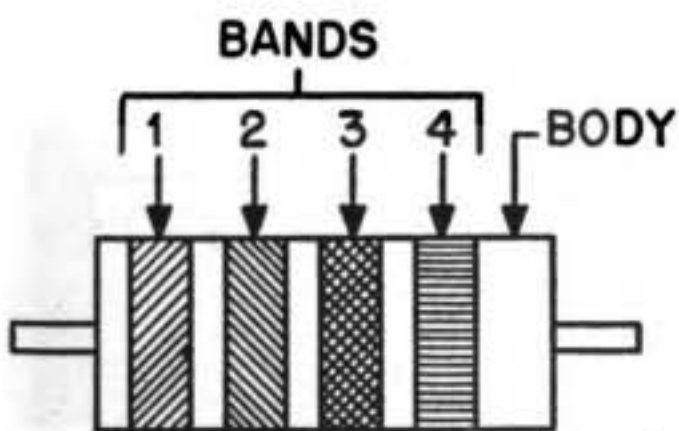

METHOD 1

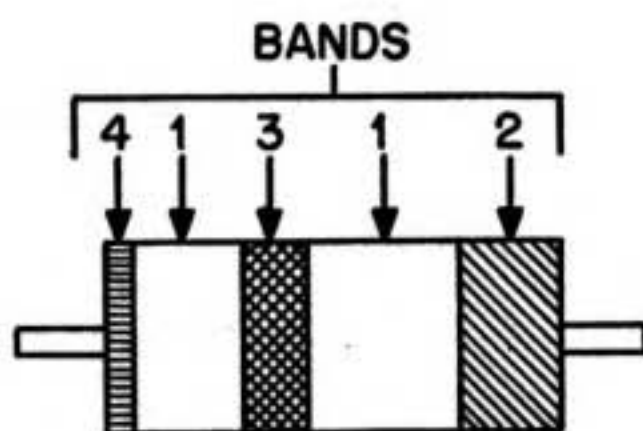

METHOD 2

COLOR	1st Band	2nd Band	3rd Band	4th Band
	<i>1st Digit</i>	<i>2nd Digit</i>	<i>Decimal Multiplier</i>	<i>Tolerance</i>
Black	0	0	1	
Brown	1	1	10	
Red	2	2	100	
Orange	3	3	1,000	
Yellow	4	4	10,000	
Green	5	5	100,000	
Blue	6	6	1,000,000	
Violet	7	7	10,000,000	
Gray	8	8	100,000,000	
White	9	9	1,000,000,000	
Gold	± 5%
Silver	± 10%
No Color	± 20%

COLOR CODE CHART FOR CAPACITORS (Tubular Ceramic)

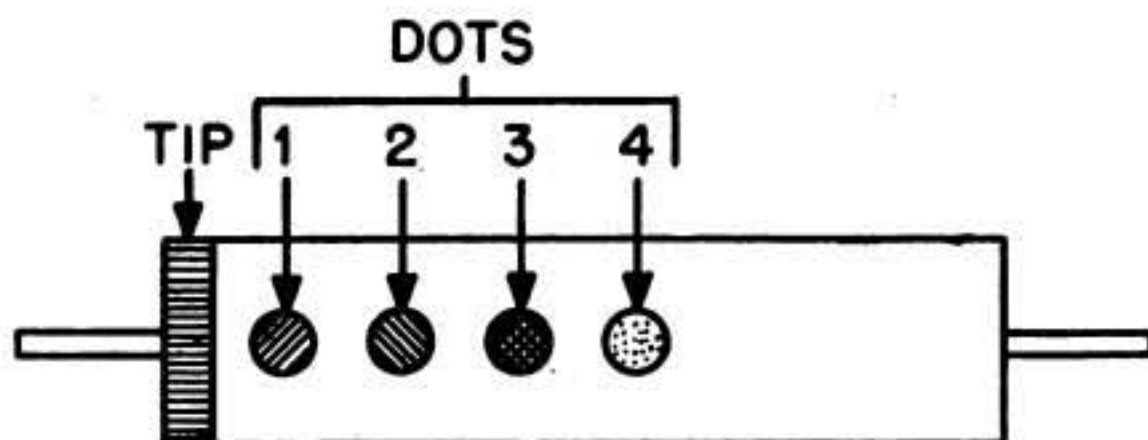

Color	Tip <i>Temperature Coefficient</i>	1st Dot <i>1st Digit</i>	2nd Dot <i>2nd Digit</i>	3rd Dot <i>Decimal Multiplier</i>	4th Dot <i>Tolerance</i>
Black	0	0	0	1	...
Brown	.00003 Neg.	1	1	10	1%
Red	.00008 "	2	2	100	2%
Orange	.00015 "	3	3	1,000	3%
Yellow	.00022 "	4	4	10,000	4%
Green	.00033 "	5	5	100,000	5%
Blue	.00047 "	6	6	1,000,000	6%
Violet	.00075 "	7	7	10,000,000	7%
Gray		8	8	0.1	
White		9	9	0.01	10%

3-DOT COLOR CODE CHART FOR CAPACITORS

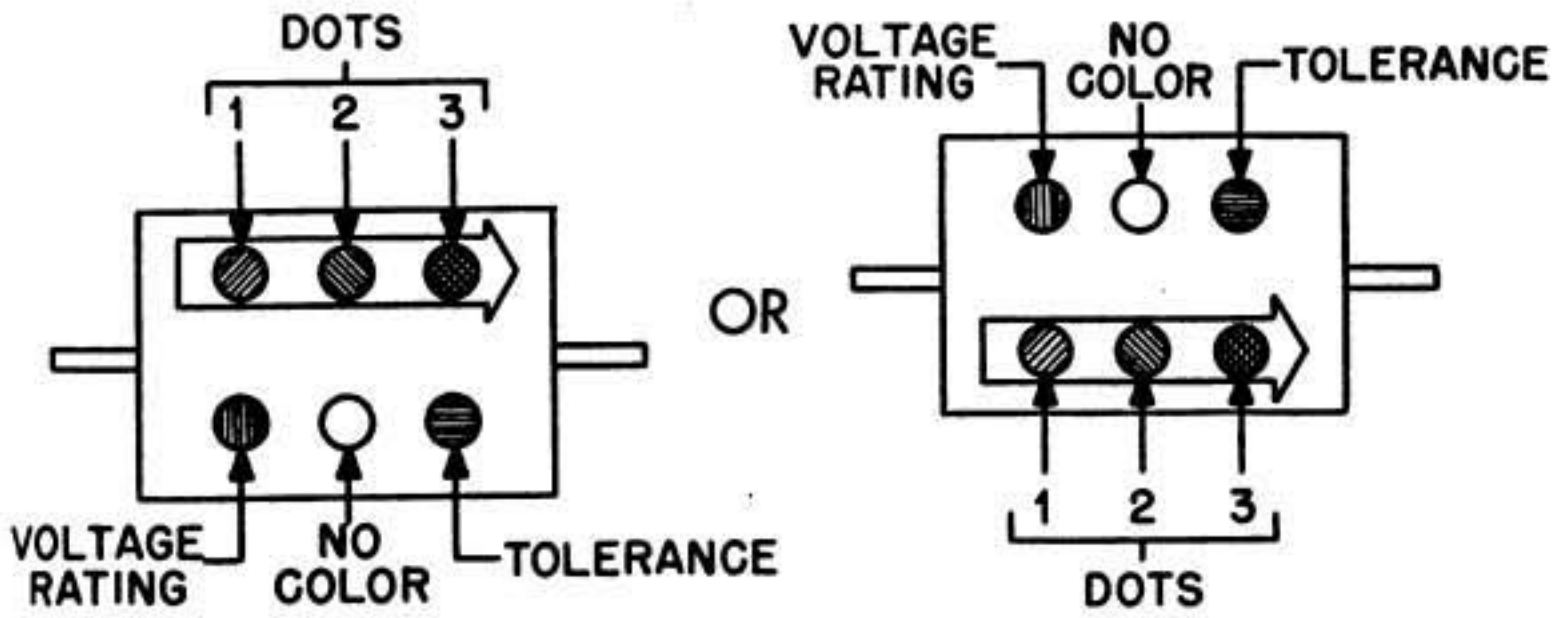

COLOR	1st Dot	2nd Dot	3rd Dot	Tolerance	Voltage Rating
	1st Digit	2nd Digit	Decimal Multiplier		
Black	0	0	1		
Brown	1	1	10	1%	100v.
Red	2	2	100	2%	200v.
Orange	3	3	1,000	3%	300v.
Yellow	4	4	10,000	4%	400v.
Green	5	5	100,000	5%	500v.
Blue	6	6	1,000,000	6%	600v.
Violet	7	7	10,000,000	7%	700v.
Gray	8	8	100,000,000	8%	800v.
White	9	9	1,000,000,000	9%	900v.
Gold	0.1		1000v.
Silver	0.01	10%	2000v.
Body	20%	*

*When no Color is indicated the Voltage Rating may be as low as 300 volts.

**AMERICAN WAR STANDARD 6-DOT COLOR CODE CHART
For Capacitors (Molded Mica)**

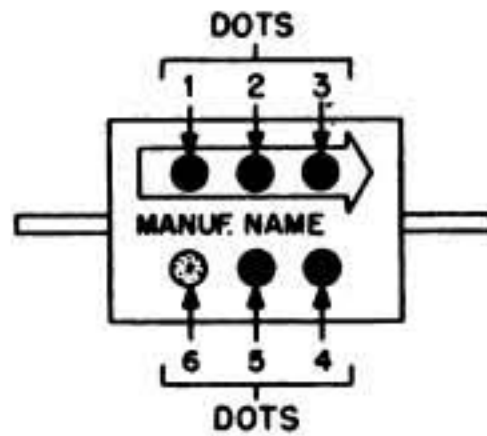

Color	1st Dot	2nd Dot	3rd Dot	4th Dot	5th Dot	6th Dot
	<i>1st Digit</i>	<i>2nd Digit</i>	<i>3rd Digit</i>	<i>Decimal Multiplier</i>	<i>Tolerance</i>	<i>Characteristics</i>
Black	0	0	0	1	±20%	*A
Brown	1	1	1	10		B
Red	2	2	2	100	± 2%	C
Orange	3	3	3	1,000		D
Yellow	4	4	4	10,000		E
Green	5	5	5	100,000		F
Blue	6	6	6	1,000,000		G
Violet	7	7	7	10,000,000		
Gray	8	8	8	100,000,000		
White	9	9	9	1,000,000,000		
Gold	0.1	± 5%	
Silver	0.01	±10%	

- *A—Ordinary Mica By-pass.
- B—Same as A—Low Loss Case
- C—By-pass or Silver Mica Capacitor (± 200 parts/Million/C)
- D—Silver Mica Capacitor— (± 100 Parts/Million/C)
- E—Silver Mica Capacitor (0 to +100 Parts/Million/C)
- F—Silver Mica Capacitor (0 to +50 Parts/Million/C)
- G—Silver Mica Capacitor (0 to -50 Parts/Million/C)

RMA STANDARD 6-DOT COLOR CODE CHART
(For Capacitors (Molded Mica))

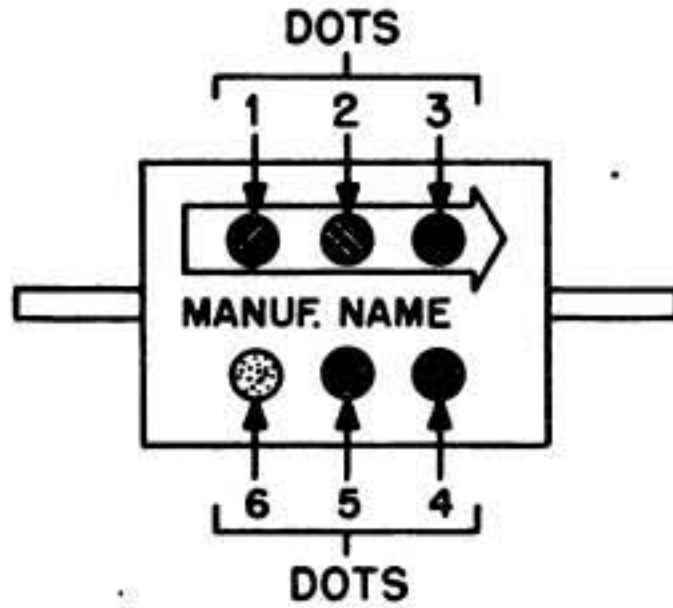

Color	1st Dot	2nd Dot	3rd Dot	4th Dot	5th Dot	6th Dot
	<i>1st Digit</i>	<i>2nd Digit</i>	<i>3rd Digit</i>	<i>Decimal Multiplier</i>	<i>Tolerance</i>	<i>Voltage</i>
Black	0	0	0	1
Brown	1	1	1	10	1%	100v.
Red	2	2	2	100	2%	200v.
Orange	3	3	3	1,000	3%	300v.
Yellow	4	4	4	10,000	4%	400v.
Green	5	5	5	100,000	5%	500v.
Blue	6	6	6	1,000,000	6%	600v.
Violet	7	7	7	10,000,000	7%	700v.
Gray	8	8	8	100,000,000	8%	800v.
White	9	9	9	1,000,000,000	9%	900v.
Gold	0.1		1,000v.
Silver	0.01	10%	2,000v.
Body	20%	500v.

RED

34

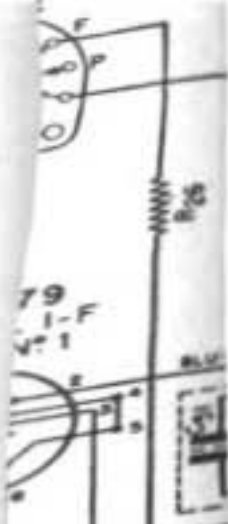

C52

000
CHg

R25

