

add
4113
2
Tm
1945

TM 11-953

ARMY DEPARTMENT TECHNICAL MANUAL

U.S. Dept of Army

RECTIFIER RA-120



RESTRICTED. DISSEMINATION OF RESTRICTED MATTER.
No person is entitled solely by virtue of his grade or position to knowl-
edge or possession of classified matter. Such matter is entrusted only
to those individuals whose official duties require such knowledge or
possession. (See also par. 23b, AR 380-5, 15 Mar 1944.)

ARMY DEPARTMENT

7 APRIL 1945

WAR DEPARTMENT TECHNICAL MANUAL
TM 11-953

RECTIFIER
RA-120



WAR DEPARTMENT

7 APRIL 1945

RESTRICTED. DISSEMINATION OF RESTRICTED MATTER.

No person is entitled solely by virtue of his grade or position to knowledge or possession of classified matter. Such matter is entrusted only to those individuals whose official duties require such knowledge or possession. (See also paragraph 23b, AR 380-5, 15 March 1944.)

WAR DEPARTMENT,
WASHINGTON 25, D. C., 7 April 1945.

TM 11-953, Rectifier RA-120, is published for the information and guidance of all concerned.

[A. G. 300.7 (29 Dec 44).]

BY ORDER OF THE SECRETARY OF WAR:

G. C. MARSHALL,
Chief of Staff.

OFFICIAL:

J. A. ULIO,
Major General,
The Adjutant General.

DISTRIBUTION:

AAF (5); AGF (5); ASF (2); T of Opn (5); Dept (5); Def Comd (2); Base Comd (5); AAF Comd (2); Arm & Sv Bd (2); S Div ASF (1); Tech Sv (2); SvC (5); Area ASvC (2); WDGS Lib(5); PC&S (2); PE (2); Dep 11 (2); Gen Overseas SOS Dep (Sig Sec) (2); GH (2); M Conc C (2); Air Base Hosp (2); Gen Sv Sch (5); Sp Sv Sch (10); USMA (2); ROTC (5); Lab 11 (2); Sig AS (2); Rep Shop 11 (2); A (5); D (2); AF (2);

Three copies to each of the following: T/O & E 2-22; 2-25; 2-26; 2-27; 2-28; 3-267; 5-215; 5-216; 5-217; 5-500 Hq. Co.; 5-627; 6-27; 6-59; 6-126; 6-160-1; 6-165; 6-166; 6-167; 6-169; 6-212-S; 6-218; 2-367; 7-22; 7-23; 7-25; 7-26; 7-27; 7-29; 8-76; 9-65; 9-66; 9-67; 10-36; 11-7; 11-16; 11-57; 11-107; 11-127; 11-237; 11-587; 11-592; 11-597; 17-2; 17-12; 17-13; 17-14; 17-15; 17-16; 17-17; 17-19; 17-20-1; 17-22; 17-25; 17-26; 17-27; 17-29; 17-37; 17-45S; 17-46S; 17-47-S; 17-49-S; 17-56; 17-57; 17-60-1; 17-115; 17-116; 17-125; 17-126; 18-25; 18-26; 18-27; 18-28; 18-35; 18-36; 18-37; 19-57; 44-76; 44-77; 55-37.

(For explanation of symbols, see FM 21-6.)

U113
12

TM 11:963
1945
★ ★

TABLE OF CONTENTS

	<i>Paragraph</i>	<i>Page</i>
PART ONE. Introduction.		
Section I. Description.		
General	1	1
Technical characteristics	2	3
Table of components	3	3
Physical description of equipment	4	3
Packaging data	5	3
II. Installation.		
Location	6	5
Unpacking	7	5
Installation instructions	8	5
Repacking instructions	9	7
PART TWO. Operating instructions.		
Section III. Operation.		
Controls and their use	10	7
Starting	11	7
Stopping	12	8
IV. Equipment performance check list.		
Purpose and use of equipment performance check list	13	8
Equipment performance check list	14	9
PART THREE. Preventive maintenance.		
Section V. Preventive maintenance techniques.		
Meaning of Preventive maintenance	15	10
Description of preventive maintenance techniques	16	10
Common materials needed	17	13
VI. Itemized preventive maintenance.		
Item 1, exterior	18	13
Item 2, chassis interior	19	13
Preventive maintenance check list	20	14

M558428

TABLE OF CONTENTS

	<i>Paragraph</i>	<i>Page</i>
Section VII. Lubrication.		
VIII. Moistureproofing and fungiproofing.		
General	21	15
Treatment	22	15
Rectifier RA-120	23	17
Moistureproofing and fungiproofing after repairs	24	19
 PART FOUR. Auxiliary equipment.		
 PART FIVE. Repair instructions.		
Section IX. Theory of equipment.		
Principle of operation	25	19
X. Trouble shooting.		
General trouble-shooting information	26	20
Test equipment	27	21
Trouble-shooting procedure	28	21
XI. Repairs.		
Replacement of parts	29	25
Minimum test requirements	30	25
Test requirements chart	31	27
Unsatisfactory Equipment Report	32	27
 APPENDIX.		
Section XII. Maintenance parts.		
Maintenance parts for Rectifier RA-120	33	30
XIII. References.		
Parts list	34	33
Decontamination	35	33
Demolition	36	33
Camouflage	37	33
Other technical publications	38	33
Forms	39	33
List of abbreviations	40	34

DESTRUCTION NOTICE

WHY—To prevent the enemy from using or salvaging this equipment for his benefit.

WHEN—When ordered by your commander.

HOW—1. **Smash**—Use sledges, axes, handaxes, pickaxes, hammers, crowbars, heavy tools.

2. **Cut**—Use axes, handaxes, machetes.

3. **Burn**—Use gasoline, kerosene, oil, flame throwers, incendiary grenades.

4. **Explosives**—Use firearms, grenades, TNT.

5. **Disposal**—Bury in slit trenches, fox holes, other holes. Throw in streams. Scatter.

USE ANYTHING IMMEDIATELY AVAILABLE FOR DESTRUCTION OF THIS EQUIPMENT.

WHAT—1. **Smash**—Front panel, chassis, all tubes, transformers, chokes, resistors, capacitors.

2. **Cut**—All wires and cables.

3. **Burn**—Manuals, circuit labels, cables.

4. **Bury or scatter**—All loose parts.

DESTROY EVERYTHING

WARNING NOTICE

Voltages up to 230 volts are used in the operation of this equipment. These voltages can cause severe shock and burns.

When working inside the equipment, after the power has been turned off, always short-circuit the high-voltage capacitors.



Figure 1. Rectifier RA-120, set up for operation.

RESTRICTED

PART ONE INTRODUCTION

SECTION I DESCRIPTION

1. GENERAL.

a. Rectifier RA-120 (figs. 2 and 3) is used to furnish the plate and filament voltages for the operation of Radio Receiver and Transmitter BC-620 of Radio Set SCR-510 and Radio Receiver and Transmitter BC-659 of Radio Set SCR-610. It operates on a power source of 115 or 230 volts, 50 to 60 cycles alternating current (ac). Rectifier RA-120 is housed in a case similar to that used for Plate Supply Units PE-117 and PE-97. Thus the rectifier may be attached to either Radio Receiver and Transmitter BC-620 or Radio Receiver and Transmitter BC-659 by means of trunk fasteners and electrically connected by means of a short length of cable and an amphenol connector in the same manner as used in Plate Supply Units PE-117 and PE-97.

b. A toggle switch allows the input windings of the power transformer to be connected for either 115- or 230-volt operation. The input cord is a standard two-conductor rubber-covered cord, terminated in a standard power plug (connector P1). The output cord is an eight-conductor rubber-covered cord, terminating in an eight-contact receptacle (connector J1). The power supply includes a power transformer, a filtered full-wave rectifier circuit, a regulator tube for direct-current (d-c) plate voltages, a filtered selenium rectifier circuit, and ballast tubes for direct-current (d-c) filament voltages.

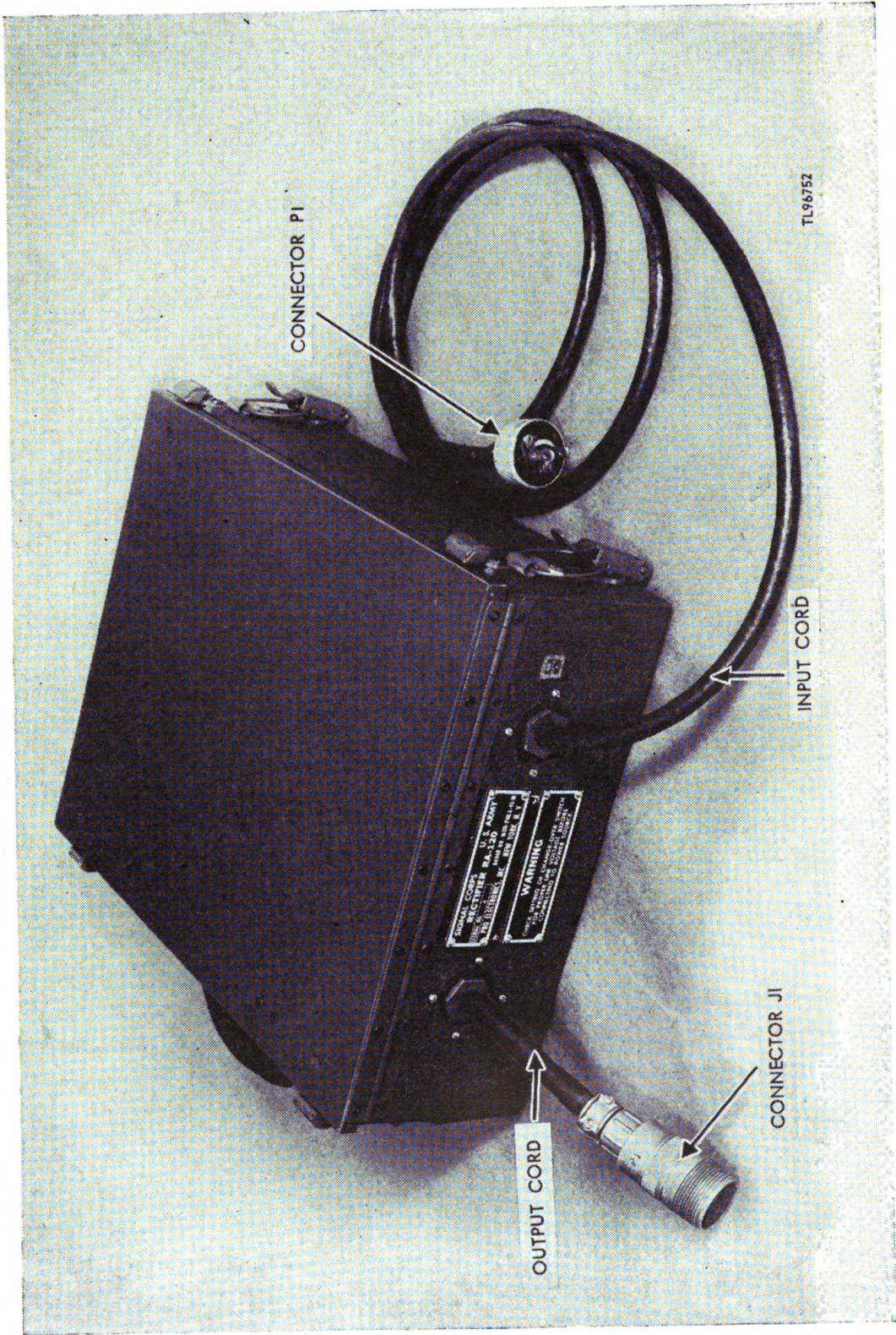

Figure 2. Rectifier RA-120, over-all view

2. TECHNICAL CHARACTERISTICS.

<i>Input volts (ac)</i>	<i>Input amperes</i>
105-125	0.7
210-250	0.35

<i>Load</i>	<i>Output volts (dc)</i>	<i>Amperes</i>
Filament circuit (BC-620)	1.6	0.650
Filament circuit (BC-659)	1.6	0.925
Plate circuit in receiver (receiver in operation)	95	0.033
Plate circuit in receiver (transmitter in operation)	85	0.045
Filament circuit in transmitter (transmitter in operation)	6.85	0.255
Plate circuit in transmitter (transmitter in operation)	148	0.045

3. TABLE OF COMPONENTS.

Component	Required No.	Height (in.)	Depth (in.)	Length (in.)	Weight (lbs)
Rectifier RA-120	1	5	14	15	30

4. PHYSICAL DESCRIPTION OF EQUIPMENT (fig. 3).

Rectifier RA-120 is constructed on a box-type chassis with a single interior deck. The chassis and spare parts (rectifier tube CK1007, capacitor, and fuses) are mounted in a carrying case having a hinged cover which is normally kept closed during operation by two latch fasteners. By opening this cover, the toggle switches controlling the input and output circuits are made accessible. Components and wiring may be exposed by removing the chassis cover which is fastened with screws. Two toggle switches, a fuse post, and box connectors for the input and output cords are mounted on a removable panel which forms one side of the chassis.

5. PACKAGING DATA.

The packed Rectifier RA-120 weighs 40 pounds and measures 18 by 20 by 10 inches.

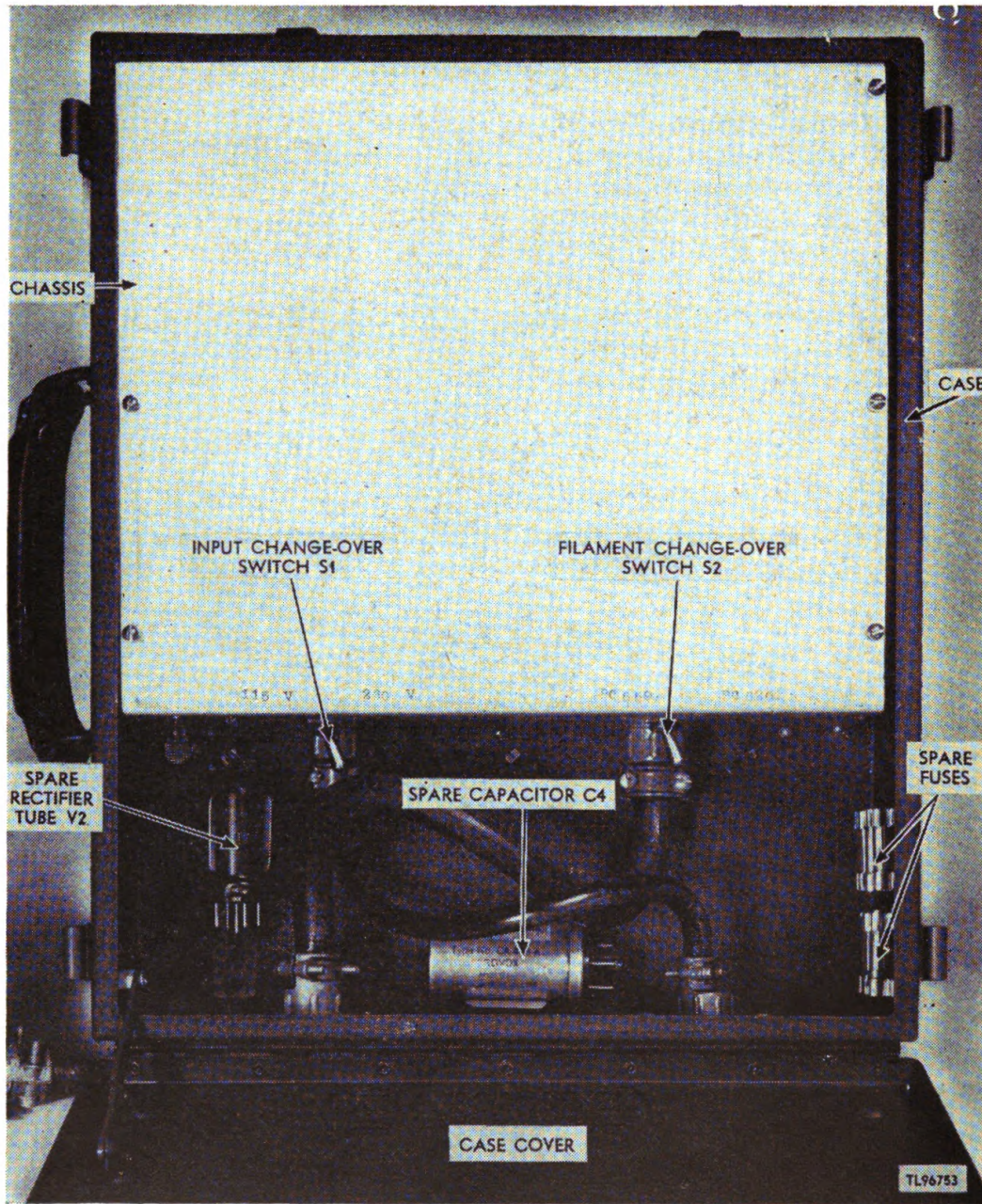

Figure 3. Rectifier RA-120, top view, case cover open.

SECTION II

INSTALLATION

6. LOCATION.

Place Rectifier RA-120 on a level surface, or in a rack mounting, if available, so that the input cord will be convenient to an outlet supplying 115 or 230 volts ac.

7. UNPACKING.

a. Use particular care when unpacking or handling the equipment because it may be easily damaged when not protected by the packing case.

b. Place the packing case as near the operating location as is convenient. In unpacking Rectifier RA-120, follow the steps outlined below (fig. 4) :

- (1) Cut the steel straps binding the crate.
- (2) Remove the nails, using a nail puller.
- (3) Remove the top and sides of the packing case. *Prying the top and sides off without removing nails may result in damage to the equipment.*
- (4) Open the outer carton.
- (5) Remove the moistureproof, vaporproof barrier.
- (6) Remove silica gel.
- (7) Open the inner carton.
- (8) Remove the cushions.
- (9) Remove the technical manual.
- (10) Remove the rectifier unit from the carton.
- (11) Inspect the equipment visually and check contents against the packing slip.

8. INSTALLATION INSTRUCTIONS.

a. Open the case cover, remove the chassis cover, and check the condition of the tubes (fig. 5).

b. Replace the chassis cover.

c. Set the input change-over switch to the proper input voltage (fig. 3).

d. Set the filament change-over switch to the position indicated for radio receiver and transmitter to be used (fig. 3).

e. Place the radio equipment on top of Rectifier RA-120 and secure it to the rectifier with the hooks and catch clips as shown in figure 1.

f. Attach the power cord connectors of the radio receiver and transmitter to the output cord connector of the rectifier unit (fig. 2).

g. Plug the input cord plug (fig. 2) into the line receptacle.

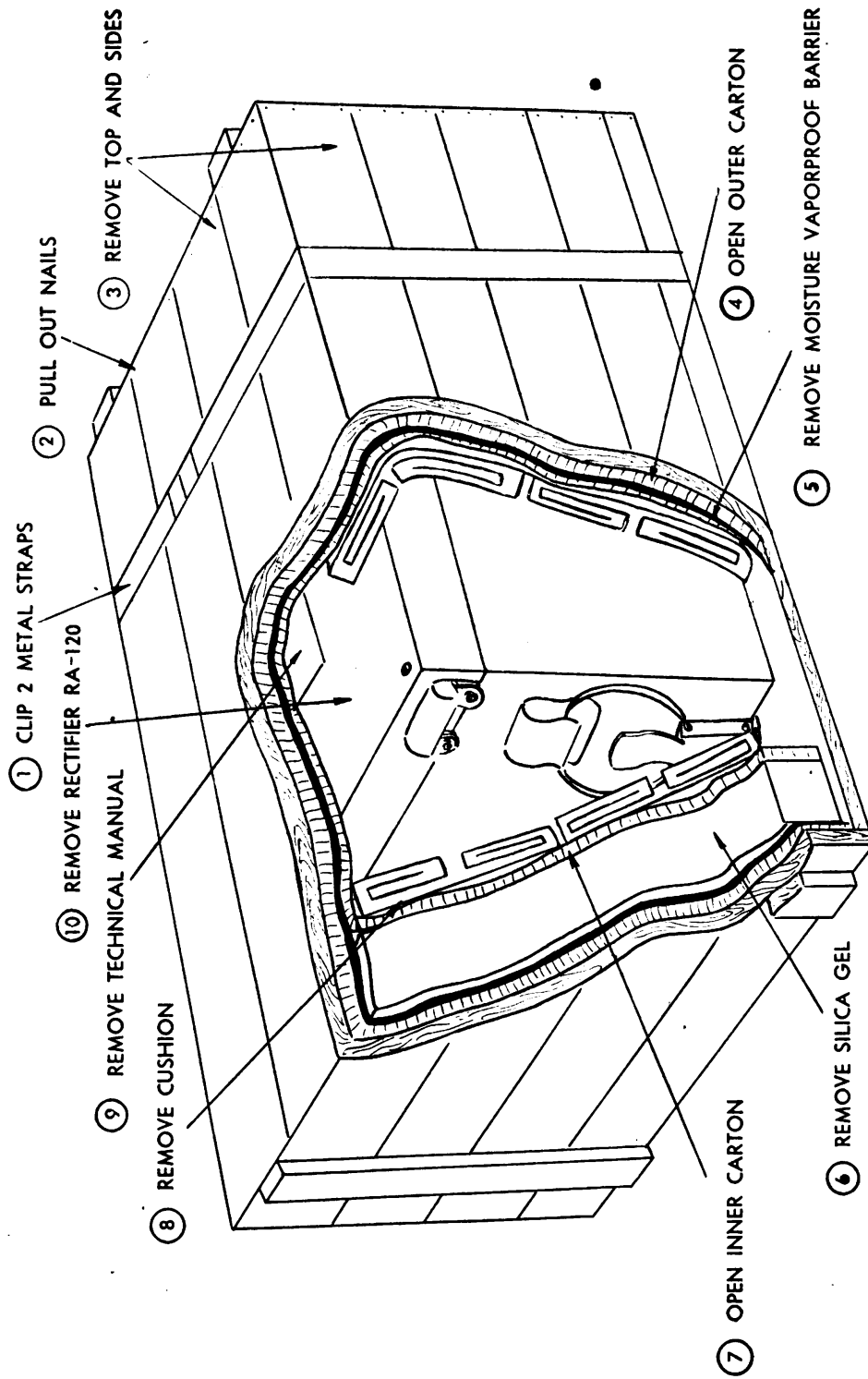

PL 9-754

Figure 4. Unpacking procedure.

9. REPACKING INSTRUCTIONS.

- a. With the carrying case that houses the rectifier affording sufficient protection, Rectifier RA-120 can be carried from one location to the other on short troop movements.
- b. For long-distance transportation, repack the unit in the shipping crate, reversing the procedure described in paragraph 7.

PART TWO

OPERATING INSTRUCTIONS

NOTE: For information on destroying the equipment to prevent enemy use, refer to the destruction notice at the front of the manual.

SECTION III

OPERATION

10. CONTROLS AND THEIR USE (fig. 3).

Rectifier RA-120 is provided with an input change-over toggle switch for operation on either 115 or 230 volts ac. A filament change-over toggle switch provides operation of either Radio Receiver and Transmitter BC-620 or Radio Receiver and Transmitter BC-659.

11. STARTING.

- a. To put Rectifier RA-120 into operation, attach the output cord connector to the connector of the radio receiver and transmitter to be operated.
- b. Open the case cover and set the filament change-over switch to the proper position for the radio equipment as indicated.
- c. Set the input change-over switch to the position indicated for the line voltage available.

CAUTION: It is important that the input change-over switch is in the correct position for the line voltage used. Placing this switch in the incorrect position will result in blowing the fuse or damaging the rectifier tube.

- d. Plug the input cord into the power source.
- e. Turn the volume control switch of the radio equipment on.

12. STOPPING.

Throw the ON-OFF switch of the radio equipment to the OFF position. Disconnect the input cord from the power source.

SECTION IV

EQUIPMENT PERFORMANCE

CHECK LIST

13. PURPOSE AND USE OF EQUIPMENT PERFORMANCE CHECK LIST.

a. General. The equipment check list will help the operator determine whether Rectifier RA-120 is functioning properly. This list gives the items to be checked; the conditions under which the item is checked; the normal indications of the correct operation; and corrective measures the operator can take if there is any trouble. All items on the list are checked when placing the rectifier in operation.

b. Action or Condition. The information given in the action or condition column represents the actions that must be taken in order to check the normal indication given in the normal indication column.

c. Normal Indication. The normal indications listed include those signs which the operator will readily see when checking the items.

d. Corrective Measures. The corrective measures in this column are those that the operator himself can make without having to turn in the unit for repairs. However, if the unit is completely inoperative and the corrective measures do not restore normal operation, trouble shooting is necessary. Reference is then made to the trouble-shooting and repair sections of part five of this manual.

e. Checking. All items should be checked each time the unit is put into operation.

14. EQUIPMENT PERFORMANCE CHECK LIST.

Item No.	Item	Action or condition	Normal indication	Corrective measures
1	Filament change-over switch.	Set switch to radio receiver and transmitter to be used.	Switch in position of radio receiver and transmitter being used.	Set switch to radio receiver and transmitter to be used.
2	Input change-over switch.	Set switch to power source to be used.	Switch in position of power source being used.	Set switch to power source to be used.
3	Power input cable.	Plug into power source. Turn on volume control knob on radio equipment.	Radio equipment will operate.	If radio set does not operate, check fuse in rectifier. If fuse is blown, refer to paragraph 28 before replacing fuse.
4	Meter control switch on radio equipment.	Check for plate and filament voltages (see par. 8 in TM 11-615 or par. 9 in TM 11-605).	Meter reads 2 for both voltages.	If readings on meter are not correct, see paragraph 28.
5	Power input cable.	Turn volume control knob on radio equipment to OFF position and disconnect power input cable.	Radio equipment will not operate.	

PART THREE

PREVENTIVE MAINTENANCE

SECTION V

PREVENTIVE MAINTENANCE TECHNIQUES

15. MEANING OF PREVENTIVE MAINTENANCE.

Preventive maintenance is a systematic series of operations performed at regular intervals on equipment, when turned off, to eliminate major break-downs and unwanted interruptions in service, and to keep the equipment operating at top efficiency. To understand what is meant by preventive maintenance, it is necessary to distinguish between preventive maintenance, trouble shooting, and repairs. The prime function of preventive maintenance is to *prevent* break-downs and, therefore, the need for repair. On the other hand, the prime function of trouble shooting and repair is to locate and correct *existing* defects. The importance of preventive maintenance cannot be overemphasized. Operators and repairmen must maintain their sets properly.

16. DESCRIPTION OF PREVENTIVE MAINTENANCE TECHNIQUES.

a. **General.** Most of the electrical parts used in Rectifier RA-120 require little routine preventive maintenance. Those requiring preventive maintenance differ in the amount and kind required. Because hit-or-miss preventive maintenance techniques cannot be applied, definite and specific instructions are needed. This section of the manual contains these specific instructions and serves as a guide for personnel assigned to perform the six basic maintenance operations, namely: Feel, Inspect, Tighten, Clean, Adjust, and Lubricate. Throughout this manual the lettering system for the six operations will be as follows:

F—Feel*
I—Inspect
T—Tighten
C—Clean
A—Adjust*
L—Lubricate*

*The Feel, Adjust, and Lubricate operations are inapplicable to Rectifier RA-120.

The first two operations establish the need for the other four. The selection of operations is based on a general knowledge of field needs. For example, the dust encountered on dirt roads during cross-country travel filters into the equipment no matter how much care is taken to prevent it. Rapid changes in weather (such as heavy rain followed by blistering heat), excessive dampness, snow, and ice tend to cause corrosion of exposed surfaces and parts. Without frequent inspections and the necessary performance of tightening, cleaning, and lubricating operations, equipment becomes undependable and subject to break-down when it is most needed.

b. Inspect. Inspection is the most important preventive maintenance operation. A careless observer will overlook the evidence of minor troubles. Although minor defects may not interfere with the performance of the equipment, valuable time and effort can be saved if they are corrected before they lead to major break-downs. Make every effort to become thoroughly familiar with the indication of normal functioning, in order to be able to recognize the signs of a defective set. Inspection consists of carefully observing all parts of equipment, noticing their color, placement, state of cleanliness, etc. Inspect for the following conditions:

(1) *Overheating.* As indicated by discoloration, blistering, or bulging of the parts or surface of the container; leakage of insulating compounds; and oxidation of metal surfaces.

(2) *Placement.* By observing that all leads and cabling are in their original positions.

(3) *Cleanliness.* By carefully examining all recesses in the unit for accumulation of dust, especially between connection terminals. Parts, connections, and joints should be free of dust, corrosion, and other foreign matter. In tropical and high-humidity locations, look for fungus growth and mildew.

(4) *Tighten and Clean.* These operations are self-explanatory. Specific procedures to be followed in performing them are given wherever necessary throughout part three.

CAUTION: Screws, bolts, and nuts should not be tightened carelessly. Fittings tightened beyond the pressure for which they are designed will be damaged or broken.

Whenever a loose connection is tightened, it should be moisture-proofed and fungiproofed again by applying the varnish with a small brush. See section VII for details of moistureproofing and fungiproofing.

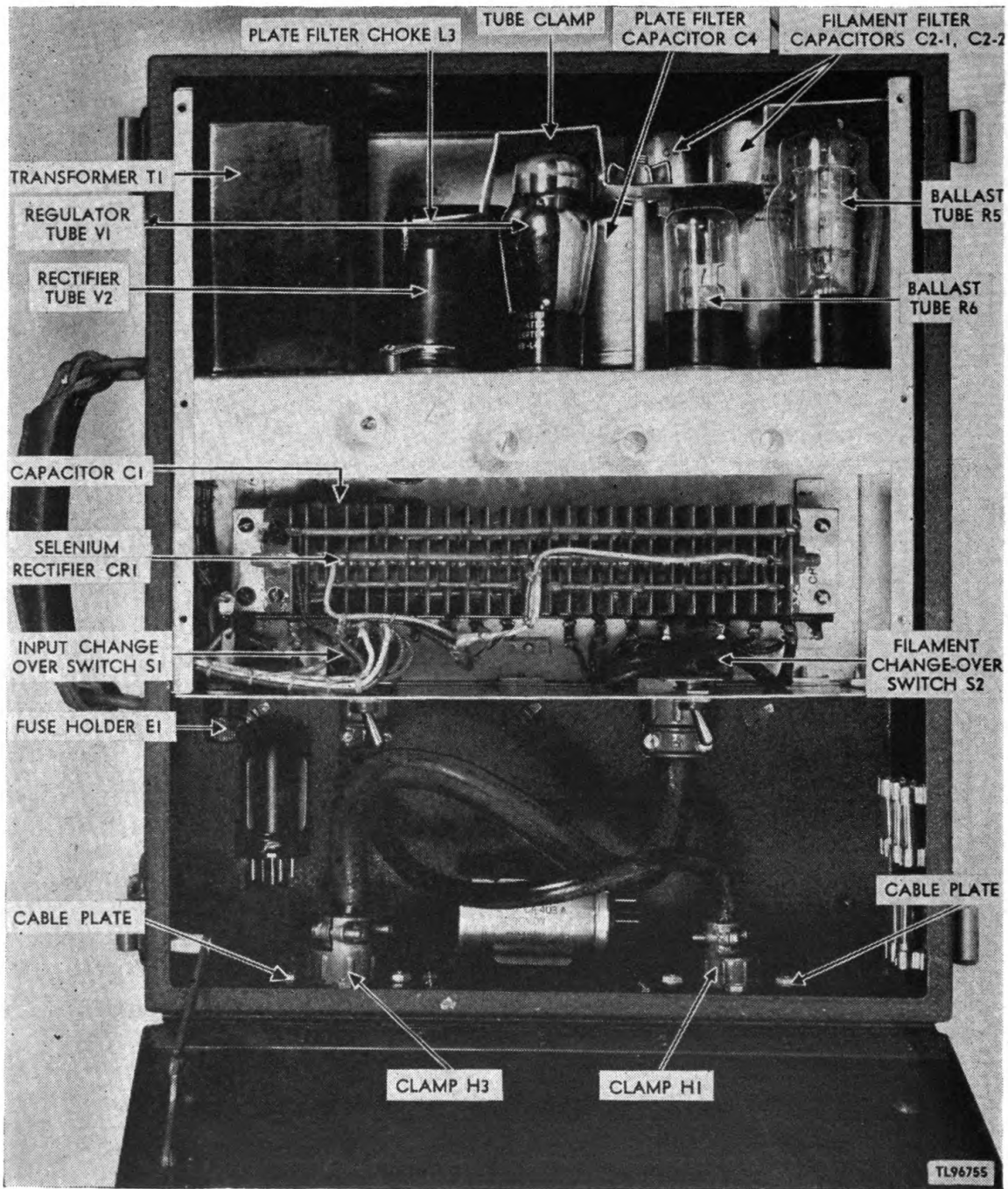

Figure 5. Rectifier RA-120, case cover open, chassis cover removed, top view.

17. COMMON MATERIALS NEEDED.

The following materials will be needed to perform preventive maintenance:

Soft cloth
Metal polish
Varnish
Paint brush
Small brush
Common hand tools
#000 sandpaper

NOTE: Gasoline will not be used as a cleaning fluid for any purpose. Solvent, Dry Cleaning, is available as a cleaning fluid through established supply channels. Oil, Fuel, Diesel, may be used for cleaning purposes when dry-cleaning solvent is not on hand. Carbon tetrachloride will be used as a cleaning fluid only where specified for cleaning contact parts of electrical equipment, or as specified where inflammable solvents cannot be used because of the fire hazard. Oil, Fuel, Diesel, *will not* be used for cleaning electrical contacts.

SECTION VI ITEMIZED PREVENTIVE MAINTENANCE

18. ITEM I—EXTERIOR (fig. 2).

a. Inspect (I). Inspect the input and output cords for excessive wear or deterioration of the rubber. Check the input and output connectors for excessive oxidation and for tightness of the connections. Check the screws on the exterior of the carrying case for tightness. Inspect the finish of the carrying case for chipping or wear of the paint.

b. Tighten (T). Tighten any connections or screws which inspection has revealed to be loose.

c. Clean (C). Clean the connector contacts with a cloth, or if necessary, with #000 sandpaper. Clean the finish of the carrying case and touch up any worn or chipped spots on the paint.

19. ITEM II—CHASSIS INTERIOR (fig. 5).

a. Inspect (I). Inspect the transformers and chokes for possible overheating as indicated by discoloration, blistering, or bulging of the parts or surface of the containers, or leakage of insulating compounds. Inspect the capacitors for leakage of electrolyte or insulating com-

pounds. Check to see that the wiring is in its original position. Check for possible loose connections. Check for tightness of any connection or-mounting which appears to be loose. Check for excessive oxidation of the tube socket contacts.

b. Tighten (T). Tighten any connections or mountings which inspection has revealed to be loose.

c. Clean (C). Clean the interior of the chassis with a soft cloth or brush. Clean the tube socket connections with a soft cloth or if necessary with #000 sandpaper.

20. PREVENTIVE MAINTENANCE CHECK LIST.

The following check list is a summary of the preventive maintenance operations to be performed on Rectifier RA-120. For best performance of the equipment, it is recommended that the operations be performed at least as frequently as called for in the check list. Operations are indicated by the letters of the word FITCAL. For example, if the letters ITC appear in the "Operations" column, the item to be treated must be inspected (I), tightened (T), and cleaned (C).

Item No.	Operations	Item	When performed					Echelons
			Before operation	After operation	Daily	Weekly	Monthly	
1	ITC	Exterior				X		1st
2	ITC	Chassis interior				X		2nd

F Feel* **I** Inspect **T** Tighten **C** Clean **A** Adjust* **L** Lubricate*

*The Feel, Adjust, and Lubricate operations are inapplicable to Rectifier RA-120.

SECTION VII LUBRICATION

NOTE: No lubrication is required.

SECTION VIII

MOISTUREPROOFING AND FUNGIPROOFING

21. GENERAL.

When operated in tropical areas where temperature and relative humidity are extremely high, Signal Corps equipment requires special attention.

These are some of the problems met:

- a. Resistors, capacitors, coils, chokes, transformer windings, etc., fail because of the effects of fungus growth and excessive moisture.
- b. Electrolytic action, often visible in the form of corrosion, takes place in resistors, coils, chokes, transformer windings, etc., causing eventual break-down.
- c. Hook-up wire insulation and cable insulation break down. Fungus growth accelerates deterioration.
- d. Moisture forms electrical leakage paths on terminal boards and insulating strips, causing flash-overs and crosstalk.
- e. Moisture provides leakage paths between battery terminals.

22. TREATMENT.

A moistureproofing and fungiproofing treatment has been devised which, if properly applied, provides a reasonable degree of protection against fungus growth, insects, corrosion, salt spray, and moisture. The treatment involves the use of a moisture-and fungi-resistant varnish applied with a spray gun or brush. Refer to TB SIG 13, Moistureproofing and Fungiproofing Signal Corps Equipment, for a detailed description of the varnish-spray method of moistureproofing and fungiproofing and the supplies and equipment required in this treatment.

CAUTION: Varnish spray may have poisonous effects if inhaled. To avoid inhaling spray, use respirator if available; otherwise, fasten cheesecloth or other cloth material over nose and mouth. Never spray varnish or lacquer near an open flame. Do not smoke in a room where varnish or lacquer is being sprayed. The spray may be highly explosive.

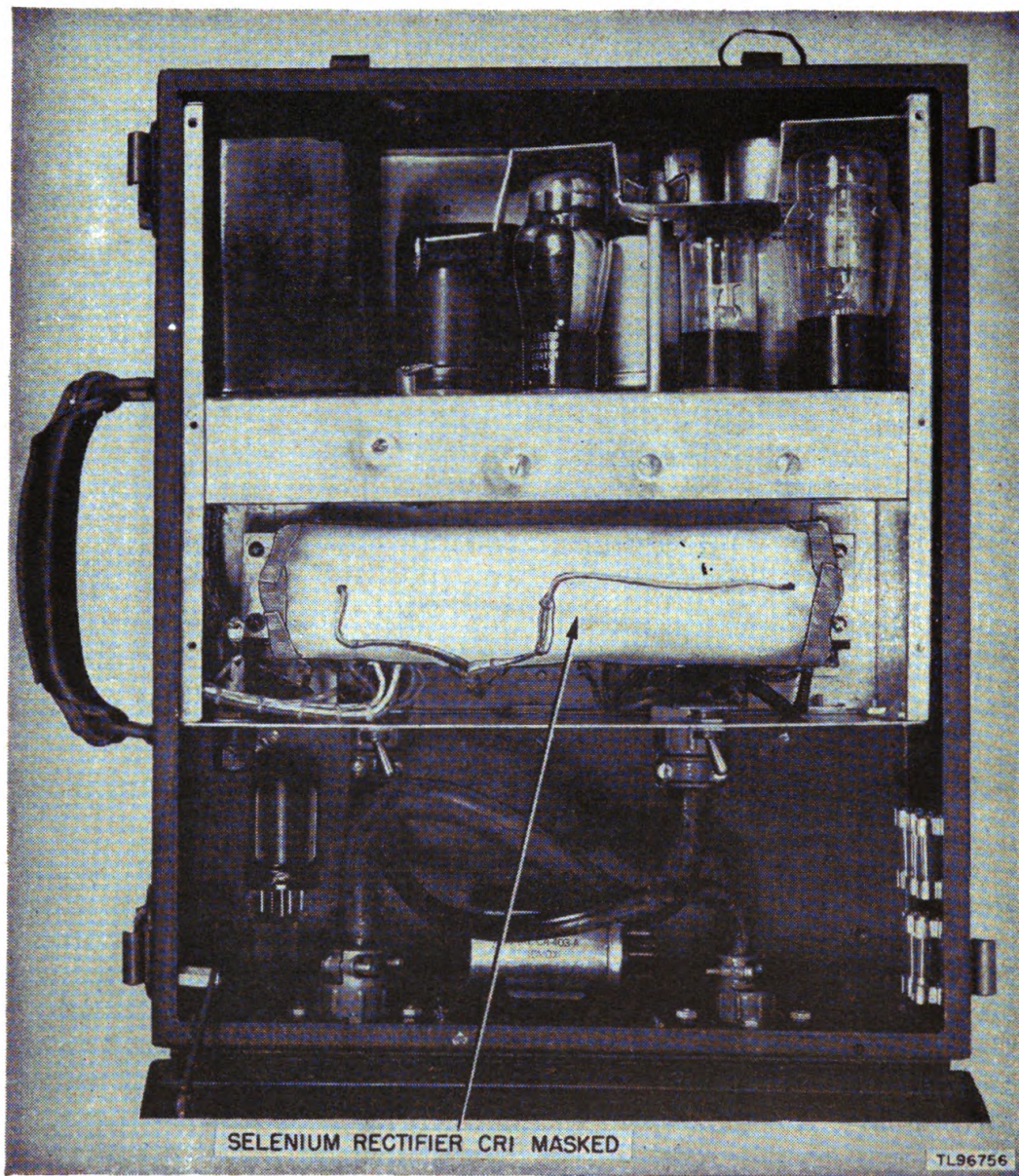

Figure 6. Top view of interior of rectifier chassis, showing selenium rectifier masked.

23. RECTIFIER RA-120.

a. Preparation. Make all repairs and adjustments necessary for proper operation of the equipment.

b. Disassembly.

- (1) Release side catches on unit and lift cover.
- (2) Remove spare rectifier tube, capacitor, and fuses (fig. 3).
- (3) Remove chassis cover plate by unscrewing the six screws on cover plate (figs. 3 and 5).

c. Cleaning. Clean all dirt, dust, rust, and fungus from the equipment to be processed. Clean all oil and grease from the surfaces to be varnished.

d. Masking. Mask or cover with cloth the selenium rectifier stack as shown in figure 6.

e. Drying. Place equipment in oven or under heat lamps and dry for 2 or 3 hours at 160° F.

f. Varnishing.

(1) Apply three coats of moistureproofing and fungiproofing varnish (Lacquer, Fungus-resistant, spec No. 71-2202 (stock No. 6G1005.3), or equal). Allow each coat to air-dry for 15 or 20 minutes before applying the next coat.

(2) Apply varnish immediately after the equipment is dried. If varnish is not applied immediately, moisture condenses on the equipment. Varnish applied over the moisture peels off readily after the varnish has dried.

(3) Spray all parts and circuit elements.

(4) Paint all parts that cannot be reached by spraying, using a small brush.

g. Reassembly.

(1) Remove all masking tape, being careful not to peel varnish from near-by areas.

(2) Replace chassis cover plate and spare parts.

(3) Reassemble the set and test its operation.

h. Marking. Mark the letters MFP and the date of treatment near the equipment nameplate and in such location that the marking will not become obliterated or rubbed off.

EXAMPLE: MFP—8 Dec 44.

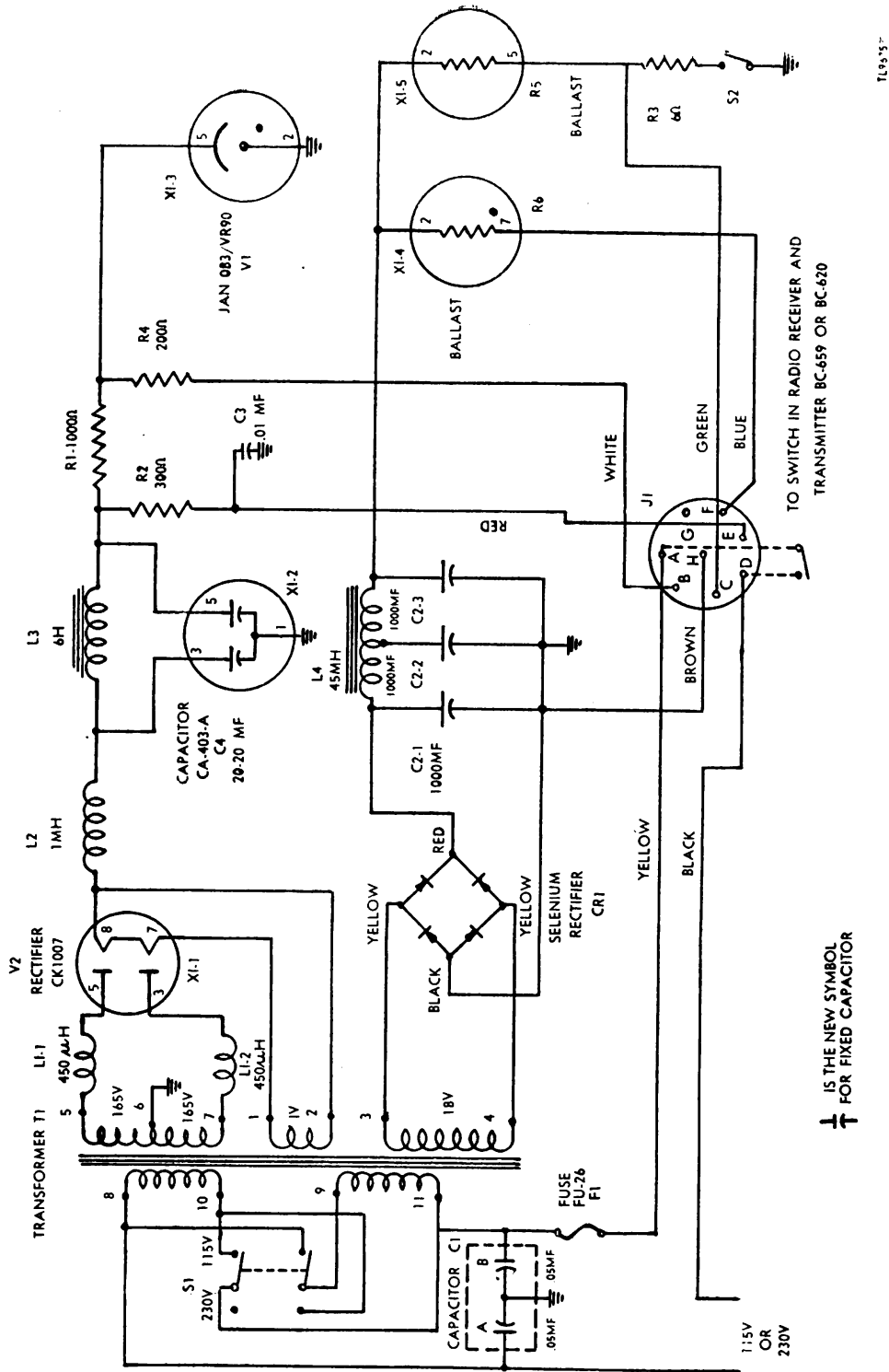

Figure 7. Rectifier RA-120, schematic diagram.

24. MOISTUREPROOFING AND FUNGIPROOFING AFTER REPAIRS.

If, during repair, the coating of protective varnish has been punctured or broken, and if complete treatment is not needed to reseal the equipment, apply a brush coat to the affected part. Be sure the break is completely sealed.

PART FOUR AUXILIARY EQUIPMENT (NOT USED)

PART FIVE REPAIR INSTRUCTIONS SECTION IX THEORY OF EQUIPMENT

NOTE: Failure or unsatisfactory performance of equipment used by Army Ground Forces and Army Service Forces will be reported on W. D., A. G. O. Form No. 468 (Unsatisfactory Equipment Report); by Army Air Forces, on Army Air Forces Form No. 54 (unsatisfactory report). If either form is not available, prepare the data according to the sample form reproduced in figure 12.

25. PRINCIPLE OF OPERATION (fig. 7).

a. The rectifier unit has two principal functional parts, one of which is to supply the plate voltages, the other to supply the filament voltages. The plate supply consists of a full-wave rectifier feeding through a capacitor input filter and dropping resistors R2 and R4 to regulator tube VI. At pin E on output connector J1, 148 volts at 45 milliamperes (ma) is available. At pin B at the output connector J1, 95 volts at 33 ma, or 85 volts at 45 ma is available.

b. The filament supply consists of bridge-type selenium rectifier CR1 feeding through a capacitor input filter through two ballast tubes R6 and R5 to the output connector P1. Ballast tube R6 provides 6.85 volts at 0.255 amperes at pin F on output connector P1. Ballast tube R5 provides 1.6 volts at either 0.925 amperes or 0.650 amperes at pin C on output connector P1, according to the setting of the filament change-over switch on the panel.

c. Both supplies operate from power transformer T1 having two 115-volt input windings, which may be connected either in series or in parallel, for 230- or 115-volt operation. The transformer also has a 330-volt center tapped secondary for the high-voltage plate supply; a 1-volt secondary winding for the filament of the plate supply rectifier tube V2; and an 18-volt secondary winding for the filament supply.

d. Rectifier V2 is a gaseous-type, full-wave rectifier with a 1-volt filament. Due to the abrupt stopping and starting of the current in the rectifier tube, radio-frequency "hash" may be produced. Radio-frequency chokes L1-1, L1-2, and L2, and capacitors C1 and C3 are included to filter this hash and prevent interference in the operation of the radio equipment.

SECTION X

TROUBLE SHOOTING

26. GENERAL TROUBLE-SHOOTING INFORMATION.

a. **Trouble-shooting Data.** This section contains general information to aid personnel engaged in the important duty of trouble shooting. Consult the following data when necessary:

- (1) Schematic diagram (fig. 7).
- (2) Voltage and resistance data for all socket connections (fig. 8).

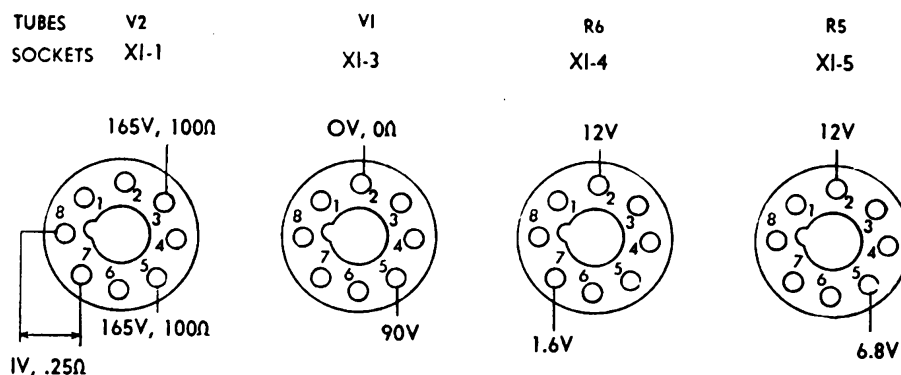

TUBE SOCKETS VOLTAGE AND RESISTANCES MEASURED TO GROUND EXCEPT WHERE OTHERWISE SHOWN.

VOLTAGE MEASUREMENTS MADE WITH POWER ON. RESISTANCE MEASUREMENTS MADE WITH POWER OFF. VACUUM TUBE OUT OF SOCKET.

TL96750

Figure 8. Voltage-resistance chart.

(3) Illustrations of components. Front, top, and interior views of the chassis (figs. 3, 5, 9, 10, and 11) aid in locating and identifying parts.

(4) Pin connections, on sockets, plugs, or receptacles. These connections are numbered or lettered on the schematic diagram. Seen from the bottom, pin connections are numbered in a clockwise direction around the sockets. On octal sockets, the first pin clockwise from the keyway is the number 1 pin.

b. Localization. Paragraph 28 describes the method of localizing faults within Rectifier RA-120. This paragraph includes the trouble-shooting chart which lists abnormal symptoms, their probable causes, and corrections. In addition, figure 8 indicates the resistances and voltages at the socket pin connections.

c. Voltage Measurements. Voltage measurements are an almost indispensable aid to the repairman, because most troubles either result from abnormal voltages or produce abnormal voltages. Voltage measurements are easily taken, because they are always made between two points in a circuit and the circuit need not be interrupted.

(1) Unless otherwise specified, the voltages listed on the voltage charts are measured between the indicated points and ground.

(2) Always begin by setting the voltmeter on the highest range so that the voltmeter will not be overloaded. Then, if it is necessary to obtain increased accuracy, set the voltmeter to a lower range.

d. Voltmeter Loading. In making voltage measurements, it is essential that the voltmeter resistance be at least 10 times as large as the resistance of the circuit across which the voltage is measured. This condition is fulfilled for this equipment when the voltmeter listed in paragraph 27 is used. Thus, the effect of voltmeter loading may be ignored.

27. TEST EQUIPMENT.

The following is the necessary test equipment: analyzer, Weston model 772; tube and battery tester, Weston model 777; and Tool Equipment TE-41-A.

28. TROUBLE-SHOOTING PROCEDURE.

a. General. The following trouble-shooting chart simplifies trouble shooting. This chart lists the various symptoms which may be easily recognized and gives the probable location of the trouble as well as the recommended correction.

b. Trouble-shooting Chart.

Symptoms	Probable trouble	Corrections
1. Rectifier RA-120 dead.	1. Volume control knob of radio equipment in OFF position.	1. Throw switch to ON position.
2. Rectifier unit dead; volume control knob on radio equipment turned on.	2. Fuse F1 blown. If fuse blows after replacing, check for defective parts; one of following parts shorted or defective: Capacitor C1. Transformer T1. Tube V2. Capacitor C4. Tube V1. Capacitor C2-1. Capacitor C2-2. Capacitor C2-3.	2. Replace fuse F1. Replace capacitor C1. Replace transformer T1. Replace tube V2. Replace capacitor C4. Replace tube V1. Replace capacitor C2-1. Replace capacitor C2-2. Replace capacitor C2-3.
3. Rectifier unit dead; volume control knob of radio equipment turned on (fuse F1 not blown).	3. Defective switch S1; broken wiring or open connections on switch S1. Open in primary circuit. Open in yellow or black wire in output cable. Broken connection to pin A or D of output connector J1. Contact pin A or D dirty.	3. Repair broken wiring on open connections on switch S1; replace defective switch S1. Repair open or broken connections and wires in primary circuit. Replace output cable. Resolder connection. Clean contact pin A or D.
4 Receiver and transmitter plate voltages present, but receiver and transmitter filament voltages missing.	4. Open or broken connections or wiring to selenium rectifier CR1. Defective selenium rectifier CR1. Open or broken connections or wiring to filament supply filter circuit. Open choke L4.	4. Repair open or broken wires on connections. Replace defective rectifier CR1. Repair open or broken wires or connections. Replace defective choke.
5. Receiver and transmitter plate voltages present, but receiver and transmitter filament voltages are low.	5. Defective selenium rectifier CR1.	5. Replace defective selenium rectifier CR1.

b. Trouble-shooting Chart (contd).

Symptoms	Probable trouble	Corrections
6. Receiver and transmitter plate voltages and receiver filament voltage present, but transmitter filament voltage missing.	6. Blue wire in output cable open. Ballast tube R6 open. Broken connection to pin F of output connector. Contact pin F dirty.	6. Replace output cable. Replace ballast tube R6. Resolder connection. Clean contact pin F.
7. Receiver and transmitter plate voltages and transmitter filament voltage present, but receiver filament voltage missing.	7. Green wire in output cable open. Ballast tube R5 open. Broken connection to pin contact C of outward connection. Contact pin C dirty.	7. Replace output cable. Replace ballast tube R5. Resolder connection. Clean contact pin C.
8. Receiver and transmitter filament voltages present, but receiver and transmitter plate voltages missing.	8. Defective rectifier tube V2. Open or broken connections or wiring to rectifier tube V2. Open or broken connections or wiring to plate supply filter circuit. Open choke L1-1, L1-2, L2, or L3.	8. Replace defective tube. Repair open or broken wires or connections. Repair open or broken wires or connections. Repair defective choke.
9. Receiver and transmitter filament voltages present, but receiver and transmitter plate voltages are low.	9. Leaky capacitor C4. Defective rectifier tube V2.	9. Replace capacitor C4. Replace rectifier tube V2.
10. Receiver and transmitter filament voltages, and receiver plate voltage present, but transmitter plate voltage missing.	10. Resistor R2 open. Capacitor C3 shorted. Broken connection to contact E of output connector. Contact pin E dirty.	10. Replace resistor R2. Replace capacitor C3. Resolder connection. Clean contact pin E.
11. Receiver and transmitter filament voltages, and transmitter plate voltage present, but receiver plate voltage missing.	11. Resistor R1 open. Resistor R4 open. Broken connection to contact B of output connector. Contact pin B dirty.	11. Replace resistor R1. Replace resistor R4. Resolder connection. Clean contact pin B.
12. Hum in receiver.	12. Open connection to capacitor C4 or open capacitor C4.	12. Repair open connection or replace capacitor C4.

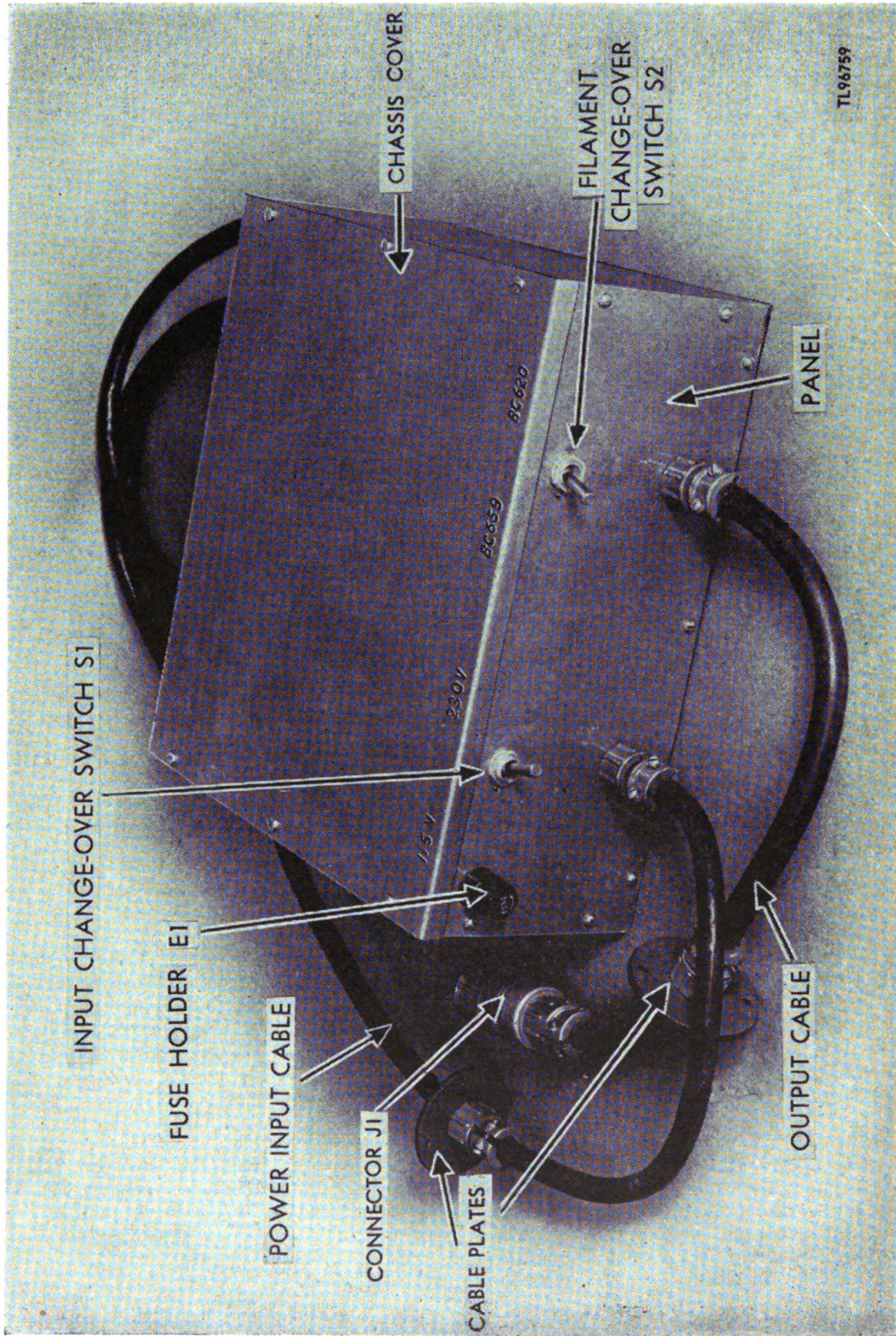

Figure 9. Rectifier chassis removed from case.

SECTION XI

REPAIRS

29. REPLACEMENT OF PARTS.

a. In order to repair Rectifier RA-120 the chassis must be removed from the carrying case (fig. 5). Remove the chassis in the following manner:

(1) Remove the four screws from the two circular cable plates (fig. 5) which carries the cable clamps where each cable passes through the carrying case.

(2) Pull the cables through the holes in the carrying case so that the chassis may be lifted free of the carrying case and set on the work bench (fig. 9).

(3) The wiring and mounting of all components may be exposed by removing the chassis cover and panel (fig. 10).

(4) The tubes and capacitor C4 may be removed by first removing the tube clamps (fig. 5).

b. Most of the parts may be made accessible by the following procedure:

(1) Remove the selenium rectifier from the chassis by unsoldering the connections on the rectifier and loosening the four mounting screws (fig. 10).

NOTE: Care should be taken in reassembling the selenium rectifier, after repairs have been made, to attach the wires to their corresponding color-coded terminals on the rectifier.

(2) Remove the mounting screws which hold resistors R1, R2, and R4 to the chassis. This allows any of these resistors to be moved aside if necessary to reach parts which normally are covered by the resistor.

30. MINIMUM TEST REQUIREMENTS

a. **General.** This paragraph is intended for use by Signal Corps repair organizations in determining the quality of a repaired Rectifier RA-120. Equipment which passes the tests outlined below is suitable for operation.

b. **Test Instruments Required.** The following instruments are required to make the necessary tests:

(1) Analyzer, Weston model 772.

(2) Output load resistors.

(a) 2.5 ohms, 2 w resistor

(b) 1.75 ohms, 2 w resistor

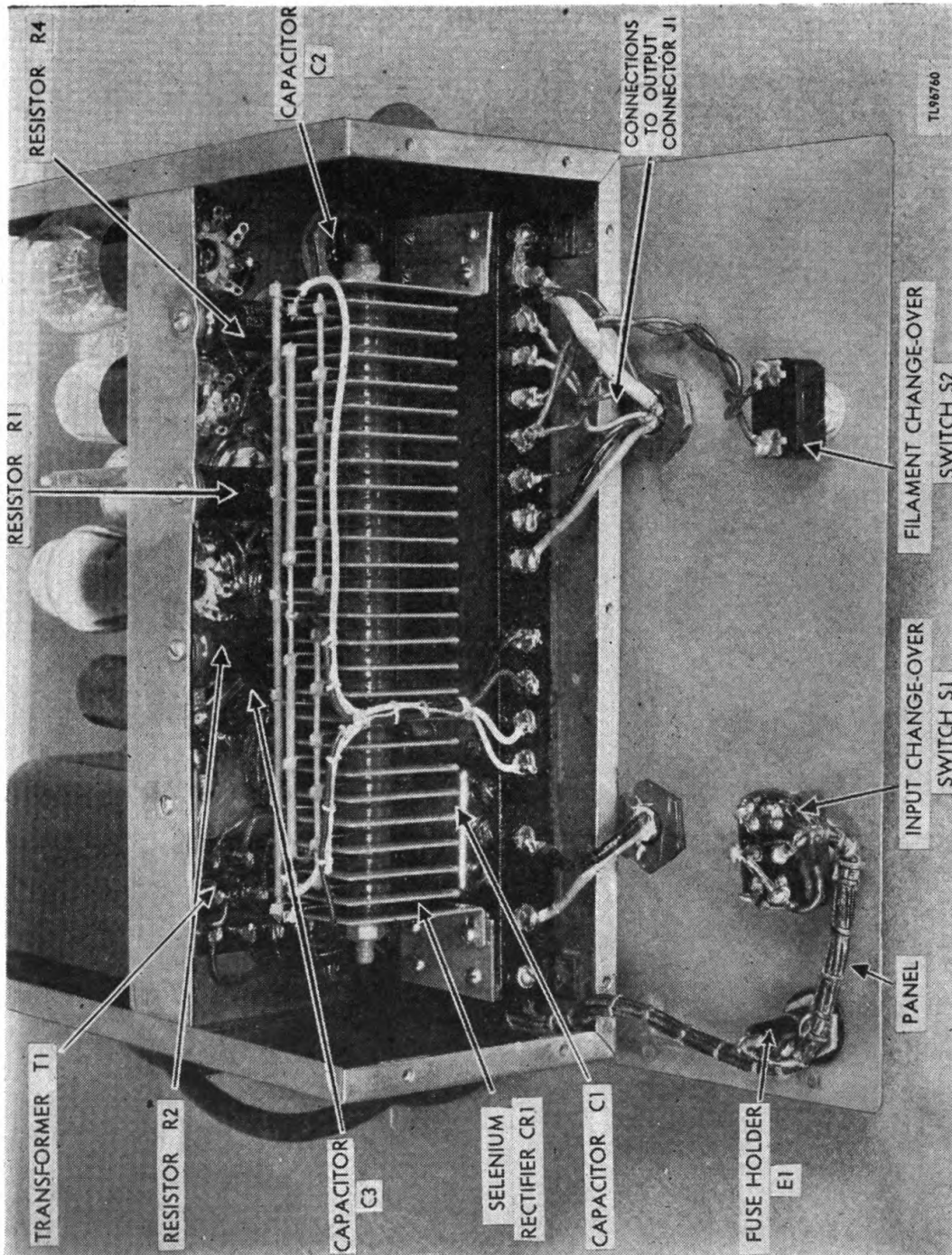

Figure 10. Rectifier chassis with cover and panel removed.

- (c) 2,900 ohms, 5 w resistor
- (d) 1,900 ohms, 5 w resistor
- (e) 27 ohms, 2 w resistor
- (f) 3,200 ohms, 10 w resistor

(g) An eight-prong male contact connector, equipped with eight wires ending in alligator clips, is necessary for attaching the proper output load resistors.

c. Electrical Check. Check Rectifier RA-120 according to the following procedure and test requirements chart (par. 31):

- (1) Set the input change-over switch to 115-volt position.
- (2) Set the filament change-over switch to the position indicated in the test chart.
- (3) Clip together the two wires coming from pins D and A of the eight-prong plug and attach the plug to the output receptacle of the rectifier unit.
- (4) Attach the load resistor to the wires coming from the pins as indicated in the test chart.
- (5) Place the input plug of the rectifier unit into the 115-volt, 60-cycle supply socket. Check the voltage across the load resistor with a Weston 772 analyzer or its equivalent.
- (6) Read the voltage across the load resistor. The values should be within the limits shown on the chart.

31. TEST REQUIREMENTS CHART.

Filament change-over switch position	Load resistance	Pin connections	Output volts
BC-620	2.5 ohms	C and H	1.3 to 1.6
BC-659	1.75 ohms	C and H	1.3 to 1.6
BC-659	2,900 ohms	B and H	85 to 95
BC-659	1,900 ohms	B and H	80 to 90
BC-659	27 ohms	F and H	5.8 to 7.8
BC-659	3,200 ohms	E and H	140 to 150

32. UNSATISFACTORY EQUIPMENT REPORT.

a. When trouble in equipment used by Army Ground Forces or Army Service Forces occurs more often than repair personnel feel is normal, War Department Unsatisfactory Equipment Report, W.D., A.G.O. Form No. 468 should be filled out and forwarded through channels to the Office of the Chief Signal Officer, Washington 25, D. C.

b. When trouble in equipment used by Army Air Forces occurs more often than repair personnel feel is normal, Army Air Forces Form No. 54 should be filled out and forwarded through channels.

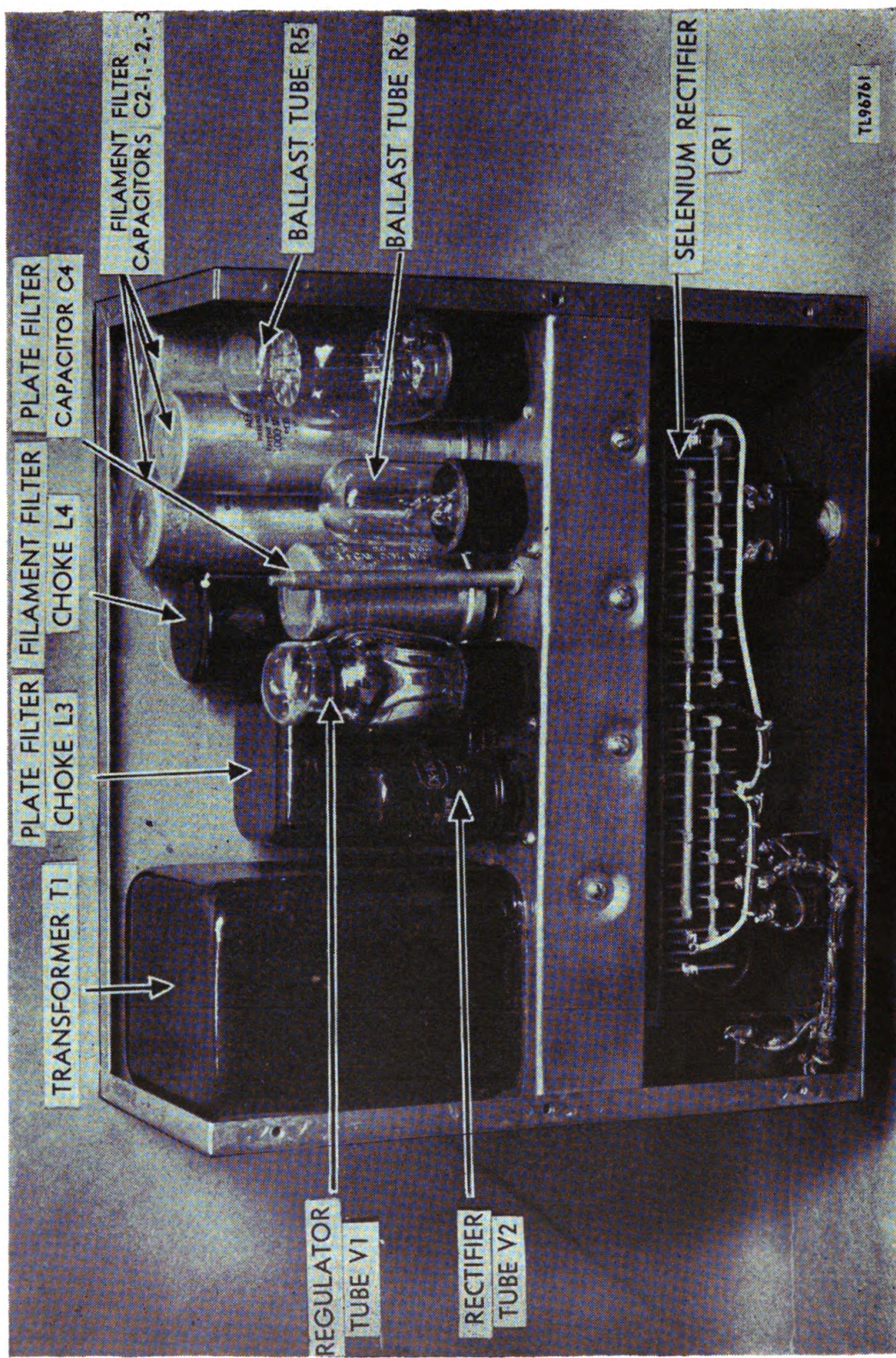

Figure 11. Rectifier chassis, top view of chassis deck.

WAR DEPARTMENT UNSATISFACTORY EQUIPMENT REPORT		
FOR	TECHNICAL SERVICE Signal Corps	MATERIEL
FROM	ORGANIZATION 697 Sig Rep Co	DATE 11 May 45
TO	NEXT SUPERIOR HEADQUARTERS Signal Officer	STATION A.P.O. #912 New York 12, N. Y.
	STATION	TECHNICAL SERVICE Signal Corps

COMPLETE MAJOR ITEM			
NOMENCLATURE Rectifier RA-120	TYPE Ground Signal	MODEL	
MANUFACTURER Pro-Electronics, Inc.	U. S. A. REG No Order No. 16331-P-45-10	SERIAL No. 4	DATE RECEIVED 8 Feb 45
EQUIPMENT WITH WHICH USED (If applicable) Radio Sets SCR 510 and SCR 610.			

DEFECTIVE COMPONENT—DESCRIPTION AND CAUSE OF TROUBLE									
PART NO.	TYPE Selenium Rectifier	MANUFACTURER AB Associates	DATE INSTALLED 3 Mar 45						
DESCRIPTION OF FAILURE AND PROBABLE CAUSE (If additional space is required, use back of form) Electrical-low voltage output from selenium rectifier due to overheating.									
DATE OF INITIAL TROUBLE 7 May 45	TOTAL TIME INSTALLED			TOTAL PERIOD OF OPERATION BEFORE FAILURE					
	YEARS	MONTHS	DAYS	YEARS	MONTHS	DAYS	HOURS	MILES	ROUNDS
			65				340		
BRIEF DESCRIPTION OF UNUSUAL SERVICE CONDITIONS AND ANY REMEDIAL ACTION TAKEN Constant use of over 14 hours in ambient temperature 110° F.									
TRAINING OR SKILL OF USING PERSONNEL			RECOMMENDATIONS (If additional space is required, use back of form)						
POOR	FAIR	GOOD	Rectifier of greater current carrying capacity to reduce heating of unit.						
		X							

TYPED NAME, GRADE, AND ORGANIZATION		SIGNATURE
George W. Burns Capt. Signal Corps 697 Repair Co.		<i>George W. Burns</i>

FIRST ENDORSEMENT		
TO CHIEF	TECHNICAL SERVICE Signal Officer, Washington 25, D. C.	OFFICE
NAME, GRADE, AND STATION	STATION	DATE

Instructions
<ol style="list-style-type: none"> It is imperative that the chief of technical service concerned be advised at the earliest practical moment of any constructional, design, or operational defect in matériel. This form is designed to facilitate such reports and to provide a uniform method of submitting the required data. This form will be used for reporting manufacturing, design, or operational defects in matériel, petroleum fuels, lubricants, and preserving materials with a view to improving and correcting such defects, and for use in recommending modifications of matériel. This form will not be used for reporting failures, isolated material defects or malfunctions of matériel resulting from fair-wear-and-tear or accidental damage nor for the replacement, repair or the issue of parts and equipment. It does not replace currently authorized operational or performance records. Reports of malfunctions and accidents involving ammunition will continue to be submitted as directed in the manner described in AR 750-10 (change No. 3). It will not be practicable or desirable in all cases to fill all blank spaces of the report. However, the report should be as complete as possible in order to expedite necessary corrective action. Additional pertinent information not provided for in the blank spaces should be submitted as inclosures to the form. Photographs, sketches, or other illustrative material are highly desirable. When cases arise where it is necessary to communicate with a chief of service in order to assure safety to personnel, more expeditious means of communication are authorized. This form should be used to confirm reports made by more expeditious means. This form will be made out in triplicate by using or service organization. Two copies will be forwarded direct to the technical service; one copy will be forwarded through command channels. Necessity for using this form will be determined by the using or service troops.

W. D., A. G. O. Form No. 468
30 August 1944

This form supersedes W. D., A. G. O. Form No. 468, 1 December 1943, which may be used until existing stocks are exhausted.

U. S. GOVERNMENT PRINTING OFFICE 16-41546-1

TL96762

Figure 12. W. D., A. G. O. Form 468 with sample entries.

APPENDIX

SECTION XII MAINTENANCE PARTS

33. MAINTENANCE PARTS FOR RECTIFIER RA-120.

The following information was compiled on 23 March 1945. The appropriate section of the ASF Signal Supply Catalog for Rectifier RA-120 is:

Sig 8-RA-120, Higher Echelon Spare Parts (when published). For the latest index of available catalog sections, see ASF Signal Supply Catalog Sig 2.

Ref symbol	Signal Corps stock No.	Name of part and description
	3H4691-120	RECTIFIER RA-120: electron tube; output 1.6 v DC, 0.65 amps; 1.6 v DC, 0.925 amps; 95 v DC, 0.033 amps; 85 v DC, 0.045 amps; 6.85 v DC, 0.255 amps; 148 v DC, 0.045 amps; input 115 v 0.66 amps, or 230 v, 0.33 amps; 50/60 cyc; single ph; overall dimen 14" wd x 17" lg x 5"h.
W1	1B3018-2.12	CABLE, power: RC; round, 0.4" diam; 2 #18 AWG stranded cond ea comprising 16 #30 AWG strands; Underwriters Lab type "S" (AC power).
W2	1B3018-15	CABLE, power: RC; round, 0.7" diam; 8 #18 AWG stranded copper cond ea comprising 16 #30 AWG strands; Underwriters Lab type "S" (DC power).
C4	3D403	CAPACITOR CA-403-A: fixed: electrolytic; 2 sect; 20-20 mf - 10%; 400 vdcw; 1-1/2" diam x 3-1/8" h (w/octal plug base).
C2	3DB1000-4	CAPACITOR, fixed: electrolytic; 1000 mf; 25 vdcw; 1-3/8" diam x 4-1/4" h; Aerovox type "G".
C3	3K3510314	CAPACITOR, fixed: mica; 10,000 mmf \pm 20%; 300 vdcw; max dimen 53/64" x 53/64" x 11/32"; CM35A103M.
C1	3DA50-190	CAPACITOR, fixed: paper, oil filled; 2 sect; 50,000-50,000 mmf \pm 20% - 10%; 1000 vdcw; max overall dimen 2-9/16" x 15/16" x 1-13/16"; CP50B4EG-503MK.
H1	2Z1587-284	CLAMP, cable: cast aluminum; natural finish; two #5-40 x 5/8" brass mach screws; overall dimen 15/16" OD x 1-5/64" lg x 1/2" ID; Amphenol #AN-3057-6 (for AC cable).

33. MAINTENANCE PARTS FOR RECTIFIER RA-120 (contd).

Ref symbol	Signal Corps stock No.	Name of part and description
H3	2ZK2636-2	CLAMP cable: cast aluminum; two #8-32 x 3/4" brass mach screws; overall dimen 1-3/16" OD x 1-1/8" lg x 11/16" ID; Amphenol #AN-3057-10 (DC cable at case).
H2	2Z2636-3	CLAMP, cable: cast aluminum; two #8-32 x 3/4" brass mach screws; overall dimen 1-3/16" OD x 1-1/8" lg x 11/16" ID; Amphenol #AN-3057-12 (for DC cable at connector).
L3	3C317-53	COIL, AF: filter; single winding; 6 hy; 80 ma, 150 ohms DC; 2" wd x 2-1/8" d x 2-3/4" h; Chi Trans #MD2815.
IA	3C362-4	COIL, AF: filter; single CT winding; 45 mh; 0.9 amp, 11 ohms DC; 1-3/8" diam x 3-1/2" h; Chi Trans #MD2813.
L2	3C323-22X	COIL, R.F: choke; single pie, bank wound; unshielded; 1 mh, 125 ma, 15 ohms DC; 5/8" lg x 1-1/8" diam less lugs; Teleradio Eng #CH113-PT62.
L1	3C323-22W	COIL, R.F: choke; 3 pie, bank wound; unshielded 450 mh, 75 ma, 20 ohms DC; 3/4" lg x 1/2" diam overall; Teleradio Eng #CH-3-PT16.
J1	2Z8678.8	CONNECTOR, female; 8 cont; straight; 2-1/8" lg x 1-1/4" OD; Amphenol #AN-3101-20-7S.
P1	6Z1727	CONNECTOR, male contact: 2 parallel cont; straight; 1-5/8" diam x 2" lg overall; cont 5/8" lg; Hubbell #7057.
H4	6Z3421-1	FITTING, conduit: box connector; cast aluminum; overall dimen 15/16" diam x 1/2" lg; 3/4"-20 thd; Amphenol #3056-6 (for AC cable).
H5	6Z3421-2	FITTING, conduit: box connector: cast aluminum; overall dimen 1-1/4" diam x 9/16" lg; 1"-20 thd; Amphenol #AN-3056-10 (for DC cable).
F1	3Z1926	FUSE FU-26: cartridge; 1 amp, 250 v; glass body; ferrule ends 1/4" diam x 7/32" lg; overall dimen 1-1/4" lg x 1/4" diam.
	2Z4866.250	GASKET: synthetic rubber; neoprene; box connector seal; 2-1/4" diam x 3/32" thk x 13/16" ID; Pro-Electronics Corp dwg #143, item 2.
	2Z4922-1	HANDLE, case: leather; 6" lg x 1" wd x 1-1/8" thk; Galvin dwg #55B30177.
E1	3Z3275-9	HOLDER, fuse: extractor post; for single 3AG fuse; bakelite; 8 amp, 125 v max; 2-1/2" lg x 7/16" diam; Littelfuse #1075F.
CR1	3H4839-40	RECTIFIER, metallic: selenium; input 18 v, 1.5 amp; output 12 v, 1.5 amp; 8-3/4" lg x 2-1/2" h x 1-3/4" wd; Horni type B4DW1U6R.

33. MAINTENANCE PARTS FOR RECTIFIER RA-120 (contd).

Ref symbol	Signal Corps stock No.	Name of part and description
R3	3Z5996-34	RESISTOR, fixed: composition; 6 ohms \pm 10%; 1 w; 5/8" lg x 1/4" diam; Erie #518B.
R4	3RW20112	RESISTOR, fixed: wire wound; 200 ohms \pm 10%; 20 w; max dimen 3-1/16" lg x 19/32" diam; RW33G201.
R2	3RW21314	RESISTOR, fixed: wire wound; 300 ohms \pm 10%; 20w; max dimen 3-1/16" lg x 19/32" diam; RW33G311.
R1	3RW24322	RESISTOR, fixed: wire wound; 1000 ohms \pm 10%; 20 w; max dimen 3-1/16" lg x 19/32" diam; RW33G102.
X1	2Z8795.12	SOCKET, tube: octal; phenolic body; 1-9/32" wd x 1-7/8" lg overall; body 1-7/64" diam x 1/2" thk less lugs; Amphenol #M1P8TM.
S1	3Z9849.22	SWITCH, toggle: DPDT; bakelite; max dimen 1-9/32" lg x 23/32" wd x 2-1/8" d overall; C-H #8825K3.
S2	3Z9859-31.1	SWITCH, toggle: SPST; bakelite body; max dimen 1-1/32" lg x 9/16" wd x 1-61/64" d; ST10A.
T1	2Z9608-57	TRANSFORMER, power: plate and fil; pri 115-230 v; secd 330 v, 0.125 amp, CT; 18 v, 1.5 amp; 1 v, 1.25 amp; fully enclosed steel case; 3" wd x 3-1/2" d x 4-1/4" h; Chi Trans #MD2814.
R5	2J10T1	TUBE, ballast: glass; 2.2 to 4.9 v, 7.6 to 11.4 v, 18.4 to 26.4 v; operating current 0.83 to 1.04 amp per sect; ST-14 bulb; 4-1/2" h x 1-13/16" diam overall; Amperite #10T-1.
R6	2J2H8	TUBE, ballast: glass 8 to 14 v, 0.24 to 0.26 amps; T-9 clear bulb; 3-1/8" h x 1-1/4" diam; Amperite #2H8.
V2	2J1007	TUBE, electron: JAN-1007.
V1	2JOB3/VR90	TUBE, electron: JAN-0B3/VR90.

SECTION XIII

REFERENCE

34. PARTS LIST.

- SIG 3 List of Items for Troop Issue.
- SIG 4-1 Allowances of Expendable Supplies.
- SIG 5 Stock List of all Items.

35. DECONTAMINATION.

- TM 3-320 Decontamination.

36. DEMOLITION.

- FM 5-25 Explosives and Demolitions.

37. CAMOUFLAGE.

- FM 5-20 Camouflage, Basic Principles.

38. OTHER TECHNICAL PUBLICATIONS.

- FM 21-6 List of Publications for Training.
- TB SIG 13 Moistureproofing and Fungiproofing Signal Corps Equipment.
- TB SIG 66 Winter Maintenance of Ground Signal Equipment.
- TB SIG 72 Tropical Maintenance of Ground Signal Equipment.
- TB SIG 75 Desert Maintenance of Ground Signal Equipment.
- TM 1-455 Electrical Fundamentals.
- TM 11-462 Reference Data.
- TM 37-250 Basic Maintenance Manual.

39. FORMS.

- Army Air Forces Form No. 54 (unsatisfactory report).
- W.D., A.G.O. Form No. 468 (Unsatisfactory Equipment Report).

40. LIST OF ABBREVIATIONS.

A	adjust
ac	alternating current
A.G.O.	Adjutant General's Office
C	clean
dc	direct current
F	feel
fig.	figure
FM	field manual
h	henry
I	inspect
in.	inch, inches
JAN	joint-Army-Navy
L	lubricate
lb	pound
mh	milihenry(ies)
mf	microfarad(s)
No.	number
par.	paragraph
T	tighten
TM	technical manual
TNT	Tri-nitro-toluene
v	volts
w	watts
W. D.	War Department

Order No. 16331 - Phila - 45-10; 58,507 copies;

April 1945

