

U113
-2
TM 1942

TM 11-345

U.S. Dept. of Army

WAR DEPARTMENT

TECHNICAL MANUAL

CABINET BE-70- ()
(WIRE CHIEF'S TESTING)

April 28, 1942





TM 11-345

U 113
0 1
.2

TECHNICAL MANUAL
CABINET BE-70-()
WIRE CHIEF'S TESTING

TM 11-345
1942
★ ★

CHANGES }
No. 1 }

U.S. WAR DEPARTMENT,
WASHINGTON 25, D. C., 24 August 1943.

TM 11-345, 28 April 1942, is changed as follows:

These changes together with TM 11-345, 28 April 1942, supersede TM 11-345-S, preliminary instruction for Cabinet BE-70-S (Wire Chief's Testing), 12 December, 1942.

1. Use.—Cabinet BE-70-() is * * * mathematical calculations. The test cabinet is equipped with a flush type, 100,000-ohm voltmeter. A 30-volt battery * * * in figure 1.

[A. G. 300.7 (18 Jun 43).] (C 1, 24 Aug 43.)

3. Installation.

* * * * *

c. Connections.

* * * * *

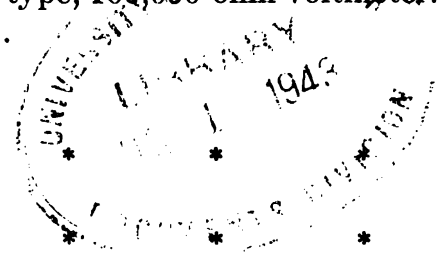

(1) The G-R-Y TEL terminals are used for connecting the wire chief's telephone set to the test cabinet. A hole is provided in the front of the test cabinet for the telephone cord or connecting wires.

(a) (Added.) *For common battery operation*, a hand set such as Hand Set TS-8 of Telephone EE-8-() or a head and chest set such as Head and Chest Set HS-19 should be connected directly to the G-R-Y TEL terminals as shown in figures 13 to 16, inclusive.

(b) (Added.) *For local battery operation*, connect a complete Telephone EE-8-() or the equivalent to the Y and R TEL terminals, leaving the G terminal vacant, and connect terminal 1 to 2 on the induction coil (17, 21, or 23 in figs. 13 to 16). These connections are all that are necessary for those Cabinets having 2-winding sidetone induction coils (21). In addition, remove the wire from induction coil terminal 5 in those cabinets having 3-winding antisidetone induction coils (17) or remove the wire from induction coil terminal 6 in those cabinets having 4-winding antisidetone induction coils (23). In all cases, the batteries must be used in Telephone EE-8-().

* * * * *

f. Rescinded.

[A. G. 300.7 (18 Jun 43).] (C 1, 24 Aug 43.)

* * * * *

18. Resistance measurements.—*a. Voltmeter method.*—The deflection indicated * * * of the voltmeter. In the BE-70-(), the resistance of the voltmeter circuit is 100,000 ohms, except when

546454°—43

M558379

the VM SHUNT key is operated, in which case it is 199.6 ohms.¹
As an example, * * * differences in resistance.

* * * * *
[A. G. 300.7 (16 Jun 43).] (C 1, 24 Aug 43.)

19. Useful information.

* * * * *
e. Resistance and weights of wires and cables.
* * * * *

	Weight per mile (pounds)	Resistance per mile of single conductor (ohms)	Resistance per loop mile (ohms)
* * * * *	*	*	*
Cable, rubber insulated, rubber covered:			
No. 19 AWG, 5 pair (type WC-534)-----	660	43	86
No. 19 AWG, 10 pair (type WC-535)-----	1,320	43	86
Bare copper-clad steel wire:			
No. 12 AWG 80 mil. 40% conductivity (type W-153)-----	192	21.3	42.6
Assault wire, 7 strand (6 steel, 1 copper):			
Twisted pair (type W-130A)-----	34	295	590
Twisted pair (type W-150)-----	49	295	590
Cable aerial or underground toll, paper insulated, lead covered:			
No. 16 AWG-----		21	42
Cable assembly, spiral-four field cable (1/4 mile sections with loading coils in connectors) 2 pair rubber insulated with rubber sheath over steel braid, paper, and shielding No. 18 AWG (type CC-358):			
Loaded side circuit, 6 mh per assembly (4 assemblies)-----	540	38.5	77
Nonloaded phantom (4 assemblies)-----	540	19.5	39
Cable, spiral-four, 2 pair, rubber insulated, with rubber sheath over steel braid, paper, and shielding No. 18 AWG (type WC-548):			
Nonloaded side circuit-----	540	37.5	75

¹ Cabinets BE-70-M and BE-70-P provide a voltmeter circuit resistance of 1,000 ohms when the VM SHUNT key is operated.

f. Table of resistance versus voltmeter reading for various test battery voltages.

Voltmeter reading	Voltmeter, 100,000 ohms (voltmeter not shunted) ²			Voltmeter, 199.6 ohms (VM SHUNT key operated) ³		
	(Maximum test battery voltage)			(Maximum test battery voltage) ¹		
	(30)	(29)	(28)	(30)	(20)	(28)
*	*	*	*	*	*	*
*	*	*	*	*	*	*

¹ Divide resistance values by 100 when using Cabinets BE-70-M and BE-70-P with the voltmeter shunted (VM SHUNT key operated). These cabinets have a voltmeter circuit resistance of 1,000 ohms when the voltmeter is shunted.

² Do not use these resistance values for Cabinets BE-70-M and BE-70-P. (See note 2.)

[A. G. 300.7 (16 Jun 43).] (C 1, 24 Aug 43.)

20. (Superseded.) **Schematic circuit.**—The schematic circuit of Cabinet BE-70-A or B, as manufactured by the Leich Electric Co., is shown in figure 4 and is used as an example in the following paragraphs. Type numbers of parts will vary for other manufacturers. (For complete details, see diagrams and lists in pars. 31.1 to 33, incl.) Schematic circuits of units made by other manufacturers are similar in all respects except for connections in the operator's telephone circuit.

[A. G. 300.7 (16 Jun 43).] (C 1, 24 Aug 43.)

Figure 3, Cabinet BE-70-(), wiring diagram (page 17) is rescinded.

[A. G. 300.7 (16 Jun 43).] (C 1, 24 Aug 43.)

29. **Test for a cross with a line carrying current.**—Figure 12 shows * * * carrying current. In order to test the tip conductor it will be necessary to operate the **REV** key. If the voltmeter * * * VM REV key.

[A. G. 300.7 (16 Jun 43).] (C 1, 24 Aug 43.)

31.1. **Wiring diagrams (Added).**—The wiring diagrams of Cabinet BE-70-() as manufactured by the Leich Electric Co., Kellogg Switchboard and Supply Co., Automatic Electric Co., and the Western Electric Co. are shown in figures 13 to 16, inclusive. Alternate coil connections shown on the Leich and Kellogg diagrams apply to earlier models where a sidetone circuit was employed. On these models should the winding become defective, a 3-winding or a 4-winding anti-sidetone coil may be substituted by making the connections indicated for the type of coil to be substituted.

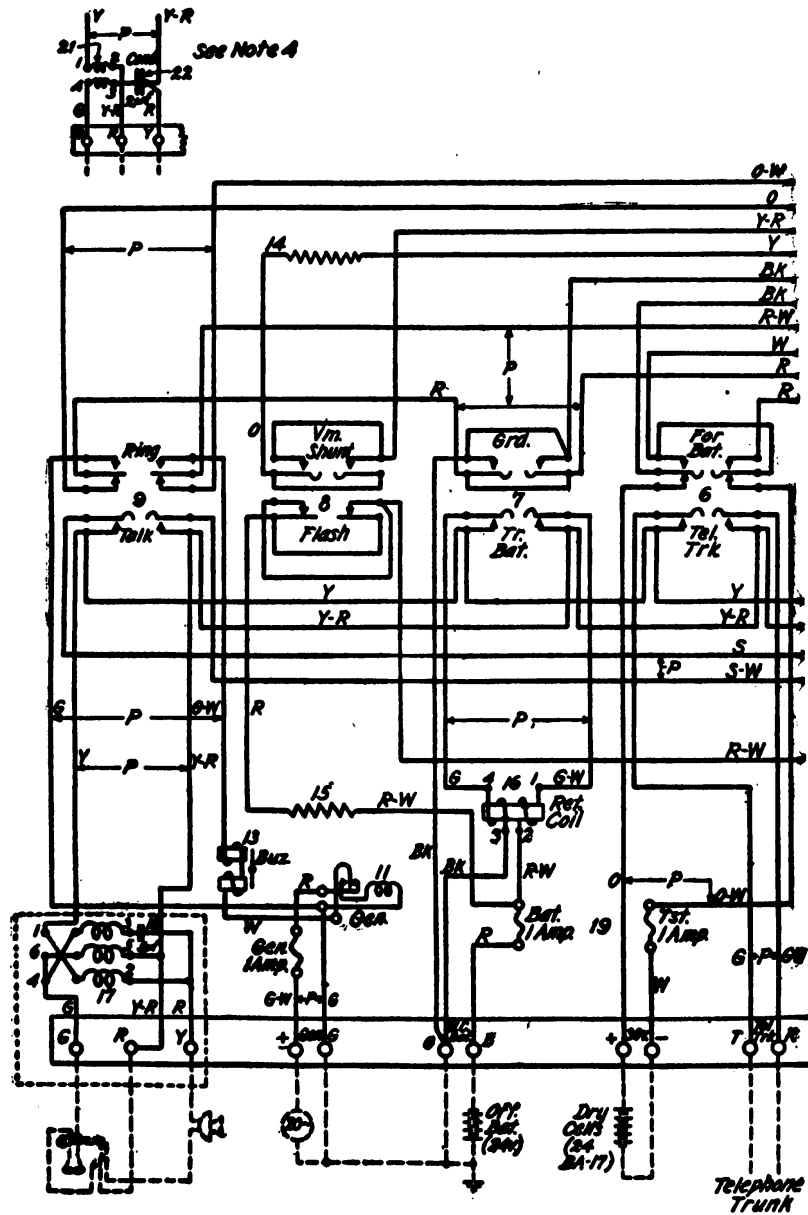

Note 1: Use 'X' wiring for grounding sleeve of test cord when "IN" or "OUT" key is operated. Use 'Y' wiring for "FLASH" key (opening sleeve of test cord to battery).
Note 2: Rear views of keys are shown. TL-666g1

FIGURE 13.—Wiring diagram for Cabinet BE-70-(), as manufactured by the Leich Electric Co.
 [A. G. 300.7 (16 Jun 43).] (C1, 24 Aug 43.)

CABINET BE-70-(), WIRE CHIEF'S TESTING C 1

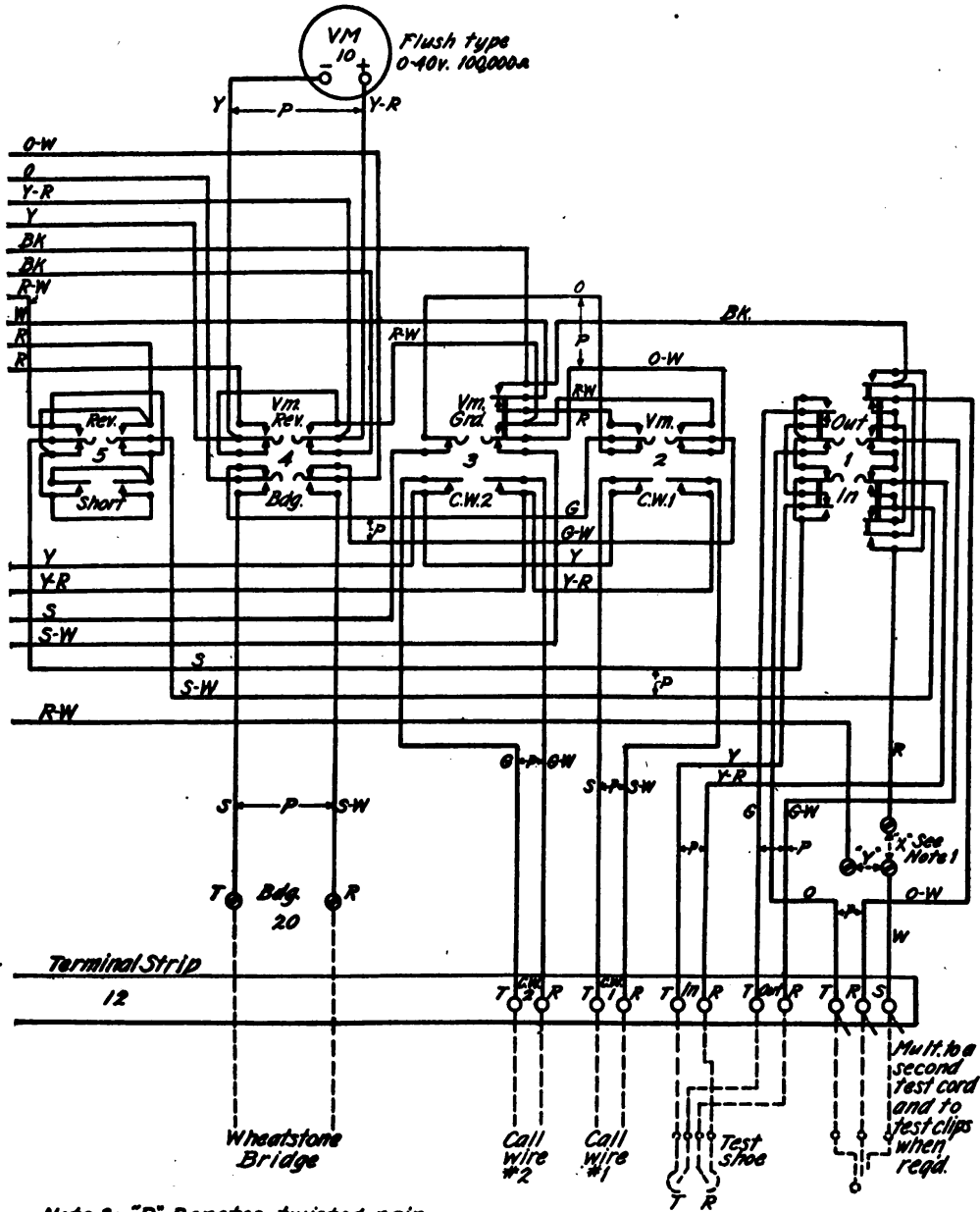

Note 3: "P" Denotes twisted pair.
 Note 4: Alternate induction coil connections where sidetone set is used.

TL-66692

TM 11-345
C 1

CABINET BE-70-(), WIRE CHIEF'S TESTING

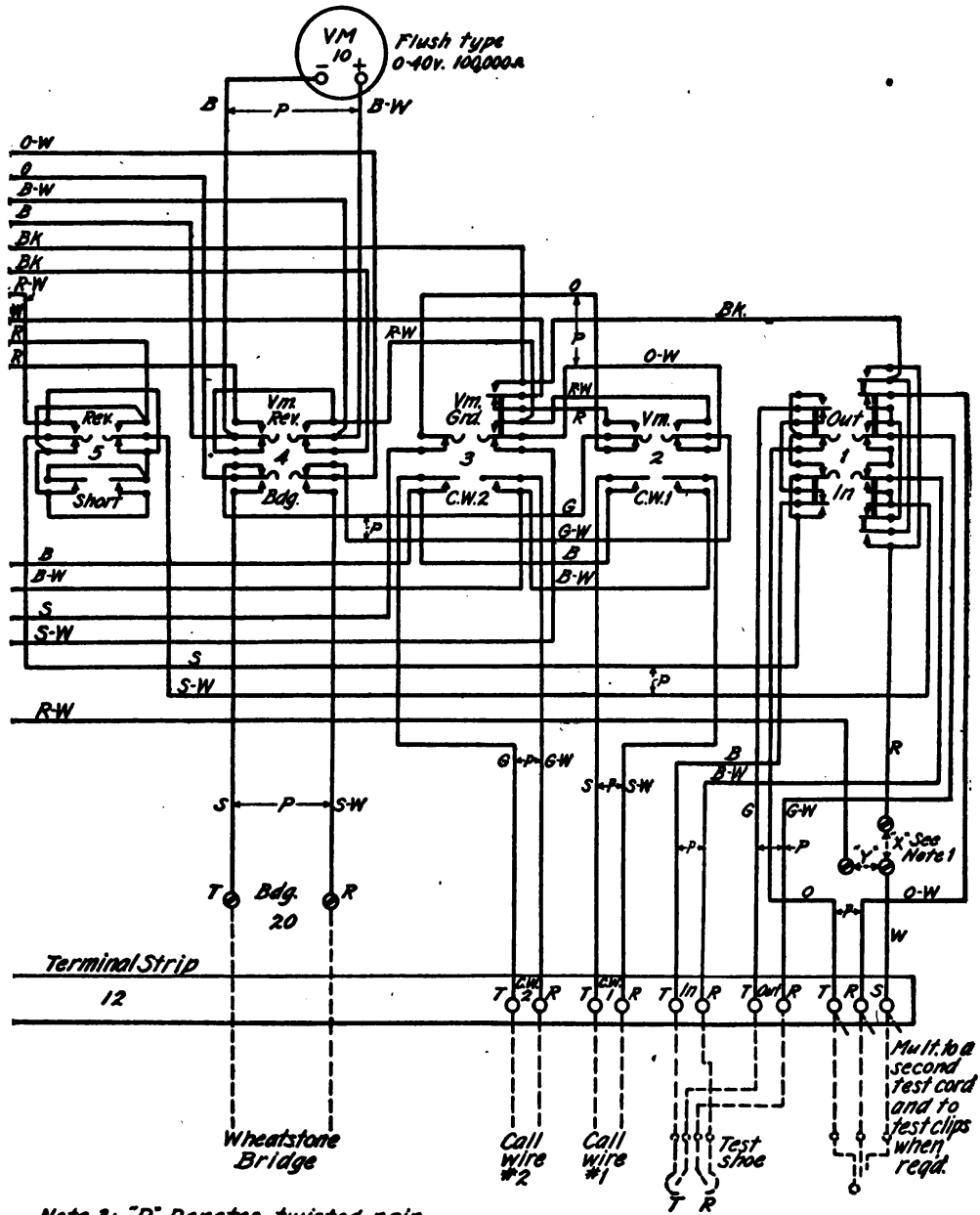

Note 3: "P" Denotes twisted pair.
 Note 4: Alternate induction coil connections where sidetone set is used.

TL-6670-2

CABINET BE-70-(), WIRE CHIEF'S TESTING C 1

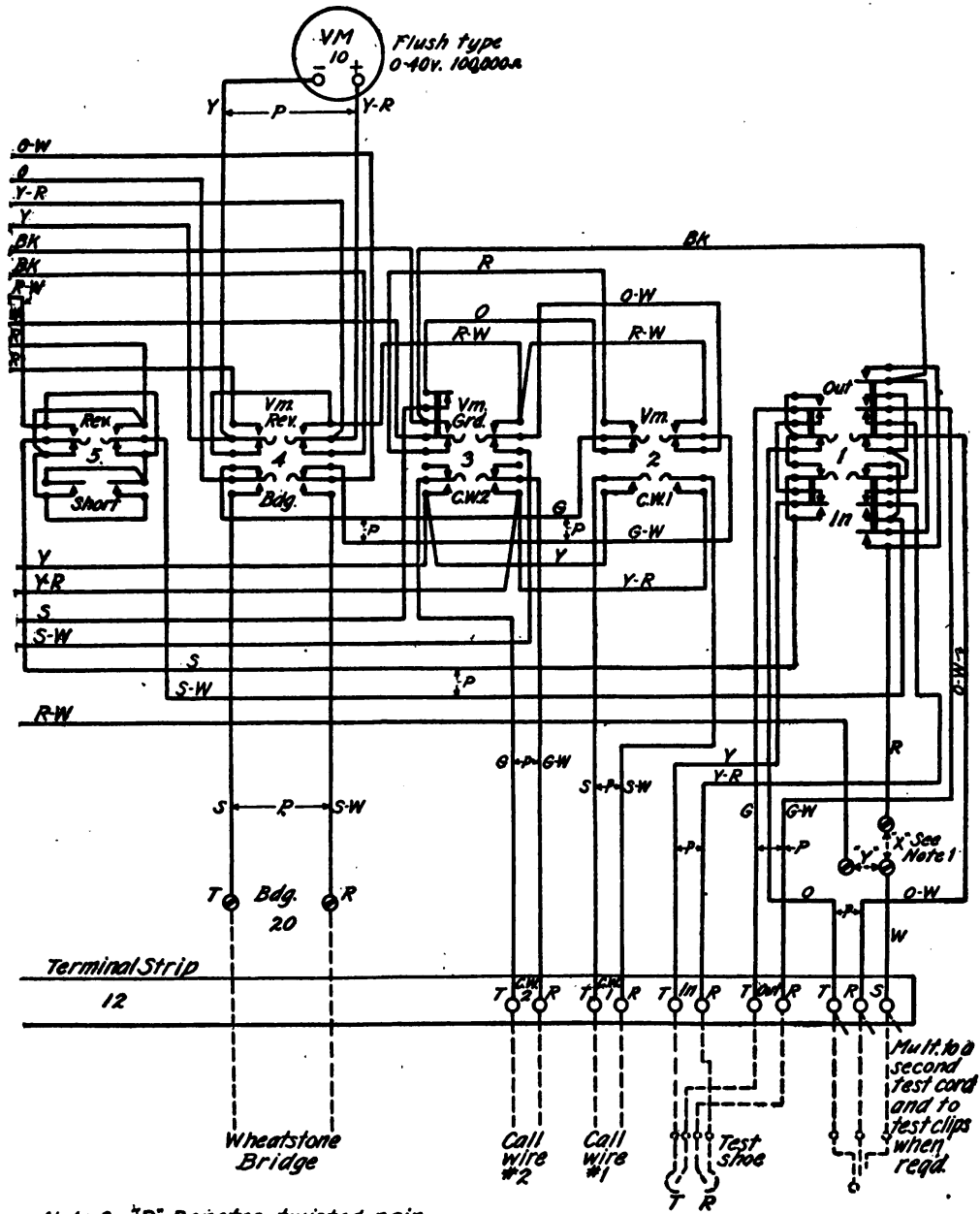

Note 3: "P" Denotes twisted pair.

TL:6671-2

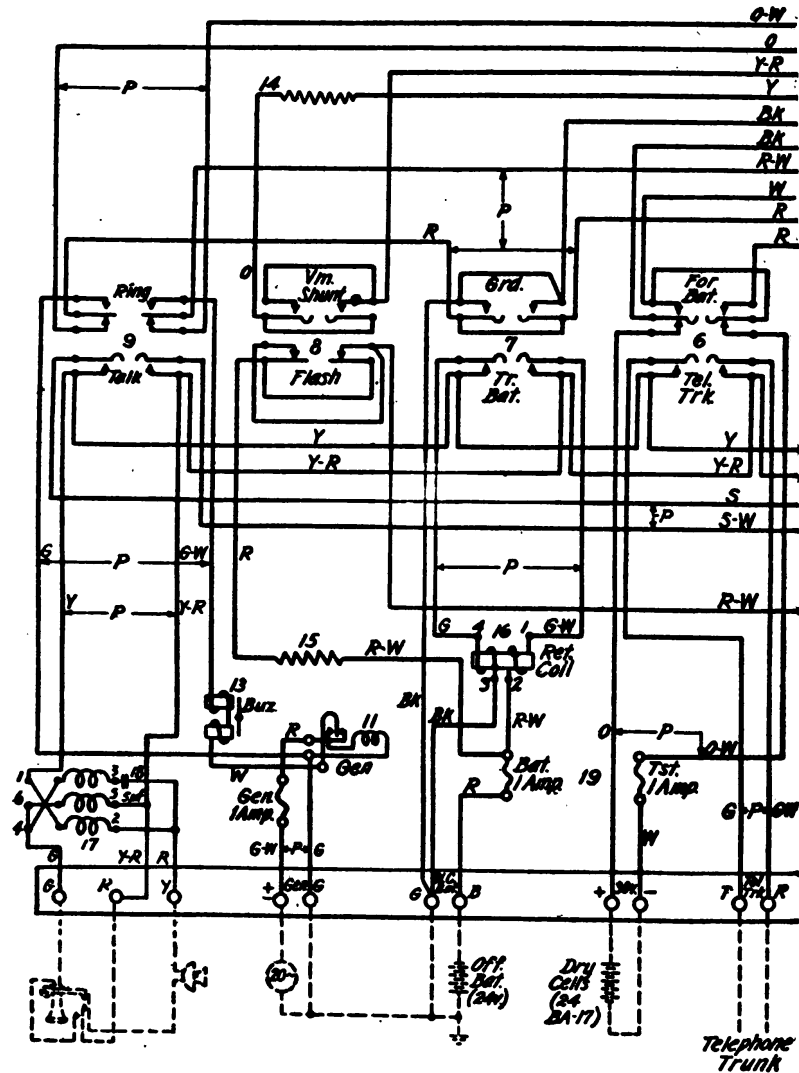

Note 1: Use 'X' wiring for grounding sleeve of test cord when 'IN' or 'OUT' key is operated. Use 'Y' wiring for 'FLASH' key (opening sleeve of test cord to battery).
 Note 2: Rear views of keys are shown.

TL-6672-1

FIGURE 16.—Wiring diagram for Cabinet BE-70(), as manufactured by the Western Electric Co. [A. G. 300.7 (16 Jun 43).] (C1, 24 Aug 43.)

Generated on 2015-12-01 14:46 GMT / http://hdl.handle.net/2027/uc1.b3245462
 Public Domain, Google-digitized / http://www.hathitrust.org/access_use#pd-google

CABINET BE-70-(), WIRE CHIEF'S TESTING C 1

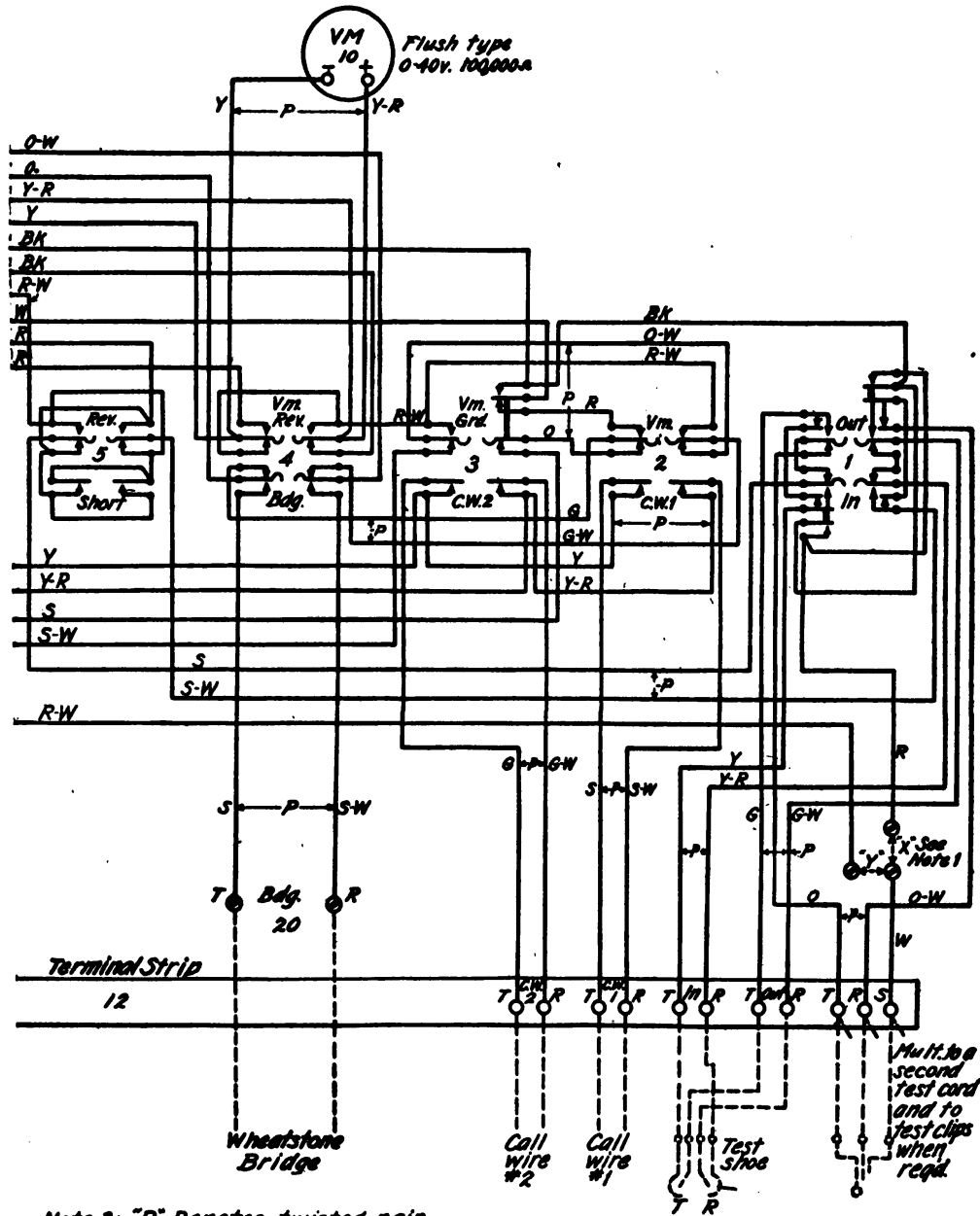

Note 3: "P" Denotes twisted pair.

TL:6672-2

32. List of replaceable parts (Superseded).—a. Cabinets of Leich Electric Co. manufacture.

Refer- ence No.	Stock No.	Name	Description	Function	Manufacturer	Manufacturer's part No.	Signal Corps drawing No.
20	3Z245A	Binding post TM-145-A	Knurled, metal, on face of test cabinet.	For connection to Wheatstone bridge.	H. H. Eby, Inc.		SC-D-2958
13	4C1601A	Buzzer	80-ohm	Ringling circuit	Leich	1-A	SC-D-2958
18		Capacitor	5-microfarad	Telephone circuit	do	58-A	
22		Capacitor	2-microfarad	do	do	34-A	SC-D-2958
17		Coil	Induction, antistatone	do	do	25-A	
21		Coil	Induction, sidetone	do	do	12-B	SC-D-2958
16		Coil	Impedance	do	do	6-D	SC-D-2958
	4B455	Crank GC-11	Generator crank	Transmitter battery supply	do		
19		Fuse and fuse block	1-ampere	Circuit protection: ringing power, test battery, and talking battery.	do		SC-D-2958
11		Generator	Hand	Manual ringling	Leich	3-A	SC-D-2958
11	4B838	Generator GN-38	do	do	Leich	181-BG	SC-D-2958
1		Key		Test IN and OUT	do	181-BE	SC-D-2958
2		Key		CW1 and VM	do	181-BF	SC-D-2958
3		Key		CW2 and VM GRD	do	181-D	SC-D-2958
4		Key		BDG and VM REV	do	181-BE	SC-D-2958
5		Key		SHORT and REV	do	181-BD	SC-D-2958
6		Key		TEL TRK and FOR BAT	do	181-AO	SC-D-2958
7		Key		TR BAT and GRD	do	181-BC	SC-D-2958
8		Key		FLASH and VM SHUNT	do	181-A	SC-D-2958
9		Key		TALK and RING	do	22-A	SC-D-2958
14		Resistor	200-ohm±1%	Voltmeter shunt	do		
15		Resistor	do	Sleeve circuit	do		
12		Terminal strip	Wood	Power and test connections	do		
10	3F8040-2	Voltmeter	100,000 ohms±1%, 0-40 volts	Test	Weston	Model 24	SC-D-2958

b. Cabinets of Kellogg Switchboard and Supply Co. manufacture.

Reference No.	Stock No.	Name	Description	Function	Manufacturer	Manufacturer's part No.	Signal Corps drawing No.
20		Binding Post TM-149-A.	Knurled, metal, on face of test cabinet.	For connection to Wheatstone bridge.	H. H. Eby, Inc.		SC-D-530
13	4C1566B	Buzzer	80-ohm	Ringing circuit.	Kellogg	66-B	SC-D-2958
18		Capacitor	1- and 1½-microfarad	Telephone circuit.	do	218	SC-D-2958
22		Capacitor	2-microfarad	do	do	66	SC-D-2958
23	3C899.6A	Coil	Induction, antisidetone	do	do	106-A	SC-D-2958
21		Coil	Induction, sidetone	do	do	99EA Spl	SC-D-2958
16		Coil	Impedance	Transmitter battery supply	do	2053 T-J	SC-D-2958
	4B455	Crank GC-11	Generator crank	do	do	21	SC-D-2956
19		Fuse block	1 ampere	{ Circuit protection; test and voice battery and generator.	Reliable Electric Co.	20	SC-D-2958
11	4B838	Generator GN-38	Hand	Manual ringing	Kellogg	15	SC-D-2956
11		Generator GN-39-B	do	do	do		
1		Key	2-way, double lock	Test IN and OUT	do	1079	SC-D-2958
2		Key	2-way, lock and restore	CW1 and VM	do	1029	SC-D-2958
3		Key	do	CW2 and VM GRD	do	ES-1897	SC-D-2958
4		Key	2-way, double lock	BDG and VM REV	do	1030	SC-D-2958
5		Key	2-way, lock and restore	SHORT and REV	do	1029	SC-D-2958
6		Key	2-way, double lock	TEL TRK and FOR BAT	do	1030	SC-D-2958
7		Key	do	TR BAT and GRD	do	1002	SC-D-2958
8		Key	2-way, lock and restore	FLASH and VM SHUNT	do	1041	SC-D-2958
9		Key	do	TALK and RING	do	1041	SC-D-2958
14		Resistor	200 ohm ± 1%	Voltmeter shunt	do	S-CT	SC-D-2958
15		Resistor	do	Sleeve circuit	do	S-CT	SC-D-2958
12		Terminal strip	Wood	Power and test connections	Reliable Electric Co.	Type E	SC-D-2958
10	3F8040-2	Voltmeter	100,000 ohms ± 1% 0-40 volts.	Test	Weston	Model 24	SC-D-2958

32. List of replaceable parts (Superseded).—a. Cabinets of Leich Electric Co. manufacture.

Reference No.	Stock No.	Name	Description	Function	Manufacturer	Manufacturer's part No.	Signal Corps drawing No.
20	3Z245A	Binding post TM-145-A	Knurled, metal, on face of test cabinet.	For connection to Wheatstone bridge.	H. H. Eby, Inc.		SC-D-2958
13	4C1601A	Buzzer	80-ohm	Ringng circuit	Leich	1-A	SC-D-2958
18		Capacitor	5-microfarad	Telephone circuit	do	58-A	
22		Capacitor	2-microfarad	do	do	34-A	SC-D-2958
17		Coil	Induction, antisidetone	do	do	25-A	
21		Coil	Induction, sidetone	do	do	12-B	SC-D-2958
16		Coil	Impedance	do	do	6-D	SC-D-2958
	4B455	Crank GC-11	Generator crank	Transmitter battery supply	do		SC-D-2958
19		Fuse and fuse block	1-ampere	Circuit protection: ringing power, test battery, and talking battery.	do		SC-D-2958
11		Generator	Hand	Manual ringing	Leich	3-A	SC-D-2958
11	4B838	Generator GN-38	do	do	Leich	181-BG	SC-D-2958
1		Key		Test IN and OUT	do	181-BE	SC-D-2958
2		Key		CW1 and VM	do	181-BF	SC-D-2958
3		Key		CW2 and VM GRD	do	181-D	SC-D-2958
4		Key		BDG and VM REV	do	181-BE	SC-D-2958
5		Key		SHORT and REV	do	181-BD	SC-D-2958
6		Key		TEL TRK and FOR BAT	do	181-AO	SC-D-2958
7		Key		TR BAT and GRD	do	181-BC	SC-D-2958
8		Key		FLASH and VM SHUNT	do	181-A	SC-D-2958
9		Key		TALK and RING	do	22-A	SC-D-2958
14		Resistor	200-ohm±1%	Voltmeter shunt	do	22-A	SC-D-2958
15		Resistor	do	Sleeve circuit	do	22-A	SC-D-2958
12		Terminal strip	Wood	Power and test connections	do		SC-D-2958
10	3F8040-2	Voltmeter	100,000 ohms±1%, 0-40 volts	Test	Weston	Model 24	SC-D-2958

CABINET BE-70-(), WIRE CHIEF'S TESTING C 1

TM 11-345

b. Cabinets of Kellogg Switchboard and Supply Co. manufacture.

Refer- ence No.	Stock No.	Name	Description	Function	Manufacturer	Manufac- turer's part No.	Signal Corps drawing No.
20		Binding Post TM-149-A.	Knurled, metal, on face of test cabinet.	For connection to Wheatstone bridge.	H. H. Eby, Inc		SC-D-530
13	4C1566B	Buzzer	80-ohm	Ringling circuit.	Kellogg	66-B	SC-D-2958
18		Capacitor	1- and 1½-microfarad.	Telephone circuit.	do	218	SC-D-2958
22		Capacitor	2-microfarad.	do	do	66	SC-D-2958
23	3C899.6A	Coil	Induction, antisidetone.	do	do	106-A	SC-D-2958
21		Coil	Induction, sidetone.	do	do	99EA Spl	SC-D-2958
16		Coil	Impedance.	do	do	2053 T-J	SC-D-2958
	4B455	Crank GC-11	Generator crank.	Transmitter battery supply	do		SC-D-2956
19		{ Fuse block	{	{ Circuit protection; test and voice battery and generator.	Reliable Electric Co.	21	SC-D-2958
11	4B838	Generator GN-38.	Hand	Manual ringling	Kellogg	20	SC-D-2956
11		Generator GN-38-B	do	do	do	15	SC-D-2956
1		Key	2-way, double lock	Test IN and OUT	do	1079	SC-D-2958
2		Key	2-way, lock and restore.	CW1 and VM	do	1029	SC-D-2958
3		Key	do	CW2 and VM GRD	do	ES-1897	SC-D-2958
4		Key	2-way, double lock	BDG and VM REV	do	1030	SC-D-2958
5		Key	2-way, lock and restore	SHORT and REV	do	1029	SC-D-2958
6		Key	2-way, double lock	TEL TRK and FOR BAT	do	1030	SC-D-2958
7		Key	do	TR BAT and GRD	do	1002	SC-D-2958
8		Key	2-way, lock and restore	FLASH and VM SHUNT	do	1041	SC-D-2958
9		Key	do	TALK and RING	do	1041	SC-D-2958
14		Resistor	200 ohm ± 1%.	Voltmeter shunt	do	S-CT	SC-D-2958
15		Resistor	do	Sleeve circuit.	do	S-CT	SC-D-2958
12		Terminal strip	Wood	Power and test connections	Reliable Electric Co.	Type E	SC-D-2958
10	3F8040-2	Voltmeter	100,000 ohms ± 1% 0-40 volts.	Test	Weston	Model 24	SC-D-2958

c. Cabinets of Automatic Electric Co. manufacture.

Refer- ence No.	Stock No.	Name	Description	Function	Manufacturer	Manufacturer's part No.	Signal Corps drawing No.
20	37245A	Binding post TM-145-A.	Knurled, metal on face of test cabinet.	For connection to Wheatstone bridge.	H. H. Eby, Inc.	13-D "sergeant"	SC-D-2956
13		Buzzer	80-ohm	Ringing current	A. E. Co.	MC-5621-A	SC-D-2958
18		Capacitor	5- μ f	Telephone circuit	do	D-68258-A	SC-D-2958
17		Coil	Induction, anti-sidetone	do	do	D-282996-A	SC-D-2958
16		Coil	Impedance	Transmitter battery supply	do	GD-283283	SC-D-2958
	4B455	Crank GC-11	Generator crank	do	do	D-32277	SC-D-2956
19		Fuse	} Buss type.	Battery and ring circuit protection.	do	3A G 4512	SC-D-2958
		Fuse block					
11	4B838	Generator GN-38	Hand	Manual ringing	do	D-9053-A	SC-D-2956
1		Key		Test IN and OUT	do	D-322269	SC-D-2958
2		Key		CW1 and VM	do	D-321015	SC-D-2958
3		Key		CW2 and VM GRD	do	D-321103	SC-D-2958
4		Key		BDG and VM REV	do	D-321171	SC-D-2958
5		Key		SHORT and REV	do	D-321015	SC-D-2958
6		Key		TEL TRK and FOR BAT	do	D-321173	SC-D-2958
7		Key		TR BAT and GRD	do	D-321013	SC-D-2958
8		Key		FLASH and VM SHUNT	do	D-321081	SC-D-2958
9		Key		TALK and RING	do	D-321081	SC-D-2958
14		Resistor	1010 ohms \pm 1%	Voltmeter shunt	do	D-282502	SC-D-2958
15		Resistor	200 ohms \pm 1%	Sleeve resistance	do	D-283234	SC-D-2958
12		Terminal strip	Wood	Power and test connections	W. E. Co.	154A	SC-D-2956
10	3F8040-2	Voltmeter	100,000 ohms, 0-40 volts.	Test	Weston	Model 24	SC-D-2958

CABINET BE-70-(), WIRE CHIEF'S TESTING C 1

d. Cabinets of Western Electric Co. manufacture.

Refer- ences No.	Stock No.	Name	Description	Function	Manufacturer	Manufacturer's part No.	Signal Corps drawing No.
20.		Binding Post TM-214	Knurled, metal, on face of test cabinet.	For connection to Wheatstone bridge.	H. H. Eby, Inc.		SC-D-530-N
13.		Buzzer	100-ohm.	Ring circuit.	W. E. Co	2E	SC-D-2958
18.		Capacitor	4- μ f	Telephone circuit.	do	137A	SC-D-2958
17.		Coil	Induction, antisidetone	do	do	D-122817	SC-D-2958
16.		Coil	Impedance.	Transmitter battery supply	do	307-P	SC-D-2958
19.	4B455	Crank GC-11	Generator crank	do	do		SC-D-1907
		Fuse.	Non-alarm type.	Battery and ring circuit protection.	do	24G	SC-D-2958
19		Fuse mounting.	Block.	Mount battery and ring fuses.	do	62D	SC-D-2958
11	4B838	Generator GN-38	Hand.	Manual ringing.	do		SC-D-816-N
1		Key		Test IN and OUT	do	D-46942	SC-D-2958
2.		Key		CWI and VM.	do	D-47509-AK	SC-D-2958
3.		Key		CW2 and VM GRD.	do	D-47509-AG	SC-D-2958
4.		Key		BDG and VM REV.	do	D-47509-Y	SC-D-2958
5.		Key		SHORT and REV.	do	D-47509-AK	SC-D-2958
6.		Key		TEL TRK and FOR BAT	do	D-47509-Y	SC-D-2958
7.		Key		TR BAT and GRD.	do	D-47509-G	SC-D-2958
8.		Key		FLASH and VM SHUNT.	do	D-47509-AK	SC-D-2958
9.		Key		TALK and RING.	do	D-47509-AK	SC-D-2958
14.		Resistor.	200 ohms \pm 1%.	Voltmeter shunt.	do	18BT	SC-D-2958
15.		Resistor.	do.	Sleeve resistance.	do	18BT	SC-D-2958
12		Terminal Strip	Wood	Power and test connections.	do	154A	SC-D-2958
10.		Voltmeter.	100,000 ohms, 0-40 volts.	Test.	W. M. Welch Mfg. Co.	3013 per Navy Spec. 17-1-12.	SC-D-2958

[A. G. 300.7 (18 Jun 45).] (C 1, 24 Aug. 43.)

33. Addresses of manufacturers.—The following list shows the names and addresses of the manufacturers for the different types of Cabinet BE-70-() procured to date:

American Automatic Electric Sales Company.	BE-70-M 1033 West Van Buren St., Chicago, Ill.
Kellogg Switchboard and Supply Company.	BE-70-P
	BE-70-A 6650 South Cicero Ave., Chicago, Ill.
	BE-70-AB
	BE-70-B ¹
	BE-70-H
	BE-70-J
	BE-70-K
Leich Electric Company-----	BE-70-N
	BE-70-Q
	BE-70-U
	BE-70-B ² Genoa, Ill.
	BE-70-C
	BE-70-D
	BE-70-E
Western Electric Company, Inc.	BE-70-F
	BE-70-G
	BE-70-L
	BE-70-R
	BE-70-S New York, N. Y.
	BE-70-T

¹ Order No. 17221-Phila-43

² Order No. 1332-Chi-40

[A. G. 300.7 (18 Jun 43).] (C1, 24 Aug 43)

BY ORDER OF THE SECRETARY OF WAR:

G. C. MARSHALL,
Chief of Staff.

OFFICIAL:

J. A. ULIO,
Major General,
The Adjutant General.

TECHNICAL MANUAL }
 No. 11-345 }

WAR DEPARTMENT,
 WASHINGTON, April 28, 1942.

CABINET BE-70-()
(WIRE CHIEF'S TESTING)

	Paragraph
SECTION I. General.	
Use-----	1
II. Employment.	
General-----	2
Installation-----	3
Test circuit transfer (IN OUT) key-----	4
Opening a line for test purposes-----	5
Method of operation-----	6
Talking on line under test-----	7
Ringing on line-----	8
Ballistic capacity tests-----	9
Test for open circuits when capacitors are in series with bells-----	10
Test for open circuits-----	11
Test for short circuits-----	12
Test for grounds-----	13
Test for crosses with lines carrying current-----	14
Test for crosses with lines not carrying cur- rent-----	15
Measuring test battery voltage-----	16
Checking condition of test battery-----	17
Resistance measurements-----	18
Useful information-----	19
III. Detailed functioning of parts.	
Wiring diagram and schematic circuit-----	20
Functional diagrams-----	21
Measuring battery voltage-----	22
Talking toward switchboard, using test shoe---	23
Talking out on line, using test shoe-----	24
Ringing bridged bells and grounded bells on ring side of line, using power ringer---	25

SECTION III. Detailed functioning of parts—Continued.

Ringing grounded bells on tip side of line, using hand generator.....	26
Continuity tests and voltmeter resistance measurements.....	27
Test for a ground on tip.....	28
Test for a cross with a line carrying current..	29
IV. Servicing and repair.	
Maintenance	30
Packing for Army transportation.....	31
V. Replaceable parts.	
List of replaceable parts.....	32
Addresses of manufacturers.....	33

SECTION I

GENERAL

Use.....	Paragraph
	1

1. Use.—Cabinet BE-70-() is a wire chief's test set which affords means of accurately locating practically all faults common to both magneto and common battery telephone exchanges. Tests can be made in a simple manner for grounds, short circuits, crosses, opens (lack of continuity), bad joints, etc., without complicated mathematical calculations. The test cabinet is equipped with a Weston model 24, flush type, 100,000-ohm voltmeter. A 30-volt battery is used for test purposes, and the 24-volt switchboard battery is used for the wire chief's talking battery in all types of offices except magneto exchanges. Cabinet BE-70-() is furnished as an integral part of certain telephone switching centrals, namely TC-1 and TC-2. Cabinet BE-70-() is shown in figure 1.

CABINET BE-70-()

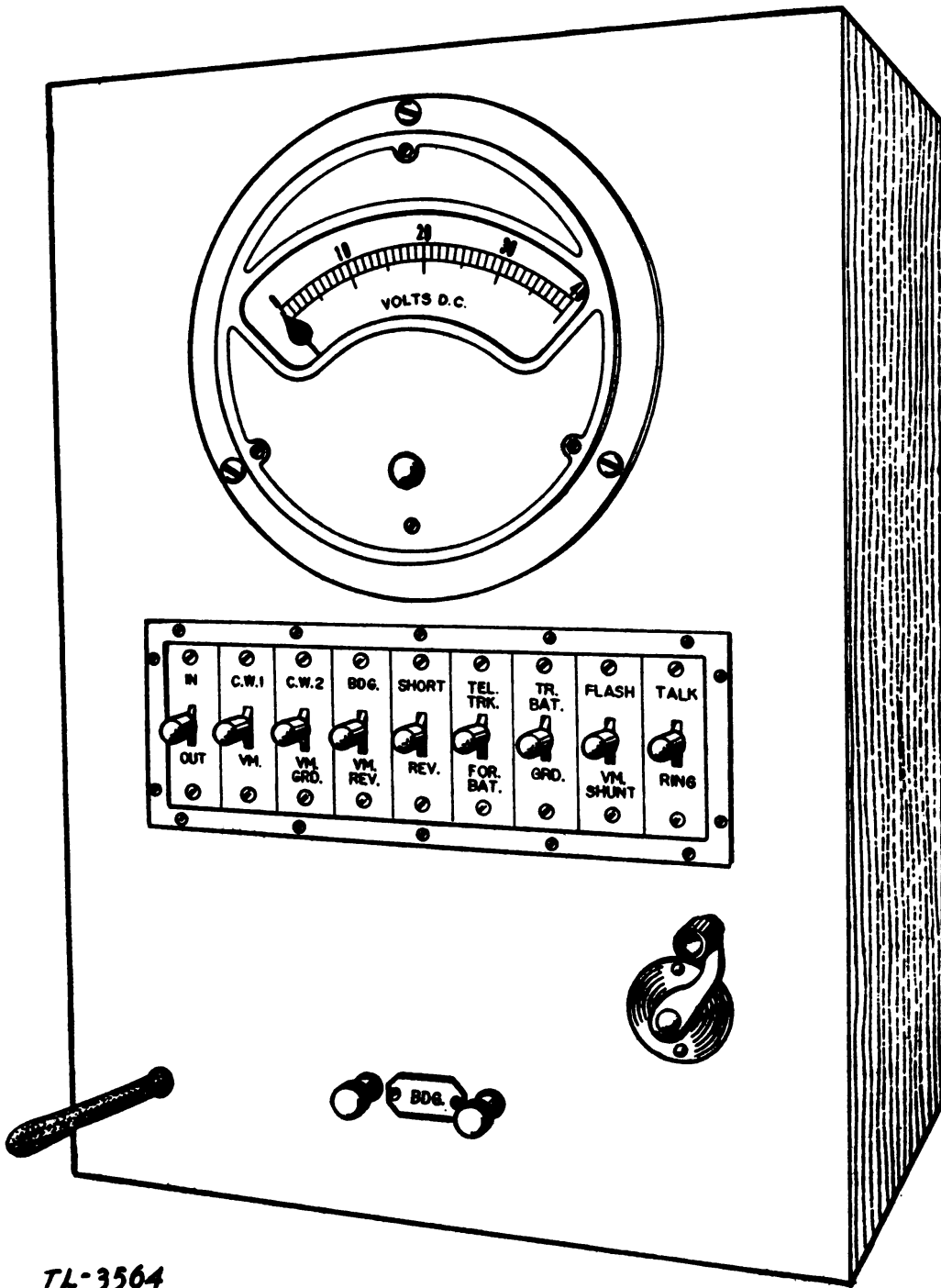

TL-3564

FIGURE 1.—Cabinet BE-70-() (wire chief's testing).

SECTION II

EMPLOYMENT

	Paragraph
General	2
Installation	3
Test circuit transfer (IN OUT) key	4
Opening a line for test purposes	5
Method of operation	6
Talking on line under test	7
Ringng on line	8
Ballistic capacity tests	9
Test for open circuits when capacitors are in series with bells	10
Test for open circuits	11
Test for short circuits	12
Test for grounds	13
Test for crosses with lines carrying current	14
Test for crosses with lines not carrying current	15
Measuring test battery voltage	16
Checking condition of test battery	17
Resistance measurements	18
Useful information	19

2. General.—The cabinet BE-70-() may be mounted in any convenient location, either adjacent to the switchboard, or in the terminal room near the distributing frame. When the test cabinet is located near the switchboard, connection is made to the line to be tested by reaching across the face of the switchboard with a test cord. When the test cabinet is located near the main distributing frame, connection to the line to be tested may be made with a test shoe; the test cord terminals in the test cabinet (see fig. 2) may also be connected to the corresponding terminals of an outgoing line circuit, in order to provide means of testing lines from the switchboard even though the test cabinet may be located at some distance from the switchboard. Connection between the outgoing line circuit jack and the line jack of the circuit to be tested is made at the switchboard by means of a patching cord. The outgoing line circuit must be of the type that has no series or bridged line equipment.

3. Installation.—*a.* Mount cabinet BE-70-() on a firm base so as to be secure from mechanical damage. Wiring and mounting arrangements should not interfere with the opening of the cabinet door for inspection purposes. Sew all loose wiring from the cabinet into a local form, wherever possible. Place this form so as to protect the wiring from damage.

b. Wiring.—All leads carrying talking circuits or ringing current should be in twisted pairs. Twisted pairs may also be used for the

other circuits, as a matter of convenience. When using twisted pair conductors, care must be exercised to avoid reversing the circuits.

c. Connections.—The necessary connections to place cabinet BE-70-() in operating condition should be made to the terminals listed below.

NOTE.—Only those connections required in a particular installation need be made (see fig. 2).

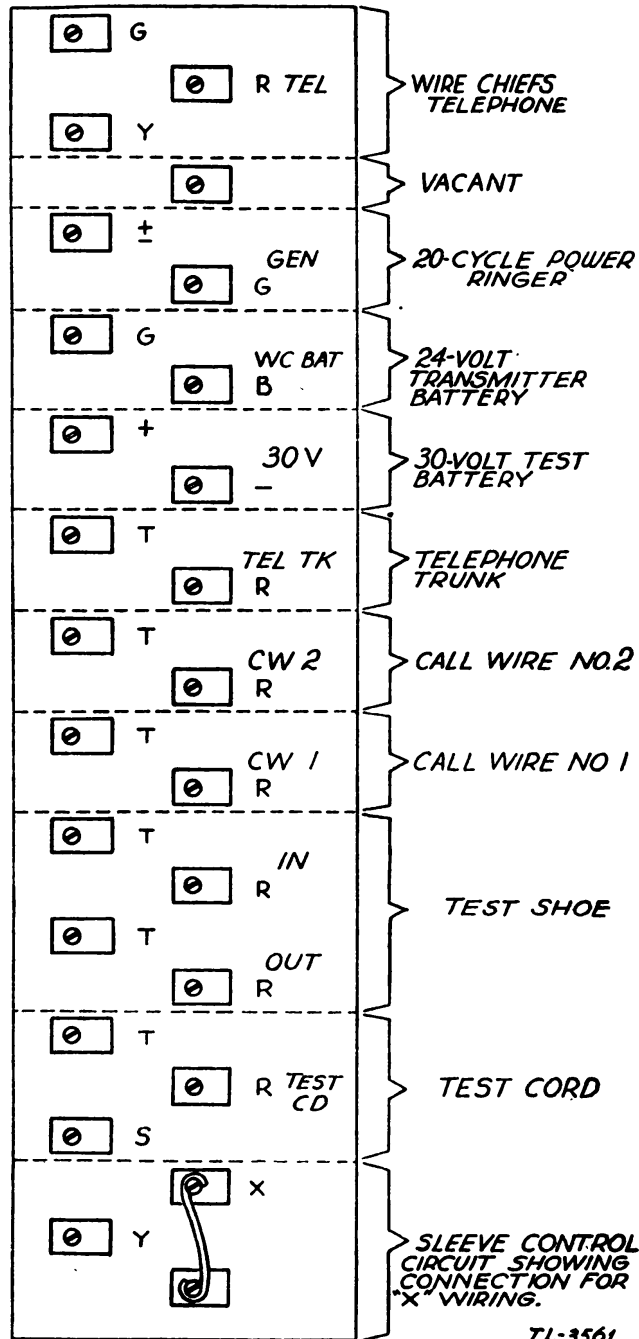

FIGURE 2.—Terminal strip, cabinet BE-70-().

(1) The G-R-Y TEL terminals are used for connecting the wire chief's telephone set to the test cabinet. When a telephone set similar to an EE-8-A is used for the wire chief's telephone, connect the two wires from the telephone to terminals R and G, leaving Y vacant; in this case it will be necessary to short-circuit the windings of the 12-B induction coil by connecting terminal 1 to terminal 2, and connecting terminal 3 to terminal 4. A hole is provided in the front of the test cabinet for the telephone cord or connecting wires.

(2) The \pm -G GEN terminals are used for supplying ringing current from the power ringer to the test cabinet. Connect \pm to the ungrounded side of the power ringer, and terminal G to the grounded side of the power ringer.

(3) The G-B WC BAT terminals are ground and battery terminals, respectively, and are used for supplying transmitter battery to the test circuit. Connect G to the positive terminal and B to the negative terminal of the 24-volt switchboard battery. Connect the positive terminal of the switchboard battery to ground.

(4) The + and - 30V terminals are used for making connection to the 30-volt test battery. Connect the negative terminal of the test battery to the terminal marked - (minus) and the positive terminal of the test battery to the terminal marked + (plus).

(5) The T-R TEL TK terminals are not normally used in connection with Army switchboards. However, they may be connected to a switchboard line circuit in order to provide outgoing service from the wire chief's telephone. This circuit should be connected to a common battery line circuit if a common battery instrument is used for the wire chief's telephone set. If an EE-8-A or similar type telephone is used as the wire chief's telephone, the trunk circuit should be connected to a magneto line circuit. In order to adapt the trunk circuit for incoming service, as well as outgoing, it will be necessary to connect an extension bell to the trunk circuit. In case the trunk circuit is connected to a common battery line circuit, the bell should be equipped with a capacitor.

(6) The T-R CW1 and T-R CW2 (call wire) terminals are not usually used in connection with Army switchboards. A call wire is used for establishing a direct connection between the wire chief's test cabinet and the switchboard operator. If a call wire is desired, it is normally connected from either of the above mentioned pairs of call wire terminals in cabinet BE-70-() to the tip and ring terminals of the operator's telephone circuit.

(7) The T-R IN terminals are for connection to the tip and ring

conductors, respectively, of the outer contacts (switchboard side) of the test shoe.

(8) The T-R OUT terminals are for connection to the tip and ring conductors, respectively, of the inner contacts (line side) of the test shoe.

(9) T-R-S TEST CD terminals are for connection to the switchboard test cord circuit. A test cord may be connected to these terminals if the test cabinet is located near the switchboard; or if the test cabinet is located near the main distributing frame, an outgoing line circuit may be connected to these terminals (see par. 2).

(10) The X-Y terminals and an unmarked terminal are used for making the proper connection for the sleeve control circuit. Usually the sleeve circuit will be connected according to X wiring, as indicated in figure 2. The Y wiring is used only on common battery manual switchboards equipped with sleeve-controlled line relay circuits. In order to connect these terminals for Y wiring, it will be necessary to disconnect the strap between terminal X and the unmarked terminal and establish a connection between terminal Y and the unmarked terminal.

(11) The T-R BDG terminals (located on the front of the cabinet) may be used for connection to a Wheatstone bridge when such an instrument is available.

d. Test battery.—Twenty BA-17 dry cells or equivalent in good condition connected in series will give approximately the 30 volts required for the test battery. If the voltage is lower than 30 volts, it may be increased by adding one or more dry cells in series with the test battery. It is desirable to maintain a constant test voltage, otherwise the voltmeter calculations will not be dependable.

(1) *Location.*—The test battery should be housed in a suitable box or cabinet, located within 30 feet (wiring distance) of cabinet BE-70-(), and connected to the cabinet with #14 B & S gage rubber-covered copper wire, or wire of equal conductivity.

(2) *Connections.*—In order to maintain the proper polarity of the test battery, care must be used to connect the negative terminal of the battery to the 30-volt terminal marked - (minus), and the positive terminal of the battery must be connected to the 30-volt terminal marked + (plus).

(3) *Condition of test battery.*—The condition of the test battery may be determined as outlined in paragraphs 16 and 17.

e. Transmitter battery.—Provision is made for supplying transmitter battery to the line under test, and to the wire chief's telephone, when these circuits are equipped with common battery instruments.

Operation of the TR BAT (transmitter battery) key provides the necessary transmitter battery.

f. Wire chief's telephone.—If a common battery instrument is available, it may be connected to terminals G-R-Y TEL. If it is desired to use an EE-8-A or similar telephone set for the wire chief's telephone, it will be necessary to short-circuit the windings of the 12-B induction coil by connecting terminal 1 to terminal 2 and connecting terminal 3 to terminal 4. The telephone should then be connected to the G and R terminals.

g. Ringing equipment.—Provision is made for making connection to a power ringer for a source of ringing current. A hand generator is also provided for use in case power ringing is not available.

h. Voltmeter adjustment.—If the voltmeter fails to read "zero" with all keys normal, adjust the screw on the face of the meter. No other adjustments to the meter are permissible (see also par. 30*b*).

4. Test circuit transfer (IN OUT) key.—A test circuit transfer key, engraved IN OUT, is provided for connecting the test circuit to the line side of the test shoe (OUT position), or to the switchboard side of the test shoe (IN position). When the IN OUT key is in the normal position, the test circuit is connected to the switchboard test cord or test jack (depending on which arrangement is used).

5. Opening a line for test purposes.—Before a line is opened at the main distributing frame for test purposes, a check should be made to make sure the line is not in use. Always replace the heat coils as soon as the test is completed. If additional tests are to be made on the same line within a very short time, it may be preferable to leave the test shoe in the protector and restore the IN OUT key to normal. When the IN OUT key is in the normal position the line, previously under test, is connected to its associated line circuit through the test shoe cord and the contacts of the IN OUT key.

6. Method of operation.—Cabinet BE-70-() is designed to make tests on common battery and magneto lines as outlined below. In order to simplify the discussions, the operation of the IN OUT key will not be considered, as it has no bearing on the operation of the rest of the test circuit. It will be understood that the IN OUT key is operated to the proper position or left nonoperated (see par. 4) depending upon which method is desired for making connection to the circuit to be tested. Detailed description of the various tests appears in paragraphs 7 to 18, inclusive.

7. Talking on line under test.—Operate the TALK and TR BAT keys when talking on either magneto or common battery lines, when the wire chief's telephone is a common battery instrument. It

is not necessary to operate the TR BAT key when talking on magneto lines and an EE-8-A or similar telephone is used for the wire chief's telephone set.

8. Ringing on line.—The ringing circuit is so wired that ringing power may be obtained either from the hand generator or the power ringer without the necessity of operating a key to transfer from one source of ringing power to the other. The 80-ohm buzzer in the ringing circuit will operate in series with the line, unless the bell circuit in the tested telephone is open. One side of the hand generator and power ringer circuits must be grounded in order to ring on grounded lines.

a. Bridged bells.—To ring bridged bells, operate the RING key.

b. Grounded bells on ring side of line.—To ring grounded bells on the ring side of the line, operate the RING key.

c. Grounded bells on tip side of line.—To ring grounded bells on the tip side of the line, operate the RING and REV (line reverse) keys.

9. Ballistic capacity tests.—This test may be made on both common battery and magneto lines. However, if this test is to be made on magneto lines, the bells must be equipped with capacitors or the telephone instruments must be disconnected from the line, otherwise it will be impossible to make the test.

a. The ballistic test may be used for roughly determining the capacitance between the tip and ring sides of the line. Operate the VM (voltmeter) key, then operate and restore the VM REV (voltmeter reverse) and FOR BAT (foreign battery) keys simultaneously several times, noting the throw of the needle. The higher the capacitance, the greater the throw will be. The capacitance is approximately proportional to the magnitude of the voltmeter deflection. This test may be used for roughly determining the distance to a break in the circuit by comparing the capacitance of the line with other lines of known length and similar capacitance characteristics.

b. To measure the capacitance between the ring side of the line and ground, operate the VM GRD (voltmeter ground) key, then operate and restore the VM REV and FOR BAT keys simultaneously several times, noting the throw of the voltmeter needle.

c. To measure the capacitance between the tip side of the line and ground, operate the VM GRD and REV keys, then operate and restore the VM REV and FOR BAT keys simultaneously several times, noting the throw of the voltmeter needle.

d. If the ballistic tests are to be limited to measuring the capacitance between the tip and ring sides of the line, the REV key may

be used to advantage instead of the VM REV and FOR BAT keys for charging and discharging the line. When the VM REV and FOR BAT keys are used the voltmeter deflections are in opposite directions, whereas with the REV key the deflections are always in the same direction and twice the magnitude. This method cannot be used for measuring the capacitance between the sides of the line and ground. The detailed method of operation follows: Operate the VM key, then operate and restore the REV key several times, noting the throw of the voltmeter needle.

10. Test for open circuits when capacitors are in series with bells.—This test is performed in the same manner as the ballistic tests outlined in paragraph 9. In general if the bell circuit is continuous the voltmeter deflections will be in the order of several scale divisions, whereas if the bell circuit is not continuous the voltmeter will indicate a very small or even no deflection.

a. Bridged bells.—See paragraph 9a or d.

b. Grounded bells on ring side of line.—See paragraph 9b.

c. Grounded bells on tip side of line.—See paragraph 9c.

11. Test for open circuits.—Operate the VM key. If the circuit is open, there will be no indication on the voltmeter.

12. Test for short circuits.—Operate the VM key. If the circuit is closed the voltmeter will show a deflection. If the resistance of the closed circuit is low the voltmeter will show a large deflection. If the resistance of the closed circuit is high the voltmeter deflection will be small. Should the voltmeter deflection be large, the VM SHUNT key should be operated in addition to the VM key. The resistance of the circuit may be calculated according to the method outlined in paragraph 18 or may be determined from the table in paragraph 19f. In general it may be stated that when the resistance of the circuit is high the VM key only should be used, and when the resistance of the circuit is low the VM and VM SHUNT keys should be used.

13. Test for grounds.—*a. Ring side of line.*—Operate the VM GRD key. If there is a ground on the ring side of the line the voltmeter will show an indication. In the case of a large voltmeter deflection the VM SHUNT key may also be operated. The table of resistances in paragraph 19f may be used for determining the approximate value of the resistance to ground.

b. Tip side of the line.—This test is the same as for the test for ground on the ring side of the line, except that the REV key must be operated in addition to the VM GRD key.

14. Test for crosses with lines carrying current.—In this test, if the voltmeter moves backward (off-scale), the VM REV key must be operated in addition to the other keys mentioned. The amount of the deflection indicates the voltage of the foreign battery. Great care should be used in making this test, as there is danger of damaging the voltmeter if the voltage on the foreign line is much in excess of the maximum voltage printed on the voltmeter scale (40 volts). If the line under test is crossed with another line carrying alternating current, the only indication observed will be a fluttering of the voltmeter needle for frequencies below 60 cycles. A listening test should be made on the line prior to making the test outlined below. This listening test will indicate whether or not alternating current will be encountered. The pitch of the sound heard will give a rough indication of the frequency of the alternating current. The lower the pitch the lower the frequency, and conversely, the higher the pitch of the sound the higher the frequency.

a. Test of ring side of line.—Operate the VM GRD and FOR BAT keys. The voltage of the foreign potential will be indicated on the voltmeter.

b. Test of tip side of line.—Operate the VM GRD, REV, and FOR BAT keys. The voltage of the foreign potential will be indicated on the voltmeter.

15. Test for crosses with lines not carrying current.—First test for foreign battery as outlined in paragraph 14. If the line is clear of foreign battery, test for ground as outlined in paragraph 13. The line under test must be free of ground or the following test will fail.

Connect ground to both sides of the line suspected of being crossed with the line under test, and test for ground on both sides of the line. A deflection on the voltmeter indicates that the two lines are crossed with each other. A cross with the ring conductor is indicated if the REV key is *not* operated, and a cross with the tip conductor is indicated if the REV key *is* operated.

16. Measuring test battery voltage.—Operate the VM and SHORT keys. The open circuit voltage of the test battery is indicated on the voltmeter.

17. Checking condition of test battery.—Operate the VM SHUNT key in addition to the VM and SHORT keys. If the voltmeter needle falls back more than four or five scale divisions (one scale division equals one volt), or if the needle moves back gradually after the keys have been left operating for a few seconds, the test bat-

tery should be replaced, as it is too far exhausted to give readings that may be considered reliable.

18. Resistance measurements.—a. Voltmeter method.—The deflection indicated by the voltmeter bears the same relation to the resistance of the voltmeter that the difference between the voltage of the test battery and voltmeter reading bears to the resistance of the line. The line resistance may be calculated as follows: The difference between the test battery voltage and the voltmeter reading is divided by the meter reading and the resultant is multiplied by the resistance of the voltmeter. In the BE-70-() wire chief's testing cabinet the resistance of the voltmeter circuit is 100,000 ohms, except when the VM SHUNT key is operated, in which case it is 199.6 ohms. As an example, if a voltmeter reading (VM SHUNT key *not* operated) of 25 volts is obtained on testing a line, and the test battery voltage is 30 volts, the line resistance is determined as follows:

$$\frac{(30-25) \times 100,000}{25} = 20,000 \text{ ohms.}$$

Operation of the VM SHUNT key shunts the voltmeter with a 200-ohm resistance. The combined resistance of the voltmeter and 200-ohm voltmeter shunt is 199.6 ohms. When the VM SHUNT key is operated, the deflection for any given line resistance is smaller than that obtained with the unshunted voltmeter, and consequently, it is easier to determine values of resistance below approximately 6,000 ohms. As an example, if a voltmeter reading (VM SHUNT key operated) of 10 volts is obtained, and the test battery measures 30 volts, the line resistance is determined as follows:

$$\frac{(30-10) \times 199.6}{10} = 399 \text{ ohms.}$$

When measuring with the VM SHUNT key operated, it is easier to distinguish between a short circuit and the effect of one or more bells (without series capacitors) bridged across the line, due to the differences in resistance.

b. Wheatstone bridge method.—Operation of the BDG (Wheatstone bridge) key connects the line under test to the terminals T and R on the face of the test cabinet. When these terminals are used, they should be wired to the LINE or X terminals of a Wheatstone bridge (not furnished as a part of cabinet BE-70-()). The location of crosses and grounds can be accurately determined by means of bridge tests, and the resistance of a short-circuited line may be more accurately determined than with voltmeter tests. Methods of operation of various bridges differ, therefore the instructions covering the bridge used should be followed.

19. Useful information.—*a.* In making measurements on mag-neto lines having several bridged bells not equipped with capacitors, it should be kept in mind that the loop resistance of the line is less than the resistance of the same line with only one bridged bell.

b. When a receiver is “off the hook” at any station, there is a low resistance shunt across the line. The resistance of this shunt is approximately 50 to 100 ohms.

c. Faulty joints and splices in the circuits may cause considerable trouble. The resistance of the joint, normally negligible, may be materially increased by corrosion. This condition has a tendency to unbalance the line, thereby producing noises and distorting the transmission, and in addition may cause a material loss in transmission.

d. Care must be used in opening for test any physical circuit forming part of a phantom circuit, because if both wires of the physical circuit are opened, the phantom circuit is likewise opened.

e. Resistance and weights of wires and cables.—The following table gives the resistance and weights of wires and cables most commonly used by the Signal Corps for communication purposes. The resistance given in this table is approximate at a temperature of 68° F. (20° C.) and will be greater for a higher temperature and less for a lower temperature. Two columns of resistance values are incorporated in the table; one column is the resistance per mile of a single conductor and the other column is the resistance per loop mile and is equal to twice the resistance of a single conductor. The loop resistance is the sum

of the resistances of the two wires in series, and is the most commonly used method of expressing line resistance.

	Weight per mile (pounds)	Resistance per mile of single conductor (ohms)	Resistance per loop mile (ohms)
Hard-drawn bare copper wire:			
No. 8 AWG	264	3.4	6.8
No. 9 AWG	209	4.3	8.6
No. 10 AWG (or No. 12 NBS) (type W-74)	166	5.4	10.8
No. 12 AWG	104	8.5	17.0
No. 14 NBS	103	8.5	17.0
Galvanized iron wire of BB grade:			
No. 9 BWG (type W-75)	312	15	30
No. 10 BWG	258	19	38
No. 12 BWG	179	29	58
No. 14 BWG (type W-76)	99	49	98
Bronze No. 17 AWG, single, solid (type W-73)	33	95	190
Outside distributing, twisted pair, copper clad, solid, No. 17 AWG (type W-38)	240	96	192
Outside twisted pair, solid, No. 14 AWG (type W-50)	375	14	28
Parallel drop wire, copper clad steel or bronze tinned, solid, No. 17 AWG (type W-108)	216	94	188
Field, 11 strand (10 steel, 1 copper):			
Single (type W-39)	90	52	-----
Twisted pair (type W-40)	184	53	106
Field, 7 strand:			
Twisted pair, 5 steel, 2 copper (type W-110)	132	130	260
Twisted pair, 4 steel, 3 copper (type W-110-B)	132	95	190
Outpost wire, 7 strand (3 steel, 4 bronze):			
Single (type W-43)	63	161	-----
Twisted pair (type W-44)	130	164	328
Buzzer (2 steel, 1 copper) (type W-45)	26	340	-----
Assault wire, 7 strand (6 steel, 1 copper):			
Twisted pair (type W-130)	32	317	634
Cable, 10 pair, paper insulated, lead covered:			
No. 19 AWG (type WC-401)	4, 224	43	86
No. 22 AWG (type WC-411)	2, 798	86	172
Cable, rubber insulated, rubber covered:			
No. 19 AWG, 5 pair (type WC-534)	660	43	86
No. 19 AWG, 10 pair (type WC-535)	1, 320	43	86

f. Table of resistance versus voltmeter reading for various test battery voltages.

Voltmeter reading	Voltmeter, 100,000 ohms (voltmeter not shunted)			Voltmeter, 199.6 ohms (VM SHUNT key operated)		
	(Maximum test battery voltage)			(Maximum test battery voltage) ¹		
	(30)	(29)	(28)	(30)	(29)	(28)
30	0			0		
29	3, 450	0		7	0	
28	7, 140	3, 570	0	14	7	0
27	11, 110	7, 410	3, 700	22	15	7
26	15, 380	11, 540	7, 690	31	23	15
25	20, 000	16, 000	12, 000	40	32	24
24	25, 000	20, 830	16, 670	50	42	33
23	30, 430	26, 090	21, 740	61	52	43
22	36, 360	31, 820	27, 420	73	63	55
21	42, 860	38, 900	33, 330	85	77	67
20	50, 000	45, 000	40, 000	100	90	80
19	57, 900	52, 630	47, 370	116	105	95
18	66, 670	61, 110	55, 560	133	122	111
17	76, 470	70, 600	64, 710	153	141	129
16	87, 500	81, 250	75, 000	175	162	150
15	100, 000	93, 330	86, 670	200	186	173
14	114, 300	107, 100	100, 000	228	214	200
13	130, 800	123, 100	115, 400	261	246	231
12	150, 000	141, 700	133, 300	300	283	267
11	172, 700	163, 600	154, 500	345	327	309
10	200, 000	190, 000	180, 000	400	380	360
9	233, 300	222, 000	211, 100	465	445	422
8	275, 000	262, 500	250, 000	550	525	500
7	328, 600	314, 300	300, 000	660	630	600
6	400, 000	383, 300	366, 700	800	770	733
5	500, 000	480, 000	460, 000	1, 000	960	920
4	650, 000	625, 000	600, 000	1, 300	1, 250	1, 200
3	900, 000	866, 700	833, 300	1, 800	1, 730	1, 667
2	1, 400, 000	1, 350, 000	1, 300, 000	2, 800	2, 700	2, 600
1	2, 900, 000	2, 800, 000	2, 700, 000	5, 800	5, 600	5, 400

¹ When the resistance measurement is to be made with the shunted voltmeter (VM SHUNT key operated), the voltage of the test battery should be measured by operating the VM SHUNT key in addition to the VM and SHORT keys.

Additional resistance values may be obtained by cross-interpolation for intermediate values of testing battery voltage and voltmeter readings.

SECTION III

DETAILED FUNCTIONING OF PARTS

	Paragraph
Wiring diagram and schematic circuit.....	20
Functional diagrams.....	21
Measuring battery voltage.....	22
Talking toward switchboard, using test shoe.....	23
Talking out on line, using test shoe.....	24
Ringling bridged bells and grounded bells on ring side of line, using power ringer.....	25
Ringling grounded bells on tip side of line, using hand generator.....	26
Continuity tests and voltmeter resistance measurements.....	27
Test for a ground on tip.....	28
Test for a cross with a line carrying current.....	29

20. Wiring diagram and schematic circuit.—The wiring diagram of cabinet BE-70-() is shown in figure 3, and the schematic circuit is shown in figure 4.

21. Functional diagrams.—*a.* The functional diagrams shown in paragraphs 22 to 29, inclusive, illustrate the circuits involved in several of the more common tests performed with cabinet BE-70-(). In order to show the relationship between the various parts of the test circuit, when used for the several tests, the functional diagrams have been superimposed in heavy lines on the schematic circuit diagram. In order to clarify the diagrams one conductor in the test circuit has been shown in solid lines, and the other conductor in dashed lines. A diagram showing the position of the keys used in making the test is included in the lower left-hand corner of each figure.

b. In the various figures, use has been made of the switchboard test cord in some instances, and of the test shoe at the main distributing frame in others. It must be remembered that any of the tests can be made at either location, depending upon the particular method desired or convenient. Also in the figures the wire chief's telephone set has been shown as a common battery set.

22. Measuring battery voltage.—Figure 5 shows the circuit and key arrangement used for measuring the voltage of the test battery.

23. Talking toward switchboard, using test shoe.—Figure 6 shows the circuit and key arrangements used when talking in toward a common battery switchboard from a test shoe at the main distributing frame. The same circuit is also used when a telephone EE-8-A is used

for the wire chief's telephone set for talking toward the switchboard on a magneto line circuit. However, if the common battery instrument

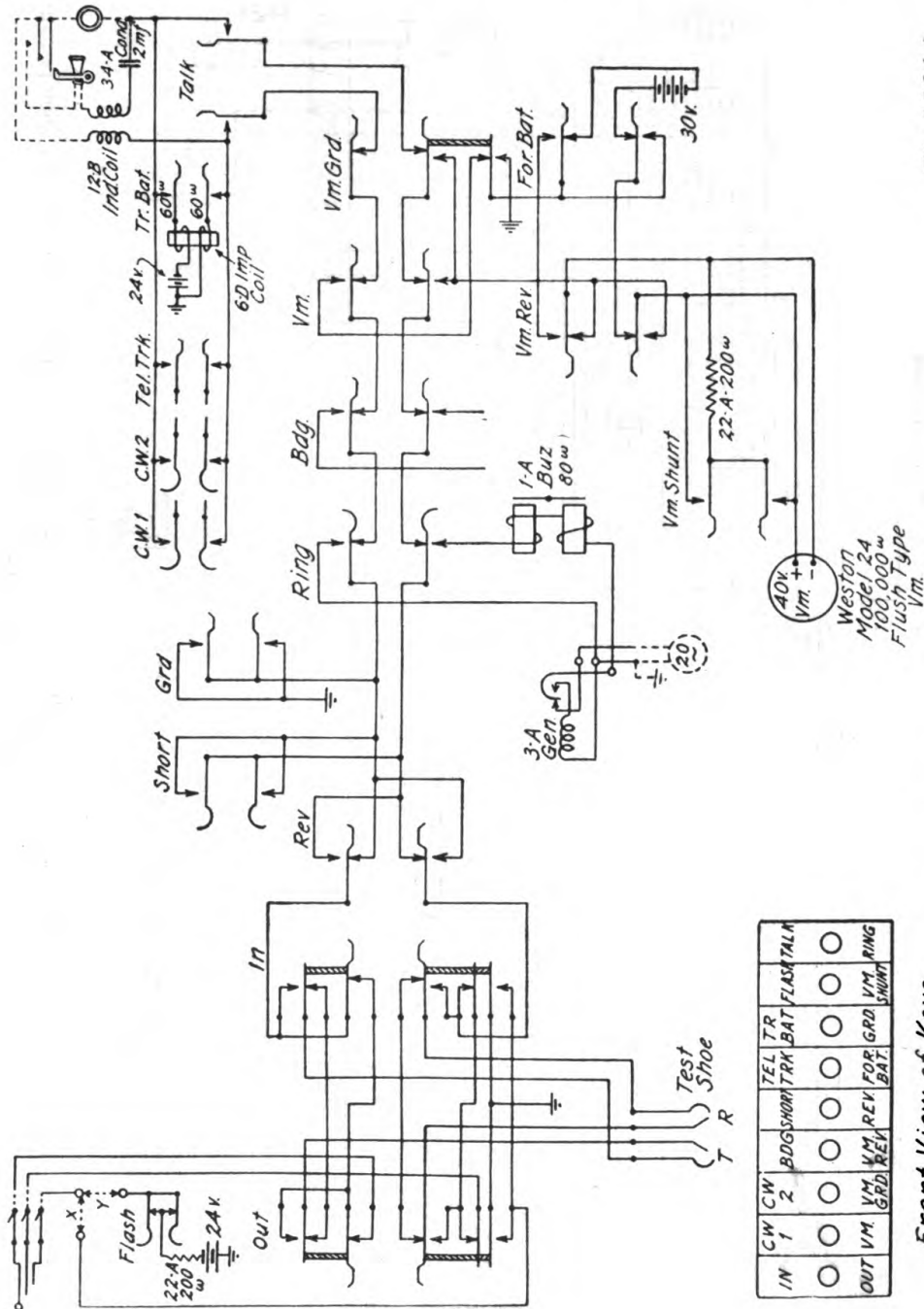

TL-3504-1

FIGURE 4.—Cabinet BE-70-(), schematic circuit.

is used for the wire chief's telephone set and it is desired to talk toward a magneto line circuit at the switchboard, it will be necessary to operate the TR BAT key in addition to those shown.

If a telephone EE-8-A is used for the wire chief's telephone set it is not necessary to operate the TR BAT key, except when talking to a common battery station.

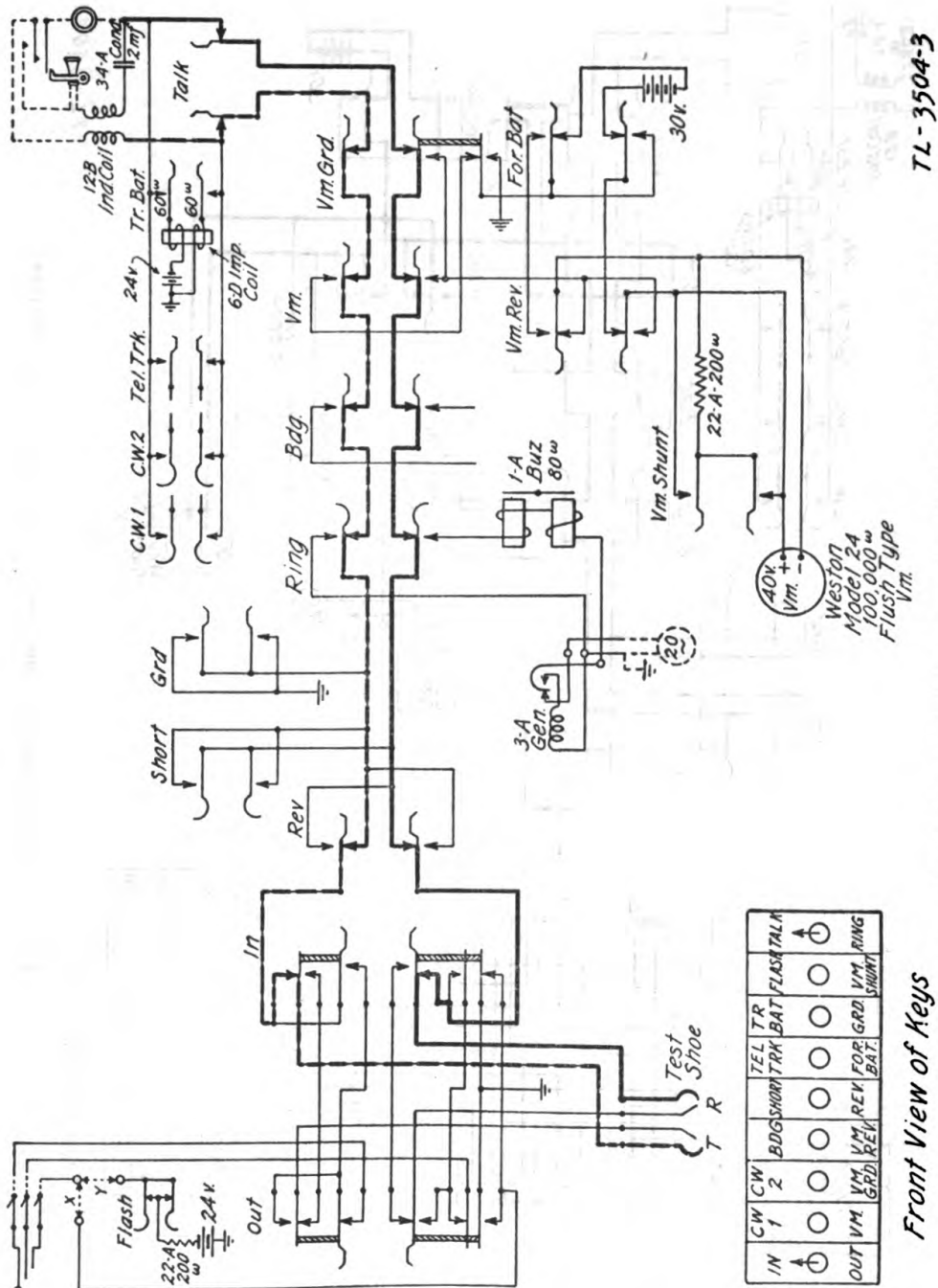

TL-3504-3

FIGURE 6.—Functional diagram, talking toward switchboard, using test shoe.

Front View of Keys

25. Ringing bridged bells and grounded bells on ring side of line using power ringer.—Figure 8 shows the circuit and key arrangements using the power ringer for ringing bridged bells. In

this diagram the test is being made using the test cord at the switch-board. When ringing a grounded bell on the ring side of the line, the same key arrangement is used, but the return path for the ringing

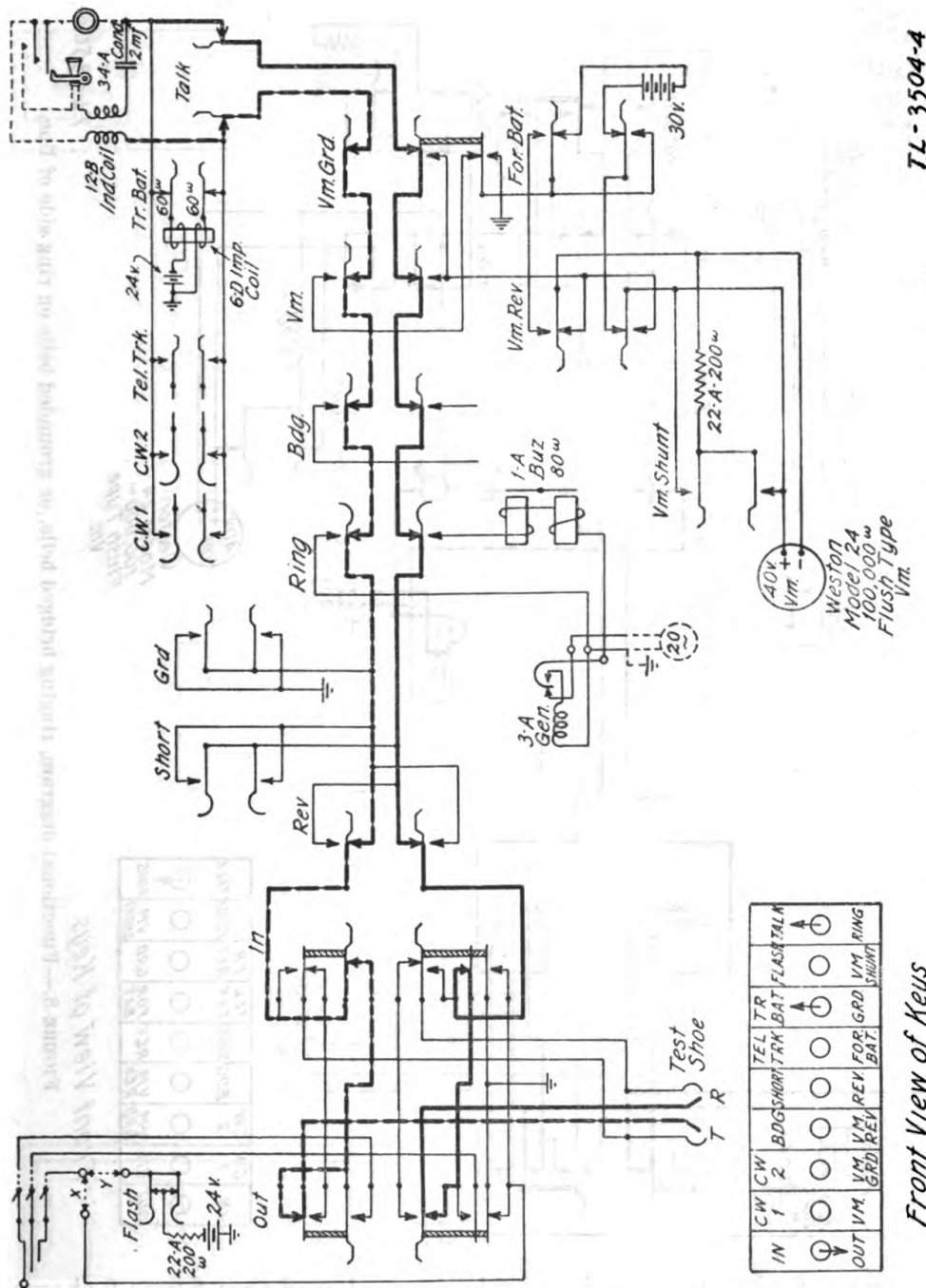

TL-3504-4

FIGURE 7.—Functional diagram, talking out on line, using test shoe.

current is through the ground instead of through the tip side of the line. The tip side of the line is still connected to ground in the test cabinet but serves no useful function when ringing the grounded bell

on the ring side of the line. Figure 9 shows the portion of the circuit used in ringing grounded bells. However, when making the compar-

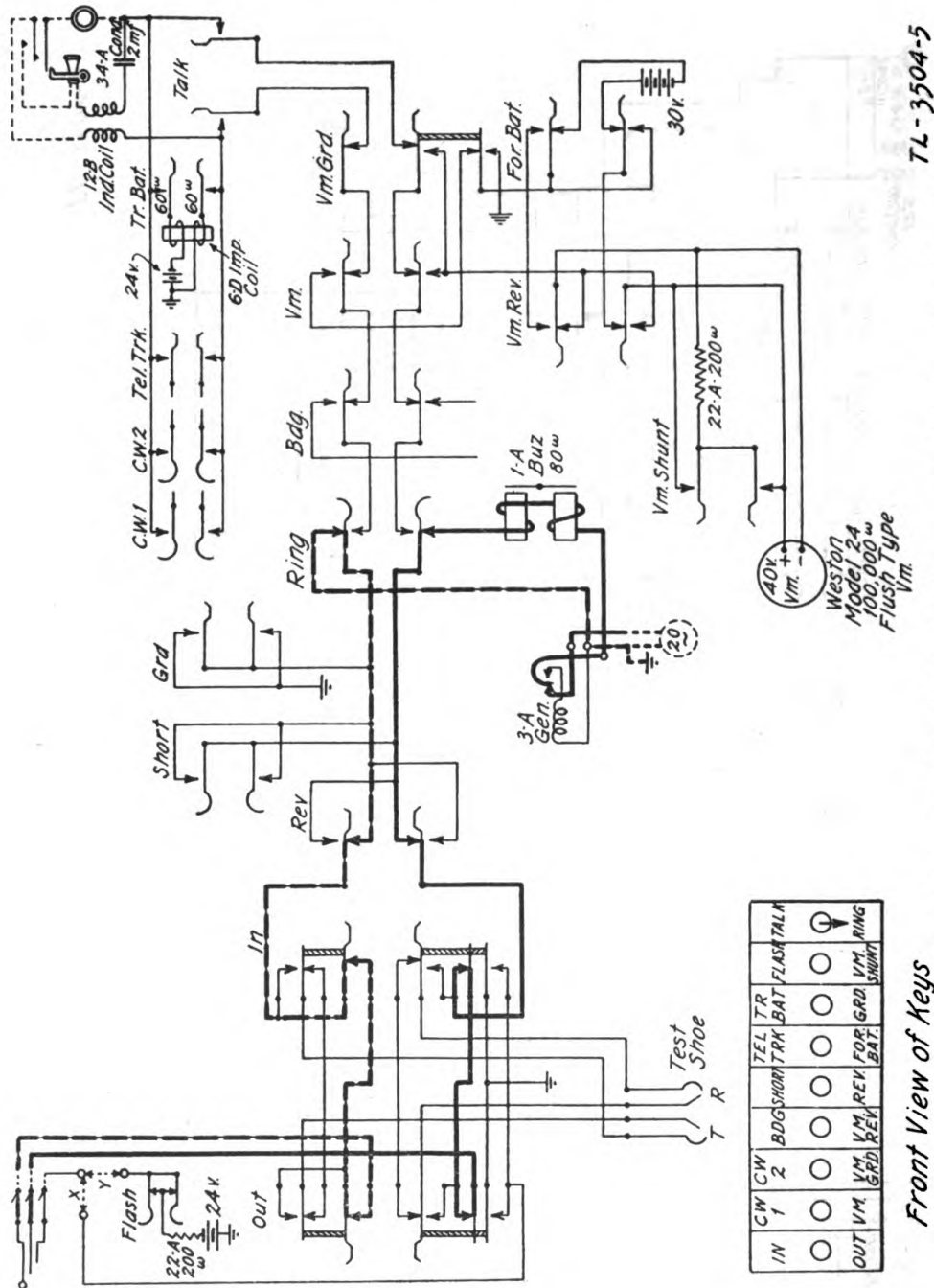

TL-3504-5

FIGURE 8.—Functional diagram, ringing bridged bells, or grounded bells on ring side of line.

ison between figures 8 and 9, it must be remembered that figure 9 shows the circuit for ringing a grounded bell on the tip side of the line.

26. Ringing grounded bells on tip side of line, using hand generator.—Figure 9 shows the circuit and key arrangements used

for ringing a bell on the tip side of the line, and using the hand generator at the test cabinet. This diagram shows the test being made using the test cord at the switchboard.

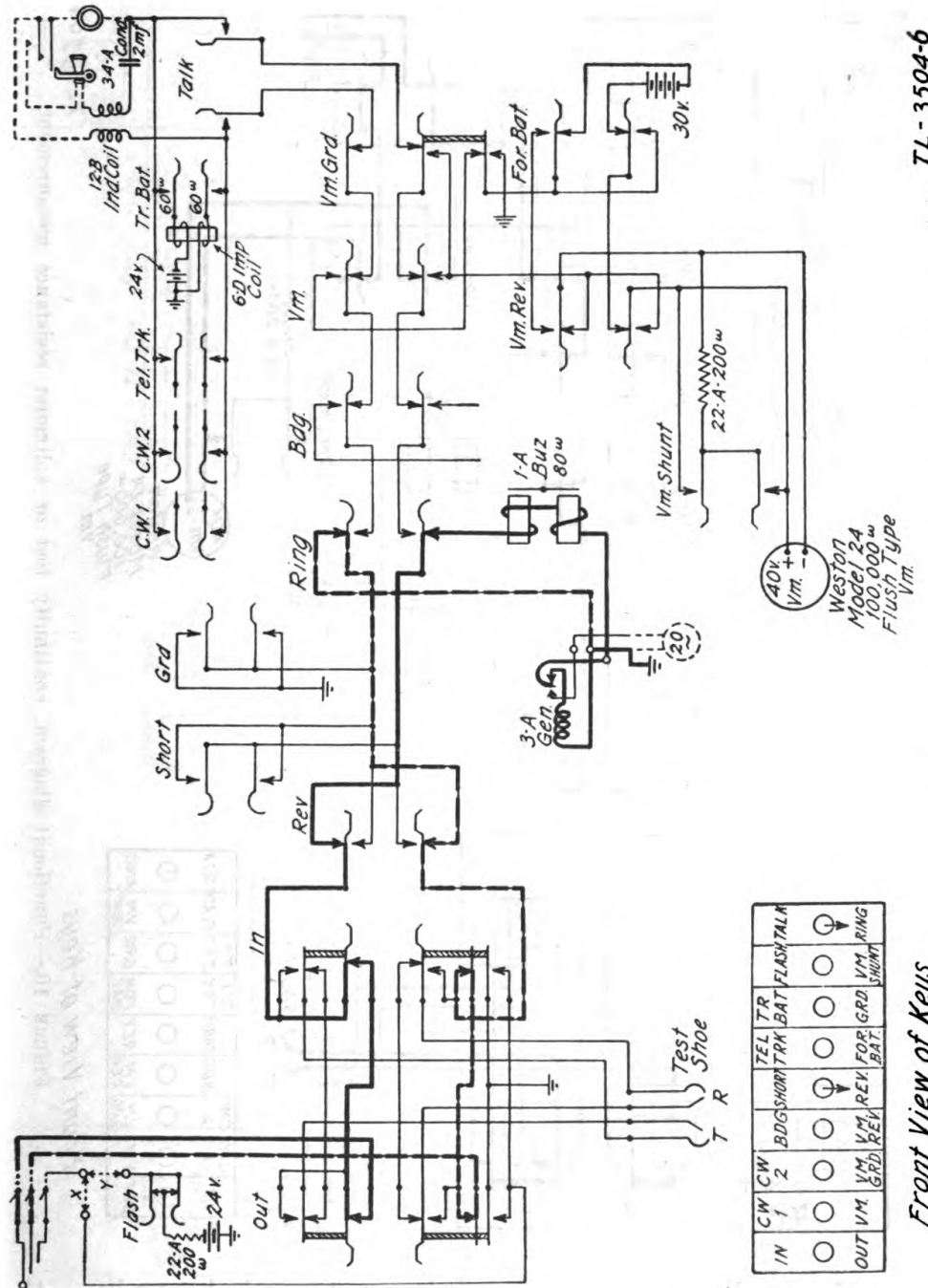
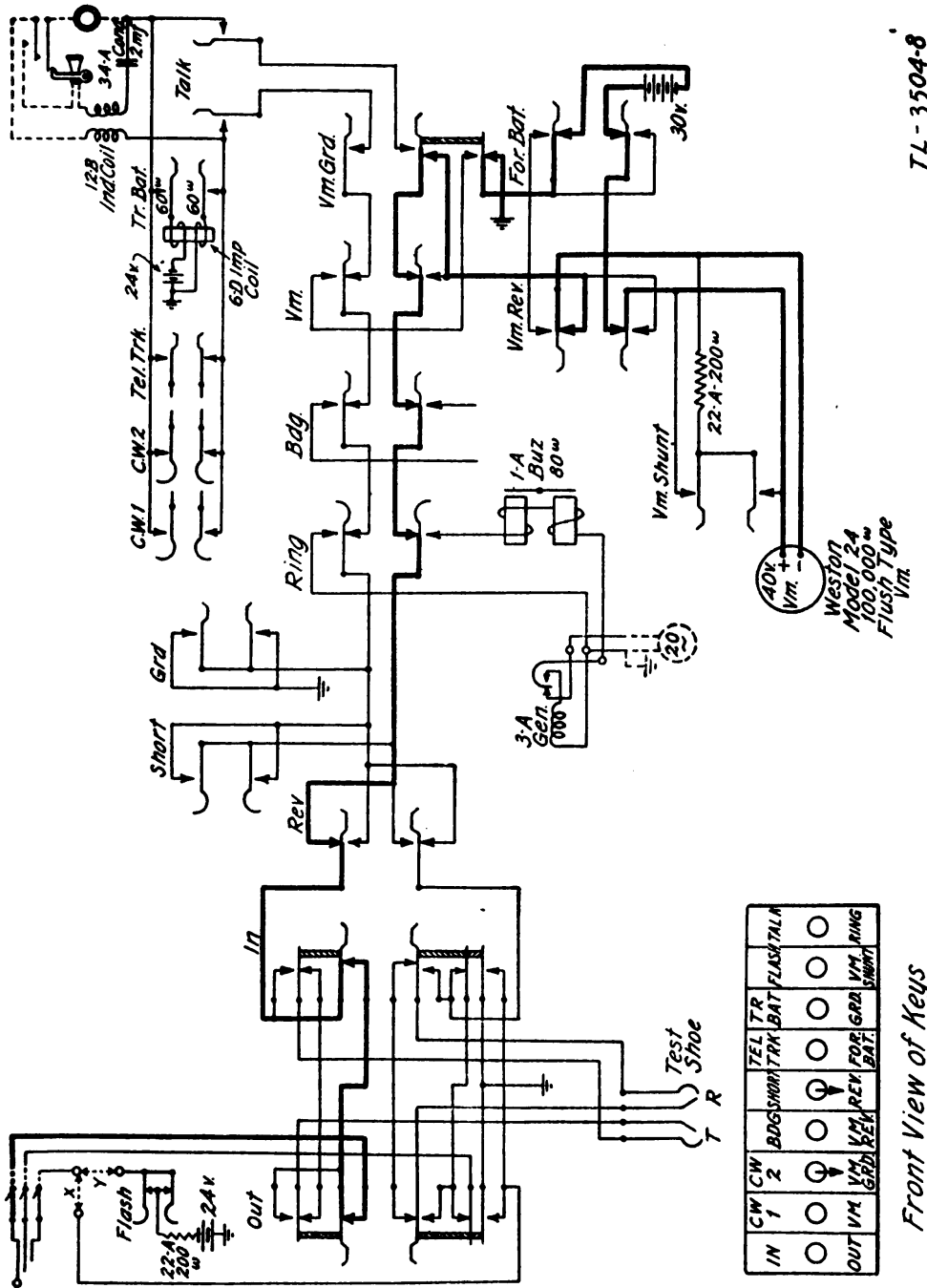

FIGURE 9.—Functional diagram, ringing grounded bell on tip side of line.

27. Continuity tests and voltmeter resistance measurements.—Figure 10 shows the circuit and key arrangements used for making continuity tests on metallic circuits and also for making re-

28. Test for a ground on tip.—Figure 11 shows the circuit and key arrangements, using the test cord at the switchboard, for testing for a ground on the tip. The test for a ground on the ring is made in



TL-3504-8

FIGURE 11.—Functional diagram, test for ground on tip.

the same manner except that the REV key is not operated. The same method of testing and circuit arrangements are used for testing for a cross between two lines, neither of which carries current.

29. Test for a cross with a line carrying current.—Figure 12 shows the circuit and key arrangements (using the test shoe) for testing the ring conductor of a pair of wires for a cross with another wire

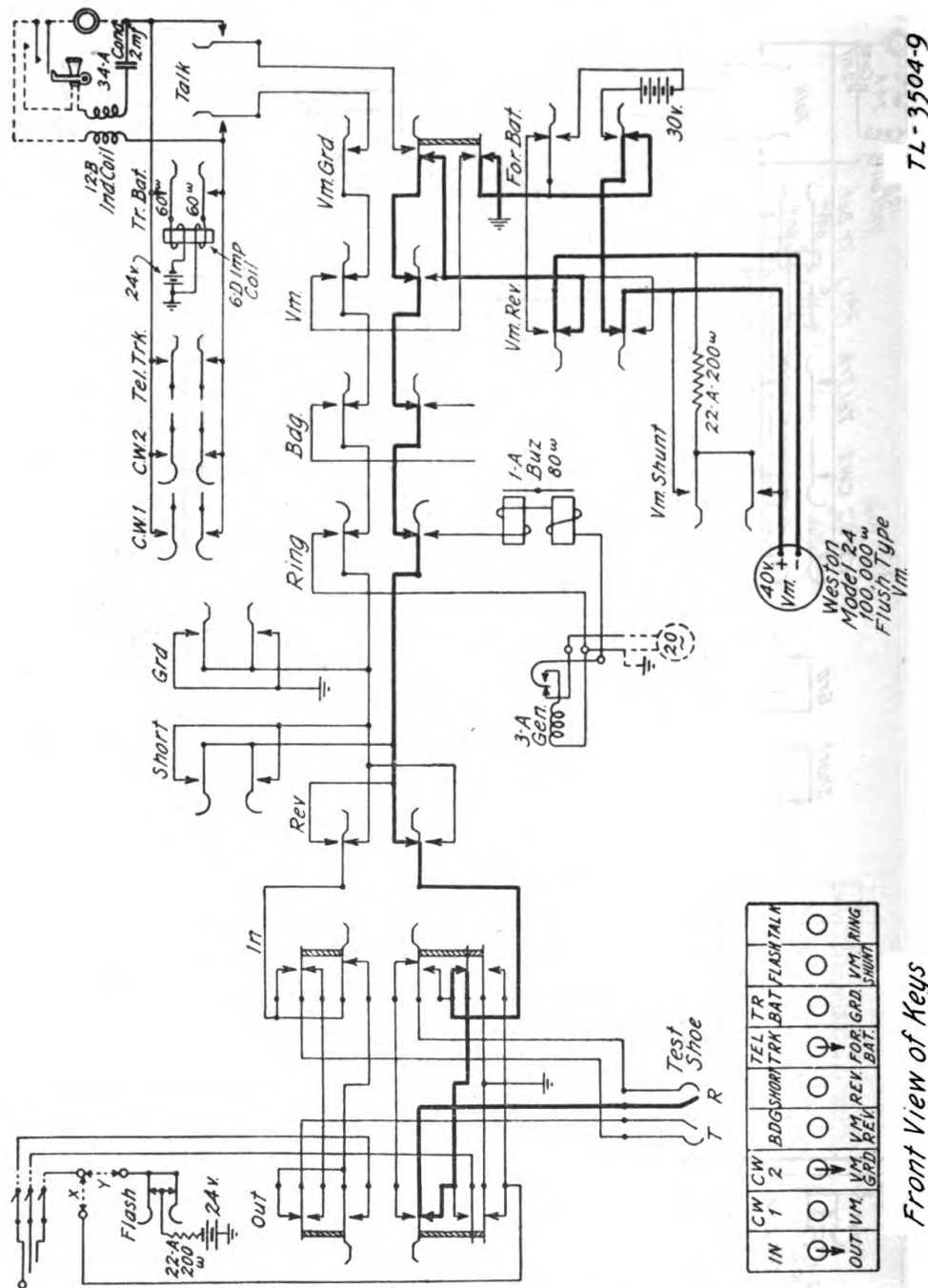

7L-3504-9
 FIGURE 12.—Functional diagram, test on ring conductor for cross with line carrying current.

carrying current. In order to test the tip conductor it will be necessary to operate the REC key. If the voltmeter goes off scale backwards when making either of the above tests, it will be necessary to operate the VM REV key.

SECTION IV

SERVICING AND REPAIR

Maintenance -----	Paragraph 30
Packing for Army transportation-----	31

30. Maintenance.—*a.* The greatest single factor in trouble-free operation is careful handling of cabinet BE-70-() while packing and unpacking, transporting, and installing. Monthly inspections should be made for loose connections, broken wires, and loose or broken equipment.

b. If the voltmeter fails to read “zero” with all keys normal, the trouble may result from faulty key adjustment or the zero adjustment of the meter. The latter is more probable, and is indicated by a very small reading, either above or below zero, on the meter. The needle may be brought to zero by adjusting the slotted adjusting screw, near the bottom of the face of the meter. No other adjustments to the meter are permissible. If a large meter deflection is noted with all keys normal, the trouble will probably be due to faulty key adjustment. As an aid in determining the source of the trouble, disconnect the test battery, wire chief’s transmitter battery, and any connected lines. Disconnect one wire at a time and note any change in the meter reading. When the disconnection of any particular wire causes the meter needle to fall to zero, it is an indication of the portion of the circuit, through the various keys, in which the trouble will be found. The trouble may be readily corrected by adjusting the particular key or keys found to be in faulty adjustment.

c. The test battery should be changed if it does not meet the requirements outlined in paragraph 17.

d. The rear door of the cabinet should be in place at all times, except while wiring the cabinet or making inspections, in order to avoid key trouble due to dust and dirt.

e. Wiring external to the cabinet should be laced, and placed so as to avoid mechanical damage and interference with opening the cabinet for inspection.

f. Only easily replaceable parts such as fuses, generator, generator crank, buzzer, resistors, and voltmeter may be readily changed in the field. All repairs other than these should be made by a signal repair company or higher repair echelon.

31. Packing for Army transportation.—Case CS-57 is designed for transporting cabinet BE-70-(), and will, in most cases, be pro-

vided. In such instances as case CS-57 has not been provided, the cabinet may be transported in any suitable case provided extreme care is exercised to protect the keys and meter.

SECTION V

REPLACEABLE PARTS

List of replaceable parts.....	Paragraph 32
Addresses of manufacturers.....	33

32. List of replaceable parts.—a. Cabinets of Leich Electric Co. manufacture.

Reference symbol	Stock No.	Name	Description	Function	Manufacturer	Manufacturer's part No.	Drawing No. Signal Corps
		Binding post TM-145-A.	Knurled, metal, on face of test cabinet.	For connection to Wheatstone bridge.			SC-D-2958
		Buzzer	80-ohm	Ringin g circuit.	Leich	1-A	Do.
		Capacitor	2-microfarad	Telephone circuit.	do	34-A	Do.
		Coil	Induction	do	do	12-B	Do.
		Coil	Impedance	Transmitter battery supply.	do	6-D	Do.
		Crank GC-11.	Generator crank		do		Do.
		Fuse	1-ampere	Circuit protection: ringin g power, test battery, and talkin g battery.			Do.
		Generator	Hand	Emergency ringin g power.	Leich	3-A	Do.
		Key		TALK-RING key	do	181-A	Do.
		Key		BDG-VM REV key.	do	181-D	Do.
		Key		TR BAT-GRD key.	do	181-AO	Do.
		Key		FLASH-VM SHUNT key.	do	181-BC	Do.
		Key		TEL TRK-FOR BAT key.	do	181-BD	Do.
		Key		SHORT-REV key	do	181-BE	Do.
		Key		OW1-VM key	do	181-BE	Do.
		Key		CW2-VM GRD key.	do	181-BF	Do.
		Key		IN-OUT key	do	181-BG	Do.
		Resistor	200-ohm	Voltmeter shunt	do	22-A	Do.
		Resistor	200-ohm	Sleeve circuit	do	22-A	Do.
		Strip	Terminal, wood		do		Do.
		Terminal		External connections.	do		Do.
	3F8040-2	Voltmeter	0-40 volts d-c, 100,000-ohm.		Weston	Model 24	Do.

b. Cabinets of Kellogg Switchboard and Supply Co. manufacture.

Stock No.	Name	Description	Function	Manufacturer	Manufacturer's part No.	Drawing number Signal Corps
	Binding post TM-145-A.	Knurled, metal, on face of test cabinet.	For connection to Wheatstone bridge.			SC-D-2956
4C1566B	Buzzer	80-ohm	Ringng circuit	Kellogg	66-B	SC-D-2958
	Capacitor	2-microfarad	Telephone circuit	do	66	SC-D-2958
	Coil	Induction	Telephone circuit	do	99EA Spl	Do.
	Coil	Relay	Transmitter battery supply.	do	2053-TJ	Do.
4B455	Crank GC-11.	Generator crank				SC-D-2956
	Fuse	1 ampere	Circuit protection: ringing power, test battery, talking battery.	Reliable Electric Co.	21	SC-D-2958
	Fuse block				20	Do.
4B838	Generator GN-38.	Hand	Emergency ringing power.	Kellogg	15	SC-D-2956
	Key		TALK-RING key	do	1041	SC-D-2958
	Key		BDG-VM REV key	do	1030	Do.
	Key		TR BAT-GRD key	do	1002	Do.
	Key		FLASH-VM SHUNT key.	do	1041	Do.
	Key		TEL TRK-FOR BAT key.	do	1030	Do.
	Key		SHORT-REV key	do	1029	Do.
	Key		CW1-VM key	do	1029	Do.
	Key		CW2-VM GRD key	do	ES-1897	Do.
	Key		IN-OUT key	do	1079	Do.
	Resistor	200-ohm	Voltmeter shunt.	do	SCT relay coil.	Do.
	Resistor	200-ohm	Sleeve circuit.	do	SCT relay coil	Do.
	Terminal strip.	Wood		W. E. Co.	154A	SC-D-2956
3F8040-2	Voltmeter	0-40 volts d-c, 100,000-ohm.		Weston	Model 24	SC-D-2958

c. Cabinets of Automatic Electric Co. manufacture.

Stock No.	Name	Description	Function	Manufacturer	Manufacturer's part No.	Drawing number Signal Corps
	Binding post TM-145-A.	Knurled, metal, on face of test cabinet.	For connection to Wheatstone bridge.	H. H. Eby	13-D "sergeant."	SC-D-2956
	Buzzer	80-ohm	Ringng circuit	A. E. Co.	MC-5621-A	SC-D-2958
	Capacitor	5-microfarad	Telephone circuit	do	D-68258-A	Do.
	Coil	Induction	Telephone circuit	do	D-282996-A	Do.
	Coil	Impedance	Transmitter battery supply.	do	GD-283233	Do.

