

TM 5-3610-287-10

OPERATOR'S MANUAL

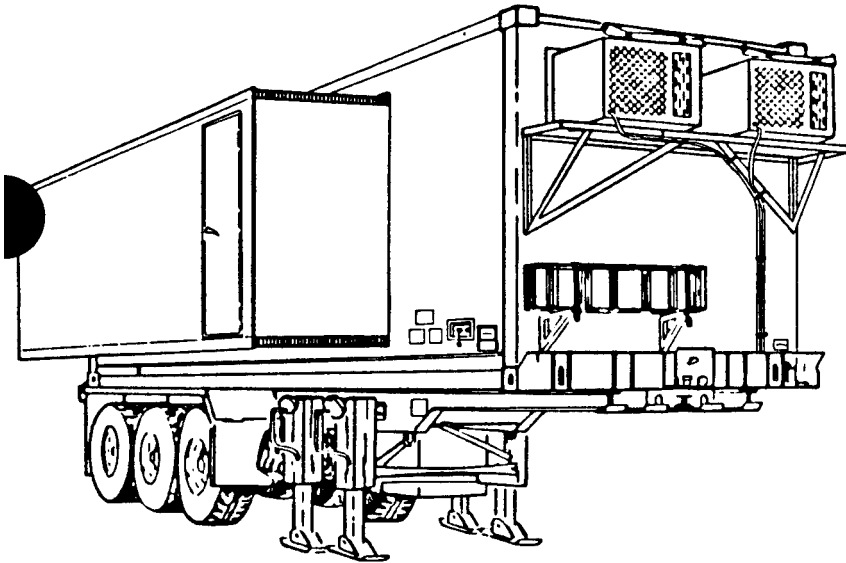

DESCRIPTION AND USE OF
OPERATOR'S CONTROLS
AND INDICATORS 2-1

PREVENTIVE MAINTENANCE
CHECKS AND
SERVICES (PMCS) 2-5

OPERATION UNDER
USUAL CONDITIONS 2-23

MAINTENANCE
INSTRUCTIONS 3-1

TROUBLESHOOTING
PROCEDURES 3-1

TOPOGRAPHIC SUPPORT SYSTEM
PRESS SECTION
MODEL NO. TEAD-TSS-21
NSN 3610-01-105-1744

HEADQUARTERS, DEPARTMENT OF THE ARMY

6 JANUARY 1986

CHANGE }
No. 1 }

HEADQUARTERS
DEPARTMENT OF THE ARMY
WASHINGTON, D.C., 20 January 1988

Operator's Manual

TOPOGRAPHIC SUPPORT SYSTEM
PRESS SECTION
MODEL NO. TEAD-TSS-21
NSN 3610-01-105-1744

TM 5-3610-287-10, 6 January 1986, is changed as follows:

1. Remove and insert pages as indicated below. New or changed text material is indicated by a vertical bar in the margin. An illustration change is indicated by a miniature pointing hand.

Remove pages

2-19 and 2-20
B-3 and B-4

Insert Pages

2-19 and 2-20
B-3 and B-4

2. Retain this sheet in front of manual for reference purposes.

By Order of the Secretary of the Army:

CARL E. VUONO
General, United States Army
Chief of Staff

Official:

R. L. DILWORTH
Brigadier General, United States Army
The Adjutant General

DISTRIBUTION:

To be distributed in accordance with DA Form 12-25A, Operator's Requirements for Press Section, Topographic Support System (TSS).

WARNING

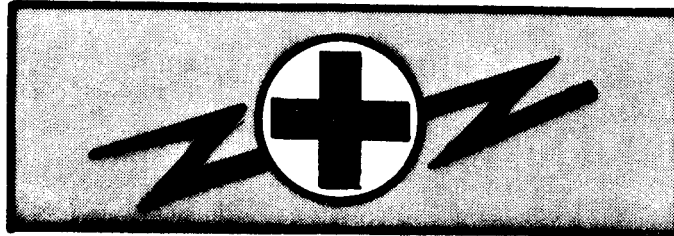

WARNING

ELECTRICAL HAZARD

- Do not perform electrical maintenance or make electrical connections/disconnections while power cable is energized. Death or serious injury may result.
- Circuit breakers and power switches must be turned OFF before performing any electrical maintenance, service, or inspections. Failure to do so may result in death or serious injury.
- Section must be grounded properly before power is connected. Failure to do so may result in death or serious injury.

WARNING

HEAVY EQUIPMENT. Stay clear as folding floors are raised or lowered. Weight of folding floors may cause serious personal injury.

WARNING

Do not allow water pressure to build up in water tank during fill-up. Personal injury or damage to equipment could result.

WARNING

When moving Section, care must be taken to avoid power lines. Serious injury or death could result from contact with power lines.

WARNING

HIGH NOISE LEVEL. Hearing protection must be worn while operating Printing Press. Failure to do so may result in hearing impairment.

For first aid procedures, refer to FM 21-11.

	Page
APPENDIX A REFERENCES	A-1
APPENDIX B COMPONENTS OF END ITEM AND BASIC ISSUE ITEMS	
LISTS	B-1
Section I Introduction	B-1
Section 11 Components of End Item	B-2
Section 111 Basic Issue Items	B-10
APPENDIX C ADDITIONAL AUTHORIZATION LIST (AAL) ITEMS	C-1
APPENDIX D EXPENDABLE/DURABLE SUPPLIES AND MATERIALS LIST	D-1
Section I Introduction	D-1
Section II Expendable/Durable Supplies and Materials	
List	D-2
INDEX	Index 1

CHAPTER 1

INTRODUCTION

Section I. GENERAL INFORMATION

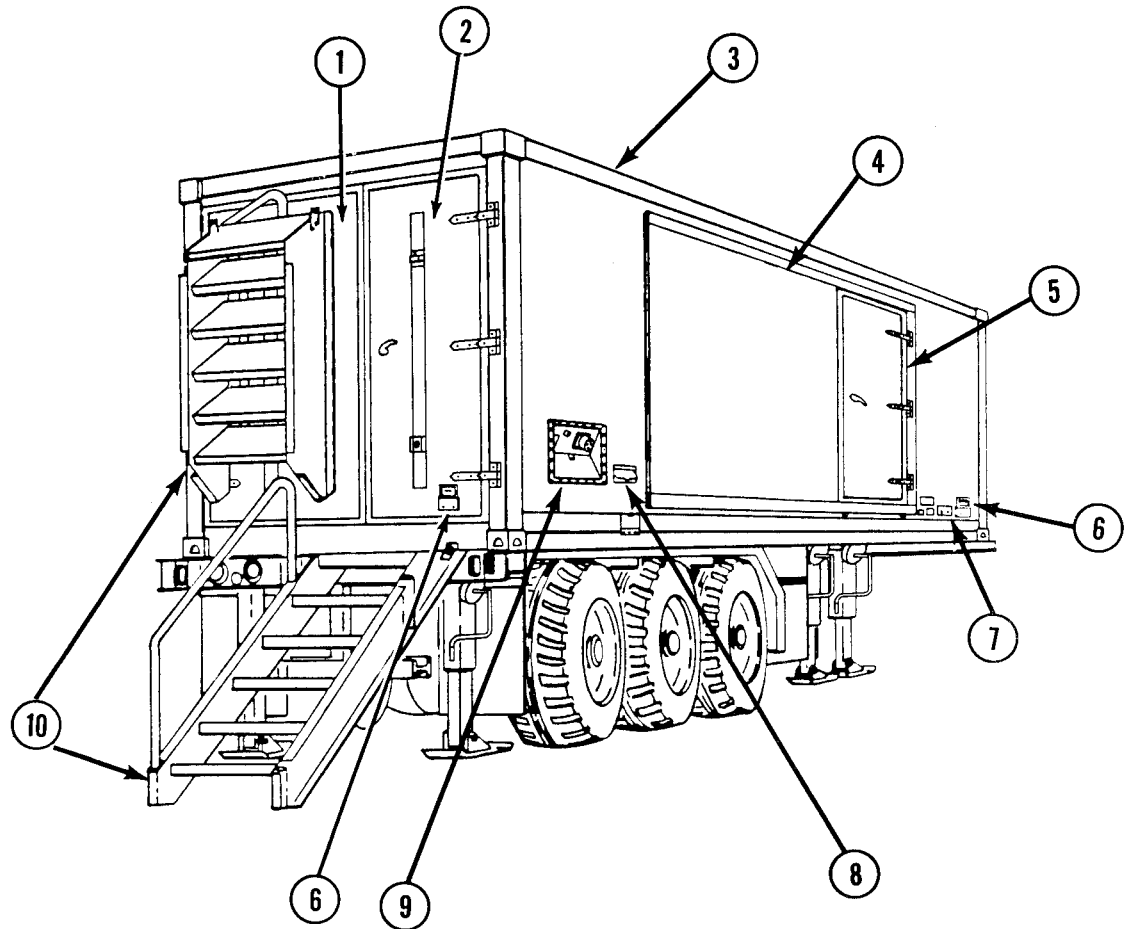

- | | | | |
|---|-------------------------|----|--------------------------|
| 1 | Cargo Door | 7 | Water Box |
| 2 | Rear Personnel Door | 8 | Telephone Entrance Panel |
| 3 | Section Body | 9 | Power Entry Panel |
| 4 | Expanding Sides | 10 | Boarding Ladders |
| 5 | Curbside Personnel Door | | |
| 6 | Inclinometer | | |

Topographic Support System Press Section Exterior

1-1. SCOPE. This manual contains operating and operator maintenance instructions for the Topographic Support System (TSS) Press Section, Model No. TEAD-TSS-21. The Section provides printing capabilities to the Topographic Support System. Organizational, Direct Support, and General Support maintenance instructions for the TSS Press Section are contained in TM 5-3610-287-24. Repair parts and special tools are listed in TM 5-3610-287-24P, Organizational, Direct Support, and General Support Maintenance Repair Parts and Special Tools List (RPSTL), Topographic Support System Press Section. Lubrication instructions are found in LO 5-3610-287-12, Lubrication Order, Topographic Support System Press Section. Authorized equipment and its location is shown in paragraph 1-6, Location and Description of Major Components.

1-2. MAINTENANCE FORMS AND RECORDS. Department of the Army forms and records will be filled out in accordance with DA PAM 738-750, The Army Maintenance Management System (TAMMS).

1-3. HAND RECEIPT (-HR) MANUAL. This manual has a companion document with a TM number followed by "-HR" (Hand Receipt). TM 5-3610-287-10-HR consists of preprinted hand receipts (DA Form 2062) that list end item related equipment (i.e., Components of End Item, Basic Issue Items, and Additional Authorization items) for which you must account. As an aid to proper accountability, additional -HR manuals may be requisitioned from the following source in accordance with procedures in chapter 3, AR 310-2: The U.S. Army Adjutant General Publications Center, 2800 Eastern Blvd, Baltimore, MD 21220-2896.

1-4. REPORTING EQUIPMENT IMPROVEMENT RECOMMENDATIONS (EIRs). If your Section needs improvement, let us know. Send us an EIR. You, the user, are the only one who can tell us what you do not like about your equipment. Let us know why you do not like the design or performance. Put it on an SF 368 (Quality Deficiency Report). Mail it to us at: Commander, U.S. Army Troop Support Command, ATTN: AMSTR-QX, 4300 Goodfellow Boulevard, St. Louis, MO 63120-1798. We'll send you a reply.

Section II. EQUIPMENT DESCRIPTION AND DATA

1-5. EQUIPMENT CHARACTERISTICS, CAPABILITIES, AND FEATURES. The Section is an insulated container with expanding sides. It houses and moves the TSS Printing Press with equipment and supplies needed for reproduction of topographic products. The Section has the following capabilities and features:

- Transportable by air, sea, or land when mounted with sides retracted on semitrailer chassis
- Cross-country capability
- Controlled temperature and humidity within interior
- Space for full operations with sides expanded

1-6. LOCATION AND DESCRIPTION OF MAJOR COMPONENTS

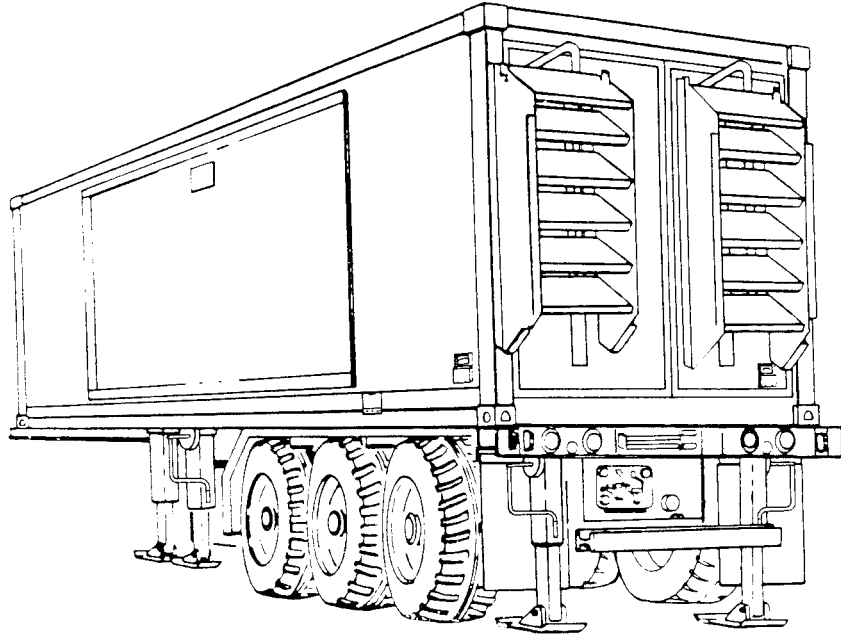

Roadside Exterior
(Left side when viewed from rear)

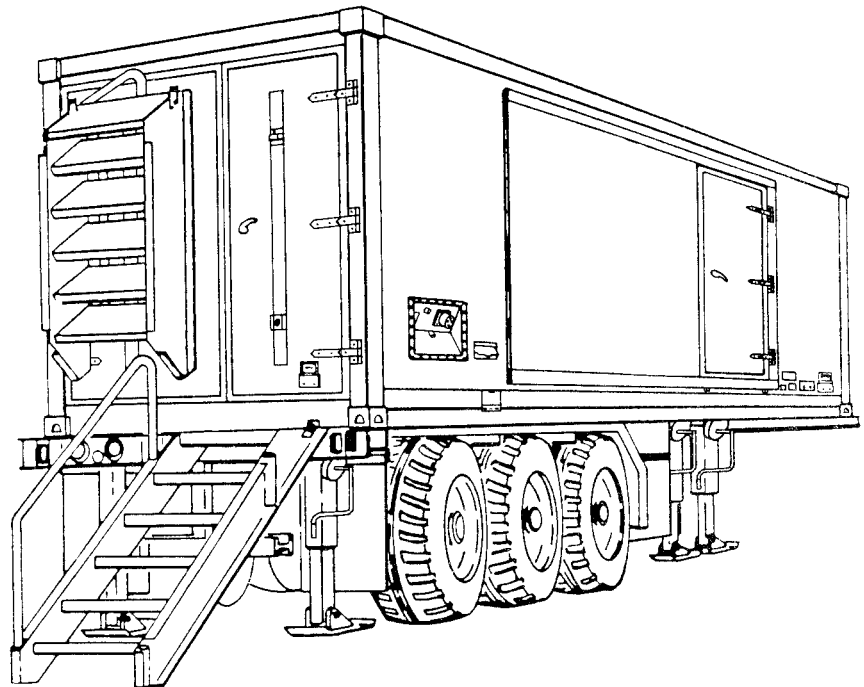

Curbside Exterior
(Right side when viewed from rear)

1-6. LOCATION AND DESCRIPTION OF MAJOR COMPONENTS (CONT)

ROADSIDE EXTERIOR

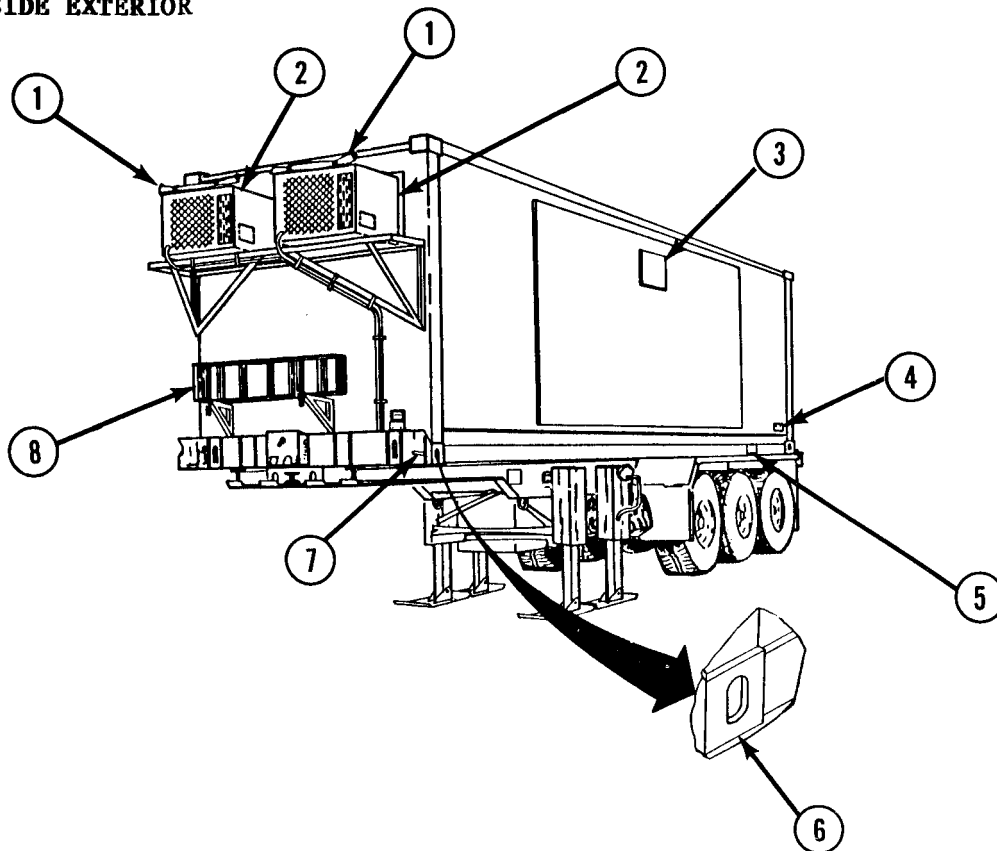

Air Conditioner/Heater Covers (1). Prevent dust, debris, and weather from damaging air conditioner/heaters during transport or storage.

Air Conditioner/Resters (2). Provide internal environmental control.

Exhaust Fan Cover (3). Covers exhaust fan opening. Controls airflow. Prevents weather elements from entering Section.

Inclinometers (4). Located on each corner of Section. Indicate when Section is level.

Expanding Side Drive Mechanism Receptacle (5). Provides handcrank access to expanding side drive mechanism.

Lifting Eyes (6). Provide points for lifting Section.

Section Body Locks (7). Located on each corner of Section. Lock Section to semitrailer chassis.

Folding Ladder (8). Provides access to roof.

1-6. LOCATION AND DESCRIPTION OF MAJOR COMPONENTS (CONT)

CURBSIDE EXTERIOR

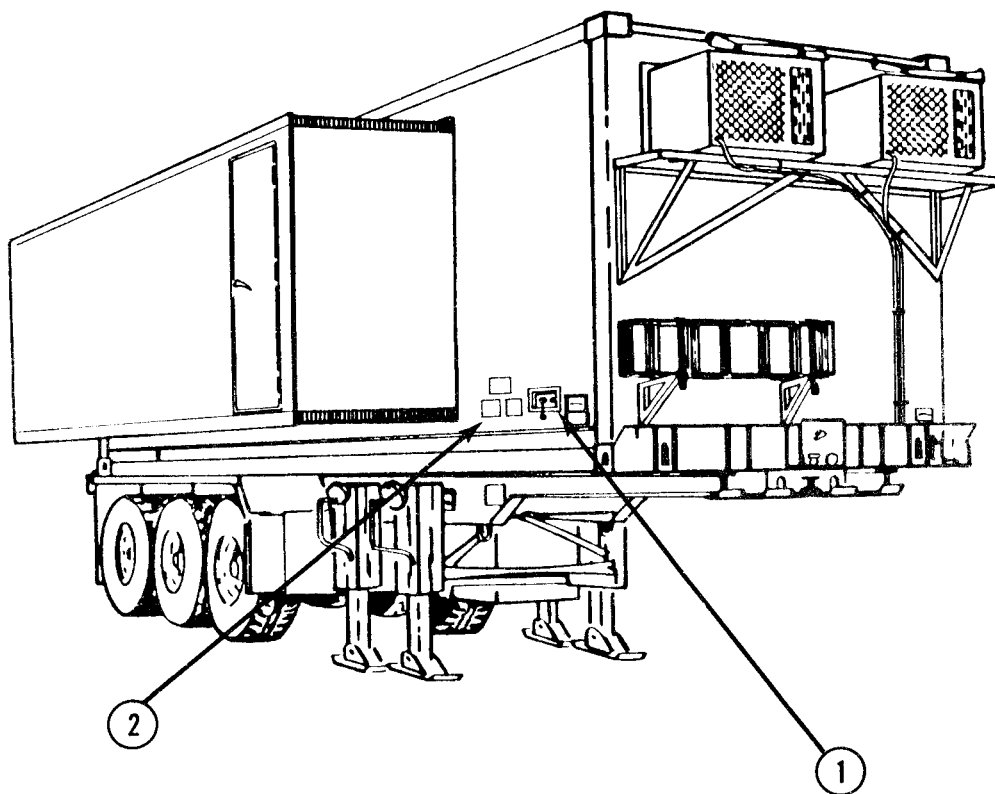

Water Box (1). Provides access for filling or draining water tank.

Data Plates (2). Provide weight and movement data.

1-6. LOCATION AND DESCRIPTION OF MAJOR COMPONENTS (CONT)

CURBSIDE EXTERIOR (CONT)

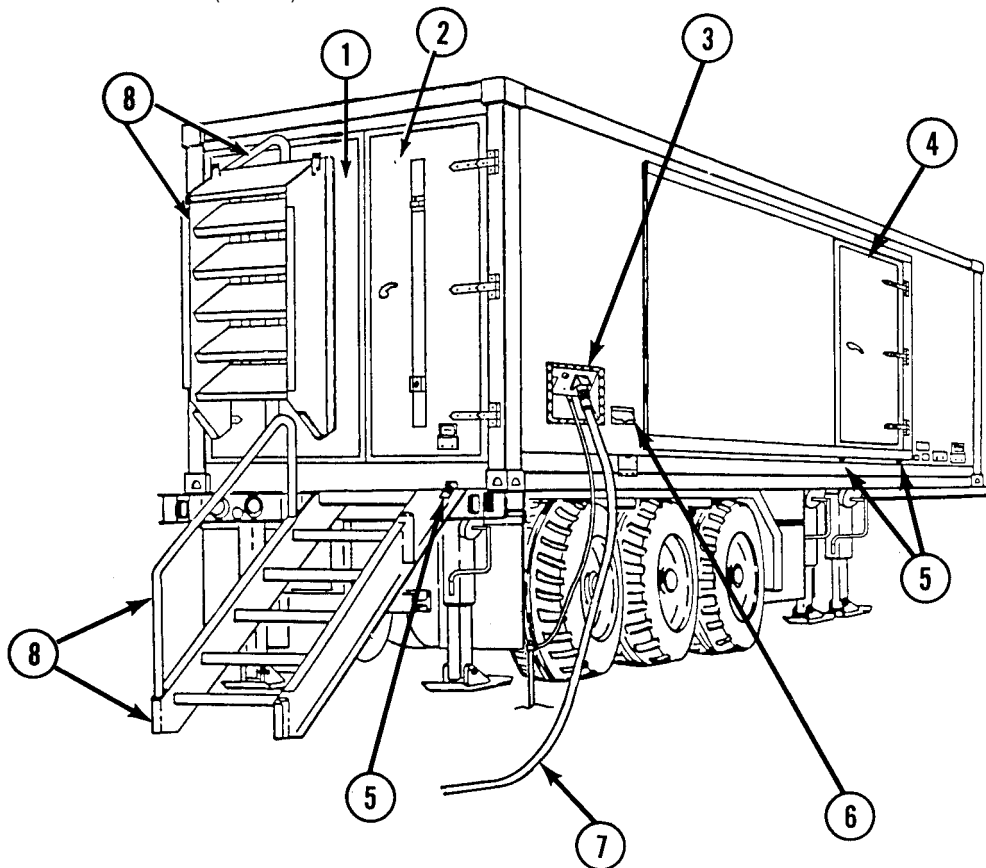

Cargo Door (1). Provides access for equipment installation and removal.

Rear Personnel Door (2). Provides entrance to Section.

Power Entry Panel (3). Contains terminals for ground cable, power cable, 12 VOLT DC INPUT receptacle, and 120 VOLT AC OUTLET receptacles.

Curbside Personnel Door (4). Provides side entrance to Section.

Ladder Attachment Eyes (5). Serve as attachment points for boarding ladders.

Telephone Entrance Panel (6). Contains terminals for telephone wires.

Power Cable (7). 100-foot long cable connects to power entry panel from external power source. Stored in semitrailer chassis tool box.

Boarding Ladders and Handrails (8). Are mounted at ladder attachment eyes for access to doors.

1-6. LOCATION AND DESCRIPTION OF MAJOR COMPONENTS (CONT)

CURBSIDE INTERIOR

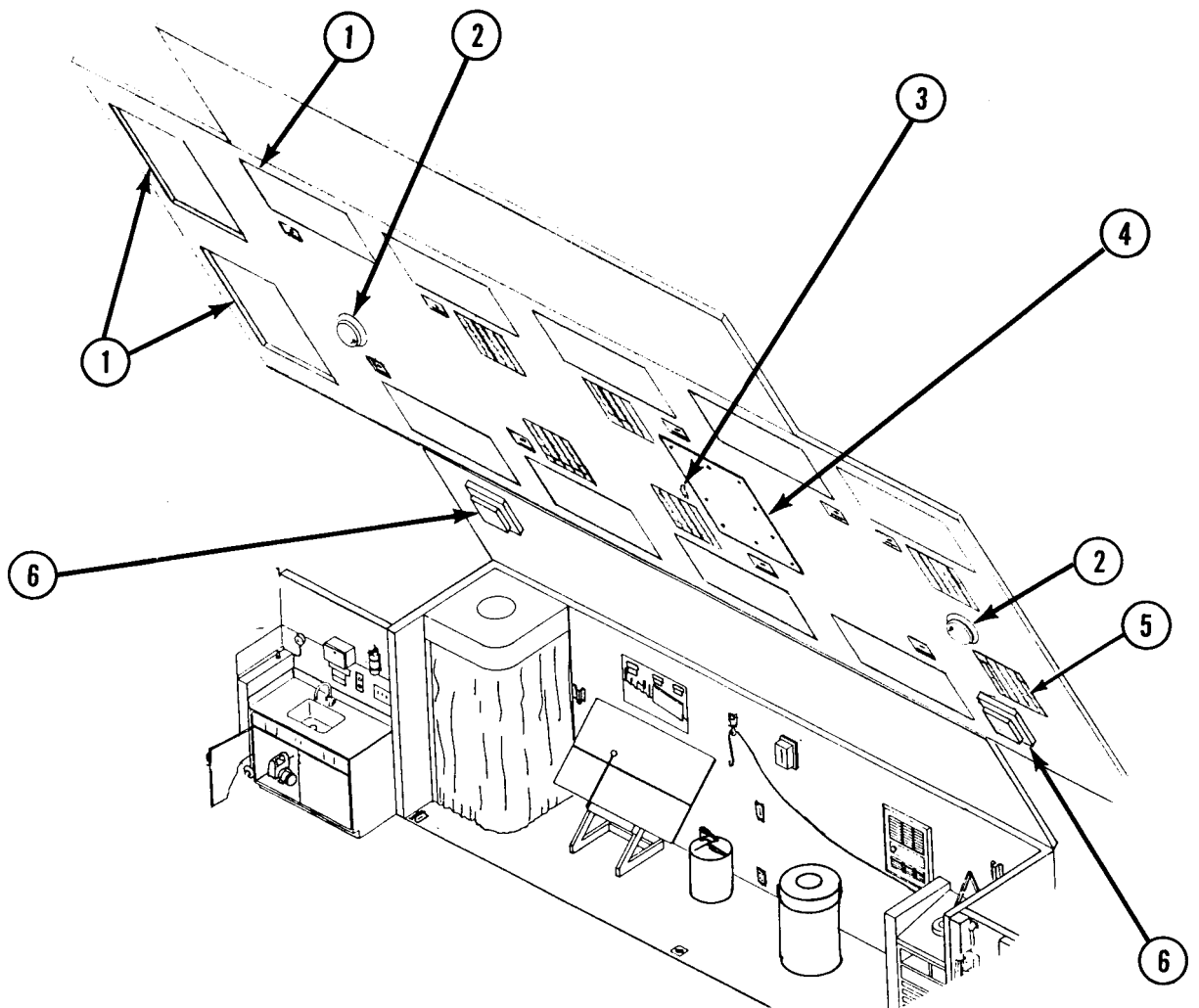

Fluorescent Ceiling Lights (1). White overhead lights.

Dome Lights (2). White-lens, 12 Vdc lights powered from auxiliary power source.

Guard Chain (3). Holds up safety guard on Printing Press during press setup.

Mirror (4). Provides Printing Press operator with top view of inking assembly.

Vents (5). Provide air outlet for Section ventilation.

Blackout Lights (6). Red-bulb, 12 Vdc lights activated when blackout switch operates.

1-6. LOCATION AND DESCRIPTION OF MAJOR COMPONENTS (CONT)

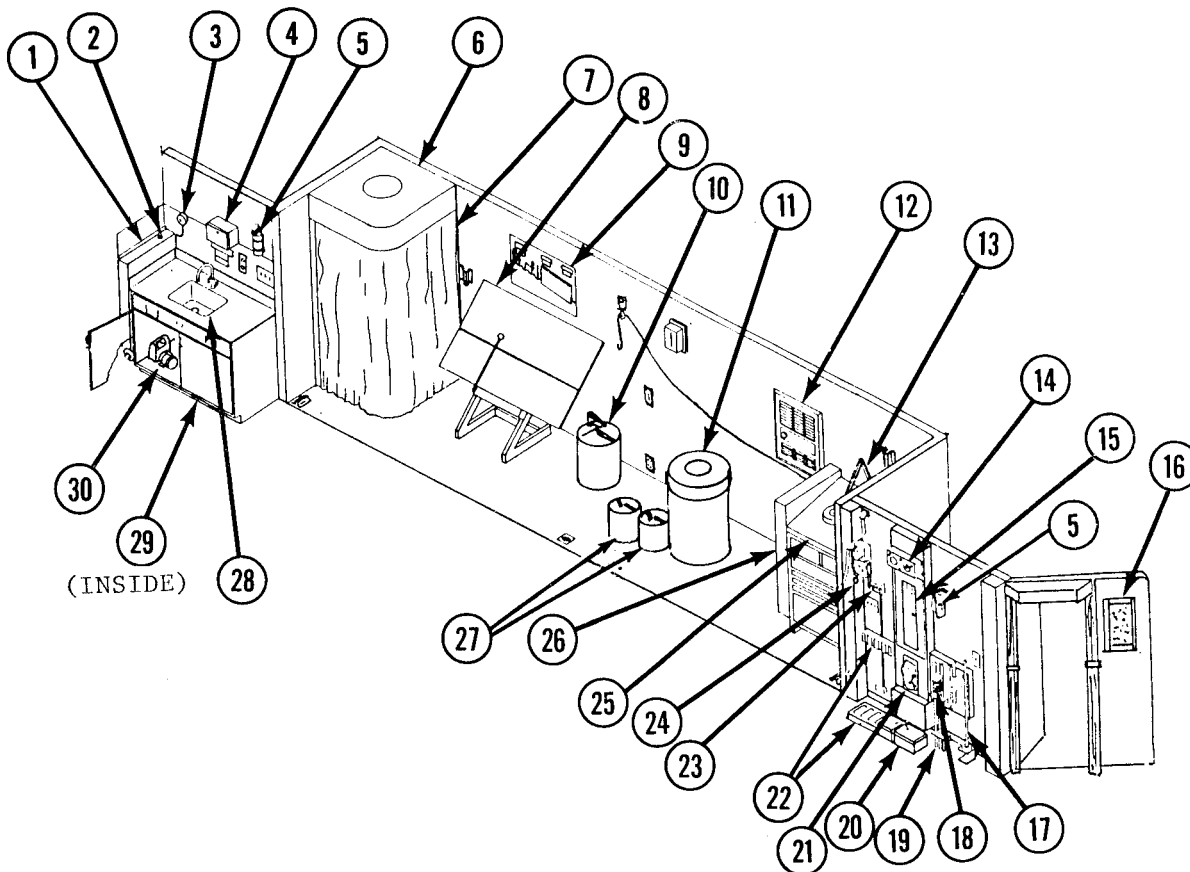

Water Tank (1). Holds 32-gallon water supply for operation of Press Section.

Water Level Indicator (2). Provides visual inspection of water supply level.

Water Tank Temperature Gage (3). Provides visual inspection of temperature of water in tank.

Paper Towel Dispenser (4). Holds paper towels.

Fire Extinguishers (5). Mounted near sink and load center. 2.75-pound capacity.

Curbside Personnel Door (6). Weatherproof door fitted with blackout switch.

Blackout Curtains (7). Provide lightproof covers for personnel door and cargo door.

Plate Register Punch (8). Punches register holes on plates.

1-6. LOCATION AND DESCRIPTION OF MAJOR COMPONENTS (CONT)

Tool Caddy (9). Holds tools for Printing Press operation.

Safety Waste Can (10). Provides safe disposal for flammable wastes such as oily rags.

Waste Basket (11). Provides disposal of paper wastes.

Wall Heaters (12). Provide heat to Section. Also located on roadside.

Magnifier Light (13). Used for close examination of printed materials.

Phase Monitor Meter (14). Gives voltage, Hertz, and phase readings.

Load Center (15). Consists of circuit breakers for Section components.

Bulletin Board (16). Cork board for work orders and bulletins.

Slide Hammer (17). Drives ground rods into ground.

Ground Cable (18). Connects ground rod to Section.

Ground Rods (19). Provide electrical ground for Section.

Tool Box (20). Stores common hand tools.

MAIN 60Hz. POWER Switch (21). Located below load center. Main power disconnect switch.

Weapons Rack (22). Stores weapons.

Telephone Line Receptacle (23). Internal binding post for phone connection.

Field Phone Mount (24). Mounting box for field phone.

GTO Storage Cabinet (25). Stores Printing Press materials and spare parts.

Plate Storage Box (26). Stores lithographic plates.

Safety Cans (27). Store chemical solvents.

Sink (28). Provides water source and washup area for personnel and equipment.

Main Pump (29). Pumps water from water tank to sink.

Portable Pump (30). Pumps water to fill water tank from external water supply.

1-6. LOCATION AND DESCRIPTION OF MAJOR COMPONENTS (CONT)

ROADSIDE INTERIOR

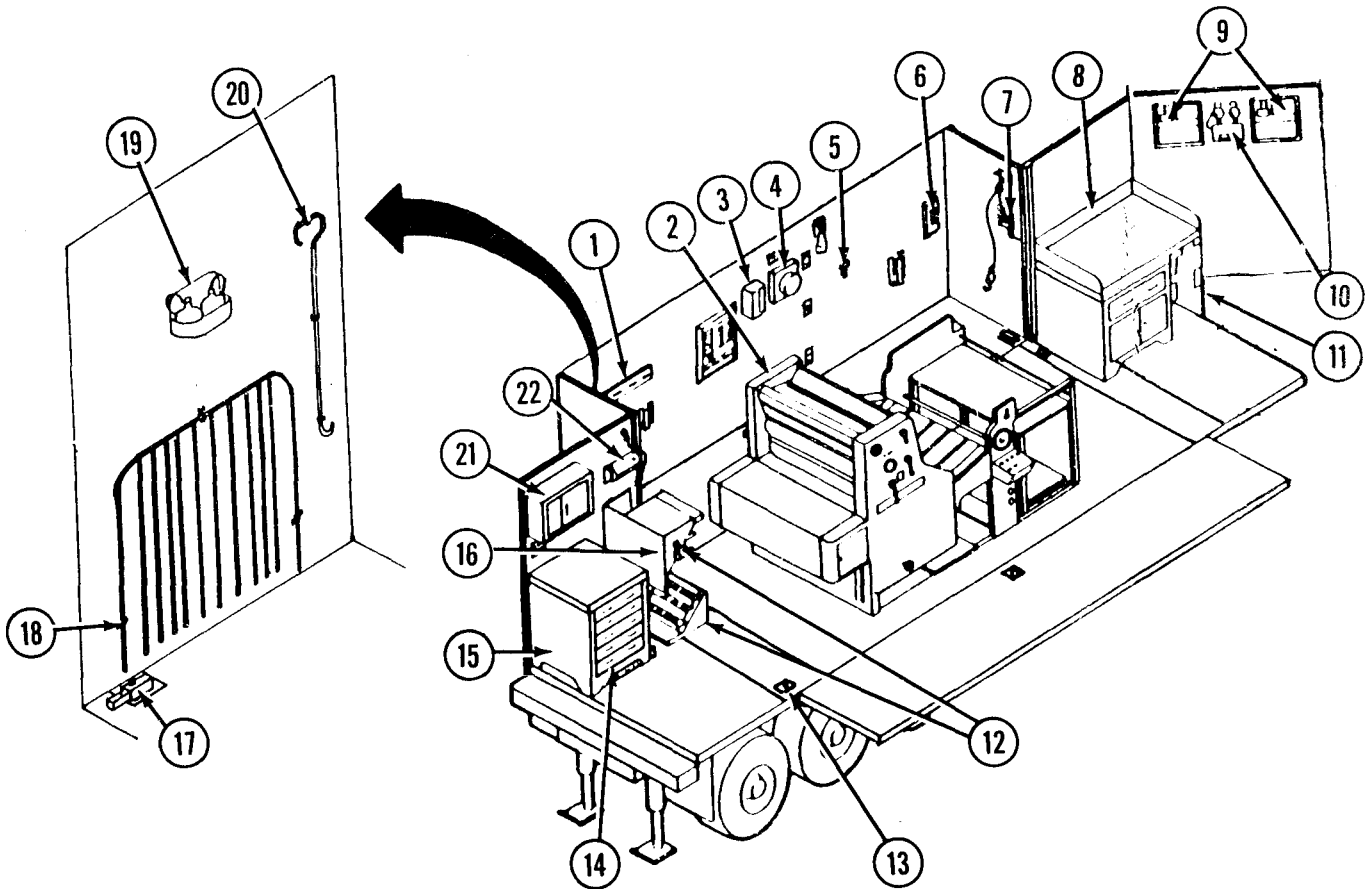

Coat Rack (1). Holds coats and protective gear.

Printing Press (2). Prints topographic products.

Side Lights (3). Provide light.

Exhaust Fan (4). Provides ventilation. Fitted with lightproof louver and waterproof cover.

Control Box Key Clip (5). Stores Printing Press control box key when not in use.

1-6. LOCATION AND DESCRIPTION OF MAJOR COMPONENTS (CONT)

Psychrometer (6). Measures temperature and humidity. Wet bulb thermometers.

Handwinch and Hoist Cable (7). Raises and lowers folding floor. Also located on curbside.

Jogging Table (8). Provides work surface for jogging paper and stores accessories.

Air Conditioner/Heaters (9). Provide internal environmental control.

Emergency Lights (10). Provide immediate emergency light when power is interrupted.

Pile Board Storage Rack (11). Stores two feeder pile boards and two delivery pile boards.

Roller Storage Rack (12). Stores rollers from Printing Press.

Removable Floor Sections (13). Are removed to retract sides of Press Section.

Spare Roller Storage Rack (14). Stores spare rollers.

Storage Cabinet (15). Stores materials and provides work space.

Pencil Sharpener (16). Sharpens pencils.

Floor Locks (17). Secure folding floors in operation and transport positions.

Continuous Delivery Rake Clips (18). Secure continuous delivery rake when not in use.

Safety Can Rack and Cans (19). Rack supports cans containing solutions and solvent for Printing Press operation.

Delivery Pile Board Hook Clips (20). Secure delivery pile board hook when not in use.

Wall Storage Cabinet (21). Stores ink.

First Aid Kit (22). Stores first aid supplies.

1-7. **EQUIPMENT DATA**

a. Section Weights and Dimensions

Gross Weight (Section on trailer chassis with Printing Press installed)	42,760 lbs (19,413.04 kg)
Tare Weight (Section only with Printing Press installed)	22,100 lbs (10,033.40 kg)
Length	30 ft (9.15 m)
Width (with sides closed)	8 ft (2.44 m)
Width (with sides open)	14 ft (4.33 m)
Height (off chassis)	8 ft 6 in. (2.59 m)
Height (on chassis)	13 ft 1 in. (3.98 m)
Length of Expanding Side	20 ft (6.10 m)
Inside Height of Expanding Side	6 ft 5-3/4 in. (1.98 m)
Inside Height of Main Body	7 ft 1 in. (2.16 m)
Center of Gravity From front	19 ft 1 in. (5.82 m)
From bottom	6 ft 7 in. (2.01 m)
To center	4 ft (1.22 m)

b. Power Data

Electrical System for Section Interior Equipment	12 Vdc; 120/208 V; 3 phase, 60 Hz
--------------------------------------------------------	-----------------------------------

1-7. EQUIPMENT DATA (CONT)

Electrical Motor System for Auxiliary Pump	12 Vdc/115 Vat; 60 Hz; single phase; 1/2 hp; 8000 rpm
Ground	Ground cable
Air Conditioner/Heater (two units)	
Cooling	18,000 Btu/hr each (5,274 w)
Heating (max)	14,300 Btu/hr each (4,190 w)
Power Requirements	208 Vat, 60 Hz, 3 phase
Exhaust Fan	289 cfm
Telephones	One telephone (three-post) connection

Section III. TECHNICAL PRINCIPLES OF OPERATION

1-8. GENERAL. The TSS Press Section is an expandable container in which the TSS Printing Press is operated and transported. For technical principles of operation of the TSS Printing Press, refer to TM 5-3610-286-10. The Press Section contains five major systems designed to support the Press. These systems are the expanding side system, the electrical system, the plumbing system, the ventilation system, and the blackout system.

1-8. GENERAL (CONT)

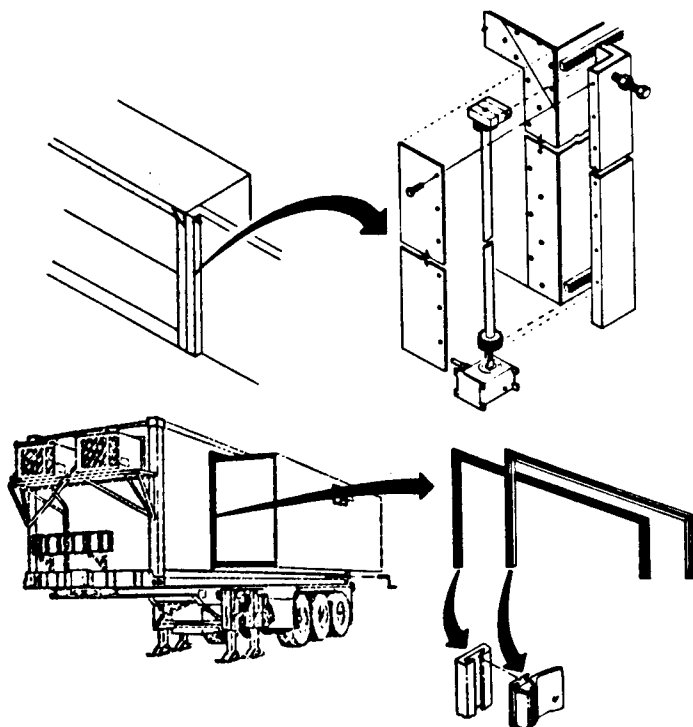

a. Expanding Side System. Each side wall of the Section contains an expanding portion to increase the work space inside the Section. Both sides of the Section must be expanded before the Section is operational.

Leveling jacks on the semitrailer chassis are used to level the Section before expanding the sides. Inclometers on each corner of the Section indicate when the Section is level. For operation of the semitrailer chassis, refer to TM 5-2330-305-14.

The operator expands and retracts the expanding sides by turning a handcrank which drives the expanding side drive mechanism. The drive mechanism consists of a vertical shaft, gear box, and horizontal shafts. The drive mechanism gears mesh with four rows of gear teeth mounted at the top and bottom of each expanding side.

The folding floor inside each expanding side folds up against the side wall when sides are retracted and folds down when sides are expanded. A handwinch assembly for each folding floor allows for raising and lowering of folding floors by attaching a cable to the lifting eye in the folding floor and turning the handcrank.

Inner and outer rubber seals between each expanding side and the main Section body prevent wind and water from entering the Section around the expanding sides.

1-8. GENERAL (CONT)

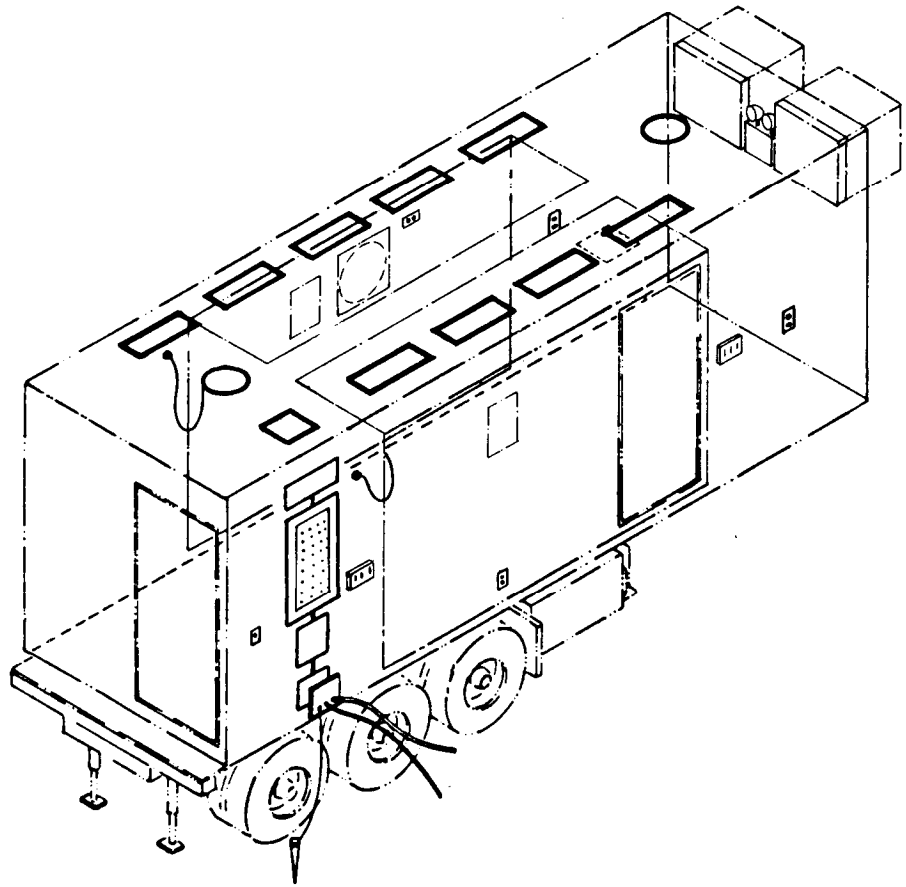

b. Electrical System. The Section electrical system provides ac and dc power for the Printing Press and support equipment within the Section.

The Section electrical system is controlled by the MAIN 60Hz. POWER switch which controls all power coming into the Section from an external power source. The phase monitor meter monitors electrical power phase and indicates voltage and frequency through the voltage and frequency meters. The load center consists of the circuit breaker control panel and electrical wiring and housing. The load center contains individual circuit breakers which allow the operator to switch power on and off to Section equipment. The main circuit breaker switches off all circuit breakers. The 100-foot power cable transfers 120/208 Vac to the Section from an external power source while the Section is stationary. A ground cable, connecting the Section to the ground rod, grounds the Section and its internal and external equipment.

1-8. GENERAL (CONT)

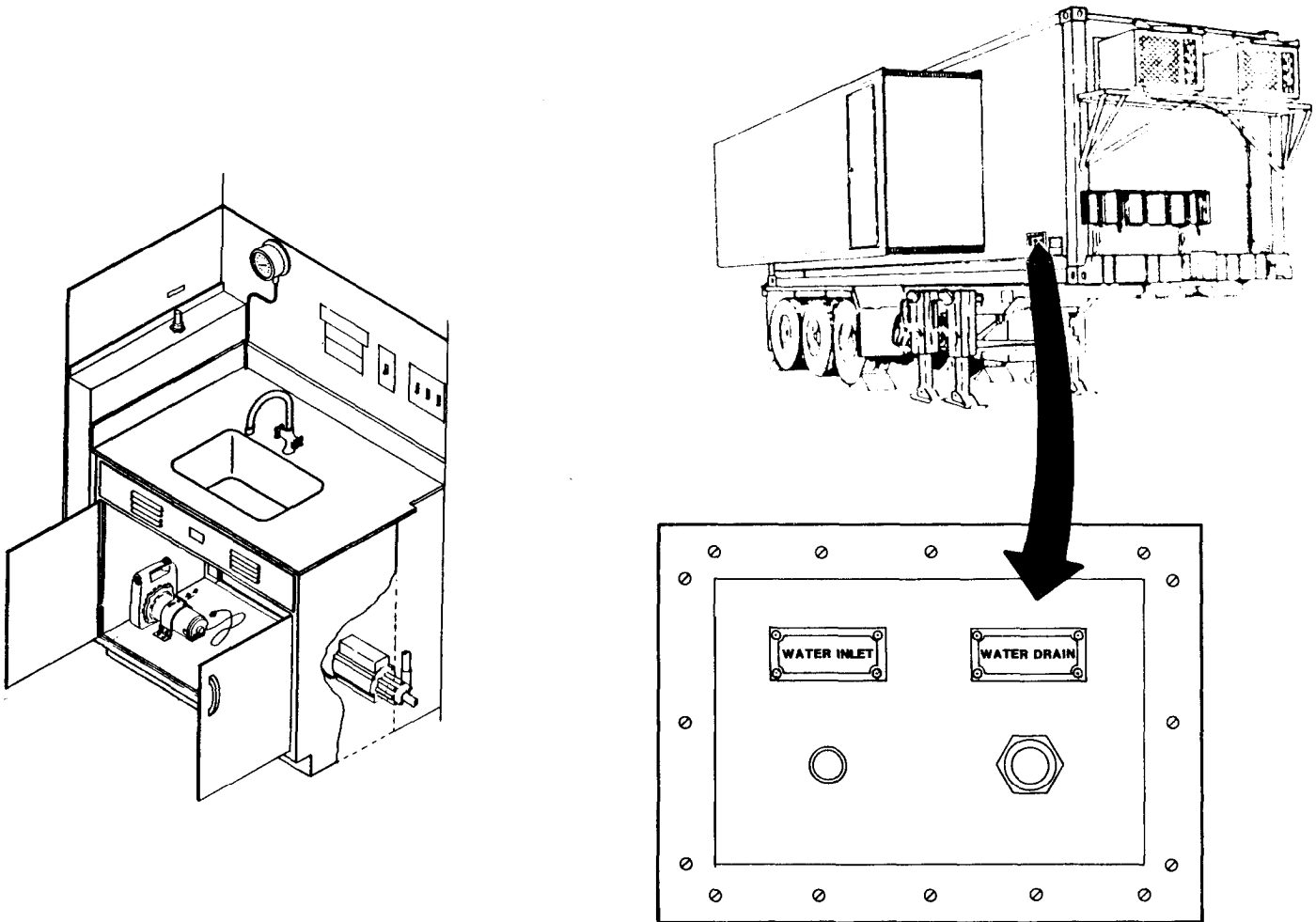

c. Plumbing System. The Section plumbing system consists of main and auxiliary water pumps, outlet and inlet hoses, sink and faucet assembly, water tank with immersion water heater, water level indicator, and temperature gage.

The main pump provides water to the faucet and sink for cleanup during and after Printing Press operation. The auxiliary pump draws water from an external source through hoses to fill the water tank. The water tank is equipped with a gage indicating water level and a thermometer indicating water temperature. Inlet and outlet hoses are attached to corresponding pipes on the outside of the Section for filling and draining the water tank.

1-8. GENERAL (CONT)

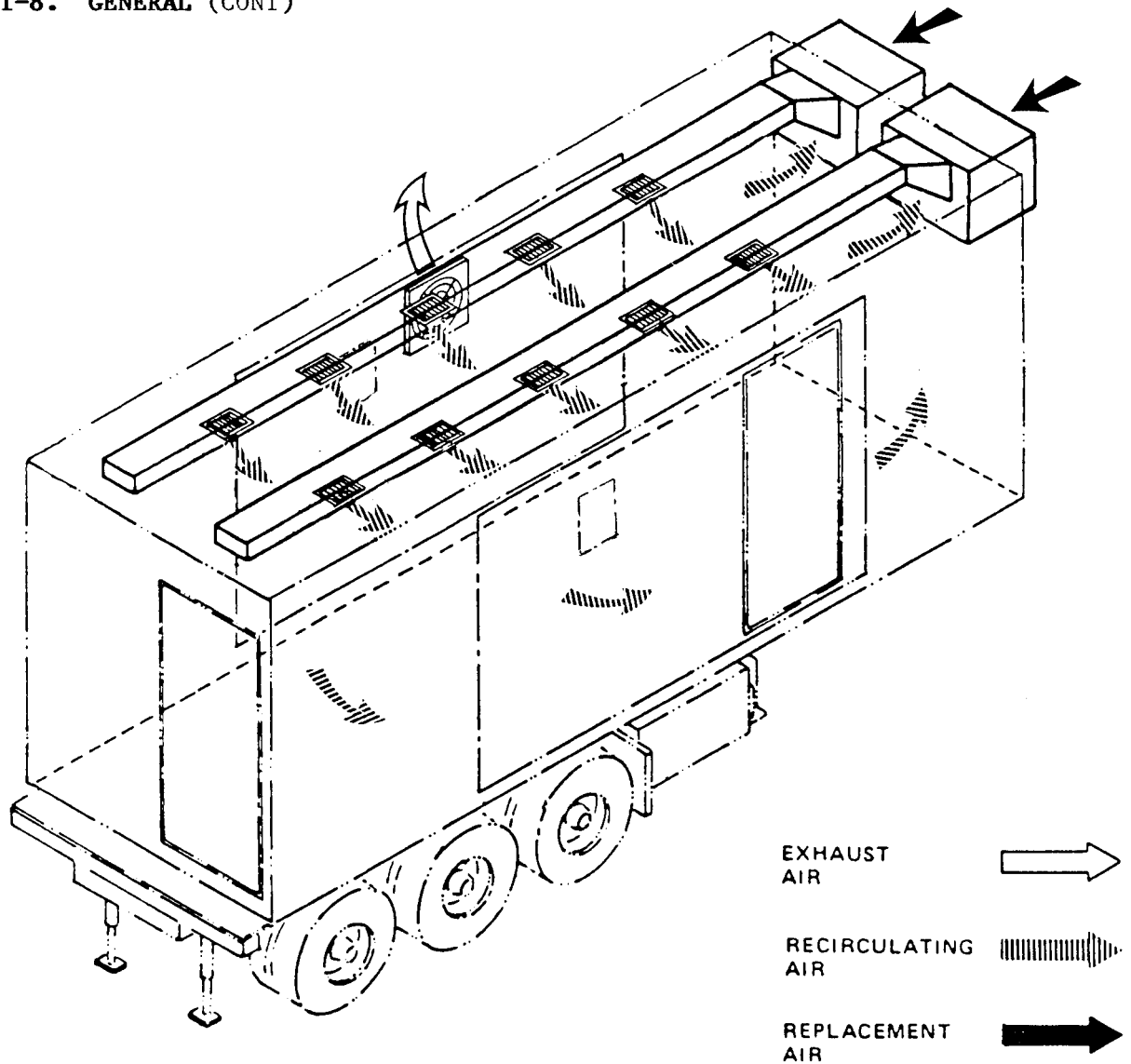

d. Ventilation System. The Section ventilation system maintains the proper environment for Printing Press operation and operator comfort and safety.

The air conditioner/heaters provide controlled humidity and temperature. For operation of air conditioner/heaters, refer to TM 5-4120-367-14. Wall heaters, located on each expanding side, provide additional heat. The exhaust fan, located on the roadside expanding side, provides ventilation and prevents buildup of undesirable fumes. The exhaust fan is operated manually by an on/off switch.

1-8. GENERAL (CONT)

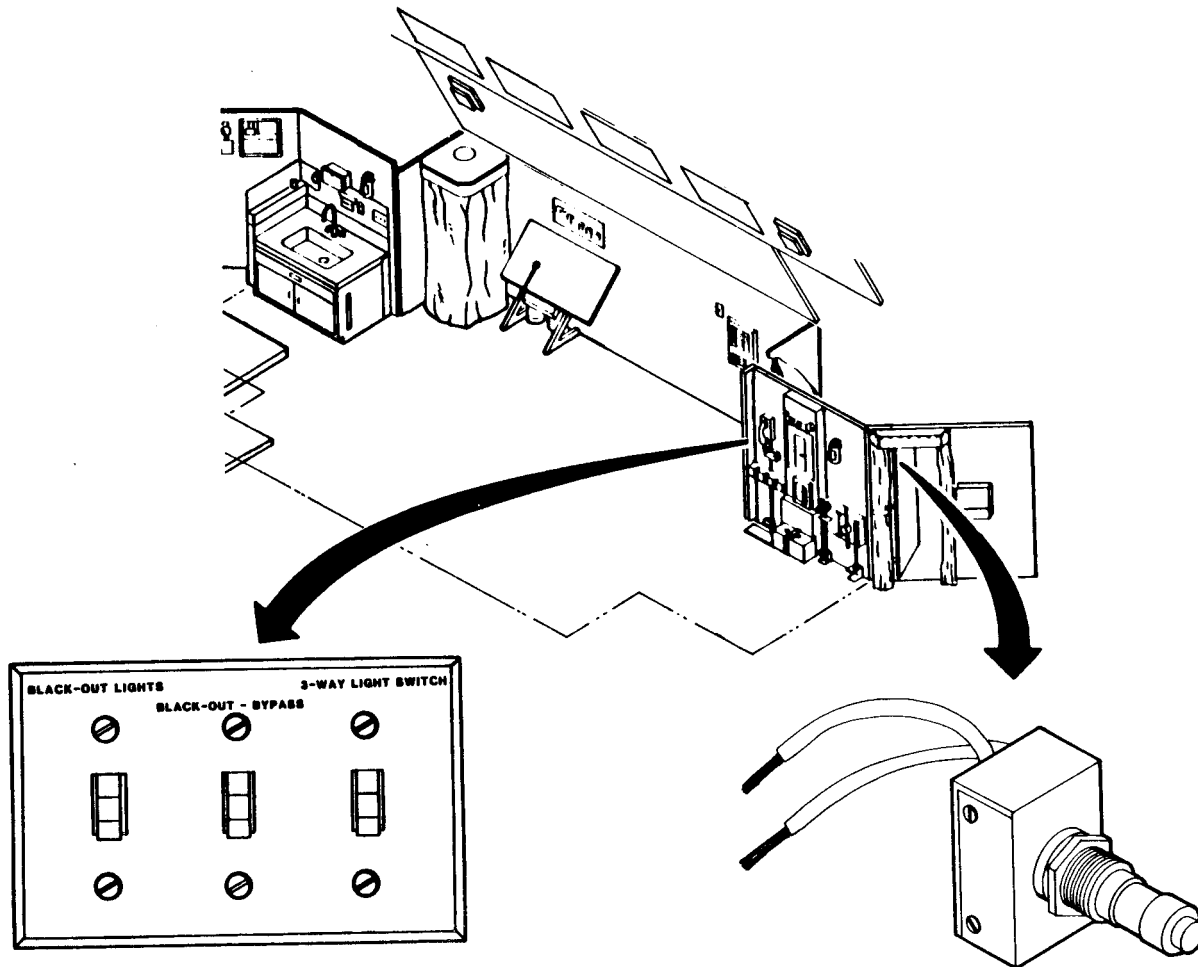

e. Blackout Light System. The blackout light system prevents light from escaping the Section through the cargo door, personnel doors, and exhaust fan door. It consists of two blackout lights on the Section ceiling. Blackout lights are automatically activated, and all overhead and side lights are switched off when either door is opened. The blackout light system can be bypassed by the blackout light bypass switch. An on/off switch is also provided for all power to the blackout light system.

Blackout curtains are located at the curbside and rear personnel doors. Each blackout curtain consists of a valance attached to the Section ceiling and two panels attached to the ceiling and sides.

CHAPTER 2

OPERATING INSTRUCTIONS

Section I. DESCRIPTION AND USE OF OPERATOR'S CONTROLS AND INDICATORS

2-1. OPERATOR'S CONTROLS AND INDICATORS

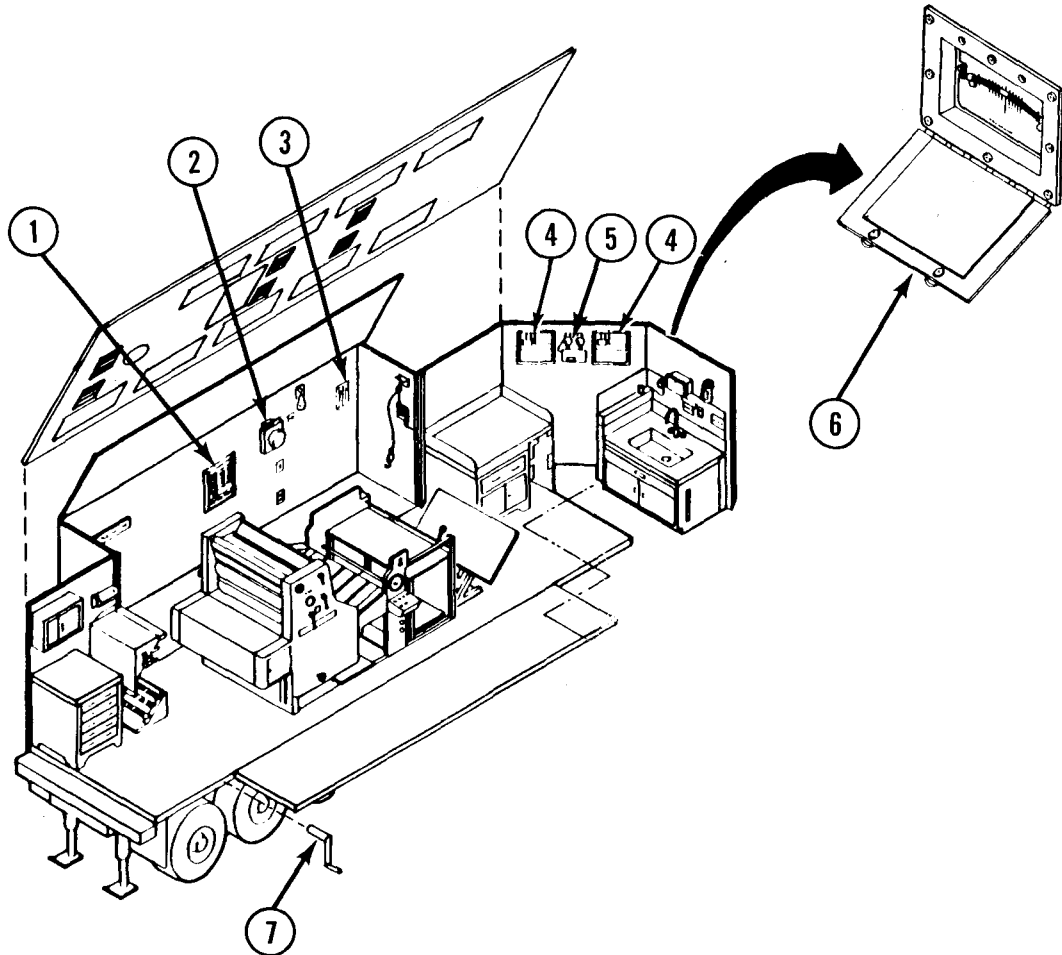

Key	Control or Indicator	Function
1	Wall Heater Control	Controls operation and temperature setting of wall heater.
2	Exhaust Fan Switch	Turns exhaust fan on or off.
3	Psychrometer	Indicates humidity in Section interior.

2-1. OPERATOR'S CONTROLS AND INDICATORS (CONT)

Key	Control or Indicator	Function
4	Air Conditioner/Heater Control Units	Select mode of operation and temperature.
5	Emergency Light Control Switches and Indicators	Switch emergency lights on and off, test battery charge, and indicate that ac power is on.
6	Inclinometers	Indicate if Section is level.
7	Expanding Side Handcrank	Used to expand or retract expanding sides.

2-1. OPERATORS CONTROLS AND INDICATORS (CONT)

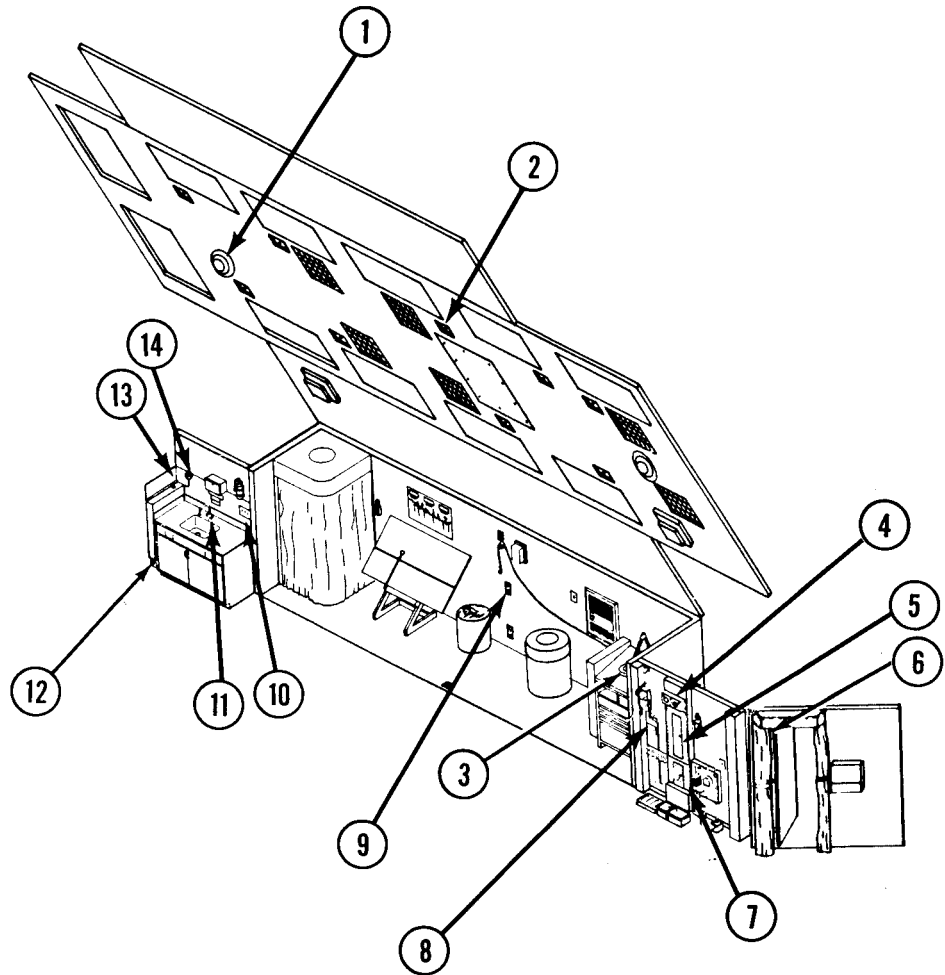

Key	Control or Indicator	Function
1	Dome Light Switches	Pushbutton switches operate dome lights when Section is connected to dc power supply.
2	Fluorescent Light Switches	Operate fluorescent lights in Section ceiling.
3	Magnifier Light Switch	Turns magnifier light on and off.
4	Phase Monitor Meter	Monitors electric power phase, voltage, and frequency.

2-1. OPERATOR'S CONTROLS AND INDICATORS (CONT)

Key	Control or Indicator	Function
5	Load Center	Contains circuit breakers for all Section components. Provides internal power control.
6	Blackout Switch	Shuts off overhead and side lights and activates blackout lights when curbside or rear personnel door is opened.
7	MAIN 60Hz. POWER Switch	Switches main power on and off to Section.
8	BLACKOUT LIGHT/BLACKOUT BYPASS/THREE-WAY LIGHT Switches	Bypasses blackout system, switches power on and off to blackout lights, and controls operation of overhead lights.
9	Side Light On/Off Switch	Controls side lights on both curbside and roadside expanding sides.
10	WATER HEATER/WATER PUMP/THREE-WAY LIGHT Switches	Control operation of water heater, water pump, and overhead lights.
11	Faucet Control	Controls water flow from water tank to sink.
12	Water Heater Control	Regulates temperature of water in tank.
13	Water Level Indicator	Measures water level in tank.
14	Water Tank Temperature Gage	Indicates temperature of water in tank.

Section II. PREVENTIVE MAINTENANCE CHECKS AND SERVICES (PMCS)

2-2. GENERAL . The Section must be inspected regularly to find and correct defects.

a. Before You Operate. Always keep in mind the CAUTIONS and WARNINGS. Perform your before (B) operation PMCS.

b. While You Operate. Always keep in mind the CAUTIONS and WARNINGS. Perform your during (D) operation PMCS.

c. After You Operate. Be sure to perform your after (A) operation PMCS.

d. If Your Equipment Fails to Operate. Troubleshoot with proper equipment. Report any deficiencies using the proper forms. Refer to DA PAM 738-750.

2-3. PMCS PROCEDURES

a. Your Preventive Maintenance Checks and Services table lists the inspections and care of your equipment required to keep it in good operating condition.

b. Use the "Item No." column of the PMCS table to supply the item number used in the "TM Number" column of DA Form 2404.

c. The interval column of your PMCS table tells you when to do a certain check or service.

d. Perform weekly as well as before operations PMCS if:

(1) You are the assigned operator and have not operated the item since the last weekly PMCS.

(2) You are operating the item for the first time.

e. The procedure column of your PMCS table tells you how to do the required checks and services. Carefully follow these instructions. If YOU do not have the tools, or if the procedure tells you to, have organizational maintenance do the work.

f. If your equipment does not perform as required, refer to chapter 3 under Troubleshooting for possible problems. Report any malfunctions or failures on DA Form 2404, or refer to DA PAM 738-750.

g. Refer to TM 5-4120-367-14 for PMCS that pertain to air conditioner/heaters.

h. Refer to TM 5-2330-305-14 for PMCS that pertain to semitrailer chassis.

2-4. EQUIPMENT IS NOT READY/AVAILABLE IF: PROCEDURES. This column tells you when and why your equipment cannot be used.

NOTE

The terms ready/available and mission capable refer to the same status: Equipment is on hand and is able to perform its combat missions. (See DA PAM 738-750.)

Table 2-1. Preventive Maintenance Checks and Services

NOTE

If the equipment must be kept in continuous operation, check and service only those items that can be checked and serviced without disturbing operation. Make complete checks and services when the equipment can be shut down.

B - Before Operation
w - Weekly

D - During Operation
M - Monthly

A - After Operation
Q - Quarterly

Item No.	Interval						Item To Be Inspected Procedure	Equipment Is Not Ready/ Available If:
	B	D	A	W	M	Q		
1	•						<u>Section Exterior</u> GROUND CONNECTIONS. Check that ground cable is connected to terminal lug and ground rod. If necessary, clean with wire brush (appendix D, item 7).	Ground connections are broken or missing.

Table 2-1. Preventive Maintenance Checks and Services (Cont)

B - Before Operation D - During Operation A - After Operation
 W - Weekly M - Monthly Q - Quarterly

Item No.	Interval						Item To Be Inspected Procedure	Equipment Is Not Ready/ Available If:
	B	D	A	W	M	Q		

Section Exterior (Cont)

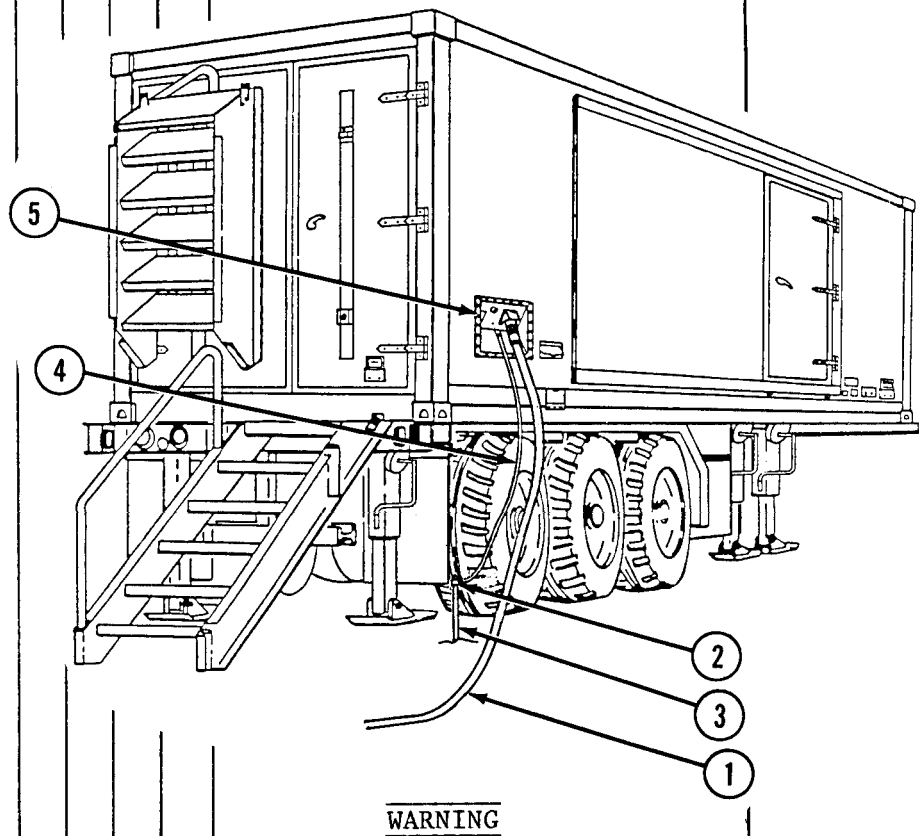

ELECTRICAL HAZARD. Power cable must be deenergized before servicing power entry panel connections. Death or serious injury may result from failure to follow steps in exact order shown here.

2

GROUND CABLE ASSEMBLY.

- a. Turn off power to power cable (1). Disconnect power cable from external power source. Disconnect ground cable lug (2) from ground rod (3). Clean ground lug,

Section is not grounded.

Table 2-1. Preventive Maintenance Checks and Services (Cont)

B - Before Operation D - During Operation A - After Operation
 W - Weekly M - Monthly Q - Quarterly

Item No.	Interval						Item To Be Inspected Procedure	Equipment Is Not Ready/ Available If:
	B	D	A	W	M	Q		
2 (Cont)							<p><u>Section Exterior</u> (Cont)</p> <p>ground cable end, and ground rod with wire brush (appendix D, item 7). Reconnect ground cable lug to ground rod.</p>	Section is not grounded.
						•	<p>b. Disconnect ground cable (4) from power entry panel (5). Clean terminal and ground cable end with wire brush (appendix D, item 7). Reconnect ground cable to power entry panel. Reconnect power cable to external power source. Turn on power.</p>	
3						•	<p>POWER ENTRY PANEL. Inspect for accumulated dirt or corrosion. Clean terminals as needed with spiral wire brush (appendix D, item 8).</p> <p style="text-align: center;"><u>WARNING</u></p>	Power entry panel or connectors are damaged.
4						•	<p>POWER CABLE. Turn off power to power cable (1). Disconnect power cable from external power source. Inspect power cable for kinks or cracks. Inspect connectors for dirt or damage. Wipe power cable insulation with clean, dry rag (appendix D, item 31) to</p>	<p>Power cable is cracked or cut.</p> <p>Connectors are damaged.</p>

SHOCK HAZARD. Do not handle or clean power cable assembly or connectors while power cable is connected to external power source. Death or serious injury may result.

Table 2-1. Preventive Maintenance Checks and Services (Cont)

B - Before Operation D - During Operation A - After Operation
 W - Weekly M - Monthly Q - Quarterly

Item No.	Interval						Item To Be Inspected Procedure	Equipment Is Not Ready/ Available If:
	B	D	A	W	M	Q		
4 (Cont)							<p><u>Section Exterior (Cont)</u></p> <p>remove dirt. Clean corrosion from terminals with spiral wire brush (appendix D, item 8).</p>	
								
5	•						<p>INCLINOMETERS. Inspect four inclinometers (1) for damage. Be sure Section is level. Bubble should be centered.</p>	Inclinometers are broken.
6	•						<p>SIDE FRAME ASSEMBLY (ROAD-SIDE). Inspect exhaust fan cover (2) for damage. Inspect handcrank opening cover (3) for damage. Check for metal filings.</p>	Exhaust fan cover will not open.

Table 2-1. Preventive Maintenance Checks and Services (Cont)

B - Before Operation D - During Operation A - After Operation
 W - Weekly M - Monthly Q - Quarterly

Item No.	Interval						Item To Be Inspected Procedure	Equipment Is Not Ready/ Available If:
	B	D	A	W	M	Q		
<u>Section Exterior (Cont)</u>								
								
7	•						<p>EXPANDING SIDE ASSEMBLIES. Check that four corners of expanding side (1) are an equal distance from the main Section body (2).</p>	<p>Expanding side does not seal. Expanding side does not expand evenly.</p>
8				•			<p>SECTION BODY. Inspect for punctures, cracks, or open seams that could permit moisture to enter wall.</p>	<p>Punctures, cracks, or open seams are present.</p>

Table 2-1. Preventive Maintenance Checks and Services (Cont)

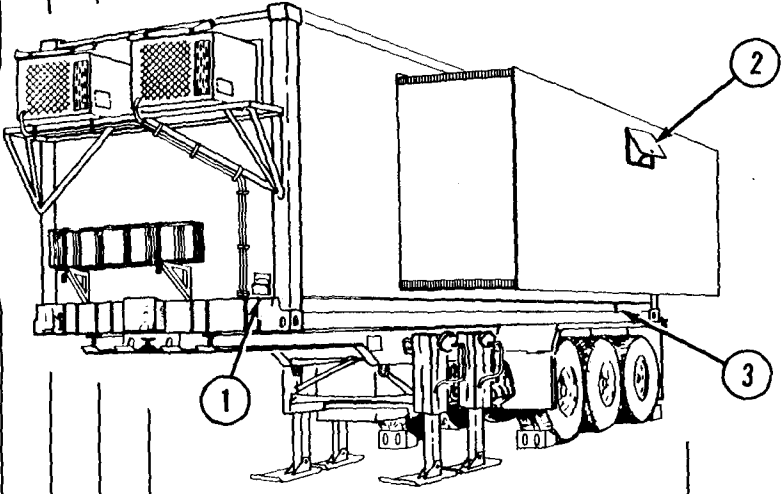
B - Before Operation D - During Operation A - After Operation
 w - Weekly M - Monthly Q - Quarterly

Item NO.	Interval						Item To Be Inspected Procedure	Equipment Is Not Ready/ Available If:
	B	D	A	W	M	Q		

Section Exterior (Cont)

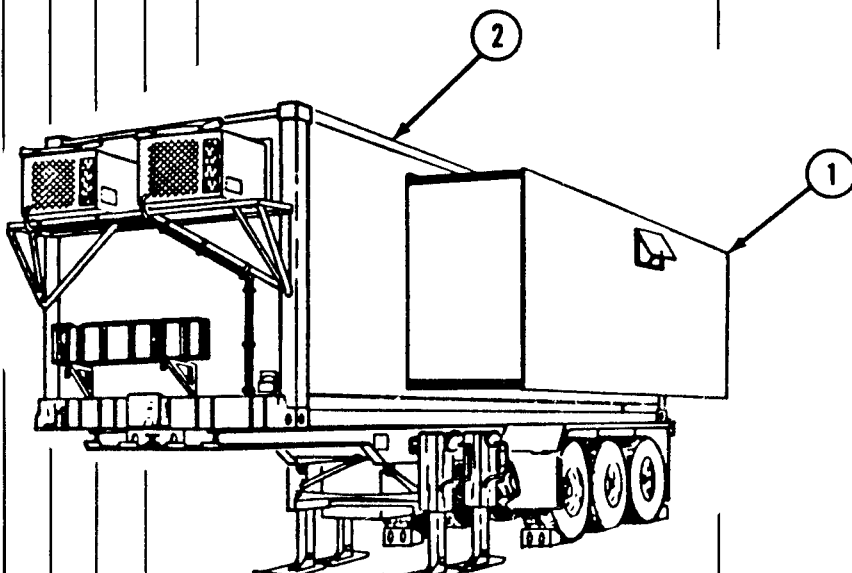
CAUTION

Before operation, be sure that air conditioner/heater covers are removed. After operation, be sure that air conditioner/heater covers are replaced. Failure to do so may damage equipment.

9	•			•		•	<p>AIR CONDITIONER/HEATERS.</p> <p>a. Check that air conditioner/heater covers are off before operation.</p> <p>b. Check drain tubes for proper drainage.</p> <p>c. Inspect covers for damage.</p>	
10		•				•	<p>BOARDING LADDERS AND MOUNTING BRACKETS .</p> <p>a. Inspect both boarding ladders for secure attachment of handrails, steps, and pins.</p> <p>b. Inspect mounting brackets for secure mounting on Section.</p> <p>c. Lubricate pins in accordance with LO 5-3610-287-12.</p>	Steps are broken or will not lock in place.

Table 2-1. Preventive Maintenance Checks and Services (Cont)

B - Before Operation D - During Operation A - After Operation
 W - Weekly M - Monthly Q - Quarterly

Item No.	Interval						Item To Be Inspected Procedure	Equipment Is Not Ready/ Available If:
	B	D	A	W	M	Q		
11					•		<p><u>Section Exterior (Cont)</u></p> <p>FOLDING LADDER AND SUPPORT BRACKETS .</p> <p>a. Inspect folding ladder for damage.</p> <p>b. Inspect support brackets and straps for secure mounting on Section.</p>	
12		•					<p>REMOVABLE FLOOR SECTION MOUNTING BRACKETS. Inspect brackets for damage and loose parts. Check that brackets are securely mounted to folding floor and that latches work properly. Lubricate hinges in accordance with LO 5-3610-287-12.</p>	
13		•					<p>WIPER SEAL. Inspect wiper seal for cracking. Check that wiper seal is securely mounted in track.</p>	
14		•					<p>WATER BOX. Inspect attachment points for breaks, rust, or corrosion. Check that dust caps are present.</p>	
15						•	<p><u>Section Interior</u></p> <p>VENTILATION DUCTS. Inspect deflectors and ventilation ducts on Section ceiling for dust. Service ventilation ducts if necessary (para 3-9).</p>	

Table 2-1. Preventive Maintenance Checks and Services (Cont)

B - Before Operation
w - Weekly

D - During Operation
M - Monthly

A - After Operation
Q - Quarterly

Item NO.	Interval						Item To Be Inspected Procedure	Equipment Is Not Ready/ Available If:
	B	D	A	W	M	Q		
							<u>Section Interior (Cont)</u>	
16		•					EXPANDING SIDE POWER CABLES. Inspect power cables for damage and fraying. Check terminals for corrosion and secure mounting in receptacles.	Expanding side power cables are damaged.
17	•						PHASE MONITOR METER. Inspect voltage and frequency meters for proper functioning. Check that LED lights and that fuse is not burned out.	Phase monitor meter malfunctions.
18		•					TELEPHONE INSTALLATION. Inspect binding posts for proper wire connections. Check that telephone is securely mounted on Section wall.	
19	•	•	•				HANDWINCH ASSEMBLIES. Inspect handwinches and pulleys for proper lubrication and security of mounting. Refer to LO 5-3610-287-12 for lubrication instructions. Inspect hoist cables and hooks for frays or cracks.	Hoist cables are frayed. Hooks are missing or cracked.
20						•	LOAD CENTER. Inspect circuit breakers. Turn each circuit breaker on, off, and back on. Inspect load center for damage, insecure mounting, or missing screws.	Circuit breaker is defective. Load center is damaged or defective.

Table 2-1. Preventive Maintenance Checks and Services (Cont)

B - Before Operation D - During Operation A - After Operation
 W - Weekly M - Monthly Q - Quarterly

Item No.	Interval						Item To Be Inspected Procedure	Equipment Is Not Ready/ Available If:
	B	D	A	W	M	Q		
							<u>Section Interior (Cont)</u>	
								
21		•					<p>REMOVABLE FLOOR SECTIONS (1). Inspect for fit and structural damage.</p>	Removable floor sections are damaged.
22		•					<p>FOLDING FLOOR ASSEMBLIES AND LOCKS .</p> <p>a. Inspect assembly and area of folding floor (2) for obstructions, or loose or missing parts. Pay close attention to lifting hook (3).</p>	<p>Folding floors do not fit.</p> <p>Folding floor parts are missing or loose.</p>

Table 2-1. Preventive Maintenance Checks and Services (Cont)

B - Before Operation D - During Operation A - After Operation
 W - Weekly M - Monthly Q - Quarterly

Item No.	Interval						Item To Be Inspected Procedure	Equipment Is Not Ready/ Available If:
	B	D	A	W	M	Q		
							<u>Section Interior</u> (Cont)	

WARNING

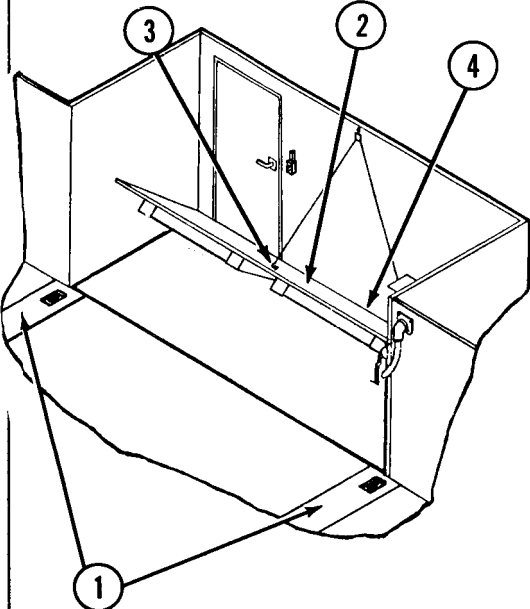
Stay clear of folding floors while they are being raised or lowered. Weight of floors may cause death or serious personal injury.

22 (Cont)		•					b. Check hinges (4) for freedom of movement. Lubricate in accordance with LO 5-3610-287-12. c. Inspect all floor locks to ensure they are fully engaged or operational.	Folding floor hinges are not operative. Folding floor locks are broken.
23		•					TOOL CADDY. a. Inspect tool caddy for secure mounting and damage. b. Check that all tools are present.	
24			•				FIRST AID KIT. Check that first aid kit is securely mounted and is fully stocked.	First aid kit is missing or not fully stocked.
25				•			FIRE EXTINGUISHERS. Check that gages indicate fire extinguishers are fully charged. Replace if necessary.	Fire extinguishers are missing or not charged.

Table 2-1. Preventive Maintenance Checks and Services (Cont)

B - Before Operation D - During Operation A - After Operation
 W - Weekly M - Monthly Q - Quarterly

Item No.	Interval						Item To Be Inspected Procedure	Equipment Is Not Ready/ Available If:
	B	D	A	W	M	Q		
26					•		<p><u>Section Interior</u> (Cont)</p> <p>WALL HEATERS (EXPANDING SIDES). Check for proper temperature selection and cut off. Inspect for dust around surfaces. Service if necessary (para 3-10).</p>	Wall heater does not work.
27				•			<p>BLACKOUT CURTAINS. Inspect blackout curtains and valances for tears, missing hooks, or broken eyelets. Inspect nylon hook tape on blackout curtain and wall for security of attachment. Repair blackout curtain clips (para 3-14).</p>	Light leaks through blackout curtain.
28		•					<p>BLACKOUT LIGHTS AND SYSTEM. Inspect lens cover for cracks. Check that bulbs are working. Turn BLACKOUT LIGHT switch ON and BLACKOUT LIGHT override switch OFF. Open personnel door and make sure interior lights go off. Replace bulbs if necessary (para 3-6).</p>	Blackout lights and system do not work.

NOTE

Dome light can only be inspected when Section is connected to 12 Volt dc power source. Interval of inspection should be based on usage.

29						•	<p>DOME LIGHT. Inspect lens cover for cracks. Check that bulb is working. Replace bulbs if necessary (para 3-7).</p>	
----	--	--	--	--	--	---	-----------------------------------------------------------------------------------------------------------------------------	--

Table 2-1. Preventive Maintenance Checks and Services (Cont)

B - Before Operation D - During Operation A - After Operation
 W - Weekly M - Monthly Q - Quarterly

Item No.	Interval						Item To Be Inspected Procedure	Equipment Is Not Ready/ Available If:
	B	D	A	W	M	Q		
30		•					<u>Section Interior (Cont)</u> ON/OFF SWITCHES. Check that all on/off switches are operating properly.	On/off switches do not work.
31		•					WALL OUTLETS. Check that all wall outlets are operating properly.	Wall outlets do not work.

CAUTION

Be sure emergency light on/off switch is set to the correct position before and after operation. Failure to set switch will cause battery to lose charge.

32		•					EMERGENCY LIGHT. a. Test batteries on emergency light by pushing test button. Check that lamps operate. Check that AC POWER ON INDICATOR lights when ac power is on. Check that on/off switch is ON. b. Test batteries on emergency light by pushing test button. Check that lamps operate. Check that AC POWER ON INDICATOR lights when ac power is on. Check that on/off switch is OFF.	Emergency light does not light. Emergency light does not light.
----	--	---	--	--	--	--	------------------------------------------------------------------------------------------------------------------------------------------------------------------------------------------------------------------------------------------------------------------------------------------------------------------------------------------------------------------------------------------------------------	------------------------------------------------------------------------

Table 2-1. Preventive Maintenance Checks and Services (Cont)

B - Before Operation D - During Operation A - After Operation
 W - Weekly M - Monthly Q - Quarterly

Item No.	Interval						Item To Be Inspected Procedure	Equipment Is Not Ready/ Available If:
	B	D	A	W	M	Q		
33		•					<p><u>Section Interior</u> (Cont)</p> <p>FLUORESCENT LIGHTS. Inspect diffusers for cracks. Check that fluorescent lights are working. Replace bulbs if necessary (para 3-5).</p>	Fluorescent lights do not work.
34		•			•		<p>MAIN PUMP. To inspect, remove four screws (1) from access panel (2), located in rear of sink (3). Check wiring harness (4) for fraying and signs of arcing. Check water system (5) for leaks. Check main pump (6)</p>	

Table 2-1. Preventive Maintenance Checks and Services-(Cont)

B-Before Operation
W-Weekly

D-During Operation
M-Monthly

A-After Operation
Q-Quarterly

Item No.	Interval						Item to Be Inspected Procedure	Equipment Is Not Ready/ Available If:
	B	D	A	W	M	Q		
34 (Cont)							Section interior (Cont) for color change due to overheating. Check for excessive pump noise.	
35		•					FAUCET ASSEMBLY. Inspect faucet assembly for leaks and secure mounting.	
36		•			•		WATER PIPING. Check water piping for cracks, leaks, and clogging. Check that all hose connections are secure.	
37		•			•		WATER TANK ASSEMBLY. Check water tank for leaks and damage. Inspect water level indicator for damage.	
38					•		PERSONNEL DOORS AND HINGES. Inspect seals for tears or missing pieces. Inspect door, latch, and hinges for corrosion or rust. Inspect lock for damaged or sticking parts. Lubricate seals in accordance with LO 5-3610-287-12.	Personnel doors are damaged.
38.1				•			Inspect hinges for proper placement of hinge pins.	Missing hinge pins
39					•		EXHAUST FAN. a. Inspect exhaust fan for damage. Clean as necessary (para 3-11). b. Open exhaust fan cover and inspect dust filter and louvers for damage. Clean as necessary (para 3-11).	Exhaust fan is damaged.

Table 2-1. Preventive Maintenance Checks and Services-(Cont)

B-Before Operation
W-Weekly

D-During Operation
M-Monthly

A-After Operation
Q-Quarterly

Item No.	Interval						Item to Be Inspected Procedure	Equipment Is Not Ready/ Available If:
	B	D	A	W	M	Q		
40					•		<p>Section Interior (Cont) CARGO DOOR AND HINGES. Inspect seals for tears or missing pieces. Inspect door, latch, and hinges for corrosion and rust. Inspect lock for damaged or sticking parts. Lubricate seals in accordance with LO 5-3610-287-12.</p>	
40.1				•			<p>Inspect hinges for proper placement of hinge pins.</p>	Missing hinge pins
41		•					<p>ROLLER STORAGE RACKS. Check that roller storage racks and spare roller rack are securely mounted to Section. Check that rollers are locked securely in each rack. Inspect racks for damage and corrosion.</p>	
42		•					<p>SINK CABINET. Check that sink cabinet is securely mounted. Inspect latches and doors for proper operation. Check work surface for damage.</p>	
43		•					<p>STORAGE CABINETS. Check that all storage cabinets are securely mounted. Inspect latches and drawers for proper operation. Check all work surfaces for damage.</p>	
44		•					<p>JOGGING TABLE. Inspect for damage to work surface. Check that metal sides are secured to Section wall.</p>	

Table 2-1. Preventive Maintenance Checks and Services (Cont)

B - Before Operation D - During Operation A - After Operation
 W - Weekly M - Monthly Q - Quarterly

Item No.	Interval						Item To Be Inspected Procedure	Equipment Is Not Ready/ Available If:
	B	D	A	W	M	Q		
45		•					<p><u>Section Interior</u> (Cont)</p> <p>GTO STORAGE CABINET. Inspect roller assembly and knobs. Inspect drawers and latch assembly for damaged or sticking parts. Lubricate in accordance with LO 5-3610-287-12.</p>	
46		•					<p>MIRROR AND SAFETY CHAIN. Inspect mirror for secure mounting on ceiling. Clean mirror as necessary. Check that safety chain is mounted securely to ceiling.</p>	Safety chain is loose.
47		•					<p>STRAP AND BUCKLE ASSEMBLIES. Inspect straps and buckles for wear and secure mounting.</p>	

Section III. OPERATION UNDER USUAL CONDITIONS

2-5. The TSS Press Section is operational when the Section is on site with the tractor disconnected and expanding sides expanded. Refer to TM 5-2330-305-14 for detailed instruction of semitrailer chassis disconnection from tractor.

2-6. ASSEMBLY AND PREPARATION FOR USE

a. Level and Stabilize Section

CAUTION

Semitrailer-mounted Section must be on approximately level surface to avoid unnecessary stress or twisting of semitrailer chassis when Section is leveled.

NOTE

- Snow or ice should be removed from under leveling footplate before attempting to level Section.
- Sand, soft ground, or mud requires that shoring or scrap material be placed under leveling footplate to increase surface area and prevent footplates from sinking into surface.

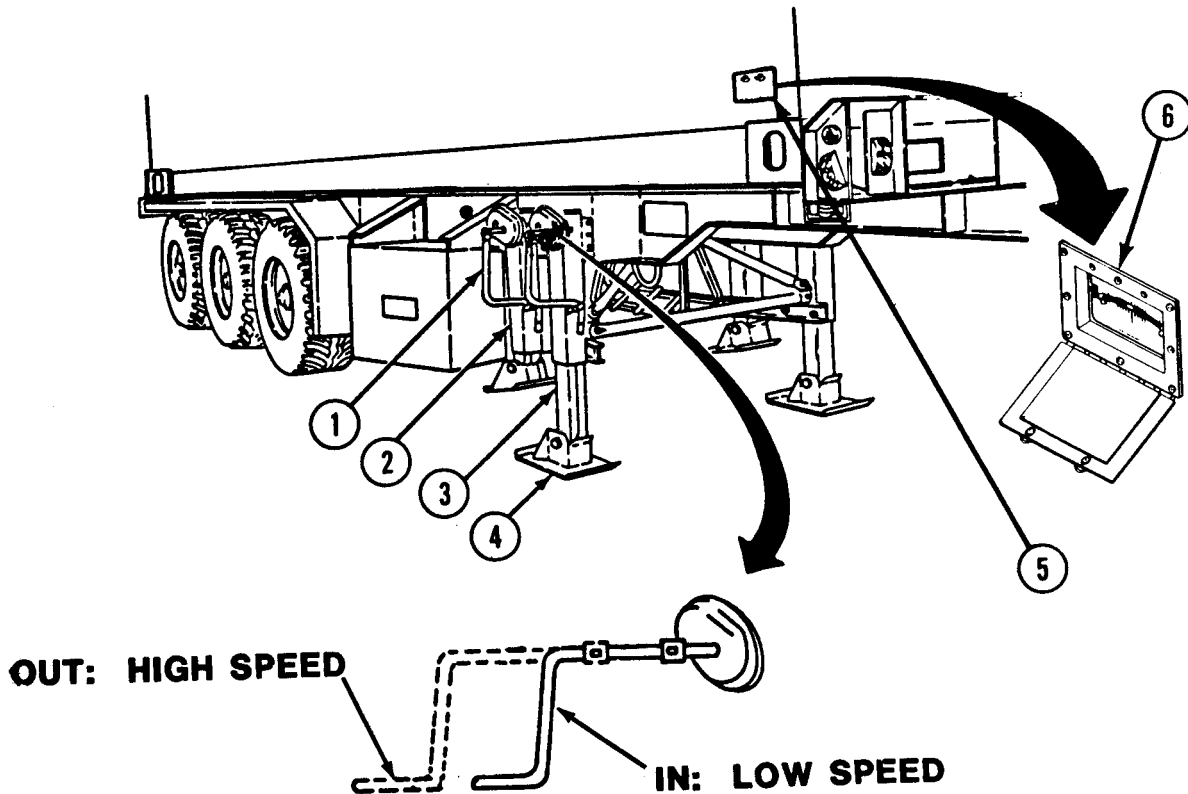

2-6. ASSEMBLY AND PREPARATION FOR USE (CONT)**NOTE**

Crank handles have two positions when engaged. High speed adjustment is made when crank handle is pulled fully out. Low speed adjustment is made when crank handle is pushed in.

1. Pull crank handles (1) out on leveling jacks (2) and landing jacks (3), and engage.
2. Clear area on ground where leveling footplate (4) will rest.
3. Lower landing jacks (3) until pressure is relieved from fifth wheel.
4. Set chocks and disconnect tractor. Deflate air suspension bags to 3 psi as indicated in TM 5-2330-305-14.
5. Lower leveling jacks (2) until pressure is relieved from landing jacks (3).
6. Open inclinometer covers (5).
7. Station personnel at locations allowing a clear view of all four inclinometers (6).
8. Observe inclinometers (6) to determine if end or side needs raising. Be sure bubble is centered on all four inclinometers.

CAUTION

Do not attempt to level Section by lifting at diagonal corners. Frame could be twisted.

9. Raise low end by extending both leveling jacks (2) at low end. Use low speed.
10. Raise low side by extending both leveling jacks (2).
11. Be sure bubble is centered on all four inclinometers (6). Close inclinometer covers (5).
12. Pull crank handles (1) away from semitrailer chassis and lower crank handle to disengaged position.

2-6. ASSEMBLY AND PREPARATION FOR USE (CONT)

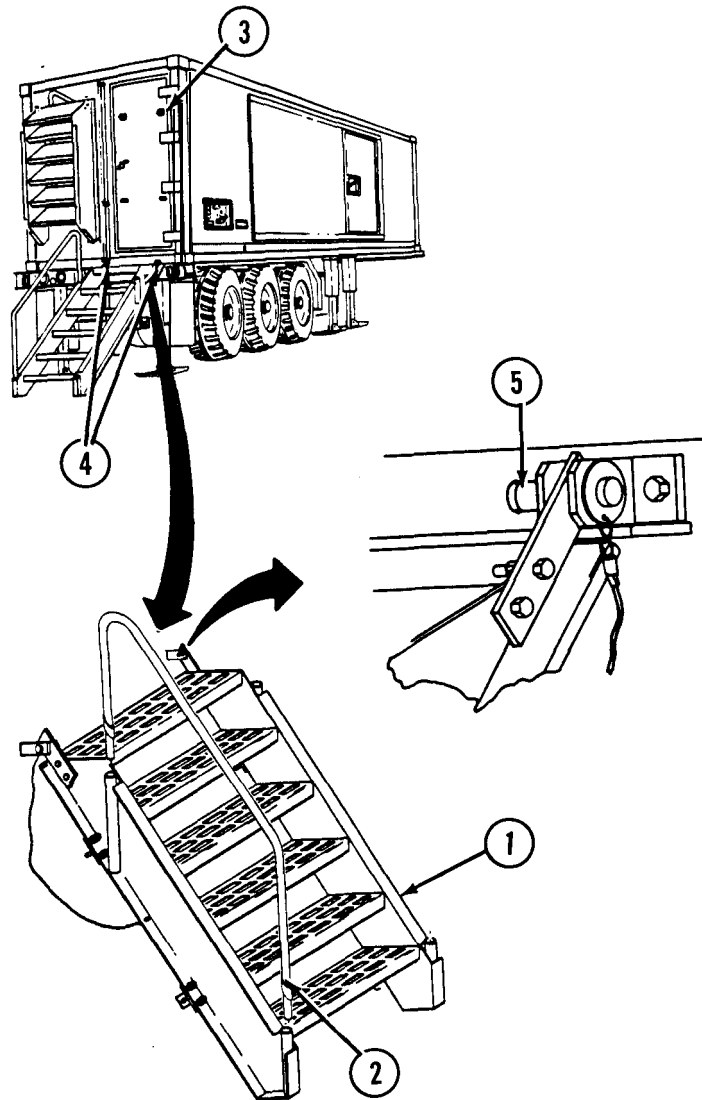

13. Remove boarding ladder (1) and handrail (2) from rear personnel door (3).
14. Remove handrail (2) from boarding ladder (1).
15. Mount boarding ladder (1) at rear attachment points (4) below rear personnel door (3) and secure with locking pins (5).
16. Mount handrail (2) on roadside of boarding ladder (1).
17. Remove covers from air conditioner/heaters.

2-6. ASSEMBLY AND PREPARATION FOR USE (CONT)

b. Ground and Provide Power to Section

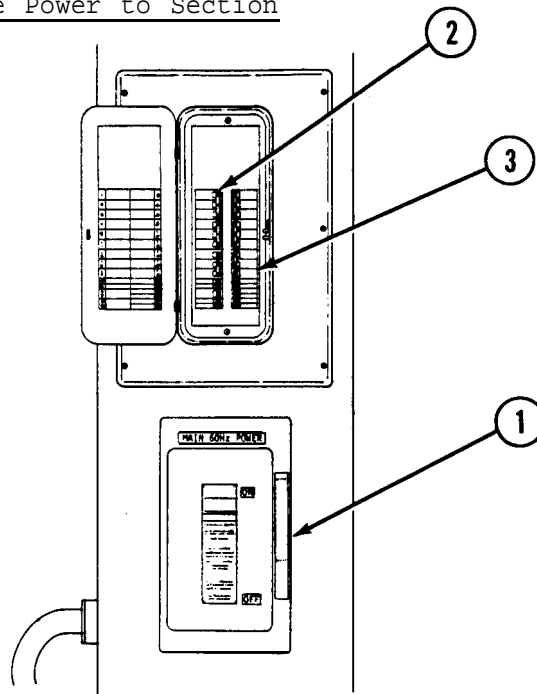

1. Enter Section and be sure MAIN 60Hz. POWER switch (1), main circuit breaker (2), and all equipment power supply circuit breakers (3) are off.

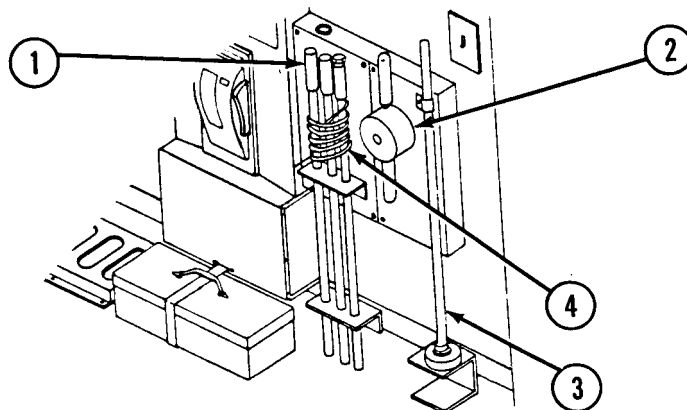

WARNING

ELECTRICAL HAZARD. Do not connect power cable to Section before grounding. Death or serious injury may result.

2. Loosen strap, unlock tool box, and remove adjustable wrench.

3. Remove ground rod (1), slide hammer (2), slide hammer rod (3), and ground cable (4) from Section.

2-6. ASSEMBLY AND PREPARATION FOR USE (CONT)

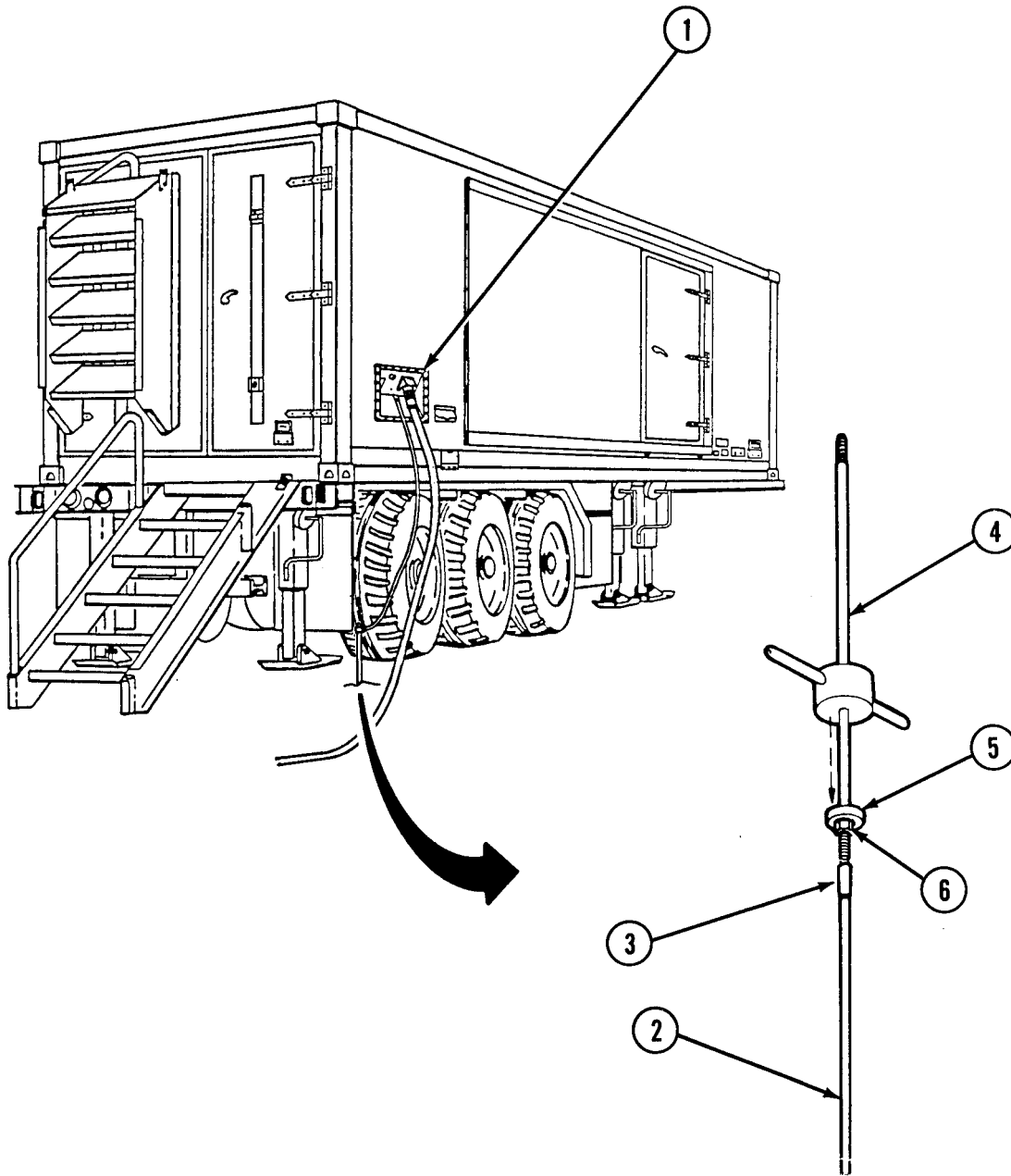

NOTE

Bottom ground rod must be numbered or identified so that it will always be the first ground rod driven.

4. Select an area as close as possible to power entry panel (1) for ground rod installation. Attach the first ground rod (2) and coupling (3) to the slide hammer rod (4). Make sure that rods meet inside coupling. Hand tighten collar (5) snugly against locknut (6).

2-6. ASSEMBLY AND PREPARATION FOR USE (CONT)

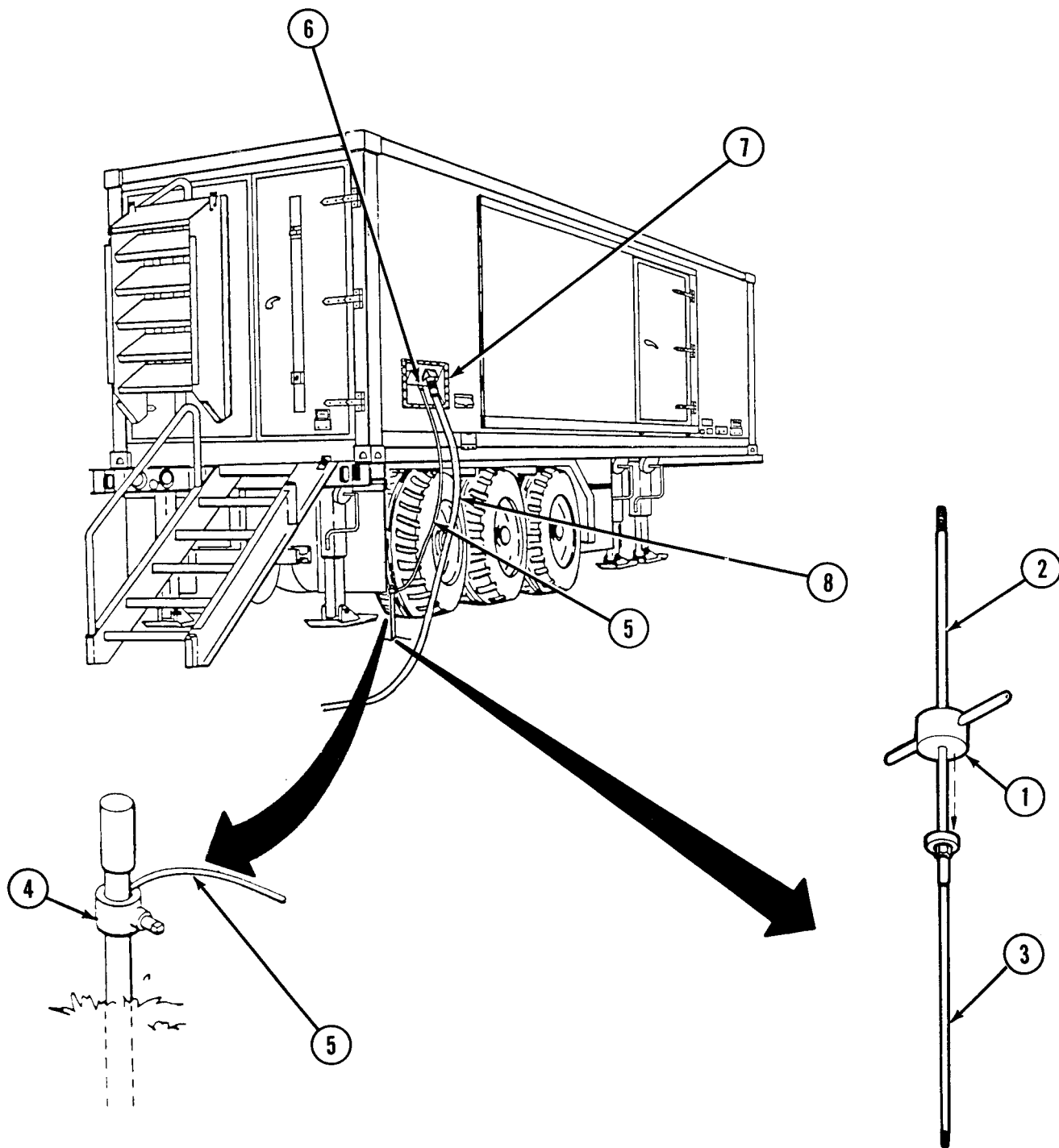

2-6. ASSEMBLY AND PREPARATION FOR USE (CONT)

WARNING

- ELECTRICAL HAZARD. Do not allow ground rod to rotate when removing slide hammer. Section could become ungrounded, resulting in death or serious injury.
- ELECTRICAL HAZARD. Section must be grounded properly before power is connected. If it is not possible to drive three sections of ground rod fully into ground, ground rods may each be driven into ground separately and connected in series. If it is impossible to drive a ground rod, a suitable alternative, such as a buried metal water pipe, must be found. Failure to ground Section may result in death or serious injury.

5. Place slide hammer (1) on slide hammer rod end (2), and drive ground rod (3) into ground. Remove slide hammer rod (2). Attach next section of ground rod to first ground rod. Attach slide hammer rod (2) to new section of ground rod (3), and repeat procedure until only 1 foot (0.305 m) of third rod is above ground.

6. Remove slide hammer (1) and slide hammer rod (2). Place in Section.

7. Using adjustable wrench, mount ground cable clamp (4) and ground cable (5) to ground rod. Attach ground cable to ground terminal (6) at power entry panel (7).

WARNING

ELECTRICAL HAZARD. Do not handle or clean power cable or connectors while power cable is connected to external power source. Death or serious injury may result.

8. Firmly connect the power cable (8) to the power entry panel (7).

NOTE

Before operating Section, perform before (B) operation PMCS. Refer to table 2-1.

9. Plug power cable into external power source.

2-6. ASSEMBLY AND PREPARATION FOR USE (CONT)

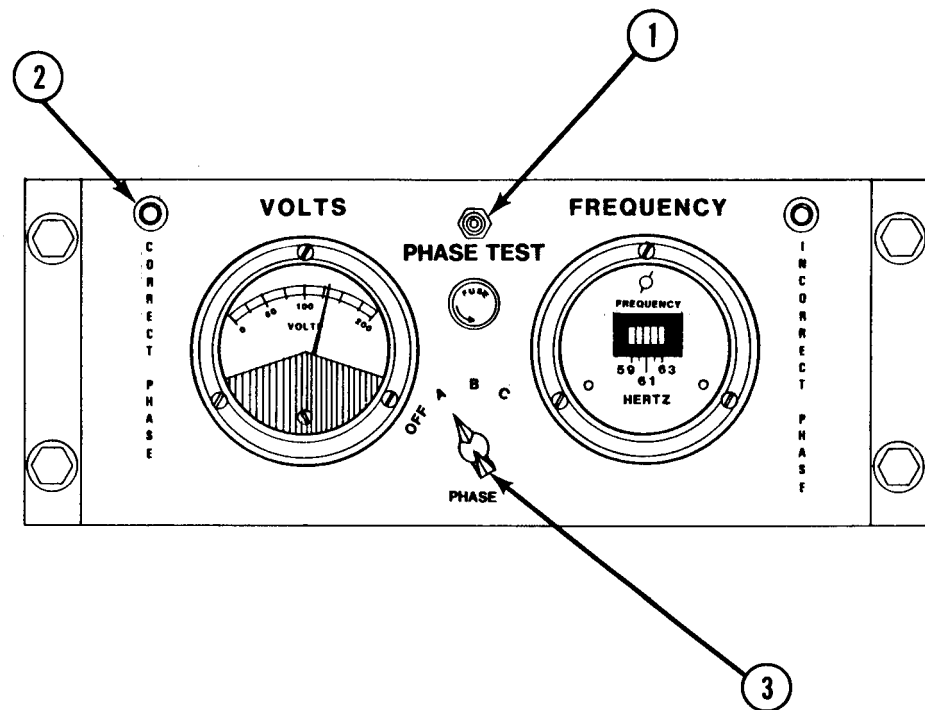

10. Pull PHASE TEST toggle switch (1) down. CORRECT PHASE lamp (2) should light.

CAUTION

- Do not energize Section if INCORRECT PHASE lamp lights. Damage to equipment may result.
- Be sure voltage is between 110 and 120 Vat. Frequency must be at 60 \pm 1 Hz on each leg. Incorrect settings will damage equipment.

11. If CORRECT PHASE lamp (2) lights, turn PHASE switch (3) to A. Read voltage and frequency. Repeat for positions B and C on PHASE switch.

2-6. ASSEMBLY AND PREPARATION FOR USE (CONT)

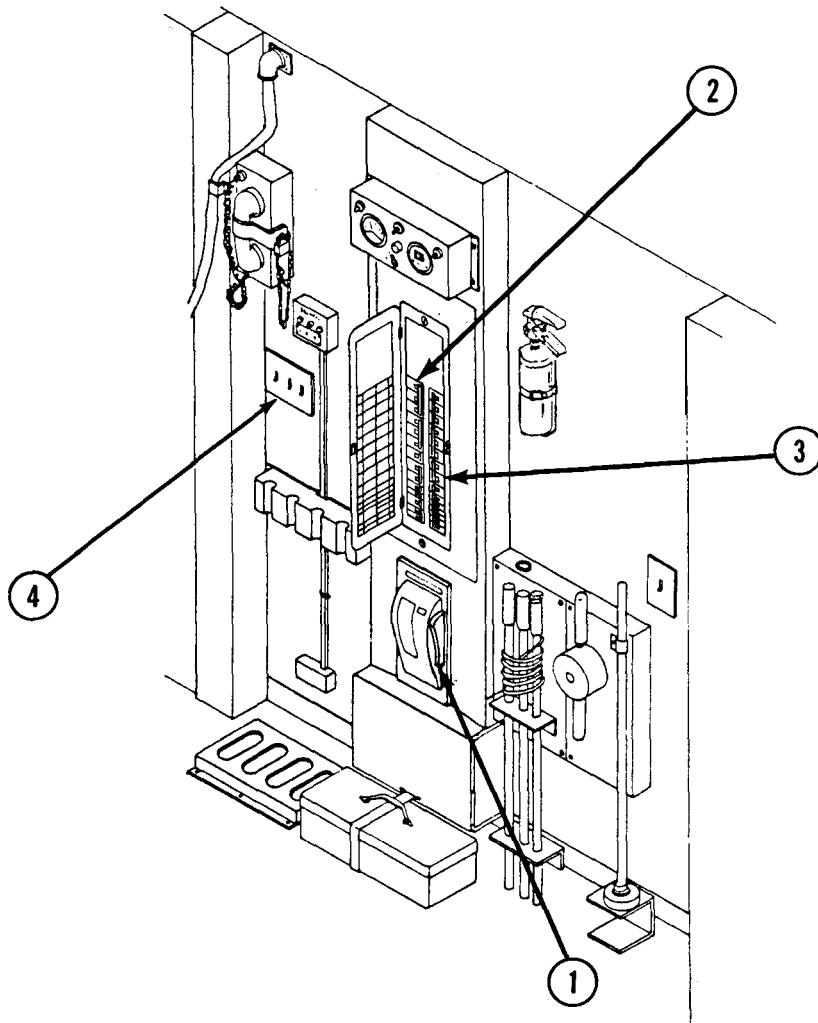

12. Set MAIN 60Hz. POWER switch (1) to ON. Set main circuit breaker (2) and desired equipment circuit breakers (3) to ON.

13. Activate overhead lights with THREE-WAY LIGHT switch (4).

2-6. ASSEMBLY AND PREPARATION FOR USE (CONT)

c. Expand Sides of Section

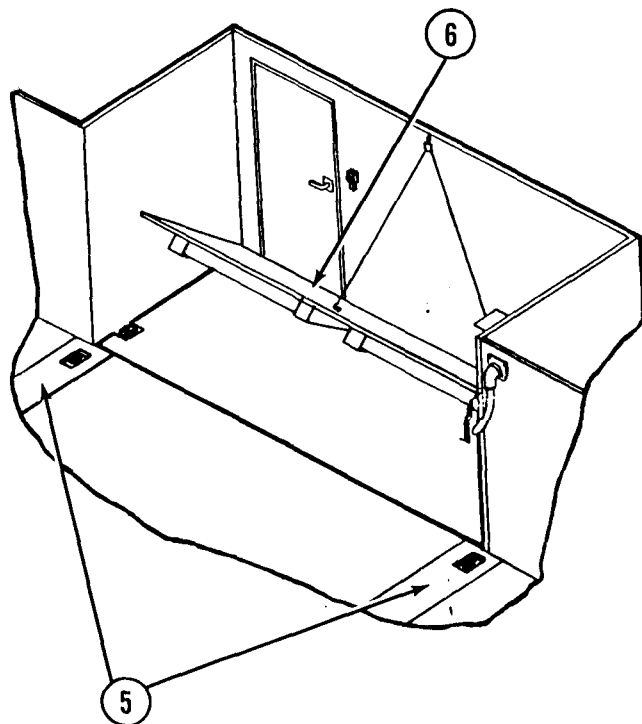
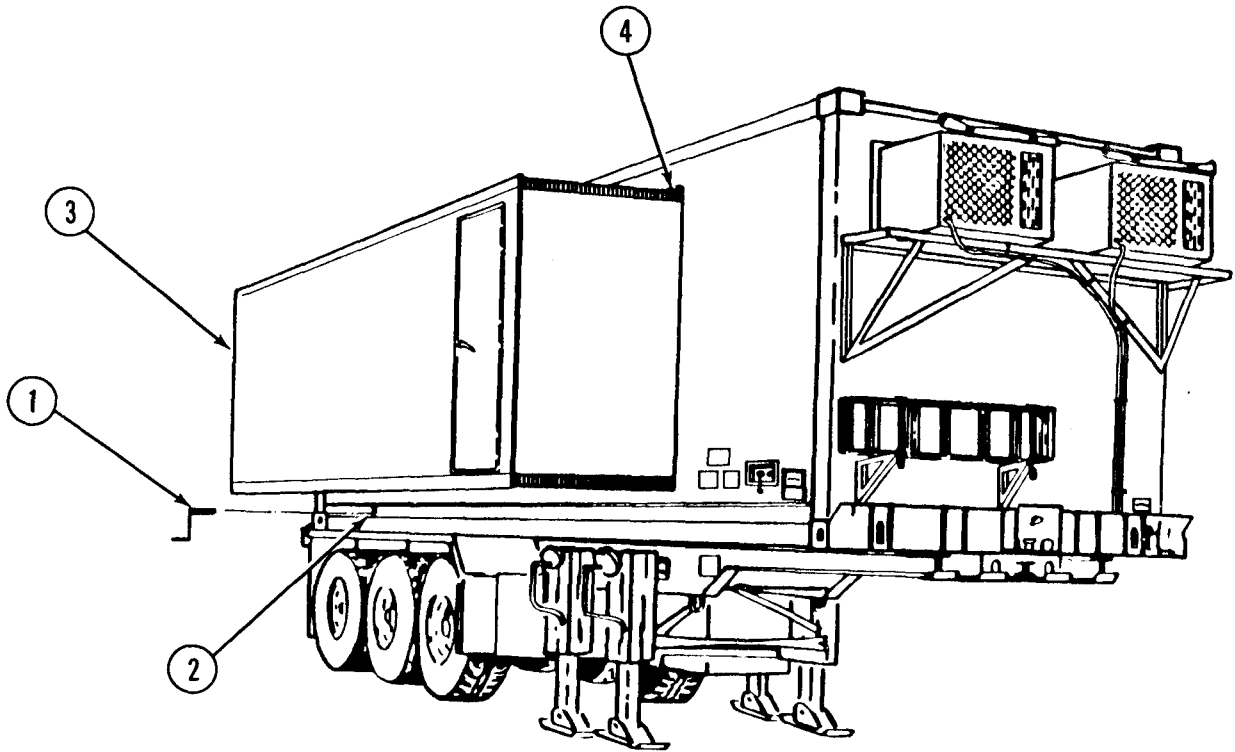

2-6. ASSEMBLY AND PREPARATION FOR USE (CONT)

CAUTION

- Do not expand Section if inclinometers show Section is not level. Equipment damage may result.
- Do not force handcrank. Damage to gears and expanding side seals may result.
- Two people are required to observe side retraction. Inside observer should watch that expanding side clears all parts of Section ceiling and Printing Press. Outside observer should watch that top, bottom, and both sides of expanding side retract evenly. If sides are not retracted evenly, they will contact Section body and become jammed.

NOTE

The same handcrank is used to operate both roadside and curbside drive mechanisms.

1. Check inclinometers to make sure that Section is level. Level Section, if needed (para 2-6a, steps 1 thru 12).
2. Insert handcrank (1) into drive mechanism (2) and extend sides (3) of Section, turning handcrank to right. Check periodically that sides expand evenly without contacting edges of Section body. Side is fully expanded when rubber seal (4) and metal plate are tightly sealed.
3. Repeat step 2 for opposite side. Store handcrank in Section.
4. Remove removable floor sections (5) from curbside folding floor (6) and install in Section.

2-6. ASSEMBLY AND PREPARATION FOR USE (CONT)

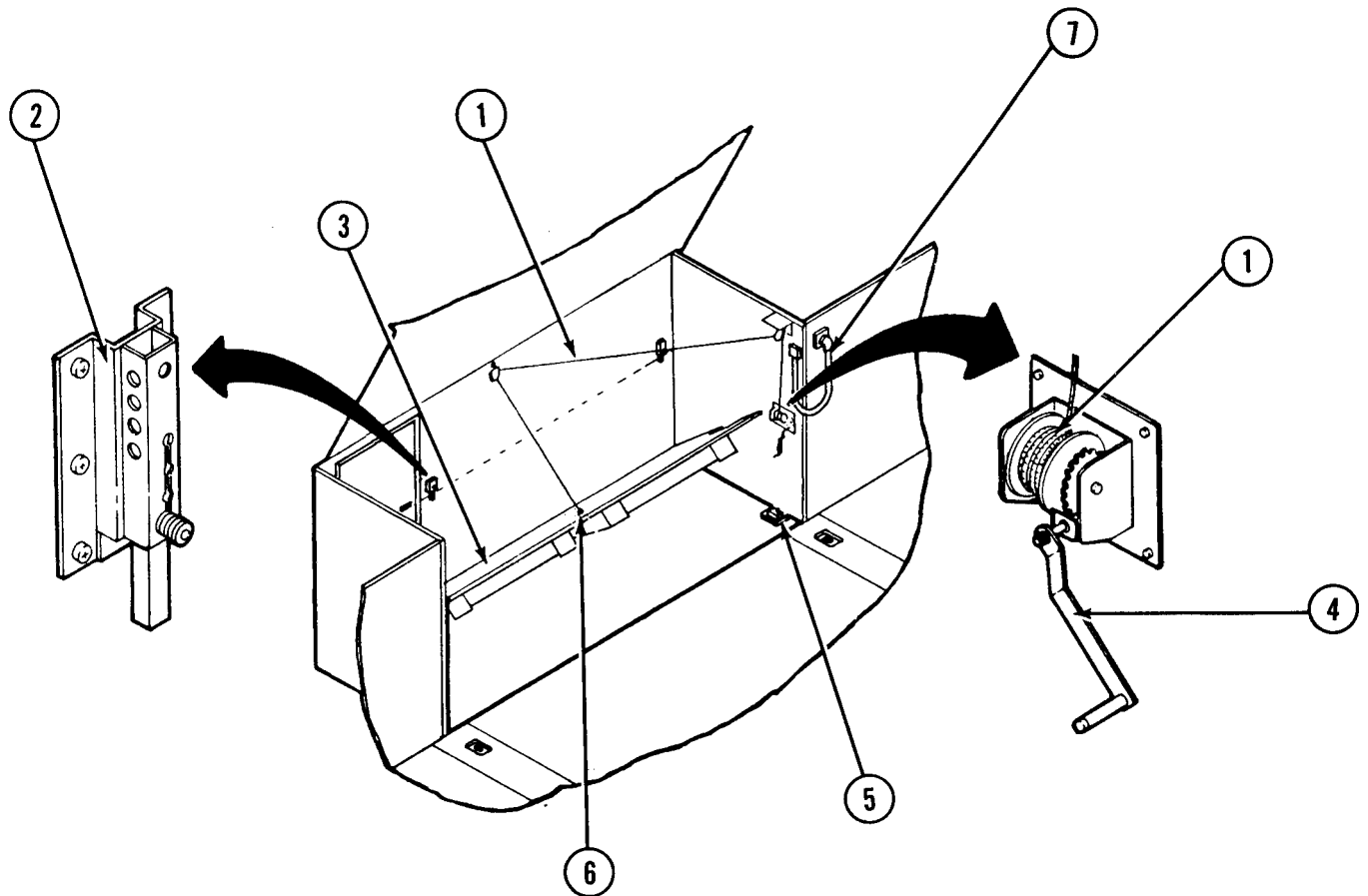

5. Take up slack in hoist cable (1).

WARNING

HEAVY EQUIPMENT. Stay clear of folding floors while they are being lowered. Weight of floors may cause death or serious personal injury.

6. Unlock wall locks (2) at each end of folding floor (3).
7. Using handwinch (4), reel out hoist cable (1) to lower folding floor (3). Lock folding floor (3) into place with floor locks (5).
8. Unhook hoist cable (1) from floor ring (6). Move hoist cable out of way.

2-6. ASSEMBLY AND PREPARATION FOR USE (CONT)

9. Repeat steps 1 through 8 for opposite folding floor.

10. When folding floors of both expanding sides are in place, recheck inclinometers to make sure that Section remains level. Refer to paragraph 2-6a, steps 7 thru 11.

11. Screw each expanding side's power supply cable (7) into its receptacle.

d. Prepare Section for Production

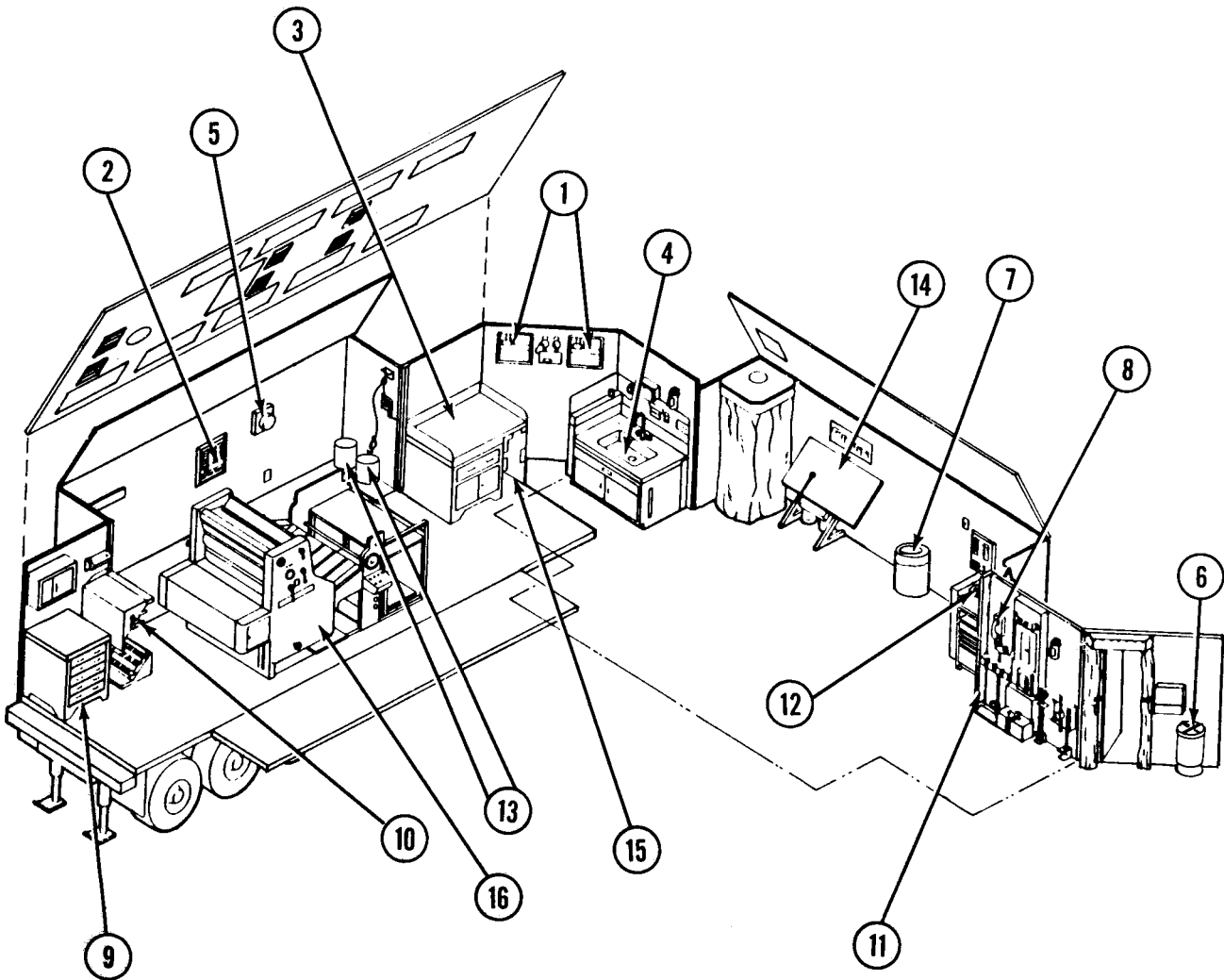

2-6. ASSEMBLY AND PREPARATION FOR USE (CONT)

1. Turn on air conditioner/heater (1). Turn on wall heaters (2) if necessary.
2. Remove floor mat from between jogging table (3) and sink (4), and place on floor at operator side of Printing Press.
3. Loosen captive screw and open exhaust fan door (5). Remove retaining ring and push cover handle out. Lock in place. Close exhaust fan door (5) and secure with captive screw.
4. Loosen strap for safety waste can (6) on cargo door.
5. Remove rubber strap from waste can (7) and place in desired location.
6. Loosen wingnut and remove clamp from telephone receiver (8).
7. Remove securing bar from front of storage cabinet (9). Secure bar on side of cabinet with thumbscrew.
8. Loosen cast iron knobs on roller storage rack (10) as needed for access to rollers.
9. Remove six transport handknobs locking GTO storage cabinet (11) to floor. Store handknobs on side of cabinet.
10. Turn wheel handknobs until GTO storage cabinet frame is one-half inch off floor.
11. Unstrap magnifier light (12) and position over GTO storage cabinet (11).
12. Roll GTO storage cabinet (11) against curbside wall at rear of expanding side.
13. Remove securing bar from front of GTO storage cabinet (11). Secure bar on side of GTO storage cabinet with thumbscrew.
14. Plug in magnifier light (12).
15. Remove rubber straps from safety cans (13) and place cans in desired location.

NOTE

Two people are required to perform the following step.

16. Loosen transport handknobs securing plate register punch (14) to floor. Store handknobs on plate register punch frame. Move plate register punch against curbside wall.

2-6. ASSEMBLY AND PREPARATION FOR USE (CONT)

17. Remove securing bar from front of sink (4). Secure bar on side of sink with thumbscrew.

18. Loosen securing bar from pile board storage rack (15).

19. Prepare the Printing Press (16) for operation (TM 5-3610-286-10, para 2-6).

e. Prepare Section Exterior

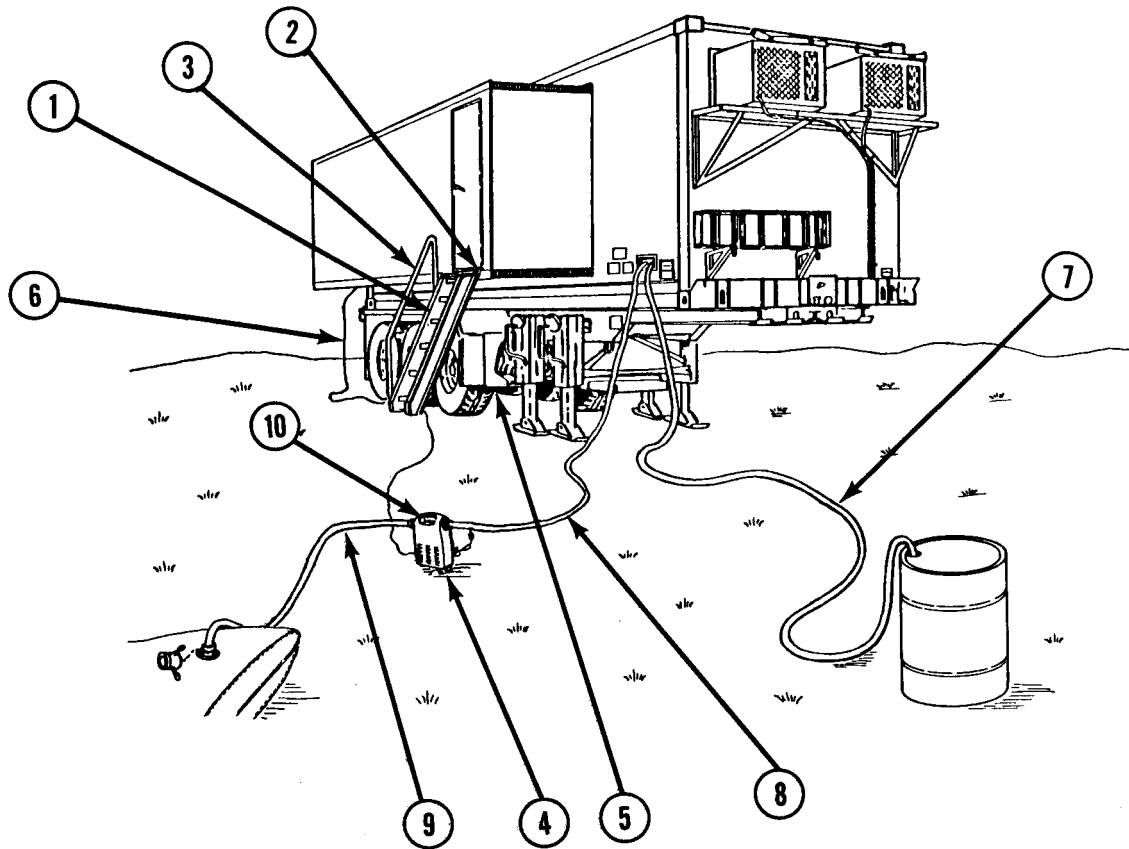

2-6. ASSEMBLY AND PREPARATION FOR USE (CONT)

1. Remove boarding ladder and handrail from cargo door. Move to curbside personnel door.
2. Remove handrail from boarding ladder.
3. Mount boarding ladder (1) at curbside personnel door attachment point (2) and secure with locking pins.
4. Mount handrail (3) on left side of boarding ladder (1).
5. Close water tank gate valve and faucet drain petcock valve located under sink in Section.
6. Remove auxiliary pump (4) from shipping bracket under sink.
7. Remove hoses and power cord from semitrailer chassis tool box (5).
8. Plug power cord (6) into 120 VOLT OUTLET at power entry panel.
9. Set auxiliary pump (4) on level surface.
10. Connect drain hose (7) to WATER DRAIN pipe on Section body.
11. Connect inlet hose (8) to WATER INLET pipe on Section body.
12. Connect other end of inlet hose (8) to outlet port of auxiliary pump (4).
13. Connect water source hose (9) to inlet port of auxiliary pump (4).
14. Place water source hose (9) in water source.

CAUTION

Make sure auxiliary pump has been primed before operating. Damage to shaft seal will result if auxiliary pump is not primed.

15. Remove plug (10) from auxiliary pump (4) priming point and fill with water. Plug in pump and continue filling with water until full. Replace plug (10).
16. Fill water tank until water spills out of drain hose (7).
17. Unplug auxiliary pump (4) and power cord (6).
18. Inside Section, turn WATER HEATER and WATER PUMP switch to ON.

2-6. ASSEMBLY AND PREPARATION FOR USE (CONT)

19. Set water temperature control to desired setting.
20. Set emergency light toggle switch to ON.
21. Turn off THREE-WAY LIGHT switch.
22. Turn off BLACKOUT BYPASS switch.
23. Turn on BLACKOUT LIGHT switch.
24. Refer to TM 5-3610-286-10 for operation of TSS Press Section Printing Press.

2-7. PREPARATION FOR MOVEMENT

a. Prepare Section Exterior

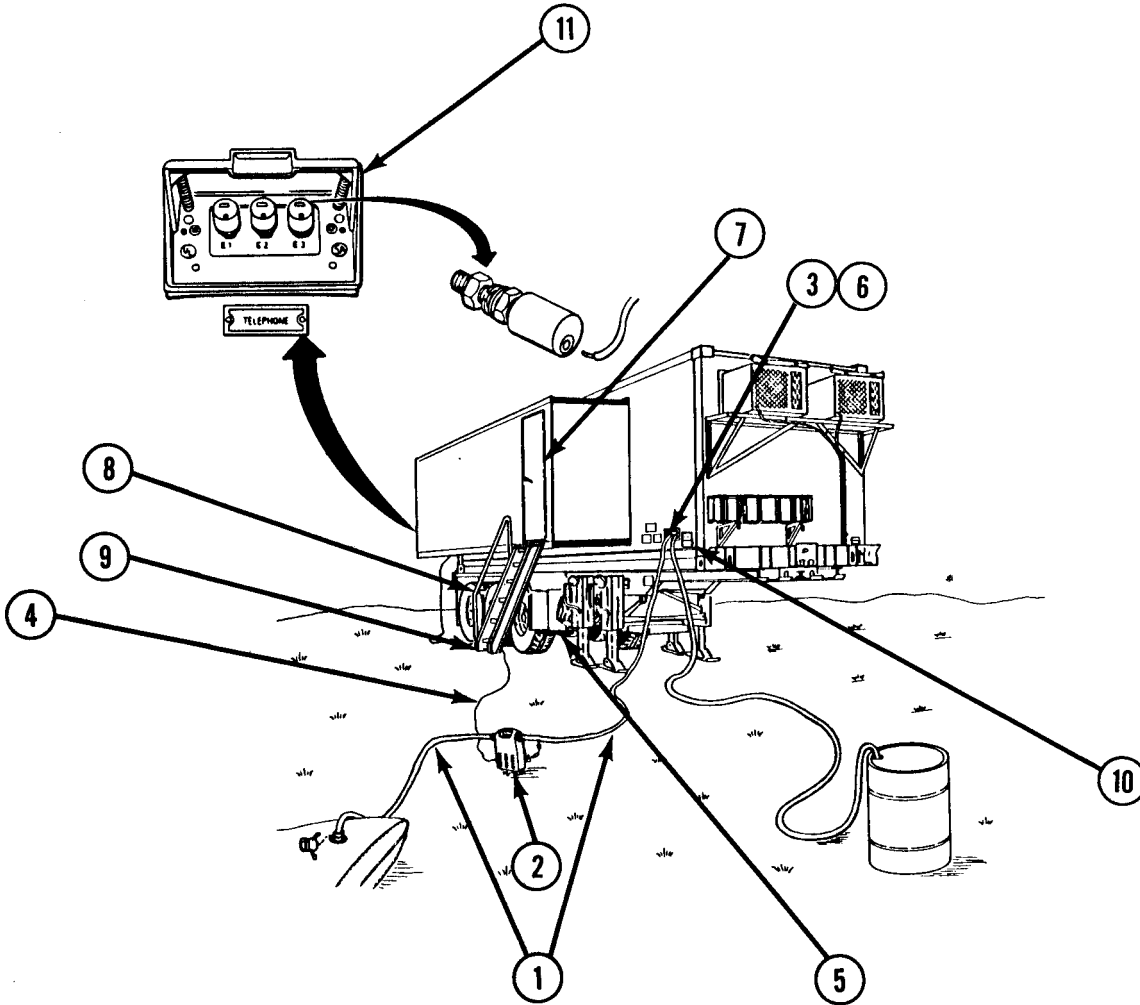

2-7. PREPARATION FOR MOVEMENT (CONT)

1. Disconnect hoses (1) from auxiliary pump (2) and from water inlet pipe (3) on Section body.
2. Disconnect and store auxiliary pump power cord (4) in semitrailer chassis tool box (5).
3. Install dustcap (6) on water inlet pipe (3) on Section body.
4. Store auxiliary pump (2) under sink in Section.
5. Store hoses (1) in semitrailer chassis tool box (5).
6. Lock curbside personnel door (7).
7. Remove handrail (8) from curbside personnel door boarding ladder (9).

NOTE

Two people are required to perform the next two steps.

8. Remove curbside personnel door boarding ladder (9). Insert handrail (8) into back of boarding ladder.
9. Secure curbside personnel door boarding ladder (9) on cargo door.
10. Close and secure inclinometer covers (10).
11. Disconnect wires from telephone entrance panel (11).

2-7. PREPARATION FOR MOVEMENT (CONT)

b. Prepare Section Interior

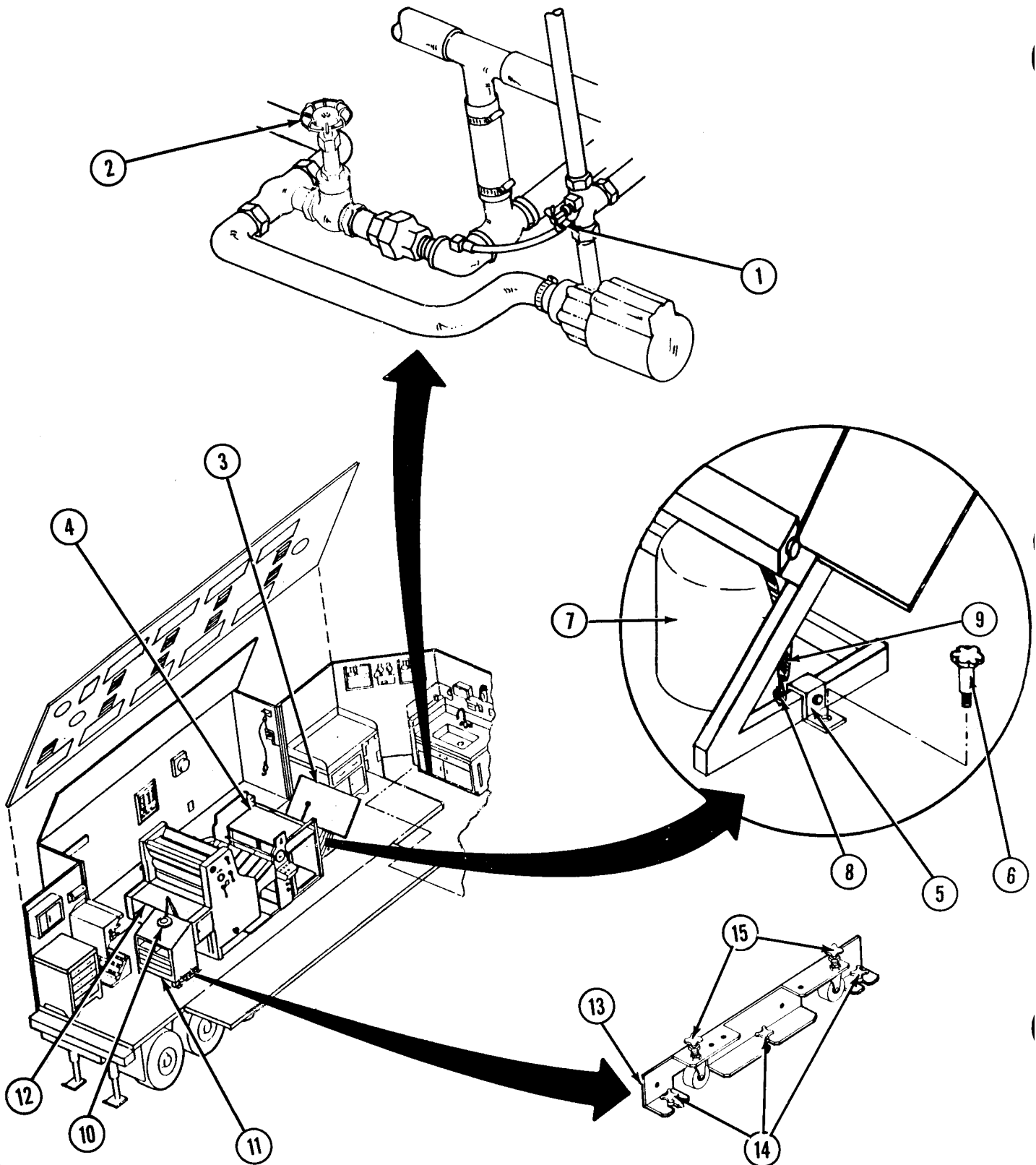

2-7. PREPARATION FOR MOVEMENT (CONT)

1. Turn petcock valve (1) to left to drain faucet.

NOTE

Be sure drain hose is attached to exterior drain line on Section body.

2. Turn gate valve (2) to left to drain water tank.
3. Turn emergency light switch to OFF.
4. Store interior accessories under sink and in cabinets.

NOTE

Securing equipment (wingnuts, securing bars, etc.) is identified by its red color.

5. Install securing bar on pile board storage rack.
6. Remove securing bar from side of sink cabinet and install across sink doors. Secure with thumbscrew.

NOTE

Two people are required to perform the following step.

7. Place plate register punch (3) in front of feeder end (4) of Printing Press. Place clamps (5) over floor openings and secure to floor with transport handknobs (6).
8. Place safety cans (7) under plate register punch and secure to ring bolts (8) with rubber straps (9).
9. Prepare Printing Press for movement (TM 5-3610-286-10, para 2-9).
10. Unplug magnifier light (10) and secure with strap at rear of GTO storage cabinet (11).
11. Remove securing bar from side of GTO storage cabinet (11) and position across front of GTO storage cabinet. Secure bar with thumbscrew. Lower viewing board.
12. Position GTO storage cabinet (11) with drawers facing cargo door in front of delivery end (12) of Printing Press. Place clamps (13) over floor openings.
13. Remove six transport handknobs (14) from sides of GTO storage cabinet (11). Turn wheel handknobs (15) to lower GTO storage cabinet to floor. Secure GTO storage cabinet with transport handknobs (14).

2-7. PREPARATION FOR MOVEMENT (CONT)

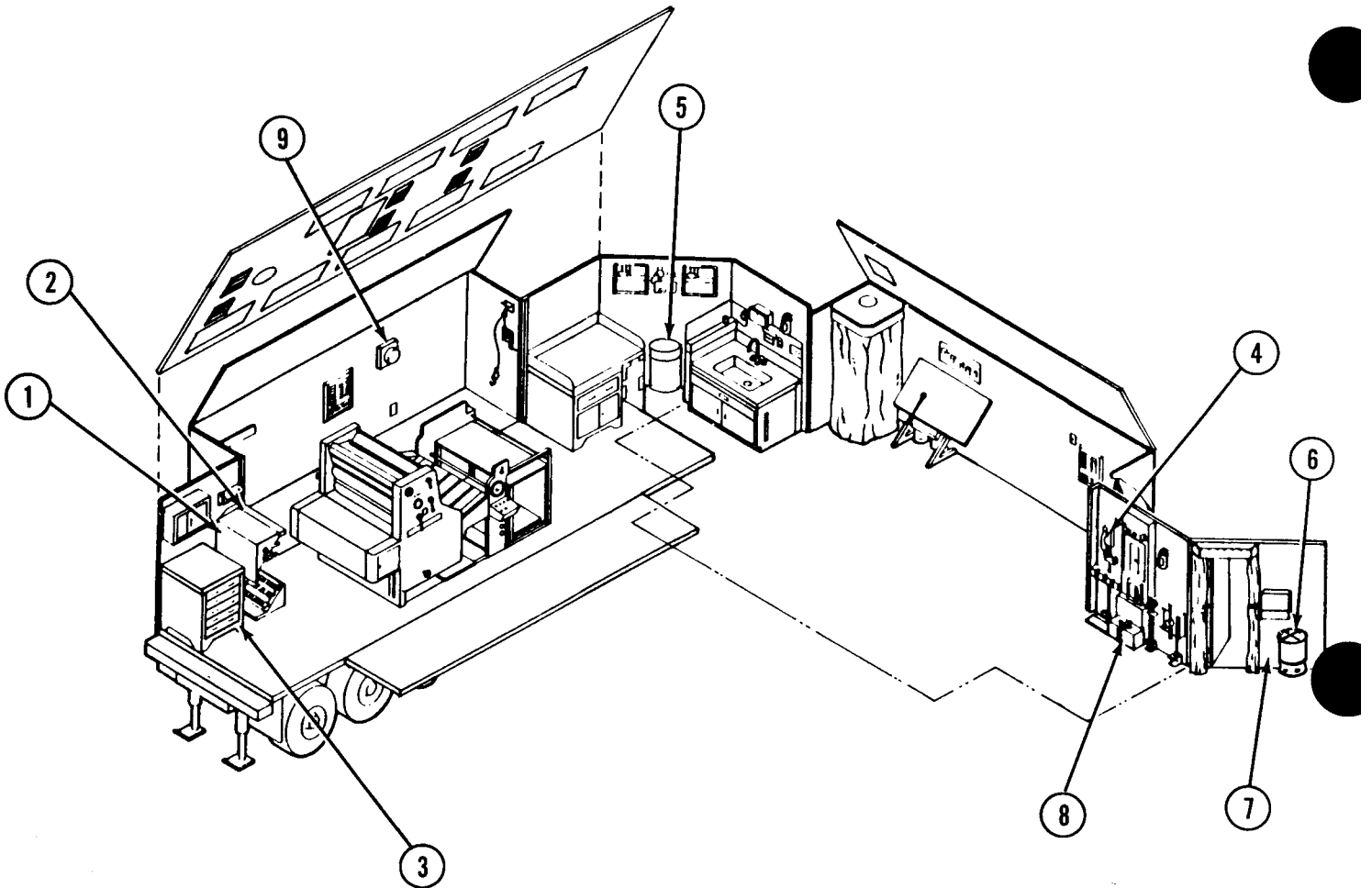

14. Secure roller storage rack (1) into position with cast iron knobs (2).

15. Remove securing bar from side of storage cabinet (3). Position securing bar across front of storage cabinet (3). Secure with thumbscrew.

16. Secure telephone receiver (4) to wall with clamp and wingnut.

17. Turn off air conditioner/heaters.

18. Secure waste can (5) against wall between sink and jogging table with rubber strap.

19. Secure safety waste can (6) to cargo door (7) with straps.

2-7. PREPARATION FOR MOVEMENT (CONT)

20. Lock tool box (8) and strap to floor under MAIN 60Hz. POWER switch.

21. Loosen captive screw and open exhaust fan door (9). Pull cover handle in and secure with retaining ring. Close exhaust fan door and tighten captive screw.

22. Roll floormat and store between sink and jogging table.

23. Inspect interior of Section for any remaining loose articles or materials. Store as necessary.

c. Retract Expanding Sides

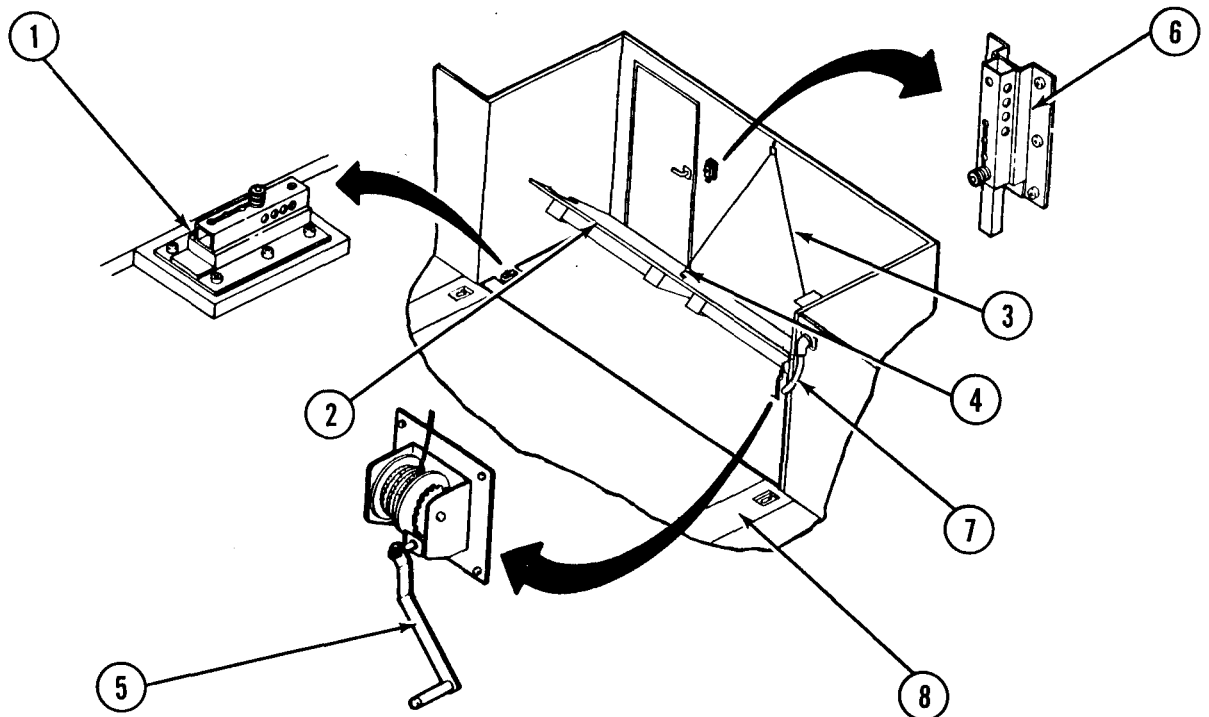

CAUTION

Be sure to inspect assembly and general area of folding floor for loose or missing parts and obstructions. Failure to do so may result in damage to equipment.

1. Unlock floor locks (1) at ends of each folding floor (2).
2. Lead hoist cable (3) down and attach cable hook to floor ring (4).

2-7. PREPARATION FOR MOVEMENT (CONT)

3. Take up slack in hoist cable (3).

WARNING

HEAVY EQUIPMENT. Stay clear as floor areas are raised or lowered. Weight of floors may cause serious personal injury.

4. Using handwinch (5), raise folding floor to about 3 inches (7.6 cm) from wall. Push floor to wall and lock into place with wall locks (6).
5. Repeat steps 1 through 4 for opposite folding floor.
6. Unscrew each expanding side's power supply cable (7) from receptacle.

NOTE

Install removable floor sections on curbside folding floor from ground level.

7. Take up both removable floor sections (8) and store on curbside folding floor (2).

CAUTION

- Two people are required to observe side retraction. Inside observer should watch that expanding side clears all parts of Section ceiling and Printing Press. Outside observer should watch that top, bottom, and both sides of expanding side retract evenly. If sides are not retracted evenly, they will contact Section body and become jammed.
- Do not force handcrank. Damage to gears and expanding side seals may result.

NOTE

The same handcrank is used to operate both roadside and curbside drive mechanisms.

8. Insert handcrank into drive mechanism and retract side of Section, turning crank to left. Check periodically that side retracts evenly without contacting sides and ceiling of Section body. Side is fully retracted when rubber seal and metal plate are tightly sealed.

2-7. PREPARATION FOR MOVEMENT (CONT)

9. Repeat step 8 for opposite side.
10. Store handcrank in hole next to load center.

d. Disconnect Power

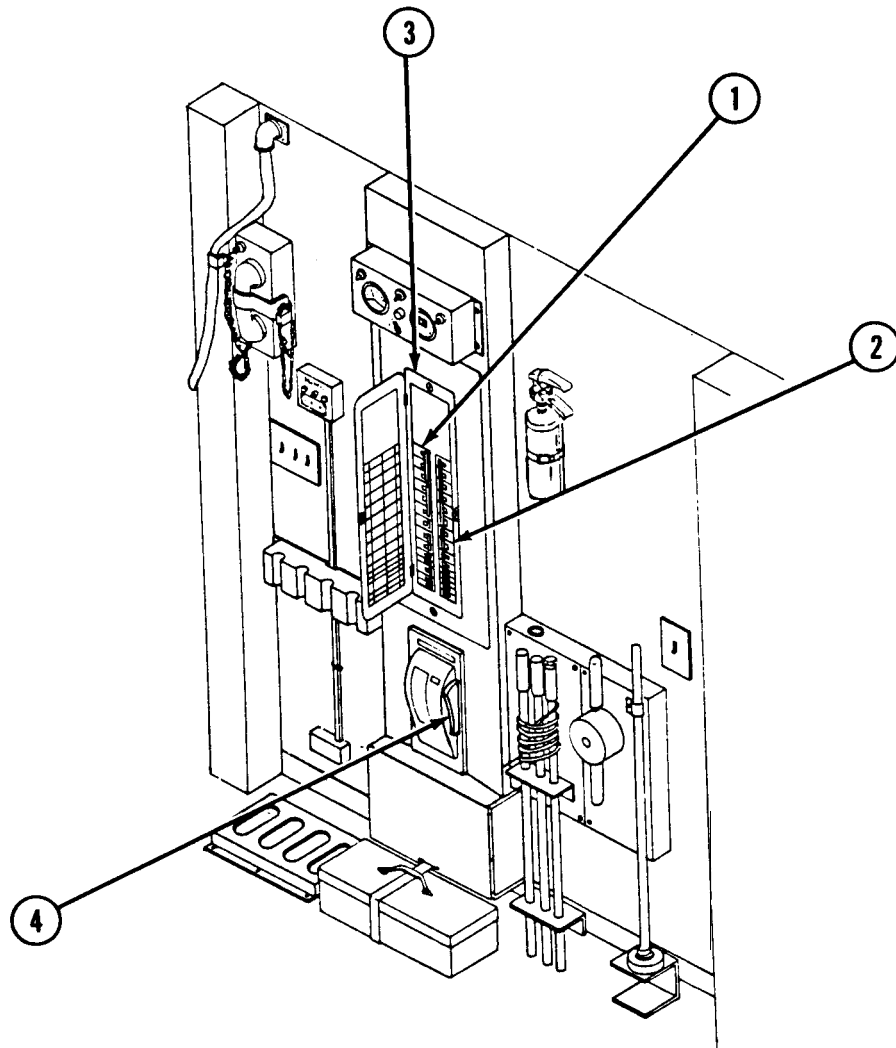

1. Turn off main circuit breaker (1) and all individual circuit breakers (2) on load center (3).

2. Turn off MAIN 60Hz. POWER switch (4) located beneath load center (3).

2-7. PREPARATION FOR MOVEMENT (CONT)

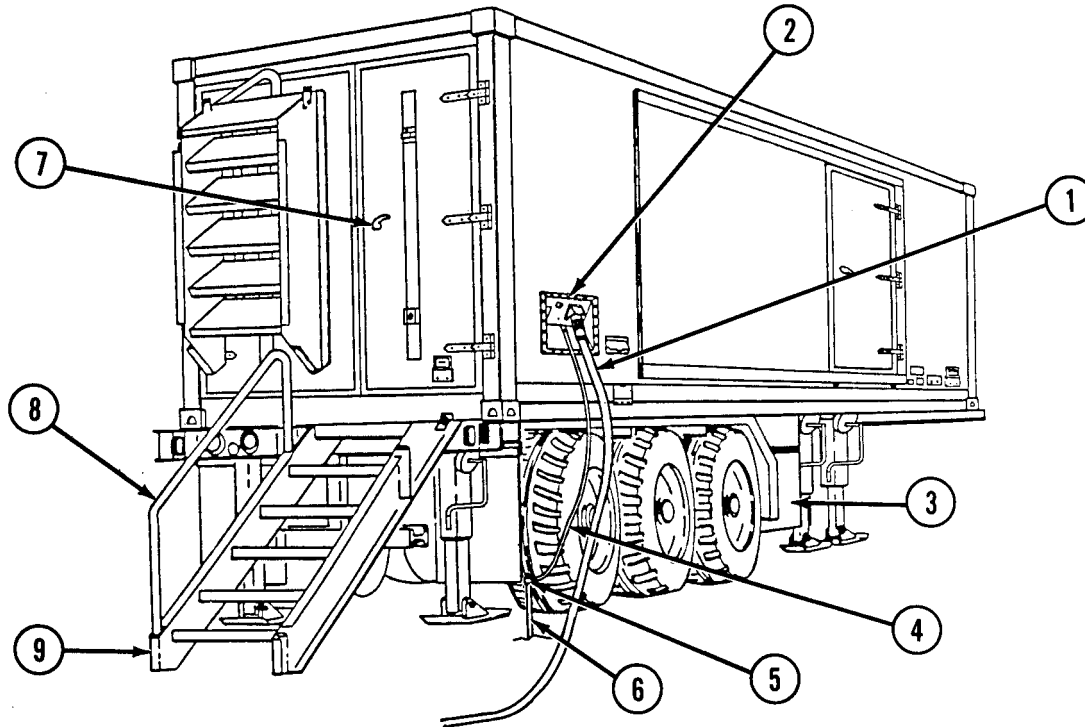

WARNING

ELECTRICAL HAZARD. Do not make electrical connections/disconnections while power cable is energized. Death or serious injury may result.

3. Disconnect power cable (1) from external power source and from power entry panel (2). Store power cable (1) in semitrailer chassis tool box (3). Disconnect ground cable (4) from ground cable clamp (5) and from power entry panel (2).

CAUTION

To prevent thread damage or loss of rod, do not allow ground rod to rotate or unscrew when removing slide hammer rod.

4. Using slide hammer, remove ground rods (6) from ground. Store ground rods (6), ground cable (4), and slide hammer inside Section in mounting brackets. Secure with knobs.

2-7. PREPARATION FOR MOVEMENT (CONT)e. Prepare for Transport

1. Using folding ladder, unroll air conditioner/heater covers and secure with snaps. Secure folding ladder.
2. Remove drain hose from water outlet on Section body and store hose in semitrailer chassis tool box (3).
3. Install cap on water outlet pipe.
4. Lock rear personnel door (7).
5. Remove handrail (8) from rear personnel door boarding ladder (9).
6. Remove rear personnel door boarding ladder (9) and insert handrail (8) into back of boarding ladder.
7. Secure rear personnel door boarding ladder (9) to rear personnel door (7).
8. Retract leveling jacks completely. Raise landing jacks high enough for tractor clearance.
9. Connect semitrailer chassis to tractor as indicated in TM 5-2330-305-14. Retract landing jacks. Remove chocks and store in semitrailer chassis tool box (3). Close and lock semitrailer chassis tool box (3).
10. Inspect Section exterior to be sure all equipment and covers are secure.

2-8. OPERATING INSTRUCTIONS ON DECALS AND INSTRUCTION PLATES

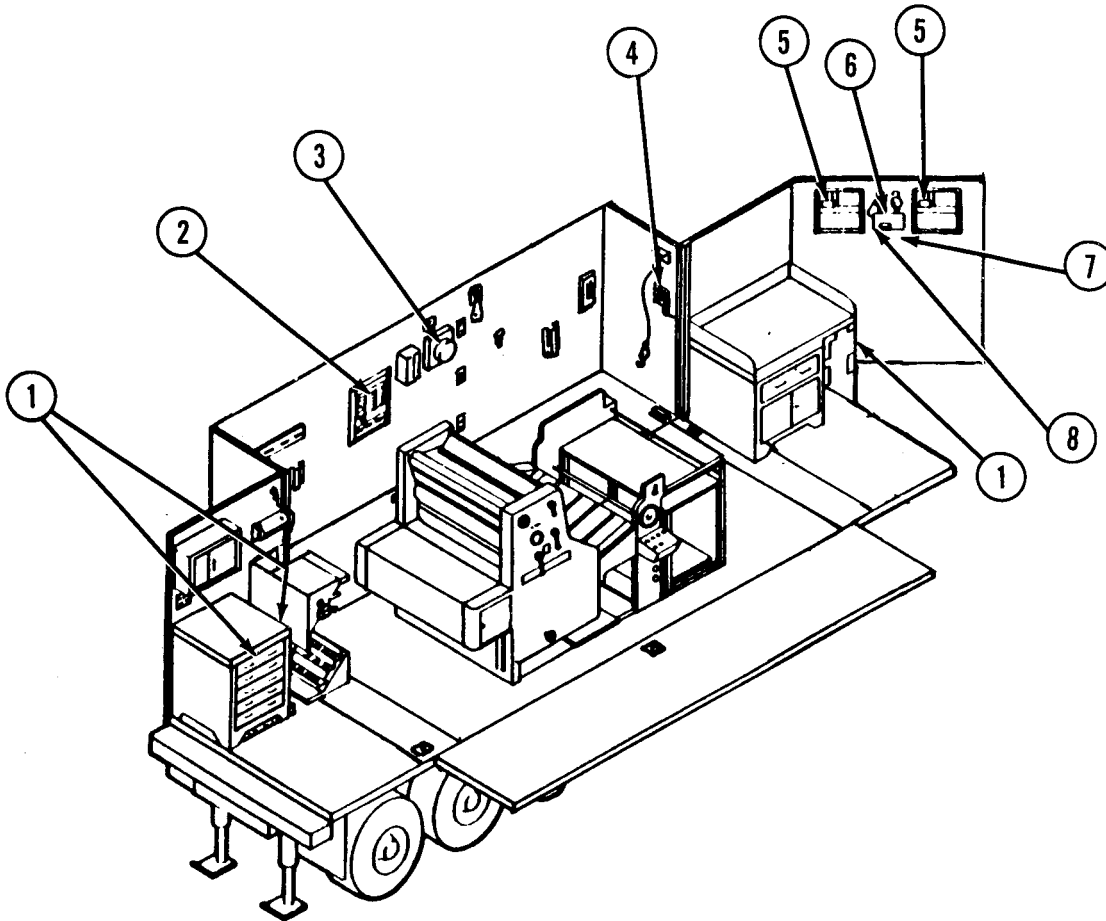

CAUTION
**SECURE RED SHIPPING
BRACKET(S) BEFORE TRANSIT**

1

WARNING
**DO NOT LEAN ON OR TOUCH
HEATER'S GRILL WHEN IN
OPERATION**

2

2-8. OPERATING INSTRUCTIONS ON DECALS AND INSTRUCTION PLATES (CONT)

CAUTION
OPEN OUTSIDE COVER BEFORE TURNING ON

3

WARNING
**KEEP FEET CLEAR OF
FOLDING FLOOR SECTION
WHEN LOWERING OR RAISING**

4

CAUTION
**FOR SAFE OPERATION
SEE TM FOR PROPER
INTERNAL AND EXTERNAL
GROUNDING**

5

CAUTION
**TO START UNIT ON "COOL"
MODE AT 0° F. AMBIENT
JUMPER LPCO SWITCH (S-5)**

2-8. OPERATING INSTRUCTIONS ON DECALS AND INSTRUCTION PLATES (CONT)

CAUTION

**EMERGENCY LIGHT SWITCH
MUST BE IN THE OFF POSITION
WHEN ELECTRICAL POWER IS
INTENTIONALLY DISCONNECTED.
SWITCH MUST BE IN THE ON POSITION
FOR NORMAL EMERGENCY LIGHT
OPERATION**

6

WARNING

**HEARING
PROTECTION
REQUIRED**

7

**LIGHTING RELAY
INSIDE PANEL**

8

2-8. OPERATING INSTRUCTIONS ON DECALS AND INSTRUCTION PLATES (CONT)

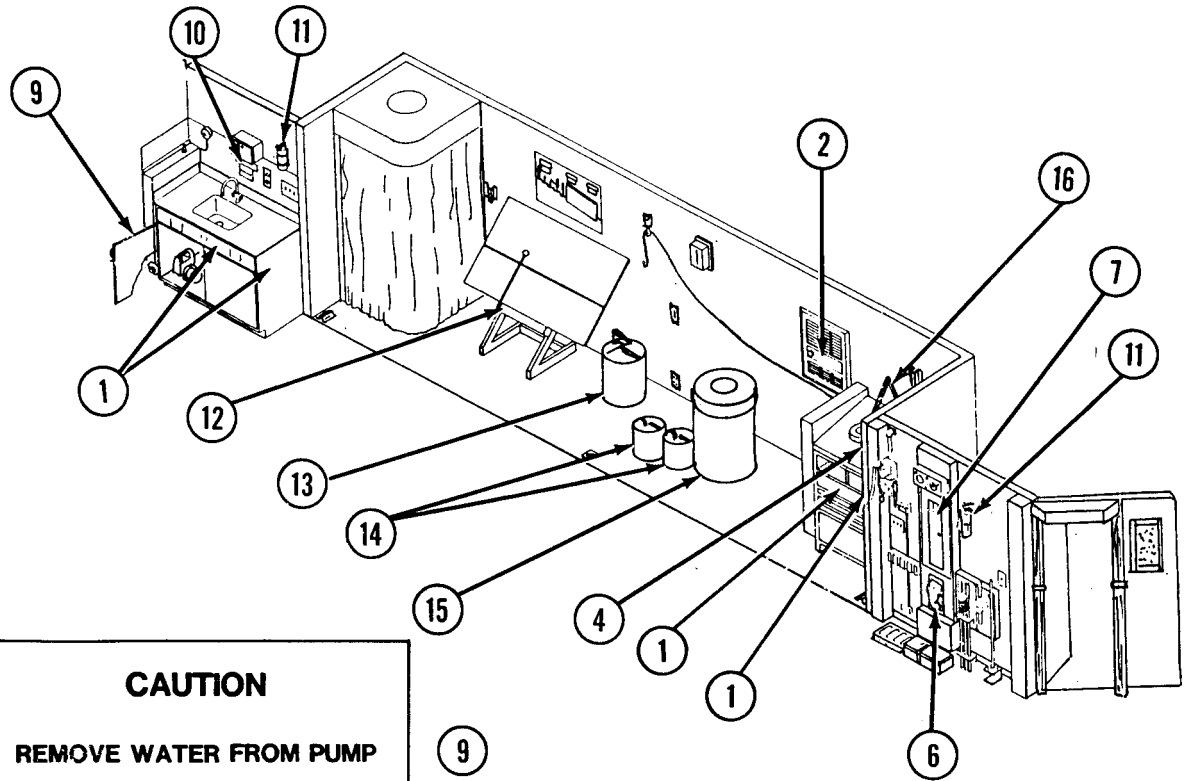

CAUTION
 REMOVE WATER FROM PUMP
 BEFORE STORAGE

WARNING
 DO NOT DRINK THIS WATER

CAUTION
 IF WATER BECOMES INTERMITTENT FROM FAUCET
 TURN WATER PUMP SWITCH TO THE OFF POSITION
 AND CHECK LEVEL OF WATER IN TANK.

CAUTION
 CONNECT DRAIN HOSE BEFORE FILLING WATER TANK.

A **B** **C**

1. **HOLD UPRIGHT.
 PULL RING PIN.**
2. **START BACK 8 FEET.
 AIM AT BASE OF FIRE.**
3. **SQUEEZE LEVER. SWEEP
 SIDE TO SIDE.**

2-8. OPERATING INSTRUCTIONS ON DECALS AND INSTRUCTION PLATES (CONT)

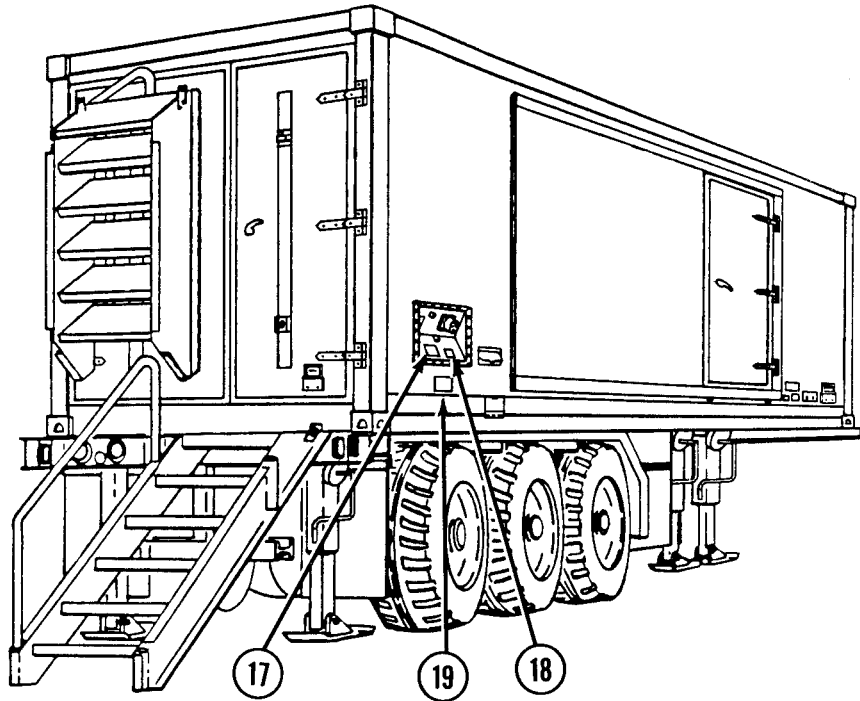

CAUTION
GROUND TRAILER
BEFORE APPLYING
MAIN POWER

17

CAUTION
SAFETY SWITCH MUST BE
IN THE OFF POSITION
WHEN CONNECTING OR
DISCONNECTING

18

CAUTION
LEVEL VAN BEFORE
EXPANDING SIDES

19

2-8. OPERATING INSTRUCTIONS ON DEALS AND INSTRUCTION PLATES (CONT)

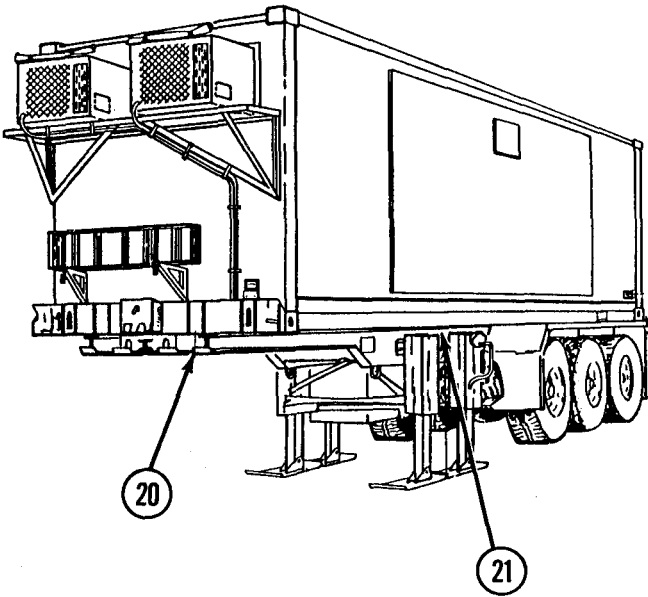

CAUTION

OVERRIDE SWITCH MUST BE OFF BEFORE CONNECTING AIR TO TRAILER. DO NOT OPERATE TRAILER WITH OVERRIDE SWITCH ON OR WITH DEFLATED AIR BAGS. SEE OPERATING INSTRUCTIONS ON LEFT SIDE (ROADSIDE) OF TRAILER.

20

CAUTION

DO NOT MOVE VEHICLE UNLESS THIS SWITCH IS OFF.

21

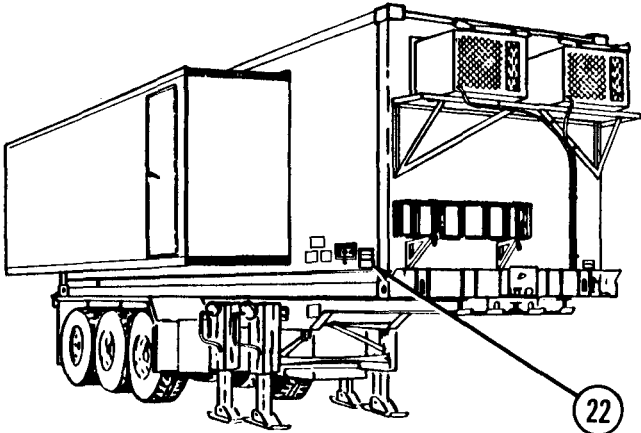

CAUTION

THIS VAN SHOULD NOT UNDER ANY CIRCUMSTANCES OR AT ANY TIME BE LIFTED BY THE UPPER CORNERS . LIFTING SHOULD ALWAYS BE BY THE LOWER CORNERS.

22

Section IV. OPERATION UNDER UNUSUAL CONDITIONS

2-9. OPERATION IN UNUSUAL WEATHER. Operation of internal equipment is performed within environmentally controlled conditions. However, the following conditions may adversely affect the equipment and its operation.

NOTE

Section damage that permits light leaks or water/dirt entry must be immediately repaired by organizational maintenance personnel.

a. High Wind or Storm Conditions. Relocate Section if trees or structures present hazard.

b. Cold Weather

(1) Remove snow and ice from leveling footplate and from area on ground where leveling footplate will rest before attempting to level and stabilize Section.

(2) In extreme cold, the power cable and ground cable will become hard, brittle, and difficult to handle. Be careful when handling and connecting cables to the Section so that kinks and unnecessary loops will not result in permanent damage.

(3) Make certain that connections and cable receptacles located on the power entry panel are free of frost, snow, or ice.

(4) When heaters are not operating, such as when Section is in transport, liquid consumable supplies may freeze and break their containers, then melt and ruin equipment or documents. Do not store liquid consumables in Section under freezing conditions.

c. Extreme Heat. When air conditioners are not operating, such as during transportation, consumable supplies may suffer reduced shelf life. Avoid storing consumable supplies in Section during periods of extreme heat.

d. Tropical Conditions. Fungi, mildew, or mold may form and damage equipment, documents, and supplies if air conditioner/heaters are not operating and if outside heat and humidity are allowed to enter the Section.

e. Desert Conditions. Take extreme care to prevent dust, grit, and sand from entering Section, or supplies, documents, or equipment (particularly the Printing Press) may be ruined. Change air filters whenever airflow is restricted. Clean Section interior more frequently than specified by PMCS schedules.

2-9. OPERATION IN UNUSUAL WEATHER (CONT)

f. Mud, Soft Ground, or Sand. Under these conditions, place shoring or scrap material under leveling footplate to increase surface area and prevent leveling footplate from sinking.

2-10. EMERGENCY PROCEDURES. There are no specific procedures for emergency operation of the Section.

a. Emergency Light System. During power failure, equipment is inoperable. However, the emergency light system will activate when ac power to the Section is lost. This allows the operator 90 minutes to secure the Section.

b. Dome Light System. The Section dome lights can be used as a backup lighting system when the Section is connected to a dc power source such as the tractor. When connected to dc power, the equipment is inoperable.

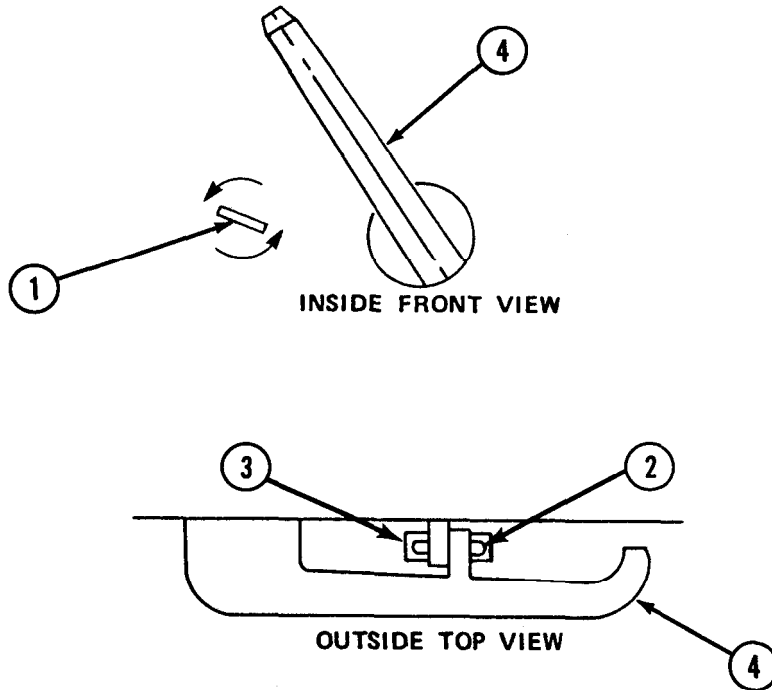

c. Emergency Exit. If personnel are locked in the Section, the tab (1) on either personnel door may be turned to the left until the bail (2) on the padlock (3) falls free. The door handle (4) will then be free to turn.

CHAPTER 3

MAINTENANCE INSTRUCTIONS

Section I. LUBRICATION INSTRUCTIONS

3-1. **GENERAL.** Lubrication instructions for the Section are located in LO 5-3610-287-12.

Section II. TROUBLESHOOTING PROCEDURES

3-2. **GENERAL.** This table contains instructions for the operator to troubleshoot the Section and its components. The table lists the common malfunctions which you may find during the operation or maintenance of the Section or its components. You should perform the tests/inspections and corrective actions in the order listed.

This manual cannot list all malfunctions that may occur, nor all tests or inspections and corrective actions. If a malfunction is not listed or is not corrected by listed corrective actions, notify your supervisor.

SYMPTOM INDEX

	Troubleshooting Procedure Page
No electrical power to equipment	3-2
No electrical power to Section	3-2
Resistance (binding) felt when expanding sides are expanding	3-3
Resistance (binding) felt when expanding sides are retracting	3-3
Folding floor does not fit	3-4
Boarding ladders will not mount on doors for transport	3-4
Auxiliary pump motor does not turn	3-4
Auxiliary pump motor turns, but does not pump water	3-5
Water tank does not fill	3-5
Air conditioner/heaters do not operate	3-6
Wall heaters do not operate	3-6
Blackout lights do not operate	3-6
Exhaust fan does not operate	3-6
Telephone does not operate	3-7

Table 3-1. Troubleshooting

MALFUNCTION	TEST OR INSPECTION	CORRECTIVE ACTION
1. NO ELECTRICAL POWER TO EQUIPMENT.		
	Step 1. Check that equipment power switch is ON.	Turn ON equipment power switch.
	Step 2. Check that electrical plug is connected to wall outlet.	Plug in.
	Step 3. Check that MAIN 60Hz. POWER switch is in ON position.	Turn MAIN 60Hz. POWER switch to ON position.
	Step 4. Inspect load center for circuit breaker in OFF position.	Reset circuit breaker.
	Step 5. Check that circuit breaker does not trip repeatedly.	If malfunction still exists, notify your supervisor.
2. NO ELECTRICAL POWER TO SECTION.		
	Step 1. Check that MAIN 60Hz. POWER switch is in ON position.	Turn MAIN 60Hz. POWER switch to ON position.
<u>WARNING</u>		
		HIGH VOLTAGE. Do not perform electrical maintenance or make electrical connections/disconnections at power entry panel while power cable is energized. Death or serious injury may result.
	Step 2. Check that power cable is firmly connected at power entry panel.	Reconnect power cable.

Table 3-1. Troubleshooting (Cont)

MALFUNCTION	TEST OR INSPECTION	CORRECTIVE ACTION
2. NO ELECTRICAL POWER TO SECTION (CONT)		
	Step 3. Inspect power cable for cracks, breaks, or frayed wiring.	If malfunction still exists, notify your supervisor.
	Step 4. Check that external power is being provided.	If malfunction still exists, notify your supervisor.
3. RESISTANCE (BINDING) FELT WHEN EXPANDING SIDES ARE EXPANDING.		
	Step 1. Check inclinometers to see if Section is level.	Level Section (para 2-6a, steps 6 thru 11).
	Step 2. Check for exterior obstructions.	Remove exterior obstructions or move Section.
	Step 3. Check that sides are expanding evenly.	If malfunction still exists, notify your supervisor.
4. RESISTANCE (BINDING) FELT WHEN EXPANDING SIDES ARE RETRACTING.		
	Step 1. Check inclinometers to see if Section is level.	Level Section (para 2-6a, steps 6 thru 11).
	Step 2. Check that removable floor sections have been taken up.	Take up removable floor sections (para 2-7c).
	Step 3. Check that Printing Press swinging step is locked under delivery end of Printing Press.	Lock swinging step under delivery end of Printing Press.
	Step 4. Check that Printing Press manual inking roller handle points toward feeder end of Printing Press.	Reposition manual inking roller handle.

Table 3-1. Troubleshooting (Cont)

MALFUNCTION	TEST OR INSPECTION	CORRECTIVE ACTION
4. RESISTANCE (BINDING) FELT WHEN EXPANDING SIDES ARE RETRACTING (CONT)	Step 5. Check that sides are retracting evenly.	If malfunction still exists, notify your supervisor.
5. FOLDING FLOOR DOES NOT FIT.	Step 1. Check that expanding sides are fully expanded.	Expand sides (para 2-6c).
	Step 2. Check for obstructions under front lip of folding floor.	Remove obstructions.
	Step 3. Check inclinometers to see if Section is level.	Level Section (para 2-6a, steps 6 thru 11).
		If malfunction still exists, notify your supervisor.
6. BOARDING LADDERS WILL NOT MOUNT ON DOORS FOR TRANSPORT.	Check mounting brackets on boarding ladder for proper adjustment.	Adjust boarding ladder mounting brackets (para 3-12).
		If malfunction still exists, notify your supervisor.
7. AUXILIARY PUMP MOTOR DOES NOT TURN.	Step 1. Check that power cord is plugged into 120 VOLT OUTLET on power entry panel.	Plug in power cord.
	Step 2. Check that OUTSIDE RECEPTACLE circuit breaker is turned ON.	Reset circuit breaker.
		If malfunction still exists, notify your supervisor.

Table 3-1. Troubleshooting (Cont)

MALFUNCTION	TEST OR INSPECTION	CORRECTIVE ACTION
8. AUXILIARY PUMP MOTOR TURNS, BUT DOES NOT PUMP WATER.	Step 1. Check that intake hose is submerged several inches below water level at source.	Lower intake hose.
	Step 2. Check that auxiliary pump has been primed.	Prime auxiliary pump (para 2-6e).
	Step 3. Check that hoses are connected correctly.	Reconnect hoses (para 2-6e).
	Step 4. Check intake hose for clogging or leaks.	Clean, repair, or replace intake hose.
		If malfunction still exists, notify your supervisor.
9. WATER TANK DOES NOT FILL.	Step 1. Check that water tank gate valve is closed.	Close valve.
	Step 2. Check that hose connections are secure.	Tighten hose connections.
	Step 3. Check inlet and outlet hoses for clogging or leaks.	Clean, repair, or replace hoses.
	Step 4. Check if field source of water is depleted.	Refill source or relocate to new source.
		If malfunction still exists, notify your supervisor.

Table 3-1. Troubleshooting (Cont)

MALFUNCTION	TEST OR INSPECTION	CORRECTIVE ACTION
10. AIR CONDITIONER/HEATERS DO NOT OPERATE.		Refer to TM 5-4120-367-14.
11. WALL HEATERS DO NOT OPERATE.		Check that circuit breaker is in ON position. Turn circuit breaker to ON. If malfunction still exists, notify your supervisor.
12. BLACKOUT LIGHTS DO NOT OPERATE.		Step 1. Check that blackout switches are set correctly. Reset blackout switches by turning BLACKOUT BYPASS switch to OFF and BLACKOUT LIGHT switch to ON. Step 2. Check to see that striker plate(s) contacts roller on microswitch. Loosen screws and move striker plate(s) up or down until microswitch operates. Step 3. Check for burnt out bulb(s). Replace bulb(s) (para 3-6). If malfunction still exists, notify your supervisor.
13. EXHAUST FAN DOES NOT OPERATE.		Step 1. Check that exhaust fan switch is ON. Turn switch ON. Step 2. Check that exhaust fan plug is connected to FAN RECEPTACLE wall outlet. Connect plug.

Table 3-1. Troubleshooting (Cont)

MALFUNCTION	TEST OR INSPECTION	CORRECTIVE ACTION
Step 3. Check that circuit breaker is in ON position.	Turn circuit breaker ON.	If malfunction still exists, notify your supervisor.
14. TELEPHONE DOES NOT OPERATE.	Check that telephone lines are connected to binding posts.	Reconnect telephone lines.
		If malfunction still exists, notify your supervisor.

Section III. MAINTENANCE PROCEDURES

3-3. INTRODUCTION. This section contains maintenance procedures which are the responsibility of the operator as authorized by the Maintenance Allocation Chart (MAC) in TM 5-3610-287-24. The following topics are included as applicable: a. Adjustment b. Service c. Repair. For maintenance of the semitrailer chassis, refer to TM 5-2330-305-14.

3-4. GENERAL . All maintenance procedures in this section are to be performed by a Photolithographer, MOS 83F10/20.

3-5. FLUORESCENT LIGHT MAINTENANCE INSTRUCTIONS

This task covers: Repair

INITIAL SETUP

Tools

Flat-tip screwdriver (appendix B, section III, item 22)

Materials/Parts

Fluorescent lamp (appendix D, item 22)

REPAIR

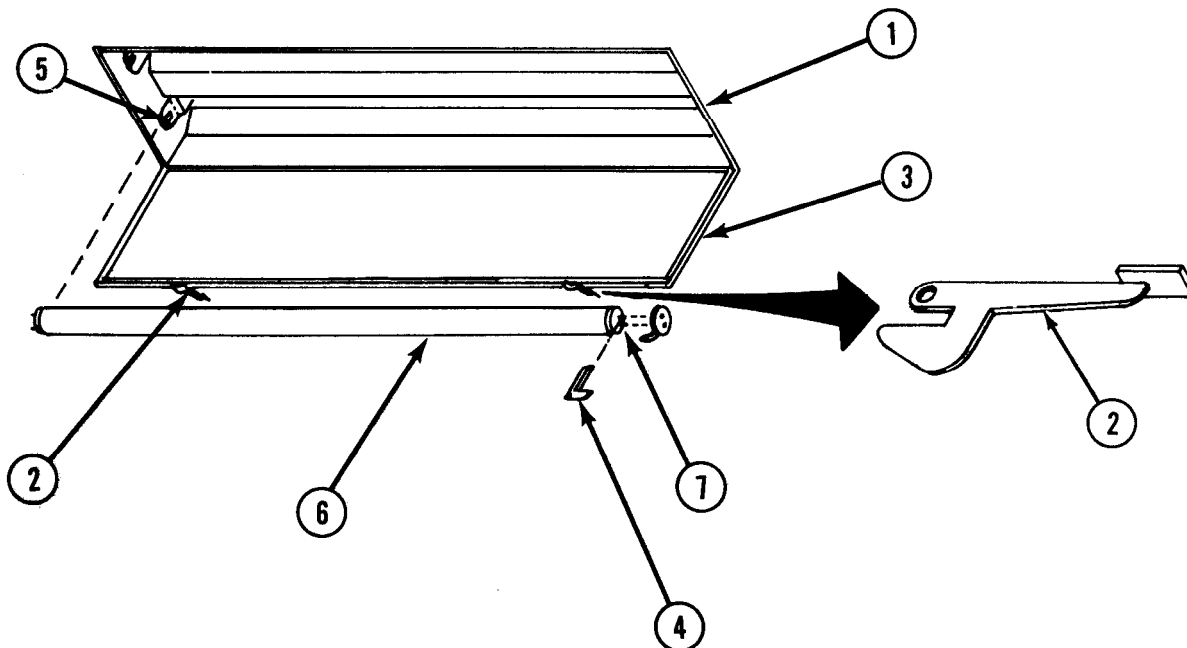

3-5. FLUORESCENT LIGHT MAINTENANCE INSTRUCTIONS (CONT)WARNING

ELECTRICAL HAZARD. Turn off power to light fixture before replacing fluorescent light. Failure to do so could result in death or serious personal injury.

1. Turn off power to light fixture (1).
2. Release two latches (2) and open diffuser door (3).
3. If present, remove safety tab (4) from fluorescent light socket (5).
4. Rotate fluorescent lamp (6) to free prongs (7) from fluorescent light socket (5). Remove fluorescent lamp (6).
5. Insert prongs (7) of new fluorescent lamp (6) into fluorescent light socket (5) and secure fluorescent lamp by rotating 90 degrees.
6. If available, insert safety tab (4) into fluorescent light socket (5).
7. Close diffuser door (3) and secure with two latches (2).
8. Turn on power to light fixture (1).

3-6. BLACKOUT LIGHT MAINTENANCE INSTRUCTIONS

This task covers: Repair

INITIAL SETUPTools

Cross-tip screwdriver (appendix B, section III, item 21)

Materials/Parts

Blackout light bulb (appendix D, item 24)
Twist/lock light bulb (appendix D, item 26)

3-6. BLACKOUT LIGHT MAINTENANCE INSTRUCTIONS (CONT)

REPAIR

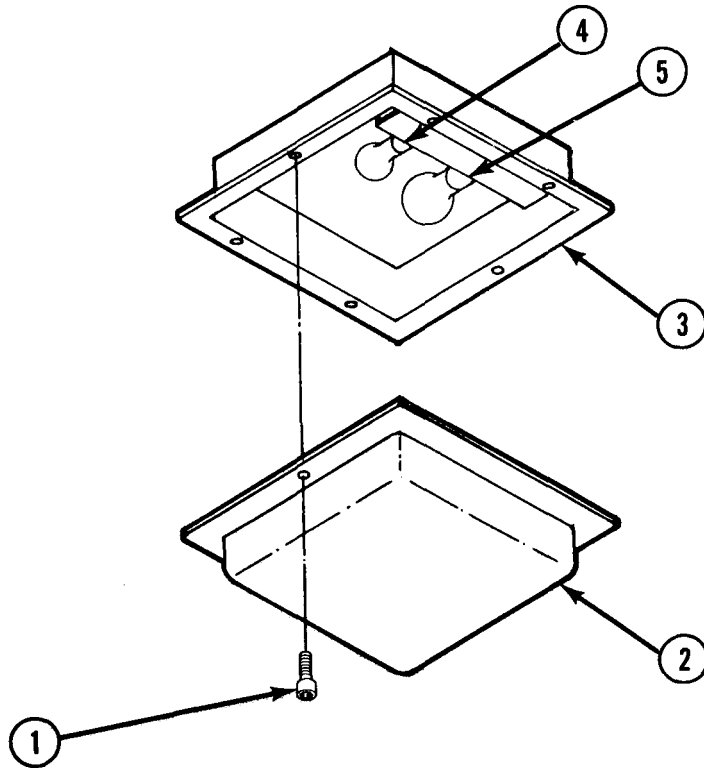

WARNING

ELECTRICAL HAZARD. Turn off power to blackout light before replacing bulb. Failure to do so could result in death or serious personal injury.

1. Turn BLACKOUT LIGHTS switch to OFF.
2. Remove two thumbscrews (1) and remove cover (2) from blackout light assembly (3).
3. If necessary, remove clear light bulb (4) from locking socket by pushing and turning.
4. Unscrew red light bulb (5) from socket.
5. Install new red light bulb (5) in socket.
6. Install new clear light bulb (4) in socket by pushing and turning.
7. Secure cover (2) on blackout light assembly (3) with two thumbscrews (1).
8. Turn BLACKOUT LIGHTS switch to ON.

3-7. DOME LIGHT MAINTENANCE INSTRUCTIONS

This task covers: Repair

INITIAL SETUP

Tools

Cross-tip screwdriver (appendix B, section III, item 21)

Materials/Parts

Dome light bulb (appendix D, item 25)

REPAIR

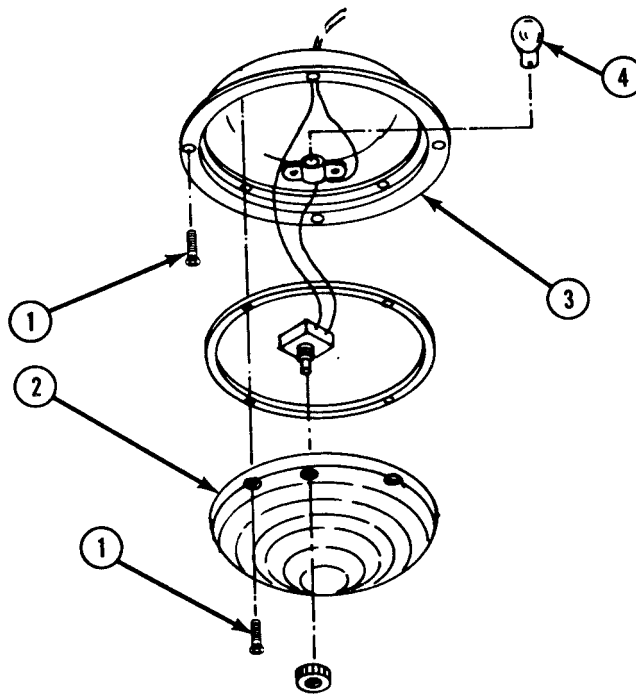

WARNING

ELECTRICAL HAZARD. Turn off power to dome light before replacing bulb. Failure to do so could result in death or serious personal injury.

NOTE

Section must be connected to dc power source for dome lights to work.

1. Turn 12 VOLT DOME LIGHT switch to OFF.

3-7. DOME LIGHT MAINTENANCE INSTRUCTIONS (CONT)

2. Remove four screws (1) and remove dome light lens (2) from dome light assembly (3).
3. Push bulb (4) in and turn. Remove bulb (4) from socket.
4. Place new bulb (4) in socket. Push and turn to secure.
5. Place dome light lens (2) on dome light assembly (3) and secure with four screws (1).
6. Turn 12 VOLT DOME LIGHT switch to ON.

3-8. SIDE LIGHT MAINTENANCE INSTRUCTIONS

This task covers: Repair

INITIAL SETUP

Tools

Flat-tip screwdriver (appendix B, section III, item 22)

Materials/Parts

Light bulb (appendix D, item 23)

REPAIR

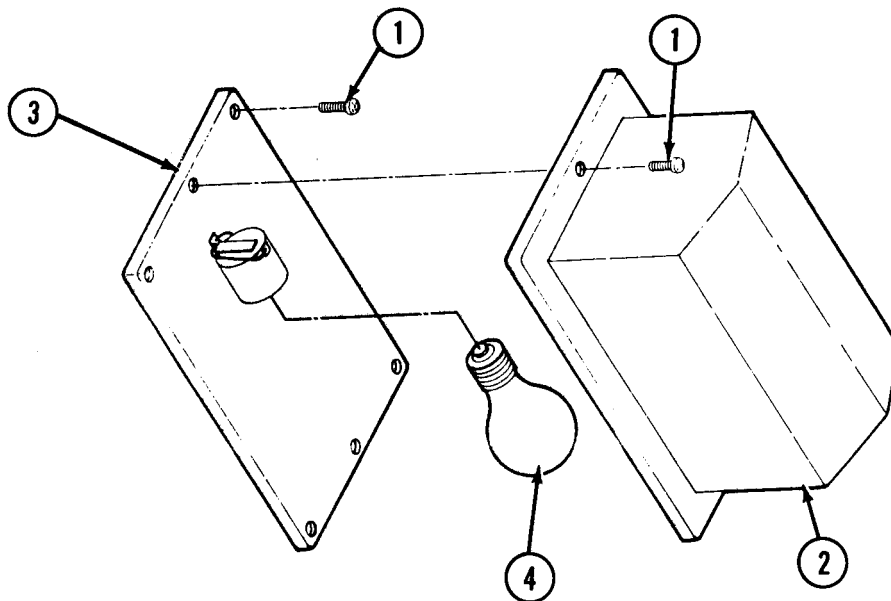

3-8. SIDE LIGHT MAINTENANCE INSTRUCTIONS (CONT)WARNING

ELECTRICAL HAZARD. Turn off side light power switch and circuit breaker. Failure to do so could result in death or serious injury.

1. Turn side light power switch and circuit breaker to OFF.
2. Remove two screws (1) and side light cover (2) from side light assembly (3).
3. Remove light bulb (4).
4. Install new light bulb (4).
5. Position side light cover (2) on side light assembly (3), and secure with two screws (1).
6. Turn power switch and circuit breaker to ON.

3-9. VENTILATION DUCTS MAINTENANCE INSTRUCTIONS

This task covers: Service

INITIAL SETUPTools

Flat-tip screwdriver (appendix B, section III, item 22)

Materials/Parts

Rag (appendix D, item 31)

3-9. VENTILATION DUCTS MAINTENANCE INSTRUCTIONS (CONT)

SERVICE

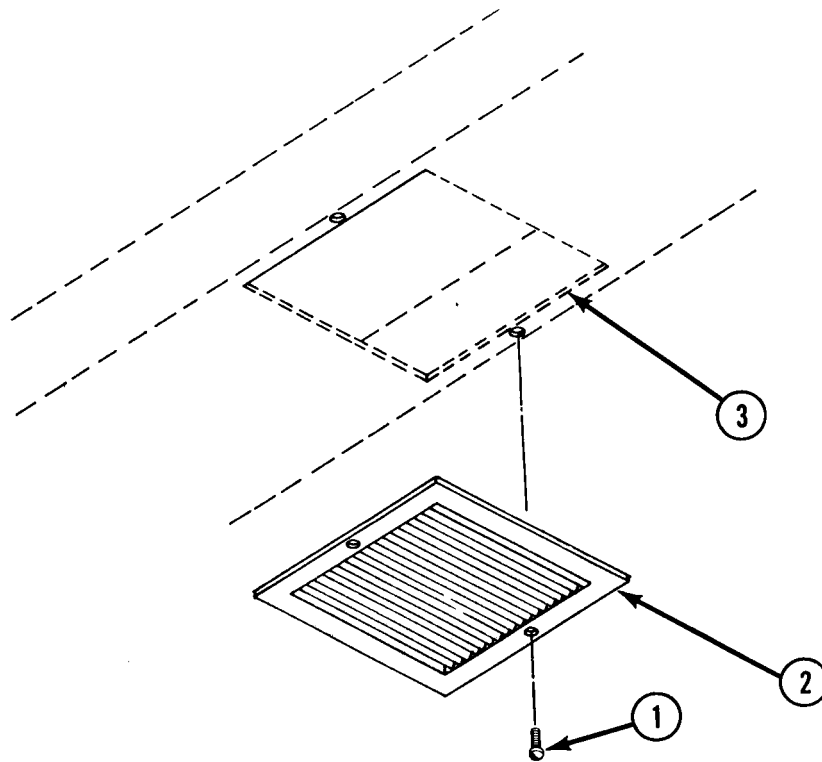

CAUTION

Dust and dirt can damage the Printing Press. When removing vents over top of Printing Press, cover top of Printing Press with paper or plastic cover to prevent dirt from entering Printing Press.

1. Turn off air conditioner/heaters.
2. Remove two screws (1) securing each ventilation duct deflector (2) to Section ceiling.
3. Clean dust and dirt from ventilation duct deflector with damp rag.
4. Clean ventilation duct (3) at each deflector hole with damp rag.
5. Install each ventilation duct deflector (2) and secure with two screws (1).

3-10 . WALL HEATER MAINTENANCE INSTRUCTIONS

This task covers: Service

INITIAL SETUP

Tools

Cross-tip screwdriver (appendix B, section III, item 21)

Materials/Parts

Rag (appendix D, item 31)

SERVICE

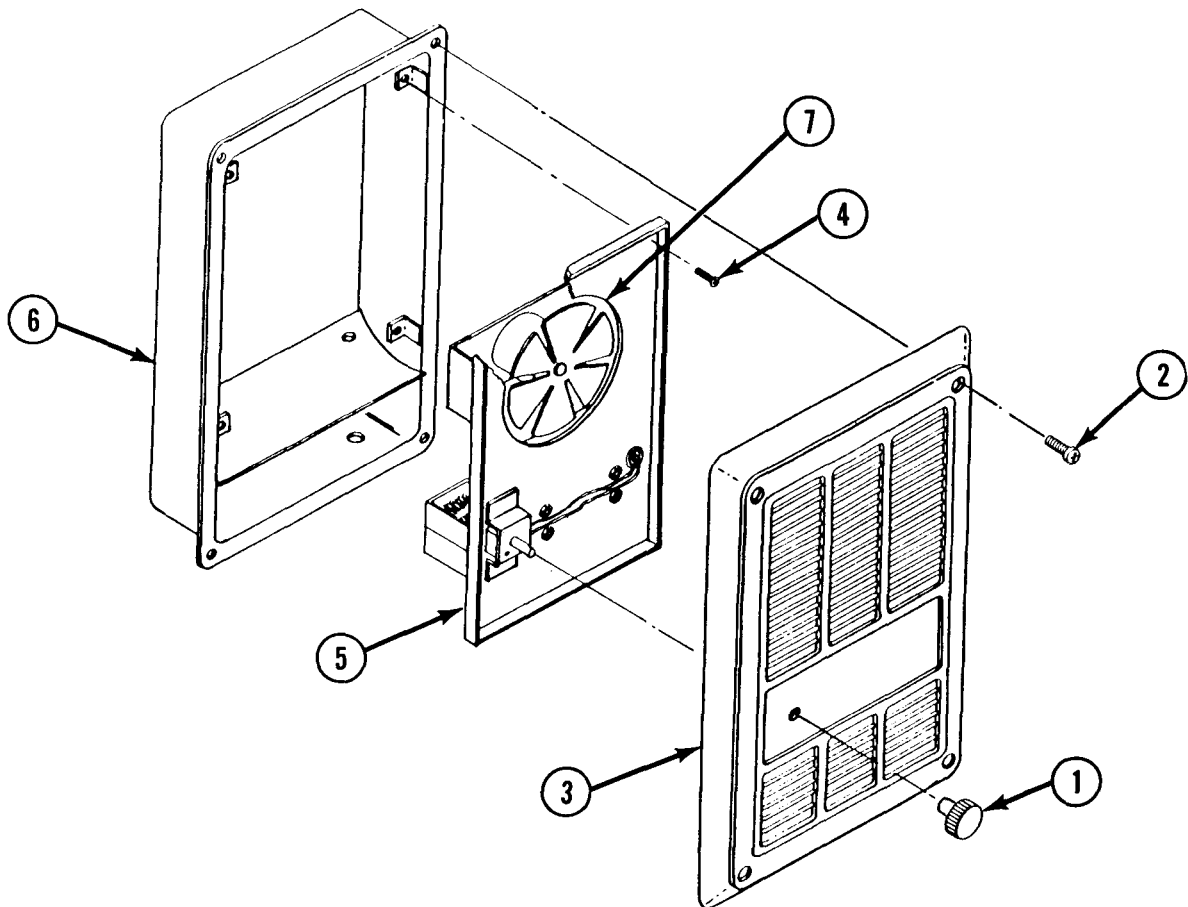

3-10. WALL HEATER MAINTENANCE INSTRUCTIONS (CONT)

WARNING

- ELECTRICAL HAZARD. Disconnect power before cleaning wall heaters. Failure to observe this warning may result in death or serious injury.
- Do not operate wall heater with grill removed. Serious personal injury may result.

1. Turn wall heater control knob (1) and circuit breaker to OFF.
2. Remove control knob (1) by pulling gently.

WARNING

Grill may fall when last screw is removed. Failure to hold grill with free hand may result in personal injury.

3. Remove four screws (2) securing grill (3) to wall heater. Remove grill.
4. Remove four interior mounting screws (4).
5. Carefully remove wall heater assembly (5) from enclosure (6).
6. Clean dust from grill (3), fan (7), and wall heater elements with rag.
7. Install wall heater assembly (5) and secure to enclosure (6) with four interior mounting screws (4).
8. Install grill (3) and secure to enclosure (6) with four screws (2).
9. Install control knob (1).
10. Turn on wall heater circuit breaker and turn wall heater control knob (1) to desired setting.

3-11. EXHAUST FAN MAINTENANCE INSTRUCTIONS

This task covers: Service

INITIAL SETUP

Materials/Parts

- Rag (appendix D, item 31)
- Detergent (appendix D, item 13)

3-11. EXHAUST FAN MAINTENANCE INSTRUCTIONS (CONT)

SERVICE

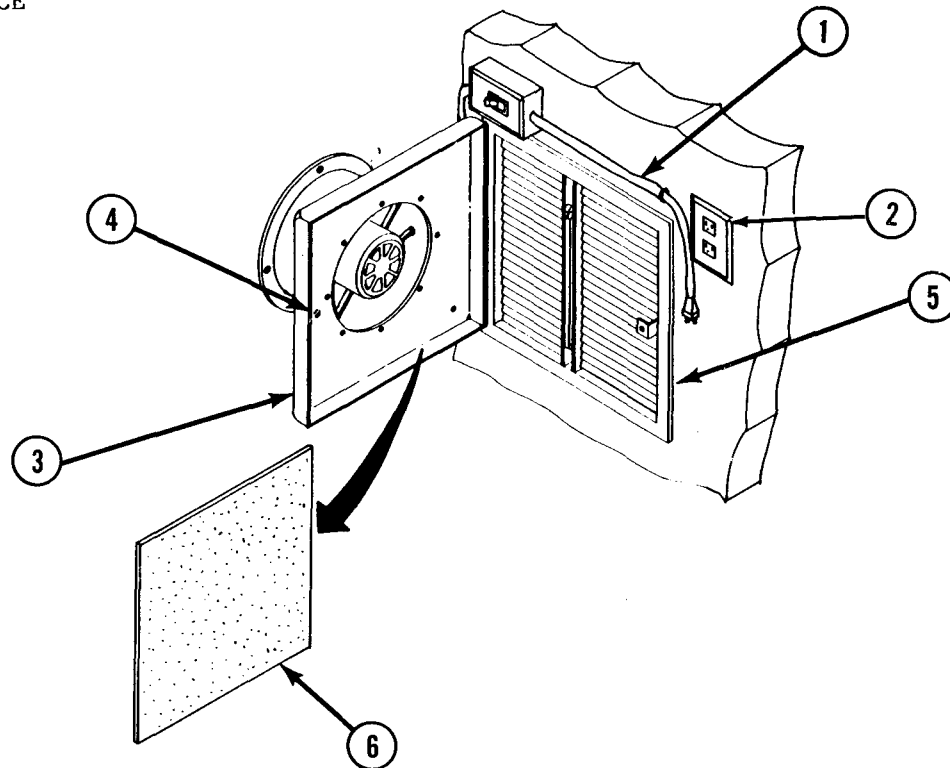
WARNING

ELECTRICAL HAZARD. Turn exhaust fan switch off and disconnect power cord before working on exhaust fan. Death or serious injury could result if power is on.

1. Unplug power cord (1) from FAN RECEPTACLE wall outlet (2).
2. Open exhaust fan door (3) by turning captive screw (4).
3. Clean dust and dirt from louvers (5) with damp rag.
4. Remove foam filter (6). Wash in sink with water and detergent. Air dry.
5. Reinstall foam filter (6).
6. Close exhaust fan door (3) and secure by turning captive screw (4).
7. Plug in power cord (1).

3-12. BOARDING LADDER MAINTENANCE INSTRUCTIONS

This task covers: Adjustment

INITIAL SETUP

Tools

Adjustable wrench (appendix B, section III, item 25)

ADJUSTMENT

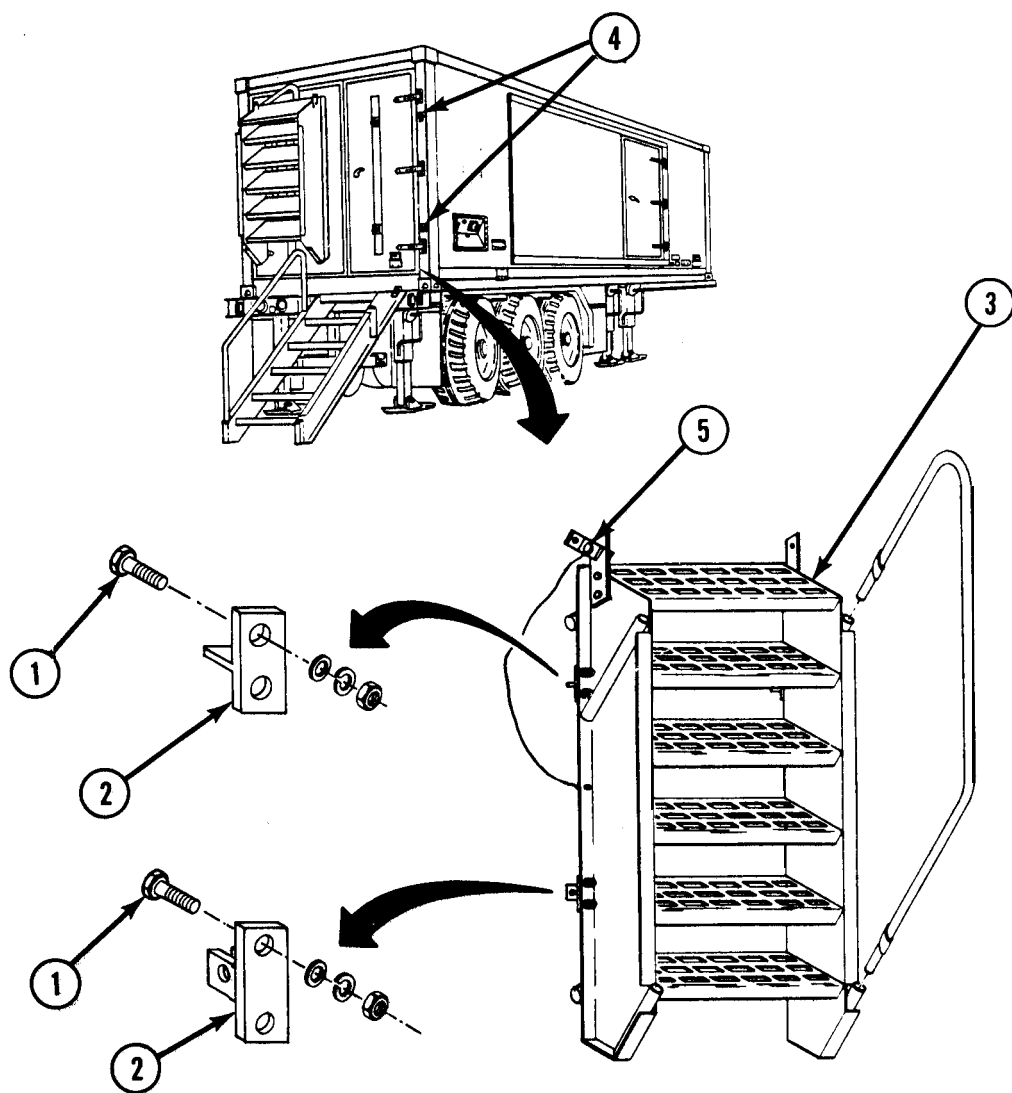

3-12. BOARDING LADDER MAINTENANCE INSTRUCTIONS (CONT)

1. Loosen two bolts (1) on four boarding ladder mounting brackets (2).
2. Hang boarding ladder (3) on cargo or rear personnel door mounting brackets (4).
3. Aline boarding ladder mounting brackets (2) with cargo or rear personnel door mounting brackets (4).
4. Insert pins (5) through mounting brackets.
5. Tighten bolts (1) on four boarding ladder mounting brackets (2).

3-13. GROUND ROD MAINTENANCE INSTRUCTIONS

This task covers: Repair

INITIAL SETUPTools

Adjustable wrench (appendix B, section III, item 25)

Materials/Parts

Slide hammer stop (appendix B, section II, item 11)
Lockwasher (appendix B, section II, item 11)
Hex head nut (appendix B, section II, item 11)
Impact bolt (appendix B, section II, item 18)
Rod sections with couplings (appendix B, section II, item 19)

3-13. GROUND ROD MAINTENANCE INSTRUCTIONS (CONT)

REPAIR

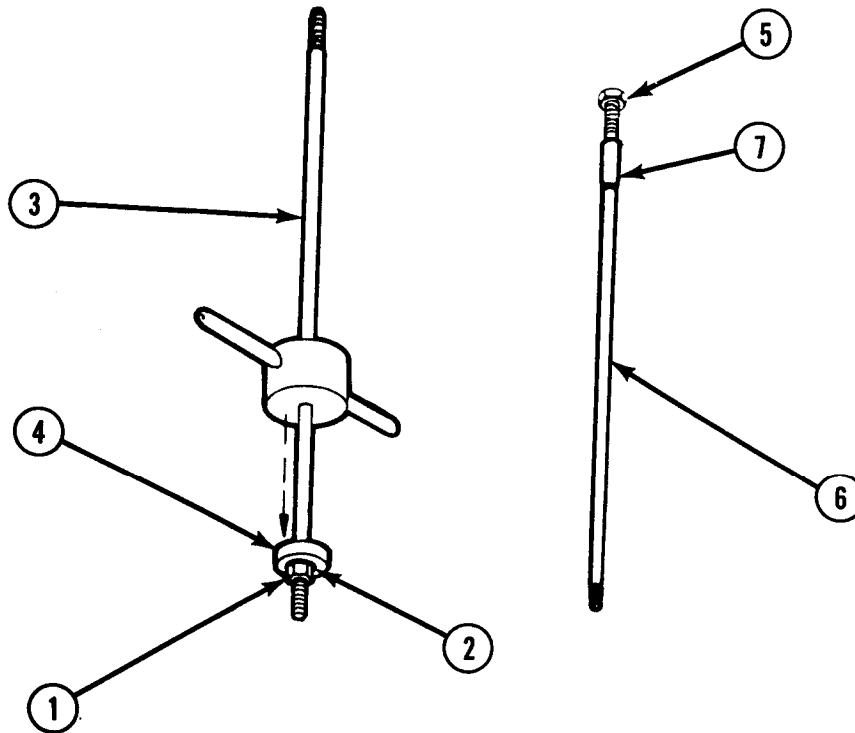

WARNING

ELECTRICAL HAZARD. Turn Section main power off before performing maintenance on ground rod assembly. Failure to do so could result in death or serious injury.

1. Remove hex head nut (1) and lockwasher (2) from slide hammer rod (3).
2. Remove slide hammer stop (4) from slide hammer rod (3).
3. Install new slide hammer stop (4) on slide hammer rod (3).
4. Install new lockwasher (2) and hex head nut (1) on slide hammer rod (3).
5. If necessary, remove impact bolt (5) from end of ground rod (6).
6. Remove coupling (7) from ground rod (6).
7. Install new coupling (7) on ground rod (6).

3-14. BLACKOUT CURTAIN MAINTENANCE INSTRUCTIONS

This task covers: Repair

INITIAL SETUP

Tools

Flat-tip screwdriver (appendix B, section III, item 22)

Materials/Parts

Curtain clips (appendix D, item 10)

Curtain hooks (appendix D, item 21)

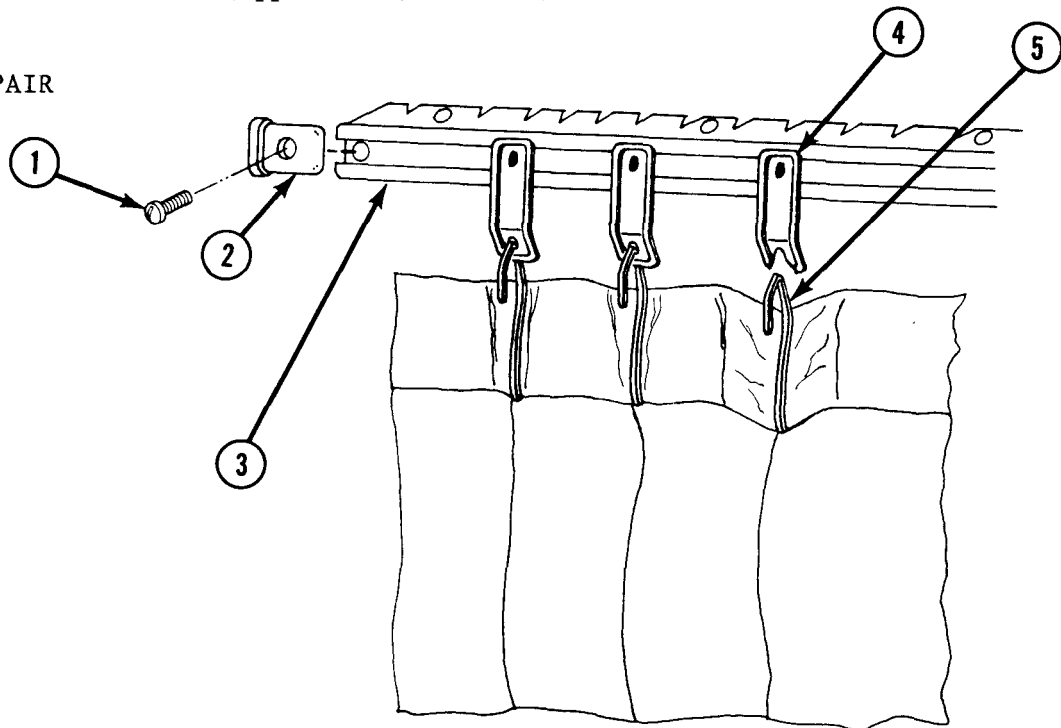
REPAIR

1. Remove screw (1) and stop (2) from curtain rail (3).
2. Remove necessary curtain clips (4) and curtain hooks (5) until broken curtain clip (4) is accessible.
3. Install new curtain clip (4) on curtain rail (3).
4. Hang curtain hook (5) on curtain clip (4).
5. Install remaining curtain clips (4) into curtain rail (3).
6. Install stop (2) and screw (1) in curtain rail (3).

APPENDIX A**REFERENCES**

A-1 . SCOPE . This appendix lists all references used in conjunction with this manual.

A-2 . FORMS

Quality Deficiency Report SF 368

Recommended Changes to Publications
and Blank Forms DA Form 2028

Recommended Changes to Equipment
Technical Publications DA Form 2028-2

Hand Receipt/Annex Number DA Form 2062

Equipment Inspection and Maintenance
Worksheet DA Form 2404

A-3 . FIELD MANUALS

First Aid for Soldiers FM 21-11

A-4 . TECHNICAL MANUALS

Operator's, Organizational, Direct Support,
and General Support Maintenance Manual
for the Topographic Support System Chassis,
Semitrailer TM 5-2330-305-14

Operator's Maintenance Manual, Topographic Support
System Press Section Printing Press TM 5-3610-286-10

Organizational Maintenance Manual, Topographic
Support System Press Section Printing Press TM 5-3610-286-20

Hand Receipt Covering Contents of Components of End
Item (COEI), Basic Issue Items (B11), and
Additional Authorization List (AAL) for Topographic
Support System Press Section TM 5-3610-287-10-HR

Organizational, Direct Support, and General Support
Maintenance Manual for the Topographic Support
System Press Section TM 5-3610-287-24

A-4 . TECHNICAL MANUALS (CONT)

Organizational, Direct Support, and General
Support Maintenance Repair Parts and
Special Tools List for the Topographic
Support System Press Section TM 5-3610-287-24P

Operator's, Organizational, Direct Support, and
General Support Maintenance Manual, Air
Conditioner, Horizontal, Compact, 18,000 BTU/HR
Cooling TM 5-4120-367-14

A-5. MISCELLANEOUS PUBLICATIONS

The Army Maintenance Management System
(TAMMS) DA PAM 738-750

Lubrication Order, Topographic Support System
Chassis, Semitrailer LO 5-2330-305-12

Lubricating Order, Topographic Support System Press
Section Printing Press LO 5-3610-286-12

Lubrication Order, Topographic Support
System Press Section LO 5-3610-287-12

APPENDIX B

COMPONENTS OF END ITEM AND BASIC ISSUE ITEMS LISTS

Section I. INTRODUCTION

B-1. SCOPE. This appendix lists components of end item and basic issue items for the TSS Press Section to help you inventory items required for safe and efficient operation.

B-2. GENERAL. The Components of End Item and Basic Issue Items Lists are divided into the following sections:

a. Section II - Components of End Item. This listing is for informational purposes only, and is not authority to requisition replacements. As part of the end item, these items must be with the end item whenever it is issued or transferred between property accounts. Illustrations are furnished to assist you in identifying the items.

b. Section III - Basic Issue Items. These are the minimum essential items required to place the Section in operation, to operate it, and to perform emergency repairs. BII must be with the Section during operation and whenever it is transferred between property accounts. The illustrations will assist you with hard-to-identify items. This manual is your authority to request/requisition replacement BII, based on TOE/MTOE authorization of the end item.

B-3. EXPLANATION OF COLUMNS. The following provides an explanation of columns found in the tabular listings:

a. Column (1) - Illustration Number (Illus Number). Indicates the number of the illustration in which the item is shown.

b. Column (2) - National Stock Number. Indicates the National stock number assigned to the item and will be used for requisitioning purposes.

c. Column (3) - Description. Indicates the Federal item name and, if required, a minimum description to identify and locate the item. The last line for each item indicates the FSCM (in parentheses) followed by the part number.

d. Column (4) - Unit of Measure (U/M). Indicates the measure used in performing the actual operational/maintenance function. This measure is expressed by a two-character alphabetical abbreviation (e.g., ea, in., pr).

e. Column (5) - Quantity Required (Qty Rqr). Indicates the quantity of the item authorized to be used with/on the equipment.

Section II. COMPONENTS OF END ITEM

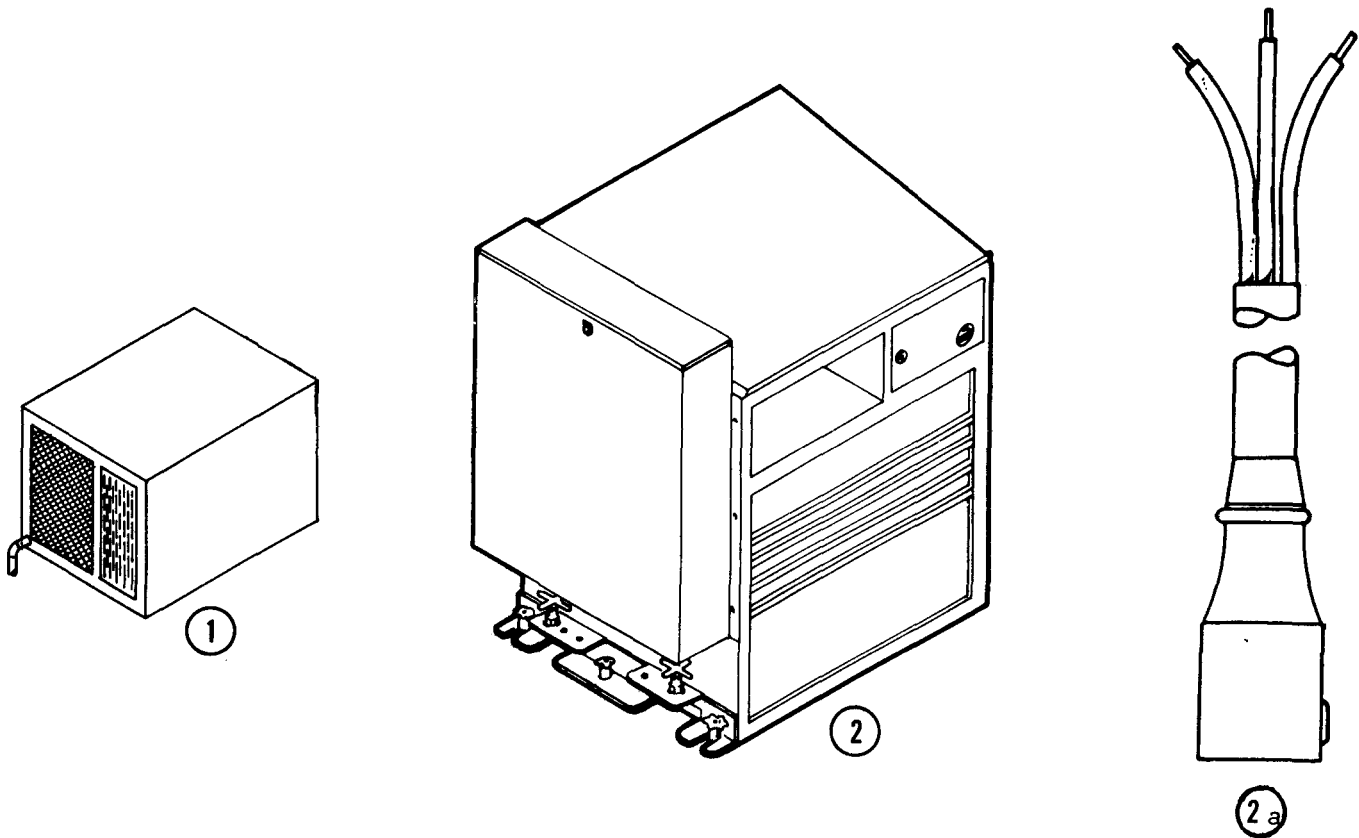

(1) Illus Number	National Stock Number	Description FSCM and Part Number	Usable On Code	(4) U/M	(5) Qty Rqr
1	4120-00-974-7206	AIR CONDITIONER/HEATER (97403) 13216E6120		EA	2
2		CABINET ASSEMBLY, GTO STORAGE (97403) 13227E5732 AND BOX ASSEMBLY, PLATE STORAGE (97403) 13226E7894		EA	1
2a	2590-00-134-0848	CABLE ASSEMBLY, SPECIAL PURPOSE (19207) 11601641		EA	1

Section II. COMPONENTS OF END ITEM (CONT)

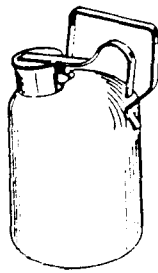

3

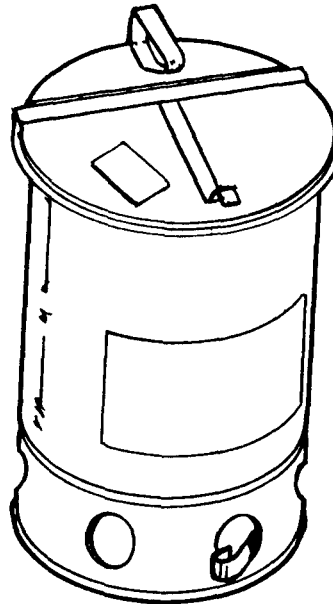

4

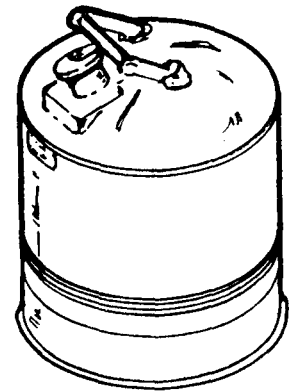

5

(1) Illus Number	(2) National Stock Number	(3) Description FSCM and Part Number	Usable On Code	(4) U/M	(5) Qty Rqr
3	7240-00-244-7412	CAN, SAFETY, .25 GAL (81 348) RR-S-30		EA	2
4	7240-00-282-8411	CAN, SAFETY WASTE, 6 GAL (81 348) RR-C-114 TYPE 1, SIZE 6		EA	1
5	7240-00-240-6958	CAN, SAFETY, 5 GAL (81 348) RR-S-30		EA	2

Section II. COMPONENTS OF END ITEM (CONT)

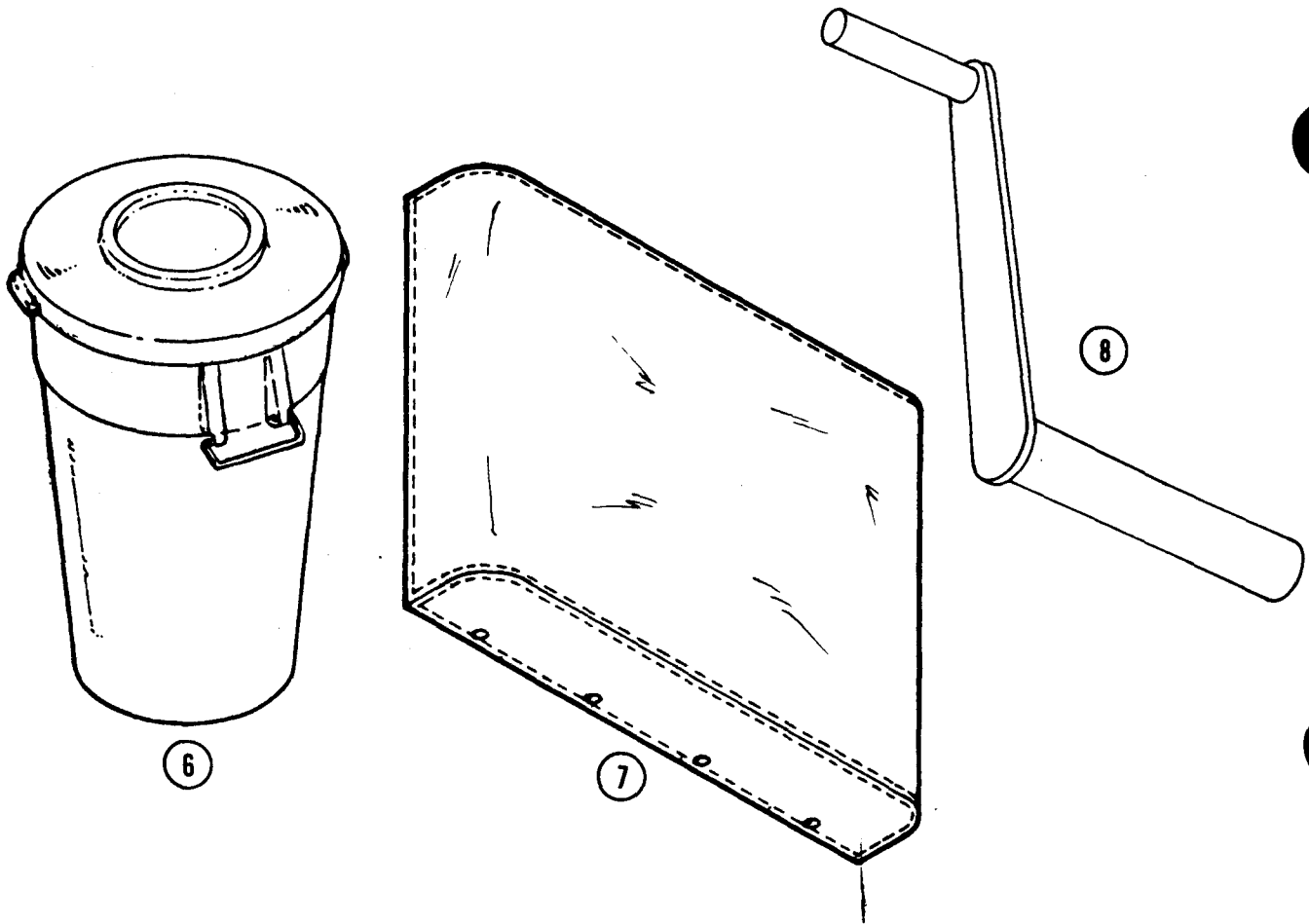

(1) Illus Number	(2) National Stock Number	(3) Description FSCM and Part Number	Usable On Code	(4) U/M	(5) Qty Rqr
6	7240-00-139-7521	CAN, WASTE, 40 GAL (81348) L-W-25, CLASS A, SIZE 1		EA	1
7		COVER, ROLLER RACK (97403) 13226E7832		EA	1
8		CRANK, HAND (73830) T33772-1		EA	1

Section II. COMPONENTS OF END ITEM (CONT)

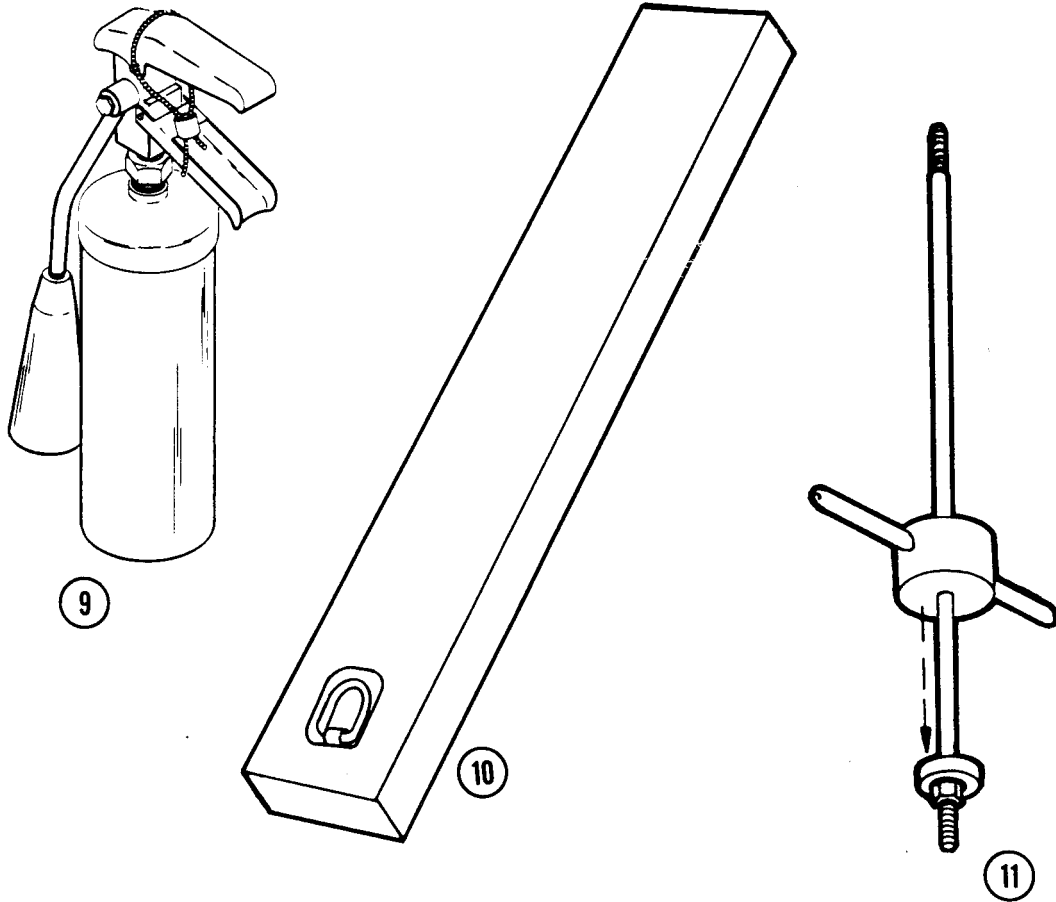

(1) Illus Number	(2) National Stock Number	(3) Description FSCM and Part Number	Usable On Code	(4) U/M	(5) Qty Rqr
9		EXTINGUISHER, FIRE (54905) 417T003311		EA	2
10		FLOOR, REMOVABLE SECTION (51225) 54-0194		EA	2
11	5120-00-013-1676	HAMMER ASSEMBLY, SLIDE (45225) P74-144		EA	1

Section II. COMPONENTS OF END ITEM (CONT)

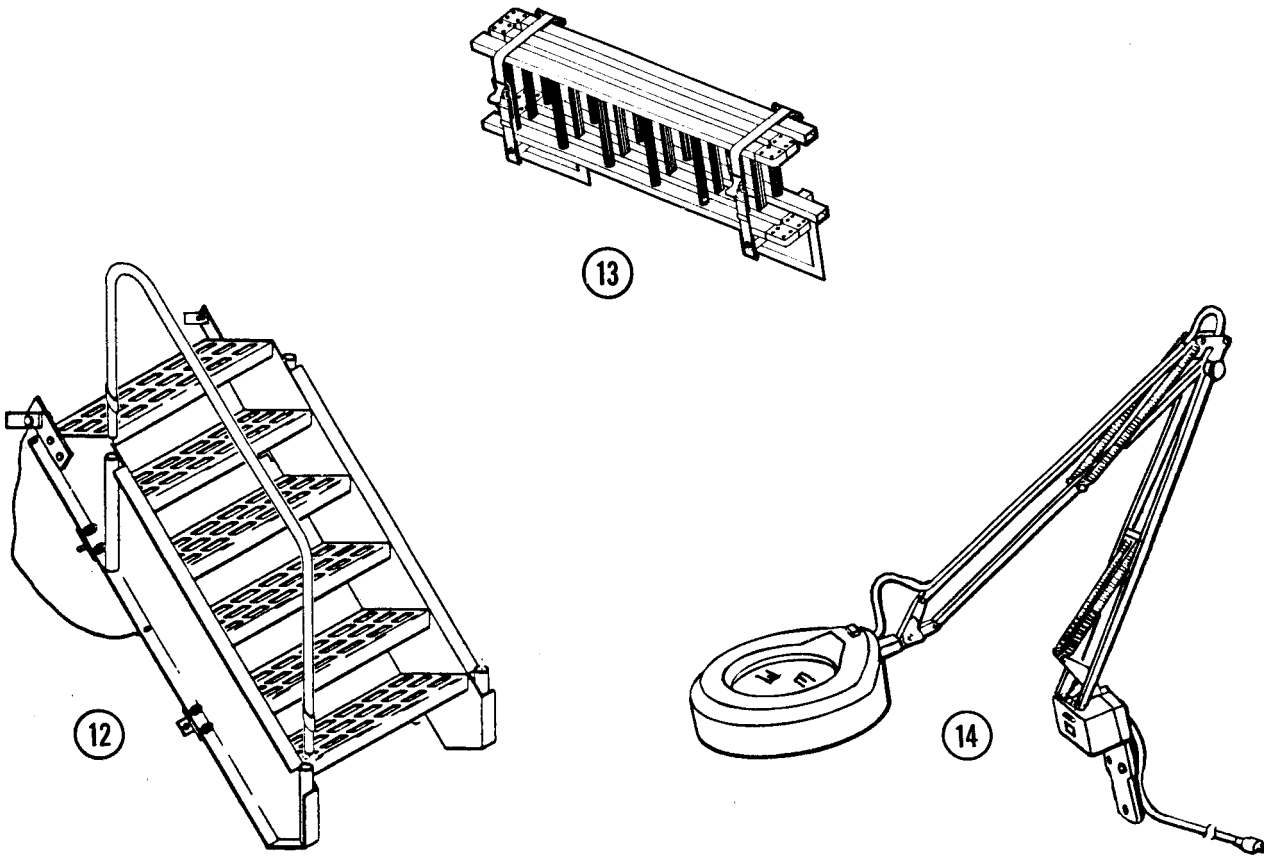

(1) Illus Number	(2) National Stock Number	(3) Description FSCM and Part Number	Usable On Code	(4) U/M	(5) Qty Rqr
12		LADDER ASSEMBLY, BOARDING (97403) 13225E3074		EA	2
13		LADDER, FOLDING (39428) 8028T16		EA	1
14	6650-00-477-9613	LIGHT, MAGNIFIER (81348) LFMIA5		EA	1

Section II. COMPONENTS OF END ITEM (CONT)

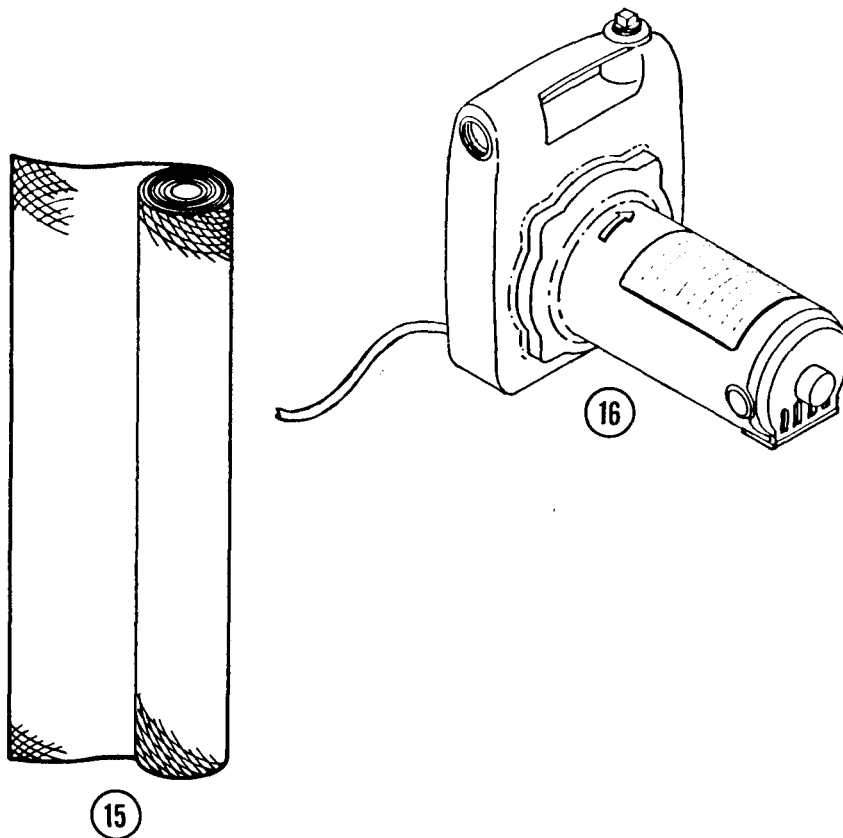

(1) Illus Number	(2) National Stock Number	(3) Description FSCM and Part Number	Usable On Code	(4) U/M	(5) Qty Rqr
15		MAT, FLOOR (TILE, DECK) (97403) 13227E6256-1-2		EA	2
16		PUMP, AUXILIARY (97403) 13226E7000		EA	1

Section II. COMPONENTS OF END ITEM (CONT)

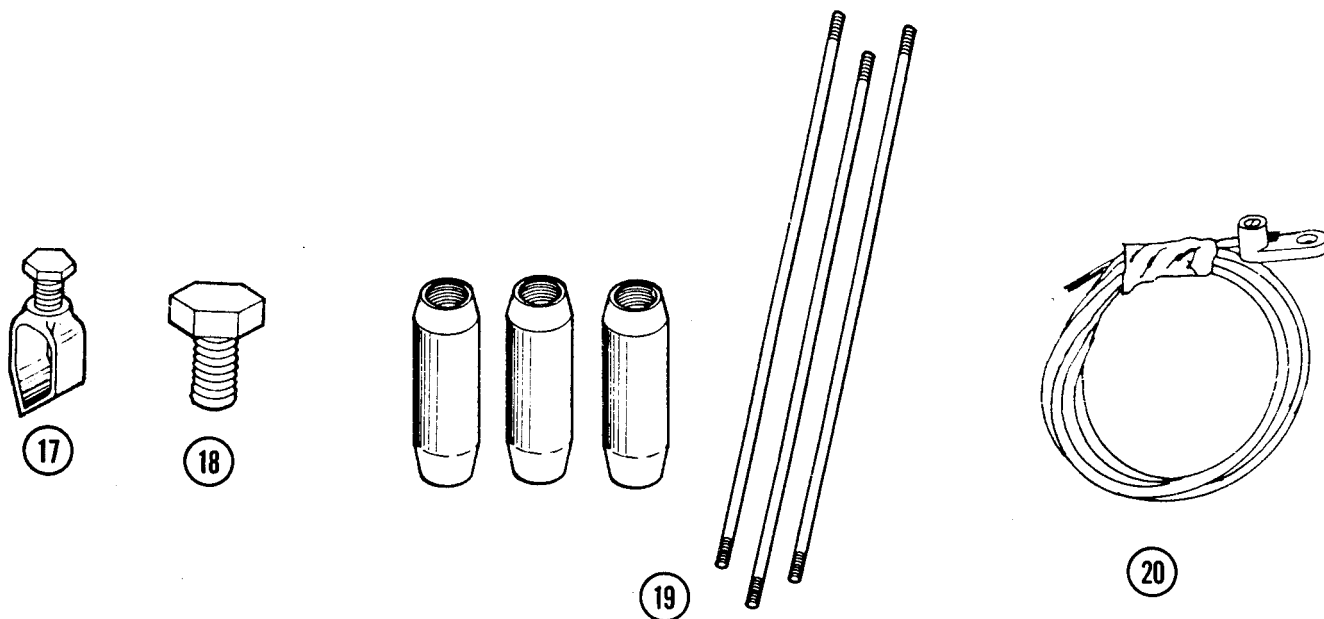

(1) Illus Number	(2) National Stock Number	(3) Description FSCM and Part Number	Usable On Code	(4) U/M	(5) Qty Rqrd
	5975-00-878-3791	ROD, ASSEMBLY, GROUND (81348) w-R-550A TYPE 3, CLASS 8 CONSISTING OF:		EA	1
17	5999-00-186-3912	CLAMP		EA	1
18	5975-00-924-9927	STUD, DRIVING (BOLT, IMPACT)		EA	1
19	5975-00-794-2523	ROD SECTIONS WITH COUPLINGS		EA	3
20	6145-00-189-6695	WIRE, NO. 6 AWG		EA	1

Section II. COMPONENTS OF END ITEM (CONT)

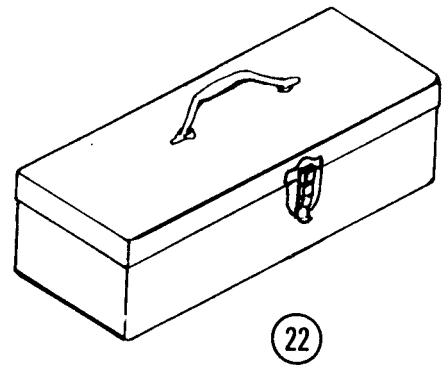
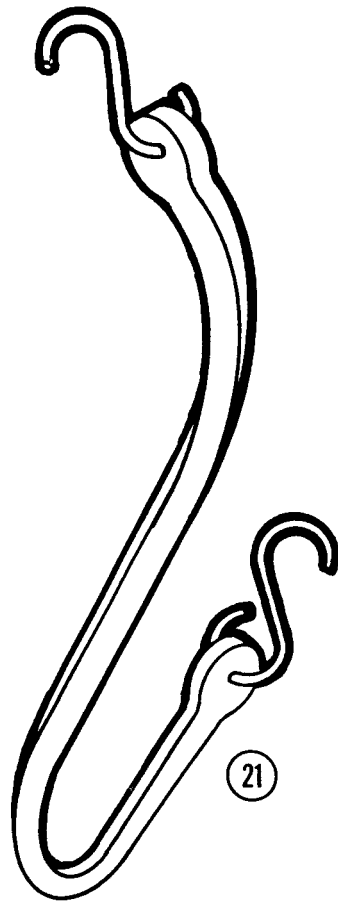

(1) Illus Number	(2) National Stock Number	(3) Description FSCM and Part Number	Usable On Code	(4) U/M	(5) Qty Rqr
21		STRAP, RUBBER (83397) 2024-S		EA	4
22	5140-00-331-5496	TOOL BOX ASSEMBLY (81348) GGG-T-558 TYPE 1, CLASS 1		EA	1

Section III. BASIC ISSUE ITEMS

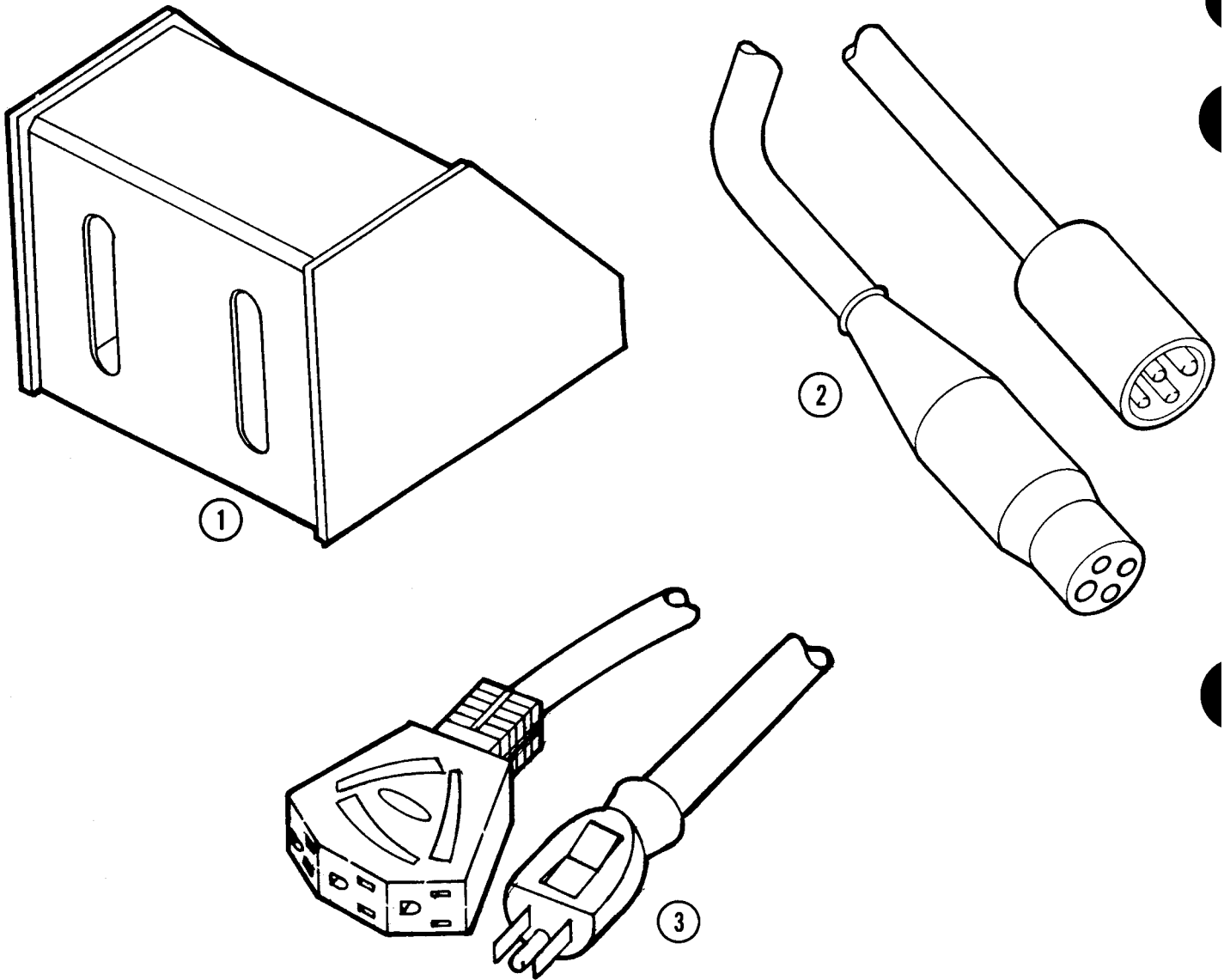

(1) Illus Number	(2) National Stock Number	(3) Description FSCM and Part Number	Usable On Code	(4) U/M	(5) Qty Rqr
1	2540-00-912-1848	BLOCK, CHOCK		EA	2
2	6150-00-134-0847	CABLE ASSEMBLY, POWER (81349) MIL-B-13207		EA	1
3	4720-00-202-6483	CORD, ELECTRICAL, 25 FOOT		EA	1

Section III. BASIC ISSUE ITEMS (CONT)

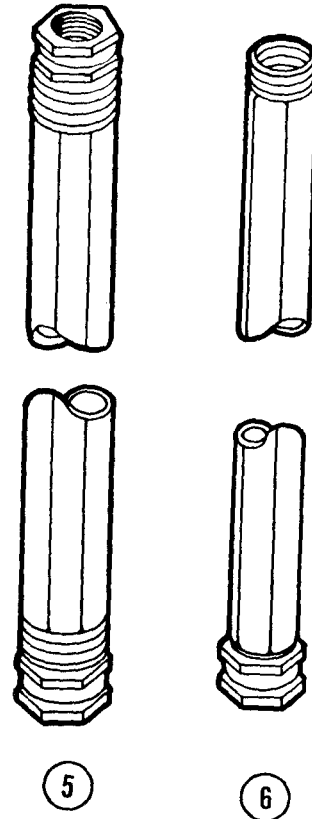
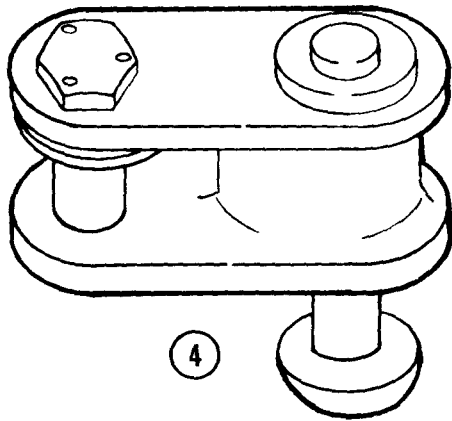

(1) Illus Number	(2) National Stock Number	(3) Description FSCM and Part Number	Usable On Code	(4) U/M	(5) Qty Rqr
4		HOOKS, TOW (TANDEMLOC, INC) 74016B-L		EA	4
5	4720-00-202-6483	HOSE ASSEMBLY, NONMETALLIC, 25 FOOT (81348) ZZ-W-561		EA	1
6	4720-00-202-6722	HOSE ASSEMBLY, NONMETALLIC, 50 FOOT		EA	1

Section III. BASIC ISSUE ITEMS (CONT)

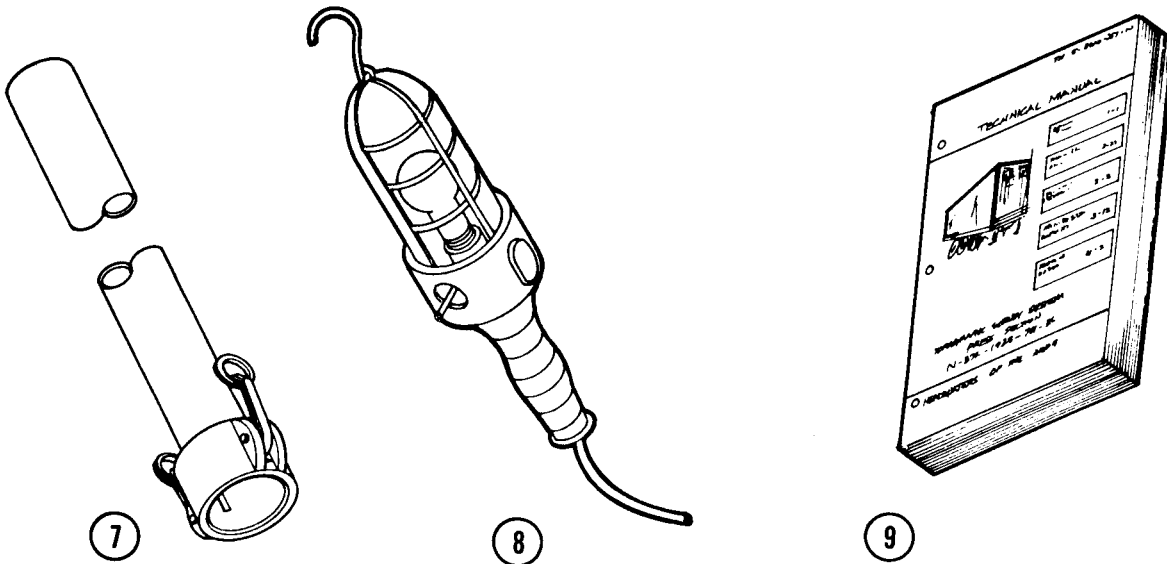

(1) Illus Number	(2) National Stock Number	(3) Description FSCM and Part Number	Usable On Code	(4) U/M	(5) Qty Rqr
7		HOSE WITH COUPLING, DRAIN (96906) H39NS27025-5		EA	1
8	6230-00-901-9755	LIGHT, EXTENSION (81348) W-L-661		EA	1
9		MANUALS, TECHNICAL			
	TM 5-3610-286-10	OPERATOR'S MANUAL, TSS PRESS SECTION PRINTING PRESS		EA	1
	TM 5-3610-287-10	OPERATOR'S MANUAL, TSS PRESS SECTION		EA	1
	TM 5-4120-367-14	OPERATOR'S, ORGANIZATIONAL, DIRECT SUPPORT, AND GENERAL SUPPORT MAINTENANCE MANUAL, AIR CONDITIONER		EA	1
	TM 5-2330-305-14	OPERATOR'S, ORGANIZATIONAL, DIRECT SUPPORT, AND GENERAL SUPPORT MAINTENANCE MANUAL, TSS CHASSIS, SEMITRAILER		EA	1

Section III. BASIC ISSUE ITEMS (CONT)

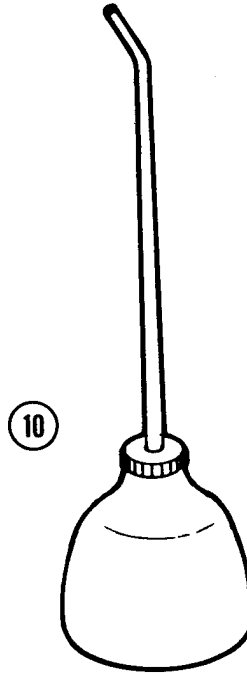

(1) Illus Number	(2) National Stock Number	(3) Description FSCM and Part Number	Usable On Code	(4) U/M	(5) Qty Rq'r
(CONT)		MANUALS, TECHNICAL (CONT)			
	LO 5-3610-287-12	LUBRICATION ORDER, TSS PRESS SECTION		EA	1
	LO 5-3610-286-12	LUBRICATION ORDER, TSS PRESS SECTION PRINTING PRESS		EA	1
	LO 5-2330-305-12	LUBRICATION ORDER, TSS CHASSIS, SEMITRAILER		EA	1
10	4930-00-141-8703	OILER, HAND, 16 OZ (81348) GGG-0-591		EA	1

Section III. BASIC ISSUE ITEMS (CONT)

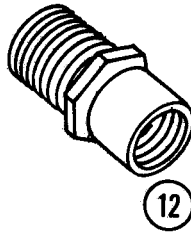
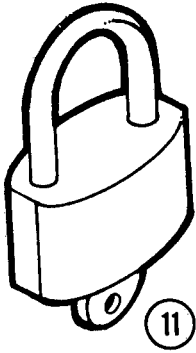

(1) Illus Number	(2) National Stock Number	(3) Description FSCM and Part Number	Usable On Code	(4) U/M	(5) Qty Rqr
11	5340-00-682-1505	PADLOCK SET (38797) MS21313-52		EA	1
12	4730-00-293-7883	PIPE END, 3/4 IN. NPT - 12 NPT INTERNAL		EA	1
13	5120-00-233-7396	PLIERS, SLIP-JOINT (81348) GGG-P-471		EA	1

Section III. BASIC ISSUE ITEMS (CONT)

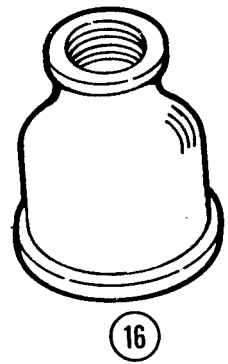
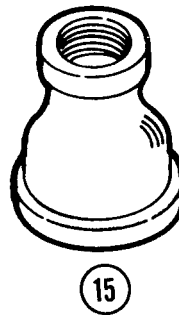

(1) Illus Number	(2) National Stock Number	(3) Description FSCM and Part Number	Usable On Code	(4) U/M	(5) Qty Rqr
14	4730-00-277-6929	REDUCER, PIPE, 3/4 IN. - 14 NPT X 1/2 IN. - 14 NPT		EA	1
15	4730-00-277-6933	REDUCER, PIPE, 1 IN. - 11-1/2 NPT X 3/4 IN. - 14 NPT		EA	1
16	4730-00-277-6935	REDUCER, PIPE, 1-1/4 IN. - 11-1/2 NPT X 3/4 IN. - 14 NPT		EA	1

Section III. BASIC ISSUE ITEMS (CONT)

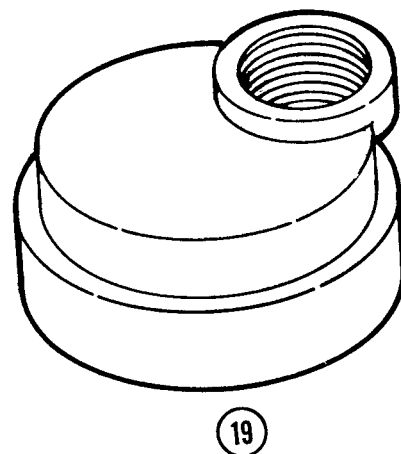
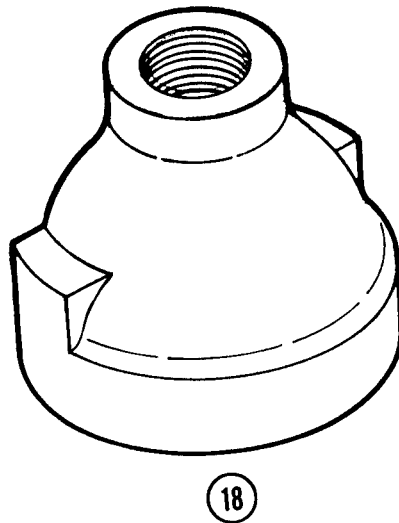
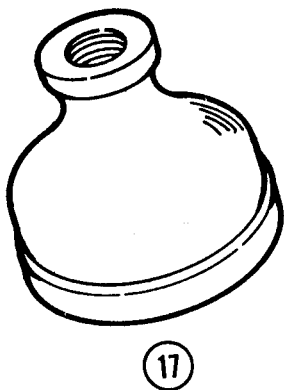

(1) Illus Number	(2) National Stock Number	(3) Description FSCM and Part Number	Usable On Code	(4) U/M	(5) Qty Rqr
17	4730-00-231-5661	REDUCER, PIPE, 1-1/2 IN. - 11-1/2 NPT X 3/4 IN. - 14 NPT		EA	1
18	4730-00-277-5539	REDUCER, PIPE, 2 IN. - 11-1/2 NPT X 3/4 IN. - 14 NPT		EA	1
19	4730-00-277-5536	REDUCER, PIPE, 3 IN. - 8 NPT X 1-1/2 IN. - 11-1/2 NPT		EA	1

Section III. BASIC ISSUE ITEMS (CONT)

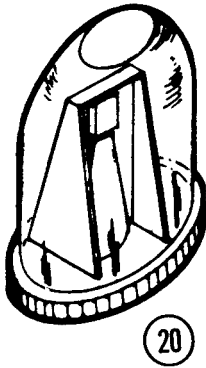

20

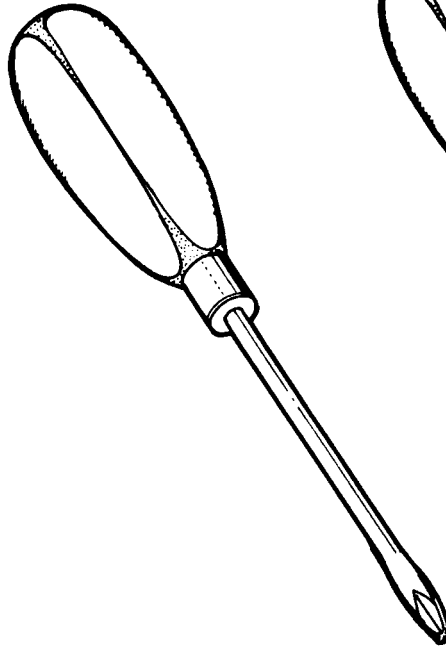

21

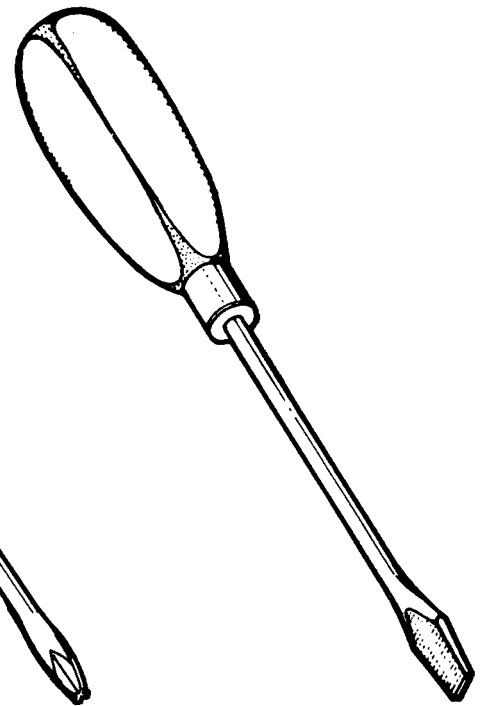

22

(1) Illus Number	(2) National Stock Number	(3) Description FSCM and Part Number	Usable On Code	(4) U/M	(5) Qty Rqr
20	7520-00-295-6170	REPOINTER, PENCIL (75361) 234		EA	1
21	5120-00-764-8080	SCREWDRIVER, CROSS-TIP NO. 1 (10670) 2751			
	5120-00-764-8102	AND NO. 3 (10670) 2753		EA	1
22	5120-00-234-8910	SCREWDRIVER, FLAT-TIP, 1/8 IN. (72368) 2143-6		EA	1

Section III. BASIC ISSUE ITEMS (CONT)

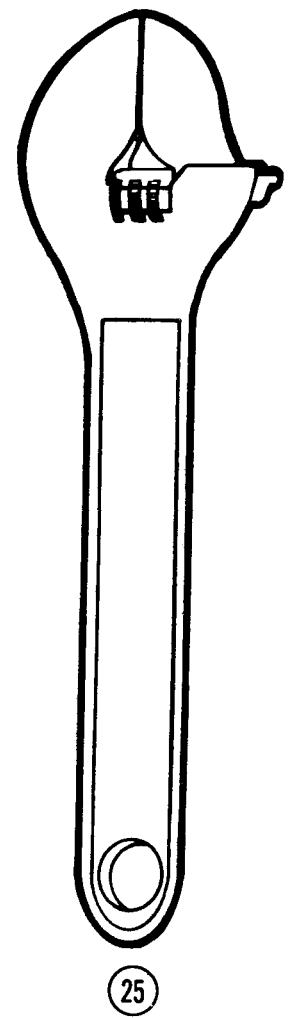
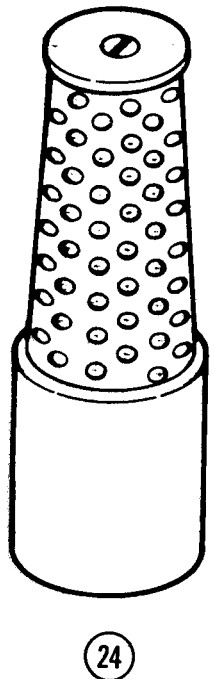
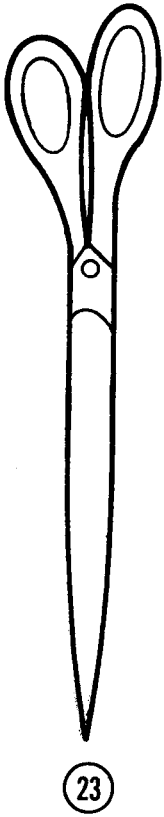

(1) Illus Number	(2) National Stock Number	(3) Description FSCM and Part Number	Usable On Code	(4) U/M	(5) Qty Rqr
23	5110-00-162-2207	SHEARS, STRAIGHT TRIMMERS, 12 IN. LONG (81348) GGG-S-278		EA	1
24		STRAINER, HOSE (55092) P211564		EA	1
25	5120-00-240-5328	WRENCH, ADJUSTABLE, SIZE 8 (81348) GGG-W-631		EA	1

Section III. BASIC ISSUE ITEMS (CONT)

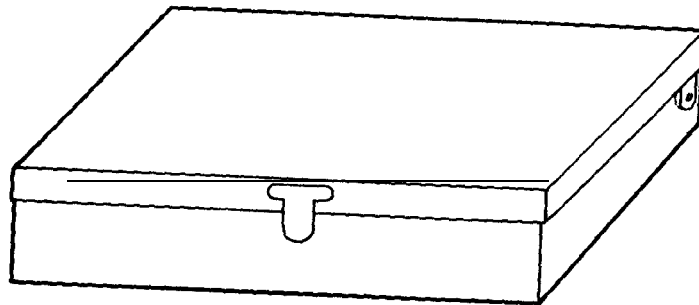

26

(1) Illus Number	(2) National Stock Number	(3) Description FSCM and Part Number	Usable On Code	(4) U/M	(5) Qty Rqr
26	5120-00-081-2305	WRENCH SET, SOCKET (81348) GGG-W-641		EA	1

APPENDIX C

ADDITIONAL AUTHORIZATION LIST (AAL) ITEMS

Section I. INTRODUCTION

C-1. SCOPE . This appendix lists additional items you are authorized for the support of the TSS Press Section.

C-2. GENERAL . This list identifies items that do not have to accompany the TSS Press Section and that do not have to be turned in with it. These items are all authorized to you by CTA, MTOE, TDA, or JTA.

C-3. EXPLANATION OF LISTING. National stock numbers, descriptions, and quantities are provided to help you identify and request the additional items you require to support this equipment. The items are listed in alphabetical sequence by item name under the type document (i.e., CTA, MTOE, TDA, or JTA) which authorizes the item(s) to you.

Section II. ADDITIONAL AUTHORIZATION LIST

(1) NATIONAL STOCK NUMBER	(2) DESCRIPTION FSCM AND PART NUMBER	(3) U/M	(4) QTY AUTH
6115-00-394-957	<p style="text-align: center;"><u>MTOE AUTHORIZED ITEM</u></p> <p>GENERATOR SET, DIESEL ENGINE, 30KW 60Hz, TRAILER-MOUNTED ON M-200A1 PU-406 B/M</p>	EA	1

APPENDIX D

EXPENDABLE/DURABLE SUPPLIES AND MATERIALS LIST

Section I. INTRODUCTION

D-1 . **SCOPE** . This appendix lists expendable/durable supplies and materials you will need to operate and maintain the TSS Press Section. This listing is for informational purposes only and is not authority to requisition listed items. These items are authorized to you by CTA 50-970, Expendable/Durable Items (Except Medical, Class V, Repair Parts and Heraldic Items).

D-2 . **EXPLANATION OF COLUMNS**

a. Column (1) - Item Number. This number is assigned to the entry in the listing and is referenced in the narrative instructions to Identify the material (e.g., "Use cleaning compound, item 5, appendix D").

b. Column (2) - Level. This column identifies the lowest level of maintenance that requires the listed item.

C - Operator/Crew
O - Organizational Maintenance
F - Direct Support Maintenance
H - General Support Maintenance

c. Column (3) - National Stock Number. This is the National stock number assigned to the item; use it to request or requisition the item.

d. Column (4) - Description. Indicates the Federal item name and, if required, a description to identify the item. The last line for each item indicates the Federal Supply Code for Manufacturer (FSCM) in parentheses followed by the part number.

e. Column (5) - Unit of Measure (U/M). Indicates the measure used in performing the actual maintenance function. This measure is expressed by a two-character alphabetical abbreviation (e.g., ea, in., pr). If the unit of measure differs from the unit of issue, requisition the lowest unit of issue that will satisfy your requirements.

Section II. EXPENDABLE/DURABLE SUPPLIES AND MATERIALS LIST

(1) ITEM NUMBER	(2) LEVEL	(3) NATIONAL STOCK NUMBER	(4) DESCRIPTION	(5) U/M
1	C	6510-01-060-1639	ADHESIVE TAPE, 1 IN.	RL
2	C	6505-00-106-0875	AMMONIA, INHALANT	BX
3	C	6510-00-913-7909	BANDAGE, ADHESIVE	PG
4	C	6510-00-201-1755	BANDAGE, GAUZE, COMPRESSED	EA
5	C	6510-00-201-1755	BANDAGE, MUSLIN, COMPRESSED	EA
6	C	6515-00-754-0426	BLADE, RAZOR	PG
7	C		BRUSH, WIRE (55719) AC58C	EA
8	C	7920-00-291-5815	BRUSH, WIRE, SPIRAL	EA
9	C	6545-00-113-3722	CASE, MEDICAL	EA
10	C		CLIPS, CURTAIN (73830) 74069	PG
11	C	8030-00-938-1947	COMPOUND, SILICONE	CN
12	C	6510-00-200-3075	COMPRESS AND BANDAGE, CAMOUFLAGED	PG
13	C	7930-00-985-6911	DETERGENT	CN
14	C	6510-00-159-4883	DRESSING, FIRST AID, FIELD	EA
15	C	7510-00-634-5035	ERASER, RUBBER: .188 IN. DIA, 7 IN. LONG	DZ
16	C	6545-00-853-6309	EYE DRESSING	EA
17	C	6510-01-112-6414	GAUZE, PEHOLATUM	EA
18	C	8415-00-248-3228	GLOVES, DISPOSABLE	BX
19	C	9150-00-190-0905	GREASE, AUTOMOTIVE AND ARTILLERY (81349) MIL-L-10924	LB

Section II. EXPENDABLE/DURABLE SUPPLIES AND MATERIALS LIST (CONT)

(1) ITEM NUMBER	(2) LEVEL	(3) NATIONAL STOCK NUMBER	(4) DESCRIPTION	(5) U/M
20	c	8520-00-965-2109	HAND CLEANER	PT
21	c		HOOKS, CURTAIN (81349) MIL-C-19219	
22	c	6240-00-556-8655	LAMP, FLUORESCENT	EA
23	c	6240-00-145-3120	LIGHT BULB	EA
24	c		LIGHT BULB, BLACKOUT (51225) 2V56B	EA
25	c		LIGHT BULB, DOME (51225) 1156	EA
26	c		LIGHT BULB, TWIST/LOCK (51225) A60	EA
27	c	9150-00-188-9858	OIL, LUBRICATING, GENERAL PURPOSE (81349) MIL-L-2104	CN
28	c	6810-00-264-6715	OIL, LUBRICATING, SPRAY (81349) MIL-M-7866, TYPE G	BT
29	c	7510-00-240-1526	PENCIL, BLACK, GLAZED SURFACE	DZ
30	c	6505-00-914-3593	POVIDONE-IODINE	BT
31	c	7920-00-148-9666	RAGS	
32	c	7920-00-240-2555	SPONGE, CELLULOSE	EA
33	c	7920-00-823-9772	TOWEL, PAPER	BX

INDEX

Subject	Paragraph, Table, Appendix
A	
Additional Authorization List Items	C
Air Conditioner/Heaters, PMCS	T 2-1
Assembly and Preparation for Use	2-6
B	
Basic Issue Items List	B
Blackout Curtain	
Maintenance Instructions	3-14
PMCS	T 2-1
Blackout Light	
Maintenance Instructions	3-6
PMCS	T 2-1
Boarding Ladder	
Maintenance Instructions	3-12
PMCS	T 2-1
C	
Cargo Door and Hinges, PMCS	T 2-1
Components of End Item List	B
Curtain, Blackout, Maintenance Instructions	3-14
D	
Description and Use of Operator's Controls and Indicators	2-1
Disconnect Power	2-7
Dome Light	
Maintenance Instructions	3-7
PMCS	T 2-1
Dome Light System Emergency Procedures	2-10
Ducts, Ventilation, Maintenance Instructions	3-9
E	
Emergency Exit Procedures	2-10
Emergency Light, PMCS	T 2-1
Emergency Light System Procedures	2-10
Emergency Procedures	2-10
Equipment Characteristics, Capabilities, and Features	1-5
Equipment Data	1-7

INDEX (CONT)

Subject	Paragraph, Table, Appendix
Exhaust Fan	
Maintenance Instructions	3-11
PMCS	T 2-1
Expanding Side Assemblies, PMCS	T 2-1
Expanding Side Power Cables, PMCS	T 2-1
Expand Sides of Section	2-6
Expendable/Durable Items and Materials List	D
F	
Fan, Exhaust, Maintenance Instructions	3-11
Faucet Assembly, PMCS	T 2-1
Fire Extinguisher(s), PMCS	T 2-1
First Aid Kit, PMCS	T 2-1
Floor Bridge Cover Mounting Brackets PMCS	T 2-1
Fluorescent Light	
Maintenance Instructions	3-5
PMCS	T 2-1
Folding Floor Assemblies and Locks, PMCS	T 2-1
Folding Ladder and Support Brackets, PMCS	T 2-1
G	
Ground and Provide Power To Section	2-6
Ground Cable Assembly, PMCS	T 2-1
Ground Connections, PMCS	T 2-1
Ground Rod Maintenance Instructions	3-13
GTO Storage Cabinet, PMCS	T 2-1
H	
Hand Receipt (-HR) Manual	1-3
Handwinch Assemblies, PMCS	T 2-1
I	
Inclinometers, PMCS	T 2-1
J	
Jogging Table, PMCS	T 2-1

INDEX (CONT)

Subject	Paragraph, Table, Appendix
L	
Ladder, Boarding, Maintenance Instructions	3-12
Level and Stabilize Section	2-6
Load Center, PMCS	T 2-1
Location and Description of Major Components	1-6
Lubrication Instructions	3-1
M	
Main Pump, PMCS	T 2-1
Maintenance Forms and Records	1-2
Maintenance Instructions	
Blackout Curtain	3-14
Blackout Light	3-6
Boarding Ladder	3-12
Dome Light	3-7
Exhaust Fan	3-11
Fluorescent Light	3-5
Ground Rod	3-13
Heater	3-10
Side Light	3-8
Ventilation Ducts	3-9
Maintenance Procedures	3-3
Mirror and Safety Chain, PMCS	T 2-1
O	
On/Off Switches, PMCS	T 2-1
Operating Instructions on Decals and Instruction Plates	2-8
Operation	
Unusual Weather	2-9
Usual Conditions	2-5
Operator's Controls and Indicators	2-1
P	
Personnel Door and Hinges, PMCS	T 2-1
Phase Monitor Meter, PMCS	T 2-1
PMCS Procedures	2-3
Power Cable, PMCS	T 2-1
Power Entry Panel, PMCS	T 2-1
Preparation for Movement	2-7

INDEX (CONT)

Subject	Paragraph, Table, Appendix
Prepare for Transport	2-7
Prepare Section Exterior	2-6
Prepare Section for Production	2-6
Prepare Section Interior	2-7
Preventive Maintenance Checks and Services (PMCS)	T 2-1
R	
References	A
Removable Floor Sections, PMCS	T 2-1
Reporting Equipment Improvement Recommendations (EIRs)	1-4
Retract Expanding Sides	2-7
Roller Storage Racks, PMCS	T 2-1
S	
Scope	1-1
Section Body, PMCS	T 2-1
Side Frame Assembly, PMCS	T 2-1
Side Light Maintenance Instructions	3-8
Sink Cabinet, PMCS	T 2-1
Storage Cabinets, PMCS	T 2-1
Strap and Buckles Assemblies, PMCS	T 2-1
Symptom Index, Troubleshooting	3-2
T	
Technical Principles of Operation	
Blackout Light System	1-8
Electrical System	1-8
Expanding Side System	1-8
General	1-8
Plumbing System	1-8
Ventilation System	1-8
Telephone Installation, PMCS	T 2-1
Tool Caddy, PMCS	T 2-1
Troubleshooting	T 3-1
Troubleshooting Procedures	3-2
V	
Ventilation Ducts	
Maintenance Instructions	3-9
PMCS	T 2-1

INDEX (CONT)

Subject	Paragraph, Table, Appendix
W	
Wall Heaters (Expanding Sides), PMCS	T 2-1
Wall Heater Maintenance Instructions	3-10
Wall Outlets, PMCS	T 2-1
Water Box, PMCS	T 2-1
Water Piping, PMCS	T 2-1
Water Tank Assembly, PMCS	T 2-1
Wiper Seal, PMCS	T 2-1

By Order of the Secretary of the Army:

JOHN A. WICKHAM, JR.
General, United States Army
Chief of Staff

Official:

MILDRED E. HEDBERG
Brigadier General, United States Army
The Adjutant General

DISTRIBUTION:

To be distributed in accordance with DA Form 12-25A, Operator Maintenance Requirements for Paper Conditioning Section, Topographic Support System, Model ADC-TSS-15

RECOMMENDED CHANGES TO EQUIPMENT TECHNICAL PUBLICATIONS



THEN... JOT DOWN THE DOPE ABOUT IT ON THIS FORM. CAREFULLY TEAR IT OUT. FOLD IT AND DROP IT IN THE MAIL!

SOMETHING WRONG WITH THIS PUBLICATION?

FROM: (PRINT YOUR UNIT'S COMPLETE ADDRESS)

PFC JOHN DOE
COA, 3d ENGINEER BN
FT. LEONARD WOOD, MO 63108

DATE SENT

PUBLICATION NUMBER

TM 5-3610-287-10

PUBLICATION DATE

6 Jan 86

PUBLICATION TITLE

Topographic Support System Press Section

BE EXACT. PIN-POINT WHERE IT IS

PAGE NO	PARA-GRAPH	FIGURE NO	TABLE NO
6	2-1 a		
B1		4-3	
125	line 20		

IN THIS SPACE TELL WHAT IS WRONG AND WHAT SHOULD BE DONE ABOUT IT:

In line 6 of paragraph 2-1a the manual states the engine has 6 cylinders. The engine on my set only has 4 cylinders. Change the manual to show 4 cylinders.

Callout 16 on figure 4-3 is pointing at a bolt. In key to figure 4-3, item 16 is called a shim - Please correct one or the other.

I ordered a gasket, item 19 on figure B-16 by NSN 2 910-00-762-3001. I got a gasket but it doesn't fit. Supply says I got what I ordered, so the NSN is wrong. Please give me a good NSN

PRINTED NAME, GRADE OR TITLE, AND TELEPHONE NUMBER

JOHN DOE, PFC (268) 317-7111

SIGN HERE

JOHN DOE

DA FORM 2028-2
1 JUL 79

PREVIOUS EDITIONS ARE OBSOLETE.
DRSTS-M Overprint 1, 1 Nov 80

P.S.--IF YOUR OUTFIT WANTS TO KNOW ABOUT YOUR RECOMMENDATION MAKE A CARBON COPY OF THIS AND GIVE IT TO YOUR HEADQUARTERS.

TEAR ALONG PERFORATED LINE

FILL IN YOUR
UNIT'S ADDRESS

FOLD BACK

DEPARTMENT OF THE ARMY

OFFICIAL BUSINESS
PENALTY FOR PRIVATE USE \$300

POSTAGE AND FEES PAID
DEPARTMENT OF THE ARMY
DOD 314



TEAR ALONG PERFORATED LINE

COMMANDER
U S ARMY TROOP SUPPORT COMMAND
ATTN: AMSTR-MCTS
4300 GOODFELLOW BOULEVARD
ST. LOUIS, MO 63120-1798

FILL IN YOUR
UNIT'S ADDRESS

FOLD BACK

DEPARTMENT OF THE ARMY

OFFICIAL BUSINESS
PENALTY FOR PRIVATE USE \$300

POSTAGE AND FEES PAID
DEPARTMENT OF THE ARMY
DOD 314



TEAR ALONG PERFORATED LINE

COMMANDER
U S ARMY TROOP SUPPORT COMMAND
ATTN: AMSTR-MCTS
4300 GOODFELLOW BOULEVARD
ST. LOUIS, MO 63120-1798

FILL IN YOUR
UNIT'S ADDRESS

FOLD BACK

DEPARTMENT OF THE ARMY

OFFICIAL BUSINESS
PENALTY FOR PRIVATE USE \$300

POSTAGE AND FEES PAID
DEPARTMENT OF THE ARMY
DOD 314



TEAR ALONG PERFORATED LINE

COMMANDER
U S ARMY TROOP SUPPORT COMMAND
ATTN: AMSTR-MCTS
4300 GOODFELLOW BOULEVARD
ST. LOUIS, MO 63120-1798

RECOMMENDED CHANGES TO EQUIPMENT TECHNICAL PUBLICATIONS



THEN... JOT DOWN THE DOPE ABOUT IT ON THIS FORM, CAREFULLY TEAR IT OUT, FOLD IT AND DROP IT IN THE MAIL!

SOMETHING WRONG WITH THIS PUBLICATION?

FROM: (PRINT YOUR UNIT'S COMPLETE ADDRESS)

DATE SENT

PUBLICATION NUMBER

TM 5-3610-287-10

PUBLICATION DATE

6 Jan 86

PUBLICATION TITLE Topographic Support System, Press Section

BE EXACT... PIN-POINT WHERE IT IS

PAGE NO

PARA-GRAPH

FIGURE NO

TABLE NO

IN THIS SPACE TELL WHAT IS WRONG AND WHAT SHOULD BE DONE ABOUT IT:

TEAR ALONG PERFORATED LINE

PRINTED NAME, GRADE OR TITLE, AND TELEPHONE NUMBER

SIGN HERE

FILL IN YOUR
UNIT'S ADDRESS

FOLD BACK

DEPARTMENT OF THE ARMY

OFFICIAL BUSINESS
PENALTY FOR PRIVATE USE \$300

POSTAGE AND FEES PAID
DEPARTMENT OF THE ARMY
DOD 314



TEAR ALONG PERFORATED LINE

COMMANDER
U S ARMY TROOP SUPPORT COMMAND
ATTN: AMSTR-MCTS
4300 GOODFELLOW BOULEVARD
ST. LOUIS, MO 63120-1798

The Metric System and Equivalents

Linear Measure

1 centimeter = 10 millimeters = .39 inch
 1 decimeter = 10 centimeters = 3.94 inches
 1 meter = 10 decimeters = 39.37 inches
 1 dekameter = 10 meters = 32.8 feet
 1 hectometer = 10 dekameters = 328.08 feet
 1 kilometer = 10 hectometers = 3,280.8 feet

Weights

1 centigram = 10 milligrams = .15 grain
 1 decigram = 10 centigrams = 1.54 grains
 1 gram = 10 decigram = .035 ounce
 1 dekagram = 10 grams = .35 ounce
 1 hectogram = 10 dekagrams = 3.52 ounces
 1 kilogram = 10 hectograms = 2.2 pounds
 1 quintal = 100 kilograms = 220.46 pounds
 1 metric ton = 10 quintals = 1.1 short tons

Liquid Measure

1 centiliter = 10 milliliters = .34 fl. ounce
 1 deciliter = 10 centiliters = 3.38 fl. ounces
 1 liter = 10 deciliters = 33.81 fl. ounces
 1 dekaliter = 10 liters = 2.64 gallons
 1 hectoliter = 10 dekaliters = 26.42 gallons
 1 kiloliter = 10 hectoliters = 264.18 gallons

Square Measure

1 sq. centimeter = 100 sq. millimeters = .155 sq. inch
 1 sq. decimeter = 100 sq. centimeters = 15.5 sq. inches
 1 sq. meter (centare) = 100 sq. decimeters = 10.76 sq. feet
 1 sq. dekameter (are) = 100 sq. meters = 1,076.4 sq. feet
 1 sq. hectometer (hectare) = 100 sq. dekameters = 2.47 acres
 1 sq. kilometer = 100 sq. hectometers = .386 sq. mile

Cubic Measure

1 cu. centimeter = 1000 cu. millimeters = .06 cu. inch
 1 cu. decimeter = 1000 cu. centimeters = 61.02 cu. inches
 1 cu. meter = 1000 cu. decimeters = 35.31 cu. feet

Approximate Conversion Factors

To change	To	Multiply by	To change	To	Multiply by
inches	centimeters	2.540	ounce-inches	newton-meters	.007062
feet	meters	.305	centimeters	inches	.394
yards	meters	.914	meters	feet	3.280
miles	kilometers	1.609	meters	yards	1.094
square inches	square centimeters	6.451	kilometers	miles	.621
square feet	square meters	.093	square centimeters	square inches	.155
square yards	square meters	.836	square meters	square feet	10.764
square miles	square kilometers	2.590	square meters	square yards	1.196
acres	square hectometers	.405	square kilometers	square miles	.386
cubic feet	cubic meters	.028	square hectometers	acres	2.471
cubic yards	cubic meters	.765	square meters	cubic feet	35.315
fluid ounces	milliliters	29.573	cubic meters	cubic yards	1.308
pints	liters	.473	milliliters	fluid ounces	.034
quarts	liters	.946	liters	pints	2.113
gallons	liters	3.785	liters	quarts	1.057
ounces	grams	28.349	liters	gallons	.264
pounds	kilograms	.454	grams	ounces	.035
short tons	metric tons	.907	kilograms	pounds	2.205
pound-feet	newton-meters	1.356	metric tons	short tons	1.102
pound-inches	newton-meters	.11296			

Temperature (Exact)

°F	Fahrenheit temperature	$\frac{5}{9}$ (after subtracting 32)	Celsius temperature	°C
----	------------------------	--------------------------------------	---------------------	----

