

UC-NRLF



QB 636 789

MANUAL No. 4  
                      
HANDBOOK  
OF  
SUBMARINE CABLES  
OF THE  
U. S. SIGNAL CORPS  
                      
1905

NOV 21 1905

LIBRARY  
OF THE  
UNIVERSITY OF CALIFORNIA.

GIFT OF

*U.S. Signal corps*

*Class*

(Manual No. 4)

# HANDBOOK

OF

# SUBMARINE CABLES

---

U. S. SIGNAL CORPS

---

Prepared under the direction of  
Brigadier-General A. W. GREELY, Chief Signal Officer, U. S. Army

By Major EDGAR RUSSEL, Signal Corps

WITH

SUPPLEMENTARY CHAPTER ON FACTORY TESTING

By Major SAMUEL REBER, Signal Corps



1905

---

WASHINGTON  
GOVERNMENT PRINTING OFFICE

1905

413 573  
127  
70.4  
11.5

WAR DEPARTMENT,

DOCUMENT No. 258,

OFFICE OF THE CHIEF SIGNAL OFFICER OF THE ARMY.





## INTRODUCTION.

---

Prior to 1898 the duties of installing and operating submarine cables devolved but rarely on the Signal Corps of the Army, and in such cases only along the coasts of the United States where technical labor and special material were readily available. The war of 1898 necessitated on the part of the Signal Corps extensive cable operations in the Carribean Sea and in the Philippine Archipelago, while later they have been extended to Alaskan waters. Under such conditions it was impracticable to either lay such cables by contract or to operate them by civilian force. In consequence, it devolved upon the Chief Signal Officer of the Army, Gen. A. W. Greely, to organize a system under which the installation, operation, and maintenance of long submarine cables should be efficiently performed by the officers and men of the Signal Corps of the Army. The situation was further complicated by the fact that up to that date no long submarine cable of American manufacture had ever been successfully installed and operated.

In 1902 it became necessary to issue a handbook, setting forth the means and methods utilized in cable operations by the Signal Corps of the Army. In preparing this manual Major Russel has utilized such extracts from the books of reference named and such Signal Corps reports and drawings as have seemed of general interest.

As the handbook was intended for a practical guide to officers of the Signal Corps, particular value was attached to the extended experiences of signal corps officers in installing and operating submarine cables. Such cable operations involving miles of cables have been conducted by the Signal Corps under varying physical conditions, from the icy waters of Bering Strait to the tropical sea of Sulu, Jolo Archipelago.

As a rule complicated formulæ or theoretical considerations have been avoided in this manual. Simplicity has been sought in describing the various tests, so that the methods followed may be readily comprehended and successfully applied. All the tests referred to have been in actual use at signal corps stations or on the cableship *Burnside*.

That the expansion of Signal Corps duties in the technical and difficult branch of submarine telegraphy has been successfully met by

the Signal Corps is especially due to the technical knowledge and administrative ability of Col. James Allen, Maj. George O. Squier, and Maj. Edgar Russel, Signal Corps. The important chapter on factory testing was contributed by Maj. Samuel Reber, Signal Corps, at a time when information and data of this character were greatly needed.

The officers of the corps were fortunate in having the services, either temporarily or permanently, of engineers of high standing, such as Dr. A. E. Kennelly, Mr. Townsend Wolcott, Mr. Henry Winter, Mr. David Lynch, and Mr. O. Struebel.

A. W. GREELY,

*Brigadier-General, Chief Signal Officer of the Army.*

WASHINGTON, D. C., *June 5, 1905.*



WAR DEPARTMENT, SIGNAL OFFICE,  
*Washington, June 5, 1905.*

The following handbook of submarine cables (Manual No. 4) is published for the information and instruction of the officers and men of the Signal Corps of the Army, who will make themselves thoroughly familiar with the information contained therein. Rapid cable laying in time of war for friendly use, and the prompt interruption of hostile cables, are recognized as military operations of primary importance. Indeed, for operations abroad, submarine cables are as essential for successful campaigning as are telegraphic and telephonic systems for land operations, and ability to install, operate, and maintain a submarine cable is part of the duty of an officer of the Signal Corps.

While mathematical formulæ are, in a few cases, necessary, yet such have been reduced to the simplest forms, and the Manual consists principally of instructions in the methods of laying and repairing cables, the installation of offices, the operations of cables, and their proper testing for faults and electrical conditions.

A thorough and careful study of the Manual should enable an intelligent and resourceful officer to successfully supervise operations of short cables at least.

A. W. GREELY,  
*Brigadier-General, Chief Signal Officer U. S. Army.*

Approved, June 7, 1905.  
ROBERT SHAW OLIVER,  
*Acting Secretary of War.*

## TABLE OF CONTENTS.

	Page.
Introduction.....	3
List of illustrations.....	9
CHAPTER I. Cables.....	11
Construction.....	11
Improvised methods of laying and repairing.....	12
CHAPTER II. Operation of short submarine cables.....	17
Office installation for Morse operation.....	17
Switchboards.....	17
Lightning arresters.....	17
Ground connections.....	18
Office wiring.....	19
Morse instruments for cable working.....	19
CHAPTER III. Operation of long submarine cables.....	27
Siphon recorders.....	27
Adjustment of recorder and its parts.....	29
Care of recorder siphons, ink, etc.....	33
Batteries and auxiliary apparatus for working recorders.....	34
Arrangement of instruments for operating long cables.....	39
Notes on efficient working of a cable station and on troubles that occur.....	42
CHAPTER IV. Cable testing.....	45
Galvanometers.....	45
Shunts.....	47
Keys.....	49
Switches, etc.....	50
Measurement of insulation resistance.....	50
Constants of the galvanometer.....	50
Preparation of the cable.....	50
Measurement of capacity.....	53
Measurement of conductor resistance.....	55
Record of cable tests.....	58
Data pertaining to Sitka-Seattle cable.....	59
Description of Fisher cable-testing set No. 2.....	60
Arrangement of testing set in Washington-Alaska cable office and on cable ship Burnside.....	70
CHAPTER V. Location of faults in submarine cables.....	73
Loop test.....	75
Break tests.....	75
Kennelly break test.....	76
Schaefer break test.....	76
Blavier test.....	79
Clark's potential test.....	81
Earth overlap test.....	84
Testing and locating faults in short cables with improvised apparatus.....	85
Instructions for shore stations during repair of cable.....	91
CHAPTER VI. Miscellaneous data.....	92
CHAPTER VII. Factory tests for electrical properties of cable.....	98

## LIST OF ILLUSTRATIONS.

	Page
Fig. 1. Typical section and parts of submarine cable .....	11
2. Splicing .....	13
3. Use of serving mallet .....	15
4. Cable switchboard, Morse line .....	18
5. Open-circuit single current, Morse diagram .....	19
6. Open-circuit double current, Morse diagram .....	21
7. Combination key .....	22
8. Three-station wiring plan, single and double current .....	23
9. Signal corps repeater set, single current, open circuit .....	24
10. Muirhead recorder for long cables .....	28
11. Muirhead recorder for short cables .....	29
12. Muirhead vibrator .....	31
13. Simple arrangement for siphon recorder set .....	34
14. Motor operation with electric-light current .....	38
15. Arrangement Muirhead apparatus for operating long cables .....	39
16. Diagram of wiring, Seattle, Juneau and Valdez cable offices .....	40
17. Diagram of wiring, Sitka office .....	41
18. Reflecting galvanometer and scale .....	46
19. Moving-coil galvanometer .....	46
20. Portable galvanometer .....	47
21. Diagram of shunt .....	47
22. Ayrton shunt .....	48
23. Reversing key .....	49
24. Reversing key .....	49
25. Short-circuit key .....	49
26. Diagram of connections for obtaining galvanometer constants .....	49
27. High insulation binding posts .....	50
28. Double plug switch .....	50
29. Preparation of cable ends .....	51
30. Diagram, measurement of insulation resistance .....	51
31. Diagram, measurement of capacity, standard condenser .....	53
32. Discharge key for capacity measurements .....	54
33. Diagram, measurement of capacity, connection with cable .....	54
34. Diagram, measurement of copper resistance .....	57
35. Wheatstone bridge, improved pattern .....	57
36. Fisher cable-testing set No. 2 .....	61
37. Theoretical diagram, Fisher testing set .....	61
38. Top plan Fisher testing set .....	63
39. Wiring diagram, Fisher testing set .....	64
40. Test set diagram, Washington-Alaskan cable office .....	71
41. Test-room connections, cable ship Burnside .....	72
42. Diagram loop test .....	74



	Page.
FIG. 43. Diagram Schaefer break test .....	76
44. Diagram Blavier test.....	79
45. Diagram Blavier test, corrections.....	80
46. Diagram main station, Clark potential test.....	82
47. Diagram secondary station, Clark potential test.....	82
48. Diagram earth overlap test .....	84
49. Insulation test with telephone receiver.....	85
50. Connections for test with improvised apparatus, telephone receiver.....	87
51. Connections for test with improvised apparatus, galvanometer.....	89
52. Connections for test with improvised apparatus, auxiliary wire.....	90
53. Same .....	90
54. Cable-tank capacity .....	96
55. Insulation test, curve sheet.....	105



# CABLES.

## CHAPTER I.

### CONSTRUCTION, LAYING, REPAIRING.

The Signal Corps has of late years had much to do with this branch of telegraph engineering. The special technical character of the work is such that if it were attempted to describe cable laying from a cable ship it would be impracticable to give much idea of it in the brief way necessary here.

Two works exist which enter quite fully into the whole subject. These are Submarine Cable Laying and Repairing, by H. D. Wilkinson, and Submarine Telegraphs, by Charles Bright. A just idea of the many practical questions involved may be obtained only by

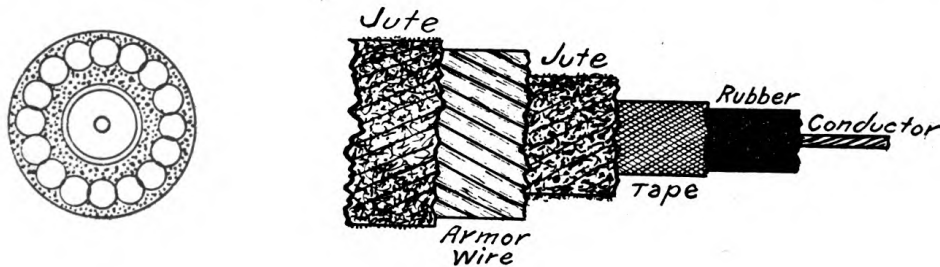

FIG. 1.

actual experience on a cable ship. It is proposed to enter only briefly into some of the questions concerning the cable, its repair, expedients for laying short pieces in shallow water, cable stations, and instruments and elementary testing which are liable to come up for practical solution.

The cables so far laid by the Signal Corps are rubber-insulated ones. Details of construction of a typical form are given in fig. 1. This is the actual size of some of the cables laid in Philippine waters. The conductor at the center consists of 7-strand tinned copper wire, the wires in the strand being usually No. 21 or No. 24 Brown & Sharpe gauge, having resistances respectively of about 10 and 20 ohms per mile.

Around this is a layer, one sixty-fourth inch thick, of pure rubber, then a vulcanized rubber composition to a diameter of nine thirty-

seconds inch. This is then covered with a layer of tape spirally put on. Outside of this two layers of tanned or tarred jute are laid on with the spirals in opposite directions. The galvanized-steel wire armor comes next. Outside this two more layers of jute are put on and served with hot asphalt compound. A final coating of air-slacked lime or soapstone, to prevent the coil from sticking together, completes the cable. When the cable is in shallow water and subject to abrasion from rocks, another armor of galvanized-steel wires and outer coatings of jute are put on. This is called shore end.

Multiple cables are made up with the india-rubber cores, as they are called, laid up closely together, and the armor wires and jute serving outside of all. The finished cable is coiled in circular tanks in the factory or ship. Cable should be kept submerged as much as possible, as it deteriorates far less rapidly when under water. It is especially needful to protect it from heat. Exposure to weather (sunlight, wind, or rain) causes very rapid deterioration.

For descriptions of cable-ship machinery and the operations of laying from the ship, reference is made to the works cited at the beginning.

However, as the Signal Corps is sometimes called upon to lay short cables in shallow waters by improvised means, an account of how it was done in Laguna de Bay, near Manila, P. I., may prove useful. The cable was coiled in a large casco, or lighter, the coil being oblong (about 24 by 16 feet). Starting on the outside, it was coiled snugly inward to a diameter of about 4 feet, the man guiding it going around in a left-handed direction, the helpers squatted around keeping the coil closed in tightly together as the cable came down from above. A wooden cone was erected in the center to the height the pile was to reach, the edges and corners being well rounded off to prevent the cable catching as it paid out. In coiling inward the cable coils are carried up snugly against the core, and then the cable is carried radially across the lower layer (flake, it is called) and another flake begun at the outer edge. If much cable is to be put on, narrow strips of wood (called feathers) are laid along the piece of cable carried straight across. Close and careful coiling, especially in the lower flakes, is necessary.

Sheaves are lashed in proper places to carry the cable up, first over the center of the cone and then aft. Near the stern the cable passed under a horizontal roller, or fair lead, and means were provided to press a timber against the cable here to pinch it and put on the necessary friction to prevent its paying out too rapidly. The necessary testing apparatus was installed, and the casco towed by one of the gunboats used on the lake. The end of the cable was carried ashore in two small boats, one buoying it between the casco and the boat nearest shore.

The end ashore having been properly trenched and anchored, paying out was begun. Several helpers were on the cable coils, handing the cable up as it started to rise and looking out that no kinks went up. An average speed of  $2\frac{1}{2}$  miles an hour was attained, the water being not over 40 or 50 feet deep. When the end was landed the cable was trenched about 3 feet deep, down to low water. Above high water a short cross trench was dug, a heavy log was buried therein, and a chain lashed to it and the cable. This constituted a "sand anchor" to prevent the end of the cable from being pulled out to sea. The best way to electrically secure the land end of the cable is to run it into the office and connect the conductor directly with the office switch board. The next best is to splice the submarine cable to lead-covered underground cable, the latter going to the office.

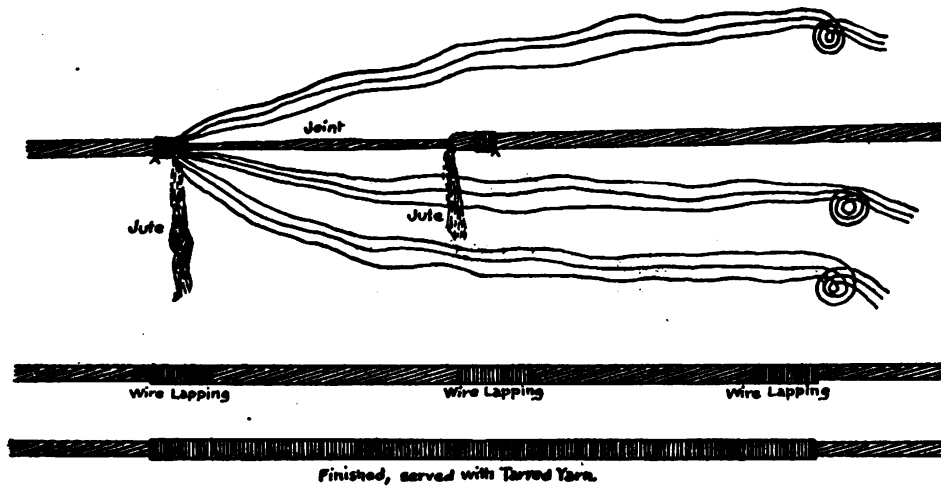

FIG. 2.

If the cable landing is far from the office and the cable must be connected with a land line, the end of the cable should go into a cable hut. This is a small structure in which the cable comes up out of the trench and is secured to the lightning arrester, the land line leading out from there. Great care should be taken in properly securing the cable terminal, either in the office or cable hut. Bad insulation or poor connections are too often left there, interfering with the working of the line or vitiating the tests.

#### SPLICING.

The splicing of submarine rubber cables is an operation which, to do properly, requires great experience and practice.

Ordinarily the cable ship staff attends to such matters; but it may happen at isolated places, like these mentioned on Laguna de Bay, that at least temporary repairs must be attempted.

Having found the fault by some of the tests subsequently explained, and raised the cable with a grapnel, a sufficiently large bight

is brought on board and lashed to give length for the splice. The fault having been cut out, the outer serving is removed for about 25 feet back of each end. This is sufficient for a short splice. The armor wires are then carefully untwisted from one end for that length in groups of about five. These should be carefully handled, so they will go back into place easily.

Some small wire, called "seizing," is wound tightly around the cable here to prevent the untwisting from going back any farther. The jute padding is then untwisted and the core is cut off to within a foot of the small-wire seizing and the jute about 2 feet from it. Meanwhile a seizing of small wire is wound about 6 inches from the other end of the cable, and the armor wires nicked with a file and broken off close to the seizing. These are then smoothed with the file. The jute is stripped off this short end. The tape is taken off for 6 inches from each end, and the rubber insulation cut in a conical shape with a sharp knife (fig. 17), leaving about 3 inches of conductor exposed at each end. The strands are spread out for  $1\frac{1}{2}$  inches, the central wire being cut out of each for that length. The wires are well cleaned with fine emery paper, and, the spread-out ends being brought together, they are neatly and closely wound about the twisted parts of each other.

The joints should be soldered, using rosin as a flux. A vulcanized insulation for the joint is always desirable and is considered necessary in deep-sea splices. However, it is impossible to make without the full kit and much experience, so the joint may be finished with the "raw" joint, as it is called by the Western Union cable repair man. Noting that the coned surfaces of the rubber, and for an inch back of these ends, are cleaned and scraped with the knife, take a strip of the black or raw rubber about half an inch wide and 4 or 5 inches long. Holding the end of the rubber strip just back of the cone, wind the strip around the cone and along the wire, making the spirals overlap, stretching the strip with moderate tension. Continue winding until a little beyond the other coned end, then wind back. The strips are thus wound on, back and forth, until the rubber slightly more than fills the space between the coned ends. A clean, warm iron tool should then be rubbed over the joint until the rubber fuses slightly.

It should then be covered with a double thickness of adhesive tape to cover the joint and the portion from which tape was removed.

It may then be slightly warmed with a lamp or warmed tool to complete the fusion of the rubber jointing, care being taken not to overheat it. The jute is then wound back over the joint and secured with a few turns of adhesive tape. The armor wires are then returned to place—they will easily do so if care has been taken in handling them. It will be observed that over 20 feet of the armor from one side will



lap over that end from which the armor was not removed. The armor replaced, wires are then bound in place with several seizings of small wire tightly and evenly wrapped. The entire splice should then be served with a closely wound layer of spun yarn. The proper way of doing this is with the serving mallet. (See fig. 3.) Of course, if means are not present to do it otherwise, it should be done by hand. After splicing the bight should be carefully lowered, by small ropes attached to each side of it, to prevent straining or jerking the splice.

On the subject of splices Mr. Henry Winter, cable engineer on the *Burnside*, has contributed the following notes:

The shorter the joint the better. The heat during vulcanization can then be concentrated—a matter of no small importance when cable operations are

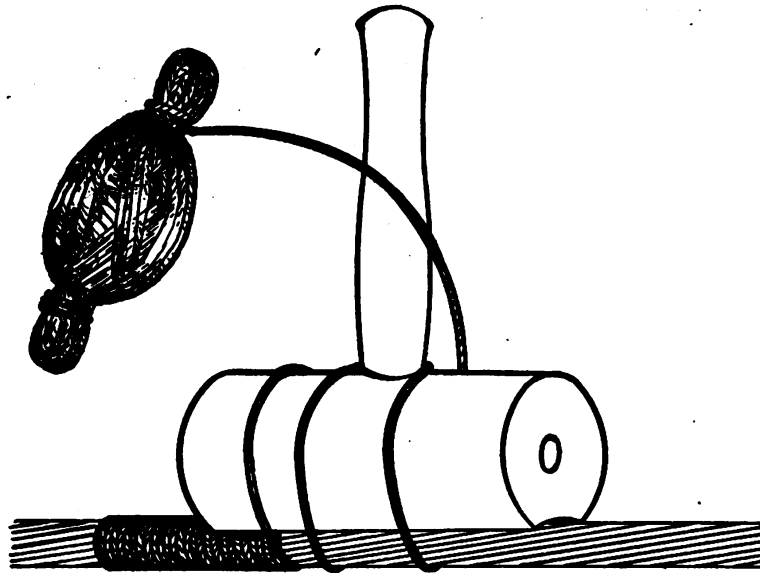

FIG. 3.—Serving mallet used in putting on spun-yarn serving.

performed during the winter months in Alaska. Whenever possible, the electrical vulcanizer should be used. When making a joint on a boat it is necessary to use the paraffin wax and vulcanizing tray, and under these conditions the less material to be vulcanized the better.

The joint when finished must be as near as possible the same size as the insulation being joined; if made larger it interferes with the regular laying on of the armor wires during splicing. When possible the joint should be steeped in ice water for about five minutes after vulcanization. Close attention should be given that the joint be not twisted before the armor wires are laid on.

When making an overlap splice, which is the one ordinarily used, it is found more convenient by the practiced hand to unlay the wires of the overlapping armor into as few strands as possible. Should the quantity of armor wires be 18, then they should be unlayed into 3 strands of 6 wires each, and if the quantity be 16 it is found easier in overlapping to use 2 strands of fine wires each and 1 strand of 6 wires than to unlay into 4 strands of 4 wires each. There is bound to be a vacant space between each of the overlapping strands, owing to the greater diameter the armor wires are spread over. These spaces should be

kept as nearly equidistant as possible in order that the wire seizings may be put on more securely. The spun yarn service will also be more effective if the strands are kept the same distance apart.

The strands should be laid on each a few inches at a time until all the strands are overlapped about 15 inches past the joint. A wire seizing should then be put on the overlap. Each strand may then be laid on separately to the end, care being taken to keep the lay as long as possible. If laid on with too short a spiral, the armor wires will birdcage when splice is being served with spun yarn.

When overlapping the strands a small mallet may be used to knock the wires into place.

When the spun yarn has been laid on a foot past the joint it should be secured there, and the other part of the overlap set very moderately tight with a small luff tackle. Wire seizings are then put on about 4 feet apart, and the whole splice served with spun yarn. If every alternate man will serve in the opposite direction it will counteract any tendency to torsion in the splice.

## CHAPTER II.

### OPERATION OF SHORT SUBMARINE CABLES.

#### OFFICE INSTALLATION.

On the short cables operated in the Philippines by the Signal Corps various modifications of the Morse office instruments have sufficed. Subsequently longer cables have been laid by the Signal Corps on the western coasts of the United States and Alaska, which require the usual siphon-recorder equipment. The simpler instruments for short cables are described first.

#### SWITCHBOARDS.

As before stated, the cable should, if possible, be brought directly to the switchboard.

A special high-insulation switchboard for cable stations is furnished by the Signal Corps and is shown diagrammatically in fig. 3.

The cable comes in at the upper left binding post. A revolving copper strip is attached thereto and the base is marked "Instruments," "Free" or "Earth," corresponding to positions of the strip. This is a useful arrangement in making tests, to conform to instructions from the ship or distant station.

The wire to ground or to cable leading to the other station (in case this station is a way office) leads to upper right-hand binding post. A disk lightning arrester is connected with a binding post leading to ground wire. The other binding posts are connected with instrument leads in the usual way, and circuits are pegged in as on the land-line switchboards. All openings in the wooden case not occupied by wires should be securely pegged up. The wooden case and glass cover protect the hard-rubber base against dust and moisture. During tests, when insulation must be carefully guarded, a small cup of chloride of calcium may be set in the closed case to absorb all moisture.

#### LIGHTNING ARRESTERS.

The disk, plate, point, and spiral arresters are all "jump" arresters, when the lightning jumps from plates of metal or carbon, or from points or spiral connected with the line to a carbon or metal plate connected with the ground wire. The metal ones are liable to be fused by a flash and should always be carefully examined to see if the

line is accidentally grounded by them. Carbon dust is liable to cause similar trouble in those made of carbon plates separated by thin perforated mica. The fuse lightning arresters, in which a short piece of fusible wire is in circuit with the line, arrest the flash by melting off. This, of course, opens the line, and spare ones should always be ready to replace the burned ones. The delicate ones mounted on mica strips with metal ends need to be especially watched. When the line comes open or is grounded, the lightning arresters should be at once carefully inspected.

## GROUND CONNECTIONS.

These should be made with special care at cable stations. The only

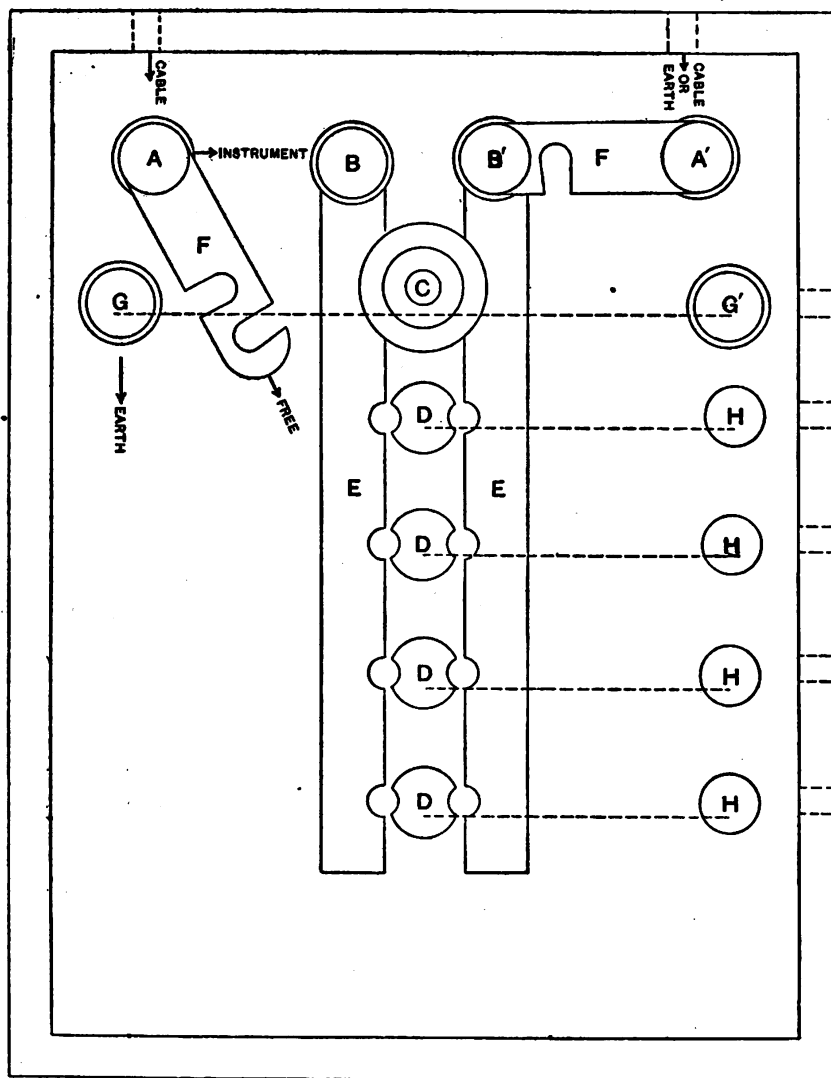

CABLE SWITCH BOARD

FIG. 4.

one which should be made where it is possible is by soldering securely to at least three or four of the armor wires a good-sized copper wire

and leading it to the switchboard. Where plate ground connections are used, the plate should be copper, of at least 5 square feet surface, with the ground wire soldered securely to it.

## OFFICE WIRING.

In tropical climates it has been found that the ordinary paraffined office wire is worthless for good insulation. In cable stations nothing should be used but heavily rubber-covered wire. The cable core itself is a type of the insulation which the wire should have. It will pay to put up the wire with extra care, using porcelain cleats and knobs—never fasten a wire with any of the ordinary staples, which in a majority of instances will be banged down on the insulation, cutting into it and causing bad leaks, which are most baffling to find.

## INSTRUMENTS FOR CABLE WORKING.

On cables up to 100 miles in length the conditions for successful working do not depart sufficiently from those of land lines to prevent

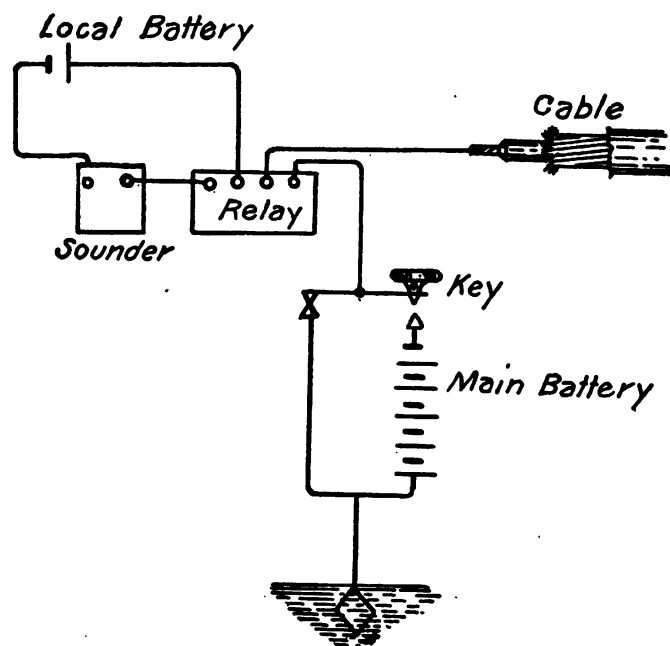

FIG. 5.

the use of ordinary Morse instruments. The ordinary closed-circuit Morse may be used as long as no incipient fault exists. But with the current constantly on, the least fault in the insulation is rapidly made greater by electrolytic action, and a break down soon occurs. For this reason the Signal Corps uses the open-circuit system of Morse on its short cables.

A simplified diagram of the open-circuit connections at a station is given in fig. 5.



As will be seen in diagram, the line comes to the relay, thence to body of key, thence to back contact of key, and to the ground. This is the receiving position, and the current from distant stations will operate the relay. When key is depressed, the back contact is broken and the front contact made; this will cause the home battery to be in the circuit and operate the relays.

Special care must be taken not to screw key so close that both front and back contacts touch. This would short-circuit the battery and speedily ruin it.

The polarized relay has two bobbins or pairs of magnets facing each other, with the armature between them. A permanent magnet supporting the bobbins or in the base gives the cores of the magnets polarity opposite to that of the armature, so that the current coming in one direction tends to send the relay tongue to the front contact, and coming in the other to the back contact. Adjustment is made with top screw, as the relay tongue tends to be more or less strongly held by the permanent magnet on the back contact, corresponding to spring adjustment of the ordinary relay. The screws controlling the magnets seldom need any adjustment. Care should be taken that the armature does not jam against the ends of magnets.

A polarized relay is used for two reasons: First, it is more sensitive and can be worked on less current; second, on account of the large capacity of cables as compared with land lines, the current first charges the cable when the key is depressed, the cable then discharges when key is released, and a momentary current rushes back through the relay. An ordinary relay would give a "kick" corresponding to this, but the polarized relay, responding to the direct current only, is not affected by this momentary discharge current in the opposite direction, and the signals are not "chopped."

The key has a back, middle, and front contact, as shown, the battery being put to line only when key is depressed. The battery used is some form of good open-circuit battery like the Gonda, or large-sized dry batteries.

The sounder should be wound to 6 ohms, to correspond to the higher voltage and lower resistance of the open-circuit type of battery used as a local.

#### DOUBLE-CURRENT WORKING.

When the cable much exceeds 100 miles in length it begins to work heavily on account of the appreciable length of time it takes for the cable to charge and discharge. A modification of the simple open-circuit method of working, just described, must be made. This is called the double-current method, and in principle consists in connecting an additional main-line battery to the back contact of the key with polarity opposite to the main-line battery connected to front

contact. These batteries, by alternately putting opposite poles to line as the key is up or down, serve to discharge the line much more rapidly and greatly increase the speed of working. A simplified diagram of the connections is given in fig. 6.

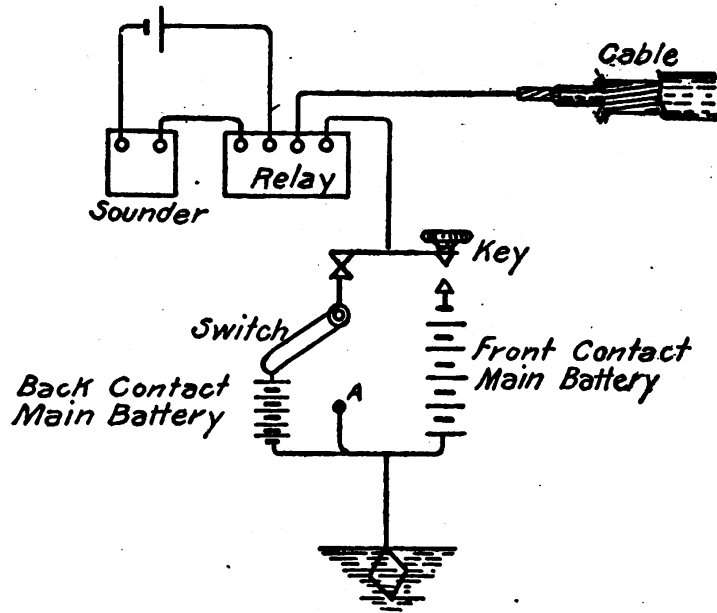

FIG. 6.

The simple change to make it a plain open-circuit set appears when the switch is thrown to *A*. With the key on the back contact, a current flows to line from the + pole of back contact battery. When key is depressed the — pole of the front contact battery is put to line. The polarized relays are so connected that they close the local circuit with front contact battery to line. Connections for a three-station line for double-current working are shown in fig. 8.

Without a switch the back contact batteries would soon be run down. As operators are accustomed to closing the key with the ordinary circuit-closer lever, a key is issued by the Signal Corps obviating the use of a separate switch. The connections are so arranged that the ordinary movements of the switch lever will make the correct connections for the double-circuit system. Other combinations can be made as stated in connection with fig. 7.

#### SINGLE-CURRENT OPEN-CIRCUIT REPEATER SETS.

[U. S. Signal Corps pattern. 1901 model. Designed especially for use on short cables (fig. 9).]

Mounted on a small table top are the following instruments: Two polarized relays, *AA*; two sounders, *BB*; two open-circuit keys, *CC*; two transmitters, *DD*; one double switch, *E*.

The main line and local batteries for each of the lines, the lines themselves, and the earth are connected to the binding posts marked on the table. These connections, especially those of lines and earth, should be made through the switchboard, lightning arresters, etc.

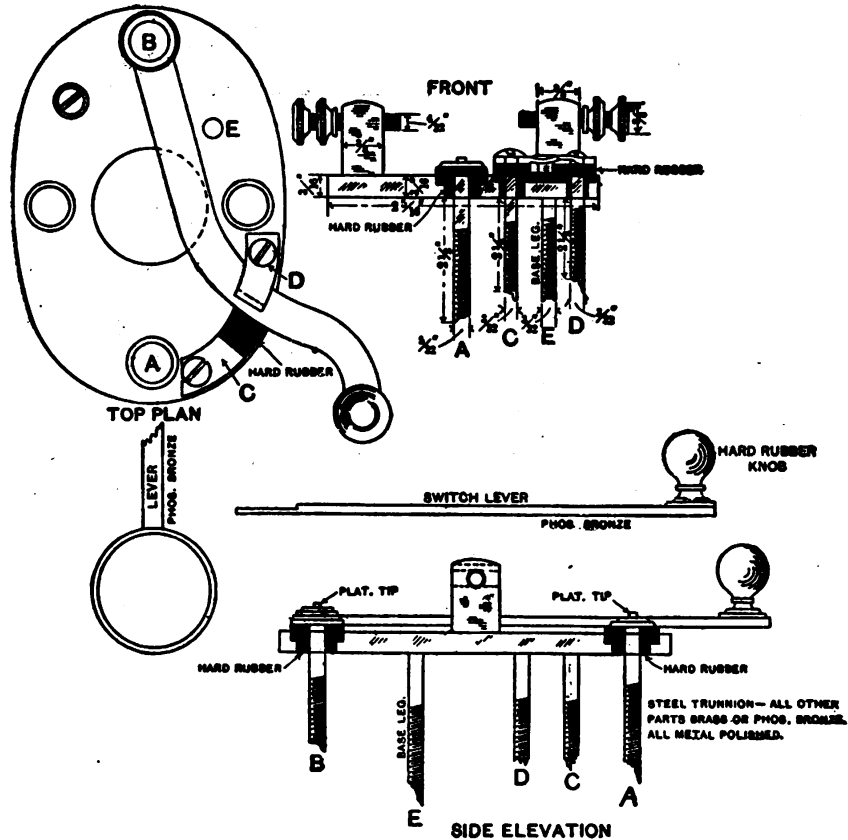

Fig. 7.—Combination key for open or closed circuit (single or double current).

With relay connected to *E*, one pole of main battery to *A*, earth to *C*, and one pole of back contact battery to *D*, the key is suited for open circuit working either single or double current. (Single current with switch closed to left. By opening switch to right the back contact battery is put into circuit for double-current sending.) By connecting *A* and *C* together and *E* and *B* together it may be used as an ordinary closed circuit key, *A* and *B* being the points connected with line and relay, respectively.

#### POLARIZED RELAYS.

These are very similar in relation of parts and construction to the square Western Union pattern used on the Philippine cables heretofore, with the addition of a small switch *F* on each, which permits the local to work on either front or back stroke. If the sending comes reversed, throw the switch to the other button.

*Adjustment.*—The lower adjusting screws on each side should be turned until the magnets are fairly close to the armature, care being taken not to jam them against the armature. The relay tongue can then be caused to fall over to one side or the other, as desired, by the top adjusting screw. The magnetic retraction corresponding to relay

spring can thus be made strong or weak, as desired. For repeating, the set works better if the relay tongue has a barely perceptible play.

Before substituting the repeater set for the two office sets find out from each operator at distant ends of both Nos. 1 and 2 lines whether zinc or carbon is connected to the front contact of his key. Suppose No. 1 says zinc. Connect up several cells of battery, put wire from carbon in "earth" binding post of repeater set. Connect two cells in local binding posts of No. 1. Then tapping with wire from zinc on line No. 1 binding post, note if it works the relay No. 1. If not, move the upper adjusting screw until relay tongue just falls over on the other contact, and it should then work it. If your sending comes reversed on the sounder, throw the relay switch *H* onto the other contact.

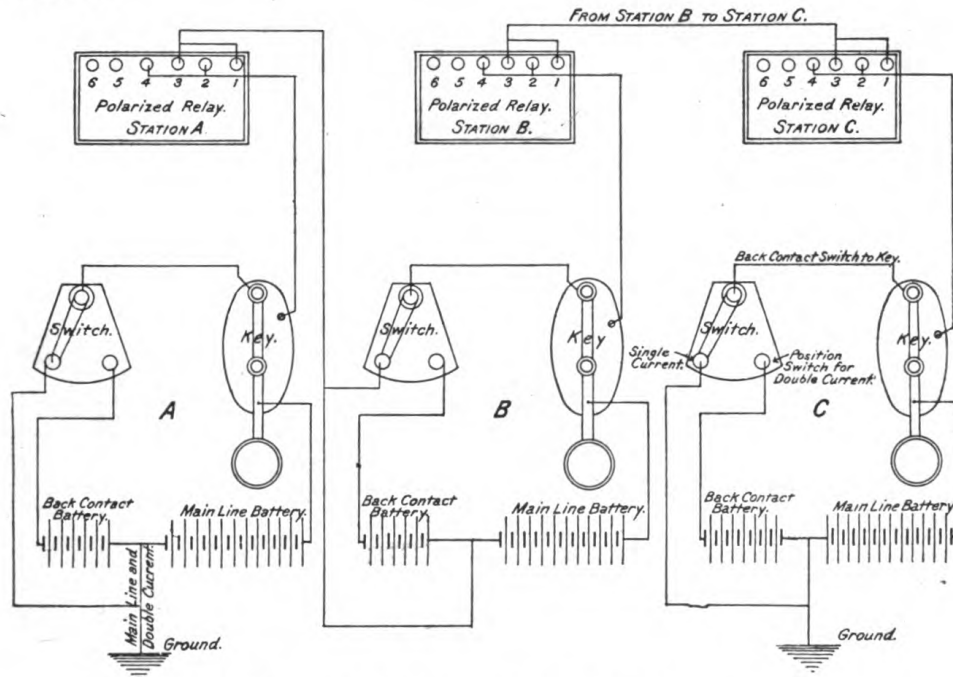

FIG. 8.—Three-station wiring plan, single and double currents sets.

Proceed in the same way with No. 2, being sure to tap on line No. 2 binding post with the wire coming from same pole of your experimental battery, as reported by distant end of No. 2 as going to line through front contact of key.

Now, having placed the table in position and run the wires from switchboard, batteries, etc., to the proper binding posts, place the switch at "cut" and try to work on, say, No. 1. If you do not succeed, reverse the wires leading to main battery No. 1 binding posts, and this will probably send the current in the right direction to work both your own and the distant relay.

Proceed in the same way with No. 2 before attempting to move the main switch to the "repeat" position.

SOUNDERS.

These should be adjusted with as little play in the lever as is consistent with sufficient loudness.

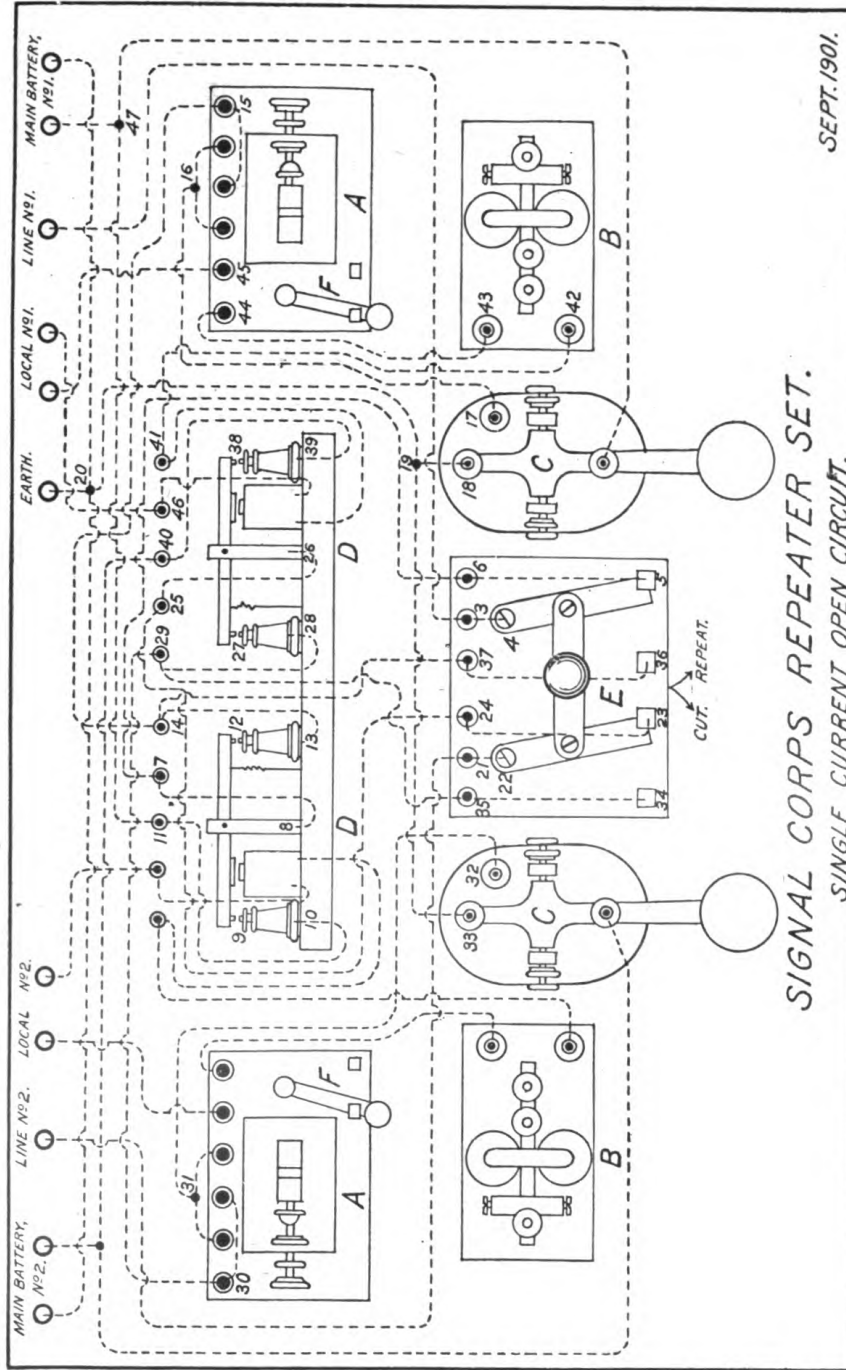

SIGNAL CORPS REPEATER SET.  
SINGLE CURRENT OPEN CIRCUIT.

FIG. 9.

TRANSMITTERS.

Each of these has a front and back contact, like the keys; in fact, it is an open-circuit key worked by its electro-magnet in the local cir-



cuit with the sounder. For good repeating, the lever should have barely a perceptible play. Be careful that the armature does not strike the magnet; this would prevent the "front contact" from being made at the contact points nearest the magnets.

Having made the various adjustments, throw the double switch from "cut" to "repeat." The two lines should then work into each other.

Note that when distant station or key of repeater set is working, say, on line No. 1, only that side of repeater set should be working, and similarly for No. 2.

If operators at distant ends complain that signals are imperfect, note if repeater, relay, and transmitter levers are set to work extremely close, or if the adjustment is not too strong on the relays. Also if the springs in the transmitters are not too strong.

Senders on lines tied together by repeaters should be cautioned that light, jerky sending is particularly hard to get through repeaters well.

#### DESCRIPTION OF OPERATION OF OPEN-CIRCUIT SINGLE-CURRENT REPEATING SET.

First, suppose distant station on line No. 1 is working, the double switch set to "repeat." The current comes in line No. 1 binding post, thence to 3 and 4 to right bar of switch, through contact 5 to 7 and 8 on left transmitter, through lever of transmitter to back contact 12 and 13, through 14 to relay at 15, through relay coils operating the relay tongue, then out at 16 through 17 on key, through body of key to 18, 19, and 20 to earth. The local circuit being closed at relay, the local battery sends in a current through binding posts local No. 1, thence to magnet of transmitter, through 46, out at 41, through sounder at 42 and 43, through relay local points at 44 and 45, thence back to local No. 1 battery. When the local current passes through transmitter magnet it closes the front contact. This permits the current of main line battery No. 2, starting at binding post, coming to transmitter on 40, to front contact 39 and 38 through lever of transmitter to 26, then to 25, to switch contact 23, through 24 to left bar of switch, to 22, 21, and to line No. 2 binding post, out to line, working the instruments in that line. An exactly similar thing happens when an operator in line No. 2 sends a current through his side of the repeater set.

When the repeater station works his key on the No. 1 side, a current comes from No. 1 main-line battery left binding post to the front contact of his key through 47, thence through key lever to body of key, then to relay No. 1 through 17, through relay and out to line No. 1, through 16, 15, 14, 13, 12, 8, 7, 6, 5, 4, 3, to "line No. 1" binding post, and out to line.

Relay No. 1 works its local circuit, causing the transmitter to repeat into line No. 2, as before explained.

When switch is turned to "cut," each key, relay, and the transmitter and sounder in local circuits work independently as two ordinary open-circuit sets.

Two small resistance coils under the board are arranged to shunt the sounder and transmitter magnets of each set. This prevents sparking and sticking at the local relay points.

## CHAPTER III.

### OPERATION OF LONG SUBMARINE CABLES.

#### SIPHON RECORDERS.

On all cables over 200 miles in length the retardation of the signals becomes so great that Morse apparatus is at a serious disadvantage; consequently some more delicate form of receiving apparatus is necessary. That almost universally adopted is the siphon recorder.

The siphon recorder may be briefly described as a moving coil galvanometer, with a delicate glass siphon attached to the coil in such a way that the motions of the coil are transmitted, very much magnified, to the point of the siphon. One end of this siphon dips into a small ink well, the other end, where the motion is greatest, touching the moving paper tape. This tape is kept moving steadily by means of a small electric, spring, or weight-driven motor. Every motion of the coil is recorded as a deviation in the straight line being drawn on the tape, and signals produced by sending quick impulses from either the positive or negative side of the battery will be recorded as short waves above or below this straight line. To render the siphon more sensitive by reducing its friction against the tape, it is kept in constant and rapid vibration by electro-magnetic means.

The construction of the recorder is shown in figs. 10 and 11.

Fig. 10 is the large siphon recorder used generally on the long cables. In the field of the permanent magnet *B* the flat rectangular coil *A* of fine insulated wire is suspended by fine threads above and below. Fine wires connect the recorder coil with the cable circuit.

When current impulses arrive, they deflect the coil, the direction depending upon the polarity of the receiving impulse. These motions are generally very small. The coil is attached by two fine silk threads to a small piece of aluminum, to which is attached the glass siphon *C*. The aluminum piece is itself suspended by a fine horizontal wire. The silk threads from the coil being near the point of suspension of the siphon, every motion of the coil and threads is thus magnified at the lower end of the siphon. The siphon dips at the upper end into the ink well *D* and at its lower end lightly touches the moving tape *E*. This tape is moved forward steadily by the gear wheels *J*, which are driven by a shaft extending back and carrying a pulley which is driven by the motor *H* through a flexible belt.

To eliminate friction of the siphon on the paper tape, the siphon is kept in vibration by means of a small electro-magnet  $F$ , to the armature of which is attached the horizontal wire carrying the piece of aluminum and the siphon. Through the electro-magnet  $F$  rapid pulsations are sent from the interrupter  $G$ , which is similar to a small vibrating bell mechanism.

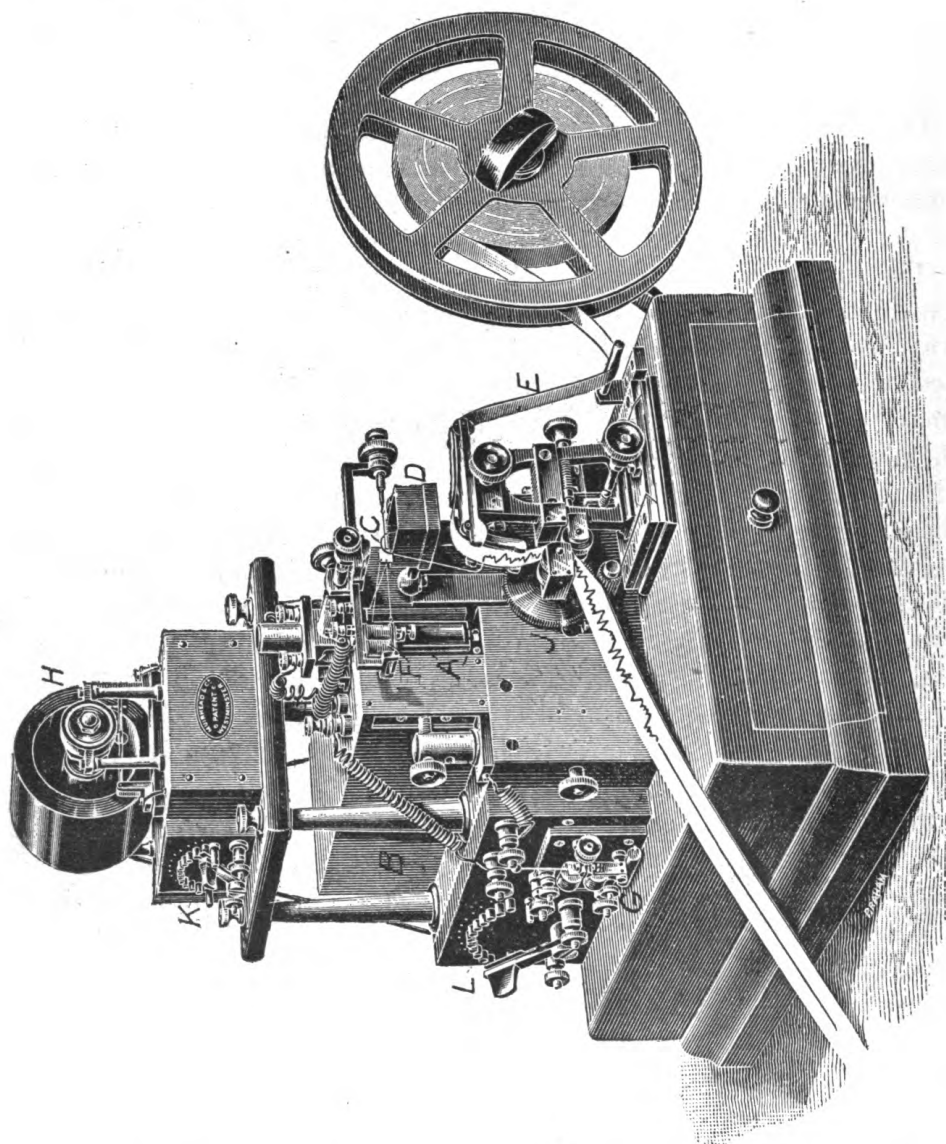

Fig. 10.

The interrupter and vibrator are controlled by a small rheostat  $L$  being included in their circuit. The speed of the motor is regulated by a rheostat  $K$ . On the other side of the recorder is an adjustable shunt coil which regulates the proportion of current through the coil  $A$ , coming from the cable.

The small recorder (fig. 11) is used on the shorter cables. It is only

about one-fourth as sensitive as the large one just described. In its essential parts it is very similar to the large one, the siphon suspension being somewhat simpler and more compactly arranged.

The permanent magnets of both these recorders have coils wound around them for the purpose of strengthening their magnetism, in case it is weakened, by sending a momentary direct current from some 100-volt source through them. Care must be taken that the current is direct (not alternating) and that it is sent in the proper direction. (See p. 30.)

The following, on adjustment of the recorder, the vibrator, and motor, is drawn in part from *Beginners' Manual of Submarine Cable Testing and Working*, by G. M. Baines:

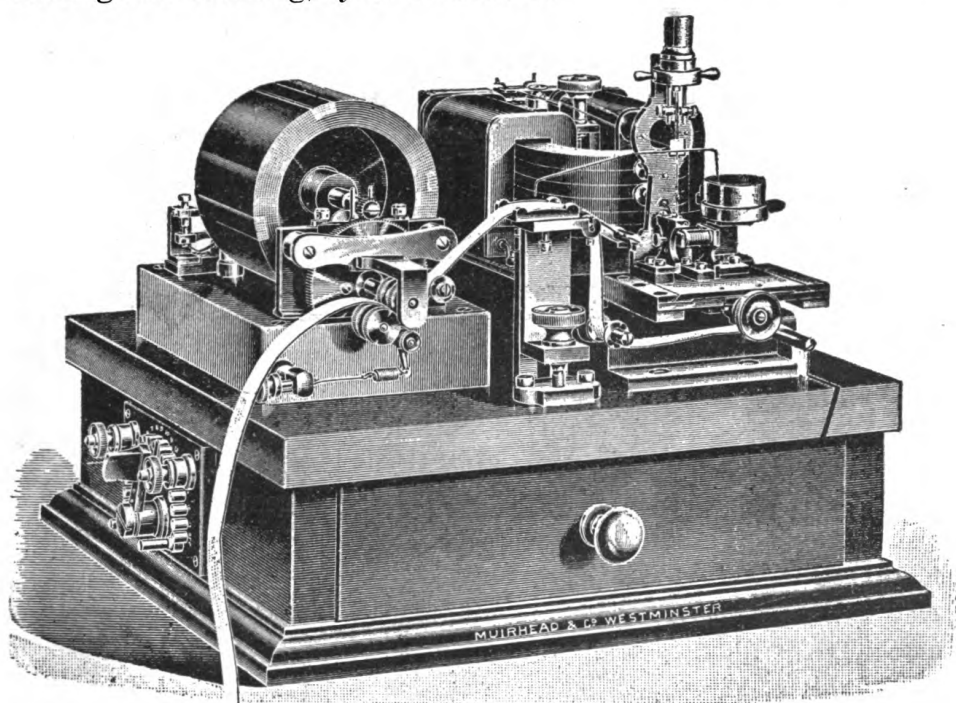

FIG. 11.

#### ADJUSTMENT OF RECORDER.

The present form of recorder, known as the "Hybrid," is of the permanent magnet type. As it has been found, however, that the magnets lose a proportion of their strength in tropical climates, a winding of insulated copper wire, with a resistance of about 8 ohms, has been provided for them. This arrangement, whence the instrument derives its name, permits of the restoration of the magnetic field strength when it falls below its normal value.

On the supposition, then, that the magnetometer proves the magnetic field to have fallen below 10 Cuff units, a current from an E. M. F. of 100 volts should be applied to the aforementioned coils. For

this purpose the ends of the coils have been conveniently brought to terminals on the instrument which are marked, respectively, with the positive and negative signs.

The operation of strengthening the magnetic field is carried out in the following manner:

The positive pole of the battery—preferably secondary cells or dynamo, because for the desired effect a large momentary current is required, therefore the I. R. must be inconsiderable—is connected to the terminal marked +. To the other terminal should be joined a short, thick wire. The current is applied by three or four momentary contacts between this wire and the negative pole of the battery or dynamo, due care being observed that the operator does not include himself in the circuit.

The "Hybrid" may be also be used as an electro-magnet recorder by maintaining a battery of tray cells on the magnet coils. It is intended, however, that it should be employed as a permanent magnet instrument, its field strength being kept at its normal value in the manner indicated.

The double fiber between the signaling coil and the siphon cradle is an improvement upon the old single-fiber attachment. By this new arrangement the full movement of the coil is imparted to the siphon.

The renewal of the double fiber, when necessary, is effected in the following manner:

1. Set the coil square and fix it.
2. Place the bridge piece in its central position.
3. Turn the milled head at the right-hand extremity of the bridge until the siphon cradle hangs perpendicularly.
4. Attach one end of the fiber to the right side of the top of the coil; fix it with the shellac supplied for the purpose; pass it round, or through, the siphon cradle; fix it there and lead it back to the top of the left side of the coil, where it will also be secured.

Great importance is attached to the preservation of the following equidistances:

1. Between the attachment of the fiber ends and the coil center.
2. The two points where the fiber passes through the siphon cradle and the cradle wire.

To obtain the most suitable adjustment of the fibers, first slacken them and set the siphon in an upright position by turning the milled head which holds the cradle wire. Next, tighten the coil fibers, and if the siphon be deflected from the perpendicular bring it back by a slight turn of the milled head carrying the coil suspension. This will square the coil and bring back the siphon to the perpendicular at the same time.

If, on again tightening the coil fibers, the siphon deviates, it will be found that the aforementioned equidistances have not been preserved.

A broken coil suspension admits of easy repair.

Thread a piece of silk through the aluminum attachment at the top of the coil, tie the ends in a loop, and pass them up through the coil cap over the small pulley above it.

A proper adjustment of the signal coil is a matter of the utmost moment for securing the double result of maximum signal speed and definition. Experiment has demonstrated that, for rapid speeds, better defined signals are obtained by discarding the shunt, and tightening the coil suspension. By this means a quicker periodic move-

### MUIRHEAD VIBRATOR DIAGRAM OF CONNECTIONS

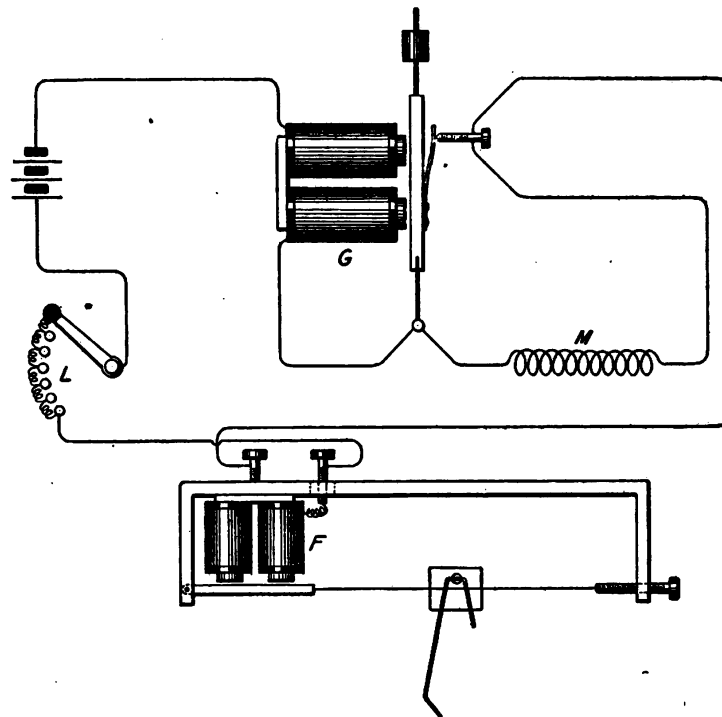

FIG. 12.

ment is given to the coil. The shunt exercises a damping effect on the coil, rounding the signals in such a manner as to render them unreadable at high speeds.

This periodic movement of the coil would also require attention if, for instance, it were found necessary to change over an electrically long cable to an instrument adjusted for a short one, or vice versa. For the long cable, with a slower signaling speed, a larger periodic movement of the coil would be required to give a sufficient amplitude to the signals.

With regard to the adjustment of the vibrator, the screw and weight on the interrupter *G*, fig. 12, is the most important factor, and

should claim first attention if a failure of ink occur. For the vibration of a long, fine siphon the weight will need a higher position on the make-and-break rod than would be required for a coarse tube. The movement of the vibrator armature should be so regulated as to be nearly invisible. Variation in the thickness of the ink flow may often be obtained by altering the rheostat resistance  $L$ .

#### MUIRHEAD'S VIBRATOR.

Fig. 12 explains the connections of this apparatus. For working it, 3 Leclanche cells of low I. R. will suffice when all the resistance  $L$  is in circuit. The action and use of the instrument are too well known to need a lengthy description. It will be found that the best result is obtained when the interrupter  $G$  works almost silently. Fine siphons are also recommended as being susceptible of greater vibration than coarse ones, with a consequent reduction of friction, also, between the siphon point and the paper. The spark coil connected between the make-and-break contacts, is indicated as  $M$  in the plan below. The resistances of the interrupter  $G$  and vibrator  $F$  coils are about 10 ohms per pair.

#### THE MOTOR.

The present form of recorder motor is a development of the original type introduced by Lord Kelvin. A cam is suitably adjusted to allow the current from the driving battery to pass at the proper points, in sequence, through the coils of the fixed electro-magnet below the revolving drum. A set of resistances  $K$ , fig. 10, on the motor base, can be introduced into the circuit of the battery and the electro-magnet coils for the regulation of the speed.

Soft-iron bars, disposed at equal distances from each other, are fixed longitudinally on the surface of the rotating brass cylinder, through the center of which passes the axle upon which the whole revolves.

At the instant a bar, attracted by the electro-magnet, arrives opposite the core of the latter the battery is cut off by the cam. The momentum carries the bar past and brings the next near the core of the electro-magnet. The cam again closes the current, giving another impulse to the drum, and so on. The result of this series of operations is a continuous revolution of the drum.

For the recorder motor, a battery of four tray cells is recommended. The speed of the motor should be kept at its maximum, and the motor band placed upon the large wheel at the back of the shaft. This plan, without greatly diminishing the speed, admits of more strain being given to the paper, and prevents the bulging of the latter against the siphon.



The motor and vibrator should not be driven by the same battery on account of the constant variation in the potential of the latter. Say the motor battery has an E. M. F. of 4 volts, and an I. R. of 1 ohm. The motor coils have, also, a resistance of about 1 ohm each. The potential, therefore, outside the battery constantly varies, by the make-and-break, between 2 and 4 volts. This variation would disturb the regularity of the vibrations.

#### CARE OF RECORDER SIPHONS, INK, ETC.

*Recorder siphons.*—The punk furnished with tool boxes makes the best material for bending siphons. A lighted paper spill made of recorder tape is also a handy means of bending siphon tubes. A small spirit lamp is better. Tilt the lamp forward; the tubes must not be thrust into flame; a slight contact with the blue flame underneath will bend the tubes without melting and closing the tube. By using a spirit lamp both hands are available.

The best way of breaking off the surplus tube is by pressing it between the thumb nail and the forefinger. This usually leaves a clean level break, requiring a very little grinding. A fine emery stick is one of the means of smoothing the siphon point, but the best is the miniature battery motor fitted with a small emery wheel.

Recorder ink is made by dissolving some of the more soluble aniline dyes in water, to which is added alcohol. In general about one-fifth alcohol is correct, but the amount of alcohol depends upon the quality of the tape and dryness of the air. "Soluble-blue" aniline is good, and some of the "Diamond dyes" make good ink. It is best to use boiled water. The bottle should be kept corked and care taken to exclude dust and lint from the ink well.

If siphon gets choked, heat the wax soldering strip used for putting siphons on and gently rub along siphon. This will force the ink out and remove the obstruction.

When recorders are not in use for some time, the siphons should be immersed in water instead of ink. Empty ink well, fill with water, letting paper tape run till all ink is drawn out. Better still is the use of alcohol instead of water. When ink is drawn out of siphons, the alcohol filling tube, the alcohol can be returned to bottle and siphon left dry. On starting recorder again the ink will flow freely without assistance, the alcohol having evaporated leaves tube dry.

*Ground connections.*—In no case should the recorders be connected with the same ground as land lines or even to the same cable sheath that connect to instruments where Morse is used. Owing to the great delicacy of the recorder this will cause the Morse working to disturb the recorder signals.

30447—05 M—3

## AUXILIARY APPARATUS FOR SIPHON RECORDER WORKING.

Double keys are used similar to those shown in fig. 13. The battery binding posts are on the sides, while the earth and line posts are at the back. Connections are shown in fig. 13. The switch used is shown in fig. 13.

The signaling condensers may be either in the transmitting circuit, in the receiving circuit, or both. In the Alaskan cable offices the condenser is inserted in the receiving circuit only as shown in figs. 13 and 15. These condensers should be very solidly made and having ample thickness of dielectric to prevent short-circuiting by puncturing or rough handling.

SIMPLEST ARRANGEMENT  
SIPHON RECORDER SET  
AT CABLE OFFICE

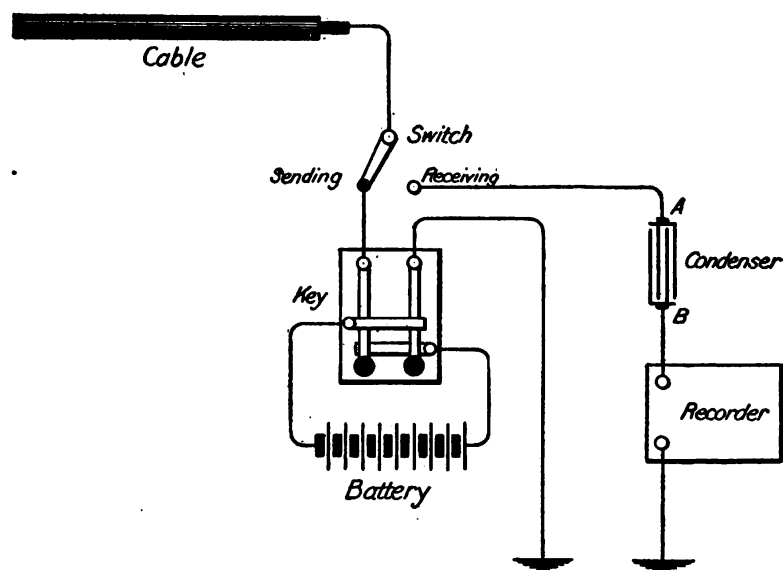

FIG. 13.

In the stations provided with spare small recorder sets there is a master switch, or "commutator board," mounted on the wall near the table sets. This has brass contact pieces with platinum faces arranged on the periphery of a strong hard-rubber disk. These make appropriate contacts with large platinum-tipped springs, and one motion makes all the changes in connections required in shifting operation from one set to the other. (Fig. 16.)

At the offices on the longer cables is provided a large coil forming an inductance shunt to the cable. (Figs. 15 and 16.) This coil has resistance in series with it mounted in the same case with the condenser shunt.

*Batteries.*—These are used for three purposes at cable offices. First, for providing the line (cable) currents for sending; second, for operating the interrupter and vibrator; third, for driving the recorder motor. When one is accustomed to land-line operation, the amount of battery required to operate long cables with siphon recorders is surprisingly small. For example, the Seattle-Sitka cable, 1,073 miles long, is operated with ten ordinary Gonda cells; the Valdez-Sitka cable, 600 miles, with two cells, and the Juneau-Sitka cable, 300 miles, with one cell. These ordinary forms of salammoniac batteries seem well suited for light-traffic cables, but for heavy-traffic cables the large companies use Fuller batteries. (See Signal Corps Manual, No. 3, for directions for setting up these and other cells.) For operating the interrupter the large-size dry batteries (No. 8) or the Fuller are satisfactory. Three of the former or two or the latter will give about the right effect. For operating the motor only batteries having low internal resistance and great staying power are satisfactory. Fuller cells will do, but they require quite frequent attention. Two or three of these are required. In an emergency the large dry cells (No. 8) will answer for a few days. Three to four of these are needed. Another cell that will do well for short periods is the Edison battery, now extensively used on the Alaskan land lines. Five or six of these will give about proper speed. But in uniformity of action and reliability for this purpose or for driving the vibrator perhaps nothing better has been found than the old Thomson tray cell. Instructions for setting them up and maintaining them are given below.

*Thompson's tray cells.*—These batteries, employed to keep the motors and vibrators active, are a modification of Daniell's sulphate of copper battery, designed so as to have very little internal resistance, and are called "tray cells." They consist of large flat wooden trays, lined with lead to make them water-tight and having for the positive metal a sheet of thin copper in the bottom of the tray. In the four corners of the tray four stoneware props are placed, and on the top of them rests a zinc grating, which forms the negative metal. The tray is filled up with a solution of sulphate of zinc, and sulphate of copper crystals are dropped in on the bottom plate. The zinc is surrounded by a sheet of stout manila paper to prevent the diffusion of the sulphate of copper solution from producing copper deposits on the zinc plate. The trays are connected to each other by being piled one on the top of another, so that the copper of one is connected to the zinc of the one below it by contact of the lead sheathing of the upper one with the four corners of the zinc plate below on which it rests. The advantage of this form of cell is its extremely low internal resistance. It requires constant attention to keep it in efficient order.

*Directions for setting up the batteries.*—Each of the lead trays must first be carefully coated with varnish over the bottom and sides and edges. Spirit varnish made with shellac or ordinary varnish will do very well. Care should be taken not to varnish over the strip of copper which is soldered to the bottom of each tray. The under surface of each thin copper plate is also to be varnished. When the varnish is dry place the sheet of copper in the tray with the varnished side down, and, cutting a slit in the center of the copper sheet, bring through the strip of copper which is soldered to the bottom of the tray; bend the strip and spring it so that its end presses firmly against the upper surface of the copper plate, taking care that both are scraped clean at the place where they touch.

Each lead tray should have a stout copper wire soldered to it, projecting about 3 inches from one corner.

Each zinc is to be protected by a square of manila paper bent round below it, and folded neatly at the corners and fixed with sealing wax.

Press the paper against the zinc between finger and thumb on each side of the corner, and draw the bight or bend of the paper diagonally away from the corner; then fold the bight around the vertical corner of the zinc, and press it against the flat zinc surface on one side or other of the corner. Secure with sealing wax in the bight, and where one side of it is pressed against the paper on the vertical zinc surface. Then tie the paper round carefully with cord in the manner described in the text. Care must be taken that the edge of the paper be generally three-fourths inch (and in no place less than one-fourth inch) above the upper level of the bars of the zinc grating. It must be bound firmly to the zinc by means of a long piece of twine passed several times round the square outside the manila paper.

To support a pile of trays take four blocks of wood or stone, each 4 or 5 inches square in horizontal dimensions and of any convenient height, and place them on the floor in positions to bear the four corners of a tray. The pile must be so placed as to give ready access to each of its sides. Then lay down the first tray upon the blocks, seeing that it is properly leveled. This is most easily done by pouring a small quantity of water into the cell, and seeing whether it lies evenly over the bottom. Put four stoneware blocks, each about 1½-inch cube, in the corners of the tray, on the top of the copper sheet, and put one of the zinc gratings resting with its four corners on these props. See that the top corners of the zinc and the bottom corners of the tray to rest upon it are all properly tinned, scraped clean, and dry. Place a lead tray resting with its four corners on the upper projecting corners of the zinc. Place four stoneware props in the corners of this second tray, put a second zinc upon them, and fill with solution as before. Proceed thus until a pile of six trays, one over the other, is made and filled with liquid. Solder a stout copper wire to

one of the corners of the top zinc, to serve as an electrode. In the same way make as many piles as are required. Leave a space at least 1 foot broad between each pile and its neighbor. Connect the piles in series, the top zinc of one pile to the lowest lead tray of the next one.

The crystals of sulphate of copper to be used should be broken into small pieces and weighed out in quantities of three-fourths of a pound each. To put the battery in action, drop in 3 pounds to each cell; three-fourths pound separately on each side, distributing it as equally as may be along the space between the stoneware props. In putting in the crystals be careful not to let any fall inside the parchment paper or in contact with the zinc. As soon as the sulphate of copper is put in the battery should be allowed to work on short circuit for forty-eight hours before putting it on the circuit which it is intended for.

From 4 to 5 cells are required to drive the recorder motor.

*Maintenance of the batteries.*—When the tray cells are in use the sulphate of copper is decomposed, copper is deposited on the copper plate, and the zinc plate is consumed; sulphate of zinc is formed, which strengthens the solution at the top of the cells. It is therefore necessary to supply more crystals of sulphate of copper, and also to draw off the sulphate of zinc solution from the top of the cell when it becomes too dense and to supply its place with fresh water. When a cell is in constant use it is desirable to draw off a little of the liquid daily. The drawing off is effected by means of a siphon, the shorter end of which is dipped into the cell between the edge of the tray and the zinc plate, so as to be just below the lowest level of the zinc, while the longer end stands out over a convenient vessel to receive the liquid. Water is to be poured into the space above the zinc grating by means of a funnel ending in a bent tube. The specific gravity should be frequently tested by a hydrometer or by specific gravity beads, and the quantity drawn off should be regulated so as to keep the specific gravity of the liquid (taken from near the surface of the cell) at about 1.24, or not greater than 1.3, and not less than 1.12. Fresh crystals of sulphate of copper are to be dropped in along the four sides of the cell, 1 ounce at a time along each side. It is easy to see when fresh sulphate is required by observing when the blue color of the liquid at the bottom of the cell disappears. When cells are in active use they generally require new sulphate almost daily. A cell, or pile of cells, should never be left out of use for any length of time with crystals or blue solution in it; before being left it should always be short-circuited until the liquid becomes clear and colorless. If sufficient care is not taken to remove the sulphate of zinc solution as it becomes too dense, crystals of sulphate of zinc will accumulate round the edges of the cell. These ought to be scraped off. When

the batteries are not properly attended to these crystals will often accumulate in such quantities as to connect the zinc ray to the lead casing, and so to short-circuit the cell.

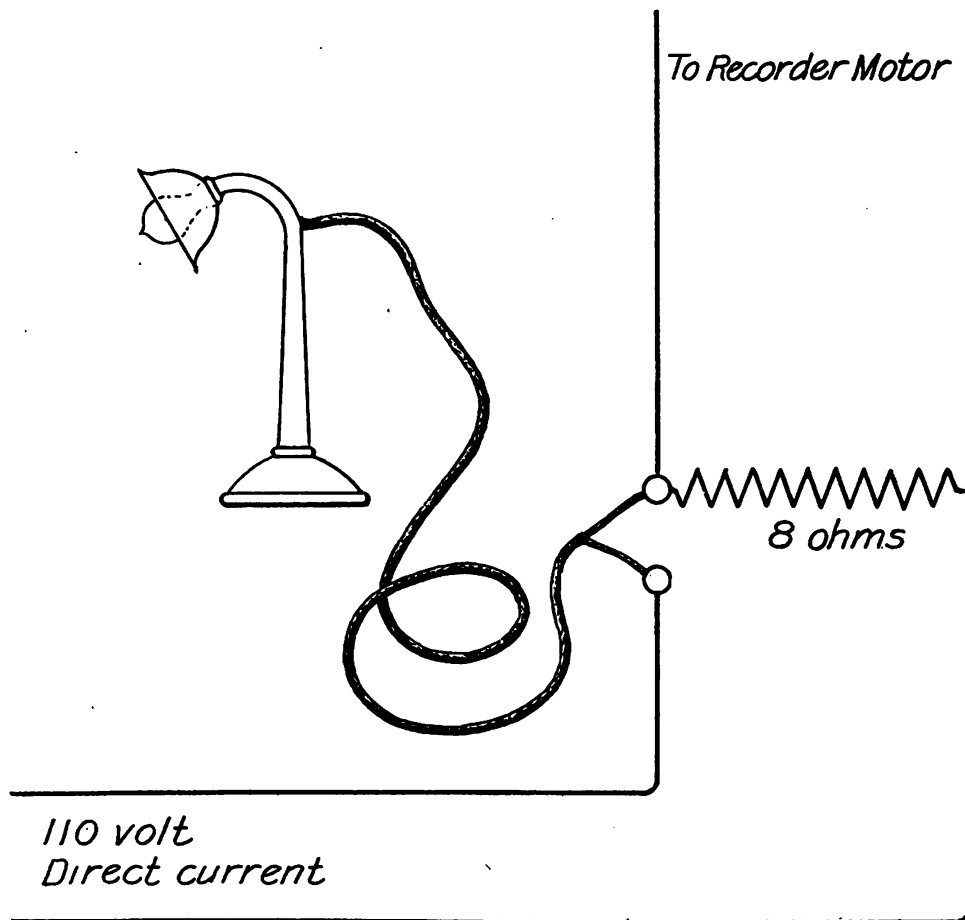

FIG. 14.

#### OPERATION OF MOTOR BY ELECTRIC-LIGHT CURRENT.

Where the office is provided with electric lights fed by direct current from 110-volt circuits the table-lamp circuit can be utilized in place of a tray battery, as shown in fig. 14 for feeding the motor.

The 8-ohm resistance coil, made up of sufficiently large wire not to heat with 1 ampere, is in circuit with the 32-candlepower table lamp. This coil is shunted by wires from the motor, as shown. The motor terminals receive a resultant voltage of about 4 volts from this arrangement. This is a cleanly and convenient substitute for the bulky and troublesome tray battery.

## ARRANGEMENT OF INSTRUMENTS FOR OPERATING LONG CABLES.

As siphon recorders are now almost universally used on long cables, office sets of this kind only will be described. The simplest arrangement of the siphon recorder set is shown in fig. 13. With the switch in sending position it is seen that the negative end of battery is put to line when the left key lever (dot) is depressed, and the positive when the right (dash) is depressed. With switch set at receiving, the incoming currents pass through condenser and recorder to earth. On the longer cables Muirhead's arrangement of the circuit is shown in fig. 15.

ARRANGEMENT  
MUIRHEAD APPARATUS.  
FOR OPERATING LONG CABLES.

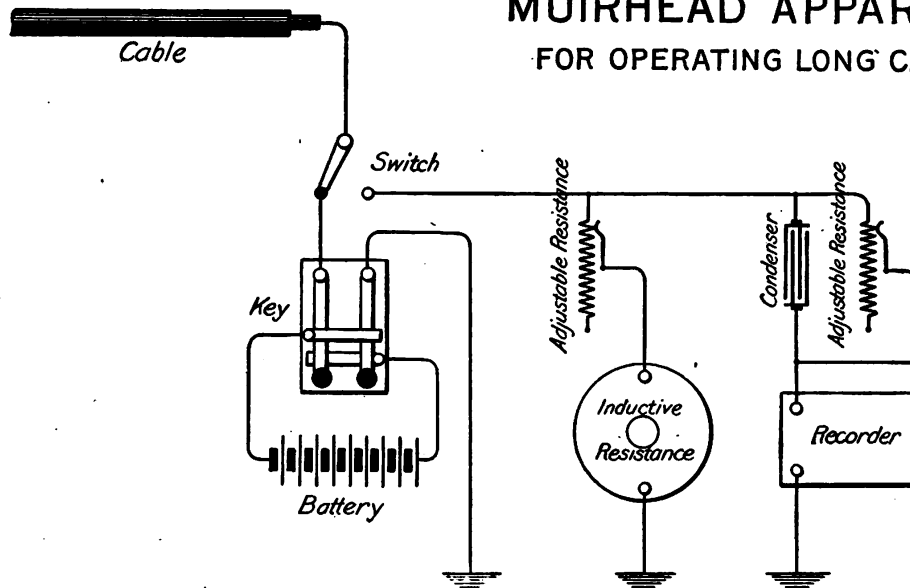

FIG. 15.

In the receiving circuit the incoming currents are first partly shunted to earth through the adjustable resistance and inductive resistance coil. This, while reducing the signals somewhat in amplitude, tends to make them squarer and more sharply defined. The unshunted portion of currents then pass on, part of them going directly to recorder and earth through the condenser shunt adjustable resistance, and the other through the condenser and recorder. By adjusting the resistances and condenser the signals can be leveled off to the most legible shape.

The actual circuit arrangement, combining switching devices with the elementary circuits just described, is shown in fig. 16.

The large commutator is so turned in the figure as to show the large recorder in use, the other set being spare and kept ready for instant use. Suppose distant station is sending. The signals come

over cable into 1, to 2, 15, 23, and, with switch in receiving position, 26, 16, part passing through resistances *BB*, inductance coil *BB*, to 20, and ground, the other part passing from 16 to 3, 4, 17, again dividing part passing through condenser shunt resistance *AA* to 43, 11, 5, 6, 18, 31, recorder, 32, 19, 7, 8, 20, and ground; the other part

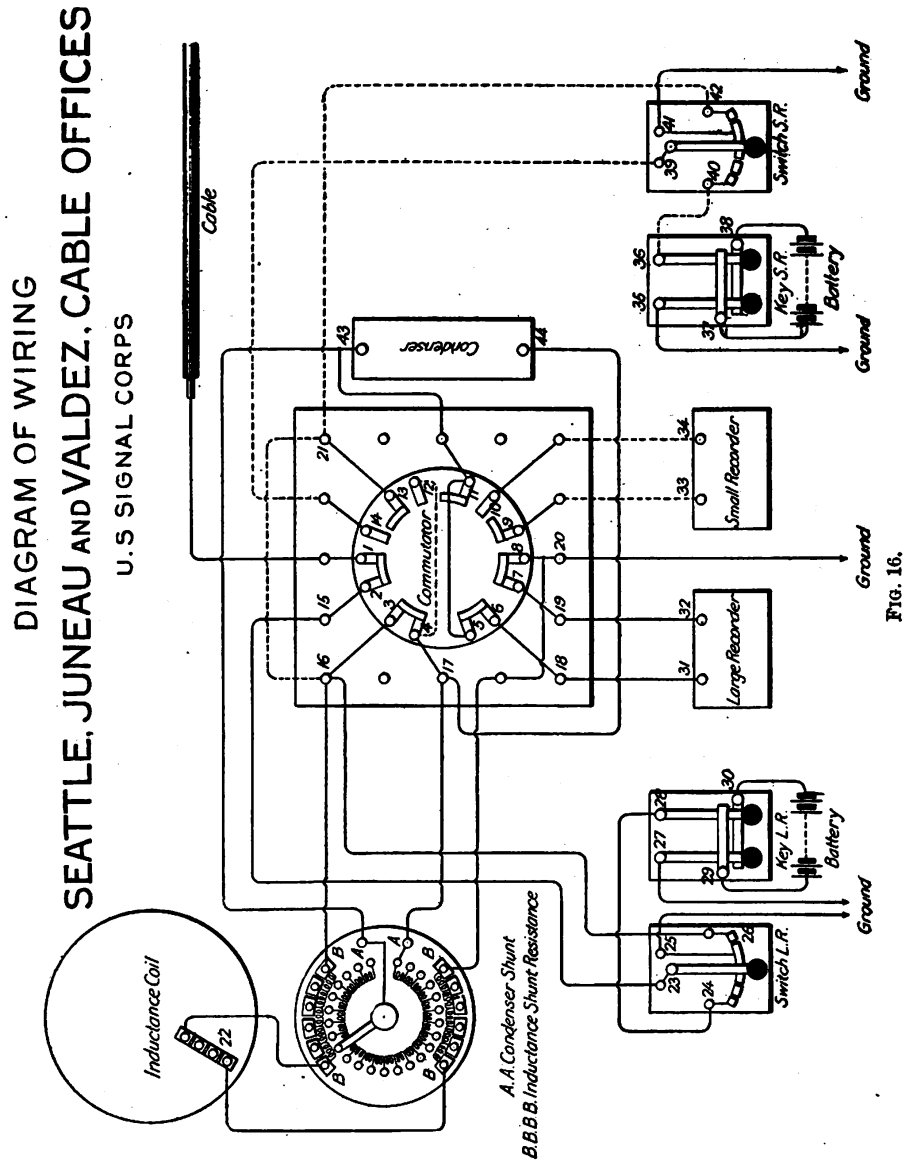

(starting at 17) going to 44 through condenser to 43 and through recorder to ground, as just described. When switch is put to sending position and left key lever depressed the current comes from positive end of battery to 29, 28, 24, 23, 15, 2, 1, and out to cable.

To put the small recorder into service the commutator is revolved one step to the right, putting 1 in connection with 14, 13 with 12,



and so on. Then a current coming from the cable comes to 1, 14, 39, 42, 21, part through 16 to inductance coil to ground, as previously described, the other going on to 13, 12, 4, 17, dividing part going through condenser shunt resistance AA to 43, 11, 10, small recorder, 9, 8, 20, and ground, and the remainder (beginning at 17) going to

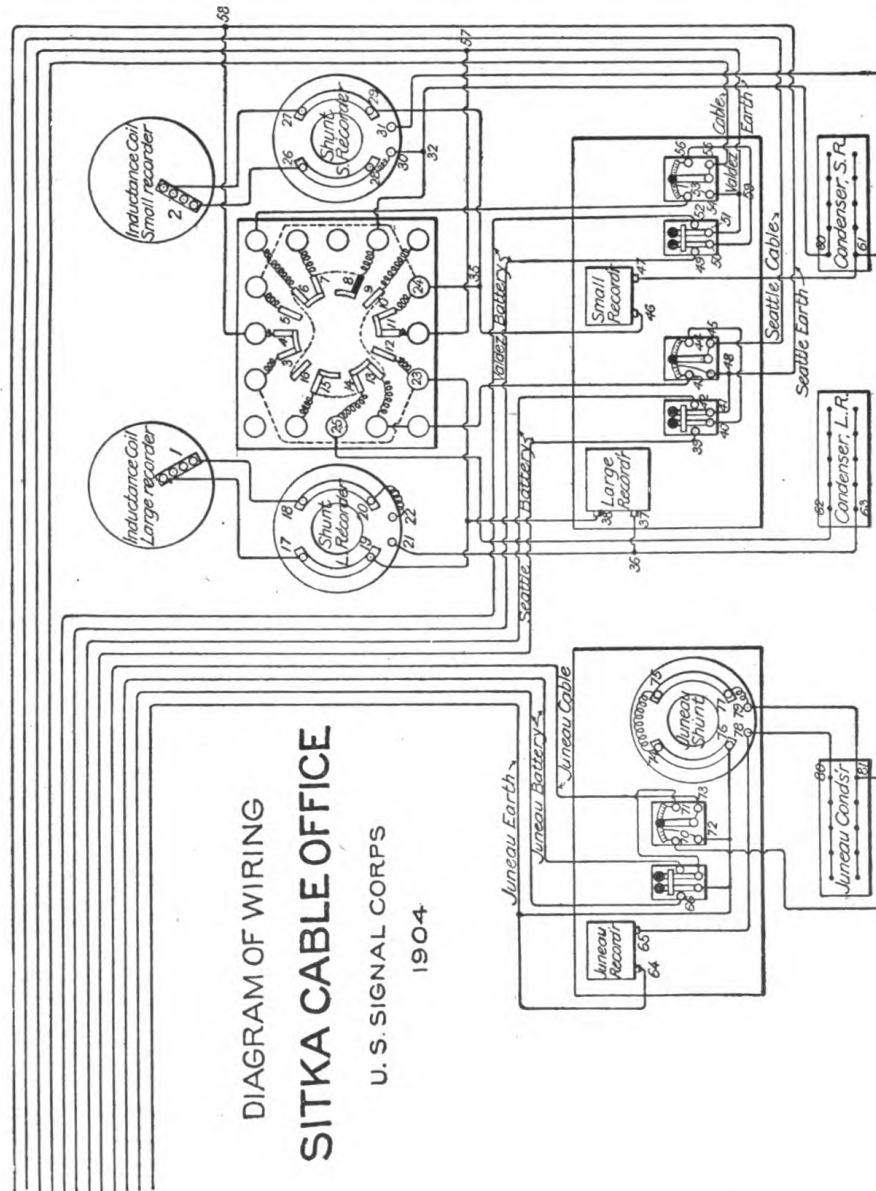

FIG. 17.

44, through condenser, 43, 11, 10, recorder, and ground, as just described.

At the Sitka cable office there is a large transfer business between the Seattle and Valdez cables. These two sets of instruments are consequently arranged on tables close together for "human-relay"

operation (fig. 17). The key and switch belonging to each recorder are mounted on a small movable base, with flexible cord connections, permitting an easy interchange of keys by an operator at the sets. The commutator is arranged so that a turn to the right transposes the large and small recorder sets between the Seattle and Valdez cables. As arranged, the large recorder is on the Seattle and the small on the Valdez cable. Current coming in on Seattle cable goes to 45, 43, 13, 14, dividing part going to 15, 22, 20, 18, 1, 17, 19, 23, 3, 4, and Seattle earth; the other (beginning at 14) going to 25, 62, condenser, 63, 36, 37, recorder, 38, 23, 3, 4, and earth; another portion going direct to recorder and earth through 14, 15, 22, condenser shunt, 21, 36, recorder, and to earth, as before. The current from Valdez cable through small recorder may be similarly traced.

When commutator is turned one division to right the current coming over Seattle cable goes to 45, 43, 13, 9, 8, 32, dividing part passing direct to earth through inductance coil, the other part dividing at 32, a portion of this going to 60, condenser, 61, 47, small recorder, 46, 35, 24, 5, 4, Seattle earth; the other portion (beginning at 32) to 30, condenser shunt, 31, 61, 47, recorder, and to earth, as above described. It is thus seen how the commutator transposes the siphon recorder sets.

The Juneau set, with small recorder, is on a separate table. As this cable is comparatively short, no inductance coil is used, a portion of the current being shunted direct to earth through 73, 70, 81, 79, 77, 75, 74, 76, and earth. The tracing of operating currents in this set may be easily done from descriptions of other sets.

#### NOTES ON THE EFFICIENT WORKING OF A CABLE STATION AND ON TROUBLES THAT OCCUR.

[By Mr. David Lynch, Cable Electrician, U. S. Signal Corps.]

See that the batteries are kept in good condition and well insulated from each other and outside damp or metallic surfaces.

All office leads should be well insulated. It is better not to bunch them together or bend sharply at an angle. Whenever binding posts or switches are used they should be frequently overhauled and cleaned. A high resistance at a connection is a very common source of trouble.

Light, snappy sending over a long cable will produce weak and distorted signals at the distant end. All contacts should be uniformly made and with a cushiony or springy style. See that the levers of key spring back well against the back contact, otherwise the line will not discharge properly through the key to earth.

The amount of sending and receiving condensers to be used can best be regulated by experiment, the resistance and capacity of the cable

and the amount of battery used being the chief basis to judge by (from 20 to 60 microfarads gives a range sufficient for all general conditions). Where no sending condensers are used it is well to interpose an inductance coil between the line and ground parallel with the receiving condenser and recorder. This inductance coil is to have a resistance in series with it for adjustment. The condenser is to be shunted by an adjustable resistance. With this inductance leak in circuit it will be necessary to increase the sending battery, as it acts as a shunt on the recorder. With a proper adjustment of the resistance in series with the inductance coil and of the resistance shunting the condenser, the signals can be made of uniform deflection and will lose that irregular rising and falling off which is a bad feature in long cables.

If the distant station complains of signals being small or weak it is well to test the battery for voltage, at the keys; and if the voltage shows normal the trouble is due to a high resistance caused either by bad contact of the key or other bad connections in the circuit. If there is a spare set in the office, switch over and ask if signals are any better. If the reply is negative the trouble must be in some connections which are common to both sets, which can be seen in the office diagram of connections. This is on the assumption that there is no trouble at the other station. If the distant station complains of key failing and states he gets no "dots" or only occasional "dots" from you the trouble will invariably be found in a dirty point either at the *front* contact of the "dot key" or the *back* contact of the "dash key." If the complaint is of "dashes" failing the positions are reversed—that is, at the *front* contact of the "dash key" and the *back* contact of the "dot key." The receiving station should overhaul and clean his connections in the switch and see that his condenser and shunt connections and contacts are all right. A jumper or bridge of a small piece of wire can be put across the different connections in the switch to prove that the contacts are all right. A variable resistance in the inductance coil circuit, or condenser shunt circuit, or a faulty condenser will produce variable signals. After seeing that the connections are properly made and contacts clean, and the signals still vary from large round signals to small sharp signals and at times come normal, the condenser should be tested for insulation. A faulty condenser will give the above effect. In case communication is lost with distant station, cut out switch and office connections and run wires to line and earth direct where they enter office and connect up as in diagram (fig. 13). After calling for a sufficient time and no answer received, short-circuit condenser by putting a wire across from plate "A" to plate "B" and call again. This will prove if trouble is local or otherwise.

After both stations have overhauled their office connections and the trouble still remains in, tests should be made of the main cable and earth cable. In the case of long underground cables it very often happens that joints get corroded and eaten away. This is particularly the case where there are electric railways in the vicinity.

By keeping the field magnets adjusted close to the signal coil the trouble from small, quick extraneous currents will be very much lessened. In case of earth currents being very strong the shunt on the receiving condenser had better be increased very much or set to infinity. The signals can be regulated by the recorder shunt to the required size. One of the principal things in maintaining good signals is the syphon and its vibration. The point of the syphon should be uniformly ground and bent so as the best flow of ink is obtainable. If the nose is bent too abruptly or not far enough a very poor line is the result. It will be found when a new syphon is put on that perhaps the period of vibration is different from what it was for the old syphon. It will then be necessary to adjust the interrupter by turning back and forth and sliding the weight on the armature lever up and down until the proper period is obtained. Also, the rheostat in the battery circuit can be changed to give desired effect. If the syphon is not properly mounted it will be difficult to get proper vibration. If blots of ink form rapidly on the nose of the syphon it is better to change it and substitute one better ground. By heating a small iron and putting a little wax on the nose of syphon a rough line can be improved. Once the kind of syphon that gives best results is established a dozen or so similar ones properly ground should be made ready for use so the one can be readily mounted when necessary. Keep the bearings of the motor well oiled and the battery contact maker cleaned and free from sparking. If the contacts are too close and an arc forms, the battery will be run down quickly and motor run irregularly.

## CHAPTER IV.

### CABLE TESTING.

The remarks made under the heading "Testing" concerning the general necessity for testing regularly apply with added force in the case of cables. By applying regular tests incipient faults will frequently disclose themselves long before they become sufficiently serious to interfere with the working, giving ample time to notify the repair ship, if the faults are out at sea. Furthermore, it is absolutely necessary in case of cables to locate them accurately by tests, though this part in its refinements belongs in general to the cable-ship experts. The subject of cable testing is extensively entered into by Kempe in his Handbook of Electrical Testing.

The works already cited by Wilkinson and Bright also describe various methods. Students' Guide to Submarine Cable Testing (Fisher & Darby), Electrical Testing for Telegraph Engineers (J. Elton Young), Beginners' Manual of Submarine Cable Testing and Working (G. M. Baines), and Testing of Insulated Wires and Cables (Webb) are recommended treatises on testing. The Students' Guide and the three latter are compact treatises which are quite elementary and easily understood.

It is proposed to describe such tests as are usually desirable at cable stations, leaving the description of complicated apparatus and methods, together with the mathematical demonstrations, to the works cited.

In making the approximate measurements at stations the Weston milliammeter and voltmeter set may be used. These, of course, will not give sufficiently accurate results when high resistance faults exist. The Wheatstone bridge may be used whenever measuring the ordinary resistances, and the ohmmeter will answer for approximations. The Fisher cable-testing set, described on pages 60-70, combining, as it does, so many necessary instruments, is convenient for Morse stations.

The reflecting galvanometer is a necessity in accurate cable measurements. Not only does it give better results than any other form with Wheatstone bridge measurements, but it is a necessity in insulation resistance and capacity measurements, both of which are very important in cable work. Before considering them the reflecting or mirror galvanometer will be described.

## REFLECTING GALVANOMETERS.

Any pointer or indicator attached to the movable coil or needle of the galvanometer increases the mass to be moved and decreases the sensitiveness. A delicate mirror being attached to the coil or needle

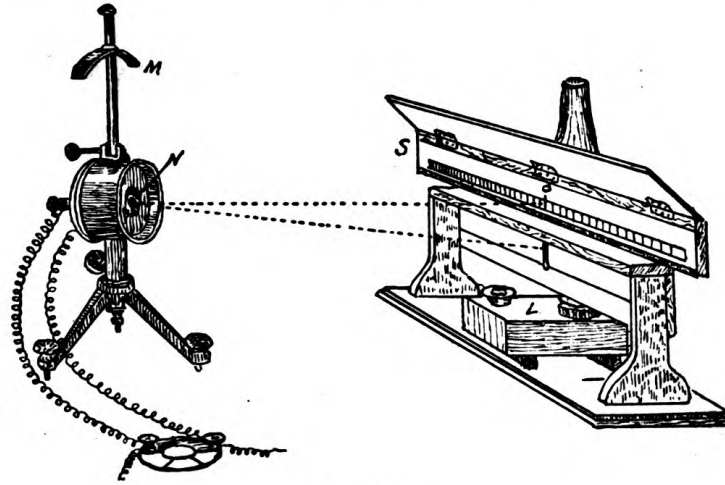

FIG. 18.

may be used to reflect a beam of light onto a scale, thus giving a weightless pointer or indicator as long as may be desired and consequently great sensitiveness. Another way of utilizing the reflecting

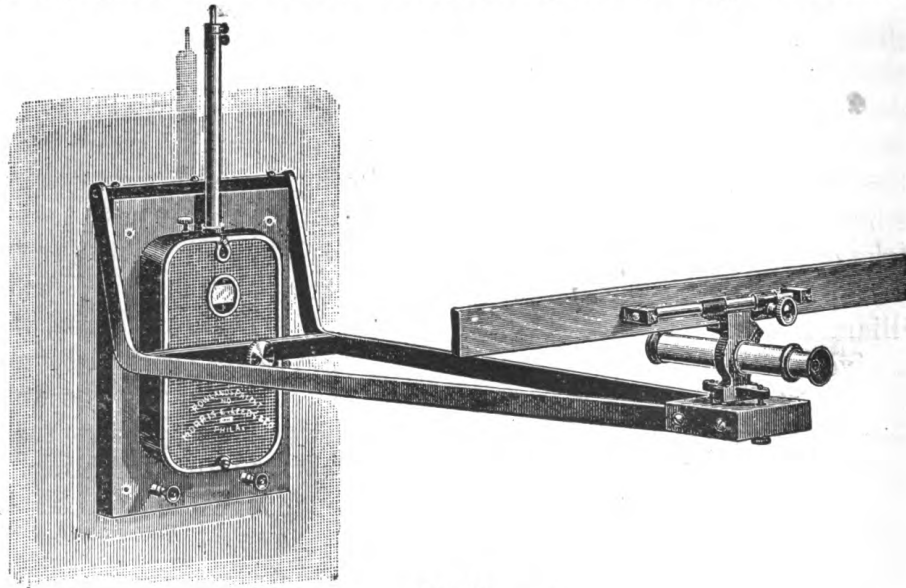

FIG. 19.

principle is to view the reflected image of the scale with a small telescope, noting the number on the scale intersected by a vertical thread in the telescope. Formerly the Thomson reflecting galvanometer

(fig. 18) was exclusively used for any case requiring great sensitiveness.

The beam of light from the lamp *L* shining through the slit in the shield is reflected from the mirror attached to the suspended magnetic needle *N* and projected on some point of the scale *S*.

The needle swings in a small space in the middle of the coils, and the direction and strength of the controlling force is given by the bar magnet *M*. By this arrangement it is seen that a very small movement of the needle and the attached mirror will be greatly magnified in the movement of the spot of light, on the scale.

Galvanometers of the D'Arsonval class, with a suspended coil turning in the field of a permanent magnet, are in general use for all kinds of measurements. While usually not of such a high degree of sensitiveness as the Thomson, they are much more "dead beat" and manageable. These are quite generally used as mirror galvanometers.

An excellent portable form for cable station use is shown in fig. 19.

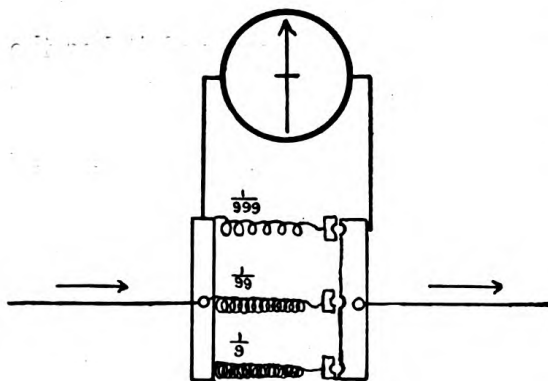

FIG. 21.

As will be noted, these use the small telescope to view the scale, and should be so mounted that the light from the window or lamp will fall on the scale.

SHUNTS.

Any delicate galvanometers like the above can not be used in most cases with the whole current involved in the measurement, as even through a very great resistance a single cell will cause the reflected image to move completely off the scale. Consequently shunts are provided which allow certain definite portions of the current (usually  $\frac{1}{10}$ ,

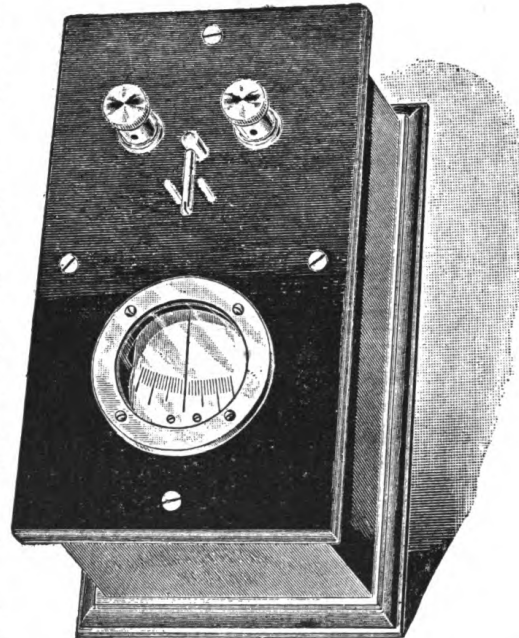

FIG. 20.—Portable pointer galvanometer, D'Arsonval pattern.



$\frac{99}{100}$ , or  $\frac{999}{1000}$ ) to pass through the shunt, and  $\frac{1}{10}$ ,  $\frac{1}{100}$ , and  $\frac{1}{1000}$ , respectively, to go through the galvanometer.

The simplified diagram is given in fig. 21.

By placing the plug at one or the other of the points a divided circuit is formed and a certain part of the current will flow through the shunt and the other through the galvanometer. For example,  $\frac{1}{9}$  has  $\frac{1}{9}$  as much resistance as the galvanometer. So  $\frac{99}{100}$  of the current will flow through this and  $\frac{1}{100}$  through the galvanometer. Hence, the deflection with this shunt will be only  $\frac{1}{100}$  as much as it would be if no plug were put in the shunt, thus bringing the deflection within readable limits.

The Ayrton universal shunt is now frequently used with galvanometers of moderate resistances. One of these can be used with any

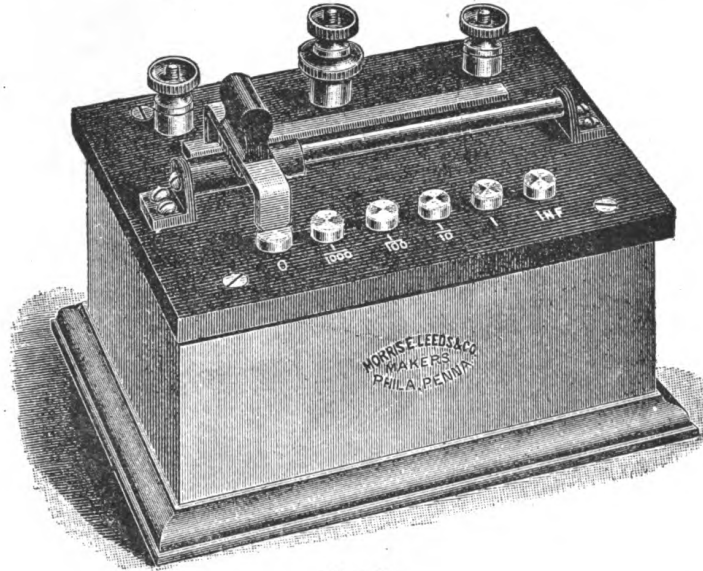

FIG. 22.

galvanometer regardless of their relative resistances, and it has the advantage of being accurate for condenser and capacity measurements as well. In this the shunts are more conveniently marked  $\frac{1}{1000}$ ,  $\frac{1}{100}$ ,  $\frac{1}{10}$ ,  $\frac{1}{1}$ . This form of shunt is now largely used and highly recommended. (See fig. 22.)

#### INSULATION RESISTANCE.

The use of reflecting galvanometers in making the important measurements of insulation resistance will first be considered. On account of the immense insulation resistance of short pieces of cable running up into many million ohms, the million ohms is adopted as the unit in insulation measurements, and is called the megohm. The Signal Corps standard submarine cable is usually specified to have 1,400 megohms insulation resistance per mile, measured at 60° F. As



will be seen by the table (pp. 64–65), this resistance decreases quite rapidly as the temperature rises.

Before proceeding with insulation measurements it is necessary to get the constant of the galvanometer. If the piece of cable to be measured is short, its insulation resistance will probably be very high, and a battery of from 50 to 100 cells in series will be required. These may be the smallest size dry cells, or one of the regular boxes of testing batteries. It is the experience of the writer that these latter are an expensive luxury, on account of their first cost and liability to be ruined by even very brief short-circuiting.

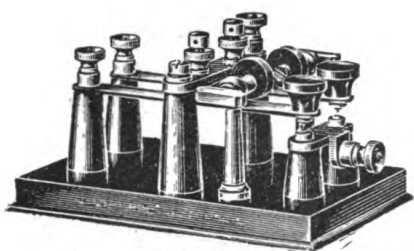

FIG. 23.

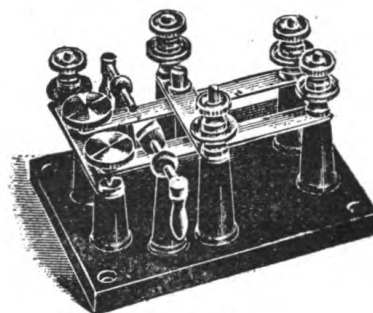

FIG. 24.

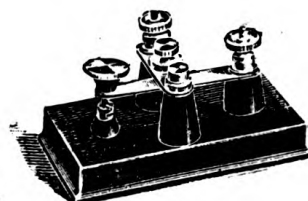

FIG. 25.

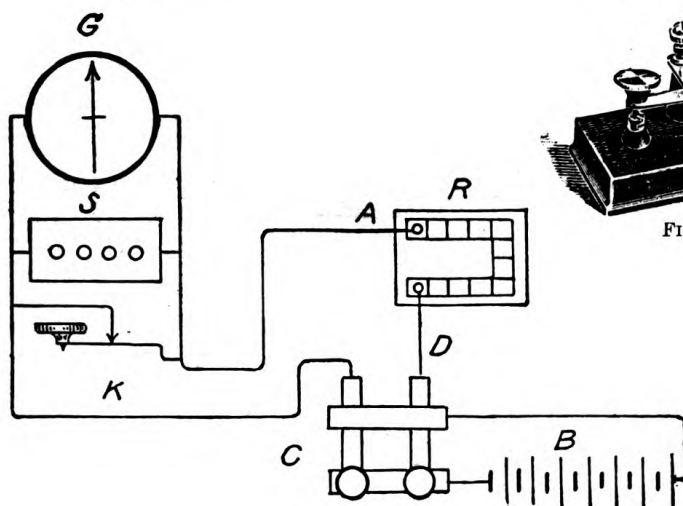

FIG. 26.

The galvanometer  $G$ , shunt  $S$ , short-circuit key  $K$  (fig. 25), reversing key  $C$  (figs. 23 and 24), high resistance 100,000 or 1,000,000 ohms  $R$ , and battery  $B$  are connected up as shown in fig. 26. In this and subsequent measurements the Ayrton shunt is assumed as used, and the shunts designated as  $\frac{1}{10}$ ,  $\frac{1}{100}$ , and  $\frac{1}{1000}$ .

Let  $D$ =Deflection.

$R$ =Value of high resistance in megohms.

$S$ =Fraction representing shunt.

$N$ =Number of cells used.

30447—05 M—4

The highest figure of shunt ( $\frac{1}{1000}$  of Ayrton) should be used first, and after depressing either lever of reversing key the short-circuit key is tapped.

If the galvanometer is greatly deflected, the amount of battery should be cut down until a deflection of, say, 100 to 150 divisions of the scale is noted when keys are depressed. Suppose 10 cells of battery with the  $\frac{1}{1000}$  shunt gives a deflection of 125 through the standard resistance of 100,000 ohms ( $\frac{1}{10}$  megohm). Then the constant

$$G = \frac{D \times R}{S \times N}; \text{ substituting, } \frac{125 \times \frac{1}{10}}{\frac{1}{1000} \times 10} = \frac{1,000 \times 125}{10 \times 10} = 1,250.$$

This means that one cell of the kind of battery used will give a deflection with the unshunted galvanometer of 1,250 division of the scale through 1 megohm. Or, as it is usually stated, will give one division of the scale deflection through 1,250 megohms. The insulation of the leads and instruments should now be tested by disconnecting the wire at *A* and noting if there is any deflection when keys are pressed, trying each lever of reversing key.

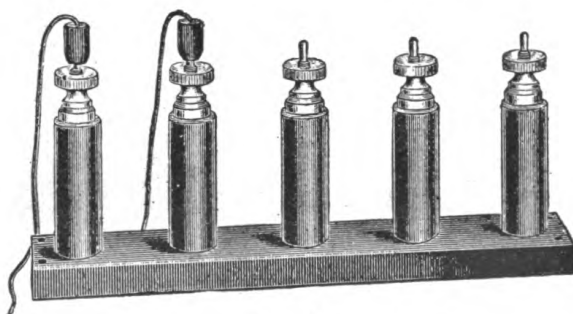

FIG. 27.

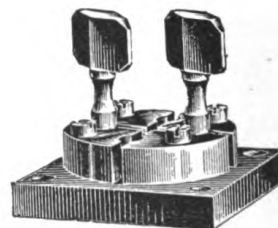

FIG. 28.

In testing rooms where the same number of cells of battery is always used, the *constant for the battery* is used in computations instead of the *constant per cell*. In this case since *N* is the same both in obtaining constant and in measuring insulation resistance, its value may be taken as 1 in both formulæ.

Having obtained the galvanometer constant, the preparation of the cable for insulation measurement must be made. If the cable is coiled, both ends must be carefully prepared. If it is a cable laid and in use, the distant end must be carefully prepared and insulated as described.

The armor, jute, and tape having been stripped off for at least a foot from the end, the rubber is scraped clean for about 6 inches from the end, and near the end the rubber is cut away with a sharp knife to a conical form. (See fig. 29.)

After preparing, great care should be taken not to touch the coned end for several inches back of it with the fingers or anything which

may cause surface leakage by forming a film over the freshly prepared surface. As an additional precaution, the coned end may be slightly warmed by the flame of an alcohol lamp just before the measurement.

If the cable is in a coil it is best to carry both ends of the conductor to *A*, as shown in fig. 30, and connect *D* with a brightened place on the armor wires, this being an effectual way of putting *D*

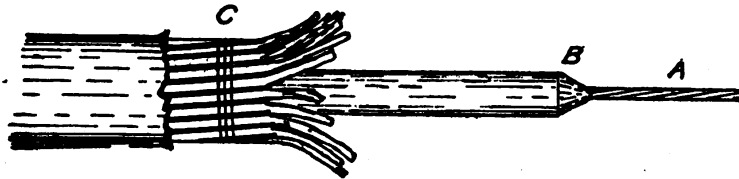

FIG. 29.

to "ground." The correspondence of fig. 30 with fig. 26 is seen, in that the ground (or sheath) and cable conductor take the place of the terminals of the high resistance box. If only one end of the cable is easily available, the other end must be placed with the exposed conductor and cone not touching anything.

Having completed the connections as shown, it is well to make a preliminary test with a few cells, pressing the keys as in obtaining the

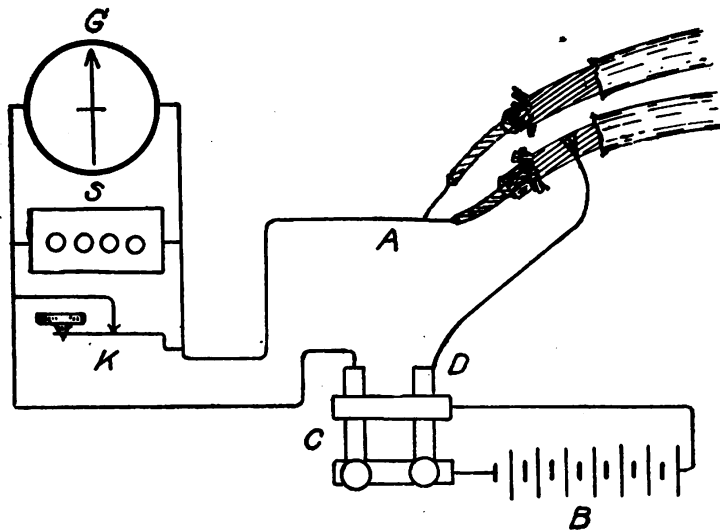

FIG. 30.

constant to make sure there is no serious leak which might give so violent a deflection as to injure the galvanometer. Use a high shunt at first ( $\frac{1}{1000}$ ) and make a test. Begin by depressing the right-hand lever of the reversing key (giving "zinc to line"), wait a few seconds, and then press the short-circuit key. The deflection will be greater at first, becoming almost steady at the end of a minute. If



the deflection is very small, decrease the shunt to  $\frac{1}{100}$ ; if still very small,  $\frac{1}{10}$ ; and, finally, if still small, remove the shunt entirely ( $\dagger$ ). If it is still somewhat small, more cells may be put on.

“Electrification” causes insulation to rise markedly for the first few seconds, and more slowly later, the effect becoming practically imperceptible after a few minutes. Insulation measurements specified are usually at the end of one minute. So, after preliminary tests let the cable stand for several minutes and completely discharge, then depress zinc end of reversing key, noting the time. A few seconds later depress the short-circuit key. The deflection at the end of a minute is noted, and the insulation resistance per mile may be worked out.

For example: Piece of “Safety” rubber cable 2 miles long in tank; 40 cells, dry battery; no shunt; galvanometer constant, 1,250; deflection at end of one minute, 120;

If  $N$  = number of cells,

$G$  = galvanometer constant,

$S$  = value of shunt used,

$M$  = number of miles of cable tested,

$D$  = deflection at end of one minute after closing circuit,

Then,

$$\text{Resistance per mile in megohms} = \frac{N \times G \times S \times M}{D}$$

$$\frac{40 \times 1,250 \times 1 \times 2}{120} = 834 \text{ megohms per mile.}$$

Taking a case in which the insulation resistance is low, due to deterioration—suppose with 10 cells and a shunt of  $\frac{1}{10}$ , a deflection of 145 is given in a piece of cable  $1\frac{1}{2}$  miles long.

$$\frac{10 \times 1,250 \times \frac{1}{10} \times 1\frac{1}{2}}{145} = 143 \text{ megohms per mile.}$$

Tests should also be made with carbon (or copper) to line by depressing left lever of reversing key. If the cable is sound, little or no difference in deflection will result. If faulty, the zinc to line usually gives the greater deflection. In all cases careful record should be made of the temperature of cable tanks or coil of cable. Reduction may be made to standard temperature, as shown in tables on pages 101-2.

#### TESTING WITH MAGNETO.

It should be remembered that a good magneto and bell will ring through a cable when connected to armor and conductor where the capacity is 0.1 microfarad or more, even when the insulation is perfectly sound. Its indications are therefore not reliable when the cable is over a few hundred feet in length.

## MEASUREMENTS OF CAPACITY.

This is of relatively small importance on land lines, and capacity effects are but little noticed in telegraphic work except on very long lines. The capacity per mile of cables is so much greater than that of land lines that the retarding effects are soon noticed. Measurements of it should be made in the regular tests of the cable; and in case of a break, with no ground connection at the broken end, as quite frequently happens with rubber cables, by measurements of capacity we may locate the break. As previously noted, the unit of capacity is the farad. But as this is inconveniently large, one millionth of it is the unit practically used, called the microfarad (abbreviated frequently to m. f.). To give some idea of the microfarad, it may be noted that this is about the capacity of 3 miles of ordinary submarine cable, and the ordinary sizes of the small box condensers referred to under telephone, buzzer and duplex telegraphy are from one-third to 1

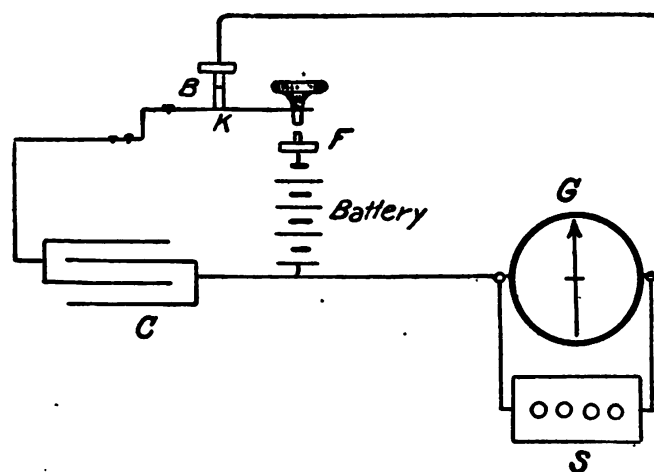

FIG. 31.

microfarad. The standard 1-microfarad condensers used in measurements is made up of tin foil and mica sheets, instead of tin foil and paper, and can usually, by means of the plugs, be subdivided into fractions of a microfarad. Above are shown the connections of a standard condenser with a battery and a mirror galvanometer.

The connection being made as shown (fig. 31) with battery, condenser *C*, galvanometer *G*, shunt *S*, key *K* having a front contact *F* and a back contact *B*. When key is depressed the battery will charge the condenser. When key is released a momentary deflection is produced by the discharge of the condenser through galvanometer and shunt.

By adjustment of the shunt, capacity in the condenser, and number of cells in series in the battery, the deflections may be varied. In general the relation between capacity *K*, number of cells (electro-

motive force)  $N$ , value of shunt  $S$  are such that deflections within moderate limits are proportional to the product of  $N$ ,  $K$ , and  $S$ .

For example, if a one-half microfarad condenser is connected up as shown with 10 cells dry battery, and the galvanometer has a shunt of

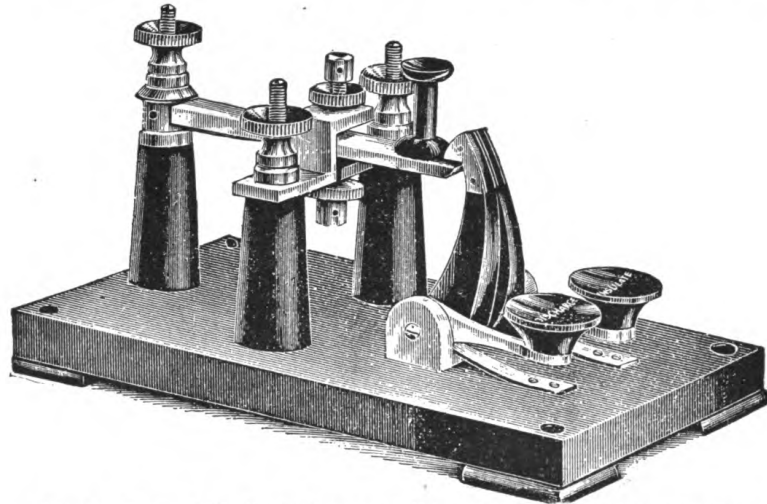

FIG. 32.—Form of discharge key generally used in capacity measurements.

one-tenth, and suppose the deflection or “throw” (extreme limit to which the coil or needle swings when condenser is discharged) to be 210.

Now put in an unknown condenser  $X$ , with same battery and shunt, and take a “throw.” Suppose it is 105:

$$210 : 105 :: \frac{1}{2} \times 10 \times \frac{1}{10} : X \times 10 \times \frac{1}{10}$$

$$210 X = \frac{105}{2}$$

$$X = \frac{1}{4} \text{ microfarad.}$$

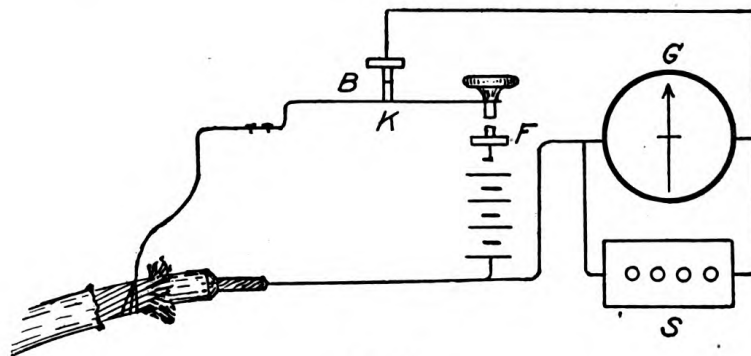

FIG. 33.

Suppose in the second case a large condenser were used and the “throw” went off the scale even with the  $\frac{1}{10}$  shunt. Then using, say,  $\frac{1}{10}$  shunt and 5-cell battery, suppose “throw” was 50:

$$210 : 50 :: \frac{1}{2} \times 10 \times \frac{1}{10} : X \times 5 \times \frac{1}{10}$$

$$\frac{210}{5} X = \frac{50}{2} ; X = \frac{25}{105} = 2.38 \text{ microfarads.}$$

To measure the capacity of a cable (less than 250 miles in length) we may proceed as follows:

First, find the deflection with a condenser of known capacity as just stated. Then connect up as shown in fig. 33, in which the cable and ground (its sheath) are substituted for the two condenser connections. The other end is prepared as for measurement of insulation resistance.

For example: As before, suppose deflection  $D$  is 210 and  $N$ ,  $K$ , and  $S$  are, respectively, 10,  $\frac{1}{2}$ , and  $\frac{1}{10}$ ; length of cable is 4 miles ( $L$ ). Deflection ( $D'$ ), when connected as shown in fig. 33, is 275, using 5 cells and same shunt  $\frac{1}{10}$ . What is capacity of cable per mile?

$$\begin{aligned} D : D' :: N K S : N' L X S' \\ 210 : 275 :: 10 \times \frac{1}{2} \times \frac{1}{10} : 5 \times 4 X \times \frac{1}{10} \\ X = 0.32 \text{+microfarad per mile.} \end{aligned}$$

In this, as in all the measurements of cable coiled in tanks or elsewhere, record of temperature should be carefully made at the time of measurement.

When the cable exceeds 100 miles in length, capacity measurements should be made by Thomson's or Gott's methods. Descriptions of these are found in the books of references.

#### CONDUCTOR RESISTANCE.

This is usually called "copper resistance" (C. R.) in books on cable testing.

To measure the resistance of sound cable when it is coiled in the tanks, when both ends are available the methods before given and cited in reference books may be followed. Of course, the most satisfactory and accurate method is with some form of Wheatstone bridge and mirror galvanometer when these instruments may be had. Good approximations may be made with the ohmmeter, or the combination of voltmeter and milliammeter, as stated in land-line testing. It is evident that if we have the resistance of the cable per mile, and find by methods just stated the total resistance of the coil, the length of the cable is equal to the total resistance divided by the resistance per mile. This method is called to attention because of its constant use in determining the lengths of pieces of cable in the coil. Of course, the temperature must be taken into account, and the resistance measured must be reduced to that at the temperature at which the resistance per mile is stated. A table of temperature coefficients is given below.

*Temperature coefficients for copper resistance.*

Difference in degrees—		Coeffi- cient.	Difference in degrees—		Coeffi- cient.
Fahren- heit.	Centi- grade.		Fahren- heit.	Centi- grade.	
1	0.5	1.002	16	8.9	1.084
2	1.1	1.004	17	9.4	1.086
3	1.7	1.006	18	10	1.0885
4	2.2	1.008	19	10.5	1.041
5	2.8	1.010	20	11.1	1.043
6	3.3	1.013	21	11.6	1.045
7	3.9	1.015	22	12.2	1.047
8	4.4	1.017	23	12.7	1.049
9	5	1.019	24	13.3	1.051
10	5.5	1.021	25	13.8	1.054
11	6.1	1.023	26	14.4	1.056
12	6.6	1.025	27	15	1.058
13	7.2	1.0275	28	15.5	1.060
14	7.7	1.030	29	16	1.062
15	8.3	1.032	30	16.6	1.065

In using this table note that in passing from a higher to a lower temperature divide the observed resistance by the number opposite the degrees of difference of temperature, and in passing from lower to higher multiply the same.

Example: A piece of cable is measured at 85° F. and has a resistance of 100 ohms. The resistance per mile (9.5 ohms) is given at 75° F. The difference is 10° F. higher than the standard.

$$100 \div 1.021 = 97.94 \text{ ohms at } 75^\circ \text{ F.}$$

and the length of the piece is  $97.94 \div 9.5 = 10.31$  miles.

After laying the cable, in attempting to measure its resistance through the ground connections at each end the simplicity vanishes of measuring with the Wheatstone bridge and balancing until the galvanometer is at zero. It will be found that after making connections and before depressing the battery key that if we depress the short-circuit key a deflection will generally be noted. This is largely due to earth current (called E. C. in reference books). If it were steady it could easily be dealt with. Unfortunately it is not, and it is constantly varying in direction as well.

Two ways of measuring to eliminate earth-current effects are described in works on cable testing called, respectively, "Quick reversals" and "False zero." (See pp. 59-62, 3d ed., Students' Guide to Submarine Cable Testing, Fisher & Darby). A brief additional description of these may be useful.

Connections for measuring copper resistance are shown in fig. 34. *A B* is the reversing key, *C* is the Wheatstone bridge, *G* is the galvanometer, *S* the universal shunt, *K* the short-circuit key, *F* the testing battery. The bridge is connected with the cable conductor *E*, prepared as shown, and *A* and the bridge are connected to a bright-



ened place on the cable armor wires for ground connections, as explained under "Capacity measurements." Of course in this case the distant end of conductor is connected with the armor wires or ground. As will be seen, by depressing *B* the copper (or carbon) end of the

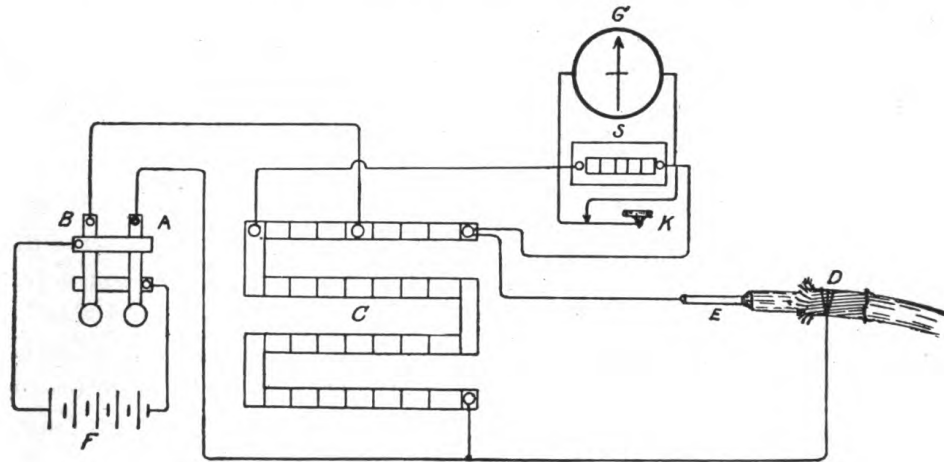

FIG. 34.

battery will remain connected with the ground, while the zinc goes to cable conductor through the bridge. Due to the fact that the "zinc current," as it is called, tends to clear away corrosion when measuring to locate a fault, measurements made with it usually show

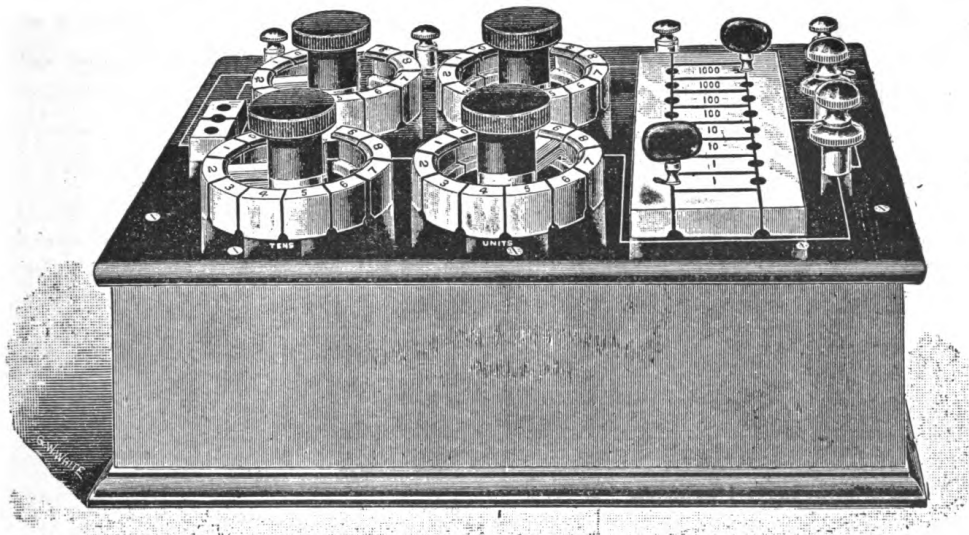

FIG. 35.—Form of Wheatstone Bridge used in Alaskan cable stations.

lower resistances than when carbon or copper is put to line by depressing *A*. However, as little effect of this kind will be noted in sound cable with distant end well connected with ground as stated, we shall assume disturbances due only to earth currents in measuring.

The method by quick reversals will first be described. Depress *B*, wait a second or two, and depress *K*. Balance as rapidly as possible, noting resistance. Release *B*, then depress *A* and *K*, and again balance quickly. The mean of these resistances will give the one approximately correct, unless there is too great a difference between them, in which case the correction on page 56, 3d ed., Fisher & Darby, should be applied.

Balancing to false zero (F. Z.) is the usual method of providing for earth currents in measurements of conductor (copper) resistances of cable.

Before depressing *A* or *B*, if we depress the short-circuit key we shall generally note a deflection. This is due to the earth current. Suppose it to be fairly steady, its direction and amount should be noted. If variable, its mean in the time usually occupied by balancing should be noted. This is the false-zero position to which we balance, instead of the true or instrumental zero we have heretofore considered. If the earth current or false zero is constantly varying, it should be noted just before and just after taking a measurement, and the false-zero position taken as the mean. Several measurements should be made until several successive results are obtained which accord fairly well. A good measurement of the copper resistance of the sound cable is an absolutely necessary preliminary to the location of faults when they occur.

The form of report below illustrates the manner of tabulating data pertaining to long submarine cables.

The "splice list" data, pages 59-60, illustrates the character of report turned in on completion of cable.

#### RECORD OF CABLE TESTS.

##### U. S. SIGNAL CORPS.

Date..... Place.....  
 Tests made by.....  
 Submarine cable between.....and.....

##### *Galvanometer constant.*

(Through 100,000 ohms.)

Kind of galvanometer.....Number and kind of cells.....  
 Shunt.....Deflection { Right.....  
   Left.....  
   Mean.....  
 Constant.....

*Insulation.*

Cable current: Deflection.....(right or left), with shunt.....  
 Number and kind of cells..... Shunt.....

Deflections.	Zinc.	Carbon.	Mean.
1st min.....			
2d min.....			
3d min.....			
4th min.....			
5th min.....			

Absolute insulation end of three minutes.....

*Copper resistance.*

Deflection.....  
 Earth current.....with shunt.....  
 Number and kind of cells..... Bridge ratios.....  
 Resistance, zinc to line.....  
 Resistance, carbon to line.....  
 Mean.....  
 Capacity measurements made when directed.

NOTE.—Connect galvanometer so that with zinc to line in insulation test the deflection will be to left.

Copy of this kept in office and duplicate mailed to officer in charge.

*Data pertaining to the Sitka-Seattle cable.*

Type.	Knots.	C. R. 60°.	C. R. temperature at bottom.	Sitka-Seattle.	Seattle-Sitka.	Temperature at bottom.
	<i>Ohms.</i>	<i>Ohms.</i>	<i>Ohms.</i>	<i>Ohms.</i>	<i>Ohms.</i>	<i>° F.</i>
S. E. Sitka, 1903.....	1.987	16.92	16.38	16.38	16.38	45
Inter., 1903.....	6.533	55.66	53.89	70.27	7.573.88	45
Do.....	9.040	77.02	74.57	144.84	7,520.49	45
Do.....	11.672	99.44	96.28	241.12	7,445.42	45
Deep-sea, 1903.....	6.768	57.66	55.82	296.94	7,349.14	45
Do.....	7.800	66.45	64.33	361.27	7,293.32	45
Do.....	4.914	41.86	40.17	401.44	7,228.90	41
Do.....	43.365	369.46	354.60	756.04	7,188.80	41
Do.....	61.264	521.97	496.59	1,252.63	6,834.22	37
Do.....	40.179	342.33	325.68	1,578.31	6,337.60	37
Do.....	19.378	165.10	157.07	1,735.38	6,011.90	37
Do.....	59.298	505.22	480.65	2,216.03	5,854.88	37
Do.....	50.172	427.46	406.67	2,622.70	5,374.23	37
Do.....	5.050	43.03	40.93	2,663.63	4,967.56	37
Deep-sea, 1904.....	21.780	185.56	176.53	2,840.16	4,926.63	37
Deep-sea, 1903.....	63.370	539.91	513.66	3,353.82	4,750.10	37
Do.....	14.860	126.60	120.44	3,474.26	4,236.44	37
Do.....	6.770	57.68	54.87	3,529.13	4,116.00	37
Deep-sea, 1904.....	2.470	21.04	20.01	3,549.14	4,061.13	37
Deep-sea, 1903.....	54.470	464.08	441.51	3,990.65	4,041.12	37
Do.....	17.000	144.84	137.79	4,128.44	3,599.61	37
Do.....	91.170	776.77	739.00	4,867.44	3,461.82	37
Do.....	12.900	109.90	104.55	4,971.99	2,722.82	37
Do.....	13.060	111.27	105.86	5,077.85	2,618.27	37
Do.....	2.800	23.85	22.69	5,100.54	2,513.41	37
Do.....	17.440	148.59	141.36	5,241.90	2,489.72	37
Deep-sea, 1904.....	.968	8.25	7.85	5,249.75	2,348.36	37
Do.....	1.832	15.60	14.83	5,264.58	2,340.51	37
Do.....	20.650	175.94	167.38	5,431.96	2,325.68	37
Do.....	20.310	173.04	164.62	5,596.58	2,158.30	37
Do.....	22.200	189.14	181.53	5,778.11	1,993.68	41
Do.....	21.540	183.52	176.14	5,954.25	1,812.15	41
Do.....	8.910	75.91	73.50	6,027.75	1,636.01	45
Inter., 1903.....	3.718	31.67	30.66	6,058.41	1,562.51	45
Do.....	32.230	274.60	265.87	6,324.28	1,531.85	45
Do.....	14.702	125.26	121.28	6,445.56	1,265.98	45
Do.....	24.386	207.77	201.17	6,646.73	1,144.70	45

## Data pertaining to the Sitka-Seattle cable—Continued.

Type.	Knots.	C. R. 60°.	C. R. temperature at bottom.	Sitka-Seattle.	Seattle-Sitka.	Temperature at bottom.
	<i>Ohms.</i>	<i>Ohms.</i>	<i>Ohms.</i>	<i>Ohms.</i>	<i>Ohms.</i>	<i>° F.</i>
Inter., 1904 .....	9.800	93.50	80.84	6,727.57	943.53	45
Do .....	11.020	93.89	90.91	6,818.48	862.69	45
Do .....	10.970	93.46	90.49	6,906.97	771.78	45
Do .....	10.950	93.29	90.32	6,999.29	681.29	45
Do .....	11.370	96.87	93.79	7,093.08	590.97	45
Inter., 1903 .....	4.660	39.70	38.44	7,131.52	497.18	45
Inter., 1904 .....	1.110	9.45	9.15	7,140.67	458.74	45
Inter., 1903 .....	16.420	139.90	136.45	7,276.12	449.59	45
Do .....	5.780	49.07	47.51	7,323.63	314.14	45
Do .....	14.020	119.45	115.66	7,439.29	295.63	45
Deep-sea, 1904 .....	8.000	68.16	66.00	7,505.29	150.97	45
Inter., 1903 .....	7.700	65.60	63.52	7,568.81	84.97	45
S. E. Seattle, 1903 .....	2.600	22.15	21.45	7,590.26	21.45	45
Total .....	951.336	7,934.96	7,590.26	-----	-----	-----
Earth, Seattle .....	4.477	40.43	39.26	-----	-----	-----
Total .....	955.813	7,975.39	7,629.52	-----	-----	-----

C. R. from buoy to Sitka .....	Ohms.	7,496.000
C. R. from buoy to Seattle through office to dock .....		94.617
Total .....		7,590.617
C. R. of Seattle ground end .....		32.265
Total .....		7,622.882

Average D. R., absolute 2.25 megohms; 2,104 megohms per knot.

Capacity "1903 type" .....	737.156 knots, at 0.593=	437 microfarads.
Capacity "1904 type" .....	183.880 knots, at 0.472=	87 microfarads.
Seattle shore end to dock .....		6 microfarads.

Total capacity by Gott's method from Arlington Dock to Sitka, Alaska.. 530 microfarads.

Average temperature, Seattle to Sitka, 39.1° F.

Distance on charts, Seattle to Sitka, 856 knots.

## DESCRIPTION OF FISHER CABLE-TESTING SET NO. 2.

This set was originally designed by Mr. H. W. Fisher. It is intended for work where a strictly portable set is required.

As it will frequently be used for hunting trouble, a special arrangement of the bridge has been adopted so as to greatly facilitate Murray & Varley loop tests for faults. Mr. Fisher has also introduced a method new to portable cable-testing sets for locating breaks in cables where the conductor has parted; and, in addition to the usual one, a new method for measuring capacity in which no galvanometer is required, a telephone being used in place of it.

The parts are mounted on corrugated hard-rubber pillars, which extend above and below the base.

This arrangement gives a very good insulation, and one that will be found entirely satisfactory, except under the most trying condition of moisture. The changes from one test to another are accomplished very easily and without the use of inconvenient flexible cords. They are effected by double-throw switches which are plainly marked so that it is not necessary to memorize a complicated scheme of connections.

The standard of capacity has a single value of  $\frac{3}{10}$  microfarad.

The standard high resistance is 100,000 ohms, and is also a single value, not subdivided.

In the Wheatstone bridge a marked variation from the usual commercial type has been made. The change is introduced to facilitate

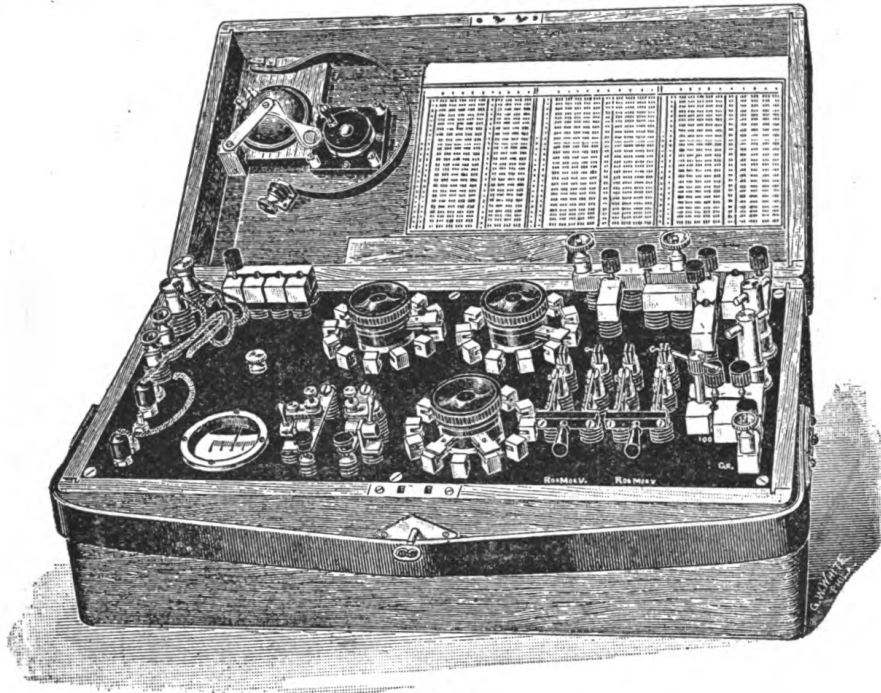

FIG. 36.

measurements for the location of faults. It is an extension of the Kelvin-Varley slides, and, since it may not be generally known, the following description is given. It is a form of Wheatstone's bridge

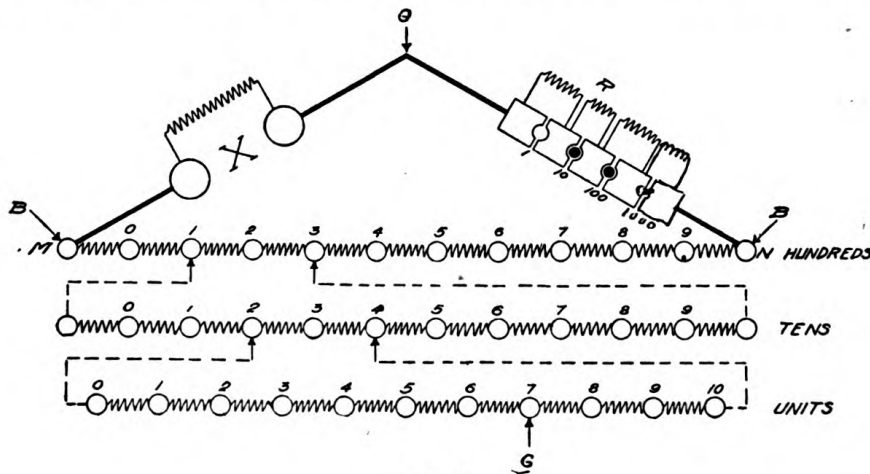

FIG. 37.

resembling those having a slide wire in which the values of the rheostat are fixed and the two arms of the bridge are varied until a balance is effected. The arrangement is represented in diagram in fig. 36.

The points marked  $G$  and  $B$  are the points of attachment for the galvanometer and battery. At  $R$  are represented the four coils of the rheostat, any one of which may be used, and at  $X$  the unknown resistance. Between  $M$  and  $N$  are eleven coils of equal value which form the bridge wire. There is a contact point between each coil and the one next to it. The other coils shown in the series marked "Tens" and "Units" are used to subdivide the coils of the bridge. They constitute what may be called an electrical vernier, by means of which the bridge wire is subdivided to thousandths of its total value. The two arrows in contact with the points marked 1 and 3 in the "Hundreds" row and with the 2 and 4 in the "Tens" row represent contact arms which can be moved along to make contact at any of the contact points, but are always at the same distance apart, so that they have two coils between them. They are connected to the ends of the row of coils below them, so that these two coils are shunted with the entire row of coils below. Consider now the result of this shunting in the case of the "Tens" and "Units" coils. The tens are, for example, eleven coils of 80 ohms each. The units are ten coils of 16 ohms each. The two 80-ohm coils between the points 2 and 4 are shunted with the ten 16-ohm coils; 160 ohms is shunted with 160 ohms, and the resistance between the points 2 and 4 becomes 80 instead of 160 ohms. There are in the "Tens" series, for any position of the double arms, actually ten resistances of 80 ohms each. The point of galvanometer contact may be placed at any position in the "Units" series, thus subdividing the shunted coils in the "Tens" series to tenths. The coils in the "Hundreds" series are 400 ohms each, and are subdivided in the same way by those in the "Tens" series. An example will make the use of the bridge clear. Assume that a balance is obtained with 100 unplugged in the rheostat and the contacts in the position shown. The bridge reading is then 237. Call this value  $A$ . Then

$$X:R::A:1000-A, \text{ and } X=R\frac{A}{1000-A}=100\frac{237}{763}=31.06.$$

The calculation of the fraction  $\frac{237}{763}$  would take considerable time and might lead to errors. To overcome the necessity for this we furnish, conveniently fastened into the lid of each set, a table giving the values of  $\frac{A}{1000-A}$  for all values of  $A$  between 0 and 1000. Reference to the table shows  $\frac{A}{1000-A}=0.3106$  for  $A=237$ . We have, consequently, simply to multiply the value taken from the table by the resistance unplugged in the rheostat to determine the value of  $X$ . From this it will be seen the Wheatstone bridge measurements may be made and calculated very rapidly.

In the actual construction the coils are arranged in three dials. The contact arms and points are constructed so as to insure good contacts.

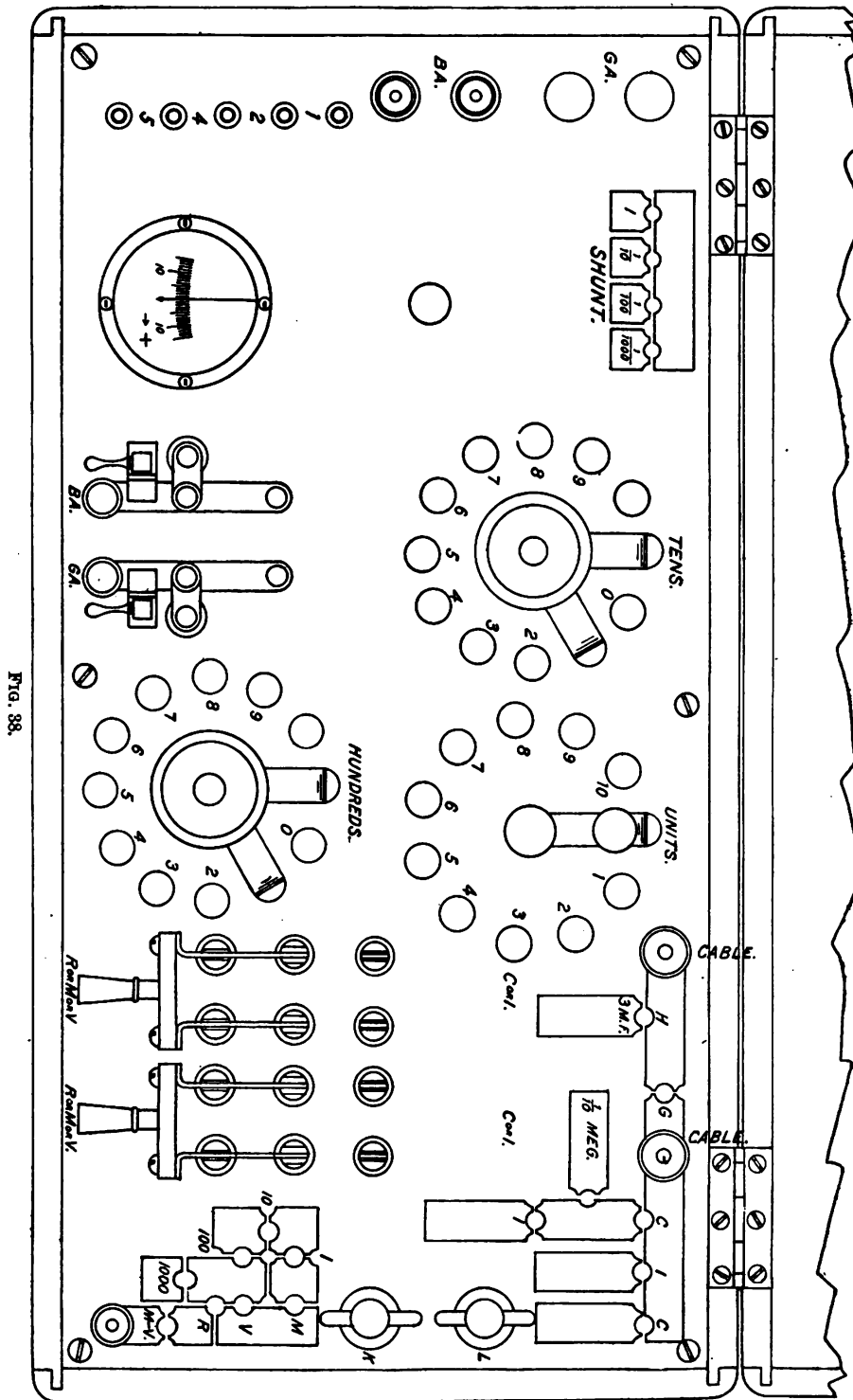

From the plan (fig. 37) and the diagram (fig. 38) the arrangement and connection of the different instruments making up the set will be

evident. Complete information in regard to the measurements for which the set may be used can be obtained from the following directions:

MEASUREMENTS OF ELECTROSTATIC CAPACITY.

In making tests of this nature a reflecting galvanometer should be employed, because the galvanometer of the testing set is not sufficiently accurate, nor has it a long enough scale to give good results. A reflecting galvanometer should therefore be connected to the posts marked *Ga*. A few cells of battery can be connected to the posts marked *Ba*.

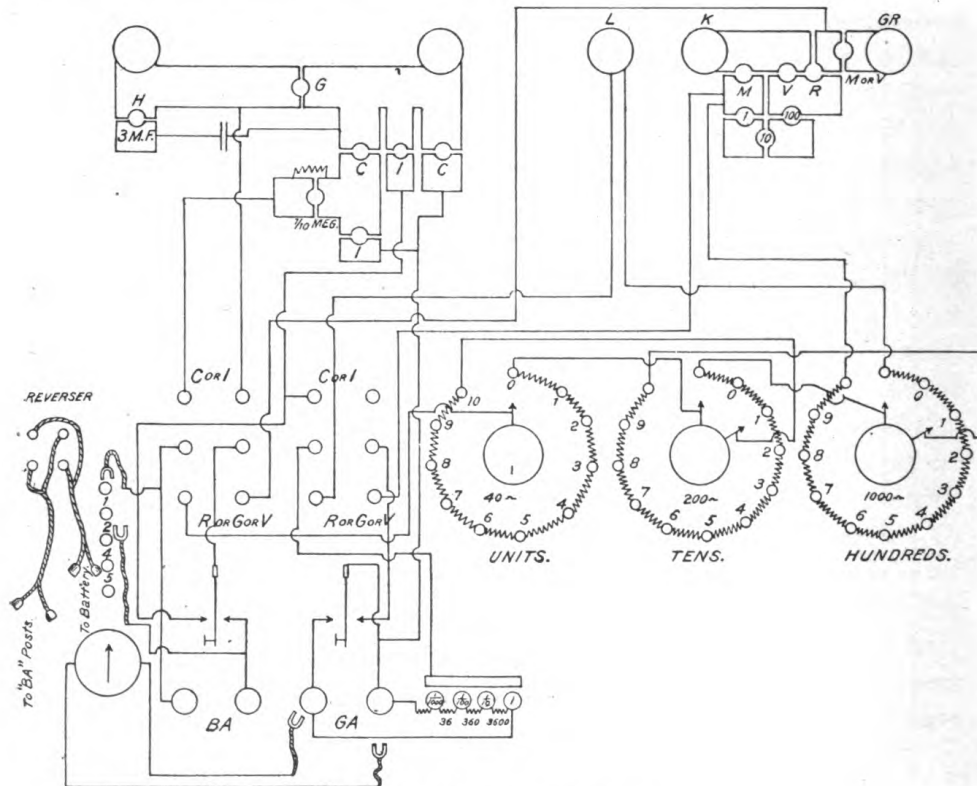

FIG. 39.—Plan of connections.

by means of the flexible cords which come out through the hard rubber opposite said posts. If a larger battery is required the flexible cords should be disconnected from the battery of the set and connection from any other battery made to the posts marked *Ba*. Connect the two leading wires running from the conductor of the cable and from the ground to "cable posts" and insert a plug in the hole marked 1 of the shunt. Place the handles of the two double-throw switches in the direction of the letters marked *C* or *I*. In this test the key marked *Ba* serves to close the battery circuit, the contact point being held in place by the finger or by pressing down the cam lever at the side of the key. The key marked *Ga* serves as a short-circuit key in



this test, and the short circuit is removed from the galvanometer by pressing the key down or by the use of the cam lever. Insert two plugs in the holes marked *C*, and be sure that no plugs are inserted in the holes marked *I* nor in the hole marked *G*.

The test can now be made in the ordinary manner, as follows:

Press down the key marked *Ba* for about ten seconds, or whatever the required time of charging may be, and the instant before releasing it press down the key marked *Ga* to remove the short circuit from the galvanometer. Then the *Ba* key can be released and the discharge deflection of the galvanometer read. If it is too small, apply more battery until a sufficiently large deflection is obtained, which record. Next disconnect the cable lead wires from the conductor and in like manner measure the discharge deflection due to the leading wires. Then, without in any way changing or disconnecting the leading wires, insert a plug at *H* to connect the 0.3 microfarad condenser across the cable posts, and in like manner read the discharge deflection of the condenser. It is not necessary to jam the plug too tightly in place, because in doing so the hard-rubber posts may be strained.

To obtain the true discharge deflection of cable and condenser, subtract the discharge deflection due to the leading wires from the observed discharge deflection of cable and condenser. Then letting

$c$  = amount of condenser capacity used = 0.3 microfarad in this case,  
 $dd$  = the true discharge deflection due to the cable,  
 $dd'$  = the true discharge deflection due to the condenser,  
 $L$  = the length of the cable in feet.

$$\text{The absolute capacity of the cable} = \frac{d \times c}{d'} = \frac{d \times .3}{d'}$$

And

$$\text{The capacity per mile of cable} = \frac{d \times .3 \times 5280}{d' \times L}$$

In order to prevent the E. M. F. of the battery from changing in case of a test being made when the leading wires were accidentally crossed or the cable grounded, the cable or condenser is normally charged through the  $\frac{1}{10}$  megohm box, but, if desirable, said resistance can be cut out of circuit by inserting a plug in the hole marked  $\frac{1}{10}$  megohm.

#### MEASUREMENTS OF INSULATION RESISTANCE.

In making the measurements of insulation resistance a reflecting galvanometer can be used by connecting it to the post marked *Ga* and disconnecting the flexible leads adjacent thereto which run to the horizontal galvanometer, or when approximate tests have to be made the galvanometer of the set can be employed by connecting the above-mentioned flexible leads to the post marked *Ga*. In like manner an auxiliary battery can be connected to the post marked *Ba*, or the bat-

tery of the testing set can be employed by connecting the number of cells required to the flexible cords adjacent to *Ba*. After making the connections indicated above the handles of the two double-pole double-throw switches are placed in the direction of the letters *C* or *I*. The two leading wires from the cable conductor and from the ground are connected to "cable posts." Insert plugs into the two holes marked *I* and see that no plugs are inserted in the holes marked *C*, *G*, and *H*. The test can now be made in the ordinary manner, as follows:

Close the battery circuit by means of the key *Ba* and its accompanying holding-down cam. Shortly before the period of electrification, which is generally one minute, has elapsed, press down the key marked *Ga* to remove the short circuit from the galvanometer, when the deflection can be read. Then disconnect the leading wires from the cable conductor and in like manner measure the deflection due to the leading wires, which must be subtracted from the observed deflection first read to give the true deflection due to the cable.

A shunt plug can generally be placed at *I*, but if the insulation is low the  $\frac{1}{10}$  or  $\frac{1}{100}$  shunt may have to be used, when the deflection must be multiplied by 10 or 100, respectively, to get the true deflection.

The insulation constant of galvanometer is next determined, as follows:

Remove the plug from the hole marked  $\frac{1}{10}$  megohm and insert a plug at *G*. Use whatever shunt will give the best readable deflection, which we will call *D'*. Then the insulation constant of galvano-

$$\text{meter} = \frac{D'}{10 \times \text{shunt used}} = G$$

Letting *D* = the true deflection due to the cable,

Letting *L* = the length of the cable in feet,

Then,

$$\text{The absolute insulation resistance of the cable} = \frac{G}{D}$$

$$\text{and the insulation resistance per mile} = \frac{G \times L}{D \times 5280}$$

It is best to make the regular insulation resistance test with the  $\frac{1}{10}$  megohm in series, and this is done by removing the plug from the hole marked  $\frac{1}{10}$  megohm. Where great accuracy is desired the  $\frac{1}{10}$  megohm can be subtracted from the calculated absolute insulation resistance to get the true insulation resistance. This is advised, so that the battery can never be short-circuited.

#### MEASUREMENTS OF CONDUCTOR RESISTANCE.

Place the handles of the two double-pole double-throw switches in the direction *R* or *M* or *V*, insert a plug in the hole marked *R*, and at the same time see that no plugs are in the holes marked *M* or *V*. It

will be noted that there are four resistances, viz, 1, 10, 100, and 1,000 ohms. Any one of these can be used in the test by removing its corresponding plug and inserting plugs in the other three holes. Before commencing the test a resistance near to the probable resistance to be measured should be left unplugged. For instance, if 5 ohms or less have to be measured the 1 ohm resistance should be left unplugged. If the probable resistance to be measured lies between 5 and 50 ohms the 10 ohms resistance should be left unplugged; if the resistance to be measured is over 50 ohms the 100 ohms resistance should be left unplugged.

Connect in the resistance to be measured to the posts *L* and *K*. By means of the flexible cords opposite the posts marked *Ba* connect a few cells of battery at first, and if necessary the whole 12 cells later. Connect the flexible cords opposite the posts marked *Ga* to said posts. For the commencement of the test the  $\frac{1}{10}$  shunt can be used, and for the final adjustment the 1 shunt.

The test can now be made by first placing the arms of the "Tens" and "Units" dials at zero and moving the "Hundreds" dial to 5. Press down first the battery key and instantly thereafter the galvanometer key, and note the direction in which the galvanometer pointer moves. If the battery flexible cords have been connected as indicated by the corresponding plus and minus signs, a deflection of the galvanometer toward the plus sign indicates that the dial resistance must be increased, while if the deflection is in the opposite direction, the dial resistance must be decreased. With this information in mind an instant only is required to determine between which two sets of "Hundreds" the balance point lies. Having found this, place the pointer at the lowest of the two, and in like manner determine between which two sets of "Tens" the balance point lies, placing the switch at the lowest of these. The final balance can then be found by rotating the "Units" switch until a point is reached when there is no deflection of the galvanometer. With the "Tens" and "Hundreds" switches the reading is taken between the two contact arms, while with the "Units" switch the reading is taken at the segment with which the rotating arms is in contact.

Letting  $R$  = the unplugged resistance to the right of the double switches,

And,

Letting  $A$  = the reading of the dial switches arranged in the order of hundreds, tens, units,

$$\text{the resistance to be measured} = \frac{A}{1000 - A} \times R \text{ ohms.}$$

The value of the term  $\frac{A}{1000 - A}$  can be found in the accompanying table, when it is only necessary to multiply said value by the amount of resistance unplugged.

## MURRAY LOOP METHOD OF LOCATING GROUNDED OR CROSSED WIRES.

This is the simplest method of locating grounds or crosses, and is applicable when the faulty and good wire are of the same size and length; hence it can be used to locate such faults in telephone and telegraph cables where all the conductors seldom become faulty before the method can be applied. It can also be used in the case of an electric cable where the outgoing and incoming cable are the same size and length and where one of them is not faulty. To apply this method, join the faulty and good conductor at the distant end of the cable and connect the faulty conductor to  $L$  and the good conductor to  $K$ . Place the two double-throw double-pole switches in the direction of  $R$  or  $M$  or  $V$ , insert plugs in the two holes marked  $M$ , and be sure that no plugs are in the two holes marked, respectively,  $V$  and  $R$ . The resistances 1, 10, and 100 can be either plugged or unplugged without affecting the test. Connect the ground, or in the case of a cross the wire crossed with the one used in the test, to the post marked  $Gr$ . The galvanometer and battery are connected in the same manner described under "Measurements of conductor resistance." The description there giving the operating of dial switches is exactly the same as must be followed in this case.

Letting  $A$  = the reading of the dials which gives a balance of the galvanometer.

$L$  = the total length of the circuit = twice the length of the cable if the good and bad wires are in the same cable,

Then,

The distance to the fault from the post  $L = \frac{A \times L}{1000}$

The check method can now be applied by connecting the faulty conductor to  $K$  and the good conductor to  $L$ .

Letting  $A'$  = the reading of the dials which gives a balance,  $1000 - A'$  should =  $A$

and therefore,

$\frac{1000 - A'}{1000} \times L$  the distance to the fault by the check method.

When dealing with faults of high resistance, 50 or more cells of battery may have to be used. Said battery should be connected to the posts  $Ba$ , and the corresponding flexible cords should be disconnected from the battery of the set.

## VARLEY LOOP METHOD OF LOCATING GROUNDED OR CROSSED WIRES.

Join the faulty and good conductor at the distant end of the cable, and at the near end of the cable connect the former to the post marked  $L$  and the latter to the post marked  $K$ . Then measure the resistance

of the circuit as described under "Measurements of conductor resistance."

Let  $r$  = said resistance.

Place the handles of the two double-throw double-pole switches in the direction of  $R$  or  $M$  or  $V$ . Insert plugs in the two holes marked  $V$ , and see that no plugs are in the two holes marked, respectively,  $M$ ,  $R$ . Join the faulty and good wires at the distant end of the cable and connect the former to  $L$  and the latter to  $K$ ; connect the ground or, in the case of a cross, the wire crossed with the one used in the test, to the post marked  $Gr$ ; unplug the resistance marked 100 and plug the resistance marked 1 and 10, connect the battery and galvanometer and operate the dial switches in the same manner described under "Measurements of conductor resistance." If the balance can not readily be obtained, it may be necessary to unplug the 10-ohm or perhaps the 1-ohm; the other two resistances must, of course, be plugged. The dial switches are now operated, as described under "Measurements of conductor resistance," until a balance is obtained, when the reading is recorded.

Let  $R$  = the resistance unplugged in the rheostat,

Let  $r$  = the resistance of the faulty and good wires,

Let  $A$  = the reading of the dials which gives a balance of the galvanometer,

and,

Let  $B = 1000 - A$ ,

Let  $a$  = the resistance to the fault from  $L$ ,

then,

$$a = \frac{A \times (r + R)}{A + B} = \frac{A \times (r + R)}{1000}$$

#### CHECK METHOD.

Connect now the faulty wire to  $K$  and the good wire to  $L$ , and proceed in the same manner to find the new values  $A$ ,  $B$ ,  $R$ , and  $a$ , which for the check method we will call  $A'$ ,  $B'$ ,  $R'$ , and  $a'$ .

The resistance to the fault from

$$K = a' = \frac{B' \times r - A' \times R'}{A' + B'} = \frac{B' \times r - A' \times R'}{1000}$$

Let  $b$  = the resistance of the faulty wire = one-half the resistance of the loop where good and bad wires are of the same size and are in one cable.

Let  $L$  = the length of cable.

Then,

The distance to the fault by the first method =  $\frac{a}{b} \times L$ .

The distance to the fault by check method =  $\frac{a'}{b} \times L$ .

## ARRANGEMENT OF TESTING SET.

The convenient arrangement of the testing set at the cable office is of great importance. Not only does this make tests easy, but it tends to accuracy as well, since troubles are easily traced in sets where the wiring is well laid out and all parts of instruments easy of access.

The wiring should invariably be done with best rubber-covered wire, or better cable core, supported on porcelain cleats or knobs. The lay out of the instruments on the table is shown in fig. 40, except the galvanometer, which should be on the right on a separate shelf not connected with the table. It should be about the height of the shoulder from the floor. On the left of the table the lamp and scale are supported at the same height on a shelf or stand separate from the table. By this arrangement of the galvanometer, lamp, and scale, the scale is in full view while the Wheatstone bridges or keys are being manipulated.

When the office has electric lights the best galvanometer lamp is an electric one with straight filament made for this purpose. It is set off to one side of the scale and the concave galvanometer mirror reflects an image of the filament as a brilliant vertical line on the scale when the scale and galvanometer are the proper distance apart for correct focusing. The oil lamp behind the slit on the scale must be used when there is no electric light available.

The cable is usually brought direct to the right of the group of six high insulation binding posts (fig. 27), the earth to second, and the testing battery to the other four, there being two wires led to intermediate points of testing battery, say, for instance, to the 4th and 10th cells in a group of 20 cells.

*After the cable is laid the testing voltages should not exceed 40 volts, except by special authority from the electrical engineer in charge of the system.*

*Circuit tracing.*—In measuring copper resistance the plug is put in *A* and throw-over switch put at position indicated.

Of course, in all these tests the wires leading to cable-office sets should first be taken off the line and earth high insulation binding posts.

The current from testing battery, usually from 4 to 10 cells, comes in on the + wire, and if left reversing key is depressed, goes to 11, 10, 1, dividing and passing through the bridge, coming out at 2, 22, 21, 9, 12, and to battery.

In the bridge the current coming in at 1 goes down and divides, part going through standard coils marked "units, tens," &c., to 2, the other part going on to 6 through earth, back through line, through plug at *A* to 5, through coils to 2, joining the other portion. The galvanometer terminals 3 and 4, connected across the standard coils

in bridge, have connections as follows: Beginning at 3, going to 26, 25, 13, through shunt, galvanometer, and short-circuit key to 14, 29, 30, and to 4.

For getting galvanometer constant, plug small commutator (fig. 28) at *C*, put throw-over switch at position indicated, see that all the 100,000 ohms are unplugged. Then if left receiving key be pressed

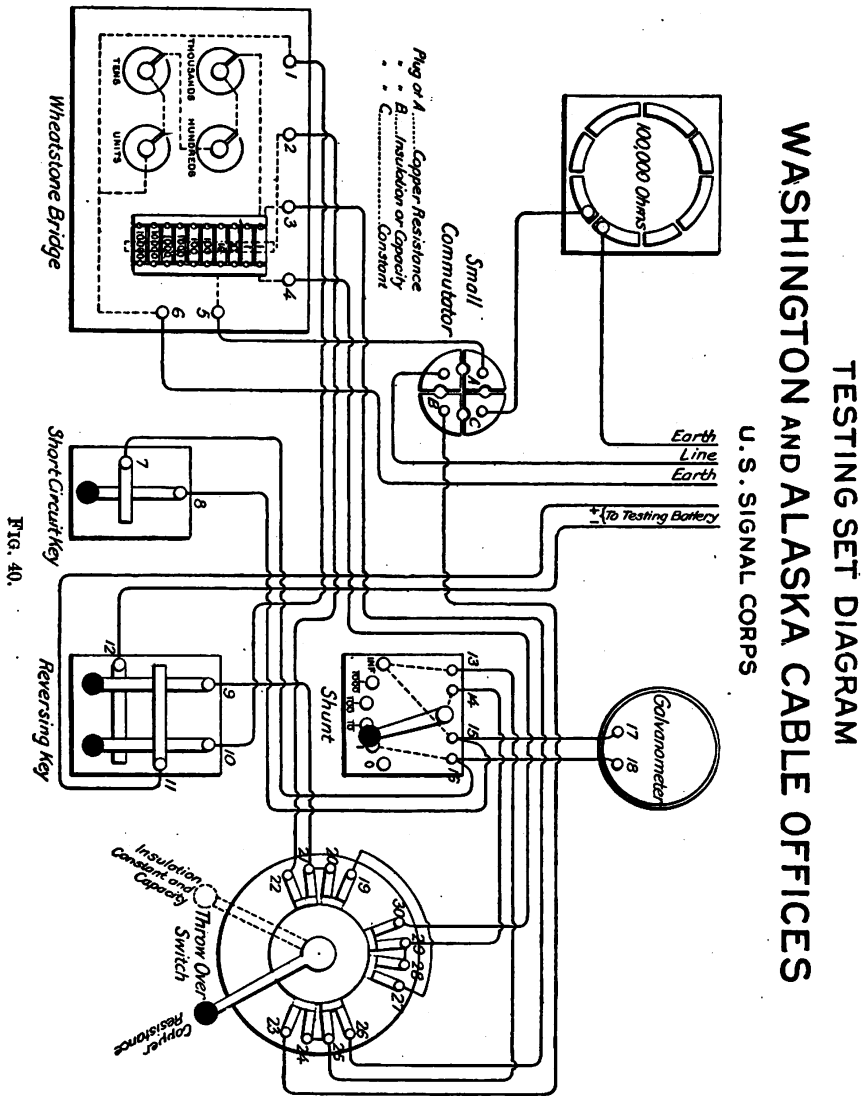

current from battery comes in on + wire to 11, 10, 1, 6, earth, to 100,000 ohms through plug *C* to 23, 24, 25, 13, through shunt, short-circuit key, and galvanometer to 14, 29, 28, 27, 19, 20, 21, 9, 12, and back to battery.

For testing insulation the plug is put at *B*. Then if left reversing key is depressed current from + battery post comes to 11, 10, 1, 6, earth, and back through line through plug at *B* to 23, and then, as

just described, in getting the constant. In getting this test, of course care must be taken not to depress short-circuit key until cable has been charged, say, for 10 or 15 seconds.

To get capacity indications on galvanometer the amount of "throw" of galvanometer on opening or closing reversing key *with the short-circuit key depressed* will give the capacity, provided the

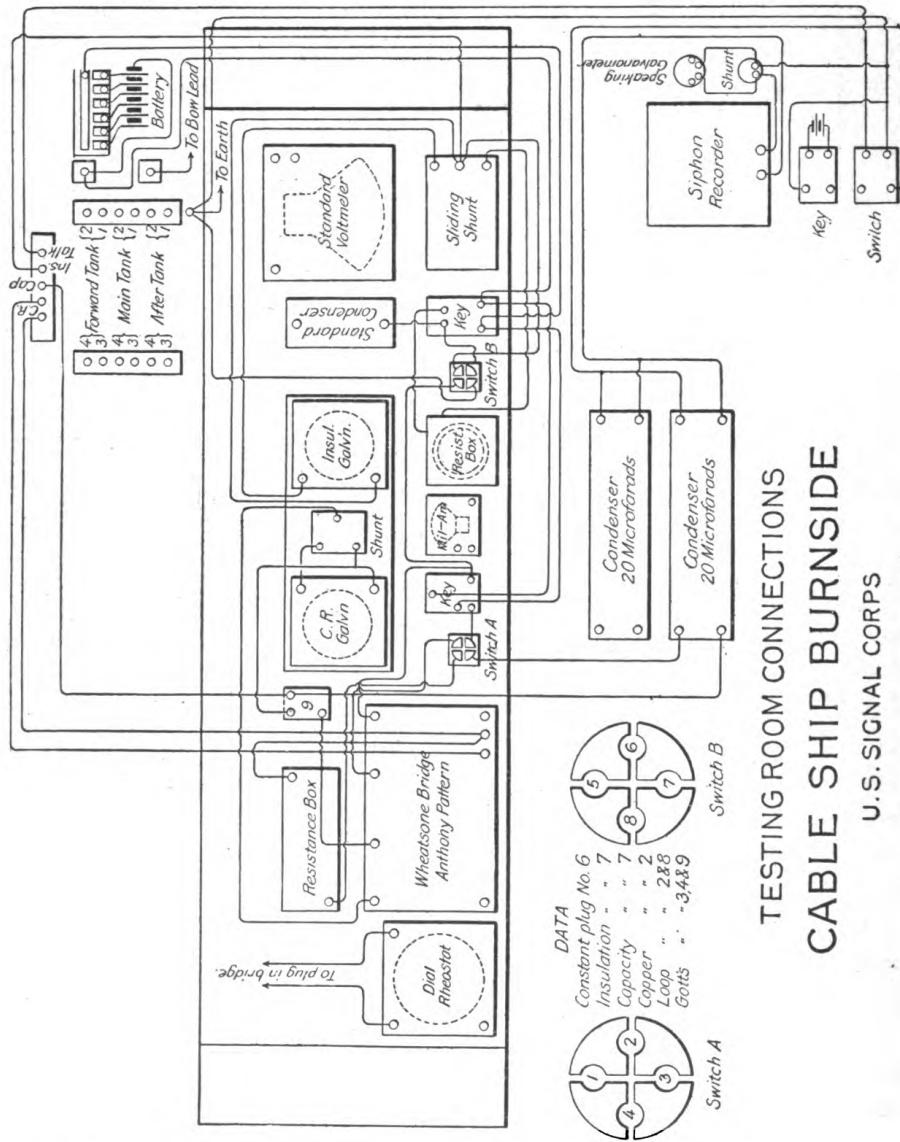

TESTING ROOM CONNECTIONS  
CABLE SHIP BURNSIDE  
U. S. SIGNAL CORPS

FIG. 41.

amount of this throw is compared with that given by a condenser of known capacity connected in place of line and earth, when battery and shunt are the same in both cases. It must be understood that this method gives reliable indications only with comparatively short cables. For long cables Gott's test, described at length in the books of reference, should be employed.



## CHAPTER V.

### LOCATION OF FAULTS IN SUBMARINE CABLES.

The application of the measurements just described in the location of faults may now be dealt with. The more complete exposition of the subject in the books of reference cited is recommended to those who desire to go into the matter more deeply.

Faults on cables are similar in nature to those on land lines. When the cable is completely ruptured faults may be described under the following headings of Class I:

Class I: First. The conductor is in contact with the metal sheathing and is "dead grounded."

Second. The conductor is considerably exposed by much of the insulation at and near the end being broken away.

Third. When the end of the conductor is only partially exposed or deeply buried in mud and sand.

Fourth. When the insulating material is drawn well over the broken end of the conductor almost completely insulating it.

Class II: Conductor ruptured; insulation remaining intact.

Class III: Break or abrasion of the insulating material, causing either a high-resistance leak (escape) or one approximating to a "dead ground," depending upon the amount of exposure of the conductor.

The behavior of the fault under working conditions or test will usually determine to which class it belongs.

Rupture of the cable is attended, of course, with total cessation of signals from the distant end, and this usually occurs suddenly. The end of the conductor is generally left more or less exposed. If left much exposed, or grounded on the cable armor, the galvanometer will indicate a comparatively steady current when moderate battery power is applied. If the exposure is small, or the end is buried in mud, great fluctuations in the current will be produced, and greatly different when different ends of the battery are placed to line. If the conductor is well drawn back into the insulation, or the conductor is ruptured inside the insulating covering, of course nothing but the transitory current of charge and discharge will be observed.

Damage to the insulation, exposing more or less of the conductor, very frequently is first noted as a "leak," which becomes worse and worse, until communication is interrupted. Unless the damage is

extensive, the reception of feeble signals from the distant station will disclose that the fault belongs to Class III, and that the cable is not ruptured.

In locating the first of Class I it is evident that it requires only the measurement of the copper resistance. This divided by the resistance per mile will locate the fault. In No. 4 of Class I and in Class II a measurement of capacity is required. This divided by capacity per mile gives the distance.

In all the others where partial exposure of the conductor is involved and only one end is available at the testing room, localization is difficult, owing to the polarization at the fault and its consequent change of resistance with different strengths and directions of current.

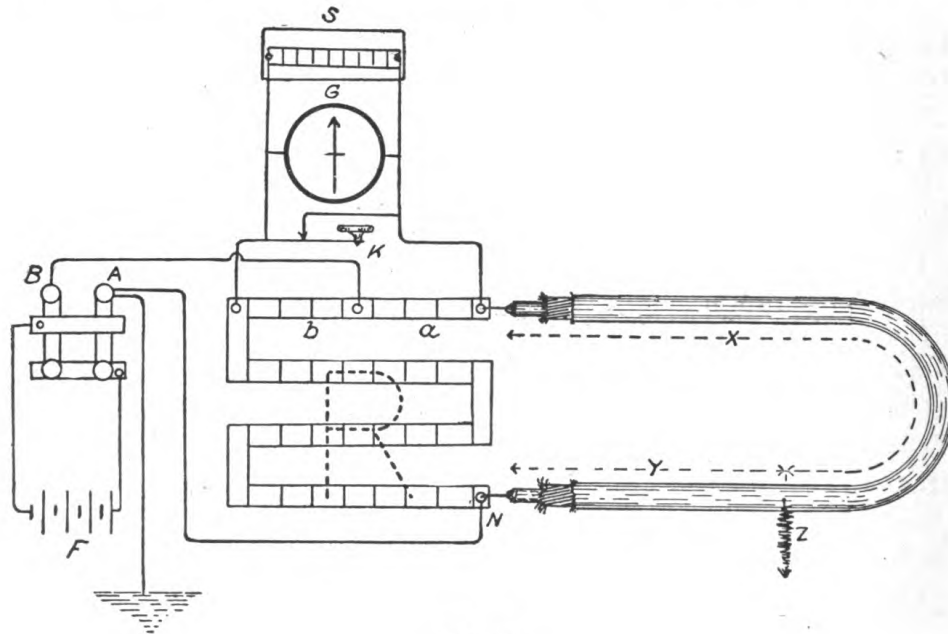

FIG. 42.

When faults are minute, this polarization changes resistances from a few ohms to thousands, and vice versa, with such rapidity as to require the greatest skill and judgment in testing. In general, by putting zinc to line, the generation of hydrogen and consequent cleansing from metallic salts at the fault tends to open it up. While putting carbon or copper to line, by coating the fault with chloride of copper will cause the resistance to rise by sealing up the fault.

If the defect in insulation is small it is sometimes difficult to detect which pole causes the most rapid polarization.

When the cable is coiled in the tanks, where both ends are available, or when two cables have been laid between two points permitting their looping at the far end, or when the cable has multiple cores, one or more of which remain uninjured, faults in the insulation

of a cable, where the conductor is not broken, may be quite accurately and easily located by the "loop test." This being the simplest method of locating these faults in cable, it will be dealt with first.

First measure the resistance of the loop with the two ends connected with Wheatstone bridge, etc. (as shown in fig. 34), connecting other end of loop to bridge in place of connecting bridge to  $D$ . Call this "L." Then change the connection, as shown in fig. 42.

It will be noted that the end with small resistance between it and the fault  $Y$  must be connected with  $N$ , otherwise no balance can be obtained. When this is found to be the case, transpose the ends. When balance is obtained call the values in balance arms  $a$  and  $b$  and amount unplugged in resistance  $R$ , as noted in diagram.

$$X = \frac{a(L + b)}{a + b}; Y = \frac{bL - aR}{a + b}.$$

$$\text{If } a = b, X = \frac{R + L}{2}; Y = \frac{L - R}{2}.$$

When the break is of the second or third kind under Class I, it is usually indicated by more or less rapid polarization when the copper or carbon pole is put to line—that is, by a rise of resistance. The fact that it is a break is indicated by the cessation of even feeble signals from the distant station. Sudden variations or jumps of resistance when the battery is applied indicates that the conductor is only partially exposed, or that it is deeply buried in mud or sand, thus preventing free escape of the gases liberated by electrolysis.

One of the successful methods of testing through the exposed end of the conductor at a total break and obtaining the copper resistance up to the break is that devised by Professor Kennelly. This method of eliminating the resistance of the exposed end itself depends upon the fact that the resistance at a given area of exposed conductor varies inversely as the square root of the current strength passed through it. Supposing the current through the break be increased four times, the resistance will be decreased one-half. The strength of the current should in no case, however, exceed 25 milliamperes. The measurements should be made by the false zero method with zinc to line, and as promptly as possible after the electrostatic condition of the cable is settled. The usual arrangement of the Wheatstone bridge for copper resistance measurements is made. An approximate measurement, which has been found sufficiently exact for most purposes on the cable ship, is made by taking it first with a certain small number of cells and then with four times as many cells. If dry cells of medium or large size are used their internal resistance is very small and will not seriously affect the result. If  $X$  be the resistance up to the break,  $A$  be the resistance obtained by measurement with, say, five cells, and  $B$  with 20 cells. Kennelly's formula reduces to

this simple expression:  $2B - A = X$ . For example, if the measurement with five cells gave 1,650 ohms, and with 20 cells 1,560 ohms, the resistance up to the break is  $1,560 \times 2 - 1,650 = 1,470$  ohms. Greater exactness can be secured by taking the exact ratio of currents going to line by inserting a milliammeter between the bridge and the cable. These ratios can be inserted in the general formula. For this formula and the general discussion of the method reference is made to the works cited at the beginning of the chapter on cable testing.

One of the late successful methods of dealing with breaks where the exposure is sufficient to not produce too great irregularities is Schaefer's method. This is described at length in Young's book, *Electrical Testing for Telegraph Engineers*.

The apparatus required in addition to the Wheatstone Bridge, reversing key, short-circuit key, galvanometer, shunt, and battery are the 100,000 ohms resistance (used in measurements of insulation resistance), a low resistance type milliammeter, like the Weston, and one or two cells of known electromotive force.

Connections are to be made as shown in fig. 43.

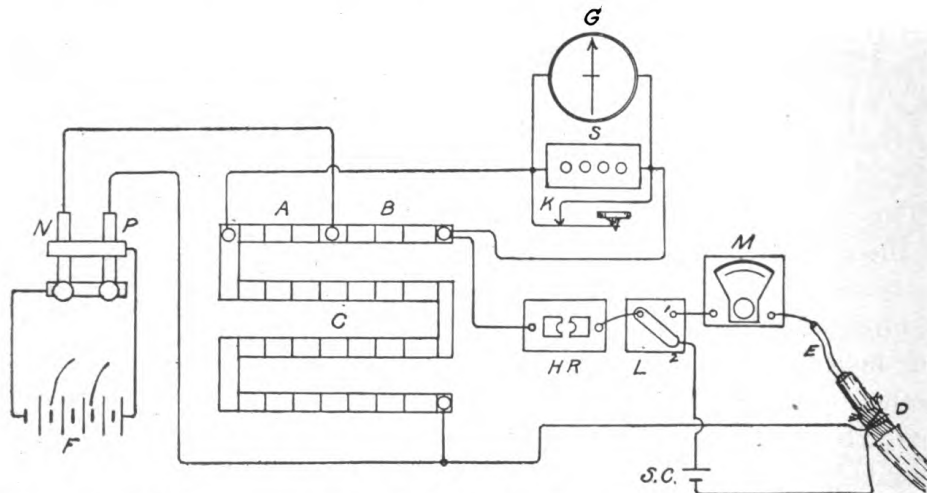

FIG. 43.—A, B, balance arms of bridge; C, standard resistance of bridge; D, ground connection (armor wires of cable); E, core of cable; F, testing battery; G, galvanometer; HR, high resistance (100,000 ohms); K, short-circuit key; L, two-point switch; M, Weston milliammeter; N, P, reversing key; S, C, standard cell.

The first operation is to use the galvanometer as a delicate voltmeter, and with it to get some scale deflection corresponding to the known voltage of SC. Unplug the 100,000 ohms in HR. Put lever of switch L on button 2, adjust the shunt S so when K is depressed a good readable deflection is produced. Plugs may be put in or removed from B for further adjustment if desired, B acting as an extra shunt in this case.

Suppose the deflection produced =  $d$ , and that the E. M. F. of the standard cell or cells is  $E$ . The deflection being proportional to E. M. F. the "division per volt"  $D = \frac{d}{E}$ . This constant is recorded together with the exact state of the shunt and the resistance in  $A$ ,  $B$ , and  $C$ .

With the same adjustment of shunt, galvanometer, and resistance move lever of  $L$  from 1 to 2 and observe deflection due to earth current ( $e$ ). If carbon or copper of  $SC$  was toward  $L$ , and earth current ( $e$ ) deflection is in the same direction as  $d$ , its direction is the same as if testing-battery zinc were to line, and its apparent resistance effects on the reading will be additive and vice versa.

If this deflection is  $d'$ ,  $e = \frac{d'}{D}$ . Proceed promptly to measure the resistance. Put plugs in  $HR$  measure with zinc to line (to true zero, not false zero), noting resistance in  $A$ ,  $B$ , and  $R$  and the reading of the milliammeter  $M$  at the time balance is obtained. Repeat this measurement, using in this case such amount of measuring battery as will give ratios of currents through milliammeter that are between 1:2 and 1:3. Always ground the cable between each set of observations for at least one minute to do away with polarization due to the testing current. Continue taking these sets of readings with two strengths of current, as noted above, until the similarity of successive sets will show a fair degree of constancy in  $e$  and the other conditions.

Suppose a set of observations gives the values of the resistances  $R$  and  $R'$ , and the corresponding milliammeter readings  $nc$  and  $c$ . Then Schaefer's formula gives as the true value of conductor resistance to the break:

$$X = R' - (R' - R)K' \mp \left[ \left( \frac{e}{c} - \frac{e}{nc} \right) K' - \frac{e}{c} \right]$$

The term in brackets represents the earth-current correction to be applied. If the earth current is with the testing current, as shown by galvanometer deflections being in the same direction, it should be recorded +, and — when in opposite direction. It is to be remembered that the order  $\mp$  in formula corresponds to the order  $\pm$  in earth-current readings.

The subjoined table gives the value of  $K'$  corresponding to the ratios of current strength  $nc$  and  $c$  in the set of observations:

Ratios $nc$ to $c$ .	$K'$ .	Ratios $nc$ to $c$ .	$K'$ .
1.1	14.140	3.4	1.640
1.2	7.644	3.5	1.617
1.3	5.475	3.6	1.595
1.4	4.585	3.7	1.576
1.5	3.732	3.8	1.558
1.6	3.296	3.9	1.541
1.7	2.985	4.0	1.525
1.8	2.749	4.1	1.510
1.9	2.566	4.2	1.496
2.0	2.420	4.3	1.483
2.1	2.299	4.4	1.470
2.2	2.199	4.5	1.459
2.3	2.114	5.0	1.408
2.4	2.040	5.5	1.369
2.5	1.977	6.0	1.337
2.6	1.921	6.5	1.310
2.7	1.871	7.0	1.289
2.8	1.828	7.5	1.269
2.9	1.789	8.0	1.253
3.0	1.753	8.5	1.239
3.1	1.721	9.0	1.228
3.2	1.692	9.5	1.215
3.3	1.665	10.0	1.205

As an example of the foregoing, the following is given of their measurements taken with each of the current strengths:

Milliamperes through break. Earth-current reading  $e = .373$  volt.

$nc$ 25.0	Ratio 2.56	$K' \int R$ 938.5	937.5	937.7
$c$ 9.75		$1.96 \int R'$ 1034.5	1033.5	1028.0
		$1.96 \times$	96.0	96.0
			188.0	188.0
			846.5	845.5
			7.7	7.7
			854.2	853.2
				858.7

$$\frac{e}{c} = \frac{.373}{.00975} = 38.3$$

$$\frac{e}{nc} = \frac{.373}{.025} = 14.9$$

$$\left( \frac{e}{c} - \frac{e}{nc} \right) = 23.4 \times K' = 46.0$$

$$\frac{e}{c} = \underline{38.3}$$

Mean 855.3 ohms.

Earth-current correction = 7.7 ohms.

The mean of several sets should be taken.

The best conditions for making the tests are stated to be:

First. Use as large currents as the bridge, length of cable, and size of break will permit. It should be remarked that irregularity of current would indicate a small area of exposed conductor and consequently too much current.

Second. Make the ratios of currents  $nc$  and  $c$  not less than 1:2 nor more than 1:3. For breaks at moderate distances Schaefer's system is very accurate and rapid.

In general, the location of faults of Class III presents the greatest difficulty. Of course, if a second and sound cable or another sound core in same cable joining the two places is available, the distant ends are looped, and the reliable "loop test" may be used.

And when the exposure of the conductor is considerable, making the fault resistance so low that none or barely perceptible signals can be got from the distant station, the Schaefer "break test" (pp. 76-78) may be applied, the distant end being insulated.

No other very satisfactory method exists of locating leaks (escapes) on cables when facilities exist for taking measurements at one end only. Where the fault resistance is 200 ohms or less the Blavier test may be used. This has already been briefly referred to under land-line testing. The success attained in cable work depends greatly on the skill and judgment of the operator. The plain Blavier test will again be briefly described and the necessary corrections for these measurements will then be taken up.

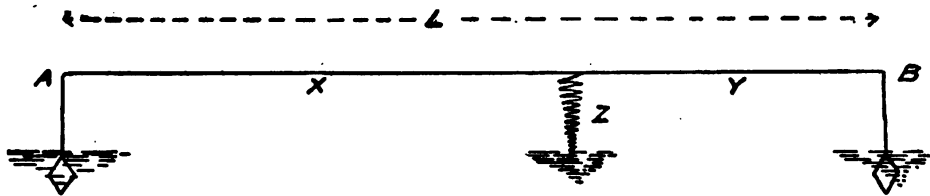

FIG. 44.

The copper resistance  $L$  of the cable when sound must be known. A leak occurs at some point,  $Z$ , and measurements are made from  $A$ —first, with end  $B$  connected with earth, and, second, with  $B$  insulated. Take these measurements with zinc to line, and preferably by false zero observations. Call the resistances obtained at  $A$ ,  $N$ , and  $M$  ohms, respectively. The resistance  $X$  to the fault from  $A$  would then be

$$N - \sqrt{(L - N)(M - N)}.$$

This is supposing that the resistance of the fault  $Z$  remained the same in each measurement. Unfortunately, it does not, owing to its resistance changing with the greater current flowing through it when  $B$  is insulated.

The arrangement made at  $A$  to make requisite changes in the two cases to cause equal currents to flow through  $Z$  is shown in fig. 45.

The usual reversing key, bridge, etc., is used, the connections being as shown.  $G'$  and  $S'$  represent a galvanometer and shunt, their combined resistance being very small. A Weston milliammeter may be used instead. A resistance  $D$ , which may be varied as required, is inserted in the battery circuit.

The resistances  $M$  and  $N$  are now measured to get the plain Blavier

test and the values of  $M$ ,  $N$ , and  $X$  obtained, no resistance being unplugged in  $D$ , and no notice being taken of the readings of  $G'$ . The current to be used in subsequent measurement with distant end insulated is obtained as follows:

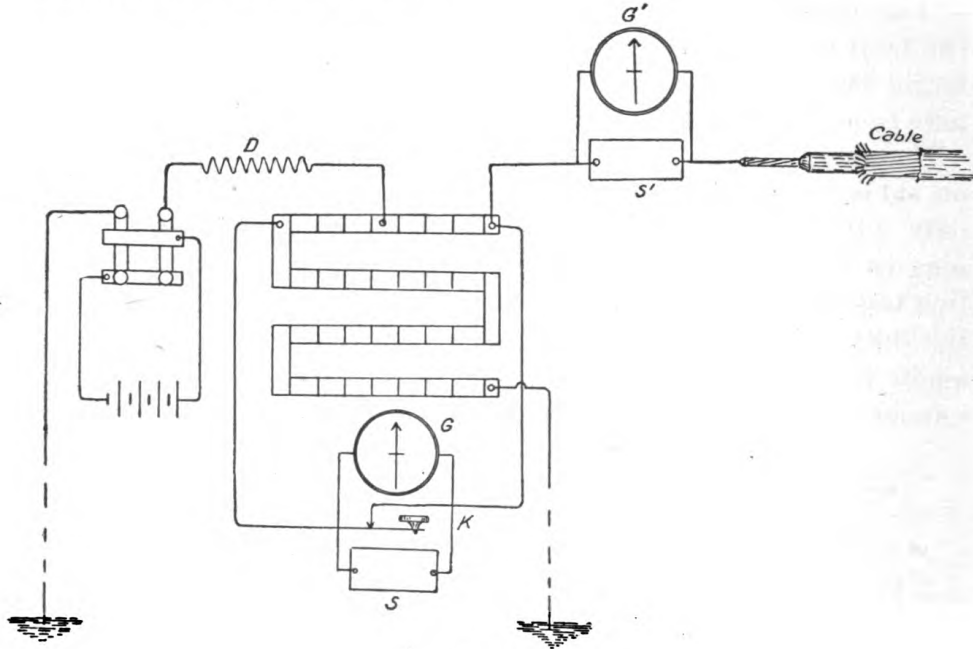

FIG. 45.

Let  $C$  = deflection of  $G'$  or millimeter corresponding to  $N$ . Multiplying  $C$  by the ratio  $\frac{N - X}{M - X}$  we get the proper deflection to be used in measuring  $M$ . In this measurement  $D$  is accordingly unplugged until the proper deflection appears. Take another pair of measurements, using the correct ratio of currents thus obtained, and from these work out another and more accurate ratio of currents. Continuing this process, concordant results for several pairs should be obtained. The mean of these should give the correct result.

Example: A cable when sound had a resistance of 3,950 ohms. The "plain Blavier" gave on the faulty cable  $M=3,200$  ohms and  $N=2,150$  ohms; zinc always to line:

$$X = 2,150 - \sqrt{(3,950 - 2,150)(3,200 - 2,150)} = 775 \text{ ohms.}$$

$$\text{Current ratio: } C \frac{2,150 - 775}{3,200 - 775} = C \frac{5}{9}.$$

The measurement of  $N$  was then made again, noting the galvanometer. This time  $N$  was found to be 1,830 ohms, and the deflection of  $G'$  noted. This was found to be 200 divisions.

Then  $M$  was measured and  $D$  unplugged until  $\frac{5}{9}$  of 200 = 110 is indicated on  $G'$ . The lowest reading obtained was 2,170.

$$X' = 1,830 - \sqrt{(3,950 - 1,830)(2,170 - 1,830)} = 981 \text{ ohms.}$$



In the next measurement correct ratio is

$$C \frac{1,830-981}{2,170-981} = C \frac{5}{7} \text{ nearly.}$$

These measurements are several times repeated and the mean of these corrected results taken.<sup>a</sup>

If first test should show  $N$  greater than  $M$ , it would make solution impossible, in which case make a rough guess at the position of the fault and begin working corrections from that as a starting point.

Ayrton's modification of Blavier's test may be used when the copper resistance  $L$  is not known with sufficient exactness. In this, in addition to  $M$  and  $N$ , a third measurement,  $P$ , is made with distant end grounded through a known resistance,  $g$ , of several hundred ohms (two relays, for instance).

The resistance to the fault is given by the formula:

$$x = M - \sqrt{\frac{(M-P)(M-N)g}{P-N}}$$

$$z = M - x$$

$$y = \frac{Nz - Xz}{x + z - N}$$

To keep the current through the fault the same in each measurement, the E. M. F. of the batteries in the three cases should be arranged after the preliminary test, as follows:

$$E_1 : E_2 : E_3 :: \left(x + z + \frac{xz}{L-x}\right) : (x + z) : \left(x + z + \frac{xz}{L-x+g}\right).$$

Corresponding to  $N$ ,  $M$ , and  $P$ , respectively,  $L$  in this case being the roughly approximate resistance of the line.

On cables where testing sets are provided at both terminal offices more accurate location of faults of Class III, especially those of high resistances, may be made by either of the following methods:

#### CLARK'S POTENTIAL TEST.

This depends on the principle that in any circuit with resistances in series the fall of potential at any point is proportional to the resistance passed over, beginning at the high potential terminal. The instruments required at the main station are a delicate galvanometer, high resistance up to 100,000 ohms, a Weston voltmeter, and a box of standard coils. The Wheatstone bridge will answer for the latter.

At the far station the box of standard coils is not required. However, it is better for each to be the main station in turn and compare results.

<sup>a</sup> See Young's Electrical Testing for Telegraph Engineers, p. 159 et seq.

The connections at the main station are as shown in fig. 46.

The connections at the distant station are as shown in fig. 47.

Before closing the circuit the voltage of the battery  $B$  is determined with the Weston voltmeter, cell by cell, so the low reading scale may be used and the sum of these voltages taken.  $AC$  is the box of standard coils, which should be at first unplugged to a resistance approximately equal to one-half that of the cable.

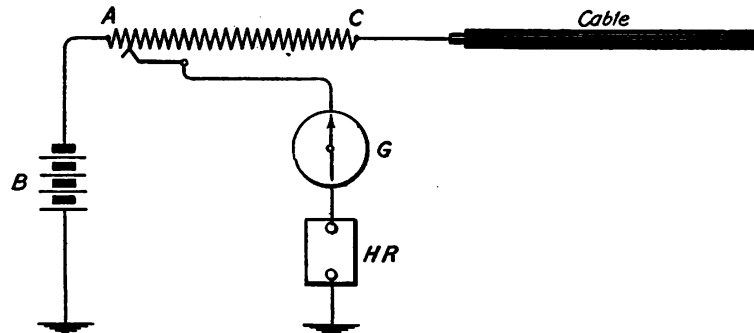

FIG. 46.

The galvanometer  $G$  and high resistance  $HR$  are connected in series, as shown. The number of cells and  $HR$  should be proportioned as to give nearly a full scale reading when the galvanometer is connected with  $A$ . First take a reading at both stations with  $G$  connected with  $A$  and line open at  $C$ . This deflection will correspond to the total battery voltage as shown by the sum of readings of the

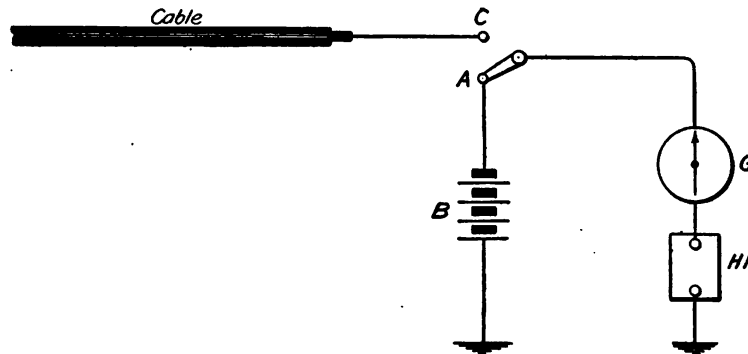

FIG. 47.

voltmeter. Suppose the total number of volts is  $P$  and the deflection is  $D$ ; then  $\frac{D}{P}$  will give the number of divisions of the scale corresponding to one volt.

Now disconnect batteries and connect the galvanometers with the line at each station and observe the deflections due to earth current ( $E. C.$ ), both in *direction* and *amount*.

The main station then connects battery, standard coils, and cable,



as shown in fig. 46, and, having arranged time with distant station, they take the following readings, as nearly together as possible:

Main station takes readings, first, with  $G$  connected with  $A$ , and then with  $G$  connected with  $C$ . Distant station with switch turned to  $C$  simply reads deflection and reports it to main station. All readings are reduced to volts.

These readings are designated as  $V$ ,  $v$ , and  $v'$ , respectively.  $v$  and  $v'$  are then corrected for earth-current readings, adding the value of earth current if it is *against* and subtracting if it is *with* the battery current.

The distant station then sends the corrected result to main station. The formula for the solution is as follows:

$x$  = resistance from main station to fault.

$R$  = number of ohms unplugged at  $AC$ .

$$x = \frac{R(v-v')}{V-v}$$

For example, suppose the total voltage of battery in fig. 46 were 11.2, and that the galvanometer through the high resistance gave a deflection of 273, then  $\frac{D}{P} = \frac{273}{11.2} = 24.4$  scale divisions per volt. In like manner distant station determines the value of his deflections. Suppose it is 27 divisions per volt. Earth current gives 18 divisions *against* direction of testing current at both stations.

Now suppose  $V$  is 265 divisions,  $v$  193 divisions, and  $v'$  65 divisions.  
 $R=800$  ohms.

These would correspond, respectively, to

$$\frac{18}{24.4} = .74 \text{ E.C. volts at main station}$$

$$\frac{18}{27} = .67 \text{ E.C. volts at distant station}$$

$$\frac{265}{24.4} = 10.9 \text{ volts } V$$

$$\frac{193}{24.4} = 7.9 \text{ volts } v$$

$$\frac{65}{27} = 1.4 \text{ volts } v'$$

$$7.9 + .74 = 8.64 \text{ corrected } v$$

$$1.4 + .67 = 2.07 \text{ corrected } v'$$

Substituting in formula

$$x = \frac{800(8.64 - 2.07)}{10.9 - 8.64} = \frac{5256}{2.26} = 2325 \text{ ohms.}$$

If the resistance of the cable is 8.5 ohms per nautical mile, the fault is  $\frac{2325}{8.5} = 273.5$  miles distant from main station.

More accuracy would probably be reached by repeating the test, using a new value of  $B$  approximating to  $x$ , as found above.

One great advantage of the Clark test is that, as readings at the two ends may be made practically simultaneously, errors due to irregular polarization and earth currents are eliminated.

#### EARTH OVERLAP TEST.

Where both stations are equipped with full sets of instruments one of the best methods of localizing faults due to defects in insulation is called the earth overlap test. It is particularly applicable to high resistance faults.

In effect the measurements are made with a view to determining how much resistance should be put in at the station nearest to the fault in order to make the resistances on each side of the fault equal.

The measurements are made by the observers alternating in measuring line resistance with distant station earthed, each allowing a specified number of minutes, say three, for each station's tests. Both should measure in the same way—that is, either with the false zero with zinc to line or with reversals. Both use the same number of cells testing battery.

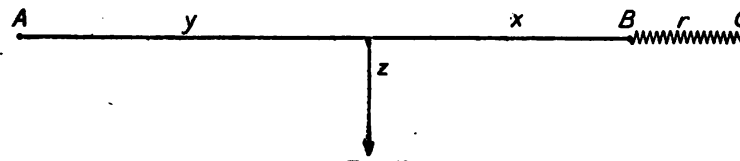

FIG. 48.

Let  $AB$  be a cable with a fault in it at  $z$  (fig. 48). Suppose the copper resistance of the cable when sound to be known having a value,  $L$ , and the fault occurs at distance  $x$  from  $B$ .

If tests are made at the end  $B$ , it is evident that when a resistance  $r$  is inserted, making  $x+r=y$ , then the following equations result:

$$\begin{aligned} x+y &= L; & x+r &= y \\ y &= L-x \\ \therefore x+r &= L-x; & x &= \frac{L-r}{2} \end{aligned}$$

The routine is as follows:  $B$  tests first and gets, say, 2,500 ohms, then  $A$  gets 3,000 ohms. They exchange results.  $B$  now inserts a resistance which should be greater at first than the difference between the results, owing to resistance at the fault.

For example,  $B$  inserts 1,000 ohms and tests three minutes with  $A$  earthed. He then earths through the inserted resistance for three minutes and  $A$  tests.

They then compare results, the *last* at  $B$  and *first* at  $A$  being considered most reliable.

*B* now gets 3,800 ohms and *A* 3,500, so 1,000 ohms is too much. *B* inserts 600, 800, 650, 700, and 670 ohms in succession, going alternately too low or too high until at 670 both *B* and *A* get a mean result practically identical or about 3,500 ohms.

It is found better to go alternately too low and too high rather than twice on the same side. Also it is recommended that when nearly the same at both ends measurements should be repeated to check errors.

Supposing the resistance of the cable when sound (*L*) to be 4,500 ohms, then by the formula  $\frac{L-r}{2} = x$

$$\frac{4500-670}{2} = 1,915 \text{ ohms from } B \text{ to the fault.}$$

#### TESTING AND LOCATING FAULTS IN SHORT CABLES WITH IMPROVED APPARATUS.

The following notes on cable testing and the location of faults where accurate instruments are not available will be found of great value where apparatus must be improvised.

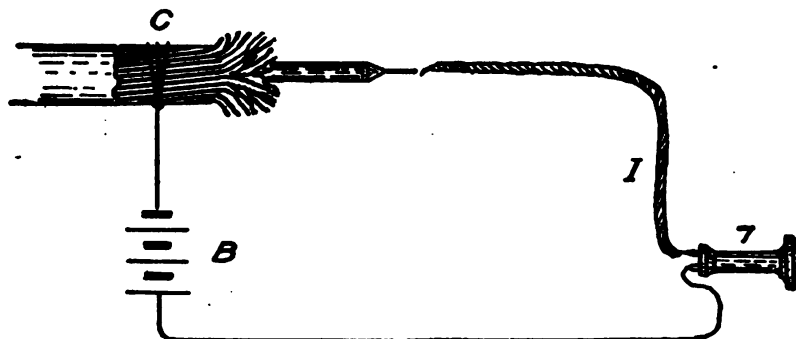

FIG. 49.

The extensive use of short subterranean and submarine cables for fire control, post telephone, and submarine-mine system generally makes some method of easy testing desirable. Very frequently testing sets are not on hand. If so, they are out of order or no one sufficiently skilled in their use for location of faults is available. By far the commonest class of faults is that due to defects in insulation. It is desirable to locate these in submarine cables, and very necessary in case of multiple core cables buried in trenches or drawn into conduits, which, of course, prevents their being taken up for examination.

In the absence of better instruments, a fairly good idea of the insulation resistance of a cable may be arrived at by means of a battery and telephone receiver, as follows:

A telephone receiver *T* is connected with the battery *B* of a

few cells, the latter being connected with the cable armor at *C*. A well insulated wire *I* is connected with the other terminal of the telephone. The ends of the conductor are prepared and insulated, as before described. When the end of *I* is touched on the cable conductor, a click is heard in the receiver. If after about one second it is touched again and no click is heard in the receiver, the insulation resistance, if one cell of battery is used, is about 50 megohms; if two cells of battery, 100 megohms, and so on for about the proportion of cells.

The click produced on first contact is due to the current rushing in to charge the cable, and, if the insulation is good, in one second so small an amount of this charge will be lost by leakage that little or no sound will be produced by subsequent contacts, as cable will still be charged. Care should be taken that wire *I* and telephone terminal attached to it are well insulated; otherwise leakage from them may give false indications.

Having found the faulty conductors, the location of these faults may then be proceeded with by the method suggested below (fig. 50). It is applicable to cables having two or more similar conductors, or to a single-conductor cable when both ends are available, as when it is coiled in a tank or on a reel. It is the Murray loop test with a "slide wire," in which simple relations of resistance to lengths exist, owing to the uniformity of resistances along the wires in the cable conductors and slide wires, respectively. It is, in fact, a combination of several well-known instrumental methods.

To prevent serious errors care must be taken that one of the conductors in this test has sound insulation.

No resistance measurements are involved, and the only apparatus required are a few cells of battery, a telephone receiver, and from 10 to 50 feet of bare resistance wire. Of this latter about No. 28 "Climax" or "S. B." wire, such as made by the Driver-Harris Company, of Newark, N. J., is suitable. However, if resistance wire is not to be had, fair results may be obtained by using No. 36 bare copper wire.

First taking the case of a multiple-conductor cable, say 3,000 yards long, in which there is one or more conductors with defective insulation and at least one good one, join the defective one to be tested with the good one at the distant end. Drive two small, bright nails (*A* and *C* in fig. 50) convenient to the terminals of the conductors at the testing end and stretch from these a piece of the resistance wire around another nail, *D*, and back, making each equal branch of the wire *AD* and *CD* of such a length as to be some exact submultiple of the length of the cable being tested. For example, have each branch of the wire in this case three thousand thirty-seconds of an inch long, or  $3,000/32 = 93.75$  inches. Join one of the two nails at the end by the

cable terminals to the defective cable conductor, the other nail to the good conductor. Join one terminal of the telephone receiver  $R$  to the ground and the other terminal to a short wire, which will be used as a "searcher." Connect a few cells of battery  $B$  across the nails to which the cable terminals are attached. Now, putting the telephone receiver to the ear, feel along the resistance wire, which is attached to the defective conductor, with the searcher wire attached to the telephone. A point,  $G$ , will be found where the frying sound produced in the telephone will cease, and if the searcher wire be moved either way from this it will again become audible. Mark this point on the resistance wire, reverse the connections of the battery, and again find the point of silence. If it is not coincident with the first, take the mean position between them.

The distance of this point  $G$ , in *thirty-seconds of an inch*, from the nail  $C$ , to which the defective cable terminal is attached, is the distance in *yards* from the cable terminal to the fault.

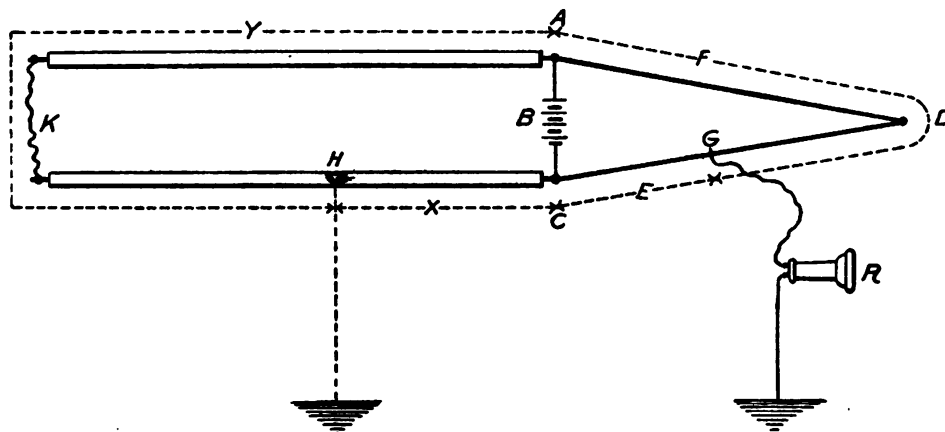

FIG. 50.

It is evident that for short cables greater accuracy is secured by taking larger representative units in proportion for the resistance wires. For example, if the cable were 1,250 yards long, the units on the resistance wires could be sixteenths and the wires be convenient in length:  $1,250/16=78\frac{1}{8}$  inches.

Care should be taken to stretch the resistance wires evenly and not wrap the loose ends back on the stretched portion, as that would destroy the uniformity of resistances throughout the length on which the assumed proportion depends.

In testing a defective single-conductor cable the two ends are joined to the resistance wire as just stated, the *whole length* of the resistance wire being in some simple proportion to the length of the cable.

For example, if the cable is 1,980 yards long, the *whole length* of the resistance wire would be  $1,980/32$  or  $1,980/16$  inches, as desired—

the greater length giving the result with greater accuracy. It will be readily seen that this and the former case are identical, as the "loop" formed by joining the distant ends of two multiple conductors is in this case replaced by the "loop" of the single conductor.

The method of securing ends of wires by nails is given to show with what ease and simplicity the necessary parts for the test may be set up. But, even roughly and hastily set up, the test will locate faults with surprising accuracy if a sufficient length of resistance wire be used to eliminate small accidental irregularities in attachments of wires.

The test is a simple application of the Wheatstone bridge principle. It may be of interest to trace this out (fig. 50).

$AK$  and  $CK$  are the two cable conductors joined at the distant end  $K$ . The lower one is defective at some unknown point  $H$ . The resistance wire  $ADC$  is joined up as shown with the cable conductors and battery  $B$ . The point of silence in the telephone is found at  $G$ . The Wheatstone bridge relation of resistances then exists in the lengths of the wire,  $X:Y::E:F$ . And since these resistances are along uniform wires the same relations exist between *lengths* as does between *resistances*. Consequently  $E$  can be read off directly in the terms of  $X$  if the lengths  $AD$  and  $CD$  are laid off numerically equal to  $AK$  and  $CK$ .

The foregoing method involves no computation. It is evident from the above proportion that if the entire length of resistance wire were made some even number of any convenient unit (say sixteenths of an inch) that a substitution of values in the proportion would give the distances. For example, if the resistance wire had a length of 1,000 and balance were found at 432 from the end to which the faulty conductor was attached, the distance to the fault would be  $\frac{432}{1000}$  of the *entire* length of the conductors or  $\frac{432}{1000} \times 2$  of the length of the *cable* from the testing point.

By this method, involving a simple computation, the same wire stretched on a convenient board or wall may be used for all measurements. It becomes in effect a form of ohmmeter, an instrument used by the Signal Corps.

If more than one faulty place exists in the conductor, the test will give approximately the mean position. So, having made the test and cut the cable at the indicated place, test both ways to ascertain if both parts are not defective. If found toward either station, the fault should be relocated in the defective part.

It will probably be found near the position of the first cut, and, having allowed a reasonable percentage error, on the second cut it is highly probable the faulty section will be cut off. It is the experience of the writer that generally the error of determination will fall within 1 per cent.



A word may be said regarding the telephone receiver as a detector of feeble currents. It is much more sensitive than the average pivoted galvanometer and will stand indefinitely more abuse. However, in noisy places the galvanometer may be substituted for the telephone in this test to advantage.

If the fault has a high resistance, so that the four or five cells of battery permissible in the manner of connecting shown in diagram can send insufficient current through, then some form of rather sensitive galvanometer becomes necessary with the increased battery and change of connections required. In place of the battery in fig. 50 connect the galvanometer. In place of the telephone receiver connect a battery of from 20 to 100 cells in series. Then proceed as with the telephone receiver, noting that for each break or irregularity of contact of the searcher wire there may be a kick of the galvanometer due

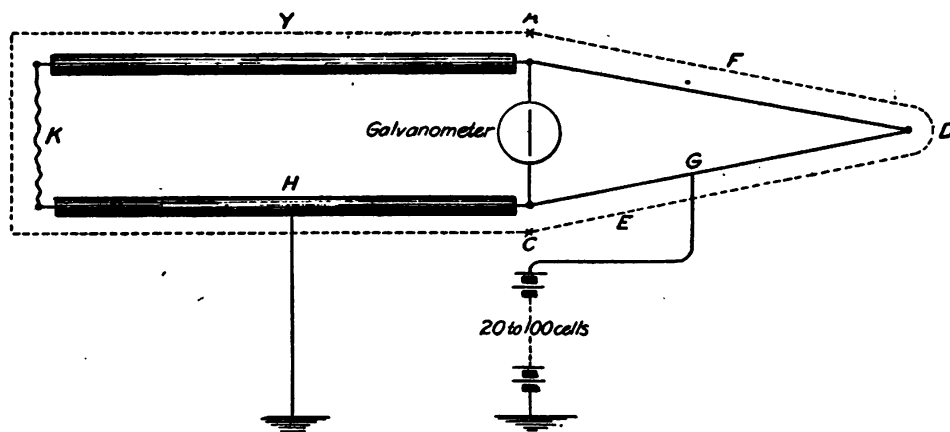

FIG. 51.

to capacity or inductance of the circuit, and that balance is obtained only when the galvanometer shows no deflection when the searcher wire is at rest (fig. 51).

A fault in single-conductor cable, or one involving *all* the conductors of a multiple cable, may be located if two additional wires of sound insulation between the points connected by the faulty cable are available.

As the lengths and resistance of these wires are immaterial, temporary or roundabout wires may be utilized.

The method of procedure is as follows: Stretch a single piece of resistance wire  $AB$  (fig. 52), whose length is some even number of parts, say 1,000 sixteenths of an inch. The two sound outside wires  $I$  and  $K$  and the defective one,  $L$ , are connected at the distant end. The galvanometer, battery, and searcher are connected as shown in fig. 52 and the point of balance obtained. Call the reading  $A$  from the point  $C$ .

Then connect up as in fig. 53, joining the battery to earth, or to

the cable sheath. If the fault appears as a leak between two adjacent wires of two-multiple cable the lower end of the battery should be

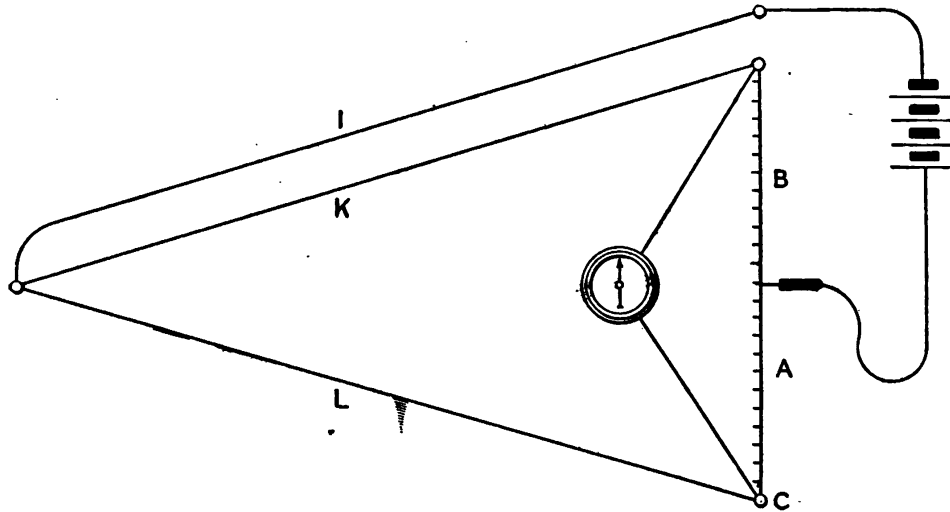

FIG. 52.

joined to the other faulty wire instead of the cable sheath or ground. When balance is obtained, note the reading on the resistance wire

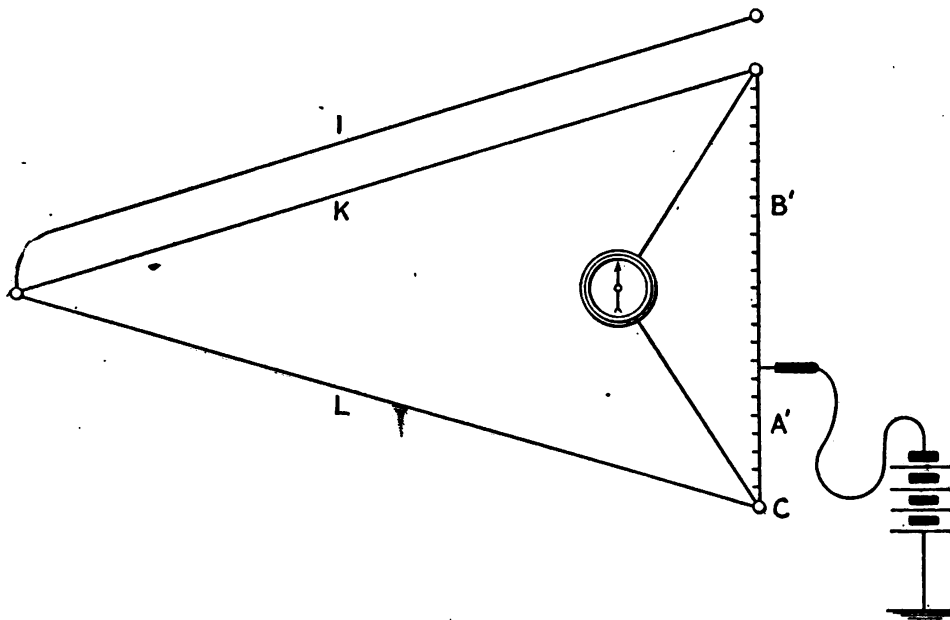

FIG. 53.

from point *C*. Call it *A'*. Then if length of faulty conductor is *L* feet, the distance of the fault from *C* is  $\frac{A'}{A} L$  feet.

This method is particularly applicable to paper cables where a leak has made the insulation of all the conductors faulty.

## INSTRUCTIONS FOR SHORE STATIONS DURING LAYING OR REPAIR OF CABLE.

Instructions will be given to look out for ship's call at a specified time. Connect up for receiving, and keep close watch in order to answer promptly.

Ship will give instructions regarding necessary connections. These instructions *must be implicitly obeyed*, and with rigid accuracy as to time.

Timepieces are to be set according to ship's instructions, and frequent comparisons with ship's time made in case timepiece is not regular.

Instructions to "free the end of the cable for so many minutes" would be abbreviated "Free — min." During this period especial care must be taken that the end is well insulated, and on no account must the conductor be permitted to touch anything.

Instructions to "Earth (ground) the cable for so many minutes" will be abbreviated "Earth — min." The end of the conductor, or its binding screw, will then be directly and securely connected to the cable armor for the time specified.

After each order is executed for the time specified connect up for receiving and await next order. Should no communication come from the ship after 15 minutes, begin at the even hour and free the cable for 15 minutes, then earth for 15 minutes, then connect up for receiving during the remaining half hour. Continue this routine every hour until communication is restored, or twelve hours has elapsed. If there is still no communication, connect up for receiving and keep close watch for ship's call.

In a book at the station will be kept a complete record of all changes in connections made and instructions received during laying and repairs and the exact time each was made. This record must be signed by the man on duty, with note of time he has been relieved. He will at the same time call attention of the one relieving him to any written note of instructions he has received from the ship.

Strict obedience to the foregoing instructions is enjoined.

## CHAPTER VI.

### MISCELLANEOUS DATA.

#### ALASKAN CABLE DATA.

(1903 type.)

	Deep sea.	Intermediate.	S. E.
Whole cable in air (per knot).....	3,605	6,787	21,620
Whole cable in air (per mile).....	3,127	5,887	18,800
Whole cable in water (per knot).....	2,328	4,812	-----
Whole cable in water (per mile).....	2,019	4,174	-----
MATERIALS.			
Iron wire (per knot).....	2,359	5,083	-----
Iron wire (per mile).....	2,046	4,409	-----
Jute and compound (per knot).....	888	1,341	-----
Jute and compound (per mile).....	770	1,163	-----
Tape (per knot).....	66	-----	-----
Tape (per mile).....	57	-----	-----
Rubber (per knot).....	177	-----	-----
Rubber (per mile).....	153	-----	-----
Copper (per knot).....	132	-----	-----
Copper (per mile).....	115	-----	-----
Diameters..... inch.....	.81	.98	1.75
C. R. at 60° F. (per mile)..... ohms.....	7.39	-----	-----
D. R. at 60° F. (per mile)..... megohms.....	1,418	-----	-----
Capacity (per mile)..... m. f.....	.428	-----	-----
C. R. at 60° F. (per knot)..... ohms.....	8.52	-----	-----
D. R. at 60° F. (per knot)..... megohms.....	1,230	-----	-----
Capacity (per knot)..... m. f.....	.493	-----	-----
Breaking strain.....	14,570	19,790	-----
Elastic strain.....	11,000	13,000	-----

NOTE.—Alaskan type of 1904 has 215 pounds of rubber per knot.  
 Shore end is intermediate (11 No. 8 B. W. G. wires) with an outer armor of 13 No. 3 B. W. G. wires.

#### SIGNAL CORPS CABLES.

[Extract from Circular No. 2, Office Chief Signal Officer of the Army, February 25, 1905.]

#### *Types of rubber-insulated submarine cables.*

Type No.	Specifi- cation No.	Kind.	Date.	Conduct- ors, No. B. and S.	Insula- tion.	Armor No. B. W. G.
22	14	F. C., Portland, 4-pair .....	1903	7-24	$\frac{8}{32}$	8
23	14	F. C., Portland, 4-pair, and 4-straight .....	1903	(4)-7-21	$\frac{3}{32}$	6
				(8)-7-24	$\frac{6}{32}$	
24	14	F. C., Portland, 2-pair, and 4-straight .....	1903	(4)-7-21	$\frac{6}{32}$	9
				(4)-7-24	$\frac{7}{32}$	
25	14	F. C., Portland, 3-pair, and 3-straight .....	1903	(2)-7-21	$\frac{8}{32}$	8
				(7)-7-24	$\frac{7}{32}$	
29	261	1-conductor, F. C .....	1904	7-21	$\frac{8}{32}$	11
30	261	2-pair, F. C .....	1904	7-24	$\frac{3}{32}$	11
31	261	3-pair, F. C .....	1904	7-24	$\frac{3}{32}$	9
32	261	4-pair, F. C .....	1904	7-24	$\frac{7}{32}$	8
33	261	5-pair, F. C .....	1904	7-24	$\frac{3}{32}$	6
34	261	6-pair, F. C .....	1904	7-24	$\frac{3}{32}$	6
40	164	1-conductor, special, light .....	1904	7-24	$\frac{3}{32}$	18
41	261	2-conductor, F. C .....	1904	7-24	$\frac{7}{32}$	11

Fire-control cables are usually furnished on reels as follows :

Types 29, 30, and 41 in lengths of 2 miles.

Types 31 and 32 in lengths of 1 mile.

Types 33 and 34 in lengths of  $\frac{1}{2}$  mile.

The weight of the standard fire-control cables per statute mile is approximately as follows :

Type 29, 2,800 pounds.                      Type 33, 21,000 pounds.

Type 30, 10,000 pounds.                    Type 34, 25,000 pounds.

Type 31, 12,500 pounds.                    Type 41, 6,000 pounds.

Type 32, 15,000 pounds.

*Types of rubber-insulated subterranean cables.*

Type No.	Specifi- cation No.	Kind.	Date.	Conduct- or. No. B. and S.	Insula- tion.	Armor, No. B. W. G.
201	-----	1-pair, lead-covered.....	1902	18	<i>Inches.</i> $\frac{5}{32}$	Lead.
202	-----	3-pair, lead-covered.....	1902	18	$\frac{5}{32}$	Lead.
203	-----	5-pair, lead-covered.....	1902	18	$\frac{5}{32}$	Lead.
204	-----	6-pair and 8-straight, lead-covered.....	1902	18	$\frac{5}{32}$	Lead.
205	-----	5-pair, lead-covered and armored.....	1902	18	$\frac{5}{32}$	10 and lead.
206	-----	6-pair and 8-straight, lead-covered and ar- mored.	1902	18	$\frac{5}{32}$	9 and lead.
207	12	1-pair, lead-covered.....	1902	14	$\frac{5}{32}$	Lead.
208	12	3-pair, lead-covered.....	1902	14	$\frac{5}{32}$	Lead.
209	12	6-pair, lead-covered.....	1902	14	$\frac{5}{32}$	Lead.
210	12	8-pair and 8-straight.....	1902	14	$\frac{5}{32}$	Lead.
211	13	6-pair, lead-covered and armored.....	1902	14	$\frac{5}{32}$	10 and lead.
212	13	8-pair and 8-straight, lead-covered and ar- mored.	1902	14	$\frac{5}{32}$	9 and lead.
213	160	1-pair, lead-covered.....	1904	7-24	$\frac{5}{32}$	Lead.
214	160	3-pair, lead-covered.....	1904	7-24	$\frac{5}{32}$	Lead.
215	160	6-pair, lead-covered.....	1904	7-24	$\frac{5}{32}$	Lead.
216	160	12-pair, lead-covered.....	1904	7-24	$\frac{5}{32}$	Lead.
217	161	6-pair, lead-covered and armored.....	1904	7-24	$\frac{5}{32}$	10 and lead.
218	161	12-pair, lead-covered and armored.....	1904	7-24	$\frac{9}{32}$	9 and lead.

Rubber-insulated subterranean cables are on reels, as follows :

Types 213 and 214 in  $\frac{1}{2}$ -mile lengths.

Types 215, 216, 217, and 218 in lengths of 1,000 feet.

The weight of cables per statute mile is as follows :

Type 213, 3,000 pounds.                      Type 216, 14,785 pounds.

Type 214, 9,200 pounds.                      Type 217, 18,800 pounds.

Type 215, 11,100 pounds.                      Type 218, 26,900 pounds.

The usual reel for the shipment of these types of cable weighs 400 pounds, has a length of 30 inches, a drum diameter of 34 inches, and sides 5 feet 6 inches high.

*Types of paper-insulated armored cables.*

Type No.	Specifi- cation No.	Kind.	Date.	Conductor, No. B. and S.	Insula- tion.	Armor, No. B. W. G.
301	8	10-pair.....	1901	19	Double, paper.	9 and lead.
302	29	25-pair.....	1904	19	Double, paper.	11 and lead.
303	174	20-pair, combination.....	1904	8-pair-19 10-pair-3-21	Double, paper.	9 and lead.
304	174	25-pair, combination.....	1904	10-pair-19 15-pair-3-21	Double, paper.	9 and lead

The armored paper-insulated cables are supplied under certain conditions for submarine or subterranean work.

Type 303 weighs 22,600 pounds per statute mile.

Type 304 weighs 25,000 pounds per statute mile.

Types 303 and 304 when shipped in mile lengths are provided with reels weighing 5,000 pounds, having a length of 7 feet, a diameter of side of 8 feet, and a shaft 5 inches in diameter and 10 feet long.

These cables are usually ordered in lengths to suit the special installation, so as to be installed without splices.

*Types of paper-insulated unarmored cables.*

Type No.	Specification No.	Kind.	Date.	Conductor, No. B. and S.	Insulation.	Armor, No. B. W. G.
401	197	10-pair, aerial .....	1904	19	Double, paper.	Lead.
402	197	15-pair, aerial .....	1904	19	Double, paper.	Lead.
403	197	20-pair, aerial .....	1904	19	Double, paper.	Lead.
404	197	25-pair, aerial .....	1904	19	Double, paper.	Lead.
405	197	30-pair, aerial .....	1904	19	Double, paper.	Lead.
406	197	40-pair, aerial .....	1904	19	Double, paper.	Lead.
407	197	50-pair, aerial .....	1904	19	Double, paper.	Lead.
408	197	75-pair, aerial .....	1904	19	Double, paper.	Lead.
409	197	100-pair, aerial .....	1904	19	Double, paper.	Lead.

This class used for temporary fire-control work and for permanent post construction, is on reels in lengths of 1,000 feet.

*Approximate weights of paper-insulated unarmored cables and reels.*

Type No.—	Weight per statute mile.	Reels, length.	Reels, diameter side.	Reels, weight.	Gross weight (1,000 feet of cable and reel).
	<i>Pounds.</i>	<i>Inches.</i>	<i>Inches.</i>	<i>Pounds.</i>	<i>Pounds.</i>
401.....	6,200	33	56	600	1,770
402.....	7,000	33	56	600	2,000
403.....	8,200	33	56	600	2,140
404.....	8,900	33	60	800	2,490
405.....	10,500	33	60	800	2,900
406.....	18,000	33	64	950	3,500
407.....	16,600	33	64	950	4,100
408.....	20,000	33	72	1,100	4,800
409.....	24,000	33	72	1,100	5,740

A. W. GREELY,

*Brigadier-General, Chief Signal Officer, U. S. Army.*

## USEFUL CONSTANTS AND FORMULÆ.

[From Electrical Tables and Formulæ, Clark and Sabine.]

## COPPER.

The specific gravity of copper wire, according to the best authorities, is about 8.899.

One cubic foot weighs about 550 pounds.

One cubic inch weighs 0.32 pound.

The ordinary breaking weight of copper wire is about 17 tons per square inch, varying greatly, however, according to the size and degree of hardness.

The weight per nautical mile of any copper wire is about  $\frac{d^2}{55}$  pounds,  $d$  being the diameter in mils.

The weight per knot of a copper strand is about  $\frac{d^2}{70.4}$  pounds.

The weight per statute mile of any copper wire is  $\frac{d^2}{63}$  pounds. A mile of No. 16 wire weighs in practice from 63 to 66 pounds.

The diameter of any copper wire weighing  $w$  pounds per nautical mile is  $7.4 \sqrt{w}$  mils.

The diameter of any copper wire weighing  $w$  pounds per statute mile is  $7.94 \sqrt{w}$  mils.

The diameter of a copper strand weighing  $w$  pounds per nautical mile is about  $8.4 \sqrt{w}$  mils.

The resistance of a nautical mile of pure copper weighing 1 pound is, at 32° F., 1,091.22 ohms; at 60° F., 1,155.48 ohms; at 75° F., 1,192.43 ohms.

The resistance per nautical mile of any pure copper wire or strand weighing  $w$  pounds is  $\frac{1192.45}{w}$  at 75° F.

The resistance per nautical mile of any pure copper wire  $d$  mils. in diameter is  $\frac{65306}{d^2}$  ohms at 75° F.

The resistance per statute mile of any pure copper wire is  $\frac{54892}{d^2}$  ohms at 60° F.

The resistance per nautical mile of any pure copper strand is  $\frac{83964}{d^2}$  ohms at 75° F.

The resistance per knot of a cable conductor is equal to 120,000 divided by the product of the percentage conductivity of the copper and its weight per knot in pounds.

The resistance of a statute mile of pure copper weighing 1 pound is 1002.4 ohms at 60° F. No. 16 copper wire of good quality has a resistance of about 19 ohms.

The resistance of a statute mile of pure copper weighing  $w$  pounds is  $\frac{1002.4}{w}$  ohms at 60° F.

The resistance of any pure copper wire  $L$  inches in length, weighing  $n$  grains, is  $\frac{.001516 \times L^2}{n}$  ohms.

## IRON.

The weight of any iron wire per nautical mile is  $\frac{d^2}{62.6}$  pounds,  $d$  being its diameter in mils.

The weight of any iron wire per statute mile is  $\frac{d^2}{72}$  pounds.

The diameter of any iron wire weighing  $w$  pounds per statute mile =  $8.49 \sqrt{w}$  mils.

The diameter of any iron wire weighing  $w$  pounds per nautical mile =  $7.91 \sqrt{w}$  mils.

The conductivity of ordinary galvanized-iron wire averages about one-seventh that of pure copper.

The resistance per statute mile of a galvanized-iron wire is about  $\frac{360,000}{d^2}$  ohms, at 60° F.

## CABLE TANKS.

To find the capacity of a circular tank—

Let  $r$ =radius of the eye.

$R$ =radius of the tank.

$d$ =diameter of the cable.

$n$ =number of coils in one flake.

## DISTANCES.

Let  $h$  be the height of tank or coil, then

$$\text{Total length of cable} = \frac{\pi h}{d^2} (R^2 - r^2).$$



FIG. 54.

## DISTANCE—SOUND.

*Distance from shore—Measurement by sound.*—It sometimes happens that the distance of the ship from shore is required to be known,



and a measurement by sound may be resorted to. For this purpose a gun is fired and the interval between the flash and the sound noted.

Let  $D$ =distance in knots;  
 $T$ =temperature of air in degree Centigrade;  
 $S$ =interval in seconds;

then

$$D=0.179 S\sqrt{1+0.00374 T}.$$

Example: A ship fired a cannon, and the sound was heard six and one-half seconds after the flash was seen. The temperature of the air was 15° C. Required, the distance ( $D$ ) of the ship.

$$D=0.179 \times 6\frac{1}{2} \sqrt{1+0.00374 \times 15}=1.2 \text{ knots.}$$

*Weights (in pounds) submarine cable, Alaskan type, 1905.*

	Per mile.	Per knot.
<b>Core:</b>		
Conductor.....	122.48	141.18
Pure Para.....	11.38	13.10
40 per cent compound.....	193.31	222.60
Tape.....	71.00	81.75
<b>Total.....</b>	<b>398.17</b>	<b>458.63</b>
<b>Deep-sea cable:</b>		
Core.....	398.17	458.63
Armor (16 No. 13 B. W. G. wires).....	2,232.00	2,570.00
Jute, tar compound, and cutch.....	656.00	755.40
<b>Total.....</b>	<b>3,286.17</b>	<b>3,784.03</b>
<b>Weight in water.....</b>	<b>2,098.00</b>	<b>2,416.00</b>
<b>Intermediate cable:</b>		
Core.....	398.17	458.63
Armor (11 No. 8 B. W. G. wires).....	4,690.00	5,400.20
Jute, tar compound, and cutch.....	1,138.00	1,310.30
<b>Total.....</b>	<b>6,226.17</b>	<b>7,169.13</b>
<b>Weight in water.....</b>	<b>3,948.00</b>	<b>4,546.00</b>
<b>Shore-end cable:</b>		
Core.....	398.17	458.63
Armor (first, 11 No. 8 B. W. G.).....	4,690.00	5,400.20
Armor (second, 14 No. 8 B. W. G.).....	13,002.00	14,972.00
Jute, tar compound, and cutch.....	3,430.00	3,949.00
<b>Total.....</b>	<b>21,520.17</b>	<b>24,779.83</b>
<b>Weight in water.....</b>	<b>15,192.00</b>	<b>17,496.00</b>
<b>Specific gravity:</b>		
Pure Para.....		.9250
40 per cent compound.....		1.5903

30447—05 M—7

## CHAPTER VII.

### **FACTORY TESTING FOR THE ELECTRICAL PROPERTIES OF CABLE.**

By Maj. SAMUEL REBER, Signal Corps.

The Signal Corps specifications require the manufacturers to supply all instruments and facilities necessary for testing the cable. As these instruments are different at the different factories, a description of them will not be attempted. At the beginning of a series of tests at the factory, bridges, condensers, and high resistances must be compared with standards to verify their accuracy.

The high-voltage test is first applied to the core. The breakdown test for the standard core, after twenty-four hours immersion in water, is the application of 6,500 volts alternating for five minutes. This test will discover any accidental impurities in the compound. While the specifications require the application of 6,500 volts for five minutes, if a breakdown occurs it will be disclosed almost instantly after the application of the high voltage. One lead from the transformer is connected with the copper of the core and the other lead immersed in the water in the tank. For the finished cable 1,000 volts are applied between the armor and the core for one minute. When the high-voltage test is applied to lengths of armor cable of 50 miles or more, it is, perhaps, better to use direct rather than alternating voltage, to avoid any possibility of resonance and the formation of stationary waves.

After the application of the breakdown test, the capacity, insulation, and copper resistances of each length of the core are determined in the order mentioned.

The capacity measurement is made by the charge method, as experience has demonstrated that, using a low voltage, the readings at charge and discharge are practically the same, as the effect of absorption is negligible. With some of the insulating compounds used the effect of the high-voltage test is to temporarily increase the capacity, and it will frequently happen that the first measurement may be higher than that required by the specifications, but if the cable is

allowed to stand for twenty-four hours the capacity will probably drop to the limit prescribed by the specifications. When the first measured capacity is too high it should be remeasured after twenty-four hours. When the capacity of long lengths of cable is being tested, either Thompson's or Gott's method is preferable to using a shunted galvanometer. In measuring insulation resistance, especially in damp weather, care should be taken to thoroughly insulate the galvanometer, keys, and shunt box. The leakage from the galvanometer can be avoided by connecting the leveling screws together and then joining them to the insulated terminal of the battery key and by supporting the leveling screws on ebonite buttons.

In making the insulation measurement care should be taken to properly prepare the ends of the core, so as to avoid surface leakage. The ends should be freshly cut in conical form, allowing 2 or 3 inches of the copper core to project so that the lead may be attached, care being taken that the freshly cut surface is not touched by the fingers. It is a good plan to dry both ends with an alcohol lamp, taking care that the flame does not come close enough to injure the compound.

The copper resistance is measured by the usual bridge method.

In all cases, at the beginning of each series of tests, the leakage of the leads, their capacity, and resistance are determined.

The results of each day's work should be entered on the test sheet, and when the cable is finally completed the data in respect to each core and finished cable length should be entered on the record sheet, a copy of which should be forwarded with each shipment, one retained in the office of the officer making the inspection, and the third copy furnished the Chief Signal Officer of the Army.

While the logarithmic method of computation is used in the illustrations which follow, it is much better to calculate the results with the Thatcher slide rule, which reads to four places of figures accurately, and by approximation to the fifth. One setting of this rule will serve for an entire series of calculations and effects a very great saving of time.

In measuring capacity the method employed is the ordinary ballistic one, using a battery of but two or three volts. A deflection is obtained by charging a standard condenser, usually one-third of a microfarad, in series with a galvanometer, battery, and key. The first throw of the galvanometer is noted and the deflection for one microfarad calculated and entered on the test sheet. The cable is then substituted for the standard condenser, earthing one end and the battery, and the deflection read and noted.

In measuring insulation resistance the galvanometer constant is first obtained by connecting the high resistance, usually a megohm, in

series with the battery of 100 volts, and galvanometer, which should be shunted with the  $\frac{1}{1000}$  shunt, and observing the deflection, which is then corrected for the shunt and noted on the test sheet. The leakage of the leads, with the same voltage, is then obtained. The lead is then connected to the cable, the battery applied, the zinc pole to the cable, and the other side grounded. The deflection of the galvanometer is noted at the expiration of a minute, and this deflection is the one from which the insulation resistance is calculated. It is well, however, to allow the battery to remain on for several minutes, noting the deflection at the end of each minute. This deflection should fall in a gradual and even manner. In the case of one of the compounds used, viz, that of the Safety Company, the deflection should halve itself, i. e., the insulation should double itself at the third and fifth minutes.

After the insulation resistance has been obtained, the bridge is used to measure the copper resistance of the core and the leads. The temperature of the tank is taken and noted. All measurements are made with the core or cable in the tank after it has been immersed for twenty-four hours, as the rubber compound will not attain its proper insulation at any given temperature until several hours after it has reached that temperature. There is always more or less uncertainty about the temperature, as the water in the different parts of the tank may not be at the same temperature; consequently care should be taken to get a uniform temperature throughout the tank. As there is less uncertainty with the core than with the finished cable, the copper resistances of the core reduced to the standard temperature may be, in case of doubt, taken as a base for calculating the test temperature of the finished cable.

The insulation resistance of rubber compound varies with the temperature, increasing as the temperature diminishes and decreasing as it rises. The temperature law of variation of the insulation resistance can be taken approximately as a simple logarithmic law. The insulation resistance, diminishing in equal ratio with an increase in the temperature, can be written in the form  $R = rC^t$ , in which  $R$  is the resistance at the higher temperature,  $r$  the resistance at the lower temperature,  $t$  the difference in temperature in degrees Fahrenheit, and  $C$  a constant, depending on the nature of the insulation compound, which, for the Safety company, can be assumed as 0.973, and for the Kerite 0.939. For reducing the insulation resistance at any observed temperature to that of the standard temperature, 60° F., it is necessary to have a factor to multiply the resistance of the observed temperature. The Okonite, Habirshaw, and Bishop companies have found that their compounds follow the logarithmic law sufficiently closely for all practical purposes. The coefficients of a number of

compounds, according to this simple logarithmic law, are plotted in sheet 1 on logarithmic paper designed by Mr. Townsend Wolcott. The ordinates represent the temperature and are plotted arithmetically, while the abscissæ, the ratio of the insulation resistance at 60° F. to that at the temperature of observation, are plotted logarithmically. The resistance at 60° F., being taken as unity, its logarithm, zero, is in the center of the paper, and the scale extends on the right to  $\log. \sqrt{10}$ , and on the left to  $\log. \sqrt{0.1}$

The following table gives the factors for reducing the insulation resistance of the Okonite, Habirshaw, and Bishop companies' compounds to 60° F. according to the simple logarithmic law, these compounds doubling their insulation with a difference of temperature of 27° F.

*Factors for reducing the insulation resistance of the Okonite, Habirshaw, and Bishop companies to 60° F.*

Temperature.	K.	Log. K.	Temperature.	K.	Log. K.
° F.			° F.		
50	0.778	9.888401	66	1.167	0.037071
51	.793	9.899629	67	1.197	.078094
52	.814	9.910802	68	1.228	.089198
53	.835	9.921906	69	1.260	.100371
54	.856	9.932929	70	1.293	.111599
55	.879	9.944240	71	1.326	.122544
56	.902	9.955460	72	1.361	.133858
57	.925	9.966576	73	1.396	.144885
58	.949	9.977572	74	1.433	.156246
59	.974	9.988353	75	1.470	.167817
60	1.000	.000000	76	1.508	.178401
61	1.028	.011147	77	1.547	.189490
62	1.053	.022428	78	1.587	.200577
63	1.080	.033424	79	1.629	.211921
64	1.108	.044540	80	1.671	.222976
65	1.137	.055760			

As the result of careful observations of the temperature variation of the Safety and Kerite compounds, Mr. Townsend Wolcott, electrical engineer, Signal Corps, gives the following formula:

$$\text{Log.} \left( \frac{R_t}{R_{60}} \right) = (.00802488 + .000044619t) (60 - t)$$

$$\text{Log.} \left( \frac{R_t}{R_{60}} \right) = (.00845964 + .000286604t) (60 - t)$$

in which  $R_t$  is the resistance at the temperature of observation and  $R_{60}$  is the resistance at 60° F. Calling the reciprocal of this ratio K, the following table has been calculated for the Safety and Kerite compounds:

Temperature coefficient for the reduction of insulation resistance to 60° F.

Temperature.	Safety.		Temperature.	Kerite.	
	K.	Log. K.		K.	Log. K.
° F.			° F.		
50	0.789	9.897441	50	0.591	9.772110
51	.807	9.907300	51	.619	9.792325
52	.826	9.917240	52	.650	9.813104
53	.845	9.927277	53	.683	9.834457
54	.865	9.937396	54	.718	9.856390
55	.886	9.947609	55	.756	9.878890
56	.907	9.957908	56	.797	9.901988
57	.929	9.968296	57	.823	9.925615
58	.952	9.978778	58	.891	9.949493
59	.975	9.989343	59	.943	9.974632
60	1.000	0.000000	60	1.000	0.000000
61	1.025	.010746	61	1.061	.025941
62	1.050	.021582	62	1.128	.052456
63	1.080	.035505	63	1.201	.079545
64	1.105	.043500	64	1.280	.107204
65	1.134	.054625	65	1.367	.135755
66	1.163	.065714	66	1.460	.164244
67	1.194	.077006	67	1.562	.193627
68	1.226	.088624	68	1.673	.223684
69	1.258	.099927	69	1.796	.254106
70	1.292	.111432	70	1.928	.285210
71	1.328	.123120	71	2.074	.316827
72	1.364	.134844	72	2.234	.349128
73	1.401	.146666	73	2.409	.381953
74	1.441	.158564	74	2.602	.415358
75	1.481	.170565	75	2.814	.449310
76	1.523	.182640	76	3.046	.483760
77	1.566	.194820	77	3.303	.518859
78	1.611	.207090	78	3.586	.554852
79	1.657	.219431	79	3.899	.590800
80	1.705	.231888	80	4.244	.627740

The resistance of copper increases with the increase of temperature. In order to reduce copper resistances at any temperature between 50° and 80° F. to 60° F., the following table has been calculated in which  $\delta$  is the factor by which the resistance at the observed temperature should be multiplied to reduce it to 60° F.

Reduction of copper resistance to 60° F.

Temperature.	$\delta$ .	Log. $\delta$ .	Temperature.	$\delta$ .	Log. $\delta$ .
° F.			° F.		
50	1.022	0.009451	66	0.9875	9.994519
51	1.019	.008174	67	.9847	9.993314
52	1.017	.007321	68	.9834	9.992707
53	1.015	.006466	69	.9813	9.991905
54	1.013	.005609	70	.9793	9.990903
55	1.011	.004751	71	.9773	9.990003
56	1.009	.003891	72	.9752	9.989107
57	1.007	.003029	73	.9732	9.988211
58	1.004	.001734	74	.9712	9.987317
59	1.002	.000868	75	.9692	9.986425
60	1.000	.000000	76	.9672	9.985535
61	.9977	9.999081	77	.9653	9.984647
62	.9958	9.998165	78	.9633	9.983760
63	.9944	9.997551	79	.9613	9.982857
64	.9916	9.996338	80	.9594	9.981968
65	.9895	.995423			

A general formula for reducing copper resistance at any observed temperature ( $T$ ) to 60° is given by the following:

$$\delta = \frac{1.063}{1 + .00225 (T - 32)}$$

The two following tables illustrate the manner in which the records of factory tests are kept, and the next is an example of a record sheet.

*Record of cable tests for Signal Corps, U. S. Army.*

[Date, July 5, 1901; place of test, Seymour, Conn.; manufacturer, W. R. Brixey; type of wire, core.]

Galvanometer constants (45,000 divisions through 2.064 megohms, 92,890 divisions through 1 megohm.

Leads (Leakage, 12 divisions. Conductor resistance, 1.64 ohms.

Capacity (Capacity, 5 divisions.

Reel or section No. —	Capacity.				Insulation.				Conductor resistance.				
	Core length.	Observed deflection.	Corrected deflection.	Total microfarads.	Microfarads per mile.	Observed deflection.	Corrected deflection.	Total insulation temperature of observation.	Total insulation per mile at 60° F.	Total resistance.	Corrected for leads.	Total resistance at 60° F.	Resistance per mile at 60° F.
1.000	116	286	291	0.298	0.298	197	185	502.1	1.426	11.87	9.73	9.43	9.43
1.004	117	292	287	.293	.292	172	160	580.5	1.649	11.34	9.70	9.40	9.30
1.002	118	295	290	.297	.296	124	112	893.4	2.356	11.26	9.62	9.32	9.30
1.001	119	287	282	.288	.291	144	144	645	1.822	11.17	9.53	9.24	9.32
1.004	120	294	283	.298	.295	150	118	787.1	2.238	11.37	9.73	9.43	9.30
1.009	121	294	289	.296	.293	169	157	591.6	1.691	11.40	9.78	9.48	9.38
1.007	122	289	284	.301	.299	168	157	615.2	1.747	11.31	9.67	9.37	9.31
1.005	123	285	280	.297	.296	149	131	709.1	2.015	11.26	9.62	9.32	9.29
1.006	124	286	285	.291	.288	174	162	573.4	1.629	11.24	9.60	9.30	9.24
.977	125	290	285	.291	.288	128	116	800.7	2.275	11.15	9.51	9.22	9.44

Observations by Townsend Wolcott; calculations by T. W.

[Date, August 23, 1900; place of test, New York City; manufacturer, Safety Insulated Wire and Cable Company; type of wire, finished cable.]

Galvanometer constants (256 divisions through 0.3 megohms, 185,000 divisions through 1 megohm.

Leads (Leakage, 29 divisions; conductor resistance, 1.38 ohms.

Reel or section No. 64.	Capacity.				Insulation.				Conductor resistance.				
	Core length.	Observed deflection.	Corrected deflection.	Total microfarads.	Microfarads per mile.	Observed deflection.	Corrected deflection.	Total insulation temperature of observation.	Total insulation per mile at 60° F.	Total resistance.	Corrected for leads.	Total resistance at 60° F.	Resistance per mile at 60° F.
1.800	1,800	1,800	2,100	0.413	0.413	970	941	196	510	94.5	63.12	87.66	17.16
Total (24,795 feet. 5.107 miles.													

Observations by S. R.; calculations by S. R.

Record sheet.

[Manufacturer, Safety Insulated Wire and Cable Company; type, deep-sea cable; loaded on U. S. Army transport *Burnside*.]

Section No.	Length (miles).	Capacity.				Insulation.		Copper.			
		Core.		Cable.		Core, per mile.	Cable, per mile.	Core.		Cable.	
		Absolute.	Per mile.	Absolute.	Per mile.			Absolute.	Per mile.	Absolute.	Per mile.
85	5.138	1.988	0.387	1.775	0.345	1,613	1,073	90.26	17.58	90.32	17.58
86	5.097	1.944	.391	1.635	.321	1,421	1,150	89.31	17.52	89.60	17.58
87	5.082	1.775	.349	1.525	.300	1,269	1,119	86.96	17.57	88.92	17.50
88	5.125	2.063	.402	1.610	.314	1,350	778	86.99	17.55	88.47	17.28
89	4.855	1.750	.360	1.480	.305	1,409	1,108	85.12	17.13	85.46	17.61
90	4.853	1.750	.360	1.500	.309	1,416	1,077	85.05	17.52	85.95	17.30
91	4.848	1.736	.370	1.613	.333	1,416	1,122	85.39	18.01	83.95	17.20
92	4.841	1.964	.405	1.709	.352	1,637	1,312	84.95	17.53	84.25	17.37
93	4.877	1.807	.370	1.590	.326	1,487	1,232	85.24	17.47	85.31	17.49
94	5.133	1.889	.368	1.702	.331	1,510	1,099	89.97	17.53	89.32	17.40
95	5.138	2.115	.411	1.596	.311	1,610	1,043	90.15	17.54	88.48	17.30
96	5.097	1.863	.365	1.630	.320	1,261	1,306	89.11	17.48	87.96	17.26
97	5.112	2.012	.393	1.637	.320	1,454	1,059	90.34	17.68	91.34	17.37
98	5.098	1.978	.388	1.699	.333	1,699	1,306	89.50	17.56	88.40	17.35
99	5.107	1.884	.369	1.589	.311	1,267	852	89.14	17.46	90.32	17.68
100	5.138	2.172	.423	1.633	.318	1,358	1,205	90.22	17.56	89.40	17.40

The following computation illustrates the logarithmic method of calculating the data contained in record sheet of Safety Company, page 103.

CAPACITY.

Log. 1800=3. 255273

Log. 853=2. 930949

Absolute capacity, 2.110 . 324324

Log. 5.107= . 708166

Capacity per mile, 0.413 1. 616158

INSULATION RESISTANCE.

970-29=941

Log. 185000=5. 267172

Log. 941=2. 973590

Insulation at temperature of observation, 196 2. 293582

Log. K = . 207090

Total insulation at 60° F., 510 2. 501672

Log. 5.107= . 708166

Insulation resistance per mile, 1621 3. 209838



## COPPER RESISTANCE.

$$94.5 - 1.38 = 93.12$$

$$\text{Log. } 93.12 = 1.969043$$

$$\text{Log. } \delta = 9.983760$$

$$\text{Total resistance at } 60^\circ \text{ F., } 87.66 \quad \underline{1.942803}$$

$$\text{Log. } 5.107 = \underline{.708166}$$

$$\text{Resistance per mile at } 60^\circ \text{ F., } 17.16 \quad .234637$$

## DATA FOR SAFETY INSULATED WIRE AND CABLE COMPANY'S COMPOUND.

Specific gravity of compound, 1.646.

Weight per cubic foot of compound, 103 pounds.

$$\text{Capacity per mile, solid conductor} = \frac{.2063}{\log. D - \log. d}$$

$$\text{Capacity per knot, solid conductor} = \frac{.2329}{\log. D - \log. d}$$

$$\text{Capacity per mile, 7-stranded conductor} = \frac{.2063}{\log. D - \log. 2.27 \delta}$$

$$\text{Capacity per knot, 7-stranded conductor} = \frac{.2329}{\log. D - \log. 2.27 \delta}$$

Insulation resistance per mile, solid conductor = 1982 (log.  $D - \log. d$ ).

Insulation resistance per knot, solid conductor = 1756 (log.  $D - \log. d$ ).

Insulation resistance per mile, 7-stranded conductor = 1982 (log.  $D - \log. 2.27 \delta$ ).

Insulation resistance per knot, 7-stranded conductor = 1756 (log.  $D - \log. 2.27 \delta$ ).

Weight per mile of compound, solid core = 2956 ( $D^2 - d^2$ ).

Weight per mile of compound, 7-stranded conductor = 2956 ( $D^2 - 6.9 \delta^2$ ).

$D$  = outside diameter of insulation.

$d$  = diameter of solid conductor.

$\delta$  = diameter of single strand.

## DATA FOR KERITE.

Specific gravity of compound, 1.233.

Weight per cubic foot, 77 pounds.

$$\text{Capacity per mile, solid conductor} = \frac{.1738}{\log. D - \log. d}$$

$$\text{Capacity per knot, solid conductor} = \frac{.1962}{\log. D - \log. d}$$

$$\text{Capacity per mile, 7-stranded conductor} = \frac{.1738}{\log. D - \log. 2.27 \delta}$$

$$\text{Capacity per knot, 7-stranded conductor} = \frac{.1962}{\log. D - \log. 2.27 \delta}$$

Insulation resistance per mile, solid conductor= $2147 (\log. D - \log. d)$ .

Insulation resistance per knot, solid conductor= $1602 (\log. D - \log. d)$ .

Insulation resistance per mile, 7-stranded conductor= $2147 (\log. D - \log. 2.27 \delta)$ .

Insulation resistance per knot, 7-stranded conductor= $1902 (\log. D - \log. 2.27 \delta)$ .

Weight per mile of compound with solid core= $2211 (D^2 - d^2)$ .

Weight per mile of compound, 7-stranded conductor= $2211 (D^2 - 6.9 \delta^2)$ .

$D$  = outside diameter of insulation.

$d$  = diameter of solid conductor.

$\delta$  = diameter of single strand.

*Conversion tables.*

Miles to knots.		Knots to miles.	
Miles.	Knots.	Knots.	Miles.
1	0.8674	1	1.1528
2	1.7348	2	2.3057
3	2.6023	3	3.4585
4	3.4697	4	4.6114
5	4.3371	5	5.7642
6	5.2045	6	6.9170
7	6.0719	7	8.0699
8	6.9394	8	9.2127
9	7.8068	9	10.3756

Miles to kilometers.		Kilometers to miles.	
Miles.	Kilometers.	Kilometers.	Miles.
1	1.60935	1	0.62137
2	3.21870	2	1.24274
3	4.82804	3	1.86411
4	6.43739	4	2.48548
5	8.04674	5	3.10685
6	9.65608	6	3.72822
7	11.26543	7	4.34959
8	12.87478	8	4.97096
9	14.48412	9	5.59233

( )



JAN 9 1966

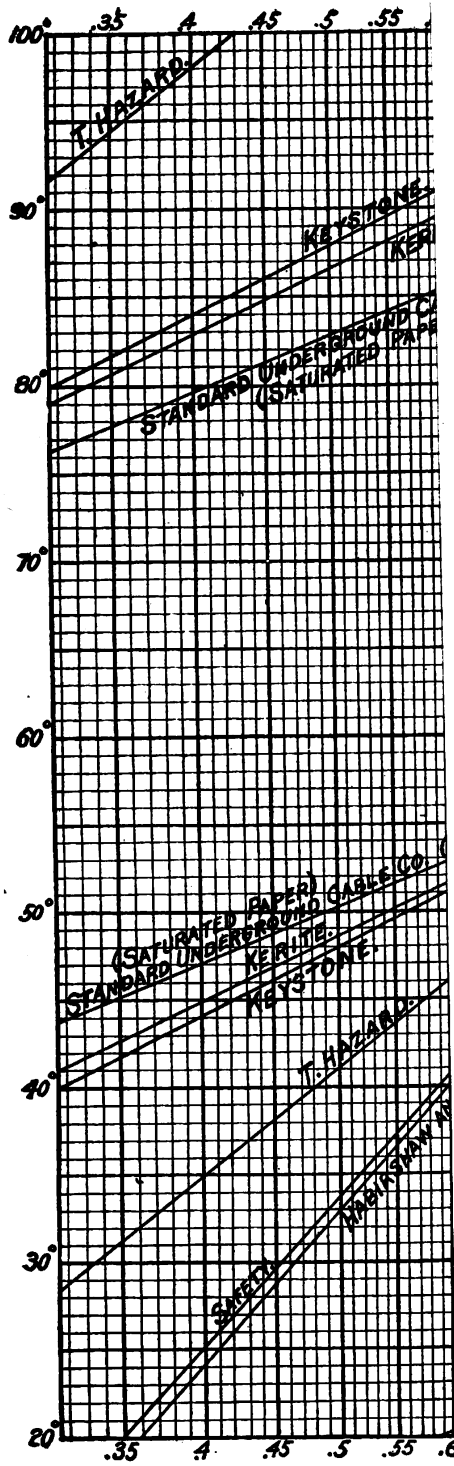

FIG. 55.—Coeff

30447—05 M. (To face pag

