

TECHNICAL MANUAL

**OPERATOR'S, ORGANIZATIONAL, DIRECT
SUPPORT AND GENERAL SUPPORT
MAINTENANCE MANUAL**

**TOPOGRAPHIC SUPPORT SYSTEM
SURVEY SECTION
MODEL ADC-TSS-6
NSN: 6675-01-105-5756**

This manual together with TM 5-6675-318-14-1, supersedes TM 5-6675-318-14, 15 September 1983, including all changes.

**HEADQUARTERS, DEPARTMENT OF THE ARMY
3 SEPTEMBER 1985**



CHANGE

NO. 5

HEADQUARTERS
DEPARTMENT OF THE ARMY
WASHINGTON, D.C., 18 MAY 1992

Operator's, Organizational, Direct
Support and General Support
Maintenance Manual

**TOPOGRAPHIC SUPPORT SYSTEM
SURVEY SECTION
MODEL ADC-TSS-6
NSN 6675-01-105-5756**

Approved for public release; Distribution is unlimited

TM 5-6675-318-14-2, 3 September 1985 is changed as follows:

1. Remove and insert pages as indicated below. New or changed text material is indicated by a vertical bar in the margin. An illustration change is indicated by a miniature pointing hand.

Remove pages

Insert pages

C-1 and C-2

C-1 and C-2

2. Retain this sheet in front of manual for reference purposes.

By Order of the Secretary of the Army:

Official:

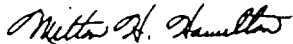

MILTON H. HAMILTON
*Administrative Assistant to the
Secretary of the Army*

01376

GORDON R. SULLIVAN
*General, United States Army
Chief of Staff*

DISTRIBUTION:

To be distributed in accordance with DA Form 12-25E, (qty rqr block no. 5355).

CHANGE
NO. 4

HEADQUARTERS
DEPARTMENT OF THE ARMY
WASHINGTON, D.C., 26 March 1990

Operator's, Organizational, Direct
Support and General Support
Maintenance Manual

TOPOGRAPHIC SUPPORT SYSTEM
SURVEY SECTION
MODEL ADC-TSS-6
NSN: 6675-01-105-5756

Approved for public release; distribution is unlimited

TM 5-6675-318-14-2, 3 September 1985, is changed as follows:

1. Remove and insert pages as indicated below. New or changed text material is indicated by, a vertical bar in the margin. An illustration change is indicated by a miniature pointing hand.

Remove pages

Insert pages

D-1 and D-2

D-1 and D-2

2. Retain this sheet in front of manual for reference purposes.

By Order of the Secretary of the Army:

CARL E. VUONO
General, United States Army
Chief of Staff

Official:

WILLIAM J. MEEHAN, II
Brigadier General, United States Army
The Adjutant General

DISTRIBUTION:

To be distributed in accordance with DA Form 12-25A, Operator, Unit, Direct Support and General Support Maintenance Requirements for Topographic Support Set, Semitrailer Mounted, Survey Section (ADC-TSS-6).

CHANGE }
 No. 3 }

HEADQUARTERS
 DEPARTMENT OF THE ARMY
 WASHINGTON, D.C., 29 May 1987

Operator's Organizational, Direct Support and
 General Support Maintenance Manual

TOPOGRAPHIC SUPPORT SYSTEM
 SURVEY SECTION
 MODEL ADC-TSS-6
 NSN: 6675-01-105-5756

TM 5-6675-318-14-2, 3 September 1985, is changed as follows:

1. Remove and insert pages as indicated below. New or changed text material is indicated by a vertical bar in the margin. An illustration change is indicated by a miniature pointing hand.

| Remove pages | Insert pages |
|-------------------|-------------------|
| 4-1 and 4-2 | 4-1 and 4-2 |
| 4-7 and 4-8 | 4-7 and 4-8 |
| 4-43 and 4-44 | 4-43 and 4-44 |
| 4-71 and 4-72 | 4-71 and 4-72 |
| --- | 4-72.1/4-72.2 |
| 4-81 through 4-84 | 4-81 through 4-84 |
| 4-89 and 4-90 | 4-89 and 4-90 |
| 4-93 and 4-94 | 4-93 and 4-94 |
| 4-101 and 4-102 | 4-101 and 4-102 |
| 4-187 and 4-188 | 4-187 and 4-188 |
| 4-191 and 4-192 | 4-191 and 4-192 |
| C-11 and C-12 | C-11 and C-12 |

2. Retain this sheet in front of manual for reference purposes.

By Order of the Secretary of the Army:

JOHN A. WICKHAM, JR.
General, United States Army
Chief of Staff

Official:

R. L. DILWORTH
Brigadier General, United States Army
The Adjutant General

DISTRIBUTION:

To be distributed in accordance with DA Form 12-25A, Operator, Unit, Direct Support and General Support Maintenance requirements for Topographic Support Set, Semitrailer Mounted, Survey Section (ADC-TSS-6).

CHANGE }
NO. 2 }

HEADQUARTERS
DEPARTMENT OF THE ARMY
WASHINGTON, D.C., 24 October 1986

Operator's, Organizational, Direct Support and
General Support Maintenance Manual

TOPOGRAPHIC SUPPORT SYSTEM
SURVEY SECTION
MODEL ADC-TSS-6
NSN: 6675-01-105-5756

TM 5-6675-318-14-2, 3 September 1985, is changed as follows:

1. Remove and insert pages as indicated below. New or changed text material is indicated by a vertical bar in the margin. An illustration change is indicated by a miniature-pointing hand.

| Remove pages | Insert pages |
|-------------------|-------------------|
| 4-1 and 4-2 | 4-1 and 4-2 |
| 4-7 and 4-8 | 4-7 and 4-8 |
| 4-13 and 4-14 | 4-13 and 4-14 |
| 4-19 and 4-20 | 4-19 and 4-20 |
| 4-35 and 4-36 | 4-35 and 4-36 |
| 4-39 through 4-56 | 4-39 through 4-56 |
| 4-59 through 4-62 | 4-59 through 4-62 |
| 4-69 through 4-72 | 4-69 through 4-72 |
| 4-77 and 4-78 | 4-77 and 4-78 |
| 4-81 through 4-84 | 4-81 through 4-84 |
| 4-87 and 4-88 | 4-87 and 4-88 |
| --- | 4-88.1/4-88.2 |
| 4-89 and 4-90 | 4-89 and 4-90 |
| 4-93 through 4-96 | 4-93 through 4-96 |
| 4-101 and 4-102 | 4-101 and 4-102 |
| 4-105 and 4-106 | 4-105 and 4-106 |
| 4-187 and 4-188 | 4-187 and 4-188 |
| --- | 4-188.1/4-188.2 |
| 4-191 and 4-192 | 4-191 and 4-192 |
| 4-217 and 4-218 | 4-217 and 4-218 |
| A-1 and A-2 | A-1 and A-2 |

2. Retain this sheet in front of manual for reference purposes.

TM 5-6675-318-14-2
C 1

By Order of the Secretary of the Army:

JOHN A. WICKHAM, JR.
General, United States Army
Chief of Staff

Official:

R. L. DILWORTH
Brigadier General, United States Army
The Adjutant General

DISTRIBUTION:

To be distributed in accordance with DA Form 12-25A, Operator, Organizational, Direct Support and General Support Maintenance Requirements for Topographic Support Set, Semitrailer Mounted, Survey Section (ADC-TSS-6).

CHANGE }
NO. 1 }

HEADQUARTERS
DEPARTMENT OF THE ARMY
WASHINGTON, D.C., 13 June, 1986

Operator's, Organizational, Direct
Support and General Support
Maintenance Manual

TOPOGRAPHIC SUPPORT SYSTEM
SURVEY SECTION
MODEL ADC-TSS-6
NSN: 6675-01-105-5756

TM 5-6675-318-14-2, 3 September 1985, is changed as follows:

1. Remove and insert pages as indicated below. New or changed text material is indicated by a vertical bar in the margin. An illustration change is indicated by a miniature pointing hand.

| Remove pages | Insert pages |
|-----------------------|-----------------------|
| 8-13 and 8-14 | 8-13 and 8-14 |
| B-5 through B-11/B-12 | B-5 through B-11/B-12 |
| C-1 and C-2 | C-1 and C-2 |
| C-5 through C-14 | C-5 through C-14 |
| C-17 through C-22 | C-17 through C-22 |
| C-25 and C-26 | C-25 and C-26 |
| D-1 and D-2 | D-1 and D-2 |
| E-1 through E-10 | E-1 through E-10 |

2. Retain this sheet in front of manual for reference purposes.

By Order of the Secretary of the Army:

JOHN A. WICKHAM, JR.
General, United States Army
Chief of Staff

Official:

R. L. DILWORTH
Brigadier General, United States Army
The Adjutant General

DISTRIBUTION:

To be distributed in accordance with DA Form 12-25A, Operator, Organizational, Direct Support and General Support Maintenance requirements for Topographic Support Set, Semitrailer Mounted, Survey Section (ADC-TSS-6).

WARNING

HIGH VOLTAGE is used in this equipment. DEATH ON CONTACT or severe injury may result if personnel fail to observe safety precautions.

Do not be misled by the term LOW VOLTAGE. Low voltage can cause serious injury or death.

Test procedures requiring the operator or maintenance personnel to investigate equipment or restore casualties with interlocks disconnected or covers removed may result in DEATH ON CONTACT if personnel fail to observe safety precautions.

Voltages in switches and circuit breaker panels may result in DEATH ON CONTACT if personnel fail to observe safety precautions.

Failure to ground the section or equipment may result in DEATH ON CONTACT if personnel fail to observe safety procedures.

For Artificial Respiration refer to FM 21-11.

WARNING

Dry cleaning solvent, P-D-680, used to clean parts is potentially dangerous to personnel and property. Avoid repeated and prolonged skin contact. Wear solvent-impermeable gloves and eye/face protective equipment when using solvent. DO not use near open flame or excessive heat. Flash point of solvent is 100° F to 138° F (38° C to 59° C).

WARNING

Rotating and spinning equipment may snag loose clothing, hair or jewelry resulting in SEVERE PERSONNEL INJURY.

WARNING

Attempting to move overweight or top heavy equipment that is unsecured may result in SEVERE PERSONNEL INJURY. Always have sufficient personnel and equipment to accomplish the task.

INTRODUCTION

This manual is divided into two volumes:

Volume 1, TM 5-6675-318-14-1 consists of Chapters 1 through 3 and index

Volume 2, TM 5-6675-318-14-2 consists of Chapters 4 through 9, Appendixes A through E, Glossary and Index.

The Appendixes, and Glossary in Volume 2 are applicable to both volumes.

Operator's Organizational, Direct Support and
General Support Maintenance Manual

TOPOGRAPHIC SUPPORT SYSTEM
SURVEY SECTION
MODEL ADC-TSS-6
NSN: 6675-01-105-5756

REPORTING ERRORS AND RECOMMENDING IMPROVEMENTS

You can help improve this manual. If you find any mistake or if you know of away to improve the procedures, please let us know. Mail your letter, DA Form 2028 (Recommended Changes to Publications and Blank Forms), or DA Form 2028-2 located in the back of this manual direct to: Commander, U.S. Army Troop Support Command, ATTN: AMSTR-MCTS, 4300 Goodfellow Boulevard, St. Louis, MO 63120-1798. A reply will be furnished directly to you.

| | | |
|-------------|-----------------------------------------------|-------|
| CHAPTER 4 | SATELLITE SURVEYOR | 4-1 |
| Section I | Introduction. | 4-1 |
| Section II | Operating Instructions | 4-14 |
| Section III | Operator Maintenance | 4-184 |
| Section IV | Organizational Maintenance | 4-189 |
| Section V | Direct/General Support Maintenance | 4-190 |
| CHAPTER 5 | AUTOMATIC BATTERY CHARGER | 5-1 |
| Section I | Introduction. | 5-1 |
| Section II | Operating Instructions | 5-4 |
| Section III | Operator Maintenance | 5-9 |
| Section IV | Organizational Maintenance | 5-11 |
| Section V | Direct/General Support Maintenance | 5-12 |
| CHAPTER 6 | ULTRASONIC CLEANER | 6-1 |
| Section I | Introduction. | 6-1 |
| Section II | Operating Instructions | 6-3 |
| Section III | Operator Maintenance | 6-8 |
| Section IV | Organizational Maintenance | 6-9 |
| Section V | Direct/General Support Maintenance | 6-17 |
| CHAPTER 7 | TI-59 POCKET CALCULATOR AND PRINTER | 7-1 |
| Section I | Introduction. | 7-1 |
| Section II | Operating Instructions | 7-29 |
| Section III | Operator Maintenance | 7-60 |
| Section IV | Organizational Maintenance | 7-73 |
| Section V | Direct/General Support Maintenance | 7-73 |

| | | |
|--------------------|------------------------------------------------------------|------------|
| CHAPTER 8 | FURNITURE AND CABINETS | 8-1 |
| Section I | Introduction. | 8-1 |
| Section II | Operating Instructions | 8-4 |
| Section III | Operator Maintenance | 8-4 |
| Section IV | Organizational Maintenance | 8-5 |
| Section V | Direct/General Support Maintenance | 8-18 |
| CHAPTER 9 | SUPPORT ITEMS | 9-1 |
| Section I | Introduction. | 9-1 |
| Section II | Operating Instructions | 9-2 |
| Section III | Operator Maintenance | 9-50 |
| Section IV | Organizational Maintenance | 9-60 |
| Section V | Direct/General Support Maintenance | 9-63 |
| APPENDIX A | REFERENCES | A-1 |
| APPENDIX B | MAINTENANCE ALLOCATION CHART | B-1 |
| APPENDIX C | COMPONENTS OF END ITEM AND BASIC ISSUE ITEMS LIST. | C-1 |
| APPENDIX D | ADDITIONAL AUTHORIZATION LIST | D-1 |
| APPENDIX E | EXPENDABLE SUPPLIES AND MATERIALS LIST. | E-1 |
| GLOSSARY | | GLOSSARY-1 |
| INDEX | | INDEX-1 |

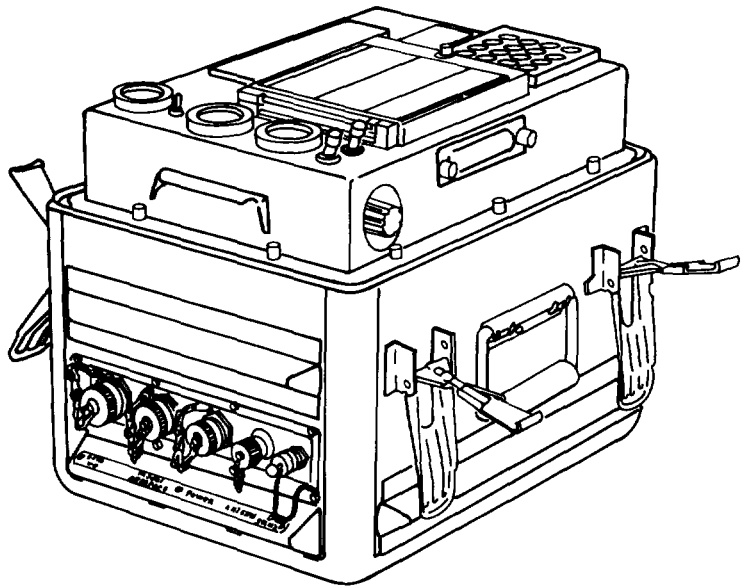
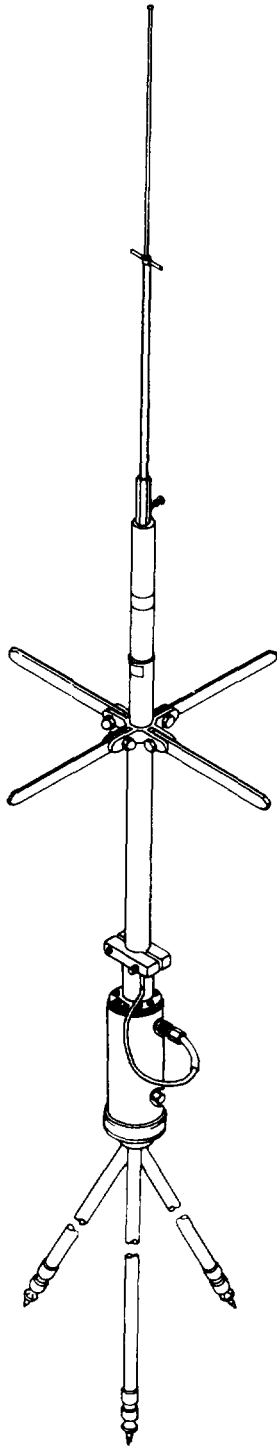

CHAPTER 4
SATELLITE SURVEYOR

Section I INTRODUCTION

4-1. GENERAL INFORMATION.

4-1.1 Scope.

a. Model Number and Equipment Name. Model MX 1502 Real Time Translocation Satellite Surveyor.

b. Purpose of Equipment. To determine 2D and 3D point positioning using the transit satellite system.

4-1.2 Reference Information.

Satellite Records Manual - Doppler Geodetic Point Positioning, DMA TM T-3-52320

Universal Transverse Mercator Grid U.S. Army Technical Manual, TM 5-241-8

Grids and Grid References U.S. Army Technical Manual, TM 5-241-1

Surveying Computers Manual, TM 5-237

Geodetic and Topographic Surveying, TM 5-441

4-1.3 List of abbreviations.

| | |
|------|---------------------------------------------|
| ANSI | American National Standards Institute |
| ECMA | European Computer Manufacturers Association |
| GMT | Greenwich Mean Time |
| I/O | Input/Output |
| ISO | International Organization of Standards |
| MSL | Mean Sea Level |
| RAM | Random Access Memory |
| RMS | Root Mean Square |
| ROM | Read Only Memory |

| | |
|--------|-------------------------------|
| SEP | Spherical Error Probable |
| UTM | Universal Transverse Mercator |
| WGS-72 | World Geodetic System of 1972 |

4-1.4 Glossary.

| | |
|-----------------------------------------------------------|-----------------------------------------------------------------------------------------------------------------------------------------------------------------------------------------------------------------------------------------------------------------------------------------------------------------------------------------------------------|
| 2D | A two dimensional position computation for latitude and longitude. |
| AD | A three dimensional position computation for latitude, longitude, and height in meters (above MSL). |
| Alert Data | Data describing orbits of transit satellites with respect to time as broadcast by satellites. |
| Control Mode | Mode of operation used to collect satellite data in real time, compute 2D fixes, 3D fixes, and transmit data over a communications link for translocation at remote MX 1502 RT. |
| Control Site | Satellite surveyor positioned at known site. |
| Diplexing. | Simultaneous reception of two radio signals. |
| Earth Fixed Rectangular Coordinates (Cartesian) | System of space rectangular coordinates with axes x, y, and z having their origin at the center of the spheroid. The center of the spheroid coincides with the center mass of the earth. The z-axis is parallel to the mean axis of earth rotation and is positive to north. The x-axis is parallel to both the mean equatorial and prime meridian planes |

Earth Fixed Rectangular Coordinates - Cont

toward the meridian of Greenwich. The y-axis is parallel to the mean equatorial plane, perpendicular to the plane of the prime meridian, and is positive toward India.

| | | | |
|-------------------|-----------|-----------|----------------------------------------------------------------------------------------------------------------------------------------------------------------------------------------------|
| Ephemeris. | | | Formatted statement of precise orbit position for satellite for regular intervals. |
| Geodetic Datum | | | Mathematical point on earth which coincides with MSL and perpendicular to force of gravity. |
| Geodetic Height | | | Algebraic sum of geoid height and elevation. |
| Heterodyning | | | Combining of two different frequencies to produce an intermediate frequency. |
| Iteration. | | | Repetition. |
| Off-Line Mode | | | Mode of operation used to process tape cassette data. Satellite receiver is disconnected. |
| Point Positioning | | | Independent reduction of observations made by a particular station under the assumption that ephemerides of all observed satellite passes are precisely known. |
| Propagate | | | The traveling of electromagnetic waves along a transmission path. |
| Remote Mode. | | | Mode of operation used to collect satellite data in real time, together with data (via communications link) from another MX 1502 RT, and compute 2D, point position and translocation fixes. |

| | |
|------------------------------------|-------------------------------------------------------------------------------------------------------------------------------------------------------------------------------|
| Remote Site | Satellite surveyor which occupies site whose position is unknown. |
| Root Mean Square (RMS). | The square root of the average of the square of the values of a periodic quantity taken throughout one complete cycle. |
| Spherical Error Probable | .The probability that the distribution of a series of three dimensional measurements will be such that 50% of those measurements will fall inside a sphere of defined radius. |
| Standard Mode. | Mode of operation used to collect satellite data in real time and compute 2D and point position fixes. |
| Translocation. | Method of using simultaneous data from separate stations to determine relative position of one station with respect to a known station. |

4-2. EQUIPMENT DESCRIPTION.

4-2.1 Equipment Characteristics, Capabilities, and Features.

a. Characteristics. Automatically collects and processes data from transit satellites to obtain single, high-precision, 2D and 3D point positions. Computes translocation fixes from tape cassette data that was recorded at two sites or using external communications link between two satellite surveyors. Translocation accuracy is within 1 m (3.28 ft) SEP with 17 acceptable satellite passes.

b. Capabilities and Features.

- (1) Portable.
- (2) Automatic power management.
- (3) Computes satellite rise times and schedules data taking.
- (4) Automatic self-test with display of faulty circuit board.
- (5) Audio alarm for trouble, end of cassette, and loss of power.
- (6) Performs datum conversions.

- (7) Verifies field data is properly recorded on tape cassette.
- (8) Collects and records satellite data.
- (9) On one satellite pass, 2D accuracy within 37 m (121.36 ft).
- (10) Fifteen acceptable satellite passes, 3D accuracy within 10 m (32.8 ft).
- (11) Computes translocation fixes to an accuracy within 1 m (3.28 ft) SEP with 17 acceptable satellite passes.
- (12) Will transmit real time translocation data from a control unit to a remote unit via a communication link.
- (13) Waterproof and buoyant with cover installed.
- (14) Weatherproof without cover.

4-2.2 Location and Description of Major Components.

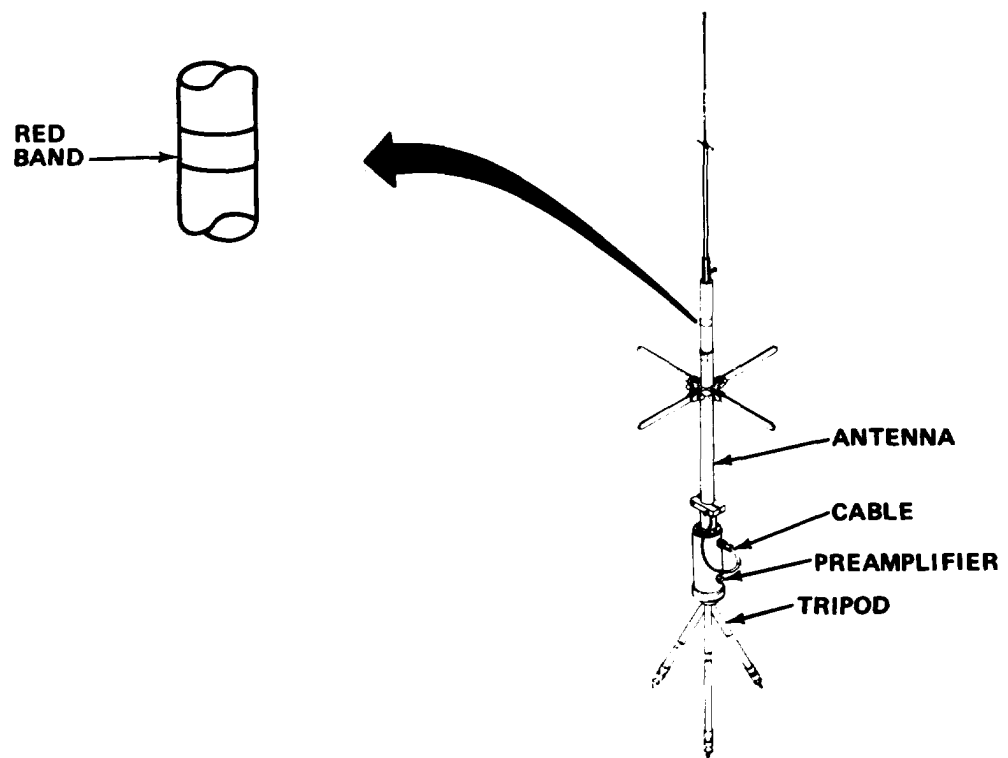

a. Antenna/Preamplifier. The antenna/preamplifier consists of antenna, pre-amplifier, tripod, and cable. The cable transmits satellite signals to the receiver and power to the preamplifier. The red band on the antenna marks the antenna electrical center.

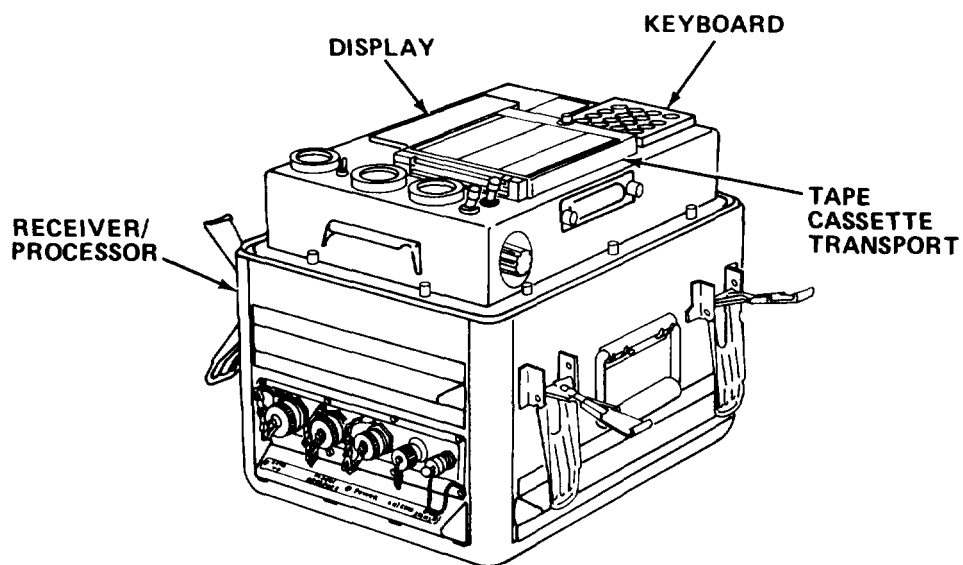

b. Receiver/Processor. The receiver/processor contains receiver, microprocessor, modem, tape cassette transport, display, keyboard, and control electronics. The control electronics converts satellite signals to data information for display and printer.

4-2.3 Equipment Data.

Weight and Dimensions

Receiver/Processor

| | |
|--------|------------------|
| Width | 0.45 m (1.48 ft) |
| Depth | 0.34 m (1.12 ft) |
| Height | 0.35 m (1.15 ft) |
| Weight | 19 kg (41.89 lb) |

Antenna/Preamplifier

| | |
|--------|------------------|
| Width | 0.58 m (1.9 ft) |
| Depth | 0.21 m (0.69 ft) |
| Height | 0.23 m (0.75 ft) |
| Weight | 7.7 kg (17 lbs) |

| | |
|---------------------------------------------|--------------------------------------------------------------|
| Power Requirements | Internal, 12 Vdc, 5.0 amp hour battery with charging circuit |
| | External, 10.5-16.0 V dc, internally regulated |
| Current Draw | |
| Average | 1.0 amp |
| Standby | 0.41 amp |
| Tracking (Display off) | 2.75 amps |
| Peak | 4.0 amps |
| Power Consumption at 25°C (77°F) | |
| Average | 12 W |
| Standby | 5 W |
| Temperature Limitations, Receiver/Processor | |
| Operating | -25°C to 55°C (-13° F to 131° F) |
| Storage | -55°C to 100°C (-67°F to 212° F) |
| Antenna | -60°C to 85°C (-76° F to 188°F) |
| Humidity - Operating and Storage | Up to 100% from 0°C to 55°C (32°F to 131°F) |
| Altitude | |
| Operating | 4600 m (Up to 15,000 ft) |
| Storage/Transporting | 15,240 m (Up to 50,000 ft) |
| External 5 MHz Reference | Rubidium or Cesium standard with 1 V rms output |
| Tape Cassette Transport | |
| Recording Technique | Biphase Level (fully ANSI/ECMA/ISO compatible) |
| Read/Write Speed | 25.4 cm/s (10 in./s) |
| Rewind Speed | 152.4 cm/s (60 in./s) |

Power Consumption

Standby 3.25 W

Running 9.75 W

Current Draw

Standby 0.27 amps

Running 0.81 amps

Accessory Equipment

| Item | Quantity |
|--------------------------|----------|
| Antenna Cable | 2 ea |
| Battery Power Cord | 1 ea |
| Connector (UG-29B) | 1 ea |
| Lacing Cord | 80 ft |
| Cable Ties | 6 ea |
| Nails | 3 ea |
| Tape Cassettes (DC-30HL) | 10 ea |
| Fuse (AGC-1) | 5 ea |
| Fuse (AGC-6) | 5 ea |
| Plumb Bob | 1 ea |
| Tripod Adaptor | 1 ea |

User-Supplied Equipment per Satellite Surveyor

| Item | Quantity |
|----------------------------------------------------------|----------|
| Standard T-2 Tripod | 1 ea |
| Deep-Cycle Storage Battery 12 V (120 amp hr. minimum) | 1 ea |
| Input/Output 15-Pin Cable | 1 ea |
| Input/Output 16-Pin Cable | 1 ea |
| Alphanumeric Printer | 1 ea |
| AN/GRC - 106 | 1 ea |

4-3. TECHNICAL PRINCIPLES OF OPERATION.

4-3.1 General. The MX 1502 tracks the 150 and 400 MHz, phase-modulated signals radiated by orbiting satellites of the TRANSIT satellite system. The frequencies transmitted are doppler shifted and contain satellite data. The use of two frequencies is to minimize the effects of ionospheric interference with the doppler shift. When both frequencies are received by the MX 1502, the computer programming will compensate for ionospheric effects using doppler shift. Using the doppler shift and satellite position data the MX 1502 calculates the position of the antenna reference point. The use of two frequencies sharply increases position fixing accuracy. Following the first usable satellite pass at each new site the MX 1502 can display a 2D position with precision that is accurate enough to verify that the location is, in fact, that of the desired site. After three or four acceptable satellite passes, the MX 1502 will have acquired enough data to display a 3D point position. Quality indices may also be displayed to determine if sufficient data has been collected in relation to the survey accuracy requirements. The 3D position is a cumulation of all acceptable satellite passes for the site. During a satellite pass, all data collected is stored in memory until the pass is completed. A 2D and 3D position is then computed and stored in memory and on magnetic tape cassette. The tape cassette can then be used for post-processing of the site position or for translocation processing. Real time translocation processing can also be computed if an external communications link is utilized from a known site to a remote, unknown site. Positions calculated by the MX 1502 are in satellite datum. The reference ellipsoid used is the same as WGS-72 datum. Automatic conversion to local datum, XYZ (Cartesian), and universal transverse mercator (UTM) can be accomplished by entering datum shift constants and commanding display of the datum shifted coordinates.

The transit satellite system was developed by the U.S. Government to support the U.S. Navy submarine force for the inertial navigation equipment aboard polaris submarines and became operational in January, 1964. The satellites circle the earth in 107 minute polar orbits at an altitude of approximately 1000 kilometers. These orbits are wide at the equator and converge at the poles. Although the orbits are from pole-to-pole, the satellites do not rotate with the earth. If the orbits could be traced out, they would suggest a spherical bird cage inside of which the earth rotates on its axis. Every point of the earth will thus pass under each orbit approximately twice a day. With five operational satellites, this will provide an acceptable satellite every 35 to 100 minutes. The transit satellite system is managed and monitored by the Naval Astronomical Group based at Point Mugu, California, with two additional tracking stations located in Hawaii and Minnesota. Data in each satellite is updated on a daily basis by the controlling authority.

a. Each satellite continuously transmits a message that lasts exactly two minutes beginning and ending at each even minute. Because this message is precisely controlled, it serves as an accurate even minute mark. The satellite message contains several different segments. The segments used by the MX 1502 are:

Satellite position

Julian date

Universal time (GMT)

Doppler cycles (23 seconds long)

b. The satellite message is interpolated by the MX 1502 to define accurately the satellite's position. To obtain a position fix, the MX 1502 measures its position relative to the known position of the satellite. This is done by counting the number of doppler cycles between each time mark. A doppler count between two time marks provides the change in range between the MX 1502 and satellite over the time interval. The doppler data from the two channels is combined to provide accurate slant ranges to the satellite. Position fix is calculated by comparing the range changes which occurred between the estimated position of the MX 1502 and the known position of the satellite as measured by the doppler counts. The MX 1502 then adjusts its internal position until the calculated range changes best match those measured by the doppler counts. A minimum of three parameters are determined in the position fix computation. These parameters are latitude, longitude and doppler frequency. After the input data has been stored in the computer memory, the MX 1502 performs 10 steps to compute a position fix. The ten steps are:

Check satellite message for new message injection.

Majority vote redundant message data.

Correct doppler data for refraction.

Compute satellite positions.

Estimate receiver position.

Calculate satellite-to-receiver ranges at the beginning and end of each doppler count period differences derived.

Compare measured range from doppler counts with calculated range differences.

Adjust estimate of receiver position until calculated and measured range differences agree.

Calculate receiver position.

Record calculated position fix on cassette tape.

c. If a new message is injected into the satellite memory while the MX 1502 is receiving the satellite signals, two different descriptions of the same orbit will be obtained. Only one description can be used. Therefore, the MX 1502 must check for an injection and eliminate unwanted data. The check is performed by a bit-by-bit majority vote among the received satellite messages. This step eliminates errors which may have occurred during receipt of the satellite message. The majority-voted message is used to calculate earth-fixed Cartesian coordinates for the satellite at the beginning and end point of each doppler count collected during the pass. The doppler data from the two channels is combined to provide refraction-corrected doppler information.

d. A set of Cartesian coordinates is calculated representing the estimated MX 1502 position at the beginning and end of each doppler count. The range from the satellite to the estimated MX 1502 position at each time mark is calculated. The doppler counts are measures of the actual changes in range between satellite and MX 1502 over the doppler counting interval. The measured range differences derived from the doppler counts are compared with the corresponding calculated range differences.

e. By computing derivatives with respect to latitude and longitude, the MX 1502 determines how far its estimated position should be moved to minimize the least squares differences between the measured and the calculated range differences. These calculations are repeated two or three times until the solution converges.

f. There are two methods for determining a three dimensional point position. They are point positioning and translocation. Point positioning is accurate to within 5 meters rms and translocation is accurate to within 1 meter rms. Both methods can be utilized in either real time or off-line mode.

g. Point positioning is a cumulation of satellite data from 10 to 50 satellite passes collected by a single MX 1502. In the real time mode, 3D point position information can be retrieved after each acceptable satellite pass. In the off-line mode, collected satellite data that has been recorded can be post-processed to derive the 3D point position.

h. Translocation uses data collected from two MX 1502's located at separate stations tracking the same satellite simultaneously. Translocation can be used in either the off-line or the real time mode. This method determines the relative position of a remote site with respect to the control site.

4-3.2 Detailed.

a. The antenna/preamplifier is a dual-frequency tuned monopole antenna designed to receive 150 MHz and 400 MHz radio signals. The preamplifier provides gain at the antenna to maintain system sensitivity. The received frequencies are amplified in narrow bandwidth receivers to filter out unwanted VHF and UHF frequencies. The power for the preamplifier is supplied through the coaxial cable by the receiver/processor and is -10 V. During a self-test, the power to the preamplifier is turned off.

b. The 6/8 board is a dual-channel satellite receiver board. It has a passive diplexer to separate the 400 MHz and 150 MHz signals which are then sent to the receiver section where the doppler and message data are developed. These signals are then processed to produce four outputs to be sent to the processor board. The four outputs are doppler count, data, signal value, and phase error.

The dual-channel satellite receiver board develops 150 and 400 MHz signals to be used in self-test. The board has two voltages supplied from the power supply +5 V and -10 V. The +5 V for use on the board and -10 V for the preamplifier. The -10 V that is applied to the preamplifier is turned off during self-test to prevent outside interfering signals.

c. The processor board 4 is the central operating control for the MX 1502 and contains the Z80 microprocessor, RAM, timing circuits, flag and interrupt logic, address decoders, and I/O buffers. The processor board receives data from the dual-channel satellite receiver board, data entry board, tape controller board, modem board, alarm clock board, and memory board. The data is stored in the RAM and is processed by the processor board. The results of the processing are supplied to various boards. In power-save operation, the alarm clock board activates the processor. The processor can also be activated by the operator via the keypad. Two switches on the board select the battery backup protection and memory configuration.

d. The NORM/PROTECT switch is for battery backup protection. The NORM position battery backup is provided to the entire MX 1502 and is short-term. The PROTECT position battery backup is provided for memory protection only and is long term. The EXT/INT switch selects the memory configuration. The EXT position enables the use of memory chips installed on the memory board. The INT position enables the use of memory chips installed on the memory/processor board. The normal operating condition of the switches will be NORM/PROTECT switch in the NORM position and the INT/EXT switch in the EXT position.

e. Memory board (3) contains a 52K Read Only Memory (ROM or PROM) and a 6K Random Access Memory (RAM). The PROM holds the program required by the processor. Program data is read into the processor when needed. The RAM is used by the processor for data storage. An arithmetic processor chip to speed up the numerical calculations is also contained on this board.

f. Alarm clock board (D) controls the satellite surveyor during power-save operations. When in power-save, the alarm clock board maintains two clocks. A time of day clock and a time remaining clock. The time of day clock maintains real time and the time-remaining clock counts down to full power-up condition. When the processor has determined the time of the next satellite pass, the time remaining clock is loaded with the time. It then powers down all components except the alarm clock board and the reference oscillator. When the time remaining clock reaches zero, all components necessary to process a satellite pass are turned on.

g. Power to the keyboard is supplied by the alarm clock board to enable the operator to activate the satellite surveyor to full power by pressing the clear key (c). The alarm clock board also controls power for overtemperature, lost power, and other circuits depending on the settings of the front panel switches. The audio alarm logic is also on this board.

h. Data entry and display board (a) has three functions - to process input commands from the keyboard, to transfer data to the display, and to be an input/output device for RS-232 data. When a key is pressed on the keyboard, a signal is sent to an encoder on the data entry and display board and then stored in a buffer until the processor acknowledges a flag. The data entry logic is then transferred to the processor. Output data is stored in buffer on the data entry and display board and gated to a RAM to provide proper driver signals to the display output control and timing circuits. The driver signals sent to the display register and buffers on the front panel display card are formatted and level shifted to drive the alphanumeric fluorescent display.

The data entry and display board is also the interface between the printer and processor. It receives data from the printer in serial RS-232 format and converts the data to 8-bit parallel for transfer to the processor. It receives 8-bit parallel data from the processor and converts the data to serial RS-232 data for transfer to the printer. The communication interface to the printer is normally configured at the factory for a 20-mA active current loop. To convert the interface to a 20-mA passive current loop, the printed circuit etch between E-points E9 and E10 must be cut.

i. Modem board (b) allows the satellite surveyor to communicate with another satellite surveyor via an external communications link connected to the MODEM INTERFACE I/O connector. Signal format and message rate are serialized digital data at 125 baud. The board encodes and decodes the digital data, employing phase modulation, and communicates with the Z80 microprocessor on the processor board via a bidirectional data bus. The board also incorporates a relay contact output for keying a radio transmitter.

j. Tape control board (c) is the interface between the processor and the tape cassette transport. Tape speed is regulated by the tape control board to read or write data at 8000 bits per second. Tape status bits are detected and passed to the processor by this board. The tape control board provides timing, buffering, and serial-to-parallel, and parallel-to-serial conversions in both read and write modes. As data is written on and read back from the tape cassette, a redundancy check is performed to provide a unique value for each tape record. This value is checked with the calculated value. If the values do not compare, an error is generated. Power-on signals from the alarm clock board apply power to the tape control board through two relays when in full power operation.

k. The 5 MHz reference oscillator provides a very stable reference frequency for use throughout the receiver/processor. An external 5 MHz may be connected to the receiver/processor and can be selected for use by the INT/EXT oscillator switch inside the satellite surveyor. The accuracy of the internal oscillator is 8×10^{-12} over a 100 second interval.

l. The power supply board has an input of 10.5 to 16 v dc from an external source and generates all voltages necessary to operate the satellite surveyor through two independent regulator circuits. One regulator supplies power in the reduced power mode to only the alarm clock board, oscillator, and battery charger. The second regulator is controlled by the alarm clock board and provides operating voltages to all other circuits while in full power operation. The battery charging circuits fast charge and maintain a constant voltage on the internal batteries.

m. The internal batteries are rechargeable 12 V dc lead acid batteries. The batteries supply power to the alarm clock board, oscillator, and memory when the external power supply is disconnected, the ON/OFF switch is in the ON position, and the STANDBY/OPERATE switch is in the STANDBY position while the satellite surveyor is being transported from site to site. The internal batteries will supply power for approximately 20 hours.

Section II OPERATING INSTRUCTIONS

4-4. DESCRIPTION AND USE OF OPERATOR'S CONTROLS AND INDICATORS.

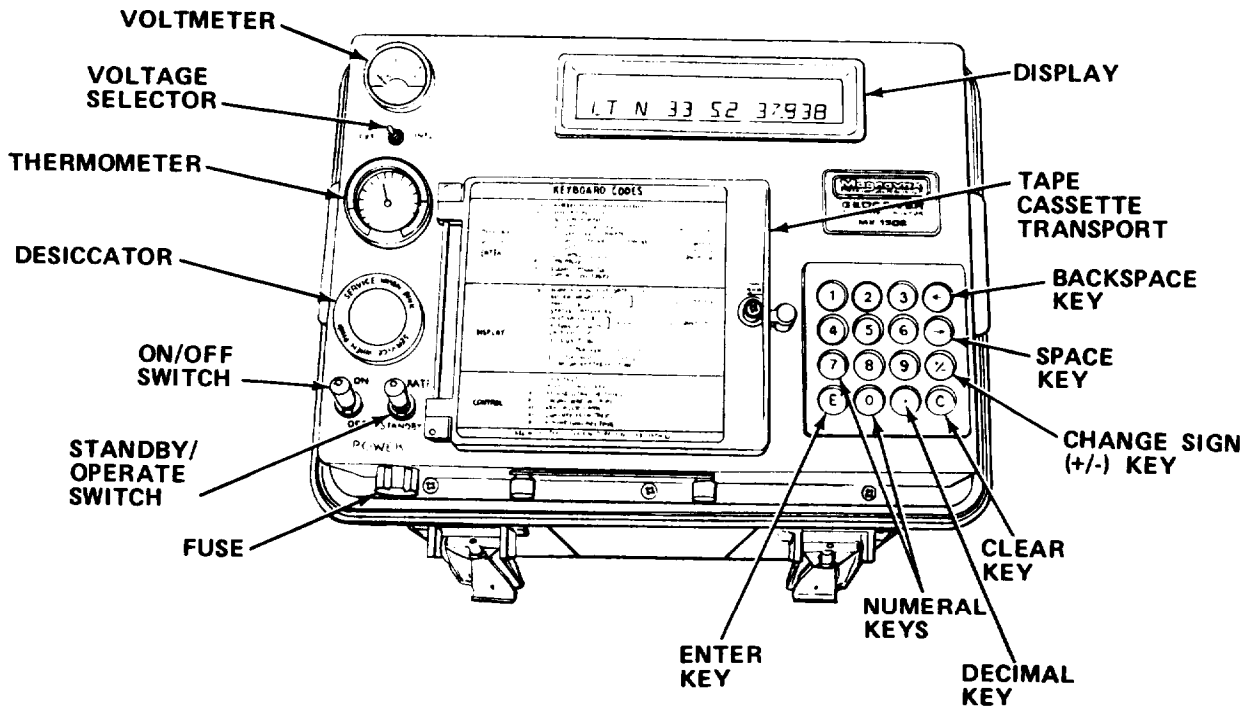

| Control or Indicator | Function |
|----------------------|------------------------------------------------------------------------------|
| Voltmeter | Indicates internal or external voltage. |
| Voltage Selector | Connects internal or external battery to voltmeter. |
| Thermometer | Indicates internal temperature in °C. |
| Desiccator | Contains desiccant that absorbs and indicates presence of internal moisture. |
| ON/OFF Switch | Applies power to system. |

| Control or Indicator | Function |
|-------------------------|----------------------------------------------------------------------------------------------------------------------------------------|
| STANDBY/OPERATE Switch | Connects and disconnects power to operating circuits. Applies power to timing circuits and memory in STANDBY when ON/OFF switch is ON. |
| Fuse | Protects system from current overload. |
| Enter (E) Key | Enters code or data. |
| Numeral Keys | For entry codes and data, 0 thru 9. |
| Decimal Key | Used to enter decimal points. |
| Clear (C) Key | Clears entry and selects code entry display. |
| Change Sign (+/-) Key | Changes entry sign from + to - , coordinates from north to south, east to west or changes modes. |
| Space Key (→) | Enters space in data entries. |
| Backspace Key (←) | Deletes incorrect entries. |
| Audible Alarm | Sounds to alert user of significant event. |
| Tape Cassette Transport | Records and plays back data. |
| Display | Indicates 16-character alphanumerics. |

4-5. OPERATOR PREVENTIVE MAINTENANCE CHECKS AND SERVICES.

- a. Before You Operate. Always keep in mind the WARNINGS and CAUTIONS. Perform your before (B) PMCS.
- b. While You Operate. Always keep in mind the WARNINGS and CAUTIONS. Perform your during (D) PMCS.
- c. After You Operate. Be sure to perform your after (A) PMCS.
- d. If Your Equipment Fails to Operate. Troubleshoot with proper equipment. Report any deficiencies using the proper forms. See DA Pam 738-750.

4-5.1 PMCS Procedures.

- a. PMCS are designed to keep the equipment in good working condition by performing periodic service tasks.
- b. Service intervals provide you, the operator, with time schedules that determine when to perform specified service tasks.
- c. The "Equipment is Not Ready/Available If" column is used for identification of conditions that make the equipment not ready/available for readiness reporting purposes or denies use of the equipment until corrective maintenance is performed.
- d. If your equipment fails to operate after PMCS is performed, immediately report this condition to your supervisor.
- e. Perform weekly as well as before operation if you are the assigned operator and have not operated the item since the last weekly or if you are operating the item for the first time.
- f. Item number column. Item numbers are assigned in chronological ascending sequence regardless of interval designation. These numbers are used for your "TM Number" column on DA Form 2404, Equipment Inspection and Maintenance Worksheet in recording results of PMCS.
- g. Interval columns. This column determines the time period designated to perform your PMCS.
- h. Item to be inspected and procedures column. This column lists functional groups and their respective assemblies and subassemblies as shown in the Maintenance Allocation Chart (Appendix B). The appropriate check or service procedure follows the specific item to be inspected.
- i. Equipment is not ready/available if: column. This column indicates the reason or cause why your equipment is not ready/available to perform its primary function.

j. List of tools and materials required for PMCS is as follows:

| <u>Item</u> | <u>Quantity</u> |
|--------------------------------------------------------------|-----------------|
| Deep Cycle Storage Battery 12 V dc | 1 ea |
| Cotton Swabs (Item 6, Appendix E) | ar |
| Isopropyl Alcohol (Item 3, Appendix E) | ar |
| Cheesecloth (Item 5, Appendix E) | ar |
| Liquid Detergent (Item 9, Appendix E) | ar |
| Battery Carrier Strap | 1 ea |
| DSCC Bead Desiccant, Indicating Type (Item 8, Appendix E) | ar |
| Bag Desiccant (Item 7, Appendix E) | ar |
| Adjustable Wrench | 1 ea |
| Desiccator Packing | 1 ea |
| Desiccator Gasket | 1 ea |

Table 4-1. OPERATOR PREVENTIVE MAINTENANCE CHECKS AND SERVICES

NOTE

If the equipment must be kept in continuous operation, check and service only those items that can safely be checked and serviced without disturbing operation. Make the complete checks and services when the equipment can be shut down.

B - Before
D - During
A - After

W - Weekly
M - Monthly
Q - Quarterly

AN - Annually
S - Semiannually
BI - Biennially

(Number) - Hundreds of Hours

| ITEM NO. | INTERVAL | ITEM TO BE INSPECTED PROCEDURE | For Readiness Reporting, Equipment Is Not Ready/ Available If: |
|----------|----------|---------------------------------------------------------------------------------------------------------------------------------------------------------------------------------------------------------------------------------------------------------------------------------------------------------------------------------------------------------------------------------------------------------------------------------------------------------------------------------------------------------------------------------------------------------------------------------------------------------|----------------------------------------------------------------|
| 1 | B | <p>SATELLITE SURVEYOR</p> <p>Inspect.</p> <div data-bbox="479 903 1088 1396" style="text-align: center;"> <p>The diagram shows a rectangular, ruggedized antenna case. It has a handle on top and four latches on the front. A small circular breather valve is located on the front panel. Arrows point from the labels 'ANTENNA CASE' and 'BREATHER VALVE' to their respective parts on the case.</p> </div> <ol style="list-style-type: none"> 1. Press breather valve to equalize pressure in antenna case. 2. Loosen four release latches on case and remove cover. | |

Table 4-1. OPERATOR PREVENTIVE MAINTENANCE CHECKS AND SERVICES - Cont

B - Before W - Weekly AN - Annually (Number) - Hundreds of Hours
 D - During M - Monthly S - Semiannually
 A - After Q - Quarterly BI - Biennially

| ITEM NO. | INTERVAL | ITEM TO BE INSPECTED PROCEDURE | For Readiness Reporting, Equipment Is Not Ready/ Available If: |
|----------|----------|------------------------------------------------------------------------------------------------------------------------------------------------------------------------------------------------------------------------------------------------------------------------------------------------------------------------------------------------------------------------------------------------------------------|----------------------------------------------------------------|
| 1 | B | <p>SATELLITE SURVEYOR - Cont</p> <p><u>Inspect - Cont</u></p> <div data-bbox="535 693 1120 1176" data-label="Image"> </div> <ol style="list-style-type: none"> 3. Remove styrofoam from antenna case and set aside. 4. Inspect antenna cables for loose or missing connectors and cracked or worn insulation. 5. Coil antenna cable ensuring that it is free from kinks. | <p>Connectors are missing. Insulation is defective.</p> |

Table 4-1. OPERATOR PREVENTIVE MAINTENANCE CHECKS AND SERVICES - Cont

B - Before
D - During
A - After

W - Weekly
M - Monthly
Q - Quarterly

AN - Annually
S - Semiannually
BI - Biennially

(Number) - Hundreds of Hours

| ITEM NO. | INTERVAL | ITEM TO BE INSPECTED | PROCEDURE | For Readiness Reporting, Equipment Is Not Ready/ Available If: |
|----------|----------|---------------------------|----------------|----------------------------------------------------------------|
| 1 | B | SATELLITE SURVEYOR - Cont | Inspect - Cont | |

The diagram shows an exploded view of the satellite surveyor's components. On the left, the antenna assembly is shown with labels for ANTENNA, TRIPOD, and PREAMPLIFIER. To the right, the ANTENNA CASE and STYROFOAM are shown. Below these, various accessories are detailed: ANTENNA CABLES, CABLE TIES, TRIPOD ADAPTER PLATE, PLUMB BOB, CASSETTES, SPARE FUSES, RF CONNECTOR, POWER CORD, NAIL CAPS, and NAILS. A hand icon points towards the antenna assembly.

Table 4-1. OPERATOR PREVENTIVE MAINTENANCE CHECKS AND SERVICES - Cont

B - Before
D - During
A - After

W - Weekly
M - Monthly
Q - Quarterly

AN - Annually
S - Semiannually
BI - Biennially

(Number) - Hundreds of Hours

| ITEM NO. | INTERVAL | ITEM TO BE INSPECTED PROCEDURE | For Readiness Reporting, Equipment Is Not Ready/ Available If: |
|----------|----------|-------------------------------------------------------------------------------------------------------------------------------------------------------------------------------------------------------------------------------------------------------------------------------------------------------------------------------------------------------------------------------------------------------------------------------------------------------------------------------------------------------------------------------------------------------------------------------------------------------------------------------------------------------------------------------------------------------------------------------------------------------------------------------------------------------------------------------------------------------------------------------------------------------------------------------------------------------------------------------------------------------------------------------------------------------------------------------------------|---------------------------------------------------------------------------------------------------------------------------------------------------------------------------------------------------------------------------|
| 1 | B | <p><u>SATELLITE SURVEYOR - Cont</u></p> <p><u>Inspect - Cont</u></p> <p>6. Inspect power cord for kinks, cracks, worn or frayed insulation, missing or cracked power plug and missing or cracked battery clamps.</p> <p>7. Inspect tripod adapter plate for damage or stripped threads. Repair or replace as required.</p> <p>8. Inspect for presence of plumb bob component parts.</p> <p>9. Check that there are at least ten cassette tapes: six in case and four in styrofoam.</p> <p>10. Check for the presence of six cable ties.</p> <p>11. Check for the presence of lacing cord, fuses, and RF connector in styrofoam top.</p> <p>12. Check for the presence of three nails and caps in styrofoam top.</p> <p>13. Separate styrofoam and remove antenna, preamplifier, and tripod.</p> <p>14. Inspect each section of antenna for dirt and corrosion, and clean as required.</p> <p>15. Inspect antenna base section for ground plane free movement, missing parts, frayed or defective cable.</p> <p>16. Inspect preamplifier for corrosion, dirt, or missing parts.</p> | <p>Power cord is defective.</p> <p>There are no cassette tapes.</p> <p>Antenna or preamplifier is missing.</p> <p>Antenna corroded.</p> <p>There is any defect or missing part.</p> <p>Parts are corroded or missing.</p> |

Table 4-1. OPERATOR PREVENTIVE MAINTENANCE CHECKS AND SERVICES - Cont

B - Before
D - During
A - After

W - Weekly
M - Monthly
Q - Quarterly

AN - Annually
S - Semiannually
BI - Biennially

(Number) - Hundreds of Hours

| ITEM NO. | INTERVAL | ITEM TO BE INSPECTED PROCEDURE | For Readiness Reporting, Equipment Is Not Ready/ Available If: |
|----------|----------|---------------------------------------|----------------------------------------------------------------|
|----------|----------|---------------------------------------|----------------------------------------------------------------|

SATELLITE SURVEYOR - Cont

1

B

Inspect - Cont

17. Inspect tripod for debris and dirt around connector.

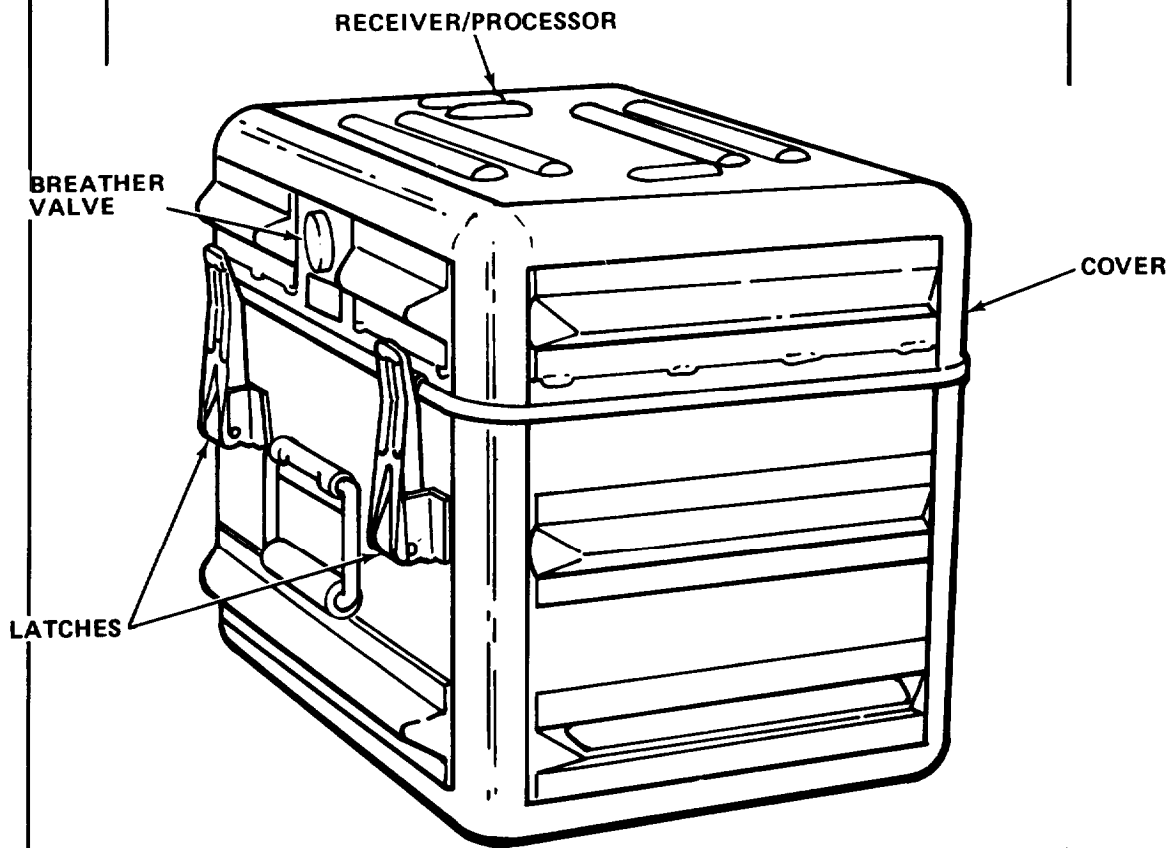

18. Place receiver/processor in convenient location. Then press breather valve to equalize pressure.

19. Open four latches and remove cover.

Table 4-1. OPERATOR PREVENTIVE MAINTENANCE CHECKS AND SERVICES - Cont

B - Before
D - During
A - After

W - Weekly
M - Monthly
Q - Quarterly

AN - Annually
S - Semiannually
BI - Biennially

(Number) - Hundreds of Hours

| ITEM NO. | INTERVAL | ITEM TO BE INSPECTED PROCEDURE | For Readiness Reporting, Equipment is Not Ready/ Available If: |
|----------------------------------|----------|---------------------------------------------------------------------------------------------------------------------------------------------------------------------------------------------------------------------------------------------------------------------------------------------------------------------------------------------------------------------------------------------------------------------------------------------------------------------------------------------------|----------------------------------------------------------------------------------------------------------------------------------------------|
| SATELLITE SURVEYOR - Cont | | | |
| 1 | B | <p data-bbox="363 533 586 562">Inspect - Cont</p>  <p data-bbox="342 1415 1166 1730"> 20. Check that desiccant is blue and has not turned pink. 21. Inspect voltmeter, thermometer, display, and moisture indicator face plates for defects. 22. Check for the presence of all connector covers. Report if missing. </p> | <p data-bbox="1305 1415 1446 1482">Desiccant is pink.</p> <p data-bbox="1305 1514 1479 1640">Indicators or lenses are cracked or broken.</p> |

Table 4-1. OPERATOR PREVENTIVE MAINTENANCE CHECKS AND SERVICES - Cont

B - Before
D - During
A - After

W - Weekly
M - Monthly
Q - Quarterly

AN - Annually
S - Semiannually
BI - Biennially

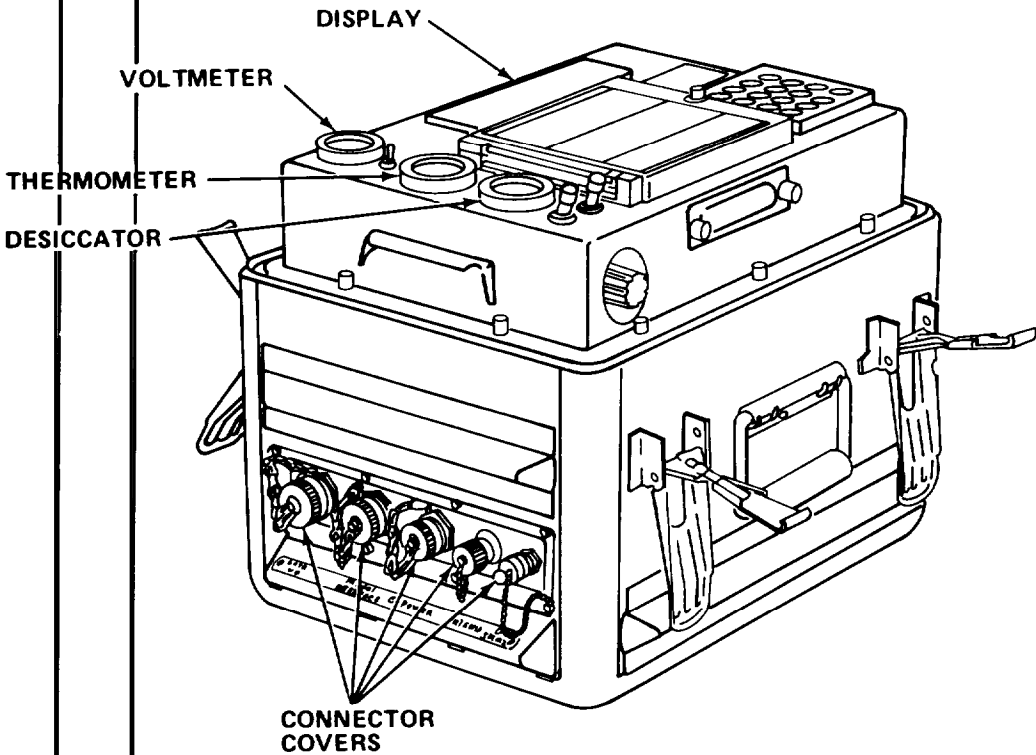
(Number) - Hundreds of Hours

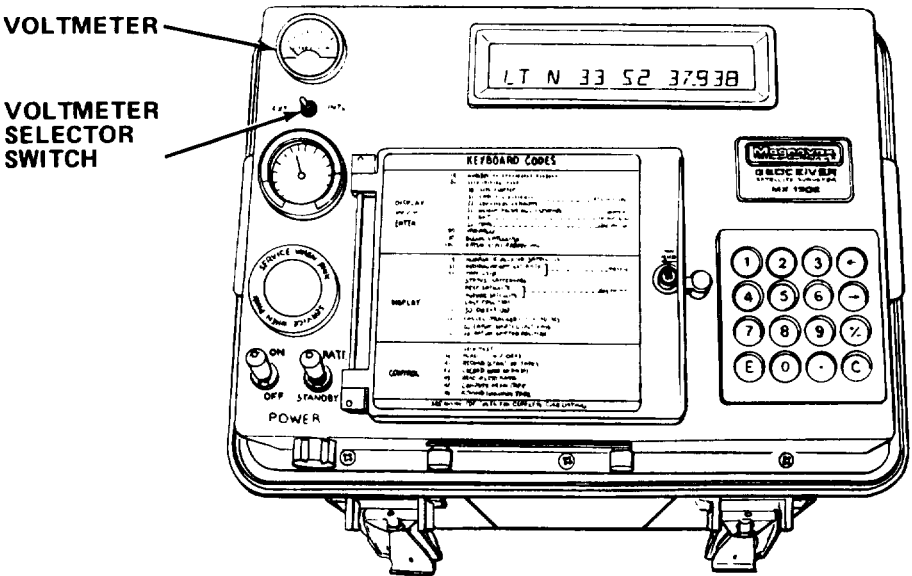
| ITEM NO. | INTERVAL | ITEM TO BE INSPECTED PROCEDURE | For Readiness Reporting, Equipment Is Not Ready/ Available If: |
|----------|----------|---------------------------------------------------------------------------------------------------------------------------------------------------------------------------------------------------------------------------------------------------------------------------------------------------------------------------------------------------------------------------------------------------------------------------------------------------------------------------------------------------------------------------------------------------------------------------|----------------------------------------------------------------|
| 2 | B | <u>SATELLITE SURVEYOR - Cont</u> | |
| | | <p data-bbox="289 541 771 573"><u>Test Internal Battery Voltage.</u></p>  <p data-bbox="673 1327 755 1354">NOTE</p> <p data-bbox="381 1392 1079 1486">If internal battery voltage is below 10.5 V, connect external deep cycle battery to unit to permit Internal battery to recharge.</p> <ol data-bbox="316 1549 1112 1644" style="list-style-type: none"> 1. Place voltage selector switch to INT. 2. Voltmeter should indicate a minimum of 10.5 V. | |

Voltmeter indicates less than 10.5 volts.

Table 4-1. OPERATOR PREVENTIVE MAINTENANCE CHECKS AND SERVICES - Cont

B - Before
D - During
A After

W - Weekly
M - Monthly
Q - Quarterly

AN - Annually
S - Semiannually
BI - Biennially

(Number) - Hundreds of Hours

| ITEM NO. | INTER-VAL | ITEM TO BE INSPECTED PROCEDURE | For Readiness Reporting, Equipment Is Not Ready/ Available If: |
|----------|-----------|-------------------------------------------------------------------------------------------------------------------------------------------------------------------------------------------------------------------------------------------------------------------------------------------------------------------------------------------------------------------------------------------------------------------------------------------------------------------------------------------------------------------------------------------------------------------------------------------------------------------------------------------------------------------------------------------------------------------------------------------------------------------|----------------------------------------------------------------|
| 3 | A | <p><u>SATELLITE SURVEYOR - Cont</u></p> <p><u>Disassembly and Inspection After Use.</u></p> <ol style="list-style-type: none"> 1. Set STANDBY/OPERATE switch to STANDBY. <p style="text-align: center;">NOTE</p> <p style="text-align: center;">If unit is to be used within 20 hours, disregard step 2.</p> <ol style="list-style-type: none"> 2. After 4 seconds, place ON/OFF switch to OFF. 3. Disconnect cable from power source. 4. Disconnect power cable from POWER jack on receiver/processor and store in case. 5. Install cover on receiver/processor. 6. Disconnect antenna cable from RCVR jack on preamplifier. Coil cable, and store cable and cable ties in case. | <p>Connectors or insulation are damaged.</p> |

Table 4-1. OPERATOR PREVENTIVE MAINTENANCE CHECKS AND SERVICES - Cont

| ITEM NO. | INTERVAL | ITEM TO BE INSPECTED PROCEDURE | For Readiness Reporting, Equipment Is Not Ready/ Available If: |
|----------------------------------|----------|----------------------------------------------------------------------------------------------------------------------------------------------------------------------------------------------------------------------------------------------------------------------------------------------------------|-------------------------------------------------------------------------|
| SATELLITE SURVEYOR - Cont | | | |
| 3 | A | <p data-bbox="303 534 992 566"><u>Disassembly and Inspection After Use - Cont</u></p>  <p data-bbox="310 1519 1141 1581">7. Remove sections 1, 2, and 3 from bottom section, disassemble, and store in styrofoam.</p> | <p data-bbox="1278 1510 1455 1604">Threads are damaged or stripped.</p> |

Table 4-1. OPERATOR PREVENTIVE MAINTENANCE CHECKS AND SERVICES - Cont

B - Before
D - During
A - After

W - Weekly
M - Monthly
Q - Quarterly

AN - Annually
S - Semiannually
BI - Biennially

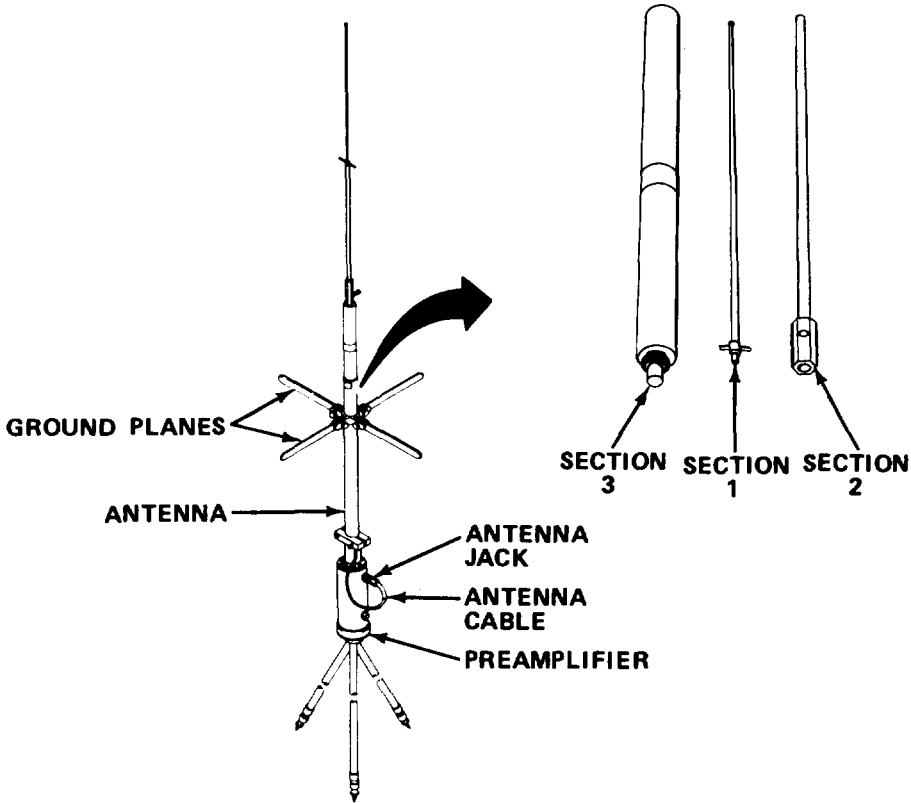
(Number) - Hundreds of Hours

| ITEM NO. | INTERVAL | ITEM TO BE INSPECTED PROCEDURE | For Readiness Reporting, Equipment Is Not Ready/ Available If: |
|----------|----------|---------------------------------------------------------------------------------------------------------------------------------------------------------------------------------------------------------------------------------------------------------------------------------------------------------------------------------------------------------------------------------------------------------------------------------------------------------------------------------------------------------------------------------------------------------------------------------------------------------------------------------------------|--------------------------------------------------------------------|
| 3 | A | SATELLITE SURVEYOR - Cont | |
| | | <u>Disassembly and Inspection After Use - Cont</u> 8. Disconnect antenna cable from ANT jack. 9. Remove antenna bottom section from preamplifier. fold ground planes, and store in styrofoam. 10. Remove preamplifier from tripod and store in styrofoam. 11. Fold tripod and store. 12. Store six tape cassettes in bottom of case. 13. Assemble styrofoam and place in case. 14. Place nails, nail caps, four tape cassettes, spare fuses, plumb bob, lacing cord, tripod adapter, and RF connector in top of styrofoam. Report missing items. 15. Install cover on antenna case. | Connector or insulation is damaged. Ground planes are bent. |

Table 4-1. OPERATOR PREVENTIVE MAINTENANCE CHECKS AND SERVICES - Cont

B - Before
D - During
A -After

W - Weekly
M - Monthly
Q - Quarterly

AN - Annually
S - Semiannually
BI - Biennially

(Number) - Hundreds of Hours

| ITEM NO. | INTERVAL | ITEM TO BE INSPECTED PROCEDURE | For Readiness Reporting, Equipment Is Not Ready/ Available If: |
|----------------------------------|----------|------------------------------------------------------------------------------------------------------------------------------------------------------------------------------------------------------------------------------------------------------------------------------------------------------------------------------------------------------------------------------------------------------------------------------------------------------------------------------------------------------------------------------------------------------------------------------------------------------------------------------------------------------------------------------------------------------------------------------------------------------------------------------------------------------------------------------------------------------------------------------------|----------------------------------------------------------------|
| SATELLITE SURVEYOR - Cont | | | |
| 4 | B | <p data-bbox="299 538 748 570"><u>Service Receiver/Processor.</u></p> <ol data-bbox="299 602 1161 634" style="list-style-type: none"> <li data-bbox="299 602 1161 634">1. Place receiver/processor in convenient location.  <ol data-bbox="299 1176 1103 1229" style="list-style-type: none"> <li data-bbox="299 1176 1103 1229">2. Press breather valve to equalize pressure in cover.  <ol data-bbox="299 1740 1103 1868" style="list-style-type: none"> <li data-bbox="299 1740 1103 1772">3. Release four latches and remove cover. <li data-bbox="299 1804 1103 1868">4. Using clean cloth dampened with clean warm water and detergent, clean exterior of unit. | |

Table 4-1. OPERATOR PREVENTIVE MAINTENANCE CHECKS AND SERVICES - Cont

| ITEM NO. | INTERVAL | ITEM TO BE INSPECTED PROCEDURE | For Readiness Reporting, Equipment Is Not Ready/ Available If: |
|----------------------------------|----------|---------------------------------------------------------------------------------------------------------------------------------------------------------------------------------------------------------------------------------------------------------------------------------------------------------------------------------------------------------------------------------------------------------------------------------------------------------------------------|----------------------------------------------------------------------------------------------------------------------------------------|
| SATELLITE SURVEYOR - Cont | | | |
| 4 | B | <p data-bbox="388 534 900 566"><u>Service Receiver/Processor - Cont</u></p> <div data-bbox="467 661 1139 861" style="text-align: center;"> </div> <p data-bbox="393 946 1139 1006">5. Open cassette cover by sliding release latch to left.</p> <div data-bbox="371 1034 1219 1604" style="text-align: center;"> </div> <p data-bbox="404 1687 1197 1783">6. Clean cassette tape read/write head with cotton swab soaked in isopropyl alcohol and inspect for damage.</p> | <p data-bbox="1346 942 1511 1002">Cover will not open.</p> <p data-bbox="1346 1683 1511 1810">Cassette read/write head is damaged.</p> |

Table 4-1. OPERATOR PREVENTIVE MAINTENANCE CHECKS AND SERVICES - Cont

| | | B - Before D During A After | W - Weekly M - Monthly Q - Quarterly | AN - Annually S - Semiannually BI - Biennially | (Number) - Hundreds of Hours |
|----------------------------------|----------|-------------------------------------------------------------------------------------------------------------------------------------------------------------------------------------------------------------------------------------------------------------------------------------------------------------------------------------------------|--------------------------------------------|------------------------------------------------------|----------------------------------------------------------------|
| ITEM NO. | INTERVAL | ITEM TO BE INSPECTED PROCEDURE | | | For Readiness Reporting, Equipment Is Not Ready/ Available If: |
| SATELLITE SURVEYOR - Cont | | | | | |
| 4 | B | <u>Service Receiver/Processor - Cont</u> 7. Clean guide blocks, cassette retainer and write permit switch with cotton swab moistened with isopropyl alcohol. 8. Inspect spooling reels. 9. Allow 5 min for components to dry. 10. Close tape cassette transport cover. 11. Replace receiver/processor cover. | | | Spooling reels are damaged. |
| 5 | B | <u>Service Desiccant.</u> 1. Place receiver/processor in convenient location.  2. Press breather valve to equalize pressure in cover. | | | |

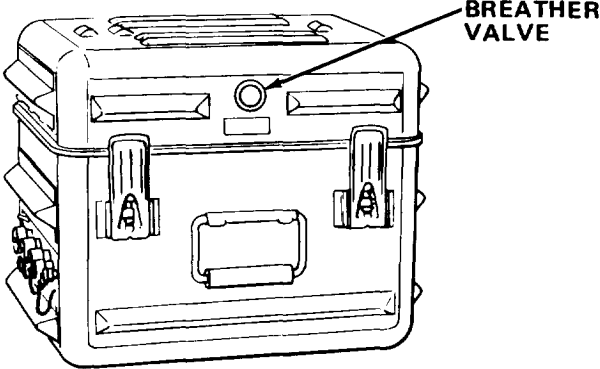
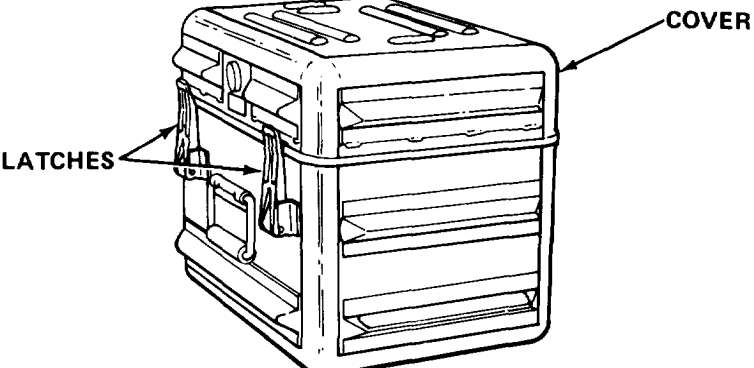
Table 4-1. OPERATOR PREVENTIVE MAINTENANCE CHECKS AND SERVICES - Cont

B - Before
D - During
A - After

W - Weekly
M - Monthly
Q - Quarterly

AN - Annually
S - Semiannually
BI - Biennially

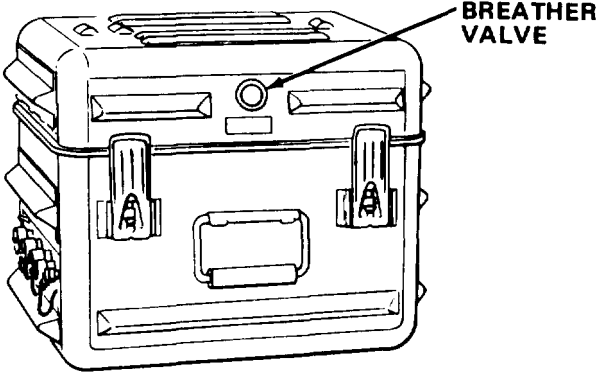
(Number) - Hundreds of Hours

| ITEM NO. | INTERVAL | ITEM TO BE INSPECTED PROCEDURE | For Readiness Reporting, Equipment Is Not Ready/ Available If: |
|----------|----------|----------------------------------------------------------------------------------------------------------------------------------------------------------------------------------------------------------------------------------------------------------------------------------------------------------------------------------------------------------------|----------------------------------------------------------------|
| 5 | B | <u>SATELLITE SURVEYOR - Cont</u> | |
| | | <p data-bbox="388 534 776 566"><u>Service Desiccant - Cont</u></p> <div data-bbox="464 636 1108 917"> </div> <p data-bbox="403 1040 1072 1072">3. Release four latches and remove cover.</p> <div data-bbox="616 1172 1172 1455"> </div> <p data-bbox="388 1549 1161 1610">4. Press breather valve to equalize pressure in interior of receiver/processor.</p> | |

Table 4-1. OPERATOR PREVENTIVE MAINTENANCE CHECKS AND SERVICES - Cont

| ITEM NO. | INTER-VAL | ITEM TO BE INSPECTED PROCEDURE | For Readiness Reporting, Equipment Is Not Ready/ Available If: |
|--------------------------------------------------------------------------------------------------------------------------------------------------------------------------------------------------------------------------------|-----------|-----------------------------------|----------------------------------------------------------------|
| 5 | B | <u>SATELLITE SURVEYOR - Cont</u> | |
| | | <u>Service Desiccant - Cont</u> | |
|  | | | |
| <p>5. Check desiccator. If color of desiccant is blue, proceed to step 10. If color is pink, proceed to step 6.</p> <p>6. Unscrew desiccator by turning cap to the left. Remove desiccant and gasket; then discard gasket.</p> | | | |

Table 4-1. OPERATOR PREVENTIVE MAINTENANCE CHECKS AND SERVICES - Cont

B - Before
D - During
A - After

W - Weekly
M - Monthly
Q - Quarterly

AN - Annually
S - Semiannually
BI - Biennially

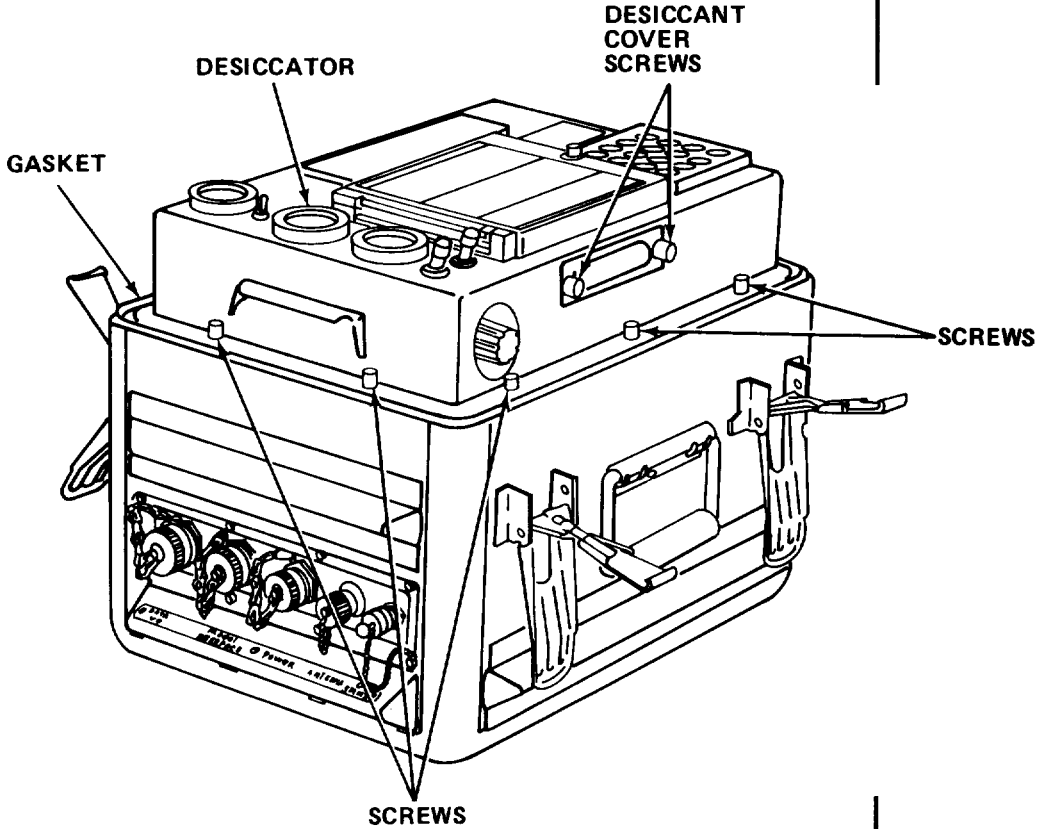
(Number) - Hundreds of Hours

| ITEM NO. | INTERVAL | ITEM TO BE INSPECTED PROCEDURE | For Readiness Reporting, Equipment Is Not Ready/ Available If: |
|----------|----------|----------------------------------------------------------------------------------------------------------------------------------------------------------------------------------------------------------------------------------------------------------------------------------------------------------------------------------------------------|----------------------------------------------------------------|
| 5 | B | <p><u>SATELLITE SURVEYOR - Cont</u></p> <p><u>Service Desiccant - Cont</u></p> <div data-bbox="714 661 1104 1438" style="text-align: center;"> </div> <p>7. Unscrew cap from housing and remove packing and sight glass. Discard packing.</p> <p>8. Replace desiccant and install sight glass, new packing, and cap. Tighten cap finger tight.</p> | |

Table 4-1. OPERATOR PREVENTIVE MAINTENANCE CHECKS AND SERVICES - Cont

B - Before
D - During
A - After

W - Weekly
M - Monthly
Q - Quarterly

AN - Annually
S - Semiannually
BI - Biennially

(Number) - Hundreds of Hours

| ITEM NO. | INTERVAL | ITEM TO BE INSPECTED PROCEDURE | For Readiness Reporting, Equipment Is Not Ready/ Available If: |
|----------|----------|--------------------------------------------------------------------------------------------------------------------------------------------------------------------------------------------------------------------------------------------------------------------------------------------------------------------------------------------------------------------------------------------------------------------------------------------------------------------------------------------------------------------------------------------------------------------------------------------------------------------------------------------------------------------------------------------------------|----------------------------------------------------------------|
| 5 | B | <u>SATELLITE SURVEYOR - Cont</u> | |
| | | <u>Service Desiccant - Cont</u> 9. Using a new gasket, reinstall desiccator and tighten finger tight. 10. Visually inspect edge of gasket on front panel for deterioration, and check for loose screws using fingers only. 11. Loosen cover screws and raise cover. 12. Inspect desiccant cover gasket. Discard if damaged or deteriorated. <p style="text-align: center;">NOTE</p> Normal color of desiccant bags is deep blue. 13. Remove desiccant bags and note color; if pink, discard. 14. Install blue-colored desiccant bags. 15. Lower cover and tighten two screws finger tight. 16. Replace receiver/processor cover. | |

Gasket is defective. Screws and front panel are loose.

4-6. OPERATION UNDER USUAL CONDITIONS.

4-6.1 Assembly and Preparation For Use.

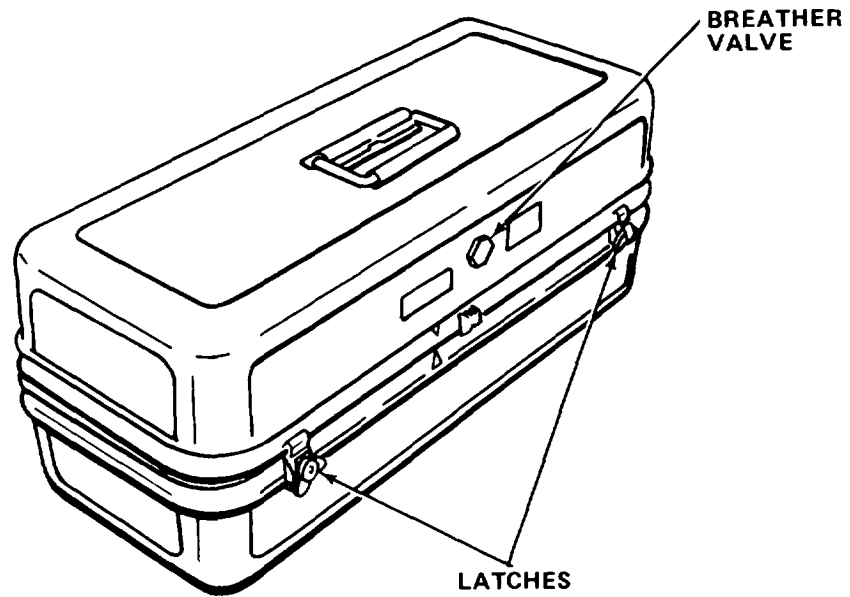

- a. Press breather valve on antenna case to equalize pressure in case.
- b. Release four latches on case and remove cover.

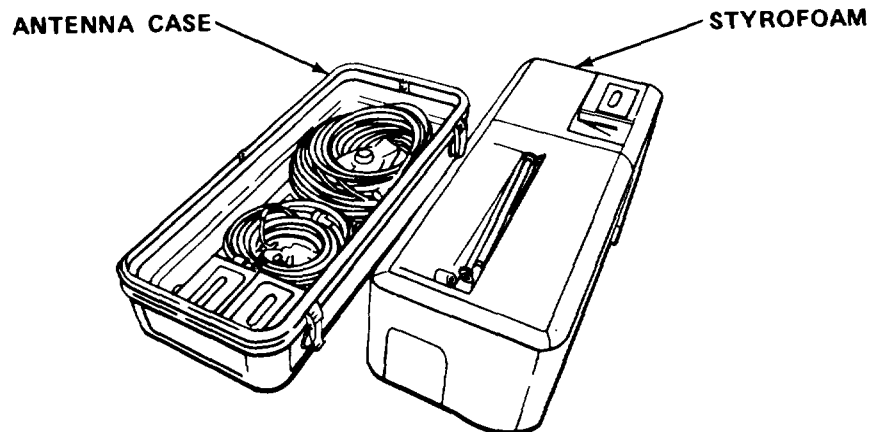

- c. Remove styrofoam from case.

NOTE

Antenna is inside styrofoam.

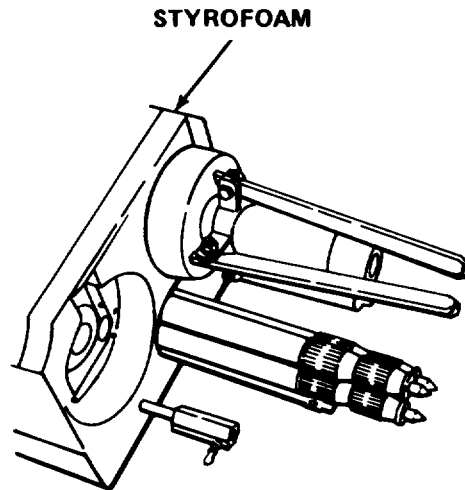

d. Separate styrofoam.

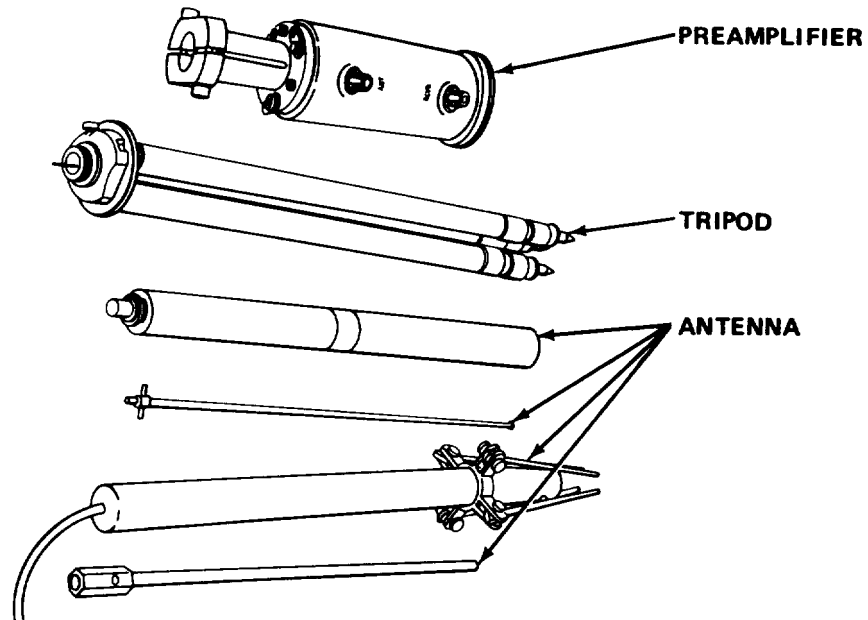

e. Remove antenna and preamplifier.

NOTE

The following instructions call out the use of the tripod packed with the equipment. It is preferred, however, to use the T2 tripod for supporting the antenna. The adapter included in the case will fit the T2 tripod. The use and maintenance of the T2 tripod is covered in TM 5-232.

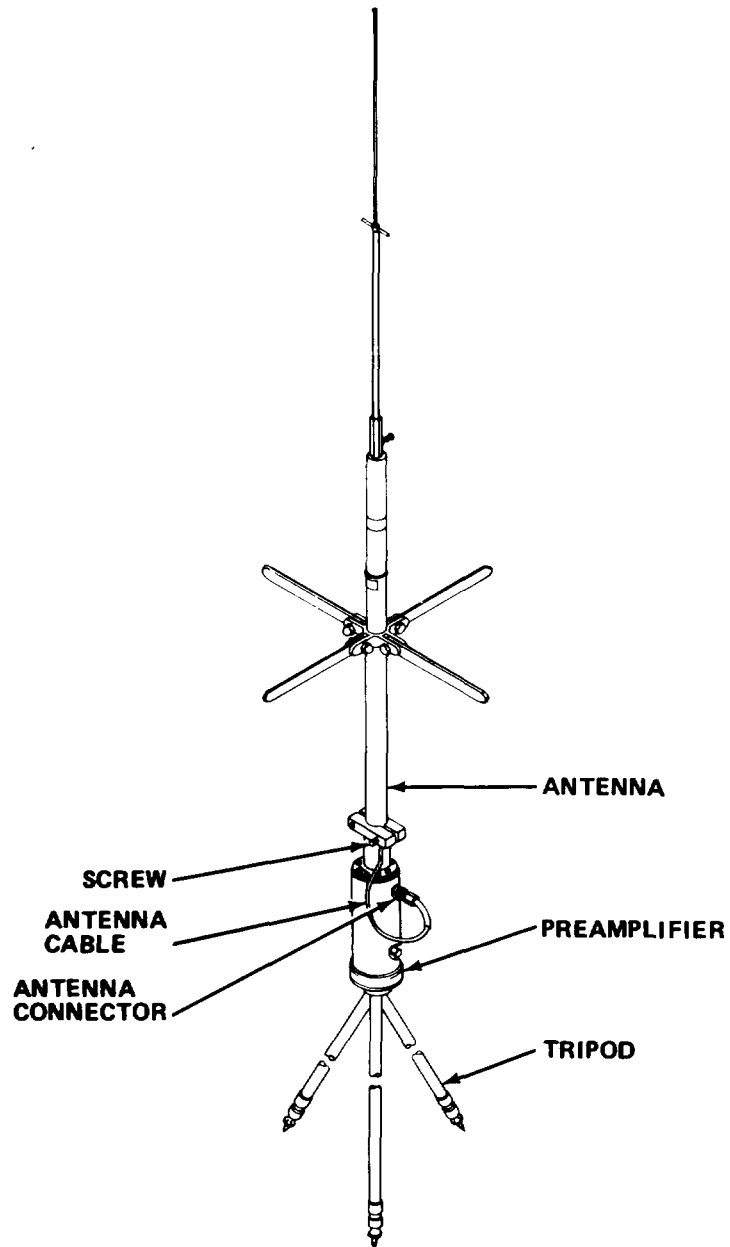

- f. Screw preamplifier onto tripod.
- g. Insert bottom section of antenna into top of preamplifier.
- h. Tighten two screws on preamplifier to hold antenna.
- i. Connect antenna cable to ANT connector.

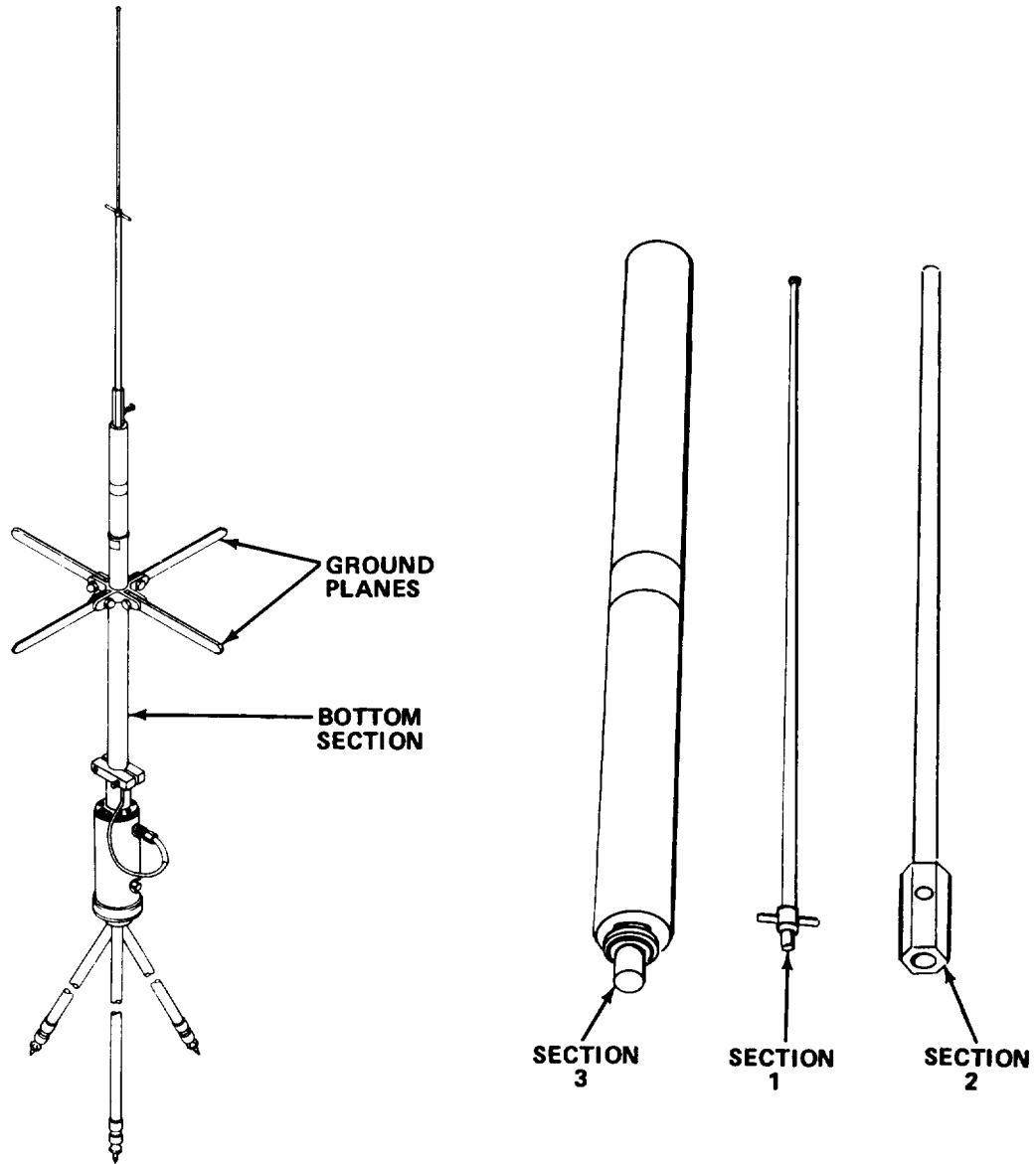

j. Connect antenna section 1 to section 2 and section 2 to section 3.

k. Connect section 3 to bottom section.

l. Place ground planes parallel to ground.

m. Select the survey site and position the equipment in accordance with the following parameters:

(1) Antenna/Preamplifier location. Antenna location will depend on signal reception factors, interfering signals, and survey requirements. The point for which a position is actually computed is the electrical Center of the antenna which is indicated by a red band. Normally, the antenna is positioned directly over the point to be determined, such as a previously established benchmark. If the antenna cannot be located directly over the fixed point due to physical constraints, poor signal reception, or interfering signals, and a more advantageous location is a short distance away, reference the red band of the antenna to the fixed point.

(2) Signal reception. The satellite signal propagates in direct line of sight. The signal could be absorbed, reflected; or refracted if there are large objects between it and the antenna/preamplifier assembly. For this reason, the antenna/preamplifier assembly should be located where it has an unobstructed view of the horizon above 10 degrees of elevation. The red band must be located a minimum of 4 meters (13 feet) from large vertical structures and 1 meter (3.25 feet) above large horizontal structures. Close proximity to such structures could cause the receiver to receive two signals whose phase relationship will change during reception. To minimize signal multipath, avoid close proximity to smooth bodies of water. Do not locate the antenna/preamplifier closer than 10 meters to antennas of the same wavelength (such as TV antennas).

(3) Interfering signals. The antenna/preamplifier assembly should be located in an area of minimum radio interference. Areas which have radio transmissions in the 150 and 400 MHz ranges must be avoided. Medium frequency radar and high power communication antennas should be avoided because they may emit enough RF energy to damage the equipment. If it is necessary to operate near such equipment, the antenna must be shielded and moved until proper operation is obtained. High voltage power lines, high voltage transformers, or excessive noise from car ignition systems should be avoided.

(4) Receiver/Processor location.

NOTE

- In most instances, the horizontal offset distance between the antenna and the survey point should not exceed 30 m (98 ft).
- If possible, locate the receiver/processor out of direct sunlight, or provide some form of shade.

The receiver/processor must be located within 30 meters (98 feet) of the antenna/preamplifier unless extra antenna cable lengths have been obtained. A maximum cable length of approximately 60 meters (196.8 feet) can be tolerated. The location of the receiver/processor must be free from vibration. Therefore, certain mobile land installations will require the receiver/processor to be shock-mounted.

n. Prepare a station description card, DA form 1559 of the antenna location in accordance with TM 5-441.

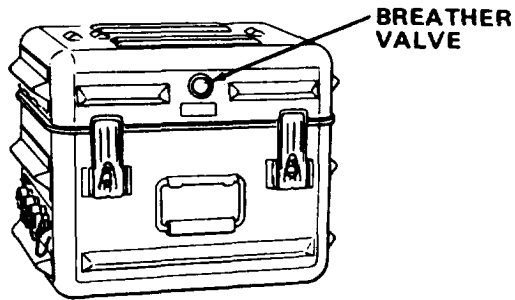

o. Press breather valve on receiver processor cover to equalize pressure under the cover.

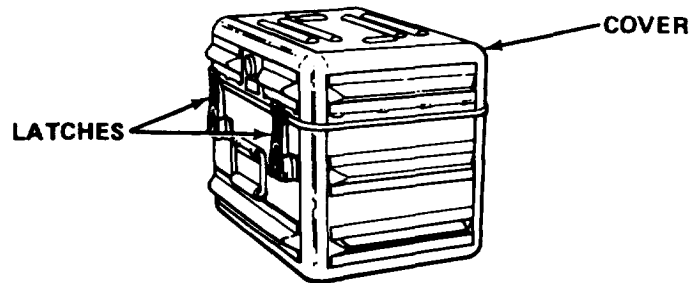

p. Release four latches and remove cover.

q. Verify that power switches are OFF and in STANDBY.

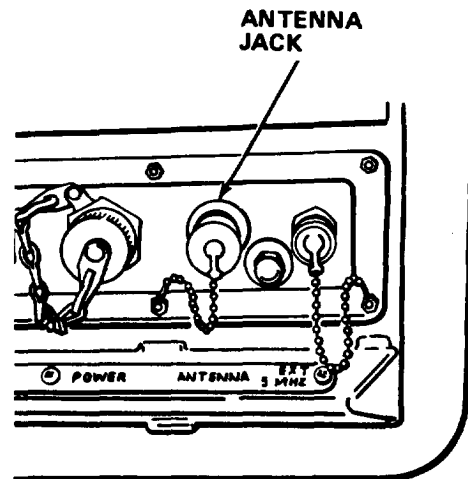
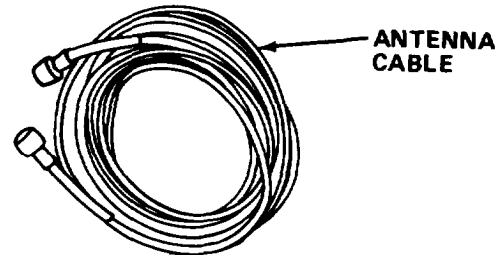
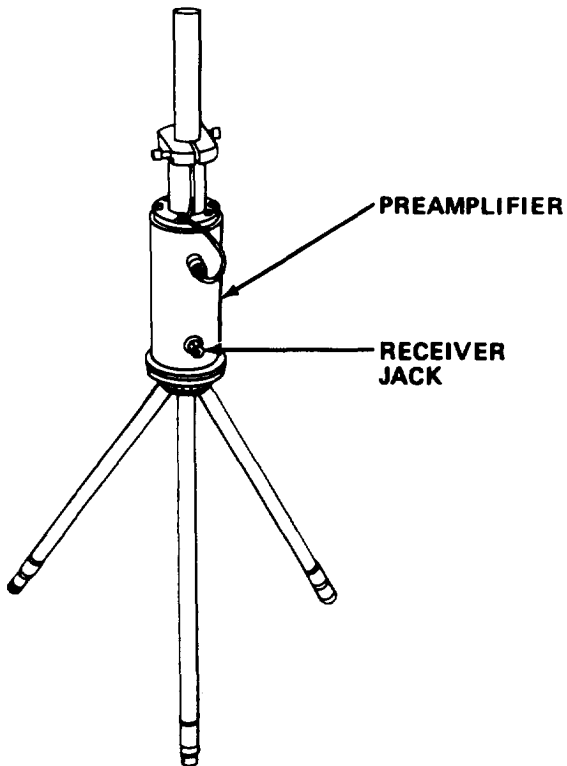

- r. Connect antenna cable between RCVR jack on preamplifier and ANTENNA jack on receiver/processor.

NOTE

If real time translocation is not being used, disregard steps s and t.

- s. Connect communications link cable to MODEM INTERFACE connector.

- t. Perform communications equipment initial checks and adjustments (TM 11-5820-520-10).

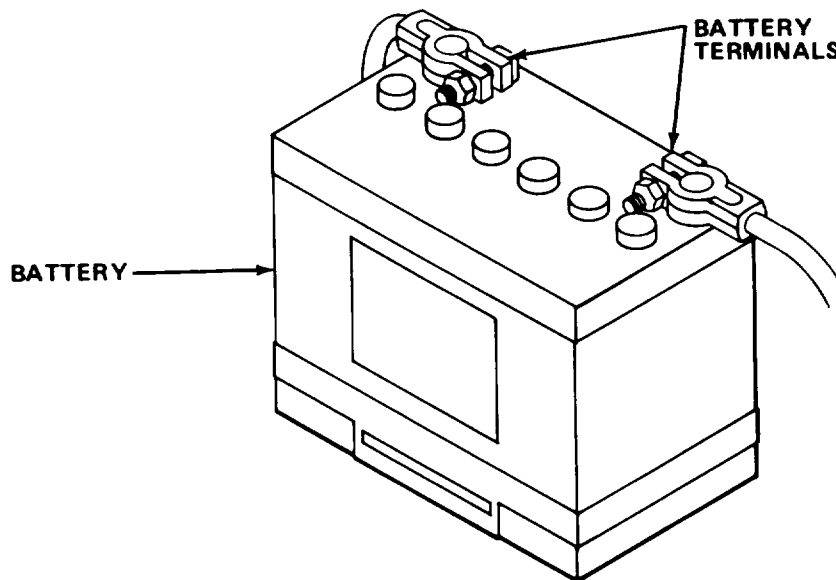

CAUTION

Use ring clamp connectors rather than alligator clips, which may cause power failures.

NOTE

If power supply is to be used, disregard step u.

- u. On battery, connect white wire (+) to positive terminal of battery and black wire (-) to negative terminal of battery.

- v. Connect power supply.

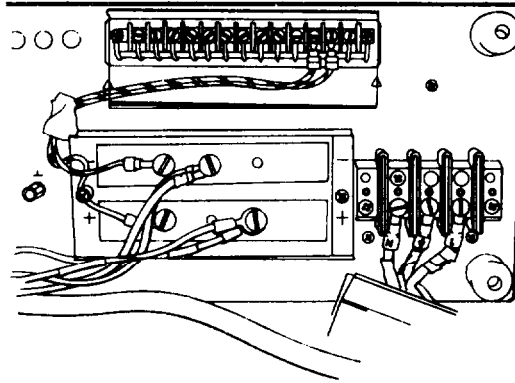

(1) Connect 115 V power cord to N, ⏏ , and L terminals on back of power supply.

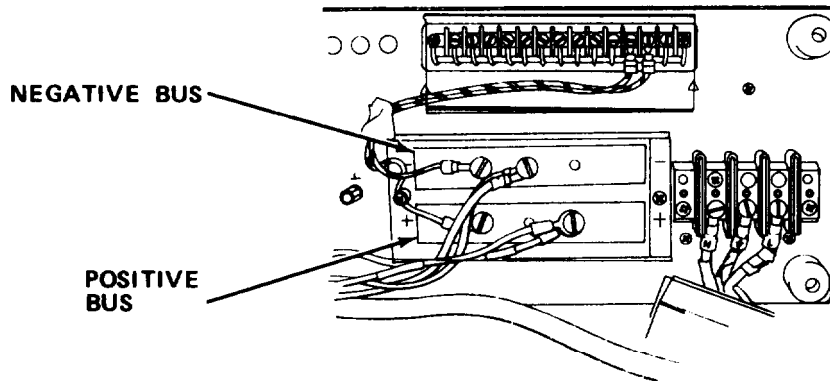

(2) Connect white wire to positive bus (+) on power supply, and black wire to negative bus (-) on power supply.

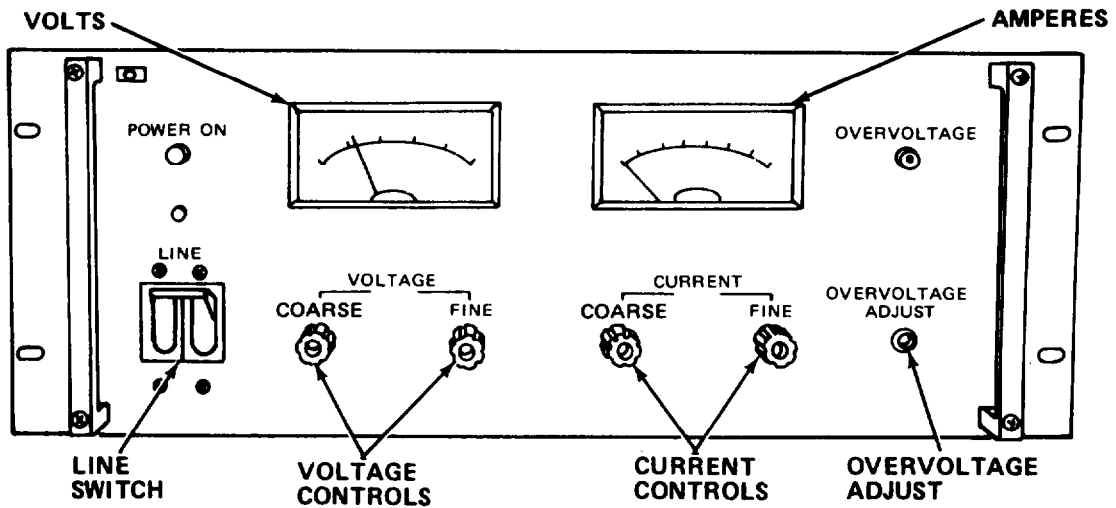

(3) Make sure that LINE switch is OFF, and turn CURRENT controls and OVERVOLTAGE ADJUST potentiometer fully to the left.

- (4) Plug power cord into 120 V ac outlet.
- (5) Turn on LINE switch and observe that pilot lamp lights.
- (5.1) Adjust COARSE control for CURRENT to fully right.
- (6) Adjust COARSE control for CURRENT to fully right.
- (7) Adjust COARSE and FINE VOLTAGE controls to between 13 and 13.8 V.

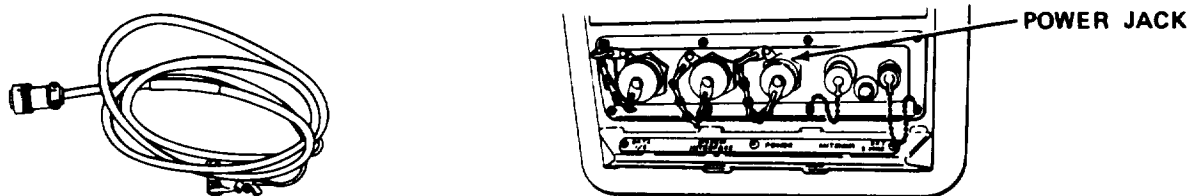

- w. Connect power cable to jack on receiver/processor labeled POWER.

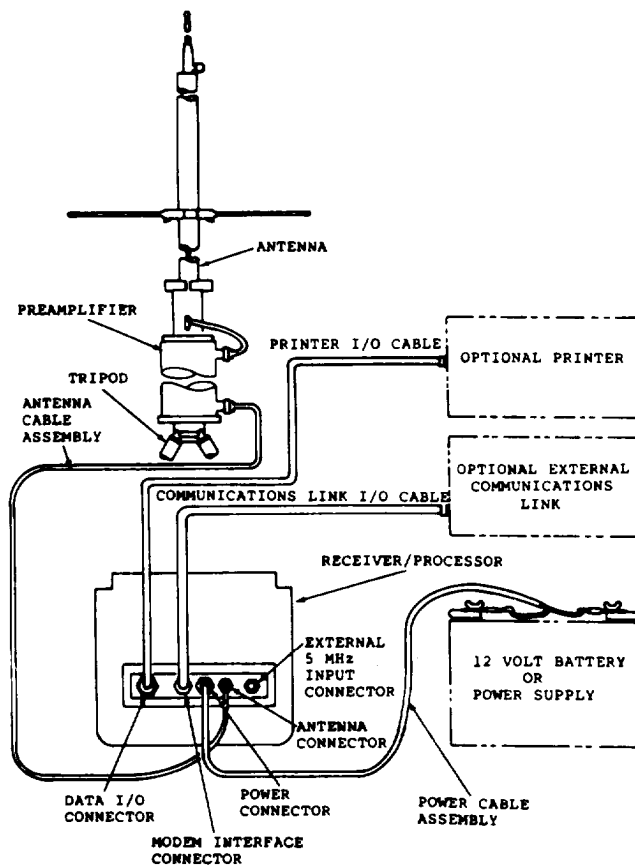

NOTE

Steps x and y are optional.

- x. Connect cable between DATA I/O connector and alphanumeric printer.
- y. Check that printer has sufficient paper and serviceable ribbon.

4-6.2 Initial Adjustments, Daily Checks, and Self-Test.

a. Test the display as follows:

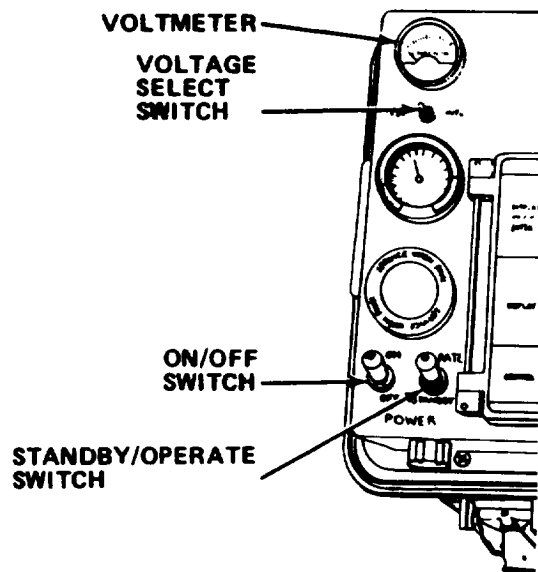

(1) Place ON/OFF switch to ON.

NOTE

If power has not been applied to oscillator during transportation, a 24 hour stabilization period should be observed. Accuracy of oscillator in satellite surveyor determines accuracy of data used to compute position.

(2) After 4 seconds, place STANDBY/OPERATE switch to OPERATE.

NOTE

If external battery voltage is less than 10.5 V, recharge or replace external battery.

(3) Place voltage selector switch to EXT. Voltmeter should indicate approximately 12 V.

NOTE

INIT 19 or INIT 20 is displayed when STANDBY/OPERATE switch is set to OPERATE.

(4) Press clear (C) key.

(5) When CODE is displayed, key in 245, verify CODE 245 is on the display, then press the enter (E) key.

(6) If PWRO OFF is displayed, press change sign (+/-) key to display PWRO ON, then press enter (E) key.

(7) Press clear (C) key.

(8) When CODE is displayed, key in 17, verify CODE 17 is on display, and press enter (E) key.

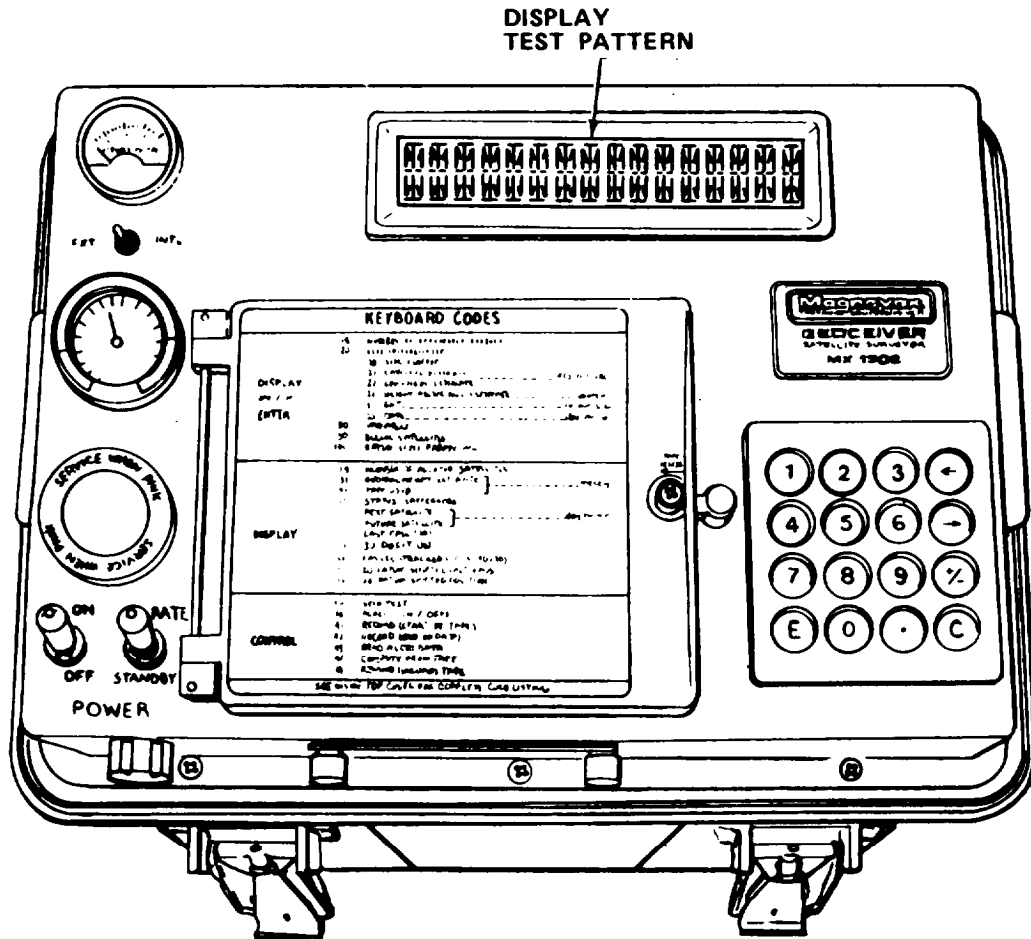

(9) Check that each segment of every character is displayed. If not, refer to higher level of maintenance.

b. Self-Test.

NOTE

- Most troubleshooting in MX 1502 can be performed by processor using self-test feature. Self-test is automatically performed every 24 hours. If faults are detected during self-test, audible alarm is sounded (unless suppressed by code 38) and error code is displayed to inform user of most probable cause. List-of error codes is contained in self-test description.
- Self-test (code 16) is automatically performed when MX 1502 is powered up after 1700 GMT and when sufficient time exists before next satellite pass. Self-test may be entered manually at any time; however, MX 1502 does not accept pass data while self-test is in progress. Self-test is typically employed after code 50 has indicated fault. Code 50 continues to indicate fault until unit passes self-test.
- During self-test, TEST is displayed along with receiver status codes and error codes if errors are detected. Multiple errors are indicated by displaying additional error codes to right of position 2.
- Upon completion of self-test, TEST is removed from display unit but any faults detected remain until corrected and successful self-test is completed.
- Error codes are also recorded on tape cassette if installed in unit.

(1) Install a blank tape in the cassette transport and position tape at BOT using code 41.

(2) Press clear (C) key.



(3) When CODE is displayed, key in 16, verify CODE 16 is on display and press enter (E) key. Test will run for approximately 4.5 minutes.

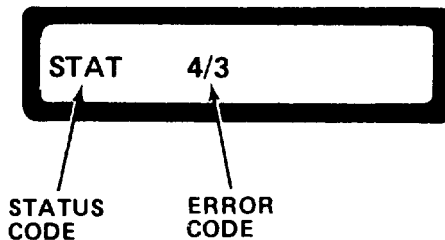

NOTE

- Receiver status codes are shown on left of slash and error codes on right of slash.
- When STAT is displayed, test is complete.

(4) Enter code 50, Table 4-21 to display status or error codes.

(5) Check equipment version as follows:

(a) Enter code 8.

(b) Enter ADDR 47.

(c) Record and retain equipment version number as it is displayed.

c. Initialization.



INIT 19

NOTE

- INIT 19 or INIT 20 is displayed when STAND BY/OPERATE switch is set to OPERATE.
- INIT is reminder to check initialization parameters.

(1) Press clear (C) key.



CODE

(2) When CODE is displayed, enter 19.

SATD 4

Initial 19 Display

(3) Enter number of transit satellites known to be operational (normally 5).

SATD 5

Display for Entry

NOTE

- XX represents a number between 00 and 16383 which is the identifying number for the survey site.
- Changing site number resets accumulated 3D position and translocation fixes and clears their current positions.

SITE XX

Display

(4) If displayed site number is correct, press enter (E) key. If a new site number is required, enter new number.

SITE XX

Display for Entry

NOTE

- Mode specifies in which mode of operation MX 1502 will be. Standard mode is automatically used if no mode is selected when power is initially applied.
- Switching MX 1502 into off-line mode and then out of off-line mode does not destroy real time fix results or accumulated fix data.
- Standard mode is used to collect satellite data in real time and compute 2D and 3D fixes.
- Off-line mode is used to process tape cassette data. The satellite receiver is disabled. Switching the MX 1502 into the off-line, then out of the off-line mode, does not destroy the real time fix results or accumulated fix data.
- Remote mode is used to collect satellite data in real time, receive data (via a communications link) from the control-site MX 1502, and compute 2D point-position, and translocation fixes.
- Control mode is used to collect satellite data in real time, compute 2D and point-position fixes, and transmit data over a communications link for translocation at a remote-site MX 1502.
- Navigate mode is not used for topographic purposes.

(5) Verify correct mode is on display.



MODE STANDARD

Display for Entry

(6) If standard mode is not desired, press change sign (+/-) until correct mode is displayed.

(7) Press enter (E) key.



LT N 33 50 20.117

Previous Latitude

(8) If latitude displayed is correct, press enter (E) key.

LT S 43 32 55.236

New Latitude

NOTE

- MX 1502 interprets latitude in terms of the satellite datum.
- When estimating latitude and longitude, you must be within 2 degrees of accuracy.

(9) If new latitude is required, key in estimated latitude of antenna in degrees, minutes and seconds to within 2 degrees. Use change sign (+/-) key to change N (North) to S (South) or vice versa. Press space key (→) to enter space between degrees and minutes and between minutes and seconds. Use decimal point for fractions of seconds as required.

(10) Verify entry on display and press enter (E) key.

LN W118 20 30.137

Previous Longitude

NOTE

MX 1502 interprets longitude in terms of the satellite datum.

(11) If longitude displayed is correct, press enter (E) key.

LN E 22 35 53.936

New Longitude

(12) If new longitude is required, key in estimated longitude of antenna in degrees, minutes and seconds to within 2 degrees. Use change sign (+/-) key to change E (East) to W (West) or vice versa. Press space key (→) to enter space between degrees and minutes and between minutes and seconds. Use decimal point for fractions of seconds as required.

(13) Verify entry on display and press enter (E) key.

HGT HT

TEXT DELETED

HGT EL

(14) Press change sign (+/-) key until HGT EL is displayed.

ELT XXXXX

(15) Press the enter (E) key.

(16) Key in estimated height in meters of antenna reference point above MSL with as much accuracy as possible (reference point is marked by red band on antenna).

(17) Verify entry and press enter (E) key.

GMT 21 58 30

(18) If the GMT displayed is correct within 14 minutes, press the enter (E) key.

(19) If a new GMT is required, key in GMT in hours, minutes and seconds. Press space key (→) to enter space between hours and minutes and between minutes and seconds. Enter time to within 14 minutes.

NOTE

Entered time is reference to time when enter (E) key is pressed. Time will be corrected to nearest second immediately after first usable satellite pass.

(20) Verify entry and press enter (E) key.

DATE 29 02 1985

(21) If date displayed is correct, press enter (E) key.

(22) If a new date is required, key in day, month and year for current GMT date. Press space key (→) to enter space between day and month and between month and year. Use four digits to enter year.

(23) Verify entry and press entry (E) key.

NOTE

The following parameters are optional and do not affect operation of MX 1502. They are recorded on tape cassette for recordkeeping purposes only.

SRNO 1348

(24) Key in serial number of MX 1502 being used. Serial number is located on name plate on right-hand side of case.

(25) Press enter (E) key.

SP1 XXX

SP4 XXX

NOTE

Site parameters 1 through 4 are defined by user and may be used to record conditions at site. Such as: distance between antenna and on between antenna and benchmark, and code number identifying terrain. Site parameters are logged on tape but are not used in fix computations. Each site parameter may range between 0 and 16383.

(26) Enter site parameter 1 through 4.

TEM+ XX

Previous Temperature

(27) If temperature (°C) displayed is correct, press enter (E) key.

TEM+ 25

Temperature

(28) If a new temperature is required, key in ambient temperature in degrees Celsius. Use change sign (+/-) key to change from positive (+) temperature to negative (-) temperature or vice versa. Temperature is entered for data logging and is not used in computations.

(29) Verify entry on display and press enter (E) key.

PRES 1015

Pressure

(30) If atmospheric pressure (millibars) displayed is correct, press enter (E) key.

PRES 1008

Pressure

(31) If new pressure is required, enter atmospheric pressure in millibars. Atmospheric pressure value is for data logging and is not used in fix computations.

(32) Verify entry on display and press enter (E) key.

HUM 51

Humidity

(33) If humidity displayed is correct, press enter (E) key.

HUM 47

Humidity

(34) If new humidity is required, enter percentage of relative humidity. Relative humidity value is for data logging and is not used in fix computations.

(35) Verify entry on display and press enter (E) key.

NOTE

Variables 1 thru 4 are defined by user and may be used to record variable conditions at site, such as wind speed, cloud cover or other problem areas. Variables 1 thru 4 may range between 0 and 16,383. User variables are used for data logging and are not used in fix computations.

(36) Enter variable parameters 1 through 4.

CODE

NOTE

- If satellite pass data is to be used, proceed to step 37. If satellite pass data is unavailable and is to be recorded on tape cassette, proceed to step 43.
- MX 1502 reduces power consumption between satellite passes. To automatically return to operational status before next satellite is due, predicted orbit (alert data) of each of the satellites must be contained in processor memory.
- If unit has been in operation at previous site and has been transported in the power on/standby mode on internal batteries, alert data is still available in processor memory. Alert data may be entered from any data tape cassette acquired at any site within 90 days. An alarm will sound if alert data is older than 90 days or if orbital parameters for fewer satellites than desired (as entered in initializing sequence of code 19) are contained on alert tape. Before loading alert data, be sure that that GMT date and time have been correctly entered.

(37) Open tape cassette transport cover by releasing latch.

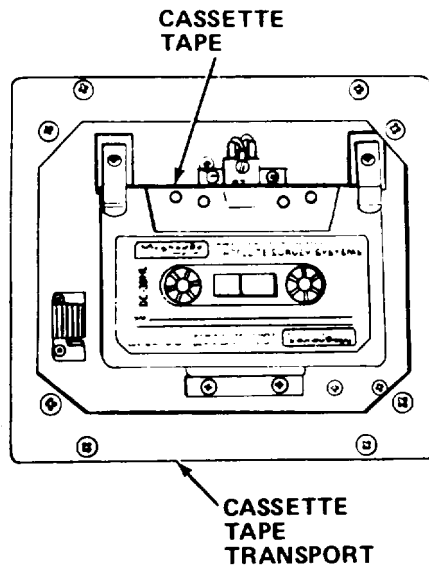

(38) Insert satellite pass data tape cassette in tape cassette transport, ensuring correct side is facing operator.

(39) Press clear (C) key and enter code 41.

(40) Press clear (C) key and enter code 43.

NOTE

- ALRT is displayed while data is being read from tape cassette.
- At end of data or tape, UNLD is displayed and tape cassette is rewound.

(41) When CODE is displayed, remove tape cassette.

(41.1) To display satellite pass predications, enter code 51 (Table 4-21, page 4-137).

(42) Insert blank tape cassette in tape cassette transport.

(43) Check that correct side is facing toward operator and that record enable tab covers hole in upper left corner.

(44) Enter code 42 and allow tape to run two to three minutes.

NOTE

If cassette is installed and neither code 41 nor code 42 is entered, data will be recorded wherever tape is positioned unless cassette is write protected. Always enter code 41 or code 42 prior to recording data. Also, if tape is not positioned at either beginning of tape or at end of data, alarm will sound when MX 1502 attempts to write on tape after first pass is received.

(45) Press clear key and when CODE is displayed, enter code 41.

(46) Close tape cassette transport cover by pressing firmly until it latches.

■ d. Receiver status.

NOTE

Enter code 50 to display functional status of MX 1502. Status is indicated by combination of code numbers and letters. Receiver status is shown on left of slash and error codes on right of slash. If self-test is being performed, TEST is displayed instead of STAT. Explanations of codes are listed below. Error codes remain until cleared by successful self-test.

(1) Press clear (C) key.

(2) Key in 50 and press enter (E) key.

Table 4-2. RECEIVER STATUS CODES

| Code | Status |
|-------|------------------------------------------------------------------------------------------------------------------------------|
| Blank | No signals available. |
| 1 | Receiver has acquired only 150 MHz signal. |
| 4 | Receiver has acquired only 400 MHz signal. |
| A | Receiver has acquired 150 and 400 MHz signals. |
| S | Receiver is searching for or has found particular satellite that has been predicted. Unit has alert data for this satellite. |
| T | Receiver is tracking satellite. The 2 min message from satellite has been detected. |

Table 4-3. ERROR CODES

| Code | Status |
|-------|------------------------------------------------------------------------------------------------------------------------------------------------------------|
| Blank | No errors detected. |
| o | Expected data not received from communication link. Occasional display of this error code is normal. Unit waits 3 min more for expected data. |
| 3 | Error detected on memory board in slot 3. |
| 4 | Error detected on processor board in slot 4. |
| 5 | Error detected on digital 150 MHz receiver interface card in slot 6. |
| 6 | Error detected on analog 150 MHz circuits in slot 6. |
| 7 | Error detected on digital 400 MHz circuits in slot 6. |
| 8 | Error detected on analog 400 MHz circuits in slot 6. |
| B | Error detected in modem board in slot B. |
| C | Error detected in tape cassette transport or tape cassette control board in slot C. |
| D | Error detected on alarm clock board in slot D. |
| E | End of tape cassette. |
| H | Power was reduced because internal temperature exceeded 70°C (158°F). |
| K | Printer enabled when no printer present, or clears to send signal reset prematurely. |
| L | More than 75 m (246 ft.) of tape used on tape cassette. |
| M | Magnetic tape I/O operation was in progress when power was lost. Some data on tape may have been lost or destroyed if recording operation was in progress. |
| N | Data received from communications link does not match data collected from satellite. |
| P | Power failure occurred. |
| S | Satellite alert data from tape is insufficient. |

Table 4-3. ERROR CODES - Cont

| Code | Status |
|------|---------------------------------------------------------------------------------------------------------------------|
| T | Tracking error detected. Satellite that was predicted to be available could not be tracked. |
| U | Excessive oscillator drift in 150 MHz receiver. May not prevent proper operation but eventual correction is needed. |
| V | Excessive oscillator drift in 400 MHz receiver. May not prevent proper operation but eventual correction is needed. |
| X | Satellite alert data on tape cassette is older than 90 days and cannot be used. |

NOTE

If printer is not connected to the satellite surveyor, disregard these steps.

4-6.2.1 Printer Activation.

NOTE

Printer switch is located on left rear of printer. Red pilot light indicates when switch is on.

- a. Turn on printer switch.
- b. Press clear (C) key.



- c. When code is displayed, key in code 71.

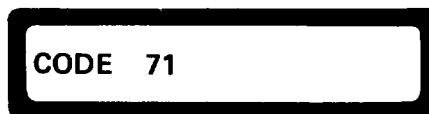

d. Press enter (E) key.

PRINT OFF

e. Press change sign (+/-) key until PRINT ON is displayed.

PRINT ON

f. Press enter (E) key.

BAUD 300.0

NOTE

Baud rate for MX 6304 printer is 110. The receiver/processor will accept printers having the following baud rates only: 50, 75, 110, 134.5, 150, 300, 600, 1200, 1800, 2000, 2400, 3600, 4800, 7200 or 9600.

BAUD 110

g. Key in baud rate for printer in use.

h. Press enter (E) key. Code will be displayed and printer will print 2D, 3D position fixes, translocation position, pass data, and status information following each satellite pass.

4-6.3 Operating Modes.

This paragraph contains information you will need to operate the receiver/processor in the various operating modes. The information and step-by-step instructions for each mode are given in separate paragraphs as follows:

| | |
|---------------------|---------|
| Standard Mode | 4-6.3.1 |
| Control/Remote Mode | 4-6.3.2 |
| Off-Line Mode | 4-6.3.3 |

Although displayed under code 10, the navigate mode is not used for topographic purposes.

4-6.3.1 Standard Mode. This mode enables the operator to obtain the two dimensional (2D) and point position location (3D) of a survey site. Satellite data is collected in real time and is used to compute a 2D and 3D position based on site location data entered into the satellite surveyor via the keyboard. The 2D, 3D, and site identification data will be recorded on tape cassettes for post processing. All doppler data and majority-voted satellite message data is recorded on tape. To obtain a 3D position requires 4 to 10 acceptable satellite passes, and the average time between satellite passes is a function of the latitude. Ten passes can be obtained in as little as 6.3 hours at high latitudes or could take 15.8 hours at the equator. Accuracy of final 3D point positioning result is dependent on the number of satellite passes as given in Table 4-4.

Table 4-4. ACCURACY REQUIREMENTS

| Horizontal Position Accuracy Requirement | Doppler Positioning Technique | Minimum Number of MX 1502 Units Required | Minimum Number of Passes Required |
|-----------------------------------------------|-------------------------------------|------------------------------------------|---------------------------------------------------------------------|
| <37 meters (<21.39 feet) | Single Pass 3D Positioning | 1 | 1 acceptable pass. (Height must be known to +20 m [+65.6 feet]). |
| ≤10 meters (≤32.81 feet) | 3D Positioning | 1 | 15 acceptable passes. |
| <1 meter (≤3.28 feet) | Field or Real Time Translocation | 2 | 4 acceptable passes common to each station. |
| >50 Centimeters >1.0 meter (>3.28 feet) | Field or Real Time Translocation | 2 | 17 acceptable passes common to each station. |

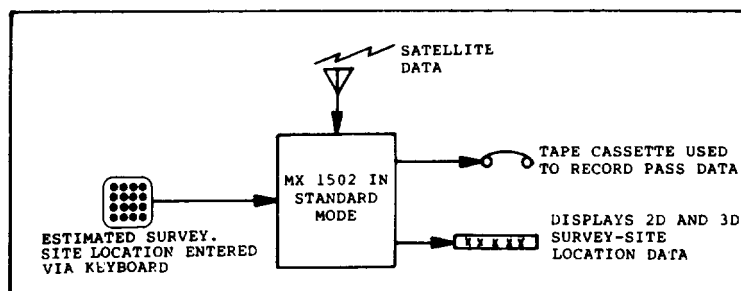

FUNCTIONAL DIAGRAM, STANDARD MODE

The functional diagram shows the standard mode of operation. The 3D positioning computation will provide location data of the survey site with an accuracy within 10 m (32.8 ft) rms. Assemble and prepare the equipment for use (paragraph 4-6.1 and 4-6.2) and operate the receiver/processor in the standard mode as follows:

- a. Select the standard mode of operation by entering code 10. If necessary, press change sign (+/-) key until standard mode is displayed and press enter (E) key.
- b. If a print-out is desired, activate the printer in accordance with paragraph 4-6.2.1, page 4-58.
- c. If not previously entered, enter the survey site location estimate and alert data (paragraph 4-6.2c, page 4-7).
- d. Install a blank tape cassette and position at BOT using code 41, to record pass data as it become available.

NOTE

If 3D position only is desired, proceed directly to paragraph f, page 4-64. If both 2D and 3D positions are desired, the initial display of the 3D position is accessed at the completion of the 2D data by pressing the enter (E) key when the standard deviation of latitude and longitude is on display.

- e. Display 2D position. If desired, the 2D position should be displayed and then recorded on DA Form 1959. Display 2D position as follows:

- (1) Press clear (C) key and key in code 53.

| | |
|-------------|-----------|
| CODE | 53 |
|-------------|-----------|

NOTE

The following data is in terms of satellite datum. If datum conversion is required refer to paragraph 4-6.3.4, page 4-98.

- (2) Press the enter (E) key to read the initial display, then press the enter (E) key to erase and view each successive display in turn. Interpret the displayed data in accordance with Table 4-5.

Table 4-5. CODE 53 DISPLAYS FOR LAST PASS 2D POSITION

Enter code 53 to display the last satellite pass and two dimensional position. The two dimensional position computation is based only on data from the last pass. The data is displayed in a sequence of seven displays. Press the enter (E) key to erase one display and view the next. The initial display shows the following information:

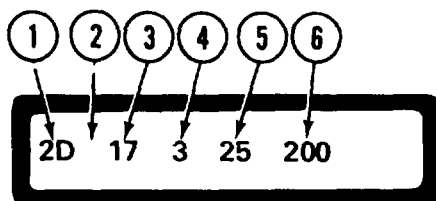

Initial Display

1. Two dimensional (2D) code mnemonic.
2. When this position is blank, both of the 150 MHz and 400 MHz channels were used in the computation. A 1 in this position indicates that only the 150 MHz channel was used; a 4 indicates that only the 400 MHz channel was used.
3. Maximum elevation angle of the satellite above the horizon in degrees. A zero indicates no position was computed.
4. Number of iterations in the 2D computation.
5. Number of 23/28 second doppler counts used in the computation.
6. Last three digits of the satellite identification number.

Press the enter (E) key. Display shows the geometry of the pass and the standard deviation of the doppler count residuals in meters. The geometry gives the direction of satellite travel at closest approach (N = north, S = south) followed by the position of the satellite at closest approach (E = east, W = west) with respect to the site.



Geometry and Standard Deviation of Residuals

Press the enter (E) key. Display shows the computed latitude in degrees, minutes, and seconds in satellite datum coordinates.

Table 4-5. CODE 53 DISPLAY FOR LAST PASS 2D POSITION - Cont



LT N 33 50 28.711

Computed Latitude

Press the enter (E) key. Display shows the computed longitude in degrees, minutes, and seconds in satellite datum coordinates.



LN E118 20 21.921

Computed Longitude

Press the enter (E) key. Display shows the Greenwich Mean Time in hours, minutes, and seconds of the satellite pass. The time shown is referenced to the Center of the satellite pass.



GMT 21 59 34

Greenwich Mean Time

Press the enter (E) key. Display shows the GMT date. The day (1) is shown first followed by the month (2) and year (3). The date is referenced to the Center of the satellite pass.



DATE 29 02 1985

Date

Press the enter (E) key. Display shows the standard deviation in meters of the latitude (1) and the longitude (2). The computations are based only on the doppler data residuals and do not include the orbital error.

Table 4-5. CODE 53 DISPLAY FOR LAST PASS 2D POSITION - Cont

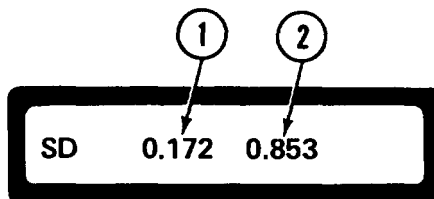

Standard Deviation of Latitude and Longitude

Press the enter (E) key to display the 3D (point) position. Refer to code 63 (Table 4-6) for a description of the 3D position display. The 3D position displays can be sequenced by continuing to press the enter (E) key or by entering code 63.

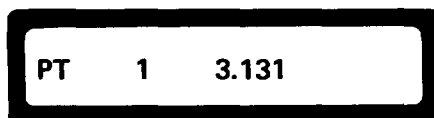

3D Position Display

(3) Rewind the pass data (one site) tape when all satellite data is collected by entering code 49, then remove, label, and store the cassette.

f. Display 3D position. If desired, the 3D position should be displayed and then recorded on DA Form 1959. Display 3D position as follows:

- (1) Press clear (C) key and key in code 63.



(2) Press the enter (E) key to read the initial display, then press the enter (E) key to erase and view each succeeding display in turn. Interpret the displayed data in accordance with Table 4-6.

Table 4-6. CODE 63 DISPLAYS FOR 3D POSITION

Enter code 63 to display the most recent computed 3D (point) position. The 3D (point) position computation is based on accumulated data from all pass data collected. The 3D (point) position is displayed in a sequence of 15 displays. Press the enter (E) key to erase one display and view the next. The initial display shows the following information:

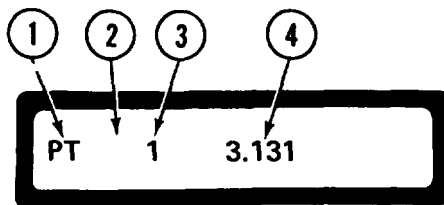
**Initial Display**

1. 3D (point) position code mnemonic (PT).
2. When this position is blank, the point position was computed using data from the last satellite pass. A one-letter code in this position indicates that the last pass data was not used. The following codes signify the reason for not using data from the last pass.
 - O - No 20 fix could be computed.
 - C - Less than eight doppler counts used in 2D computation.
 - D - More than 1 km (0.62 miles) between 2D position and reference position.

NOTE

Entry of correct height estimate will usually correct this code after the next-acceptable satellite pass.

- E - Maximum elevation angle of satellite less than 15 degrees.
- H - Maximum elevation angle greater than 70 degrees immediately after 3D position was reset.
- I - More than six iterations occurred in 2D computation.
- R - Only one of two satellite receiver channels was used to calculate 2D position due to insufficient data on other channel.

Table 4-6. CODE 63 DISPLAY FOR 3D POSITION - Cont

- S - Standard deviation of residuals was too large, indicating that satellite data was in error (see code 91, Table 4-21).
- U - Data from satellite was asymmetrical about point of closest approach.
- X - Last satellite class data was taken from a satellite that indicated within its message that it should not be used for precise applications (for example, a negative satellite number).
- Y - Satellite pass data was taken from a satellite that was deleted by user.

3. Number of satellite passes used in the 3D (point) position computation. If this number is very low compared to the total number of-passes that occurred (code 66, Table 4-21), check the initialization parameters.

4. Distance from the previously computed 3D (point) position computation in meters. This value is meaningless for the first pass.

Press the enter (E) key. Display shows the computed latitude in degrees, minutes, and seconds using satellite datum coordinates.

LT N 33 50 28.021

Computed Latitude

Press the enter (E) key. Display shows the computed longitude in degrees, minutes, and seconds using satellite datum coordinates.

LN W118 20 21.021

Computed Longitude

Press the enter (E) key. Display shows the computed geodetic height in meters, using the satellite datum.

Table 4-6. CODE 63 DISPLAY FOR 3D POSITION - Cont

| | |
|----|-------|
| HT | 40.10 |
|----|-------|

Computed Geodetic Height

Press the enter (E) key. Display shows the computed standard deviation in meters of the latitude (1) and the longitude (2).

| | | |
|----|-------|-------|
| | ① | ② |
| SD | 3.721 | 5.147 |

Latitude and Longitude Standard Deviation

Press the enter (E) key. Display shows the computed standard deviation in meters of the height.

| | |
|-----|-------|
| SDH | 0.626 |
|-----|-------|

Height Standard Deviation

Press the enter (E) key. Display shows the number of passes whose geometry lies in the northwest and northeast quadrants respectively.

| | | |
|------|---|----|
| N-WE | 7 | 11 |
|------|---|----|

Northern Geometry

Press the enter (E) key. Display shows the number of passes whose geometry lies in the southwest and southeast quadrants respectively.

| | | |
|------|----|---|
| S-WE | 10 | 9 |
|------|----|---|

Southern Geometry

Press the enter (E) key. Display shows the latitude distance of the point position from the reference position in meters. The + indicates that the point position is north of the reference position and - indicates that it is south.

Table 4-6. CODE 63 DISPLAY FOR 3D POSITION - Cont

DLT+ 42.76

Latitude Distance from Reference

Press the enter (E) key. Display shows the longitude distance of the point position from the reference position in meters. The + indicates that the point position is east of the reference position and - indicates that it is west.

DLN- 7.15

Longitude Distance from Reference

Press the enter (E) key. Display shows the height distance in meters of the point position from the reference position. The + indicates that the point position is above the reference position and - indicates that it is below.

DHT+ 4.38

Height Distance from Reference

Press the enter (E) key. Display shows the radial distance in meters of the point position from the reference position.

DREF 57.06

Radial Distance from Reference

Press the enter (E) key. Display shows the latitude in degrees, minutes, and seconds of the reference position using the satellite datum.

Table 4-6. CODE 63 DISPLAY FOR 3D POSITION - Cont



RT N 27 14 16.725

Reference Latitude

Press the enter (E) key. Display shows the longitude in degrees, minutes, and seconds of the reference position using the satellite datum.

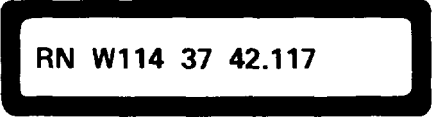

RN W114 37 42.117

Reference Longitude

Press the enter (E) key. Display shows the geodetic height in meters of the reference position using the satellite datum.



RHT+ 13.74

Reference Geodetic Height

Press the enter (E) key to display the translocation position. Refer to code 73.



TR 1 7.241

Translocation Display

(3) Rewind the pass data (one site) tape, when all satellite data is collected, by entering 49, then remove, label, and store the cassette.

- g. If all data has been collected, perform your after PMCS, Table 4-1.

4-6.3.2 Control/Remote Mode. This mode enables the operator to transmit translocation data to remote sites with real time translocation. Satellite data is collected in real time. Positioning and site identification will be recorded on tape cassettes for field processing and verification at a later date. The control site tape will be a one site tape and the remote site tape will be a two site tape. Translocation parameters are transmitted in real time via an external communications link to remote site satellite surveyor for computing real time translocation positions at remote sites. Accuracy requirements are contained in Table 4-4.

The functional diagram shows the control/remote mode of operation. Set up and operate the equipment as follows:

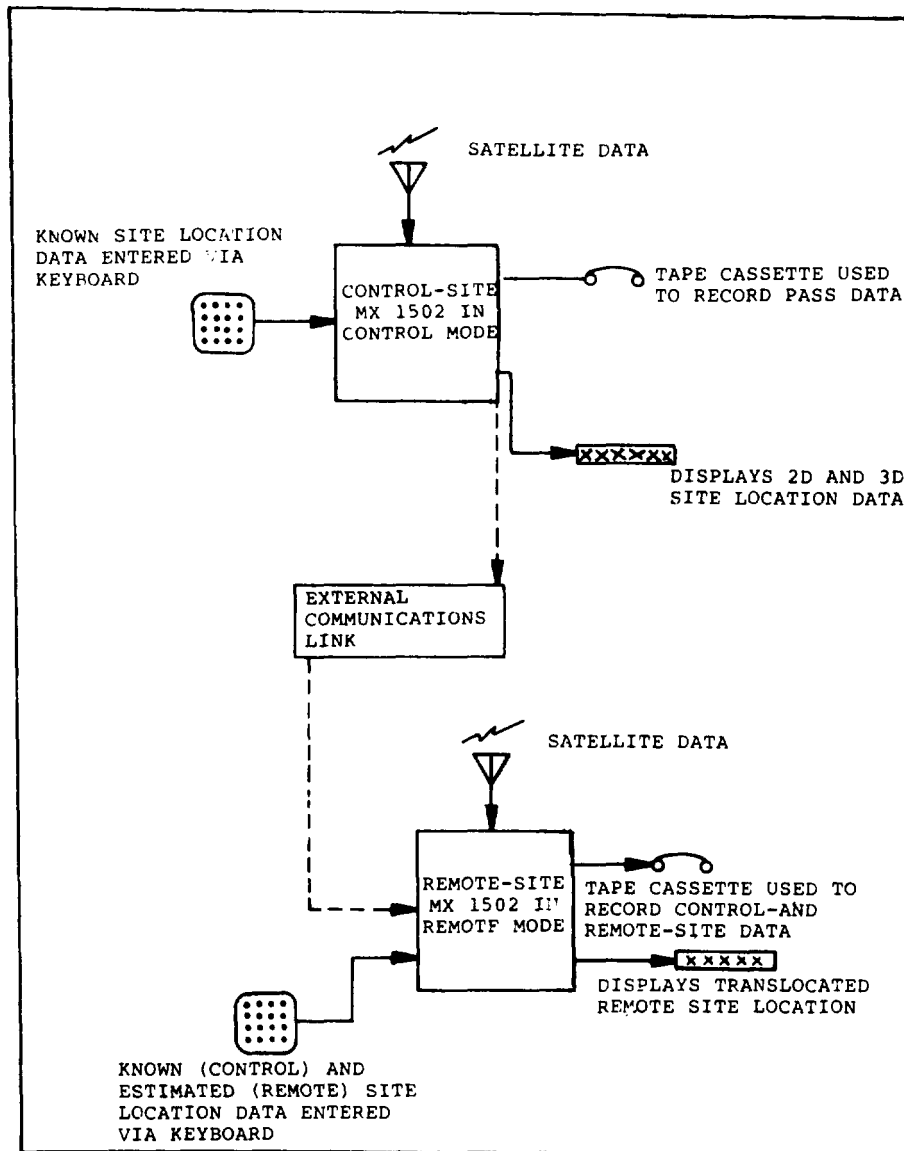

FUNCTIONAL DIAGRAM, CONTROL/REMOTE MODE

a. Control site. Assemble and prepare the equipment (selecting the control mode in accordance with paragraph 4-6.1, page 4-35 and paragraph 4-6.2, page 4-44.

b. Remote site. Assemble and prepare the equipment (selecting the remote mode) at the remote site in accordance with paragraphs 4-6.1 and 4-6.2.

c. Establish radio communications.

(1) Assemble and prepare radio, AN/GRC-106-H, in accordance with TM 11-5820-520-12.

Input/output from the MX1502 satellite surveyor to the AN/GRC 106.

- PIN A - RADIO OUT RETURN
- PIN B - RADIO IN RETURN
- PIN E - FM OUTPUT (10 MV RMS TO 50 OHMS)
- PIN F - AM OUTPUT (19.5 MV RMS TO 200 OHMS)
- PIN H - PHONE LINE OUTPUT (USE WITH TRANSFORMER) 600 OHMS
- PIN J - KEY
- PIN L - SIGNAL RETURN
- PIN M - RADIO IN (USED FOR AM OR FM)
- PIN P - PHONE LINE IN

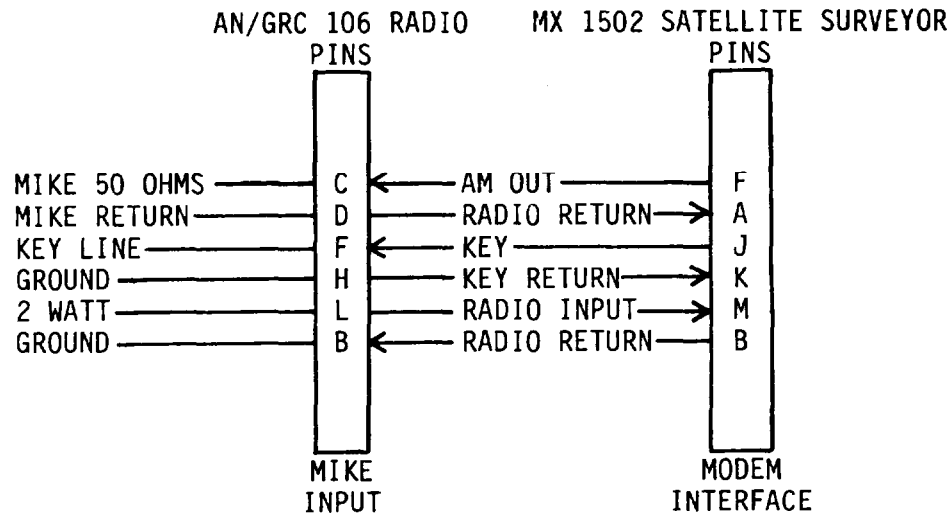

(2) Perform a communications check between the control and remote sites to verify proper operation.

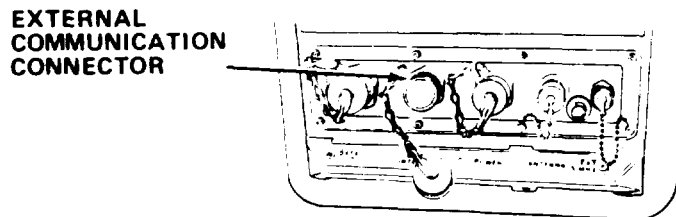

d. Connect radios to control and remote sites.

(1) Connect the radios at the control and remote sites to the MODEM INTERFACE connector on the side of the receiver/processor.

(2) Turn on the modem on the remote receiver/processor by entering code 230.

(3) Enter code 59 on the remote receiver/processor to check the modem status. Display should show MODM only; if a code is displayed, refer to table 4-7 and take appropriate action before continuing.

Table 4-7. CODE 59 DISPLAYS FOR MODEM STATUS

NOTE

This code applies only to Version 110 and above units.



Enter code 59 to display the status of the communications modem. The following symbols may be displayed:

- OFF - Modem not being used.
- E - Error detected in modem.
- S - Modem currently running self-test.
- T - Modem currently transmitting message.
- L - Modem receiver currently locked onto incoming signal.
- R - Modem received incoming message.
- C - Incoming message changed instead of repeating.

e. Data collection. Press the clear (C) key to start data collection. Record the number of passes necessary to obtain the required accuracy (Table 4-4).

f. Display and record control site data.

(1) Press clear (C) key and key in Code 53.



NOTE

The following data is in terms of satellite datum. If datum conversion is required, refer to paragraph 4-6.3.4.

(2) Press the enter (E) key to read the initial display, then press the enter (E) key to erase and view each succeeding display in turn. Interpret the displayed data in accordance with Table 4-5, page 4-62.

(3) Press the enter (E) key to read the initial 3D display, then press the enter (E) key to erase and view each succeeding diisplay in turn. Interpret the displayed data in accordance with Table 4-6, Code 63 and record on DA Form 1959.

g. Display and record remote site data.

(1) Display and record the remote site data in accordance with step f, above.

(2) Press the enter (E) key to display the translocation position, then press the enter (E) key to erase and view each succeeding display in turn. Interpret the displayed data in accordance with Table 4-8 and record on DA Form 1959.

| | | |
|----|---|-------|
| TR | 1 | 7.241 |
|----|---|-------|

Table 4-8. CODE 73 DISPLAYS FOR TRANSLOCATION POSITION

Enter code 73 to display the most recently computed translocation position. The translocation position computation is based on accumulated data. The translocated position is displayed in a sequence of 15 displays. Press the enter (E) key to erase one display and view the next. The initial display shows the following information:

Table 4-8. CODE 73 DISPLAYS FOR TRANSLOCATION POSITION - Cont

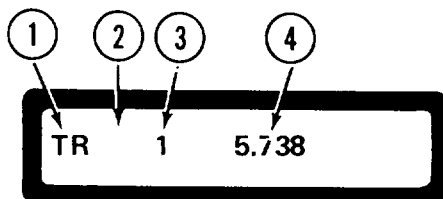

Initial Display

1. Translocation code mnemonic (TR).
2. When this position is blank, the translocation position was computed using data from the last satellite pass. A one-letter code in this position indicates that the last pass data was not used. The following codes signify the reason for not using data from the last pass:
 - 0 - No 2D fix could be computed.
 - C - Less than eight doppler counts used in 2D computations.
 - D - More than 1 km (0.62 miles) between 2D position and reference position.
 - E - Maximum elevation angle of satellite less than 15 degrees.
 - H - Maximum elevation angle greater than 70 degrees immediately after point position was reset.
 - I - More than six iterations occurred in 2D computation.
 - R - Only one of two satellite receiver channels was used to calculate 2D position due to insufficient data on other channel.
 - S - Standard deviation of residuals was too large, indicating that satellite data was in error (see code 91).
 - U - Data from satellite was asymmetrical about point of closest approach.
 - X - Last satellite pass data was taken from a satellite that indicated within its message that it should not be used for precise applications (i.e., negative satellite number).
 - Y - Satellite pass data was taken from a satellite that was deleted by user.
3. Number of satellite passes used in the translocation position computation.
4. Distance in meters from the previously computed translocation position. This value is meaningless for the first computation.

Press the enter (E) key. Display shows the computed latitude in degrees, minutes, and seconds using satellite datum coordinates.

Table 4-8. CODE 73 DISPLAYS FOR TRANSLOCATION POSITION - Cont

LT N 33 50 28.711

Computed Latitude

Press the enter (E) key. Display shows the computed longitude in degrees, minutes, and seconds using satellite datum coordinates.

LN W 118 20 21.021

Computed Longitude

Press the enter (E) key. Display shows the computed geodetic height in meters, using the satellite datum.

HT 40.10

Computed Geodetic Height

Press the enter (E) key. Display shows the computed standard deviation in meters of the latitude (1) and longitude (2).

SD 3.166 2.144

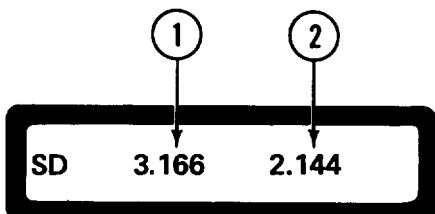

Standard Deviation of Latitude and Longitude

Press the enter (E) key. Display shows the computed standard deviation in meters of the height.

Table 4-8. CODE 73 DISPLAYS FOR TRANSLOCATION POSITION - Cont

SDH 0.167

Standard Deviation of Height

Press the enter (E) key. Display shows the number of passes whose geometry lies in the northwest and northeast quadrants respectively.

N-WE 7 11

Northern Geometry

Press the enter (E) key. Display shows the number of passes whose geometry lies in the southwest and southeast quadrants respectively.

S-WE 10 9

Southern Geometry

Press the enter (E) key. Display shows the latitude distance of the translocation position from the reference position in meters. Positive (+) indicates that the translocation position is north of the reference position and negative (-) indicates that it is south.

DLT+ 5.24

Latitude Distance from Reference

Press the enter (E) key. Display shows the longitude distance in meters of the translocation position from the reference position. Positive (+) indicates that the translocation position is east of the reference position and negative (-) indicates that it is west.

Table 4-8. CODE 73 DISPLAYS FOR TRANSLOCATION POSITION - Cont



DLN- 7.15

Longitude Distance from Reference

Press the enter (E) key. Display shows the height distance in meters of the translocation position from the reference position. A positive (+) indicates that the translocation position is above the reference position and negative (-) indicates that it is below.



DHT+ 4.38

Height Distance from Reference

Press the enter (E) key. Display shows the radial distance in meters of the translocation position from the reference position.



DREF 57.06

Radial Distance from Reference

Press the enter (E) key. Display shows the latitude in degrees, minutes, and seconds of the reference position, using the satellite datum.



RT N 27 14 16.725

Reference Latitude

Press the enter (E) key. Display shows the longitude in degrees, minutes, and seconds of the reference position, using the satellite datum.

Table 4-8. CODE 73 DISPLAYS FOR TRANSLOCATION POSITION - Cont



RN W114 37 42.117

Reference Longitude

Press the enter (E) key. Display shows the geodetic height in meters of the reference position, using the satellite datum.



RHT+ 13.74

Reference Geodetic Height

Press the enter (E) key to display the relative translocation data. Refer to code 74 (Table 4-9).



RANG 274.32576

Relative Translocation Data

(3) Press the enter (E) key to display the relative translocation data, then press the enter (E) key to erase and display each succeeding display in turn. Interpret the displayed data in accordance with Table 4-9, and record on DA Form 1959.

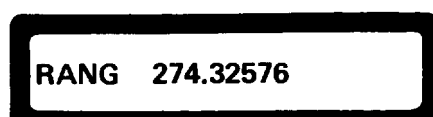

RANG 274.32576

Table 4-9. CODE 74 DISPLAYS FOR RELATIVE TRANSLOCATION DATA

Enter code 74 to display the relative translocation distance associated with the last translocation fix. The first display shows the range in kilometers (straight-line or chord distance) between the control site and the remote site.

RANG 274.32576

Range Between Sites

Press the enter (E) key to display the geodetic azimuth off north in the satellite datum of the remote site with respect to the control site. This is shown in degrees measured clockwise off true north with respect to the satellite datum.

AZN 117.282

Azimuth of Remote Site

Press the enter (E) key to display the difference between the control and remote sites (remote-control) in the X coordinate of the satellite datum. The units are kilometers.

$\Delta X + 132.65281$

X Coordinate Difference

Press the enter (E) key to display the difference between the control and remote sites (remote-control) in the Y coordinate of the satellite datum. The units are kilometers.

$\Delta Y - 257.43787$

Y Coordinate Difference

Press the enter (E) key to display the difference between the control and remote sites (remote-control) in the Z coordinate of the satellite datum. The units are kilometers.

Table 4-9. CODE 74 DISPLAYS FOR RELATIVE TRANSLOCATION DATA - Cont



ΔZ + 347.74271

Z Coordinate Difference

Press the enter (E) key to display the latitude in degrees, minutes, and seconds of the control site position, using the satellite datum.



CT N 71 22 14.628

Control Latitude

Press the enter (E) key to display the longitude in degrees, minutes, and seconds of the control site position, using the satellite datum.

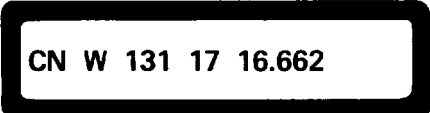

CN W 131 17 16.662

Control Longitude

Press the enter (E) key to display the geodetic height in meters of the control site position, using the satellite datum.



CHT 47.32

Control Height

h. Rewind the remote site pass data tape by entering code 49, then remove, label, and store the cassette.

i. Secure remote site. Disconnect the external communications link, and perform your after PMCS in accordance with Table 4-1.

4-6.3.3 Off-Line Mode. This mode enables the operator to determine two dimensional, 3D position, and translocated positions of survey sites, using data recorded on tape cassettes. The positions are computed by the satellite surveyor using keyboard entered data and satellite pass data read from the tape. The off line mode may use one or more 1-site or 2-site tapes. The tapes recorded in the standard or control mode are called 1-site tapes. Tapes recorded in the remote mode are called 2-site tapes. The 2-site tapes contain both control site data and remote site data. If the satellite surveyor is to operate in off-line mode only, the antenna need not be assembled or connected to the receiver/processor. The functional diagram shows the off-line mode of operation. The 3D positioning computation will provide location data of the survey site with an accuracy within 10 m (32.8 ft) rms. Assemble and prepare the equipment for use (paragraph 4-6.1 and 4-6.2) and operate the receiver/processor in the off-line mode as-follows:

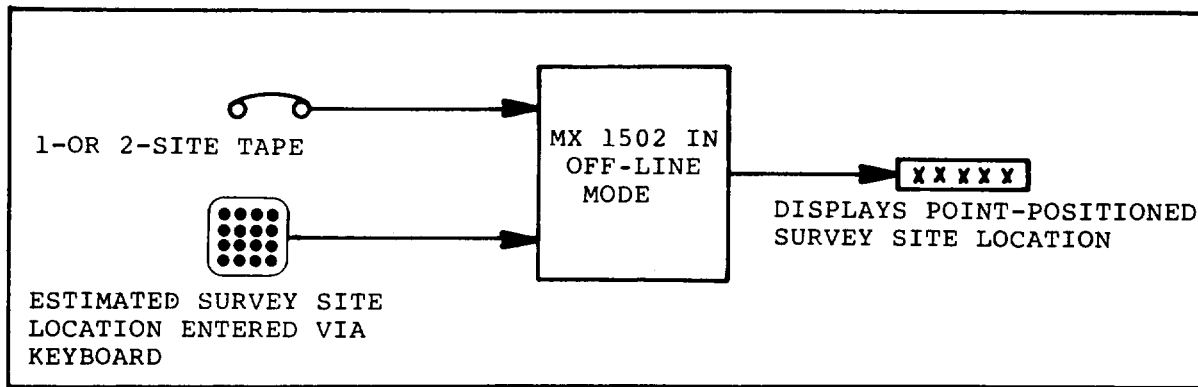

a. Three D positioning with 1- or 2-site tapes. The following procedure is used to determine the survey site 3D positioning using either 1- or 2-site tapes. If a 2-site tape is used, the computation ignores control site data. The accuracy of the 3D position computation depends on the number of acceptable satellite passes collected (Table 4-4).

- (1) Select the off-line mode of operation by entering code 10.
- (2) Position the tape to the beginning of tape (BOT), by entering code 41.

NOTE

If 3D position estimate must be extracted from the tape, proceed to step (3). If data is available from previously recorded tape, proceed to step (4).

- (3) Extract 3D position estimate as follows:

(a) Enter code 42 to have tape search for end of data. End of data is located when CODE is displayed.

LOOK

CODE

(b) Enter code 44. Press change sign (+/-) and 1 to change display to PS-1. Then press enter (E) key.

PS- 1

(c) Tape will search backward until last pass data is found.

BACK

(d) Computer will then read pass data.

READ

(e) Once data is read in, the pass number will be displayed

PASS XX

(f) Enter code 99 (last pass and 3D position) and display information. Record 3D position data.

(4) Enter the survey site 3D position estimate (latitude, longitude, and height) by entering code 77 (Table 4-10).

(5) Position tape to the beginning of tape (BOT) by entering code 41.

Table 4-10. CODE 77 DISPLAYS FOR INPUT POSITION

Enter code 77 to input a position in one of several formats. Press the +/- key to select the desired format for position entry. Then press the enter (E) key to begin the prompted data entry. Changing the input position resets the 3D position and translocation position fix computations.

Table 4-10. CODE 77 DISPLAYS FOR INPUT POSITION - Cont

Geographic position entry. The user may select geographic position entry in either the satellite datum or a local datum. Before selecting local datum, specify constants identifying the local datum using code 100 (refer to paragraph 4-6.3.4).

INPS GEO-SAT

Geodetic Satellite Datum Selected

INPS GEO-LOC

Geodetic Local Datum Selected

The first parameter to be displayed and/or entered is the latitude in degrees, minutes, and seconds of the input position. If the currently displayed value is correct, press only the enter (E) key. If it is not correct, enter the new value. Enter a space (→) between degrees and minute, and between minutes and seconds. Use the +/- key to change from N (north) to S (south) or vice versa. Then press the enter (E) key to enter the latitude.

LT N 33 50 17.478

Latitude

The next parameter to be displayed and/or entered is the longitude in degrees, minutes, and seconds of the input position. If the currently displayed value is correct, press only the enter (E) key. If it is not correct, enter the new value. Enter a space (→) between degrees and minutes, and between minutes and seconds. Use the +/- key to change from E (east) to W (west) or vice versa. Then press the enter (E) key to enter the new longitude.

LN W118 20 14.727

Longitude

Table 4-10. CODE 77 DISPLAYS FOR INPUT POSITION - Cont

The MX 1502 then asks the user to select whether height will be entered in the form of geodetic height (HT) or elevation above mean sea level (EL). Press the +/- key to select the desired mode, then press the enter (E) key. The elevation mode should be used only when the geodetic height is unknown.

HGT HT

Height Entry Mode

When the geodetic height mode is selected, the geodetic height of the antenna reference point will be displayed in meters. The antenna reference point is marked by a red band on the antenna/preamplifier unit. If the geodetic height is correct, press only the enter (E) key. If it is not correct, enter the new value. Use the +/- key to change from + to - or vice versa. Then press the enter (E) key.

HT + 17.72

Geodetic Height

If the elevation mode is selected, the elevation in meters of the antenna reference point above mean sea level will be displayed. If it is correct, press only the enter (E) key. If it is not correct, enter the new value. Use the +/- key to change from + to - or vice versa. Then press the enter (E) key.

EL + 4.06

Elevation

XYZ Position Entry. The user may select XYZ (Cartesian coordinate) position entry in either the satellite datum or a local datum. Before selecting local datum, first specify constants identifying the local datum using code 100 (paragraph 4-6.3.4). 4-98).

INPS XYZ-SAT

XYZ Satellite Datum Selected

INPS XYZ-LOC

XYZ Local Datum Selected

Table 4-10. CODE 77 DISPLAYS FOR INPUT POSITION - Cont

The first parameter to be displayed and/or entered is the X coordinate in kilometers of the input position. If the currently displayed value is correct, press only the enter (E) key. If it is not correct, enter the new value. Press the +/- key to select the appropriate sign. Then press the enter (E) key to enter the new X coordinate.



X - 2317.50623

X Coordinate

The next parameter to be displayed and/or entered is the Y coordinate in kilometers of the input position. If the currently displayed value is correct, press only the enter (E) key. If it is not correct, enter the new value. Press the +/- key to select the appropriate sign. Then press the enter (E) key to enter the new Y coordinate.



Y + 237.15152

Y Coordinate

The last parameter to be displayed and/or entered is the Z coordinate in kilometers of the input position. If the currently displayed value is correct, press only the enter (E) key. If it is not correct, enter the new value. Press the +/- key to select the appropriate sign. Then press the enter (E) key to enter the new Z coordinate.

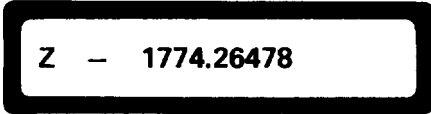

Z - 1774.26478

Z Coordinate

(6) To compute a 3D position from tape, enter code 47 (Table 4-11). When PNTF is displayed, press the enter (E) key. If REST NO is displayed, change to RSET YES using the change sign (+/-) key. Press the enter (E) key. The MX 1502 will compute a 3D position from the tape.

Table 4-11. CODE 47 DISPLAYS FOR 3D POSITION FROM TAPE

This code is operative only in the off-line mode. Enter code 47 to compute a 3D position fix from the raw satellite data on tape. The tape will stop after reading a site record. Code 47 must be reentered to continue.

When code 47 is entered, the unit asks the user how many satellite passes to process.



PNTP

Initial Display

Enter either no number, one number, or two numbers. Entering no number causes all passes in the site to be processed. Entering one number indicates the number of passes to process in the 3D position computation.



PNTP 5

Process 5 Passes

To process all passes up to and including a pass which is identified by a pass number on the tape, enter a 0 digit, space, then the pass number. Entering no number causes all passes in the site to be processed.



PNTP 0 38

Process to Pass 38

After selecting the passes to be processed, press the enter (E) key.

The unit then asks whether or not the 3D position computation should be reset. Reset should be selected only at the beginning of a 3D position computation.

Table 4-11. CODE 47 DISPLAYS FOR 3D POSITION FROM TAPE - Cont

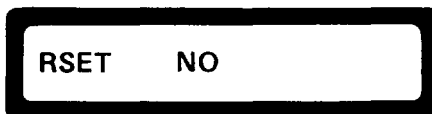

Initial Display

If reset is desired, press the +/- key. After selecting reset or not, press the enter (E) key.



Reset Selected

The unit then reads satellite pass data from the tape and computes a 3D Position fix based upon that data.



Reading Tape

While the unit is processing data from a particular pass, it displays that pass number.



Processing Pass 27

When it finishes processing all pass data, it displays CODE, SITE if a new site record is encountered, or END if the end of data on tape is encountered.

Table 4-11. CODE 47 DISPLAYS FOR 3D POSITION FROM TAPE - Cont

CODE

Done Processing

When computing a point position, the unit also stores in its memory the data needed for subsequent translocation processing with another site. The last 17 acceptable passes are held in memory. Code 99 may be used to display the field processed data.

(a) If the tape stops immediately at a site record, display will indicate site and number. Press clear (C) key and re-enter code 47.

(b) When PNTP is displayed, press enter (E) key. If RSET YES appears, press change sign (+/-) key to display RSET NO, then press enter (E) key.

NOTE

It will take two to three minutes to process each pass.

(c) When END is displayed, press the clear (C) key.

(d) Rewind the tape by entering code 49 and remove cassette.

(e) If there is more data to be processed, continue at step (f). If no more data is to be processed, proceed to step (h).

(f) Install new tape and position to BOT using code 41.

(g) Enter code 47 and repeat steps (b) through (e) above.

(h) Display the survey site 3D position location in satellite datum using code 63 (Table 4-6, page 4-65). Record the display 3D position on DA Form 1959.

(i) Convert the 3D position to both local and UTM datum in accordance with paragraph 4-6.3.4, page 4-98.

(7) If all data has been processed, perform your after PMCS, Table 4-1.

b. Translocation with 1-site tapes. The following procedures enable the determination of a remote site location, using two separate tape sets: one recorded at a control site (known position) and one recorded at a remote site (estimated position). With data collected on tape from a sufficient number of acceptable satellite passes (Table 4-4), the translocated position of the remote site will be accurate to within 1 meter (3.28 ft) rms. Translocated position is computed in the satellite datum, eliminating errors due to local datum distortion. This technique requires system initialization in the satellite datum. The simplest way to initialize a position in the satellite datum is to use the 3D position solution already recorded on cassette tape during data collection. The functional diagram shows translocation with 1-site tapes. Assemble and prepare the equipment for use (paragraphs 4-6.1 and 4-6.2), and proceed as follows:

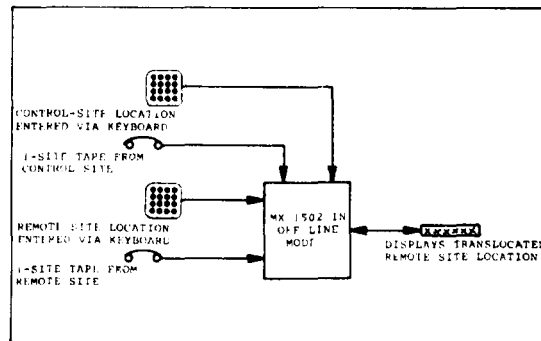

FUNCTIONAL DIAGRAM, TRANSLOCATION WITH 1-SITE TAPES

- (1) Select the off-line mode of operation by entering code 10.

NOTE

The first tape (usually from the remote site) is the one whose first pass recorded occurred at a later time than first pass recorded on the second tape.

- (1.1) To check which tape has the later recorded pass, perform the following:

- (a) Install one tape and rewind it using a code 41.
- (b) Enter code 44, followed by a +1 to read the first pass on the tape.
- (c) After the tape stops, enter code 99 to display the pass information.
- (d) Record the time and day of the first pass.
- (e) Enter code 41 to rewind the tape, then remove tape.
- (f) Repeat the above steps for the second tape.

- (2) Install the first tape.

- (3) Extract the point position of the last pass recorded in accordance with step a, (2) and (3) above, page 4-80.

(4) Enter the survey 3D position estimate (latitude, longitude, and height), by entering code 77 (Table 4-10, page 4-81).

(4.1) Rewind the tape using code 41.

NOTE

Only 17 acceptable passes from the tape will be loaded into memory at one time. Processing each pass will take from two to three minutes.

(5) Load the contents of the first tape by entering code 40 (Table 4-121). When LOAD is displayed, press the enter (E) key. If RSET NO display, change to RSET YES by pressing the change sign (+/-) key. Then press the enter (E) key. Tape data will then be loaded into memory.

Table 4-12. CODE 40 DISPLAY FOR LOADING TAPE

This code is operative only in the off-line mode. Enter code 40 to load satellite data from a tape into the memory for subsequent translocation processing. The tape will stop after reading a site record. Code 40 must be re-entered to continued.

When code 40 is entered, the unit asks the user how many satellite passes to load.



LOAD

Initial Display

Enter either no number, one number, or two numbers. Entering no number causes all passes in the site to be loaded into memory. Entering one or two numbers indicates the number of passes to load into memory.



LOAD 5

Load 5 Passes

To load all passes up to and including a pass which is identified by a pass number on the tape, enter a 0 digit, space, then the pass number.

After selecting the passes to be loaded, press the enter (E) key.



LOAD 0 38

Load to Pass 38

When available memory is full, loading stops with FULL being displayed. When loading stops at the end of tape data, END is displayed.



FULL

Available Memory Full

(6) If the tape stops immediately at a site record, press the clear (C) key and re-enter code 40 (Table 4-12). When load is displayed, press enter (E) key. If RSET YES is displayed, change to RSET NO by pressing the change sign (+/-) key, then press the enter (E) key. Tape will continue to be read into memory.

(7) If END is displayed, 17 acceptable passes were not available on this tape. If more data is available, load new tape as follows:

(a) Position the tape to the beginning of tape (BOT) by entering code 41 (Table 4-12).

(b) Load contents into memory by entering code 40. If RSET YES is displayed, change to RSET NO by pressing change sign (+/-) key, and then enter (E) key. Tape will load until FULL is displayed.

(8) When FULL is displayed, press clear (C) key, then enter code 99. Display and record the last pass number in memory, then press clear (C) key.

(9) Rewind the tape by entering code 49 and remove the cassette.

(10) Install the second tape.

(11) Extract the 3D position of the last pass recorded in accordance with step a, (2) and (3) above.

(12) Enter the 3D position of the second tape by entering code 77 (Table 4-10, Code 77).

(12.1) Rewind tape using code 41.

(13) Start translocation process by entering code 46 (Table 4-13). When TRAN is displayed, press the enter (E) key. If RSET NO is displayed, change to read RSET YES by pressing change sign (+/-) key then enter (E) key.

Table 4-13. CODE 46 DISPLAYS FOR TRANSLOCATING FROM TAPE

This code is operative only in the off-line mode. Enter code 46 to read satellite data from tape and compute a translocated position. The tape will stop after reading a site record. Code 46 must be re-entered to continue.

When code 46 is entered, the unit asks the user how many satellite passes to process.



Initial Display

Table 4-13. CODE 46 DISPLAYS FOR TRANSLOCATING FROM TAPE - Cont

Enter either no number, one number, or two numbers. Entering no number causes all passes in the site to be processed. Entering one or two numbers indicates the number of passes to process in the translocation computation.



TRAN 8

Process 8 Passes

To process all passes up to and including a pass which is identified by a pass number on the tape, enter a 0 digit, space, then the pass number.

After selecting the passes to be processed, press the enter (E) key.



TRAN 0 27

Process to Pass 27

The unit then asks whether or not the translocation computation should be reset. Reset should be selected only at the beginning of a translocation computation.



RSET NO

Initial Display

If reset is desired, press the +/- key. After selecting or not selecting reset, press the enter (E) key.



RSET YES

Reset Selected

Table 4-13. CODE 46 DISPLAYS FOR TRANSLOCATING FROM TAPE - Cont

If reset was selected, the unit asks for the site where the tape was recorded. Use the +/- key to select either the control or the remote site. Then press the enter (E) key.



Control Site Selected

The unit then reads satellite pass data from the tape cassette and computes a translocation position fix based on that data.



Reading Tape

While the unit is processing data from a particular pass, it displays that pass number.



Processing Pass 17

When the unit finishes processing all pass data, it displays SITE if a new site record is encountered; END if the end of data on tape is encountered; or DONE if all corresponding data in memory from the other site has been used.



Done Processing

(14) When TAPE CONTROL is displayed, proceed as follows:

(a) If a control site tape is being used, press the enter (E) key.

(b) If a remote site tape is being used, press the change sign (+/-) key to display TAPE CONTROL, then press the enter (E) key.

(15) If the tape stops immediately at a site record, press the clear (C) key and re-enter code 46 (Table 4-13). If RSET YES is displayed, change it to RSET NO by pressing the change sign (+/-) key. This will continue the translocation process until either DONE or END is displayed.

(16) If END is displayed, proceed to step (17). If DONE is displayed and no more tape data is desired, rewind tape using Code 49 and proceed to next step. If more tape data is desired, enter Code 99, display and record last pass number, and proceed as follows:

(a) Rewind the tape by entering code 49, then remove the cassette.

Table 4-14. CODE 44 DISPLAY FOR READ PASS

This code is operative only in the off-line mode. It does not affect current position fix results. Enter code 44 to move the tape forward or backward a given number of passes. The tape will stop after reading a site record. Code 44 must be re-entered to continue.

When code 44 is entered, the unit asks the user how to move the tape. The + sign means move forward. To move backward, press the +/- key to display a - sign. The first displayed number indicates the number of passes to move.

PS + 1

Initial Display

Enter the number of passes to move if desired.

PS + 7

Move Forward 7 Passes

Table 4-14. CODE 44 DISPLAY FOR READ PASS - Cont

To move to a desired pass that is identified by a pass number on the tape, enter a 0 digit, space, then the pass number.

After selecting the tape movement, press the enter (E) key and the tape will move as specified. Pressing (E) with no entry moves the tape forward to the next pass on tape. Code 99 may be used to display data read by code 44.



Move Forward To Pass 22

(b) If more data is to be processed, reinstall the first tape and enter code 44 (Table 4-14).

(c) Key in 0, space, (→), and the pass number recorded in step (8), above, page 4-90.

(d) Repeat steps (6) through (10), above, page 4-90.

(e) Reinstall the second tape and enter code 44.

(f) Key in 0, space (→), and the pass number recorded in step (16), above.

(g) Continue the translocation process by entering code 46 (Table 4-13). When TRAN is displayed, press the enter (E) key. IF RSET YES is displayed, change to read RSET NO by pressing the change sign (+/-) key, then the enter (E) key.

(h) Repeat steps (14) and (15) above.

(i) Repeat steps (a) through (h) above until all desired data has been processed.

(j) Rewind tape by entering code 49, remove the cassette, and proceed to step (18).

(17) If END was displayed in step (15), more tape data is required. Rewind the tape by entering code 49, remove the cassette, and proceed as follows:

(a) Install a new control site tape and position the tape to the beginning of tape (BOT) by entering code 40 (Table 4-12).

(b) Continue the translocation process by entering code 46 (Table 4-13). When TRAN is displayed, press the enter (E) key. If RSET YES is displayed, change to read RSET NO by pressing the change sign (+/-) key, then the enter (E) key.

(c) The translocation process will continue until DONE is displayed. When DONE is displayed, repeat step (16) above.

(18) Display the translocation positioning by entering code 73 (Table 4-8), and record the position on DA Form 1959.

(19) If all data has been processed, perform your after PMCS, Table 4-1.

Translocation with 2-site tapes. The following procedure enables the determination of remote site translocated position, using data from 2-site tapes. The tape data is recorded at the remote site, with the MX 1502 in the REMOTE mode. The data consists of both the remote site data and control site data. The translocated position will be accurate to within 1 meter rms (3.28 ft) (Table 4-4). The functional diagram shows translocation with 2-site tapes.

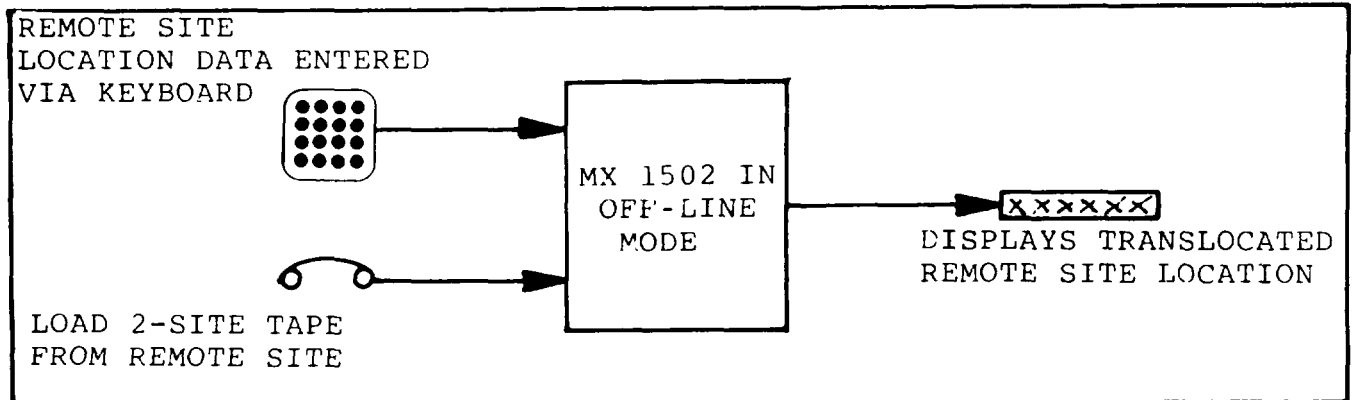

FUNCTIONAL DIAGRAM, TRANSLOCATION WITH 2-SITE TAPES

Assemble and prepare the equipment for use (paragraph 4-6.1 and 4-6.2) and operate the receiver/processor in the off-line mode as follows:

- (1) Select the off-line mode of operation by entering code 10.
- (2) Install the first recorded 2-site tape.
- (3) Repeat step a, (2) through (4) above, page 4-80.
- (4) Reposition the tape to the beginning of tape (BOT) by entering code 41.
- (5) Start the translocation process by entering code 39 (Table 4-15). When TRAN is displayed, press the enter (E) key. If RSET NO is displayed, change to RSET YES by pressing the change sign (+/-) key.
- (6) If the tape stops immediately at a site record, press the clear (C) key and re-enter code 39. If RSET YES is displayed, change to RSET NO by pressing the change sign (+/-) key.

- (7) When END is displayed, press the clear (C) key.
- (8) Rewind the tape by entering code 49, then remove the cassette.

NOTE

During the performance of the next procedure, if RSET NO is displayed, press the enter (E) key.

(9) If more data is to be processed, install the next cassette, and repeat steps (4) through (8) above until all tapes for that site are processed.

(10) Display the translocation position by entering code 73 (Table 4-8, page 4-72) and record the position on DA Form 1959.

(11) If all data has been processed, perform your after PMCS, Table 4-1.

Table 4-15. CODE 39 DISPLAYS FOR TRANSLOCATING FROM 2-SITE TAPE

This code is operative only in the off-line mode. The tape must have been recorded on a remote MX 1502 in the remote mode that received data via a communications link from a control MX 1502 at another site.

Enter code 39 to read satellite and modem data from tape and compute 3D and translocation positions. When code 39 is entered, the MX 1502 asks the user how many satellite passes to process.



Initial Display

Enter either no number, one number, or two numbers. Entering no number causes all passes at the site to be processed. Entering one number indicates the number of passes to process in the computations.



Process Eight Passes

Table 4-15. CODE 39 DISPLAYS FOR TRANSLOCATING FROM 2-SITE TAPE - Cont

To process all passes, up to and including a pass that is identified by a pass number on the tape, enter a 0 digit, a space, then the pass number. After selecting the passes to be processed, press the enter (E) key.



TRAN 0 14

Process to Pass 14

The MX 1502 then asks whether or not the translocation/3D position computations should be reset. Reset should be selected only at the beginning or iteration of translocation/3D position computations.

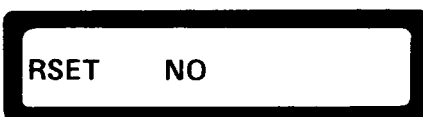

RSET NO

Initial Display

To reset the computations, press the +/- key. To maintain the computation, press the enter (E) key again.



RSET YES

Reset Selected

The MX 1502 then reads satellite pass and modem data from the tape cassette and computes translocation/3D position fixes based on that data.



READ

Reading Tape

Table 4-15. CODE 39 DISPLAYS FOR TRANSLOCATING FROM 2-SITE TAPE - Cont

While the MX 1502 is processing the data from a particular pass, it displays the number of that pass.



READ 34

Processing Pass 34

When the MX 1502 has completed processing pass data, it displays either CODE, SITE if a new site record is encountered, or END if the end of data on tape is encountered.



CODE

Processing Completed

4-6.3.4 Datum Conversions.

4-6.3.4.1 General. Initial computations for a satellite-derived position define its location in a satellite datum that is similar, but not identical, to the WGS-72 datum. When entering the datum shift transformations, a rotation about the Z axis (RZ) of +0.26 arc seconds should be included. Since most national survey organizations work in coordinates referenced to a local datum and reference ellipsoid, the satellite datum solution must be converted to the local datum by using the datum shift constants and the Z axis rotation. Table 4-16 lists the constants required to convert from WGS-72 coordinates to local datums. These constants may be used to define a local datum, using code 100. Origin offset constants X, Y, and Z have the appropriate signs for converting from WGS-72 to local datums. Other publications may list constants for converting from local datums to WGS-72, and the signs will be opposite to those listed in Table 4-16.

NOTE

These constants in Table 4-16 are approximate values that have been averaged over large areas. Therefore, they may not be accurate enough for specific areas and applications.

Table 4-16. DATUM SHIFT CONSTANTS

| Datum | Semimajor Axis (km) A | Reciprocal of Flattening 1/F | Origin Offset (m) | | |
|---------------------------------------------|-----------------------------|------------------------------------|-------------------|------------|------------|
| | | | ΔX | ΔY | ΔZ |
| Adindan | 6378.249145 | 293.465 | 152 | 26 | -212 |
| Arc 1950 and 1960 | 6378.249145 | 293.465 | 129 | 131 | 282 |
| Ascension Island Astro 1958 | 6378.388 | 297 | 214 | -91 | -48 |
| Australian Geodetic | 6378.160 | 298.25 | 122 | 41 | -146 |
| Camp Area Astro | 6378.388 | 297 | 103 | 122 | -233 |
| Canton Island Astro 1966 | 6378.388 | 297 | 294 | 288 | 382 |
| European | 6378.388 | 297 | 84 | 103 | 127 |
| Geodetic Datum 1949 | 6378.388 | 297 | -82 | 38 | -195 |
| Hu-Tzu-Shan | 6378.388 | 297 | 620 | 542 | 206 |
| Indian | 6377.276344 | 300.8017 | -189 | -746 | -259 |
| Johnston Island Astro 1961 | 6378.388 | 297 | -192 | 59 | 211 |
| Kertau (Malayan Re- vised Triangulation) | 6377.304063 | 300.8017 | 12 | -857 | -15 |
| Liberia 1964 | 6378.249145 | 293.465 | 63 | -12 | -80 |
| Mercury 1960 | | | | | |
| NAD 27 Area | 6378.166 | 298.3 | 25 | -46 | 49 |
| ED Area | 6378.166 | 298.3 | 13 | 88 | 5 |
| TD Area | 6378.166 | 298.3 | -18 | 132 | -60 |
| Modified Mercury 1968 | | | | | |
| NAD 27 Area | 6378.150 | 298.3 | 4 | -12 | 7 |
| ED Area | 6378.150 | 298.3 | 3 | -1 | 6 |
| TD Area | 6378.150 | 298.3 | -22 | -34 | -2 |
| Nanking 1960 | 6378.388 | 297 | 131 | 347 | 0 |
| Nigeria | 6378.249145 | 293.465 | 89 | 112 | -124 |

Table 4-16. DATUM SHIFT CONSTANTS - Cont

| Datum | Semimajor Axis (km) A | Reciprocal of Flattening 1/F | Origin Offset (m) | | |
|-------------------------------------------|-----------------------------|------------------------------------|-------------------|------------|------------|
| | | | ΔX | ΔY | ΔZ |
| North American 1927 | | | | | |
| CONUS | 6378.2064 | 294.9786982 | 22 | -157 | -176 |
| Alaska and Canada | 6378.2064 | 294.9786982 | 9 | -139 | -173 |
| Old Hawaiian | | | | | |
| Maui | 6378.2064 | 294.9786982 | -65 | 272 | 197 |
| Oahu | 6378.2064 | 294.9786982 | -56 | 268 | 187 |
| Kauai | 6378.2064 | 294.9786982 | -46 | 271 | 181 |
| Ordinance Survey of Great Britain 1936 | 6377.563396 | 299.3249646 | -368 | 120 | -425 |
| Pulkovo 1942 | 6378.245 | 298.30 | -27 | 135 | 89 |
| Qornoq | 6378.388 | 297 | -163 | -127 | 151 |
| South American 1969 | 6378.160 | 298.25 | 77 | -3 | 45 |
| Provisional South American 1956 | 6378.388 | 297 | 302 | -105 | 371 |
| Corrego Alegre | 6378.388 | 297 | 261 | -140 | 24 |
| Campo Inchauspe | 6378.388 | 297 | 160 | -133 | -75 |
| Chua Astro | 6378.388 | 297 | 154 | -242 | 40 |
| Yacare | 6378.388 | 297 | 167 | -163 | -33 |
| South Asia | 6378.155 | 298.3 | -21 | 61 | 15 |
| Tananarive Observatory 1925 | 6378.388 | 297 | 178 | 254 | 95 |
| Timbalai | 6377.397155 | 299.1528128 | 650 | -525 | 76 |
| Tokyo | 6377.397155 | 299.1528128 | 140 | -516 | -673 |
| UTM | 6378.135 | 298.26 | 0 | 0 | -2.6 |

Table 4-16. DATUM SHIFT CONSTANTS - Cont

| Datum | Semi major Axis (km) A | Reciprocal of Flattening 1/F | Origin Offset (m) | | |
|------------------------|------------------------------|------------------------------------|-------------------|------------|------------|
| | | | ΔX | ΔY | ΔZ |
| Wake-Eniwetok 1960 | | | | | |
| Kwajalein Atoll | 6378.270 | 297 | -112 | -68 | 44 |
| Wake Island | 6378.270 | 297 | -121 | -62 | 22 |
| Eniwetok Atoll | 6378.270 | 297 | -144 | -62 | 38 |
| Wake Island Astro 1952 | 6378.388 | 297 | -283 | 44 | -141 |

4-6.3.4.2 Datum Conversions. The following procedures are used to enter parameters and display and retrieve datum conversions while processing data in the various operating modes.

a. Local datum based on WGS-72.

(1) Press the clear (C) key and enter code 100 (Table 4-17).

(2) When A is displayed, enter the A value from Table 4-16 for the datum required.

(3) When 1/F is displayed, enter the reciprocal of flattening value from Table 4-16 for the datum required.

NOTE

In the following steps, if the number to be entered is negative, press the change sign (+/-) key before entering the number.

(4) When ΔX is displayed, enter the ΔX value from Table 4-16 for the datum required.

(5) When ΔY is displayed, enter the ΔY value from Table 4-16 for the datum required.

(6) When ΔZ is displayed, enter the ΔZ value from Table 4-16 for the datum required.

(7) When RX is displayed, enter 0.

(8) When RY is displayed, enter 0.

(9) When RZ is displayed, enter + 0.26.

(10) When BS is displayed, enter 0.

(11) When Zone is displayed, and UTM conversion is desired, see Table 4-19, Code 106.

Table 4-17. DISPLAYS FOR DATUM CONVERSION PARAMETERS

Enter code 100 to display and/or enter the datum conversion parameters. Refer to Table 4-16 for a list of datum conversion constants. The first parameter is the value in kilometers of the semimajor axis for the reference ellipsoid of the local datum.

A 6378.20640

Semimajor Axis

Press the enter (E) key to display and/or enter the reciprocal of the flattening coefficient (1/F) of the reference ellipsoid of the local datum.

1/F 294.97870

Flattening Coefficient

Press the enter (E) key to display and/or enter the ΔX -origin offset in meters between the centers of the reference ellipsoids of the satellite datum and the local datum.

ΔX + 22.34

ΔX Origin Offset

Press the enter (E) key to display and/or enter the ΔY -origin offset in meters between the center of the reference ellipsoids of the satellite datum and the local datum.

ΔY - 157.07

ΔY Origin Offset

Table 4-17. DISPLAYS FOR DATUM CONVERSION PARAMETERS - Cont

Press the enter (E) key to display and/or enter the ΔZ -origin offset in meters between the centers of the reference ellipsoids of the satellite datum and the local datum.



$\Delta Z - 176.41$

ΔZ Origin Offset

NOTE

The ΔX , ΔY , and ΔZ datum shift constants listed in Table 4-16 have appropriate signs for converting from satellite datum to the corresponding local datum. Constants listed in other publications may have signs for converting from a local datum to the satellite datum. When entering datum constants, carefully note whether the sign is for conversion to or from the satellite datum.

Press the enter (E) key to display and/or enter the rotation angle in arc seconds about the X-axis. A positive (+) rotation is counterclockwise with respect to the origin of the XYZ coordinate system.



$RX + 1.71$

X-Axis Rotation Angle

Press the enter (E) key to display and/or enter the rotation angle in arc seconds about the Y-axis. A positive (+) rotation is counterclockwise with respect to the origin of the XYZ coordinate system.

Table 4-17. DISPLAYS FOR DATUM CONVERSION PARAMETERS - Cont



RY - 0.24

Y-Axis Rotation Angle

Press the enter (E) key to display and/or enter the rotation angle in arc seconds about the Z-axis. A positive (+) rotation is counterclockwise with respect to the origin of the XYZ coordinate system.

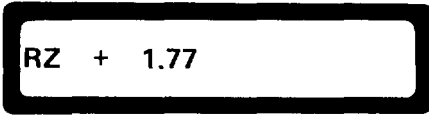

RZ + 1.77

Z-Axis Rotation Angle

NOTE

The signs of the rotation angles may be reversed in certain publications.

Press the enter (E) key to display and/or enter the bias in parts-per-million to the scale factor. The scale factor is $(1 \pm \text{bias})$ and is multiplied by the X, Y, and Z coordinates of the position.



BS + 3.18

Scale Factor Bias

(12) When CODE is displayed, enter 110 (Table 4-21).

(13) When DATM 2D is displayed, press change sign (+/-) key as many times as necessary to display the desired position to be converted. The positions displayed will be: 2D, POINT (3D), TRANSLOC, INPUT, REFERENCE, CONTROL, DR, and WAYPOINT.

(14) When the desired location is displayed, press the enter (E) key. the displayed number will be the datum shifted latitude.

(15) Press the enter (E) key to erase and display the remaining datum shifted data (Table 4-18).

b. UTM coordiantes. The initial procedures for extracting UTM coordinates are exactly the same as performed for local datum based on WGS-72. Perform step a, (1) through (10) above (page 4-101) and proceed as follows:

(1) When ZONE is displayed, the computer has automatically entered code 106 (Table 4-19). Enter 0 if the zone is unknown, or enter the zone number upon which computations are to be based.

(2) If a zone number was entered, display the parameters is accordance with Table 4-19, then go to step (4).

(3) If a 0 was entered, press the enter (E) key repeatedly until CODE is displayed.

(4) When CODE is displayed, enter 130 to display UTM coordinates (Table 4-20).

(5) When UTM 2D is displayed, press the change sign (+/-) key as many times as necessary to display the desired position to be converted. The positions displayed will be: 2D, POINT(3D), TRANSLOC, INPUT, REFERENCE, CONTROL, DR, and WAYPOINT.

Table 4-18. CODE 110 DISPLAYS FOR LOCAL DATUM POSITION

NOTE

Datum conversion parameters must be entered using code 100 before code 110 may be used.

Enter code 110 to select the position to be displayed in a local datum. Press the +/- key to select the desired position as shown by the display.



2D Position Selected

Press the enter (E) key to display the datum shifted latitude in degrees, minutes, and seconds.

Table 4-18. CODE 110 DISPLAYS FOR LOCAL DATUM POSITION - Cont

LT N 37 22 12.471

Local Datum Latitude

Press the enter (E) key to display the datum shifted longitude in degrees, minutes, and seconds.

LN W112 17 37.781

Local Datum Longitude

Press the enter (E) key to display the geodetic height in meters, using the local datum.

HT + 12.04

Geodetic Height

Press the enter (E) key to display the X coordinate in kilometers, using the local datum.

X - 3871.29832

Local Datum X Coordinate

Press the enter (E) key to display the Y coordinate in kilometers, using the local datum.

Table 4-18. CODE 110 DISPLAYS FOR LOCAL DATUM POSITION - Cont



Y + 2531.56620

Local Datum Y Coordinate

Press the enter (E) key to display the Z coordinate in kilometers, using the local datum.



Z - 1747.25837

Local Datum Z Coordinate

Table 4-19. CODE 108 DISPLAYS FOR UTM CONVERSION PARAMETERS

Enter code 106 to display and/or enter the UTM conversion parameters. The first parameter is the UTM zone number. Enter a 0 for zone number if the MX 1502 is to automatically calculate the zone number based upon the longitude. The zone is defined to be 6 degrees wide in longitude.



ZONE 32

Zone Number

Press the enter (E) key to display and/or enter the UTM central meridian. No entry results in the MX 1502 calculating the central meridian automatically.



CM E107 16 22.741

Central Meridian

Table 4-19. CODE 106 DISPLAYS FOR UTM CONVERSION PARAMETERS - Cont

NOTE

When operating in the southern hemisphere, enter a false northing bias value of 100000 km.

Press the enter (E) key to display and/or enter the false northing bias in kilometers that is added to the UTM northing. If no value is entered, +0 kilometer is automatically used. The standard UTM values are 0 for the northern hemisphere and 10,000 kilometers (6,200 miles) for the southern hemisphere.



FN + 0.00000

False Northing Bias

Press the enter (E) key to display and/or enter the false easting bias in kilometers that is added to the UTM easting. If no value is entered, +500 kilometers (310 miles) is automatically used.



FE + 500.00000

False Easting Bias

Press the enter (E) key to display and/or enter the UTM scale factor multiplied by 1000. The scale factor is applied to the UTM coordinates. If no value is entered, 999.6 is automatically used.



SF 999.60000

Scale Factor

(6) When the desired location is displayed, press the enter (E) key. The number displayed will be the UTM easting coordinate in kilometers.

(7) Press the enter (E) key to erase and display the remaining datum shifted coordinates (Table 4-20).

Table 4-20. CODE 130 DISPLAY FOR UTM COORDINATES

NOTE

Datum and UTM conversion parameters must be entered using code 100 before code 130 may be used.

Enter code 130 to select the position to be displayed in UTM coordinates. Press the +/- key to select the desired position as shown by the display.



UTM 2D

2D Position Selected

Press the enter (E) key to display the UTM casting coordinate in kilometers.



E + 23.37242

UTM X-Coordinate

Press the enter (E) key to display the UTM northing coordinate in kilometers.



N - 14.72718

UTM Y-Coordinate

Press the enter (E) key to display the geodetic height in meters using the local datum.



HT + 17.07

Geodetic Height

Table 4-20. CODE 130 DISPLAY FOR UTM COORDINATES - Cont

Press the enter (E) key to display the UTM zone number.

ZONE 37

UTM Zone Number

Press the enter (E) key to display the UTM central meridian in degrees, minutes, and seconds.

CM E 22 14 16.281

UTM Central Meridian

4-6.3.5 Operating Codes. Operating codes are used to perform the various functions necessary when operating the equipment. To enter a code, press the clear (C) key. When CODE is displayed, key in the code number and press the enter (E) key. A complete listing of codes is given in Table 4-21.

Table 4-21. CODE DESCRIPTIONS

Code 8, Display Octal Notation

Enter code 8 to display the contents of a memory location in octal notation. Enter the memory address in octal notation.

ADDR 014477

Memory Address

Table 4-21. CODE DESCRIPTIONS - Cont

Press the enter (E) key to display the contents of that address.



OCT 147

Memory Contents

Code 9, Display Decimal Notation

Enter code 9 to display the contents of a memory location in decimal notation. Enter the memory address in octal notation.



ADDR 01224

Memory Address

Press the enter (E) key to display the contents of that address.



DEC 289.94527

Memory Contents

Code 10 Display and/or Enter Mode

Enter code 10 to display or change the mode of the MX 1502. The modes are as follows:



MODE STANDARD

Previous Mode

STANDARD - Standard mode is used to acquire satellite data in real time and compute 2D and 3D position fixes.

OFF LINE - Off line mode is used to process cassette tape data. The satellite receiver is disabled.

Table 4-21. CODE DESCRIPTIONS - Cont

REMOTE - Remote mode is used to collect satellite data in real time, receive translocation data (via a communications link) from another MX 1502, and compute 2D, 3D position, and translocation fixes.

CONTROL - Control mode is used to collect satellite data in real time, compute 2D and 3D position fixes. and transmit translocation data over a communications link for translocation at a remote MX 1502.

NAVIGATE - Navgate mode is used for navigation when the MX 1502 is moving with respect to the earth's surface. A dead reckoned position, and the 2D position fix, are computed.



New Mode

Press the enter (E) key to retain the displayed mode. To select a new mode, press the +/- key until the desired mode is displayed. Then press the enter (E) key.

When switching from the off-line mode to another mode, a message will be displayed to remind the user to position the tape cassette for recording data. Switching the MX 1502 to the off-line mode, then out of the off-line mode, does not destroy the realtime fix results or accumulated fix data. If MX 1502 power goes off while in the off-line or navigate mode, the unit will be in the standard mode when power is restored.

Code 16, Self-Test

Enter code 16 to initiate the self-test. The results of the self-test are indicated by a combination of code numbers and letters. The receiver status (1) is shown on the left of the slash and error codes (2) on the right of the slash. Explanations of the codes are listed below. Error codes remain until cleared by a successful self-test. The self-test may be aborted with code 237.

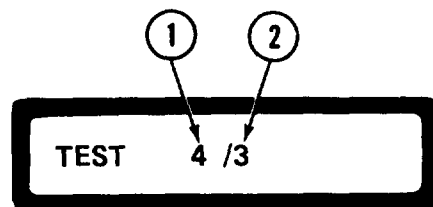

Receiver Status Codes (1)

Table 4-21. CODE DESCRIPTIONS - Cont

Blank - No signals available

S - Receiver is searching for or has found a particular satellite that has been predicted. MX 1502 has alert data for this satellite.

A - Receiver has acquired 150 and 400 MHz signals.

4 - Receiver has acquired only 400 MHz signal.

1 - Receiver has acquired only 150 MHz signal.

T - Receiver is tracking a satellite. Two-minute message from satellite detected.

Error Codes (2)

Blank - No errors detected.

3 - Error detected on memory board in slot 3.

4 - Error detected on processor board slot 4.

5 - Error detected on dual satellite interface board in slot 6.

6 - Error detected on 150 MHz satellite receiver board in slot 6.

7 - Error detected on dual satellite interface board in slot 6.

8 - Error detected on 400 MHz satellite receiver board in slot 6.

B - Error detected in modem board in slot B.

C - Error detected in tape cassette transport or tape control board in slot C.

D - Error detected on alarm clock board in slot D.

E - End of cassette.

H - Power was reduced because internal temperature exceeded 70°C (158°F).

L - More than 75 meters (245 feet) of tape used on cassette.

M - Magnetic tape I/O operation was in progress when power was lost. Some data on tape may have been lost or destroyed if a recording operation was in progress.

N - Data received from communications link does not match data collected from satellite.

Table 4-21. CODE DESCRIPTIONS - Cont

-
- O - Expected data not received from communications link. Occasional display of this code is normal.
 - P - Power failure occurred.
 - S - Satellite alert data from tape is insufficient.
 - T - Tracking error detected. A satellite that was predicted to be available could not be tracked.
 - U - Oscillator drift in 150 MHz receiver.
 - V - Oscillator drift in 400 MHz receiver.
 - X - Satellite alert data on tape cassette is older than 90 days and cannot be used.

Code 17, Display Test Pattern

Enter code 17 to test all characters in the display. Every segment of every character is displayed.

Code 18, Display Number of Alerted Satellites

Enter code 18 to display the number of different satellites for which the MX 1502 has satellite alert data.

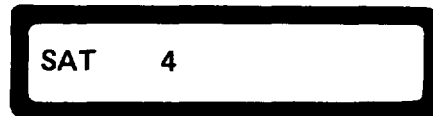

NOTE

When the code 18 value is less than the code 19 value, the MX 1502 will automatically search for the additional satellites.

Code 19, Display and/or Enter Number of Satellites Desired

Enter code 19 to display or enter the number of satellites from which to gather data. Power consumption is reduced between satellite passes when the number of alerted satellites (code 18) is equal to the number of satellites desired. In the reduced power mode, full power is used only when predicted acceptable satellite passes are occurring.

Table 4-21. CODE DESCRIPTIONS - Cont

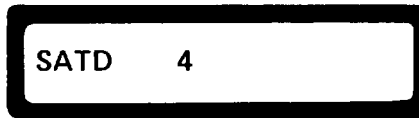
A rectangular terminal window with a thick black border. Inside, the text "SATD 4" is displayed in a monospaced font.

Stored Number

The number of satellites desired may be changed by keying in the new number and pressing the enter (E) key. Refer to code 90 to delete the satellites not to be utilized in the data acquisition process.

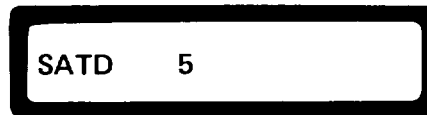
A rectangular terminal window with a thick black border. Inside, the text "SATD 5" is displayed in a monospaced font.

New Number

Code 20, Display and/or Enter

Enter code 20 to display or enter the site number. The site number is the identifying number of the survey site. The site number may range between 0 and 16,383. A zero is used if no number is entered when power is initially applied.

A rectangular terminal window with a thick black border. Inside, the text "SITE 48" is displayed in a monospaced font.

Current Number

NOTE

Changing the site number resets the 3D position and translocation fixes and clears their current positions.

A rectangular terminal window with a thick black border. Inside, the text "SITE 47" is displayed in a monospaced font.

Revised Number

Table 4-21. CODE DESCRIPTIONS - Cont

Code 21, Display and/or Enter Latitude Estimate

Enter code 21 to display or enter the input latitude in degrees, minutes, and seconds of the site. The MX 1502 interprets latitude in terms of the satellite datum. The input latitude entered into the MX 1502 remains unchanged throughout the position fixing computations. Changing the displayed value resets the 3D position and translocation fix computation. Press the enter (E) key to retain the displayed latitude.



LT N 33 50 20.17

Previous Latitude

To enter a new latitude, enter the degrees, minutes, and seconds with a space (→) between degrees and minutes, and between minutes and seconds. Use the change sign +/- key to change from N (north) to S (south) or vice versa. Use a decimal point between seconds and fractions of seconds. Press the enter (E) key.



LT S 43 32 55.236

New Latitude

Code 22, Display and/or Enter Longitude Estimate

Enter code 22 to display or enter the input longitude in degrees, minutes, and seconds of the site. The MX 1502 interprets longitude in terms of the satellite datum. The input longitude entered into the MX 1502 remains unchanged throughout the position fixing computations. Changing the displayed value resets the 3D position and translocation fix computations. Press the enter (E) key to retain the displayed longitude.



LN W118 20 30.137

Previous Longitude

Table 4-21. CODE DESCRIPTIONS - Cont

To enter a new longitude, enter the degrees, minutes, and seconds, with a space (—→) between degrees and minutes, and between minutes and seconds. Use the change sign(+/-)key to change from E (east) to W (west) or vice versa Use a decimal point between seconds and fractions of seconds. Press the enter (E) key.



LN E 22 35 53.936

New Longitude

Code 23, Display and/or Enter Height Estimate

Enter code 23 to display or enter the input height in meters of the antenna. The display initially appears as shown. The user may select the height entry mode as either the geodetic height (HT) or the elevation above mean sea level (EL). Press the +/- key to select the desired height entry mode, then press the enter (E) key. The elevation mode should be used only when the geodetic height is unknown.



HGT HT

Initial Height Entry Mode

If the geodetic height mode was selected, enter the estimated height in meters of the antenna reference point above the reference ellipsoid for the satellite datum. The antenna reference point is marked by a red band on the antenna/preamplifier unit. Then press the enter (E) key.



HT + 17.48

Geodetic Height

If the elevation mode was selected, enter the estimated elevation in meters of the antenna reference point above mean sea level. Then press the enter (E) key.

Table 4-21. CODE DESCRIPTIONS - Cont



EL + 12.44

Elevation

Changing the displayed value resets the 3D position and translocation fix computations.

Code 24, Display and/or Enter GMT

Enter code 24 to display or enter Greenwich Mean Time in hours, minutes, and seconds. The time entry need only be within 14 minutes when collecting satellite data, so entry of seconds may be omitted.



GMT 21 59 34

Previous Time

To enter a new time, key in the hours, minutes, and seconds. Use a space (←→) between hours and minutes, and between minutes and seconds. Press the enter (E) key. The entered time is referenced to the time when the enter (E) key is pressed. Greenwich Mean Time is automatically corrected to the nearest second after the first usable satellite pass.



GMT 21 58 30

Newly Entered Time

Table 4-21. CODE DESCRIPTIONS - Cont

Code 25, Display and/or Enter DATE

Enter code 25 to display or enter the date. The date is displayed with the day (1) on the left, the month (2) in the middle, and the year (3) on the right.

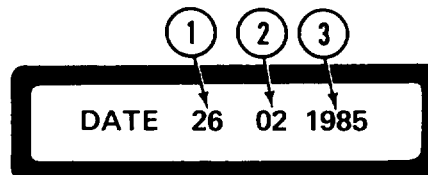

Previous Date

To enter a new date, key in the day and a space (→), the number for the month and a space (→) and four digits for the year. Press the enter (E) key. The date is automatically corrected after the first usable satellite pass.



Entered Date

Code 26, Display and/or Enter Serial Number

Enter code 26 to display or enter the serial number of the MX 1502. The serial number of the MX 1502 is located on the outside right side of the case. Changing the displayed value creates a new site record. To change the serial number displayed, key in the new number. Press the enter (E) key.



Table 4-21. CODE DESCRIPTIONS - Cont

Code 27, Display and/or Enter Site Parameters

Enter code 27 to display or enter site parameters 1 through 4. Site parameters are user-defined and can be used to record conditions at the site (for example, the distance and direction between the antenna and benchmark). A code number to identify the terrain may be used. Site parameters, although not used in the computations, are recorded on tape. The range of values for each of the site parameters is between 0 and 16,383. Changing the displayed value creates a new site record.



SP1 1001



SP4 16383

Code 33, Display Computed Elevation/Geoidal Height

Enter code 33 to select the position for which to display the computed elevation and geoidal height in the satellite datum. Press the +/- key to select the desired position as shown by the display. Selectable positions are 2D, 3D, TRANS-LOCATION, INPUT, REFERENCE, CONTROL, DR, and WAYPOINT. Then press the enter (E) key.



E/GH 2D

2D Position Selected

Table 4-21. CODE DESCRIPTIONS - Cont

The elevation in meters of the antenna reference point above mean sea level is displayed. It is computed from the geodetic height (HT) and the internal geoidal height (GHT). Then press the enter (E) key.

EL - 12.72

Elevation

The geoidal height in meters is displayed with respect to the reference ellipsoid for the satellite datum. It is computed via an internal map that gives an approximate value.

GHT + 7.74

Geoidal Height

Code 35, Display Julian Day

Enter code 35 to display the current GMT Julian day number.

DAY 313

Code 36, Control Alarm (On/Off)

Enter code 36 to reverse the on/off state of the audio alarm. If it is on, code 36 turns it off and vice versa. Pressing the clear (C) key also turns off the audio alarm.

If the alarm sounds because an error occurred, proceed as follows:

1. Press the clear (C) key to silence the alarm.
2. Enter code 50 to determine the error that caused the alarm.
3. Refer to the troubleshooting procedures to determine corrective action.

Using the clear (C) key or code 36 to silence the alarm does not disable it. Another fault will cause the alarm to sound again. To totally suppress the error alarm, use code 38.

Table 4-21. CODE DESCRIPTIONS - Cont

Code 37, Control Satellite Alarm

Enter code 37 to display or change the enable/disable status of the satellite alarm. The satellite alarm sounds the audio alarm for 6 seconds and displays status when a satellite is detected. When OFF is displayed, the satellite alarm is disabled. When ON is displayed, the satellite alarm is enabled. Use the +/- key to change alarm status. Press the enter (E) key when the desired state is displayed.



SATA OFF



SATA ON

If the MX 1502 is in either the remote or control mode (see code 10), the audio alarm will also sound for 2 seconds to notify the user that a modem transmission or reception is about to occur. This feature is disabled when power is initially applied.

Code 38, Display and/or Control Suppress Error Alarm

Enter code 38 to display or change the status of the error alarm suppression. When NO is displayed, the error alarm is not suppressed. When YES is displayed, the error alarm is suppressed. Use the change sign (+/-) key to change the display from NO to YES or vice versa. Press the enter (E) key when the desired state is displayed.



XALM YES



XALM NO

The error alarm is not suppressed (NO) when power is initially applied. Neither is it suppressed if main power is lost while the MX 1502 power switch is in the OPERATE position.

Table 4-21. CODE DESCRIPTIONS - Cont

Code 39, Control Translocate 2-Site Tape

NOTE

This code applies only to Version 110 and above units.

This code is operative only in the off-line mode. The tape must have been recorded on a remote MX 1502 in the remote mode that received data via a communications link from a control MX 1502 at another site.

Enter code 39 to read satellite and modem data from tape and compute 3D and translocation positions. When code 39 is entered, the MX 1502 asks the user how many satellite passes to process.



TRAN

Initial Display

Enter either no number, one number, or two numbers. Entering no number causes all passes at the site to be processed. Entering one number indicates the number of passes to process in the computations.



TRAN 8

Process Eight Passes

Table 4-21. CODE DESCRIPTIONS - Cont

To process all passes, up to and including a pass that is identified by a pass number on the tape, enter a 0 digit, a space, then the pass number. After selecting the passes to be processed, press the enter (E) key.

A rectangular terminal window with a thick black border containing the text "TRAN 0 14".

TRAN 0 14

Process to Pass 14

The MX 1502 then asks whether or not the translocation/3D position computations should be reset. Reset should be selected only at the beginning or reiteration of translocation/3D position computations.

A rectangular terminal window with a thick black border containing the text "RSET NO".

RSET NO

Initial Display

To reset the computations, press the +/- key. To maintain the computation, press the enter (E) key again.

A rectangular terminal window with a thick black border containing the text "RSET YES".

RSET YES

Reset Selected

The MX 1502 then reads satellite pass and modem data from the tape cassette and computes translocation/3D position fixes based on that data.

A rectangular terminal window with a thick black border containing the text "READ".

READ

Reading Tape

Table 4-21. CODE DESCRIPTIONS - Cont

While the MX 1502 is processing data from a particular pass, it displays the number of that pass.



PASS 34

Processing Pass 34

When the MX 1502 has completed processing pass data, it displays either CODE, SITE if a new site record is encountered, or END if the end of data on tape is encountered.



CODE

Processing Completed

Code 40, Control, Load Tape

NOTE

This code applies only to Version 100 and above units.

This code is operative only in the off-line mode. Enter code 40 to load satellite data from a tape into the memory for subsequent translocation processing. The tape will stop after reading a site record. Code 40 must be re-entered to continue.

When code 40 is entered, the unit asks the user how many satellite passes to load.



LOAD

Initial Display

Table 4-21. CODE DESCRIPTIONS - Cont

Enter either no number, one number, or two numbers. Entering no number causes all passes in the site to be loaded into memory. Entering one number indicates the number of passes to load into memory.

LOAD 5

Load 5 Passes

To load all passes up to and including a pass which is identified by a pass number on the tape, enter a 0 digit, space, then the pass number.

After selecting the passes to be loaded, press the enter (E) key.

LOAD 0 38

Load to Pass 38

When available memory is full, loading stops with FULL being displayed. When loading stops at the end of tape data, END is displayed.

FULL

Available Memory Full

Code 41, Control Start of Tape

Enter code 41 to position the tape at the beginning of tape (BOT) and enable the tape cassette transport to record or read satellite pass data. This code does not affect current position fix results. If recording, data previously recorded on the tape will be erased and new data will be recorded over it.

BOT

Table 4-21. CODE DESCRIPTIONS - Cont

A question (?) mark on the display following entry of code 41 indicates that no tape is installed, tape is installed incorrectly, or the record enable tab on the recording side of the cassette is in the wrong position for recording data.

NOTE

If a cassette is installed when recording data and neither code 41 nor code 42 is entered, data will be recorded starting where the tape is positioned. Also, if the tape is not positioned at the end of the data, the alarm will sound when the MX 1502 attempts to write on tape after the first pass data is received. A cassette failure will be indicated on the status (code 50) display.

Code 42, Control End of Data

Enter code 42 to search a tape for the end of previously recorded data. This code does not affect current position fix results. The tape cassette transport is enabled to record satellite pass data at the end of the previously recorded data.

**LOOK**

A question mark (?) on the display following entry of code 42 indicates that no tape cassette is installed, tape cassette is wrongly installed, or the record enable tab on the recording side of the cassette is in the wrong position for recording data. LOOK is displayed while unit searches for the end of the data.

Code 43, Control Read Alert Data

Enter code 43 to search a tape previously recorded with satellite pass data and read the satellite alert data. The search is terminated when the end of data is found or when the number of satellites desired is satisfied (refer to code 19 description).

**ALRT**

The MX 1502 cannot acquire satellite pass data while searching for alert data. The satellite alert data must not be older than 90 days. The alarm will sound if satellite alert data is older than 90 days, or if orbital parameters for fewer satellites than desired (per initialization entry or code 19) are contained on the alert tape. A check of code 18 will indicate how many satellites have been alerted.

NOTE

It is recommended that alert data be less than 30 days old.

Table 4-21. CODE DESCRIPTIONS - Cont

Code 44, Control Read Pass

This code is operative only in the off-line mode. It does not affect current position fix results. Enter code 44 to move the tape forward or backward a given number of passes. The tape will stop after reading a site record. Code 44 must be re-entered to continue.

When code 44 is entered, the unit asks the user how to move the tape. The positive (+) sign means move forward. To move backward, press the +/- key to display a negative (-) sign. The first displayed number indicates the number of passes to move.



PS + 1

Initial Display

Enter the number of passes to move if desired.



PS + 7

Move Forward 7 Passes

To move to a desired pass that is identified by a pass number on the tape, enter a 0 digit, space, then the pass number.

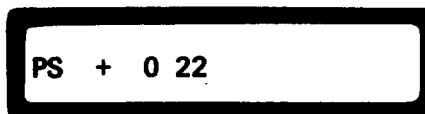

PS + 0 22

Move Forward to Pass 22

Table 4-21. CODE DESCRIPTIONS - Cont

After selecting the tape movement, press the enter (E) key and the tape will move as specified. Pressing E with no entry moves the tape forward to the next pass on tape. Code 99 may be used to display data read by code 44.

Code 45, Control Read Site

This code is operative only in the off-line mode. It does not affect current position fix results. Enter code 45 to move the tape forward a given number of site records. The tape will stop after reading a site record. Code 45 must be re-entered to continue.

When code 45 is entered, the unit asks the user how to move the tape. The first displayed number indicates the number of site records to move.



SITE 1

Initial Display

Enter the number of site records to move if desired.



SITE 3

Move Forward 3 Site Records

To move to a desired site record that is identified by a site number in the site record, enter a 0 digit, space, then the site number.

After selecting the site, press the enter (E) key and the tape will move as specified. Pressing E with no entry moves the tape forward to the next site record on tape.



SITE 0 14

Move Forward to Site Record 14

Table 4-21. CODE DESCRIPTIONS - Cont

Code 46, Control Translocate From Tape

NOTE

This code applies only to version 100 and above units.

This code is operative only in the off-line mode. Enter code 46 to read satellite data from tape and compute a translocated position. The tape will stop after reading a site record. Code 46 must be re-entered to continue.

When code 46 is entered, the unit asks the user how many satellite passes to process.

A rectangular terminal window with a thick black border containing the text "TRAN" in a bold, monospaced font.

Initial Display

Enter either no number, one number, or two numbers. Entering no number causes all passes in the site to be processed. Entering one number indicates the number of passes to process in the translocation computation.

A rectangular terminal window with a thick black border containing the text "TRAN 8" in a bold, monospaced font.

Process 8 Passes

To process all passes up to and including a pass which is identified by a pass number on the tape, enter a 0 digit, space, then the pass number.

After selecting the passes to be processed, press the enter (E) key.

A rectangular terminal window with a thick black border containing the text "TRAN 0 27" in a bold, monospaced font.

Process to Pass 27

Table 4-21. CODE DESCRIPTIONS - Cont

The unit then asks whether or not the translocation computation should be reset. Reset should be selected only at the beginning of a translocation commutation or a reiteration of a translocation computation.



RSET NO

Initial Display

If reset is desired, press the +/- key. After selecting or not selecting reset, press the enter (E) key.



RSET YES

Reset Selected

If reset was selected, the unit asks for the site where the tape was recorded. Use the +/- key to select either the control or the remote site. Then press the enter (E) key.



TAPE CONTROL

Control Site Selected

The unit then reads satellite pass data from the tape cassette and computes a translocation position fix based on that data.



READ

Reading Tape

Table 4-21. CODE DESCRIPTIONS - Cont

Code 46, Control Translocate From Tape - Cont

While the unit is processing data from a particular pass, it displays that pass number.



PASS 17

Processing Pass 17

When it finishes processing all pass data, it displays CODE, SITE if a new site record is encountered, END if the end of data on tape is encountered, or DONE if all corresponding data in memory from the other site has been used.



CODE

Done Processing

Code 47, Control 3D Position From Tape

This code is operative only in the off-line mode. Enter code 47 to compute a 3D position fix from the raw satellite data on tape. The tape will stop after reading a site record. Code 47 must be re-entered to continue.

When code 47 is entered, the unit asks the user how many satellite passes to process.



PNTP

Initial Display

Enter either no number, one number, or two numbers. Entering no number causes all passes in the site to be processed. Entering one number indicates the number of passes to process in the 3D position computation.



PNTP 5

Process 5 Passes

Table 4-21. CODE DESCRIPTIONS - Cont

To process all passes up to and including a pass which is identified by a pass number on the tape, enter a 0 digit, space, then the pass number. Entering no number causes all passes in the site to be processed.



PNTP 0 38

Process to Pass 38

After selecting the passes to be processed, press the enter (E) key.

The unit then asks whether or not the 3D position computation should be reset. Reset should be selected only at the beginning of a 3D position computation.



RSET NO

Initial Display

If reset is desired, press the +/- key. After selecting reset or not, press the enter (E) key.



RSET YES

Reset Selected

The unit then reads satellite pass data from the tape and computes a 3D position fix based upon that data.



READ

Reading Tape

Table 4-21. CODE DESCRIPTIONS - Cont

While the unit is processing data from a particular pass, it displays that pass number.

PASS 27

Processing Pass 27

When it finishes processing all pass data, it displays CODE, SITE if a new site record is encountered, or END if the end of data on tape is encountered.

CODE

Done Processing

When computing a 3D position, the unit also stores in its memory the data needed for subsequent translocation processing with another site. The last 17 acceptable passes are held in memory. Code 99 may be used to display the field processed data.

Code 48, Display Tape Used

Enter code 48 to display the length of magnetic tape in the tape transport that has been recorded. The units are meters. The cassette contains approximately 80 meters (264 feet) of tape.

NOTE

The error alarm will sound when 75 meters (247 feet) of tape have been used.

TAPE 7.3

Table 4-21. CODE DESCRIPTIONS - Cont

Code 49, Control Rewind (Unload) Tape

Enter code 49 to rewind and unload the tape cassette. UNLD is displayed while the cassette is being rewound.



Code 50, Display Status (Sat/Errors)

Enter code 50 to display the functional status of the MX 1502. The status is indicated by a combination of code numbers and letters. The receiver status (1) is shown on the left of the slash and error codes (2) on the right of the slash. If self-test is being performed, TEST is displayed instead of STAT. Explanations of the codes are listed below. Error codes remain displayed until cleared by a successful self-test.

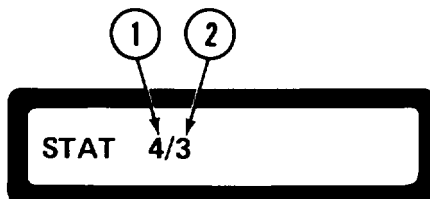

Receiver Status Codes (1)

Blank - No signals available.

1 - Receiver acquired only 150 MHz signal.

4 - Receiver acquired only 400 MHz signal.

A - Receiver acquired 150 and 400 MHz signals.

S - Receiver searching for or has found particular predicted satellite. Unit has alert data for this satellite.

T - Receiver tracking a satellite. Two-minute message from satellite detected.

Error Codes (2)

Blank - No errors detected.

Table 4-21. CODE DESCRIPTIONS - Cont

-
- 0 - Expected data from communications link not received. Occasional display of this error code is normal. The unit waits 3 more minutes for the expected data.
 - 3 - Error detected on memory board slot 3.
 - 4 - Error detected on processor board in slot 4.
 - 5 - Error detected on dual satellite interface board in slot 6.
 - 6 - Error detected on 150 MHz satellite receiver board in slot 6.
 - 7 - Error detected on dual satellite interface board in slot 6.
 - 8 - Error detected on 400 MHz satellite receiver board in slot 6.
 - B - Error detected on modem board in slot B.
 - C - Error detected in tape cassette transport or tape control board in slot C.
 - D - Error detected on alarm clock board in slot D.
 - E - End of cassette.
 - H - Power was reduced because internal temperature exceeded 70°C.
 - K - Printer enabled when no printer present, or clear-to-send signal reset prematurely.
 - L - More than 75 meters (245 feet) of tape used on cassette.
 - M - Magnetic tape I/O operation in progress when power lost. Some tape data may have been lost or destroyed if recording operation was in progress.
 - N - Data received from communications link does not match data received from satellite.
 - P - Power failure occurred.
 - S - Satellite alert data from tape insufficient.
 - T - Tracking error detected. Satellite that was predicted to be available could not be tracked.
 - U - Excessive oscillator drift in 150 MHz receiver. May not prevent proper operation, but eventual correction needed.
 - V - Excessive oscillator drift in 400 MHz receiver. May not prevent proper operation, but eventual correction needed.

Table 4-21. CODE DESCRIPTIONS - Cont

X - Satellite alert data on tape cassette older than 90 days. Will not be used.

Code 51, Display Next Satellite

Enter code 51 to display data associated with the next satellite pass. Only satellite passes for which the MX 1502 has alert data are available for display. From left to right, the displayed data consists of:

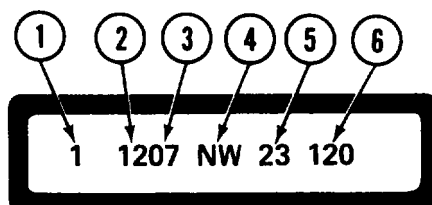

- (1) Number of the future satellite passes. The first satellite pass will be numbered 1, the second satellite pass will be numbered 2, and so on.
- (2) Two-digit hour (GMT) when the satellite will rise above the horizon.
- (3) Two-digit minutes (GMT) when the satellite will rise above the horizon.
- (4) Two characters indicating the geometry of the satellite pass. The first character indicates the direction of satellite travel (N = north, S = south) at the point of closest approach. The second character indicates the direction of the satellite from the MX 1502 (E = east, W = west) at the point of closest approach.
- (5) Two-digit maximum elevation angle of the satellite above the horizon.
- (6) Least significant three digits of the satellite identification number.

Table 4-21. CODE DESCRIPTIONS - Cont

Press the enter (E) key each time to display data associated with the following satellites. When finished with the display of future satellite data, press the clear (C) key.

Code 53, Display Last Pass (2D)

Enter code 53 to display the last satellite pass and two dimensional position. The two dimensional position computation is based only on data from the last pass. The data is displayed in a sequence of seven displays. Press the enter (E) key to erase one display and view the next. The initial display shows the following information:

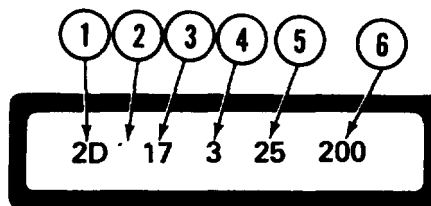

Initial Display

- (1) Two dimensional (2D) code mnemonic.
- (2) When this position is blank, both of the 150 MHz and 400 MHz channels were used in the computation. A 1 or 4 in this position indicates that only the 150 MHz or 400 MHz channel respectively was used in the computation.
- (3) Maximum elevation angle of the satellite above the horizon in degrees. A 0 indicates no position was computed.
- (4) Number of iterations in the 2D computation.
- (5) Number of 23/28-second doppler counts used in the computation.
- (6) Last three digits of the satellite identification number.

Press the enter (E) key. Display shows the geometry of the pass and the standard deviation of the doppler count residuals in meters. The geometry gives the direction of satellite travel at closest approach (N = north, S - south) followed by the position of the satellite at closest approach (E = east, W - west) with respect to the site.

Table 4-21. CODE DESCRIPTIONS - Cont

N-W 0.017

Geometry and Standard Deviation of Residuals

Press the enter (E) key. Display shows the computed latitude in degrees, minutes, and seconds in satellite datum coordinates.

LT N 33 50 28.711

Computed Latitude

Press the enter (E) key. Display shows the computed longitude in degrees, minutes, and seconds in satellite datum coordinates.

LN E118 20 21.921

Computed Longitude

Press the enter (E) key. Display shows the Greenwich Mean Time in hours, minutes, and seconds of the satellite pass. The time shown is referenced to the center of the satellite pass.

GMT 21 59 34

Greenwich Mean Time

Table 4-21. CODE DESCRIPTIONS - Cont

Press the enter (E) key. Display shows the GMT date. The day (1) is shown first followed by the month (2) and year (3). The date is referenced to the center of the satellite pass.

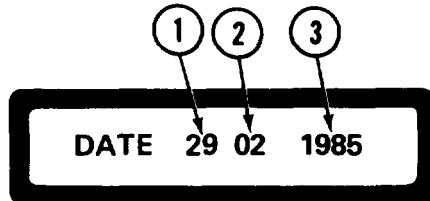

Date

Press the enter (E) key. Display shows the standard deviation in meters of the latitude (1) and longitude (2). The computations are based only on the doppler data residuals and do not include the orbital error.

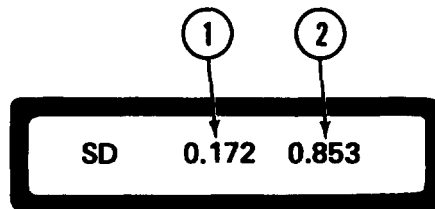

Standard Deviation of Latitude and Longitude

If the MX 1502 is in the navigate mode, press the enter (E) key to display the dead reckoned update data. Display shows why no update occurred to the dead reckoned position (1), the update distance in nautical miles (N) or kilometers (k) (2), and the update direction in degrees (3). The units for displaying the update distance (2) will depend on whether speed was specified in knots or km/hour. If an update occurred to the dead reckoned position, display position (1) will be blank. The codes for the no update conditions are as follows:

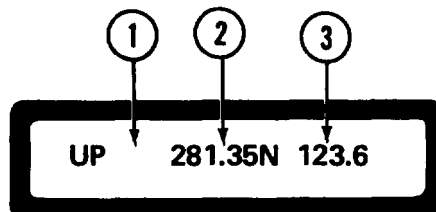

DR Update Data

Table 4-21. CODE DESCRIPTIONS - Cont

- 0 - No 2D fix could be computed.
- C - Less than eight doppler counts used in 2D computations.
- D - More than 20 nm (37.04 km) between 2D position and dead reckoned position.
- E - Maximum elevation angle of satellite not between 10 and 70 degrees.
- I - More than six iterations occurred in 2D computations.
- R - Only one of two satellite receiver channels was used to calculate 2D position due to insufficient data on other channel.
- S - Standard deviation of residuals was too large, indicating that satellite data was in error (see code 91).
- U - Data from satellite was asymmetrical about point of closest approach.
- X - Last satellite pass data was taken from a satellite that indicated within its message that it should not be used for precise applications (i.e., negative satellite number).
- Y - Satellite pass data was taken from a satellite that was deleted by user.

Press the enter (E) key to display the 3D position. Refer to code 63 for a description of the 3D position display. The 3D position displays can be sequenced by continuing to press the enter (E) key or by entering code 63.

| | | |
|-----------|----------|--------------|
| PT | 1 | 3.131 |
|-----------|----------|--------------|

3D Position Display

Code 54, Display 400 Tune and Signal Levels

Enter code 54 to display the frequency of the 400 MHz channel receiver oscillator and the signal-to-noise ratio. The units of frequency are kilohertz. The displayed range for the 400 channel is 23 to 42 kilohertz. A signal-to-noise ratio of 0 indicates no signal and 100 indicates a perfect signal.

| | | |
|-------------|-------------|------------|
| F/S4 | 26.0 | 4.3 |
|-------------|-------------|------------|

Table 4-21. CODE DESCRIPTIONS - Cont

Code 56, Display Reference Oscillator

Enter code 56 to display the offset frequency of the reference oscillator from 400 MHz. The units of displayed frequency are hertz. The offset is calculated and set after each satellite pass that yields a 2D position fix.



REF 0.6

The reference oscillator frequency offset should not exceed 40 Hz without resetting the oscillator frequency. Oscillator stability from pass to pass is most important, however. The offset should not vary more than 0.5 Hz in a 24-hour period.

Code 58, Display Time Of Next Transmission

NOTE

This code applies to version 110 and above units, and only to the remote and control modes (refer to code 10).

Enter code 58 to display the time of the next communication via the communications link. Time is shown in GMT hours, minutes, and seconds.



GMT 12 14 00

Time of Next Transmission

Code 59, Display Modem Status

NOTE

This code applies only to version 110 and above units.



MODM T

Table 4-21. CODE DESCRIPTIONS - Cont

Enter code 59 to display the status of the communications modem. The following symbols may be displayed:

- OFF - Modem not being used.
- E - Error detected in modem.
- S - Modem currently running self-test.
- T - Modem currently transmitting message.
- L - Modem receiver currently locked onto incoming signal.
- R - Modem received incoming message.
- C - Incoming message changed instead of repeating.

Code 63, Display Point Position

Enter code 63 to display the most recently computed 3D position. The 3D position computation is based on accumulated data from all pass data collected. The 3D position is displayed in a sequence of 15 displays. Press the enter (E) key to erase one display and view the next. The initial display shows the following information:

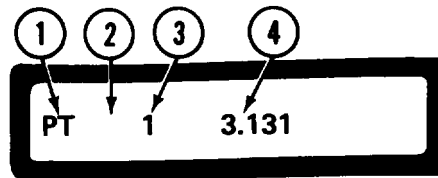

Initial Display

(1) 3D position code mnemonic (PT).

(2) When this position is blank, the 3D position was computed using data from the last satellite pass. A one-letter code in this position indicates that the last pass data was not used. The following codes signify the reason for not using data from the last pass.

0 - No 2D fix could be computed.

C - Less than eight doppler counts used in 2D computation.

NOTE

Entry of correct height estimate will usually correct this display.

D - More than 1 km (0.62 miles) between 2D position and reference position.

E - Maximum elevation angle of satellite less than 15 degrees.

H - Maximum elevation angle greater than 70 degrees immediately after point position was reset.

Table 4-21. CODE DESCRIPTIONS - Cont

- I - More than six iterations occurred in 2D computation.
- R - Only one of two satellite receiver channels was used to calculate 2D position due to insufficient data on other channel.
- S - Standard deviation of residuals was too large, indicating that satellite data was in error (see code 91).
- U - Data from satellite was asymmetrical about point of closest approach.
- X - Last satellite pass data was taken from a satellite that indicated within its message that it should not be used for precise applications (i.e., negative satellite number).
- Y - Satellite pass data was taken from a satellite that was deleted by user.

(3) Number of satellite passes used in the 3D position computation. If this number is very low compared to the total number of passes that occurred (code 66), check the initialization parameters.

(4) Distance from the previously computed 3D position computation in meters. This value is meaningless for the first pass.

Press the enter (E) key. Display shows the computed latitude in degrees, minutes, and seconds using satellite datum coordinates.

LT N 33 50 23.021

Computed Latitude

Press the enter (E) key. Display shows the computed longitude in degrees, minutes, and seconds using satellite datum coordinates.

LN W118 20 21.021

Computed Longitude

Table 4-21. CODE DESCRIPTIONS - Cont

Press the enter (E) key. Display shows the computed geodetic height in meters, using the satellite datum.

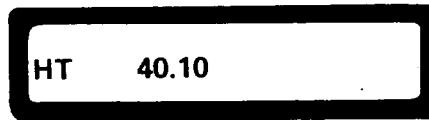

HT 40.10

Computed Geodetic Height

Press the enter (E) key. Display shows the computed standard deviation in meters of the latitude (1) and the longitude (2).

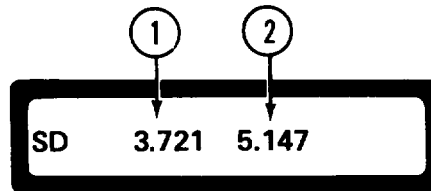

SD 3.721 5.147

Latitude and Longitude Standard Deviation

Press the enter (E) key. Display shows the computed standard deviation in meters of the height.



SDH 0.626

Height Standard Deviation

Press the enter (E) key. Display shows the number of passes whose geometry lies in the northwest and northeast quadrants respectively.

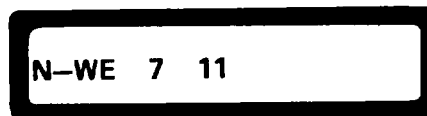

N-WE 7 11

Northern Geometry

Table 4-21. CODE DESCRIPTIONS - Cont

Press the enter (E) key. Display shows the number of passes whose geometry lies in the southwest and southeast quadrants respectively.

S-WE 10 9

Southern Geometry

Press the enter (E) key. Display shows the latitude distance of the 3D position from the reference position in meters. Positive (+) indicates that 3D position is north of the reference position and negative (-) indicates that it is south.

DLT+ 42.76

Latitude Distance from Reference

Press the enter (E) key. Display shows the longitude distance of the 3D position from the reference position. Positive (+) indicates that the 3D position is east of the reference position and negative (-) indicates that it is west.

DLN- 7.15

Longitude Distance from Reference

Press the enter (E) key. Display shows the height distance in meters of the 3D position from the reference position. Positive (+) indicates that the 3D position is above the reference position and negative (-) indicates that it is below.

DHT+ 4.38

Height Distance from Reference

Table 4-21. CODE DESCRIPTIONS - Cont

Press the enter (E) key. Display shows the radial distance in meters of the 3D position from the reference position.



DREF 57.06

Radial Distance from Reference

Press the enter (E) key. Display shows the latitude in degrees, minutes, and seconds of the reference position using the satellite datum.



RT N 27 14 16.725

Reference Latitude

Press the enter (E) key. Display shows the longitude in degrees, minutes, and seconds of the reference position using the satellite datum.

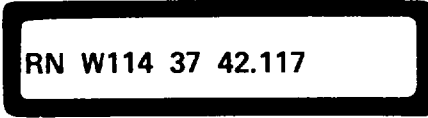

RN W114 37 42.117

Reference Longitude

Press the enter (E) key. Display shows the geodetic height in meters of the reference position using the satellite datum.



RHT+ 13.74

Reference Geodetic Height

Table 4-21. CODE DESCRIPTIONS - Cont

Press the enter (E) key to display the translocation position. Refer to code 73.

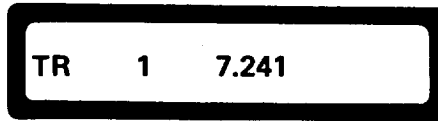

Translocation Display

Code 66, Display Passes (Tracked/Recorded/PT)

Enter code 66 to display the number of satellite passes that have occurred since the current site was established. The number of passes displayed may be used to determine if enough data has been accumulated at a site. Three values are displayed:

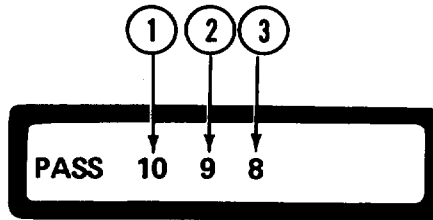

(1) Total number of passes.

(2) Total number of passes recorded correctly on tape.

(3) Total number of acceptable 3D position passes recorded correctly on tape. An acceptable pass is defined as one used in the 3D position computation.

If the tape cassette transport was off or no cassette was installed, a 0 is displayed in positions (2) and (3).

NOTE

The highest pass number possible is 255. Thereafter, the pass number resets to 1.

Table 4-21. CODE DESCRIPTIONS - Cont

Code 70, Control Print Now

Enter code 70 to output a full set of data to the printer. This code is used to cause an immediate printout at any desired time. A question mark (?) on the display indicates that the print feature is disabled. Commanding a print with the print enable but with no appropriate printer connected will cause an error K. There is a delay of approximately 7 seconds from when the code is entered until the printing begins.

Code 71, Display and/or Control Print Enable

Enter code 71 to display or change the status of the print feature. When OFF is displayed, the print feature is disabled. Use the change sign (+/-) key to change from off to on or vice versa. Press the enter (E) key when the desired state is displayed. The print feature is disabled when power is initially applied.



Print Disabled

If the enter (E) key is pressed with ON displayed, the current baud rate used for printing is displayed. If this baud rate is compatible with the printer in use, press the enter (E) key. If not, enter the appropriate baud rate, then press the enter (E) key. The baud rates are:

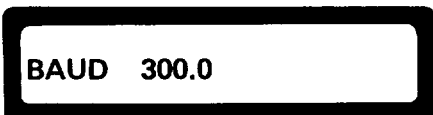

Printer Baud Rate Selection

| | | | | |
|-----|-------|------|------|------|
| 50 | 134.5 | 600 | 2000 | 4800 |
| 75 | 150 | 1200 | 2400 | 7200 |
| 110 | 300 | 1800 | 3600 | 9600 |

Entering an unacceptable baud rate will cause a question mark (?) to be displayed and the print feature to be disabled.

When enabled, the print feature will supply a full set of data to the printer following each satellite pass. A full set of data consists of all last pass 2D data, 3D position data, translocation position data, pass data (see code 66) and status information (see code 50). Entering tape codes 39, 40, 46, or 47 while the print feature is enabled causes the respective data to be printed following the computations for each pass on the tape. Entering code 51 while the print feature is enabled causes the predicted satellite data to be printed.

Table 4-21. CODE DESCRIPTIONS - Cont

Code 73, Display Translocation Position

NOTE

This code applies only to Version 100 and above units.

Enter code 73 to display the most recently computed translocation position. The translocation position computation is based on accumulated data. The translocation position is displayed in a sequence of 15 displays. Press the enter (E) key to erase one display and view the next. The initial display shows the following information:

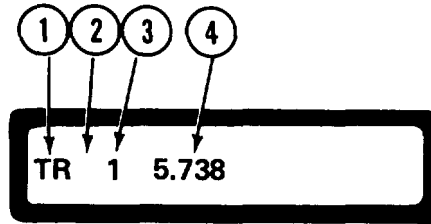

Initial Display

(1) Translocation code mnemonic (TR).

(2) When this position is blank, the translocation position was computed using data from the last satellite pass. A one-letter code in this position indicates that the last pass data was not used. The following codes signify the reason for not using data from the last pass:

0 - No 2D fix could be computed.

C - Less than eight doppler counts used in 2D computation.

D - More than 1 km (0.62 miles) between 2D position and reference position.

E - Maximum elevation angle of satellite less than 15 degrees.

H - Maximum elevation angle greater than 70 degrees immediately after 3D position was reset.

I - More than six iterations occurred in 2D computation.

R - Only one of two satellite receiver channels was used to calculate 2D position due to insufficient data on other channel.

S - Standard deviation of residuals was too large, indicating that satellite data was in error (see code 91).

Table 4-21. CODE DESCRIPTIONS - Cont

U - Data from satellite was asymmetrical about point of closest approach.

X - Last satellite pass data was taken from a satellite that indicated within its message that it should not be used for precise applications (i.e., negative satellite number).

Y - Satellite pass data was taken from a satellite that was deleted by user.

(3) Number of satellite passes used in the translocation position computation.

(4) Distance in meters from the previously computed translocation position. This value is meaningless for the first pass.

Press the enter (E) key. Display shows the computed latitude in degrees, minutes, and seconds using satellite datum coordinates.

LT N 33 50 28.711

Computed Latitude

Press the enter (E) key. Display shows the computed longitude in degrees, minutes, and seconds using satellite datum coordinates.

LN W118 20 21.021

Computed Longitude

Press the enter (E) key. Display shows the computed geodetic height in meters, using the satellite datum.

HT 40.10

Computed Geodetic Height

Table 4-21. CODE DESCRIPTIONS - Cont

Press the enter (E) key. Display shows the computed standard deviation in meters of the latitude (1) and the longitude (2).

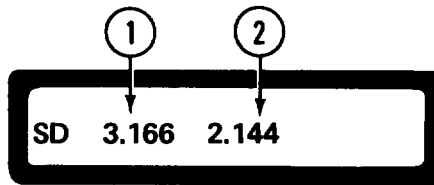

Standard Deviation of Latitude and Longitude

Press the enter (E) key. Display shows the computed standard deviation in meters of the height.

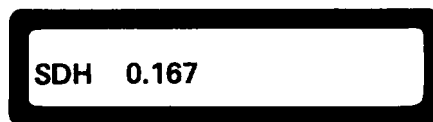

Standard Deviation of Height

Press the enter (E) key. Display shows the number of passes whose geometry lies in the northwest and northeast quadrants respectively.



Northern Geometry

Press the enter (E) key. Display shows the number of passes whose geometry lies in the southwest and southeast quadrants respectively.

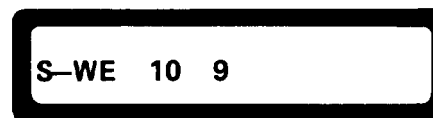

Southern Geometry

Press the enter (E) key. Display shows the latitude distance of the translocation position from the reference position in meters. Positive (+) indicates that translocation position is north of the reference position and negative (-) indicates that it is south.

Table 4-21. CODE DESCRIPTIONS - Cont



DLT+ 5.24

Latitude Distance from Reference

Press the enter (E) key. Display shows the longitude distance of the translocation position from the reference position in meters. Positive (+) indicates that the translocation position is east of the reference position and negative (-) indicates that it is west.



DLN- 7.15

Longitude Distance from Reference

Press the enter (E) key. Display shows the height distance in meters of the translocation position from the reference position. Positive (+) indicates that the translocation position is above the reference position and negative (-) indicates that it is below.



DHT+ 4.38

Height Distance from Reference

Press the enter (E) key. Display shows the radial distance in meters of the translocation position from the reference position.



DREF 57.06

Radial Distance from Reference

Table 4-21. CODE DESCRIPTIONS - Cont

Press the enter (E) key. Display shows the latitude in degrees, minutes, and seconds of the reference position using the satellite datum.

RT N 27 14 16.725

Reference Latitude

Press the enter (E) key. Display shows the longitude in degrees, minutes, and seconds of the reference position using the satellite datum.

RN W114 37 42.117

Reference Longitude

Press the enter (E) key. Display shows the geodetic height in meters of the reference position using the satellite datum.

RHT+ 13.74

Reference Geodetic Height

Press the enter (E) key to display the relative translocation position. Refer to code 74.

RANG 274.32576

Relative Translocation Data

Code 74, Display Relative Translocation Data

NOTE

This code applies only to version 100 and above units.

Table 4-21. CODE DESCRIPTIONS - Cont

Enter code 74 to display the relative translocation distance associated with the last translocation fix. The first display shows the range in kilometers (straight-line or chord distance) between the control site and the remote site.

RANG 274.32576

Range Between Sites

Press the enter (E) key to display the geodetic azimuth off north in the satellite datum of the remote site with respect to the control site. This is shown in degrees measured clockwise off true north with respect to the satellite datum.

AZN 117.282

Azimuth of Remote Site

Press the enter (E) key to display the difference between the control and remote sites (remote-control) in the X coordinate of the satellite datum. The units are kilometers.

$\Delta X + 132.64281$

X Coordinate Difference

Press the enter (E) key to display the difference between the control and remote sites (remote-control) in the Y coordinate of the satellite datum. The units are kilometers.

$\Delta Y - 257.43787$

Y Coordinate Difference

Table 4-21. CODE DESCRIPTIONS - Cont

Press the enter (E) key to display the difference between the control and remote sites (remote-control) in the Z coordinate of the satellite datum. The units are kilometers.



ΔZ + 347.72

Z Coordinate Difference

Press the enter (E) key to display the latitude in degrees, minutes, and seconds of the control site position, using the satellite datum.



CT N 71 22 14.628

Control Latitude

Press the enter (E) key to display the longitude in degrees, minutes, and seconds of the control site position, using the satellite datum.



CN W131 17 16.662

Control Longitude

Press the enter (E) key to display the geodetic height in meters of the control site position, using the satellite datum.



CHT 47.32

Control Height

Code 75, Display and/or Enter Post Translocate

NOTE

This code applies only to Version 100 and above units.

Table 4-21. CODE DESCRIPTIONS - Cont

Enter code 75 to recalculate the translocation position based upon a new control position. It is assumed that a translocation computation has previously taken place. The new control position must be within 1 kilometer (0.62 miles) of the old control position.

The unit first asks the user to input a new control position. Enter the new control position similarly to the code 77 entry.



INPS GEO-SAT

Initial Display

Then the unit will display the new translocation position in the same format as code 73. Press the enter (E) key to display each new translocation position parameter.



TR 7 12.732

New Translocation Display

Code 77, Display and/or Enter Input Position

Enter code 77 to input a position in one of several formats. Press the +/- key to select the desired format for position entry. Then press the enter (E) key to begin the prompted data entry. Changing the input position resets the 3D position and translocation position fix computations.

Geographic position entry.

The user may select geographic position entry in either the satellite datum or a local datum. Before selecting local datum, specify constants identifying the local datum using code 100.

Table 4-21. CODE DESCRIPTIONS - Cont

INPS GEO-SAT

Geodetic Satellite Datum Selected

INPS GEO-LOC

Geodetic Local Datum Selected

The first parameter to be displayed and/or entered is the latitude in degrees, minutes, and seconds of the input position. If the currently displayed value is correct, press only the enter (E) key. If it is not correct, enter the new value. Enter a space (→) between degrees and minutes, and between minutes and seconds. Use the +/- key to change from N (north) to S (south) or vice versa. Then press the enter (E) key to enter the latitude.

LT N 33 50 17.478

Latitude

The next parameter to be displayed and/or entered is the longitude in degrees, minutes, and seconds of the input position. If the currently displayed value is correct, press only the enter (E) key. If it is not correct, enter the new value. Enter a space (→) between degrees and minutes, and between minutes and seconds. Use the +/- key to change from E (east) to W (west) or vice versa. Then press the enter (E) key to enter the new longitude.

LN W118 20 14.727

Longitude

Table 4-21. CODE DESCRIPTIONS - Cont

The MX 1502 then asks the user to select whether height will be entered in the form of geodetic height (HT) or elevation above mean sea level (EL). Press the +/- key to select the desired mode, then press the enter (E) key. The elevation mode should be used only when the geodetic height is unknown.



HGT HT

Height Entry Mode

When the geodetic height mode is selected, the geodetic height of the antenna reference point will be displayed in meters. The antenna reference point is marked by a red band on the antenna/preamplifier unit. If the geodetic height is correct, press only the enter (E) key. If it is not correct, enter the new value. Use the +/- key to change from + to - or vice versa. Then press the enter (E) key.

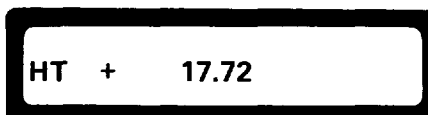

HT + 17.72

Geodetic Height

If the elevation mode is selected, the elevation in meters of the antenna reference point above mean sea level will be displayed. If it is correct, press only the enter (E) key. If it is not correct, enter the new value. Use the +/- key to change from + to - or vice versa. Then press the enter (E) key.

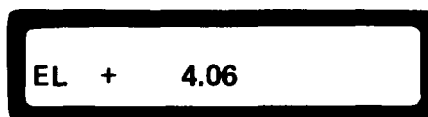

EL + 4.06

Elevation

Table 4-21. CODE DESCRIPTIONS - Cont

XYZ position entry

The user may select XYZ (Cartesian coordinate) position entry in either the satellite datum or a local datum. Before selecting local datum, first specify constants identifying the local datum using code 100.



INPS XYZ-SAT

XYZ Satellite Datum Selected



INPS XYZ-LOC

XYZ Local Datum Selected

The first parameter to be displayed and/or entered is the X coordinate in kilometers of the input position. If the currently displayed value is correct, press only the enter (E) key. If it is not correct, enter the new value. Press the +/- key to select the appropriate sign. Then press the enter (E) key to enter the new X coordinate.



X - 2317.50623

X Coordinate

The next parameter to be displayed and/or entered is the Y coordinate in kilometers of the input position. If the currently displayed value is correct, press only the enter (E) key. If it is not correct, enter the new value. Press the +/- key to select the appropriate sign. Then press the enter (E) key to enter the new Y coordinate.



Y + 237.15152

Y Coordinate

Table 4-21. CODE DESCRIPTIONS - Cont

The last parameter to be displayed and/or entered is the Z coordinate in kilometers of the input position. If the currently displayed value is correct, press only the enter (E) key. If it is not correct, enter the new value. Press the +/- key to select the appropriate sign. Then press the enter (E) key to enter the new Z coordinate.

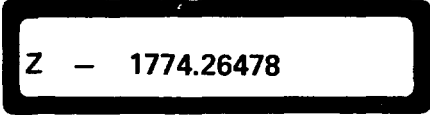

Z - 1774.26478

Z Coordinate

Code 80, Display and/or Enter Weather Conditions

Enter code 80 to display or enter weather conditions in sequence. The weather parameters are used for data logging, not position computation. They are maintained in memory after entry and recorded with each subsequent pass until changed.

Temperature may be displayed or entered in degrees Celsius. The temperature should be changed when the ambient temperature changes significantly.



TEM+ 22

Previous Temperature

To enter a new temperature, key in the value. Use the change sign (+/-) key to change from a temperature above zero (+) to a temperature below zero (-) or vice versa.

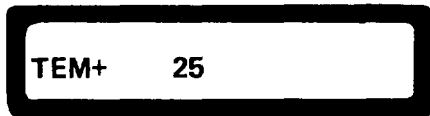

TEM+ 25

Recent Temperature

Table 4-21. CODE DESCRIPTIONS - Cont

Press the enter (E) key to display or enter the value of atmospheric pressure in millibars. The recorded pressure should be changed when a significant change occurs in the atmospheric pressure.

PRES 1015

Previous Pressure

To change the recorded value, key in the new value and press the enter (E) key.

PRES 1008

Recent Pressure

Press the enter (E) key to display or enter the percent of relative humidity. The relative humidity should be changed when a significant change in the relative humidity occurs.

HUM 75

Previous Humidity

To change the humidity, key in the new value. Use the decimal point key if required. Press the enter (E) key.

HUM 51

Recent Humidity

Table 4-21. CODE DESCRIPTIONS - Cont

Code 84, Display and/or Enter Variables

Enter code 84 to display or enter user variables 1 through 4 respectively. User variables are used to record variable conditions at the site such as wind speed, cloud cover, or problem areas. User variables are not used in the computations but are recorded on tape. The range of values that can be assigned to each variable is between 0 and 16,383. These variables are maintained in memory after entry and recorded with each subsequent pass until changed.



VAR1 16383

Maximum Value



VAR4 0

Minimum Value

Code 90, Display and/or Enter Delete Satellites

Enter code 90 to display or enter the last three digits of the identification number of satellites that are not to be utilized in the data acquisition process. A zero indicates no entry. Press the enter (E) key to display additional satellite identification numbers up to a maximum of five.



XSAT 0

CAUTION

When deleting satellites, verify that code 19 (satellites desired) equals number of valid satellites to be tracked. Optimum power management is dependent upon code 18 being equal to code 19.

Table 4-21. CODE DESCRIPTIONS - Cont

Code 91, Display and/or Enter Residual Limit

Enter code 91 to display or enter the standard deviation of the 2D residuals limit in meters. To change the limit, key in the new number and press the enter (E) key. Satellite pass data whose 2D residual standard deviations are greater than this limit will not be used in 3D position or translocation computations.

RES 0.25

When the MX 1502 is first turned on, a limit of 0.25 meters (0.81 feet) is used. In a noisy environment, the limit may be raised. When entering the navigate mode, the residual limit is automatically raised to 10.0 meters.

Code 94, Display 150 Tune and Signal Level

Enter code 94 to display the frequency of the 150 MHz channel receiver oscillator and the signal-to-noise ratio. The units of frequency are kilohertz. The displayed range for the 150 channel is 23 to 42 kilohertz. This frequency is scaled to correspond to the 400 channel display (code 54). A signal-to-noise ratio of 0 indicates no signal and 100 indicates a perfect signal.

F/S1 26.0 2.5

Code 98, Display Passes in Memory

Enter code 98 to display the number of satellite passes for which data is currently being held in memory for translocation processing.

MEM 13

Code 99, Display Tape

Table 4-21. CODE DESCRIPTIONS - Cont

Enter code 99 to display the last pass or site data that was read by the tape reading codes. If a pass was read in last, the display will show the pass number first. The display sequence is similar to that of codes 53 and 63.



PASS 27

Pass Data

If a site record was read in last, the display will show the site number first. The display sequence is similar to that of code 20.



SITE 4

Site Data

Code 100, Display and/or Enter Datum Conversion Parameters

Enter code 100 to display and/or enter the datum conversion parameters. Refer to Table 4-16 for a list of datum conversion constants. The first parameter is the value in kilometers of the semimajor axis for the reference ellipsoid of the local datum.



A 6378.20640

Semimajor Axis

Press the enter (E) key to display and/or enter the reciprocal of the flattening coefficient (1/F) of the reference ellipsoid of the local datum.



1/F 294.97870

Flattening Coefficient

Table 4-21. CODE DESCRIPTIONS - Cont

Press the enter (E) key to display and/or enter the X-coordinate distance (ΔX) in meters between the centers of the reference ellipsoids of the satellite datum and the local datum.



$\Delta X + 22.34$

X-Coordinate Distance

Press the enter (E) key to display and/or enter the Y-coordinate distance (ΔY) in meters between the center of the reference ellipsoids of the satellite datum and the local datum.



$\Delta Y - 157.07$

Y-Coordinate Distance

Press the enter (E) key to display and/or enter the Z-coordinate distance (ΔZ) in meters between the centers of the reference ellipsoids of the satellite datum and the local datum.



$\Delta Z - 176.41$

Z-Coordinate Distance

NOTE

- The ΔX , ΔY , and ΔZ datum shift constants listed in Table 4-16 have appropriate signs for converting from satellite datum to the corresponding local datum. Constants listed in other publications may have signs for converting from a local datum to the satellite datum. When entering datum constants, carefully note whether the sign is for conversion to or from the satellite datum.
- The signs of the rotation angles may be reversed in certain publications.

Table 4-21. CODE DESCRIPTIONS - Cont

Press the enter (E) key to display and/or enter the rotation angle in arc seconds about the X-axis. A positive (+) rotation is counterclockwise with respect to the origin of the XYZ coordinate system.



RX + 1.71

X-Axis Rotation Angle

Press the enter (E) key to display and/or enter the rotation angle in arc seconds about the Y-axis. A positive (+) rotation is counterclockwise with respect to the origin of the XYZ coordinate system.



RY - 0.24

Y-Axis Rotation Angle

Press the enter (E) key to display and/or enter the rotation angle in arc seconds about the Z-axis. A positive (+) rotation is counterclockwise with respect to the origin of the XYZ coordinate system.



RZ + 1.77

Z-Axis Rotation Angle

Press the enter (E) key to display and/or enter the bias in parts-per-million to the scale factor. The scale factor is $(1 \pm \text{bias})$ and is multiplied by the X, Y, and Z coordinates of the position.



BS + 3.18

Scale Factor Bias

Table 4-21. CODE DESCRIPTIONS - Cont

Code 106, Display and/or Enter UTM Conversion Parameters

Enter code 106 to display and/or enter the UTM conversion parameters. The first parameter is the UTM zone number. Enter a 0 for zone number if the MX 1502 is to automatically calculate the zone number based upon the longitude. The zone is defined to be 6 degrees wide in longitude.

ZONE 32

Zone Number

Press the enter (E) key to display and/or enter the UTM central meridian. No entry results in the MX 1502 calculating the central meridian automatically.

CM E107 16 22.741

Central Meridian

Press the enter (E) key to display and/or enter the false northing bias in kilometers that is added to the UTM northing. If no value is entered, +0 kilometer is automatically used. The standard UTM values are 0 for the northern hemisphere and 10,000 kilometers (6,200 miles) for the southern hemisphere.

FN + 0.00000

False Northing Bias

Press the enter (E) key to display and/or enter the false easting bias in kilometers that is added to the UTM easting. If no value is entered, +500 kilometers (310 miles) is automatically used.

FE + 500.00000

False Easting Bias

Table 4-21. CODE DESCRIPTIONS - Cont

Press the enter (E) key to display and/or enter the UTM scale factor multiplied by 1000. The scale factor is applied to the UTM coordinates. If no value is entered, 999.6 is automatically used.

SF 999.60000

Scale Factor

Code 110, Display Local Datum Position

NOTE

Datum conversion parameters must be entered using code 100 before code 110 may be used.

Enter code 110 to select the position to be displayed in a local datum. Press the +/- key to select the desired position as shown by the display.

DATM 2D

2D Position Selected

Press the enter (E) key to display the datum shifted latitude in degrees, minutes, and seconds.

LT N 37 22 12.471

Local Datum Latitude

Press the enter (E) key to display the datum shifted longitude in degrees, minutes, and seconds.

LN W112 17 37.781

Local Datum Longitude

Table 4-21. CODE DESCRIPTIONS - Cont

Press the enter (E) key to display the geodetic height in meters, using the local datum.

HT + 12.04

Geodetic Height

Press the enter (E) key to display the X coordinate in kilometers, using the local datum.

X - 3871.29832

Local Datum X Coordinate

Press the enter (E) key to display the Y coordinate in kilometers, using the local datum.

Y + 2631.56620

Local Datum Y Coordinate

Press the enter (E) key to display the Z coordinate in kilometers, using the local datum.

Z - 1747.25837

Local Datum Z Coordinate

Table 4-21. CODE DESCRIPTIONS - Cont

Code 120, Display XYZ Coordinates

Enter code 120 to select the position to be displayed in XYZ coordinates, using the satellite datum. Press the +/- key to select the desired position as shown by the display.



XYZ 2D

2D Position Selected

Press the enter (E) key to display the X coordinate in kilometers, using the satellite datum.



X + 2847.53292

X Coordinate

Press the enter (E) key to display the Y coordinate in kilometers, using the satellite datum.



Y - 1748.52507

Y Coordinate

Press the enter (E) key to display the Z coordinate in kilometers, using the satellite datum.



Z + 727.48397

Z Coordinate

Table 4-21. CODE DESCRIPTIONS - Cont

Code 130, Display UTM Coordinates

NOTE

Datum and UTM conversion parameters must be entered using code 100 before code 130 may be used.

Enter code 130 to select the position to be displayed in UTM coordinates. Press the +/- key to select the desired position as shown by the display.

UTM 2D

2D Position Selected

Press the enter (E) key to display the UTM easting coordinate in kilometers.

E + 23.37242

UTM X-Coordinate

Press the enter (E) key to display the UTM northing coordinate in kilometers.

N - 14.72718

UTM Y-Coordinate

Press the enter (E) key to display the geodetic height in meters using the local datum.

HT 3 17.07

Geodetic Height

Table 4-21. CODE DESCRIPTIONS - Cont

Press the enter (E) key to display the UTM zone number.



UTM Zone Number

Press the enter (E) key to display the UTM central meridian in degrees, minutes, and seconds.

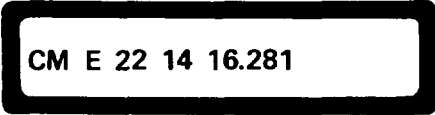

UTM Central Meridian

Code 140, Display and/or Enter SPD/HDG

NOTE

This code is operative only in the navigate mode.

Enter code 140 to display or enter the speed and heading of the MX 1502. The speed units must first be selected. The choices are knots (for sea travel) or kilometers per hour (for land travel). Press the +/- key to select the desired units. Then press the enter (E) key.



Previous Mode

Table 4-21. CODE DESCRIPTIONS - Cont

The speed is then displayed in the selected units. The speed may be changed, using the numeric keys. Then press the enter (E) key.

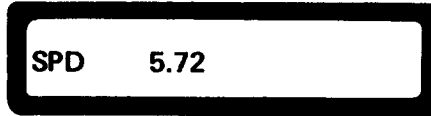

SPD 5.72

Speed

The heading in degrees is then displayed, which is measured from true north. The heading may be changed, using the numeric keys. Then press the enter (E) key.



HDG 175.74

Heading

The speed is now displayed again so that the user may re-enter it if desired. Press the clear (C) key to exit speed/heading entry.

Code 141, Display and/or Enter Waypoint

NOTE

This code is operative only in the navigate mode.

Enter code 141 to display or enter a waypoint position. The waypoint latitude is displayed in degrees, minutes, and seconds. A new latitude may be entered, using the numeric keys. There must be a space(→) between degrees and minutes, and between minutes and seconds. Then press the enter (E) key.

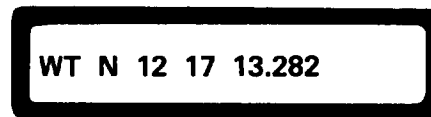

WT N 12 17 13.282

Waypoint Latitude

Table 4-21. CODE DESCRIPTIONS - Cont

The waypoint longitude is displayed in degrees, minutes, and seconds. A new longitude may be entered, using the numeric keys. There must be a space (→) between degrees and minutes and between minutes and seconds. Then press the enter (E) key.

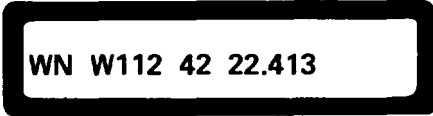

WN W112 42 22.413

Waypoint Longitude

The route to be taken from the present position to the waypoint position must be specified. The choices are great circle or rhumb line. Press the +/- key to select the desired route. Then press the enter (E) key.



ROUT G CIRCLE

Waypoint Route

Code 142, Display DR Data

NOTE

This code is operative only in the NAVIGATE mode.

Enter code 142 to display the current dead reckoned position data. The dead reckoned latitude is displayed in degrees, minutes, and seconds.

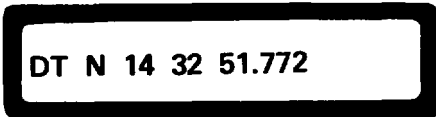

DT N 14 32 51.772

DR Latitude

Table 4-21. CODE DESCRIPTIONS - Cont

Code 142, Display DR Data - Cont

Press the enter (E) key to display the dead reckoned longitude in degrees, minutes, and seconds.

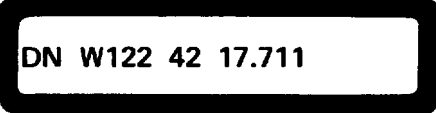

DN W122 42 17.711

DR Longitude

Press the enter (E) key to display the Greenwich Mean Time in hours, minutes, and seconds.



GMT 12 46 22

Greenwich Mean Time

Press the enter (E) key to display the range and bearing in degrees from the dead reckoned position to the waypoint position. The range will be in units of either nautical miles (N) or kilometers (K) depending upon the units selected for the speed entry (code 140).



GC 32.41N 171.4

Waypoint Range/Bearing

The route will be displayed on either great circle (GC) or rhumb line (RL). Press the enter (E) key to repeat the above displays.

Table 4-21. CODE DESCRIPTIONS - Cont

Code 143, Display Sequencing DR Data

NOTE

The code is operative only in the navigate mode.

Enter code 143 to display the current dead reckoned position data on an automatic sequencing basis. The time length for display must first be selected. Enter the time length for display in seconds, using the numeric keys. The time length may range from 1 to 255 seconds. Then press the enter (E) key.

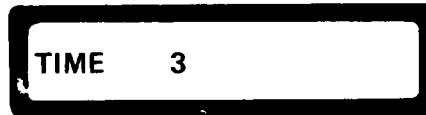

TIME 3

Time Length

The following data will be displayed sequentially until the user presses either the C or E keys:

1. The dead reckoned latitude in degrees, minutes, and seconds.

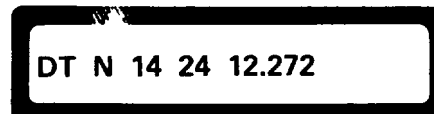

DT N 14 24 12.272

DR Latitude

2. The dead reckoned longitude in degrees, minutes, and seconds.

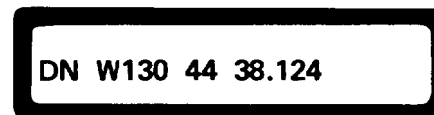

DN W130 44 38.124

DR Longitude

3. The Greenwich Mean Time in hours, minutes, and seconds.



GMT 13 14 43

Greenwich Mean Time

Table 4-21. CODE DESCRIPTIONS - Cont

4. The range and bearing in degrees from the dead reckoned position to the waypoint. The range will be in units of either nautical miles (N) or kilometers (K) depending upon the units selected for the speed entry (code 140).

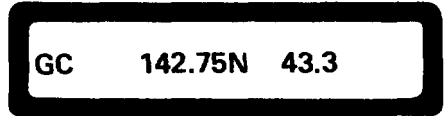

Waypoint Range/Bearing

The route is shown as either great circle (GC) or rhumb line (RL).

Code 144, Display Print DR

NOTE

This code is operative only in the navigate mode.

Enter code 144 to enable printing of the dead reckoned data on the optional printer. The printer must first be enabled using code 71. The time interval between consecutive dead reckoned printouts must be specified. Enter the time interval in minutes, using the numeric keys. The time interval may range from 1 to 32,767 integer minutes (22 days, 18 hours, 6 minutes). Entering a time of zero disables the DR printout. Then press the enter (E) key.

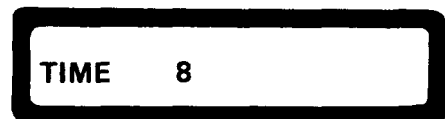

DR Print Interval

The DR printout will then occur at the specified time intervals, and will consist of DR latitude, DR longitude, Greenwich Mean Time, and range/bearing to waypoint.

Code 145, Display Force Update

NOTE

This code is operative only in the navigate mode.

Table 4-21. CODE DESCRIPTIONS - Cont

Enter code 145 to manually update the dead reckoned position with the last satellite fix if that fix did not automatically update. Determine the current update status using code 53.

Code 222, Control Transmit Now

NOTE

This code is applicable only to version 110 and above units.

The MX 1502 must be in the control mode in order to use this code. Enter code 222 to transmit a message immediately via the communications link. If translocation and next satellite data were previously transmitted and the MX 1502 did not power-down since that transmission, that same data is re-transmitted. Otherwise, a dummy message is transmitted.

Code 230, Control Turn on Modem

NOTE

This code is applicable only to version 110 and above units.

The MX 1502 must be in the remote mode in order to use this code. It is used only for test purposes to verify that the communication link is operating properly.

Enter code 230 to turn on the modem immediately for data reception. The modem will remain on until turned off either by code 231 or the next automatic turn off. The modem will normally be turned on and off axiomatically at the appropriate times for data reception.

PWRO OFF

Code 231, Control Turn Off Modem

NOTE

This code is applicable only to version 110 and above units.

The MX 1502 must be in the remote mode in order to use this code. It is normally used in conjunction with code 230 (turn on modem). Enter code 231 to turn off the modem immediately.

Table 4-21. CODE DESCRIPTIONS - Cont

Code 237, Control Abort Self-Test

Enter code 237 to abort the automatic or manually entered self-test (code 16). The MX 1502 will immediately exit the self-test operation, leaving intact those error codes displayed as a result of faults encountered during the current self-test.

Code 245, Display and/or Control Power Override

Enter code 245 to display or change the status of the power override feature. The power override feature maintains power to most circuits in the MX 1502 including the keyboard and display. The power override feature is useful during troubleshooting operations.

When OFF is displayed, the power override feature is disabled. Use the change sign (+/-) key to change the display from OFF to ON or vice versa. Press the enter (E) key when the desired state is displayed. The power override feature is disabled when power is initially applied. It is also disabled after an acceptable satellite pass when the number of satellites desired (code 19) equals the number of satellites alerted (code 18).

4-6.4 Preparation for Movement.

CAUTION

To prevent corrosion, be sure to dry all components before storing in the case.

- a. Press clear (C) key.
- b. When CODE is displayed, enter 49.



NOTE

UNLD is displayed while cassette is being rewind.

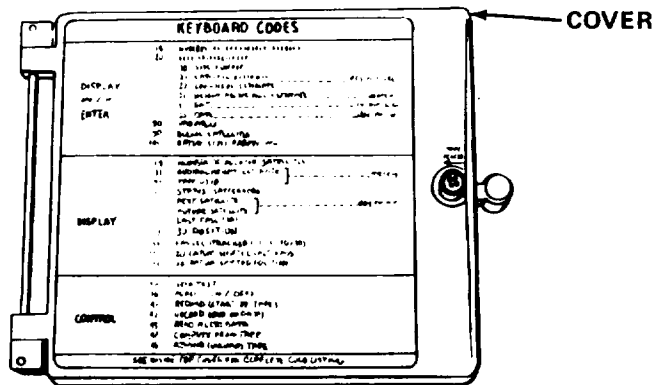

- c. Open tape cassette transport cover.

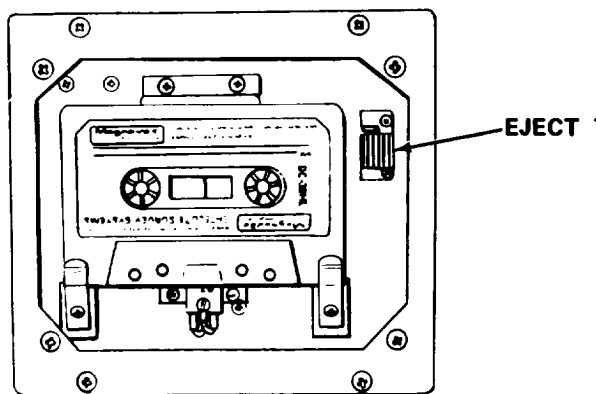

- d. Press eject tab to remove tape cassette.
- e. Close tape cassette transport cover.
- f. Perform your after PMCS (Table 4-1).

4-6.5 Operating Instruction on Decals and Instructions Plates.

| KEYBOARD CODES | |
|------------------------------------------|------------------------------------------|
| DISPLAY and/or ENTER | |
| 19 | NUMBER OF SATELLITES DESIRED |
| 20 | SITE INITIALIZATION |
| 20 | SITE NUMBER |
| 21 | LATITUDE ESTIMATE |
| 22 | LONGITUDE ESTIMATE |
| 23 | HEIGHT ABOVE MSG-ESTIMATE |
| 24 | GMT |
| 25 | DATE |
| 26 | UNIT SERIAL NUMBER |
| 27 | SITE PARAMETER 1 |
| 28 | SITE PARAMETER 2 |
| 29 | SITE PARAMETER 3 |
| 30 | SITE PARAMETER 4 |
| 80 | VARIABLES |
| 81 | TEMPERATURE |
| 82 | PRESSURE |
| 83 | RELATIVE HUMIDITY |
| 84 | VARIABLE 1 |
| 85 | VARIABLE 2 |
| 86 | VARIABLE 3 |
| 87 | VARIABLE 4 |
| 90 | DELETE SATELLITES |
| 100 | DATUM SHIFT PARAMETERS (WGS 72 TO LOCAL) |
| 100 | a (LOCAL) |
| 101 | 1/f (LOCAL) |
| 102 | ΔX |
| 103 | ΔY |
| 104 | ΔZ |
| 105 | $\Delta 2$ |
| 106 | ZONE NUMBER |
| 107 | CENTRAL MERIDIAN |
| 108 | FALSE NORTHING |
| 109 | FALSE EASTING |
| 113 | SCALE FACTOR |
| DISPLAY | |
| 18 | NUMBER OF ALERTED SATELLITES |
| 33 | GEOIDAL HEIGHT ESTIMATE |
| 35 | JULIAN DAY |
| 48 | TAPE USED |
| 50 | STATUS (SAT/ERRORS) |
| 51 | NEXT SATELLITE |
| 52 | FUTURE SATELLITE |
| 53 | LAST PASS (20) |
| 63 | 3D POSITION |
| 66 | PASSES (TRACKED/RECORD/3D) |
| 110 | 2D DATUM SHIFTED LAST PASS |
| 111 | 3D DATUM SHIFTED POSITION |
| 120 | 2D XYZ LAST PASS |
| 121 | 3D XYZ POSITION |
| 130 | 2D UTM |
| 131 | 3D UTM |
| CONTROL | |
| 16 | SELF TEST |
| 36 | ALARM (ON/OFF) |
| 37 | SATELLITE ALARM (ON/OFF) |
| 41 | RECORD (START OF TAPE) |
| 42 | RECORD (END OF DATA) |
| 43 | READ ALERT DATA |
| 44 | READ TAPE |
| 47 | COMPUTE FROM TAPE |
| 49 | REWIND (UNLOAD) TAPE |
| MAINTENANCE | |
| 8 | DISPLAY OCTAL |
| 9 | DISPLAY DECIMAL |
| 17 | TEST DISPLAY |
| 54 | 400 MHz TUNE |
| 55 | 400 MHz SIGNAL LEVEL |
| 56 | LOCAL OSCILLATOR OFFSET |
| 94 | 150 MHz TUNE |
| 95 | 150 MHz SIGNAL LEVEL |
| 245 | STAY AWAKE (ON/OFF) |
| FOR DETAILED CODE DESCRIPTION SEE MANUAL | |

| KEYBOARD CODES | |
|------------------------------------------|------------------------------|
| REAL TIME TRANSLOCATION OPTION | |
| 39 | TRANSLOCATE FROM 2 SITE TAPE |
| 58 | TIME OF NEXT TRANSMISSION |
| 59 | MODEM STATUS |
| 222 | TRANSMIT NOW |
| 230 | TURN ON MODEM |
| 231 | TURN OFF MODEM |
| FOR DETAILED CODE DESCRIPTION SEE MANUAL | |

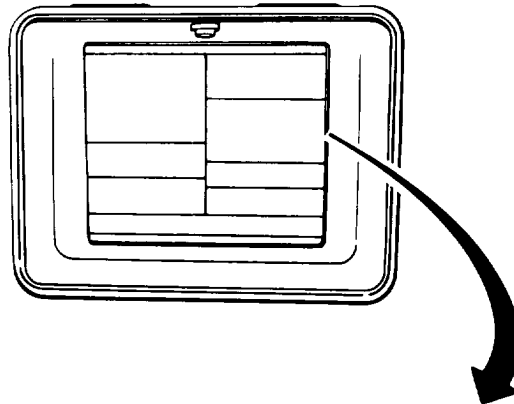

| KEYBOARD CODES | |
|------------------------------------------------|------------------------------------------------|
| | 19 NUMBER OF SATELLITES DESIRED |
| | 20 SITE INITIALIZATION |
| | 20 SITE NUMBER |
| DISPLAY | 21 LATITUDE ESTIMATE deg. min. sec. |
| | 22 LONGITUDE ESTIMATE deg. min. sec. |
| | 23 HEIGHT ABOVE MSL ESTIMATE meters. |
| and/or | 24 GMT hr. min. sec. |
| | 25 DATE day. mo. yr. |
| ENTER | 80 VARIABLES |
| | 90 DELETE SATELLITES |
| | 100 DATUM SHIFT PARAMETERS |
| <hr/> | |
| | 18 NUMBER OF ALERTED SATELLITES |
| | 33 GEOIDAL HEIGHT ESTIMATE meters. |
| | 48 TAPE USED |
| DISPLAY | 50 STATUS (SAT/ERRORS) |
| | 51 NEXT SATELLITE day hr. min. |
| | 52 FUTURE SATELLITE |
| | 53 LAST PASS (2D) |
| | 63 3D POSITION |
| | 66 PASSES (TRACKED/RECORDED/3D) |
| | 110 2D DATUM SHIFTED LAST PASS |
| | 111 3D DATUM SHIFTED POSITION |
| <hr/> | |
| | 16 SELF TEST |
| | 36 ALARM (ON/OFF) |
| | 41 RECORD (START OF TAPE) |
| CONTROL | 42 RECORD (END OF DATA) |
| | 43 READ ALERT DATA |
| | 47 COMPUTE FROM TAPE |
| | 49 REWIND (UNLOAD) TAPE |
| SEE INSIDE TOP COVER FOR COMPLETE CODE LISTING | |

KEYBOARD CODES

| INITIALIZATION | TAPE/PROCESSING |
|-----------------------------------------------------------------------------------------------------------------------------------------------------------------------------------------------------------------------------------------------------------------------------------------------------------------------------------------------------------------------------------------------------------------------------------------------------------------------------------------------------------------------------------------------------------------------------------------------------------------------------------------------------------------------------------------------------------------------------------------------------------------------------------------------------------------------------------------------------------------------------------------|------------------------------------------------------------------------------------------------------------------------------------------------------------------------------------------------------------------------------------------------------------------------------------------------------------------------------------------------------------------------------------------------------------------------------------------------------------------------------------------------------------------------------------------------------------------------------------------------------------------------------------------------------------------------------------------------------------------------------------------------|
| <p>△ 10 MODE</p> <p>19 NUMBER OF SATELLITES DESIRED</p> <p>20 SITE NUMBER</p> <p>21 LATITUDE ESTIMATE deg. min. sec.</p> <p>22 LONGITUDE ESTIMATE deg. min. sec.</p> <p>23 HEIGHT ESTIMATE meters</p> <p>24 GMT hr. min. sec.</p> <p>25 DATE day mon. yr.</p> <p>* 27 → 30 UNIT SERIAL NUMBER</p> <p>31 SITE PARAMETERS 1 → 4</p> <p>32 SATELLITE ALARM</p> <p>38 ALARM SUPPRESSION</p> <p>41 RECORD AT START OF TAPE</p> <p>42 RECORD AT END OF DATA</p> <p>43 READ ALERT TAPE</p> <p>70 PRINT NOW</p> <p>71 PRINT ENABLE</p> <p>* 80 → 87 VARIABLES</p> <p>81 TEMPERATURE deg. C</p> <p>82 PRESSURE m bar</p> <p>83 RELATIVE HUMIDITY %</p> <p>84 VARIABLE 1</p> <p>85 VARIABLE 2</p> <p>86 VARIABLE 3</p> <p>87 VARIABLE 4</p> <p>90 DELETE SATELLITES</p> <p>91 RESIDUAL LIMIT meters</p> | <p>△ 40 LOAD TAPE</p> <p>44 READ PASS</p> <p>△ 45 READ SITE</p> <p>△ 46 TRANSLOCATE FROM TAPE</p> <p>47 POINT POSITION FROM TAPE</p> <p>49 UNLOAD TAPE</p> <p>△ 73 TRANSLOCATION POSITION</p> <p>△ 74 RELATIVE TRANSLOCATION DATA</p> <p>△ 75 POST - TRANSLOCATE</p> <p>△ 77 INPUT POSITION</p> <p>△ 98 PASSES IN MEMORY</p> <p>△ 99 DISPLAY TAPE DATA</p> |
| <p>△ 18 NUMBER OF SATELLITES</p> <p>33 JULIAN DAY</p> <p>35 ELEVATION GEODIAL HEIGHT ESTIMATE meters</p> <p>48 TAPE USED meters</p> <p>50 STATUS (SAT/ERRORS)</p> <p>51 FUTURE SATELLITES</p> <p>53 LAST PASS (2D)</p> <p>66 PASSES (TRACKED/RECORDED/POINT POSITION)</p> | <p>* 100 → 105 DATUM SHIFT PARAMETERS</p> <p>100 a km.</p> <p>101 1/f</p> <p>102 X meters</p> <p>103 Y meters</p> <p>104 Z meters</p> <p>* 106 → 109 & 113 UTM CONVERSION</p> <p>106 ZONE NUMBER</p> <p>107 CENTRAL MERIDIAN deg. min. sec.</p> <p>108 FALSE NORTHING km.</p> <p>109 FALSE EASTING km.</p> <p>* 110 → 111 DATUM SHIFTED POSITION: (LAST PASS)</p> <p>110 DATUM SHIFTED POSITION (POINT POSITION)</p> <p>111 SCALE FACTOR</p> <p>* 120 → 121 XYZ COORDINATES (POINT POSITION)</p> <p>120 XYZ COORDINATES km.</p> <p>* 130 → 131 UTM COORDINATES (POINT POSITION)</p> <p>130 UTM COORDINATES km.</p> |
| <p>8 DISPLAY OCTAL</p> <p>9 DISPLAY DECIMAL</p> <p>16 SELF-TEST</p> <p>17 TEST DISPLAY</p> <p>36 ALARM ON/OFF</p> <p>54 400 MHZ TUNE/SIGNAL LEVEL kHz/</p> <p>56 REFERENCE OSCILLATOR</p> <p>94 150 MHZ TUNE/SIGNAL LEVEL kHz/</p> <p>237 ABORT SELF-TEST</p> <p>245 STAY AWAKE</p> | <p>140 SPEED/HEADING</p> <p>141 WAYPOINT deg. min. sec.</p> <p>142 DR DATA</p> <p>143 SEQUENCING DR DATA</p> <p>144 PRINT DR DATA</p> <p>145 FORCE UPDATE</p> |
| <p>△ 39 TRANSLOCATE 2-SITE TAPE</p> <p>58 TIME OF NEXT TRANSMISSION hr. min. sec.</p> <p>△ 222 TRANSMIT NOW</p> <p>△ 230 TURN ON MODEM</p> <p>△ 231 TURN OFF MODEM</p> | <p>NAVIGATION</p> <p>REAL TIME TRANSLOCATION (Requires optional MODEM card)</p> |
| <p>△ APPLICABLE TO PROGRAM VERSION 112 AND UP.</p> <p>* IN UNITS WITH VERSION 112 AND UP, CODES PAST FIRST NUMBER IN THESE SEQUENCES ARE REACHED BY STEPPING THROUGH FROM THE FIRST NUMBER IN THE SERIES, PRESSING ENTER KEY.</p> | |
| <p>FOR DETAILED CODE DESCRIPTIONS SEE MANUAL.</p> | |

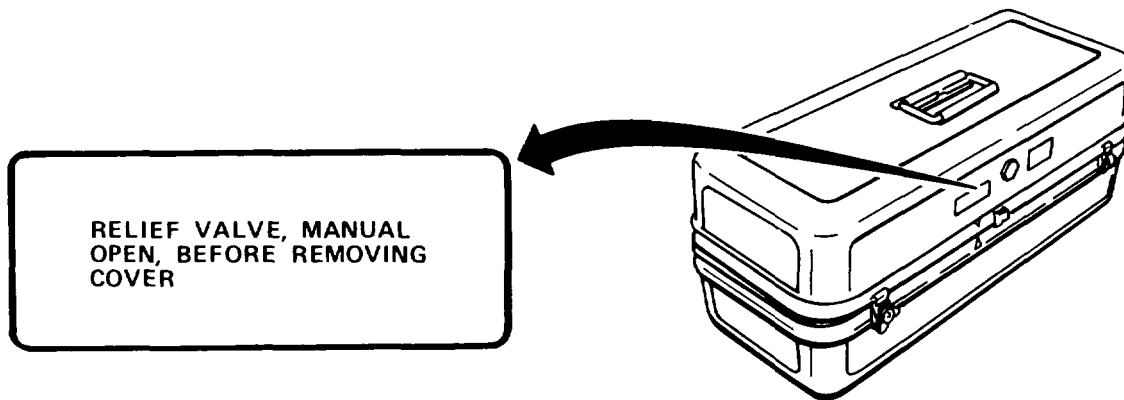

a. The codes and descriptions are located in two places. A partial list of frequently used codes is located on the cover of the tape cassette transport. A complete list of codes is located on the inside cover of the receiver/processor.

b. Code descriptions. One, two, and three digit codes are used to display information, enter initialization parameters, and to perform various surveying, maintenance, and printout operations.

4-7. OPERATION UNDER UNUSUAL CONDITIONS. The receiver/processor is weatherproof and bouyant with the cover in place and weatherproof with the front panel unprotected; if the tape transport cover is to be opened, a rain screen is required. Automatic shutdown will occur if the internal temperature reaches 70°C (158°F). If the receiver/processor is to be used in direct sunlight, a sun screen is required. In polar regions, a thermal blanket or climate control enclosure is required if the ambient temperature is expected to be below -25°C (-13°F).

Section III OPERATOR MAINTENANCE

4-8. LUBRICATION INSTRUCTIONS. This equipment does not require lubrication.

4-9. TROUBLESHOOTING PROCEDURES.

a. The table lists the common malfunctions which you may find during the operation or maintenance of the satellite surveyor. Malfunctions 1 through 10 are keyed to the error codes displayed as a result of the self-test. The self-test is initiated by entering code 16, or will occur automatically during a 24-hour period. Errors can also be displayed at any time by entering status code 50. Unless turned off, the audible alarm will sound to indicate a malfunction.

b. This manual cannot list all malfunctions that may occur, nor all test or inspections and corrective actions. If a malfunction is not listed or is not corrected by listed corrective actions, notify your supervisor.

Table 4-22. TROUBLESHOOTING

| MALFUNCTION | TEST OR INSPECTION | CORRECTIVE ACTION |
|----------------------------------------------------------------------------------------------------|------------------------------------------------------------------------|--------------------------------------------------------------------------------------------------------------------------------------------------------------------------------------------------------------------------------------|
| 1. ERROR C, DAMAGED TAPE CASSETTE. | Inspect cassette for physical damage and freedom of movement. | <ul style="list-style-type: none"> (a) Replace cassette. (b) If error still exists, refer to direct/general support maintenance. |
| 2. ERROR E, END OF CASSETTE. | Install new cassette. | |
| 3. ERROR H, INTERNAL TEMPERATURE EXCEEDED 70°C (158°F). | Automatic shutdown has occurred. | <ul style="list-style-type: none"> (a) Cool unit to operating temperature, less than 131° F (55°C), and restart. Provide sun screen. (b) If error still exists, refer to direct/general support maintenance. |
| 4. ERROR L, CASSETTE TAPE USED BEYOND 75 M (246 FT) . | Rewind and replace tape cassette. | |
| 5. ERROR M, CASSETTE TAPE WAS BEING USED WHEN POWER WAS INTERRUPTED. SOME DATA MAY HAVE BEEN LOST. | Note on cassette that last record on tape may have incomplete data. | NOTE |
| | Malfunction 6 and 7 will only occur when operating in the remote mode. | |
| 6. ERROR N, CONTROL SITE HAS PROBLEMS IN ITS PROCESSOR OR MODEM. | Notify control site. | |

Table 4-22. TROUBLESHOOTING - Cont

| MALFUNCTION | TEST OR INSPECTION | CORRECTIVE ACTION |
|---------------------------------------------------------------------------------------------------------------|--------------------|--------------------------------------------------------------------------------------------------------------------------------------------------------------------------------------------------------------------------------------------------------------------------------------------------------------------------------------------------------------|
| 7. ERROR O, EXPECTED DATA WAS NOT RECEIVED FROM COMMUNICATION LINK. | | <p style="text-align: center;">NOTE</p> <p>Occasional display of this code is normal, such as when control site is conducting self-test or is not using modem.</p> <p style="text-align: center;">Notify control site to check equipment condition.</p> |
| 8. ERROR P, EXTERNAL POWER FAILURE HAS OCCURRED. | | <p style="text-align: center;">Replace or recharge external battery or repair or replace external power supply.</p> |
| 9. ERROR T, FAULTY ANTENNA CABLE OR ANTENNA/PREAMPLIFIER. | | <p style="text-align: center;">Inspect antenna cables for physical damage.</p> <p style="text-align: center;">(a) Replace damaged antenna cable.</p> <p style="text-align: center;">(b) If trouble still exists, refer to direct/general support maintenance.</p> |
| 10. ERROR X, SATELLITE ALERT DATA ON TAPE IS TOO OLD (OVER 90 DAYS) TO PREDICT ACCURATE SATELLITE PASS TIMES. | | <p style="text-align: center;">(a) Use newer satellite data (less than 90 days old).</p> <p style="text-align: center;">(b) If an updated tape is unavailable, initialize unit and allow it to track all available satellites until enough data is gathered.</p> |
| 10.1 ERROR S, SATELLITE ALERT DATA FROM TAPE IS INSUFFICIENT. | | <p style="text-align: center;">Check that Code 18 and Code 19 are in agreement and that the Code 19 value is valid.</p> <p style="text-align: center;">(a) If not in agreement and Code 19 value is valid, use a tape with new data or more passes recorded.</p> <p style="text-align: center;">(b) If Code 19 value is not valid, enter a valid number.</p> |

Table 4-22. TROUBLESHOOTING - Cont

| MALFUNCTION | TEST OR INSPECTION | CORRECTIVE ACTION |
|-----------------------------------------------------------------------|--------------------|---------------------------------------------------------------------------------------------------------------------------------------------------------------------------------------------------------------------------------------------------------------------------------------------------------------------------------------------------------------------------------------|
| 10.1. ERROR S, SATELLITE ALERT DATA FROM TAPE IS INSUFFICIENT (Con't) | | (c) If a newer tape is not available, initialize the unit and allow it to track all available satellites until enough data is gathered. |
| 11. NO DISPLAY. | | <p>Step 1. Check external power supply.</p> <p>(a) Replace or recharge battery, or repair or replace external power supply.</p> <p>Step 2. Check for blown fuse.</p> <p>(a) Replace fuse.</p> <p>(b) If malfunction still exists, refer to direct/general support maintenance.</p> |
| 12. NO POSITION FIX CALCULATION BUT SATELLITE SIGNAL WAS ACQUIRED. | | <p>Step 1. Incorrect GMT entered or large error in position entered.</p> <p>Enter correct GMT, latitude and longitude. Use code 20 to correct any errors.</p> <p>Step 2. Incorrect data received from satellite.</p> <p>Wait for next satellite.</p> |
| 13. 2D FIX BUT NO 3D FIX. | | <p>Step 1. Check that elevation angle is acceptable for 3D fix.</p> <p>(a) If angle was not acceptable, wait for next satellite pass.</p> <p>(b) If angle was acceptable, proceed to step 2.</p> <p>Step 2. Enter code 50.</p> <p>(a) If no errors are displayed, wait for next pass.</p> <p>(b) If error 5, 6, 7 or 8 is displayed, refer to direct/general support maintenance.</p> |

Table 422. TROUBLESHOOTING - Cont

| MALFUNCTION |
|--------------------------------------------------------------|
| TEST OR INSPECTION |
| CORRECTIVE ACTION |
| 14. CODE 41 OR 42 WAS REJECTED. |
| Step 1. Check that tape was installed. |
| Install tape. |
| Step 2. Check that record enable tab is in correct position. |
| Position record enable tab to cover slot. |

4-10. MAINTENANCE PROCEDURES.

a. This section contains instructions covering operator maintenance functions for the satellite surveyor. Personnel required are listed only if the task requires more than one.

b. After completing each maintenance procedure, perform operational check to be sure that equipment is properly functioning.

INDEX

| PROCEDURES | PARAGRAPH |
|------------------------|-----------|
| Replace Fuse | 4-10.1 |

4-10.1 Replace Fuse.

MOS: 82D, Topographic Surveyor

SUPPLIES: Fuse (Slo-Blo) 6 Amp

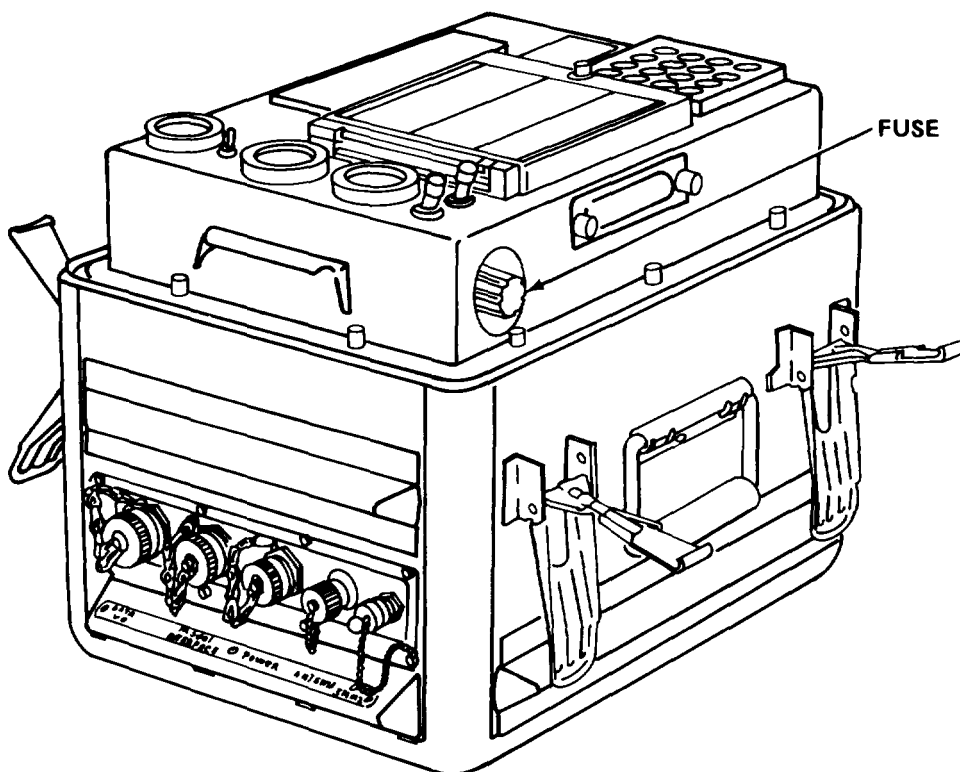

- a. Remove fuse holder.
- b. Install new fuse in fuse holder.
- c. Install fuse cover.

Section IV ORGANIZATIONAL MAINTENANCE

4-11. LUBRICATION INSTRUCTIONS. This equipment does not require lubrication.

4-12. REPAIR PARTS, SPECIAL TOOLS; TEST, MEASUREMENT, AND DIAGNOSTIC EQUIPMENT (TMDE); AND SUPPORT EQUIPMENT. These items are not required at this level of maintenance.

4-13. SERVICE UPON RECEIPT.

4-13.1 Checking Unpacked Equipment.

a. Inspect the equipment for damage incurred during shipment. If equipment has been damaged, report the damage on DD Form 6, Packing Improvement Report.

b. Check the equipment against the packing list to see if the shipment is complete. Report all discrepancies in accordance with the instructions of DA Pam 738-750.

c. Check to see whether the equipment has been modified.

4-14. ORGANIZATIONAL PREVENTIVE MAINTENANCE CHECKS AND SERVICES. There are no organizational PMCS procedures assigned for this equipment.

4-15. ORGANIZATIONAL TROUBLESHOOTING PROCEDURES. There are no organizational troubleshooting procedures assigned for this equipment.

4-16. MAINTENANCE PROCEDURES. There are no organizational maintenance procedures assigned for this equipment.

4-17. PREPARATION FOR STORAGE OR SHIPMENT. Contact your battalion for packing and shipping instructions.

Section V DIRECT/GENERAL SUPPORT MAINTENANCE

4-18. REPAIR PARTS, SPECIAL TOOLS; TEST, MEASUREMENT, AND DIAGNOSTIC EQUIPMENT (TMDE) ; AND SUPPORT EQUIPMENT.

4-18.1 Common Tools and Equipment. For authorized common tools and equipment, refer to the Modified Table of Organization and Equipment (MTOE) applicable to your unit.

4-18.2 Special Tools; Test, Measurement, and Diagnostic Equipment; and Support Equipment. Special Tools, TMDE, and Support Equipment is listed in the applicable repair parts and special tools list and in Appendix B of this manual.

4-18.3 Repair Parts. Repair parts are listed and illustrated in the Repair Parts and Special Tools List, TM 5-6675-318-24P covering direct/general support maintenance for this equipment.

4-19. DIRECT/GENERAL SUPPORT TROUBLESHOOTING PROCEDURES. The most common failures covered in this section use the self-test feature (paragraph 4-6.2). Failure or malfunction not covered requires that systematic evaluation and step-by-step analysis of the problem be made to isolate the fault. Perform the preliminary steps as follows:

- a. Assemble and prepare the equipment in accordance with paragraph 4-6.1.
- b. Perform a display test and self-test in accordance with paragraph 4-6.2.
- c. During self-test, TEST is displayed with receiver status codes, and error codes are detected. Multiple errors are indicated by displaying additional error codes to the right of the first-displayed error code. Upon completion of self-test, TEST is removed from the display but the codes of any faults detected remain until the faults are corrected and a successful self-test is completed.
- d. Error codes are also recorded on tape if a tape cassette is installed in the unit. Refer to "Diagnostic Indicators" and "Troubleshooting Aids" in the following sub-sections for corrective action if self-test cannot be completed successfully or for procedures to correct listed faults.
- e. Maintenance displays. Several maintenance displays are provided as an aid in troubleshooting the MX 1502. The maintenance displays include the self-test, the 150 and 400 MHz channel frequencies, the reference oscillator offset, the 150 and 400 MHz channel signal-to-noise ratios and the display test. The codes are as follows:

| <u>Code</u> | <u>Function</u> |
|-------------|--------------------------------------------------------------------------------------------------------------------------|
| 8 | Displays contents of selected memory locations in octal notation (reference paragraph entitled "Diagnostic Indicators"). |
| 9 | Displays contents of selected memory locations in decimal notation. |
| 16 | Starts self-test. |
| 17 | Tests display. |
| 54 | Displays 400 MHz receiver oscillator frequency and S/N ratio. |
| 56 | Displays reference oscillator offset from 400 MHz. |
| 59 | Displays modem status. |
| 94 | Displays 150 MHz receiver oscillator frequency and S/N ratio. |
| 230 | Turns on modem. |
| 231 | Turns off modem. |
| 245 | Controls power override. |
| 237 | Aborts self-test. |

f. Diagnostic Indicators. The error codes displayed by codes 16 and 50 isolate malfunctions to the board or major module level. To help isolate errors beyond that level, diagnostic indicators are set within the microprocessor memory (Table 4-23).

g. Code 8 is used to examine the diagnostic indicators in memory. The diagnostic indicators are stored in consecutive memory locations, beginning with memory address 142000 (octal) and ending with memory address 142017 (octal). The diagnostic indicators are cleared to 000's at the beginning of each self-test. They are lost when the MX 1502 is shut down or placed in standby.

h. The diagnostic indicators shown in Table 4-23 have a separate diagnostic indicator associated with each error code displayed by codes 16 and 50. Due to the length limitation of the display, all errors may not be shown. Therefore, an examination of consecutive memory addresses is recommended. Examine the diagnostic error memory block as follows:

(1) Enter code 8 to examine the diagnostic indicators in memory. The diagnostic indicators are stored in consecutive memory address, beginning with memory address 142000 (octal), and ending with memory address 142017 (octal). A reading of 000 at any consecutive address, indicates that there are no entries at succeeding addresses. The diagnostic indicators are cleared to 000's at the beginning of each self test. They are lost when the satellite surveyor is powered down or placed in STANDBY.

(2) Refer to Table 4-23 to interpret the displayed octal number. A 000 or 177 indicates that no error has been diagnosed. A 145, for example, indicates that the 400-MHz satellite receiver board cannot lock onto the test frequency.

i. Troubleshoot the system in accordance with Table 4-24, which is keyed to the error codes found in Table 4-23. After each corrective action, perform self-test (paragraph 4-6.2).

j. Table 4-24 shows a step-by-step procedure to isolate a malfunction to a printed circuit board or other field replaceable assembly. Table 4-23 lists several indications of troubles that may be encountered, with the probable cause of each. Error codes from the self-test with corrective action are also listed.

Table 4-23. DIAGNOSTIC INDICATOR CODE DESCRIPTION

| Diagnostic Indicator (Octal) | Displayed Error Code | Description of Failure |
|---------------------------------|-------------------------|------------------------------------------|
| 000 | -- | (No diagnosed failure). |
| 001 | 3 | ROM memory failure. |
| 002 | 4 | Microprocessor chip failure. |
| 003 | 4 | RAM memory failure. |
| 004 | 3 | RAM memory failure. |
| 010 | D | RAM memory failure. |
| 030 | C | Beginning of tape not detected. |
| 031 | C | End of data cannot be found. |
| 032 | E | End of tape detected during read. |
| 033 | E | End of tape detected during write. |
| 034 | C | Cannot write tape record. |
| 035 | C | Incomplete pass read from tape. |
| 036 | C | No tape controller board. |
| 037 | C | No tape transport. |
| 063 | 6 | Cannot lock to test frequency. |
| 064 | 6 | More than 1 percent doublet errors. |
| 065 | 6 | Doppler count error. |
| 066 | 5 | Cannot lock to signal. |
| 067 | 5 | Doublet error. |
| 070 | 5 | Signal level error. |
| 071 | 5 | Doppler count error. |
| 072 | U | Too much VCO drift. |
| 073 | 5 | Clock stuck. |
| 100 | B | Illegal command code sent to modem. |
| 101 | B | Data output to modem while transmitting. |
| 102 | B | Illegal byte count for transmission. |
| 103 | B | 8085 failure. |
| 104 | B | ROM failure on modem card. |
| 105 | B | RAM failure on modem card. |
| 106 | B | Illegal byte count for receiving data. |
| 107 | B | Received message changed. |
| 110 | B | Jamming signal received. |
| 111 | B | No byte count for received data. |
| 112 | B | No lock during LSI self-test. |
| 113 | B | Bit error during LSI self-test. |
| 114 | B | Frequency error during LSI self-test. |
| 115 | B | Signal level error during LSI self-test. |
| 116 | B | No lock during full modem self-test. |

Table 4-23. DIAGNOSTIC INDICATOR CODE DESCRIPTION - Cont

| Diagnostic Indicator (Octal) | Displayed Error Code | Description of Failure |
|---------------------------------|-------------------------|----------------------------------------------------------------------------|
| 117 | B | Bit error during full modem self-test. |
| 120 | B | Frequency error during full modem self-test. |
| 122 | B | Missing interrupt from Z-80. |
| 123 | B | Missing interrupt from LSI chip. |
| 124 | B | Missing interrupt from transmit logic. |
| 125 | B | Transmission already in progress. |
| 130 | B | Illegal repeat count for transmission. |
| 131 | B | Majority voting not completed. |
| 132 | B | Transmission buffer full. |
| 133 | N | Data received from communications link does not match data from satellite. |
| 134 | 0 | Expected data not received from communications link. |
| 135 | B | Incorrect data read from modem during self-test. |
| 136 | B | Incorrect status read from modem during self-test. |
| 137 | B | Modem self-test did not terminate within 2 min. |
| 145 | 8 | Cannot lock to test frequency. |
| 146 | 8 | More than 1 percent doublet errors. |
| 147 | 8 | Doppler count error. |
| 150 | 7 | Cannot lock to signal. |
| 151 | 7 | Doublet error. |
| 152 | 7 | Signal level error. |
| 153 | 7 | Doppler count error. |
| 154 | V | Too much VCO drift. |
| 155 | 7 | Missing receiver interrupt. |
| 156 | 7 | Clock stuck. |
| 177 | -- | (No diagnosed failure). |

Table 4-24. DIRECT/GENERAL SUPPORT TROUBLESHOOTING

| MALFUNCTION |
|--------------------|
| TEST OR INSPECTION |
| CORRECTIVE ACTION |

WARNING

Death or serious injury may occur from electrical shock unless power cord is disconnected. To avoid injury and equipment damage, turn off the unit and disconnect the power supply before performing any corrective actions.

1. DISPLAY SHOWS MISSING CHARACTERS OR SEGMENTS.

Replace front panel display board (paragraph 4-20.4).

NOTE

In the following malfunctions where an error code is given, the code number or letter refers to the corresponding board except for codes 5, 6, 7, and 8. Codes 5, 6, 7, and 8 refer to board 6/8.

2. ERROR 3, FAULT IN MEMORY BOARD.

Replace memory board (paragraph 4-20.2).

3. ERROR 4, FAULT IN MEMORY/PROCESSOR BOARD.

Replace memory/processor board (paragraph 4-20.2).

4. ERROR 5, FAULT IN DIGITAL 150 MHz CIRCUITS.

Replace dual channel receiver board (paragraph 4-20.3).

5. ERROR 6, FAULT IN ANALOG 150 MHz CIRCUITS.

Replace dual channel receiver board (paragraph 4-20.3).

Table 4-24. DIRECT/GENERAL SUPPORT TROUBLESHOOTING - Cont

| MALFUNCTION | TEST OR INSPECTION | CORRECTIVE ACTION |
|------------------------------------------------------------------------------------------|--------------------|---------------------------------------------------------------------------------------------------------------------------------------------------------------------|
| 6. ERROR 7, FAULT IN DIGITAL 400 MHz CIRCUITS. | | Replace dual channel receiver board (paragraph 4-20.3). |
| 7. ERROR 8, FAULT IN ANALOG 400 MHz CIRCUITS. | | Replace dual channel receiver board (paragraph 4-20.3). |
| 8. ERROR B, ERROR DETECTED IN MODEM BOARD. | | Replace modem board (paragraph 4-20.2). |
| 9. ERROR C, FAULT IN TAPE CASSETTE SYSTEM. | | Replace tape cassette transport (paragraph 4-20.1). If malfunction persists, replace tape controller board (paragraph 4-20.2). |
| 10. ERROR D, FAULT IN ALARM CLOCK BOARD. | | Replace alarm clock board (paragraph 4-20.3). |
| 11. ERROR H, INTERNAL TEMPERATURE EXCEEDED 70°C (158°F) AUTOMATIC SHUTDOWN HAS OCCURRED. | | Check fan operation. (a) If fan does not operate, replace fan (paragraph 4-20.9). (b) If fan is operating, replace thermal switch (paragraph 4-20.6). |

Table 4-24. DIRECT/GENERAL SUPPORT TROUBLESHOOTING - Cont

| MALFUNCTION | TEST OR INSPECTION | CORRECTIVE ACTION |
|-------------------------------------------------------|--------------------------------------------------------------------------------------------------------------------------------------------------|-------------------------------------------------------------------------------------------------------------------------------------------------------|
| 12. ERROR T, FAULTY ANTENNA SYSTEM. | Step 1. Disconnect the antenna cable from the preamplifier. With the receiver/processor in operation, check for -10 V through the antenna cable. | (a) If voltage is not present, proceed to step 2. (b) If voltage is present, replace the preamplifier. |
| | Step 2. Remove the antenna cable from the receiver/processor and check for continuity. | (a) If continuity exists, replace the dual channel receiver board (paragraph 4-20.3). (b) If continuity does not exist, replace the antenna cable. |
| 13. ERROR U, EXCESSIVE VCO DRIFT IN 150 MHz RECEIVER. | | Replace dual channel receiver board (paragraph 4-20.3). |
| 14. ERROR V, EXCESSIVE VCO DRIFT IN 400 MHz RECEIVER. | | Replace dual channel receiver board (paragraph 4-20.3). |
| 15. NO DISPLAY. | Step 1. Check for correct voltages at connector J13, pins 5 through 13 and 17 through 25, and ground at pins 1, 2, 3, 14, and 15. | |

Table 4-24. DIRECT/GENERAL SUPPORT TROUBLESHOOTING - Cont

| | | |
|--------------------|--|--|
| MALFUNCTION | | |
| TEST OR INSPECTION | | |
| CORRECTIVE ACTION | | |

15. NO DISPLAY - Cont

| Pin | Voltages |
|-----------------|--------------------------|
| 1, 2, 3, 14, 15 | Common |
| 5 | Oscillator (+15V) |
| 6, 7 | +12 V |
| 8, 9 | -12 V |
| 10, 11 | -5 V |
| 12, 13 | +5 V |
| 17 | Power Control (PWR) |
| 20, 21 | Internal Battery (+14 V) |
| 22, 23 | Input Power RTN |
| 24, 25 | Input Power (+10.5-16 V) |

- (a) If voltages are incorrect, one of the boards in slots A through 6 is defective. Remove and install each board in turn (paragraph 4-20.2) and recheck the voltages while the board is removed. The defective board is indicated when the voltages are normal with that board removed. Replace the defective board.

Table 4-24. DIRECT/GENERAL SUPPORT TROUBLESHOOTING - Cont

| MALFUNCTION | TEST OR INSPECTION | CORRECTIVE ACTION |
|-------------|--------------------|-------------------|
|-------------|--------------------|-------------------|

15. NO DISPLAY - Cont.

- (b) If the voltages are correct, the problem is a defective alarm clock board (slot D), data entry and display board (slot A), or the front panel display board. Replace each board in turn until the display returns.
- (c) If the voltages are still incorrect after performing step a, above, replace the power supply (paragraph 4-20.2).

16. NO DISPLAY AND NO ALARM WHEN CODE 36 IS ENTERED.

Isolate the problem using the substitution method, with components known to be good.

- (a) Replace memory/processor board (paragraph 4-20.2).
- (b) Replace memory board (paragraph 4-20.2).
- (c) Replace oscillator (paragraph 4-20.8).

17. INCORRECT DISPLAY.

Isolate the problem by the substitution method using boards known to be good.

- (a) Replace memory board (paragraph 4-20.2).
- (b) Replace memory/processor board (paragraph 4-20.2).
- (c) Replace data entry and display board (paragraph 4-20.2).
- (d) Replace front panel display board (paragraph 4-20.4).

Table 4-24. DIRECT/GENERAL SUPPORT TROUBLESHOOTING - Cont

| MALFUNCTION |
|--------------------|
| TEST OR INSPECTION |
| CORRECTIVE ACTION |

18. NO KEYBOARD RESPONSE.

Isolate the problem by the substitution method using boards known to be good.

- (a) Replace data entry and display board (paragraph 4-20.2).
- (b) Replace memory processor board (paragraph 4-20.2).
- (c) Replace memory board (paragraph 4-20.2).
- (d) Replace keyboard (paragraph 4-20.4).

19. NO POSITION FIX CALCULATION BUT SATELLITE SIGNAL WAS ACQUIRED.

Step 1. Check the reference oscillator frequency offset by entering code 56.

- (a) If the reference oscillator frequency is within 40 Hz, proceed to step 2.

NOTE

New oscillator must stabilize for 24 hours before making further checks.

- (b) If the reference oscillator frequency exceeds 40 HZ, replace the oscillator (paragraph 4-20.8).

Step 2. Isolate the problem by substitution method using boards known to be good.

- (a) Replace memory board (paragraph 4-20.2).
- (b) Replace the memory/processor board (paragraph 4-20.2).

Table 4-24. DIRECT/GENERAL SUPPORT TROUBLESHOOTING - Cont

| MALFUNCTION | TEST OR INSPECTION | CORRECTIVE ACTION |
|-----------------------------------------------------------|--------------------------------------------------------------------------------------------------------------------------------------------------------------------------|---------------------------------------------------------------------------------------------------------------------------------------------------------------------------------------------------------------------------------------------------------------------------------------------------------------------------------------------------------------------------------------------------------------------------|
| 20. 2D FIX BUT NOT 3D FIX. | Set up the equipment to track a satellite in accordance with paragraphs 4-6.2 and 4-6.3. While the satellite is being tracked, enter code 50 to display receiver status. | <div data-bbox="669 632 1105 747" style="border: 2px solid black; padding: 5px; text-align: center; margin: 10px auto; width: fit-content;"> STAT 4/3 </div> <p>(a) If receiver status indicates a constant 1 or 4, replace dual satellite receiver board (paragraph 4-20.4).</p> <p>(b) If receiver status varies between 1, 4 and A, check reference oscillator frequency in accordance with malfunction 19.</p> |
| 21. VOLTMETER DOES NOT INDICATE INTERNAL BATTERY VOLTAGE. | Step 1. Check voltage at pins 20 and 21 on connector J13 with external power applied. Voltmeter should indicate 14 V. | <p>(a) If 14 V was indicated, proceed to step 2.</p> <p>(b) If 14 V was not indicated, replace the power supply board (paragraph 4-20.2).</p> |
| | Step 2. Disconnect external power supply and check internal fuse. | <p>(a) If fuse was not defective, proceed to step 3.</p> <p>(b) Replace defective internal fuse.</p> |
| | Step 3. Check internal battery voltage. Voltmeter should read at least 10.5 V. | |

Table 4-24. DIRECT/GENERAL SUPPORT TROUBLESHOOTING - Cont

| MALFUNCTION | TEST OR INSPECTION | CORRECTIVE ACTION |
|------------------------------------------------------------------------|---------------------------------------------------------------------------------------------------------------------|------------------------------------------------------------------------------------------------------------------------------------------------------------------------------------|
| <p>21. VOLTMETER DOES NOT INDICATE INTERNAL BATTERY VOLTAGE - Cont</p> | | |
| | | <p>(a) If voltage is 10.5 V or above, proceed to step 4.</p> <p>(b) If voltage is below 10.5 V, replace battery packs 1 and 2 (paragraph 4-20.5).</p> |
| | <p>Step 4. Check the voltage at pins E1 and E2 on the voltmeter driver board. Voltage should be 10.5 v to 14 v.</p> | <p>(a) If voltage is between 10.5 and 14 V, proceed to step 5.</p> <p>(b) If voltage is below 10.5 V, replace the driver board (paragraph 4-20.4).</p> |
| | <p>Step 5. Check voltage output at the voltage selector switch. Voltage should be 10.5 to 14 V.</p> | <p>(a) If voltage is between 10.5 and 14 V, replace the voltmeter (paragraph 4-20-10).</p> <p>(b) If voltage is not present, replace voltage select switch (paragraph 4-20.6).</p> |

4-20. MAINTENANCE PROCEDURES .

a. This section contains instructions covering direct/general support maintenance functions for the satellite surveyor. Personnel required are listed only if the task requires more than one.

b. After completing each maintenance procedure, perform operational check to be sure that equipment is properly functioning.

INDEX

| PROCEDURES | PARAGRAPH |
|------------------------------------------------------------------------------------------------------------------|-----------|
| Replace Tape Cassette Transport | 4-20.1 |
| Replace Power Supply, Data Entry and Display, Modem, Tape Control, Memory, and Memory Processor Boards | 4-20.2 |
| Replace Alarm Clock and Dual Channel Receiver Boards | 4-20.3 |
| Replace Keyboard, Front Panel Display, Voltmeter Driver Boards. | 4-20.4 |
| Replace Battery Packs 1 and 2 | 4-20.5 |
| Replace Switches | 4-20.6 |
| Replace Thermometer. | 4-20.7 |
| Replace Oscillator | 4-20.8 |
| Replace Fan Assembly | ...4-20.9 |

4-20.1 Replace Tape Cassette Transport.

MOS: 35E, Special Electronic Devices Repairer

TOOLS: Cross Tip Screwdriver
Flat Tip Screwdriver

SUPPLIES: Tape Cassette Transport

WARNING

Death or serious injury may occur from electrical shock unless power cord is disconnected before servicing.

- a. Press breather valve to equalize pressure in cover and remove cover.

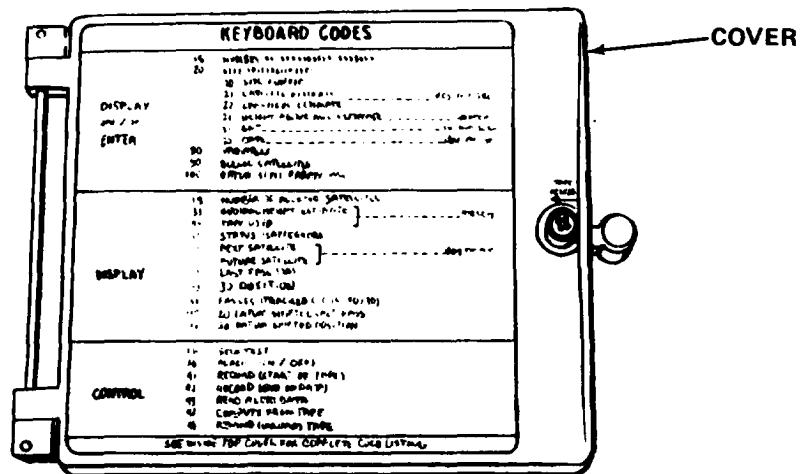

- b. Open tape cassette transport cover.

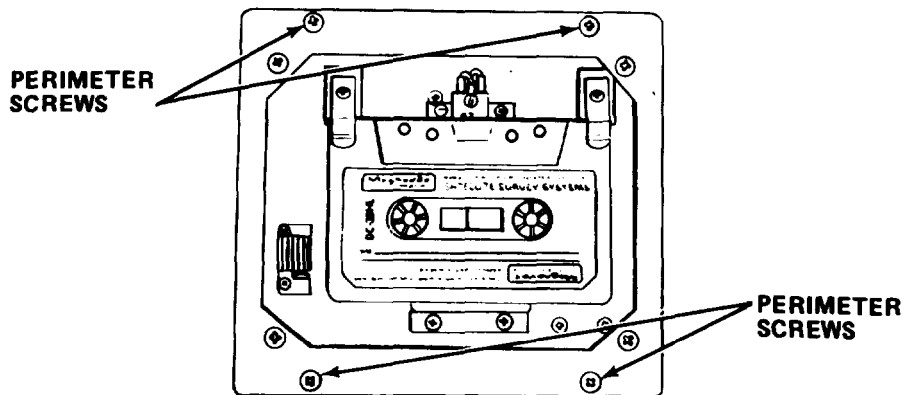

- c. Remove screws on tape cassette transport perimeter.
- d. Lift tape cassette transport out of chassis far enough to gain access to connector on rear.

CAUTION

To avoid damage to the connector, loosen both connector screws evenly, several turns at a time, until connector comes free.

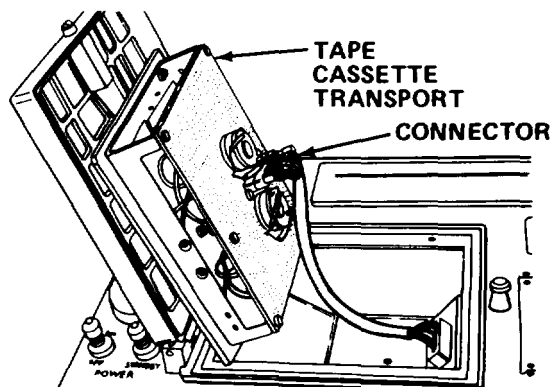

- e. Disconnect connector and remove defective tape cassette transport.

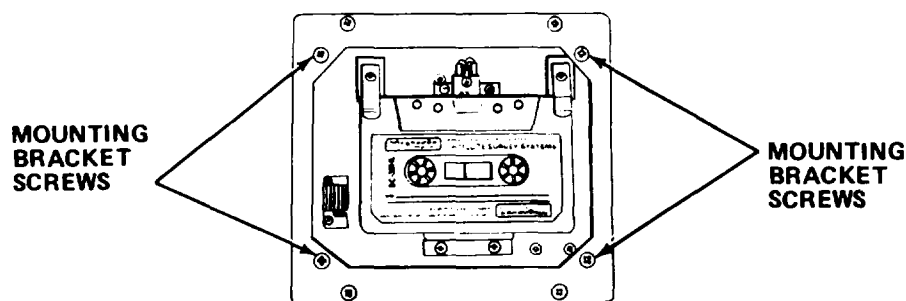

- f. Remove screws holding tape cassette transport to mounting bracket.
- g. Install mounting bracket on new tape cassette transport and tighten screws.

CAUTION

To avoid damage to the connector, tighten both connector screws evenly, several turns at a time.

- h. Attach connector on rear.

CAUTION

Install long perimeter screws at the bottom. Damage to circuits will result if screws are incorrectly installed.

- i. Install four perimeter screws.
- j. Perform self-test (paragraph 4-6.2).
- k. Close tape cassette transport cover.
- l. Replace cover.

4-20.2 Replace Power Supply, Data Entry and Display, Modem, Tape Control, Memory, and Memory Processor Boards.

MOS: 35E, Special Electronic Devices Repairer

TOOLS: Cross Tip Screwdriver
Needle Nose Pliers

SUPPLIES: Power Supply Board
Data Entry and Display Board
Modem Board
Tape Control Board
Memory Board
Memory Processor Board

WARNING

Death or serious injury may occur from electrical shock unless power cord is disconnected before servicing.

- a. Press breather valve to equalize pressure in cover and remove cover.

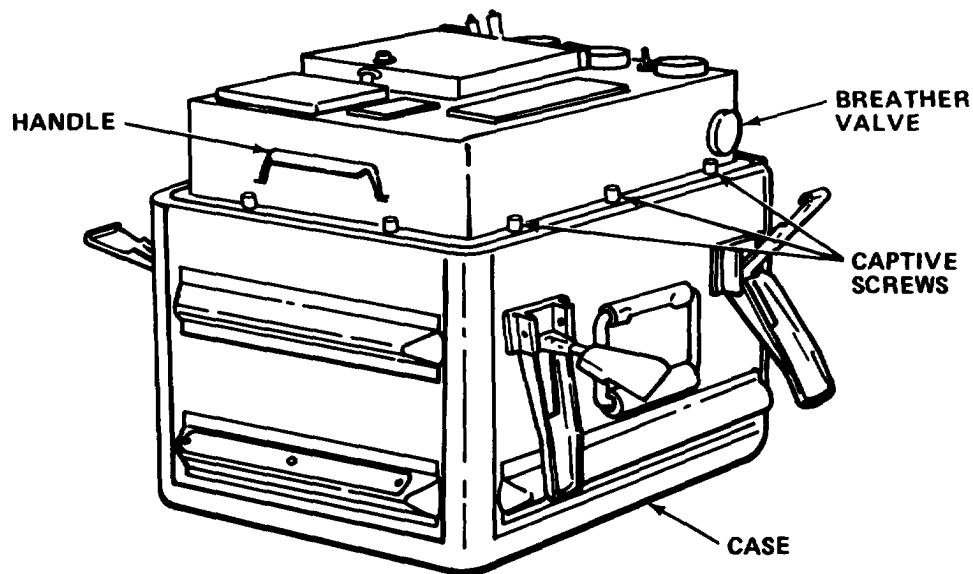

- b. Press breather valve to equalize pressure in case.
- c. Loosen captive screws and lift receiver/processor chassis from case.

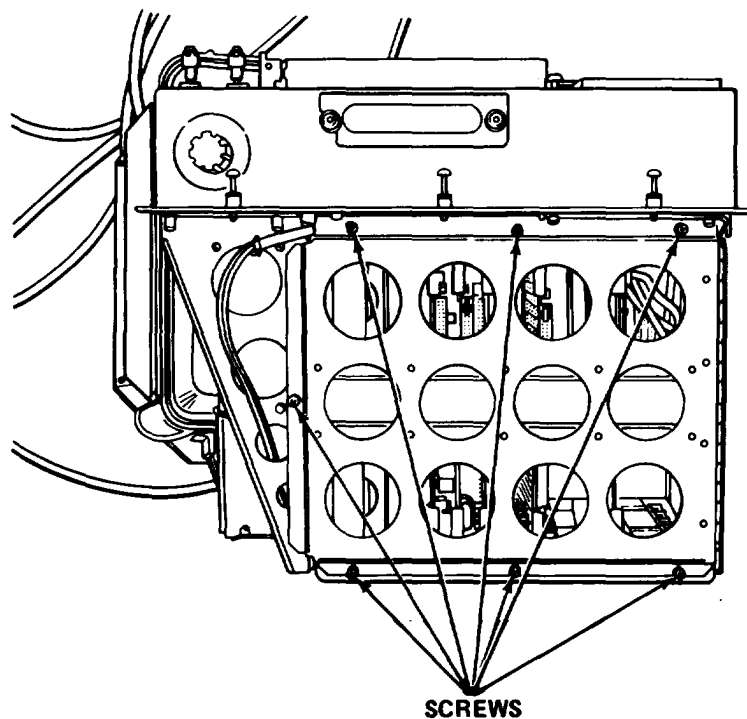

- d. Loosen seven captive screws on card cage door and open door.

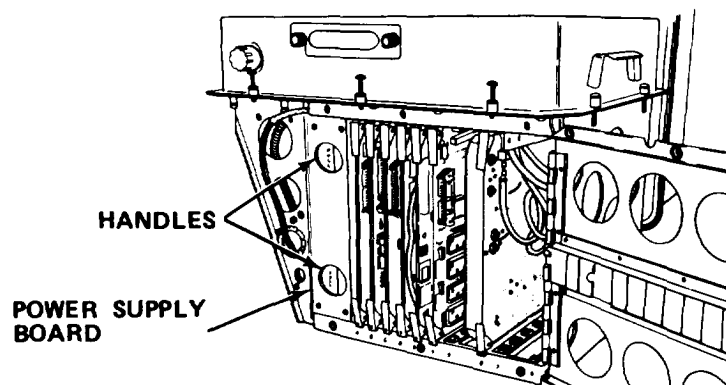

- e. Replace power supply board in slot P/S.
- (1) Pull out handle from recess on power supply board, grasp handle, and pull board straight out.
 - (2) Install new board, push firmly into place, and push handle into recess.

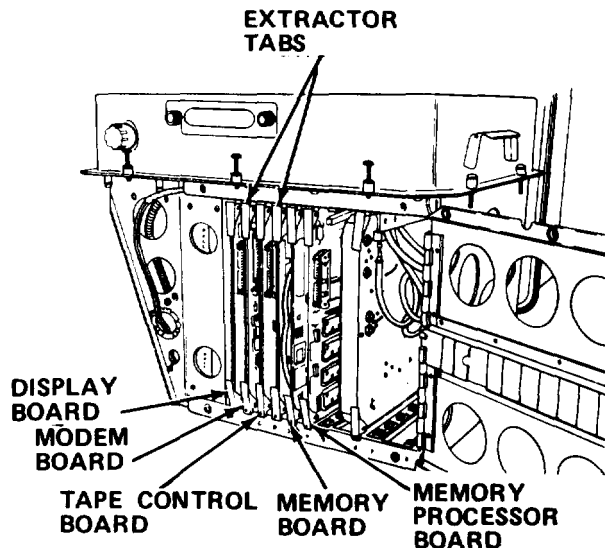

- f. Replace data entry and display board (slot A), modem board (slot B), tape control board (slot C), memory board (slot 3), or memory processor board (slot 4).

(1) Using extractor tabs, slide board out of chassis.

NOTE

- The memory processor board has two switches: a power management switch and a memory switch. After installing the memory processor board, pull both switches toward you so that the power management switch is set to NORM, and the memory switch is set to EXT.
- The memory board (3) has PROM chips that may require replacement. All chips are numbered and are replaced by removing a chip and inserting a new chip with the same number.
- Prior to installing the memory board (3), check the PROM chips to see that all PROM chips have the same program number.

(2) Insert new board and press firmly on extractor tabs to be sure board is seated.

- g. Perform self-test (paragraph 4-6.2).

4-20.3 Replace Alarm Clock Board and/or Dual Channel Receiver Board.

MOS: 35E, Special Electronic Devices Repairer

TOOLS: Cross Tip Screwdriver
Flat Tip Screwdriver
Needle Nose Pliers

SUPPLIES: Alarm Clock Board
Dual Channel Receiver Board

WARNING

Death or serious injury may occur from electrical shock unless power cord is disconnected before servicing.

a. Alarm clock board (slot D).

(1) Using exactor tabs, pull board out slightly to allow access to cables.

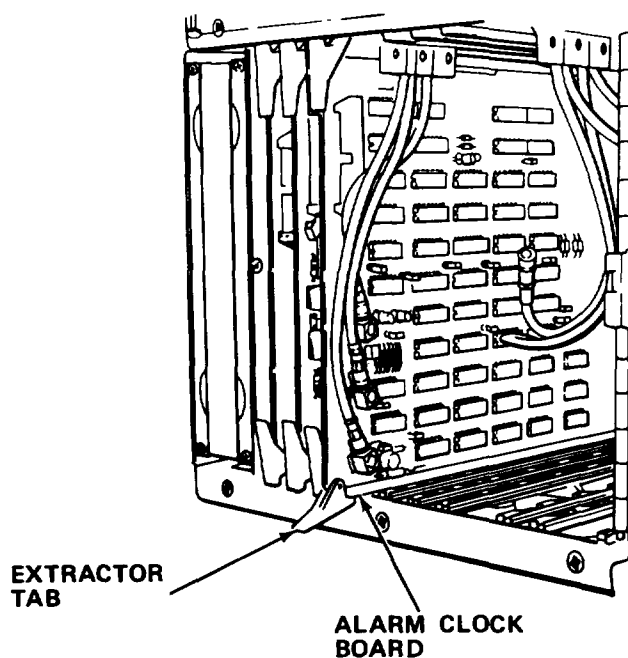

(2) Disconnect RF cables from alarm clock board (slot D) by grasping brass fittings with needle nose pliers and pulling straight off.

(3) Slide defective alarm clock board out of chassis.

(4) Insert new alarm clock board into slot and connect cables.

(5) Press firmly on extractor tabs to ensure alarm clock board is seated.

(6) Perform self-test (paragraph 4-6.2).

b. Dual channel receiver board (slot 6/8).

CAUTION

Do not attempt to remove dual channel receiver board without disconnecting RF cables. Damage to cables or board may occur.

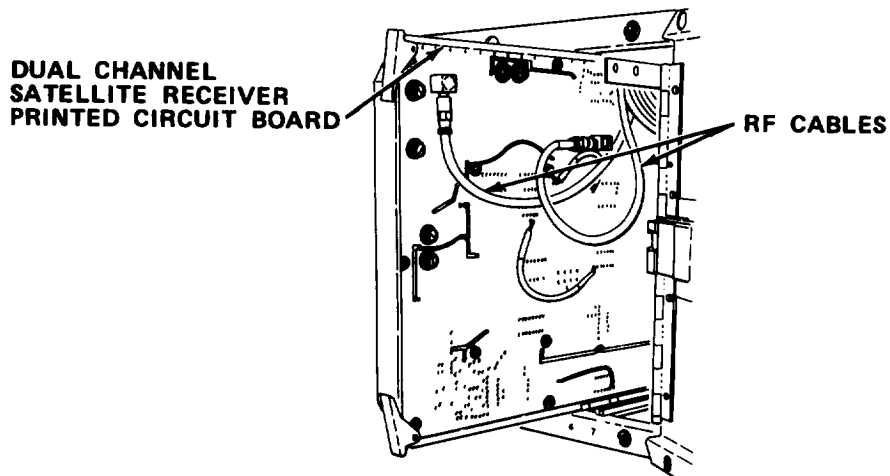

- (1) Using extractor tabs, pull board out slightly to allow access to cables.
- (2) Tag and disconnect RF cables from board by grasping brass fitting with needle nose pliers and pulling straight off.
- (3) Slide defective dual channel receiver board out of chassis.
- (4) Insert new dual channel receiver board into slot and reconnect cables.
- (5) Press firmly on extractor tabs to seat board.
- (6) Perform self-test (paragraph 4-6.2).

4-20.4 Replace Keyboard, Front Panel Display, and Voltmeter Driver Board.

MOS: 35E, Special Electronic Devices Repairer

TOOLS: Flat Tip Screwdriver
Cross Tip Screwdrivers (2)
Soldering Iron
1/4 in. Nut Driver
5/16 in. Nut Driver

SUPPLIES: Keyboard Assembly
Front Panel Display
Voltmeter Driver Board
Solder (Item 19, Appendix E)

WARNING

Death or serious injury may occur from electrical shock unless power cord is disconnected before servicing.

- a. Keyboard.

CAUTION

Damage to motherboard will occur unless two top panel screws are removed before raising front panel.

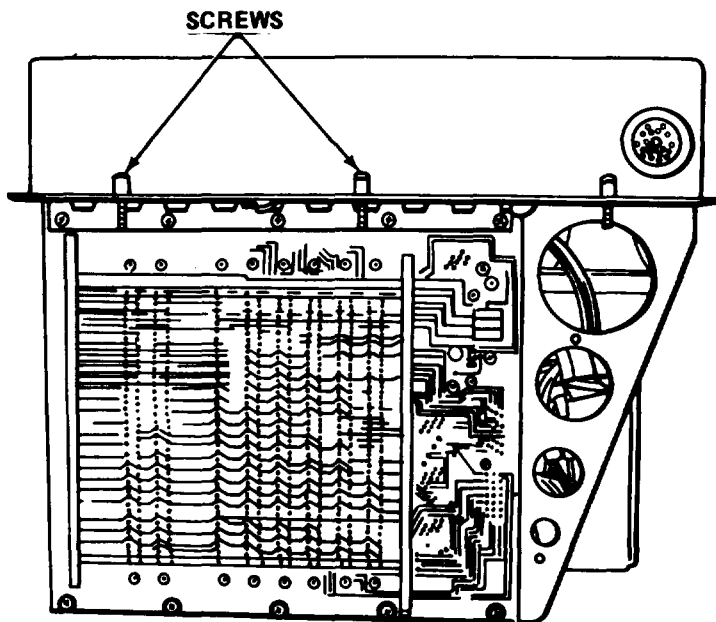

- (1) Press breather valve to equalize pressure in cover and remove cover.

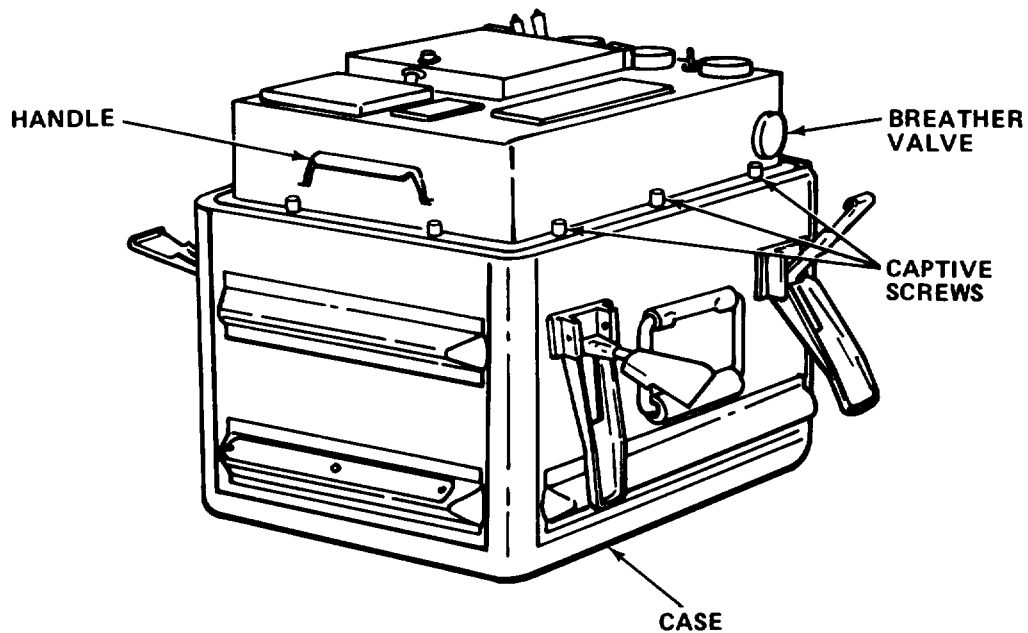

- (2) Press breather valve to equalize pressure in case.
- (3) Loosen captive screws and lift receiver/processor chassis from case.
- (4) Remove two top panel screws adjacent to motherboard.
- (5) Loosen captive screws numbered 1 through 10 on bottom of front panel assembly and raise front panel.

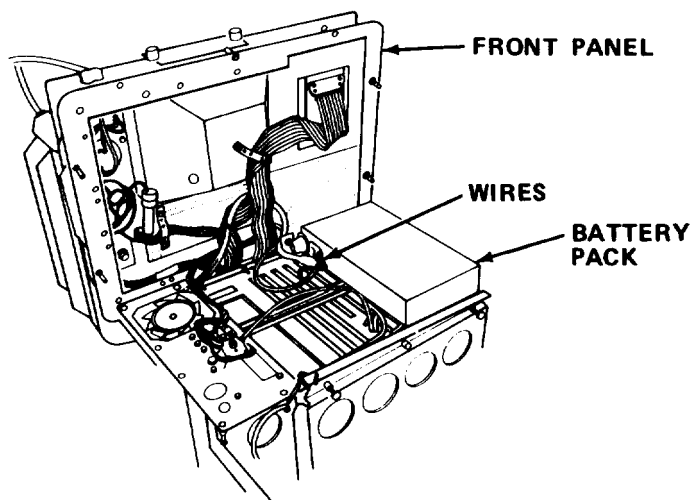

- (6) Remove screws and ground wire securing battery pack to front panel assembly and lay battery pack on card case.

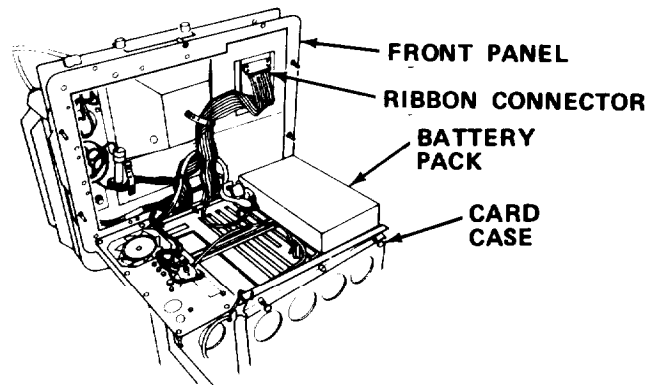

- (7) Disconnect ribbon connector from keyboard.
- (8) Remove screws and remove defective keyboard from front panel.
- (9) Inspect gasket and replace if defective.
- (10) Install new keyboard through front panel.
- (11) Connect ribbon connector to keyboard with keys lots facing out.
- (12) Perform self-test (paragraph 4-6.2).

b. Front panel display board.

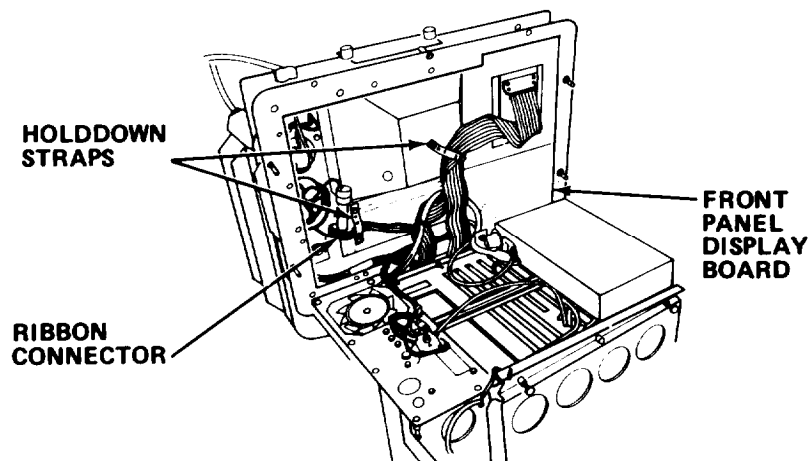

- (1) Remove ribbon cable holddown straps and disconnect ribbon connector from display board.

- (2) Remove defective display board.
- (3) Install new display board.
- (4) Connect ribbon connector to new display board and install holddown straps.
- (5) Install battery pack and ground wire on front panel assembly.
- (6) Perform self-test (paragraph 4-6.2).

c. Voltmeter driver board.

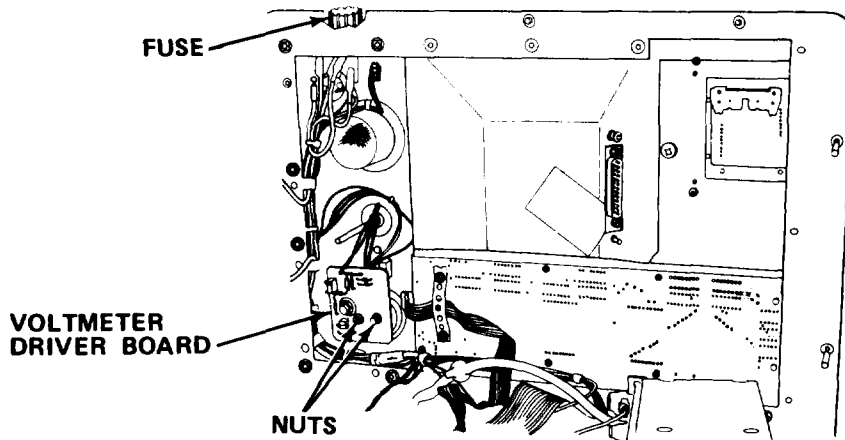

- (1) Remove internal fuse from fuse holder.
- (2) Remove nuts and pull out defective driver board to allow access to wiring.
- (3) Tag and unsolder wires.
- (4) Solder wires to new board.
- (5) Install driver board on front panel.
- (6) Install internal fuse in fuse holder.
- (7) Check that voltmeter indicates properly.

d. Lower front panel and secure.

e. Close and secure card cage door.

f. Inspect gasket on case and replace if damaged.

g. Install chassis in case.

h. Perform self-test (paragraph 4-6.2).

i. Replace cover.

4-20.5 Replace Battery Packs 1 and 2.

MOS: 35E, Special Electronic Devices Repairer

TOOLS: Cross Tip Screwdriver
Needle Nose Pliers
Diagonal Pliers
3/16 in. Nut DriverSUPPLIES: Battery Pack (2)
Cable Ties**WARNING**

Death or serious injury may occur from electrical shock unless power cord is disconnected before servicing.

CAUTION

To avoid equipment damage, both battery packs must be replaced. Do not replace one battery pack without replacing the other.

a. Battery pack 1.

- (1) Press breather valve to equalize pressure in cover and remove cover.

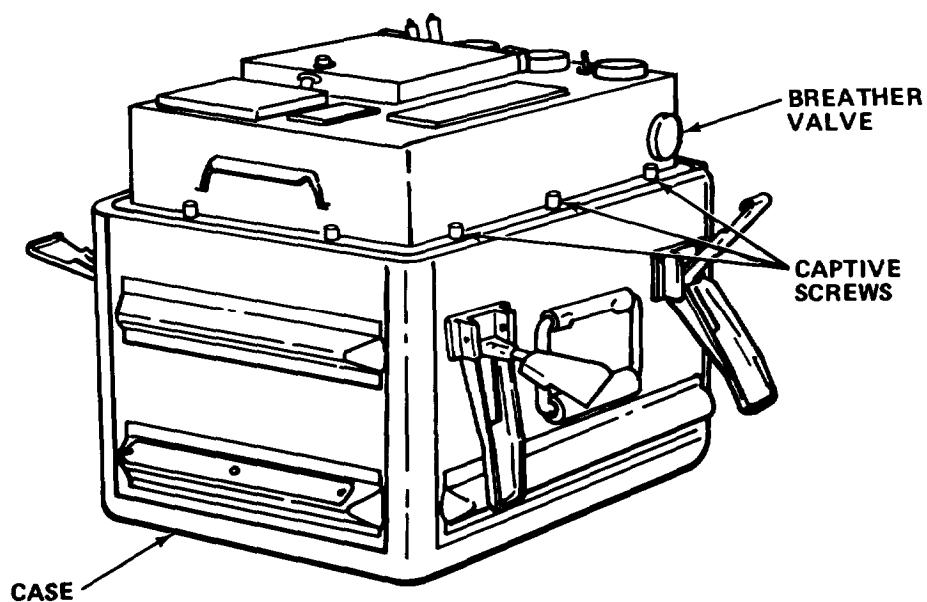

- (2) Press breather valve to equalize pressure in case.
- (3) Loosen captive screws and lift chassis out of case.

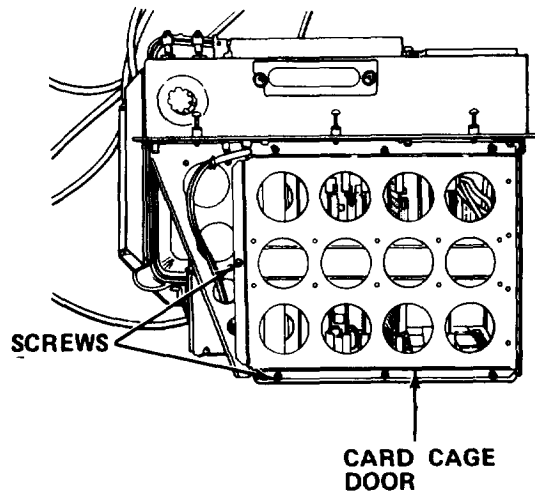

- (4) Loosen captive screws on card cage door and open door.

CAUTION

Damage to motherboard will occur unless two top panel screws are removed before raising panel.

- (5) Remove two top panel screws adjacent to motherboard.
- (6) Loosen captive screws numbered 1 through 10 on bottom of front panel assembly and raise front panel.

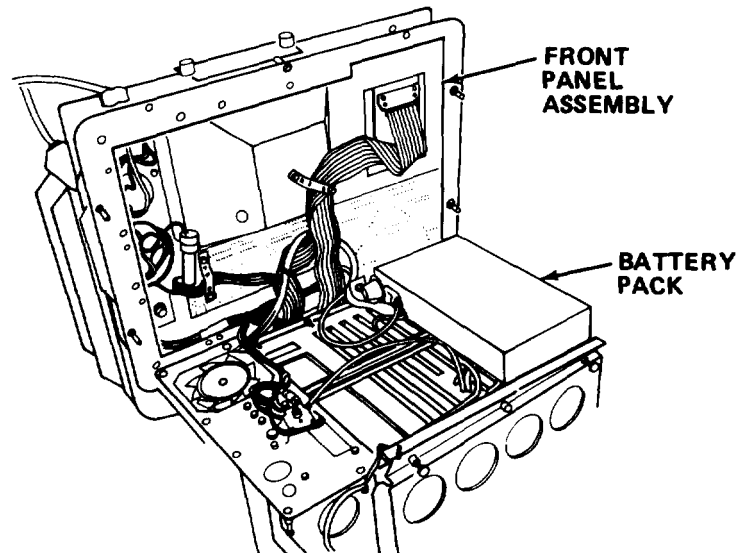

- (7) Remove screws and ground wire securing battery pack and mounting bracket to front panel assembly.

- (8) Tag and disconnect wires from both battery packs.
- (9) Disconnect vent tube at connector and remove defective battery pack and mounting bracket.
- (10) Remove battery pack from mounting bracket.
- (11) Secure new battery pack to mounting bracket.
- (12) Connect vent tube to connector.

NOTE

Positive (+) wire is red wire.

- (13) Connect wires to battery terminals.
 - (14) Install battery pack assembly and ground wire on front panel.
- b. Battery pack 2.

- (1) Perform steps (1) through (6) paragraph 4-20. 5a.
- (1.1) Remove circuit boards (paragraph 4-20.2).
- (2) Disconnect vent tube at three-way connector.
- (3) Remove ground wire from chassis.

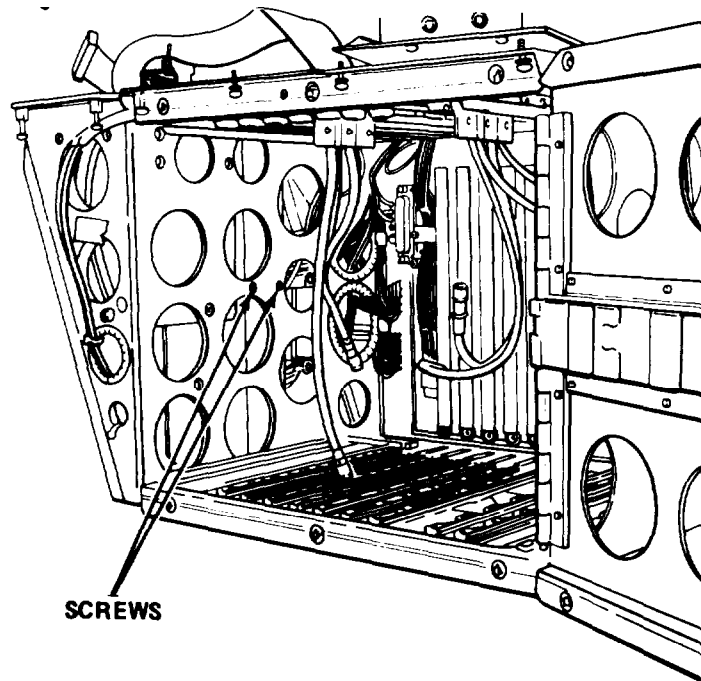

- (4) Starting with the two screws inside card cage, remove securing screws and defective battery pack.

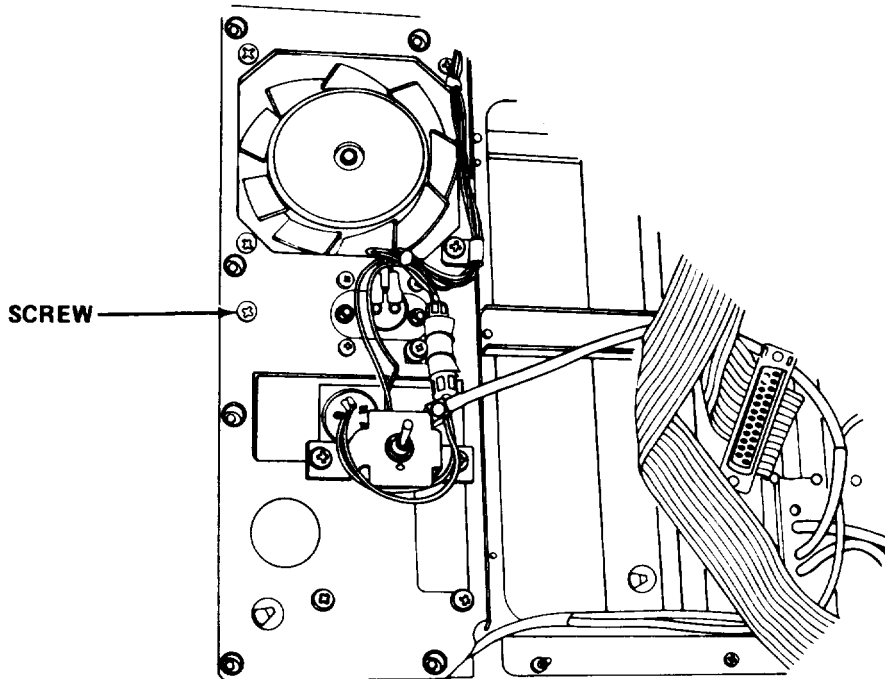

- (5) Position new battery pack and install screws at each end of battery.
- (6) Install two screws from inside card cage.

NOTE

Positive (+) wire is red wire.

- (7) Connect wires to battery terminals and ground wire to chassis.
- (8) Connect vent tube to three way connector.
- (9) Lower front panel and secure.
- (10) Install circuit boards (paragraph 4-20.2).
- (11) Close card cage door and secure.
- (12) Perform self-test (paragraph 4-6.2).
- (13) Inspect gasket on case and replace if necessary.
- (14) Install chassis in case.
- (15) Install cover.

4-20.6 Replace Switches.

MOS: 35E, Special Electronic Devices Repairer

TOOLS: Cross Tip Screwdriver
Soldering Iron
5/16 in. Open End Wrench
13/16 in. Open End Wrench
6 in. Adjustable Wrench
3/16 in. Nut Driver

SUPPLIES: ON/OFF Switch
Standby/Operate
Voltmeter Select
Thermal Switch
Oscillator Switch
Solder (Item 19, Appendix E)

- a. On-off/standby-operate switch.

WARNING

Death or serious injury may occur from electrical shock unless power cord is disconnected before servicing.

- (1) Press breather valve to equalize pressure in cover and remove cover.

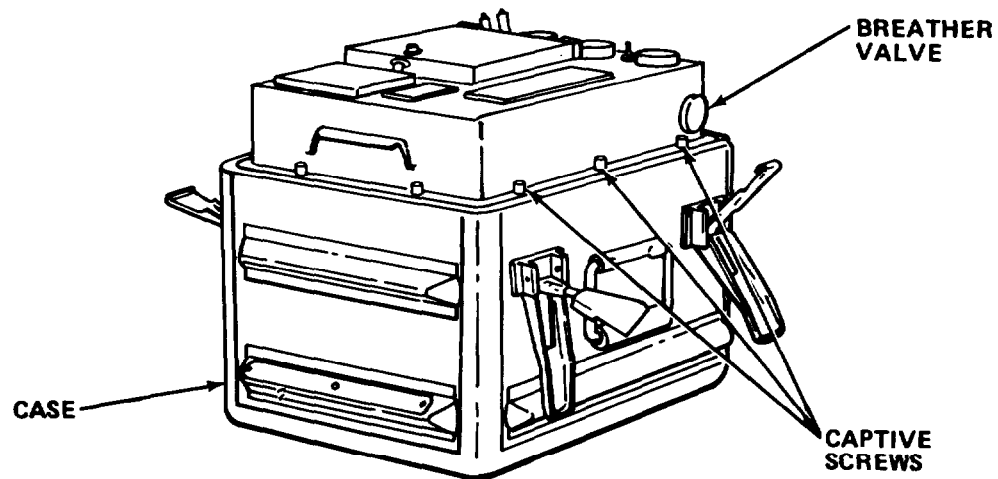

- (2) Press breather valve to equalize pressure in case.
(3) Loosen captive screws and lift chassis out of case.

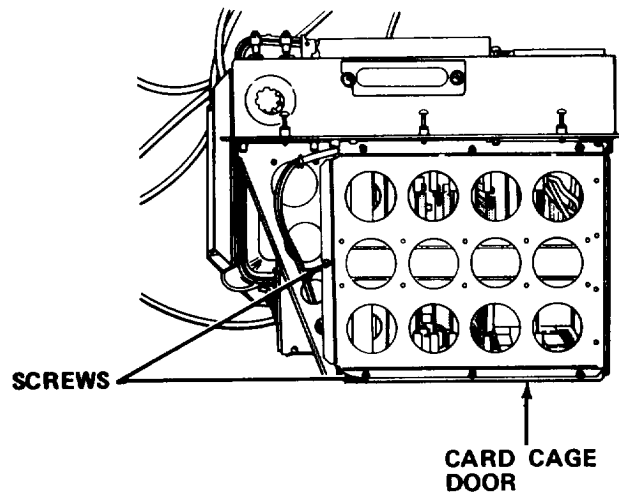

- (4) Loosen captive screws and open card cage door.

CAUTION

Damage to motherboard will occur unless two top panel screws are removed before raising panel.

- (5) Remove two top panel screws adjacent to motherboard.
- (6) Loosen captive screws numbered 1 through 10 on bottom of front panel assembly and raise front panel.

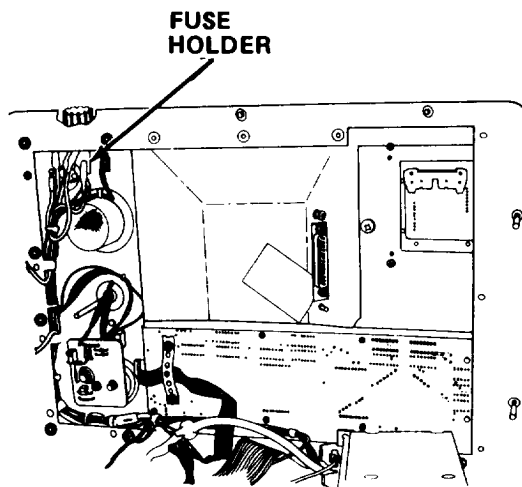

- (7) Tag and unsolder wires from external fuse holder and remove fuse holder.

- (8) Remove nut securing switch to panel and pull out switch to allow access to wires.
- (9) Tag and disconnect wires from defective ON/OFF switch, or tag and unsolder wires from defective STANDBY/OPERATE switch.
- (10) Connect wires to new switch.
- (11) Check gasket and replace if necessary.
- (12) Install new switch with key slot facing down and secure with nut.
- (13) Reinstall external fuse holder and connect wires.
- (14) Perform self-test (paragraph 4-6.2).

b. Voltmeter select switch.

- (1) Remove internal fuse.

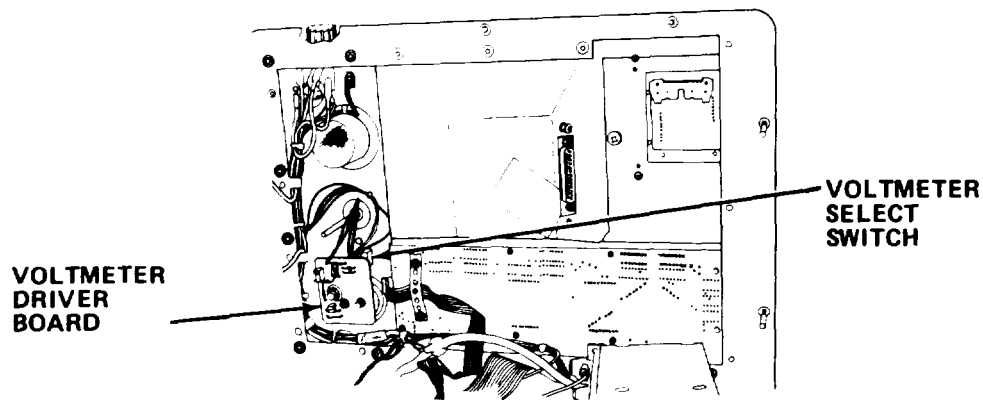

- (2) Remove voltmeter driver board to allow access to switch.
- (3) Remove nut securing switch to panel and pull out switch to allow access to wires.
- (4) Tag and unsolder wires from defective switch.
- (5) Connect wires to new switch.
- (6) Check gasket and replace if necessary.
- (7) Install switch with key slot facing to the right, and secure with nut.
- (8) Reinstall voltmeter driver board.
- (9) Reinstall internal fuse.
- (10) Check operations of switch.

c. Thermal switch.

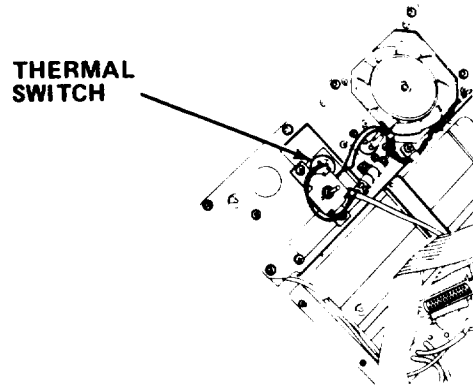

- (1) Tag and unsolder wires from thermal switch.
- (2) Remove defective thermal switch.
- (3) Install new thermal switch.
- (4) Connect wires to switch.

d. Oscillator switch.

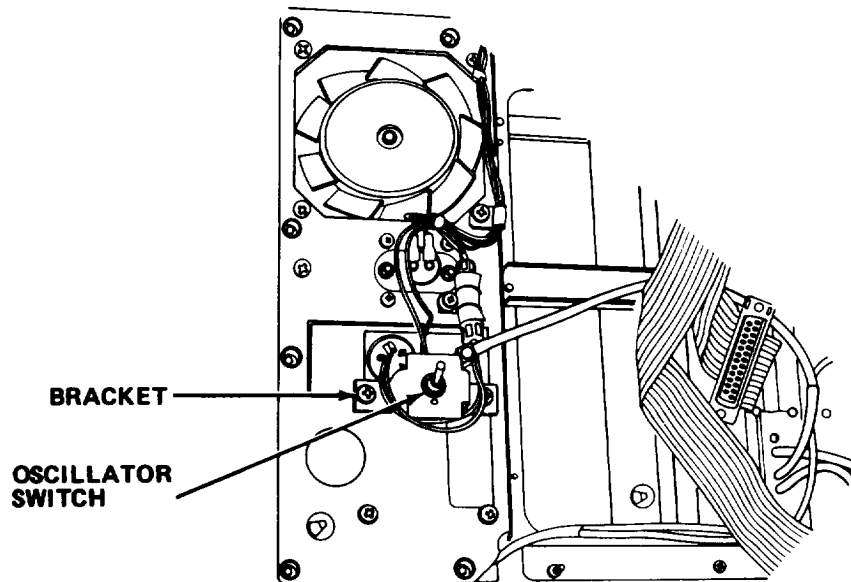

- (1) Remove oscillator switch and bracket from chassis.

- (2) Tag and unsolder wires from defective switch.
- (3) Remove switch from bracket.
- (4) Install new switch in bracket, alining key with hole in bracket.
- (5) Connect wires to switch.
- (6) Install switch and bracket on chassis.
- (7) Turn on switch.
- (8) Lower front panel and secure.
- (9) Close cage door and secure.
- (10) Perform self-test (paragraph 4-6.2).
- (11) Inspect gasket on case and replace if necessary.
- (12) Install chassis in case.
- (13) Install cover.

4-20.7 Replace Thermometer.

MOS: 35E, Special Electronic Devices Repairer

TOOLS: Cross Tip Screwdriver

SUPPLIES: Thermometer

WARNING

Death or serious injury may occur from electrical shock unless power cord is disconnected before-servicing.

- a. Press breather valve to equalize pressure in cover and remove cover.

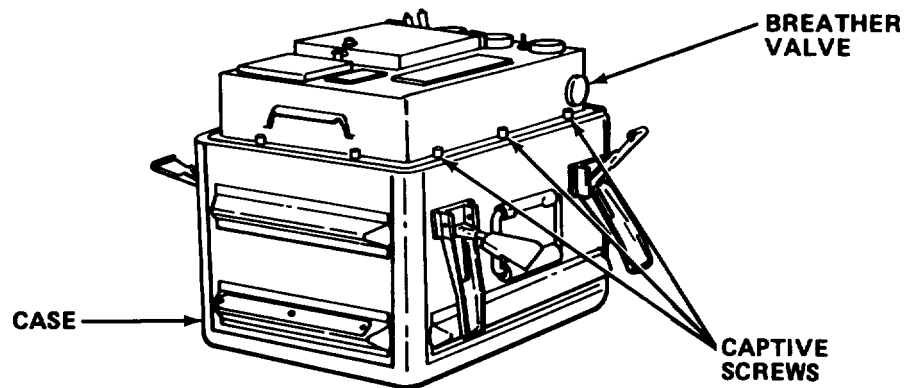

- b. Press breather valve to equalize pressure in case.
- c. Loosen captive screws and lift chassis out of case.

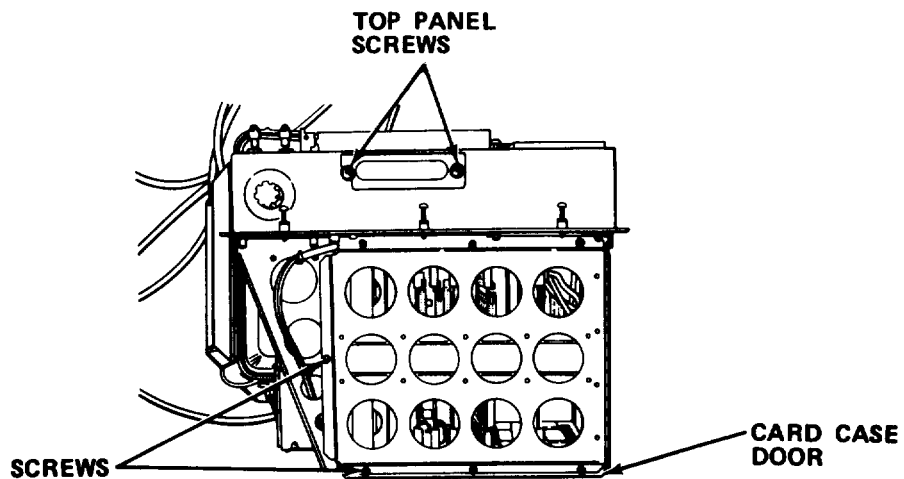

- d. Loosen captive screws and open card case door.
- e. Remove two top panel screws adjacent to motherboard.

CAUTION

Damage to motherboard will occur unless two top panel screws are removed before raising panel.

- f. Loosen captive screws numbered 1 through 10 on bottom of front panel assembly and raise front panel.

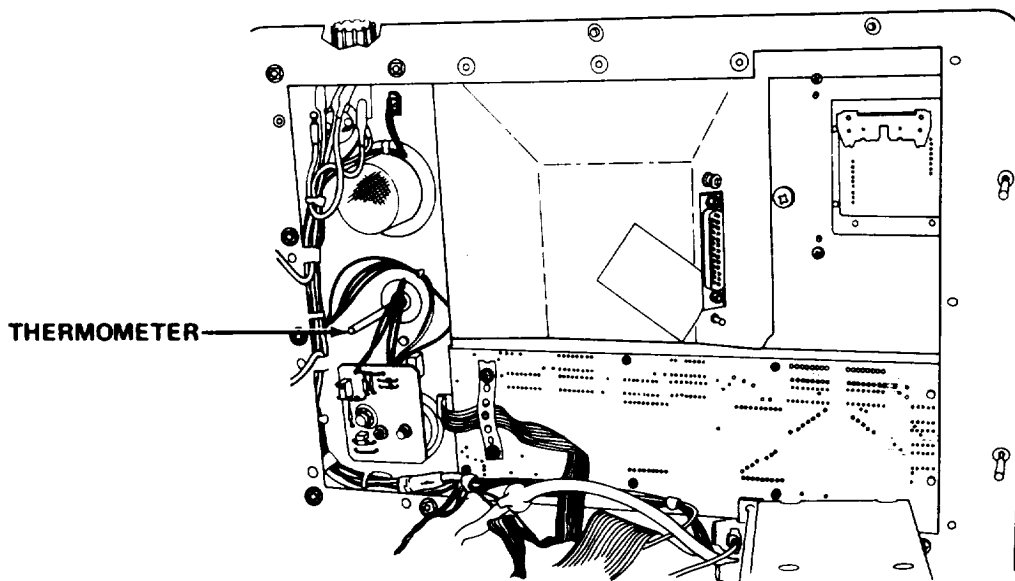

- g. Remove defective thermometer.
- h. Check gasket and replace if necessary.
- i. Install new thermometer with green band on bezel up.
- j. Lower front panel and secure.
- k. Close card cage door and secure.
- l. Inspect gasket in case and replace if necessary.
- m. Install chassis in case.
- n. Install cover.

4-20.8 Replace Oscillator.

MOS: 35E, Special Electronic Devices Repairer

TOOLS: Cross Tip Screwdriver
Soldering Iron

SUPPLIES: Oscillator (5 MHz)
Solder (Item 19, Appendix E)

WARNING

Death or serious injury may occur from electrical shock unless power cord is disconnected before servicing.

- a. Press breather valve to equalize pressure in cover and remove cover.

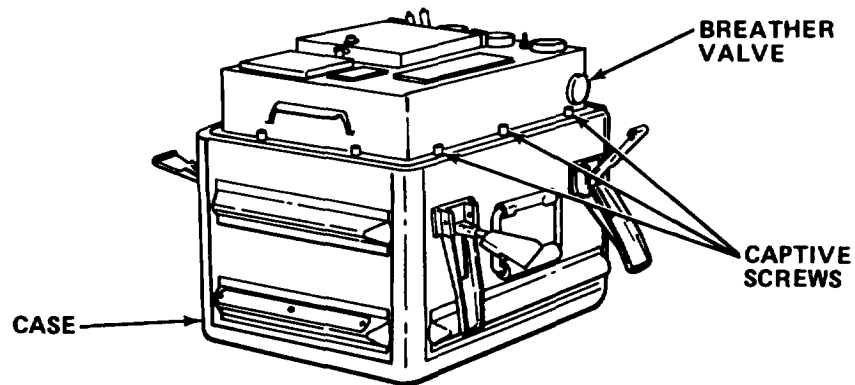

- b. Press breather valve to equalize pressure in case.
- c. Loosen captive screws and lift unit out of case.

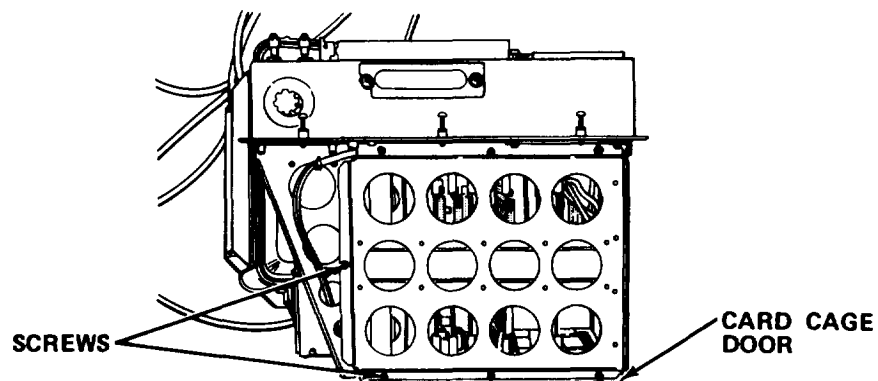

- d. Loosen captive screws and open card cage door.

CAUTION

Damage to motherboard will occur unless two top panel screws are removed before raising panel.

- e. Remove two top panel screws adjacent to motherboard.
- f. Loosen captive screws numbered 1 through 10 on bottom of front panel assembly and raise front panel.
- g. Disconnect RF cable and power connector.
- h. Remove circuit boards (paragraph 4-20.2).

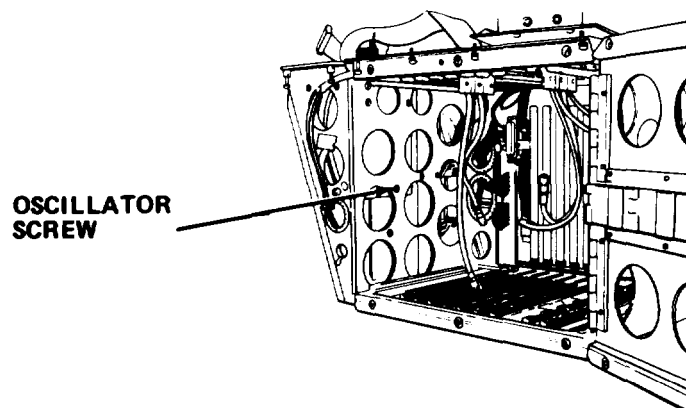

- i. Remove screw on inside of card cage.
- j. Remove one screw securing side of oscillator to frame.

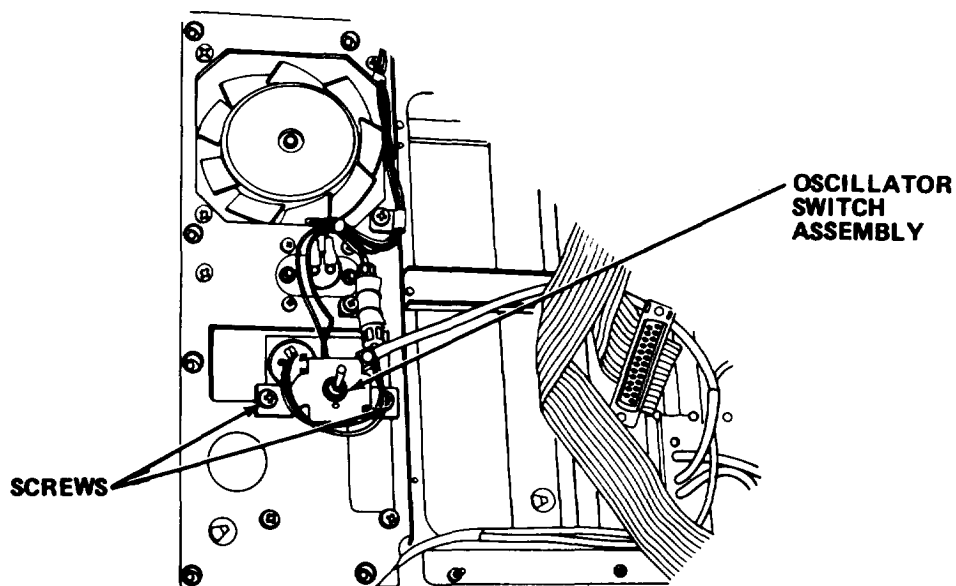

- k. Remove screws and switch assembly securing top of oscillator to chassis.
- l. Remove oscillator and spacer plate.

- m. Tag and unsolder wires from defective oscillator.
- n. Solder wires to new oscillator.

NOTE

When securing the top of the oscillator, the two longer screws are used to secure the switch assembly.

- o. Install oscillator and spacer plate and tighten oscillator mounting screws.
- p. Reconnect RF cable and power connector.
- q. Install circuit boards (paragraph 4-20.2).
- r. Close and secure front panel assembly.
- s. Close and secure card cage door.
- t. Perform self-test (paragraph 4-6.2).
- u. Inspect gasket in cover and replace if necessary.
- v. Install chassis in case.
- w. Install cover.

4-20.9 Replace Fan Assembly.

MOS: 35E, Special Electronic Devices Repairer

TOOLS: 5/16 in. Combination Wrench
 Cross Tip Screwdriver
 Diagonal Cutters

SUPPLIES: Fan
 Wire Ties

WARNING

Death or serious injury may occur from electrical shock unless power cord is disconnected before servicing.

- a. Press breather valve to equalize pressure in cover and remove cover.

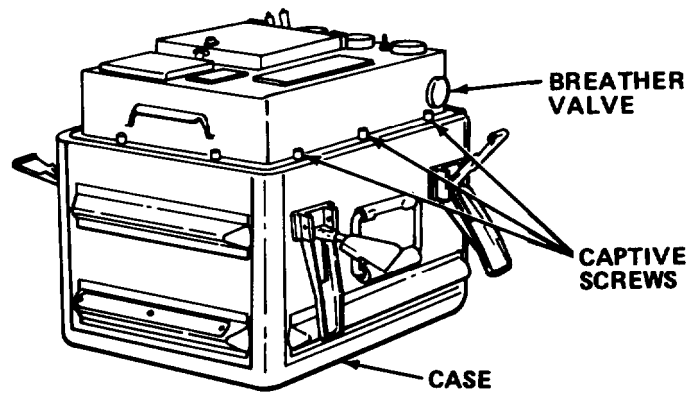

- b. Press breather valve to equalize pressure in case.
 c. Loosen captive screws and lift chassis out of case.

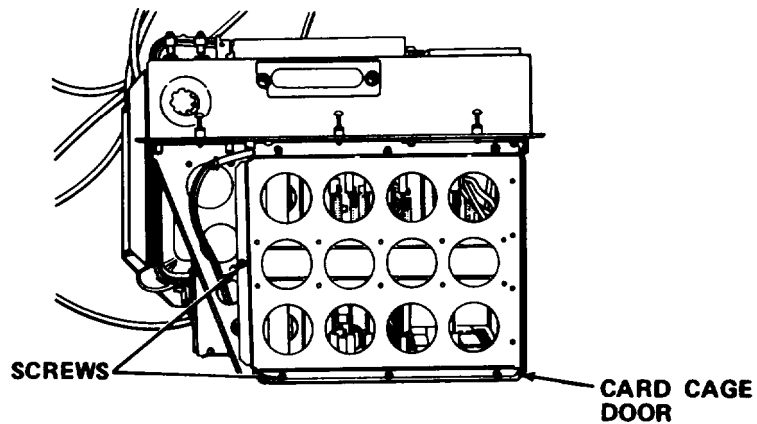

- d. Loosen captive screws and open card cage door.

CAUTION

Damage to motherboard will occur unless two top panel screws are removed before raising panel.

- e. Remove two top panel screws adjacent to motherboard.
- f. Loosen captive screws numbered 1 through 10 on bottom of front panel assembly and raise front panel.

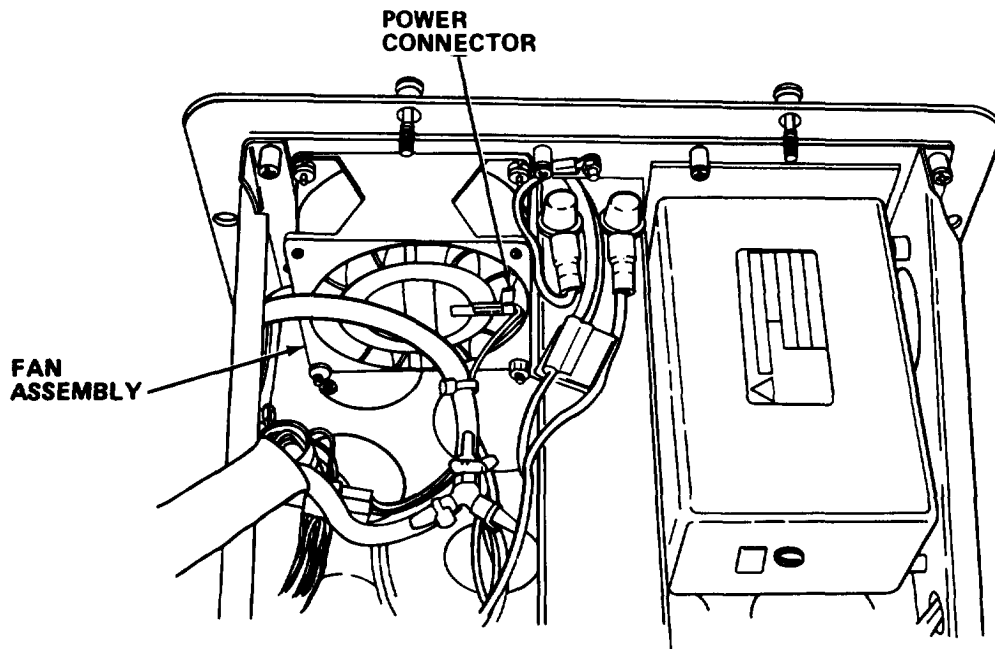

- g. Unplug connector to fan assembly.

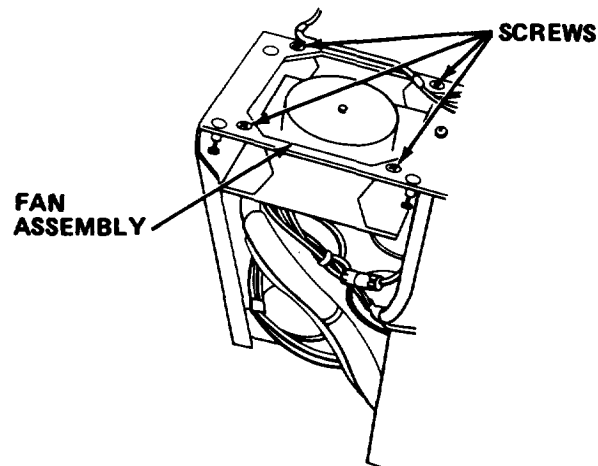

- h. Remove screws and defective fan assembly from chassis.

- i. Install new fan assembly.
- j. Plug in connector to fan assembly.
- k. Check fan operation.
- l. Close and secure front panel assembly.
- m. Close and secure card cage door.
- n. Inspect gasket in case and replace if necessary.
- o. Install chassis in case.
- p. Perform self-test (paragraph 4-6.2).
- q. Install cover.

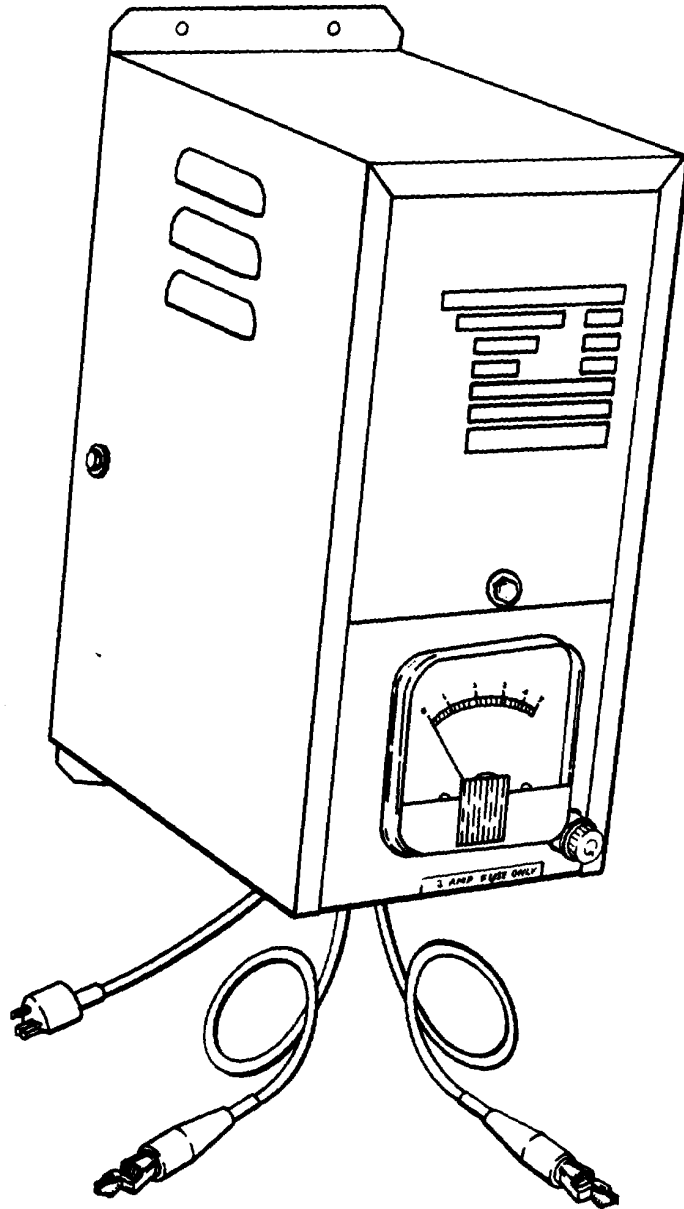

CHAPTER 5
AUTOMATIC BATTERY CHARGER

Section I INTRODUCTION

5-1. GENERAL INFORMATION.

5-1.1 Scope.

a. Model Number and Equipment Name. Model A18J-3-12V-A1 Automatic Battery Charger.

b. Purpose of Equipment. To charge 12 V battery.

5-2. EQUIPMENT DESCRIPTION.

5-2.1 Equipment Characteristics, Capabilities, and Features.

a. Cannot overcharge battery.

b. Compensation taps allow output voltage to be increased or decreased.

c. Convection cooled.

d. Must be mounted upright in vertical position.

5-2.2 Location and Description of Major Components.

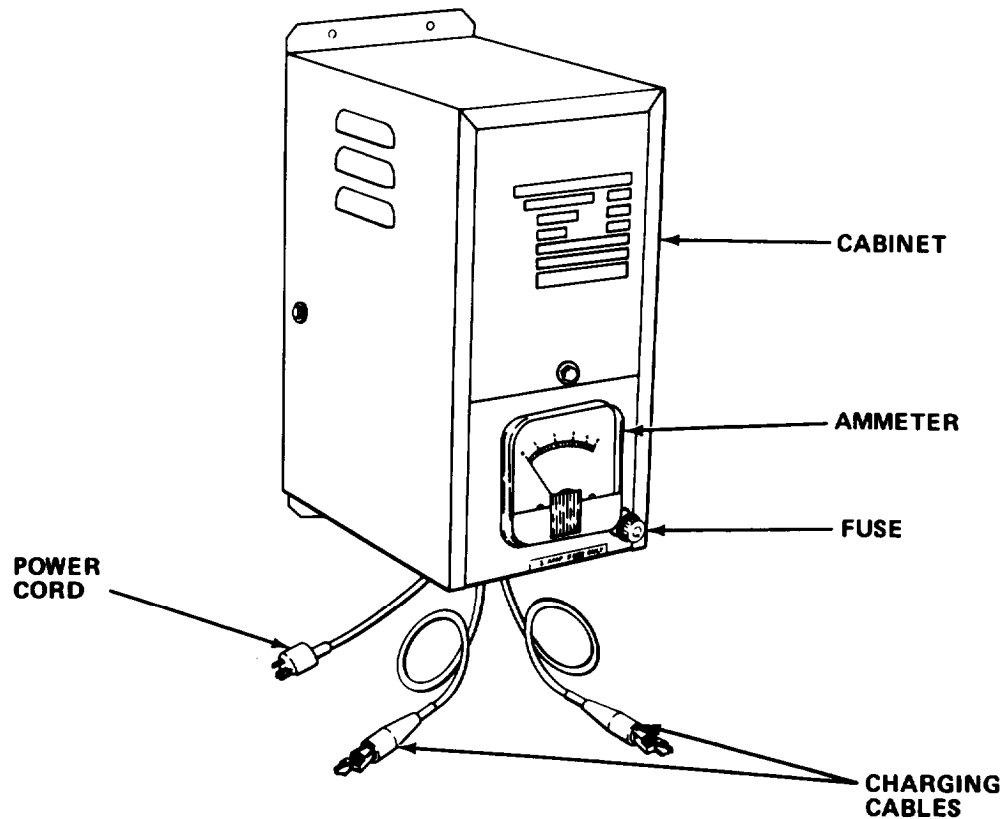

CABINET. Houses electrical components.

AMMETER. Indicates charging current from 0 to 5 amp.

FUSE. A 3 amp fuse protects electrical system.

CHARGING CABLES. Red (positive) and black (negative) to connect battery to charger.

POWER CORD. To connect charger to 120 V duplex receptacle.

5-2.3 Equipment Data.

Dimensions

| | |
|--------|--------------------|
| Width | 5.5 in. (13.9 cm) |
| Length | 13.6 in. (34.5 cm) |
| Height | 7.75 in. (19.7 cm) |

Power Requirements

120 V, 1 amp, 50-60 Hz,
single-phase

5-3. TECHNICAL PRINCIPLES OF OPERATION.

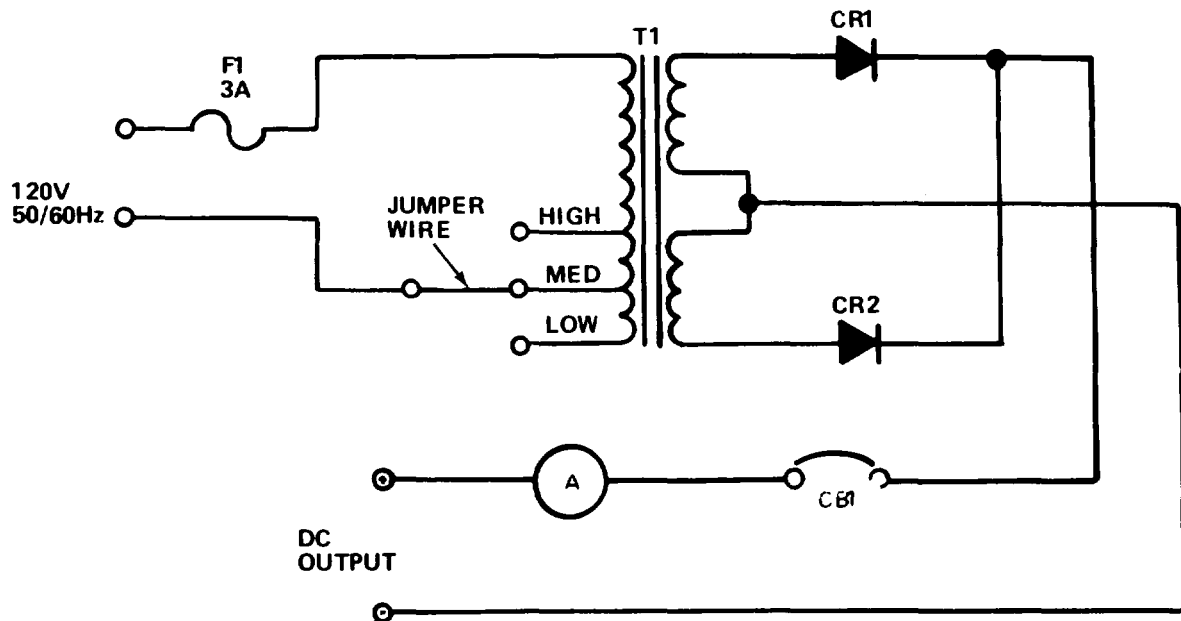

a. The pulsating 12 V dc output is provided by step-down transformer T-1 and half-wave rectifiers CR1 and CR2. The primary of the transformer is protected by 3 amp fuse F1. The LOW, MED, and HIGH compensation taps are used to compensate for continuously low or high ac input.

b. The ammeter indicates charging current from 0 to 5 amp, and circuit breaker CB1 protects the ammeter and battery from charging currents in excess of 5 amp. The nominal output of the battery charger is 12 V dc, 3 amp.

Section II OPERATING INSTRUCTIONS

5-4. DESCRIPTION AND USE OF OPERATOR'S CONTROLS AND INDICATORS.

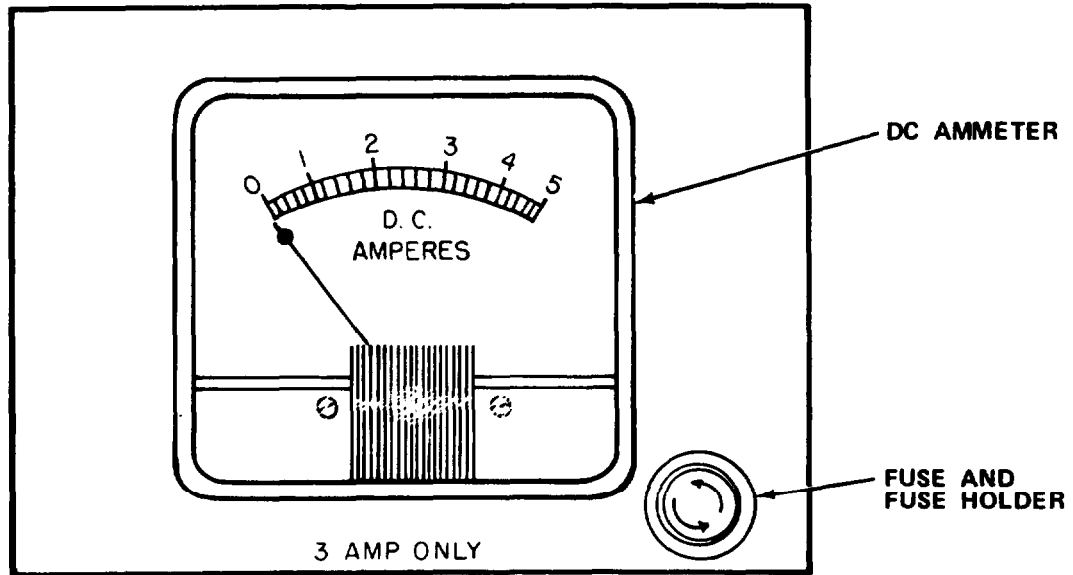

| Control or Indicator | Function |
|----------------------|------------------------------------------------------------------------------------------------------------------------------------------|
| DC Ammeter | Monitors battery-charging current; scale 0-5 amps. |
| Fuse and Fuse Holder | Protects battery charger from overloads. Fuse is 3 amp. |
| Battery Connections | Output leads are connected to battery: positive terminal to positive post on battery, and negative terminal to negative post on battery. |

5-5. OPERATOR PREVENTIVE MAINTENANCE CHECKS AND SERVICES.

- a. Before You Operate. Always keep in mind the WARNINGS and CAUTIONS. Perform your before (B) PMCS.
- b. While You Operate. Always keep in mind the WARNINGS and CAUTIONS. Perform your during (D) PMCS.
- c. After You Operate. Be sure to perform your after (A) PMCS.
- d. If Your Equipment Fails to Operate. Troubleshoot with proper equipment. Report any deficiencies using the proper forms. See DA Pam 738-750.

5-5.1 PMCS Procedures.

- a. PMCS are designed to keep the equipment in good working condition by performing periodic service tasks.
- b. Service intervals provide you, the operator, with time schedules that determine when to perform specified service tasks.
- c. The "Equipment is Not Ready/Available If" column is used for identification of conditions that make the equipment not ready/available for readiness reporting purposes or denies use of the equipment until corrective maintenance is performed.
- d. If your equipment fails to operate after PMCS is performed, immediately report this condition to your supervisor.
- e. Perform weekly as well as before operation if you are the assigned operator and have not operated the item since the last weekly or if you are operating the item for the first time.
- f. Item number column. Item numbers are assigned in chronological ascending sequence regardless of interval designation. These numbers are used for your "TM Number" column on DA Form 2404, Equipment Inspection and Maintenance Worksheet in recording results of PMCS.
- g. Interval columns. This column determines the time period designated to perform your PMCS.
- h. Item to be inspected and procedures column. This column lists functional groups and their respective assemblies and subassemblies as shown in the Maintenance Allocation Chart (Appendix B). The appropriate check or service procedure follows the specific item to be inspected.
- i. Equipment is not ready/available if: column. This column indicates the reason or cause why your equipment is not ready/available to perform its primary mission.

Table 5-1. OPERATOR PREVENTIVE MAINTENANCE CHECKS AND SERVICES

NOTE

If the equipment must be kept in continuous operation, check and service only those items that can safely be checked and serviced without disturbing operation. Make the complete checks and services when the equipment can be shut down.

B - Before
D - During
A - After

W - Weekly
M - Monthly
Q - Quarterly

AN - Annually
S - Semiannually
BI - Biennially

(Number) - Hundreds of Hours

| ITEM NO. | INTERVAL | ITEM TO BE INSPECTED PROCEDURE | For Readiness Reporting, Equipment is Not Ready/ Available If: |
|----------|----------|-----------------------------------------------------------------------------------------------------------------------------------------------------------------------------------------------------------------------------------------------------------------------------------------------------------------------------------------------------------------------------------------------------------------------------------------------------------------------------------------------------------------------------------------------------------------------------------------------------------------------------------------------------------------------------------------------------------------------------------------------|--------------------------------------------------------------------------------------------------------|
| 1 | B | <p><u>AUTOMATIC BATTERY CHARGER</u></p> <p><u>Inspect.</u></p> <ol style="list-style-type: none"> 1. Unplug power cord. 2. Carefully inspect power cord for cracked or broken plug, loose pins, frayed or cut insulation, broken wires, kinks, and breaks. 3. Inspect battery clips for corrosion and weak springs. 4. Inspect battery cables for broken wires, kinks, and frayed or cut insulation. 5. Inspect meter face for scratches and cracked glass. Report defective meter to direct/general support. 6. Check that ventilating grilles are free of debris. Clean grilles. 7. Inspect rear and sides for loose or missing screws. Replace missing screws. | <p>Power cord is defective.</p> <p>Battery clip is defective.</p> <p>Battery cables are defective.</p> |

5-6. OPERATION UNDER USUAL CONDITIONS.**WARNING**

- Charging batteries generate explosive mixtures. Do not charge batteries where flames or other ignition sources may occur. Use in a well-ventilated area. Be extra cautious to reduce the risk of dropping a metal tool onto the battery. It may spark or short-circuit battery or other electrical parts, and cause an explosion. Death or injury may occur.
 - Remove personal metal items such as rings, bracelets and watches when working with a lead-acid battery. Jewelry can produce a short-circuit current high enough to weld a ring or the like, causing a severe burn.
 - Caustic Chemicals in Batteries: Use rubber gloves, apron, and face shield to avoid burns. If chemicals get on skin, clothes, or equipment, wash immediately with water. If chemicals get in your eyes, flush thoroughly with water and get medical help immediately.
 - Use charger for charging a lead-acid type battery only. It is not intended to supply power to a low voltage electrical system other than in an automotive application. Do not use for charging dry-cell batteries as they may burst and cause injury to personnel.
- a. Check for the leakage of electrolyte around battery.
 - b. Inspect battery case for cracks.
 - c. Inspect battery terminals for damage.
 - d. Clean battery terminals.
 - e. Remove battery vent covers.
 - f. Check and refill battery with electrolyte as required.

CAUTION

To prevent damage to battery, be sure to observe correct polarity. Positive (red) output cable has red connector. Negative (black) output cable has black connector.

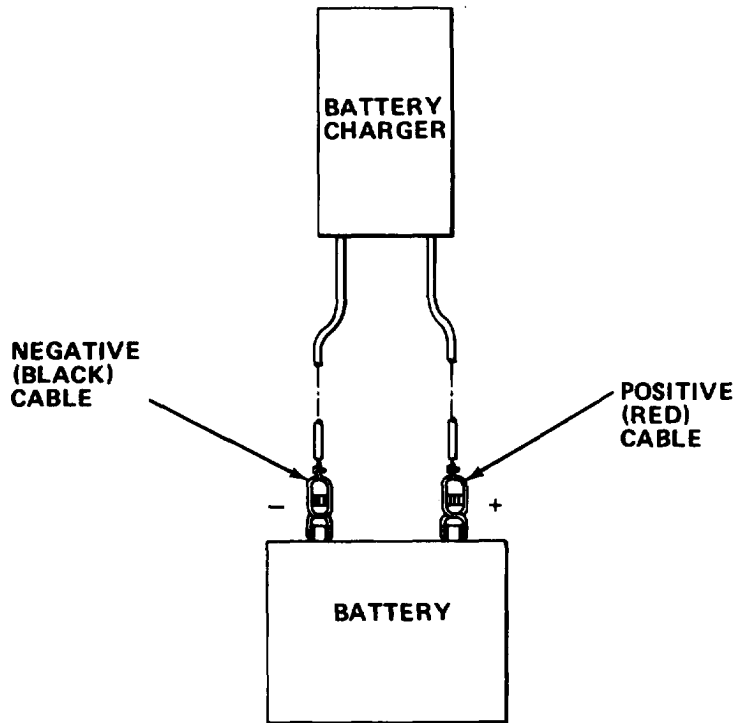

g. Determine the state-of-charge of the battery. Refer to TM 9-6140-200-14 for lead acid batteries.

h. Place wet cloth over cap and battery.

i. Connect positive (red) cable to positive (+) terminal of battery, and connect negative (black) cable to negative (-) terminal of battery.

j. Plug in power cord.

NOTE

When ammeter on battery charger does not show any noticeable current flow, battery is fully charged.

k. Unplug power cord.

l. Remove cloth from battery.

m. Disconnect negative and positive cables from battery terminals.

n. Reinstall battery vent covers.

5-7. OPERATION UNDER UNUSUAL CONDITIONS. This equipment is designed for operation only in a controlled environment.

Section III OPERATOR MAINTENANCE

5-8. LUBRICATION INSTRUCTIONS. This equipment does not require lubrication.

5-9. TROUBLESHOOTING PROCEDURES.

a. The table lists the common malfunctions which you may find during operation or maintenance of the automatic battery charger. You should perform the test/inspections and corrective actions in the order listed.

b. This manual cannot list all malfunctions that may occur, nor all test or inspections and corrective actions. If a malfunction is not listed or is not corrected by listed corrective actions, notify your supervisor.

Table 5-2. TROUBLESHOOTING

| MALFUNCTION | TEST OR INSPECTION | CORRECTIVE ACTION |
|----------------------------------------------|----------------------------------------------------|------------------------------------------------------------------------------------------------------------------|
| NO CHARGING CURRENT IS INDICATED ON AMMETER. | | |
| | Step 1. Check to see if power cord is plugged in. | (a) If power cord is plugged in, proceed to step 2. (b) Plug in power cord. |
| | Step 2. Visually check to see if fuse F1 is blown. | (a) If fuse is good, proceed to step 2. (b) Replace defective fuse (paragraph 5-10.1). |
| | Step 3. Check connections at battery. | (a) If connections are clean and tight, proceed to step 4. (b) Clean battery terminals and reposition clamps. |
| | Step 4. Check for sulfated battery. | Replace battery. |

5-10. MAINTENANCE PROCEDURES.

a. This section contains instructions covering operator maintenance functions for the automatic battery charger. Personnel required are listed only if the task requires more than one.

b. After completing each maintenance procedure, perform operational check to be sure that equipment is properly functioning.

INDEX

| PROCEDURE | PARAGRAPH |
|------------------------|-----------|
| Replace Fuse | 5-10.1 |

5-10.1 Replace Fuses.

MOS: 82D, Topographic Surveyor

SUPPLIES: Fuse (3 amp)

WARNING

Death or serious injury may occur from electrical shock unless power cord is unplugged before servicing.

a. Unplug power cord.

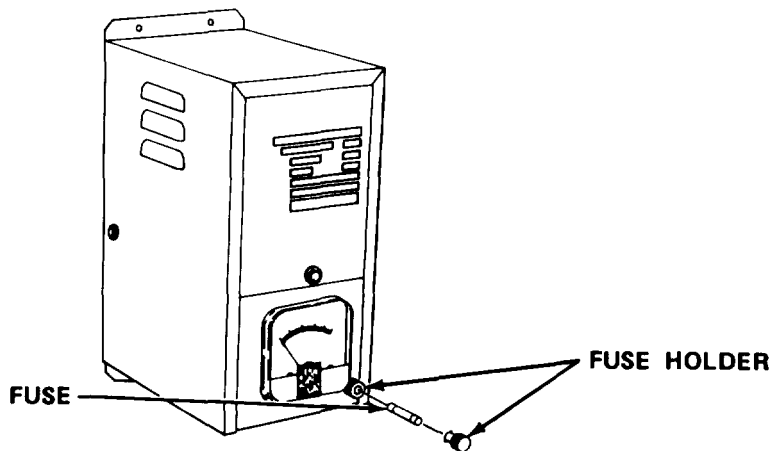

b. Push fuse holder in, turn left and pull out.

c. Replace defective fuse.

d. Reinstall fuse holder and turn right to lock.

e. Plug in power cord.

Section IV. ORGANIZATIONAL MAINTENANCE

5-11. LUBRICATION INSTRUCTIONS. This equipment does not require lubrication.

5-12. REPAIR PARTS, SPECIAL TOOLS; TEST, MEASUREMENT, AND DIAGNOSTIC EQUIPMENT (TMDE) ; AND SUPPORT EQUIPMENT. These items are not required at the organizational level.

5-13. SERVICE UPON RECEIPT.

5-13.1 Checking Unpacked Equipment.

a. Inspect the equipment for damage incurred during shipment. If the equipment has been damaged, report the damage on DD Form 6, Packing Improvement Report.

b. Check the equipment against the packing list to see if the shipment is complete. Report all discrepancies in accordance with the instructions of DA Pam 738-750.

c. Check to see whether the equipment has been modified.

5-14. ORGANIZATIONAL PREVENTIVE MAINTENANCE CHECKS AND SERVICES. There are no organizational PMCS procedures assigned for this equipment.

5-15. ORGANIZATIONAL TROUBLESHOOTING PROCEDURES. There are no organizational troubleshooting procedures assigned for this equipment.

5-16. MAINTENANCE PROCEDURES. There are no organizational maintenance procedures assigned for this equipment.

5-17. PREPARATION FOR STORAGE OR SHIPMENT. Contact your battalion for packing and shipping instructions.

Section V DIRECT/GENERAL SUPPORT MAINTENANCE

5-18. REPAIR PARTS, SPECIAL TOOLS; TEST, MEASUREMENT, AND DIAGNOSTIC EQUIPMENT (TMDE); AND SUPPORT EQUIPMENT.

5-18.1 Common Tools and Equipment. For authorized common tools and equipment, refer to the Modified Table of Organization and Equipment (MTOE) applicable to your unit.

5-18.2 Special Tools; Test, Measurement, and Diagnostic Equipment; and Support Equipment. Special Tools, TMDE, and Support Equipment is listed in the applicable repair parts and special tools list and in Appendix B of this manual.

5-18.3 Repair Parts. Repair parts are listed and illustrated in the Repair Parts and Special Tools List, TM 5-6675-318-24P covering direct/general support maintenance for this equipment.

5-19. DIRECT/GENERAL SUPPORT TROUBLESHOOTING PROCEDURES.

a. Direct/general support troubleshooting procedures cover the most common malfunctions that may be repaired at the direct/general support level. Repair or adjustment requiring specialized equipment is not authorized unless such equipment is available. Troubleshooting procedures used by lower level maintenance should be conducted in addition to the direct/general support troubleshooting procedures.

b. This manual cannot list all the possible malfunctions or every possible test/inspection and corrective action. If a malfunction is not listed or is not corrected by a listed corrective action, notify your supervisor.

c. For unidentified malfunctions, use the following schematic or the foldout located at the end of this manual for further fault analysis.

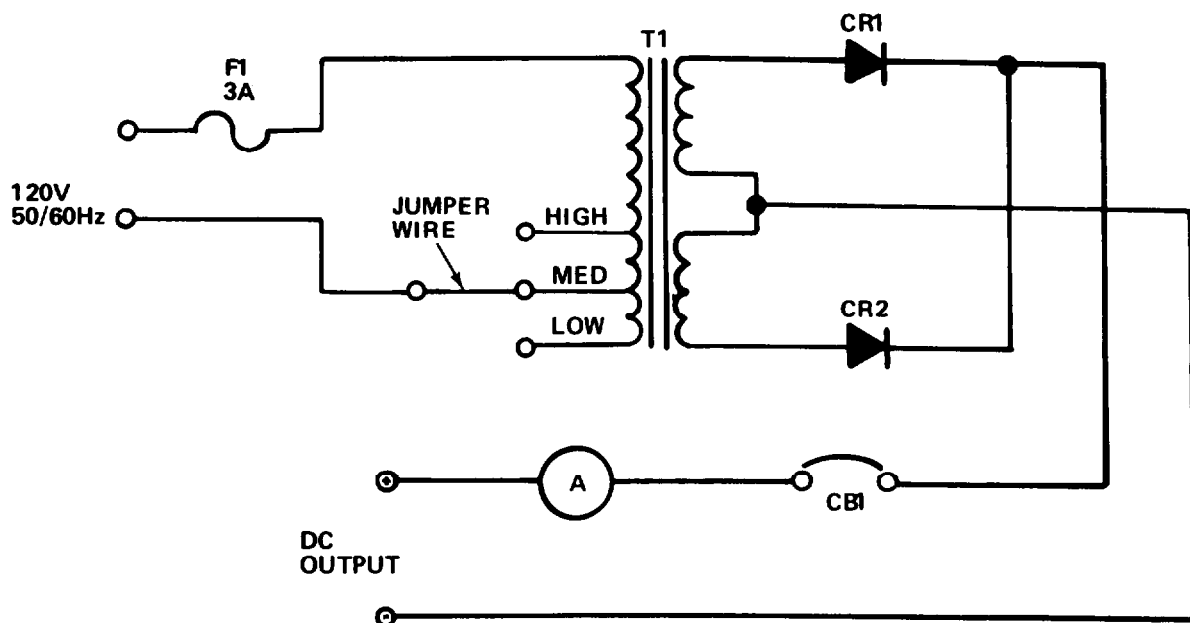

Table 5-3. DIRECT/GENERAL SUPPORT TROUBLESHOOTING

| MALFUNCTION | TEST OR INSPECTION | CORRECTIVE ACTION |
|-------------|--------------------|-------------------|
|-------------|--------------------|-------------------|

NO CHARGING CURRENT IS INDICATED ON AMMETER.

Step 1. Remove fuse and check for continuity.

- (a) If continuity exists, proceed to step 2.
- (b) If continuity does not exist, replace fuse (paragraph 5-10.1).

Step 2. Check power outlet for 120 V ac using a multimeter.

- (a) If power is present, proceed to step 7.
- (b) If power is not present, proceed to step 3.

Step 3. Check power panel indicators for correct voltage, frequency, and phase.

- (a) If correct, proceed to step 4.
- (b) If incorrect, notify power supply supervisor.

Step 4. Check circuit breaker on/off position.

- (a) If circuit breaker is on, proceed to step 5.
- (b) If circuit breaker is off, turn on.
- (c) If circuit breaker trips repeatedly, notify power supply supervisor.

Table 5-3. DIRECT/GENERAL SUPPORT TROUBLESHOOTING - Cont

MALFUNCTION

TEST OR INSPECTION

CORRECTIVE ACTION

NO CHARGING CURRENT IS INDICATED ON AMMETER - Cont

Step 5. Check circuit breaker output for 120 V ac.

(a) If voltage is present, proceed to step 6.

(b) If voltage is not present, replace circuit breaker (paragraph 1-20.5).

Step 6. Remove receptacle and check for 120 V ac input.

(a) If present, replace receptacle (paragraph 1-16.6).

(b) If not present, repair or replace defective wiring.

Step 7. Check continuity of power cord.

(a) If continuity exists, proceed to step 8.

(b) If continuity does not exist, replace power cord (paragraph 5-20.6).

Step 8. Check for battery lead connections.

(a) If battery leads are not connected to terminal board, connect battery leads.

(b) If battery leads are connected, perform continuity-check of battery leads.

(1) If continuity exists, proceed to step 9.

Table 5-3. DIRECT/GENERAL SUPPORT TROUBLESHOOTING - Cont

| MALFUNCTION | TEST OR INSPECTION | CORRECTIVE ACTION |
|-------------|--------------------|-------------------|
|-------------|--------------------|-------------------|

NO CHARGING CURRENT IS INDICATED ON AMMETER - Cont

(2) If no continuity exists, replace battery leads (paragraph 5-20.4).

Step 9. Check for low output voltage.

(a) Move compensation tap from med (normal) to high.

(b) Check output of rectifiers CR1 and CR2.

(1) If rectifiers are good, proceed to (c).

(2) Replace defective diodes.

(c) Check primary and secondary voltage.

(1) If correct, proceed to step 10.

(2) Replace defective transformer (paragraph 5-20.3).

Step 10. Check resistance across circuit breaker.

(a) if resistance is high, replace circuit breaker (paragraph 5-20.5).

(b) If resistance is normal, replace ammeter (paragraph 5-20.1).

5-20. MAINTENANCE PROCEDURES.

a. This section contains instructions covering direct/general support maintenance functions for the automatic battery charger. Personnel required are listed only if the task requires more than one.

b. After completing each maintenance procedure, perform operational check to be sure that equipment is properly functioning.

INDEX

| PROCEDURE | PARAGRAPH |
|----------------------------------|-----------|
| Replace Ammeter. | 5-20.1 |
| Replace Diodes | 5-20.2 |
| Replace Transformer. | 5-20.3 |
| Replace Battery Leads. | 5-20.4 |
| Replace Circuit Breaker. | 5-20.5 |
| Replace Power Cord | 5-20.6 |

5-20.1 Replace Ammeter.

Mos: 35E, Special Electronic Devices Repairer

TOOLS: 5/16 in. Combination Wrench
5/16 in. Nut Driver

SUPPLIES: Ammeter

WARNING

Death or serious injury may occur from electrical shock unless power cord is unplugged before servicing.

- a. Unplug power cord.

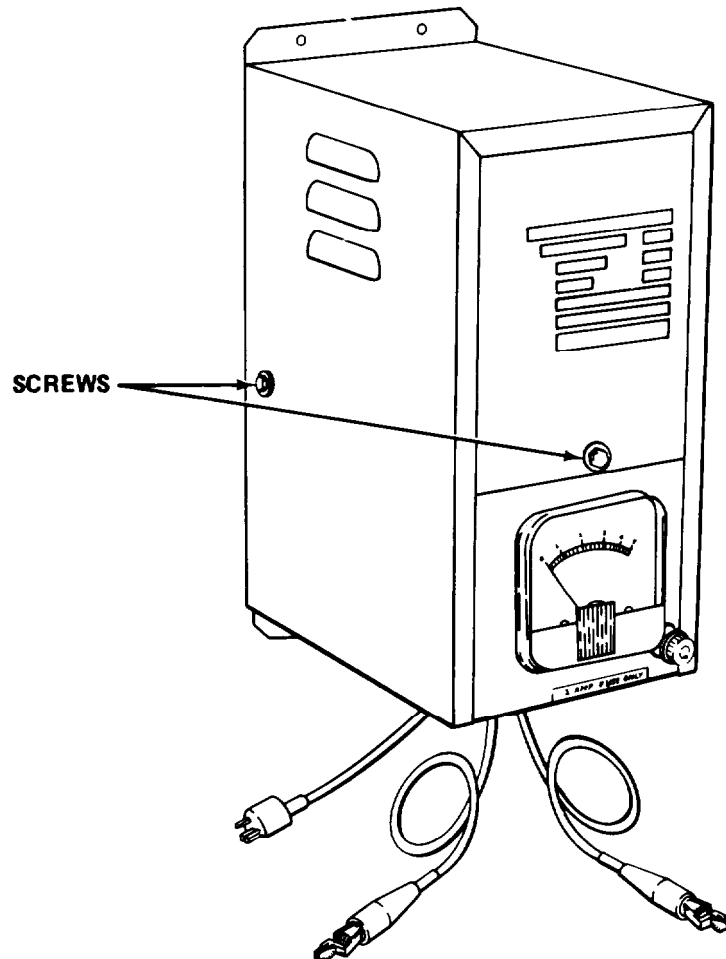

-
- b. Remove three screws, two located on sides and one above ammeter, and remove cover.

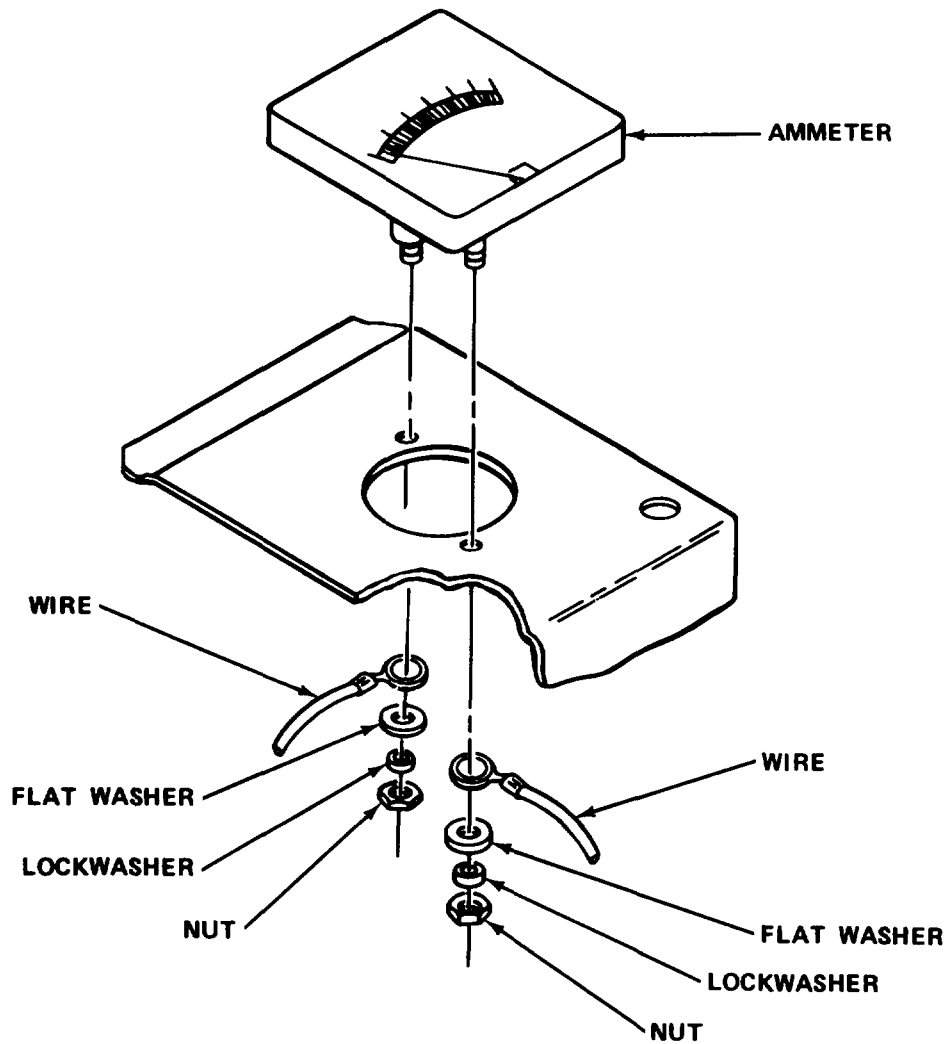

- c. Tag and remove wires at rear of ammeter.
- d. Remove ammeter mounting screws and lift out defective ammeter.
- e. Install new ammeter.
- f. Reconnect wires.
- g. Reinstall cover and secure with three screws.

5-20.2 Replace Diodes.

MOS: 35E, Special Electronic Devices Repairer

TOOLS: Offset Flat Tip Screwdriver
5/16 in. Nut Driver
5/16 in. Combination Wrench
Torque Wrench
11/16 in. Combination Wrench
7/16 in. Socket

SUPPLIES: Diode(s)

WARNING

Death or serious injury may occur from electrical shock unless power cord is unplugged before servicing.

- a. Unplug power cord.

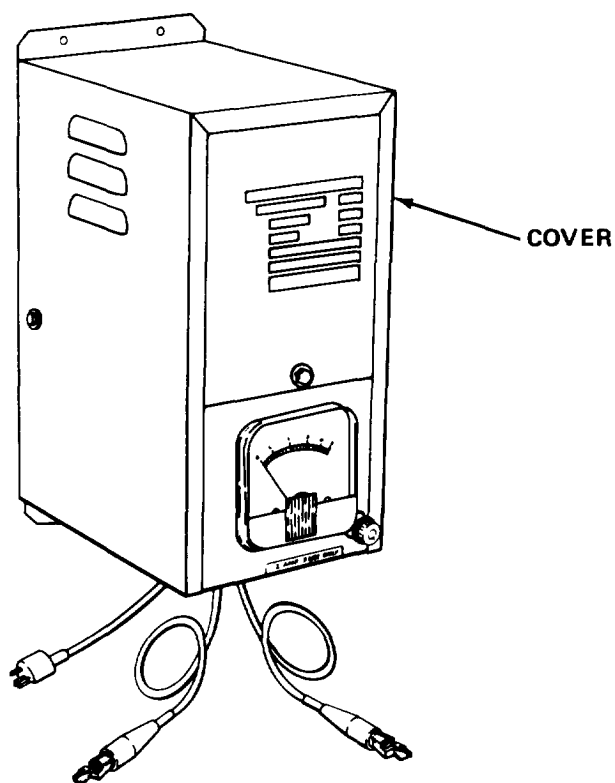

- b. Remove cover.

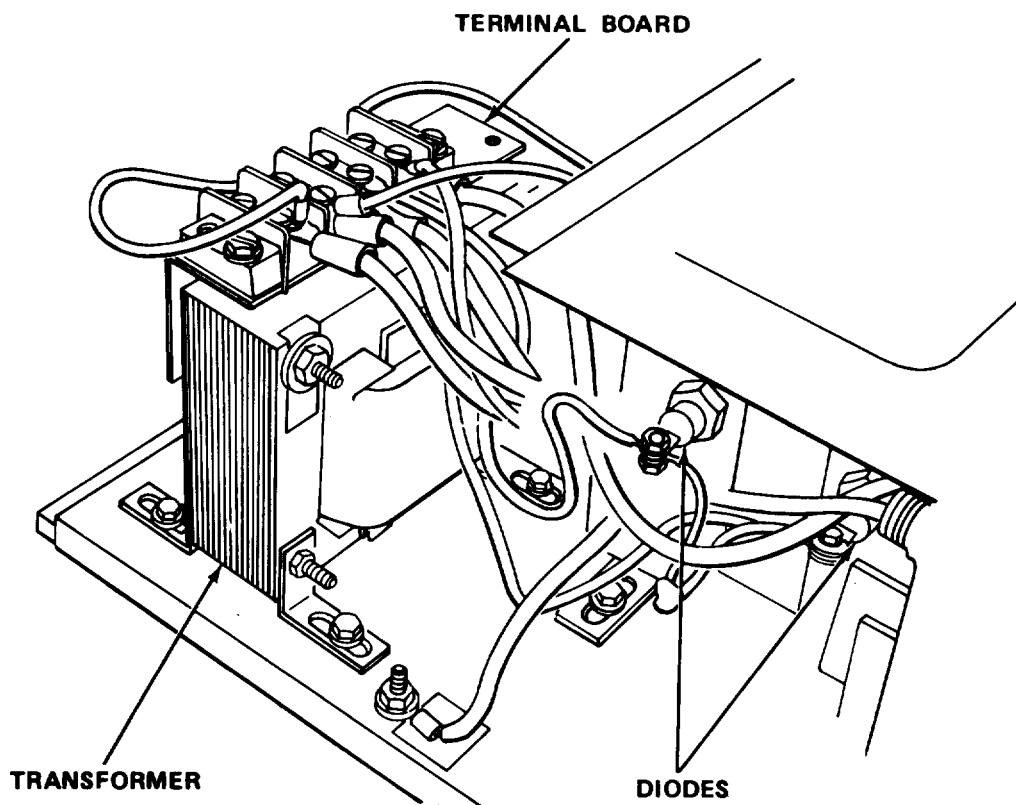

- c. Tag and remove wires and surge protector connected to diode.
- d. Remove diode from heat sink.
- e. Install new diode and tighten nut to 12-15 lbf. in. (1.36 - 1.69 N•m).
- f. Reconnect wires and surge protector to diode.
- g. Reinstall cover.

5-20.3 Replace Transformer.

MOS: 35E, Special Electronic Devices Repairer

TOOLS: Offset Flat Tip Screwdriver
 5/16 in. Nut Driver
 5/16 in. Combination Wrench

SUPPLIES: Transformer

WARNING

Death or serious injury may occur from electrical shock unless power cord is unplugged before servicing.

- a. Unplug power cord.

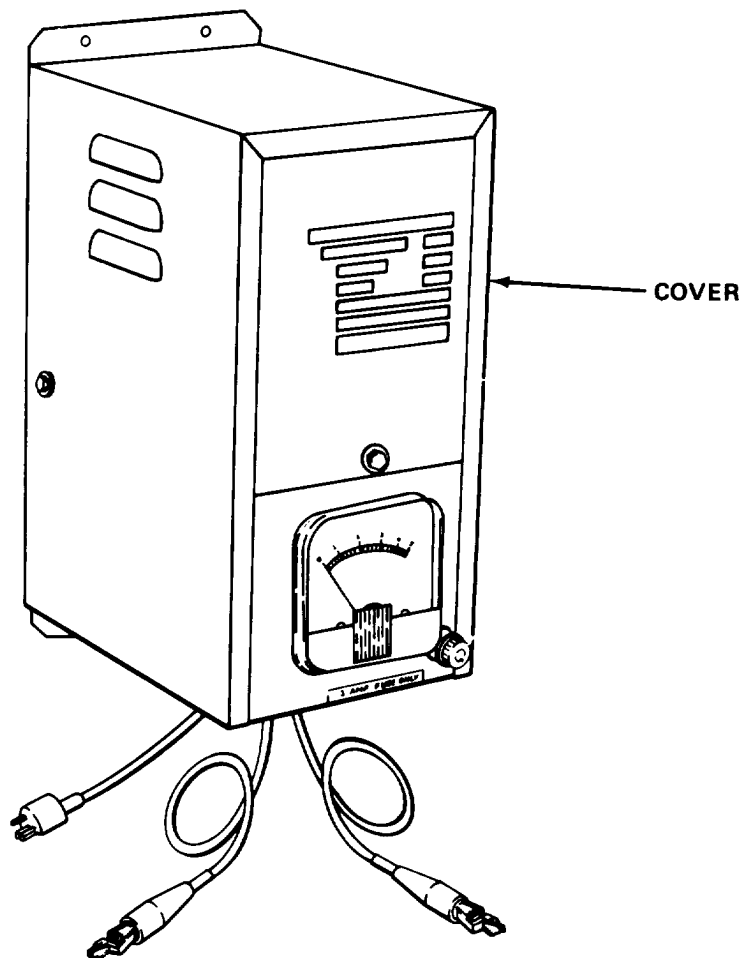

- b. Remove cover.

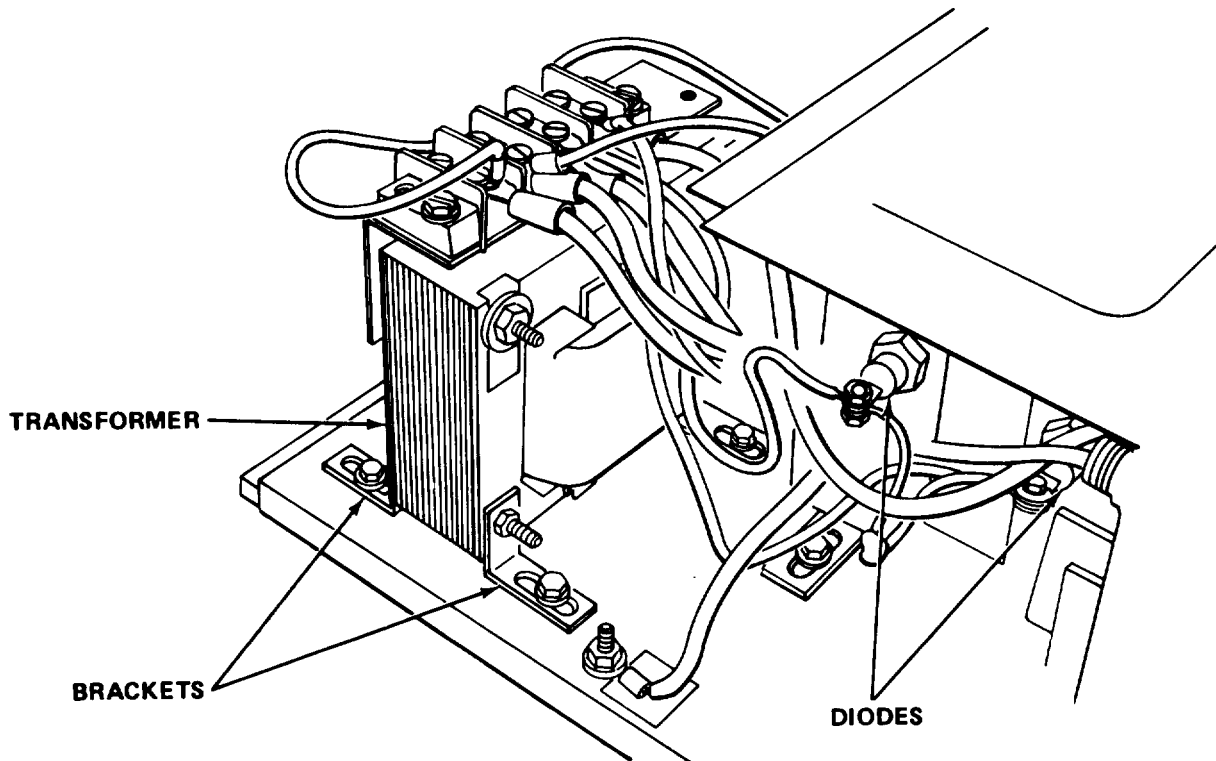

- c. Tag and remove wires from transformer.
- d. Tag and remove wires from diodes.
- e. Remove sheet metal screws and carefully raise terminal board.
- f. Remove screws from brackets and remove transformer.
- g. Install transformer and secure.
- h. Reinstall terminal board.
- i. Reconnect wires to transformer and diodes.
- j. Reinstall cover.

5-20.4 Replace Battery Leads.

MOS: 35E, Special Electronic Devices Repairer

TOOLS: 5/16 in. Nut Driver
Flat Tip Screwdriver
Crimping Tool

SUPPLIES: Battery Cables, 14 gage stranded, 6 ft. (1.8 m) length (2)
Terminal lugs (4)
Insulator boots, size 26, red or black as required.
Alligator clips size 25-C (2)

WARNING

Death or serious injury may occur from electrical shock unless power cord is unplugged before servicing.

- a. Unplug power cord.

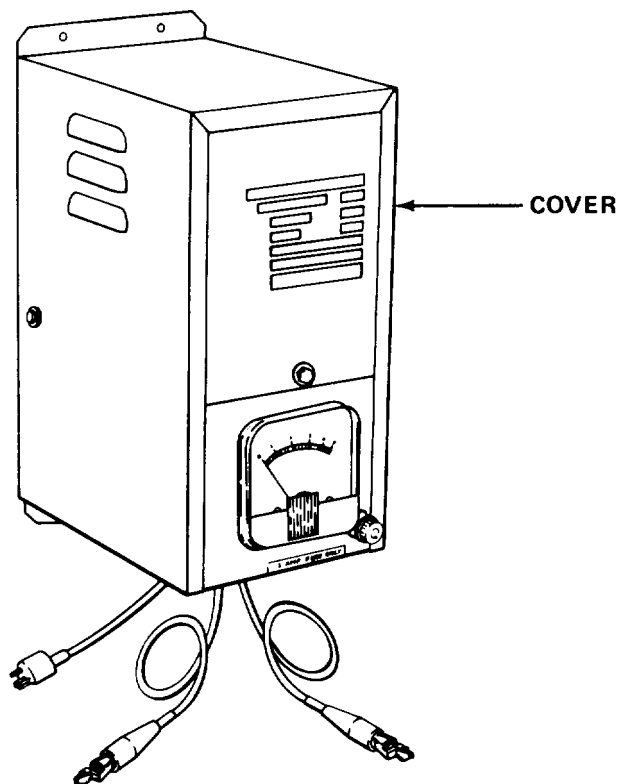

- b. Remove cover.

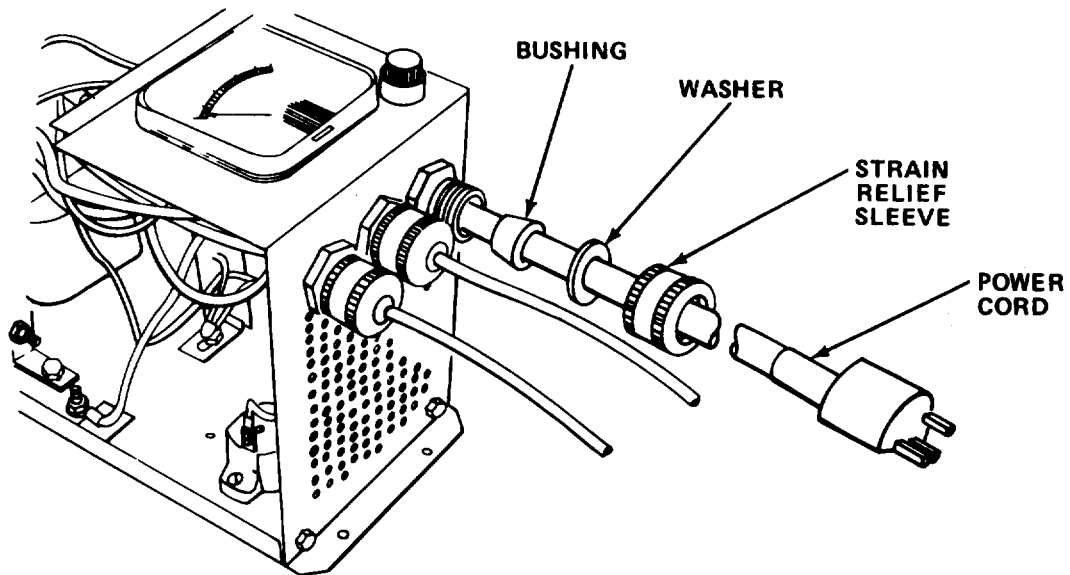

- c. Tag and remove lead(s) from terminal board.
- d. Unscrew strain relief sleeve and remove wire from charger, then remove bushing, washer, and sleeve.

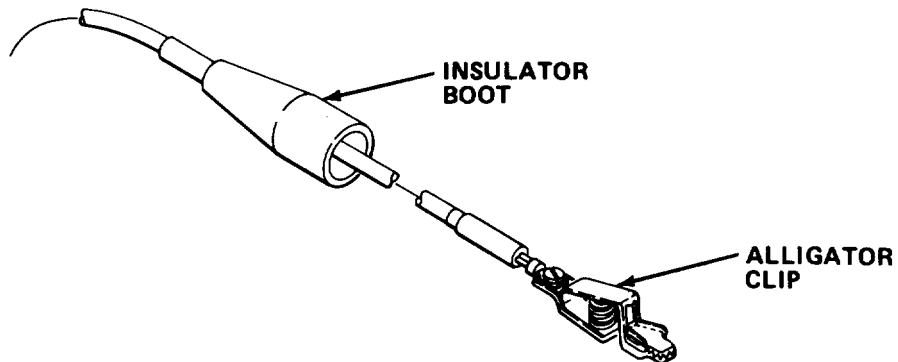

- e. Slide insulator boot(s) off alligator clip(s).
- f. Disconnect defective battery cable(s) from alligator clip(s).
- g. Slide insulator or boot(s) off defective battery cable(s).
- h. Replace defective insulator boots and alligator clips if required.

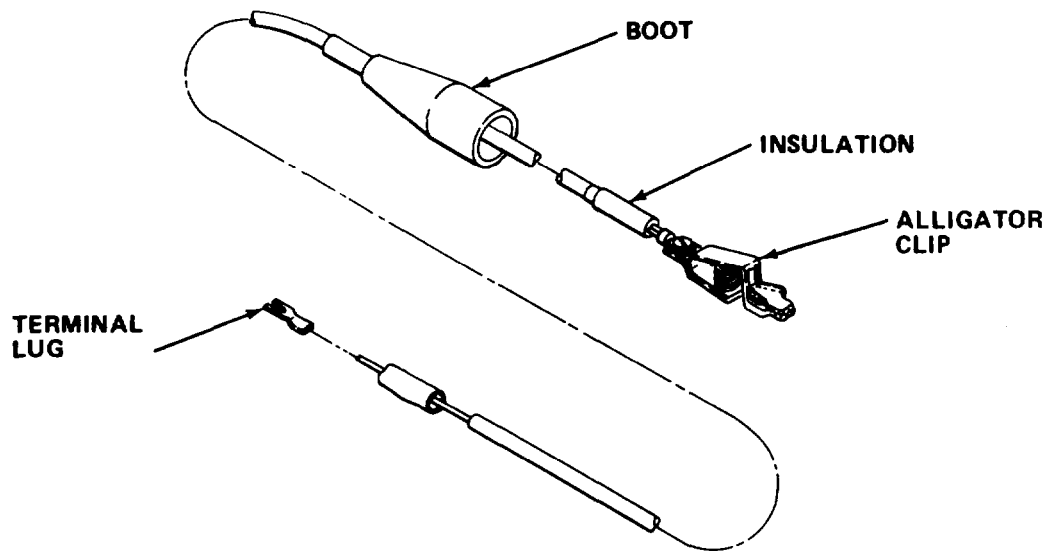

- i. Strip approximately 1/2 inch (13 mm) of insulation from both ends of the battery cable(s).

NOTE

Black color-coded insulator boot should be connected to negative battery cable. Red color-coded insulator boot should be connected to the positive battery cable.

- j. Slide insulator or boot(s) onto battery cable(s).
- k. Slide cable(s) through strain relief sleeve, washer, and bushing.
- l. Crimp new terminal lug(s) to battery cable(s).
- m. Secure battery cable(s) to alligator clip(s).
- n. Slide insulator or boot over alligataor clip(s).

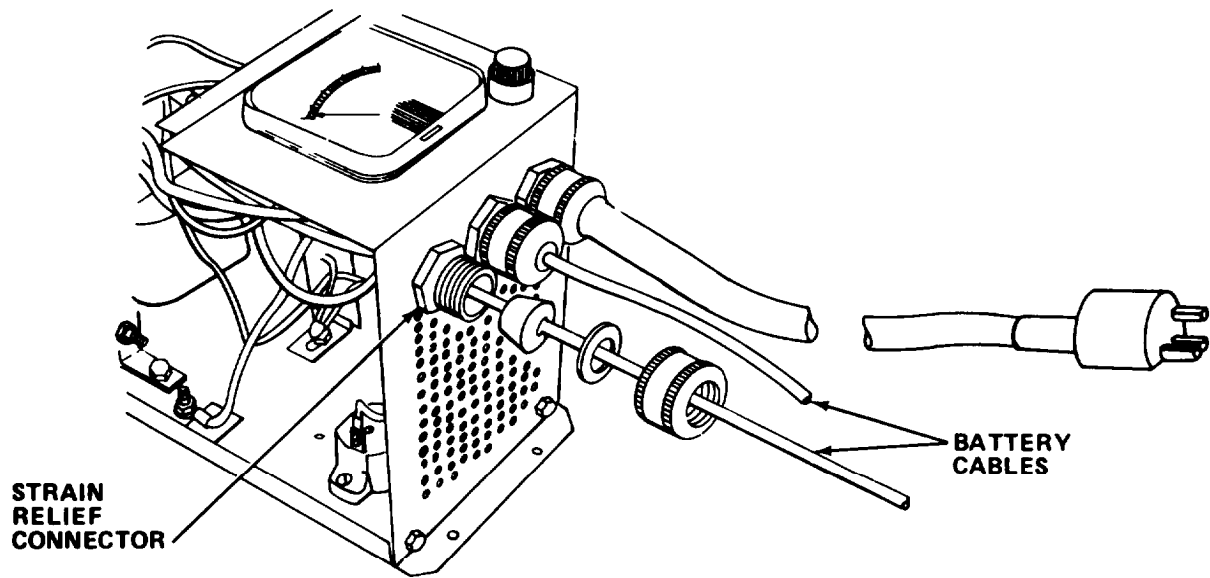

- o. Insert battery cable(s), terminal lug(s) first, through strain relief connector.
- p. Connect terminal lug(s) to terminal board.
- q. Connect strain relief sleeve and tighten finger tight.
- r. Reinstall cover.

5-20.5 Replace Circuit Breaker

Mos: 35E, Special Electronic Devices Repairer

TOOLS: 5/16 in. Nut Driver
Short Blade Flat Tip Screwdriver

SUPPLIES: Circuit Breaker

WARNING

Death or serious injury may occur from electrical shock unless power cord is unplugged before servicing.

- a. Unplug power cord.

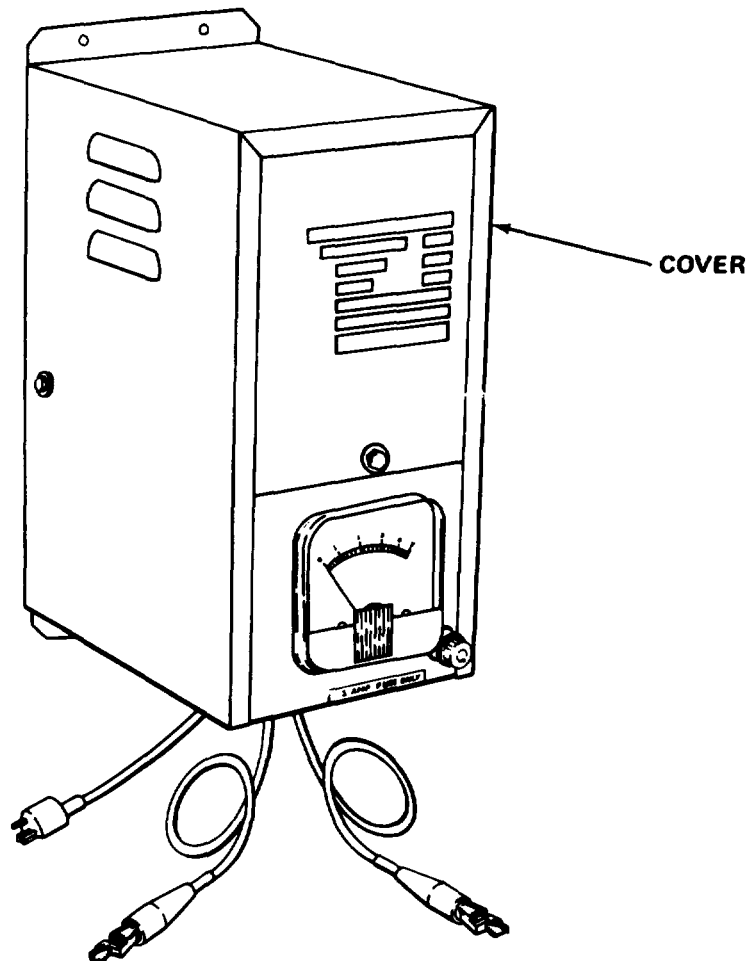

-
- b. Remove cover.

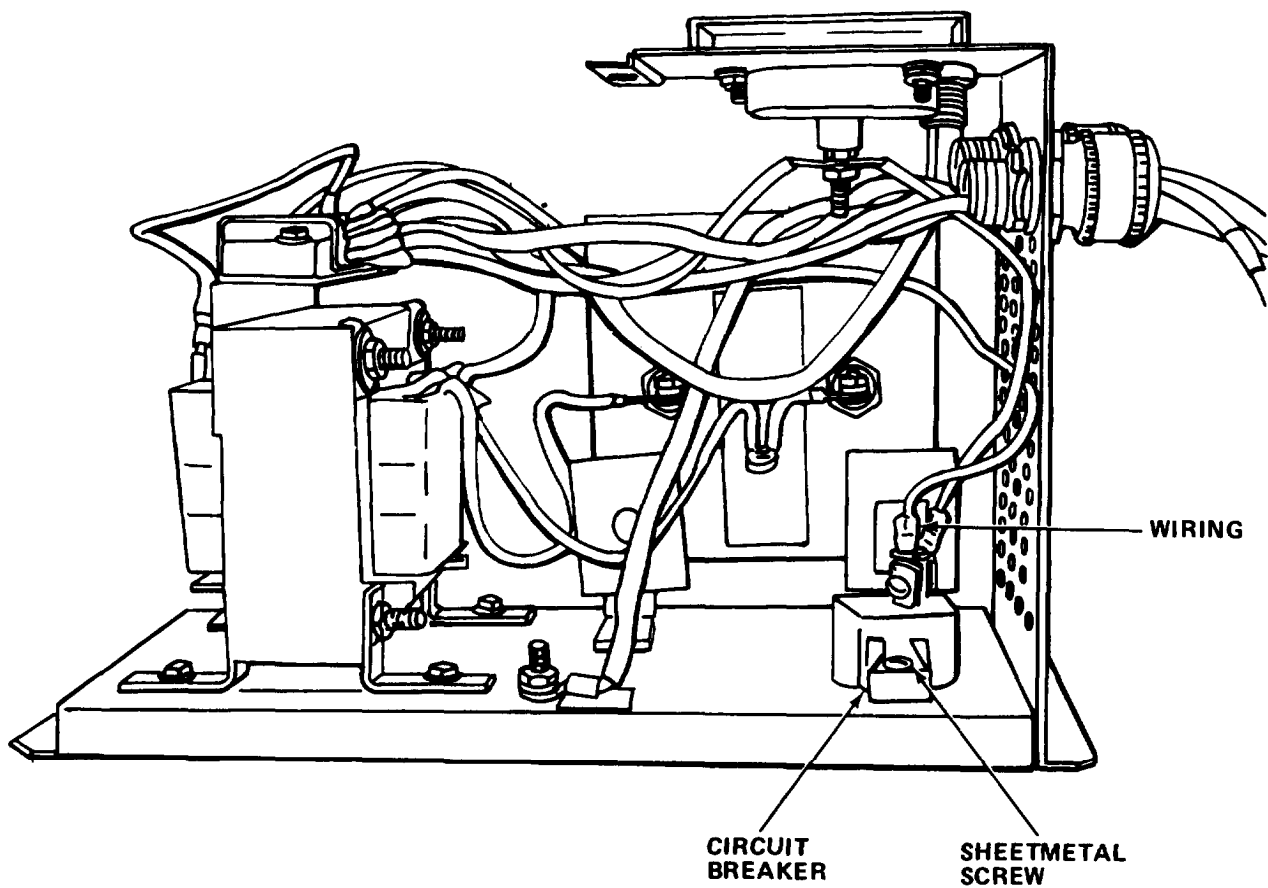

- c. Remove sheet metal screws and pull out circuit breaker to gain access to wires.
- d. Tag and remove the wiring from circuit breaker.
- e. Connect wires to new circuit breaker.
- f. Install circuit breaker and secure with sheet metal screws.
- g. Reinstall cover.

5-20.6 Replace Power Cord

MOS: 35E, Special Electronic Devices Repairer

TOOLS: 5/16 in. Nut Driver
Crimping ToolSUPPLIES: Terminal Lugs
Power Cord
Plug**WARNING**

Death or serious injury may occur from electrical shock unless power cord is unplugged before servicing.

- a. Unplug power cord.

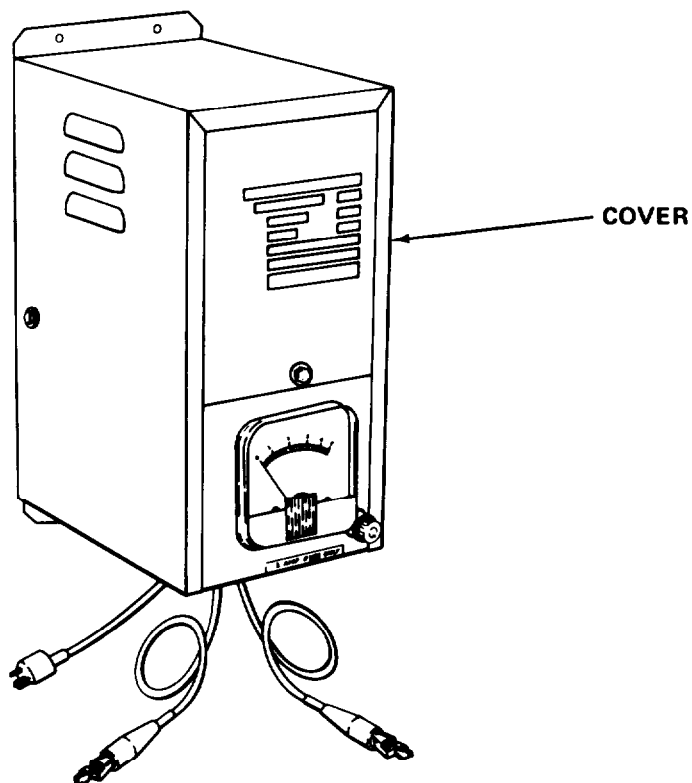

- b. Remove cover.

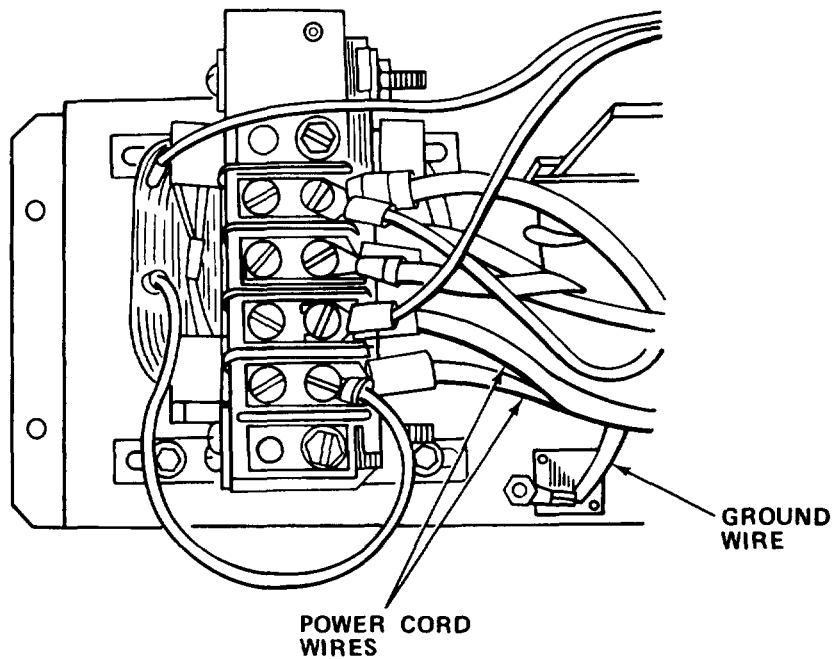

- c. Tag and remove two wires from terminal board and one from ground.
- d. Unscrew strain relief sleeve and remove power cord from charger, then remove bushing, washer, and sleeve.

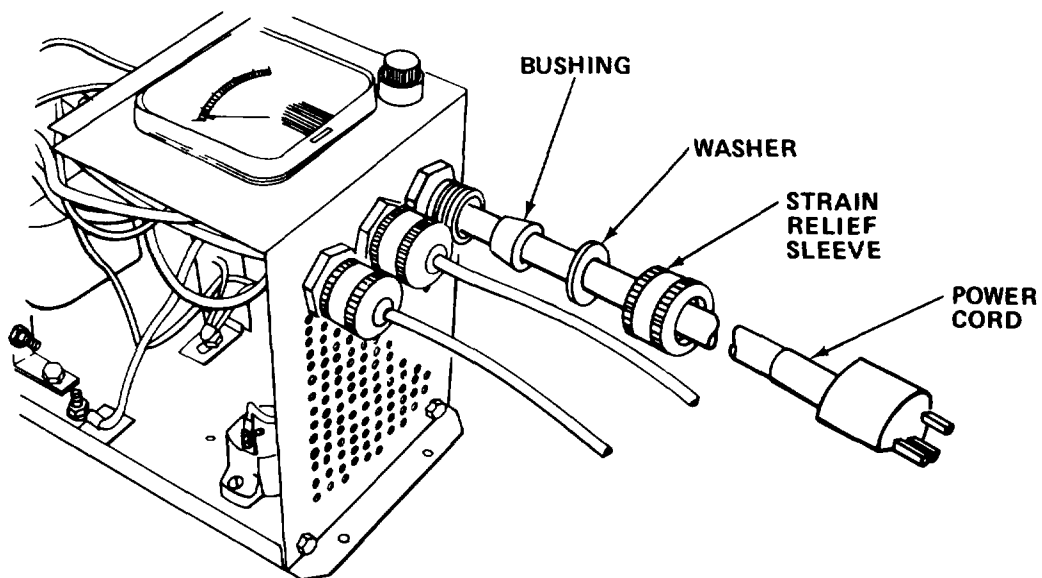

- e. Tag and disconnect power cord leads from plug. Discard plug if defective.

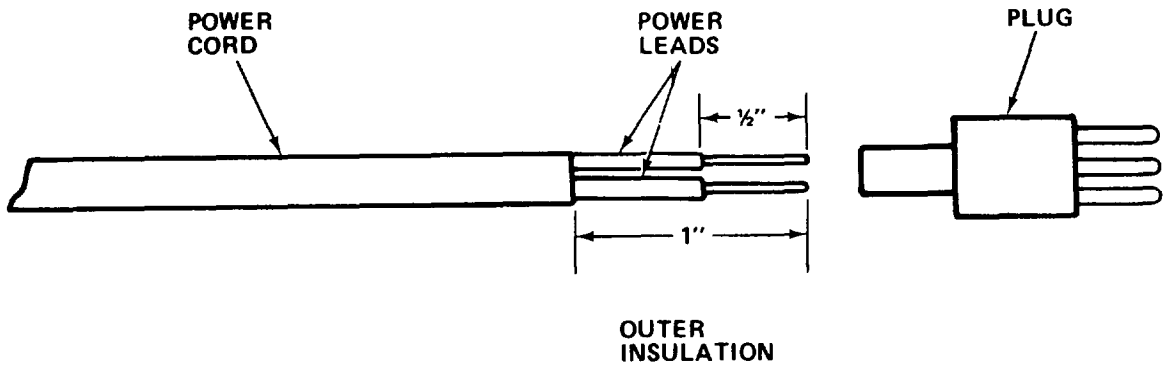
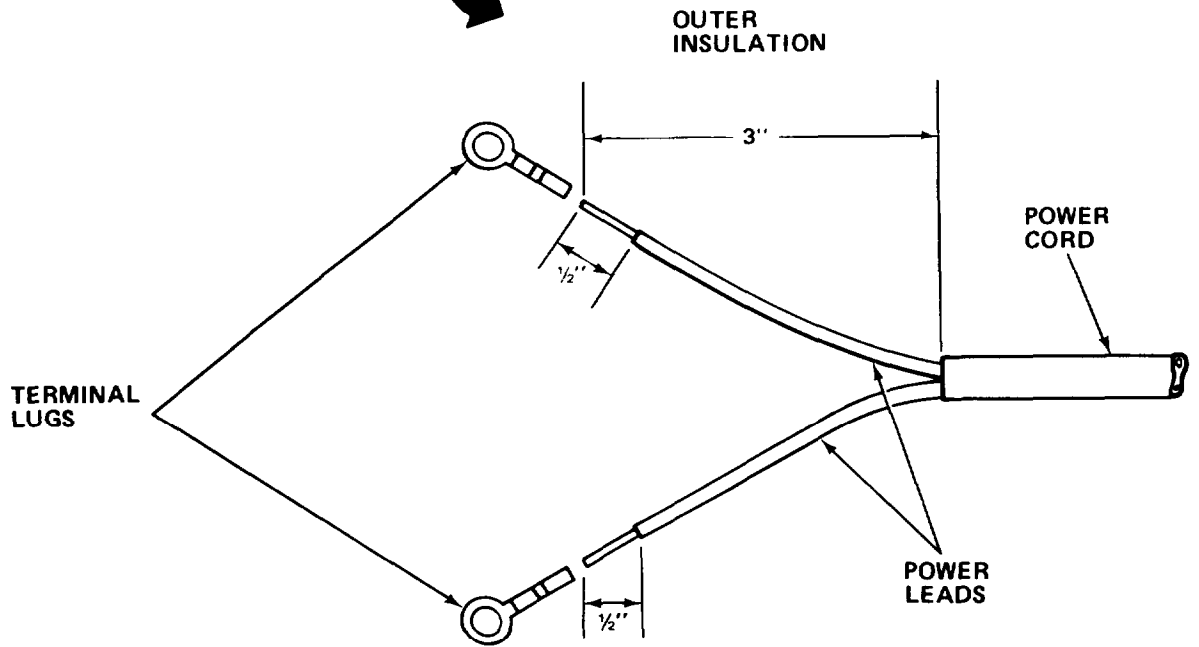
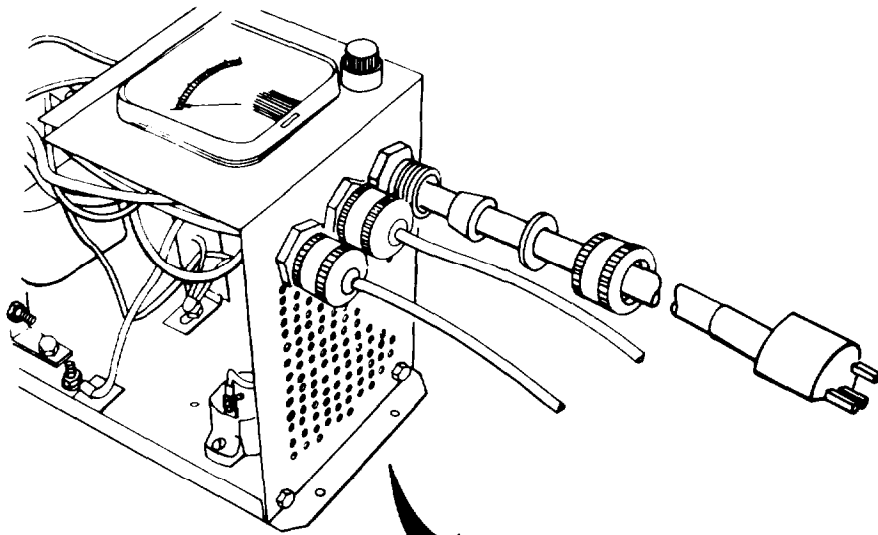

NOTE

Use defective power cord as a guide to install terminal lugs and plug on power cord.

- f. Strip approximately 3 in. (7.6 cm) of outer insulation from one end of power cord.
- g. Strip approximately 1 in. (2.5 cm) of outer insulation from the other end of power cord.
- h. Strip approximately 1/2 in. (13.0 mm) of insulation from both ends of power cord leads.
- i. Crimp new terminal lugs on power cord.
- j. Reconnect plug.
- k. Slide power cord through strain relief sleeve, washer, and bushing.
- l. Insert power cord through strain relief connector.
- m. Connect terminal lugs to terminal board and ground.
- n. Connect strain relief sleeve and tighten finger tight.
- o. Reinstall cover.

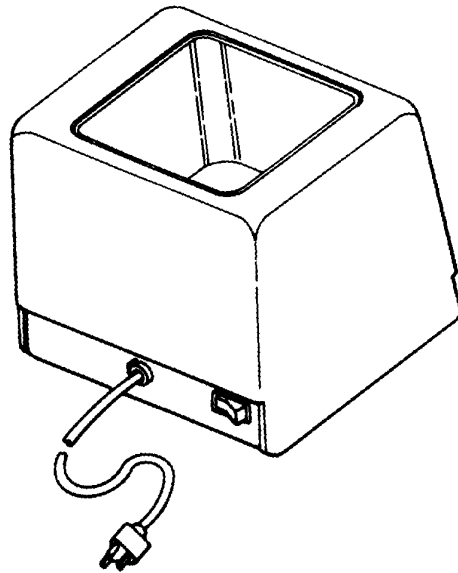

CHAPTER 6

ULTRASONIC CLEANER

Section I INTRODUCTION

6-1. GENERAL INFORMATION.

6-1.1 Scope.

- a. Model Number and Equipment Name. Model 3069USC3 Ultrasonic Cleaner
- b. Purpose of Equipment. To clean drafting/drawing pens.

6-2. EQUIPMENT DESCRIPTION.

6-2.1 Equipment Characteristics, Capabilities, and Features.

- a. Cleans without disassembly.
- b. Removes dried ink.
- c. Portable.

6-2.2 Location and Description of Major Components.

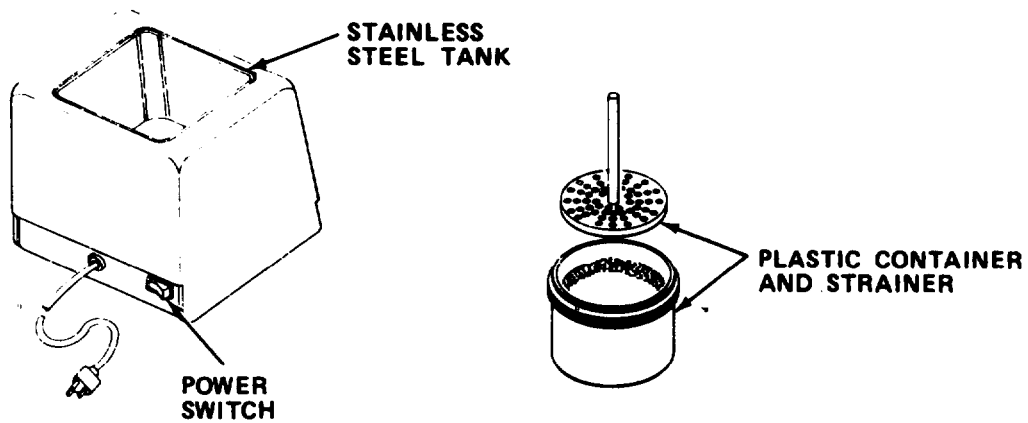

STAINLESS STEEL TANK. Holds water.

PLASTIC CONTAINER AND STRAINER. Holds small parts in solution for cleaning.

POWER SWITCH. Turns machine on or off.

6-2.3 Equipment Data.

| | |
|--------------------|-----------------------|
| Weight | 5.51 lbs (2.5 kg) |
| Power Requirements | 115 V, 60 HZ, 60 W |

6-3. TECHNICAL PRINCIPLES OF OPERATION.

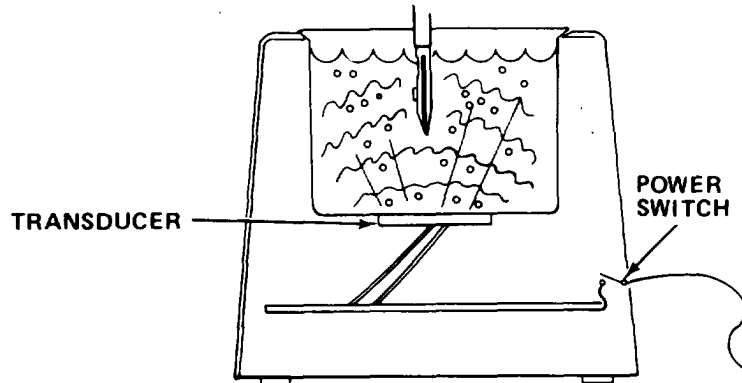

POWER SWITCH. When turned on, provides power to the transducer.

TRANSDUCER. Generates ultrahigh frequency sound waves.

Section II OPERATING INSTRUCTIONS

6-4. DESCRIPTION AND USE OF OPERATOR'S CONTROLS AND INDICATORS.

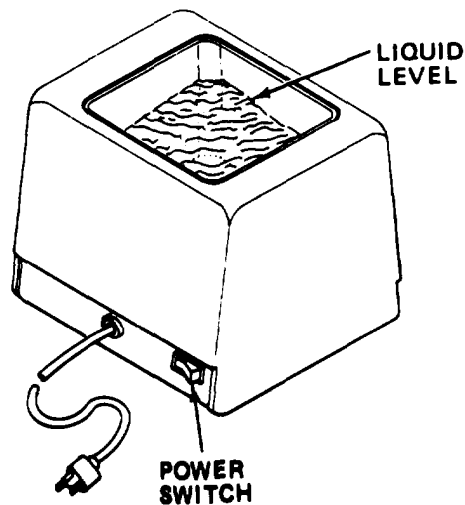

| Control or Indicator | Function |
|----------------------|-----------------------------------------------------------|
| Liquid Level | Level of liquid in stainless steel tank must be 1/3 full. |
| Power Switch | Turns power on or off. |

6-5. OPERATOR PREVENTIVE MAINTENANCE CHECKS AND SERVICES.

- a. Before You Operate. Always keep in mind the WARNINGS and CAUTIONS. Perform your before (B) PMCS.
- b. While You Operate. Always keep in mind the WARNINGS and CAUTIONS. Perform your during (D) PMCS.
- c. After You Operate. Be sure to perform your after (A) PMCS.
- d. If Your Equipment Fails to Operate. Troubleshoot with proper equipment. Report any deficiencies using the proper forms. See DA Pam 738-750.

6-5.1 PMCS Procedures.

- a. PMCS are designed to keep the equipment in good working condition by performing periodic-service tasks.
- b. Service intervals provide you, the operator, with time schedules that determine when to perform specified service tasks.
- c. The "Equipment is Not Ready/Available If" column is used for identification of conditions that make the equipment not ready/available for readiness reporting purposes or denies use of the equipment until corrective maintenance is performed.
- d. If your equipment fails to operate after PMCS is performed, immediately report this condition to your supervisor.
- e. Perform weekly as well as before operation if you are the assigned operator and have not operated the item since the last weekly or if you are operating the item for the first time.
- f. Item number column. Item numbers are assigned in chronological ascending sequence regardless of interval designation. These numbers are used for your "TM Number" Column on DA Form 2404, Equipment Inspection and Maintenance Worksheet in recording results of PMCS.
- g. Interval columns. This column determines the time period designated to perform your PMCS.
- h. Item to be inspected and procedures column. This column lists functional groups and their respective assemblies and subassemblies as shown in the Maintenance Allocation Chart (Appendix B). The appropriate check or service procedure follows the specific item to be inspected.
- i. Equipment is not ready/available if: column. This column indicates the reason or cause why your equipment is not ready/available to perform its primary mission.
- j. List of tools and materials required for PMCS is as follows:

| <u>Item</u> | <u>Quantity</u> |
|----------------------------------|-----------------|
| Cheesecloth (Item 5, Appendix E) | ar |

Table 6-1. OPERATOR PREVENTIVE MAINTENANCE CHECKS AND SERVICES

NOTE

If the equipment must be kept in continuous operation, check and service only those items that can safely be checked and serviced without disturbing operation. Make the complete checks and services when the equipment can be shut down.

B - Before
D - During
A - After

W - Weekly
M - Monthly
Q - Quarterly

AN - Annually
S - Semiannually
BI - Biennially

(Number) - Hundreds of Hours

| ITEM NO. | INTERVAL | ITEM TO BE INSPECTED PROCEDURE | For Readiness Reporting, Equipment is Not Ready/ Available if: |
|----------|----------|------------------------------------------------------------------------------------------------------------------------------------------------------------------------------------------------------------------------------------------------------------------------------------------------------------------------------------------------------------------------------------------------------------------------------------------------------------------------------------------------------------------------------------------------------------------------------------------------------------------------------------------------------------------------------------------------------------------------------|----------------------------------------------------------------|
| 1 | B | <p><u>ULTRASONIC CLEANER</u></p> <p><u>Inspect Cleaner.</u></p> <p style="text-align: center;">WARNING</p> <p>Death or serious injury may occur from electrical shock unless power cord is unplugged before servicing.</p> <div style="text-align: center;">  <p>The diagram shows a rectangular ultrasonic cleaner. An arrow points to the top surface, labeled 'ULTRASONIC CLEANER'. Another arrow points to the interior of the top surface, labeled 'TANK'. A third arrow points to the power cord at the bottom front, labeled 'POWER CORD'. The tank contains a liquid with wavy lines representing sound waves.</p> </div> | |

Table 6-1. OPERATOR PREVENTIVE MAINTENANCE CHECKS AND SERVICES - Cont

B - Before
D - During
A - After

W - Weekly
M - Monthly
Q - Quarterly

AN - Annually
S - Semiannually
BI - Biennially

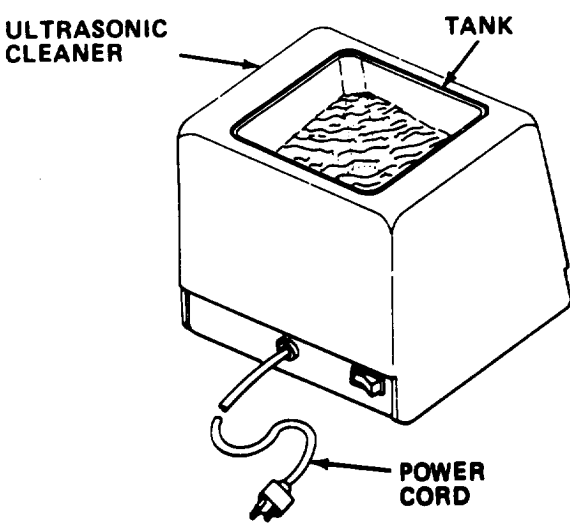
(Number) - Hundreds of Hours

| ITEM NO. | INTERVAL | ITEM TO BE INSPECTED PROCEDURE | For Readiness Reporting, Equipment is Not Ready/ Available If: |
|----------|----------|------------------------------------------------------------------------------------------------------------------------------------------------------------------------------------------------------------------------------------------------------------------------------------------------------------------------------------------------------------------------------------------------------------------|----------------------------------------------------------------------|
| 1 | B | <p><u>ULTRASONIC CLEANER - Cont</u></p> <p><u>Inspect Cleaner - Cont</u></p> <ol style="list-style-type: none"> 1. Check power cord for kinks, frays, or burns. If power cord is defective, notify organizational maintenance. 2. Check tank for dirt or chemical residue. Clean tank by wiping with cheesecloth moistened with water. 3. Check for agitation of water surface. | <p>Power cord is damaged.</p> <p>Water surface is not agitating.</p> |

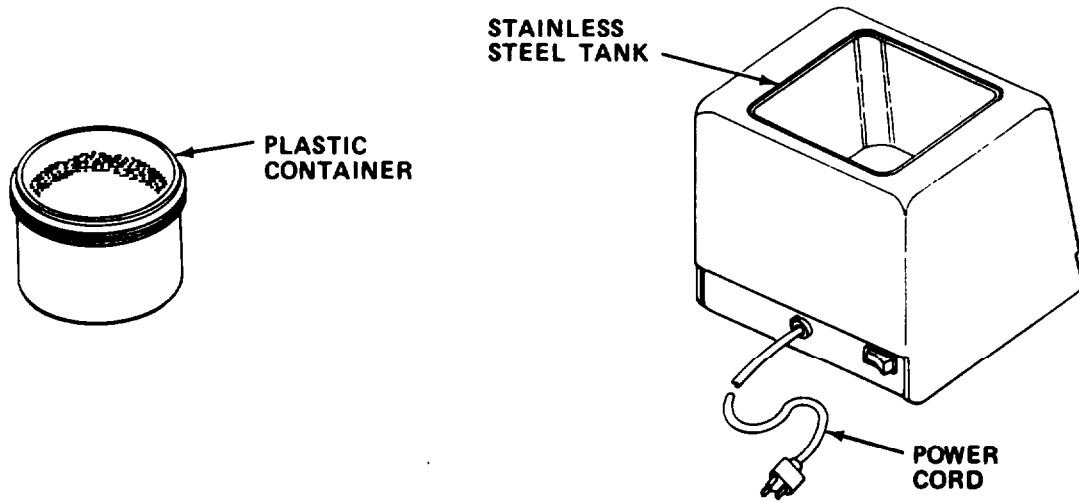
6-6. OPERATION UNDER USUAL CONDITIONS.6-6.1 Operating Procedure

- a. Fill stainless steel tank 1/3 full with fresh, clean water. Fill plastic container with water to within 1/2 in. (12.7 mm) of top.
- b. Add .135 oz (4 ml) of cleaning solution to plastic container.
- c. Plug in power cord to 120 V, 60 Hz grounded outlet.
- d. Turn power on. Be sure water surface in stainless steel tank is agitating.

WARNING

Do not place fingers in stainless steel tank when ultrasonic cleaner is operating. Cleaning solution may be driven through skin or ultrasonic waves may cause injury to body tissue.

- e. Prepare cleaning solution by operating ultrasonic cleaner for one minute before cleaning pen tips.

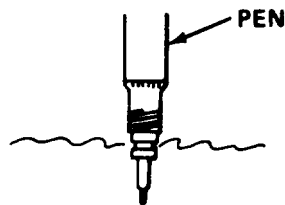

CAUTION

Do not immerse pen beyond cap threads. Damage to pen may result.

- f. Dip pen about 3/4 in. (19 mm) in cleaning solution.
- g. Lift pen from cleaning solution. Keeping point downward, shake solution from pen into cheesecloth (Item 5, Appendix E).
- h. Wipe pen.
- i. Draw pen over scrap paper until ink flows freely and shows uniform color.
- j. Turn power off. Unplug power cord.
- k. Dispose of cleaning solution when dirty.

CAUTION

Avoid getting water into body of ultrasonic cleaner. Damage to circuit board can result.

- l. Carefully rinse stainless steel tank.
- m. Wipe stainless steel tank dry with cheesecloth (Item 5, Appendix E).

6-7. OPERATION UNDER UNUSUAL CONDITIONS. This equipment is designed for operation only in a controlled environment.

Section III OPERATOR MAINTENANCE

6-8. LUBRICATION INSTRUCTIONS. This equipment does not require lubrication.

6-9. TROUBLESHOOTING PROCEDURES. There are no operator troubleshooting procedures assigned for this equipment.

6-10. MAINTENANCE PROCEDURES. Operator maintenance is limited to performance of regular preventive maintenance checks and services and replenishment of cleaning solution.

Section IV ORGANIZATIONAL MAINTENANCE

6-11. LUBRICATION INSTRUCTIONS. This equipment does not require lubrication.

6-12. REPAIR PARTS, SPECIAL TOOLS; TEST, MEASUREMENT, AND DIAGNOSTIC EQUIPMENT (TMDE) ; AND SUPPORT EQUIPMENT

6-12.1 Common Tools and Equipment. For authorized common tools and equipment, refer to the Modified Table of Organization and Equipment (MTOE) applicable to your unit.

6-12.2 Special Tools; Test, Measurement, and Diagnostic Equipment; and Support Equipment. Special Tools, TMDE, and Support Equipment is listed in the applicable repair parts and special tools list and in Appendix B of this manual.

6-12.3 Repair Parts. Repair parts are listed and illustrated in the Repair Parts and Special Tools List, TM 5-6675-318-24P covering organizational maintenance for this equipment.

6-13. SERVICE UPON RECEIPT.

6-13.1 Checking Unpacked Equipment.

a. Inspect the equipment for damage incurred during shipment. If equipment has been damaged, report the damage on DD Form 6, Packing Improvement Report.

b. Check the equipment against the packing list to see if the shipment is complete. Report all discrepancies in accordance with the instructions of DA Pam 738-750.

c. Check to see whether the equipment has been modified.

6-14. ORGANIZATIONAL PREVENTIVE MAINTENANCE CHECKS AND SERVICES. There are no organizational PMCS procedures assigned for this equipment.

6-15. ORGANIZATIONAL TROUBLESHOOTING PROCEDURES.

a. Organizational troubleshooting procedures cover the most common malfunctions that may be repaired at the organizational level. Repair or adjustment requiring specialized equipment is not authorized unless such equipment is available. Troubleshooting procedures used by the operator should be conducted in addition to the organizational troubleshooting procedures.

b. This manual cannot list all the possible malfunctions or every possible test/inspection and corrective action. If a malfunction is not listed or corrected by a listed corrective action, notify your supervisor.

c. For unidentified malfunctions, use the following schematic or the foldout located at the end of this manual for further fault analysis.

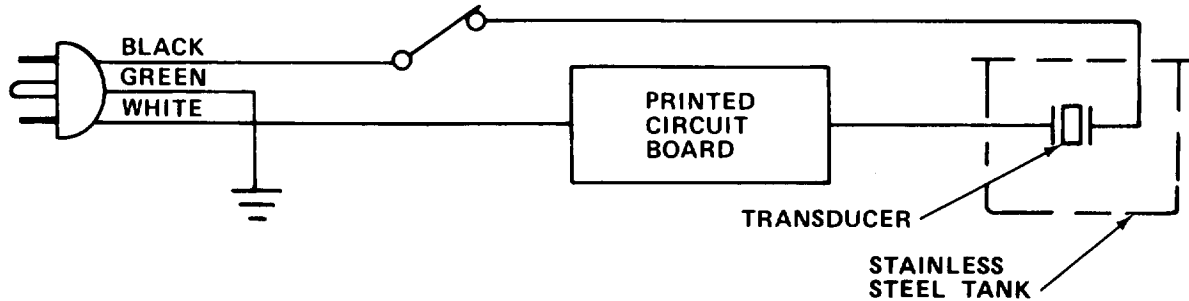

d. If the ultrasonic cleaner does not power up when turned on, verify that 120V ac is present at the receptacle. If voltage is not present, plug equipment into receptacle with power available and proceed with equipment troubleshooting. Perform no-power procedure for dead receptacle (Table 1-4).

Table 6-2. ORGANIZATIONAL TROUBLESHOOTING

| MALFUNCTION | TEST OR INSPECTION | CORRECTIVE ACTION |
|----------------------------------------|--------------------|-----------------------------------------------------------------------------------------------------------------------------------------------------------------------------------------------------------------------------------------------|
| 1. NO CLEANING ACTION, WATER AGITATES. | | <p>Check cleaning action using fresh cleaning solution.</p> <p>(a) If test was satisfactory, instruct operator to change cleaning solution when dirty.</p> <p>(b) If test was not satisfactory, replace circuit board (paragraph 6-16.3).</p> |
| 2. NO WATER AGITATION. | | <p>Step 1. Using multimeter, check for continuity of power cord.</p> <p>(a) If continuity exists, proceed to step 2.</p> <p>(b) If continuity does not exist, replace power cord (paragraph 6-16.1).</p> |

Table 6-2. ORGANIZATIONAL TROUBLESHOOTING - Cont

| |
|--------------------|
| MALFUNCTION |
| TEST OR INSPECTION |
| CORRECTIVE ACTION |

2. NO WATER AGITATION - Cont

Step 2. Check continuity of power switch.

(a) If continuity does not exist, replace power switch (paragraph 6-16.2).

(b) If continuity does exist, replace circuit board (paragraph 6-16.3).

6-16. MAINTENANCE PROCEDURES .

a. This section contains instructions covering organizational maintenance functions for the ultrasonic cleaner. Personnel required are listed only if the task requires more than one.

b. After completing each maintenance procedure, perform operational check to be sure that equipment is properly functioning.

INDEX

| PROCEDURE | PARAGRAPH |
|---------------------------------|-----------|
| Replace Power Cord | 6-16.1 |
| Replace Power Switch | 6-16.2 |
| Replace Circuit Board | 6-16.3 |

6-16.1 Replace Power Cord.

MOS: 41B, Topographic Instrument Repair Specialist

TOOLS: Flat Tip Screwdriver

SUPPLIES: Power Cord
Wire Clips

WARNING

Death or serious injury may occur if power cord is not unplugged before servicing.

- a. Turn power off. Unplug power cord.

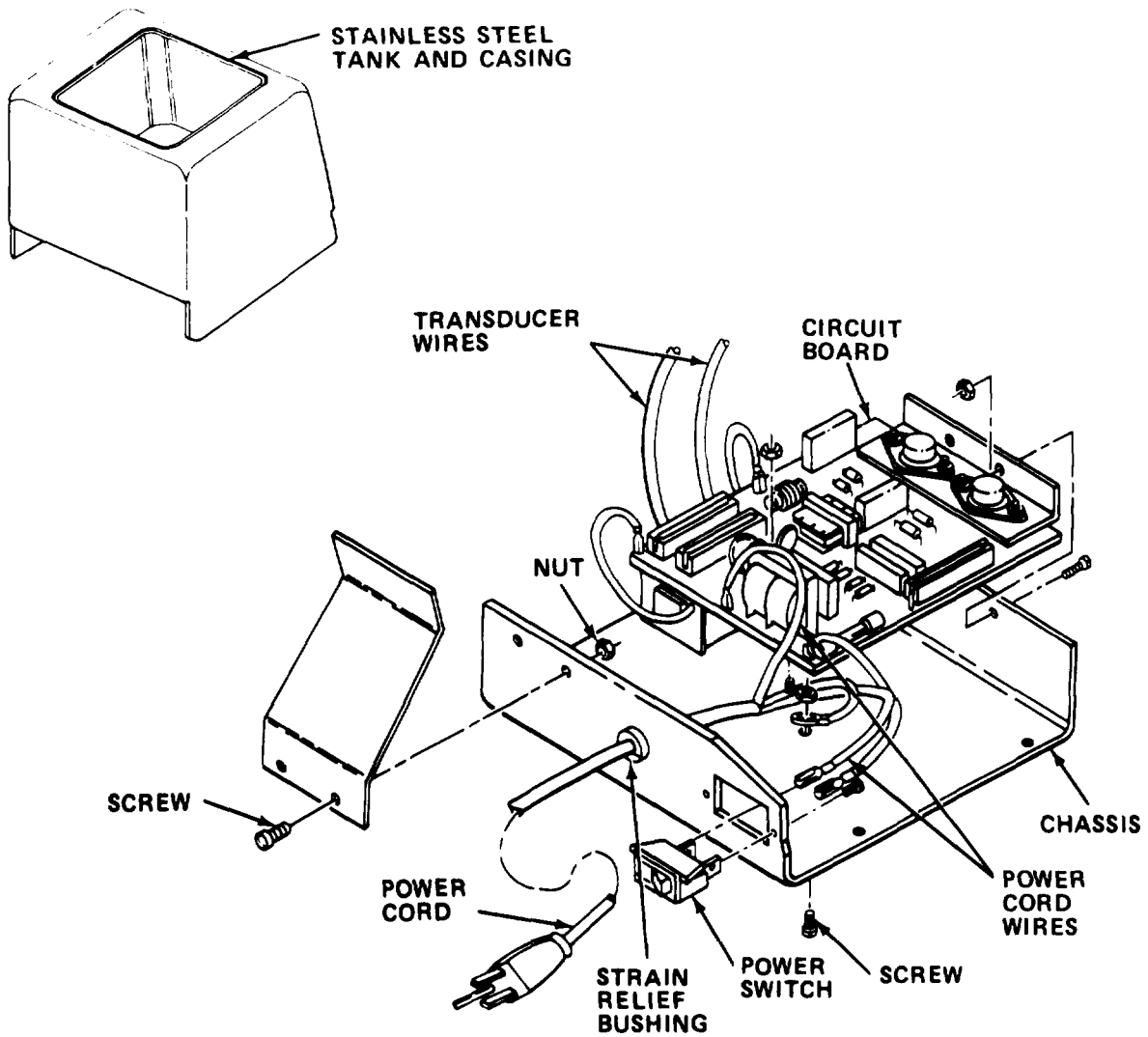

- b. Remove screws and washers holding stainless steel tank and casing to chassis.
- c. Lift stainless steel tank and casing free. Set aside.

NOTE

Do not disconnect wires to transducer.

- d. Remove three screws, one nut, and one washer holding circuit board to chassis.
- e. Disconnect power cord wire from power switch, chassis ground, and circuit board.
- f. Loosen strain relief bushing from chassis and remove defective power cord.
- g. Install strain relief bushing on new power cord. Insert terminal ends of cord into chassis.
- h. Fit strain relief bushing into chassis.
- i. Reconnect power cord wire to circuit board, chassis, and power switch.
- j. Reinstall circuit board into chassis and secure with one washer, one nut, and three screws.
- k. Reinstall stainless steel tank and casing. Secure with screws and washers.
- l. Fill stainless steel tank 1/3 full with water.
- m. Plug in power cord and turn power on. Check that water surface agitates.

6-16.2 Replace Power Switch.

MOS: 41B, Topographic Instrument Repair Specialist

TOOLS: Flat Tip Screwdriver

SUPPLIES: Switch

WARNING

Death or serious injury may occur from electrical shock unless power cord is unplugged before servicing.

- a. Turn power off and unplug power cord.

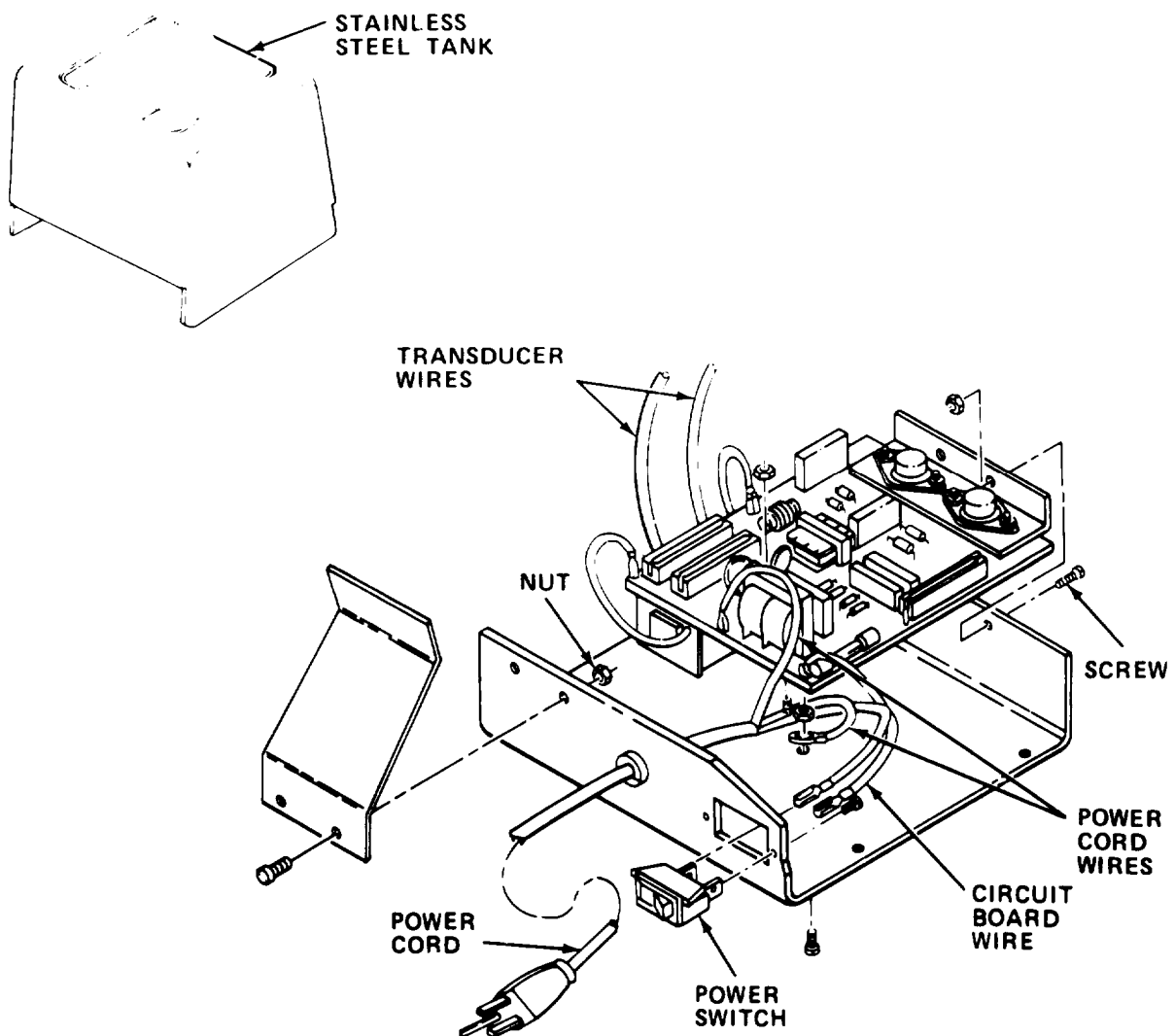

- b. Remove screws and washers holding stainless steel tank and casing to chassis.
- c. Lift stainless steel tank and casing free. Set aside.

NOTE

Do not disconnect wires to transducer.

- d. Tag and disconnect power cord wire and circuit board wire from power switch.
- e. Press sides of defective power switch and remove from chassis.
- f. Install new power switch in chassis. Push power switch until tabs lock into hole.
- g. Reconnect wires to power switch.
- h. Reinstall stainless steel tank and casing. Secure with screws and washers.
- i. Fill stainless steel tank 1/3 full with water.
- j. Plug in power cord and turn power on. Check that water surface agitates.

6-16.3 Replace Circuit Board.

MOS: 41B, Topographic Instrument Repair Specialist

TOOLS: Flat Tip Screwdriver

SUPPLIES: Circuit Board

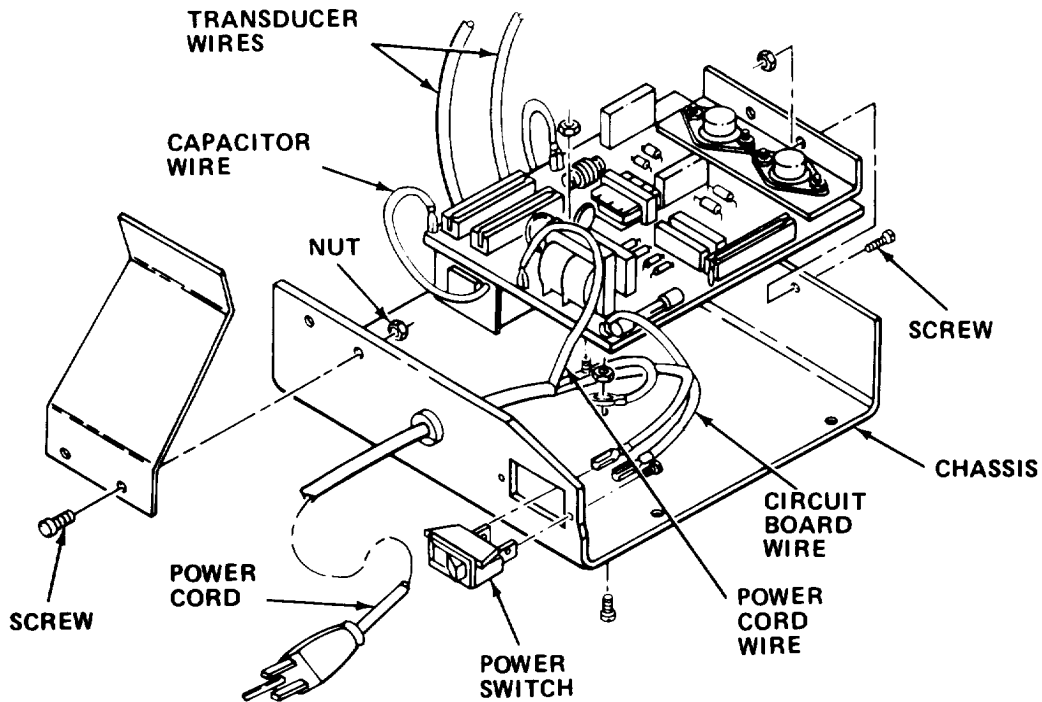

WARNING

Death or serious injury may occur from electrical shock unless power cord is unplugged before servicing.

- a. Turn power off and unplug power cord.
- b. Remove screws and washers holding stainless steel tank and casing to chassis.
- c. Lift stainless steel tank and casing free. Set aside.

NOTE

Do not disconnect wires to transducer.

- d. Remove three screws, one nut, and one washer holding circuit board to chassis.
- e. Tag and disconnect power cord wire and circuit board wire from circuit board.
- f. Disconnect capacitor wires from circuit board.
- g. Tag and disconnect two transducer wires from circuit board.
- h. Remove defective circuit board.
- i. Install new circuit board.
- j. Reconnect two transducer wires to circuit board.
- k. Reconnect capacitor wires to circuit board.
- l. Reconnect circuit board wire and power cord wire to circuit board.
- m. Reinstall one washer, one nut, and three screws holding circuit board to chassis.
- n. Reinstall stainless steel tank and casing. Secure with screws and washers.
- o. Fill stainless steel tank 1/3 full with water.
- p. Plug in power cord and turn power on. Check that water surface agitates.

6-17. PREPARATION FOR STORAGE OR SHIPMENT. Contact your battalion for packing and shipping instructions.

Section V DIRECT/GENERAL SUPPORT MAINTENANCE

There are no direct/general support maintenance procedures assigned for this equipment.

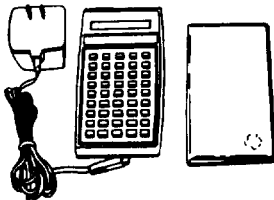
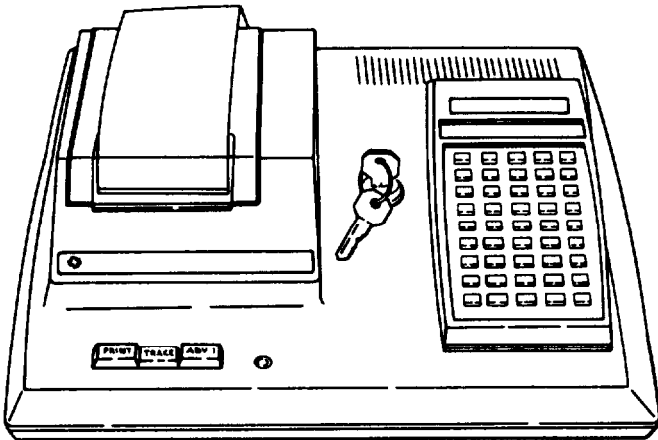

CHAPTER 7
PROGRAMMABLE CALCULATOR WITH PRINTER

Section I INTRODUCTION

7-1. GENERAL INFORMATION.

7-1.1 Scope.

a. Model Number and Equipment Name. Model TI-59 Programmable Calculator with PC-100C Print/Security Cradle.

b. Purpose of Equipment. Mathematical operations and programs, prints results, and/or records programs.

7-1.2 Glossary.

| | |
|-------------------------------|---------------------------------------------------------------------------------------------------------------------------------------------------------------------------------------------|
| Absolute Addressing | Transferring in program mode to designated, specific program location (step). Usually accomplished with go to instruction. |
| Algorithm. | Set procedure for solving a problem (usually mathematical) that can be used to solve all problems of same type. |
| AOS. | Algebraic operating system. Method of entering a calculation into calculator. Calculation is entered exactly as it is written. Calculator performs operation according to preset hierarchy. |
| Common Label | Undefined label (program marker) that is set using one of first or second functions (keys) on calculator keyboard. Pressing a common label from keyboard cannot start program execution. |

| | |
|---------------------------------|----------------------------------------------------------------------------------------------------------------------------------------------------------------------------------------------------------------------------------------------------------|
| Conditional Transfer | Tests some number produced in program against set value. Program execution is transferred to another step in program only if tested number fulfills conditions of test. If test is negative (fails), program ignores transfer and proceeds to next step. |
| Data Memory Registers | Portion of total memory registers used for storing data. |
| Display Register | Stores current value of calculator display internally to 13 digits, regardless of how it is rounded off for display purposes. All calculations performed use complete number. |
| Downloading | Dumping copy of protected or master library program into calculator's program memory. |
| Flag | Internal switch or indicator in calculator memory that can be on (raised) or off (lowered). Flag that is set is on. |
| Flow Diagram | Graphic block-type diagram used to describe different operations and calculations performed by program and flow (order of occurrence) of program execution. |
| Indirect Address | Produces transfer of memory address. When called, it points to address of memory register that contains desired data or instruction. |

| | |
|--------------------------|---------------------------------------------------------------------------------------------------------------------------------------------------------------------------------------------------------------------------------------------------------------------------------------------------------------------------------------------------|
| Key Code | Describes key as some number according to its location on keyboard, for purpose of identification in program. First digit denotes one of nine rows of keys (from top to bottom). Second digit denotes which of five columns (1 to 5, left to right) in which key is located. 2nd functions are generally designated by adding 5 to column number. |
| Label | Program marker used to split up and identify portions of program or to identify entire program. Some labels can be used to call up program or portion of program and start it running (i.e., pressing key for label starts program with that label). |
| Looping | Instructing calculator (in program mode) to perform same sequence of instructions over and over again, until instructed to stop. Looping instructions resets program pointer to earlier location. |
| Mantissa | Decimal part of logarithm or of number expressed as power of 10. |
| Merged | Program instructions that are combined and stored in one program (memory) location. |
| Merged Key Code. | Key codes are merged into single two-digit code. |
| Partitioning | Dividing memory registers of calculator into registers for storing data and registers for storing program instructions. |

| | |
|--------------------------------------|---------------------------------------------------------------------------------------------------------------------------------------------------------------------------------------------------------------------------------------------------------------------|
| Program | List of precise instructions arranged in specific order to be executed in specific way. |
| Program Instruction | Tells calculator how to do something. Usually designation for key or set of keys on keyboard. When calculator encounters key designation in running program, function of that key is performed. |
| Program Memory | Those registers in memory partitioned for storing program instructions. |
| Program pointer | Internal device used by calculator to determine which instruction it should perform next when executing program. Points at instruction currently being executed. |
| Software | Programs (written or pre-stored) and instructions on how to use them. |
| Subroutine. | Sequences of calculations or instructions that have unique purpose and are used repeatedly, arranged in mini-program that can be run alone or used as internal part of larger program. Normally labeled, and called up by pressing label or by a go to instruction. |
| Subroutine Return Register | Designates in the program mode where (at what step) subroutine transfer was called. When calculator finishes subroutine, it returns to step in program designated by this register and continues executing program from that point. |

| | |
|----------------------------------|---------------------------------------------------------------------------------------------------------------------------------------------|
| Transfer Instructions | Tell calculator to jump ahead or backward in program to a different step. Program execution continues at that step. |
| T-Register | Special data-type test register where numbers can be stored, recalled, and compared against displayed number. |
| Unconditional Transfer | Transfer instruction that is performed immediately (when encountered). |
| User-Defined Key | Keys that are used as labels. When pressed, they cause program pointer to relocate to that label and begin running program from that point. |
| Variables. | Those items in program or mathematical expression whose value can be anything, i.e., can vary. |

7-2. EQUIPMENT DESCRIPTION.

7-2.1 Equipment Characteristics, Capabilities, and Features.

- a. Reads and records magnetic cards.
- b. Up to 100 registers for storing data or 960 memory locations for storing program steps.
- c. Contains master library module with 25 prerecorded programs.
- d. Rechargeable battery pack.
- e. Uses algebraic operating system.
- f. Four types of display testing.
- g. Up to 10 user flags available.
- h. 72 useful labels, with 10 user-defined label keys.
- i. Six levels of subroutines available.
- j. Flexible addressing of program steps and data memories.
- k. Complete program editing.

- l. Up to nine sets of parentheses.
- m. Over 175 functions and operations.
- n. Printer provides operating power and simultaneously recharges battery pack.
- o. Printer uses thermal paper to provide permanent record of calculations, plots, programs, labels, displays, contents of data registers and messages.
- p. Printer is controlled by calculator or from printer keyboard.
- q. Printer locks calculator in place for security.

7-2.2 Location and Description of Major Components.

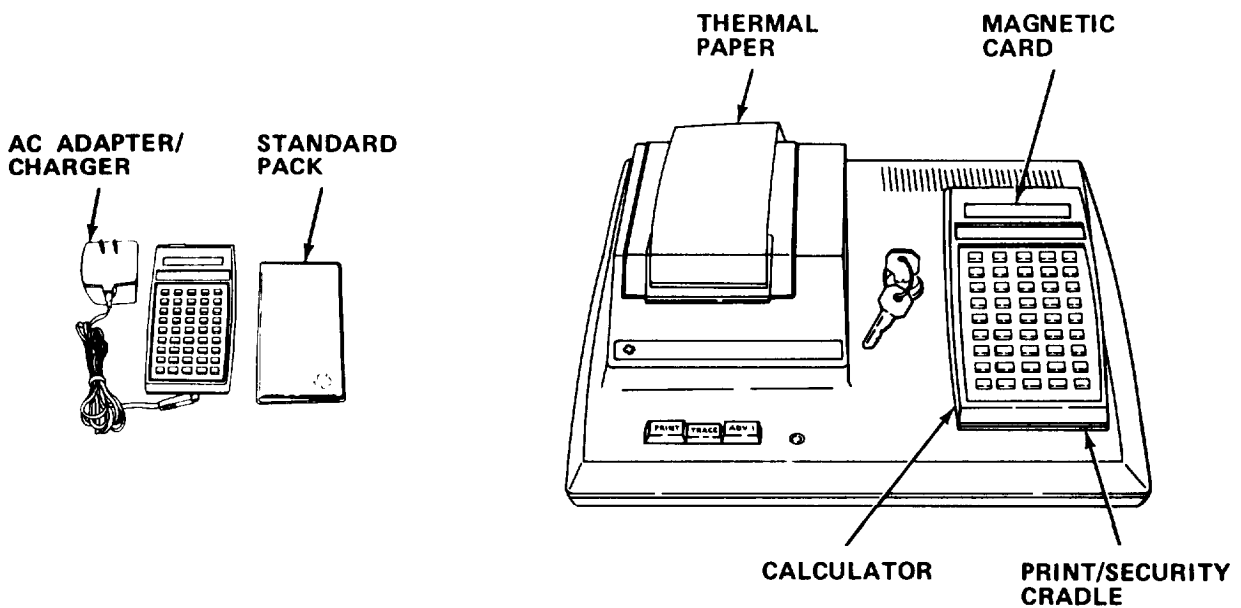

AC ADAPTER/CHARGER. Provides AC power input to calculator when print/security cradle is not used.

STANDARD PACK. Holds and protects magnetic cards.

THERMAL PAPER. Records printout.

MAGNETIC CARD. Used to read and/or record programs.

PRINT/SECURITY CRADLE. Performs printing for calculator. Locks calculator in place, and recharges battery.

CALCULATOR. Performs calculations and programming.

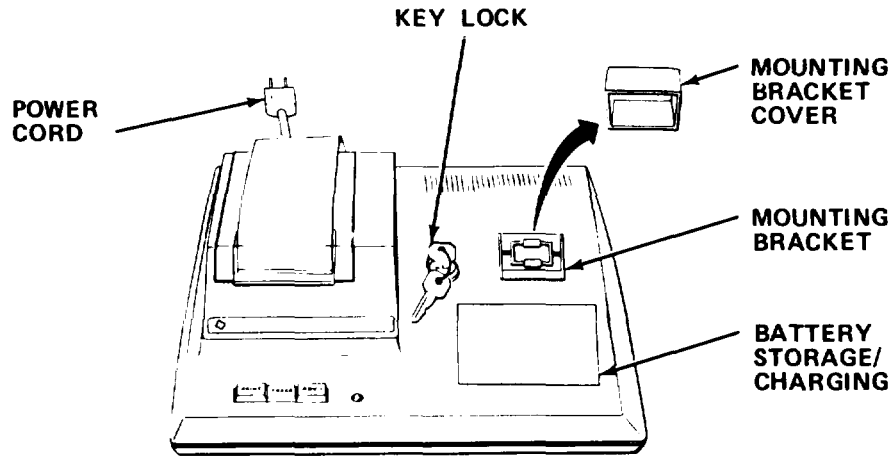

POWER CORD. Provides power input.

KEY LOCK. Locks calculator to mounting bracket.

MOUNTING BRACKET COVER. Covers and protects mounting bracket from dust when calculator is unmounted.

MOUNTING BRACKET. Mounts calculator, supplies power to calculator, and inputs signals to printer.

BATTERY STORAGE/CHARGING. Stores and charges battery pack when calculator is mounted. Also stores mounting bracket cover.

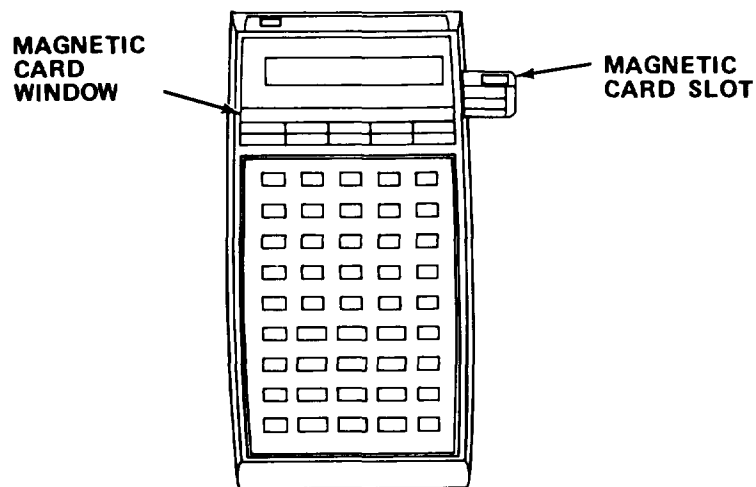

MAGNETIC CARD WINDOW. Provides a place to display card just inputted into calculator memory. Card is slid into window by operator

MAGNETIC CARD SLOT. Input for magnetic card.

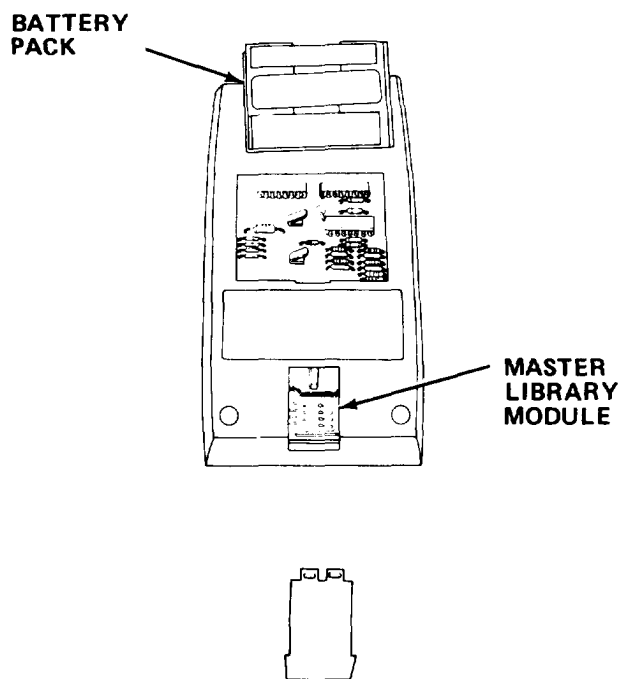

BATTERY PACK. Provides battery power.

MASTER LIBRARY MODULE. Mounted inside calculator. Hold prerecorded programs for internal access.

7-2.3 Equipment Data.

| | |
|------------------------|-----------------------------------------------|
| Manufacturer | Texas Instruments, Inc. |
| Calculator | |
| Power Requirements | 3.3 V ac |
| Battery Operating Time | 2-1/2 hrs per charge |
| Battery Charge Time | 4 hrs; calculator off 7 hrs; calculator on |
| Dimensions | |
| Width | 3.24 in. (8.23 cm) |
| Length | 6.43 in. (16.33 cm) |
| Height | 1.44 in. (3.66 cm) |
| Weight | 10.74 oz (304.5 grams) |

| | |
|------------------------------|-------------------------------|
| Maximum Program Length | 960 Steps (10 data registers) |
| Max Number of Data Registers | 100 (160 program steps) |
| Display Size | 12-character LED |

Printer

| | |
|--------------------|--------------------------|
| Power Requirements | 20 V, 60 Hz |
| Paper Type | Heat-sensitive, roll |
| Paper Size | 2-1/2 in. (6.35 cm) wide |
| Weight | 3.5 lbs (1.59 kg) |

7-3. TECHNICAL PRINCIPLES OF OPERATION.

7-3.1 TI-59 Calculator. Is a programmable calculator that can be used to perform calculations and operations manually or programmed to perform the same calculations and operations as part of a program.

The TI-59 uses an algebraic operating system (AOS). With the exception of implied multiplication using parentheses, such as $(2)(3) = 6$, calculations are entered exactly as they are written. The AOS sorts operations as they are entered and performs them in order according to an algebraic hierarchy. The hierarchy is as listed in Table 7-1. For any given equation, some operations are performed immediately, while others are held pending until hierarchy says they should be performed.

Table 7-1. AOS HIERARCHY

| Sequence Performed (Priority) | Operation | Example (Operation of Equation:) |
|-------------------------------|--------------------------------|-------------------------------------------------------|
| 1st | Single Variable Function Keys | $1/x$ |
| 2nd | Any Operations in Parentheses | $(1 + 2)$ of: $(1 + 2) \times 3 = 9$ |
| 3rd | Exponential (Powers and Roots) | 3^5 and $\sqrt[4]{3}$ of: $3^5 + 5 \sqrt[4]{3} = ?$ |
| 4th | Multiplications and Divisions | 2×3 of: $2 \times 3 + 1 + 5 = 12$ |
| 5th | Additions and Subtractions | $1 + 5$ of: $2 \times 3 + 1 + 5 = 12$ |

In two operations with same or lower priority level, the second operation will complete the first when it is entered.

Example: In the equation $3 + 10 \times 2 + 4^2 = 39$, the calculator squares 4 to get 16, then multiplies 10 by 2 to get 20, then adds 3 to 20 to get 23, and finally adds 23 to 16 to get 39. (Exponents - multiplication - addition.)

The TI-59 Calculator consists of six functional parts:

Battery Pack with Charger

Keyboard

Display

Internal Memory

Magnetic Card Memory

Master Library Module

a. Battery pack with charger. Battery pack is mounted inside calculator and provides main source of power. The charger is used to recharge pack and can be used to power calculator when batteries are low. When calculator is used in conjunction with print/security cradle, battery pack is removed to provide access to contact used by battery for cradle mounting bracket.

b. Keyboard. Used to input data, programs and instructions into calculator. Each key on keyboard performs a dual function, except 2nd key. pressing a single key will input whatever instruction, function or data is written on top of key into calculator. Press 2nd key before pressing another key, input instruction, function or data written above second key into calculator.

NOTE

In this chapter, all key identifications will be written in capitals. Instructions written on top of key will appear boxed.

EXAMPLE LRN; PGM

Any single entry from keyboard cannot contain more than 10 digits. Every digit after the tenth is ignored. Keyboard is also used to control operation of print/security cradle when it is connected.

c. Display. Presents numerical information to operator, representing last information or instruction input, or results of operations performed. Flashes on and off to indicate overflow, underflow or error conditions. The display is divided into two parts:

Display Window

Display Register

(1) Display window. Shows digits, decimal point and/or signs actually seen by operator. Standard format includes an integer, decimal, floating decimal point and floating minus sign.

-0.0000621

If a number calculated or input is too large to fit in standard format, calculator automatically reverts to a display in scientific notation, where number represented

-6.21000 -05

Equals: Mantissa x 10^{Exponent}.

The format of display window can be changed via keyboard to appear in engineering notation (exponent is always a multiple of 3) or with a fixed (unmovable) decimal point.

(2) Display register. Is an internal memory register that retains, to 13 digits, all numbers calculated, regardless of how number appears in display window. Large numbers can be rounded off for display in display window, but complete number is still retained in register.

d. Internal memory. Is composed of the following memory registers:

Subroutine return register

T-register

Program/Data storage registers

Reserved registers

AOS registers

Flag registers

(1) Subroutine return register. An automatic register used by calculator to store the last location of program pointer when an SBR (go to subroutine) instruction was implemented. If the subroutine has a return instruction, this register tells the calculator to return to the proper point for continuing program.

(2) T-register. Data-type test register for storing numbers, one at a time, that will be compared to the display at some point in a program or calculation. The location and use of T-register in the calculator cannot be changed.

(3) Program/Data Storage Registers. Used to store data and/or program memory locations. There are a total of 120 registers available to the operator. One register can contain one piece of data (a number) or eight program locations (key codes). The registers are divided into four banks, numbered 1 thru 4, with 30

registers in a bank. The registers are divided (partitioned) by the operator into two parts: program locations and data registers. Data registers are assigned ten registers at a time, and no more than 100 registers can be assigned. When the calculator is first turned on, it is partitioned into 60 data registers and 480 program locations (60 program registers). Each data register is identified by its address, a two-digit number. The addresses begin at the end of bank four and are numbered to the partition that corresponds to its location in memory.

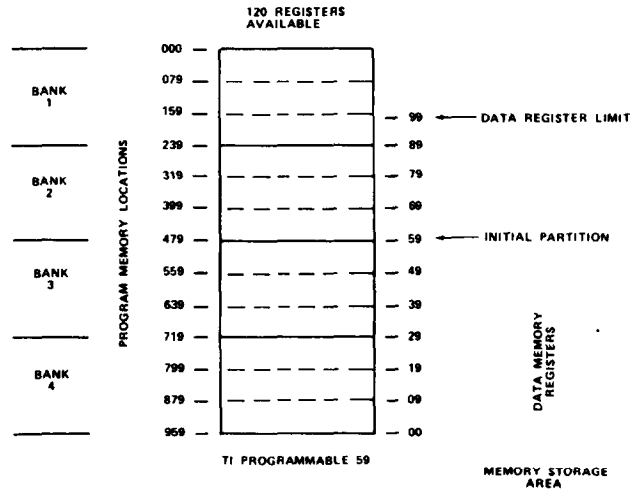

The flow of processing (execution) input, or a review of memory contents, in this portion of memory is controlled using a program pointer. When a program is being input or run, the program pointer points, i.e., tells the calculator, where in program/data registers processing is currently located. Figure below shows how the program pointer works when a program is run:

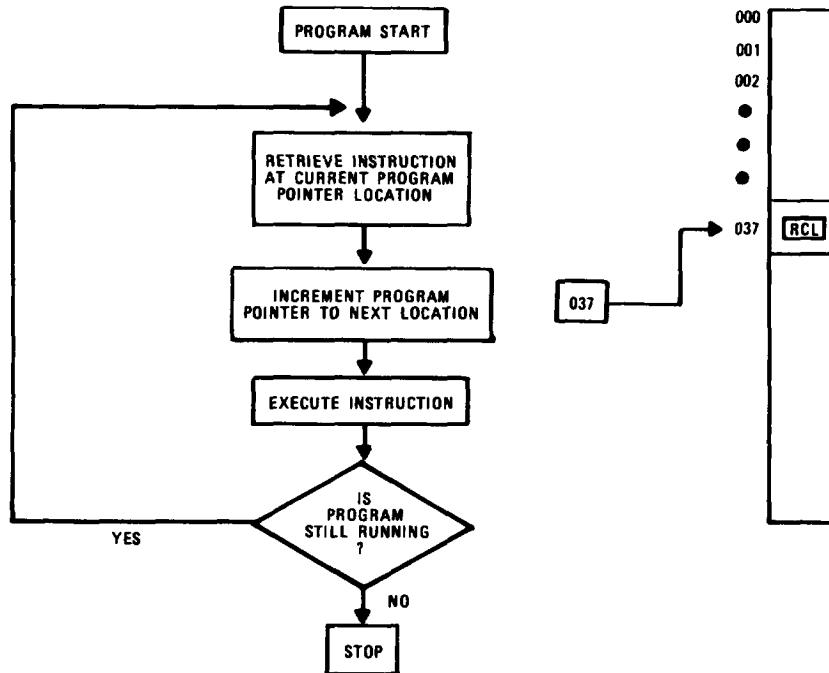

When running a program, instructions are executed in sequential order beginning at the current location of the program pointer. In the run mode, the program pointer points to each instruction as it is executed or, in the learn mode, as it is input or reviewed. In the learn mode, the display will show both where the program pointer is pointing and the instruction stored there.

Program instructions are stored in memory registers in a coded form called key code. Instructions are composed of a keystroke or set of keystrokes, called a key sequence. Each keystroke (function), except 2nd key, on keyboard has a unique key code assigned to it based on its location on the keyboard. The 2nd key code is merged with the key code for secondary function selected. Table 7-2 shows all possible key codes and the key function/stroke they represent.

7-2. KEY CODES IN NUMERICAL ORDER

| Key Code | Key Sequences | Key Code | Key Sequences | Key Code | Key Sequences |
|----------|---------------------------------|----------|---------------------|----------|-----------------------------------------|
| 00 | \square | 33 | \square^{x^2} | 60 | $\square \Rightarrow g$ |
| ↓ | ↓ | 34 | \square^x | 61* | $\square \Rightarrow 0$ |
| 09 | \square^9 | 35 | $\square^{1/x}$ | 62 | \square^{2nd} Pgm \square^{2nd} .nd |
| 10 | \square^{2nd} \square' | 36* | \square^{2nd} Pgm | 63 | \square^{2nd} Exc \square^{2nd} Ind |
| 11 | \square^A | 37 | \square^{2nd} P→R | 64 | \square^{2nd} Prd \square^{2nd} Ind |
| 12 | \square^B | 38 | \square^{2nd} sin | 65 | \square^x |
| 13 | \square^C | 39 | \square^{2nd} cos | 66 | \square^{2nd} Pause |
| 14 | \square^D | 40 | \square^{2nd} Ind | 67* | \square^{2nd} x=t |
| 15 | \square^E | 42* | \square^{STO} | 68 | \square^{2nd} Nop |
| 16 | \square^{2nd} A' | 43* | \square^{RCL} | 69* | \square^{2nd} Op |
| 17 | \square^{2nd} B' | 44* | \square^{SUM} | 70 | \square^{2nd} Rad |
| 18 | \square^{2nd} C' | 45 | \square^{j^x} | 71 | \square^{SBR} |
| 19 | \square^{2nd} D' | 47 | \square^{2nd} CMs | 72 | \square^{STO} \square^{2nd} Ind |
| 20 | \square^{2nd} CLR | 48* | \square^{2nd} Exc | 73 | \square^{RCL} \square^{2nd} Ind |
| 22 | \square^{INV} | 49* | \square^{2nd} Prd | 74 | \square^{SUM} \square^{2nd} Ind |
| 23 | \square^{inx} | 50 | \square^{2nd} x | 75 | \square (minus) |
| 24 | CE | 52 | \square^{EE} | 76* | \square^{2nd} Lbl |
| 25 | \square^{CLR} | 53 | \square^j | 77* | \square^{2nd} $\square^{x \geq t}$ |
| 27 | \square^{2nd} \square^{INV} | 54 | \square^L | 78 | \square^{2nd} Σ^+ |
| 28 | \square^{2nd} log | 55 | \square^{+} | 79 | \square^{2nd} x |
| 29 | \square^{2nd} CP | 57 | \square^{2nd} Eng | 80 | \square^{2nd} Grad |
| 30 | \square^{2nd} tan | 58 | \square^{2nd} Fix | 81 | \square^{RST} |
| 32 | $\square^{x \cong t}$ | 59 | \square^{2nd} Int | 83 | \square^{GTO} \square^{2nd} Ind |

Table 7-2. KEY CODES IN NUMERICAL ORDER - Cont

| Key Code | Key Sequences | Key Code | Key Sequences | Key Code | Key Sequences |
|----------|-------------------------------|----------|--------------------|----------|-----------------------|
| 84 | [2nd] Op [2nd] | 92 | [INV] [SBR] | None | [2nd] (merged) |
| 85 | [+] (plus) | 93 | [.] | None | [SST] |
| 86* | [2nd] St flg | 94 | [+/-] | None | [LRN] (merged) |
| 87* | [2nd] If flg | 95 | [=] (equal) | None | [2nd] Del |
| 88 | [2nd] DMs | 96 | [2nd] Write | None | [2nd] INS |
| 89 | [2nd] π | 97 | [2nd] Dsz | None | [BST] |
| 90 | [2nd] Lst | 98 | [2nd] Adv | | |
| 91 | [R/S] | 99 | [2nd] Prt | | |

* These instructions require an address on second instruction to be complete.

A single location in program/data memory can hold only a two-digit number. Most instructions occupy one location in program memory, with a single key code. The two-digit addresses needed to make instructions for data memory, program library access or special control operations complete are not stored with their instruction but occupy a second location in memory. Unconditional transfer addresses which have an address of three-digits are stored in three locations.

Example: For the instruction **[GTO] 123**, go to is stored in one location, 01 in a second and 23 in a third.

The calculator handles instructions that require more than one memory location automatically, advancing program pointer ahead according to number of locations required.

(4) Reserved registers. Registers 01 thru 06 are reserved by the calculator when working mean standard deviation calculations. They are available for normal use for any other operations.

(5) AOS registers. Set of internal registers used by calculator to store numbers and operations so that calculations are processed in proper order. A copy of results and intermediate instructions are sent to display, as well as latest numerical entry input. These internal registers cannot be used by operator.

(6) Flag registers. Used to store flag settings (set flag on or off). There are 10 flags available to the operator numbered 0 thru 9. Three flags have established special functions as follows:

Table 7-3. SPECIAL FUNCTIONS OF FLAGS

| Flag | Function |
|--------|-----------------------------------------------------------------------------------------------|
| Flag 7 | Used to indicate error conditions. |
| Flag 8 | When set, causes calculator to stop program if error occurs while program is running. |
| Flag 9 | Used to control trace mode of print/security cradle. If set, printer is placed in trace mode. |

Flags are set or unset in a program so they can be used for testing and conditional transfers. Once a flag is set or reset, repeating the set instruction, repeating a reset instruction or testing status of a flag will not affect status of flag or calculations. Unlike T-register or other registers, flag status cannot be seen on the display except by testing it.

e. Magnetic card memory. Stores or records programs and data not contained in master library module. It consists of:

Magnetic Card Reader

Magnetic Cards

(1) Magnetic card reader. Transfers data and programs to and from calculator's internal memory registers and magnetic cards. Programs stored in calculator's memory are written onto a card magnetically and can be similarly read from a card and dumped into the calculator's memory ready to run. Also, unless protected magnetic cards can be erased (i.e., made blank) by recording a card when calculator's internal memory is empty or re-recorded with a different program. The magnetic card reader reads or writes cards one side and one bank at a time.

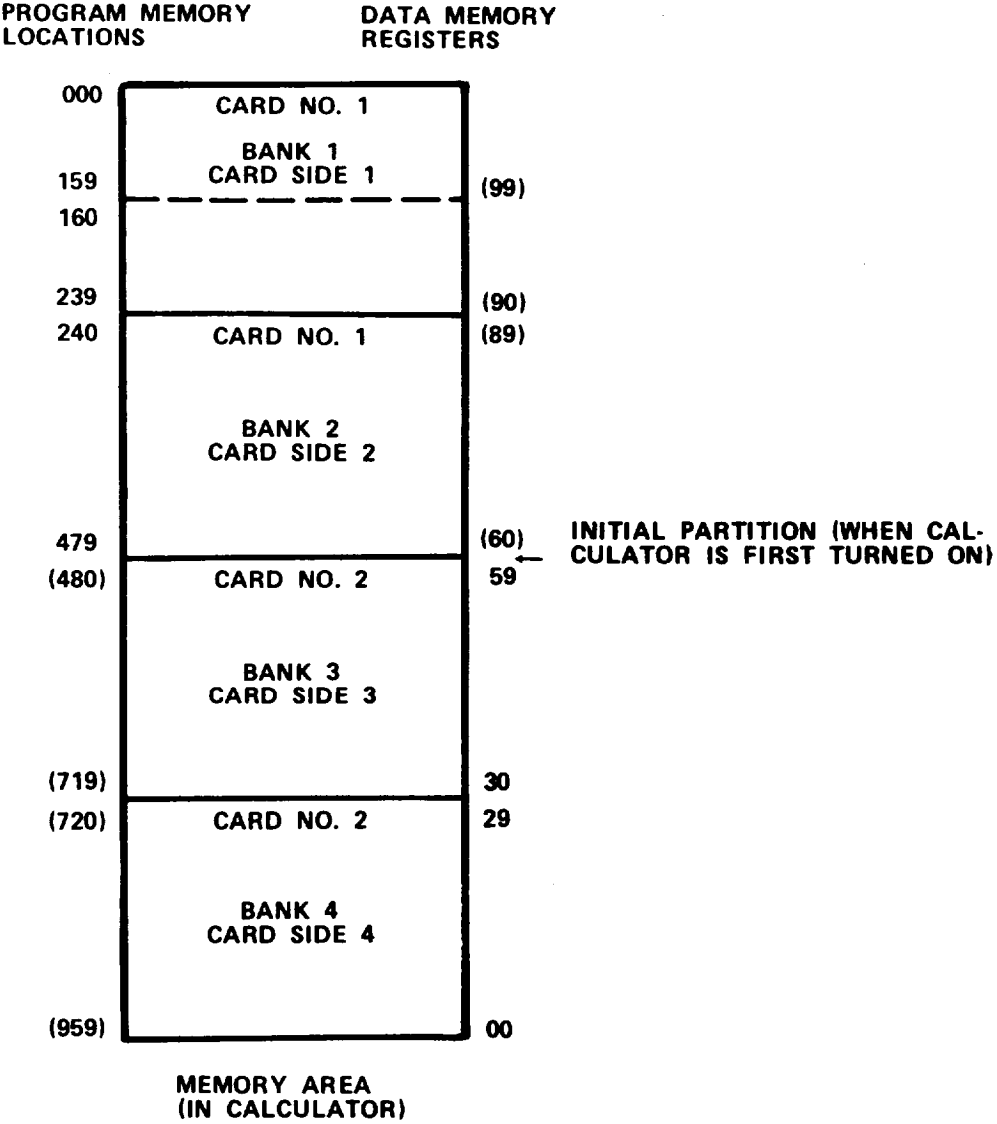

(2) Magnetic cards. Store programs and/or data. One magnetic card can store the contents of 60 program/data registers, 30 per side. A set of 30 registers is designated as a bank. When one side of a card is recorded, the bank is recorded with an identifying number of ± 1, 2, 3 or 4. This bank number corresponds to the bank number in the calculator's internal memory. Information is recorded on a card along the length of edge on both sides. When register bank is recorded, current partitioning of calculator memory is also recorded.

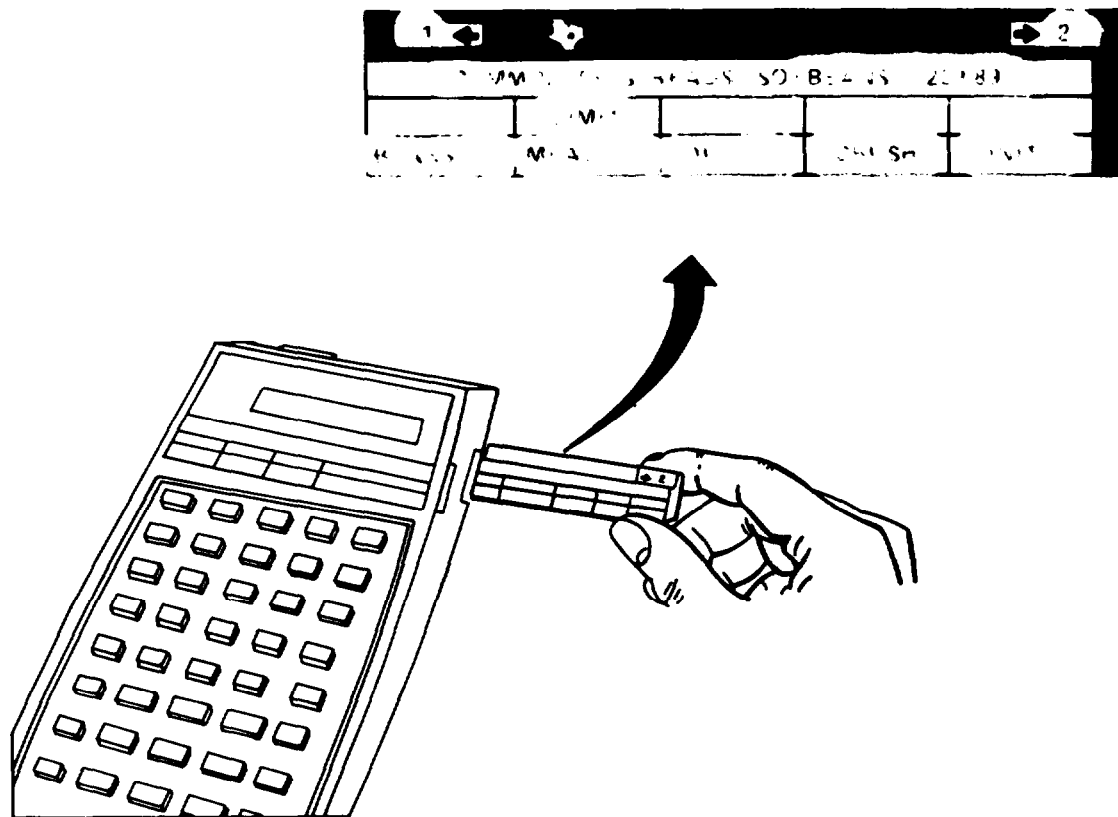

In upper corners of each card, spaces are provided to write bank numbers recorded on that card. An arrow in each space shows which direction card was entered into the calculator when recording. The space across the center of the card is used for program titles and other pertinent information, such as required partition. Along the bottom of the card, two rows of boxes used to indicate function, within the recorded program, of user-defined labels **A** thru **G** and **A'** thru **E'**.

Paragraph 7-3.1e describes how data memory and program memory for a full program is arranged in calculator memory and on magnetic cards when recording. If data is being recorded, data register 00 begins at the end of bank 4 and proceeds toward bank 1 or the partition. If programs are being recorded, the program location/step begins in bank 1 and proceeds to the end of bank 4 or to where partition between data and program is set.

Tables 7-4 and 7-5 detail how normal and protected programs are recorded and read and the display expected each time.

Table 7-4. RECORDING MAGNETIC CARDS

NOTE

Program or data is assumed to be present in calculator memory.

| Display (After Pressing Bank #, 2nd, Write) | Card Reader Operation For Normal Program | Card Reader Operation For Protected Program |
|---------------------------------------------|--------------------------------------------------------------------------------------------------------------------------------------|------------------------------------------------------------------------------------------------------------------------------------------------------------------------------------|
| 1,2,3 or 4 | Writes bank of this number (containing program and/or data) and bank number to this side of card. Records current partition on card. | If bank contains only program, card passes without being written. Displayed number flashes. If bank contains some data and program, bank is recorded but not protected. |
| -1, -2, -3 or -4 | Writes and protects bank with this number and bank number onto card side. Records current partition on card. | If bank contains only program, card is passed without writing. Displayed number flashes. If bank contains some data, bank is recorded and protected with minus sign number. |
| Any Other Number | Card is passed without recording. Rightmost two integers in display flash. | Same as normal program. |

Table 7-5. READING MAGNETIC CARDS

| Display When Card Entered | Card with Normal Program | Card with Protected Program |
|---------------------------|-------------------------------------------------------------------------------------------------------------------------------------------------------------------------------------------------------------------------------------|------------------------------------------------------------------------------------------------------------------------------------------------------------------------------------------------------------------------------------------------------|
| 0 | <p>Reads information into bank, according to number listed on card, if current partition matches that on card.</p> <p>If partition is incorrect, card is passed, but not read. Display flashes number of card side that passed.</p> | Same as for normal program. |
| 1,2,3 or 4 | <p>Expects card with this side number to be read. Displays that side number.</p> <p>If another side is entered or if partition is incorrect, card is passed but not read. Display flashes card side number that passed.</p> | <p>If side passed numerically matches display, card is read and side number is displayed as negative.</p> <p>If another side is entered or if partition is incorrect, card is passed but not read. Display flashes card side number that passed.</p> |
| -1, -2, -3 or -4 | <p>Forces side read into bank with this number regardless of card number or partition.</p> <p>Protected program cannot be forced into any bank.</p> | <p>Reader expects card with this side number to be read. Display that side number.</p> <p>If another side is entered or if partition is incorrect, card is passed but not read. Display flashes card side number that passed.</p> |
| Any Other Number | <p>Card is passed but not read. Rightmost two integers in display flash.</p> | Same as for normal program. |

f. Master library module. Contains a library of ready-to-run programs. The programs can be run alone or as a subroutine. Current mater library module can be replaced with a different module containing different programs. A copy of any master library program can be downloaded onto calculator program/data registers, beginning with location 000, unless program is proprietary and protected. When master library programs are used, the program operates from inside the master library module and does not affect memory. The original programs in the master library module cannot be altered. Downloaded master library programs will write over any instructions currently stored in that portion of program memory, so a program in program memory (running) cannot download a master library program. During normal use, when a master library program is called as a subroutine, the calculator actually enters the master library module to perform the task and then returns to the master program. Downloaded master library programs can be altered, but the altered version cannot be returned to the master library module. It must be recorded on magnetic card.

7-3.2 PC-100C Print/Security Cradle. Provides printouts of TI-59 display, programs, contents of data registers, results of a running program, a trace of calculation steps, program labels, plots and alphanumeric messages. Locks TI-59 in place on cradle for security. The print/security cradle consists of the following:

- Printer
- Mounting Bracket
- Storage Compartment
- Keys

a. Printer. Prints desired information on a roll of heat-sensitive paper via a heated prin head. Printer is controlled by keys on print/security cradle or calculator. Each printed line can have a maximum of 20 characters. Each line is divided into four sets of five characters, with each set identified by a different operation (OP) code. Character positions are numbered from 0 to 19, left to right.

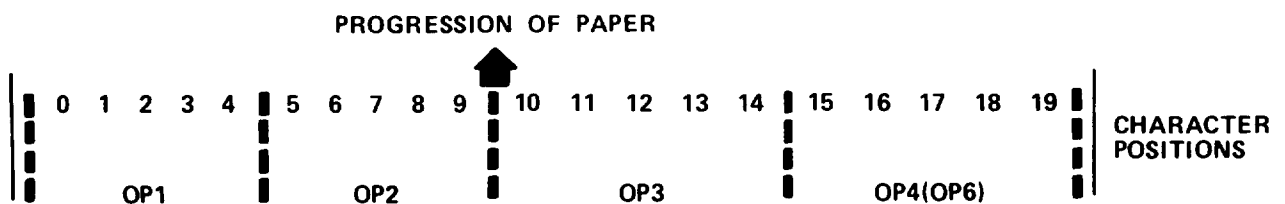

The calculator has eight (00 thru 08) special control operations (OP) used for the printer. These tell the printer to perform one of five possible types of printing:

- Alphanumeric Printing
- Plotting
- Listing
- Tracing
- Selective Printing

When printing a list or trace, the printer uses audit symbols to identify key sequences. Refer to Table 7-6 for a complete listing of audit trail symbols used by the printer.

Table 7-6. AUDIT TRAIL SYMBOLS

| Printer Listing | Key Sequence | Symbols | Printer Listing | Key Sequence |
|-----------------|-------------------------------------|---------|-----------------|------------------------------------------------------|
| A - E | \boxed{A} \boxed{E} | | IFF | $\boxed{2nd}$ If flg* |
| A - E' | $\boxed{2nd}$ A' - $\boxed{2nd}$ E' | | IFIX | \boxed{INV} $\boxed{2nd}$ Fix** |
| ADV | $\boxed{2nd}$ Adv | | IIFF | \boxed{INV} $\boxed{2nd}$ If flg*** |
| BST | See Note | | IINT | \boxed{INV} $\boxed{2nd}$ Int** |
| CE | \boxed{CE} | | ILNX | \boxed{INV} lnx** |
| CLR | \boxed{CLR} | | ILOG | \boxed{INV} $\boxed{2nd}$ log** |
| CP | $\boxed{2nd}$ CP | | IND | $\boxed{2nd}$ Ind |
| CMS | $\boxed{2nd}$ CMs | | INS | See Note |
| COS | $\boxed{2nd}$ Cos | | INT | $\boxed{2nd}$ Int |
| DEG | $\boxed{2nd}$ Deg | | INV | \boxed{INV} |
| DMS | $\boxed{2nd}$ D.Ms | | IPD | ** \boxed{INV} $\boxed{2nd}$ Prd $\boxed{2nd}$ Ind |
| DSZ | $\boxed{2nd}$ Dsz | | IP/R | \boxed{INV} $\boxed{2nd}$ P→R** |
| EE | \boxed{EE} | | IPRD | \boxed{INV} $\boxed{2nd}$ Prd** |
| ENG | $\boxed{2nd}$ Eng | | ISBR | \boxed{INV} SBR** |
| EQ | $\boxed{2nd}$ = | | ISIN | \boxed{INV} $\boxed{2nd}$ sin** |

Table 7-6. AUDIT TRAIL SYMBOLS - Cont

| Printer Listing | Key Sequence | Symbols | Printer Listing | Key Sequence |
|-----------------|----------------------|---------|------------------|-------------------------|
| EX | [2nd] Exr [2nd] Ind | | ISTF | [INV] [2nd] \$t flg** |
| EXC | [2nd] Exc | | ISUM | [INV] UM** |
| FIX | [2nd] Fix | | ITAN | [INV] [2nd] an** |
| GE | [2nd] ≥t | | I x | [INV] [2nd] x** |
| GO | [GTO] [2nd] Ind | | X | [2nd] x |
| GRD | [2nd] Grad | | I Y ^x | [INV] y ^x ** |
| GTO | [GTO] | | LBL | [2nd] b |
| IEQ | [INV] [2nd] x=t*** | | LNx | [Inv] |
| IGE | [INV] [2nd] x ≥ t*** | | LOG | [2nd] log |
| IΣ + | [INV] [2nd] Σ+ | | LRN | See Note |
| ICOS | [INV] [2nd] cos | | LST | [2nd] Lst |
| IDMS | [INV] [2nd] D.Ms** | | NOP | [2nd] Nop |
| IDSZ | [INV] [2nd] Dsz** | | | |
| OP | [2nd] Op | + | SIN | [2nd] sin |
| OP | [2nd] Op [2nd] Ind | | SM | [SUM] [2nd] Ind |
| PAU | [2nd] Pause | | SST | See Note |
| PD | [2nd] Prd [2nd] Ind | Σ+ | ST | [STO] [2nd] Ind |
| PG | [2nd] Pgm [2nd] Ind | π | STF | [2nd] St flg |
| PGM | [2nd] Pgm |) | STO | [STO] |
| P/R | [2nd] P → R | (| SUM | [SUM] |
| PRD | [2nd] Prd | - | TAN | [2nd] tan |
| PRT | [2nd] Prt | + | WRT | [2nd] Write |
| RAD | [2nd] Rad | x | X ≅ T | [x ≅ t] |

Table 7-6. AUDIT TRAIL SYMBOLS - Cont

| Printer Listing | Key Sequence | Symbols | Printer Listing | Key Sequence |
|-----------------|----------------------------------|---------|-----------------|----------------------|
| RC | RCL 2nd Ind | ÷ | x^2 | x² |
| RCL | RCL | = | x | 2nd \bar{x} |
| R/S | R/S | . | X | 2nd x |
| RST | RST | +/- | 1/x | 1/x |
| RTN | INV SBR | | x | \sqrt{x} |
| SBR | SBR | | y^x | y^x |

NOTE

*TI Programmable 58C only: The symbol " " prints during trace when branch is taken.

**Printed in TRACE mode only.

***This instruction is only seen when its key is encountered while listing a program. Because the key code cannot be placed in program memory by pressing the key, the key code can only be a remnant from edit of some other instruction and should be corrected.

(1) Alphanumeric Printing. Accomplished by placing a two-digit-row column address code representing each character to be printed, in the order it will appear on a line, into the print register. The entire message is printed by the print register containing all the codes. The code for a particular character is taken from the illustration below.

| | | UNITS DIGIT | | | | | | | |
|------------|---|---------------------------|---|---|---|---|---|---|-----------|
| | | 0 | 1 | 2 | 3 | 4 | 5 | 6 | 7 |
| TENS DIGIT | 0 | blank | 0 | 1 | 2 | 3 | 4 | 5 | 6 |
| | 1 | 7 | 8 | 9 | A | B | C | D | E |
| | 2 | . | F | G | H | I | J | K | L |
| | 3 | M | N | O | P | Q | R | S | T |
| | 4 | . | U | V | W | X | Y | Z | + |
| | 5 | X | ≠ | √ | π | θ | (|) | , |
| | 6 | ↑ | % | ∴ | / | = | ≠ | ∕ | \bar{x} |
| | 7 | $\frac{\square}{\square}$ | ? | ÷ | Φ | ∏ | ∴ | ∏ | Σ |

Spaces are printed by inputting zeros.

(2) Plotting. Can only be performed by running the applicable program. When printing a data plot, data points are printed along the length of the paper (vertically) using an asterisk (*) for each point. Points are placed in one of the character positions from 0 to 19, with 0 being the first position on the left.

| KEY SEQUENCE | RESULT |
|----------------|-----------------------------------|
| 2nd LBL | 0 1 3 5 7 9 11 13 15 17 19 VALUES |
| A | |
| RCL | * |
| 1 | * |
| 2nd SIN | * |
| ÷ | * |
| 1 | * |
| = | * |
| X | * |
| 9 | * |
| • | * |
| 9 | * |
| = | * |
| 2nd OP | * |
| 0 7 | * |
| 1 | * |
| 8 | * |
| SUM | * |
| 1 | * |
| A | * |

Only one asterisk/point is printed per position per line. Any fractional part of a number cannot be plotted by the printer, and the integer portion of any value to be printed must be less than 20 (or the program will halt and display flashes). Data plotting is initiated by Op 07.

| Program Location | Key Code | Key Symbol |
|------------------|----------|------------|
| 000 | 85 | + |
| 001 | 04 | 4 |
| 002 | 95 | = |
| 003 | 99 | PRT |
| 004 | 98 | ADV |
| 005 | 81 | RST |
| 006 | 00 | 0 |
| 007 | 00 | 0 |

(3) Listing. The printer can list a program, the contents of data registers or program labels being used. All three lists are printed sequentially. A program listing has three columns that identify program location, key code and key symbol for each step of a program.

| Register Contents | Register Number |
|-------------------|-----------------|
| 14.18181818 | 50 |
| 665.8568182 | 51 |
| 110.9761364 | 52 |
| 0. | 53 |
| 0. | 54 |
| -5.5488068-12 | 55 |
| 0. | 56 |
| 0. | 57 |
| 1. | 58 |
| 0.085106383 | 59 |

Data register listing has two columns showing register contents and corresponding register number. Data register listing continues, once initiated, until contents of highest number register (partitioned) is listed or **R/S**(run/stop) is pressed from keyboard.

PROGRAM LABEL LISTING

| Program Location | Key Code | Audit Symbols |
|-----------------------------|---------------------|--------------------------|
| 001 | 11 | A |
| 018 | 12 | B |
| 062 | 19 | D' |
| 129 | 13 | C |
| 205 | 88 | DMS |
| 239 | 70 | RAD |
| 273 | 80 | GRD |
| 282 | 14 | D |
| 288 | 15 | E |
| 294 | 16 | A' |
| 300 | 10 | E' |
| 306 | 28 | LOG |

Program label lists have three columns that identify program location of each label in program memory, key code and audit symbol for each. The listing will run from the current position of the program pointer on.

TRACING

| Display Register | Audit Symbols |
|-----------------------------|--------------------------|
| 0. | + |
| 4. | = |
| 4. | |
| 4. | PRT |
| | |
| | RST |
| 4. | + |
| 4. | = |
| 8. | |
| 8. | PRT |
| | |
| | RST |
| 8. | + |
| 4. | = |
| 12. | |
| 12. | PRT |
| | |
| | RST |
| 12. | + |
| 4. | = |
| 16. | |
| 16. | PRT |

(4) Tracing. Causes the printer to print every step of a calculation, whether or not it is a keyboard or program calculation. Two columns in the printout identify the calculated value and instruction that created it. In the TRACE mode, every new function or result is printed and the printer automatically advances. A number entry is only printed if followed immediately by a function or operation. Error conditions result in a question mark being printed on far right column.

SELECTIVE PRINTING CALCULATION RESULTS

| Results | |
|---------|------|
| 4. | 56. |
| 8. | 60. |
| 12. | 64. |
| 16. | 68. |
| 20. | 72. |
| 24. | 76. |
| 28. | 80. |
| 32. | 84. |
| 36. | 88. |
| 40. | 92. |
| 44. | 96. |
| 48. | 100. |
| 52. | |

(5) Selective Printing. Is controlled from calculator keyboard or print/security cradle keys. Whatever value that is in calculator display is printed. If an error condition exists when print instructions are received, the display is printed with a question mark to the right of value.

b. Mounting Bracket. Performs two functions: It holds and locks the calculator in place on the print/security cradle, and it has electrical contacts that enable signals and power to travel to and from the calculator.

The mounting bracket fits into space normally occupied by the calculator battery pack, so that the calculator housing rests on the print/security cradle. Contacts in the mounting bracket press against contacts within calculator to provide electrical connection between the calculator and printer. When the key lock is locked, tabs in the mounting bracket expand into the interior of the calculator housing to prevent its removal or movement.

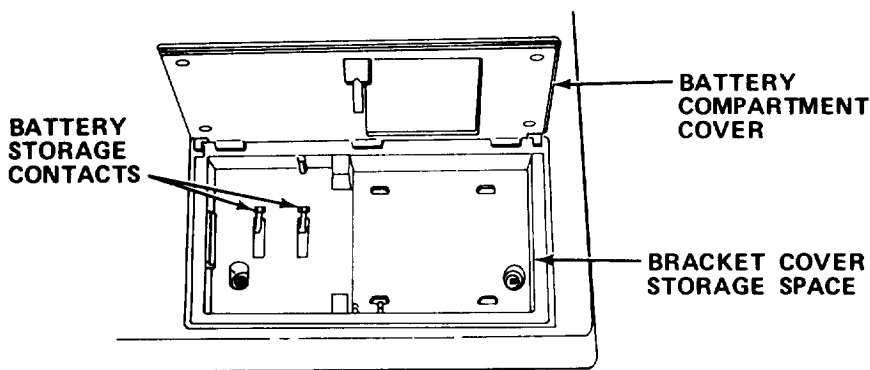

c. Storage Compartment. Stores calculator battery pack and cover for the mounting bracket. When the battery pack is stored in the storage compartment, a pair of contacts press against battery contacts and enable the battery pack to be recharged by the print/security cradle. The storage compartment cover is held in place by the calculator.

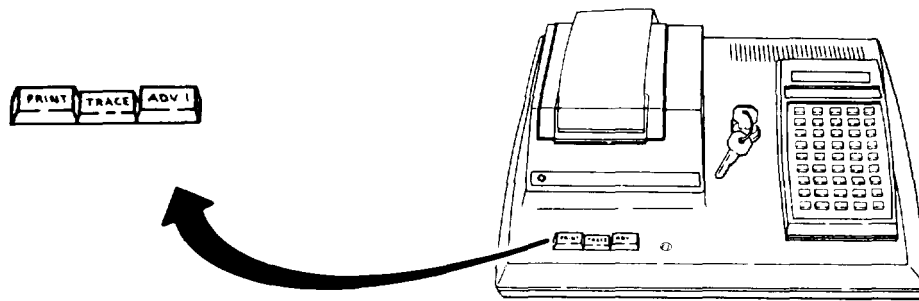

d. Keys. Provide direct control of printer operation. Except for the TRACE key, print/security cradle keys cannot affect printer operation while it is being controlled by a running program on the calculator. The TRACE key is a self-latching key that causes the print/security cradle to monitor all calculator operations and print results of all calculations as they occur.

Section II. OPERATING INSTRUCTIONS

7-4. DESCRIPTION AND USE OF OPERATOR'S CONTROLS AND INDICATORS.

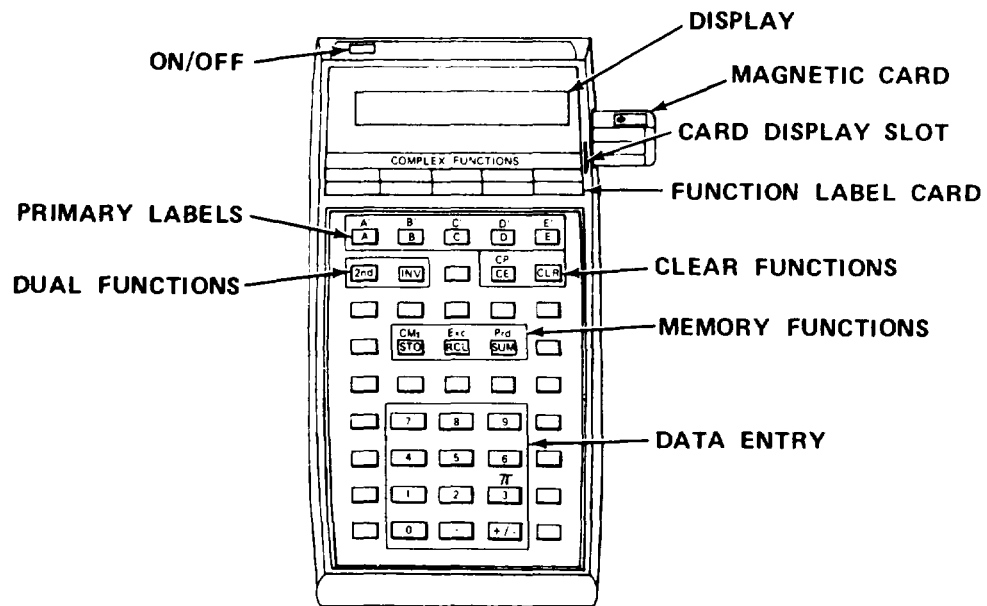

Key



Control or Indicator

Function

On/Off Switch

Controls power to calculator.

| Key | Control or Indicator | Function |
|-------------------------------|----------------------|----------------------------------------------------------------------------------------------------------------------------------------------------------------------------------------------------------------------------------------------------------------------------------------------------------|
| | Display | Displays data and error codes. |
| | Magnetic Card | Inputs and/or records data and programs. |
| | Card Display Slot | Holds magnetic or label function card for quick reference to card contents or label functions labeled on card. |
| | Function Label Card | Identifies function or operation in program corresponding to primary label key. When placed in card display slot, each function/operation written on card is positioned above corresponding primary label. Top line in each position corresponds to label/function written above label keys, such as A'. |
| A thru E A' thru E' | Primary Labels | Used to label sections or subroutines of program and to recall them for execution when program is run. Pressing key gives that section of program label that is written on key. Pressing 2nd before key assigns label written above key. |
| <u>Clear Functions</u> | | |
| CLR | Clear Key | Clears contents of display register, error conditions and any calculations in progress. |
| CE | Clear Entry Key | Clears last number entered into display or stops flashing display. Will not affect operations in progress. |

| Key | Control or Indicator | Function |
|-------------------------------------------------------------------------------------|----------------------|----------------------------------------------------------------------------------------------------------------------------------------------------------------------------------------------------------|
| CP | Clear Program Key | Clears program memory and display. Also resets or turns off all program flags, clears T-register, sets program pointer to 000 and removes any program/memory protection. |
| <u>Dual Function</u> | | |
|  | 2nd Function Key | Pressed before any key, selects operation, data or label written above that key on keyboard. |
|  | Inverse Function Key | Pressed before any key or key sequence, it causes inverse of that operation to be performed. |
| <u>Data Entry</u> | | |
|  | Number Key | Enters number from right to left into display and places number to left of decimal place. If more than one number is entered in succession, last displayed entry moves to left when next one is entered. |
|  | Decimal Key | Enters decimal point in display. |
|  | Sign Change Key | Changes sign of number and/or exponent in display so that it is opposite value of what it was before. If number was positive, negative sign appears. If number was negative, negative sign disappears. |

| Key | Control or Indicator | Function |
|-----------------------------------------------------|----------------------|-------------------------------------------------------------------------------------------------------------------------------------------------------------------------------------------------------------|
| | | If number is entered with exponent, only sign of exponent can be changed by key. If number and exponent are result of calculation, only sign of number can be changed by key. |
| π | pi | Enters first 10 digits of value for pi into display. |
| NOTE | | |
| Pressing CE cannot remove pi from display. | | |
| <u>Memory Functions</u> | | |
| STO | Store Key | Copies number in display into data register. Data register to be used must be specified using two-digit number. Any number previously held in register is erased. Display does not change. |
| CMS | Clear Memories | Clears (places zero) in all data registers. |
| RCL | Recall Key | Copies contents of specified data register into display. Data register must be specified after key using two-digit number. Contents of register are not disturbed. Previous contents of display are erased. |
| Exc | Exchange Memory Key | Swaps whatever is in display with number in specified data register. Data register to be used must be specified after pressing key using its two-digit number. |

| Key | Control or Indicator | Function |
|-----|----------------------|---------------------------------------------------------------------------------------------------------------------------------------------------------------------------------------|
| | Memory Sum Key | Ados number in display register to contents of specified data register, and stores result in that same register. Data register must be specified using its two-digit number. |
| Prd | Memory Product Key | Multiplies contents of specified data register by number in display register, and stores result in same data register. Display register must be specified using its two-digit number. |

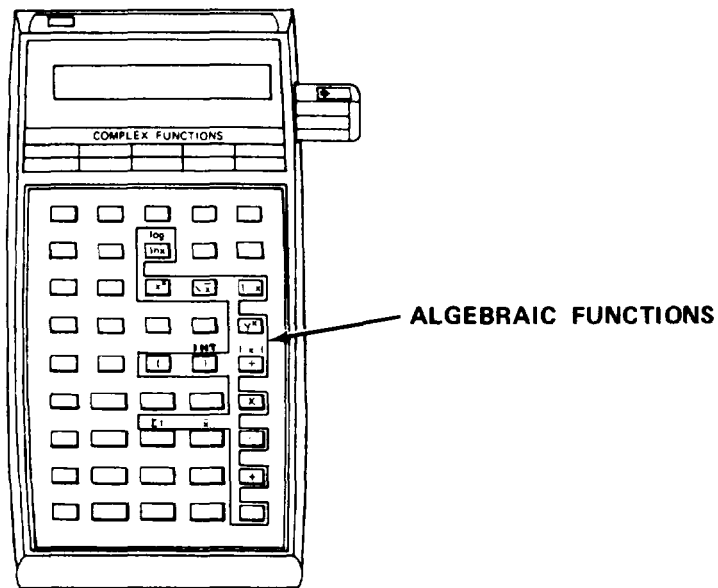

Algebraic Functions

□, □, □, □, □

Basic Operation Key

Enters indicated operation at desired place in calculation. Calculations are entered as written. Equal key ends all pending calculations.

| Key | Control or Indicator | Function |
|----------------|----------------------|-----------------------------------------------------------------------------------------------------------------------------------------------------------------------------------------------------------------------------------------------------------------------------|
| $[[]]$ | Parenthesis Keys | Used to cluster numbers and operations and to specify and change exact order in which expressions are to be evaluated. |
| NOTE | | |
| | | <ul style="list-style-type: none"> ● Parentheses cannot be used to perform implied multiplications, such as $(3)(5) = 15$. Multiplication key must always be used to multiply. ● Up to nine sets of parentheses can be used at one time. |
| $[x^2]$ | Square Key | Multiplies number in display by itself. Displays result. |
| $[\sqrt{x}]$ | Square Root Key | Calculates and displays square root of number currently in display register. |
| $[1/x]$ | Reciprocal Key | Calculates and displays reciprocal of number currently in display register. |
| $[y^x]$ | Exponential Key | Calculates and displays results of number y , raised to exponent x . Number y is entered first; exponent last. |
| $[\ln x]$ | Natural Log Key | Calculates and displays natural (base e) log of number currently in display register. |

| Key | Control or Indicator | Function |
|------------------------------------------------------------------------------------------|----------------------|----------------------------------------------------------------------------------------------------------------------------------------------|
| Int | Integer Key | Eliminates decimal portion of any number in display register and displays only that portion of number greater than 0. |
| NOTE | | |
| Pressing $\boxed{\text{INV}}$, $\boxed{2\text{nd}}$, and Int will convert number to 0. | | |
| log | Common Log Key | Calculates and displays common (base 10) log of number currently in display register. |
| $ X $ | Absolute Value Key | Calculates and displays absolute value of number currently in display register. |
| \bar{x} | Mean Key | Calculates and displays mean of set of numbers summed using summation key. Used in statistical operations to calculate the mean of an array. |
| $\Sigma+$ | Summation Key | Calculates sum of running set of numbers. As each new number is input, it displays sum of all entries made to that point. |

| Key | Control or Indicator | Function |
|-----|----------------------|----------|
|-----|----------------------|----------|

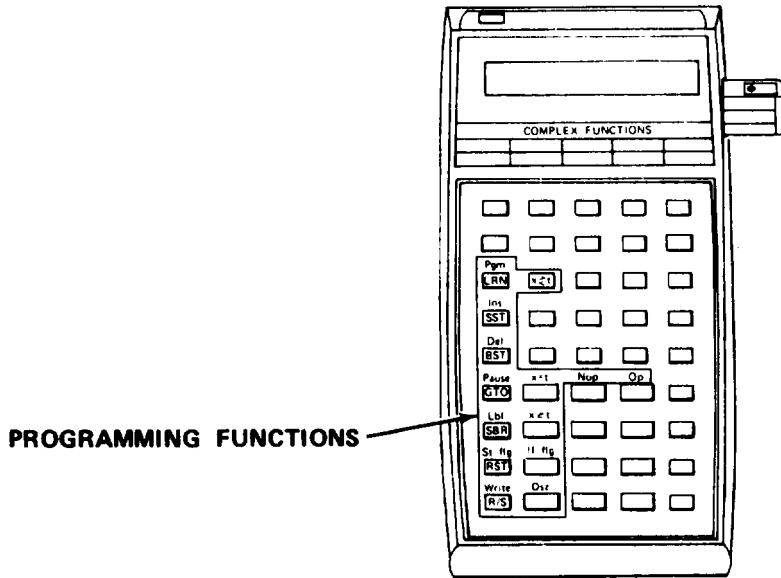



Programming Functions

| | | |
|------------|-------------|------------------------------------------------------------------------------------------------------------------------------------------------------------------------------------|
| Pgm | Program Key | Used to call up master library program. Program called up is designated by its two-digit code number. |
| LRN | Learn Key | Pressing once places calculator in learn mode of operation for entering program. Pressing again puts calculator under keyboard control and restores display to its original state. |

NOTE

Keystroke input at any point in existing program while in learn mode writes over instruction previously stored in that location.

| Key | Control or Indicator | Function |
|-------------------------------------------------------------------------------------|----------------------|------------------------------------------------------------------------------------------------------------------------------------------------------------------------------------------------------------------------------------------------------------------------------------------------------------------|
| Ins | Insert Key | Used in learn mode. Moves all instructions down one location in memory, beginning with displayed location. Resulting blank location used to insert commands or data. |
|  | Single-Step Key | In learn mode, causes program pointer to move to next storage location and instruction key code stored there to be displayed. When pressed under keyboard control, causes program to be executed one step at a time with result of each step being displayed. Inoperative when running a master library program. |
|  | Back-Step Key | In learn mode, causes program pointer to back-step by one and show key code of instruction stored there. Inoperative under keyboard control or when program is running. |
| Del | Delete Key | In learn mode, removes displayed instruction and moves all instructions below the old instruction in memory up one location to eliminate gap. Program pointer does not move. |
| Pause | Pause Key | During program execution, causes current value of display register to be displayed for portion of 1 sec. When held down, displays results of each program step. Inoperative when running master library program. |

| Key | Control or Indicator | Function |
|----------------------------------------------------------------------------------------------------------------------------------------------|----------------------|--------------------------------------------------------------------------------------------------------------------------------------------------------------------------------------------------------------------------------------------------------------------------------|
| GTO | Go To (Address) Key | In program, instantly diverts flow of program execution to designated label or program memory location. When program is not being run, it positions program pointer to designated label or memory location in program currently in memory, without starting program execution. |
| NOTE | | |
| If at least one digit is not specified after pressing GTO , for desired memory location, calculator will take next entry to be label. | | |
| Lbl | Label Key | Used only in learn mode to label segments of program. Instructs calculator to use next keyboard entry as label marker and not as instruction. |

| Key | Control or Indicator | Function |
|------------|----------------------|---------------------------------------------------------------------------------------------------------------------------------------------------------------------------------------------------------------------------------------------------------------------------------------------------------------------------------------------------------------------------------------------------------------------------------------------------------------------------------|
| SBR | Subroutine Key | In program, transfers flow instantly to designated subroutine. Used in learn mode to program such transfer. Transfer designation can be label or memory location. Number for memory location immediately after SBR call is stored in special memory register to facilitate transferring back after subroutine is executed. When used under keyboard control (program not being run), program pointer moves to designated subroutine and program execution begins at that point. |
| St flg | Set Flag Key | Sets (turns on) designated flag, when pressed from keyboard or encountered in program execution. |
| RST | Reset Key | Instructs calculator to reset program pointer to location 000 of program memory, clears subroutine return register and resets all program flags. Can also be used to exit Master Library program. |
| If flg | Flag Set Test Key | Tests designated flag to see if it is set (raised). If flag is set, program flow is transferred to designated label or memory location. |

| Key | Control or Indicator | Function |
|---------------------------------------------------------------------------------------------------------------------------------------------------------------------------------------------------------------------------------|------------------------|------------------------------------------------------------------------------------------------------------------------------------------------------------------------------------------------------------------------------------------------------------------------------------------------------|
| Write | Write Key | Used to store program on magnetic card. Places contents of designated bank of locations in program memory onto side of magnetic card. |
| R/S | Run/Stop Key | Reverses status of processing (program execution). If program is not running, pressing starts execution at current position of program pointer. If program is running, pressing causes program to stop. If entered in learn mode as instruction, program will stop executing when it is encountered. |
| NOTE | | |
| Normally, program will continue at next instruction when R/S is pressed to restart program, but this automatic advance is cancelled if Master Library program is called or statistic function is used while program is stopped. | | |
| Op | Special Operations Key | Used to call up special control operation from keyboard or in program. |

| Key | Control or Indicator | Function |
|------------|-------------------------|-----------------------------------------------------------------------------------------------------------------------------------------------------------------------------------------------------------------------------------------------------------------------------------------------------------------------------------------------|
| Nop | No Operation Key | In learn mode, used to delete unwanted instruction or to provide spacing between program parts for later additions. When encountered in program, no operation is performed and execution continues. Use of key does not interfere or alter any key, execution sequence or data entry, except when used as label. |
| $x \neq t$ | Register Exchange Key | Exchanges number, in display register with T-register value, t. |
| $x = t$ | Registers Equal ? Key | Compares number in display register to that in T-register. If numbers are equal, execution branches to designated address. If not equal, execution continues. |
| $x \geq t$ | Registers Compare ? Key | |
| Ind | Indirect Address Key | Used after transfer-type instructions that require address to complete instruction. Ind key followed by two-digit data register designation replaces normal address after instruction. Recalls contents of designated data register. Register contents are used as correct transfer address for instruction or as actual data for processing. |

| Key | Control or Indicator | Function |
|-----|--------------------------------|-----------------------------------------------------------------------------------------------------------------------------------------------------------------------------------------------------------------------------------------------------------------------------------------------------------------------------|
| Dsz | Decrement and Skip-if-Zero Key | Decrements (decreases), by one, magnitude of contents of specified data register (0-9). As long as content of register is not zero, program execution is transferred to designated label or memory location. If data register is equal to 0 after decrement, no transfer takes place and program moves to next instruction. |

NOTE

If contents of data register is negative, decrement function actually adds 1 to register contents.

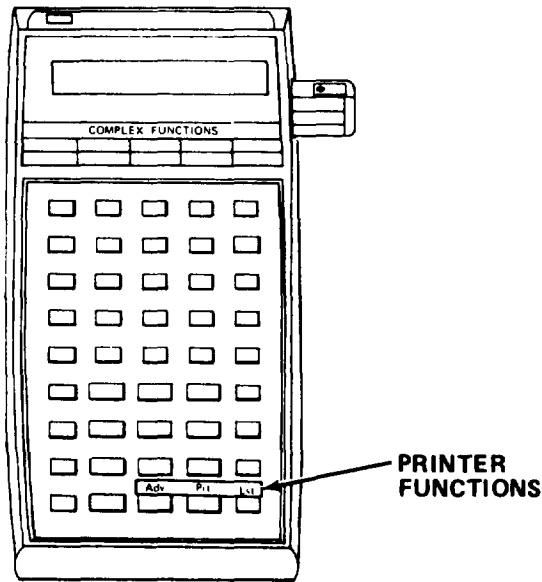

| | | |
|-----|----------------------|----------|
| Key | Control or Indicator | Function |
|-----|----------------------|----------|

Printer Control Functions

| | | |
|-----|-------------|------------------------------------------------------------------------------------------------|
| Adv | Advance Key | When encountered in program or from keyboard, advances paper one blank space without printing. |
|-----|-------------|------------------------------------------------------------------------------------------------|

| | | |
|-----|----------|-----------------------------------------------------------------------------------|
| Lst | List Key | Causes printer to list program or contents of data registers currently in memory. |
|-----|----------|-----------------------------------------------------------------------------------|

| | | |
|-----|-----------|---------------------------------------------------------------------------------------------------------------|
| Prt | Print Key | When encountered in program or pressed from keyboard, prints whatever value is currently in display register. |
|-----|-----------|---------------------------------------------------------------------------------------------------------------|

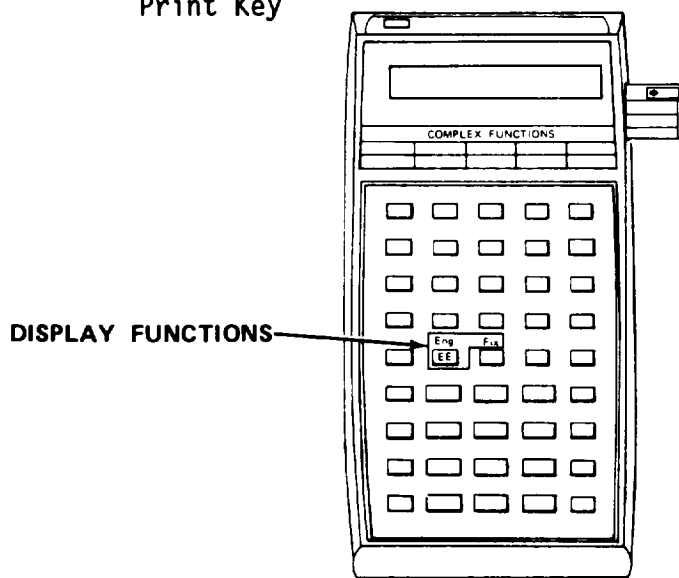

Display Functions

| | | |
|------------------|-----------------------------------------------------|---------------------------------------------------------------------------------------------------------------------------------------------------------------------------------------------------------------------------------------------------------------------------------------------------------------------------------------------------|
| <p>EE</p> | <p>Enter Exponent Key (Scientific Notation)</p> | <p>Instructs calculator that number entry following this key is exponent of 10. After pressing, all subsequent results are in scientific notation, until CLR is pressed or calculator is turned off. If pressed after result, last three internal digits of number are lost and only value displayed is used for further calculations.</p> |
|------------------|-----------------------------------------------------|---------------------------------------------------------------------------------------------------------------------------------------------------------------------------------------------------------------------------------------------------------------------------------------------------------------------------------------------------|

| Key | Control or Indicator | Function |
|-----|----------------------|----------|
|-----|----------------------|----------|

NOTE

You cannot use \boxed{EE} if mantissa of more than eight digits was entered, or for an exponent larger than 99.

Eng Engineering Notation Key

Instructs calculator to use modified form of scientific notation. Number immediately following key is exponent. Calculator automatically adjusts format of display so that exponents are multiple of 3 and mantissa has no more than three numbers to left of decimal point. Calculator remains in this format until cleared.

NOTE

You cannot use \boxed{EE} if mantissa of more than eight digits was entered, or for an exponent larger than 99.

Fix Fix Notation Key

Used to set number of digits calculator will display to right of decimal point. Instructs calculator to round all displayed results to selected number of decimal places.

| Key | Control or Indicator | Function |
|-----|----------------------|----------|
|-----|----------------------|----------|

NOTE

- Only display, not contents of display register, are affected by rounding.
- Calculator will remain in this format until cleared or Fix 9 is selected.

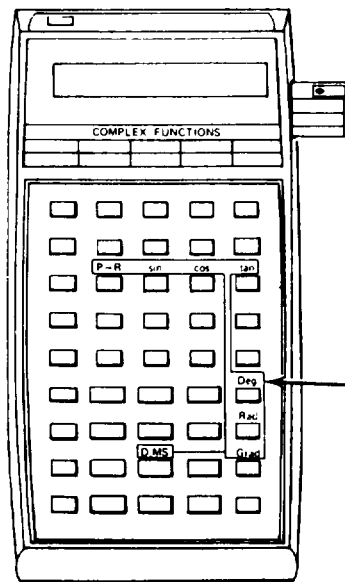

TRIGONOMETRIC FUNCTIONS

Angle Functions

sin, cos, tan Sine, Cosine and Tangent Key

Calculates sine, cosine or tangent of value in display register.

P→R Polar-to-Rectangular Conversion Key

Converts polar coordinates to rectangular coordinates. Value for R is stored (inputted) in T-register. Angle coordinate is inputted to display register. After conversion, value of X is stored in T-register and display shows Y-value.

| Key | Control or Indicator | Function |
|--------------------|-----------------------------------------------------|---------------------------------------------------------------------------------------------------------------------------------------------------------------------------------------------------|
| Deg Rad Grad | Degree Mode Key Radian Mode Key Grad Mode Key | Instructs calculator that all values entered and calculated for angles or trig functions are in degrees, radians, or grads, Remains in effect until changed. Has no effect on other calculations. |
| D.Ms | Degree Format Conversion Key | Used in degree mode to convert format for angular values inputted or displayed. Press to convert value entered in degree-minute-second format to decimal degrees. |

NOTE

Also used to convert hours-minutes-seconds to decimal hours.

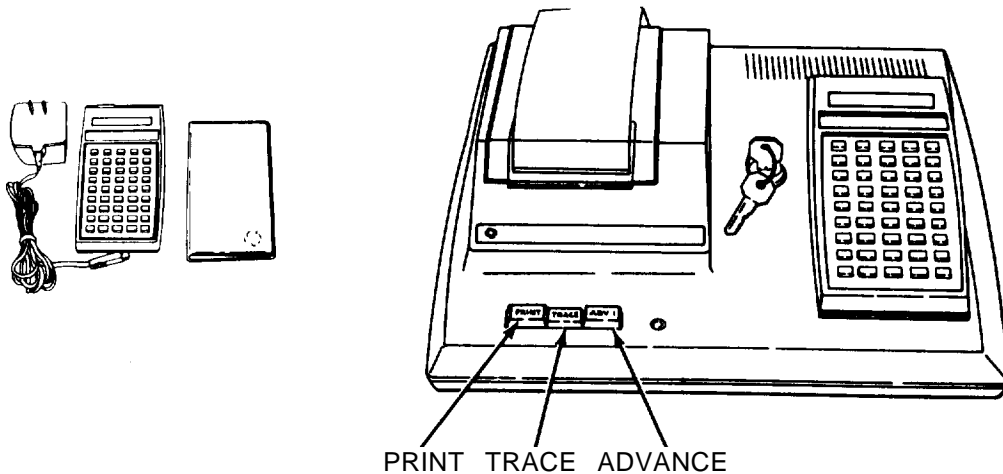

PRINT

Print Key

Causes contents of display to be printed.

| Key | Control or Indicator | Function |
|--------------|----------------------|---------------------------------------------------------------------------------------------------------------------------------------------------------------------------------------------------------------------------------------------------------------------------------------------------------|
| TRACE | Trace Key | Latching switch. Down position causes operation in TRACE mode. In this mode every new function or result is automatically printed. Number entries do not cause a line to be printed. A number entry followed by a function will cause a line to be printed. Press key again to release from trace mode. |
| ADV I | Paper Advance Key | Advances paper. |
| | Power Switch | Turns power on/off. |
| | Power Indicator | Indicates when power is on/off. |
| | Key Lock | Locks calculator to printer. Turn right to lock, left to unlock. |

7-5. OPERATOR PREVENTIVE MAINTENANCE CHECKS AND SERVICES.

a. Before You Operate. Always keep in mind the WARNINGS and CAUTIONS. Perform you before (B) PMCS.

b. While You Operate. Always keep in mind the WARNINGS and CAUTIONS. Perform your during (D) PMCS.

c. After You Operate. Be sure to perform your after (A) PMCS.

d. If Your Equipment Fails to Operate. Troubleshoot with proper equipment. Report any deficiencies using the proper forms. See DA Pam 738-750.

7-5.1 PMCS Procedures.

a. PMCS are designed to keep the equipment in good working condition by performing periodic service tasks.

b. Service intervals provide you, the operator, with time schedules that determine when to perform specified service tasks.

c. The "Equipment is Not Ready/Available If" column is used for identification of conditions that make the equipment not ready/available for readiness reporting purposes or denies use of the equipment until corrective maintenance is performed.

d. If your equipment fails to operate after PMCS is performed, immediately report this condition to your supervisor.

d. If your equipment fails to operate after PMCS is performed, immediately report this condition to your supervisor.

e. Perform weekly as well as before operation if you are the assigned operator and have not operated the item since the last weekly or if you are operating the item for the first time.

f. Item number column. Item numbers are assigned in chronological ascending sequence regardless of interval designation. These numbers are used for your "TM Number" column on DA Form 2404, Equipment Inspection and Maintenance Worksheet, in recording results of PMCS.

g. Interval columns. This column determines the time period designated to perform your PMCS.

h. Item to be inspected and procedures column. This column lists functional groups and their respective assemblies and subassemblies as shown in the Maintenance Allocation Chart (Appendix B). The appropriate check or service procedure follows the specific item to be inspected.

i. Equipment is not ready/available if: column. This column indicates the reason or cause why your equipment is not ready/available to perform its primary mission.

j. List of tools and materials required for PMCS is as follows:

| <u>Item</u> | <u>Quantity</u> |
|----------------------------------------|-----------------|
| Cotton Swabs (Item 6, Appendix E) | ar |
| Denatured Alcohol (Item 3, Appendix E) | ar |
| Print Head Cleaning Card | 1 ea |
| Paper Towel (Item 25, Appendix E) | ar |
| Drive Roller Cleaner Card | 1 ea |

Table 7-7. OPERATOR PREVENTIVE MAINTENANCE CHECKS AND SERVICES

NOTE

If the equipment must be kept in continuous operation check and service only those items that can safely be checked and serviced without disturbing operation. Make the complete checks and services when the equipment can be shut down.

B- Before
D- During
A- After

W- Weekly
M - Monthly
Q - Quarterly

AN - Annually
S - Semiannually
Bi Biennially

(Number) - Hundreds of Hours

| ITEM NO. | INTERVAL | ITEM TO BE INSPECTED PROCEDURE | For Readiness Reporting, Equipment Is Not Ready/ Available If: |
|----------|----------|-----------------------------------------------------------------------------------------------------------------------------------------------------------------------|----------------------------------------------------------------|
| 1 | B | <p><u>PROGRAMMABLE CALCULATOR WITH PRINTER</u></p> <p><u>Inspect Calculator.</u></p> <p>1. Inspect casing and keyboard of calculator for cracks or breaks.</p> | <p>Calculator does not perform as required.</p> |
| | |  | |
| 2 | B | <p><u>Service Calculator.</u></p> <p>Wipe dust, dirt, and any other foreign particles from display and keyboard.</p> | |

Table 7-7. OPERATOR PREVENTIVE MAINTENANCE CHECKS AND SERVICES - Cont

B - Before
D - During
A - After

W - Weekly
M - Monthly
Q - Quarterly

AN - Annually
S - Semiannually
BI - Biennially

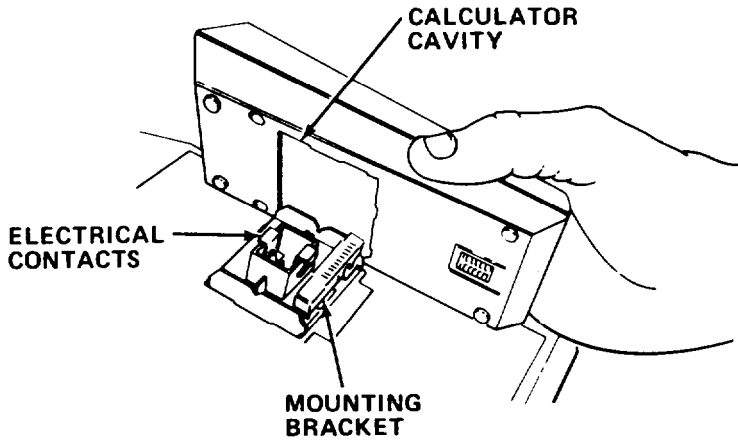
(Number) - Hundreds of Hours

| ITEM NO | INTERVAL | ITEM TO BE INSPECTED PROCEDURE | For Readiness Reporting, Equipment Is Not Ready/ Available If: |
|----------------------------------------------------|----------|--------------------------------------------------------------------------------------------------------------------------------------------------------------------------------------------------------------------------------------------------------------------------------------------------------------------------------------------------------------------------------------------------------------------------------------------------------------------------------------------------------------------------------------------------------------------------------------------------------------------|----------------------------------------------------------------|
| PROGRAMMABLE CALCULATOR WITH PRINTER - Cont | | | |
| 3 | M | <p><u>Clean Drive Rollers.</u></p> <ol style="list-style-type: none"> 1. Turn on calculator. 2. Press CLR . 3. Press 1 , 2nd , and write. 4. Insert drive roller cleaner card into slot on side of calculator. Hold onto edge of card and move card in and out of slot for at least four seconds. 5. Pull out card. 6. Press R/S . Turn off calculator. | |
| 4 | AN | <p><u>Clean Calculator Heads.</u></p> <ol style="list-style-type: none"> 1. Turn on calculator. 2. Press. CLR . 3. Press 1, 2nd and write. 4. Insert calculator head cleaning card into slot on side of calculator. Hold onto edge of card and move card in and out of slot for at least four seconds. 5. Pull out card. 6. Press R/S . Turn off calculator. | |

Table 7-7. OPERATOR PREVENTIVE MAINTENANCE CHECKS AND SERVICES - Cont

B - Before
D - During
A - After

W - Weekly
M - Monthly
Q - Quarterly

AN - Annually
S - Semiannually
BI - Biennially

(Number) - Hundreds of Hours

| ITEM NO. | INTERVAL | ITEM TO BE INSPECTED PROCEDURE | For Readiness Reporting, Equipment Is Not Ready/ Available If: |
|----------|----------|-------------------------------------------------------------------------------------------------------------------------------------------------------------------------------------------------------------------------------------------------------------------------------------------------------------------------------------------------------------------------------------------------------------------------------------------------------------------------------------------------------------------------------------------------------------------------------------------------------------------------------------------------------------------------------------------------------------------------------------------------------------------------------------|------------------------------------------------------------------------------------------------------------------------------------------------------------------------------------------------------------------------|
| 5 | B | <p><u>PROGRAMMABLE CALCULATOR WITH PRINTER - Cont</u></p> <p>Inspect Printer.</p> <p style="text-align: center;"><u>CAUTION</u></p> <p style="text-align: center;">Do not remove calculator with power on or damage to calculator may occur.</p> <ol style="list-style-type: none"> 1. Turn printer and calculator off. Turn key to left and inspect mounting contacts on printer for foreign particles. Clean as required. 2. Inspect mounting bracket for cracks or breaks. 3. Inspect battery compartment for cracks or breaks. 4. Inspect battery contacts for foreign particles, cracks or breaks. Clean as required. 5. Reinstall calculator and lock in place. Be sure calculator is snugly mounted and not loose. | <p>Contacts heavily corroded, broken, or missing.</p> <p>Mounting bracket broken.</p> <p>Contacts broken or heavily corroded.</p> <p>Calculator will not lock in place or calculator and printer will not perform.</p> |

Table 7-7. OPERATOR PREVENTIVE MAINTENANCE CHECKS AND SERVICES - Cont

B - Before
D - During
A - After

W - Weekly
M - Monthly
Q - Quarterly

AN - Annually
S - Semiannually
BI - Biennially

(Number) - Hundreds of Hours

| ITEM NO. | INTERVAL | ITEM TO BE INSPECTED PROCEDURE | For Readiness Reporting, Equipment Is Not Ready/ Available If: |
|-----------------------------------------------------------|----------|---------------------------------------------------------------------------------------------------------------------------------------------------------------------------------------------------------------------------------------------------------------------------------------------------------------------------------------------------------------------------------------------------------------------------------------------------------------------------------------------------------------------------------|----------------------------------------------------------------|
| <u>PROGRAMMABLE CALCULATOR WITH PRINTER - Cont</u> | | | |
| 5 | B | <p data-bbox="331 519 618 551"><u>Inspect Printer -Cont</u></p>  <p data-bbox="298 1123 1019 1378"> 6. Lift paper roll cover. Pull paper release lever up and remove roll of paper. Inspect paper roller for dirt or foreign particles. Clean if required. 7. Reinstall paper (paragraph 7-6.2). Turn calculator and printer power on and check for free roller operation. </p> | <p data-bbox="1247 1283 1414 1342">Paper will not advance.</p> |
| 6 | M | <p data-bbox="354 1442 558 1474"><u>Service Printer.</u></p> <p data-bbox="643 1538 773 1570" style="text-align: center;"><u>CAUTION</u></p> <p data-bbox="380 1602 1036 1666" style="text-align: center;">Do not remove calculator with power on or damage to calculator may occur.</p> <p data-bbox="305 1730 1146 1793">1. Turn off printer power. Remove calculator. Open printer battery compartment.</p> | |

Table 7-7. OPERATOR PREVENTIVE MAINTENANCE CHECKS AND SERVICES - Cont

B - Before
D - During
A - After

W - Weekly
M - Monthly
Q - Quarterly

AN - Annually
S - Semiannually
BI - Biennially

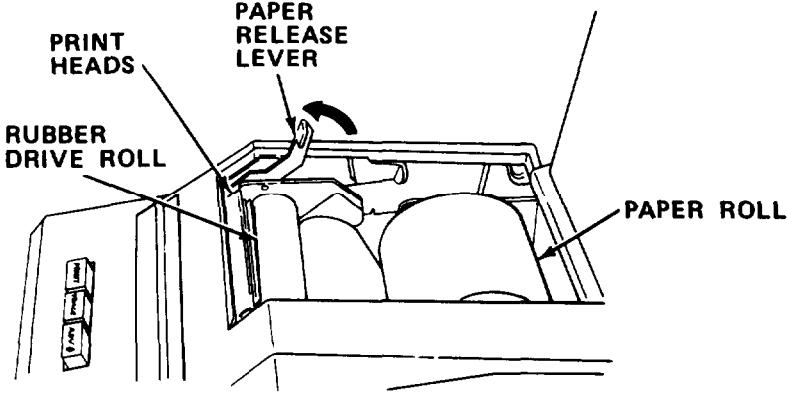
(Number) - Hundreds of Hours

| ITEM NO. | INTERVAL | ITEM TO BE INSPECTED PROCEDURE | For Readiness Reporting, Equipment Is Not Ready/ Available If: |
|----------|----------|--------------------------------------------------------------------------------------------------------------------------------------------------------------------------------------------------------------------------------------------------------------------------------------------------------------------------------------------------------------------------------------------------------------------------------------------------------------------------------------------------------------|----------------------------------------------------------------|
| 6 | M | <p>PROGRAMMABLE CALCULATOR WITH PRINTER-Cont</p> <p><u>Service Printer - Cont</u></p> <div data-bbox="446 609 1274 997" data-label="Diagram"> </div> <p style="text-align: center;"><u>CAUTION</u></p> <p>Do not use any solvent except alcohol on printer or damage to unit may result.</p> <ol style="list-style-type: none"> 2. Clean battery contacts and calculator mounting contacts with cotton swab soaked in alcohol. 3. Reinstall calculator. Turn on power. | |

Table 7-7. OPERATOR PREVENTIVE MAINTENANCE CHECKS AND SERVICES - Cont

B - Before
 D - During
 A - After

W - Weekly
 M - Monthly
 Q - Quarterly

AN - Annually
 S - Semiannually
 BI - Biennially

(Number) - Hundreds of Hours

| ITEM NO. | IN-TERVAL | ITEM TO BE INSPECTED | PROCEDURE | For Readiness Reporting, Equipment Is Not Ready Available If: |
|----------|-----------|---------------------------------------------------------------------------|-------------------------------------------------------------------|---------------------------------------------------------------|
| 7 | M | PROGRAMMABLE CALCULATOR WITH PRINTER - Cont Service Printer Heads. | 1. Check that calculator is locked in place. Plug in power cable. | |

HEAD CLEANING PROGRAM

| LOCATION AND KEY CODE | KEY SEQUENCE | LOCATION AND KEY CODE | KEY SEQUENCE |
|-----------------------|-------------------|-----------------------|------------------------------|
| | LRN | 014 11 | A |
| 000 04 | 4 | 015 84 | 2nd OP 2nd IND |
| 001 42 | STO | 016 00 | 0 |
| 002 00 | 0 0 | 017 97 | 2nd DSZ |
| 003 09 | 9 | 018 00 | 0 |
| 004 42 | STO | 019 11 | A |
| 005 06 | 6 | 020 76 | 2nd LBL |
| 006 52 | EE | 021 12 | B |
| 007 01 | 1 | 022 69 | 2nd OP |
| 008 00 | 0 | 023 05 | 5 |
| 009 94 | +/- | 024 97 | 2nd DSZ |
| 010 22 | INV | 025 06 | 6 |
| 011 52 | EE | 026 12 | 8 |
| 012 35 | 1/x | 027 91 | R/S |
| 013 76 | 2nd LBL | | LRN |

2. Input head cleaning program shown above.

NOTE

Be sure that printer is not in TRACE mode and there is paper in printer.

Table 7-7. OPERATOR PREVENTIVE MAINTENANCE CHECKS AND SERVICES - Cont

B - Before
 D During
 A - After

W - Weekly
 M - Monthly
 Q - Quarterly

AN - Annually
 S - Semiannually
 BI Biennially

(Number) - Hundreds of Hours

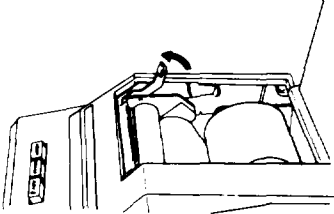
| ITEM NO. | INTERVAL | ITEM TO BE INSPECTED PROCEDURE | For Readiness Reporting, Equipment Is Not Ready Available If: |
|----------|----------|-------------------------------------------------------------------------------------------------------------------------------------------------------------------------------------------------------------------------------------------------------------------------------------------------------------------------------------------------------------------------------------------------------------------------------------------------------------------------------------------------------------------------------------------------------------------------------------------------------------------------------------------------------------------------------------------------------------------------------------------------------------------------------------------------------------------------------------------------------------------------------------------------------------------------------------------------------------------------------------------|------------------------------------------------------------------|
| 7 | M | <p>PROGRAMMABLE CALCULATOR WITH PRINTER - Cont</p> <p><u>Service Printer Heads - Cont</u></p> <p>3. Start program by pressing [PST] and [P/S] When program is finished, lift paper cover.</p>  <p>4. Move paper release lever to release position. Manually turn paper roll and lift out of printer.</p> <p style="text-align: center;">NOTE</p> <p>A strip of bond paper 2-1/2 in. wide (6.4 cm) may be used instead of print head cleaning card.</p> <p>5. Install print head cleaning card in place of normal printing paper. Return paper release lever to normal position.</p> <p>6. Repeat step 3 until most of the card has been passed through printer. Inspect print head cleaning card to be sure there is faint printing trail on card.</p> <p>7. Remove print head cleaning card. Reinstall printing paper. Repeat step 3 and inspect for improved printing.</p> | <p>No printer improvements, illegible or missing characters.</p> |

7-6. OPERATION UNDER USUAL CONDITIONS.

7-6.1 Assembly and Preparation for Use.

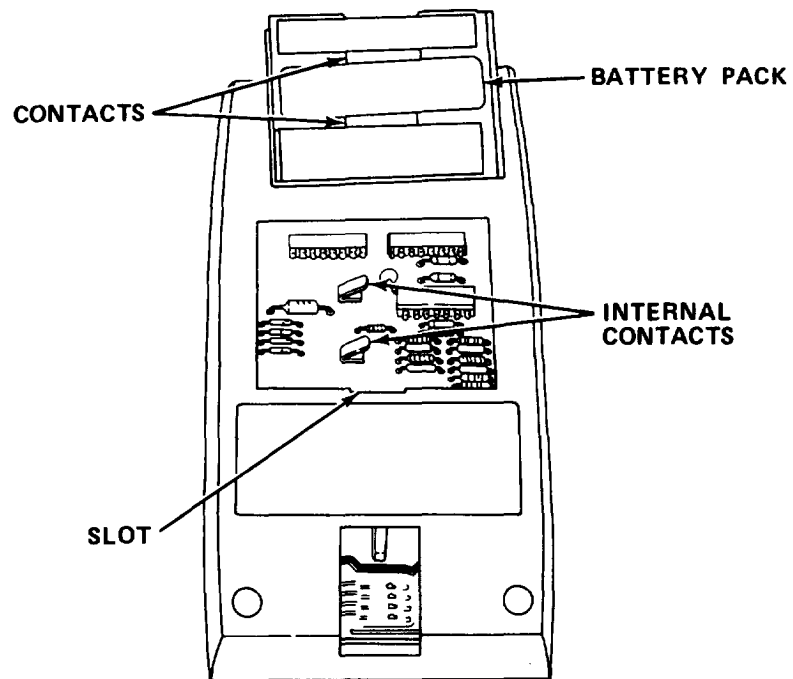

- a. Remove battery pack by prying up one edge and lifting pack out.
- b. Lay printer on flat, level surface.

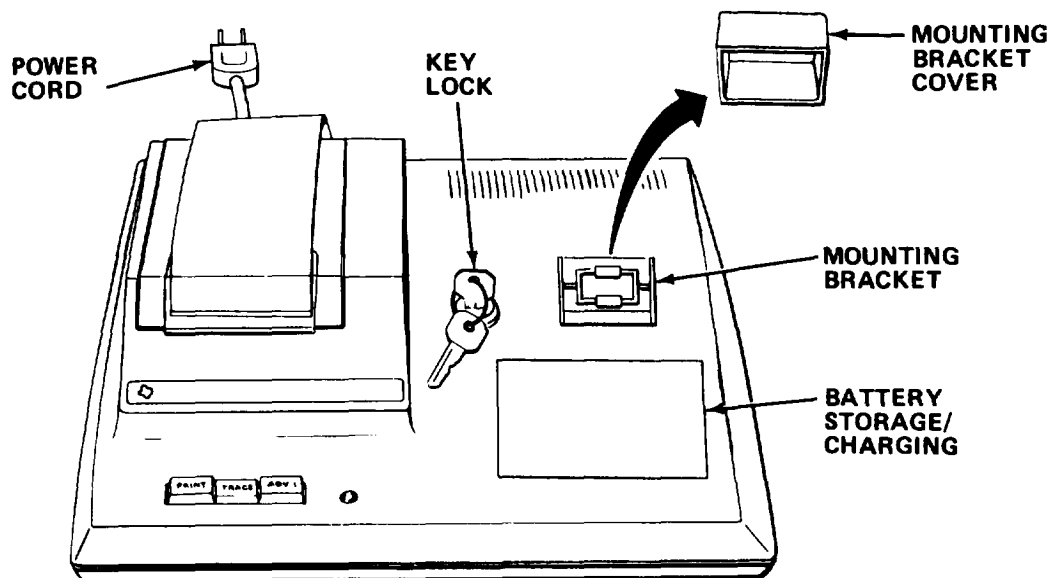

- c. Remove mounting bracket cover. Store cover in battery compartment.

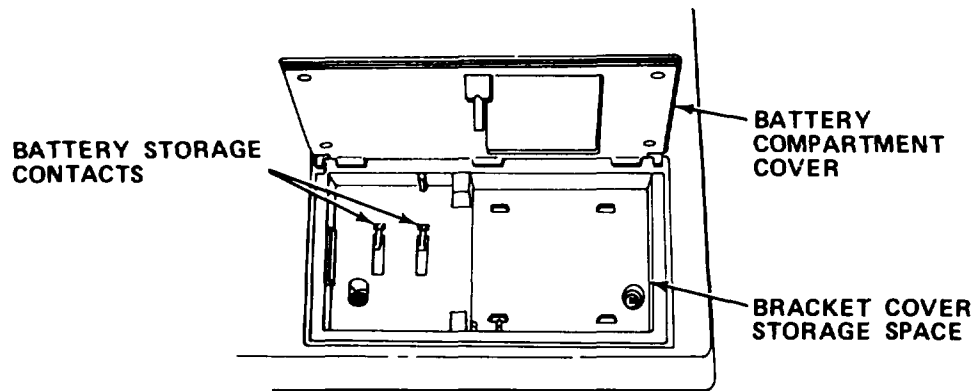

- d. Place calculator battery pack in storage compartment with batteries face down with pack notch to the left, so that metal contacts on battery pack touch contacts in storage compartment.

- e. Close storage compartment cover.

CAUTION

Do not mount calculator with power on or damage to calculator may occur.

- f. Turn key fully left.

- g. Place calculator on printer so that mounting bracket is inserted into space used by battery pack.

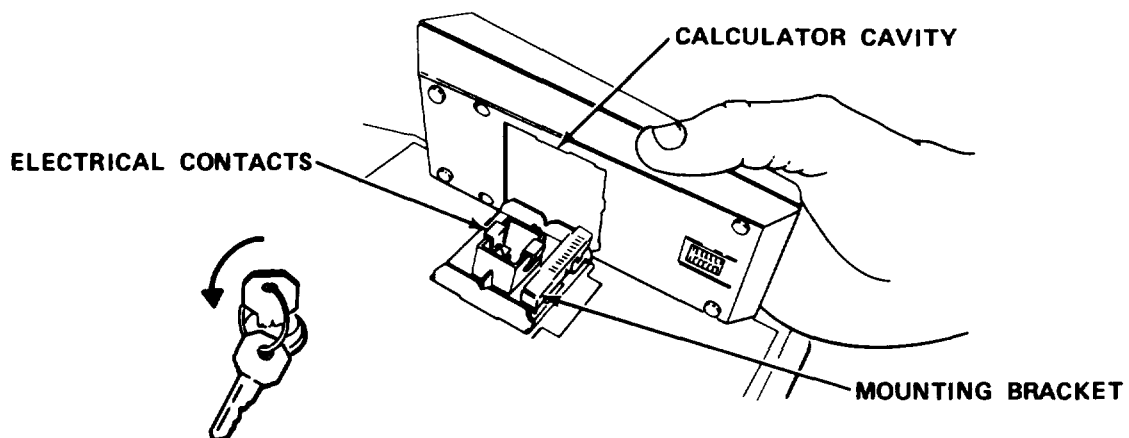

- h. Gently push down and forward on calculator with one hand until it is mounted flush and level on surface of printer.

NOTE

If key will not turn freely, calculator is not properly mounted.

i. While holding calculator down, turn key one-half turn right to lock calculator place.

j. Plug power cord into 120 V ac outlet. Turn printer power on by sliding power switch on side toward front.

k. Be sure LED power indicator comes on.

l. Turn on calculator power.

m. Install printer paper.

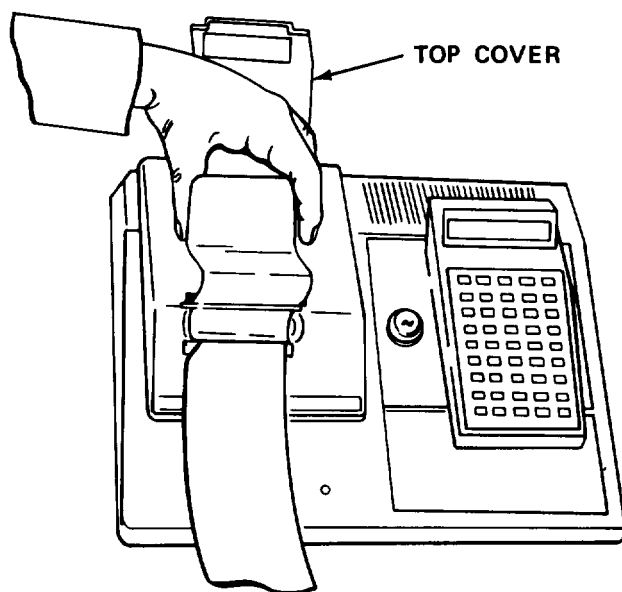

(1) Lift paper roll cover.

(2) Insert paper spindle into center of thermal printer paper roll.

(3) Position paper over paper compartment so that paper unrolls from bottom.

(4) Lower roll of paper into compartment while guiding ends of spindle into slots.

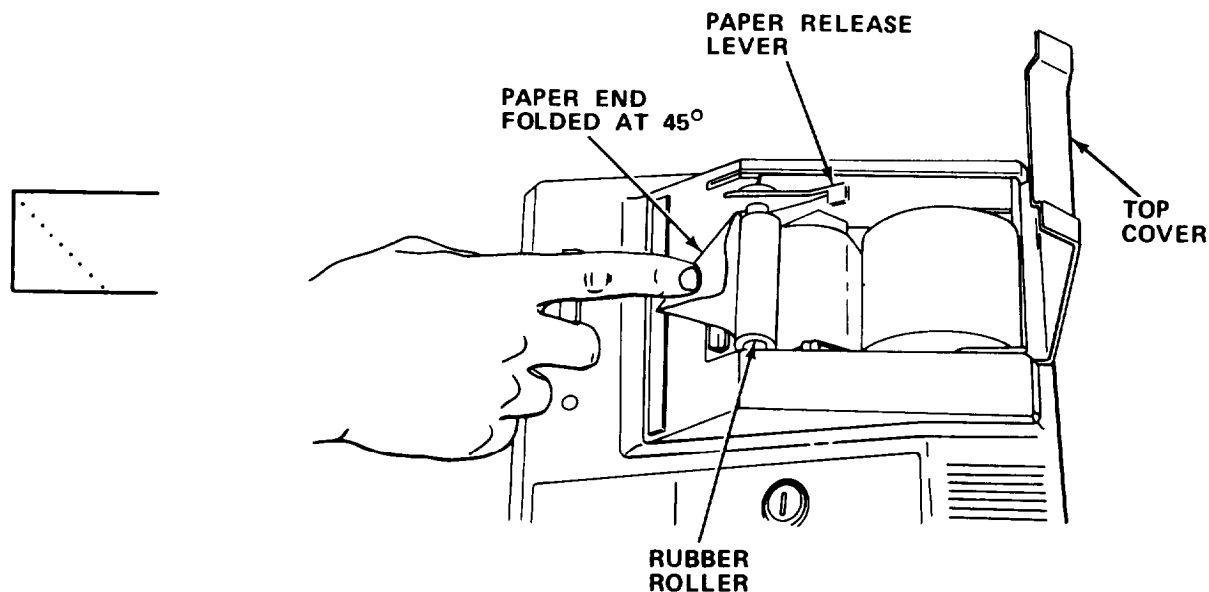

- (5) Fold end of paper as shown to form a 45 degree angle.
- (6) Lift paper release lever to full up position.
- (7) Insert point of folded paper under rubber roller.
- (8) Slide power switch on. Turn on calculator power.

NOTE

ADV key will not operate unless calculator is mounted and on.

(9) Press **ADV** to pull paper through printer. When point of paper appears above print heads, return paper release lever to normal locked position.

(10) Hold **ADV** key down until folded portion of paper is completely through printer.

(11) Hold end of paper slightly forward and guide it through slot as top cover is closed.

7-6.2 Operating Procedures. Operate the calculator and printer in accordance with the operator manuals packed with the equipment.

7-7. OPERATION UNDER UNUSUAL CONDITIONS. This equipment is designed for operation only in a controlled environment.

Section III MAINTENANCE INSTRUCTIONS

7-8. LUBRICATION INSTRUCTIONS. This equipment does not require lubrication.

7-9. TROUBLESHOOTING PROCEDURES.

a. The table lists the common malfunctions which you may find during operation or maintenance of the TI-59 calculator, or its components. You should perform the test/inspections and corrective actions in the order listed.

b. This manual cannot list all malfunctions that may occur, nor all test or inspections and corrective actions. If a malfunction is not listed or is not corrected by listed corrective actions, notify your supervisor.

Table 7-8. TROUBLESHOOTING

| MALFUNCTION | TEST OR INSPECTION | CORRECTIVE ACTION |
|-------------|--------------------|-------------------|
|-------------|--------------------|-------------------|

1. PRINTER DOES NOT OPERATE.

Step 1. Check that power cord is plugged into live power outlet.

(a) If power is available at outlet, proceed to step 2.

(b) Plug cord into 120 V ac outlet.

Step 2. Check that printer fuse is not blown.

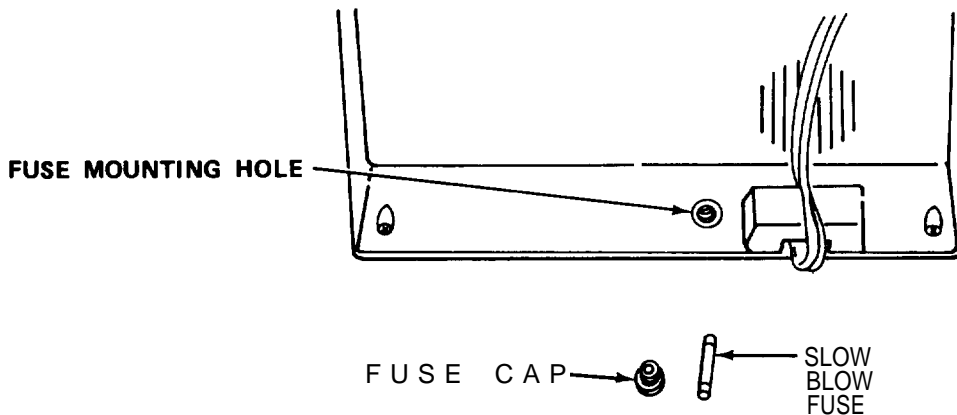

(a) If fuse is not defective, proceed to step 3.

(b) Replace defective fuse (paragraph 7-10.1).

Table 7-8. TROUBLESHOOTING - Cont

MALFUNCTION

TEST OR INSPECTION

CORRECTIVE ACTION

1. PRINTER DOES NOT OPERATE - Cont

Step 3. Check to be sure calculator is held snugly in place.

(a) If calculator is properly mounted, proceed to step 4.

(b) Mount calculator Properly.

Step 4. Be sure that calculator and printer are turned on.

(a) If calculator and printer are turned on, proceed to step 5.

(b) Turn on calculator and printer.

Step 5. Check to see if printer mounting contacts are clean and contacting calculator contacts.

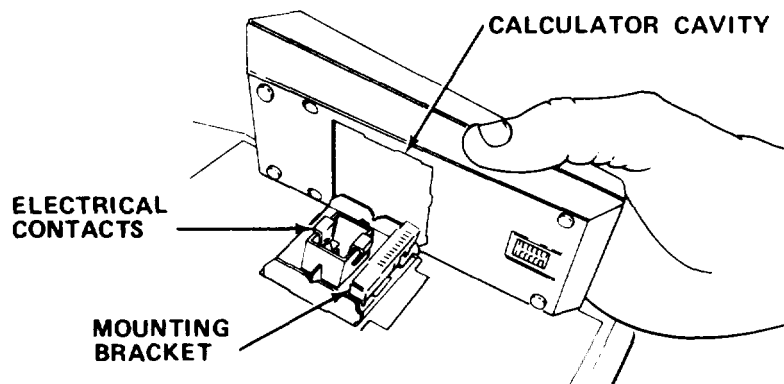

(a) If contacts are clean, proceed to step 6.

(b) Clean contacts (Table 7-7).

Step 6. Check to see if printer mounting bracket is cracked or broken.

Replace printer.

Table 7-8. TROUBLESHOOTING - Cont

MALFUNCTION

TEST OR INSPECTION

CORRECTIVE ACTION

2. PRINTER DOES NOT RESPOND CORRECTLY .

Step 1. Try to advance paper roll by using **ADV** key on printer.

(a) If paper advances, proceed to step 2.

(b) If paper does not advance, replace printer.

Step 2. Press **PRINT** key and check to see if value in calculator display is printed.

(a) If printer responds correctly, refer to malfunction 7.

(b) If paper does not advance, replace printer.

3. PRINTER STOPS OPERATING. POWER CYCLES ON AND OFF.

Step 1. Check for foreign particles on printer and calculator contacts.

(a) If contacts are clean, proceed to step 2.

(b) Clean contacts.

Step 2. Check to be sure printer mounting bracket is not cracked or broken.

(a) If mounting bracket is intact, proceed to step 3.

(b) Replace printer.

Step 3. Check to be sure calculator housing or internal contacts are not cracked or broken.

(a) If housing and internal contacts are intact, proceed to step 3.

(b) Replace calculator.

Step 4. Check that calculator is held snugly in place.

Mount calculator correctly.

Table 7-8. TROUBLESHOOTING - Cont

| MALFUNCTION | TEST OR INSPECTION | CORRECTIVE ACTION |
|--------------------------------------------------------------|------------------------------------------------------------------------------------------------------|----------------------------------------------------------------------------------------------------------|
| 4. NO DIGITS APPEAR WHEN PRINTING OR DIGITS APPEAR STREAKED. | Step 1. Check to be sure paper was not installed with wrong side against print heads. | (a) If paper is properly installed, proceed to step 2. (b) Install paper correctly (paragraph 7-6.2). |
| | Step 2. Check to be sure print heads are clean. | (a) If print heads are clean, proceed to step 3. (b) Clean print heads. (Table 7-7) |
| | Step 3. Check to be sure correct paper was installed and paper roll rotates when commanded to print. | Print heads are defective. Replace printer. |
| 5. UNEXPECTED OR INCORRECT RESULTS PRINTED. | Check to be sure correct key sequence was used and/or program is operating correctly. | Use correct key sequence and/or check program for errors. |
| 6. PRINTER PAPER RUBBER ROLLER CHATTERS OR DOES NOT ROTATE. | Check to see if paper is installed correctly. | Install paper correctly. |

Table 7-8. TROUBLESHOOTING - Cont

MALFUNCTION

TEST OR INSPECTION

CORRECTIVE ACTION

7. CALCULATOR DISPLAY LOCKS UP OR DOES NOT APPEAR.

Step 1. Press **[R/S]** key and hold for a moment. Check to see if display returns.

(a) If display returns, calculator was running long program, hung in loop or waiting for card to be inserted. Correct key sequence or program just entered.

(b) If display does not return, proceed to step 2.

Step 2. Press **[RST]** key and hold momentarily. Check to see if display returns.

(a) If display returns, processing was in Master Library module, hung in loop or was running a long program. Correct key sequence or program just entered.

(b) If display does not return, proceed to step 3.

Step 3. Press calculator power switch off, then on, and press **[CLR]** key. Check to see if display appears.

(a) If display does not appear, clean printer and calculator mounting contacts.

(b) If display still does not appear, proceed to step 4.

Step 4. Remove calculator from printer. Insert battery pack and check calculator operation.

8. DISPLAY FLASHES WHILE PERFORMING KEYBOARD OPERATIONS.

Check that proper key sequence was used.

Table 7-8. TROUBLESHOOTING - Cont

| MALFUNCTION | TEST OR INSPECTION | CORRECTIVE ACTION |
|-------------|--------------------|-------------------|
|-------------|--------------------|-------------------|

9. DISPLAY FLASHES EACH TIME LIBRARY PROGRAM IS CALLED.

Step 1. Check that program called exists on library module.

(a) If program is correct, proceed to step 2.

(b) Call correct program number or insert correct library module.

Step 2. Check to see if library module is properly installed.

(a) Turn off calculator.

(b) Slide small panel covering 1 library module back.

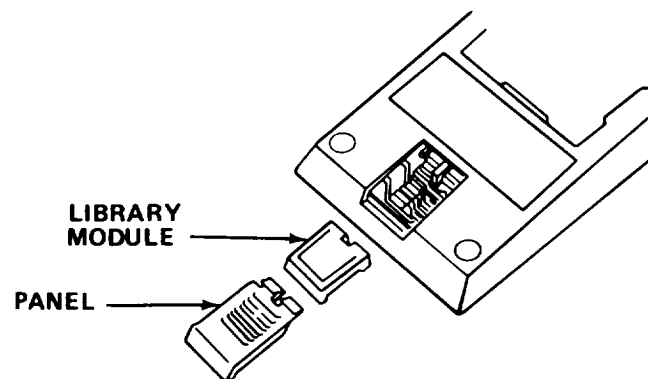
**CAUTION**

To avoid damaging the module, discharge body static charge by grasping a metal object before touching module.

(c) Turn calculator over and shake library module into hand.

(d) Inspect and clean contacts.

CAUTION

Be careful when inserting library module so contacts are not bent or damaged.

Table 7-8. TROUBLESHOOTING - Cont

MALFUNCTION

TEST OR INSPECTION

CORRECTIVE ACTION

9. DISPLAY FLASHES EACH TIME LIBRARY PROGRAM IS CALLED - Cont

- (e) Insert library module as shown, so that notch points toward top of calculator, and labeled side is up.
- (f) Slide cover panel back in place.

10. DISPLAY FLASHES OR PRODUCES INCORRECT RESULTS WHEN RUNNING A LIBRARY PROGRAM.

Step 1. Check that correct library program was used.

- (a) If program is correct, proceed to step 2.
- (b) Call correct library program.

Step 2. Check that correct call procedure was used.

- (a) If call procedure is correct, proceed to step 3.
- (b) Repeat program call.

Step 3. Check to see if partitioning of data registers is sufficient for program.

- (a) If partitioning is correct, proceed to step 4.
- (b) Repartition calculator memory.

Step 4. Check to see if calculator is operating in fixed-decimal format.

- (a) If format is correct, proceed to step 5.
- (b) Remove format by pressing **[INV]**, **[2nd]** and **Fix**, and rerun program.

Step 5. Press **[CLR]**, **[2nd]**, **Pgm**, **[0]**, **[SBR]**, and **=** to run library module diagnostic.

If result is flashing, perform step 2 of malfunction 9.

Step 6. Repeat library module diagnostic.

If malfunction persists, install new or different library module.

Table 7-8. TROUBLESHOOTING - Cont

| MALFUNCTION | TEST OR INSPECTION | CORRECTIVE ACTION |
|-------------------------------------------------------------------------------------------------------|------------------------------------------------------------------------------------------------------------------------------------------------------------------------|----------------------------------------------------------------------------------|
| 11. DISPLAY FLASHES OR PRODUCES INCORRECT RESULTS WHEN RUNNING PERSONALIZED PROGRAM STORED IN MEMORY. | Step 1. Check program to see if it is written correctly or uses improper operation. | (a) If program is written correctly, proceed to step 2. (b) Rewrite program. |
| | Step 2. Press CLR , 2nd , Pgm , 1 , SBR , and = to run library module diagnostic. If display flashes, see malfunction 9, step 2. | |
| | Step 3. Repeat library module diagnostic. | If display flashes, insert new library module. |
| | Step 4. Test calculator with calculator diagnostic card as follows: | (a) Load side 1 of card by pressing CLR key and inserting card into slot. |
| | NOTE | |
| | Calculator should pull card through unassisted and display 1. | |
| | (b) Press E key to run side 1. | |

Table 7-8. TROUBLESHOOTING - Cont

| MALFUNCTION | TEST OR INSPECTION | CORRECTIVE ACTION |
|-------------|--------------------|-------------------|
|-------------|--------------------|-------------------|

11. DISPLAY FLASHES OR PRODUCES INCORRECT RESULTS WHEN RUNNING PERSONALIZED PROGRAM STORED IN MEMORY - Cont

NOTE

- Display -.8888888888 indicates calculator passed.
- Display should also be printed automatically by printer. Flashing display indicates test failure.

- (c) Press **CLR** key and insert side 2 into slot to be read. Calculator should display 2. If not, repeat read.
- (d) Press **GTO**, **2**, **4**, **0**, **2nd** and Lst. Verify that printer prints code 77 for all locations 240-479.

NOTE

If each location does not contain code 77, card is not reading correctly.

- (e) If all locations contain code 77, press **CLR**, **2**, **2nd**, Write, and insert blank card into reader slot of calculator.
- (f) When blank card is recorded, press **2nd** and CP and insert card just recorded into calculator. Repeat (d).
- (g) If calculator fails test, repeat test. If it fails both times, replace calculator.

Table 7-8. TROUBLESHOOTING - Cont

| MALFUNCTION | TEST OR INSPECTION | CORRECTIVE ACTION |
|----------------------------------------------------------------------------------------|-----------------------------------------------------------------------------------------|--------------------------------------------------------------------------------------------------------------------------------------------------------------------|
| 12. DISPLAY FLASHES AFTER READING OR RECORDING CARD. | Step 1. Check that correct read procedure was used. | (a) If correct procedure was used, proceed to step 2. (b) Use correct read procedure. |
| | Step 2. Check to see if calculator memory partitioning is sufficient for program input. | (a) If partitioning is correct, proceed to step 3. (b) Repartition calculator. |
| | Step 3. Check to see if card is dirty or damaged. | (a) If card is not defective, proceed to step 4. (b) Clean. or replace card. If card was dirty, service (clean heads of) calculator before reading other cards. |
| | Step 4. Run library module diagnostics (steps 2, 8, 3, malfunction 11). | If display flashes, insert new library module. |
| 13. CALCULATOR WILL NOT GO INTO SINGLE STEP. LIST, RECORD CARD, OR GO INTO LEARN MODE. | Step 1. Check to see if program is protected. | The above functions cannot be performed on protected program, use unprotected program. |
| | Step 2. Check that calculator is partitioned correctly for program. | Partition calculator correctly. |

Table 7-8. TROUBLESHOOTING - Cont

| MALFUNCTION | TEST OR INSPECTION | CORRECTIVE ACTION |
|-------------|--------------------|-------------------|
|-------------|--------------------|-------------------|

14. CALCULATOR EXHIBITS MALFUNCTIONS 7, 8, 10 OR 12 ONLY WHEN BATTERY PACK IS USED.

Step 1. Check that battery pack is fully charged.

(a) Charge battery pack if it is low.

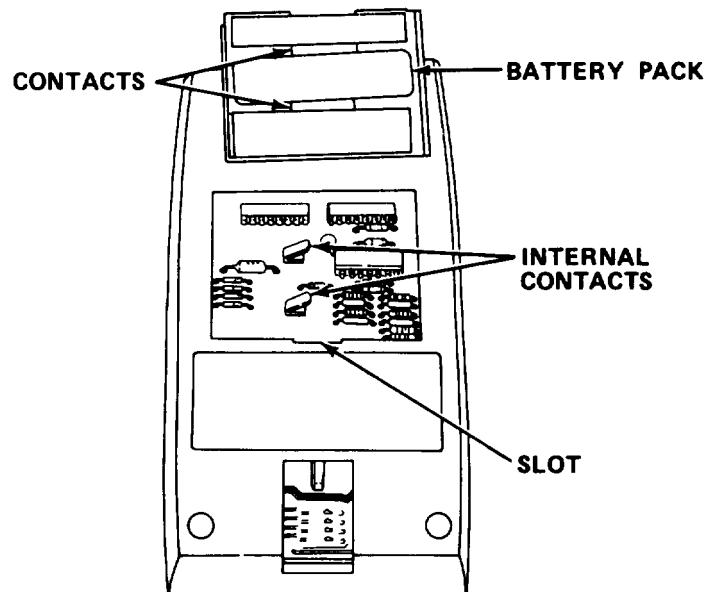

(b) If battery pack will not hold charge, replace as follows:

- (1) Insert screwdriver or pointed tool into slot on back of battery pack.
- (2) Gently release latch and remove battery pack.
- (3) Insert new battery pack and snap in place.

15. DISPLAY SHOWS ERRONEOUS RESULTS, FLASHES ERRATIC NUMBERS, GROWS DIM, GOES BLANK OR CARD READER RUNS CONTINUOUSLY WHEN BATTERY PACK IS USED.

See Malfunction 14.

7-10. MAINTENANCE PROCEDURES.

This section contains instructions covering operator maintenance functions for the TI-59 calculator. Personnel required are listed only if the task requires more than one.

b. After completing each maintenance procedure, perform operational check to be sure that equipment is properly functioning.

INDEX

| PROCEDURE | PARAGRAPH |
|------------------------|-----------|
| Replace Fuse | 7-10.1 |

7-10.1 Replace Fuse.

MOS: 82D, Topographic Surveyor

SUPPLIES: 1/4 amp SLO-BLO Fuse

WARNING

Death or serious injury may occur from electrical shock if power cord is not unplugged before servicing.

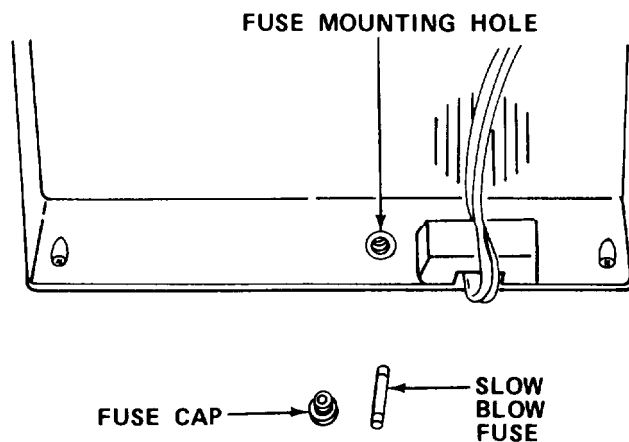

- a. Unplug power cord.
- b. Remove fuse holder by pushing in and turning 1/4 turn to the left, and remove blown fuse from holder.
- c. Install new fuse in holder, and install holder by pushing in and turning 1/4 turn to the right.
- d. Plug in power cord.

Section IV ORGANIZATIONAL MAINTENANCE

7-11. LUBRICATION INSTRUCTIONS. This equipment does not require lubrication.

7-12. REPAIR PARTS, SPECIAL TOOLS; TEST, MEASUREMENT, AND DIAGNOSTIC EQUIPMENT (TMDE); AND SUPPORT EQUIPMENT. These items are not required at this level of maintenance.

7-13. SERVICE UPON RECEIPT.

7-13.1 Checking Unpacked Equipment.

a. Inspect the equipment for damage incurred during shipment. If equipment has been, report the damage on DD Form 6, Packing Improvement Report.

b. Check the equipment against the packing list to see if the shipment is complete. Report all discrepancies in accordance with the instructions of DA Pam 738-750.

c. Check to see whether the equipment has been modified.

7-14. ORGANIZATIONAL PREVENTIVE MAINTENANCE CHECKS AND SERVICES. There are no organizational PMCS procedures assigned for this equipment.

7-15. ORGANIZATIONAL TROUBLESHOOTING PROCEDURES. There are no organizational troubleshooting procedures assigned for this equipment.

7-16. MAINTENANCE PROCEDURES. There are no organizational maintenance procedures assigned for this equipment.

7-17. PREPARATION FOR STORAGE OR SHIPMENT. Contact your battalion for packing and shipping instructions.

Section V DIRECT/GENERAL SUPPORT MAINTENANCE

There are no direct/general support maintenance procedures assigned for this equipment.

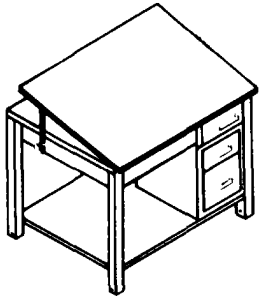

DRAWING TABLE

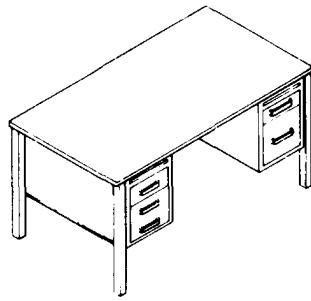

FLAT TOP DESK

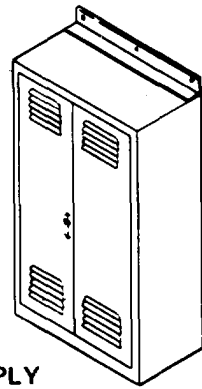

SUPPLY CABINET

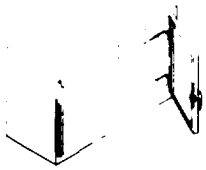

WALL STORAGE CABINET

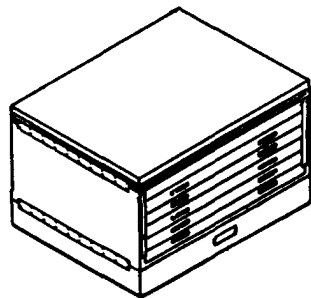

MAP AND PLAN FILING CABINET

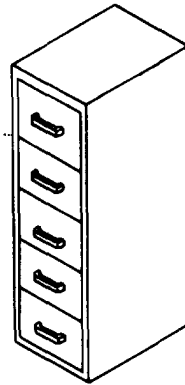

FILING CABINET

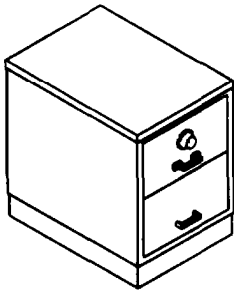

SECURITY FILING CABINET

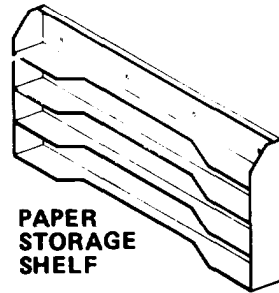

PAPER STORAGE SHELF

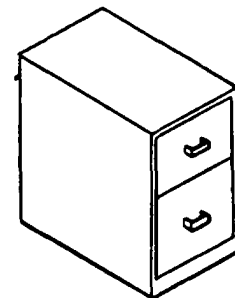

TWO-DRAWER FILING CABINET



ROTARY DRAFTING CHAIR

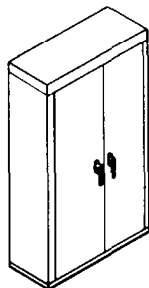

FORM STORAGE CABINET



ROTARY DESK CHAIR

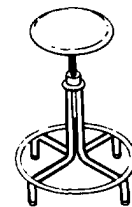

REVOLVING STOOL

CHAPTER 8

FURNITURE AND CABINETS

Section I INTRODUCTION

8-1. GENERAL INFORMATION.

8-1.1 Scope. This chapter contains the description of all furniture and cabinets contained in this section.

8-2. EQUIPMENT DESCRIPTION.

a. Drawing table. Provides a smooth work surface for drafting and cartographic revision. The drafting surface has adjustable angle. There is a three-drawer storage unit located underneath the drafting surface. Dimensions:

| | |
|--------|--------------------|
| Width | 48 in. (121.9 cm) |
| Depth | 37.5 in. (95.3 cm) |
| Height | 37 in. (93.9 cm) |

b. Supply cabinet. Provides storage for miscellaneous items. Cabinet has two louvered doors with a built-in latch and four shelves. Dimensions:

| | |
|--------|-------------------|
| Width | 36 in. (91.4 cm) |
| Depth | 18 in. (45.7 cm) |
| Height | 72 in. (182.9 cm) |

c. Wall storage cabinet. Used for miscellaneous storage. There are two shelves. The two doors are held shut by a handle-type latch. Dimensions:

| | |
|--------|------------------|
| Width | 30 in. (76.2 cm) |
| Depth | 12 in. (30.5 cm) |
| Height | 18 in. (45.7 cm) |

d. Flat top desk. Provides work space for clerical personnel. It has five drawers and a pull-out writing table. The five drawers can be locked. Dimensions:

| | |
|--------|--------------------|
| Width | 60 in. (152.4 cm) |
| Depth | 34 in. (86.4 cm) |
| Height | 30.5 in. (77.5 cm) |

e. Filing cabinet. Provided for storage of legal-sized documents. There are five drawers with a built-in lock. Dimensions:

| | |
|--------|---------------------|
| Width | 18 in. (45.7 cm) |
| Depth | 26.5 in. (67.3 cm) |
| Height | 57.5 in. (146.1 cm) |

f. Security filing cabinet. Used for security storage of classified documents. It has two drawers locked by a latch and combination lock located on the top drawer. Dimensions:

| | |
|--------|---------------------|
| Width | 20.75 in. (52.7 cm) |
| Depth | 28.0 in. (71.1 cm) |
| Height | 52.0 in. (132.1 cm) |

g. Map and plan filing cabinet. Used for flat, horizontal storage of maps, blue-prints, charts and plans of various sizes. The five drawers are held shut by two locking bars located on either side of the front of the cabinet. Dimensions:

| | |
|--------|----------------------|
| Width | 40.75 in. (103.5 cm) |
| Depth | 28.62 in. (72.7 cm) |
| Height | 20.84 in. (52.9 cm) |

h. Two-drawer filing cabinet. Used for storage of documents, correspondence and office supplies. Cabinet has two drawers. Each drawer has a built-in latch. Dimensions:

| | |
|--------|---------------------|
| Width | 15 in. (38.1 cm) |
| Depth | 28 in. (71.1 cm) |
| Height | 29.95 in. (74.3 cm) |

i. Rotary desk chair. Provides seating for personnel working at desk. It has a 3-3/4 in. (9.5 cm) seat height adjustment, ball bearing casters, tilt movement tension adjustment and adjustable back height. Dimensions:

| | |
|--------|--------------------|
| Width | 20.0 in. (50.8 cm) |
| Depth | 21.0 in. (53.3 cm) |
| Height | 32.0 in. (81.3 cm) |

j. Rotary drafting chair, Provides seating for drafting personnel. It has adjustable seat height and back position. Dimensions:

| | |
|--------|-------------------------------------------------|
| Width | 17.12 in. (43.5 cm) |
| Depth | 17.12 in. (43.5 cm) |
| Height | 42 in. (106.7 cm), Max 36 in. (91.4 cm), Min |

k. Revolving stool. Provides seating for personnel working at equipment. It has adjustable height. Dimensions:

| | |
|--------|---------------------------------------------------|
| Height | 28 in. (71.1 cm), Max 22.75 in. (57.8 cm), Min |
|--------|---------------------------------------------------|

l. Form storage cabinet. Used for storing many different types of forms.

| | |
|--------|----------------------|
| Width | 25.75 in. (65.41 cm) |
| Depth | 13 in. (33 cm) |
| Height | 36 in. (91.4 cm) |

m. Paper storage shelf. Used for storage of rolls of paper.

| | |
|--------|-------------------|
| Width | 43 in. (109.2 cm) |
| Depth | 5 in. (12.7 cm) |
| Height | 22 in. (55.9 cm) |

n. Double security file work station.

| | |
|--------|--------------------|
| Width | 66 in. (167.6 cm) |
| Depth | 34.5 in. (87.6 cm) |
| Height | 30.5 in. (77.5 cm) |

8-3. TECHNICAL PRINCIPLES OF OPERATION. There are no specific principles of operation for this equipment.

Section II OPERATING INSTRUCTIONS

8-4. DESCRIPTION AND USE OF OPERATOR'S CONTROLS AND INDICATORS. This equipment has no operator's controls or indicators.

8-5. OPERATOR PREVENTIVE MAINTENANCE CHECKS AND SERVICES. There are no operator PMCS procedures assigned for this equipment.

8-6. OPERATION UNDER USUAL CONDITIONS. There are no specific operational procedures for this equipment.

8-7. OPERATION UNDER UNUSUAL CONDITIONS. This equipment is designed for operation only in a controlled environment.

Section III OPERATOR MAINTENANCE

8-8. LUBRICATION INSTRUCTIONS. This equipment does not require lubrication.

8-9. TROUBLESHOOTING PROCEDURES. There are no operator troubleshooting procedures assigned for this equipment.

8-10. MAINTENANCE PROCEDURES.

a. This section contains instructions covering operator maintenance functions for the furniture and cabinets. Personnel required are listed only if the task requires more than one.

b. After completing each maintenance procedure, perform operational check to be sure that equipment is properly functioning.

8-10.1 Inspect Furniture and Cabinets. Inspect furniture and cabinets for structural damage, rust, and proper operation of all latches, hinges, and adjustment mechanisms.

Section IV ORGANIZATIONAL MAINTENANCE

8-11. LUBRICATION INSTRUCTIONS. This equipment does not require lubrication.

8-12. REPAIR PARTS, SPECIAL TOOLS; TEST, MEASUREMENT, AND DIAGNOSTIC EQUIPMENT (TMDE); AND SUPPORT EQUIPMENT.

8-12.1 Common Tools and Equipment. For authorized common tools and equipment, refer to the Modified Table of Organization and Equipment (MTOE) applicable to your unit.

8-12.2 Special Tools; Test, Measurement, and Diagnostic Equipment; and Support Equipment. Special Tools, TMDE, and Support Equipment is listed in the applicable repair parts and special tools list and in Appendix B of this manual.

8-12.3 Repair Parts. Repair parts are listed and illustrated in the Repair Parts and Special Tools List, TM 5-6675-318-24P covering organizational maintenance for this equipment.

8-13. SERVICE UPON RECEIPT.

8-13.1 Checking Unpacked Equipment.

a. Inspect the equipment for damage incurred during shipment. If the equipment has been damaged, report the damage on DD Form 6, Packing Improvement Report.

b. Check the equipment against the packing list to see if the shipment is complete. Report all discrepancies in accordance with the instructions of DA Pam 738-750.

c. Check to see whether the equipment has been modified.

8-14. ORGANIZATIONAL PREVENTIVE MAINTENANCE CHECKS AND SERVICES. There are no organizational PMCS procedures assigned for this equipment.

8-15. ORGANIZATIONAL TROUBLESHOOTING PROCEDURES. There are no organizational troubleshooting procedures assigned for this equipment.

8-16. MAINTENANCE PROCEDURES.

a. This section contains instructions covering organizational maintenance functions for the furniture and cabinets. Personnel required are listed only if the task requires more than one.

b. After completing each maintenance procedure, perform operational check to be sure that equipment is properly functioning.

INDEX

| PROCEDURE | PARAGRAPH |
|-------------------------------------------------------------------------------------------|-----------|
| Replace Hinge (Piano Hinge) | 8-16.1 |
| Replace Latch (Wall Storage Cabinet) | 8-16.2 |
| Remove/Install Work Station (Two-Drawer Filing Cabinet and Security Cabinet) | 8-16.3 |
| Remove/Install Work Station (Double Security Cabinets) | 8-16.4 |
| Remove/Install Wall Storage Cabinet. | 8-16.5 |
| Remove/Install Map and Plan Filing Cabinet | 8-16.6 |
| Remove/Install Filing Cabinet | 8-16.7 |
| Remove/Install Supply Cabinet | 8-16.8 |
| Remove/Install Flat Top Desk | 8-16.9 |
| Remove/Install Drawing Table. | 8-16.10 |
| Remove/Install Paper Storage Shelf | 8-16.11 |
| Remove/Install Form Storage Cabinet | 8-16.12 |

8-16.1 Replace Hinge (Piano Hinge)

MOS: 83FJ6, Reproduction Equipment Repairer

TOOLS: 1/4 in. Electric Drill
5/32 in. Drill Bit
Pop Rivet Gun

SUPPLIES: Piano Hinge
5/32 in. Pop Rivets
8-32 x 1/2 in. Screws (4 required)
8-32 Nuts (4 required)

- a. Drill out rivets holding hinge to cabinet and remove hinge.
- b. Install new hinge and temporarily secure with four screws and nuts.
- c. Close and latch cabinet door and install pop rivets
- d. Remove temporarily installed screws and nuts, and install remaining pop rivets.

8-16.2 Replace Door Latch (Wall Storage Cabinet).

MOS : 83FJ6, Reproduction Equipment Repairer

TOOLS: 9/16 in. Combination Wrench
Flat Tip Screwdriver

SUPPLIES: Handle Type Latch

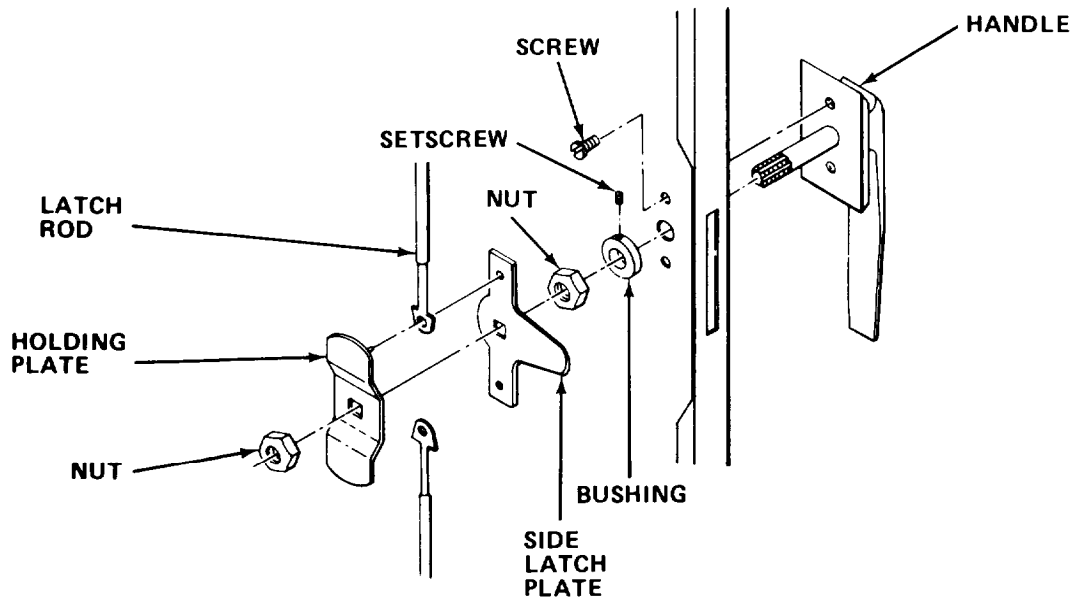

- a. Remove holding plate retaining nut.
- b. Remove holding plate and latch rods.
- c. Remove side latch plate.
- d. Remove handle retaining nut.
- e. Loosen setscrew and remove bushing from handle shaft.
- f. Remove two handle retaining screws and remove handle.
- g. Install new handle and secure with two screws.
- h. Reinstall bushing on handle shaft and tighten setscrew,
- i. Reinstall handle retaining nut.
- j. Reinstall side latch plate.
- k. Reinstall latch rod holding plate and latch rods.
- l. Reinstall holding plate retaining nut.

8-16.3 Remove/Install Work Station. (Two-Drawer Filing Cabinet and Security Cabinet).

MOS: 83FJ6, Reproduction Equipment Repairer

TOOLS: Cross Tip Screwdriver
7/16 in. Combination Wrench
1/2 in. Combination Wrench

SUPPLIES: Table Top
Two-Drawer Filing Cabinet
Frame
Panel
Security Cabinet

- a. Open security cabinet and move materials to security storage. Tape combination to outside of cabinet.

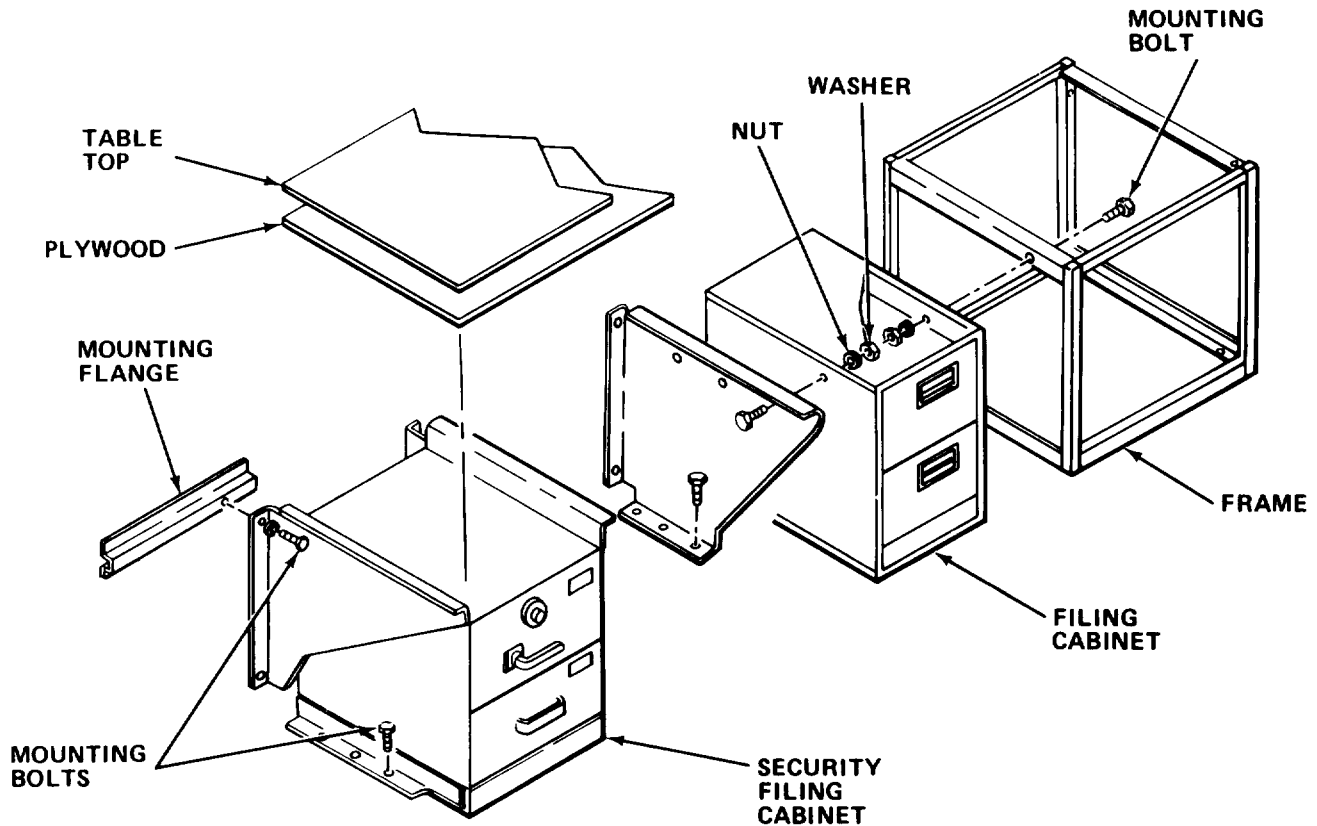

- b. Remove drawers from both filing cabinets. Tape keys to filing cabinet top.

- c. Remove bolts, washers, and nuts holding panel, filing cabinets, and frame together.
- d. Remove bolts holding frame and panel to floor.
- e. Remove bolts and washers holding frame and panel to wall.
- f. Remove table top screws.
- g. Remove table top and separate filing cabinets and frame.
- h. Replace defective components.
- i. Bolt filing cabinets to frame, secure with washers and nuts.
- j. Bolt panel to filing cabinet, secure with washers and nuts.
- k. Screw table top to frame and panel.
- l. Line up holes and secure assembly to floor with bolts.
- m. Secure assembly to wall with bolts.
- n. Reinstall and replace drawers in file cabinet(s).
- o. Have combination lock changed to new combination before storing materials in security filing cabinet.

8-16.4 Removal/Instal Work Station (Double Security Cabinets)

MOS: 83FJ6, Reproduction Equipment Repairer

TOOLS : 1/2 in. Combination Wrench
Cross Tip Screwdriver

SUPPLIES: Table top
Security Cabinet(s)

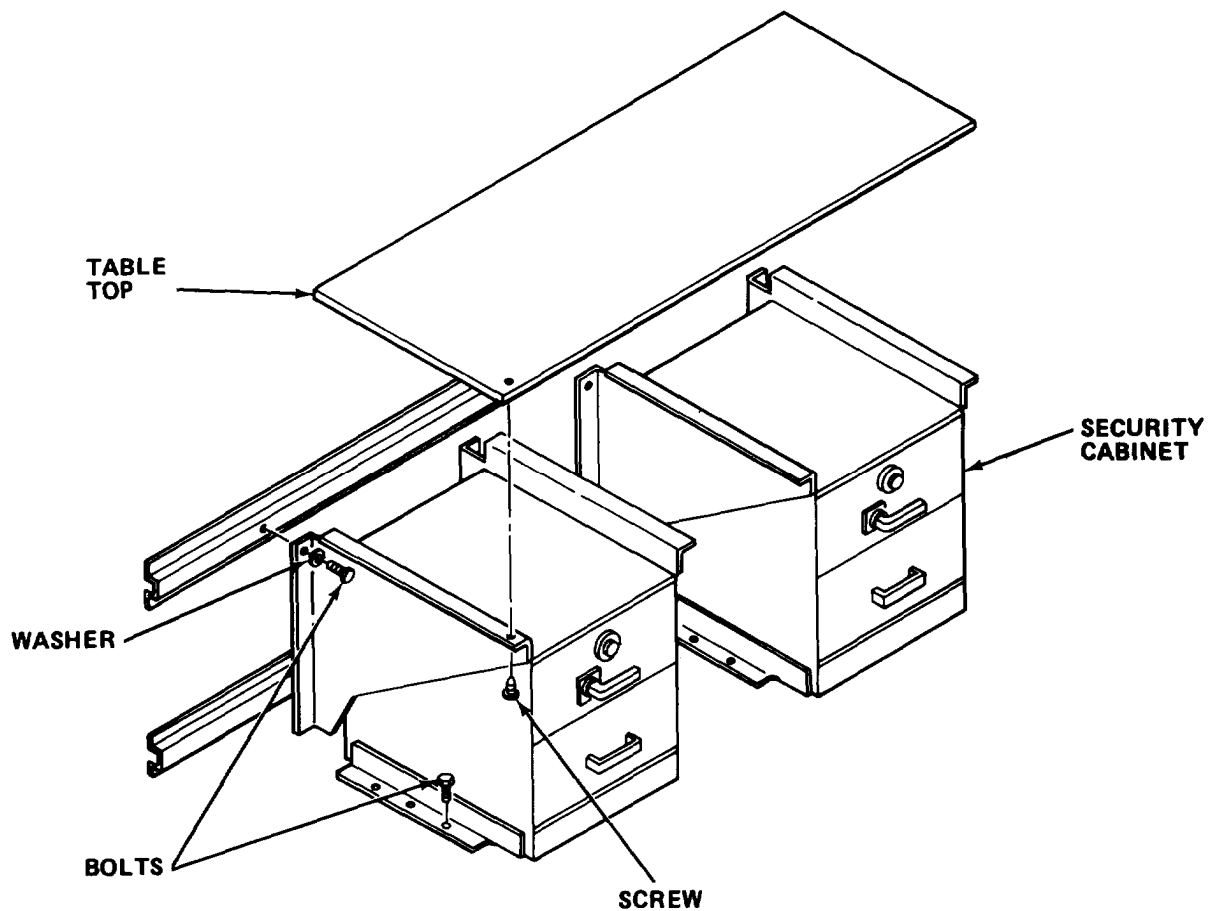

- a. Remove/install table top.
 - (1) Remove screws securing defective table top to security cabinets.
 - (2) Lift off defective table top and place new table top into position on top of security cabinets.
 - (3) Reinstall screws to secure table top to security cabinets.
- b. Remove/install security cabinet(s).
 - (1) Remove table top (step a above).

- (2) Open security cabinet(s) and move materials to security storage.
Tape combination to outside of cabinet(s).
- (3) Remove drawers.
- (4) Remove bolts securing defective cabinet(s) to the floor.
- (5) Remove bolts and washers securing defective cabinet(s) to the wall.
- (6) Remove defective cabinet(s) and position new cabinet(s) into place.
- (7) Install bolts and washers that secure cabinet(s) to wall.
- (8) Install bolts that secure cabinet(s) to floor.
- (9) Reinstall table top (step a above).
- (10) Have new combination(s) made to security locks before storing materials in cabinet(s).

8-16.5 Remove/Install Wall Storage Cabinet.

MOS: 83FJ6, Reproduction Equipment Repairer

TOOLS: 1/2 in. Socket, 1/2 in. Drive
1/2 in. Drive Ratchet
1/2 in. Socket Extension, 2 in. Long

SUPPLIES: Wall Storage Cabinet

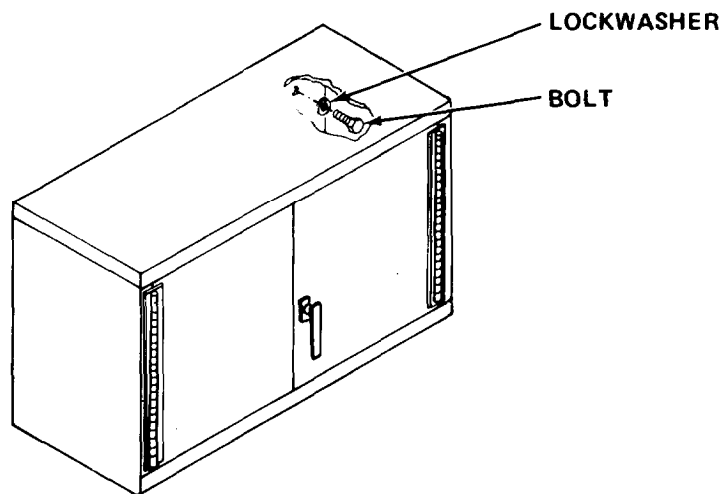

- a. Remove bolts and washers which secure cabinet to wall.
- b. Remove defective cabinet.
- c. Install new cabinet and secure to wall with washers and bolts.

8-16.6 Remove/Install Map and Plan Filing Cabinet.

MOS: 83FJ6, Reproduction Equipment Repairer

TOOLS: 1/2 in. Combination Wrench

SUPPLIES: Map and Plan Filing Cabinet

- a. Remove drawers from map and plan filing cabinet.

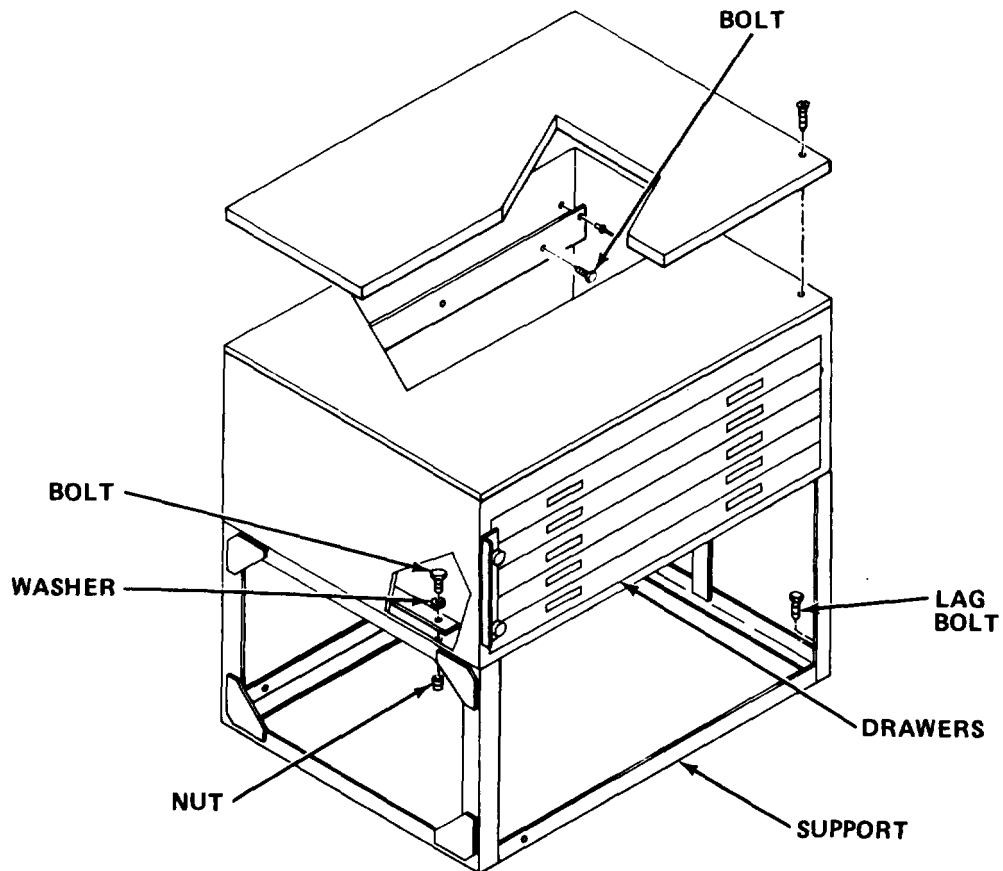

- b. Remove bolts and washers holding cabinet to wall.
- c. Remove bolts, washers, and clinch nuts holding cabinet to support.
- d. Remove cabinet.
- e. Secure cabinet to support with bolts, washers, and clinch nuts.
- f. Secure cabinet to wall.
- g. Reinstall drawers.

8-16.7 Remove/Install Filing Cabinet.

MOS: 83FJ6, Reproduction Equipment Repairer

TOOLS: 1/2 in. Combination Wrench

SUPPLIES: Filing Cabinet

- a. Remove drawers from filing cabinet.

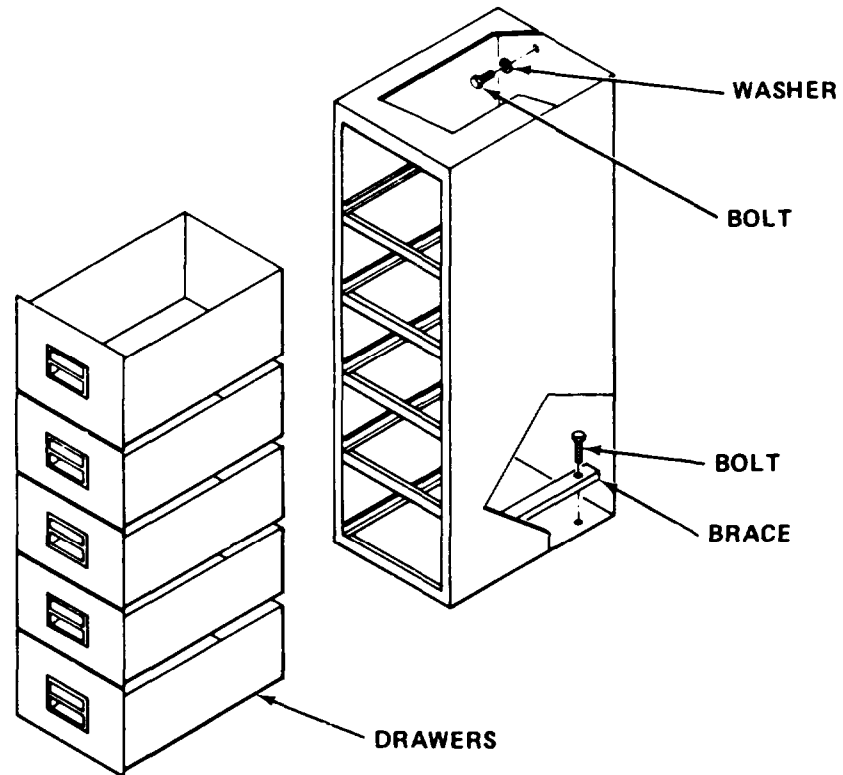

- b. Remove bolts and washers securing cabinet to wall.
- c. Remove bolts and braces securing cabinet to floor.
- d. Remove cabinet.
- e. Remove drawers from new cabinet and line up cabinet with holes in floor.
- f. Reinstall bolts to bottom braces.
- g. Reinstall bolts and washers to wall.
- h. Reinstall drawers in cabinet.

8-16.8 Remove/Install Supply Cabinet

MOS: 83FJ6, Reproduction Equipment Repairer

TOOLS: 1/4 in. Socket Set
 6 in. Socket Extension
 11/32 in. Combination Wrench
 Flat Tip Screwdriver
 Cross tip Screwdriver

SUPPLIES: Supply Cabinet

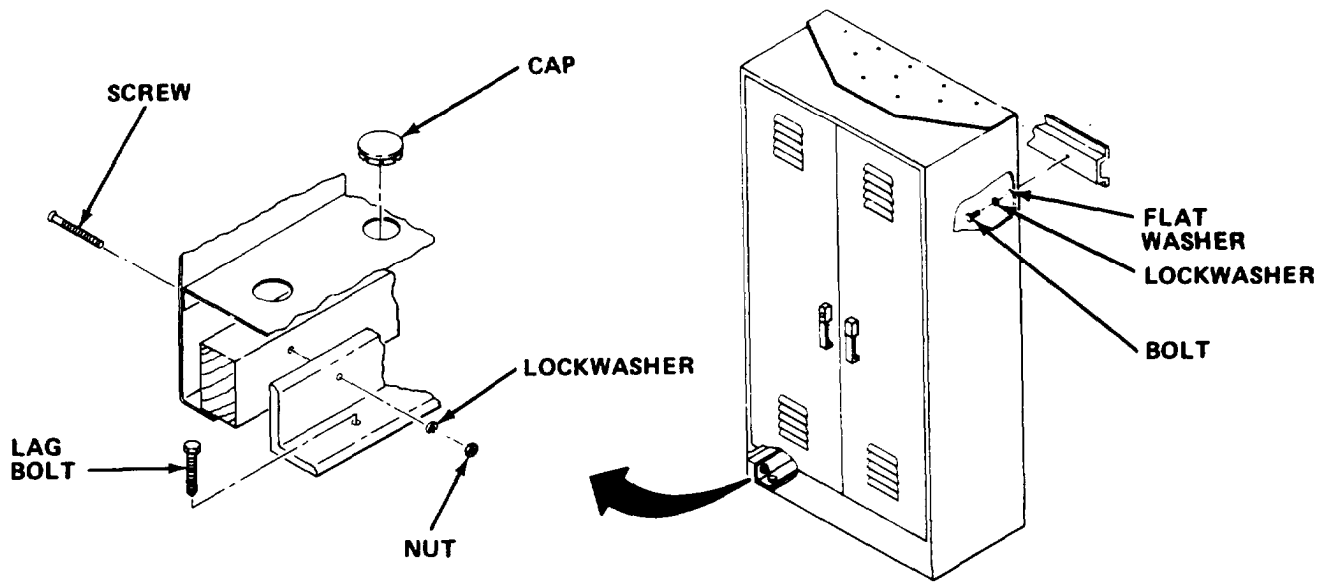

- a. Remove bolts, lockwashers, and flat washers holding cabinet to wall.
- b. Remove caps and lag bolts holding mounting bracket to floor and remove defective cabinet.
- c. Remove nuts, lockwashers, screws, mounting bracket, and spacer from cabinet. Retain mounting bracket and spacers for use on new cabinet.
- d. Position spacers and mounting bracket on new cabinet, and install but do not tighten screws, lockwashers, and nuts.
- e. Place new cabinet in position, and install but do not tighten lag bolts.
- f. Secure cabinet to wall with flatwashers, lockwashers, and bolts.
- g. Tighten the bracket retaining screws and nuts.
- h. Tighten the bolts holding mounting bracket to the floor, and install caps.

8-16.9 Remove/Install Flat Top Desk.

MOS: 83FJ6, Reproduction Equipment Repairer

TOOLS: 9/16 in. Combination Wrench

SUPPLIES: Flat Top Desk

- a. Remove material from drawers and tape key to desk.

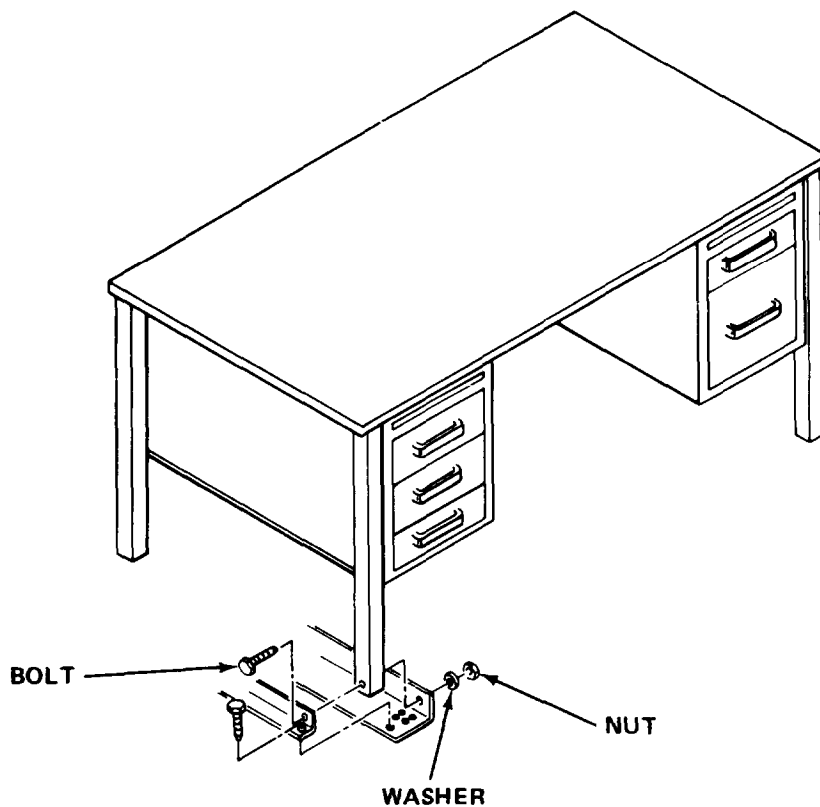

- b. Remove bolts, washers, and nuts from legs.
- c. Remove desk.
- d. Position new desk and line up holes in legs with bracket holes.
- e. Secure desk with bolts, washers, and nuts.

8-16.10 Remove/Install Drawing Table.

MOS: 83FJ6, Reproduction Equipment Repairer

TOOLS: 9/16 in. Combination Wrench

SUPPLIES: Drawing Table

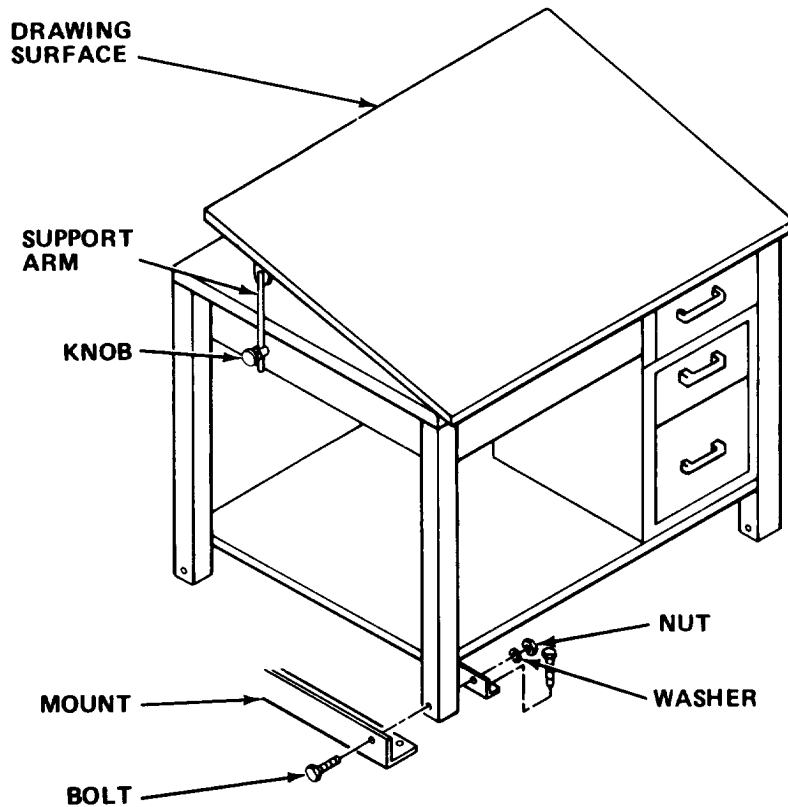

- a. Loosen knobs on support arms and lower drawing surfaces.
- b. Tighten knobs to hold drawing surface down.
- c. Remove contents from drawers; then lock drawers closed and tape key to table.
- d. Remove bolts, washers, and nuts from legs.
- e. Replace table.
- f. Line up holes in legs with holes in mount and secure table with bolts, washers, and nuts.
- g. Store table contents in drawer.

8-16.11 Remove/Install Paper Storage Shelf.

MOS: 83FJ6, Reproduction Equipment Repairer

TOOLS: 1/4 in. Drive Socket Set

SUPPLIES: Paper Storage Shelf

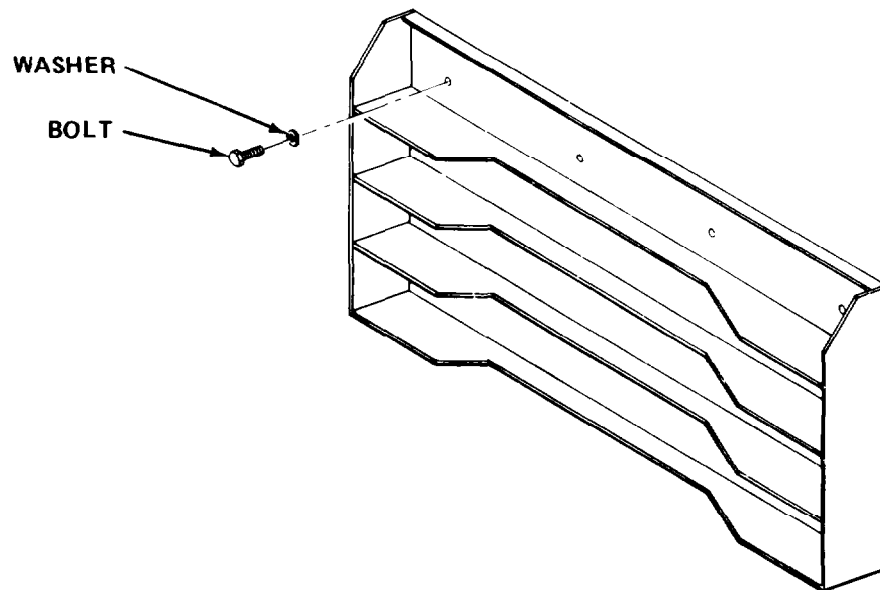

- a. Remove attaching hardware securing defective paper shelf to wall.
- b. Remove defective paper shelf.
- c. Position new paper shelf and align mounting holes.
- d. Secure new paper shelf to wall with attaching hardware.

8-16.12 Remove/Install Form Storage Cabinet.

MOS: 83FJ6, Reproduction Equipment Repairer

TOOLS: 1/2 in. Combination Wrench

SUPPLIES: Form Storage Cabinet

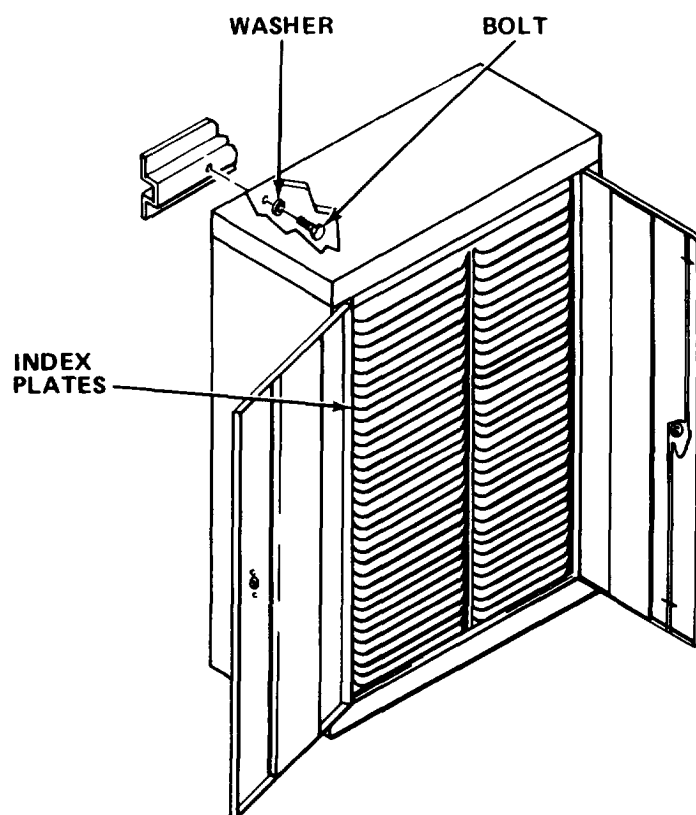

- a. Open cabinet and remove index plates.
- b. Remove bolts and washers holding cabinet to wall and remove cabinet.
- c. Install new cabinet and retain with bolts and washers.

8-17. PREPARATION FOR STORAGE OR SHIPMENT. Contact your battalion for packing and shipping instructions.

Section V DIRECT/GENERAL SUPPORT MAINTENANCE

There are no direct/general support maintenance procedures assigned for this equipment.

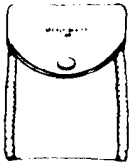

POCKET STEREOSCOPE

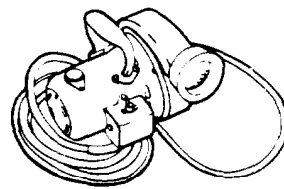
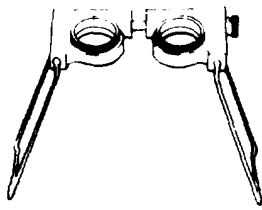

VACUUM CLEANER

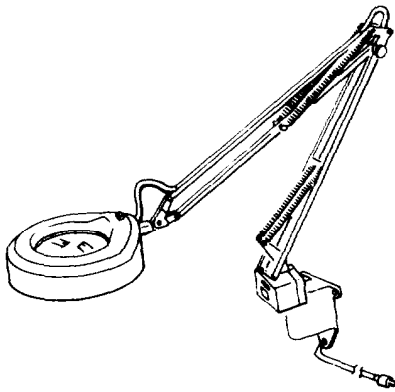

**MAGNIFIER
LAMP**

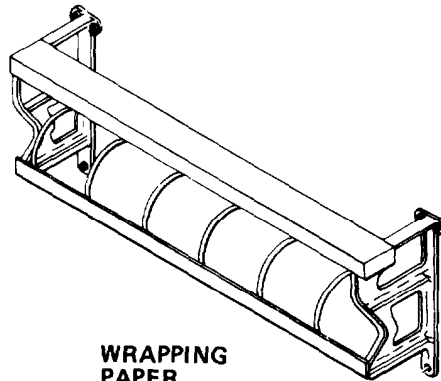

**WRAPPING
PAPER
HOLDER/
CUTTER**

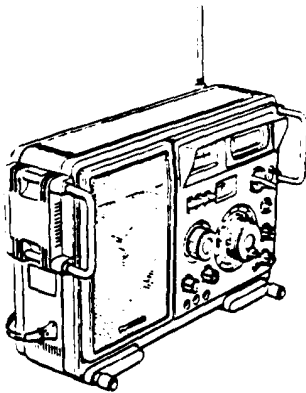

RADIO RECEIVER

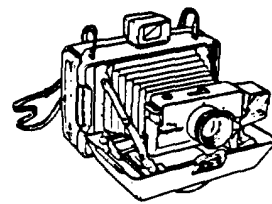

**STILL PICTURE
(INSTANT)
CAMERA SET**

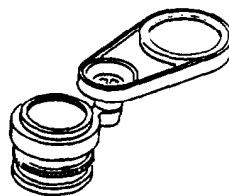

PHOTO ENGRAVING MAGNIFIER

CHAPTER 9

SUPPORT ITEMS

Section I INTRODUCTION

9-1. GENERAL INFORMATION.

9-1.1 Scope. This chapter covers the support items contained in this section. The support items consist of the following equipment:

- a. Model LFM1BX5 Magnifier Lamp.
- b. Model 3400 Vacuum Cleaner.
- c. Type 1 Pocket 2X Stereoscope.
- d. EE-100 Still Picture (Instant) Camera Set.
- e. Model 20 Photoengraving Magnifier.
- f. Model RF-2900 Portable Radio Receiver.
- g. Model FF-H-571 Wrapping Paper Holder and Cutter.

9-1.2 Reference Information.

List of Abbreviations

| | |
|-----|-----------------------------|
| AFC | Automatic Frequency Control |
| AM | Amplitude Modulated |
| BFO | Beat Frequency Oscillator |
| CW | Continuous Wave |
| DSB | Double-Side Band |
| FM | Frequency Modulated |
| LSB | Lower Side Band |
| RF | Radio Frequency |
| SSB | Single-Side Band |
| SW | Shortwave |
| USB | Upper Side Band |

9-2. EQUIPMENT DESCRIPTION.

9-2.1 Equipment Characteristics, Capabilities, and Features.

- a. Magnifier lamp. Adjustable for accurate positioning to provide illuminated magnification of precision work. Provision for both wall and bench mounting.
- b. Vacuum cleaner. High speed, heavy duty, used for general cleaning.
- c. Pocket stereoscope. Optically matches and gives operator an apparent single image of two maps or photographs.
- d. EE-100 Still picture (instant) camera set. Refer to operator's manual supplied with camera for characteristics, capabilities, and features.
- e. Wrapping paper holder and cutter. Holds and cuts up to 36 in. wide rolled paper.

9-2.2 Equipment Data.

- a. Magnifier lamp. Replaceable 120 V ac lamp and diffuser.
- b. Vacuum cleaner. Packed in storage box containing hose, various vacuum and blowing attachments, liquid spray attachments, and motor repair kit containing motor bearings and brushes.

9-3. TECHNICAL PRINCIPLES OF OPERATION. Principles of operation are combined with operator's controls and indicators.

Section II OPERATING INSTRUCTIONS

9-4. DESCRIPTION AND USE OF OPERATOR'S CONTROLS AND INDICATORS.

9-4.1 Magnifier Lamp.

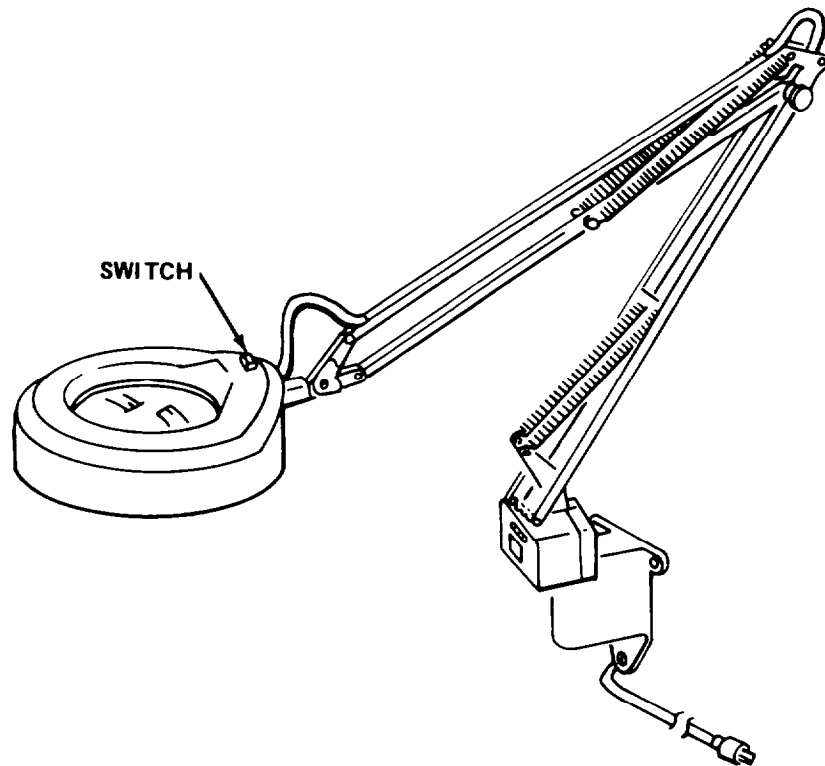

Control or Indicator

Function

Switch

Turns lamp on/off.

9-4.2 Vacuum Cleaner

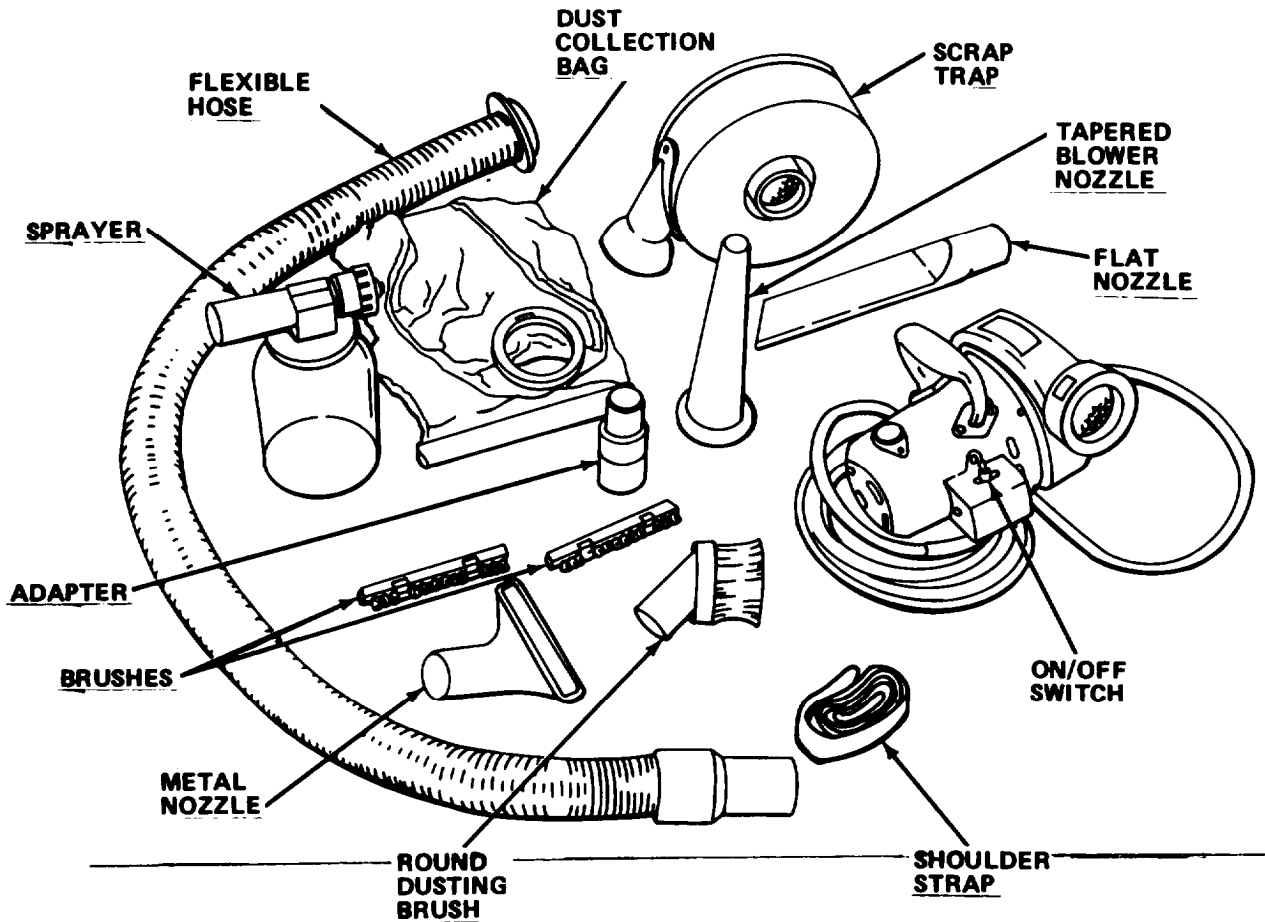

Control or Indicator

Function

Sprayer

Sprays liquids when hooked to blower side of vacuum cleaner.

Flexible Hose

Directs airflow in hard-to-reach areas.

Dust Collection Bag

Collects and holds dust and dirt.

Scrap Trap

Traps large particles before they enter fan.

Tapered Blower Nozzle

Directs airflow.

Flat Nozzle

Used for hard-to-reach areas.

ON/OFF Switch

Turns power on or off.

| Control or Indicator | Function |
|----------------------|-------------------------------------------------|
| Shoulder Strap | Attaches to vacuum cleaner for easier carrying. |
| Round Dusting Brush | Used for light dust and dirt. |
| Metal Nozzle | Used for large, flat surfaces. |
| Brushes | Used on metal nozzle. |
| Adapter | Connects various attachments to hose. |

9-4.3 Pocket Stereoscope.

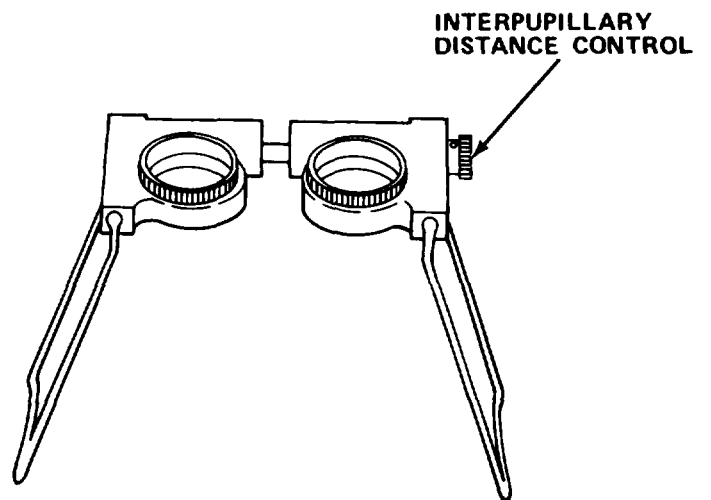
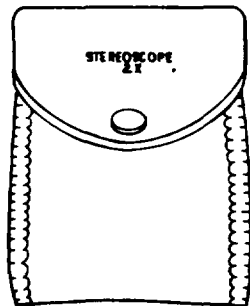

| Control or Indicator | Function |
|---------------------------------|--------------------------------------------------------------------|
| Interpupillary Distance Control | Adjusts interpupillary distance of lenses to match that of viewer. |

9-4.4 Still Picture (Instant) Camera Set

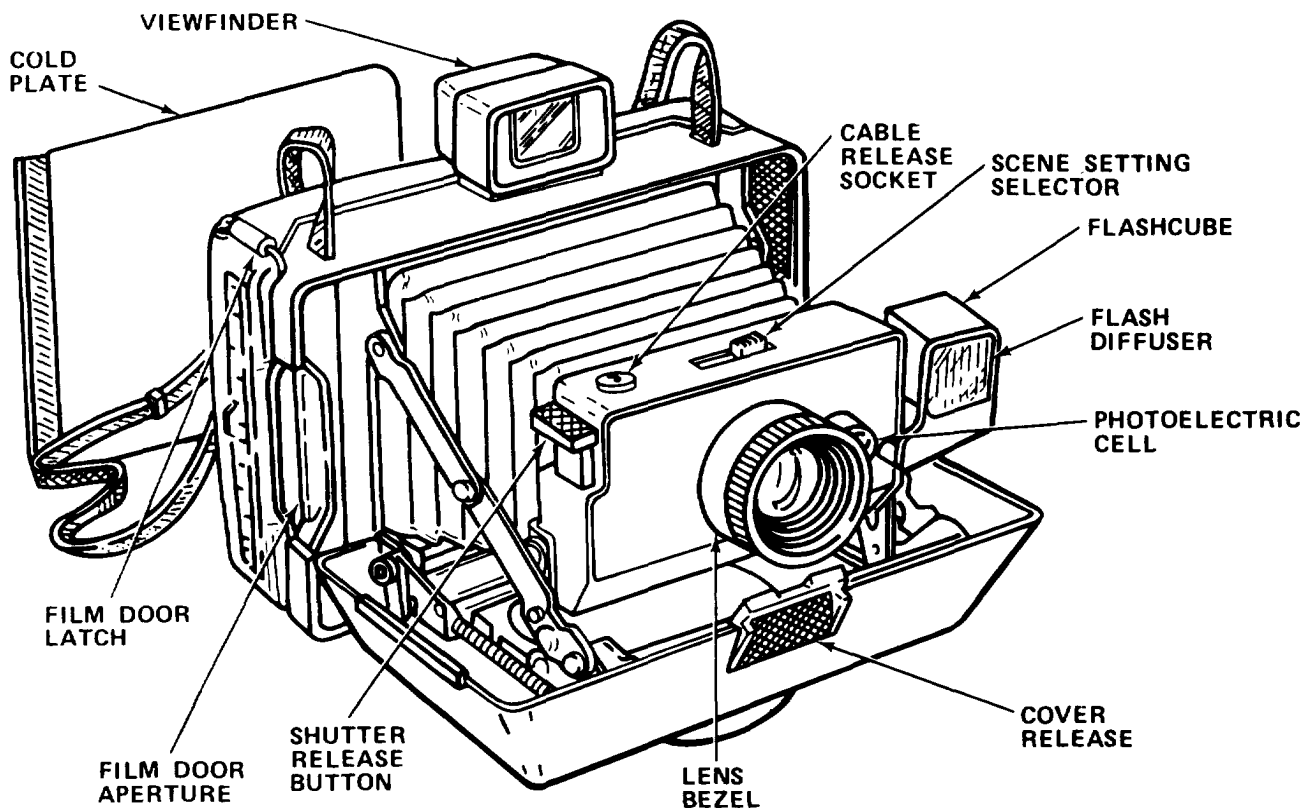

| Control or Indicator | Function |
|------------------------|--------------------------------------------------|
| Viewfinder | Contains framing lines for series film in use. |
| Scene Setting Selector | Settings for outdoors, flash. |
| Flashcube | Automatically advances as exposures are made. |
| Photoelectric Cell | Measures reflected light from subject. |
| Flash Diffuser | Prevents overillumination of close subjects. |
| Cover Release | Locks camera door. |
| Lens Bezel | Scale for setting estimated distance to subject. |

| Control or Indicator | Function |
|------------------------|---------------------------------------------------------------------------------------------|
| Shutter Release Button | Activates shutter and flashcube (if used). |
| Cable Release Socket | For optional cable release. |
| Film Door Aperture | Photographs are pulled out here. |
| Film Door Latch | Locks film door shut. |
| Cold Plate | Assists in developing color prints in cold weather. (Stored in back cover when not in use.) |

9-4.5 Radio Receiver.

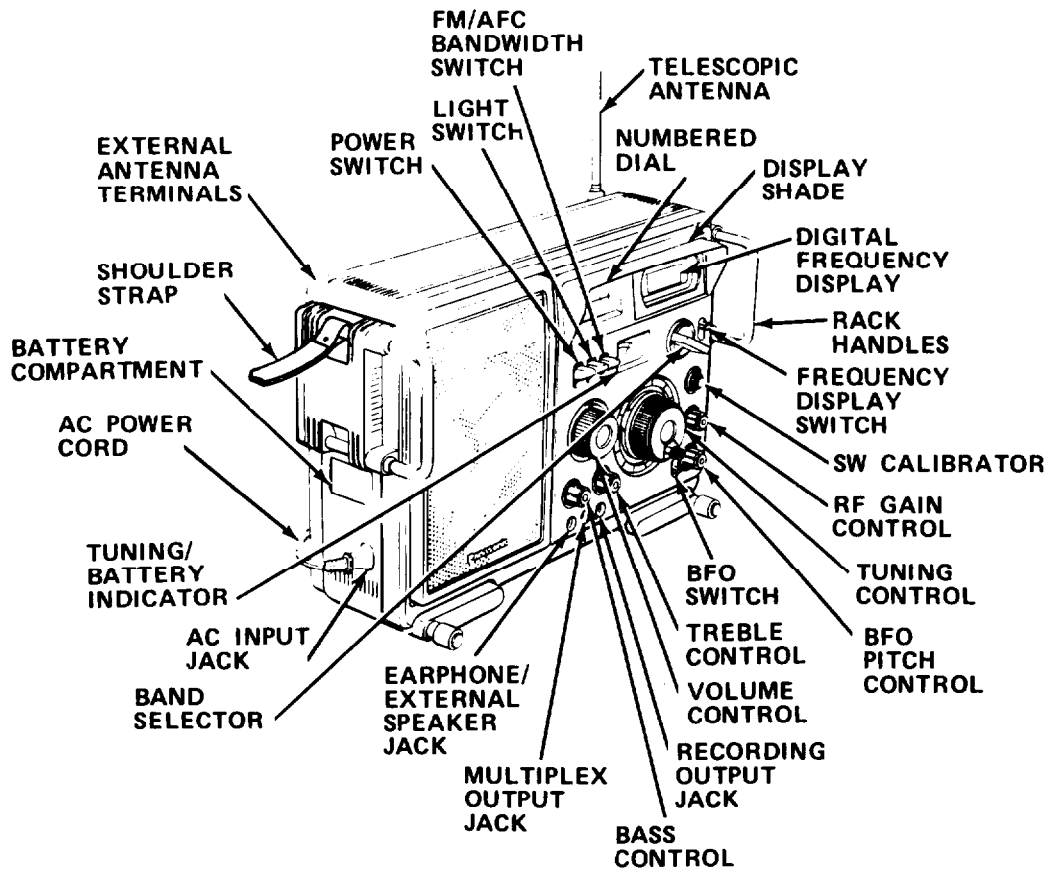

| Control or Indicator | Function |
|----------------------------|-------------------------------------------------------------------------------------------------|
| External Antenna Terminals | Terminals in rear for connecting external antenna. |
| Power Switch | Turns radio receiver on and off. |
| Light Switch | Used to enable tuning in dark. When on, tuning dial and tuning/battery indicator will light up. |

| Control or Indicator | Function |
|---------------------------|-------------------------------------------------------------------------------------------------------------------------------------------------------------------------------------------------------------------------------------------------------------------|
| FM/AFC Bandwidth Switch | Used to provide drift-free FM reception and interference-free AM/SW reception. If AM or SW reception is marred by interference from adjacent station, set switch to narrow (down). If FM reception is marred by strong adjacent station, turn switch off (down). |
| Display Shade | Reduces glare on digital frequency display to make it easier to read when in sunshine and highly lighted areas. Snaps in place around display. |
| Telescopic Antenna | Ferrite core antenna extends and adjusts its angle for FM and SW transmission reception. |
| Numbered Dial | Used to indicate frequency when digital frequency display is not in use. |
| Digital Frequency Display | When display switch is ON, fluorescent numerals indicate tuned frequency. For FM and SW reception, display shows frequency in MHz as decimal fraction (less than 1 MHz). For AM reception, display is three- or four-digit integer representing frequency in kHz. |
| Rack Handles | Used for lifting, handling and moving radio. |

| Control or Indicator | Function |
|--------------------------|----------------------------------------------------------------------------------------------------------------------------------------------------------------------------------------------------------------------------------------------------------------------|
| Frequency Display Switch | Controls digital frequency display. With switch on, display is continuous. If switch is pressed down, temporary display comes on. |
| Band Selector | Sets tuning and display to desired band. |
| SW Calibrator | Used to correct errors between frequency display and actual frequency of optionally tuned station. Functions for SW reception only. |
| RF Gain Control | Adjusts radio receiver sensitivity for optimal AM or SW reception. Normally kept in fully right position. Rotate control left to reduce or eliminate overloading or distortion caused by station located too close to radio receiver. Has no effect on FM reception. |
| Tuning Control | Used to tune in desired station signal at one of two possible speeds. For precise tuning (slower), pull control dial out. For faster tuning, push in. |
| BFO Pitch Control | Control is rotated to obtain optimal reception of SSB or CW signal. Frequency of signal should be tuned in with BFO switch on. |
| BFO Switch | Turns BFO on and off. For SSB or CW reception, set switch on. For all other reception, keep switch off. |

| Control or Indicator | Function |
|--------------------------------|--------------------------------------------------------------------------------------------------------------------------------------------------------------------------------------------------------------------|
| Volume Control | Regulates volume of signal . |
| Treble Control | Regulates signal treble (high) tones. |
| Recording Output Jack | Used to connect tape recorder for recording signals received. Sound level at jack is fixed. All signals received by unit are outputted through jack. |
| Multiplex Output Jack | Used to connect FM stereo multiplexer to reproduce FM stereo programs. |
| Bass Control | Regulates bass (low) tone. |
| Earphone/External Speaker Jack | Used to connect accessory earphone or external speaker. Inserting plug into this jack disconnects built-in speaker. |
| AC Input Jack | Used to connect ac power cord. When power cord is connected, internal batteries are automatically disconnected. |
| AC Power Cord | Used to input ac power. |
| Battery Compartment | Stores ac power cord and earphone, and contains batteries. |
| Tuning/Battery Indicator | Used as tuning aid. Also used to check battery. When signal is being received, meter needle deflects to left to indicate relative strength of signal. The greater the deflection to left, the stronger the signal. |

| Control or Indicator | Function |
|----------------------|----------------------|
| Shoulder Strap | Attached to handles. |

9-5. OPERATOR PREVENTIVE MAINTENANCE CHECKS AND SERVICES.

- a. Before You Operate. Always keep in mind the WARNINGS and CAUTIONS. Perform your before (B) PMCS.
- b. While You Operate. Always keep in mind the WARNINGS and CAUTIONS. Perform your during (D) PMCS.
- c. After You Operate. Be sure to perform your after (A) PMCS.
- d. If Your Equipment Fails To Operate. Troubleshoot with proper equipment. Report any deficiencies using the proper forms. See DA Pam 738-750.

9-5.1 PMCS Procedures.

- a. PMCS are designed to keep the equipment in good working condition by performing periodic service tasks.
- b. Service intervals provide you, the operator, with time schedules that determine when to perform specified service tasks.
- c. The "Equipment is Not Ready/Available If" column is used for identification of conditions that make the equipment not ready/available for readiness reporting purposes or denies use of the equipment until corrective maintenance is performed.
- d. If your equipment fails to operate after PMCS is performed, immediately report this condition to your supervisor.
- e. Perform weekly as well as before operation if you are the assigned operator and have not operated the item since the last weekly or if you are operating the item for the first time.
- f. Item number column. Item numbers are assigned in chronological ascending sequence regardless of interval designation. These numbers are used for your "TM Number" column on DA Form 2404, Equipment Inspection and Maintenance Worksheet in recording results of PMCS.
- g. Interval columns. This column determines the time period designated to perform your PMCS.
- h. Item to be inspected and procedures column. This column lists functional groups and their respective assemblies and subassemblies as shown in the Maintenance Allocation Chart (Appendix B). The appropriate check or service procedure follows the specific item to be inspected.

i. Equipment is not ready/available if: column. This column indicates the reason or cause why your equipment is not ready/available to perform its primary mission.

j. List of tools and materials required for PMCS is as follows:

| <u>Equipment</u> | <u>Items</u> | <u>Quantity</u> |
|---------------------------------------|-------------------------------------------|-----------------|
| Still Picture (Instant) Camera Set | Watchmaker's Blower | 1 ea |
| | Lens Paper (Item 11, Appendix E) | ar |
| | Denatured Alcohol (Item 3, Appendix E) | ar |
| | Cotton Swabs (Item 6, Appendix E) | ar |
| | Batteries (Size AA 1.5V) | 2 ea |
| | | |
| Magnifier Lamp | Lens Cleaner (Item 4, Appendix E) | ar |
| | Cheesecloth (Item 5, Appendix E) | ar |
| Pocket Stereoscope | Lens Paper (Item 11, Appendix E) | ar |
| Photoengraving Magnifier | Lens Paper (Item 11, Appendix E) | ar |

Table 9-1. OPERATOR PREVENTIVE MAINTENANCE CHECKS AND SERVICES

NOTE

If the equipment must be kept in continuous operation, check and service only those items that can be checked and serviced without disturbing operation. Make the complete checks and services when the equipment can be shut down.

B - Before
D - During
A - After

W - Weekly
M - Monthly
Q - Quarterly

AN - Annually
S - Semiannually
BI - Biennially

(Number) - Hundreds of Hours

| ITEM NO. | INTERVAL | ITEM TO BE INSPECTED PROCEDURE | For Readiness Reporting, Equipment Is Not Ready/ Available if: |
|----------|----------|--------------------------------------------------------------------------------------------------------------------------------------------------------------------------------------------------------------------------------------------------------|----------------------------------------------------------------------------------------------------------------------------------|
| 1 | B | <p><u>SUPPORT ITEMS</u></p> <p><u>Magnifier Lamp.</u></p> <ol style="list-style-type: none"> 1. Inspect lens for cracks, breaks, or dirt. Clean as required. 2. Inspect arms and base for cracks or breaks. | <p>Lens cracked or broken.</p> <p>Arms or base cracked or broken.</p> |
| 2 | B | <p><u>Service Magnifier Lamp.</u></p> <ol style="list-style-type: none"> 1. Turn off magnifier lamp. 2. Apply small amount of liquid lens cleaner to lens and wipe clean with cheesecloth. 3. Turn on magnifier lamp. | |
| 3 | Q | <p><u>Vacuum Cleaner.</u></p> <p>Inspect vacuum cleaner for damage to housing, frayed or worn power cord, and proper operation of motor.</p> | <p>Housing is cracked or broken.</p> <p>Power cord is frayed, worn, or damaged.</p> <p>Motor operation is noisy or improper.</p> |

Table 9-1. OPERATOR PREVENTIVE MAINTENANCE CHECKS AND SERVICES - Cont

B - Before
D - During
A - After

W - Weekly
M - Monthly
Q - Quarterly

AN - Annually
S - Semiannually
BI - Biennially

(Number) - Hundreds of Hours

| ITEM NO. | IN-TER-VAL | ITEM TO BE INSPECTED PROCEDURE | For Readiness Reporting, Equipment Is Not Ready Available If: |
|------------------------------------|------------|-----------------------------------------------------------------------------------------------------------------------------------------------------------------------------------------------------------------------------------------------------------------------------------------------------------------------------------------------------------------------------------------------------------------------------------------------------------------------------------------------------------------------------------------------------------------------------------------------------------------------------------------------------------------------------------------------------------------------------------------------------|-------------------------------------------------------------------------------------------------------------------------------------------|
| <u>SUPPORT ITEMS - Cont</u> | | | |
| 4 | B | <p data-bbox="354 520 743 550"><u>Clean Pocket Stereoscope.</u></p> <ol data-bbox="354 583 1149 772" style="list-style-type: none"> <li data-bbox="354 583 1019 646">1. Inspect lenses for dust., dirt, cracks, or breaks. <li data-bbox="354 678 893 707">2. Clean lenses with lens tissue. <li data-bbox="354 739 1149 768">3. Inspect housing and legs for cracks or breaks. | |
| 5 | B | <p data-bbox="354 840 977 869"><u>Inspect Still Picture (Instant) Camera.</u></p> <div data-bbox="393 940 1201 1285" style="text-align: center;">  </div> <ol data-bbox="354 1348 1136 1507" style="list-style-type: none"> <li data-bbox="354 1348 1136 1411">1. Press release on top of front cover to open, extend bellows and secure with camera latch. <li data-bbox="354 1474 1120 1503">2. Inspect camera for broken or missing parts. <p data-bbox="727 1596 860 1625" style="text-align: center;"><u>CAUTION</u></p> <p data-bbox="438 1663 1140 1726">Opening camera door when film pack is loaded may ruin unexposed film.</p> | <p data-bbox="1328 1348 1513 1432">Release button is inoperative.</p> <p data-bbox="1328 1470 1497 1558">Parts are missing or broken.</p> |

Table 9-1. OPERATOR PREVENTIVE MAINTENANCE CHECKS AND SERVICES - Cont

B - Before
D -During
A -After

W - Weekly
M - Monthly
Q - Quarterly

AN - Annually
S - Semiannually
BI - Biennially

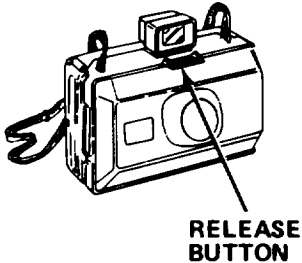
(Number) - Hundreds of Hours

| ITEM NO. | INTERVAL | ITEM TO BE INSPECTED PROCEDURE | For Readiness Reporting, Equipment Is Not Ready/ Available If: |
|-----------------------------|----------|------------------------------------------------------------------------------------------------------------------------------------------------------------------------------------------------------------------------------------------------------------------------------------------------------------------------------------------------------------------------------------------------------------------------------------------------------------------------------------------------------------------------------------------|------------------------------------------------------------------|
| <u>SUPPORT ITEMS - Cont</u> | | | |
| 5 | B | <p data-bbox="289 548 1008 579"><u>Inspect Still Picture (Instant) Camera - Cont</u></p> <div data-bbox="440 655 954 1041"> <p data-bbox="383 1010 521 1079">CAMERA DOOR APERTURE</p> </div> <p data-bbox="289 1150 1154 1241">3. Inspect camera door aperture to be sure camera is not loaded with film pack. (No paper tabs show in slot.)</p> <div data-bbox="347 1276 943 1663"> <p data-bbox="347 1381 423 1430">DOOR CLIP</p> </div> <p data-bbox="289 1724 971 1755">4. Release door clip and open camera door.</p> | <p data-bbox="1256 1717 1446 1780">Door clip is inoperative.</p> |

Table 9-1. OPERATOR PREVENTIVE MAINTENANCE CHECKS AND SERVICES - Cont

B - Before
D - During
A - After

W - Weekly
M - Monthly
Q - Quarterly

AN - Annually
S - Semiannually
BI - Biennially

(Number) - Hundreds of Hours

| ITEM NO. | INTERVAL | ITEM TO BE INSPECTED PROCEDURE | For Readiness Reporting, Equipment Is Not Ready/ Available if: |
|----------|----------|------------------------------------------------------------------------------------------------------------------------------------------------------------------------------------------------------------------------------------------------------------------------------------------------------------------------------------------------------------------|---------------------------------------------------------------------------------------------|
| 5 | B | <p>SUPPORT ITEMS - Cont</p> <p><u>Inspect Still Picture (Instant) Camera - Cont</u></p>  <p>5. Inspect film rollers for dirt or residue.</p> <p>6. Check that cold pack is in camera door.</p> <p>7. Inspect batteries for signs of corrosion, bulging, or damage.</p> | <p>Film rollers have dirt and/or residue.</p> <p>Batteries are corroded and/or damaged.</p> |

Table 9-1. OPERATOR PREVENTIVE MAINTENANCE CHECKS AND SERVICES - Cont

B - Before
D - During
A - After

W - Weekly
M - Monthly
Q - Quarterly

AN - Annually
S - Semiannually
BI - Biennially

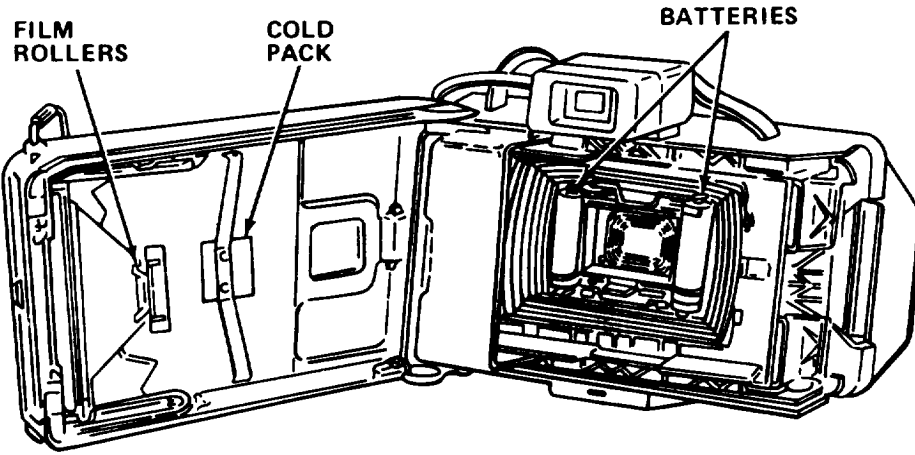
(Number) - Hundreds of Hours

| ITEM NO. | INTERVAL | ITEM TO BE INSPECTED | PROCEDURE | For Readiness Reporting, Equipment is Not Ready/ Available If: |
|--------------------------------------------------------------------------------------------------------------------------------------------------------------------------------------|----------|------------------------------------------------------|-------------------------------------------------------------------------------------|----------------------------------------------------------------|
| <u>SUPPORT ITEMS - Cont</u> | | | | |
| 5 | B | <u>Inspect Still Picture (Instant) Camera - Cont</u> |  | Bellows is torn. |
| <p>8. Hold lens of camera toward light and inspect bellows for light leaks.</p> <p>9. Close and latch camera door.</p> <p>10. Press cover release button and close camera cover.</p> | | | | |

Table 9-1. OPERATOR PREVENTIVE MAINTENANCE CHECKS AND SERVICES - Cont

B - Before
D - During
A - After

W - Weekly
M - Monthly
Q - Quarterly

AN - Annually
S - Semiannually
BI - Biennially

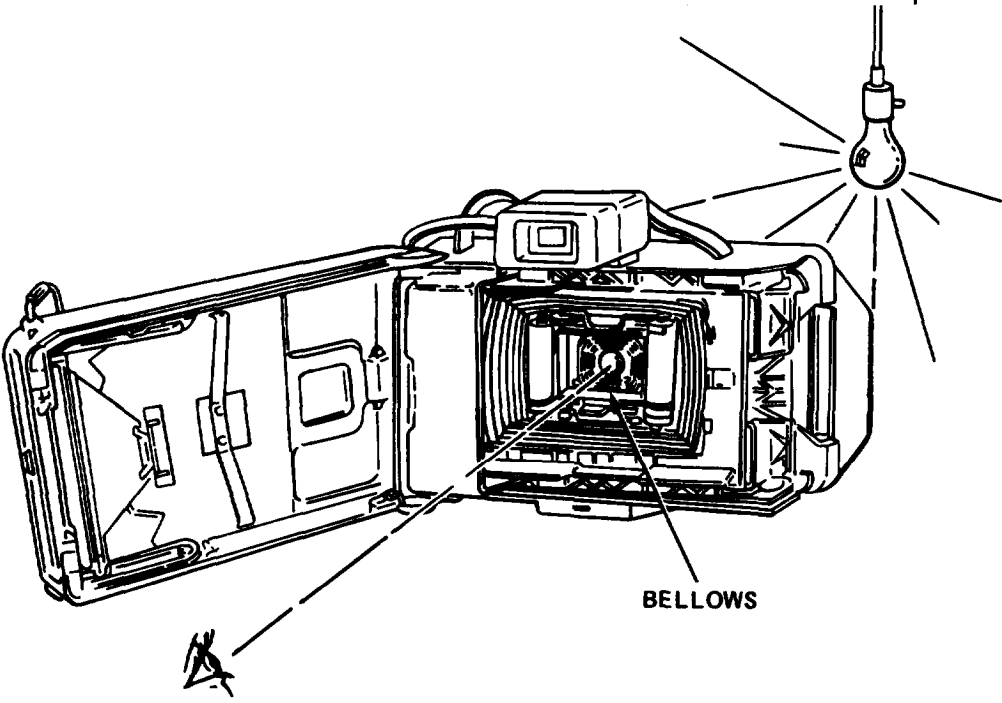
(Number) - Hundreds of Hours

| ITEM NO. | INTERVAL | ITEM TO BE INSPECTED PROCEDURE | For Readiness Reporting, Equipment Is Not Ready/ Available If: |
|----------|----------|---------------------------------------------------------------------------------------------------------------------------------------------------------------------------------------------------------------------------------------------------------------------------------------------------------------------------------------------------------------------------------------------------------------|----------------------------------------------------------------|
| 6 | M | <p><u>SUPPORT ITEMS - Cont</u></p> <p><u>Clean Still Picture (Instant) Camera.</u></p>  <p>1. Press cover release on top of front cover to open and latch camera bellows.</p> <p style="text-align: center;"><u>CAUTION</u></p> <p>Opening camera door when film pack is loaded may ruin unexposed film.</p> | <p>Release button is inoperative.</p> |

Table 9-1. OPERATOR PREVENTIVE MAINTENANCE CHECKS AND SERVICES - Cont

B - Before
D - During
A - After

W - Weekly
M - Monthly
Q - Quarterly

AN - Annually
S - Semiannually
BI - Biennially

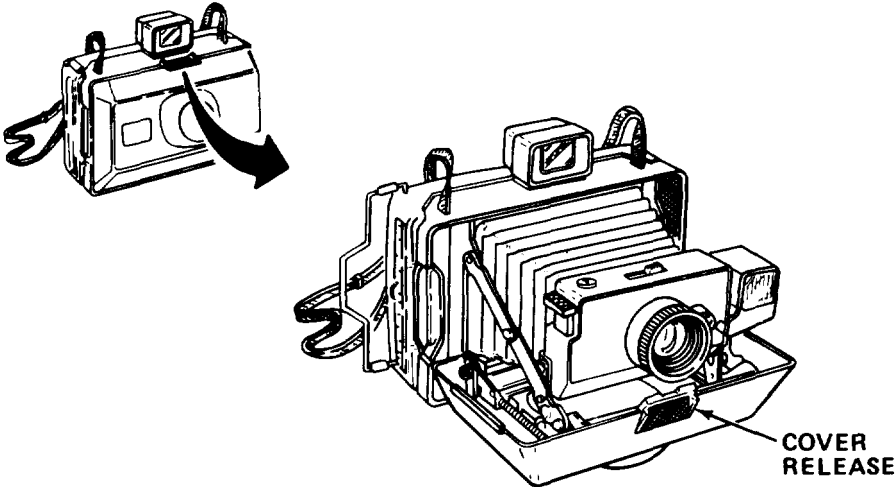
[Number] - Hundreds of Hours

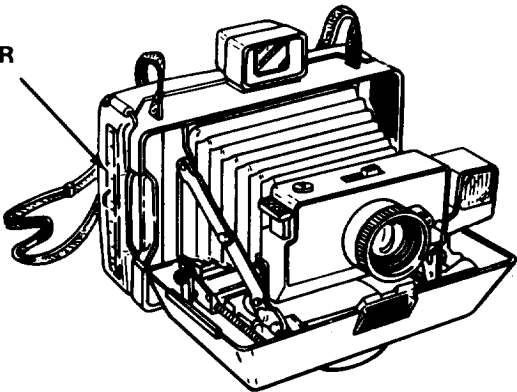
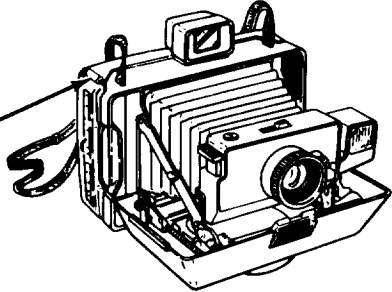
| ITEM NO. | INTERVAL | ITEM TO BE INSPECTED PROCEDURE | For Readiness Reporting, Equipment Is Not Ready/ Available If: |
|----------|----------|------------------------------------------------------------------------------------------------------------------------------------------------------------------------------------------------------------------------------------------------------------------------------------------------------------------------------------------------------------------------------------------------------------------------------------------------------------------------------------------------------------------------------------------------------------------------------------------------------------------------------------------------------------------------------------------------------------------------------|----------------------------------------------------------------|
| 6 | M | <u>SUPPORT ITEMS - Cont</u> | |
| | | <p data-bbox="297 548 987 579"><u>Clean Still Picture (Instant) Camera - Cont</u></p> <div data-bbox="297 653 943 1035">  <p data-bbox="297 688 444 737">FILM DOOR APERTURE</p> </div> <p data-bbox="313 1146 1094 1241">2. Inspect film door aperture to be sure camera is not loaded with film pack. (No paper tabs show in slot).</p> <div data-bbox="391 1272 899 1560">  <p data-bbox="391 1367 480 1415">DOOR LATCH</p> </div> <p data-bbox="313 1619 1097 1682">3. Release door latch and open camera door; then lay camera on work surface.</p> | |

Door latch is inoperative.

Table 9-1. OPERATOR PREVENTIVE MAINTENANCE CHECKS AND SERVICES - Cont

B - Before
D - During
A - After

W - Weekly
M - Monthly
Q - Quarterly

AN - Annually
S - Semiannually
BI - Biennially

(Number) - Hundreds of Hours

| ITEM NO. | INTERVAL | ITEM TO BE INSPECTED PROCEDURE | For Readiness Reporting, Equipment Is Not Ready/ Available If: |
|----------|----------|----------------------------------------------------------------------------------------------------------------------------------------------------------------------------------------------------------------------------------------------------------------------------------------------------------------------------------------------------------------------------------------------------------------------------------------------------------------------------------------------|----------------------------------------------------------------|
| 6 | M | <p>SUPPORT ITEMS - Cont</p> <p><u>Clean Still Picture (Instant) Camera - Cont</u></p>  <p>4. Use thumbs to push outward on roller assembly. Remove assembly.</p>  <p>5. Moisten cotton swab in denatured alcohol and swab rollers until all dirt and residue are removed from rollers. Let rollers air dry.</p> | <p>Roller assembly is corroded.</p> |

Table 9-1. OPERATOR PREVENTIVE MAINTENANCE CHECKS AND SERVICES - Cont

B - Before
D - During
A - After

W - Weekly
M - Monthly
Q - Quarterly

AN - Annually
S - Semiannually
BI - Biennially

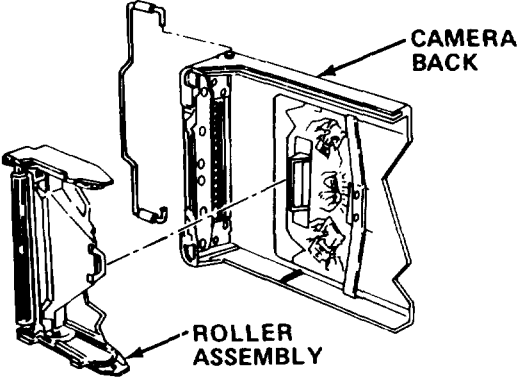
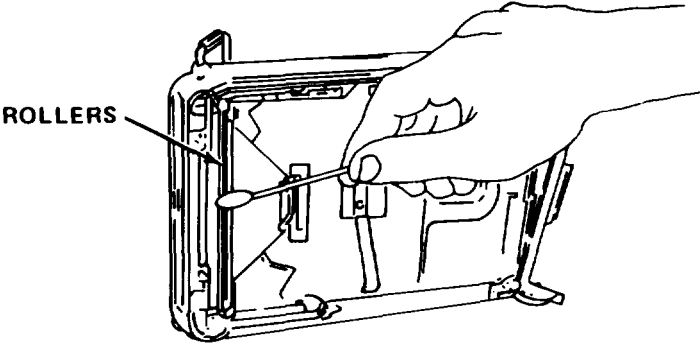
(Number) - Hundreds of Hours

| ITEM NO. | INTERVAL | ITEM TO BE INSPECTED PROCEDURE | For Readiness Reporting, Equipment Is Not Ready/ Available If: |
|----------|----------|--------------------------------------------------------------------------------------------------------------------------------------------------------------------------------------------------------------------------------------------------------------------------------------------------------------------------------------------------------------------------------------------------------------------------------------------------------------------------------------------------------------------------------------------------------------------------------------------------------------------------------------------------------------------------------------------------------------------------------------------------------------------------------------------------------------------------------------------------------------------------------------------------------------------------------------------------------------------------------------------------------------------------------------------------------------------------------------------------------------------------------------------------------------------------------------------------------------------------------------------------------|----------------------------------------------------------------------------------------------------------------------------------------------|
| | | <u>SUPPORT ITEMS - Cont</u> | |
| 6 | M | <u>Clean Still Picture (Instant) Camera - Cont</u> | |
| | | <div data-bbox="537 611 1016 825" style="text-align: center;">  <p>WATCHMAKER'S BLOWER</p> </div> <p data-bbox="305 856 1105 1108"> 6. Blow all dust and dirt from inside camera back and bellows with watchmaker's blower. 7. Reinstall roller assembly by pressing plastic spring clip into roller assembly and pressing down until it snaps into place. 8. Close camera back and fasten door latch. </p> <div data-bbox="435 1150 1019 1356" style="text-align: center;">  <p>VIEWFINDER ELECTRIC EYE LENS MAIN LENS</p> </div> <p data-bbox="305 1398 1143 1713"> 9. Gently wipe the following lenses with lens paper using a clean paper for each lens: Viewfinder (both sides) Main Lens Electric eye lens 10. Press cover release button and close cover. </p> | <p data-bbox="1252 951 1430 1045">Plastic spring clip missing.</p> <p data-bbox="1252 1398 1446 1486">Lens(es) are scratched or cracked.</p> |

Table 9-1. OPERATOR PREVENTIVE MAINTENANCE CHECKS AND SERVICES - Cont

B - Before
D - During
A - After

W - Weekly
M - Monthly
Q - Quarterly

AN - Annually
S - Semiannually
BI - Biennially

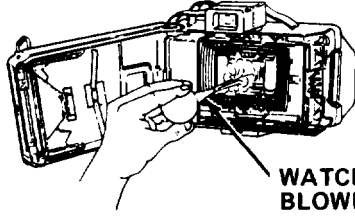
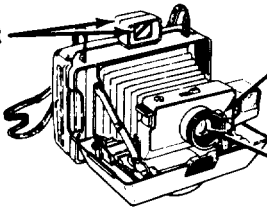
(Number) - Hundreds of Hours

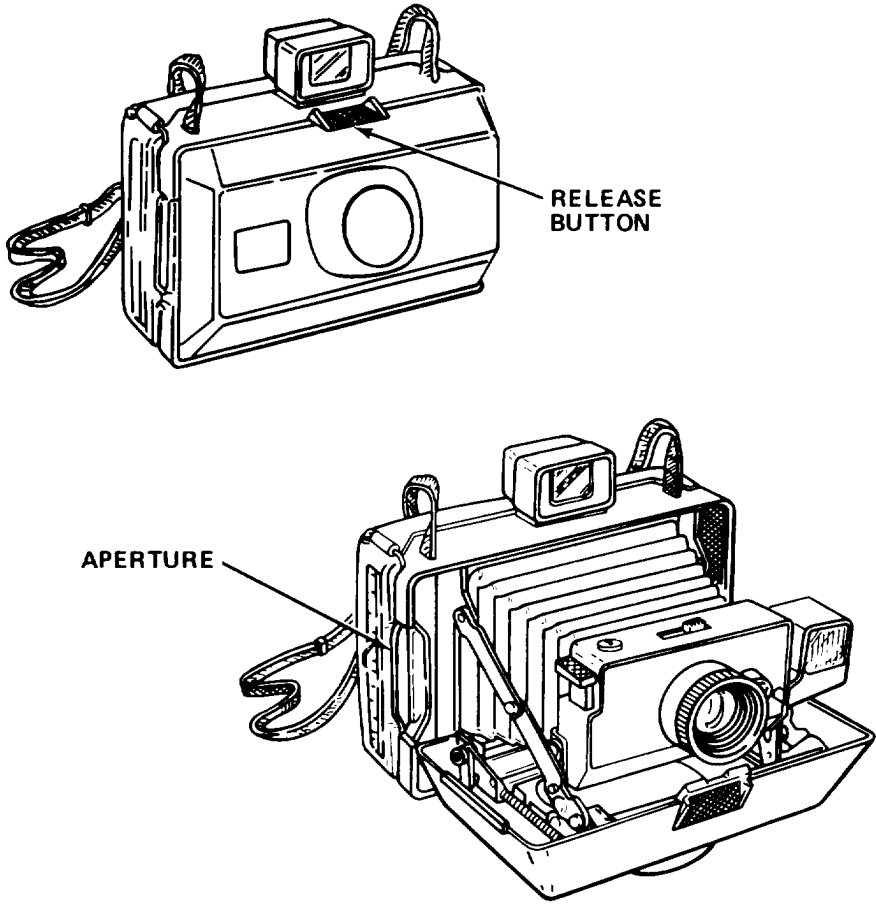
| ITEM NO. | INTERVAL | ITEM TO BE INSPECTED PROCEDURE | For Readiness Reporting, Equipment Is Not Ready/ Available If: |
|----------|----------|----------------------------------------------------------------------------------------------------------------------------------------------------------------------------------------------------------------------------------------------------------------------------------------------------------------------------------------------------------------------------------------------------------------------------------------------------------------------------------------------------------|----------------------------------------------------------------|
| 7 | B | SUPPORT ITEMS - Cont | |
| | | <p data-bbox="342 533 1094 569">Test Shutter on Still Picture (Instant) Camera.</p> <div data-bbox="354 615 1224 1514">  </div> <p data-bbox="365 1581 1146 1646">1. Press release button on top of front cover to open and latch camera bellows.</p> <p data-bbox="688 1738 823 1770">CAUTION</p> <p data-bbox="423 1801 1127 1866">Opening camera door when film pack is loaded may ruin unexposed film.</p> | |

Release button is inoperative.

Table 9-1. OPERATOR PREVENTIVE MAINTENANCE CHECKS AND SERVICES - Cont

B - Before
D - During
A - After

W - Weekly
M - Monthly
Q - Quarterly

AN - Annually
S - Semiannually
BI - Biennially

(Number) - Hundreds of Hours

| ITEM NO. | INTERVAL | ITEM TO BE INSPECTED PROCEDURE | For Readiness Reporting, Equipment Is Not Ready/ Available If: |
|-----------------------------|----------|-----------------------------------------------------------------------------------------------------------------------------------------------------------------------------------------------------------------------------------------------------------------------------------------------------------------------------------------------------------------------------------------------------------------------------------------------------------------------------------------------------------------|-----------------------------------------------------------------------------------------------------------------------------------------|
| SUPPORT ITEMS - Cont | | | |
| 7 | B | <p data-bbox="293 541 1247 569"><u>Test Shutter on Still Picture (Instant) Camera - Cont</u></p> <p data-bbox="293 604 1247 695">2. Inspect camera door aperture to be sure camera is not loaded with film pack. (No paper tabs show in slot.)</p>  <p data-bbox="293 1457 1247 1484">3. Release door latch and open camera door.</p> <p data-bbox="293 1583 1247 1610">4. Set scene selector to 75 (move to far right).</p> | <p data-bbox="1252 1457 1466 1547">Door latch is inoperative.</p> <p data-bbox="1252 1583 1466 1673">Scene selector is inoperative.</p> |

Table 9-1. OPERATOR PREVENTIVE MAINTENANCE CHECKS AND SERVICES - Cont

B - Before W - Weekly AN - Annually (Number) - Hundreds of Hours
 D - During M - Monthly S - Semiannually
 A - After Q - Quarterly BI - Biennially

| ITEM NO. | INTERVAL | ITEM TO BE INSPECTED PROCEDURE | For Readiness Reporting, Equipment Is Not Ready/ Available If: |
|----------|----------|--------------------------------------------------------------------------------------------------------------------------------------------------------------------------------------------------------------------------------------------------------------------------------------------------------------------------------------------------------------------------------------------------------------------------------------------------------------------------------------------------------------------------------------------------------------------------------------------------------------------------------------------------------------------------------------------------------------------------------------------------------------------------------------------------------------------------------------------------------------------------------------------------------------------------------------------------------------------------------------------------------------------------------|----------------------------------------------------------------|
| 7 | B | SUPPORT ITEMS - Cont | |
| | | <p data-bbox="370 535 1218 567"><u>Test Shutter on Still Picture (Instant) Camera - Cont</u></p> <div data-bbox="581 659 1300 1073" style="text-align: center;">  <p>The diagram shows a top-down view of a still camera. A line points from the text 'SHUTTER RELEASE BUTTON' to a button on the left side of the camera body. Another line points from the text 'PHOTOELECTRIC CELL LENS' to a lens-like component on the right side of the camera body.</p> </div> <ol style="list-style-type: none"> <li data-bbox="396 1142 1159 1203">5. Cover photoelectric cell lens with finger or cloth to block light. <li data-bbox="396 1239 1206 1299">6. Look through lens from back of camera and press shutter release button. <li data-bbox="396 1333 1156 1360">7. Observe that shutter opens and remains open. <li data-bbox="396 1459 1115 1520">8. Uncover photoelectric cell. Observe that shutter closes. | |

Table 9-1. OPERATOR PREVENTIVE MAINTENANCE CHECKS AND SERVICES - Cont

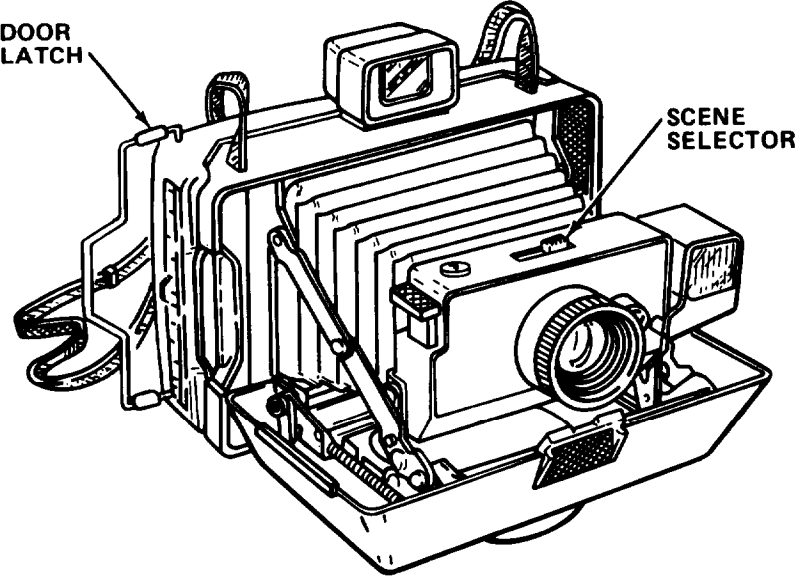
B - Before
D - During
A - After

W - Weekly
M - Monthly
Q - Quarterly

AN - Annually
S - Semiannually
BI - Biennially

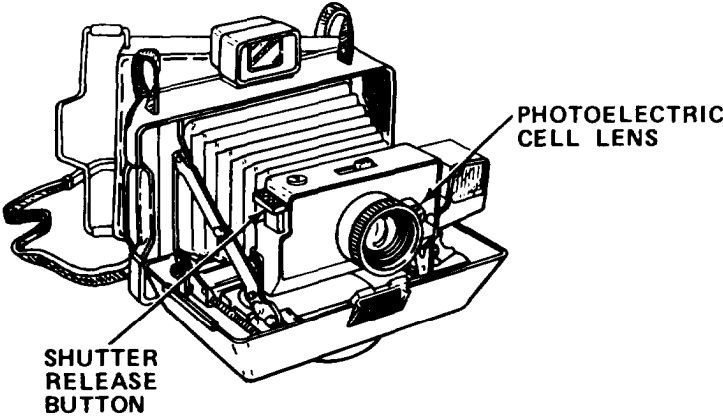
(Number) - Hundreds of Hours

| ITEM NO. | INTERVAL | ITEM TO BE INSPECTED PROCEDURE | For Readiness Reporting, Equipment Is Not Ready/ Available If: |
|-----------------------------|----------|-------------------------------------------------------------------------------------------------------------------------------------------------------------------------------------------------------------------------------------------------------------------------------------------------------------------------------------------------------------------------------------------------------------------------------------------------------------------------------------------------------------------------------------------------------------------------------------------------------------------------------------------------------------------------------------|----------------------------------------------------------------|
| SUPPORT ITEMS - Cont | | | |
| 7 | B | <p data-bbox="316 541 1166 573"><u>Test Shutter on Still Picture (Instant) Camera - Cont</u></p> <div data-bbox="347 632 1159 1087" style="text-align: center;">  <p data-bbox="837 632 977 657">BATTERIES</p> </div> <p data-bbox="337 1144 1101 1203">g. If shutter does not close, replace batteries and repeat test.</p> <p data-bbox="711 1266 786 1291" style="text-align: center;">NOTE</p> <p data-bbox="402 1333 1117 1392">If shutter fails with fresh batteries, camera must be replaced.</p> <p data-bbox="326 1459 1003 1486">10. Close camera door and latch with clip.</p> | |
| 8 | Q | <p data-bbox="321 1556 977 1583"><u>Inspect Wrapping Paper Holder and Cutter.</u></p> <p data-bbox="326 1619 862 1646">Inspect blade for nicks and burrs.</p> | |

Table 9-1. OPERATOR PREVENTIVE MAINTENANCE CHECKS AND SERVICES - Cont

B - Before
D - During
A - After

W - Weekly
M - Monthly
Q - Quarterly

AN - Annually
S - Semiannually
BI - Biennially

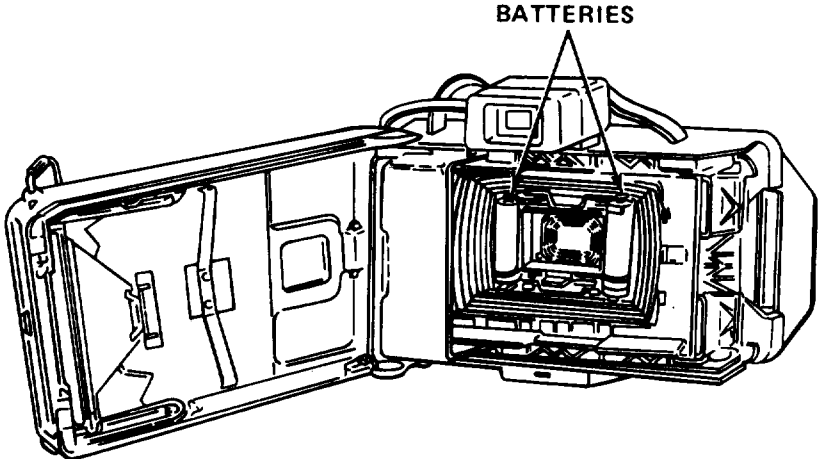
(Number) - Hundreds of Hours

| ITEM NO. | INTERVAL | ITEM TO BE INSPECTED PROCEDURE | For Readiness Reporting, Equipment Is Not Ready/ Available If: |
|-----------------------------|----------|------------------------------------------------------------------------------------------------------------------------------------------------------------------------------------------------------------------------------------------------------------------------------------------------------------------------------------|----------------------------------------------------------------|
| SUPPORT ITEMS - Cont | | | |
| 9 | B | <p><u>Photoengraving Magnifier.</u></p> <ol style="list-style-type: none"> 1. Inspect housing for dirt or dust. 2. Inspect lens and housing for cracks or breaks. | <p>Lens and/or housing is cracked or broken.</p> |
| 10 | B | <p><u>Service Photoengraving Magnifier.</u></p> <p>Wipe dirt and dust from lens using clean lens paper.</p> | |
| 11 | B | <p><u>Inspect Radio Receiver.</u></p> <div style="text-align: center;"> <p>LATCHES</p>  </div> <ol style="list-style-type: none"> 1. Open battery compartment cover by depressing two latches and pulling it toward you. | |

Table 9-1. OPERATOR PREVENTIVE MAINTENANCE CHECKS AND SERVICES - Cont

B - Before
D - During
A - After

W - Weekly
M - Monthly
Q - Quarterly

AN - Annually
S - Semiannually
BI - Biennially

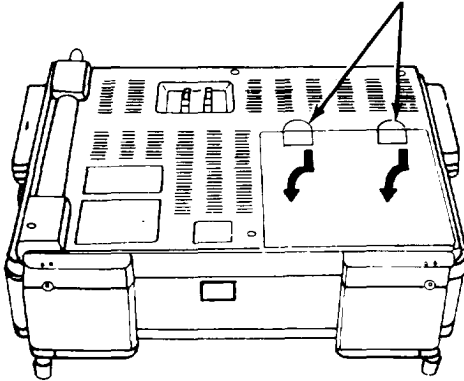
(Number) - Hundreds of Hours

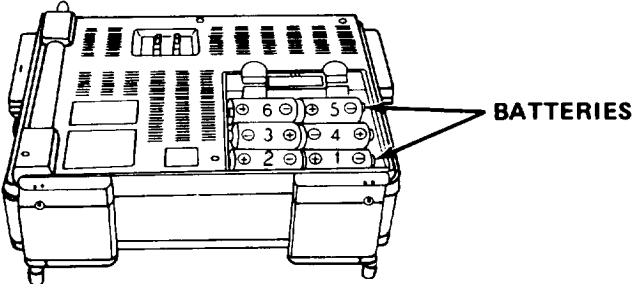
| ITEM NO. | INTERVAL | ITEM TO BE INSPECTED PROCEDURE | For Readiness Reporting, Equipment Is Not Ready/ Available If: |
|----------|----------|----------------------------------------------------------------------------------------------------------------------------------------------------------------------------------------------------------------------------------------------------------------------------------------------------------------------------------------------------------------------------------------------------------------------------------------------------------------------------------------------------------------------------------------------------------------------------------------------------------------------------------------------|-------------------------------------------------------------------------------------|
| 11 | B | <p>SUPPORT ITEMS - Cont</p> <p><u>Inspect Radio Receiver - Cont</u></p>  <ol style="list-style-type: none"> 2. Inspect batteries for proper alinement of battery polarity. Realine batteries as necessary. 3. Inspect battery contacts for rust, corrosion, or dirt. Clean as required. 4. Replace battery compartment cover. 5. Inspect radio casing for cracks or breaks. 6. Inspect display windows for dirt. Clean as required. 7. Inspect ac power cord jack for cracks or breaks. | <p>Casing is cracked or broken.</p> <p>AC power cord jack is cracked or broken.</p> |

9-6. OPERATION UNDER USUAL CONDITIONS.9-6.1 Operating Procedures.9-6.1.1 Magnifier lamp.

- a. Move magnifier lamp from mounting bracket.
- b. Plug in power cord.
- c. Turn on fluorescent lamp.
- d. Position magnifier lamp over object.
- e. Examine object through lens.

9-6.1.2 Vacuum cleaner.

- a. Using as vacuum.
 - (1) Attach dust collection bag to air discharge opening.
 - (2) Remove protective screen lock from air intake opening and attach scrap trap to that opening.
 - (3) Attach swivel end of hose to scrap trap by turning lock to right until secure.
 - (4) Attach required tool to other end of hose.
 - (5) Insert plug into 120 V ac wall outlet and turn ON/OFF switch to on.
- b. Using as blower.
 - (1) Attach tapered rubber nozzle to discharge opening.
 - (2) Attach protective screen lock to air intake opening.
 - (3) Insert plug into 120 V ac wall outlet and turn ON/OFF switch to on.
- c. Using as sprayer.
 - (1) Attach protective screen lock to air intake opening.
 - (2) Attach swivel end of hose to air discharge opening by turning lock to right until secure.
 - (3) Attach sprayer to other end of hose.

NOTE

Size of spray pattern is determined by adjusting screw located on top of sprayer.

- (4) Insert Plug into 120 V ac wall outlet and turn ON/OFF switch on.

9-6.1.3 Pocket stereoscope.

- a. Position photographs in preparation for viewing in stereo.

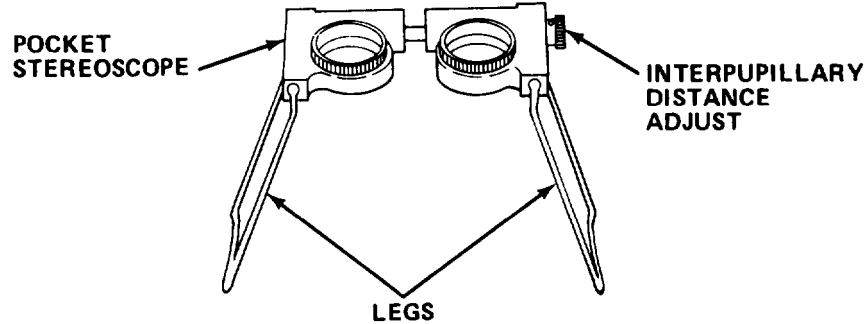

- b. Remove pocket stereoscope from case and unfold legs.

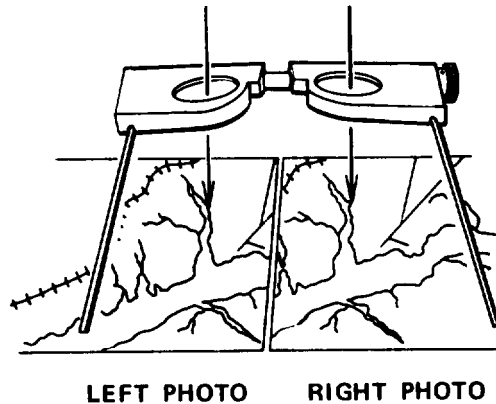

- c. Set pocket stereoscope on photos so that left lens is over left photograph and right lens is over right photograph.

- d. Adjust interpupillary distance between lenses until it matches that of viewer.

- e. Locate detail to be viewed on left photograph and center left lens over it.

- f. Move right photograph until the same detail is centered under right lens. When viewed simultaneously, two details should merge into one. Adjust photographs until this effect is achieved.

9-6.1.4 Load still picture (instant) camera.

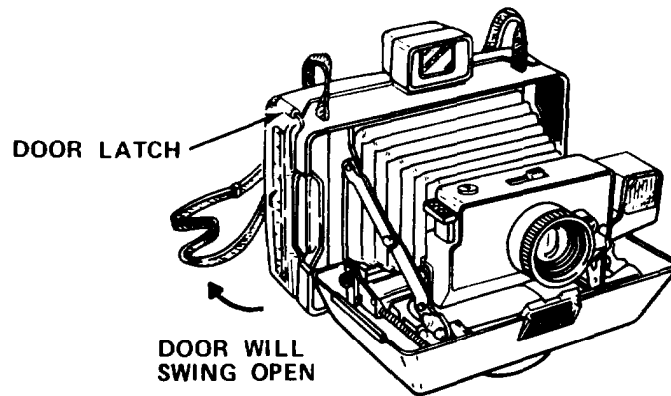

a. Release door latch.

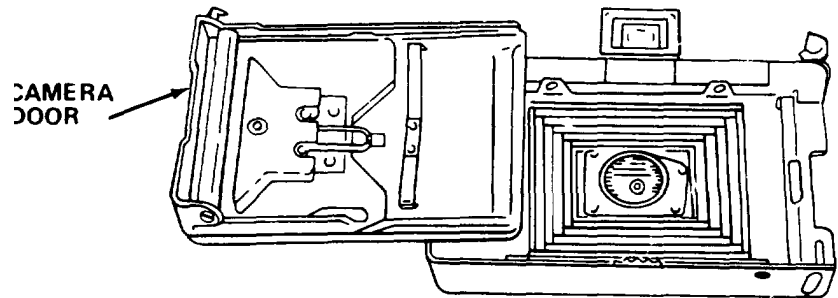

b. Door will swing open.

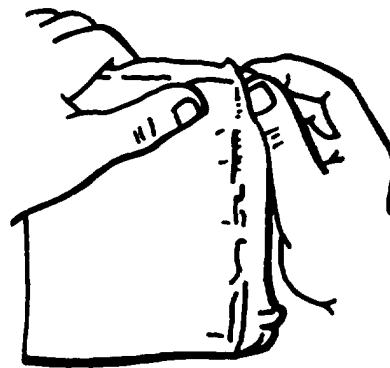
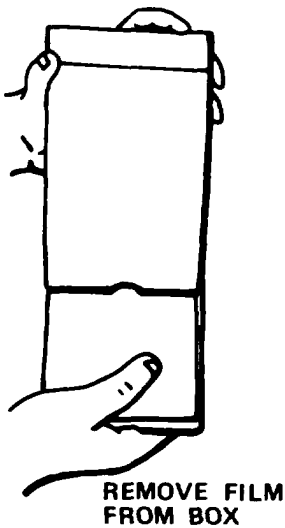

HOLD FILM BY EDGE AND REMOVE TEARSTRIP

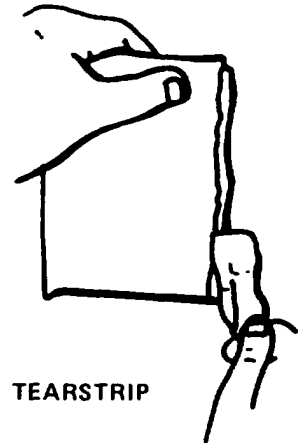

c. Choose type of film and open film pack.

d. Hold film pack by edges as shown and push closed end of pack under door hinge against spring tension.

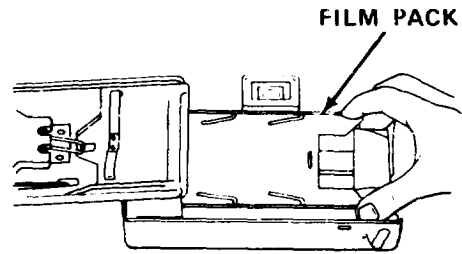

e. Push film back down into camera. You will feel it snap into place.

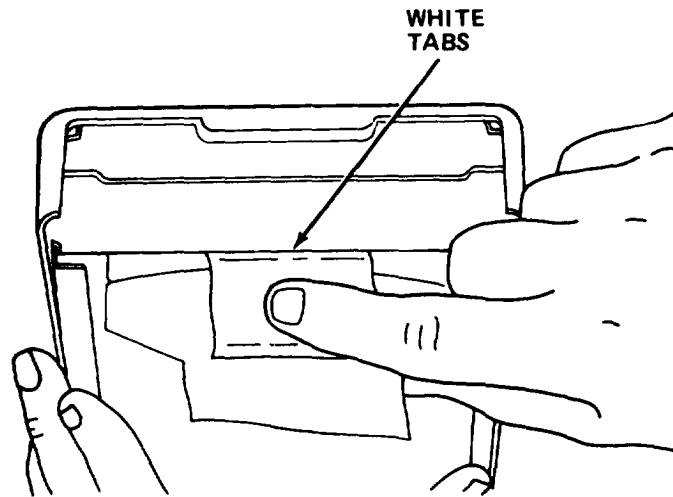

f. Check that white tabs are free and not folded under. Close camera back door.

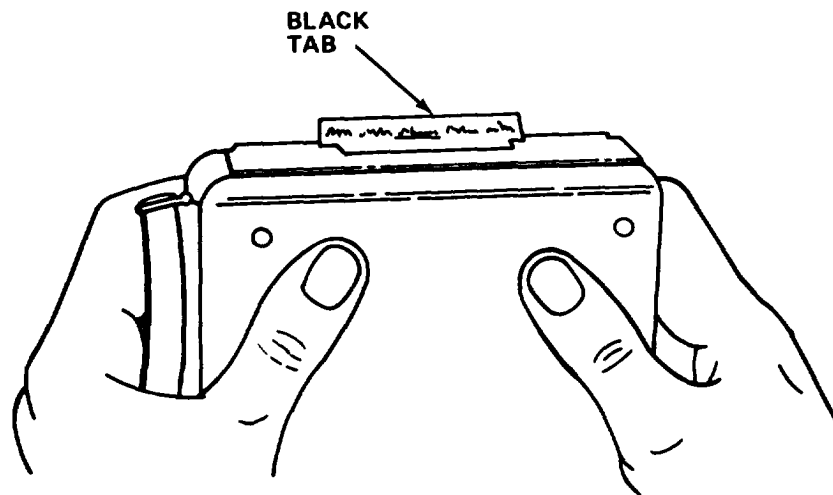

g. Press both sides firmly to be sure that both sides latch. The black tab of safety cover must stick out of small slot. If not, reopen back and lead tab out.

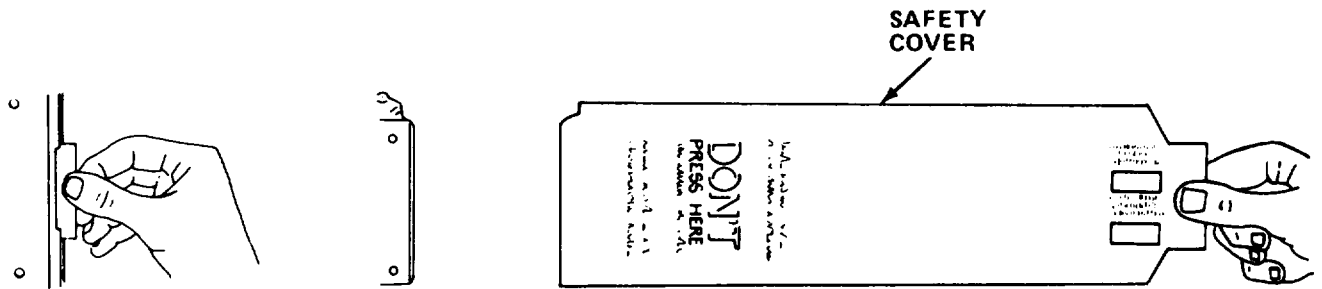

h. Pull safety cover all the way out of camera without stopping. Do not rip it.

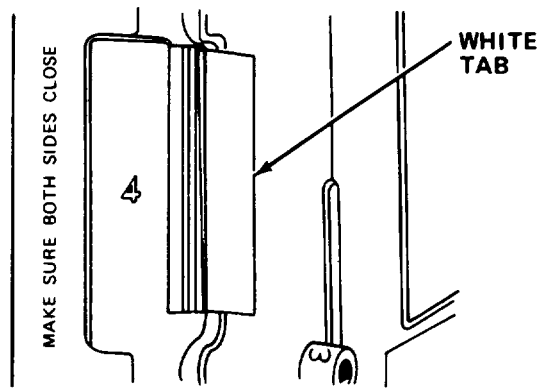

i. With safety cover out, white tab should stick out of small slot (no. 4). Do not pull white tab. You are now ready for the first picture.

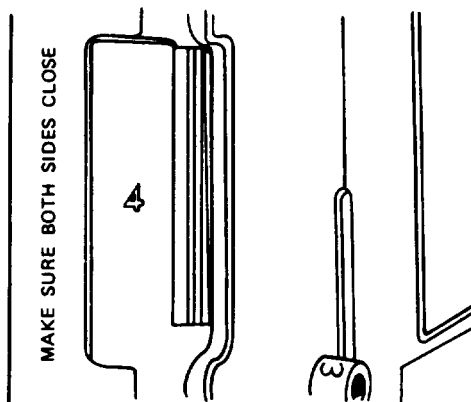

NO TAB VISIBLE

NOTE

If there is no white tab in the no. 3 slot, perform steps j and k in the shade or indoors, not in bright light.

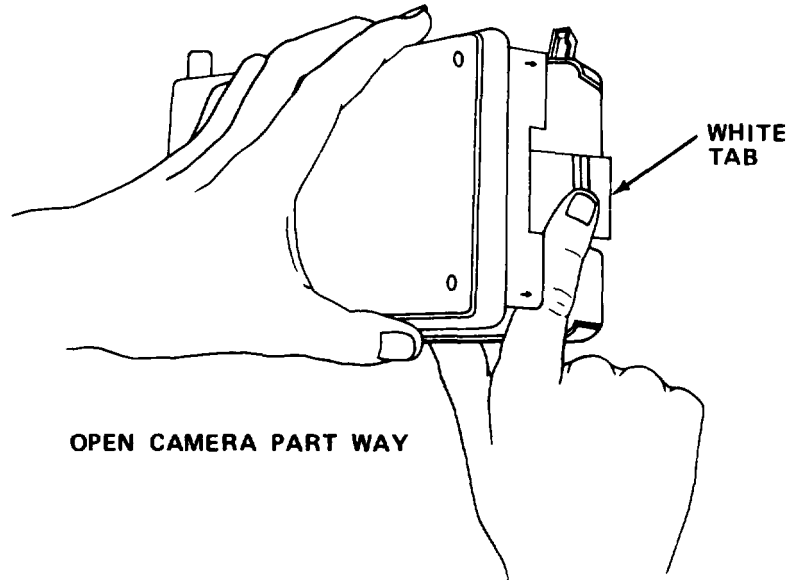

j. Partially open back of camera and, without disturbing or moving film pack, push white tab out into the open.

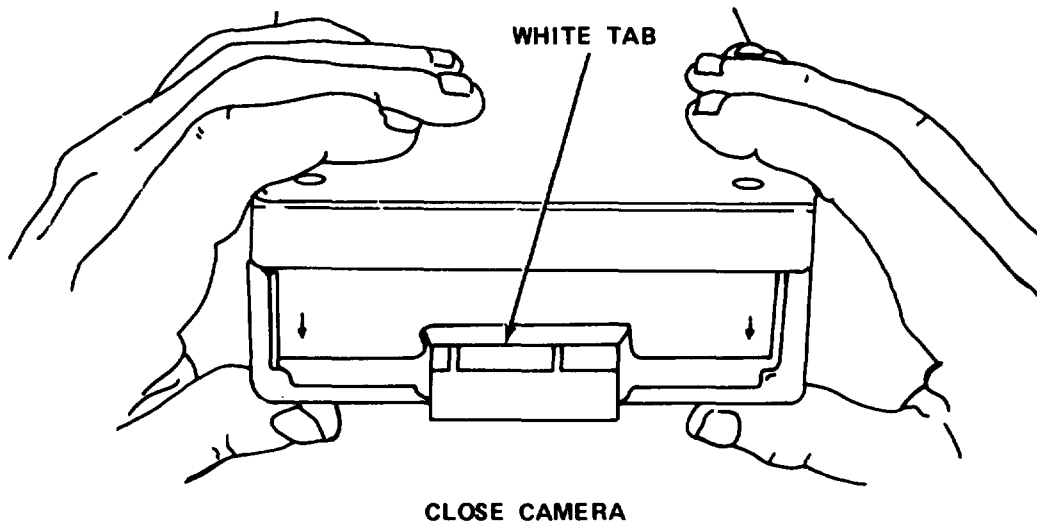

k. Close back of camera making sure that both sides are locked securely and white tab is outside in the no. 4 slot.

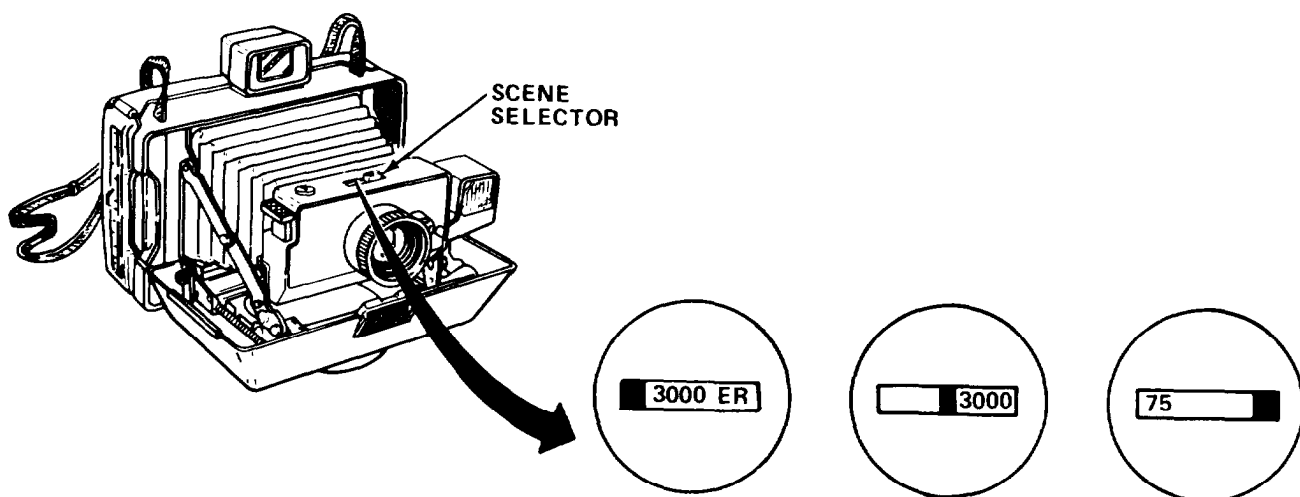

1. Change scene selector setting by pushing lever to left or right. (For black and white film, 3000 (outdoor or flash) or 3000 ER (dim light); color, 75.)

NOTE

Use of flashcube will cause bright flash. Do not mount flashcube unless flash is required and expected.

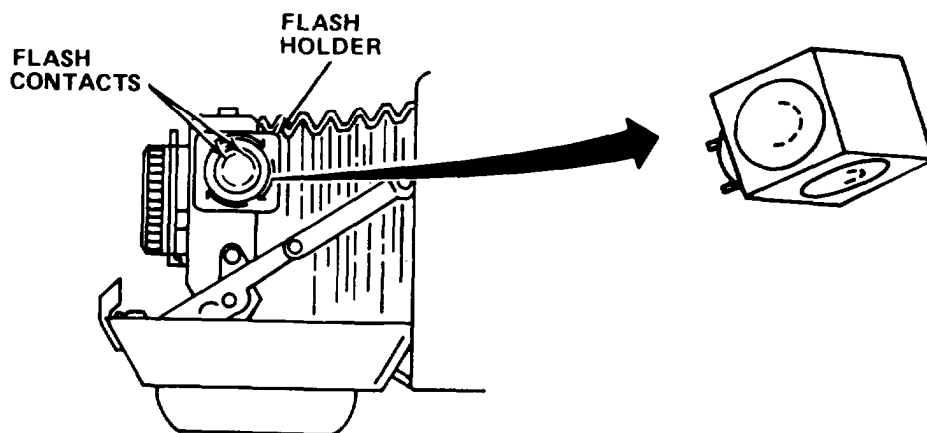

- m. Aline projection on flashcube with flash contacts and attach flashcube.
- n. Press into flash socket.

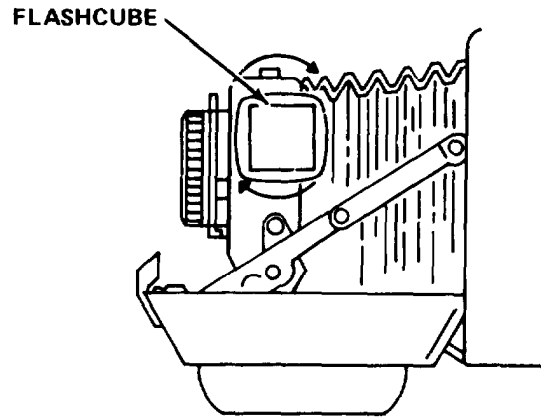

- o. Wind flashcube until a stop is felt.

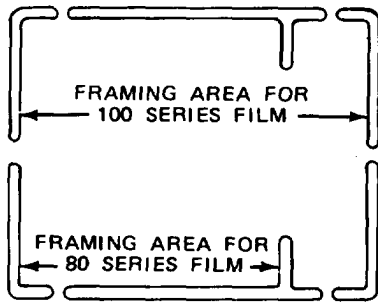

- p. Observe object in viewfinder and frame desired object in appropriate lines.

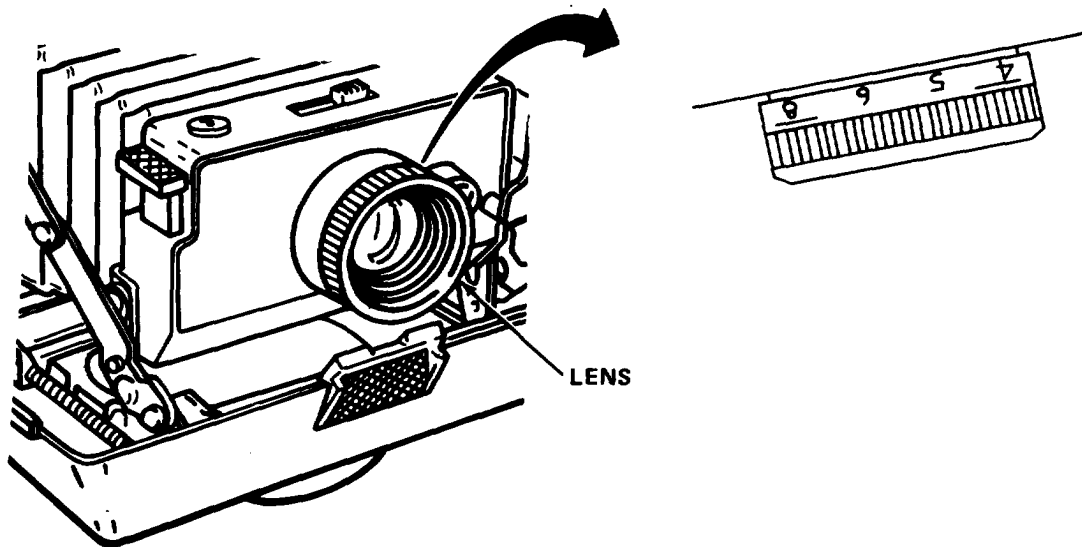

- q. Estimate range to object and set lens to estimated range in feet.

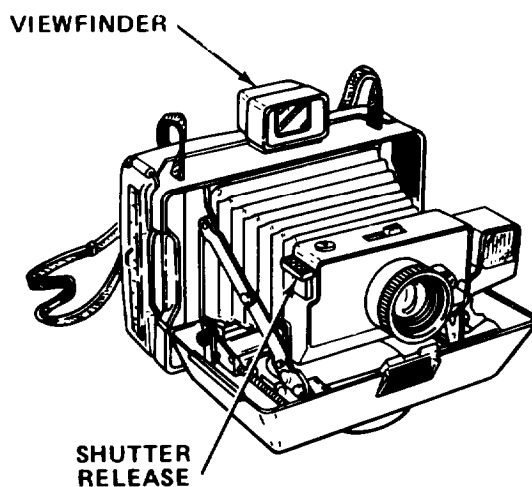

r. Hold camera firmly with object framed in viewfinder. Press shutter release.

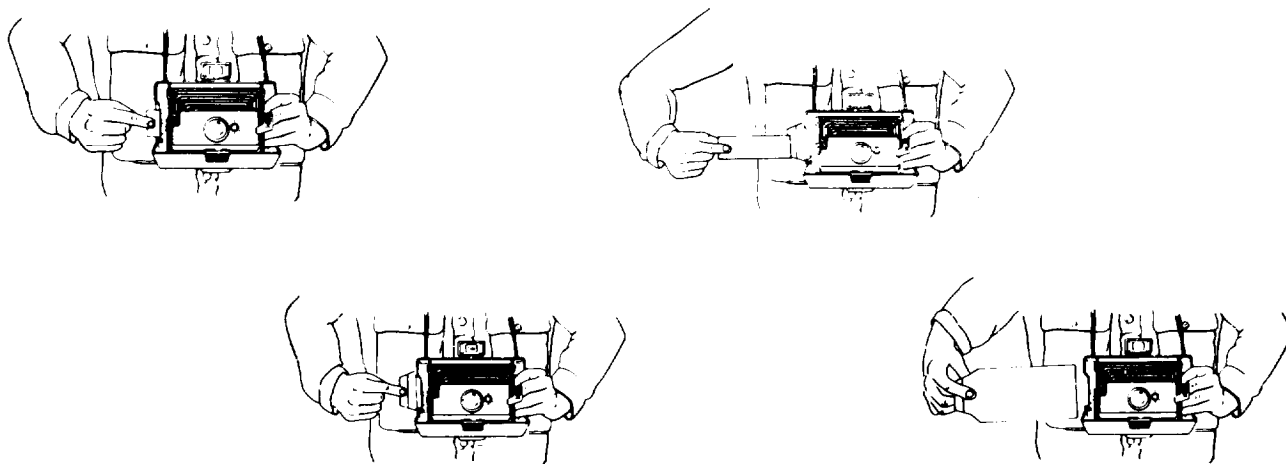

s. Remove exposed print with a firm, steady pull.

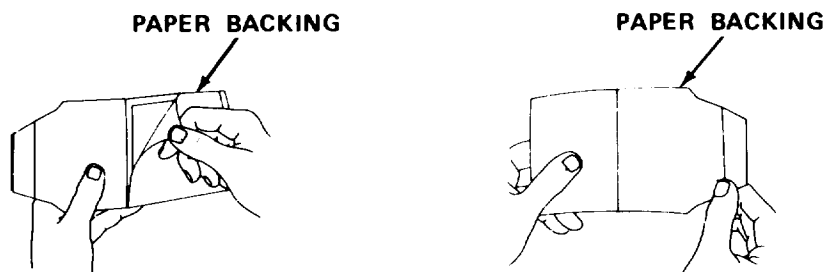

t. Wait 60 seconds before removing paper backing.

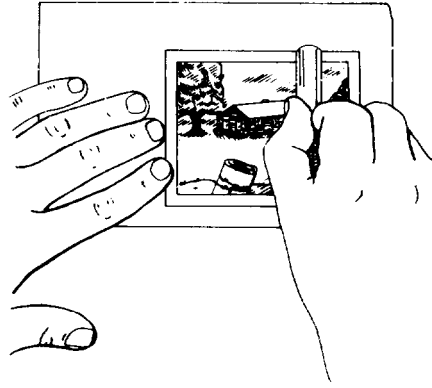

- u. Coat black and white prints.

9-6.1.5 Photoengraving Magnifier.

- a. Place photoengraving magnifier on flat surface next to object to be examined.
 - (1) Swing lens into place over object.
 - (2) Loosen locking ring.
 - (3) Adjust focal length between lens and object by turning lens in threaded socket until object is in focus.
 - (4) Lock lens in position with locking ring.

9-6.1.6 Radio Receiver.

- a. Remove radio from storage. Lay radio on face on flat surface.

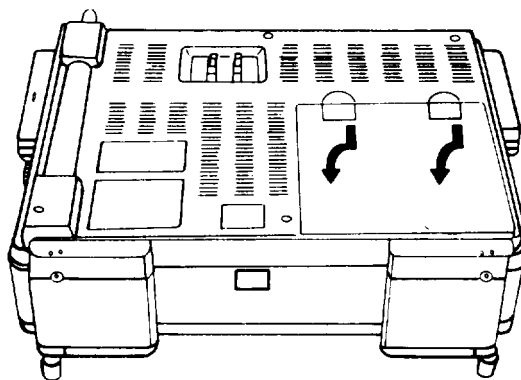

- b. Open battery compartment cover by depressing its two latches and pulling them toward you.

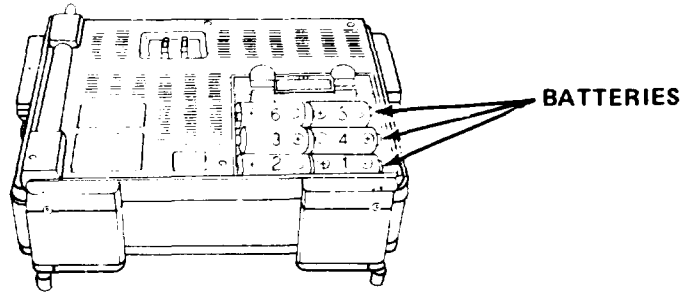

c. Insert six D-size batteries into compartment making sure polarities are aligned correctly. If batteries are already installed, be sure polarity alignment is correct.

CAUTION

If unit is to be operated for extended period on ac power alone, remove batteries to prevent damage due to leakage.

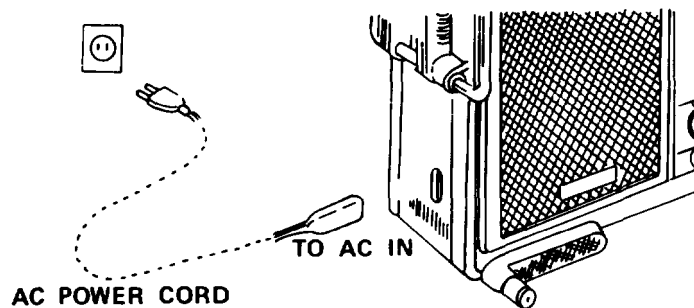

d. If ac power is to be used, remove ac power cord. Insert power cord into ac input jack and 120 V ac power outlet.

e. Replace battery compartment cover. Stand radio receiver up.

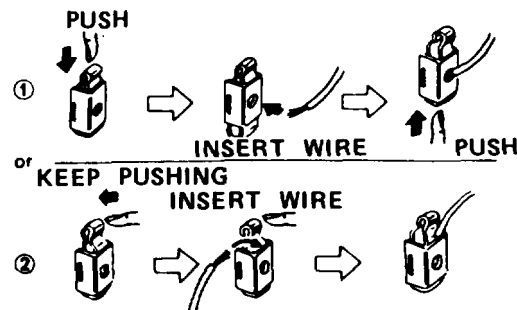

f. Extend telescopic antenna full length. If external antenna is to be used, push down on terminal, insert wire into hole and release.

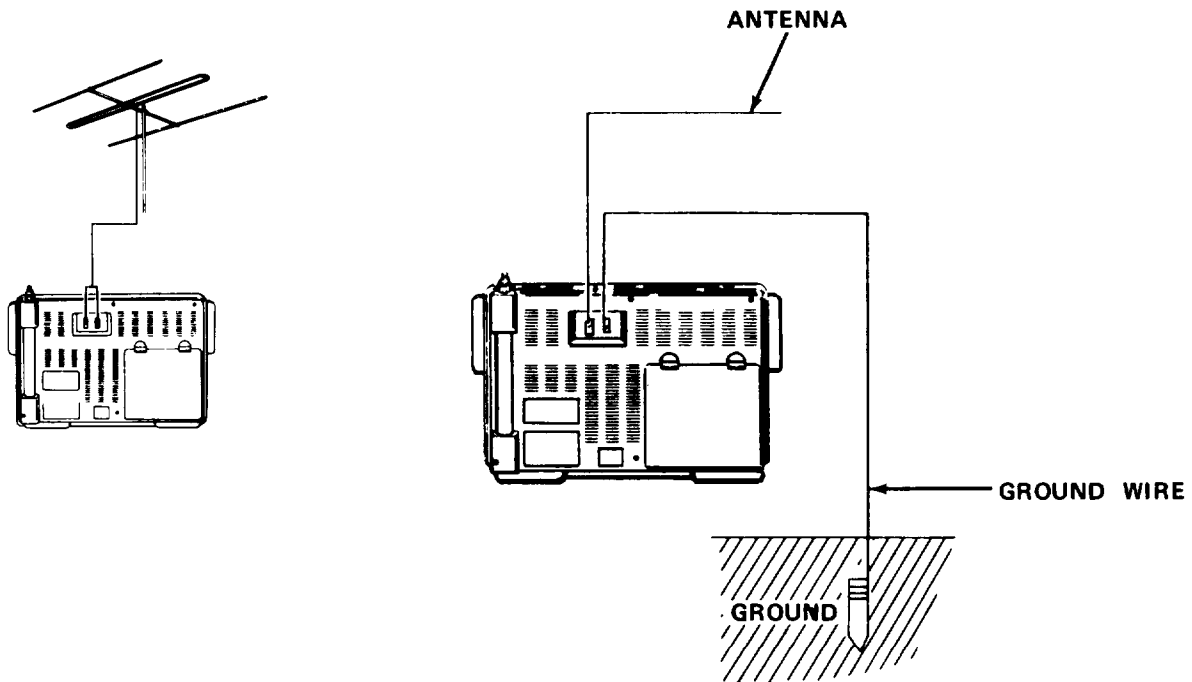

NOTE

- For reception of distant FM stations, connect 75 ohm antenna to external antenna terminals.
- For reception of AM broadcasts in poor receiving areas, such as inside buildings, connect external antenna wire and ground wire.

g. Snap display shade in place.

h. Operating modes.

(1) FM reception.

- (a) Turn power switch on and turn band selector switch to FM.
- (b) Turn FM AFC switch up to on.
- (c) Turn frequency display switch on.

NOTE

Frequency display switch should only be on during tuning.

(d) Tune in desired station signal.

(e) Adjust length and angle of telescopic antenna for optimum reception. Tuning indicator will deflect to show strongest signal reception.

NOTE

If desired station is close to stronger station, AFC may tune receiver into stronger station. If so, tune in desired station with AFC switch in off (down) position.

(f) Adjust volume, bass and treble controls as desired.

(2) AM reception.

(a) Turn power switch on and band selector switch to AM.

(b) Turn RF gain control to DX (fully right).

(c) Turn BFO switch off.

(d) Turn frequency display switch for tuning.

NOTE

Frequency display switch should only be on during tuning. Turning frequency display switch on and then off may slightly shift the tuned frequency.

(e) Tune in desired station signal with tuning dial.

(f) Turn radio receiver until optimum reception is received. Deflection of tuning indicator needle will indicate strongest signal.

NOTE

Built-in AM ferrite core antenna is somewhat directional in operation.

(g) Adjust volume, bass, and treble control as desired.

(h) To reduce any interference, turn bandwidth switch to narrow (down) and retune. When station is tuned in, turn RF gain control left until interference fades away.

(i) Readjust volume, bass, and treble controls.

(3) SW reception.

(a) Assemble unit and turn power switch on.

(b) Turn band selector switch to the desired SW band. See Table 9-2 for description of each band.

(c) Place SW calibrator dial in center position.

(d) Turn RF gain control to DX (fully right).

(e) Turn BFO switch to off.

(f) Extend telescopic antenna fully and keep it vertical. If signal desired is broadcast from distant point or excessive interference is expected, connect external antenna similar to one of the following configurations shown below.

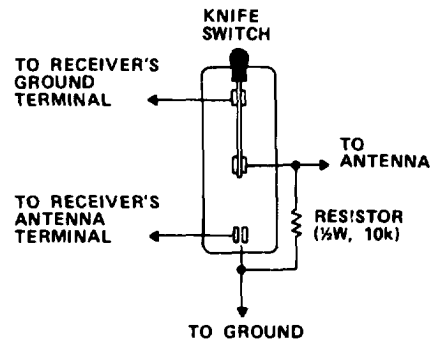
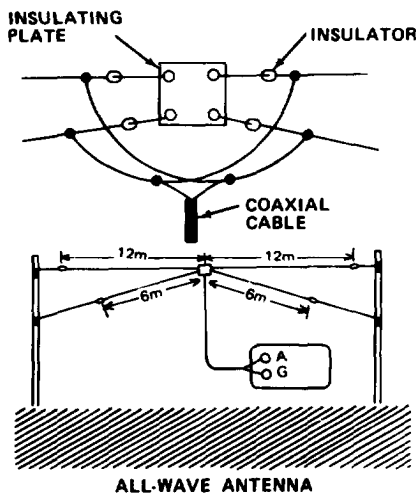
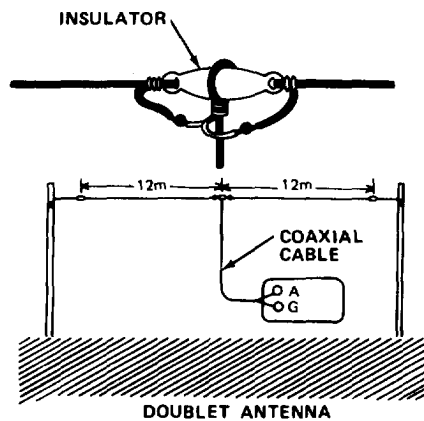
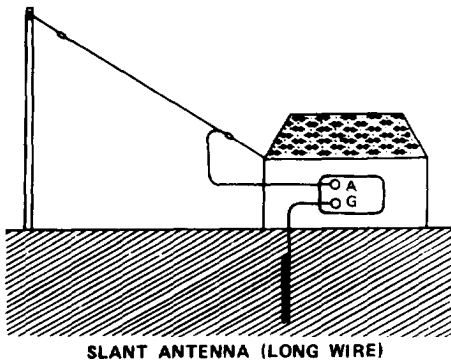
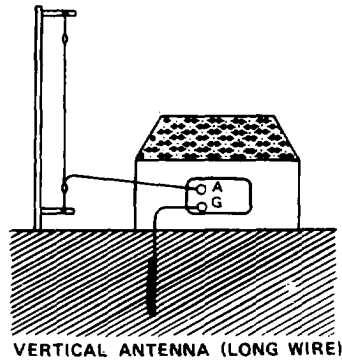
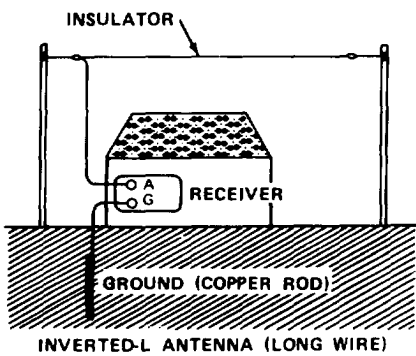

(g) Turn frequency display switch on for tuning.

NOTE

- Frequency display switch should only be on during tuning.
- Turning frequency display switch to on and then off may slightly shift tuned frequency. Readjust as necessary.
- Allow about 30 minutes warm-up period to ensure exact and stable frequency display.

(h) Turn tuning dial to tune in desired signal. Tune until tuning indicator needle deflection indicates strongest signal reception.

NOTE

- If you do not know exact frequency of any station, use any of standard frequency signals broadcast by National Bureau of Standards Radio Station WWV on 2.5, 5, 10 and 15 MHz.
- If tuning indicator needle exceeds full scale because signals are too strong, decrease radio receiver sensitivity to optimum tuning readout level by turning RF gain control left.

(i) Adjust volume, bass, and treble controls to desired level.

(4) SSB and CW reception. SSB corresponds to modulated wave in AM band DSB signal. Regarded as special type of AM wave, it has no carrier wave. Therefore, special detection method is necessary.

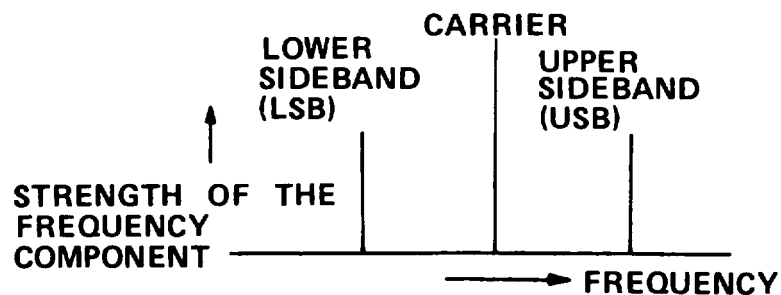

NOTE

- Electromagnetic waves (carrier and both side bands) are transmitted as single group in AM form. Side bands are USB, higher than carrier frequency. LBS is lower than carrier frequency. Either USB signal or LSB signal is transmitted, and it depends upon individual circumstances. Usually for amateur communication, LSB is used under 10 MHz and USB over 10 MHz. SSB waves are generated by passing AM wave through band pass filter, then selecting either USB or LSB and sending signal through transmitting antenna. In receiving SSB (USB or LSB) waves on ordinary AM receiver, it is not possible to hear transmitted voice unless special alteration is made at detection stage. It is possible either to construct carrier and detect AM after adding SSB or to use switching method (product detection) on frequency of carrier for SSB. Latter method has less distortion and is used in this unit.
- Continuous Waves (CW). In practice, these waves are used to transmit Morse code signals by intermittent carrier, but it is difficult to hear sound even after AM detection. Using detection circuit of SSB, intermittent sound can be heard by product-detecting carrier and by varying frequency a little. Set up radio receiver same as for SW reception.
 - (a) Before tuning in desired signal, turn BFO switch on.
 - (b) Tune in desired signal.
 - (c) Carefully move BFO pitch control until signal is clearest.

NOTE

In receiving two-way communication signals, possible difference between two frequencies may require another BFO pitch control adjustment.

Table 9-2. METER AND AMATEUR RF BANDS

| BANDWIDTH | DESCRIPTION |
|----------------------------------------------|------------------------------------------------------------------------------------------------------------------------------------------------------------------------------------------------------------------------------------------------------------------------------------------------|
| 120 m (2.3-2.495 MHz) and 90 m (3.2-3.4 MHz) | These two bands are used solely in tropical regions where unusual electrical activity and other types of noise make MW (AM) reception impractical. They are used mainly for local broadcasting. In comparison with MW, they are difficult to receive because of noise or intermittent signals. |
| 75 m Band (3.9-4.0 MHz) | Used for short-distance broadcasting in tropical regions. |

Table 9-2. METER AND AMATEUR RF BANDS - Cont

| BANDWIDTH | DESCRIPTION |
|-----------------------------|------------------------------------------------------------------------------------------------------------------------------------------------------------------------------------------------------------------------------------------|
| 60 m Band (4.75-5.06 MHz) | Like 120 m and 90 m bands and is used chiefly for local broadcasts in tropical regions. |
| 49 m Band (5.95-6.2 MHz) | Mainly used for short and medium distance international broadcasts and local broadcasts. |
| 41 m Band (7.1-7.3 MHz) | Propagation of this wave is similar to that of 49 m band. It is chiefly used for medium- to short-distance broadcasting. |
| 31 m Band (9.5-9.775 MHz) | Heavily used for international as well as local broadcasts. Shortwave broadcasts of different countries are transmitted in this band and, if receiving conditions are favorable, it is possible to receive many stations at every 5 kHz. |
| 25 m Band (11.7-11.975 MHz) | Propagation of this wave is similar to that of 31 m band. Many international broadcasting stations with strong output signals use this band throughout the year. |
| 19 m Band (15.1-14.45 MHz) | Chiefly used by international broadcasting stations and is regarded as "main band." From this band to higher frequency bands, reception becomes difficult as number of solar spots decreases. |
| 16 m Band (17.7-17.9 MHz) | Used by international stations for purposes similar to 19 m band, but because it is greatly affected by any slight change in solar spots and in different seasons, reception is often impossible. |
| 13 m Band (21.45-21.75 MHz) | Used for long-distance international broadcasts. It is used regardless of seasons when solar spots are active. Condition of this band changes from time to time. |

Table 9-2. METER AND AMATEUR RF BANDS - Cont

| BANDWIDTH | DESCRIPTION |
|---------------------------|------------------------------------------------------------------------------------------------------------------------------------------------------------------------------------------------------------------------------------------------|
| 11 m Band (25.6-26.1 MHz) | Used for long-distance international broadcasts during heavy activity of solar spots. Like 13 m band, its condition changes from time to time. When conditions are good, reception is easy, as there is neither noise nor interfering signals. |
| AMATEUR BANDS | |
| 160 m Band (1.9 MHz) | Also called "top band," and among amateur bands it has longest wavelength. It is good for short-distance transmissions. |
| 80 m Band (3.5 MHz) | This band is generally used for short-distance broadcast. However, depending on season and time, it can be used for DX traffic communication. |
| 40 m Band (7 MHz) | When solar spots are least active, this band is most efficient for DX communications. However, its allotted bandwidth is narrow and it is susceptible to interfering signals. |
| 20 m Band (14 MHz) | Also called "amateurs' main band." Its listening area changes with time and season. It can be used as world-wide traffic communication band, and it is usually possible to receive broadcasts from every country. |
| 15 m Band (21 MHz) | When solar spots decrease, DX station and traffic communication signals are difficult to receive. When spots are active, it is possible to receive low-power DX stations as surprisingly strong signals. |
| 10 m Band (28 MHz) | Among amateur bands, this has one of higher frequencies (HF). This band has both HF and VHF characteristics and more features than 15 m band. When solar spots are active, You can tune into every distant DX station. |

9-6.2 Operating Instructions on Decals and Instruction Plates.**WARNING**

THIS DEVICE IS NOT TO BE USED IN "HAZARDOUS LOCATIONS" AS DEFINED BY UNDERWRITERS LABORATORIES. IT SHOULD BE GROUNDED IN ACCORDANCE WITH PROVISIONS OF THE NATIONAL ELECTRIC CODE, OR ANY APPLICABLE LOCAL CODE, AND MAINTAINED IN ACCORDANCE WITH MANUFACTURER'S RECOMMENDATIONS.

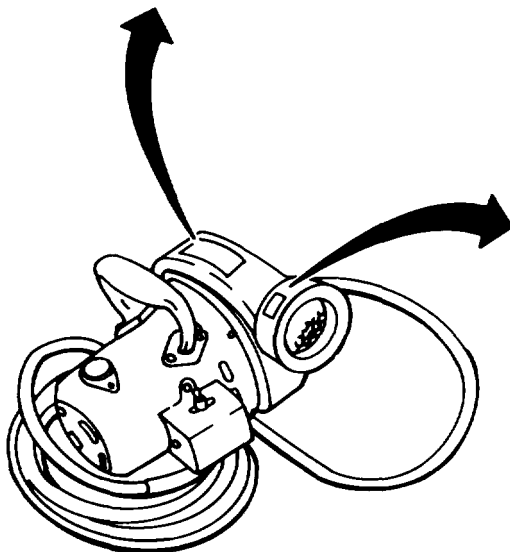
**WARNING!**

ELECTRIC SHOCK COULD OCCUR IF USED ON WET SURFACES. DO NOT EXPOSE TO RAIN. STORE INDOORS.

9-7. OPERATION UNDER UNUSUAL CONDITIONS.

9-7.1 Still Picture (Instant) Camera Set.

- a. Cold weather conditions: Under 65°F (18°C)

NOTE

Never use cold clip for black and white pictures. Instead, follow cold weather directions on instruction sheet packed with each box of film.

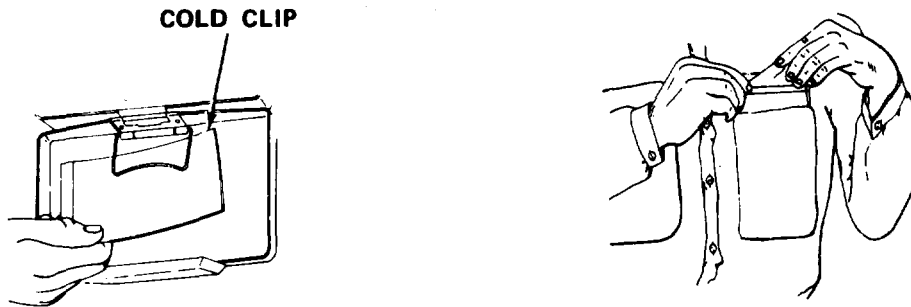

- (1) Remove cold clip from back of camera and warm by placing in an inner pocket.

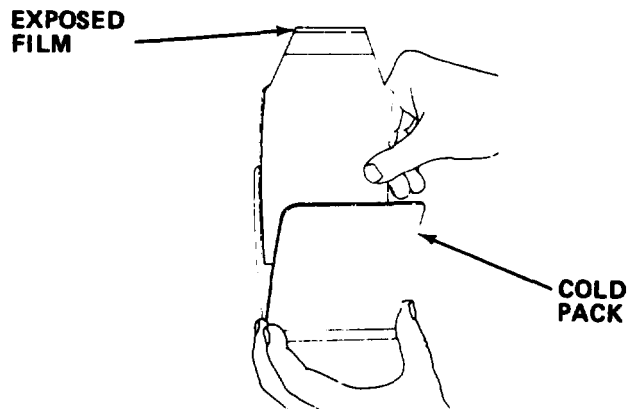

- (2) As soon as exposed film is removed from camera, place it in cold pack.

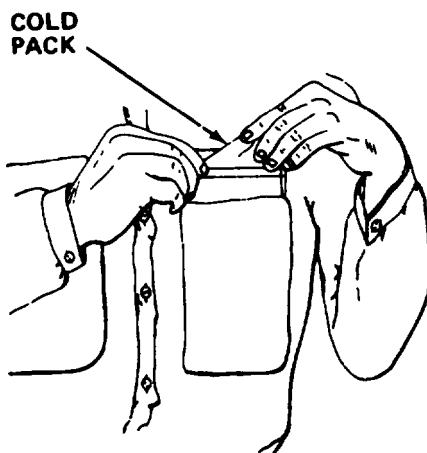

- (3) Place cold pack next to body.
 - (4) After warming cold pack for 60 seconds, remove exposed film and separate picture.
 - (5) Battery life will be shortened by cold weather. Fresh batteries should be used in cold weather.
 - (6) Protect camera from sudden changes in temperature. Avoid going from heated spaces to cold spaces repeatedly with camera.
 - (7) Allow additional time for black and white prints to develop.
- b. Hot weather conditions:
- (1) Do not leave camera in sun or closed vehicles.
 - (2) Do not open film packs until ready to use.

Section III OPERATOR MAINTENANCE

9-8. LUBRICATION INSTRUCTIONS. This equipment does not require lubrication.

9-9. TROUBLESHOOTING PROCEDURES.

a. The table lists the common malfunctions which you may find during operation or maintenance of the support equipment. You should perform the test/inspection and corrective actions in the order listed.

b. This manual cannot list all malfunctions that may occur, nor all test or inspection and corrective actions. If a malfunction is not listed or is not corrected by listed corrective actions, notify your supervisor.

Table 9-2. TROUBLESHOOTING

| MALFUNCTION | TEST OR INSPECTION | CORRECTIVE ACTION |
|--------------------------------------------|-----------------------------------------------------------------------------------------------------------------------------------------------------------------------------------------------------------------------------------|--------------------------------------------------------------------------------------------------------------------------------------------------------------------------------------------------------------------------------------------------|
| 1. MAGNIFIER LAMP ASSEMBLY WILL NOT LIGHT. | Check that magnifier lamp assembly is plugged into active power outlet. Press switch OFF then ON. | <ul style="list-style-type: none"> (a) If lamp still does not light, replace lamp (paragraph 9-10.1). (b) If new lamp does not light, refer to organizational maintenance. |
| 2. VACUUM CLEANER MOTOR DOES NOT OPERATE. | <ul style="list-style-type: none"> Step 1. Check power cord. <ul style="list-style-type: none"> (a) If plugged in, proceed to step 2. (b) Plug in power cord. | <ul style="list-style-type: none"> Step 2. Check position of power switch. <ul style="list-style-type: none"> (a) If turned on, proceed to step 3. (b) Turn power switch on. |

Table 9-3. TROUBLESHOOTING - Cont

| MALFUNCTION | TEST OR INSPECTION | CORRECTIVE ACTION |
|-------------|--------------------|-------------------|
|-------------|--------------------|-------------------|

2. VACUUM CLEANER MOTOR DOES NOT OPERATE - Cont

Step 3. Check circuit breaker position in circuit breaker box.

- (a) If turned off or tripped, turn circuit breaker on.
- (b) If turned on, refer to organizational maintenance.

3. CAMERA FLASHCUBE WILL NOT INDEX FOR ALL FOUR FLASHES.

Step 1. Turn flashcube.

- (a) If flashcube turns easily, proceed to step 2.
- (b) Wind flashcube to limit.

Step 2. Inspect flashcube holder for dirt.

Clean holder.

4. CAMERA FLASHCUBE WILL NOT FLASH.

Step 1. Inspect for loose battery latch.

- (a) If battery is latched properly, proceed to step 2.
- (b) Latch battery firmly.

Step 2. Check for charged batteries.

- (a) If batteries are charged, proceed to step 3.
- (b) Replace batteries (paragraph 9-10.1).

Step 3. Check for defective flashcube.

Replace flashcube.

Table 9-3. TROUBLESHOOTING - Cont

| MALFUNCTION | TEST OR INSPECTION | CORRECTIVE ACTION |
|-------------------------------------------------------------|------------------------------------------------------|-----------------------------------------------------------------------------------------------------------------------------------------------------------|
| 5. CAMERA BATTERIES DRAINING (UNUSUAL IN 6 MONTHS OR LESS). | Step 1. Inspect for corrosion on batteries. | <ul style="list-style-type: none"> (a) If batteries and contacts are clean, proceed to step 2. (b) Clean battery contacts. |
| | Step 2. Check for charged batteries. | <ul style="list-style-type: none"> (a) Replace batteries (paragraph 9-10.1). (b) Replace camera. |
| 6. CAMERA SHUTTER NOT OPERATING. | Test shutter. | <ul style="list-style-type: none"> (a) Replace batteries (paragraph 9-10.1). (b) Replace camera. |
| 7. PICTURE TOO DARK OR TOO LIGHT. | Step 1. Check film speed selector. | <ul style="list-style-type: none"> (a) If film speed selector is correct, proceed to step 2. (b) Correct film speed setting. |
| | Step 2. Check that photoelectric cell lens is clean. | <ul style="list-style-type: none"> (a) If photoelectric cell lens is clean, proceed to step 3. (b) Clean photoelectric cell lens. |

Table 9-3. TROUBLESHOOTING - Cont

| MALFUNCTION | TEST OR INSPECTION | CORRECTIVE ACTION |
|-----------------------------------------|---------------------------------------------|--------------------------------------------------------------------|
| 7. PICTURE TOO DARK OR TOO LIGHT - Cont | Step 3. Check that main lens is clean. | (a) If lens is clean, proceed to step 4. (b) Clean lens. |
| | Step 4. Check for charged batteries. | (a) Replace batteries (paragraph 9-10.1). (b) Replace camera. |
| 8. PICTURE NOT SHARP. | Step 1. Check that camera lenses are clean. | (a) If lenses are clean, proceed to step 2. (b) Clean lenses. |
| | Step 2. Check that camera focuses properly. | (a) Correct focus. (b) Replace camera. |
| 9. POOR SPREAD IN DEVELOPING. | Step 1. Inspect for dirt on rollers. | (a) If rollers are clean, proceed to step 2. (b) Clean rollers. |
| | Step 2. Inspect for dirt on exit door. | Clean door. |

Table 9-3. TROUBLESHOOTING - Cont

| MALFUNCTION | TEST OR INSPECTION | CORRECTIVE ACTION |
|-----------------------------------------|----------------------------------------------------------------|------------------------------------------------------------------------------------|
| 10. RADIO DOES NOT OPERATE ON 120 V AC. | Check to see if power cord is plugged into 120 V ac. | Plug in power cord. |
| 11. RADIO DOES NOT OPERATE ON DC. | Step 1. Check to see if power cord is disconnected from radio. | (a) If disconnected, proceed to step 2. (b) Disconnect power cord. |
| | Step 2. Check that polarity of batteries is correct. | (a) If correctly polarized, proceed to step 3. (b) Install batteries correctly. |
| | Step 3. Check condition of battery charge. | Replace batteries (paragraph 9-10.1). |

12. SIGNALS ARE WEAK.

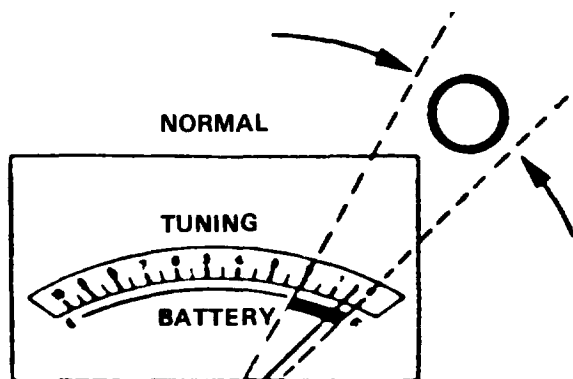

WHEN THE INDICATOR POINTS WITHIN THE "0" RANGE AS SHOWN ABOVE; THE BATTERIES CAN STILL BE USED.

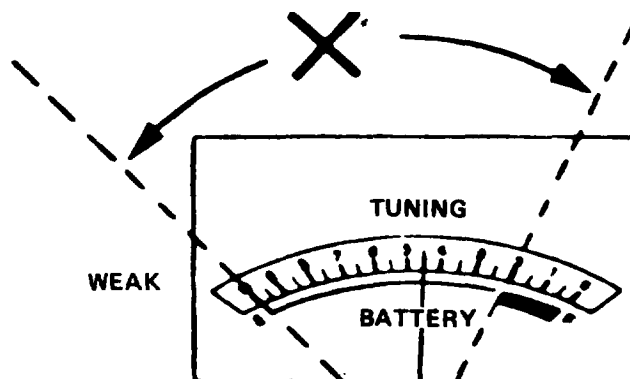

WHEN THE INDICATOR POINTS WITHIN THE "X" RANGE AS SHOWN ABOVE, REPLACE ALL THE BATTERIES WITH NEW ONES.

Table 9-3. TROUBLESHOOTING - Cont

| MALFUNCTION | TEST OR INSPECTION | CORRECTIVE ACTION |
|-----------------------------|------------------------------------------------------------------------------------------------------------------|---------------------------------------------------------------------------------------------------------------------------------------------------------------------------------------------------------------------------------------------------------------------------------------------------------------------------------------------------------------|
| 12. SIGNALS ARE WEAK - Cont | Step 1. Tune radio receiver to frequency with no signal. Check that battery/tuning indicator is in normal range. |  <p>(a) Open battery compartment cover by depressing its two latches and pulling them toward you.</p>  <p>(b) Remove old batteries and insert new batteries with correct polarity.</p> |
| | Step 2. Plug in power cord. Check that signal reception is normal. | Replace unit. |

Table 9-3. TROUBLESHOOTING - Cont

| MALFUNCTION | TEST OR INSPECTION | CORRECTIVE ACTION |
|-------------|---------------------------------------------------------------|----------------------------------------------------------------------------------------------------------------------------------------------------------------------------------------------------------------------------------------------------------------------------------------------------------------------------------------------------------------------------------------------------------------------------------|
| 13. | FREQUENCY DISPLAY DOES NOT AGREE WITH KNOWN SIGNAL FREQUENCY. | <p>Step 1. Tune in SW signal whose frequency is accurately known. Check that frequency display shows correct frequency.</p> <p>(a) Turn tuning dial until correct frequency is displayed.</p> <p>(b) Slowly move SW calibrator dial while watching tuning indicator. Stop when needle indicates maximum deflection to left.</p> <p>Step 2. Let unit sit for approximately 30 minutes and repeat Step 1.</p> <p>Replace unit.</p> |

9-10. MAINTENANCE PROCEDURES.

This section contains instructions covering operator maintenance functions for the support items. Personnel required are listed only if the task requires more than one.

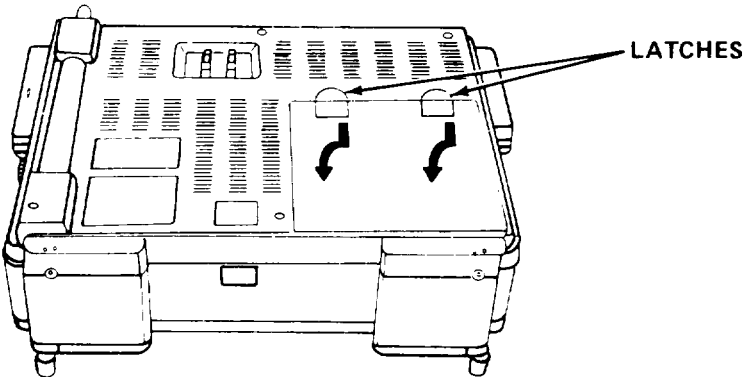
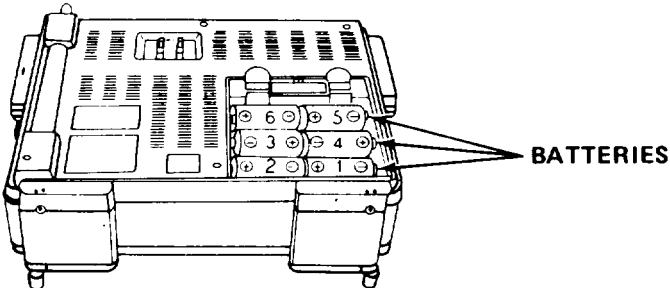
b. After completing each maintenance procedure, perform operational check to be sure that equipment is properly functioning.

INDEX

| PROCEDURE | PARAGRAPH |
|-------------------------------------------------------------------|-----------|
| Replace Lamp in Magnifier Lamp Assembly | 9-10.1 |
| Replace Batteries in Still Picture (Instant) Camera Set | 9-10.2 |

9-10.1 Replace Lamp in Magnifier Lamp Assembly.

MOS: 82D, Topographic Surveyor

SUPPLIES: Fluorescent Lamp (22W)

WARNING

Death or serious injury may occur from electrical shock unless power cord is unplugged before servicing.

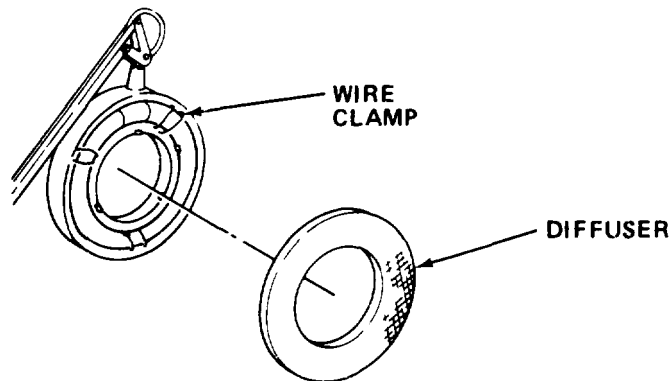

- a. Unplug magnifier lamp assembly and remove diffuser.

NOTE

On some magnifier lamp models, tube is held in place with friction clamps.

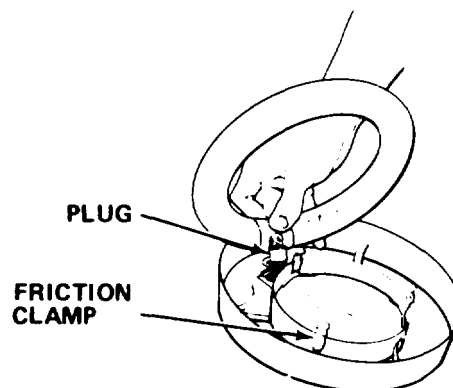

- b. Release wire clamps, pull out lamp, and disconnect plug from lamp.
- c. Connect plug to new lamp and retain lamp with wire clamps.
- d. Reinstall diffuser.

9-10.2 Replace Batteries in Still Picture (Instant) Camera Set.

MOS: 82D, Topographic Surveyor

SUPPLIES: Two Batteries (SizeAA 1.5 V)

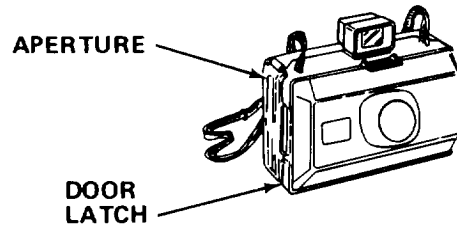

- a. Inspect camera door aperture to confirm camera is not loaded with film pack.
- b. Release door latch and open camera door.

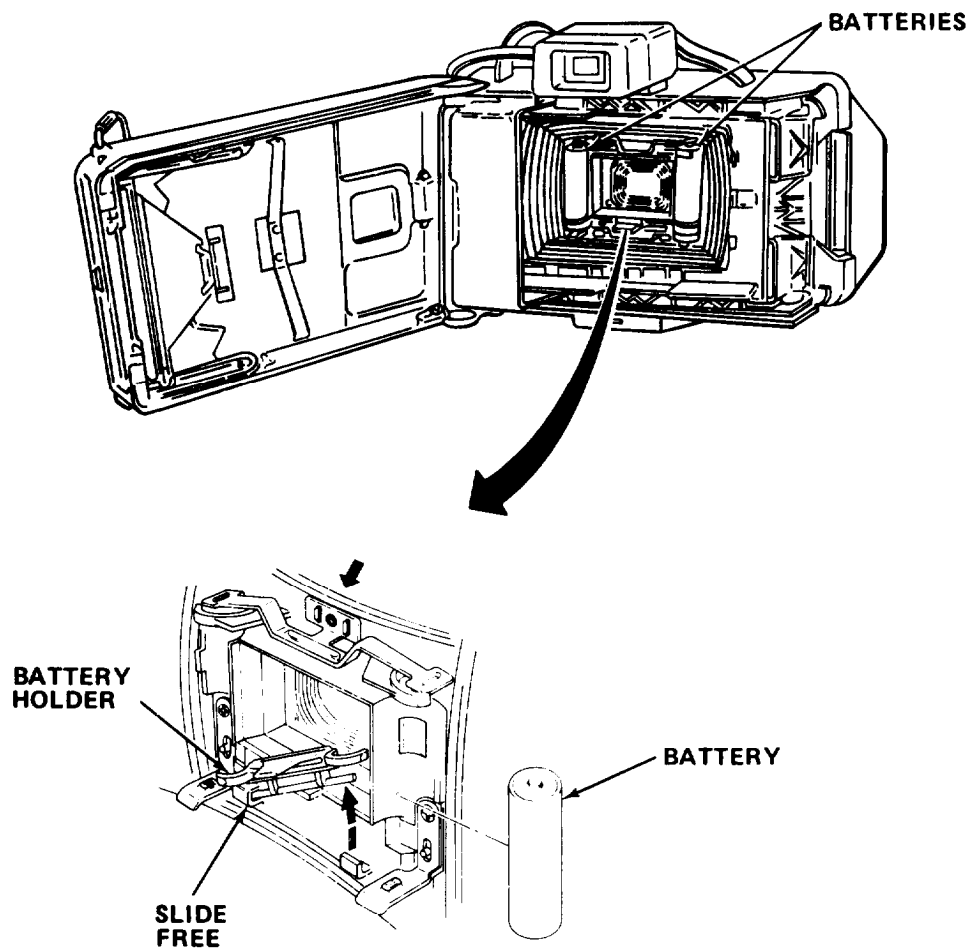

- c. Lift right end of battery holder and slide holder From retainer on left.
- d. Note position of each battery (positive or negative end up) and pull batteries out of holder with fingers.
- e. Place fresh batteries in same positions as old batteries.
- f. Reinstall battery holder by sliding left edge in slot and then pushing right end down.
- g. Cover photoelectric cell lens with finger or cloth.
- h. Set scene selector to 75.
- i. Press shutter button and observe that shutter opens.
- j. Uncover photoelectric cell lens. Observe shutter closes.
- k. Close and latch camera door.

Section IV ORGANIZATIONAL MAINTENANCE

9-11. LUBRICATION INSTRUCTIONS. This equipment does not require lubrication.

9-12. REPAIR PARTS, SPECIAL TOOLS: TEST, MEASUREMENT, AND DIAGNOSTIC EQUIPMENT (TMDE): AND SUPPORT EQUIPMENT.

9-12.1 Common Tools and Equipment. For authorized common tools and equipment refer to the Modified Table of Organization and Equipment (MTOE) applicable to your unit.

9-12.2 Special Tools: Test, Measurement, and Diagnostic Equipment: and Support Equipment. Special Tools, TMDE, and Support Equipment is listed in the applicable repair parts and special tools list and in Appendix B of this manual.

9-12.3 Repair Parts. Repair parts are listed and illustrated in the Repair Parts and Special Tools List, TM 5-6675-318-24P covering organizational maintenance for this equipment.

9-13. SERVICE UPON RECEIPT.

9-13.1 Checking Unpacked Equipment.

a. Inspect the equipment for damage incurred during shipment. If equipment has been damaged, report the damage on DD Form 6, Packing Improvement Report.

b. Check the equipment against the packing list to see if the shipment is complete. Report all discrepancies in accordance with the instructions of DA Pam 738-750.

c. Check to see whether the equipment has been modified.

9-14. ORGANIZATIONAL PREVENTIVE MAINTENANCE CHECKS AND SERVICES. There are no organizational PMCS procedures assigned for this equipment.

9-15. ORGANIZATIONAL TROUBLESHOOTING PROCEDURES.

a. Organizational troubleshooting procedures cover the most common malfunctions that may be repaired at the organizational level. Repair or adjustment requiring specialized equipment is not authorized unless such equipment is available. Troubleshooting procedures used by lower level maintenance should be conducted in addition to the organizational troubleshooting procedures.

b. This manual cannot list all the possible malfunctions or every possible test/inspection and corrective action. If a malfunction is not listed or corrected by a listed corrective action, notify your supervisor.

If the support item does not power up when turned on, verify that 120 V ac is present at the receptacle. If voltage is not present, plug equipment into receptacle with power available and proceed with equipment troubleshooting. Perform no-power procedure for dead receptacle (Table 1-4).

Table 9-5. ORGANIZATIONAL TROUBLESHOOTING

| |
|--------------------|
| MALFUNCTION |
| TEST OR INSPECTION |
| CORRECTIVE ACTION |

WARNING

Death or serious injury may occur from electrical shock unless power cord is unplugged before servicing.

1. VACUUM CLEANER MOTOR DOES NOT OPERATE.

Check that the vacuum cleaner is plugged into active outlet. Turn switch on.

If motor does not operate, replace vacuum cleaner.

2. MAGNIFIER LAMP WILL NOT LIGHT.

Check that magnifier lamp is plugged into active power outlet. Press switch OFF then ON.

Replace magnifier lamp assembly (paragraph 9-16.1).

9-16. MAINTENANCE PROCEDURES.

a. This section contains instructions covering organizational maintenance functions for the support items. Personnel required are listed only if the task requires more than one.

b. After completing each maintenance procedure, perform operational check to be sure that equipment is properly functioning.

INDEX

| PROCEDURE | PARAGRAPH |
|-----------------------------------------------------------|-----------|
| Replace Magnifier Lamp Assembly | 9-16.1 |
| Remove/Install Wrapping Paper Holder and Cutter | 9-16.2 |

9-16.1 Replace Magnifier Lamp Assembly.

MOS: 83FJ6, Reproduction Equipment Repairer

TOOLS: Flat Tip Screwdriver

SUPPLIES: Magnifier Lamp Assembly

WARNING

Death or serious injury may occur from electrical shock if power cord is not unplugged before servicing.

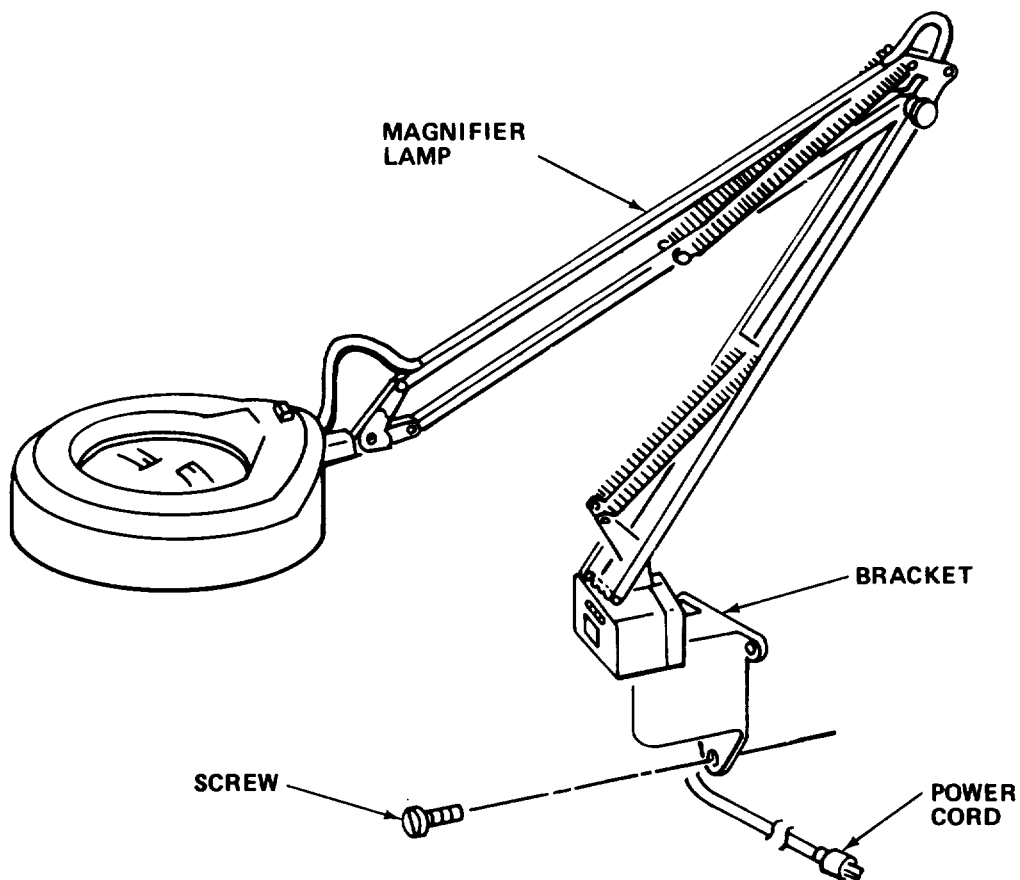

- a. Unplug power cord and remove magnifier lamp assembly from bracket.
- b. Remove screws to release bracket from wall.
- c. Install new bracket and secure with screws.
- d. Install new magnifier lamp assembly on bracket and plug in power cord.

9-16.2 Remove/Install Wrapping Paper Holder and Cutter.

MOS: 83FJ6, Reproduction Equipment Repairer

TOOLS: 5/8 in. Combination Wrench

SUPPLIES: Wrapping Paper Holder and Cutter

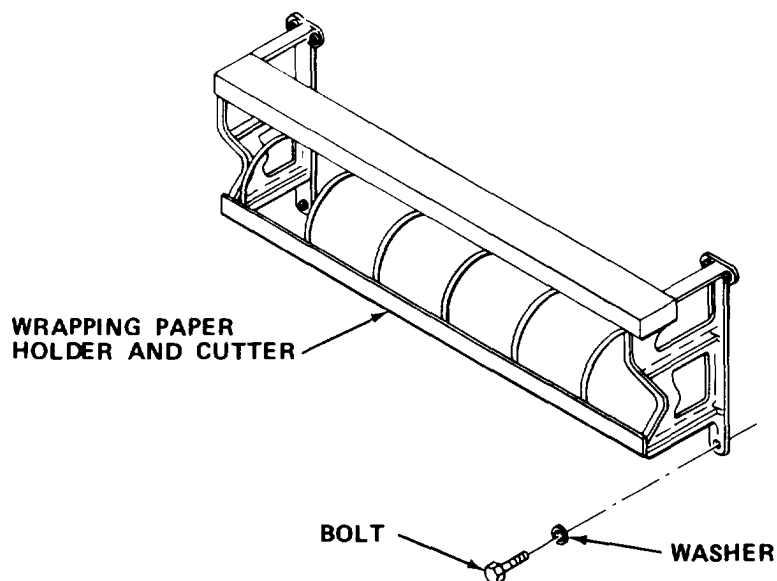

- a. Remove paper roll.
- b. Remove bolts and washers securing defective wrapping paper holder and cutter to wall.
- c. Remove defective wrapping paper holder and cutter.
- d. Aline holes of new wrapping paper holder and cutter with holes on wall.
- e. Secure new wrapping paper holder and cutter with washers and bolts.
- f. Install roll of paper.
- g. Secure mounting bracket with capnuts.

9-17. PREPARATION FOR STORAGE OR SHIPMENT. Contact your battalion packing and shipping instructions.

Section V DIRECT/GENERAL SUPPORT MAINTENANCE

There are no direct/general support maintenance procedures assigned for this equipment.

APPENDIX A

REFERENCES

A-1. SCOPE.

This appendix lists all forms, field manuals, technical manuals and miscellaneous publications referenced in this manual.

A-2. FORMS.

Recommended Changes to Publications and Blank Forms DA Form 2028

Recommended Changes to Equipment Technical Publications DA Form 2028-2

Equipment Inspection and Maintenance Worksheet DA Form 2404

The Army Maintenance Management System (TAMMS). DA Pam 738-750

Quality Deficiency Report SF 368

A-3. FIELD MANUALS.

Camouflage. FM 5-20

First Aid for Soldiers FM 21-11

Nuclear, Biological and Chemical (NBC)
 Defense (Reprinted w/Basic Incl C1) FM 21-40

Basic Cold Weather Manual FM 31-70

Northern Operations FM 31-71

Metal Body Repair and Related Operations FM 43-2

A-4. TECHNICAL MANUALS.

Administrative Storage of Equipment TM 740-90-1

Geodetic and Topographic Surveying TM 5-441

Chemical, Biological and Radiological (CBR)
 Decontamination TM 3-220

Surveying Computers Manual TM 5-237

Operator, Organizational, Direct Support and General
 Support Maintenance Manual: Air Conditioner, Horizontal,
 Compact, 208-Volt, 3-Phase, 18,000 Btu Cooling, 12,000
 Btu Heating. TM 5-4120-367-14

TM 5-6675-318-14

Universal Transverse Mercator Grid TM 5-241-8

Satellite Records Manual - Doppler Geodetic Point Positioning . . . DMA TM T-3-52320

Grids and Grid References TM 5-241-1

Elements of Surveying 5-232

Operator, Organizational, Direct Support and
General Support Maintenance Manual for Chassis,
Semi-Trailer, Container Transporter (ADCOR) TM 5-2330-305-14

Organizational, Direct Support and General Support
Maintenance Repair Parts and Special Tools List
(Including Depot Maintenance Repair Parts and
Special Tools) for Air Conditioner/Heater TM 5-4120-367-24P

Organizational, Direct Support and General Support
Maintenance Repair Parts and Special Tools List
(Including Depot Maintenance Repair Parts and
Special Tools) for Chassis, Semi-Trailer,
Container Transporter (ADCOR) TM 5-2330-305-24P

Organizational, Direct Support and General Support
Maintenance Repair Parts and Special Tools List
(RPSTL) (Including Depot Maintenance Repair Parts
and Special Tools) for Survey Section TM 5-6675-318-24P

Operator's and Organizational Support Maintenance
Manual (Including Repair Parts and Special Tools
List) for Analytical Photogrammetric Positioning
System, APPS AN/UYK-48 TM 5-1260-206-12

Operator's Manual for Radio Sets, AN/GRC 106
and AN/GRC 106A TM 11-5820-520-10

Operator's, Organizational, Direct Support and
General Support Maintenance Manual for Lead-Acid
Storage Batteries TM 9-6140-200-14

Direct Support and General Support Maintenance
Manual (Including Repair Parts and Special
Tools) for Analytical Photogrammetric Positioning
System APPS AN/UYK-48 TM 5-1260-206-34

Organizational, Direct Support and General
Support Maintenance Manual for Calculator,
Hewlett-Packard Model 9825A (Desk Top
Computer, an APPS Component). TM 11-2660-263-24/1 &/2

Organizational, Direct Support and General Support Maintenance Repair Parts and Special Tools List (Including Depot Maintenance Repair Parts and Special Tools) for Calculator, Hewlett-Packard Model 9825A (Desk Top Computer, an APPS Component) TM 11-2660-263-1079-24P

Painting Instructions for Field Use TM 43-0139

Procedure for the Destruction of Equipment to Prevent Enemy Use TM 750-244-3

Use and Care of Hand Tools and Measuring Tools TM 9-243

A-5. MISCELLANEOUS PUBLICATIONS.

Lubrication Order: Topographic Support System, Survey Section, Model ADC-TSS-06 LO 5-6675-318-12

Power Supply, Direct Current, Hewlett Packard, Model 6268B TB 9-6625-1906

Lubrication Order: Topographic Support System, Chassis, Semi-Trailer, Container Transporter (ADCOR) LO 5-2330-305-12

APPENDIX B

MAINTENANCE ALLOCATION CHART

Section I INTRODUCTION

B-1. GENERAL.

a. This section provides a general explanation of all maintenance and repair functions authorized at various maintenance categories.

b. The Maintenance Allocation Chart (MAC) in section II designates overall responsibility for the performance of maintenance functions on the identified end item or component. The application of the maintenance functions to the end item or component will be consistent with the capacities and capabilities of the designated maintenance categories.

c. Section III lists the tools and test equipment (both special tools and common tool sets) required for each maintenance function as referenced from Section II.

d. Section IV contains supplemental instructions and explanatory notes for a particular maintenance function.

B-2. MAINTENANCE FUNCTIONS. Maintenance functions will be limited to and defined as follows:

a. **Inspect.** To determine the serviceability of an item by comparing its physical, mechanical, and/or electrical characteristics with established standards through examination (e.g., by sight, sound, or feel).

b. **Test.** To verify serviceability by measuring the mechanical, pneumatic, hydraulic or electrical characteristics of an item and comparing those characteristics with prescribed standards.

c. **Service.** Operations required periodically to keep an item in proper operating condition, i.e., to clean (includes decontaminate, when required), to preserve, to drain, to paint, or to replenish fuel, lubricants, chemical fluids, or gases.

d. **Adjust.** To maintain or regulate, within prescribed limits, by bringing into proper or exact position, or by setting the operating characteristics to specified parameters.

e. **Aline.** To adjust specified variable elements of an item to bring about optimum or desired performance.

f. **Calibrate.** To determine and cause corrections to be made or to be adjusted on instruments or test, measuring, and diagnostic equipment used in precision measurement. Consists of comparisons of two instruments, one of which is a certified standard of known accuracy, to detect and adjust any discrepancy in the accuracy of the instrument being compared.

g. Remove/ Install. To remove and install the same item when required to perform service or other maintenance functions. Install may be the act of emplacing, seating, or fixing into position a spare, repair part, or module (component or assembly) in a manner to allow the proper functioning of an equipment or system.

h. Replace. To remove an unserviceable item and install a serviceable counterpart in its place. "Replace" is authorized by the MAC and is shown as the 3d position code of the SMR code.

i. Repair. The application of maintenance services¹, including fault location/-troubleshooting², removal/installation, and disassembly/assembly³ procedures, and maintenance actions⁴ to identify troubles and restore serviceability to an item by correcting specific damage, fault, malfunction, or failure in a part, subassembly, module (component or assembly), end item or system.

j. Overhaul. That maintenance effort (service/action) prescribed to restore an item to a completely serviceable/operational condition as required by maintenance standards in appropriate technical publications (i.e., DMWR). Overhaul is normally the highest degree of maintenance performed by the Army. Overhaul does not normally return-an item-to like new condition.

k. Rebuild. Consists of those services/actions necessary for the restoration of unserviceable equipment to a like new condition in accordance with original manufacturing standards. Rebuild is the highest degree of material maintenance applied to Army equipment. The rebuild operation includes the act of returning to zero those age measurements (hours/miles, etc.) considered in classifying Army equipment/components.

B-3. EXPLANATION OF COLUMNS IN THE MAC, SECTION II.

a. Column 1, Group Number. Column 1 lists functional group code numbers, the purpose of which is to identify maintenance significant components, assemblies, subassemblies and modules with the next higher assembly. End item group number shall be "00."

b. Column 2, Component/Assembly. Column 2 contains the names of components, assemblies, subassemblies, and modules for which maintenance is authorized.

c. Column 3, Maintenance Function. Column 3 lists the functions to be performed on the item listed in Column 2. (For detailed explanation of these functions, see paragraph B-2.)

¹Services - Inspect, test, service, adjust, aline, calibrate and/or replace.

²Fault locate/troubleshoot - The process of investigating and detecting the cause of equipment malfunctioning; the act of isolating a fault within a system or unit under test (UUT).

³Disassemble/assemble - Encompasses the step-by-step taking apart (or breakdown) of a spare/functional group coded item to the level of its least componency identified as maintenance significant (i.e., assigned an SMR code) for the category of maintenance under consideration.

⁴Actions - Welding, grinding, riveting, straightening, facing, remachining and/or resurfacing.

d. Column 4, Maintenance Category. Column 4 specifies, by the listing of a work time figure in the appropriate subcolumn(s), the category of maintenance authorized to perform the function listed in Column 3. This figure represents the active time required to perform that maintenance function at the indicated category of maintenance. If the number or complexity of the tasks within the listed maintenance function varies at different maintenance categories, appropriate work time figures will be shown for each category. The work time figure represents the average time required to restore an item (assembly, subassembly, component, module, end item or system) to a serviceable condition under typical field operation conditions. This time includes preparation time (including any necessary disassembly/assembly time), troubleshooting/fault location time, and quality assurance/quality control time in addition to the time required to perform the specific tasks identified for the maintenance functions authorized in the Maintenance Allocation Chart. The symbol designations for the various maintenance categories are as follows:

- C Operator or Crew
- O Organizational Maintenance
- F Direct Support Maintenance
- H General Support Maintenance
- L Specialized Repair Activity⁵
- D Depot Maintenance

e. Column 5, Tools and Equipment. Column 5 specifies, by code, those common tool sets (not individual tools) and special tools, TMDE and support equipment required to perform the designated function.

f. Column 6, Remarks. This column shall, when applicable, contain a letter code, in alphabetical order, which shall be keyed to the remarks contained in Section IV.

⁵This maintenance category is not included in Section II, column (4) of the Maintenance Allocation Chart. To identify functions to this category of maintenance, enter a work time figure in the "H" column of Section II, column (4), and use an associated reference code in the Remarks column (6). Key the code to Section IV, Remarks, and explain the SRA complete repair application there. The explanatory remark(s) shall reference the specific Repair Parts and Special Tools List (RPSTL) TM which contains additional SRA criteria and the authorized spare/repair parts.

B-4. EXPLANATION OF COLUMNS IN TOOL AND TEST EQUIPMENT REQUIREMENTS, SECTION III

- a. Column 1, Reference Code. The tool and test equipment reference code correlates with a code used in the MAC, Section II, Column 5.
- b. Column 2, Maintenance Category. The lowest category of maintenance authorized to use the tool or test equipment.
- c. Column 3, Nomenclature. Name or identification of the tool or test equipment.
- d. Column 4, National Stock Number. The National stock number of the tool or test equipment.
- e. Column 5, Tool Number. The manufacturer's part number.

B-5. EXPLANATION OF COLUMNS IN REMARKS, SECTION IV.

- a. Column 1, Reference Code. The code recorded in Column 6, Section II.
- b. Column 2, Remarks. This column lists information pertinent to the maintenance function being performed as indicated in the MAC, Section II.

Section II. MAINTENANCE ALLOCATION CHART

| (1) Group Number | (2) Component/Assembly | (3) Maintenance Function | (4) Maintenance Cat. | | | | | (5) Tools and Eqpt | (6) Remarks |
|---------------------|----------------------------------|------------------------------|-------------------------|------------|------------|-----|---|------------------------|----------------|
| | | | C | O | F | H | D | | |
| 00 | SURVEY SECTION | Overhaul | | | | | | | |
| 01 | VAN BODY (ISO CONTAINER) | Inspect Service Repair | 0.8 0.9 | 0.5 1.0 | 1.5 | 2.0 | | 9,11,13,17 1,3,6,19 | F |
| | FLUORESCENT LIGHT ASSY. | Repair | 0.1 | 0.7 | | | | 1 | |
| | BLACKOUT/DOME LIGHT ASSY. | Repair | 0.2 | | | | | | |
| | EXHAUST FAN ASSEMBLY | Repair | | 0.5 | | | | 1 | |
| | AIR CONDITIONER/ HEATER ASSY. | Replace | | | | 2.0 | | 1 | D |
| | ELECTRICAL ASSEMBLY | Inspect Repair | | 0.5 0.9 | 1.0 | | | 1,3 | |
| | TELEPHONE BINDING POST ASSY. | Repair | | 0.7 | | | | 1 | |
| | EMERGENCY LIGHT ASSY. | Replace | | 0.3 | | | | 1 | |
| | TIEDOWN SOCKET ASSY. | Replace | | 0.3 | | | | 6 | |
| | LEVEL INDICATOR ASSY. | Repair | | 0.6 | | | | 2,3 | |
| | BLACKOUT CURTAIN ASSY. | Repair | | 1.0 | | | | 6 | |
| | PERSONNEL LADDER ASSY. | Repair | | 0.8 | | | | 6,19 | F |
| | PERSONNEL/CARGO DOOR ASSY. | Replace Repair | | | 1.5 2.0 | | | 6 6 | |

** Depot will determine work time

Section II MAINTENANCE ALLOCATION CHART — Cont

| (1) Group Number | (2) Component/Assembly | (3) Maintenance Function | (4) Maintenance Cat. | | | | | (5) Tools and Eqpt | (6) Remarks |
|---------------------|-------------------------------------------------------|---------------------------------------------------------------|-------------------------|------------|------------|---|---|--------------------------------------------|----------------|
| | | | C | O | F | H | D | | |
| 02 | ANALYTICAL PHOTO-GRAMMETRIC POSITIONING SYSTEM (APPS) | | | | | | | | E |
| 03 | XY GRAPHICS PLOTTER (9872B) | Inspect Test Service | 0.2 0.8 0.2 | | | | | 7,8,16 | |
| 03A | XY GRAPHICS PLOTTER (9872C) | Inspect Test Service Adjust Repair Replace | 0.2 0.8 | 0.5 0.2 | 0.8 | | | 7,8,16 5 1,4,5,14,15 5,14,15 5 | F |
| | FRONT CONTROL PANEL ASSEMBLY | Adjust Repair | | | 0.3 1.8 | | | 5 5 | |
| | PCA - A3 CARD | Repair Replace | | | 0.3 | | | 5 | A C |
| | PCA - A2 CARD | Adjust Repair Replace | | | 0.3 | | | 5 | A C |
| | PCA -A1 CARD | Repair Replace | | | 0.3 | | | 5 | A C |
| | PCA - A4 CARD | Repair Replace | | | 0.3 | | | 5 | A C |
| | PCA - A5 CARD | Repair Replace | | | 0.3 | | | 5 | A C |
| | PCA - A6 CARD | Repair Replace | | | 0.3 | | | 5 | A C |

Section II MAINTENANCE ALLOCATION CHART — Cont

| (1) Group Number | (2) Component/Assembly | (3) Maintenance Function | (4) Maintenance Cat. | | | | | (5) Tools and Eqpt | (6) Remarks |
|------------------------|-----------------------------|--------------------------------------|-------------------------|---|-----|-----|-------|-----------------------------|----------------|
| | | | C | O | F | H | D | | |
| 30B | HP-IB INTERFACE ASSEMBLY | Test | 0.5 | | 0.8 | | | 5 | A |
| | | Repair | | | 0.5 | | | | |
| | | Replace | | | 0.8 | | | | |
| | PCA A1 CARD | Repair | | | 0.4 | | 5 | A C | |
| | | Replace | | | | | | | |
| | | | | | | | | | |
| | PCA A2 CARD | Repair | | | 0.4 | | 5 | A C | |
| | | Replace | | | | | | | |
| | | | | | | | | | |
| 04 | SATELLITE SURVEYOR | Inspect | 0.1 | | | | 13,18 | | |
| | | Test | 0.3 | | | | | | |
| | | Service | 0.2 | | | | | | |
| | | Repair | 0.2 | | | | | | 13.8 |
| | ELECTRICAL ASSEMBLY | Repair | | | | 6.0 | | 4,5 | |
| | | FAN ASSEMBLY | Replace | | | 1.0 | | 4,5 | |
| | | OSCILLATOR ASSEMBLY | Replace | | | 1.0 | | 4,5 | |
| | | THERMOMETER | Replace | | | 0.5 | | 4,5 | |
| | | BATTERY PACK 1 | Replace | | | 1.0 | | 4,5 | |
| | | BATTERY PACK 2 | Replace | | | 1.0 | | 4,5 | |
| | | SWITCHES | Replace | | | 1.5 | | 4,5 | |
| | | ELECTRONICS ASSEMBLY | Repair | | | 7.8 | | 4,5 | |
| | | TAPE CASSETTE TRANSPORT 250 BH | Replace | | | 0.5 | | 4,5 | |

Section II MAINTENANCE ALLOCATION CHART — Cont

| (1) Group Number | (2) Component/Assembly | (3) Maintenance Function | (4) Maintenance Cat. | | | | | (5) Tools and Eqpt | (6) Remarks |
|---------------------|-------------------------------------|------------------------------|-------------------------|-----|-----|---|---|-----------------------|----------------|
| | | | C | O | F | H | D | | |
| 04 | SATELLITE SURVEYOR - Cont | | | | | | | | |
| | KEYBOARD PRINTED WIRING BOARD | Replace | | | 1.0 | | | 4,5 | B |
| | FRONT PANEL DISPLAY BOARD | Replace | | | 1.0 | | | 4,5 | B |
| | TAPE CONTROL BOARD | Replace | | | 0.5 | | | 4,5 | B |
| | DUAL CHANNEL RECEIVER BOARD | Replace | | | 0.5 | | | 4,5 | B |
| | VOLTMETER DRIVER BOARDS | Replace | | | 0.8 | | | 4,5 | B |
| | ALARM CLOCK BOARD | Replace | | | 0.5 | | | 4,5 | B |
| | MODEM BOARD | Replace | | | 0.5 | | | 4,5 | B |
| | POWER SUPPLY BOARD | Replace | | | 0.5 | | | 4,5 | B |
| | MEMORY BOARD | Replace | | | 0.5 | | | 4,5 | B |
| | DATA ENTRY AND DISPLAY CARD | Replace | | | 1.0 | | | 4,5 | B |
| | MEMORY/ PROCESSOR BOARD | Replace | | | 0.5 | | | 4,5 | B |
| 05 | AUTOMATIC BATTERY CHARGER | Inspect Replace Repair | 0.2 | 0.1 | 0.5 | | | | |
| | ELECTRICAL ASSEMBLY | Repair | | | 0.5 | | | 4,5,20 | F |

Section II MAINTENANCE ALLOCATION CHART — Cont

| (1) Group Number | (2) Component/Assembly | (3) Maintenance Function | (4) Maintenance Cat. | | | | | (5) Tools and Eqpt | (6) Remarks |
|------------------------|--------------------------------------------|--------------------------------|-------------------------|------------|---|---|---|-----------------------------|----------------|
| | | | C | O | F | H | D | | |
| 06 | ULTRASONIC CLEANER | Inspect Repair | 0.2 | 0.7 | | | | 1 | |
| | CIRCUIT BOARD | Replace | | 0.6 | | | | 1 | C |
| 07 | PROGRAMMABLE CALCULATOR WITH PRINTER | Inspect Service | 0.1 0.1 | | | | | | |
| 08 | FURNITURE AND CABINETS | Inspect | 0.3 | | | | | | |
| | | Replace Repair | | 1.5 0.8 | | | | 1,3,19 1,3 | F |
| 09 | SUPPORT ITEMS | Inspect | 0.3 | | | | | | |
| | | Service Replace | 0.3 | 0.3 | | | | 12 1 | |

Section III TOOL AND TEST EQUIPMENT REQUIREMENTS

| (1) Reference Code | (2) Maintenance Category | (3) Nomenclature | (4) National/NATO Stock Number | (5) Tool Number |
|--------------------------|--------------------------------|-------------------------------------------------------------------------------------|--------------------------------------|-----------------------|
| 1 | 0 | Shop, Equipment Automatize Maintenance and Repair, Common No. 1, plus Metric Option | 4910-00-754-0654 | |
| 2 | 0 | Tool Kit, Carpenter's, Engineer Squad | 5180-00-293-2875 | |
| 3 | 0 | Tool Kit, General Mechanic's Automotive, plus Metric Option | 5180-00-177-7033 | |
| 4 | F,H | Tool Kit, Electronic Equipment | 5180-00-605-0079 | |
| 5 | O,F,H | Tool Kit, Electronic Equipment | 5180-00-610-8177 | |
| 6 | O,F,H | Tool Kit, Light Machine Repair | 5180-00-596-1540 | |
| 7 | C | Optical Comparator | 6650-00-668-5703 | |
| 8 | C | Brush, Lens | 5920-00-205-0565 | |
| 9 | C | Brush, Wire | 7920-00-291-5815 | |
| 10 | C | Screwdriver, Cross Tip No. 2 | 5120-00-234-8913 | |
| 11 | C | Screwdriver, Flat Tip | 5120-00-234-8910 | |
| 12 | C | Watchmaker's Blower | 5120-00-254-4612 | |
| 13 | C | Wrench, Adjustable, 6 in. | 5120-00-264-3795 | |
| 14 | O | Gram Gage (O-65 gr) | 1355-00-024-9516 | |
| 15 | O | Dynamometer (100 -500 gr) | | (60998) 62-6381-00 |
| 16 | C | Metric Scaler | | (06175) 81-34-38 |
| 17 | O | Spring Scale | 6670-00-238-9777 | |

Section III TOOL AND TEST EQUIPMENT REQUIREMENTS - Cont

| (1) Reference Code | (2) Maintenance Category | (3) Nomenclature | (4) National/NATO Stock Number | (5) Tool Number |
|--------------------------|--------------------------------|-----------------------------------|--------------------------------------|-----------------------|
| 18 | C | Carrier, Storage Battery, Hand | | (43331) M180 |
| 19 | O,F,H | Rivet Gun | 5120-00-017-2849 | |
| 20 | F | Wrench, Torque | 5120-00-890-7816 | |

Section IV REMARKS

| Reference Code | Remarks |
|----------------|--------------------------------------------------------------------------------------------------------------------------------------------------------------------------------------------------------------------------------------------------------------------------------------------------------------------------------------------------|
| A | Printed circuit boards will be repaired at the general support maintenance level to the maximum extent possible as required by AR 750-1. |
| B | Direct support maintenance will provide printed circuit board diagnosis and fault isolation which can be readily accomplished with assigned tools and test, measurement, and diagnostic equipment (TMDE). |
| C | Replacement of printed circuit boards authorized by the MAC are those identified as damaged, or otherwise defective which: <ul style="list-style-type: none"> a) Can be readily removed/installed with easy to use tools. b) Do not require critical adjustment, calibration, or alignment before or after installation. |
| D | See TM 5-4120-367-14 for maintenance procedures. |
| E | See TM 9-1260-206-12&P and TM 9-1 260-20&34&P for maintenance procedures. |
| F | Maintenance personnel and TSS Section 7, Maintenance Van (which carries the required tools) are authorized by HHC TOE 05336 H600 |

APPENDIX C

COMPONENTS OF END ITEMS AND BASIC ISSUE ITEMS LISTS

Section I INTRODUCTION

C-1. SCOPE.

This appendix lists components of end item and basic issue items for the Survey Section to help you inventory items required for safe and efficient operation.

C-2. GENERAL.

The Components of End Item and Basic Issue Items Lists are divided into the following sections:

a. Section II: Components of End Item. This listing is for informational purposes only, and is not authority to requisition replacements. As part of the end item, these items must be with the end item whenever it is issued or transferred between property accounts. Illustrations are furnished to assist you in identifying the items.

b. Section III: Basic Issue Items. These are the minimum essential items required to place the Survey Section in operation, to operate it, and to perform emergency repairs, BII must be with the Survey Section during operation and whenever it is transferred between property accounts. The illustrations will assist you with hard-to-identify items. This manual is your authority to request/requisition replacement BII based on TOE/MTOE authorization of the end item.

C-3. EXPLANATION OF COLUMNS.

The following provides an explanation of columns found in the tabular listings:

a. Column (1): Illustration Number (Illus Number). This column indicates the number of the illustration in which the item is shown.

b. Column (2): National Stock Number. Indicates the National stock number assigned to the item and will be used for requisitioning purposes.

c. Column (3): Description. Indicates the Federal item name and, if required, a minimum description to identify and locate the item. The last line for each item indicates the FSCM (in parentheses) followed by the part number.

d. Column (4): Unit of Measure (U/M). Indicates the measure used in performing the actual operational/maintenance function. This measure is expressed by a two-character alphabetical abbreviation (e.g., ea, in, pr).

e. Column (5): Quantity Required (Qty Rqr). Indicates the quantity of the item authorized to be used with/on the equipment.

Section II COMPONENTS OF END ITEM

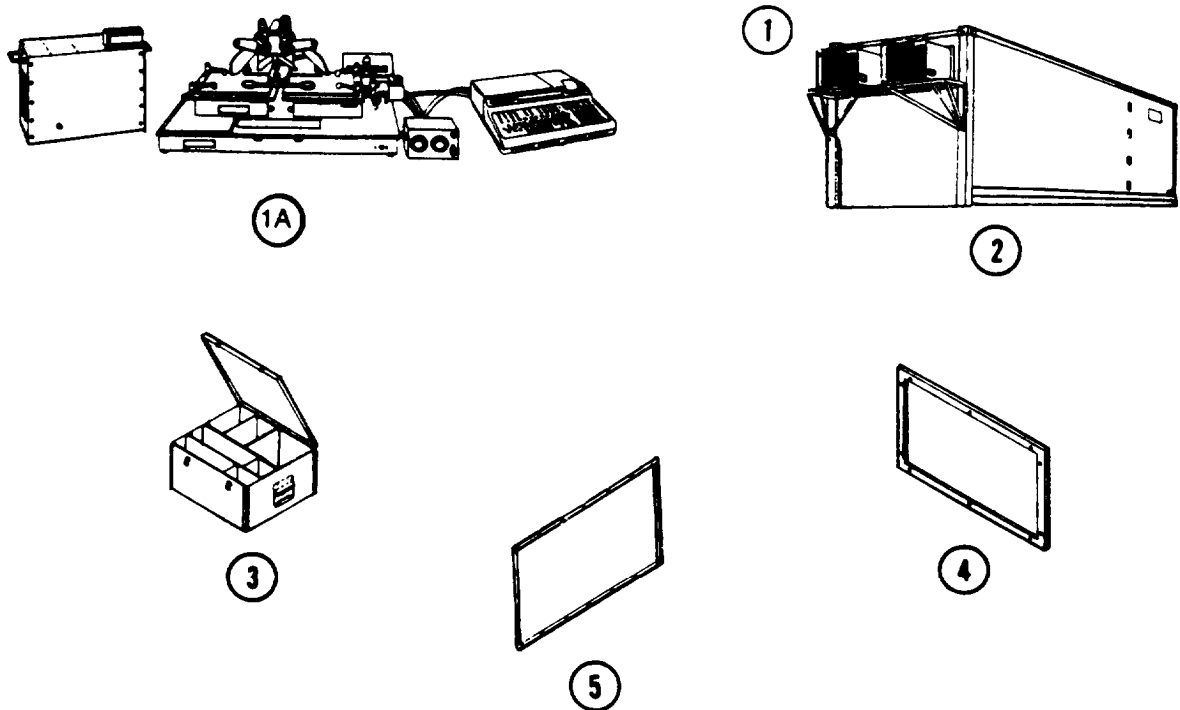

| (1) Illus Number | (2) National Stock Number | (3) Description FSCM and Part Number | (4) U/M | (5) Qty Rqr |
|------------------------|---------------------------------|---------------------------------------------------------------------------------------|------------|-------------------|
| 1 | 4120-00-974-7206 | AIR CONDITIONER (81 349) MIL-A-52767 | ea | 2 |
| 1A | 1260-01-061-7081 | ANALYTICAL PHOTOGRAMMETRIC POSITIONING SYSTEM: APPS AN/UYK-48 (52326) 1100-2 | ea | 1 |
| 2 | 6675-01-220-2581 | VAN ASSEMBLY, MODIFIED (97403) 13225E3032 | ea | 1 |
| 3 | | BOX, VEHICULAR ACCESSORIES for vacuum cleaner (97403) 13225E3490 | ea | 1 |
| 4 | 7195-00-105-7941 | BULLETIN BOARD: (7981 9) T5-2303 | ea | 1 |
| 5 | 7125-00-286-5259 | CABINET STORAGE, WALL: (81349) MIL-C-40060/1 Type 1 | ea | 2 |

Section II COMPONENTS OF END ITEM - Cont

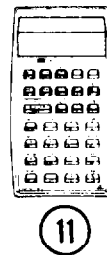
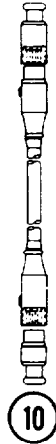
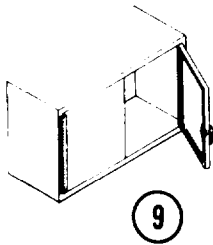
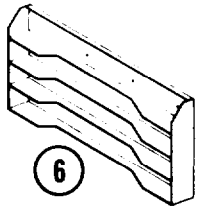

| (1) Illus Number | (2) National Stock Number | (3) Description FSCM and Part Number | (4) U/M | (5) Qty Rqr |
|------------------------|---------------------------------|--------------------------------------------------------------------------|------------|-------------------|
| 6 | | CABINET, STORAGE, PAPER: (97403) 13225E4185 | ea | 1 |
| 7 | 7125-00-269-8534 | CABINET, STORAGE, SUPPLY: (04718) 41-094/4A | ea | 1 |
| 8 | 7125-00-724-9975 | CABINET, STORAGE, FORMS: (37296) MIL-C-40060/21 | ea | 1 |
| 9 | | CABINET, STORAGE, TECH MANUAL: (97403) 13225E4648 | ea | 1 |
| 10 | 6150-01-134-0847 | CABLE ASSEMBLY, POWER ELECTRICAL: (75477) 11601643, except 50.5 ft lg | ea | 2 |
| 11 | 7420-01-054-4382 | CALCULATING MACHINE: (56634) TI-59 | ea | 3 |

Section II COMPONENTS OF END ITEM - Cont

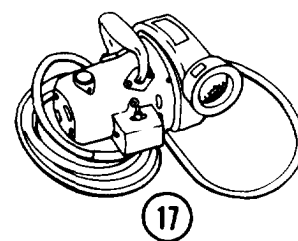
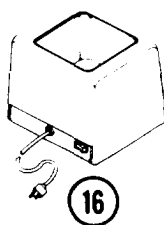
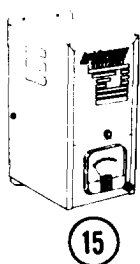
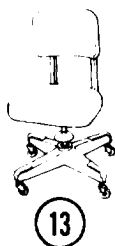
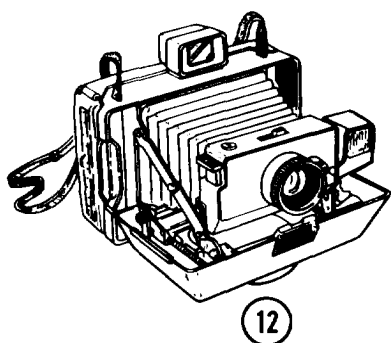

| (1) Illus Number | (2) National Stock Number | (3) Description FSCM and Part Number | (4) U/M | (5) Qty Rqr |
|------------------------|---------------------------------|------------------------------------------------|------------|-------------------|
| 12 | 6720-01-064-8071 | CAMERA SET, STILL (INSTANT): (47904) EE100 | ea | 1 |
| 13 | 7110-00-273-8791 | CHAIR, ROTARY: (8D190) UC-S-17 | ea | 4 |
| 14 | 7110-00-281-4472 | CHAIR, DRAFTING: (8D190) UC-D42-L | ea | 1 |
| 15 | 6130-01-181-4032 | CHARGER, BATTERY: (92731) A18J-12 | ea | 1 |
| 16 | 4940-01-118-1890 | CLEANER, ULTRASONIC: (79819) 3069 USC 3 | ea | 1 |
| 17 | 7910-00-205-3400 | CLEANER, VACUUM, ELECTRIC: (51745) MVV 3400 | ea | 1 |

Section II COMPONENTS OF END ITEM - Cont

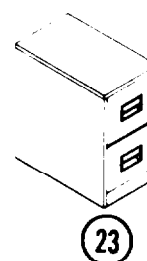
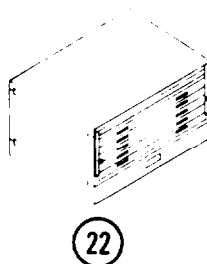
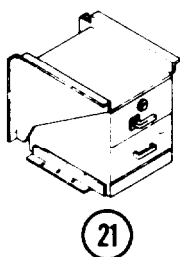
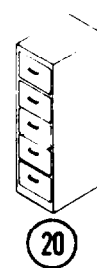
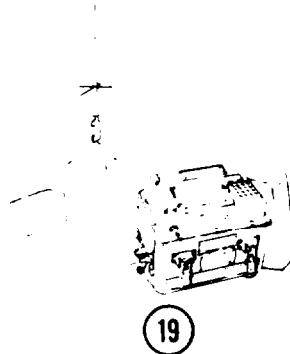
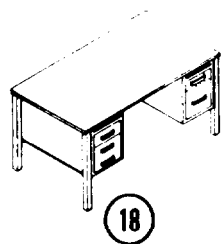

| (1) Illus Number | (2) National Stock Number | (3) Description FSCM and Part Number | (4) U/M | (5) Qty Rqr |
|------------------------|---------------------------------|------------------------------------------------------------------------------------------|------------|-------------------|
| 18 | 7110-00-143-0832 | DESK, FLAT TOP: (37296) AA-D-191, type I, class I | ea | 1 |
| 19 | 1810-01-174-4954 | DOPPLER SURVEY SET: (12813) 70028001, 802 | se | 2 |
| 20 | 7110-00-286-3796 | FILING CABINET: (37296) AA-F-359, type IV, size 1, 28 in, d. 57.5 in., h, 18 in. w | ea | 3 |
| 21 | 7110-00-920-9310 | FILING CABINET, SECURITY: (41729) AA-F-358, class 6, size 1 | ea | 3 |
| 22 | | FILING ASSEMBLY: Map/plan size (97403) 13225E4331 | ea | 1 |
| 23 | 7110-00-551-5487 | FILING CABINET: Letter unit size (96247) AA-F-359, type I, size 2 | ea | 1 |

Section II COMPONENTS OF END ITEM - Cont

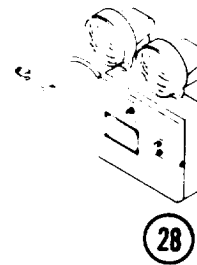
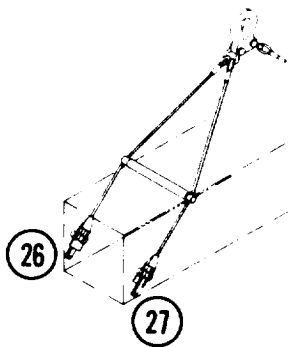
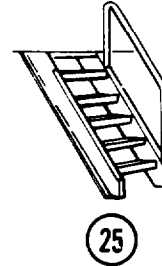
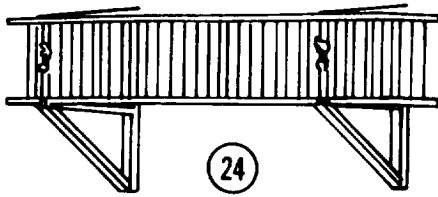

| (1) Illus Number | (2) National Stock Number | (3) Description FSCM and Part Number | (4) U/M | (5) Qty Rqr |
|------------------------|---------------------------------|------------------------------------------------------------------------------------|------------|-------------------|
| 24 | 5440-01-152-7751 | LADDER, EXTENSION-FOLDING: (39428) 8028T16 | ea | 1 |
| 25 | 2540-01-133-9726 | LADDER, VEHICLE BOARDING: (97403) 13225E3074 | ea | 2 |
| 26 | | LIFTING AND TIEDOWN DEVICE, TRANSPORTABLE SHELTER: Left hand (52555) 1390-4 | ea | 2 |
| 27 | | LIFTING AND TIEDOWN DEVICE, TRANSPORTABLE SHELTER: Right hand (52555) 1390-3 | ea | 2 |
| 28 | | LIGHT, EMERGENCY (97403) 13225E396 | ea | 1 |

Section II COMPONENTS OF END ITEM - Cont

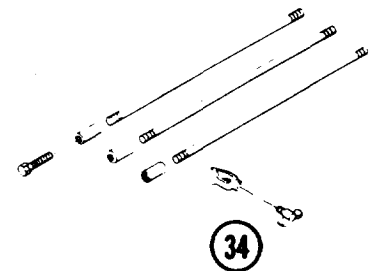
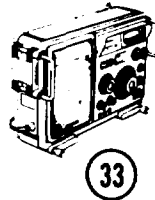
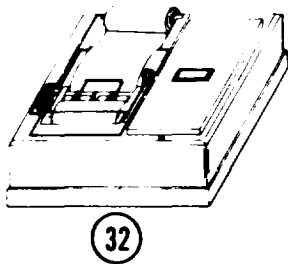
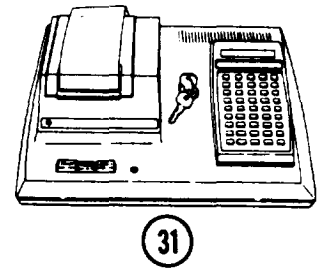
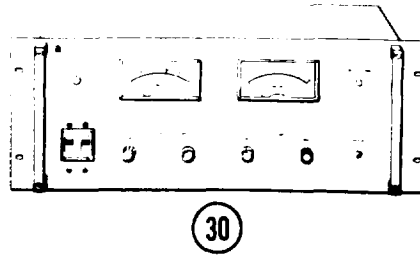
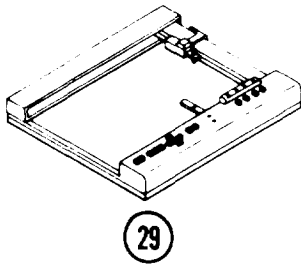

| (1) Illus Number | (2) National Stock Number | (3) Description FSCM and Part Number | (4) U/M | (5) Qty Rqr |
|------------------------|---------------------------------|-------------------------------------------------------------------------------------|------------|-------------------|
| 29 | 7025-01-121-4099 | PLOTTER, GRAPHICS: (28480) 9872C, Option 25 | ea | 1 |
| 30 | | POWER SUPPLY: (28480) 62686, options 15,26 and C-15 | ea | 1 |
| 31 | | PRINTER: (56634) PC-100C | ea | 1 |
| 32 | | PRINTER, OUTPUT SIGNAL, DOPPLER SURVEY: (161 52) 81042-801 w/cable model 6430 | ea | 1 |
| 33 | | RECEIVER, RADIO: (62676) DX-400 | ea | 1 |
| 34 | 5975-00-878-3791 | ROD, GROUND: (82370) AI 04 | ea | 1 |

Section II COMPONENTS OF END ITEM - Cont

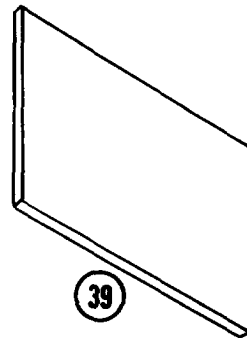
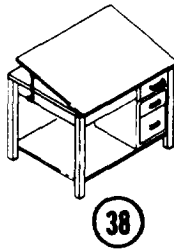
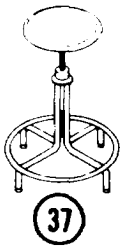
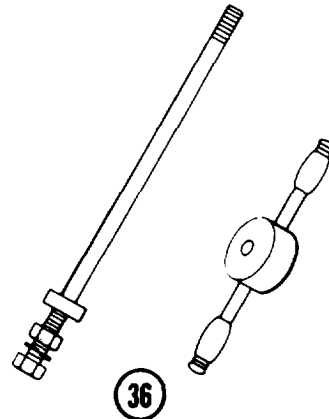
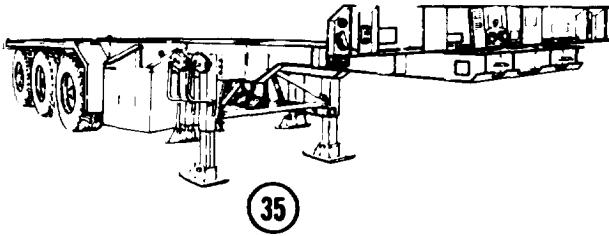

| (1) Illus Number | (2) National Stock Number | (3) Description FSCM and Part Number | (4) U/M | (5) Qty Rqr |
|------------------------|---------------------------------|-------------------------------------------------------------------------------------------|------------|-------------------|
| 35 | 2330-01-076-4797 | SEMI-TRAILER, FLATBED: (97403) TL/MIL-B-13207, par. 3.11, Fig 12, tables 111 and IV | ea | 1 |
| 36 | 5120-01-013-1676 | SLIDE HAMMER, GROUND ROD EMPLACEMENT: (45225) P74-144 | ea | 1 |
| 37 | 7110-00-634-8596 | STOOL, REVOLVING: (09177) 60-100 | ea | 1 |
| 38 | 6675-01-181-4077 | TABLE, DRAWING: (26954) 33J1 with Auxiliary Drawer unit 57J22 | ea | 1 |
| 39 | | TOP, FILING CABINET: (88915) T3445 | ea | 1 |

Section III BASIC ISSUE ITEMS

| (1) Illus Number | (2) National Stock Number | (3) Description FSCM and Part Number | (4) U/M | (5) Qty Rqr |
|------------------------|---------------------------------|----------------------------------------------------------------------------------------------------------------------------------------------------------------|------------|-------------------|
| | 6140-01-102-1642 | BATTERY, STORAGE: (19728) 30HA9Y | ea | 2 |
| | 5120-00-754-4612 | BLOWER, WATCHMAKER (64959) R8950 | ea | 1 |
| | | BOOK: Adjustments, Computations, Practical Least Squares (7D560) 37484 | ea | 1 |
| | 7610-00-233-9600 | BOOK: American Electricians Handbook; Vol 1 (80758) | ea | 1 |
| | | BOOK: Apparent Places of Fundamental Stars; by Nerlag G. Braun Defense Mapping Agency Technical Publications 6500 Brooks Lane, Washington DC 20315 | ea | 2 |
| | | BOOK: Astronomical Almanac (881 33) Naval Observatory Washington DC 20001 | ea | 1 |
| | 7610-00-205-1051 | BOOK: Civil Engineering Handbook; Vol 1; by L. C. Urquart (80758) McGraw Hill Inc Publisher | ea | 1 |
| | | BOOK: Classification Standards of Accuracy and General Specifications of Geodetic Control Surveys NOAA Publications S/T81 -29 | ea | 2 |
| | 7610-00-265-7598 | BOOK: Computation of Traverse by Plane Coordinates; NOAA, special publication 624 | ea | 2 |
| | 7610-00-634-6080 | BOOK: Definitions of Terms Used in Geodetic and Other Surveys; by Hugh C. Mitchell NOAA, special publication | ea | 1 |
| | 7610-00-142-9051 | BOOK: Dictionary (2R792) H05061 | ea | 1 |
| | 7610-00-727-0441 | BOOK: Dutton Navigation and Piloting (3L521) | ea | 1 |

Section III BASIC ISSUE ITEMS - Cont

| (1) Illus Number | (2) National Stock Number | (3) Description FSCM and Part Number | (4) U/M | (5) Qty Rqr |
|------------------------|---------------------------------|--------------------------------------------------------------------------------------------------------------------------------------------------------------------------|------------|-------------------|
| | | BOOK: Electronic Surveying and Navigation (7D560) 59815 | ea | 1 |
| | 7610-00-250-6622 | BOOK: Elements of Map Projection with Applications to Map and Chart Construction; NOAA, special publication 68 | ea | 2 |
| | | BOOK: Elevations from Zenith Distances; NOAA Numbered publications G-56 | ea | 2 |
| | | BOOK: Geodesy for the Layman; by R. K. Burkhard (3G214) AD-670-156 | ea | 2 |
| | | BOOK: Glossary, Department of Defense; Glossary of Mapping, Charting and Geodetic Terms of Defense Mapping Agency | ea | 2 |
| | 7610-00-239-4581 | BOOK: Manual of Geodetic Astronomy Determination of Longitude and Azimuth; by Albert J. Hoskinson and J. A. Duerksen, NOAA special publication 237 (3G214) PB-267-465 | ea | 2 |
| | | BOOK: Geodetic Leveling, by Shoemaker, M. Christine and Barry, Ralph M., 1981 NOAA Manual NOS NGS 3 | ea | 2 |
| | 7610-00-263-9752 | BOOK: Manual of Geodetic Triangulation (3G214) COM-71-50047 | ea | 2 |
| | 7610-00-250-6606 | BOOK: Manual of Leveling Computation and Adjustment; NOAA special publication 240 (3G214) | ea | 2 |
| | 7610-00-233-9616 | BOOK: Manual of Photogrammetry | ea | 1 |

Section III BASIC ISSUE ITEMS - Cont

| (1) Illus Number | (2) National Stock Number | (3) Description FSCM and Part Number | (4) U/M | (5) Qty Rqr |
|------------------------|---------------------------------|-----------------------------------------------------------------------------------------------------------------------------------------------------------------------|------------|-------------------|
| | 7610-00-242-6444 | BOOK: Manual of Reconnaissance for Triangulation (3G214) PB-267-457 | ea | 1 |
| | 7610-00-242-6446 | BOOK: Manual of Triangulation Computation and Adjustment (3G214) PB-267-458 | ea | 4 |
| | | BOOK: Map Projections: by Richards and Adler; latest year and edition; Americal Elsevier Publishing Co. | ea | 2 |
| | | BOOK: Natural Sines and Cosines to Eight Decimal Places (81955) GPO 003-002 -00019-5 | ea | 4 |
| | 7610-00-234-8450 | BOOK: Numerical Mathematical Analysis (80758) | ea | 1 |
| | 7610-00-250-6615 | BOOK: Plane and Spherical Trigonometry (27344) | ea | 1 |
| | | BOOK: Second Order Astronomical Position Determination Manual; NOAA numbered publications 64-1 | ea | 2 |
| | | BOOK: Sines, Cosines, and Tangents, Ten Decimal Places with Ten Second Interval, 0 to 6 deg; NOAA special publication 246 (3G214) COM-71-50369 | ea | 2 |
| | | BOOK: Specifications to Support Classification, Standards of Accuracy, and General Specifications of Geodetic Control Surveys NOAA Publications S/1 80-98 | ea | 2 |
| | | BOOK: Spherical and Practical Astronomy: by I I Mueller; latest yr and edition | ea | 1 |

Section III BASIC ISSUE ITEMS - Cont

| (1) Illus Number | (2) National Stock Number | (3) Description FSCM and Part Number | (4) U/M | (5) Qty Rqr |
|------------------------|---------------------------------|---------------------------------------------------------------------------------------------------------------------------------------------------------------------------------------------------------|------------|-------------------|
| | | BOOK: Spherical Astronomy: textbook; by W. M. Smart; latest yr and edition; Cambridge University Press Publisher New York City, N.Y. | ea | 2 |
| | | BOOK: Standard Mathematical Tables (90874) Chemical Publishing Co. Inc. 155W, 19th St. New York, NY 10011 | ea | 1 |
| | | BOOK: State Plane Coordinates; NOAA numbered publications 62-4 | ea | 2 |
| | | BOOK: Surveying: by Bouchard and Moffit; (90954) Intext Inc. a sub of National Education Corp., Oak and Pawnee, Scranton, PA 18515 | ea | 3 |
| | 7610-00-250-6624 | BOOK: Surveying Theory and Practice; by R. E. Davis and F. S. Foote (80758) McGraw Hill Inc. Publisher | ea | 4 |
| | 7610-00-239-4577 | BOOK: Tables for a Polyconic Projection of Maps and Lengths of Terrestrial Arcs of Meridian and Parallels Based Upon Clarke's Reference Spheroid of 1866; NOAA special publications 5(3G214) PB-267-481 | ea | 2 |
| | 7610-00-233-9626 | BOOK: Tide Tables: West Coast North and South America including the Hawaiian Islands (7M036) National Ocean Survey, Distribution Division (OA/C44), Riverdale, MD 20840 | ea | 1 |
| | 7920-00-205-0565 | BRUSH, LENS: (17866) R698 | ea | 1 |
| | 7920-00-291-5815 | BRUSH, WIRE, SCRATCH: (39428) 7187T2 | ea | 1 |
| | 5120-00-529-4124 | CARRIER, STORAGE BATTERY, HAND: (28528) W70-39 | ea | 2 |
| | | CASE, STORAGE AND TRANSPORT: (30562) M91-233 | ea | 1 |

Section III BASIC ISSUE ITEMS - Cont

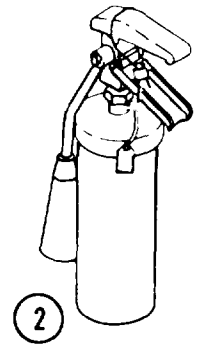
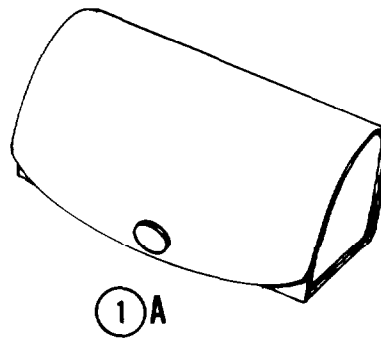
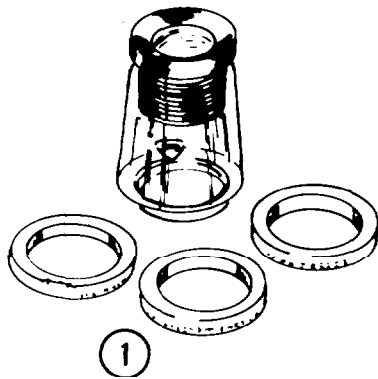

| (1) Illus Number | (2) National Stock Number | (3) Description FSCM and Part Number | (4) U/M | (5) Qty Rqr |
|------------------------|---------------------------------|---------------------------------------------------------------------------------------------------------------------------|------------|-------------------|
| | | CATALOG: HEWLETT PACKARD (28480) 5953-2450 | ea | 1 |
| | | CHART: magnetic variation, chart of the world; published by Defense Mapping Agency, WOBZC42 | ea | 2 |
| | | CHART: magnetic variation, chart for north and south polar regions; published by Defense Mapping Agency, WOXZC43 | ea | 2 |
| | 6675-00-551-5248 | CHEST, PHOTOGRAPHIC PAPER ROLLS: (97403) 13225E3681 | ea | 1 |
| 1 | 6650-00-668-5703 | COMPARATOR, OPTICAL (06175) 81-34-35 | ea | 1 |
| | 6675-00-248-1240 | COMPASS, DRAFTING, PIVOT: (33363) 55-1776 | ea | 1 |
| | | COVER, DUST: (28480) 9222-0742 | ea | 1 |
| | 5110-00-293-1905 | DIE SET, METAL STAMPING, HAND: (39428) 1556T | se | 1 |
| | 6675-00-240-2049 | DIVIDERS, DRAFTING, PROPORTIONAL: (09177) 64-584 | ea | 1 |
| 1A | 6675-00-841-3531 | DRAFTING INSTRUMENT SET: (19099) SC6675-90-CL-N07 | ea | 1 |
| 2 | 4210-00-555-8837 | EXTINGUISHER, FIRE, MONOBROMO- TRIFLUOROMETHANE: (33525) T2 | ea | 2 |

Section III BASIC ISSUE ITEMS - Cont

| (1) Illus Number | (2) National Stock Number | (3) Description FSCM and Part Number | (4) U/M | (5) Qty Rqr |
|------------------------|---------------------------------|--------------------------------------------|------------|-------------------|
| | | FORM, PRINTED: DA Form; 1931 | cs | 200 |
| | | FORM, PRINTED: DA Form; 1932 | cs | 200 |
| | | FORM, PRINTED: DA Form; 1933 | cs | 200 |
| | | FORM, PRINTED: DA Form; 1934 | cs | 200 |
| | | FORM, PRINTED: DA Form; 1935 | cs | 200 |
| | | FORM, PRINTED: DA Form; 1938 | cs | 100 |
| | | FORM, PRINTED: DA Form; 1940 | cs | 200 |
| | | FORM, PRINTED: DA Form; 1941 | cs | 25 |
| | | FORM, PRINTED: DA Form; 1942 | cs | 50 |
| | | FORM, PRINTED: DA Form; 1943 | cs | 200 |
| | | FORM, PRINTED: DA Form; 1944 | cs | 25 |
| | | FORM, PRINTED: DA Form; 1945 | cs | 200 |
| | | FORM, PRINTED: DA Form; 1946 | cs | 25 |
| | | FORM, PRINTED: DA Form; 1947 | cs | 50 |
| | | FORM, PRINTED: DA Form; 1950 | cs | 25 |
| | | FORM, PRINTED: DA Form; 1951 | cs | 25 |
| | | FORM, PRINTED: DA Form; 1952 | cs | 25 |
| | | FORM, PRINTED: DA Form; 1953 | cs | 25 |
| | | FORM, PRINTED: DA Form; 1954 | cs | 50 |
| | | FORM, PRINTED: DA Form; 1955 | cs | 50 |
| | | FORM, PRINTED: DA Form; 1957 | cs | 50 |
| | | FORM, PRINTED: DA Form; 1958 | cd | 100 |
| | | FORM, PRINTED: DA Form; 1959 | cd | 400 |

Section III BASIC ISSUE ITEMS - Cont

| (1) Illus Number | (2) National Stock Number | (3) Description FSCM and Part Number | (4) U/M | (5) Qty Rqr |
|------------------------|---------------------------------|------------------------------------------------------|------------|-------------------|
| | | FORM, PRINTED: DA Form; 1961 | cs | 100 |
| | | FORM, PRINTED: DA Form; 1962 | cs | 400 |
| | | FORM, PRINTED: DA Form; 1964 | cs | 100 |
| | | FORM, PRINTED: DA Form; 2843 | cs | 100 |
| | | FORM, PRINTED: DA Form; 2844 | cs | 100 |
| | | FORM, PRINTED: DA Form; 2845 | cs | 100 |
| | | FORM, PRINTED: DA Form; 2846 | cs | 100 |
| | | FORM, PRINTED: DA Form; 2847 | cs | 200 |
| | | FORM, PRINTED: DA Form; 2848 | cs | 100 |
| | | FORM, PRINTED: DA Form; 2849 | cs | 100 |
| | | FORM, PRINTED: DA Form; 2850 | cs | 100 |
| | | FORM, PRINTED: DA Form; 2851 | cs | 25 |
| | | FORM, PRINTED: DA Form; 2857 | cs | 200 |
| | | FORM, PRINTED: DA Form; 2858 | cs | 25 |
| | | FORM, PRINTED: DA Form; 2859 | cs | 25 |
| | | FORM, PRINTED: DA Form; 2860 | cs | 25 |
| | | FORM, PRINTED: DA Form; 2861 | cs | 25 |
| | | FORM, PRINTED: DA Form; 2862 | cd | 25 |
| | | FORM, PRINTED: DA Form; 2865 | cs | 100 |
| | | FORM, PRINTED: DA Form; NOAA Form 77-51 | cs | 100 |
| | | GUIDE, POCKET: (28480) 09872-90013 | ea | 1 |
| | 5120-01-022-6250 | KEY SET, SOCKET HEAD SCREW: (55719) AW-9K, w/case | se | 1 |

Section III BASIC ISSUE ITEMS - Cont

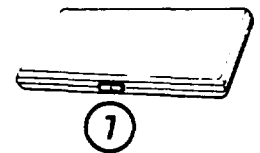
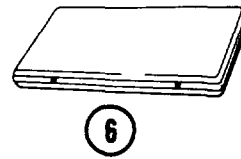

| (1) Illus Number | (2) National Stock Number | (3) Description FSCM and Part Number | (4) u/M | (5) Qty Rqr |
|------------------------|---------------------------------|-------------------------------------------------------------------------|--------------|-------------------|
| 4 | 5110-00-595-8400 | KNIFE, CRAFTSMAN'S: (99941) 3001 | ea | 4 |
| 5 | 5110-00-595-8406 | KNIFE, CRAFTSMAN'S: stencil (79819) Q5-3041-2 | ea | 12 |
| | 7520-01-008-7640 | LEAD REPOINTER, PENCIL: (79819) 992WB | ea | 2 |
| 6 | 6675-01-034-3110 | LETTERING SET: (79819) 4001 JS9 | se | 1 |
| 7 | 6230-00-299-7771 | LETTERING SET: (33363) 99-9973 LIGHT, DESK: (39428) 1517P5 | se ea | 1 2 |

Section III BASIC ISSUE ITEMS - Cont

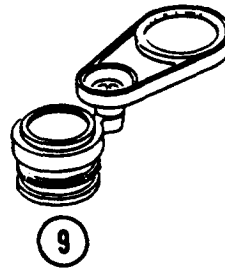
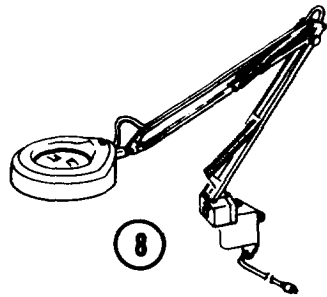

| (1) Illus Number | (2) National Stock Number | (3) Description FSCM and Part Number | (4) U/M | (5) Qty Rqr |
|------------------------|---------------------------------|-----------------------------------------------------------------------------------------------------------------------------------------------------------------------------------------------------------------------------------------------------------------------------------------------------------------------------------------------------------------------------------------------------------------------------------------------------------------------------------------------------------------------------------------------------------------------------------------------------------------------------------------------------------------------------------------------------------------------------------------------------------------------------------------------------|------------------------------------------------------|------------------------------------------------|
| 8 | 6650-00-477-9613 | MAGNIFIER: monocular; lamp type (15607) KFM-1/B5D | ea | 1 |
| 9 | 6650-00-559-1462 | MAGNIFIER: monocular; photo engravers (18370) Model 20 MANUAL, OPERATING: (28480) 09872-90011 TM 5-2330-305-14 OPERATOR'S, ORGANIZATIONAL, DIRECT SUPPORT, AND GENERAL SUPPORT MAINTENANCE MANUAL TSS CHASSIS, SEMITRAILER TM 5-4120-367-14 OPERATOR'S, ORGANIZATIONAL, DIRECT SUPPORT, AND GENERAL SUPPORT MAINTENANCE MANUAL, AIR CONDITIONER TM 5-6675-318-14 (Vols. 1 and 2) OPERATOR'S, ORGANIZATIONAL, DIRECT SUPPORT, AND GENERAL SUPPORT MAINTENANCE MANUAL TSS SURVEY SECTION TM 5-6675-318-24P ORGANIZATIONAL, DIRECT SUPPORT AND GENERAL SUPPORT MAINTENANCE REPAIR PARTS AND SPECIAL TOOLS LIST (INCLUDING DEPOT) LO 5-2330-305-12 LUBRICATION ORDER, TSS CHASSIS, SEMITRAILER | ea ea ea ea ea ea | 2 1 1 1 1 1 |

Section III BASIC ISSUE ITEMS - Cont



| (1) Illus Number | (2) National Stock Number | (3) Description FSCM and Part Number | (4) U/M | (5) Qty Rqr |
|------------------------|---------------------------------|--------------------------------------------------------------------------------------------------|------------|-------------------|
| | LO 5-6675-318-12 | LUBRICATION ORDER, TSS SURVEY SECTION | ea | 1 |
| | | MAP: magnetic declination, United States; published by U.S. Geological Survey, MAP, I-1283 | ea | 2 |
| | | MAP SYMBOLS: (33363) 61-2300, size 140 | ea | 4 |
| | 6675-00-781-8327 | MAP SYMBOLS: (33363) 61-2250, size 80 | ea | 4 |
| 10 | 6675-00-222-2542 | MEASURER, MAP: (33363) 62-0300 | ea | 1 |
| 11 | 5340-00-682-1505 | PADLOCK SET: (77765) MS21 313-52 | se | 1 |
| | 7510-00-237-4926 | PENCIL POINTER: (33363) 58-0540 | ea | 1 |
| | 7510-01-030-7427 | PEN POINT ASSORTMENT AND PENHOLDER: (7981 9)3165-JDCS-9 | se | 1 |
| 12 | Deleted | | | |
| | 6675-00-291-9381 | PROTRACTOR, CIRCULAR: (33363) 57-0506,6 in. | ea | 1 |
| | 6675-00-222-2535 | PROTRACTOR) SEMICIRCULAR: (23366) P478 | ea | 1 |

Section III BASIC ISSUE ITEMS - Cont

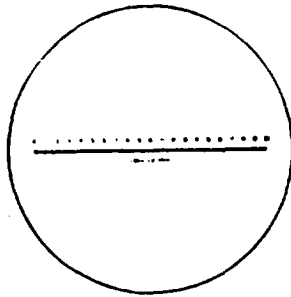

12 A

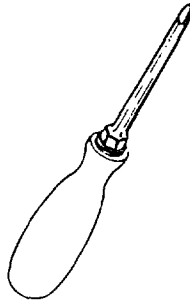

13

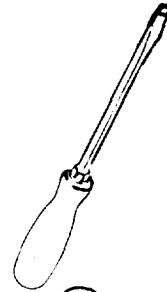

14

| (1) Illus Number | (2) National Stock Number | (3) Description FSCM and Part Number | (4) U/M | (5) Qty Rqr |
|------------------------|---------------------------------|------------------------------------------------------------------------------------------------------------|------------|-------------------|
| | 6675-00-238-3498 | SCALE, DRAFTING: (79819) 3262, 12 in. | ea | 1 |
| | 6675-00-514-3549 | SCALE, DRAFTING: (33363) 56-3846, 12 in. | ea | 1 |
| | 6675-00-283-0035 | SCALE, PLOTTING: (17866) GG-S-161/8c, type VIII, size B, scale graduation 1, numbering A, style A | ea | 1 |
| | 6675-00-283-0037 | SCALE, PLOTTING: (23366) 28/MR, 12 in. | ea | 1 |
| 12A | | SCALER, METRIC (06175) 81-34-38 | ea | 1 |
| 13 | 5120-00-234-8913 | SCREWDRIVER, CROSS TIP: SIZE 2 (81348) GGG-S-121 | ea | 1 |
| 14 | 5120-00-238-8910 | SCREWDRIVER, FLAT TIP: (78525) 1006 | ea | 1 |
| | 7520-00-224-7593 | SHARPENER, PENCIL: (17866) 3243A | ea | 1 |
| | 7520-00-227-1451 | SHARPENER, PENCIL: (79819) 983 | ea | 2 |

Section III BASIC ISSUE ITEMS - Cont

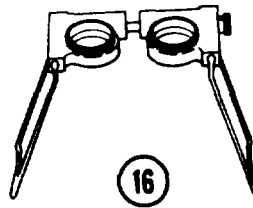

| (1) Illus Number | (2) National Stock Number | (3) Description FSCM and Part Number | (4) U/M | (5) Qty Rqr |
|------------------------|---------------------------------|------------------------------------------------------------------------------------------------------------------------------------------------------------------------------------------------------------------------------------------------------------------------------------------------------------------------------------------------------------------------------------------------------------------------------------------------------------------------------------------------------------------------------------------------------------------------------------------------------------|------------------------------------------------------------------------------------|----------------------------------------------------------------------------|
| 15 | Deleted | | | |
| | 7510-00-224-7242 | SHIELD, ERASING: (79819) 03-605 | dz | 1 |
| 16 | 6675-00-641-3561 | STEREOSCOPE, LENS, AERIAL PHOTOGRAPH INTERPRETATION: (7D560) 51034, Abrams Model SV-1 STRAP ASSEMBLY, BUCKLE-END: 6.0 in. (82820) 1844-104 STRAP ASSEMBLY, BUCKLE-END: 8.0 in. (82820) 1844-101 STRAP ASSEMBLY, BUCKLE-END: 9.0 in. (82820) 1844-103 STRAP ASSEMBLY, TIP-END: 20.0 in. (82820) 1845-102 STRAP ASSEMBLY, TIP-END: 23 in. (82820) 1845-103 STRAP ASSEMBLY, TIP-END: 36.0 in. (82820) 1845-106 STRAP ASSEMBLY, TIP-END: 40.0 in. (82820) 1845-101 STRAP ASSEMBLY, TIP-END: 58.0 in. (82820) 1845-105 | ea ea ea ea ea ea ea ea ea | 4 4 4 1 3 1 12 2 1 |

Section III BASIC ISSUE ITEMS - Cont

| (1) Illus Number | (2) National Stock Number | (3) Description FSCM and Part Number | (4) U/M | (5) Qty Rqr |
|------------------------|---------------------------------|-------------------------------------------------------------------------------------------------------------|------------|-------------------|
| | | STRAP ASSEMBLY, WEBBING: 35.00 in. (98313) 13225E3695-2 | ea | 1 |
| | | STRAP ASSEMBLY, WEBBING: 45.00 in. (98313) 13225E3695-3 | ea | 2 |
| | | STRAP ASSEMBLY, WEBBING: 55.00 in. (98313) 13225E3695-4 | ea | 3 |
| | | STRAP ASSEMBLY, WEBBING: 55.00 in. (98313) 13225E3695-6 | ea | 8 |
| | | STRAP ASSEMBLY, WEBBING: 65.00 in. (98313) 13225E3695-5 | ea | 2 |
| | | STRAP ASSEMBLY, WEBBING: 94.00 in. (98313) 13225E3695-10 | ea | 1 |
| | | STRAP ASSEMBLY, WEBBING: 29.00 in. (98313) 13225E3695-13 | ea | 2 |
| | | STRAP ASSEMBLY, WEBBING: 162.00 in. (96603) 90201-D-18-12 | ea | 4 |
| | | TECHNICAL MANUAL: DMA TM T-1-52220 JMR-1 Doppler Survey Set, Geodetic Survey Squadron Manual, 8240.16 | ea | 2 |
| | | TECHNICAL MANUAL: DMA TM T-2-52220 Field Operations Manual; Doppler Geodetic Point Positioning | ea | 2 |
| | | TECHNICAL MANUAL: DMA TM T-3-52320 Satellite Records Manual; Doppler Geodetic Point Positioning | ea | 2 |
| | | TECHNICAL MANUAL: TM 5-232; Elements of Surveying | ea | 1 |
| | | TECHNICAL MANUAL: TM 5-233; Construction Surveying | ea | 1 |
| | | TECHNICAL MANUAL: TM 5-235; Special Surveys | ea | 1 |

Section III BASIC ISSUE ITEMS - Cont

| (1) Illus Number | (2) National Stock Number | (3) Description FSCM and Part Number | (4) U/M | (5) Qty Rqr |
|------------------------|---------------------------------|------------------------------------------------------------------------------------------------------------------------|------------|-------------------|
| | | TECHNICAL MANUAL: TM 5-237, Surveying Computer's Manual | ea | 6 |
| | | TECHNICAL MANUAL: TM 5-241-1; Grids and Grid References | ea | 2 |
| | | TECHNICAL MANUAL: TM 5-241-2; Universal Transverse Mercator Grid | ea | 1 |
| | | TECHNICAL MANUAL: TM 5-241-3/1; Universal Transverse Mercator Grid Tables for Latitudes 0 Degree to 80 Degree | ea | 4 |
| | | TECHNICAL MANUAL: TM 5-241-3/2; Universal Transverse Mercator Grid Tables for Latitudes 0 Degree to 80 Degree | ea | 4 |
| | | TECHNICAL MANUAL: TM 5-241-4/1; Universal Transverse Mercator Grid Tables for Latitudes 0 Degree to 80 Degree | ea | 4 |
| | | TECHNICAL MANUAL: TM 5-241-4/2; Universal Transverse Mercator Grid Tables for Latitudes 0 Degree to 80 Degree | ea | 4 |
| | | TECHNICAL MANUAL: TM 5-241-5/1; Universal Transverse Mercator Grid Tables for Latitudes 0 degree to 80 degree | ea | 4 |
| | | TECHNICAL MANUAL: TM 5-241-5/2; Universal Transverse Mercator Grid Tables for Latitudes 0 Degree to 80 Degree | ea | 4 |
| | | TECHNICAL MANUAL: TM 5-241-6/1; Universal Transverse Mercator Grid Tables for Latitudes 0 Degree to 80 Degree | ea | 4 |

Section III BASIC ISSUE ITEMS - Cont

| (1) Illus Number | (2) National Stock Number | (3) Description FSCM and Part Number | (4) U/M | (5) Qty Rqr |
|------------------------|---------------------------------|---------------------------------------------------------------------------------------------------------------------------|------------|-------------------|
| | | TECHNICAL MANUAL: TM 5-241-6/2; Universal Transverse Mercator Grid Tables | ea | 4 |
| | | TECHNICAL MANUAL: TM 5-241-7; Universal Transverse Mercator Grid Tables for Latitudes 0 Degree to 45 Degree | ea | 4 |
| | | TECHNICAL MANUAL: TM 5-241-8; Universal Transverse Mercator Grid | ea | 4 |
| | | TECHNICAL MANUAL: TM 5-241-9; Universal Polar Stereographic Grid Tables for Latitudes 79 Degree to 90 Degree | ea | 4 |
| | | TECHNICAL MANUAL: TM 5-241-10; Universal Transverse Mercator Grid Extension of Zone to Zone Transformation Table | ea | 1 |
| | | TECHNICAL MANUAL: TM 5-241-11; Universal Transverse Mercator Grid Tables for Latitudes 0 Degree to 80 Degree | ea | 1 |
| | | TECHNICAL MANUAL: TM 5-241-12; Universal Transverse Mercator Grid Table for Latitudes 0 Degree to 33 Degree | ea | 1 |
| | | TECHNICAL MANUAL: TM 5-241-13; Universal Transverse Mercator Grid Tables for Latitudes 0 Degree to 80 Degree | ea | 1 |
| | | TECHNICAL MANUAL: TM 5-241-14; Universal Transverse Mercator Grid Tables for Latitudes 0 Degree to 80 Degree | ea | 1 |

Section III BASIC ISSUE ITEMS - Cont

| (1) Illus Number | (2) National Stock Number | (3) Description FSCM and Part Number | (4) U/M | (5) Qty Rqr |
|------------------------|---------------------------------|---------------------------------------------------------------------------------------------------------------------------|------------|-------------------|
| | | TECHNICAL MANUAL: TM 5-241-15; Universal Transverse Mercator Grid Tables for Latitudes 0 Degree to 45 Degree 05' | ea | 1 |
| | | TECHNICAL MANUAL: TM 5-241-16; Universal Transverse Mercator Grid Table for Latitudes 0 Degree to 40 Degree 05' | ea | 1 |
| | | TECHNICAL MANUAL: TM 5-241-17; Latitude Functions | ea | 4 |
| | | TECHNICAL MANUAL: TM 5-241-18; Latitude Functions: Clarke 1866 Spheroid | ea | 4 |
| | | TECHNICAL MANUAL: TM 5-241-19; Latitude Functions: Bessel Spheroid | ea | 4 |
| | | TECHNICAL MANUAL: TM 5-241-20 Latitude Functions: Clarke 1880 Spheroid | ea | 4 |
| | | TECHNICAL MANUAL: TM 5-241-21 Latitude Functions: Everest Spheroid | ea | 4 |
| | | TECHNICAL MANUAL: TM 5-330; Planning and Design of Roads, Airbases, and Heliports in the Theater of Operations | ea | 1 |
| | | TECHNICAL MANUAL: TM 5-9413; Tower, Triangulation Structural Aluminum | ea | 1 |
| | 6675-00-187-6112 | TEMPLATE, DRAFTING: (21724) 1053 | ea | 4 |
| | 6675-00-253-5501 | TEMPLATE, DRAFTING: (79819) 831040 | ea | 1 |

Section III BASIC ISSUE ITEMS - Cont

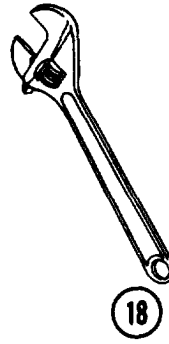
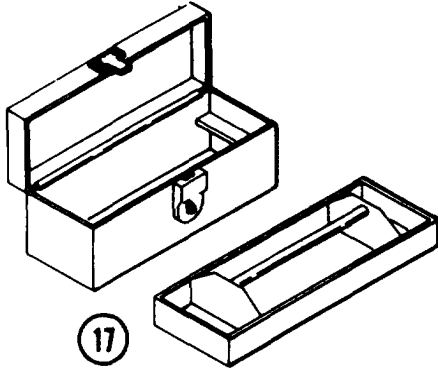

| (1) Illus Number | (2) National Stock Number | (3) Description FSCM and Part Number | (4) U/M | (5) Qty Rqr |
|------------------------|---------------------------------|----------------------------------------------------------------------|------------|-------------------|
| 17 | 5140-00-315-2747 | TOOL BOX, PORTABLE: 75206) CS 16 | ea | 1 |
| | 6675-00-190-5867 | TRIANGLE, DRAFTING: 130 deg; 1 60 deg (33363) 57-0220, size 10 | ea | 1 |
| | 6675-00-190-5863 | TRIANGLE, DRAFTING: 245 degs (33363) 57-0292, size 10 | ea | 1 |
| | 6675-00-183-6487 | T-SQUARE: (81562) 8068E, 42 in. | ea | 1 |
| | | WATCH DIGITAL: (61515) 48511 | ea | 3 |
| 18 | 5120-00-264-3795 | WRENCH, ADJUSTABLE: (80244) GGG-W-631 , TY1 , CL1 | ea | 1 |

APPENDIX D
ADDITIONAL AUTHORIZATION LIST
Section I INTRODUCTION

D-1 . SCOPE.

This appendix lists additional items you are authorized for the support of the Survey Section.

D-2. GENERAL.

This list identifies items that do not have to accompany the Survey Section and that do not have to be turned in with it. These items are all authorized to you by CTA, MTOE, TDA or JTA.

D-3. EXPLANATION OF LISTING.

National stock numbers, descriptions and quantities are provided to help you identify and request the additional items you require to support this equipment. The items are listed in alphabetical sequence by item name under the type document (i.e., CTA, MTOE, TDA, or JTA) which authorizes the item(s) to you.

Section II ADDITIONAL AUTHORIZATION LIST

| (1) National Stock Number | (2) Description FSCM and Part Number | (3) U/M | (4) Qty Auth |
|---------------------------------|--------------------------------------------|------------|--------------------|
| <u>TOE AUTHORIZED ITEMS</u> | | | |
| 4210-00-974-7206 | Air Conditioner (B1349) MIL-A-52767 | ea | 2 |
| 5985-00-892-0758 | Antenna Group: AN/GRA50 | ea | 1 |
| 6720-00-965-4922 | Camera, Still Picture: KE40 | ea | 1 |
| 6130-00-985-8185 | Charger, Battery: PP-1659/G | ea | 1 |
| 6115-00-722-3760 | Gen. Set, DSL Eng TM: 15 Kw | ea | 1 |
| 6115-00-017-8239 | Gen. Set, Gas Eng: 3 Kw DC | ea | 1 |
| 5820-00-351-3058 | Installation Kit: MK-1373/GRC106 | ea | 1 |

Section II ADDITIONAL AUTHORIZATION LIST - Cont

| (1) National Stock Number | (2) Description FSCM and Part Number | (3) U/M | (4) Qty Auth |
|-----------------------------------------|------------------------------------------------|------------|--------------------|
| <u>TOE AUTHORIZED ITEMS Cont</u> | | | |
| 5820-00-113-9768 | Power Supply: PP-4763A/GRC | ea | 1 |
| 5820-00-223-7548 | Radio Set: AN/GRC-106A | ea | 1 |
| 6675-00-062-8579 | Survey Instrument: Azimuth Gyro Lightweight | ea | 1 |
| 6675-00-641-3604 | Survey Set, Precise Level | ea | 2 |
| 6675-00-641-3603 | Survey Set, Triangulation Reconnaissance | ea | 1 |
| 5805-00-543-0012 | Telephone Set: TA-312/PT | ea | 1 |
| 6675-00-455-9200 | Theodolite, Survey: Kern DKM3M w/tripod | ea | 2 |
| 6675-00-641-5735 | Transit, Pocket | ea | 1 |

APPENDIX E

EXPENDABLE/DURABLE SUPPLIES AND MATERIALS LIST

Section I INTRODUCTION

E-1 . SCOPE.

This appendix lists expendable supplies and materials you will need to operate and maintain the Survey Section. This listing is for information purposes only and is not authority to requisition the listed items. These items are authorized to you by CTA 50-970, Expendable/Durable Items (except Medical, Class V, Repair Parts and Heraldic Items), or CTA 8-100, Army Medical Department Expendable/Durable Items.

E-2. EXPLANATION OF COLUMNS

a. *Column (1) - Item Number.* This number is assigned to the entry in the listing and is referenced in the narrative instructions to identify the material (e.g., "Use cleaning compound, Item 5, Appendix E.").

b. *Column (2) - Level* This column identifies the lowest level of maintenance that requires the listed item.

C - Operator/Crew

O - Organizational Maintenance

F - Direct Support Maintenance

H - General Support Maintenance

c. *Column (3) - National Stock Number.* This is the National stock number assigned to the item; use it to request or requisition the item.

d. *Column (4) - Description.* Indicates the Federal item name and, if required, a description to identify the item. The last line for each item indicates the part number followed by Federal Supply Code for Manufacturer (FSCM) in parentheses followed by the part number.

e. *Column (5) - Unit of Measure (U/M).* Indicates the measure used in performing the actual maintenance function. This measure is expressed by two-character alphabetical abbreviations (e.g., ea, in, pr). If the unit of measure differs from the unit of issue, requisition the lowest unit of issue that will satisfy your requirements.

Section II EXPENDABLE/DURABLE SUPPLIES AND MATERIALS LIST

| (1) Item Number | (2) Level | (3) National Stock Number | (4) Description | (5) U/M |
|-----------------------|--------------|------------------------------------|-------------------------------------------------------------------------------|------------|
| 1 | O | 8040-00-174-2610 | Adhesive, Rubber | cn |
| 2 | F | 8040-00-152-0063 | Adhesive, Waterproof | cn |
| 3 | C | 6810-00-205-6786 | Alcohol, Denatured | qt |
| | C | 7520-00-281-5911 | Basket, Wastepaper: (8D190) H10-34 | ea |
| | C | 7510-00-616-7471 | Binder and Filler, Loose Leaf: (65957) UU-B-356, grade C, 5 x 3 in. sh. | ea |
| | C | 5110-00-359-6478 | Blade, Craftsman Knife: Beveled (99941) 11 | pg |
| | C | 5110-00-542-2043 | Blade, Craftsman Knife: Curved (99941) 10 | pg |
| | C | 5110-00-542-2044 | Blade, Craftsman Knife: Square (99941) 17 | pg |
| | C | 5110-00-765-4144 | Blade, Craftsman Knife: Stencil (99941) 16 | pg |
| | C | 5110-00-355-6138 | Blade, Craftsman Knife: Swivel (79819) Q5-0841-2 | ea |
| 4 | C | 6850-00-592-3283 | Cleaner, Lens | bx |
| | C | 6850-01-007-8073 | Cleaning Concentrate (79819) 3069 CON | bt |
| 5 | C | 8305-00-222-2423 | Cloth, Cheesecloth | yd |
| 6 | C | 6515-00-303-8250 | Cotton Swabs | bg |
| 7 | C | | Desiccant, Bag (12813) 5A040H08 | ea |
| 8 | C | | Desiccant, Bead (22627) NATRASORBT4X12 | bg |
| 9 | C | 7930-00-530-8067 | Detergent, General Purpose | gl |

Section II EXPENDABLE/DURABLE SUPPLIES AND MATERIALS LIST-Cont

| (1) Item Number | (2) Level | (3) National Stock Number | (4) Description | (5) U/M |
|-----------------------|--------------|------------------------------------|-------------------------------------------------|------------|
| | C | 7510-01-034-1278 | Eraser, Film (79819) 9600PT20 | bx |
| | C | 7510-01-035-1317 | Eraser Kit (79819) 290K | kt |
| | C | 7510-00-223-7046 | Eraser, Rubber (33363) 58-0608 | dz |
| | C | 7510-00-223-7044 | Eraser, Rubber: cleaning (33363) 58-0634 | dz |
| | C | 7510-00-264-3672 | Eraser, Rubber: gritty matl (76604) 3-852177 | gr |
| | C | 7510-00-634-3513 | Eraser, Rubber: soft (76604) T9-14 | gr |
| 10 | F | 5610-00-618-0258 | Floor Patch | gl |
| | C | 7510-01-028-2877 | Ink, Drawing (79819) 3080-F1 | bt |
| | C | 7510-01-070-8947 | Ink, Drawing (79819) 3084-F | bt |
| | C | 7510-01-035-8133 | Ink, Drawing: Blue (79819) 3080-F, BL | bt |
| | C | 7510-01-035-8131 | Ink, Drawing: Brown (79819) 3080-F, BR | bt |
| | C | 7510-01-039-5075 | Ink, Drawing: Carmine Red (79819) 3080-F, CR | bt |
| | C | 7510-01-035-8132 | Ink, Drawing: Green (79819) 3080-F, G | bt |
| | C | 7510-01-036-3726 | Ink, Drawing: Orange (79819) 3080-F, O | bt |
| | C | 7510-01-080-1481 | Ink, Drawing: Red (79819) 3080-F, R | bt |

Section II EXPENDABLE/DURABLE SUPPLIES AND MATERIALS LIST - Cont

| (1) Item Number | (2) Level | (3) National Stock Number | (4) Description | (5) U/M |
|-----------------------|--------------|------------------------------------|----------------------------------------------------------------------------|------------|
| | C | 7510-01-036-3725 | Ink, Drawing: Violet (79819) 3080-F, V | bt |
| | C | 7510-01-035-8130 | Ink, Drawing: Yellow (79819) 3080-F, Y | bt |
| | C | 8010-00-515-2487 | Lacquer (87187) Krylon Acrylic Spray | pt |
| | C | 6240-00-556-8655 | Lamp, Fluorescent: (88204) FC8T9/CW/RS | ea |
| | C | 7510-00-285-5847 | Lead, Pencil, Graphite: artist's and drafting; 2H (8D190) U2-F350-2H | pk |
| | C | 7510-00-285-5863 | Lead, Pencil, Graphite: artist's and drafting; 2H (79819) 2200-2H | pk |
| | C | 7510-00-272-9820 | Lead, Pencil, Graphite: artist's and drafting; 3H (79819) 2200-3H | pk |
| | C | 7510-00-285-5864 | Lead, Pencil, Graphite: artist's and drafting; 4H (79819) 2200-4H | pk |
| | C | 7510-00-285-5865 | Lead, Pencil, Graphite: artist's and drafting; F (79819) 2200-F | pk |
| | C | 7510-00-285-5866 | Lead, Pencil, Graphite: artist's and drafting; H (79819) 2200-H | pk |
| | C | 7510-00-281-2143 | Lead, Pencil, Graphite: artist's and drafting; HB (79819) 2200-HB | bx |
| | C | 7510-00-285-5862 | Lead, Pencil, Graphite: artist's and drafting; HB (8D190) U2-F370-HB | pk |

Section II EXPENDABLE/DURABLE SUPPLIES AND MATERIALS LIST - Cont

| (1) Item Number | (2) Level | (3) National Stock Number | (4) Description | (5) U/M |
|-----------------------|--------------|------------------------------------|----------------------------------------------------|------------|
| 11 | C | 6840-00-597-6745 | Lens Paper | bk |
| 12 | F | 9150-00-273-2389 | Oil, Lubricating, General Purpose | cn |
| | C | 7530-00-285-3083 | Pad, Writing Paper (8D190)M9-21-112 | pk |
| 13 | O | 8010-01-131-6254 | Paint, Black | kt |
| 13A | O | 8010-01-160-6745 | Paint, Brown | kt |
| 13B | O | 8010-01-162-5578 | Paint, Green | kt |
| 14 | O | 8010-00-298-3859 | Paint, Light Green, INT. | gl |
| 15 | C | 5350-00-619-9166 | Paper, Abrasive | pk |
| | C | 7530-00-238-8337 | Paper, Blotting (19139) 152-1988 | hd |
| | C | | Paper, Chart, 8.5 x 11 (28480) 9280-0517 | ea |
| | C | | Paper, Chart, 11 x 16 (28480) 9280-0518 | ea |
| | C | | Paper, Chart, A4 (28480) 9280-0519 | ea |
| | C | 7530-00-871-8310 | Paper, Drawing (33363) 15-2155, 24 x 30 in. | pg |
| | C | | Paper, Graph (33363) 48-5094, 50 yd. x 22 in. w | ro |
| | C | 8135-00-160-7776 | Paper, Kraft, Untreated (39428) 1916T 36 in. | ro |
| | C | 7530-01-006-4496 | Paper, Tracing (33363) 10-9155, 24x 30 in. | pk |
| | C | 7510-00-286-6985 | Paperweight: (33363) 58-0810 | ea |
| | C | 7510-00-233-2027 | Pencil: blue (79819) 1344, blue | dz |

Section II EXPENDABLE/DURABLE SUPPLIES AND MATERIALS LIST - Cont

| (1) Item Number | (2) Level | (3) National Stock Number | (4) Description | (5) U/M |
|-----------------------|--------------|------------------------------------|--------------------------------------------------|------------|
| | C | 7510-00-264-4610 | Pencil: green (79819) 1800-16, green | dz |
| | C | 7510-00-233-2021 | Pencil: red (79819) 1800-39, red | dz |
| | C | 7510-00-264-4608 | Pencil: yellow (79819) 1800-5, yellow | dz |
| | C | 7510-00-240-1526 | Pencil: black (79819) 1555, black | dz |
| | C | 7510-00-436-5210 | Pencil: blue (79819) 1555, blue | dz |
| | C | 7510-00-275-7212 | Pencil: green (79819) 1555, green | dz |
| | C | 7510-00-174-3205 | Pencil: red (79819) 1555, red | dz |
| | C | 7510-00-264-4614 | Pencil: H (79819) 1500 | dz |
| | C | 7510-00-189-7833 | Pencil: 5H (79819) 1500 | dz |
| | C | 7510-00-281-5234 | Pencil: No. 2 (79819) 1132 | dz |
| | C | 7520-00-724-5664 | Pencil, Mechanical: automatic (8D190)VSC-P400 | ea |

Section II EXPENDABLE/DURABLE SUPPLIES AND MATERIALS LIST - Cont

| (1) Item Number | (2) Level | (3) National Stock Number | (4) Description | (5) U/M |
|-----------------------|--------------|------------------------------------|------------------------------------------------------------------------------------------------------------------------------------|------------|
| | C | 7520-01-083-6734 | Pencil, Mechanical: non automatic (79819) 5611 | ea |
| | C | 6675-01-107-9678 | Pen Points (79819) 72DJ, 0.13 mm | ea |
| | C | 6675-01-098-1219 | Pen Points (79819) 72DJ, 0.18 mm | ea |
| | C | 6675-01-098-1220 | Pen Points (79819) 72DJ, 0.25 mm | ea |
| | C | 6675-01-107-9679 | Pen Points (79819) 72DJ, 0.35 mm | ea |
| | C | 6675-01-098-1221 | Pen Points (79819) 72DJ, 0.50 mm | ea |
| | C | 6675-01-099-3440 | Pen Points (79819) 72DJ, 0.70 mm | ea |
| | C | 6675-01-098-0308 | Pen Points (79819) 72DJ, 1.00 mm | ea |
| | C | 6675-01-098-1222 | Pen Points (79819) 72DJ, 1.40 mm | ea |
| | C | 6675-01-097-4516 | Pen Points (79819) 72DJ, 2.00 mm | ea |
| | C | 6685-01-112-1920 | Pen, Recorder: Blue, 0.3 mm (28480) 5060-6785 | pk |
| | C | 6685-01-113-0856 | Pen, Recorder: Green, 0.3 mm (28480) 5060-6786 | pk |
| | C | 6685-01-112-1919 | Pen, Recorder: Red, 0,3 mm (28480) 5060-6784 | pk |
| | C | | Pen, Recorder: <u>Brown, Burnt Orange, Gold, Lime Green, Turquoise, Violet</u> ; 6 pens/pkg 0.3 mm (28480) 5060-6894 | pk |

Section II EXPENDABLE/DURABLE SUPPLIES AND MATERIALS LIST-Cont

| (1) Item Number | (2) Level | (3) National Stock Number | (4) Description | (5) U/M |
|-----------------------|--------------|------------------------------------|--------------------------------------------------------------------------------------------------------------------------|------------|
| | C | | Pen, Recorder: Black, 0.7 mm (28480) 5060-6890 | pk |
| | C | | Pen, Recorder: Blue, 0.7 mm (28480) 5060-6891 | pk |
| | C | | Pen, Recorder: Green, 0.7 mm (28480) 5060-6892 | pk |
| | C | | Pen, Recorder: Red, 0.7 mm (28480) 5060-6893 | pk |
| | C | | Pen, Recorder: Brown, Burnt Orange, Gold, Lime Green, Turquoise, Violet 6 pens/pkg, 0.7 mm (28480) 5060-6895 | pk |
| | C | 6625-01-107-0338 | Pen Plotter: Black, 0.3 mm (28480) 5060-6787 | pk |
| | C | 7520-00-224-7589 | Perforator, Paper, Desk: (79819) Y4-160N | ea |
| | C | 6750-00-868-7901 | Picture Pack, Rapid Processing, Photographic (29556) 108 POLACOLOR 2 | pk |
| | C | 7510-00-174-7343 | Pin, Straight (8D190) P3-780C | bx |
| | C | 9330-00-286-1231 | Plastic Sheet (33363) 17-0153,50 ft. lg, 40 in. w | ro |
| | C | 9330-00-954-9367 | Plastic Sheet (33363) 19-1253, 22 x 34 in. | pk |
| | C | 9330-00-320-1465 | Plastic Strip, Pressure Sensitive Adhesive Coating (05134) 999109 | ro |
| | C | 8010-01-193-0520 | Primer | kt |
| 16 | F | 8010-01-030-7254 | Resin, Epoxy | kt |

Section II EXPENDABLE/DURABLE SUPPLIES AND MATERIALS LIST - Cont

| (1) Item Number | (2) Level | (3) National Stock Number | (4) Description | (5) U/M |
|-----------------------|--------------|------------------------------------|--------------------------------------------------------------|------------|
| 17 | O | | Screen, Nylon (39428) 1017A31 | ro |
| 18 | O | 8040-00-851-0211 | Sealant, Silicone | tu |
| | C | 5110-00-161-6912 | Shears, Straight Trimmers (90137) 509-S9 | ea |
| | C | | Sheet, Data (28480)5953-4004 | ea |
| 19 | O | 3439-00-273-3722 | Solder, Rosin Core | s1 |
| 20 | O | 6850-00-274-5421 | Solvent, P-D-680 | cn |
| 21 | C | 6850-00-880-1013 | Spray, Silicone | cn |
| 22 | O | | Sprayfoam Sealant (39428) 7627T1 | cn |
| | C | 7520-00-281-5895 | Stapler, Paper Fastener, Office | ea |
| | C | 7510-00-272-9662 | Staples, Paper Fastening, Office Type | bx |
| 23 | O | 5640-00-103-2254 | Tape, Cloth, Duct Sealing, 2 in. | ro |
| 24 | F | 5970-00-926-7218 | Tape, Electrical, Insulating | ro |
| 24A | C | 7045-01-060-6452 | Tape, Electronic Data | ea |
| | C | | Tape, Paper (56634) TP-30250 | pk |
| | C | 7530-00-222-3456 | Tape, Paper, Computing Machine (161 52) 19-18592 | ro |
| | C | 7510-00-551-9824 | Tape, Pressure Sensitive Adhesive (76381) 810, 0.78 in. w | ro |
| | C | 7510-00-582-4772 | Tape, Pressure Sensitive Adhesive (76381) 898, 1.0 in. w | ro |
| | C | 7510-00-198-5831 | Tape, Pressure Sensitive Adhesive (76381) 230, 1.0 in. w | ro |
| | C | 7510-00-272-6887 | Thumbtack (79819) W-53 | hd |

Section II EXPENDABLE/DURABLE SUPPLIES AND MATERIALS LIST - Cont

| (1) Item Number | (2) Level | (3) National Stock Number | (4) Description | (5) U/M |
|-----------------------|--------------|------------------------------------|----------------------------------------------|------------|
| 25 | C | 7920-00-982-1203 | Towel, Paper | bx |
| 26 | C | 6675-00-285-6027 | Tracing Cloth Powder (33363) 58-0690 | cn |
| 27 | C | 8110-00-291-0348 | Tube, Mailing and Filing: (76604) 14-4043 | ea |
| 28 | C | 4020-00-257-5396 | Twine, Fibrous (79819) S9-9 | lb |

U.S. GOVERNMENT PRINTING OFFICE: 1986 - 652-032/40148

GLOSSARY

| ABBREVIATION/TERM | DEFINITION |
|--------------------------------|----------------------------------------------------------------------------------------------------------------------------------------------------------------------------------------------------------------------------------------------------------|
| Absolute Addressing | Transferring in program to designated, specific program location (step). Usually accomplished with GTO instruction. |
| AFC | Automatic Frequency Control. |
| Alert Data | Data describing orbits of transit satellites with respect to time as broadcast by satellites. |
| Algorithm | Set procedure for solving a problem (usually mathematical) that can be used to solve all problems of same type. |
| AM | Amplitude Modulated. |
| ANSI | American National Standards Institute. |
| AOS | Algebraic Operating System. Method of entering a calculation into calculator. Calculation is entered exactly as it is written. Calculator performs operation according to preset hierarchy. |
| BFO | Beat Frequency Oscillator. |
| Common Label | Undefined label (program marker) that is set using one of first or second functions (keys) on calculator keyboard. Pressing a common label from keyboard cannot start program execution. |
| Conditional Transfer | Tests some number produced in program against set value. Program execution is transferred to another step in program only if tested number fulfills conditions of test. If test is negative (fails), program ignores transfer and proceeds to next step. |
| Control Mode | Mode of operation used to collect satellite data in real time, compute 2D and point position fixes and transmit data over communications link for translocation at remote MX 1502 RT. |
| Control Site | Satellite surveyor positioned at known site. |

GLOSSARY - Cont

| ABBREVIATION/TERM | DEFINITION |
|-----------------------------------------------|----------------------------------------------------------------------------------------------------------------------------------------------------------------------------------------------------------------------------------------------------------------------------------------------------------------------------------------------------------------------------------------------------------------------------------------------------------------------------------------------------|
| CW | Continuous wave. |
| Data Memory Registers | Portion of total memory registers used for storing data. |
| Datum. | Mathematical reference point at right angles to gravity. |
| Default Conditions | Automatic parameters and conditions for program statements set by factory. |
| Diplexing. | Simultaneous reception of two radio signals. |
| Display Register | Stores current value of calculator display internally to 13 digits, regardless of how it is rounded off for display purposes. All calculations performed use complete number. |
| Downloading. | Dumping copy of protected or Master Library program into calculator's program memory. |
| DAB | Double-Side Band. |
| Earth Fixed Rectangular Coordinates | System of space rectangular coordinates with axes X, Y, and Z having their origin at center of spheroid. Center of spheroid coincides with center of mass of earth. Z-axis is parallel to mean axis of rotation of earth and is positive to North. X-axis is parallel to both mean equatorial and prime meridian planes of earth and is positive toward meridian of Greenwich. Y-axis is parallel to mean equatorial plane, perpendicular to plane of prime meridian and is positive toward India. |
| ECMA | European Computer Manufacturers Association. |
| Ephemeris. | Formatted statement of precise orbit position for satellite for regular intervals. |
| Flag | Internal switch or indicator in calculator memory that can be ON (raised) or OFF (lowered). Flag that is set is ON. |

GLOSSARY - Cont

| ABBREVIATION/TERM | DEFINITION |
|----------------------------|---------------------------------------------------------------------------------------------------------------------------------------------------------------------------------------------------------------------------------------------------------------------------------------------------------------------------------------------------|
| Flow Diagram | Graphic block-type diagram used to describe different operations and calculations performed by program and flow (order of occurrence) of program execution. |
| FM | Frequency Modulated. |
| Geodetic Datum | Mathematical reference point on earth which coincides with MSL and perpendicular to force of gravity. |
| Geodetic Height | Algebraic sum of geoid height and elevation. |
| GMT | Greenwich Mean Time. |
| Heterodyning | Combining of two different frequencies to produce an intermediate frequency. |
| Indirect Address | Produces transfer of memory address. When called, it points to address of memory register that contains desired data or instruction. |
| I/O | Input/Output. |
| ISO | International Organization of Standards. |
| Key Code | Describes key as some number according to its location on keyboard, for purpose of identification in program. First digit denotes one of nine rows of keys (from top to bottom). Second digit denotes which of five columns (1 to 5, left to right) in which key is located. 2nd functions are generally designated by adding 5 to column number. |
| Label | Program marker used to split up and identify portions of program or to identify entire program. Some labels can be used to call up program or portion of program and start it running (i.e., pressing key for label starts program with that label). |
| Looping. | Instructing calculator (in program) to perform same sequence of instructions over and over again, until instructed to stop. Looping instructions resets program pointer to earlier location. |

GLOSSARY - Cont

| ABBREVIATION/TERM | DEFINITION |
|-------------------------------|-------------------------------------------------------------------------------------------------------------------------------------------------------------------------------------------------|
| LSB | Lower Side Band. |
| Mantissa | Decimal part of logarithm or of number expressed as power of 10. |
| Merged | Program instructions that are combined and stored in one program (memory) location. |
| Merged Key Code | Key codes are merged into single two-digit code. |
| MOS | Metal-Oxide Semiconductor. |
| MSL | Mean Sea Level. |
| Off-Line Mode | Mode of operation used to process tape cassette data. Satellite receiver is disconnected. |
| Partitioning | Dividing memory registers of calculator into registers for storing data and registers for storing program instructions. |
| Point Positioning | Independent reduction of observations made by particular station under assumption that ephemerides of all observed satellite passes are perfectly known. |
| Program. | List of precise instructions arranged in specific order to be executed in specific way. |
| Program Instruction | Tells calculator how to do something. Usually designation for key or set of keys on keyboard. When calculator encounters key designation in running program, function of that key is performed. |
| Program Memory | Those registers in memory partitioned for storing program instructions. |
| Program Pointer | Internal device used by calculator to determine which instruction it should perform next when executing program. Points at instruction currently being executed. |
| Program Statement | Programming command recognized by plotter's internal circuits. |

GLOSSARY - Cont

| ABBREVIATION/TERM | DEFINITION |
|--------------------------------------|----------------------------------------------------------------------------------------------------------------------------------------------------------------------------------------------------------------------------------------------------------------------|
| RAM | Reader Addressable Memory. Can be changed by operator. |
| Remote Mode | Mode of operation used to collect satellite data in real time, together with data (via communications link) from another MX 1502 RT, and compute 2D, point position and translocation fixes. |
| Remote Site | Satellite surveyor which occupies site whose position is unknown. |
| RF | Radio Frequency. |
| ROM | Read Only Memory. Cannot be changed by operator. |
| Software | Programs (written or pre-stored) and instructions on how to use them. |
| SSB | Single-Side Band. |
| Standard Mode | Mode of operation used to collect satellite data in real time and compute 2D and point position fixes. |
| Statement Parameters | Functional limits of each plotter programming statement. Normally a set of tolerances. |
| Subroutine | Sequences of calculations or instructions, that have unique purpose and are used repeatedly, arranged in mini-program that can be run alone or used as internal part of larger program. Normally labeled, and called up by pressing label or by a GO TO instruction. |
| Subroutine Return Register | Designates in program where (at what step) subroutine transfer was called. When calculator finishes subroutine, it returns to step in program designated by this register and continues executing program from that point. |
| SW | Shortwave. |
| 3D | A three dimensional position computation for latitude, longitude and height in meters (above MSL). |

GLOSSARY - Cont

| ABBREVIATION/TERM | DEFINITION |
|----------------------------------|---------------------------------------------------------------------------------------------------------------------------------------------|
| Transfer Instructions | Tell calculator to jump ahead or backward in program to a different step. Program execution continues at that step. |
| Translocation | Method of using simultaneous data from separate stations to determine relative position of one station with respect to known station. |
| T-Register | Special data-type test register where numbers can be stored, recalled, and compared against displayed number. |
| TTL | Transistor-Transistor Logic. Ic chip contains linked transistors to accomplish logic functions. |
| AD | A two dimensional position computation for latitude and longitude. |
| Unconditional Transfer | Transfer instruction that is performed immediately (when encountered). |
| USB | Upper Side Band. |
| User-Defined Key | Keys that are used as labels. When pressed, they cause program pointer to relocate to that label and begin running program from that point. |
| UTM | Universal Transverse Mercator. |
| Variables. | Those items in program or mathematical expression whose value can be anything, i.e., can vary. |
| WGS-72 | World Geodetic System of 1972. |

INDEX

SUBJECT PARAGRAPH

ANALYTICAL PHOTOGRAMMETRIC POSITIONING SYSTEM

G

General Information 2-1

I

Information, General 2-1
 Information, Reference 2-1.2

R

Reference Information 2-1.2

S

Scope 2-1.1

AUTOMATIC BATTERY CHARGER

A

Ammeter, Replace 5-20.1

B

Battery Leads, Replace 5-20.4

C

Circuit Breaker, Replace 5-20.5
 Components, Location and Description of Major 5-2.2
 Conditions, Operation Under Unusual 5-7
 Conditions, Operation Under Usual 5-6

D

Data, Equipment 5-2.3
 Description, Equipment 5-2
 Description-and Use of Operator's Controls
 and Indicators. 5-4
 Diodes, Replace 5-20.2

INDEX - Cont

SUBJECT PARAGRAPH

AUTOMATIC BATTERY CHARGER - Cont

E

Equipment Data 5-2.3
 Equipment Description 5-2
 Equipment, Repair Parts, Special Tools; Test,
 Measurement, and Diagnostic Equipment; and
 Support 5-12,5-18

F

Fuse, Replace 5-10.1

G

General Information 5-1

I

Indicators, Description and Use of Operator's
 Controls and. 5-4
 Information, General 5-1
 Instructions, Lubrication 5-7, 5-11

L

Location and Description of Major Components 5-2.2
 Lubrication Instructions 5-8, 5-11

M

Maintenance Procedures 5-10, 5-16, 5-20

O

Operation, Technical Principles of 5-3
 Operation Under Unusual Conditions 5-7
 Operation Under Usual Conditions 5-6

P

Power Cord, Replace 5-20.6
 preparation for Storage or Shipment 5-17
 Preventive Maintenance Checks and Services 5-5, 5-14
 Procedures, Maintenance 5-10, 5-16, 5-20

INDEX - Cont

SUBJECT PARAGRAPH

AUTOMATIC BATTERY CHARGER - Cont

R

Repair Parts, Special Tools; Test, Measurement,
and Diagnostic Equipment; and Support Equipment 5-12, 5-18

Replace:

- Ammeter 5-20.1
- Breaker,Circuit 5-20.5
- Cord, Power 5-20.6
- Diodes 5-20.2
- Fuse. 5-10.1
- Leads, Battery. 5-20.4
- Transformer 5-20.3

S

- Scope 5-1.1
- Service Upon Receipt. 5-13
- Services, Preventive Maintenance Checks and 5-5, 5-14
- Shipment, Preparation for Storage or 5-17

T

- Technical Principles of Operation 5-3
- Transformer, Replace. 5-20.3
- Troubleshooting Procedures 5-9, 5-15, 5-19

FURNITURE AND CABINETS

C

- Cabinet, Form Storage, Remove/Install. 8-16.12
- Cabinet, Map and Plan Filing, Remove/Install 8-16.6
- Cabinet, Supply, Remove/Install. 8-16.8
- Cabinet, Wall Storage, Remove/Install. 8-16.5
- Chair, Rotary Desk. 8-2
- Chair, Rotary Drafting 8-2

D

- Desk, Flat Top, Remove/Install 8-16.9
- Drawing Table, Remove/Install. 8-16.10

F

- Filing Cabinet, Remove/Install 8-16.7
- Filing Cabinet, Map and Plan, Remove/Install 8-16.6
- Form Storage Cabinet, Remove/Install 8-16.12

INDEX - Cont

SUBJECT PARAGRAPH

FURNITURE AND CABINETS - Cont

H

Hinge (Piano Hinge), Replace 8-16.1

I

Inspect Furniture and Cabinets 8-10.1
 Instructions, Lubrication 8-8, 8-11

L

Latch (Wall Storage Cabinet), Replace. 8-16.2
 Lubrication Instructions 8-8, 8-11

M

Maintenance Procedures 8-10, 8-16
 Map and Plan Filing Cabinet, Remove/Install. 8-16.6

P

Paper Storage Shelf, Remove/Install. 8-16.11
 preparation for Storage or Shipment 8-17
 Preventive Maintenance Checks and Services 8-5, 8-14
 Procedures, Maintenance 8-10, 8-16

R

Remove/Install:
 Drawing Table 8-16.10
 Filing Cabinet. 8-16.7
 FlatTopDesk 8-16.9
 Form Storage Cabinet 8-16.12
 Map and Plan Filing Cabinet 8-16.6
 Paper Storage Shelf 8-16.11
 Supply Cabinet. 8-16.8
 Wall Storage Cabinet. 8-16.5
 Work Station (Double Security Cabinets). 8-16.4
 Work Station (Two-Drawer Filing Cabinet and
 Security Cabinet) 8-16.3
 Replace:
 Hinge (Piano Hinge) 8-16.1
 Latch (Wall Storage Cabinet) 8-16.5
 Revolving Stool 8-2
 Rotary Desk Chair 8-2
 Rotary Drafting Chair 8-2

INDEX - Cont

SUBJECT PARAGRAPH

FURNITURE AND CABINETS - Cont

S

| | |
|------------------------------------------|--------|
| Scope. | 8-1.1 |
| Service Upon Receipt | 8-13 |
| Stool, Revolving. | 8-2 |
| Supply Cabinet, Remove/Install | 8-16.8 |

T

| | |
|------------------------------------------|--------------|
| Table, Drawing, Remove/Install | 8 - 16 . 1 0 |
| Troubleshooting | 8-9, 8-15 |

U

| | |
|--------------------------------------------------------------------------------------------|--------|
| Wall Storage Cabinet, Remove/Install | 8-16.5 |
| Work Station (Double Security Cabinets), Remove/Install. . . | 8-16.4 |
| Work Station (Two-Drawer Filing Cabinet and Security Cabinet), Remove/Install | 8-16.3 |

GRAPHICS PLOTTER HP-9872B

A

| | |
|--------------------------------------------|-------|
| Assembly and Preparation for Use | 3-6.1 |
|--------------------------------------------|-------|

D

| | |
|--------------------------------------------------------------|-----|
| Description and Use of Operator's Controls and Indicators. . | 3-4 |
|--------------------------------------------------------------|-----|

E

| | |
|----------------------------------------------------------------|-------|
| Equipment Characteristics, Capabilities and Features | 3-2.1 |
| Equipment Data. | 3-2.3 |
| Equipment Description | 3-2 |

G

| | |
|-------------------------------|-------|
| General Information | 3 - 1 |
| Glossary. | 3-1.2 |

I

| | |
|------------------------------------------------------------|-------|
| Information, General | 3-1 |
| Initial Adjustments, Daily Checks, and Self-Test | 3-6.2 |
| Instructions, Lubrication | 3-8 |

INDEX - Cont

SUBJECT PARAGRAPH

GRAPHICS PLOTTER HP-9872B - Cont

L

| | |
|--------------------------------------------------------|-------|
| Location and Description of Major Components | 3-2.2 |
| Lubrication Instructions | 3-8 |

O

| | |
|----------------------------------------------------------------------|-------|
| Operation Under Unusual Conditions | 3-7 |
| Operation Under Usual Conditions | 3-6 |
| Operating Procedures | 3-6.3 |
| Operator's Controls and Indicators, Description and Use of | 3-4 |

P

| | |
|------------------------------------------------------|-------|
| Preventive Maintenance Checks and Services | 3-5 |
| Procedures, Operating | 3-6.3 |
| Procedures, Troubleshooting | 3-9 |

S

| | |
|-----------------|-------|
| Scope | 3-1.1 |
|-----------------|-------|

T

| | |
|---------------------------------------------|---------|
| Technical Principles of Operation | 3-3 |
| Data Processing. | 3-3.2.3 |
| Detailed. | 3-3.2 |
| General | 3-3.1 |
| Interface Circuits | 3-3.2.2 |
| Interface ROM | 3-3.2.1 |
| Local Control Circuits | 3-3.2.4 |
| Pen Drive Circuits. | 3-3.2.5 |
| Power Supply. | 3-3.2.6 |
| Troubleshooting Procedures | 3-9 |

GRAPHICS PLOTTER HP-9872C

A

| | |
|--------------------------------------------|--------|
| Adjust: | |
| Cable Tension | 3-29.3 |
| Pen | 3-29.1 |
| Pen Arm (X-Drive). | 3-29.2 |
| X-Limit and Y-Limit Switch | 3-29.4 |
| X-Axis MotorDriver | 3-29.5 |
| Y-Axis MotorDriver | 3-29.6 |
| Assembly and Preparation for Use | 3-15.1 |

INDEX - Cont

| SUBJECT | PARAGRAPH |
|------------------------------------------------------------------------|------------|
| GRAPHICS PLOTTER HP-9872C - Cont | |
| B | |
| Board, HP-IB Logic, Replacement | 3-29.18 |
| C | |
| Cable Tension Adjustment.. | 3-29.3 |
| Components, Location and Description of Major | 3-11.2 |
| D | |
| Description and Use of Operator's Controls and Indicators. | 3-13 |
| E | |
| Electrostatic Table Replacement | 3-29.8 |
| Equipment Data. | 3-11.3 |
| Equipment Description | 3-11 |
| Equipment Characteristics, Capabilities, and Features. | 3-11.1 |
| F | |
| Front Panel PCA A6 Replacement | 3-29.7 |
| G | |
| General Information | 3-1 |
| H | |
| HP-IB Logic Board Replacement | 3-29.18 |
| HP-IB Test. | 3-15.2 |
| I | |
| Indicators, Description and Use of Operator's Controls and. | 3-13 |
| information, General | 3-1 |
| Initial Adjustments, Daily Checks, and Self-Test | 3-15.2 |
| Instructions, Lubrication | 3-17, 3-20 |
| Interface Cable Replacement | 3-29.19 |
| L | |
| Location and Description of Major Components | 3-11.2 |
| Lubrication Instructions | 3-17, 3-20 |

INDEX - Cont

SUBJECT PARAGRAPH

GRAPHICS PLOTTER HP-9872C - Cont

M

| | |
|----------------------------------|-----------------------------|
| Maintenance Procedures | 3 - 1 9 , 3 - 2 5 , 3 - 2 9 |
| X-Axis. | 3-29.5 |
| Y-Axis. | 3-29.6 |

O

| | |
|----------------------------------------------|--------|
| Operating Procedures | 3-15.3 |
| Operation, Technical Principles of | 3-12 |
| Operation Under Unusual Conditions | 3-16 |
| Operation Under Usual Conditions | 3-15 |

P

| | |
|------------------------------------------------------|------------|
| PCA A7 Replacement | 3-29.7 |
| PCA Card Replacement | 3-29.7 |
| Pen Adjustments. | 3-29.1 |
| Pen Arm Adjustment (X-Drive) | 3-29.2 |
| Pen Solenoid Replacement | 3-29.13 |
| Preparation for Storage or Shipment | 3-26 |
| Preventive Maintenance Checks and Services | 3-14, 3-23 |
| Procedures, Maintenance | 3-19, 3-25 |

R

| | |
|------------------------------------|---------|
| Replace: | |
| Electrostatic Table | 3-29.8 |
| Fan | 3-29.12 |
| Front Panel PCA A6 | 3-29.7 |
| Interface Cable Assembly | 3-29.19 |
| PCA A7 | 3-29.7 |
| PCA Card | 3-29.7 |
| Pen Solenoid | 3-29.13 |
| Power Supply | |
| Transformer | 3-29.11 |
| X-Cable | 3-29.16 |
| X-Drive Cable | 3-29.15 |
| X-Limit Switch | 3-29.9 |
| X-Drive Motor. | 3-29.14 |
| Y- Cable | 3-29.17 |
| Y-Limit Switch | 3-29.10 |
| Y-Drive Motor. | 3-29.14 |

INDEX - Cont

SUBJECT PARAGRAPH

GRAPHICS PLOTTER HP-9872C - Cont

S

Scope 3-1.1
 Self-Test 3-15
 Service Upon Receipt. 3-22
 Services, Preventive Maintenance Checks and 3-14, 3-23

T

Technical Principles of Operation 3-12
 Detailed 3-12.2
 General 3-12.1
 HP-IB Interface. 3-12.3
 Test, HP-IB 3-15.2
 Transformer Replacement 3-29.11
 Troubleshooting Procedures 3-18, 3-24, 3-28

X

X-Axis Motor Driver Adjustments 3-29.5
 X-Cable Replacement 3-29.16
 X-Drive Cable Replacement 3-29.15
 X-Limit Switch Adjustment 3-29.4
 X-Limit Switch Replacement 3-29.9
 X-Drive Motor Replacement. 3-29.14

Y

Y-Axis Motor Driver Adjustments 3-29.6
 Y-Cable Replacement 3-29.17
 Y-Limit Switch Adjustment. 3-29.4
 Y-Limit Switch Replacement 3-29.10
 Y-Drive Motor Replacement. 3-29.14

PROGRAMMABLE CALCULATOR WITH PRINTER

A

Assembly and Preparation for Use 7-6.1

C

Conditions, Operation Under Unusual 7-7
 Conditions, Operation Under Usual 7-6

INDEX - Cont

SUBJECT PARAGRAPH

PROGRAMMABLE CALCULATOR WITH PRINTER - Cont

D

Data, Equipment 7-2.3
 Description and Use of Operator's Controls
 and Indicators 7-4
 Description, Equipment 7-2

E

Equipment Characteristics, Capabilities, and Features 7-2.1
 Equipment Data 7-2.3
 Equipment Description 7-2

F

Fuse, Replace 7-10.1

G

General Information 7-1
 Glossary 7-1.2

I

Indicators, Description and Use of Operator's
 Controls and 7-4
 Information, General 7-1
 Instructions, Lubrication 7-8, 7-11

L

Location and Description of Major Components 7-2.2
 Lubrication Instructions 7-8, 7-11

M

Maintenance Procedures 7-10, 7-16

O

Operating Procedures 7-6.2
 Operation, Technical Principles of 7-3
 Operation Under Unusual Conditions 7-7
 Operation Under Usual Conditions 7-6
 Operation Controls and Indicators, Description
 and Use of 7-4

INDEX - Cont

SUBJECT PARAGRAPH

PROGRAMMABLE CALCULATOR WITH PRINTER - Cont

P

Preparation for Storage and Shipment 7-17
 Preventive Maintenance Checks and Services 7-5, 7-14
 Procedures, Operating 7-6.2

R

Replace Fuse. 7-10.1

S

Scope 7-1.1
 Service Upon Receipt. 7-13
 Services, Preventive Maintenance Checks and 7-5, 7-14

T

Technical Principles of Operation
 Troubleshooting 7-9, 7-15

SATELLITE SURVEYOR

A

Alarm Clock Board, Replace.. 4-20.3
 Assembly and Preparation for Use 4-6.1

B

Battery Pack No. 1, Replace 4-20.5
 Battery Pack No. 2, Replace 4-20.5

C

Components, Location and Description of 4-2.2
 Conditions, Operation Under Unusual 4-7
 Conditions, Operation under Usual 4-6

D

Data Entry and Display Board, Replace. 4-20.2
 Data, Equipment 4-2.3
 Description, Equipment 4-2
 Description and Use of Operator's Controls
 and Indicators. 4-4
 Dual Channel Receiver Board, Replace 4-20.3

INDEX - Cont

SUBJECT PARAGRAPH

SATELLITE SURVEYOR - Cont

E

| | |
|-----------------------------------------------------------------------------------------------------------------|------------|
| Equipment Characteristics, Capabilities, and Features. | 4-2.1 |
| Equipment Data. | 4-2 3 |
| Equipment Description | 4-2 |
| Equipment, Repair Parts; Special Tools; Test, Measurement, and Diagnostic Equipment; and Support. | 4-12, 4-18 |

F

| | |
|----------------------------------------------|--------|
| Fan Assembly, Replace | 4-20.9 |
| Front Panel Display Board, Replace | 4-20.4 |
| Fuse, Replace | 4-10.1 |

G

| | |
|-------------------------------|-------|
| General Information | 4-1 |
| Glossary. | 4-1.4 |

I

| | |
|------------------------------------------------------------------------|-----------|
| Indicators, Description and Use of Operator's Controls and. | 4-4 |
| Information, General | 4-1 |
| Information, Reference | 4-1.2 |
| Initial Adjustments, Daily Checks, and Self Test | 4-6.2 |
| Instructions, Lubrication | 4-8, 4-11 |

K

| | |
|-----------------------------|--------|
| Keyboard, Replace | 4-20.4 |
|-----------------------------|--------|

L

| | |
|--------------------------------------------------------|-------|
| List of Abbreviations | 4-1.3 |
| Location and Description of Major Components | 4-2.2 |
| Lubrication Instructions | 4-11 |

M

| | |
|------------------------------------------|------------------|
| Maintenance Procedures | 4-10, 4-16, 4-20 |
| Memory Board, Replace. | 4-20.2 |
| Memory/Processor Board, Replace. | 4-20.2 |
| Modem Board, Replace. | 4-20.2 |
| Modes, Operating. | 4-6.3 |

INDEX - Cont

SUBJECT PARAGRAPH

SATELLITE SURVEYOR - Cont

0

Operating Instructions on Decals and Instruction Plates. . . 4-6.5
 Operating Modes 4-6.3
 Operation, Technical Principles of 4-3
 Operation Under Unusual Conditions 4-7
 Operation Under Usual Conditions 4-6
 Oscillator, Replace 4-20.8

P

Power Supply Board, Replace. 4-20.2
 Preparation for Storage or Shipment 4-17
 Preventive Maintenance Checks and Services 4-5, 4-14
 Procedures, Maintenance 4-10, 4-16, 4-20

R

Receipt, Service Upon 4-13
 Reference Information 4-1.2
 Repair Parts; Special Tools; Test,
 Measurement, and Diagnostic Equipment;
 and Support Equipment 4-12, 4-18
 Replace:
 Assembly, Fan 4-20.9
 Battery Pack, No.1 4-20.5
 Battery Pack, No.2 4-20.5
 Board, Alarm Clock. 4-20.3
 Board, Modem. 4-20.2
 Board, Data Entry and Display. 4-20.2
 Board, Front Panel Display 4-20.4
 Board, Dual Channel Receiver 4-20.3
 Board, Memory. 4-20.2
 Board, Memory/Processor. 4-20.2
 Board, Power Supply. 4-20.2
 Board, Tape Control 4-20.2
 Board, Voltmeter Driver 4-20.4
 Fuse. 4-10.1
 Key board 4-20.4
 Oscillator. 4-20.8
 Switches. 4-20.6
 Tape Cassette Transport 250 BH 4-20.1
 Thermometer 4-20.7

INDEX - Cont

SUBJECT PARAGRAPH
 SATELLITE SURVEYOR - Cont

S

Scope 4-1.1
 Service Upon Receipt. 4-13
 Services, Preventive Maintenance Checks and 4-5, 4-14
 Shipment, Preparation for Storage or 4-17
 Switches, Replace 4-20.6

T

Tape Cassette Transport 250 BH, Replace 4-20.1
 Tape Control Board, Replace 4-20.2
 Technical Principles of Operation 4-3
 Thermometer, Replace 4-20.7
 Troubleshooting 4-9, 4-15, 4-19

V

Voltmeter Driver Board, Replace 4-20.4

SUPPORT ITEMS

B

Batteries in Still Picture (Instant) Camera Set, Replace 9-10.2

D

Description and Use of Operator's Controls and Indicators:
 Magnifier Lamp. 9-4.1
 Pocket Stereoscope. 9-4.3
 Radio Receiver. 9-4.5
 Still Picture (Instant) Camera Set 9-4.4
 Vacuum Cleaner. 9-4.2

E

Equipment Characteristics, Capabilities, and Features 9-2.1
 Equipment Data. 9-2.2
 Equipment Description 9-2

G

General Information 9-1

INDEX - Cont

SUBJECT PARAGRAPH

SUPPORT ITEMS - Cont

I

Information, General 9-1
 Information, Reference 9-1.2
 Instructions, Lubrication 9-8, 9-11

L

Lamp in Magnifier Lamp Assembly, Replace 9-10.1
 Lubrication Instructions 9-8, 9-11

M

Magnifier Lamp Assembly, Replace 9-16.1
 Magnifier Lamp, Description and Use of Operator's
 Controls and Indicators 9-4.1
 Magnifier Lamp, Operation Under Usual Conditions 9-6.1.1
 Maintenance Procedures 9-10, 9-16

O

Operating Instructions on Decals and Instruction Plates 9-6.2
 Operating Procedures 9-6.1
 Operation Under Unusual Conditions, Still Picture
 (Instant) Camera Set 9-7.1
 Operation Under Usual Conditions:
 Magnifier Lamp. 9-6.1.1
 Pocket Stereoscope. 9-6.1.3
 Photoengraving Magnifier 9-6.1.5
 Radio Receiver. 9-6.
 Still Picture (Instant) Camera Set 9-6.1.4
 Vacuum Cleaner. 9-6.1.2

P

Photoengraving Magnifier, Operation Under
 Usual Conditions 9-6.1.5
 Pocket Stereoscope, Description and Use of Operator's
 Controls and Indicators. 9-4.3
 Pocket Stereoscope, Operation Under Usual Conditions 9-6.1.3
 Preparation for Storage or Shipment 9-17
 Preventive Maintenance Checks and Services 9-5, 9-14
 Procedures, Maintenance 9-10, 9-16
 Procedures, Operating 9-6.1

INDEX - Cont

SUBJECT PARAGRAPH

SUPPORT ITEMS - Cont

R

| | |
|----------------------------------------------------------------------------------------|---------|
| Radio Receiver, Description and Use of Operator's Controls and Indicators | 9-4.5 |
| Radio Receiver, Operation Usual Conditions. | 9-6.1.6 |
| Reference Information | 9-1.2 |
| Remove/Install Wrapping Paper Holder and Cutter | 9-16.2 |
| Replace Batteries in Still Picture (Instant) Camera Set. | 9-10.2 |
| Replace Lamp in Magnifier Lamp Assembly. | 9-10.1 |
| Replace Magnifier Lamp Assembly | 9-16.1 |

S

| | |
|------------------------------------------------------------------------------------------------------------|-----------|
| Scope | 9-1.1 |
| Service Upon Receipt. | 9-13 |
| Services, Preventive Maintenance Checks and | 9-5, 9-14 |
| Still Picture (Instant) Camera, Load | 9-6.1.4 |
| Still Picture (Instant) Camera Set, Description and Use of Operator's Controls and Indicators | 9-4.4 |
| Still Picture (Instant) Camera Set, Operation Under Unusual Conditions | 9-7.1 |

T

| | |
|---------------------------|--------------|
| Troubleshooting | ...9-9. 9-15 |
|---------------------------|--------------|

V

| | |
|----------------------------------------------------------------------------------------|---------|
| Vacuum Cleaner, Description and Use of Operator's Controls and Indicators | 9-4.2 |
| Vacuum Cleaner, Operation Under Usual Conditions. | 9-6.1.2 |

W

| | |
|------------------------------------------------------------|--------|
| Wrapping Paper Holder and Cutter, Remove/Install | 9-16.2 |
|------------------------------------------------------------|--------|

SURVEY SECTION

A

| | |
|----------------------------------------------------|---------|
| Air Conditioner/Heater, Replace | 1-20.8 |
| Air Conditioner Support Bracket, Replace | 1-20.9 |
| Air Vent Cover, Replace | 1-16.17 |
| Air Vent Screen, Replace | 1-16.16 |

INDEX - Cont

SUBJECT PARAGRAPH

SURVEY SECTION - Cont

B

| | |
|----------------------------------------------------|--------|
| Ballast, Fluorescent Lamp, Replace | 1-16.1 |
| Blackout/Dome Light, Replace | 1-10.3 |
| Blackout/Dome Light Microswitch, Replace | 1-16.5 |
| Blackout Curtain, Repair.. | 1-16.2 |
| Breaker, Circuit, Replace | 1-20.5 |

C

| | |
|---------------------------------------------------------|------------|
| Cargo Door Latch Assembly, Replace | 1-20.2 |
| Characteristics, Capabilities, and Features | 1-2.1 |
| Circuit Breaker, Replace | 1-20.5 |
| Common Tools and Equipment | 1-12, 1-18 |
| Components, Location and Description of Major | 1-2.2 |
| Conditions, Operation Under Unusual | 1-7 |
| Conditions, Operation Under Usual | 1-6 |
| Cover, Air Vent, Replace | 1-16.17 |
| Cover, Exhaust Fan, Replace | 1-16.10 |
| Curtain, Blackout, Repair | 1-16.12 |

D

| | |
|-----------------------------------------------------------------------|---------|
| Data, Equipment | 1-2.3 |
| Description and Use of Operator's Controls and Indicators. | 1-4 |
| Destruction of Material to Prevent Enemy Use | 1-1.5 |
| Door, Personnel/Cargo, Replace | 1-20.4 |
| Door Handle, Personnel, Repair | 1-20.1 |
| Door Latch Assembly, Cargo, Replace | 1-20.2 |
| Duct, Ventilation, Replace | 1-20.10 |
| Ducts, Ventilation, Service | 1-10.2 |

E

| | |
|-----------------------------------------------------------------|---------|
| Emergency Light Assembly, Replace | 1-16.11 |
| Equipment Data. | 1-2.3 |
| Equipment Description | 1-2 |
| Equipment Characteristics, Capabilities, and Features | 1-2.1 |
| Exhaust Fan, Replace. | 1-16.9 |
| Exhaust Fan Cover, Replace | 1-16.10 |

INDEX - Cont

SUBJECT PARAGRAPH

SURVEY SECTION - Cont

F

Fan, Exhaust, Replace 1-16.9
 Features, Equipment Characteristics, Capabilities, and 1-2.1
 Filter, Radio Frequency (RF), Replace 1-16.2
 Floor Covering, Repair 1-20.6
 Fluorescent Lamp, Replace.. 1-10.1
 Fluorescent Lamp Ballast, Replace 1-16.1
 Fluorescent Lamp Switch, Replace 1-16.3
 Forms and Records, Maintenance 1-1.3

G

General Information 1-1

I

Indicator, Level, Repair 1-16.15
 Indicators, Description and Use of Operator's
 Controls-and. 1-4
 Instructions, Lubrication 1-8, 1-11

L

Ladder, Personnel, Repair 1-16.18
 Level Indicator, Repair 1-10.3
 Light, Blackout/Dome, Replace 1-10.3
 Light, Emergency Assembly, Replace 1-16.11
 Location and Description of Major Components 1-2.2
 Lubrication Instructions 1-8, 1-11

H

Maintenance Procedures 1-10, 1-16, 1-20
 Maintenance Forms and Records 1-1.3
 Microswitch, Blackout/Dome Light, Replace 1-16.5
 Molding, Wire, Replace 1-16.7

O

On/Off Switch, Replace 1-16.4
 Operations, Technical Principles of 1-3
 Operation Under Unusual Conditions 1-7
 Operation Under Usual Conditions 1-6
 Operator's Controls and Indicators, Description
 and Use of. 1-4
 Operator Preventive Maintenance Checks and Services 1-5
 Organizational Preventive Maintenance Checks and Services 1-14
 Organizational Troubleshooting 1-15

INDEX - Cont

SUBJECT PARAGRAPH

SURVEY SECTION - Cont

P

Parts, Repair 1-12, 1-18
 Personnel Door Handle, Repair 1-20.1
 Personnel/Cargo Door, Replace 1-20.4
 Personnel/Cargo Door Gasket, Replace 1-20.3
 Personnel Ladder, Repair 1-16.18
 Preparation for Movement 1-6.2
 Preparation for Storage or Shipment 1-17
 Preventive Maintenance Checks and Services 1-5, 1-14
 Procedures, Maintenance 1-10, 1-16, 1-20

R

Radio Frequency (RF) Filter, Replace 1-16.2
 Receipt, Service Upon 1-13
 Receptacle, Replace 1-16.6
 Repair Parts. 1-12,1-18
 Repair:
 Blackout Curtain 1-16.12
 Floor Covering. 1-20.6
 Level Indicator 1-16.15
 Personnel Door Handel 1-20.1
 Personnel Ladder. 1-16.18
 Telephone Binding Post Assembly 1-16.8
 Van Body Skin 1-16.12, 1-20.7
 Replace:
 Air Conditioner/Heater 1-20.8
 Air Conditioner Support Bracket 1-20.9
 Air Vent Cover. 1-16.17
 Air Vent Screen 1-16.16
 Blackout/Dome Light 1-10.3
 Blackout/Dome Light Microswitch 1-16.5
 Cargo Door Latch Assembly 1-20.2
 Circuit Breaker 1-20.5
 Emergency Light Assembly 1-16.11
 Exhaust Fan 1-16.9
 Exhaust Fan Cover 1-16.10
 Fluorescent Lamp. 1-10.1
 Fluorescent Lamp Ballast 1-16.1
 Fluorescent Lamp Switch 1-16.3
 On/Off Switch 1-16.4
 Personnel/Cargo Door 1-20.4
 Personnel/Cargo Door Gasket 1-20.3
 Radio Frequency (RF) Filter 1-16.2
 Receptacle. 1-16.6
 Tiedown Socket. 1-16.14

INDEX - Cont

SUBJECT

PARAGRAPH

SURVEY SECTION - Cont

R - Cont

| | |
|----------------------------|---------|
| Ventilation Duct | 1-20.10 |
| Wire Molding. | 1-16.7 |

S

| | |
|--------------------------------------------------------------------------------|------------|
| Scope | 1-1.1 |
| Service Upon Receipt. | 1-13 |
| Service Ventilation Ducts | 1-10.2 |
| Services, Preventive Maintenance Checks and | 1-5, 1-14 |
| Shipment, Preparation for Storage or | 1-17 |
| Socket, Tiedown, Replace | 1-16.14 |
| Special Tools; Test, Measurement, Diagnostic and Support Equipment. | 1-12, 1-18 |
| Switch, Fluorescent Lamp, Replace | 1-16.3 |
| Switch, On/Off, Replace.. . . . | 1-16.4 |

T

| | |
|----------------------------------------------------------------------------------|-----------------|
| Technical Principles of Operation | 1-3 |
| Telephone Binding Post Assembly, Repair | 1-16.8 |
| Tiedown Socket, Replace | 1-16.14 |
| Tools and Equipment, Special | 1-12, 1-18 |
| Tools; Test, Measurement, Diagnostic and Support Equipment, Special | 1-12, 1-18 |
| Troubleshooting | 1-9, 1-15, 1-19 |

V

| | |
|--------------------------------------|-----------------|
| Van Body Skin, Repair | 1-16.13, 1-20.7 |
| Ventilation Duct, Replace | 1-20.10 |
| Ventilation Ducts, Service | 1-10.2 |

U

| | |
|---------------------------------|--------|
| Wire Molding, Replace | 1-16.7 |
|---------------------------------|--------|

INDEX - Cont

| SUBJECT | PARAGRAPH |
|------------------------------------------------------------------------|-----------|
| ULTRASONIC CLEANER | |
| C | |
| Characteristics, Capabilities, and Features. | 6-2.1 |
| Circuit Board, Replace | 6-16,3 |
| Cleaning Pens | 6-6.1 |
| Cleaning Small Parts. | 6-6.1 |
| D | |
| Data, Equipment | 6-2.3 |
| Description and Use of Operator's Controls and Indicators. | 6-4 |
| E | |
| Equipment Data. | 6-2.3 |
| Equipment Description | 6-2 |
| G | |
| General Information | 6-1 |
| I | |
| Information, General | 6-1 |
| Instructions, Lubrication | 6-8, 6-11 |
| L | |
| Location and Description of Major Components | 6-2.2 |
| Lubrication Instructions | 6-8, 6-11 |
| O | |
| Operating Procedures | 6-6.1 |
| Operation, Technical Principles of | 6-3 |
| Operation Under Unusual Conditions | 6-7 |
| Operation Under Usual Conditions | 6-6 |
| Operator Preventive Maintenance Checks and Services | 6-5 |
| Organizational Preventive Maintenance Checks and Services | 6-14 |
| Organizational Troubleshooting | 6-15 |

INDEX - Cont

SUBJECT PARAGRAPH

ULTRASONIC CLEANER - Cont

P

| | |
|------------------------------------------------------|-----------|
| Parts, Cleaning | 6-6.1 |
| Pens, Cleaning. | 6-6.1 |
| Power Cord, Replace | 6-16.1 |
| Power Switch, Replace | 6-16.2 |
| Preparation for Storage or Shipment | 6-17 |
| Preventive Maintenance Checks and Services | 6-5, 6-14 |

R

| | |
|---------------------------------|--------|
| Receipt, Service Upon | 6-13 |
| Replace: | |
| Circuit Board | 6-16.3 |
| Power Cord. | 6-16.1 |
| Power Switch. | 6-16.2 |

S

| | |
|-------------------------------------------------------|-----------|
| Scope | 6-1.1 |
| Service Upon Receipt. | 6-13 |
| Services, Preventive Maintenance Checks and | 6-5, 6-14 |
| Shipment, Preparation for Storage or | 6-17 |

T

| | |
|---------------------------------------------|-----------|
| Technical Principles of Operation | 6-3 |
| Troubleshooting | 6-9, 6-15 |

By Order of the Secretary of the Army:

JOHN A. WICKHAM, JR.
General, United States Army
Chief of Staff

Official:

DONALD J. DELANDRO
Brigadier General, United States Army
The Adjutant General

DISTRIBUTION:

To be distributed in accordance with DA Form 12-25A, Operator, Organizational, Direct Support and General Support Maintenance Requirements for Topographic Support Set, Semitrailer Mounted, Survey Section (ADC-TSS-6) (TM 5-6675-318 Series).

RECOMMENDED CHANGES TO EQUIPMENT TECHNICAL PUBLICATIONS



THEN, JOT DOWN THE DOPE ABOUT IT ON THIS FORM. CAREFULLY TEAR IT OUT. FOLD IT AND DROP IT IN THE MAIL!

SOMETHING WRONG WITH THIS PUBLICATION?

FROM (PRINT YOUR UNIT'S COMPLETE ADDRESS)

PFC JOHN DOE
COA, 3d ENGINEER BN
FT. LEONARDWOOD, MA 63108

DATE SENT

PUBLICATION NUMBER

TM 5-6675-318-14-2

PUBLICATION DATE

3 Sep 85

PUBLICATION TITLE

TOPOGRAPHIC SUPPORT SYSTEM
SURVEY SECTION

BE EXACT PIN-POINT WHERE IT IS

| PAGE NO | PARA-GRAPH | FIGURE NO | TABLE NO |
|---------|------------|-----------|----------|
| 6 | 2-1 a | | |
| B1 | | 4-3 | |
| 125 | line 20 | | |

IN THIS SPACE TELL WHAT IS WRONG AND WHAT SHOULD BE DONE ABOUT IT:

In line 6 of paragraph 2-1a the manual states the engine has 6 cylinders. The engine on my set only has 4 cylinders. Change the manual to show 4 cylinders.

Callout 16 on figure 4-3 is pointing at a bolt. In key to figure 4-3, item 16 is called a shim - Please correct one or the other.

I ordered a gasket, item 19 on figure B-16 by NSN 2 910-00-762-3001. I got a gasket but it doesn't fit. Supply says I got what I ordered, so the NSN is wrong. Please give me a good NSN

PRINTED NAME, GRADE OR TITLE, AND TELEPHONE NUMBER

JOHN DOE, PFC (268) 317-7111

SIGN HERE

JOHN DOE

DA FORM 2028-2
1 JUL 79

PREVIOUS EDITIONS ARE OBSOLETE.

DRSTS-M Overprint 1, 1 Nov 80

PS--IF YOUR OUTFIT WANTS TO KNOW ABOUT YOUR RECOMMENDATION MAKE A CARBON COPY OF THIS AND GIVE IT TO YOUR HEADQUARTERS

TEAR ALONG PERFORATED LINE

FILL IN YOUR
UNIT'S ADDRESS

FOLD BACK

DEPARTMENT OF THE ARMY

OFFICIAL BUSINESS
PENALTY FOR PRIVATE USE \$300

POSTAGE AND FEES PAID
DEPARTMENT OF THE ARMY
DOD 314



COMMANDER
U S ARMY TROOP SUPPORT COMMAND
ATTN: AMSTR-MCTS
4300 GOODFELLOW BOULEVARD
ST. LOUIS, MO 63120-1798

TEAR ALONG PERFORATED LINE

RECOMMENDED CHANGES TO EQUIPMENT TECHNICAL PUBLICATIONS



THEN... JOT DOWN THE DOPE ABOUT IT ON THIS FORM. CAREFULLY TEAR IT OUT. FOLD IT AND DROP IT IN THE MAIL!

SOMETHING WRONG WITH THIS PUBLICATION?

FROM (PRINT YOUR UNIT'S COMPLETE ADDRESS)

DATE SENT

PUBLICATION NUMBER

TM 5-6675-318-14-2

PUBLICATION DATE

3 Sep 85

PUBLICATION TITLE

TOPOGRAPHIC SUPPORT SYSTEM
SURVEY SECTION

BE EXACT PIN-POINT WHERE IT IS

| PAGE NO | PARA-GRAPH | FIGURE NO | TABLE NO |
|---------|------------|-----------|----------|
|---------|------------|-----------|----------|

IN THIS SPACE TELL WHAT IS WRONG AND WHAT SHOULD BE DONE ABOUT IT:

TEAR ALONG PERFORATED LINE

PRINTED NAME, GRADE OR TITLE, AND TELEPHONE NUMBER

SIGN HERE

DA FORM 2028-2
1 JUL 79

PREVIOUS EDITIONS ARE OBSOLETE.
DRSTS-M Overprint 2, 1 Nov 80.

P S --IF YOUR OUTFIT WANTS TO KNOW ABOUT YOUR RECOMMENDATION MAKE A CARBON COPY OF THIS AND GIVE IT TO YOUR HEADQUARTERS.

FILL IN YOUR
UNIT'S ADDRESS

FOLD BACK

DEPARTMENT OF THE ARMY

OFFICIAL BUSINESS
PENALTY FOR PRIVATE USE \$300

POSTAGE AND FEES PAID
DEPARTMENT OF THE ARMY
DOD 314



COMMANDER
U S ARMY TROOP SUPPORT COMMAND
ATTN: AMSTR-MCTS
4300 GOODFELLOW BOULEVARD
ST. LOUIS, MO 63120-1798

TEAR ALONG PERFORATED LINE

RECOMMENDED CHANGES TO EQUIPMENT TECHNICAL PUBLICATIONS



THEN... JOT DOWN THE DOPE ABOUT IT ON THIS FORM. CAREFULLY TEAR IT OUT. FOLD IT AND DROP IT IN THE MAIL!

SOMETHING WRONG WITH THIS PUBLICATION?

FROM (PRINT YOUR UNIT'S COMPLETE ADDRESS)

DATE SENT

PUBLICATION NUMBER

TM 5-6675-318-14-2

PUBLICATION DATE

3 Sep 85

PUBLICATION TITLE

TOPOGRAPHIC SUPPORT SYSTEM
SURVEY SECTION

BE EXACT PIN-POINT WHERE IT IS

| PAGE NO | PARA-GRAPH | FIGURE NO | TABLE NO |
|---------|------------|-----------|----------|
|---------|------------|-----------|----------|

IN THIS SPACE TELL WHAT IS WRONG AND WHAT SHOULD BE DONE ABOUT IT:

TEAR ALONG PERFORATED LINE

PRINTED NAME, GRADE OR TITLE, AND TELEPHONE NUMBER

SIGN HERE

DA FORM 2028-2
1 JUL 79

PREVIOUS EDITIONS ARE OBSOLETE.
DRSTS-M Overprint 2, 1 Nov 80.

P.S.--IF YOUR OUTFIT WANTS TO KNOW ABOUT YOUR RECOMMENDATION MAKE A CARBON COPY OF THIS AND GIVE IT TO YOUR HEADQUARTERS.

FILL IN YOUR
UNIT'S ADDRESS

FOLD BACK

DEPARTMENT OF THE ARMY

OFFICIAL BUSINESS
PENALTY FOR PRIVATE USE \$300

POSTAGE AND FEES PAID
DEPARTMENT OF THE ARMY
DOD 314



TEAR ALONG PERFORATED LINE

COMMANDER
U S ARMY TROOP SUPPORT COMMAND
ATTN: AMSTR-MCTS
4300 GOODFELLOW BOULEVARD
ST. LOUIS, MO 63120-1798

FILL IN YOUR
UNIT'S ADDRESS

FOLD BACK

DEPARTMENT OF THE ARMY

OFFICIAL BUSINESS
PENALTY FOR PRIVATE USE \$300

POSTAGE AND FEES PAID
DEPARTMENT OF THE ARMY
DOD 314



COMMANDER
U S ARMY TROOP SUPPORT COMMAND
ATTN: AMSTR-MCTS
4300 GOODFELLOW BOULEVARD
ST. LOUIS, MO 63120-1798

TEAR ALONG PERFORATED LINE

The Metric System and Equivalents

Linear Measure

1 centimeter = 10 millimeters = .39 inch
 1 decimeter = 10 centimeters = 3.94 inches
 1 meter = 10 decimeters = 39.37 inches
 1 dekameter = 10 meters = 32.8 feet
 1 hectometer = 10 dekameters = 328.08 feet
 1 kilometer = 10 hectometers = 3,280.8 feet

Weights

1 centigram = 10 milligrams = .15 grain
 1 decigram = 10 centigrams = 1.54 grains
 1 gram = 10 decigrams = .035 ounce
 1 dekagram = 10 grams = .35 ounce
 1 hectogram = 10 dekagrams = 3.52 ounces
 1 kilogram = 10 hectograms = 2.2 pounds
 1 quintal = 100 kilograms = 220.46 pounds
 1 metric ton = 10 quintals = 1.1 short tons

Liquid Measure

1 centiliter = 10 milliliters = .34 fl. ounce
 1 deciliter = 10 centiliters = 3.38 fl. ounces
 1 liter = 10 deciliters = 33.81 fl. ounces
 1 dekaliter = 10 liters = 2.64 gallons
 1 hectoliter = 10 dekaliters = 26.42 gallons
 1 kiloliter = 10 hectoliters = 264.18 gallons

Square Measure

1 sq. centimeter = 100 sq. millimeters = .155 sq. inch
 1 sq. decimeter = 100 sq. centimeters = 15.5 sq. inches
 1 sq. meter (centare) = 100 sq. decimeters = 10.76 sq. feet
 1 sq. dekameter (are) = 100 sq. meters = 1,076.4 sq. feet
 1 sq. hectometer (hectare) = 100 sq. dekameters = 2.47 acres
 1 sq. kilometer = 100 sq. hectometers = .386 sq. mile

Cubic Measure

1 cu. centimeter = 1000 cu. millimeters = .06 cu. inch
 1 cu. decimeter = 1000 cu. centimeters = 61.02 cu. inches
 1 cu. meter = 1000 cu. decimeters = 35.31 cu. feet

Approximate Conversion Factors

| To change | To | Multiply by | To change | To | Multiply by |
|---------------|--------------------|-------------|--------------------|---------------|-------------|
| inches | centimeters | 2.540 | ounce-inches | newton-meters | .007062 |
| feet | meters | .305 | centimeters | inches | .394 |
| yards | meters | .914 | meters | feet | 3.280 |
| miles | kilometers | 1.609 | meters | yards | 1.094 |
| square inches | square centimeters | 6.451 | kilometers | miles | .621 |
| square feet | square meters | .093 | square centimeters | square inches | .155 |
| square yards | square meters | .836 | square meters | square feet | 10.764 |
| square miles | square kilometers | 2.590 | square meters | square yards | 1.196 |
| acres | square hectometers | .405 | square kilometers | square miles | .386 |
| cubic feet | cubic meters | .028 | square hectometers | acres | 2.471 |
| cubic yards | cubic meters | .765 | cubic meters | cubic feet | 35.315 |
| fluid ounces | milliliters | 29.573 | cubic meters | cubic yards | 1.308 |
| pints | liters | .473 | milliliters | fluid ounces | .034 |
| quarts | liters | .946 | liters | pints | 2.113 |
| gallons | liters | 3.785 | liters | quarts | 1.057 |
| ounces | grams | 28.349 | liters | gallons | .264 |
| pounds | kilograms | .454 | grams | ounces | .035 |
| short tons | metric tons | .907 | kilograms | pounds | 2.205 |
| pound-foot | newton-meters | 1.356 | metric tons | short tons | 1.102 |
| pound-inches | newton-meters | .11296 | | | |

Temperature (Exact)

°F Fahrenheit temperature 5/9 (after subtracting 32) Celsius temperature °C

