

U113  
.2  
TM  
1942

TM5-1050



WAR DEPARTMENT TECHNICAL MANUAL

*U.S. Dept. of Army*

**BATCHING PLANT  
AGGREGATE,  
3-COMPARTMENT  
105-TON**

(BLAW-KNOX MODEL P 3105)

WAR DEPARTMENT • 11 DECEMBER 1942



WAR DEPARTMENT,  
WASHINGTON 25, D. C., 11 December 1942.

TM 5-1050, Batching Plant, Aggregate, 3-Compartment, 150-Ton (Blaw-Knox Model P 3105), is published for the information and guidance of all concerned.

[AG 300.7 (11 Dec 42).]

BY ORDER OF THE SECRETARY OF WAR:

G. C. MARSHALL,  
*Chief of Staff.*

OFFICIAL:

J. A. ULIO,  
*Major General,*  
*The Adjutant General.*

DISTRIBUTION:

-----

This manual applies to machines bearing the following serial numbers:

PURCHASE ORDER-56571

- 5 Bins—BD-8381-1 to BD-8381-5 Incl.
- 5 Bins—BD-8383-1 to BD-8383-5 Incl.
- 5 Bins—BD-8385-1 to BD-8385-5 Incl.
- 5 Bins—BD-8387-1 to BD-8387-5 Incl.
- 5 Batchers—BD-8382-1 to BD-8382-5 Incl.
- 5 Batchers—BD-8384-1 to BD-8384-5 Incl.
- 5 Batchers—BD-8386-1 to BD-8386-5 Incl.
- 5 Batchers—BD-8388-1 to BD-8388-5 Incl.

PURCHASE ORDER-P1-2367

- 105 Bins—BD-8989-1 to BD-8989-105 Incl.
- 105 Batchers—BD-8990-1 to BD-8990-105 Incl.

WAR DEPARTMENT TECHNICAL MANUAL  
TM 5-1050

---

BATCHING PLANT,  
AGGREGATE,  
3-COMPARTMENT,  
105-TON

(BLAW-KNOX MODEL P 3105)



WAR DEPARTMENT • 11 DECEMBER 1942

---

*United States Government Printing Office*

*Washington : 1944*



# BRIEF INTRODUCTION

---



The Blaw-Knox Bin and Batcher is of all-steel construction with steep slopes free from ledges or other obstructions to the flow of material.

Each of the three bin compartments is equipped with a double clamshell type gate easy to operate, durable, and accurate for cutting off material. Each gate has a discharge opening of 12" x 18" and is bolted to a flange at the bottom of the bin. All interior surfaces are smooth and free from obstructions to facilitate flow of material.

The weighing hopper is of all welded steel construction with steep slopes to insure rapid and clean discharge through a discharge opening 10-1/2" x 3'7". This opening is also equipped with a double clamshell gate which does not project below the bottom of the batcher when open, thus preventing injury by truck and saving headroom. There are two accessible openings in the side of the weighing hopper for the removal of excess material (overweight).

The scales are equipped with three weighing beams, one for each of the three materials, thus to permit the independent weighing of each material according to the poise setting on the respective beams - no need to reset or tamper with poises during weighing operation. The scales are of modern and high quality design conforming in every respect to the requirements of the specifications adopted by the 27th National Conference of Weights and Measures as published in the National Bureau of Standards Handbook H-22.



U 113  
.2

TM 5:1050  
1942  
\* \*

**INDEX  
TO  
FOUNDATION  
AND  
ERECTION  
INSTRUCTIONS**

<b>FOUNDATION</b>	<b>1</b>
<b>ERECTION AGGREGATE BIN</b>	<b>2</b>
<b>ERECTION BATCHER AND SCALE</b>	<b>3</b>

M558420





FOUNDATION

---

1

FOUNDATION PAGES - 1 - 2 - 3

FOUNDATION

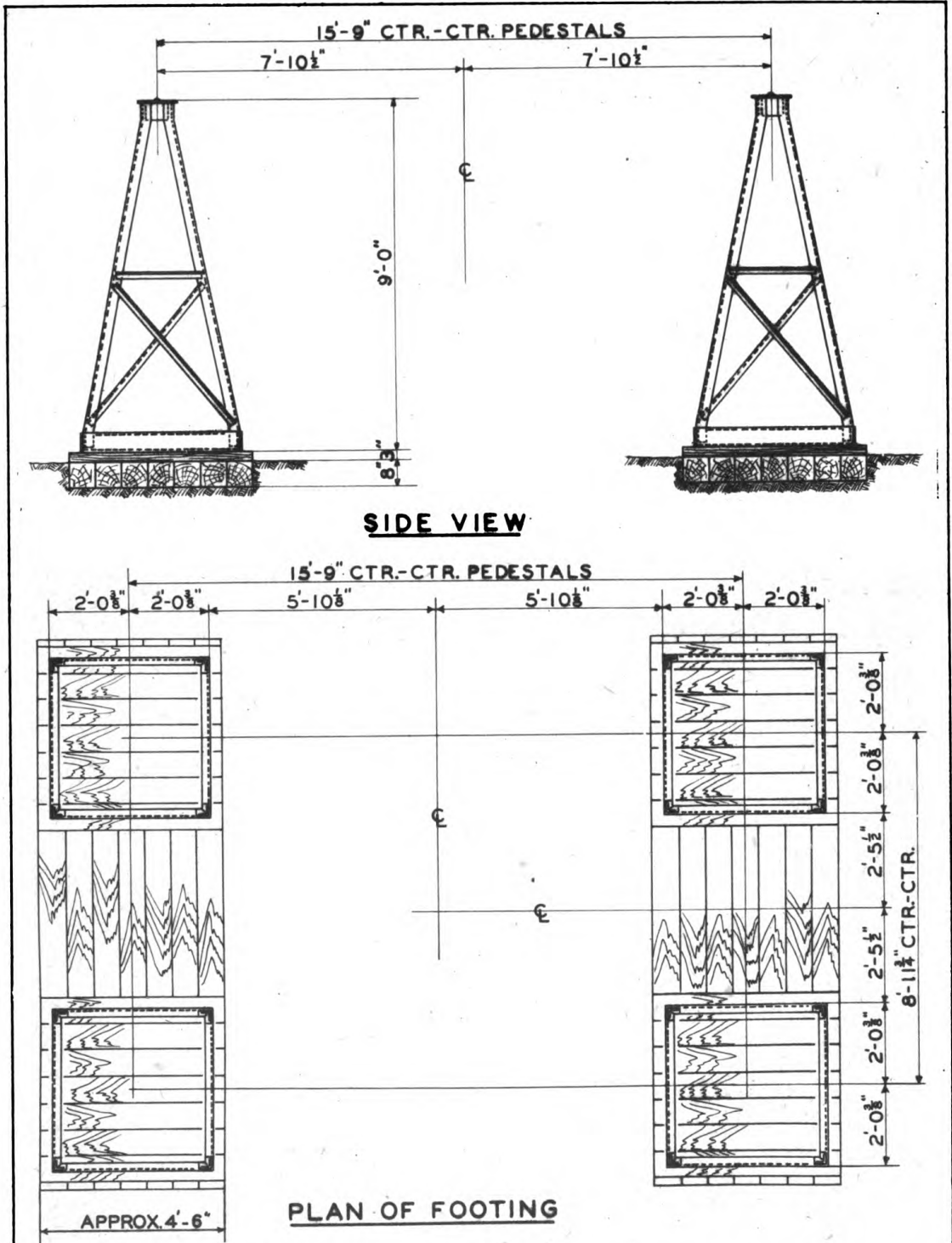

Maximum load 240,000 lb. (60,000 lb. on each of the four pedestals).

Timber supports for pedestals supplied by purchaser.



FOUNDATION

FOUNDATION (continued)

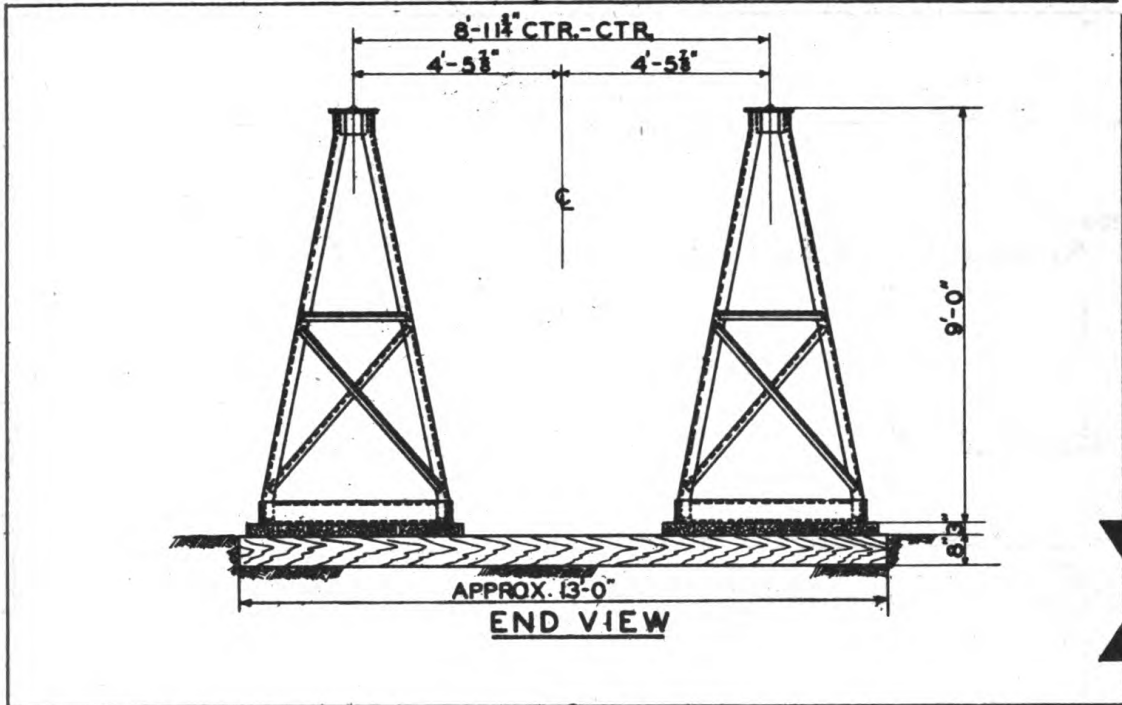

1

These illustrations show the customary method of setting the four pedestals on their timber foundations. These pedestals support the bin and batcher plant and should be secured to the timber work with eight lag screws per pedestal (a total of 32 lag screws), 5/8" diameter x 4" long.

The supporting timbers should be placed on carefully leveled, firm soil, tamped if necessary to insure absolute level of pedestals.

After a good, substantial and level foundation is prepared, then lay the timbers and set the pedestals to dimensions shown. Blaw-Knox Company does not assume any responsibility for foundations.

Timber supports and lag screws are supplied by purchaser.









**E R E C T I O N**

*AGGREGATE BIN (continued)*

2. Next, place the two partitions GR-248 between the side plates GR-249.
3. Place the partition braces, GR-259, GR-253 and GR-258 at the bottom of the side plates. Braces GR-252, GR-256 and GR-257 are then placed as shown.
4. Corner plates GR-254, GR-255, GR-260 and GR-261 are then bolted into position as shown.
5. Lift the extension by means of the four lifting lugs and place on the middle unit. Bolt the two together.
6. Check all bolted connections to ascertain that none of the assembly bolts are omitted. The bolt list is given as follows:

Bolts 5/8" dia. N.C. x 1-1/4" sq. hd. - - - - -	344
Bolts 5/8" dia. N.C. x 1-1/2" sq. hd. - - - - -	136
Bolts 5/8" dia. N.C. x 1-3/4" sq. hd. - - - - -	74
Bolts 5/8" dia. N.C. x 2" sq. hd. - - - - -	20
Bolts 5/8" dia. N.C. x 2-1/4" sq. hd. - - - - -	4
Bolts 5/8" dia. N.C. x 2-1/2" sq. hd. - - - - -	20
Bolts 5/8" dia. N.C. x 1-3/4" csk. hd. - - - - -	12
Nuts 5/8" dia. sq. - - - - -	610
Bolts 3/4" dia. N.C. x 1-1/2" sq. hd. - - - - -	8
Bolts 3/4" dia. N.C. x 1-3/4" sq. hd. - - - - -	32
Bolts 3/4" dia. N.C. x 2" sq. hd. - - - - -	20
Bolts 3/4" dia. N.C. x 2-1/2" sq. hd. - - - - -	8
Nuts 3/4" dia. sq. - - - - -	68



ERECTION

AGGREGATE BIN (end)

The illustration shown on this page suggests the type of wooden operator's platform commonly installed by the purchaser.

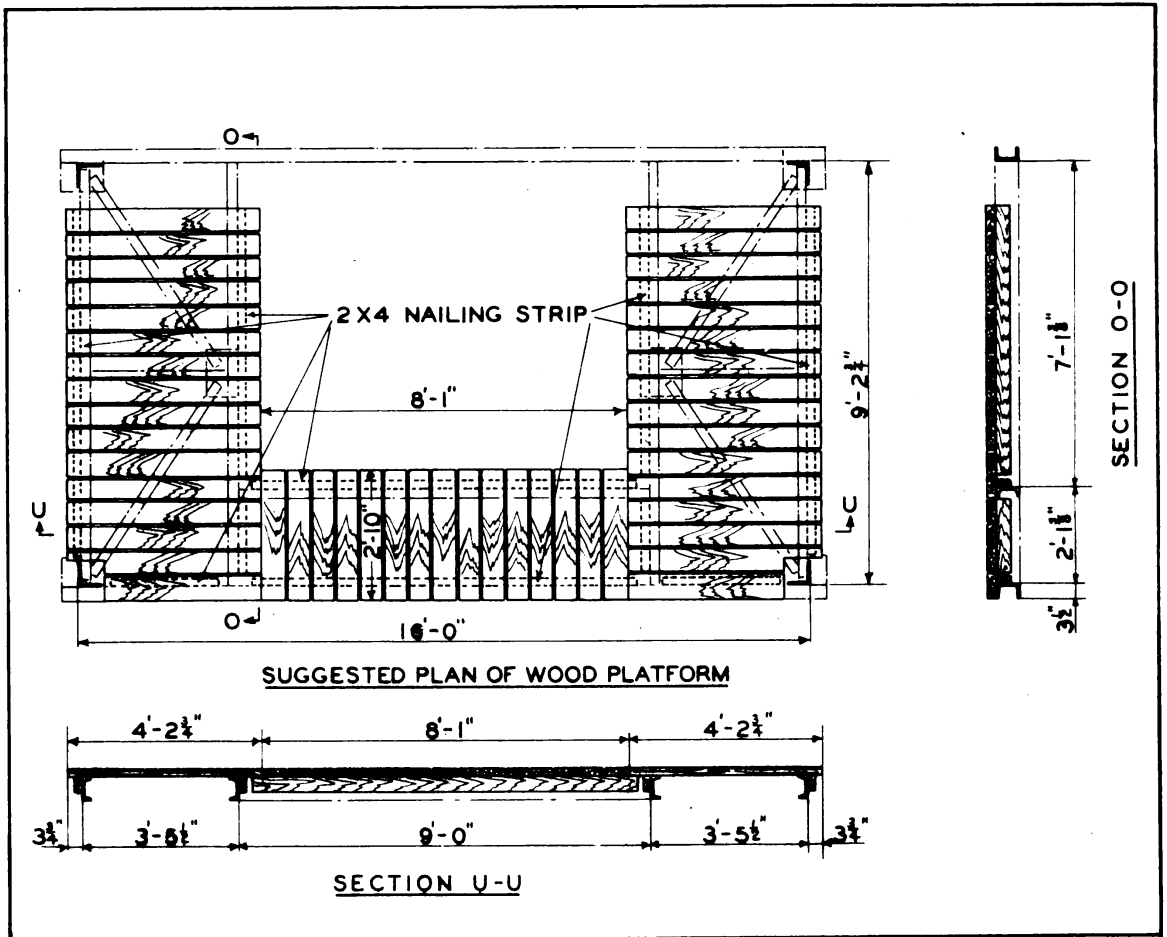

Section C-C on page one shows the structure which supports this operator's wooden platform. It is the same structure as indicated by dot-and-dash lines in this illustration.

The channels 6569, X310, X311 and 16K are punched as required for fastening the nailing strips to which the platform can be nailed.

In addition to the nailing strips the purchaser should also procure approximately 210 board feet of 2" planking for building the platform.



E R E C T I O N

B A T C H E R & S C A L E

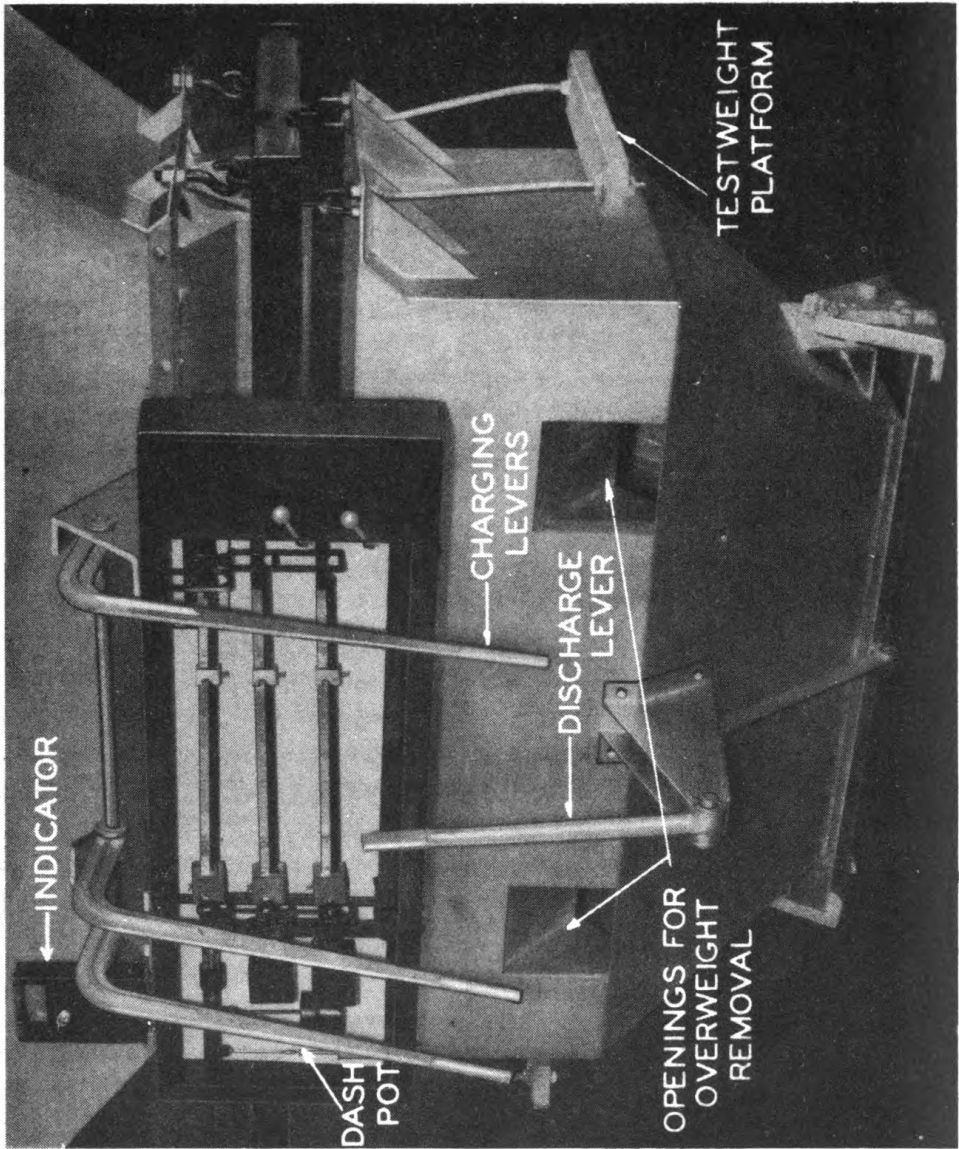

Blaw-Knox 1-1/4-cubic-yard (No. 63B) weighing batcher for three aggregates. Batcher is equipped with three beam scale and springless indicator which tells operator when he is approaching final weight and comes to zero when beam is at exact balance. Minimum graduation on weighing beams is 2 lb. Complete instructions for erection and adjustment are given on superseding pages 4 to 17 inclusive.

E R E C T I O N

---

B A T C H E R & S C A L E ( c o n t i n u e d )

---

GENERAL DESCRIPTION OF SCALES (*Refer to illustrations on  
Pages 6-7-12-13*)

The scales consist of two essential parts; the torque lever assembly 7340-W which hangs from the bin neck and supports the batcher; and the scale beam-box to which the load is transmitted from the torque levers by means of the extension lever W-36.

There are three weighing beams in the beam-box; one for each of the three different aggregates. The top beam is called the master beam and is supplied with two poises. The major poise is movable through a range of 5000-pound by 100-pound increments and the minor poise is movable through a range of 100-pound by 2-pound increments. The two lower beams are called auxiliary beams; these likewise have two weighing poises, the major poise operative through a range of 3500-pound by 100-pound increments and the minor poise operative through a range of 100-pound by 2-pound increments. The top beam is called the master beam because it must come to balance for every weighing operation regardless of which of the materials is being weighed.

The customary method of first bringing the master beam to balance is to weigh out first the particular material corresponding to the setting of the poises W-43 and W-47 on the master beam.

The next material is weighed to correspond with the setting of the poises on one of the auxiliary beams W-46 which is released for operation by means of the trig lock W-51. When an auxiliary beam is released for operation it immediately throws the master beam out of balance because the movement of either of the auxiliary beams is communicated to the master beam through the ladder W-50. When the auxiliary beam that has been released for operation comes to a balanced position, the master beam also recovers its balanced position because of the communicating ladder W-50.

The same procedure applies for either of the two auxiliary beams.

It is now evident that the master beam is a master beam in every sense of the word, because it cannot be in balance with either of the auxiliary beams out of balance,

ERECTION

BATCHER & SCALE (continued)

and no weighing operation can be completed until the master beam is in balance.

If, for some unusual reasons, it should be desired to weigh out first some material corresponding to the setting of the poises W-44 and W-48 on one of the auxiliary beams, this can be accomplished by moving the poises on the master beam to zero, thus establishing that beam in a balanced position to start with. Then, when releasing the particular auxiliary beam in this case, the master beam would be pulled out of balance and would be permitted to return to a balanced position again only by movement of the auxiliary beam which will free the communicating ladder W-50 from restraint.

There are several other prominent functions accomplished by the master beam. Near the butt end of this beam are hung counterweights W-52. These are for the purpose of balancing out the tare weight of the weighing hopper. -- The extreme butt end of the master beam is connected to the dashpot W-57, thus dampening the motion of the beam so it comes quickly to rest at balance.

The master beam is the only one which is connected directly to the scale lever system. This connection is made through the shelf lever W-37. Loads are communicated to the auxiliary beams indirectly through contact with the ladder W-50, as explained previously.

Inasmuch as the master beam must come to balance for each and every weighing operation, it is the only beam which controls the movement of the pointer in the indicator sitting on top of the scale box. The point of connection between the master beam and this indicator is the loop W-29.

3







ERECTION

BATCHER & SCALE (continued)

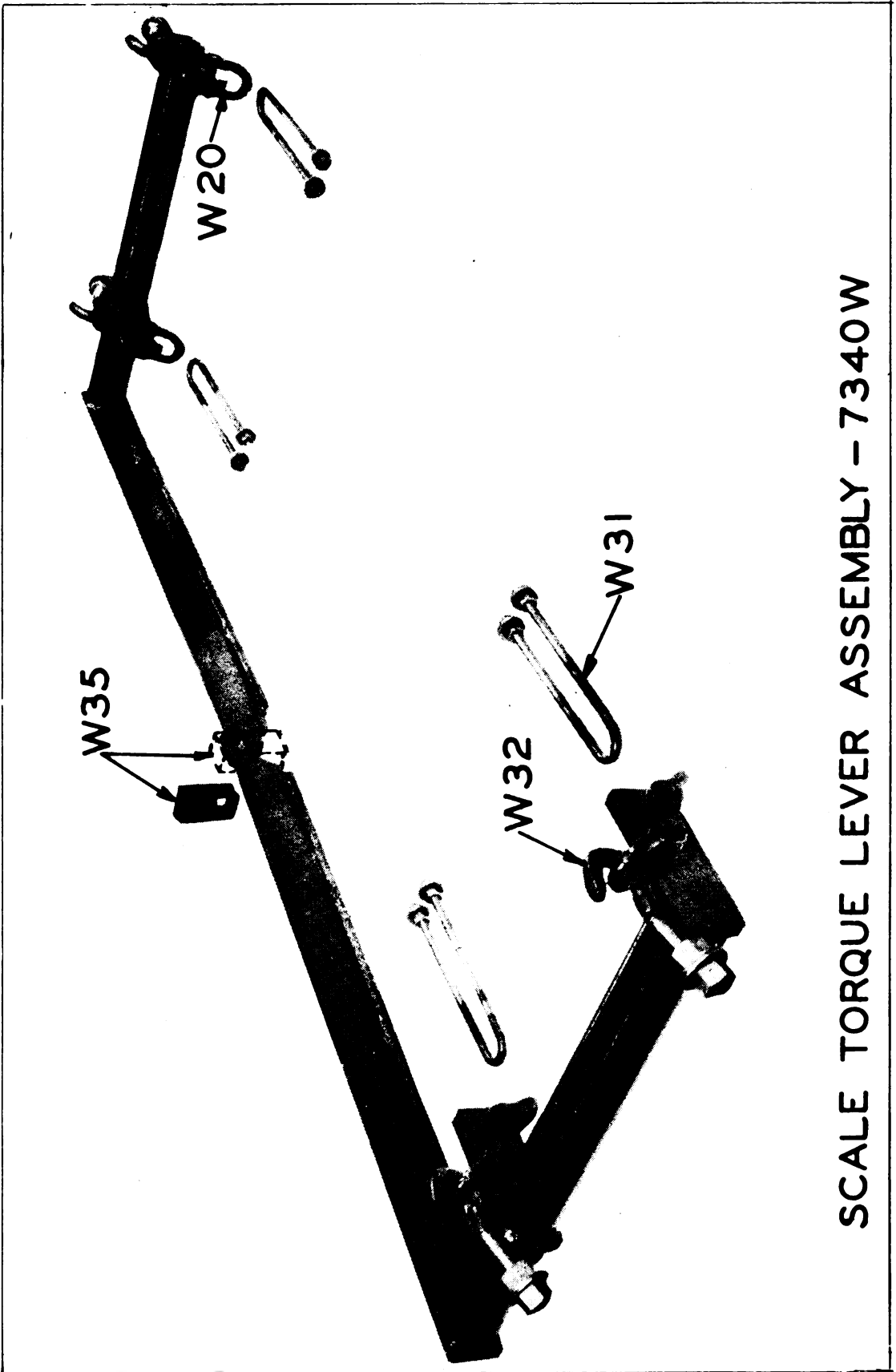

SCALE TORQUE LEVER ASSEMBLY - 7340W

ERECTION

BATCHER & SCALE (continued)

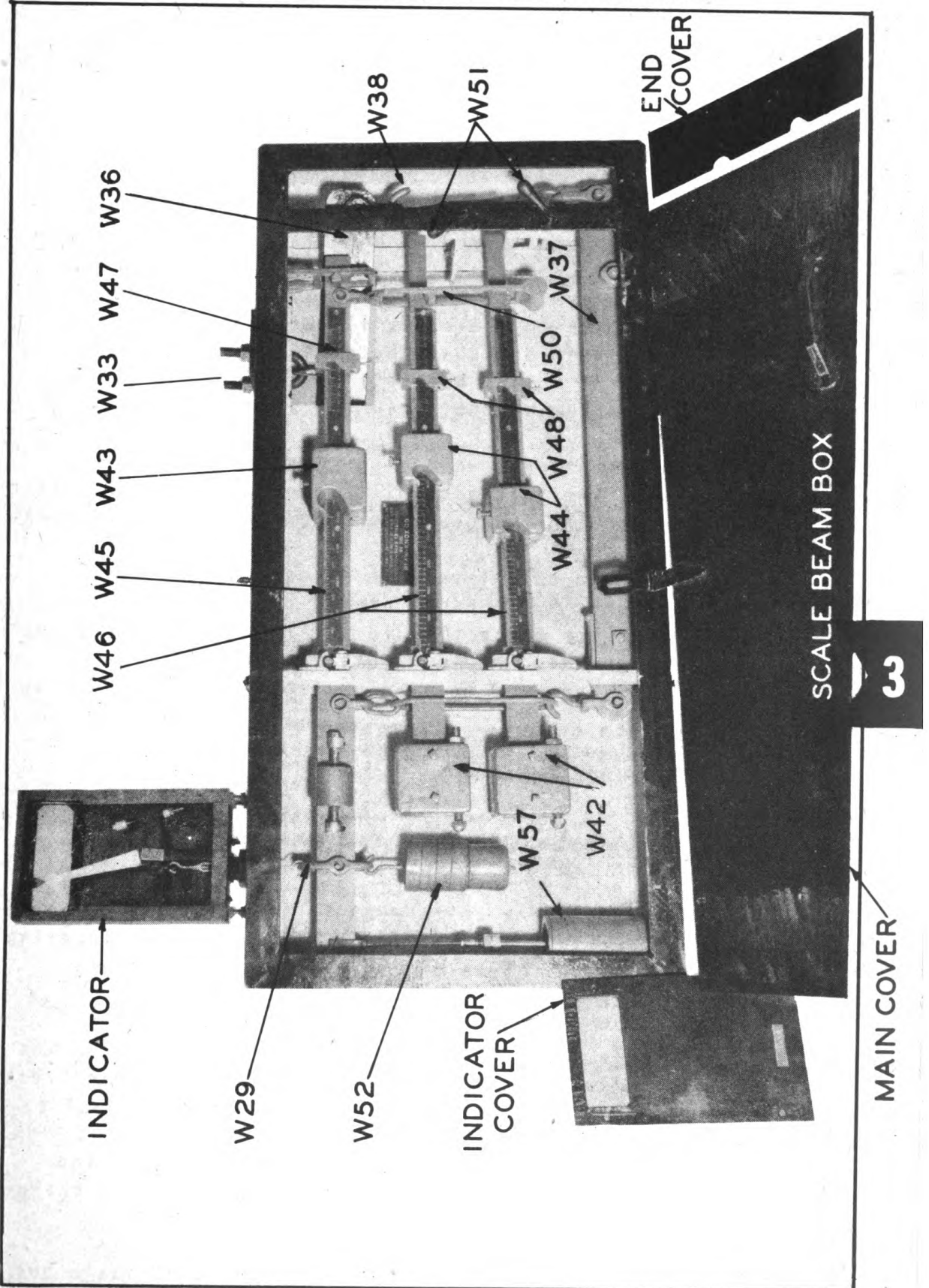

## ERECTION

### *BATCHER & SCALE (continued)*

The weighing batcher and scales are erected in three steps described as follows: *(See illustrations on Pages 4-5-6-7-11-12-13)*

#### FIRST STEP - (Gates and Levers) *(Pages 4 & 5)*

1. X-21 is the control lever assembly consisting of the three charging gate levers, the shaft on which they are mounted and the two brackets which support the shaft. These brackets are bolted to the bin, and the location of the bolt holes in the bin will serve to properly position the shaft and charging gate levers because washers adjacent to the brackets and levers are positioned from cotter pin holes in the shaft.
2. Drop a hoisting line down through one compartment at a time and lift the gate assemblies, No. GE-640, into place for bolting to the flanges at the bottom of the bin neck.
3. Connect charging gate levers to gates by means of the connecting links X-20. Each gate is provided with a shoulder bolt for connecting to this link. The gates are symmetrical so this shoulder bolt can be installed at either end as required to line up properly with the connecting link.

#### SECOND STEP - (Scales)

1. Bolt the four brackets, 859 and 860, for supporting the scale levers, to ends of bin hopper. *(Page 4)*
2. Install the four hook bolts W-32 in the brackets 859 and 860 with the nuts and washers loosely assembled, locating one nut and washer above the bracket and one nut and washer beneath the bracket. *(Pages 12 & 13)*
3. Hang the scale torque lever assembly W-4 & W-5 on the four hook bolts W-32 as shown. The knife edges which rest on the nose shackle W-35 must point downward. *(Pages 6, 12 & 13)*
4. Lift the scale beam box into place and bolt it to the same brackets which support the shaft on which the charging gate levers X-21 are mounted. *(Pages 4 & 5)*
5. Remove the narrow cover panel at right hand of scale box,



## E R E C T I O N

*B A T C H E R & S C A L E ( c o n t i n u e d )*

thus exposing and making accessible the hook rod W-38. Insert the extension lever W-36 through hole in back of box (the long end of lever arm extending into the box). Connect the extension lever to the shelf lever W-37 in the bottom of the beam box by means of the hook rod W-38. (Page 7)

6. Hang the four U-bolts W-31 from the shackles W-20 as shown. Each U-bolt is assembled with four nuts and four washers. The two lower nuts and washers must be removed before the batcher can be installed. (Pages 12 & 13)
7. Place the torque lever ends into the nose shackle W-35 with the highest knife edge supported on the upper shelf of the shackle, as shown. (Page 13)
8. For approximate setting of the torque levers, draw up the hook bolts W-32 to obtain approximately 7-1/2" between the underside of brackets 859 and 860 and the shackle knife edges, as shown. (Page 4)
9. For final adjustment of the torque levers, the 7-1/2" dimension may be varied slightly in order to perfectly level the torque levers and the extension lever. This final leveling process also involves proper adjustment of the U-bolt W-33 and the hook rod W-38 in the beam-box which support the extension lever W-36. Apply spirit level both lengthwise and crosswise of torque levers in conducting these final adjustments. (Pages 4, 5 & 7)
10. After carefully leveling the torque levers and extension lever, tighten up all check nuts to maintain the level positions established.

### THIRD STEP - (Batcher) (Pages 4 & 5)

1. Drop a hoist line through the center compartment of bin down through the center gate and lift the batcher GW-883-BA by hitching to a piece of timber placed across the opening at the bottom of the batcher on the outside of the gate in open position.
2. Lift the batcher into a position of engagement with the U-bolts. Be sure that the batcher is turned so that the operating lever GW-823 is on the side toward the scale box.

E R E C T I O N

---

B A T C H E R & S C A L E ( c o n t i n u e d )

3. Draw up the bottom nuts on the U-bolts to obtain a dimension of approximately 6-1/2" from the top of the brackets on the batcher to the top of the knife edges, as shown.
4. Be sure that the batcher is hanging evenly on all four knife edges, then tighten the top and bottom check nuts on the U-bolts to maintain the position established.
5. Bolt the bracket XW-13 with discharge lever GW-823 to the side of the batcher and connect the link X-18 to discharge gate.
6. Install the hangar bolts GW-861, as shown. These bolts are for the purpose of supporting the wooden test weight platforms. These wooden platforms, each 2" x 6" x 24" long, are supplied by the purchaser. The test weights used for final adjustment of scales are likewise supplied by the purchaser. (*For final adjustment of scales see Pages 11 to 17 inclusive*).

INDICATOR - (*See illustrations on Page 11*)

The scale indicator is mounted on top of the beam-box and directly connected to the master beam. As the correct weight is approached the pointer has a sufficient range of travel to aid the operator in knowing when to restrict the rate of flow of material into the weighing hopper and when to finally cut off the flow by closing the gate entirely.

After the scale levers and the beam-box have been adjusted and leveled, the indicator is then secured to the top of the beam-box by means of the pipe nuts D-18 screwed onto the nipple D-16 which extends through a hole in the beam-box. There are three leveling screws D-15 in the bottom of the indicator case to be used as a means for adjusting the case into a level position, after which the pipe nuts are tightened.

The indicator mechanism is attached to the master beam in the scale box by means of the indicator connecting rod D-13 and the loop W-29 pivoted near the butt end of the master beam. Be sure turnbuckle rod does not touch side of threaded pipe. Any movement of the master beam is directly transmitted to the indicator pointer.

ERECTION

BATCHER & SCALE (continued)

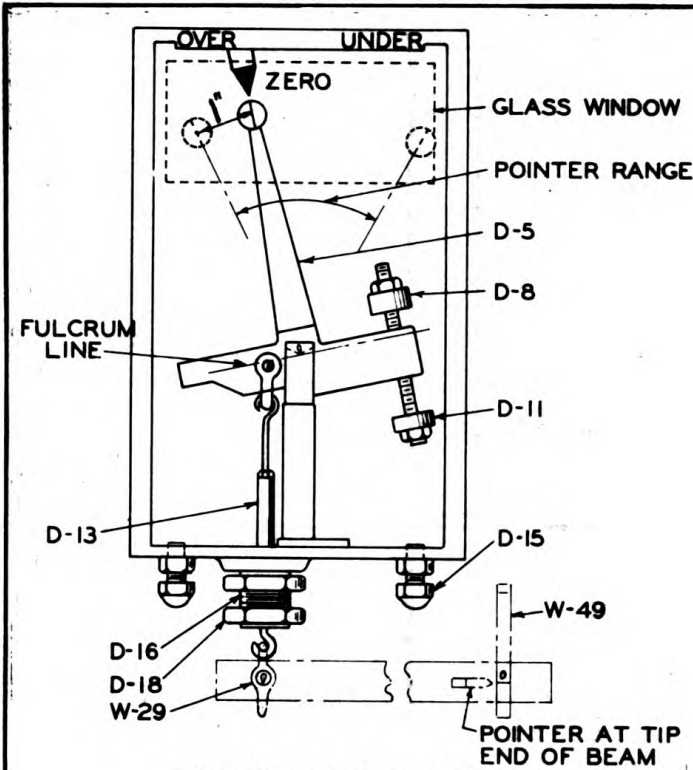

INDICATOR GQ 100  
WITH COVER REMOVED

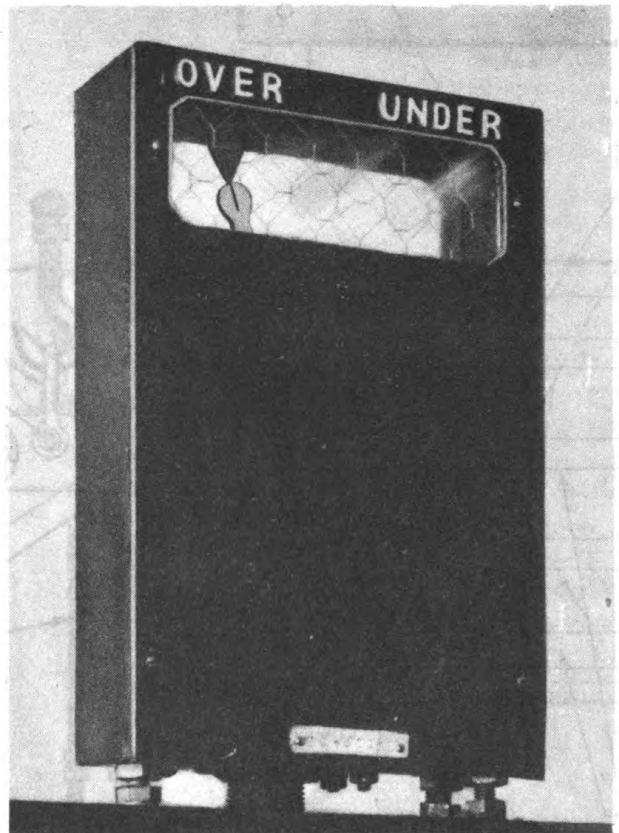





## E R E C T I O N

---

*B A T C H E R & S C A L E ( c o n t i n u e d )*

---

ADJUSTMENT OF INDICATOR - *(See illustration on pages 6-7-11-12&13)*

Lock all three beams out of play. The two auxiliary beams are thus locked by means of the trig lock W-51 and the master beam is locked in its uppermost position by an improvised wedge or block (or it can be held up). With all beams locked out of play, adjust the length of the indicator rod D-13 by means of the turnbuckle adjustment until the pointer D-5 of the indicator is at least one inch past the zero mark on the "over" side. The purpose of this adjustment is to establish the range of pointer movement centrally with the glass window in the cover of the indicator case; then tighten the check nut above the turnbuckle D-13.

Adjusting the indicator as explained above bears a specific relation to a small pointer near the tip end of the master beam. The next step, therefore, in completing the relationship between these two points of indication is to release the top or master beam and hold it by hand in a position that will cause the pointer D-5 in the indicator to read truly on zero. Then, if necessary, bend the small pointer on the tip of the master beam up or down to make it also register on the zero mark inscribed on the trig loop W-49.

## RESULTS

By following the above instructions the pointer in the indicator has a sufficient range of counterclockwise travel before reaching zero so that the operator has ample time to operate the gate and cut off the flow of material at correct weight. Over and underweight are shown on either side of the zero mark. The pointer will start to move in a counterclockwise direction toward zero at approximately 200 pounds short of final weight. This increment of approximately 200 pounds is commonly referred to as "catch". Adjustments of counterweights D-8 and D-11 in the indicator, increasing the weight below the fulcrum line, will increase the amount of "catch".

## SCALE ADJUSTMENT

The scales having been set up and leveled according to instructions, are now ready for final assembly and adjustment. The scale box when shipped has all three beams in place. The counterweights W-42 must be put on the butt ends of the



## E R E C T I O N

---

*B A T C H E R & S C A L E ( c o n t i n u e d )*

---

auxiliary beams. The counterweight W-52 must also be hung from the butt end of the master beam W-45. The dashpot, disc and connecting rod W-56 must be assembled to the butt end of the master beam and lined up without rubbing the side of the dashpot.

Continue with final adjustment in accordance with the following procedure:

1. Make sure there is no rubbing or friction in any moving scale parts.
2. Inspect the dashpot W-57 and clean thoroughly; then fill the dashpot at least three-quarters full with kerosene oil. The dampening effect produced by this dashpot results from the up-and-down movement of the piston or disc submerged in the oil. This piston consists of two perforated discs. In warm weather it is usually necessary to adjust these two discs in relation to each other so as to close or nearly close the passages, and in cooler weather it is customary to adjust these discs so the perforations in both discs will coincide with each other and thus permit a minimum resistance to piston action within the oil. In extremely hot weather it may be found necessary to add to the kerosene a small amount of SAE #10 oil, even with the two discs fully closed in order to obtain adequate dampening action. The dashpot damper W-56-A is marked with two letters: "O" for open and "C" for closed, thus to indicate the direction in which the knurled thumb screw should be turned for adjusting the dashpot piston. Make sure that the dashpot is plumb and that there is absolutely no internal friction.
3. Lock the auxiliary beams W-46 by means of the trig lock W-61 so they do not engage the ladder W-50; then set the poises W-43 and W-47 on the master beam at zero in order to allow the master beam to come to balance. If it does not come perfectly to balance, then adjust the counterweight W-52 at the butt end of the master beam. This adjustment may consist of either increasing or reducing the counterweight. Increasing the counterweight is accomplished by adding shot or some other suitable weight to the pot which forms the lower section of the counterweight. Reducing the counterweight consists of removing the top section of weight, then possibly adding a certain

## ERECTION

### *BATCHER & SCALE (continued)*

amount of shot in the pot at the bottom. The small auxiliary balance weight, W-41, is for the purpose of obtaining final accurate adjustment so that the master beam can be brought perfectly to balance with the indicator pointing to zero.

When this adjustment is properly made the indicator pointer will register an overweight travel of about one inch, when the tip of the master beam is lifted to the top of the trig loop (beam stop W-49). The underweight travel of the indicator pointer will register 3-1/2 to 4 inches from zero on the underweight side when the tip of the master beam is pushed down to the bottom of the trig loop. With this adjustment the "catch" is approximately 200 pounds.

4. Release one of the trig locks W-51, thus releasing one of the auxiliary beams. Set the poises W-44 and W-48 at zero, then adjust the counterweight W-42 at the butt of this beam so that the indicator registers at zero. Repeat the same procedure in adjusting the other auxiliary beam.

### TESTING

Lock up the two auxiliary beams W-46 by means of the trig locks W-51, leaving the master beam free for testing. Then test the master beam with the poise set for 500 pounds with 500 pounds of test weights sitting on the test weight platform. -- The indicator should point to zero.

Test the two auxiliary beams in like manner, but first run the poise on the master beam to zero. Release only one auxiliary beam at a time with its poise set at 500 pounds. The readings at the indicator should be zero.

This checking operation can be continued to the full capacity of the scales by using sand or gravel from the bin as a supplement to the 500-pound test weights. After it has been proved that the scales test accurately to the 500-pound weight, as explained above, then the weights may be removed from the test weight platform and a charge of 500 pounds of material placed in the batcher, after which the 500 pound test weights are replaced and the same procedure can be followed as explained above, except with the poises set at 1000 pounds,

## ERECTION

*B A T C H E R & S C A L E ( e n d )*

thus to permit a second use of the 500-pound test weights on the test weight platform. As in the first case, each beam is tested separately. In like manner a third use of the test weights may be permitted by loading still more material into the batcher from the bin, thus checking each of the three weighing beams to full capacity. This method of checking the scales is frequently employed when only 500 pounds of test weights are available.

### SUGGESTIONS FOR CORRECTING TROUBLES

If, in following the above instructions, the scales do not check out properly, it will then be necessary to go over each of the important steps previously explained and briefly reviewed as follows:

1. Level all horizontal scale parts and check the four shackles W-20 and W-21 to make sure that the weight of the hopper is bearing on all four shackles and knife edges.
2. Check the dashpot to make sure that there is no binding between the piston and the sides of the oil reservoir.
3. Check the knife seats in indicator; one may have turned over, thus providing a flat seat for the knife edge.
4. Check nose shackle W-35 where the torque arms meet. There may be friction at this point, or one connecting arm may be touching the other.
5. Check the jam nuts which hold weights inside of indicator, to keep them in position.
6. Check counterweights at butt end of auxiliary beams; they may have moved.
7. Check tightness of jam nut on turnbuckle between indicator and master beam.





ERECTION

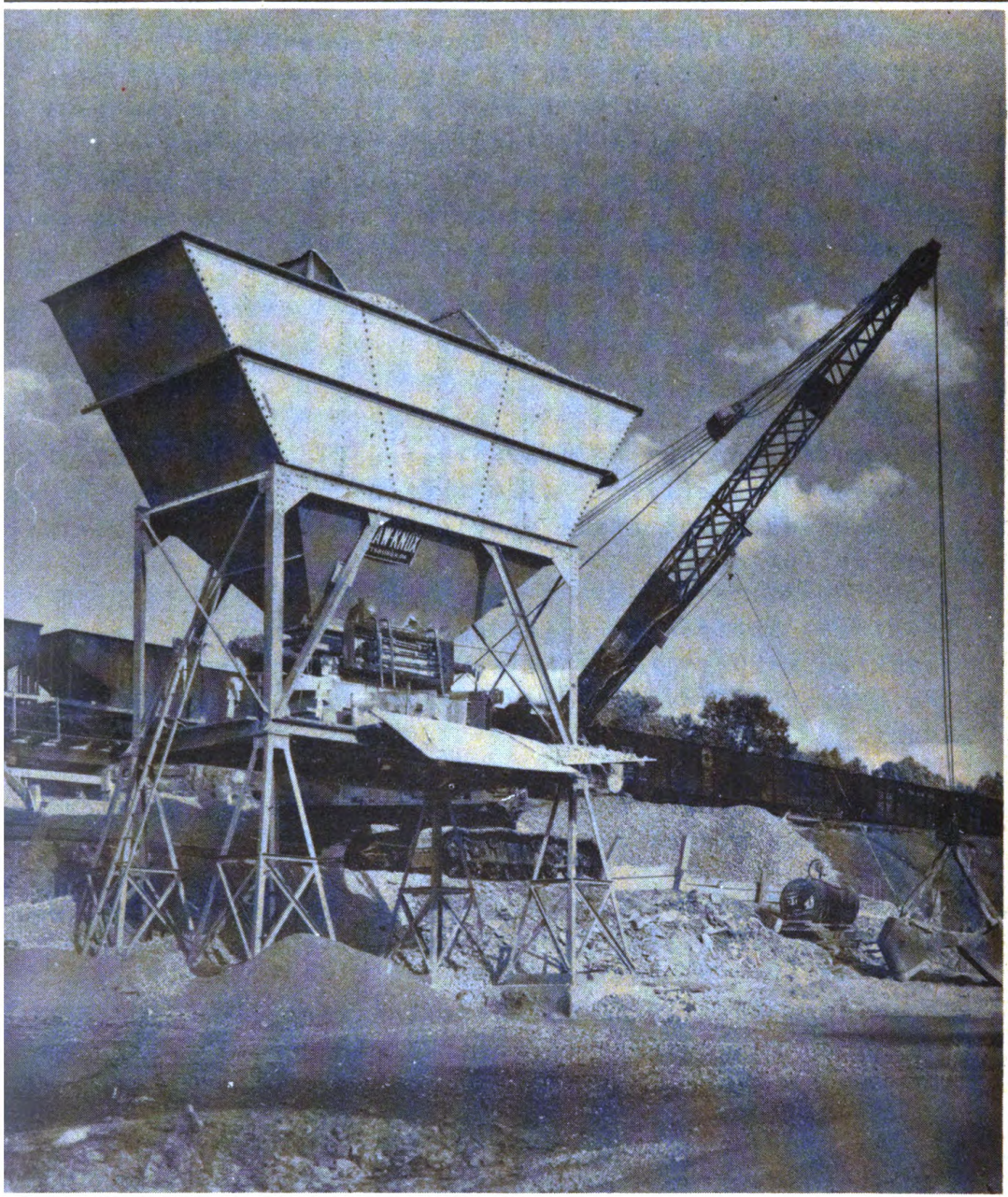

TYPICAL PLANT LAYOUT

Showing Blaw-Knox P-3105 bin and 63-B batcher for loading batch trucks. Trucks are backed in beneath bin to be loaded. Contractor took advantage of difference in elevation between aggregate delivery track and driveway level to load hopper bottom gondola cars of aggregate by gravity into track pits. Crawler crane and clamshell bucket are used for loading overhead bin with aggregates.



## E R E C T I O N



## TYPICAL PLANT LAYOUT

Showing Blaw-Knox P-3105 bin with batcher loaded by gravity from truck. Fine and coarse aggregate have previously been delivered to large stock piles and the trucks delivering to the batching plant were loaded by clamshell bucket. Note the wooden extensions built on the aggregate bin. These were not authorized by the bin manufacturer, and it is evident that the bin is being overloaded.



ERECTION

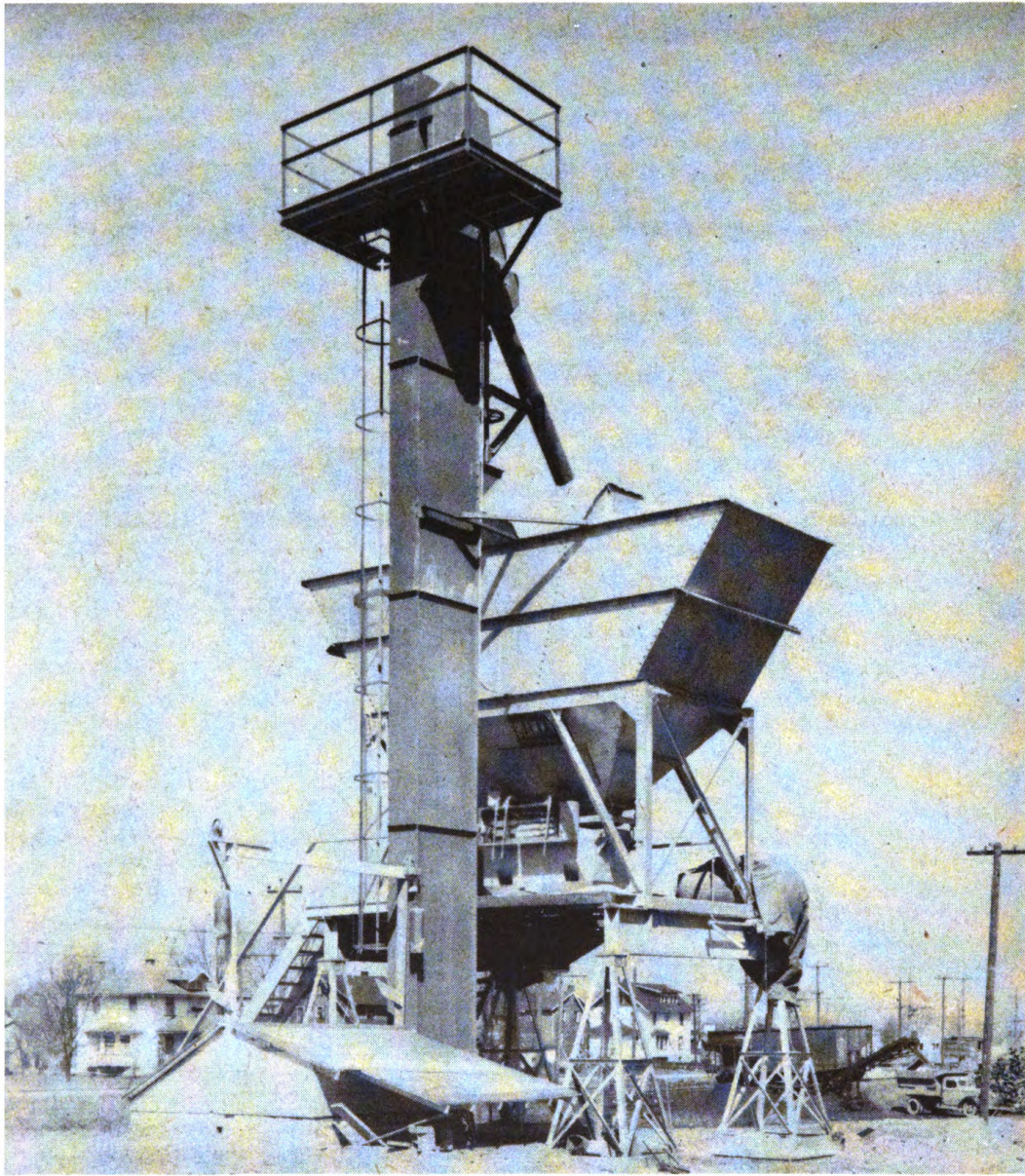

TYPICAL PLANT LAYOUT

Showing Blaw-Knox P-3105 bin being loaded with vertical bucket elevator which in turn is supplied by truck delivery of aggregates. Note that in this plant setup the trucks drive through the narrow way of the bin instead of backing in beneath the bin. To obtain necessary lateral clearance between pedestals, the latter are spread and the upper portion of the bin is supported on 24" I-beams. Beneath the weighing batcher there is a fixed confining hopper for loading the trucks.



**INDEX**  
**TO**  
**OPERATOR'S**  
**INSTRUCTIONS**

<b>GENERAL</b>	<b>1</b>
<b>BATCHER AND SCALES</b>	<b>2</b>





## OPERATORS INSTRUCTIONS

---

*GENERAL (continued)*

---

## LOCATION OF BATCHING PLANT

No specific rules can be laid down as a guide for locating the site for the erection of the batching plant. -- The procurement of aggregates may depend upon railroad shipment, or barge shipment, or, as in many cases, local deposits of sand and gravel may be utilized. Consequently, the source of supply and means of delivery represent extremely variable factors which have a certain bearing upon choosing a plant site.

The thing of principal importance in choosing a plant site is to avoid too long a haul of the aggregates from the batching plant to the paving mixer. A haul of from one to five miles represents common practice, and in extreme cases hauls of as much as thirty miles have been made. In one such case a fleet of 85 trucks was required to service a 27-E dual paver on a 30-mile haul.

The normal operating cycle for a size 34-E dual paver is 45 to 50 seconds per batch, and for a single drum 34-E paver the normal cycle ranges from 1 to 1-3/4 minutes per batch. The batcher plant operator should experience no difficulty whatsoever in weighing out the aggregates at the rate required for the minimum mixer cycle.

In determining the number of batch trucks that should be required to service a given job, consideration must be given not only to the mixer cycle but also to the length of haul between the batching plant and the mixer.

## LOADING THE BIN

When loading the bin for the first time it should be loaded by gradually filling all three compartments so they will be brought up to full capacity simultaneously, thus avoiding abnormal and eccentric loading stresses within the bin structure.

The three compartments of the bin are intended for sand and two grades of stone (or gravel). Under certain conditions it is sometimes found expedient to use but one grade of stone (or gravel). Under such conditions the stone should be loaded into two of the bin compartments and sand into the other one, thus to maintain a uniform loaded condition of the bin.

## OPERATORS INSTRUCTIONS

### GENERAL (continued)

The recommended procedure is to load sand into one of the end compartments. Either of the two end compartments may be used, depending upon which is the nearest to the most convenient location of the sand storage pile.

The weighing batcher has one large compartment for the stone (or gravel) and one small compartment for the sand. These two compartments are separated by a partition that can be moved either toward one end or the other so that the smaller compartment in the weighing batcher will coincide with the sand compartment in the bin.

### STORING AND MOVING BATCHING PLANT

1. When the batching plant is not to be used for a considerable period of time, it should be emptied of material, cleaned and painted where necessary to prevent rusting.

860 N.S.  
859 F.S.

HANGER  
BOLT GW 861

2. The three charging gates at the bottom of the bin, also the discharge gate at the bottom of the batcher should be blocked open so rain water will not lie in them.
3. The scale knife edges should be relieved of the batcher weight. This is accomplished by using the four hanger bolts GW-861, (normally used for supporting the test weight platforms), in the manner shown by the accompanying illustration. The four brackets on the bin, Nos. 859 and 860, each have two holes, one for the hook bolt which supports the scale lever system and the other through which this hanger bolt can be inserted. By means of these four hanger bolts thus installed, the weight of the batcher should be lifted from bearing on the scale knife edges.

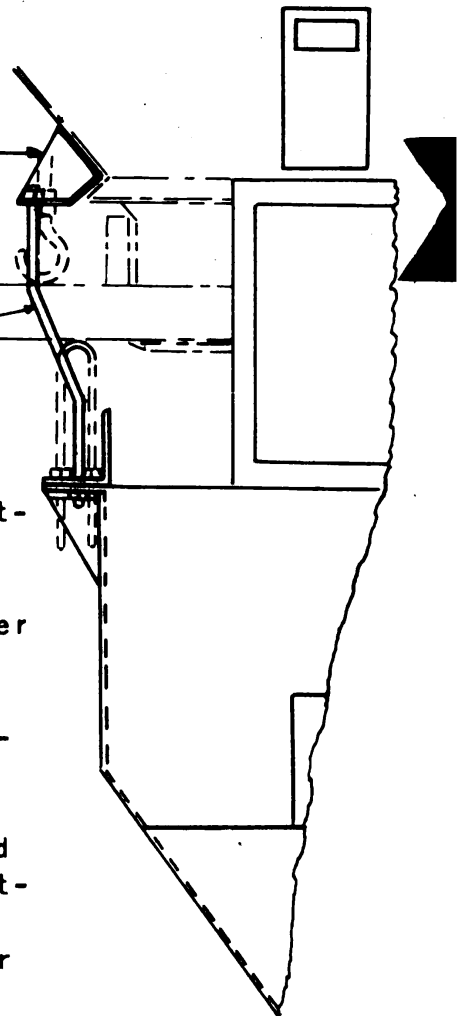

---

**OPERATORS INSTRUCTIONS**

---

*GENERAL (end)*

4. All knife edges should be carefully sealed with grease to prevent rusting. The three graduated beams in the scale box should also be greased and all threaded adjustments should be greased.
5. If the batching plant is to be moved from one locality to another, it is the customary practice to leave the scales and batcher assembled with the middle unit. It is imperative, however, that the weight of the batcher be supported by the hanger bolts, as explained above, and it is equally important that all knife edges be protected by inserting a small piece of oil-soaked felt or leather between the knife edges and their seats, thus to avoid damage in transit.
6. All bolts and nuts that are removed when dismantling should be soaked in oil to prevent rusting.

**RESUMING OPERATION OF BATCHER PLANT AFTER IT HAS BEEN OUT OF SERVICE A CONSIDERABLE PERIOD OF TIME OR AFTER IT HAS BEEN MOVED TO A NEW LOCATION**

1. Grease the gear segments on the three charging gates at the bottom of the bin and the discharge gate at the bottom of the batcher. Use SAE #50 oil to lubricate the bearings of these gates; also use SAE #50 oil to lubricate the pins connecting the operating levers.
2. Disconnect the four hanger bolts GW-861 and return them to their normal position for supporting the test weight platforms.
3. Remove all grease from knife edges and shackles and clean with kerosene; also remove the grease from threaded adjustments.
4. Remove old oil from dashpot in scales and replace with new, clean kerosene oil.
5. If leather or felt has been inserted between the knife edges and their seats, be sure that such obstructions are all removed.



# OPERATORS INSTRUCTIONS

---

## BATCHER & SCALES

### WEIGHING THREE MATERIALS

The most usual practice in making concrete is to use sand and two grades of stone (or gravel). This explains the provision of three bin compartments and three weighing beams in the scale beam-box.

The operator sets the poises W-43 and W-47 on the master beam W-45 for the required amount of sand; then the poises W-44 and W-48 on the two auxiliary beams W-46 are set to the required amount of each of the two different kinds of stone (or gravel). -- With these poise settings established for the respective materials weighing operations may continue without interruption or movement of poises until a change in the proportion of the batch may be required.

During the weighing of each material, as soon as the pointer in the indicator begins to move the operator should be on the alert and gradually reduce the flow of material into the batcher so that the filling gate may be quickly closed the instant the pointer registers zero. -- If an objectionable overweight should occur, it may be removed from the side pockets or openings provided in the batcher for that purpose.

After the sand has been weighed, then the two different grades of stone (or gravel) are successively weighed on the two auxiliary beams W-46. The first auxiliary beam is released for operation by means of the trig lock W-51 (the other auxiliary beam remaining locked). After this weighing operation is completed, the second auxiliary beam is likewise released for operation, thus making all three of the beams free to co-operate in obtaining the final, total weight of the complete batch, as a result of weighing the second grade of stone (or gravel).

From the above explanation it will be evident that the first step is to permit the master beam to work alone; the second step is to permit the master beam and the first auxiliary beam to work in conjunction with each other, and the third step is to permit the master beam and both auxiliary beams to work in conjunction with one another, thus building up the total weight by increments corresponding to the setting of poises on the various beams.

---

**OPERATORS INSTRUCTIONS**

---

*BATCHER & SCALES (continued)*

After the complete batch is weighed and dumped from the batcher, then the two auxiliary beams are again locked out of play and another weighing cycle started.

**WEIGHING TWO  
MATERIALS ONLY**

It is occasionally expedient to make concrete by using sand and only one grade of stone (or gravel). This is accomplished in one of two different ways, depending upon the quantity of the materials involved.

1. If the amount of stone (or gravel) does not exceed the capacity of the master beam, then the poises on the master beam should be set to the required amount and, of course, this would require weighing the stone (or gravel) first. -- Then with one of the auxiliary beams locked continuously out of operation, the remaining auxiliary beam could be used for weighing the required amount of sand; thus the entire batching operation would be accomplished with the use of only two of the weighing beams-- the master beam and one auxiliary beam.
2. If the amount of stone (or gravel) exceeds the capacity of the master beam, then the master beam poises should be set for weighing the sand which, under these conditions, should be weighed first. If this condition prevails, it is a foregone conclusion that one of the auxiliary beams would not be adequate for weighing all the stone. It becomes necessary, therefore, to use both auxiliary beams at the same time, allowing them to operate as one beam. This is accomplished by adding the value of the poise settings on both of the auxiliary beams so that their total value will correspond to the required amount of stone. When operating in this manner, the two auxiliary beams must be released for operation simultaneously. (Although this method of operation is perfectly acceptable, it is not often found necessary.)

---

*(Continued on next page)*

OPERATORS INSTRUCTIONS

BATCHER & SCALES (continued)

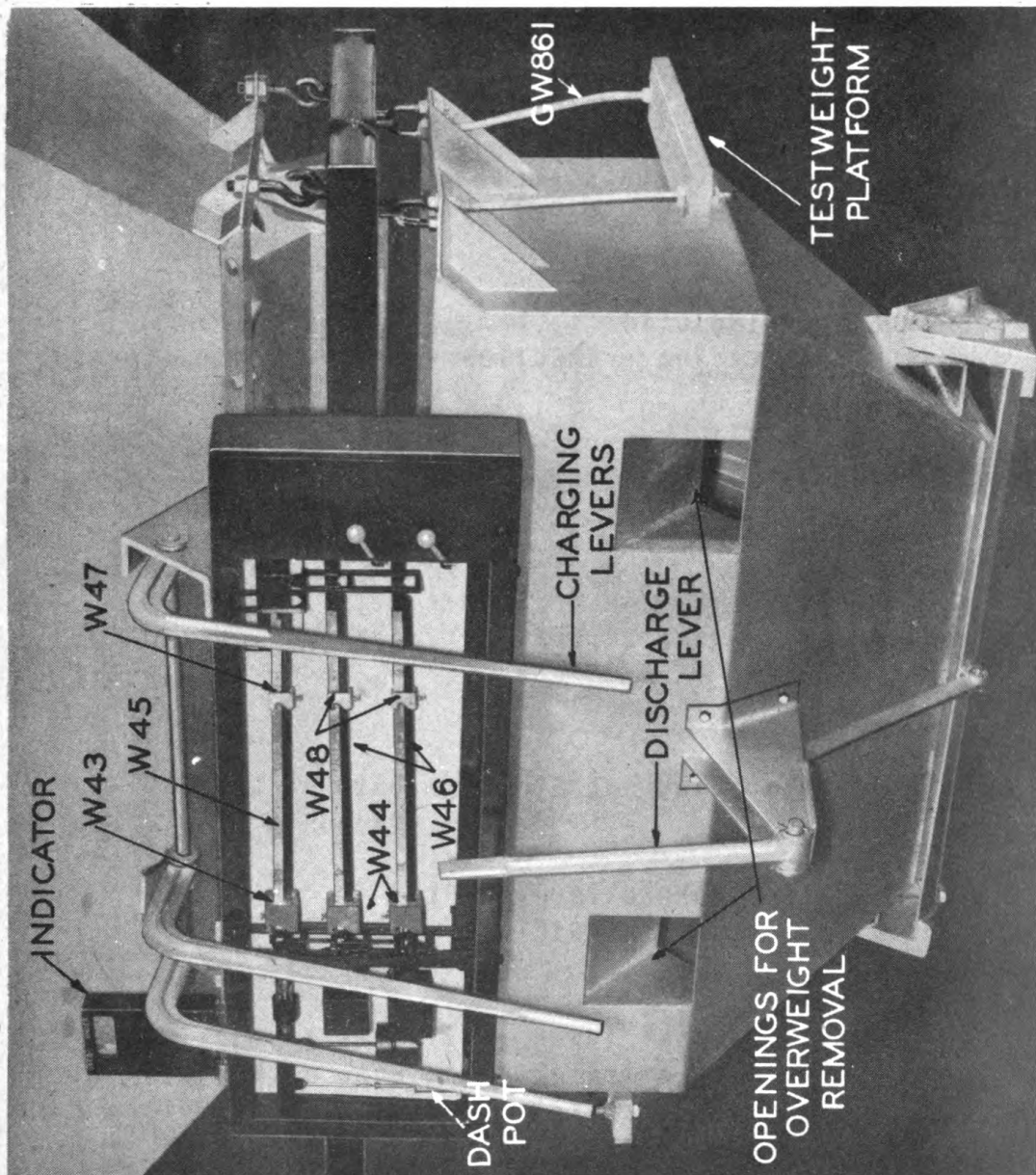

**O P E R A T O R S   I N S T R U C T I O N S**

---

*B A T C H E R   &   S C A L E   ( e n d )*

**SPECIAL INSTRUCTIONS TO  
OPERATOR CONCERNING SCALE  
ADJUSTMENT, TESTING AND METHOD  
OF CORRECTING TROUBLES**

It is imperative that a successful operator be thoroughly familiar with these subjects which are fully explained in complete detail elsewhere in this book, as follows:

**GENERAL DESCRIPTION OF SCALES**

Under the heading - ERECTION - Batcher & Scale - 3  
Pages 2 and 3

**ADJUSTMENT OF INDICATOR**

Under the heading - ERECTION - Batcher & Scale - 3  
Page 14

**RESULTS**

Under the heading - ERECTION - Batcher & Scale - 3  
Page 14

**SCALE ADJUSTMENT**

Under the heading - ERECTION - Batcher & Scale - 3  
Pages 14, 15 and 16

**TESTING**

Under the heading - ERECTION - Batcher & Scale - 3  
Pages 16 and 17

**SUGGESTIONS FOR CORRECTING TROUBLES**

Under the heading - ERECTION - Batcher & Scale - 3  
Page 17

It is important that these references be considered a part of the operator's training, because a thorough familiarity with the scales is required by the successful operator in order that he may be able to make occasional simple adjustments to keep the scales in proper working order as required to obtain consistently correct batch weight.

**INDEX**  
**TO**  
**MAINTENANCE**  
**INSTRUCTIONS**

<b>BIN AND BATCHER</b>	<b>1</b>
<b>SCALE AND INDICATOR</b>	<b>2</b>





# MAINTENANCE INSTRUCTIONS

---

## AGGREGATE BIN & BATCHER

The aggregate bin is of all steel construction except for the operator's wooden platform. A structure of this kind does not require much maintenance. -- Of first importance - if any of the angle braces get bent during the course of erection, or when in service as might be caused by a careless truck driver, such braces should be immediately straightened.

Occasional inspection should be made to determine when the bin or portions thereof should be painted to prevent rusting.

The assembly bolts should be kept tight, however there is little likelihood of their becoming loose if properly tightened when the bin is erected.

## LUBRICATION

The gear segments on the three charging gates at the bottom of the bin, also the gear segments on the charging gate at the bottom of the batcher should be greased occasionally.

Use SAE #50 oil to lubricate pin connections for the charging levers and the discharge lever.



---

**M A I N T E N A N C E   I N S T R U C T I O N S**

---

**S C A L E   &   I N D I C A T O R****SCALE**

Maintenance of the scale mechanism requires principally that all vital parts be kept cleaned and that all check nuts be kept securely tight so that the scale adjustment does not get out of order.

Under conditions of extreme temperature changes it may be necessary to change the consistency of the oil in the dashpot, or to adjust the piston that operates in the dashpot so as to vary the resistance as it moves up and down in the bath of oil. These particular subjects are fully covered elsewhere in this book and specific references will be given in this section.

Obstructions should not be permitted to accumulate and lie in the bottom of the scale beam-box because they might get beneath the shelf lever and seriously interfere with scale operations.

All knife edges and shackles should be kept clean and properly centered to prevent binding in the scale. -- After a long period of use if the scale should become sluggish due to dull knife edges, then the knife edges either should be replaced or field repairs can be made by removing the knife edges and honing them.

**INDICATOR**

The indicator mounted on top of the scale beam-box should be kept level at all times and the glass window cleaned so pointer and zero mark will be visible to operator. The jam nuts which retain the setting of the turnbuckle and of the counterweight should be kept tight; otherwise, the scale adjustment will become affected.

**LUBRICATION**

No lubrication is required inside the indicator housing.

A few drops of machine oil should be applied occasionally to the poise release pin, and a few drops of the same kind of oil should also be applied occasionally to the trig locks. -- Keep clean oil in the dashpot. -- Apply a small amount of machine oil occasionally to the

MAINTENANCE INSTRUCTIONS

SCALE & INDICATOR (continued)

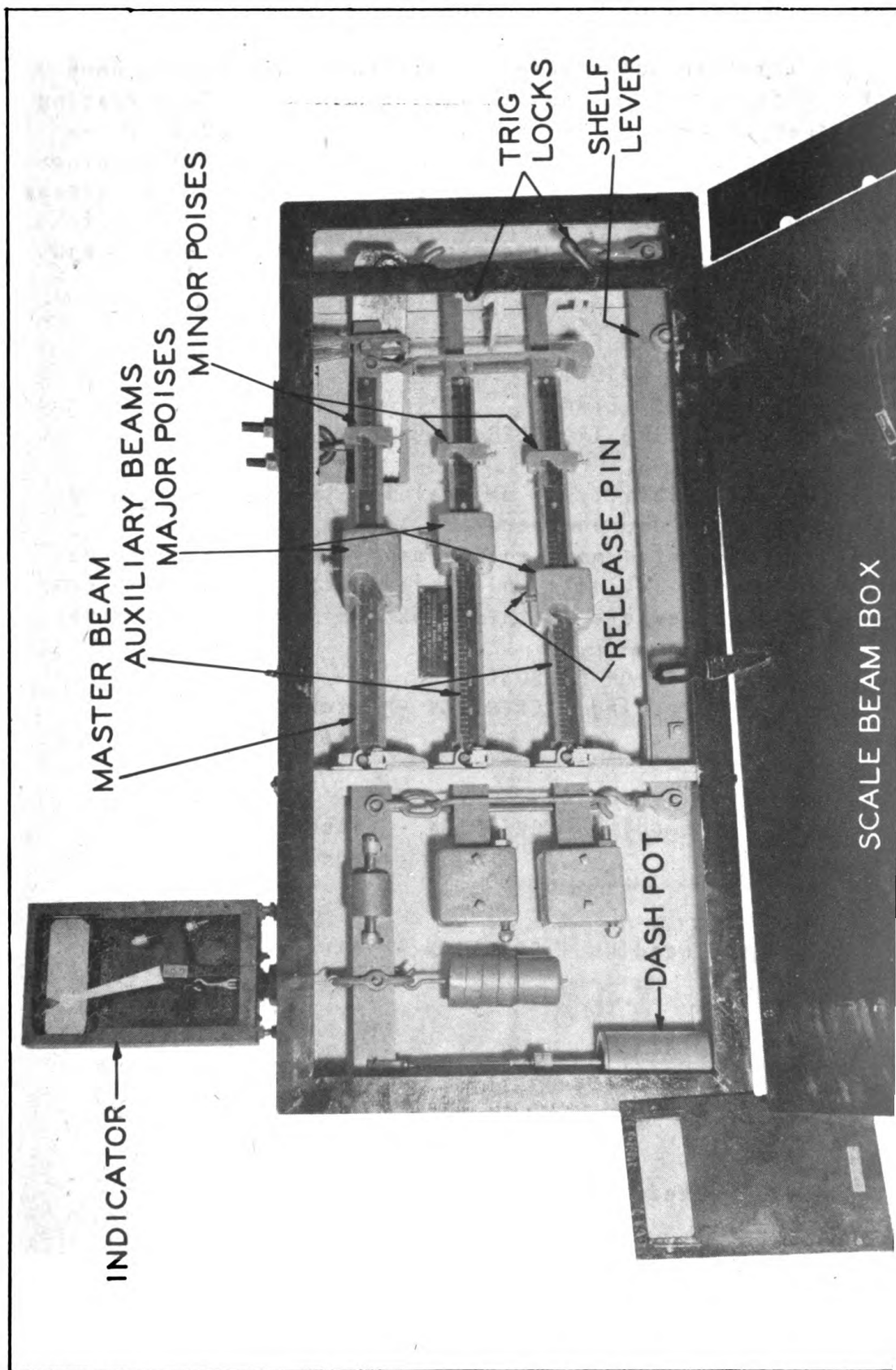

INDICATOR

MASTER BEAM

AUXILIARY BEAMS

MAJOR POISES

MINOR POISES

TRIG LOCKS

SHELF LEVER

RELEASE PIN

DASH POT

SCALE BEAM BOX

**M A I N T E N A N C E   I N S T R U C T I O N S***S C A L E   &   I N D I C A T O R   ( e n d )*

various threaded adjustable connections, such as the hook bolts, U-bolts, etc., thus to keep the threads from rusting so that adjustment can be readily made when necessary. -- Wipe the graduated faces of the reading beams with machine oil occasionally to prevent rusting. -- Do not oil or grease around any knife edges or shackles on the scales, thus to avoid an accumulation of sediment or dust which would tend to make the scales sluggish.

**SPECIAL INSTRUCTIONS FOR  
MAINTAINING SCALE ADJUST-  
MENT, TESTING OF SCALE, AND  
METHOD OF CORRECTING TROUBLES**

The responsibility of maintaining the scales in good operating condition, whether left to the operator or a specially designated maintenance man, requires a thorough familiarity with subjects which are fully explained in complete detail elsewhere in this book and listed as follows:

**GENERAL DESCRIPTION OF SCALES**

Under the heading - ERECTION - Batcher & Scale - 3  
Pages 2 and 3

**ADJUSTMENT OF INDICATOR**

Under the heading - ERECTION - Batcher & Scale - 3  
Page 14

**RESULTS**

Under the heading - ERECTION - Batcher & Scale - 3  
Page 14

**SCALE ADJUSTMENT**

Under the heading - ERECTION - Batcher & Scale - 3  
Pages 14, 15 and 16

**TESTING**

Under the heading - ERECTION - Batcher & Scale - 3  
Pages 16 and 17

**SUGGESTIONS FOR CORRECTING TROUBLES**

Under the heading - ERECTION - Batcher & Scale - 3  
Page 17

**INDEX  
TO  
PARTS  
LIST**

<b>AGGREGATE BIN</b>	<b>1</b>
<b>AGGREGATE BATCHER</b>	<b>2</b>
<b>SCALES</b>	<b>3</b>
<b>INDICATOR</b>	<b>4</b>
<b>NUMERICAL INDEX</b>	<b>5</b>



PARTS LIST

---

AGGREGATE BIN SECTION



AGGREGATE BIN - - - - - PAGE 1 - 2 - 3 - 4



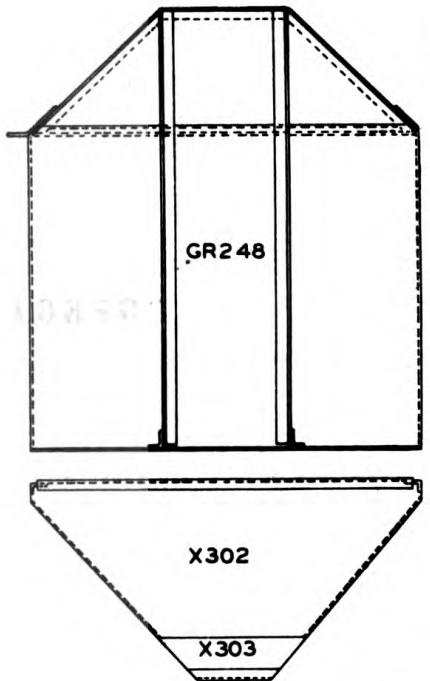
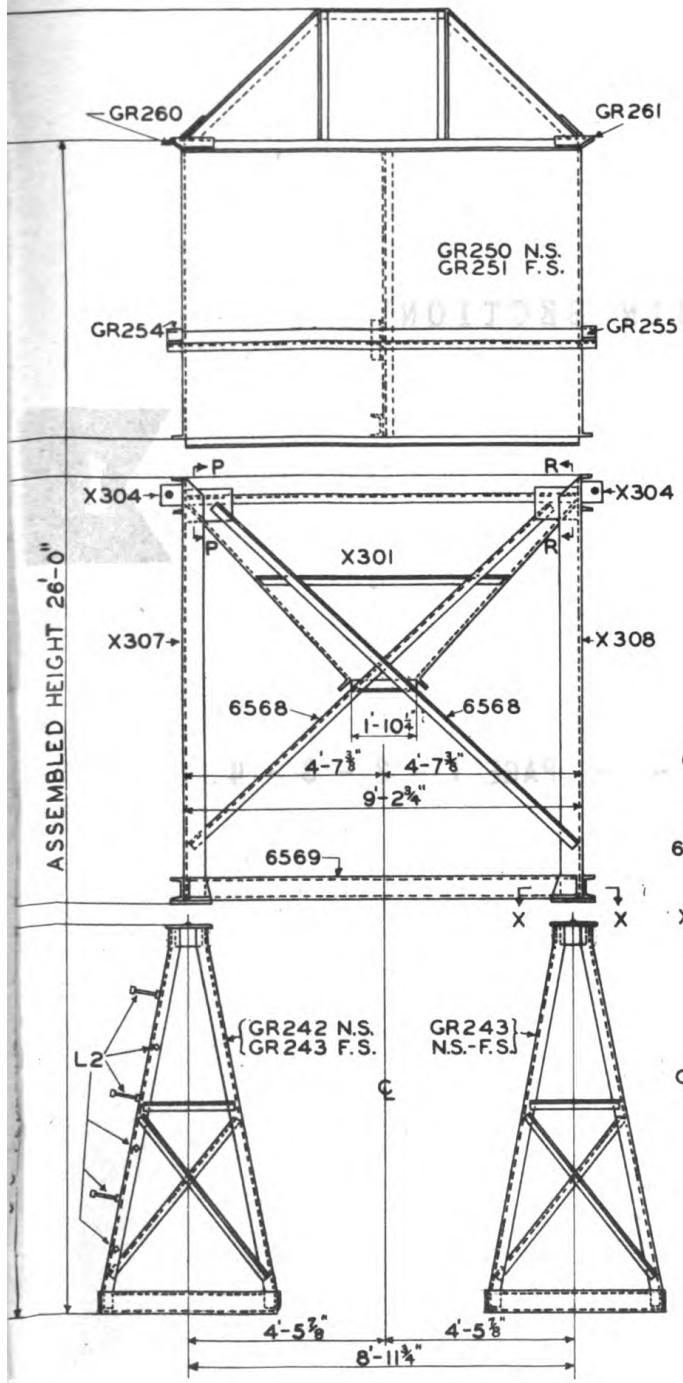

SECTION D-D DEVELOPED

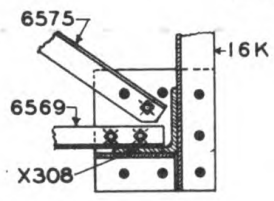

SECTION X-X



SECTION I-I



SECTION K-K



SECTION P-P AS SHOWN  
SECTION R-R OPP. HAND

END VIEW

PARTS LIST

B I N

B.K. PART NO.	DESCRIPTION	NO. USED
GR-242	Pedestal - - - - -	1
GR-243	Pedestal - - - - -	3
GR-248	Bulkheads - - - - -	2
GR-249	Plates - - - - -	2
GR-250	Plates - - - - -	1
GR-251	Plates - - - - -	1
GR-252	Channel - - - - -	1
GR-253	Channel - - - - -	1
GR-254	Plate - Tie - - - - -	2
GR-255	Plate - Tie - - - - -	2
GR-256	Channel - - - - -	1
GR-257	Channel - - - - -	1
GR-258	Channel - - - - -	1
GR-259	Channel - - - - -	1
GR-260	Plate - - - - -	2
GR-261	Plate - - - - -	2
X-301	Hopper - - - - -	1
X-302	Bulkhead - - - - -	2
X-303	Bulkhead - - - - -	2
X-304	Lifting Lug - - - - -	4
X-305	Strut - - - - -	2
X-306	Brace - - - - -	4
X-307	Post - - - - -	2
X-308	Post - - - - -	2
X-309	Strut - - - - -	2
X-310	Strut - - - - -	2
X-311	Strut - - - - -	1





PARTS LIST

BATCHER

B.K. PART NO.	DESCRIPTION	NO. USED
B-10	Gate - Body - - - - -	3
	Bolts 5/8"φ N.C. x 1-1/2" Sq.Hd. & Sq.Nut-	32
	Bolts 5/8"φ N.C. x 2" Sq.Hd. & Sq.Nut- - -	4
B-11	Hangers - Gate- - - - -	6
B-12	Hangers - Gate- - - - -	6
B-13	Bottom - Gate - - - - -	6
	Tap Bolts 3/4"φ N.C. x 1-1/4"- - - - -	12
	Tap Bolts 3/4"φ N.C. x 2-1/4"- - - - -	9
	Lock Washers 3/4"φ - - - - -	21
B-14	Bolts - Shoulder- - - - -	3
	Lock Washers - 3/4"φ - - - - -	3
B-15	Bracket - R.H.- - - - -	1
	Bolts 5/8"φ N.C. x 1-1/4" Sq.Hd. & Sq.Nut-	7
B-16	Bracket - L.H.- - - - -	1
	Bolts 5/8"φ N.C. x 1-1/4" Sq.Hd. & Sq.Nut-	7
B-17	Shaft - - - - -	1
	Washers 2-1/2"φ x 1-5/16" x 1/8" - - - - -	8
	Cotters 3/16"φ x 2"- - - - -	8
B-18	Lever - - - - -	2
	Washer 1-3/4" x 11/16"φ x 1/8" - - - - -	2
	Cotter 1/8"φ x 1"- - - - -	2
B-19	Lever - - - - -	1
	Washer 1-3/4"φ x 11/16"φ x 1/8"- - - - -	1
	Cotter 1/8"φ x 1"- - - - -	1
B-20	Link - - - - -	3
B-21	Bracket - - - - -	2
	Bolts 5/8"φ N.C. x 1-1/4" Sq.Hd. & Sq.Nut-	6
B-22	Bracket - - - - -	2
	Bolts 5/8"φ N.C. x 1-1/4" Sq.Hd. & Sq.Nut-	6
B-23	Indicator (Assembly) - Section 4, Page 3 - -	1



Continued on next page

PARTS LIST

BATCHER (end)

B.K. PART NO.	DESCRIPTION	NO. USED
B-24	Scale (Assembly Complete)-Section 3 Page 3	1
B-25	Batcher (Complete with Gate & Lever) - - - -	1
B-26	Extension - - - - -	2
	Bolts 3/4"φ N.C. x 1-1/4" Sq.Hd. & Sq.Nut	2
B-27	Plate - Partition- - - - -	1
	Bolts 3/8"φ N.C. x 1" Sq.Hd. & Sq.Nut - -	15
B-28	Bracket - - - - -	1
	Bolts 5/8"φ N.C. x 1-1/4" Sq.Hd. & Sq.Nut	6
	Pin 1-1/4"φ x 3-7/8"- - - - -	1
	Cotter 3/16"φ x 1-3/4"- - - - -	1
	Washer 2-1/2"φ x 1-5/16"φ x 1/8"- - - - -	1
B-29	Lever - - - - -	1
	Rod 1/2"φ x 2-1/4"- - - - -	1
	Washers 1-3/8"φ x 9/16"φ x #12- - - - -	4
	Cotters 1/8"φ x 1"- - - - -	2
B-30	Link - - - - -	1
B-31	Hanger - Gate- - - - -	2
B-32	Hanger - Gate- - - - -	2
B-33	Bottom - Gate- - - - -	1
	Pin 1/2"φ x 1-3/4"- - - - -	1
	Washer 1/2"φ Std. - - - - -	1
	Cotter 1/8"φ x 1" - - - - -	1
	Bolts 5/8"φ N.C. x 1-1/2" Sq.Hd. & Sq.Nut	4
	Lock Washers 5/8"φ Std. - - - - -	4
B-34	Bottom - Gate - - - - -	1
	Bolts 5/8"φ N.C. x 1-1/2" Sq.Hd. & Sq.Nut	4
	Lock Washer 5/8"φ Std.- - - - -	4
B-35	Rods - - - - -	4
	Nuts 3/4"φ Sq.- - - - -	16

PARTS LIST

---

SCALE SECTION

SCALES - - - - - PAGE 1 - 2 - 3 - 4



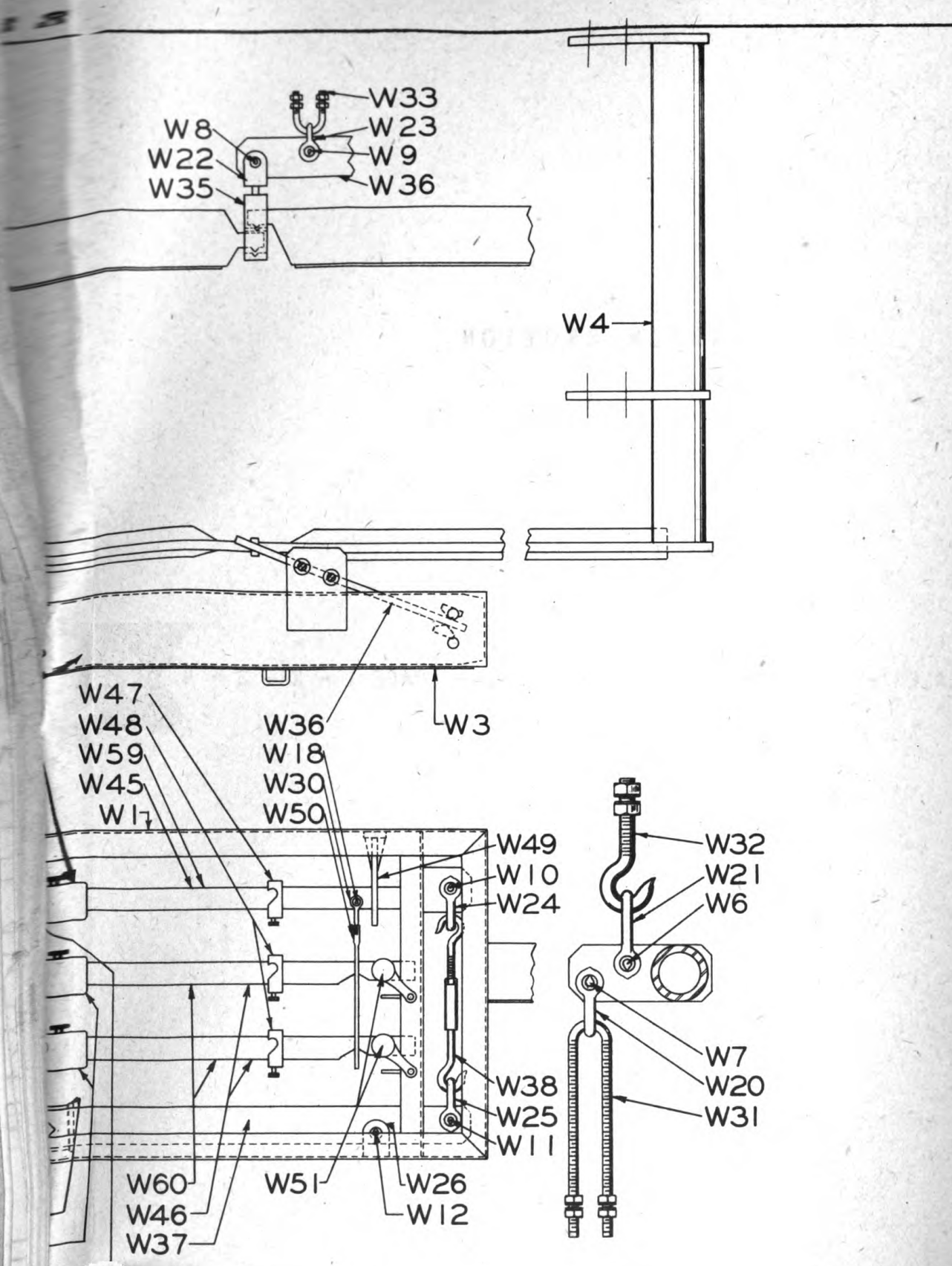

PARTS LIST

BATCHER SCALE

B.K. PART NO.	DESCRIPTION	NO. USED
B-24	Scale Assembly - - - - -	1
W-1	Frame - Beam Box - - - - -	1
W-2	Cover - Removable Beam Box - - - - -	1
W-3	Cover - Bolted Beam Box - - - - -	1
W-4	Lever - Torque - Right Hand - - - - -	1
W-5	Lever - Torque - Left Hand - - - - -	1
*W-6	Pin - Pivot - - - - -	4
*W-7	Pin - Pivot - - - - -	4
W-8	Pin - Pivot - - - - -	1
W-9	Pin - Pivot - - - - -	1
W-10	Pin - Pivot - - - - -	1
W-11	Pin - Pivot - - - - -	1
W-12	Pin - Pivot - - - - -	1
W-13	Pin - Pivot - - - - -	1
W-14	Pin - Pivot - - - - -	1
W-15	Pin - Pivot - - - - -	1
W-16	Pin - Pivot - - - - -	1
W-17	Pin - Pivot - - - - -	2
W-18	Pin - Pivot - - - - -	1
W-19	Pin - Clevis (Dash Pot) - - - - -	1
**W-20	Loop - Pivot - - - - -	4
**W-21	Loop - Pivot - - - - -	4
W-22	Loop - Pivot - - - - -	1
W-23	Loop - Pivot - - - - -	1
W-24	Loop - Pivot - - - - -	1
W-25	Loop - Pivot - - - - -	1
W-26	Loop - Pivot - - - - -	1
W-27	Loop - Pivot - - - - -	1
W-28	Loop - Pivot - - - - -	1
W-29	Loop - Pivot (For Indicator Connection) - - -	1
W-30	Loop - Pivot - - - - -	1
W-31	Bolt - U - - - - -	4

\*Interchangeable  
\*\*Interchangeable



Continued on next page



PARTS LIST

BATCHER SCALE (end)

B.K. PART NO.	DESCRIPTION	NO. USED
W-32	Bolt - Hook - - - - -	4
W-33	Bolt - U - - - - -	1
W-34	Clevis - - - - -	1
W-35	Shackle - Nose - - - - -	1
W-36	Lever - Extension - - - - -	1
W-37	Lever - Shelf - - - - -	1
W-38	Rod - Hooked - - - - -	1
W-39	Lever End - Shelf - - - - -	1
W-40	Link - Beam Connecting - - - - -	1
W-41	Weight - Balance - - - - -	1
W-42	Weight - Balance - - - - -	2
W-43	Poise - Main Beam (Major) - - - - -	1
W-44	Poise - Auxiliary Beam (Major) - - - - -	2
W-45	Beam - Main - - - - -	1
W-46	Beam - Auxiliary - - - - -	2
***W-47	Poise - Main Beam (Minor) - - - - -	1
***W-48	Poise - Auxiliary Beam (Minor) - - - - -	2
W-49	Stop - Beam - - - - -	1
W-50	Ladder - - - - -	1
W-51	Bolts - Trig - - - - -	2
W-52	Counterweight - - - - -	1
W-53	Bolt - Counter Poise Hook - - - - -	1
W-54	Guard - Beam Pivot - - - - -	3
W-55	Support - Beam - - - - -	1
W-55A	Seat - Beam - - - - -	6
W-56	Rod - Dash Pot Connecting - - - - -	1
W-56A	Damper - Dash Pot - - - - -	1
W-57	Pot - Dash - - - - -	1
W-59	Main Beam Assembly (Consists of W-45, W-15, W-29, W-41, W-14, W-28, W-16, W-43, W-47, W-18 and W-30	1
W-60	Auxiliary Beam Assembly (Consists of W-46, W-42, W-17, W-44 and W-48	2

\*\*\*Interchangeable

PARTS LIST

---

INDICATOR SECTION

INDICATOR - - - - - PAGE 1 - 2 - 3



# PARTS LIST

INDICATOR

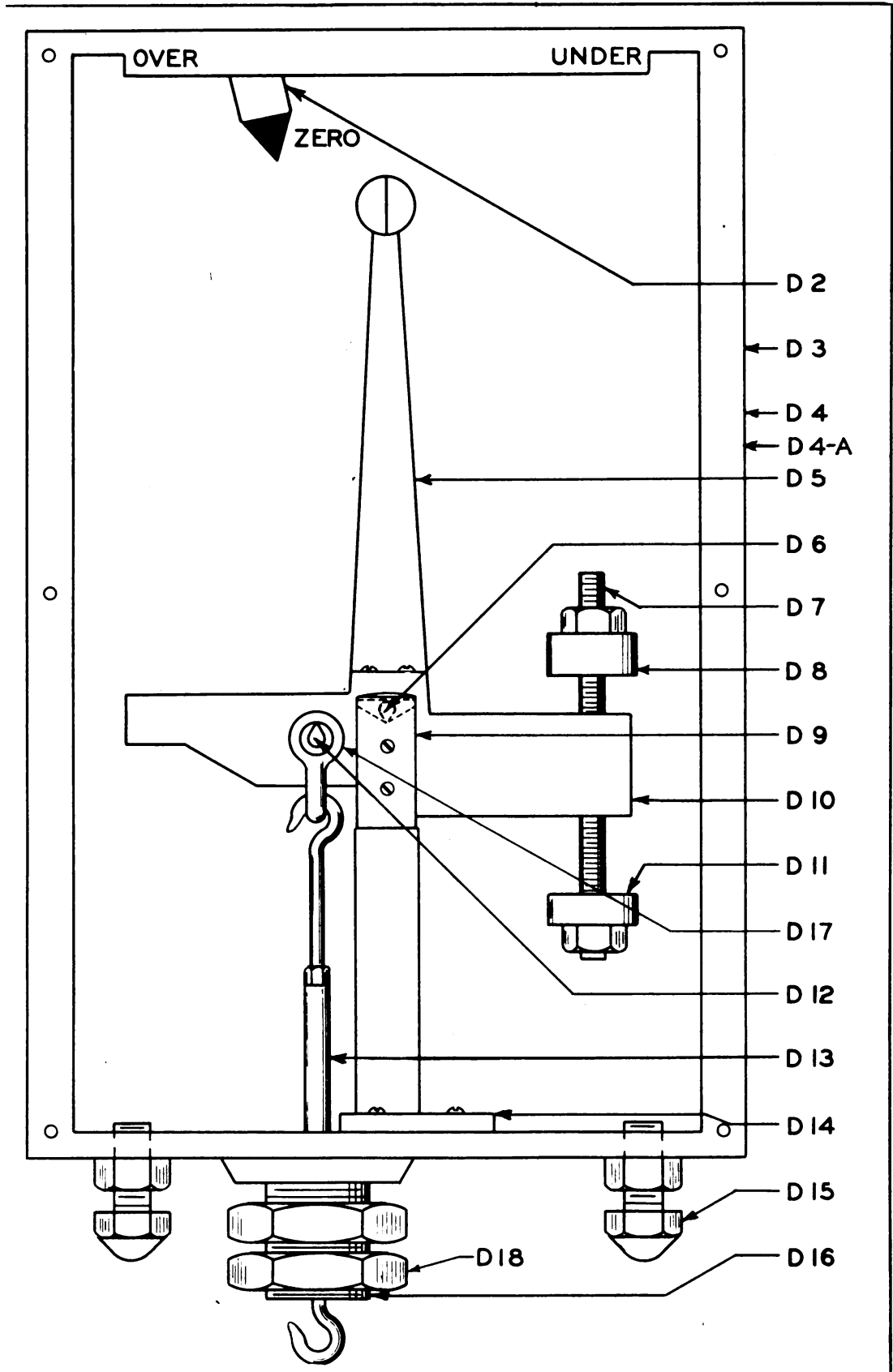

PARTS LIST

INDICATOR

B.K. PART NO.	DESCRIPTION	NO. USED
B-23	Indicator Assembly - - - - -	1
D-2	Marker - Zero - - - - -	1
	Screw - Round Head Steel Machine -	
	#10 - 24 Thread x 3/8" Long - - - - -	2
D-3	Box - Indicator - - - - -	1
D-4	Cover - Indicator Box - - - - -	1
	Screw - Round Head Steel Machine -	
	#8 - 32 Thread x 1/2" Long - - - - -	4
D-4A	Glass - Indicator Cover - - - - -	1
D-5	Pointer - - - - -	1
	Screw - Round Head Brass Machine -	
	#5 - 40 Thread x 3/8" Long - - - - -	2
D-6	Pin - Pivot - - - - -	1
D-7	Rod & Lock Nuts - Counterweight Adjusting - -	1
D-8	Counterweight - Upper - - - - -	1
D-9	Cover - Pivot Pin - - - - -	2
	Screw - Round Head Brass Machine -	
	#5 - 40 Thread x 3/8" Long - - - - -	4
D-10	Fulcrum - - - - -	1
D-11	Counterweight - Lower - - - - -	1
D-12	Pin - Pivot - - - - -	1
D-13	Rod - Indicator Connecting - - - - -	1
	Bolt - Hook - #6 - 32 Threads - R.H. - - -	1
	Bolt - Hook - #6 - 32 Threads - L.H. - - -	1
	Nut - #6 Hex. - - - - -	1
D-14	Pedestal - Fulcrum - - - - -	1
	Bolt 1/4"φ - 20 Thd. x 3/4" Long Hex.& Hex.	2
D-15	Bolts & Lock Nuts - Leveling - - - - -	3
D-16	Pipe Nipple - 1"φ - - - - -	1
D-17	Loop - Pivot - - - - -	1
D-18	Pipe Nut - 1"φ - - - - -	2





PARTS LIST

The numbers of all parts used on Blaw-Knox Aggregate Batching Plant are arranged in groups and listed on the following pages. The first group does not have an alphabetical prefix and is arranged in numerical order. The following groups have either an alphabetical prefix or suffix. These groups are arranged in alphabetical order according to prefix or suffix. Each group is then arranged in numerical order.

Where the parts number is followed by the code letters WS, the original parts manufacturer is the Winslow Government Standard Scale Works, Inc., Terre Haute, Indiana. Where no code letters appear, the part originates with Blaw-Knox Company.

B.K. PART NO.	SECTION		ORIGINAL MFG.	
	NO.	PAGE	CODE	PART NO.
6568	1	4		
6569	1	4		
6574	1	4		
6575	1	4		
		"B"		
B-10	2	3		
B-11	2	3		
B-12	2	3		
B-13	2	3		
B-14	2	3		
B-15	2	3		
B-16	2	3		
B-17	2	3		
B-18	2	3		
B-19	2	3		
B-20	2	3		
B-21	2	3		
B-22	2	3		
B-23	4	3	WS	B-23
B-24	2	4		
B-25	2	4		
B-26	2	4		
B-27	2	4		
B-28	2	4		

PARTS LIST

B.K. PART NO.	SECTION		ORIGINAL MFG.	
	NO.	PAGE	CODE	PART NO.
B-29	2	4		
B-30	2	4		
B-31	2	4		
B-32	2	4		
B-33	2	4		
B-34	2	4		
B-35	2	4		
		"D"		
D-2	4	3	WS	D-2
D-3	4	3	WS	D-3
D-4	4	3	WS	D-4
D-4A	4	3	WS	D-4A
D-5	4	3	WS	D-5
D-6	4	3	WS	D-6
D-7	4	3	WS	D-7
D-8	4	3	WS	D-8
D-9	4	3	WS	D-9
D-10	4	3	WS	D-10
D-11	4	3	WS	D-11
D-12	4	3	WS	D-12
D-13	4	3	WS	D-13
D-14	4	3	WS	D-14
D-15	4	3	WS	D-15
D-16	4	3	WS	D-16
D-17	4	3	WS	D-17
D-18	4	3	WS	D-18
		"G"		
GR-242	1	3		
GR-243	1	3		
GR-248	1	3		
GR-249	1	3		
GR-250	1	3		
GR-251	1	3		
GR-252	1	3		
GR-253	1	3		
GR-254	1	3		
GR-255	1	3		
GR-256	1	3		
GR-257	1	3		
GR-258	1	3		
GR-259	1	3		
GR-260	1	3		
GR-261	1	3		

PARTS LIST

B.K. PART NO.	SECTION		ORIGINAL MFG.	
	NO.	PAGE	CODE	PART NO.
		"K"		
13-K	1	4		
16-K	1	4		
		"L"		
L-2	1	4		
		"W"		
W-1	3	3	WS	W-1
W-2	3	3	WS	W-2
W-3	3	3	WS	W-3
W-4	3	3	WS	W-4
W-5	3	3	WS	W-5
W-6	3	3	WS	W-6
W-7	3	3	WS	W-7
W-8	3	3	WS	W-8
W-9	3	3	WS	W-9
W-10	3	3	WS	W-10
W-11	3	3	WS	W-11
W-12	3	3	WS	W-12
W-13	3	3	WS	W-13
W-14	3	3	WS	W-14
W-15	3	3	WS	W-15
W-16	3	3	WS	W-16
W-17	3	3	WS	W-17
W-18	3	3	WS	W-18
W-19	3	3	WS	W-19
W-20	3	3	WS	W-20
W-21	3	3	WS	W-21
W-22	3	3	WS	W-22
W-23	3	3	WS	W-23
W-24	3	3	WS	W-24
W-25	3	3	WS	W-25
W-26	3	3	WS	W-26
W-27	3	3	WS	W-27
W-28	3	3	WS	W-28
W-29	3	3	WS	W-29
W-30	3	3	WS	W-30
W-31	3	3	WS	W-31
W-32	3	4	WS	W-32
W-33	3	4	WS	W-33
W-34	3	4	WS	W-34
W-35	3	4	WS	W-35
W-36	3	4	WS	W-36
W-37	3	4	WS	W-37





PARTS LIST

B.K. PART NO.	SECTION		ORIGINAL MFG.	
	NO.	PAGE	CODE	PART NO.
W-38	3	4	WS	W-38
W-39	3	4	WS	W-39
W-40	3	4	WS	W-40
W-41	3	4	WS	W-41
W-42	3	4	WS	W-42
W-43	3	4	WS	W-43
W-44	3	4	WS	W-44
W-45	3	4	WS	W-45
W-46	3	4	WS	W-46
W-47	3	4	WS	W-47
W-48	3	4	WS	W-48
W-49	3	4	WS	W-49
W-50	3	4	WS	W-50
W-51	3	4	WS	W-51
W-52	3	4	WS	W-52
W-53	3	4	WS	W-53
W-54	3	4	WS	W-54
W-55	3	4	WS	W-55
W-55A	3	4	WS	W-55A
W-56	3	4	WS	W-56
W-56A	3	4	WS	W-56A
W-57	3	4	WS	W-57
W-59	3	4	WS	W-59
W-60	3	4	WS	W-60
		"X"		
X-301	1	3		
X-302	1	3		
X-303	1	3		
X-304	1	3		
X-305	1	3		
X-306	1	3		
X-307	1	3		
X-308	1	3		
X-309	1	3		
X-310	1	3		
X-311	1	3		

# NOTES

# NOTES

# NOTES

# NOTES

# NOTES

# NOTES





