

✓ *Ed* U113
12
Tm
1443
Army

TM 5-9060

**WAR DEPARTMENT
MAINTENANCE MANUAL
AND PARTS CATALOG**

CRANE, TRACTOR, 20 TON

20 FOOT BOOM

MODEL M20

R. G. LeTOURNEAU, INC.

PEORIA, ILL.

MARCH 24, 1943

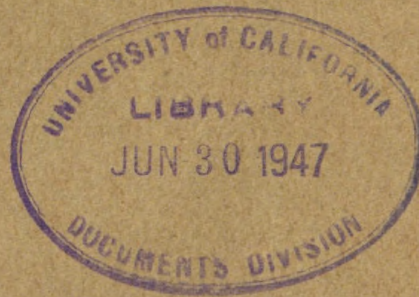

TM5-9060

**CRANE, TRACTOR, 20 TON
20 FOOT BOOM**

MODEL M20

MANUFACTURED BY

R. G. LETOURNEAU, INC.

PEORIA, ILL.

STOCKTON, CALIF.

(THIS BOOK COVERS CRANES C-2158—M20A & UP)

(WAR DEPARTMENT PURCHASE ORDER No. 07-2981)

TM5-9060

War Department

TM5-9060, Maintenance Manual and Parts Catalog,
Crane, Tractor, 20 Ton, 20 Foot Boom, Model
M20, published by the R. G. LeTourneau, Inc.,
is furnished for the information and guidance
of all concerned.

(AG 300.7 (7/21/43) PC (C), June 10, 1941.)

G. C. MARSHALL
Chief of Staff

Official:

J. A. ULIO,
Major General,
The Adjutant General

TABLE OF CONTENTS

Description of Crane.....Frontispiece

OPERATION SECTION

SECT. 1

	Page	
Operating Features.....	1	U113
Cable	2	.2
Cable Threading.....	2	TMS:
Connecting Crane to Tractor.....	4	9060
Uncoupling Crane from Tractor.....	4	1940
Operation	4	
Functions of Crane.....	9	
Points of Lubrication and Adjustment that can be taken care of by Operator.....	10	★ ★
Specifications	11	
Preparation for Initial Operation.....	11	
Lubrication	12	
Tire Inflation	14	
Operation under Dusty, Muddy, Low Temperature and Other Abnormal Conditions.....	14	
Preparation for Storage.....	14	

REPAIR SECTION

SECT. 2

	Page
Care of Crane.....	1
Adjustments	1
Removing and Installing Tires.....	5
Disassembling	6
Overhauling	9
Assembling	9
Table of Tolerances and Clearances of Bearings and Adjustable Parts.....	9

PARTS CATALOG

SECT. 3

	Page
Cable Threading.....	1 & 2
Boom Group.....	3
Head Group	4 & 5
Tongue Group	6 & 7
Hook Sheave Group.....	8
Wheel Group	9 & 10

M574503

INDEX

Adjustments	Page 1 (Repair Section)
Assembling	Page 9 (Repair Section)
Boom Group (Parts Illustration)	Page 3 (Parts Catalog)
Cable (Type)	Page 2 (Operation Section)
Cable (Size and Length)	Page 1 (Parts Catalog)
Cable Threading	Page 2 (Operation Section)
Care of Crane	Page 1 (Operation Section)
Connecting Crane to Tractor	Page 4 (Operation Section)
Disassembling	Page 6 (Repair Section)
Description of Crane	Frontispiece
Head Group (Parts Illustration)	Page 4 & 5 (Parts Catalog)
Hook Sheave Assembly (Parts Illustration)	Page 8 (Parts Catalog)
Features of Crane	Page 1 (Operation Section)
Functions of Crane	Page 9 (Operation Section)
Lubrication	Page 12 (Operation Section)
Operation	Page 4 (Operation Section)
Operation under Dusty, Muddy, Low Temperature and other Abnormal Conditions	Page 14 (Operation Section)
Overhauling	Page 9 (Repair Section)
Points of Lubrication and Adjustment that can be taken care of by operator	Page 10 (Operation Section)
Preparation for Initial Operation	Page 11 (Operation Section)
Preparation for Storage	Page 14 (Operation Section)
Removing and Installing Tires	Page 5 (Repair Section)
Specifications	Page 11 (Operation Section)
Table of Tolerances and Clearances of Bearings and Adjustable Parts	Page 9 (Repair Section)
Tire Inflation	Page 14 (Operation Section)
Tongue Group (Parts Illustration)	Page 6 & 7 (Parts Catalog)
Transporting Crane	Page 9 (Operation Section)
Uncoupling Crane from Tractor	Page 4 (Operation Section)
Wheel Group (Parts Illustration)	Page 9 & 10 (Parts Catalog)

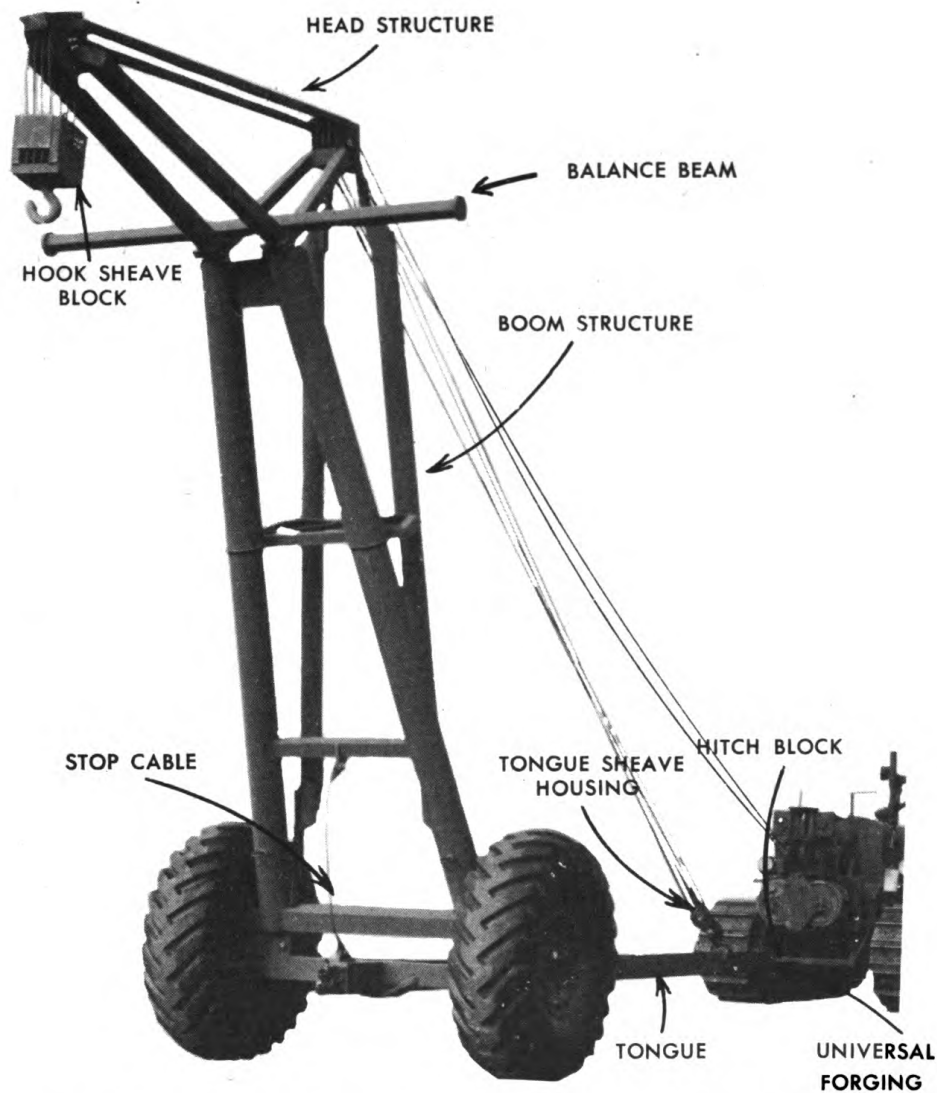

THE LETOURNEAU MODEL M-20 CRANE

The LeTourneau Model M-20 Tractor Crane is an electrically arc welded, all steel unit, mounted on low pressure pneumatic tires, designed to be pulled and operated behind track-type tractors.

The Crane is cable controlled by a LeTourneau two drum Power Control Unit, mounted on the rear of the tractor. By moving the Power Control Unit control levers, the tractor operator can raise or lower the load being carried at the hook sheave block, and can also raise and lower the boom as needed.

The Model M-20 Crane is capable of lifting and carrying from one place to another loads up to 40,000 lbs.

PARTS OF CRANE

BOOM—The upright tubular members of Crane which support the head structure.

HEAD STRUCTURE—The upper-most member of Crane, consisting of sheave housings supported by box beams. The head structure is bolted to the top of the boom.

TONGUE STRUCTURE—The boxbeam member which extends back from tractor hitch to the Crane wheels. The axle housings are parts of the tongue structure.

HOOK SHEAVE BLOCK—Consists of Crane hook, sheave housing, sheaves, etc., to which the load is attached and with which the load is raised and lowered.

TONGUE SHEAVE HOUSING—The sheave housing located at the front of the tongue through which the boom cable passes.

UNIVERSAL FORGING—The part at the front of the tongue to which the hitch block is attached and which turns in bushings in the tongue when traveling over unlevel ground.

HITCH BLOCK—The steel block at the front of the universal forging through which the tractor drawbar pin is inserted when connecting the Crane to the tractor.

WHEELS AND AXLES—The wheels and axles at the rear of the tongue structure.

BOOM CABLE—The wire rope which raises and lowers the boom.

HOIST CABLE—The wire rope which raises and lowers the hook sheave housing and load.

STOP CABLE—The short piece of wire rope extending from the lower part of the boom to the rear of the tongue structure. This cable prevents the boom from being moved back over-center.

BALANCE BEAM—The horizontal beam at the top of the boom by means of which the Crane can be balanced or stabilized on rough or uncertain ground conditions by a crew of men by throwing a rope sling over either end of the beam.

SHEAVE WHEELS—The grooved wheels located in the sheave housings over which the cable passes.

OPERATING TERMS

“BOOMING OUT”—Lowering the boom to the rear, away from the tractor.

“BOOMING IN”—Raising the boom, moving it forward toward the tractor.

“HOISTING”—Raising the hook sheave housing and load.



OPERATING FEATURES OF LeTOURNEAU MODEL M-20 CRANE

LeTourneau M-20 Cranes offer the following features:

1. They are highly mobile, being able to move quickly from one lifting operation to another.
2. They may be maneuvered into positions impossible with ordinary truck or crawler Cranes.
3. By changing hitch blocks and universal forgings, M-20 Cranes can be used with any size track-type tractor. (Lifting capacity, determined largely by tractor tonnage, can be increased on smaller tractors by the addition of counterweights.)
4. They can be knocked-down for flat shipping.
5. All-welded, special analysis, boxbeam or tubular steel construction provides maximum strength and lifting capacity.

Because of the above features, the LeTourneau M-20 tractor crane makes an excellent tool for use wherever lifting operations are being performed.

CABLE

The cable that is used with LeTourneau Cranes should meet the following specifications:

Use Tournarope or other high quality wire rope meeting the following specifications:—6 x 19 wire rope of Warrington construction with strand center, preformed, Langlay, and made from improved plow steel. It should be internally lubricated during the manufacturing process. Right lay cable is ordinarily used but left lay cable can be used with equal success.

For correct sizes (diameter) and lengths of the hoist and boom cables, refer to the cable threading diagram in the front of the Parts Catalog.

CABLE THREADING

The cable threading should be done with the boom on the ground behind the tractor. (The cable threading is usually done before the hitch block on the end of the tongue is connected to the tractor drawbar, and the tongue can then be raised into position by engaging the Power Control Unit left clutch, thereby spooling in the boom cable.)

The instructions below explain the cable threading procedure.

HOIST CABLE

From right drum of Power Control Unit
 Cable goes up and under bottom of sheave in housing 2
 Then over top of sheave A in housing 3
 Then forward and over top of sheave . . . B in housing 4
 Then down and under bottom of sheave . C in housing 5
 Then up and over top of sheave D in housing 4
 Then down and under sheave E in housing 5
 Then up and over top of sheave F in housing 4
 Then down and under bottom of sheave . G in housing 5
 Then up and over top of sheave H in housing 4
 Then down and under bottom of sheave . I in housing 5
 Then up and dead end cable at J with cable wedge

BOOM CABLE

From left drum of Power Control Unit
 Cable goes up and over top of sheave . . . K in housing 3
 Then down and around sheave L in housing 1
 Then up and over top of sheave M in housing 3
 Then down and around sheave N in housing 1
 Then up and over top of sheave O in housing 3
 Then down and through cable loop on top of housing 1
 Then up and tie with cable clamp at . . P

SECT. 1

OPERATION SECTION

Digitized by Google

Original from
UNIVERSITY OF CALIFORNIA

OPERATION SECTION

NOTE: Cranes having serial number C-2567-M20A and up have a different dead end setup than that shown on diagram. After cable has been threaded under sheave I, it is taken up and through housing H, but over curved protector plate, and through hole in top and dead ends at wedge on top of housing 4. **SEE SKETCH.**

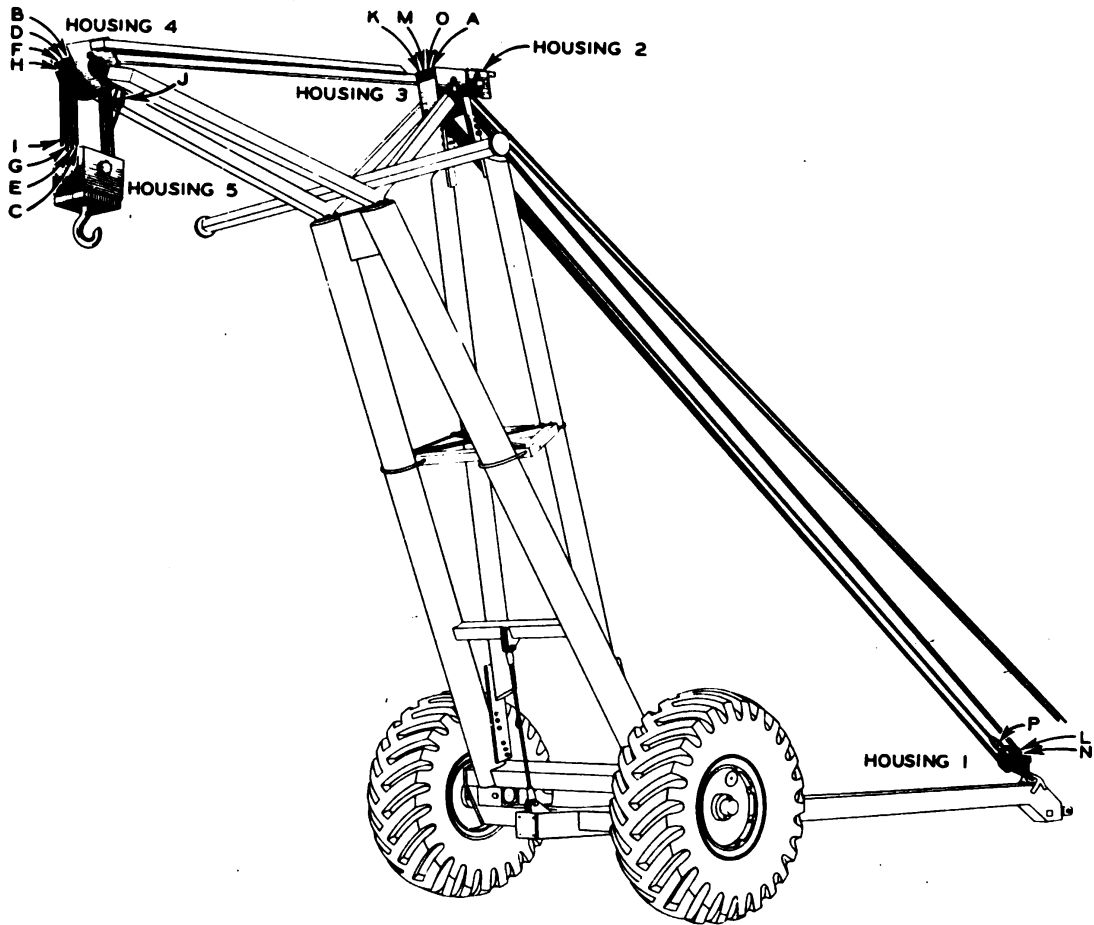
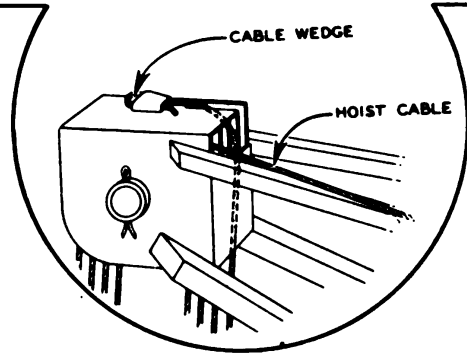

LEFT AND RIGHT DETERMINED BY STANDING IN REAR OF CRANE,
LOOKING TOWARD TRACTOR.

CONNECTING CRANE TO TRACTOR

With the cable correctly threaded through the Crane and onto the Power Control Unit cable drums, the Crane tongue can easily be connected to the tractor drawbar by blocking the wheels and then engaging the Power Control Unit left-hand clutch, thereby spooling in the boom cable and raising the tongue to the proper height.

Back up the tractor and insert the drawbar pin to effect the connection.

UNCOUPLING CRANE FROM TRACTOR

To uncouple the Crane from a tractor, first lower the boom to the ground. Then disconnect the cable from the cable drums and remove the drawbar pin.

OPERATION

The operation of a LeTourneau Crane is comparatively simple and requires few instructions. The new operator, however, should use a certain amount of care when operating the Crane until he has become familiar with the operation. Control is quite sensitive and an inexperienced operator should experiment several times to get the "feel" of the operation before attempting important work.

The Power Control Unit right-hand control lever controls hoisting at the hook block. The left-hand control lever controls the position of the boom.

To hoist the load, move the control lever for the Power Control Unit right clutch into the engaged position. To hold the load in the hoisted position, allow the control lever to return to neutral position, thereby applying the brake to the cable drum. To lower the load, move the control lever **SLOWLY** in the direction opposite that with which the clutch was engaged. If the movement of the control lever in this position is too fast, the load will be dropped.

Use the left clutch control lever in the same manner to raise and lower the boom.

Do not drop boom with sudden impact when lowering it to the ground.

The precautions listed on the following pages should be observed when operating the Crane:

OPERATION

1. Release Power Control Unit brakes slowly to avoid dropping the load.



2. Raise and lower the boom slowly. Do not allow the boom to drop with a sudden impact. When raising the boom, do not leave the Power Control Unit Clutch engaged after the boom has reached its extreme front position, or in other words, after the stop cable has been drawn tight. When traveling, leave some slack in the stop cable.



3. When traveling a long distance without a load, secure the hook at the bottom of the hook sheave block to the boom, to prevent the hook block from swinging. Allow some slack in the hoist line. Keep the boom comparatively low.



4. Keep the Power Control Unit in correct adjustment at all times. It is essential that the brakes be working properly in order to hold up the load.



OPERATION SECTION

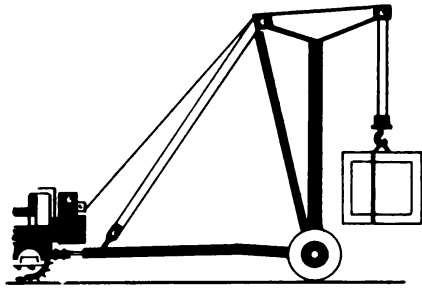

CORRECT

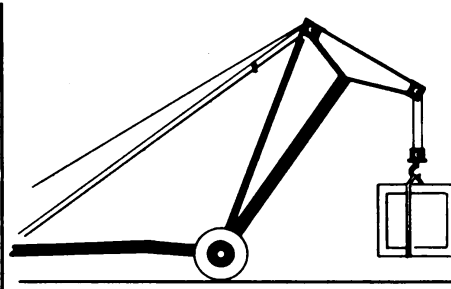

INCORRECT

5. When lifting heavy loads, have the boom as nearly erect as possible. Generally speaking, the heavier the load, the more erect the boom should be.

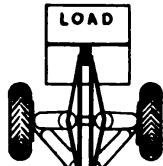

CORRECT

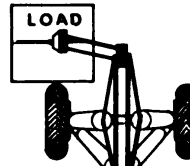

INCORRECT

6. When picking up a load, have the hoist sheave housing at the end of the boom positioned as nearly over the center of the load as possible. If this is not done, the load will have a tendency to swing back and forth when raised off the ground.

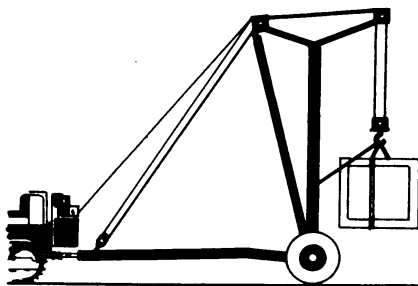

CORRECT

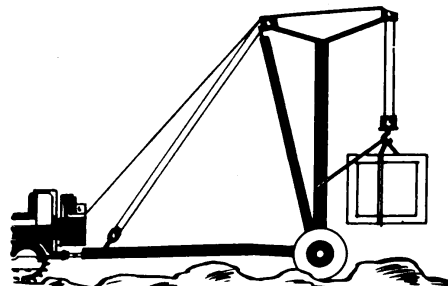

INCORRECT

7. Operate the Crane on as nearly level ground as possible.

OPERATION SECTION

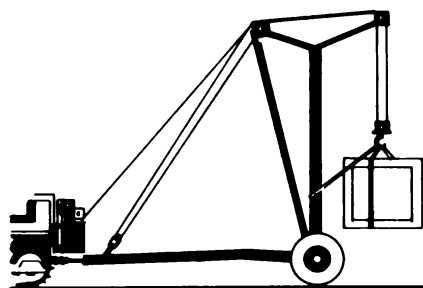

CORRECT

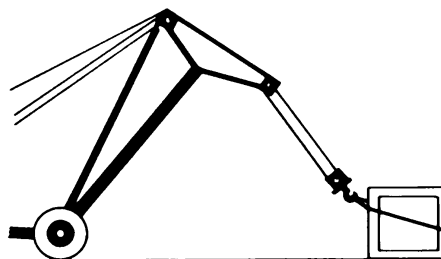

INCORRECT

8. Don't try to pull or drag heavy loads across the ground with the Crane.

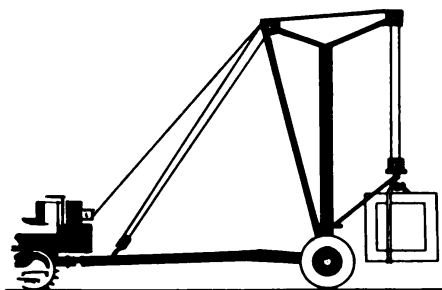

CORRECT

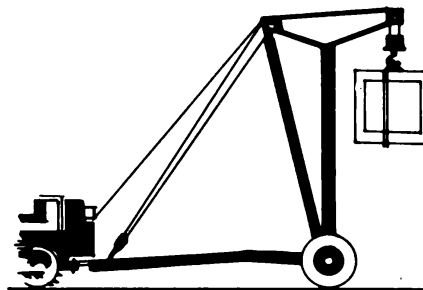

INCORRECT

9. Keep the load comparatively close to the ground when traveling. If the load is of a size and shape that would cut the tires if carried low, it may be necessary to carry the load above the tires. In this case, extreme care should be used to avoid upsetting Crane.

To prevent heavy loads from swinging back against boom and thereby damaging it, travel over smooth, level ground and start and stop slowly. Also extend a rope, cable, or chain from one side of Crane to the suspended load and then to other side of Crane to steady the load.

10. Do not endanger those working around the Crane by using weak, frayed cable.

11. Do not attempt to lift loads in excess of the recommended lifting capacity of the Crane.

The lifting capacity of the Crane, dependent largely upon the weight of the tractor to which the Crane is connected, de-

creases as the boom is lowered. This is true because by means of leverage the weight of the tractor must offset the weight of the load (in addition to providing weight for traction).

The chart below gives the recommended lifting capacities for different positions of the boom when the Crane is connected to Caterpillar D8, D7, D6, D4 and R4 tractors.

RECOMMENDED LIFTING CAPACITIES IN POUNDS

*Reach In Feet	D8 Tractor	D7 Tractor	D6 Tractor	D4 or R4 Tractor
3' 3"	40,000 lb.	40,000 lb.	20,000 lb.	10,000 lb.
5	39,500 lb.	35,000 lb.	17,000 lb.	8,500 lb.
6	36,800 lb.	31,400 lb.	16,100 lb.	8,000 lb.
7	33,600 lb.	27,800 lb.	15,200 lb.	7,500 lb.
8	30,400 lb.	24,200 lb.	14,300 lb.	7,000 lb.
9	27,200 lb.	20,600 lb.	13,400 lb.	6,500 lb.
10	24,000 lb.	17,000 lb.	12,500 lb.	6,000 lb.
11	22,400 lb.	15,600 lb.	11,500 lb.	5,500 lb.
12	20,800 lb.	14,200 lb.	10,600 lb.	5,000 lb.
13	19,200 lb.	12,800 lb.	9,600 lb.	4,500 lb.
14	17,600 lb.	11,400 lb.	8,700 lb.	4,000 lb.
15	16,000 lb.	10,000 lb.	7,700 lb.	3,500 lb.
16	15,200 lb.	9,400 lb.	7,250 lb.	3,250 lb.
17	14,400 lb.	8,800 lb.	6,800 lb.	3,000 lb.
18	13,600 lb.	8,200 lb.	6,300 lb.	2,700 lb.
19	12,800 lb.	7,600 lb.	5,850 lb.	2,450 lb.
20	12,000 lb.	7,000 lb.	5,400 lb.	2,200 lb.

* Horizontal distance from center of Crane wheel to Center of Crane hook.

The new operator will, with a little practice, be able to maneuver the Crane into practically any position without difficulty. If, in backing into position, the boom should approach the load to be lifted a short distance either to the right or left of the load, a sharp turn in the correct direction will usually swing the boom around directly over the load. If the boom is to the right of the load, turn the tractor to the left. If the boom is to the left of the load, turn the tractor to the right.

As a safety measure, stay out from under load or boom at all times.

OPERATION

TRANSPORTING CRANE

When transporting the Crane for quite a distance from one job to another, it is usually advisable to lower the boom onto the tongue. To do this, first secure the hook sheave block to some stationary object, such as a tree.

Disconnect the stop cable. Then allow enough slack in the hoist line to permit the boom to be moved back past center. Move the boom over center by engaging the Power Control Unit clutch for the boom line.

Then lower the boom onto the tongue by slowly releasing the brake on the Power Control Unit hoist drum. If there is not enough cable on the hoist drum to lower it onto the tongue, this can be done by backing up toward the hoist sheave block. As boom is lowered, spool in slack boom cable until cable drum is filled, using care to prevent cable from fouling as boom approaches tongue. Before traveling, tie hook sheave to Crane and spool in slack hoist cable.

To again raise the boom, attach the hook sheave block to a stationary object, several feet above the ground, and engage the hoist clutch. Pay out boom cable until the boom is raised.

FUNCTIONS OF CRANE

The functions of the Crane are simply the raising or lowering of the boom and lifting or lowering of the load. The Crane is controlled by the Power Control Unit on the rear of the tractor.

The boom is controlled by the left Power Control Unit drum. When the left hand clutch is engaged the cable drum spools in the cable and raises the boom. When the control lever is returned to neutral position the boom is held stationary by the cable drum brake. When the brake is released the boom is lowered.

When the right hand clutch is engaged the cable drum spools in the cable and lifts the load. When the control lever is returned to neutral position the cable drum brake holds the load in the raised position. When the brake is released the load is lowered.



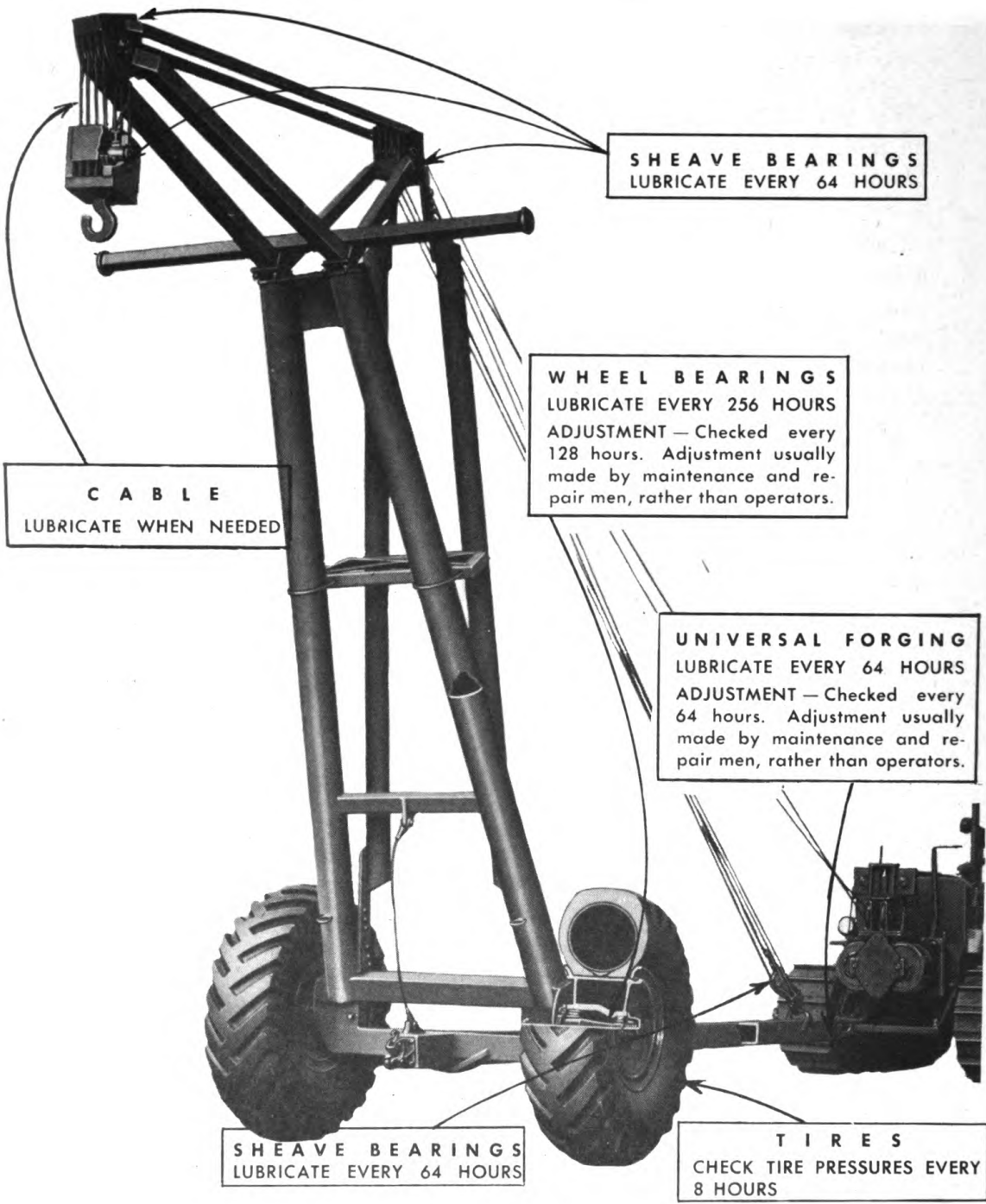

CUT-AWAY VIEW OF CRANE, SHOWING POINTS OF LUBRICATION AND ADJUSTMENT WHICH CAN BE TAKEN CARE OF BY OPERATOR

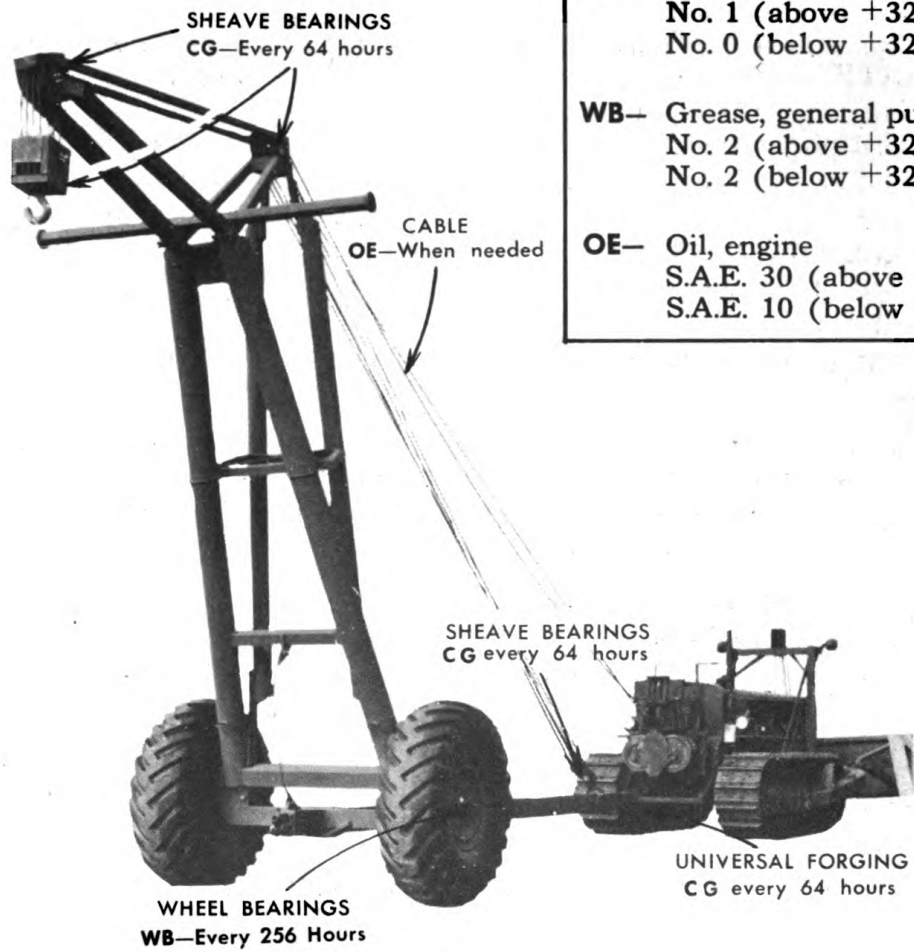

LUBRICANTS	
CG—	Grease, general purpose No. 1 (above +32°F.) No. 0 (below +32°F.)
WB—	Grease, general purpose No. 2 (above +32°F.) No. 2 (below +32°F.)
OE—	Oil, engine S.A.E. 30 (above +32°F.) S.A.E. 10 (below +32°F.)

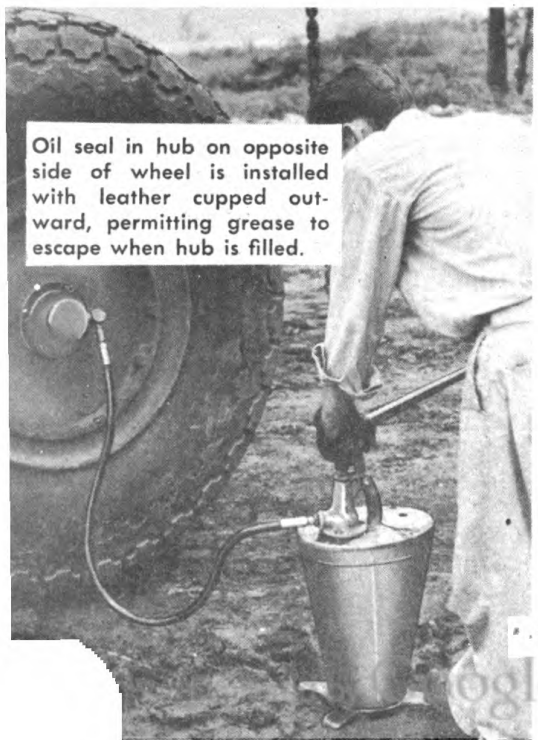

LUBRICATION

WHEEL BEARINGS

The wheel bearings receive lubrication through the button-head grease fittings on the hub caps.

Lubricate the wheel bearings with WB-2 (grease, general purpose, No. 2) every 256 hours of operation, using a conventional type pressure grease gun. Pump grease through the grease fittings until lubricant is forced out around the wheel hub oil seals. (The oil seals should be installed with the leathers cupped outward.)

OPERATION

UNIVERSAL FORGING

The universal forging receives lubrication through the button-head grease fitting in the side of the tongue.

Lubricate the universal forging every 64 hours of operation, using a conventional type pressure grease gun. Pump one or two shots of grease through the fitting, forcing out a small amount of grease around the bushing at the front of the tongue.

Use CG-1 (grease, general purpose, No. 1) in temperatures above +32°F., and CG-0 (grease, general purpose, No. 0) in temperatures below +32°F.

SHEAVE BEARINGS

The roller bearings in the sheave wheels receive lubrication through the grease fittings in the ends of the sheave pins. Insert one or two shots of the recommended grease through the grease fittings every 64 hours of operation, using a conventional type pressure grease gun. This will force out a small amount of grease at the sheave hub, removing any dirt or grit that may have worked in at this point.

Use CG-1 (grease, general purpose, No. 1) in temperatures above +32°F., and CG-0 (grease, general purpose, No. 0) in temperatures below +32°F.

CABLE LUBRICATION

Coat the cable (wire rope) sparingly with OE-10 or OE-30 at infrequent intervals to serve as a rust preventative. If the Power Control Unit that is used to operate the Crane is equipped with woven clutch and brake facings, do not coat that portion of the cable that wraps onto the cable drums, because of the danger of oil getting on the facings and causing clutch and brake slippage.

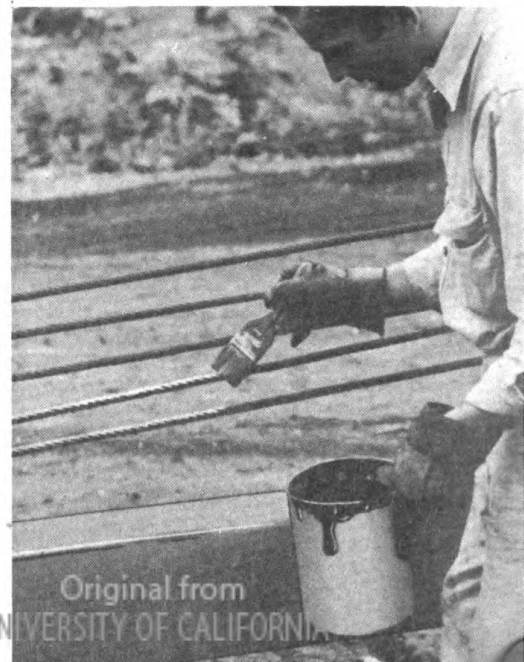

TIRE INFLATION DATA

Check tire pressures every 8 hours of operation.

On Cranes equipped with two 18.00 x 24 20 ply tires, inflate the tires to 50 lb. air pressure in average conditions. On Cranes equipped with 21.00 x 24 20 ply tires, inflate the tires to 40 lb. air pressure under the same conditions.

In extremely soft underfoot conditions where loads up to 40,000 lb. cannot be carried, necessitating a reduction in load capacity to 15,000 to 20,000 lb., air pressures can be reduced 5 to 10 lbs., depending upon load and conditions.

By reducing the air pressures, added flotation will be obtained.

ADJUSTMENTS

All of the Crane adjustments are of a type which are ordinarily taken care of by maintenance men. For adjustment instructions, refer to pages 1, 2, 3 and 4 of the Repair Section.

OPERATION UNDER DUSTY, MUDDY, LOW TEMPERATURE AND OTHER ABNORMAL CONDITIONS

Dust or mud should not hinder the operation of the Crane so long as the ground is solid enough to permit the tractor and Crane to travel.

Slightly lighter greases should be used when operating in cold temperatures than those which are used when operating in warmer temperatures. (Refer to lubrication instructions.)

PREPARATION FOR STORAGE

To prepare the Crane for storage:

1. Wash the Crane free of all dirt.
2. Grease all points of lubrication.
3. Coat the cable with OE (S.A.E. 10 or 30).
4. Block up the wheels in order to take the weight off the tires. Reduce tire pressures.

To prepare the Crane for export shipment, first remove wheel and axle assemblies and disassemble main structures of Crane. (Refer to Disassembling instructions on page 8 of Repair Section.) Then, place tongue structure (1) on blocks on ground and lay boom structure (2) on top of tongue, with axle plates (3) slipped over ends of axle housings (4), and wood blocks (5) installed between end of boom and housing. Lay boom pipes (6) and (7) over boom structure and place head structure (8) between boom pipes as shown. Lay center brace (9) and hook

OPERATION SECTION

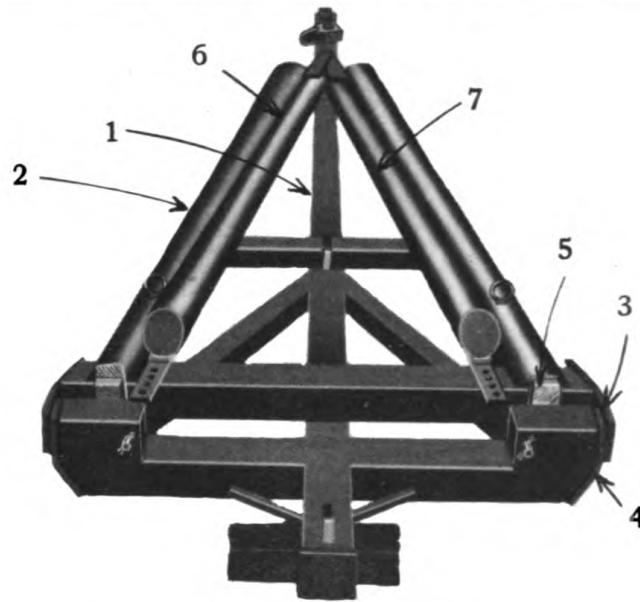

sheave block (10) inside head structure. Place balance beam (11) alongside head structure. Securely wire parts together. Coil up cable. Grease cable and U-bolts and wrap in waterproof paper. Pack all bolts, capscrews, etc., in box or burlap bag and wrap with waterproof paper. Wire cable and packages to Crane. Left and right wheel and axle assemblies can be shipped as separate packages, exactly as removed from Crane.

To re-assemble, follow Assembling instructions on page 9 of Repair Section.

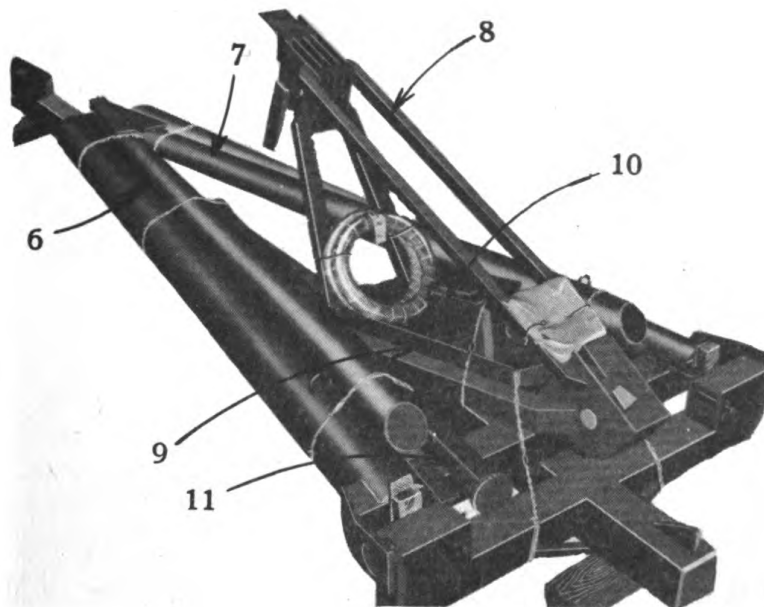

REPAIR SECTION

SECT. 2

REPAIR AND MAINTENANCE

Due to its comparatively simple design, few instructions are required for disassembling, overhauling, assembling, and maintaining LeTourneau Cranes.

CARE OF CRANE

Time spent on inspection and care of the Crane will be many times repaid in long life and trouble-free operation.

The Crane should be serviced as specified below at the intervals shown.

WHEN CRANE IS DELIVERED

Check all points of adjustment and make any necessary corrections.

Check all points of lubrication to determine if properly lubricated.

Check cable threading to determine if correctly threaded.

ONCE EVERY 8 HOURS

Check tire pressures.

ONCE EVERY 64 HOURS

Check universal forging adjustment.

Grease sheave bearings.

Grease universal forging.

ONCE EVERY 128 HOURS

Check wheel bearing adjustment.

ONCE EVERY 256 HOURS

Grease wheel bearings.

LUBRICATION

Refer to the lubrication instructions on page 12 of the Operation Section.

TIRE INFLATION DATA

Refer to tire inflation instructions on page 14 of the Operation Section.

ADJUSTMENTS

The Crane has two points of adjustment:

1. Wheel bearing adjustment.
2. Universal forging adjustment.

The instructions on the following pages give complete information for checking and making these adjustments.

WHEEL BEARING ADJUSTMENT

CHECKING ADJUSTMENT

Check the wheel bearing adjustment every 128 hours of operation.

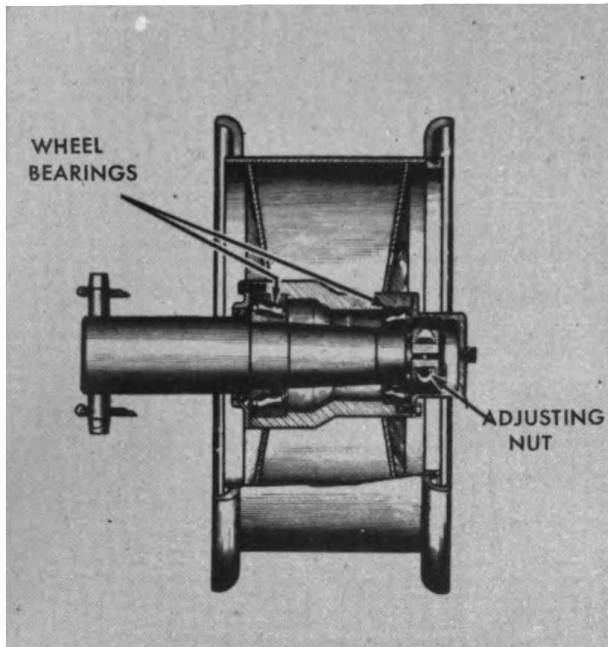

To check the adjustment first raise the wheel off the ground with a jack.



Insert a pry bar between the wheel and axle housing. Pry back and forth with the bar, noticing any end movement between the wheel and axle. If there is any movement an adjustment should be made.

MAKING ADJUSTMENT

To make the adjustment, first remove hub cap by removing capscrews.

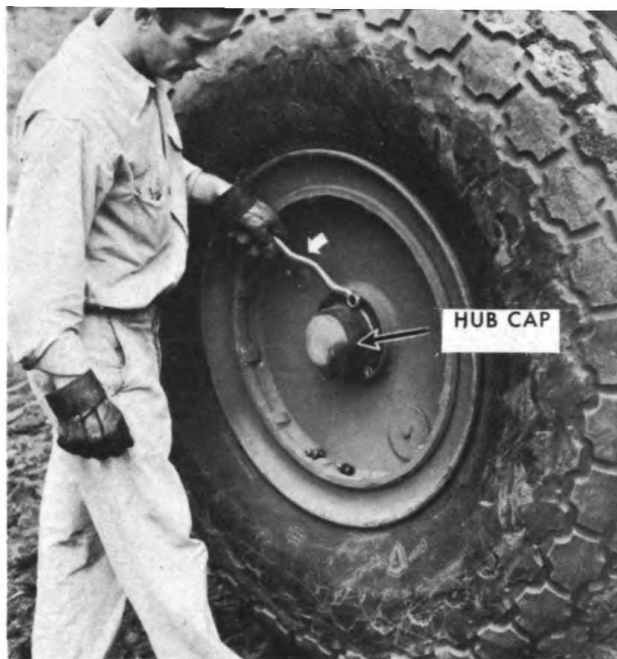

Loosen the adjusting nut clamp bolt and remove cotter pin from end of the axle.



Start wheel rotating slowly. While rotating, turn adjusting nut in a clockwise direction until the wheel binds heavily. Then relieve binding by backing off adjusting nut $\frac{1}{8}$ turn minimum, and not more than $\frac{1}{4}$ turn. Lock adjusting nut by re-inserting cotter pin and tightening adjusting nut clamp bolt. Check adjustment by rotating wheel, making certain that it is free rolling without perceptible end play. If adjustment is correct, re-install hub cap.

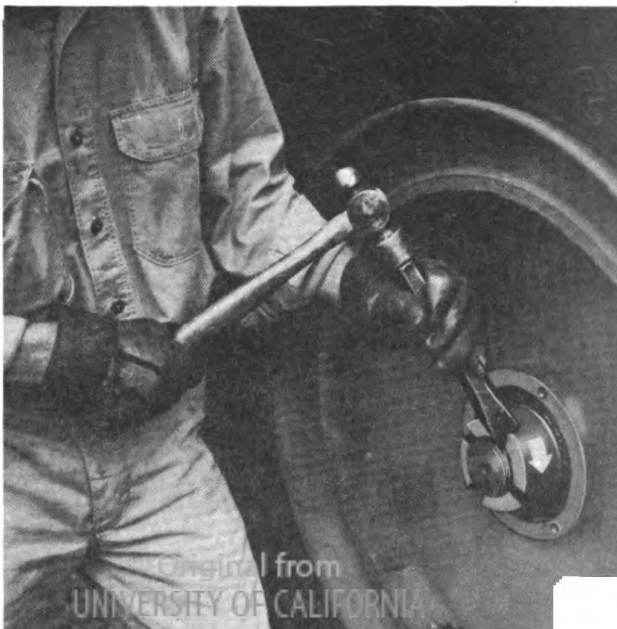

UNIVERSAL FORGING ADJUSTMENT

Check universal forging for end play every 64 hours of operation.

If tractor is disconnected, check adjustment by moving forging back and forth by hand. If tractor is connected, check by moving the tractor forward and backward while watching for any end movement of the forging.

To tighten the adjustment, first remove inspection plate.

Loosen adjusting nut clamp bolts and remove cotter pin from end of forging.

Insert a chisel in slot in adjusting nut to keep nut from turning. Then insert a bar through hitch block and turn forging in a clockwise direction until all end play has been eliminated with forging still left free to turn. Lock the adjustment by reinstalling cotter pin and tightening adjusting nut, clamp bolts. Then re-install inspection plate.

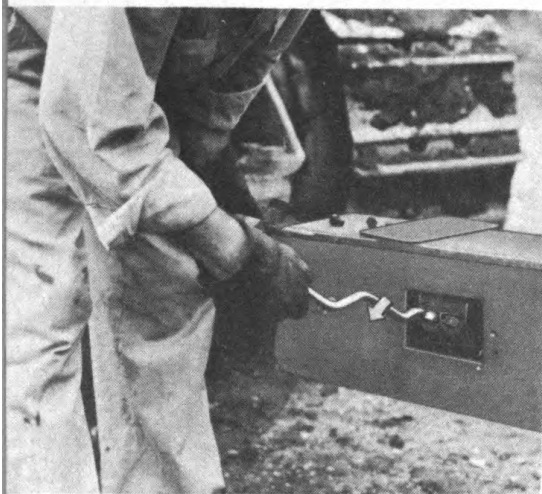
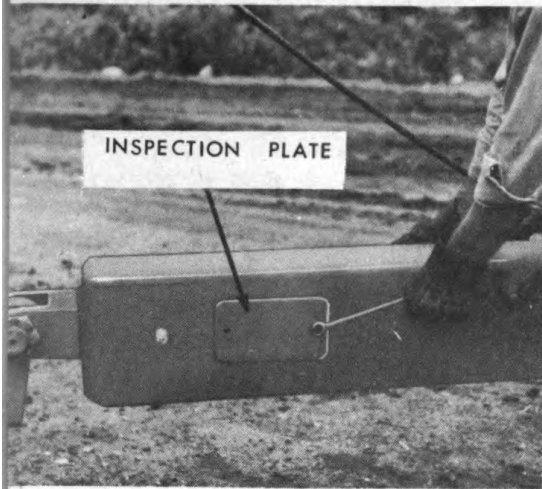

REMOVING AND INSTALLING TIRES

Crane tires may be changed either with the wheels on the Crane or with the wheels removed. However, due to the large size and weight of the tires, it is usually less difficult to remove or install the tires with the wheels removed. The use of a hoist or Crane in handling the tires and wheels is recommended.

To change a tire, lower the boom to the ground and raise the wheel with a jack or similar device. If the wheel is to be removed, take the steps necessary to effect its removal. (Refer to Disassembly Instructions on following pages).

Let all the air out of the tire. Insert a bar in the small groove in the locking ring. Then, while prying up on the locking ring, use a sledge hammer to drive the sliding ring toward the center of the rim. This will release the locking ring, and both the locking ring and sliding ring can be removed from the wheel.

If available, place a round valve cap on the valve stem. Push the valve stem through the rim, into the tire. Then insert a bar between the side of the tire and the inner retainer ring and pry the tire off the wheel.

To install the tire, reverse the above procedure. Be careful not to pinch the inner tube with the bar. Insert only enough air in the tube to hold it in place. Be sure the valve stem is in the center of the hole in the wheel before installing the sliding ring and locking ring. Then install the sliding ring and locking ring and inflate the tires to the correct pressures. (Refer to tire inflation instructions on page 14 of the Operation Section)



DISASSEMBLING

REMOVING AND DISASSEMBLING WHEELS

The wheels can be disassembled and removed either with or without the axles removed from the axle housings.

First remove hub cap by removing capscrews.

Remove cotter pin from end of axle and loosen adjusting nut clamp bolt.

Remove bearing adjusting nut by backing it off over threads on end of axle.

Remove oil seal retainer plate from opposite side of wheel by removing capscrews.

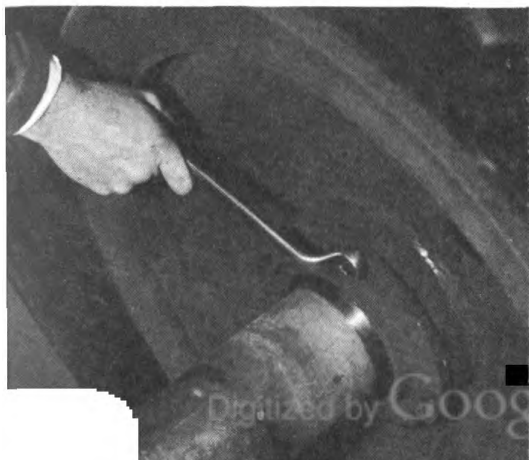
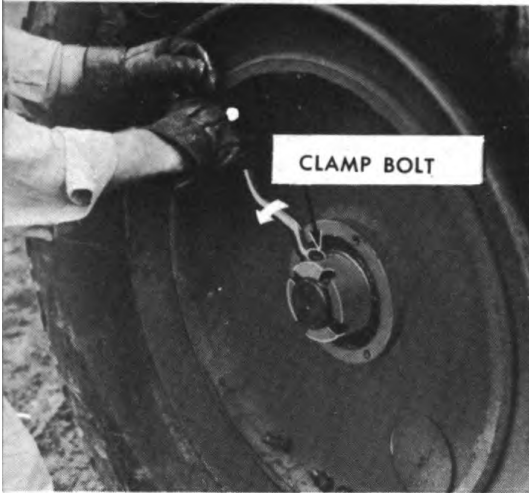

SECTION

Remove wheel from axle. To do this, first remove outer bearing cone. It may be necessary to jar outer bearing loose from axle by striking against the opposite side of wheel (if axle is not removed from axle housing) or against outer end of axle (if axle is removed from axle housing). The inner bearing cone can then be pulled off the axle. If the bearings are to be replaced, remove bearing cups from wheel hub.

REMOVING SHEAVE WHEELS, BEARINGS, PINS, ETC.

To remove the sheave wheels, bearings, pins, etc., from a sheave housing, first remove cotter pin from end of the sheave pin. Then pull sheave pin out the side of the sheave housing and lift sheave wheel out of the sheave housing.

Complete the job by sliding the sheave bearing out of the hub of the sheave wheel.

REMOVING UNIVERSAL FORGING

To remove the universal forging, first remove inspection plate from the side of the tongue. Then remove cotter pin from end of forging and loosen adjusting nut clamp bolts.

Insert a chisel in slot in adjusting nut to keep the nut from turning. Insert a bar through hitch block and turn forging counter-clockwise until forging is turned out of the adjusting nut. Then pull forging out of end of tongue. Remove adjusting nut through inspection hole.

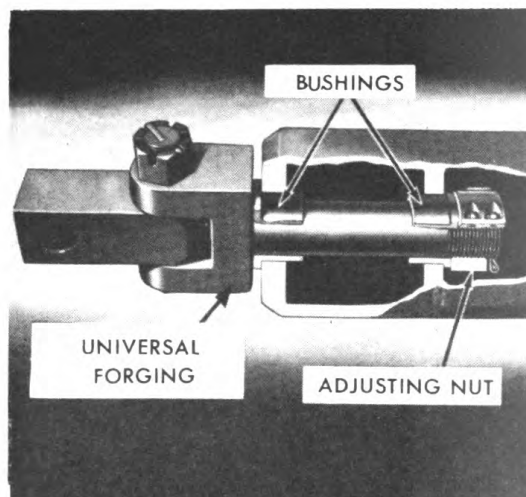
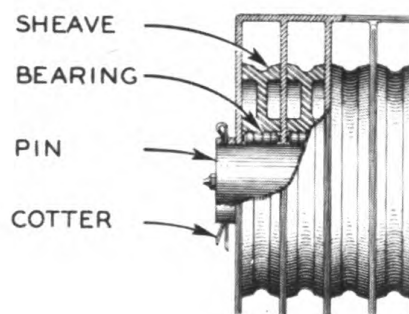
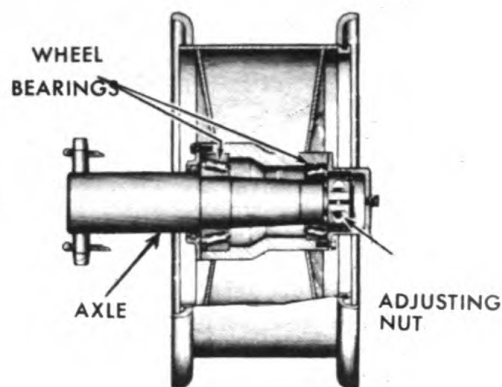

REPAIR SECTION

REMOVING HEAD STRUCTURE

To remove the head structure, first lower the boom to the ground and remove the cable. Then, with blocks placed under the rear of the boom to keep it from dropping to the ground when the head is removed, remove the capscrews which secure the head structure to the boom.

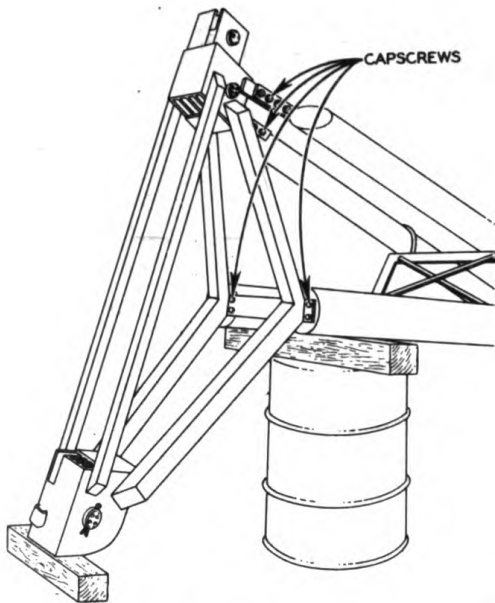

REMOVING BOOM STRUCTURE

The lower part of the boom slips over the Crane axles. To remove the boom, first disconnect the stop cable. Remove the wheels and axles by pulling the cotter pin and removing the axle retainer pin from each axle housing. Then pull the axle out of the axle housing. This will free the boom from the remainder of the Crane.

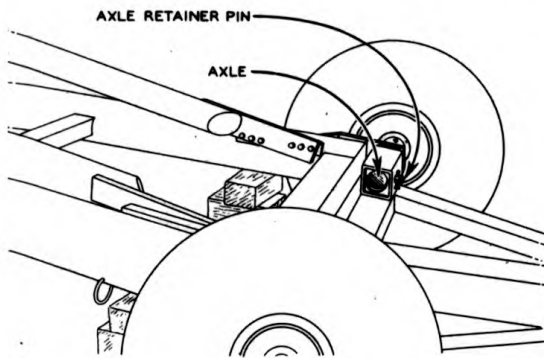

DISASSEMBLING BOOM

To disassemble the boom, first remove the capscrews which secure the tubular members together at the lower end of the boom.

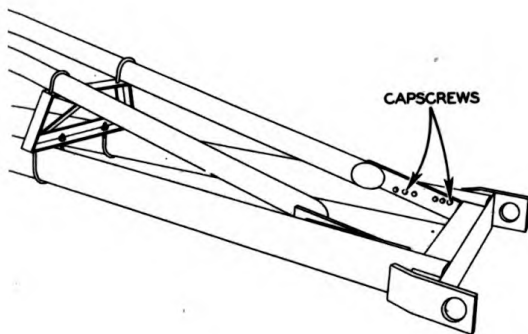

Complete the disassembly by removing the U-bolts which connect the tubular members to the center brace.

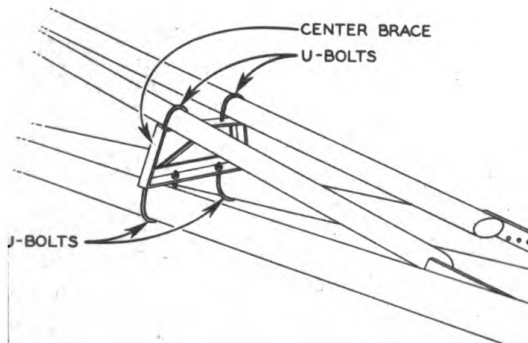

OVERHAULING

Other than replacing bearings, oil seals, etc. when they become worn, practically the only type of repair ever required on LeTourneau Cranes is welding up any small cracks or breaks that might result from abusing a welded member of the Crane, or straightening a bent member.

When welding, use only coated arc electrodes. Keep the welding heat comparatively low to avoid burning up the alloy qualities of the steel.

Always weld a crack or break before it becomes serious. Reinforce the crack or break to give added strength.

ASSEMBLING

To assemble a LeTourneau Crane, simply reverse the procedure for disassembling.

Be sure the bearings are free of grit, dirt, or other foreign matter before installing. Do not replace bearing cones without replacing bearing cups, and vice-versa.

Lubricate all points of lubrication before operating the Crane.

During assembly, follow the adjustment instructions on pages 2, 3, and 4 of the Repair Section.

OIL SEALS

If the leather in an oil seal becomes dry, soak in kerosene until soft. Before installing the seal, rub the leather with some smooth round surface such as a hammer handle. This will seat the leather seal in place and round off the sharp edge, making possible quick and easy installation without danger of injury to the leather.

The seals should be installed in place with uniform pressure all around to avoid distorting and breaking the seal cage. The wheel hub oil seals should be installed with the leather cupped outward, away from the grease chamber.

TABLE OF TOLERANCES AND CLEARANCES OF BEARINGS AND ADJUSTABLE PARTS

POINT OF ADJUSTMENT	CORRECT ADJUSTMENT	ALLOWABLE TOLERANCE
Wheel Bearings (Tapered Roller)	.000"	.008" preload to .008" loose.
Sheave Bearings (Straight Roller)	Non-Adjustable
Universal Forging	Free turning with no end play.

PARTS CATALOG

WARNING

SPARE PARTS can be supplied promptly and accurately only if positively identified by correct part number and correct part name.

FURNISH THIS INFORMATION ON ALL REQUISITIONS. WITHOUT FAIL, on all requisitions, give name of machine, name of manufacturer, model or size, manufacturer's serial number of each machine and subassemblies attached to machine, and components and accessories for which spare parts are required.

List spare parts for only one make or kind of machine on each requisition.

Requisitions must be double spaced to provide room for office notations when necessary.

SECT. 3

PREPARATION OF REQUISITIONS

SAMPLE COPY FOR USE IN THE PREPARATION OF REQUISITIONS

State PERIOD designation by use of one of the following terms:

- (1) "INITIAL"—first requisition of authorized allowances.
- (2) "REPLENISHMENT"—subsequent requisitions to maintain authorized allowances.
- (3) "SPECIAL"—requisitions for necessary repairs not covered by allowances.

Emergency requisitions sent by telephone, telegraph, or radio must always be confirmed immediately with requisition marked: "Confirming (state identifying data)"

Prepare a separate requisition for each different machine.

Type "SPARE PARTS" in upper right hand corner of requisition form.

Give complete shipping instructions for packing, marking, routing, etc. should be given at the end of the requisition.

State proper nomenclature of machine and make, model, serial number and registration number.

State basis or authority, and date delivery is required, immediately below description of machine.

State manufacturers' parts numbers and nomenclature descriptions accurately and completely. Do not use abbreviations.

Group parts required under group headings as shown in manufacturers' parts catalogs.

Double space between items.

Nonexpendable items must be accounted for.

WAR DEPARTMENT
Q. M. C. Form No. 400
(Revised Apr. 6, 1941)

(SAMPLE)
REQUISITION

SPARE PARTS

To: Engineer Supply Officer, No. of Sheets 1 Sheet No. 1
Columbus Quartermaster Depot, Columbus, Ohio

Requisition No. E-531-3-43 Date August 14, 1942 Period Special

SHIP TO Engineer Property Officer, Pine Camp, New York

MARKED FOR: Engineer Supply Officer, 802nd Engr. Battalion, Pine Camp, N.Y.

REQUISITIONED BY (show Signature, Rank, Organization, Destination. If different from "mark to" include address):
Robert E. Roe
Robert E. Roe,
Major, C.E.,
Engineer Property Officer

APPROVED:
John E. Doe
John E. Doe,
Col., C.E.,
Executive Officer

STOCK No	ARTICLES	UNIT	ON HAND AND DUR	CONSUMED	REQUIRED	APPROVED
PARTS FOR LeTOURNEAU CRANE 20-FOOT, MODEL M20, SERIAL NUMBER C-2500-M20A						
Basis: Repair of disabled equipment						
Delivery is requested by August 30, 1942						
BOOM GROUP						
R-762	U-BOLT	ea	0	4	4	
R-1971	CROSS TIE	ea	0	4	4	
R-1973	RIGHT TENSION BEAM	ea	0	4	4	
R-1974	LEFT TENSION BEAM	ea	0	4	4	
HEAD GROUP						
R-2353	SHEAVE HOUSING STRUCTURE	ea	0	4	4	
R-1970	BALANCE BEAM STRUCTURE	ea	0	4	4	
R-995	HEAD STRUCTURE	ea	0	4	4	
H-2801	GASKET	ea	0	4	4	
NONEXPENDABLE ARTICLES SHOWN HAVE BEEN PLACED ON I & I REPORT (REPORT OF SURVEY, ETC.)						

PREPARATION OF REQUISITIONS

A Sample requisition in the correct form for submission by the Engineer Property Officer is shown on the opposite page.

THIS SHALL BE FOLLOWED IN MAKING OUT REQUISITIONS.

In order to eliminate duplication of work, Property Officers may authorize organizations to prepare requisitions in final form, leaving requisition number space blank for completion by Property Officer.

THE FOLLOWING RULES WILL BE OBSERVED CAREFULLY IN PREPARING REQUISITIONS FOR SPARE PARTS:

- a. Prepare a separate requisition for each different machine.
- b. Type "SPARE PARTS" in upper right hand corner of requisition form.
- c. State PERIOD designation by use of one of the following terms:
 - (1) "INITIAL"—first requisition of authorized allowances.
 - (2) "REPLENISHMENT"—subsequent requisitions to maintain authorized allowances.
 - (3) "SPECIAL"—requisitions for necessary repairs not covered by allowances.
- d. Give complete shipping instructions.
- e. State proper nomenclature of machine, and make, model, serial number and registration number.
- f. State basis or authority, and date delivery is required, immediately below description of machine.
- g. Group parts required under group headings as shown in manufacturers' parts catalogs.
- h. State manufacturers' parts numbers and nomenclature descriptions accurately and completely. Do not use abbreviations.
- i. Double space between items.
- j. Emergency requisitions sent by telephone, telegraph, or radio must always be confirmed immediately with requisition marked: "Confirming (state identifying data)".
- k. Nonexpendable items must be accounted for.

MODEL M20 CRANE

HOIST CABLE

From right drum of Power Control Unit
 Cable goes up and under bottom of sheave..... in housing 2
 Then over top of sheave..... A in housing 3
 Then forward and over top of sheave... B in housing 4
 Then down and under bottom of sheave. C in housing 5
 Then up and over top of sheave..... D in housing 4
 Then down and under sheave..... E in housing 5
 Then up and over top of sheave..... F in housing 4
 Then down and under bottom of sheave. G in housing 5
 Then up and over top of sheave..... H in housing 4
 Then down and under bottom of sheave. I in housing 5
 Then up and dead end cable at..... J with cable wedge

NOTE: Cranes having serial number C-2251-M20A and up have a different dead end set-up than that shown on diagram. After cable has been threaded under sheave I, it is taken up and through housing H but over curved protector plate and through hole in top and dead ends at wedge on top of housing 4. SEE SKETCH ON DIAGRAM SHOWING DETAILS OF THIS.

BOOM CABLE

From left drum of Power Control Unit
 Cable goes up and over top of sheave... K in housing 3
 Then down and around sheave..... L in housing 1
 Then up and over top of sheave..... M in housing 3
 Then down and around sheave..... N in housing 1
 Then up and over top of sheave..... O in housing 3
 Then down and through cable loop..... on top of housing 1
 Then up and tie with cable clamp at... P

HOIST CABLE

1/2 x 6x19=210 feet long

BOOM CABLE

1/2 x 6x19=255 feet long

R-4379

R-4378

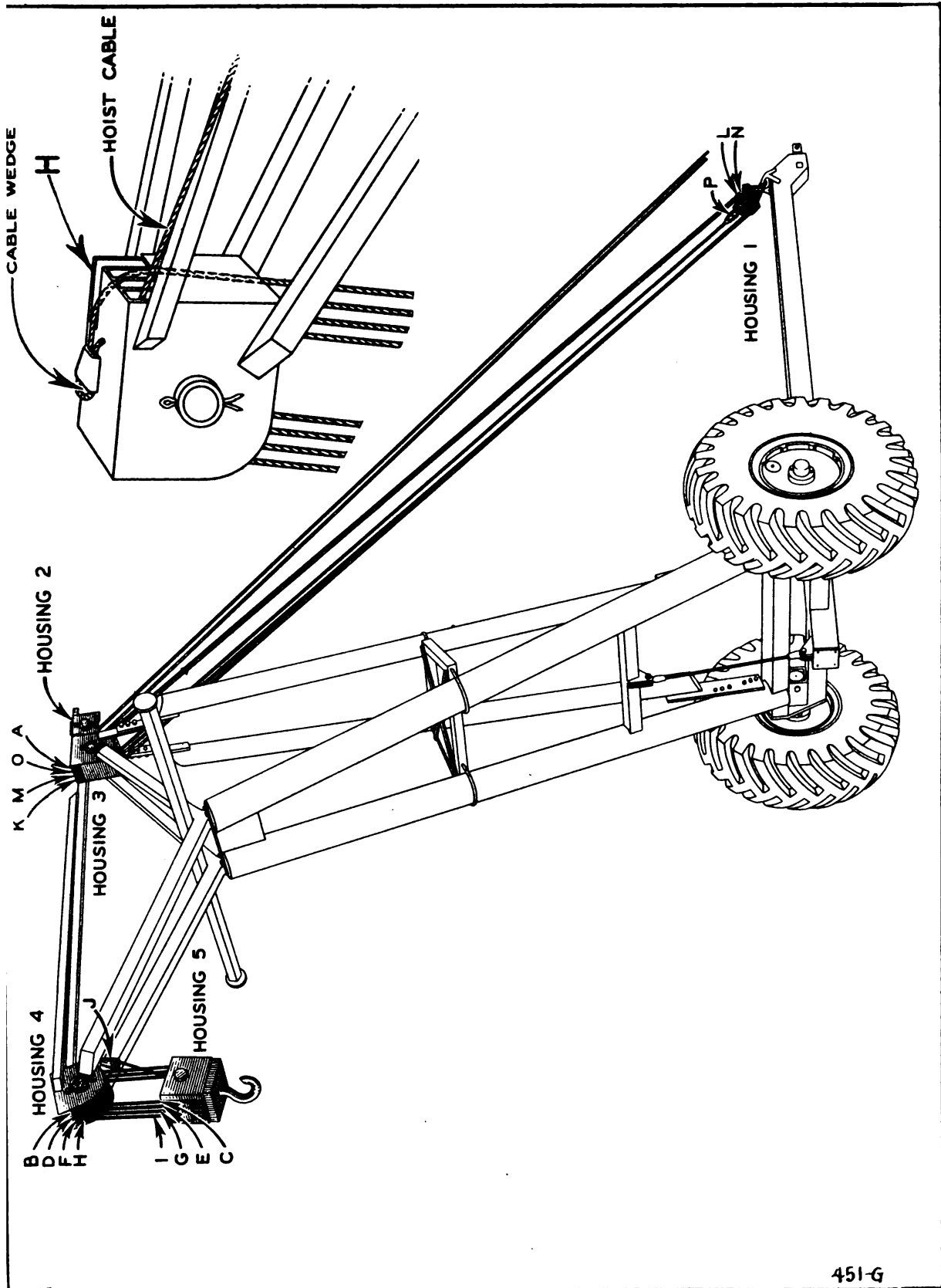

451-G

CABLE THREADING DIAGRAM

Digitized by Google
Original from
UNIVERSITY OF CALIFORNIA
ALWAYS GIVE MACHINE NUMBER WHEN ORDERING PARTS

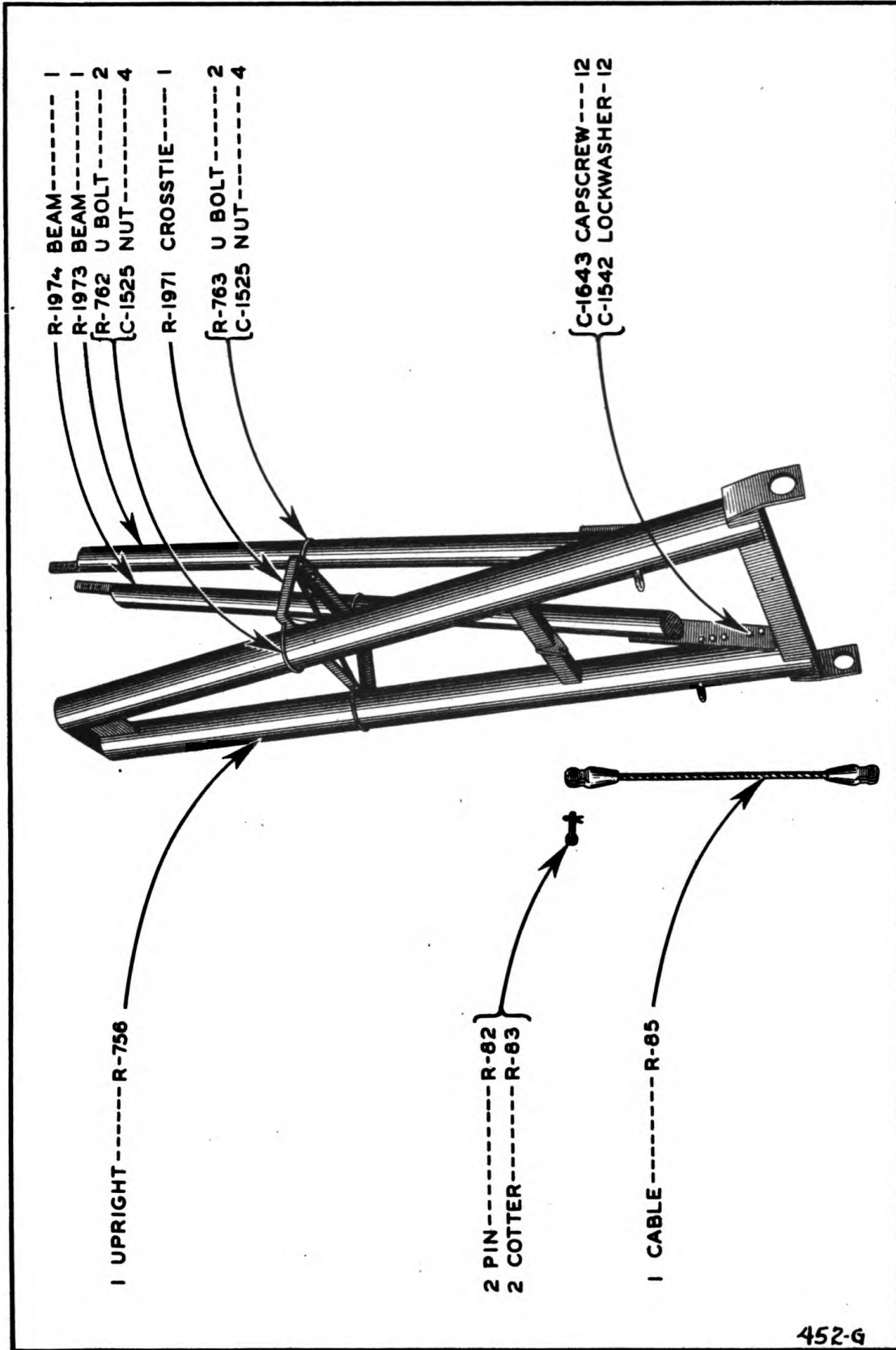

452-G

BOOM GROUP

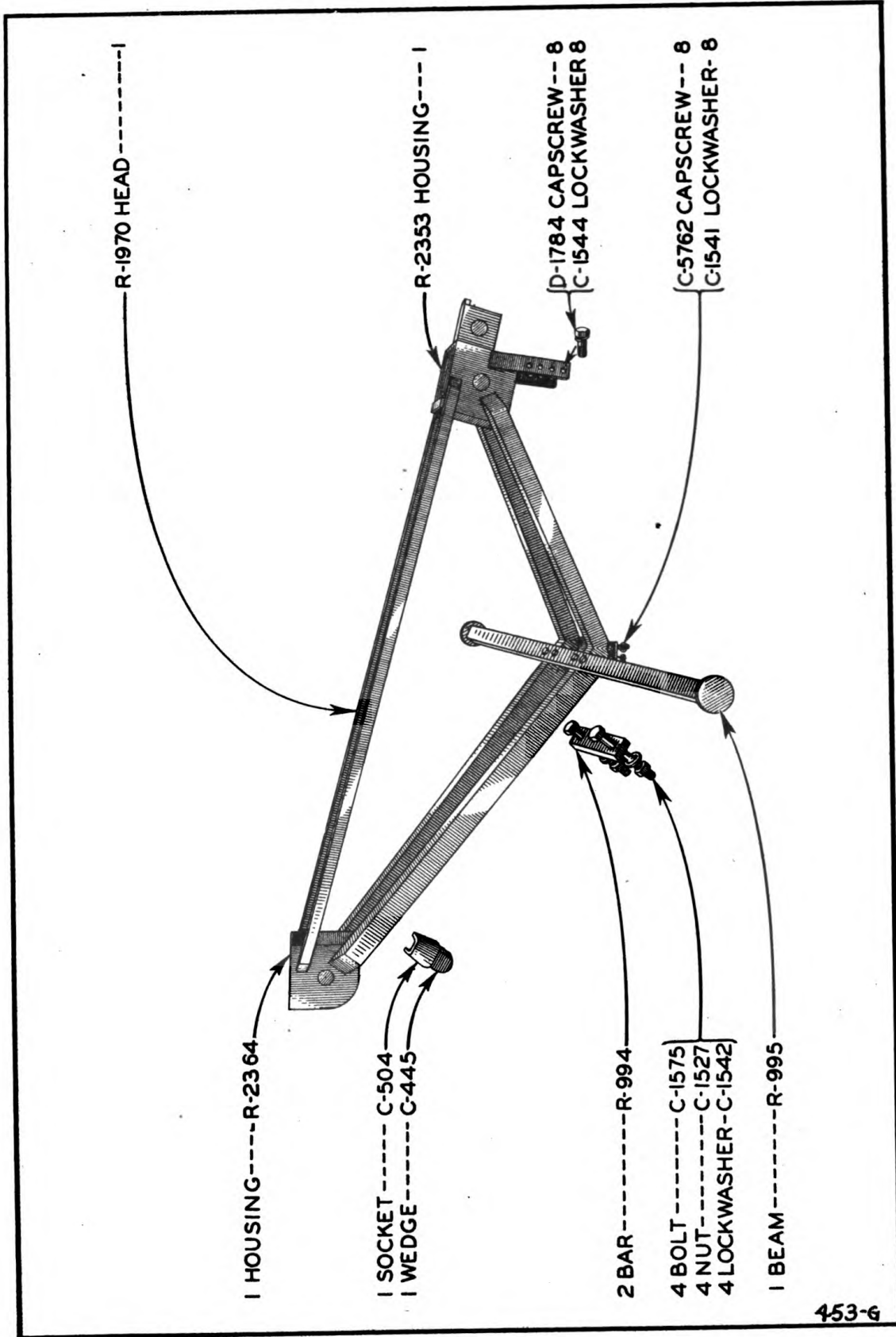

R-1970 HEAD ----- 1

R-2353 HOUSING ----- 1

D-1784 CAPSCREW -- 8
C-1544 LOCKWASHER 8

C-5762 CAPSCREW -- 8
C-1541 LOCKWASHER- 8

1 HOUSING ----- R-2364

1 SOCKET ----- C-504
1 WEDGE ----- C-445

2 BAR ----- R-994

4 BOLT ----- C-1575
4 NUT ----- C-1527
4 LOCKWASHER - C-1542

1 BEAM ----- R-995

453-6

HEAD GROUP

Generated on 2013-05-27 16:49 GMT / http://hdl.handle.net/2027/uc1.b3241427
Public Domain, Google-digitized / http://www.hathitrust.org/access_use#pd-google

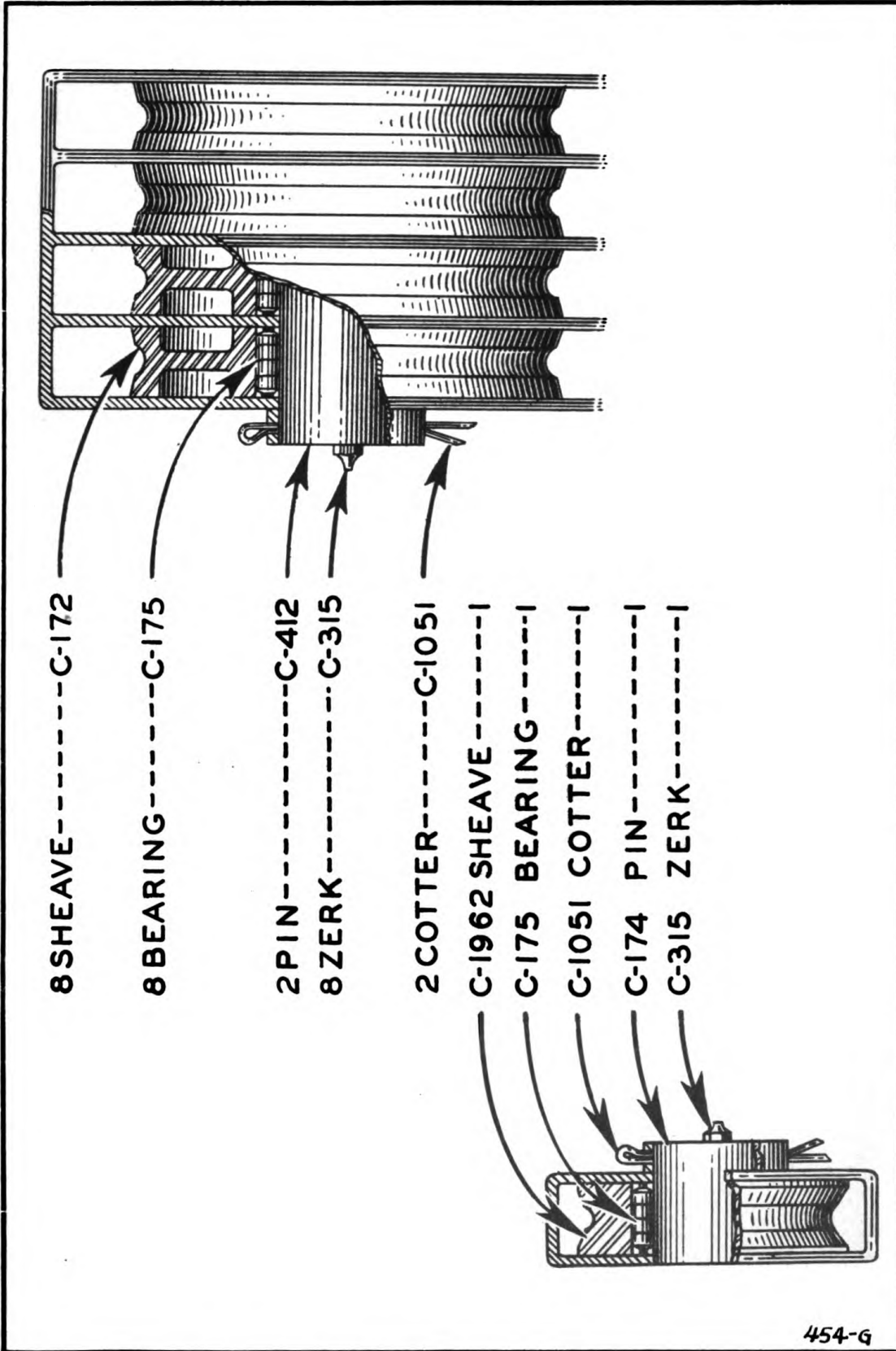

HEAD SUB ASSEMBLIES

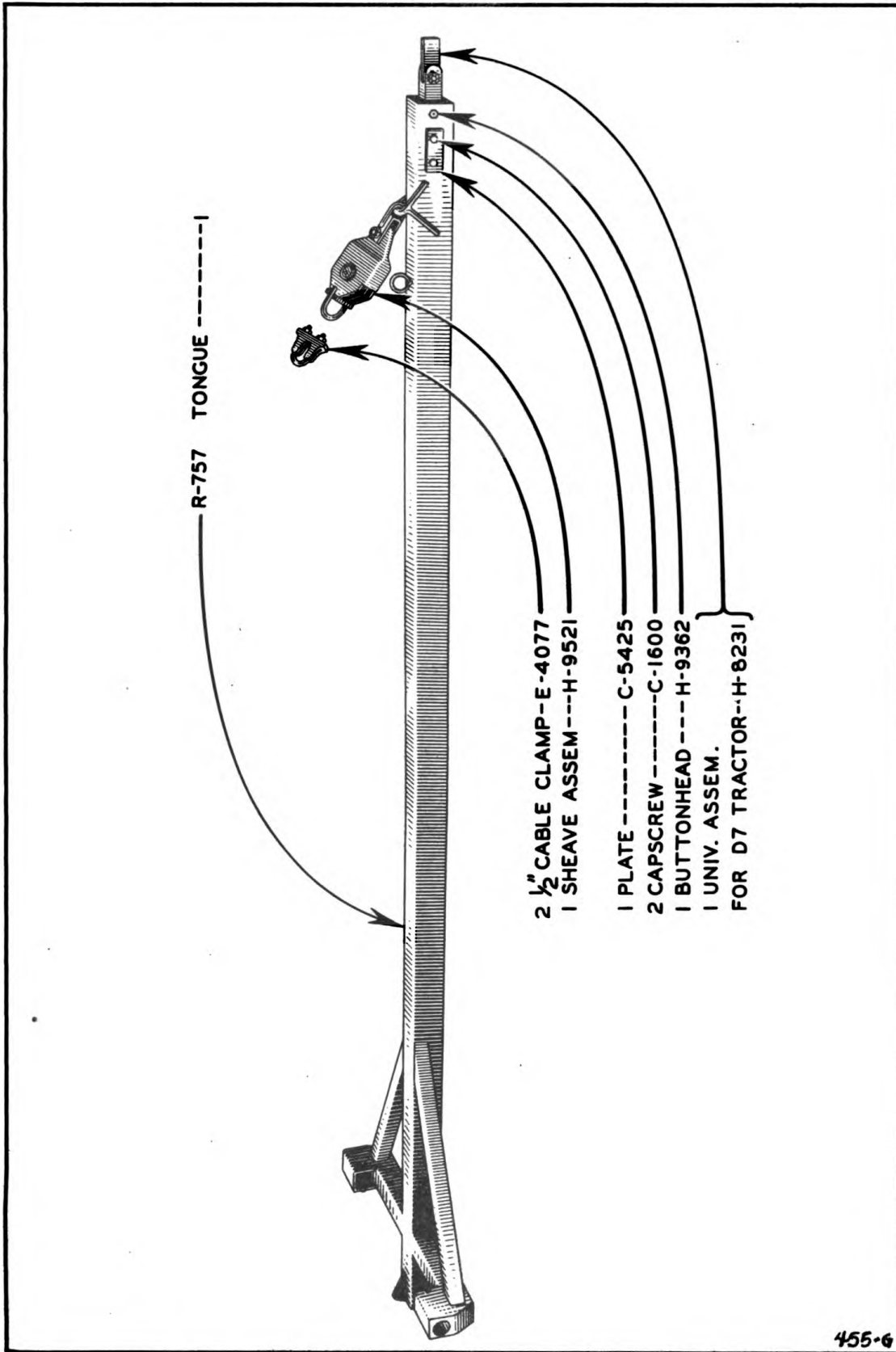

455-6

TONGUE GROUP

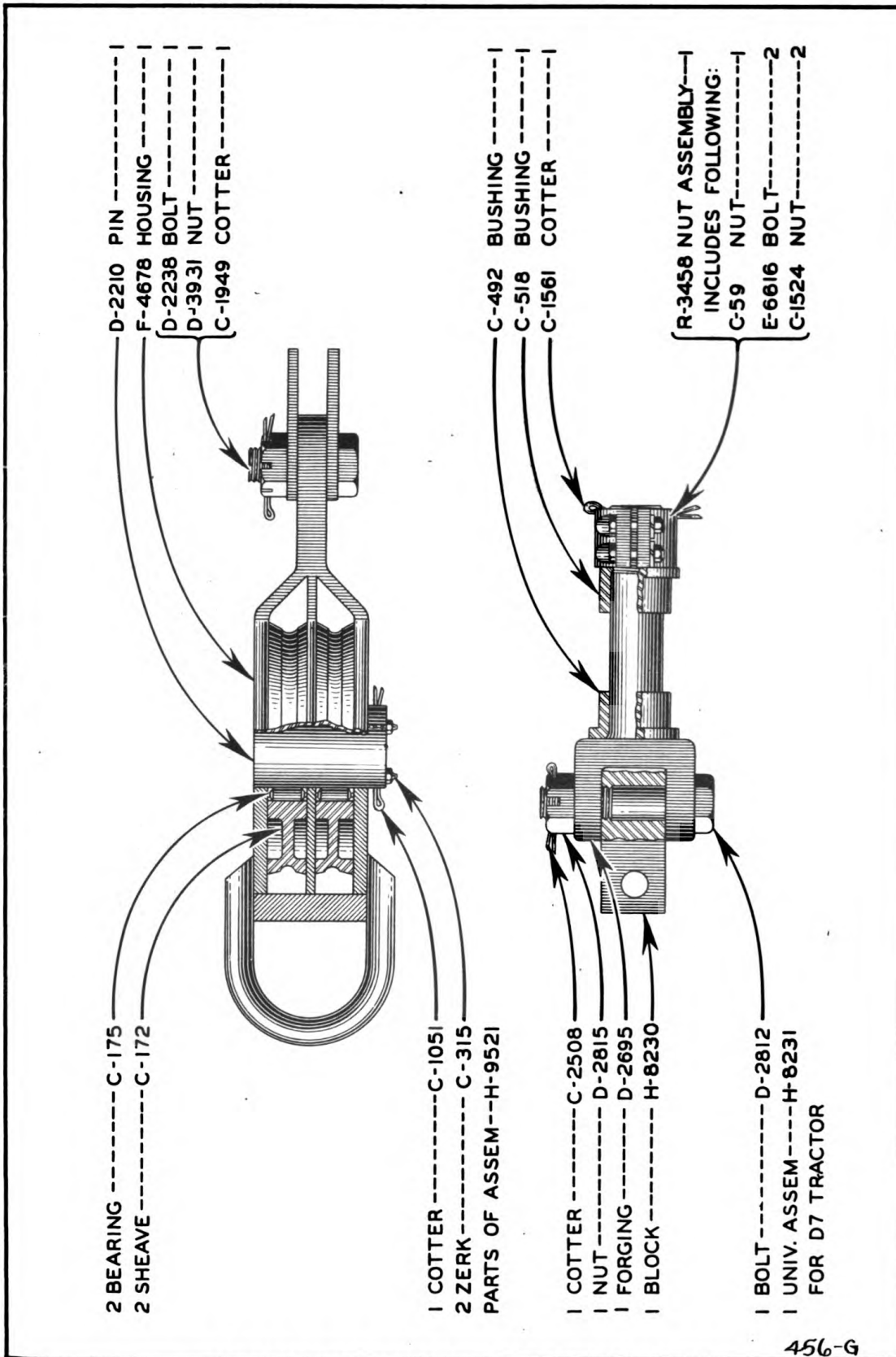

456-G

TONGUE SUB ASSEMBLIES

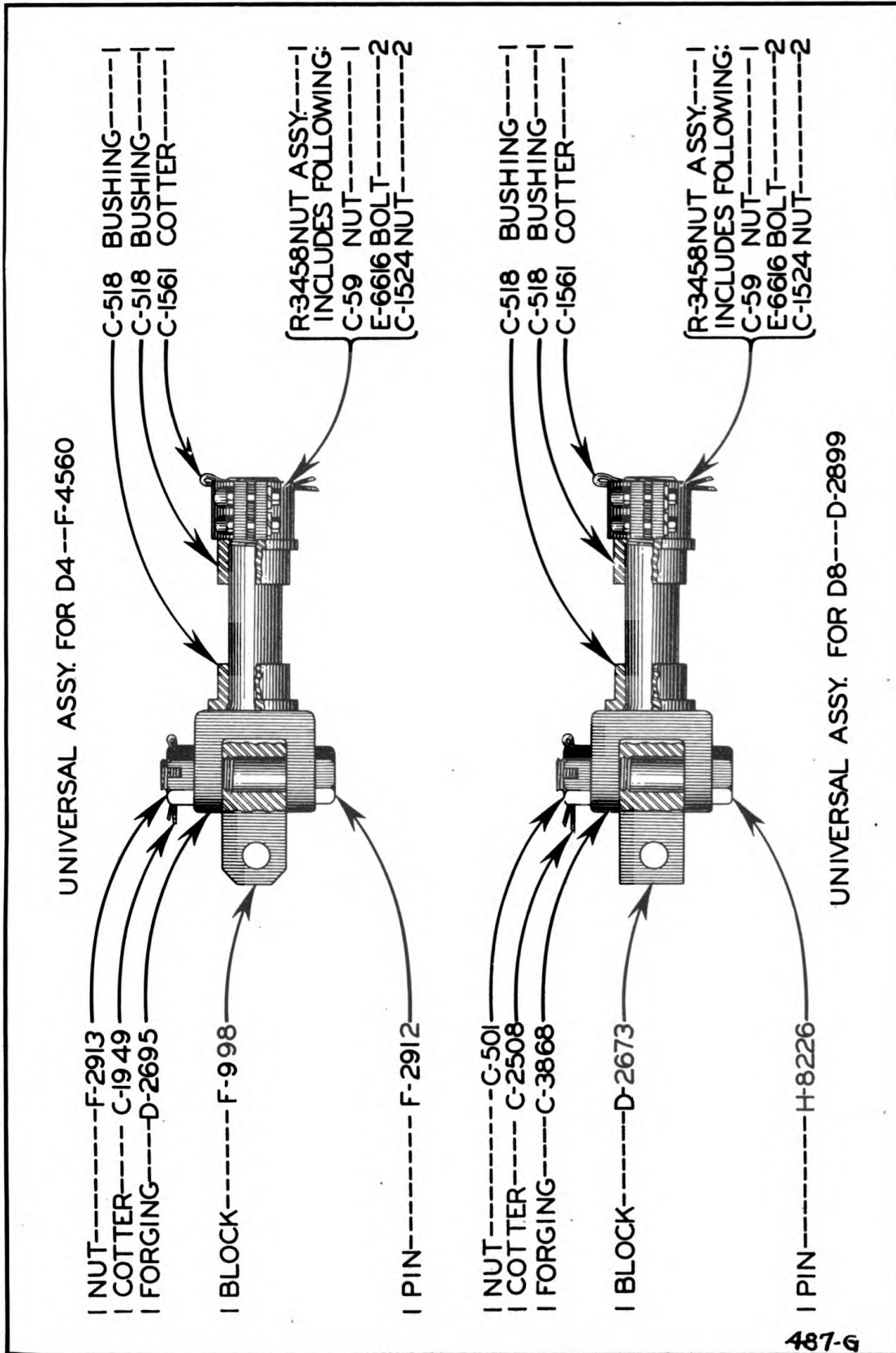

OPTIONAL UNIVERSAL ASSYS.

Digitized by Google

Original from
UNIVERSITY OF CALIFORNIA

ALWAYS GIVE MACHINE NUMBER WHEN ORDERING PARTS

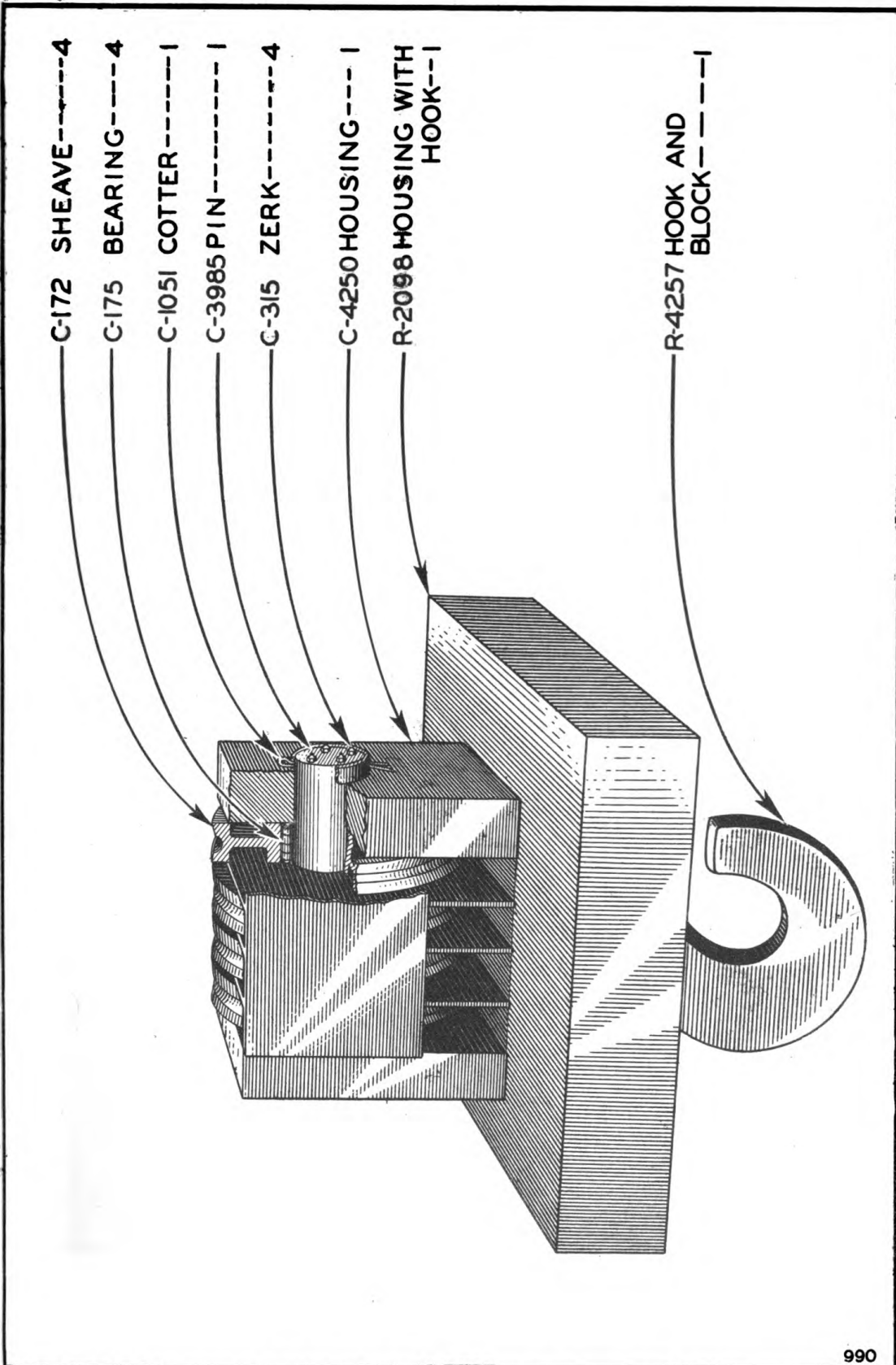

C-172 SHEAVE---4

C-175 BEARING---4

C-1051 COTTER---1

C-3985 PIN---1

C-315 ZERK---4

C-4250 HOUSING---1

R-2098 HOUSING WITH
HOOK---1

R-4257 HOOK AND
BLOCK---1

990

HOOK SHEAVE ASSEMBLY

Generated on 2013-05-27 16:55 GMT / http://hdl.handle.net/2027/uc1.b3241427
Public Domain, Google-digitized / http://www.hathitrust.org/access_use#pd-google

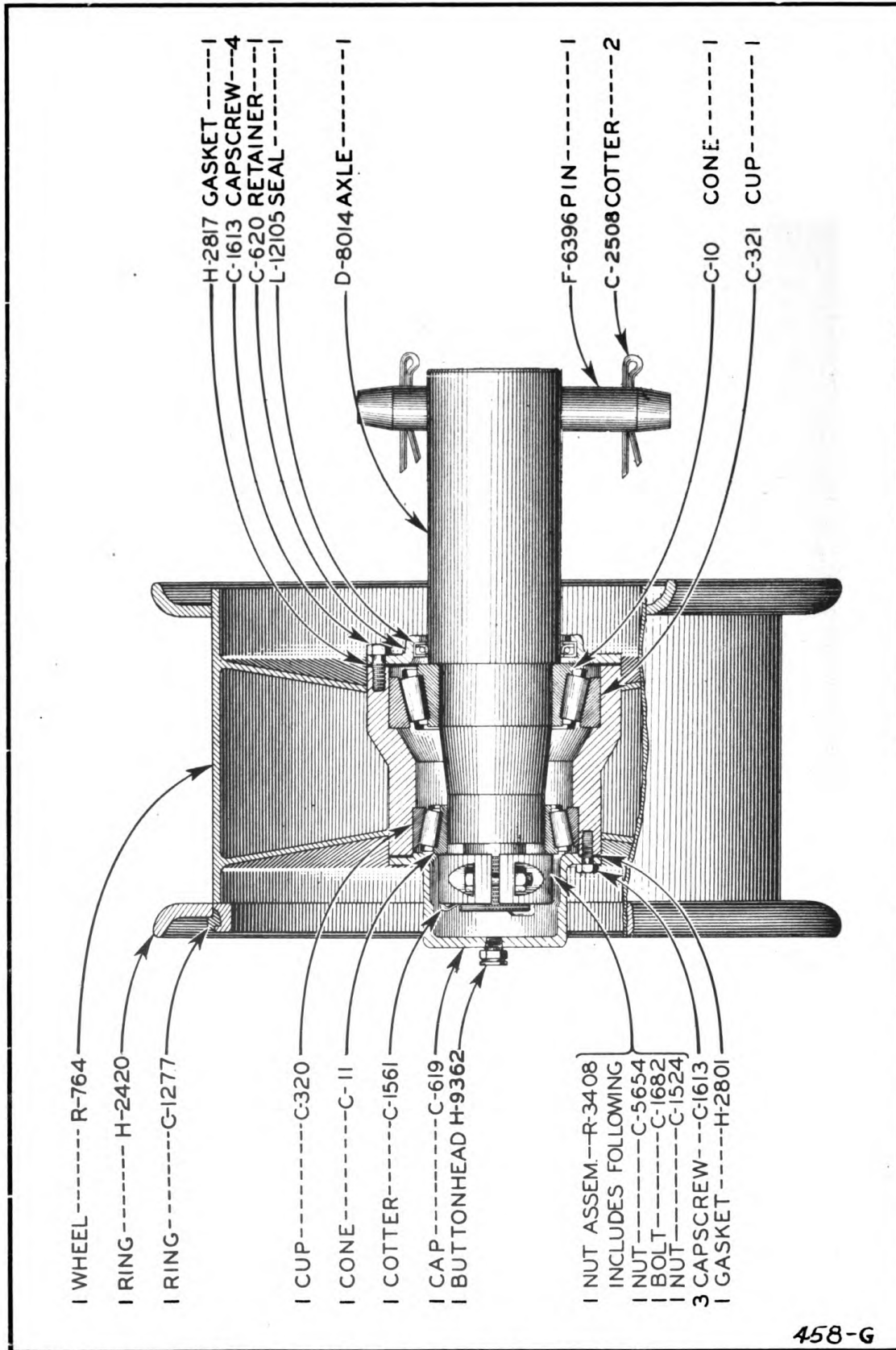

18X24 SINGLE WHEEL-CROSS SECTIONED

458-G

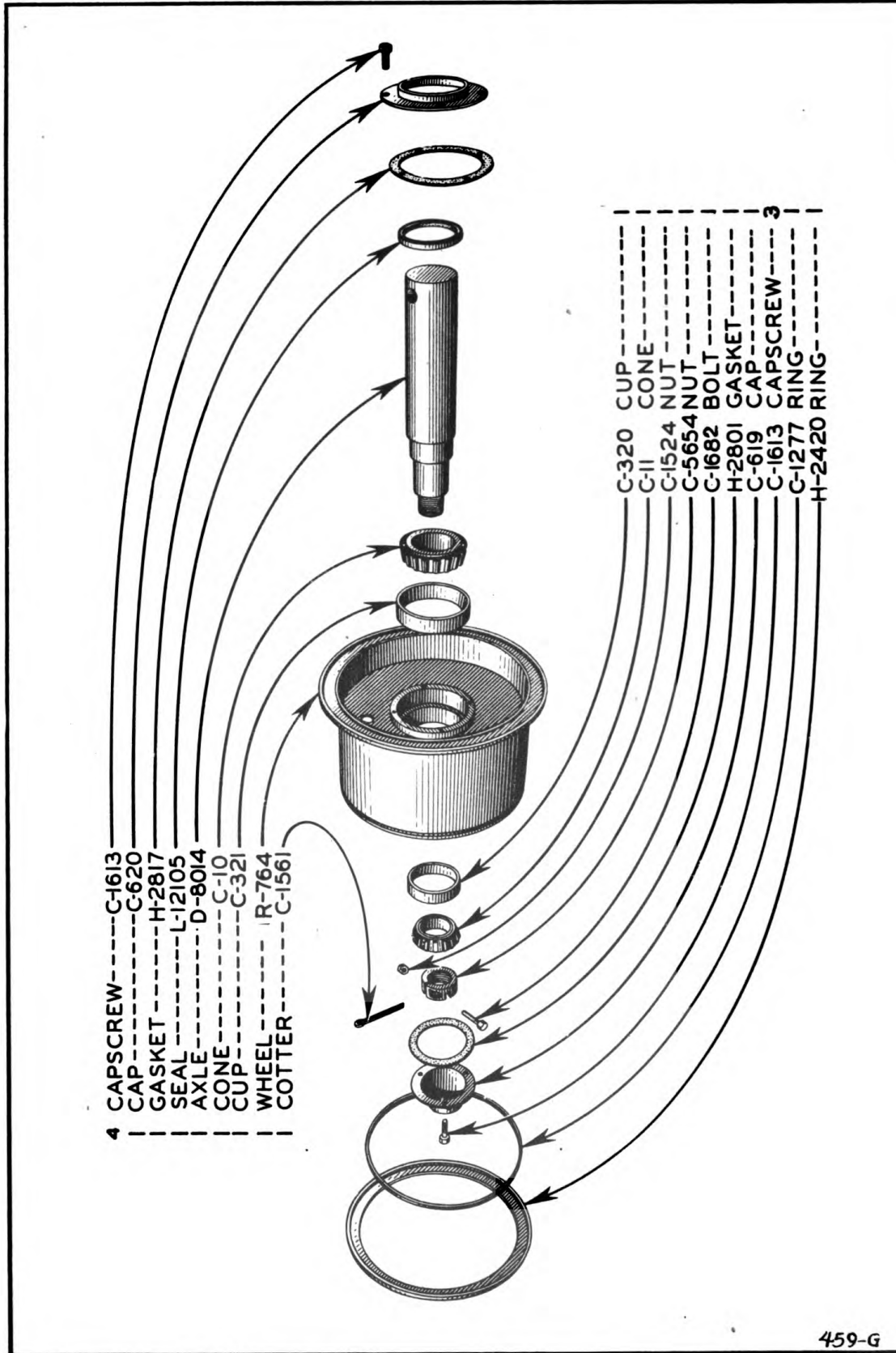

- 4 CAPSCREW-----C-1613
- CAP-----C-620
- GASKET-----H-2817
- SEAL-----L-12105
- AXLE-----D-8014
- CONE-----C-10
- CUP-----C-321
- WHEEL-----R-764
- COTTER-----C-1561

- C-320 CUP-----
- C-11 CONE-----
- C-1524 NUT-----
- C-5654 NUT-----
- C-1682 BOLT-----
- H-2801 GASKET-----
- C-619 CAP-----
- C-1613 CAPSCREW-----3
- C-1277 RING-----
- H-2420 RING-----

18 X 24 SINGLE WHEEL-EXPLODED

459-G

MODEL M20 CRANE

11

2 OF 18 x 24, EARTHMOVER, 20 PLY TIRES, USING 18 x 24 TRANSPORT,
TRUCK-BUS, HEAVY DUTY TUBES, WITH VALVE STEM No. TR-14M.

PART NUMBER	DESCRIPTION	PAGE	QTY.	WEIGHT		Price Each
				Lbs.	Oz.	
C-10	CONE—TIMKEN #861.....	9, 10	2	9	2	17.25
C-11	CONE—TIMKEN #749.....	9, 10	2	4	8	8.58
C-59	NUT	7	1	6	8	5.41
C-172	SHEAVE	5, 7, 8	14	12	..	5.20
C-174	PIN	5	1	5	..	2.38
C-175	BEARING—HYATT #RA-212.....	5, 7, 8	15	1	8	2.38
C-315	ZERK— $\frac{1}{8}$ " STRAIGHT	5, 7, 8	1506
C-320	CUP—TIMKEN #742	9, 10	2	2	8	5.45
C-321	CUP—TIMKEN #854	9, 10	2	6	..	14.10
C-412	PIN	5	1	14	..	7.10
C-445	WEDGE	4	1	..	8	.38
C-492	BUSHING	7	1	6	..	6.15
C-504	SOCKET	4	1	1	4	.68
C-518	BUSHING	7	1	4	4	6.11
C-619	CAP	9, 10	2	9	..	6.23
C-620	RETAINER	9, 10	2	4	8	1.86
C-1051	COTTER— $\frac{3}{8}$ " x 5"	5, 7, 8	5	..	4	.06
C-1277	CAP	9, 10	2	5	8	3.04
C-1524	NUT— $\frac{1}{2}$ " NF HEX.....	7	403
C-1525	NUT— $\frac{5}{8}$ " NC HEX.....	3	804
C-1527	NUT— $\frac{3}{4}$ " NC HEX.....	4	405
C-1540	LOCKWASHER— $\frac{1}{2}$ "	7	201
C-1541	LOCKWASHER— $\frac{5}{8}$ "	4	802
C-1542	LOCKWASHER— $\frac{3}{4}$ "	3, 4	1603
C-1544	LOCKWASHER—1"	4	807
C-1561	COTTER— $\frac{1}{2}$ " x 5"	7, 9, 10	3	..	8	.11
C-1575	BOLT— $\frac{3}{4}$ " x 10" MACHINE	4	4	1	8	.30
C-1600	CAPSCREW— $\frac{3}{8}$ " x $\frac{1}{2}$ " NC.....	6	203
C-1613	CAPSCREW— $\frac{1}{2}$ " x $1\frac{1}{4}$ " NC.....	9, 10	1406
C-1643	CAPSCREW— $\frac{3}{4}$ " x $1\frac{3}{4}$ " NC.....	3	12	..	6	.16
C-1685	CAPSCREW— $\frac{1}{2}$ " x 3" NF.....	7	210
C-1949	COTTER— $\frac{1}{4}$ " x 3"	7	101
C-1962	SHEAVE	5	1	5	8	3.99
C-2508	COTTER— $\frac{5}{16}$ " x 3"	7, 9,	401
C-3985	PIN	8	1	20	..	9.25
C-4250	HOOK SHEAVE HOUSING.....	8	1	142	..	51.75
C-5425	PLATE	6	1	2	8	.56
C-5654	NUT	9, 10	2	3	12	2.84
C-5762	CAPSCREW— $\frac{5}{8}$ " x $1\frac{1}{2}$ " NC	4	810
D-1784	CAPSCREW—1" x $2\frac{1}{4}$ " NC.....	4	8	..	12	.42
D-2210	PIN	7	1	9	..	3.98
D-2238	BOLT— $1\frac{1}{2}$ " x $3\frac{3}{8}$ " NF SPECIAL.....	7	1	2	8	1.01
D-2695	FORGING	7	1	42	8	29.96
D-2812	PIN	7	1	4	12	2.07
D-2815	NUT— $1\frac{1}{8}$ " NF CASTELLATED.....	7	1	1	..	.68
D-3931	NUT—CASTELLATED	7	1	..	8	.62
D-8014	AXLE	9	1	97	..	39.93
E-4077	$\frac{1}{2}$ " CABLE CLAMP.....	6	1	..	8	.24
F-4678	HOOK SHEAVE STRUCTURE.....	7	1
F-6396	PIN	9, 10	2	4	8	2.86

460-G

SPARE PARTS & PRICE LIST

Digitized by Google

Original from
UNIVERSITY OF CALIFORNIA

ALWAYS GIVE MACHINE NUMBER WHEN ORDERING PARTS

MODEL M20 CRANE

12

H-2420	RING—SLIDING	9, 10	2	51	..	17.03
H-2801	GASKET	9, 10	215
H-2817	GASKET	9, 10	220
H-4249	COTTER—5/16" x 2"	9, 10	201
H-8230	BLOCK	7	1	17	4	8.45
H-8231	UNIVERSAL ASSEMBLY	6, 7	1	67	..	41.20
H-9362	BUTTONHEAD	6, 9, 10	3	..	4	.33
H-9521	HOIST SHEAVE ASSEMBLY	6, 7	1	100	..	40.90
L-12105	OIL SEAL	9, 10	2	..	8	2.11
R-82	PIN—FOR CABLE SOCKET	3	2	..	10	.80
R-83	COTTER—1/4" x 1 1/2"	3	201
R-85	STOP CABLE STRUCTURE	3	1	12.25
R-756	FRONT BOOM STRUCTURE	3	1	1200	..	330.00
R-757	TONGUE STRUCTURE	6	1	1900	..	527.50
R-762	"U" BOLT	3	2	2	8	.85
R-763	"U" BOLT	3	2	1	12	.65
R-764	18 x 24 SINGLE WHEEL STRUCTURE	9	2	220	..	60.85
R-994	CLAMP	4	2	4	8	1.95
R-995	BALANCE BEAM STRUCTURE	4	1	110	..	42.75
R-1970	HEAD STRUCTURE	4	1	500	..	180.50
R-1971	CROSS TIE	3	1	59	..	19.60
R-1973	BEAM—RIGHT TENSION	3	1	304	..	110.00
R-1974	BEAM—LEFT TENSION	3	1	304	..	110.00
R-2098	HOOK SHEAVE HOUSING STRUCTURE	8	1	290	..	87.25
R-2350	HOOK & BOTTOM PLATE STRUCTURE	8	1	100	..	38.50
R-2353	HOUSING	4	1	80	..	34.00
R-2364	HOUSING	4	1	70	..	21.75
*R-3408	NUT ASSEMBLY	9, 10	2	3	12	2.84
*R-3458	NUT ASSEMBLY	7	1	6	8	5.41
R-4378	1/2 x 6 x 19 CABLE—255' LONG	1	1
R-4379	1/2 x 6 x 19 CABLE—210' LONG	1	1
*R-3408	NUT ASSEMBLY—INCLUDES FOLLOWING:					
C-5654	NUT	9, 10	2
C-1682	BOLT	9, 10	2
C-1524	NUT	9, 10	2
*R-3458	NUT ASSEMBLY—INCLUDES FOLLOWING:					
C-59	NUT	7	1
E-6616	BOLT	7	1
C-1524	NUT	7	1
OPTIONAL UNIVERSAL ASSEMBLY						
F-4560	D4 UNIVERSAL ASSEMBLY	7A	1	60	..	37.66
D-2899	D8 UNIVERSAL ASSEMBLY	7A	1	88	..	45.92

NOTE: THE H-8231 UNIVERSAL ASSEMBLY IS USED FOR BOTH D6 & D7 TRACTORS.

461-G

SPARE PARTS & PRICE LIST

Digitized by Google

Original from
UNIVERSITY OF CALIFORNIA

ALWAYS GIVE MACHINE NUMBER WHEN ORDERING PARTS

