

DEPARTMENT OF THE ARMY TECHNICAL MANUAL

DIRECT CURRENT
GENERATOR
G-43/G

This copy is a reprint which includes current pages from Changes 1,2,4,5,and 6.

WARNING

DANGEROUS VOLTAGES EXIST IN THIS EQUIPMENT

Be careful when working on the 425-volt dc circuits.

DON'T TAKE CHANCES!

CHANGE }
No.6 }

HEADQUARTERS
DEPARTMENT OF THE ARMY
WASHINGTON, DC, 3 August 1979

**DIRECT CURRENT GENERATORS
G-43/G (NSN 6115-00-510-0611) AND G-77/G**

TM 11-5122, 14 May 1957, is changed as follows:

Page 1. Make the following changes:

Table of Contents. After index add:

APPENDIX A References
B Maintenance Allocation Chart
C Basic Issue Items List (BIIL) and Items Troop Installed on
Authorized List (ITIAL)

Page 3. Make the following changes:

Paragraph 2.1. Last two lines are changed as follows:

Commander, US Army Communications and Electronics Materiel Readiness Command, ATTN:
DRSEL-ME-MQ, Fort Monmouth, NJ 07703.

Paragraph 3.1 is added after paragraph 3:

3.1. Common Names (G-77/G)

The common names for Direct Current Generator G-77/G and its associated operating components are listed below:

Nomenclature	Common name
Direct Current Generator G-77/G	Generator
Electrical Generator Tripod MT-1643/U	Tripod
Crank GC-7	Crank
Receiver-Transmitter RT-794/PRC-74	Receiver-transmitter, receiver or transmitter
Radio Set AN/PRC 74	Radio set
Direct Current Generator G-77/G	
Power Cable CX-13103/PRC 74	Power cable

Paragraph 4.1 is added after paragraph 4:

4.1. Purpose and use (G-77/G)

Direct Current Generator G-77/G is a transportable, hand-operated power supply used to furnish operating power for Receiver-Transmitter RT-794/PRC-74, a component of Radio Set AN/PRC-74, with a secondary capability of field charging MA6982-3A Ni Cad battery packs.

Paragraph 5-1 is added after paragraph 5:

5.1. Technical Characteristics (G-77/G)

- Crank speed50 to 70 rpm.
- Output power: 10.5 volts to 5.0 amperes
17.5 volts at 2.0 amperes
17.5 volts at 100.0 milliamperes
- Maximum output power 52.5 watts (approx).
- Weight 18 lb.
- Operating temperature range -40° to + 125°F.

Paragraph 6 is superseded as follows:

6. Components and Dimensions

(Fig. 1)

Quantity	Item	Dimensions (in.)			Unit weight (lb)
		Height	Depth	Width	
1	Generator unit (G-43/G) OR	9¼	5 7/8	9 5/16	16
1	Generator unit (G-77/G)	9¼	5 7/8	9 5/16	12
2	Crank	7 long	1
1	Tripod folded (Fig. 3)	4½	6½	35½ long	5

Paragraph 6.1. Second item is changed as follows:

1 Generator Assembly (G-43/G) SM-C-202337, 80063
OR

1 Generator Assembly (G-77/G) P/N 44402, 83311
Page 5. Paragraph 11.1 is added after paragraph 11.

11.1. Connections (G-77 (G))

(Fig. 6.2 and 6.3)

The generator connection to the AN/PRC-74 is made using cable CX-13103/PRC-74. To power the AN/PRC-74 the cable is connected to the AN/PRC 74, battery box cover CY 7773/PRC-74 POWER connector. To charge the AN/PRC-74 battery, the RT-794/PRC-74 is separated from the battery box and the cable is connected to the CHARGE connector on the CY 7773/PRC-74. For connections of the generator to a test load, refer to paragraph 38.1.

Paragraph 12.1 is added after paragraph 12:

12.1. Operation (G-77/G)

To operate the generator for testing or checking, rotate the cranks clockwise (in direction of arrow stamped on generator housing, Fig. 6.1) at approximately 60 revolutions per minute (rpm). The external indicator light provides visual indication of adequate output current/voltage during battery charging.

Paragraph 19.

Subparagraphs a and c are superseded as follows:

- a. *Tools.* All tools required are included in Tool Kit, Electronic Equipment TK-101/G
- c. *Test Equipment.* The following test equipment is required:
 - (1) Multimeter AN/USM-223.
 - (2) Voltmeter, Meter ME-30(*)/U.
 - (3) Ohmmeter ZM-21B/U.
 - (4) Resistance Bridge ZM-4.
 - (5) Test Set, Capacitance AN/URM-90.

Page 11. Paragraph 23.1 is added after paragraph 23:

23.1. Removal of Alternator Assembly (G-77/G)

a. Unscrew the four captive screws (Fig. 6.1) that hold the main cover to the housing and remove the cover. When replacing the cover, tighten each of the screws a little at a time to make sure of an even watertight fit.

b. Remove the three screws that connect the alternator assembly leads to terminal board TB1 (Fig. 7.1). Unsolder capacitors C7 and C8 leads (Fig. 6.1).

c. Unscrew the mounting clamp screw (Fig. 6.1) that holds the alternator assembly and spread the clamp open.

d. To remove the alternator from the drive unit, lift the free end, and carefully slide it out of the flexible rubber-drive coupling unit (Fig. 11.1).

Figures 6.1, 6.2, and 6.3 are added after fig. 6.

Page 12. Paragraph 25.1 is added after paragraph 25.

25.1. Removal of Generator Drive Assembly and Alternator Assembly (G-77/G)

(Fig. 7.1)

a. Remove the main cover (paragraph 12.1a).

b. Unsolder capacitors C7 and C8 leads. Remove the six generator drive mounting screws and lockwashers at each end of the housing (Fig. 6.1).

c. Rock the alternator assembly and generator drive assembly back and forth in the housing to loosen the shock mounts (Fig. 11.1) and pull the alternator assembly and generator drive assembly out of the housing.

d. Remove three leads attached to TB1 terminal board (Fig. 8.1) by backing off screws.

Fig. 7.1 is added after fig. 7.

CHANGE }
No. 5 }

HEADQUARTERS
DEPARTMENT OF THE ARMY
WASHINGTON, D.C. 10 December 1973

DIRECT CURRENT GENERATOR G-43/G

TM 11-5122, 14 May 1957. is changed as follows:

Page 3, paragraph 1.1. Delete paragraph 1.1 and substitute:

1.1. Indexes of Publications

a. *DA Pam 310-4.* Refer to the latest issue of DA Pam 310-4 to determine whether there are new editions, changes, or additional publications pertaining to the equipment.

b. *DA Pam 310-7.* Refer to DA Pam 310-7 to determine whether there are modification work orders (MWO's) pertaining to the equipment.

Paragraph 2.

Delete paragraph 2 and substitute:

2. Maintenance Forms and Records

Maintenance forms, records, and reports which are to be used by maintenance personnel at all maintenance levels are listed in and prescribed by TM 38-750.

2.1. Reporting of Errors

The report of errors, omissions, and recommendations for improving this publication by the individual user is encouraged. Reports should be submitted on DA Form 2028, Recommended Changes in Publications, and forwarded direct to Commander, US Army Electronics Command, ATTN: AMSEL-MA-C, Fort Monmouth, NJ 07703.

Page 3. paragraph 6. Change "Components of Generator" to: Components and Dimensions. After paragraph 6 add:

6.1. Components Comprising the Operable End Item

FSN	QTY	Nomenclature, part No., and UPC code
		NOTE The part number is followed by the applicable 5-digit Federal supply code for manufacturers (FSCM) identified in SB 708 42 and used to identify manufacturer, distributor, or Government Agency, etc.
6115-498-4143	2	Crank, Hand GC-7 SM-D-202426. 80063
6115-569-9441	1	Generator Assembly SM-C-202337, 80063
6115-569-9440	1	Tripod. MT 1643/U, SM-D-202180, 80063

Page 5, paragraph 9b. Delete the second sentence in paragraph b and substitute: If a packing slip is not available, check the equipment against the components comprising the operable end item chart (paragraph 6.1).

page 24, appendix II. Delete appendix II and substitute:

**APPENDIX II
BASIC ISSUE ITEMS LIST (BIIL) AND ITEMS TROOP
INSTALLED OR AUTHORIZED LIST (ITIAL)**

Section I. INTRODUCTION

1. Scope

This appendix list only basic issue items required by the crew/operator for installation, operation, and maintenance of Direct Current Generator G-43/G.

2. General

This Basic Issue Items and Items Troop Installed or Authorized List is divided into the following sections:

- a. *Basic Issue Items List—Section II.* A list in alphabetical sequence, of items which are furnished with, and which must be turned in with the end item.
- b. *Items Troop Installed or Authorized List—Section III.* Not applicable.

3. Explanation of Columns.

The following provides an explanation of columns found in the tabular listing:

- a. *Illustration.* Not applicable.
- b. *Federal Stock Number.* Indicates the Federal stock number assigned to the item and will be used for requisitioning purposes.
- c. *Part Number.* Indicates the primary number used by the manufacturer (individual, company, firm, corporation, or government activity), which controls the design and characteristics of the item by means of its engineering drawings, specifications standards, and inspection requirements, to identify an item or range of items.
- d. *Federal Supply Code for Manufacturer (FSCM).* The FSCM is a 5-digit numeric code used to identify the manufacturer, distributor, or Government agency, etc., and is identified in SB 708-42.
- e. *Description.* Indicates the Federal item name and a minimum description required to identify the item.
- f. *Unit of Measure (U/M).* Indicates the standard of basic quantity of the listed item as used in performing the actual maintenance function. This measure is expressed by a two character alphabetical abbreviation, (e.g., ea. in., pr, etc.). When the unit of measure differs from the unit of issue, the lowest unit of issue that will satisfy the required units of measure will be requisitioned.
- g. *Quantity Furnished with Equipment (Basic Issue Items Only).* Indicates the quantity of the basic issue item furnished with the equipment.

Section II. BASIC ISSUE ITEMS LIST

(1) Illustration		(2) Federal Stock Number	(3) Part Number	(4) FSCM	(5) Description Usable on code	(6) Unit of Meas	(7) Qty Furn with Equip
(A) Fig No.	(B) Item No.						
		6115-498-3973	PM0048	36004	BAG, CARRYING: BG-175 Canvas Craftsman	EA	1

By Order of the Secretary of the Army:
Official:

CREIGHTON W. ABRAMS
General, United States Army
Chief of Staff

VERNE L BOWERS
Major General, United States Army
The Adjutant General

Distribution:

To be distributed in accordance with DA Form 12-51, operator maintenance requirements for AN/GRC-87 and AN/GRC-109.

Section II. MAINTENANCE ALLOCATION CHART

(1) PART OR COMPONENT	(2) MAINTENANCE FUNCTION	(3) 1ST ECH	(4) 2ND ECH	(5) 3RD ECH	(6) 4TH ECH	(7) 5TH ECH	(8) TOOLS REQUIRED	(9) REMARKS
GENERATOR, DIRECT CURRENT G-43/G	service	X					7	Clean exterior and tighten all screws and bolts cleans interior and lubricates Visual, external Internal, brushes, wiring and gaskets Continuity of circuits Performs resistance, voltage and current measurements, to determine conditions of circuits. Conducts all tests required to meet minimum mechanical, visual, and electrical requirements. Plus shop support
	adjust			X			6,8	
	inspect	X		X			8	
	test		X				7	
				X	X			
					X		2	
	repair						2, 3, 4, 5	
	rebuild				X		8	
						X	8	
GEAR ASSEMBLY, SPEED INCREASER	service			X			8, 6	
	replace		X				7	
	repair				X		8	
GENERATOR ASSEMBLY	service			X			8, 6	
	replace		X				7	
	repair			X				
PANEL ASSEMBLY	replace		X				7	
	repair			X			8	

Section III. ALLOCATION OF TOOLS FOR MAINTENANCE FUNCTIONS

(1)	(2)	(3)	(4)	(5)	(6)	(7)	(8)
TOOLS REQUIRED FOR MAINTENANCE FUNCTIONS	1ST ECH	2ND ECH	3RD ECH	4TH ECH	5TH ECH	TOOL CODE	REMARKS
G-43/G (continued)							
MULTIMETER AN/URM-105		†				1	AN/URM will replace TS-297/U
MULTIMETER TS-352/U			†	†	†	2	
VOLTMETER ME-30A/U				†	†	3	
OHMMETER ZZM-21/U				†	†	4	
TEST SET, ELECTRICAL POWER I-199				†	†	5	
GREASE GUN, HOLLOW-NEEDLE INJECTOR TYPE			†	†	†	6	
TOOL EQUIPMENT TE-41		†				7	
POWER TOOL KIT TK-89			†	†	†	8	

CHANGE }
No. 4 }

HEADQUARTERS
DEPARTMENT OF THE ARMY
WASHINGTON, D.C., 24 April 1967

DIRECT CURRENT GENERATOR G-43/G

TM 11-5122, 14 May 1957, is changed as follows:

Page 3, paragraph 2c (as changed by C 3, 8 Feb 65). Delete paragraph 2c and substitute:

c. *Reporting of Equipment Manual Improvements.* Report of errors, omissions and recommendations for improving this manual by the individual user is encouraged. Reports should be submitted on DA Form 2028 (Recommended Changes to DA Publications) and forwarded direct to Commanding General, U.S. Army Electronics Command, ATTN: AMSEL-MR-NMP-AD, Fort Monmouth, NJ. 07703.

Page 16, fig. 9. Add the following to the notes:

3. IN LATER MODELS, CAPACITOR C2 HAS A VALUE OF .01 UF.

Page 20, paragraph 41 (as changed by C 3, 8 Feb 65). Delete paragraph 41 and substitute:

41. Detailed Lubrication Instructions

(Fig. 12)

Remove the oil from the lower portion of the case of units which contain oil. Lubrication is only required when replacing parts. Only grease will be used in accordance with the following chart when lubrication is necessary.

Part	Reference symbol	Lubricant
Gear train teeth.....	MP 21, MP 23, MP 25.	Grease (GL).
Sprockets.....	MP 24, MP 22.....	Do.
Chain.....	MP 48.....	Do.
Ball bearings (double seal).	MP 29, MP 30,MP 31.	None.

*This change supersedes C 3, 8 February 1965.

By Order of the Secretary of the Army:

HAROLD K. JOHNSON,
General United States Army,
Chief of Staff

Official:

KENNETH G. WICKHAM,
Major General, United States Army,
The Adjutant General

Distribution:

Active Army:

USASA (2)	Armies (2) except	Gen Dep (2)
CNGB (1)	Seventh USA (5)	Sig Sec, Gen Dep (5)
CC-E (7)	Eighth USA (5)	Sig Dep (12)
Dir of Trans (1)	Corps (2)	AMS (1)
CofEngrs (1)	USAC (3)	WRAMC (1)
TSG (1)	Instl (2) except	Army Pic Cen (2)
CofSptS (1)	Ft Hancock (4)	USAJFKCENSPWAR (5)
USAARENBD (2)	Ft Gordon (10)	Sig, FLDMS (2)
USAAESWBD (5)	Ft Huachuca (10)	USAERDAA (2)
USACDCEA (1)	WSMR (6)	USAERDAW (13)
USACDCEC (10)	Ft Carson (25)	USACRREL (2)
USACDCCBRA (1)	Ft Knox (12)	MAAG (Ethiopia) (5)
USACDCCEA (1)	Svc Colleges (2)	MAAG (Rep of China) (5)
USACDCCEA (Ft Huachuca) (1)	USASCS (5)	MAAG (Thailand) (5)
USACDCOA (1)	USASESCS (20)	MAAG (Vietnam) (5)
USACDCQMA (1)	USAADS (5)	USARMIS (El Salvador) (5)
USACDCTA (1)	USAAMS (5)	USARMIS (Ecuador) (5)
USACDCARMA (1)	USAARMS (5)	USARMIS (Honduras) (5)
USACDCAVNA (1)	USAIS (20)	Units organized under following
USACDCARTYA (1)	USAES (2)	TOE's (2 ea.):
USACDCSWA (1)	USAQMS (5)	5-110 11-500 (AA-
USACDCADA (1)	USATC Armor (2)	5-348 AC)
USAMC (5)	USAECFB (2)	5-600 11-587
USCONARC (5)	USATC Inf ((2)	5-627 11-592
ARADCOM (5)	USASTC (2)	7-158 11-597
ARADCOM Rgn (2)	Army Dep (2) except	11-57 20-45
OS Maj Comd (4)	LBAD (14)	11-97 20-47
USARJ (5)	SAAD (30)	11-98 30-25
USARYIS (5)	TOAD (14)	11-117 30-29
USARHAW (5)	LEAD (7)	11-127 31-105
LOGCOMD (2)	SHAD (3)	11-155 31-107
USAMICOM (4)	NAAD (5)	11-158 51-1
USASTRATCOM (4)	SVAD (5)	55-27
USAESC (70)	CHAD (3)	
MDW (1)	ATAD (10)	

NG: State AG (3); units--same as Active Army except allowance is one (1) copy each.

USAR: None.

For explanation of abbreviations used, see AR 320-50.

TAGO 1563A

DIRECT CURRENT GENERATOR G-43/G

CHANGE }
NO 2 }

HEADQUARTERS
DEPARTMENT OF THE ARMY
WASHINGTON, D.C., 4 November 1963

TM 11-5122, 14 May 1957, is changed as follow:

Note. The parenthetical reference to previous Changes (example: "page 5 of C 2 ") indicates that pertinent material was published in that Change.

Page 3, paragraph 1. Delete subparagraph *b.*

Add paragraph 1.1 after paragraph 1.

1.1. Index of Publications

Refer to the latest issue of DA Pam 310-4 to determine whether there are new editions, changes, or additional publications pertaining to the equipment. DA Pam 310-4 is an index of current technical manuals, technical bulletins, supply manuals (types 4, 6, 7, 8, and 9), supply bulletins, lubrication orders, and modification work orders available through publications supply channels. The index lists the individual parts (-10,-20,-35P, etc.) and the latest changes to and revisions of each equipment publication. Delete paragraph 2 (page 1 of C 1) and substitute:

2. Forms and Records

a. Reports of Maintenance and Unsatisfactory Equipment. Use equipment forms and records in accordance with instructions in TM 38 750.

b. Report of Damaged or Improper Shipment. Fill out and forward DD Form 6 (Report of Damaged or Improper Shipment) as prescribed in AR 700-58 (Army), NAVASANDA Publication 378 (Navy), and AFR 71-4 (Air Force).

c. Reporting of Equipment Manual Improvements. The direct reporting by the individual user of errors, omissions, and recommendations for improving this manual is authorized and encouraged. DA Form 2028 (Recommended changes to DA technical manual parts lists or supply manual 7, 8, or 9) will be used for reporting these improvements. This form will be completed in triplicate using pencil, pen, or typewriter. The original and one copy will be forwarded direct to: Commanding Officer, U.S. Army Electronics Materiel Supplor Agency, ATTN: SELMS-MP, Fort Monmouth, New Jersey 07703. One information copy will be furnished to the individual's immediate supervisor (officer, noncommissioned officer, supervisor, etc.).

Page 5. Delete paragraph 9 and substitute:

9. Checking Unpacked Equipment

a. Inspect the equipment for damage incurred during shipment. If the equipment has been damaged, report the damage on DD Form 6 (par. 2).

b. See that the equipment is complete as listed on the packing slip. If a packing slip is not available, check the equipment against the basic issue items list (app. III). Report all discrepancies in accordance with TM 38 750. Shortage of a minor assembly or part that does not affect proper functioning of the equipment should not prevent use of the generator.

c. If the generator has been used or reconditioned, see whether it has been changed by a modification work order (MWO). If the generator has been modified, the MWO number will appear on the rear of the generating unit near the nomenclature plate. Check to see whether the MWO number (if any) and appropriate notations concerning the modification have been entered in the generator manual.

Note. Current MWO's applicable to the equipment are listed in DA Pam 310-4.

Page 8, chapter 3, heading. Change heading to: MAINTENANCE INSTRUCTIONS

Delete sections I and II and substitute:

Section I. OPERATOR'S PREVENTIVE MAINTENANCE

13. Scope of Operator's Maintenance

The maintenance duties assigned to the operator of the equipment are listed below together with a reference to the paragraphs covering the operator's specific maintenance functions. The duties assigned do not require tools or test equipment.

- a. Daily preventive maintenance and services (par. 16).
- b. Cleaning (par. 17).

14. Preventive Maintenance

Preventive maintenance is the systematic care, servicing, and inspection of equipment to prevent the occurrence of trouble, to reduce downtime, and to assure that the equipment is serviceable.

a. *Systematic Care.* The procedures given in paragraphs 16 and 17 cover routine systematic care and cleaning essential to proper upkeep and operation of the equipment.

b. *Preventive Maintenance Checks and Services.* The preventive maintenance checks and services chart (par. 16) outlines functions to be performed at specific intervals. These checks and services are to maintain Army electronic equipment in a combat serviceable condition; that is, in good general (physical) condition and in good operating condition. To assist operators in maintaining combat serviceability the charts indicate what to check, how to check, and what the normal conditions are. The References column lists the illustrations, paragraphs, or manuals that contain supplementary information. If the defect cannot be remedied by the operator, higher echelon maintenance or repair is required. Records and reports of these checks and services must be made in accordance with the requirements set forth in TM 38 750.

15. Preventive Maintenance Checks and Services Periods

Preventive maintenance checks and services of the equipment are required daily and quarterly. Paragraph 16 specifies the checks and services that must be accomplished daily and under the conditions listed below.

- a. When the equipment is initially assembled.
- b. When the equipment is reassembled after having been disassembled for any reason.
- c. At least once each week if the equipment is maintained in standby condition.

16. Daily Preventive Maintenance Checks and Services Chart

Sequence No.	Item	Procedure	References
1	End item equipment...	Inspect equipment for completeness	App. III.
2	Exterior surfaces.....	Clean exterior surface and keep free of dirt and moisture.	Par. 17.
3	Connectors	Check tightness of all connectors	Par. 11.
4	Crank.....	While making operating checks (item 5) observe that mechanical action of each crank is smooth and free of internal binding, and that there is no excessive looseness.	Fig. 1.
5	Operation.....	Operate equipment according to paragraph 12. During operation, be alert for any unusual signs or conditions.	Par. 12.

17. Cleaning

Inspect the exterior of the equipment. The exterior surfaces should be clean, and free of dust, dirt, grease, and fungus.

a. Remove dust and loose dirt with a clean soft cloth. If dirt is difficult to remove, use mild soap and water.

Warning: Cleaning (Compound (FSN 7930-395-9542) is flammable and its fumes are toxic. Provide adequate ventilation. Do not use near a flame.

b. Remove grease, fungus, and ground-in dirt from the cases; use a cloth dampened (not wet) with cleaning compound.

c. Remove dust or dirt from plugs and jacks with a brush

Section II. ORGANIZATIONAL MAINTENANCE

18. Scope of Organizational Maintenance

This section contains instructions covering second echelon maintenance of the equipment. It includes instructions for performing preventive and periodic maintenance services to be accomplished by the organizational repairman.

19. Tools, Materials, and Test Equipment Required

A list of parts authorized for second echelon maintenance appears in TM 11-6115-218-20P. The tools, materials, and test equipment required for organizational maintenance are listed below.

- a. *Tools.* Tool Kit, Radio Repair TK-115/G.
- b. *Materials.*
 - (1) Cleaning compound.
 - (2) Cleaning cloth.
 - (3) Fine sandpaper (#000).
- c. *Test Equipment.* Multimeter AN/URM-105.

19.1. Organizational Preventive Maintenance

a. Preventive maintenance is the systematic care, inspection, and servicing of equipment to maintain it in serviceable condition, prevent break-downs, and assure maximum operational capability. Preventive maintenance is the responsibility of all echelons concerned with the equipment and includes the inspection, testing, and repair or replacement of parts, subassemblies, or units that inspection and tests indicate would probably fail before the next scheduled periodic service. Preventive maintenance checks and services of the equipment at the second echelon level are made at quarterly intervals unless otherwise directed by the commanding officer..

b. Maintenance forms and records to be used and maintained on this equipment are specified in TM 38-750.

19.2. Quarterly Preventive Maintenance

Quarterly preventive maintenance checks and services on the equipment are required. Periodic daily services constitute a part of the quarterly preventive maintenance checks and services and must be performed concurrently. All deficiencies or shortcomings will be recorded in accordance with the requirements of TM 38-750. Perform all the checks and services listed in the quarterly preventive maintenance checks and services chart (par. 19.3) in the sequence listed.

19.3. Quarterly Preventive Maintenance Checks and Services Chart

Sequence No.	Item	Procedure	Reference
1	Publications	See that all publications are complete, serviceable, and current.	DA Pam 310-4.
2	Modifications.....	Check DA Pam 310-4 to determine if new applicable MWO's have been published. All URGENT MWO's must be applied immediately. All NORMAL MWO'S must be scheduled.	TM 38-750 and DA Pam 310-4
3	Spare Parts.....	Check all spare parts (organizational) for general condition and method of storage. There should be no evidence of overstock, and all shortages must be on valid requisitions.	TM 11-6115-218-20P
4	Installation	See that equipment is properly installed.	Par. 10.
5	Preservation	Check all surfaces for evidence of fungus. Remove rust and corrosion and spot-paint bare spots.	Par. 19.4.
6	Mounting.....	See that all bolts, nuts, and washers are correctly positioned and properly tightened. Check for cracked, bent, or broken brackets.	Fig. 3.
7	Gaskets and insulators.	Inspect gaskets, insulator, bushings, and sleeves for .cracks, chipping, and excessive wear.	Fig. 6.
8	Brushes.....	Inspect for brush wear, spring tension, arcing, and commutator wear.	Fig. 6.
9	Operational performance	Operate the generator with a known working receiver-transmitter.	Par. 29.

19.4. Touchup Painting Instructions

Clean rust and corrosion from metal surfaces by lightly sanding them with fine sandpaper. Brush two thin coats of paint on the bare metal to protect it from further corrosion. Refer to the applicable cleaning and refinishing practices specified in TM 9-213.

Page 9, figure 4. Rescinded.

Page 10, figure 5. Rescinded.

Page 22. Add the following note after paragraph 45g:

Note. After assembly of generator take a high voltage measurement under load (par. 38). If the voltage is not normal, rotate the higher voltage commutator end bracket (Fig. 11) to a position which gives the required output voltage.

Page 23. Add appendix I after chapter 6.

APPENDIX I REFERENCES

- DA Pam 310-4 Index of Technical Manuals, Technical Bulletins. Supply Manuals (types 4, 6, 7, 8, and 9), Supply Bulletins, Lubrication Orders, and Modification Work Orders.
- TM 9-213 Painting Instructions for Field Use.
- TM 11-6115-218-20P Organizational Maintenance Repair Parts and Special Tool Lists: Generator, Direct Current G-43/G.
- TM 38-750 The Army Equipment Record System and Procedures.
Redesignate "APPENDIX I" (page 1 of C 1) as: APPENDIX II.
Redesignate "APPENDIX II" (page 5 of C 1) as: APPENDIX III.

Section I. INTRODUCTION

1. Scope

a. This appendix lists items supplied for initial operation. The list includes tools, parts, and material issued as part of the major end item. The list includes all items authorized for basic operator maintenance of the equipment. End items of equipment are issued on the basis of allowances prescribed in equipment authorization tables and other documents that are a basis for requisitioning.

b. Columns are as follows:

- (1) *Source, maintenance, and recoverability code.* Not used.
- (2) *Federal stock number.* This column lists the 11-digit Federal stock number.
- (3) *Designation by model.* Not used.
- (4) *Description.* Nomenclature or the standard item name and brief identifying data for each item are listed in this column. When requisitioning, enter the nomenclature and description.
- (5) *Unit of issue.* The unit of issue is the supply term by which the individual item is counted for procurement, storage, requisitioning, allowances, and issue purposes.
- (6) *Expendability.* Nonexpendable items are indicated by NX.
- (7) *Quantity authorized.* Under "Items comprising an operable equipment," the column lists the quantity of items supplied for the initial operation of the equipment.
- (8) *Illustration.* Not used.

SECTION II. FUNCTIONAL PARTS LIST

(1)				(2)		(3)				(4)	(5)	(6)	(7)	(8)		(9)
SOURCE MAINTENANCE AND RECOVERABILITY CODE				FEDERAL STOCK NUMBER		DESIGNATION BY MODEL				DESCRIPTION	UNIT OF ISSUE	EXPEND- ABILITY	QUANTITY AUTHO- RIZED	ILLUSTRATION		
														FIGURE NO.	ITEM NO.	
				6115-510-0611						GENERATOR, DIRECT CURRENT, G-43/G: 425v at 115 ma: 105v at 32ma; 6.3v at 2.5 amp: 1.4v at .465 amp; 50 to 70 rpm: Sig dwg No. SM-D-202177						
				Ord thru AGC 6115-498-3973						ITEMS COMPRISING AN OPERABLE EQUIPMENT						
				6115-498-4143						GENERATOR, DIRECT CURRENT G-43/G (BASIC COMPONENT)		NX	1			
				6115-569-9441						TECHNICAL MANUAL TM 11-5122			2			
				6115-569-9440						BAG, CARRYING BG-175: Canvas Craftsman per Lewyt B/P No. PM0048.			1			
										CRANK, HAND GC-7: Sig dwg No. SM-D-202426			2			
										GENERATOR ASSEMBLY: Sig dwg No. SM-C-202337		NX	1			
										TRIPOD, MT-1643/U: Sig dwg No. SM-D-202180			1			
										RUNNING SPARES AND ACCESSORY ITEMS						
										NO PARTS AUTHORIZED FOR STOCKAGE AT FIRST ECHELON						

BY ORDER OF THE SECRETARY OF THE ARMY:

G. H. DECKER,
General, United States Army,
Chief of Staff.

Official

R. V. LEE,
Major General, United States Army
The Adjutant General.

Distribution:

Active Army:

DASA (6)	AFIP (1)
USASA (2)	WRAMC (1)
CNGB (1)	AFSSC (1)
Tech Stf, DA (1) except CSigO (15)	USAEPG (2)
Tech Stf Bd (1)	EMC (1)
USCONARC (4)	USACA (2)
USAARTYBD (1)	USASEA (1)
USAARMBD (2)	USA Caribbean Sig Agcy (1)
USAIB (1)	USA Sig Msl Spt Agcy (12)
USARADB (2)	USASSA (20)
USAABELCTBD (1)	USASSAMRO (1)
USAAVNBD (1)	Army Pictorial Cen (2)
USAATBD (1)	USAOMC (3)
ARADCOM (2)	USA Trans Tml Comd (1)
ARADCOM Rgn (2)	Army Tml (1)
OS Maj Comd (2)	POE (1)
OS Base Comd (2)	OSA (1)
LOGCOMD (2)	AMS (1)
MDW (1)	Sig Fld Maint Shops (2)
Armies (2)	JBUSMC (2)
Corps (5)	Units org under fol TOE: Two copies to each units unless otherwise indicated:
USATC AD (2)	11-7
USATC Armor (2)	11-16
USATC Engr (2)	11-57
USATC FA (2)	11-98
USATC Inf (2)	11-117
Svc College (2)	11-155
Br Svc Sch (2)	11-500 (AA-AE) (4)
GENDEP (2) except Atlanta GENDEP (None)	11-557
Sig Sec. GENDEP (5)	11-587
Sig Dep (12)	11-592
Ft Monmouth (63)	11-597

NG: State AG (3); units-same as Active Army except allowance is one copy to each unit.

USAR: None.

For explanation of abbreviations used, see AR 320-50.

TECHNICAL MANUAL

DIRECT CURRENT GENERATOR G-43/G

TM 11-5122 }
Change No. 1 }

HEADQUARTERS,
DEPARTMENT OF THE ARMY
WASHINGTON 25, D.C., 25 September 1961

TM 11-5122, 14 May 1957, is changed as follows:

Page 3, paragraph 2. Add subparagraph *d* after subparagraph *c*.

b Comments or Suggestions: Any comments concerning omissions and discrepancies in this change will be prepared on DA Form 2028 and forwarded direct to Commanding Officer, U.S. Army Signal Materiel Support Agency, ATTN: SIGMS-ML, Fort Monmouth, N. J.

Add the following:

APPENDIX I
MAINTENANCE ALLOCATION
GENERATOR, DIRECT CURRENT G-43/G

Section 1. MAINTENANCE ALLOCATION

1. General

a. This section assigns maintenance functions and repair operations to be performed by the lowest appropriate maintenance echelon.

b. Columns in the maintenance allocation chart are as follows:

- (1) *Part or component.* This column shows only the nomenclature or standard item name. Additional descriptive data is included only where clarification is necessary to identify the part. Components and parts comprising a major end item are listed alphabetically. Assemblies and subassemblies are in alphabetical sequence with their components listed alphabetically immediately below the assembly listing.
- (2) *Maintenance function.* This column indicates the various maintenance functions allocated to the echelon capable of performing the operations.
 - (a) Service. To clean, to preserve, and to replenish fuel and lubricants.
 - (b) Adjust. To regulate periodically to prevent malfunction.
 - (c) Inspect. To verify serviceability and to detect incipient electrical or mechanical failure by scrutiny.

*These Changes supersede the first echelon portion of DA Supply Manual SIG 7&8-G-43/G, 4 June 1957.

- (d) *Test*. To verify serviceability and to detect incipient electrical or mechanical failure by use of special equipment such as gages, meters, etc.
 - (e) *Replace*. To substitute service assemblies, subassemblies, and parts for unserviceable components.
 - (f) *Repair*. To restore an item to serviceable condition through correction of a specific failure or unserviceable condition. This function includes but is not limited to, inspecting, cleaning, preserving, adjusting, replacing, welding, riveting, and straightening.
 - (g) *Aline*. To adjust two or more components of an electrical system so that their functions are properly synchronized.
 - (h) *Calibrate*. To determine, check, or rectify the graduation of an instrument, weapon, or weapons system, or components of a weapons system.
 - (i) *Rebuild*. To restore an item to a standard as near as possible to original or new condition in appearance, performance and life expectancy. This is accomplished through the maintenance technique of complete disassembly of the item, inspection of all parts or components, repair or replacement of worn or unserviceable elements using original manufacturing tolerances and/or specifications, and subsequent reassembly of the item.
 - (j) *Overhaul*. To restore an item to completely serviceable condition as prescribed by serviceability standards developed and published by heads of technical services. This is accomplished through employment of the technique of "inspect and repair only as necessary" (IROAN). Maximum utilization of diagnostic and test equipment is combined with minimum disassembly of the item during the overhaul process.
 - (3) *1st, 2d, 3d, 4th, 5th echelon*. The symbol X indicates the echelon responsible for performing that particular maintenance operation, but does not necessarily indicate that repair parts will be stocked at that level. Echelons higher than the echelon marked by X are authorized to perform the indicated operation.
 - (4) *Tools required*. This column indicates codes assigned to each individual tool equipment, test equipment, and maintenance equipment referenced. The grouping of codes in this column of the maintenance allocation chart indicates the tool, test, and maintenance equipment required to perform the maintenance function.
 - (5) *Remarks*. Entries in this column will be utilized when necessary to clarify any of the data cited in the preceding columns.
- c. Columns in the allocation of tools for maintenance functions are as follows:
- (1) *Tools required for maintenance functions*. This column lists tools, test, and maintenance equipment required to perform the maintenance functions.
 - (2) *1st, 2d, 3d, 4th, and 5th echelon*. The dagger (†) symbol indicates the echelons allocated the facility.
 - (3) *Tool code*. This column lists the tool code assigned.

2. Maintenance by Using Organizations.

When this equipment is used by signal services organizations organic to theater headquarters or communication zones to provide theater communications, those maintenance functions allocated up to and including fourth echelon are authorized to the organization operating this equipment.

3. Mounting Hardware.

The basic entries of the maintenance allocation chart do not include mounting hardware such as screws, nuts, bolts, washers, brackets, clamps, etc.

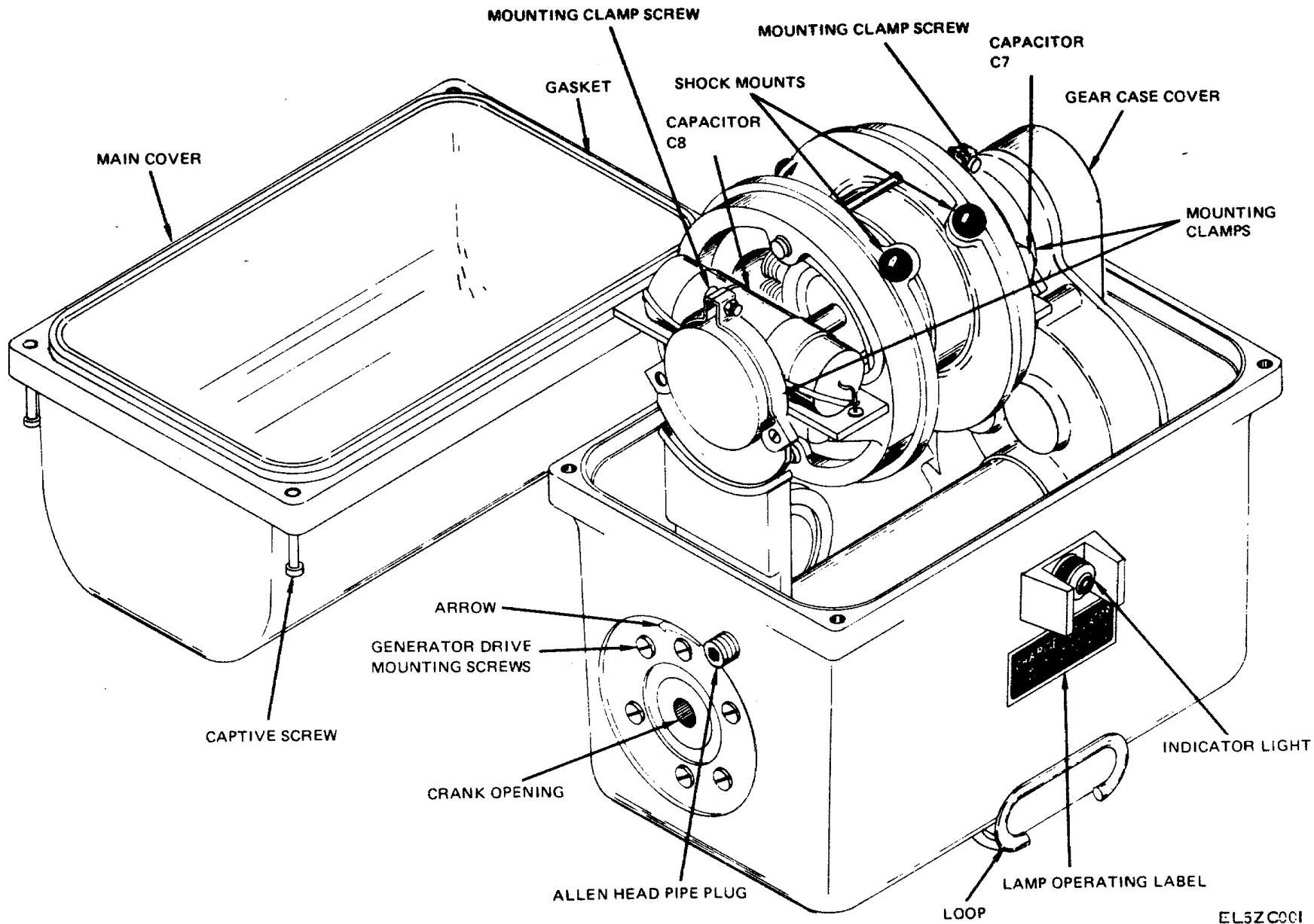
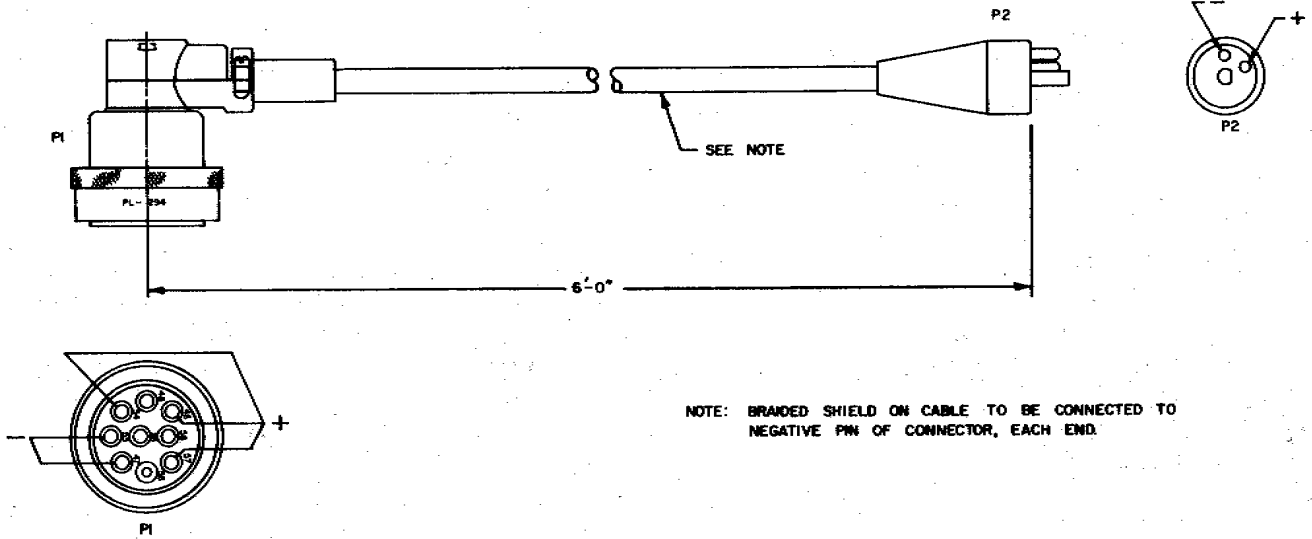

Figure 6.1. Generator unit, main cover removed (G-77/G).



EL52C009

Figure 6.2. Power Cable CX-13103/PRC-74.

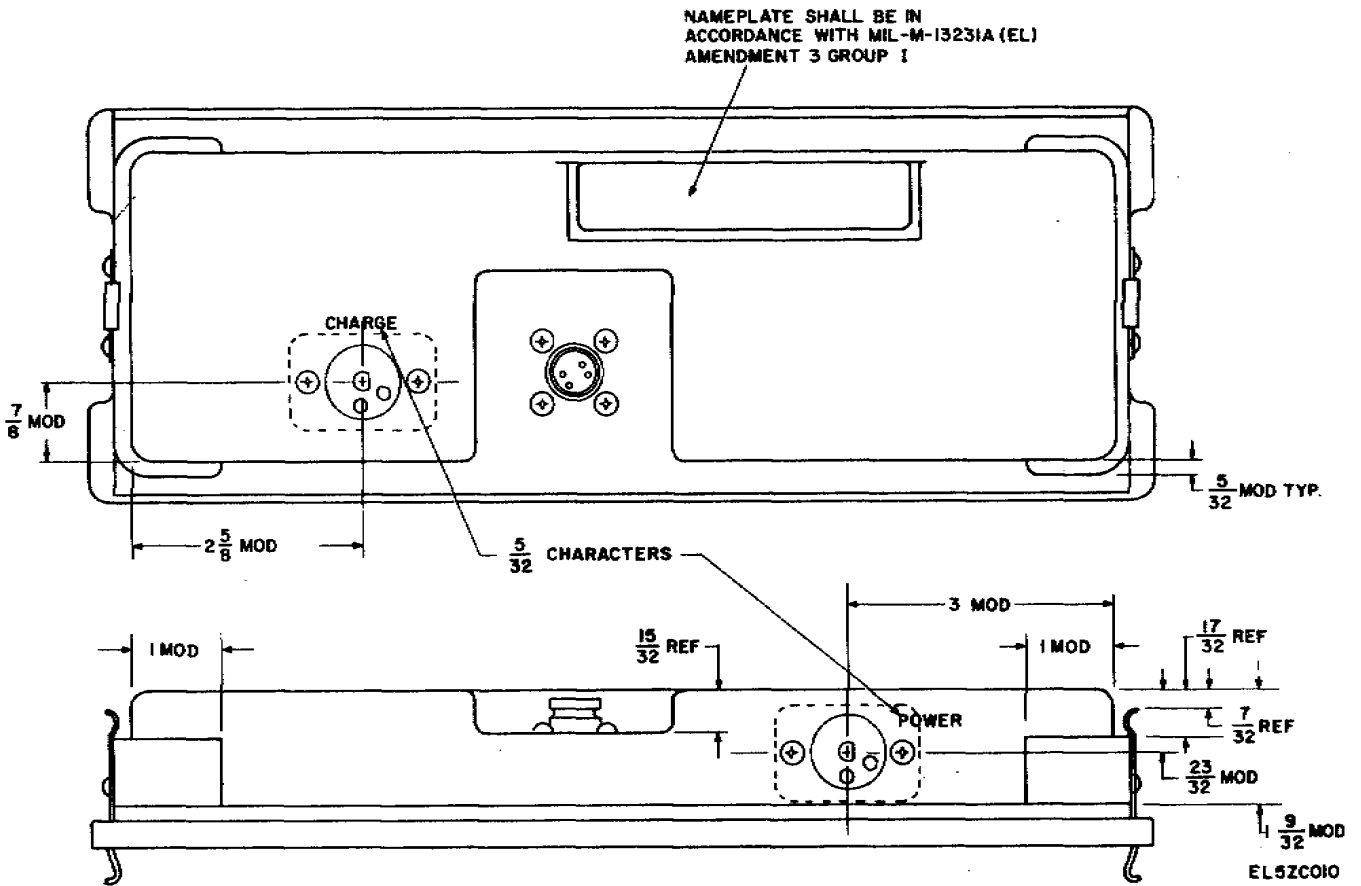

Figure 6.3. Battery Box, Cover CY 7773/PRC-74

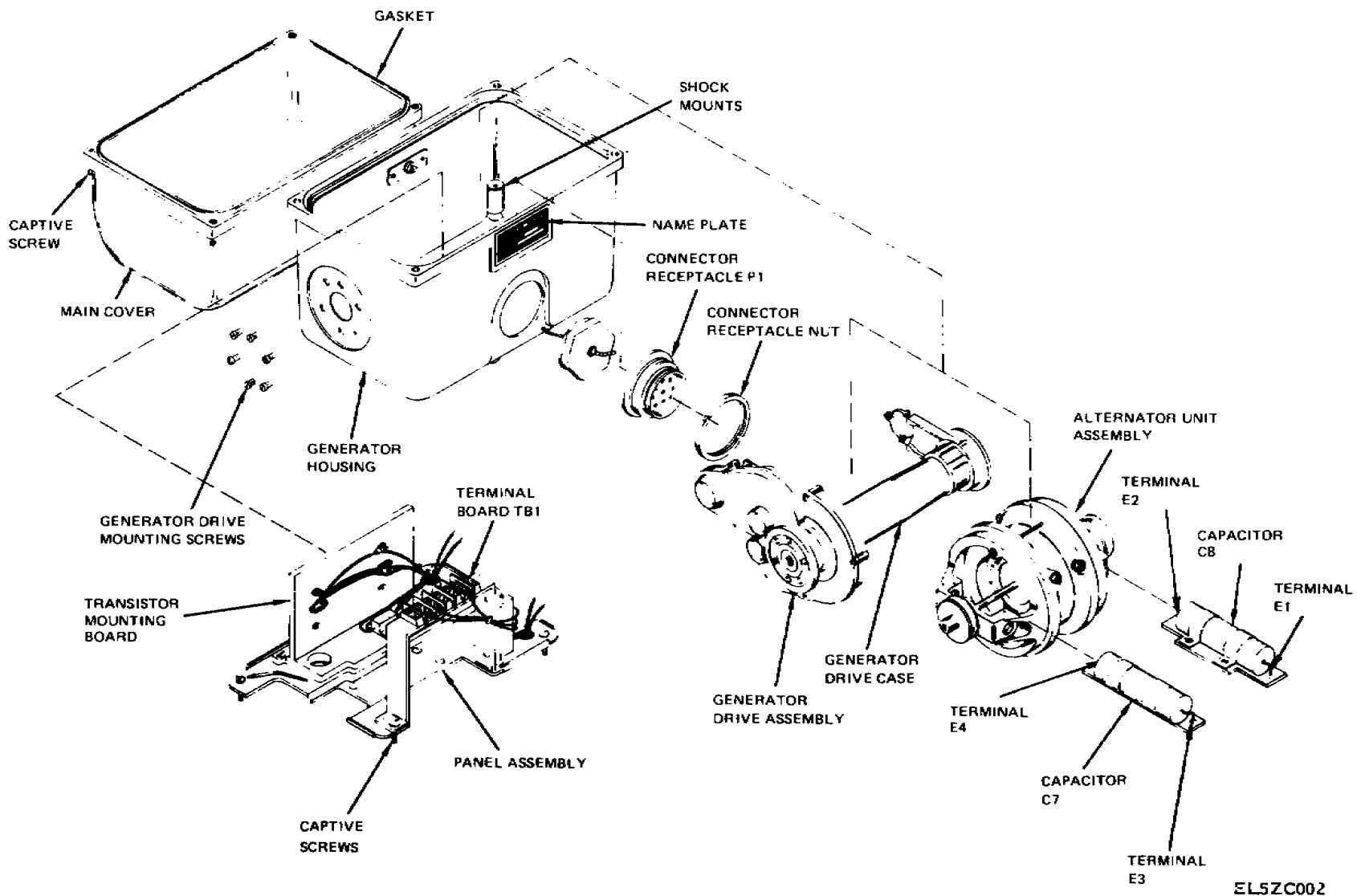

Figure 7.1. Disassembly of housing components (G-77/G).

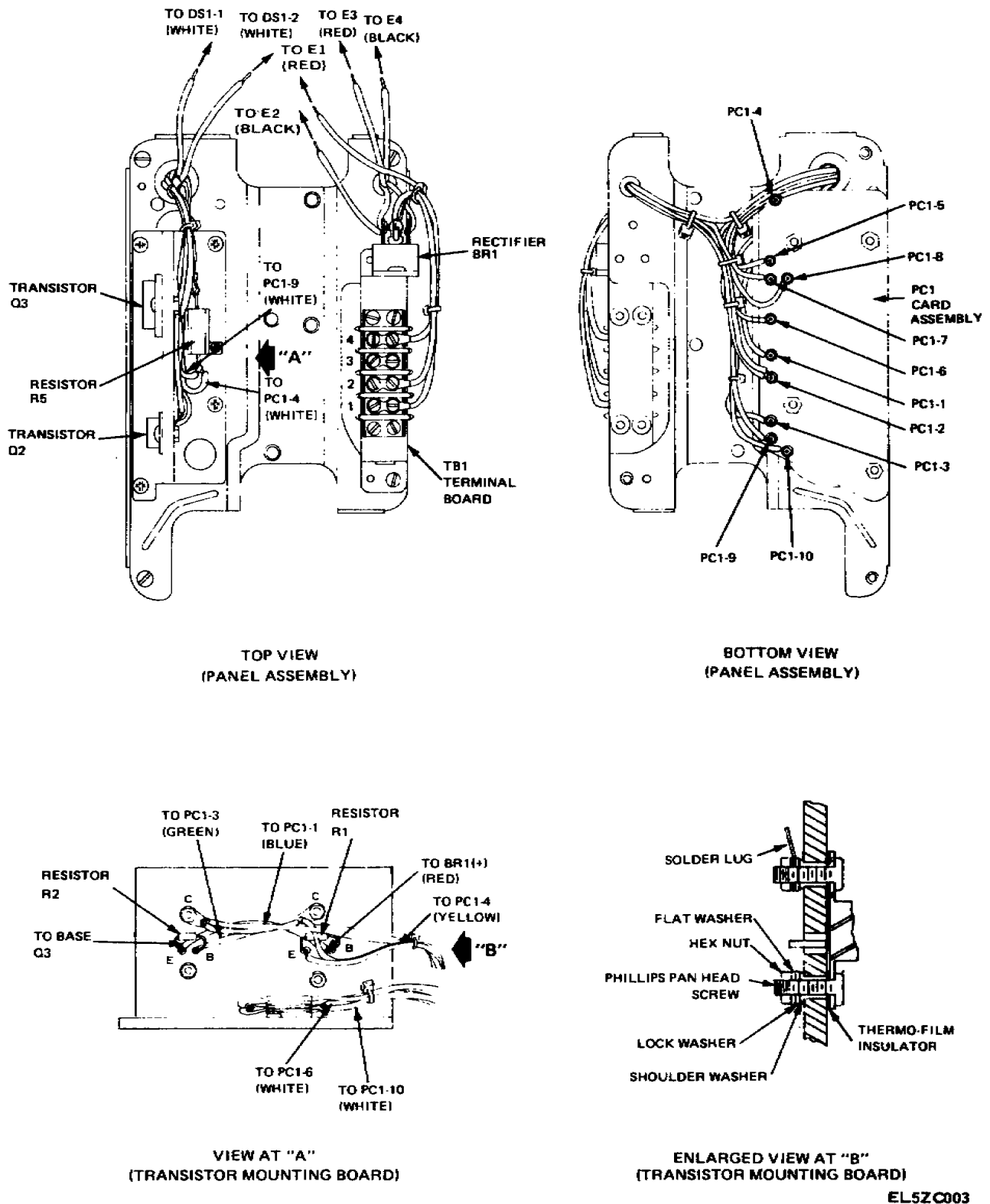
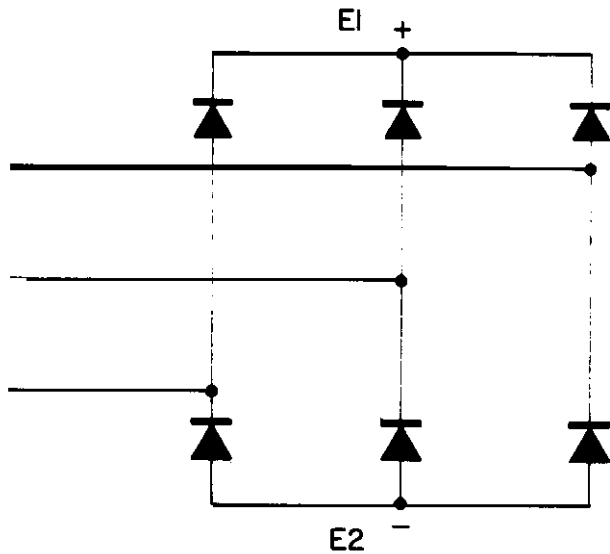

Figure 8.1, Parts locations, generator unit panel assembly, G-77/G.



EL5ZC004

Figure 8.2. Rectifier schematic diagram

Part	Reference symbol	Consumable material
Bumper	Fig. 11.1	Adhesive cement MIL-C-5092 Type 11
All attaching screws	- - -	Anti-seize compound MIL-I 22361
Panel assembly (Fig. 8.1)- resistor, transistors, rectifier	R5, Q2, Q3 and E1, Fig. 8.1	Thermal grease (THERM-ALLOY 251)

EL5ZC005

Figure 8.3. Consumable materials list.

Paragraph 27.1 is added after paragraph 27.

27.1. Test and Replacement of Components on Panel Assembly (G-77/G)

(fig. 8.1)

a. *Electrical Tests.* Test components in place on panel assembly as follows:

(1) Using the ZM-4 (Whetstone bridge device), Check the value of resistor R5 (Fig. 8.1). Resistance must be from 0.160 to 0.198 ohm. (Use a known low value resistor in series with R5 preferably the 5-ohm dummy load) to determine the resistance of R5.)

(2) Using a capacitance bridge tester (paragraph 19), check capacitance value of capacitor C7 (fig. 7.1). Reading must be from 2430 to 3510 microfarads.

(3) Using an ohmmeter (para 19), Check continuity of collector-to-emitter junctions on transistors Q2 and Q3 (fig. 8.1). Check continuity between the collector junction and heat sink on each transistor with megohmmeter. Reading must exceed 1000 megohms.

(4) Using an ohmmeter (para. 19), RX1 scale, test rectifier BR1 (fig. 8.1). Connect rectifier for test (fig. 8.2) by attaching positive leads individually to each of three terminals with the negative lead to negative terminal. The meter should indicate an open or no deflection condition. Reverse negative and positive lead connections on meter. Reading should now be approximately 15 ohms.

(5) Check serviceability of card assembly by substituting a new card in the circuit. By design, no individual testing is possible on card assembly.

b. *Replacement.* Replace faulty components on panel assembly as follows:

(1) To replace resistor R5 (fig. 8.1), unsolder leads attached to each end of the resistor, remove two attaching screws and lockwashers, and remove resistor from panel assembly. On a new resistor, apply thermal grease (fig. 8.3) to underside, position resistor on panel assembly, and secure with new screws and lockwashers. Before installing attaching screws, coat threads with antiseize compound (fig. 8.3). Solder leads to new resistor, making joints at each end mechanically firm before soldering.

(2) To replace capacitor C7 (fig. 7.1), unsolder integral capacitor leads from terminals on underside of card assembly. Apply pressure, free the capacitor from loop clamp. Install a new capacitor in clamp as shown in figure 7.1. Cut integral capacitor leads to required lengths, install sleeving over leads. Connect leads to terminals on card assembly, making mechanically firm joints, and solder leads in position.

(3) To replace either transistor Q2 or Q3 (fig. 8.1), detach leads by unsoldering from transistor terminals and identify leads for subsequent reattachment. Remove two attaching screws and all mounting hardware. Using new parts provided in transistor mounting kit, install new transistor, coating thermofilm insulators with thermal grease (fig. 8.3) before installing transistor. Position transistor and all mounting hardware as shown in figure 8.1. Test assembled transistor as described previously. Attach and solder leads in position.

(4) To replace rectifier BR1 (fig. 8.1), detach leads from terminals and identify removed leads. Remove attaching screws and lockwashers, and discard faulty rectifier. Apply thermal grease (fig. 8.3) to mounting surface of new rectifier, install rectifier and secure with new attaching hardware. Attach leads, making mechanically firm joints, and solder in position.

(5) To replace card assembly (fig. 8.1), detach leads by unsoldering at interconnected components. Identify leads for later reattachment. Remove four nuts to free card assembly. Install new card assembly, secure with attaching hardware, and solder mechanical firm leads in position.

Page 14. Paragraphs 28.1 and 28.2 are added after paragraph 28:

28.1. Check and Replacement of Generator Unit Capacitor (G-77/G)
(fig. 7.1)

a. Test capacitor C8 (fig. 7.1) in place on generator unit. Using a capacitance bridge tester (para 8.3), Check capacitance value of capacitor C8. Reading must be from 612 to 1190 microfarads.

b. Replace faulty capacitor C8 by unsoldering integral capacitor leads and removing from loop clamp. Install a new capacitor in clamp, positioning as shown in figure 7.1, and solder leads in position.

28.2. Replacement of indicator Light Bulb (G-77/G)
(fig. 6.1)

To replace bulb in indicator light, remove cover assembly (para 23a), unscrew mechanical dimmer lens assembly, and remove bulb from rear of lens.

NOTE

A spare replacement bulb is attached to the generator unit stator housing.

Paragraph 30.1 is added after paragraph 30.

30.1. Voltage Output Test (G-77/G)

With the power cord disconnected, and the generator cranked at approximately 60 rpm, measure 17.75 +/-0.25 volts dc across terminal 20 (fig. 9.1) and ground (terminal 24) using the multimeter (para 19). The 2-ampere indicator light should not come on during this test.

Paragraph 31.1 is added after paragraph 31.

31.1. Continuity Tests and Probable Trouble (G-77/G)

These tests should be performed after the voltage output test (para 30.1). The tests which follow enable the unit technician to isolate the different subsections of the generator by a series of resistance measurements. Remove the power cord before measuring resistance.

NOTE

If a measurement is called for from point A to point B. the positive lead of the ohmmeter is connected to point B and the negative lead to point A.

a. *Connector Receptacle J1* (fig. 9.1). The first column of the chart below lists the terminals to be measured, the second column gives the approximate normal resistance readings, and the third column shows the probable troubles when the measured readings are different.

Measurements to ground and between terminals are as follows:

Measure between:	Normal Reading in Ohms	Probable trouble
J1-24 to J1-32	0	Open jumper wire
J1-20 to J1-21	0	Open jumper wire
J1-20 to J1-34	0	Open jumper wire
J1-20 to J1-24	580 ohms +/-20%	Shorted or leaky C7 Faulty card assembly (PCI)

b. *Generator Unit Assembly* (fig. 9.1). The first column in the chart below shows the component to be measured, the second column indicates the terminals required to make the measurement, the third column gives the approximate normal resistance reading, and the fourth column lists the probable trouble. Remove the generator unit and drive assembly (paragraph 25.1) and card assembly (paragraph 27.1b(5)) and perform the measurements indicated in the following chart.

Component	Terminals	Normal Reading in ohms	Probable Trouble
Q2	Collector to base	Forward biased diode	Q2 faulty:PC1 faulty
	Base to collector	>5000	Q2 faulty:PC1 faulty
	Emitter to base	7 +/-15%	Q2 faulty.
	Base to emitter	7 +/-15%	Q2 faulty.
	Emitter to collector	5000	Q2 faulty: Q3 faulty.
R5	R5-2 to R5-1	.18 +/-5%	R5 shorted or open: PC1 faulty
BR1	E2 to E1	>4500	C8 shorted; PC1 faulty: BR1 faulty
	E1 to TB1-1	Forward biased diode	BR1 faulty
	E1 to TB1-2	Forward biased diode	BR1 faulty
	E1 to TB1-4	Forward biased diode	BR1 faulty
	TB1-1 to E2	Forward biased diode	BR1 faulty
	TB1-2 to E2	Forward biased diode	BR1 faulty
	TB1-4 to E2	Forward biased diode	BR1 faulty
	Generator unit	Measure between each combination of stator leads (TB1)	0.5 +/-20%
Q3	Collector to base	Forward biased diode	Q3 faulty:Q2 faulty
	Emitter to base	Forward biased diode	Q3 faulty
	Base to emitter	68 +/-10%	Q3 faulty: PC1 faulty.
	Emitter to collector	>5000	Q3 faulty: PC1 faulty.
PC1	Ter 2 to Ter 3	750 +/-10%	PC1 faulty.
	Ter 2 to Ter 4	675 +/-10%	PC1 faulty.
	Ter 2 to Ter 10	675 +/-10%	PC1 faulty.
	Ter 2 to Ter 6	675 +/-10%	PC1 faulty.
	Ter 2 to Ter 1	>5000	PC1 faulty.
	Ter 2 to Ter 5	>3000	PC1 faulty.
	(Remove lamp DS1 for the above measurement)		
DS1	DS1-1 to DS1-2	200 +/-20%	DS1 faulty

Page 16. In chapter 4, change heading to read: **SECTION I FUNCTIONING OF G-43/G.**

Page 17. Section II is added after paragraph 35d as follows:

Section II. FUNCTIONING OF G-77/G

35.1. System Operation (fig. 9.1)

The generator assembly is a six-pole, three phase permanent magnet alternator operated through an 80:1 speed increaser providing a single output for field operation of Receiver Transmitter RT-794 PRC-74, with the secondary capability of field charging MA6982-3A NiCad battery packs. Output voltage regulation and protective circuitry maintain minimum output voltages at normal generating range for alternator at 4000 to 5,600 RPM. An external

indicator light provides visual indication of adequate current/voltage during battery charging.
 Figure 9.1 is added after paragraph 35.1.

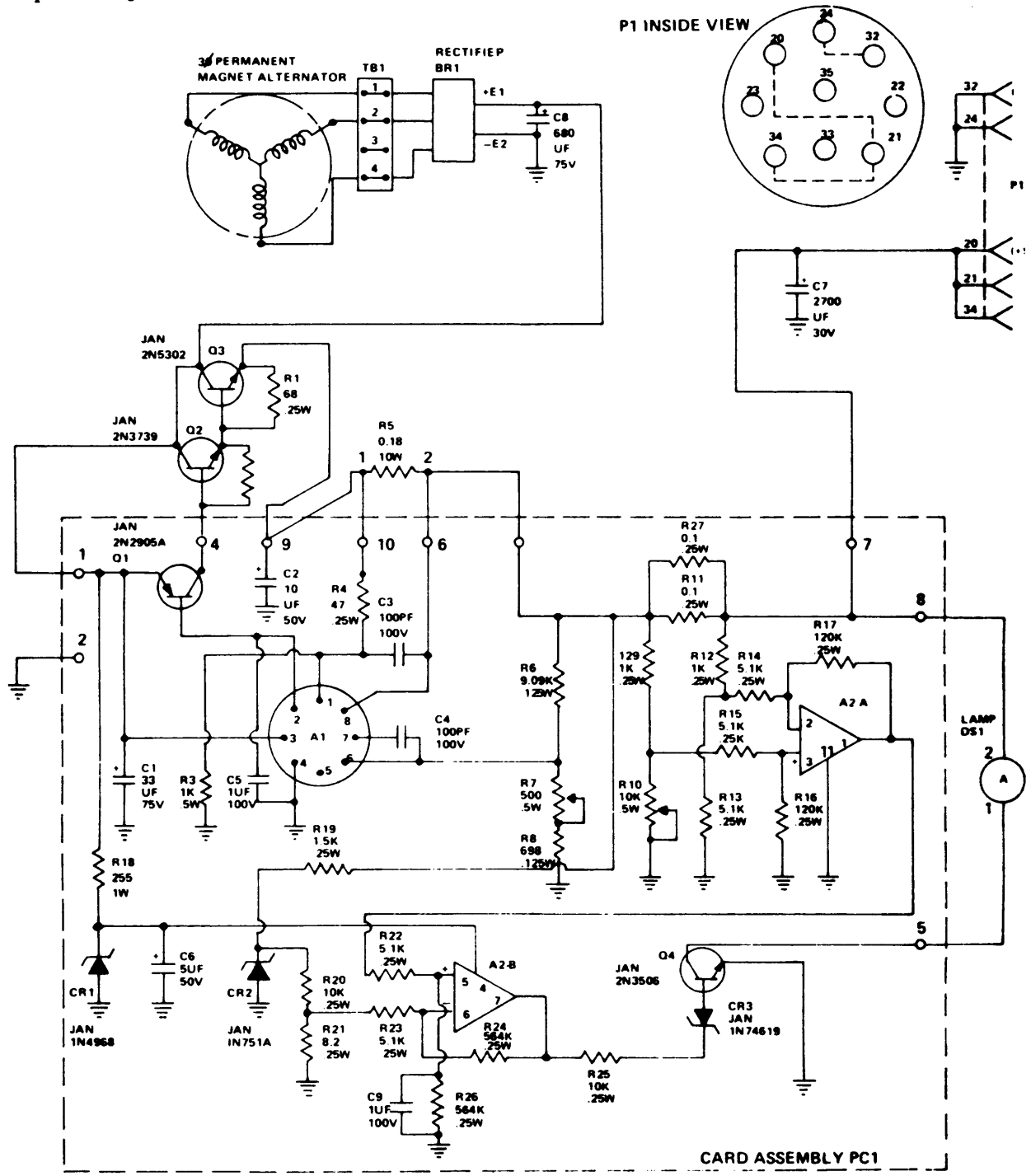

- NOTES:
1. All resistance values are in ohms.
 2. ground is not case ground.

EL5ZC006

Figure 9.1. Main schematic diagram

35.2. Voltage Generation

When the rotor is cranked, the rotating magnetic field induces a voltage in the stator windings. The 3-phase output from the Wye-connected stator is rectified by BR1, a 3-phase, full-wave diode bridge, filtered by capacitor CB and regulated to 17.75 volts by the voltage regulator assembly.

35.3. Voltage Regulator and Current Sense Circuit

(fig. 9.1)

a. *Voltage Regulator.* The voltage regulator is a linear series pass type. The pass transistor, consisting of darlington pair Q2 and Q3, is controlled by integrated circuit A1. A sample of the output voltage is divided by the resistor combination R6, R7 and R8 and sensed at pin 6 of A1. This voltage is compared to an internal reference of 1.80 volts. The integrated circuit adjusts the pass transistor drive to maintain the output voltage at 17.75 volts. This voltage level is adjusted by R7. The current through R5 and the voltage drop across divider R3 and R4 provide current limiting to protect the generator from short circuits.

b. *Current Sense Circuitry.* The current sense circuitry will light an indicator lamp when the load current exceeds 2 amperes. The voltage across the parallel combination of R11 and R27 is amplified by operational amplifier A2-A and compared to the output of Zener diode CR2 by differential amplifier A2-B. When this voltage exceeds the Zener output voltage, amplifier A2-B will have a positive output in pin 7. This output will enable current to flow in the collector circuit of Q4 and DS1 will light.

35.4. Voltage Output

(fig. 9.1)

a. The alternating current (ac) voltage induced in the stator winding is rectified and filtered through three-phase, full-wave bridge BR1 and capacitor C8. This filtered input voltage is fed to regulator lamp driver card assembly PC1 through transistors Q2 and Q3. Output voltage value is set through a variable resistor on the card assembly.

b. The indicator lamp (DS1) is controlled by a sealed output comparator in the regulator circuit, which limits the voltage seen by the indicator lamp to the regulated maximum. Lamp turn-on current is set through a variable resistor on the card assembly.

35.6. Voltage Regulator

(fig. 9.1)

A voltage regulator is connected in series with the rectified alternator output. Regulation is accomplished by the use of a precision linear series regulator which limits the maximum output voltage under changes in load, cranking speed and temperature. This circuit provides fold-back current limiting for short circuit and overload protection. The voltage regulator is set to maintain maximum output voltage of $18.0 \pm 0.0/-0.5$ volts from no load to full load over the operating temperature range at crank speeds between 50 and 100 RPM.

Page 18. Paragraph 37.1 is added after paragraph 37.

37.1. Equipment Required for Trouble shooting (G -77/G)

- a. The test equipment required is Multimeter AN/USM-223.
- b. The following is required for a dummy test load (fabricated as shown in fig. 10.1):
 - (1) Resistor, 25-ohm, 15-watt (RE60G-24R9).
 - (2) Resistor, 5-ohm, 100-watt (RE77G-4R99).

Paragraph 38.1 is added after paragraph 38.

38.1. Troubleshooting G-77/G Using Dummy Load

(fig-10.1)

Connect the dummy load and multimeter (A, fig. 10.1) as indicated on B. figure 10.1. Crank the generator at approximately 60 rpm. The multimeter should indicate $17.75 \pm .25$ volts, and the lamp should be off. Disconnect the circuit and reconnect it as shown at C, figure 10.1. Again crank the generator at approximately 60 rpm. The multimeter should indicate a minimum of 10 volts, and the lamp should be on.

Figure 10 1 is added after figure 10.

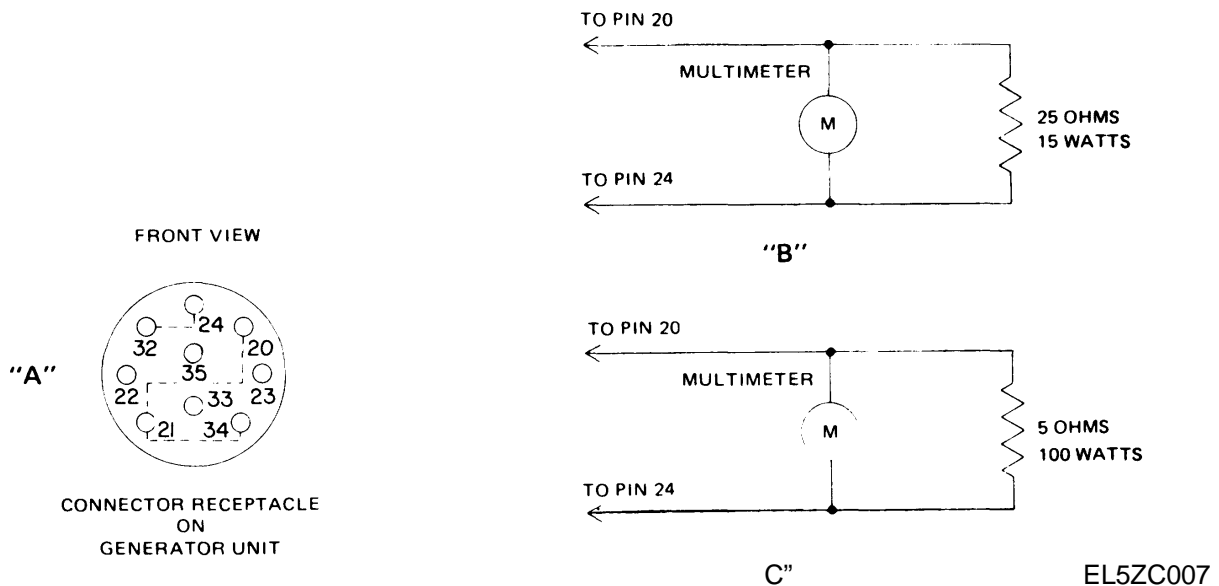

Figure 10.1. Dummy load test board (G-77/G).

Page 20, paragraph 41. Delete Grease (GL) from *Lubricant* column in chart and substitute: Grease per MIL-G-23827 with additive per MIL-M-7866B (additive 3 to 4 percent by weight).

Paragraph 42.1 is added after paragraph 42:

42.1. Replacement of Stator Assembly (G-77/G)
(fig. 11.1)

- a. Remove the alternator assembly (para 23).
- b. Remove the two thru-bolts (fig. 11.1) that hold the stator housings and end brackets together.

CAUTION

Shims may be located in the end bracket bearing housing. During disassembly be careful not to lose shims.

- c. Remove either end bracket and associated stator housing from alternator by tapping gently with a hammer. With one end bracket removed, remove stator from housing and slide out rotor shaft and bearing assembly from end bracket.
- d. insert rotor shaft and bearing assembly in end bracket. Position stator housing on end bracket and install stator. Install other end bracket and stator housing and secure alternator with two thru-bolts, lockwashers and nut. Check end play (fig. 11.1).

NOTE

Before securing thru-bolts, check alignment and positioning of shock mounts and bolts as shown in fig. 6.1.

Paragraph 44.1 is added after paragraph 44.

44.1. Replacement of Rotor and Shaft Assembly (G-77/G)

- a. Disassemble the alternator as outlined in paragraph 42.1a, b, and c.
- b. install a new rotor and shaft assembly, complete with bearings.

Page 21. Figure 11.1 is added after figure 11.

Page 22. Paragraphs 46.1 and 46.2 is added after paragraph 46.

46.1. Regulator and Lamp Driver Adjustments (G-77/G)

NOTE

The following are factory and depot category adjustments and are performed with card assembly PC1 disconnected from the generator unit.

- a. Regulator output voltage is initially set by adjusting trimmer R7 on the circuit card assembly to obtain a maximum value of 18.00 +

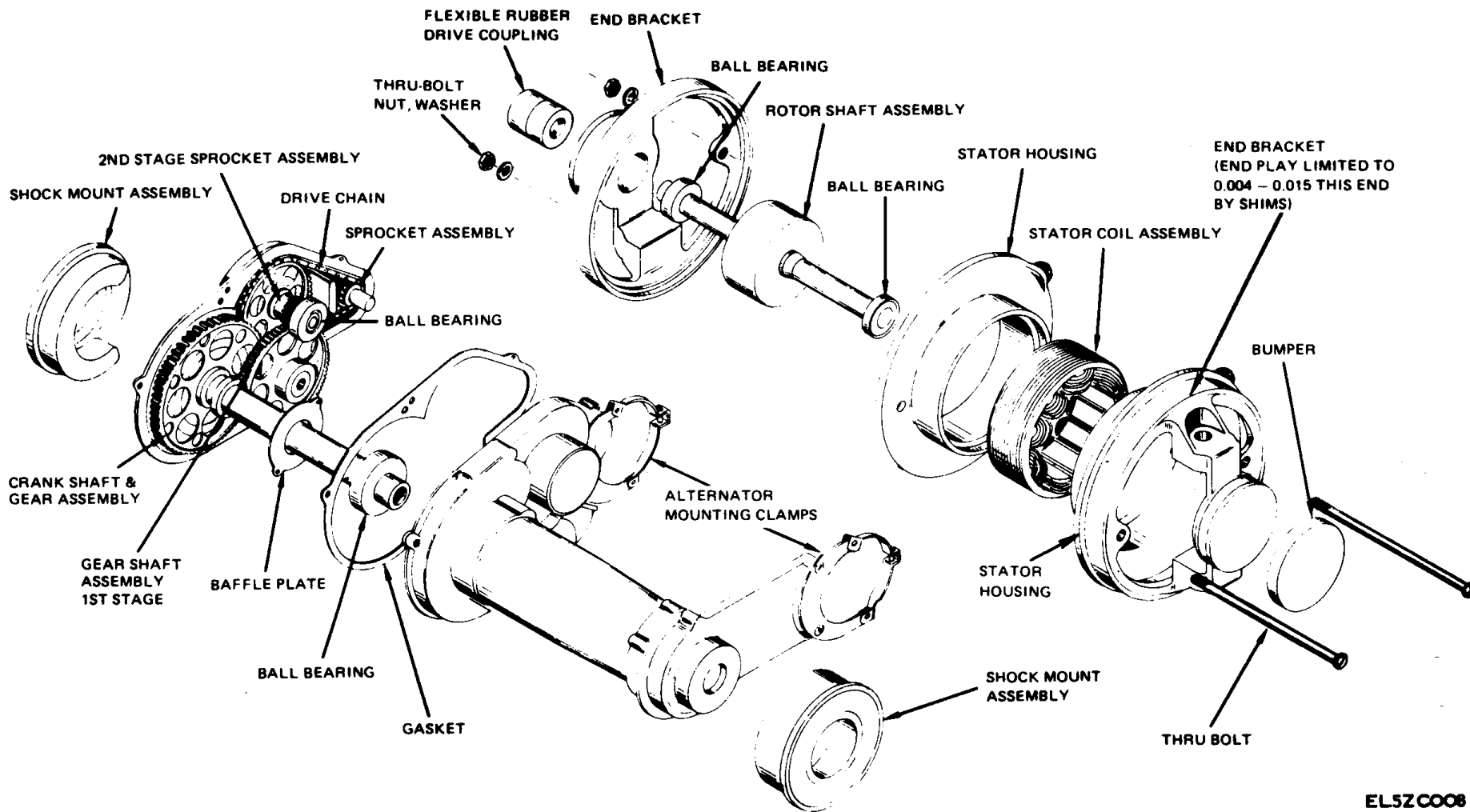

EL5ZCO08

Figure 11-1. Disassembly for lubrication (G-77/G).

.00-.50V at the output connector. Indicator lamp turn-on current is initially set by adjusting trimmer R10 on the card assembly to turn on at 2.0 +/-0.2 amperes. The adjustments should not be changed unless the proper values are not attained when an operational test or trial test under load is made.

b. If adjustments are required, remove the generator unit assembly, drive case, and panel assemblies as outlined in paragraph 23, to reach circuit card assembly.

46.2. Replacement of Indicator Light Components (G-77/G)

a. To remove or replace indicator light housing, remove cover assembly (para 23a) and detach leads at rear of housing by unsoldering. Back off retaining nut on housing and remove from generator case.

b. To replace mechanical dimmer, unscrew dimmer from lens assembly.

Appendix I. References is superseded as follows:

APPENDIX A

REFERENCES

DA Pam 310-4	Index of Technical Publications: Technical Manuals, Technical Bulletins, Supply Manuals (Types 7, 8, and 9), Supply Bulletins, and Lubrication Orders.
DA Pam 310-7	US Army Equipment Index of Modification Work Orders.
SB 38-100	Preservation, Packaging, Packing and Marking Materials, Supplies and Equipment Used by the Army.
TB 43-0118	Field Instructions for Painting and Preserving Electronics Command Equipment Including Camouflage Pattern Painting of Electrical Equipment Shelters.
TM 11-2019	Test Sets I-49, I-49-A, and I-49-B and Resistance Bridges ZM-4A/U and ZM-4B/U (TO 33A1-12-15-1).
TM 11-2646A	Capacitance-Inductance-Resistance Test Set AN/URM-90.
TM 11-6625-298-14	Operator's, Organizational, Direct Support, General Support, Maintenance Manual: Ohmmeter ZM-21/U (NSN 5950-00-645-2197) Ohmmeter ZM-21A/U (NSN 6625-00-643-1030), and Ohmmeter ZM-21B/U (NSN 6625-00-581-2466).
TM 11-6625-320-12	Operator's and Organizational Maintenance Manual: Voltmeter Meter ME-30A/U and Voltmeters, Electronic ME-30B/U, ME-30C/U, and ME-30E/U.
TM 11-6625-654-14	Operator's Organizational, Direct Support, and General Support Maintenance Repair Parts and Special Tools List (Including Depot Maintenance Repair Parts and Special Tools) for Multimeter, AN/USM-223.
TM 11-6625-2745-14	Operator, Organizational, Direct Support, and General Support Maintenance Manual: Voltmeter, Electronic ME-30F/U (NSN 6625-00-420-9354) and Voltmeter AN/USM-265A.

Appendix I. Maintenance Allocation is superseded as follows:

APPENDIX B

MAINTENANCE ALLOCATION

Section I. INTRODUCTION

B-1. General.

This appendix provides a summary of the maintenance operations for Direct Current Generator G-43/G and G-77/G. It authorizes categories of maintenance for specific maintenance functions on repairable items and components and the tools and equipment required to perform each function. This appendix may be used as an aid in planning maintenance operations.

B-2. Maintenance Function.

Maintenance functions will be limited to and defined as follows:

- a. Inspect.* To determine the serviceability of an item by comparing its physical, mechanical, and/or electrical characteristics with established standards through examination.
- b. Test.* To verify serviceability and to detect incipient failure by measuring the mechanical or electrical characteristics of an item and comparing/hose characteristics with prescribed standards.
- c. Service.* Operations required periodically to keep an item in proper operating condition; i.e., to clean (decontaminate), to preserve, to drain, to paint, or to replenish fuel, lubricants, hydraulic fluids, or compressed air supplies.

d. *Adjust.* To maintain, within prescribed limits, by bringing into proper or exact position, or by setting the operating characteristics to the specified parameters.

e. *Align.* To adjust specified variable elements of an item to bring about optimum or desired assembly performance.

f. *Calibrate.* To determine and cause corrections to be made or to be adjusted on instruments or test measuring and diagnostic equipments used in precision measurement. Consists of comparisons of two instruments, one of which is a certified standard of known accuracy, to detect and adjust any discrepancy in the accuracy of the instrument being compared.

g. *Install.* The act of emplacing, seating, or fixing into position an item, part, module (component or assembly) in a manner to allow the proper functioning of the equipment or system.

h. *Replace.* The act of substituting a serviceable like type part, subassembly, or module (component or assembly) for an unserviceable counterpart.

i. *Repair.* The application of maintenance services (inspect, test, service, adjust, align, calibrate, replace) or other maintenance actions (welding, grinding, riveting, straightening, facing, remachining, or resurfacing) to restore serviceability to an item by correcting specific damage, fault, malfunction, or failure in a part, subassembly, module (component or assembly), end item, or system.

j. *Overhaul.* That maintenance effort (service/action) necessary to restore an item to a completely serviceable/operational condition as prescribed by maintenance standards (i.e., DMWR) in appropriate technical publications. Overhaul is normally the highest degree of maintenance performed by the Army. Overhaul does not normally return an item to like new condition.

k. *Rebuild.* Consists of those services/actions necessary for the restoration of unserviceable equipment to a like new condition in accordance with original manufacturing standards. Rebuild is the highest degree of material maintenance applied to Army equipment. The rebuild operation includes the act of returning to zero those age measurements (hours, miles, etc.) considered in classifying Army equipments/components.

B-3. Column Entries.

a. *Column 1, Group Number.* Column 1 lists group numbers, the purpose of which is to identify components, assemblies, subassemblies, and modules with the next higher assembly.

b. *Column 2, Component/Assembly.* Column 2 contains the noun names of components, assemblies, subassemblies, and modules for which maintenance is authorized.

c. *Column 8, Maintenance Functions.* Column 3 lists the functions to be performed on the item listed in column 2. When items are listed without maintenance functions, it is solely for purpose of having the group numbers in the MAC and RPSTL coincide.

d. *Column 4, Maintenance Category.* Column 4 specifies, by the listing of a "worktime" figure in the appropriate subcolumn(s), the lowest level of maintenance authorized to perform the function listed in column 3. This figure represents the active time required to perform that maintenance function at the indicated category of maintenance. If the number or complexity of the tasks within the listed maintenance function vary at different maintenance categories, appropriate "worktime" figures will be shown for each category. The number of task-hours specified by the "worktime" figure represents the average time required to restore an item (assembly, subassembly, component, module, end item or system) to a serviceable condition under typical field operating conditions. This time includes preparation time, troubleshooting time, and quality assurance/quality control time in addition to the time required to perform the specific tasks identified for the maintenance functions authorized in the maintenance allocation chart. Subcolumns of column 4 are as follows:

C - Operator/Crew

O - Organizational

F - Direct Support

H - General Support

D - Depot

e. *Column 5, Tools and Equipment.* Column 5 specifies by code, those common tool sets (not individual tools) and special tools, test, and support equipment required to perform the designated function.

f. *Column 6, Remarks.* Column 6 contains an alphabetic code which leads to the remark in section IV, Remarks, which is pertinent to the item opposite the particular code.

B-4. Tool and Test Equipment Requirements (Sect. III).

- a. *Tool or Test Equipment Reference code.* The numbers in this column coincide with the numbers used in the tools and equipment column of the MAC. The numbers indicate the applicable tool or test equipment for the maintenance functions.
- b. *Maintenance Category.* The codes in this column indicate the maintenance category allocated the tool or test equipment.
- c. *Nomenclature.* This column lists the noun name and nomenclature of the tools and test equipment required to perform the maintenance functions.
- d. *National/NATO Stock Number.* This column lists the National/NATO stock number of the specific tool or test equipment.
- e. *Tool Number.* This column lists the manufacturers part number of the tool followed by the Federal Supply Code for manufacturers (5-digit) in parentheses.

B-5. Remarks (Sect. IV).

- a. *Reference Code.* This code refers to the appropriate item in section II, column 6.
- b. *Remarks.* This column provides the required explanatory information necessary to clarify items appearing in section II.

**Section II. MAINTENANCE ALLOCATION CHART
FOR
GENERATOR, DIRECT CURRENT G-43, G-77**

(1) GROUP NUMBER	(2) COMPONENT/ASSEMBLY	(3) MAINTENANCE FUNCTION	(4) MAINTENANCE CATEGORY					(5) TOOLS AND EQPT	(6) REMARKS
			C	O	F	H	D		
00	GENERATOR, D.C G-43. G-77	Inspect		0.2				5	A
		Adjust			0.2				
		Test			0.3			1	
		Test Repair Overhaul				1.0 2.0		5 5 Depot Fac	B C
01	GEAR ASSEMBLY, SPEED-INCREASER	Inspect		0.1					
		Replace		0.4			5		
		Repair Service				2.0		5	
02	GENERATOR ASSEMBLY	Inspect		0.1					
		Replace		0.4			5		
		Repair Service				2.0		5	
03	PANEL ASSEMBLY	Inspect		0.1					
		Replace		0.4			5		
		Repair			0.7		5		

**Section III. TOOL AND TEST EQUIPMENT REQUIREMENTS
FOR**

GENERATOR, D.C. G-43 and G-77

TOOL OR TEST EQUIPMENT REF CODE	MAINTENANCE CATEGORY	NOMENCLATURE	NATIONAL/NATO STOCK NUMBER	TOOL NUMBER
1	O, F, H, D	MULTIMETER, AN/USM-223	6625-00-999-7465	
2	H, D	VOLTMETER, ME-30 ()	6625-00-643-1670	
3	H, D	OHMMETER, ZM-21B/U	6625-00-581-2466	
4	H, D	RESISTANCE BRIDGE, ZM-4	6625-00-166-0398	
5	O, F, H, D	TOOL KIT. ELECTRONIC EQUIPMENT, TK-101	5180-00-064-5178	
6	H, D	CAPACITANCE TEST SET, AN/URM-90	6625-00-534-7458	
7	H, D	DUMMY LOADS C/O: RESISTOR 25 OHMS, 15W (RE60G24R9) RESISTOR 5 OHMS, 100W (RE77G4R99)	 5905-00-912-8379 5905-00-917-3244	

Section IV. REMARKS

REFERENCE REMARKS CODE	REMARKS
A	INSPECT BRUSHES, WIRING, GASKETS
B	DETERMINE CONDITIONS OF CIRCUITS WITH RESISTANCE, VOLTAGE AND CURRENT MEASUREMENTS
C	CONDUCT ALL REQUIRED MAINTENANCE TESTS

By Order of the Secretary of the Army:

E. C. MEYER
General, United States Army
Chief of Staff

Official:

J. C. PENNINGTON
Major General, United States Army
The Adjutant General

Distribution:

To be distributed in accordance with DA Form 12-51, Operator Literature requirements for AN/GRC-87
and AN/GRC-109.

DIRECT CURRENT GENERATOR G-43/G

	Paragraph	Page
CHAPTER 1. INTRODUCTION		
Section I. General	1-3	3
II. Description and Data	4-7	3
CHAPTER 2. INSTALLATION.....	8-12	5
3. ORGANIZATIONAL MAINTENANCE		
Section I. Tools, materials, and test equipment required	13,14	8
II. Preventive maintenance services.....	15-19	8
III. Troubleshooting at organizational maintenance level.....	20-31	11-14
CHAPTER 4. THEORY	32-35	16-17
5. FIELD MAINTENANCE		
Section I. Troubleshooting at field maintenance level.....	36-38	18
II. Repairs.....	39-46	20
III. Adjustments and final testing.....	46,47	22
CHAPTER 6. SHIPMENT AND LIMITED STORAGE AND DEMOLITION TO PREVENT ENEMY USE.		
Section I. Shipment and limited storage	48-50	23
II. Demolition to prevent enemy use	51-52	23
INDEX		26

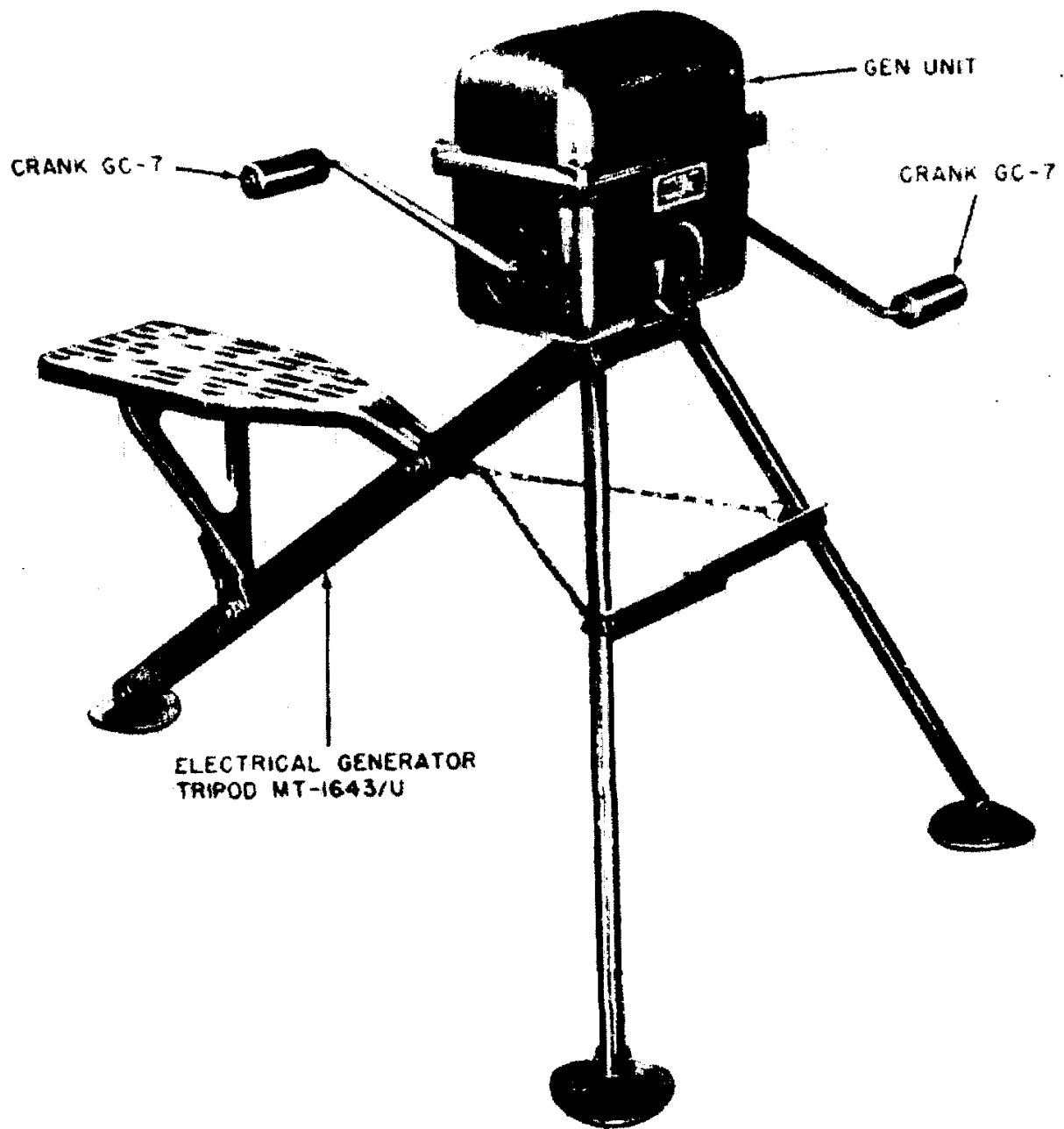

Figure 1. Direct Current Generator G-43/G, components.

TM 5122-1

CHAPTER 1
INTRODUCTION

Section I. GENERAL

1. Scope

a. This manual covers the installation, operation, maintenance, and repair of Direct Current Generator G-43/G (fig. 1).

b. Forward comments on this publication directly to Commanding Officer, United States Army Signal Publications Agency, Fort Monmouth, New Jersey.

2. Forms and Records

a. *Unsatisfactory Equipment Reports.* Fill out and forward DA forms 468 (Unsatisfactory Equipment Report) to Commanding Officer, U.S. Army Signal Equipment Support Agency, Fort Monmouth, N.J., as prescribed in AR 700-38.

b. *Damaged or Improper Shipment.* Fill out and forward DD Form 6, Report of Damaged or Improper Shipment, as prescribed in AR 700-68 (Army).

c. *Preventive Maintenance Forms.*

(1) Prepare DA Form 11-238 (Operator First Echelon Maintenance Check List for Signal Corps Equipment (Radio Communication, Direction Finding, Carrier, Radar)) (fig. 4), in accordance with instructions on the back of the form.

(2) Prepare DA Form 11-239 (Second and Third Echelon Maintenance Check List for Signal Corps Equipment (Radio Communication, Direction Finding, Carrier, Radar)) (fig. 5), in accordance with instructions on the back of the form.

3. Common Names

The common names for Direct Current Generator G-43/G and its associated operating components are listed below.

Nomenclature	Common name
Direct Current Generator G-43/G.	Generator.
Electrical Generator Tripod MT-1643/U.	Tripod.
Crank GC-7	Crank.
Receiver-Transmitter RT77A/GRC-9.	Receiver-transmitter, receiver, or transmitter.
Radio Set AN/GRC-9AX	Radio set.

Section II. DESCRIPTION AND DATA

4. Purpose and Use

Direct Current Generator G-43/G is a transportable hand-operated power supply used to furnish operating power for Receiver-Transmitter AT-77A/ GRC-9, a component of Radio Set AN/GRC-9AX.

5. Technical Characteristics

Crank speed 50 to 70 rpm.

Power output to transmitter:

Filament power..... 1.4 volts at 465 milliamperes

Plate power 105 volts at 320 milliamperes.

Power output to receiver:

Filament power..... 6.3 volts at 2.5 amperes.

Plate power, 425 volts at 115 milliamperes.

Total output power 85 watts (approx).

Weight..... 22 lb.

Operating temperature range..... -40° to +125° F.

6. Components of Generator (fig 1)

Quantity	Item	Height (in.)	Depth (in.)	Width (in.)	Unit weight (lb)
1	Generator unit	9 1/4	5 7/8	9 5/16	16
2	Crank	7 long	1
1	Tripod (folded, fig. 3)	4 1/2	6 1/2	35 1/2 long	5

7. Description (fig 1)

a. *Generator Unit.* All of the working components of the generator unit are shock-mounted inside a rectangular waterproof aluminum housing. The sides of the housing contain openings for the operating

cranks and the power connector receptacle. A mounting plate attached to the bottom of the housing contains a metal loop and a mounting strap for attachment to the tripod (fig. 3).

b. Tripod. The tripod is made up of three legs and a seat. Two legs are tubular; the third leg is rectangular and has the seat fastened to it. Each leg is provided with a footplate (fig. 3) to keep the legs from sinking into soft ground. When the tripod is set up, it becomes a self-sustaining unit and will form a sturdy means of supporting the generating unit and the operator.

CHAPTER 2
INSTALLATION

8. Unpacking

(fig. 2)

a. *Packing Data.* When packing for shipment, the components of the generator are placed in two corrugated fiberboard cartons. The following list indicates the dimensions and the contents of each carton:

Carton No.	Height (in.)	Width (in.)	Depth (in.)	Volume (cu ft)	Unit weight (lb)	Contents of box
1 of 2	11	10 ¼	11	.46	23	Generator unit Crank
2 of 2	33	7	5	.66	8	Tripod

b. *Remove Contents.*

(1) Place the cartons as near the operating position as convenient.

(2) Open the cartons and remove the equipment.

9. Checking Unpacked Equipment

a. Inspect the equipment for possible damage incurred during shipment. If the equipment has been damaged, refer to paragraph 2.

b. See that the equipment is complete as listed on the packing slip. If a packing slip is not available, check it against the table of components in paragraph 6.

c. If the generator has been used or reconditioned, see whether it has been changed by a modification work order (MWO). If modified, the MWO number will appear on the back face of the generating unit near the nomenclature plate. Check to see that this MWO number also appears on the schematic diagram of the manual accompanying the equipment. If not, add a note to the overall schematic diagram.

10. Installation

(fig. 3)

a. Unfold the tripod and set it up on the ground. Press the front brace between the front legs as far down as it will go. This brace spreads and holds the front legs of the tripod and keeps it from collapsing. Raise the metal seat up, and position the seat support bracket under the seat as far as it will go. Lower the seat on the support bracket and press down firmly until the seat and support bracket are engaged.

b. Pick up the generator unit so that the side containing the power connector receptacle is facing the front of the tripod. Insert the mounting strap over the lug on the top of the tripod and pull it forward until it is hooked. Hold the generator unit in place with one hand and swing the metal loop attached to it over the clip on the tripod. Be sure to press the loop down until it snaps and locks the generator unit in place.

c. Insert the cranks into the crank openings (fig. 1) so that they are at opposite positions to each other (one points up and the other points down).

11. Connections

For connections to the radio set, refer to TM 11-263 which covers Radio Sets AN/GRC-9, AN/GRC-9A, and AN/GRC-9X. Direct Current Generator G-43/G is connected in the same manner as generator GN-58, the hand generator issued with the above sets. For connections of the generator to a test load, refer to paragraph 38.

12. Operation

The operation of the generator GN-58. Refer to TM 11-263 for the operational procedure of the generator as part of a radio set. To operate the generator for test or checking, rotate the cranks clockwise (in direction of arrow stamped on generator housing, (fig. 6) at approximately 1 revolution per second (rps).

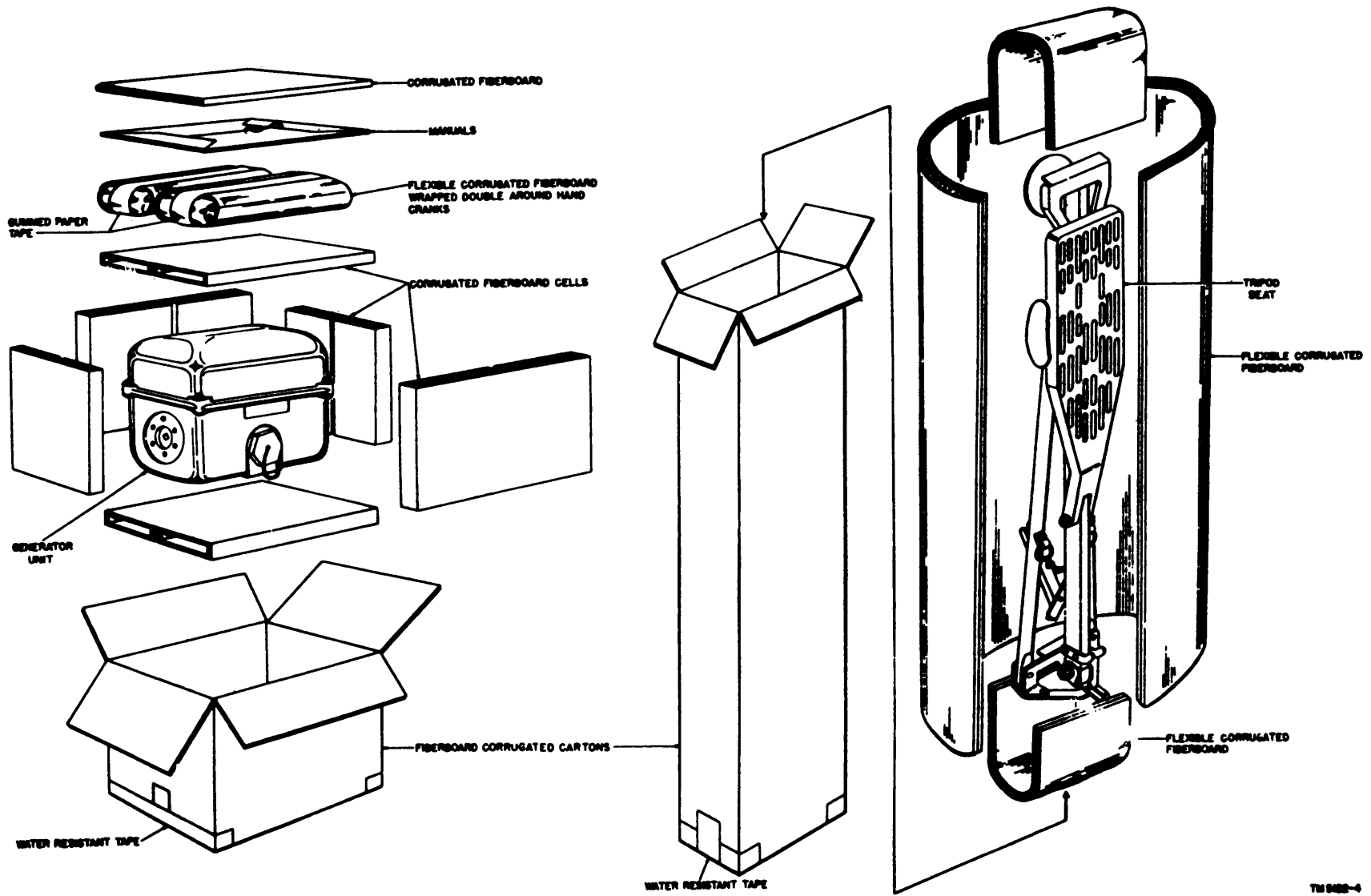

Figure 2. Packaging of generator.

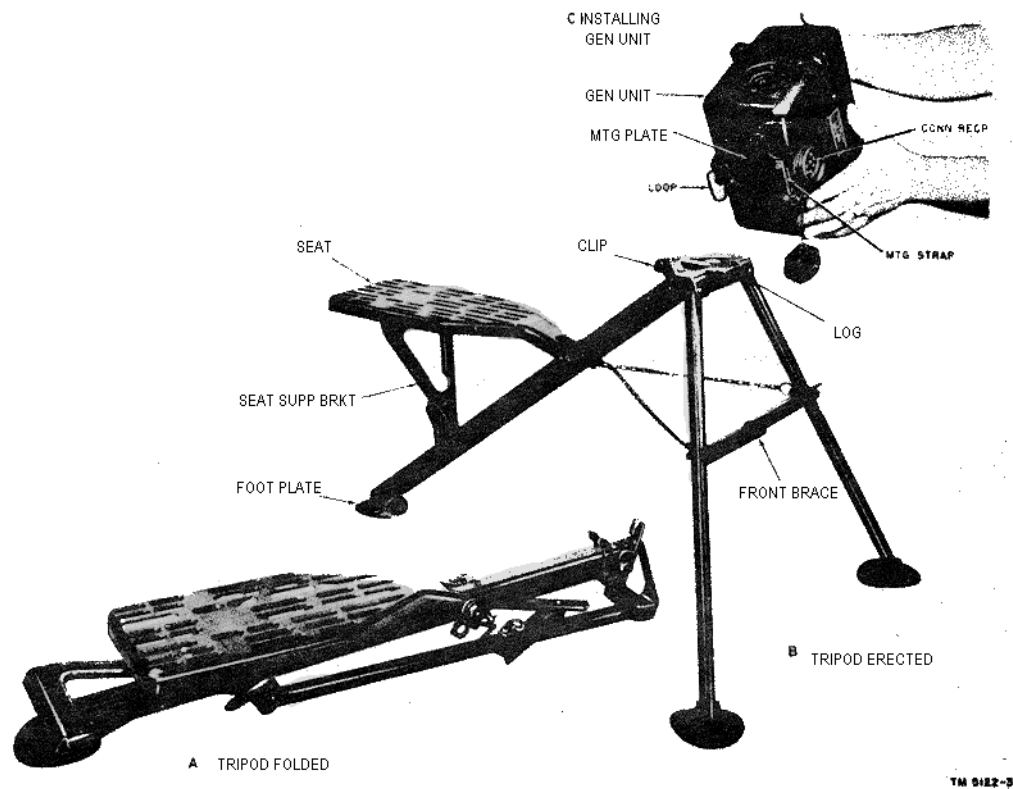

Figure 3. Installation.

CHAPTER 3
ORGANIZATIONAL MAINTENANCE

Section I. TOOLS, MATERIALS AND TEST EQUIPMENT REQUIRED

13. General

Organizational maintenance is maintenance performed at first and second echelon. First echelon maintenance is operator's maintenance; second echelon is unit repairman's maintenance.

14. Tools, Materials, and Test Equipment Required

The following tools, materials, and test equipment (not supplied as part of the generator) are required for organizational maintenance.

- a. Tools and Materials.
 - (1) Tool Equipment TE-41.
 - (2) Cleaning Compound (Federal stock No. 7930-395-9541)
 - (3) Oil, Lubricating Preservative, Special (PL, Special).
 - (4) Spanner wrench, 2 inches center to center, with diameter 1/8-inch by 1/4-inch long.
- b. Test Equipment. Multimeter TS-297/U (TM 11-5500)

Section II. PREVENTIVE MAINTENANCE SERVICE

15. Definition of Preventive Maintenance

Preventive maintenance is work performed on equipment (usually when the equipment is not in use) to keep it in good working order so that break downs and needless interruptions in service will be kept to a minimum. Preventive maintenance differs from trouble shooting and repair since its object is to prevent certain troubles from occurring

16. General Preventive Maintenance Technique.

- a. Use No. 000 sandpaper to remove corrosion.
- b. Use a clean, dry lint-free cloth or a dry brush for cleaning. Moisten the cloth or brush with Cleaning Compound when necessary; then wipe the parts dry with a cloth.

Warning: Clean Compound is flammable and its fumes are toxic. Do not use near a flame and provide adequate ventilation.

- c. Screws, nuts and bolts should not be tightened carelessly. Fittings tightened beyond the pressure for which they are designed will be damaged or broken

17. Use of First Echelon Preventive Maintenance Forms

(fig. 4)

- a. DA Form 11-238 is a preventive maintenance checklist to be used by the operator.
- b. Items that do not apply to the generator are lined out on figure 1. References in the ITEM block in the figure are to paragraphs in this manual that contain additional information about the item.

18. Use of Second and Third Echelon Preventive Maintenance Form

(fig. 5)

- a. OA Form 11-239 is A Preventive maintenance check list to be used by second and third echelon repairmen.

b. Items that do not apply to the generator are lined out on figure 5. References in the ITEM block in the figure are to paragraphs in this manual that contain additional information about the item.

19. Performing Preventive Maintenance

- a. If the cranks are difficult to turn, have the unit repairman perform trouble shooting (par. 29).
- b. With PL Special, oil the crank bearing front brace hinge, and footplate hinges (fig. 3).
- c. Remove the generator unit (par. 23) and check the components on the top of the panel assembly (fig. 7).

OPERATOR FIRST ECHELON MAINTENANCE CHECK LIST FOR SIGNAL CORPS EQUIPMENT
RADIO COMMUNICATION, DIRECTION FINDING, CARRIER, RADAR

INSTRUCTIONS: See other side

EQUIPMENT NOMENCLATURE

DIRECT CURRENT GENERATOR G-43/U

EQUIPMENT SERIAL NO.

9

LEGEND FOR MARKING CONDITIONS: ✓ Satisfactory; X Adjustment, repair or replacement required; ① Defect corrected.
 NOTE: Strike out items not applicable.

DAILY

NO.	ITEM	CONDITION						
		S	M	T	W	T	F	S
1	COMPLETENESS AND GENERAL CONDITION OF EQUIPMENT (receiver, transmitter, carrying cases, wire and cable, microphones, tubes, spare parts, technical manuals and accessories).		✓	✓				
2	LOCATION AND INSTALLATION SUITABLE FOR NORMAL OPERATION.		✓	✓				
3	CLEAN DIRT AND MOISTURE FROM ANTENNA, MICROPHONE, HEADSETS, CHECKSETS, KEYS, JACKS, PLUGS, TELEPHONES, CARRYING BAGS, COMPONENT PANELS.		✓	✓				
4	INSPECT SEATING OF READILY ACCESSIBLE PLUG-IN ITEMS: TUBES, LAMPS, CRYSOTOLS, FUSES, CONNECTORS, VIBRATORS, PLUG-IN COILS AND RESISTORS.		✓	✓				
5	INSPECT CONTROLS FOR BINDING, SCRAPING, EXCESSIVE LOOSENESS, WORN OR CHIPPED GEARS, MISALIGNMENT, POSITIVE ACTION. PAR. 19 a		✓	✓				
6	CHECK FOR NORMAL OPERATION. PAR. 12		✓	✓				

WEEKLY

NO.	ITEM	CORRECTION	NO.	ITEM	CORRECTION
7	CLEAN AND TIGHTEN EXTERIOR OF COMPONENTS AND BASES, RASH MOUNTS, CUSHION MOUNTS, ANTENNA MOUNTS, COAXIAL TRANSMISSION LINES, BAYE CABLES, AND CABLE CONNECTIONS.	✓	13	INSPECT STORAGE BATTERIES FOR DIRT, LOOSE TERMINALS, FIVE-TROLYTE LEVEL AND SPECIFIC GRAVITY, AND DRAINAGE CHES.	
8	INSPECT CASES, MOUNTINGS, ANTENNAS, TOWERS, AND EXPOSED METAL SURFACES, FOR RUST, CORROSION, AND MOISTURE. PAR. 19 b	⊗	14	CLEAN AIR FILTERS, BRASS NAME PLATES, DIAL AND METER WINDOWS, JEWEL ASSEMBLIES.	✓
9	INSPECT CORDS, CABLE, WIRE, AND LIGNIN MOUNTS FOR CUTS, SWELING, FRAYING, DEGENERATION, STINK, AND STAIN.		15	INSPECT METERS FOR DAMAGED GLASS AND DIALS.	
10	INSPECT ANTENNA FOR CONCENTRICITIES, CORROSION, LOOSE FIT, DAMAGED INSULATORS AND REFLECTORS.		16	INSPECT SHELTERS AND COVERS FOR ADEQUACY OF WEATHER-PROOFING.	
11	INSPECT ANVUS ITEMS, LEATHER, AND SHOELING FOR WILDER, TEARS, AND FRAYING.		17	CHECK ANTENNA GUY WIRES FOR LOOSENESS AND PROPER TENSION.	
12	INSPECT FOR LOOSENESS OF ACCESSIBLE ITEMS: SWAPPINGS, JACKS, CONNECTORS, ELECTRICAL TRANSFORMERS, POWER STAYS, RELAYS, SELECTORS, SWITCHES, CLOWNS, CAPACITORS, GENERATORS, AND ALLOT LIGHT ASSEMBLIES.		18	CHECK TERMINAL BOX COVERS FOR CRACKS, LEAKS, DAMAGED BASKETS, DIRT AND GREASE.	

19 IF DEFICIENCIES NOTED ARE NOT CORRECTED DURING INSPECTION, INDICATE ACTION TAKEN FOR CORRECTION.

DA FORM 11-238
1 MAY 51

REPLACES DA AGO FORM 439, 1 DEC 50, WHICH IS OBSOLETE.

TM5122-14

Figure 4. DA Form 11-238.

SECOND AND THIRD ECHELON MAINTENANCE CHECK LIST FOR SIGNAL CORPS EQUIPMENT RADIO COMMUNICATION, DIRECTION FINDING, CARRIER, RADAR			
INSTRUCTIONS - See other side			
EQUIPMENT NOMENCLATURE DIRECT CURRENT GENERATOR G-4316		EQUIPMENT SERIAL NO. 9	
LEGEND FOR MARKING CONDITIONS: \checkmark Satisfactory; X Adjustment, repair, or replacement required; \odot Defect corrected NOTE: Strike out items not applicable			
NO.	ITEM	DATE	NO.
1	COMPLETENESS AND GENERAL CONDITION OF EQUIPMENT - (Inspector; Test equipment - covering cases, wires and cable, connections, tubes, spare parts, technical manual, and accessories)	<input checked="" type="checkbox"/>	19
2	LOCATION AND INSTALLATION SUITABLE FOR NORMAL OPERATION	<input checked="" type="checkbox"/>	20
3	CLEAR DIRT AND MOISTURE FROM ANTENNA, MONITORING, MESSING, SHIPMENTS, MAPS, JACKS, PUMPS, TELEPHONES, CARRYING BAGS, COMPASS, PANELS	<input checked="" type="checkbox"/>	21
4	INSPECT SEATING OF REARLY-ACCESSIBLE PLUGS, SWITCHES, PUMPS, LAMPS, CIRCUITS, PUMPS, CONNECTORS, WIRING, PLUGS IN CASES, AND RELAYS	<input checked="" type="checkbox"/>	22
5	INSPECT CONTROLS FOR BINDING, SCRAPPING, SKEWING, LOOSENESS, WORK OR CRIPPED GEARS, MISALIGNMENT, POSITIVE ACTION	<input checked="" type="checkbox"/>	23
6	CHECK FOR NORMAL OPERATION PAR. 12	<input checked="" type="checkbox"/>	24
7	CLEAN AND TIGHTEN EXTERIOR OF COMPONENTS AND CASES, BUSH MOUNTS, GASKETS, BUSHINGS, ANTENNA BRACKETS, GRABARS, SHOCK MOUNTS, LAMPS, BAYS, BUSHES, AND CABLE CONNECTIONS	<input checked="" type="checkbox"/>	25
8	INSPECT CASES, MOUNTINGS, ANTENNAS, BUSHES, AND EXPOSED METAL SURFACES FOR RUST, CORROSION, AND MOISTURE	<input checked="" type="checkbox"/>	26
9	INSPECT BARS, SAILS, WIRE, AND BRUSH HEIGHTS FOR CRACKS, BENDING, FRAYING, DEFORMATION, HANGS, AND BREAKS	<input checked="" type="checkbox"/>	27
10	INSPECT ANTENNA FOR SECURITY, CORROSION, LOOSE FIT, GASKETS, MOUNTINGS, AND REFLECTORS	<input checked="" type="checkbox"/>	28
11	INSPECT CANNING, PINS, LEADERS, AND SAILING T DRUMS, PULLEY, AND FRAMING	<input checked="" type="checkbox"/>	29
12	INSPECT FOR LOOSENESS OF ACCESSIBLE ITEMS, SWITCHES, BUSHES, JACKS, CONNECTORS, ELECTRICAL CONNECTIONS, POWER SWITCHES, RELAYS, BELT DRIVES, BUSHES, SLIDERS, SHAPERS, GENERATORS, AND PUMP LAMP ASSEMBLIES PAR. 19c	<input checked="" type="checkbox"/>	30
13	INSPECT SPRING TENSION FOR CRACKS, LOOSE TERMINALS, BUSHINGS, SPRINGS, AND SPECIAL CRACKS, AND BUSHING CASES	<input checked="" type="checkbox"/>	31
14	CLEAN AIR FILTERS, DRIVE TRANSMISSION, BUSH AND WIRE WINDINGS, WIRE, ASSEMBLIES	<input checked="" type="checkbox"/>	32
15	INSPECT WIRE FOR DAMAGED GLASS AND CASES	<input checked="" type="checkbox"/>	33
16	INSPECT CASES AND COVERS FOR ABSENCE OF BENT OR PROTRUSION	<input checked="" type="checkbox"/>	34
17	INSPECT ANTENNA BUSH WIRE FOR CORROSION AND PROPER TENSION	<input checked="" type="checkbox"/>	35
18	INSPECT TERMINAL BOX CASES FOR CRACKS, LEAKS, DAMAGED GASKETS, BUSH, AND CRACKS	<input checked="" type="checkbox"/>	36
			37
38	IF DEFICIENCIES NOTED ARE NOT CORRECTED DURING INSPECTION, INDICATE ACTION TAKEN FOR CORRECTION		

DA FORM 11-239

Replaces DA AGO Form 11-239, 1 Dec 48, which is obsolete.

11-239-1

TMS122-15

Figure 5. DA Form 11-239.

Section III. TROUBLESHOOTING AT ORGANIZATIONAL MAINTENANCE LEVEL

20. Extent of Instructions

The techniques that are utilized for organization troubleshooting include visual inspection, operational tests, and simple continuity checks. The material is presented in the order which the repairman would normally use in servicing a defective generator. When the procedures indicated are sufficient to determine the source of trouble, troubleshooting at a field maintenance level (pars. 36-3 will be required).

21. Inspection

a. Failure of this equipment to operate the radio set properly will usually be caused by one or more the following:

- (1) Worn, broken, or disconnected cord plug.
- (2) Wires broken because of excessive vibration.
- (3) Worn out brushes or dirty commutators.

b. When failure appears and the cause is not immediately apparent, check as many of the above items as is *practicable* before starting a detailed examination of the component parts of the generator. If possible, obtain information from the operator of the generator regarding performance at the time trouble occurred.

22. Removal of Brushes

a. Unscrew the four captive screws (fig. 6) that hold the main cover to the housing and remove the cover. When replacing the cover, tighten each of the screws a little at a time to make sure of an even watertight fit.

b. Unscrew each of the four black bakelite brush caps (figs. 6 and 11) and slide out the brushes.

Note. Carefully mark the brushes in respect to their voltage rating, either high or low, so that replacement of the original brushes can be made correctly.

c. To replace the brushes, slide them back into their holders and tighten the brush caps. Be sure the polarity markings of the brushes match the polarity markings on the generator frame.

23. Removal of Generator Unit Assembly

a. Remove the main cover (par. 22a).

b. Loosen the four screws that connect the generator unit assembly leads to terminal board TB1

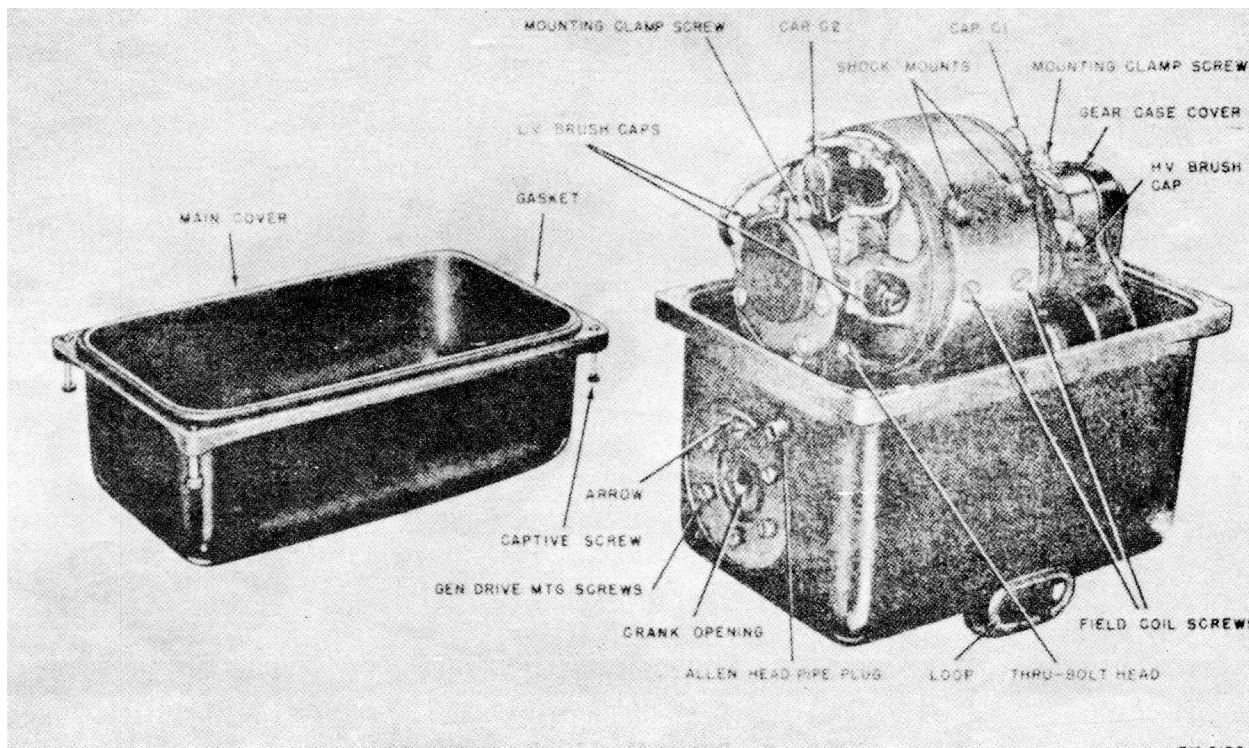

Figure 6. Generator unit, main cover removed.

(fig. 7). Loosen the screws only enough to remove the leads.

c. Unscrew the, mounting clamp screw (fig. 6) that holds the generator unit assembly and spread the clamp open.

d. To remove the generator from the drive unit lift the low-voltage end, and carefully slide it out of the flexible rubber-drive coupling unit (fig. 11).

24. Removal of Voltage Regulator

a. Remove the generator unit assembly (par. 23).

b. Unscrew and remove the two clip screws (fig. 7) that hold the voltage regulator in its socket. Grasp the regulator firmly and rock it back and forth gently while pulling it straight up until it is removed from the socket.

25. Removal of Generator Drive Assembly and Generator Unit Assembly

(fig. 7)

a. Remove the main cover (par. 22a).

b. Remove the six screws at each end of the housing (fig. 6).

c. Rock the generator unit assembly and generator drive assembly back and forth in the housing to loosen the shock mounts (fig. 11) and pull the generator unit assembly and generator drive assembly out of the housing.

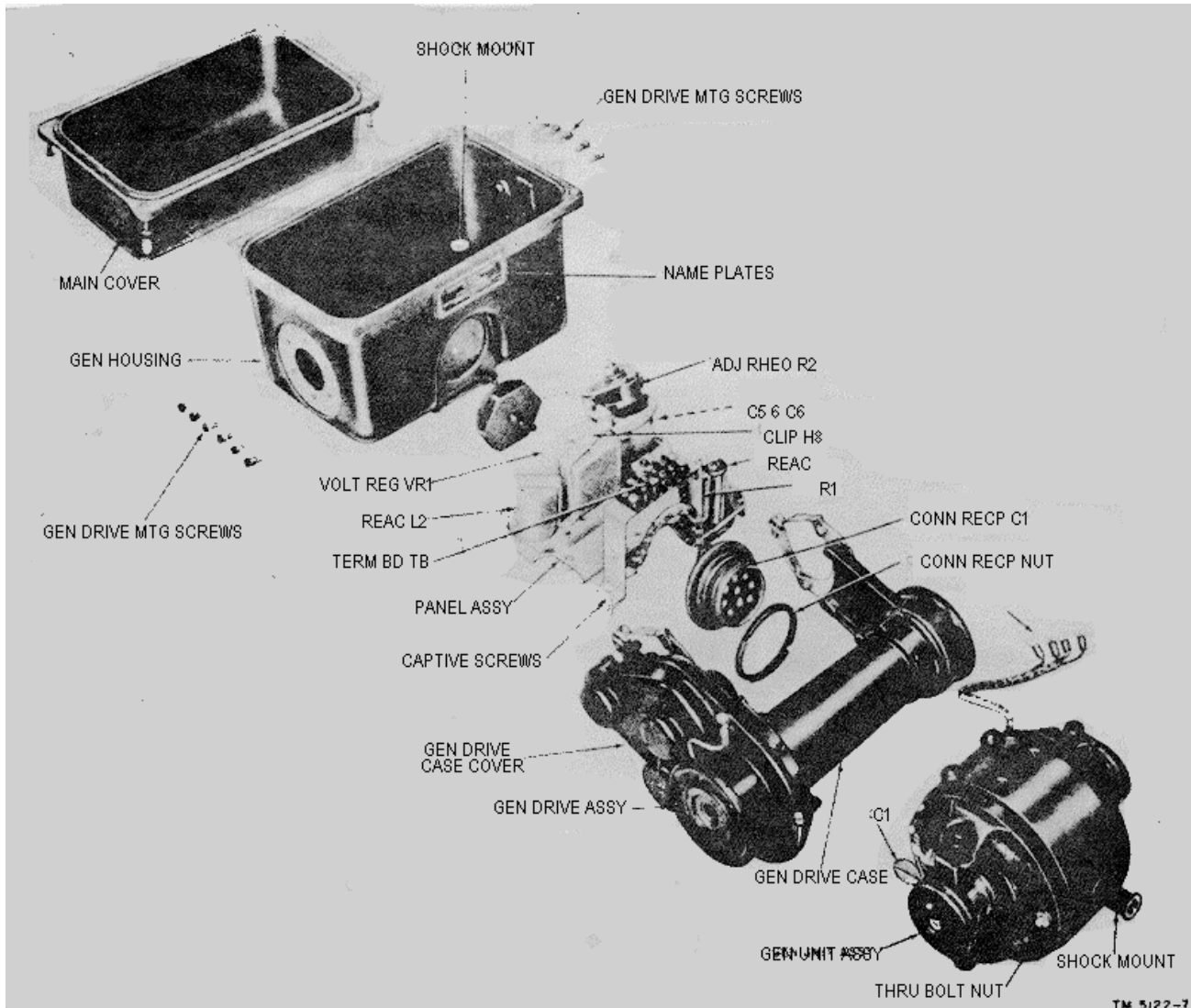

Figure 7. Disassembly of housing components.

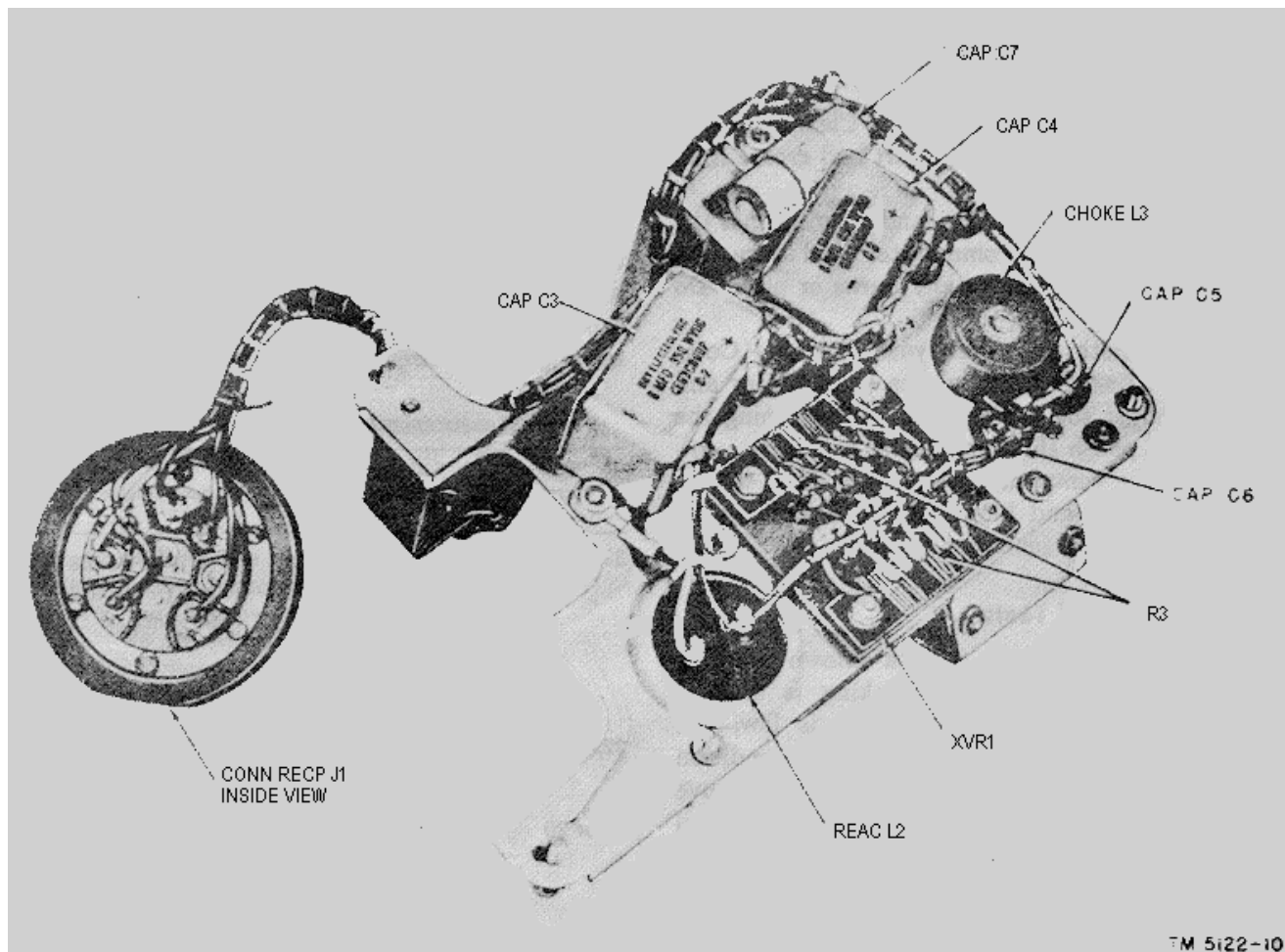

Figure 8. Bottom view of panel assembly.

26. Removal of Panel Assembly

(fig. 7)

- a. Remove the generator unit assembly and generator drive assembly (par. 25).
- b. With the spanner wrench, loosen the nut that holds the connector receptacle to the housing. Remove the nut and push the receptacle into the case.
- c. Use a long-handled screw driver to loosen the four captive screws at each corner of the panel assembly (fig. 8) and remove the unit.

27. Checking and Replacement of Brushes

- a. *Maintenance.* Remove the brushes (par. 22) and check them as follows:
 - (1) Wipe off the brushes with a clean cloth and remove the burs from the brush edge that contacts the commutator.
 - (2) Replace brushes that are worn to less than one-fourth inch.

Note. The brushes are constructed in such manner that they will outlast the generator mechanisms.

 - (3) See that the brush springs have adequate tension and are in firm contact with the brushes as follows:
 - (a) Insert the brush into the brush holder and compare the tension of it and of a corresponding new brush.
 - (b) If there is a noticeable difference in either the length or in the spring tension, replace the old brush with a new one.
- b. *Replacement of New Brushes.* Replace a new brush as instructed below:
 - (1) Insert a new brush and tighten the inrush cap.
 - (2) Crank the generator slowly for a short period of time and remove the new brush for examination. The surface of the brush contacting the commutator should be smooth and shiny for about 75 percent of the contact surface. This indicates that there is a proper fit between the brush and commutator.

28. Cleaning

Remove the main cover (par. 22a) and clean the commutator as follows:

- a. Use a cloth moistened with Cleaning Compound to remove accumulated dirt and grease from the commutator.
- b. Hold a piece of No. 000 sandpaper against the exposed part of the commutator and turn the armature slowly to remove any burns or pits. Do not use emery cloth.
- c. Fold a cloth moistened with Cleaning Compound to the exact width of the commutator and press it against the commutator while turning the armature to polish the commutator segments.
- d. Wipe the commutator segments clean with a clean, dry cloth, and blow out the dust and dirt accumulated in the generator housing.

29. Operational Tests

Operate the generator with a known working receiver-transmitter. If the cranking is difficult and the receiver-transmitter output is low, the trouble lies in the generator unit. If the condition of the receiver-transmitter is not known, remove the power cord from the generator receptacle and operate the generator at normal speed for several turns. If the cranking is still difficult, the trouble must be in the generator unit. When the cranking torque is normal and the known good receiver-transmitter output is poor, use another generator. If the receiver-transmitter operates normally, then the trouble lies in the generator.

30. Voltage Output Test

The direct-current (dc) voltages listed in the chart below were taken with the multimeter connected to the terminals of the power connector receptacle (fig. 10) with the power cord disconnected and the generator cranked at approximately 1 rps:

Output designation	Measured terminals to ground (terminal 24)	Measured voltage (dc)
High voltage (transmitter B plus).	32	400 to 500
Low voltage (receiver B plus)	21	95 to 200
Filament (transmitter)	34 or 20	6.2 to 6.4
Filament (receiver)	23	1.33 to 1.46

31. Continuity Tests and Probable Trouble

These tests should be performed after the voltage output test (par. 30). The tests below enable the unit repairman to isolate the different subsections of the generator unit by a series of resistance measurements. Remove the power cord before measuring resistance.

- a. *Connector Receptacle J1* (fig. 10). The first column of the tables lists the terminal to be measured, the second column gives the approximate normal resistance readings, and the third column shows the probable troubles when the measured readings are different.

(1) Measurements to ground.

Terminal	Normal reading in ohms	Probable trouble
32	190	Open or shorted winding of L1 armature or E6 (fig. 9). High-voltage brushes loose or defective (fig. 6). Shorted capacitor C1 or either C3 or C4 defective (figs. 8 and 9).
22, 33, or 35	Open circuit (∞).	Terminals shorted to housing (ground).
21	10,000	Open resistor R1 (fig. 9).
34 or 20	.1	Open winding of L3 or low voltage winding of (fig. 9). Low-voltage brushes loose or defective (par. 27).
23	10	Open winding of L2 (fig. 9).
24	0	Open jumper wire.

(2) Measurements between terminals.

Terminal	Normal reading in ohms	Probable trouble
22, 33, or 35 to all other terminals.	Open circuit (∞).	Defective receptacle J1 (fig 10).
32 to 21	10,000	Open R1 (fig. 9).
34 to 20	0	Open jumper wire (fig. 9).
34 or 20 to 23	10	Open L2 (fig. 9).

- b. *Individual Components*. The first column in the table shows the component to be measured, the second column indicates the terminals required to make the measurement, the third column gives the approximate normal resistance reading, and the fourth column lists the probable trouble. Remove the generator unit assembly (par. 23) and voltage regulator (par. 24) and perform the measurements indicated in following table.

(1) *Generator unit assembly.* (fig. 7).

Component	Terminals	Normal reading in ohms	Probable trouble
Field coil E5 (fig. 11)	White and black wires	35 to 100	Shorted or open winding.
High-voltage winding of armature E6 (4.11).	Red and black wires	160 to 200.	Shorted or open winding. Shorted C1 (fig. 9). Defective brushes
Low-voltage winding E6.	Green and black wires	0 (short circuit)	Open winding. Defective brushes.
C1 (remove positive brush).	Red and black wires	Open circuit	Shorted or leaky C1 (fig 9).
C2 (remove positive brush).	Green and black wires	Open circuit	Shorted or leaky C2 (fig 9).

(2) *Panel assembly* (figs. 7, 8, and 9).

Component	Terminals	Normal reading in ohms	Probable trouble
C3 and C4.....	Red and black wires (terminal 1 and 4 on TB1, fig. 9).	Slight charge and then open circuit,	Shorted or leaky C3 or C4.
C5, C6, or C7	Green and black wires (terminals 2 and 4 on TB1 fig. 9).	Charge effect and then slow return to open circuit.	Shorted or leaky C5, C6, or C7. (To check these capacitors individually remove their ground leads and check for open circuit reading.)
L1	Red wire on TB1 to 32 on J1.	7	Open winding.
L3	Green wire on TB1 to 20 or 34 on J1.	Short circuit	Open winding.
Adjustable rheostat R2	15 on XVR1 to ground.....	Between 0 and 25	Open resistance
R4.....	14 to 15 on XVR1	7	Open resistor
R3.....	1 through 11 on XVR1	Follow values given on figure 9.	Open resistor
R5.....	14 to 15 on VR1	12	Open resistor
Relay coil	13 to 14 on VR1	8	Open winding
Relay contacts	1 through 11 on VR1	Short circuit	Faulty contacts. Clean shore contacts gently; do not use air blower.

CHAPTER 4

THEORY

32. Main Sections (fig. 9)

The main sections of the generator are a two commutator unit with an actuating gear train, a radio noise filter, and a voltage regulator. Four voltage outputs are provided to operate Receiver-Transmitter RT-77(A)/GR-9. High voltages (420 and 105 volts) are obtained from one of two independent windings on a single lapwound armature. A second winding provides two low voltages (6.3 and 1.4 volts) output. Each winding is connected to its individual commutator. A voltage regulator is used to maintain constant output voltages.

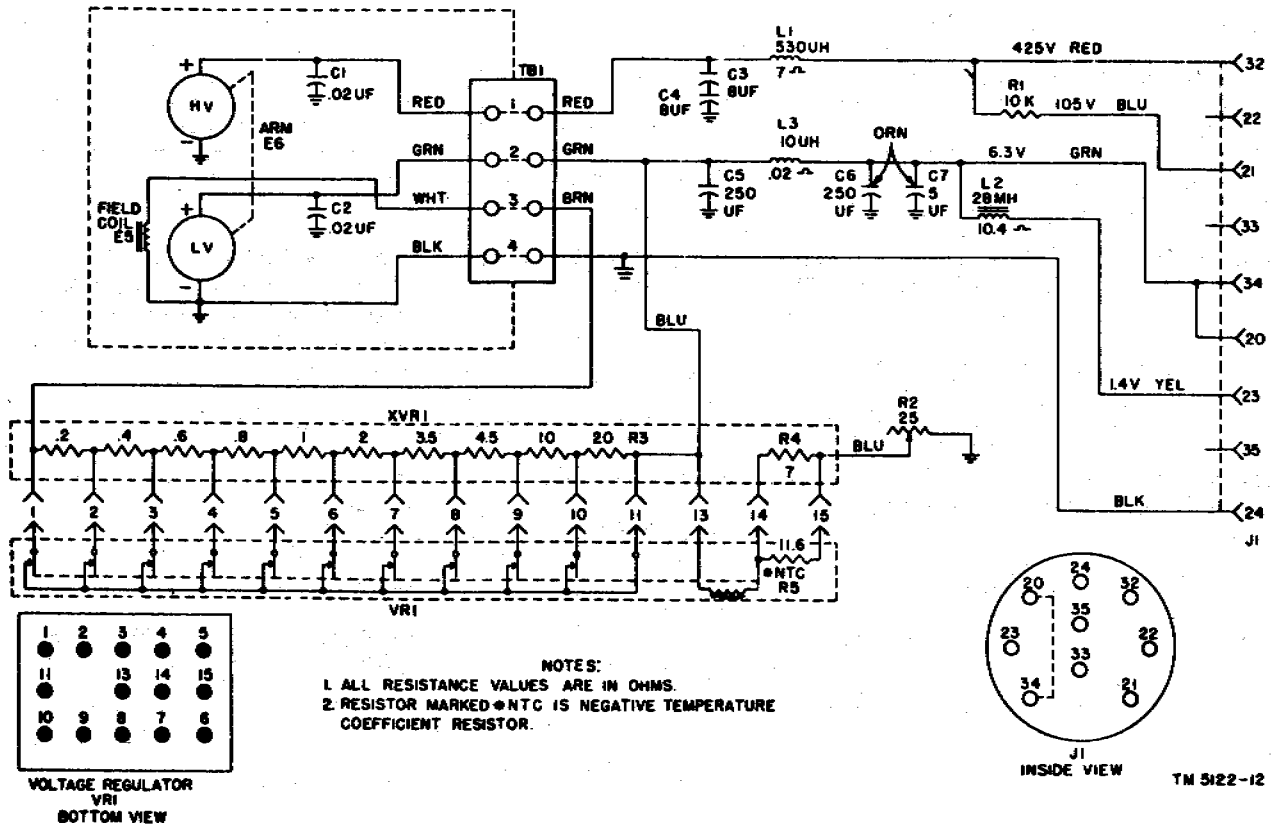

Figure 9. Main schematic diagram.

33. Voltage Generation

Armature E. is rotated between field coil E5 by use of the cranks and a step-up gear train. When the cranks are first turned, the magnetic field present is weak because the residual magnetism in the core of the field is low. The field is strong enough, however, to induce a low voltage in the armature. This induced voltage causes a current to flow through the field coil, thereby increasing the strength of the magnetic field. A strong magnetic field results in an increased induced voltage in the armature so that a cumulative effect is obtained. The induced voltage continues to build up until it reaches its rated value at a hand-cranked speed of 50 to 70 revolutions per minute (rpm).

34. Voltage Outputs (fig. 9)

a. *High-Voltage Outputs.* The alternating current (ac) voltage induced in the high-voltage winding of the armature is converted to pulsating dc voltage by its associated commutator. Filter capacitors C3 and C4 and choice L1 smooth the pulsations to dc.

This output (426 volts) is used to power the transmitter section of the radio set. Capacitor C1 is used to remove the ac variations coming from the winding. Resistor R1 drops the 425 volts to 105 volts to power the low-voltage circuits of the transmitter and all of the plate circuits of the receiver. The negative or return side of high voltage is grounded to the housing

b. *Low-Voltage Outputs.* The ac voltage induced in the low-voltage winding of the armature is converted to pulsating dc by its associated commutator. Filter capacitors C5 through C7 and choke L3 smooth the pulsations to dc. This output (6.3 volts) is used in the transmitter filament and keying circuits. Choke L2 acts as an additional filter and drops the 6.3 volts to 1.4 volts, used as filament voltage for the receiver. The negative or return side of the low voltage is grounded to the housing.

35. Voltage Regulator VR1 (fig. 9)

a. *Purpose and Principal of Operation.* The voltage regulator maintains the output voltages constant under changes in load conditions, variations in cranking speed, and changes in temperature. The regulator is connected in series with the field winding across the low-voltage commutator and affects the field current to maintain a constant armature voltage. The voltage regulator is set to maintain a 6.3-volt output from the low-voltage circuit. As the high- and low-voltage armature windings all revolve in the same field; controlling the voltage on the low-voltage commutator also provides control of the outputs on the high-voltage commutators.

b. *Circuit Components.* Negative temperature coefficient (ntc) resistor R5 and an operating coil that controls 10 switch fingers or contacts are contained in the regulator proper. Regulating and temperature-compensating resistors R3 and R4, respectively, are an integral part of socket XVR1. Resistor R3 is tapped at 11 points and the tape are connected to contacts of socket XVR1. The normally closed contacts of VR1 are shunted across the various tape of R3 so that when the generator is not being cranked the entire resistor is short-circuited. An adjustable rheostat R2 is connected between contact 15 of XVR1 and ground for setting the regulator operating voltage.

c. *Theory of Operation.* Field winding E5 of the generator is connected in series with the normally closed contacts of the voltage regulator across the low-voltage commutator. The operating coil of VR1, the temperature compensating parallel resistors R4 and R5, and rheostat R2 are connected in series with the 6.3-volt circuit. As the voltage builds up, the current through the field and through the operating coil of the regulator increases. The regulator is set by means of R2, so that the armature of the operating coil will be activated when the cranking speed of the generator is greater than 50 rpm. When the armature is activated, it opens, in sequence, the series of 10 contacts. As the short circuit across each section is removed, the resistance of that section is placed in series with the field coil so that the current through the field, and hence the voltage induced in the armature winding, is controlled. As the cranking speed is increased, additional resistance is inserted in series with the field coil until sufficient resistance of R3 is in series with the field coil to maintain a constant voltage. The voltage regulator thus limits changes in the current through the field coil produced by variations in cranking speed between 50 and 70 rpm combined with load variations. This limits changes in output voltages of both windings. Changes in field coil current produced by different loads on the generator are limited by the voltage regulator in the same way. A small load causes the voltage regulator to throw in more series resistance than a large load. Therefore, changes in field coil current and in output voltage of the two armatures are limited. The above regulation keeps output voltages close enough to maintain good receiver-transmitter operation.

d. *Temperature Compensation.* Changes in temperature can affect the resistance of the voltage regulator coil causing variation in output voltages. To offset this effect, a temperature-compensating network consisting of resistance's R4 and R5 is included in the regulating or reference circuit. Resistor R5 has a negative temperature coefficient which cancels the opposite variations in resistance produced by variations in temperature of other circuit components. In a similar manner, R4 opposes changes in temperature but it has a positive coefficient. The regulated voltage, therefore, is almost independent of temperature changes.

CHAPTER 5

FIELD MAINTENANCE

Section I. TROUBLESHOOTING AT FIELD MAINTENANCE LEVEL

36. Troubleshooting Procedures

Troubleshooting at field maintenance level includes all the techniques outlined for preventive maintenance and troubleshooting at the organizational maintenance level. The troubleshooting procedures can be divided into two sections: electrical and mechanical. The electrical tests are given in paragraphs 30, 31, 38, 46, and 47. The brushes can be considered either electrical or mechanical for testing purposes. Paragraph 27 describes the checking procedure. Troubleshooting in the mechanical section is covered in paragraphs 22 through 28.

37. Equipment Required for Troubleshooting

- a. Multimeter TS-352/U which will be referred to as multimeter.
- b. Electronic Multimeter ME 6/U which will be referred to as vtvm.
- c. A dummy test load fabricated as shown in figure 10.
- d. Grease, Aircraft and Instrument (GL).

38. Troubleshooting Using Dummy Load (fig. 10)

a. Connect the dummy load as indicated on B, figure 10. Either banana plugs or male plug PL294, part of Cord CD-1086, can be used to connect the lead wires from the dummy load to J1 on the generator. If the cord is available, cut off the female plug and use the following table as a guide to connect the required wires from the cord to the dummy load

Wire color	Voltage (dc)	Terminal No. on PL-294	Corresponding terminal No. on J1
Red	425	47	32
Blue	105	57	21
Green	6.3	54	34 or 20
Yellow	1.4	46	23
Black	0 (ground)	53	24

b. All of the load resistors must be connected to obtain the normal readings indicated in the chart in c below. If sufficient meters are not available to make all the meter connections shown in figure 10 simultaneously, make sure that each dummy resistor is connected either directly or through an ammeter to its appropriate terminal connection on receptacle J1. This will insure that all circuits are drawing their proper load current. Proper voltage and current readings then will be obtained.

c. The following chart indicates the voltage and current readings which should be obtained when the generator is cranked at normal speed with an appropriate load connected. Symptoms which indicate abnormal operation are also listed, along with possible causes of trouble. Once a particular circuit has been found defective, additional voltage and/or resistance measurements (par. 30 and 31) should isolate the defective part. To use the chart effectively, the measurements should be taken in the sequence listed. In column 1 of the chart, the letter indicates the location of the meter (fig. 10). The multimeter is used for dc and resistance readings. For ac readings, use the vtvm.

Warning: Be careful of the 425 volts across the dummy load when testing. With the equipment off short out the high-voltage circuits to ground before touching the exposed parts.

Meter designation and type	Meter range	Normal reading (at 60 rpm)	Symptom	Probable main trouble
A: dc ammeter	0-5 amp, dc	2.46 to 2.54 amp	No reading	Defective L2, C7, C6, L3, C5, E3, E4 low armature winding, E5, R3, VR1 R2, open wires or connections.
B: dc voltmeter	0-10 volts, dc	6.2 to 6.4 volts	Incorrect voltage (and current at A).	Defective or incorrectly adjusted R2, defective C7, E3, E4, EB, R3, VR1,, E5.
C: ac voltmeter	0-.1 volts ac	.064 volts	High reading	Defective C7, CB, L3, C5, C2, E3, E4, EI, E2, E6, VR1, R3, commutator brush setting.
D: dc ammeter	0-.5 amp, dc	.445 to .485 amp	No reading	Defective L2, wiring or connections.
E: dc voltmeter	0-5 volts, dc	1.33 to 1.46 volts	Incorrect voltage (and current at E).	Defective L2
F: dc ammeter	0-.150 amp dc	.108 to .122 amp	No reading (low voltages are correct).	Defective L1, EI, E2, open
G: dc voltmeter	0-500 volts, dc	400 to 500 volts	Incorrect voltage (and current at F).	Defective L1, C3, C4, CI, E:I, E2, E6, wiring.
H: ac voltmeter	0-5 volts, ac	4.6 volts max	High reading (low voltage ripple is normal).	Defective L1,, C3, C4, E2, E6 commutator brush setting.
I: dc ammeter	0-.05 amp dc	.0295 to .0345 amp	No reading (other voltages are correct).	Defective R1, wiring or connections.
J: de voltmeter	0-50 volts, dc	97.5 to 200 volts	Incorrect voltage (and current at μ I; other outputs are correct).	Defective R1.

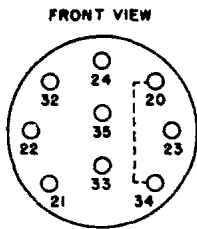

A. CONN RECP ON GEN UNIT

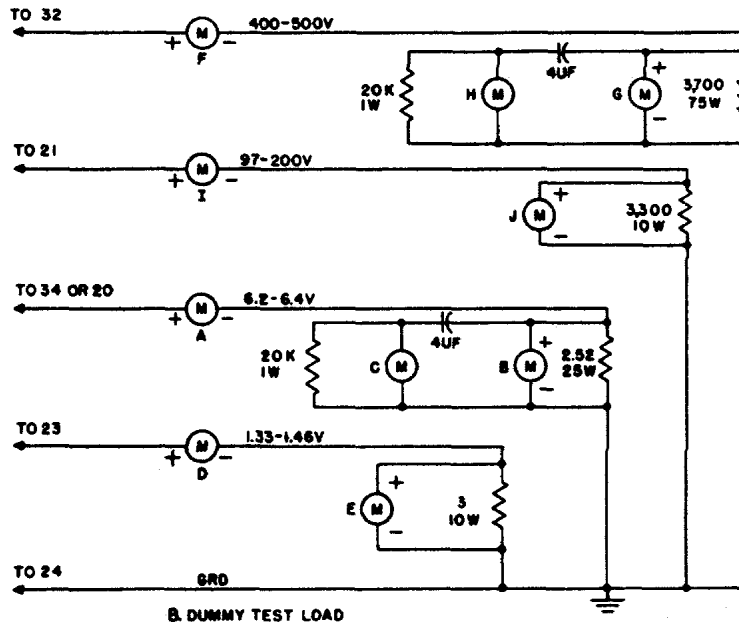

B. DUMMY TEST LOAD

Figure 10. Dummy load test board.

Section II. REPAIR

39. Disassembly for lubrication (fig. 11)

- a. Remove the generator unit assembly (par. 23) and the generator drive assembly (par. 25).
- b. Remove the five screws that hold the drive case cover to the drive case. Carefully pry off the cover. Be careful not to damage the gasket. If the gasket has been damaged, replace it with a new one before reassembling the generator. With the cover removed, all lubrication (pars. 40 and 41) for the gears can be performed.

40. Preliminary Lubrication Instruction.

- a. Do not use excessive amounts of grease and do not allow electrical contacts to become greasy.
- b. Do not use gasoline as a cleaning fluid for any purpose. When the unit is overhauled or repairs are made, clean parts with Cleaning Compound. Clean electrical contact (voltage regulator, connector, commutators and brushes) with a cloth moistened with Cleaning Compound, then wipe them dry with a clean cloth.
- c. Make certain that lubricants and points to be lubricated are free from sand, grit or dirt. These abrasives are the chief cause of bearing wear and thus often cause bearing replacements. Use Cleaning Compound to clean all parts. Before lubrication, wipe clean all surfaces to be lubricated; use lint-free cloth dampened with Cleaning Compound. Keep Cleaning Compound off surrounding parts.
- d. Never lubricate brushes or commutators.

41. Detailed Lubrication Instructions (fig. 12)

Lubrication is only required when replacing parts. Use the chart given below when lubrication is necessary.

Part	Reference symbol	Lubricant
Gear train teeth	MP 21, MP 23, MP 25.	Grease (GL)
Sprockets	MP 24, MP 22	Grease (GL)
Chain	MP 48	Grease (GL)
Ball bearings (double seal)	MP29, MP 30, MP 31.	None

42. Replacement of Field Winding (fig. 11)

- a. Remove the generator unit assembly (par. 23).
- b. Remove all brushes.
- c. Remove the two through-bolts (figs. 6 and ?) that hold the field frame and end brackets together.
- d. Remove either end bracket of the generator by tapping it gently with a hammer. When one end bracket is removed, slide the armature out for removal.
- e. Loosen the four screws that secure the windings to the field frame and remove winding E5, (Two of the screws are visible in fig. 6; the other two screws are directly opposite.)
- f. Insert new windings into the frame and secure them with the four screws.

43. Special Replacement Techniques

The replacement of ball bearings and gears (par. 45) requires the use of an arbor press ; proceed as follows:

- a. When a ball bearing is associated with a defective part, it should be discarded with the part and a new-bearing should be used.
- b. Use an arbor press for separating gears, sprocket and bearings from shafts.
- c. For reassembling the gears, bearing, shafts, etc. place the parts, suitably supported, in an arbor press; keep the parts carefully aligned while a moderate pressure is applied. If a heavy pressure is required, stop immediately and check the alignment of parts.

44. Replacement of Armature E6

- a. Disassemble the generator unit as outlined in paragraph 42a through d.
- b. Install a new armature complete with ball bearings.

45. Replacement of Gears (figs. 11 and 12)

- a. Disassemble the generator as outlined in paragraph 39.
- b. Remove the two screws that hold baffle plate MP 10 on the crankshaft to the drive case and pull out the crankshaft.
- c. Separate the gear drive assembly from the cover plate by supporting the entire assembly and cover plate in an arbor press and carefully press ball bearing MP 31 off of the second stage sprocket assembly. Remove the gear drive assembly from the arbor press, turn it over and support the entire assembly again in the press. Carefully press out the crank- and gear assembly from the cover. When the

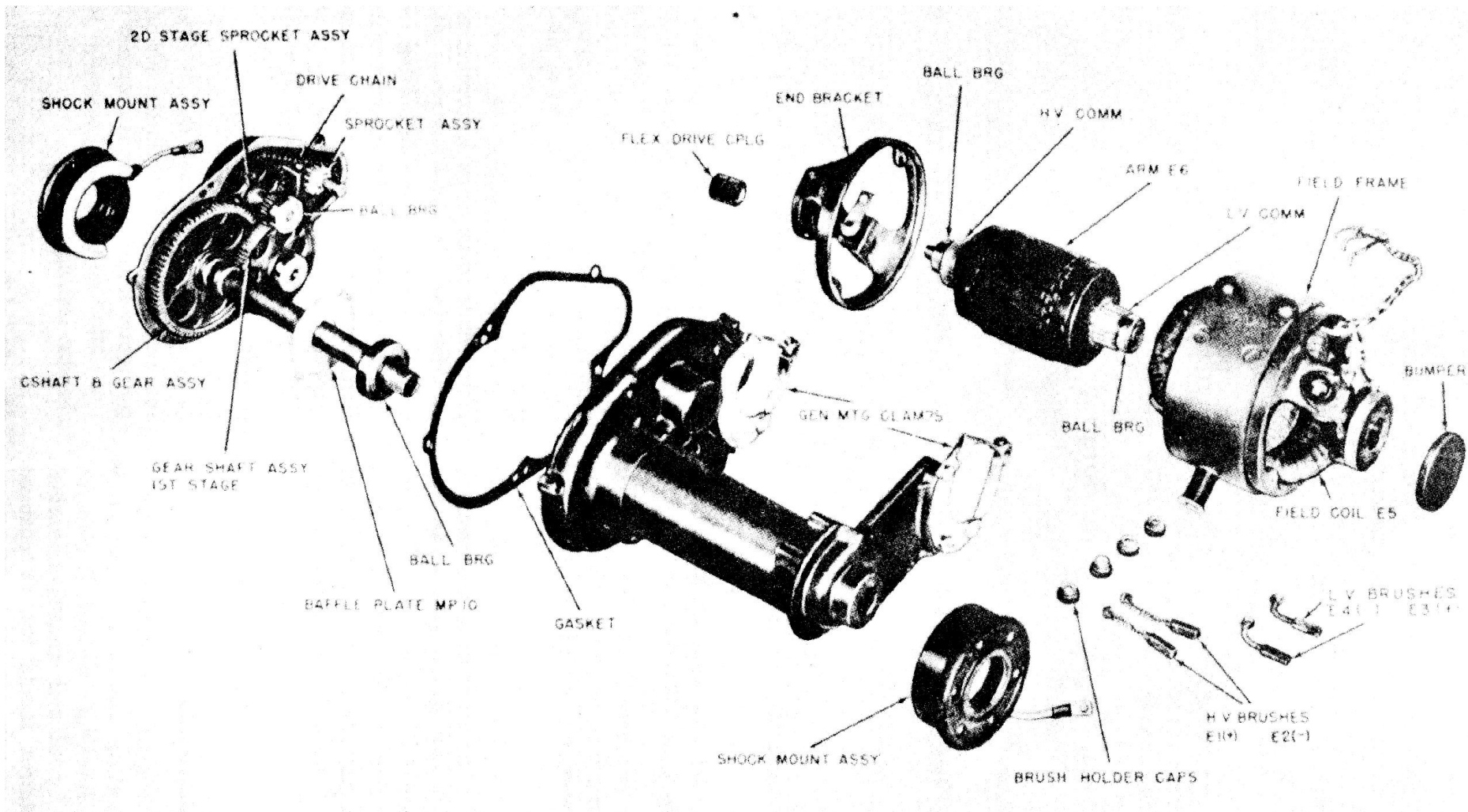

Figure 11. Disassemble for lubrication.

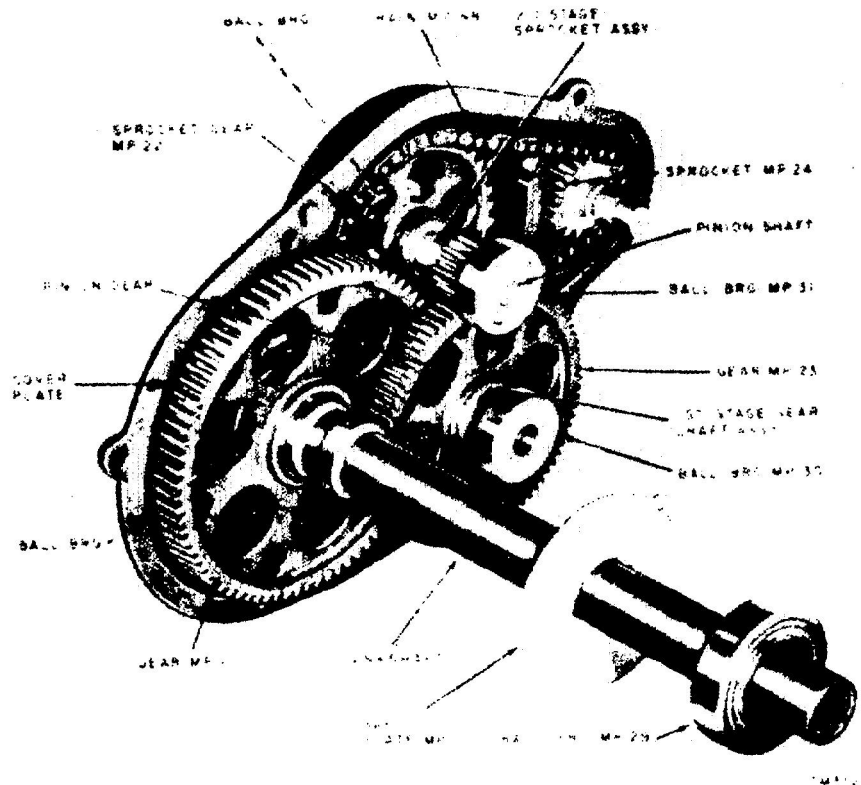

Figure 12. Gear train components.

crankshaft and gear assembly come out, it will bring with it the first stage gear shaft assembly.

d. To remove the second stage sprocket assembly, gently pull it out of the cover plate. All the gear drive components are now removed from the cover plate.

e. Separate gear MP 21 from the crankshaft by supporting the gear in an arbor press and carefully press the crankshaft out of the gear. The ball bearing located behind the crankshaft will be removed at the same time; the key will remain with the shaft. Replace gear MP 21 and reassemble the shaft the gear and the ball bearing with a light press fit (par. 43).

f. Separate the first stage gear assembly and its pinion shaft by supporting gear MP 23 in an arbor press and carefully press the pinion shaft out of the gear. Ball bearing MP 30 will be removed at the same time. Replace gear MP 23 and reassemble the gear and the ball bearing on the shaft with a light press fit.

g. Separate the second stage sprocket gear and its pinion shaft by supporting sprocket gear MP 22 in an arbor press and carefully press the pinion shaft out of the gear. The ball bearing located behind the sprocket gear will be removed at the same time. Replace sprocket gear MP 22 and reassemble the sprocket gear and the ball bearing on the shaft with a light press fit. The original key may be used.

Section III. ADJUSTMENTS AND FINAL TESTING

46. Rheostat Adjustment

a. Rheostat R2 is initially adjusted to obtain a 6.3-volt potential between terminals 20 and 24 or 34 and 24 (ground) of output connector J1 with the generator properly loaded and cranked at normal speed. The adjustment should not be changed unless the proper voltage is not obtained when an operational test or trial test under load is made.

b. Remove the generator top cover (par. 22a) and connect the multimeter between terminals 20 and 24 or 34 and 24. Loosen the rheostat locking nut and insert a screwdriver in the slot of the bushing and rotate until 6.3 volts is obtained (meter B, fig. 10). Make an operational test after tightening the rheostat locking nut.

47. Final Testing

The minimum test requirements in determining the quality of a repaired generator are equal to those outlined in paragraph 38c.

CHAPTER 6
SHIPMENT AND LIMITED STORAGE AND DEMOLITION TO PREVENT ENEMY USE

Section I. SHIPMENT AND LIMITED STORAGE

48. Disassembly

The following instructions are recommended as a guide for preparing the generator for either shipment or storage.

- a. Remove the cranks and disconnect the power cable.
- b. Remove the generator unit from the tripod. Replace and tighten the power receptacle cap.
- c. Fold the tripod.

49. Field Repackaging Data

The following chart lists the estimated amount of materials required to prepare the generator for storage or shipment:

Materials	Amount
Waterproof barrier	20 sq ft
Flexible corrugated paper	12 ft
Gummed paper tape.....	25 sq ft
Water-resistant tape	12 ft.
Corrugated fiberboard carton .	2 ea (par. 8a)
Activated desiccant.....	8 bags

50. Repacking

Use figure 2 as, a guide in repacking the generator as follows:

- a. *Technical Manuals.* Wrap the manuals in waterproof barrier material. Seal all seams and fold with water-resistant tape.
- b. *Cranks.* Package the cranks by wrapping each one with flexible corrugated paper around them and secure the cushioning with gummed paper tape.
- c. *Tripod.* Wrap the tripod around its length with flexible corrugated fiberboard and fasten with gummed paper tape. Wrap each end of the tripod in a similar manner. Wrap the package with waterproof barrier material and seal with water-resistant tape.
- d. *Generator Unit.* Fold six pieces of corrugated fiberboard paper (cells) as shown in figure 2. Place the generator unit on one piece and lean four pieces around the generator unit to act as the sides of the package. Use the gummed paper tape to bind the five sides together and then add the last side as a top and secure it to the other sides with gummed paper tape. Wrap the package in waterproof barrier material and seal the package with water resistant tape.
- e. *Tripod Carton.* Place two packages of desiccant into the bottom of the tripod corrugated carton and then slide in the folded tripod. Fill in voids with flexible corrugated fiberboard material. Place two more packages of desiccant into the carton, fold the top flaps of the carton, and seal with gummed paper tape. Wrap the package in waterproof barrier material and seal it with water-resistant tape.
- f. *Generator Unit Carton.* Package the generator unit, cranks, and manuals by following the instructions given in e above.

Section II. DEMOLITION TO PREVENT ENEMY USE

51. General

The demolition procedures outlined in paragraph 52 will be used to prevent the enemy from using or salvaging this equipment. Demolition of the equipment will be accompanied only upon order of the commander.

52. Methods of Destruction

- a. *Smash.* Smash the brushes, controls, resistors, coils, housing, capacitors, and connectors; use sledges, axes, handaxes, pickaxes, hammers, crow- or heavy tools.
- b. *Cut.* Cut cords, cables, and wiring; use axes, handaxes, or machetes.
- c. *Burn.* Burn cords, resistors, capacitors, coils, wiring, technical manuals; use gasoline, kerosene, oil, flame throwers, or incendiary grenades.
- d. *Bend.* Bend brackets, mountings, and hous ing.
- e. *Explosives.* If explosives are necessary, use firearms, grenades, or TNT.
- f. *Dispose.* Bury or scatter the destroyed parts in slit trenches, fox holes, or other holes, or throw them into streams.

**CAPACITOR COLOR CODE MARKING
(MIL-STD CAPACITORS)**

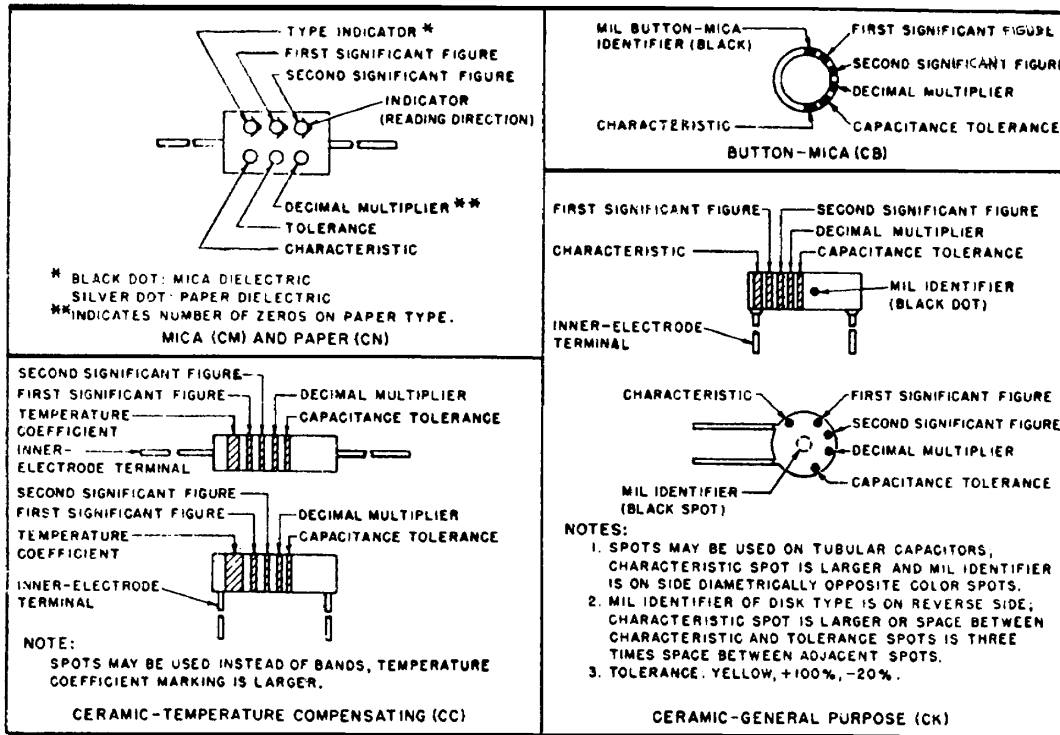

CAPACITOR COLOR CODE

COLOR	SIG FIG.	MULTIPLIER		CHARACTERISTIC ¹				TOLERANCE ²					TEMPERATURE COEFFICIENT (UUF/UF/°C)
		DECIMAL	NUMBER OF ZEROS	CM	CN	CB	CK	CM	CN	CB	CC		
											OVER 10UUF	10UUF OR LESS	
BLACK	0	1	NONE		A			20	20	20	20	2	ZERO
BROWN	1	10	1	B	E	B	W					1	-30
RED	2	100	2	C	H		X	2		2	2		-80
ORANGE	3	1,000	3	D	J	D			30				-150
YELLOW	4	10,000	4	E	P								-220
GREEN	5		5	F	R						5	0.5	-330
BLUE	6		6		S								-470
PURPLE (VIOLET)	7		7		T	W							-750
GRAY	8		8			X						0.25	+30
WHITE	9		9								10	1	-330(±500) ³
GOLD		0.1						5		5			+100
SILVER		0.01						10	10	10			

- LETTERS ARE IN TYPE DESIGNATIONS GIVEN IN MIL-C SPECIFICATIONS.
- IN PERCENT, EXCEPT IN UUF FOR CC-TYPE CAPACITORS OF 10 UUF OR LESS.
- INTENDED FOR USE IN CIRCUITS NOT REQUIRING COMPENSATION

STD-C1

Figure 13. MIL-STD capacitor color codes

AGO 6417A

**RESISTOR COLOR CODE MARKING
(MIL-STD RESISTORS)**

**AXIAL-LEAD RESISTORS
(INSULATED)**

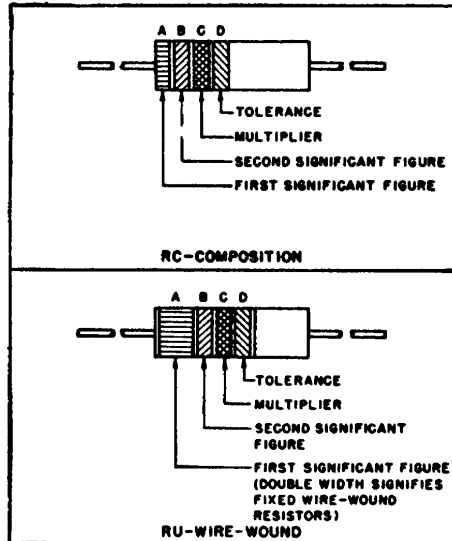

**RADIAL-LEAD RESISTORS
(UNINSULATED)**

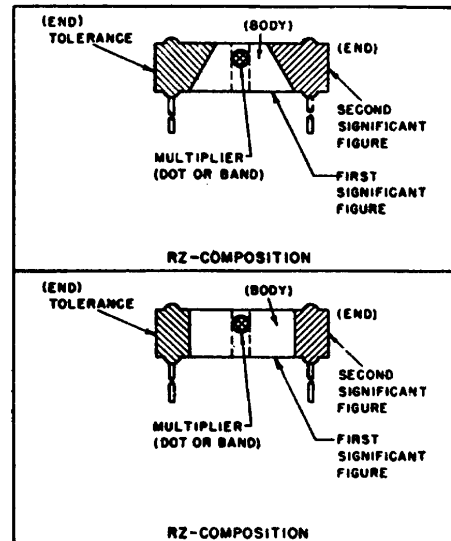

RESISTOR COLOR CODE

BAND A OR BODY*		BAND B OR END*		BAND C OR DOT OR BAND*		BAND D OR END*	
COLOR	FIRST SIGNIFICANT FIGURE	COLOR	SECOND SIGNIFICANT FIGURE	COLOR	MULTIPLIER	COLOR	RESISTANCE TOLERANCE (PERCENT)
BLACK	0	BLACK	0	BLACK	1	BODY	± 20
BROWN	1	BROWN	1	BROWN	10	SILVER	± 10
RED	2	RED	2	RED	100	GOLD	± 5
ORANGE	3	ORANGE	3	ORANGE	1,000		
YELLOW	4	YELLOW	4	YELLOW	10,000		
GREEN	5	GREEN	5	GREEN	100,000		
BLUE	6	BLUE	6	BLUE	1,000,000		
PURPLE (VIOLET)	7	PURPLE (VIOLET)	7				
GRAY	8	GRAY	8	GOLD	0.1		
WHITE	9	WHITE	9	SILVER	0.01		

*FOR WIRE-WOUND-TYPE RESISTORS, BAND A SHALL BE DOUBLE-WIDTH..

WHEN BODY COLOR IS THE SAME AS THE DOT (OR BAND) OR END COLOR, THE COLORS ARE DIFFERENTIATED BY SHADE, GLOSS, OR OTHER MEANS..

EXAMPLES (BAND MARKING):

10 OHMS ± 20 PERCENT: BROWN BAND A; BLACK BAND B, BLACK BAND C, NO BAND D.

4.7 OHMS ± 5 PERCENT: YELLOW BAND A, PURPLE BAND B; GOLD BAND C; GOLD BAND D.

EXAMPLES (BODY MARKING)

10 OHMS ± 20 PERCENT: BROWN BODY. BLACK END;; BLACK DOT OR BAND, BODY COLOR ON TOLERANCE END.

3,000 OHMS ± 10 PERCENT: ORANGE BODY, BLACK END, RED DOT OR BAND ; SILVER END.

Figure 14. MIL-STD resistor color codes.

INDEX

	Paragraph	Page
Adjustments:		
Final testing.....	47	22
Rheostat.....	46	22
Charts:43		
Circuit resistance chart.....	31	14
Lubrication chart.....	41	20
Trouble chart.....	38c	18
Checking unpacked equipment.....	9	5
Common names.....	3	3
Components of generator.....	6	3
Connections.....	11	5
Description.....	7	3
Disassembly.....	48	23
Field maintenance:		
Equipment required.....	37	18
Procedures.....	36	18
Using dummy load.....	38	18
Field winding, replacement.....	42	20
Final testing.....	47	22
Forms and records.....	2	3
Generator, description.....	7	3
Generator unit.....	7a	3
Tripod.....	7b	4
Installation of Generator G-43/6.....	10	5
Lubrication:		
Detailed lubrication instructions.....	41	20
Disassembly for lubrication.....	39	20
Preliminary lubrication instructions.....	40	20
Methods of destruction.....	52	23
Operation.....	12	5
Organizational maintenance:		
General.....	13	8
Tools, materials and test equipment required.....	14	8
Packaging data.....	8	5
Preventive maintenance services:		
Definition of preventive maintenance.....	15	8
General preventive maintenance techniques.....	16	8
Performing preventive maintenance.....	19	8
Use of preventive maintenance forms.....	17,18	8
Purpose and use.....	4	3
Removal:		
Brushes.....	22	11
Generator drive unit assembly.....	25	12
Generator unit assembly.....	23	11
Panel assembly.....	26	13
Voltage regulator.....	24	12
Repacking.....	49,50	23
Repairs:		
Disassembly for lubrication.....	39	20
Lubrication.....	40,41	20
Reassembling generator unit assembly.....	42a	20
Replacement of armature.....	44	20
Replacement of armature E6.....	44	20
Replacement of brushes.....	27b	13

	Paragraph	Page
Replacement of field windings	42	20
Replacement of gears	45	20
Special replacement techniques	43	20
Scope	1	3
Shipment and limited storage:		
Demolition	61, 52	23
Disassembly	48	23
Repacking	49, 50	23
Special replacement techniques	43	20
Tables:		
Packaging data	8a	6
Table of components	6	3
Technical characteristics	5	3
Tests:		
Continuity	31	14
Operational	29	14
Voltage output	30	14
Theory of Generator G-43/G:		
Circuit components	35b	17
General	32	16
High-voltage winding	34a	16
Low-voltage winding	34b	17
Operation, purpose and principal	35a	17
Temperature compensation	35d	17
Theory of operation	35c	17
Voltage generation	33	16
Voltage outputs	34	16
Voltage regulator	35	17
Troubleshooting at organizational maintenance level:		
Extent	20	11
Inspection	21	11
Uncrating, unpacking and checking unpacked equipment	9	5
Unpacking ,	8	5

By Order of *Wilber M. Brucker*, Secretary of the Army:

MAXWELL D. TAYLOR
General, United States Army,
Chief of Staff.

Official:

HERBERT M. JONES,
Major General, United States Army,
The Adjutant General.

Distribution:

Active Army:

CNGB	5-16
ASA	5-17
Tec Svc, DA	5-35
Tec Svc Bd	5-36
Arctic Test Bd	5-37
Hq CONARC	5-192
CONARC Bd	5-315
CONARC Teat Sec	5-316
Army Air Def Comd	5-317
OS Maj Comd	5-346
OS Base Comd	5-348
Log Comd	5-352
M DW	5-367
Armies	5-412
Corps	5-415
Div	5-416
US Army Tng Cen	5-417
Ft&Cp	6-100
Sp Wpn Comd	6-101
Engr Maint Cen	6-115
Sp War Cen	6-116
Army Pictorial Cen	6-125
USMA	6-126
Gen & Br Svc Sch	6-135
Gen Depots	6-136
Sig Sec. Gen Depots	6-200
Sig Depots	6-201
WRAMC	6-225
AFIP	6-226
AMS	6-235
POE (OS)	6-236
Trans Terminal Comd	6-300
Army Terminabls	6-401
OS Sup Agencies	6-415
Army Sag Pub Agency	6-416
Army Sag Comm Engr Agency	6-435
Army Comm Agency	6-501
White Sands Sag Agency	6-515
Yuma Teat Sta	6-525
Army Elct PG	6-535
Sag Fld Maint Shops	6-536
Sag Lab	6-537
Mil Dist	6-575
JBUSMC	6-576
Mil MOD	6-577
Units org under fol TOE:	6-625
3-266	7-11
3-267	7-12
5-15	7-13

7-14	19-500 (AA-AE)
7-15	20-47
7-16	20-300
7-31	20 611
7-32	20-512
7-33	30-600 (AA-AE)
7-34	33-2
7-35	33-510
7-36	39-61
7-95	44-7
7-96	44-12
8-15	44-16
8-16	44-16
8-18	44-17
9-25	44-25
9-26	44-26
9-35	44-27
9-36	44-35
9-167	44-36
10-17	44-37
11-7	44-75
11-16	44-76
11-57	44-77
11-117	44-101
11-127	44-115
11-128	44-116
11-500	44-117
11-537	44-145
11-657	44-146
11-687	44-147
11-592	44-316
11-597	44-316
17-51	44-317
17-52	44-415
17-115	44-416
17-116	44-417
17-125	44-446
17-126	62-2
19-35	56-27
19-36	55-68
19-37	66-157
19-55	67-2
19-56	67-57
19-57	

NG: State AG; unit-same as Active Army.

USAR: None.

For explanation of abbreviations used, e" SR 320-50-1.

GO 6417A

*U.S. GOVERNMENT PRINTING OFFICE: 1992 - 311-831/43792

RECOMMENDED CHANGES TO EQUIPMENT TECHNICAL PUBLICATIONS



THEN...JOT DOWN THE
DOPE ABOUT IT ON THIS FORM.
CAREFULLY TEAR IT OUT, FOLD IT
AND DROP IT IN THE MAIL.

SOMETHING WRONG WITH PUBLICATION

FROM: (PRINT YOUR UNIT'S COMPLETE ADDRESS)

DATE SENT

PUBLICATION NUMBER

PUBLICATION DATE

PUBLICATION TITLE

BE EXACT PIN-POINT WHERE IT IS

PAGE
NO.

PARA-
GRAPH

FIGURE
NO.

TABLE
NO.

IN THIS SPACE, TELL WHAT IS WRONG
AND WHAT SHOULD BE DONE ABOUT IT.

PRINTED NAME, GRADE OR TITLE AND TELEPHONE NUMBER

SIGN HERE

