

✓ 4/13
u113
TM
1945

UNIVERSITY of CALIFORNIA
LIBRARY
MAY 1947
DOCUMENTS DIVISION

TM 9-2858

WAR DEPARTMENT TECHNICAL MANUAL

U.S. Dept. of Army

COOLING SYSTEMS: VEHICLES AND POWERED GROUND EQUIPMENT

WAR DEPARTMENT

8 MAY 1945

WAR DEPARTMENT TECHNICAL MANUAL

TM 9-2858

**COOLING SYSTEMS:
VEHICLES AND
POWERED GROUND
EQUIPMENT**



WAR DEPARTMENT

8 MAY 1945

WAR DEPARTMENT
Washington 25, D. C., 8 May 1945

TM 9-2858, Cooling Systems: Vehicles and Powered Ground Equipment, is published for the information and guidance of all concerned.

[A.G. 300.7 (13 Jul 44)
O.O.M. 461/Rar. Ars. (5-9-45)]

BY ORDER OF THE SECRETARY OF WAR:

G. C. MARSHALL,
Chief of Staff.

OFFICIAL:

J. A. ULIO,
*Major General,
The Adjutant General.*

DISTRIBUTION: AAF (10); AGF (5); ASF (2); S Div ASF (1); T of Opns (25); Dept (10); Def Comd (5); AAF Comd (2); Arm & Sv Bd (1); Tech Sv (2); SvC (10); PC&S (1); PE (Ord O) (5); Dist O, 9 (5); Dist Br O, 9 (3); Reg O, 9 (3); Establishments, 9 (5); Decentralized Sub-O, 9 (3); Gen & Sp Sv Sch (10); USMA (20); A (10); CHQ (10); D (2); B (3); R (2); Bn (2); AF (2).

(Refer to FM 21-6 for explanation of distribution formula.)

U113
 .2
 TIM 9:
 2858
 1745
 ★ ★

CONTENTS

	Paragraphs	Pages
CHAPTER 1. INTRODUCTION	1- 2	1
CHAPTER 2. COOLING SYSTEM CONSTRUCTION, FUNCTION, AND OPERATION	3-33	2- 39
SECTION I. General function	3- 7	2- 7
II. Component units	8-22	7- 27
III. Coolant	23-30	27- 38
IV. Inter-relation of cooling system and other engine systems	31-33	38- 39
CHAPTER 3. DRIVER OR OPERATOR PREVENTIVE MAINTENANCE	34-37	40- 46
SECTION I. Importance of driver preventive maintenance services	34-37	40- 46
CHAPTER 4. MECHANIC PREVENTIVE MAINTENANCE	38-54	47- 78
SECTION I. Importance of mechanic preventive maintenance services	38-54	47- 78
CHAPTER 5. TROUBLE SHOOTING	55-75	79-100
SECTION I. Diagnosis instructions	55-60	79- 85
II. Diagnosis procedures	61-65	85- 89
III. Special trouble shooting instructions	66-75	89-100
APPENDIX		
References	76-78	101-102
INDEX		103-105

M571700

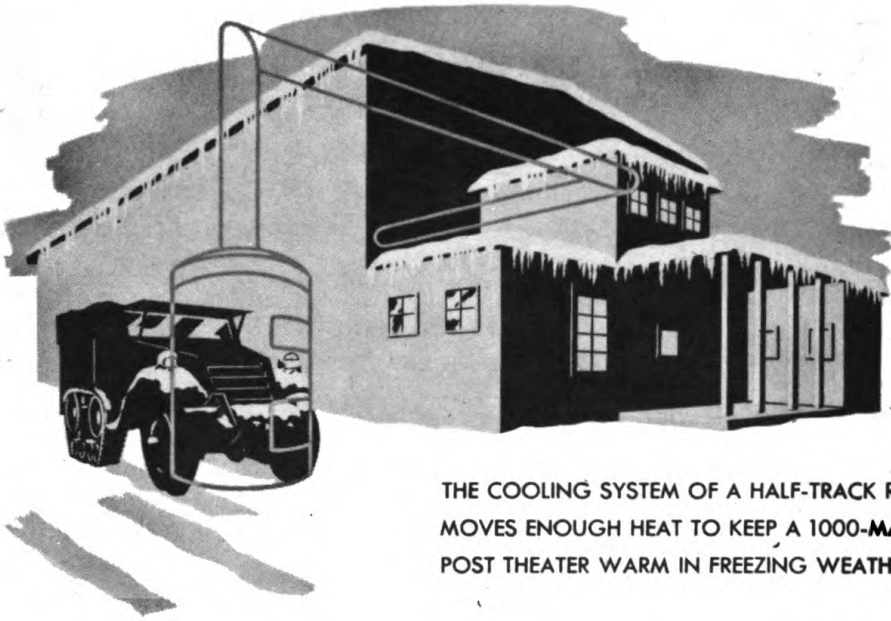

RA PD 341912

Figure 1 — Amount of Heat Generated by an Engine

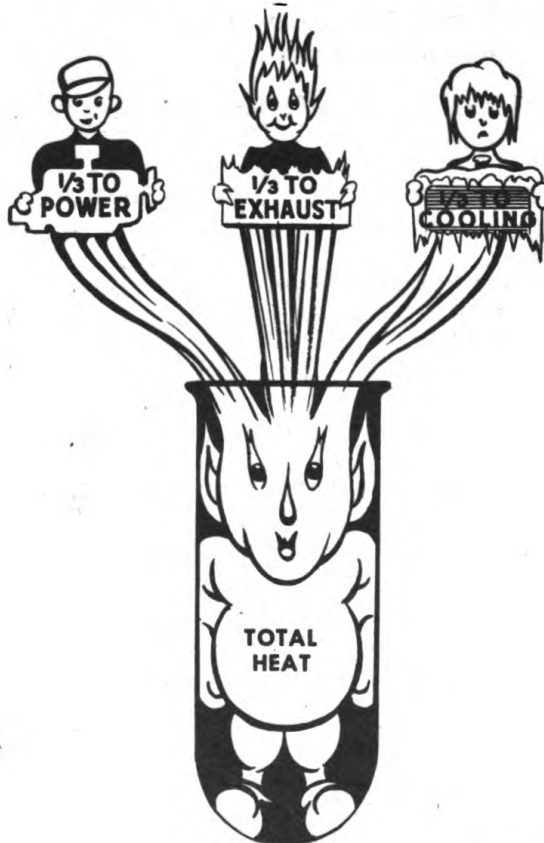

RA PD 341924

Figure 2 — Distribution of Fuel Energy

CHAPTER 1 – INTRODUCTION

1. PURPOSE.

a. These instructions are published for the information and guidance of all concerned. They contain information on the construction, purpose, care, and maintenance of cooling systems for vehicles and powered ground equipment engines. They are to be used when instructing operating and maintenance personnel on the care and maintenance of cooling systems.

2. SCOPE.

a. Liquid-cooled engines are the primary subject of these instructions, however, a brief discussion of air-cooled engines is included.

b. The instructions are divided into five chapters and an appendix. Chapter One defines the purpose and scope of the manual; Chapter Two describes the construction, function and operation of cooling systems; Chapter Three contains information on driver or operator preventive maintenance; Chapter Four discusses mechanic preventive maintenance; Trouble shooting procedures are contained in Chapter Five. The Appendix contains a list of references.

CHAPTER 2 – COOLING SYSTEM CONSTRUCTION, FUNCTION, AND OPERATION

Section I

GENERAL FUNCTION

3. SOURCE OF HEAT.

a. **The Heat Engine.** Engines that operate on gasoline, fuel oil, or steam are called heat engines because they get their power from heat. The heat is produced by burning fuel, a chemical process called combustion. In the case of the steam engine, heat is produced outside of the engine by burning fuel under a boiler to obtain steam pressure. A large amount of heat is wasted in making steam, but this waste heat is carried off through the smoke stack and therefore does not create a cooling problem in steam engine operation.

b. **The Internal Combustion Engine.** In the internal-combustion engine, the heat is produced by burning fuel inside the engine. Fuel, such as gasoline, is mixed with air and forced into the cylinders of the engine where it is ignited by a spark or other means. The heat from the rapid combustion that follows causes sudden expansion of the burning gas, which forces the piston downward, producing the power stroke of the engine. Unlike the steam engine, where fuel is burned outside the cylinder, the internal-combustion engine has energy-producing burning taking place within the cylinders. The resulting heat produces a cooling problem.

c. **Quantity of Heat (fig. 1).** In a 6-cylinder automotive engine, there may be as many as 10,000 power impulses every minute, and a large amount of heat is developed by the fuel burned for each impulse. The combustion process in a half-track engine, for example, can produce as much heat as would be required to keep a large War Department theatre building warm in freezing weather.

4. DISTRIBUTION OF HEAT (fig. 2).

a. **Heat Converted to Power.** Only about one-third of the heat produced by combustion is used to make the gas pressure that drives the engine; the remaining two-thirds is waste heat, and most of it must be removed to prevent destruction of the engine.

b. Waste Heat.

(1) **REMOVAL BY EXHAUST SYSTEM.** Only about one-half of the waste heat is carried off through the exhaust pipe. This leaves a large amount of excess heat remaining in the engine which must be removed by some other means.

(2) **REMOVAL BY COOLING SYSTEM.** The temperature of exhaust gas leaving the engine may be over 1,000° F, and combustion tempera-

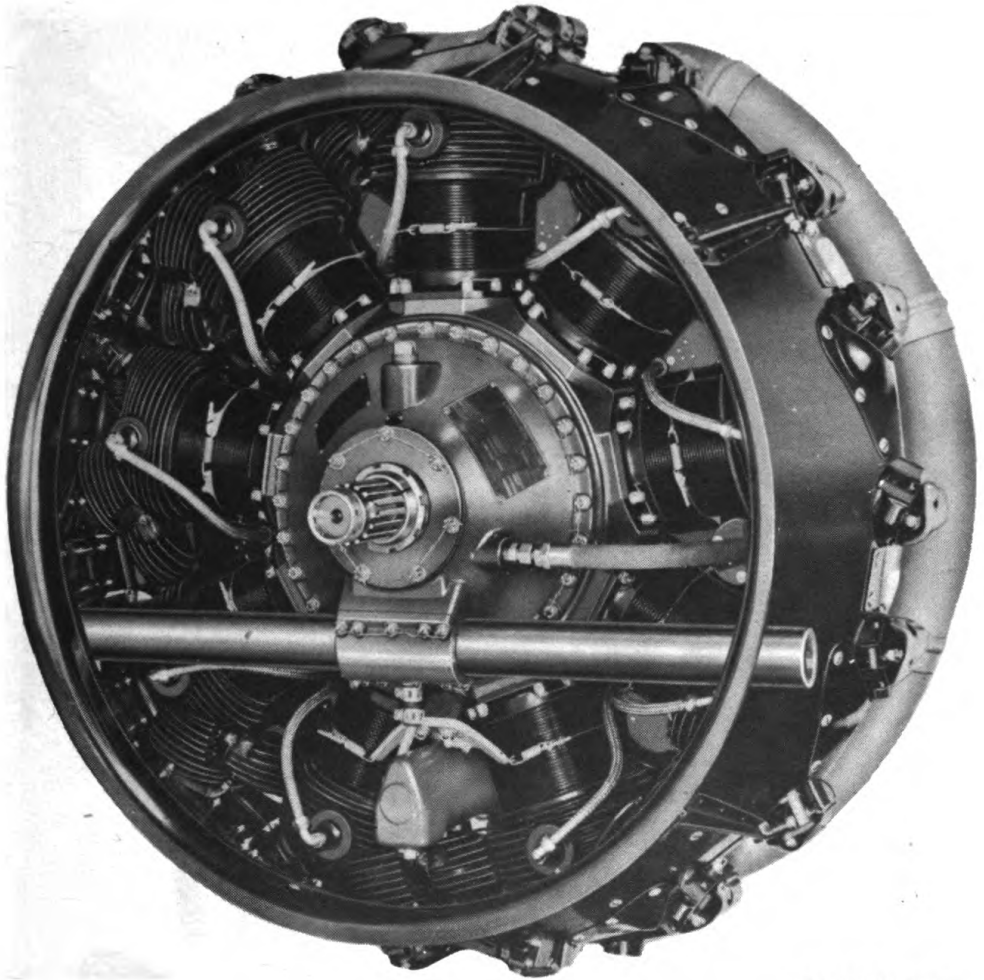

RA PD 309751

Figure 3 – Military-type Radial Air-cooled Engine

tures inside the engine may rise as high as 4,000° F. To prevent these high internal temperatures from damaging the engine, a cooling system is provided to draw off the excess waste heat as fast as it is produced and to keep the operating temperature of the engine within safe limits.

5. TYPES OF COOLING SYSTEMS.

a. Air Cooling.

(1) **DESCRIPTION.** The simplest type of cooling is the air-cooled, or direct method in which the heat is drawn off by moving air in direct contact with the engine. Cylinders and other hot parts of the engine are provided with air fins to increase the surface of metal exposed to the cooling effect of the air. Air-cooling systems

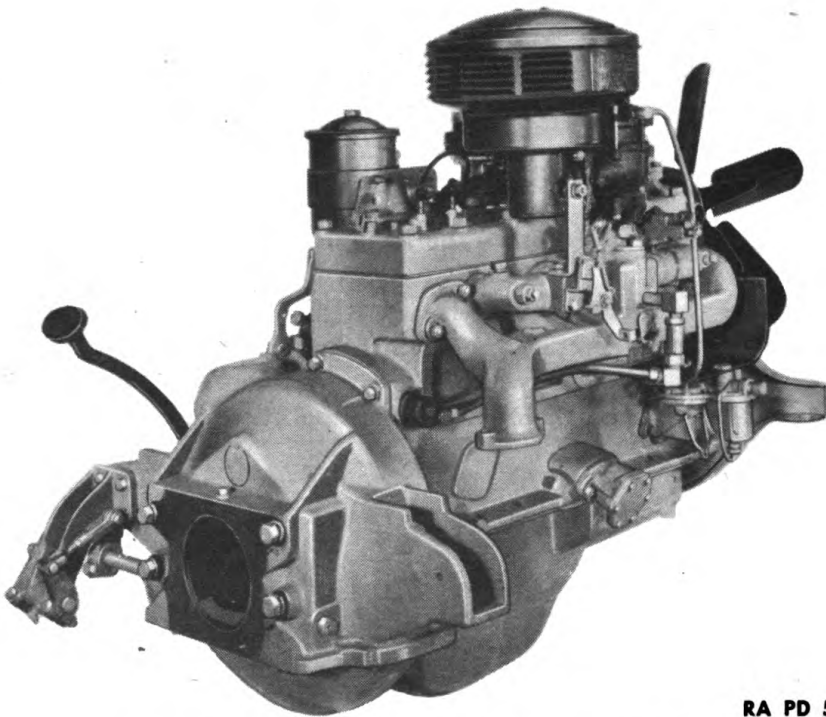
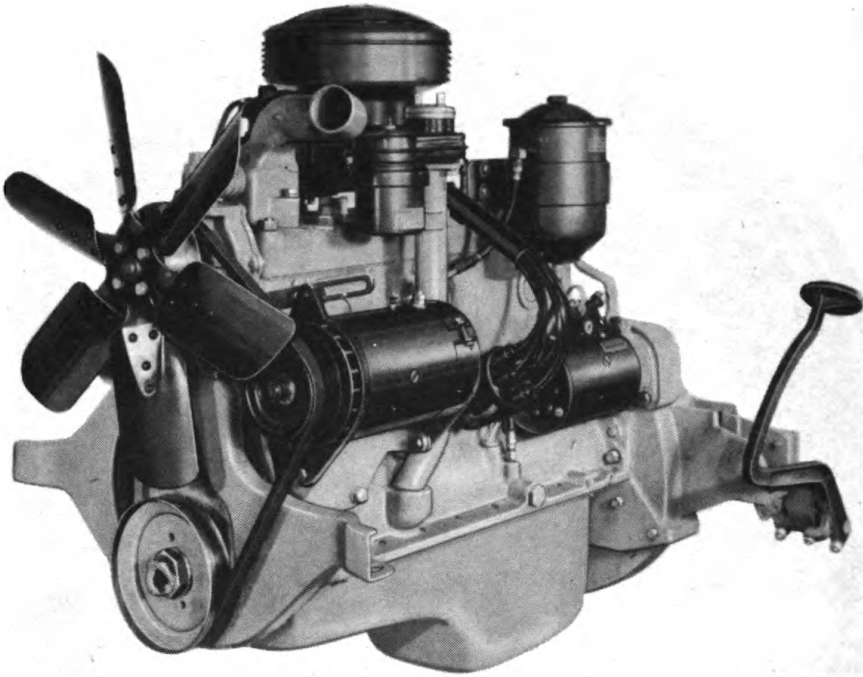

RA PD 53233

Figure 4 — Military-type Water-cooled Engine

General Function

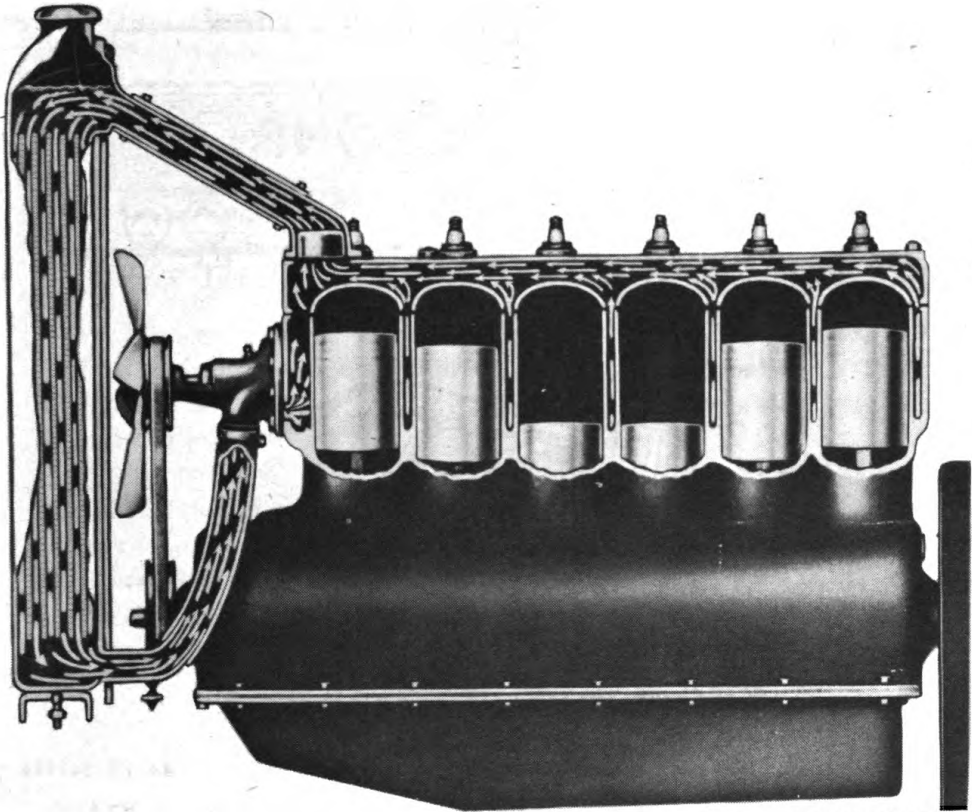

RA PD 341873

Figure 5 — Flow of Heat in Cooling System

may require a comparatively large fan or blower and special air tunnels, shrouds, and baffles, for controlling the distribution of large amounts of air to hot parts of the engine where cooling is most needed. Air cooling is used in motorcycle engines and in radial engines (fig. 3) installed in certain tanks.

(2) MAINTENANCE.

(a) Maintenance of the cooling system of air-cooled engines consists largely of keeping the component parts clean to permit rapid transfer and dissipation of heat, and making sure that nothing interferes with the proper flow of air through the cooling system.

(b) To accomplish this, keep the baffles, fins, shrouds, and fans free of dirt, grease and other foreign matter. Periodically inspect and tighten the shrouds, baffles and deflectors. Replace or straighten broken or bent shrouds, baffles and deflectors.

b. Liquid Cooling. The most common type of cooling system makes use of a liquid, such as water, as an indirect medium to carry

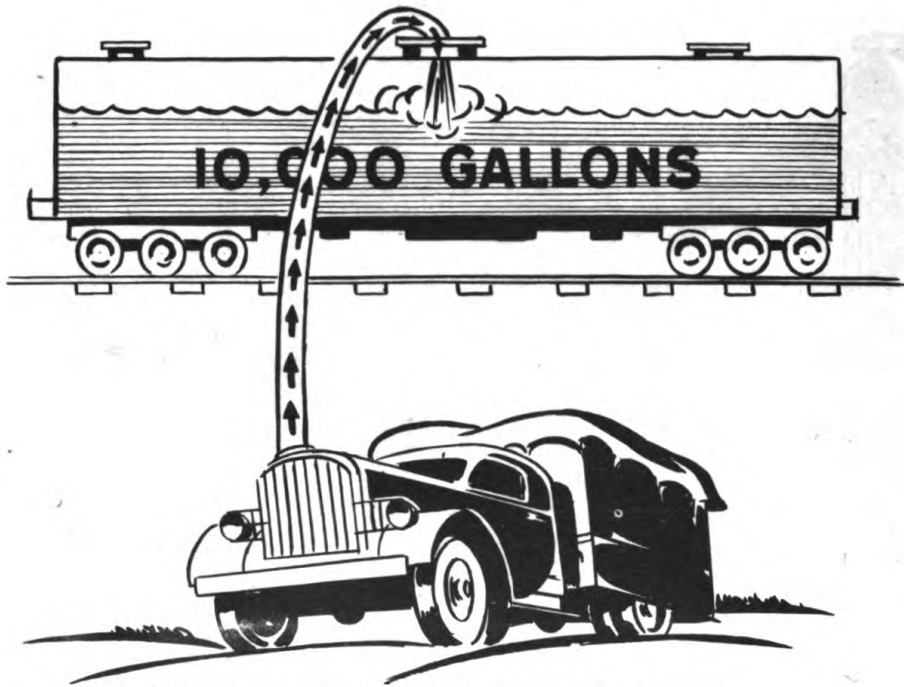

AS MUCH AS 10,000 GALLONS OF COOLANT PER HOUR
MAY BE CIRCULATED THROUGH COOLING SYSTEM

RA PD 341916

Figure 6 — Hourly Circulation of Coolant in Large Military Vehicle

the heat from the inside of the engine and transfer it into the air. Such a cooling liquid is called a coolant. Liquid-cooling systems are used for the majority of military vehicle engines (fig. 4) and for certain tank engines. The remainder of this chapter is confined to the liquid-cooling system, which is designed to use water as a coolant, such as is commonly used with internal-combustion engines.

6. FLOW OF HEAT IN THE COOLING SYSTEM (fig. 5).

a. **Removal From Engine.** In the usual water-cooled engine, waste heat is removed by the coolant circulating through hollow passages surrounding the hottest parts of the engine. Heat first flows into the coolant while the coolant is being pumped through the passages of the cylinder block and up into the cylinder head. The coolant then moves on through similar passages in the head, picks up more heat as it circulates, and finally leaves the engine through an outlet at the top.

b. **Removal From Radiator.** After leaving the engine, the coolant passes through an upper hose connection and carries the heat into a radiator. As the coolant flows down through the radiator, the

heat is removed by a stream of air forced through the radiator, by the action of a fan only in stationary engines, and by both the fan and forward motion in vehicles.

c. **Cooling Cycle.** From the bottom of the radiator, the coolant flows through a lower hose connection to the pump where it is again forced into the cylinder block and repeats the cooling cycle, removing more heat from the engine and carrying the heat into the radiator.

7. HEAT LOAD.

a. The amount of engine heat which must be removed by the cooling system is much greater than is generally realized. The cooling system of a 2½-ton 6 x 6 truck, for example, removes enough heat at cruising speed to keep a 35-room house warm in freezing weather. Similarly, the heat that can be removed by the cooling system of a medium tank engine is sufficient to heat a 200-room hotel. To handle this heat load, it may be necessary for the cooling system in some engines to circulate 4,000 to 10,000 gallons of coolant per hour (fig. 6).

Section II

COMPONENT UNITS

8. ENGINE WATER JACKET.

a. **Construction.** The water passages (par. 6 a) in the cylinder block and cylinder head form the engine water jacket. In the cylinder block, the water jacket completely surrounds all cylinders along their full length. Within the jacket, narrow water passages are provided between cylinders for coolant circulation around them. In addition, water passages are provided around the valve seats and other hot parts of the cylinder block. In the cylinder head, the water jacket covers the combustion chambers at the top of the cylinders and contains water passages around the valve seats when the valves are located in the head.

b. **Function and Operation** (fig. 7). The passages of the water jacket are designed to control circulation of coolant and provide proper cooling throughout the engine. Waste heat flows directly to the coolant through the metal walls of the combustion chambers and the cylinders. Heat absorbed by the pistons passes into the coolant by way of the cylinder wall. The heat in the valves flows to the coolant through the valve seats and guides. Since exhaust valves may run as hot as 2,000° F (yellow-red heat), proper cooling around the exhaust valve seat is of special importance.

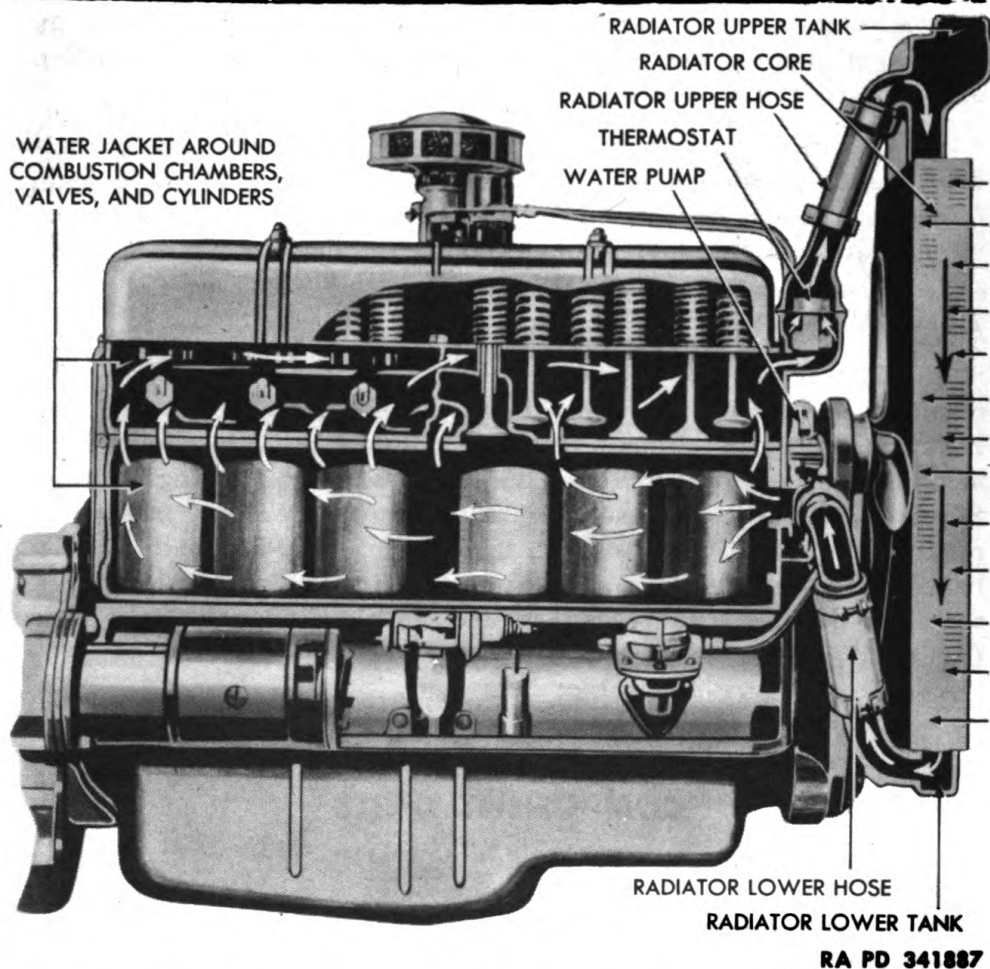

Figure 7 — Circulation of Coolant Around Cylinders and Valves in Engine Water Jacket

9. CYLINDER HEAD JOINT.

a. **Water Transfer Ports.** The coolant flows from the cylinder block up into the cylinder head through passages called water transfer ports. The lower part of each passage is in the block, and the upper part is in the head. A tight seal in the joint between the two parts of these water passages is very important.

b. **Cylinder Head Gasket (fig. 8).** The joints in the numerous water transfer ports, as well as the combustion chamber joints, are all sealed with one large gasket called the cylinder head gasket. To obtain the tightest possible seal in these joints, the openings in the gasket, which match the water transfer ports and combustion chamber openings, are reinforced with metal eyelets described as grommets. The head gasket has a double duty to perform; it must seal the extreme pressures of combustion within the cylinders and at the same

Component Units

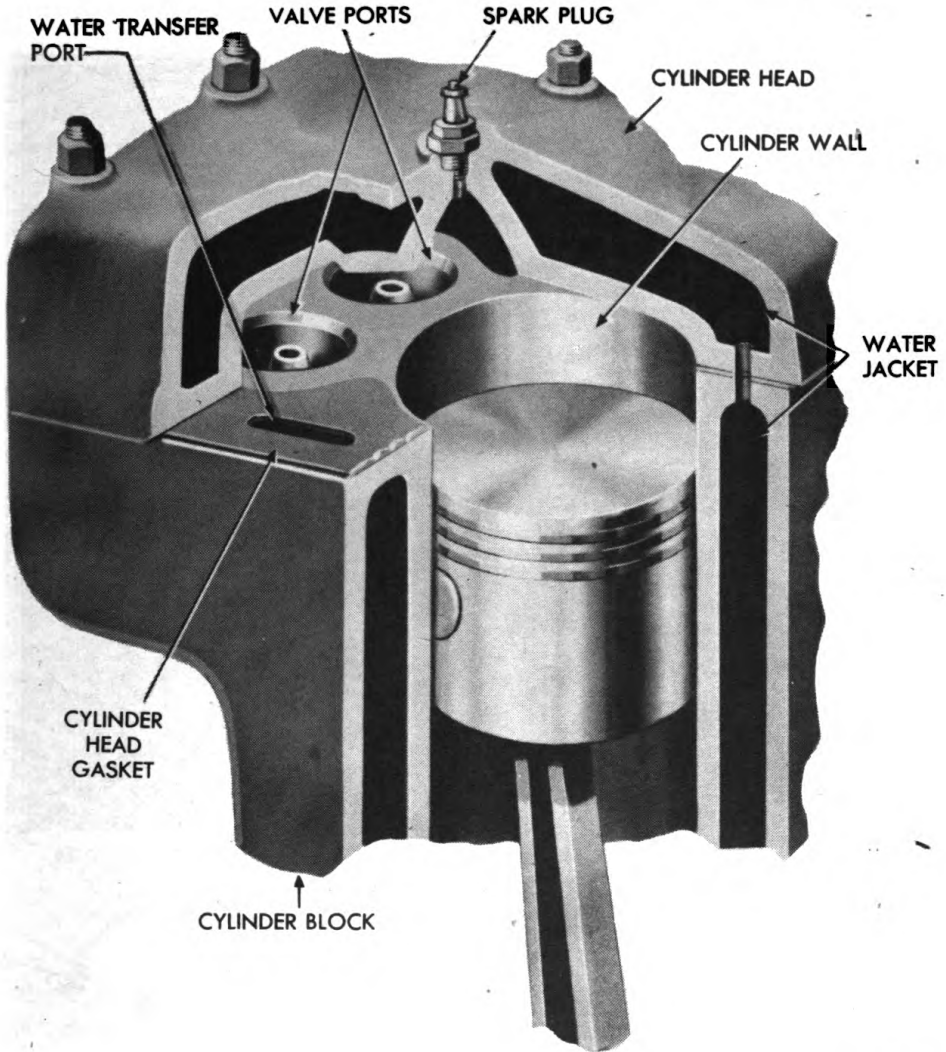

RA PD 341891

Figure 8 – Liquid and Gas Joints in Cylinder Head Gasket

time maintain leakproof coolant joints at the water transfer ports. To be specific, the cylinder head gasket must prevent combustion gas leakage (1) to the outside of the engine (2) between cylinders and (3) into the water passages; it must also prevent coolant leakage (1) outside the engine and (2) to the cylinders of the engine. Proper uniform tightness of the cylinder head bolts is necessary to maintain a leakproof head gasket joint.

10. RADIATOR.

a. **Construction of Assembly (fig. 9).** The usual radiator assembly consists of a radiator core with a top tank and a bottom tank,

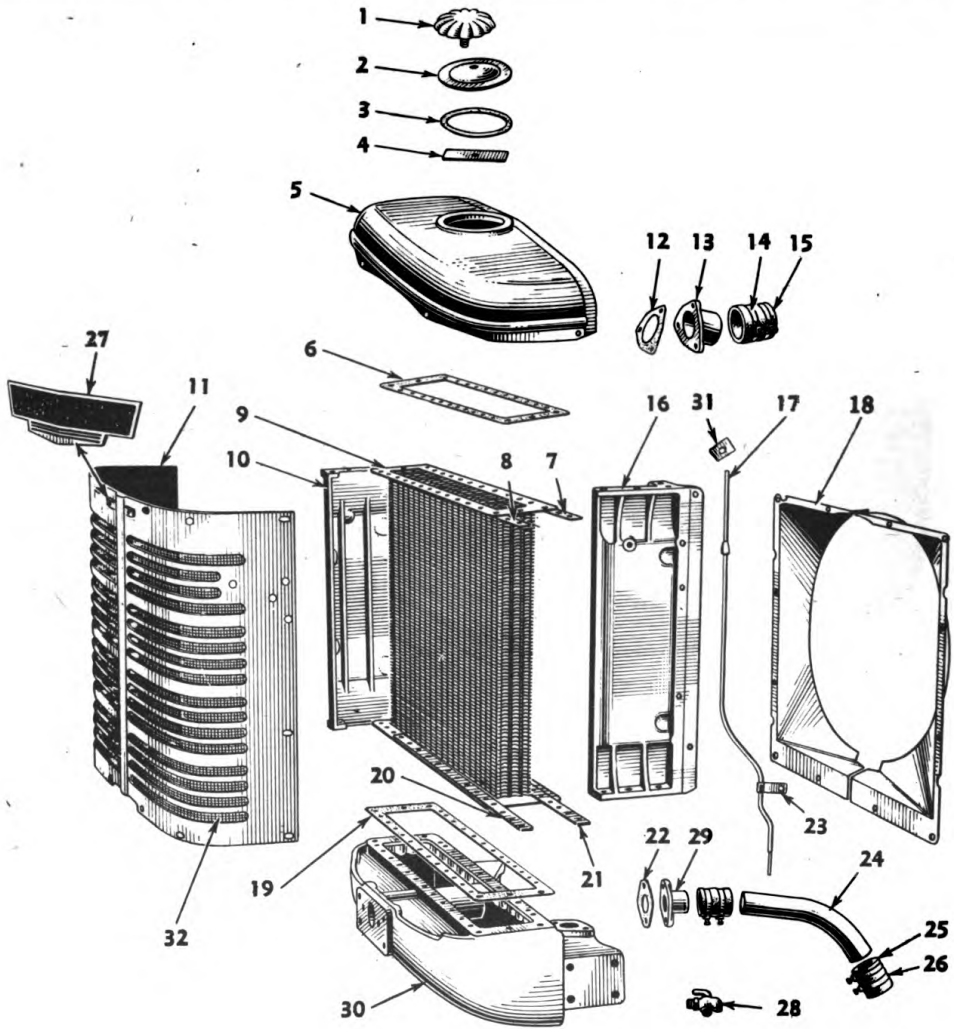

- | | |
|--|-----------------------------------|
| 1 — HANDLE | 18 — (SHEET, L.H.
(SHEET, R.H. |
| 2 — COVER | 19 — GASKET |
| 3 — GASKET | 20 — CORE STIFFENER, FRONT |
| 4 — CLAMP | 21 — CORE STIFFENER, LOWER, REAR |
| 5 — WATER TANK, UPPER | 22 — OUTLET ELBOW GASKET |
| 6 — GASKET | 23 — PIPE CLIP |
| 7 — CORE STIFFENER, UPPER REAR | 24 — OUTLET PIPE |
| 8 — CORE STIFFENER, FRONT | 25 — OUTLET HOSE |
| 9 — CORE, COMPLETE
RADIATOR REPAIR TUBE | 26 — OUTLET HOSE CLAMP |
| 10 — CORE SPACER, R.H. | 27 — NAME PLATE |
| 11 — GRILLE, COMPLETE | 28 — DRAIN COCK |
| 12 — ELBOW GASKET | 29 — OUTLET FLANGE |
| 13 — INLET ELBOW | 30 — WATER TANK, LOWER |
| 14 — INLET HOSE CLAMP | 31 — OVERFLOW PIPE GASKET |
| 15 — INLET HOSE | 32 — GRILLE SCREEN |
| 16 — CORE SPACER, L.H. | |
| 17 — OVERFLOW PIPE | |

RA PD 341928

Figure 9 — Radiator — Disassembled

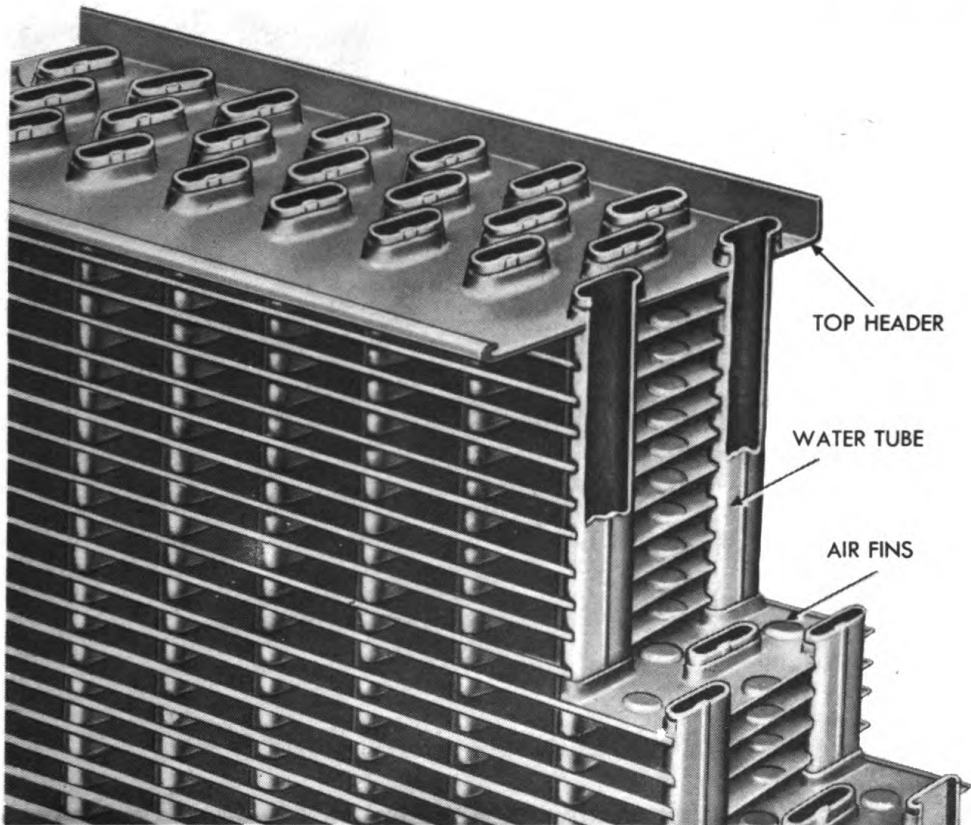

RA PD 341907

Figure 10 – Tubular Radiator Core Construction

although in some designs the tanks may be located on the sides of the cores. The top, or inlet tank contains an outside pipe called the radiator inlet and usually has a coolant baffle inside and above, or at the inlet opening. The radiator filler neck is generally attached to the upper part of the top tank and has an outlet to the overflow pipe. The bottom tank also has a pipe opening which is called the radiator outlet.

b. Function of Tanks. The top tank collects the incoming coolant and distributes it across the top of the radiator core. The baffle in the top tank assists in distributing the coolant to the water tubes and also prevents coolant from being thrown out of the radiator. The overflow pipe provides an opening from the radiator for escape of coolant or steam that otherwise might cause excessive pressure in the cooling system. The bottom tank collects coolant flowing from the core and discharges it through the radiator outlet.

c. Core Construction (fig. 10). Practically all military cooling systems have tubular radiator cores which consist of a large number

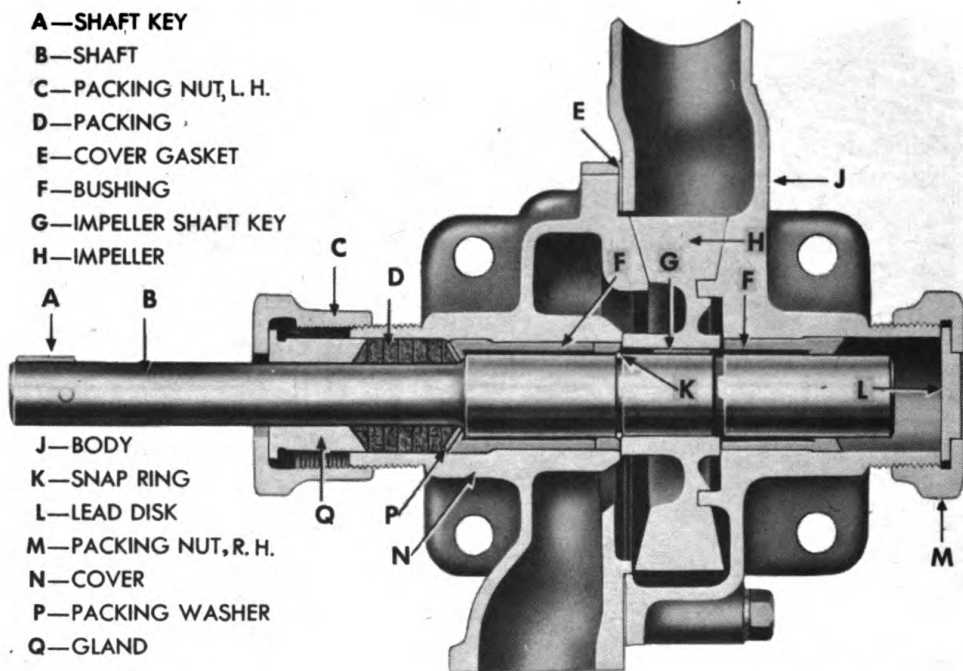

RA PD 341908

Figure 11 — Packing-gland Type Water Pump

of vertical water tubes and many horizontal air fins around the tubes. Water passages in the tubes are usually very narrow, and the tube itself is made of very thin metal.

d. Core Function. In the radiator core, a large amount of heat is rapidly transferred from the coolant into the air. Through the water tubes, the flow of coolant is divided into many small streams which causes a small amount of cooling liquid to be exposed to a comparatively large cooling surface in the tubes. This results in rapid flow of heat from the coolant to the tubes and air fins. Heat is carried away from the tubes and fins by the air moving through the core.

11. HOSE CONNECTIONS AND PIPES.

a. Connections must be provided to carry coolant from the engine water jacket to the radiator, and from the radiator back to the engine. Vibration and movement between the radiator and engine would cause breakage of metal pipes, and for this reason flexible hose is used for radiator connections, sometimes with pieces of pipe between sections of hose where the connections are long.

12. WATER PUMP.

a. Function. Every modern cooling system has a water pump to circulate the coolant in the system. The pump, which is usually

Component Units

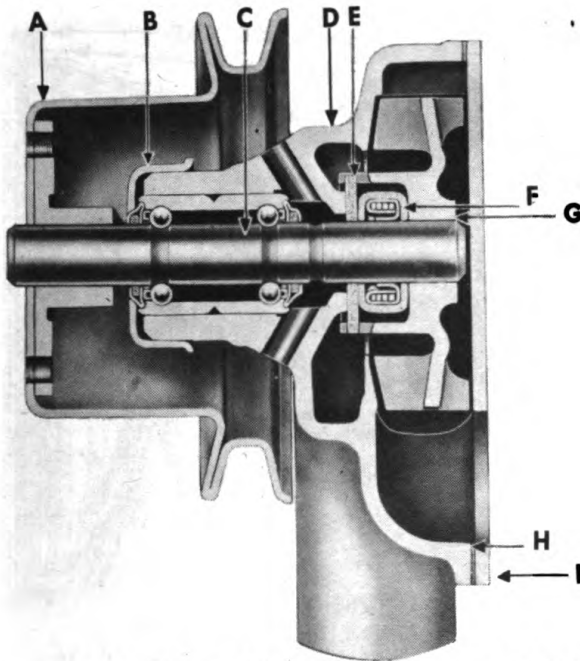

- | | |
|---|---|
| <p>A PULLEY AND HUB ASSEMBLY
B WATER PUMP BEARING
RETAINER
C SHAFT AND BEARING
ASSEMBLY</p> | <p>D WATER PUMP BODY
E WATER PUMP SEAL WASHER
F WATER PUMP SEAL ASSEMBLY
G WATER PUMP IMPELLER
H WATER PUMP PLATE GASKET
I WATER PUMP PLATE</p> |
|---|---|

RA PD 303199

Figure 12 — Packless-type Water Pump

located on the front or side of the engine block, receives coolant from the bottom of the radiator and forces it through the water jacket into the radiator top tank. Cooling the present-day engine would be difficult or impossible without such forced circulation. Pumps on military engines may circulate as much as 4,000 or 10,000 gallons of coolant per hour, running at speeds as high as 5,000 revolutions per minute (fig. 6).

h. General Construction. The water pump is a centrifugal-type pump, having an impeller with blades which force the coolant outward as the impeller rotates. The impeller is located in a pump housing and is mounted on a shaft which runs on one or more bearings. The shaft is driven by the engine through a belt or a shaft (par. 15). The fact that the impeller is submerged in the coolant but must be driven from outside of the cooling system, creates the problem of sealing the impeller shaft against leakage. The water pump shaft seal is the only moving water joint in the cooling system. For different cooling systems, pumps vary considerably in construction of seal, bearings, mounting, drive, etc.

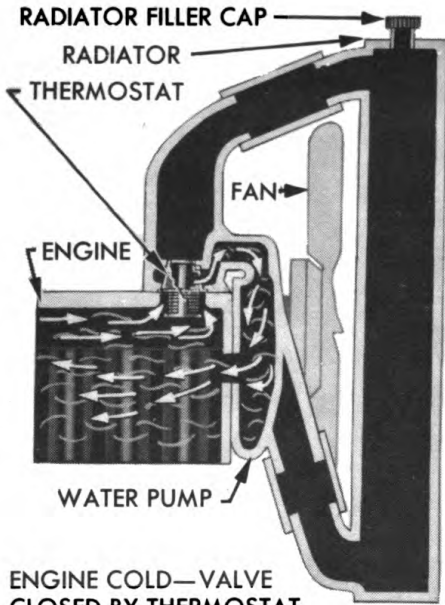

ENGINE COLD— VALVE CLOSED BY THERMOSTAT ALLOWS WATER TO CIRCULATE THROUGH THE ENGINE BUT NOT THE RADIATOR.

CLOSED

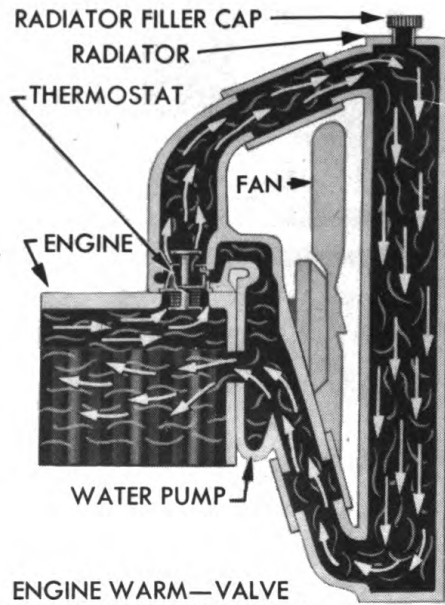

ENGINE WARM— VALVE OPENED BY THERMOSTAT ALLOWS WATER TO CIRCULATE THROUGH THE ENGINE AND THE RADIATOR

OPENED

RA PD 58353

Figure 13 — Cooling System Operation Diagram

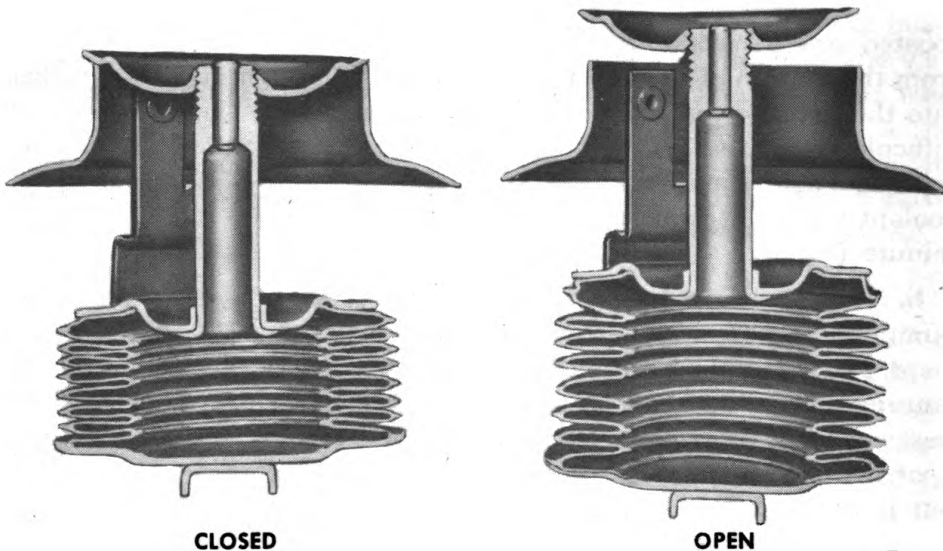

CLOSED

OPEN

PA PD 341900

Figure 14 — Bellows-type Thermostat — Cutaway View

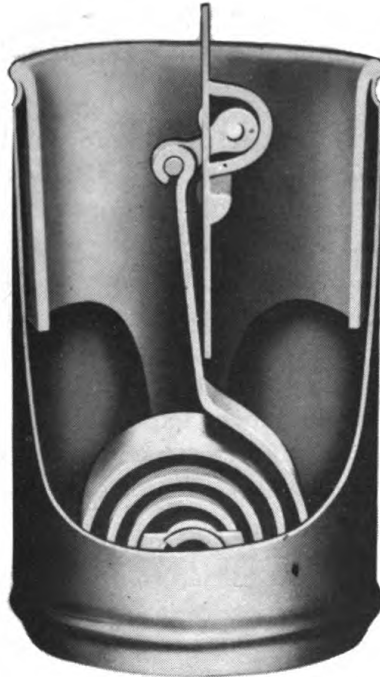

RA PD 341888

Figure 15 – Coil Spring-type Thermostat – Cutaway View

c. **Packing-gland Type** (fig. 11). One type of pump is sealed by placing packing around the shaft and holding it in place with a special adjusting nut. The packing must be tightened periodically and replaced at longer intervals. This type of pump requires periodic lubrication.

d. **Packless Type** (fig. 12). The most commonly used type of pump on military vehicles is the nonadjustable packless type. The packless pump has a built-in, self-adjusting seal. Individual pumps vary somewhat in seal materials and arrangement of assembly. Some packless pumps are prelubricated when assembled, but others require periodic lubrication.

13. THERMOSTAT.

a. **Function.** Full-length engine water jackets, large efficient radiator cores, and rapid coolant circulation in the system provide the extra cooling required for engine operation under heavy load in hot weather. However, under lighter engine load in cool weather, the same amount of cooling would remove too much heat from the engine. Overcooling of the engine results in waste of fuel, loss of power, and rapid wear of moving parts. Therefore, the amount of heat removed from the engine must be controlled for different

operating conditions and air temperatures. This is done by the thermostat which regulates engine temperature by automatically controlling the amount of coolant flowing through the radiator core.

b. Construction. The thermostat (figs. 14 and 15) consists of a valve and a heat-operated unit which moves the valve. One type of thermostat-operating unit is a closed bellows, which contains a special liquid designed to boil at a certain temperature. When that temperature is reached, the boiling liquid creates gas pressure which expands the bellows and opens the thermostat valve. When the liquid cools and condenses, the pressure is reduced, allowing the bellows to contract and close the valve. In another type of thermostat, the valve is operated by a bimetallic coil which depends for its operation upon the difference of the coefficients of expansion of the two metals. The coil expands and opens the valve when heated above a certain temperature. As the coil cools down, it contracts and closes the valve.

c. Operation (fig. 13). The thermostat is located between the engine water jacket and the radiator, usually in the housing at the cylinder head water outlet. Automatic operation of the thermostat valve holds the coolant temperature within proper limits by controlling the flow of coolant through the radiator. When the engine is cold, the thermostat valve stays closed and shuts off practically all circulation to the radiator. As the engine warms up, the valve opens slowly, allowing some coolant to flow. In actual operation, the valve may move frequently to regulate coolant flow into the radiator in accordance with variations in heat output from the engine.

d. Thermostat By-pass. Cooling systems equipped with a by-pass arrangement have coolant circulation within the engine water jacket when the thermostat is closed. The external-type by-pass consists of short hose, pipes, or tubes connecting the cylinder head outlet directly with the inlet of the water pump. The internal-type by-pass provides for coolant flow from the head directly back to the pump through passages built into engine water jacket.

14. FAN AND SHROUD (fig. 16).

a. Fan. Operation of the fan pulls a large volume of air through the radiator core (par. 10 d). Besides removing heat from the radiator, this flow of air also provides some direct air cooling of the engine. In vehicles, the fan provides most of the air flow through the radiator at low road speeds when the forward motion of the vehicle forces comparatively little air through the core. Reducing the size of the drive pulley increases the speed of the fan. For operation in extremely hot climates, larger fans and smaller pulleys are sometimes installed.

Component Units

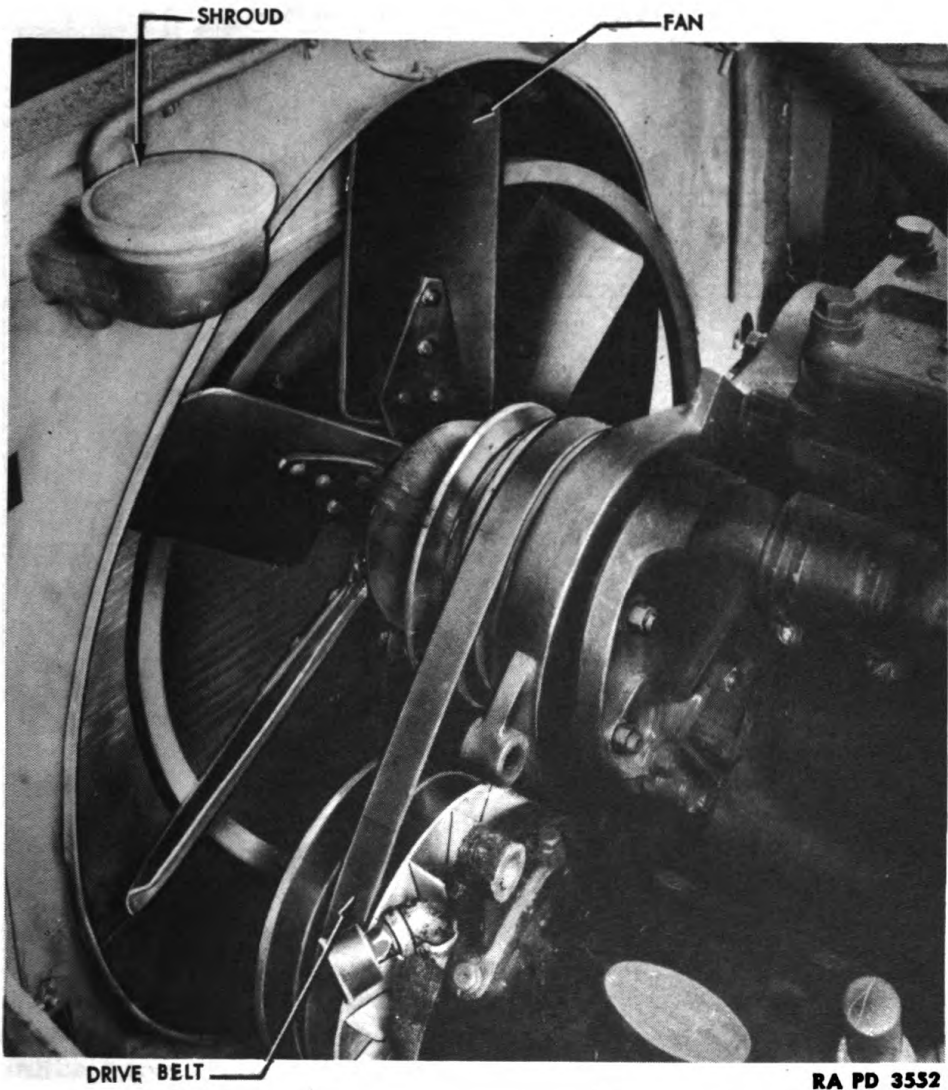
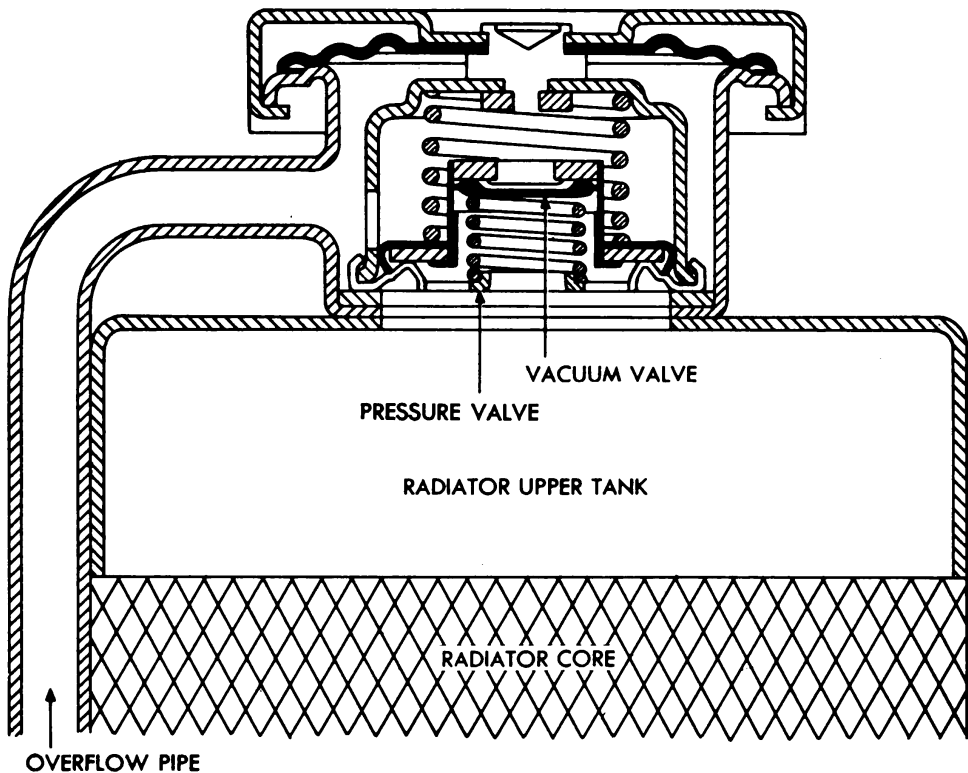

Figure 16 – Fan, Shroud, and Drive Belt Assembly

b. Shroud. Military vehicles are generally equipped with a tunnel-like structure around and behind the fan called a shroud. The purpose of the shroud is to direct the flow of air for most effective cooling. Some vehicles have air baffles on the front side of the radiator to direct air flow through the core.

15. DRIVE BELTS AND SHAFTS.

a. Belts. (fig. 16). The most common type of fan and water pump drive makes use of a single belt which is driven by a pulley on the engine crankshaft. This belt usually drives the generator



RA PD 341911

Figure 17 — Radiator Cap, Pressure and Vacuum Valves — Cross-sectional View

also. Other vehicles may have separate belts for one or two of these units, or two belts to drive a single unit. In any case, proper operation of the water pump drive belt is the most critical. When the water pump stops during engine operation, overheating of the engine follows almost immediately. Since belts stretch in service, adjustment of belt tension is provided by movable mountings on one or more units driven by the belt, usually the generator.

b. Shafts. Some heavy-duty engines make use of a shaft to drive the water pump. Such a shaft is usually driven from the engine crankshaft or camshaft by gears. The shaft often drives the generator as well as the water pump. Flexible couplings are installed in drive shafts to keep them properly lined up in their bearings.

16. RADIATOR PRESSURE CAP.

a. Construction. The radiator pressure cap (fig. 17) used on military vehicles differs considerably from the ordinary type of cap commonly found on civilian vehicles. The pressure cap contains two spring-loaded normally closed valves, which seal the cooling system.

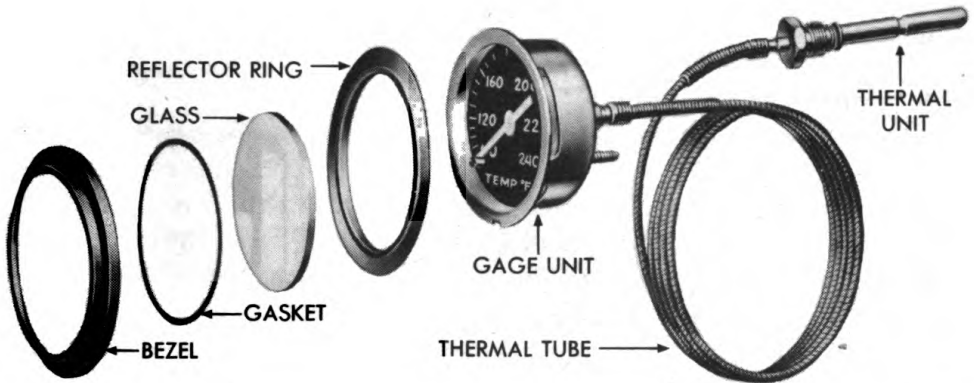

RA PD 341934

Figure 18 – Engine Temperature Gage and Thermal Unit

The larger valve is called the pressure valve and the smaller one is called the vacuum valve. A shoulder in the radiator filler neck provides a seat for the bottom of the cap assembly and a gasket on this seat prevents leakage between the cap and the filler neck.

b. Function.

(1) **GENERAL.** By closing off the overflow pipe opening, the pressure cap prevents overflow loss of coolant during normal operation. It also allows a certain amount of pressure to develop within the system which raises the boiling point of the coolant and permits the engine to operate at higher temperatures without coolant overflow from boiling.

(2) **PRESSURE VALVE** (fig. 17). The pressure valve acts as a safety valve to relieve extra pressure within the system. In the majority of transport vehicles, the pressure valves open at about 4 pounds per square inch. When the valve is forced open, it allows steam and coolant to escape through the overflow pipe until the pressure drops below its opening point. Four pounds pressure in the cooling system will prevent overflow loss from boiling of water until a coolant temperature of about 225° F (at sea level) is reached (par. 26). Some combat vehicles have valves with opening pressures as high as 17 pounds. This pressure raises the boiling point of water to about 255° F.

(3) **VACUUM VALVES** (fig. 17). The vacuum valve opens only when the pressure within the cooling system drops below the outside air pressure as the engine cools down. The higher outside pressure then forces the valve open, which allows air to enter the system by way of the overflow pipe. When the pressure inside and outside again becomes approximately the same the vacuum valve closes. This automatic action of the vacuum valve prevents collapse of hose

and other thin-walled parts of the cooling system without internal support.

c. Operation of Pressure System.

(1) When a system is equipped with a pressure cap it is generally referred to as a pressure-cooling system. The radiator used in such a system is especially designed to withstand the extra pressure. Tightness of all connections and joints is particularly important since pressure naturally aggravates any existing leakage. An airtight cooling system is necessary to obtain the benefits of pressure cooling.

(2) The majority of military engines can be operated without either boiling of coolant or pressure in the system, except under the heaviest driving conditions or in extremely hot weather. In some vehicles, however, the normal operating temperature is always above the boiling point of the coolant. Proper functioning of the pressure-cooling system is absolutely necessary to avoid large overflow losses of coolant from boiling, even under average operating conditions.

17. ENGINE TEMPERATURE GAGE.

a. The engine temperature gage provides a convenient means for checking engine-operating temperatures. There are two principal parts in the assembly, the gage unit and the engine thermal unit (fig. 18). The engine unit is usually installed in the cylinder head toward the rear. The gage unit, mounted on the instrument panel and connected to the engine unit, registers the temperature of the coolant surrounding the engine unit.

18. WATER DISTRIBUTION TUBE.

a. **Construction.** Some engines, particularly L-head types, have a water distribution tube in the water jacket extending from the water pump to the rear end of the engine. This long, flat, thin-walled tube has an opening at one end facing the pump outlet. It also has a number of outlet openings along one side which face the water passages around the exhaust valves.

b. **Function** (fig. 19). The water distribution tube receives the coolant from the pump and delivers it through the spaced outlet openings directly to the hottest parts of the engine, such as the exhaust valve seats (par. 8 b). This tube is removable, but the water pump must first be taken off before the tube can be reached. In order to draw the tube completely out of the water jacket, it is necessary to remove the radiator.

c. **Other Coolant Distributing Devices.** Some valve-in-head engines have small water nozzles or jets built into the cylinder head to direct the flow of coolant toward exhaust valve seats. Other sys-

Component Units

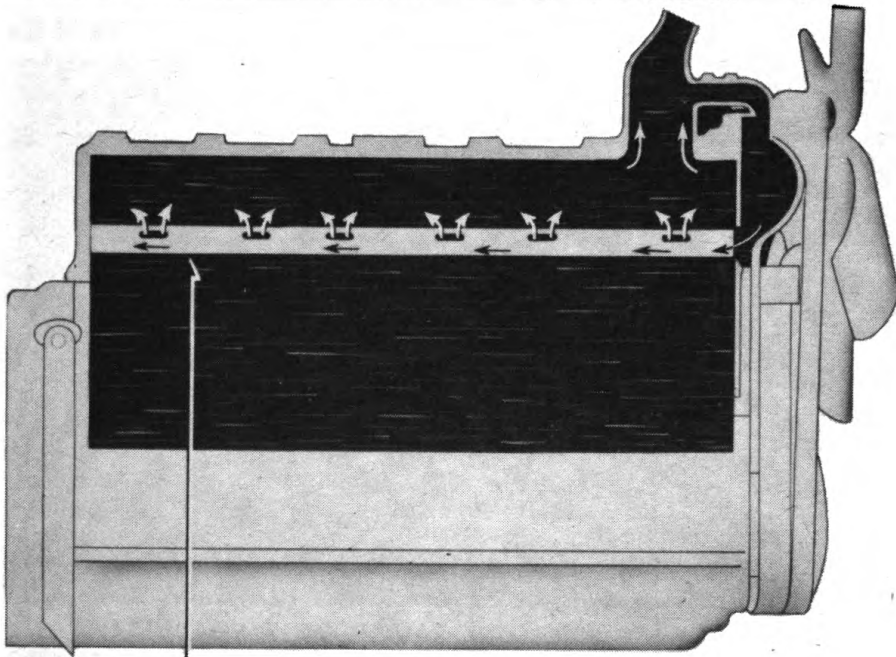

DISTRIBUTING TUBE CARRIES
WATER FROM THE FRONT TO
THE REAR OF THE ENGINE
AND DIRECTS WATER TO THE
EXHAUST VALVE SEATS

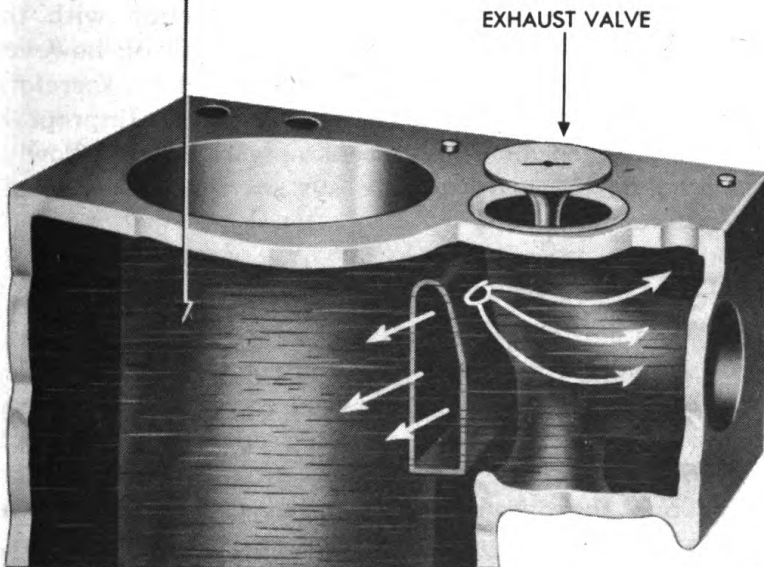

RA PD 341909

**Figure 19 – Coolant Flow Through Water Distributor Tube
in Engine Water Jacket**

OVERFLOW TANK PRESSURE CAP

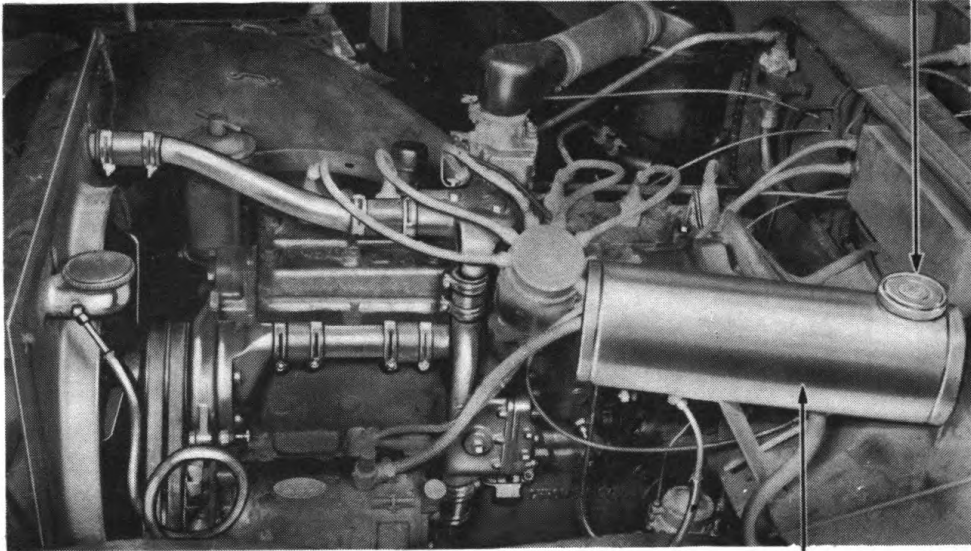

RADIATOR OVERFLOW TANK

RA PD 341937

Figure 20 — Radiator Overflow Tank Installation

tems use built-in plates or baffles to direct coolant circulation in the water jacket.

19. SHUTTERS, SCREENS, ETC.

a. Military vehicles are often equipped with brush guards, air inlet screens, or similar attachments not commonly found on civilian vehicles. Such devices may have no direct connection with the cooling system and may be entirely for protective purposes; however, they all restrict the flow of air through the radiator and, therefore, must be considered in connection with engine cooling. Improperly adjusted shutters or clogged air inlet screens may reduce air flow so much that the cooling capacity of the system will be seriously affected.

20. RADIATOR OVERFLOW TANK (fig. 20).

a. **Function.** Radiator overflow tanks, sometimes called surge tanks or expansion tanks, are standard equipment for some vehicles. They are installed on other vehicles as special equipment for operation in hot or dry country. The overflow tank serves as a receptacle for coolant overflowing from the radiator and provides for its return to the system. Thus, the overflow tank conserves coolant and reduces the need for frequent filling of the radiator.

b. **Construction.** Overflow tanks may vary in capacity from 2 quarts to a gallon or more. They are usually mounted fairly high with reference to the cooling system. The bottom of the tank is

Component Units

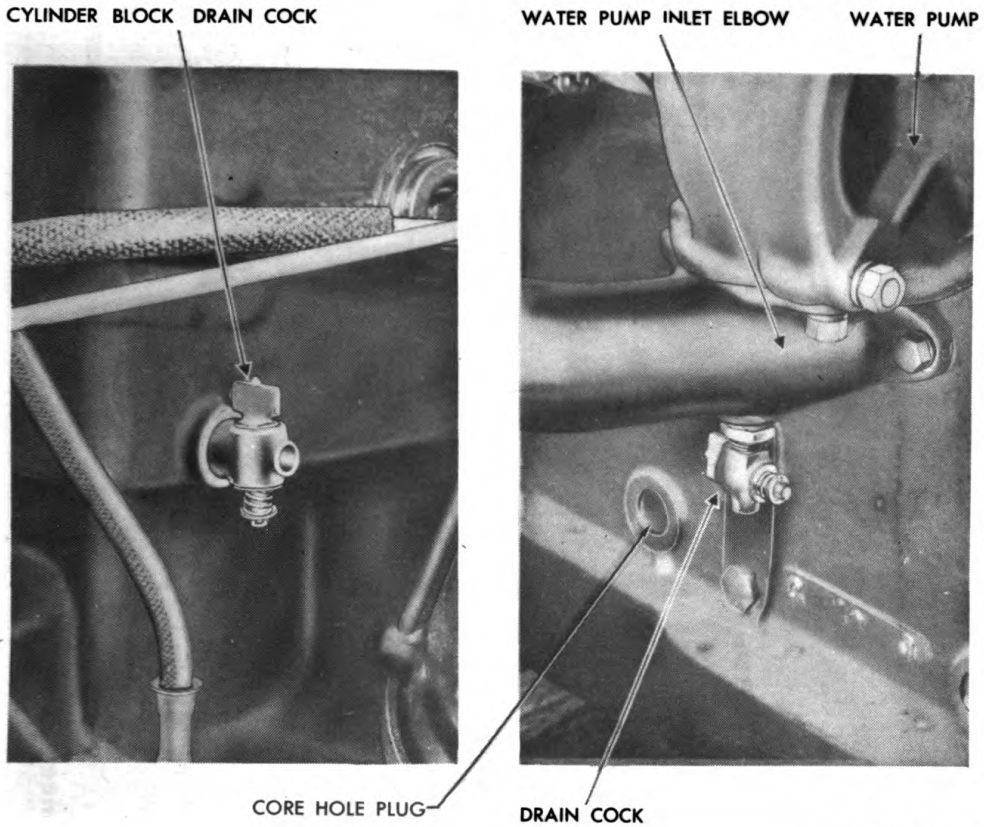
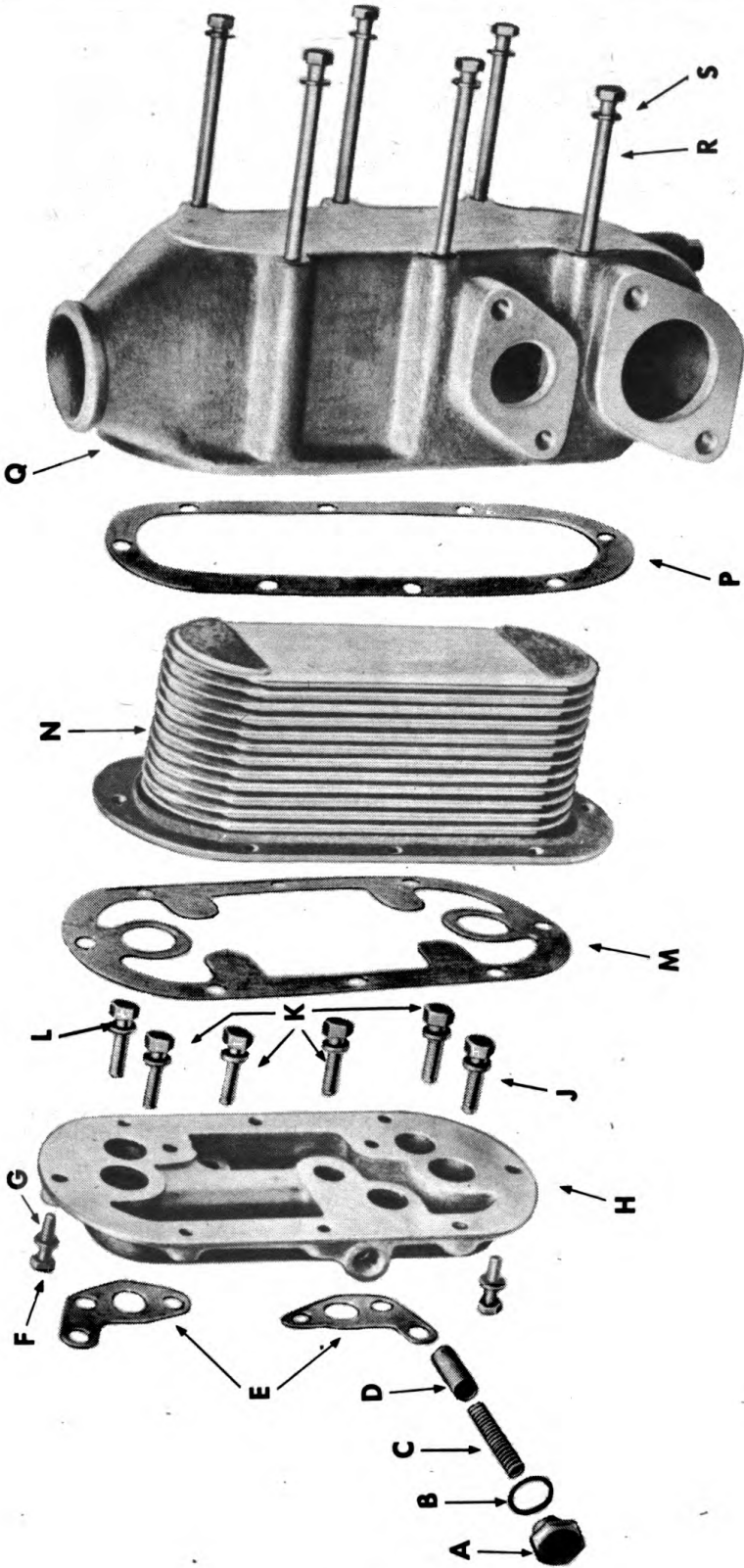

Figure 21 - Cooling System Drain Cocks

RA PD 315237

connected to the radiator overflow pipe through a metal tube which is usually connected by short pieces of flexible hose. When the cooling system is equipped with an overflow tank, the pressure cap (par. 16) is placed on the tank instead of the radiator and a plain cap is used on the radiator. This cap arrangement leaves the overflow pipe open to the tank. The plain cap on the radiator must always be pressure-tight to permit the tank to operate properly. Most tanks are equipped with an overflow pipe and a drain cock.

c. Operation. Either expansion of the coolant when it is heated (par. 25) or steam pressure due to boiling will force coolant into the overflow tank. Boiling may occur during operation, but it happens more often after the engine is stopped (par. 26 e). When the engine cools down, the pressure in the system drops below the pressure of the air outside and any coolant held in the overflow tank is forced back into the radiator. The overflow tank prevents loss of coolant from boiling during periods of severe vehicle operation. However, if the overflow from the radiator is so great that the tank is filled, the coolant will be lost through the tank overflow.



RA PD 341935

Figure 22 — Oil Cooler Connected to Cooling System

Component Units

RA PD 341935A

- A—PLUG, RELIEF VALVE
- B—GASKET, RELIEF VALVE PLUG
- C—SPRING, RELIEF VALVE
- D—VALVE, RELIEF
- E—GASKET, ADAPTER TO CYLINDER BLOCK
- F—BOLT, ADAPTER TO HOUSING
- G—WASHER, LOCK
- H—ADAPTER, OIL COOLER, ASSEMBLY
- J—BOLT, ADAPTER TO CYLINDER BLOCK, LOWER HOLE
- K—BOLT, ADAPTER TO CYLINDER BLOCK, SIDE HOLES
- L—BOLT, ADAPTER TO CYLINDER BLOCK, UPPER HOLE
- M—GASKET, OIL COOLER TO ADAPTER
- N—COOLER, OIL, ASSEMBLY
- P—GASKET, COOLER TO HOUSING
- Q—HOUSING, OIL COOLER
- R—BOLT, HOUSING TO ADAPTER
- S—WASHER, LOCK

RA PD 341935A

Legend for Figure 22 — Oil Cooler Connected to Cooling System

21. MISCELLANEOUS FITTINGS.

a. **Drain Cocks** (fig. 21). There is always a drain cock or removable screw-type plug located at the bottom tank of the radiator or at the outlet to permit draining of the coolant. Similar points of drainage are provided for the engine block. In some systems, there will be a drain cock or plug in the pump housing if it is the lowest point in the system. For complete draining of all parts of the system, every coolant drain plug must be removed and every drain cock opened.

b. **Steam Escape and Recirculation Tubes.** Some overhead valve engines have a coolant tube connecting the rear end of the cylinder head with the top tank of the radiator, which allows the escape of steam from the water jacket without causing overflow loss. Coolant flows through this tube into the radiator even with the thermostat valve closed; and to prevent overcooling of the engine during cold weather, the tube is equipped with a shut-off valve that can be closed. In another design, the tube from the rear of the cylinder head is connected into the thermostat by-pass so that coolant flowing in the tube is recirculated in the water jacket without entering the radiator.

c. **Core Hole Plugs.** In practically all engine water jackets will be found a number of round openings which are sealed by metal plugs driven into the holes. These openings in the outside walls of the cylinder block or cylinder head are necessary in the casting process, but perform no cooling system function. The core hole plugs which permanently close these openings are often incorrectly called "freeze plugs." Although core hole plugs may be forced out by a solid freeze-up in the water jacket, they are not a safety device which can be depended on for the prevention of freeze-cracking damage in the engine (par. 23 a).

d. **Other Fittings.** In some engines a cover plate or side plate is used to close a large opening on the side of the cylinder block water jacket. One type of cover plate is constructed with passages and outlet holes to provide for distribution of the coolant in a manner similar to that of the water distribution tube (par. 18). A few cooling systems have more than one water outlet from the cylinder head and use an assembly of metal piping called a water manifold to carry the coolant to the radiator.

22. ACCESSORIES CONNECTED TO THE SYSTEM.

a. **Oil Cooler** (fig. 22). The liquid-cooled oil cooler has a separate radiator connected to the cooling system which is designed to transfer heat from one liquid to another. The oil cooler contains two sets of liquid passages which are separated only by very thin walls. One

set of passages is connected to the engine lubricating system so that oil circulates through them. The other set, connected with the cooling system, carries the circulating coolant. Large cooling surfaces in the passages allow the heat to flow freely from one liquid to the other. During-vehicle operation when the engine is hot, the flow of heat is from the oil to the coolant. During engine warm-up, the heat flows from the coolant to the oil. Therefore, the oil cooler is actually an oil temperature regulator.

b. **Other Accessories.** Separate circulating systems may be connected to the engine cooling system to provide cooling for auxiliary engines and air compressors. In some cases, temperature regulation for a chassis unit, such as the transmission, is provided by circulating engine coolant through the unit.

Section III

COOLANT

23. IMPORTANCE OF THE COOLANT.

a. Like an endless belt conveyor (fig. 23), the flow of coolant is continually carrying a load of heat from the engine water jacket into the radiator (par. 5). During operation, the transfer of waste heat from the inside of the engine to the outside air through the coolant must never be interrupted. The coolant plays as important a part in the operation of the automotive engine as the fuel or the lubricating oil.

24. WATER AS A COOLANT.

a. Water has always been the most commonly used coolant for internal combustion engines because it has good ability to transfer heat and can be readily obtained almost anywhere. Some properties of water, such as its boiling point and freezing point, limits its usefulness as a coolant. The natural corrosive action of water on metals is definitely undesirable.

25. THERMAL EXPANSION.

a. Water, like other liquids, expands when it is heated. This means that the same quantity of water takes up more room when it is hot than when it is cold. The expansion of coolant when heated and the shrinkage in volume when cooled has a direct effect on cooling system operation. Water expands about $\frac{1}{4}$ pint per gallon when its temperature is raised from 40° to 180° F. If a 4-gallon cooling system is filled completely full of water at 40° F, 1 pint of coolant will

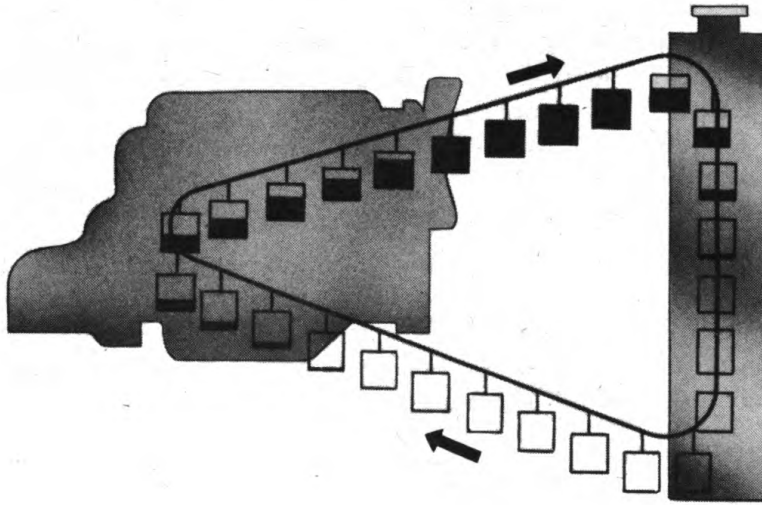

RA PD 341917

Figure 23 — Flow of Coolant Which Carries Heat From Engine to Radiator

overflow out of the radiator by the time the coolant temperature reaches 180° F.

26. BOILING AND EVAPORATION.

a. **Nature of Boiling.** Boiling causes heated coolant to change rapidly and violently from a liquid to a gas. Boiling of a liquid is controlled by two conditions, the temperature of the liquid and the pressure on it. Boiling of water takes place at 212° F under the pressure of the atmosphere at sea level. When water boils and changes to a gas called steam, it is capable of expanding 1,600 times. Therefore, a gallon of water can make as much as 1,600 gallons of steam. However, when water boils in the limited space of an engine water jacket, this extreme expansion cannot take place. Under this condition, the force of the expansion creates steam pressure.

b. **Effect of Altitude** (fig. 24). Air pressure on the earth at sea level is about 15 pounds per square inch. This pressure becomes less at higher altitudes, and the reduced pressure causes water and other liquids to boil at a lower temperature. For example, the reduced air pressure at 1,000 feet above sea level lowers the boiling point of water from 212° to 210° F. At an altitude of 5,000 feet, the boiling point of water is only 203° F.

c. **Effect of Pressure in the Cooling System** (fig. 25). If the pressure in the coolant is raised above atmospheric pressure, the coolant will not boil until a higher temperature is reached. For each

Coolant

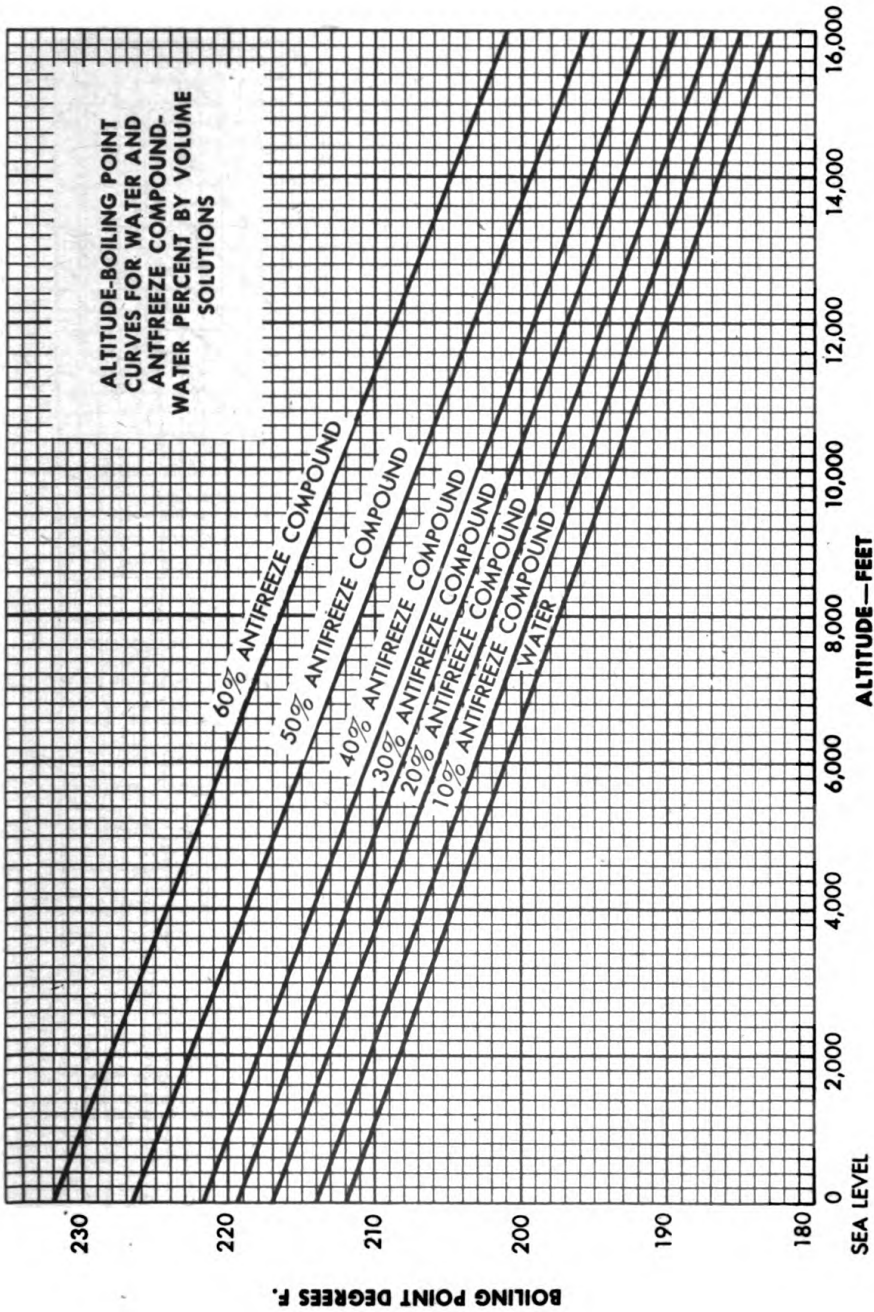

ALTITUDE-BOILING POINT
CURVES FOR WATER AND
ANTIFREEZE COMPOUND-
WATER PERCENT BY VOLUME
SOLUTIONS

RA PD 341930

Figure 24. — Effect of Altitude on Boiling Points of Water and Antifreeze Compound Solution

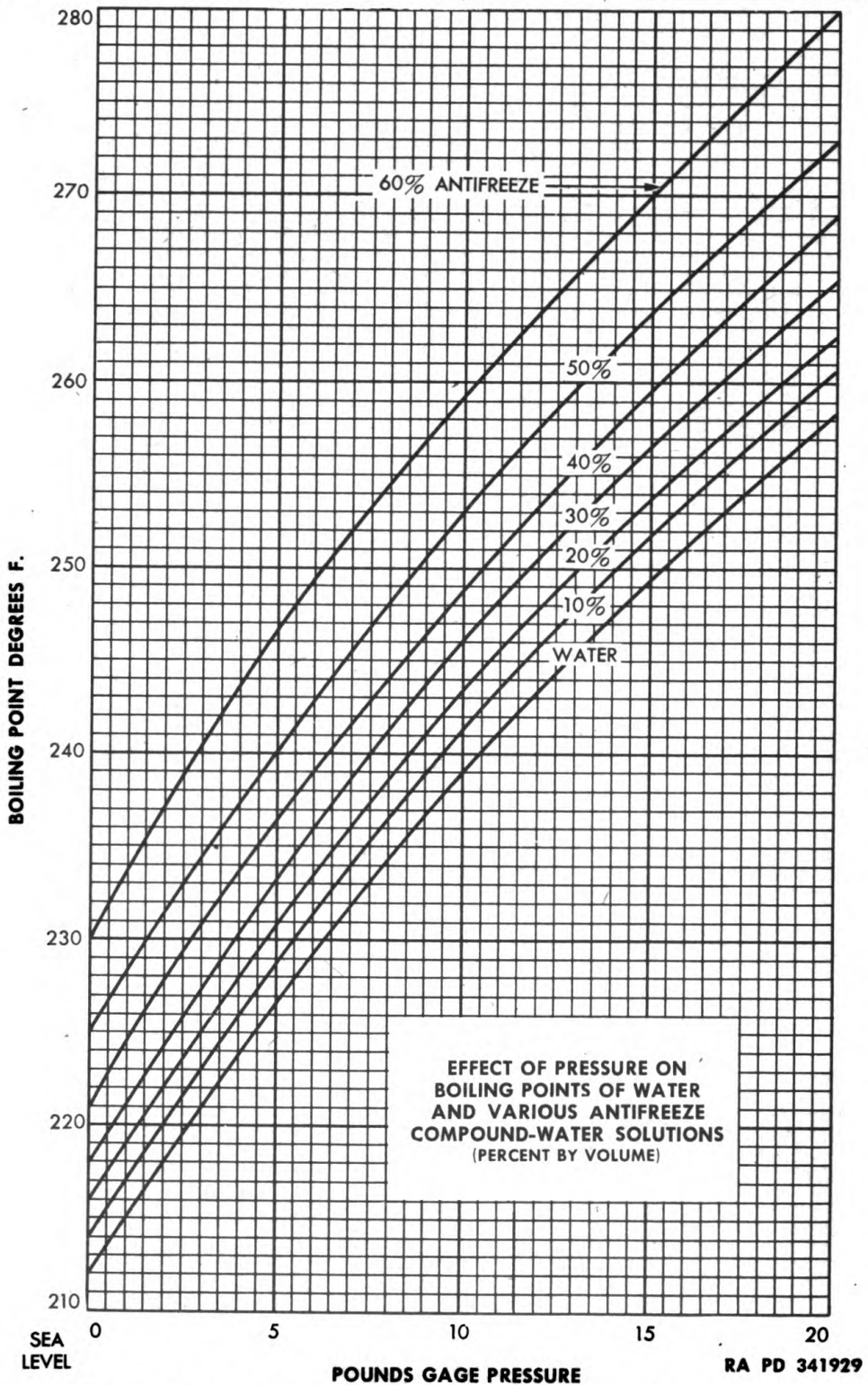
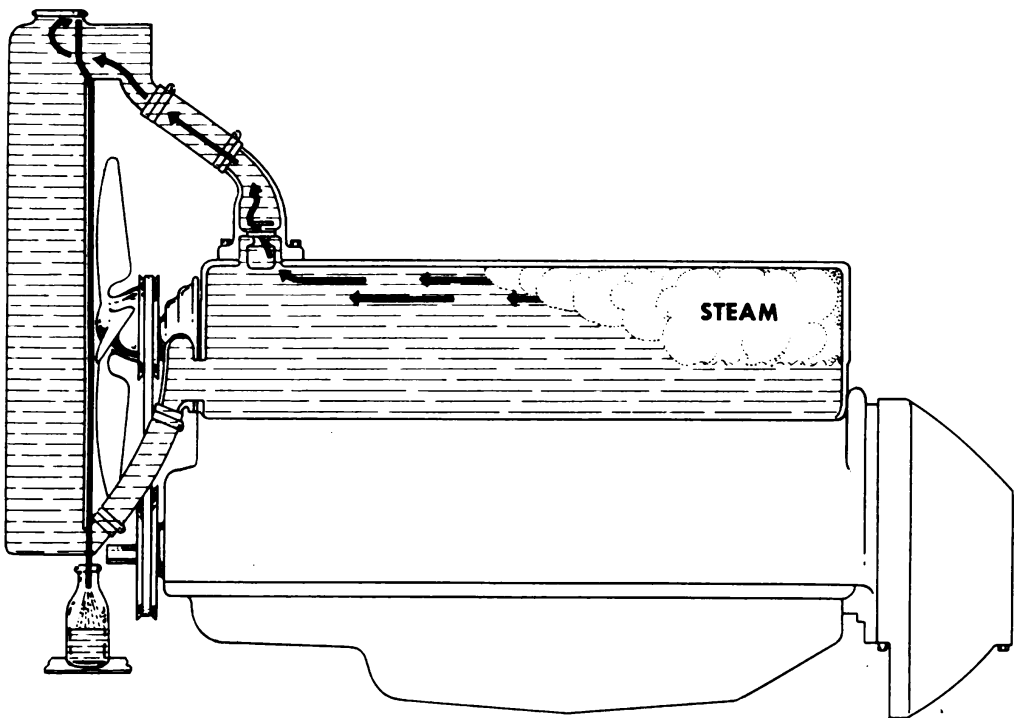

Figure 25 — Effect of Increased Pressure in Cooling System on Boiling Points of Water and Antifreeze Compound Solution



RA PD 341892

Figure 26 — After-boil of Coolant After Stopping Hot Engine

pound of additional pressure in the system, the boiling point of the coolant will rise about 3° F. In the military vehicle cooling system, pressure is applied to the coolant through the use of a radiator pressure cap (par. 16).

d. Boiling During Engine Operation. Violent boiling of the coolant affects the operation of the cooling system in several ways. The formation of steam in the water jacket results in steam pockets which prevent the coolant from coming in contact with the metal. This interferes with transfer of heat to the coolant. Pressure developing from steam formation in the water jacket forces coolant out the overflow pipe. Continued operation of the engine with boiling coolant can run the cooling system almost completely dry.

e. After-boil (fig. 28). Following long, hard operation, boiling may occur after the engine is shut off, even though the coolant was not boiling during operation. This after-boil is caused by the rapid rise of coolant temperature in the water jacket, sometimes as much as 20° F or more. The temperature rise is due to the fact that the coolant is still absorbing heat produced in the engine during operation and cannot get rid of it with circulation and air flow stopped. After-boil occurs less frequently and results in less overflow loss when

the boiling point of the coolant is comparatively high. After-boil losses of coolant can be prevented by use of radiator pressure caps and overflow tanks.

f. **Evaporation.** A liquid can change to a gas by evaporation as well as by boiling. Boiling takes place within the liquid, and evaporation occurs on the surface. The rate of evaporation is controlled by a number of conditions which include the temperature of the liquid and the amount of surface exposed to the air. Water evaporates at all temperatures, but contrary to common opinion, the loss of water from the cooling system by evaporation is negligible as compared to other causes of coolant loss, especially in systems equipped with pressure caps. Evaporation of slight water leakage outside the cooling system may be so rapid that the leakage will be dried up as fast as it is formed, and there will be no moisture at the leak, especially when the system is hot.

27. FREEZING.

a. **Freezing of Water.** When water freezes at 32° F above zero, it forms solid ice and expands approximately 9 percent in volume. This expansion takes place with a force that can exert tons of pressure. If water is allowed to freeze inside the cooling system, this extreme pressure will cause serious damage.

b. **Antifreeze.** Another liquid must be added to the water in order to prevent it from freezing. Water containing antifreeze will not cause freeze-cracking damage from expansion and will continue to circulate freely in the cooling system at very low temperatures if the proper amount of antifreeze has been added. Methanol, ethanol, and ethylene glycol are the types of antifreeze commonly used in civilian vehicles. However, antifreeze compound (ethylene glycol type) is the only type of antifreeze material authorized for use in water-cooled military engines.

28. PROPERTIES OF ANTIFREEZE COMPOUND SOLUTION.

a. **Freezing Protection** (fig. 27). Mixing antifreeze compound with water lowers the freezing point of the water in proportion to the amount of antifreeze compound used. The addition of 1 gallon of antifreeze compound to 3 gallons of water (25 percent concentration) lowers the freezing point of the water from $+32^{\circ}$ F to $+10^{\circ}$ F. A solution containing one-third antifreeze compound and two-thirds water will freeze at 0° F, while a solution which is half antifreeze compound and half water will protect against freezing down to -34° F. The greatest freezing protection that can be obtained with antifreeze compound, -62° F, is given by solution containing 60 percent antifreeze compound and 40 percent water.

Coolant

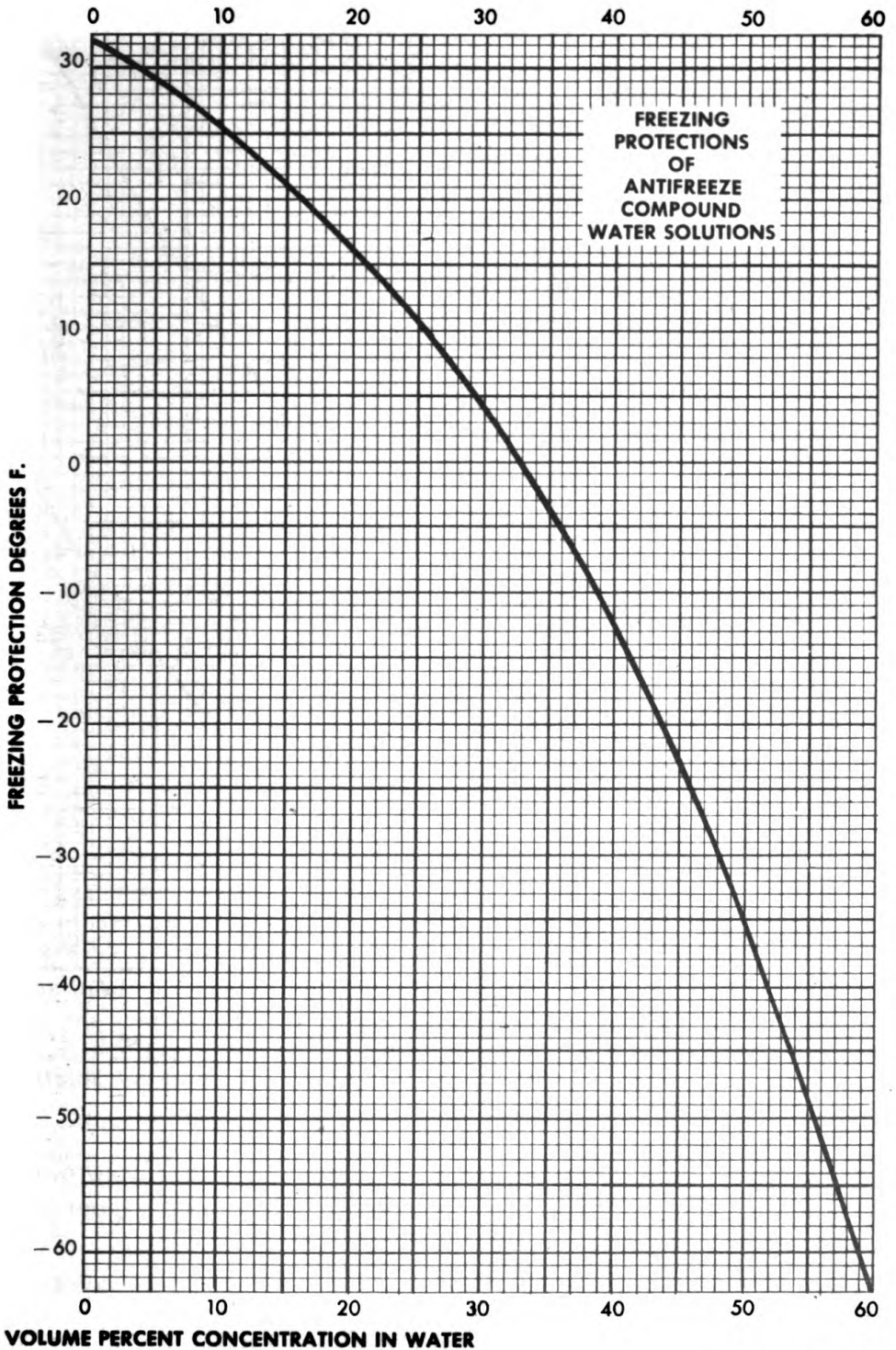

RA PD 341931

Figure 27 — Relation Between Concentration of Antifreeze Compound in Solution and Freezing Protection of Solution

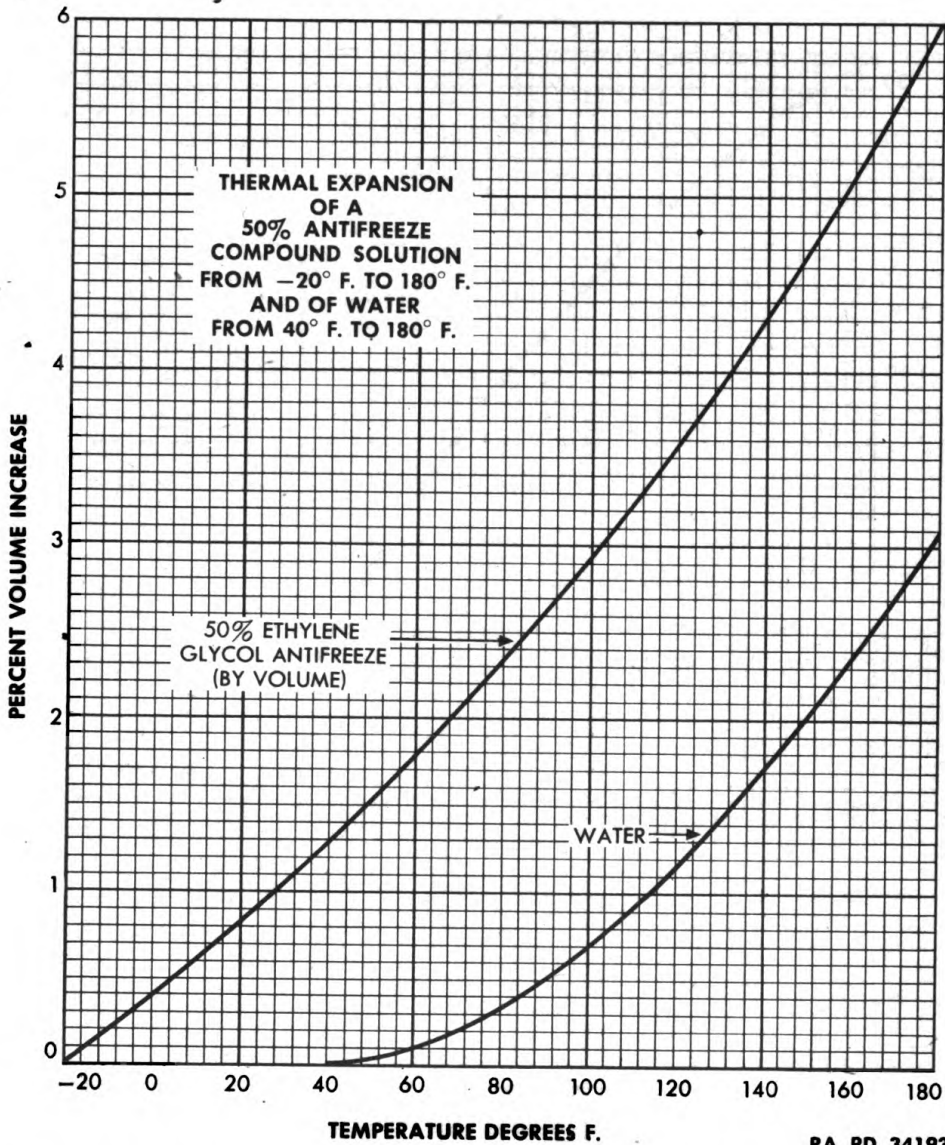

RA PD 341933

Figure 28 — Expansion of Water and Antifreeze Compound Solution Caused by Heat

CAUTION: Solutions containing more than 60 percent antifreeze compound give less protection. Antifreeze compound, without any water added, will freeze at about 0° F.

b. **Thermal Expansion** (fig. 28). Antifreeze compound solutions expand slightly more than water when heated. When the temperature of a 50 percent antifreeze solution is raised from 40° to 180° F, the solution expands about $\frac{1}{7}$ pint per gallon more than water under the same conditions (par. 25). However, during very cold weather, the range between atmospheric and maximum operating temperatures

Coolant

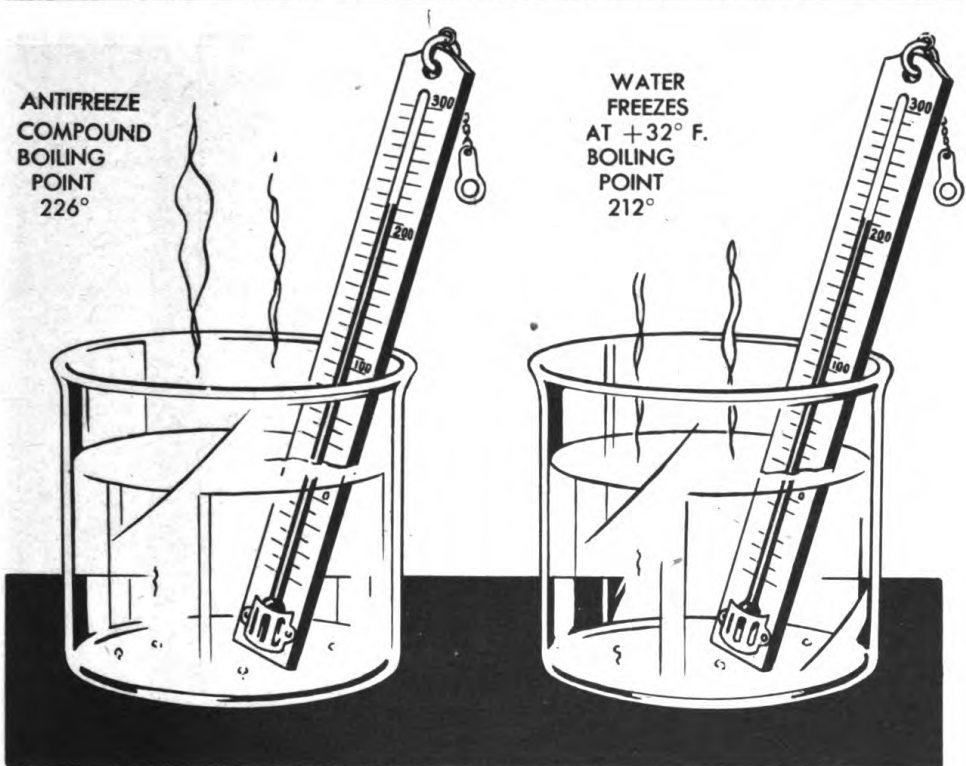

RA PD 341932

Figure 29 – Comparison of Boiling Point of Water With Boiling Point of Antifreeze Solution Which Protects to -20° F

is much greater than when water is used, and thermal expansion of solution is therefore a more serious matter. For example, the expansion of a 50 percent antifreeze solution when heated from -20° to 180° F is nearly $\frac{1}{2}$ pint per gallon. If a 5-gallon cooling system containing a 50 percent solution were filled completely full with the coolant temperature at -20° , about $2\frac{1}{2}$ pints of solution would overflow out of the radiator by the time the coolant temperature had reached 180° F.

c. **Boiling Point** (fig. 29). The addition of antifreeze compound to water raises the boiling point of the coolant somewhat. A solution containing one-third antifreeze compound, protecting to 0° F, has a boiling point of 220° F as compared to 212° F for water; and a 60 percent solution boils at 231° F. Cooling systems can therefore operate at higher temperatures without boiling when using antifreeze solution than when using water. However, 100 percent concentrated antifreeze compound (fig. 30) has a boiling point far above safe operating temperatures for water-cooled engines and should not be used for coolant except with water added. Alcohol antifreeze solutions boil at temperatures below the boiling point of water.

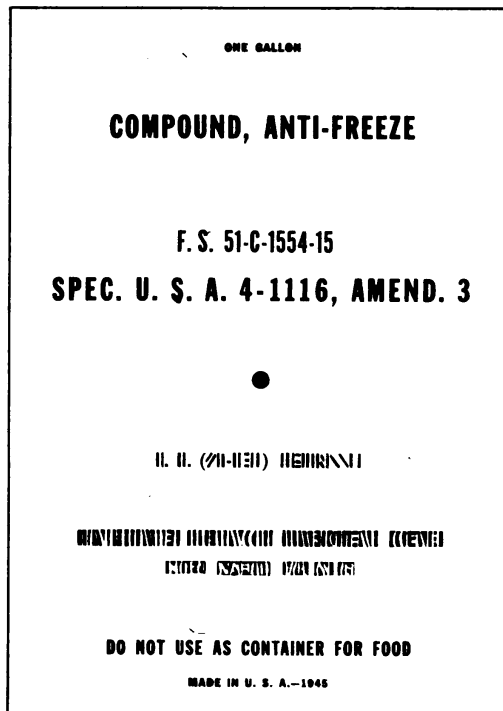

RA PD 341880

Figure 30 — Container Label for U. S. Army Spec. 4-1116, Antifreeze

d. **Evaporation.** Any evaporation from antifreeze solutions is practically all water. Losses of solution from the cooling system by evaporation are negligible as compared to other causes of coolant loss (par. 26 f).

e. **Heat Transfer.** Antifreeze solutions have slightly less ability to carry away heat than water has. However, this apparent disadvantage is offset to a large extent by higher boiling points. Therefore, no cooling problem is created by the use of antifreeze solutions for antifreeze protection in engines designed for water cooling.

f. **Other Properties.** Foaming and leakage tendencies, as well as chemical properties of both antifreeze compound and water, may affect cooling system operation and create maintenance problems. These properties are described in paragraph 53 f.

29. CORROSION INHIBITORS (fig. 31).

a. **The Corrosion Problem.** Water has the natural tendency to combine chemically with iron and air in the system. This chemical action forms rust and may also cause corrosion damage to metal parts of the system. Details of the causes and effects of rust and corrosion are covered in paragraph 49.

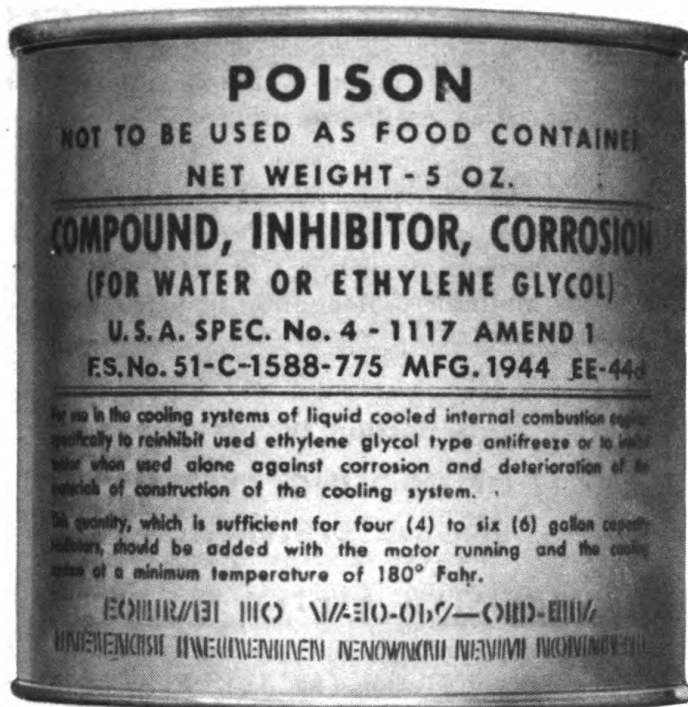

RA PD 341872

Figure 31 – Container Label for U. S. Army Spec. 4-1117, Inhibitor

b. Nature of Corrosion Inhibitors. Protection of the cooling system against corrosion and rust formation is secured by the addition of special materials called inhibitors to the coolant. Although the quantities of materials added to provide inhibitor treatment are very small, their effectiveness in preventing rust and corrosion is very great. Laboratory tests have shown that inhibitor treatment of water can reduce the rusting of iron in the cooling system by as much as 95 percent.

c. Inhibitor in Antifreeze. The proper kind and amount of inhibitor is added to antifreeze compound by the manufacturer. Consequently, there is no need for adding an inhibitor to fresh unused antifreeze solution. In fact, nothing but fresh, clean water should be added to new antifreeze when preparing solution.

d. Antifreeze Reinhibitor. The original corrosion inhibitor in new antifreeze may gradually be weakened and finally exhausted by extended use of the solution in the cooling system. It is therefore necessary to add corrosion inhibitor compound (51-C-1588-775) to antifreeze solutions that are to be used for a second season.

e. **Inhibitor for Water.** Inhibitor treatment is even more necessary when water is used as coolant than it is during the antifreeze season. The approved material which is provided for adding to water for summer rust prevention is the same as approved re-inhibitor for use with used antifreeze solutions.

30. APPROVED COOLANTS.

a. The only coolants authorized for Ordnance vehicles are anti-freeze compound (ethylene-glycol type) or solution inhibited water. Plain water without inhibitor protection is not an approved coolant.

Section IV

INTER-RELATION OF COOLING SYSTEM AND OTHER ENGINE SYSTEMS

31. ENGINE LUBRICATING SYSTEM.

a. The cooling system and the lubricating system are dependent on each other for proper operation (fig. 32). Flow of lubricating oil assists in keeping the engine at proper operating temperatures by transferring part of the waste heat from pistons to cylinder walls and by removing the heat from bearings. In addition, the oil reduces waste heat from friction by properly lubricating the moving parts. On the other hand, satisfactory lubrication depends on proper operation of the cooling system. If the coolant fails to remove its share of waste heat, excessive metal temperatures may reduce or destroy the lubricating value of the oil. Excessive heat may also cause chemical changes in the oil which produce sludge, "varnish," and other harmful deposits. Overcooling also interferes with proper lubrication (par. 35 c).

32. OTHER ENGINE ACCESSORY SYSTEMS.

a. **General.** In a number of ways, the operation of the cooling system affects and is affected by the operation of other engine accessory systems.

b. **Fuel System.** Overcooling wastes fuel and overheating may cause vapor lock. Conversely, an improper mixture of fuel and air raises the coolant temperature by increasing the amount of waste heat in the engine which must be carried away by the cooling system (par. 4 b).

c. **Exhaust System.** Since the exhaust system normally removes as much waste heat as the cooling system (par. 4 b), any obstruc-

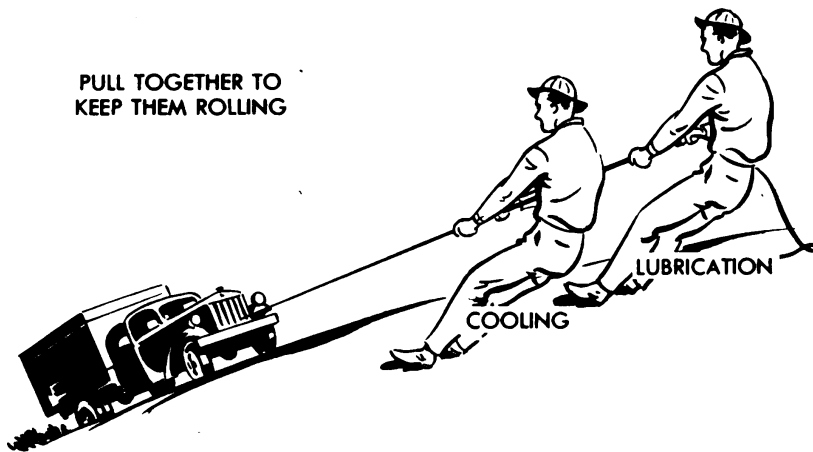

RA PD 341918

Figure 32 – Interdependence of Cooling System and Lubrication System

tion or defect which interferes with the flow of heat from the exhaust system will throw a greater heat load on the cooling system. On the other hand, insufficient cooling can result in excessive wear or other damage of the exhaust valves (par. 8 b).

d. **Electrical System.** Improper cooling of the combustion chamber walls may result in such high temperatures that the spark plugs will be rapidly deteriorated or even damaged. In turn, improper ignition, especially late timing, increases the amount of waste heat thrown into the cooling system and is a common cause of overheating.

33. ENGINE ASSEMBLY.

a. **Adjustments and Clearances.** The mechanical condition of the engine itself has an important bearing on proper cooling. Valve timing and fit of pistons, piston rings, and bearings may increase or reduce the amount of heat which the cooling system must carry away. Conversely, the proper regulation of temperature in these parts is required to prolong their useful life and to avoid rapid wear or damage.

b. **Engine Performance.** The regulation of engine operating temperatures by the cooling system is indispensable for dependable performance, maximum power, and economy of operation. None of these are possible without a properly functioning cooling system.

CHAPTER 3 — DRIVER OR OPERATOR PREVENTIVE MAINTENANCE

Section I

**IMPORTANCE OF DRIVER PREVENTIVE
MAINTENANCE SERVICES**

34. DRIVER FUNCTION.

a. The vehicle driver is the most important single factor in preventive maintenance. Only through him can the mechanic ever hope to know what trouble a piece of equipment is giving. This applies particularly to vehicle engine cooling, because practically all cooling system troubles can be detected by the driver in their early stages before they seriously affect vehicle operation and while they are still easy to correct. For the stationary engine operator or the vehicle driver, the two most important indications of cooling system condition are coolant operating temperature and coolant level. Therefore, driver preventive maintenance services to the cooling system should always be concentrated on these two as first requirements. While all other driver preventive maintenance services, such as for leakage or defective mechanical condition of parts, are also necessary, these conditions are nearly always indicated by the engine temperature gage, by level of the coolant in the radiator, or by both.

35. COOLANT OPERATING TEMPERATURE.

a. **General.** Frequent observation of the engine temperature gage during operation is a primary preventive maintenance service for detecting overheating or overcooling of the engine in the first stages, before serious trouble develops.

b. **Overheating Difficulties** (fig. 33). Excessively high engine temperatures not only cause "knock" and loss of power, but also will result in damage to bearings and other moving parts. Cylinder heads and engine blocks are often warped and cracked by terrific strains set up in the overheated metal, especially when coolant is added immediately afterward without allowing the engine to cool. Overheating first causes coolant boiling. If the vehicle is operated with boiling coolant, steam pressure forces large quantities of coolant out of the system through the radiator overflow pipe. More violent boiling then occurs, and still more coolant is lost. Finally, coolant circulation stops and cooling fails completely. This means that operating an engine with the coolant boiling for even a short length of time may be actually driving that engine to destruction.

c. **Overcooling Difficulties** (fig. 34). Although less sudden in effect than overheating, overcooling may be equally dangerous to the engine. Low engine operating temperature, especially during



RA PD 341889

**Figure 33 – Burned Valves and Scored Piston,
Damaged by Overheating**

freezing weather, results in excessive fuel consumption, dilution of engine oil by unburned fuel, and formation of sludge from condensation of water in cylinders and crankcase. Lubrication failure may follow sludge formation and lead to serious engine damage. Burned fuel vapors also mix with water in the crankcase and form corrosive acids which attack engine parts.

d. Temperature Gage Observation (fig. 35).

(1) To avoid overheating difficulties, the driver or engine operator must be constantly alert to see that the temperature gage does not exceed the maximum safe operating temperature specified for the vehicle. Whenever the gage registers above this temperature, the vehicle should be halted, the engine stopped, and the cause investigated and corrected before further operation is attempted. It is also important to watch the gage for a sudden rise in temperature during engine warm-up as an indication of defective cooling.

(2) To prevent overcooling difficulties, keep any necessary warm-up period before operation as short as possible, and avoid continued operation of the vehicle if the temperature gage does not

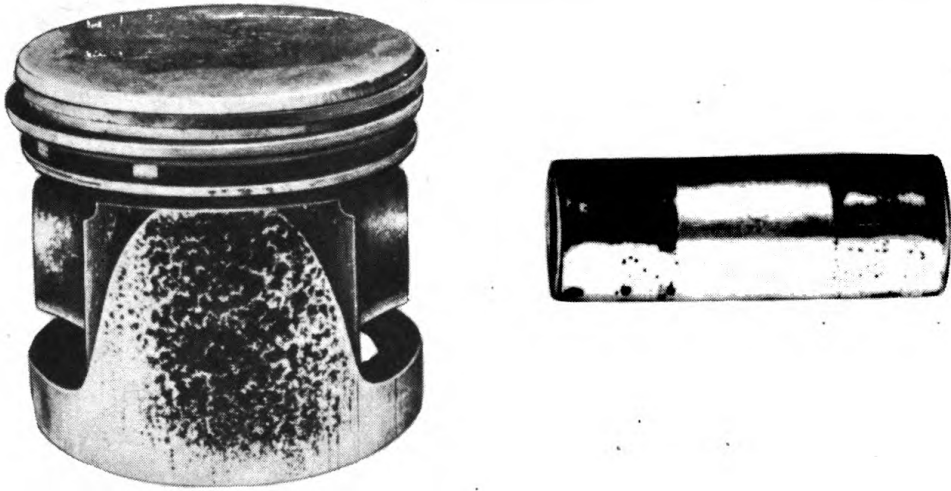

RA PD 341881

Figure 34 — Corroded Piston and Wrist Pin, Damaged by Overcooling

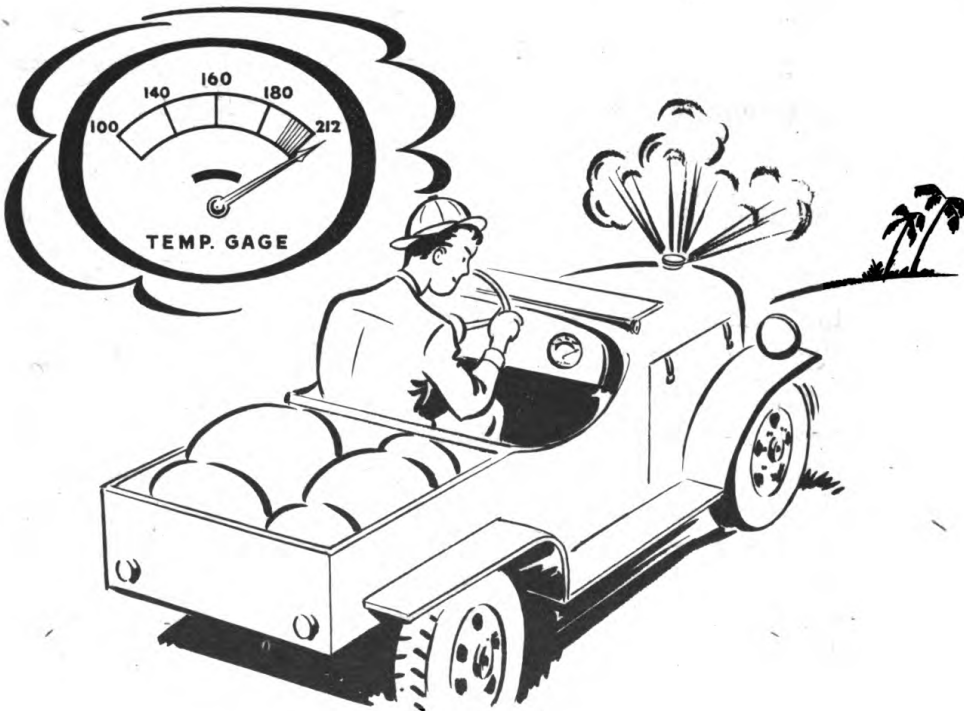

RA PD 341919

Figure 35 — Checking Engine Temperature Gage During Operation

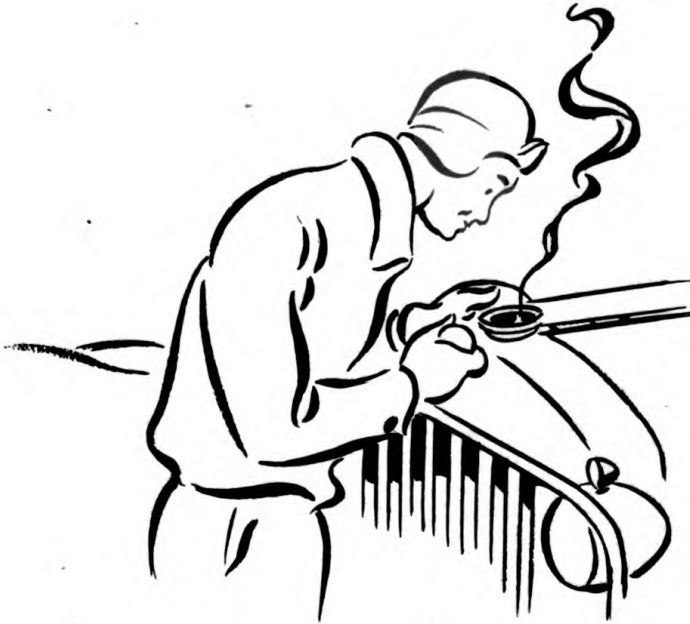

RA PD 341923

**Figure 36 – Checking Coolant Level in Radiator
at Engine Operating Temperature**

reach the minimum safe operating temperature specified for the vehicle.

(3) When checking for either overheating or overcooling, the possibility of a false temperature indication from a defective gage should not be overlooked.

(4) Prevention of both overheating and overcooling difficulties thus requires temperature gage observations both before and during operation. It also requires a positive knowledge by the driver or engine operator, of the highest and lowest safe operating temperature specified for the particular engine.

36. COOLANT LEVEL (fig. 36).

a. Coolant Level Checking. The level of coolant in the radiator is the starting point for proper cooling system preventive maintenance. Coolant level should be checked accurately as well as frequently for three separate purposes: (1) to make sure the system always contains enough coolant; (2) as a guide to cooling system condition; and (3) to avoid overfilling.

b. Coolant Shortage. It is important to make sure that the system contains a sufficient quantity of coolant at all times, if the most common cause of overheating is to be avoided. Low coolant level

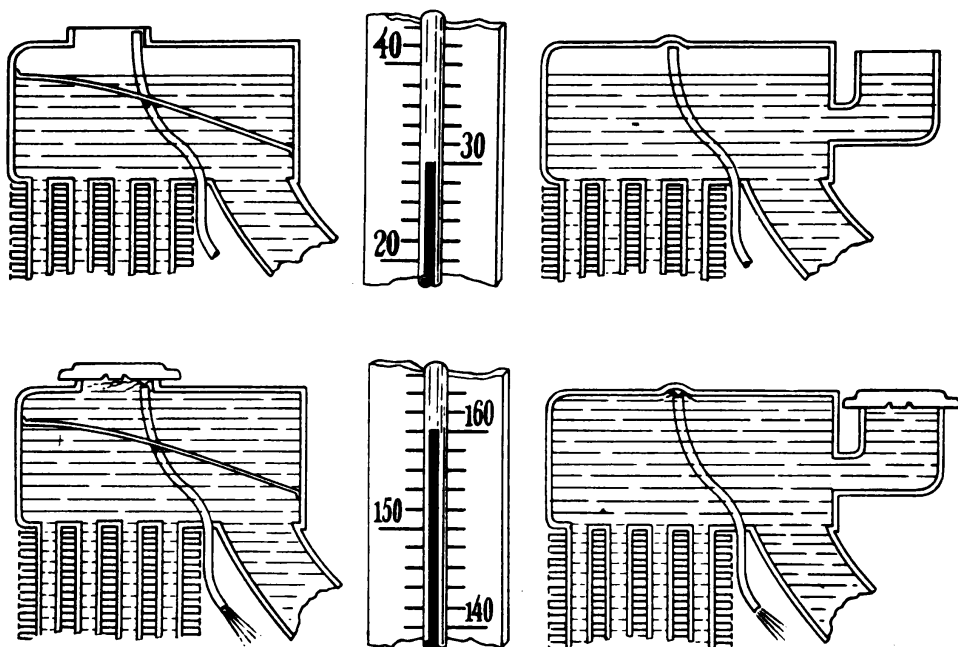

RA PD 341901

Figure 37 — Loss of Coolant Through Expansion by Heat When Radiator Is Overfilled

may prevent proper circulation, especially at lower engine speeds. At higher engine speeds, low coolant level allows a large volume of air to become mixed with the liquid. Air bubbles in the coolant not only reduce the capacity of the coolant to carry away heat, but also promote rapid rust formation and corrosion, and may cause excessive foaming and coolant loss out the overflow pipe. In any case, coolant shortage leads to overheating, operating difficulties, and engine damage (par. 35 b). Having sufficient coolant in the system at all times is especially important in military operations, due to the necessity of being constantly prepared for all possible operating emergencies.

c. Coolant Level as Indicator of Cooling System Condition.

The second reason for checking coolant level is less generally understood. In the military vehicle cooling system equipped with a radiator pressure cap, very little coolant should be lost through evaporation or from any other cause if the system is clean, leakproof, and in proper working order. Therefore, any unusual coolant loss over a period of normal operation may indicate an improper condition within the system; any such condition should be located and corrected before it causes serious trouble.

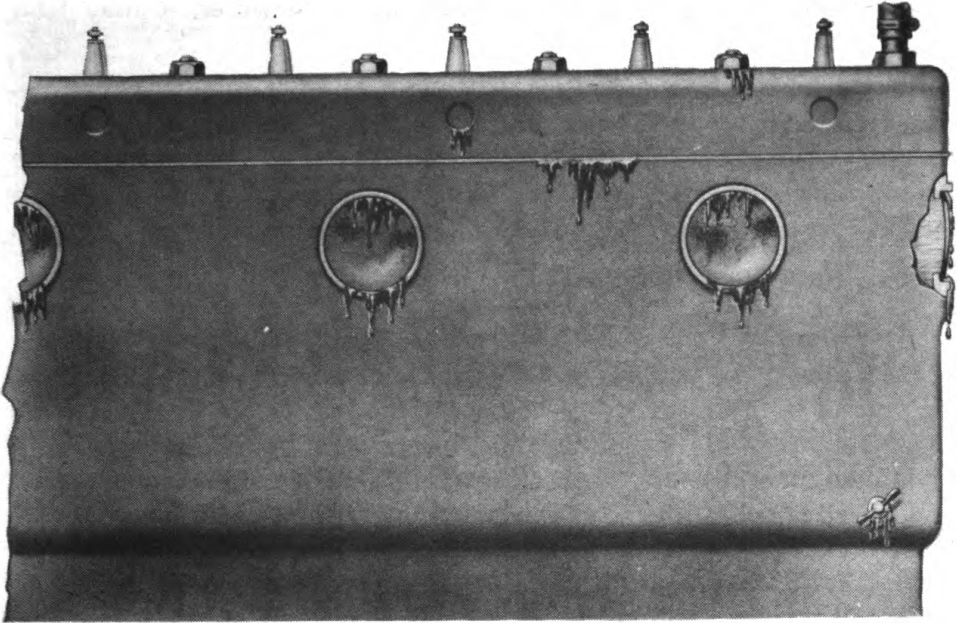

RA PD 341868

Figure 38 – Outside Leakage of Engine Water Jacket

d. **Standard Coolant Level Maintenance.** The driver or engine operator can assist greatly in the early detection of irregular conditions inside the cooling system by keeping track of the quantities of coolant necessary to maintain the standard height of liquid level in the radiator as specified for his equipment. The coolant level should always be checked at approximately the minimum safe operating temperature, if possible, since the level rises as the engine warms up and falls as the engine cools down (par. 25). Any unusual increase in the amount of coolant needed to bring the level up to standard height should be investigated. It should be corrected by the operator or reported by him as a possible indication of trouble developing in the system.

e. **Overfilling (fig. 37).** If the radiator is continually filled above specified level or when the engine is not up to minimum safe operating temperature, any changes in the level or the quantity of coolant additions will be of little value as an indicator of cooling system condition. Both water and antifreeze expand when heated (par. 28 b), and if there is not enough air space left in the radiator for this expansion, some coolant will be lost through overflow. Overfilling the radiator while using water results in dilution and weakening of corrosion inhibitor solution (par. 29). Unnecessary additions of water increase water scale deposits which interfere with removal of heat from the engine. Overfilling also wastes antifreeze and when

a system containing antifreeze is overfilled with water, it may lead to a freeze-up.

f. **Driver's Responsibility.** Coolant level preventive maintenance services by the driver consist not only of keeping sufficient coolant in the system at all times without overfilling, but also include maintaining a standard level at a specified temperature to provide a sensitive indication of any hidden trouble that might develop in the system.

37. LEAKAGE (fig. 38).

a. **Causes.** Leakage is probably more common in the vehicle cooling system than in any other liquid-carrying unit, due to the stresses and strains set up in joints and connections by wide changes in coolant and metal temperatures, especially during cold-weather operation. Engine vibration, road shock, and deterioration of gaskets, and wear, breakage, or corrosion of metal parts may create leakage, and these conditions are often more severe in military operation. The radiator pressure cap, which is used on nearly all military vehicles, creates additional pressure in the system; thereby increasing the leakage tendency at hose connections and other water joints. Radiator leakage may be caused by accidental damage to the core from flying stones and debris, minor collisions with other vehicles or objects, or from sabotage and combat damage. Such damage can easily occur without the driver's knowledge.

b. **Appearance and Effects.** Small coolant leaks, which show dampness or even dripping when cold, may not be noticed when the engine is hot, due to rapid evaporation of the leakage. Leakage of antifreeze compound may be easier to find because it evaporates much more slowly than water (par. 26 f). Rusty or grayish-white stains at joints in the radiator or engine water jacket are usually indications of leakage, even though there appears to be no dampness. Even small leaks should not be neglected, since they often become larger, sometimes suddenly, and generally while the vehicle is being driven. When a driver neglects leakage inspection he risks overheating during operation, possible mechanical breakdown, and failure of his mission.

CHAPTER 4 — MECHANIC PREVENTIVE MAINTENANCE**Section I****IMPORTANCE OF MECHANIC PREVENTIVE MAINTENANCE SERVICES****38. ENGINE COOLING PROBLEMS IN MILITARY OPERATION**
(fig. 39).

- a. Special requirements of military engines and the severe conditions of transport and combat operation make it necessary that the engine cooling system be maintained as closely as possible to maximum efficiency at all times. Many military vehicles are powered with comparatively large engines which develop proportionately large amounts of heat that must be carried off. Also, cooling is often made more difficult by the presence of air flow obstructions necessary for protection. Weather conditions vary from the extreme heat of the desert to the bitter cold of the Arctic. Power requirements, which range from emergency high speeds on surfaced roads to heavy uphill hauling through deep mud, add further to the problem of engine cooling. At the same time, military operating conditions, severe shocks and vibration, flying debris, sand and dust, weather exposure, and accidental and combat damage, are causing rapid deterioration of the cooling system and loss of cooling efficiency. To keep the cooling system constantly in repair and in best working order requires the most careful attention to periodic preventive maintenance services by the organizational mechanic.

39. RADIATOR.

- a. **Leakage and Failure** (fig. 40). Engine vibration and road shocks put a strain on all radiator seams and joints that may lead to breakage and leakage, particularly in the water tubes, tanks, and outlet and inlet fittings. Additional strain is set up by extreme changes in metal temperatures, especially during cold-weather operation. Cross-country driving over rough terrain multiplies the effects of ordinary shock and vibration. Neglect of small leaks may result in complete radiator failure, excessive leakage, rust clogging, and overheating difficulties. Thus, it is extremely important to keep the radiator mounting properly adjusted and tight at all times, and to detect and correct promptly even the smallest leaks.

- b. **Air Passage Obstruction** (fig. 41). The primary function of the radiator is to transfer heat efficiently from the coolant to the air (par. 10 d). This is not possible without clean, straight air fins and unobstructed air passages. Flying dust, sand, grass, leaves, and other debris may clog air passages in a very short time. Air fins are easily

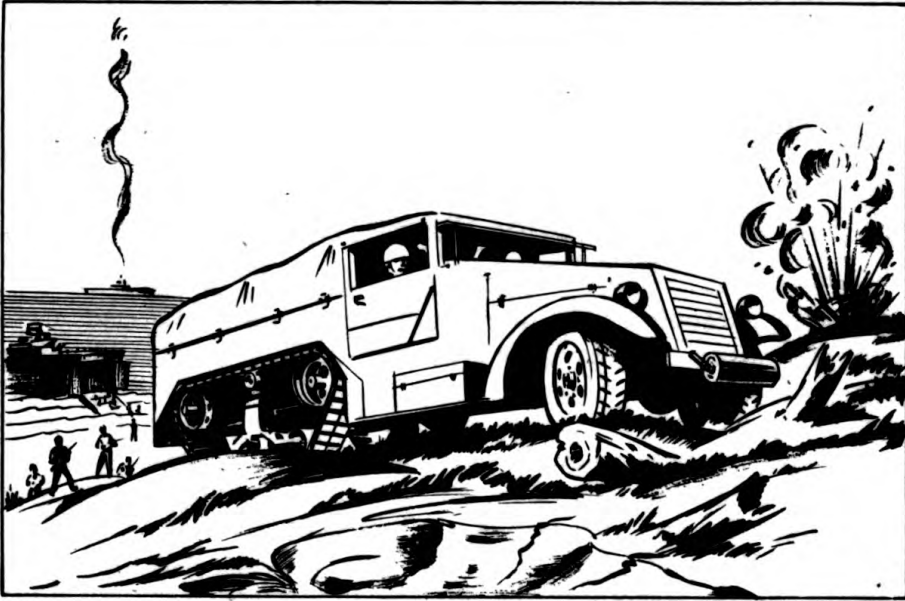

RA PD 341920

Figure 39 — Operation Under Typically Severe Conditions

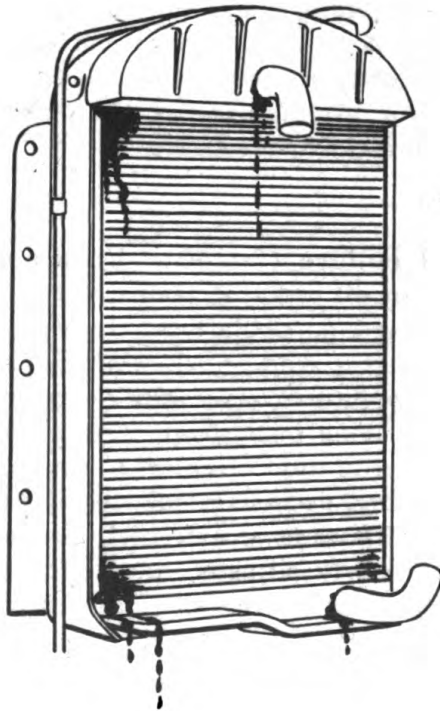

RA PD 341905

Figure 40 — Radiator Leakage

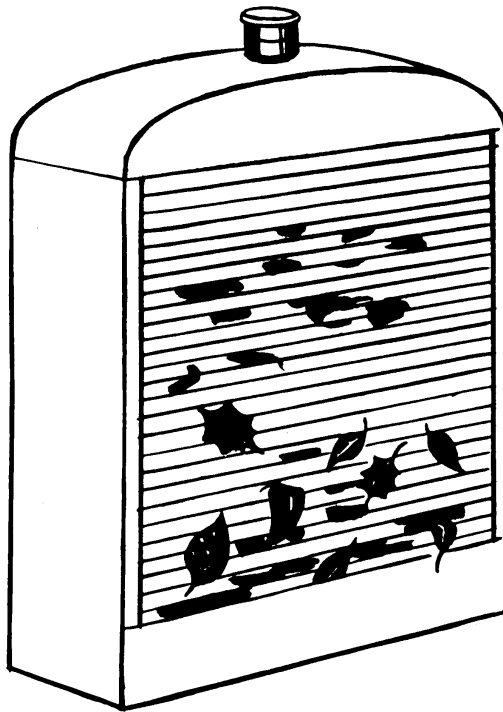

RA PD 341921

Figure 41 – Clogged Air Passages in Radiator Core

bent and damaged by impact of small stones and from other accidental causes. The problem of maintaining sufficient air flow through the radiator is often further complicated by brush guards, air inlet screens, shutters, armor, etc. Therefore, constant attention to the condition of all air passages and restrictions is required in order to avoid the danger of overheating. In extreme cases, cleaning may be required daily or even oftener.

40. RUBBER HOSE AND METAL TUBING.

a. Leaks are more common at radiator hose connections than anywhere else in the cooling system. Engine vibration has a tendency to wear and loosen rubber hose connections. Clamps may buckle the hose and threads on the clamp bolt are sometimes stripped. The hose itself has a limited service life. Heat and water cause hose swelling, hardening, cracking, and rotting. Deterioration of hose usually takes place more rapidly from the inside (fig. 42) so that outside inspection is not dependable. Hardening of old hose increases the difficulty of keeping connections leakproof. Hose failures not only result in leakage, but may also cause restriction of coolant circulation through clogging or collapsing. Rubber particles from rotted hose linings will clog the radiator water tubes and are very difficult

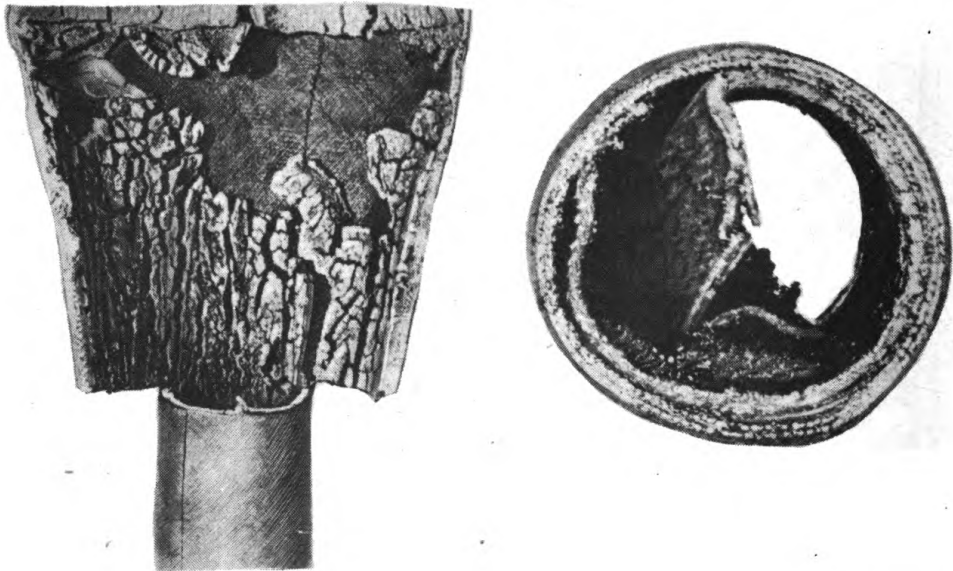

RA PD 341867

Figure 42 — Inside Deterioration and Clogging of Rubber Hose

to remove. Rotted hose may break open without warning and cause sudden large coolant losses. In addition to the usual radiator hose, some military vehicles have other coolant hose and tubes, such as the cylinder head water by-pass and steam relief, and overflow tank tubes. Frequent outside examination of all hose and connections and careful inside inspection of radiator hose whenever the connections are opened, require little time and can save much trouble.

41. ENGINE WATER JACKET.

a. The engine water jacket has many gasketed water joints and a number of metal water joints in both block and head, where preventive maintenance neglect may result in leakage. Vibration, pressure, and wide changes in engine temperature, impose strains on all these points. Gaskets deteriorate from the effects of heat, water, and pressure, and this applies particularly to wartime gasket materials. Gasket joints at the thermostat housing and water pump mounting are common points of leakage. Metal joints, such as core hole plugs, drain plugs, shut-off valves, temperature gage fittings, and connections at water by-pass or recirculation tubes, are all subject to leakage. Corrosion leakage occasionally develops in metal water joints. Any leakage at water jacket joints or casting cracks is aggravated by pump pressures which may run as high as 35 pounds per square inch. Pump pressures are naturally greater at higher engine speeds and while the thermostat is closed. The radiator pressure cap also

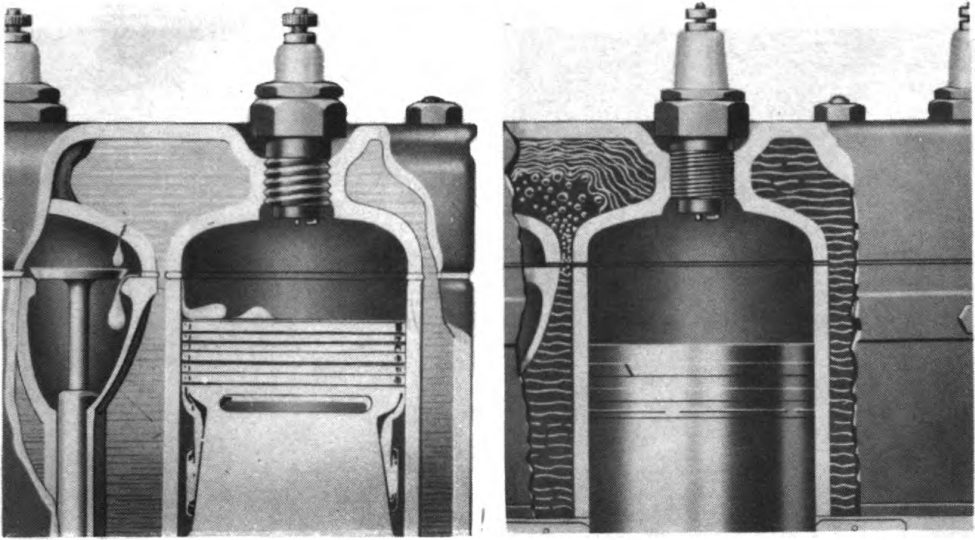

RA PD 341938

**Figure 43 – Coolant Leakage
Into Engine**

RA PD 341910

**Figure 44 – Exhaust Gas Leak-
age Into Cooling System**

allows additional pressure to build up when the coolant is boiling (fig. 38).

42. CYLINDER HEAD JOINT.

a. **Causes and Effects of Leakage.** The joint between the cylinder head and engine block actually consists of a large number of individual water joints at water transfer ports, which are all sealed by one gasket. All of these joints are subjected to the strain of extreme temperature changes within the engine, and also to combustion pressures as high as 600 pounds per square inch or more. Internal leakage at the cylinder head gasket cannot be detected from outside inspection. Leakage of coolant into the engine (fig. 43) can cause serious damage, especially in cold weather. Either water or antifreeze solution, when mixed in large quantities with engine oil, will form sludge which may cause lubrication difficulties. If internal coolant leakage is not promptly discovered and corrected, serious engine damage can result. Even though the joint is tight enough to prevent liquid leakage, the slightest looseness will allow combustion gases to be blown into the cooling system (fig. 44). This can force coolant out the overflow pipe. Burned gases dissolve in the coolant to form acids which cause rapid rust formation and attack metal parts.

b. **Prevention of Leakage.** Considering the many possible points of leakage at the cylinder head joint and the seriousness of coolant

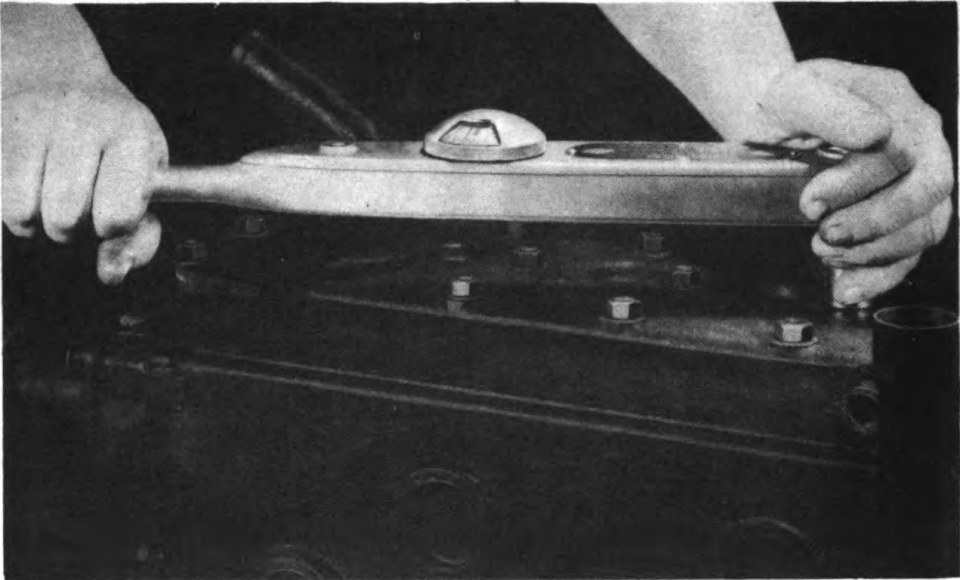

RA PD 49328

Figure 45 — Use of Torque Wrench in Tightening Cylinder Head Bolts

leakage into the engine, it is imperative that the cylinder head always be kept perfectly leakproof. Cylinder head bolts cannot be evenly tightened with an ordinary wrench. The use of a torque-indicating wrench (fig. 45) is necessary to obtain proper uniform pressure on all bolts and to avoid warpage of the head or distortion of the block at valve seats and cylinder bores from overtightening. The extreme importance of maintaining cylinder head joint tightness demands careful attention to all instructions on installation of new gaskets, proper order for tightening bolts, correct torque to apply, and re-checking torque following a new gasket installation. If any stud bolts are loosened in the block when removing cylinder head, they should be tightened before the head is installed.

43. WATER PUMP.

a. **Pumping Failure.** The water pump is the only power-driven unit in the coolant system. Maximum pump speed of 5,000 revolutions per minute is not uncommon. Some pumps circulate more than 6,000 gallons of coolant an hour. Pumping failures are most often caused by broken or loose drive belts, but edge wear of impeller blades and wear of the pump housing also reduce pumping capacity. Sand, rust, and other abrasive foreign matter in the coolant have a tendency to wear away impeller blades. Corrosion of the impeller (fig. 46) and housing may result from failure to install corrosion inhibitor with water, or to discard rusty antifreeze solution.



RA PD 341882

Figure 46 – Corrosion of Water Pump Impeller

Operation of the engine with the coolant frozen may shear off the impeller pin and leave the impeller loose on the shaft, or cause slippage of the pump belt drive that would burn the belt at the driving pulley.

b. **Leakage** (figs. 47 and 48). Leakage is a more common trouble than pumping failure. The pump housing joint is under strain from the pump drive and may work loose and leak if the mounting bolts are not kept tight. The water pump shaft and seal assembly forms the only moving water joint in the cooling system (par. 12 b). In the adjustable gland-type pump, normal wear of the packing will allow leakage unless the gland is tightened periodically and the packing replaced when worn. The shaft and bearing will be damaged if the packing gland is too tight. In the newer packless-type pumps (par. 12 d), the self-adjusting seals are subject to wear, deterioration, and leakage. Thrust seal washers and seats are prematurely worn by abrasive action of sand, dirt, and rust in the coolant and by operation with the engine overheating. Bearing and shaft damage, which leads to leakage and pump failure, can result from neglect of lubrication in pumps that require it. But over-lubrication, especially with a high pressure gun, forces grease into the cooling system, which contributes to clogging and overheating.

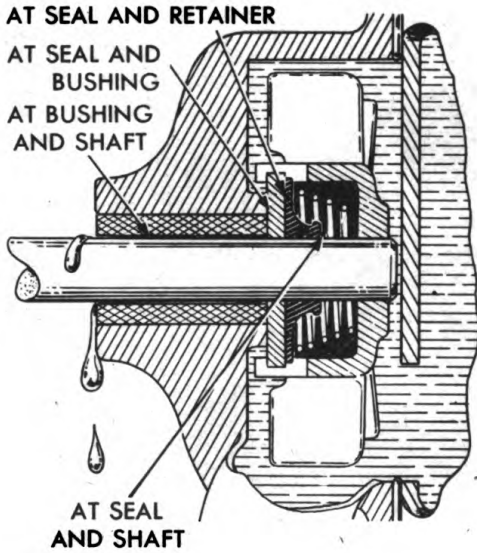

RA PD 341940

Figure 47 — Points of Leakage in Packless-type Pump Seal

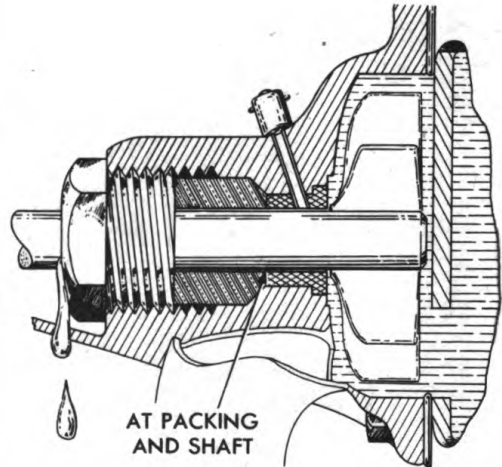

RA PD 341902

Figure 48 — Leakage in Adjustable Gland-type Pump Seal

c. **Effects of Failures and Leakage.** Forced coolant circulation is so necessary in the modern cooling system that any reduction in pumping capacity causes a loss of cooling effectiveness. Complete pumping failure is invariably followed by sudden overheating and operating difficulties. Loss of coolant is not the only trouble that can result from a water pump leak. Coolant leakage at the shaft, if not properly corrected, will destroy lubrication and cause corrosion and wear of the shaft and bearings. Even a slight leak at the pump seal or in the connections between pump and radiator, will allow air to be sucked into the cooling system at high engine speeds (fig. 49). Air suction into the system through a perforated rubber shaft seal can force enough liquid out the overflow pipe to cause serious coolant shortage in a short period of high-speed engine operation. Mixing air with the coolant reduces heat transfer and may raise engine temperature enough to cause overheating at high engine output. Furthermore, the introduction of air into the system may speed up rusting as much as 30 times and also greatly increase corrosion of all cooling system metals (par. 49 c). Clogging and corrosion go hand-in-hand with neglected water pump leakage and air suction.

d. **Preventive Service.** Since the results of pumping failure, leakage of coolant, or air suction into the system can be serious, water pumps require careful maintenance in the form of frequent inspection, periodic tightening, and proper lubrication. Prompt detection

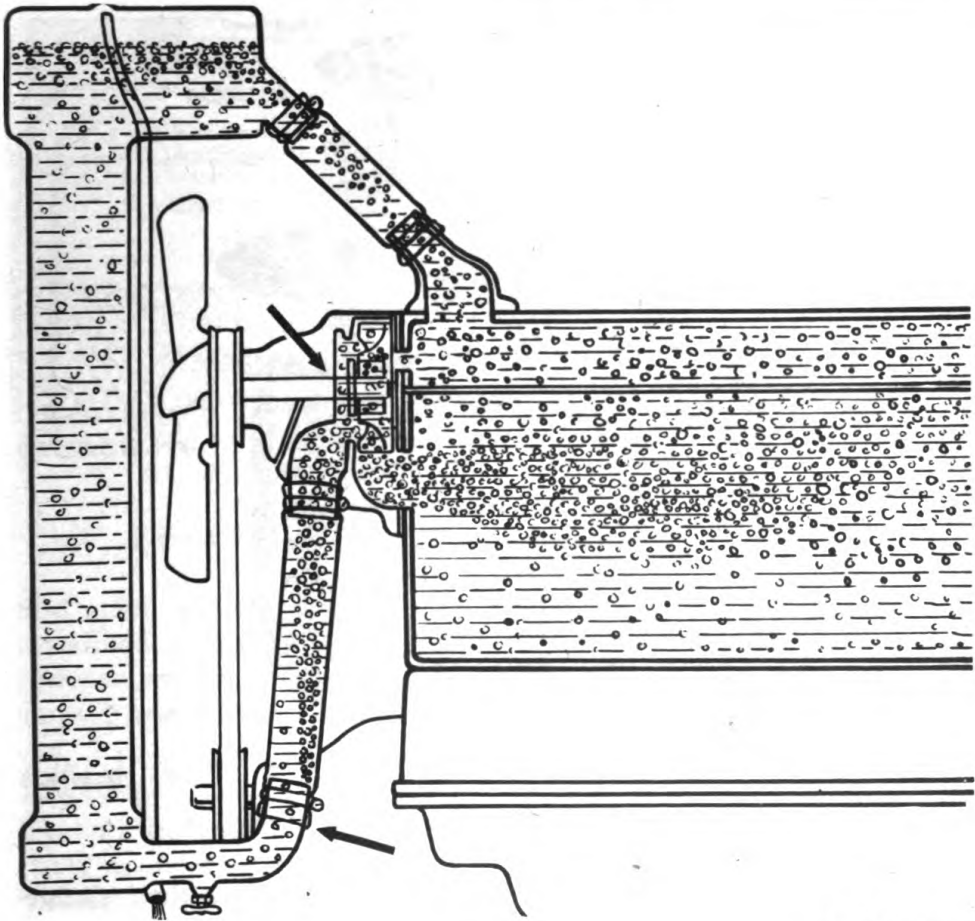
Importance of Mechanic Preventive Maintenance Services

RA PD 341915

Figure 49 — Points of Air Suction Into Cooling System

and correction of leakage is the most important of all water pump preventive maintenance services.

44. THERMOSTAT.

a. **Causes of Failure** (fig. 50). The function and operation of the thermostat is such that this indispensable unit does not have an indefinite service life and can fail with little or no advance warning. The valve and operating mechanism is subjected to extreme temperature changes, corrosion, and also to wear and bending movement. Rust or foreign matter in the coolant interferes with proper thermostat operation, and overheating from any cause may damage it.

b. **Effects of Failure.** The automatic control of engine operating temperatures provided by the thermostat is absolutely necessary, summer and winter, for efficient engine performance. If the valve

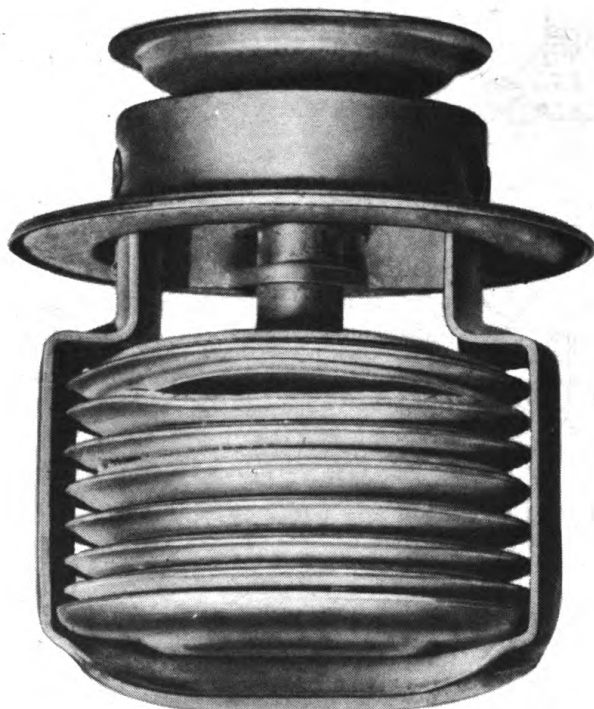

RA PD 341875

Figure 50 — Failure of Bellows-type Thermostat

fails to close properly, the engine will run too cool; then sludge formation and other harmful effects of overcooling can take place (par. 35 c). If the valve fails to open properly, engine temperature will rise and overheating difficulties may follow. Engines should not be operated with the thermostat removed, except in case of emergency (figs. 33 and 34).

c. **Temperature Gage Check on Thermostat Operation.** The temperature gage should be observed during engine warm-up and on road tests in order to be sure the thermostat is functioning properly. Whenever the gage continually indicates unsafe low or high temperatures, the thermostat should be removed and tested (par. 71).

45. FAN AND DRIVE BELTS.

a. **Fan and Shroud.** Military vehicle operation often requires high engine output at comparatively low vehicle speeds. Under these conditions, the amount of engine heat increases faster than the natural flow of air through the radiator resulting from movement of the vehicle. Therefore, adequate engine cooling must depend on the forced air draft of the fan. Fan efficiency is even more important in stationary engines and in military vehicles having armor, screens,

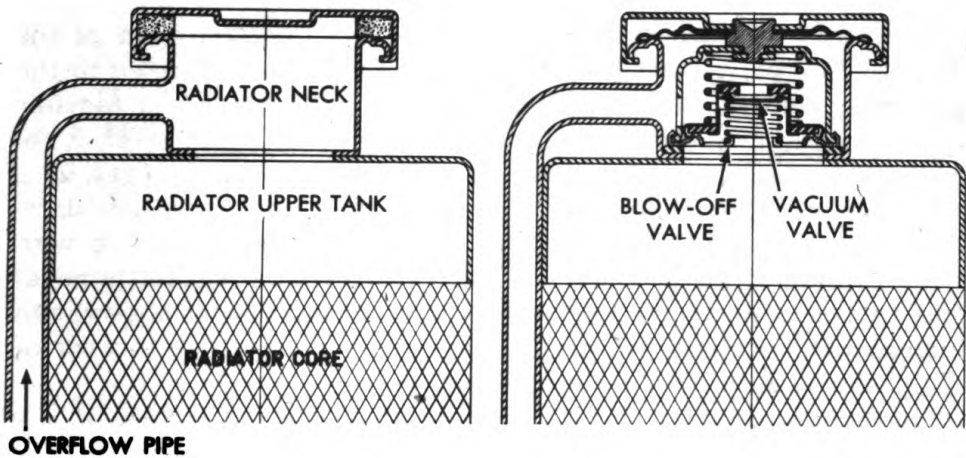

RA PD 341874

Figure 51 — Radiator Caps, Plain- and Pressure-type

and other restrictions to air flow. Bent fan blades, or a loose, bent, misaligned, or damaged fan shroud interferes with proper air flow and reduces cooling. Periodic inspection and servicing of the fan and shroud assembly is essential to proper engine cooling (fig. 16).

b. Drive Belts. Preventive maintenance of the fan drive belt is also of first importance, because this belt usually drives both the fan and the water pump and often the generator. Continuous flexing, friction, and heat cause fan belt cracking, fraying, wear, and deterioration. Loose adjustment may result in slippage, rapid belt wear, and an overheated engine. Overtight adjustment also wears the belt and causes early failure of shafts and bearings in the fan, water pump, or generator. A neglected fan belt may break without warning and cause sudden overheating and operating difficulties. Therefore, inspection of fan belt condition and adjustment should never be neglected. Close examination is necessary to discover small flaws, particularly since belts usually begin to crack through from the inside. Immediate replacement of doubtful fan belts is good insurance against vehicle failure during operation.

46. RADIATOR PRESSURE CAP (fig. 51).

a. Importance of Proper Operation. The radiator pressure cap has more effect on cooling system operation than is generally realized. A properly operating pressure cap increases the normal margin of safety between coolant operating temperature and boiling point from 5° F to 17° F on transport vehicles and as high as 50° F on some combat vehicles (par. 16). This additional margin of safety helps to prevent boiling during operation in hot weather, at high altitudes, and under heavy load.

b. Causes of Failure. The radiator cap is subjected to high coolant temperatures which cause relatively rapid deterioration of the gasket. The valves and the underside of the cap are exposed to the extremely corrosive effects of hot steam and air in the upper radiator tank. Since the cap is located above the normal liquid level, it receives little protection from rust inhibitors in the coolant (par. 29), with the result that cap and valves may fail from corrosion damage. Even a small amount of rust scale or dirt will interfere with the operation of the pressure and vacuum valves. Frequent removal and replacement of the radiator cap for coolant level observation increases the possibility of leakage and pressure loss, due to wear of the gasket and cap-locking mechanism.

c. Effects of Failure. An air leak above the liquid level in the radiator, such as at the cap gasket or pressure valve, will prevent pressure from building up, and the benefits of the pressure cap will be lost. Coolant may boil in some cooling systems even at normal operating temperatures if the cap is not pressure-tight. If the pressure valve fails to open, sufficient pressure may build up in the system to break radiator seams or blow off hose connections. Failure of the vacuum valve to open when the system cools may cause collapse of hose and other parts which have no internal support.

d. Handling and Maintenance. To avoid damage to the cap gasket and gasket seat on the filler neck, care should be exercised in removing and replacing the cap. The cap should be turned to the "vent" position before removing, to allow escape of hot steam that might cause personal injury. When filling the radiator, metal filling spouts or nozzles should not be allowed to come in contact with the filler neck gasket seat. Proper maintenance consists of daily inspection of the gap, seat, and gasket, and periodic cleaning of cap and valves, checking of valve operation, and testing for tightness of valves and cap seal.

47. RADIATOR OVERFLOW TANK.

a. Function. The radiator overflow tank serves as a temporary reservoir for coolant overflowing from the radiator while driving, or immediately after the engine is stopped. Any coolant collected in the tank is forced back into the radiator when the engine cools down and creates a vacuum in the cooling system (par. 20) (fig. 20).

b. Causes of Failure. Like the radiator cap, the overflow tank is exposed to the corrosive effects of steam and air. Being empty most of the time, it receives little protection from rust inhibitors in the coolant. Thin-walled steel overflow tanks may therefore rust through from the inside and allow coolant overflow to leak out and become lost. Water, condensed in the tube connecting tank with radiator, may freeze or the tube may become clogged with foreign matter.

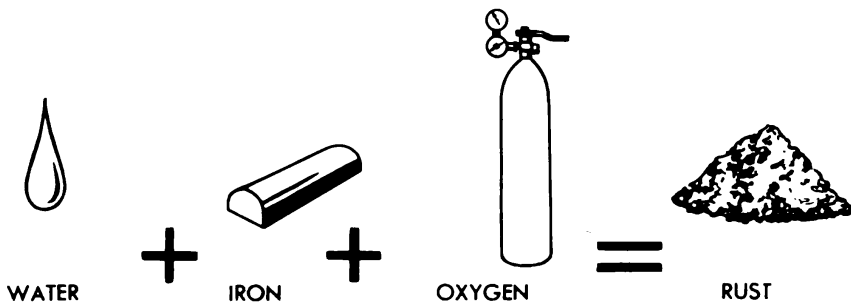

RA PD 341913

Figure 52 — Rust, a Chemical Combination of Water, Iron, and Air

c. **Effects of Failure.** An air leak in the tank-to-radiator tube or above the liquid level in the radiator can cause failure of the vacuum and prevent coolant in the tank from returning to the radiator. In fact, a liquid or air leak anywhere in the cooling system will make overflow tank operation less effective. Clogging of the connecting tube not only puts the tank out of service but also seals the system, creating the possibility of harmful pressures.

d. **Prevention of Failure.** Proper functioning of the overflow tank depends on maintaining an airtight cooling system, and free unobstructed flow between tank and radiator. This requires frequent inspection for coolant leakage, as well as periodic checks for air leaks above coolant level, for connecting tube clogging, and for presence of coolant in overflow tank with the engine cold.

48. ACCESSORIES CONNECTED TO COOLING SYSTEM.

a. **Description.** Many military vehicles have one or more independent circulating systems connected by hose or tubing to the engine cooling system for the purpose of heating or cooling of oil coolers, air compressors, transmissions, etc. (par. 22). The water pump circulates coolant to radiators and water jackets of these accessories in the same manner as to the vehicle radiator and engine water jacket.

b. **Effects of Leakage and Clogging.** Leakage in these units may affect cooling in the entire system either through coolant shortage or by excessive coolant contamination, such as with oil from the engine oil cooler. The unit itself may be damaged by leakage, as in the case of coolant leakage into a transmission. Restriction of coolant flow in the connecting hose and tubes may also seriously interfere with proper operation of such units.

c. **Preventive Maintenance.** Cooling system preventive maintenance includes inspection of all special circulating systems to see that they are secure, leakproof, and in good condition.

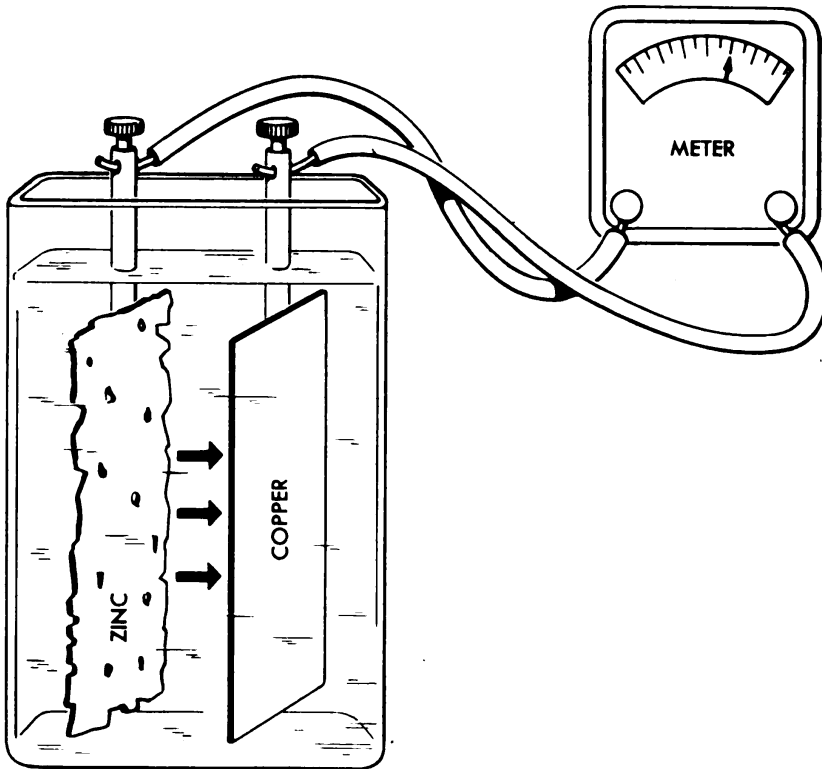

RA PD 341914

Figure 53 — Electric Current in Battery Produced by Electrolytic Corrosion of Metal

49. COOLING SYSTEM CORROSION.

a. **Rust Formation** (fig. 52). A chemical combination of iron, water, and air produces rust. The water jacket of the automotive engine has a large mass of iron exposed to the cooling water, and no cooling system is free of air. Thus all elements of rust formation are found in the cooling system. Rust is a product of a chemical process called corrosion. Over 90 percent of the solid matter that clogs radiators is rust.

b. **Electrolytic Corrosion** (fig. 53). Corrosion not only produces harmful products like rust, but also damages iron and other cooling system metals. When two different metals, such as iron and copper, are placed in contact with each other and then immersed in water, a corrosive action called electrolysis takes place and electric currents flow through the water from one metal to the other in exactly the same manner that electricity is produced in a battery (fig. 53). Although these currents are very weak, over a period of time they cause localized corrosion that weakens, pits, and sometimes eats completely through the metal. Electrolytic corrosion in the cooling sys-

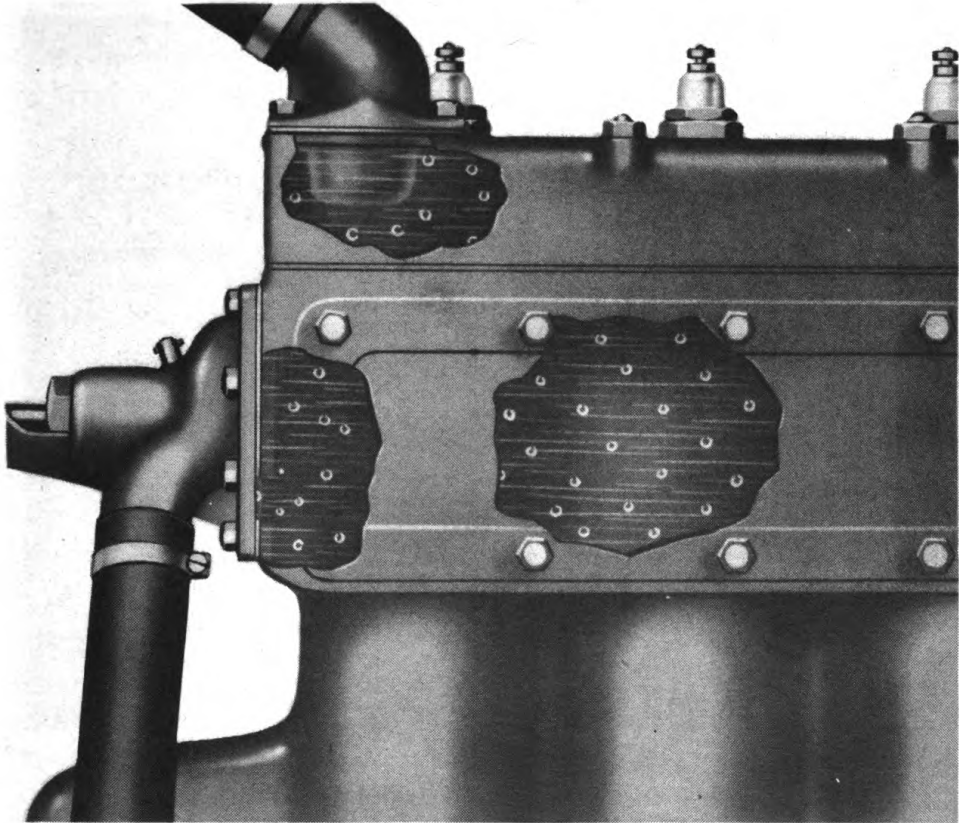

RA PD 341893

Figure 54 – Engine Water Jacket Showing Air Mixed With Coolant

tem can result from a combination of different metals in contact with each other, such as the soldered seams in copper or brass radiators, brazed joints in steel tubes, copper gaskets in contact with iron, and imperfect plating on thin steel parts.

c. Contributing Causes. The rate of rust formation and corrosion within the cooling system is influenced by many conditions of service and operation.

(1) **AIR IN THE COOLANT** (fig. 54). Aeration (mixing air with water) can increase corrosion of iron as much as 30 times. The normal source of aeration in the cooling system is the radiator top tank. At higher engine speeds, the rush of coolant into the radiator is great enough to drive air into the liquid and carry air bubbles down through the water tubes (par. 36 b). If the coolant level is allowed to drop as low as the top of the water tubes, suction of the water pump will draw air in through the overflow pipe and down through the water tubes.

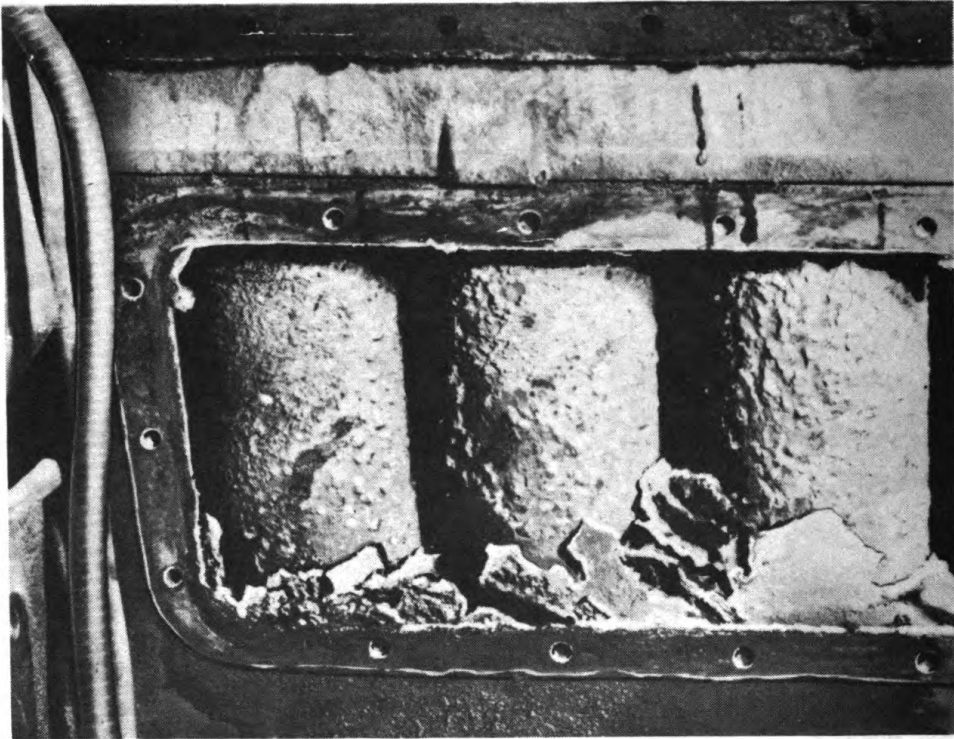

RA PD 341883

Figure 55 — Rust Deposits in Engine Water Jacket

(2) **TEMPERATURE.** Heat speeds up corrosion, and unfortunately the rate of corrosion with iron appears greatest at coolant temperatures corresponding to best engine performance. Iron, solder, and copper will corrode more than twice as fast at 175° F than at 70° F.

(3) **IMPURITIES IN WATER.** Some natural waters are less corrosive to iron than distilled or rain water, but others, which contain dissolved mineral salt impurities, are particularly harmful to cooling system metals. Any acid condition in natural waters will increase iron corrosion and rust formation. Hard water containing large amounts of lime and certain other minerals will deposit scale at "hot spots" in the engine water jacket, if large quantities of the water are added to the cooling system over a period of time.

(4) **CONTAMINATION OF COOLANT.** Coolant may become contaminated as a result of extended service (par. 53 g), a faulty condition within the system, or from improper maintenance. Excessive aeration from a neglected suction leak at the water pump (par. 43 c) (fig. 49) or at any point between pump and radiator, speeds up corrosion and shortens the rust-free life of the coolant. Combustion gas dissolved in the coolant from a leak at the cylinder head

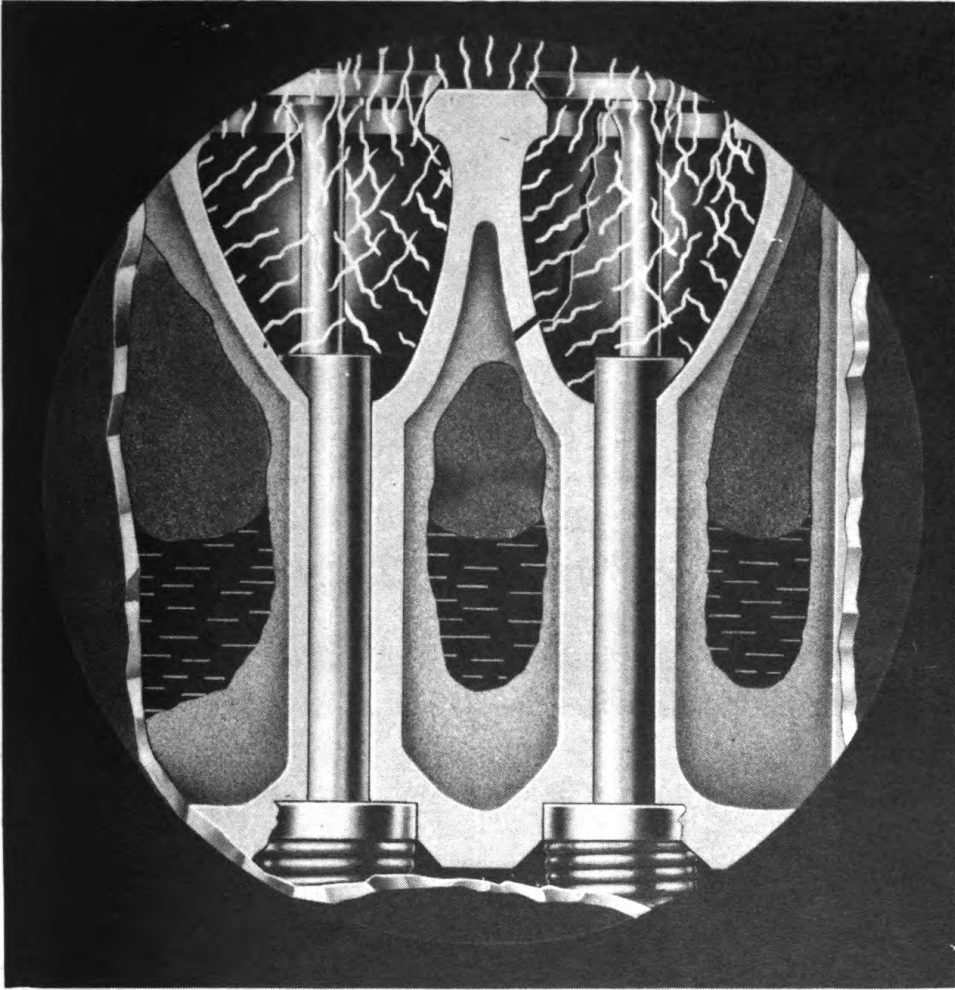

RA PD 341869

Figure 56 – Heat Cracking at Valve Seat From Rust Clogging

joint has a similar effect to aeration (par. 42 a) (fig. 44). Corrosive contamination of coolant can also result from failure to neutralize and flush out cleaning solution (par. 52 b).

d. Effects of Rust Formation.

(1) **WATER JACKET DEPOSITS.** If rust deposits are allowed to build up in water passages of the block or head (fig. 55), they may hold enough heat in the metal to create local "hot spots," especially around the valve seats. Steam pressure from local boiling at such hot spots is a hidden, although common cause of overflow loss. The metal may get so hot as to cause sticking, warping, or burned valves (fig. 56), or even a cracked block or head.

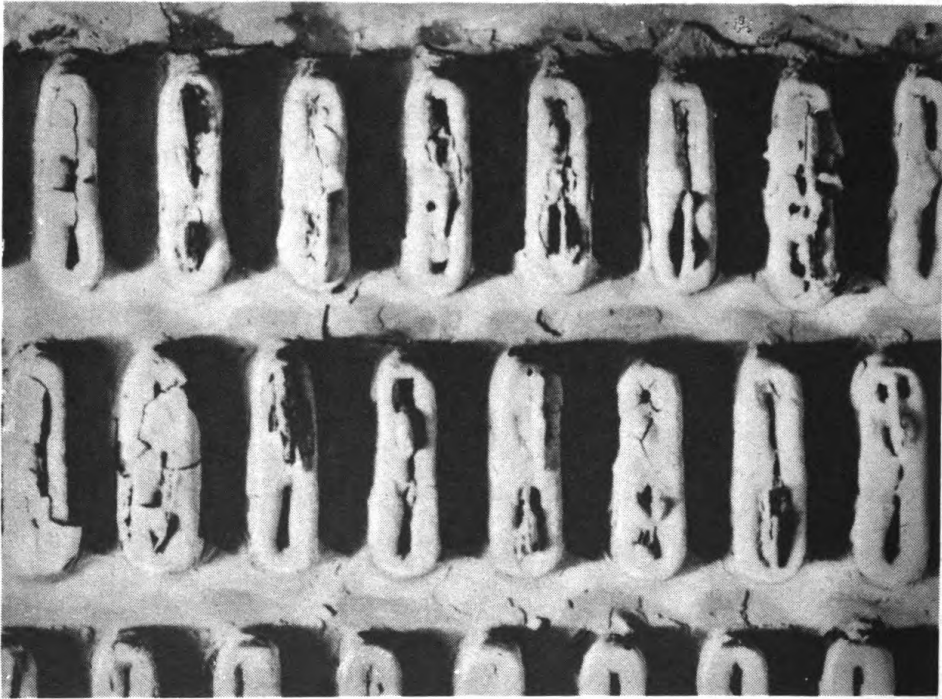

RA PD 341884

Figure 57 — Rust Clogging of Water Passages in Tubular Radiator Core

(2) **RADIATOR CLOGGING.** Rust deposits have their most harmful effects in the radiator. Even a small amount of fine rust particles continually circulating through the radiator has a tendency to plate out in the form of a thin, hard scale on the inside of the narrow water tubes (fig. 57). This scale first reduces cooling efficiency of the radiator by insulating the tubes from the coolant. As more rust becomes lodged in the tubes, circulation is restricted and clogging may progress to the point where coolant will be forced out the overflow pipe. When boiling starts, large amounts of rust are stirred up in the water jacket and carried over into the radiator to completely plug the tubes. Further operation of the vehicle will result in serious overheating, loss of power, and engine damage.

e. **Corrosion Damage.** Although a less common cause of trouble than rust clogging, corrosion damage to metal parts can be equally serious. For example, when a water distribution tube in the block becomes perforated by corrosion (fig. 58), coolant distribution in the water jacket is completely upset. Some valves and cylinders will be robbed of proper circulation and cooling, and hot spots, overheating, sticking valves, and even heat-cracking may follow. Corrosion prevention is especially important for such parts which are so



RA PD 341890

Figure 58 – Corroded Water Distributor Tube Which Shows Irregular Corrosion Holes

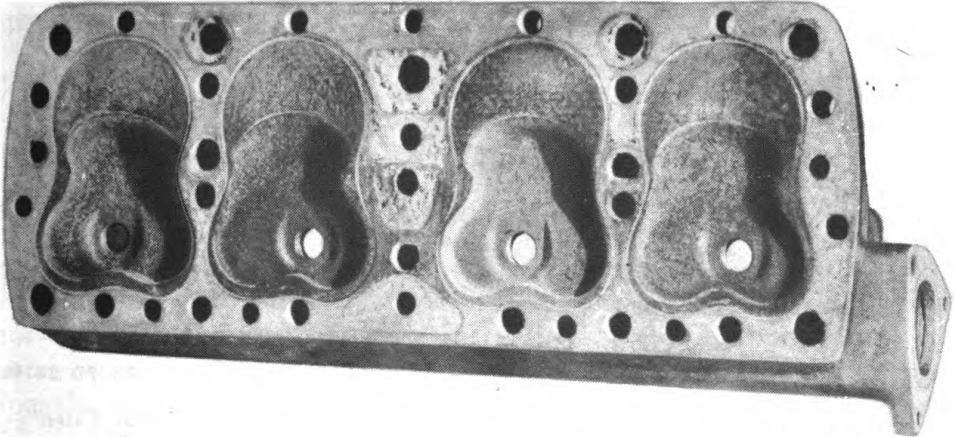

RA PD 341894

Figure 59 – Aluminum Cylinder Head Showing Corrosion Damage

completely hidden within the engine that preventive inspection is impractical and detection of failure is difficult. Among other metal parts sometimes damaged by corrosion are radiators, water pumps, cylinder heads (fig. 59), and core hole plugs. Thin metal parts are weakened by corrosion and crack more easily when subjected to vibration and strain.

f. Importance of Rust Prevention. A rusty cooling system may seem to function satisfactorily under moderate operating conditions, but will fail to cool the engine under more severe conditions, often just at the time when full power output is most urgently needed. The system can be kept practically rust-free, and loss of cooling efficiency from rust formation can be avoided, by periodic corrosion-prevention services.

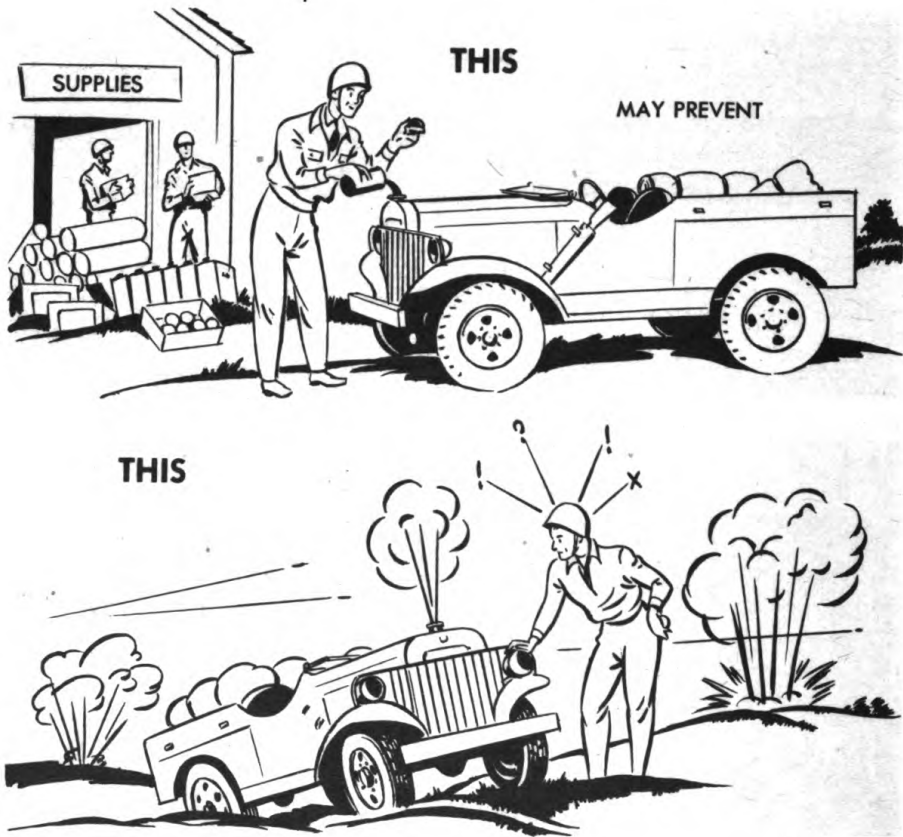

RA PD 341922

Figure 60 — "An Ounce of Prevention Is Worth a Pound of Cure"

50. PREVENTION OF RUST AND CORROSION.

a. **Inhibitors.** Protection of the cooling system against rust and corrosion is accomplished by adding inhibitor to the coolant (par. 29). Laboratory tests show that a corrosion inhibitor in water reduces the normal rusting of iron at least 95 percent.

b. **Inhibitor in Antifreeze.** Since inhibitors are included in anti-freeze compounds (par. 29 e), no inhibitors of any kind should be added to fresh antifreeze solutions. However, corrosion inhibitors may be weakened by use in the cooling system. Therefore, it is important to add an inhibitor to reclaimed antifreeze solutions that are to be used a second winter (par. 53 h).

c. **Inhibitor for Water.** Corrosion protection is particularly important during warm-weather driving when water is used as coolant, since there is more air in the coolant and more rusting in the system. In very cold weather, control of coolant circulation by the thermostat may reduce the flow into the radiator to only a few



RA PD 341939

Figure 61 – Periodic Examination of Coolant for Color and Cleanliness

gallons per minute and very little air is driven into the coolant. In hot weather, with the thermostat wide open, the flow into the radiator at high engine speeds may increase to 100 gallons a minute or more in some engines. The resulting increase in coolant aeration, together with a higher metal and coolant temperature, greatly speeds up the rate of rusting (par. 49 c). The installation of inhibitor with water coolant is one of the most essential preventive maintenance services. Do not add any more or any less inhibitor than specified in current directives.

d. **Rust Prevention vs. Cleaning or Replacement (fig. 60).** The time and effort required for adding inhibitor to a filling of fresh water or for adding reinhibitor to reclaimed antifreeze solution is only a fraction of what is necessary for cleaning a rusty system in which corrosion-prevention services have been neglected, or for replacing a clogged or corroded radiator.

51. COOLANT EXAMINATION (fig. 61).

a. Another most important cooling system preventive maintenance service is examination of the coolant for color and cleanliness, at least weekly. This can be conveniently done during coolant level inspection by drawing a sample into a suitable hydrometer or antifreeze tester. In a system that was reasonably clean when the coolant was originally installed, the appearance of rust in the radiator



RA PD 349305

Figure 62 — Cooling System Cleaning Compound 51-C-1568-500

or in the coolant is an indication that the corrosion inhibitor has lost its effectiveness. Rusty cooling water or antifreeze solution should be drained, discarded, and replaced at the first opportunity. Rust in the radiator, rusty coolant, or coolant containing oil or other foreign matter also indicates the need for preventive cleaning of the system.

52. PREVENTIVE CLEANING.

a. The cooling system should always be cleaned following the draining of rusty or contaminated coolant before fresh coolant is installed. Neglect of cleaning at this time may result in overheating difficulties later. Prompt attention to preventive cleaning is the only sure way to avoid loss of equipment use and extra work, time, tools, and materials required for corrective cleaning of a rust-clogged system. Effective and safe preventive cleaning requires that only approved cleaning compounds be used, and that all service operation specified in current directives be performed.

b. The prescribed cooling system cleaning compound (fig. 62) consists of the cleaner compound and the neutralizer compound packed in separate containers within a single package. The preventive cooling system cleaning procedure is performed as follows:

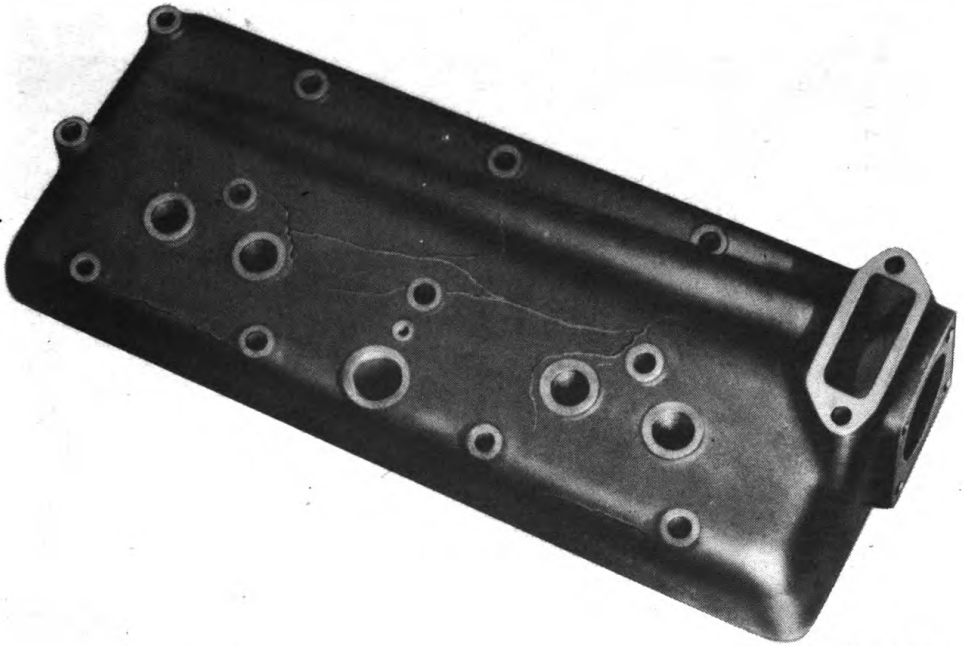

RA PD 341895

**Figure 63 – Freeze-cracking Damage to Cylinder Head
From Frozen Water**

- (1) Completely drain the system.
- (2) Add cleaner compound and fill system with water.
- (3) Run engine at fast idling speed for at least 30 minutes after cleaning solution is heated up.
- (4) Completely drain cleaning solution, add neutralizer, and fill system with water.
- (5) Run engine at fast idling speed for at least 5 minutes after neutralizing solution is heated up.
- (6) Completely drain neutralizing solution and fill system with water.
- (7) Run engine at fast idling speed at least 5 minutes after water is heated up; then completely drain system to complete the procedure.

c. During engine idling periods, it is important to cover the radiator and keep the cover adjusted so that a temperature of 180° to 200° F is maintained. The engine develops so little heat while running without load that the thermostat valve remains partially or fully closed. Covering the radiator opens the valve quickly; but if the cover is removed, the valve will close again, even though the temperature gage shows little change. With flow to the radiator restricted by the thermostat valve, cleaning, neutralizing, and flushing

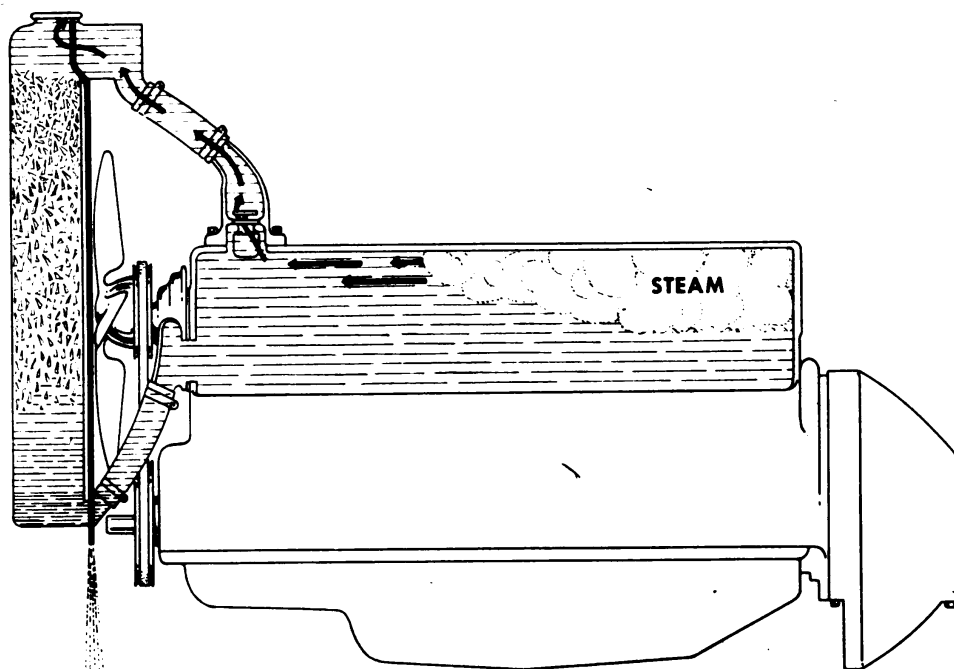

RA PD 341896

Figure 64 — Engine Overheating and Loss of Coolant Which Results From Slush Ice Freeze-up in Radiator

are not effective. Each time after stopping the engine and draining the system, the engine temperature should be below 200° F before cold water is added. Following the final flushing operation, the system is filled with coolant and inspected for leaks. As a part of the cleaning procedure, sediment and foreign matter is removed from the radiator pressure cap valves, the overflow pipe, and radiator core air passages. Complete details on the specified preventive cleaning procedure are found in TM 9-850.

53. ANTIFREEZE PROTECTION.

a. **Freezing Damage.** When water freezes at +32° F, it forms solid ice and expands approximately 9 percent in volume (par. 27 a). This expansion takes place with a terrific force. If water is allowed to freeze in the cooling system, the force of the expansion will crack the engine water jacket (figs. 63 and 65) and cause serious damage to the radiator and other parts. For this reason, the vehicle must never be exposed to freezing temperatures without antifreeze protection in the system.

b. **Antifreeze Installation.** Servicing the engine cooling system for operation at anticipated temperatures below +32° F is performed as follows:

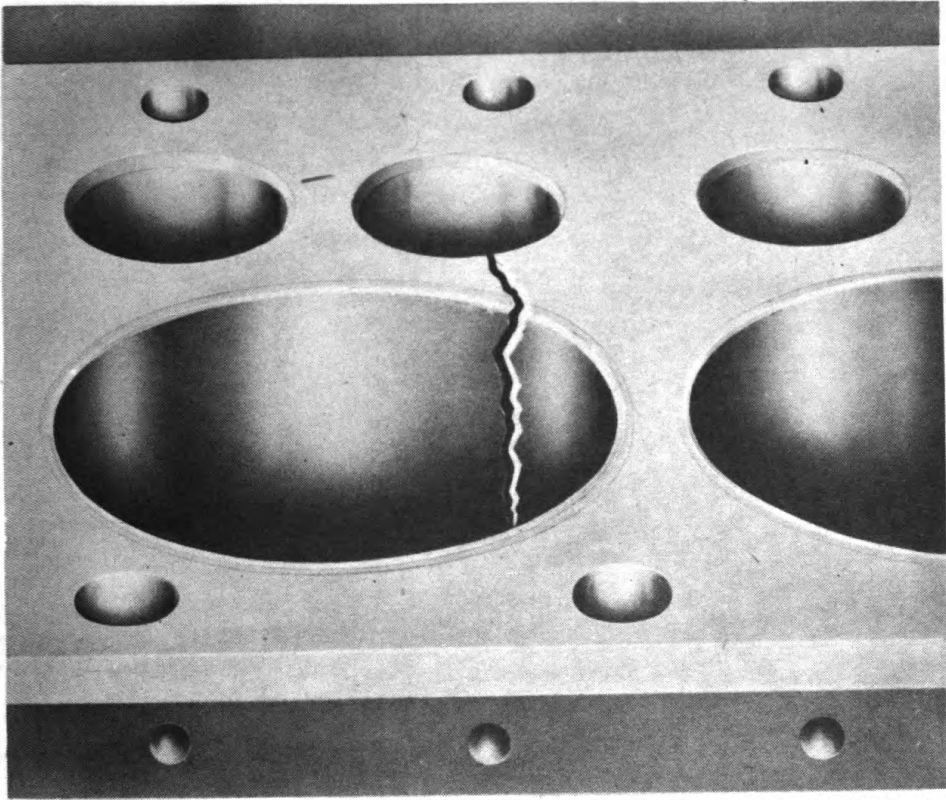

RA PD 341897

Figure 65 – Heat-cracking Damage to Cylinder Block Which Results From Slush Ice Freeze-up in Radiator

- (1) Completely drain coolant from the system with the engine warmed up above specified thermostat-opening temperature.
- (2) Fill system with water, run engine at fast idling speed until thermostat full open temperature is reached, and drain water.
- (3) Perform preventive cleaning of system if coolant is rusty or otherwise contaminated, or radiator is rusty or greasy inside (par. 52).
- (4) Determine required amount of antifreeze compound from protection guide (fig. 71).
- (5) Fill system about one-third full of water, add required amount of antifreeze, and finish filling with water, but leave room for expansion.
- (6) Run engine at fast idling speed with radiator covered until thermostat full open temperature is reached, to release any trapped air and thoroughly mix solution (fig. 70).
- (7) Tighten hose clamps and inspect for leakage.

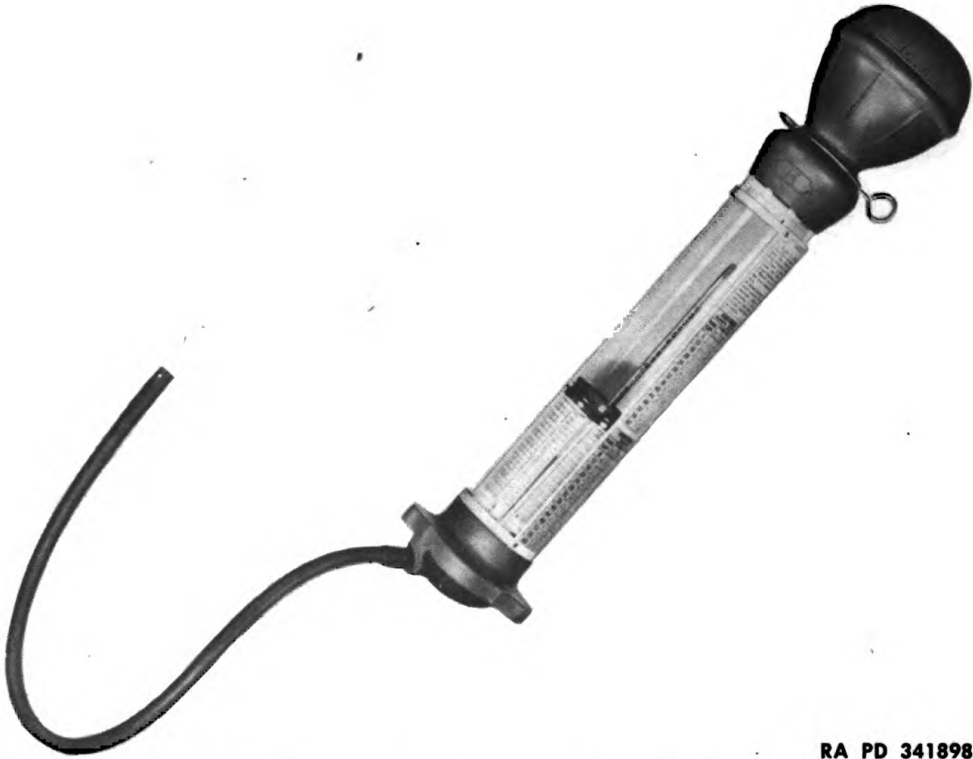

RA PD 341898

Figure 66 — Antifreeze Tester, Federal Stock Number 18-H-940

(8) With engine stopped, test freezing protection of solution, and add water if necessary to bring coolant up to specified level. Complete details on antifreeze installation procedure will be found in TM 9-850. The capacity of the cooling system can be obtained from the vehicle maintenance manual.

c. **Slush Freeze-up** (figs. 64 and 65). At temperatures below its freezing point, antifreeze solution does not freeze solid, but a mass of small ice crystals forms in the solution. The slush ice stops circulation through the radiator core. Even after the engine is started, the slush ice may not melt in the radiator, due to the cold draft of air from the fan. If operation is attempted before the radiator is thawed out, the engine will overheat, and steam pressure in the water jacket will force large quantities of solution out the overflow pipe. Serious heat-cracking damage may follow. It is always highly important to maintain adequate freezing protection against the coldest weather expected.

d. **Testing Antifreeze.** To be sure that the antifreeze will give protection at the coldest temperature to which the engine is likely to be exposed, and to avoid overheating difficulties from slush freeze-

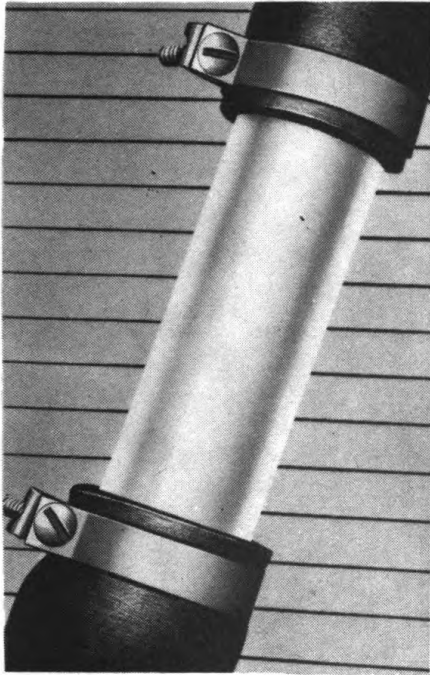

AERATED COOLANT

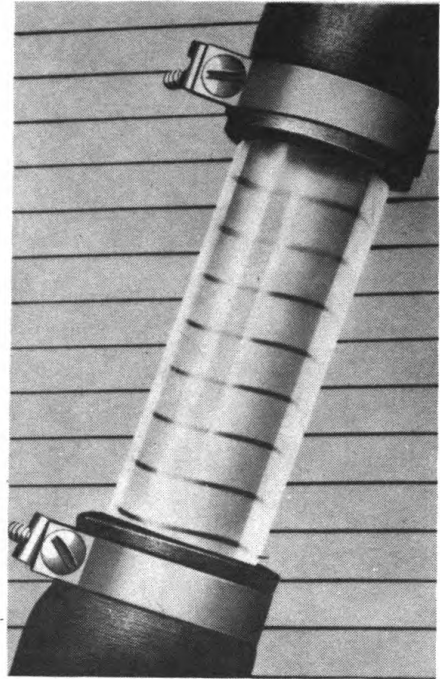

AIR-FREE COOLANT

RA PD 341870

Figure 67 – Glass Tube in Upper Radiator Hose Showing Aerated Coolant and Air-free Coolant

up, the freezing protection of solution should be tested at least weekly and more often if the need is indicated because of water additions or weather conditions. Only hydrometers designed for testing ethylene-glycol type antifreeze compound will give an accurate reading (fig. 66). Check the accuracy of the antifreeze tester occasionally by taking readings on prepared solution of known freezing point. A mixture of one part of antifreeze compound and two parts of water should test to zero degree F, and one part antifreeze compound and one part water should test to -34° F. Tester manufacturers' instructions should be followed for proper use and care of the hydrometer. Accurate readings are not possible if the float and inside of the glass barrel are dirty.

e. **Use of Antifreeze Tester.** Before reading tester, the hydrometer barrel should be filled and emptied several times in order to equalize the temperature of all parts. The first number or letter on the float above the surface of the liquid is first read and the solution temperature is then noted from the first division or number, above the top of the thermometer column. These two readings should be made at the same time and as soon as possible after drawing solu-

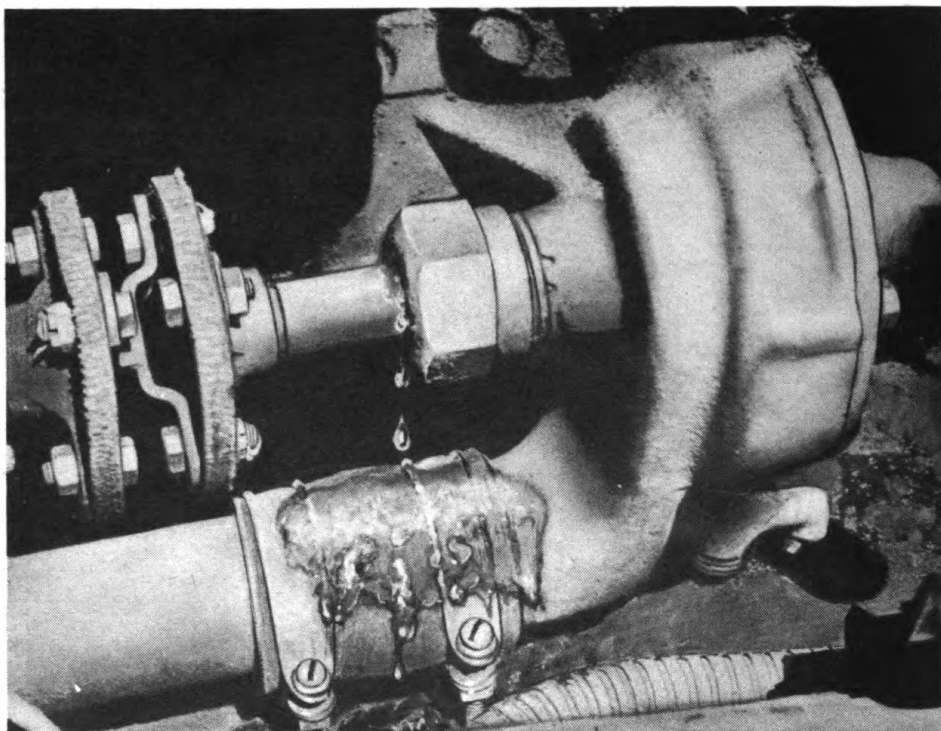

RA PD 341871

Figure 68 — Leakage of Packing-gland Type Shaft-driven Water Pump

tion into the hydrometer. The freezing protection of the solution is determined from float and thermometer readings by referring them to the protection chart on the hydrometer. Tests will be inaccurate if made immediately after adding either water or antifreeze. Most antifreeze hydrometers give best reading accuracy at solution temperatures around 110° F. Even with hydrometers designed to read at solution temperatures below 0° F, tests should always be made with temperature of coolant above 60° F if possible, because the solution is more viscous when cold. This condition prevents the float from finding its true level quickly and may result in a false float reading.

f. Properties of Antifreeze Solution. Certain properties of antifreeze solution differ from those of water (par. 28). Some of the differences between antifreeze solution and water have a bearing on cooling system preventive maintenance.

(1) **FREEZING POINT.** Adding antifreeze compound to water lowers the freezing point of the water in proportion to the amount added until the lowest possible freezing protection, -62° F, is reached in a solution containing 60 percent antifreeze compound and 40 percent water. Solutions which contain more than 60 percent antifreeze



RA PD 341925

Figure 69 – Discarding Weak or Rusty Solution Drained From Cooling System

compound give less protection. When preparing antifreeze solutions, current directives should be consulted.

(2) **BOILING POINT.** Antifreeze solutions boil at somewhat higher temperatures than water (par. 28 c), and this offers the advantage of higher engine temperatures without boiling. However, 100 percent concentrated antifreeze compound has a boiling point far above safe operating temperatures for water-cooled engines and should not be used for coolant except with water added.

(3) **EVAPORATION.** Loss of freezing protection from evaporation is no problem in antifreeze solutions. Practically all coolant losses are leakage and overflow losses of liquid, and the only way that the freezing protection of the solution can be lost is through adding water.

(4) **FOAMING OF COOLANT.** Some natural waters have a greater tendency to foam than others, due to the minerals or impurities contained in them. Contamination of antifreeze solution or aging of solution from extended service increases foaming tendencies. Foaming condition of the coolant does not mean a head of foam on the surface of the coolant in the radiator, but refers to the small air bubbles which are caught and held in the body of the coolant, giving coolant a milky appearance and increasing its volume (fig. 67).

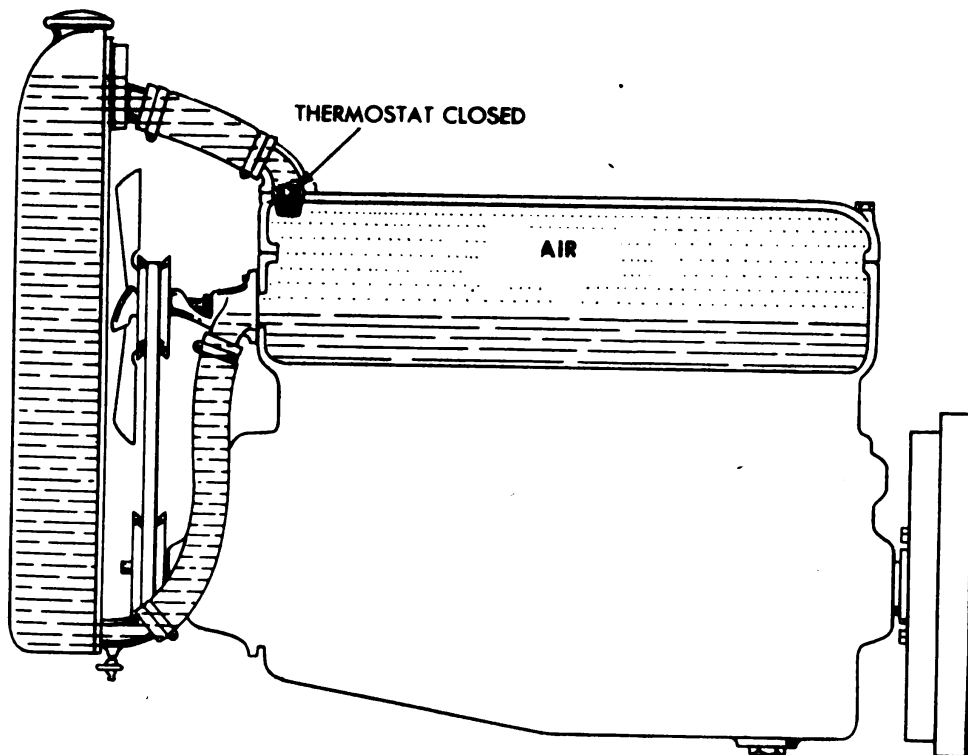

RA PD 341885

Figure 70 — Air Trapped in Cooling System by Thermostat Being Closed While System Is Filled

(5) **COOLANT LEAKAGE.** The leakage rate of inhibited anti-freeze solutions is no more than that of water, although it may appear to be more (fig. 68). The explanation for the appearance of more wetness at small leaks with the antifreeze solution is that anti-freeze compound evaporates more slowly than water. Leakage difficulties with either water coolant or antifreeze solution can be avoided only by proper attention to preventive maintenance leakage services (figs. 38, 47, and 48).

(6) **CHEMICAL PROPERTIES.** While water itself is chemically very stable, it attacks certain cooling system metals quite vigorously under the influence of heat and aeration, conditions constantly present during cooling system operation (par. 49). To protect the system from corrosion, it is necessary to use corrosion inhibitor in water coolant. The inhibitors already contained in antifreeze compound have two purposes. They prevent the corrosive attack of the water used in preparing solution and also prevent deterioration of the antifreeze compound, so that the solution remains noncorrosive for at least one winter's use under average operating conditions.

Importance of Mechanic Preventive Maintenance Services

**PINTS OF ANTIFREEZE
COMPOUND REQUIRED TO
MAKE ONE GALLON OF
ANTIFREEZE SOLUTION**

PROTECTION TO	
+ 10°F.....	2
0°F.....	2 1/2
- 10°F.....	3
- 20°F.....	3 1/2
- 30°F.....	4
- 40°F.....	4 1/2
- 50°F.....	5
- 60°F.....	5

RA PD 341866

Figure 71 – Table of Antifreeze Protections

g. Effect of Operation on Antifreeze Inhibitors. Antifreeze inhibitors may slowly weaken with use and give less corrosion protection to the system. Contamination of solution also decreases inhibitor effectiveness and increases corrosion. Complete exhaustion of corrosion inhibitors is generally indicated by an unusually rusty condition of solution. Such a solution is not suitable for saving and reuse (fig. 69).

h. Conservation of Antifreeze. In the interest of conservation, antifreeze solutions should be drained when the danger of freezing weather is passed and suitable solutions should be saved for a second winter's use. Current directives specify that reuse of antifreeze solution should be confined to administrative vehicles. It is obviously a false economy to save very weak solutions. Clean solutions only should be saved. Solutions containing rust will contaminate clean solutions when mixed together in the same storage container, making the resulting mixture unfit for further use. Reclaimed antifreeze solutions should always be tested, and fresh antifreeze should be added if necessary to increase the freezing protection before such solutions are returned to the cooling system. As explained in paragraph 50 h, a reinhibitor must be added to restore corrosion protection. It is desirable to make more frequent inspections of coolant appearance when using reclaimed solution, since the effectiveness and service life of the reinhibitor may not equal that of fresh solution.

i. Unapproved Antifreeze. The use of unapproved antifreeze material may cause overheating difficulties and damage to the metal or rubber parts of the cooling system. If ever necessary to use unapproved material in a temporary emergency, it should be drained at the earliest possible moment, and the cooling system should be thoroughly cleaned before the proper coolant is installed.



RA PD 341926

Figure 72 — Cooling System Failure in Emergency

54. BENEFITS OF PREVENTIVE MAINTENANCE SERVICES VS. PENALTIES OF NEGLECT (fig. 72).

a. Cooling system preventive maintenance requires comparatively little time, work, or equipment. In addition, preventive maintenance service schedules are arranged for performance at convenient periods when the use of the materiel is not demanded. Most important of all, cooling system preventive maintenance avoids engine-cooling failures, operating difficulties, and loss of equipment use. On the other hand, neglect of cooling system preventive maintenance services often results in avoidable work, expense, and time required for corrective repairs and replacements. Tools or replacement parts are not always readily available for emergency corrective services, and engine-cooling failures may occur in situations when it is inconvenient or even impossible to perform corrective repair work. However, the most serious penalty for neglecting cooling system preventive maintenance services are operating difficulties, loss of mobility, failure of the mission, and finally the serious effect that such failure may have on critical military operations (fig. 72).

CHAPTER 5 — TROUBLE SHOOTING

Section I

DIAGNOSIS INSTRUCTIONS

55. ENGINE OVERHEATING (fig. 73).

a. **Investigate All Causes.** Since overheating of the engine can be caused by vehicle units outside of the cooling system, trouble shooting for correction of overheating should not be confined strictly to the cooling system, but should be directed toward all possible causes. The trouble shooting procedures for overheating described in this chapter are therefore based on a broad general approach to the problem, rather than on trouble shooting in the cooling system alone. This also applies to paragraphs 65 and 71, which are devoted to trouble shooting for overcooling.

b. **Three Types of Overheating.** One of the most common causes of engine overheating is shortage of coolant, resulting from leakage or from loss of coolant out the overflow pipe. However, there are many other causes of overheating that are easily confused with coolant shortage, since this condition always follows overheating after the coolant begins to boil violently. As a practical guide for trouble shooting, all overheating can be divided into three general types based on the following conditions preceding overheating: (1) coolant shortage from overflow loss; (2) coolant shortage from leakage; and (3) no coolant shortage (fig. 74).

c. **Determine Type of Overheating.** Time and effort can be saved in locating the cause of overheating by first determining which of these three conditions exists before boiling occurs. All causes of overheating finally result in violent boiling and coolant overflow loss. Therefore, it is not safe to assume that coolant shortage was the original cause of overheating, merely because the coolant level is low when overheating is discovered. To definitely determine whether coolant shortage is the real cause of overheating or whether it has only resulted from overheating, the investigation must be started with the coolant level at the correct height in the radiator and the coolant temperature must be well below the boiling point. The engine should then be run until overheating occurs. During the period of operation, it can be determined if leakage or overflow loss of coolant occurs before the coolant boils.

56. PRELIMINARY DIAGNOSIS.

a. **Preliminary Cooling System Test.** To determine which type of overheating is present (par. 55), frequent observations of the coolant level are made during engine operation with the vehicle standing,

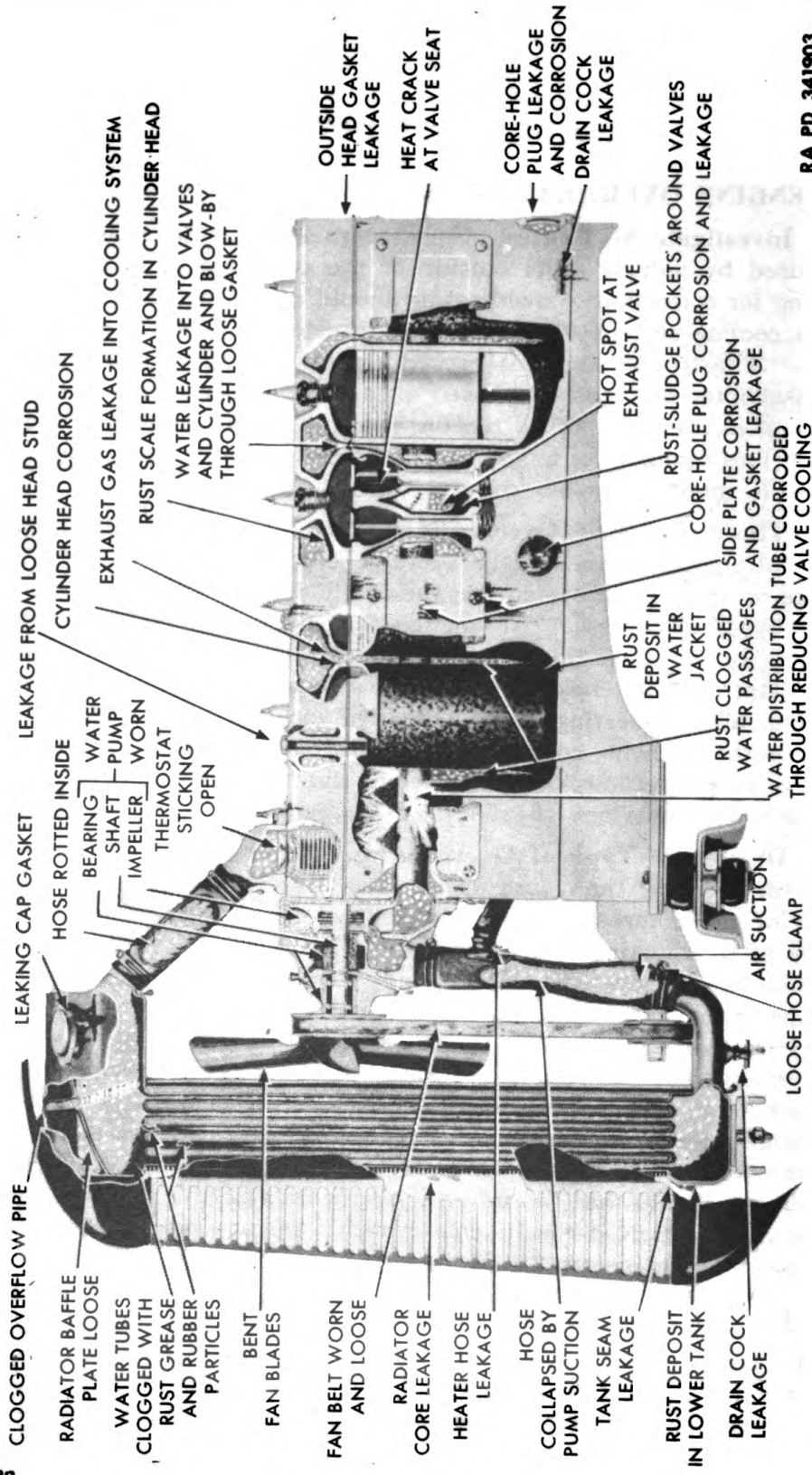

RA PD 341903

Figure 73 - Points in Cooling System Where Neglect Is Likely To Cause Trouble

Diagnosis Instructions

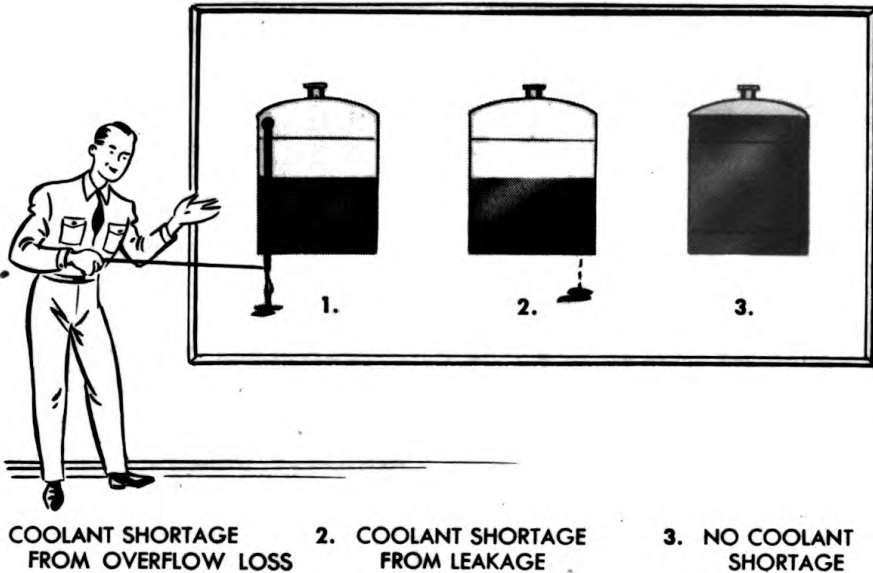

RA PD 341927

Figure 74 – Three Coolant Conditions Which Precede Overheating

to see whether or not it rises or drops to any extent before the boiling point is reached. At the same time, the rise in coolant temperature is noted by closely watching the engine temperature gage, and preferably by checking the coolant directly with a thermometer in the upper tank of the radiator. The type of overheating is determined by observing whether coolant shortage from overflow loss or leakage takes place before boiling. Following this, the proper procedure can be selected for diagnosing the particular type of overheating found (par. 58).

b. Preliminary Inspection. Before and during the preliminary test, an inspection of the cooling system for easily found causes of overheating, such as a broken fan belt, may greatly simplify the trouble shooting process. The individual steps for this inspection and for the tests that determine the type of overheating will be found in paragraph 61, where they are arranged in the proper order for fastest performance. Complete preliminary diagnosis, including all necessary inspections and tests, can be made without tools or equipment and requires very little time.

57. PRELIMINARY ROAD TEST.

a. Purpose. Since the preliminary diagnosis (par. 56) is made with the vehicle standing without any load on the engine, its usefulness is limited. A road test which duplicates operating conditions is often required to determine the type of overheating.

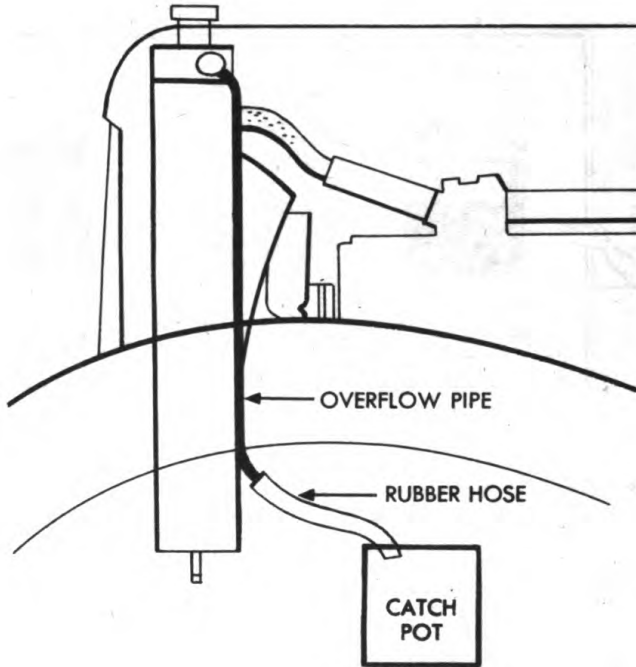

RA PD 341906

Figure 75 — Cooling System "Catchpot" Installation

b. **Overflow "Catchpot"** (fig. 75). Install a container having a capacity of a gallon or more in the engine compartment, or preferably in the driver's compartment. Attach a suitable length of rubber hose to the end of the overflow pipe and attach the free end of the hose to the catchpot so that it extends down into the opening about 1 inch. Kinks and low bends in the rubber tube must be avoided.

c. Procedure.

(1) With the vehicle operating, disengage the clutch for dragging brakes or other excessive chassis friction.

(2) Gradually increase severity of vehicle operating conditions, and at the same time closely watch the temperature gage and observe whether the liquid is discharging into the catchpot. Halt vehicle, stop engine periodically, and note amount of coolant in catchpot, if any.

(3) After each halt in step (2) above, with engine running at fast idle, check for normal drop in coolant level not accounted for by the amount of coolant in catchpot, to determine whether there have been any losses from leakage. If the level is out of sight, it can be checked with a rubber hose on the drain cock as follows: attach small rubber hose to radiator drain cock, shut off engine, remove radiator cap, and hold free end of hose above top of radiator. Then open drain cock and slowly lower free end of hose. The point at which

Diagnosis Instructions

liquid begins to flow from end of hose indicates level of coolant in radiator.

(4) Continue steps (2) and (3) above, but before boiling and overheating occur, it is necessary to determine whether coolant shortage preceded overheating and if so, whether this shortage was due to overflow loss or leakage. The amount of coolant in the catchpot indicates the extent of overflow loss. When the original coolant level is not restored by pouring the overflow back into the radiator, the difference between the original and the final level represents leakage loss. If there is no drop in coolant level before overheating occurs, shortage of coolant can be disregarded as the primary cause of overheating.

(5) After definitely determining whether overflow loss or leakage, or neither of these conditions preceded overheating, follow the diagnosis procedure for the particular coolant condition which was found to exist (par. 58).

58. SEPARATE DIAGNOSIS FOR EACH TYPE OF OVERHEATING.

a. By always following the specified diagnosis procedure for the particular type of overheating found, a great deal of unnecessary work can be avoided. For instance, if a defective thermostat were the cause of overheating, the preliminary diagnosis (par. 56 a) or the road test (par. 57 c) would indicate that overheating is not preceded by coolant shortage, and it would not be necessary to spend any time looking for causes of leakage or overflow loss. On the other hand, if the thermostat were not at fault, unnecessary removal might be avoided by following the proper procedure. The specified procedures for diagnosis of overflow loss (par. 62), leakage (par. 63), and for overheating not preceded by cooling shortage (par. 64), provide quick methods for locating the causes of these conditions. By following the individual operations of each procedure in the proper order, the easiest operations will be performed first. Thus, the more common causes of trouble will be located earlier, and the necessity of reinstalling any part previously removed for testing will be avoided.

59. FINAL ROAD TEST.

a. After the trouble is thought to have been located and corrected, a final road test should always be made in order to be sure that all causes of overheating are removed. For example, overheating caused by a broken or loose fan belt may have resulted in such violent boiling as to stir up rust deposits in the water jacket and carry them over into the radiator, causing a clogging condition. In this case, merely adjusting or replacing the fan belt would not remedy the trouble. Or, in a rust-clogged cooling system, the thermostat might be defective

or the water distribution tube corroded. In this case, the cooling system might be cleaned or the radiator replaced without correcting the other causes of overheating. Damage to the thermostat by severe overheating usually leaves the valve standing permanently open. If the defective thermostat is not discovered and replaced at the time the primary cause of overheating is corrected, overcooling of the engine will follow. Therefore, a final road test should include a check for overcooling as well as for further evidence of overheating.

60. TROUBLE SHOOTING PROCEDURE.

a. **Purpose.** Trouble shooting for overheating can be greatly simplified and speeded up, and unnecessary expenditure of time, effort, and material can be avoided by narrowing down the search through a logical step-by-step procedure.

b. **Procedure.**

(1) Make preliminary diagnosis to locate easily found troubles or to determine the type of overheating (par. 61).

(2) If necessary, make road test to determine type of overheating (par. 57).

(3) Follow specified diagnosis procedure for type of overheating found (pars. 62, 63, and 64).

(4) When overcooling trouble is discovered, proceed with diagnosis for overcooling (par. 65).

(5) As soon as an improper condition is found (step (1), (2), (3), or (4) above), stop diagnosis and correct the condition.

(6) Make final road test to be certain all causes of trouble are remedied (par. 59).

(7) If cause of trouble is not located after performing operations in step (3) or (4) above, refer vehicle to higher echelon.

c. **Refer Vehicle to Higher Echelon.** In some cases where it is not possible to locate the cause of trouble or to perform corrective services, it is necessary to refer the vehicle to a higher echelon. Partial clogging of the radiator, for example, which can cause overflow loss before overheating, may not be discovered with the available facilities. In the case of severe radiator clogging, the vehicle rather than the radiator only should be sent to the higher echelon, since the engine water jacket should receive corrective cleaning and flushing as well as the radiator.

d. **Preventive Trouble Shooting.** While the first purpose of cooling system trouble shooting procedures is the correction of conditions which interrupt vehicle operations, they can be used just as effectively for the prevention of motive power failure. For instance, the prompt performance of the procedure in subparagraph b above,

following a report by the driver of unusual or frequent additions of coolant, would get to the cause before serious overheating trouble occurs. Likewise, when the engine temperature gage first begins to indicate higher or lower temperatures than usual without any change in vehicle operating conditions, possible overheating difficulties and loss of vehicle use may be avoided by preventive trouble shooting. The organizational mechanic can do much to keep vehicles off the deadline by following the proper trouble shooting procedure when the first symptoms of trouble are discovered during preventive maintenance services.

Section II

DIAGNOSIS PROCEDURES

61. PRELIMINARY DIAGNOSIS PROCEDURE.

a. Coolant Level. Check level of coolant in radiator against level known to be correct. If level is low, fill cooling system as follows:

(1) Remove radiator cap slowly, especially if engine is hot. Turn cap in direction of arrow until it reaches vent position. If escaping steam or air is heard, take hand away from cap until noise stops.

(2) After pressure is released, turn cap as far as it will go and lift off. Add coolant slowly with engine running at fast idle. **CAUTION:** *Never add coolant to overheated engine until boiling stops and temperature gage reads under 200° F.*

(3) Run engine until it warms up to a point where thermostat opens and releases trapped air. If necessary, add more coolant to bring level to proper point. **NOTE:** *Allow engine to cool to 160° to 180° F if necessary while performing subparagraphs b to g below.*

b. Pressure Cap, Pressure and Vacuum Valves, Gasket, and Seat. Inspect pressure cap, pressure and vacuum valves, gasket, and seat for fit and condition. Replace defective parts.

c. Fan and Water Pump Belt. Check condition and adjustment of fan and water pump belt. Adjust or replace as required.

d. Outside Leakage. Make a general inspection for outside leakage. If leakage is found, correct.

e. Incorrect Oil Level. Examine dip stick for low or unusually high oil level. If too high, check for internal leakage of coolant (par. 70).

f. Frozen Coolant. Check for frozen coolant (par. 66 a). If found, thaw cooling system (par. 66 c).

g. Radiator and Air Passages. Inspect radiator and all other air passages. Clean air passages and straighten fins. **NOTE:** *After starting engine, continue above inspection as coolant temperature increases.*

h. Clogged Radiator Core. Feel radiator core for cold spots that would indicate clogging. Repeat occasionally as engine heats up. If clogging is indicated, refer vehicle to higher echelon.

i. Lower Hose. Check lower hose for collapsing during sudden acceleration and continued running of engine at maximum safe speed. Replace lower hose if necessary.

j. Upper Hose. Inspect upper hose for collapsing (subpar. i above). Replace upper hose if necessary.

k. Pumping Pressure. With engine running at maximum safe speed, and temperature gage reading is approximately 180° F, grip hose with hand to check pumping pressure. If pressure is incorrect, test thermostat (par. 71 b). Remove and inspect water pump.

l. Fuel Mixture. Run engine at maximum safe continuous speed and gradually pull out choke button. If engine speed increases, carburetor mixture is too lean. Adjust carburetor. **NOTE:** *Perform subparagraphs m to p below at the same time.*

m. Coolant Foaming. Watch for foaming of coolant in radiator with engine running at maximum safe speed and temperature at approximately 180° F. If foaming occurs, replace coolant and repeat test at same temperature (par. 67).

n. Coolant Level Rise. Watch in radiator filler neck for abnormal rise in coolant level when suddenly accelerating engine and when running engine at maximum safe speed. If an abnormal rise is observed, follow overflow loss diagnosis procedure (par. 62).

o. Coolant Level Drop. Continue running engine to heat it up and note whether coolant level in radiator drops before coolant boils. If so, follow leakage diagnosis procedure (par. 63).

p. High Level Coolant Boiling. Observe whether coolant boils with radiator full. Follow diagnosis procedure for overheating not preceded by coolant shortage (par. 64).

q. Preliminary Road Test. Make preliminary road test as instructed in paragraph 57.

62. OVERFLOW LOSS DIAGNOSIS PROCEDURE.

a. Pressure Cap, Gasket, and Seat. Examine pressure cap, gasket, and seat for tight fit, and test pressure and vacuum valves, as instructed in paragraph 72. Replace cap or gasket, or clean seat, as required.

Diagnosis Procedures

b. Upper Radiator Tank Baffle. Check upper radiator tank baffle for looseness. If found, refer to higher echelon.

c. Leaks Above Coolant Level. Test for leaks above liquid level, including overflow tank, as instructed in paragraph 72 b. Locate and correct leaks.

d. Air Suction. Test for air suction into cooling system (par. 69 b). If found, correct as instructed in paragraph 69 c.

e. Lower Hose. Remove and examine inside of lower hose for condition of lining. Replace if necessary.

f. Clogged Radiator. Test for radiator clogging (par. 74 a). If found, refer vehicle to higher echelon (par. 74 b).

g. Upper Hose. Remove and examine upper hose for condition of lining (subpar. e above). Replace if necessary.

h. Removed Thermostat. Check to see if thermostat has been removed. If so, install thermostat.

i. Water Pump Drive Belt. Check condition of water pump drive belt. Replace if necessary.

j. Combustion Gas Leakage. Test for combustion gas leakage into cooling system (par. 70 d). To correct, follow procedure outlined in paragraph 70 f.

k. Thermostat Valve Operation. Test thermostat valve operation as instructed in paragraph 71 b. If defective, replace thermostat.

l. Faulty Water Distributing Tube. When so equipped, remove and inspect the water distributing tube; replace if found corroded, straighten if bent, or reinstall properly if found out of normal position.

m. Clogged Coolant Passages. Remove the cylinder head and inspect for clogged water transfer holes, nozzles, and other passages. Determine whether correct head gasket was used and properly installed. Correct any troubles found.

63. LEAKAGE DIAGNOSIS PROCEDURE.

a. External Inspection (par. 68).

(1) ALL HOSE, PIPES, AND CONNECTIONS. Tighten or replace.

(2) RADIATOR CORE, SEAMS, TANKS, AND JOINTS. Replace radiator.

(3) WATER PUMP SHAFT AND HOUSING. Tighten or repack seal, or replace pump.

(4) THERMOSTAT HOUSING. Replace gasket.

(5) CYLINDER HEAD JOINT EXTERNAL. Tighten or replace gasket.

(6) **CYLINDER HEAD BOLTS OR STUDS.** Tighten, or remove and seal threads, or replace (par. 68 b).

(7) **CORE HOLE PLUGS.** Replace (par. 68 b).

(8) **DRAIN COCKS.** Tighten, or remove and seal threads, or replace (par. 68 b).

(9) **ACCESSORIES AND CONNECTIONS (AIR COMPRESSOR, OIL COOLER, ETC.).** Tighten or replace defective parts.

(10) **ENGINE BLOCKS OR HEAD CASTING CRACKS.** Refer to higher echelon.

(11) **TEMPERATURE GAGE THERMAL UNIT.** Tighten, or remove and seal threads, or replace gage assembly.

(12) **WATER JACKET OIL LINES.** Tighten or replace fittings.

b. Internal Test Procedure. Check for internal water jacket leakage, using combustion gas leakage test (par. 70 d and e). Correct as instructed in paragraph 70 f.

64. DIAGNOSIS PROCEDURE FOR OVERHEATING NOT PRECEDED BY COOLANT SHORTAGE.

a. Obstruction and Faulty Conditions.

(1) **RADIATOR AIR PASSAGES.** Clean passages and straighten fins.

(2) **RADIATOR AIR BAFFLES AND FAN SHROUD.** Tighten, straighten, or replace.

(3) **BRUSH GUARDS, SHUTTERS, AND AIR INLET SCREENS.** Clean repair, or replace.

b. Fan Blades, Fan Shaft, and Bearing. Check blades for pitch and tightness. Check shaft and bearing for wear, end play, etc. Straighten, tighten, or replace as required.

c. Ignition Timing, Centrifugal and Vacuum Spark Advance. Adjust ignition timing.

d. Exhaust System. Inspect exhaust system for back pressure, using vacuum gage for test. Replace defective part or refer to higher echelon.

e. Water Pump Drive Belt. Loosen belt and check condition. Replace if necessary.

f. Water Pump Shaft and Bearing. Check shaft and bearing for wear and end play. See that shaft is free. Replace pump if necessary.

g. Temperature Gage. Test (par. 73 b) and replace if necessary.

h. Lower Hose. Remove and examine inside. Replace if necessary.

Special Trouble Shooting Instructions

i. **Clogged Radiator.** Test radiator for clogged condition by observing gravity flow from outlet (par. 74 a). Refer vehicle to higher echelon if necessary.

j. **Upper Hose.** Remove and examine lining. Replace if required.

k. **Thermostat.** Remove, examine, and test thermostat (par. 71 b). Replace as required.

l. **Engine Freeness.** Turn engine over with hand crank to see that it is free. If not, refer to higher echelon.

m. **Water Pump Impeller and Blades.** Remove pump and inspect condition of impeller and blades. Replace as required.

n. **Water Distribution Tube.** Remove water pump and, using hook-shaped piece of heavy wire or other proper tool, slide tube part way out from behind pump. Direct beam from flashlight into tube and hold mirror so inside of tube is visible. Pay particular attention to water holes. NOTE: *For complete inspection, tube must be removed.* Tube must be replaced if found defective. To do this, radiator and water pump must first be removed. Then remove damaged tube with hook-shaped piece of heavy wire, or other suitable tool, and replace.

o. **Valve Timing.** Check valve timing adjustment. Adjust timing as required.

p. **Clogged Coolant Passages.** Remove the cylinder head and inspect for clogged water transfer holes, nozzles, and other passages. Determine whether correct head gasket was used and properly installed. Correct any troubles found.

65. OVERCOOLING DIAGNOSIS PROCEDURE.

a. **Thermostat.** Remove and test thermostat. Replace if found defective.

b. **Temperature Gage.** Test gage (par. 73 b) and replace if found defective.

c. **Vehicle Operating Conditions.** Investigate vehicle operating conditions (par. 75 c).

Section III

SPECIAL TROUBLE SHOOTING INSTRUCTIONS

66. FROZEN COOLANT.

a. **Check for Frozen Coolant.** If the vehicle has been exposed to freezing temperatures, a sudden rise in engine temperature when the engine is first started may indicate frozen coolant. A freeze-up can be checked by examining the coolant in the upper radiator tank or

attempting to draw it into a hydrometer, or by opening a drain cock. Squeezing the radiator hose is not a dependable test, because the hose may feel hard when cold, even though the coolant is not frozen. Feeling the radiator core with the bare hand for cold spots after the engine has been running a short time may reveal the temporary clogging condition caused by a slush freeze-up of antifreeze solution.

b. Thaw Solid Freeze-up. If water is allowed to freeze solid in the cooling system, the practical way to thaw it out, without causing further damage to the engine or cooling system, is to allow the vehicle to stand in a warm place, or keep the cooling system warm until all the ice is melted. Under no circumstances should operation of the engine be attempted with the coolant frozen solid.

c. Thaw Slush Freeze-up. At temperatures below the freezing point of antifreeze solution, there is no solid freezing, but a mass of small ice crystals is formed in the solution which may stop circulation through the radiator (par. 53 c). The safest way to thaw out a slush freeze-up is to stand the vehicle in a warm place without running the engine. Depending on how thoroughly the solution is frozen, it may be safely thawed by running the engine, if certain precautions are followed:

- (1) Cover radiator and turn pressure cap in direction of arrow until it reaches vent position.
- (2) With vehicle standing, run the engine as slowly as possible.
- (3) Use 60 percent antifreeze solution to make up for any coolant shortage.
- (4) Watch the temperature gage closely and stop the engine whenever the gage indicates that coolant temperature is approaching the boiling point.
- (5) Start the engine again when the temperature gage indicates 180° F.
- (6) Do not attempt to drive vehicle until entire radiator core feels warm.

67. FOAMING.

a. Foaming of coolant may indicate combustion gas leakage into the coolant, air suction into the cooling system, or abnormal foaming tendencies in the coolant itself (par. 53 f).

- (1) If foaming is found, drain the coolant and replace with plain water; then repeat engine operation under same conditions of speed and temperature as before.
- (2) If there is no foaming with water, discard the drained coolant and add corrosion inhibitor to the water in the system, or drain the water and install fresh antifreeze solution depending on the season.

(3) If foaming continues with plain water, test for air suction into cooling system (par. 69 b) and for combustion gas leakage into cooling system (par. 70 d) if found necessary after air suction test.

68. EXTERNAL COOLANT LEAKAGE.

a. Inspection.

(1) To detect slow leaks of coolant, inspection should be made with the engine cold. Small leaks which may show dampness or even dripping when cold can easily escape detection when the engine is hot, due to rapid evaporation of the liquid.

(2) Certain types of water jacket leaks may appear only when the engine is cold and running at high speed. Under these conditions the higher pumping pressures, with the thermostat closed, increase any existing leakage tendencies at joints and connections.

(3) Pressure leakage in other parts of a sealed cooling system will appear only when the engine is hot enough to keep the system under pressure.

(4) Grayish-white or rust-colored stains at joints in the radiator or engine water jacket usually indicate leakage even when there is no noticeable moisture present.

(5) Certain parts of the cooling system are difficult to inspect for coolant leakage, such as the rear of the water jacket, the underside of the radiator bottom tank, and the water pump shaft seal, which in some cases is practically covered up by the driving pulley. To check for leakage at such inaccessible points, it may be necessary to stand the vehicle over a clean dry spot for several hours or more.

b. Remedy. Some leaks can be corrected by tightening, but often the leaking parts must be replaced. When replacing gaskets, core hole plugs, cylinder block studs, cylinder head bolts, drain cocks, etc., a more positive seal can be made by applying joint and thread cement compound to the gasket, the threads, or other parts of the joint.

69. AIR SUCTION INTO COOLING SYSTEM (fig. 76).

a. Effects. Air suction into cooling system through a leak at the water pump or any point between pump and radiator core speeds up rust formation and corrosion, and may cause excessive foaming and overflow loss of coolant.

b. Test Procedure.

(1) Adjust coolant level low enough to avoid any overflow from heat expansion during test.

(2) Block open radiator cap pressure valve and put cap on tight.

(3) Attach suitable length of rubber hose to overflow pipe and test for air leaks (par. 72 b).

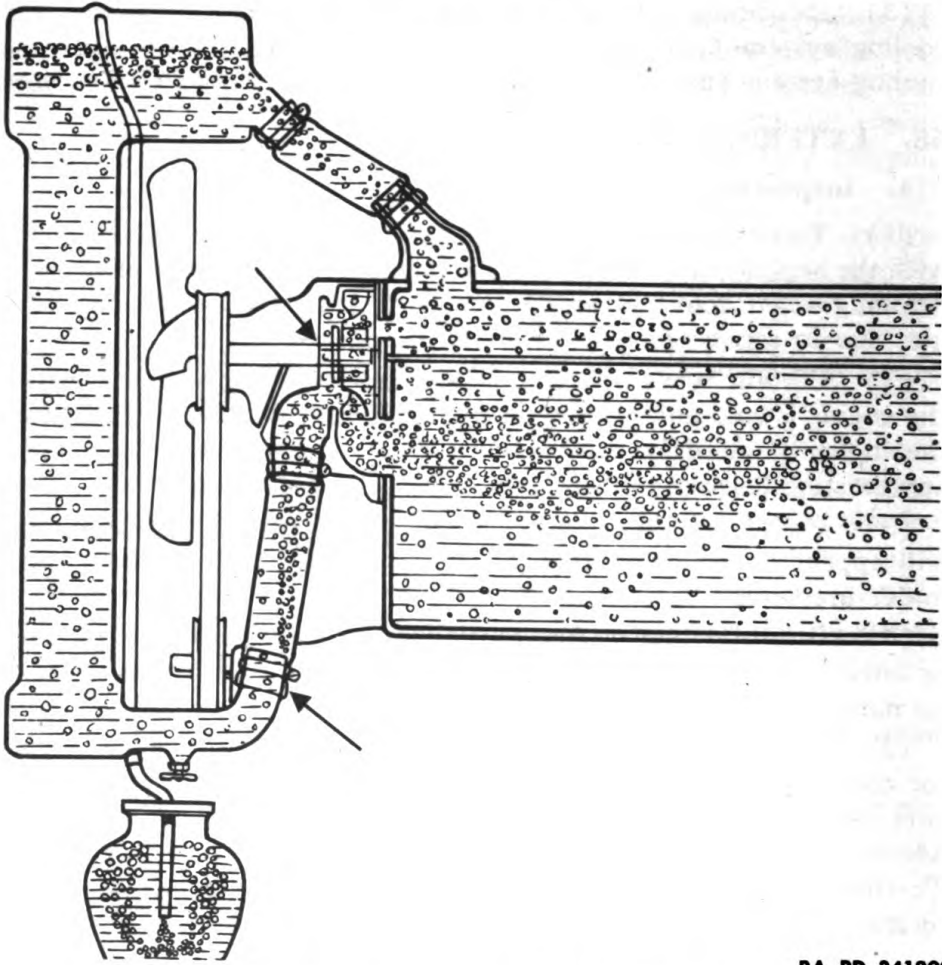

RA PD 341899

Figure 76 — Test for Air Suction Into Cooling System

- (4) Run engine until temperature gage stops rising and remains stationary. Make test at a constant operating temperature.
- (5) Insert free end of rubber hose into a small container of water, avoiding kinks and low bends that might block flow of air.
- (6) With engine running at maximum safe speed for several minutes, watch for bubbles in water.
- (7) In absence of combustion gas leakage (par. 70 d), a continuous stream of bubbles indicates that air is being sucked into system.

c. Remedy.

- (1) Carefully examine water pump shaft seal, lower hose connections, lower part of radiator, and all other possible points of leakage on suction side of pump, including coolant return connections from oil cooler, etc.

Special Trouble Shooting Instructions

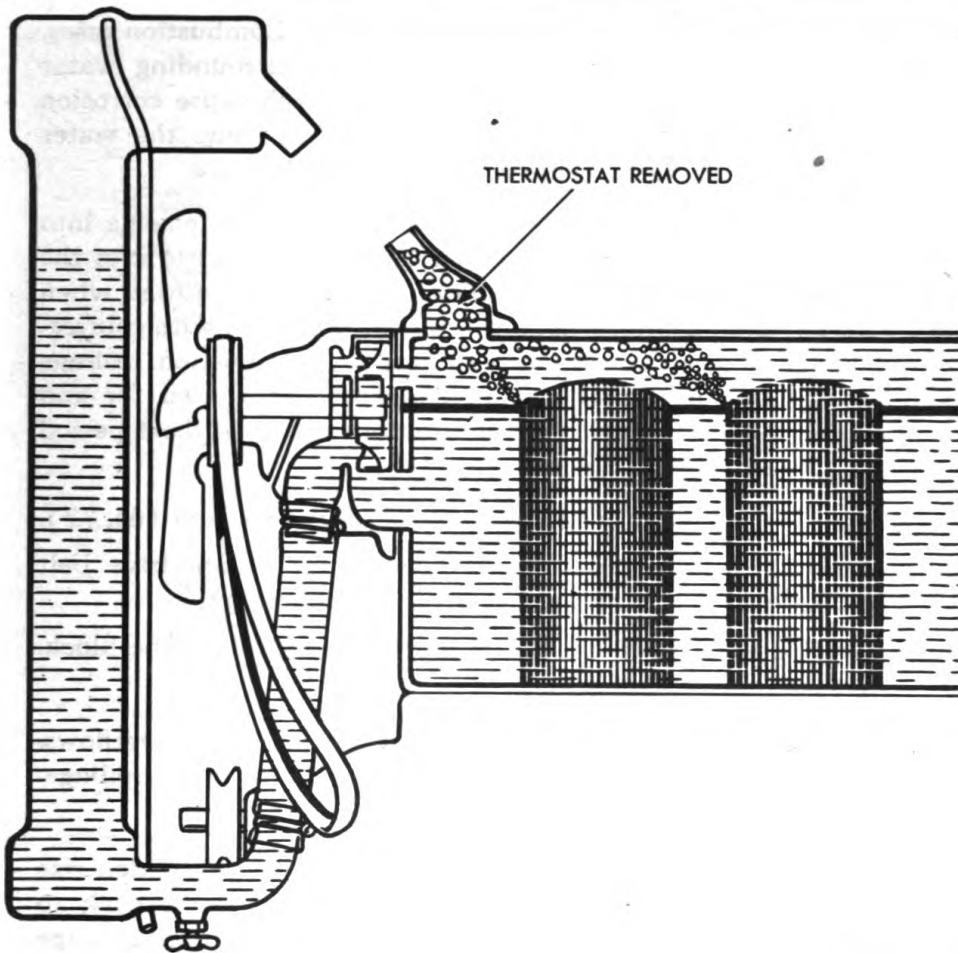

RA PD 341877

Figure 77 – Test for Combustion Leakage Into Cooling System

- (2) Correct leaks and repeat test (subpar. **h** above).
- (3) If air bubbles continue (or if no leaks could be located), test for combustion leakage into cooling system (par. 70 **d**).
- (4) If combustion leakage is found, correct (par. 70 **f**) and repeat air suction test (subpar. **h** above) to be sure condition is remedied.
- (5) If no combustion leakage is found or if air suction test still shows bubbles, replace water pump.

70. INTERNAL LEAKAGE.

a. Leakage Causes. Internal leakage most commonly results from a faulty cylinder head gasket or loose head, but it may also be caused by warpage in the head joint or small cracks in the cylinder head or block.

b. Combustion Leakage Into Cooling System. Combustion gases, leaking from the combustion chamber into the surrounding water passages, dissolve in the coolant to form acids which cause corrosion and rust formation. If the amount of gas leakage into the water jacket is large, it also forces coolant out the overflow pipe.

c. Coolant Leakage Into the Engine. Combustion leakage into the cooling system is often accompanied by coolant leakage into the engine. Either water or antifreeze solution in large quantities, when mixed with engine oil, will form sludge which interferes with lubrication and affects engine performance. Test for combustion leakage should be made when loss of coolant cannot be accounted for and also whenever the coolant becomes unusually rusty in a short period of use.

d. Test for Combustion Leakage Into Cooling System (fig. 77).

(1) Starting with engine cold, remove water pump drive belt from drive pulley (or disconnect water pump coupling).

(2) Drain system until coolant is level with top of engine block.

(3) Remove upper hose and thermostat.

(4) Pour water in radiator until engine water jacket overflows. Place hand over radiator inlet opening, if necessary, to avoid spillage.

(5) Start engine and accelerate it 6 or 8 times.

(6) Watch the engine outlet opening for bubbles or sudden rise of liquid while accelerating, and also when engine drops back to idling. Either bubble or liquid rise indicates combustion leakage into coolant.

(7) To detect very small leaks, jack up drive wheels, run engine at maximum safe speed in high gear, and load it gradually and intermittently by applying foot brake.

(8) Make test quickly before boiling starts, since steam bubbles give misleading results.

e. Air Pressure Test for Internal Leakage. If a suitable spark plug adapter is available, compressed air can be used to detect internal leakage in the combustion chamber and upper cylinder walls. With the cylinder head water outlet open and the water jacket filled with coolant, the engine is turned over by hand until the piston in the cylinder to be tested is at top dead center on the compression stroke. Full pressure from the compressed air tank is then applied to the combustion chamber through the adapter in the spark plug hole. Leakage between the combustion chamber and the water jacket is indicated by air bubbles or rise of coolant in the cylinder head outlet opening. The test is repeated for each cylinder.

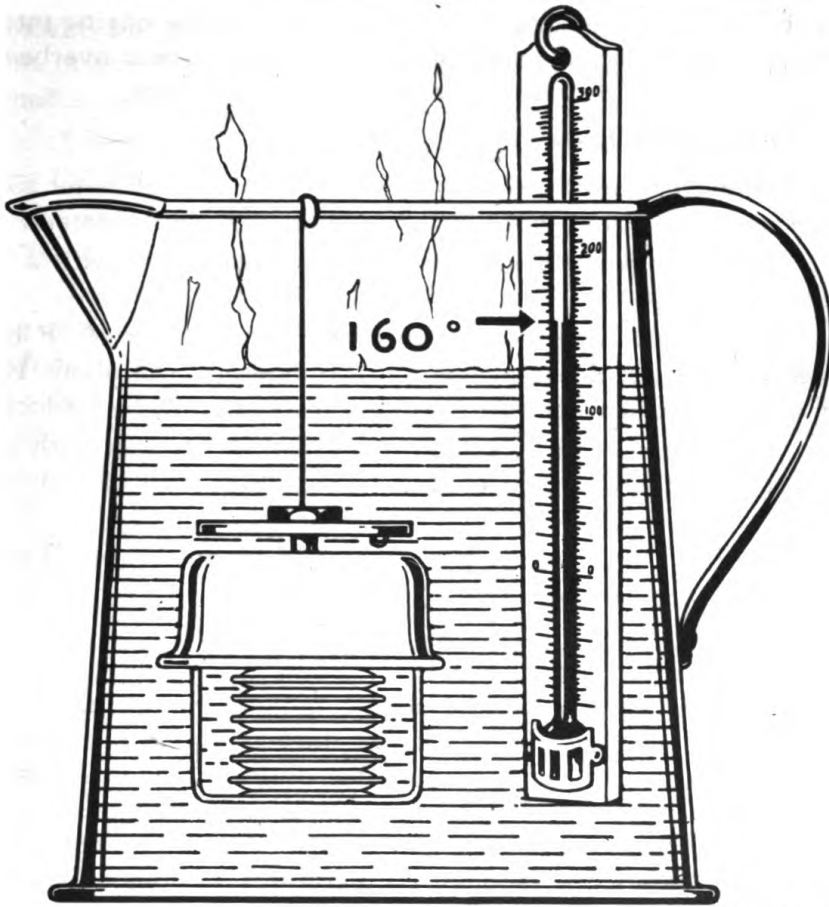

RA PD 341904

Figure 78 — Simple Shop Test for Checking Thermostat Operation

f. Remedy.

- (1) Remove cylinder head.
- (2) Inspect head gasket, head and block gasket surfaces, cylinder bores, combustion chambers, and water jacket for evidence of leaks, blowby, coolant obstructions, and any other defects.
- (3) Note whether gasket was properly installed.
- (4) Refer vehicle to higher echelon if defect cannot be corrected.
- (5) Install new cylinder head gasket and install head.
- (6) Repeat test (subpar. d above). Refer vehicle to higher echelon if leakage is still indicated.

71. THERMOSTAT OPERATION.

a. The thermostat consists of either a poppet or a butterfly valve operated by a bellows or bi-metal, spring-type thermostatic unit. The thermostat is usually located at the cylinder head coolant outlet

where the valve controls the flow of coolant from the engine into the radiator. Failure of the valve to open properly causes overheating, and failure to close results in overcooling of the engine.

b. Thermostat Tests (fig. 78).

(1) Hang thermostat by its frame in a container of water so that the thermostat unit does not touch the bottom of the container.

(2) Heat the water and measure the temperature with a thermometer.

(3) If the valve opens at a temperature more than 10° F below specified opening, or does not open at a temperature of about 10° to 15° F above specified opening, the thermostat should be replaced.

(4) If the valve can be pulled or pushed off its seat with slight effort when the thermostat is cold, the thermostat may be considered defective.

(5) Whenever the thermostat is removed for any reason, it should be cleaned, tested, and examined carefully.

72. RADIATOR PRESSURE CAP OPERATION.

a. The pressure cap, located on the radiator or on the overflow tank, prevents overflow loss of coolant during normal operation. A spring-loaded valve in the cap closes the outlet of the overflow pipe of the radiator or the overflow tank and thus seals the system, so that pressure developing within the system raises the boiling point of the coolant and allows higher coolant temperatures without overflow loss from boiling. When the pressure in the system rises to the rated opening pressure of the valve, the valve is forced open, allowing a mixture of steam and coolant to escape to the overflow until the pressure drops and the valve closes again. The cap also contains a vacuum valve, which opens when the system cools down and thus allows air to enter the system, preventing collapse of hose and other parts. Proper operation of the pressure cap depends on an airtight cooling system as well as on tightly seated pressure and vacuum valves in the cap. The fit between the cap, filler neck gasket, and seating shoulder in the filler neck must also be pressure-tight.

b. Tests for Tightness and Valve Operation.

(1) To test the cooling system for airtightness, attach a rubber tube to the overflow pipe of the radiator or the overflow tank, and block open the pressure valve. With the cooling system cold, suck on the tube and apply tongue to the tube opening. If the tongue adheres to the tube, the system is reasonably airtight. Point of air leakage can usually be located by blowing tobacco smoke into the tube and watching to see where it comes out. These tests will generally reveal air leaks above liquid level, including leakage at valve

Special Trouble Shooting Instructions

cap gasket, but will not show whether the valves leak. Presence of coolant in overflow tank indicates that coolant overflow is not being returned to radiator, and that system should be tested for air leakage.

(2) Pressure and vacuum valves may be checked for leakage by putting the bottom side of the cap in mouth with lips over valve cage opening. If it is possible to blow through opening, one or both valves are leaking.

(3) The tightness of cap and valve can be checked by the following test, using water as a coolant. Start with coolant level low enough to avoid overflow from expansion, cover radiator, and run engine until steam begins to come out overflow pipe. If engine temperature gage registers appreciably below 210°F plus $2\frac{1}{2}^{\circ}\text{F}$ per pound of rated cap pressure, this is an indication that the valves or cap are leaking, providing that the system is otherwise leakproof. If the system contains antifreeze solution, any steaming out of overflow will take place at higher gage temperature. With a 50 percent solution of antifreeze compound, for instance, there should be no steam coming out the overflow pipe below 224°F gage temperature, even if the valves are leaking.

(4) Collapsing of hose or other cooling system parts indicates that vacuum valve is not opening when the engine cools down, and the cap should be replaced.

(5) Cap and valve should be flushed by spraying a stream of water (preferably hot) through holes in cap valve cage while moving the pressure valve up and down with a suitably shaped blunt wooden pin or pencil. The valve should work freely and seat properly; otherwise, the cap should be replaced.

(6) The gasket and gasket seats in cap and filler neck should be examined for damage to gasket or seat that might cause leakage.

73. ENGINE TEMPERATURE GAGE OPERATION.

a. Temperature Gage Registration. The instrument panel temperature gage indicates engine temperature, usually in degrees Fahrenheit, by registering coolant temperature at the thermal unit in the water jacket. The temperature gage does not start to register until the coolant temperature at the thermal unit is approximately 100°F .

b. Temperature Gage Tests.

(1) With the engine started and running at fast idle, watch the action of the gage to see that it indicates gradual temperature rise. No movement in the gage after a reasonable warm-up period may indicate that the thermostat is stuck open. Suddenly rising or unusually high temperature may indicate coolant shortage or freeze-up, or other serious defect in the cooling system.

(2) The possibility of a false temperature indication from a defective gage should not be overlooked when checking for either overheating or overcooling. An approximate check of gage accuracy can be made by inserting a thermometer into the coolant in the upper radiator tank. Stop the engine when the thermometer indicates rated full open thermostat temperature. Wait until the thermometer stops rising and compare its reading with the temperature gage on the instrument panel. The gage should normally read within about 10° F of the thermometer reading.

(3) For a more accurate test, remove the temperature gage thermal unit from the engine and suspend it in water which has been heated up to at least 120° F. Then suspend a thermometer in the water and compare the thermometer readings at several temperatures with readings of the temperature gage on the instrument panel taken at the same time.

74. RADIATOR CLOGGING.

a. Tests for Clogging. The radiator cannot be accurately tested for clogging of the core with second echelon tools and equipment. Severe clogging, however, may be detected by feeling the radiator core for cold spots immediately after engine operation. Another approximate method for checking radiator clogging is to remove the lower hose, plug the radiator outlet, block inlet openings, and fill the radiator with water. Then with the radiator cap open, remove the radiator outlet plug and check the time for draining. The radiator may be considered clogged if the draining time is noticeably longer than that required for a clean radiator of the same type.

b. Corrective Cleaning of Clogged Radiators.

(1) For more accurate testing of radiator clogging and for corrective cleaning, the vehicle should be referred to the higher echelon, where the engine water jacket as well as the radiator must be cleaned.

(2) Whenever a radiator is clogged so badly that it must be removed for replacement or for corrective cleaning, the water jacket will also be found to contain heavy rust deposits. If these deposits are not cleaned out at the time of radiator removal, they will later be carried over into the clean radiator by coolant circulation and cause further clogging. In any case, when inspection through the radiator filler opening shows a very dirty, rusty, or clogged condition inside the upper tank, or when radiator clogging is indicated by overflow losses of coolant or abnormally high operating temperatures, the corrective

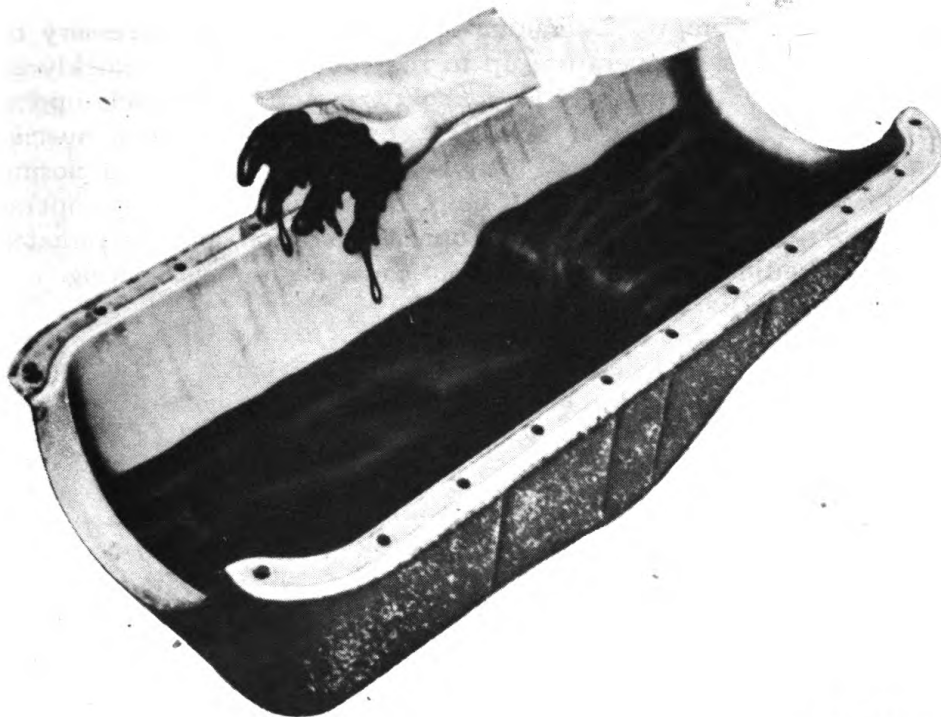

RA PD 341886

**Figure 79 — Sludge Formation in Crankcase Oil
Caused by Cold-running Engine**

cleaning procedure prescribed in current directives, employing pressure flushing where a flushing gun and a water and air pressure supply are available, should be followed by the higher echelon.

75. OVERCOOLING.

a. Effects. Continuously low engine operating temperature wastes fuel, increases engine wear, and causes sludge that may affect engine performance (fig. 79). Whenever the temperature gage registers continuously below minimum safe operating temperature, the cause of overcooling should be investigated by following the overcooling diagnosis procedure (par. 65).

b. Operating Causes. Sometimes overcooling may be caused by vehicle operating conditions rather than by any improper condition within the cooling system itself. Common causes of overcooling are extremely cold weather, underloading, and short operating periods, particularly between comparatively long halt periods which do not provide sufficient opportunity for complete warm-up.

c. **Remedy.** Whatever the cause, cold engine operation should be corrected promptly by taking whatever steps are necessary to bring the coolant temperature up to the proper point as quickly as possible and to keep it there throughout the period of vehicle operation. When overcooling is caused by operating conditions, special remedies may be necessary. Partly covering the radiator and closing or covering the hood louvers will help considerably, but the temperature gage must be closely watched during operation, and the radiator cover kept adjusted so that it does not cause engine overheating.

APPENDIX

REFERENCES

76. PUBLICATIONS INDEXES.

a. The following publications indexes should be consulted frequently for latest changes to or revisions of the publications given in this list of references and for new publications relating to materiel covered in this manual:

Introduction to Ordnance Catalog (explains SNL system)	ASF Cat. ORD-1 IOC
Ordnance publications for supply index (index to SNL's)	ASF Cat. ORD-2 OPSI
Ordnance major items and combinations and pertinent publications (alphabetical listing of ordnance major items with available publications pertaining thereto, including TM's, OFSTB's, WDTB's, FSMWO's, MWO's, and ASF catalogs)	SB 9-1
List of publications for training (lists MTP's, TR's, TC's, FM's, TM's, WDTB's, Firing Tables and charts and Lubrication Orders)	FM 21-6
List of miscellaneous publications (lists MR's, MWO's, SB's, RR's, and War Department Pamphlets)	WD Pamphlet 12-6
List of training films, film strips and film bulletins (lists TF's, FS's, and FB's, by serial number and subject)	FM 21-7
Military training aids (lists graphic training aids, models, devices and display)	FM 21-8

77. STANDARD NOMENCLATURE LISTS.

a. **Maintenance.**

Cleaning, preserving and lubricating materials: recoil fluids, special oils, and miscellaneous items	SNL K-1
Lubricating equipment, accessories and related dispensers	SNL K-3
Soldering, brazing and welding material, gases and related items	SNL K-2
Tool sets, for ordnance service command automotive shops	SNL N-30

Tool sets (common), specialists' and organizational	SNL G-27 (Section 2)
Tool sets (special), automotive and semiautomotive	SNL G-27 (Section 1)
78. EXPLANATORY PUBLICATIONS.	
a. Fundamental Principles.	
Basic maintenance manual	TM 37-250
Care and maintenance of ball and roller bearings	TM 37-265
Cleaning, preserving, lubricating and welding materials and similar items issued by the Ordnance Department	TM 9-850
Driver's manual	TM 21-305
Driver selection and training	TM 21-300
Electrical fundamentals	TM 1-455
Military motor vehicles	AR 850-15
Motor vehicle inspections and preventive maintenance service	TM 37-2810
Ordnance service in the field	FM 9-5
Precautions in handling gasoline	AR 850-20
Standard military motor vehicles	TM 9-2800
b. Protection of Materiel.	
Camouflage	FM 5-20
Chemical decontamination, materials and equipment	TM 3-220
Decontamination of armored force vehicles	FM 17-59
Defense against chemical attack	FM 21-40
Explosives and demolitions	FM 5-25
c. Storage and Shipment.	
Ordnance company, depot	FM 9-25
Ordnance packing and shipping (posts, camps, and stations)	TM 9-2854
Ordnance storage and shipment chart, group G-major items	SB 9-OSSC-G
Protection of ordnance materiel in open storage	SB 9-47
Registration of motor vehicle	AR 850-10
Rules governing the loading of mechanized and motorized army equipment, also major caliber guns, for the United States Army and Navy, on open top equipment published by Operations and Maintenance Department of Association of American Railroads	
Storage of motor vehicle equipment	AR 850-18

INDEX

A	Page		Page
Accessories connected to cooling system	27, 59	types of	3
Antifreeze solution		use of liquid for cooling.....	5
conservation	77	Core hole plugs	26
engine protection and installation	70	Cores, radiator	
properties	32, 74	construction	11
testing	72	function	12
		Corrosion inhibitors	36
		Cylinder head joint	
		causes and effects of leakage.....	51
		description	8
		D	
		Diagnosis procedure	
		leakage	87
		overflow loss	86
		overheating	88
		preliminary	85
		Drain cocks	26
		Drive belt shafts	
		construction	18
		function	19
		Drive belts	
		construction and function.....	17
		mechanic preventive maintenance	56
		E	
		Electrical system	39
		Electrolytic corrosion	60
		Engine accessory systems	38
		Engine assembly	39
		Engine cooling problems in military operation	47
		Engine lubricating system.....	38
		Engine overheating	
		diagnosis	79
		final road test	83
		road test	81
		trouble shooting	84
		Engine water jacket	
		construction, function, and operation	7
		mechanic preventive maintenance	50

Index

T	Page		Page
Tanks (coolant), construction.....	11	Tubes, construction and function....	26
Temperature gage, engine		Tubing, metal	49
check thermostat operation.....	56		
construction and function.....	20	V	
observation	41	Valves	
operation	97	pressure and vacuum.....	19
Thawing frozen coolant.....	89	test operation	97
Thermal expansion	27, 34	thermostat	87
Thermostat		W	
causes and effects of failure.....	55	Water distribution tube.....	89
construction and operation.....	16	Water jacket (See Engine water jacket)	
description and function.....	16	Water pump	
operation	95	construction	13
overflow loss	87, 88	function	12
tests	96	Water pump belt	85
Trouble shooting procedure,		Water pump impeller.....	89
engine overheating	84		

