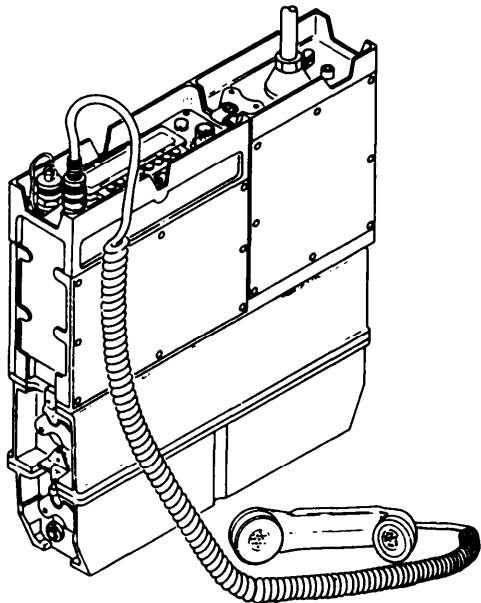


# MARINE CORPS TM 07748B-12/1 ARMY TM 11-5820-1046-12

## OPERATOR'S AND ORGANIZATIONAL MAINTENANCE MANUAL



### RADIO SET AN/PRC-104B(V)1,(V)4 (NSN 5820-01-269-5603) (NSN 5820-01-262-9550)

This document required for official use or for administrative purposes only. Distribution authorized to U.S. Government Agencies only. Other requests for this document must be referred to: Commandant of the Marine Corps (HSPQ-2), Washington, D.C. 20380-0001 or Commander, U.S. Army Communications Electronics Command, ATTN: AMSEL-LC-ME-P, Fort Monmouth, N.J. 07703-5000.

Destroy by any method that will prevent disclosure of contents or reconstruction of document.

**HEADQUARTERS, U.S. MARINE CORPS  
HEADQUARTERS, DEPARTMENT OF THE ARMY**

**PRINCIPLES OF OPERATION 1-9**

**CONTROLS, INDICATORS, AND CONNECTORS 3-1**

**OPERATOR PREVENTIVE MAINTENANCE CHECKS AND SERVICES 3-9**

**OPERATION UNDER USUAL CONDITIONS 3-11**

**OPERATION UNDER UNUSUAL CONDITIONS 3-15**

**PCN 1840 77480 00**

**1 SEPTEMBER 1989**



DEPARTMENT OF THE NAVY  
Headquarter , U. S. Marine Corps  
Washington, D. C. 20380-0001

1 September 1989

1. This Manual is effective upon receipt and contains Operation Instructions and Organizational Maintenance Instructions including Components List for the Radio Set, AN/PRC-104B (V)1, (V)4.
2. Notice of discrepancies or suggested changes should be forwarded on NAVMC 10772 to: Commanding General, Marine Corps Logistics Base (Code 850), Albany, Georgia 31704-8000,

BY DIRECTION OF THE COMMMDANT OF THE MARINE CORPS

OFFICIAL:



J. G. O' Neill  
Director, Program Support  
Marine Corps Research, Development, 1 nd Acquisition Command

By Order of the Secretary of the Army:

CARL E. VOUNO  
General, United States Army  
Chief of Staff

OFFICIAL:

WILLIAM J. MEEHAN II  
Brigadier General, United States Army  
The Adjutant General

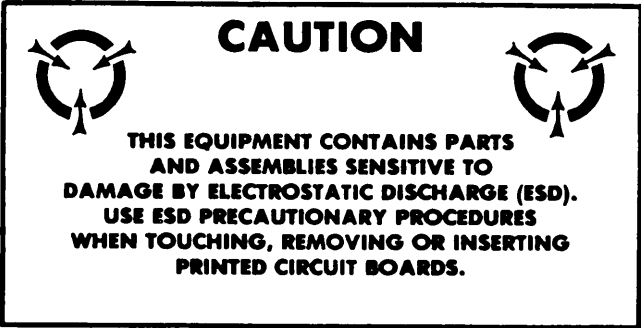
DISTRIBUTION: 07748B

copy to: 7230054 (2)



**SAFETY SUMMARY (1 of 2)**

The following are general safety precautions that are not related to any specific procedures and therefore do not appear elsewhere in this publication. These are recommended precautions that personnel must understand and apply during many phases of operation and maintenance.



For ESD precautionary procedures, refer to: AF TO 00-25-234, Army TM 43-0158, or USMC TM 9999-15/2.



**5**

SAFETY STEPS TO FOLLOW IF SOMEONE IS THE VICTIM OF ELECTRICAL SHOCK

- 1** DO NOT TRY TO PULL OR GRAB THE INDIVIDUAL
- 2** IF POSSIBLE, TURN OFF THE ELECTRICAL POWER
- 3** IF YOU CANNOT TURN OFF THE ELECTRICAL POWER, PULL, PUSH, OR LIFT THE PERSON TO SAFETY USING A WOODEN POLE OR A ROPE OR SOME OTHER INSULATING MATERIAL
- 4** SEND FOR HELP AS SOON AS POSSIBLE
- 5** AFTER THE INJURED PERSON IS FREE OF CONTACT WITH THE SOURCE OF ELECTRICAL SHOCK, MOVE THE PERSON A SHORT DISTANCE AWAY AND IMMEDIATELY START ARTIFICIAL RESUSCITATION

**SAFETY SUMMARY (2 of 2)**

The following warnings appear in the text of this volume and are repeated here for emphasis.

**WARNING**

Dangerous voltages exist at the radio antennas on the shelter when the radio sets are operating. Do not touch these antennas. Observe the precautions given in TB SIG 291 concerning vehicular whip antennas.

**WARNING**

A lithium-sulfur dioxide (lithium) battery used with the radio set contains pressurized sulfur dioxide (SO<sub>2</sub>) gas. To prevent rupture, do not heat, short circuit, crush, puncture, mutilate, or disassemble lithium batteries; do not recharge or test lithium batteries for capacity; do not use a Halon type fire extinguisher on a lithium battery.

Do not use any lithium battery which shows the following signs of rupture: bulging, swelling, disfigurement, brown liquid in the plastic wrap, or a swollen plastic wrap. If the battery compartment becomes hot to the touch, or a hissing sound or the smell of SO<sub>2</sub> gas (rotten egg smell) is present, immediately turn off the equipment. Move the equipment to a well-ventilated area or leave the area.

In the event of a fire near a lithium battery, use a carbon dioxide (CO<sub>2</sub>) type extinguisher. Rapid cooling of lithium batteries is necessary to prevent venting and the potential exposure of lithium. In the event that lithium metal becomes involved in fire, the use of a graphite-based Class D fire extinguisher is recommended, such as Lith-X or MET-L-X.

Do not store lithium batteries with other hazardous materials and keep away from open flame or heat. (Pages 2-1 and 6-1.)

**WARNING**

Do not touch or stand near antenna when equipment is energized. Dangerously high rf voltages exist on and around antennas and antenna terminals during transmission. Protect yourself by knowing safety procedure in TB SIG 291. (Pages 3-12 and 4-7.)

**WARNING**

When using a compressed airjet, use eyeshields to prevent severe eye injury. (Page 4-2.)

**WARNING**

Antenna installation area must be free of power lines. Antenna contact with power lines during installation may cause serious injury or DEATH to operator. (Page 2-6.)

TECHNICAL MANUAL  
No. TM 07748B-12/1,  
TM 11-5820-1046-12

HEADQUARTERS, US MARINE CORPS  
HEADQUARTERS, DEPARTMENT OF THE ARMY  
Washington, DC, 1 September 1989

**Operator's and Organizational  
Maintenance Manual**

**AN/PRC-104B(V)1,(V)4  
(NSN 5820-01-269-5603)  
(NSN 5820-01-262-9550)**

**REPORTING ERRORS AND RECOMMENDING IMPROVEMENTS**

You can help improve this manual. If you find any mistakes or if you know of a way to improve the procedures, please let us know. Mail your letter, DA Form 2028 (Recommended Changes to Publications and Blank Forms) or DA Form 2028-2 located in the back of this manual, direct to: Commander, US Army Communications-Electronics Command and Fort Monmouth, ATTN: AMSEL-LC-ME-PS, Fort Monmouth, New Jersey 07703-5000. For Air Force, submit AFTO Form 22 (Technical Order System Publication Improvement Report and Reply) in accordance with paragraph 6-5, Section VI, T.O. 00-5-1. Forward direct to prime ALC/MST.

In either case, a reply will be furnished direct to you.

Marine Corps units, submit NAVMC 10772 (Recommended Changes to Technical Publications) to: Commanding General, Marine Corps Logistics Base (Code 850) Albany, Georgia 31704-5000.

		Page
Chapter 1	INTRODUCTION .....	1-1
Section I	General Information .....	1-1
Section II	Equipment Description and Data .....	1-5
Section III	Principles of Operation .....	1-9
Chapter 2	SERVICE UPON RECEIPT AND INSTALLATION .....	2-1
Section I	Service Upon Receipt .....	2-1
Section II	Installation Procedures .....	2-3
Chapter 3	OPERATION .....	3-1
Section I	Controls, Indicators, and Connectors .....	3-1
Section II	Operator Preventive Maintenance Checks and Services (PMCS)	3-9

	Page
Section III Operation Under Usual Conditions .....	3-11
Section IV Operation Under Unusual Conditions .....	3-15
Chapter 4 OPERATOR MAINTENANCE .....	4-1
Section I Maintenance Procedures .....	4-1
Section II Lubrication .....	4-5
Section III Operator Troubleshooting .....	4-5
Section IV Preoperational Check.....	4-5
Chapter 5 ORGANIZATIONAL MAINTENANCE .....	5-1
Section I Repair Parts; Special Tools; Test, Measurement, and Diagnostic Equipment (TMDE); Support Equipment; and Materials .....	5-1
Section II PMCS .....	5-3
Section III Organizational Troubleshooting .....	5-3
Section IV Maintenance Procedures .....	5-15
Chapter 6 PREPARATION FOR STORAGE OR SHIPMENT .....	6-1
APPENDIX A References .....	A-1
APPENDIX B Maintenance Allocation Chart .....	B-1
APPENDIX C Components of End Item and Basic Issue items Lists .....	C-1
APPENDIX D Additional Authorization List .....	D-1
APPENDIX E Expendable/Durable Supplies and Materials List .....	E-1
APPENDIX F Propagation of Radio Waves and Operating Considerations .....	F-1
GLOSSARY .....	Glossary-1
INDEX .....	Index-1



## LIST OF ILLUSTRATIONS

Figure	Title	Page
1-0	Radio Set AN/PRC-104B .....	1-0
1-1	Location and Description of Major Components .....	1-5
1-2	Principles of Operation .....	1-9
2-1	Radio Set Installation .....	2-4
2-2	Manpack Whip Antenna Installation .....	2-5
2-3	NVIS Antenna Installation .....	2-7
2-4	Dipole Antenna Installation (5 Sheets).....	2-8
3-1	RT Controls and Indicators .....	3-3
3-2	RT Connectors .....	3-4
3-3	Amplifier/Coupler Controls and Indicators .....	3-5
3-4	Amplifier/Coupler Connectors .....	3-6
3-5	Initial Checks .....	3-11
3-6	Single Sideband Operation .....	3-13
4-1	Maintenance Procedures .....	4-4
4-2	Preoperational Check .....	4-7
5-1	Test Setup .....	5-4
5-2	RT and Amplifier/Coupler Removal and Replacement .....	5-16
5-3	Battery Pack Removal and Replacement .....	5-19

Copyright © 1989 Hughes Aircraft Company  
All Rights Reserved

The contents of this document may not be reproduced in whole or in part without the written consent of the copyright owner.

[Note: This material may be reproduced by or for the U.S. Government pursuant to the Copyright License under the Clause at 52.227-7013 (1987 May).]

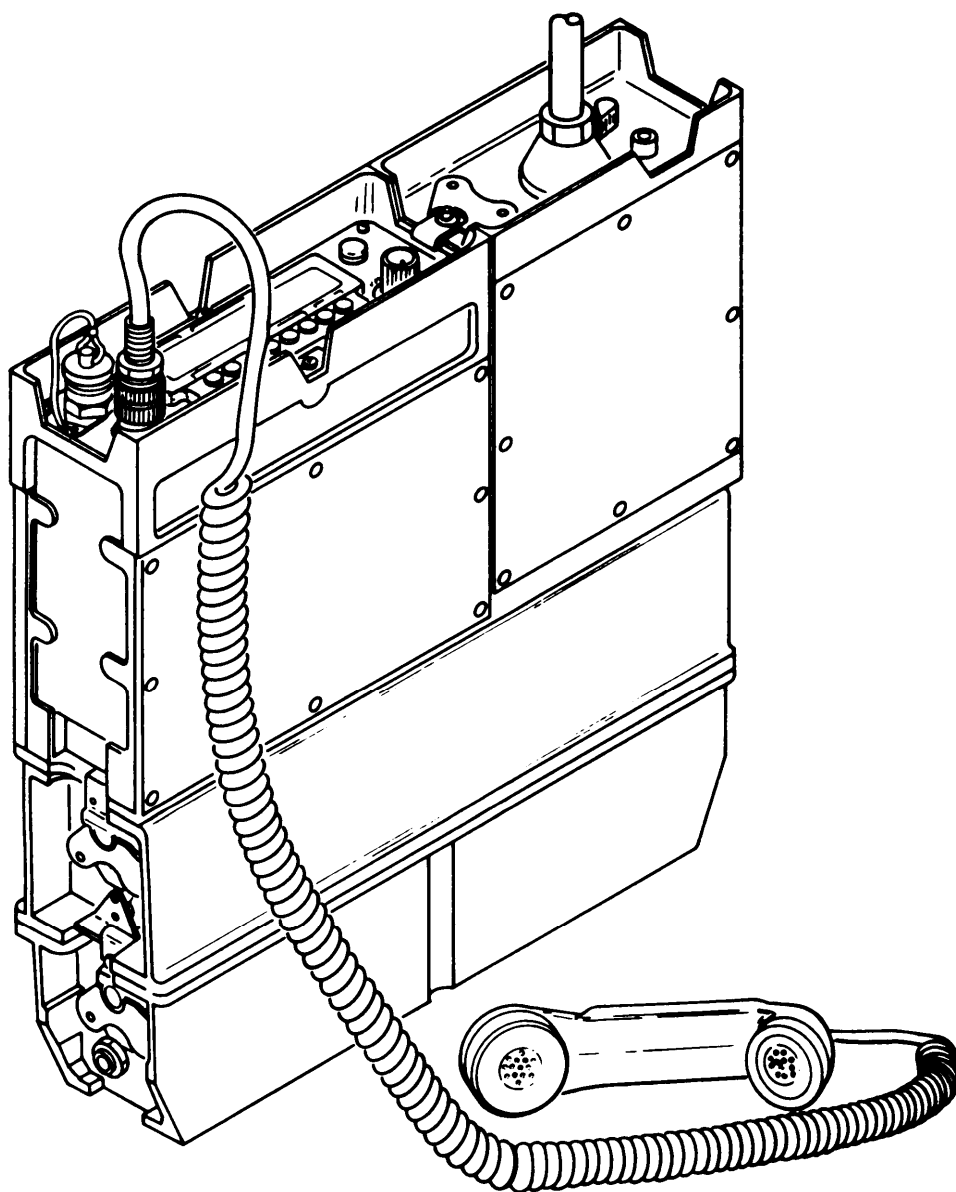


Figure 1-0. Radio Set AN/PRC-104B

# CHAPTER 1 INTRODUCTION

## Section I. GENERAL INFORMATION

	Page
Scope.....	1-1
Maintenance Forms, Records, and Reports .....	1-1
Consolidated Index of Army Publications and Blank Forms .....	1-1
Destruction of Electronics Materiel .....	1-2
Preparation for Storage or Shipment.....	1-2
Reporting Equipment Improvement Recommendations (EIR) .....	1-2
Administrative Storage.....	1-2
Nomenclature Cross-Reference.....	1-3

### SCOPE

This manual provides operator and organizational level operating and maintenance information for the short term antijam (STAJ) compatible Radio Sets AN/PRC-104B(V)1 and AN/PRC-104B(V)4. These two radio sets are identical except for the antennas and antenna mounting hardware furnished. The STAJ compatible AN/PRC-104B radios differ from previous versions of the AN/PRC-104 because they contain a modified RT-1209A. The information in this manual applies to both radio sets, except where noted for the Marine Corps or Army use only.

The radio set is configured for the manpack using Receiver-Transmitter RT-1209A/URC (RT), Radio Frequency Amplifier AM-6874/PRC-104 (amplifier/coupler), and Battery Case CY-7875/PRC-104 (battery pack).

### MAINTENANCE FORMS, RECORDS, AND REPORTS

#### REPORTS OF MAINTENANCE AND UNSATISFACTORY EQUIPMENT

USMC personnel will use Equipment Record Procedures TM 4700-15/1. Department of the Army forms and procedures used for equipment maintenance are those prescribed by DA Pam 738-750 as contained in Maintenance Management Update. Air Force personnel will use AFR 66-1 for maintenance reporting and TO-00-35D54 for unsatisfactory equipment reporting. Navy personnel will report maintenance performed utilizing the Maintenance Data Collection Subsystem (MDCS) IAW OPNAVINST 4790.2, Vol 3 and unsatisfactory material/conditions (UR submissions) IAW OPNAVINST 4790.2, Vol 2, chapter 17.

#### REPORTING OF ITEM AND PACKAGING DISCREPANCIES

Fill out and forward SF 364 (Report of Discrepancy (ROD)) as prescribed in AR 735-11-2/DLAR 4140.55/SECNAVINST 4355.18/AFR 400-54/MCO 4430.3J.

#### TRANSPORTATION DISCREPANCY REPORT (TDR) (SF 361)

Fill out and forward TDR (SF 361) as prescribed in AR 55-38/NAVSUPINST 4610.33C/AFR 75-18/MCO P4610.19D/DLAR 4500.15.

### CONSOLIDATED INDEX OF ARMY PUBLICATIONS AND BLANK FORMS

Refer to the latest issue of DA Pam 25-30 to determine if there are new editions, changes, or additional publications for the equipment.

USMC, refer to Marine Corps stocklist 1-2 for complete list of required publications.

### **DESTRUCTION OF ELECTRONICS MATERIEL**

Destruction of electronics materiel to prevent enemy use will be in accordance with TM 750-244-2.

### **PREPARATION FOR STORAGE OR SHIPMENT**

Disassembly and repacking of equipment for shipment or limited storage is covered in chapter 6, Preparation for Storage or Shipment.

### **REPORTING EQUIPMENT IMPROVEMENT RECOMMENDATIONS (EIR)**

- a. USMC personnel shall submit SF 368 in accordance with MCO 4855.10.
- b. Army. If your equipment needs improvement, let us know. Send us an EIR. You, the user, are the only one who can tell us what you don't like about the design or performance. Put it on an SF 368 (Product Quality Deficiency Report). Mail it to Commander, US Army Communications-Electronics Command and Fort Monmouth, ATTN: AMSEL-PA-MA-D, Fort Monmouth, New Jersey 07703-5000. We'll send you a reply.
- c. Air Force. Air Force personnel are encouraged to submit EIRs in accordance with AFR 900-4.
- d. Navy. Navy personnel are encouraged to submit EIRs through their local Beneficial Suggestion Program.

### **ADMINISTRATIVE STORAGE**

Administrative storage of equipment issued to and used by Army activities will have preventive maintenance performed in accordance with the PMCS charts before storing. When removing the equipment from administrative storage the PMCS should be performed to assure operational readiness. Disassembly and repacking of equipment for shipment or limited storage are covered in chapter 6, Preparation for Storage or Shipment. Marine Corps personnel will refer to MCO P4450.7 for preparation of storage (Marine Corps Warehousing Manual).

**NOMENCLATURE CROSS-REFERENCE (1 of 2)**

Common names are used for the equipment listed in the following table throughout the rest of this manual. Refer to this table whenever official nomenclature is desired for a common name.

Common Name	Official Nomenclature
Amplifier/Coupler	Radio Frequency Amplifier AM-6874/PRC-I 04
Antenna Base	(NVIS) Antenna Base AB-1241/PRC-104
Antenna Ground Base	(NVIS) Antenna Ground Base P/N A3023292*
Antenna Pack	Carrying Case
Antenna Wire	Antenna Wire Assembly CX-7303/G
Battery Charger Cable	Electrical Power Cable Assembly CX-13032/PRC-104
Battery Extender Cable	Electrical Power Cable Assembly CX-13031/PRC-104
Battery Pack (for Lithium or NICAD batteries)	Battery Case CY-7875/PRC-104
Bench Test Cable	Electrical Power Cable Assembly CX-13030/PRC-104
Cargo Shelf	Cargo Support Shelf 2-3-291
CW Key	Telegraph Key KY-872/PRC-104
Dipole Antenna	Antenna Group AN/GRA-50
Dipole Antenna Adapter	(AN/GRA-50) Adapter UG-349A/U
Dipole Carrying Bag	Bag BG-175
Dipole Rf Cable	Radio Frequency Cable Assembly CG-678/U
Field Pack	Field Pack 2-2-344
Halyard	Halyard MX-2706/G
Handset	Handset H-250A/U
Instruction Card	Instruction Card
Insulator	Insulator IL-4/GRA-4
Manpack Whip Antenna	Antenna AT-271A/PRC

\* Note: For Army installations, use antenna ground base (P/N A3023292). Do not use base assembly P/N 7270-5061-001 or adapter MX-9313/GR that is part of NAVIS antenna.

**NOMENCLATURE CROSS-REFERENCE (2 of 2)**

Common Name	Official Nomenclature
Mast Sections	Mast Sections
NVIS Antenna	(NVIS) Antenna AS-2259( )/GR
NVIS Rf Cable	Radio Frequency Cable Assembly CG-3815/U
NVIS Rf Cables	Radio Frequency Cable Assemblies
Pack Frame	Pack Frame 2-3-290
Radio Set	Radio Set AN/PRC-104B(V)1,(V)4
Reel	Hand Cable Reeling Machine RC-432-G
RT	Receiver-Transmitter RT-1209A/URC
Shock Mount	Antenna Spring Section AB-129/PR
Tape Measure	Measuring Tape
Top Mast	Top Mast Assembly
Transit Case	Radio Case CY-8291/PRC-104
Webbing Strap	Webbing Strap 2-2-313

**Section II. EQUIPMENT DESCRIPTION AND DATA**

	Page
Equipment Characteristics, Capabilities, and Features .....	1-5
Location and Description of Major Components .....	1-5
Differences Between Models .....	1-6
Radio Set Data .....	1-6
Equipment Configuration .....	1-8
Safety, Care, and Handling .....	1-8

**EQUIPMENT CHARACTERISTICS, CAPABILITIES, AND FEATURES**

- Radio set components are RT, amplifier/coupler, and battery pack.
- Quick disconnect latches secure RT to amplifier/coupler.
- RT is electrically interconnected with amplifier/coupler via a built-in connector.
- Radio set provides single sideband transmit and receive operation.
- Total weight of RT and amplifier/coupler is 10.1 pounds, making a lightweight package.

**LOCATION AND DESCRIPTION OF MAJOR COMPONENTS, fig 1-1**

1. RT — Provides single sideband radio communications in the HF band (2,000 — 29,999.9 KHz).
2. AMPLIFIER/COUPLER — Provides antenna tuning or matching and 20 watts of rf power amplification.
3. BATTERY PACK — Provides all dc power required for operation in the manpack configuration.

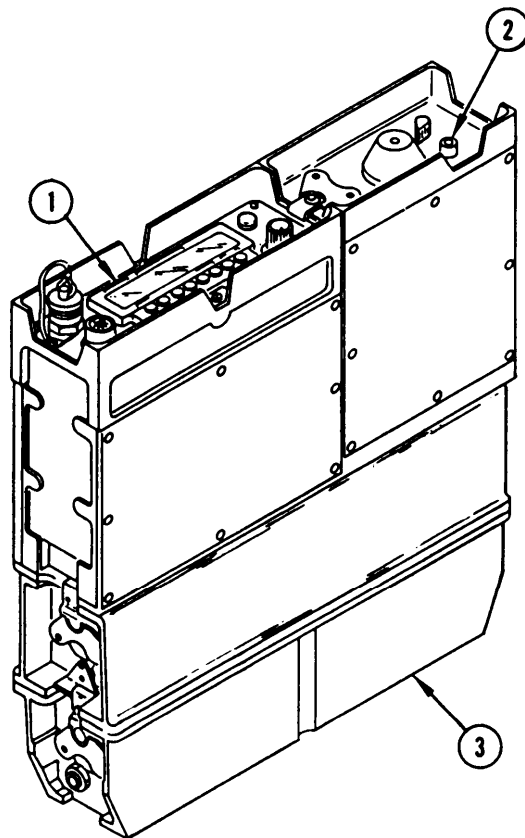


Figure 1-1. Location and Description of Major Components.

**DIFFERENCES BETWEEN MODELS**

Refer to equipment configuration data on page 1-8.

**RADIO SET DATA (1 of 2)**

This data applies only to the standard radio mode of the radio set.

Specification	Description
Antennas	Whip Dipole NVIS
Antenna Tuning	Automatic to 1.5:1 vswr (3 seconds nominal, 12 seconds maximum)
Audio input impedance	0.6 mv rms
Battery Case CY-7875/PRC-104 Dimensions	3-1/4 x 12/1/2 x 6-1/2 in. (8.26 x 31.75 x 16.51 cm) H x W x D
Battery Types	Two Battery Cases CY-7875/PRC-104, each containing two 12-Volt lithium primary batteries BA-5590/U or two NICAD storage batteries BB-590/U
Dimensions	12-1/2 x 10 1/2 x 2 5/8 in. (31.75 x 26.67 x 6.66 cm) W x D x H
Duty Cycle	1 minute keydown, 9 minute receive 1:9 ratio
Frequency Accuracy	±1 ppm for -51°F (-46°C) to +160°F (+71°C) (±2 to 30 Hz of setting) from 2 to 30 MHz, respectively
Frequency Range	2,000 to 29,999.9 kHz in 100-Hz increments (280,000 frequency settings)
Operating Modes	<ul style="list-style-type: none"> <li>— Single sideband (selectable USB or LSB)</li> <li>— Voice/cw (Morse or burst cw at 300 wpm)</li> <li>— Data (FSK or DPSK up to 2400 bps) compatible with 75 baud military teletype</li> <li>— Receive only (inhibits transmit operation)</li> </ul>



**RADIO SET DATA (2 of 2)**

Specification	Description
Operating Temperature Range	-51°F (-46°C) to +160°F (+71°C)
Power Requirements	20.0 to 32.0 V dc with input at 3.5 A (24.0 V dc) for transmit (typical); 200 mA for receive (typical)
Receiver Audio Output	25 mW into 500 Ω (nominal)
Receiver Sensitivity	0.7 μV for 10 db SINAD (-110 dbm voice, -70 dbm data)
RF Output Impedance	50 Ω
RF Output Power	0.3 to 1.0 W (PEP) for RT-1209A, 20 W (PEP or average) with AM-6874
Weight	17.94 lb (8.15 kg), including lithium batteries (without accessories), or 20.59 lb (9.32 kg), including nickel-cadmium batteries (without accessories)

**EQUIPMENT CONFIGURATION**

Equipment (Common Name)	AN/PRC-1048 Configurations	
	V1(Marine Corps)	V4(Army)
Amplifier/Coupler	X	X
Antenna Ground Base	X	X
Battery Charger Cable	X	X
Battery Extender Cable	X	X
Battery Pack (for lithium or NICAD batteries)	X	X
Bench Test Cable	X	
Cargo Shelf	X	X
CW Key	X	X
Dipole Antenna		X
Dipole Antenna Adapter		X
Field Pack	X	X
Handset	X	X
Instruction Card	X	X
Manpack Whip Antenna	X	X
NVIS Antenna		X
NVIS Rf Cable	X	X
Pack Frame	X	X
Radio Set	X	X
RT	X	X
Shock Mount	X	X
Transit Case	X	X
Webbing Strap	X	X

**SAFETY, CARE, AND HANDLING**

There are no safety, care, and handling instructions for the radio set other than the warnings, cautions, and notes in the maintenance instructions.

Section III. PRINCIPLES OF OPERATION

**PRINCIPLES OF OPERATION, fig 1-2**

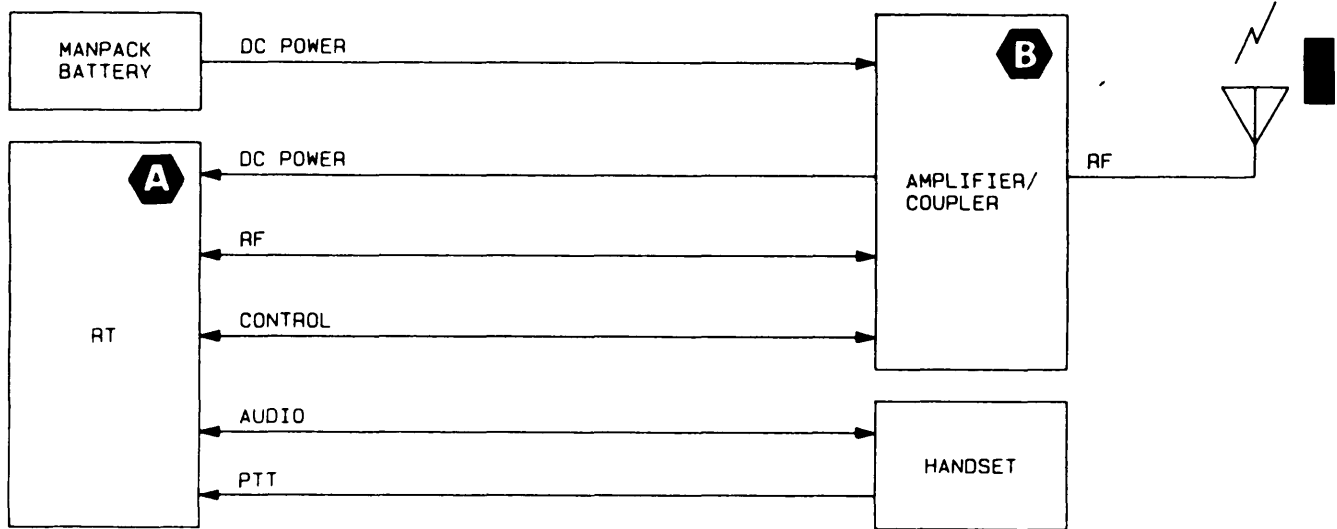


Figure 1-2. Principles of Operation

**A** RT — The RT performs the conversion of audio signals to rf and rf to audio. The RT operates as a standard Receiver-Transmitter RT-1209 A/URC. The RT control panel contains **AUDIO** and **CONT** connectors and the following controls which are described in detail in chapter 3, Controls, Indicators, and Connectors:

- **FREQUENCY KHz** pushbutton switches (six)
- **MODE** select pushbutton switches (two)
- **LIGHT** pushbutton switch
- **VOLUME OFF/MAX** control switch

**B** **Amplifier/Coupler** — The amplifier/coupler contains a power amplifier and an antenna tuner. During transmit operation, the power amplifier boosts the transmitted rf from the RT to 20 watts. Rf is then routed through the harmonic filter to the antenna tuner. The antenna tuner automatically matches antenna impedance to the radio set at the selected frequency, during transmit and receive operation. In receive operation, the amplification circuits are bypassed. The amplifier/coupler control panel contains the whip antenna socket, **BNC** connector, **GND** terminal, receiver/exciter interface connector P1, amplifier/coupler interface connector J1, and the **ANT SEL** switch, which are described in detail in chapter 3, Controls, Indicators, and Connectors.



# CHAPTER 2 SERVICE UPON RECEIPT AND INSTALLATION

## Section I. SERVICE UPON RECEIPT

	Page
Unpacking Radio Set .....	2-1
Checking Unpacked Radio Set .....	2-2
Equipment Supplied .....	2-2

**UNPACKING RADIO SET**

**WARNING**

A lithium-sulfur dioxide (lithium) battery used with the radio set contains pressurized sulfur dioxide (SO<sub>2</sub>) gas. To prevent rupture, do not heat, short circuit, crush, puncture, mutilate, or disassemble lithium batteries; do not recharge or test lithium batteries for capacity; do not use a Halon type fire extinguisher on a lithium battery.

Do not use any lithium battery which shows the following signs of rupture: bulging, swelling, disfigurement, brown liquid in the plastic wrap, or a swollen plastic wrap. If the battery compartment becomes hot to the touch, or a hissing sound or the smell of SO<sub>2</sub> gas (rotten egg smell) is present, immediately turn off the equipment. Move the equipment to a well-ventilated area or leave the area.

In the event of a fire near a lithium battery, use a carbon dioxide (CO<sub>2</sub>) type extinguisher. Rapid cooling of lithium batteries is necessary to prevent venting and the potential exposure of lithium. In the event that lithium metal becomes involved in fire, the use of a graphite-based Class D fire extinguisher is recommended, such as Lith-X or MD-L-X.

Do not store lithium batteries with other hazardous materials and keep away from open flame or heat.

**CAUTION**

To prevent equipment damage, press relief valve button to equalize pressure before unlatching transit case cover.

The radio set is normally placed in a transit case and closed for transportation, storage, or shipment. Check transit case for damage. To unpack the equipment, unfasten the four latches and remove the transit case cover. Each of the individual pieces of equipment fits in a molded space in the case.

**CHECKING UNPACKED RADIO SET**

1. Inspect equipment for any damage that may have occurred during shipment. If equipment has been damaged, report damage on DD Form 6, Packaging Improvement Report.
2. Check equipment against packing slip to see if shipment is complete. Report all discrepancies in accordance with instructions of DA Pam 738-750. Marine Corps personnel will refer to MCO P4610.19 (Transportation and Travel Record of Transportation Discrepancies).
3. Check MWO/MI to see if equipment has been modified.

**EQUIPMENT SUPPLIED**

Refer to appendix C, Components of End Item and Basic Issue Items Lists.

## Section II. INSTALLATION PROCEDURES

	Page
Tools and Materials Required for Installation.....	2-3
Installation Instructions.....	2-4
Radio Set Installation.....	2-4
Manpack Whip Antenna Installation .....	2-5
NVIS Antenna Installation.....	2-6
Dipole Antenna Installation.....	2-8

**TOOLS AND MATERIALS REQUIRED FOR INSTALLATION**

This paragraph lists the tools and materials required for installing the radio set.

Name	Qty	National Stock Number
Electronic Equipment Tool Kit TK-101/G	1	5180-00-064-5178

## INSTALLATION INSTRUCTIONS

The installations of the manpack whip antenna, Near Vertical Incidence Skywave (NVIS), and dipole antennas are outlined in the following paragraphs. For Marine Corps, before installing the antenna, select the type of antenna to be installed per Operating Considerations paragraph on page F-9.

### RADIO SET INSTALLATION, fig 2-1

Attach battery pack (1) to power connector (2) on bottom of latched RT (3) - amplifier/coupler (4) combination and secure by fastening and tightening 2 latches (5).

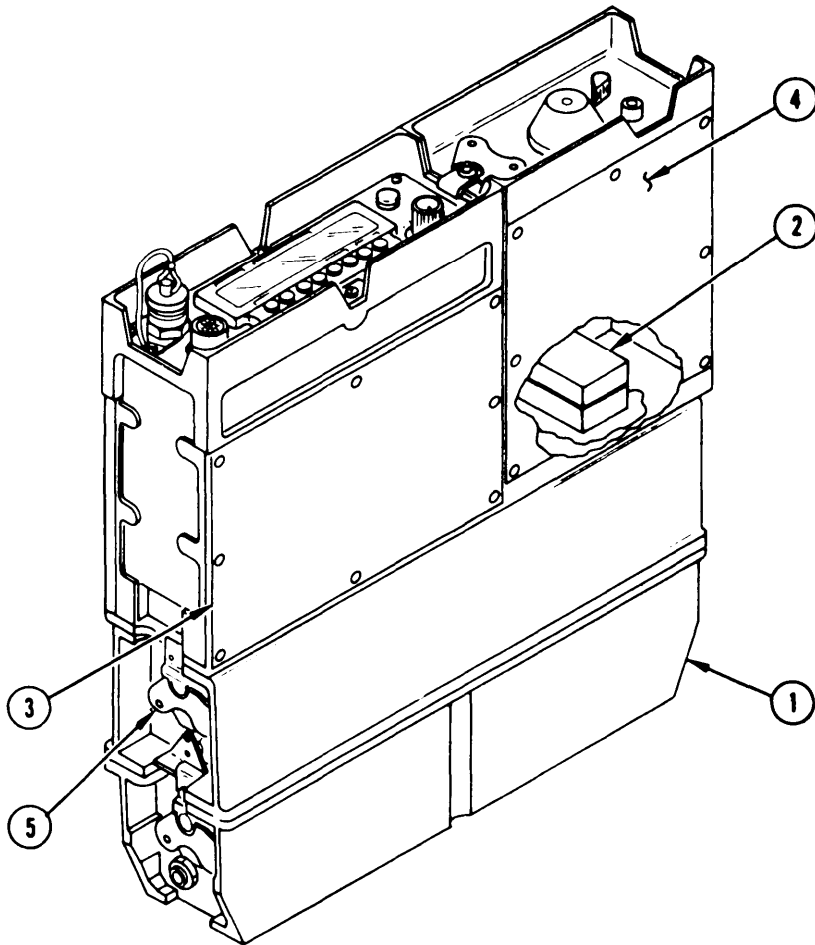


Figure 2-1. Radio Set Installation



**MANPACK WHIP ANTENNA INSTALLATION, fig 2-2**

1. Attach whip antenna (1) to antenna shock mount (2).
2. Attach antenna shock mount (2) (with whip antenna (1) attached) to antenna socket (3) on amplifier/coupler (4).

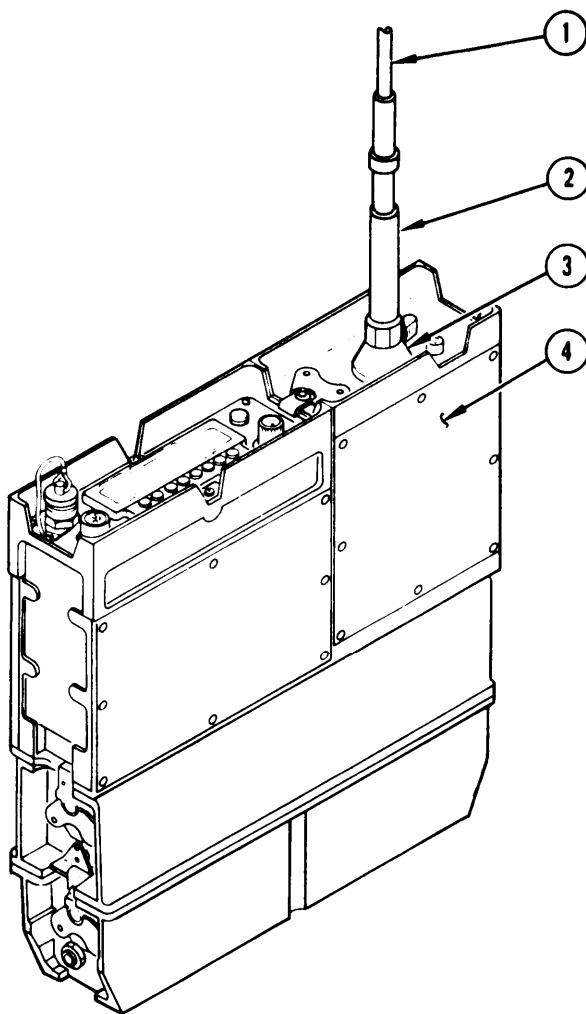


Figure 2-2. Manpack Whip Antenna Installation

**NVIS ANTENNA INSTALLATION (1 of 2), fig 2-3**

To erect the NVIS antenna, perform the following steps:

**WARNING**

Antenna installation area must be free of power lines. Antenna contact with power lines during installation may cause serious injury or DEATH to operator.

**NOTE**

The NVIS antenna is efficient at frequencies between 2 and 12 MHz.

1. Determine installation area. An 85- by 85-ft area is required for NVIS installation.

**NOTE**

For Army installations, use antenna ground base (P/N A3023292). Do not use base assembly P/N 7270-5061-001 or adapter MX-9313/GR that is part of NVIS antenna.

2. Place antenna base **(1)** on ground next to radio set **(2)**. Antenna base **(1)** must be located close enough to allow NVIS rf cable **(3)** to connect between antenna base **(1)** and amplifier/coupler **(4)**.
3. Open antenna pack and remove top mast section **(5)**.
4. Install top mast section **(5)** in antenna base **(1)** on ground and uncoil antenna elements **(6)** one at a time. Verify antenna elements **(6)** are stretched along direction in which they leave top housing **(7)** and are not shorted to each other or to mast. If necessary, adjust direction of antenna elements **(6)**.
5. Measure anchor **(8)** positions, using metal sleeve cable markers **(9)** as guides, and install anchors. Leave slack in antenna elements **(6)** lying on ground.

**NOTE**

Dirty mast sections **(10)** reduce NVIS antenna performance.

6. Before connecting mast sections **(10)**, wipe unpainted mating surfaces clean of mud or dirt to provide good electrical contact.
7. Assemble mast by raising top mast section **(5)** and inserting each of seven 22-inch mast sections **(10)** one at a time. Insert bottom mast section **(10)** in antenna base **(1)**.
8. Adjust tightness of all elements **(6)** until mast sections **(10)** are vertical and straight. Antenna elements **(6)** need not be excessively tight.

**NVIS ANTENNA INSTALLATION (2 of 2)**

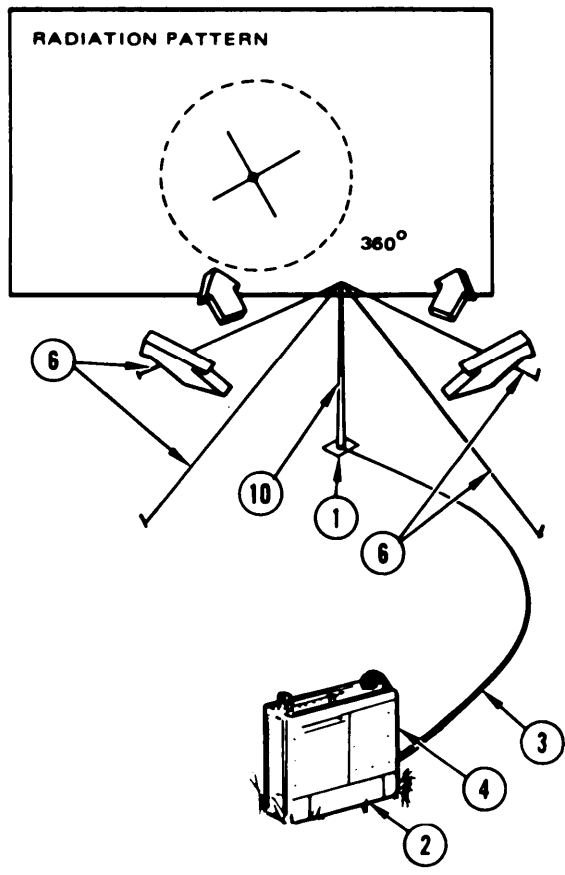
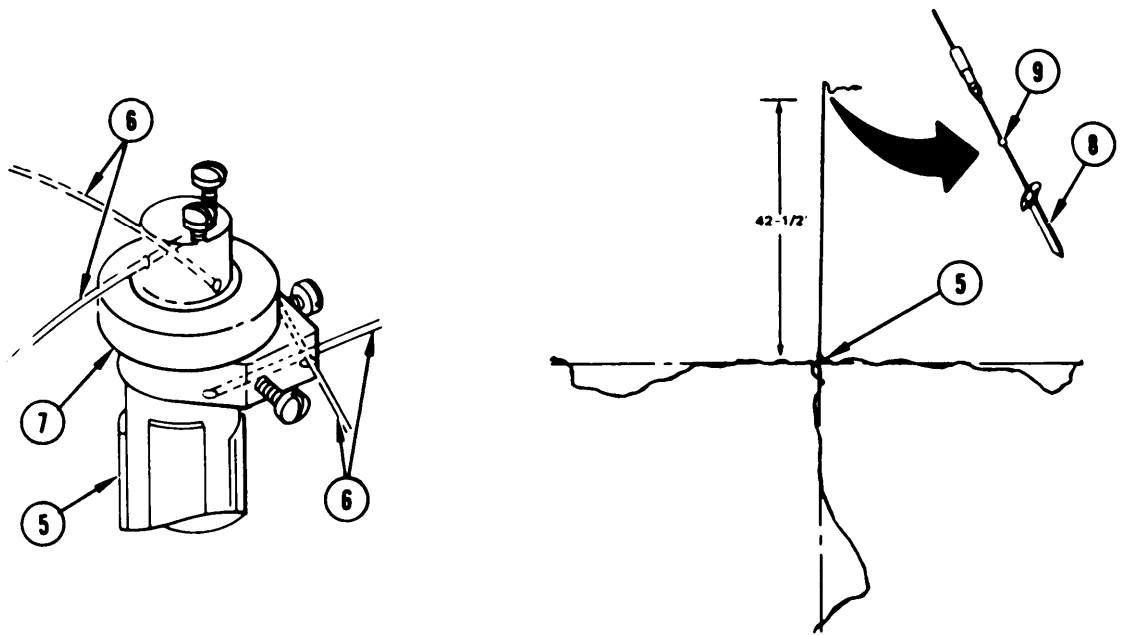


Figure 2-3. NAVIS Antenna Installation

**DIPOLE ANTENNA INSTALLATION (1 of 5), fig 2-4, sh 1**

To put up a dipole antenna, refer to Illustrations on pages 2-8 thru 2-12, and perform the following steps:

**NOTE**

The two-support, one-support sloping, and one-support Inverted V dipole antennas are shown on pages 2-11 and 2-12.

- 1. Connect antenna wire (1) and terminal hooks (2) to thumb nuts (3) on opposite ends of insulator (4).
- 2. Connect rf cable (5) to insulator (4).
- 3. Temporarily fasten insulator (4) to one of supports (6).

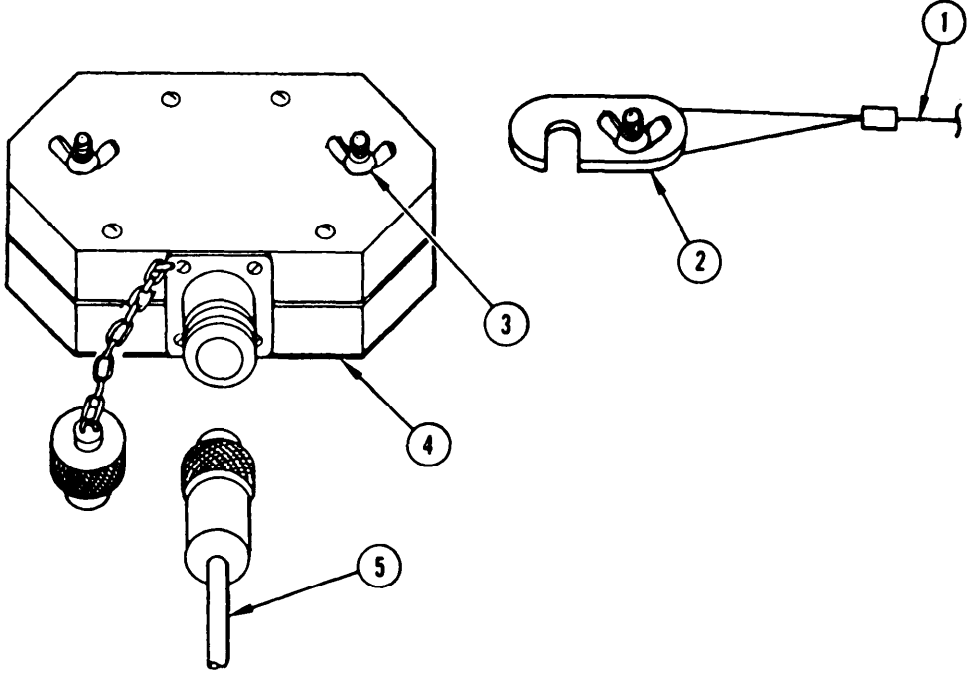


Figure 2-4. Dipole Antenna installation (Sheet 1)

**DIPOLE ANTENNA INSTALLATION (2 of 5), fig 2-4, sh 2**

4. Temporarily fasten free end of frequency tape measure (7) to center of Insulator (4).
5. Unwind frequency tape measure (7) to length for desired frequency, using marks on back of tape.
6. Grasp one reel (8) firmly in one hand, loosen center thumb nut (9), and clamp thumb nut (10).
7. Slowly move away from insulator (4) center, keeping wire (1) tight at all times. Hold thumb on wire (1) to prevent backlash.
8. After unwinding required amount of wire (1), tighten clamp thumb nut (10) and then center thumb nut (9).
9. Repeat steps 6,7, and 8 for other reel.
10. Unfasten frequency tape measure (7) (if used) from insulator (4).
11. Unfasten insulator (4) from support and lay wires (1) out in a straight line.
12. Check overall length of two wires (1) plus insulator (4) and reels (8). Overall length should be twice length indicated in step 5 by frequency tape measure (7). Adjust wires (1) for exact overall length. Keep insulator (4) centered.

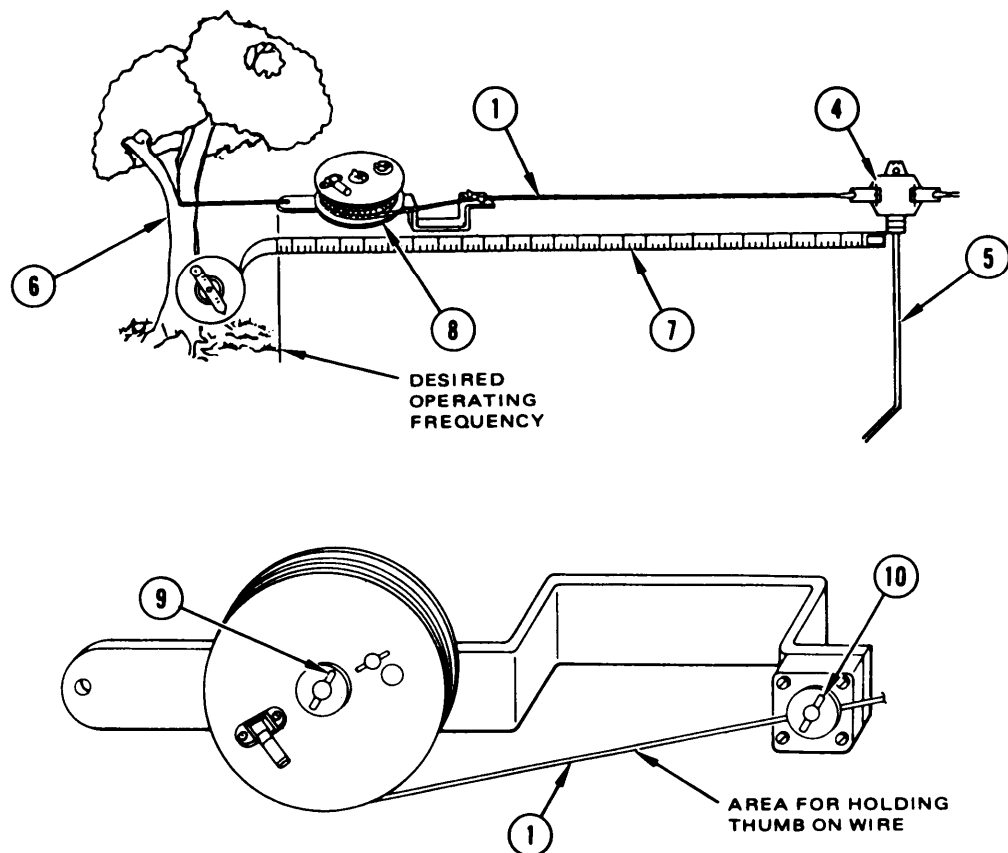
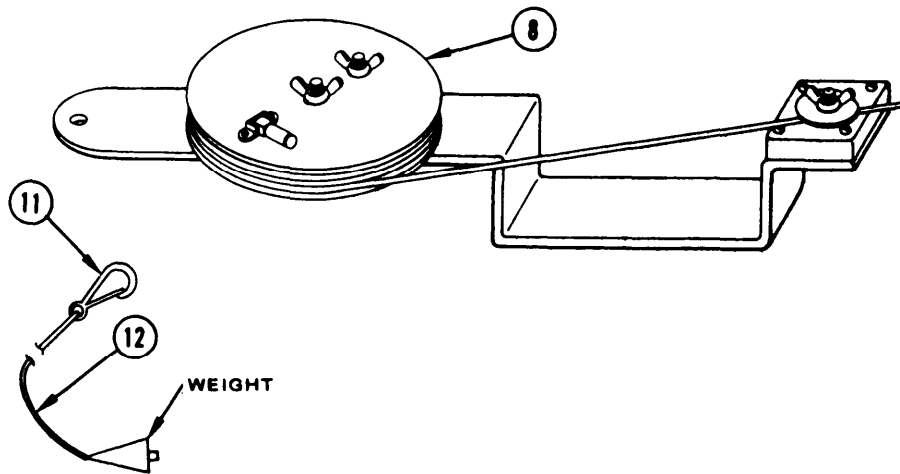


Figure 2-4. Dipole Antenna Installation (Sheet 2)

**DIPOLE ANTENNA INSTALLATION (3 of 5), fig 2-4, sh 3**



**Figure 2-4. Dipole Antenna Installation (Sheet 3)**

**13.** Attach each reel (8) to halyard snaphook fastener (11).

**CAUTION**

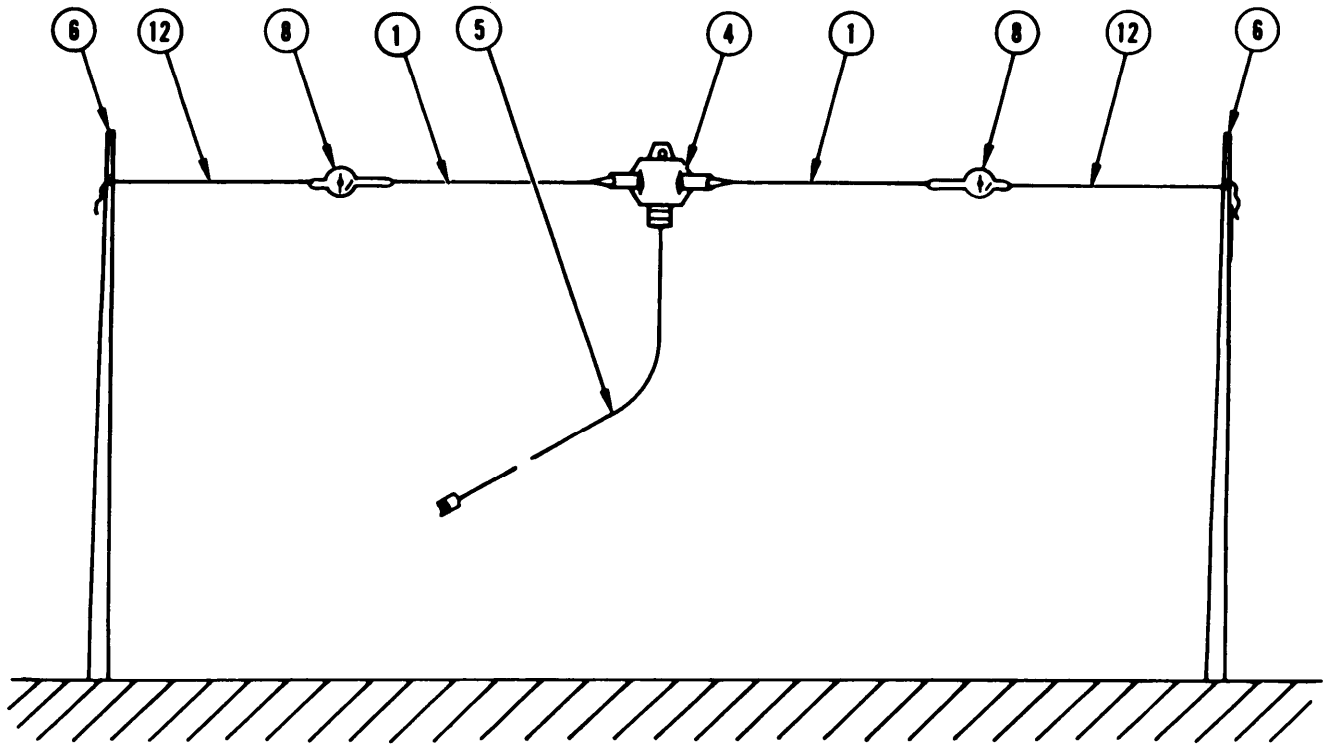
To avoid equipment damage, allow antenna to sag at least 6 inches when installing.

**NOTE**

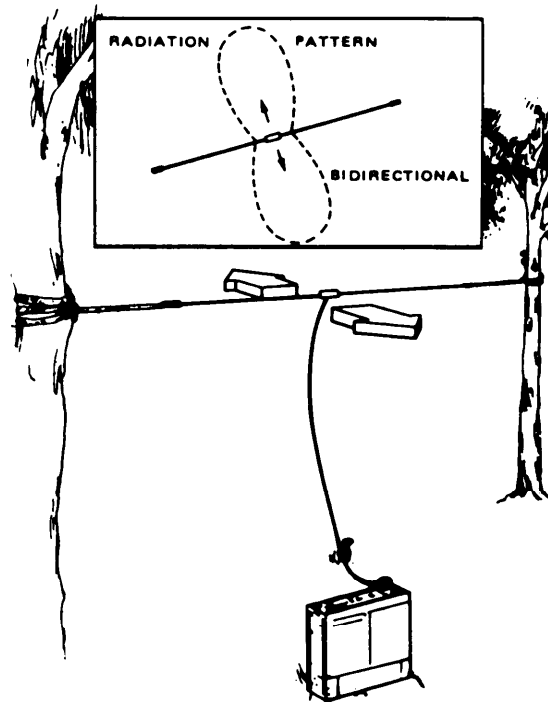
Rf cable (5) should be at right angles to antenna for first several feet from insulator (4). Lay rf cable (5) out as straight as possible. Do not allow loops to form in rf cable (5).

**14.** Tie halyard (12) to tree, fence post, vehicle, etc at a height of at least 3 feet or 1/3 the antenna length.

**DIPOLE ANTENNA INSTALLATION (4 of 5), fig 2-4, sh 4**

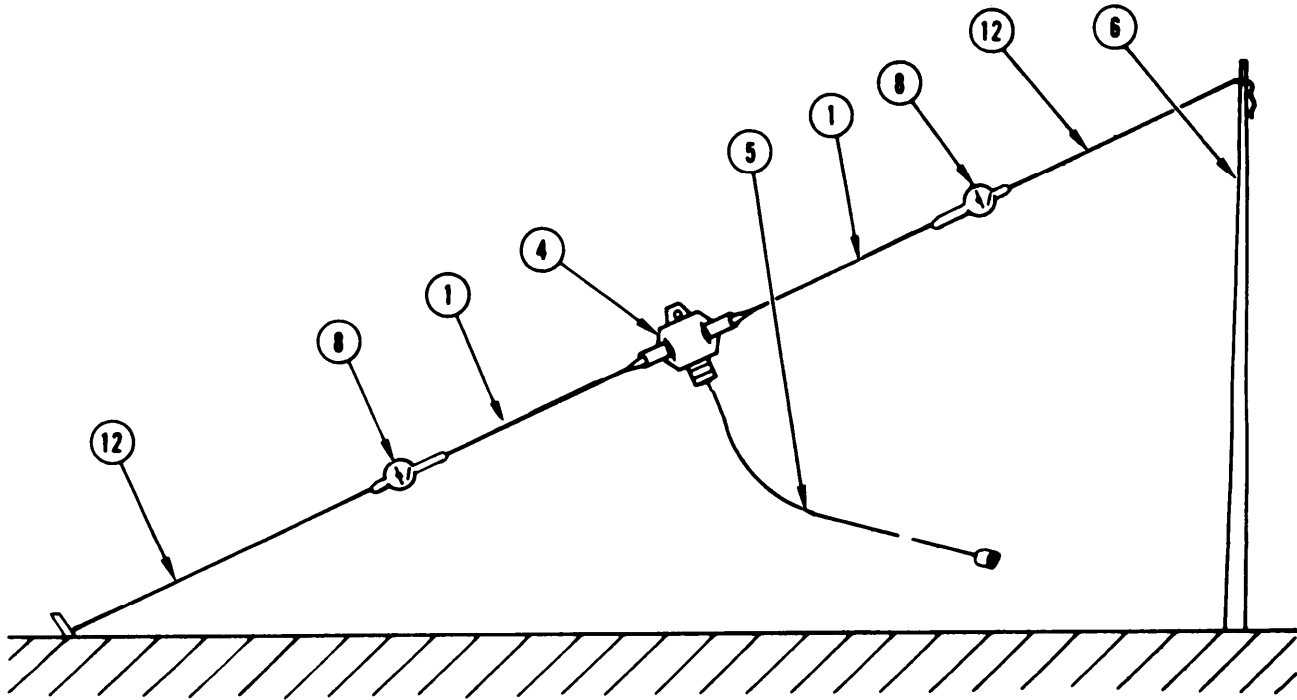


**TWO-SUPPORT DIPOLE**

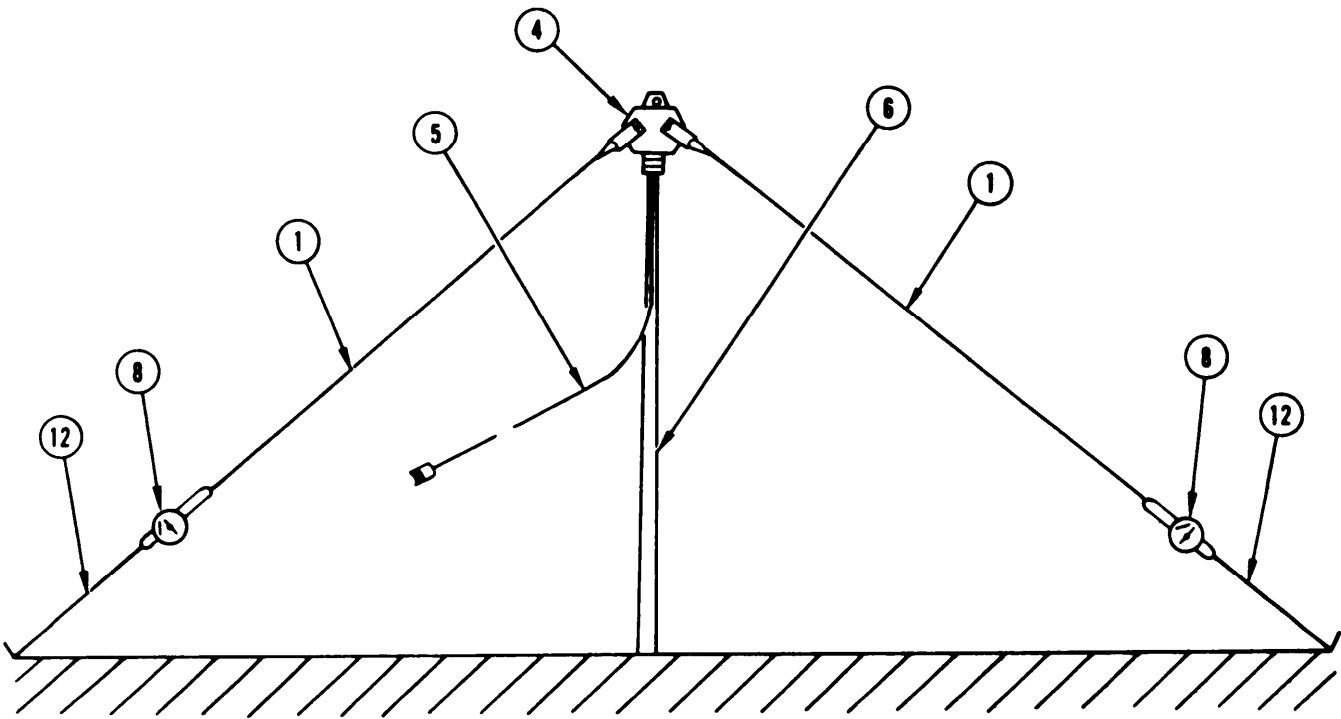


**Figure 2-4. Dipole Antenna Inatallation (Sheet 4)**

**DIPOLE ANTENNA INSTALLATION (5 of 5), fig 2-4, sh 5**



**ONE-SUPPORT SLOPING DIPOLE**



**Figure 2-4. Dipole Antenna Installation (Sheet 5)**



## CHAPTER 3 OPERATION

### Section I. CONTROLS, INDICATORS, AND CONNECTORS

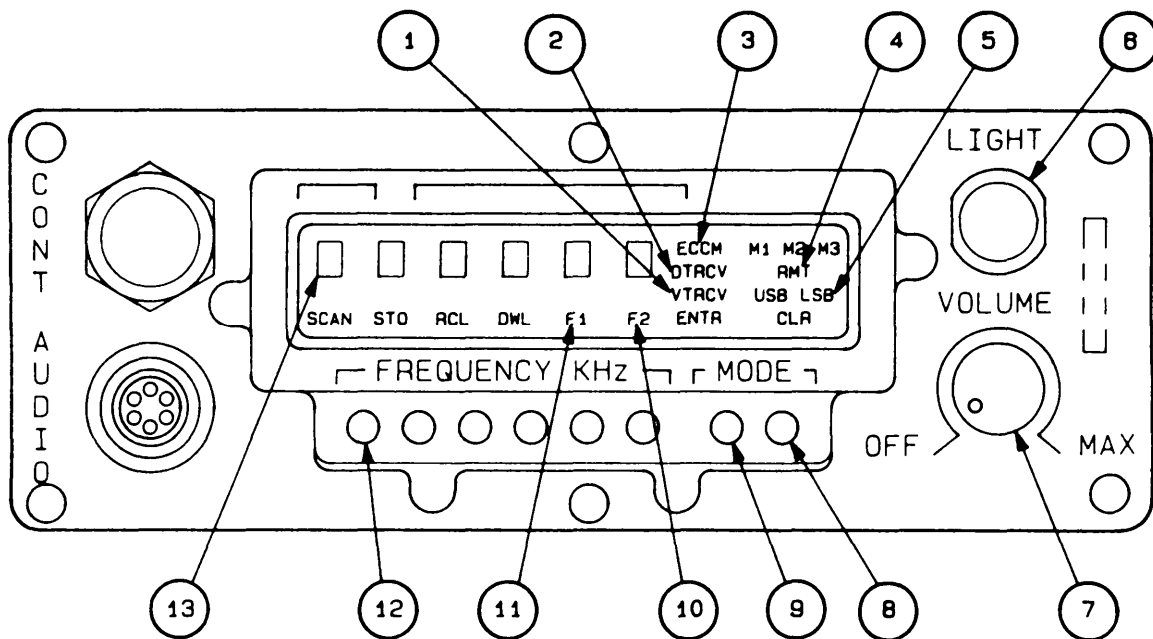
	<b>Page</b>
RT Controls and Indicators .....	3-2
RT Connectors .....	3-4
Amplifier/Coupler Controls and Indicators .....	3-5
Amplifier/Coupler Connectors .....	3-6
Audible Indicators .....	3-7



**RT CONTROLS AND INDICATORS (1 of 2), fig 3-1**

Key	Control or Indicator	Function
1	<b>VTRCV</b> indicator	<p><b>V RCV</b> - indicates voice and cw receive only during single sideband operation when turned on by repeated pressing and releasing of left-hand <b>MODE</b> pushbutton, as necessary.</p> <p><b>VTR</b> - indicates voice and cw transmit and receive during single sideband operation, when turned on by repeated pressing and releasing of left-hand <b>MODE</b> pushbutton, as necessary.</p>
2	<b>DTRCV</b> indicator	<p><b>D RCV</b> - indicates data receive only during single sideband operation, when turned on by repeated pressing and releasing of left-hand <b>MODE</b> pushbutton, as necessary.</p> <p><b>DTR</b> - indicates data transmit and receive during single sideband operation, when turned on by repeated pressing and releasing of left-hand <b>MODE</b> pushbutton, as necessary.</p>
3	<b>ECCM</b> indicator	Not used.
4	<b>RMT</b> indicator	Not used.
5	<b>USB LSB</b> indicator	<p><b>USB</b> - indicates upper sideband has been selected during single sideband operation, when turned on by repeated pressing and releasing of right-hand <b>MODE</b> pushbutton, as necessary.</p> <p><b>LSB</b> - indicates lower sideband has been selected during single sideband operation, when turned on by repeated pressing and releasing of right-hand <b>MODE</b> pushbutton, as necessary.</p>
6	<b>LIGHT</b> pushbutton	Turns on display light while pressed. Turns off display light when released.

**RT CONTROLS AND INDICATORS (2 of 2)**



**Figure 3-1. RT Controls and Indicators**

Key	Control or Indicator	Function
7	<b>VOLUME OFF/MAX</b> switch	Turns power on or off and adjusts audio (volume) level of RT. At <b>OFF</b> , power is removed. At <b>MAX</b> , audio level is maximum.
8	<b>MODE</b> pushbutton(s) (right-hand)	<b>USB LSB</b> - repeated pressing and releasing, as necessary, turns on <b>USB</b> and <b>LSB</b> indicators, indicating upper sideband or lower sideband has been selected during single sideband operation.
9	<b>MODE</b> pushbutton(s) (left-hand)	<b>V RCV</b> , <b>VTR</b> , <b>D RCV</b> , and <b>DTR</b> - repeated pressing and releasing, as necessary, during single sideband operation, turns on <b>V RCV</b> , <b>VTR</b> , <b>D RCV</b> , or <b>DTR</b> indicator. This indicates voice and cw receive mode, voice and cw transmit and receive mode, data receive mode, or data transmit and receive mode has been selected.
10	<b>F2</b> indicator	Not used.
11	<b>F1</b> indicator	Not used.
12	<b>FREQUENCY KHz</b> pushbuttons (6)	Turns on and sequences 6-digit display of single sideband operating frequency when pressed. 280,000 frequencies between 2,000 and 29,999.9 KHz are available in 100-Hz steps.
13	Frequency display indicators (6-digit)	<b>FREQUENCY KHz</b> - lights when <b>FREQUENCY KHz</b> pushbuttons are pressed during single sideband operation to select 1 of 280,000 frequencies between 2,000 and 29,999.9 KHz, in 100-Hz steps.

**RT CONNECTORS, fig 3-2**

Key	Connector	Function
1	<b>CONT</b>	RT 19-pin connector provides Interface connection between RT and controller. (The controller is not provided in this configuration).
2	Receiver/Transmitter interface connector P1	Connects RT to amplifier/coupler (not shown). This connector is on the side of the RT.
3	<b>AUDIO</b>	6-pin connector provides interface connection between RT and handset or amplifier-power supply.

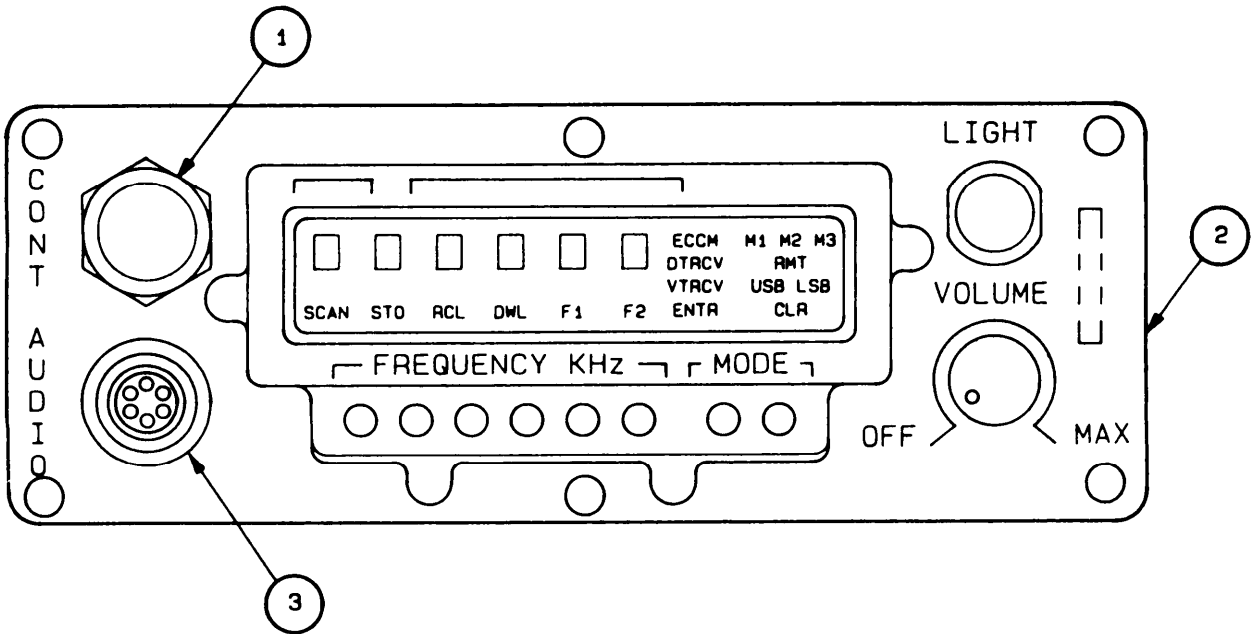


Figure 3-2. RT Connectors

**AMPLIFIER/COUPLER CONTROLS AND INDICATORS, fig 3-3**

Key	Control or Indicator	Function
1	ANT SEL switch	Selects whip antenna socket, BNC connector through antenna tuner, or BNC connector with antenna tuner bypassed (50 Ω position).

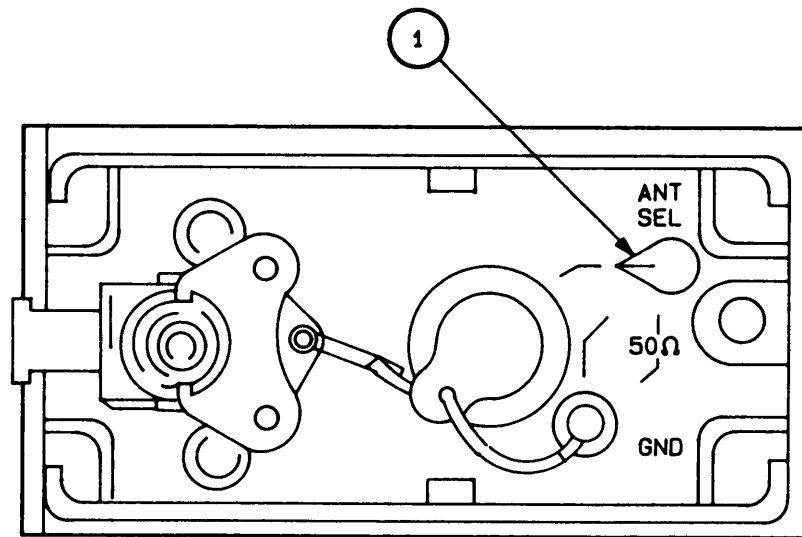


Figure 3-3. Amplifier/Coupler Controls and Indicators

**AMPLIFIER/COUPLER CONNECTORS, fig 3-4**

Key	Connector	Function
1	Amplifier/Coupler Interface connector J1	Connects amplifier/coupler to RT (not shown).
2	Whip antenna socket	Screw-in connection for shock mount of whip antenna.
3	BNC connector	Provides BNC connection to compatible antenna other than the whip.
4	<b>GND</b> terminal	Ground point for counterpoise or earth ground.
5	AN/PRC-104 power input connector	Connects AN/PRC-104 to connector on battery pack.

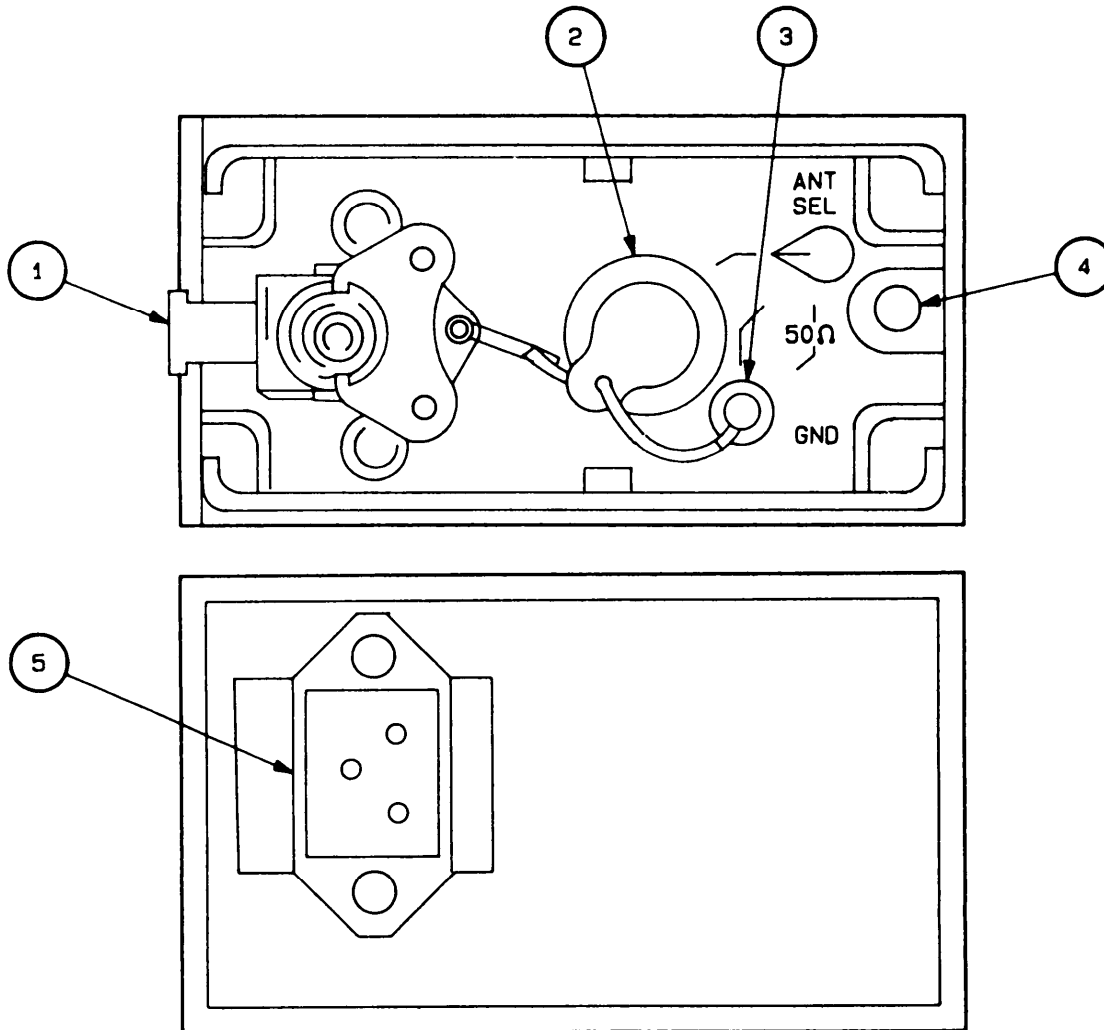


Figure 3-4. Amplifier/Coupler Connectors

## AUDIBLE INDICATORS (1 of 2)

Audio signals are provided in the handset to tell the trained operator the operational condition of the radio set.

### LOW VOLTAGE INDICATOR

On a properly operating radio, a repetitive clicking sound indicates the battery voltage has fallen to less than 20 volts. The clicking sound is first heard when the PTT is pressed during a tune-up or voice transmission. The sound stops when the PTT switch is released, and the radio receives when the power drain is at a minimum. At this point, the battery retains only enough charge for limited transmission and reception. When the voltage level falls low enough that the clicking sound is heard continuously in the receive mode, the battery must be replaced.

### POWER OUTPUT INDICATOR

Sidetone occurs when the operator's own voice is heard in the handset during transmission. The presence of sidetone guarantees that the radio set is generating an rf signal and the power output to the antenna is within 3 dB (500A) of the normal limits. The absence of sidetone during transmission means the handset or radio set is defective.

### TUNING INDICATOR

The tuning indicator is a continuous high-pitched tone that is heard in the handset. The **ANT SEL** switch must be set to the BNC (middle) or whip (top) position. This tone is typically heard for 3 seconds when the radio set is turned on and the PTT switch is first pressed to start the tuning operation. The PTT switch may be released before the tuning operation is complete. After the tuning operation is complete, the tone is heard again if the frequency is changed and the PTT switch is pressed. When the tone stops during single sideband operation, an increase in receiver noise level (static) indicates the antenna has been matched and the radio set is now receiving atmospheric noise. If the tone stops but the static does not increase, the selected antenna is shorted or otherwise faulty.

### TUNE FAULT INDICATOR

If the tuning tone continues for a long time (8 thru 12 seconds) and a tune fault consisting of high-pitched beeping tones is heard after the tuning stops with no static, the tuner has failed to tune. The tune fault indicator may be caused by the following:

- Selecting a frequency below 2 MHz
- An open or short in the antenna
- An antenna not suitable for the frequency in use
- Antenna obstructions
- Malfunction of the amplifier/coupler.

This fault can be cleared by any of the following:

- Turning the radio off and back on
- Switching to D RCV or V RCV mode and back to DTR or VTR mode
- Changing frequencies by at least 1 kHz

**AUDIBLE INDICATORS (2 of 2)**

**VSWR INDICATOR**

The vswr indicator is a singular, short, high-pitched tone heard in the handset earpiece at the beginning of a transmission (when vswr is greater than 1.5 to 1 but less than 1.6 to 1). The meaning of the vswr indicator depends on the setting of the **ANT SEL** switch on the amplifier/coupler.

**NORMAL OPERATION** — If the **ANT SEL** switch is in the BNC (middle) position, the vswr indicator indicates a previous momentarily high vswr condition. The high vswr condition can occur if the antenna or its immediate environment is disturbed. Such a disturbance causes the antenna's impedance to change, which produces the high vswr (unmatched) condition. The antenna tuner measures the vswr at the beginning of the next transmission and retunes if the impedance change is permanent.

**ANTENNA TUNER BYPASSED** — If the **ANT SEL** switch is set to **50 Ω**(bottom), which bypasses the antenna tuner, the vswr indicator indicates the antenna vswr is higher than 4 to 1, but can still provide useful communications.



**Section II. OPERATOR PREVENTIVE MAINTENANCE CHECKS AND SERVICES (PMCS)**

**INTRODUCTION**

The PMCS table lists the Inspections and care of the radio set required to keep it in good operating condition.

The interval column of the PMCS table indicates how often to perform a certain check or service. The item to be inspected column lists what to inspect or service. The procedure column of the PMCS table explains how to perform the check or service.

**PMCS TABLE (1 of 2)**

Item No.	Interval					Item to Be Inspected	Check and Have Repaired or Adjusted as Necessary
	B	D	A	W	M		
1	●					Dipole RF, NVIS RF, handset, and CW key electrical cables	Check cables for cracked or worn insulation and bare wires.  <div style="border: 1px dashed black; padding: 5px; width: fit-content; margin: 10px auto;"> <b>CAUTION</b> </div> To avoid damage from electrostatic discharge (ESD), use ESD precautionary procedures when removing or replacing the RT CONT connector cap.
2	●					RT and amplifier/coupler connectors, and electrical cable connectors	Check connectors for damage or corrosion. Tighten connectors, if loose. Clean, if necessary. Check that RT CONT connector cap is secured to connector; attach if necessary.
3	●					RT and amplifier/coupler external surfaces	Check for cracks, dents, or holes.
4	●					RT and amplifier/coupler knobs	Check for broken knobs.
5					●	RT and amplifier/coupler external surfaces	Check for loose nuts and bolts.
6		●				RT and amplifier/coupler controls and switches	Check that mechanical action is smooth and free of binding.

**PMCS TABLE (2 of 2)**

						B-Before D-During	A-After W-Weekly	M-Monthly		
Item No.	Interval					Item to Be Inspected	Check and Have Repaired or Adjusted as Necessary			
	B	D	A	W	M					
7	●					Dipole reel	Check that mechanical action is smooth and free of binding.			
8	●					Dipole tape measure	Check that mechanical action is smooth and free of binding.			
9	●					Canvas bags (dipole, NVIS, and field pack)	Check for cuts or tears.			

Section III. OPERATION UNDER USUAL CONDITIONS

	Page
Initial Checks .....	3-11
Single Sideband Operation.....	3-12
Shutdown .....	3-13

**INITIAL CHECKS, fig 3-5**

1. Verify PMCS procedure on *page 3-9* has been completed.
2. Verify Installation procedures on *page 2-4* have been performed.
3. Verify radio set troubleshooting procedure on *page 4-6* has been completed.
4. Connect handset and, if applicable, voice encryption device to RT **AUDIO (1)** connector.

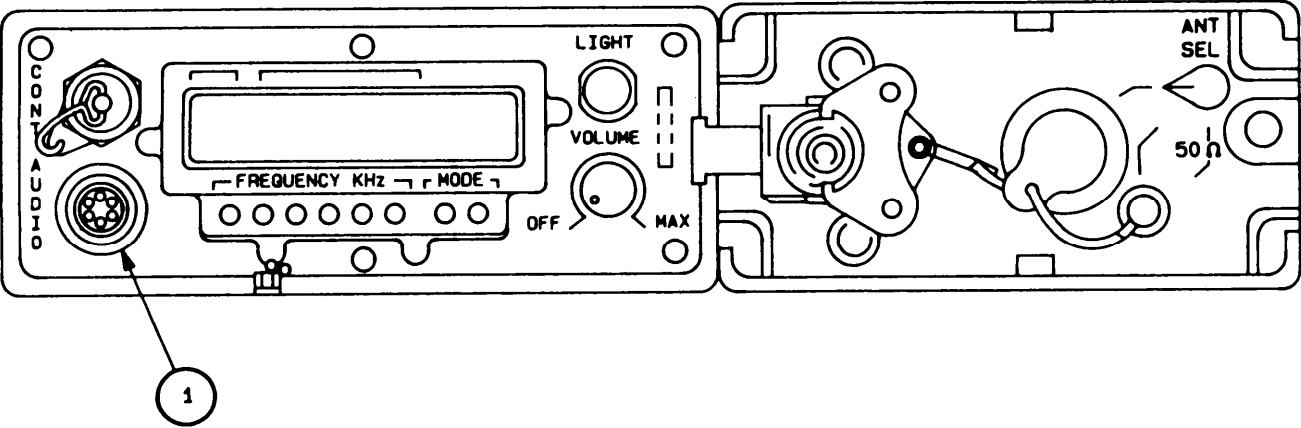


Figure 3-5 Initial Checks

**SINGLE SIDEBAND OPERATION (1 of 2), fig 3-6**

**WARNING**

Do not touch or stand near antenna when equipment is energized. Dangerously high rf voltages exist on and around antennas and antenna terminals during transmission. Protect yourself by knowing safety procedure in TB SIG 291.

**CAUTION**

To prevent equipment damage, avoid operating transmitter with antenna touching any natural or man-made object (metal, power lines, etc).

The following procedure is used to operate the STAJ radio in the single sideband mode.

Step	Procedure	Normal Indication	Remarks
1.	VERIFY INITIAL CHECKS PROCEDURE HAS BEEN PERFORMED.		Refer to <i>page 3-11</i> .
2.	SET <b>VOLUME OFF/MAX SWITCH (3)</b> TO MIDRANGE.	1. On RT display, all LCD segments are on. 2. On RT, sideband, frequency, and mode are displayed.	Self-test Indication lasts approx 4 seconds. Last sideband, frequency, and mode chosen are displayed after self-test.
3.	SET AMPLIFIER/COUPLER <b>ANT SEL SWITCH (4)</b> TO CORRECT POSITION.		
4.	ENTER FREQUENCY AND MODE OF OPERATION.		
	a. Sequentially press <b>FREQUENCY KHz</b> pushbuttons <b>(7)</b> to select a frequency.	Frequency is displayed.	Any frequency from 2,000 to 29,999 KHz can be selected.
	b. Press right-hand <b>MODE</b> pushbutton <b>(5)</b> to select a sideband.	<b>LSB</b> or <b>USB</b> indicator <b>(2)</b> lights.	
	c. Press left-hand <b>MODE</b> pushbutton <b>(6)</b> to select an operating mode.	<b>VTR, V RCV, DTR, or D RCV</b> indicator <b>(1)</b> lights.	

**SINGLE SIDEBAND OPERATION (2 of 2)**

Step	Procedure	Normal Indication	Remarks
5.	PRESS AND RELEASE PTT SWITCH ON HANDSET.	Tune tone in handset.	A continuous high-pitched tune tone is heard in handset for 3 seconds typical. Tone indicates radio is being tuned to antenna.
6.	COMMUNICATE WITH OTHER RADIOS.		

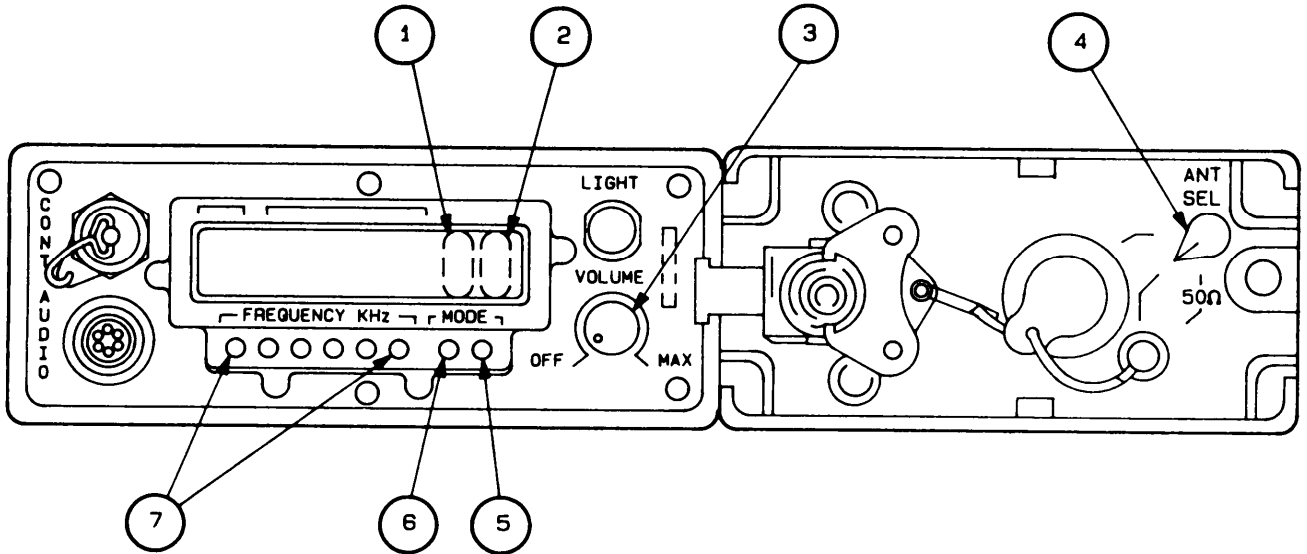


Figure 3-6. Single Sideband Operation

**SHUTDOWN, fig 3-6**

1. Set **VOLUME OFF/MAX (3)** switch on RT to **OFF**.



#### SECTION IV. OPERATION UNDER UNUSUAL CONDITIONS

##### **COLD WEATHER**

When the temperature is lower than -20°C, it takes up to 5 seconds to change the frequency and mode display indicators after a pushbutton switch has been pressed. No other special operating procedures are required for operation of the radio in cold weather. All other operation is normal.

##### **RADIO SILENCE**

When no transmissions may be made, the operating mode selected should be **V RCV** or **D RCV**. These modes prevent accidental transmission if the handset PTT switch is pressed and released.







## CHAPTER 4 OPERATOR MAINTENANCE

### Section I. MAINTENANCE PROCEDURES

	Page
Initial Setup .....	4-1
Cleaning .....	4-1
Inspection.....	4-2
Painting .....	4-2
Test .....	4-3

**MAINTENANCE PROCEDURES (1 of 4), fig 4-1**

**INITIAL SETUP**

**Tools:**

None

**Material/Parts:**

Brush, Bristle (item 1, App E)  
 Brush, Paint (item 2, App E)  
 Cheesecloth (item 3, App E)  
 Cleaning Compound (solvent)  
 (item 4, App E)  
 Detergent (item 5, App E)  
 Paint, (item 6, App E)  
 Paint, Primer (item 7, App E)  
 Sandpaper (item 8, App E)  
 Tape, Masking (item 9, App E)  
 Wiping Rags (item 10, App E)

**Personnel Required:**

1

**CLEANING**

1. Verify RT **VOLUME OFF/MAX** switch is set to **OFF**.
2. Disconnect handset **(4)** from RT **(1)** and manpack whip antenna **(5)** from amplifier/coupler **(2)**.

**CAUTION**

Avoid water contact with the handset and any other items that may be damaged.

3. Remove all dirt, dust, grease, or other debris from RT **(1)**, amplifier/coupler **(2)**, and battery pack **(3)** with a cloth or brush moistened with cleaning compound or soap and water.
4. Dry RT **(1)**, amplifier/coupler **(2)**, and battery pack **(3)** with a clean cloth.

## MAINTENANCE PROCEDURES (2 of 4)

### INSPECTION

1. Visually inspect each connector for bent, recessed, or missing pins. If any pins are bent, recessed, or missing, notify organizational maintenance.
2. Visually inspect rubber seal on each connector at front end of radio to verify it is not out of place or damaged. If any rubber seals are out of place, adjust them to correct position. If any rubber seals are damaged, notify organizational maintenance.
3. Position radio set so RT (1) and amplifier/coupler (2) panels are facing you.
4. Loosen and unfasten 2 latches (6) that secure battery pack (3) to RT (1) and amplifier/coupler (2).
5. Pull attached battery pack (3) toward rear of RT (1) and amplifier/coupler (2). When battery pack connector (7) disengages from power connector (8) on rear of amplifier/coupler (2), remove battery pack (3).
6. Visually inspect RT (1), amplifier/coupler (2), and battery pack (3) for dents, cracks, holes, or missing items. If any equipment is dented, cracked, missing, or punctured, notify organizational maintenance.
7. Visually inspect RT (1), amplifier/coupler (2), and battery pack (3) for bare metal or corrosion. If any equipment is corroded or has exposed metal, complete the painting procedure below.
8. Position RT (1) with attached amplifier/coupler (2) facing you when ready to install battery pack (3).
9. Position battery pack (3) on back of RT (1) and attached amplifier/coupler (2).
10. Pull battery pack (3) toward front of RT (1) and amplifier/coupler (2). Power connector (8) on rear of amplifier/coupler (2) will engage battery pack connector (7).
11. Secure battery pack (3) to RT (1) and attached amplifier/coupler (2) and fasten and tighten 2 latches (6).
12. Connect handset (4) to RT AUDIO) connector (9) and manpack whip antenna (5) to whip antenna socket (10).

### PAINTING

1. Locate all areas of exposed bare metal on exterior of RT (1), amplifier/coupler (2), and battery pack (3).
2. Use masking tape to cover all areas or items (connectors, knobs, and switches) that do not warrant painting.
3. Prepare surfaces to be painted by sanding each with sandpaper.
4. Wipe each surface after sanding with a cloth to remove dust caused by sanding.
5. Use paint brush to apply primer to cover exposed bare metal. Let primer dry for six hours.
6. Use paint brush to apply epoxy paint to cover primer and let dry for four hours.
7. Remove all masking tape.

**MAINTENANCE PROCEDURES (3 of 4)**

**PAINTING (CONT)**

When using a compressed airjet, use eyeshields to prevent severe eye injury.

**CAUTION**

To prevent equipment damage, compressed air must be clean, dry, and at a maximum pressure of 28 psi. Do not overlook the force of the airjet when cleaning delicate parts.

8. Dry components and remove water from inside of each connector with an airjet (if available) or dry cloth.

**TEST**

Perform operator troubleshooting procedure on *page 4-6*.

**MAINTENANCE PROCEDURES (4 of 4)**

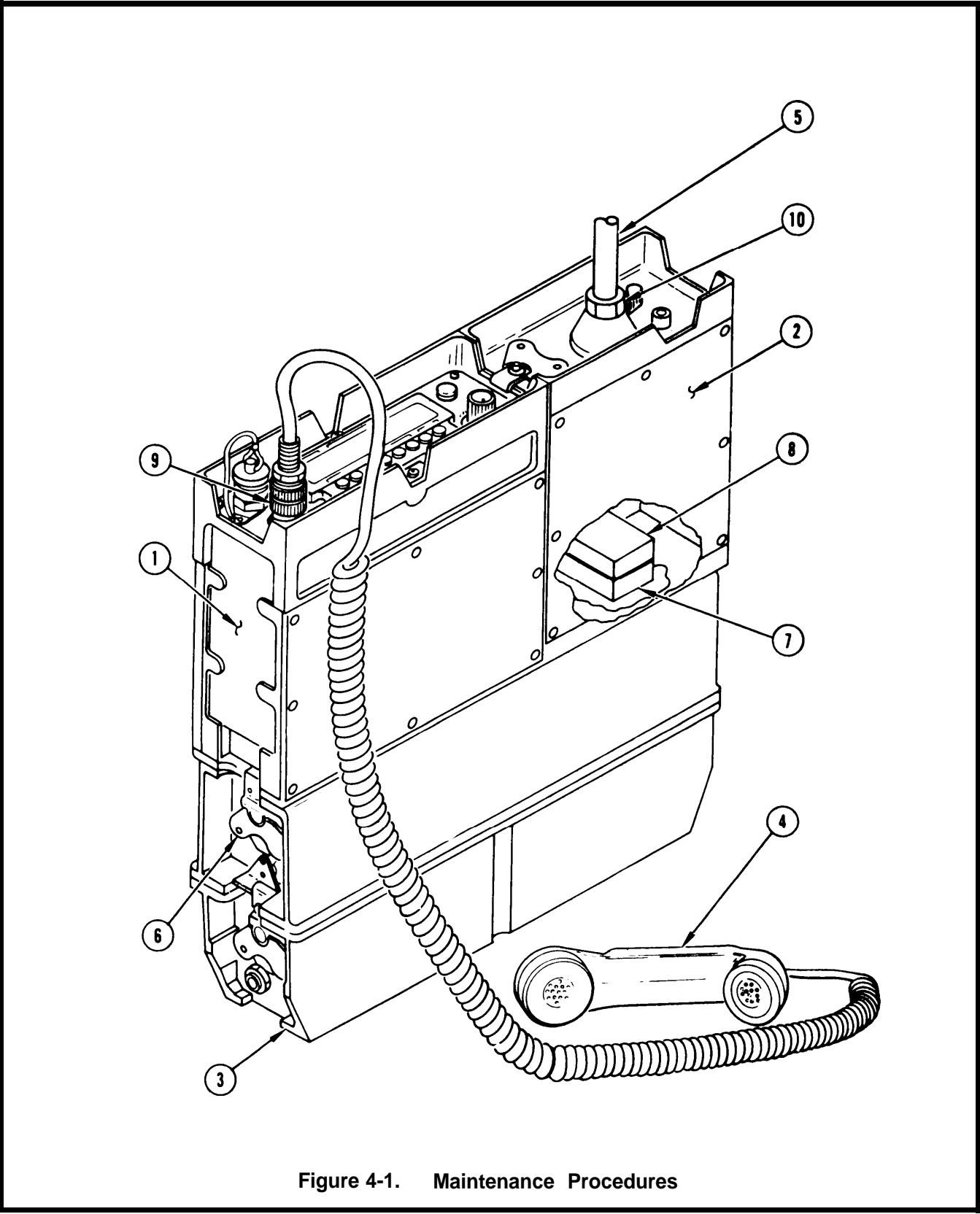


Figure 4-1. Maintenance Procedures

**Section II. LUBRICATION**

No lubrication is required during operator maintenance.

**Section III. OPERATOR TROUBLESHOOTING**

**FAULT INDICATION BY AUDIBLE TONES**

Item	Symptom	Probable Cause
1.	No receiver noise at turn-on	a. Dead battery b. RT faulty
2.	Clicking sound	Battery low
3.	No tune-up tone	a. Amplifier/coupler faulty b. RT faulty
4.	Tune-up tone then tune fault tone	a. Amplifier/coupler faulty b. Antenna connection bad
5.	Tune fault tone at turn-on	RT faulty or frequency selected is lower than 2 MHz
6.	No transmit sidetone	a. RT faulty b. Amplifier/coupler faulty
7.	No receiver audio	a. Volume too low b. Antenna connection bad c. RT faulty d. Amplifier/coupler faulty

**Section IV. PREOPERATIONAL CHECK**

**INTRODUCTION**

The operator preoperational check is performed when:

- any unit or accessory is replaced to verify the system is operating properly
- the radio set does not operate in accordance with operating procedures

Another similar radio set is needed to perform this procedure. If any of the requirements are not met or if fault tones are evident, refer to organizational troubleshooting on page 5-3.

**PREOPERATIONAL CHECK (1 of 3), fig 4-2**

Tools:	Materials/Parts:	Personnel Required:
TK-101/G	None	1

1. Verify installation instructions procedure on *page 2-4* has been performed.
2. Verify there is no evident damage that affect operation.

NOTE

An automatic power-up test of RT is run, lasting approximately 4 seconds. If operational, the RT display indicates the digit O and asterisk for all characters during test. The **RT ECCM, DTRCV, VTRCV, USB, LSB** and unused display indicators should turn on. If test is successful, RT display changes to indicate frequency, sideband, and mode of operation last used. If test is unsuccessful, RT display alternately indicates failed internal component and **NO-GO**. RT must be repaired or replaced.

3. Turn RT **VOLUME OFF/MAX** switch (1) on and adjust for desired listening level of received noise in handset.

NOTE

Failure of RT display lights in steps 4 and 5 is not a high maintenance priority. Radio set under test will still perform its mission.

4. Press and hold **RT LIGHT** button (2). Display light turns on.
5. Release **RT LIGHT** button (2). Display light turns off immediately.
6. Press and release **RT FREQUENCY KHz** pushbuttons (6) to select authorized operating frequency of a similar radio set.
7. Verify authorized operating frequency is selected on similar radio.
8. Verify amplifier coupler **ANT SEL** switch (3) is set to whip (top).
9. Press and release left-hand **RT MODE** pushbutton (5) until **V RCV** indicator turns on.
10. Press and release right-hand **RT MODE** pushbutton (4) until **USB** indicator turns on.
11. Verify **USB** has been selected on RT indicator of similar radio set.
12. Verify transmission from similar unit is clearly heard in handset.
13. Press and release right-hand **RT MODE** pushbutton (4) until **LSB** indicator turns on.
14. Verify **LSB** has been selected on RT indicator of similar radio set.
15. Verify transmission from similar radio set is clearly heard in handset.
16. Press and release right-hand **RT MODE** pushbutton (4) until **USB** indicator turns on.
17. Verify **USB** has been selected on RT indicator of similar radio set.
16. Press and release left-hand **RT MODE** pushbutton until **VTR** (5) indicator turns on.
19. Press and release **RT FREQUENCY KHz** pushbuttons (6) to select another authorized operating frequency of a similar radio set.
20. Verify authorized operating frequency is selected on similar radio.

**PREOPERATIONAL CHECK (2 of 3)**

**TEST (CONT)**

**WARNING**

Do not touch or stand near antenna when equipment is energized. Dangerously high rf voltages exist on and around antennas and antenna terminals during transmission. Protect yourself by knowing safety procedures in TB SIG 291.

**CAUTION**

To prevent equipment damage, avoid operating transmitter with antenna touching any natural or man-made object (metal, power lines, etc).

21. Press and release PTT switch to begin tuning radio set under test to antenna.

**NOTE**

A series of beeps may be heard in handset following tuning indicator. These beeps indicate a tune fault has occurred. This maybe corrected by one of the following:

- Turn the radio off and back on
- Switch to **D RCV** or **V RCV** mode and back to **DTR** or **VTR** mode
- Change frequency by at least 1 kHz

22. Verify a continuous, high-pitched tone (tuning indicator) is heard in handset for approximately 3 seconds, depending on frequency of operation selected. If no tone is heard, press and release PTT switch again.

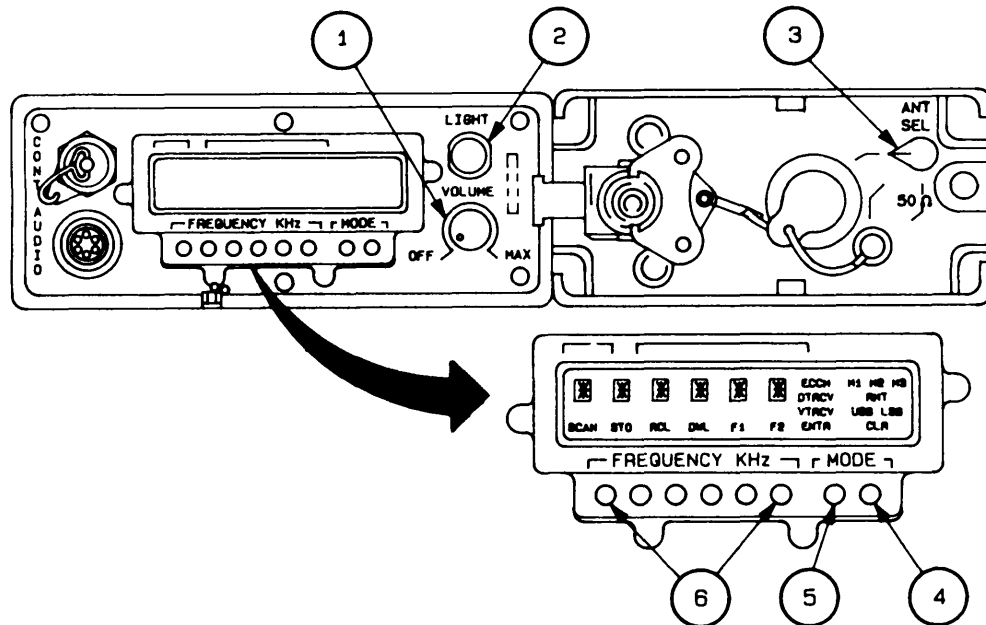


Figure 4-2. Preoperational Check

**PREOPERATIONAL CHECK (3 of 3)**

**TEST (CONT)**

**NOTE**

One short beep (vswr indicator) maybe heard at beginning of transmission. This is normal.

23. Press and hold PTT switch and speak into handset. Establish two-way communication with similar radio set. The voice audio should be heard in handset when transmitting. Check quality of transmitted signals.
24. Release PTT switch to hear reply from similar radio set when transmission is complete. If similar radio set is heard, check quality of received signals.
25. Readjust RT **VOLUME OFF/MAX** switch **(1)** to a comfortable listening position.
26. When communications are completed, set RT **VOLUME OFF/MAX** switch **(1)** to OFF.



## CHAPTER 5 ORGANIZATIONAL MAINTENANCE

### Section I. REPAIR PARTS; SPECIAL TOOLS; TEST, MEASUREMENT, AND DIAGNOSTIC EQUIPMENT (TMDE); SUPPORT EQUIPMENT; AND MATERIALS

#### **COMMON TOOLS AND EQUIPMENT**

U.S. Army, for authorized common tools and equipment refer to the Modified Table of Organization and Equipment (MTOE) applicable to your unit.

#### **REPAIR PARTS, SPECIAL TOOLS, TMDE, AND SUPPORT EQUIPMENT**

For a list of the repair parts and special tools used in organizational maintenance of the radio set, refer to the repair parts and special tools list, TM 11-5820-1046-20P. Tools and test equipment used in organizational maintenance of the radio set are listed in appendix B, Maintenance Allocation Chart.

#### **MATERIALS**

No materials are required for organizational maintenance of the radio sets.



## Section II. PMCS

There are no organizational level preventive maintenance checks and services. Refer to *page 3-9* for operator level preventive maintenance checks and services.

## Section III. ORGANIZATIONAL TROUBLESHOOTING

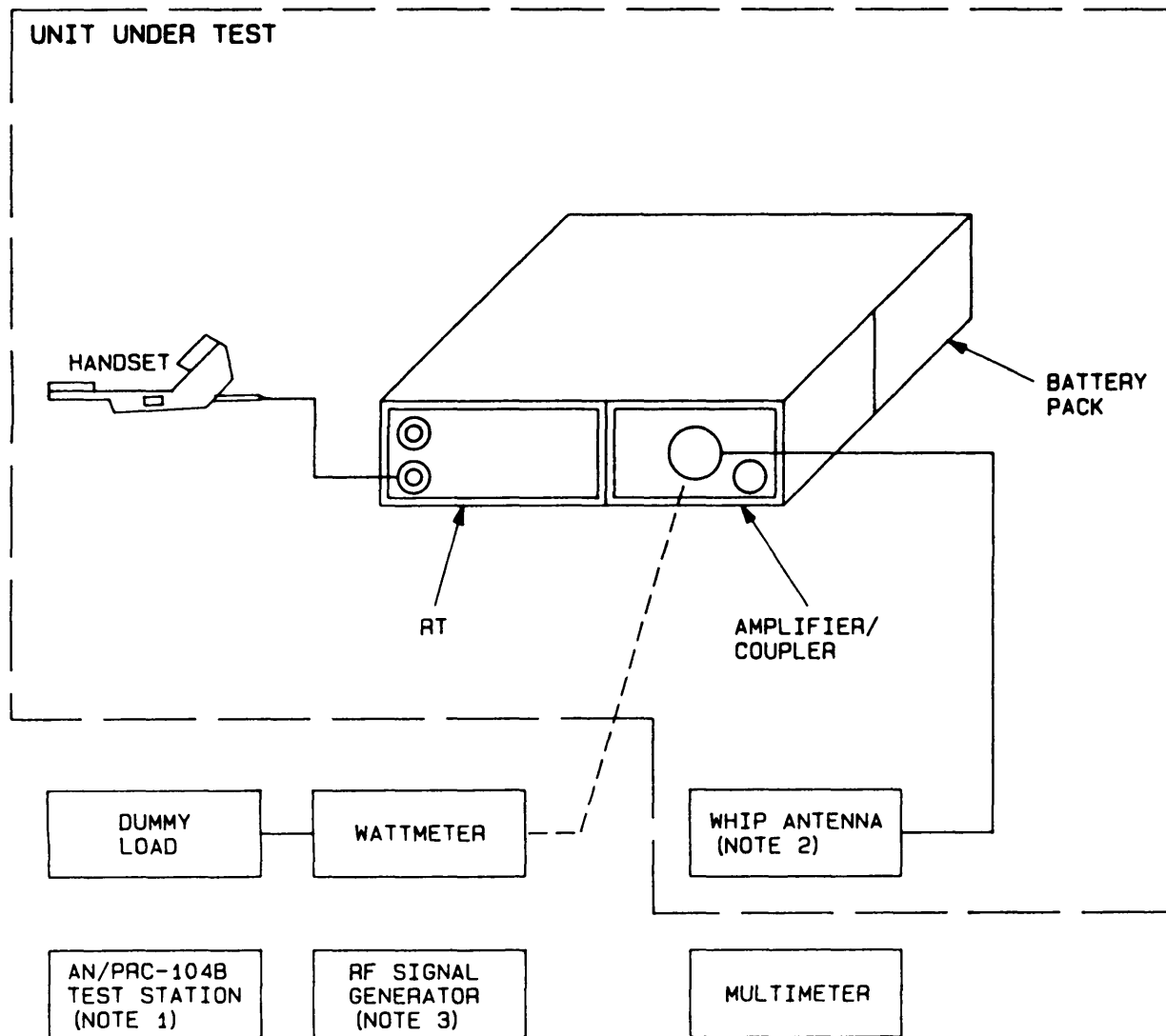
	Page
Introduction .....	5-3
Test Setup .....	5-4
Troubleshooting Flowchart.....	5-5
Receiver Sensitivity Test.....	5-11

### **INTRODUCTION**

Radio set organizational troubleshooting is performed using the test setup shown on *page 5-4*. Upon completion of radio set troubleshooting, the faulty unit is removed, if applicable, in accordance with maintenance instructions starting on *page 5-15*. The replacement unit is then installed. Upon installing a replacement unit, the radio set preoperational check procedure on *page 4-6* is run to verify proper operation.

**TEST SETUP, fig 5-1**

Detailed setup instructions and initial control settings are discussed in the troubleshooting charts starting on page 5-5. Distinct audio tones produced by the radio set, along with measurements taken with an rf wattmeter and a multimeter, will aid you in isolating a faulty unit.

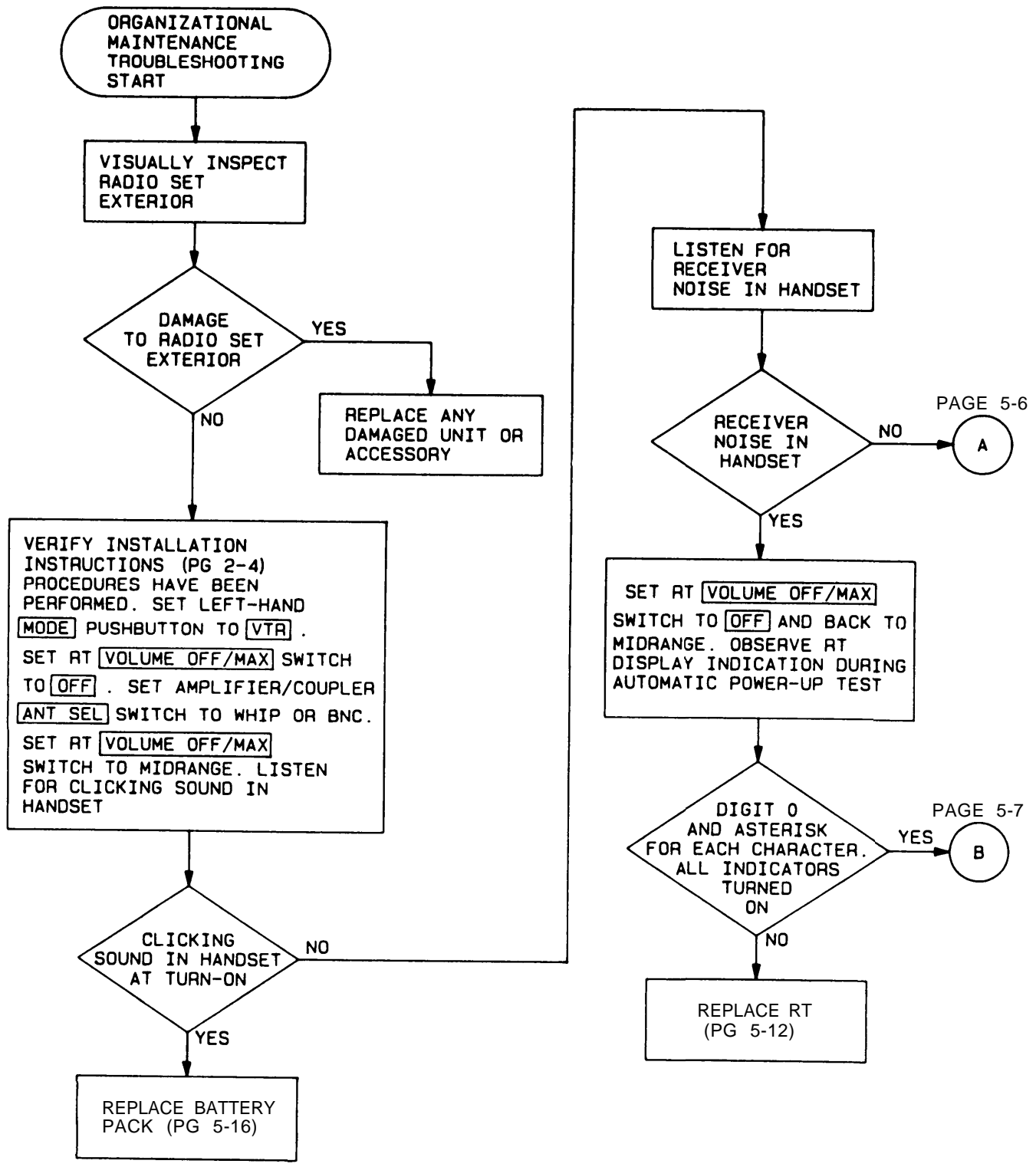


NOTES:

1. TEST STATION SHOULD BE WITHIN 50 METERS OF UNIT UNDER TEST AND SET TO SAME FREQUENCY.
2. OTHER ANTENNA CONFIGURATIONS CAN BE USED.
3. MARINE CORPS ONLY

**Figure 5-1. Test Setup**

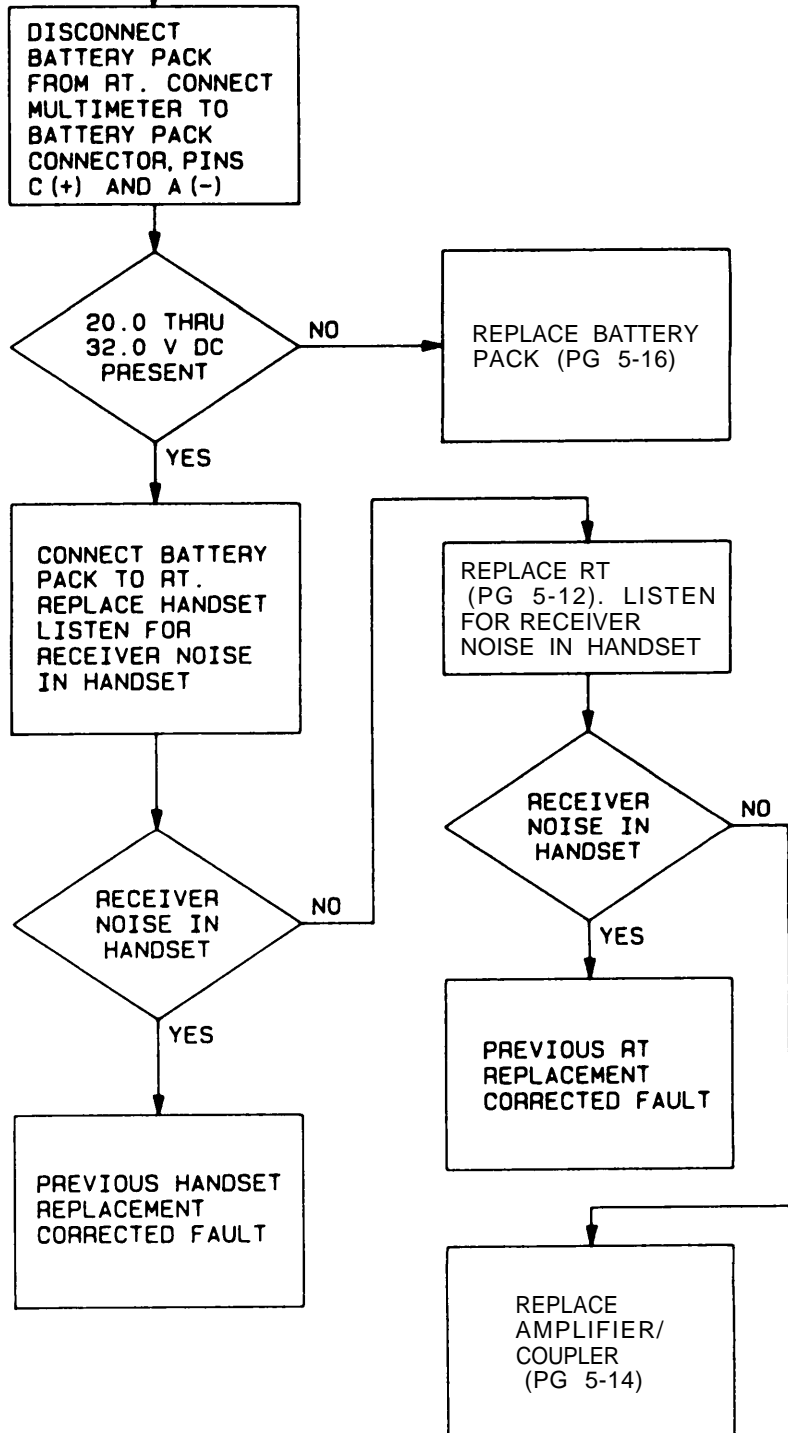
**TROUBLESHOOTING FLOWCHART (1 of 6)**



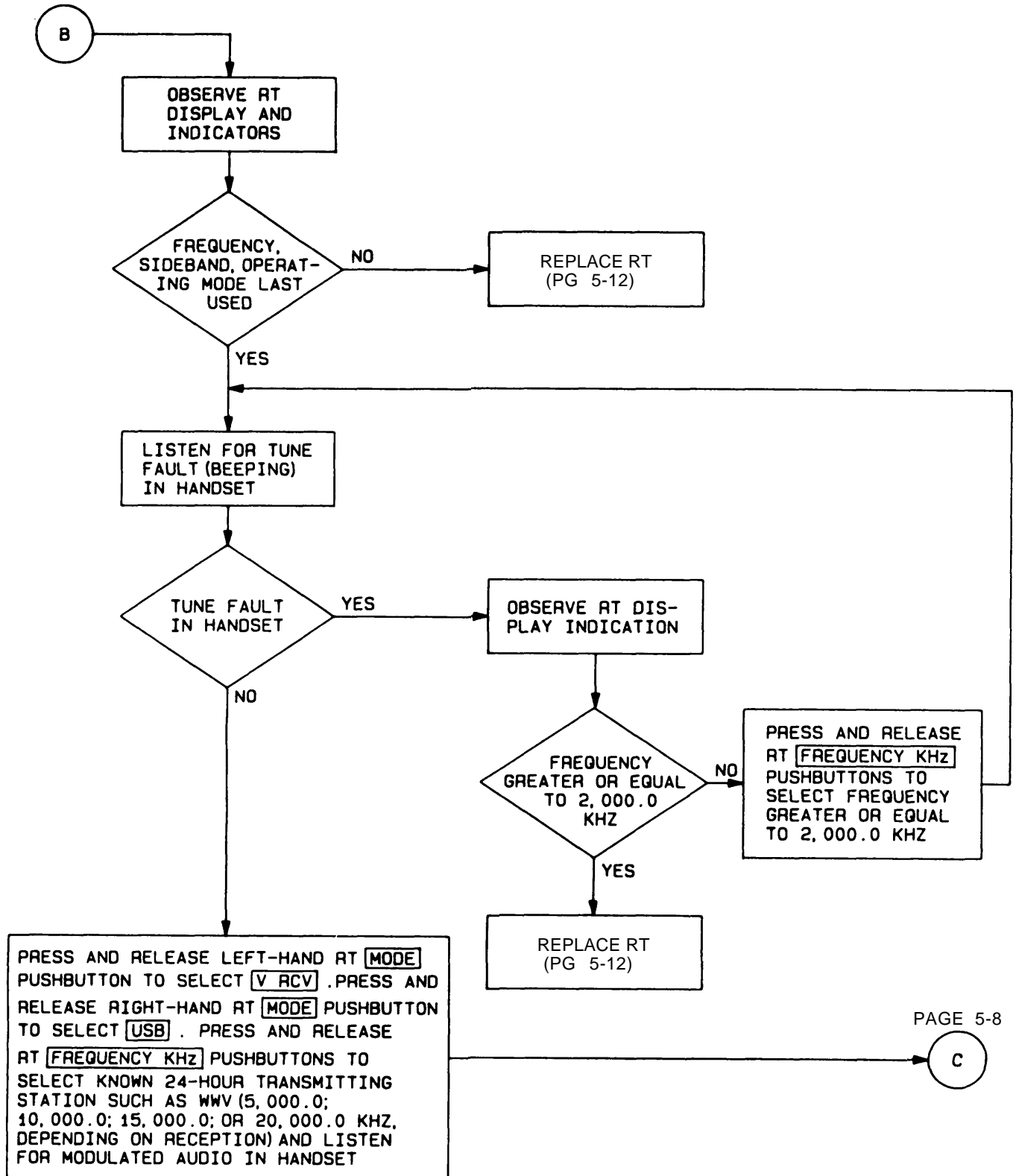
**TROUBLESHOOTING FLOWCHART (2 of 6)**

PAGE 5-5

A



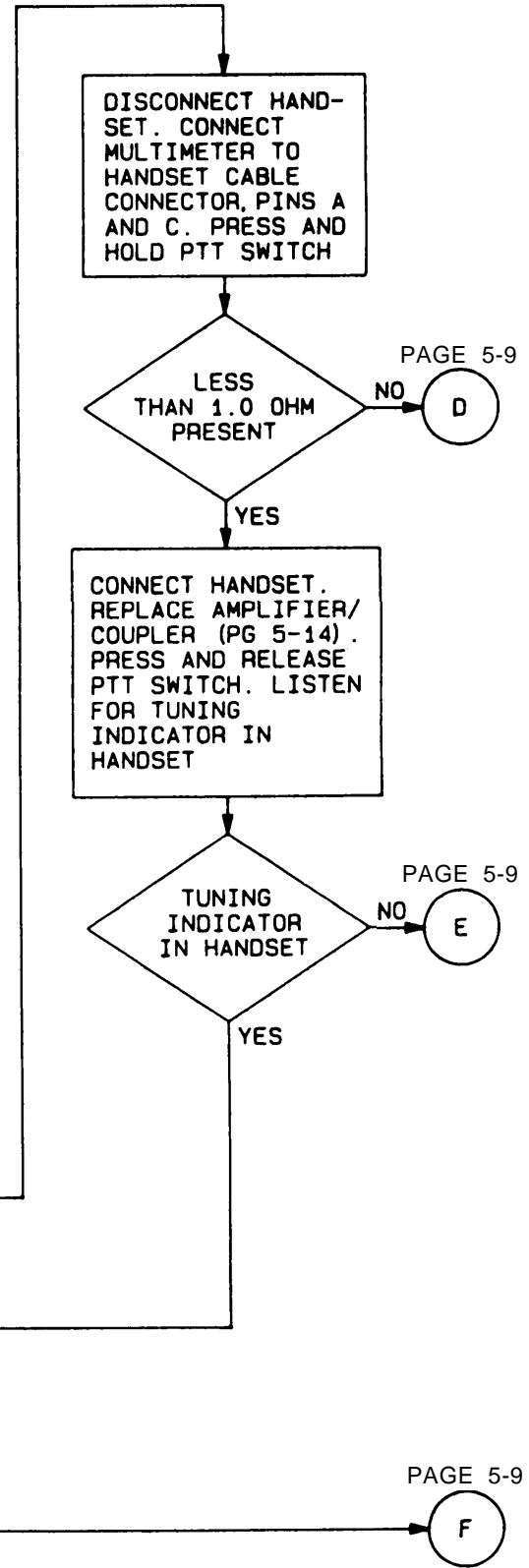
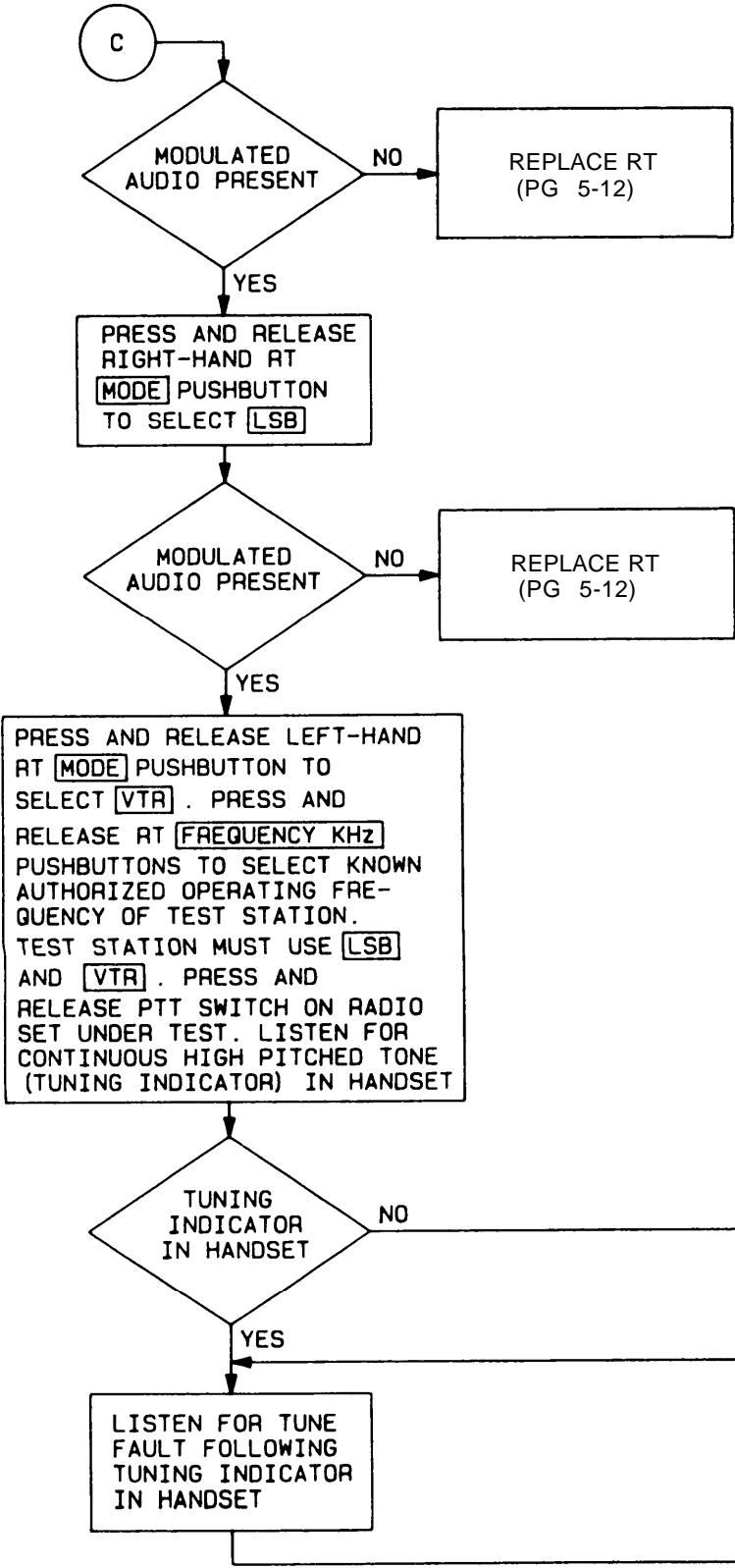
PAGE 5-5



PAGE 5-8

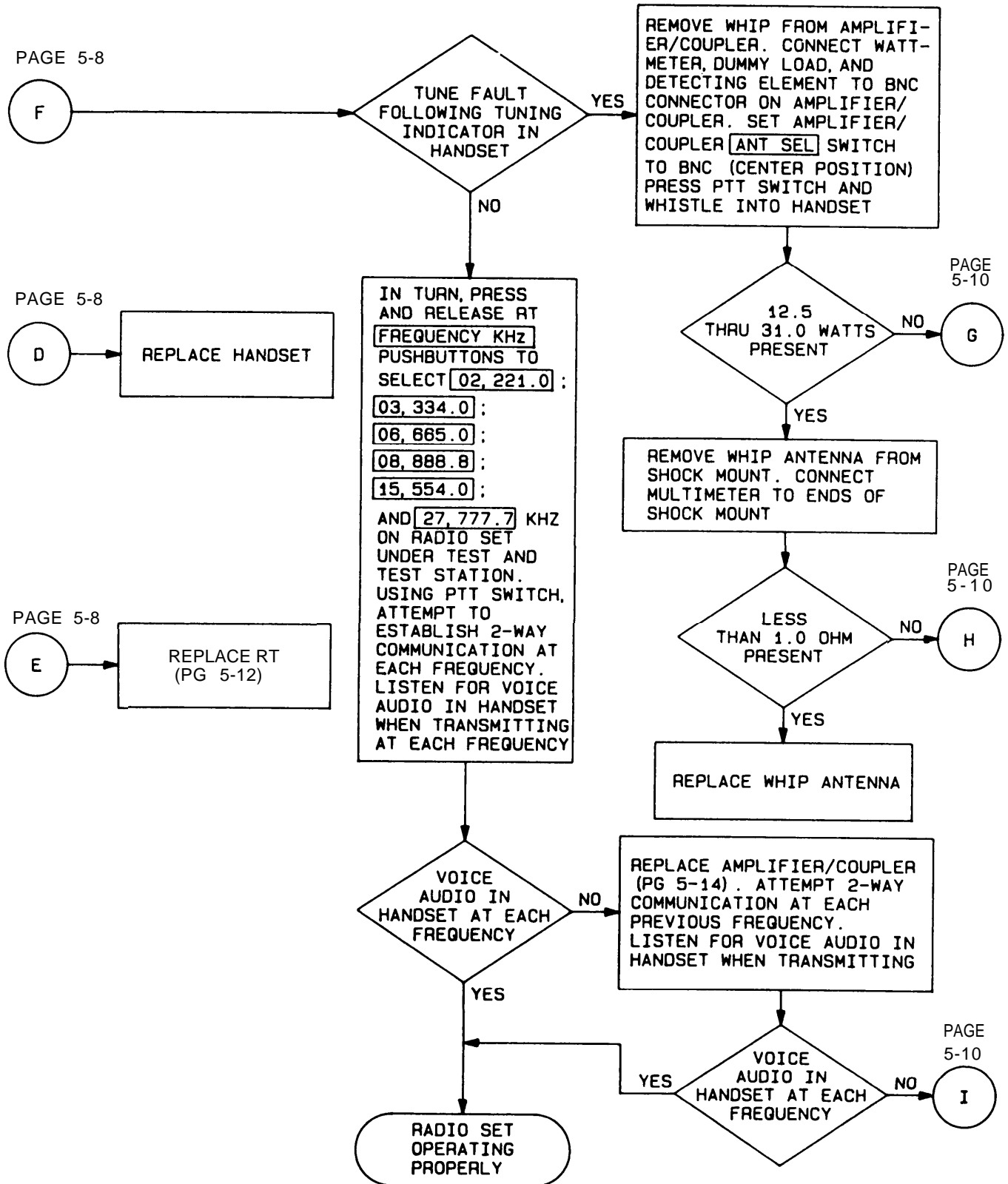
**TROUBLESHOOTING FLOWCHART (4 of 6)**

PAGE 5-7

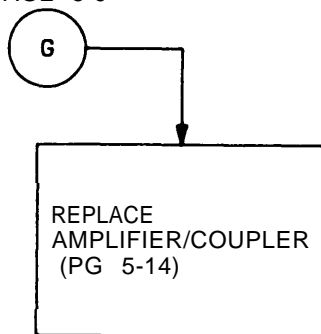




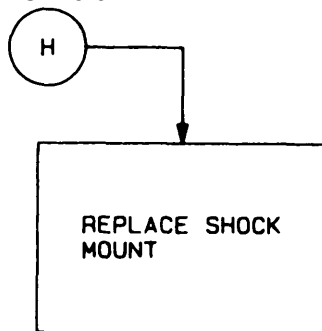
**TROUBLESHOOTING FLOWCHART (5 of 6)**



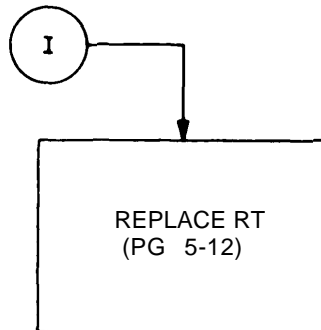
PAGE 5-9



PAGE 5-9

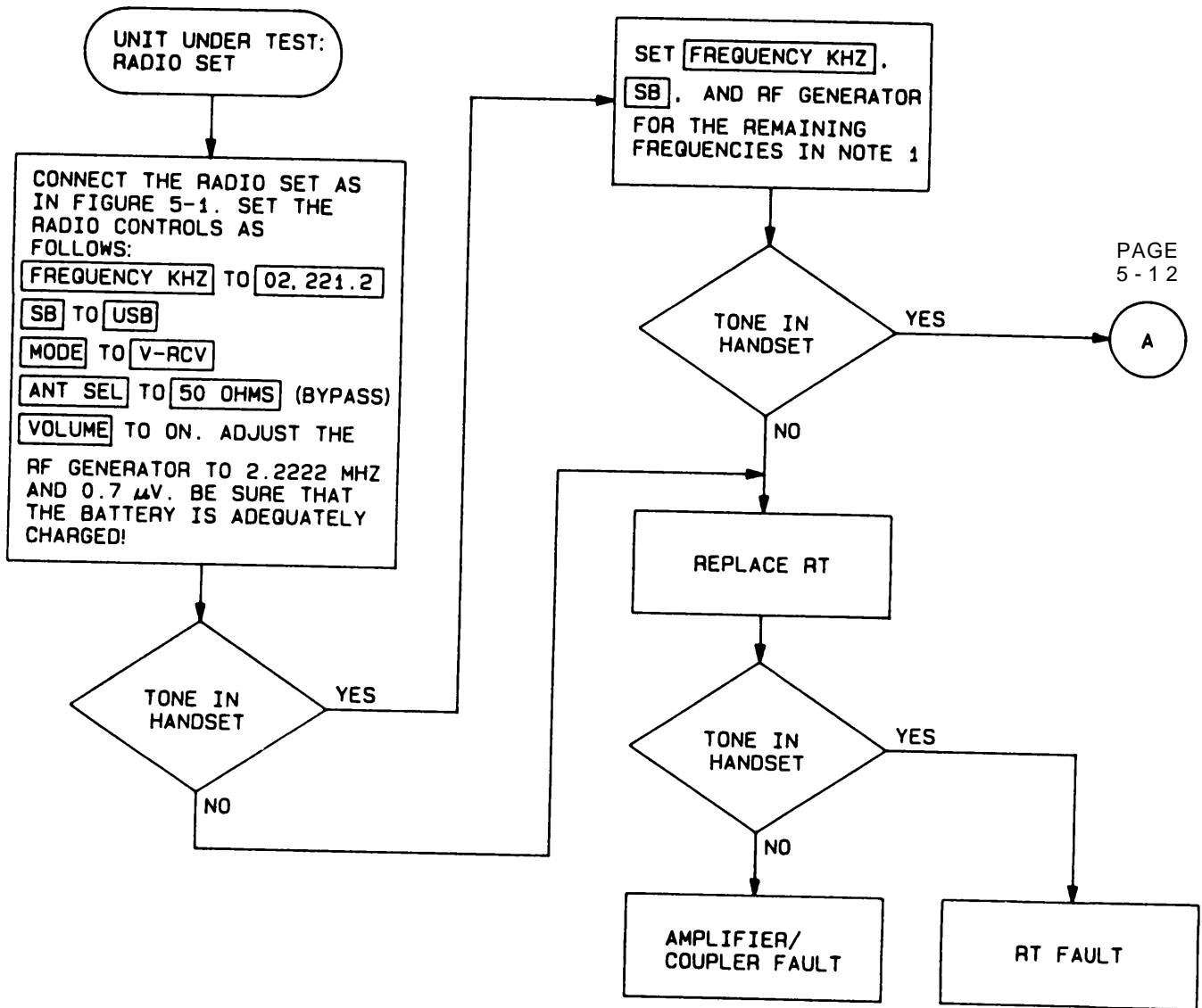


PAGE 5-9



**RECEIVER SENSITIVITY TEST (1 of 3)**

**(MARINE CORPS ONLY)**



PAGE 5-12

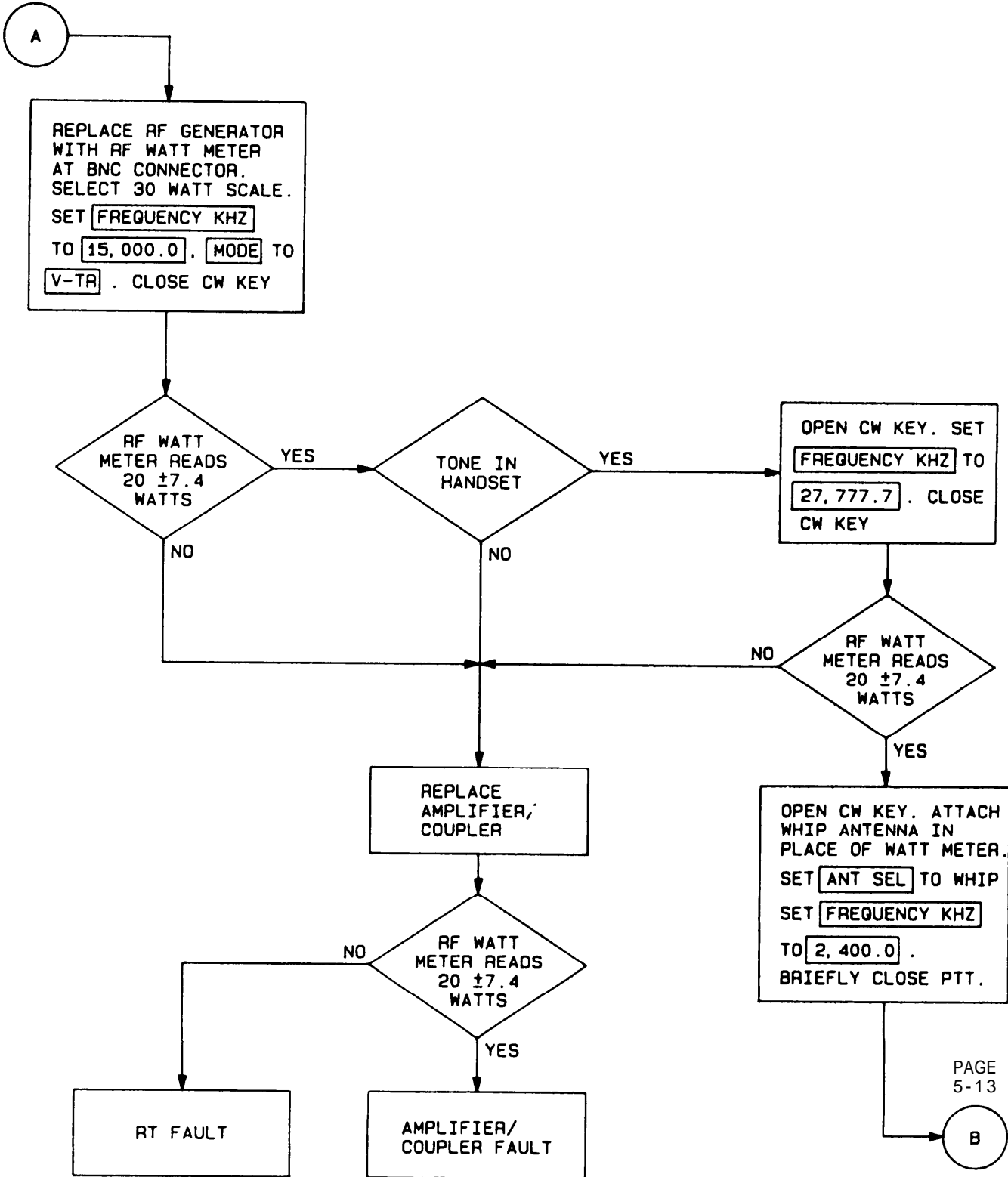
NOTE 1.

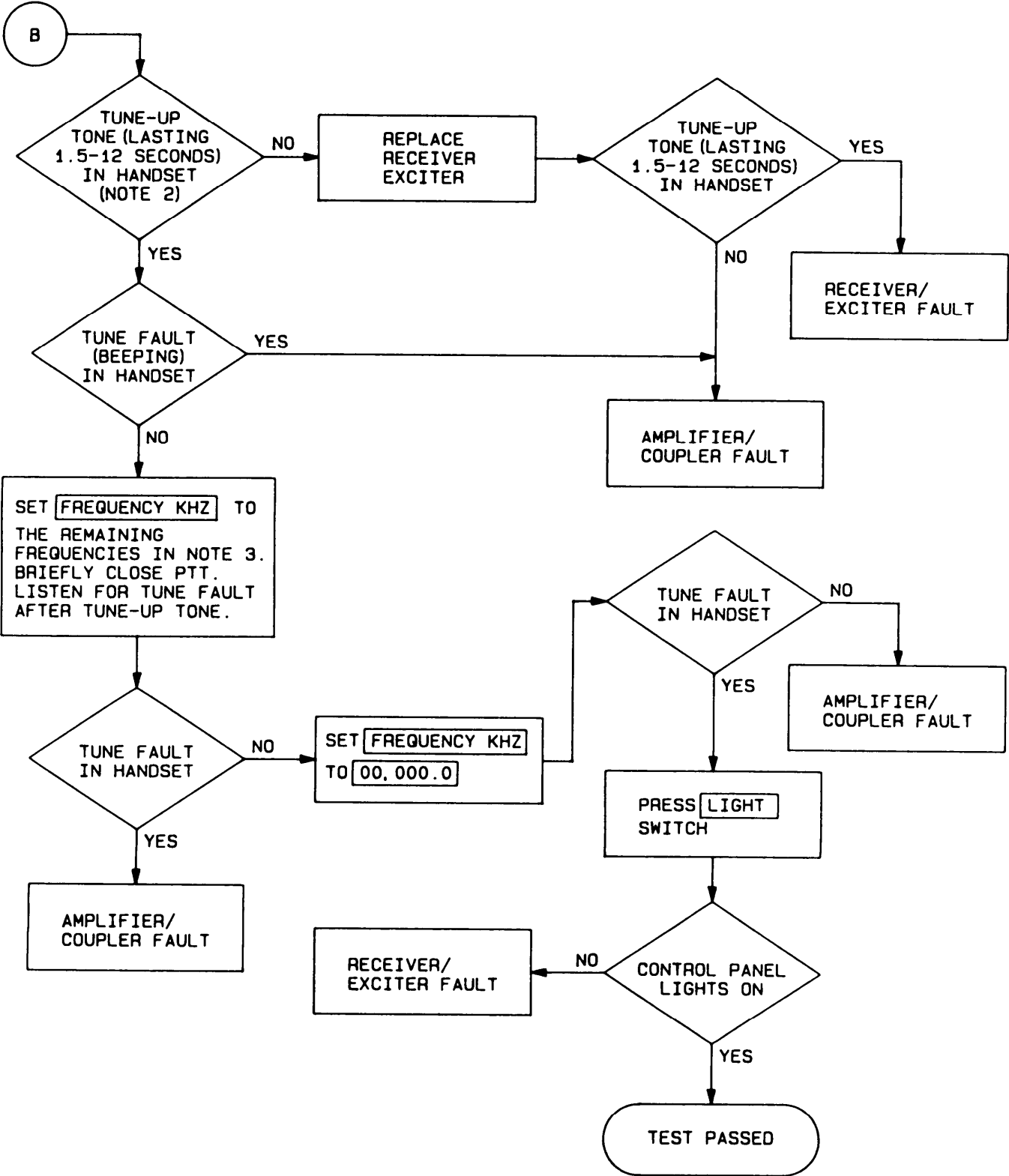
TEST FREQUENCY	RADIO SET FREQUENCY	SIDEBAND	RF GENERATOR FREQUENCY
1.	2,221.2 KHZ	USB	2.2222 MHZ
2.	3,334.3 KHZ	LSB	3.3333 MHZ
3.	6,665.6 KHZ	USB	6.6666 MHZ
4.	8,889.8 KHZ	LSB	8.8888 MHZ
5.	15,554.5 KHZ	US8	15.5555 MHZ
6.	29,993.9 KHZ	LSB	29.9929 MHZ

NOTE 2. TUNE-UP TONE WILL ONLY BE HEARD FIRST TIME PTT IS CLOSED AFTER THE FREQUENCY IS CHANGED, AND ALSO AFTER MODE IS CHANGED FROM V-TR TO V-RCV AND BACK TO V-TR

NOTE 3. TEST FREQUENCIES FOR IMPEDANCE MATCHING:

1. 2,400.0	5. 8,500.0	9. 25,000.0
2. 3,200.0	6. 12,000.0	10. 27,000.0
3. 4,300.0	7. 16,000.0	11. 29,000.0
4. 6,000.0	8. 20,000.0	







**Section IV. MAINTENANCE PROCEDURES**

	Page
Introduction .....	5-15
RT Removal and Replacement .....	5-15
Amplifier/Coupler Removal and Replacement .....	5-17
Battery Pack Removal and Replacement .....	5-18

**INTRODUCTION**

To verify proper operation, the preoperational check procedure on *page 4-6* should be run when a replacement unit is installed.

<b>INITIAL SETUP</b>		
<b>Tools:</b>	<b>Material/Parts:</b>	<b>Personnel Required:</b>
None	None	1
<b>REMOVAL</b>		
<ol style="list-style-type: none"> <li>1. Lay RT <b>(2)</b> and amplifier/coupler <b>(3)</b> on fiat surface and align guide with hole between the two units.</li> <li>2. Verify <b>VOLUME OFF/MAX</b> switch on RT is set to <b>OFF</b>.</li> <li>3. Remove battery pack <b>(1)</b> in accordance with removal instructions on <i>page 5-18</i>.</li> <li>3. Lay latched RT <b>(2)</b> and amplifier/coupler <b>(3)</b> on a fiat surface and unfasten front and rear latches <b>(4)</b>, respectively, securing the RT and amplifier/coupler together.</li> <li>4. Carefully separate RT <b>(2)</b> from amplifier/coupler <b>(3)</b>.</li> </ol>		
<b>REPLACEMENT</b>		
<ol style="list-style-type: none"> <li>1. Lay RT <b>(2)</b> and amplifier/coupler <b>(3)</b> on fiat surface and align guide with hole between the two units.</li> <li>2. Secure RT <b>(2)</b> to amplifier/coupler <b>(3)</b> and fasten latches <b>(4)</b>.</li> <li>3. Replace battery pack <b>(1)</b> in accordance with replacement instructions on <i>page 5-18</i>.</li> </ol>		
<b>TEST</b>		
Perform preoperational check procedure on <i>page 4-6</i> .		

RT REMOVAL AND REPLACEMENT (2 of 2)

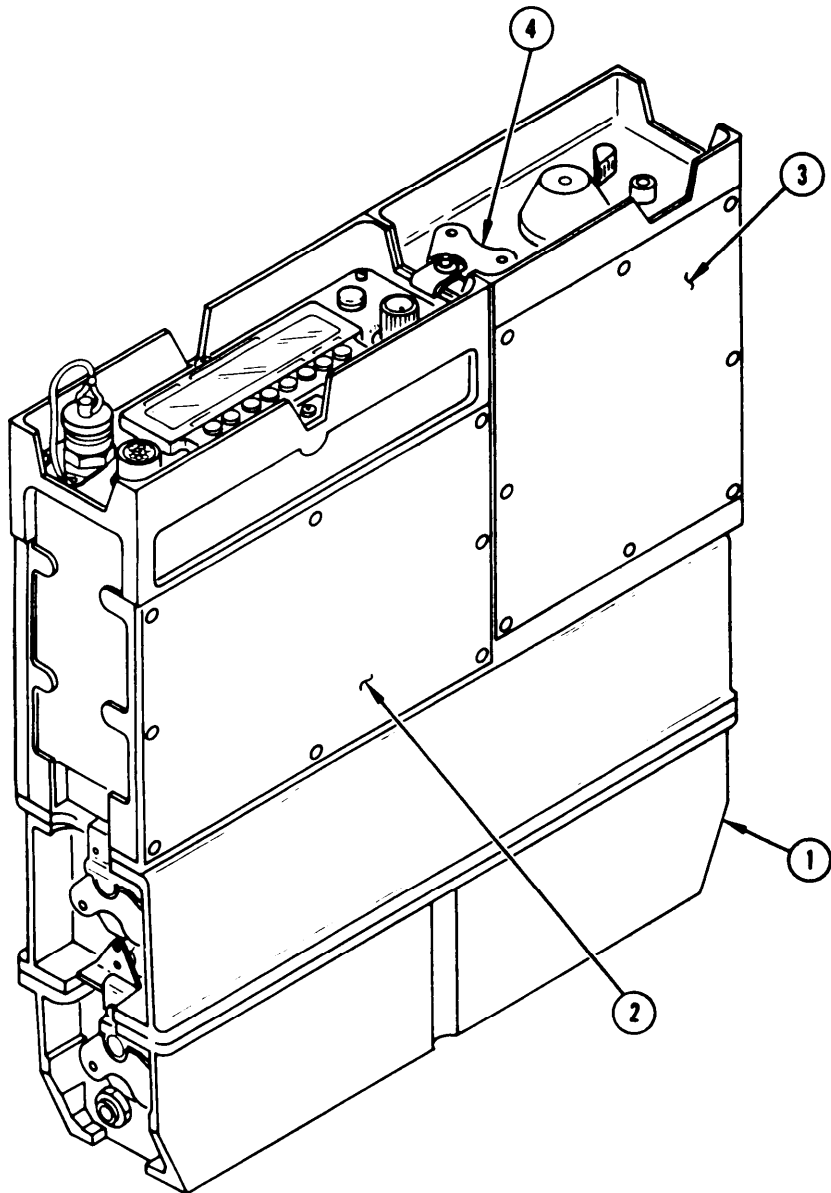


Figure 5-2. RT and Amplifier/Coupler Removal and Replacement



**AMPLIFIER/COUPLER REMOVAL AND REPLACEMENT, fig 5-2**

**INITIAL SETUP**

Tools	Material/Parts	Personnel Required:
None	None	1

1. Lay RT (2) and amplifier/coupler (3) on a flat surface and align guide with hole between the two units.
2. Verify **VOLUME OFF/MAX** switch on RT is set to **OFF**.
3. Remove battery pack (1) in accordance with removal instructions on page 5-18.
3. Lay latched RT (2) and amplifier/coupler (3) on a flat surface and unfasten front and rear latches (4), respectively, securing the RT and amplifier/coupler together.
4. Carefully separate amplifier/coupler (3) from RT (2).

**REPLACEMENT**

1. Lay RT (2) and amplifier/coupler (3) on a flat surface and align guide with hole between the two units.
2. Secure amplifier/coupler (3) to RT (2) and fasten latches (4).
3. Replace battery pack (1) in accordance with replacement instructions on page 5-18.

**TEST**

Perform preoperational check procedure on page 4-6.

**BATTERY PACK REMOVAL AND REPLACEMENT (1 of 2), fig 5-3**

**INITIAL SETUP**

Tools:	Material/Parts	Personnel Required:
None	None	1

**REMOVAL**

1. Verify RT **VOLUME OFF/MAX** switch is set to **OFF**.
2. Position radio set so RT **(1)** and amplifier/coupler **(2)** panels are facing you.
3. Loosen and unfasten 2 latches **(3)** that secure battery pack **(4)** to RT **(1)** and amplifier/coupler **(2)**.
4. Pull attached battery pack **(4)** toward rear of RT **(1)** and amplifier/coupler **(2)**. When battery pack connector **(5)** disengages from power connector **(6)** on rear of amplifier/coupler **(2)**, remove battery pack **(4)**.

**REPLACEMENT**

1. Position RT **(1)** with attached amplifier/coupler **(2)** facing you when ready to replace battery pack **(4)**.
2. Position battery pack **(4)** on back of RT **(1)** and attached amplifier/coupler **(2)**.
3. Pull battery pack **(4)** toward front of RT **(1)** and amplifier/coupler **(2)**. Power connector **(6)** on rear of amplifier/coupler **(2)** will engage battery pack connector **(5)**.
4. Secure battery pack **(4)** to RT **(1)** and attached amplifier/coupler **(2)** and fasten and tighten 2 latches **(3)**.

**TEST**

Perform preoperational check procedure on *page 4-6*.

**BATTERY PACK REMOVAL AND REPLACEMENT (2 of 2)**

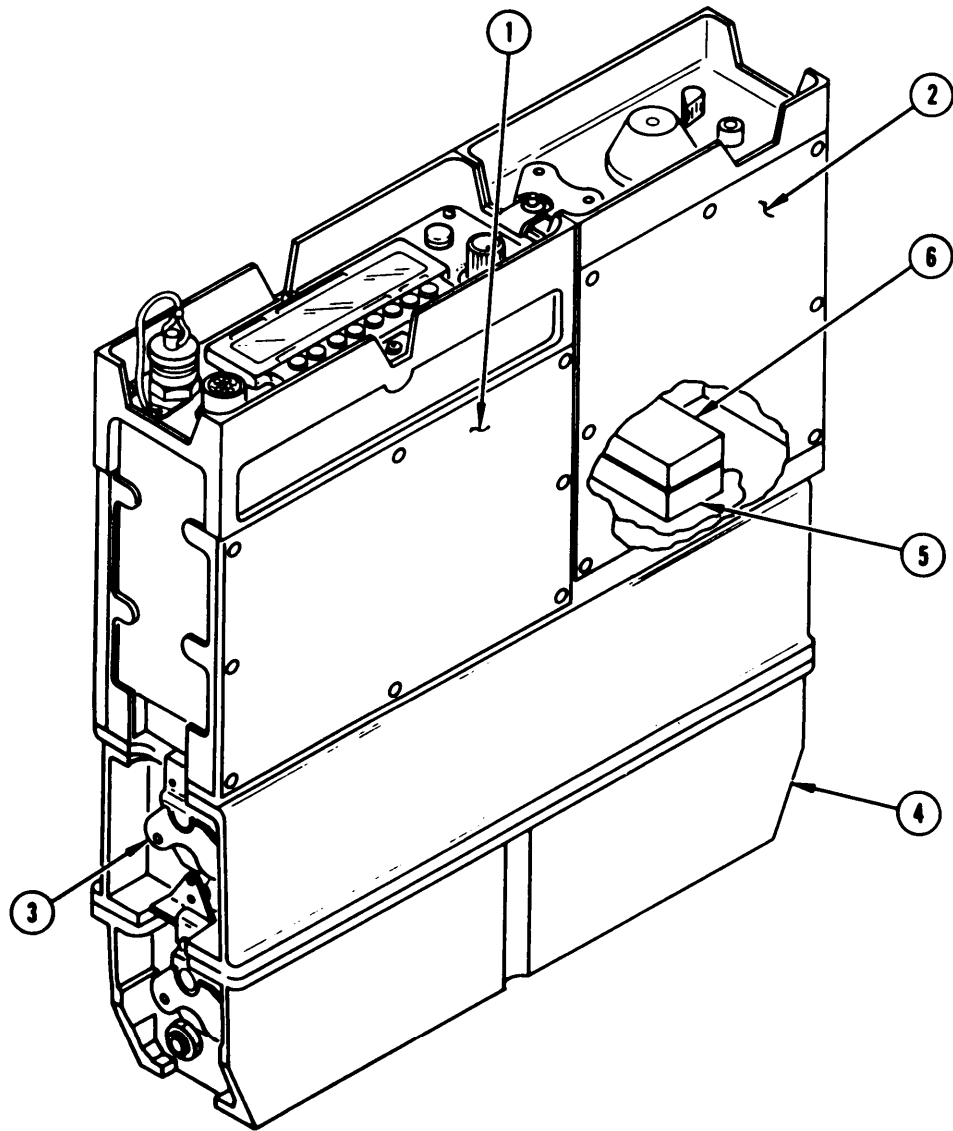


Figure 5-3. Battery Pack Removal and Replacement



## CHAPTER 6

### PREPARATION FOR STORAGE OR SHIPMENT

#### STORAGE

The radio set should be stored in the best available site that provides protection from the elements and unauthorized personnel. Covered sites are the best. If there is not enough covered space for all items, keep items covered that are most likely to be damaged by the weather. Items that cannot be covered should be stored on hard surfaces that drain well. Trucks, vans, and containers may be used if they give the best available protection. Be sure to comply with the fire plan for fire-fighting equipment and personnel.

#### WARNING

A lithium-sulfur dioxide (lithium) battery used with the radio set contains pressurized sulfur dioxide (SO<sub>2</sub>) gas. To prevent rupture, do not heat, short circuit, crush, puncture, mutilate, or disassemble lithium batteries; do not recharge or test lithium batteries for capacity; do not use a Halon type fire extinguisher on a lithium battery.

Do not use any lithium battery which shows the following signs of rupture: bulging, swelling, disfigurement, brown liquid in the plastic wrap, or a swollen plastic wrap. If the battery compartment becomes hot to the touch, or a hissing sound or the smell of SO<sub>2</sub> gas (rotten egg smell) is present, immediately turn off the equipment. Move the equipment to a well-ventilated area or leave the area.

In the event of a fire near a lithium battery, use a carbon dioxide (CO<sub>2</sub>) type extinguisher. Rapid cooling of lithium batteries is necessary to prevent venting and the potential exposure of lithium. In the event that lithium metal becomes involved in fire, the use of a graphite-based Class D fire extinguisher is recommended, such as Lith-X or MET-L-X.

Do not store lithium batteries with other hazardous materials and keep away from open flame or heat.

#### SHIPMENT

#### PREPARATION

Preparation consists of disassembling the radio set in accordance with organizational maintenance removal procedures on *pages 5-15 thru 5-19*.

#### PACKAGING

To package the radio set for reshipment, proceed as follows:

1. Place latched RT and amplifier/coupler in space provided in transit case.
2. Place handset, telegraph key (if used), antenna, and battery pack in transit case.
3. Replace transit case cover and fasten four latches.



## APPENDIX A REFERENCES

### SCOPE

This appendix lists all forms, field manuals, technical manuals, and miscellaneous publications referenced in this manual.

### FORMS

DA Form 2028  
DA Form 2028-2

NAVMC 10772  
SF 361  
SF 368

Recommended Changes to Publications and Blank Forms  
Recommended Changes to Equipment Technical Publications  
Recommended Changes to Technical Publications  
Transportation Discrepancy Report (TDR)  
Product Quality Deficiency Report

### FIELD MANUALS

FM 21-11  
FM 21-26

Artificial Respiration  
Map Reading

### TECHNICAL MANUALS

RS-07748A-50/4

Rebuild Standards for Radio Set AN/PRC-104

TM 07748B-45/2/TM 11-5820-1046-40

Field and Depot Maintenance Instructions for Radio Set AN/PRC-104

TM 11-5820-1046-20P

Organizational Maintenance Repair Parts and Special Tools List for Radio Set AN/PRC-104

TM 11-5820-1046-40P

General Support Maintenance Repair Parts and Special Tools List for Radio Set AN/PRC-104

TM 4700-15/1

Equipment Record Procedures

TM 750-244-2

Procedures for Destruction of Army Electronic Materiel to Prevent Enemy Use (Electronic Command)

### MISCELLANEOUS PUBLICATIONS

AMDF

(AR708-1) IAW Packaging Segment of AMDF by NSN

AR 55-38

Reporting of Transportation Discrepancies in Shipments

AR 735-11-2

Reporting of Item and Packaging Discrepancies

**MISCELLANEOUS PUBLICATIONS (Cont)**

AR 750-244-2	Destruction of Army Materiel
AR 755-2	Disposal of Excess, Surplus, Foreign Excess, Captured, and Unwanted Material
CTA 8-100	Army Medical Department Expendable/Durable Items
CTA 50-970	Expendable/Durable Items (Except Medical, Class V, Repair Parts, and Heraldic Items)
DA Pam 25-30	Consolidated Index of Army Publications and Blank Forms
DA Pam 738-750	The Army Maintenance-Management System (TAMMS)
MCO 4430.3J	Report of Discrepancy (ROD)
MCO P4450.7	Marine Corps Warehousing Manual
MCO P4610.19	Transportation and Travel Record of Transportation Discrepancies
SB 11-131	Vehicular Radio Sets and Authorized Installations
SB 11-573	Painting and Preserving of Supplies Available for Field Use for Electronics Command Equipment
SB 11-614	Caution Notice for Antenna Bases, Towers, and Other Mast Structures
SB 38-100	Preservation, Packaging, Packing and Marking Materials, Supplies and Equipment Used by the Army
TB 43-0118	Field Instructions for Painting and Preserving Electronics Command Equipment Including Camouflage Pattern Painting of Electrical Equipment Shelters
TB SIG 291	Safety Measures to Be Observed When Installing and Using Whip Antennas, Field Type Masts, Towers, Antennas, and Metal Poles That Are Used with Communication, Radar, and Direction Finder Equipment



**(ARMY ONLY)**  
**APPENDIX B**  
**MAINTENANCE ALLOCATION CHART**

**Section I. INTRODUCTION**

**GENERAL**

This appendix provides a summary of the maintenance operations for STAJ. It authorizes categories of maintenance for specific maintenance functions on repairable items and components and the tools and equipment required to perform each function. This appendix may be used as an aid in planning maintenance operations.

**MAINTENANCE FUNCTIONS**

Maintenance functions will be limited to and defined as follows:

**a. Inspect.** To determine the serviceability of an item by comparing its physical, mechanical, and/or electrical characteristics with established standards through examination.

**b. Test.** To verify serviceability and to detect incipient failure by measuring the mechanical, or electrical characteristics of an item and comparing those characteristics with prescribed standards.

**c. Service.** Operations required periodically to keep an item in proper operating condition, ie, to clean (decontaminate), to preserve, to drain, to paint, or to replenish fuel, lubricants, hydraulic fluids, or compressed air supplies.

**d. Adjust.** To maintain, within prescribed limits, by bringing into proper or exact position, or by setting the operating characteristics to the specified parameters.

**e. Aline.** To adjust specified variable elements of an item to bring about optimum or desired performance.

**f. Calibrate.** To determine and cause corrections to be made or adjusted on instruments or test, measuring, and diagnostic equipments used in precision measurement. Consists of comparisons of two instruments, one of which is a certified standard of known accuracy, to detect and adjust any discrepancy in the accuracy of the instrument being compared.

**g. Install.** The act of emplacing, seating, or fixing into position an item, part, or module (component or assembly) in a manner to allow the proper functioning of an equipment or system.

**h. Replace.** The act of substituting a serviceable like type part, subassembly, or module (component or assembly) for an unserviceable counterpart.

**i. Repair.** The application of maintenance services (inspect, test, service, adjust, align, calibrate, replace) or other maintenance actions (welding, grinding, riveting, straightening, facing, remachining, or resurfacing) to restore serviceability to an item by correcting specific damage, fault, malfunction, or failure in a part, subassembly, module (component or assembly), end item, or system.

**j. Overhaul.** That maintenance effort (service/action) necessary to restore an item to a completely serviceable/operational condition as prescribed by maintenance standards (ie, DMWR) in appropriate technical publications. Overhaul is normally the highest degree of maintenance performed by the Army. Overhaul does not normally return an item to a like new condition.

**k. Rebuild.** Consists of those services/actions necessary for the restoration of unserviceable equipment to a like new condition in accordance with original manufacturing standards. Rebuild is the highest degree of materiel maintenance applied to Army equipment. The rebuild operation includes the act of returning to zero those age measurements (hours/miles, etc) considered in classifying Army equipment/components.

### **EXPLANATION OF COLUMNS IN THE MAC, SECTION II**

**a. Column (1) — Group Number.** Column 1 lists group numbers, the purpose of which is to identify components, assemblies, subassemblies, and modules with the next higher assembly.

**b. Column (2) — Component/Assembly.** Column 2 contains the noun names of components, assemblies, subassemblies, and modules for which maintenance is authorized.

**c. Column (3) — Maintenance Function.** Column 3 lists the functions to be performed on the item listed in column 2. When items are listed without maintenance functions, it is solely for the purpose of having the group numbers in the MAC and RPSTL coincide.

**d. Column (4) — Maintenance Category.** Column 4 specifies, by the listing of a “work item” figure in the appropriate subcolumn(s), the lowest level of maintenance authorized to perform the function listed in column 3. This figure represents the active time required to perform that maintenance function at the indicated category of maintenance. If the number or complexity of the tasks within the listed maintenance function varies at different maintenance categories, appropriate “work time” figures will be shown for each category. The number of task-hours specified by the “work time” figure represents the average time required to restore an item (assembly, subassembly, component, module, end item, or system) to a serviceable condition under typical field operating conditions. This time includes preparation time, troubleshooting time, and quality assurance/quality control time in addition to the time required to perform the specific tasks identified for the maintenance functions authorized in the maintenance allocation chart. Subcolumns of column 4 are as follows:

- C — Operator/Crew
- O — Organizational
- F — Direct Support
- H — General Support
- D — Depot

**e. Column (5) — Tools and Equipment.** Column 5 specifies, by code, those common tool sets (not individual tools) and special tools, test, and support equipment required to perform the designated function.

**f. Column (6) — Remarks.** Column 6 contains an alphabetic code that leads to the remark in section IV, Remarks, which is pertinent to the item opposite the particular code.

**EXPLANATION OF COLUMNS IN TOOL AND TEST EQUIPMENT REQUIREMENTS, SECTION III**

**a. Tool or Test Equipment Reference Code.** The numbers in this column coincide with the numbers used in the tools and equipment column of the MAC. The numbers indicate the applicable tool or test equipment for the maintenance functions.

**b. Maintenance Category.** The codes in this column indicate the maintenance category allocated the tool or test equipment.

**c. Nomenclature.** This column lists the noun name and nomenclature of the tools and test equipment required to perform the maintenance functions.

**d. National/NATO Stock Number.** This column lists the National/NATO stock number of the specific tool or test equipment.

**e. Tool Number.** This column lists the manufacturer's part number of the tool followed by the Commercial and Government Entity (5-digit) in parentheses.

**EXPLANATION OF COLUMNS IN REMARKS, SECTION IV**

**a. Reference Code.** This code refers to the appropriate item in section II, column 6.

**b. Remarks.** This column provides the required explanatory information necessary to clarify items appearing in section II.

**Section II. MAINTENANCE ALLOCATION CHART  
FOR  
RADIO SET AN/PRC-104B**

(1) Group Number	(2) Component/Assembly	(3) Maintenance Function	(4) Maintenance Category					(6) Tools and Eqpt	(6) Remarks
			C	O	F	H	D		
00	RADIO SET AN/PRC-104B	SERVICE INSPECT TEST TEST REPAIR	0.2 0.2 0.2	0.2				1,9,10,11 1,9,10,11	A B D,F
01	RECEIVER-TRANSMITTER RT-1209A/URC	REPLACE SERVICE INSPECT TEST REPAIR OVERHAUL	0.1 0.1	0.1		0.4 0.4	2.5	1,2,7 thru 12,14 1,2,7 thru 12,14 1 thru 11,14,20	G K E,H,N I
0101	HOUSING, RT ASSEMBLY	REPLACE TEST REPAIR				0.3	0.5 0.8	12 1 1,2,7 thru 12,14	K,I E,H,I
010101	PTD CA ASSEMBLY FLEX	REPLACE TEST REPAIR					0.6 0.4 0.4	12 1 1,12,19	C,I E,H,I
0102	HARMONIC FILTER ASSEMBLY	REPLACE TEST REPAIR ALIGN				0.1	0.3 0.4 0.1	12 1,3,thru 12,14,20 1,2,7 thru 12, 14,19 1,7 thru 11,14,20	C,I H,I I
0103	MODULATOR/DEMODULATOR ASSEMBLY	REPLACE				0.1		12	P
0104	SYNTHESIZER ASSEMBLY	REPLACE				0.1		12	P
0105	ELECTRONIC FRONT PANEL	REPLACE				0.1		12	P
0106	POWER SUPPLY ASSEMBLY	REPLACE TEST REPAIR ALIGN				0.1	0.7 0.4 0.1	12 1,8,9 thru 11, 14,20 1,2,7 thru 11, 12,14,19 1,8,12, 14,20	C,I H,I I

**Section II. MAINTENANCE ALLOCATION CHART  
FOR  
RADIO SET AN/PRC-104B**

(1) Group Number	(2) Component/Assembly	(3) Maintenance Function	(4) Maintenance Category					(8) Tools and Eqpt	(6) Remark
			C	O	F	H	D		
02	AMPLIFIER, RADIO FREQUENCY AM-6874( )/PRC-104	REPLACE							G
		SERVICE	0.2						
		INSPECT	0.2						
		TEST					0.1	1,8 thru 12, 14	K
		REPAIR					0.2	1,8 thru 12,14	E,H
	OVERHAUL					2.5	1,8 thru 2,14,20	I	
0201	RF AMPLIFIER ASSEMBLY	REPLACE				0.1	12		
		TEST				0.5	1	C,I	
		REPAIR				0.2	1,8 thru 12,14,20	H,I	
0202	POWER AMPLIFIER MODULE ASSEMBLY	REPLACE				0.4	12		
		TEST				0.9	1,3 thru 11,14,15, 20	C,I	
		REPAIR				0.2	1,8 thru 12,14,19	E,H,I	
		ALIGN				0.1	1,3 thru 12,14,15, 20	I	
020201	AMPLIFIER, POWER TOP CCA	REPLACE				0.4	13		
		TEST				0.9	1,3 thru 11,14,15, 20	C,I	
	REPAIR					0.2	1,8 thru 12,14,19	H,I	
020202	AMPLIFIER, POWER BOTTOM CCA	REPLACE				0.4	12		
		TEST				0.9	1,3 thru 11,14,15, 20	C,I	
	REPAIR					0.2	1,3 thru 12,14,19	H,I	
0203	ANTENNA TUNER MODULE ASSEMBLY	REPLACE				0.1	12		
		TEST				0.7	1,7 thru 11,14,15, 20	C,I	
		REPAIR				0.2	1,8 thru 12,14,19	E,H,I	
	ALIGN					0.1	1,7,8, 12,14,20	I	

**Section II. MAINTENANCE ALLOCATION CHART  
FOR  
RADIO SET AN/PRC-104B**

(1) Group Number	(2) Component/Assembly	(3) Maintenance Function	(4) Maintenance Category					(5) Tools and Eqpt	(6) Remarks
			C	O	F	H	D		
020301	TUNER, ANTENNA TOP CCA	REPLACE TEST					0.4 0.7	12 1,7 thru 11,14,15 20	C,I
		REPAIR					0.2	1,3 thru 12,14,19	H,I
020302	TUNER, ANTENNA BOTTOM CCA	REPLACE TEST					0.4 0.7	12 1,7 thru 11,14,15, 20	C,I
		REPAIR					0.2	1,8 thru 12,14,19	H,I
03	CASE RADIO SET CY-8291/PRC-104(V)	REPLACE REPAIR		0.1		0.3		12,21	
04	ANTENNA AS-2259( )/GR	REPAIR		0.1					L
05	ANTENNA GROUP AN/GRA-50	REPAIR		0.1				13	M
06	BATTERY, STORAGE BB-590/U	REPLACE SERVICE	0.1	0.3				18	J
07	BATTERY ASSEMBLY CASE CY-7875/PRC-104A	REPAIR		0.1				13	O

**Section III. TOOL AND TEST EQUIPMENT REQUIREMENTS  
FOR  
RADIO SET AN/PRC-104B**

Tool or Test Equipment Ref Code	Maintenance Category	Nomenclature	National/NATO Stock Number	Tool Number
1	O,H,D	MULTIMETER AN/PSM-45	6625-01-139-2519	
2	H,D	GENERATOR, SIGNAL SG-1171( )/U	6615-01-133-6160	
3	D	SPECTRUM ANALYZER, MAINFRAME IP-1216(T)/GR	6625-00-424-4370	
4	D	— SPECTRUM ANALYZER, IF SECTION PL-1388/11	6625-00-431-9339	
5	D	— SPECTRUM ANALYZER, RF SECTION PL-1399/U	6625-00-432-5055	
6	D	— SPECTRUM ANALYZER, TRACKING GENERATOR SG-1122/U	6625-00-155-5990	
7	H,D	RF SIGNAL GENERATOR SG-1170/U	6625-01-120-3501	
8	H,D	DC POWER SUPPLY PP-2309C/U	6130-01-139-2514	
9	O,H,D	TEST SET, RADIO FREQUENCY AN/USM-298	6625-00-880-5119	
10	O,H,D	DETECTING ELEMENT, 50H	6625-00-945-6092	
11	O,H,D	DUMMY LOAD, 8085	5985-00-477-8165	
12	H,D	TOOL KIT, ELECTRONIC EQUIPMENT TK-105/G	5180-00-610-8177	
13	0	TOOL KIT, ELECTRONIC EQUIPMENT TK-101/G	5180-00-064-5178	
14	H,D	GENERAL SUPPORT MAINTENANCE KIT 0A-9161/GRC-213A  — RECEIVER/TRANSMITTER RT-1209A — AMPLIFIER, RF, AM-6874/PRC-104 — HANDSET H-250 — CABLE ASSEMBLY, ELECTRICAL POWER CX-13030 — AUDIO INPUT/KEYING, ADAPTER — AMPLIFIER, POWER SUPPLY AM-7152/GRC-213 — ADAPTER, WHIP —MOUNT, ELECTRICAL EQUIPMENT MT-6234/GRC-213 — CABLE ASSEMBLY, RF. — CABLE ASSEMBLY, AUDIO — CABLE ASSEMBLY, CONDITIONED POWER — ATTENUATOR, STEP, CN-1128/U — ATTENUATOR, COAXIAL, NARDA 765-20 — PROBE HIGH IMPEDANCE, HP MODEL NO. 1121A — TECHNICAL MANUAL — SPEAKER LS-454 — DC POWER CABLE CX-4720		

**Section III. TOOL AND TEST EQUIPMENT REQUIREMENTS  
FOR  
RADIO SET AN/PRC-104B**

Tool or Test Equipment Ref Code	Maintenance Category	Nomenclature	National/NATO Stock Number	Tool Number
		<ul style="list-style-type: none"> <li>— EXTENDER CABLE, AM-7152 POWER CONDITIONER CCA</li> <li>— EXTENDER CABLE AM-7152 VIC-1 CCA</li> <li>— EXTENDER CABLE AM-7152 AMPLIFIER/SQULECH CCA</li> </ul>		
15	D	OSCILLOSCOPE OS-261 C(V)1/U	6825-01-119-7314	
16	D	DISTORTION ANALYZER AN/URM-184A	8625-00-802-8718	
17	D	FREQUENCY COUNTER AN/USM-459	8625-01-061-8828	
18	O	BATTERY CHARGER PP-6241/U	6130-00-106-6445	
19	D	BENCH REPAIR CENTER PRC-350C	4940-00-403-8176	
20	D	DEPOT ACCESSORIES: <ul style="list-style-type: none"> <li>— MODULATOR/DEMODOUIATOR TEST EXTENDER CABLE, 755002B9420</li> <li>— RF COAXIAL CABLE, 755002B9425</li> <li>— RF EXTENDER CABLE, 75500269430</li> <li>— FREQUENCY CONVERTER TEST BED A1A1A1, 755002B9440</li> <li>— FREQUENCY CONVERTER TEST BED A1A1A2, 755002B9450</li> <li>— FREQUENCY CONVERTER TEST BED A1A1A3, 755002B9480</li> <li>— HARMONIC FILTER/POWER AMPLIFIER TEST EXTENDER CABLES, 755002B9435</li> <li>— SYNTHESIZER TEST EXTENDER CABLE, 755002B9470</li> <li>— ANTENNA TUNER EXTENDER CABLE, 755002B9480</li> <li>— 100 OHM LOAD, 755002B9475</li> <li>— 130 OHM LOAD, 755002B9490</li> </ul>		
21	H	DENT FILLER	8010-00-926-2135	

NOTE: ALL EQUIPMENT DEFINED IN THIS SECTION (III) MAY BE SUBSTITUTED WITH EQUIVALENT ITEMS. EACH MAINTENANCE SHOP SHOULD EVALUATE THEIR CURRENT EQUIPMENT AVAILABLE AGAINST THEIR REQUIREMENTS.



**Section IV. REMARKS**  
**RADIO SET AN/PRC-104B**

Reference Code	Remarks
A	OPERATIONAL TEST.
B	TEST REQUIRED TO FAULT ISOLATE DEFECTIVE RT-1209A, AM-6874, AM-7152, SA-2365 ASSEMBLIES/COMPONENTS OR WIRING PROBLEMS.
C	TEST REQUIRED TO FAULT ISOLATE DEFECTIVE MODULES, CIRCUIT CARDS, OR WIRING PROBLEMS.
D	REPAIR IS ACCOMPLISHED BY REPLACEMENT OF ASSEMBLIES/COMPONENTS OR CABLE ASSEMBLIES.
E	REPAIR IS ACCOMPLISHED BY REPLACEMENT OF MODULES, CIRCUIT CARDS, OR CABLE ASSEMBLIES.
F	THIS TASK CAN INCLUDE THE REPLACEMENT OF NONREPAIRABLE ASSEMBLIES (CABLE ASSEMBLY CG-3815 ( )/U, ADAPTER UG-3490( )U, BATTERY EXTENDER CABLE ASSEMBLY CX-13031, ANTENNA SPRING AB-129/PR, FRAME PACK FIELD, PACK SHELF, CARGO SHELF, HANDSET H-250/U, BATTERY CASE CY-7875, ANTENNA BASE AB-1241, TELEGRAPH KEY KY-872/PRC-104, WHIP ANTENNA AT-271 , PRIMARY BATTERY BA-590/U, CARGO STRAP TIE-DOWN, CHARGER CABLE ASSEMBLY).
G	THIS TASK INVOLVES REMOVING THE RT-1209A OR AM-6874 FROM THE AN/PRC-104B.
H	THIS TASK CAN INCLUDE THE REPLACEMENT OF NONREPAIRABLE ASSEMBLY/PIECE PARTS.
I	THIS TASK WILL BE PERFORMED BY USMC DEPOT, ALBANY, GEORGIA.
J	THIS TASK INCLUDES THE REPLACEMENT OR BRINGING CURRENT CHEMICAL LEVELS WITHIN SPECIFIED STANDARDS. SEE TM 11-5820-( )-12
K	TEST REQUIRED TO FAULT ISOLATE TO DEFECTIVE MODULES, CIRCUIT CARDS, OR WIRING PROBLEMS.
L	SEE TM 11-5895-( )-14&P FOR MAINTENANCE ALLOCATION.
M	SEE TM 11-5820-467-15 FOR MAINTENANCE ALLOCATION.
N	ALTHOUGH THE REPLACEMENT OF FUSE (F-1) IS PERFORMED AT GSM, THE CONFIGURATION DRAWINGS IDENTIFY THIS ITEM AS PART OF FGC 01010101.
O	SEE TM 11-5820-( )-12 FOR MAINTENANCE ALLOCATION.
P	THE MODULES, CIRCUIT CARD SUBASSEMBLIES, OR PIECE PARTS WILL BE REPAIRED BY THE USMC DEPOT, ALBANY, GEORGIA.



**(ARMY ONLY)**  
**APPENDIX C**  
**COMPONENTS OF END ITEM AND**  
**BASIC ISSUE ITEMS LISTS**

**Section I. INTRODUCTION**

**SCOPE**

This appendix lists STAJ-unique components and basic issue items for Radio Set AN/PRC-1046 to help inventory items required for safe and efficient operation.

**GENERAL**

This Components of End Item List is divided into the following sections:

**a. Section II. Components of End Item.** These items, when assembled, make up Radio Set AN/PRC-104B and must accompany it whenever it is transferred or turned in. The illustrations will help identify these items.

**b. Section III. Basic Issue Items (BII).** These are the minimum essential items required to place Radio Set AN/PRC-104B in operation, to operate it, and to perform emergency repairs. Although shipped separately packed, they must accompany Radio Set AN/PRC-1046 during operation and whenever it is transferred between accountable officers. The illustrations will assist you with hard-to-identify items. This manual is your authority to requisition replacement BII, based on TOE/MTOE authorization of the end item.

**EXPLANATION OF COLUMNS**

**a. Column (1) — Illustration Number (Illus Number).** Indicates the number of the illustration on which the item is shown.

**b. Column (2) — National Stock Number.** Indicates the National stock number assigned to the item; use it to request or requisition the item.

**c. Column (3) — Description.** Indicates the Federal item name and, if required, a minimum description to identify the item. The physical location of each item follows the description in this column. The lists are designed to inventory all items in one area of the major item before moving on to an adjacent area.

**d. Column (3) — CAGE and Part Number.** Indicates the primary number used by the manufacturer that controls the design and characteristics of the item by means of its engineering drawings, specifications, standards, and inspection requirements to identify an item or range of items. Preceding the part number, the Commercial and Government Entity (CAGE) is shown in parentheses. If the required item differs between serial numbers of the same model, effective serial numbers are shown in the last line of the description. If the required item differs for different models of this equipment, the model number is shown under the Usable On Code heading in the description column. These codes are identified in paragraph e.

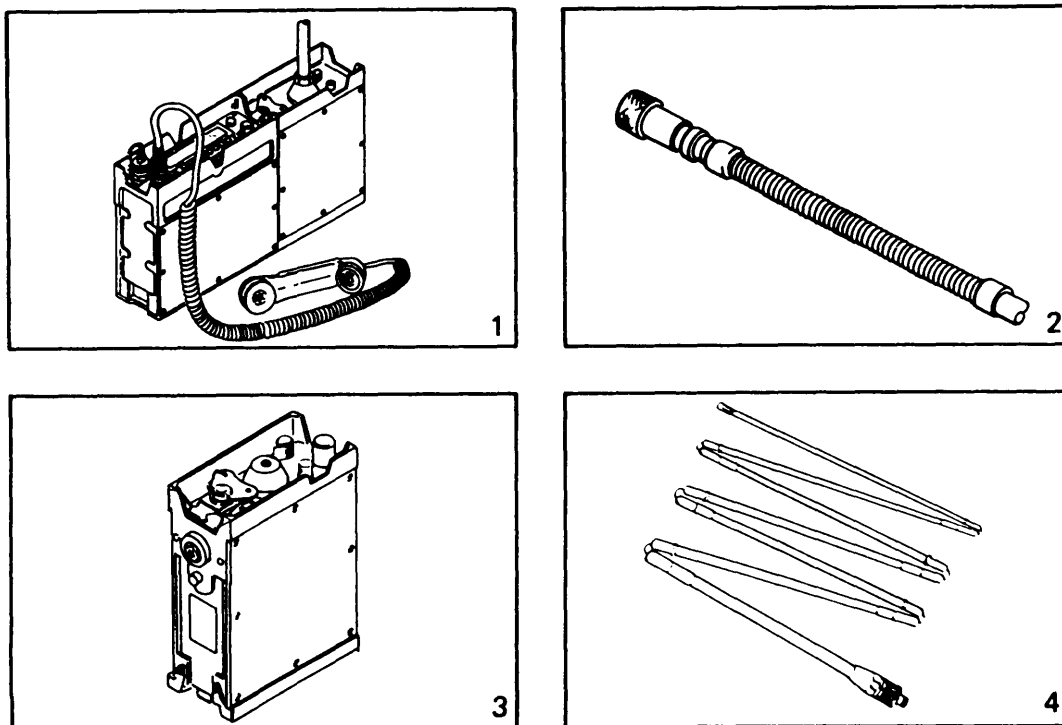
**e. Usable On Code.** Usable on codes, when included, help identify which component items are used on the different models. Identification of the codes used in these lists are:

<u>Code</u>	<u>Used on</u>
-------------	----------------

**f. Column (4) — Unit of Measure (U/M).** Indicates the measure used in performing the actual operational/maintenance function. This measure is expressed by a two-character alphabetical abbreviation (for example, ea. in., pr).

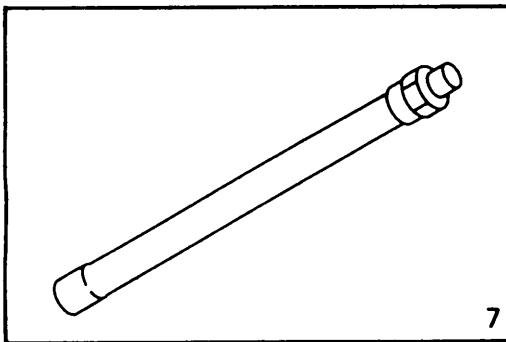
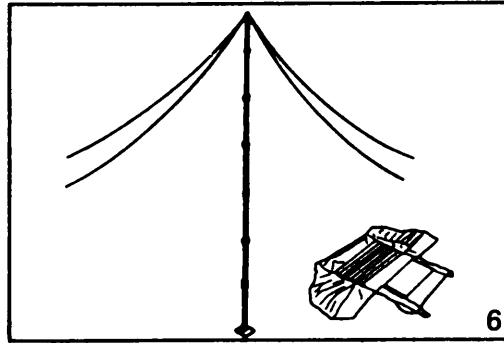
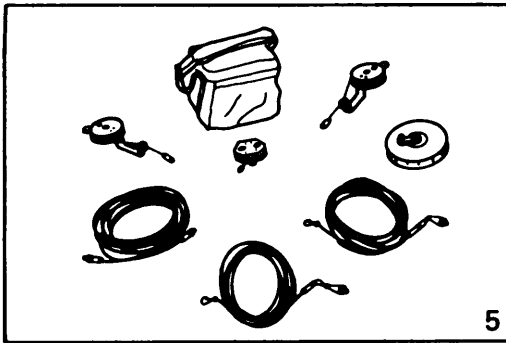
**g. Column (5) — Quantity Required (Qty Reqd).** This column lists the quantity of each item required for a complete major item.

Section II. COMPONENTS OF END ITEM



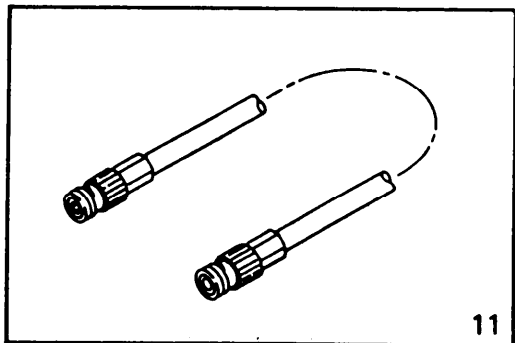
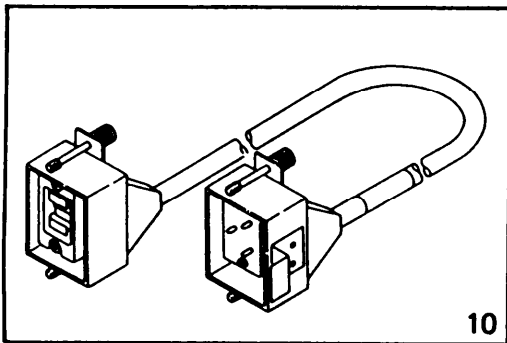
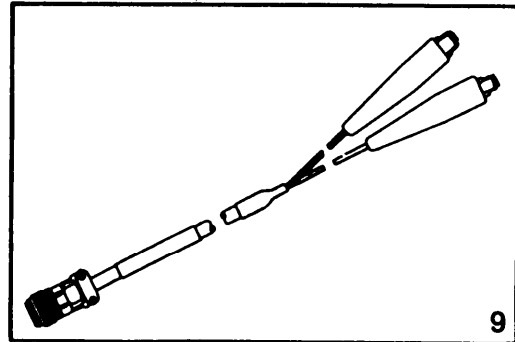
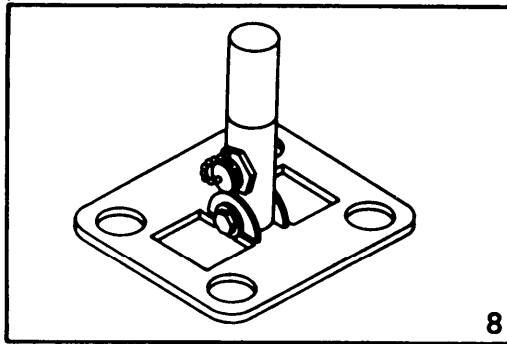
(1) Illus Number	(2) National Stock Number	(3) Description CAGE and Part Number	Usable On Code	(4) U/M	(5) Qty Reqd
1	5820-01-262-9550	RADIO SET AN/PRC-104B  (87990) 755002C0050		EA	1
2	5935-00-204-5118	(AN/GRA-50) ADAPTER UG-349A/U (in transit case) Army only (80058)		EA	1
3	5820-01-065-5044	RADIO FREQUENCY AMPLIFIER AM-6874/PRC-104 (connected to RT) (80058)		EA	1
4	5985-00-646-2365	ANTENNA AT-271A/PRC (in transit case) (80058)		EA	1

COMPONENTS OF END ITEM (Cont)



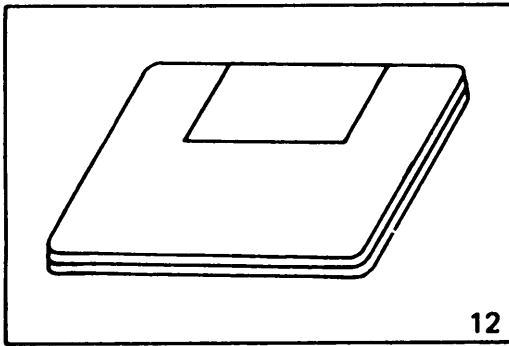
(1) Illus Number	(2) National Stock Number	(3) Description CAGE and Part Number	Usable On Code	(4) U/M	(5) Qty Reqd
5	5985-00-892-0758	ANTENNA GROUP AN/GRA-50 (in bag) Army only (80058)		EA	1
6	5985-00-106-6130	(NVIS) ANTENNA AS-2259( )/GR (in roll pack) Army only (80058)		EA	1
7	5820-00-234-4127	ANTENNA SPRING SECTION AB-129/PR (in transit case) (80058)		EA	1

COMPONENTS OF END ITEM (Cont)

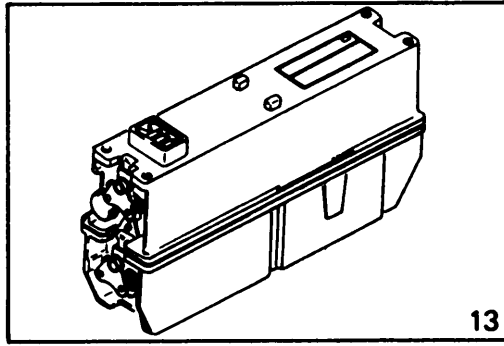


(1) Illus Number	(2) National Stock Number	(3) Description CAGE and Part Number	Usable On Code	(4) U/M	(5) Qty Reqd
8	5895-01-245-6160	(NVIS) ANTENNA GROUND BASE (in transit case) (80063) A3023292		EA	1
9	5935-00-231-3180	ELECTRICAL POWER CABLE ASSEMBLY CX-13032/PRC-104 (in transit case) (01365) 755002A1250		EA	1
10	5820-01-065-4442	ELECTRICAL POWER CABLE ASSEMBLY CX-13023/PRC-104 (in transit case) (87990) 755002A1260		EA	1
11	5995-00-405-9097	RF CABLE ASSEMBLY 2249-C-22 (in transit case) (05276)		EA	1

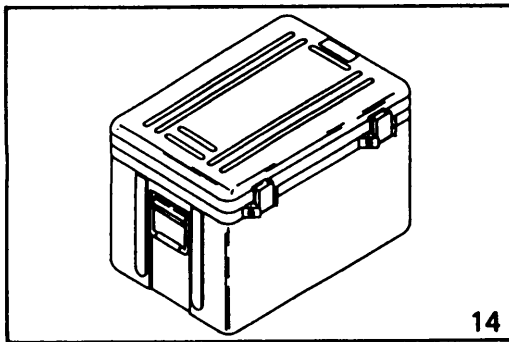
COMPONENTS OF END ITEM (Cont)



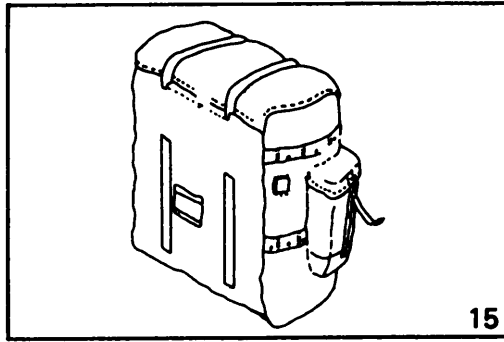
12



13



14

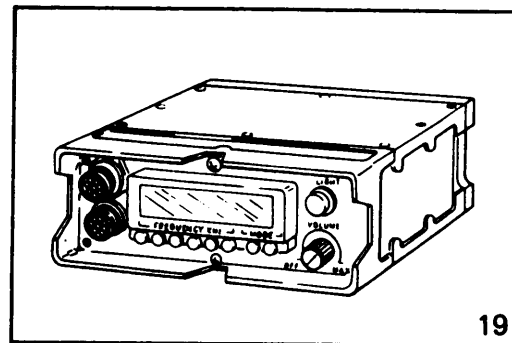
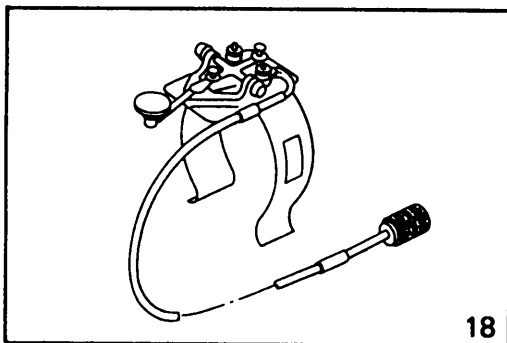
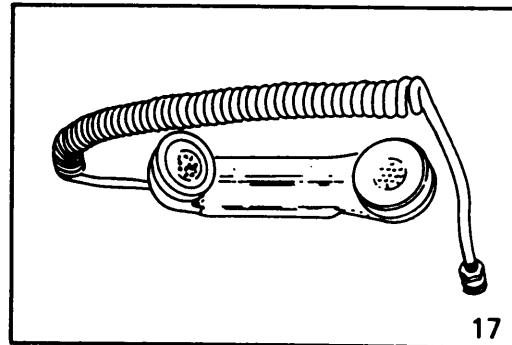
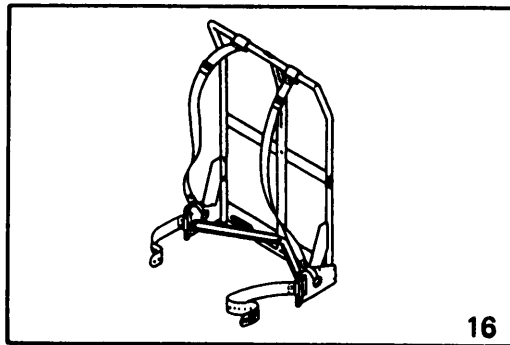


15

(1) Illus Number	(2) National Stock Number	(3) Description CAGE and Part Number	Usable On Code	(4) U/M	(5) Qty Reqd
12		INSTRUCTION CARD (in transit case) (87990) 755002C0057		EA	1
13	6135-01-080-2886	BATTERY CASE CY-7875/PRC-104 (in transit case) (01365) 79A5029A0000		EA	2
14	5820-01-214-8802	TRANSIT CASE CY-8291/PRC-104 (in vehicle) (80058) 755002A3108		EA	1
15	8465-01-019-9102	FIELD PACK 2-2-344 (in transit case) (81337)		EA	1

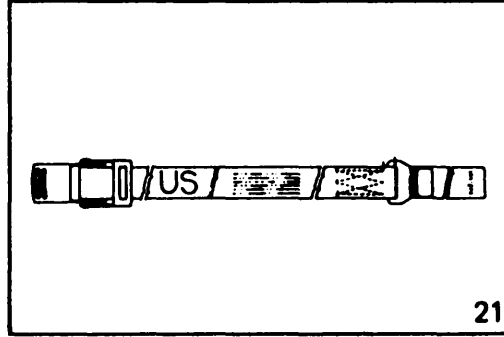
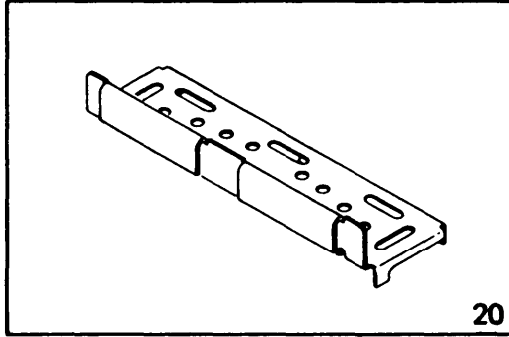


COMPONENTS OF END ITEM (Cont)



(1) Illus Number	(2) National Stock Number	(3) Description CAGE and Part Number	Usable On Code	(4) U/M	(5) Qty Reqd
16	8465-00-001-6475	PACK FRAME 2-3-290 (in transit case) (81337)		EA	1
17	5965-00-043-3463	HANDSET H-250A/U (connected to RT) (80058)		EA	1
18	5305-01-067-5388	TELEGRAPH KEY (in transit case) (87990) 755002A1000		EA	1
19		RECEIVER-TRANSMITTER RT-1209A/URC (connected to amplifier/coupler) (87990) 755002C0150		EA	1

COMPONENTS OF END ITEM (Cont)



(1) Illus Number	(2) National Stock Number	(3) Description CAGE and Part Number	Usable On Code	(4) U/M	(5) Qty Reqd
20	8465-00-001-6476	CARGO SUPPORT SHELF 2-3-291 (within frame) (81337)		EA	1
21	8465-00-001-6477	WEBBING STRAP 2-2-313 (in transit case) (81337)		EA	1

**Section III. BASIC ISSUE ITEMS**

(1) Illus Number	(2) National Stock Number	(3) Description CAGE and Part Number	Usable On Code	(4) U/M	(5) Qty Reqd
		Operator's and Organizational Maintenance Manual for Radio Set AN/PRC-104B TM 07748B-12/1, TM 11-5820-1046-12		EA	1



## APPENDIX D ADDITIONAL AUTHORIZATION LIST

### Section I. INTRODUCTION

#### **SCOPE**

This appendix lists additional items authorized for the support of Radio Set AN/PRC-104B.

#### **GENERAL**

This list identifies items that do not have to accompany Radio Set AN/PRC-104B and that do not have to be turned in with it. These items are all authorized by CTA, MTOE, TDA, or JTA.

#### **EXPLANATION OF LISTING**

National stock numbers, descriptions, and quantities are provided to help identify and request the additional items required to support this equipment. The items are listed in alphabetical sequence by item name under type document (ie, CTA, MTOE, TDA, or JTA) that authorizes the item(s).



**Section II. ADDITIONAL AUTHORIZATION LIST**

(1) National Stock Number	(2) Description CAGE and Part Number	Usable On Code	(3) U/M	(4) Qty Reqd
6130-00-106-6445	Battery Charger (80058) PP-6241/U		EA	1
6625-00-945-6092	Detecting Element (70998) 50H		EA	1
5985-00-477-8165	Dummy Load (70998) 8085		EA	1
6625-01-139-2512	Multimeter (55026) AN/PSM-45		EA	1
6625-00-880-5119	Test Set, Radio Frequency Power (70998) AN/USM-298		EA	1
5180-00-064-5178	Tool Kit, Electronic Equipment (80058) TK-101/G		EA	1
6140-01-063-3918	STORAGE BATTERY BB-590/U (in vehicle) (80058) NOTE: Do not store batteries in electronic equipment		EA	2
6135-01-036-3495	PRIMARY BATTERY BA-5590/U (in vehicle) (80058) NOTE: Do not store batteries in electronic equipment		EA	2





## APPENDIX E

### EXPENDABLE/DURABLE SUPPLIES AND MATERIALS LIST

#### Section I. INTRODUCTION

##### **SCOPE**

This appendix lists expendable supplies and materials needed to operate and maintain the radio set. This listing is for informational purposes only and is not authority to requisition the listed items. These items are authorized by CTA 50-970, Expendable/Durable Items (except Medical, Class V, Repair Parts, and Heraldic Items) or CTA 8-100, Army Medical Department Expendable/Durable Items.

##### **EXPLANATION OF COLUMNS**

**a. Column (1) — Item Number.** This number is assigned to the entry in the listing and is referenced in the narrative Instructions to identify the material (eg, Use cleaning compound (item 4, App E)).

**b. Column (2) — Level.** This column identifies the lowest level of maintenance that requires the listed item.

- C — Operator/Crew
- O — Organizational Maintenance
- F — Direct Support Maintenance
- H — General Support Maintenance

**c. Column (3) — National Stock Number.** This is the National stock number assigned to the item; use it to request or requisition the item.

**d. Column (4) — Description.** Indicates the Federal Item name and, if required, a description to identify the item. The last line for each item indicates the part number followed by the Commercial and Government Entity (CAGE) in parentheses, if applicable.

**e. Column (5) — Unit of Measure (U/M).** Indicates the measure used in performing the actual maintenance function. This measure is expressed by a two-character alphabetical abbreviation (for example, in., pr). If the unit of measure differs from the unit of issue, requisition the lowest unit of issue that will satisfy your requirements.



## Section II. EXPENDABLE/DURABLE SUPPLIES AND MATERIALS LIST

(1) Item Number	(2) Level	(3) National Stock Number	(4) Description CAGE and Part Number	(5) U/M
1	C	7920-00-178-8315	Brush, Bristle, 2 3/4" long	ea
2	C		Brush, Paint	ea
3	C	8305-00-267-3015	Cheesecloth (81348)	yd
4	C	6850-00-10-3084	Cleaning Compound (solvent), Trichlorotrifluorothane	oz
5	C	7930-01-055-6121	Detergent, GP, Liq	gl
6	C		Paint (type 1 or type 2, forest green MIL-T-704 type G, apply per MIL-C-46168)	gl
7	C		Paint, Primer, (type 1, kit, apply per MIL-P-23377)	gl
8	C	5350-00-264-3485	Sandpaper, PP-105	sh
9	C		Tape, Masking	ea
10	C		Wiping Rags	ea



**(MARINE CORPS ONLY)**  
**APPENDIX F**  
**PROPAGATION OF RADIO WAVES AND OPERATING CONSIDERATIONS**

**Section I. PROPAGATION OF RADIO WAVES**

**GENERAL**

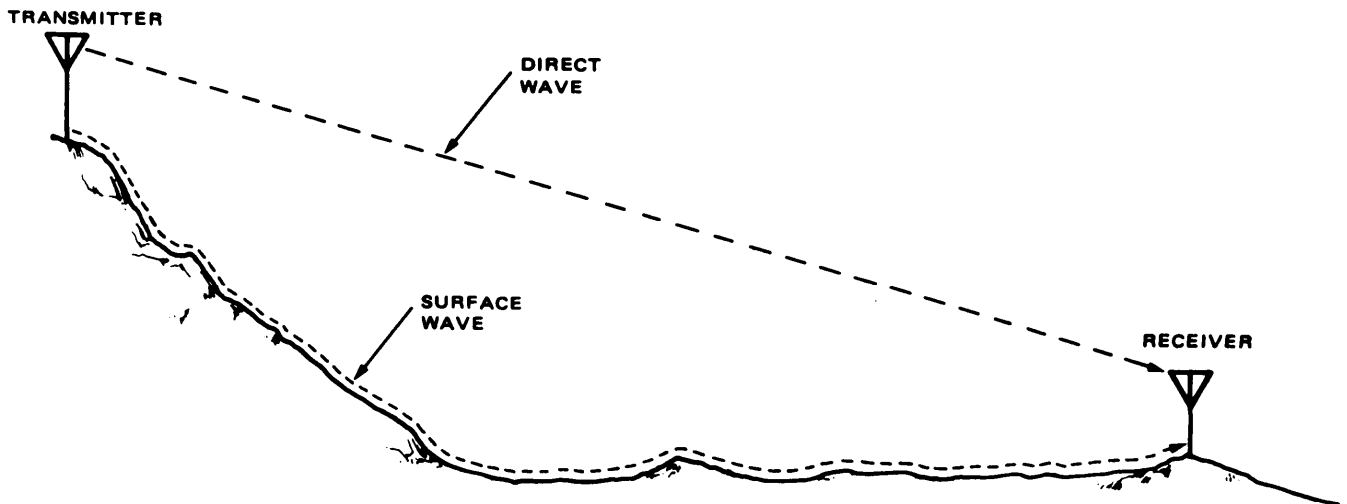
This section provides information on propagation of radio waves in the high frequency (hf) band used by the radio set. The data and illustrations are based on average propagation characteristics of various hf band segments and indicate relative effectiveness during the day and night. They are to be used only as a general guide. Also discussed are two situational examples for optimizing communications. For improved performance of the radio set, the modification described in MI-07743B-35/1 should be performed.

**RADIO WAVES**

Radio waves in the 2 thru 30 MHz region of the electromagnetic spectrum are propagated in two ways: the ground wave and the sky wave.

**GROUND WAVE (1 of 2)**

There are two types of ground waves which exist in various magnitudes depending on the frequency, type of antenna, and terrain conditions.



**Ground Wave Propagation**

**SURFACE WAVE**

This electromagnetic wave travels directly along the earth's surface and is dependent on the ground conductivity. Because ground conductivity is generally poor, unless propagated over water, this wave is rapidly attenuated. This attenuation is particularly pronounced at frequencies greater than 3 MHz, making it unreliable for low-power communication networks beyond about 10 miles. Although attenuation is greater as frequency increases, better efficiency of the whip antenna and a drop in atmospheric noise favor the use of higher frequencies for links dependent on surface wave.

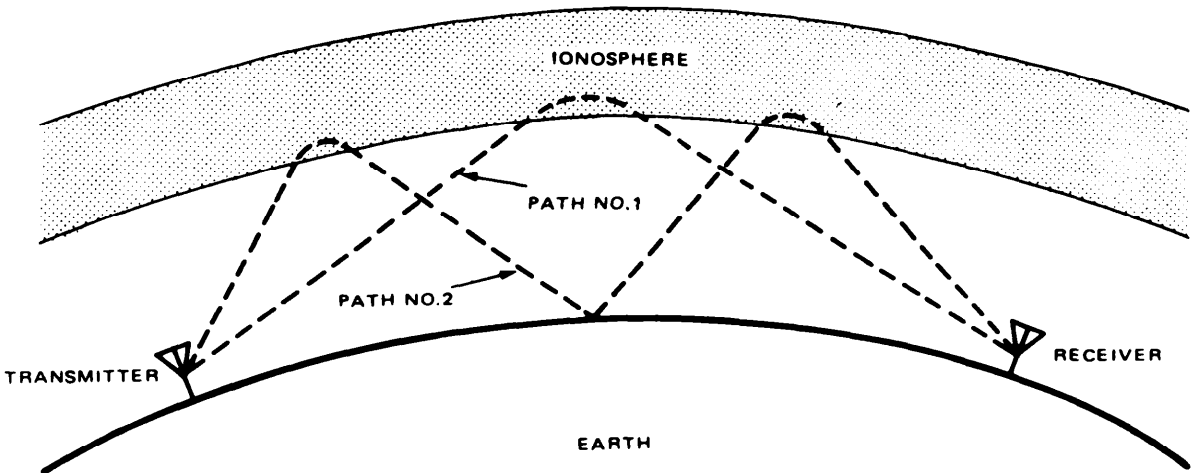
**GROUND WAVE (2 of 2)**

**DIRECT WAVE**

This is the 'line-of-sight' wave that exists at all frequencies. The range of this wave is limited by the horizon. The direct wave is utilized most frequently for short range communication.

**SKYWAVE**

Skywaves (ionospheric waves) are basically direct waves that have been reflected (skipped) back to earth by the ionosphere. The ionosphere exists at altitudes between 30 and 300 miles and consists of several layers of ionized gases. These gases are ionized by several factors, the primary of which is ultraviolet radiation; the greater the level of ionization the more reflective the ionosphere will be. The ultraviolet radiation level is directly proportional to the amount of sunspot activity and is predictable with a high degree of accuracy. This reflective power of the ionosphere makes it possible to communicate over great distances using hf radio transmissions.



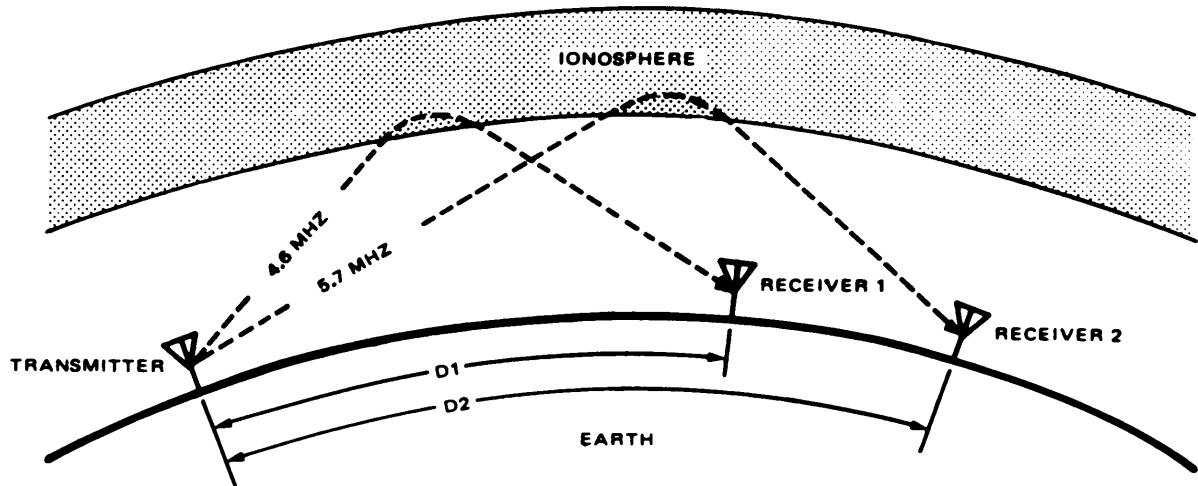
**Skywave Propagation**

**MAXIMUM USABLE FREQUENCY**

At any given time, for a predetermined path length (skip distance), there exists a Maximum Usable Frequency (MUF). This MUF is the highest frequency radio wave that will be reflected back to earth in a specified geographical region for that path length. The MUF is a predictable number and is available in the form of propagation prediction charts. The MUF is highest at noon or early afternoon and drops to its lowest in the early morning hours. The MUF is lower on short paths and higher on long paths.

TYPICAL PROPAGATION PREDICTION CHART

TIME OF DAY (LOCAL)	D1		D2	
	MUF	FOT	MUF	FOT
0001	5.3	4.6	7.0	5.7
0002	4.9	3.8	6.5	4.9
0003	4.7	3.5	6.1	4.7
0004	4.6	3.5	6.1	4.6



Relative Skip Distance for Two Different Frequencies

**FREQUENCY OF OPTIMUM TRANSMISSION (FOT)**

If the MUF is known, the best frequency selection would be one that is sufficiently close to the MUF to be reflected but not so close that it is affected by minor changes in ionospheric density. This is around 85 percent of the MUF. (Example: if MUF is 10 MHz, optimum frequency will be 0.85 x 10 or 8.5 MHz.) This frequency is called the Frequency of Optimum Transmission (FOT) and is commonly referred to as the Optimum Traffic Frequency.

**MULTISKIP PHENOMENON**

There will be instances when the skywave is reflected between the ionosphere and the earth surface several times. This multiskip phenomenon occurs frequently making global communications possible in the hf band. In addition to multiskip, there also exists a multipath propagation characteristic. If this occurs, two waves that took different paths reach the receiver simultaneously. Depending on their relative phases, the signal strength is enhanced or reduced. If the two waves are of equal amplitude and phase shifted 180 degrees, total cancellation results and the received signal fades out. Operating near the FOT minimizes multipath degradation.

## **HF BAND SEGMENTS (1 of 3)**

The following is a breakdown of the hf band and a general description of the behavior of each segment. There are exceptions but the descriptions hold true in most cases. The illustrations on pages F-5 and F-6 show relative effectiveness of different segments depending on the time (less than 100 miles and between 100-500 miles, respectively).

### **2 THRU 5 MHZ**

This band is useful during daylight hours for intermediate and short-range skywave communications and good for long range (several thousand miles) during the night. The static level is highest during the summer.

### **5 THRU 10 MHZ**

This band is similar to the 2 thru 5 MHz band except long-range communication is possible during daylight hours under good conditions (high sunspot activity). The signals follow the darkness path best and during winter it is possible to communicate with stations on the other side of the world. The winter months are better than the summer months because of the high summer static level, especially in equatorial parts of the world.

### **10 THRU 15 MHZ**

This band is the best choice for reliable intermediate and long-range communications during all propagation conditions. During very low levels of sunspot activity, the band is not useful at night but improves greatly at dawn and holds up well until dusk.

### **15 THRU 25 MHZ**

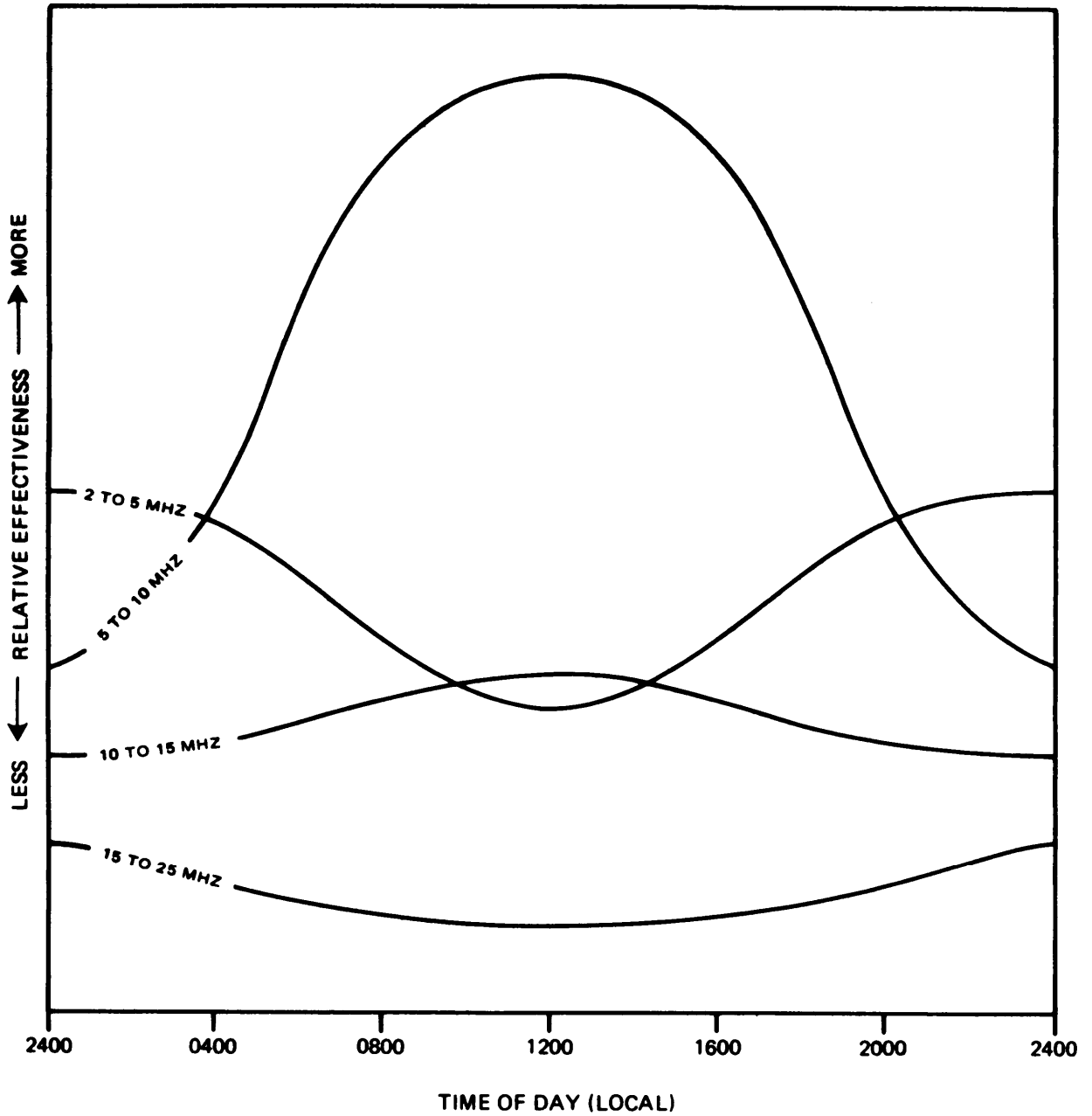
This band is highly variable and dependent on sunspot activity. When conditions are good, it is useful during day and early night, but if sunspot conditions are poor, it may not be usable at all. This band is suitable for short range (less than 10 miles) surface wave communication using a whip antenna.

### **25 THRU 30 MHZ**

This band is useful as a very short-range communication band (less than 10 miles) and is excellent for long-range (several thousand miles) communication during good propagation conditions. It is generally unusable for intermediate range communication.

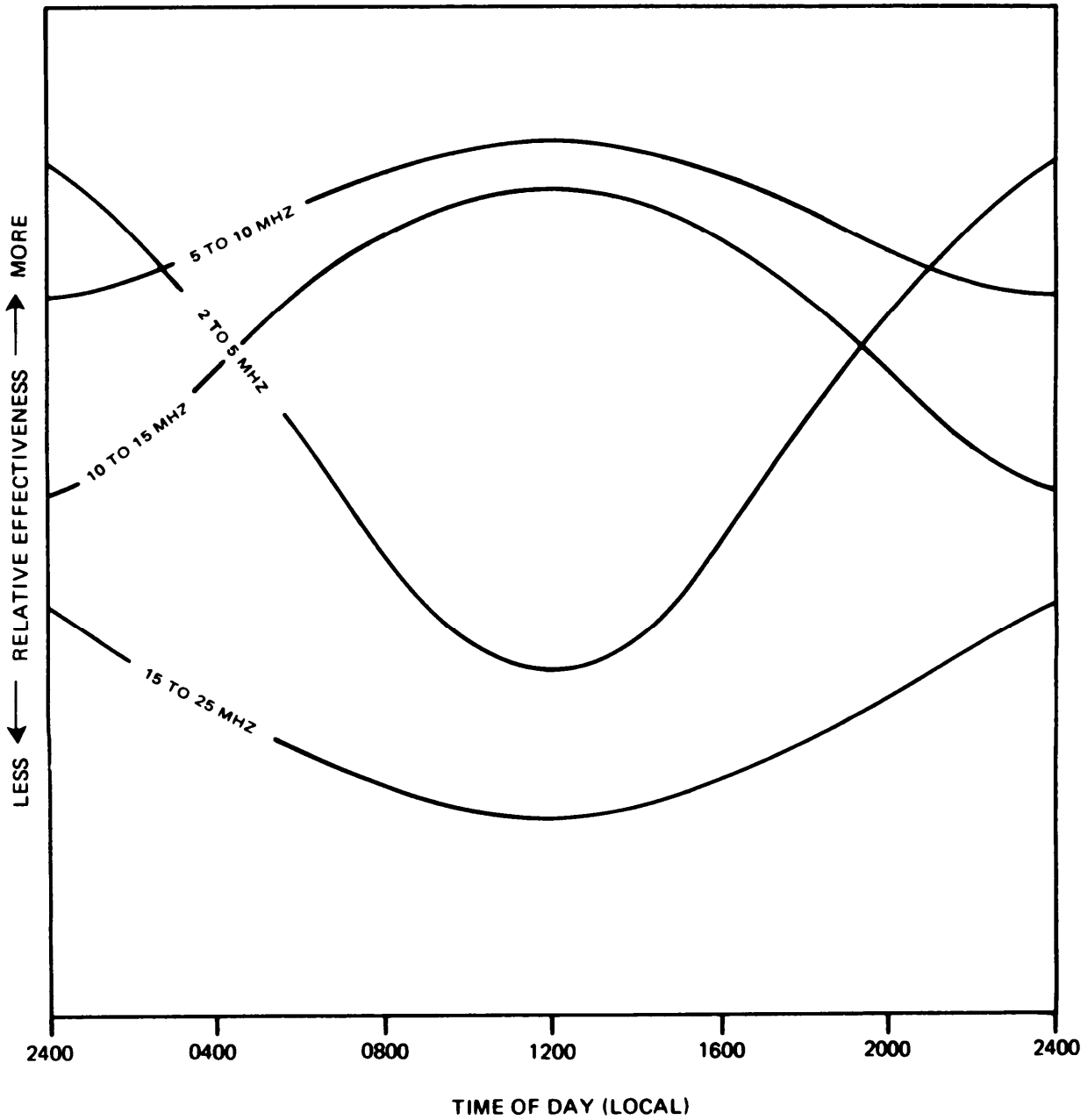


**HF BAND SEGMENTS (2 of 3)**



Short Range (Less Than 100 Miles) HF Communications Effectiveness

**HF BAND SEGMENTS (3 of 3)**



Intermediate Range (100-500 Miles) HF Communications Effectiveness

**SITUATIONAL EXAMPLES**

The following examples demonstrate several different situations that might occur when attempting to establish a communications link. These examples will help clarify the information on optimizing communication.

**SITUATION 1**

**SCENARIO**

You are under enemy fire and cannot move without great risk. It is 1400 hours local time and you are trying to contact your Tactical Operation Center (10 miles south) to request air support. Your available frequencies are 2.138, 5.672, 9.193, 11.272, and 16.385 MHz.

**RECOMMENDATION**

The tactical situation only permits the use of the whip antenna. Since the station with whom you want to communicate is only 10 miles south, the whip antenna will be adequate. Considering this to be short range surface wave, the best frequency selection would be a high one, in this case either 16.385 or 11.272 MHz.

**SITUATION 2**

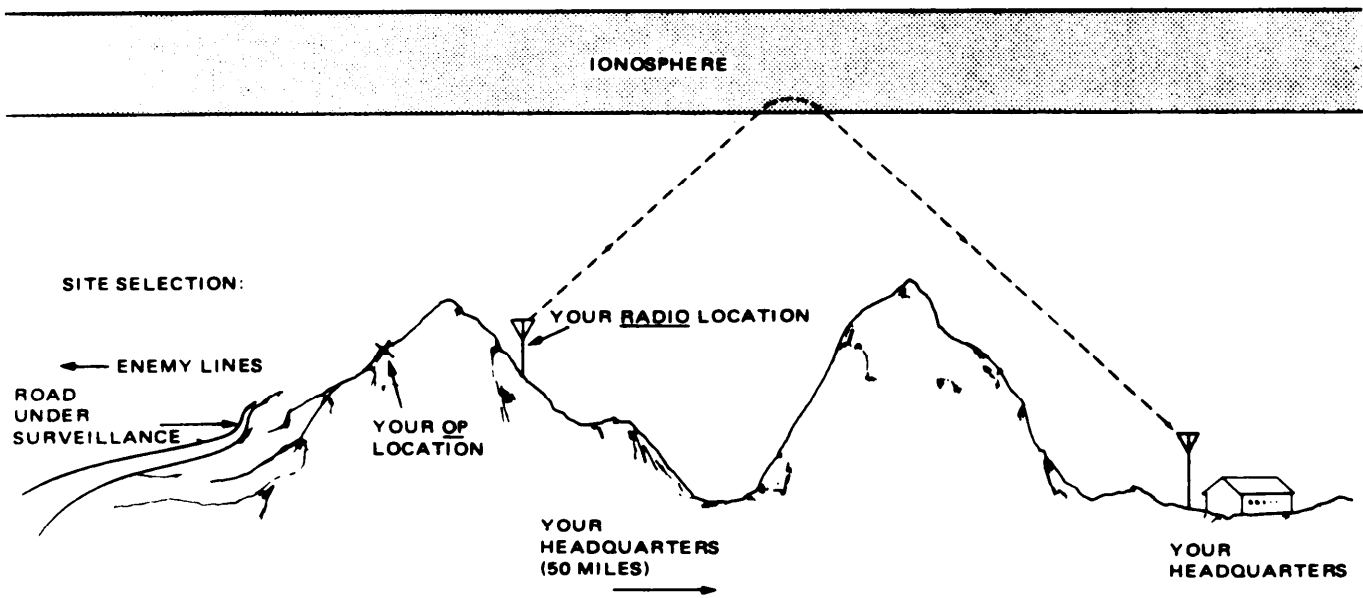
**SCENARIO**

See the illustration on page F-8. Your squad must set up an observation post (OP) as part of a road surveillance team. You are required to check in with your headquarters (50 miles east) once every hour. Your OP is in a mountainous region and a large mountain is located between you and your headquarters. Your frequency possibilities are the same as in situation 1.

**RECOMMENDATION**

Your OP is selected to give you a clear view of the area while camouflaging your position with the mountain as a background. Your radio location is selected to provide a clear path to your headquarters while shielding your transmissions from the enemy to reduce the possibility of being located with radio direction finding equipment. Because you will be maintaining a fixed location for an extended period of time, you may use any antenna you wish. The best choice would be the NVIS antenna. Your headquarters is only 50 miles east. However, there is a large mountain blocking direct waves. The NVIS, with a very high angle of radiation, will bounce off the ionosphere and over the mountain. Your transmissions might be copied by the enemy but your shielded location will minimize the chances of being located. As the day progresses, you will want to change frequency in order to optimize communications. The following recommendation should ensure constant communications.

0001 to 0500 (dawn)	2.138 or 5.672 MHz
0500 to 1200	5.672 or 9.913 MHz
1200 to 2000 (dusk)	9.913 or 11.272 MHz
2000 to 2400	5.672 or 9.913 MHz



Site Selection, Situation 2

## Section II. OPERATING CONSIDERATIONS

### INTRODUCTION

This section provides information to assist the operator in selecting the proper antenna, frequency, and site for achieving best communication with this radio set. Refer to Section I on *page F-1* for information on propagation of radio waves and some situational examples for optimizing radio communication.

### OPTIMIZING COMMUNICATION WITH THE RADIO SET

The reliability and effectiveness of radio communications in the high frequency (hf) range is dependent on several factors:

- Type of antenna used
- Operating frequency selected
- Terrain around transmitting site
- Time of day
- Geographic location and distance between stations
- Atmospheric conditions
- The effects of the ionosphere on radio waves

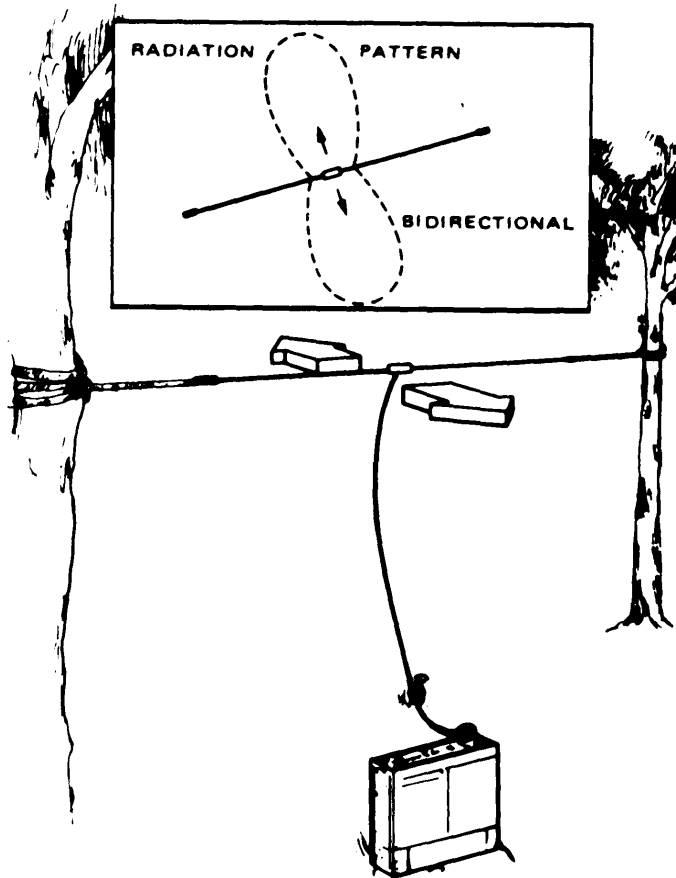
The radio operator can control, to some degree, only the first four or five of these factors. The others affect propagation characteristics and background interference, and are beyond operator control. The antenna and frequency are the most important factors under operator control, and should be selected to best suit the propagation characteristics and distance of the link. Several frequencies will probably have been assigned from upper echelon. They will have been selected in various portions of the band in order to allow a frequency change when propagation conditions change.

### ANTENNA SELECTION

The field environment, tactical situation, and range required determine the antenna selection. Refer to the following for major characteristics of each antenna.

**DIPOLE ANTENNA**

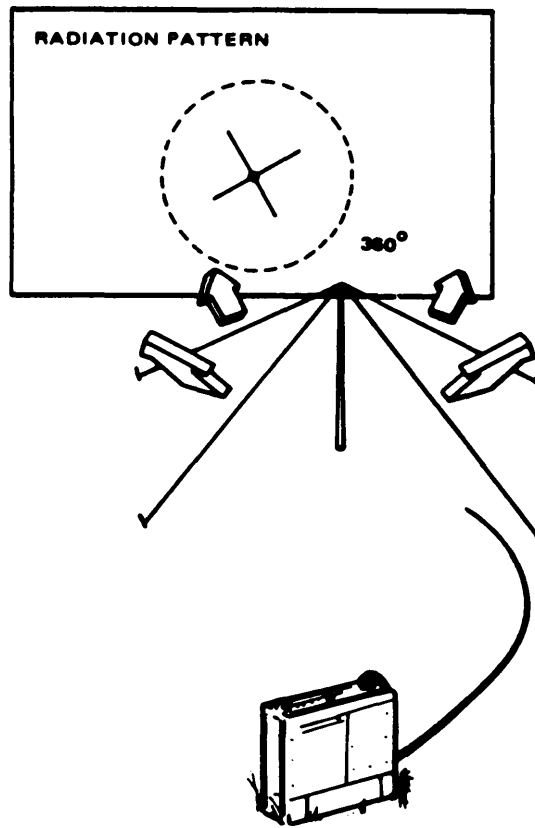
- Good gain; extended range (0 to 300 miles)
- Quickly assembled and erected
- Requires one or two vertical supports (depending upon configuration chosen)
- Bidirectional radiation pattern (perpendicular to the wire) requiring proper orientation for best transmitting and receiving results in direction of other radio set(s)  
Cannot be used when radio set is moving



**Half-Wave Dipole**

**NVIS ANTENNA**

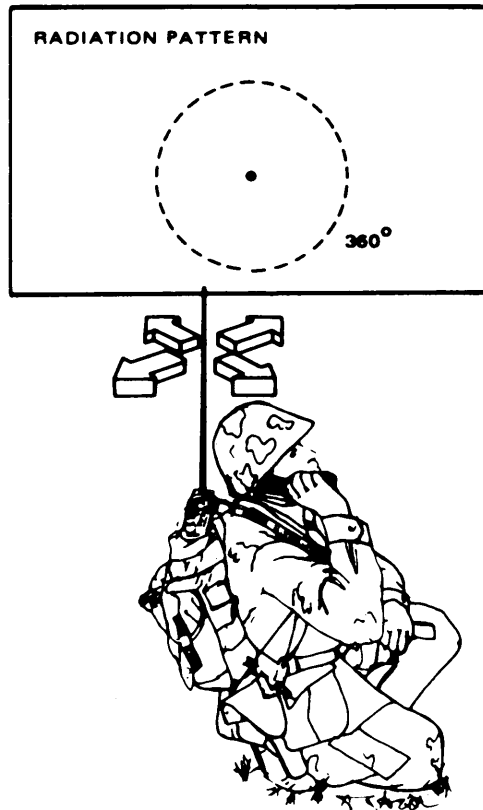
- Good gain; extended range (0 to 300 miles)
- Omnidirectional (360-degree radiation pattern); does not require orientation for best transmitting and receiving results in direction of other radio set(s)
- Requires a large clear area (60-feet square) for proper operation
- Fully tuned only between frequencies of 2 and 12 MHz (maybe used at frequencies above 12 MHz, but may not work at all frequencies)
- Requires two people to assemble and erect
- ▼ Cannot be used when radio set is moving



**Near Vertical Incidence Skywave (NVIS)**

### MANPACK WHIP ANTENNA

- Already installed
- Allows communications while the radio set is moving (other antennas do not)
- Omnidirectional (360-degree radiation pattern); does not require orientation for best transmitting and receiving results in direction of other radio set(s)
- Requires no support
- Communications are restricted to less than 10 miles (range may be better under good propagation conditions)



Manpack Whip

### FREQUENCY SELECTION (1 of 2)

The primary consideration when selecting an operating frequency is the distance between the sending and receiving stations, and the time of day. Refer to the illustrations on *pages F-5 and F-6*, which relate the relative effectiveness of communications for four sub-band segments to the time of day. These illustrations are based on average propagation characteristics for the sub-bands and are intended for use only as a general guide. For detailed frequency planning over a specific time period, propagation prediction charts are available from several government agencies. ("Intermediate and Short Distance Skywave Propagation Charts," Headquarters U.S. Army Communications — Electronics Engineering Installation Agency, Ft. Huachuca, Arizona 85613).



**FREQUENCY SELECTION (2 of 2)**

Another consideration when selecting an operating frequency is the atmospheric condition. If rain or other precipitation is present, signals at the lower end of the hf band may be degraded by atmospheric noise while the higher frequencies are affected to a lesser degree. Therefore, higher frequencies provide more effective communication in inclement weather.

The most useful phenomenon in radio wave propagation is the “skip” effect. This effect occurs because the layers of the ionosphere become ionized by the ultraviolet radiation of the sun. This level of ionization determines the highest frequency for skip over a given distance. Generally, the higher the ionization level, the higher the frequency that can be used in “skip” mode and, therefore, the broader the range of frequencies available for use.

**SITE SELECTION**

Site selection is particularly important for short-range, ground wave communication. The existing tactical situation determines how much of a selection is available. Generally, the best communications are obtained if the transmitting site is clear of all obstructions, located in an area with good ground conductivity (wet or plowed ground), and as high above ground as possible. Several locations in the same general vicinity should be checked as possible sites. A slight change in antenna location can make a substantial difference in effectiveness.

Avoid areas near sources of electrical interference such as power lines, radar sets, field hospitals with X-ray machines, etc. Also avoid large structures having metallic content — bridges, tanks, steel reinforced buildings, etc. If enemy jamming is a possibility, the site should be selected so that a large object or terrain feature is situated between the radio and the jamming source. This minimizes the effects of the jamming station and makes it more difficult to locate your transmitter using direction-finding equipment.



## GLOSSARY

### Section I. ABBREVIATIONS

Term or Abbreviation	Definition or Description
ANT	Antenna
bps	Bits per second
CAGE	Commercial and Government entity
CONT	Controller
CTA	Common table of allowance
CW	Continuous wave
dc	Direct current
DPSK	Differential phase-shift keying
D RCV	Data receive
DTR	Data transceiver (transmit/receive)
ECCM	Electronic counter countermeasures
EIR	Equipment improvement recommendation
FOT	Frequency of optimum transmission
FSK	Frequency shift keying
GND	Ground
hf	High frequency
LCD	Liquid crystal display
LSB	Lower sideband
MAC	Maintenance allocation chart
MAX	Maximum
MHZ	One million Hertz
MTOE	Modified table of organization and equipment
MUF	Maximum usable frequency
NVIS	Near vertical incidence skywave
PMCS	Preventive maintenance checks and services
PTT	Press-to-talk
RPSTL	Repair parts and special tools list
rf	Radio frequency
RT	Receiver-Transmitter
SEL	Select
STAJ	Short term antijam

Term or Abbreviation	Definition or Description
TMDE TTY	Test measurement and diagnostic equipment Teletypewriter
USB U/M	Upper sideband Unit of measure
V	Volt
V RCV	Voice receive
vswr	Voltage standing wave ratio
VTR	Voice transceiver (transmit/receive)
wpm	Words per minute

**INDEX (1 of 3)**

	<b>Page</b>
<b>A</b>	
Additional Authorization List .....	D-1
Administrative Storage .....	1-2
Amplifier/Coupler Connectors .....	3-6
Amplifier/Coupler Controls and Indicators .....	3-5
Audible Indicators .....	3-7
<b>C</b>	
Checking Unpacked Radio Set .....	2-2
Cleaning the Radio Set .....	4-1
Common Tools and Equipment .....	5-1
Components of End Item and Basic Issue Items Lists .....	C-1
Consolidated index of Army Publications and Blank Forms .....	1-1
Controls, Indicators, and Connectors .....	3-1
<b>D</b>	
Destruction of Electronics Materiel .....	1-2
Differences Between Models .....	1-6
Dipole Antenna Installation .....	2-8
<b>E</b>	
Equipment Characteristics, Capabilities, and Features .....	1-5
Equipment Configuration .....	1-8
Equipment Description and Data .....	1-5
Equipment Supplied .....	2-2
Expendable/Durable Supplies and Materials List .....	E-1
<b>G</b>	
General Information .....	1-1
Glossary .....	Glossary-1
<b>I</b>	
Initial Checks .....	3-11
Installation Instructions .....	2-4
Installation Procedures .....	2-3
<b>L</b>	
Location and Description of Major Components .....	1-5
Lubrication .....	4-5
<b>M</b>	
Maintenance Allocation Chart .....	B-1
Maintenance Forms, Records, and Reports .....	1-1
Manpack Whip Antenna Installation .....	2-5

**INDEX (2 of 3)**

	<b>Page</b>
<b>M (cont)</b>	
Materials .....	5-1
<b>N</b>	
Nomenclature Cross-Reference .....	1-3
NVIS Antenna Installation .....	2-6
<b>O</b>	
Operation .....	3-1
Under Unusual Conditions .....	3-11
Cold Weather .....	3-15
Radio Silence .....	3-15
Operator Maintenance Procedures, Radio Set .....	4-1
Operator Preventive Maintenance Checks and Semites (PMCS) .....	3-9
Operator Troubleshooting .....	4-5
Organizational Maintenance .....	5-1
Procedures .....	5-15
Amplifier/Coupler .....	5-17
Battery Pack .....	5-18
RT .....	5-15
Organizational PMCS .....	5-3
Organizational Troubleshooting .....	5-3
<b>P</b>	
PMCS Table .....	3-9
Preoperational Check .....	4-5
Preparation for Storage or Shipment .....	1-2
Principles of Operation .....	1-9
Amplifier/Coupler .....	1-9
RT .....	1-9
Propagation of Radio Waves and Operating Considerations .....	F-1
<b>R</b>	
Radio Set Data .....	1-6
Radio Set Installation .....	2-4
References .....	A-1
Removal and Replacement .....	5-15
Amplifier/Coupler .....	5-17
Battery Pack .....	5-18
RT .....	5-15
Repair Parts, Special Tools, TMDE, and Support Equipment .....	5-1
Reporting Equipment Improvement Recommendations (EIR) .....	1-2
RT Connectors .....	3-4
RT Controls and Indicators .....	3-2
<b>S</b>	
Safety, Care, and Handling .....	1-8
Scope of Manual .....	1-1

**INDEX (3 of 3)**

	Page
<b>S (cont)</b>	
Service Upon Receipt.....	2-1
Service Upon Receipt and Installation.....	2-1
Shipment.....	6-1
Shutdown.....	3-13
Single Sideband Operation.....	3-12
Storage.....	6-1
<b>T</b>	
Test Setup.....	5-4
Tools and Materials Required for Installation.....	2-3
Troubleshooting Flowchart.....	5-5
<b>U</b>	
Unpacking Radio Set.....	2-1







THEN, JOT DOWN THE DOPE ABOUT IT ON THIS FORM. CAREFULLY TEAR IT OUT. FOLD IT AND DROP IT IN THE MAIL.

**SOMETHING WRONG WITH THIS PUBLICATION?**

FROM (PRINT YOUR UNIT'S COMPLETE ADDRESS)  
 Commander  
 Stateside Army Depot  
 ATTN: AMSTA-US  
 Stateside, N.J. 07703-5007

DATE SENT  
 10 July 1975

PUBLICATION NUMBER  
 TM 07748B-12/1  
 TM 11-5840-340-12

PUBLICATION DATE  
 23 Jan 74

PUBLICATION TITLE  
 Radar Set AN/PRC-76

BE EXACT PIN-POINT WHERE IT IS			
PAGE NO	PARA-GRAPH	FIGURE NO	TABLE NO
2-25	2-28		
3-10	3-3		3-1
5-6	5-8		
		F03	

**IN THIS SPACE TELL WHAT IS WRONG AND WHAT SHOULD BE DONE ABOUT IT:**

Recommend that the installation antenna alignment procedure be changed throughout to specify a 2° IFF antenna lag rather than 1°.

REASON: Experience has shown that with only a 1° lag, the antenna servo system is too sensitive to wind gusting in excess of 25 knots, and has a tendency to rapidly accelerate and decelerate as it hunts, causing strain to the drive train. Hunting is minimized by adjusting the lag to 2° without degradation of operation.

Item 5, Function column. Change "2 db" to "3db."

REASON: The adjustment procedure for the TRANS POWER FAULT indicator calls for a 3 db (500 watts) adjustment to light the TRANS POWER FAULT indicator.

Add new step f.1 to read, "Replace cover plate removed in step e.1, above."

REASON: To replace the cover plate.

Zone C 3. On J1-2, change "+24 VDC to "+5 VDC."

REASON: This is the output line of the 5 VDC power supply. +24 VDC is the input voltage.

PRINTED NAME, GRADE OR TITLE AND TELEPHONE NUMBER  
 SSG I. M. DeSpirito 999-1776

SIGN HERE

TEAR ALONG PERFORATION LINE

FILL IN YOUR  
UNIT'S ADDRESS

FOLD BACK

DEPARTMENT OF THE ARMY

OFFICIAL BUSINESS

**SAMPLE**

Commander  
US Army Communications-Electronics Command  
and Fort Monmouth  
ATTN: AMSEL-LC-ME-PS  
Fort Monmouth, New Jersey 07703-5000

TEAR ALONG REINFORCED LINE

**\*\* FOR USE BY U.S. ARMY PERSONNEL ONLY \*\***

**RECOMMENDED CHANGES TO EQUIPMENT TECHNICAL PUBLICATIONS**



**SOMETHING WRONG WITH THIS PUBLICATION?**

FROM: (PRINT YOUR UNIT'S COMPLETE ADDRESS)

DATE SENT

PUBLICATION NUMBER

PUBLICATION DATE

PUBLICATION TITLE

BE EXACT. PIN-POINT WHERE IT IS

PAGE NO

PARA-GRAPH

FIGURE NO

TABLE NO

IN THIS SPACE TELL WHAT IS WRONG AND WHAT SHOULD BE DONE ABOUT IT:

TEAR ALONG PERFORATED LINE

PRINTED NAME, GRADE OR TITLE, AND TELEPHONE NUMBER

SIGN HERE

DA FORM 2028-2  
1 JUL 79

PREVIOUS EDITIONS ARE OBSOLETE.

P S --IF YOUR OUTFIT WANTS TO KNOW ABOUT YOUR RECOMMENDATION MAKE A CARBON COPY OF THIS AND GIVE IT TO YOUR HEADQUARTERS

**\*\* FOR USE BY U.S. ARMY PERSONNEL ONLY \*\***

FILL IN YOUR  
UNIT'S ADDRESS

FOLD BACK

DEPARTMENT OF THE ARMY

OFFICIAL BUSINESS

Commander  
US Army Communications-Electronics Command  
and Fort Monmouth  
ATTN: AMSEL-LC-ME-PS  
Fort Monmouth, New Jersey 07703-5000

TEAR ALONG PERFORATED LINE







