

402 U/13
TM
1942

TM 11-453

U.S. Army

WAR DEPARTMENT

TECHNICAL MANUAL

✻

SHOP WORK

March 11, 1942

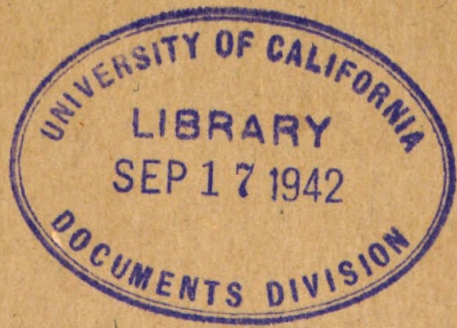

Shop Work

U113
12
TM 11:453
1942
★ ★

PREFACE

This text has been prepared by the Enlisted Men's Department of The Signal Corps School, to provide a progressive course in the use and maintenance of such woodworking and metal tools, as a soldier may be called upon to use in the various units of the Signal Corps.

Acknowledgement is made for the use of certain sections of Bell System Practices in lesson number eight, in the use, care, and maintenance of manila rope and blocks.

M574737

i

TABLE OF CONTENTS

Lesson	Page
1—Classification, Care and Maintenance of Tools	1
2—Use of Knife and Pliers, Wire Splices	9
3—Measuring and Gauging	20
4—Metal Working	27
5—Soldering	45
5A—Wiring of Radio Equipment, Cords and Plugs	65
6—Woodworking	79
7—Miscellaneous Tools	92
8—Rope, Splices, Knots and Blocks	99

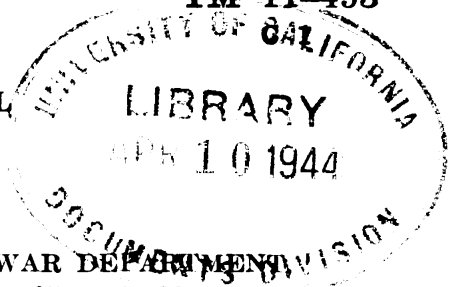

TECHNICAL MANUAL

SHOP WORK

ANGES }
No. 1 }

WAR DEPARTMENT
WASHINGTON 25, D. C., 20 March 1944.

TM 11-453, 11 March 1942, is changed as follows:

LESSON 1

CLASSIFICATION, CARE AND MAINTENANCE OF TOOLS

* * * * *

6. Maintenance of screwdrivers.—The screwdriver is * * *
ly, driving screws. Do not use it as a chisel, nailpuller, can opener
for any job that may damage the tool. The screwdriver
* * * he commonly uses. Some errors of maintenance and
e of this tool are illustrated in figures 3a, 3b, 3c, and 3d.
The broad flat * * * of uniform thickness.

Figure 3d

To repoint a screwdriver blade, square the point of the tip
and bevel the edges and the flat surfaces of the blade. This
may be done in the following manner:

Select a flat steel file. Clean as indicated in lesson 4, para-
graph 1, if the teeth of the file are clogged. Set up the work
so that the elbow will be level with the surface being filed.

Use a vise, if available, to secure the screwdriver in place,
leaving both hands free for guiding the motion of the file.

To square the point of the tip, the screwdriver is secured in
perpendicular position, with the tip pointing upward (fig.
5①). File with a diagonal stroke, making the tip smooth
and straight and squared with the edge of the blade.

To bevel the edges of the blade the screwdriver is placed in
horizontal position (fig. 5②). The upper edge of the blade
is filed at a slight angle, using a diagonal stroke. When the
edge is filed to the required width, the other side of the edge
is turned up, and is filed in the same manner.

To bevel the flat surfaces of the blade (fig. 5③), follow the
same procedure as described in beveling the edges of the
blade. (Lesson 4, paragraph 1, contains additional filing
directions.)

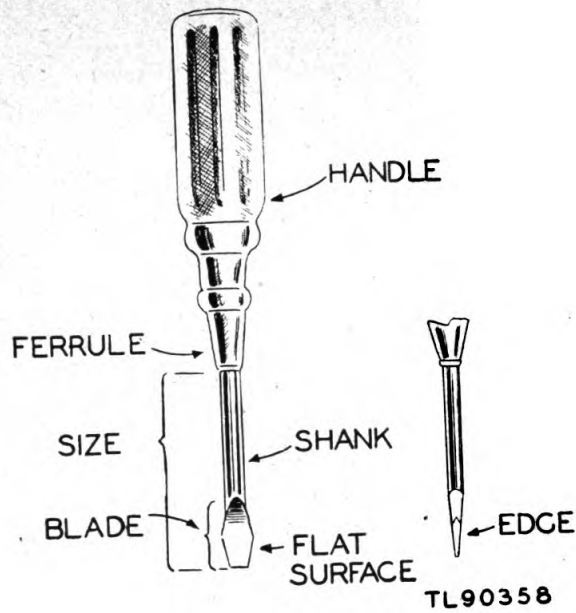

Figure 4 (Added.)

[A. G. 300.7 (14 Jan 44).] (C 1, 20 Mar 44.)

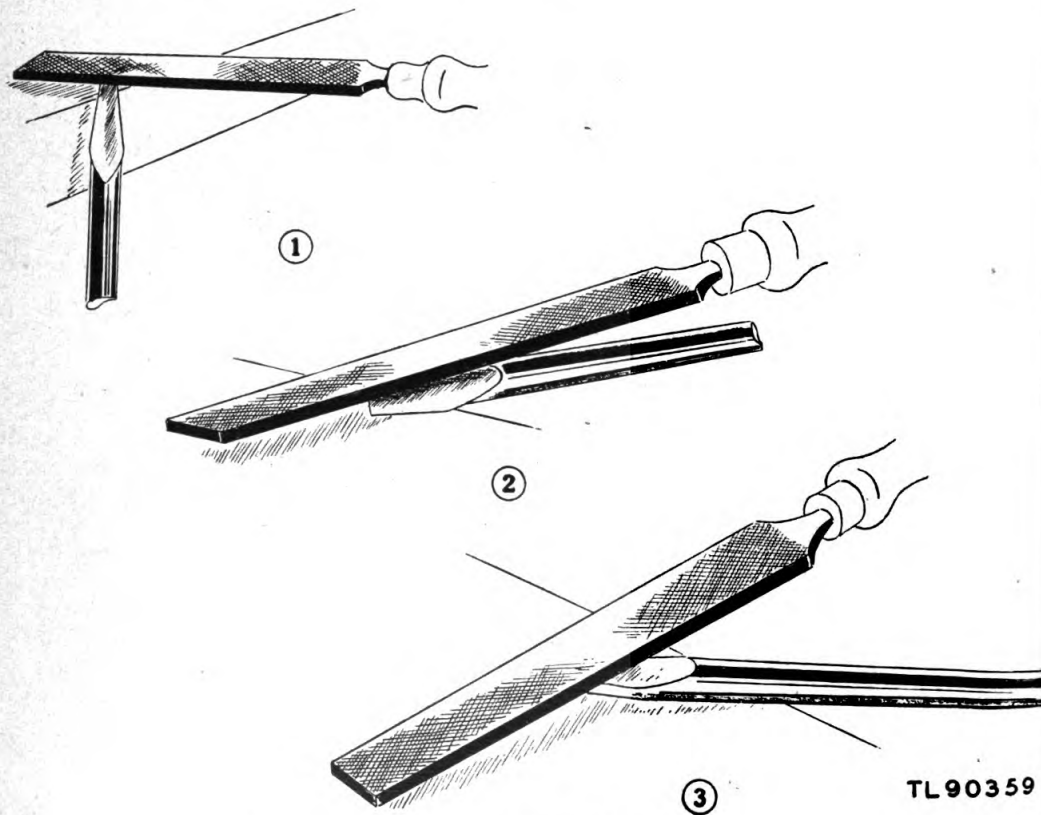

Figure 5 (Added.)

[A. G. 300.7 (14 Jan 44).] (C 1, 20 Mar 44.)

Some safety precautions * * * hands or face.

[A. G. 300.7 (14 Jan 44).] (C 1, 20 Mar 44.)

SHOP WORK

7. **Wood bits (Added).**—Wood bits are sharpened by filing. The filing tools should include a small, half-round file, an auger bit with safe edges, and a small triangular or square file. All wood bits have the same general features and are sharpened in the same manner. The two parts which may need sharpening are the cutting

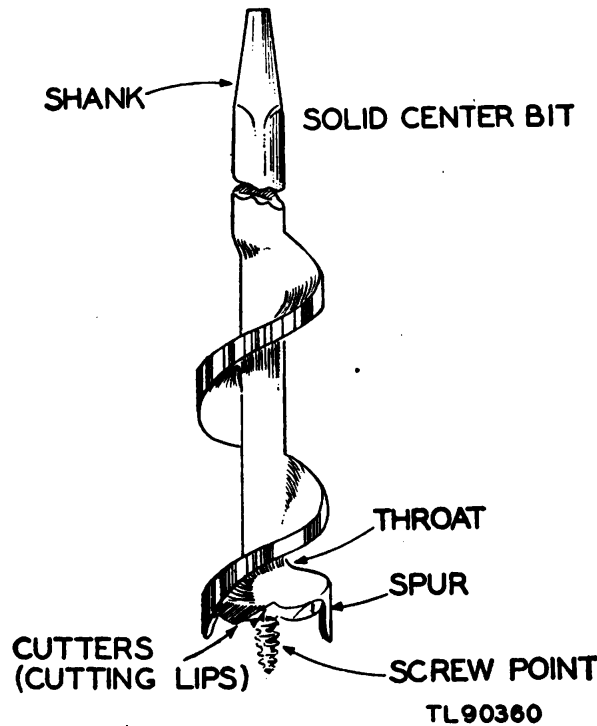

Figure 6 (Added.)

[A. G. 300.7 (14 Jan 44).] (C 1, 20 Mar 44.)

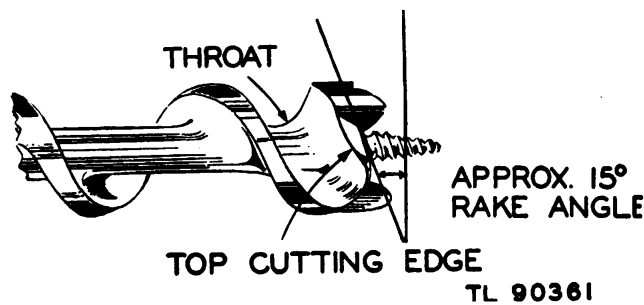
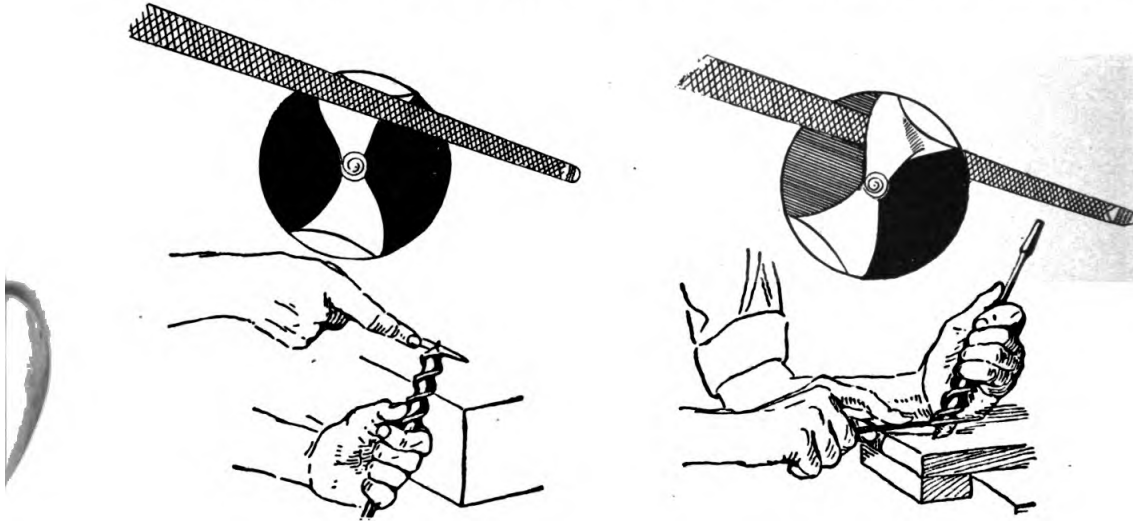

Figure 7 (Added.)

[A. G. 300.7 (14 Jan 44).] (C 1, 20 Mar 44.)

ps or cutters (fig. 6) and the spurs. With the usual types of wood bits, touch-up filing is worked through the throat (fig. 7), using either the half-round file (if the throat is rounded and small) or the auger bit file (if the throat is open). Spurs are always sharpened on the side, never on the outside (fig. 8). An auger bit file should be used when sharpening spurs, because its uncut edges minimize accidental

cutting of the lip surface. If the bit is very dull, the top of the cutting edge should be filed (fig. 8). It is important that the original bevel be maintained and that the surface following the cutting edge be filed *flat* completely across its width. If only a small portion of the edge of the lip is filed, the rake angle of the bevel is lessened and the chip-lift-



SHARPEN AUGER BITS WITH A BIT FILE. FOR A KEEN EDGE ALSO WHET WITH A SLIPSTONE. SHARPEN THE SPURS ON THE INSIDE TO PRESERVE THE DIAMETER.

SHARPEN THE CUTTING EDGES ON THE TOP TO MAINTAIN THE CLEARANCE ON THE UNDER SIDE. THE CUTTING EDGES MUST BE KEPT EVEN.

TL 90362

Figure 8 (Added.)

[A. G. 300.7 (14 Jan 44).] (C 1, 20 Mar 44.)

ing ability of the cutting edge is destroyed. The use of small stones on the filed surface will give the sharpened surface a polish which increases the cutting efficiency of the tool.

[A. G. 300.7 (14 Jan 44).] (C 1, 20 Mar 44.)

Review questions.—

* * * * *
 9. Name the safety precautions to be observed when using a screwdriver.

[A. G. 300.7 (14 Jan 44).] (C 1, 20 Mar 44.)

LESSON 2

USE OF KNIFE AND PLIERS, WIRE SPLICES

* * * * *
 7. Field wire splice.
 * * * * *
 b. Measure one plier's * * * * * in figure 1.

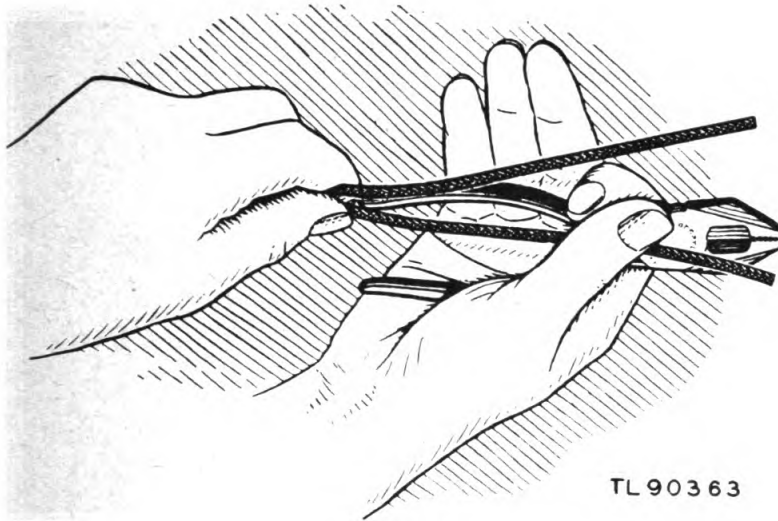

TL 90363

Figure 1

[A. G. 300.7 (14 Jan 44).] (C 1, 20 Mar 44.)

c. Crush and remove * * * in figure 2.

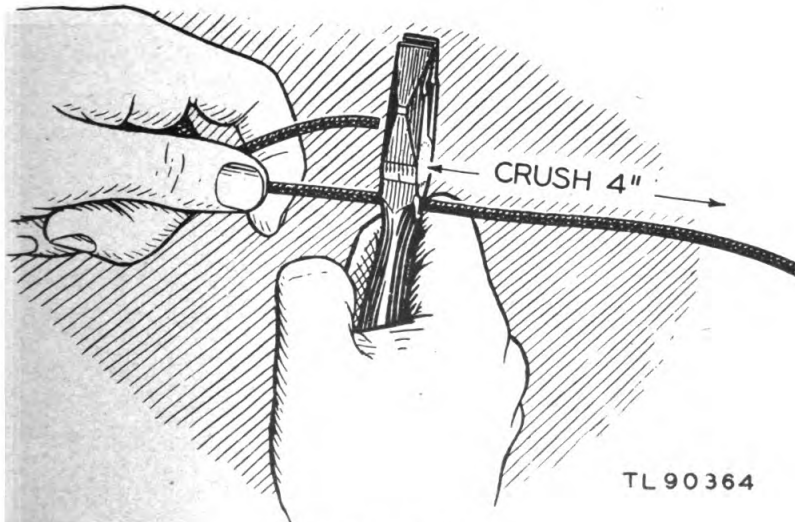

TL 90364

Figure 2a

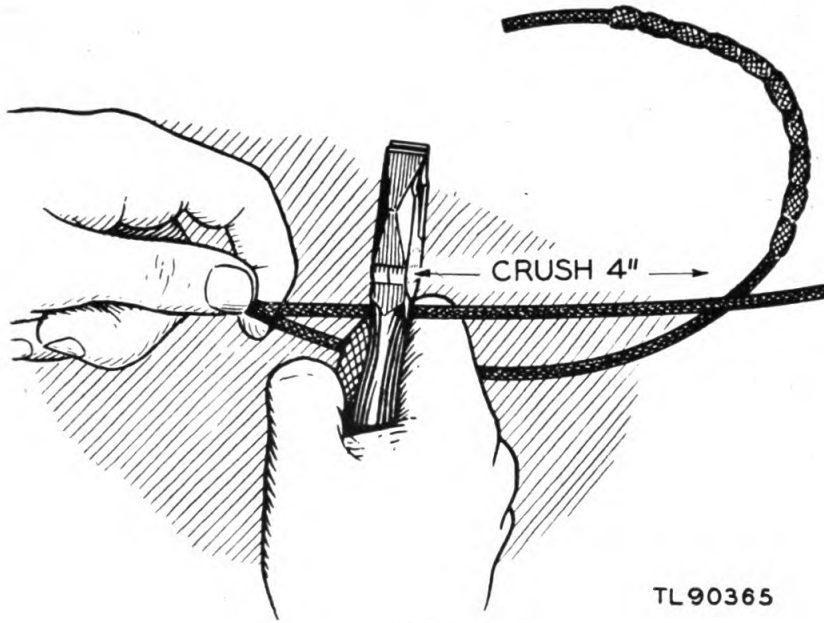

TL90365

Figure 2b

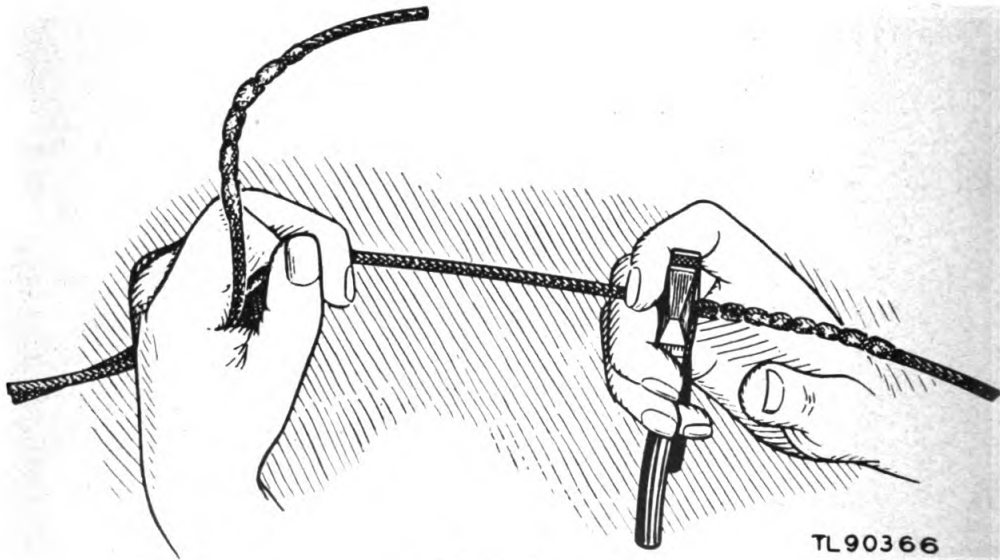

TL90366

Figure 2c

[A. G. 300.7 (14 Jan 44).] (C 1, 20 Mar 44.)

* * * * *
d. Place the wires to be spliced in the position as illustrated
in figure 2d. Tie a square knot as indicated in figure 3.

* * * * *

[A. G. 300.7 (14 Jan 44).] (C 1, 20 Mar 44.)

SHOP WORK

11. The field wire "T" splice.

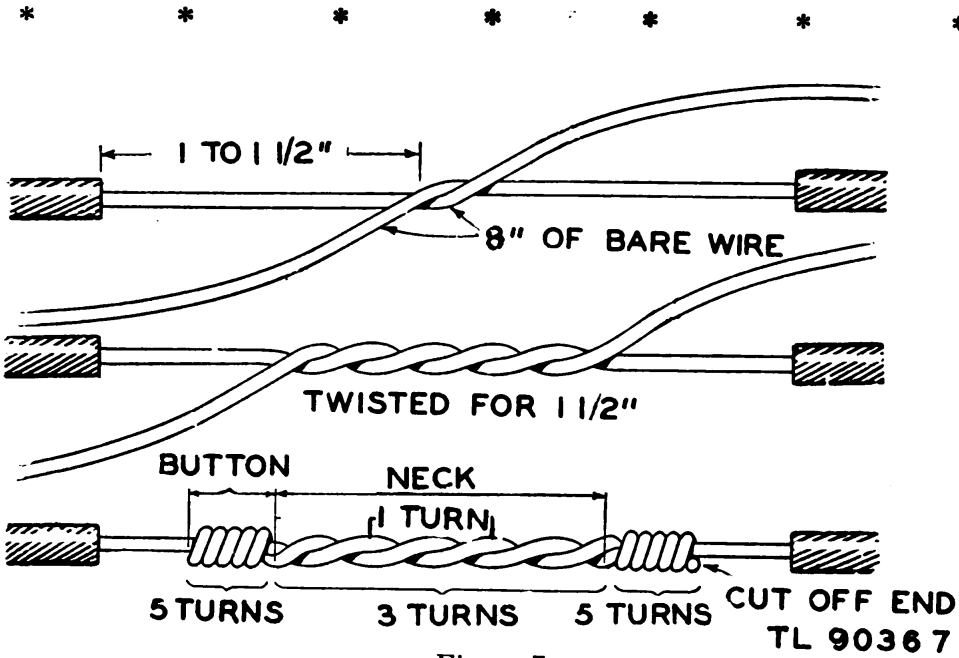

Figure 7

[A. G. 300.7 (14 Jan 44).] (C 1, 20 Mar 44.)

After the splice * * * in figure 8.

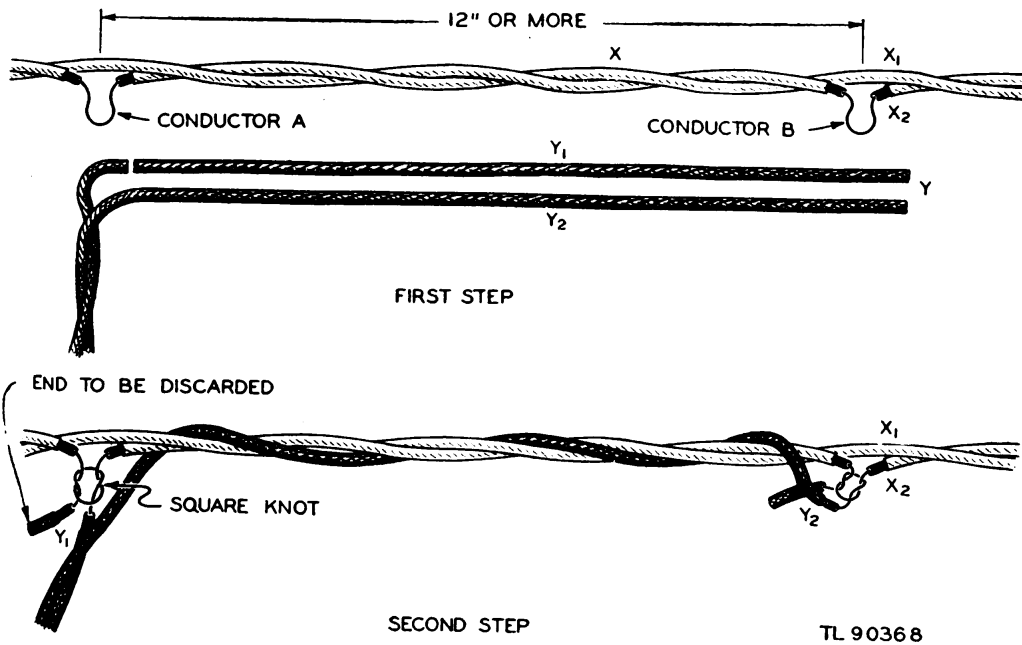

Figure 8

[A. G. 300.7 (14 Jan 44).] (C 1, 20 Mar 44.)

* * * * *

Review questions.—

* * * * *

16. (Added.) How many complete turns are made in the buttons of the Western Union splice?

17. (Added.) How many turns are made in the neck of the Western Union splice?

[A. G. 300.7 (14 Jan 44).] (C 1, 20 Mar 44.)

LESSON 2

LABORATORY

Tools and materials.—

- | | |
|----------------------|--------------------------------|
| Knife, TL-29 | *Wire, bare copper, W-74 (104- |
| Pliers, side-cutting | mil bare hard-drawn cop- |
| Pliers, long-nose | per, also known as wire |
| Pliers, diagonal | 104) |
| *Wire W-110 | *Seizing wire, 22-gauge bare |
| | copper |

Items marked * are not placed on the memorandum receipt.

[A. G. 300.7 (14 Jan 44).] (C 1, 20 Mar 44.)

Procedure.—

* * * * *

Operation 3.—Using 104 bare copper wire and W-110, make a combination seizing wire splice.

----- Ins. check

Operation 4.—Using wire furnished, make a tap splice.

----- Ins. check

Operation 5.—Using wire furnished, make a Western Union splice. Submit all splices to instructor for approval.

----- Ins. check

* * * * *

[A. G. 300.7 (14 Jan 44).] (C 1, 20 Mar 44.)

SHOP WORK

LESSON 3

MEASURING AND GAUGING

1. Steel scale.

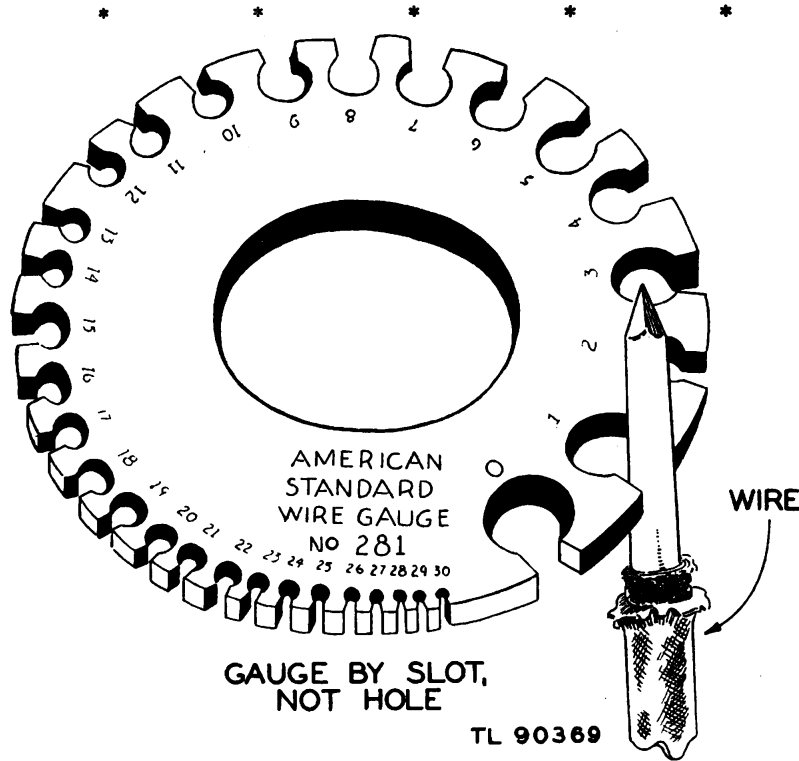

Figure 1

[A. G. 300.7 (14 Jan 44).] (C 1, 20 Mar 44.)

2. Wire gauges.—The wire gauge * * * *the copper wire.*

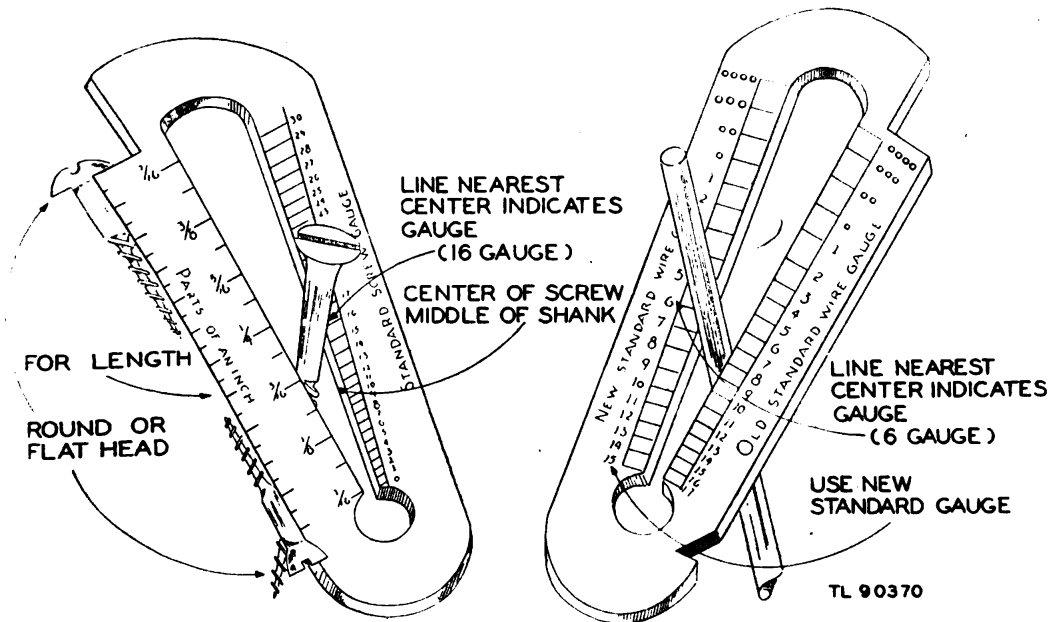

Figure 1.1 (Added.)

The circular wire * * * the correct gauge (fig. 1.1).

* * * * *

[A. G. 300.7 (14 Jan 44).] (C 1, 20 Mar 44.)

LESSON 4

METAL WORKING

* * * * *

6. Taps and dies.

* * * * *

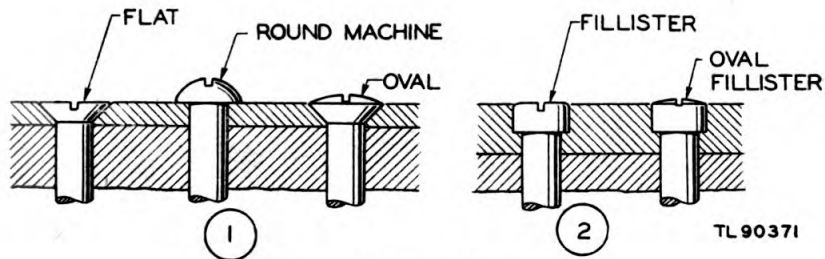

Figure 6

[A. G. 300.7 (14 Jan 44).] (C 1, 20 Mar 44.)

* * * * *

LESSON 4

LABORATORY

* * * * *

Procedure.—

Operation 1.—Using the 1/2-inch x 1-inch brass stock, square the ends with the files. Drill and tap a hole for a 12-24 thread.

-----Ins. check

Figure 8 (page 38) is rescinded.

Operation 2.—Using the brass rod furnished, and size 14-20 die, cut a 1/2-inch thread on one end only.

-----Ins. check

Operation 3.—Using the length of iron stock furnished, cut 1/4-inch from one end and square the ends of the remaining stock.

-----Ins. check

Operation 4.—Cut a piece of sheet brass 1 inch square and square all sides.

-----Ins. check

Operation 5.—Cut a piece of iron plate and square it. Form the bracket shown in figure 9.

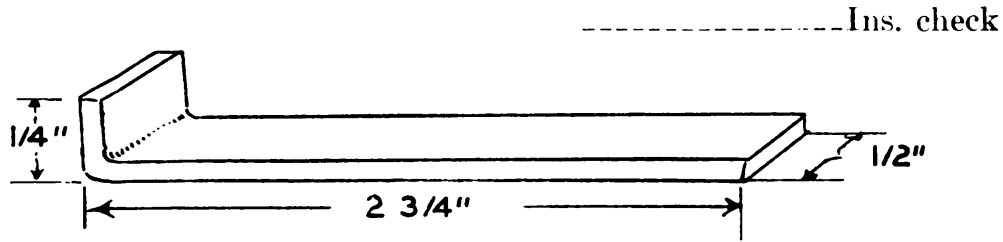

TL 90372

Figure 9

Operation 6.—Cut a piece of bakelite 1 inch square and square all sides.

-----Ins. check

[A. G. 300.7 (14 Jan 44).] (C 1, 20 Mar 44.)

LESSON 5 (page 58)

LABORATORY

(Wire Students Only)

Tools and materials for operations 1, 2, 3, 4, and 5.—

* * * * *

*¹/₄ pcs. Wire, copper, 104

* * * * *

[A. G. 300.7 (14 Jan 44).] (C 1, 20 Mar 44.)

Procedure.—

* * * * *

Operation 3.—Clean and tin one end of each of the four pieces of 104 copper wire. The tinned portion * * * will be secured.

-----Ins. check

* * * * *

[A. G. 300.7 (14 Jan 44).] (C 1, 20 Mar 44.)

Tools and materials for operations 6 to 16 inclusive.—

* * * * *

*1 pc. 20-pr. switchboard cable

*1 ea. Brass rods, 1/4 inch x 12 inch

* * * * *

Items marked * are not placed on the memorandum receipt.

Inspect models on display board and table before doing any of the operations below.

* * * * *

Operation 9.—Place the pairs * * * wires in place. If two brass rods are used, lay the other rod * * * the terminal block.

----- Ins. check

Operation 10.—Separate the first pair of wires (blue with white mate). Lay the white wire across the edge of the mounting strip so that it will be out of the way. Bend the coded (blue) wire into the notch of the top terminal of the second row. (The terminals are counted from the front to the back of the terminal block. The pairs are counted from the top to the bottom of a vertical strip.) The next step is to remove the insulation from the wire. Using a pair of long-nosed pliers, and starting at a point marked by the notch, crush the insulation about 1 inch toward the end of the wire. Remove crushed insulation. Wind the loose ends of the insulation tightly around the wire with the fingers, and slip back about 1/4-inch to facilitate the removal of enamel or tarnish. Enamel or tarnish may be removed by use of insulation strippers or the long-nose pliers. After the wire has been cleaned thoroughly, pull the insulation back and wind tightly so that the insulation comes under the terminal but does not enter the notch. Wind the bare wire around the terminal, making one complete turn, beginning and ending in the notch. Excess wire is removed by severing it in the notch. When working with wire of a larger gauge (18 gauge or larger), or on terminals that are not very rigid, severing may be accomplished by pulling the wire taut and bending it from side to side.

Solder the connection and inspect for the faults listed below :

* * * * *

c. Rosin joints. (Not enough heat.)

d. Solder not adhering to wire. (Must be unsoldered and wire scraped.)

After the connection has been inspected, and all faults corrected, if the student is in doubt as to whether the connection has been soldered properly, have the instructor check it before soldering others. Continue with the coded wires until all 20 have been soldered.

----- Ins. check

* * * * *

Operation 12.—Lash another piece * * * block mounted horizontally. Wires should be fanned through the bottom of the

horizontal strip. Place and solder * * * instructor for approval.

-----Ins. check

Operation 13.—Place five pairs of cross-connecting wires from the vertical protector strip to the top punchings of the horizontally mounted terminal block. This wire is not dressed back against the fanning strip. Each pair of cross-connecting wires should have approximately 3 inches of slack. These wires are connected and soldered on the horizontal block as in operation 10. In connecting to the vertical protector strip, the insulation should come up to, but not enter, the notch. The method outlined in operation 10 for removing insulation and attaching wires to punching will be followed. Solder is applied on the face of the punchings. Check the connections for faults and submit to the instructor for approval.

-----Ins. check

* * * * *

Operation 16.—Rescinded.

[A. G. 300.7 (14 Jan 44).] (C 1, 20 Mar 44.)

LESSON 5A

WIRING OF RADIO EQUIPMENT, CORDS AND PLUGS

(For Radio Students Only)

* * * * *

3. Cable wiring.—Cable wiring is * * * work being done.

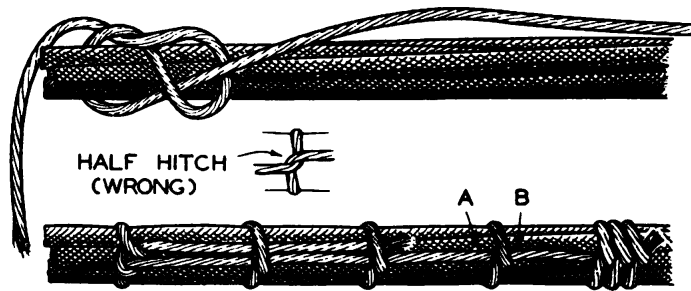

TL 90373

Figure 9

A figure eight * * * then cut off. The wires are laced together with a lock stitch. Do not use a half-hitch. The half-hitch will not hold the form together if the lacing cord is broken. At the points marked A and B in figure 9, the twine must be on the under side. If either A or B is on top when

SHOP WORK

Tools and materials for operations 7 to 14 inclusive.—

- | | |
|--|---|
| 1 each Soldering iron TL-117 | 1 each Plug PL-50 |
| 1 each Pliers, 6-inch side-cutting (TL-13) | 1 each Plug PL-61 |
| 1 each Pliers, long-nose (TL-126) | *1 ea. File, 10-inch, with handle |
| 1 each Pliers, diagonal (TL-103) | 1 ea. File, card |
| 1 each Knife TL-29 | *6 pcs. Wire No. 14, enameled |
| 1 each Small screwdriver | *1 bundle Wire, for chassis wiring |
| 1 each Chassis | *3 Terminals, mounted on block |
| | *1 pc. Cordage CO-130 |
| | *1 pc. Cordage CO-138 |

Items marked * are not placed on the memorandum receipt.

*Inspect models on * * * the operations below.*

* * * * *

*Operation 10.—*One satisfactory loop must be completed to fit the machine screw furnished.

----- Ins. check

* * * * *

*Operation 13.—*Rescinded.

* * * * *

[A. G. 300.7 (14 Jan 44).] (C 1, 20 Mar 44.)

LESSON 6

WOODWORKING

* * * * *

3. Laying out the work.

* * * * *

*Marking gauge.—*This tool consists * * * along the grain.

Do not use the tool across the grain.

* * * * *

*Transferring the dimensions.—*A pencil with * * * cannot be used. **A pencil or knife used in conjunction with a square or straight edge should be used to mark across the grain. The knife or pencil should have the upper end tilted away from the square or rule.**

(Figure 1)

[A. G. 300.7 (14 Jan 44).] (C 1, 20 Mar 44.)

7. Mallets.—The wood mallet * * * wooden pins, etc. Mallets are sometimes made of lead, brass, or plastic.

[A. G. 300.7 (14 Jan 44).] (C 1, 20 Mar 44.)

12. Claw hammer.—The claw hammer * * * for removing nails.

If it is necessary to hammer a nail with the use of only one hand, proceed as follows: insert the nail between the hammer claws (fig. 3.1①), with the head of the nail against the base of the hammer head, so that the nail remains rigidly in position. Drive the nail deep enough with the first blow so that it will remain in the wood until struck again with the face of the hammer.

Another method for hammering a nail with one hand is shown in figure 3.1②. Grasp the hammer head so that the side of it will be used for driving. Hold the nail head against the side of the hammer, and drive the nail deep enough with the first blow so that it will remain in place to be struck again in the usual manner.

[A. G. 300.7 (14 Jan 44).] (C 1, 20 Mar 44.)

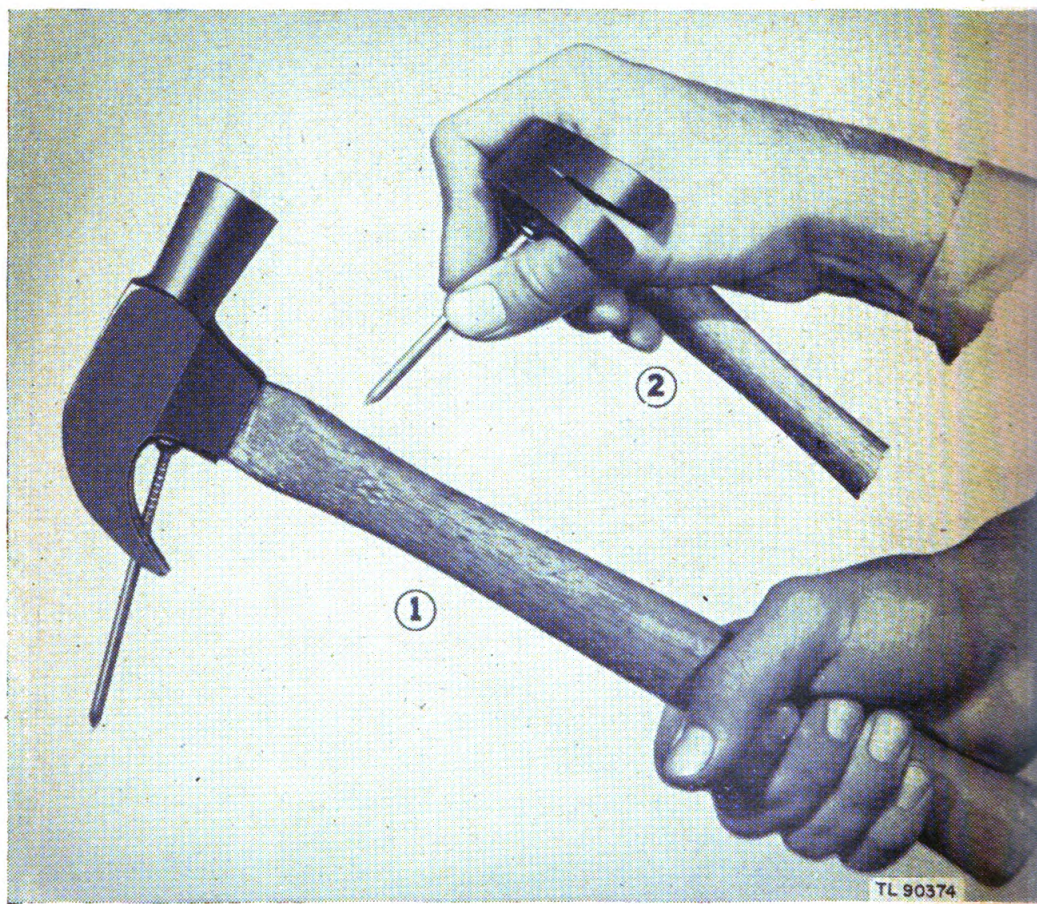

Figure 3.1 (Added.)

[A. G. 300.7 (14 Jan 44).] (C 1, 20 Mar 44.)

16. Fastening devices.

* * * * *

Nails.—The wire nail * * * by the figure.

Common Wire Nails (Added.)

Size	Length (inches)	Gauge number	Diameter (inches) approximate	Approximate number to 1 pound
2D	1	15	$\frac{5}{64}$	876
3D	$1\frac{1}{4}$	14	$\frac{5}{64}$	568
4D	$1\frac{1}{2}$	$12\frac{1}{2}$	$\frac{3}{32}$	316
5D	$1\frac{3}{4}$	$12\frac{1}{2}$	$\frac{3}{32}$	271
6D	2	$11\frac{1}{2}$	$\frac{7}{64}$	181
7D	$2\frac{1}{4}$	$11\frac{1}{2}$	$\frac{7}{64}$	161
8D	$2\frac{1}{2}$	$10\frac{1}{4}$	$\frac{1}{8}$	106
9D	$2\frac{3}{4}$	$10\frac{1}{4}$	$\frac{1}{8}$	96
10D	3	9	$\frac{5}{32}$	69
12D	$3\frac{1}{4}$	9	$\frac{5}{32}$	63
16D	$3\frac{1}{2}$	8	$\frac{5}{32}$	49
20D	4	6	$\frac{3}{16}$	31

[A. G. 300.7 (14 Jan 44).] (C 1, 20 Mar 44.)

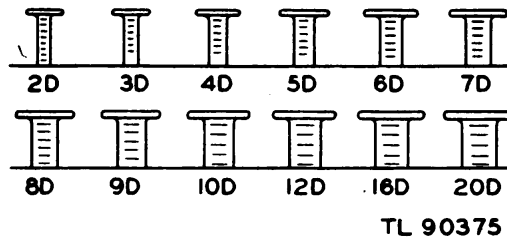

Figure 5 (Added.)

[A. G. 300.7 (14 Jan 44).] (C 1, 20 Mar 44.)

* * * * *

LESSON 7

LABORATORY

Tools and materials.—

* * * * *

*4 pcs. 104 copper wire.

* * * * *

Items marked * are not placed on the memorandum receipt.

* * * * *

[A. G. 300.7 (14 Jan 44).] (C 1, 20 Mar 44.)

LESSON 8

ROPES, SPLICES, KNOTS, AND BLOCKS

1. General information on rope.—

* * * * *

e. Selecting the size of rope for the work to be performed.—The approximate weight * * * fibres to break. Table 3, page 130, shows the proper size ropes for the various size blocks. (See rigging.)

* * * * *

[A. G. 300.7 (14 Jan 44).] (C 1, 20 Mar 44.)

2. The more common rope splices.—

* * * * *

b. Crown splice.—See figure 2 (b).

* * * * *

(6) Continue the weaving in the following manner (fig. 2(b)F):

(a) Place one of the loose strands over the nearest main strand; tuck it under the next main strand, pulling it at a 45° angle to the rope.

(b) Turn the rope counterclockwise until the next loose strand is forward. Place this strand over the nearest main strand and tuck it under the next main strand.

(c) Again turn the rope counterclockwise until the next loose strand is in the forward position. Follow the same procedure as in (b) above.

* * * * *

c. Eye splice.—The eye splice * * * in figure 3-A-D.

(1) Untwist the strands * * * the eye required. Be certain that the middle strand 2 is placed under the rope (fig. 3-A).

(2) (Superseded.) Tuck strand 1 under one of the main strands of the rope at the point where weaving is to start (fig. 3-B).

(3) (Superseded.) Place strand 2 behind the rope (fig. 3-A).

(4) (Superseded.) Tuck strand 3 under the next main strand, directly below strand 1 (fig. 3-B).

(5) (Added.) Turn the rope over, and tuck strand 2 under the third main strand of the rope. This brings strand 2 through the main rope between strands 1 and 3 (fig. 3-B).

(6) (Added.) When all the ends have been tucked through for the first time, pull them down tight as in 3-C. Proceed to interweave the strands as follows:

(a) Pull strand 2 toward the top of the eye. Place strand 1 over the nearest main strand and tuck strand 1 under the next main strand. This should place strand 1 between strands 2 and 3.

(b) Place strand 2 over the nearest main strand and tuck it under the next main strand.

(c) Check the weaving to make certain that one main strand of the rope always separates the two other strands.

(d) Continue interweaving as in b(6) above until the total length of the interwoven strands, for 1/4-inch rope, extends a distance of 4 inches. Add one tuck for each next larger standard size rope.

(e) Roll the splice between two flat surfaces under pressure as between foot and floor, and trim off surplus ends flush with the outside strands. The completed splice is shown in figure 3-D.

d. *Short straight splice.*—Short straight splice * * * of the rope. See figure 3-E-G.

(1) Untwist the strands * * * 10 to 16 inches. Butt the ends of the rope tightly together as in figure 3-E laying the strands * * * locking the strand.

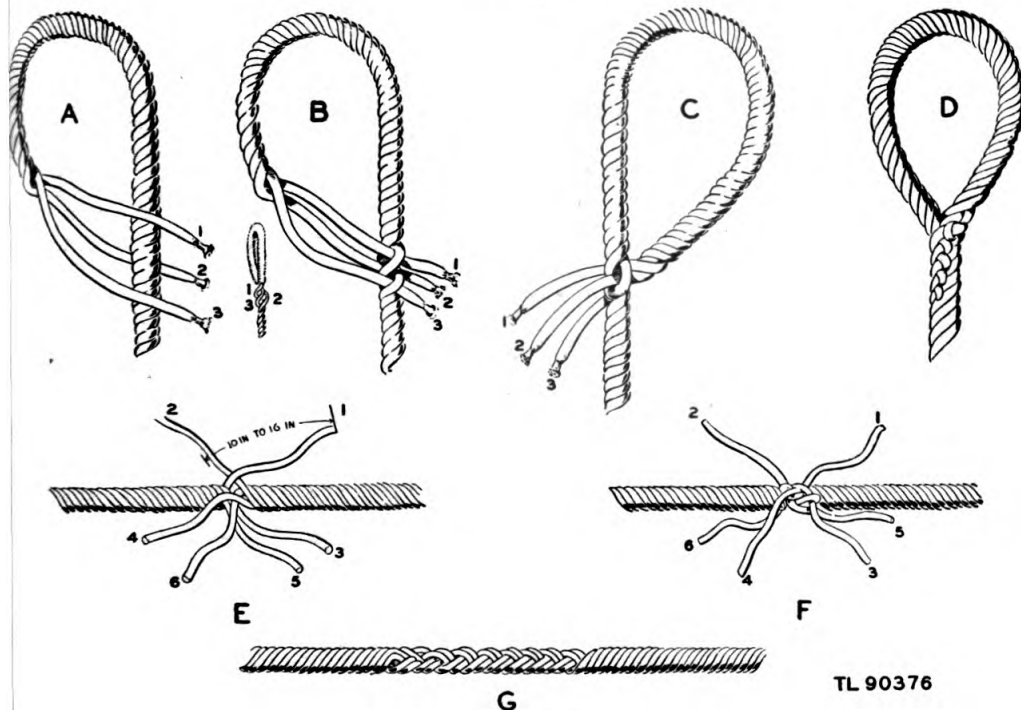

Figure 3.

[A. G. 300.7 (14 Jan 44).] (C 1, 20 Mar 44.)

(2) (Superseded.) Hold the even-numbered strands and the rope tightly in the left hand. With the right hand, aided by the thumb and forefinger of the left hand, weave the odd-numbered strands in the following manner:

(a) Place one of the loose odd-numbered strands over the nearest main strand and tuck it under the next main strand, pulling it up to a 45° angle to the rope. Turn the rope counterclockwise until the next loose odd-numbered strand is forward. This strand, as well as the next, and last odd-numbered strand, are handled in the same manner as described above.

(b) The operation just explained is repeated with the even-numbered strands, producing an arrangement similar to that shown in figure 3-F. Continue the interweaving on alternate sides until its total length extends a distance of 4 inches for ¼-inch rope. Add another tuck for each next larger standard size rope.

(3) (Superseded.) Roll the splice between two flat surfaces under pressure (between the foot and floor), and trim off the surplus ends flush with the outside strands. The completed splice is shown in figure 3-G.

(4) Rescinded.

(5) Rescinded.

* * * * *

[A. G. 300.7 (14 Jan 44).] (C 1, 20 Mar 44.)

4. Blocks.

* * * * *

c. *Manila rope snatch blocks.*—Snatch blocks are * * * they will carry. A snatch block may be defined as a single sheave block, with a hinged swivel hook. Snatch blocks are illustrated in figure 21 (b).

* * * * *

[A. G. 300.7 (14 Jan 44).] (C 1, 20 Mar 44.)

LESSON 8

LABORATORY

Tools and materials.—

1 ea. Knife TL-29

* * * * *

Blocks for reeving will be found in the class room.

* * * * *

[A. G. 300.7 (14 Jan 44).] (C 1, 20 Mar 44.)

BY ORDER OF THE SECRETARY OF WAR:

G. C. MARSHALL,
Chief of Staff.

OFFICIAL:

J. A. ULIO,
Major General,
The Adjutant General.

SHOP WORK

LESSON 1

CLASSIFICATION, CARE AND MAINTENANCE OF TOOLS

1. **Classification.**—Tools are divided into two general classes: machine tools and hand tools. Machine tools are usually driven by electric motors, and are used where the volume of work performed is great enough or the labor saved is sufficient to warrant their cost. Examples: lathe, circular and jig saws, drill presses and milling machines. Hand tools are those held in the hand, or those in which the operator furnishes the motive power. Examples: hand saws, knives, pliers, planes, miter boxes, etc.

Tools are further subdivided according to their use as layout, cutting, boring, driving, holding and sharpening.

2. **Care of tools.**—The work bench, classed as a holding tool, very seldom gets the care it should have. The top should be cleaned at the completion of each job, or daily, before leaving the shop. Vises attached to the work bench should be wiped off and inspected for rust at the same time. Do not allow trash to accumulate in the drawers. Heavy or rough work, assemblies which have sharp edges and other types of work that might gouge into the top of the bench should be handled from the floor or on special racks.

A salt, present in perspiration, causes rust to form on metal tools. Wipe all metal tools off with an oily rag, after a job has been completed; also before returning them to the store room.

The correct storage of tools plays an important part in their care. Cutting and boring tools should be placed in racks or drawers which will protect their cutting edges, and while in use on the work bench, should be placed so that their cutting edges will not come in contact with other tools. The rivets in the hinges of pliers and similar tools should

be oiled occasionally to keep them working freely. Layout tools must not be dropped, used as a pry, to drive screws or as a scraper. This abuse will render them inaccurate. Inspect the handles of all driving tools frequently, see that they are tight and free from checks and splinters. When tools are to be stored for some length of time, a lubricant such as vaseline or heavy gunoil should be spread over all metal parts. Thin oil breaks down and allows atmospheric moisture to corrode the metal. No mechanic, however expert, can do first class work with an unserviceable tool.

3. Maintenance of tools, shaping and sharpening.—Cutting and driving tools such as chisels, knives, twist drills, wood bits and screwdrivers must be correctly shaped and sharpened in order to perform first class work. Tools are shaped and large nicks removed from cutting edges by the use of carborundum wheels and stones, and grindstones. Oilstones are used for honing, which brings the cutting edge to the correct degree of keenness.

The grindstone is used for shaping and sharpening low temper tools such as adzes, hatchets, axes, cable knives, etc. Water is used on the grindstone to reduce the heat caused by friction, thus preserving the temper of the tool. The surface speed of wheels used to shape and sharpen high temper tools such as plane cutters, wood chisels, twist drills, metal working bits, etc., is too great to permit the use of a lubricant on the wheel itself. The temper of the tool is preserved during the grinding process by dipping it frequently into a can of water to keep it cool. Grindstones and carborundum wheels should revolve toward the user. This removes the metal from the cutting edge of the bevel and not from the heel.

A light oil is used on the surface of all flat stones, whether carborundum or oilstones, to prevent the small particles of metal removed from the tool from sinking into the stone. When the oil becomes dirty, wipe it off with a rag and place fresh oil on the stone. *Do not* grind or hone in one spot, work the tool over the entire surface of the stone. This keeps the surface level.

The following is a good test for a serviceable cutting edge. Place the cutting edge on the thumbnail, exert a light pressure, and draw the edge along the nail. If it "clings" to the nail the tool is correctly sharpened.

4. Sharpening the knife.—The knife is a double bevel tool, usually of low temper steel. *Do not grind the knife on the carborundum wheel.* If the nicks are too large to remove with a flat stone use the grindstone. The knife is sharpened by stroking first on one side of the blade and then on the other, moving the tool so that the cutting edge always meets the stone first.

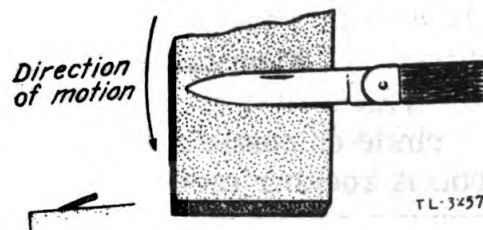

Figure 1

The correct stroking motion is illustrated in figure 1. The angle between the knife blade and the stone is about twenty degrees. After the nicks have been removed, hone to the correct cutting edge on the oilstone.

5. Chisels and plane cutters.—Plane cutters, chisels, gouges and similar single bevel cutting tools should first be ground square on the carborundum wheel. Check with a try-square, testing from one edge of the tool only. With proper care, the single bevel type of tool need not be ground often. A few minutes spent in honing the tool on the oil stone will keep the cutting edge serviceable. A good general rule to follow is: If the honed part of the bevel exceeds one half of its total length the tool should be reground.

The angle of the bevel varies with the type of work to be performed. A good angle for general work is 25 degrees, soft wood or material is worked with a 20 degree bevel while hard wood requires a 30 degree bevel. Small nicks are removed by flat grinding on a carborundum stone. The bevel of the tool must be exactly parallel with the surface of the stone. Use one hand to guide the tool, the other to apply a

moderate amount of pressure and move the tool over the entire surface of the stone with a rotary motion as illustrated in figure 2.

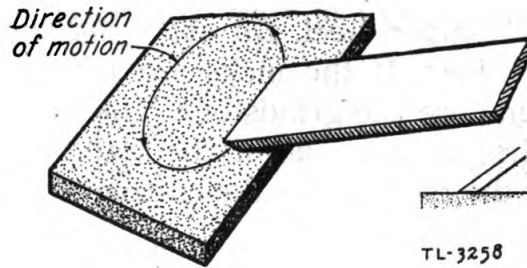

Figure 2

Use as small a circle as possible, as this gives better control over the tool. A rocking motion should be avoided, as this soon destroys the hollow grind obtained from the carborundum wheel and makes it practically impossible to sharpen the tool on a flat stone without regrinding. As the cutting edge of the bevel becomes thin, it will be noted that a burr or wire edge is formed on the back of the tool. This is removed by placing the back of the tool absolutely flat on the stone and using the rotary motion illustrated in figure 2. Plane cutters usually have a small portion of each end ground off to prevent them from biting into the wood being smoothed. When all nicks have been removed from the tool, hone to the correct cutting edge on the oilstone, using the procedure given above.

6. Maintenance of screwdrivers.—The screwdriver is probably more abused than any other tool. It is made for one purpose only, driving screws. Do not use it as a chisel, nailpuller, canopener or other jobs for which it is unfitted. The screwdriver is made of a very tough grade of steel due to the torque applied to it when driving screws. Every mechanic should have several screwdrivers each ground and correctly shaped to fit some screw he commonly uses. Some errors of maintenance and use of this tool are illustrated in figure 3.

The broad flat surfaces are ground slightly concave on the carborundum wheel or shaped with a file. The two surfaces must have an equal taper in order to keep the tip on the center line of the shank. *The end of the blade must have the sides parallel for the depth of the screw slot.* The tip should be square and of uniform thickness.

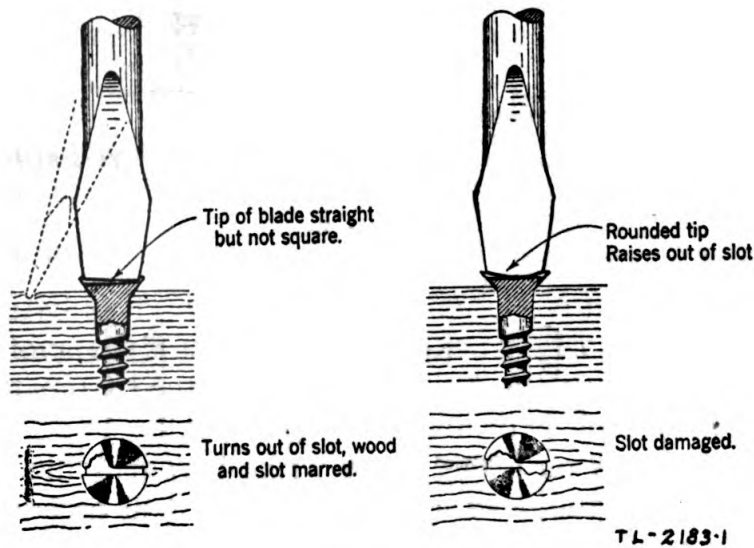

Figure 3a

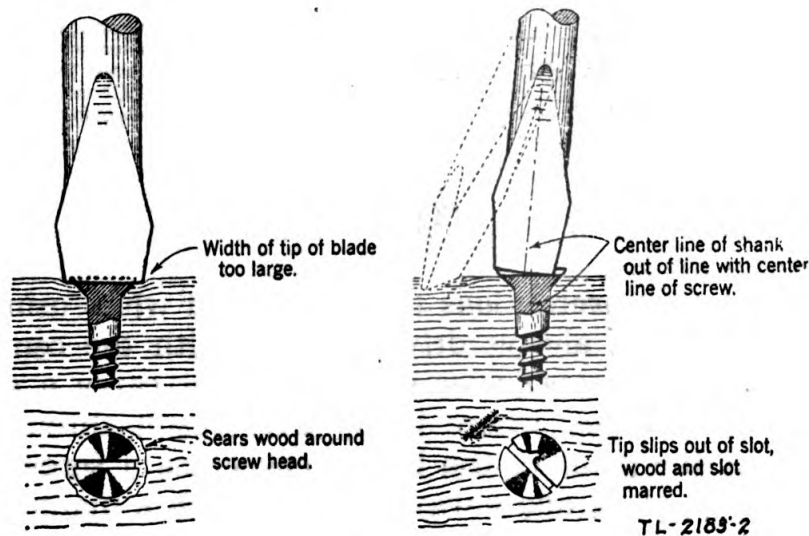
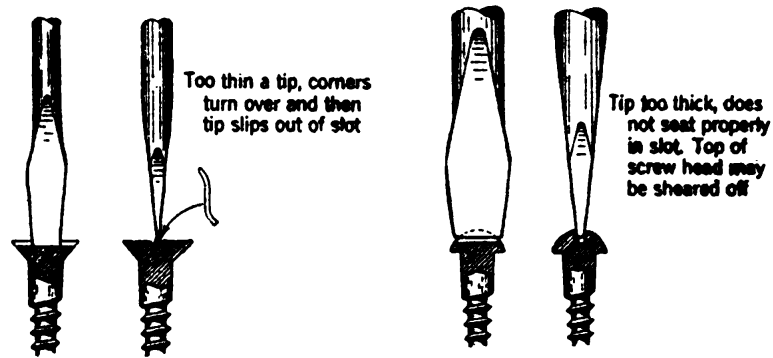

Figure 3b



Screws with damaged slots are difficult to remove. Difficult jobs take extra time. Extra time increases maintenance costs

TL-2183-3

Figure 3c

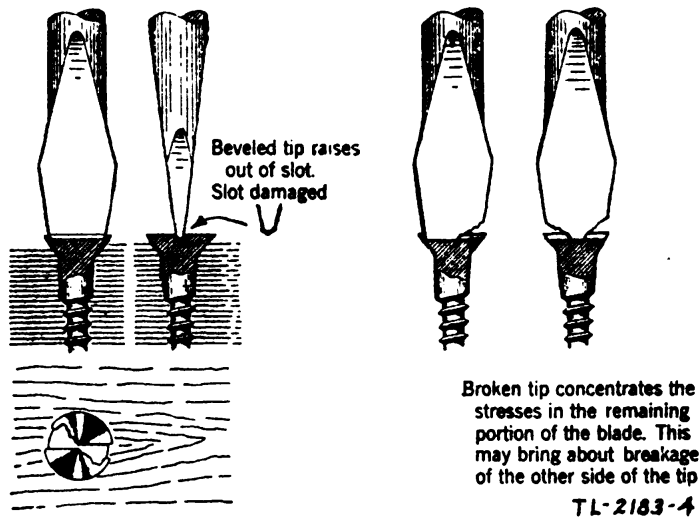

TL-2183-4

Figure 3d

Some safety precautions to be observed when using the screwdriver are, always drive a screw with the center of the screw and screwdriver in line; do not carry a screwdriver in a pocket, where injury may result through exposure of the point of the blade; never use a screwdriver with a bent blade and always work in such a manner that if the screwdriver slips, it will not cause injury to the hands or face.

The maintenance of twist drills and wood bits is an exacting job. The instructor will give group instruction in the correct procedure when necessary.

Review questions.—

The answers to all review questions will be found in the text. Do not consult the instructor regarding these questions unless you are unable to find an answer for them.

1. Name the two general classes of tools.
2. Name two things to be remembered about the care of hand tools.
3. Name two stones that are used to remove nicks from tools.
4. What is the oilstone used for?
5. What test is used to determine if a tool has a serviceable cutting edge?
6. Are knives and plane blades sharpened the same way?
7. How is the wire edge removed from plane blades and chisels?
8. Should a screwdriver with a bent blade ever be used to drive screws?
9. Name one safety precaution to be observed when using a screwdriver.

RESTRICTED**LESSON 1****LABORATORY****Tools and materials.—**

Oilstone	Plane cutter
Carborundum stone	*Oilcan
Knife, TL-29	*Rags
Wood chisel	

Items marked * are not placed on the memorandum receipt.

Procedure.—

Operation 1.—Using the oil and carborundum stones, sharpen the knife, TL-29. These stones break easily, and must be handled carefully.

..... Ins. check

Operation 2.—Sharpen the plane cutter. Follow instructions given in the lesson sheet.

..... Ins. check

Operation 3.—Sharpen the wood chisel. If the student is unable to determine if the plane cutter or wood chisel requires grinding, consult the instructor. Submit sharpened tools to instructor for approval.

..... Ins. check

Operation 4.—Examine one of the sets of screwdrivers displayed on bulletin board.

..... Ins. check

List the faults found below:

- 1.
- 2.
- 3.

LESSON 2

USE OF KNIFE AND PLIERS, WIRE SPLICES

1. Electricians knife, TL-29.—The three major parts of this knife are: handle, screwdriver and cutting blade. The screwdriver blade is provided with a lock, which protects the user when this blade is opened. Never have both blades open at the same time. The cutting blade is used to whittle soft materials and to remove insulation from wires. *Do not use this blade to scrape wires.* The screwdriver blade is used to drive small screws. If necessary, it may also be used to clean wires. When using the cutting blade, *do not cut toward the body.*

2. Pliers, general.—Pliers are classified according to their length and by the shape of their jaws. Examples: 6-inch side-cutting, 4-inch diagonals. Pliers are made in various lengths, with a wide variety of jaw shapes, each intended for some specific use. The important points to remember when using pliers are: keep them clean and free from rust, use a size and jaw shape that will do the work correctly, never use the pliers as a wrench or hammer. The three types of pliers used most commonly by signal specialists are: side-cutting, diagonal and long-nose.

3. Side-cutting pliers, TL-13 (Commercial lineman's 6-inch side-cutting).—This type of pliers is equipped with blunt jaws, which have a scored gripping surface, side wire cutters, parallel heel surfaces, and strong handles. The gripping surfaces do not close completely, as this would interfere with the cutters. These pliers are used for insulation crushing (use the heel), gripping, wire splicing, wire cutting and insulation stripping. When removing insulation, do not permit the jaws to touch bare wire. Never cut solid wire completely apart with pliers, as this may damage the cut-

ters. Nick it, then use the gripping part of the jaws to bend the wire back and forth until it breaks.

4. Long-nose pliers. TL-126 (Commercial 6- or 6½-inch).—Long-nose pliers have long, slender jaws, flat on the inside. They are usually scored on the inside of the jaw, near the end of the pliers. Some long-nose pliers are made with cutters, but the greater majority do not have them. Long-nose pliers are used for gripping, reaching places not readily accessible to the hand, holding wires, bending loops, attaching wires to terminals and punchings, skinning and splicing small wires.

Wire insulation is crushed with the long-nose pliers, providing they are not equipped with cutting jaws, by sliding the wire down the base of the jaws and squeezing down on the handles. The insulation can now be removed easily from the wire, and if necessary, the gripping surfaces of the jaws may be used to clean the wire.

Do not use this type of pliers to hold large objects, tighten nuts or bend the larger gauges of wire and sheet metal. Such practice soon springs the jaws, rendering the pliers unserviceable.

5. Diagonal pliers, TL-103, (Commercial 5-inch).—This type of pliers is equipped with cutting jaws, set at an angle of about fifteen degrees from the handles, making them more efficient in close places than side cutting pliers. The principal use of these pliers is cutting small gauge wires. These pliers should not be used to cut wires larger than 16 gauge steel or 14 gauge copper.

6. Wire splices, general.—The installation of wire systems, both field and permanent, requires the use of a variety of wire splices. The splice used will depend primarily on the types of wires to be connected. Regardless of the type of splice used, the following principals must be observed:

Thoroughly clean bare portion wires before joining.

A wire is not clean unless all tarnish or oxide is removed.

Do not nick the conductor, if the wire is stranded care must be exercised in removing insulation so that all strands remain intact.

Apply tape to splices on insulated wire, to restore the insulation and render the splice waterproof (see paragraph 12).

When splicing twisted pair, (field wire splice), the joints should be staggered at least 6 inches. This helps to prevent short circuits, and reduces the bulk of the splice.

7. Field wire splice.—The standard field wire splice, made in wires type W-110 and W-110-B, using copper seizing wire, is made as follows (also on older obsolete types of wire):

- a. Cut the ends of both wires off square.
- b. Measure one plier's length on one conductor (about 6 inches) and cut this length off, as illustrated in figure 1.

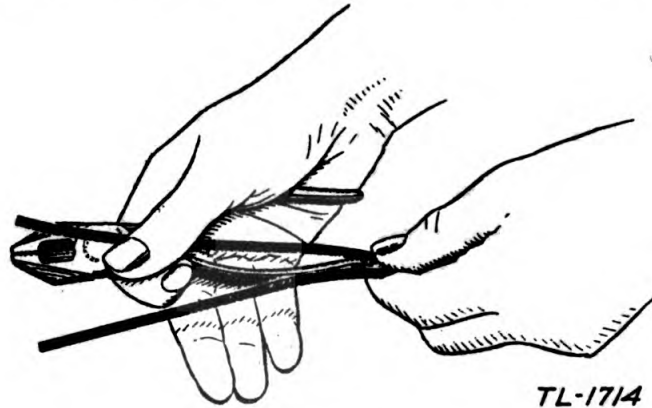

Figure 1

- c. Crush and remove insulation from long and short conductor as indicated in figure 2.

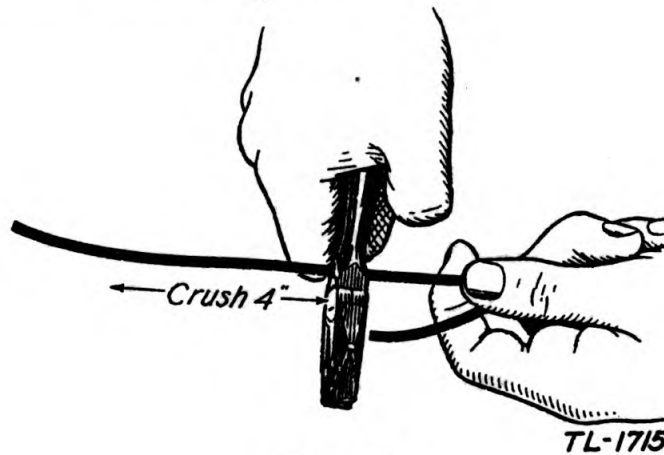

Figure 2a

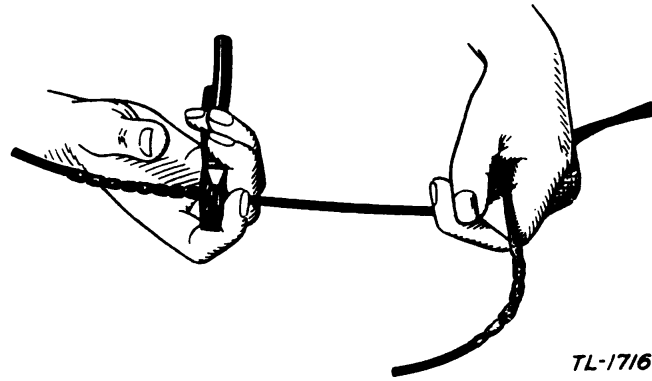

Figure 2b

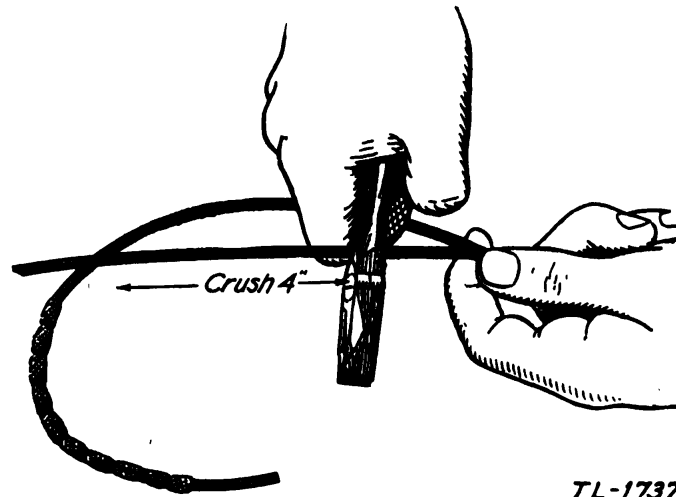

Figure 2c

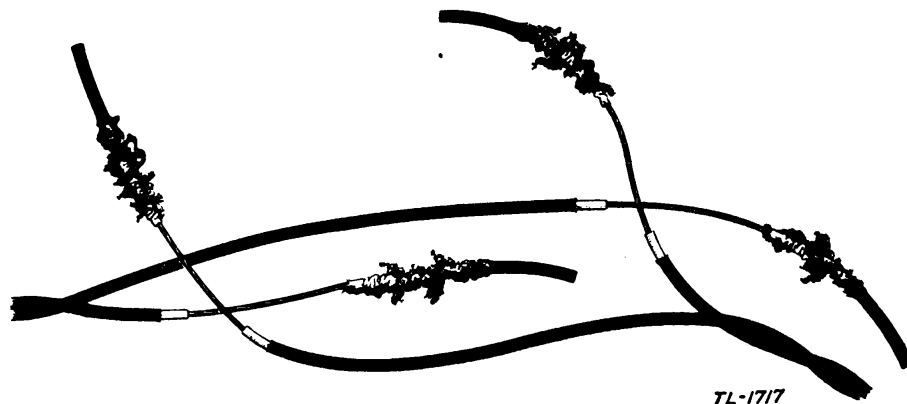

Figure 2d

d. Tie the square knot, using one long and one short conductor, as indicated in figure 3.

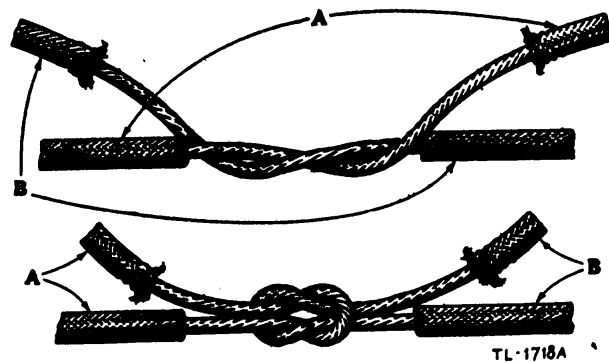

Figure 3

Note.—The square knot should be tied in both conductors without delay, to restore service to circuit before starting to perform the following operations:

e. Seize the splice as shown in figure 4.

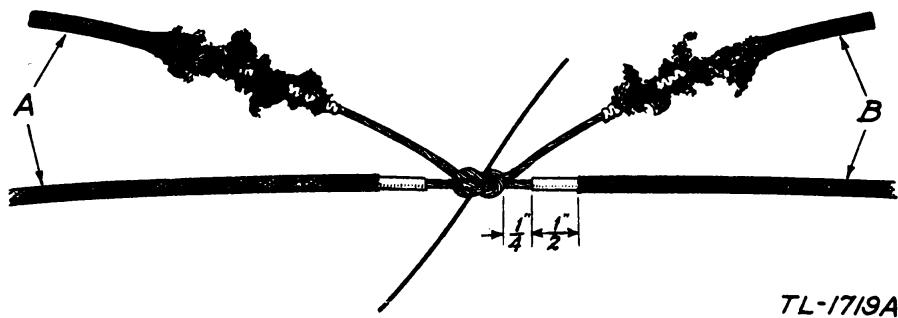

Figure 4a

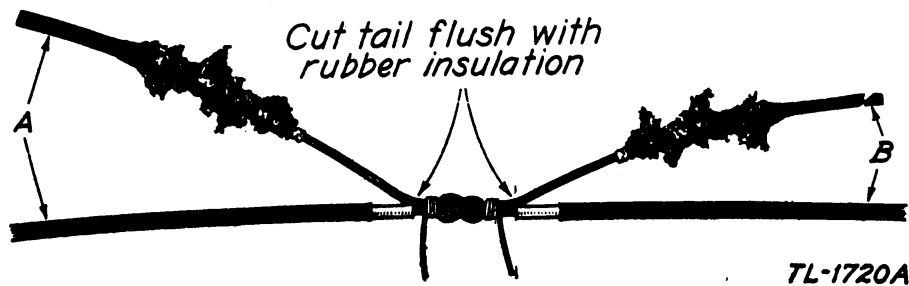

Figure 4b

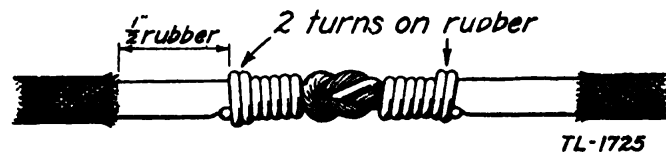

Figure 4c

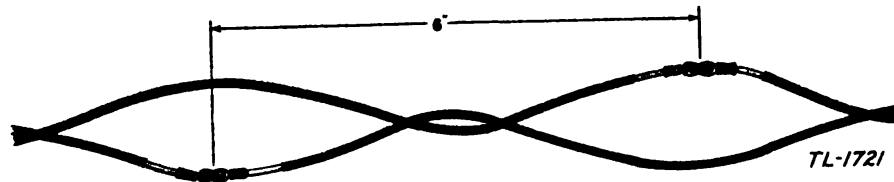

Figure 4d

8. Combination seizing wire splice.—This splice is used to splice a stranded conductor insulated wire to a solid conductor bare wire. Strip about one inch of insulation from the stranded wire and clean both wires so that they are bright and free of corrosion. Lay this end of the stranded wire along the solid wire. Begin the seizing by taking four turns with the seizing wire around the solid wire only, back of the stranded wire. Continue wrapping, including several turns over the insulation of the stranded wire, then over the bare end of the stranded wire, and finish with four turns over

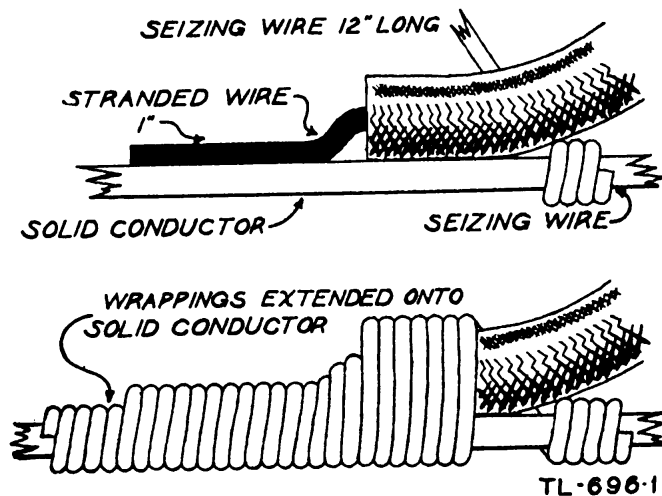
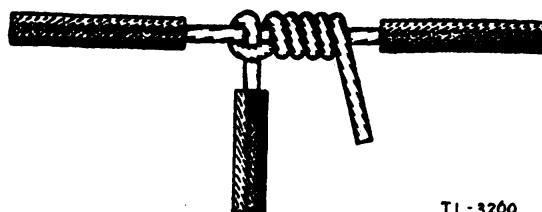

Figure 5

the solid wire only. Wrap the seizing wire tightly and draw the turns closely together. This splice will pull away very easily, therefore the stranded wire should be tied in to a fixed object near the splice to prevent any strain being imparted to the splice proper. See figure 5.

9. Tap splice.—This splice is used to tap a wire into a permanently installed line wire without cutting it. It may be made with either solid or stranded conductors, or a combination of both. To make the splice, remove 1 inch of insulation from the permanently installed wire and about 3 inches from the other wire. Lay the cleaned end of the tapping wire over the line wire. Make one wrap around the permanent wire with the tapping wire. Bring the end of the tapping wire across the standing part of the tapping wire, underneath the permanent wire, and with the remainder of the cleaned end of the tapping wire, place five close turns around the permanent wire. See figure 6.



TL-3200

Figure 6

10. Western Union splice.—The Western Union splice is used when splicing two solid wires together. Strip the insulation from the ends of both wires for about 8 inches and clean them so that they are bright and free of corrosion. Make the splice as illustrated in figure 7. The twisted portion, composed of three complete turns is called the "neck." The five close turns at each end are known as the "buttons." The wires in the neck should be in close contact with each other. Cut the ends of the buttons off as closely as possible, being careful not to leave a sharp point that will puncture the tape wrapping.

11. The field wire "T" splice.—This splice is used to tap a field wire circuit without causing interruption to service.

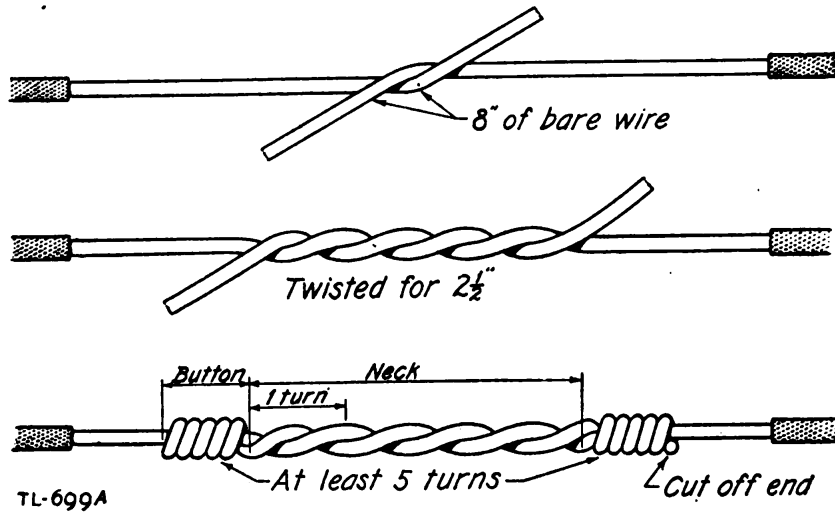

Figure 7

After the splice is completed, the end of the circuit if no longer required, may be cut free. In any case, this splice is seized and taped in the same manner as other field wire splices. The amount of insulation removed from the main wire is about 1½ inches. Make the splice as illustrated in figure 8.

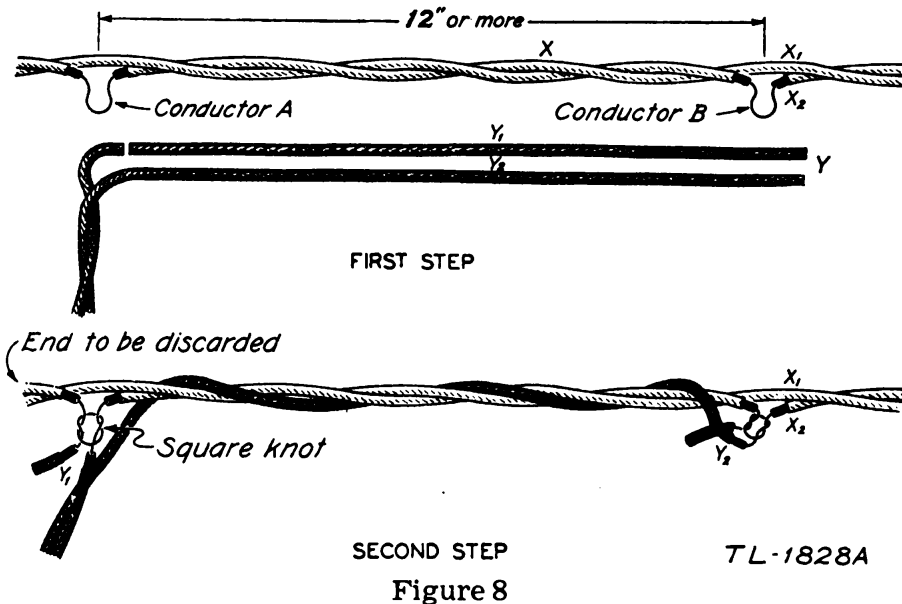

Figure 8

12. Taping the splice.—For best results, the splice should be held taut when applying the tape. Each splice is protected with two reversed layers of rubber tape and friction tape.

Applying the rubber tape: Use a piece about 4 inches long. Start in the center of the splice and wrap toward the right until the $\frac{1}{2}$ inch of rubber insulation has been covered. Reverse the wrap toward the left until $\frac{1}{2}$ inch of rubber insulation is covered then reverse and end wrap in center. The tape must be stretched, the ends of the wrapping should be pressed down tightly to keep the splice waterproof and each turn of the tape should cover half of the one previously applied. See figure 9.

Applying the friction tape: Apply two reversed layers of friction tape over the rubber tape in the same manner except this time extend the wrap to inclose about 1 inch of braid to hold the braid in place. The overall length of the finished

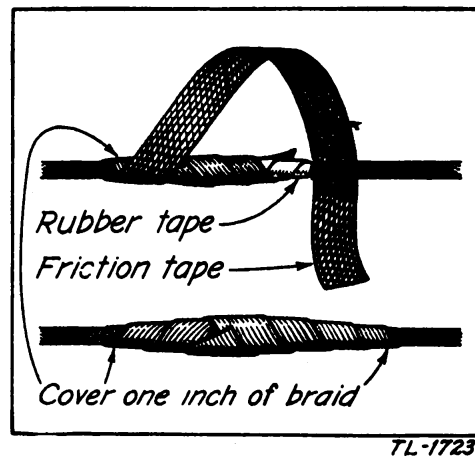

Figure 9a

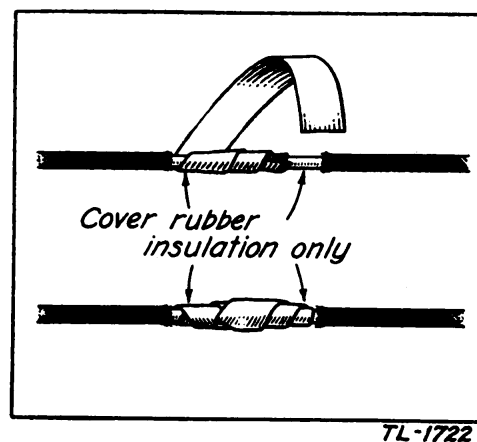

Figure 9b

splice should not exceed 4 inches. Roll the splice several times in the hands to seal the edges of the tape.

Review questions.—

1. Name the three major parts of the electricians knife.
2. How are pliers classified?
3. What is the principal use of the diagonal pliers? Name the largest size steel wire that may be cut with these pliers, the largest size copper.
4. Name two uses of the side-cutting pliers.
5. How much stagger is placed in a field wire splice?
6. What knot is used to make a field wire splice?
7. How much space is left between the knot and the rubber insulation in a field wire splice? How much rubber insulation is exposed?
8. When would a combination seizing wire splice be used?
9. What is used to insulate a field wire splice?
10. Name one important point to be observed when using pliers.
11. Why is it advisable to stagger the splices made in twisted pair wire?
12. What is the tap splice used for?
13. How is solid wire parted when using side-cutting pliers to cut it?
14. What is the amount of stagger used when making a "T" splice?
15. Name three uses of the long-nose pliers.

LESSON 2

LABORATORY

Tools and materials.—

- Knife, TL-29
- Pliers, side-cutting
- Pliers, long-nose
- Pliers, diagonal
- *Wire W-110
- *Wire, bare copper No. 10
- *Wire W-38 or W-50
- *Seizing wire, 22-gauge bare copper

Items marked * are not placed on the memorandum receipt.

Procedure.—

Operation 1.—Using wire W-110, make a field wire splice.
..... Ins. check

Operation 2.—Using wire W-110 make a "T" or field wire tap splice.
..... Ins. check

Operation 3.—Using number 10 bare copper wire and W-110, make a combination seizing wire splice.
..... Ins. check

Operation 4.—Using wire W-38 or W-50, make a tap splice.
..... Ins. check

Operation 5.—Using wire W-38 or W-50 make a Western Union splice. Submit all splices to instructor for approval.
..... Ins. check

Operation 6.—Following the instructions in the information sheet, tape the splices made under operations 1 and 3.
..... Ins. check

LESSON 3

MEASURING AND GAUGING

1. **Steel scale.**—The steel scale is a metal ruler with one or more of its edges accurately marked with some fractional part of the inch or meter. The most commonly used scale is *the number 4 graduation*. The edges of this scale are laid out as follows: 1st edge, 8th of an inch; 2d edge, 16ths of an inch; 3d edge, 32ds of an inch; 4th edge, 64ths of an inch.

The steel scale is used for all linear measurements where a high order of accuracy is required, also as a straight edge to determine whether a surface is absolutely flat.

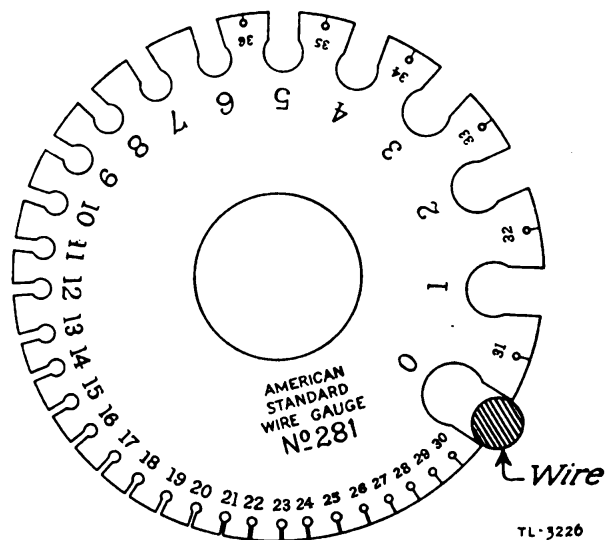

Figure 1

2. **Wire gauges.**—The wire gauge is a tool used for measuring the diameter of wire. The most common forms of this gauge are, the circular wire gauge and the combination wire and screw gauge. Wire diameters are given in two ways, by a gauge number and in mils. One mil equals 1/1000th of an inch. Examination of the gauges will reveal that the

larger the gauge number, the smaller the diameter of the wire. There are several different standards for wire gauges in the United States (see table I). The wire standards most commonly used are the American or Brown and Sharpe for copper and Birmingham or Stubbs for iron wire. It will be noted that *for any given gauge size the iron wire is few mils larger in diameter than the copper wire.*

The circular wire gauge is used to measure wire as shown in figure 1.

Do not force the wire into a slot. Find the slot that refuses to pass the wire without forcing, then try next larger until one is found that passes the wire. This is the correct size. The combination wire and screw gauge is used in practically the same way, except that the wires are slipped into a "V" shaped opening in the scale. The number that comes the nearest to the center of the wire or screw being measured, gives the correct gauge.

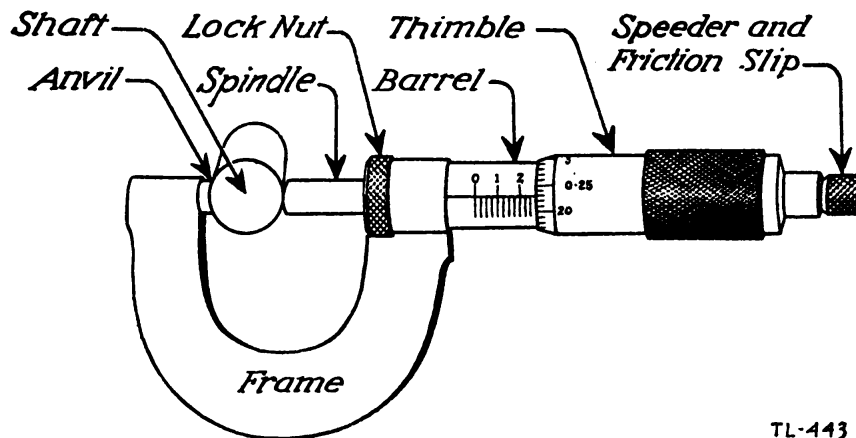

TL-443

Figure 2

3. The micrometer caliper.—This tool is used to measure the diameters of objects in thousandths of an inch. The illustration given in figure 2 shows the method of measuring and names the major parts of the tool. The micrometer, in conjunction with a table showing wire sizes and diameter in thousandths of inches is frequently used as a wire gauge.

The instructor will demonstrate the use of this tool.

4. Speed indicator.—This tool is used to determine the revolutions per minute (rpm) of motors and shafts revolving either clockwise or counterclockwise. There are several types of this instrument, the one usually encountered in the Signal Corps being the I-16. The instructor will demonstrate its use.

5. Tapes.—Tapes are flexible measuring devices, laid off in fractions of an inch, inches and feet. The most common lengths are the 6 ft, 50 ft and the 100 ft tapes. These tapes are furnished in three grades; the cloth tape of woven cotton or linen, the metallic tape, which is cloth interwoven with metal strands; and the steel tape which is a high grade metal ribbon. The steel tape is the most efficient, being little affected by temperature changes, does not stretch and is very durable. Care should be exercised to keep the steel tape flat when using it since a kink may cause it to break.

6. Thickness gauges.—The thickness gauge is a steel leaf, with its diameter in thousandths of an inch stamped on one surface. This type of gauge is used to measure small air gaps between relay springs, gear teeth, armatures and cores, etc. The correct gauging of a gap is obtained by using a gauge leaf that touches each side of the gap without moving either of the two parts, or, is tight without sideplay or bind. A sensitive touch must be acquired in order to obtain the correct reading of clearances.

Review questions.—

1. Name one use of the steel scale.
2. What is the wire gauge used for?
3. What part of an inch is a mil?
4. Which wire has the greater diameter, No. 10 or No. 22?
5. What is the smallest measurement that can be made with the micrometer caliper?
6. What is the name of the instrument used to count rpm's of shafts and motors.
7. Which is the most accurate tape, metallic or steel?

8. What is the thickness gauge used for?

Note.—In order to determine the area of a given cross section of wire, square the diameter as given in mils. For example, it is desired to know the area in circular mils of the cross section of No. 0000 B&S copper wire. By reference to table I, the diameter is found to be 0.46 inch. This is equal to 460 mils. 460^2 equals 211,600 circular mils, the area of the cross section.

TABLE I
DIFFERENT STANDARDS FOR WIRE GAUGES IN USE
IN THE UNITED STATES

(Dimensions of sizes in decimal parts of an inch)

<i>No. of wire gauge</i>	<i>American or Brown & Sharpe Co.</i>	<i>Birming- ham, or Stubs iron wire</i>	<i>Washburn & Moen Mfg. Co. or Roebing</i>	<i>English legal Standard</i>	<i>Stubs steel wire</i>	<i>U S Stand- ard gauge for sheet and plate iron and steel</i>	<i>No. of wire gauge</i>
000000				0.464		0.46875	000000
00000				.432		.4375	00000
0000	0.46	.4540	0.3938	.400		.40625	0000
000	.40964	.425	.3625	.372		.375	000
00	.3648	.38	.3310	.348		.34375	00
0	.32486	.34	.3065	.324		.3125	0
1	.2893	.3	.2830	.300	.0227	.28125	1
2	.25763	.284	.2625	.276	.219	.265625	2
3	.22942	.259	.2437	.252	.212	.25	3
4	.20431	.238	.2253	.232	.207	.234375	4
5	.18194	.22	.2070	.212	.204	.21875	5
6	.16202	.203	.1920	.192	.201	.203135	6
7	.14428	.18	.1770	.176	.199	.1875	7
8	.12849	.165	.1620	.160	.197	.171875	8
9	.11443	.148	.1483	.144	.194	.15625	9
10	.10189	.134	.1350	.128	.191	.140625	10
11	.090742	.12	.1205	.116	.188	.125	11
12	.080808	.109	.1055	.104	.185	.109375	12
13	.071961	.095	.0915	.092	.182	.09375	13
14	.064084	.083	.0800	.080	.180	.078125	14
15	.057068	.072	.0720	.072	.178	.0703125	15
16	.05082	.065	.0625	.064	.175	.0625	16

TABLE 1 (continued)
DIFFERENT STANDARDS FOR WIRE GAUGES IN USE
IN THE UNITED STATES

(Dimensions of sizes in decimal parts of an inch)

<i>No. of wire gauge</i>	<i>American or Brown & Sharpe Co.</i>	<i>Birmingham, or Stubs iron wire</i>	<i>Washburn & Moen Mfg. Co. or Rochling</i>	<i>English legal Standard</i>	<i>Stubs steel wire</i>	<i>U S Standard gauge for sheet and plate iron and steel</i>	<i>No. of wire gauge</i>
17	.045257	.058	.0540	.056	.172	.05625	17
18	.040303	.049	.0475	.048	.168	.05	18
19	.03589	.042	.0410	.040	.164	.04375	19
20	.031961	.035	.0348	.036	.161	.0375	20
21	.028462	.032	.03175	.032	.157	.034375	21
22	.025347	.028	.0286	.028	.155	.03125	22
23	.022571	.025	.0258	.024	.153	.028125	23
24	.0201	.022	.0230	.022	.151	.025	24
25	.0179	.02	.0204	.020	.148	.021875	25
26	.01594	.018	.0181	.018	.146	.01875	26
27	.014195	.016	.0173	.0164	.143	.0171875	27
28	.012641	.014	.0162	.0149	.139	.015625	28
29	.011257	.013	.0150	.0136	.134	.0140625	29
30	.010025	.012	.0140	.0124	.127	.0125	30
31	.008928	.01	.0132	.0016	.120	.0109375	31
32	.00795	.009	.0123	.0108	.115	.01015625	32
33	.00708	.008	.0118	.0100	.112	.009375	33
34	.006304	.007	.0104	.0092	.110	.00859375	34
35	.005614	.005	.0095	.0084	.108	.0078125	35
36	.005	.004	.0090	.0076	.106	.00703125	36
37	.0044530068	.103	.006640623	37
38	.0039650060	.101	.00625	38
39	.0035310052	.099	39
40	.0031440048	.097	40

LESSON 3

LABORATORY

Tools and materials.—

Combination wire and screw gauge	Speed indicator, I-16
Wire gauge, American standard	Micrometer caliper
Thickness gauge	*Wire, screw and plate
Steel scale	samples

Items marked * are not placed on the memorandum receipt.

Procedure.—

Operation 1.—Examine the steel scale, and record in the space below the different graduations on its edges.

..... Ins. check

Operation 2.—Use the wire gauges furnished. Measure the wire samples and record the results in the space below. Measure the screw samples, as to length and gauge. Record results in the space below.

<i>Wires</i>	<i>Length</i>	<i>Screws</i>	<i>Gauge No.</i>
1.....	1.....		
2.....	2.....		
3.....	3.....		

..... Ins. check

Operation 3.—Measure the wire and plate samples with the micrometer caliper. Record the results of the operation below. Compare your measurements with the ones shown on the attached chart. Check the gauge thus determined with those. The instructor will demonstrate the use of this instrument.

<i>Diameter in mils</i>		<i>Ga.</i>	<i>Thickness in mils</i>		<i>Ga.</i>
	1.....			1.....	
Wire	2.....		Plate	2.....	
Samples	3.....		Samples	3.....	
.....Ins. check					

Operation 4.—Examine the speed indicator. The instructor will demonstrate the use of this instrument. Find the rpm of motor mounted on work bench. Record result below.

.....Ins. check

Operation 5.—Examine the thickness gauge furnished. Measure the air gaps of one of the sample sets on the bulletin board, and record the results below.

A	B	C	(Underline the set used)
1.....			2.....
3.....			4.....

.....Ins. check

LESSON 4

METAL WORKING

1. **Files.**—A file is a tool used for smoothing and shaping hard materials such as brass, copper, iron bakelite, etc. Files are classified according to length, measured from the shoulder to the point, by shape, and by the cut. There are twelve standard file shapes, the most common being, flat, half round, round, triangular and square. The lengths usually run from 2 to 14 inches.

Cuts of files.—This classification, which pertains to the teeth of a file, has three subdivisions, single cut, double cut and rasp, which are illustrated in figure 1.

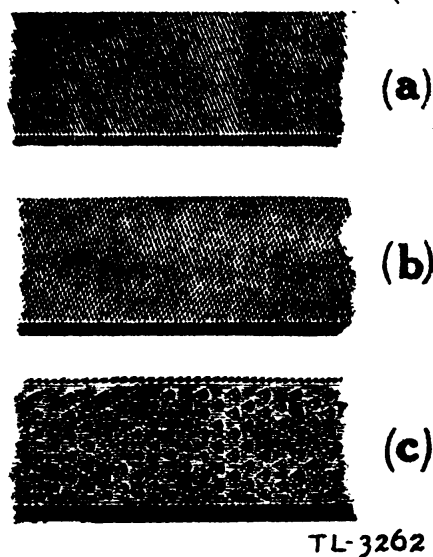

Figure 1

File teeth.—The cut of a file is also classified according to the coarseness of the teeth as rough, coarse, bastard, second cut, smooth and dead smooth. Do not confuse the term “second cut,” which applies to the size of the teeth,

with the term "double cut" which refers to the kind of teeth.

Selecting the file.—The proper file to use for any given job depends on a number of factors; the ones listed below are general rules only.

The type of metal, whether cast or wrought. Cast metals are the hardest to cut and a new file should be used if possible.

The shape of the piece to be smoothed. Use a file that will reach all parts of an irregularly shaped piece. As an example, a slitting file would be the correct shape for a diamond shaped opening; an equaling file is the best shape for a narrow slot; a flat file is the best for squaring ends and surfaces.

The area of the surface being dressed. A large surface should be brought to shape with a rough or course file of a large size. Smaller pieces should be shaped with smaller files in either the bastard or second cut grade of teeth.

The degree of accuracy required. The bastard file is the best for general use where the fit tolerance is not so critical and the appearance of the finished work is not important. For close fits and where it is desired to prepare the work for buffing or polishing, the final shaping should be done with the second cut or smooth file. The dead smooth file is seldom used.

A flat file is not exactly flat, but slightly convex on both sides. This concentrates the pressure on a few teeth in the center of the file, reducing the amount of force required to move the tool over the piece. This gives the operator better control over the file.

Hand filing is a difficult job. It requires considerable skill and patience. The beginner will find that the slower he runs the file over the work, the less chance there is of rounding the corners of the piece being squared. Some general rules for the use of the file are given below:

Select the proper shape, size and cut of file.

Always use a file handle; this gives the user the best control of the file.

Apply pressure on the forward stroke only. The teeth are

not supported by the body of the file on the backstroke. Pressure in this direction breaks the teeth and the file soon becomes useless.

Assume a natural position and use as long a stroke as possible.

The work should be held securely, and if in a vice, should be below the line of the workman's elbow.

The file should be held firmly and an effort should be made to apply an equal amount of pressure with each hand.

Keep the file free of cuttings. This is best done with a file card, which is simply a flat wire brush. Copper and tin, also lead to a certain extent, have a tendency to clog the file teeth. This may be reduced by rubbing chalk over the file.

The file needs more care than it normally gets. Keep it free from rust, do not drop it across other tools and do not carry it loose in a tool bag.

2. Hacksaws.—The hacksaw is a metal frame used to hold blades specially made for the cutting of metals and other hard materials. The frame is usually adjustable to accommodate the various lengths of blades. It is equipped with two pin spindles to hold the blades under tension, the one on the handle being equipped with a knurled sleeve. This locks the blade in place after the proper tension has been placed on it, by turning the handle. Examination of the spindles will disclose the fact that they may be moved to various positions in the frame. This permits the blade to be turned at right angles to the frame which is necessary for some classes of work.

There are two grades of hacksaw blades, coarse and fine. The coarse blades are used for general work and the finer blades to cut thin plate, sheet metal, thin walled tubes and small rods. The teeth of the hacksaw blade are given set to prevent the blade from binding in the cut. To insure a straight cut and ease of operation, the following rules should be observed:

Insert the blade with the teeth pointing away from the handle, turn the handle until the blade is tight and run the sleeve down to prevent it from slipping.

Apply pressure on the forward stroke only.

Use a long slow stroke; do not force the cut.

Hold the work securely. Have the cut as close to the point of support as possible.

3. Hand drills.—The hand drill is a tool used for driving twist drills. Hand drills are made with various chuck capacities, the $\frac{1}{4}$ and $\frac{3}{8}$ inch being the ones most commonly used. Some hand drills are equipped with a speed change, ratchets for working in close quarters, and a lock to hold the gear assembly steady while tightening or loosening the chuck. The chuck of the hand drill is of the three jaw type and is designed to hold drills with round shanks only. *The chuck is tightened by hand only.* Do not use a vice or wrench.

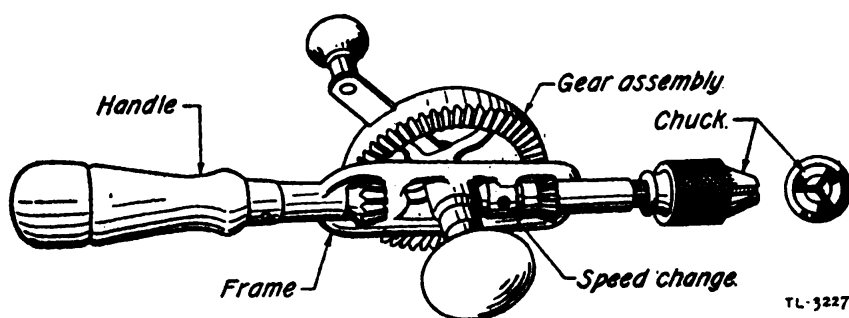

Figure 2

4. Twist drills.—The twist drill is a tool designed to bore holes in practically any material. Small twist drills usually have a round shank for use with the three jaw chuck. There are three classes of drills in common use: the wire gauge series, numbered from 1 to 80; the lettered series A (.243) to Z (.413); and the series that begins at $\frac{1}{64}$ th of an inch and increases in size by 64ths to $\frac{1}{2}$ inch. The twist drill for general work is made of carbon steel, those used for production work and drilling in the better grades of steel are made of high speed steel.

A twist drill, in order to bore a perfectly round hole, should have both lips ground at the same angle and be of equal length. The angle should be about 60 degrees. Drills should have a lip clearance of 10 to 15 degrees to insure the lip biting the material without interference. See figure 3.

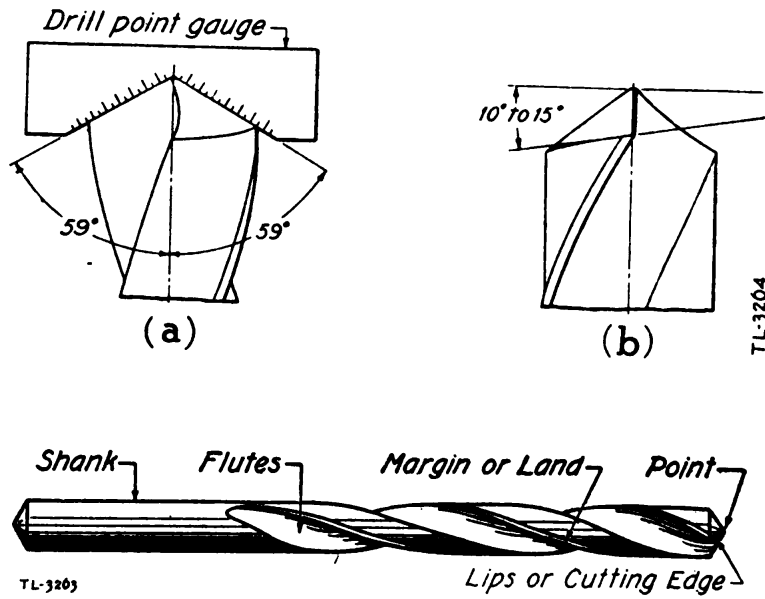

Figure 3

The important points to be remembered when drilling are: the speed with which the drill is turned and the rate at which the drill is fed into the material. A good general rule to follow is, the harder the material the slower the speed and the lighter the feed. This does not apply to bakelite and similar thermo (heat) setting materials. These materials, although they are comparatively soft, clog the drill and heat rapidly unless a slow feed and speed is used. A lubricant, such as lard oil, turpentine or castor oil, should be used to preserve the temper of twist drills. Never use a mineral oil for a cutting oil.

5. Center punch.—The center punch is a steel rod (usually knurled), with one end tapered to a 60 degree tempered point. It is used to dent material prior to drilling. The dent acts as a guide for the point of the drill. This prevents the drill from wandering or taking hold at a place other than the center of the proposed hole. It is not necessary to strike a center punch hard. Tilt the top of the punch to one side, place the point at the site of the proposed hole, raise the punch to the vertical and strike the top *once* with a light hammer.

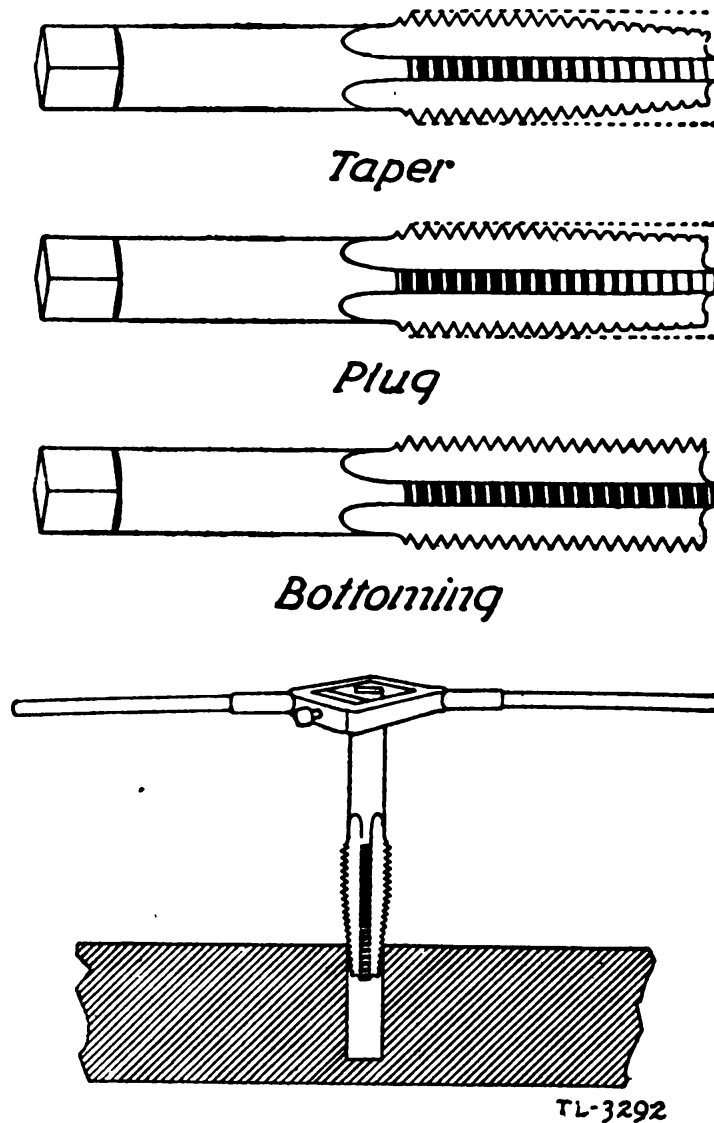

Figure 4

6. Taps and dies.—The tap is a hard steel tool used to cut internal threads. The three kinds of taps are: the taper tap, used where the tap can be run completely thru the hole; the plug tap, used where it is desired to thread a hole which does not run thru the stock; and the bottoming tap, which is used to thread the full depth of the hole. Taps are highly tempered and therefore very brittle. Great care to avoid lateral stresses must be exercised to prevent breaking the tap. A tap broken off in the hole, particularly if broken

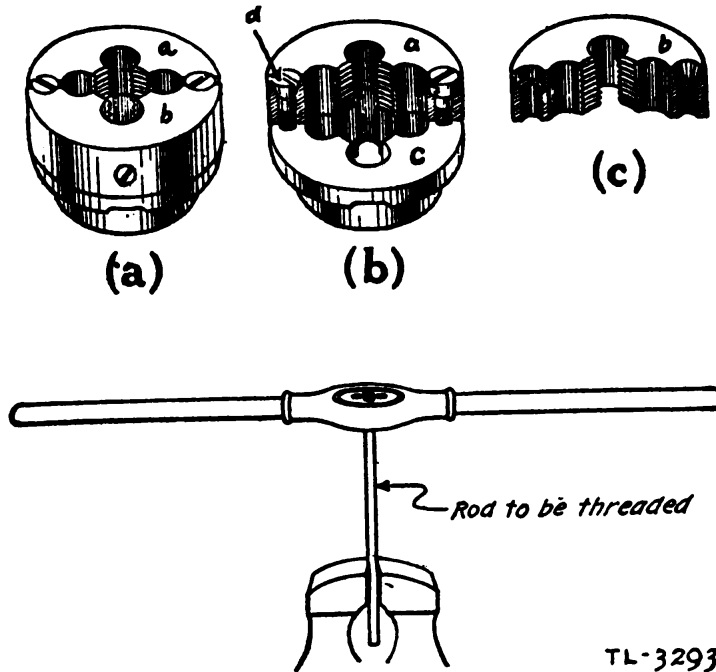

Figure 5

flush with the surface, causes a great deal of extra work. In using the tap, see that it starts straight; this can be checked with the square. After it is started, check it again and if the tap is running slightly crooked, make the attempt to straighten it while turning and not when the tap is standing still. Turn the tap several revolutions to the right and then to the left about a half turn. This prevents the tap from binding, which might cause it to break. In tapping thin brass and bakelite, no lubrication is necessary; for heavy or hard materials, the same lubricants as used for drilling are satisfactory. The tap is held in a special tool called a tap wrench. See figure 4.

The die is a tool used to cut outside threads. It consists of a screwplate, two adjusting screws and a set of thread cutters. The screwplate has a hole in its center which is the size of the outside threads and acts as a guide. The cutters are tapered so that the cut is made gradually, in the same manner as the tap. The threading operation must always be started from the screwplate side. Wear on the cutters may be compensated for, within a small limit, by use of the adjusting screws. A lubricant should be used in the same

manner as specified for taps. The die is held in a special tool called a stock. See figure 5.

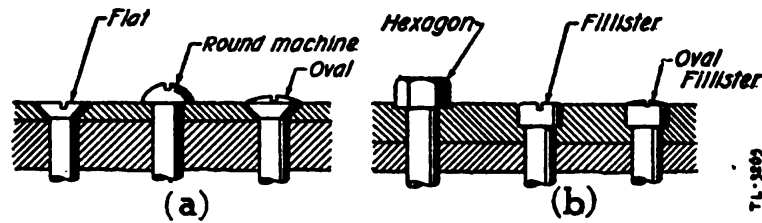

Figure 6

7. Abrasives.—There are a great many tools and materials used to smooth and polish metals, plastics, bakelite or other hard substances. Emery cloth, which consists of powdered emery, glued to a strong cloth, is the abrasive most used to remove tool marks and polish hard metals such as iron and steel. The grades in common use are 000 to No. 2. The emery cloth graded by zeros is considered fine; the greater the number of zeros, the finer the cloth. That graded in whole numbers is considered coarse; the larger the number the coarser the cloth. In the finer polishing operations, lard oil used with emery cloth, produces an excellent finish. A still finer finish is procured if flour is used. *Never use emery or carborundum on soft metals such as copper and brass.* The particles of abrasive will break off and imbed in soft metals and cannot be removed.

Crocus cloth is a heavy cloth faced with jewelers' rouge. It is primarily an abrasive for soft metals, but is useful as a finisher for hard metals. Another use for crocus cloth is the brightening of a commutator of a motor where the least possible amount of material should be removed without danger of leaving abrasives on moving parts.

8. Scribes.—The scribe is a tool used to layoff lines on any hard material. It is simply a metal rod with a sharp point on one end and may be anything from a commercial article to a nail with the point ground down so that it will make a fine line. The top of the scribe should be tilted away from the square or scale when scribing a line, in order that the dimension laid off will be as accurate as possible.

9. Machine screws.—Machine screws are used to hold metal or other hard material parts together. They are classified in the following manner: length, type of head, number of threads per inch, diameter of gauge and the material made of. The common types of machine screw heads are illustrated in figure 6.

10. Nuts.—A nut is a piece of metal having a threaded hole through its center and designed to screw on to the threaded portion of a bolt or machine screw. Nuts are classified according to their shape as square, hexagonal, etc. Nuts are also classified according to the screw or bolt which they are intended to fit. For machine screws, nuts are ordered by specifying the material, shape, the gauge of the diameter and the number of threads per inch, as nuts, hexagonal brass 6-32.

11. The countersink.—On all flat-head machine screws, the angle of the under side of the head is 82 degrees. Therefore, when a flat head screw is used, the hole in which it fits must be countersunk at the surface of the hole where the the head of the screw fits. This allows a screw to be used in a place where the surface of the work must remain flat. The tool which makes this 82 degree hole is called a countersink. They are made of steel and have a round or square shank. The point is cut to a taper of 82 degrees. The cutting edges are usually three or four in number. The flutes which lead to the cutting edges are 60 degree, concave, angular grooves. The back rake of the cutting edges are approximately 15 degrees. This is a good angle for most metals. The flutes of a countersink are not cut back full length of the body as in the case of a twist drill because a countersink never is used deeper than about $\frac{3}{8}$ inches.

Another type of metal countersink is used when a nut is to be sunk below the surface. This small type of tool has the same kind of cutting edges, but instead of a point, a small pin is set into the end of the tool; also, the angle of the cutters is a right angle to the axis of the tool. This tool must be used with a given size hole which fits the pin of the countersink. This type is made in various sizes and pin

diameters. Various types of countersinks are illustrated in figure 7.

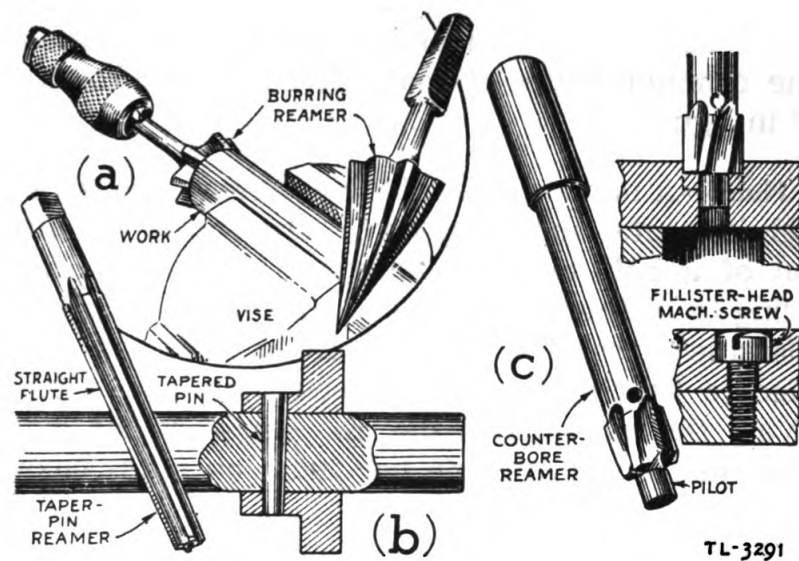

Figure 7

The countersink is usually used in a hand drill provided it has a round shank. If it is equipped with a square shank it must be used in a brace.

Review questions.—

1. What is a file used for?
2. Name two cuts of files according to the coarseness of the teeth.
3. What is used to clean the teeth of a file?
4. Which way should the teeth of a hacksaw point?
5. What important point should be remembered when using the hacksaw?
6. How are files classified?
7. Name two important points to be remembered when using the twist drill.
8. Name one solution used as a cutting oil.

9. What tool is used to mark the center of a hole prior to drilling?
10. Name the three kinds of taps.
11. What tool is used to cut outside threads?
12. Name two materials used to polish metals.
13. Give the five classifications of machine screws.
14. What is the scriber used for?

LESSON 4

LABORATORY

Tools and materials.—

- | | |
|---------------------------------|--------------------------|
| Files, assorted (3) | Center punch |
| Hacksaw frame | Tap and die set, AA-4 |
| Hacksaw blades, fine and coarse | File card |
| Try or combination square | *Brass stock, 1/2x1 inch |
| Hand drill | *Iron stock, 1/2x1 inch |
| Twist drill No. 35 | *Sheet brass |
| Twist drill No. 17 | *Iron plate |
| Hammer, ball peen | *Bakelite |
| | *1/4-inch brass rod. |

Items marked * are not placed on the memorandum receipt.

Procedure.—

Operation 1.—Using the 1/2-inch x 1-inch brass stock, cut, square the ends with the files, lay out the holes, drill and tap the following figure. Refer to figure 4 before using taps.

..... Ins. check

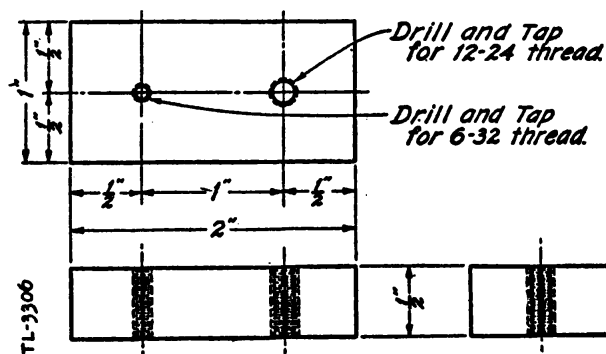
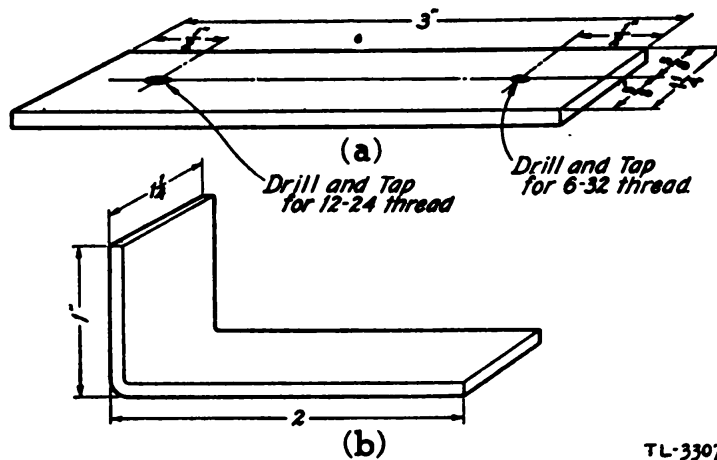

Figure 8

Operation 2.—Cut a piece of the iron stock furnished, 1½ inches long. Square the ends with the files.

.....Ins. check

Operation 3.—Cut a piece of sheet brass using figure 9(a) for dimensions. Square the piece, layout the holes, drill and tap as shown.



TL-3307

Figure 9

After this piece has been checked by the instructor, cut it into two pieces 1¼ inches by 1½ inches. Save these pieces as they are to be used in a later lesson.

.....Ins. check

Operation 4.—Cut a piece of the iron plate and square it. Make the bracket shown in figure 9(b).

.....Ins. check

Operation 5.—Cut a piece of bakelite 1 inch by 2½ inches. Square the piece. Use the emery cloth furnished and smooth the surfaces.

.....Ins. check

Operation 6.—Use the brass rod furnished. Cut 1 inch of threads on one end only.

.....Ins. check

ANNEX LESSON FOUR

BASIC THREAD DIMENSIONS, TAP AND CLEARANCE
DRILL SIZES

Machine Screw Sizes—National Form

<i>Nominal Size</i>	<i>Major Diameter</i>	<i>Tap Drill Number</i>	<i>Clearance Drill Number</i>	<i>Decimal Equivalent of Tap Drill</i>	<i>Decimal Equivalent of Clearance Drill</i>
0-80	.0600	56	48	.0469	.0760
1-56	.0730	54	45	.0550	.0820
-64	.0730	53	45	.0595	.0820
-72	.0730	53	45	.0595	.0820
2-56	.0860	50	42	.0700	.0930
-64	.0860	50	42	.0700	.0930
3-48	.0990	47	37	.0785	.1040
-56	.0990	45	38	.0820	.1040
4-32	.1120	45	32	.0820	.1160
-36	.1120	44	31	.0860	.1200
-40	.1120	43	31	.0890	.1200
-48	.1120	42	30	.0935	.1280
5-36	.1250	40	30	.0980	.1280
-40	.1250	38	29	.1015	.1360
-44	.1250	37	29	.1040	.1360
6-32	.1380	35	28	.1100	.1400
-36	.1380	34	28	.1110	.1400
-40	.1380	33	28	.1130	.1400
7-30	.1510	31	22	.1200	.1570
-32	.1510	31	22	.1200	.1570
-36	.1510	30	22	.1280	.1570
8-30	.1640	30	18	.1285	.1690
-32	.1640	29	18	.1360	.1690
-36	.1640	29	18	.1360	.1690
-40	.1640	28	18	.1405	.1690
9-24	.1770	29	13	.1360	.1850
-30	.1770	27	13	.1440	.1850
-32	.1770	26	13	.1470	.1850
10-24	.1900	25	9	.1495	.1960
-28	.1900	23	9	.1540	.1960
-30	.1900	22	9	.1570	.1960
-32	.1900	21	9	.1590	.1960

Machine Screw Sizes—National Form (continued)

<i>Nominal Size</i>	<i>Major Diameter</i>	<i>Tap Drill Number</i>	<i>Clearance Drill Number</i>	<i>Decimal Equivalent of Tap Drill</i>	<i>Decimal Equivalent of Clearance Drill</i>
12-24	.2160	16	1	.1770	.2280
-28	.2160	14	1	.1820	.2280
-32	.2160	13	1	.1850	.2280
14-20	.2420	10	$\frac{1}{2}$.1935	.2500
-24	.2420	7	$\frac{1}{2}$.2010	.2500
16-18	.2680	3	9/32	.2130	.2810
-20	.2680	3	9/32	.2130	.2810
-22	.2680	2	9/32	.2130	.2810

Fractional Sizes—National Form

<i>Nominal Size</i>	<i>Major Diameter</i>	<i>Tap Drill Number</i>	<i>Clearance Drill Number</i>	<i>Decimal Equivalent of Tap Drill</i>	<i>Decimal Equivalent of Clearance Drill</i>
$\frac{1}{8}$ -64	.0625	3/64	50	.0469	.0700
-72	.0625	3/64	50	.0469	.0700
5/64-60	.0781	$\frac{1}{8}$	44	.0625	.0860
-72	.0781	52	44	.0635	.0860
3/32-48	.0938	49	38	.0730	.1010
-50	.0938	49	38	.0730	.1010
7/64-48	.1094	43	31	.0890	.1200
$\frac{1}{4}$ -32	.1250	3/32	29	.0937	.1360
-40	.1250	38	29	.1015	.1360
9/64-40	.1406	32	25	.1160	.1490
5/32-32	.1563	$\frac{1}{4}$	19	.1250	.1660
-36	.1563	30	19	.1285	.1660
11/64-32	.1719	9/64	14	.1408	.1820
$\frac{3}{8}$ -24	.1875	26	9	.1470	.1960
-32	.1875	22	9	.1570	.1960
13/64-24	.2031	20	3	.1610	.2190
7/32-24	.2188	16	1	.1770	.2280
-32	.2188	12	1	.1890	.2280
15/64-24	.2344	10	$\frac{1}{4}$.1935	.2500

Fractional Sizes—National Form (continued)

No. in Size	Major Diameter	Tap Drill Number	Clearance Drill Number	Decimal Equivalent of Tap Drill	Decimal Equivalent of Clearance Drill
1/8-20	.2500	7	17/64	.2010	.2650
-24	.2500	4	17/64	.2090	.2650
5/16-18	.3125	17/64	21/64	.2656	.3281
-24	.3125	9/32	21/64	.2812	.3281
-32	.3125	19/64	21/64	.2968	.3281
3/8-16	.3750	17/64	25/64	.3125	.3906
-20	.3750	21/64	25/64	.3231	.3906
-24	.3750	21/64	25/64	.3281	.3906
7/16-14	.4375	3/8	29/64	.3750	.4531
-20	.4375	25/64	29/64	.3906	.4531
-24	.4375	25/64	29/64	.3906	.4531
1/2-12	.5000	27/64	33/64	.4218	.5156
-20	.5000	29/64	33/64	.4531	.5156
-24	.5000	29/64	33/64	.4531	.5156
9/16-12	.5625	31/64	37/64	.4843	.5781
-18	.5625	33/64	37/64	.5156	.5781
5/8-11	.6250	17/32	41/64	.5312	.6406
-12	.6250	35/64	41/64	.5468	.6406
-18	.6250	37/64	41/64	.5781	.6406
11/16-11	.6875	19/32	45/64	.5937	.7031
-16	.6875	3/8	45/64	.6250	.7031
3/4-10	.7500	21/32	49/64	.6562	.7656
-12	.7500	43/64	49/64	.6781	.7656

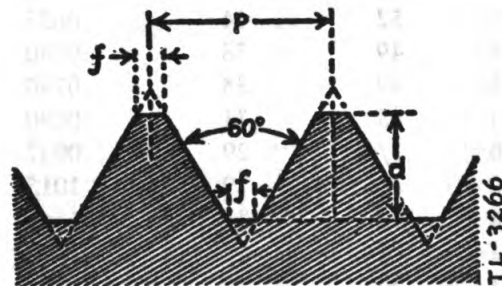

p = pitch
d = depth
f = flat

Formula

$$\left\{ \begin{array}{l} p = 1/\text{No. thds. per in.} \\ d = p \times .64952 \\ f = p/8 \end{array} \right.$$

Figure 10

DECIMAL EQUIVALENT OF DRILLS NO. 1 TO 60

<i>Drill No.</i>	<i>Decimal</i>	<i>Drill No.</i>	<i>Decimal</i>
1	.228	31	.120
2	.221	32	.116
3	.213	33	.113
4	.209	34	.111
5	.205	35	.110
6	.204	36	.106
7	.201	37	.104
8	.199	38	.101
9	.196	39	.099
10	.193	40	.098
11	.191	41	.096
12	.189	42	.093
13	.185	43	.089
14	.182	44	.086
15	.180	45	.082
16	.177	46	.081
17	.173	47	.078
18	.169	48	.076
19	.166	49	.073
20	.161	50	.070
21	.159	51	.067
22	.157	52	.063
23	.154	53	.059
24	.152	54	.055
25	.149	55	.052
26	.147	56	.046
27	.144	57	.043
28	.140	58	.042
29	.136	59	.041
30	.128	60	.040

DECIMAL EQUIVALENT OF FRACTIONAL DRILLS 1/64 TO 1 INCH

<i>Drill Size</i>	<i>Decimal</i>	<i>Drill Size</i>	<i>Decimal</i>
1/64	.0156	33/64	.5156
1/32	.0312	17/32	.5312
3/64	.0468	35/64	.5468
$\frac{1}{8}$.0625	$\frac{1}{8}$.5625
5/64	.0781	37/64	.5781
3/32	.0937	19/32	.5937
7/64	.1093	39/64	.6093
$\frac{1}{4}$.1250	$\frac{1}{4}$.6250
9/64	.1406	41/64	.6406

**DECIMAL EQUIVALENT OF
FRACTIONAL DRILLS 1/64 TO 1 INCH (continued)**

<i>Drill Size</i>	<i>Decimal</i>	<i>Drill Size</i>	<i>Decimal</i>
5/32	.1562	21/32	.6562
11/64	.1718	43/64	.6718
$\frac{1}{8}$.1875	$\frac{11}{16}$.6875
13/64	.2031	45/64	.7031
7/32	.2187	23/32	.7187
15/64	.2343	47/64	.7343
$\frac{3}{8}$.2500	$\frac{3}{4}$.7500
17/64	.2656	49/64	.7656
9/32	.2812	25/32	.7812
19/64	.2968	51/64	.7968
$\frac{5}{16}$.3125	$\frac{13}{16}$.8125
21/64	.3281	53/64	.8281
11/32	.3437	27/32	.8437
23/64	.3593	55/64	.8593
$\frac{1}{2}$.3750	$\frac{7}{8}$.8750
25/64	.3906	57/64	.8906
13/32	.4062	29/32	.9062
27/64	.4218	59/64	.9218
$\frac{7}{16}$.4375	$\frac{15}{16}$.9375
29/64	.4531	61/64	.9531
15/32	.4687	31/32	.9687
31/64	.4843	63/64	.9843
$\frac{3}{4}$.5000	1	1.0000

LESSON 5

SOLDERING

1. General.—Soldering is the binding together of two or more metals by means of a fusible alloy of tin and lead called solder. The solder used in the operation must melt at a lower temperature than the metals being joined together. However, the nearer the melting points of the solder and the soldered metals, the stronger the completed joint.

2. Fluxes.—When a metal is heated, its surface combines with the oxygen of the air, forming a substance called oxide. A flux is used to prevent this oxide from forming when soldering. If a flux were not used, it would be impossible to solder a joint. Rust on a piece of iron is a kind of oxide.

There are two classes of fluxes, *corrosive* and *noncorrosive*. A corrosive flux is used when soldering galvanized iron, zinc, iron and steel. Borax, sal ammoniac and zinc chloride are corrosive fluxes. A corrosive flux should seldom be used in electrical work, as it eats away the metal being soldered. After using a corrosive flux, the joint must be thoroughly cleaned to remove traces of the flux that are left on it, thus preventing the flux from eating away any more of the material. Stearine, rosin, and tallow are noncorrosive fluxes. These are used when soldering copper, lead, tin, etc. A noncorrosive flux prevents and cleans the oxide, when soldering, without eating away any of the material. Rosin is the most common noncorrosive flux. It may be in the form of a powder, a liquid, or a paste.

A flux, to have a cleansing effect on a surface, must melt at or below the fusing point of the solder and must prevent any oxidation by excluding the air during the process of soldering. Different substances solder better with different

fluxes, although rosin is the best all-around flux for general use. The usual fluxes for common metals are as follows:

Noncorrosive

Aluminum	Stearine
Brass	Rosin
Copper	Rosin
Lead	Rosin, tallow, or Stearine
Tin	Rosin

Corrosive

Iron or steel	Borax or sal ammoniac
Zinc	Zinc chloride
Galvanized iron	Zinc chloride

3. Solder.—Solders are divided into two general classes, hard and soft. Hard solders are usually used in brazing. They are composed of silver and its alloys or other compositions of the harder metals, and have a high melting point. Soft solders are used for general soldering and electrical work. They are composed of lead and tin. The types of soft solders usually encountered in the Signal Corps are; a bar composed of 50 parts tin and 50 parts lead used for general soldering work; and a wire solder with a rosin core, which is very convenient to use when soldering small terminals, lugs, radio or telephone parts.

4. Soldering irons.—The heat for soldering is generally supplied by a soldering copper, commonly called soldering iron. The soldering iron consists of a copper bit fitted with a suitable shank and handle. The bit of the soldering iron is made of copper, because copper has a high thermal conductivity and readily permits the heat to flow from the body of the copper to its tip. In addition, copper tins readily. Different size coppers are used for different kinds of work and are classified according to their weight.

Soldering irons are heated by one of two methods, *externally* or *internally*. The externally heated iron is heated by a gasoline blow torch or a gasoline furnace. The internally

heated, or electric iron, is heated by an electric heating element in the shank of the iron. The electric iron has two great advantages over the torch heated iron. First, it is easier to keep hot while in use. Second, it is easier to keep from overheating. Overheating an iron oxidizes the tinned surface, thus preventing the even flow of solder over the copper surface. Overheating also causes the copper to become rough and pitted. To solder efficiently, the point of the soldering copper must be clean. To free the iron of tarnish and oxide, the point is covered with a thin coat of solder. This process is called tinning. The tinning is usually done on a soft brick, with a part of the top hollowed out. To tin the iron, proceed as follows:

Place a small amount of powdered rosin on one end of the brick and some scrap solder on the other end. Heat the iron with the blow torch.

File one side of the iron, immediately turn it over and rub the filed side first in the rosin and then in the solder. Wipe the excess solder from the point with a clean rag.

Continue filing and tinning each side in succession until all four sides are tinned.

The iron must not be too hot for the best results. If it is too hot, the solder will not stick. To prevent the destruction of the tinning, when heating the iron for use, keep the point of the soldering iron from direct contact with an open flame.

The electric iron is tinned on one side only. File the side selected after the iron is hot and melt a small amount of rosin core solder on the cleaned surface. Wipe off the excess solder with a clean rag.

Usually the irons are made with a removable tip. It is very important that the tip be removed from the element and that both tip and tip socket are cleaned of all scale. This *must* be done after every *thirty hours of operation*. This cleaning is done to prevent the tip from sticking in the element.

If it becomes necessary to remove the element from the iron, the following procedure should be followed:

Remove the tip.

Hold the element end of the iron in the left hand and unscrew the handle with the right hand.

Slide the handle back on the cord.

Remove the two screws that hold the flat wires which lead to the element.

Remove the element lock nut.

Slide the element case forward and off the element.

Remove the element by sliding it forward.

When renewing the cord of the iron, do not use any wire other than *heater cord*, that is, a cord which has a covering of asbestos on each wire.

5. The blowtorch.—The gasoline blowtorch consists of a round, brass tank, an air pump and a burner assembly. The tank is filled with gasoline through a filler plug in the bottom of the tank. On top of the tank near the handle is the air pump which keeps the fuel under pressure; also on top and near the edge of the tank is the threaded vent for the fuel supply tube. The fuel supply tube contains a wick and also supports the burner assembly. The burner assembly consists of a gas orifice, a needle control valve, a vaporizing chamber and a perforated combustion chamber. Just beneath the burner assembly is a priming cup. The procedure in placing the torch in operation is as follows:

Invert the torch and remove the filler plug. *Use drift pin.*

Fill the tank three-fourths full with ordinary gasoline. Do not use high test gasoline and do not fill the tank completely full, because some space must be left for air pressure.

Replace the filler plug and place the torch in an upright position. In replacing the filler plug do not use excessive force. A little soap on the threads of the plug will help seal the container.

Place the fuel under pressure with the air pump. Pump until it works hard.

Hold palm of hand over the end of the combustion chamber and open the needle valve slightly. This allows the fuel to flow into the priming cup. Shut the needle valve when the cup is $\frac{3}{4}$ full.

Light the gasoline in the priming cup and keep the flame directed toward the combustion chamber.

Just before the fuel is completely burned out of the cup open the needle valve. If the gas does not ignite hold a match near the vent holes in the combustion chamber. Do not hold the match at the end of the chamber.

To increase the flame increase the pressure in the tank and adjust the needle valve. Avoid excessive pressure, because the flame cannot be controlled so well.

The purpose of burning fuel in the priming cup is to thoroughly heat the vaporizing chamber. This causes the liquid fuel to be turned into gas.

When using the torch to heat an iron do not let the point come in direct contact with the flame. To do so will necessitate retinning the point. A blow torch is seldom cared for properly. This results in a great deal of unnecessary repair work. Some general rules for the care of the torch are given below:

After the priming cup has been filled, wipe any spilled gasoline from the other parts of the torch before lighting it.

When the gasoline is nearly consumed in the priming cup, do not open the needle valve fast. If the torch is not hot enough, this will cause a stream of flaming gas to leave the combustion chamber, and create a fire or burn the user seriously.

As the gasoline in the torch is consumed, more air is required. Pump the torch up occasionally.

Metal contracts and expands with changes of temperature. When closing the needle valve, shut it down tight enough to put out the flame and then turn it back a little to prevent freezing.

6. Requirements for good soldering.—In order to do good soldering, it is necessary that the following be observed:

The surface to be joined should be clean, it being impossible to make solder stick to a dirty or greasy surface.

The soldering iron should be cleaned and properly tinned.

The metals being soldered must be heated in order that the solder will adhere to the surface.

The surfaces being joined should be as close together as possible, with the least amount of solder between the surfaces. Too much solder means a poor joint.

The area of the joint being soldered should always be comparatively large to secure the necessary strength. With a properly tinned iron and the proper flux, the success of any soldering operation depends upon the cleansing of the surfaces to be joined and the heat applied to the joint during the soldering operation. The heat which is applied depends upon the speed with which the iron is drawn along the joint. If the iron is moved too slowly, the solder tends to spread too much and if moved too rapidly, the solder will not have time to melt completely and the joint will not be filled with solder. If heavy material is being soldered, the iron will have to be moved more slowly than if the metals being joined are metals whose melting point approaches that of solder. When using an extremely heated iron, the position of the iron is varied as the work progresses. When starting, the point of the iron is used. As the iron cools, it is lowered so that more of the flat tinned surface of the point is in contact with the work. This is not so important with electric irons, as the heat does not vary so greatly if properly used.

7. Soldering splices.—Half and half solder has an electrical conductivity of about one-seventh that of copper. All splices between conductors that are to carry current should have the smallest possible amount of solder separating conductors. This means that the wires to be joined must be as close together as possible before the solder is applied.

There are two methods of soldering a splice. The first, known as flowing, is to hold the hot iron on the top side of the splice and run the solder into the joint. The second, known as sweating, is to heat the joint from the under side while the flux and the solder are applied from the upper side. The wires melt the solder as soon as they become hot enough, and the melted solder is drawn into the cracks between the wires. Sweating is the better method. When

soldering a Western Union splice, it is soldered only in the neck and not in the buttons.

8. Soldering flat surfaces.—When soldering two flat surfaces, such as two overlapping plates of metal, it is usually desirable to tack the two pieces together at several points by drops of solder, before attempting to solder the entire length of the seam. This will hold the two plates in position while the main soldering is being done. When soldering one flat piece of metal to another, they are usually sweated because of the difficulty in getting solder into the joint. If the surfaces to be joined are first tinned, then placed in contact with each other and heated, there is more chance that a better joint will result, than if the solder is drawn into the joint. To sweat such joints, the metals must be close together after being tinned. If the surfaces are uneven, the sweating process is not successful unless it is combined with soldering in the ordinary manner. That is, the surfaces are first tinned, placed in contact, and while being sweated, solder is applied to the edge of the seam and drawn into the joint.

9. Using the electric iron.—The electric soldering iron is delicate in construction and requires careful handling. When soldering, do not swing or jerk the iron to remove excessive solder. This practice endangers men working nearby and may damage adjacent equipment. Do not strike the iron against a solid substance as this is likely to crack the heating element and cause a breakdown of the insulation. When the iron is not in use, always keep it in its holder.

10. Soldering large terminals.—Wiring that terminates at power boards and other apparatus is generally sweated into terminal lugs.

Terminal lugs, especially for the larger sizes of wire, usually have a cup socket at the bottom. When soldering a solid or stranded wire into the socket, the preferable method is to tin the end of the wire and fill the socket with solder; ordinary methods, where the wire is placed in the socket and the solder heated and run into the socket with the iron, make it difficult to get the solder down in the plug. The socket is then heated in the flame of the torch in the case of

large sockets, or with the iron for small sockets. When the solder in the socket is hot, the tinned end of the wire is inserted into the socket and the source of heat removed. The wire should not be moved while the solder is cooling. After the solder has set more solder may be worked in if the socket is not full.

11. Soldering small terminals.—Small terminals are more easily soldered with an electric iron. When soldering wires to terminals, which are mounted near a sealing compound, such as transformers, only enough heat should be applied to melt the solder. Otherwise, the sealing compound will melt and run over the work; but be sure to apply sufficient heat. Only a small amount of solder is necessary on small terminal lugs to make the required joint. The use of too much solder makes a messy and lumpy looking job. An improper joint, one which will probably cause trouble, is where the solder has sweated only to the wire, while between the wire and the lug there is a flux which acts as an insulator. A connection of this kind is due to one of the following causes: A cold soldering iron; the soldering iron held on the work an insufficient length of time; improper use of the iron; and untinned or unclean lugs and wire. The iron should be held on the lug and wire until both become hot enough to melt the solder. This is one of the fundamental rules of good soldering. A satisfactory job cannot be done if the solder is run on a cold or improperly cleaned lug, even though the iron is sufficiently hot and properly tinned.

Terminals and terminal punchings encountered in the telephone work are usually small ones and are of various shapes and sizes. The word "punching" means, that the kind of terminal is punched from a sheet of metal. Punched terminals are usually small and flat, though sometimes they have been shaped to give clearance and accessibility. Other terminals of a similar size are actually the ends of the contact springs of relays, lamps and jack strips, keys and switches of various types. Terminal punchings must have a mounting to hold them in place. Some are mounted separately, or in groups of two or three, by means of screws or merely stuck into the wood frame of an instrument, telephone or

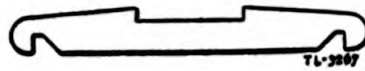

Figure 1

switchboard. The greatest number are mounted in terminal blocks. Standard terminal blocks are assembled to accommodate twenty circuits, having from two to six rows of terminals with twenty terminals in each row, depending upon the purpose they are to serve. The employment of these blocks on main and intermediate distributing frames is covered in another course. A single terminal punching and the end view of the block in which this kind of punching is mounted is shown in figure 1.

An end view of a horizontally mounted terminal block is shown in figure 2.

Note 1.—When blocks are mounted vertically switchboard cable wires are brought in on the left side and under their respective terminals.

Note 2.—Wires are skinned, and scraped of enamel, so that the insulation comes up to but not in the notch or hole of a notched or drilled terminal.

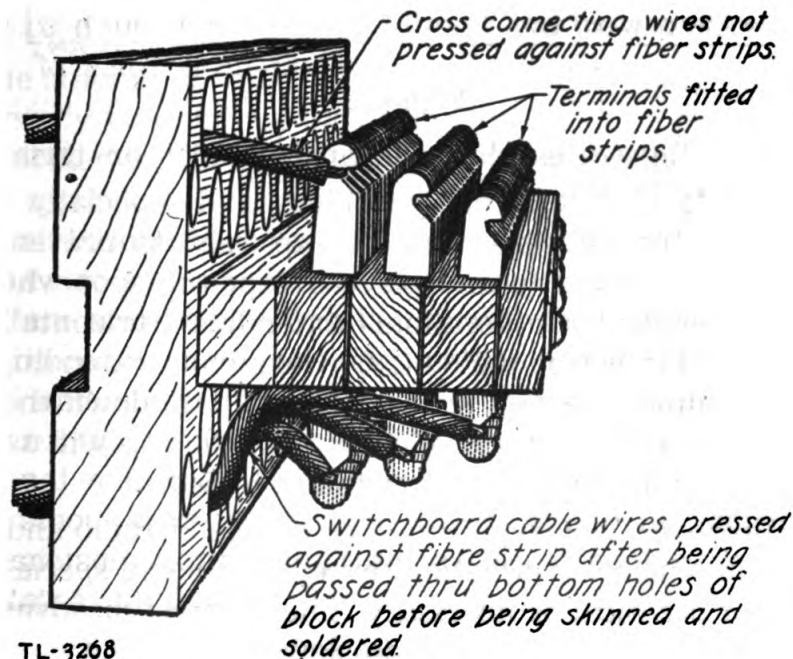

Figure 2

Types of improperly soldered connections are shown in figure 3.

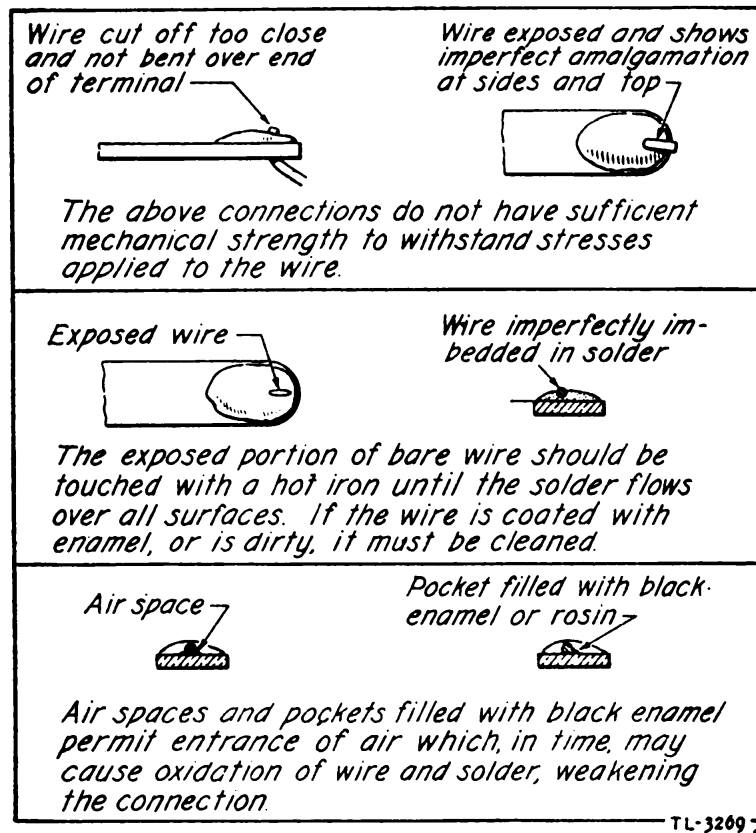

Figure 3

Figure 4 illustrates places to apply solder on terminals.

When soldering terminal punchings and especially those of terminal blocks, care must be exercised to prevent the solder from running to any place except the spot where it should be applied. On terminals extending horizontally or downward this is not difficult. On terminals extending upward it is almost certain that solder will run down the side of the terminal if too much solder is applied. This will usually result in circuit troubles and must be avoided.

The process of soldering small terminals of radio and telephone equipment by sweating, except for some special reason, is not practical or necessary. The greatest disadvantage to its use is that sweating is too slow. The second objection being that it requires more heat to sweat the joint. This

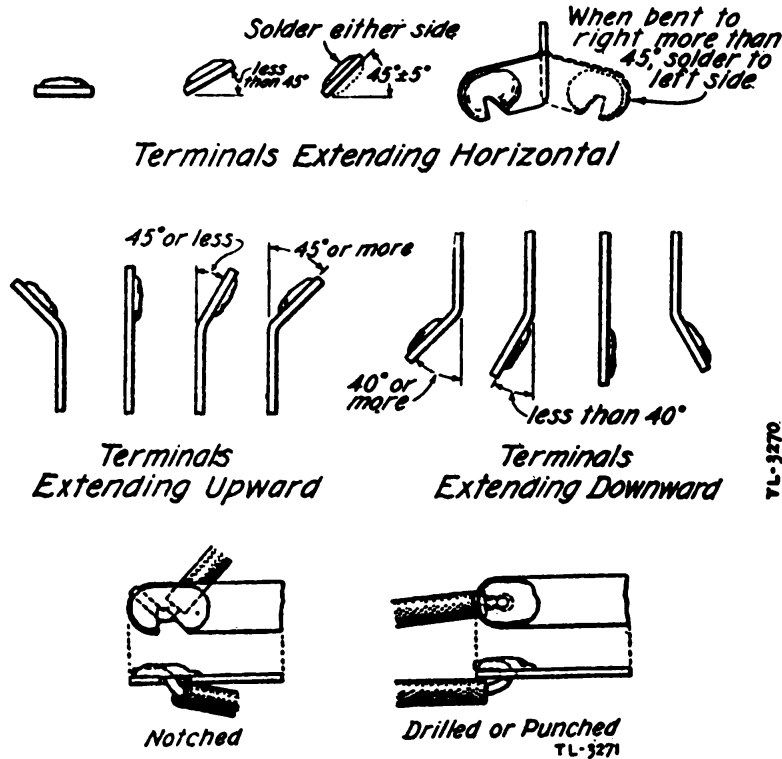

Figure 4

added heat will sometimes cause the compound or fibre in which the terminals are set to melt and loosen the terminal.

The amount of solder usually required for small terminals can easily be obtained by laying the end of a piece of rosin core solder on the terminal so that the length of the solder lying against the terminal extends over the spot where the solder is required. Then place the tip of a properly tinned and heated iron on the solder. As soon as the solder melts, the piece of solder held in the hand is moved away from the iron tip. As soon as the solder on the terminal is completely liquid and is adhering to the wire and terminal as it did to the iron tip, remove the iron by dragging it off toward the terminal end. Allow the soldered joint to cool before attempting to move wire or terminal. Excess solder may be removed by remelting it and flicking the excess off with a small wooden stick or toothpick.

All terminal blocks, relays, cable forms, or other equipment that is underneath terminals to be soldered, must be

covered with canvas or cheesecloth before starting to skin or solder the wires.

Review questions.—

1. What is meant by the term soldering?
2. Should solder melt at a higher or a lower temperature than the metals being soldered?
3. Why must a flux be used when soldering?
4. Which is the most common noncorrosive flux?
5. What are the two classes of solder?
6. Which class should be used to solder tin, lead, and copper?
7. What is the bit of the soldering iron made of?
8. What advantages does the electric iron have over the torch heated iron?
9. What must be done to the point of the iron before it can be used for soldering?
10. Should the blow torch be completely filled with gasoline?
11. Should high test gasoline be used in the blow torch?
12. Why is gasoline burned in the priming cup before the torch is turned on?
13. What are four requirements for good soldering?
14. Which has the best electrical conductivity, 50-50 solder or copper?
15. What are the two methods of soldering?
16. Which of the two methods should be used in soldering small terminals?
17. On which side should terminals extending downward be soldered?

18. Should the tinned point of an externally heated iron be placed in the flame of the blow torch? Why?

19. Should the melting point of the flux be below or above that of solder?

20. Which part of the Western Union splice should be soldered?

21. Is the sweating process used in soldering small terminals?

LESSON 5

LABORATORY

(Wire Students Only)

Tools and materials for operations 1, 2, 3, 4 and 5.—

- *1 ea. Blow torch
- 1 ea. Pliers, 8-inch, side-cutting
- *1 ea. Soldering iron, 1½ lb.
- 1 ea. File, 10-inch, with handle
- 1 ea. File card
- *4 pcs. Wire, copper, No. 10
- *2 pcs. Brass sheet (from lesson 4)
- *1 pc. Wire, copper, No. 6
- *1 ea. Large terminal lug
- * Bar solder, rosin core solder, rags, seizing wire.

Items marked * are not placed on the memorandum receipt.

Procedure.—

Operation 1.—The blow torch will not be taken to a work bench while burning.

Check the blow torch for broken or missing parts.

Following the instructions in the lesson sheet, fill and light the torch.

Have the operation checked by the instructor.

..... Ins. check

Operation 2.—Check the soldering iron. Make sure the handle is serviceable.

Use the tinning jig furnished. Follow the instructions in the lesson sheet and tin the iron.

..... Ins. check

Operation 3.—Clean and tin one end of each of the four pieces of No. 10 copper wire. The tinned portion should be about 3 inches long. This wire is tinned in the same manner as the soldering iron, except that it is heated by the iron instead of the open flame of the blow torch. Lay two pieces of the wire together with the tinned ends overlapping. Seize the wires with a few turns of seizing wire at each end of the tinned part.

Solder this joint using the flow method.

Prepare the other two wires.

Solder this joint using the sweating method.

Note the difference between the two joints.

The best way to solder the joints in this operation is to place a piece of scrap wood on each side of the wire and place it in a vise in such a manner that the portion to be soldered is out to one side. The scrap wood will keep the heat from running into the vise and a better joint will be secured.

..... Ins. Check

Operation 4.—Solder a butt joint with the two pieces of brass sheet. Use the information contained in the lesson sheet and the illustration given in figure 5. Lay the pieces on a piece of scrap wood for the soldering operation.

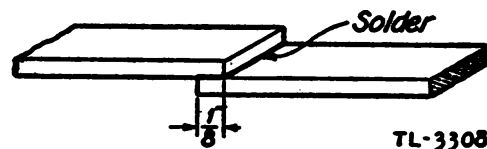

Figure 5

..... Ins. check

Operation 5.—Use the No. 6 wire and the terminal furnished. Follow the information in the lesson sheet and solder the lug to the wire according to the illustration given in figure 6.

..... Ins. check

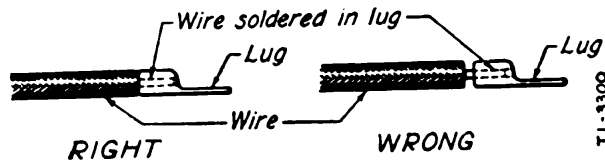

Figure 6

..... Ins. check

After completing Operation 5, the student will return to the supply room, all tools and materials left over.

Tools and materials for operations 6 to 16 inclusive.—

Report to instructor before drawing equipment for operations 6 to 16.

- *1 ea. Terminal block frame
- 1 ea. File, with handle
- 1 ea. Soldering iron, electric (TL-117)
- 1 ea. Pliers, long-nose (TL-126)
- 1 ea. Pliers, diagonal (TL-103)
- 1 ea. Insulation stripper.
- *2 pcs. 20-pr. switchboard cable
- *2 ea. Brass rods, $\frac{1}{4}$ inch x 12 inch
- * Lacing twine
- * Rosin core solder
- * Rags

Items marked * are not placed on the memorandum receipt.

Operation 6.—Clean and tin the electric soldering iron.

..... Ins. check

Operation 7.—All operations with the terminal rack will be performed with the bottom of the rack on the work bench. In this position, the parts mounted on the rack present the same appearance as the parts of a switchboard or main frame.

Clean all of the terminals on the frame. This is best done by heating the terminals with the electric soldering iron and flicking the excess solder from them with a small wooden paddle.

..... Ins. check

Operation 8.—Lash a piece of the 20-pair switchboard cable to the frame, with the braid of the cable about $\frac{1}{2}$ inch below the vertical terminal block. Separate all of the pairs in the cable and twist the ends of each pair together. Use the following table and distribute the pairs, starting at the top of the terminal block, with pair No. 1.

<i>Colored Wires</i>	<i>Mate</i>
Pair No. 1 Blue	White
No. 2 Orange	"
No. 3 Green	"
No. 4 Brown	"
No. 5 Slate	"
No. 6 Blue-White	"
No. 7 Blue-Orange	"
No. 8 Blue-Green	"
No. 9 Blue-Brown	"
No. 10 Blue-Slate	"
No. 11 Orange-White	"
No. 12 Orange-Green	"
No. 13 Orange-Brown	"
No. 14 Orange-Slate	"
No. 15 Green-White	"
No. 16 Green-Brown	"
No. 17 Green-Slate	"
No. 18 Brown-White	"
No. 19 Brown-Slate	"
No. 20 Slate-White	"

Note.—The color code given above is standard for all types of coded switchboard cables, whether braid or lead covered.

.....Ins. check

Operation 9.—Place the pairs under their respective rows of terminals. Hold the pairs tightly in place and at the same time push each pair sharply back against the fibre strip, in which the terminals are mounted, with the blunt wood stick. Then lay the $\frac{1}{4}$ inch brass rod between the base of the block and the back row of terminals, to hold the wires in place.

Lay the other rod in the same position on the opposite sides of the block and lash the protruding ends of the rods firmly together with lacing cord. Pull all pairs tight so that there is no slack between the cable butt and the terminal block.

.....Ins. check

Operation 10.—Separate the first pair of wires. Lay the white wire across the edge of the mounting strip so that it will be out of the way. Bend the coded wire into the notch of the top terminal of the second row. The terminal rows are counted from the front to the back of the terminal block. The next step is to remove the insulation from the wire. This may be done with either the long-nose pliers or the insulation stripper. *Do not start to remove the insulation at the point marked on the wire by the notch of the terminal.* Drop down toward the end of the wire about $\frac{1}{8}$ of an inch and remove the insulation for a distance of about 1 inch. Hold the wire under the terminal and push the insulation back until the part of the wire that goes into the notch is uncovered. Remove all tarnish or enamel from the wire. Wind the loose ends of the insulation tightly around the wire in such a manner, that the insulation comes under the terminal but does not enter the notch. Bend the bared part of the wire into the notch and lay it across the top of the terminal at an angle of 45 degrees toward the rear of the terminal block. It is necessary to leave the insulation long and push it back on this type of wire, otherwise when the iron is used to solder the connection the loose ends will unravel and this might cause a short circuit.

Solder the connection and inspect each separate connection for the faults listed below:

- a. Insulation in notch of terminal.
(Connection must be unsoldered and insulation pushed back.)
- b. Chalky solder. (Not enough heat)
- c. Rosin core joints. (Not enough heat)
- d. Solder not adhering to wire.
(Must be unsoldered and wire scraped.)

e. Wire not laying against terminal.

(Hold wire tight, melt solder and let solder set before releasing wire.)

After the connection has been inspected, and all faults corrected, cut the excess wire off as close to the terminal as possible. If the student is in doubt as to whether the connection has been soldered properly, have the instructor check it before soldering others. Continue with the coded wires until all 20 have been soldered.

.....Ins. check

Operation 11.—Solder the white wires to the first row of terminals on the block.

.....Ins. check

Operation 12.—Lash another piece of switchboard cable to the left and at the back side of the terminal block mounted horizontally. Place and solder the wires using the same method as that for the vertically mounted block, except that wires are wrapped from left to right so that the soldering is done on the right side of the terminal. When finished and checked for faults, submit to the instructor for approval.

.....Ins. check

Operation 13.—Run three pairs of lacquered cross-connecting wires from the vertical to the horizontal terminal block. These wires are run on the opposite side of the blocks from the cable. This wire is not dressed back against the fanning strip. Each pair of cross connecting wires should have approximately 3 inches of slack. Solder the white wire to the first row of terminals and the colored wire to the second row. Check the connections for faults and submit to the instructor for approval.

.....Ins. check

Operation 14.—Solder a piece of scrap wire at least 6 inches long to each drilled terminal on the lamp strip.

.....Ins. check

Operation 15.—Solder a piece of scrap wire at least 6 inches long to the center terminal of each group on the jack strip. Submit to the instructor for approval.

.....Ins. check

Operation 16.—Solder a piece of wire to each of the terminals of the 5-pair section of vertical protectors. The insulation of the wire should come up to, but not enter the notch. In no case will the distance between the notch and insulation exceed $1/16$ of an inch. When attaching wire to this type of terminal proceed as follows: Remove insulation at the proper point, grasp wire at the end with a pair of long-nose pliers and make one complete wrap around the terminal, starting with the wire in the notch. Upon completion of this wrap, bend the free end of the wire down along the face of the terminal and cut it off within $1/32$ of an inch of the bottom. Solder the connection on the face of the terminal.

LESSON 5A

WIRING OF RADIO EQUIPMENT, CORDS AND PLUGS

(For Radio Students Only)

1. **Bus wiring.**—Bus wire for radio equipment is usually No. 14 B&S gauge, or larger tinned copper wire. This wire may be round or square. Heavy, enameled copper wire may also be used for bus wiring. The tin or enamel coating on the bus wire prevents corrosion and in the case of the tinning, simplifies soldering.

Bus wire is used where a large current or a high frequency current is to flow through the wire. Bus wire makes a very strong job mechanically, however, if there is any danger of it coming in contact with other wires in the set, it should have some sort of insulation placed over it.

There are two methods of joining one piece of bus wire to another. The butt joint and the loop joint. See figure 7.

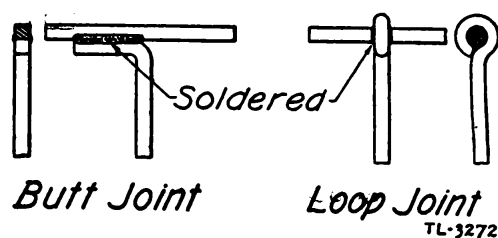

Figure 7

In the butt joint, one end of the wire to be soldered to the other is bent to a right angle to form an "L." The bent over part should be from one-fourth to three-eighths of an inch long. The bend must not be too sharp or the wire will be broken. Solder is then run in between the wires, a small amount of solder is built up on the joint. This type of joint is usually used when wiring with square bus wire.

The loop joint is used when wiring with round bus wire, or with enameled wire. This joint is made by bending a small loop on the end of the wire to be fastened to another wire, then this loop is placed over the wire and clamped in place with a pair of pliers. The joint is then soldered. The solder *must* be run in the loop.

Comparison of the two connections show the loop joint to be much stronger than the butt joint as the loop joint has added strength, because one wire is actually clamped around the other. The strength of the butt joint depends on the *solder only*.

When enameled wire is to be used, the enamel must be removed from the wire before soldering. A fine line should be scribed around the wire, then the enamel scraped off from that point to the end of the wire. This makes a neat job. When making a joint in the middle or part other than the ends, two lines are scribed and the enamel removed between these two lines.

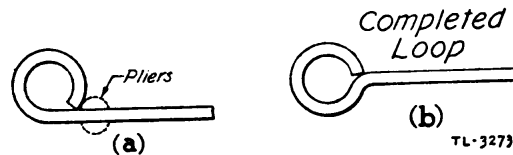

Figure 8

2. Loop bending.—It is sometimes necessary to bend loops where a wire is to be fastened around a screw. This is best accomplished with the aid of a pair of long-nose pliers. The loop is made by holding the extreme end of the wire in the points of the pliers, the left thumb resting on the wire and partly on the points of the pliers. Make a slight bend on the end of the wire, the amount of this bend will depend on the size of the loops required. Move the pliers slightly back on the wire and make another bend, continue until the loop is completely formed. Place the pliers at A, as in figure 8, shape the loop to look like the figure marked "completed loop."

A loop in stranded wire is made in the same manner; however, it is necessary to clean and twist the strands together,

then tin the wire before a satisfactory loop can be completed.

3. Cable wiring.—Cable wiring is used where a number of wires follow the same path. The wires are laced into a form, either before or after being soldered to their respective terminals, depending on the type of work being done. The wires are laced together with the lock stitch, illustrated in figure 9. *Do not use a half-hitch.* This knot will not hold the form together if the lacing cord is broken.

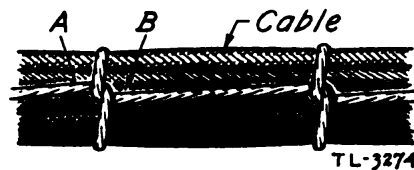

Figure 9

Note the points on the diagram in figure 9 marked "A" and "B." At these points the twine must be on the *under* side. If either "A" or "B" is on top when the stitch is made, it is called a *half-hitch* stitch. When the half-hitch is used it will come loose if the twine is broken.

A figure eight knot is used to start the lacing. The short end of the cord should be carried under the first two stitches and then cut off. When the cable lacing is completed, the twine is anchored by placing two or three stitches behind the last stitch of the form. See figure 10.

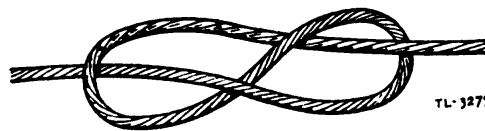

Figure 10

Do not lace wires carrying *high voltage* or *high frequency* currents in a cable form with other wires.

A type of wire, called "pushback" is normally used to wire radio sets. It is simply a tinned copper wire with an insulation that can be easily pushed back from the end. This saves time and gives the installation a neat appearance.

Shielded wire is usually grounded to the frame of a set or if used externally in vehicles, to the body of the vehicle.

This is accomplished by either soldering a pigtail and lug to the shield or unraveling the strands of the shielding, twisting them to form a wire, and soldering this to the nearest ground. If the ground is not near enough to the point of termination to use this method, solder a piece of stranded pushback wire to the shield and run it to the ground.

4. Cords and cordage.—

Definition.—Cordage is the bulk cable used in the fabrication of cords. *Cords* are pieces of cordage cut to the proper length and with the ends prepared for the application of plugs. They may be prepared with or without the proper plugs.

Use.—There are many types of cords used in the installation of radio sets. Cords are used to interconnect the component parts of radio sets in aircraft, portable and vehicular installations. The type of cord to be used is determined by the particular installation and is covered by instructions for the installation of each different type of equipment.

Description.—Cordage in general has from 2 to 8 conductors, each conductor having an insulating cover of rubber. The conductors are twisted together, jute or cotton packing being added to give shape to the cord, and covered with an insulating tape which, in turn, usually is covered by the shield. The shield is composed of small tinned copper wires braided around the taped conductors. The shield is covered with a rubber jacket which insulates and protects the entire assembly. In some cases the shield is on the outside of the rubber jacket. This last type of cordage is used extensively in aircraft and vehicular installations where bonding of the cords at frequent intervals is essential. The conductors in cordage are generally color coded, each conductor having a different color rubber insulation to facilitate the tracing and connecting of the conductors. When the conductors are not coded, an ohmmeter or some similar means must be used in tracing the conductors. Cords, in most cases, are fitted with plugs which fit into sockets on the equipment thus making the necessary connections between the units. This is not true in all cases

however. In some equipment the cords are connected to terminal strips in the units.

Common troubles.—One of the most common troubles to be found in cords is the breakage of conductors at or near the plugs or at points where the cord is bent too sharply, as in going around the corner of some piece of equipment. A cord should be long enough so that no strain is placed on it at any time. Another common trouble is twisting of the cord in the plug, thus shorting or breaking the conductors in the plug. Be sure the plug is properly clamped on the cord.

5. Plugs and sockets.—

Use and description.—Plugs are used on the ends of most cords to facilitate the connecting of the cords to the units. The plugs fit into sockets which are usually mounted in the various units of the equipment. There are so many different types of plugs and sockets that no attempt will be made to describe them in this lesson, as the student will become more familiar with the various types as he works with the equipment. Most plugs and sockets have the connecting pins so positioned that the plug can only be inserted into the socket in the correct position. Most plugs are also equipped with some locking device to prevent the plug from being pulled out of the socket accidentally. Plugs and sockets usually have the pins and connections numbered or marked in some manner so that they may be properly connected. The wiring diagrams of the equipment shows these numbers or markings so that trouble shooting and repair of the equipment is simplified.

Common troubles.—One of the most common troubles found in plugs and sockets is poor connections between the plug and socket. One type of socket commonly used has banana plugs for the socket pins. The springs on these pins become compressed and fail to make a good connection. This may be cured by spreading the springs with a small screwdriver or a scribe. Plug shells frequently become so battered from dropping and other abuse that they do not fit the sockets properly. If not too badly damaged they may be reshaped and continued in service. The locking devices

sometimes become damaged through accident or abuse. If not too badly damaged they should be repaired and continued in service.

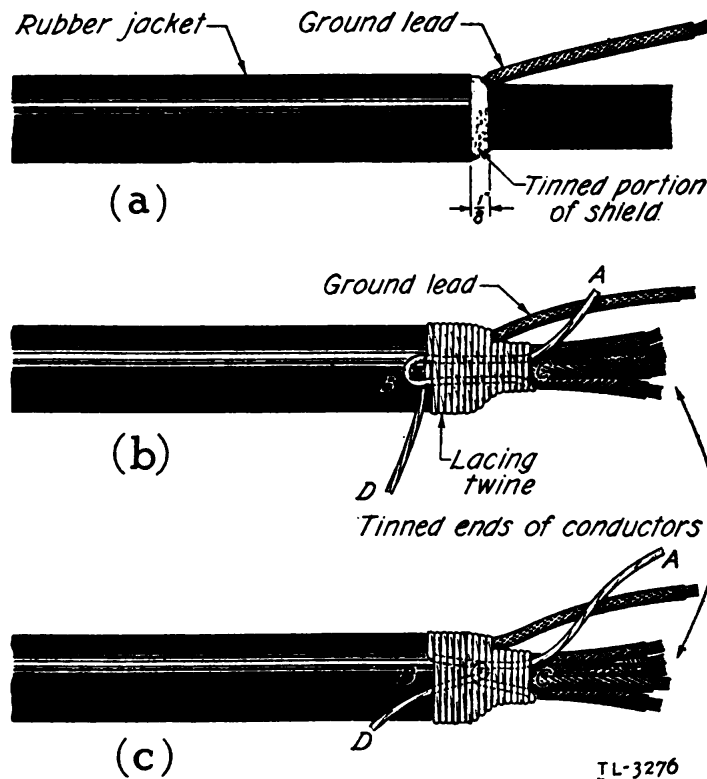

Figure 11

6. Repair of cords.—The following information on the repair of cords is necessarily of a general nature. The instruction books covering the different types of equipment and the installation of the units usually covers the makeup of the associated cord. In all cases these instruction books should be consulted and local instructions followed when repairing or making cords.

Preparation of cords.—Rubber jacketed cords will be considered in this lesson since this is the most commonly used type. The first step is to cut the cordage to the proper length. If an old cord is being used or repaired the conductors should be checked for continuity with an ohmmeter or by some similar means. Next cut off the rubber jacket for about 1 inch being very careful not to cut into the shield. Diagonal pliers are the proper tool to use in cutting off

the jacket. Tin the shield for a space about $\frac{1}{8}$ -inch wide next to the rubber jacket. Refer to figure 11a.

The next operation is to solder the ground lead to the shield, where the shield was tinned. Remove about $1\frac{1}{2}$ -inch of insulation from one end of a 6-inch piece of No. 18 stranded, rubber covered wire. Wrap the bare end around the tinned portion of the shield and solder into place. Be sure it is well soldered. Next cut the shield off back to the tinned portion at the same time removing the insulating tape and cutting out the cotton or jute packing cords. Be careful not to cut the insulation on any of the conductors. Now the insulation may be removed from the ends of the conductors and the ends tinned. Do not remove too much insulation, an eighth of an inch being sufficient in most cases. The insulation on the conductors is usually live rubber and unless extreme care is used too much insulation may be pulled off. Do not use a knife to remove the insulation. Nip it loose with the points of the diagonal pliers. Twist the strands of each conductor together neatly and tin them as soon as the insulation is removed. As soon as this operation is finished the end of the cord will be served with waxed lacing twine. The Signal Corps type number of the twine generally used for this purpose is RP-13. The following explanation and figures 11b and 11c will show how this serving is applied.

A piece of twine about 18 inches long is used. One end of the twine is laid along the cord in a loop as shown by ABC in figure 11c. Leave end of twine A about 4 or 5 inches long and end of loop B about 1 inch back from the end of the jacket. Beginning at C wrap 3 or 4 turns of twine around the conductors drawing the twine very tight. Do not include the ground lead when making these first 3 or 4 turns. Now include the ground lead and continue wrapping the twine until about 4 turns are made over the rubber jacket. Keep the twine pulled tight at all times and keep the turns as close together as possible. Make the serving look as neat as you can by working the turns, into place with the fingers, as they are put on. Now put the end of the twine D, figure 11b, through the loop B. Pull on end A pulling loop B under the wrapping as shown in figure 11c.

This draws the end D under the wrapping at the same time and thus ties the serving in place without the use of knots. Cut off the ends A and D close to the wrap and the job is finished.

Preparation of plugs.—The plugs should be inspected to see that they are of the proper type and are clean and free from corrosion. If old plugs are to be used, the old solder should be removed and the plugs thoroughly cleaned. When removing solder from the plugs having the pins or jacks permanently fastened into a bakelite block, care should be exercised not to use too much heat as this causes the bakelite to swell and the shell will no longer fit over it. Too much heat also causes the bakelite to break down and results in electrical leakage between the pins. See that all screws are in place and have lock washers on them, and that the locking device is not damaged.

Soldering.—When soldering the conductors into the plug do not hold the soldering iron on the connection too long. As stated previously, this will cause trouble during and after assembly. Be sure that the necessary plug parts are threaded on the cord, before soldering the plug in place. Check your wiring diagram and color code thoroughly before starting to solder the conductors. Double check all connections while soldering. If there is any doubt as to the colors of any of the conductors, use an ohmmeter or some similar means to check them through. Do not use too much flux or solder. Surplus flux and solder should be cleaned from the connections and plugs. Be sure that all strands of the conductors are soldered into place. Free strands may cause short circuits or grounds. See that the insulation is not damaged on the conductors. If necessary, insulating tape or cloth should be used to insulate the conductors.

Assembly of cords and plugs.—When all connections have been soldered and inspected, the plugs may be reassembled. When fitting the plug parts together be sure that the conductors are not pulled tight or twisted together any more than is absolutely necessary. See that all the screws used in the assembly have lock washers on them. Be sure that the locking device is free and operates properly. See that the cord is

properly clamped in the plug. If necessary a layer of rubber tape should be used under the cord clamp.

Testing of cords.—After assembly it is advisable to check the cord with an ohmmeter or by some similar means to see that the conductors connect through the proper pins at each plug. The most satisfactory method of testing the cord is by installing it in the proper equipment, and trying it under actual service conditions. Quite often a cord will develop trouble in service that does not show when tested by other means.

LESSON 5A

LABORATORY

(For Radio Students Only)

Tools and materials for operations 1 to 6 inclusive.—

*1 ea. Blow torch	*4 pcs. Wire, copper No. 10
*1 ea. Soldering iron	*4 pcs. Wire W-50
1 ea. Pliers, 8-inch side-cutting	*1 pc. Wire, copper No. 6
1 ea. Pliers, long-nose (TL-126)	*1 ea. Large terminal lug
1 ea. File, with handle	*2 pcs. Brass sheet (from lesson No. 4)
1 ea. File card	*Bar solder, rosin core solder, rags, seizing wire

Items marked * are not placed on the memorandum receipt.

Procedure.—

Operation 1.—Check the blow torch for broken or missing parts. Fill and light the blow torch, using the information contained in lesson 5. Have the operation checked by the instructor. *The blow torch will not be taken to the work bench while burning.*

Operation 2.—Check the soldering iron. Make sure the handle is serviceable. Use the tinning jig furnished. Follow the information contained in lesson 5 and tin the iron.

..... Ins. check

Operation 3.—Clean and tin one end of each of the four pieces of No. 10 copper wire. The tinned portion should be about 3 inches long. This wire is tinned in the same manner as the soldering iron, except that it is heated by the soldering iron instead of the open flame of the blow torch. Lay two pieces of the wire together with the tinned ends overlap-

ping. Seize the wires with a few turns of seizing wire at each end of the tinned part. Solder this joint, using the flow method. Prepare a joint with the other two wires. Solder this joint, using the sweat method. Note the difference between the two joints. The best way to solder the joints in this operation is to place a piece of scrap wood on each side of the wire, and place it in a vise in such a manner that the portion to be soldered is out to one side. The scrap wood will keep the heat from running into the vise and a better joint will be secured.

..... Ins. check

Operation 4.—Solder a butt joint with the two pieces of brass sheet. Follow the information contained in lesson 5, and the illustration given in figure 12. Lay the pieces on a piece of scrap wood for the soldering operation.

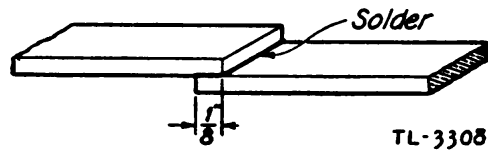

Figure 12

..... Ins. check

Operation 5.—Use the No. 6 wire and the terminal lug furnished. Follow the information contained in lesson 5 and the illustration given in figure 13. Solder the wire and lug.

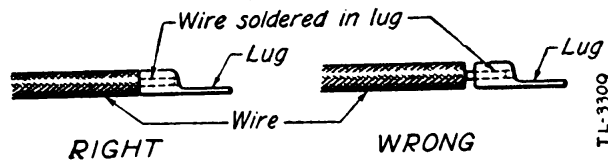

Figure 13

..... Ins. check

Operation 6.—Use the wire W-50. Make two Western Union splices. Solder one splice using the flow method, the other using the sweat method.

..... Ins. check

After completing operation 6, the student will return all tools and material left over to the supply room. See instructor on floor of soldering classroom, before drawing equipment for operations 7 to 14.

Tools and materials for operations 7 to 14 inclusive.—

1 ea. Soldering iron TL-117	*1 pc. Wire W-50
1 ea. Pliers, 6-inch side-cutting (TL-13)	*6 pcs. Wire No. 14, enameled
1 ea. Pliers, long-nose (TL-126)	*1 bundle Wire, for chassis wiring
1 ea. Pliers, diagonal (TL-103)	*3 Terminals, mounted on block
1 ea. Knife TL-29	*1 pc. Cordage CO-130
1 ea. Small screwdriver	*1 pc. Cordage CO-138
1 ea. Chassis	*Small terminals assorted, bus wire tinned, rosin core solder, rubber and friction tape, lacing cord, stranded pushback wire.
1 ea. Plug PL-50	
1 ea. Plug PL-61	

Items marked * are not placed on the memorandum receipt.

Inspect models on display board and table, before doing any of the operations below.

Operation 7.—Clean and tin the electric soldering iron.

Operation 8.—Solder a terminal, TM-10 on one end of the lamp cord.

Solder a lug on each end of the No. 14 enameled wire. Use information contained in lesson 5 and solder the lug according to the illustration given under operation 5.

Solder a short piece of solid conductor pushback wire to each terminal on the block furnished.

..... Ins. check

Operation 9.—Use the information contained in lesson 5A, solder a butt joint. This joint is made with the square bus wire. Two satisfactory joints must be completed.

..... Ins. check

Complete two soldered loop joints.

Operation 10.—Use the No. 14 enameled wire to practice bending loops. One satisfactory loop must be completed to fit the machine-screw furnished.

..... Ins. check

Operation 11.—This operation consists of wiring a chassis according to figure 14 and information. The finished job must present a neat appearance. All soldering flux must be removed. The bus wiring shall be straight and all corners shall be square. Soldered connection must be smooth.

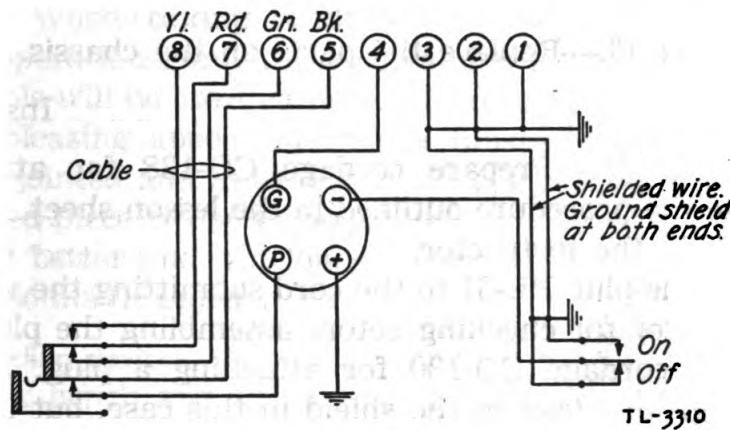

Figure 14

Use pushback wire, connect terminals 5, 6, 7 and 8 to the four lower terminals on the jack. These wires must follow the same path so that they can be laced into a cable.

Using lacing twine, lace the four wires together.

Using enamel wire, connect the top terminal on the jack to the "P" terminal on the tube socket.

Using enamel wire, connect the "G" terminal on the tube socket to terminal No. 4 on the terminal strip.

Using enamel wire, connect the negative (—) terminal of the tube socket to the center terminal of the switch.

Using the shielded wire, connect the terminals 2 and 3 of the terminal strip to the two remaining terminals on the switch. The shield of these two wires must be grounded. That is, the shields are connected together by direct soldering or by soldering a piece of wire to both shields and then soldering a lug on the end of the wire. The lug is then bolted

to the chassis with a machine-screw.

Using square bus wire, connect terminal No. 1 of the terminal strip to the nearest ground lug.

Using square bus wire, connect the positive (+) terminal of the tube socket to the ground lug.

..... Ins. check

Operation 12.—Remove all wiring from the chassis. Clean the terminals of all solder by heating the terminal and then brushing the solder off with a clean cloth. *Do not file or scrape the terminals.*

Operation 13.—Replace the parts on the chassis.

..... Ins. check

Operation 14.—Prepare cordage CO-138 for attaching plug. Use the procedure outlined in the lesson sheet. Submit the work to the instructor.

Attach the plug PL-61 to the cord submitting the work to the instructor for checking before assembling the plug.

Prepare cordage CO-130 for attaching a plug. Do not solder a ground lead to the shield in this case, but unbraid the shield and twist it into two pigtails. Tin these pigtails thoroughly. Cut the conductors and pigtails to about $\frac{3}{8}$ -inch in length. Remove $\frac{1}{8}$ -inch of insulation from the conductors and tin them. Solder a terminal TM-142 to each conductor and each pigtail. Submit the work to the instructor.

Attach the plug PL-50 to the cord after taping the shanks of the terminals to prevent their shorting. Be careful when putting the nuts and screws in place that they are not scarred unnecessarily. Submit the work to the instructor for checking.

..... Ins. check

LESSON 6

WOODWORKING

1. General.—Woodworking is the art of taking rough lumber as it comes from the mill and turning it into a finished product. Woodworking is divided into a large number of special operations, only those pertaining to the use of simple hand tools will be covered here. Woodwork, in order to present a pleasing appearance when finished, should be cut, shaped, jointed and assembled with care. Even though the completed piece is not to be painted or stained, it will hold together better and last longer if the parts are cut square and the joints fit tightly.

2. Holding devices.—The most common holding devices are the work bench and the vise. A heavy, well braced work bench is necessary regardless of the type of woodwork being done. It is a convenient place to layout and assemble the work, keep the tools required for the job, and store the fastening devices and finishing material required. The bench should be equipped with a vise, bench stop, drawer and shelf.

The bench stop is simply a steel plate, with teeth on two sides, which may be raised or lowered by means of a screw in its center. The bench stop acts as a backing for surface planing or where pieces are too small or thin to be held in the vise.

The vise usually consists of two jaws faced with wood and a steel screw equipped with a handle. It is used to hold the wood stock during the cutting and smoothing operations. The wood faces on the steel jaws prevent the wood stock from becoming marred. It is a very poor practice to hold a piece of wood in a metal working vise. If this becomes necessary, place a piece of scrap stock on each side of the piece being cut or shaped.

3. Laying out the work. —The more care exercised in measuring the pieces, the less time and labor the worker will be required to expend in squaring and finishing the parts. The layout devices most frequently used in hand woodwork are: the try square, steel square, marking gauge, 2-foot boxwood rule and the 6-foot zigzag rule.

The try square consists of a steel blade, 4 to 12 inches long set in a beam or head of wood or steel. The angle between the inner edge of the blade and the beam is 90 degrees. The outer edge of the blade is graduated in fractions of an inch, the smallest division usually being $\frac{1}{8}$ th of an inch. In addition to being used as a layout tool, the try square is used to test the straightness and flatness of small pieces of wood, and test edges and ends for squareness.

The steel square is similar in construction to the try square, except that it is usually made in one piece and is not so accurate. The shorter part is called the tongue, the longer part is known as the blade. There are several graduations found on the edges of the steel square. Usually they are $\frac{1}{8}$, $\frac{1}{4}$, $\frac{1}{10}$, $\frac{1}{12}$ and $\frac{1}{32}$ parts of an inch. The square also normally contains a board foot scale and a rafter table.

Marking gauge.—This tool consists of a square ruler, with a pin set in one end, a head with a square hole in its center and a set screw. The ruler slides in the hole in the head permitting measurements from $\frac{1}{16}$ of an inch to 6 inches to be laid off along the grain.

Rules.—The 2-foot boxwood rule and the 6-foot rule are used in general measurements, to estimate the number of pieces that may be cut from a large board and when constructing large frames or braces. These rules should not be used where a high degree of accuracy is required.

Transferring the dimensions.—A pencil with a thin flat point should be used to mark with the grain if the marking gauge cannot be used. A sharp knife is best suited for marking across the grain. Knife or pencil should have the upper end tilted away from the square or rule. This causes the marking end to run close to the layout device, giving an accurate measurement.

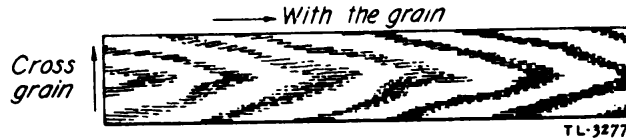

Figure 1

4. Cutting out the parts.—All parts required should be cut first. Do not cut them exactly to size, except where very rough work is being done, as some waste wood is required for smoothing and squaring. Letter or number each piece as it is cut to eliminate duplication of parts. The saw cut should be made outside of the line never exactly on it. Splitting the line will cause the piece to be too small.

Pieces are usually cut out of the lumber stock with some type of rip or crosscut saw. The rip saw is used to cut with the grain, the crosscut saw cuts across the grain. A cut with the grain separates the long wood fibers, a cut across the grain severs them. See figure 1.

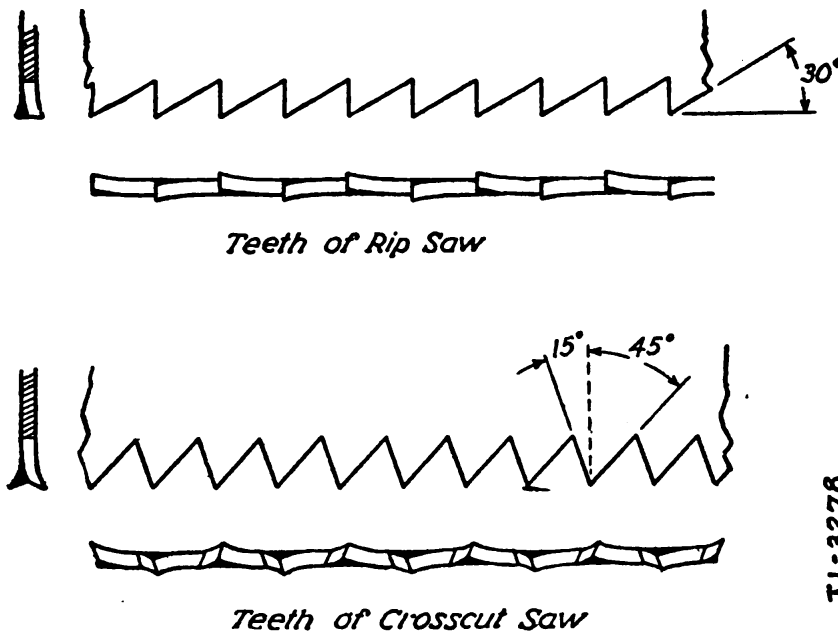

Figure 2

Saws, with a few exceptions, have their teeth alternately bent out of line. This is called set. It makes the saw cut or or kerf wider than the saw back and prevents binding. Saws used on damp spongy lumber require a greater set than

those used on dry well seasoned lumber. The principal differences between the rip and the crosscut saws are: The shape of the teeth, the way the teeth are sharpened, and the amount of set. See figure 2.

To make a cut with either type of saw, the following rules should be observed.

Start the cut with the end of the saw, using a back stroke.

After the kerf is started, use a long stroke, running the saw in line with the arm and shoulder after the cut is started. The correct angle between the saw and the work for ripping is 60 degrees, for cutting across the grain 45 degrees. If possible the work should be held in a vise or supported on a sawhorse or other frame, high enough from the floor to prevent the end of the saw from striking. This gives the operator the best control over the saw. A very square and even cut can be made across the grain by placing the beam of a square on the work, with the blade in line with the proposed cut. The saw blade is then placed along the blade of the square, which acts as a guide. The beam of the square is moved toward the operator as the cut is increased. See figure 3.

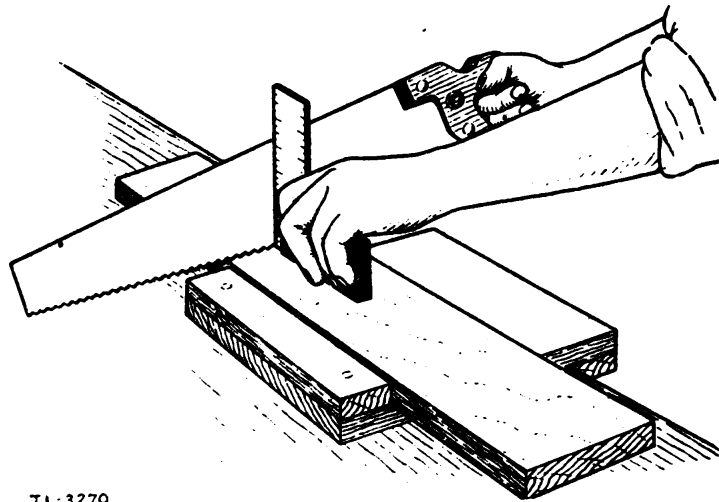

TL-3279

Figure 3

Selecting the saw.—Saws have a number stamped on the blade near the handle which indicates the number of points per inch. The larger this number, the finer the saw. Rip saws

usually run from 5 to 9 points, crosscut saws from 5 to 11 points. The back saw, a crosscut saw used for finer cuts, has from 12 to 16 points per inch.

The 5½-point rip saw, 26 inches long is best for general work. A finer saw should be used for thin material. The 10-point crosscut saw, 26 inches long, is the most popular and is very efficient for general work. Lumber 2 x 4 inches and heavier should be cut across the grain with a 7 or 8 point saw. Crosscutting thin wood, cutting mitres and other types of wood joints should be done with the back saw. This leaves an end surface which requires very little dressing.

Inside, circular and irregular cuts.—These cuts are made with the compass, keyhole and coping saws. The compass and keyhole saws have narrow, tapered blades and are used to cut out circles, braces, round corners, for circular and irregular openings, etc. The coping saw is used mainly for scroll and fret work.

5. Planing.—This operation brings the piece to exact size, squares it, smoothes the edges and surfaces. The plane is nothing more than a beveled cutter set in a block of wood or steel, so that the operator can use both hands and rapidly smooth, true and bring the stock to size. The plane is equipped with an adjusting lever which is used to square the cutter with the sole or bottom of the plane, and an adjusting nut which regulates the depth of the cut. A common mistake is to set the blade too far out. Take off thin shavings, not thicker on one edge than the other, and the best results will be obtained without gouging the work or clogging the plane with shavings.

Outside of having the plane cutter sharp (See lesson 1) and holding the tool as square as possible, there is very little to think about while planing. The start of a stroke is made with more pressure on the knob with the left hand than is exerted by the right. The pressure should be even in the middle of the stroke. At the end of the stroke apply pressure to the handle with the right hand and practically none with the left hand. The steps to follow when truing up stock are: Plane work face flat and smooth; plane work edge straight, square and smooth; measure and plane to width;

usually run from 5 to 9 points, crosscut saws from 5 to 11 points. The back saw, a crosscut saw used for finer cuts, has from 12 to 16 points per inch.

The 5½-point rip saw, 26 inches long is best for general work. A finer saw should be used for thin material. The 10-point crosscut saw, 26 inches long, is the most popular and is very efficient for general work. Lumber 2 x 4 inches and heavier should be cut across the grain with a 7 or 8 point saw. Crosscutting thin wood, cutting mitres and other types of wood joints should be done with the back saw. This leaves an end surface which requires very little dressing.

Inside, circular and irregular cuts.—These cuts are made with the compass, keyhole and coping saws. The compass and keyhole saws have narrow, tapered blades and are used to cut out circles, braces, round corners, for circular and irregular openings, etc. The coping saw is used mainly for scroll and fret work.

5. Planing.—This operation brings the piece to exact size, squares it, smoothes the edges and surfaces. The plane is nothing more than a beveled cutter set in a block of wood or steel, so that the operator can use both hands and rapidly smooth, true and bring the stock to size. The plane is equipped with an adjusting lever which is used to square the cutter with the sole or bottom of the plane, and an adjusting nut which regulates the depth of the cut. A common mistake is to set the blade too far out. Take off thin shavings, not thicker on one edge than the other, and the best results will be obtained without gouging the work or clogging the plane with shavings.

Outside of having the plane cutter sharp (See lesson 1) and holding the tool as square as possible, there is very little to think about while planing. The start of a stroke is made with more pressure on the knob with the left hand than is exerted by the right. The pressure should be even in the middle of the stroke. At the end of the stroke apply pressure to the handle with the right hand and practically none with the left hand. The steps to follow when truing up stock are: Plane work face flat and smooth; plane work edge straight, square and smooth; measure and plane to width;

plane piece to thickness required; mark for square end on all four surfaces, saw and plane end, allowing a little waste stock for planing; (plane from edges to center); measure to length, cut and square second end.

Planes.—The two general types of planes are the bench and block. The block plane is used across the grain. The bevel of the cutter is turned up and the cutter is set in the plane at a low angle for ease of operation. Block planes run from about 4 to 6½ inches long. The bench plane is used with the grain. The bevel of the cutter is down and the edge is backed by a cap iron, which acts as a deflector for the shavings. The four most commonly used bench planes are:

Smooth.—5½ to 10 inches long. This plane is very useful in getting down into the hollows of a piece of wood.

Jack.—14 inches long. This is the best plane for general work.

Fore.—18 inches long. This plane is used for planing long pieces.

Jointer.—20-24 inches long. This plane is used to smooth exceptionally long pieces and even up pieces for glue joints.

6. Wood chisels.—The wood chisel is a hand guided, sharp edged cutting tool. One end is ground to a bevel from 20 to 30 degrees, the other end is equipped with a handle. This tool is made in a large variety of shapes for cutting joints, grooves, slots, fluting, wood turning, wood carving, box core work, etc. The four types of wood chisels most commonly used are:

Butt.—A short thin chisel, used like a pocket knife in confined places, such as seating a hinge or door lock.

Paring.—A long thin blade, used like a plane to remove a thin shaving from a piece that does not fit well.

Firmer.—A medium thick chisel for general work.

Framing.—A thick heavy chisel, for use on heavy timbers or other places where a severe strain is placed on the tool. The butt and paring chisels are worked by hand only, the firmer and framing chisels may be driven by a wooden mallet.

7. Mallets.—The wood mallet is a very heavy wooden hammer provided with a large cylindrical shaped head. It is used for driving wood chisels, wooden pins, etc. Mallets are sometimes made of leather, lead or brass.

8. Rasps.—The wood rasp is a tool similar to a file, except that each tooth is punched from the body of the tool. It is used for rough cutting and shaping of wood and soft metals. The rasp is used with pressure on the forward stroke only. This tool cuts very rapidly but leaves the surface very rough.

9. Wood bits.—The wood bit is a tool used for boring holes of various sizes in all types of wood. Usually it has a feed screw to draw the bit into the wood, a spur to score the outer edge of the hole to prevent splintering, and cutting lips that cut the chip out after it has been scored. The bit usually has a square taper on the end of the shank. There are three common types of wood bits.

Single twist.—This bit has a single spiral and one spur only. It is used in rough construction work. The ship's auger is also a single twist bit which is used to bore holes in heavy timber. It has no spur but the cutting lip is continued vertically, which causes a heavy chip to be cut out.

Double twist.—This bit has a double spiral and two spurs and cutting lips. It cuts a smoother hole than the single twist bit. It is used for general work, also in plain cabinet and sash work.

Straight core.—This bit has a spiral milled around a straight center core, two spurs and two cutting lips. It bores a much smoother hole than the single or double twist bits, and is used in all types of cabinet and furniture construction.

In boring holes, do not run the bit completely through the wood from one side. When the point of the feed screw comes through, reverse the piece and finish the hole from the other side. This prevents splintering the surface of the wood around the hole. Wood bits are usually graduated in sixteenths. The smallest is a No. 3 or 3/16 inch, the largest, No. 16 or 1 inch. The number stamped on the shank of the bit indicates the diameter in sixteenths of the bit. Example: A number 7 bit will bore a hole 7/16 inches in diameter.

See display board for examples of wood bits.

10. Ratchet brace. Angle brace.—The brace is a tool used to hold, rotate and apply pressure to wood bits. It is a metal crank with a handle on one end and a chuck on the other. The chuck has two jaws to hold the square taper end of the wood bit. This chuck should never be tightened with a wrench, but by hand only. There is a ratchet located just above the chuck which permits the bit to be rotated continuously when a full sweep of the handle cannot be obtained. This feature is very helpful when boring holes in corners and attics.

The angle brace is equipped with a double sweep, connected together by means of a universal joint. This makes it more efficient in close quarters than the ratchet brace because the user can always make a full sweep with the inner handle.

11. Draw knife.—The draw knife is a large, sharp edged blade having at each end a handle at right angles to the blade. The blade is beveled on one side only. The draw knife is used to trim telephone poles, the quick shaping of rough parts and other dressing to shape where appearance is not critical. The draw knife is pulled toward the user when making the cut.

12. Claw hammer.—The claw hammer is composed of a metal head fastened onto a wooden handle. One end of the head has a flat or slightly rounded face for driving nails, the other is shaped into a claw for removing nails.

13. The level.—The level is used for guiding and testing. It is a bar of wood or steel, equipped with two glass tubes, both filled with alcohol and a bubble of hydrogen. One tube is located in the side of the frame, the other in the end. The level can be used to test either horizontal or vertical surfaces for levelness.

14. The screwdriver.—The use of this tool was described in lesson 1.

15. Wood joints.—There are a large variety of joints used to fasten wood parts together, from the butt joint, which is

simply placing the two pieces together at an angle and nailing or screwing them in place, to the blind dovetail which is used in the finest furniture construction. A few of the more common joints are illustrated in figure 4. Regardless of the type of joint used, the measurements must be accurate and the members cut square to insure a snug fit. A loose joint will weaken the entire structure.

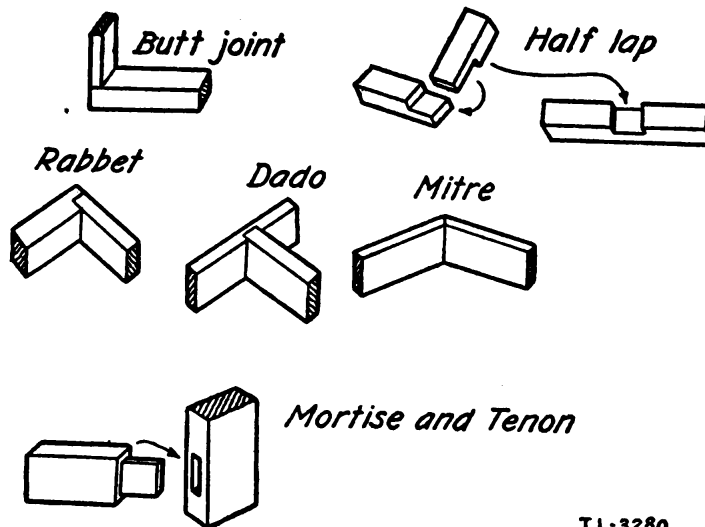

TL-3280

Figure 4

16. Fastening devices.—The most common devices used to hold woodwork together are: nails, screws, bolts, glue, dowels, straps, corrugated nails, spikes, etc. A few general rules to be followed when fastening wooden parts together are given below.

Metal such as hinges and locks, requires a wood screw.

Do not use a screw or nail large enough to cause the work to split.

If the nails go through the wood, they should be bent over and clinched.

Never use wood screws that go completely through the wood, as this reduces the holding power of the screw.

Where bolts are used through the wood, a washer should be used both under the head and the nut.

Nails.—The wire nail is the one most commonly used. Nails run in size from 2d (one inch) to 60d (6 inches). For

certain classes of work nails are made of copper or brass. Wire nails also may have a blue cement or galvanized finish to prevent rust. For general work, the common nail is used. This is the one with the wide head. Cabinet work requires the use of a finishing nail. This nail has a very small head. Rules have been formulated regarding the length of nails to be used for any given work, they are listed below.

General work in medium hard timber requires a nail, the penny length of which shall not exceed the thickness of the board in eighths of an inch. For example, $\frac{3}{4}$ inch lumber requires a six penny nail.

In soft wood, the nail may be one penny larger.

In hard wood, the nail should be one penny smaller.

The term penny, written as 2d, 4d, originally indicated that one thousand of these nails weighed the number of pounds indicated by the figure.

Wood screws.—Wood screws are usually made of brass, iron or steel. They are used to hold woodwork together where a neat appearance is required or greater holding power than that afforded by nails is needed. A wood screw does not injure the material as much as a nail, also they are easier to remove. If a screw is hard to drive, a small pilot hole may be bored or else the threads of the screw may be covered with soap before driving. Two other types of wood screws are: lag and drive screws. These screws have square or hex heads and are driven with a hammer or turned with a wrench. Wood screws sometimes rust or become stuck in the wood. The following methods may be used to ease their extraction. They may be tapped on the head with a hammer or the head heated with a hot soldering iron. If in a piece where appearance is not important, oil may be applied around the head and allowed to soak in. The student is referred to lesson 3 for the method used in measuring wood screws.

17. Wood finishing.—The plane usually leaves some small ridges or rough places on the surfaces of piece of wood. Before the work can be painted or stained, these must be removed. There are a great many elaborate methods used to

prepare wood for finishing, only the simplest is described here.

Wood scraper.—This tool is a thin piece of sheet steel, with the sides filed flat and a portion of the filed surface turned over to form a burr. It is used where the grain is not even and the plane has gouged out portions of the wood. The scraper must always be used with the grain, running it across the grain makes the surface rougher instead of smoothing it. The scraper should be pushed away from the operator as this gives the best control over the tool.

Sandpaper and garnet paper.—The scraper will not leave a surface very smooth as it cuts at a fairly rapid rate, and leaves some of the wood fibers turned up in the form of fuzz on the surface. An abrasive paper is used to cut this fuzz from the wood. "Sandpaper" consists of small particles of flint glued to a paper backing. Garnet paper is made in the same way except that the abrasive material cuts much better than flint and lasts longer.

Sandpaper is graded from 3/0 to number three, those grades in the zero series are considered fine, while those in the whole number series are considered coarse. Garnet paper is graded in the same way, except that the finest grade is 7/0.

A fairly coarse grade is used first and then the piece is finished with a fine grade. Always sand with the grain, sanding across the grain, scores the wood and this will show thru a stained finish.

Sandpaper is also used to finish or polish some of the softer metals.

Review questions.—

1. Name the two common holding devices required for woodwork.
2. Name the two parts of the try square.
3. Name the two parts of the steel square.

4. What two tools are used to lay off dimensions across the grain?
5. Name two tools used to cut out wooden parts.
6. Name the two general classes of planes.
7. What is the rasp used for?
8. A wood bit has the No. 6 on the shank. How large a hole will it bore?
9. Name two types of braces used to hold wood bits.
10. Name two types of common wood joints.
11. Name three fastening devices.
12. Which has the greater holding power, nails or screws.

LESSON 6

LABORATORY

Tools and materials.—

Tools and materials that are required to perform the job assigned to you by the instructor.

Procedure.—

Report to the instructor for an assignment to a job. When all work is completed, submit to the instructor for approval.

The student should be able to identify any tool described in the lesson sheet. Those with which he is not familiar may be drawn from the supply room and taken to the instructor for explanation.

.....Ins. check

LESSON 7

MISCELLANEOUS TOOLS

1. **Splicing clamps, 10 inch (LC-24).**—The splicing clamp is a tool used to make Western Union and sleeve splices in the larger sizes of wires. In lesson 2, the student learned to splice wires with the fingers, aided by small pliers. This method is not satisfactory for copper and phosphor bronze wires from 12 to 6 gauge and galvanized iron wires from 12 to 9 gauge.

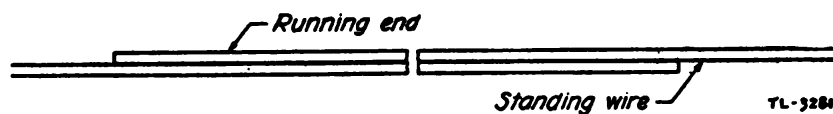

Figure 1

The Western Union splice is not satisfactory for joining wires of the sizes indicated in the paragraph above. It does not give as good an electrical contact as a sleeve splice and should be used only in an emergency, where there are no sleeves available. In addition, hard drawn copper wire nicks easily because it is very brittle. A nick in the Western Union splice, made while forming the neck or buttons will cause the wire to break very quickly. The steps required to form the Western Union splice with the aid of splicing clamps are illustrated in figures 1, 2, and 3.

Clean copper wire with No. 0 emery cloth and wipe galvanized iron wire with a cloth before splicing.

Overlap the ends of the wires about 12 inches. Turn the clamps so that the single holes are on the inside of the handles, select the hole that fits the wire being spliced, place the clamps on the wires as indicated in figure 2 and fasten the handles.

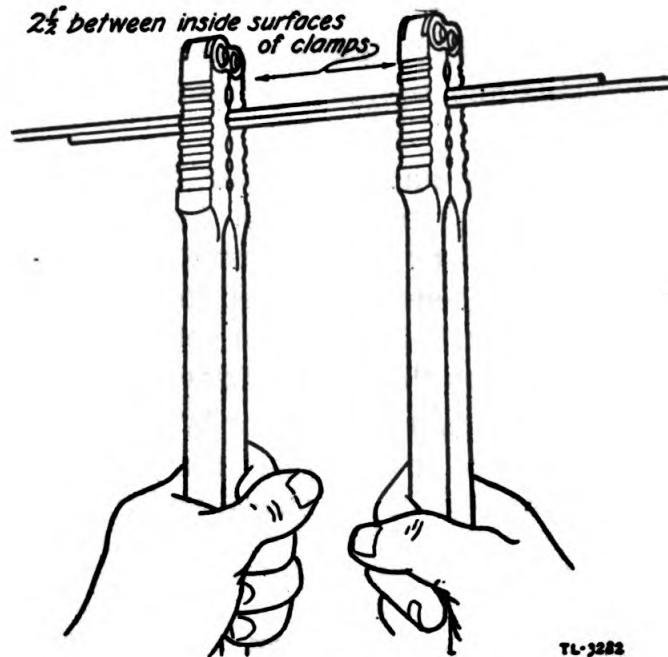

Figure 2

Rotate the right hand clamps one and one-half turns in one direction and the left hand clamp one and one-half turns in the other direction. This should form the neck, which is required to have six half turns or three full turns. As soon as the turns in the neck have been checked, remove both clamps. Place one clamp over the last turn of the neck but do not fasten the handles. This will damage the wire and weaken the splice.

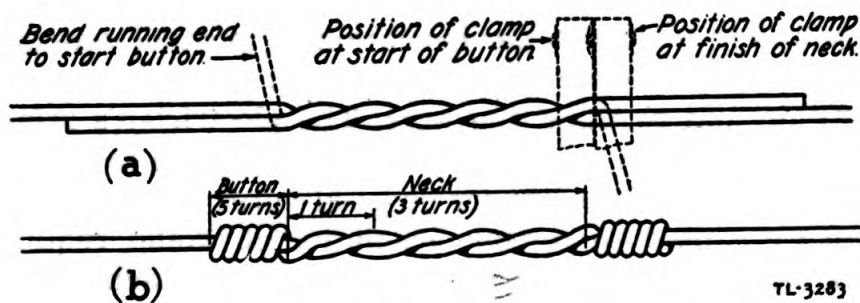

Figure 3

Use the 8-inch pliers and place the five close turns, which form the button, around the standing wire and cut off the excess portion of the running wire as short as possible. Move

the splicing clamp to the other end of the splice and form the other button. The turns in the buttons should be as close together as possible and tightly wrapped about the standing wire.

Splicing sleeves are made of copper, for copper and phosphor bronze wire, and tinned steel for joining galvanized iron wire. Clean all dirt from the tubes of the sleeve before inserting the wire. The steps required to make a sleeve splice are illustrated in figure 4. Turn the splicing clamps so that the double holes are on the inside of the handles.

Rotate the clamps as described for Western Union splices. When six half turns have been placed in the sleeve, bend the ends of the wire back over the sleeve and cut off as illustrated in figure 4.

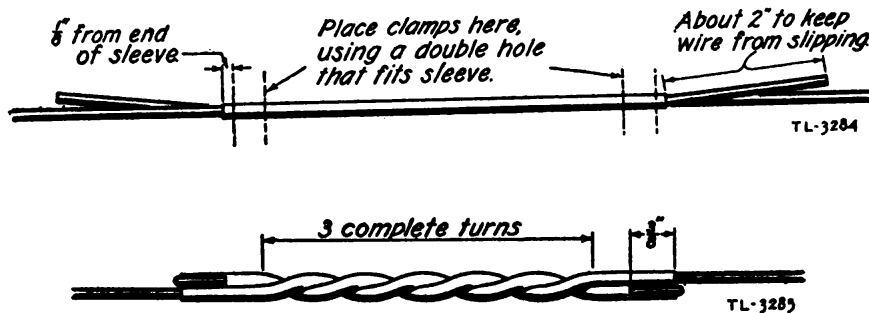

Figure 4

2. Electrician's scissors.—These scissors are a short heavy bladed tool used to cut soft copper wires not larger than 18 gauge and to remove paper insulation from small wires. The back of the blades are corrugated to aid in the removing of insulation and cleaning the wire. The electrician's scissors find their greatest use in splicing cables. These cables have a great many pairs of paper covered wires in them, and if pliers were used to remove insulation it would require a great deal of extra labor in picking them up each time the insulation was removed from a wire, laying them down again to twist the joint and so on. The scissors can be held in the hand, with one finger through one of the loops in the handles and are always ready for use. The method of holding and cutting with the scissors is illustrated in figure 5.

3. Wrenches.—The wrench is a tool used for gripping and turning bolt-heads, nuts and pipes. Wrenches are divided into three general classes: plain or fixed, adjustable and socket.

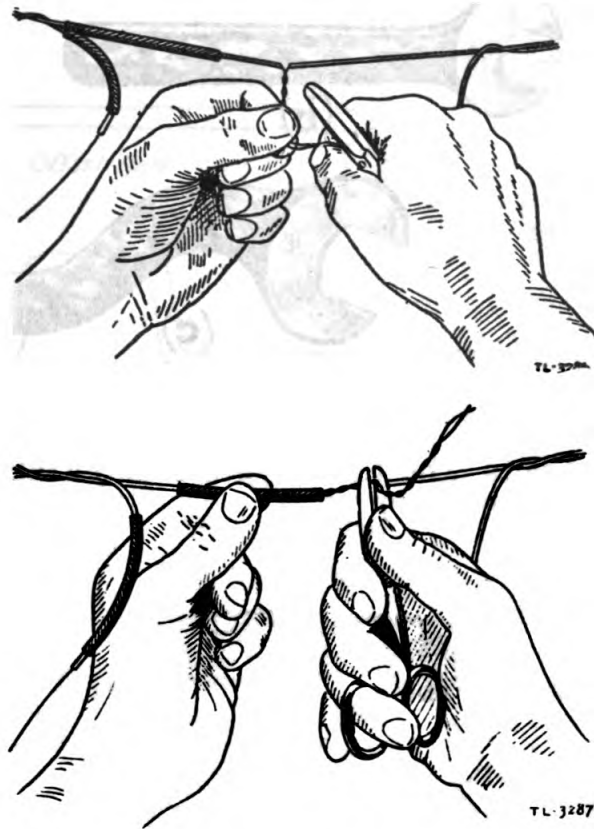

Figure 5

Plain or fixed wrenches.—This type of wrench is made to fit only one or two sizes of bolts or nuts, depending on whether it is single or double ended. Some examples of fixed wrenches are illustrated in figure 6.

Adjustable wrenches.—Since the average mechanic cannot have a complete assortment of fixed wrenches, a type of wrench with one fixed and one movable jaw is made. There are three general types of adjustable wrenches: monkey, crescent and Stillson. The monkey and crescent wrenches are used for nuts and bolt-heads. The Stillson wrench is used for pipes only because the toothed jaws will damage

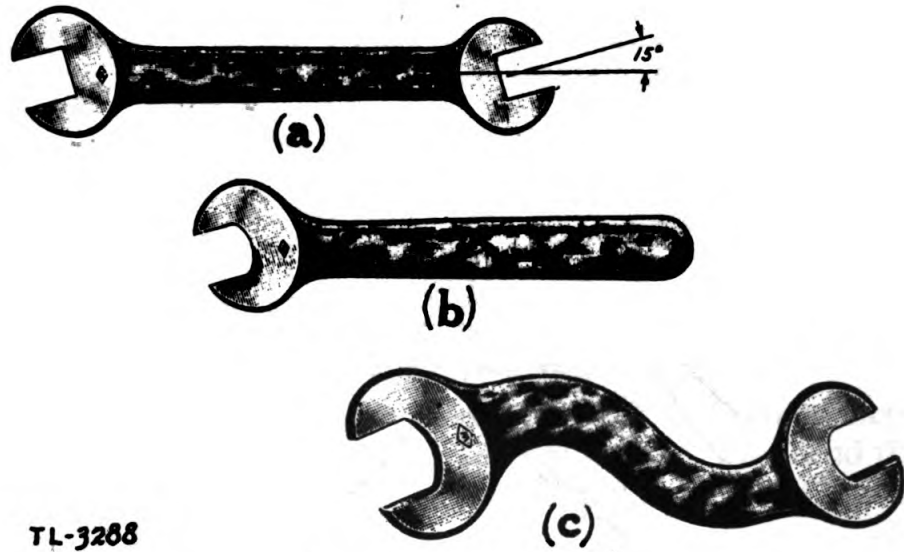

Figure 6

bolt-heads or nuts. The three types of adjustable wrenches are illustrated in figure 7.

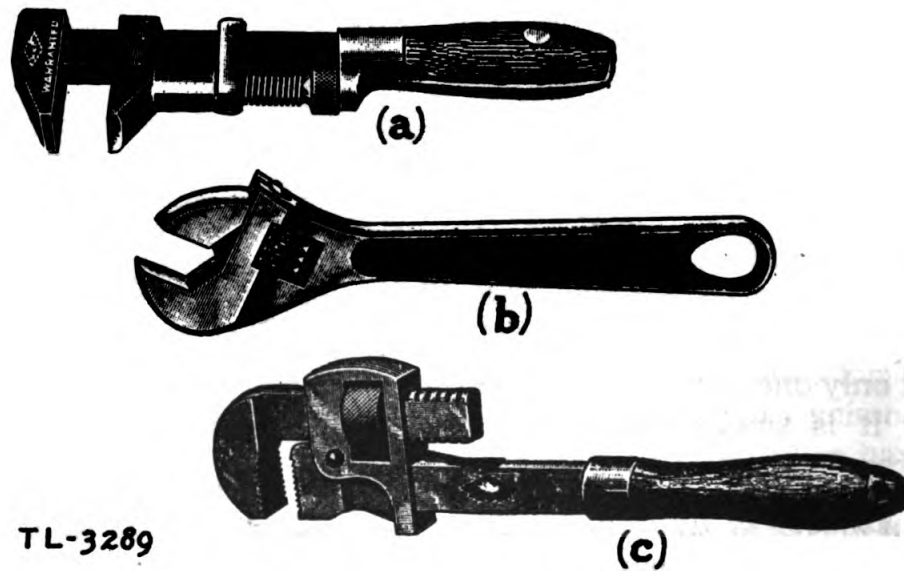

Figure 7

Socket wrenches.—This type of wrench is usually stronger and more useful than the fixed or adjustable wrenches because they grip all sides of the nut or bolt-head at the same

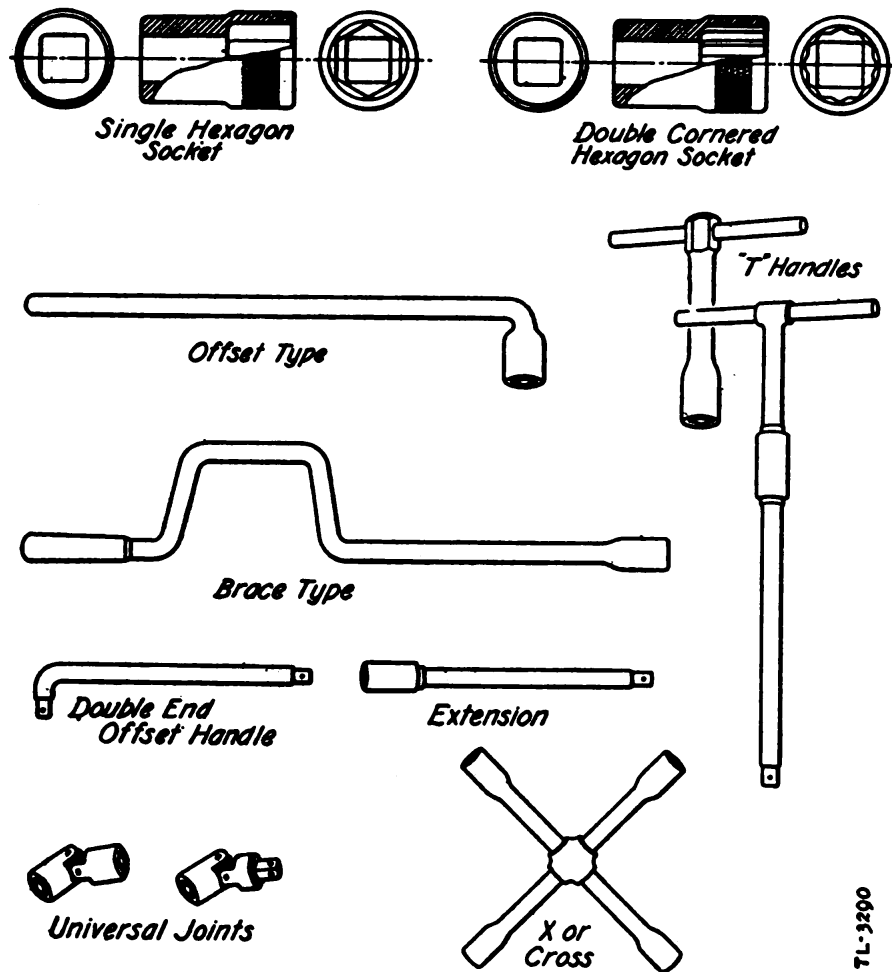

Figure 8

time, which is less likely to cause damage than are the other types of wrenches. The socket wrench is also more efficient for work in close places and for speed of operation. In using the socket wrench it is well to remember that it is possible to apply more force to it than the work can stand. If the user of a socket wrench will bear this fact in mind, he will probably never be faced with the tedious job of removing a screw or bolt with a battered head or sheared off end.

Types of socket wrenches are illustrated in figure 8.

LESSON 7

LABORATORY

Tools and materials.—

- 2 ea. Splicing clamps (LC-24)
- 1 ea. Pliers, 8-inch side-cutting
- 1 ea. Scissors, electrician's
- *4 pcs. No. 10 copper wire
- *4 pcs. No. 12 galvanized iron wire
- *Sleeves, copper No. 10
- *Sleeves, tinned steel No. 12
- *Emery cloth

Items marked * are not placed on the memorandum receipt.

Operation 1.—Make a Western Union splice, use the No. 10 copper wire.

Make a Western Union splice, use No. 12 galvanized iron wire.

.....Ins. check

Operation 2.—Make a sleeve splice, use the No. 10 copper wire.

Make a sleeve splice, use the No. 12 galvanized iron wire.

.....Ins. check

Operation 3.—Practice cutting wires with the electrician's scissors. If the student experiences any difficulty with this operation, the instructor will demonstrate the proper method of using the scissors.

.....Ins. check

LESSON 8

ROPE, SPLICES, KNOTS AND BLOCKS

1. General information on rope.—**a. Terms used in the manufacture of rope.—**

Fibres.—Materials from which yarns are spun.

Strand.—Yarns twisted together.

Rope.—Strands twisted together.

Laying.—The process of twisting strands together in making rope.

b. Terms used in the handling of rope.—

Bight.—A section of the rope turned back on itself.

Turn or loop.—A turn on a rope with the ends extending in opposite directions.

Round turn or bend.—Any turn in a rope around itself or some other object.

Knot.—A combination of bights and turns arranged so the tight part of the rope will bear on the free end of the rope.

Hitch.—Attaching a rope to an object so it may be readily detached.

Half-hitch.—A turn of the rope arranged so a section of the turn will bear on another section of the turn.

Haul.—Pull on a rope.

Running part or fall line.—The free end or that part of the rope that is hauled upon.

Standing part.—The stationary end or that part of the rope that is tight.

Seized.—Two parallel ropes bound together.

Served (whipped).—The end of a rope wrapped to keep the strands from untwisting.

Splice.—Two ropes joined together by interweaving the strands.

Taut.—Hauled tight or under tension.

c. Standard manila rope.—Manila rope is furnished in the following sizes and each size may be obtained in coils up to 1200 feet in length.

TABLE 1

Size, (Diameter in inches)	Breaking strength, new rope (lbs.)	Safe working strength, new rope (lbs.)	Weight of rope, (lbs. per ft.)
$\frac{1}{4}$	700	200	.02
$\frac{3}{8}$	1450	400	.0417
$\frac{1}{2}$	2450	700	.075
$\frac{5}{8}$	4000	1100	.133
$\frac{3}{4}$	4900	1400	.165
1	8200	2300	.27
$1\frac{1}{4}$	12500	3000	.42
$1\frac{1}{2}$	17500	5000	.6

Half the value of the loads specified in this table shall be used if the rope has been in service more than 6 months. New rope loses one-third to one-half of its strength in 6 months of ordinary use. Spliced rope has approximately 80 percent of its original strength. Rope is usually sold by the pound. When ordering rope, where this method is used, convert the footage into pounds by multiplying the required number of feet by the number of pounds per foot as given in table 1.

Example: Required 1500 feet of $\frac{1}{2}$ -inch. 1500 times .075 equals 112.5 lbs.

d. Uses of manila rope.—In telephone work the rope used will depend on the load and other conditions encountered. Manila rope, preferably dry, should be used where there is a possibility of contact with wires carrying current. If the rope is wet or damp the workmen should wear rubber gloves. If manila rope other than the standard rope is used, examine it carefully, to make sure it does not contain a metallic strand. To do this untwist the strands for a few inches, then untwist the yarns.

e. Selecting the size of rope for the work to be performed.—The approximate weight of the load to be handled must be known, before selection of the proper size rope. After determining the load, and the rigging that is to be used, select a size of rope, whose working strength will not be exceeded by the weight of the load to be applied. If necessary to use blocks, select the simplest rigging to accomplish the work with safety and without loss of time. The size of rope required for use with blocks is determined by the diameter of the sheave groove. A sheave groove with too small a diameter places an excessive bend in the rope, causing the fibres to break. Table 3 shows the proper size ropes for the various size blocks. (See rigging.)

f. Storing rope when not in use.—New rope shall be left in the original coil until required and shall be stored in a dry place, in a manner to provide a circulation of air. Used rope shall be stored in the same manner, after it has been coiled or placed on reels. *Do not store new or used rope unless it is completely dry.* To dry rope hang it up in loose coils on harness hooks or rounded pegs, to permit a free circulation of air around and through the coils. Rope should be dried as soon as practical after it is wet. The drying should be done by placing the rope in the sunshine or in a warm room. Rope, wet or dry, should never be placed over a hot radiator or placed too near a fire.

g. Transporting rope.—When transporting rope in trucks, it shall be hung on brackets provided for this purpose; the floor being kept clear to prevent tripping men, cutting the rope with edged tools, and tangling of rope. Never store or transport rope near a storage battery, as the acid or alkali will seriously injure the rope.

h. Inspection routine.—The man in charge of a construction crew should inspect tackle for faults when it is issued, and at least once, during each week of use. He shall make an inspection of the surface of the rope and blocks for any faults that may have developed. Inspection shall be made once each month for the internal condition of the rope.

The person responsible for the tackle shall at all times assume the responsibility of determining that the ropes and blocks are in good condition, and that their appearance indicates neither deterioration nor injury, sufficient to affect their strength.

i. Inspection of manila rope.—In view of the numerous conditions that may affect the strength and, that only part of the rope may be affected, examination should be made to determine the condition of the rope through its entire length, as explained below. If there is any doubt of the safeness of the rope, it shall be exchanged for rope in good condition. The important things to look for on the surface of the rope are as follows:

(1) Abrasions or broken fibres.—Caused by dragging rope over sharp stones, by kinks or crosses in the rope when under tension, cutting with a sharp tool or by exposure to acids such as the acid used in storage batteries.

(2) Extremely soft.—Caused by overstressing rope, wearing out due to normal life of the rope, or by exposure to any cause that will injure the inner fibres.

When inspecting rope for internal faults, the strands should be separated at 3-foot intervals and the fibres inspected for the following:

(1) Broken fibres.—Caused by working rope through sheaves which are too small, or tying to an object which is too small.

(2) Mildew, mould or fine powder.—Caused by rope not being dried nor cleaned properly after being subjected to mud or sand. The fibres of a rope will change color if it is not properly dried before being stored. Fine powder in rope indicates the presence of grit. To remove grit, the rope should be whipped up and down on a hard surfaced road, after being thoroughly dried.

j. Inspection of blocks.—Blocks should be inspected to determine their condition as suggested below:

- (1) Bent, broken or cracked shell.
- (2) Cracked or broken sheave.

- (3) Cracked or broken becket.
- (4) Cracked or broken straps.
- (5) Bent hook.
- (6) Cotter pin missing.
- (7) Roller bushing not functioning.

If any of the above conditions exist and there is any doubt as to the safety of the block, it shall be exchanged for one in good condition.

k. Maintaining blocks in the field.—Keep blocks free of oil and dirt. The sheaves of the standard blocks are roller bushed, and operate better without oil which tends to collect oil and grit, thereby causing the rollers to bind. If the sheaves do not function properly, remove the sheave as outlined below and remove the dirt by tapping the sides of the sheave lightly.

If the hook of a block has started to open, exchange the block, or if a spare hook is available replace the hook. This is done by removing the cotter pin from the sheave pin with pliers. It may sometimes be necessary to oil the pin with kerosene and drive it out with a hammer. After removing the cotter pin, pull out the sheave pin, being very careful not to drop the sheave which will break or scar the edges of the sheave. Pull hook straps out and replace the new hook in position.

l. Coiling and uncoiling rope.—When used rope is not placed on reels, lay out a turn of the desired size and continue the turns in a clockwise direction.

In uncoiling used rope, turn the coil over and draw the end first laid down, from the inverted coil. Be careful not to select the wrong end, if the coil has been tangled or upset.

Remove new rope from coil as explained below; this method retains the rope in its proper form and prevents kinks. See figure 1.

(1) Remove the binding material and secure outside end of rope to an adjacent coil.

(2) Lay the coil on the flat side with the inside end nearest the floor.

(3) Reach down through the coil, grasp the free end of rope and draw out through the top of coil.

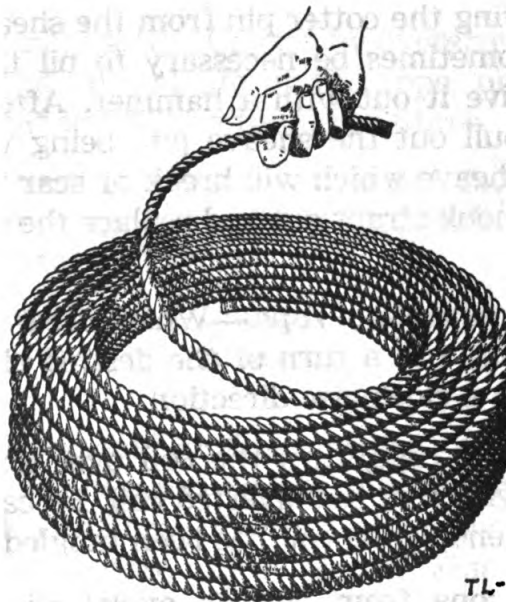
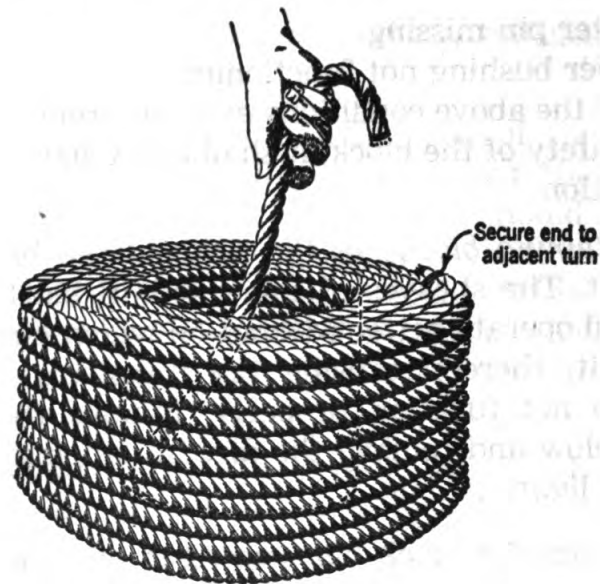

TL-3316

Figure 1

m. Cutting manila rope.—Before cutting rope, wrap several turns of friction tape around the rope on each side of cut, and cut rope with a sharp tool. If it is desired to keep the ends from permanently untwisting, serve or whip them with a strong twine or place a crown splice in the ends.

2. The more common rope splices.—*a. Serving splice (whipping).*—The operations required to serve the ends of a rope are as follows. See figure 2(a).

(1) Unlay one strand of the rope back a little more than one turn, to a point where the serving is to begin. Under this strand lay the twine, leaving the end marked 1, 8 to 10 inches long as shown in 2-A. Then relay the strand into the rope, keeping it tightly twisted and held firmly in place.

(2) Let the short end of the twine 1, hang down the rope. Wind the long end of the rope marked 2, around the rope, just above the short end as shown in 2-B.

(3) Lay the end of twine 1, along the rope towards its end and there bend it back, thus forming the open bight 3, as shown in 2-C, which can be pulled in under the serving when tucking the ends.

(4) Lay the sides of the bight 3, in a groove of the rope. Wind the long end of the twine 2, around the rope and the doubled twine, being careful to pull it up tightly and to leave no open spaces between the turns as shown in 2-D.

(5) Continue winding as far as desired, then pass the long end 2 of the twine through the bight 3, as shown in 2-E, and pull the long end up firmly. By pulling on the free end 1, of the bight 3, draw the long end of the twine 2, downward underneath the serving, to about the center, *not all the way through*.

(6) Finish the serving by cutting off the two protruding ends of the twine as closely as possible. Cut off excess rope as shown in 2-F.

b. Crown splice.—See figure 2(b).

(1) Unlay the rope for 10 to 12 inches and hold it in one hand with the loose ends up as shown in 2-A.

(2) Take strand 1 on the left and lay it across the end of the rope between the other two strands as shown in 2-B.

(3) Take strand 2 back and down over strand 1 as shown in 2-C.

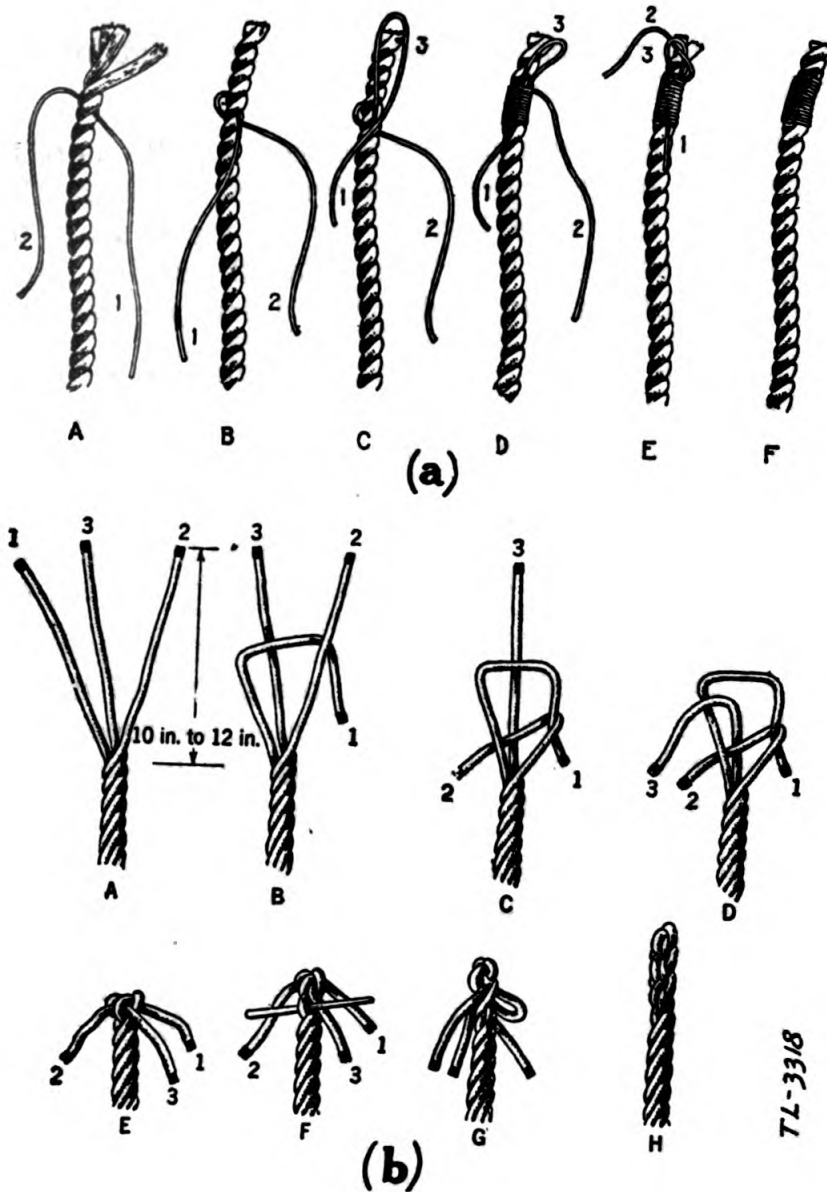

Figure 2

(4) Take strand 3 across 2 through bight in 1 as shown in 2-D.

(5) Pull all ends tight as shown in 2-E.

(6) Continue tucking each successive strand over the nearest strand and under the next strand of the main rope as shown in 2-F.

(7) Tuck until about four complete operations are made.

(8) Roll between two surfaces under pressure, as between foot and floor, to smooth out splice, then cut off surplus ends flush with the outside strands. The completed splice is shown in 2-H.

c. Eye splice.—The eye splice is used to form a permanent loop or eye, in the end of the rope. This splice has 90 percent of the strength of a straight rope. When heavy wear will take place on the inside of the eye, it is advisable to splice an oval thimble in the eye. An eye splice is illustrated in figure 3(a).

(1) Untwist the strands of the rope for a length of 10 to 16 inches. Throw a bight into the rope of a size to correspond with the size of the eye required. Select as strand 1 the strand that is on top of the rope and between the other two loose strands as shown in 3-A.

(2) Raise a strand on the top of the main rope and tuck 1 under it at right angles, as in 3-B, pulling it down securely. Raise the adjoining strand in the main rope and tuck 2 under it as in 3-B. Raise the remaining strand in the main rope and tuck 3 through.

(3) When all the ends have been tucked through for the first time, pull them down tight as in 3-C. Proceed to interweave the strands as in a short splice.

(4) Roll the splice between two flat surfaces under pressure, as between foot and floor, and trim off surplus ends flush with the outside strands. The completed splice is shown in 3-D.

d. Short straight splice.—Short straight splice is used to unite the ends of rope by interweaving strands, and when properly made it has 80 percent of the strength of the rope. See figure 3(b).

(1) Untwist the strands at one end of each rope for a length of 10 to 16 inches. Butt the ends of the rope tightly together as in 3-A laying the strands of each rope alternately between the strands of the other rope; that is, strand 1, is between 2 and 4; strand 3, is between 4 and 6, and strand 5, is between 2 and 6. This process is called locking the strand.

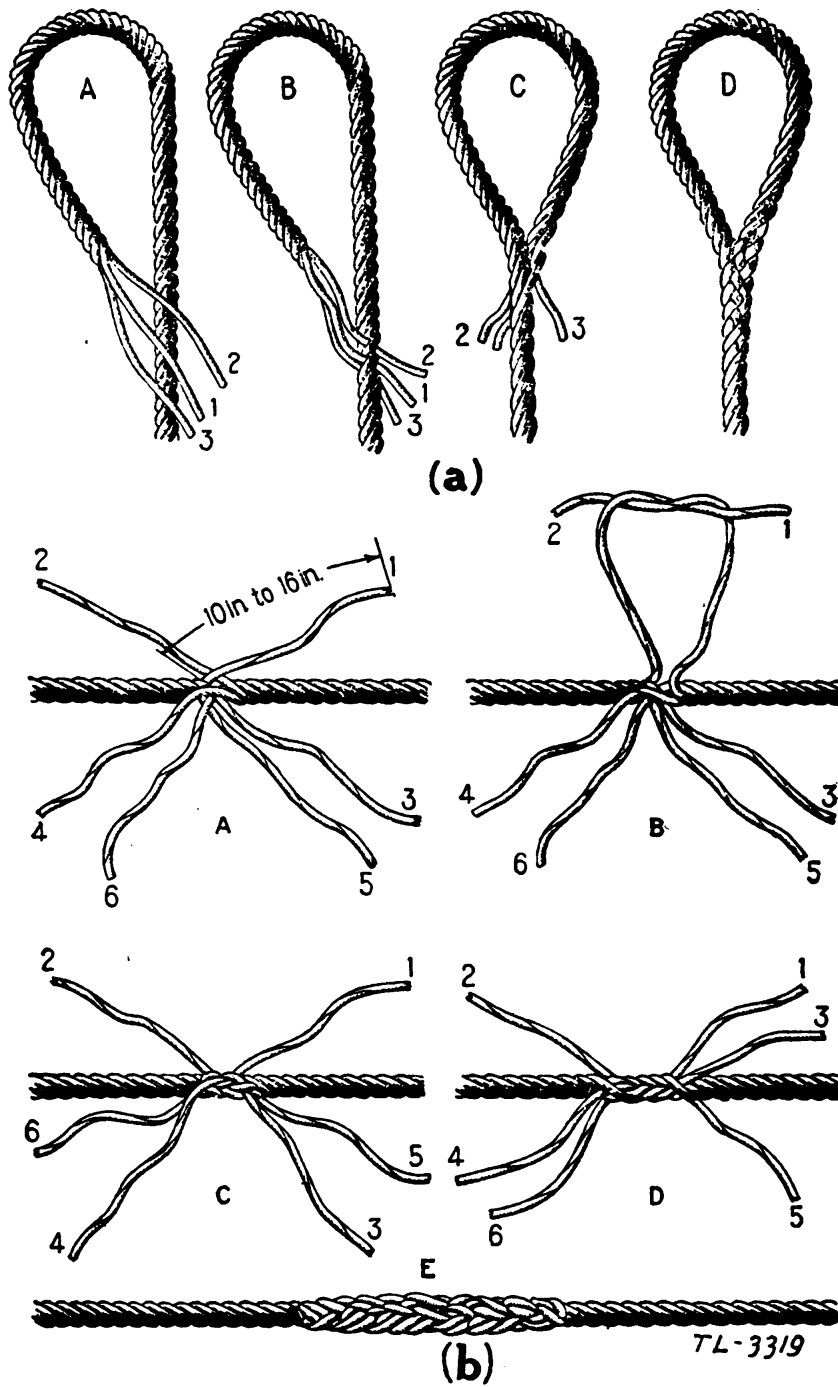

Figure 3

(2) Tie each strand of one rope to the corresponding strand of the other rope with a regular overhand knot as

1 and 2, of 3-B. Complete tying, 3 to 4, and 5 to 6, in a similar manner.

(3) Pull all knots down tight as in 3-C.

(4) Carry each end over the adjacent strand of the rope and tuck it under the next strand. Start with and proceed to strand 6, in progressive order. This will produce an arrangement as in 3-D. Repeat this operation until the total length of the interweaving strands extends through a distance of 4 inches, for one-quarter inch rope, and add an additional tuck for each next largest standard size rope.

(5) Roll splice between two flat surfaces under pressure, as between foot and floor, and trim off the surplus ends flush with the outside strands. The completed splice is shown in 3-E.

e. Long straight splice.—The long straight splice is used to unite the ends of rope required for passing over sheaves, by interweaving strands, and when properly made it has 90 percent of the strength of the rope and therefore it is stronger than the short straight splice. Figures 4 and 5 illustrate, in sequence, the steps in making the long straight splice. The advantages of this splice are; stronger than the short straight splice, and smaller than the short straight splice, thereby allowing it to pass through the sheaves of a block.

(1) Unlay only one strand of each rope for 10 or 12 turns. Lock and draw ends of the rope tightly together, having the single strands 1 and 2 side by side, as illustrated in figure 4.

(2) Taking care not to let the ends of the ropes separate, unlay strand 1 from its rope one turn, and follow it with strand 2. Keep 2 twisted up tightly and pulled down firmly into its place. Continue this procedure until only 6 to 9 inches of strand 2 is left out, depending on the size of the rope.

(3) Untwist the two pairs of strands left at the center and lock them as shown in figure 4. Strand 3 between strands 4 and 6, and strand 6 between strands 3 and 5. Unlay toward the left, strand 4 and follow it with strand 3, as was done

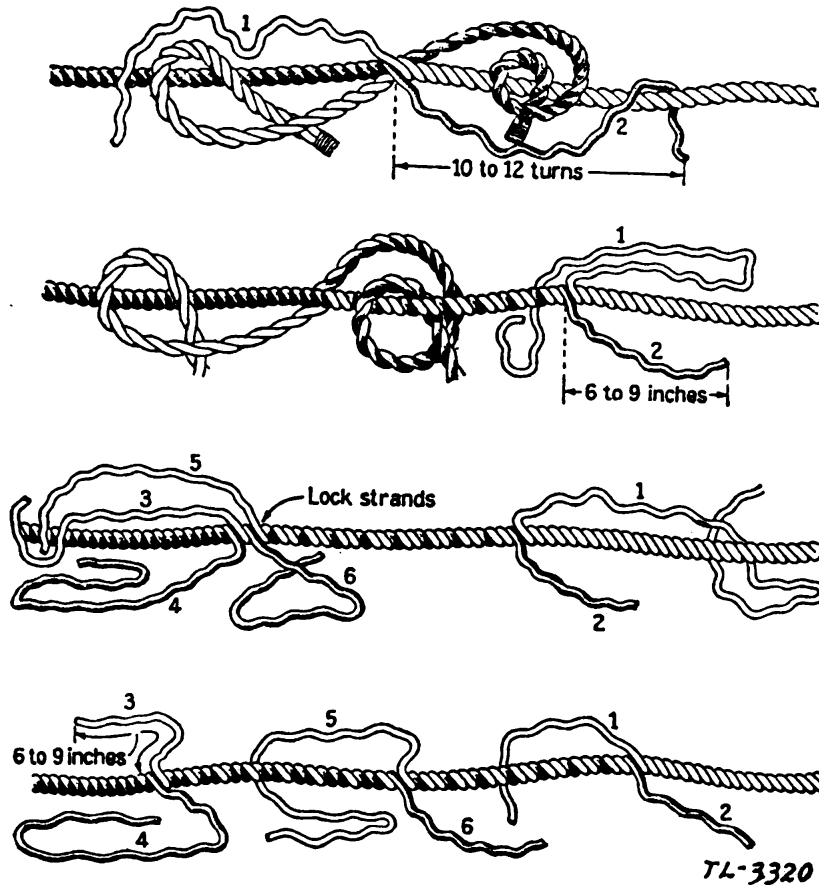

Figure 4

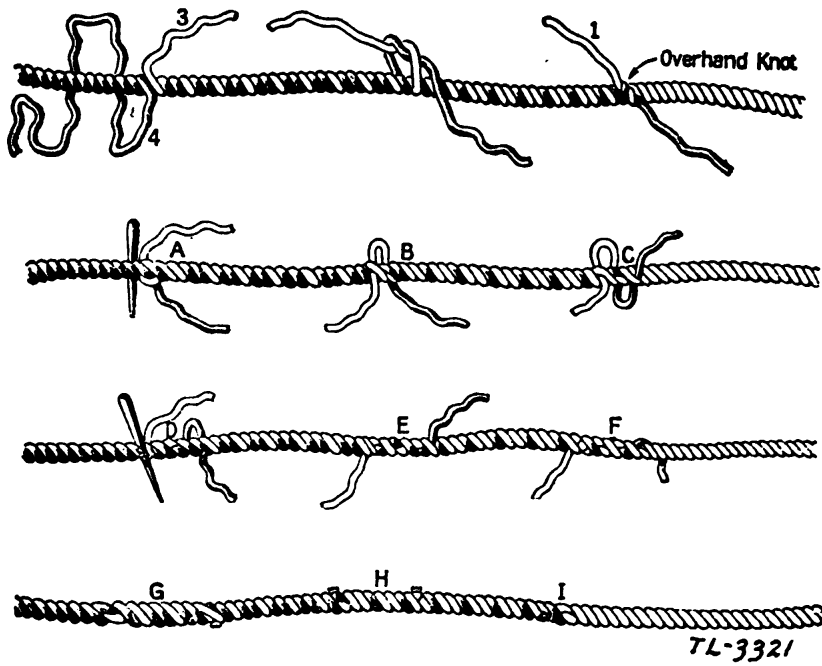

Figure 5

toward the right with strands 1 and 2. *Note.*—Do not unlay strand 6 instead of 4 and follow it with 3.

(4) Continue until strand 3 is only 6 to 9 inches long. The breaks in the strand are now separated as shown in figure 4.

(5) Each pair of strands is tied together now, and the end of each strand tucked. Cut all strands the length of the shortest, that is, 6 to 9 inches long. Arrange each pair so that the strand from the left is in front of the strand from the right; or, in other words, arrange the strands so that they cannot untwist from the rope without first uncrossing. Tie each pair of strands together with an overhand knot and pull down tightly into rope as shown in figure 5.

(6) Tuck each strand as shown in figure 5.

(7) Tuck each strand twice more, tapering the ends if desired, and cut the end $\frac{1}{2}$ inch long.

(8) With a round stick pound down each part of the splice and roll it between two flat surfaces under pressure, as between foot and floor. The completed splice is shown in figure 5.

3. The more common knots, bends and hitches used in telephone work.—The strength of manila rope containing a knot is reduced about 60 percent, as the bend in the rope places most of the strain on the outside fibres.

a. Figure eight knot.—This knot is used to prevent the end of a fall line from running through the blocks. See figure 6(a). Throw a turn into the rope leaving sufficient end to complete the knot, then pass the end around the rope and through the bight. Draw all parts down tight.

b. Block becket bend.—This knot is used when attaching a rope to the eye of a guy rod or to the becket of a block, where a temporary connection is desired. See figure 6(b).

(1) Pass the rope around the thimble on the becket of a block as shown in 6-A.

(2) Take a turn around the standing part outside of the bight as illustrated in 6-B.

(3) Take a second turn around the standing part through the bight, forming two half-hitches in reverse as shown in 6-C.

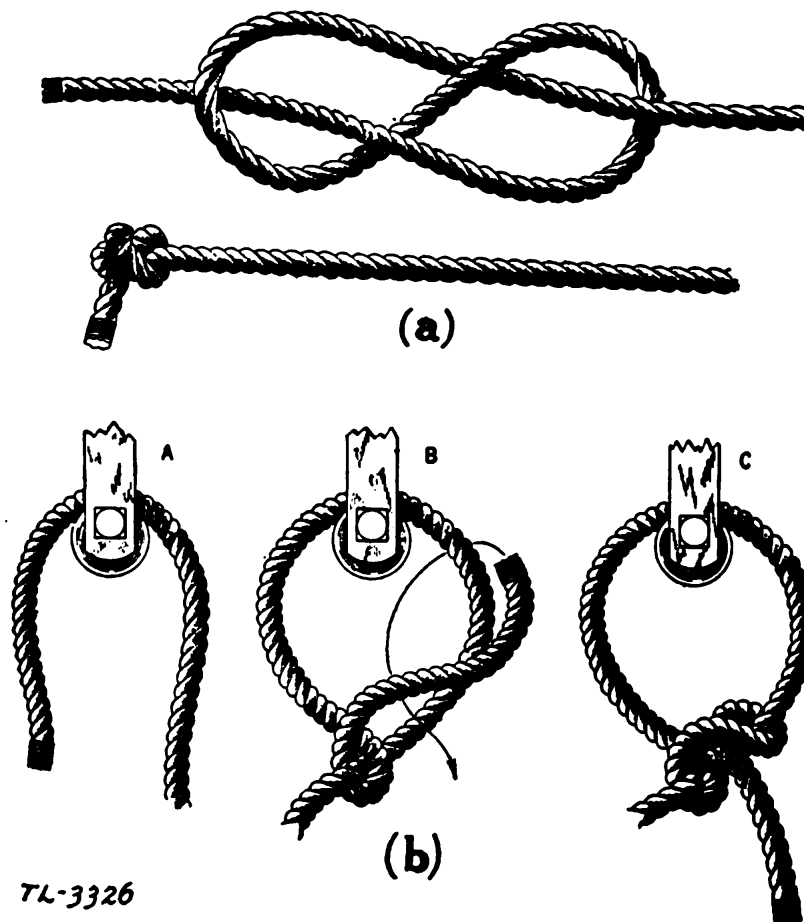

TL-3326

Figure 6

c. Square knot.—This knot is used in uniting the ends of the same size ropes, that may be placed under strain. A square knot, joining two ropes of unequal size is very apt to slip. Figure 7 illustrates a square knot.

- (1) Cross the ends of the rope, placing the right under the left as in figure 7-A.
- (2) Bend each rope back on itself as shown in 7-B.
- (3) Wrap end marked 1, around the end marked 2, away from you as shown in 7-C.

(4) Pull all parts down tight. The completed knot is shown in 7-D.

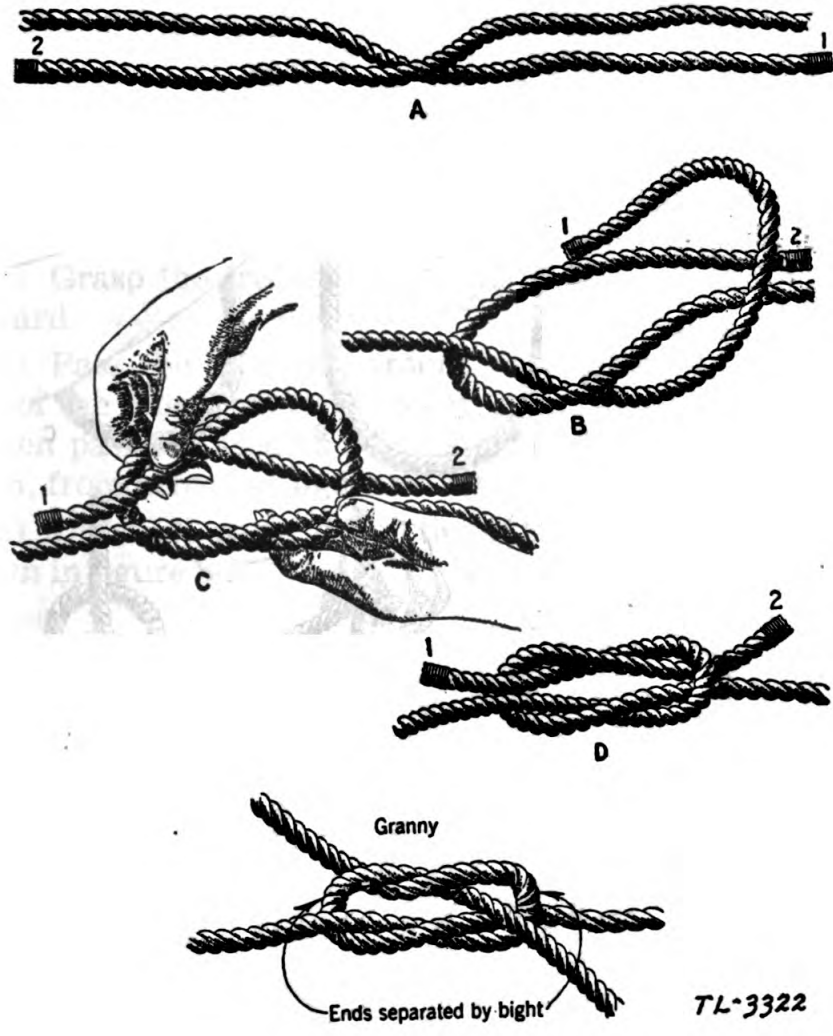

Figure 7

A *granny knot* is shown in figure 7, so that it may be readily identified and avoided.

d. Bowline knots, general.—The bowline knots are used in making hitches of all types and are formed in various ways, depending upon the conditions encountered. It is a tie of universal use, and is the best known method for forming a bight that will not slip under tension and is easily untied.

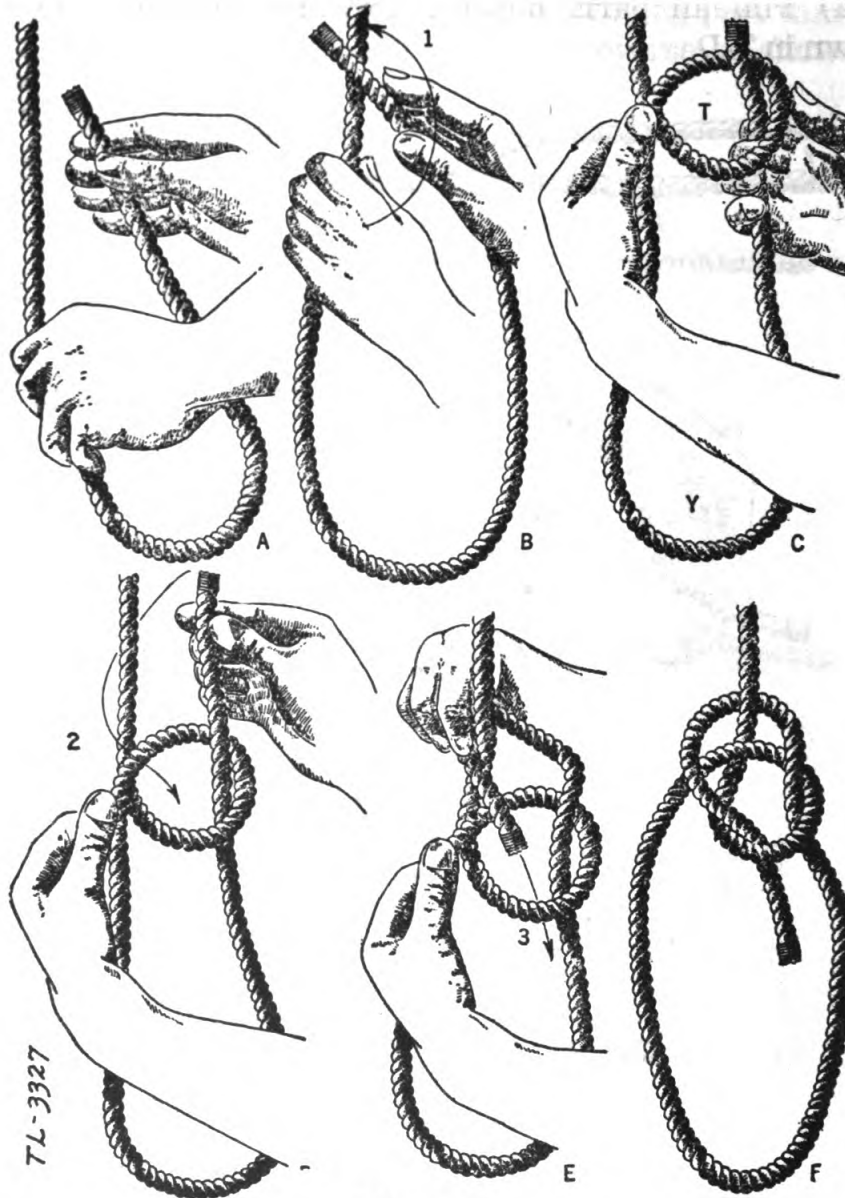

Figure 8

e. Single bowline at the end of a rope, not attached to an object.—This knot is used for attaching a rope to the hook of a block or joining the ends of ropes of different sizes. See figure 8.

(1) Grasp the standing part of the rope with the left hand, at a point where the turn *T* is desired. This position is determined from the size of the bight *Y*, required. Hold the free end in the right hand.

(2) Move the right hand forward and lay the free end across the standing part of the rope, above the left hand, with sufficient end to complete the subsequent turns. Hold the right hand stationary and bring the left hand upward and forward as indicated by the arrow 1.

(3) Just as the left hand is passing the right, turn the right hand palm up, which will result in the formation of a loop in the standing part of the rope, with the end of the rope projecting up through it.

(4) Grasp the free end with the right hand and move it forward.

(5) Pass the free end around and behind the standing part of the rope from right to left, as indicated by the arrow 2, then pass the free end forward and down into the turn again, from above, as indicated by the arrow 3.

(6) Draw all parts down tight. The completed knot is shown in figure 8-F.

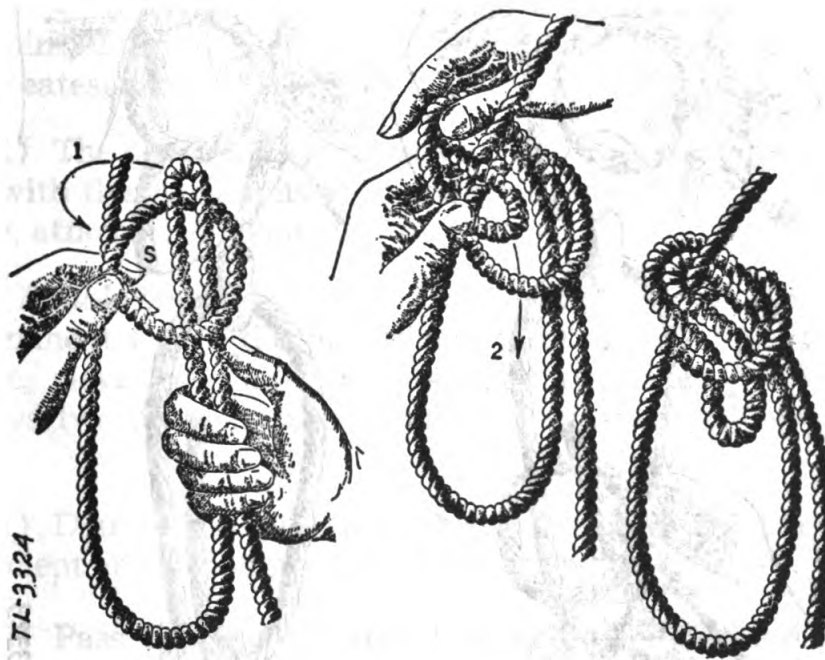

Figure 9

f. Single intermediate bowline.—This knot is used to attach the rope to the hook of a block, where the end of the rope is not readily available. See figure 9.

(1) The operations required in making this knot are identical with the single bowline, not attached to an object, with one exception; that is, in step (D) the part with which the knot is completed is not a free end but a part of the rope doubled back in a bight.

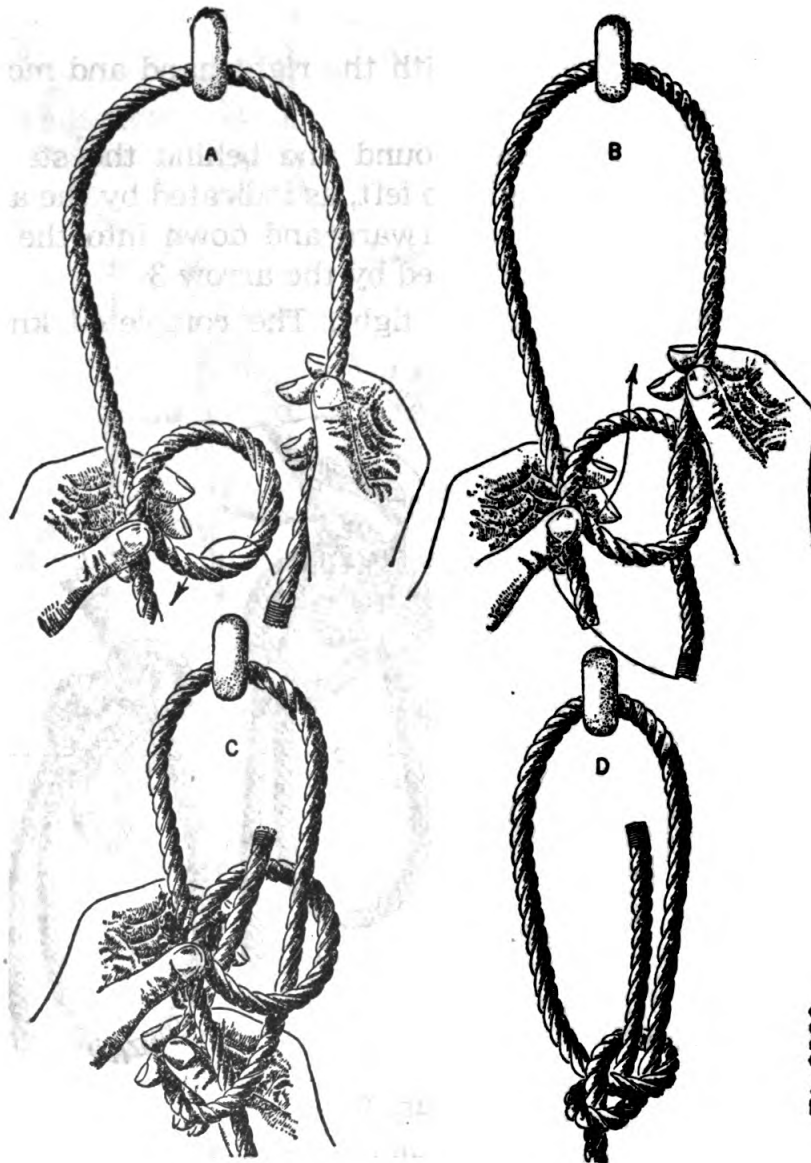

Figure 10

g. Single bowline, at the end of a rope, attached to an object.—This knot is for tying a bowline through a ring or eye. See figure 10.

(1) Throw a turn into the rope, leaving sufficient end to complete the knot, then pass the free end through the eye or around the object, holding the standing part with the turn in the left hand as shown in 10-A.

(2) Pass the free end through the turn in the standing part of the rope as illustrated in 10-B.

(3) Bring the free end from right to left, over the standing part of the rope and turn it under, passing the end through the turn as shown in 10-C.

(4) Draw all parts down tight. The completed knot is shown in figure 10-D.

h. Double bowline.—This knot is used in tying at intermediate points, and allows two ropes to pass through the eye or point of strain, thereby doubling the strength at the point of greatest stress. See figure 11.

(1) The operations required to make this knot are identical with the operations of the single bowline, at the end of a rope, attached to an object.

i. Double bowline on a bight.—This knot is used as a semi-permanent eye in the middle or end of a rope, to engage a hook, clevis or some other similar fastening. This knot allows two ropes to pass through the fastening. See figure 12.

(1) Double the rope and throw a turn into it leaving sufficient end to complete the knot as shown in 12-A.

(2) Pass the end through the turn, as explained for a single type bowline, until the position shown at *Z*, is reached as shown in 12-B.

(3) Turn the bight *S*, down over the front and then up in back of turn *Y* as shown in 12-C.

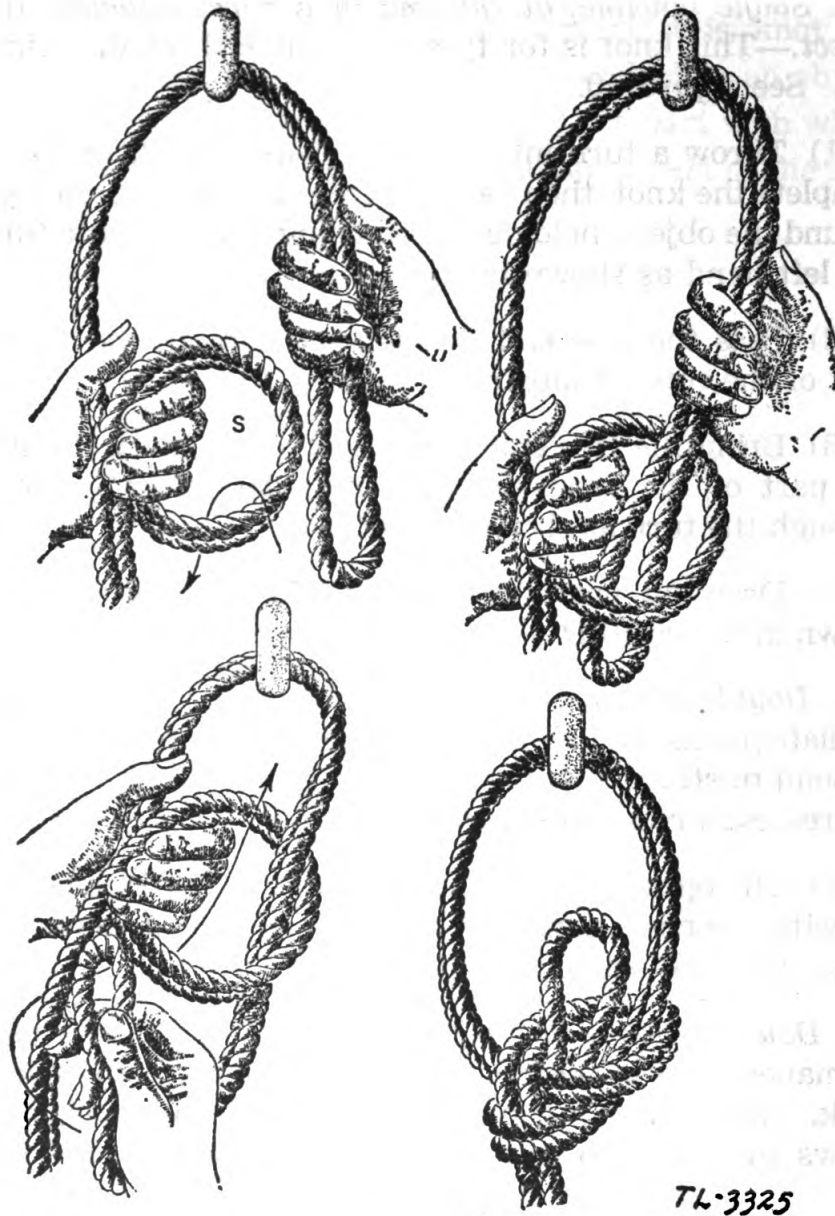

Figure 11

(4) Pull all parts down tight. The completed knot is shown in 12-D.

j. Clove hitch.—The clove hitch is used in attaching tools and materials to a hand line. It may also be used in guying gin poles, when the tension is equally divided along the guy ropes in opposite directions. This hitch will stand a stress in either direction when properly set. It is quickly made and

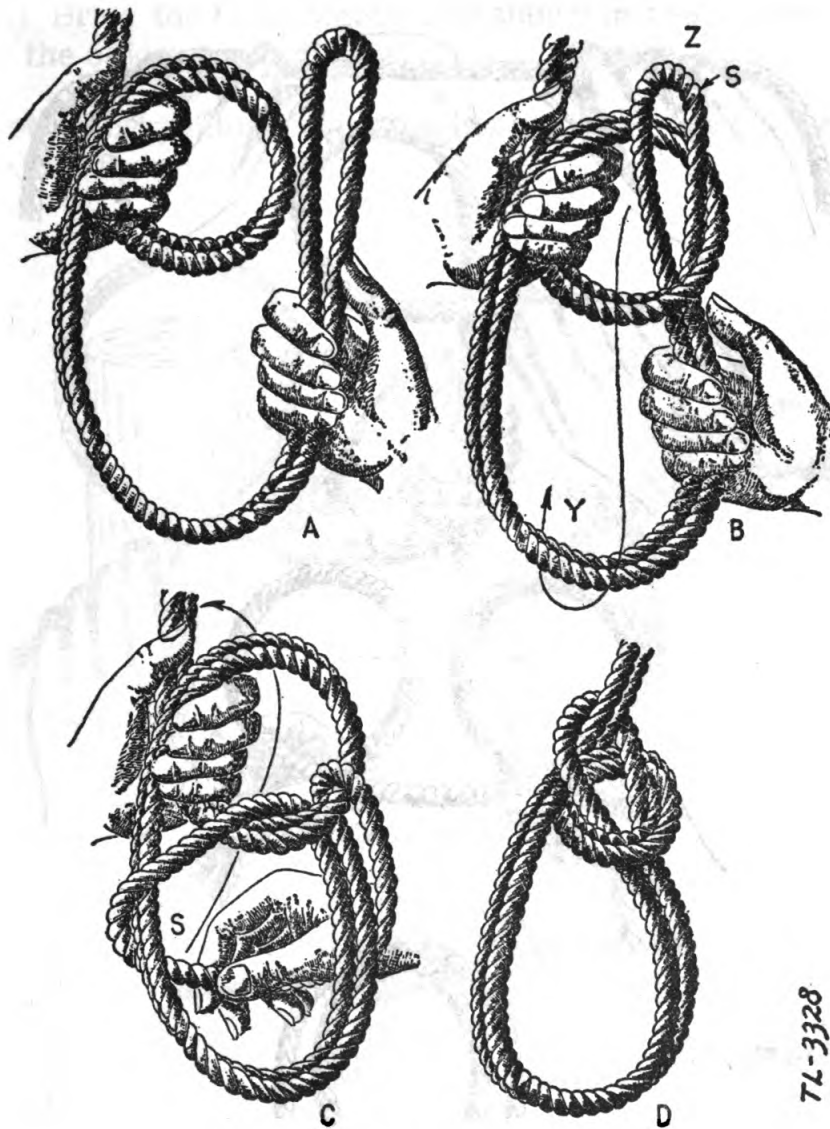

Figure 12

easily undone. The clove hitch is composed of two half-hitches made either at the end of a rope or in the middle without access to the ends. It can be made in a number of ways, three of which are explained and illustrated in figure 13, 14 and 15.

Method of making a clove hitch to pass over low objects, such as a stub pole or stakes. See figure 13.

- (1) Hold the rope as shown in 13-A.

7L-3328

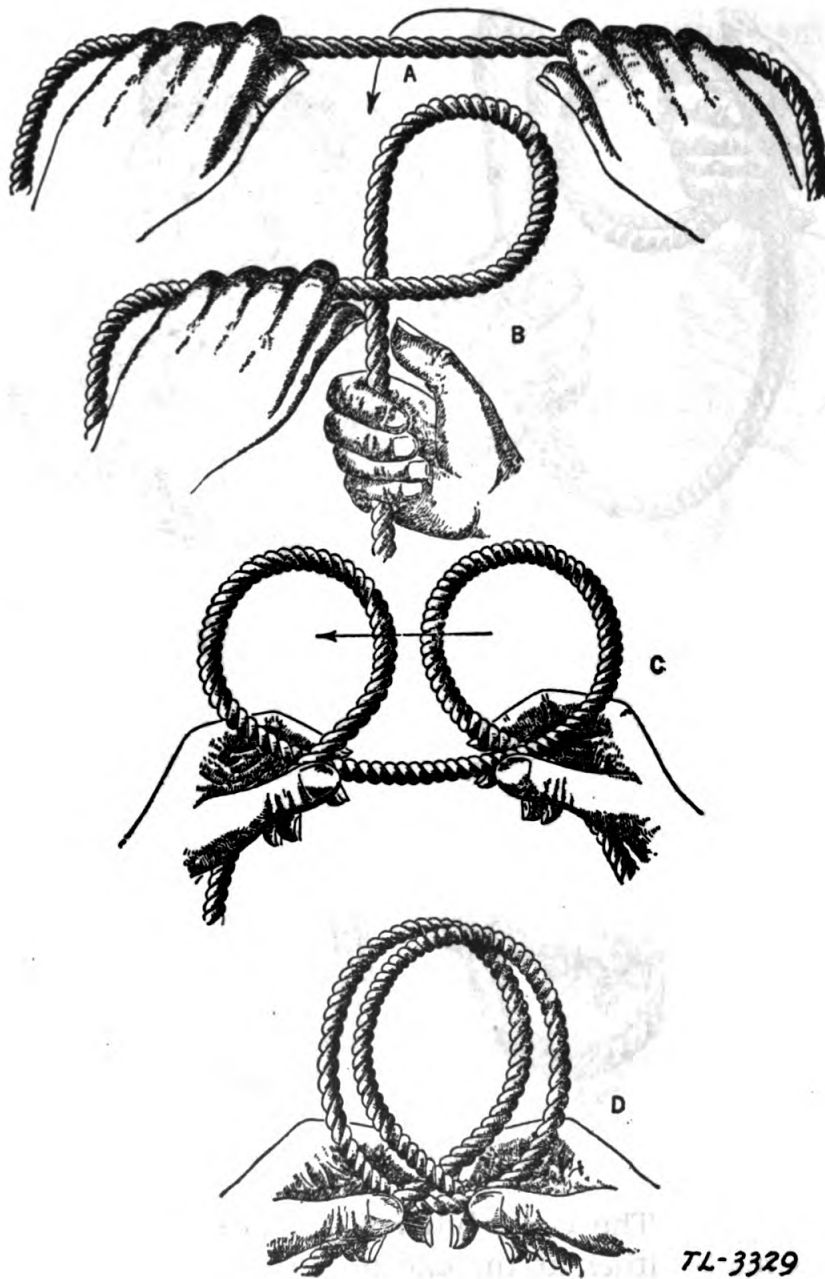
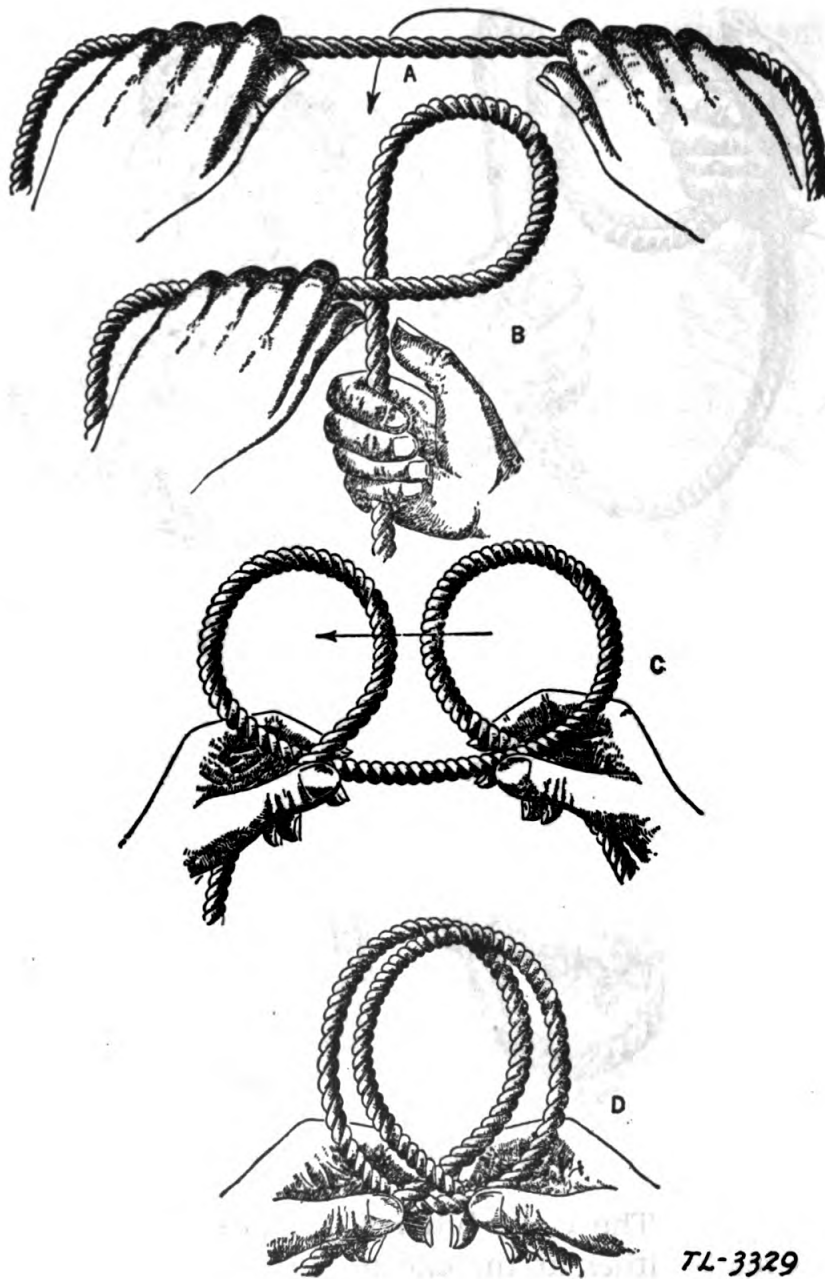

Figure 13

(2) Twist the rope held in the right hand to form a loop, shown in 13-B.

(3) Hold this loop with the left hand and throw a second loop with the right hand in the same manner, shown in 13-C.



7L-3329

Figure 13

(2) Twist the rope held in the right hand to form a loop, shown in 13-B.

(3) Hold this loop with the left hand and throw a second loop with the right hand in the same manner, shown in 13-C.

(4) Bring the loops together as shown in 13-D, then place over the object and pull taut.

Method of making a clove hitch when there is a pull on the rope. See figure 14.

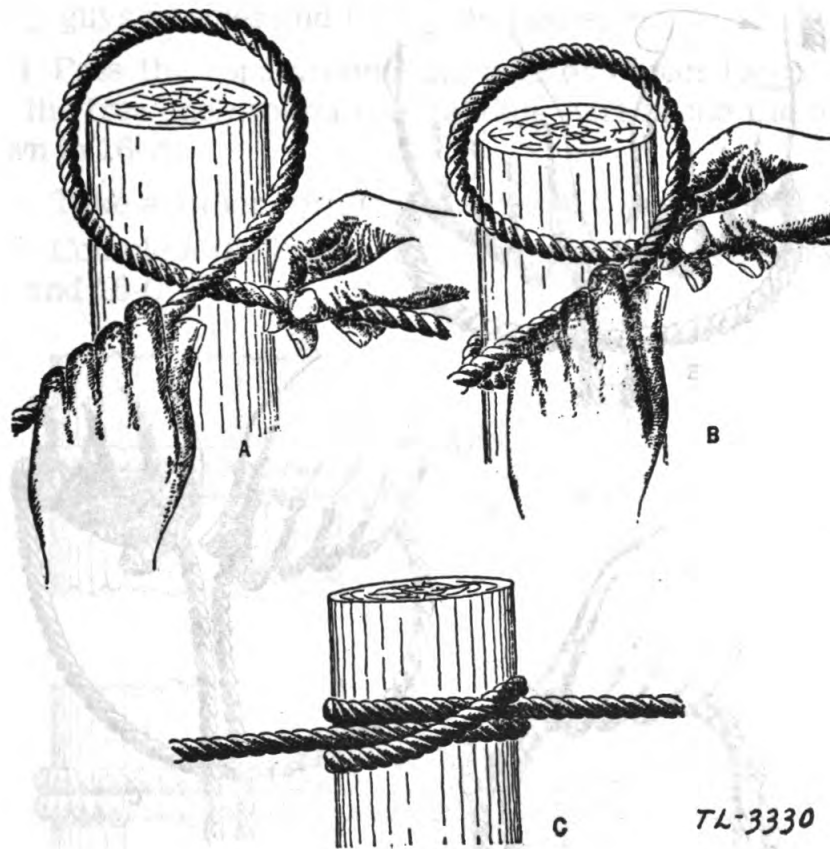
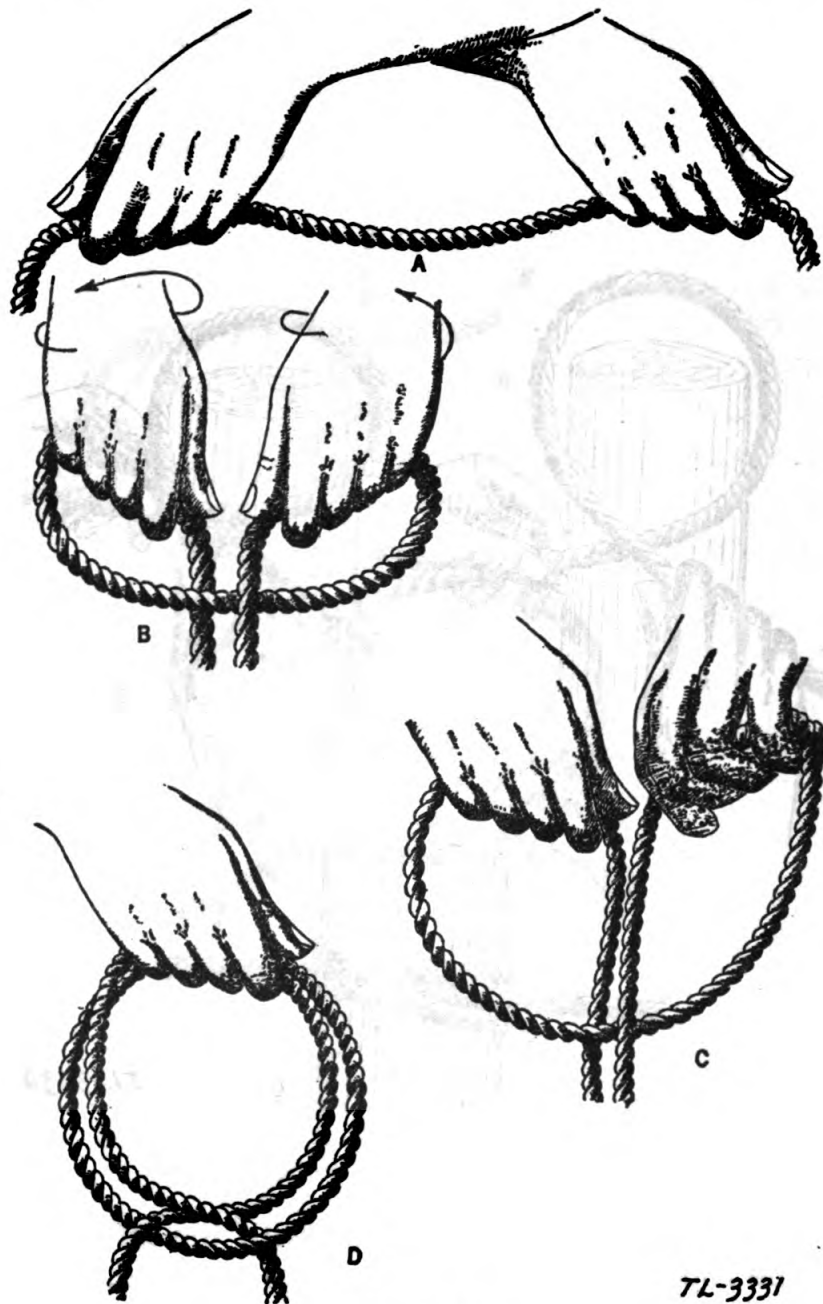

Figure 14

(1) Hold the strain on the rope with the left hand and twist the rope to the right, with the right hand, to form a loop in the rope, and then roll the loop over the top of the post. Shown in 14-A.

(2) Move the left hand up beyond the loop, hold the rope there and with the right hand form a second loop, roll it in place and pull taut.

(3) The completed knot, in place, is shown in 14-C.



7L-3331

Figure 15

The quickest method of making a clove hitch is shown in figure 15.

(1) Cross the arms in front of the body, with the left arm outside the right and pick up the rope as shown in 15-A.

(2) Without twisting the wrists, uncross the arms. Shown in 15-B.

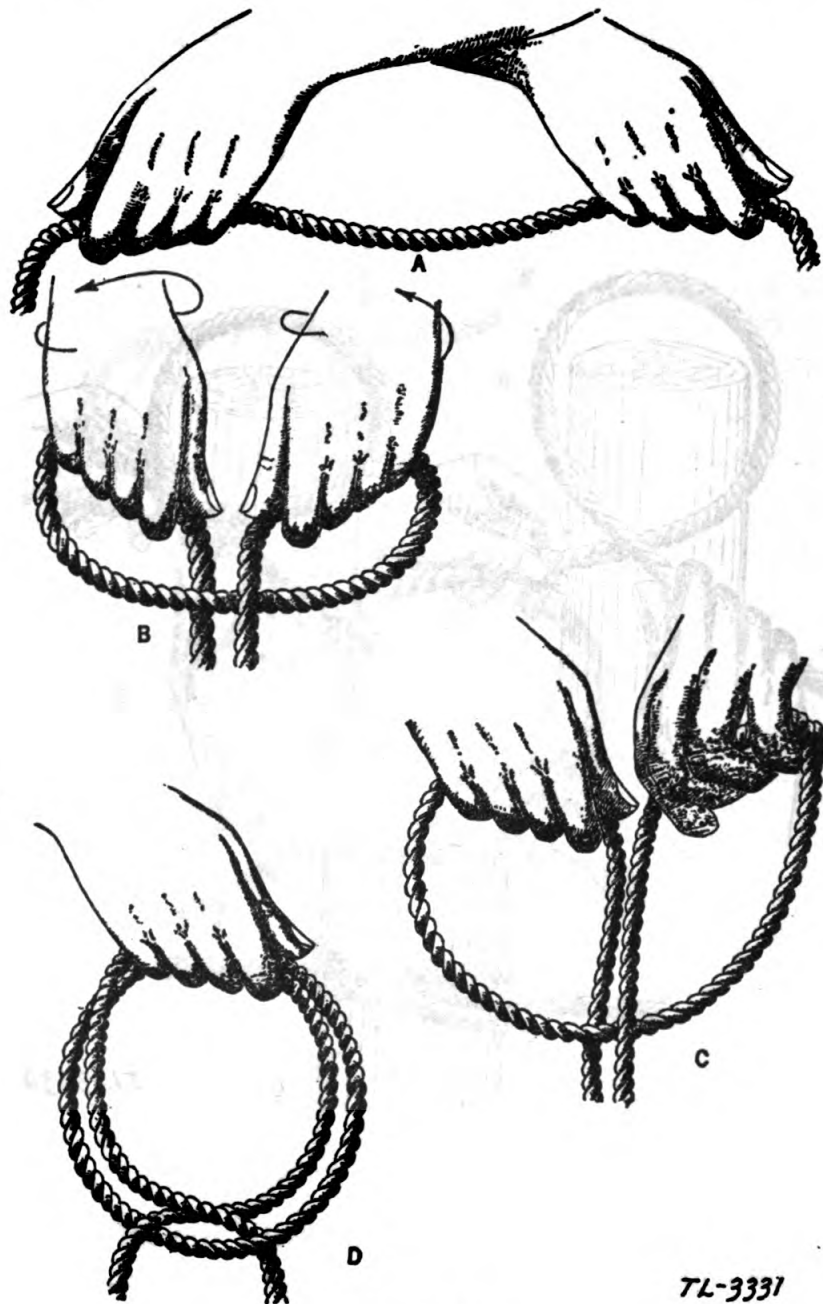

7L-3331

Figure 15

The quickest method of making a clove hitch is shown in figure 15.

(1) Cross the arms in front of the body, with the left arm outside the right and pick up the rope as shown in 15-A.

(2) Without twisting the wrists, uncross the arms. Shown in 15-B.

(3) Now rotate both hands to the right, as indicated by the arrows around the wrists, shown in 15-B, and put the knuckles of the left hand into the palm of the right hand.

(4) Slip the loop from the left hand into the right hand, and the hitch is ready to pass over the object. Shown in 15-D.

k. Snubbing hitch.—This knot is used for securing temporary guys to poles and trees. See figure 16.

(1) Pass the rope around the pole or object twice, then turn the free end around the standing part inside the bight. Shown in 16-A.

(2) Take another turn inside the bight as shown in 16-A.

(3) Complete the hitch with two half-hitches as shown in 16-B and 16-C.

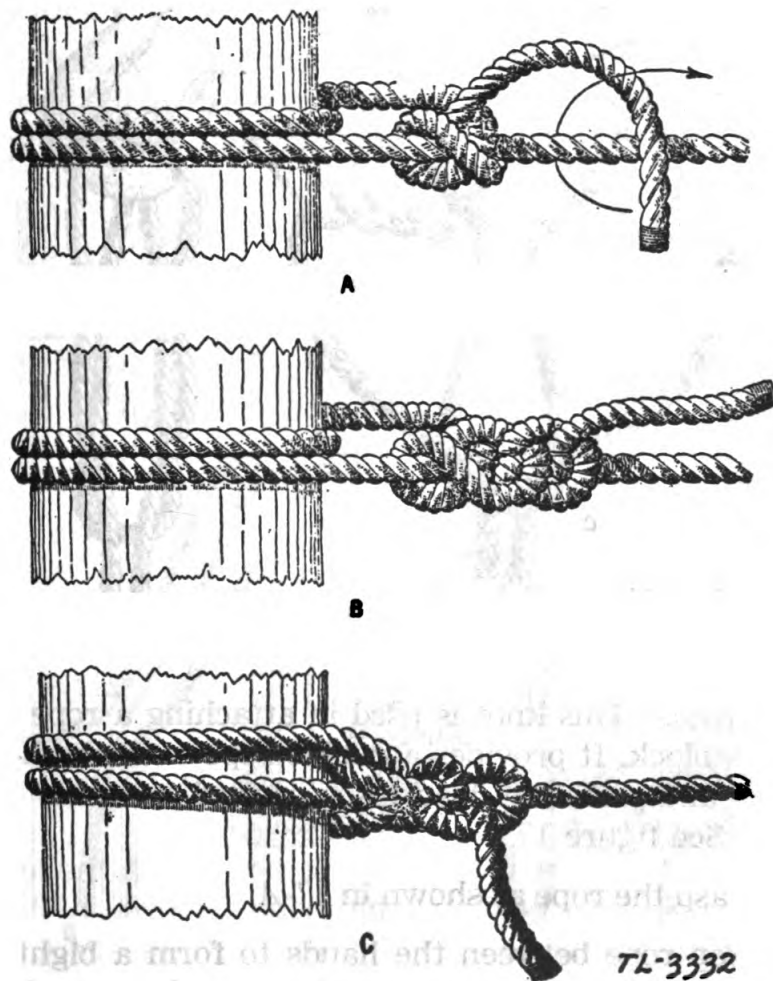
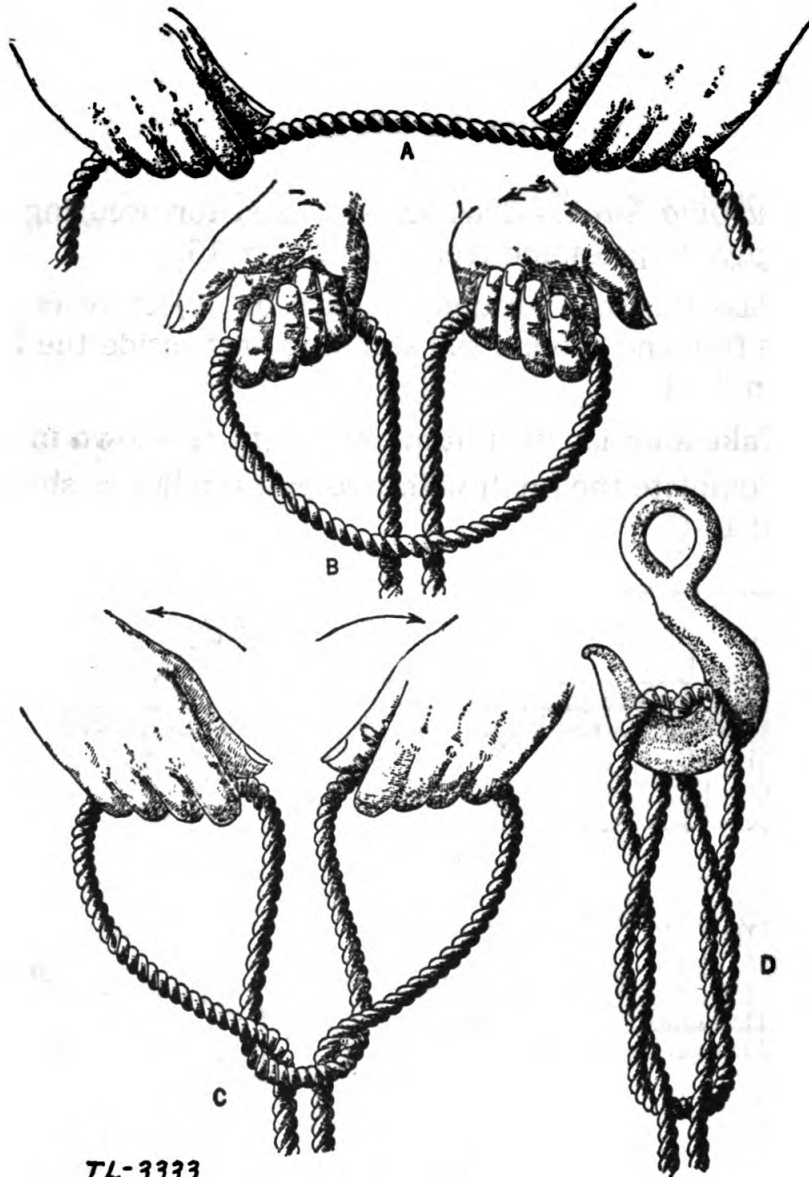

Figure 16



TL-3333

Figure 17

1. *Catspaw*.—This knot is used in attaching a rope to the hook of a block. It provides a double rope over the hook of the block and permits a load to be carried on either end of the rope. See figure 17.

(1) Grasp the rope as shown in 17-A.

(2) Drop rope between the hands to form a bight, then twist the hands, thus forming two loops as shown in 17-B.

(3) Twist each loop a half turn in the direction indicated by the arrows in 17-C.

(4) Twist each loop another half turn and hang loop on the hook. The completed hitch is shown in 17-D.

m. Platform guy knot.—This knot is used in securing the ropes, leading from the splicers platform to the pole, ladders, and other supports. See figure 18.

(1) Select the side of the platform from which the splicer is to work. Grasp loose end of guy rope from opposite side of the platform and pass it around the pole, about 3 feet from the ground and pull tight. Keep the guy rope clear of steps and avoid blocking the climbing space.

(2) Take a turn over and around the standing part of the rope with the loose end, and pull to the desired tension.

(3) Pass the rope around the pole so that it crosses the first turn. Hold the free end of the rope in this position to snub pull on the platform. Pull to the desired tension.

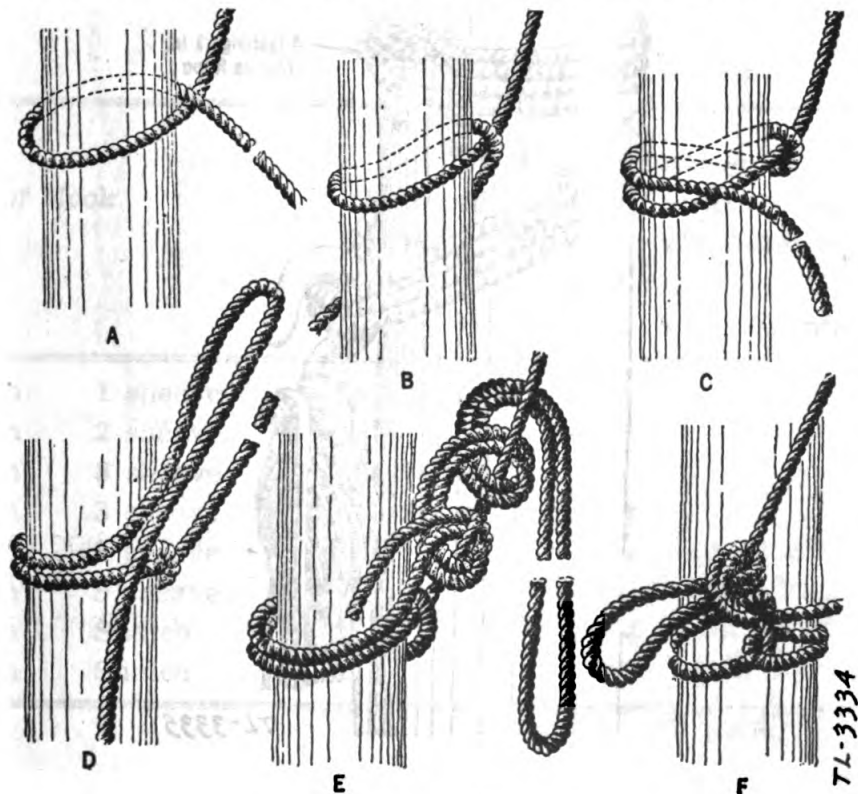

Figure 18

(4) If the free end is too long to handle, double the rope as shown in 18-D.

(5) Secure with two half-hitches on the standing rope. The completed knot is shown in 18-F.

(6) The other guy rope shall be secured on the same side of the pole, near the turns of the first guy rope. Since this guy leads from the opposite direction, it must necessarily be snubbed in the opposite direction.

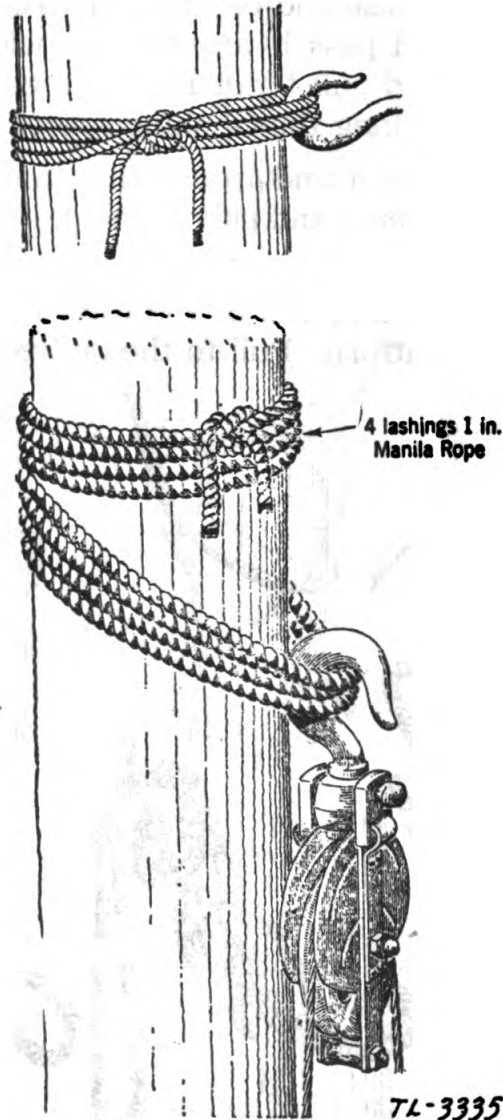

Figure 19

n. Lashing.—Lashings are used when a temporary attachment is desired. The ease of attaching and detaching and the safety factor, will determine the type of lashings that will be used in various conditions. Lashings to be used where the pull is perpendicular to the axis of the pole and where the pull is parallel to the axis of the pole are shown in figure 19.

The rope used for lashing should be of the size shown in table 2, and in good condition. Rope which has been discarded as unsafe for pulling line or for use in blocks, should not be used for lashings. When lashing a block to a pole, the number of turns around the pole shall be the same as the number of turns through the hook.

TABLE 2

<i>Size of block</i>		<i>Size of rope lashings</i>			
		<i>Required number of turns through hooks of blocks for the following sizes of rope</i>			
		$\frac{3}{8}$	$\frac{1}{2}$	$\frac{5}{8}$ or $\frac{3}{4}$	1 (inches)
3 inch	1 sheave	2			
3 inch	2 sheave	3	2		
3 inch	3 sheave	4	3		
4 inch	3 sheave		4	3	
6 inch	3 sheave			4	3
8 inch	3 sheave				4
6 inch	Snatch			4	3
8 inch	Snatch				4

465422 O - 42 - 9

Figure 20 shows the type of lashing to be used when lashing two poles together. Figure 20 also shows the lashing used in securing a ladder to a messenger. A ladder should not be moved after it has been lashed to the messenger.

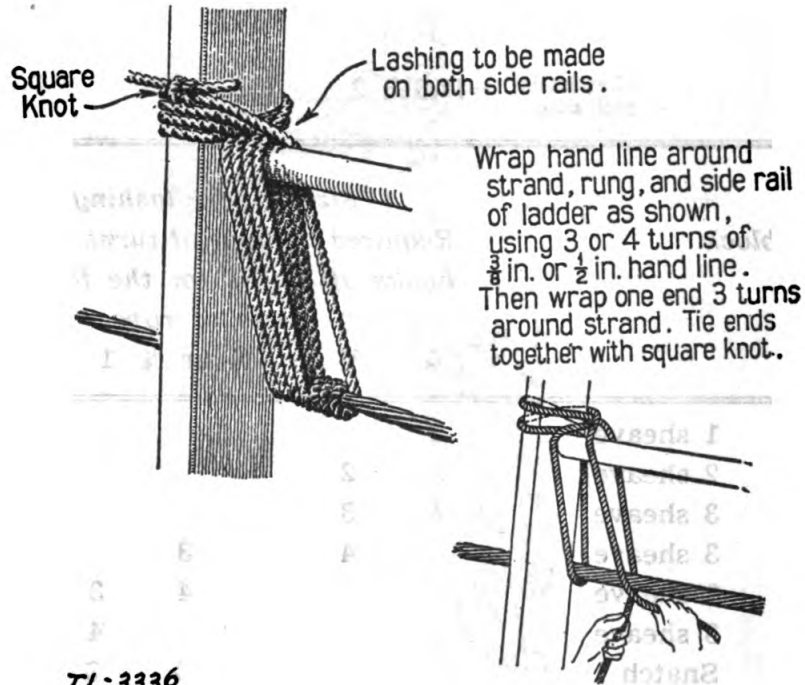
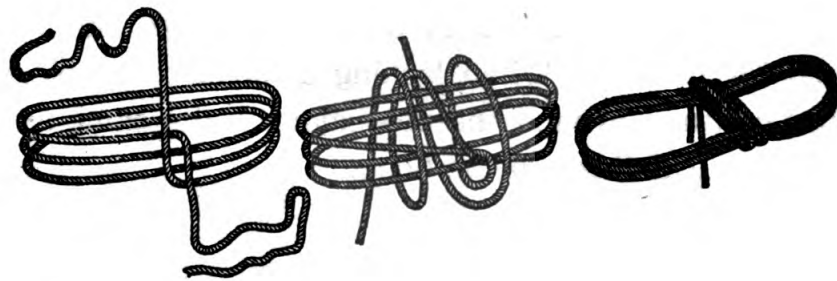

Figure 20

4. **Blocks.**—*a. General.*—The parts of a block are the shell, sheave, hook, becket, becket bolt, bushing, cotter pin, center strap, outside strap and roller bushing. See figure 21 (a).

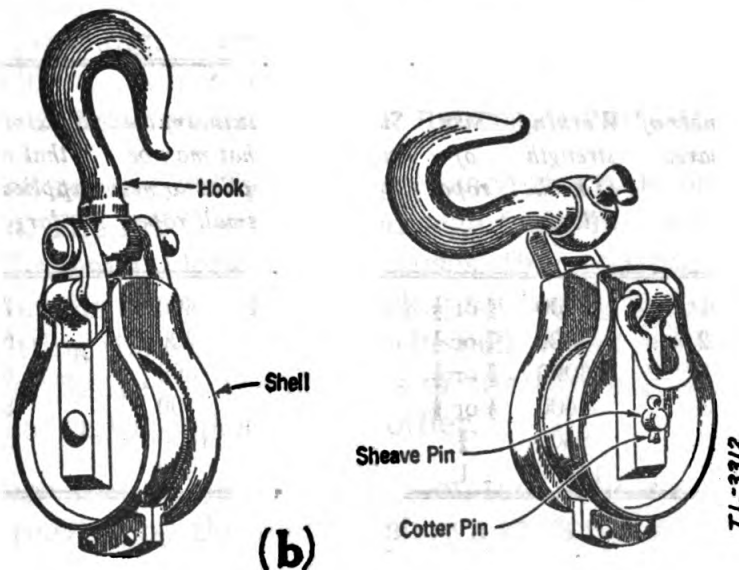
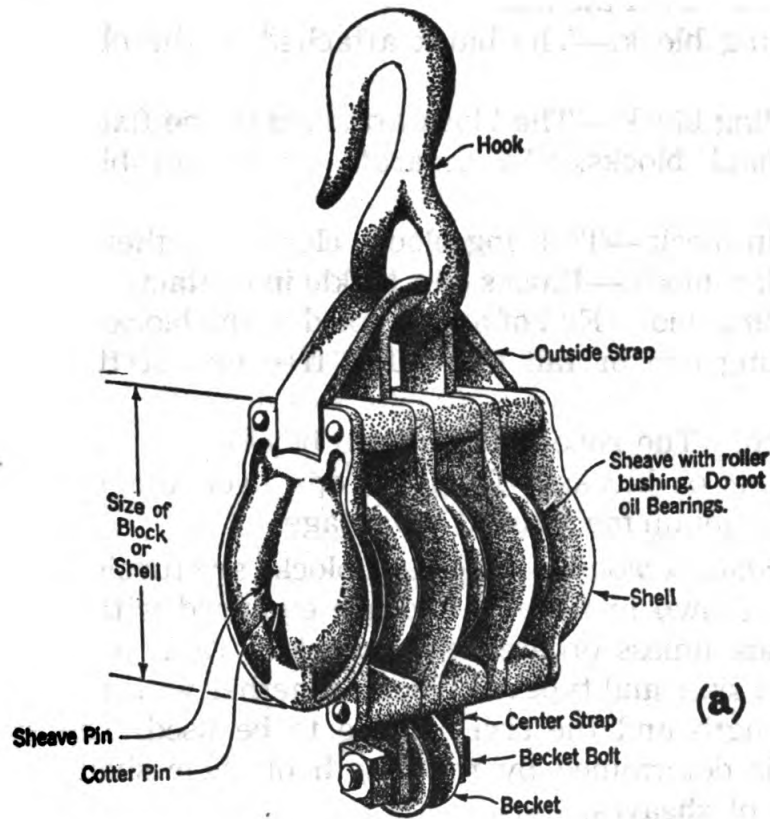

Figure 21

The terms commonly used in reference to blocks are as follows:

Tackle.—An assembly of ropes and blocks. The rope is commonly called the fall.

Running block.—The block attached to the object to be moved.

Standing block.—The block attached to the fixed support.

Overhaul blocks.—To separate or spread blocks in a tackle.

Run in block.—To bring blocks closer together.

Chock-a-block.—Blocks of a tackle in contact.

Standing end.—End of a rope fixed to the block.

Running end or fall line.—The free end of the rope in tackle.

Return.—The rope between two blocks.

Reeving of blocks.—To pass rope over the sheaves of blocks to obtain mechanical advantage.

b. Standard blocks.—Standard blocks are furnished in the sizes as shown in table 3, and are equipped with the open type hook unless ordered with shackle. Table 3 shows the standard sizes and types of blocks, together with their working strength and the size of rope to be used. The size of blocks is determined by the length of their shell and the number of sheaves.

TABLE 3

Size of blocks	Number of sheaves	Working strength of hooks (lbs.) *	Size of rope **	Suggested length (ft)	Maximum load that may be applied to new small rope	Maximum load that may be applied to new large rope
3 inch	1	2100	$\frac{3}{8}$ or $\frac{1}{2}$	50	400	700
3 inch	2	2300	$\frac{3}{8}$ or $\frac{1}{2}$	75	400	600
3 inch	3	3900	$\frac{3}{8}$ or $\frac{1}{2}$	100	400	650
4 inch	3	4600	$\frac{1}{2}$ or $\frac{5}{8}$	150	700	800
6 inch	3	8600	$\frac{3}{4}$	200	1400
8 inch	3	12000	1	275	2300

* Maximum load permitted on hooks.

** The smaller size rope shall be used, in general, where the weather conditions are humid.

The hooks of the standard and snatch blocks have been designed so that they start to open at approximately 70 percent of the maximum load they will carry, thus acting as a visible safety link to warn against overstressing, before complete failure of the block. To obtain the maximum strength, the load should be applied at the lowest point of curvature of the hook. The maximum working strength of the hooks, as given in table 3, is based on the load being applied at the lowest point of curvature of the hook. It is impracticable to give the strengths of the hooks for all conditions, as the load may not always be applied in the same manner. When blocks are in use, the hook should be under observation at all times, to determine if the hook has the required strength to withstand the applied load.

c. Manila rope snatch blocks.—Snatch blocks are furnished in two sizes: 6-inch or 8-inch. The hooks have a working strength of 11,000 pounds and 17,000 pounds respectively. This working strength is approximately 70 percent of the maximum load they will carry. The 6-inch block is intended for use with $\frac{5}{8}$ - or $\frac{3}{4}$ -inch manila rope and the 8-inch block is intended for use with 1- or $1\frac{1}{4}$ -inch manila rope. Snatch blocks are illustrated in figure 21 (b).

d. Reeving of blocks.—It is important that blocks be reeved properly to have them operate to the best advantage and avoid jamming, which would lose time and possibly cause an accident. The 2- or 3-sheave blocks shall be reeved in either of the ways as shown in figures 22 and 23.

When reeving with new rope, place the rope under slight tension. The fall line should emerge from the center sheave of a 3-sheave block. This causes the hoisting strain to come on the center of the block, preventing it from turning and cutting the rope on the block shell. When reeving by this method, figure 22, the sheaves of the two blocks should be placed at right angles to each other.

Where there is a possibility of the rope being tangled, when reeving by the method shown in figure 22, the blocks may be reeved left over right, as shown in figure 23.

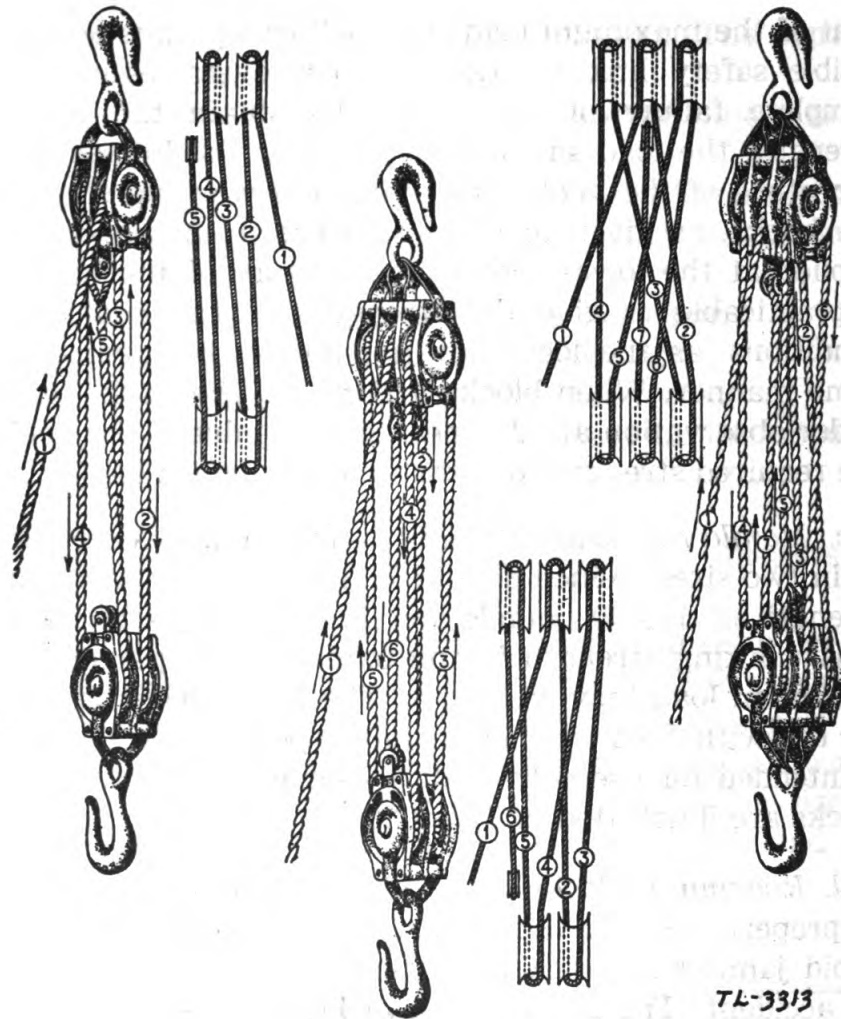

Figure 22

e. Rigging.—The type of rigging used will depend upon the weight to be handled and the available motive power. The simplest rigging, that will adequately perform the work, should be selected. Luffing tackle is a commonly used type of rigging. A simple definition of luffing tackle is; additional tackle (blocks and necessary rope), attached to the fall line of the main tackle (tackle attached to the load). Figure 24 shows luffing tackle used two different ways, lifting a load and hauling a load.

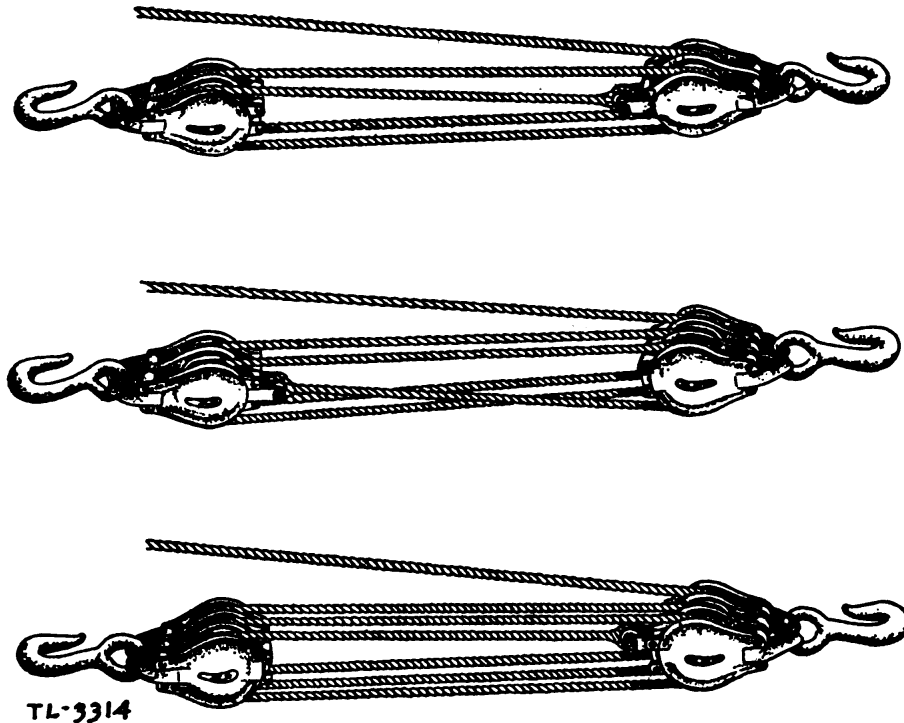
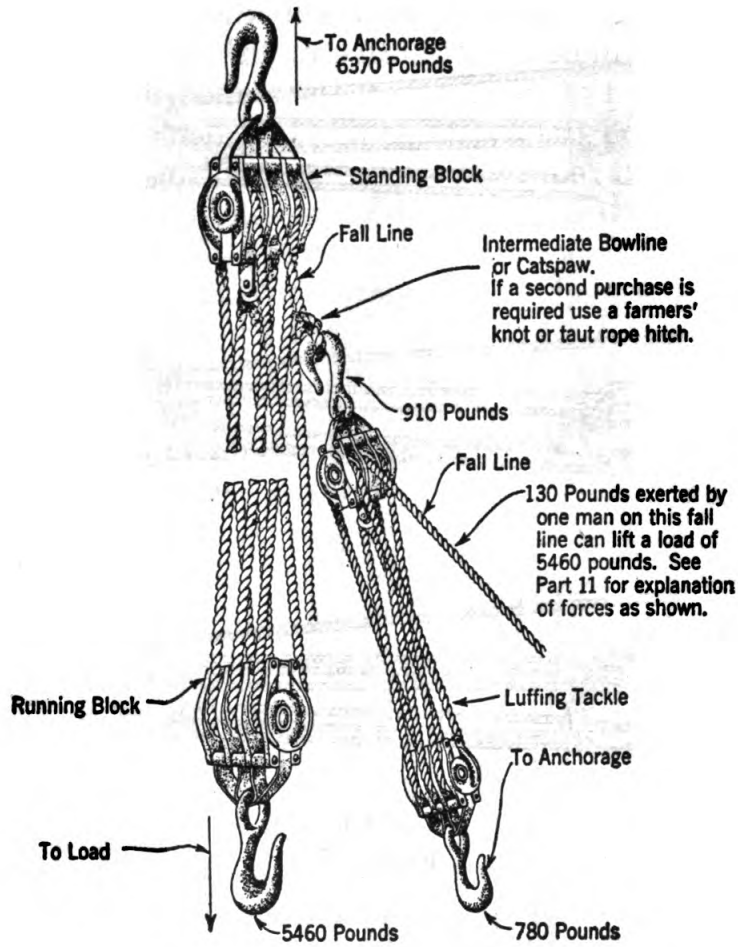

Figure 23

When the load to be handled is greater than can be handled safely by the workmen, then block and tackle shall be used to gain a mechanical advantage. For practical purposes, the weight capable of being lifted is equal to the applied force times the number of ropes leaving the movable block. For example, if a man can exert a force of 130 pounds on the fall line of a three sheave tackle, he will be able to lift 6 times 130 or 780 pounds. This assumes the fall line leaves the fixed block, as in lifting a load, figure 24. If the fall line leaves the movable block as in hauling a load, figure 24, the same man can lift 7 times 130 or 910 pounds.

LIFTING A LOAD



HAULING A LOAD

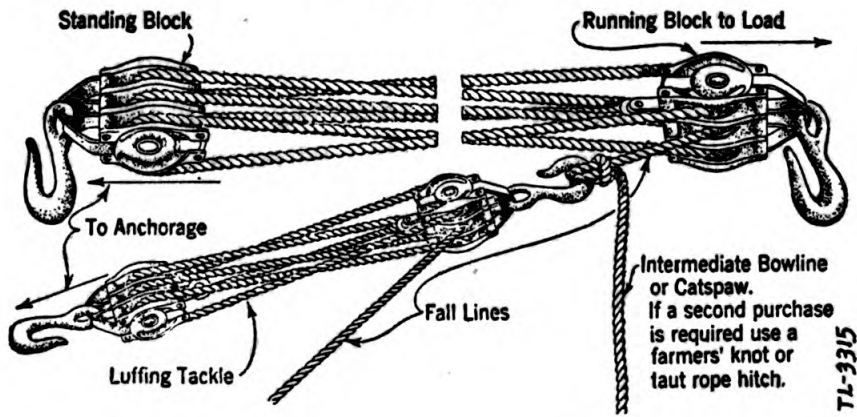

Figure 24

f. Selecting the proper size blocks for the work to be performed.—To do this it is necessary to know the approximate weight to be handled, the motive or lifting power available and the strength of the hooks of the standard blocks. Knowing the load and the available power, calculate the number of sheaves required, by dividing the load by two times the power. If this result is three or less, select one of the standard blocks with the number of sheaves as calculated and a hook strong enough to withstand the load. If this result is over three, it will be necessary to select a system of rigging from the standard blocks available. This rigging will require luffing tackle, which in general is a 3-sheave arrangement. See figure 24. When using luffing tackle, remember that for practicable purposes, the stress in the fall line of the tackle attached to the load, is equal to the force applied to the fall line of the luffing tackle, times the number of ropes leaving the movable block of the luffing tackle, which will be six or seven.

To determine the number of sheaves required in the tackle attached to the load, divide the load to be lifted by twice the applied power. Select a block with a hook capable of withstanding the load. Be sure that the load applied to the fall line of the tackle attached to the load, is not too great for the size of the rope as specified in table 1.

Example: Refer to figure 24, (lifting a load). 5460 pounds to be lifted by one man who can exert a force of 130 pounds.

To find the number of sheaves required $5460/2 \times 130$ equals 20 (approximate).

The number of sheaves required is greater than three, therefore luffing tackle is required. Three-sheave blocks will be used in the tackle attached to the load, with the fall line leaving the fixed block, which makes the man capable of lifting 6 times 130 or 780 pounds.

Number of sheaves required in luffing tackle $5460/2 \times 780$ equals 2 plus. (use 3)

Using 3-sheave blocks in the luffing tackle, the fall line leaving the moving block, the man can lift 7 times 130 or 910 pounds.

With a 910 pound pull exerted on the fall line of the main tackle (by use of the luffing tackle), the man will be able to lift 6 times 910 or 5460 pounds.

When the approximate weight and motive power is known, the proper size blocks can be selected from table 3, in most cases.

5. Safety precautions.—Safety to life and property requires that rope and blocks be well cared for. A few precautions, in addition to those previously listed in the text are given below:

(1) A hook that has begun to straighten shall be discarded immediately.

(2) Do not use blocks with sheave holes too small to give clearance, between the sheaves and the sides and top of the shell.

(3) When moving from one location to another, do not drag rope on the ground.

(4) Do not stand unnecessarily close to, and never straddle rope under tension.

(5) Do not stand in the inside angle, or in the path of rope being paid out or under tension.

(6) Do not use frozen rope.

(7) The hand line shall not be attached to the belt, when working on poles. Make it fast to the crossarm or to the pole.

(8) Hand line or other rope secured aloft, when not in use, shall be secured at a point near the ground to prevent it from being blown about.

(9) Rope shall be placed as to create no obstruction on highways or thoroughfares, unless unavoidable; in that case, place a man to warn traffic.

(10) Gloves should be worn when handling new rope to avoid the possibility of injury from fibre slivers.

Review questions.—

1. Name the various parts of a block.
2. How are the sizes of blocks determined?
3. What is the weakest part of the block?
4. In what way does a snatch block differ from other blocks?
5. What is the process of threading rope through blocks called?
6. What is the fall end of rope?
7. What is the term applied to a set of blocks, attached to the fall line of the main tackle?
8. What should blocks be inspected for, to determine their condition?
9. How and where should rope be stored?
10. How should new rope be removed from the original coil?
11. What should be done to rope before it is cut?
12. What is the purpose of a serving and a crown splice?
13. What two advantages does the long straight splice have over the short straight splice?
14. What is the eye splice used for?
15. What are the two great advantages of the bowline?
16. What is the block becket bend used for?
17. What is the snubbing hitch used for?
18. What knot is used for securing the guy ropes of cable splicers platforms?
19. What are lashings?
20. Should the bearings be oiled on a sheave equipped with roller bushings?

LESSON 8

LABORATORY

Tools and materials.—

1 ea. Knife TL-19

*Rope for reeving, knot tying, splicing.

*Friction tape, lacing twine.

Items marked * are not placed on the memorandum receipt.

Do not cut the reeving nor the knot tying ropes.

Blocks for reeving will be found in the class room.

Operation 1.—Inspect the blocks selected and list the faults below.

.....Ins. check

Operation 2.—Reeve the two 3-sheave blocks as shown in figure 22.

.....Ins. check

Operation 3.—Reeve the 3-sheave and the 2-sheave block as shown in figure 22.

.....Ins. check

Operation 4.—Reeve the two 2-sheave blocks as shown in figure 22.

.....Ins. check

Operation 5.—Using short pieces of rope make the following: a serving splice, a crown splice, an eye splice and a short straight splice. Submit to the instructor.

.....Ins. check

Operation 6.—Practice tying the following knots: the figure 8 knot, the square knot, single bowline, intermediate bowline, double bowline, bowline on a bight, block becket bend, clove hitch, snubbing hitch, catspaw, and platform guy knot. These knots should be learned well enough so that the student can tie any of them from memory when called upon to do so by the instructor.

.....Ins. check

[A. G. 062.11 (8-11-42).]

BY ORDER OF THE SECRETARY OF WAR:

G. C. MARSHALL,

Chief of Staff.

OFFICIAL:

J. A. ULIO,

Major General,

The Adjutant General.

DISTRIBUTION:

C and H 11 (2).

(For explanation of distribution symbols see FM21-6.)

U. S. GOVERNMENT PRINTING OFFICE: 1942

the stitch is made, it is called a half-hitch. When the lacing is completed, the twine is anchored by placing two or three stitches behind the last stitch of the form. See figure 9.

Figure 10. Rescinded.

* * * * *

[A. G. 300.7 (14 Jan 44).] (C 1, 20 Mar 44.)

Review questions (Added).—

1. Should bus wire be insulated if it is likely to come in contact with other wires in a radio set?
2. How long is the bent-over part of the butt joint?
3. What is done to a stranded wire before a satisfactory loop can be made?
4. When is cable wiring used?
5. Will cordage shielding in any case be found on the outside of the rubber jacket?
6. What is the proper tool to use in removing the rubber jacket from a cord?
7. What trouble may develop if all the strands of a conductor are not soldered into place?
8. Should the cutting blade of a knife be used to clean wire?

[A. G. 300.7 (14 Jan 44).] (C 1, 20 Mar 44.)

LESSON 5A

LABORATORY

(For Radio Students Only)

Tools and materials for operations 1 to 6 inclusive.—

* 1 ea. Blow torch * 4 pcs. Wire, copper, 104
 * * * * *

Items marked * are not placed on memorandum receipt,

[A. G. 300.7 (14 Jan 44).] (C 1, 20 Mar 44.)

Procedure.—

* * * * *

Operation 3.—Clean and tin one end of each of the four pieces of 104 copper wire. The tinned portion * * * will be secured.

----- Ins. check

* * * * *

[A. G. 300.7 (14 Jan 44).] (C 1, 20 Mar 44.)