

TM11-2754

DEPARTMENT OF THE ARMY TECHNICAL MANUAL

GEDEGISTREERD
12 JUL 1951
R. & V. - HKGS

T7-538

INSTALLATION OF RADIO AND INTERPHONE EQUIPMENT IN TANK, LIGHT, M24

This information is furnished with the understanding that it will not be released to another nation without specific approval of the United States of America, Department of the Army, Navy, that it will not be used for other than military purposes; that individual or corporation rights originating in the information, whether patented or not will be respected; and that the information will be afforded substantially the same degree of security as afforded by the United States of America, Department of the Navy, Army, or Air Force.

DEPARTMENT OF THE ARMY • FEBRUARY 1950

This manual supersedes TM 11-2754, 19 February 1945

**INSTALLATION
OF RADIO AND
INTERPHONE
EQUIPMENT
IN TANK, LIGHT, M24**



DEPARTMENT OF THE ARMY

FEBRUARY 1950

United States Government Printing Office

Washington: 1950

DEPARTMENT OF THE ARMY
WASHINGTON 25, D. C., 6 February 1950

TM 11-2754 is published for the information and guidance of all concerned.

[AG 300.7 (7 Nov 49)]

BY ORDER OF THE SECRETARY OF THE ARMY:

OFFICIAL:

J. LAWTON COLLINS
Chief of Staff, United States Army

EDWARD F. WITSELL
Major General, USA
The Adjutant General

DISTRIBUTION:

Tech Sv (2) except 11 (50); Arm & Sv Bd (1); AFF Bd (ea Sv Test Sec) (1); AFF (5); OS Maj Comd (5); Base Comd (3); MDW (5); A (5); CHQ (2); FC (2); Sch (2) except 11 (10); Gen Dep (2); Dep 11 (5); Tng Div (2); PE (10), OSD (2); Lab 11 (2); 4th & 5th Ech Maint Shops 11 (2); Two (2) copies to each of the following T/O&E's: 2-26; 2-27; 2-28; 3-157; 5-16; 5-216; 5-217; 6-12; 6-160-1; 6-166; 6-167; 6-169; 6-196; 6-197; 7-12; 7-14; 7-19; 7-26; 7-27; 9-37; 11-7; 11-47; 11-57; 11-107; 11-127; 11-587; 11-592; 11-597; 17-2; 17-17; 17-20-1; 17-26; 17-27; 17-36; 17-37; 17-46; 17-52; 17-53; 17-56; 17-57; 17-58; 17-60-1; 17-116; 17-117; 17-126; 17-127; 19-27; 44-76; 44-77; SPECIAL DISTRIBUTION.

For explanation of distribution formula, see SR 310-90-1.

CONTENTS

SECTION		Paragraph	Page
I.	INTRODUCTION.		
	Purpose	1	1
	Symbols and references	2	1
	Waterproofing requirements	3	1
II.	IGNITION NOISE SUPPRESSION IN TANK, LIGHT, M24.		
	General	4	2
	Procedure	5	2
III.	RADIO SET SCR-506-A.		
	Nomenclature and reference.....	6	4
	Required parts	7	4
	Precautions	8	5
	Assembly and installation.....	9	5
	Operation check	10	14
IV.	RADIO SET SCR-508-() OR SCR-528-() AND ASSOCIATED INTERPHONE EQUIPMENT.		
	Nomenclature and reference.....	11	15
	Required parts	12	15
	Precautions	13	16
	Assembly and installation	14	16
	Operation check	15	29
V.	INTERPHONE EXTENSION KIT RC-298.		
	Nomenclature and reference	16	31
	Required parts	17	31
	Precautions	18	31
	Assembly and installation	19	32
	Operation check	20	34
VI.	RADIO SET AN/VRC-3 AND ASSOCIATED INTERPHONE EQUIPMENT.		
	General	21	35
	Nomenclature and reference.....	22	35
	Required parts	23	35
	Precautions	24	37
	Assembly and installation.....	25	37
	Operation check	26	45
VII.	DEMOLITION TO PREVENT ENEMY USE.		
	General	27	47
	Methods of destruction.....	28	47
	Destruction of components.....	29	47

SECTION I

INTRODUCTION

1. Purpose

This manual provides methods and procedures, based upon actual field experience, for the installation of radio and interphone equipment in Tank, Light, M24. For further information on Tank, Light, M24, see TM 9-729.

2. Symbols and References

a. NOMENCLATURE SYMBOLS. Whenever nomenclature symbols are used in this manual, an explanation of the symbols is given in the first paragraph of the section covering the items of the equipment. (For a complete listing of nomenclature symbols, see TB SIG 103.)

b. DEPARTMENT OF THE ARMY PUBLICATIONS. A list of pertinent Department of the Army publications is given in the first paragraph of the section covering an item of equipment.

3. Waterproofing Requirements

If used in amphibious operations or in open vehicles, Interphone Control Boxes BC-606-A through -G, Control Box BC-739, and Switchboxes BC-658-A and -B must be waterproofed. Waterproofing materials are listed below and may be requisitioned through regular channels in accordance with existing regulations.

Name and description	Quantity	Signal Corps stock No.
Tape, moistureproof: 2 inches wide, 60-yard roll.	1 yd.....	6N8525-5
Seal, waterproof: 6 fluid ounces.	1 can.....	6G275.2
Lacquer: fungus-resistant.....	8 oz.....	6G1005.3

a. PROCEDURE.

- (1) Remove the cover from the box.
- (2) If there is water or moisture in the box, wipe the box with a dry cloth. Complete the drying process with any available heat source, such as an infrared lamp or hot-air blower.
- (3) Mask the jack contacts with masking tape.
- (4) Spray lacquer over all interior surfaces of the box, including switches and wires. If a spray gun is not available, use a brush to apply the protective coating evenly to all parts.
- (5) Remove the masking tape.
- (6) Fill all unused mounting holes with sealing compound.
- (7) Seal all cable entrance holes by applying sealing compound around each cable at the point of entry.
- (8) Apply sealing compound around the lever (at the bushing) of each switch.
- (9) Remove the volume control knobs and apply sealing compound around the shaft and bushing of each control. Replace the knobs.
- (10) Cover the openings of unused jacks with moistureproof tape and cover the tape with sealing compound.

b. RETREATMENT. When a waterproofed box is opened for maintenance or repair, reapply the waterproofing procedure given in *a* above.

SECTION II

IGNITION NOISE SUPPRESSION IN TANK, LIGHT, M24

4. General

Excessive ignition or other electrical noises will interfere with the operation of radio equipment in Tank, Light, M24. Refer to TM 9-738 for information on the noise suppression system in the vehicle. For additional information on the suppression of noise in vehicles, refer to TM 11-483. Also refer to the technical manuals for the radio sets.

5. Procedure

a. TESTING FOR SOURCE OF NOISE. To determine the source of electrical noises in the vehicles, proceed as follows:

- (1) As a source of test signals, use a radio of the same type as that in the vehicle.
- (2) Operate the test set at a distance from the vehicle, so that the signals received at the vehicle are as weak as possible without loss of distinctness.
- (3) Use headphones for reception. Set the gain control of the vehicle radio receiver to maximum.

- (4) Start the vehicle motor and run it at about 1,500 to 1,800 rpm (revolutions per minute).

Caution: Do not race the motor. Excessive racing damages the motor.

- (5) At each of the frequencies used for communication, check the reception of weak signals from the test radio set.
- (6) With the vehicle radio receiver tuned to the frequency at which the noise level is highest, turn off the ignition switch. Noise caused by the ignition system disappears when the motor is turned off; noise caused by the voltage regulator or the battery-charging generator continues until the motor stops.
- (7) Repeat step (6) above at each of the frequencies used for communication.
- (8) Auxiliary equipment, such as gages (oil, fuel, and temperature), fans, and motors should be turned on and off (or disconnected) individually to locate the noise caused by them. The table below will be

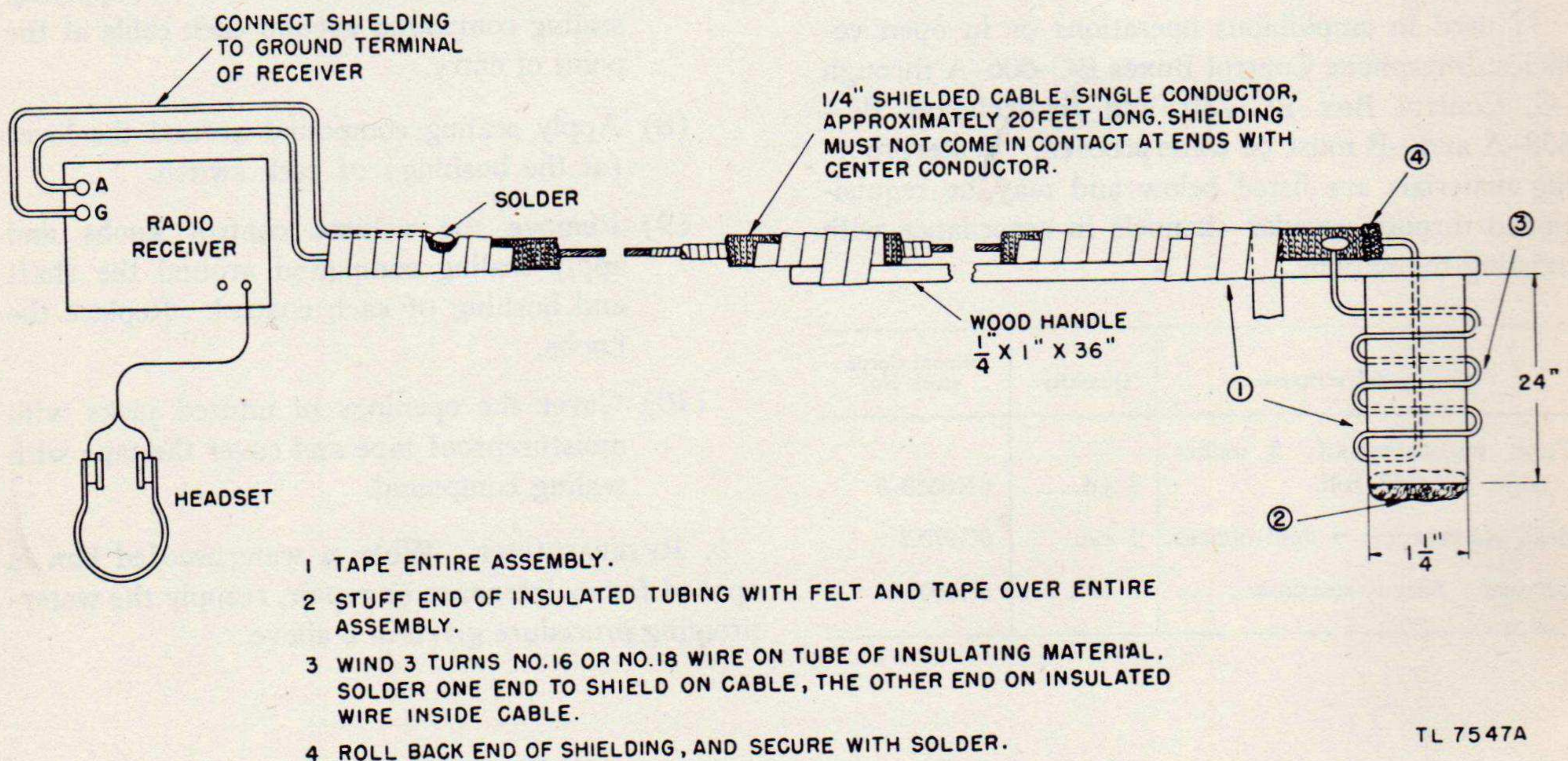

TL 7547A

Figure 1. Probe antenna.

helpful in distinguishing noises from static, etc.

Interference	Usual source
Popping: regular clicks corresponding to ignition firing; stops when motor is turned off; accelerates when motor speed is increased.	Ignition system.
Intermittent clicks: continues several seconds after the ignition system is turned off.	Generator regulator.
Whine: varies with speed of motor; ceases when motor comes to a complete stop.	Generator.

(9) A probe antenna (fig. 1) will aid in locating sources of noise interference. Connect the probe antenna to the antenna and ground terminals of the vehicle radio receiver. Place the test radio set so that signals are received on the installed radio set. The

signal from the test set is needed to actuate the limiter in the radio set installed in the vehicle. Slowly move the probe antenna close to, *but not in contact with*, the various parts of the vehicle electrical system. Noise from interference-producing parts will be heard in the receiver headphones.

b. NOISE ELIMINATION. Usually, the interference can be eliminated by cleaning, tightening, or replacing the noise suppressing parts.

- (1) Examine and tighten all suppressor and shielding components.
- (2) Clean and tighten all connections and grounding bonds. Thoroughly clean the contact surfaces between wires and terminals and between metal casings and the frame of the vehicle. Ungrounded metal parts reflect and reradiate noise signal energy picked up from other components.
- (3) If noise interference persists, check the noise suppressor components by substituting new components.

SECTION III

RADIO SET SCR-506-A

6. Nomenclature and Reference

a. NOMENCLATURE.

- (1) Official nomenclature followed by () is used to indicate all models of the item of equipment.
- (2) Official nomenclature followed by (*) is used to indicate certain models of the item of equipment included in this section. Thus, Switchbox BC-658-(*) represents Switchbox BC-658-A or -B.

b. REFERENCE.

TM 11-630, Radio Set SCR-506-A.

7. Required Parts

For installation in Tank, Light, M24, Radio Set SCR-506-A (Sig C stock No. 2S506-V85) consists of a basic unit (Sig C stock No. 2S506/24) and an installation unit (Sig C stock No. 2S506-V85/50).

a. BASIC UNIT, SIGNAL CORPS STOCK NO. 2S506/24.

Quantity	Signal Corps stock No.	Item
1	2A275-27	Antenna A-27, Phantom.
1	2A224	Antenna A-24-A (auxiliary antenna).
1	2Z1250.82	Bracket (fig. 3) for Loudspeaker LS-3.
1	2Z2599-263	Chest CH-263, for spare parts.
2	6Z3147	Connector No. 61007 and Bondnut BL-50.
1	3E1314	Cord CD-314, for Loudspeaker LS-3.
1	3H1641	Dynamotor DM-41-().
1	3H1643	Dynamotor DM-43-().
1	Guy set, consisting of the following:
1	2Z525	Bag BG-125.
1	2A1312	Guy GY-12.
1	2A1336-46	Guy GY-42.
1	2A3129	Reel RL-29.

Quantity	Signal Corps stock No.	Item
4	2A3327	Stake GP-27.
3	3G586	Insulator IN-86, two for auxiliary antenna, one for tying down mast sections.
2	3Z3445	Key J-45.
1	2Z6303.1	Loudspeaker LS-3.
1	2A2088-65	Mast Base MP-65.
9	2A2416	Mast Section MS-116-A, six with guy set for stationary operation, three for mobile operation.
2	2A2417	Mast Section MS-117-A.
2	2A2418	Mast Section MS-118-A.
1	2S193/1	Modification kit for Loudspeaker LS-3; includes Cover CW-41/U and bracket.
1	2Z6721-253	Mounting FT-253-A; includes two Cords CO-280 attached, spacer plates, spare fuses, and hardware in bag.
1	2C4452	Radio Receiver BC-652-A, including necessary tubes and Crystal Unit DC-24, installed, spare fuses, and lamps.
1	2C6530-653	Radio Transmitter BC-653-A; includes one set of spare tubes, spare fuses, and lamps.
1	2Z8056	Roll BG-56-A.
50 ft	6Z7926	Rope RP-5, for auxiliary antenna and tying down mast sections.
2	Technical manual, TM 11-630.
15 ft	1B146	Wire W-146, for antenna lead-in.

Note. When the basic unit contains Mast Sections MS-49 through MS-53 with Mast Base MP-57, one Guy Set GY-40 shall be issued in place of the following five items: 1 Guy GY-42, 1 Guy GY-12, 4 Stakes GP-27, 1 Bag BG-125, and 1 Reel RL-29.

b. INSTALLATION UNIT, SIGNAL CORPS STOCK
No. 2S506-V85/50.

Quantity	Signal Corps stock No.	Item
1 ²	4B417-4	Chest Set TD-4.
1	6L50-506V85	Hardware bag, containing the following items:
3	Screw, cap, hex head, 5/16"-24 x 3/4".
15	Screw, cap, hex head, 1/4"-20 x 3/4".
6	Screw, machine, round head, #8-32 x 3/8".
28	Washer, shakeproof, 1/4" IET (internal-external toothed).
4	2Z2637-7	Clamp, No. 7 (per SC-A-8637).
3	2Z2637-8	Clamp, No. 8 (per SC-A-8637).
3	2Z2637-9	Clamp, No. 9 (per SC-A-8637).
2	6L54016	Washer, rubber (per SC-A-7146).
4	Screw, machine, round head, #8-32 x 5/8".
4	Screw, machine, round head, #6-32 x 1/2".
4	Screw, cap, hex head, steel, electro-galvanized, 1/4"-20 x 3/8".
3	Lockwasher, steel, electrogalvanized, SAE std for 5/16" screw.
2 ²	2B800-16	Headset, H-16/U.
2	3G601	Insulator IN-101.
3	3G604	Insulator IN-104.
1	2Z7090.36	Mounting plate (per SC-A-8550).
1	2B1617	Microphone T-17.
2	2B250-110	Microphone Cover CW-110/U.
1	2B1645	Microphone T-45.
3 ¹	2C7978	Switchbox BC-658-C.

¹ When Chest Set TD-4 is not available, use one Cord CD-307-A (Sig C stock No. 3E1307-5.5) and one Cord CD-318-B (Sig C stock No. 3E1318) in place of each chest set.

² When Headset H-16/U is not available, use two Headsets HS-30-(*) (Sig C stock No. 2B830) and two Cords CD-604 (Sig C stock No. 3E1604).

³ Switchbox BC-658-C includes Mounting FT-507 and conduit connector. When Switchbox BC-658-C is not available, use Switchbox BC-658-A or -B, without conduit connector and Mounting FT-507.

c. ITEMS SUPPLIED BY ORDNANCE DEPARTMENT.

Quantity	Signal Corps stock No.	Item
1	None	Frame per Ord dwg No. D-76445.
1	None	Bracket per Ord dwg No. D-67439.

8. Precautions

a. ELECTRICAL SYSTEMS. Tank, Light, M24, is equipped with a 24-volt electrical system. Before installing any electrical equipment, make certain that the equipment is designed and/or properly adjusted for operation on a 24-volt supply. Radio sets, interphone equipment, and power supply units may be damaged by operation on incorrect power sources.

b. HOLES AND BRACKETS. Brackets for these radio sets are installed prior to delivery of the vehicle. Instructions for any other holes and brackets are given in this section. Do not relocate any holes or brackets *unless absolutely necessary*.

9. Assembly and Installation

Install the components of Radio Set SCR-506-A in Tank, Light, M24, as shown in figure 2 and as directed below.

a. PHANTOM ANTENNA MOUNTING PLATE AND BRACKET.

- (1) Weld the mounting plate (fig. 22) on the right wall of the hull, 9 inches above the floor, as shown in figure 2 (item 39).
- (2) Attach bracket (item 26) (fig. 2) to the mounting plate (item 39), using the 1/4 inch 20 by 3/8-inch screws and 1/4-inch lockwashers provided (hardware bag).
- (3) Place the phantom Antenna A-27 (item 16) in the bracket (item 26) and secure by tightening the wingnuts on the bracket.

b. LOUDSPEAKER MOUNTING BRACKET.

- (1) Remove the smoke bomb rack from the torsion bar housing at rear of codriver's seat.
- (2) Heat and bend the handle 90° as shown in figure 2, view B-B.
- (3) Drill two holes in the torsion bar housing and tap the holes for 5/16 inch-24 screws as shown in figure 2, view A-A. Secure bracket (item 25) (fig. 3) to the torsion

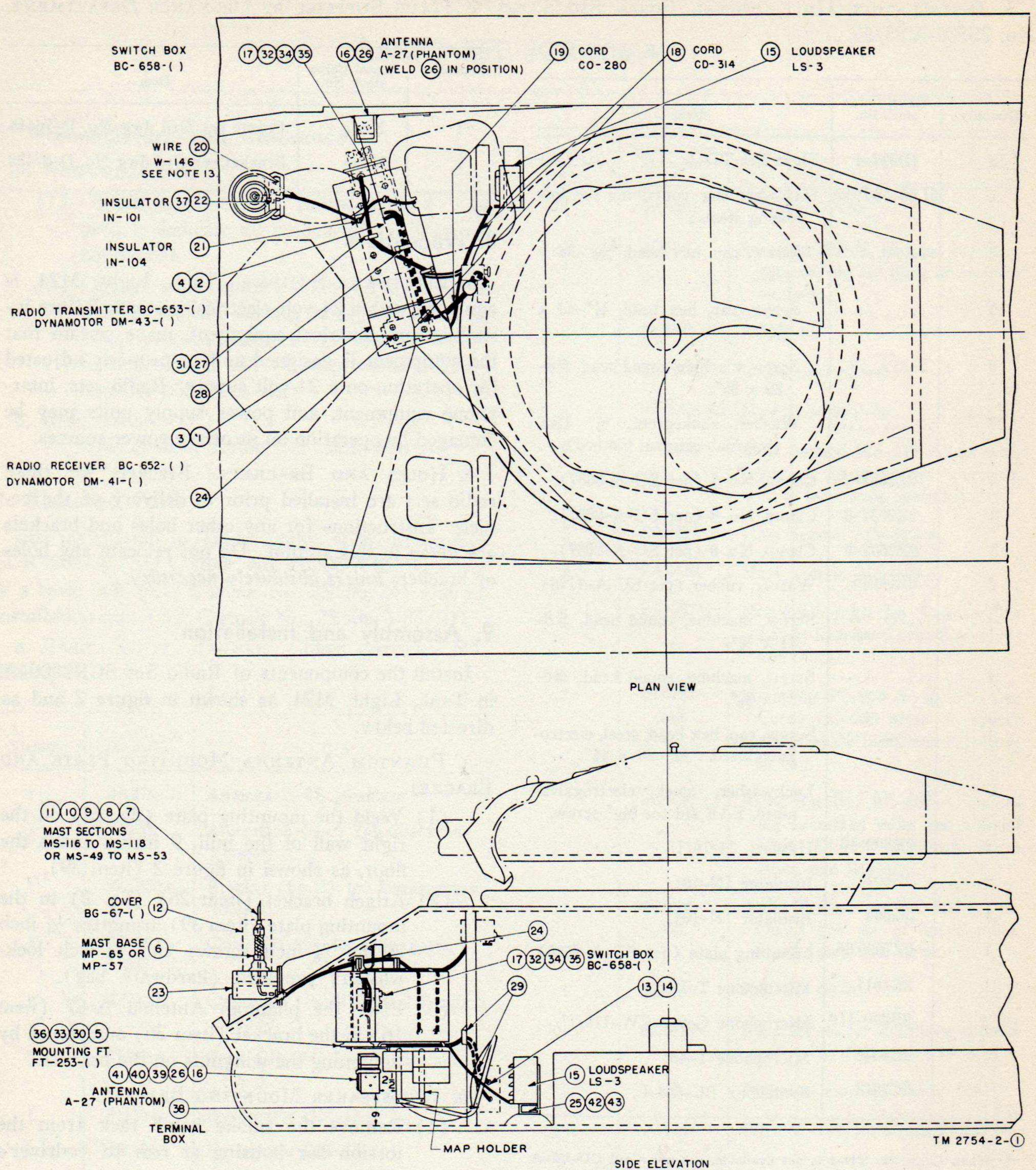
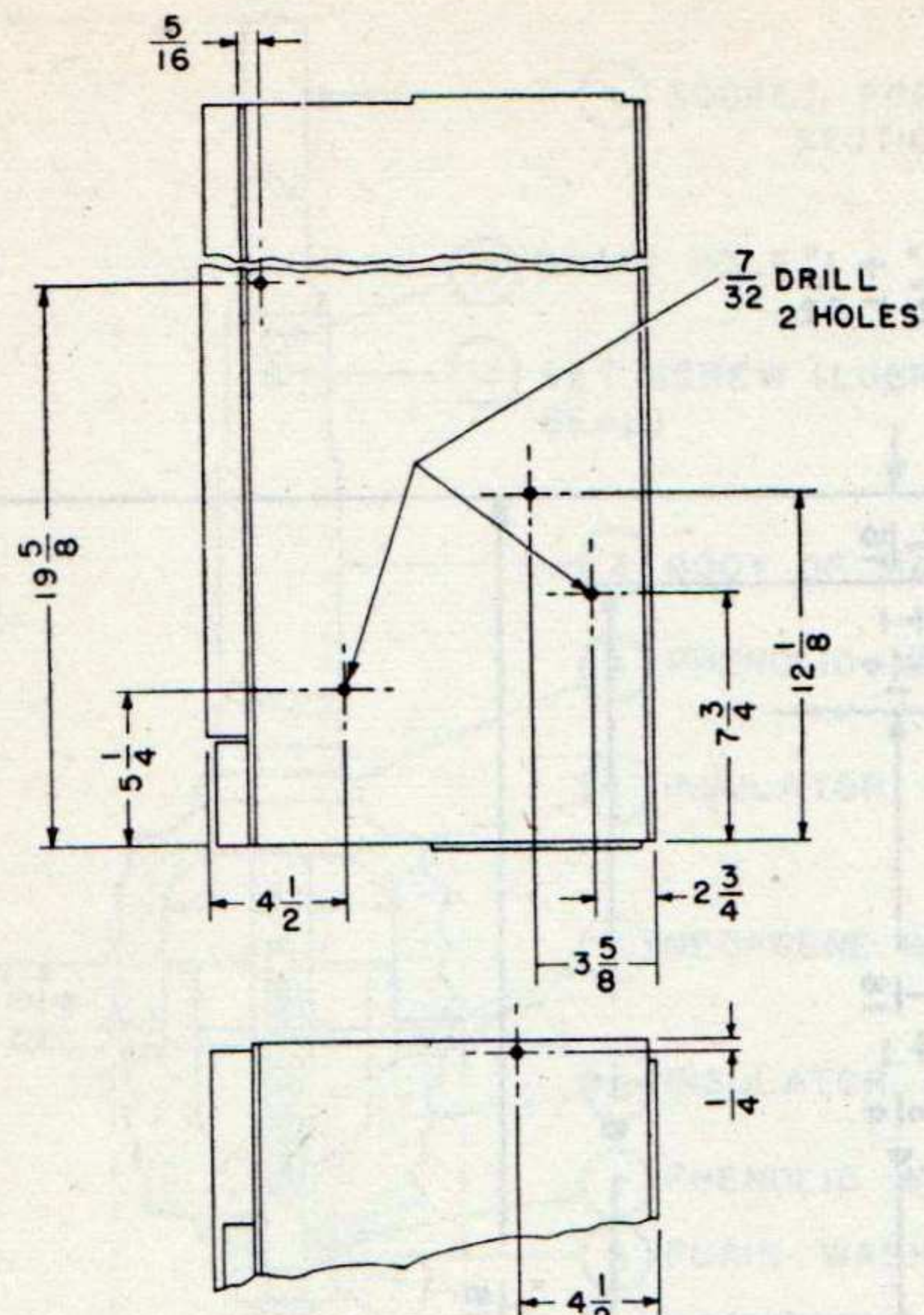

Figure 2. Installation of Radio Set SCR-506-(*)
in Tank, Light, M24.

bar housing, using the 5/16 inch-24 by 3/4-inch cap screws and 5/16-inch lock-washers supplied in the hardware bag.

(4) Remove the front panel retaining screws of Loudspeaker LS-3. Place Cover CW-41/U over the loudspeaker panel and se-



LOCATION OF MOUNTING HOLES FOR CLAMPS AND INSULATORS IN-104, ON TOP AND RIGHT SIDE OF RADIO SET SCR-506-()

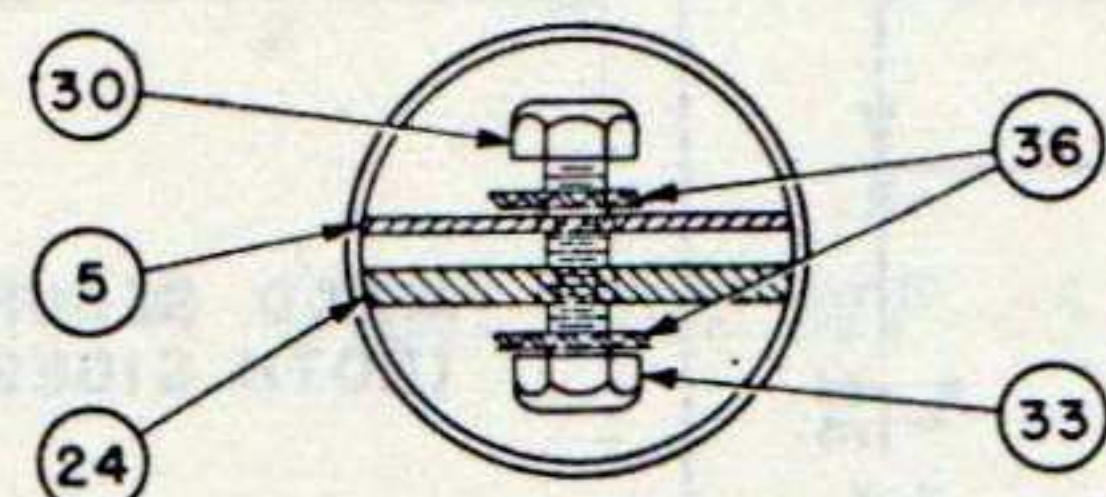

LOCATION OF SHAKEPROOF WASHERS

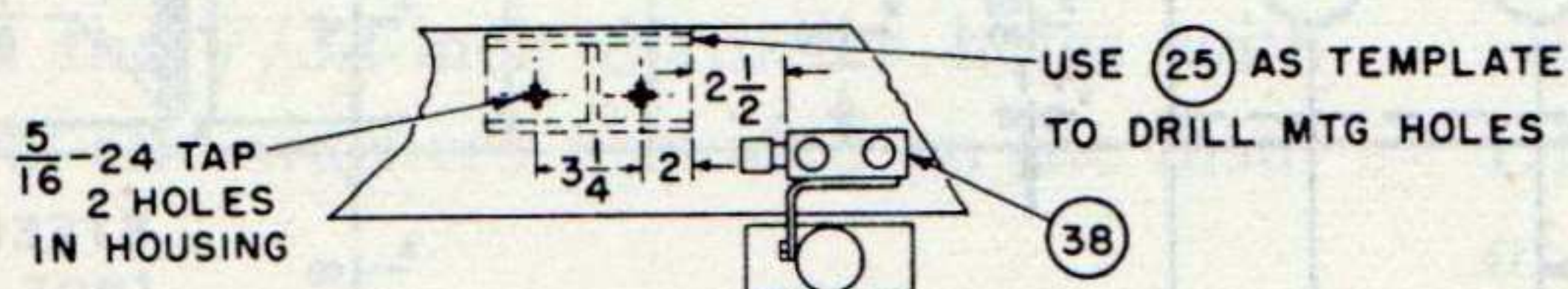

5/16-24 TAP 2 HOLES IN HOUSING

USE (25) AS TEMPLATE TO DRILL MTG HOLES

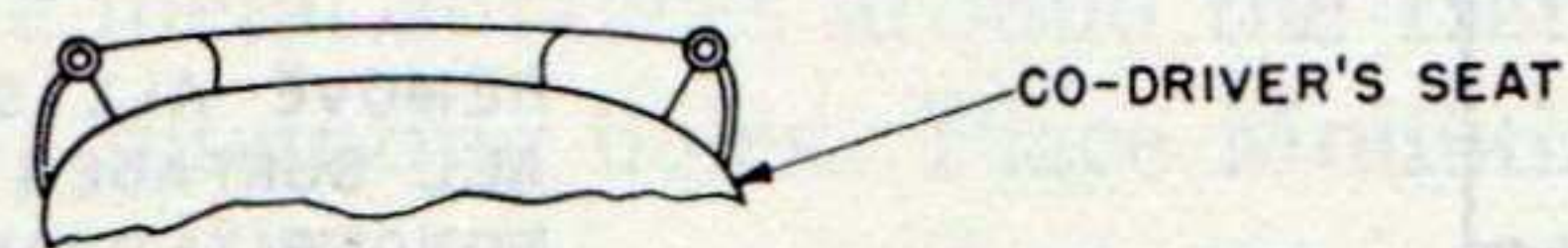

LOCATION OF LOUDSPEAKER LS-3
VIEW A-A



HEAT HANDLE A AND BEND UP 90° AT EDGE OF FLOOR PLATE

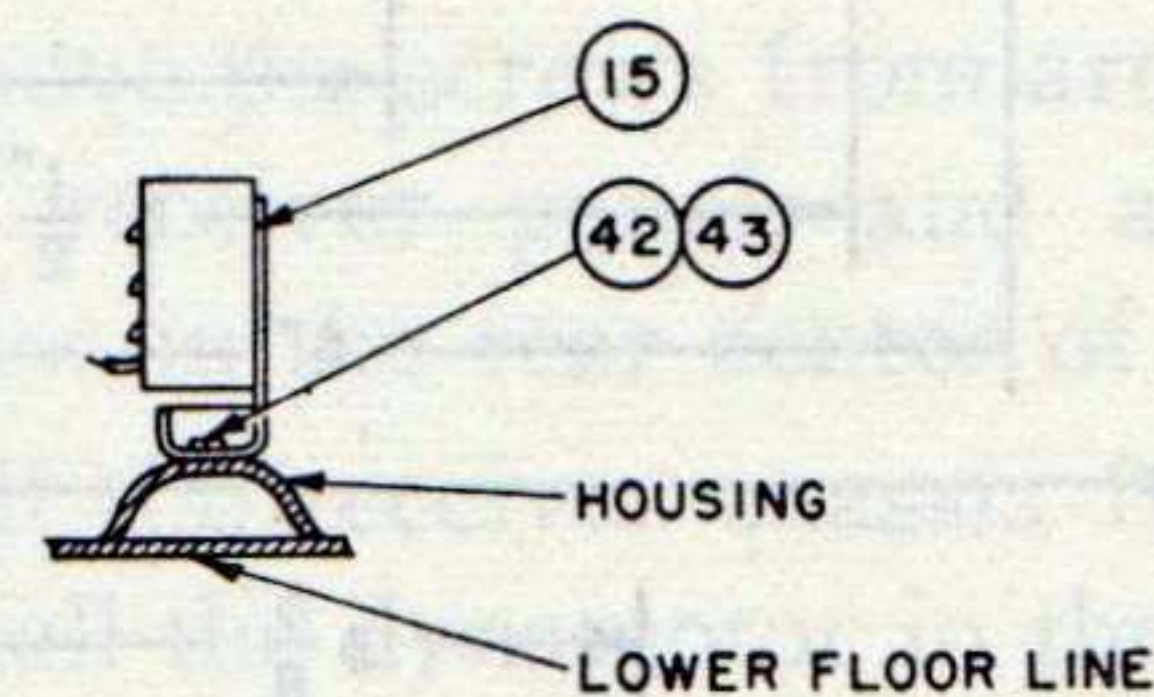

FLOOR HANDLE MODIFICATION
VIEW B-B

NOTES:

1. FOR ADDITIONAL COMPONENTS AND SPARE PARTS, SEE COMPONENT PARTS LIST
2. DIMENSIONS UNLESS OTHERWISE SHOWN ARE IN INCHES

TM 2754-2-2

ITEM NO.	NAME OF ITEM	QUAN REQ
1	RADIO RECEIVER BC-652-()	1
2	RADIO TRANSMITTER BC-653-()	1
3	DYNAMOTOR DM-41-()	1
4	DYNAMOTOR DM-43-()	1
5	MOUNTING FT-253-()	1
6	MAST BASE MP-57	1
7	MAST SECTION MS-116 OR MS-49 AND CLAMP MC-421	1
8	MAST SECTION MS-117 OR MS-50 AND CLAMP MC-422	1
9	MAST SECTION MS-118 OR MS-51 AND CLAMP MC-423	1
10	MAST SECTION MS-52 AND CLAMP MC-424	1
11	MAST SECTION MS-53	1
12	COVER BG-67-()	1
13	APPLETON CONNECTOR CAT. NO. 61007	2
14	APPLETON BONDNUT CAT. NO. BL-50	2
15	LOUDSPEAKER LS-3	1
16	ANTENNA (PHANTOM) A-27	1
17	SWITCH BOX BC-658-()	1
18	CORD CD-314	1
19	CORD CO-280	2
20	WIRE W-146, 40 IN. LONG	1
21	INSULATOR IN-104	2
22	INSULATOR IN-101	1
23	MAST BASE BRACKET	1
24	FRAME	1
25	BRACKET, PER FIG. 3	1
26	BRACKET, PER FIG. 2	1
27	CLAMP NO. 7	3
28	CLAMP NO. 8	2
29	CLAMP NO. 9	2
30	HEX HD CAP SCR, 1/4-20 X 3/4 LONG	12
31	RD HD MACH SCR, NO. 6-32 X 1/2 LONG	3
32	RD HD MACH SCR, NO. 8-32 X 5/8 LONG	3
33	HEX NUT, 1/4-20, ST'D	12
34	HEX NUT, NO. 8-32 ST'D	3
35	LOCKWASHER, S.A.E. ST'D FOR NO. 8 SCR.	3
36	SHAKEPROOF WASHER, 1/4 I.E.T.	24
37	WASHER, RUBBER	1
38	TERMINAL BOX	1
39	MOUNTING PLATE	1
40	HEX HD CAP SCR	3
41	LOCKWASHER	3
42	HEX HD CAP SCR	2
43	LOCKWASHER	2

Figure 2—Continued.

cure by replacing the original screws. Remove the four 1/4 inch-20 by 5/8-inch screws on the loudspeaker back and, using these same screws, secure Loudspeaker LS-3 to bracket (fig. 2, item 15).

c. MAST BASE BRACKET.

- (1) Remove the machine gun and its mounting from the front of the vehicle hull.
- (2) Secure the mast base bracket (item 23) as

shown in figure 2, using the same screws that secured the machine gun mounting.

- (3) Remove the spring clip from Insulator IN-101 (item 22) and place a rubber washer (item 37) over the insulator. Insert the insulator in the 1 1/8-inch diameter hole in the mast base bracket and replace the spring clip.
- (4) Drill holes in the top and side of Radio

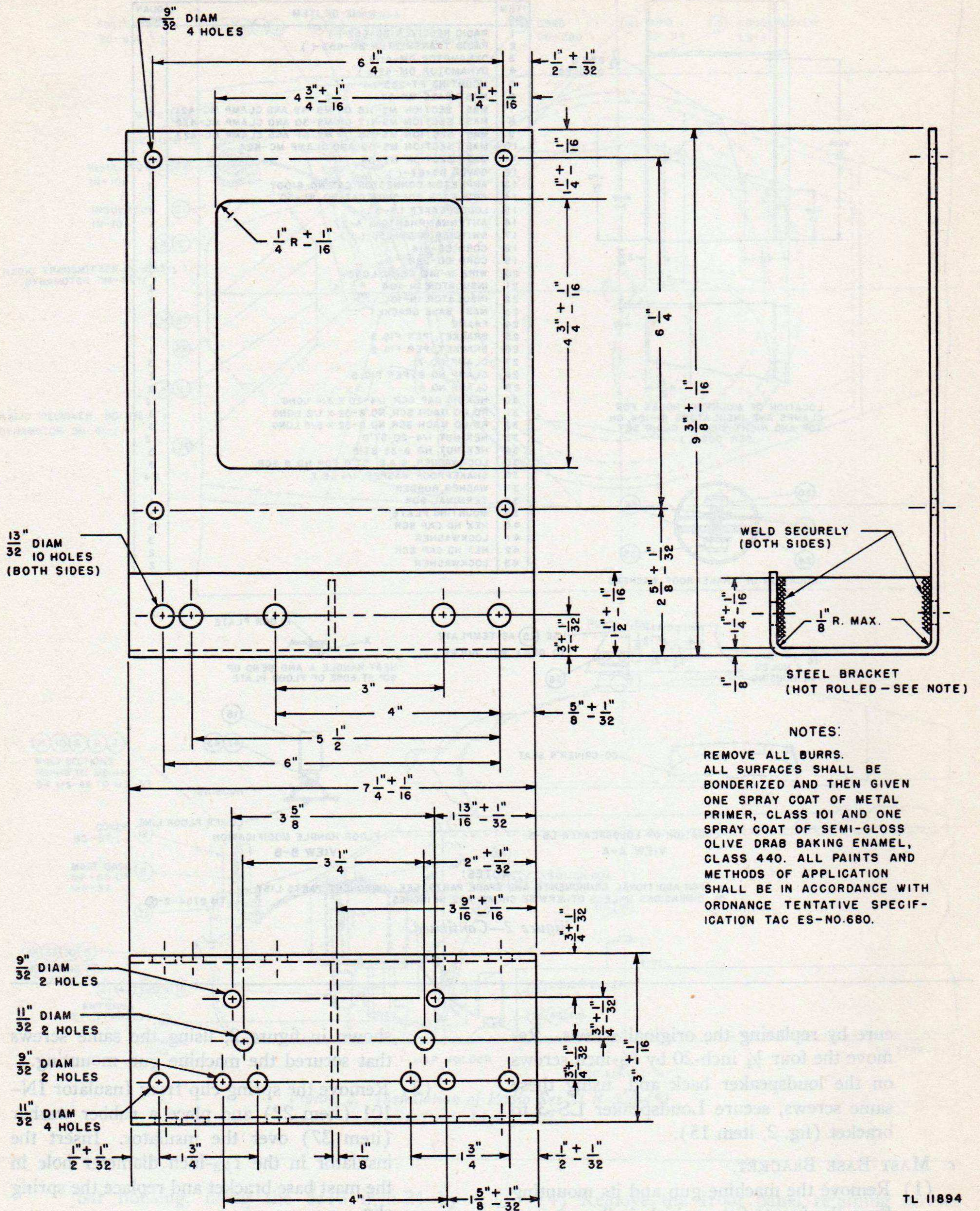

Figure 3. Bracket for Loudspeaker LS-3.

TL 11894

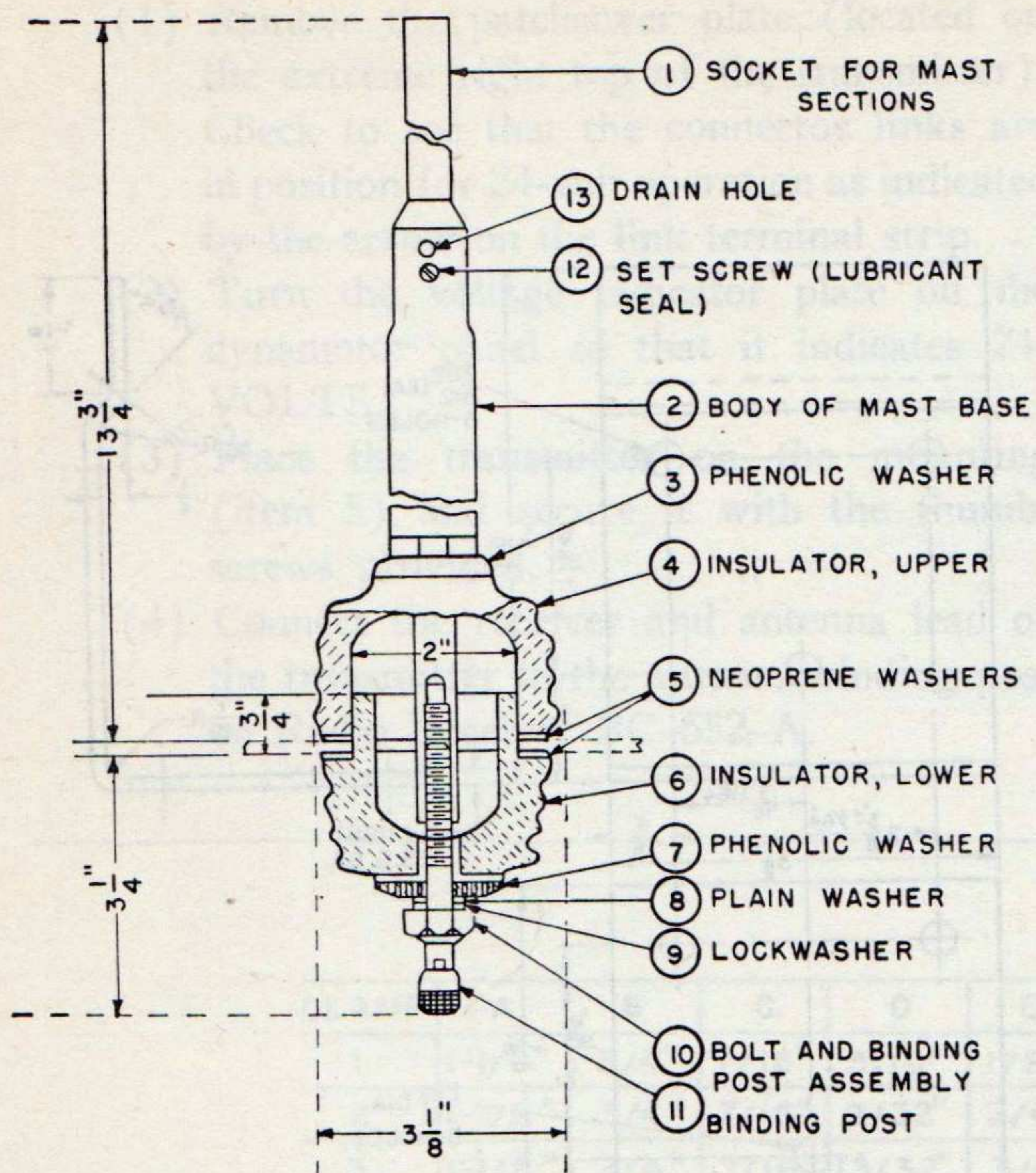

Figure 4. Mast Base MP-65-A.

Transmitter BC-653-A as shown in figure 2. Secure two Insulators IN-104 (item 21) in the 7/32-inch diameter holes with the nuts and washers provided on the insulators.

d. MOUNTING FT-253-A AND FRAME.

- (1) Clean the metal surfaces around the frame (item 24) mounting holes. Place Mounting FT-253-A on the frame and secure it with the hardware and shakeproof washers as shown in figure 2.
- (2) Two Cords CO-280 (attached to Mounting FT-253-A) are supplied with the basic unit. Using one of the cords, prepare two 5-foot lengths for use as power cords. Prepare the cord ends and apply suitable terminals. Secure the power cord tips to the terminal strip on Mounting FT-253-A, and route the cords to the terminal box, securing the cords with clamps (fig. 6) as shown in figure 2. Remove the proper knockouts from the radio terminal box (item 38, fig. 2) and secure the power cords through the knockout holes with connectors and bond-nuts (items 13 and 14). Connect the power cords to terminals inside the terminal box, being careful to observe proper polarity.

- (3) Place the left end of the frame (item 24) on the bracket that is attached to the top of the stowage cabinet (located between the driver's and codriver's seats in the hull). Hook the rear of the frame in the bracket; then secure the front of the frame to the bracket by means of the long bolt provided. Secure the vertical portion of the frame to the hull ceiling with the screws provided, using shakeproof washers (fig. 2).

e. SWITCHBOX BC-658-C.

- (1) Refer to figure 2 for proper location and to detail BA in figure 15 for proper positioning of the switchbox. Secure Mounting FT-507 on the outside of the vertical member of the frame (item 24). Fasten Switchbox BC-658-C to Mounting FT-507 by means of the studs and hex nuts on the switchbox.
- (2) When Switchbox BC-658-(*) is issued instead of Switchbox BC-658-C, Mounting FT-507 is not used. Secure Switchbox BC-658-(*) directly to the frame (item 24).

f. RADIO RECEIVER BC-652-A. If Radio Receiver BC-652-A is not equipped with Dynamotor DM-41-(), proceed as follows in the installation of the dynamotor.

- (1) Remove the screws from around the edge of the receiver panel, and also remove the screw in the rear center of the cabinet.
- (2) Pull the receiver chassis from the cabinet, install the dynamotor in the place provided, and secure with the snap slide fasteners.
- (3) All connections to the dynamotor are made by the flexible lead terminating in Plug PL-250. Insert the plug in the dynamotor socket. The receiver circuit operating voltages are automatically adjusted to the correct value.
- (4) Reverse the nameplate on the receiver panel so that it reads 24-VOLT OPERATION.
- (5) Place the receiver on Mounting FT-253-A and secure with the thumbscrews.

g. RADIO TRANSMITTER BC-653-A. If Dynamotor DM-43-() is not installed, slide it into the dynamotor compartment at the lower right of the transmitter and secure it with the screws provided on the dynamotor.

- (1) Remove the patchcover plate (located on the extreme right top of the transmitter). Check to see that the connector links are in position for 24-volt operation as indicated by the arrow on the link terminal strip.
- (2) Turn the voltage indicator plate on the dynamotor panel so that it indicates 24-VOLTS.
- (3) Place the transmitter on the mounting (item 5) and secure it with the thumb-screws provided.
- (4) Connect the receiver and antenna lead of the transmitter to the antenna binding post on Radio Receiver BC-652-A.
- (5) Route the patch cords from Switchbox BC-658-() over the top of the transmitter and secure the cords with the No. 7 clamps (item 27) as shown in figure 2. Insert Plug PL-68 and PLUG PL-55 of one pair of cords into the microphone and phone jacks on the radio transmitter and receiver. Insert the plugs of the other pair of patch cords into the jacks on the codriver's Interphone Control Box BC-606-() as shown in figure 2.
- (6) Insert Plug PL-68 of Cord CD-314 into the jack on Loudspeaker LS-3 and Plug PL-55 of the same cord into the

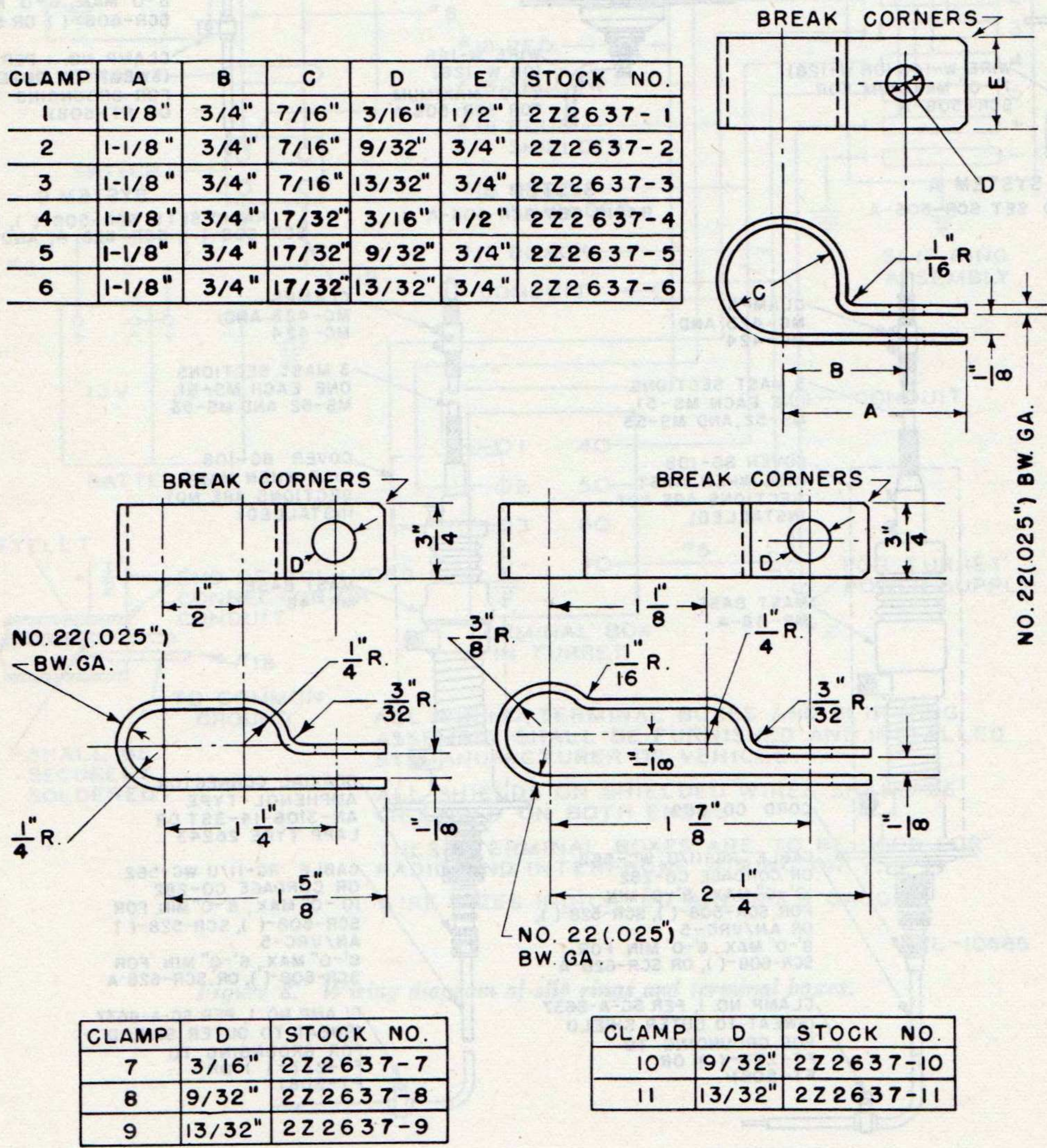

NOTE:
TOLERANCES $\pm 1/32$ "

TL13319

Figure 6. Clamps.

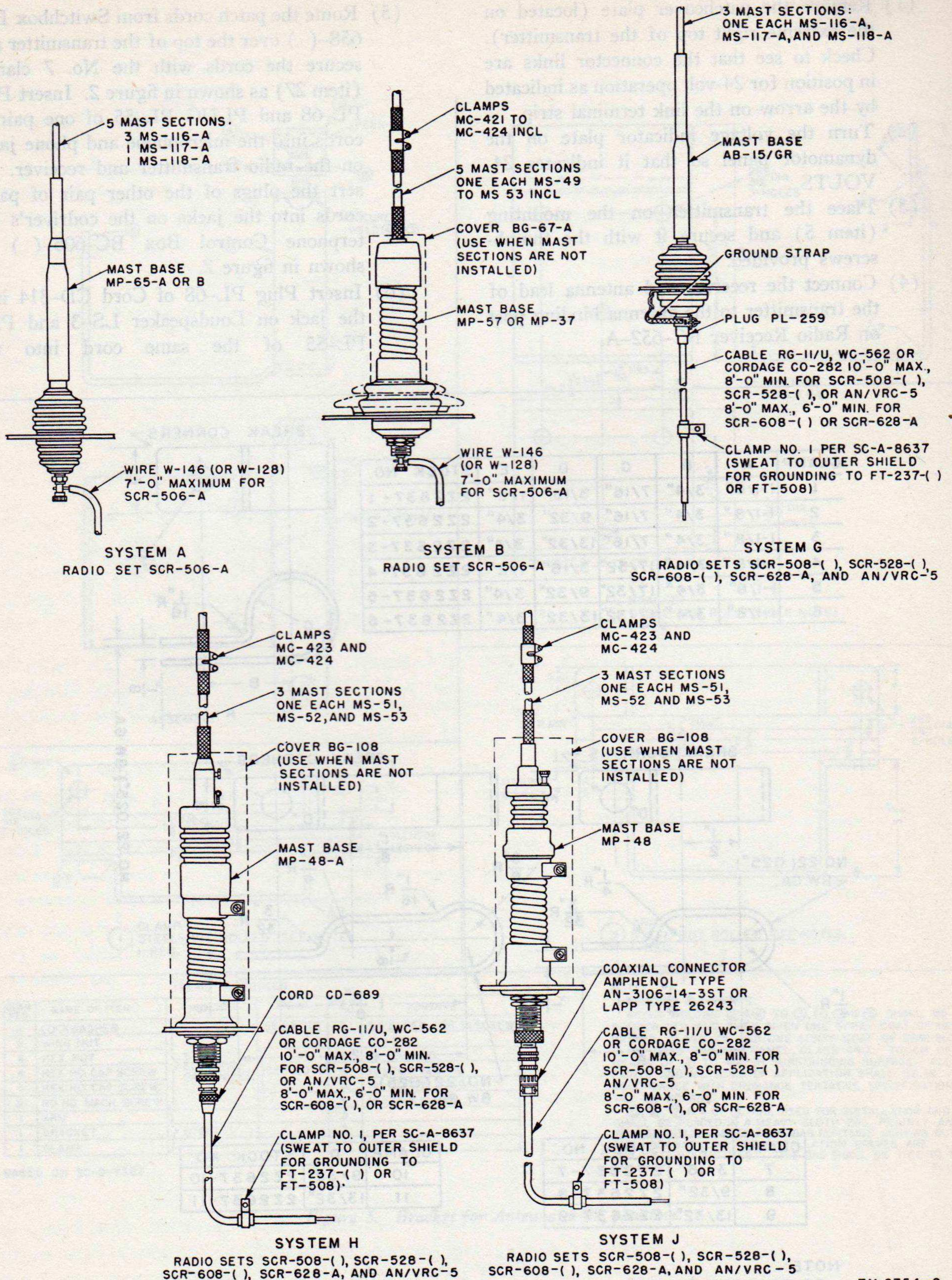
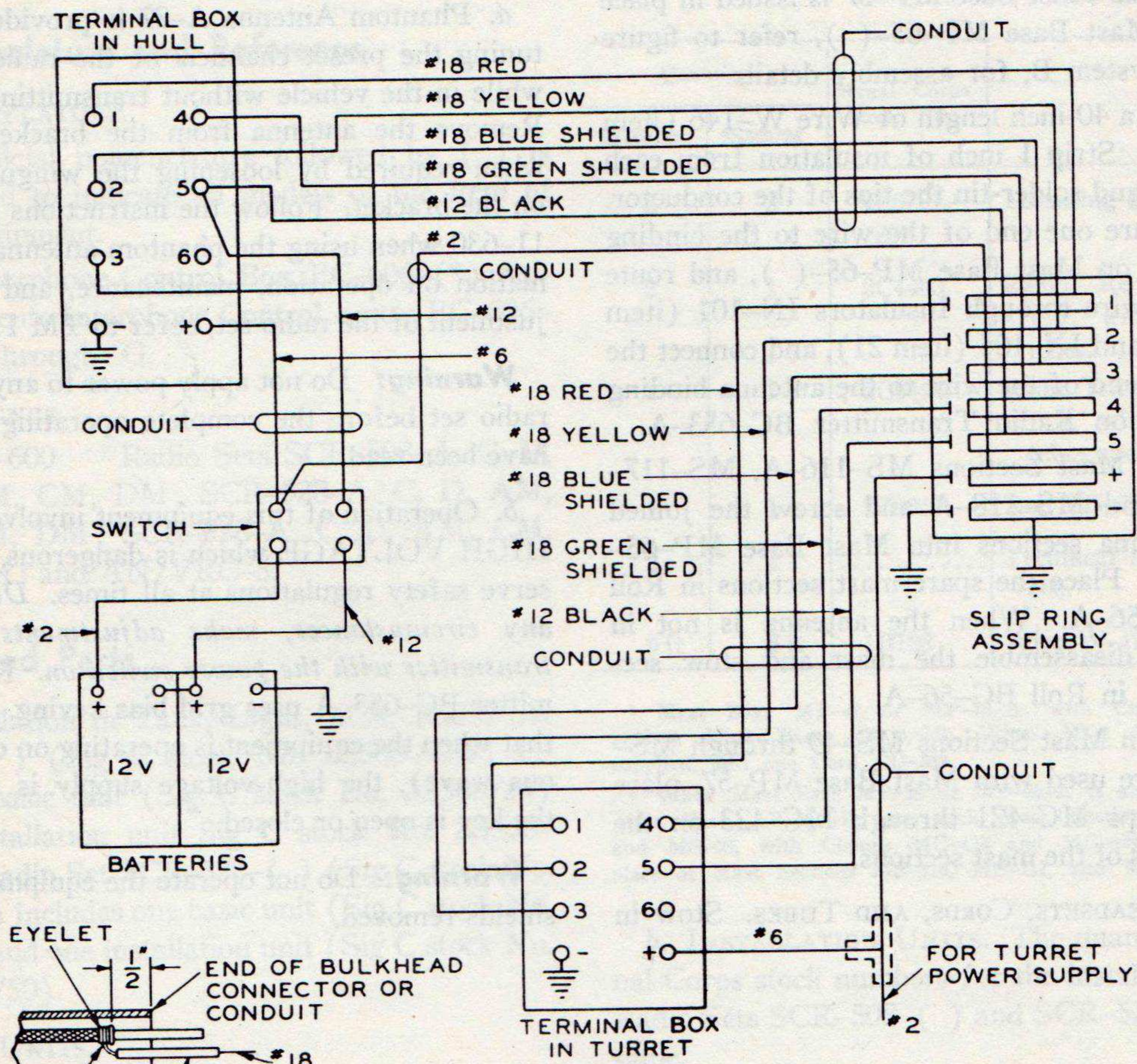

Figure 7. Antenna systems for vehicular radio installations.



ALL WIRING, TERMINAL BOXES AND SLIP RING ASSEMBLY SHALL BE FURNISHED AND INSTALLED BY MANUFACTURER OF VEHICLE.

ALL SHIELDS ON SHIELDED WIRES SHALL BE GROUNDED ON BOTH ENDS.

THESE TERMINAL BOXES ARE TO BE USED FOR RADIO AND INTERPHONE WIRING ONLY.

WIRE SIZES INDICATED ARE B & S GAUGE.

TL-10665

Figure 8. Wiring diagram of slip rings and terminal boxes.

SPEAKER jack on Radio Receiver BC-652-A.

h. ANTENNA MAST BASE.

- (1) Install Mast Base MP-65-() (item 6) on mast base bracket (item 23). Assemble the mast base as shown in figure 4.
- (2) When Mast Base MP-57 is issued in place of Mast Base MP-65-(), refer to figure 7, system B, for assembly details.
- (3) Cut a 40-inch length of Wire W-146 (item 20). Strip 1 inch of insulation from each end and solder-tin the tips of the conductor. Secure one end of the wire to the binding post on Mast Base MP-65-(), and route the wire through Insulators IN-101 (item 22) and IN-104 (item 21), and connect the free end of the wire to the antenna binding post on Radio Transmitter BC-653-A.
- (4) Join Mast Sections MS-116-A, MS-117-A, and MS-118-A and screw the joined antenna sections into Mast Base MP-65-(). Place the spare mast sections in Roll BG-56-A. When the antenna is not in use, disassemble the mast and stow sections in Roll BG-56-A.
- (5) When Mast Sections MS-49 through MS-54 are used with Mast Base MP-57, place Clamps MC-421 through MC-423 on the joints of the mast sections.

i. SPARE HEADSETS, CORDS, AND TUBES. Stow in

Chest CH-263. See chart supplied with chest for location of items.

j. CHEST CH-263. Place chest in tool box of vehicle or in any convenient place.

10. Operation Check

a. Phantom Antenna A-27 is provided for use in tuning the preset channels of the radio transmitter while in the vehicle without transmitting any signal. Remove the antenna from the bracket (item 26) when required by loosening the wingnuts provided on the bracket. Follow the instructions given in TM 11-630 when using the phantom antenna. For information on operation, maintenance, and channel adjustment of the radio set, refer to TM 11-630.

Warning: Do not apply power to any unit of this radio set before the complete operating instructions have been read.

b. Operation of this equipment involves the use of HIGH VOLTAGE which is dangerous to life. Observe safety regulations at all times. *Do not, under any circumstances, make adjustments inside the transmitter with the power switch on.* Radio Transmitter BC-653-A uses grid bias keying. This means that when the equipment is operating on cw (continuous wave), the high-voltage supply is on, whether the key is open or closed.

Warning: Do not operate the equipment with the shields removed.

SECTION IV

RADIO SET SCR-508-() OR SCR-528-() AND ASSOCIATED INTERPHONE EQUIPMENT

II. Nomenclature and Reference

a. NOMENCLATURE.

- (1) Official nomenclature followed by () is used to indicate all models of the item of equipment.
- (2) Interphone Control Box EC-606-(*) represents Interphone Control Boxes BC-606-A through -G.

b. REFERENCE.

TM 11-600 Radio Sets SCR-508-A, C, D, AM, CM, DM; SCR-528-A, C, D, AM, CM, DM; SCR-528-A, C, D, AM, CM, DM; and AN/VRC-5.

12. Required Parts

For installation in Tank, Light, M24, Radio Set SCR-508-() (Sig C stock No. 2S508-V85) includes one basic unit (Sig C stock No. 2S508/24) and one installation unit Sig C stock No. 2S508-V85/50); Radio Set SCR-528-() (Sig C stock No. 2S528-V85) includes one basic unit (Sig C stock No. 2S528/24) and one installation unit (Sig C stock No. 2S508-V85/50).

a. BASIC UNITS.

Quantity		Signal Corps stock No.	Item
2S508/24	2S528/24		
1	1	2A262	Antenna A-62, Phantom.
1	1	2Z2599-264	Chest CH-264.
1	1	6Z3147	Connector No. 61007 and Bondnut BL-50.
1	1	2Z3396	Cover BG-96.
2	1	3H1636	Dynamotor DM-36-().
1	1	3H1637	Dynamotor DM-37-().
1	1	2A2081-15	Mast Base AB-15/GR.
2	2	2A2417	Mast Section MS-117-A.
2	2	2A2418	Mast Section MS-118-A.

Quantity		Signal Corps stock No.	Item
2S508/24	2S528/24		
2	2	2Z6721-237	Mounting FT-237-().
2	1	2C4403	Radio Receiver BC-603-(), with set of spare tubes.
1	1	2C6494	Radio Transmitter BC-604-(), with set of spare tubes and 80 crystal units.
1	1	2Z8056	Roll BG-56-A.
2	2	Technical manual, TM 11-600.
6 ft	6 ft	1B128	Wire W-128.

¹ Mast Base MP-48 or MP-48-A, with Cover BG-108, may replace Mast Base AB-15/GR. When Mast Base MP-48-A is supplied, add one Cord CD-689.

² When Mast Base MP-48 or MP-48-A is supplied in place of Mast Base AB-15/GR, one each Mast Sections MS-51, MS-52, and MS-53, with Clamps MC-423 and MC-424, are supplied in place of Mast Sections MS-116, MS-117, and MS-118.

b. INSTALLATION UNITS. The quantities and Signal Corps stock numbers for the installation units of Radio Sets SCR-508-() and SCR-528-() are the same.

Quantity	Signal Corps stock No.	Item
16	4B417-4	Chest Set TD-4.
2	6Z3147	Connector No. 51007 and Bondnut BL-50.
29 ft	3E2213	Cordage CO-213.
26	2B800	Headset H-16/U.
1	6L50-508V85	Hardware bag containing the following:
3	2Z2637-1	Clamp, No. 1 (per SC-A-8637).
3	2Z2637-6	Clamp, No. 6 (per SC-A-8637).
3	2Z2637-7	Clamp, No. 7 (per SC-A-8637).
6	2Z2637-9	Clamp, No. 9 (per SC-A-8637).

Quantity	Signal Corps stock No.	Item
12	6L2218-24C	Washer, shakeproof, 5/16" IET.
2	6L54016	Washer, rubber (per SC-A-7146).
1	3G601	Insulator IN-101.
5	2C1738	Interphone Control Box BC-606-(), including hardware.
1	2C1963-298	Interphone Extension Kit RC-298.
2	2A2416	Mast Section MS-116-A.
1	2B1617	Microphone T-17 (spare).
5	2B1645	Microphone T-45.
2	2B250-110	Microphone Cover CW-110/U.
9 ft	1F430-11	Radio Frequency Cable RG-11/U.

¹ If Chest Set TD-4 is not available, issue six Cords CD-307-A and five Cords CD-318-A.

² If Headset H-16/U is not available, issue six Headsets HS-30-() and six Cords CD-604.

³ When Interphone Control Box BC-606-H is issued, Mounting FT-507 and two each conduit connectors are included for installation.

⁴ See note ², a above.

13. Precautions

a. ELECTRICAL SYSTEM. Tank, Light, M24, is equipped with a 24-volt electrical system. Before installing any electrical equipment, make certain that it is designed and/or properly adjusted for operation on a 24-volt supply. Radio sets, interphone equipment, and power supply units may be damaged by operation on incorrect power sources.

b. HOLES AND BRACKETS. Brackets for the radio and interphone equipment are installed prior to delivery of the vehicle. Instructions for other holes and brackets are given in this section. Do not relocate any holes or brackets *unless absolutely necessary*.

c. INSTRUCTIONS. Before installing equipment in the vehicle, study the illustrations and instructions in this manual; also use the reference listed in paragraph 11b.

14. Assembly and Installation

Install the components of Radio Set SCR-508-() or SCR-528-() in Tank, Light, M24, as shown in figure 12 and as directed below.

a. INTERCONNECTIONS. Interconnect the commander, gunner, and loader Interphone Control Boxes BC-606-H (item 13) and Cordage CO-213

before installation in the vehicle. Similarly, interconnect the interphone control boxes for the driver and codriver. As given in figure 12, items 25 through 30, the lengths of Cordage CO-213 are approximate *terminal to terminal* lengths; for a first or trial installation, add about 10 percent to the given lengths. For additional installations, cut the cordage to the exact lengths determined by the trial installation. Instructions for preparing cordage and interconnecting the components are given below.

- (1) Cut the required lengths of Cordage CO-213.
- (2) Strip back 3½ inches of the outer rubber covering and 2½ inches of the inner and outer shields from both ends of items 28 and 30, and from one end of items 26, 27, and 29 (for connections to interphone control boxes).
- (3) Strip 6 inches of the outer rubber covering and 5 inches of the shields from one end of items 25, 26, and 27 for connection to Mounting FT-237-().
- (4) Strip back 8½ inches of the outer rubber covering and 7½ inches of the shields from the other end of items 29 and 25 (for connections to vehicle terminal boxes).
- (5) Complete preparation of the cord ends in accordance with the instructions given in figure 13.
- (6) Obtain solder terminal lugs from the vehicle terminal boxes in the turret and driving compartment. Refer to figure 14 and solder the lugs to the 8½-inch leads to be used on items 25 and 29.
- (7) Refer to figure 15 and determine the entrance holes to be used in each interphone control box.
- (8) Remove the sweated disks from over the holes to be used.
- (9) Disassemble the conduit connectors (items 14 and 15), place one rubber washer over the stem of each connector, and secure a connector in each entrance hole.
- (10) Pass the coupling nut and grommet over the prepared cordage and pass the cordage leads into the proper box (figs. 12 and 14).
- (11) Connect the cordage to the numbered terminals on the terminal block in each interphone control box. Tape the ends of the unused red and green leads. Screw each coupling nut firmly to its connector.

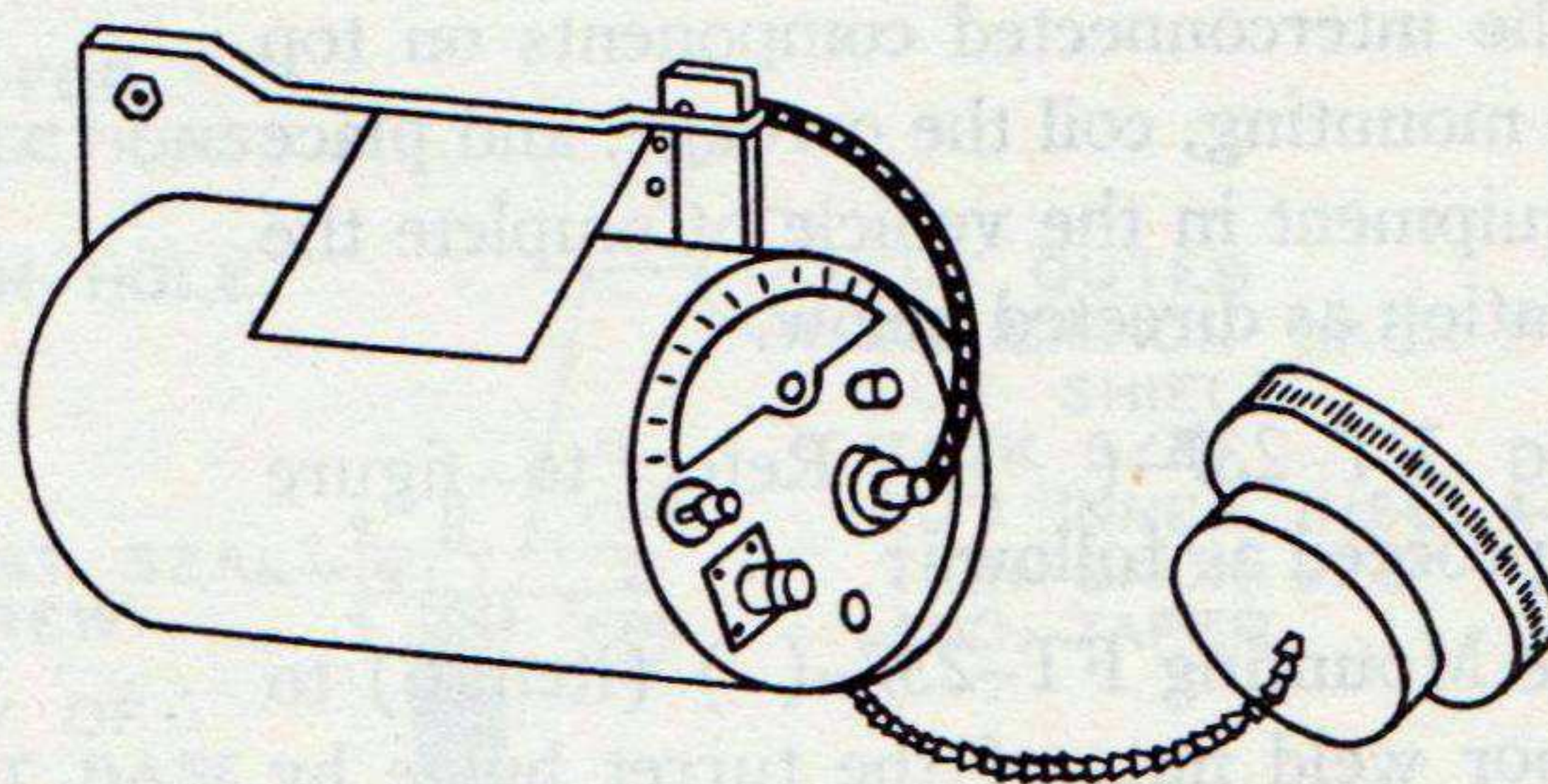
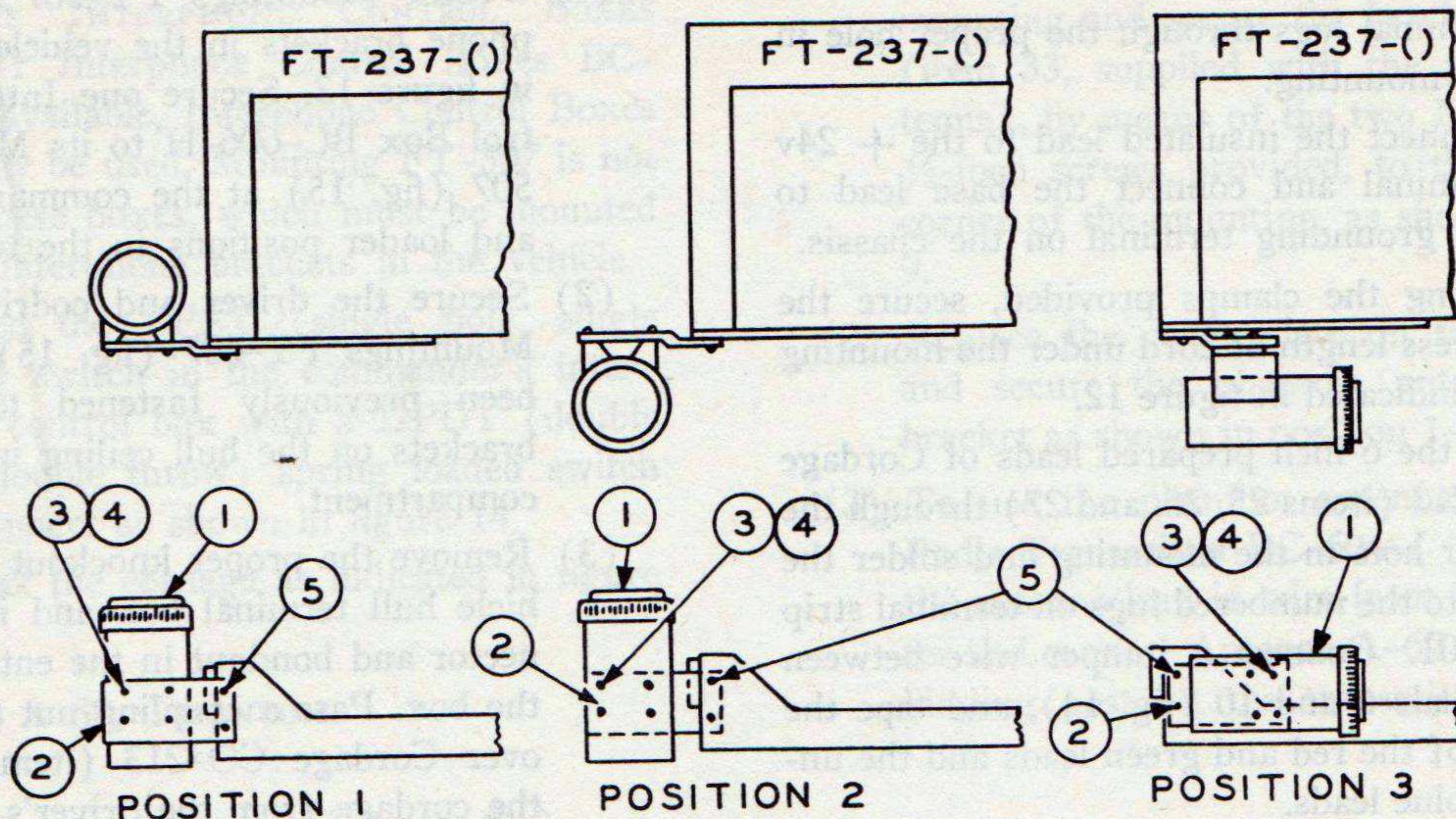

APPLICATION OF GROUND CLIP

ITEM NO.	NAME OF ITEM AND REMARKS	QUAN. REQ.
1	ANTENNA A-62 (PHANTOM)	1
2	BRACKET	1
3	RD. HD. MACH. SCR., NO. 6-32 X 1/2" FURN. WITH NO. 1	4
4	LOCKWASHER, NO. 6 STD. FURN. WITH NO. 1	4
5	RD. HD. MACH. SCR., NO. 10-32 X 5/8"	2

NOTES:

1. FOR ALL POSITIONS USE TIP OF BRACKET TO RECEIVE THE GROUND CLAMP OF ANTENNA A-62.
2. USE LONGER SCREW (5) WHEN INSTALLING BRACKET (2) ON MOUNTING FT-237-() AND RE-APPLY TOOTH-TYPE LOCKWASHERS.

TL 13376

Figure 9. Antenna A-62, phantom.

(12) Connect power Cord CO-278 (item 31) to Mounting FT-237-() as follows:

- (a) Pass the power cord end with the small terminal lugs through the proper hole in the mounting.
- (b) Connect the insulated lead to the + 24v terminal and connect the base lead to the grounding terminal on the chassis.
- (c) Using the clamps provided, secure the excess length of cord under the mounting as indicated in figure 12.

(13) Pass the 6-inch prepared leads of Cordage CO-213 (items 25, 26, and 27) through the proper hole in the mounting and solder the leads to the numbered lugs on terminal strip TS-401. Connect a jumper wire between terminals 6 and 10 (fig. 14), and tape the ends of the red and green leads and the unused blue leads.

(14) Put the interconnected components on top of the mounting, coil the cordage, and place the equipment in the vehicle. Complete the installation as directed below.

b. MOUNTING FT-237-(). Refer to figure 12, item 6, and proceed as follows:

(1) Secure Mounting FT-237-() (item 6) to the floor weld nuts of the turret bulge by means of the eight 5/16-inch screws and IET lockwashers provided.

(2) Route the power cord (item 31) and Cordage CO-213 (item 25) to the vehicle turret terminal box. Remove the proper knockouts from the terminal box and install a connector and bondnut (items 14 and 15) in each entrance hole, applying a rubber washer over the threaded stem of each connector. Secure each cord in its entrance hole by passing a coupling nut and grommet over each cord and screwing the coupling nut to its connector.

(3) Secure the cords to the spacers (item 44), using the clamps and hardware provided.

(4) Connect the insulated lead of the power cord to the positive terminal (marked +) in the vehicle terminal box. Connect the bare lead to the negative terminal (marked -).

(5) Connect the terminals of Cordage CO-213 (item 25) to the vehicle terminal box (turret) as indicated in figure 14.

c. MOUNTINGS FT-507 AND INTERPHONE CONTROL BOX BC-606-H.

(1) Secure Mountings FT-507 to the interphone brackets in the vehicle as indicated in figure 12. Secure one Interphone Control Box BC-606-H to its Mounting FT-507 (fig. 15) at the commander, gunner, and loader positions in the turret.

(2) Secure the driver and codriver boxes to Mountings FT-507 (fig. 15) which have been previously fastened to interphone brackets on the hull ceiling in the driver's compartment.

(3) Remove the proper knockout from the vehicle hull terminal box and install a connector and bondnut in the entrance hole of the box. Pass a coupling nut and grommet over Cordage CO-213 (item 29). Route the cordage from the driver's box through the entrance hole into the terminal box and secure the cordage terminals to the numbered terminals in the hull terminal box as shown in figure 14. Tighten the coupling nut.

(4) Using the clamps (item 18) provided, se-

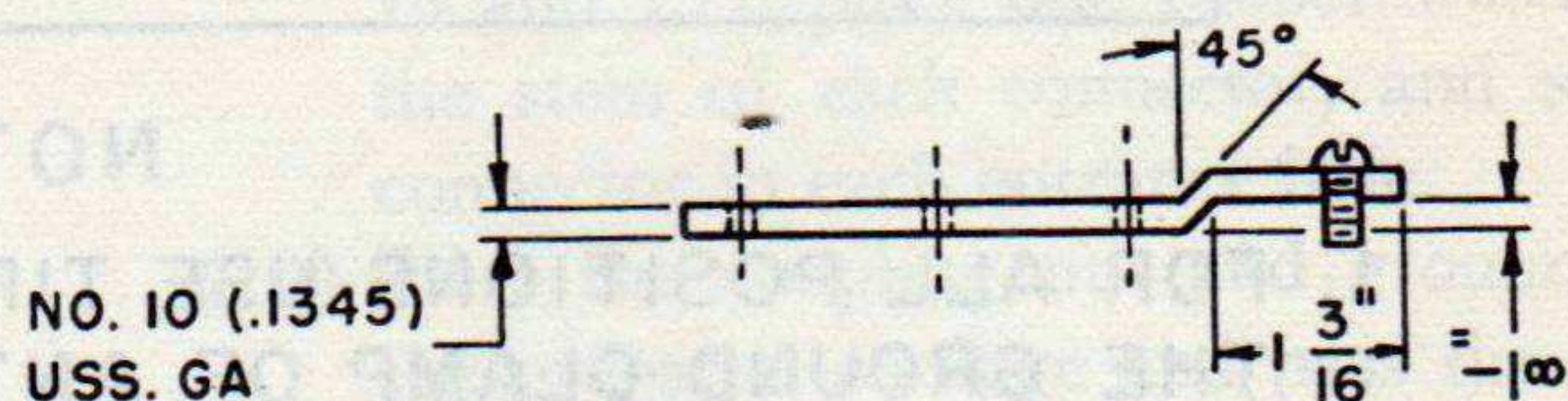
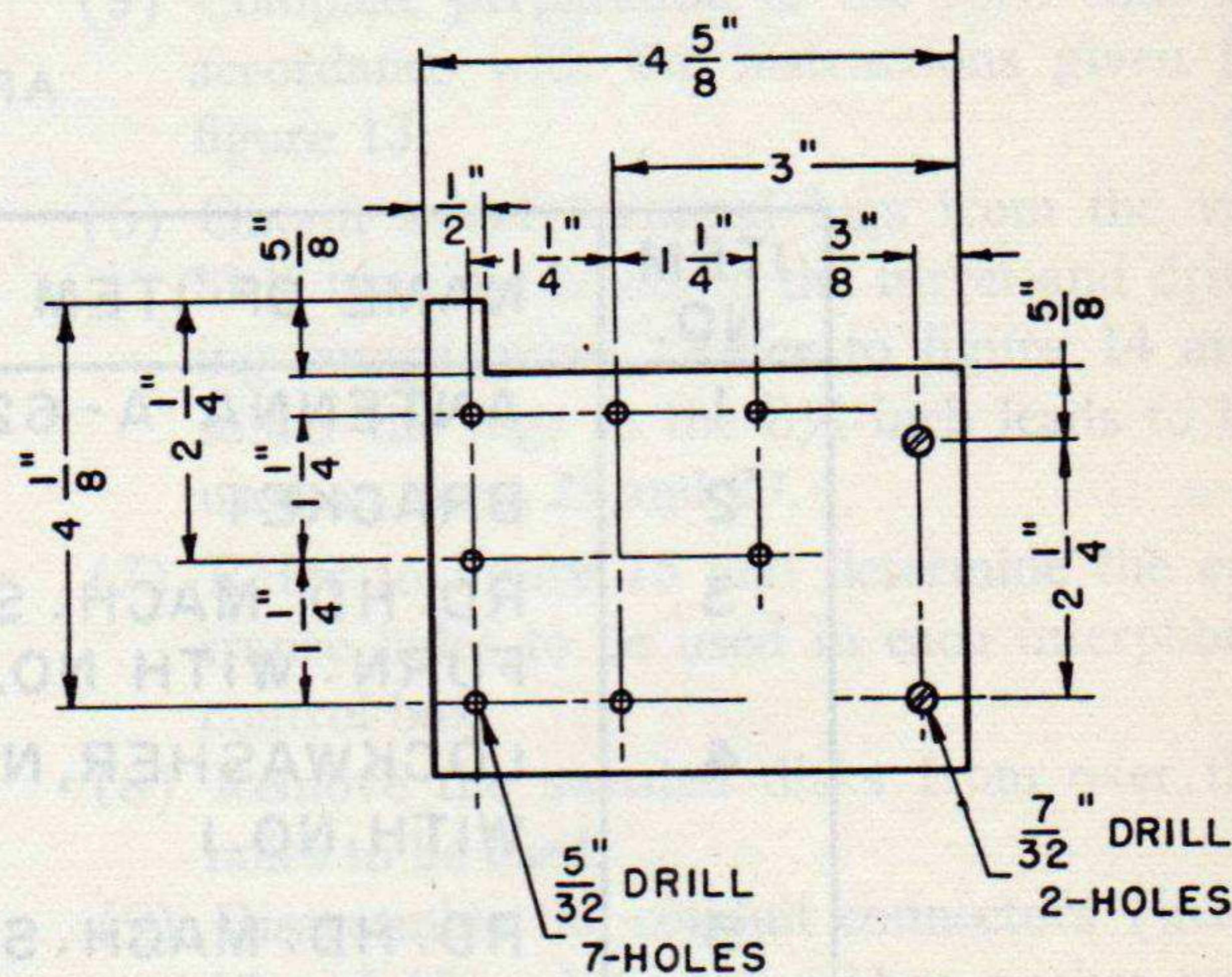

STEEL - HOT ROLLED
NOTES:

TOLERANCE WHERE NOT SHOWN OTHERWISE SHALL BE HELD TO $\pm 1/64$ ".
REMOVE ALL BURRS.

TL 13375

Figure 10. Bracket for Antenna A-62, phantom.

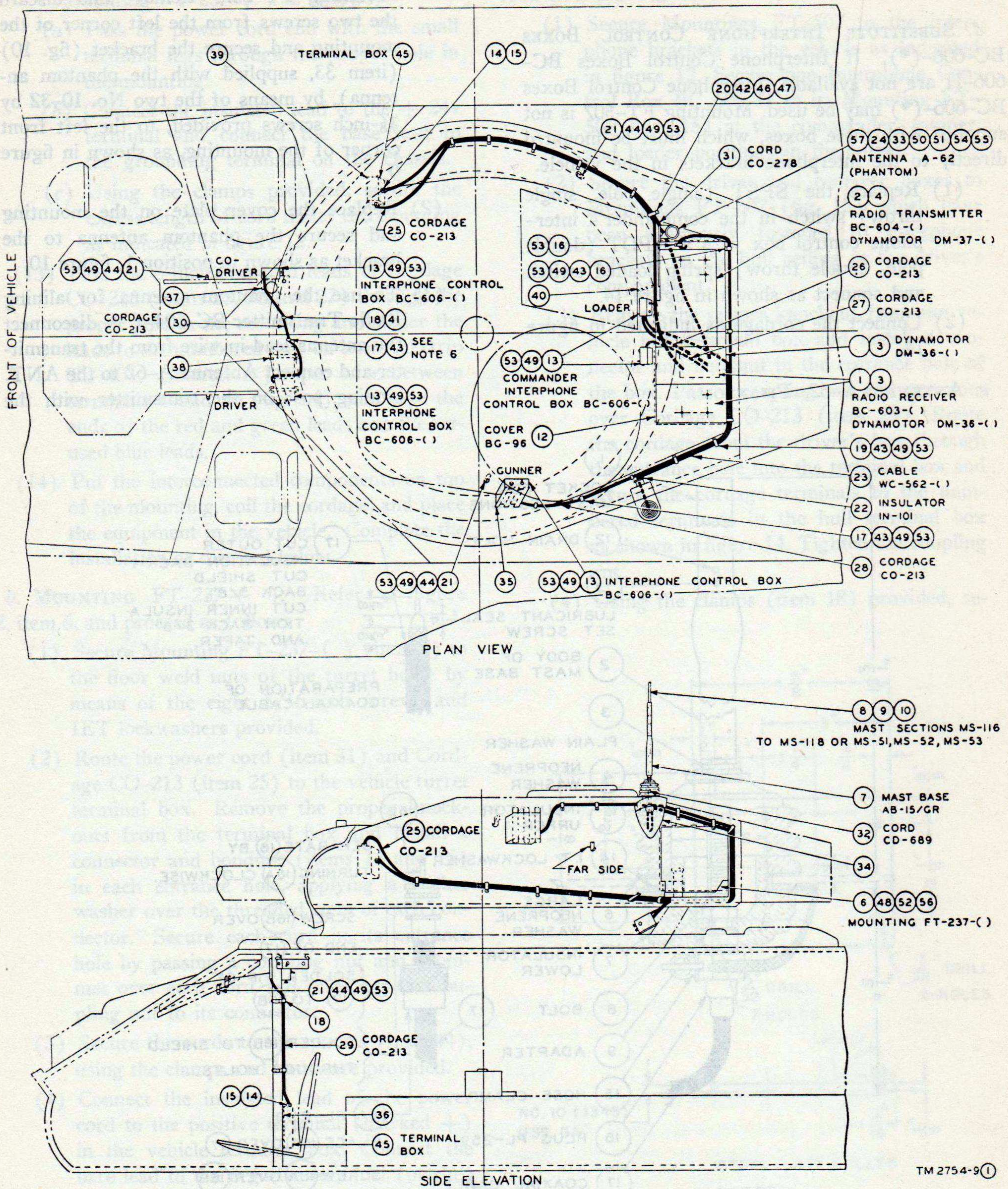
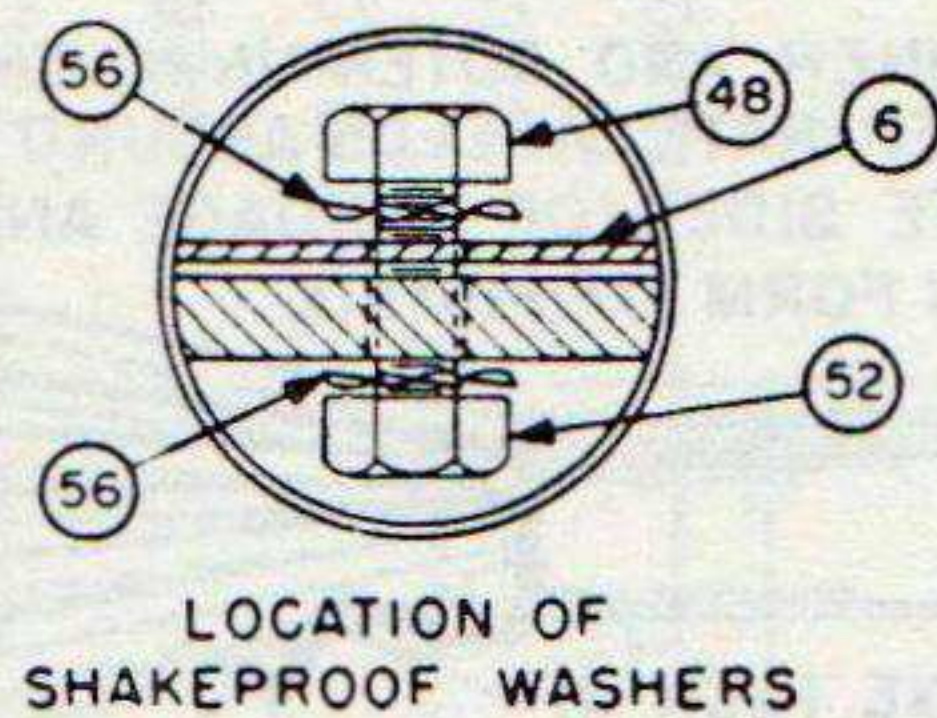

Figure 12. Installation of Radio Set SCR-508-(*) or SCR-528-(*) and associated interphone equipment in Tank, Light, M24.

TM 2754-9①



- NOTES:
- 1 FOR ADDITIONAL COMPONENTS AND SPARE PARTS, SEE COMPONENT PARTS LIST.
 - 2 (34) TO (47) INCLUSIVE SHALL BE FURNISHED WITH THE VEHICLE BY THE MANUFACTURER
 - 3 (17), (21), (43), AND (53) ARE FURNISHED WITH (13)
 - 4 (31), (48), AND (52) ARE FURNISHED WITH (6)
 - 5 DIMENSIONS UNLESS OTHERWISE SHOWN ARE IN INCHES.
 - 6 (17) AND (18) MOUNTED WITH HARDWARE PROVIDED WITH THE VEHICLE BY THE MANUFACTURER.
 - 7 USE STANDARD ANTENNA SYSTEM G PER FIG. 7 SUBSTITUTE SYSTEMS ARE -H AND -J.
 - 8 USE INTERPHONE CONTROL BOXES BC-606-H IF AVAILABLE, IF NOT, SUBSTITUTE BC-606-(*) REFER TO FIG. 14

ITEM NO.	NAME OF ITEM	QUAN REQ	
		RADIO SET SCR-528-(1)	RADIO SET SCR-508-(1)
1	RADIO RECEIVER BC-603-()	1	2
2	RADIO TRANSMITTER BC-604-()	1	1
3	DYNAMOTOR DM-36-()	1	2
4	DYNAMOTOR DM-37-()	1	1
5	CHEST CH-264	1	1
6	MOUNTING FT-237-()	1	1
7	MAST BASE AB-15/GR	1	1
8	MAST SECTION MS-118-A	1	1
9	MAST SECTION MS-117-A	1	1
10	MAST SECTION MS-116-A	1	1
11			
12	COVER BG-96	1	1
13	INTERPHONE CONTROL BOX BC-606-()	5	5
14	APPLETON CONNECTOR CAT NO. 61007	3	3
15	APPLETON BONDNUT CAT. NO. BL-50	3	3
16	CLAMP, PER FIG. 6	3	3
17	CLAMP, SEE NOTE 6, PER FIG. 6	4	4
18	CLAMP, SEE NOTE 6, PER FIG. 6	3	3
19	CLAMP, PER FIG. 6	3	3
20	CLAMP, PER FIG. 6	6	6
21	HOOK, SEE NOTE 3	4	4
22	INSULATOR IN-101	1	1
23	RADIO FREQUENCY CABLE RG-11/U, 8 FT LONG	1	1
24	WIRE W-128 20 IN. LONG	1	1
25	CORDAGE CO-213, 9 FT LONG	1	1
26	CORDAGE CO-213, 32 IN. LONG	1	1
27	CORDAGE CO-213, 23 IN. LONG	1	1
28	CORDAGE CO-213, 8 FT LONG	1	1
29	CORDAGE CO-213, 37 IN. LONG	1	1
30	CORDAGE CO-213, 31 IN. LONG	1	1
31	CORD, CO-278, SEE NOTE 4	1	1
32	CORD, CO-689	1	1
33	BRACKET, PER FIG. 110:	1	1
34	MAST BASE BRACKET	1	1
35	BRACKET B-210579	1	1
36	BRACKET C-7051196	1	1
37	BRACKET 7051180	1	1
38	BRACKET C-136627	1	1
39	BRACKET B-183663	1	1
40	BASE RING PLATE C-7051417	1	1
41	SPACER 7050875	1	1
42	SPACER A-261970	8	8
43	SPACER A-260933	9	9
44	SPACER A-227968	4	4
45	TERMINAL BOX C-100443	2	2
46	HEX HEAD CAP SCREW $\frac{3}{8}$ -24 X $\frac{5}{8}$ LONG	6	6
47	LOCKWASHER S.A.E. STD FOR $\frac{3}{8}$ SCREW	6	6
48	HEX HEAD CAP SCREW, $\frac{5}{16}$ -24 X $1\frac{3}{8}$ LONG	6	6
49	ROUND HEAD MACH SCREW, NO. 8-32 X $\frac{3}{8}$ LONG	32	32
50	ROUND HEAD MACH SCREW, NO. 10-32 X $\frac{5}{8}$ LONG	2	2
51	ROUND HEAD MACH SCREW, NO. 6-32 X $\frac{1}{2}$ LONG	4	4
52	STOP NUT, $\frac{5}{16}$ -24 STD	6	6
53	LOCKWASHER, S.A.E. STD FOR NO. 8 SCREW	33	33
54	LOCKWASHER, S.A.E. STD FOR NO. 6 SCREW	4	4
55	LOCKWASHER, S.A.E. STD FOR NO. 10 SCREW	2	2
56	SHAKEPROOF WASHER, $\frac{5}{16}$ IN. I.E.T.	12	12
57	ANTENNA (PHANTOM) A-62	1	1
58	WASHER, RUBBER (SIG C STOCK NO. 3Z11004-7)	1	1

TM 2754-9 (2)

Figure 12—Continued.

length of Wire W-128 (item 24) provided. Refer to TM 11-600 for alinement instructions.

f. HOOKS AND CLIPS. Secure the microphone and headset hooks (items 21) to the spacers (item 44) provided in the vehicle, as shown in figure 12.

g. MAST BASE AB-15/GR. To install this mast base (item 7, fig. 12) through the hole in the top plate of the mast base bracket (turret right rear), refer to figure 11 and proceed as follows:

- (1) Remove the three bolts that secure the top plate to the bracket.
- (2) Disassemble the mast base by holding the lower insulator (item 7) and turning the mast body counterclockwise.
- (3) Place the upper insulator (item 5) over the bracket top plate hole. A large neoprene washer (item 6) is cemented to each insulator (items 5 and 7).

- (4) Place a small neoprene washer (item 4) over item 5.
- (5) Insert the mast base body (item 2) through items 4, 5, 6, and 7. Insert the bolt (item 8) into the mast base body from underneath the top plate of the mast base bracket.
- (6) Turn the mast base body clockwise until the mast base is tightened securely. Apply a slight additional pressure, if necessary, with a hexagonal wrench so that the large toothed washer (item 14) makes good contact with the top plate.
- (7) Place the top plate on the mast base bracket and secure it by replacing the three bolts.

h. RADIO FREQUENCY CABLE RG-11/U. To prepare the length of Radio Frequency Cable RG-11/U for use as an antenna lead-in, proceed as follows:

- (1) Cut an 8-foot length of cable (item 23, fig. 12). Prepare one end of the cable as shown in figure 16, stripping back $4\frac{1}{2}$ inches of the outer insulation, $3\frac{1}{2}$ inches of the shielding, and 1 inch of the inner insulation, leaving 1 inch of the inner conductor and 1 inch of the shielding exposed.
- (2) Flare and fold the exposed end of the shielding back over the outer insulation. Place a clamp (item 16) over the shielding.
- (3) Solder-tin the tip of the inner conductor.
- (4) Refer to figure 11 for preparation of the other end of the cable for connection to Plug PL-259 (part of Mast Base AB-15/GR).
- (5) Strip 1 inch of the outer insulation, five-eighths inch of the shielding, and three-eighths inch of the inner insulation, leaving three-eighths inch of the inner conductor and three-eighths inch of the shielding exposed.
- (6) Place a rubber washer (fig. 12, item 58) over feed-through Insulator IN-101. Pass the insulator over the cable flange first.
- (7) Remove Plug PL-259 from the mast base, unscrew the coupling nut from the plug, and pass the nut over the cable end.
- (8) Screw the insert assembly (item 16) over the cable and solder the cable inner conductor tip to the contact of the insert assembly. Solder the assembly to the cable shield through the four holes in the insert assembly. Screw the coupling nut on the insert assembly.

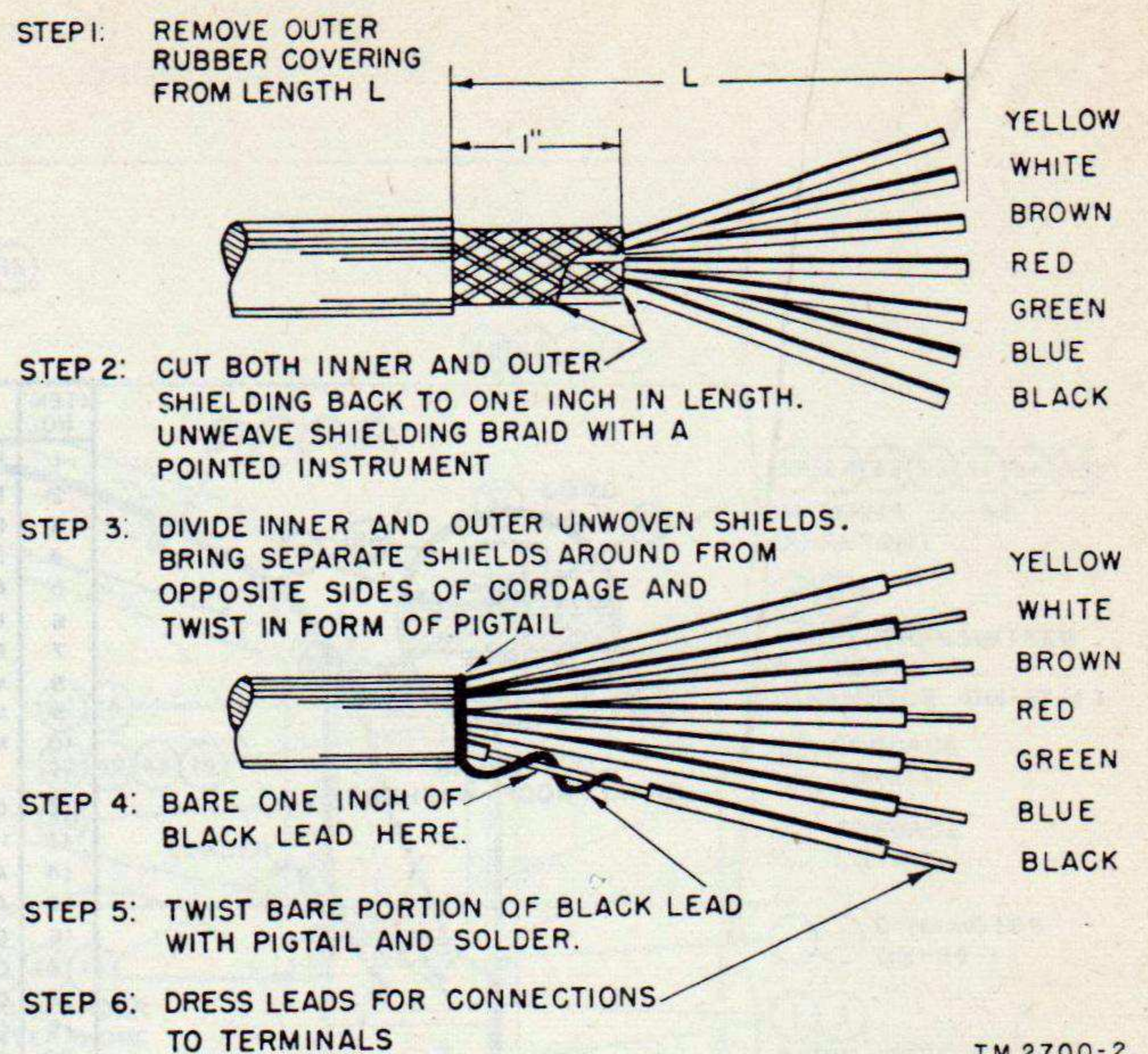

Figure 13. Preparation of Cordage CO-213.

- (9) Feed the cable from the inside of the turret, connector first, through the hole in the mast base bracket. Secure Insulator IN-101 in the hole with the clip provided. Place a hose clamp (item 15) over Plug PL-259 and secure the plug to the adapter (item 9). Tighten the hose clamp.
- (10) Route and secure the cable within the turret as shown on figure 12, connecting the prepared tip of the cable to the TR binding post on Mounting FT-237-(). Fasten the cable clamp to the mounting by means of the ground screw provided on the mounting. If the mounting is not provided with a ground screw, follow the procedure shown in figure 16 for securing the clamp.

i. MAST BASE MP-48 OR MP-48-A. When Mast Base MP-48 or MP-48-A is issued with the installation kit, see figure 7 systems J and H, for assembly. When Mast Sections MS-51, MS-52, and MS-53 are used with Mast Base MP-48 or MP-48-A, place Clamps MC-423 and MC-424 on the mast section joints to prevent loss of the mast sections (fig. 7).

j. RADIO TRANSMITTER BC-604-(). If Dynamotor DM-37-() (fig. 12, item 4) is not installed in the transmitter (item 2), proceed as follows:

- (1) Loosen the two screw locks on the front

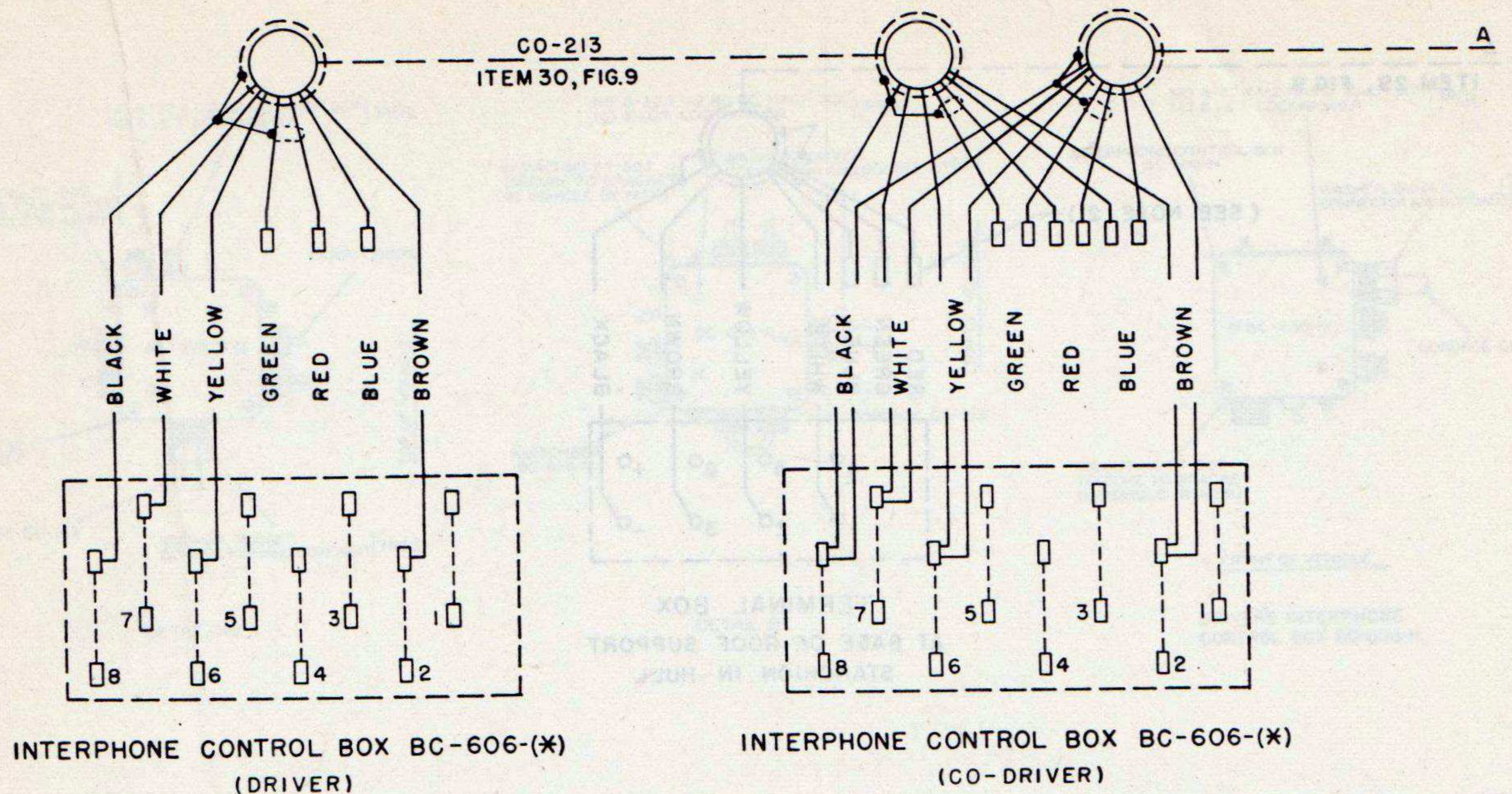

INTERPHONE CONTROL BOX BC-606-(*)
(DRIVER)

INTERPHONE CONTROL BOX BC-606-(*)
(CO-DRIVER)

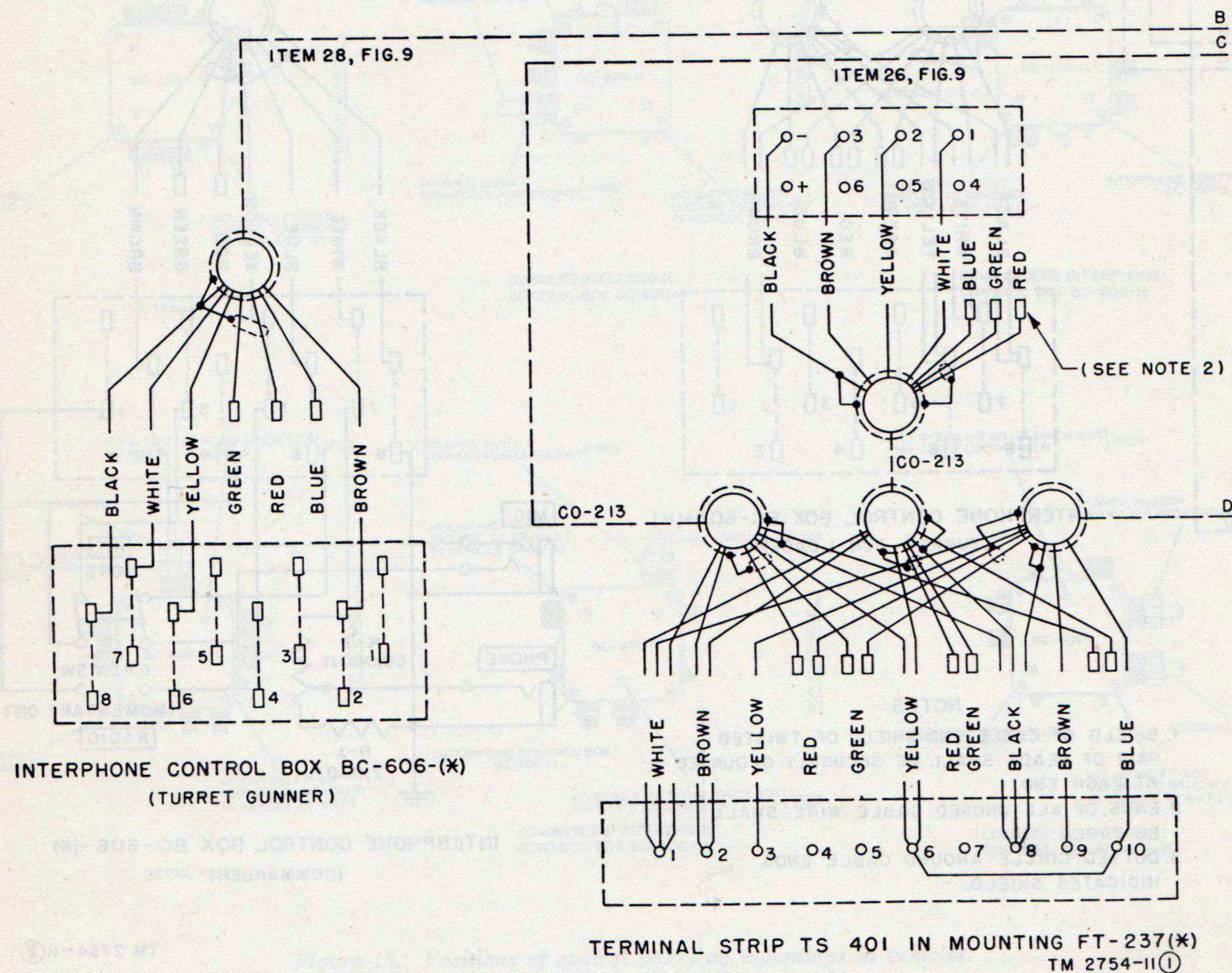

INTERPHONE CONTROL BOX BC-606-(*)
(TURRET GUNNER)

TERMINAL STRIP TS 401 IN MOUNTING FT-237(*)
TM 2754-II ①

Figure 14. Wiring diagram of interphone equipment for Radio Set SCR-508-(*) or SCR-528-(*) and associated interphone equipment in Tank, Light, M24.

A
ITEM 29, FIG. 9

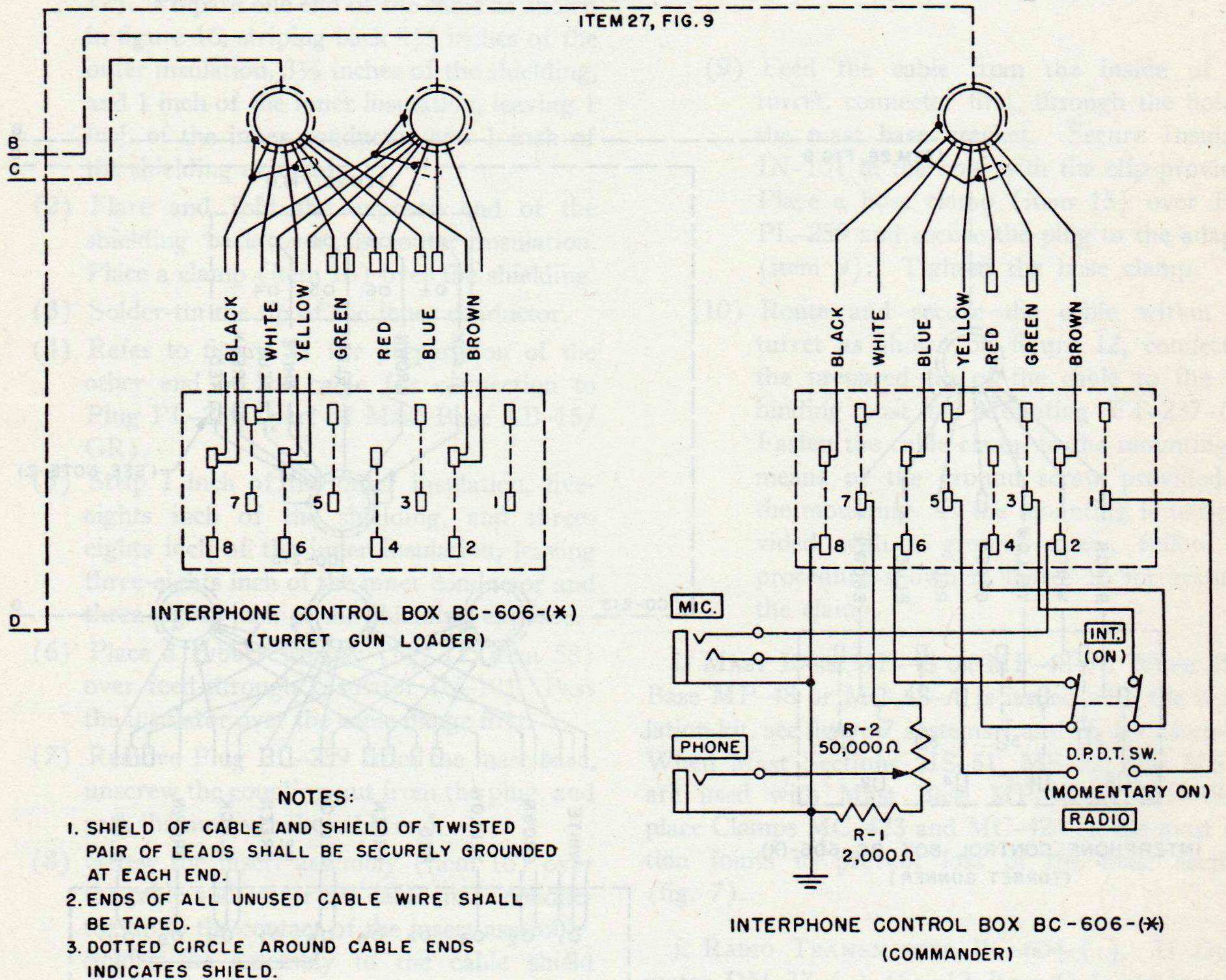
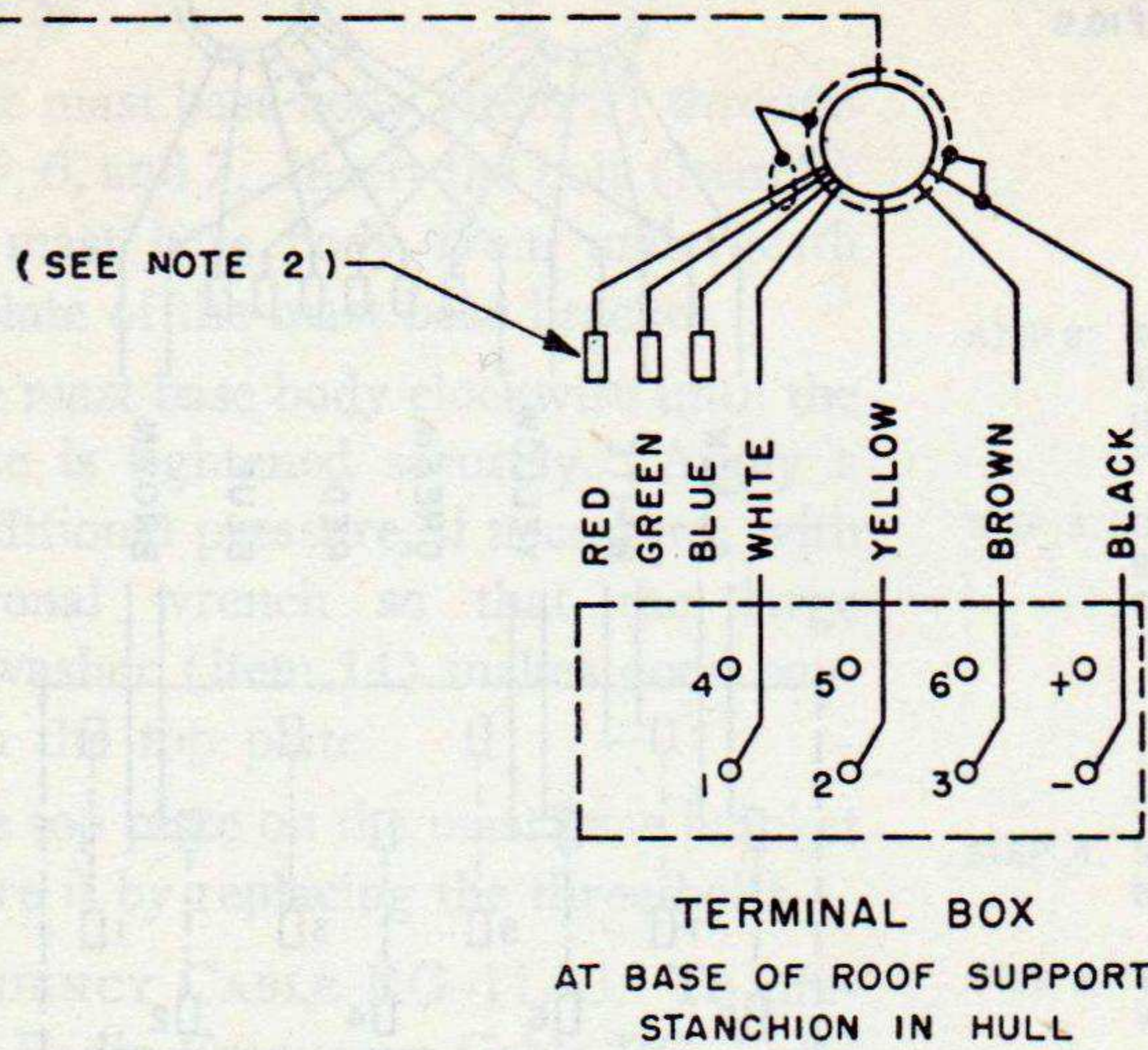

TM 2754-11(2)

Figure 14—Continued.

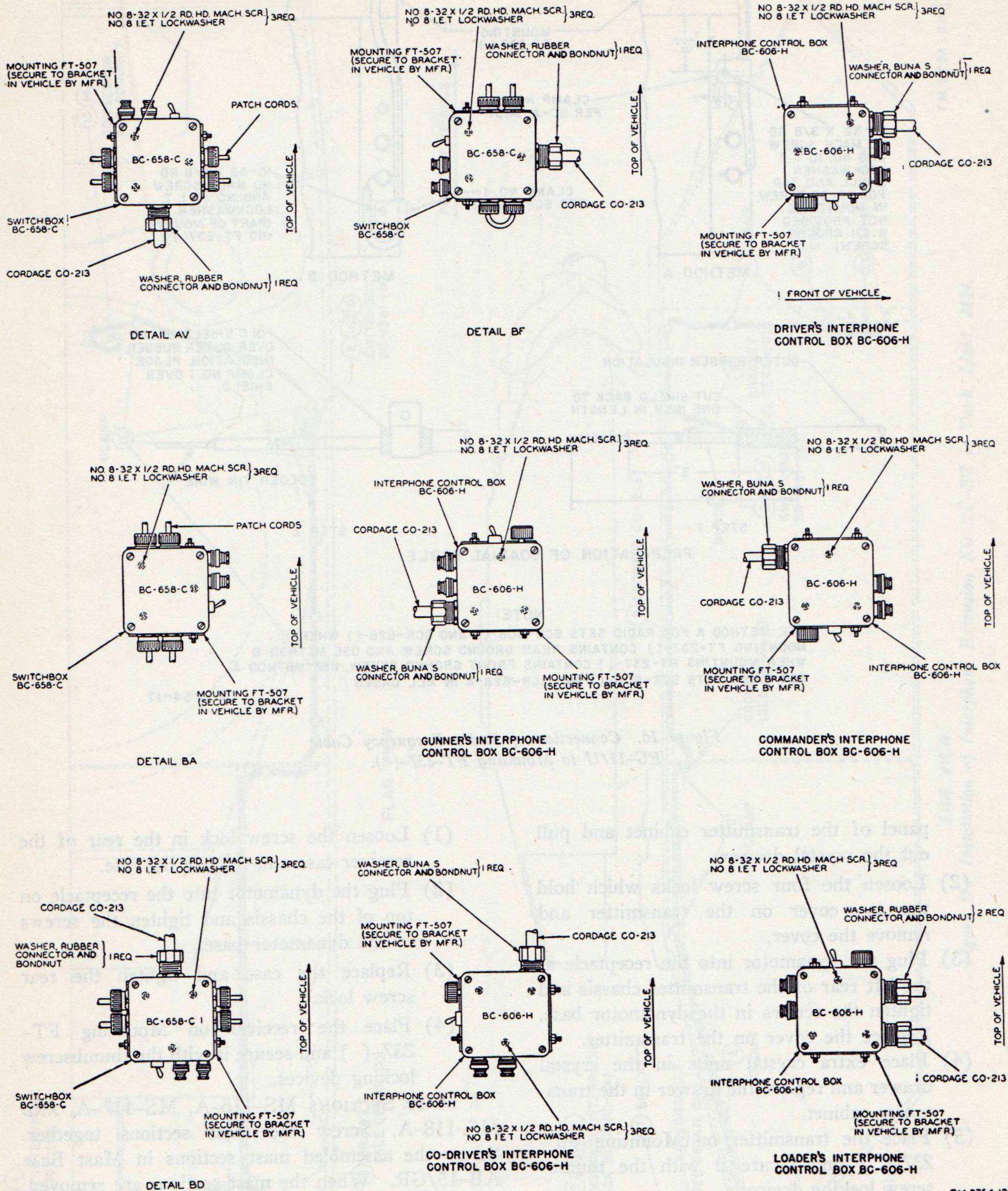

TM 2754-12

Figure 15. Positions of control boxes on mountings in vehicles.

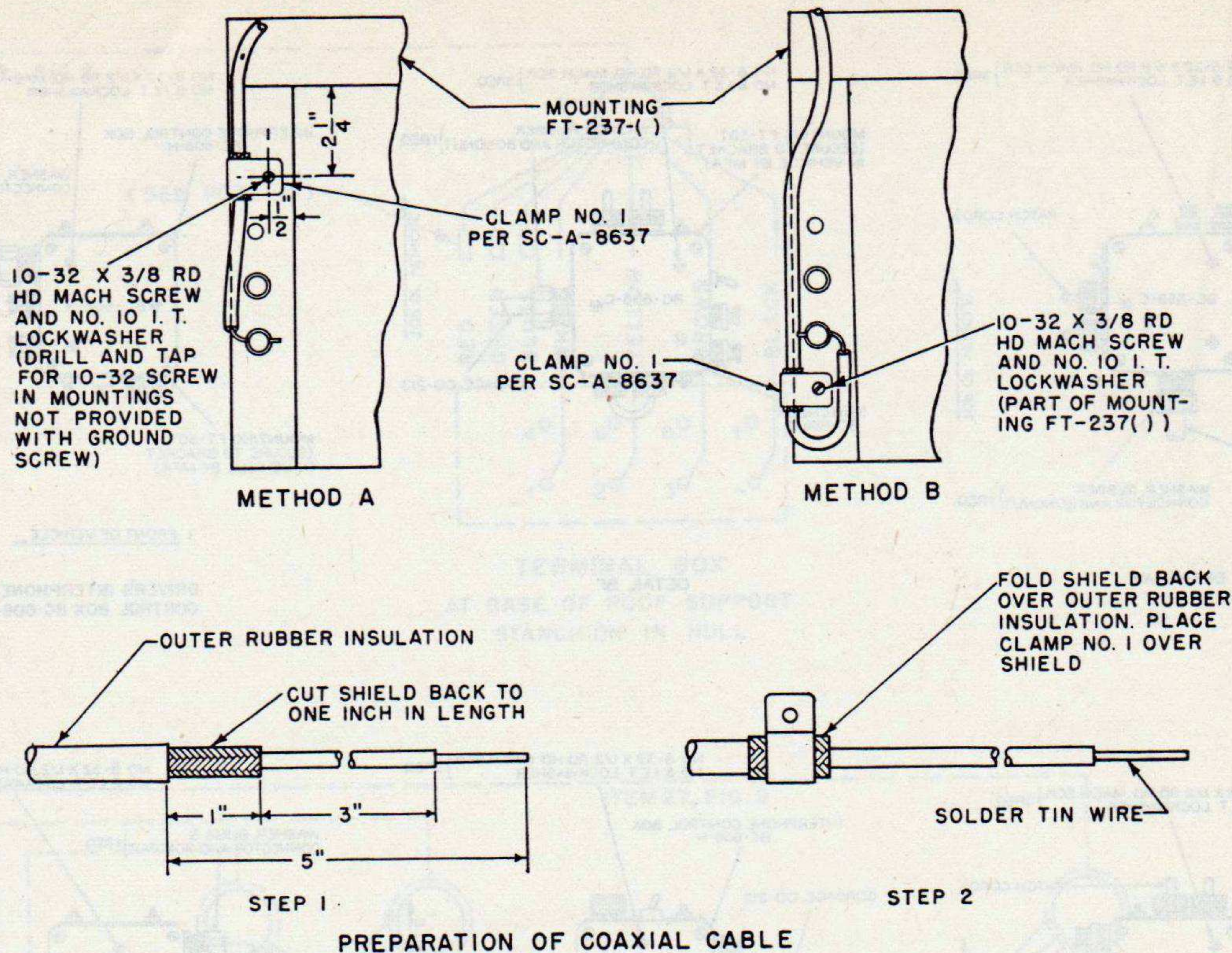

NOTE:
 USE METHOD A FOR RADIO SETS SCR-508-() AND SCR-528-() WHEN MOUNTING FT-237-() CONTAINS REAR GROUND SCREW AND USE METHOD B WHEN MOUNTING FT-237-() CONTAINS FRONT GROUND SCREW. USE METHOD A FOR RADIO SETS SCR-608-() AND SCR-628-A IN ALL CASES

TM 2754-17

Figure 16. Connection of Radio Frequency Cable RG-11/U to Mounting FT-237-(*)

panel of the transmitter cabinet and pull out the crystal drawer.

- (2) Loosen the four screw locks which hold the top cover on the transmitter and remove the cover.
- (3) Plug the dynamotor into the receptacle at the left rear of the transmitter chassis and tighten the screws in the dynamotor base. Replace the cover on the transmitter.
- (4) Place extra crystal units in the crystal drawer and replace the drawer in the transmitter cabinet.
- (5) Place the transmitter on Mounting FT-237-() and secure it with the thumbscrew locking devices.

k. RADIO RECEIVER BC-603-() If Dynamotor DM-36-() (fig. 12, item 3) is not installed in the receiver, proceed as follows:

- (1) Loosen the screw lock in the rear of the receiver case and remove the case.
- (2) Plug the dynamotor into the receptacle on top of the chassis and tighten the screws in the dynamotor base.
- (3) Replace the case and tighten the rear screw lock.
- (4) Place the receiver on Mounting FT-237-() and secure it with the thumbscrew locking devices.

l. MAST SECTIONS MS-116-A, MS-117-A, AND MS-118-A. Screw the mast sections together. Screw the assembled mast sections in Mast Base AB-15/GR. When the mast sections are removed, disassemble and stow them in Roll BG-56.

m. SPARE HEADSETS, CORDS, AND TUBES. Stow in Chest CH-264. See chart supplied with chest for location of items.

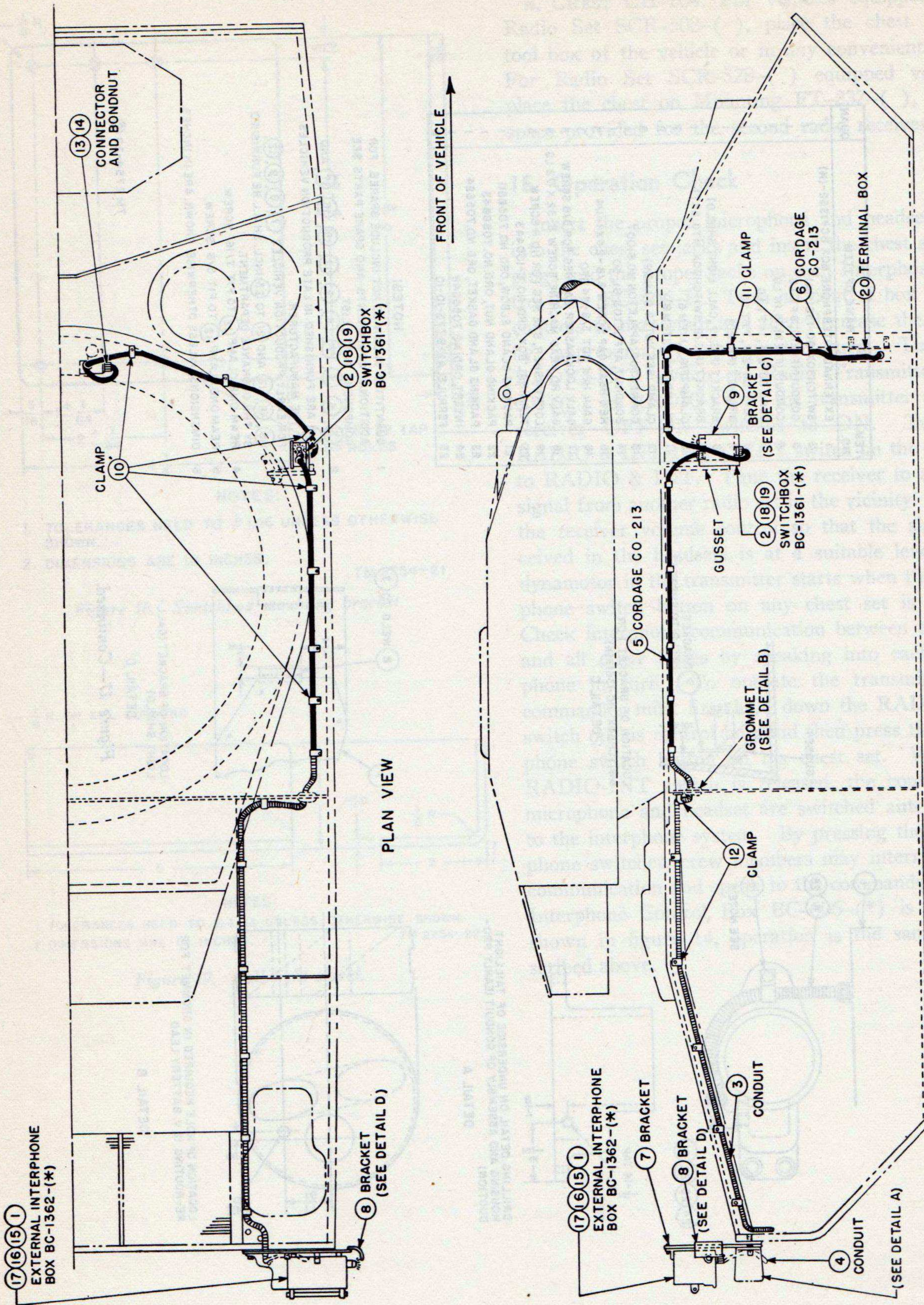

TM 2754-20①

Figure 17. Installation of Interphone Extension Kit RC-298 in Tank, Light, M24.

ITEM NO.	NAME OF ITEM	QUAN
1	EXTERNAL INTERPHONE BOX BC-1362-(*)	1
2	SWITCHBOX BC-1361-(*)	1
3	CONDUIT (FLEX), 9 FT. LG.	1
4	CONDUIT (FLEX), 16 IN. LG.	1
5	CORD CO-213, 14 FT. LG.	1
6	CORD CO-213, 7 FT. LG.	1
7	BRACKET (FIG. 20)	1
8	BRACKET (FIG. 19, CALL LIGHT SHIELD)	1
9	BRACKET (FIG. 18, SWITCHBOX MTG BKT)	1
10	CLAMP (FIG. 6, ITEM 6)	7
11	CLAMP (FIG. 6, ITEM 9)	2
12	CLAMP (SEE NOTES 5 AND 9)	8
13	CONNECTOR, APPLETON NO. 61007	1
14	BOND NUT, APPLETON BL-50	1
15	HEX HEAD CAP SCREW 3/8-24 X 1-1/4 LG.	3
16	GALV. HEX NUT 3/8-24 STD	3
17	GALV. LOCKWASHER SAE REG FOR 3/8 SCREW	3
18	GALV. RD HEAD MACHINE SCREW 8-32 X 1/2 LG.	3
19	LOCKWASHER, SAE REG FOR NO. 8 SCREW	3
20	TERMINAL BOX, ORD. NO. C-100443	1
21	PACKING GLAND ELBOW, ORD. NO. 7056611	1
22	PACKING GLAND NUT, ORD. NO. 7056643	1
23	PACKING GLAND GASKET, ORD. NO. 7056624	1
24	INSERT, ORD. NO. 7056648	1
25	FERRULE, AN-9775-10-10	2

NOTES:

- 1 QUANTITIES SHOWN DO NOT INCLUDE SPARES. FOR ADDITIONAL COMPONENTS AND SPARE PARTS SEE COMPONENT PARTS LIST.
- 2 (3), (4), (5), (7), (8), (9), (12), (15), (16), (17), AND (20) ARE FURNISHED IN LATE PRODUCTION VEHICLES BY THE MANUFACTURER.
- 3 FOR EARLY PRODUCTION VEHICLES (7), (8), (9), (12), (15), (16), (17) AND (21) TO (25) INCL. SHALL BE FURNISHED BY THE ORDNANCE DEPARTMENT.
- 4 REAM ONE CLAMP (12) TO FIT 7/16 SCREW.
- 5 REAM ONE CLAMP (12) TO FIT 5/8 SCREW.
- 6 DIMENSIONS, UNLESS OTHERWISE SHOWN, ARE IN INCHES.

TM 2754-20 (2)

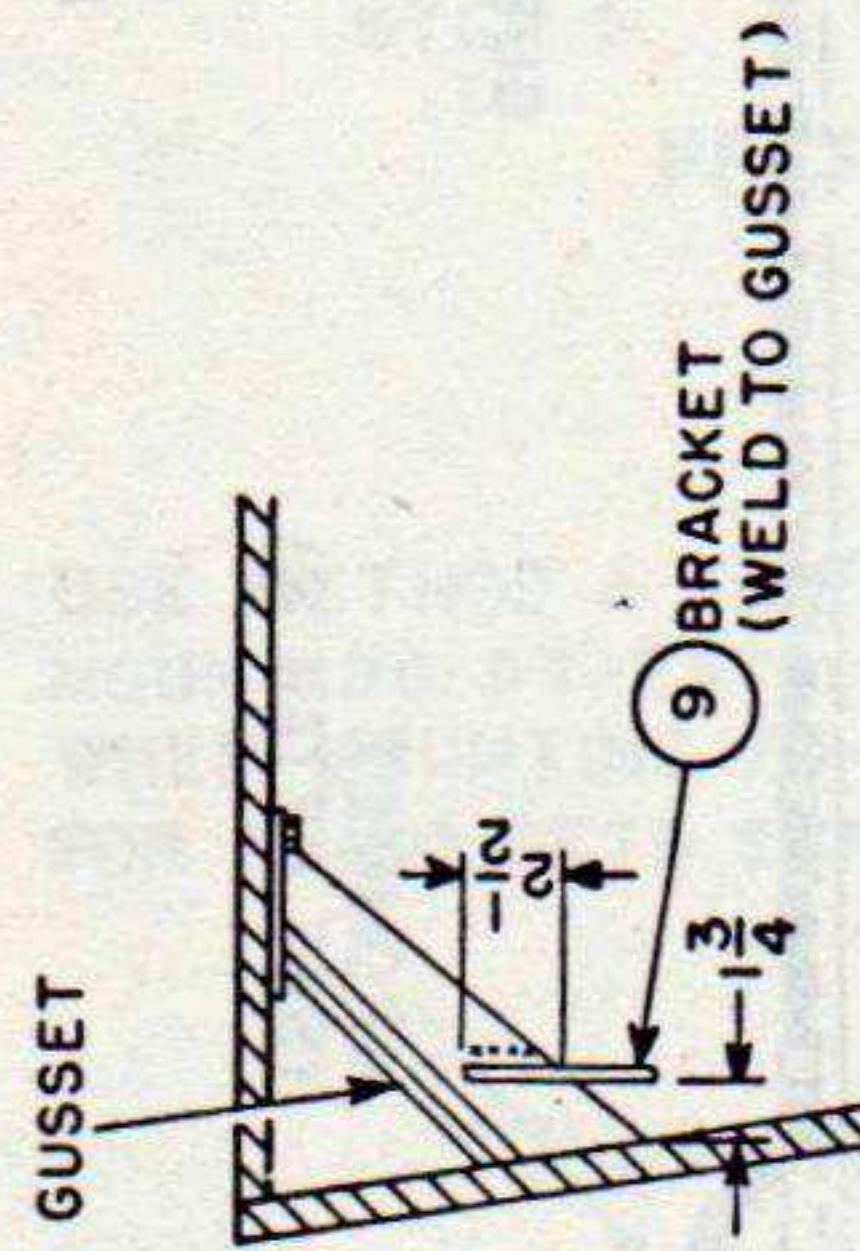
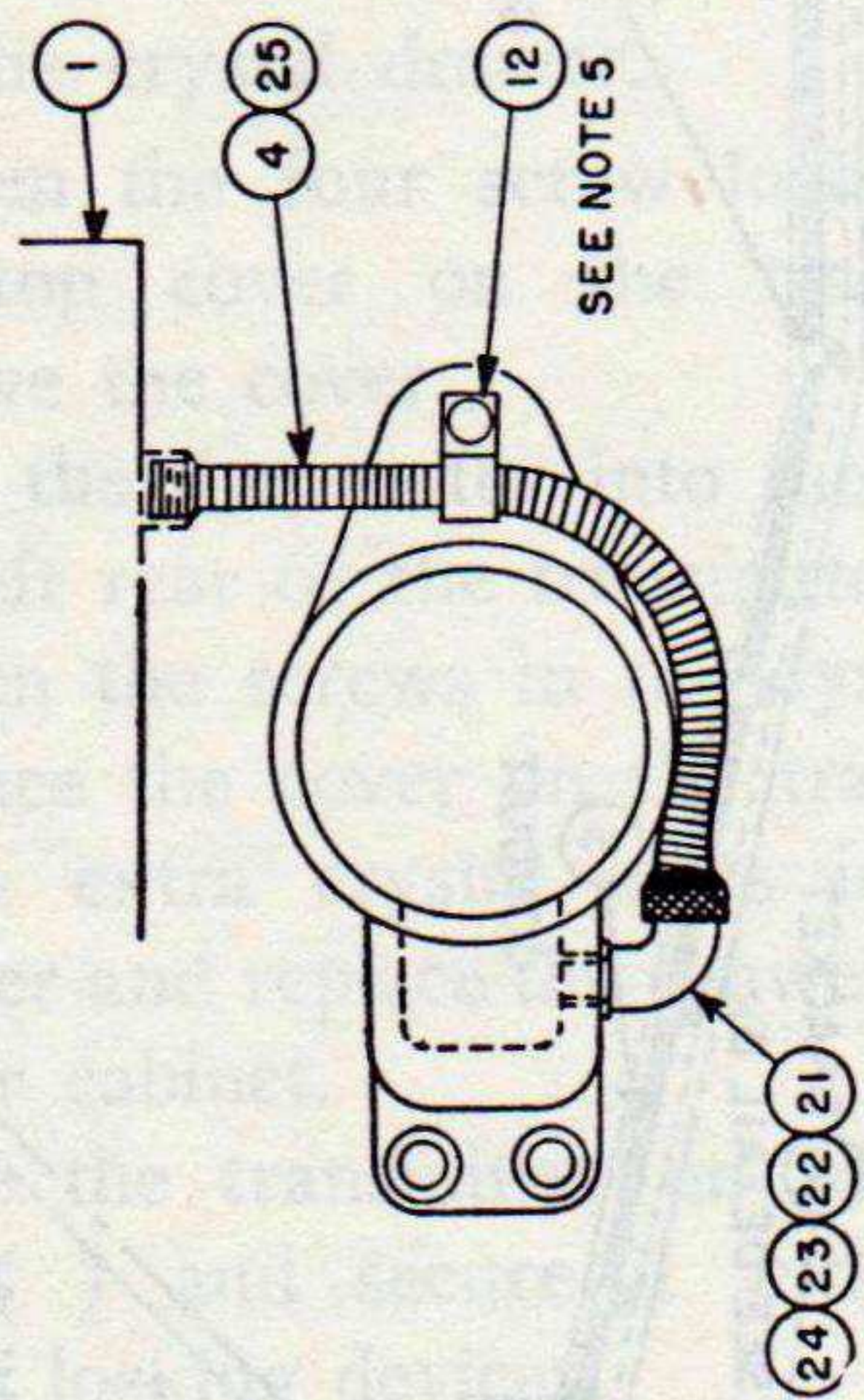

LOCATION OF BRACKET FOR SWITCHBOX BC-1361-(*)
DETAIL C

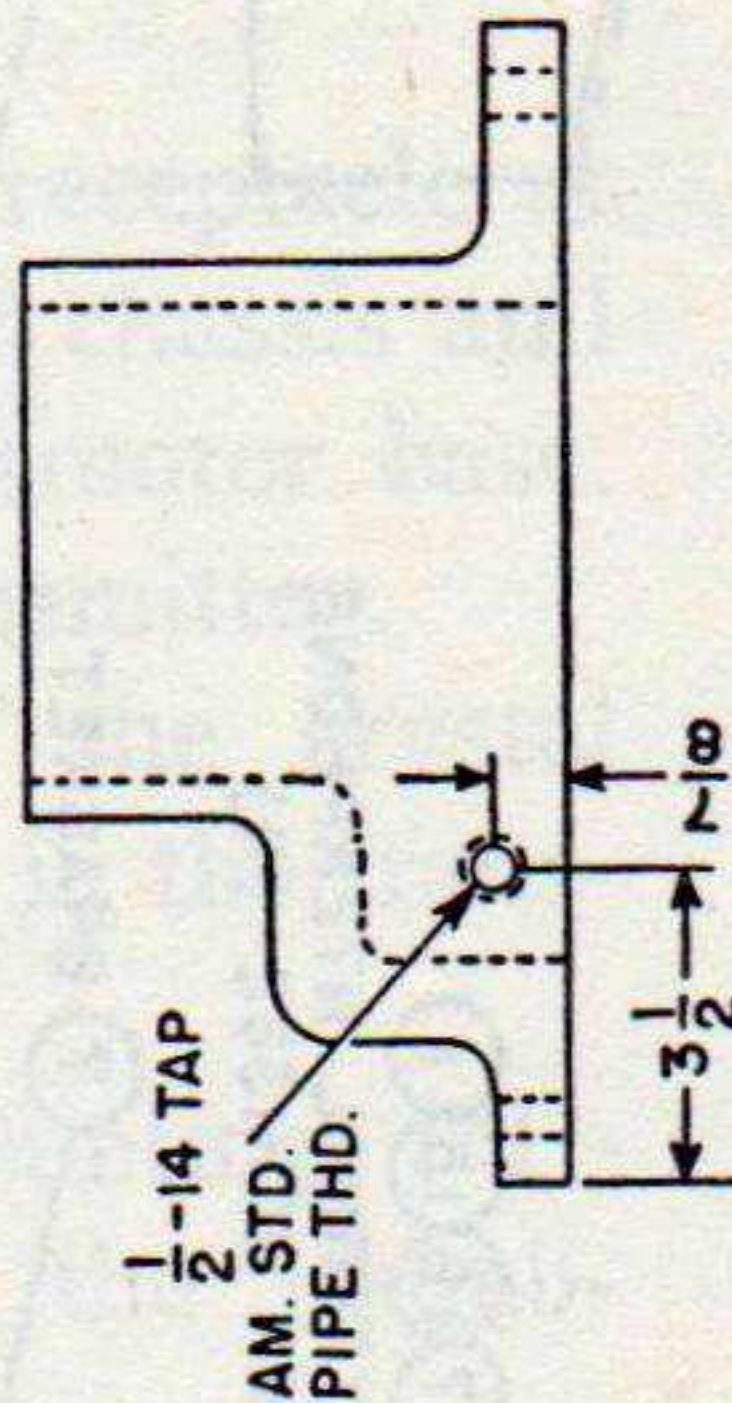

DRILLING DETAIL ON UNDERSIDE OF TAILLIGHT HOUSING AND ASSEMBLY OF CONDUIT (EARLY PRODUCTION)
DETAIL A

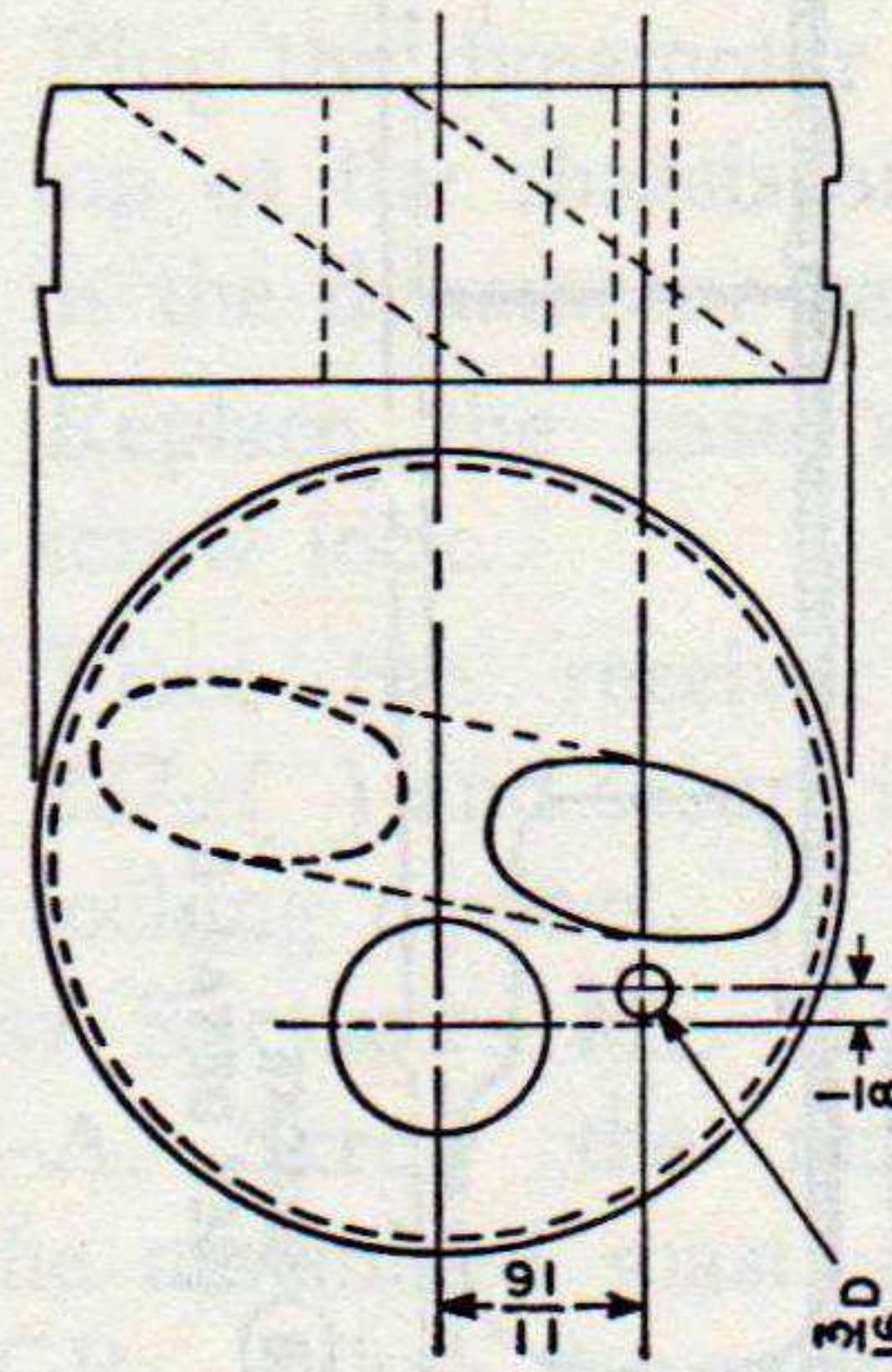

LOCATION OF HOLE REQUIRED IN GROMMET FOR RE-ROUTING 12 V. BATTERY LEAD
DETAIL B

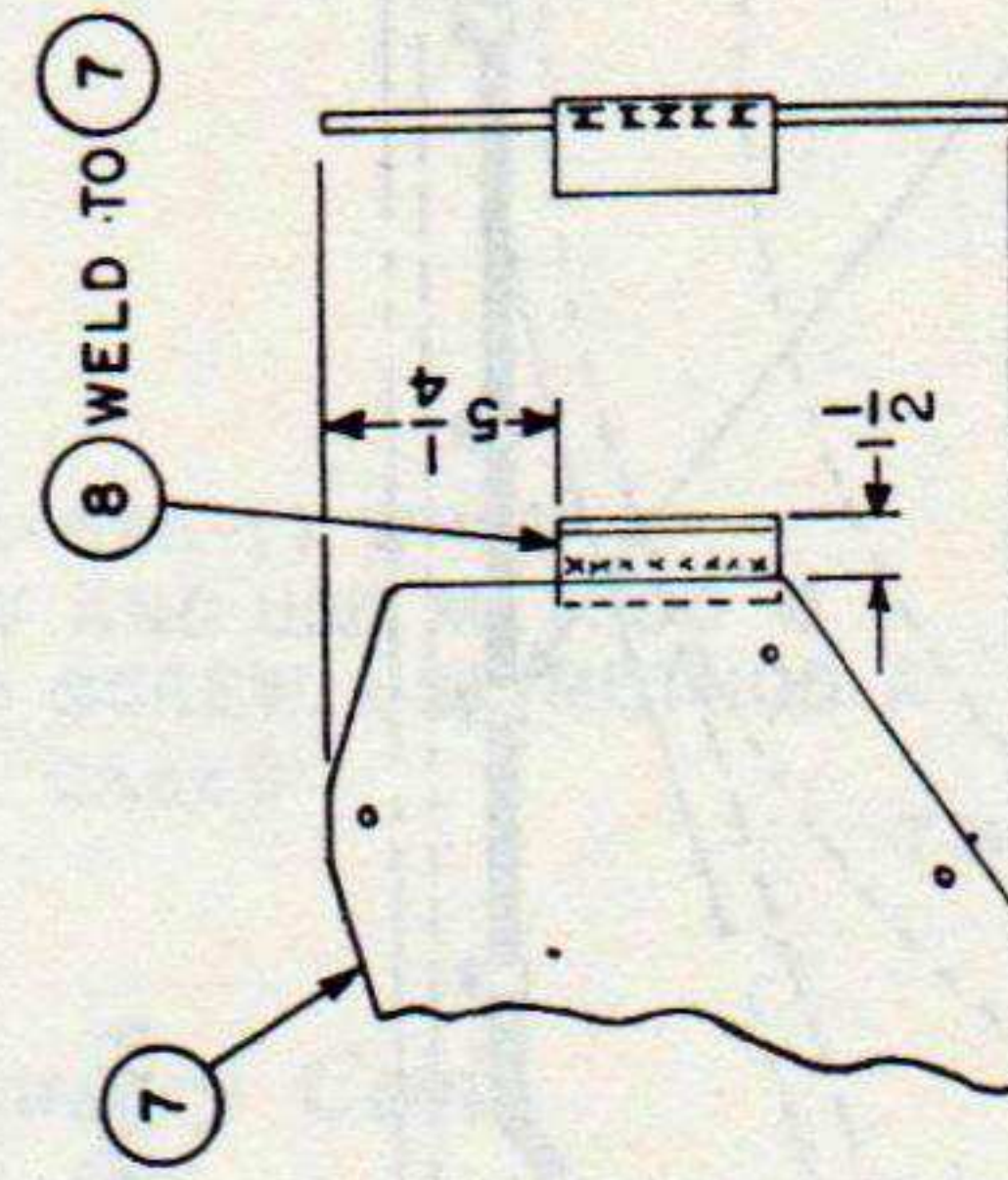

LOCATION OF BRACKET (CALL-LIGHT SHIELD)
DETAIL D

Figure 17—Continued.

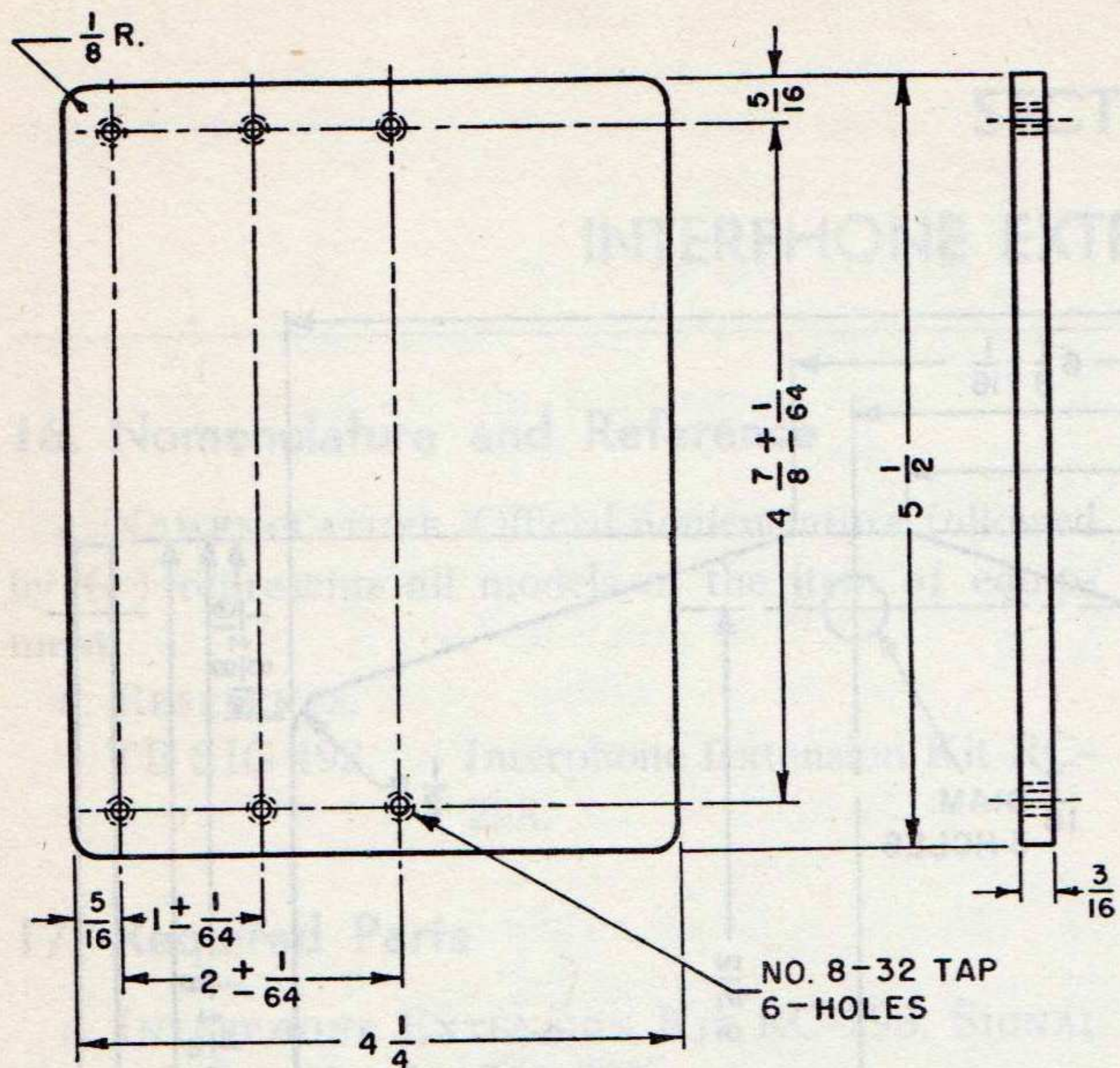

NOTES:

1. TOLERANCES HELD TO $\pm 1/16$ UNLESS OTHERWISE SHOWN.
2. DIMENSIONS ARE IN INCHES.

TM 2754-21

Figure 18. Switchbox mounting bracket.

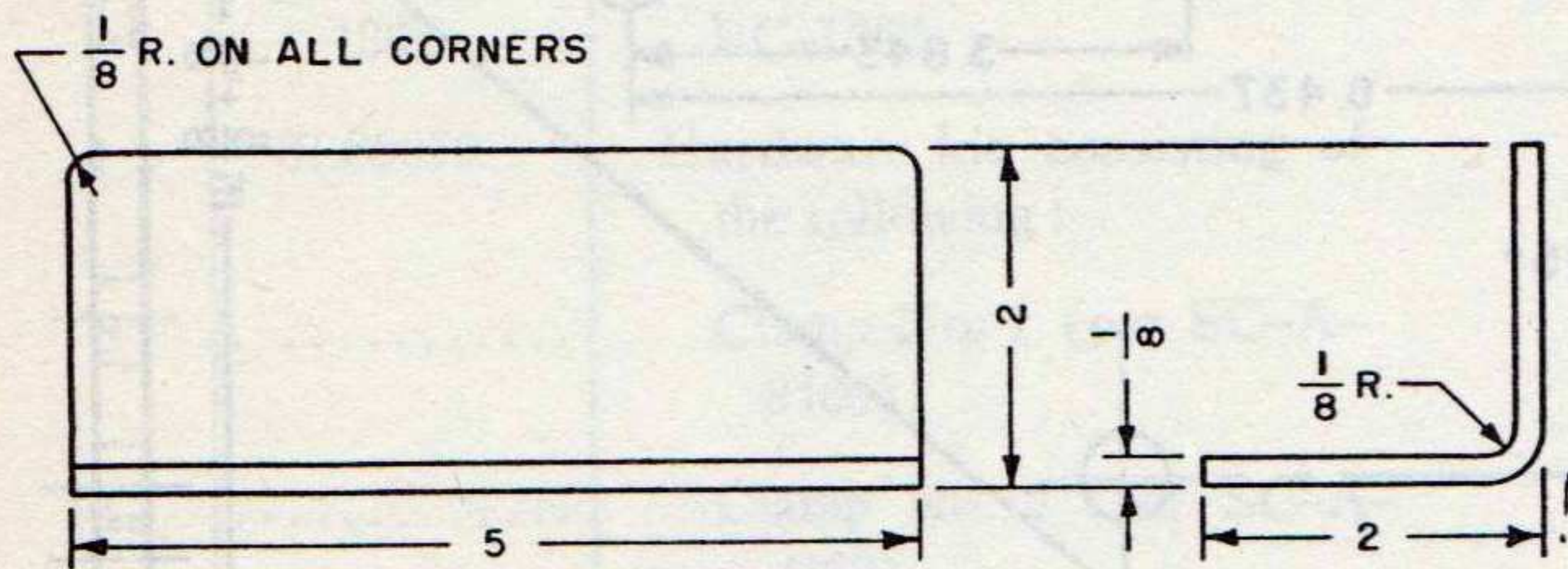

NOTES:

1. TOLERANCES HELD TO $\pm 1/16$ UNLESS OTHERWISE SHOWN.
2. DIMENSIONS ARE IN INCHES.

TM 2754-22

Figure 19. Call light shield.

n. CHEST CH-264. For vehicles equipped with Radio Set SCR-508-(), place the chest in the tool box of the vehicle or in any convenient place. For Radio Set SCR-528-() equipped vehicles, place the chest on Mounting FT-237-(), in the space provided for the second radio receiver.

15. Operation Check

Insert the proper microphone and headset plugs into the chest set jacks and insert the chest set cord plugs into the proper jacks on each Interphone Control Box BC-606-H. Turn all control box volume controls to maximum and then decrease the setting by approximately one-quarter turn. Turn the RADIO-INT switch on Radio Transmitter BC-604-() to RADIO; turn the transmitter and the receiver OFF-ON switches to ON. Turn the RADIO & INT-INT ONLY switch on the receiver to RADIO & INT. Tune the receiver to a strong signal from another radio set in the vicinity. Adjust the receiver volume control so that the signal received in the headsets is at a suitable level. The dynamotor in the transmitter starts when the microphone switch button on any chest set is pressed. Check interphone communication between each box and all other boxes by speaking into each microphone in turn. To operate the transmitter, the commander must first hold down the RADIO-INT switch on his control box and then press the microphone switch button on his chest set. When the RADIO-INT switch is released, the commander's microphone and headset are switched automatically to the interphone system. By pressing their microphone switches, crew members may interrupt radio communication and speak to the commander. When Interphone Control Box BC-606-(*) is wired as shown in figure 14, operation is the same as described above.

SECTION V

INTERPHONE EXTENSION KIT RC-298

16. Nomenclature and Reference

a. **NOMENCLATURE.** Official nomenclature followed by () represents all models of the item of equipment.

b. **REFERENCE.**

TB SIG 192 Interphone Extension Kit RC-298.

17. Required Parts

a. **INTERPHONE EXTENSION KIT RC-298, SIGNAL CORPS STOCK NO. 2C1963-298.**

Quantity	Signal Corps stock No.	Item
10 ft	6Z2252-2	Conduit, flexible, 1/2".
1	6Z3147	Connector and bondnut.
35 ft	3E2213	Cordage CO-213.
1	2C1738-1362	External Interphone Box BC-1362.
1	6L80070	Hardware kit, consisting of the following:
8	Clamp No. 1 (per SC-A-8460).
15	Clamp No. 2 (per SC-A-8460).
12	Clamp No. 4 (per SC-A-8637).
10	Lockwasher, No. 8.
8	Lockwasher, 1/4".
8	Srew cap, hex head, 1/4"-20 x 1/2".
10	Screw, machine, round head, No. 8-32 x 3/8".
10	Spacer (per SC-A-5249).
8	Spacer (per SC-A-8436).
4	Terminal (Amer Hdwe cat. No. 2844, or equal).
3	Terminal (Amer Hdwe No. 10, or equal).
2	6Z6812-3	Lamp LM-44.

Quantity	Signal Corps stock No.	Item
2	2Z6125-21	Lamp, lens.
1 oz	6G212.2	Sealing compound.
1	3Z983-22R	Switch, toggle.
1	2C7995-1361	Switchbox BC-1361.
1 roll	6N8583	Tape TL-83 (friction).
2	4B1109A.6/19	Transmitter cap.
2 ft	1B1220.7	Wire, No. 20, solid rubber-covered.

b. ORDNANCE PARTS.

Quantity	Item
1	Bracket (fig. 18).
1	Bracket (fig. 19), call light shield.
1	Bracket (fig. 20).
2	Ferrule (Amphenol No. 9775-10-10-).
7	Clamp No. 6 (per SC-A-8637).
2	Clamp No. 9 (per SC-A-8637).
7	Clamp No. 5 (per SC-A-8460).
1	Elbow, packing gland (Ord. No. 7056611).
1	Nut, packing gland (Ord No. 7056643).
1	Insert (Ord No. 7056648).
1	Gasket, packing gland (Ord No. 7056652).
3	Screw, cap, hex head, 3/8"-24 x 1 1/4".
3	Nut, hex, 3/8"-24.
3	Lockwasher, 3/8".

18. Precautions

a. **ELECTRICAL SYSTEMS.** Tank, Light, M24, is equipped with a 24-volt electrical system. Before installing any electrical equipment, make certain that the equipment is designed and/or properly adjusted for operation on a 24-volt supply. Radio sets, interphone equipment, and power supply units may be

damaged by operation on incorrect power sources.

b. HOLES AND BRACKETS. Brackets for Interphone Extension Kit RC-298 are installed prior to delivery of the vehicle. Instructions for any other holes and brackets are given in this section. Do not relocate any holes or brackets *unless it is absolutely necessary*.

19. Assembly and Installation

a. BRACKETS. Weld the bracket (item 9) (fig. 18) to the gusset in the vehicle hull near the codriver's interphone control box (fig. 17). Weld the call light shield bracket (fig. 19) to the bracket (item 7) (fig. 20) as shown in figure 17, detail D.

b. SWITCHBOX BC-1361. Connect Cordage CO-213 to Switchbox BC-1361 before installing the switchbox in the vehicle. As given in figure 17, items 5 and 6, the lengths of Cordage CO-213 are approximate *terminal to terminal* lengths; for a first or trial installation add about 10 percent to the given lengths. For additional installations cut the cordage to the exact lengths determined by the trial installation. Instructions for the preparation of the cordage and its connection to Switchbox BC-1361 are given below. Refer to figure 13.

- (1) Cut a 7-foot length of Cordage CO-213 (item 6) and a 14-foot length of Cordage CO-213 (item 5).
- (2) Strip the insulation from the one end of each length of Cordage CO-213, leaving 3½-inch leads.
- (3) Prepare 8½-inch leads on the other end of the short length of Cordage CO-213 (item 6) and 6-inch leads on the other end of Cordage CO-213 (item 5).
- (4) Insert the 3½-inch leads of the 7-foot and 14-foot lengths of Cordage CO-213 through the connector of Switchbox BC-1361. (Use the connector adjacent to the call lamp for entrance of the 14-foot length). Connect the cordage leads to the terminal strip in the switchbox as shown in figure 21. Splice the black leads together and tape the joint as indicated.
- (5) Coil the cordage and carry the cordage and the switchbox into the hull.
- (6) Mount Switchbox BC-1361 on the bracket (item 9) in the hull, using the hardware provided. Connect the leads of the short

length of Cordage CO-213 (item 6) to the terminals in the vehicle terminal box as shown in figure 21. Secure the cordage with clamps (item 11).

c. CONDUIT (ITEMS 3 AND 4).

- (1) Remove the cover plates from the gasoline tank compartment and the battery compartment.
- (2) Disconnect the 12-volt battery lead passing through the rubber grommet in the firewall. Punch, or drill, one hole ⅜-inch in diameter in the rubber grommet as shown in figure 17, detail B. Pass the 12-volt lead through the ⅜-inch hole, and reconnect the lead.
- (3) Cut a length of flexible conduit 16 inches long (item 4) and a length 9 feet long (item 3). Remove the connector coupling nut on External Interphone Box BC-1362, and ream the opening in the nut to a 1⅜-inch diameter. Place the coupling nut and the packing gland nut (item 22) over the 16-inch length of conduit (item 4). Solder the ferrules (item 25) to the conduit ends.
- (4) Route the length of cordage (item 5) through the hole in the rubber grommet formerly used for the 12-volt lead. Pass the longest length of conduit (item 3) over the cordage and pass the end of the conduit through the rubber grommet. Route the conduit and cordage as shown in figure 17, securing the conduit with the cable clamps as indicated, allowing about 6 inches slack in the conduit after the last clamp.
- (5) Remove the tail light lens, and disconnect the tail light wiring. Remove the gas tank and battery compartment cover. Loosen the three screws that secure the cast armor tail light shield, and remove the shield. Drill and tap a hole for ½"-14 American Standard pipe thread in the under side of the light shield as shown in figure 17, detail A. Secure the packing gland elbow (item 21) in the ½-inch hole drilled in the tail light. Pass the longer lengths of Cordage CO-213 (item 5) outward through the hole in the rear of the vehicle used for the tail light wire and outward through the elbow (item 21).
- (6) Place the bracket (item 7) between the tail light shield and the vehicle, and secure the

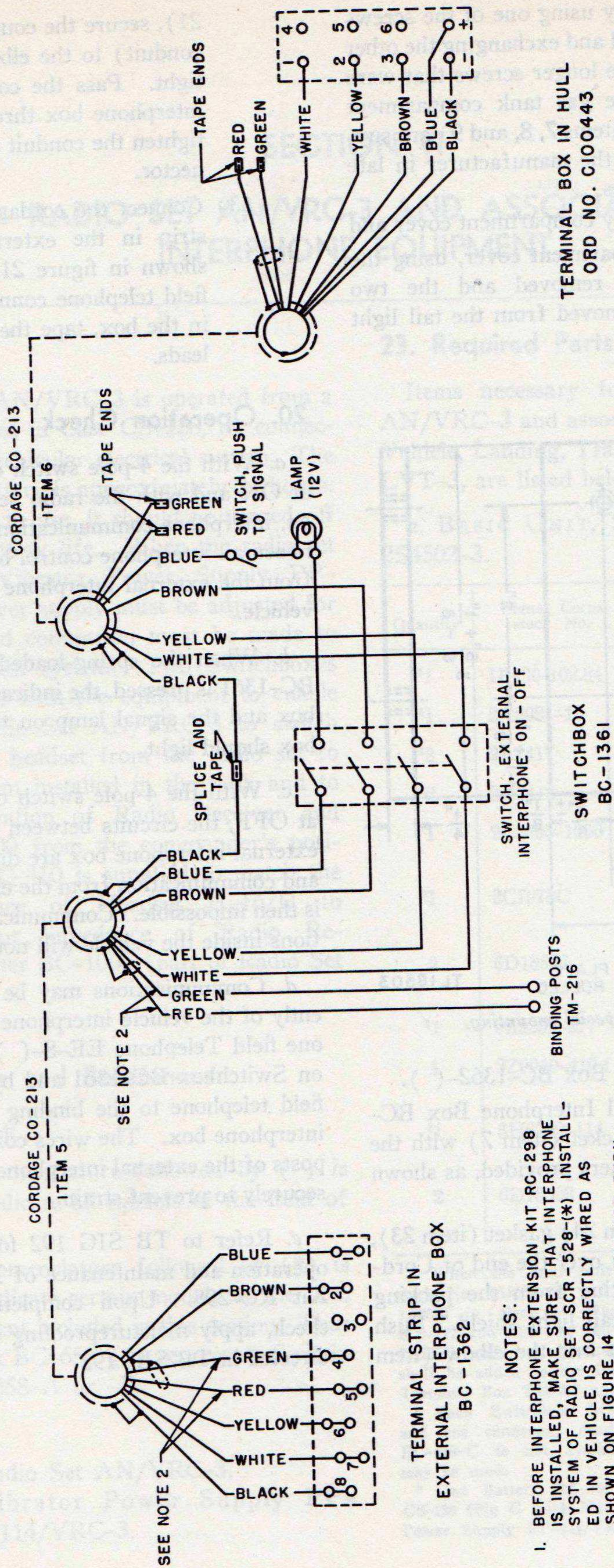

Figure 21. Interphone Extension Kit RC-298, wiring diagram.

- NOTES:
1. BEFORE INTERPHONE EXTENSION KIT RC-298 IS INSTALLED, MAKE SURE THAT INTERPHONE SYSTEM OF RADIO SET SCR-528-(*) INSTALLED IN VEHICLE IS CORRECTLY WIRED AS SHOWN ON FIGURE 14
 2. IF BINDING POSTS TM-216 ARE NOT FURNISHED ON BC-1361 OR BC-1362, TAPE ENDS OF RED AND GREEN WIRES.

bracket in place by using one of the screws originally removed and exchanging the other two for two of the longer screws that were removed from the gas tank compartment cover. Brackets (items 7, 8, and 9) are supplied installed by the manufacturer in late production vehicles.

- (7) Replace the battery compartment cover and the gas tank compartment cover, using the screws originally removed and the two shorter screws removed from the tail light housing.

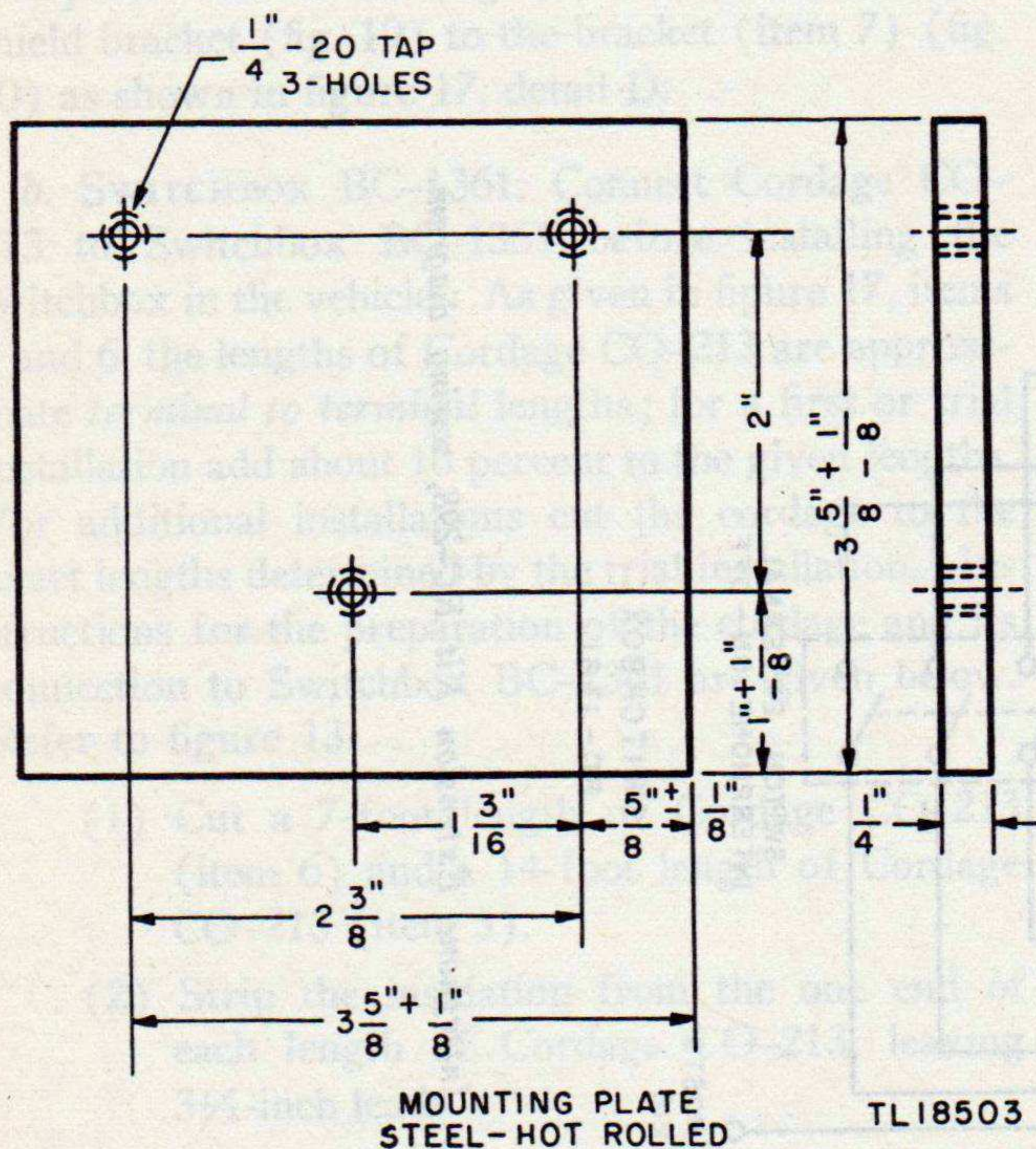

Figure 22. Bracket, special mounting.

d. EXTERNAL INTERPHONE BOX BC-1362-().

- (1) Secure the External Interphone Box BC-1362-() to the bracket (item 7) with the screws and lockwashers provided, as shown in figure 17.
- (2) Place the insert (item 24) gasket (item 23), and conduit (item 4) over the end of Cordage CO-213 projecting from the packing gland elbow in the tail light shield. Push the insert and gasket into the elbow (item

21), secure the coupling nut (item 22) (on conduit) to the elbow, drawing the nut up tight. Pass the cordage into the external interphone box through the connector, and tighten the conduit coupling nut to the connector.

- (3) Connect the cordage leads to the terminal strip in the external interphone box as shown in figure 21. If binding posts for field telephone connection are not provided in the box, tape the red and green cordage leads.

20. Operation Check

a. With the 4-pole switch of Switchbox BC-1361 at ON and with the radio set in the vehicle turned on, interphone communication should be possible between all interphone control boxes in the vehicle and from the external interphone box at the rear of the vehicle.

b. When the spring-loaded switch of Switchbox BC-1361 is pressed, the indicator lamp on the switchbox and the signal lamp on the external interphone box should light.

c. With the 4-pole switch of Switchbox BC-1361 at OFF, the circuits between the switchbox and the external interphone box are disconnected. Signaling and communication from the external interphone box is then impossible. Communications between all positions inside the vehicle will not be affected.

d. Communications may be established independently of the vehicle interphone system by connecting one field Telephone EE-8-() to the binding posts on Switchbox BC-1361 and by connecting a second field telephone to the binding posts in the external interphone box. The wires connected to the binding posts of the external interphone box must be fastened securely to prevent strain.

e. Refer to TB SIG 192 for information on the operation and maintenance of Interphone Extension Kit RC-298. Upon completion of the operation check, apply moistureproofing and fungiproofing as directed in TB SIG 192.

SECTION VI

RADIO SET AN/VRC-3 AND ASSOCIATED INTERPHONE EQUIPMENT

21. General

When Radio Set AN/VRC-3 is operated from a battery pack contained in Case CS-128, no connection is made to the vehicular electrical system. The service life of one battery is approximately 24 hours. When the set is not in use, it should be turned off so as to conserve battery life. When the radio set is operated from Vibrator Power Supply PP-114/VRC-3, the power supply must be adjusted for 24-volt operation and connection must be made to the vehicular electrical system. Two Switchboxes BC-658 are supplied with the equipment to enable the operator of Radio Set AN/VRC-3 to switch his microphone and headset from the radio set to the interphone system installed in the tank and to permit remote operation of Radio Receiver and Transmitter BC-1000 from the commander's position. Transformer C-410 is supplied to match the 8,000-ohm impedance of Headset H-16/U to the 250-ohm output impedance of Radio Receiver and Transmitter BC-1000 (part of Radio Set AN/VRC-3).

22. Nomenclature and References

a. NOMENCLATURE.

- (1) Official nomenclature followed by () is used to indicate all models of the item of equipment.
- (2) Official nomenclature followed by (*) is used to indicate certain models of the item of equipment included in this section. Thus Switchbox BC-658-(*) represents Switchbox BC-658-A or -B.

b. REFERENCES.

TM 11-637 Radio Set AN/VRC-3.
 TM 11-983 Vibrator Power Supply PP-114/VRC-3.

23. Required Parts

Items necessary for installation of Radio Set AN/VRC-3 and associated interphone equipment in Vehicle, Landing, Tracked (Unarmored), Mark III, LVT-3, are listed below:

a. BASIC UNIT, SIGNAL CORPS STOCK NO. 2S4502-3.

Quantity	Signal Corps stock No.	Item
¹ 1	1F430-102.84	Cord CG-102/TRC-7 (7 ft. 0").
¹ 1	2A2081-15	Mast Base AB-15/GR.
¹ 2	2A2417	Mast Section MS-117-A.
¹ 2	2A2418	Mast Section MS-118-A.
1	2C5395-1000	Radio Receiver and Transmitter BC-1000.
² 1	2C7978C	Switchbox BC-658-C (per SC-D-14703).
2	6D13502	Technical manual, TM 11-637 (for AN/VRC-3).
¹ 1	2Z9299-217	Terminal Box TM-217.
1	2Z9940-410.1	Transformer C-410 (per SC-D-7996).
² 1	3H6702-114	Vibrator Power Supply PP-114/VRC-3.
2	6D13503	Technical manual, TM 11-983 (for PP-114/VRC-3).

¹ When the basic unit contains Mast Base MP-48-A (Sig C stock No. 2A2088-48) and Mast Section MS-53 (Sig C stock No. 2A2353 in place of Mast Base AB-15/GR and Mast Sections MS-117 and MS-118, two Mast Sections MS-52 (Sig C stock No. 2A2352) and two Clamps MC-424 (Sig C stock No. 2Z2651-424) shall be added to the installation unit. Cord CG-102/TRC-7 and Terminal Box TM-217 are issued only with Mast Base AB-15/GR.

² Each Switchbox BC-658-C includes one Mounting FT-507 and one connector, conduit, Appleton No. 61007. If Switchbox BC-658-C is not available, Switchbox BC-658-A or BC-658-B may be used.

³ One Battery BA-70 (Sig C stock No. 3A70) and one Case CS-128 (Sig C stock No. 6F428) may be issued instead of Vibrator Power Supply PP-114/VRC-3.

b. INSTALLATION UNIT, SIGNAL CORPS STOCK NO. 2S4502-3-V85/50.

Quantity	Signal Corps stock No.	Item
2	2Z299-359	Adapter M-359.
2	2Z1250.112	Bracket for Switchbox BC-658-C (per SC-A-7327).
1	4B417-4	Chest Set TD-4 includes: Chest Unit T-51. Cord CD-802.
1	4B419-51	
1	3E1802	Cordage CO-144 (for BC-658-C).
6 ft	3E2144	
6 ft	3E2145	Cordage CO-145 (for BC-658-C).
8 ft	3E2213	Cordage CO-213. Hardware kit, includes:
1	6L50-VRC-3V85	
2	2Z2637-3	Clamp No. 3 (per SC-A-8637).
3	2Z2637-4	Clamp No. 4 (per SC-A-8637).
3	2Z2637-7	Clamp No. 7 (per SC-A-8637).
3	2Z2637-9	Clamp No. 9 (per SC-A-8637).
3	2Z2637-1	Clamp No. 1 (per SC-A-8637).
4	Spacer (per SC-A-8533).
2	Washer, rubber (per SC-A-7146).
2	2Z1104-7	Terminal (per SC-A-7147).
1	3E9991	Terminal TM-91 (per RL-A-886).
1	Screw, hex hd cap, 3/8"-24 x 1/2", steel galv.
4	3Z10163	Terminal TM-163 (per SC-A-942).
4	Screw, hex hd cap, 3/8"-24 x 3/4", steel galv.
6	Screw, RH, mach, No. 8-32 x 3/8", steel galv.
4	Lockwasher, 3/8" std, steel galv.
6	Lockwasher, No. 8 std, steel galv.
1	Lockwasher, 3/8" IET, cat. No. 4020-26, Shakeproof, Inc., or equal, cadmium plated.
1	2B800-16	Headset H-16/U.
1	3G1837-52.1	Insulator IL-2/U, 1 spare.
1	2Z1250.132	Mast base bracket (per SC-D-8532).
1	2B1645	Microphone T-45.
1	2S4502-3-1	Modification kit, including:
1	3RC30BF302K	Resistor, fixed, composition, 1 watt, AWS (3,900 ohms).

Quantity	Signal Corps stock No.	Item
6 in.	6Z8043.2	Tubing, rubber, synthetic, 3/16" OD, 1/8" ID.
12 in.	1B820.6	Wire, No. 20 AWG, solid, push-back.
1	2Z6721-250/2	Mounting (per SC-D-7398).
1	2Z7090.23	Plate for antenna lead-in (per SC-A-7399).
1	2C7978C	Switchbox BC-658-C.
6 ft	1B128	Wire W-128 for ground and substitute antenna.

¹ One Cord CD-307-A (Sig C stock No. 3E1307-5.5) and one Cord CD-318-A (Sig C stock No. 3E1318A) may replace Chest Set TD-4. One Headset HS-30 (Sig C stock No. 2B830) and one Cord CD-604 (Sig C stock No. 3E1604) may replace Headset H-16/U.

² Required only for vehicles not equipped with production installation provisions.

³ Two Insulators IN-121 (Sig C stock No. 3G621) may replace Insulator IL-2/U.

⁴ See footnote ², in *a* above.

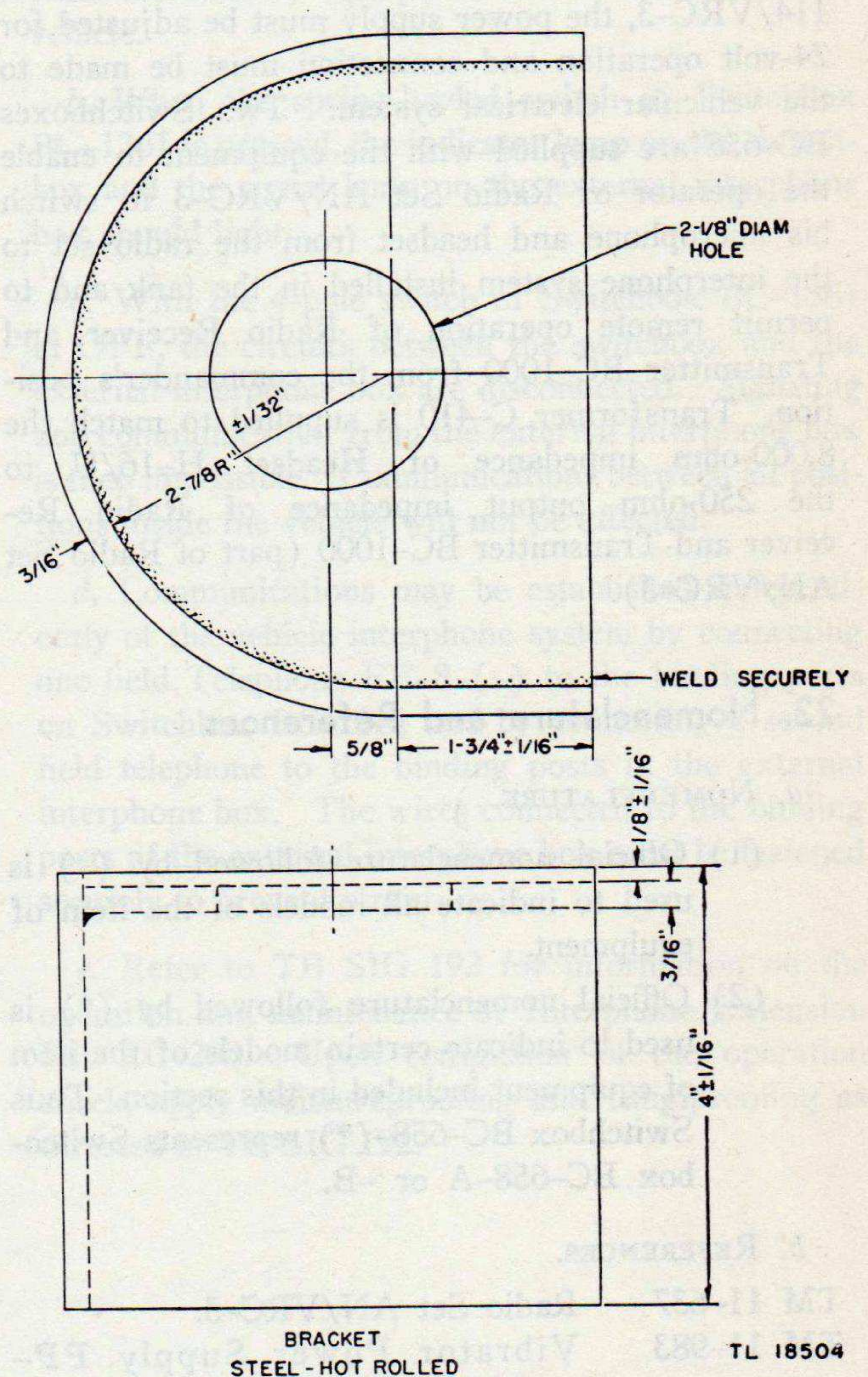
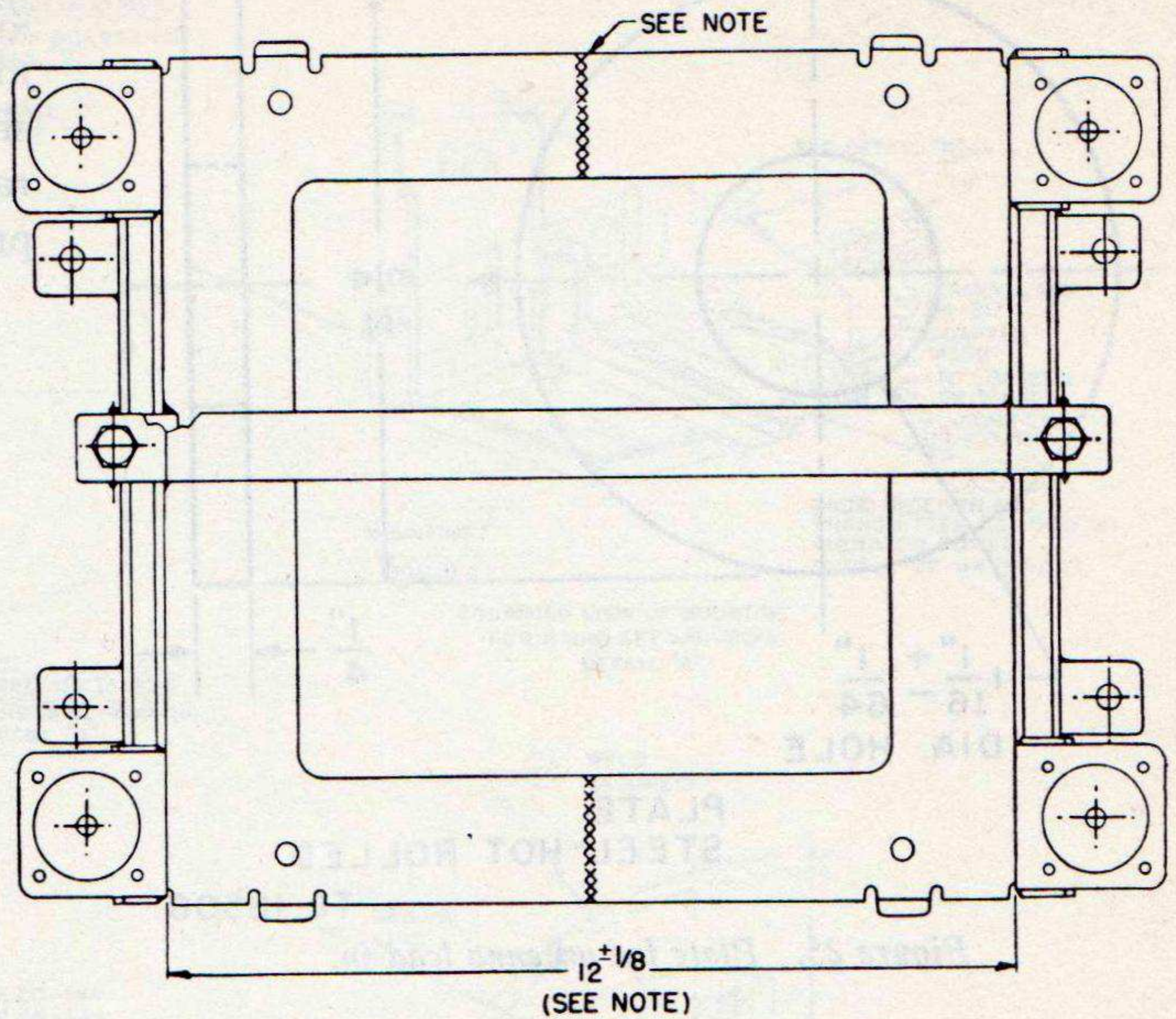
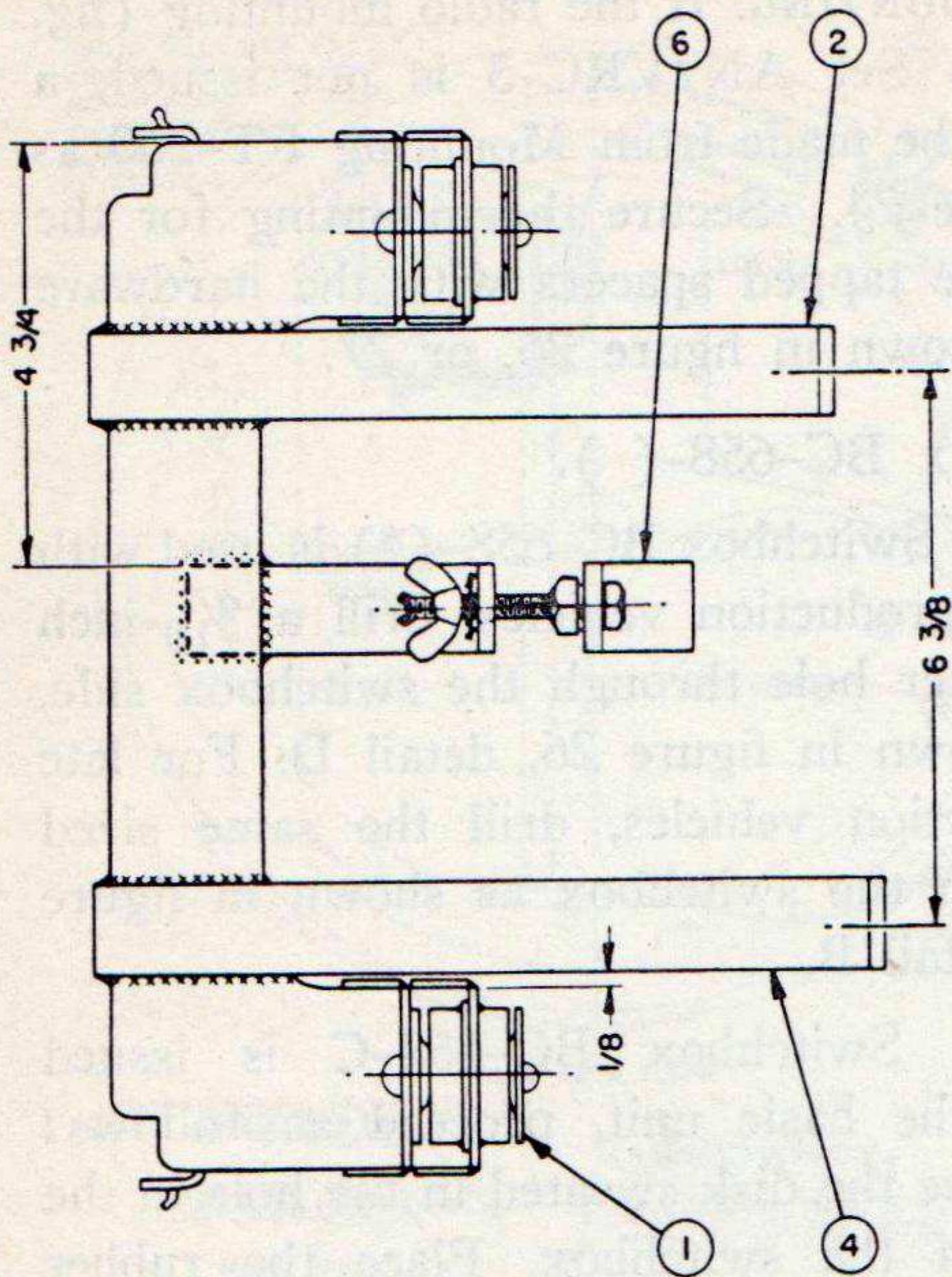

Figure 23. Bracket for mast base.



NOTES:

① SHALL BE MOUNTING FT-250 CUT AND SECURELY WELDED TO DIMENSION SHOWN, AND GROUND OFF SMOOTH. UNLESS OTHERWISE SPECIFIED, DIMENSIONS ARE IN INCHES. WELDED ITEMS SHALL BE GIVEN ONE SPRAY COAT OF METAL PRIMER AND ONE SPRAY COAT OF SEMI-GLOSS OLIVE DRAB AIR DRYING ENAMEL. ALL PAINTS AND METHODS OF APPLICATION SHALL BE IN ACCORDANCE WITH SPECIFICATION NO. 72-53.

ITEM NO.	NAME OF ITEM	QUAN. REQ.
1	MOUNTING	1
2	SUPPORT	2
3	BRACKET	1
4	SUPPORT	2
5	BRACKET	1
6	CLAMP	1

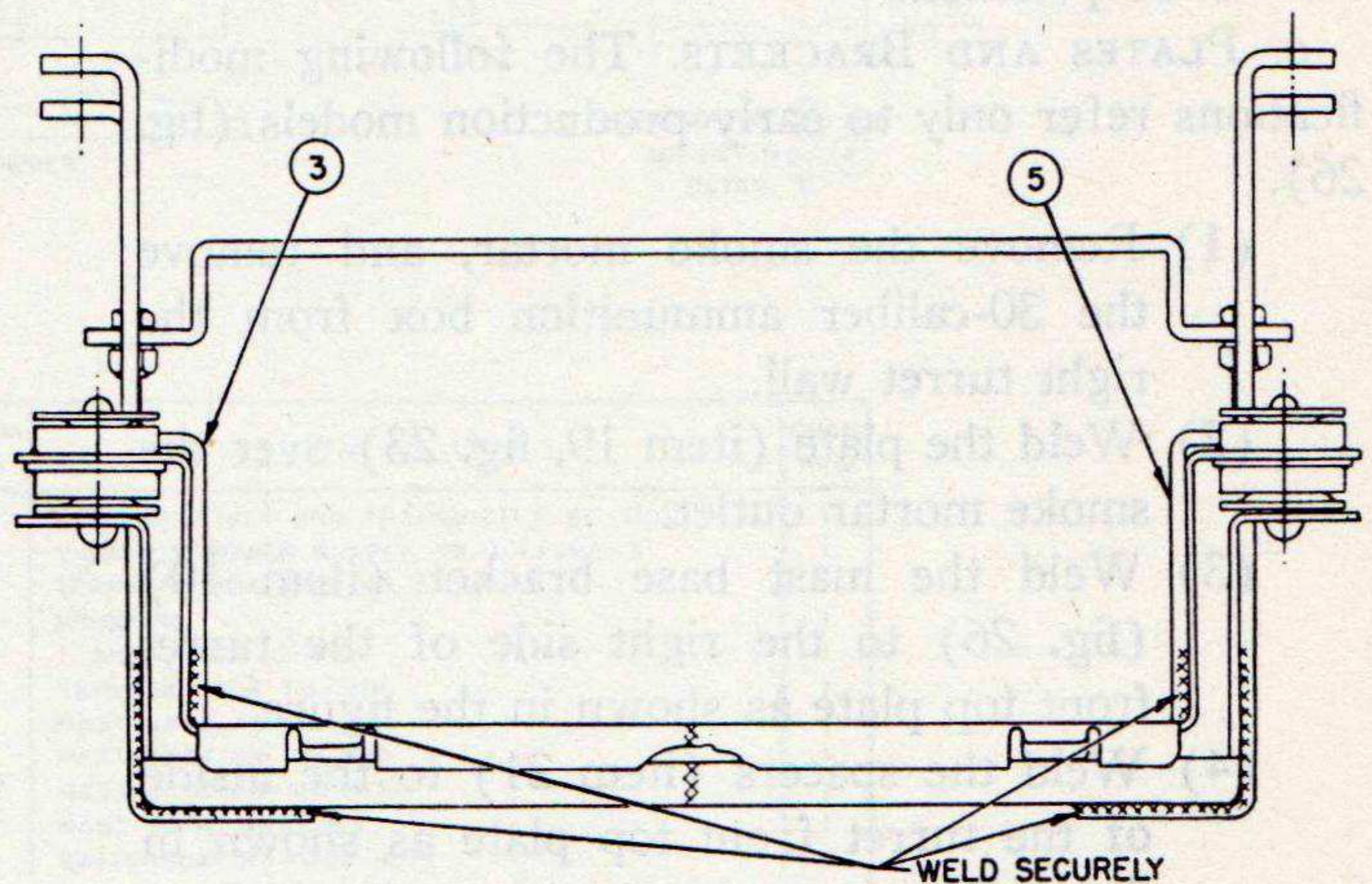

TL18505

Figure 24. Mounting for Radio Set AN/VRC-3 in Tank, Light, M24.

24. Precautions

a. ELECTRICAL SYSTEMS. Tank, Light M24, is equipped with a 24-volt electrical system. Before installing any electrical equipment, make certain that the equipment is designed and/or properly adjusted for operation on a 24-volt supply. Radio sets, inter-phone equipment, and power supply units may be damaged by operation on incorrect power sources.

b. HOLES AND BRACKETS. Brackets for Radio Set AN/VRC-3 are installed on late production vehicles

prior to delivery of the vehicle. Instructions for mounting any other brackets are given in this section. Do not relocate any holes or brackets *unless it is absolutely necessary*.

25. Assembly and Installation

The assembly and installation procedure described in a through l below differs for certain models of Tank, Light, M24. Hereinafter, the term "early production model" (fig. 25) refers only to

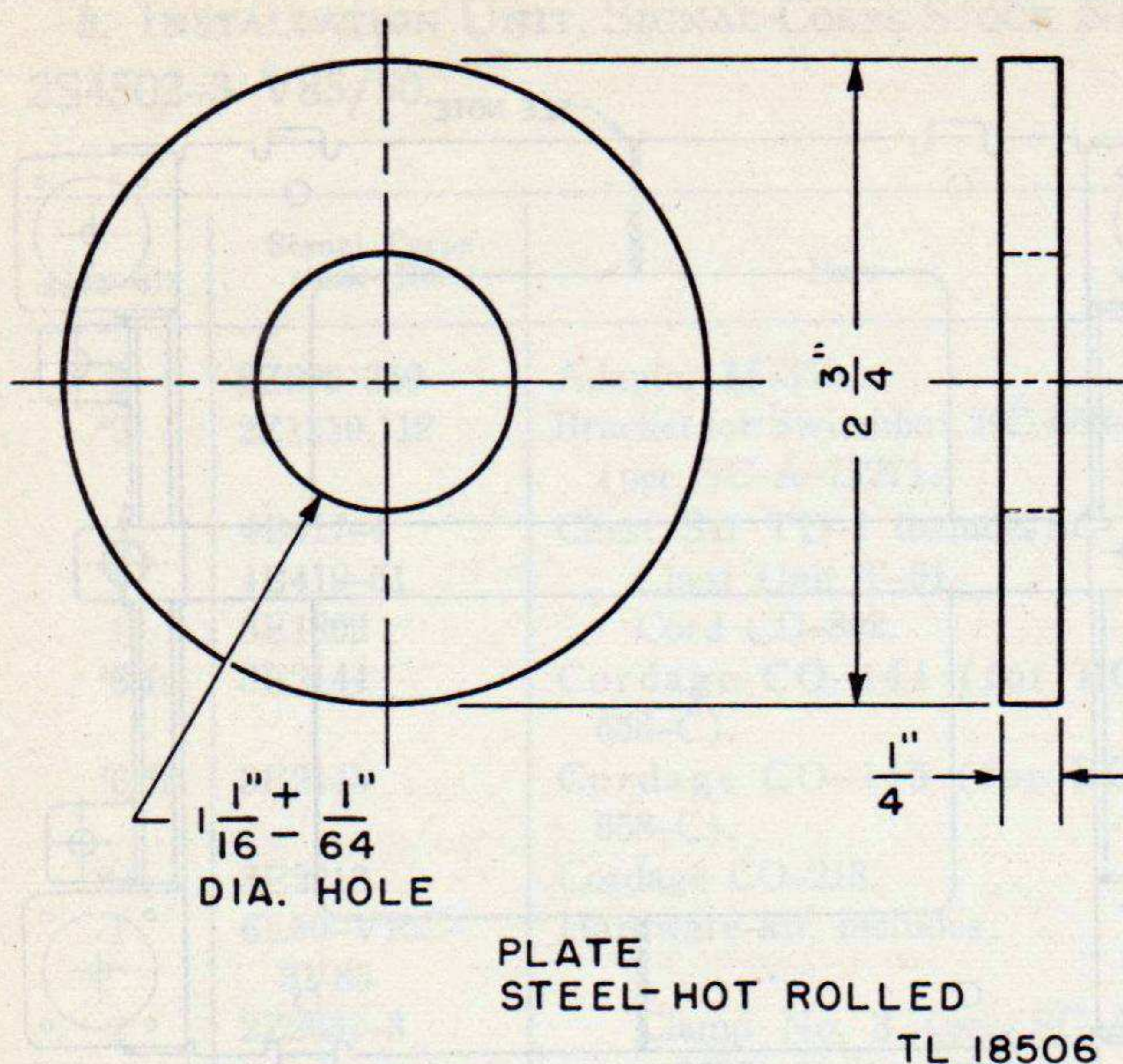

Figure 25. Plate for antenna lead-in.

Light Tanks M24 with serial Nos. under 2914 as manufactured by Cadillac Motor Division and serial Nos. 5742 and higher as manufactured by Massey-Harris Corporation.

a. PLATES AND BRACKETS. The following modifications refer only to early production models (fig. 26).

- (1) Remove the smoke mortar, and remove the 30-caliber ammunition box from the right turret wall.
- (2) Weld the plate (item 19, fig. 23) over the smoke mortar outlet.
- (3) Weld the mast base bracket (item 10) (fig. 26) to the right side of the turret front top plate as shown in the figure.
- (4) Weld the spacers (item 21) to the inside of the turret front top plate as shown in figure 26.
- (5) Weld the brackets (item 18) (fig. 26) to the turret in the positions shown in the figures.
- (6) After welding, paint items 10, 18, 19, and 21.

b. RADIO MOUNTING. If the radio mounting (fig. 26) for Radio Set AN/VRC-3 is not issued, a mounting may be made from Mounting FT-250 as shown in figure 24. Secure the mounting for the radio set to the tapped spacers with the hardware provided, as shown in figure 26, or 27.

c. SWITCHBOX BC-658-().

- (1) When Switchbox BC-658-(*) is used with early production vehicles, drill a $\frac{9}{16}$ -inch diameter hole through the switchbox side, as shown in figure 26, detail D. For late production vehicles, drill the same sized hole in the switchbox as shown in figure 27, detail B.
- (2) When Switchbox BC-658-C is issued with the basic unit, proceed as follows: Remove the disk sweated in the hole in the side of the switchbox. Place the rubber washer provided over the threaded stem of the connector; insert the connector in the switchbox hole, and secure with the bondnut.
- (3) Remove the patch cords from the radio side of the switch in the commander's switchbox. Make Switchbox BC-658-C watertight in either of the following ways: Install short lengths of cordage through the connectors provided for the patch cords, or remove the connectors and solder a strip of metal over the holes.
- (4) Cut four 1-inch lengths of rubber tubing. Place a length of tubing over the leads of each of the 3,900-ohm resistors. Connect the resistor between the center terminal and the terminal on the interphone side of the section of Switch SW-155 (headset transfer switch), as shown in figure 28. Connect the jumper wires between the Switch SW-155 terminals used to transfer the headset circuit in each switchbox, as shown in figure 28.

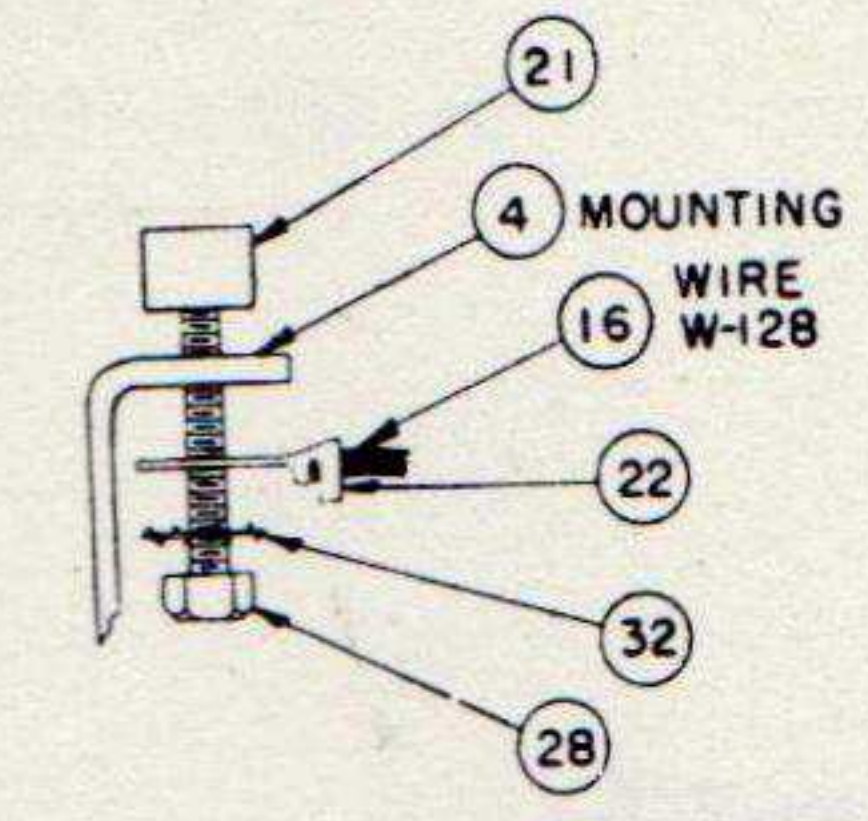
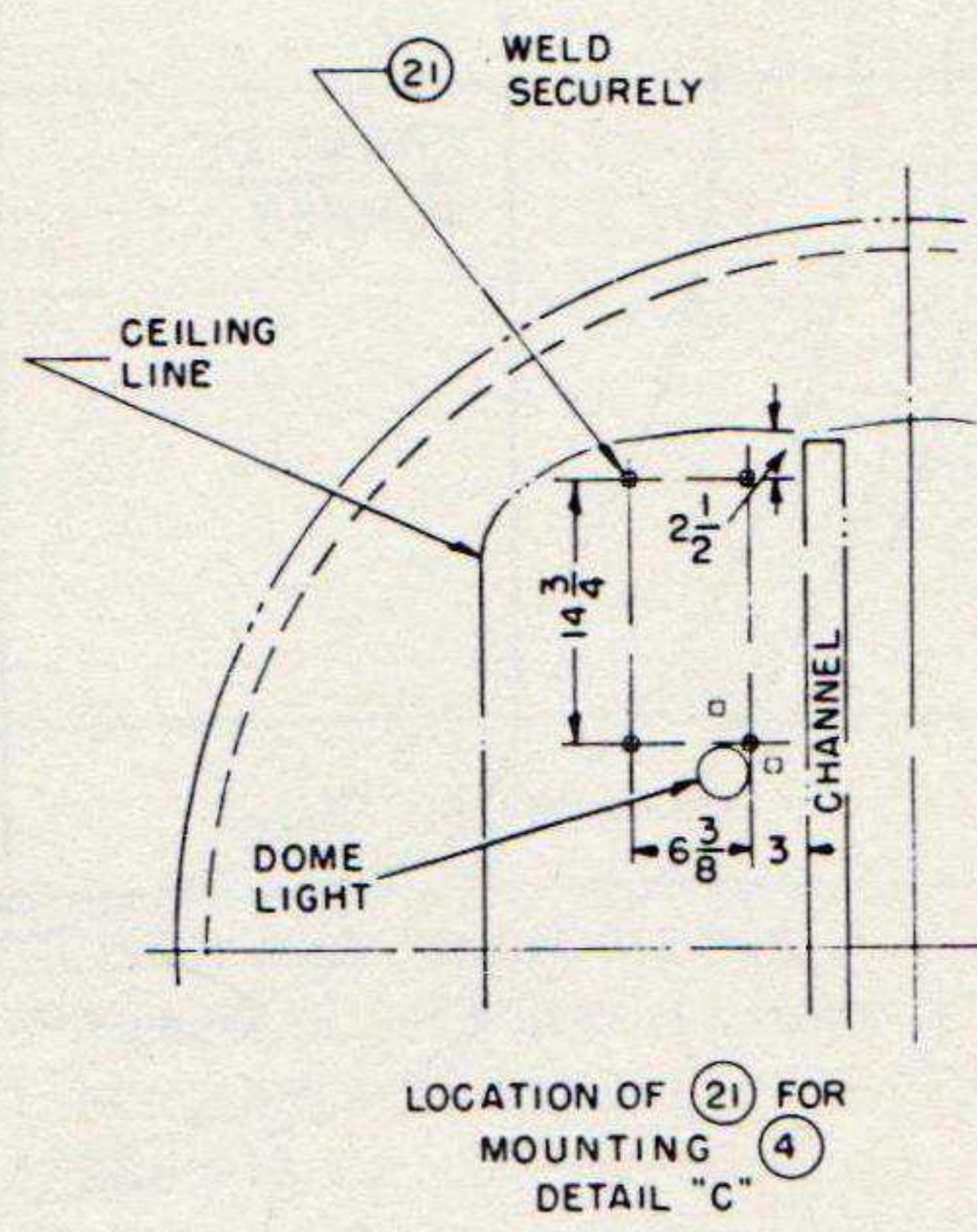
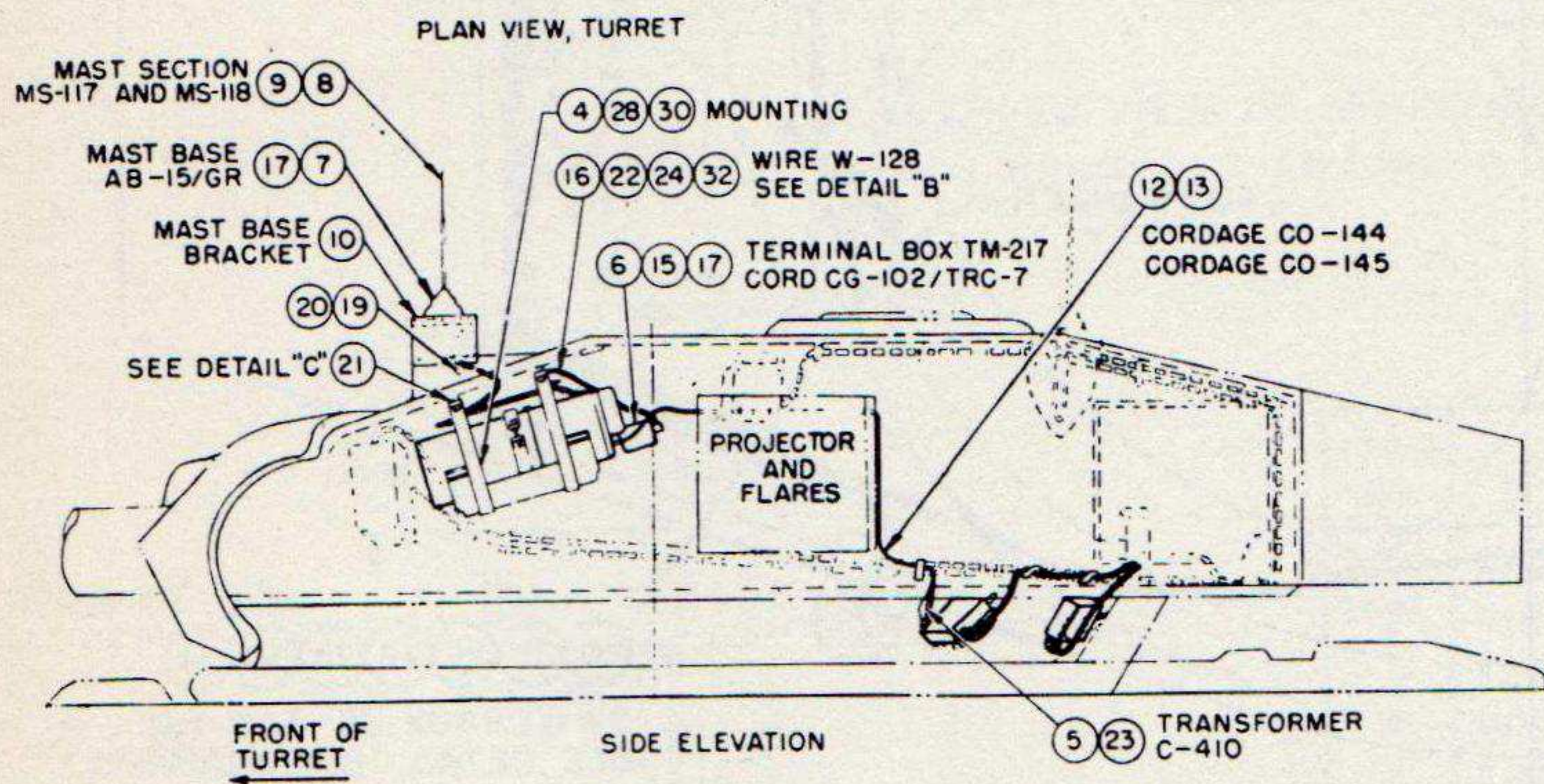
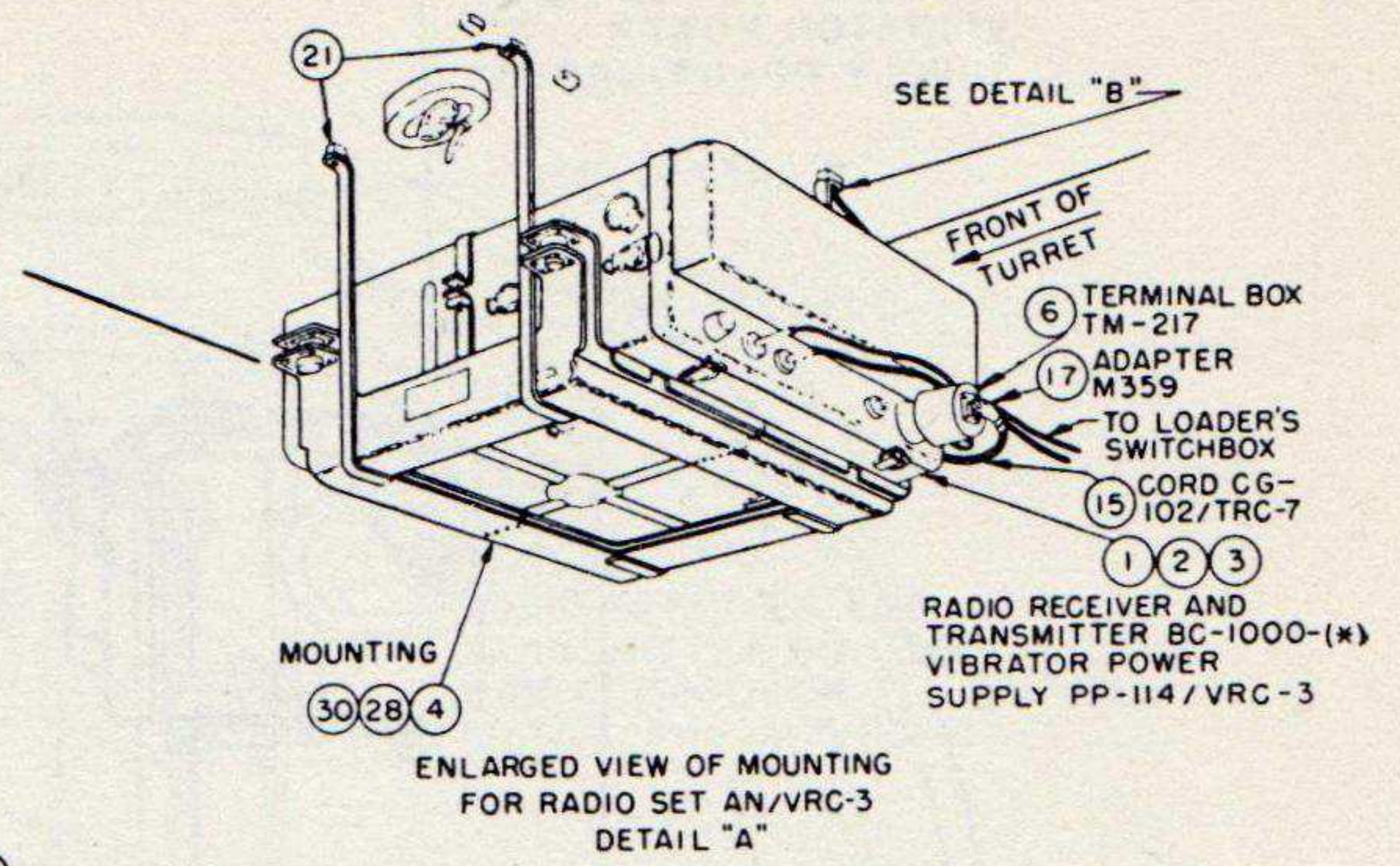
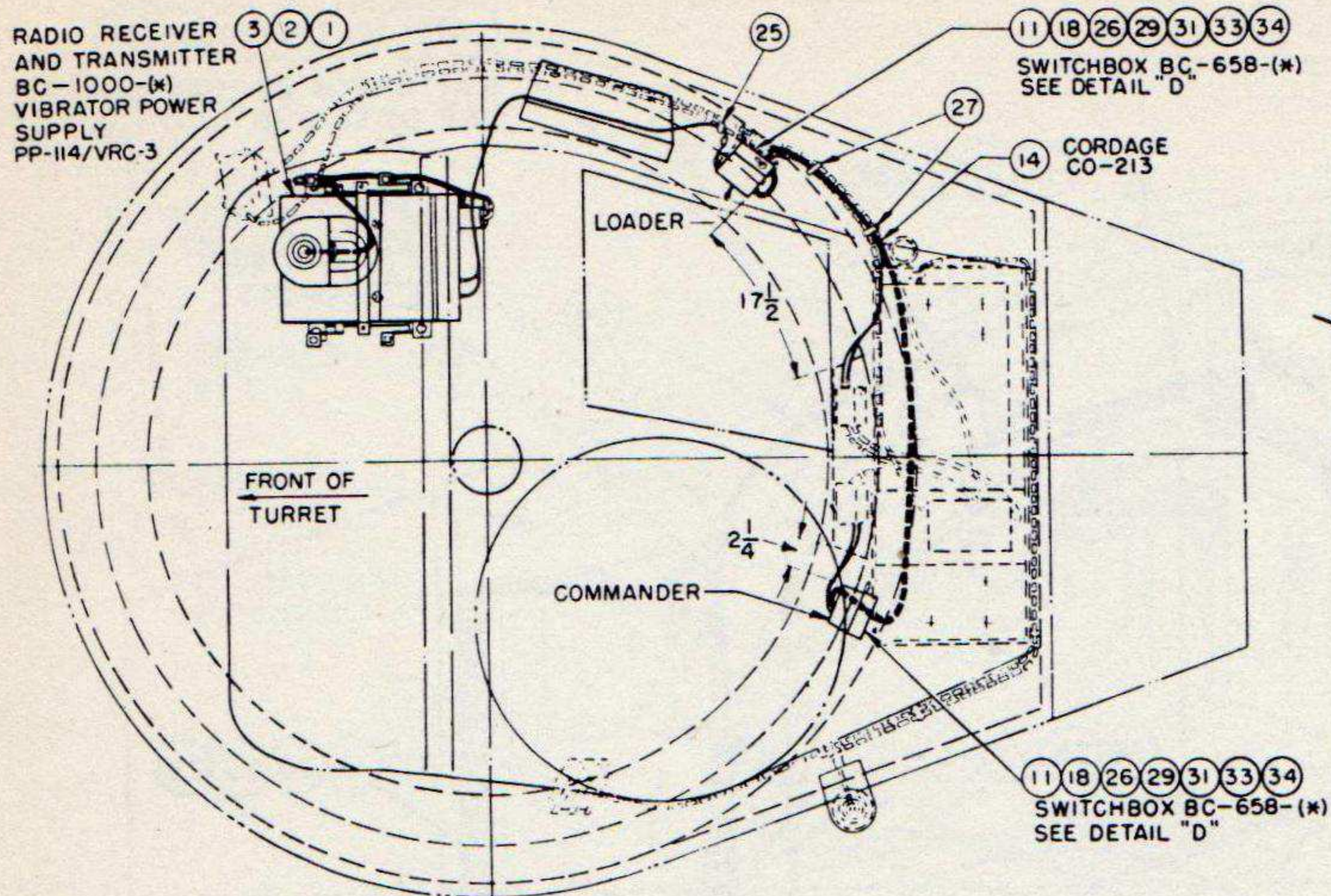

APPLICATION OF LOCKWASHER WITH TERMINAL (22) DETAIL "B"

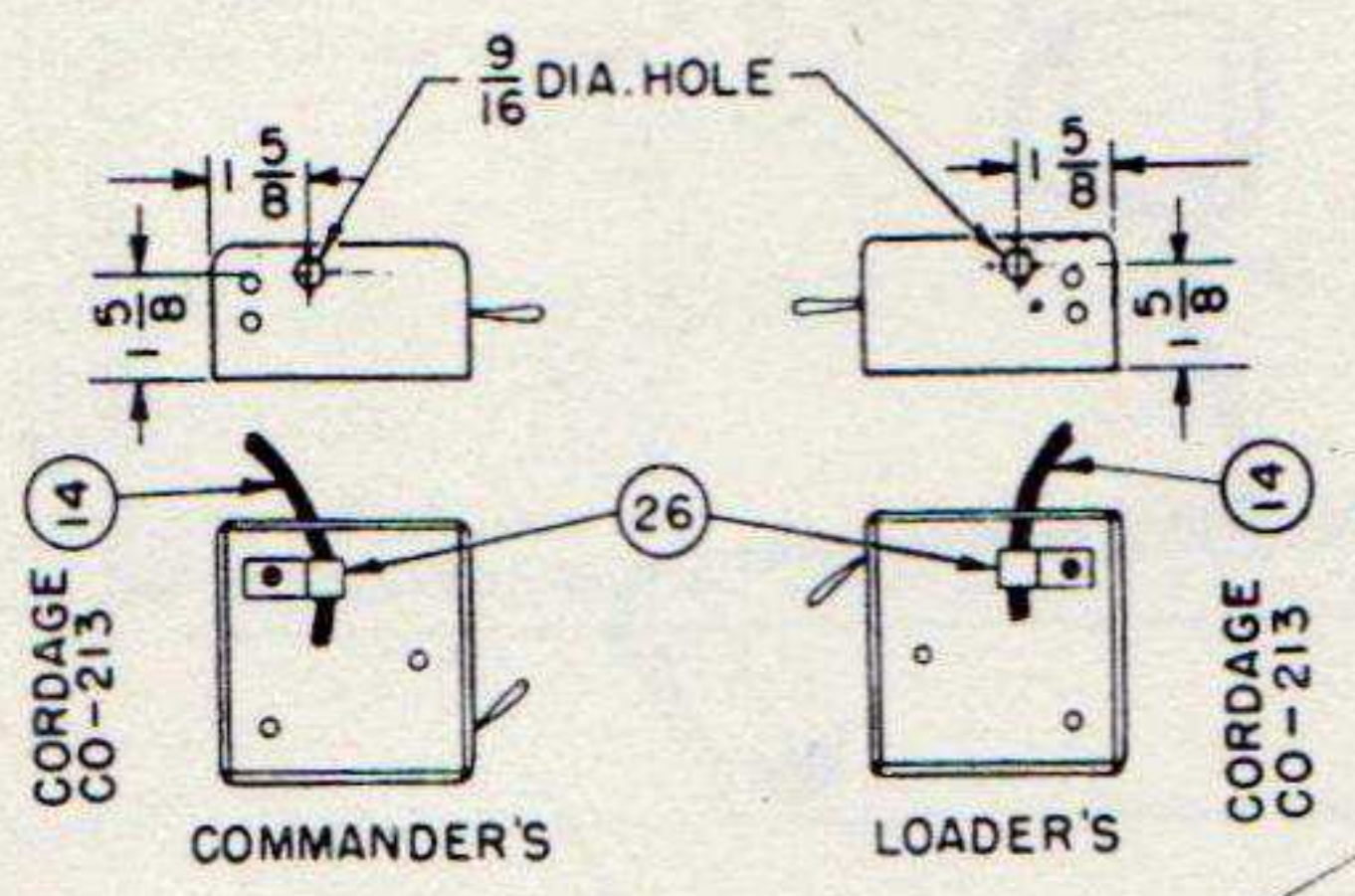

MODIFICATION OF SWITCHBOXES BC-658 A OR B DETAIL "D"

ITEM NO.	NAME OF ITEM	QUAN REQ
1	RADIO RECEIVER AND TRANSMITTER BC-1000	1
2	VIBRATOR POWER SUPPLY PP-114/VRC-3	1
3	TERMINAL BOX, ORD NO. C100443	1
4	MOUNTING	1
5	TRANSFORMER C-410	1
6	TERMINAL BOX TM-217	1
7	MAST BASE AB-15/GR	1
8	MAST SECTION MS-117	1
9	MAST SECTION MS-118	1
10	MAST BASE BRACKET	1
11	SWITCHBOX BC-658-C	2
12	CORDAGE CO-144, 5 FT LONG	1
13	CORDAGE CO-145, 5 FT LONG	1
14	CORDAGE CO-213, 7 FT LONG	1
15	CORD CG-102/TRC-7, 7 FT LONG	1
16	WIRE W-128, 11 IN LONG	1
17	ADAPTER M-359	2
18	BRACKET, ORD NO. B-210579	2
19	PLATE	1
20	INSULATOR IL-2/U	1
21	SPACER, ORD NO. A-261970	4
22	TERMINAL, SLG CORPS STOCK NO 3211004-7	1
23	TERMINAL TM-163	4
24	TERMINAL TM-91	1
25	CLAMP, NO 3	1
26	CLAMP, NO. 4	2
27	CLAMP, NO 9	2
28	HEX HEAD MACH SCREW NO 3/8-24 X 3/4 LONG	4
29	RD HEAD MACH. SCREW NO 8-32 X 3/8 LONG	6
30	LOCKWASHER, S.A E REG. FOR 3/8 SCREW	3
31	LOCKWASHER, S A E REG FOR NO 8 SCREW	6
32	LOCKWASHER, I E.T. FOR 3/8 SCREW	1
33	RESISTOR, 3,900 OHM, ±10%, 1 WATT	2
34	TUBING, RUBBER, 3/16 O.D. X 1/8 I.D.	AS REQ

NOTES:

1. FOR ADDITIONAL COMPONENTS AND SPARE PARTS SEE COMPONENTS PARTS LIST.
2. UNLESS OTHERWISE SPECIFIED, DIMENSIONS ARE IN INCHES.

TM 2754-25

Figure 26. Installation of Radio Set AN/VRC-3 in Tank, Light, M24, early production models.

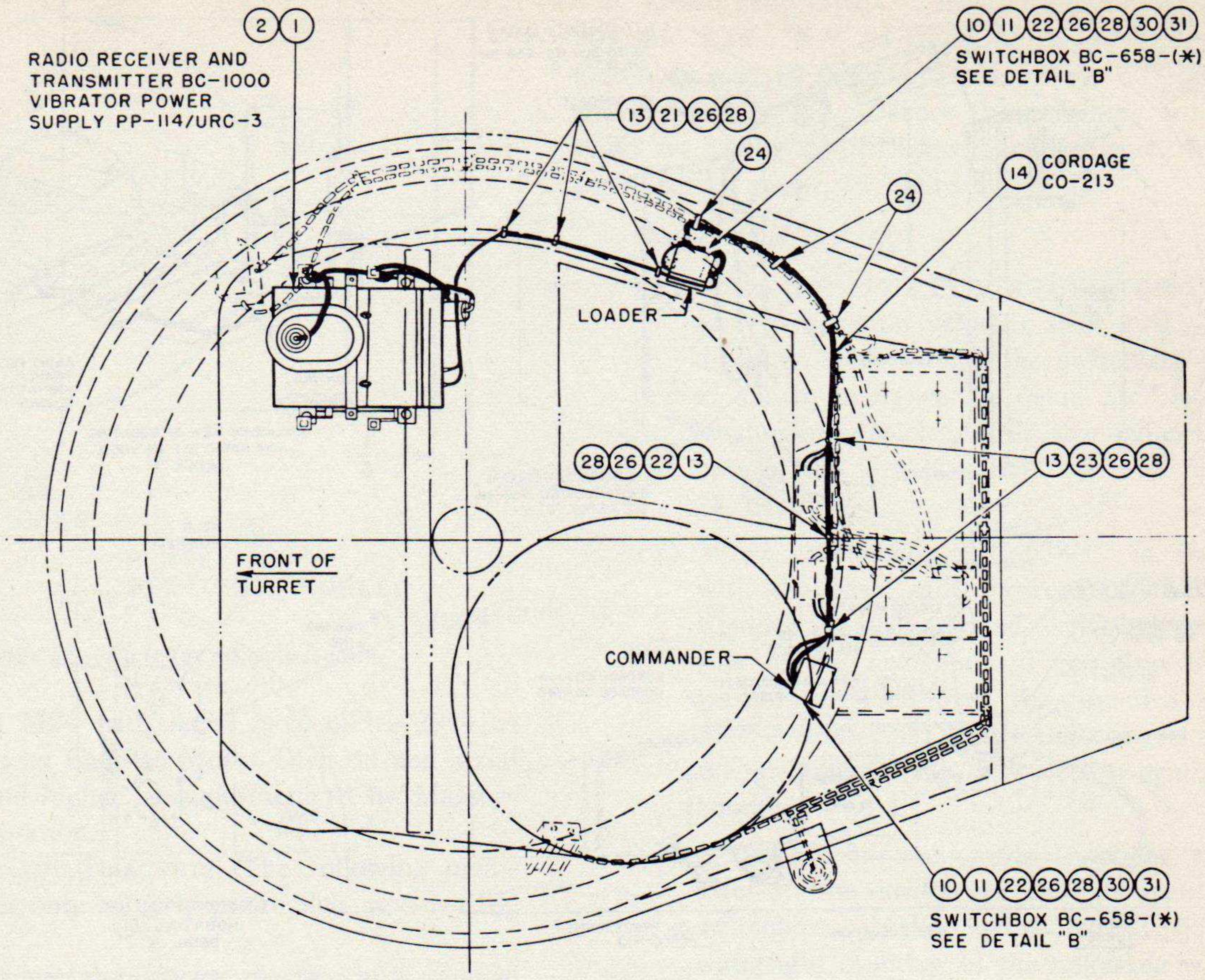

PLAN VIEW, TURRET

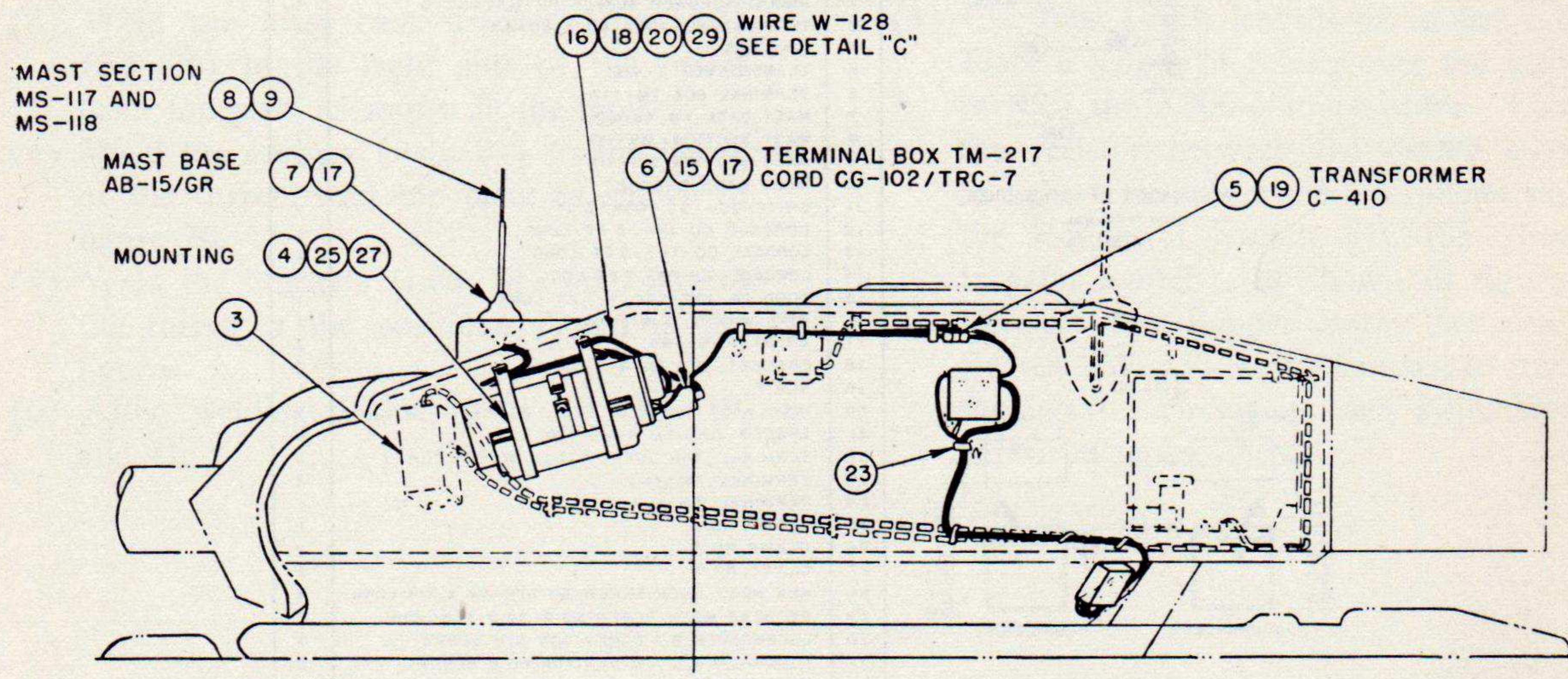

SIDE ELEVATION

TM 2754-26 ①

Figure 27. Installation of Radio Set AN/VRC-3 in Tank, Light, M24, late production models.

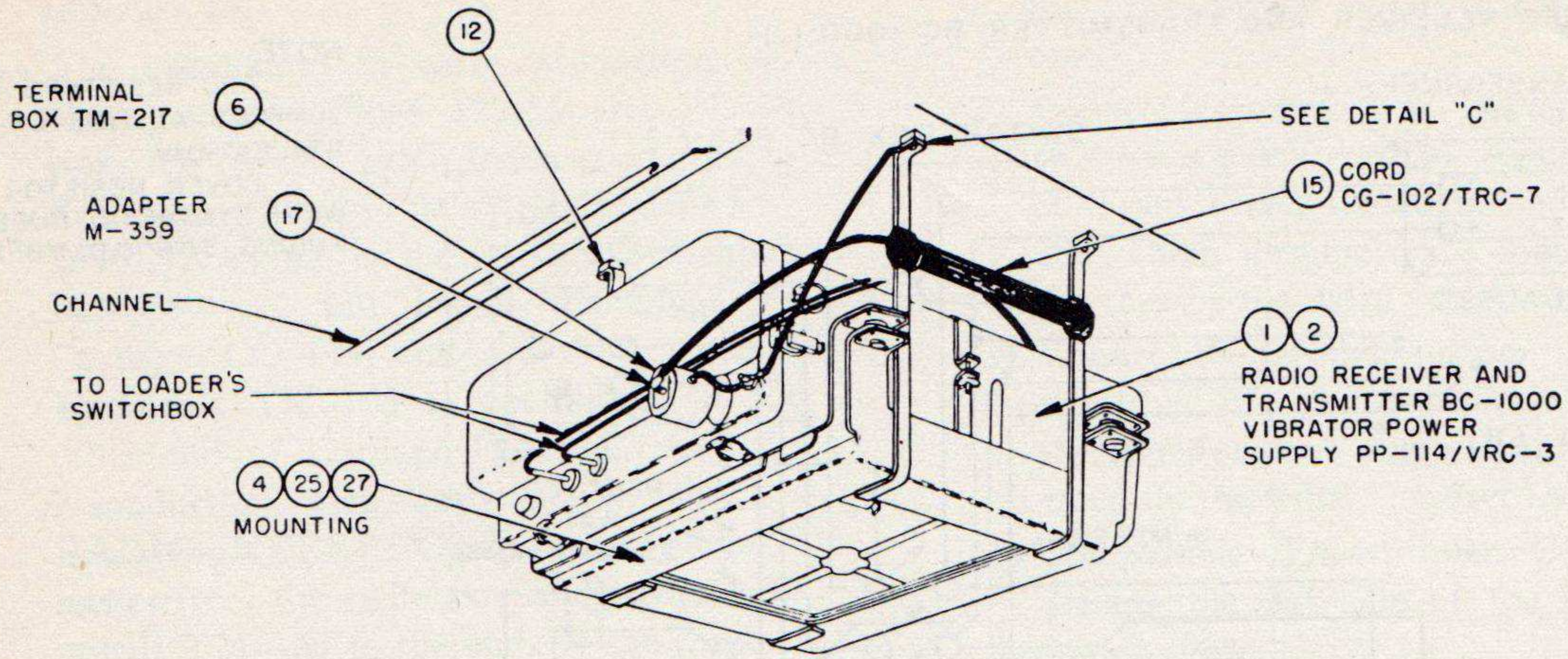

ENLARGED VIEW OF MOUNTING
FOR RADIO SET AN/VRC-3
DETAIL "A"

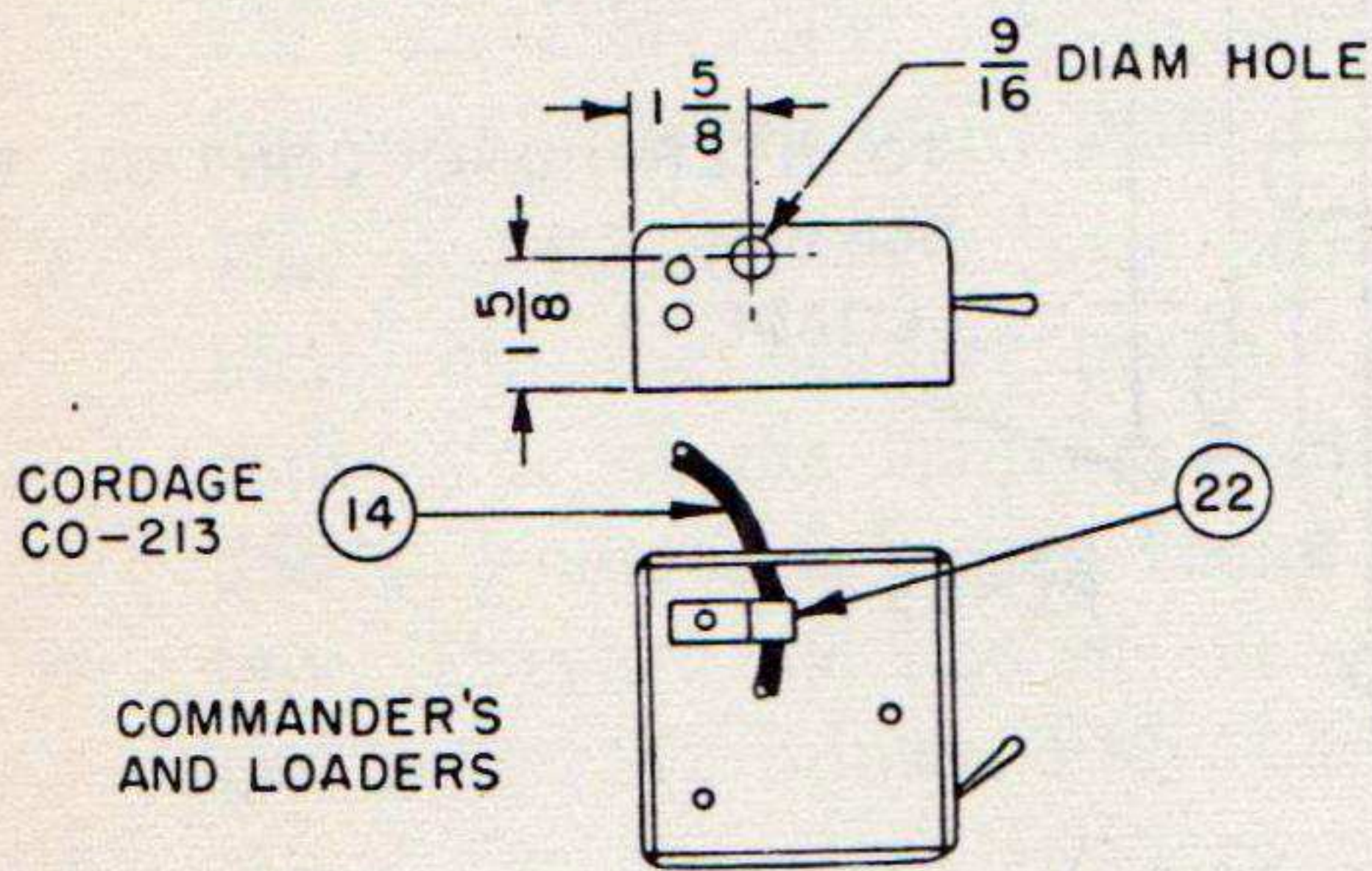

MODIFICATION OF
SWITCHBOX BC-658-A OR -B
DETAIL "B"

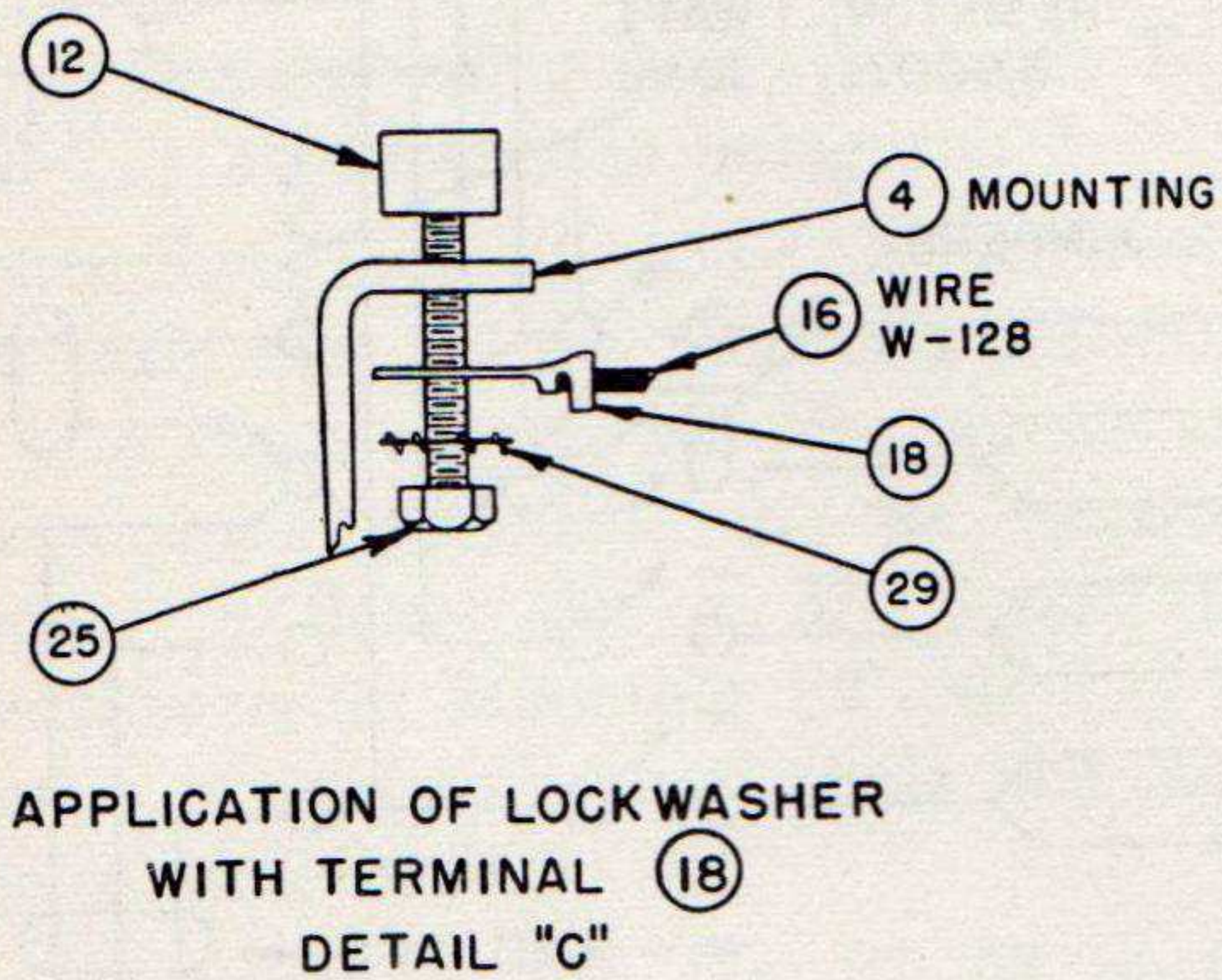

APPLICATION OF LOCKWASHER
WITH TERMINAL (18)
DETAIL "C"

ITEM NO.	NAME OF ITEM	QUAN. REQ.
1	RADIO RECEIVER AND TRANSMITTER	1
2	VIBRATOR POWER SUPPLY PP-114/VRC-3	1
3	TERMINAL BOX, ORD. NO. C100443	1
4	MOUNTING, SEE FIG. 27	1
5	TRANSFORMER C-410	1
6	TERMINAL BOX TM-217	1
7	MAST BASE AB-15/GR	1
8	MAST SECTION MS-117	1
9	MAST SECTION MS-118	1
10	SWITCHBOX BC-658-(*)	2
11	BRACKET, ORD. NO. B-210579	2
12	SPACER, ORD. NO. A-261970	4
13	SPACER, A-260934	6
14	CORDAGE CO-213, 6 FT. 6 IN. LG.	1
15	CORD CG-102/TRC-7, 7 FT. LG.	1
16	WIRE W-128, 11 IN. LG.	1
17	ADAPTER M-359	2
18	TERMINAL, SIG. C STOCK NO. 3Z11004-7	1
19	TERMINAL, TM-163	4
20	TERMINAL, TM-91	1
21	CLAMP, NO. 1	3
22	CLAMP, NO. 4	3
23	CLAMP, NO. 7	3
24	CLAMP, NO. 9	3
25	HEX. HD. MACHINE SCREW, NO. 3/8-24 X 3/4 LG.	4
26	RD. HD. MACHINE SCREW, NO. 8-32 X 3/8 LG.	12
27	LOCKWASHER, S.A.E. REGULAR FOR 3/8 SCREW	3
28	LOCKWASHER, S.A.E. REGULAR FOR 3/8 SCREW	12
29	LOCKWASHER, I.E.T. FOR 3/8 SCREW	1
30	RESISTOR, 3900-OHM, ± 10%, 1 WATT	2
31	TUBING, RUBBER, 3/16 O.D. X 1/8 I.D.	AS REQ.

NOTES:

1. FOR ADDITIONAL COMPONENTS AND SPARE PARTS SEE COMPONENTS PARTS LISTS.
2. UNLESS OTHERWISE SPECIFIED, DIMENSIONS ARE IN INCHES.

TM 2754-26 (2)

Figure 27—Continued.

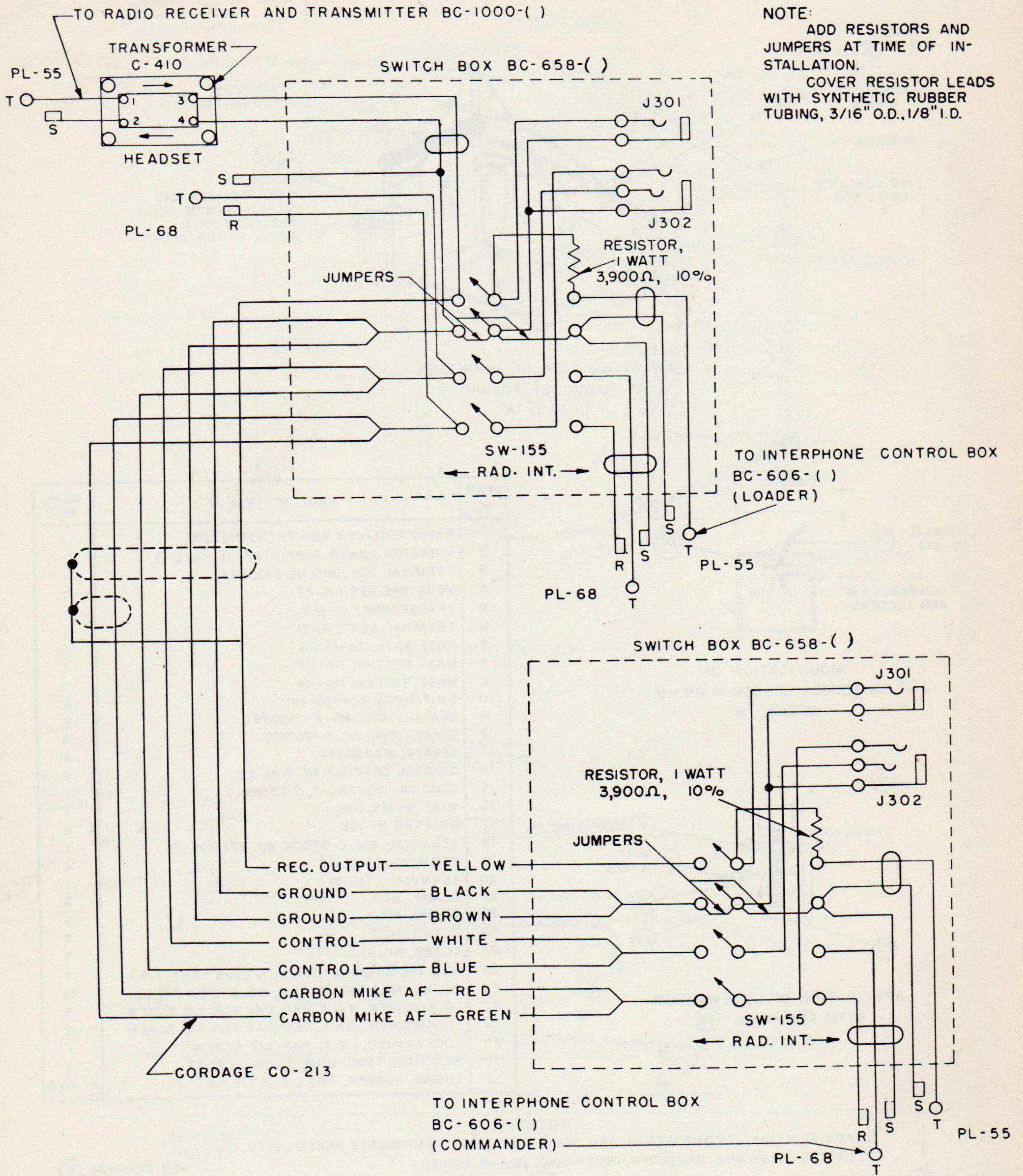

Figure 28. Switchbox BC-658-(*) interconnections.

TM 2758-29

- (5) Interconnect the two Switchboxes BC-658-() with Cordage CO-213 as shown in figure 28.
- (6) For installation in early production vehicles, remove Plugs PL-55 and PL-68 from the pair of patch cords connected to the radio side of the RADIO-INTERPHONE switch in the loader's Switchbox BC-658-(), and install the plugs on Cordage CO-144 and CO-145. Solder Terminals TM-163 to conductors at the other end of Cordage CO-144. Cut the 2-conductor patch cord (radio side of RADIO-INTERPHONE switch) about 4 inches from the switchbox and solder Terminals TM-163 to the ends of the conductors on the 4-inch length remaining on the switchbox. Remove the 3-conductor patch cord from the radio side of the RADIO-INTERPHONE switch, and connect Cordage CO-145 in its place.
- (7) For installation in a late production vehicle, cut the headset patch cord on the radio side of the loader's Switchbox BC-658-() about 6 inches from the switchbox. Prepare the tips of the cut cordage, and solder Terminals TM-163 to the tips.
- (8) Secure Switchboxes BC-658-(*) directly to the brackets (fig. 29) with the screws and lockwashers provided, as shown in figures 26 or 27. Secure a No. 4 clamp around Cordage CO-213 in each switchbox by means of one of the mounting screws. Apply waterproofing to Switchboxes BC-658-() as directed in paragraph 3.
- (9) When Switchbox BC-658-C is issued with the basic unit, secure Mounting FT-507-() to the brackets, with the screws and lockwashers provided, in the locations shown in figure 26 or 27. Secure the switchboxes to Mounting FT-507-() by means of the switchbox studs and hexagonal nuts.
- (10) Insert Plugs PL-55 and PL-68 of the commander's switchbox patch cords into the proper jacks on the commander's Interphone Control Box BC-606. Insert Plugs PL-55 and PL-68 on the loader's switchbox (interphone side) patch cords in the proper jacks on the loader's Interphone Control Box BC-606.

d. TRANSFORMER C-410.

- (1) Remove the four screws in the flat side of the Transformer C-410 case and open the case.
- (2) Connect Terminals TM-163 on the loader's switchbox patch cord to terminals 3 and 4 on Transformer C-410, as shown in figure 28. These terminals are indicated within the case by the word "cord" and an arrow.
- (3) Connect the terminal lugs on the cord having Plug PL-55 to terminals 1 and 2 on the transformer. These terminals are indicated by the word "headset" and an arrow.
- (4) Reassemble Transformer C-410 by replacing the flat side of the case and the four screws.

e. VIBRATOR POWER SUPPLY PP-114/VRC-3. When the vibrator power supply is issued with Radio Set AN/VRC-3, install the supply as follows:

- (1) Refer to TM 11-983. Remove the power supply chassis from the Radio Receiver and Transmitter BC-1000 case. Adjust the power supply for 24-volt operation. Re-

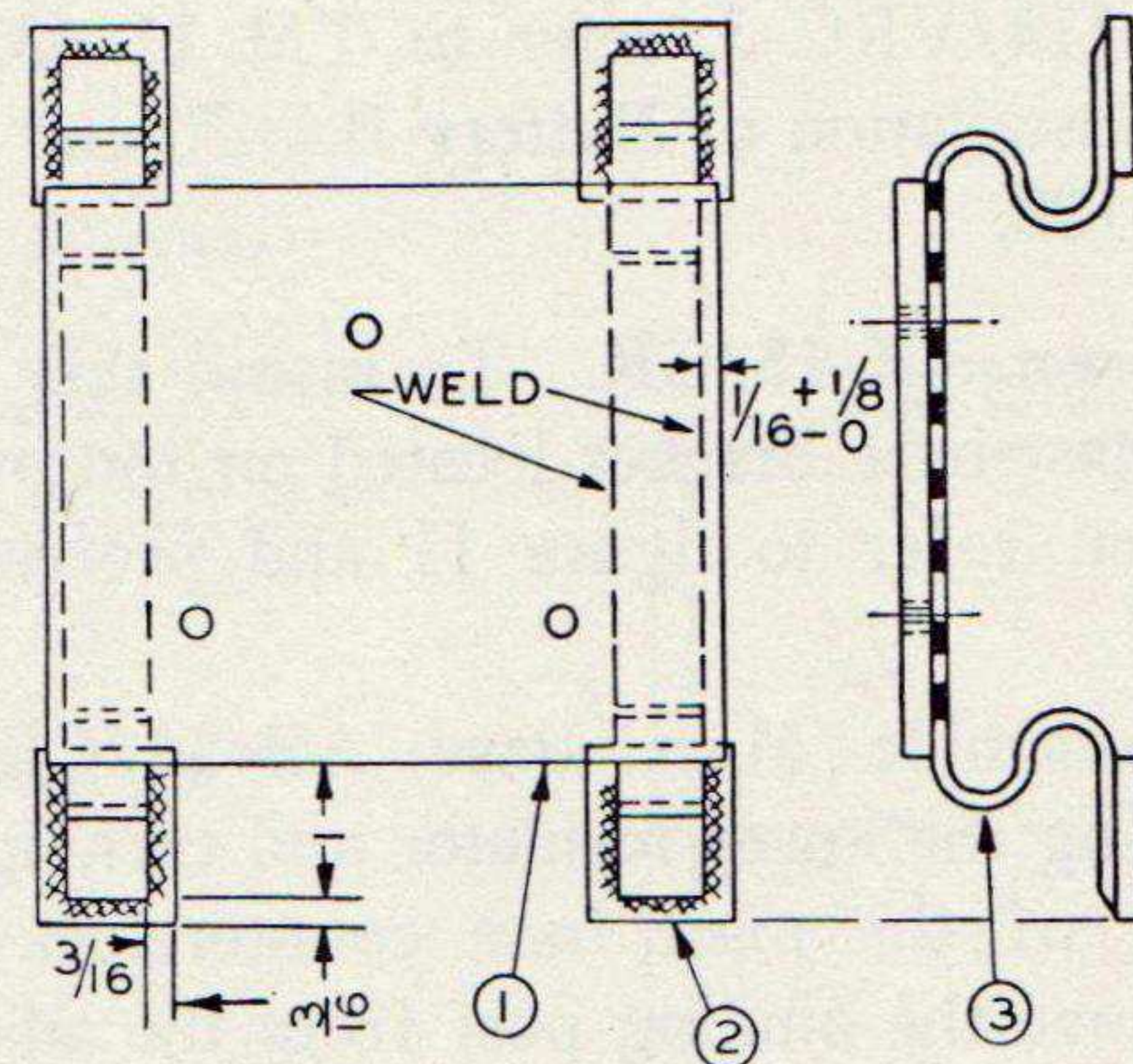

NOTE.

REMOVE ALL BURRS.
 DIMENSIONS WHERE NOT SHOWN OTHERWISE ARE IN INCHES.
 TOLERANCE WHERE NOT SHOWN OTHERWISE SHALL BE HELD TO $\pm 1/16$.
 BRACKET SHALL BE PAINTED TO MATCH SURROUNDING SURFACES AT THE TIME OF INSTALLATION.
 DO NOT PAINT TAPPED HOLES.

TL 13378

Figure 29. Bracket, interphone.

place the chassis in the case, and secure it to the bottom of the receiver-transmitter by means of the clip catches provided.

- (2) Secure the receiver-transmitter in the radio mounting (fig. 24) with the mounting straps and wingnuts (fig. 26 or 27).

- (3) Cut an 11-inch length of Wire W-128. Strip $\frac{1}{2}$ inch of insulation from each end of the wire, and solder a terminal (item 22) to one end and a Terminal TM-91 to the other end. Secure Terminal TM-91 to the GROUND binding post on the panel of Radio Receiver and Transmitter BC-1000. Secure the terminal on the other end of Wire W-128 to the radio mounting, as shown in figure 26 or 27.
- (4) Route the power cord from the vibrator supply to the vehicle terminal box as shown in figure 26 or 27, using the connector and bondnut provided to secure the power cord to the terminal box. Connect the power cord leads to the box terminals, observing polarity.
- (5) Insert Plug PL-68 on the loader's switch-box patch cords in the microphone jack, and insert Plug PL-55 (on the patch cord having the transformer attached) into the PHONE No. 1 jack.
- (6) If Case CS-128 and Battery BA-70 are supplied in place of Vibrator Power Supply PP-114/VRC-3, refer to TM 11-637 for the installation of Battery BA-70 and Case CS-128.

f. MAST BASE AB-15/GR. To install this mast base on the mast base bracket located on top of the forward turret, refer to figure 11 and proceed as follows:

- (1) Disassemble Mast Base AB-15/GR by holding the lower insulator and turning the body of the mast base counterclockwise. Remove the binding post from the adapter socket on the bottom of the mast base.
- (2) Place the upper insulator (item 5) over the hole in the mast base bracket (fig. 25) (a neoprene washer (item 6) is cemented to each insulator, items 5 and 7).
- (3) Place the small neoprene washer (item 4) over item 5, and place the plain washer (item 3) over the small neoprene washer (item 4).
- (4) Insert the body of the mast base (item 2) through the hole in items 3, 4, 5, and 6 and the mast base bracket.
- (5) Place the grounding ring (item 14), with the large internal-toothed lockwasher attached, over the flange of the lower insu-

lator (item 7).

- (6) Insert the bolt (item 8) (attached to insulator, item 7) into item 2 from underneath.
- (7) Turn the mast base body clockwise until the mast base is tightened securely. The large toothed lockwasher must make good contact with the under side of the mast base bracket. Apply a slight additional pressure, if necessary, with a hexagonal wrench.

g. TERMINAL BOX TM-217.

- (1) Insert the threaded stud on Terminal Box TM-217 into the antenna socket on Radio Receiver and Transmitter BC-1000. Tighten by turning the terminal box clockwise.
- (2) Connect a ground lead from Terminal Box TM-217 to the ground terminal on the receiver-transmitter.

h. ADAPTER M-359.

- (1) Secure an Adapter M-359 to the adapter socket on the bottom of Mast Base AB-15/GR and on Terminal Box TM-217.
- (2) Place the hose clamp (item 15) over the knurled coupling nut of Adapter M-359, and tighten the hose clamp.
- (3) Secure an Adapter M-359 to the socket on Terminal Box TM-217.

i. CORD CG-102/TRC-7. Connect Cord CG-102/TRC-7 to Adapter M-359 on Mast Base AB-15/GR and on Terminal Box TM-217. In early production vehicles, the bushing (item 20, fig. 26) must be placed over Cord CG-102/TRC-7 and secured through the hole in the plate (item 19), as shown in figures 26 and 25. If the bushing is not available, Insulator IN-121 must be installed in the hole through the plate (item 19) before Cord CG-102/TRC-7 is installed. One Plug PL-259 must be removed from Cord CG-102/TRC-7 in order to pass the cord through Insulator IN-121. The bushing (item 20) and Insulator IN-121 are not required in late production vehicles.

j. MAST SECTIONS MS-117-A AND MS-118-A.

- (1) Screw the mast sections together. Screw the assembled antenna into Mast Base AB-15/GR.
- (2) When the radio set is not in use, uncouple the mast sections and store them in Roll BG-56-A (supplied with Radio Set SCR-508-()).

k. **SUBSTITUTE ANTENNA SYSTEM.** System Z of figure 30 shows the standard antenna system for Radio Set AN/VRC-3. Systems AA and AB are substitute systems.

- (1) If mast Base MP-48 or MP-48-A and Mast Sections MS-52 and MS-53 are issued in the basic unit, a 32-inch antenna lead-in Wire W-128 must be used rather than Cord CG-102/TRC-7 and Terminal Box TM-217.
- (2) When Mast Sections MS-52 and MS-53 are used with Mast Base MP-48 or MP-48-A, screw the mast sections together, place Clamp MC-424 on the section joints to prevent loss of sections, and screw the antenna into the mast base.

l. **MICROPHONE AND HEADSET.** Headset H-16/U is used with Microphone T-45 and Chest Set TD-4. Headset H-16/U and Chest Set TD-4 must be used in conjunction with the interphone equipment in the tank and may not be used for portable operation of the radio set, since the impedance of Headset H-16/U does not match the impedance of the radio set.

26. Operation Check

a. For information on Radio Set AN/VRC-3, refer to TM 11-637; for information on Vibrator Power Supply PP-114/VRC-3, refer to TM 11-983. Do not attempt to operate the equipment before reading the technical manuals.

b. Radio Set AN/VRC-3 is installed in Tank, Light, M24, in combination with Radio Set SCR-508-(*) or SCR-528-(*). Radio Set AN/VRC-3 is adjusted and operated from the loader's position in the turret of the tank. Remote operation is effected from the commander's position. Check the operation of the equipment as follows:

- (1) Connect the headset and microphone cords in the usual manner. Insert the chest set cord Plugs PL-68 and PL-55 in the proper jacks on Switchboxes BC-658-().
- (2) Turn the RADIO-INTERPHONE switch on the loader's Interphone Control Box BC-606 to the RADIO position. Turn the RADIO-INTERPHONE switch on the commander's Interphone Control Box BC-

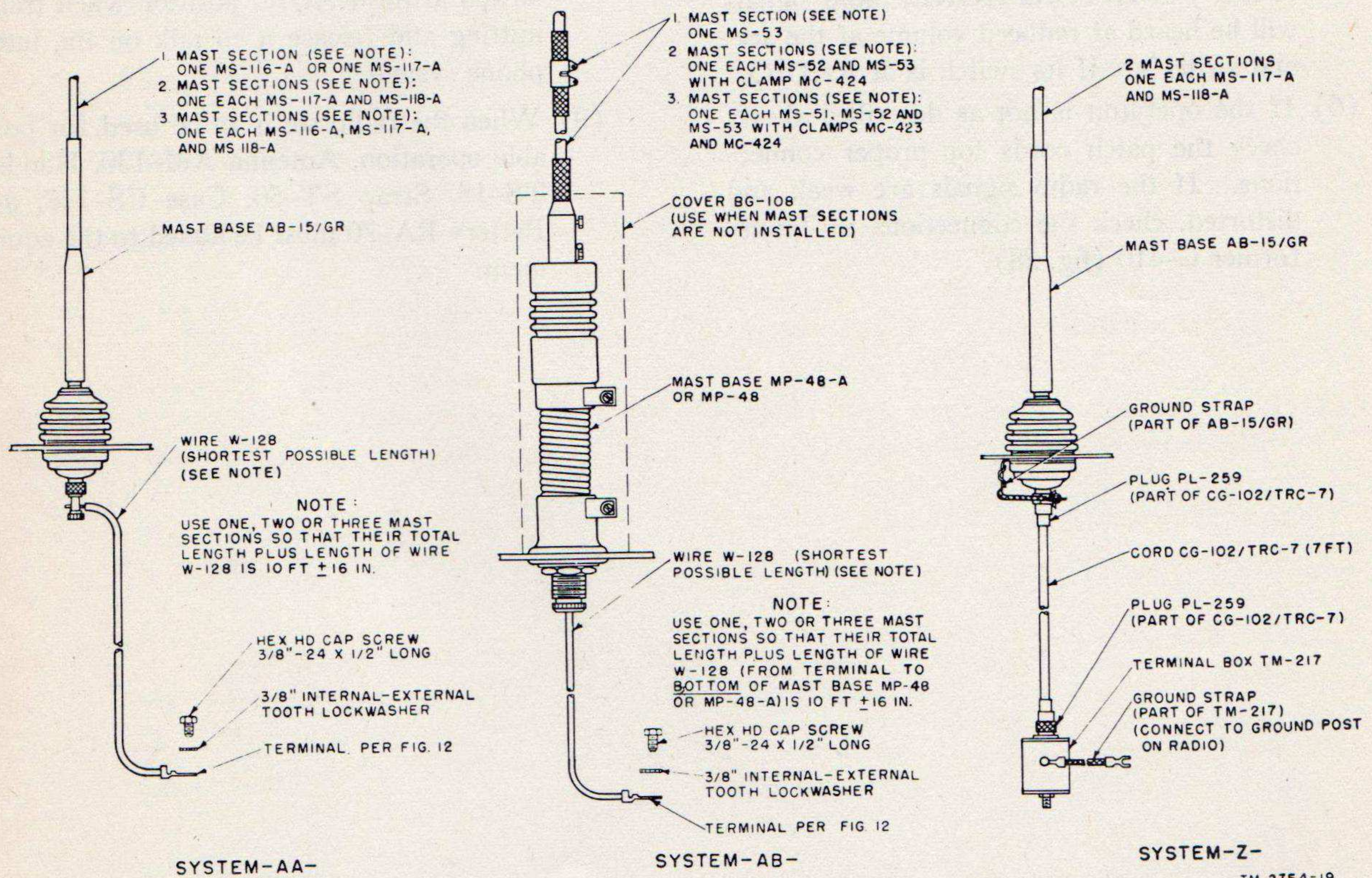

Figure 30. Antenna systems for Radio Set AN/VRC-3.

- 606 to the INTERPHONE position. Turn the RADIO-INTERPHONE switch on both Switchboxes BC-658 to the INTERPHONE position. The interphone system of the companion Radio Set SCR-508 should operate properly between loader and commander positions.
- (3) While listening to the interphone signals, push the RADIO-INTERPHONE switch of each Switchbox BC-658- () from the INTERPHONE to the RADIO position. Signals from the interphone system should be at the same volume level, regardless of the switch position.
 - (4) Turn on Radio Receiver and Transmitter BC-1000- () by turning the volume control clockwise. Turn the SQUELCH control OFF by turning it counterclockwise. A rushing noise should be heard in the headset. Press the microphone switch. If the transmitter is operating, the rushing noise in the headset will cease. Speak into the microphone to modulate the transmitter. The transmitter should be operable through either Switchbox BC-658- ().
 - (5) With the switch of one Switchbox BC-658- () at INTERPHONE, radio signals will be heard at reduced volume at the second switchbox if its switch is at RADIO.
 - (6) If the operation is not as described above, check the patch cords for proper connections. If the radio signals are weak and distorted, check the connections to Transformer C-410 (fig. 28).
 - (7) When the RADIO-INTERPHONE switches on both Switchboxes BC-658- () are in the INTERPHONE position, the microphones and headsets are disconnected from Radio Receiver and Transmitter BC-1000 and connected to the interphone system. In this position, operation of the transmitter of Radio Receiver and Transmitter BC-1000- () from the switchboxes should not be possible. No signals should be heard from the receiver, although the receiver will still be in operation. Turn the volume control to OFF if the receiver is no longer required.
 - (8) When the interphone system of Radio Set SCR-508 or SCR-528 has been modified to incorporate a spring-loaded switch on the commander's Interphone Control Box BC-606- () (fig. 28), the operation as described above remains unchanged. To call the commander, the loader must turn the RADIO-INTERPHONE switch on Switchbox BC-658- () to the INTERPHONE position, press the microphone switch, and speak into the microphone. The commander must hold the spring-loaded switch in the RADIO position when transmitting and release it to talk on the interphone system.
 - (9) When the radio set is to be used for portable operation, Antenna AM-130, Handset TS-15, Strap ST-50, Case CS-128, and Battery BA-70 must be added to the equipment.

SECTION VII

DEMOLITION TO PREVENT ENEMY USE

27. General

The demolition procedures outlined in paragraphs 28 and 29 will be used to prevent the enemy from using or salvaging this equipment. Demolition of the equipment will be accomplished *only* upon order of the commander.

28. Methods of Destruction

a. Smash. Use sledges, axes, handaxes, pickaxes, hammers, crowbars, and heavy tools.

b. Cut. Use axes, handaxes, and machetes.

c. Burn. Use gasoline, kerosene, oil, flame throwers, incendiary grenades.

d. Explosives. Use firearms, grenades, and TNT.

e. Other. Use anything immediately available for destruction of this equipment.

f. Disposal. Bury in slit trenches, fox holes, and other holes. Throw in streams. Scatter.

29. Destruction of Components

a. Smash all vacuum tubes, crystals, control dials, coupling coils, transformers, speakers in receivers, external loudspeakers, microphones, headsets, dynamotors, and cable connectors.

b. Cut all connecting wires, cording, and cabling.

c. Burn all equipment and all associated training, technical, and installation manuals.

d. Bury or scatter all remains, after destroying their usefulness.

e. Destroy everything.

☆ U. S. GOVERNMENT PRINTING OFFICE : 1951 O—932330

THE END!