

462

# TM 9-1796

US WAR DEPARTMENT TECHNICAL MANUAL

U113  
.2  
Tm 9:1796  
1944

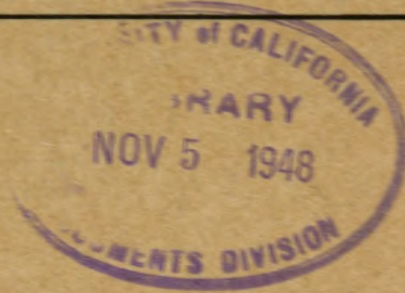

## ORDNANCE MAINTENANCE

# Crane For Heavy Wrecking

# Truck M1A1

(Ward La France and Kenworth)

WAR DEPARTMENT •

26 APRIL 1944

**FOR ORDNANCE PERSONNEL ONLY**

WAR DEPARTMENT TECHNICAL MANUAL

TM 9-1796

---

ORDNANCE MAINTENANCE

# Crane For Heavy Wrecking

## Truck M1A1

(Ward La France and Kenworth)



---

WAR DEPARTMENT

26 APRIL 1944

Digitized by Google

Original from  
UNIVERSITY OF CALIFORNIA

**WAR DEPARTMENT**

Washington 25, D. C., 26 April 1944

TM 9-1796, Ordnance Maintenance: Crane for Heavy Wrecking Truck M1A1 (Ward La France and Kenworth), is published for the information and guidance of all concerned.

[ A.G. 300.7 (25 Jan 44)  
O.O.M. 461/(TM-9) Rar. Ars. (4-25-44) ]

BY ORDER OF THE SECRETARY OF WAR:

**G. C. MARSHALL,**  
*Chief of Staff.*

OFFICIAL:

**J. A. ULIO,**  
*Major General,*  
*The Adjutant General.*

DISTRIBUTION: R 9 (4); Bn 9 (2); IC 9 (3).

(For explanation of symbols, see FM 21-6.)

# CONTENTS

113  
12  
- 119.1796  
1944  
★

|  | Paragraphs | Pages   |
|--|------------|---------|
| CHAPTER 1. INTRODUCTION .....  | 1- 2       | 6- 7    |
| CHAPTER 2. CRANE .....   | 3-86       | 8       |
| SECTION I. Crane description and data .....  | 3- 4       | 8       |
| II. Crane assembly removal .....   | 5-16       | 9- 18   |
| III. Disassembly of crane into sub-<br>assemblies .....                                  | 17-25      | 18- 29  |
| IV. Boom disassembly, inspection,<br>repair, and assembly .....                          | 26-29      | 29- 35  |
| V. Main drive shaft disassembly, in-<br>spection, repair, and assembly .....             | 30-31      | 35- 37  |
| VI. Crane control disassembly, in-<br>spection, repair, and assembly .....               | 32-34      | 37- 42  |
| VII. Topping pivot disassembly, in-<br>spection, repair, and assembly .....              | 35-37      | 42- 47  |
| VIII. Boom pivot disassembly, inspec-<br>tion, repair, and assembly .....                | 38-40      | 48- 60  |
| IX. Swinger gear case disassembly,<br>inspection, repair, and assem-<br>bly .....        | 41-45      | 60- 72  |
| X. Double drum disassembly, in-<br>spection, repair, and assembly .....                  | 46-48      | 72- 75  |
| XI. Hoist and boom gear case disas-<br>sembly, inspection, repair, and<br>assembly ..... | 49-52      | 76- 85  |
| XII. Assembly of crane .....   | 53-67      | 85- 99  |
| XIII. Installation .....   | 68-79      | 99-105  |
| XIV. Test and adjustment .....   | 80-86      | 105-108 |
| CHAPTER 3. SPECIAL TOOLS .....   | 87         | 109     |
| REFERENCES .....   |            | 110-111 |
| INDEX .....  |            | 112-116 |

**M609738**  
3

Generated on 2016-07-20 15:25 GMT / http://hdl.handle.net/2027/uc1.b3243988  
Public Domain, Google-digitized / http://www.hathitrust.org/access\_use#pd-google

TM 9-1796

**ORDNANCE MAINTENANCE — CRANE FOR HEAVY WRECKING  
TRUCK M1A1 (WARD LA FRANCE AND KENWORTH)**

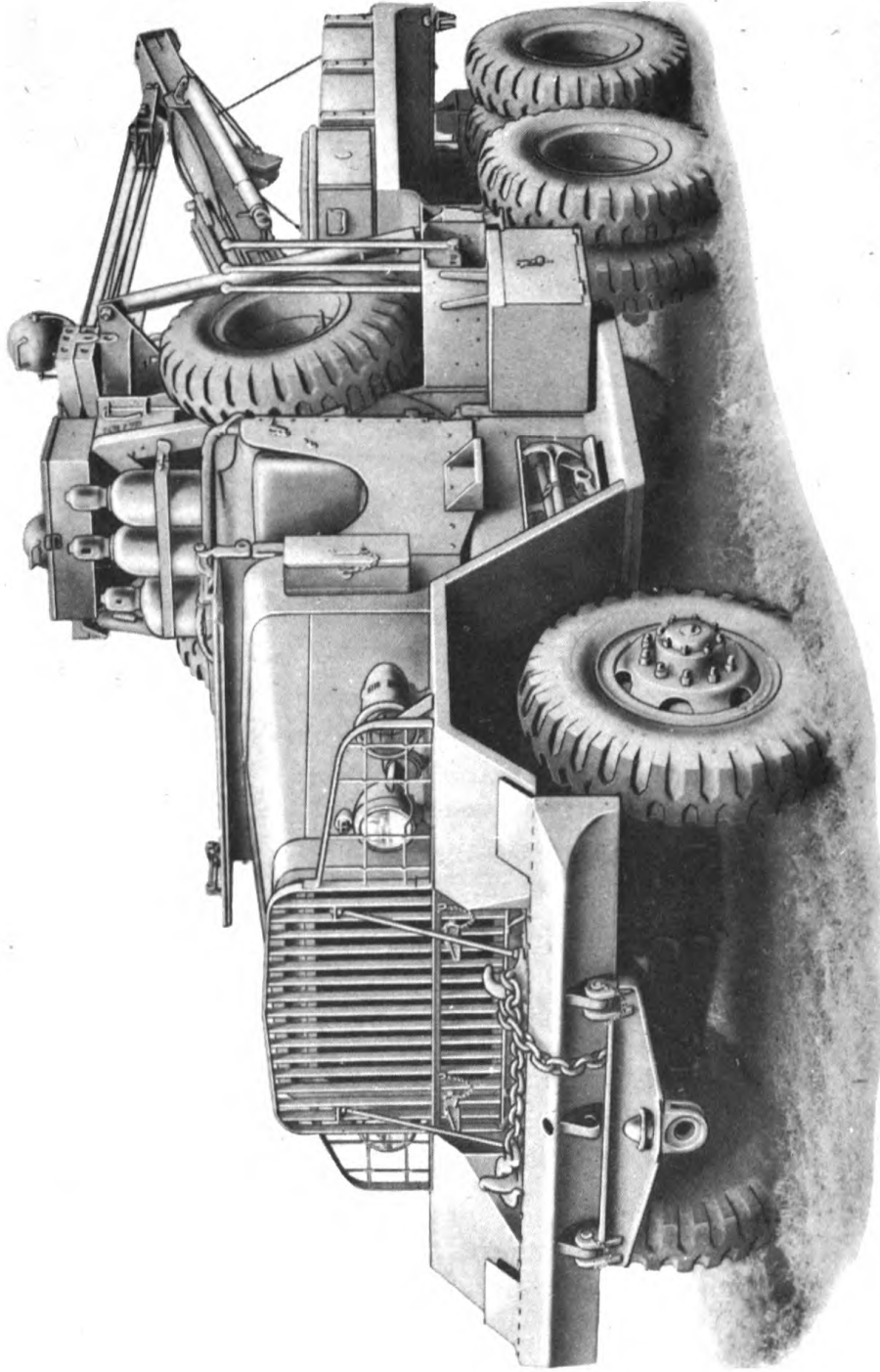

RA PD 315151

**Figure 1 — Heavy Wrecking Truck M1A1 — Three-quarter Front View**

TM 9-1796

**ORDNANCE MAINTENANCE – CRANE FOR HEAVY WRECKING  
TRUCK M1A1 (WARD LA FRANCE AND KENWORTH)**

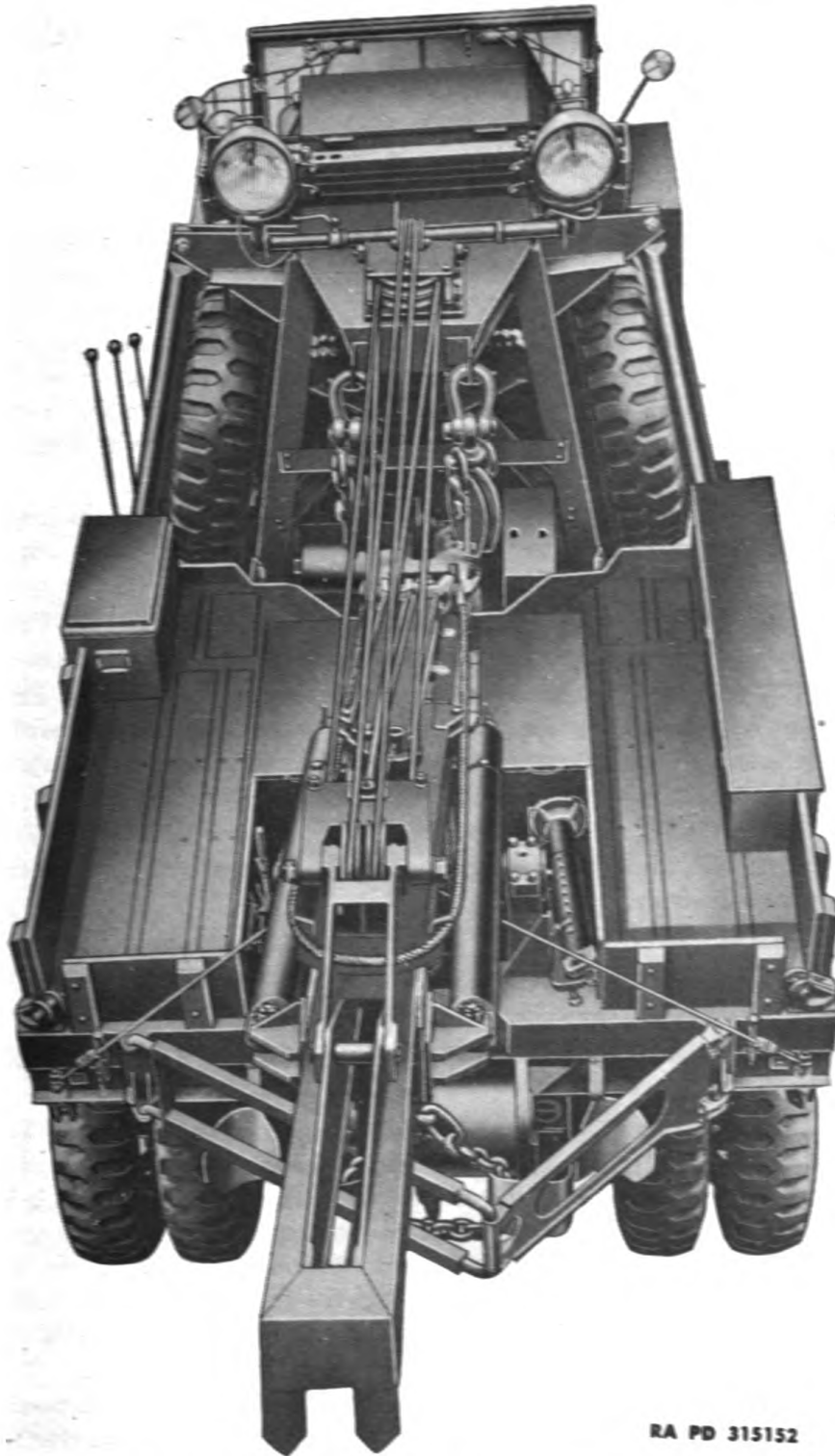

RA PD 315152

**Figure 2 – Heavy Wrecking Truck M1A1 – Top View**

**TM 9-1796**

**1-2**

**ORDNANCE MAINTENANCE — CRANE FOR HEAVY WRECKING  
TRUCK M1A1 (WARD LA FRANCE AND KENWORTH)**

**CHAPTER 1**

**INTRODUCTION**

**1. SCOPE.**

a. The instructions contained in this manual are for the information and guidance of personnel charged with the maintenance and repair of the crane for the Heavy Wrecking Truck M1A1. These instructions are supplementary to field and technical manuals prepared for the using arms. This manual does not contain information which is intended primarily for the using arms, since such information is available to ordnance maintenance personnel in 100-series Technical Manuals or Field Manuals.

b. This manual contains a description of, and procedure for, the disassembly, inspection, repair, and assembly of the crane for the Heavy Wrecking Truck M1A1.

c. TM 9-796, Heavy Wrecking Truck M1A1 (Ward La France and Kenworth) contains instructions for organization maintenance.

d. TM 9-1795A, Ordnance Maintenance: Power Train for Heavy Wrecker M1 series 2 (axles, transmissions, wheels, and tires), contains instructions for the disassembly, inspection, repair and assembly of the axle, transmission, wheels, and tires.

e. TM 9-1795B, Ordnance Maintenance: Engine for Heavy Wrecking Truck M1, contains instructions for the disassembly, inspection, repair, and assembly of the engine.

f. TM 9-1795D, Ordnance Maintenance: Body and Chassis for Heavy Wrecking Truck M1, contains instructions for the disassembly, inspection, repair, and assembly of the body and chassis.

**2. MWO AND MAJOR UNIT ASSEMBLY REPLACEMENT RECORD.**

a. **Description.** Every vehicle is supplied with a copy of W.D., A.G.O. Form No. 478 which provides a means of keeping a record of each MWO completed or major unit assembly replaced. This form includes spaces for the vehicle name and U. S. A. registration number, instructions for use, and information pertinent to the work accomplished. It is very important that the form be used as directed, and that it remain with the vehicle until the vehicle is removed from service.

b. **Instructions for Use.** Personnel performing modifications or major unit assembly replacements must record clearly on the form a description of the work completed, and must initial the form in the

## INTRODUCTION

columns provided. When each modification is completed, record the date, hours and or mileage, and MWO number. When major unit assemblies, such as engines, transmissions, transfer cases, are replaced, record the date, hours and or mileage, and nomenclature of the unit assembly. Minor repairs and minor parts and accessory replacements need not be recorded.

c. **Early Modifications.** Upon receipt by a third or fourth echelon repair facility of a vehicle for modification or repair, maintenance personnel will record the MWO numbers of modifications applied prior to the date of W.D., A.G.O. Form No. 478.



**ORDNANCE MAINTENANCE – CRANE FOR HEAVY WRECKING  
TRUCK M1A1 (WARD LA FRANCE AND KENWORTH)**

**CHAPTER 2**

**CRANE**

**Section I**

**CRANE DESCRIPTION AND DATA**

**3. DESCRIPTION AND OPERATION.**

a. The crane is full-powered direct from the engine through a power take-off mounted on the transfer case. The raising and lowering of the boom and load, and the swinging of the boom and load, are all power driven and can be used independent of and in conjunction with one another. The boom can be raised from 6 feet 3 inches to 16 feet, measurements being taken at the hoist line sheave positions. The crane assembly consists briefly of longitudinal base channels and A-frame on which are installed the boom topping pivot and boom pivot, and in which is installed the necessary gear cases and driving mechanism to hoist the load and raise and swing the boom.

**4. DATA (CRANE).**

|                                  |                  |
|----------------------------------|------------------|
| Model                            | U S 6 A          |
| Make                             | Gar Wood         |
| Type                             | Full-powered     |
| Number of gear cases             | 3                |
| Maximum lift capacity            | 16,000 lb        |
| Maximum transport capacity       | 11,000 lb        |
| Swinging arc                     | 180 deg          |
| Boom cable length                | 115 ft           |
| Boom cable size                  | 1/2 in.          |
| Hoist cable length               | 115 ft           |
| Hoist cable size                 | 1/2 in.          |
| Maximum allowable engine speed   | 1,000 rpm        |
| Engine clutch control            | Air              |
| Engine throttle control          | Manual           |
| Gear case shift control          | Manual           |
| Gear case lubricant capacity     | 2 qt each        |
| Boom pivot lubricant capacity    | 4 qt             |
| Sheave lubrication               | Pressure fitting |
| Bushing lubrication              | Pressure fitting |
| Antifriction bearing lubrication | Pressure fitting |
| Topping pivot lubrication        | Pressure fitting |

## CRANE

### Section II

## CRANE ASSEMBLY REMOVAL

### 5. GENERAL.

a. All of the subassemblies of the crane can be removed from the vehicle without removing the crane A-frame from the vehicle (fig. 3). The boom pivot must be removed to remove any one of the three gear cases. To remove the hoist gear case it is necessary to remove the swinger gear case; to remove the boom gear case it is necessary to remove the swinger and hoist gear cases. The swinger gear case can be removed without disturbing the boom or hoist gear cases. The boom pivot, topping pivot, and any portion of the drive or control mechanism may be removed as independent units.

### 6. TOOL BOX REMOVAL.

a. **Remove Tool Box on Right Side Under Body.** Remove Pioneer tools from Pioneer tool bracket. Remove four  $\frac{3}{8}$ -inch palnuts, nuts, and bolts attaching Pioneer tool bracket to vehicle. Lift Pioneer tool bracket from vehicle. Remove two tow chains, three sets of tire chains, and boom jack ground plates from under body tool box. Remove two double sheave snatch blocks from space formed by crane crossmember, and under body tool box. Remove seven  $\frac{3}{8}$ -inch bolts, nuts, and lock washers attaching under body tool box to crane frame crossmembers. Lift tool box directly out from vehicle.

b. **Remove Tool Box on Left Side Under Body.** Remove Pioneer tools from bracket and remove four  $\frac{3}{8}$ -inch palnuts, nuts, and bolts attaching Pioneer tool bracket to vehicle. Remove the following materiel from the under body tool box: Hand tool kit, grease gun, front and rear axle bearing and spring seat bearing wrenches, wheel wrench and handle, two pry bars, two  $\frac{3}{4}$ -inch round pin anchor shackles, three jacks and handles, vise and bracket, tow chain hook, twelve rope thimbles, two tow bar clevises, six  $\frac{5}{8}$ -inch and six  $\frac{3}{4}$ -inch wire rope clamps. Remove seven  $\frac{3}{8}$ -inch bolts, nuts, and lock washers attaching tool box to crane frame. Lift tool box directly out from vehicle and remove.

c. **Remove Tool Box on Crane Frame.** Remove the following materiel: Two electric lanterns, one canvas water bag, one oxygen and acetylene set of gages, one welding torch, one cutting torch with tips, one spark lighter, one welding equipment wrench, one pair of asbestos gloves, one pair of goggles, one trouble light, one tire inflation hose, one towing air hose, one acetylene and one oxygen hose, one operators manual, and one Service Parts Catalogue and tool list. Remove three  $\frac{3}{8}$ -inch bolts, nuts, and lock washers attaching tool box to crane frame, and remove box from frame.

**ORDNANCE MAINTENANCE – CRANE FOR HEAVY WRECKING  
TRUCK M1A1 (WARD LA FRANCE AND KENWORTH)**

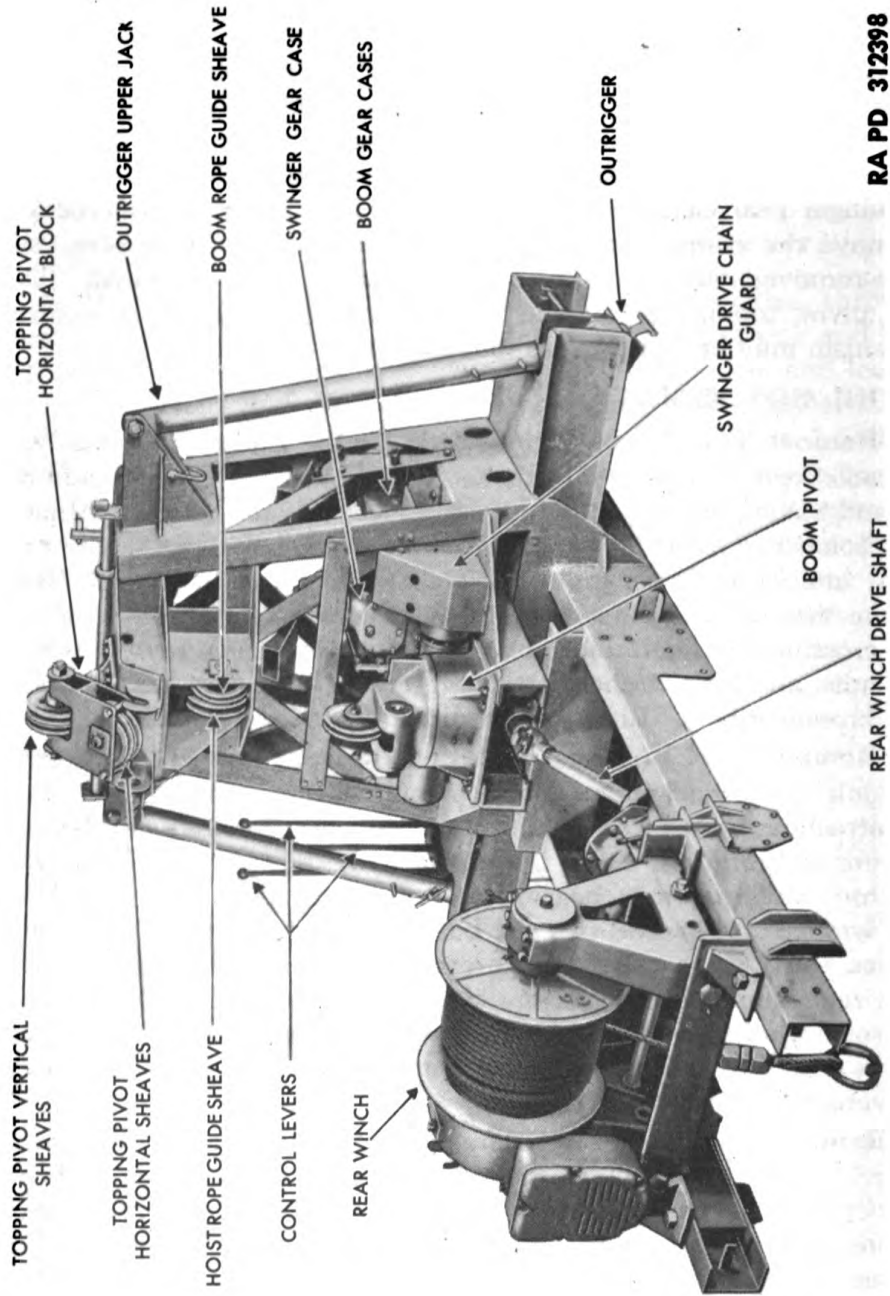

RA PD 312398

**Figure 3 – Crane Assembly**

**CRANE****7. EQUIPMENT REMOVAL.**

**a. Remove Spare Tires.** Using the wheel wrench and handle remove three wheel nuts attaching spare tires to each side of the crane frame. Using a chain hoist and chain, lift the spare tires from the sides of the crane frame.

**b. Remove Anchor Stakes and Ground Anchors.** Four ground anchors are located on top of the crane A-frame and 14 ground anchor stakes are stowed in brackets on each side of crane frame. Remove the above materiel from the crane.

**c. Remove Snatch Blocks.** Two single sheave snatch blocks are stowed on hooks on rear of crane A-frame. Lift the blocks off hooks and remove.

**d. Remove Oxygen and Acetylene Tanks.** Loosen two acetylene tank bracket nuts and, using a chain fall, remove one acetylene and two oxygen tanks from front of crane frame.

**e. Remove Tow Cable and Bar.** The tow cable eyes are hooked onto pins and looped over clips welded to the boom. The tow bar is also mounted on the top of the boom on welded pins. To remove, lift directly up.

**f. Remove Directional Beam.** Lift out two clevis pins, swing directional beam parallel to the vehicle axis, and lift out.

**g. Remove Searchlight.** Remove searchlight wire connection from back of light. Press and turn counterclockwise to remove. Remove nut, tension spring, and cup holding searchlight yoke to searchlight bracket. Lift searchlight from vehicle.

**h. Remove Field Chocks.** Remove retaining pins and pull field chock toward rear of vehicle.

**i. Remove Body Jacks.** Remove body jacks from bed of vehicle.

**j. Remove Outrigger Lower Jacks.** Remove four flat-head screws holding lower outrigger jack in ball socket. Remove lower outrigger jack from outrigger.

**k. Remove Taillights.** The blackout taillight and service stop light is located on the left side, at rear of the vehicle. To remove the light assembly turn the connection clockwise when looking from the back of the light and pull directly out. The tan lead connects the blackout taillight, the green lead connects the taillight, and the green lead with the yellow tracer, the service stop light. Remove the two nuts and lock washers securing the light assembly to the bracket, and lift light assembly off vehicle. The blackout tail and stop light is located on the right rear of the vehicle. To remove the blackout taillight and stop light assembly turn the connection clockwise when looking from the back of the light and pull directly out. The tan lead connects the blackout taillight and the black lead the blackout

TM 9-1796  
7

**ORDNANCE MAINTENANCE – CRANE FOR HEAVY WRECKING  
TRUCK M1A1 (WARD LA FRANCE AND KENWORTH)**

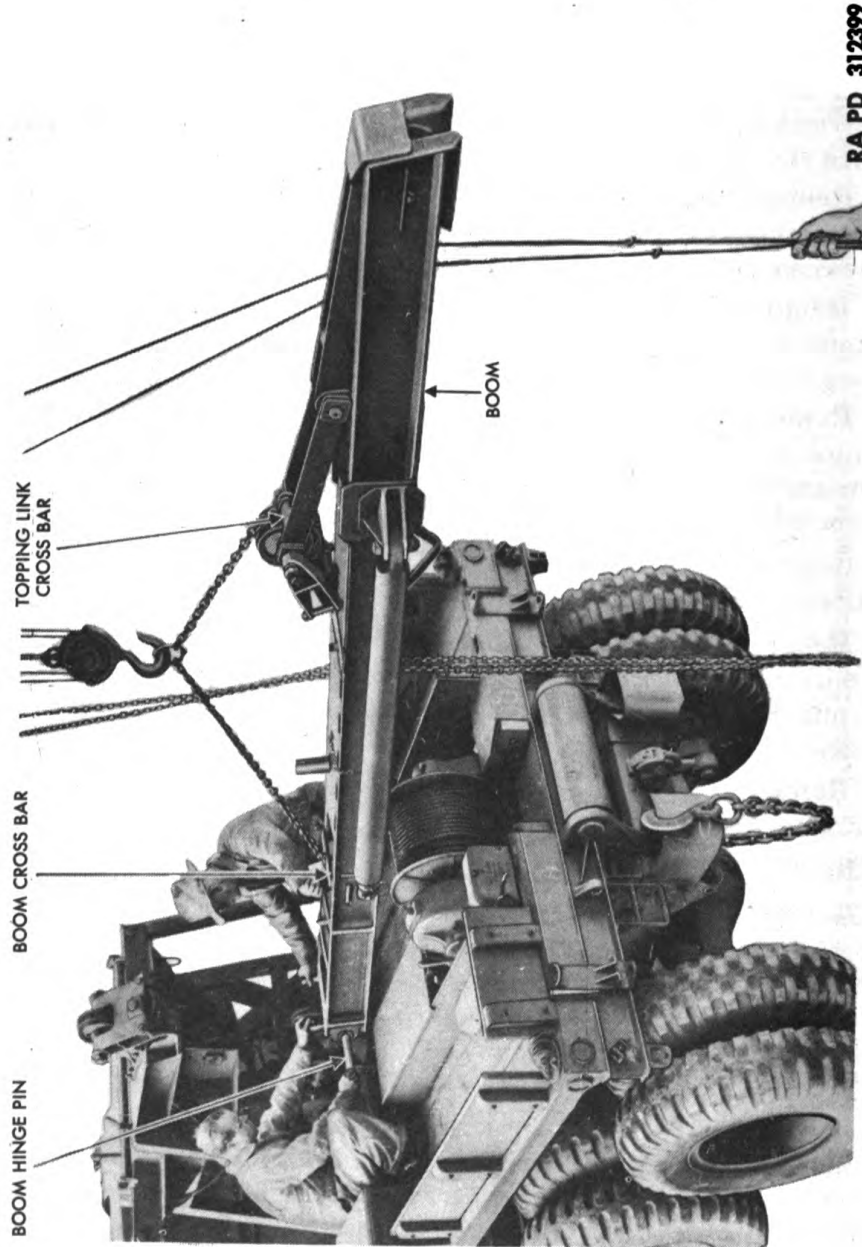

**Figure 4 – Removing Boom**

## CRANE

stop light. Remove the two nuts and lock washers securing the light assembly to the bracket, and lift light assembly off vehicle.

**l. Remove Rear Winch Control.** Before removing, slack off on rear winch line so hook and pin can be removed from the bumperettes. Refer to TM 9-796 for rear winch control removal.

### 8. CABLE REMOVAL.

**a. Remove Load Line.** Engage crane to lower hook until line is off drum. Remove two 1/2-inch nuts and lock washers from cable clamp on drum. Pull cable from fleeting sheaves, guide sheaves, and boom sheaves.

**b. Remove Boom Line.** Place lagging on the rear winch. Lower the boom until it comes to rest on the lagging. Continue to pay out boom line until free from drum. Remove two 1/2-inch nuts and lock washers on cable clamp on drum, freeing end of line. Pull cable free of fleeting sheaves, guide sheaves, topping sheaves, and boom sheaves. Remove cotter pin from sheave and cable eye pin.

**c. Remove Sway Cable.** Remove two pins from corners of body releasing lower end of sway cable. Remove two 3/4-inch bolts, nuts, and lock washers from lower side of boom, releasing upper end of sway cable.

### 9. BOOM REMOVAL.

**a. Locate Lifting Chain on Boom.** Using a chain fall and an 84-inch chain with a hook on each end, hook into the cross bars on the topping link and boom proper. Position the hook of the chain fall 34 inches from the topping link end and 5 feet from the boom end (fig. 4). *NOTE: This positioning will balance the boom for a safe and easy removal.*

**b. Remove Boom.** The boom is anchored to the boom pivot by means of a 1 1/2-inch bolt. Remove cotter pin and castellated nut, and drive the hinge pin to the left of the vehicle to remove (fig. 4). The hinge pin bushings may come out of the boom when the pin is removed (fig. 19). Raise the boom clear of the boom pivot and remove from vehicle.

### 10. BODY REMOVAL.

**a. Disconnect Rear Winch Roller Brackets.** Remove sideboards and rear winch roller bracket bolts. Lift four side boards free of sockets. Remove four 5/8-inch bolts, nuts, and lock washers from each side of body mounting angles. Remove crane load indicator plate (M, fig. 31). Disconnect swinger cut-out valve air line clamp at body side board. Remove four 1/2-inch bolts, nuts, and lock washers retaining rear winch rope roller brackets to vehicle frame (fig. 5).

TM 9-1796  
10

**ORDNANCE MAINTENANCE — CRANE FOR HEAVY WRECKING  
TRUCK M1A1 (WARD LA FRANCE AND KENWORTH)**

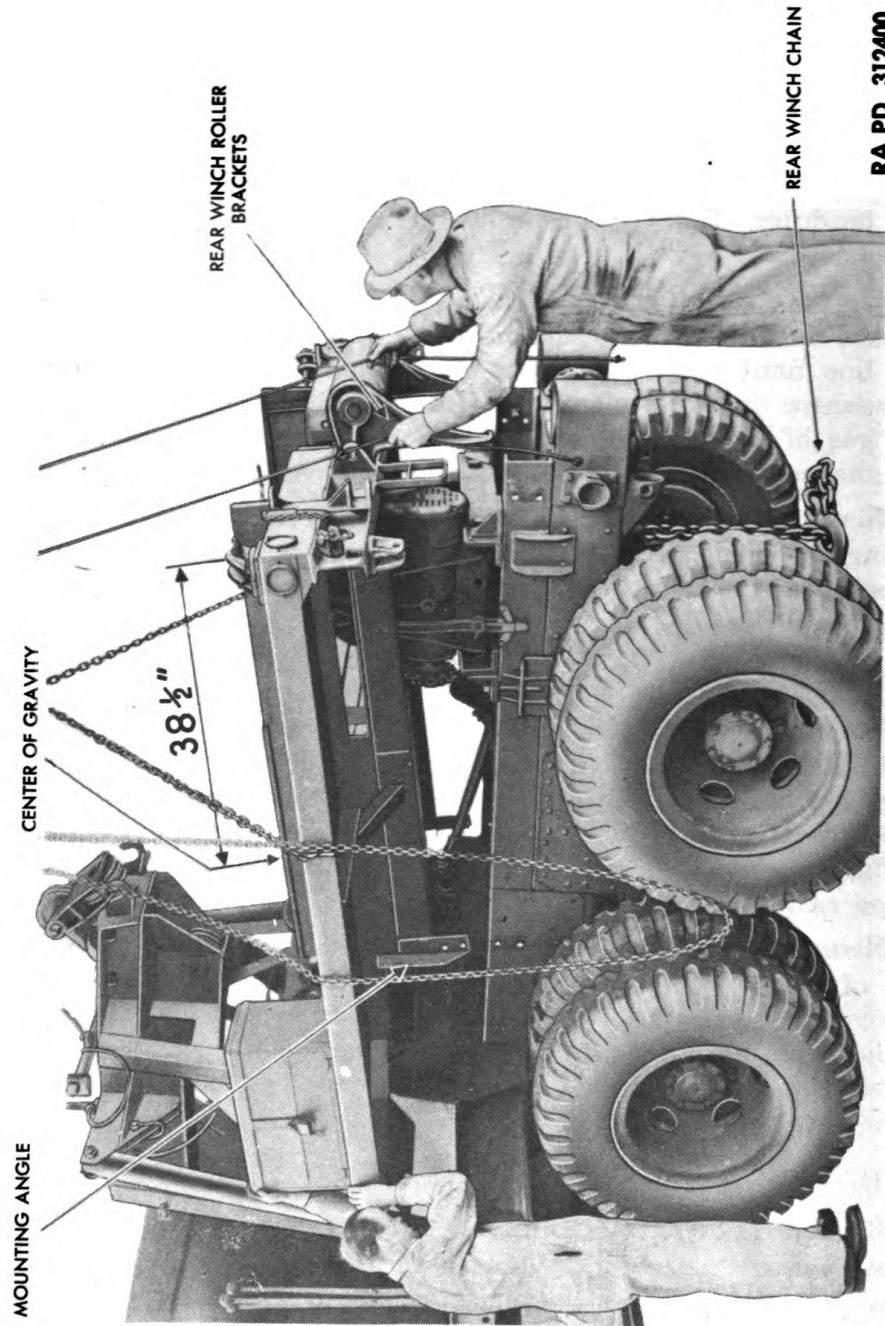

RA PD 312400

**Figure 5 — Removing Body**

CRANE

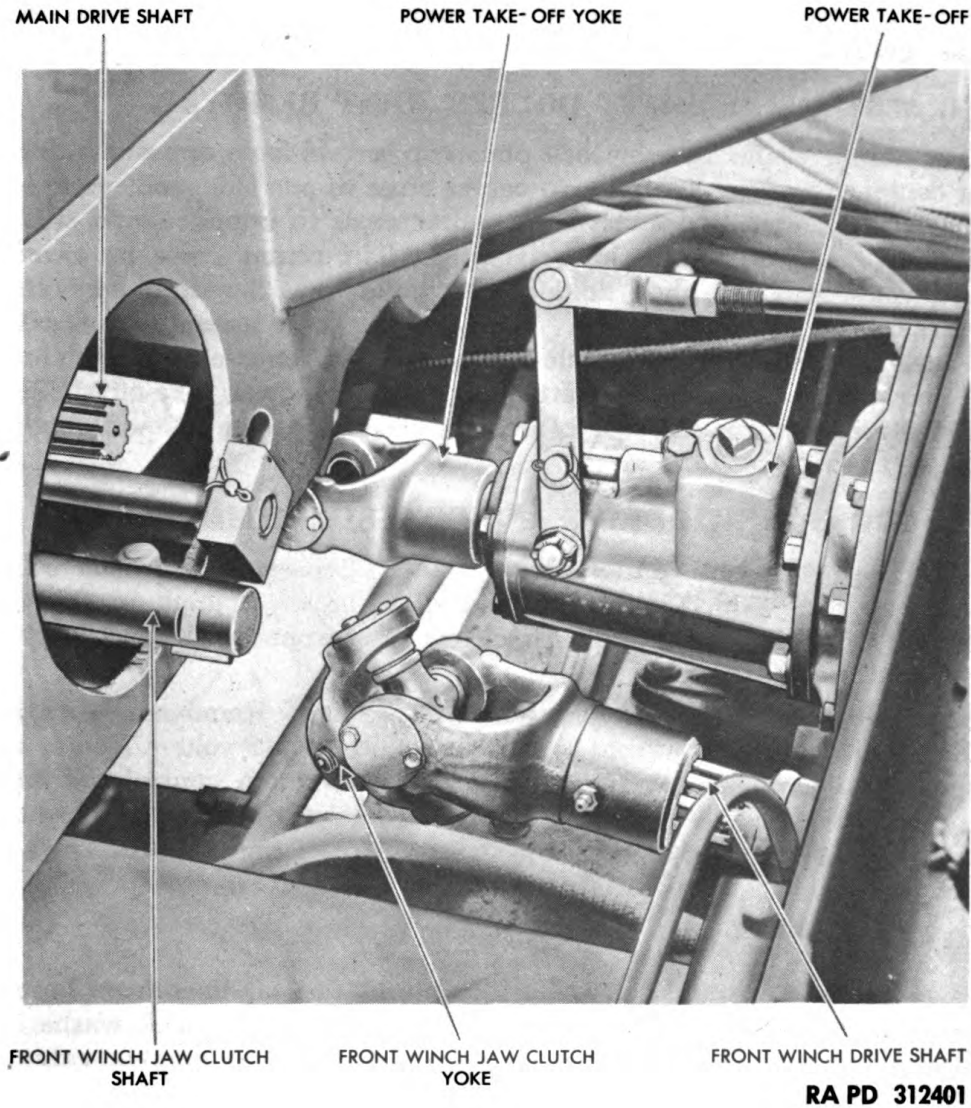

**Figure 6 – Main Drive Shaft and Front Winch Shaft Disconnected**



**ORDNANCE MAINTENANCE – CRANE FOR HEAVY WRECKING  
TRUCK M1A1 (WARD LA FRANCE AND KENWORTH)**

b. **Remove Body** (fig. 5). The center of gravity of the body with the tool equipment in the body tool boxes is 38½ inches ahead of the rear face of the body platform. A single bridal chain hooked under the platform angles connected to a chain hoist can be used for lifting. The body can then be raised and tilted front end down in order to clear the rear winch. Continue raising until it is clear of the vehicle and remove.

**11. MAIN DRIVE SHAFT DOUBLE JOINT REMOVAL.**

a. Remove four bearing lock plate cap screws from opposite sides of center cross (fig. 23). Drive center cross to one side, and remove the bearing assembly. Drive the center cross to opposite side, and remove opposite double joint bearing. Tilt center cross to clear end yoke boss and slide double joint yoke toward rear of vehicle onto main drive shaft spline. Slide double joint assembly toward front of vehicle until yoke is clear of spline, and remove from vehicle. Remove cotter pin and nut attaching yoke to power take-off shaft, and drive yoke toward rear of vehicle clear of power take-off shaft (fig. 6).

**12. FRONT WINCH DRIVE AND CONTROL REMOVAL.**

a. **Remove Front Winch Drive Shaft.** Loosen socket head set screw in front winch end yoke, and slide universal joint assembly toward front of vehicle until it is clear of the front winch jaw clutch shaft (fig. 6).

b. **Remove Front Winch Jaw Clutch Control.** Remove a ¾-inch nut from rear side of front winch jaw clutch shift yoke. Remove cotter pin and clevis yoke pin attaching jaw clutch control rod to control lever directly under the cab, slide the control rod to the front of the vehicle until the rear end is clear of the crane A-frame cross-members, and remove from the vehicle.

**13. CRANE CONTROL REMOVAL.**

a. **Remove Clutch Control.** Disconnect two air lines from base of control valve, remove two 5/16-inch bolts, nuts, and lock washers attaching clutch control valve to crane A-frame, and remove valve. Disconnect air line at swinger cut-out valve and remove from vehicle; disconnect clutch control valve air line at double check valve, and remove from vehicle.

b. **Remove Throttle Control.** Remove cotter pin attaching control cable to control lever at crane A-frame. Remove 5/16-inch draw bolt at throttle control clamp bracket, and remove yoke from end of control cable. Slide cable out of clamping bracket, and remove control cable from crane frame. It is not necessary to disconnect the

**CRANE**

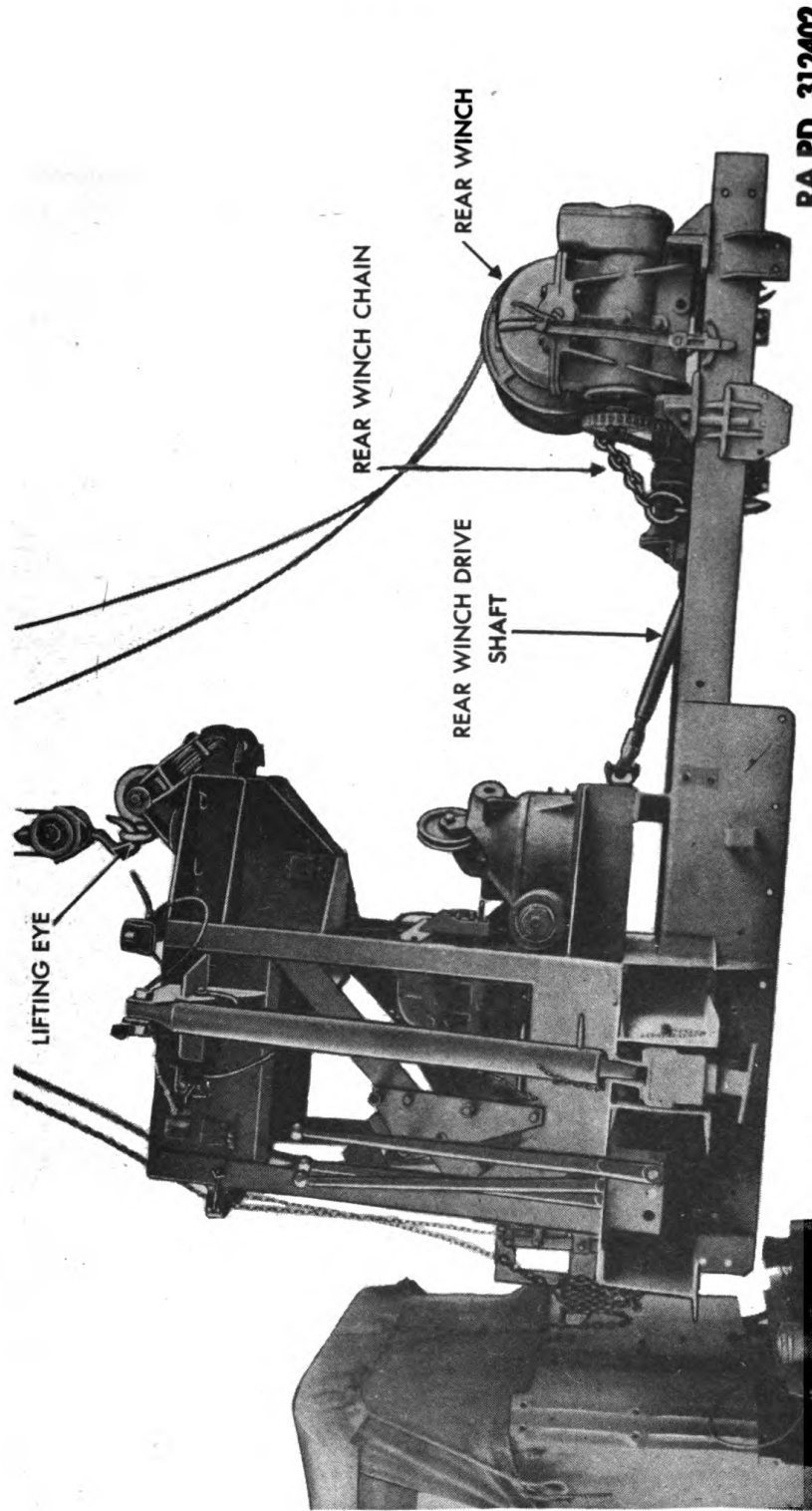

**Figure 7 -- Lifting Crane and Winch Assembly With Lifting Eye 41-E-610**

**TM 9-1796**  
**13-18**

**ORDNANCE MAINTENANCE – CRANE FOR HEAVY WRECKING  
TRUCK M1A1 (WARD LA FRANCE AND KENWORTH)**

crane throttle cable at the accelerator cross shaft to remove the crane assembly.

**14. SWINGER CUT-OUT REMOVAL.**

a. **Remove Swinger Cut-out Valve Assembly.** Remove two  $\frac{3}{8}$ -inch bolts, nuts, and lock washers and lift swinger cut-out valve assembly from crane A-frame.

b. **Remove Swinger Cut-out Air Lines.** Disconnect two air lines at cut-out valve, double check valve, and crane clutch control valve, and remove from vehicle.

**15. AIR TANK REMOVAL.**

a. Refer to TM 9-796 for air tank removal.

**16. CRANE REMOVAL.**

a. **Remove Rear Winch Clutch Control Air Lines.** Remove crane frame attaching bolts. Remove two 1-inch palnuts and nuts securing crane frame to under frame rail crossmember. Remove crossmember. Remove four  $\frac{3}{4}$ -inch and sixteen  $\frac{5}{8}$ -inch bolts, nuts, and lock washers securing each side of crane frame to vehicle frame. Remove rear winch clutch control air lines, and remove searchlight wiring harness.

b. **Remove Crane.** To lift crane from vehicle use lifting eye 41-F-610. Run the eye bolt through the boom cable opening of the topping pivot. Place a 4-inch washer on eye bolt and install two 1-inch nuts. Center the eye bolt under a chain hoist. Wind the rear winch cable chain around the rear winch drum. Raise the chain hoist until the crane is free of the vehicle (fig. 7).

---

**Section III**

**DISASSEMBLY OF CRANE INTO SUBASSEMBLIES**

**17. GENERAL.**

a. The crane assembly is composed of the mounting base, the A-frame, the hoist, swinger and boom gear cases and their controls, the cable and cable drums, the boom, and the boom and topping pivots (fig. 3).

**18. REAR WINCH REMOVAL.**

a. The removal, maintenance, repair, and installation of the rear winch, which is mounted on the crane frame, is covered in TM 9-1795C.

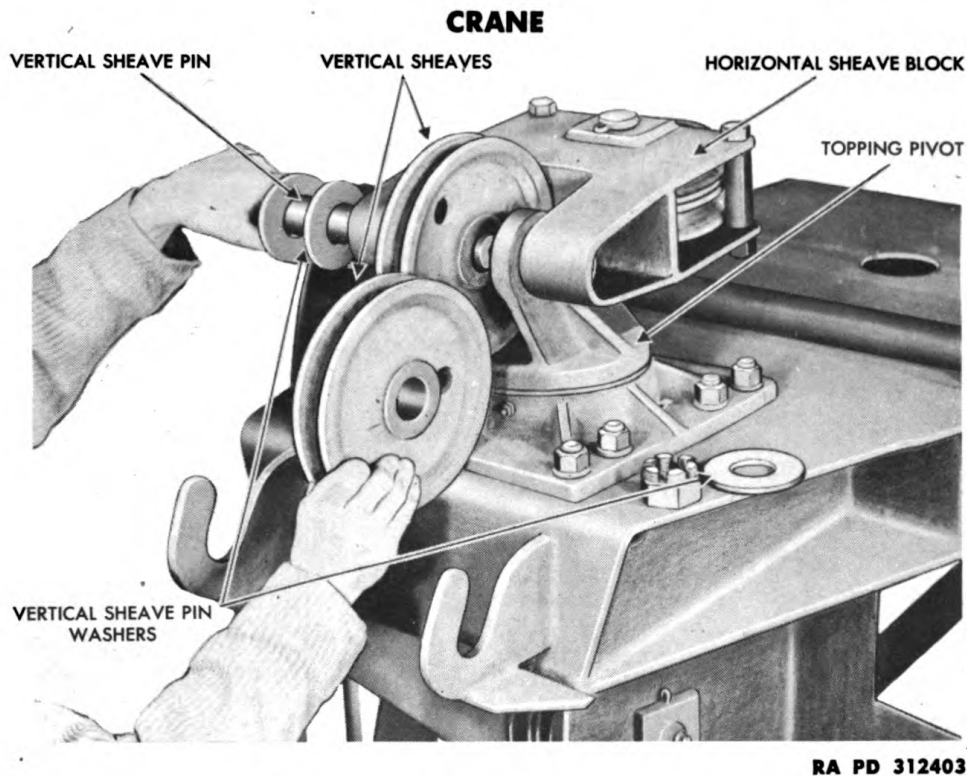

Figure 8 – Removing Topping Pivot Vertical Sheaves

## 19. TOPPING PIVOT REMOVAL.

a. **Remove Horizontal Sheave Block** (fig. 8). Remove the cotter pin and nut from the end of the vertical sheave pin, and pull the horizontal sheave block pin out of topping pivot, at the same time removing the topping pivot vertical sheaves. Three washers are used; one on the nut end, and two under the head of the sheave pin. Pull sheave pin clear of topping pivot and block, and remove block from crane frame.

b. **Remove Topping Pivot** (fig. 9). Replace topping pivot sheave pin in the topping pivot. Place a chain hoist directly over topping pivot and hook through sheave pin. Remove eight  $\frac{3}{4}$ -inch bolts, nuts, and lock washers attaching topping pivot to crane frame. There are openings under the topping pivot base plate to facilitate removal of the topping pivot attaching bolts. Raise topping pivot assembly directly up out of crane A-frame. The topping pivot attaching bolts which have fallen down inside the crane frame can then be lifted out through the topping pivot opening.

## 20. BOOM PIVOT REMOVAL.

a. **Remove Boom Pivot Sheave.** Remove cotter pin from left side of boom pivot load line sheave, and drive the pin to the right side far enough to lift out the sheave. Replace the sheave pin and cotter pin

TM 9-1796  
20-21

**ORDNANCE MAINTENANCE – CRANE FOR HEAVY WRECKING  
TRUCK M1A1 (WARD LA FRANCE AND KENWORTH)**

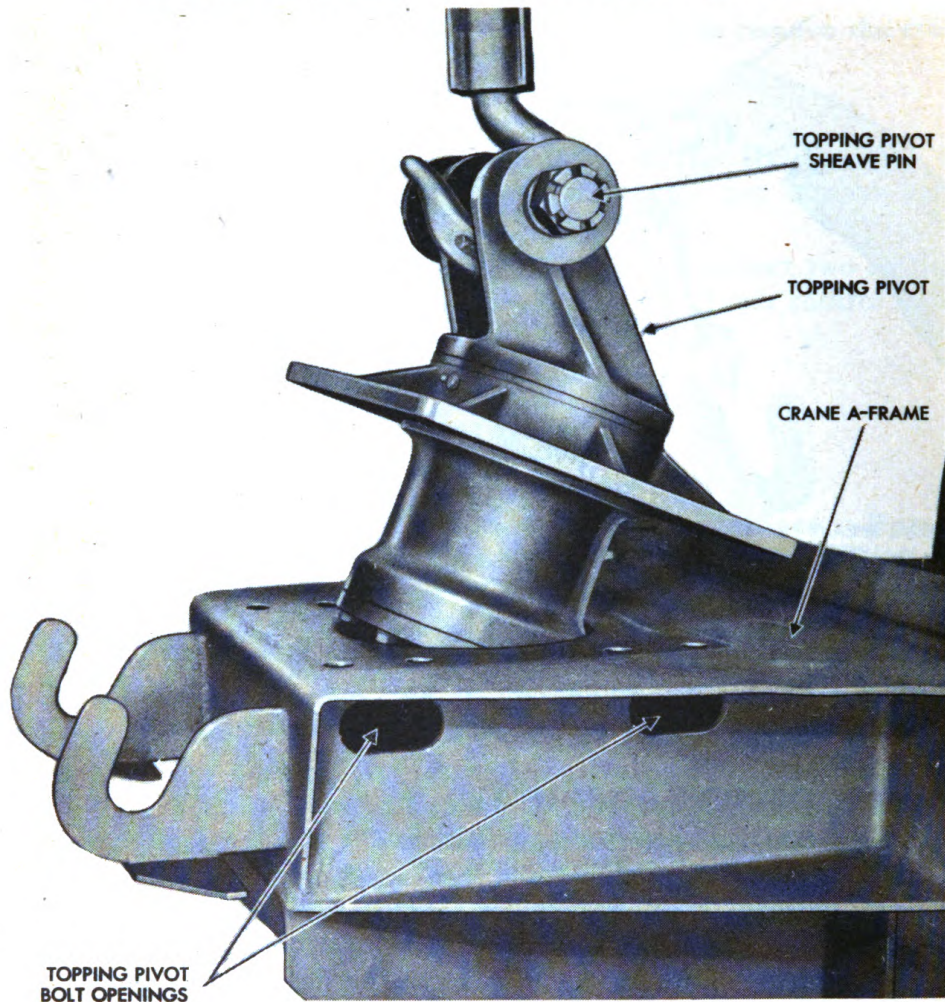

RA PD 312404

**Figure 9 – Lifting Topping Pivot**

to form a suitable anchor for the chain hoist, to be used lifting the boom pivot from the crane frame (fig. 10).

**b. Remove Boom Pivot (fig. 10).** Remove eight  $\frac{3}{4}$ -inch bolts, nuts and lock washers attaching boom pivot to the crane A-frame. Hook a chain hoist into the hoist line sheave pin, and raise just sufficient to take the load off the boom pivot. Slide the boom pivot assembly to the left of the vehicle until the drive coupling is clear of the swinger drive splined shaft. Swing the pivot assembly clear of the crane and remove.

**21. SWINGER DRIVE ASSEMBLY REMOVAL.**

**a. Remove Swinger Drive Chain.** Remove three  $\frac{3}{8}$ -inch bolts, nuts, and lock washers attaching swinger drive chain guard to crane

**CRANE**

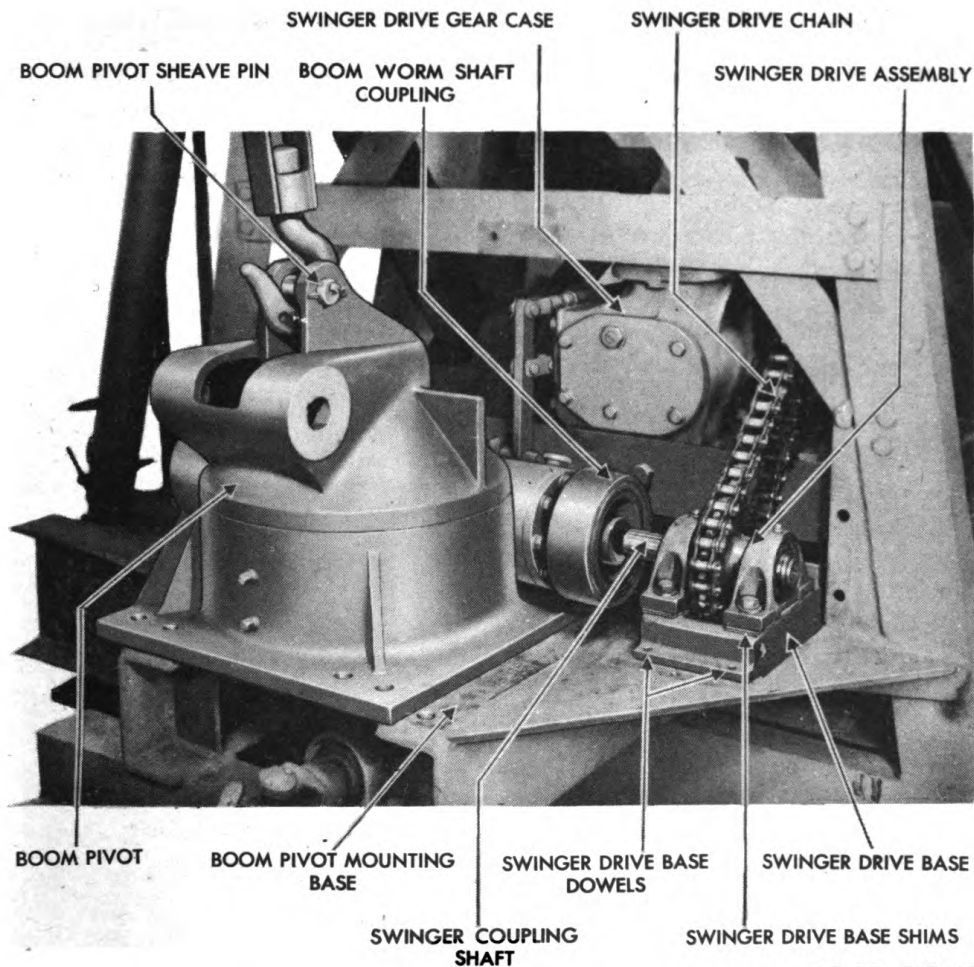

RA PD 312405

**Figure 10 – Removing Boom Pivot**

**A-frame (fig. 3).** Release the eccentric chain tightener draw bolts to slack off the chain, and permit easy removal of the link pins (fig. 69). Remove two cotter pins from the same link, and using two hammers as shown in figure 69, break the pins loose and lift off the lock plate. Continue to drive the pins out of the chain rollers by means of a punch and hammer. Remove the drive chain (fig. 10).

**b. Remove Swinger Drive Assembly.** Remove four swinger drive attaching bolts, nuts, flat washers, and lock washers attaching drive assembly to crane frame. Spacer shims will be found between the swinger drive and base (fig. 10). These spacer shims are required for alinement of the swinger drive with the boom pivot drive coupling; therefore, wire them to the base so that they will not be misplaced, and make certain that the same amount will be used in installation. Pry the swinger drive mounting base off the dowel pins and remove (fig. 10).

**ORDNANCE MAINTENANCE – CRANE FOR HEAVY WRECKING  
TRUCK M1A1 (WARD LA FRANCE AND KENWORTH)**

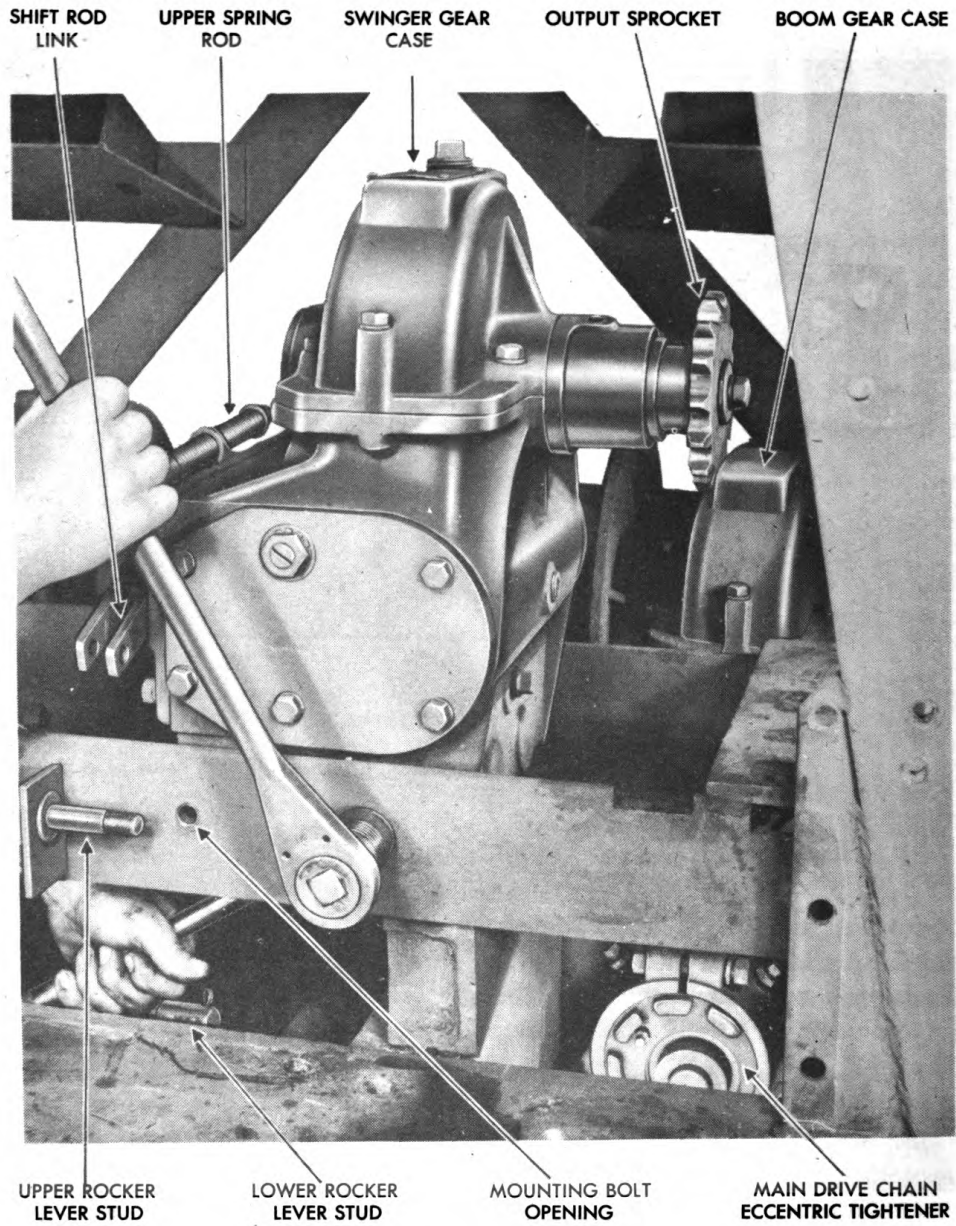

RA PD 312406

**Figure 11 – Removing Swinger Gear Case Pivot Bolt**

## CRANE

c. **Remove Swinger Drive Chain Tightener.** Remove four 1/2-inch bolts, nuts, and lock washers attaching eccentric chain tightener to swinger gear case base angles (fig. 69). Lift eccentric chain tightener with bolts out of base angle and remove.

### 22. SWINGER GEAR CASE REMOVAL.

a. **Remove Upper Rocker Lever.** Remove cotter pins and clevis pins attaching rocker lever to upper spring rod, gear case shift rod and connecting link between upper and lower rocker levers. Remove the 5/8-inch safety nut from the upper rocker lever pivot stud and slide upper rocker lever free of crane frame (fig. 71).

b. **Remove Lower Rocker Link.** Remove three cotter pins from lower rocker link and two clevis pins. Pry lower rocker lever off of its pivot stud.

c. **Remove Swinger Control Lever Cross Shaft.** Loosen the 3/8-inch draw bolts at swinger hand control lever and cross shaft inboard lever. Using a socket head set screw wrench loosen the set screw in the cross shaft positioning collar on the inside face of the A-frame base channel. Drive the cross shaft to the right of the crane until the swinger hand control lever key is clear of the lever and remove the key. Drive the lever further onto the control cross shaft and drive the shaft to the left of the crane until it is free of the inboard lever. Remove the inboard lever key and again drive the cross shaft to the right of the crane until it is free of the swinger hand control lever and then drive the cross shaft to the left of the crane and remove (fig. 70).

d. **Remove A-frame Cross Brace.** Remove two 1/2-inch bolts, nuts, and lock washers from each side of the horizontal A-frame rear cross brace. Remove twelve 1/2-inch bolts, nuts, and lock washers attaching the A-frame rear diagonal braces and lift braces from A-frame.

e. **Remove Main Drive Chain.** Release the eccentric chain tightener draw bolts, which are in back of the boom gear case and just to the right and below the swinger gear case, to slack off chain. Remove two cotter pins from the same link and using two hammers as shown in figure 69 break the pins loose and lift off the lock plate. Continue to drive the pins out of the chain rollers by means of a punch and hammer. Remove the chain.

f. **Remove Swinger Gear Case.** Remove two 1/2-inch and two 7/8-inch bolts, nuts, and lock washers securing swinger gear case to gear case base angles (fig. 11). An opening has been provided in the top deck of the crane A-frame to provide a means of lifting the gear cases out of the crane frame. Place a chain around the input and output sprockets and over the top of the gear case. Raise the chain hoist sufficient to clear the gear case of its base angles and then as the



**ORDNANCE MAINTENANCE — CRANE FOR HEAVY WRECKING  
TRUCK M1A1 (WARD LA FRANCE AND KENWORTH)**

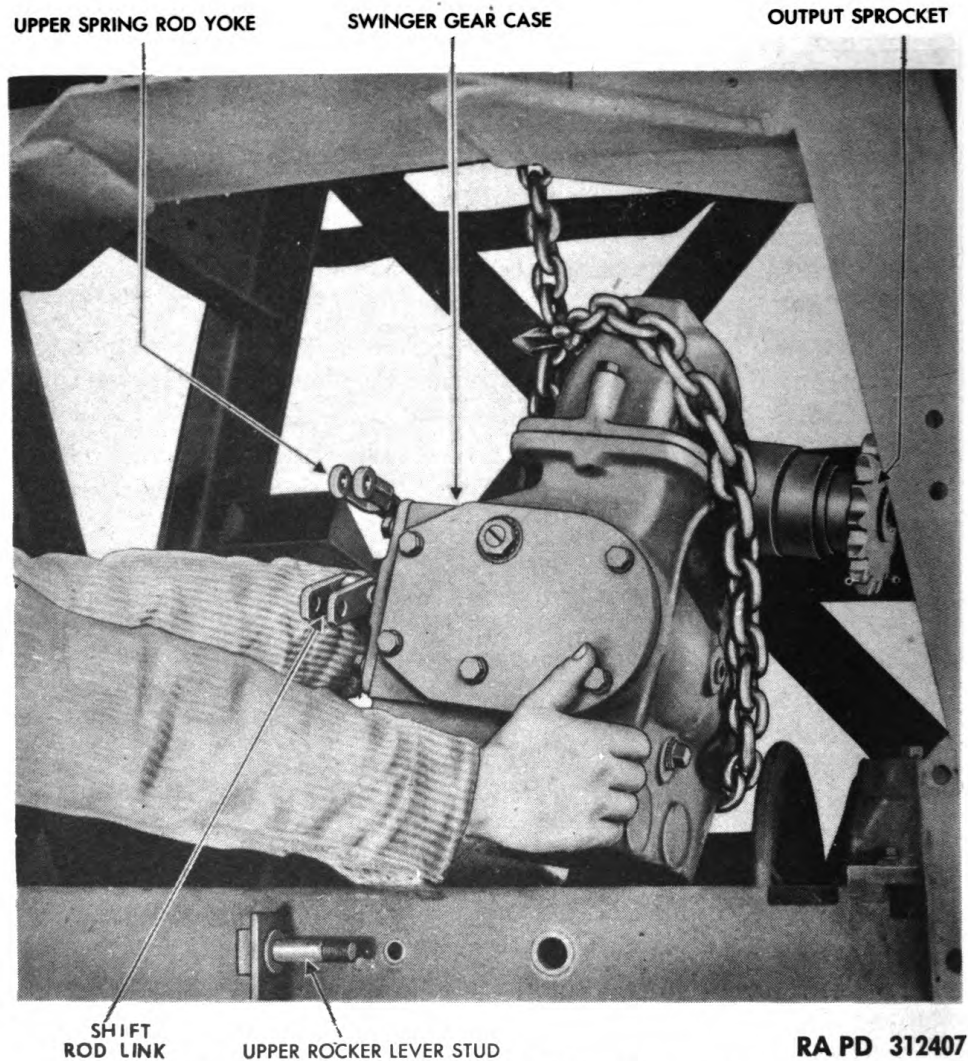

**Figure 12 — Lifting Swinger Gear Case**

chain hoist is lowered pull the gear case forward out of the A-frame onto the boom pivot mounting base plate (fig. 12).

**g. Remove Swinger Gear Case Support.** Remove four  $\frac{5}{8}$ -inch bolts, nuts, and lock washers attaching swinger gear case base angles to the A-frame. Remove four  $\frac{5}{8}$ -inch bolts, nuts, and lock washers attaching base angles center supports to crane A-frame and lift base angles and center support out of A-frame. Use care not to disturb the alinement shims under the four corners of the base angles. Wire these to the crane frame to insure their being returned in the same quantity to the same position (fig. 13).

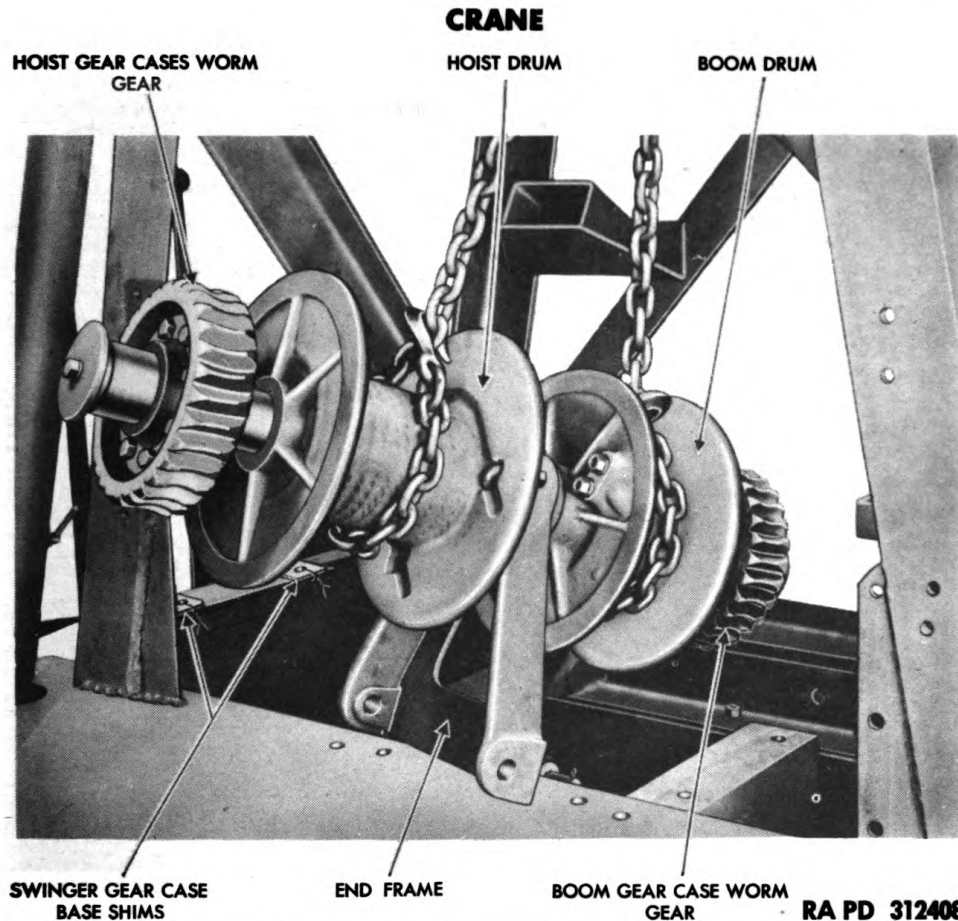

**Figure 13 – Removing Double Drum Assembly**

**h. Remove Main Drive Chain Eccentric Chain Tightener.** Remove four  $\frac{1}{2}$ -inch bolts, nuts, and lock washers attaching the chain tightener to the crane A-frame, and lift the chain tightener clear of A-frame. The two front bolts have wedges under the heads of the bolts to compensate for the angularity of the base mounting channel (fig. 69).

### **23. DOUBLE DRUM AND GEAR CASE REMOVAL.**

**a. Remove Rear Winch Layshaft.** Refer to TM 9-1795C.

**b. Remove Hoist and Boom Gear Case Upper Halves.** Remove six  $\frac{1}{16}$ -inch cap screws from each upper half of the hoist and boom gear cases. Punch mark both halves of each case for identification in assembly and lift off the upper halves (fig. 65).

**c. Remove Double Drum Shaft and End Frame.** Run a bridal chain around the boom and hoist drums and up through the opening provided in the top deck of the crane A-frame and hook onto a chain hoist. Raise the double drum with the drum shafts, end frame and

**ORDNANCE MAINTENANCE — CRANE FOR HEAVY WRECKING  
TRUCK M1A1 (WARD LA FRANCE AND KENWORTH)**

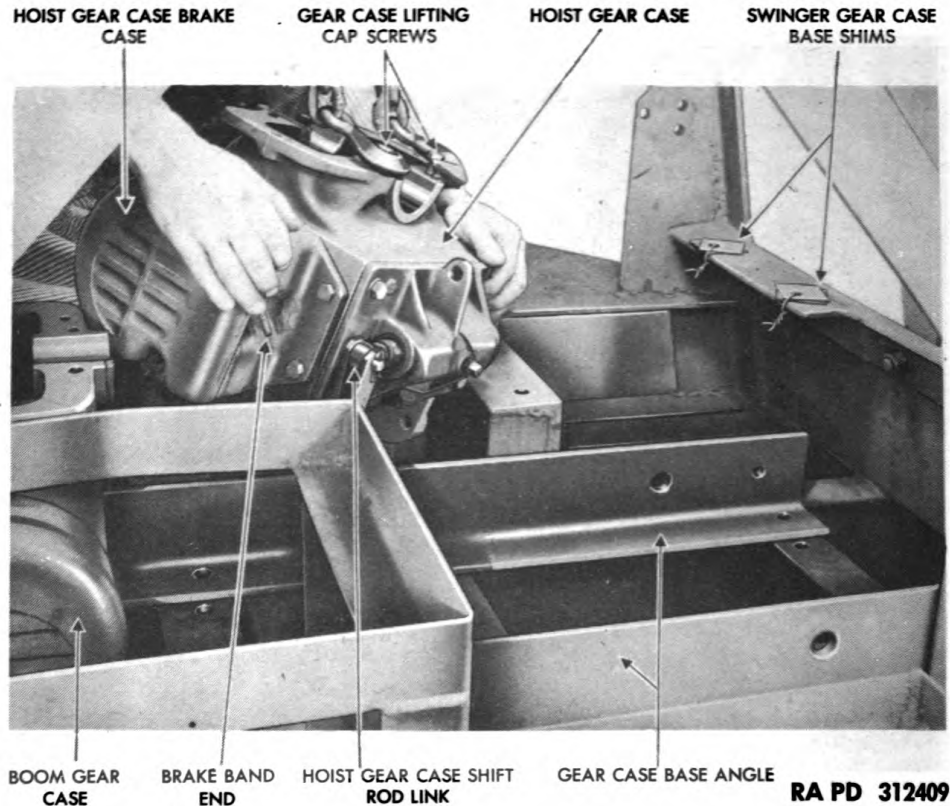

**Figure 14 — Lifting Hoist Gear Case**

worm gears up and out of the gear cases. Rotate this assembly and pull it through the rear face of the crane A-frame, at the same time lower the chain hoist to permit the assembly to come to the rear and onto the boom pivot base plate (fig. 13). Disconnect the bridal chain and pull out the boom drum, shaft, and worm wheel and lower to the ground. Lift off the center support and then the hoist drum, shaft, and worm wheel assembly. This is a split shaft assembly and can be taken from the boom pivot base plate in three pieces to facilitate ease of handling (fig. 52).

**d. Remove Hoist Control Rocker Lever** (fig. 67). Remove four cotter pins from clevis yoke and pivot pins. Drive out clevis pins and shift rod link pivot pin using care not to misplace washers on either side of rocker lever pivot stud, slide rocker lever off pivot stud.

**e. Remove Hoist Control Cross Shaft** (fig. 67). Using a socket head set screw wrench, loosen the positioning collar set screw inside the outboard cross shaft support. Loosen the draw bolt in the cross shaft inboard lever. Pry the cross shaft to the left of the crane and at the same time drive the inboard lever off the cross shaft. Remove

**CRANE**

the key from the cross shaft. Loosen the hoist hand control lever draw bolt and drive the hand control lever off the cross shaft. Remove the control lever key and slide the cross shaft into the inboard bearing and remove the cross shaft locating collar. Pull the hoist control cross shaft out of its support bearings.

**f. Remove Spring Rod.** Remove the lock and adjusting nuts from rear of the spring rod. Remove the flat washer and rear spring and pull spring rod through front of the crane frame.

**g. Remove Hoist Gear Case Attaching Bolts.** Remove four  $\frac{5}{8}$ -inch bolts, nuts, and lock washers securing rear base angle to crane frame. Remove one  $\frac{7}{8}$ -inch and one  $\frac{1}{2}$ -inch bolt, nut, and lock washer from rear end of boom gear case. Remove one  $\frac{7}{8}$ -inch and one  $\frac{1}{2}$ -inch bolt, nut, and lock washer from rear end of hoist gear case. Slide gear case rear base angle to the rear as far as possible. Remove one  $\frac{7}{8}$ -inch bolt, nut, and lock washer from front of hoist gear case and remove the nut and lock washer from the  $\frac{1}{2}$ -inch bolt attaching the hoist gear case to the forward base angle (fig. 14).

**h. Relocate Brake Band for Frame Clearance.** Remove the brake band end lock and adjusting nuts, spring washer, and spring from the brake band end and pry the band back into the brake case for A-frame clearance (fig. 14).

**i. Remove Gear Case.** Install two  $\frac{7}{16}$ -inch standard cap screws in gear case, hook onto case, and pry gear case forward off of the  $\frac{1}{2}$ -inch gear case to base angle attaching bolt. Run the bridal chain through the opening in the top deck of the crane frame and raise the gear case by means of a chain hoist high enough to clear the boom pivot base angles. As the chain hoist is lowered, pull the gear case through the rear opening of the crane frame onto the boom pivot base plate (fig. 14).

**j. Remove Boom Gear Case Rocker Lever** (fig. 66). Remove four cotter pins from the clevis yoke pins and pivot stud. Remove three clevis pins and pivot pin and lift rocker lever free of front of the crane frame.

**k. Remove Boom Gear Case Upper Spring Rod** (fig. 66). Remove the lock and adjusting nuts from rear of spring rod. Remove spring washer and rear spring and slide spring rod through front face of crane frame.

**l. Remove Boom Gear Case Cross Shaft Inboard Lever and Spring Rod** (fig. 66). Loosen the inboard lever draw bolt and pry the cross shaft lever off of the cross shaft. Remove the inboard lever shaft key.

**m. Remove Boom Gear Case Cross Shaft and Boom Hand Control Lever.** Loosen the socket head set screw in the cross shaft positioning collar at the left side rail of the crane frame. Loosen

**ORDNANCE MAINTENANCE – CRANE FOR HEAVY WRECKING  
TRUCK M1A1 (WARD LA FRANCE AND KENWORTH)**

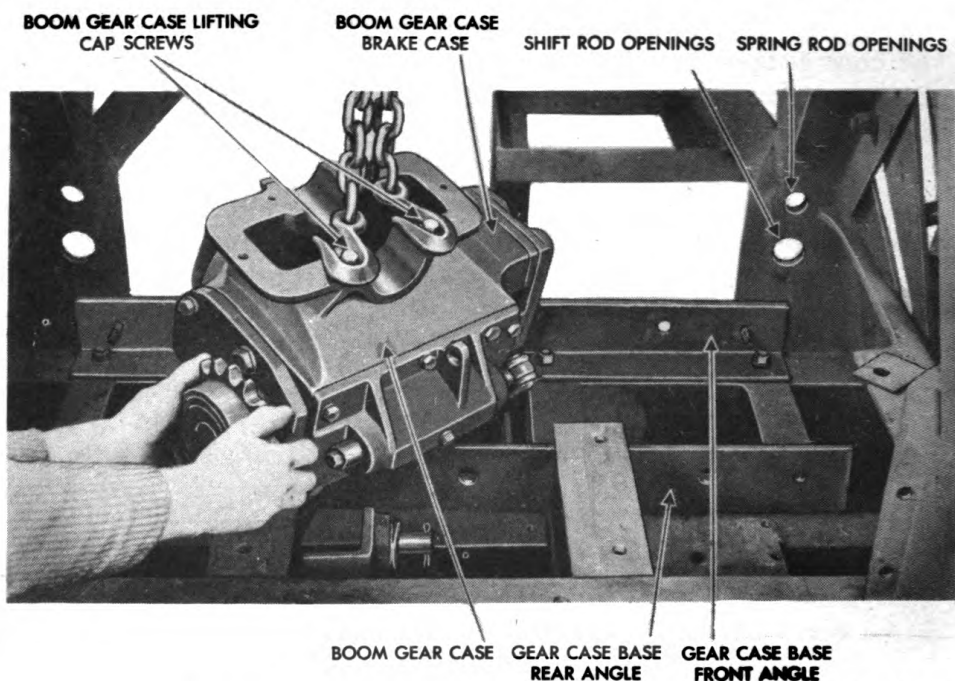

**Figure 15 – Lifting Boom Gear Case**

RA PD 312410

the boom hand control lever draw bolt and drive the cross shaft to the right of the crane until it is free of the hand control lever and lift off the hand control lever. Remove hand control lever key and continue to drive cross shaft through to the right of the crane and remove the cross shaft positioning collar and cross shaft (fig. 66).

n. **Remove Boom Gear Case** (fig. 15). Remove one  $\frac{7}{8}$ -inch bolt, nut, and lock washer and remove one  $\frac{1}{2}$ -inch nut and lock washer attaching the boom gear case to the forward base angle. Install two  $\frac{7}{16}$ -inch cap screws in gear case and running a bridal chain through the A-frame top plate, hook onto the gear case. Remove the lock and adjusting nuts, spring washer and spring from brake band and slide band end back into the brake case. Push the gear case to the rear of the vehicle until the shift control links are free of the crane frame and raise gear case high enough to clear boom pivot base angles and then as the chain hoist is lowered pull the gear case forward onto the boom pivot base plate and remove from vehicle.

o. **Remove Hoist and Boom Gear Case Support.** Remove four  $\frac{5}{8}$ -inch bolts, nuts, and lock washers attaching the front base angle to the crane A-frame. Lift the base angles through rear of crane opening.

## CRANE

### 24. MAIN DRIVE SHAFT REMOVAL.

a. **Remove Chain.** The main drive and front winch drive chains are both driven from the double sprocket on the main drive shaft (fig. 73). To remove the drive chains remove two cotter pins from one link and drive off side plate, and using two hammers as shown in figure 69 drive the link out of chain rollers and lift chains off of the sprockets.

b. **Remove Main Drive Shaft.** Remove four 1/2-inch bolts, nuts, lock washers, and wedge washers attaching the main drive shaft to crane A-frame and remove the main drive shaft assembly (fig. 73).

### 25. JACK AND OUTRIGGER REMOVAL.

a. **Remove Outrigger Upper Jacks.** Remove the 1 1/4-inch bolt, nut, and lock washer from upper half of the outrigger jack. Remove the outrigger securing pin and slide outrigger out from crane frame and remove the lower 1 1/4-inch bolt, nut, and lock washer. Lift off outrigger upper jack (fig. 74).

b. **Remove Outrigger.** Slide outriggers directly out from crane A-frame and remove (fig. 74).

---

## Section IV

### BOOM DISASSEMBLY, INSPECTION, REPAIR, AND ASSEMBLY

#### 26. GENERAL.

a. The topping link, boom jacks, jack swivels, and sheaves can be removed for repair without removing the boom from the vehicle.

#### 27. DISASSEMBLY.

a. **Remove Hoist Line Sheave.** Remove sheave pin spring-loaded lock pin and slide sheave pin to the right out of boom side members and sheaves (fig. 21).

b. **Remove Topping Link.** Remove the cotter pin from topping link pin and drive pin out of topping link arms and boom center member (fig. 16). Lift off topping link with horizontal sheave block installed.

c. **Disassemble Topping Link** (fig. 20). Remove cotter pin, nut and bolt attaching the horizontal sheave block to the topping link. This will disconnect the topping link from horizontal sheave block. Remove horizontal sheave pin cotter pin and drive out of block and sheaves. Remove sheave and washers either side of sheave. Remove topping link to boom attaching pin.

**ORDNANCE MAINTENANCE – CRANE FOR HEAVY WRECKING  
TRUCK M1A1 (WARD LA FRANCE AND KENWORTH)**

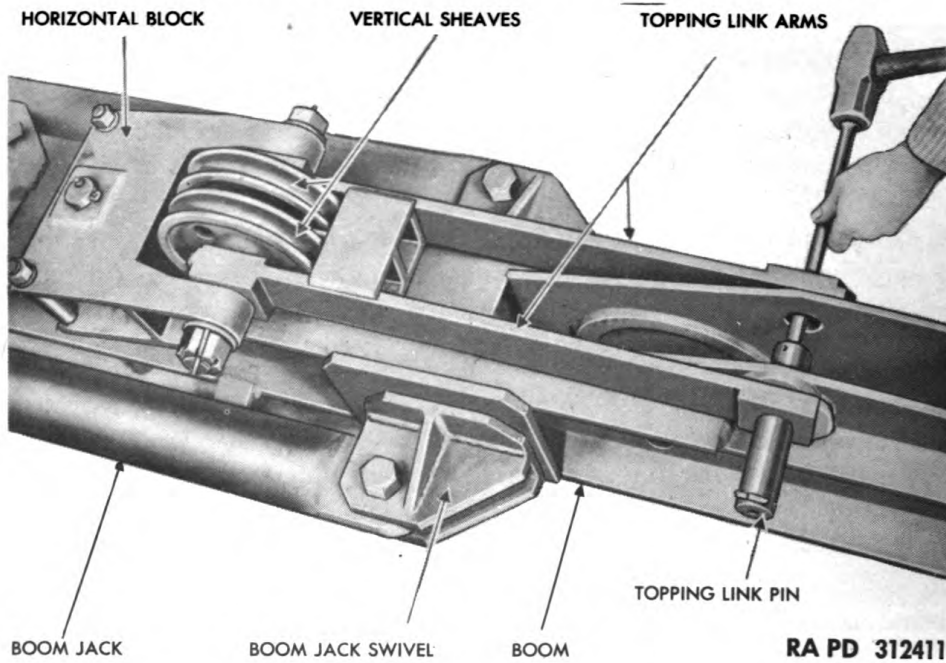

**Figure 16 – Removing Topping Link**

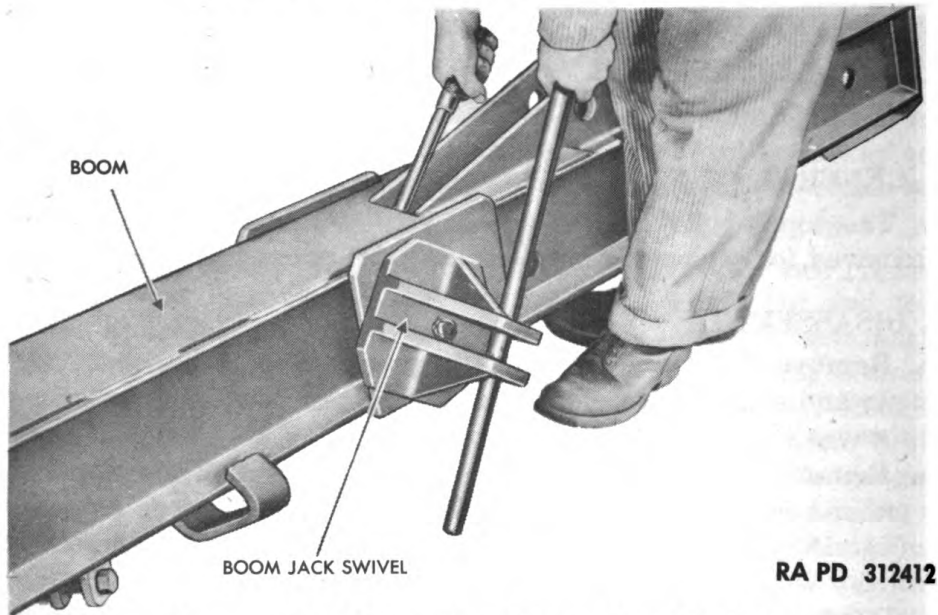

**Figure 17 – Removing Boom Jack Swivel**

**d. Remove Boom Jack and Upper Swivel.** Remove cotter pin and remove 1¼-inch castellated nut and bolt securing boom jack to upper swivel (fig. 16). Lift the jack free of the upper swivel. Remove cotter pin and castellated nut from the upper swivel pin and pull swivel outward free of boom (fig. 17).

CRANE

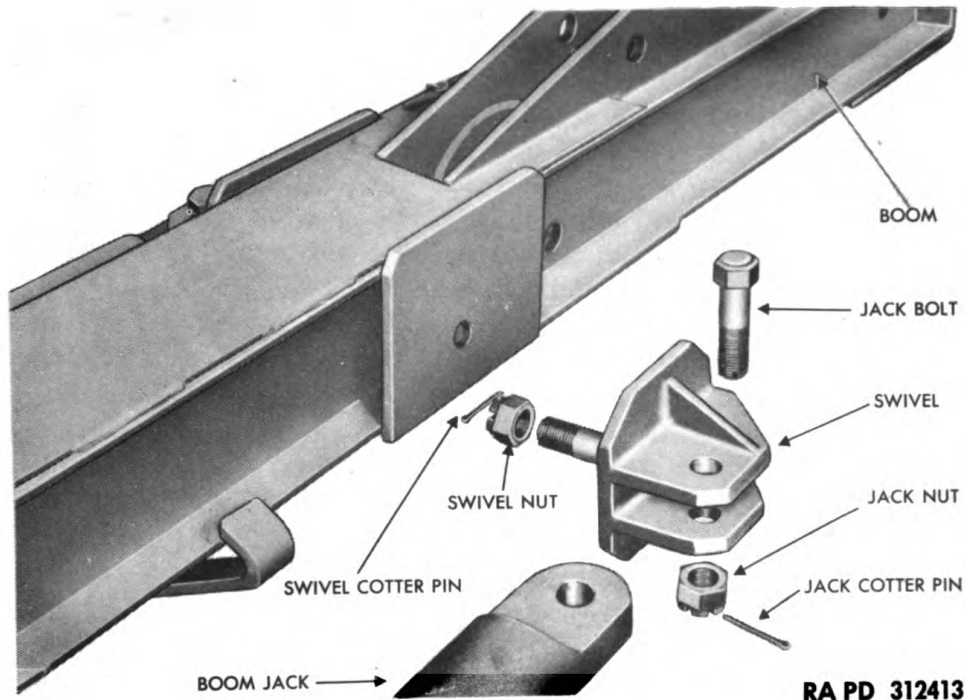

**Figure 18 – Boom Jack Swivel – Disassembled**

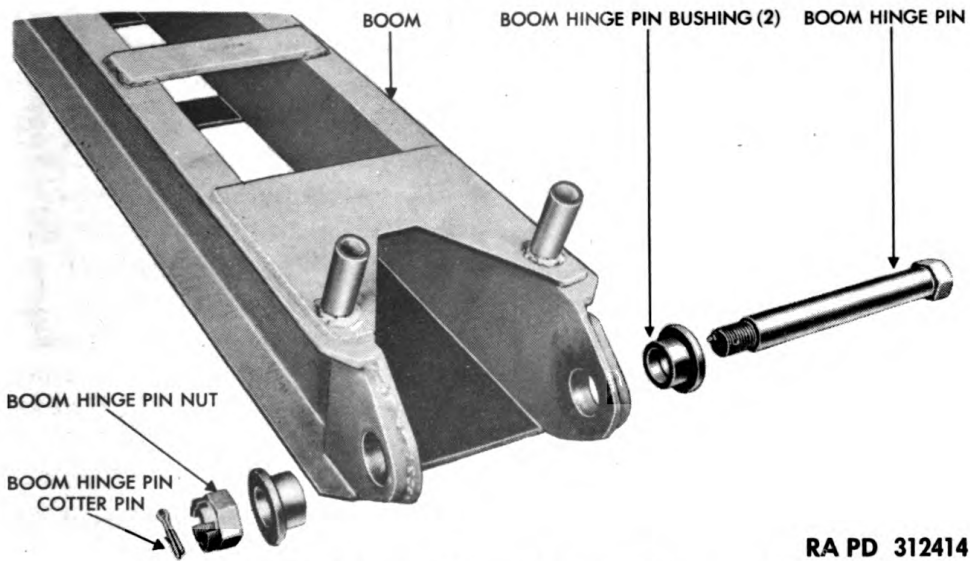

**Figure 19 – Boom Hinge End – Disassembled**

**28. CLEANING, INSPECTION, AND REPAIR.**

**a. General.** Inspect the boom for broken welds, stretched or worn sheave pin eyes, missing brackets and stretched or worn anchor pin holes. Inspect boom jack swivel mounting plate for excessive wear and alinement (fig. 21).



ORDNANCE MAINTENANCE – CRANE FOR HEAVY WRECKING  
TRUCK M1A1 (WARD LA FRANCE AND KENWORTH)

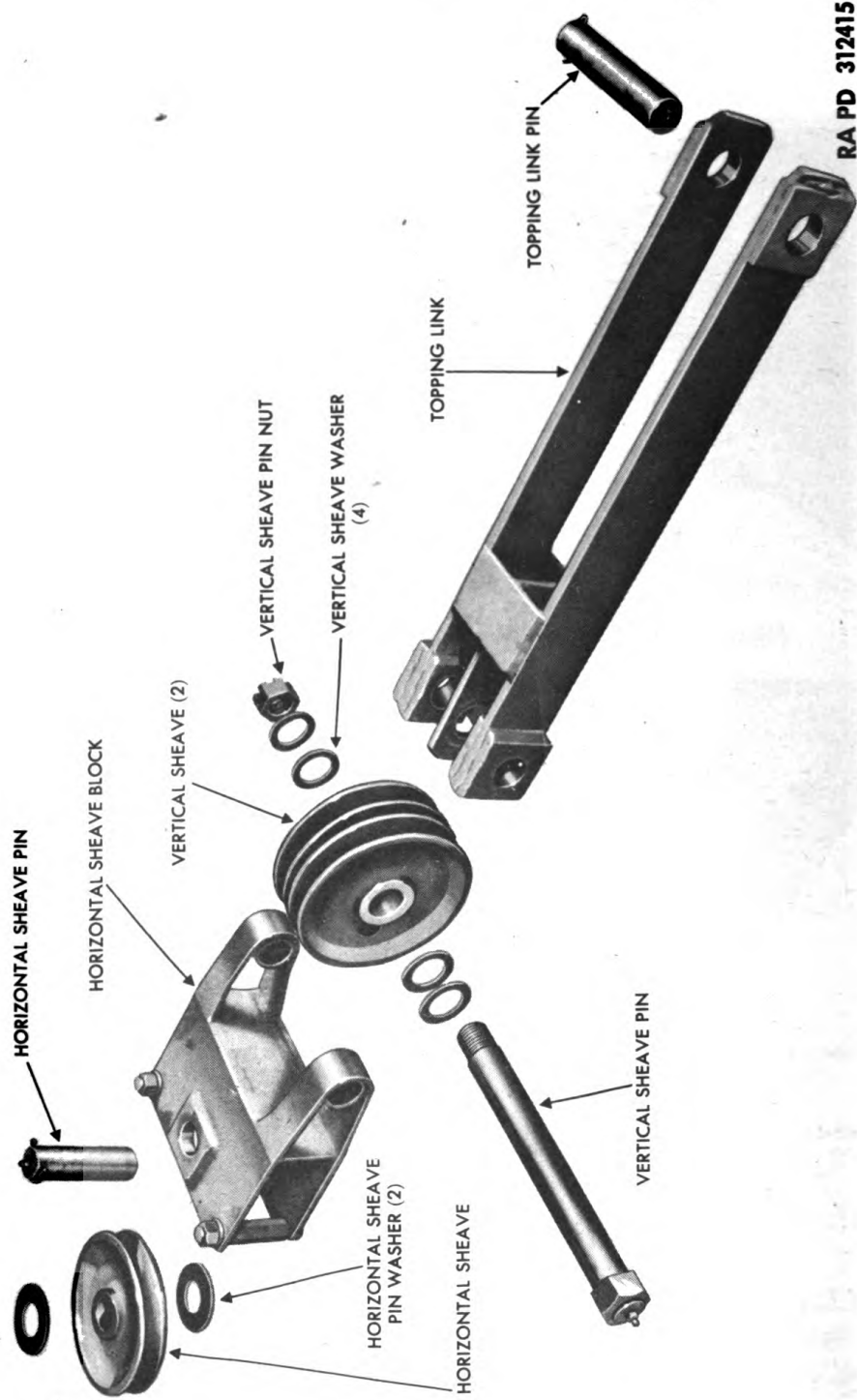

RA PD 312415

Figure 20 – Topping Link – Disassembled

## CRANE

**b. Boom Inspection and Repair.** If sheave pin openings show excessive wear or distortion cut out square around pin openings. Bore or drill new opening in plate of same thickness and cut plate to size of opening cut out of boom side member. Set in boom side member and check fit of plate and install pin to make certain that hole pin openings are in alignment. Remove plate and bevel edges of plate and the boom side member and again set plate in side member and install pin and weld plate in position in V formed by beveled edges of side member and plate. Replace and weld in position all missing brackets. Reweld any broken member welds.

**c. Boom Hinge End Inspection and Repair.** If the boom pivot pin openings become worn or distorted, build openings up by welding and rebore openings using care to prevent misalignment of the boom to the boom pivot.

**d. Sheave Inspection and Repair.**

(1) Inspect sheaves for broken groove flanges and replace if broken. Inspect sheaves for worn or scored bushings and replace bushings if indicated.

(2) SHEAVE BUSHING REPLACEMENT. Place the sheave in a hydraulic press and press out the sheave bushing. Press a new bushing in the sheave. Ream the bushing to 1.501 inches.

**e. Boom Jack Swivel Repair.** If the boom jack swivel stud is bent or worn use a cutting torch and cut the welds loose from the swivel plate. Install new stud and weld in position.

**f. Boom Jack Inspection and Repair.** Inspect boom jacks for sliding freely within one another. Slide out inner and center tubes and inspect for foreign matter. If jack tubes are bent they cannot be straightened, they must be replaced.

**g. Topping Link Assembly Repair.** Clean all parts in dry-cleaning solvent and inspect for pin and sheave bushing wear, pin opening wear and distortion. Replace bushings as outlined in subparagraph d (2) above. If the topping link is bent it can be straightened in a press cold without the aid of a heating torch.

## 29. ASSEMBLY.

**a. Install Boom Jack Upper Swivel.** Set the boom jack upper swivels in position and install castellated nuts on swivel pins and draw up nuts until all end play is removed from swivel plate but swivel can still be rotated by hand. Install cotter pins in swivel pins.

**b. Install Boom Jack.** Place upper end of the boom jack in the boom upper swivel and install bolt and castellated nut and cotter pins. Place lower end of boom jack on lower anchor pin and install retaining cotter pin (fig. 18).

ORDNANCE MAINTENANCE – CRANE FOR HEAVY WRECKING  
TRUCK M1A1 (WARD LA FRANCE AND KENWORTH)

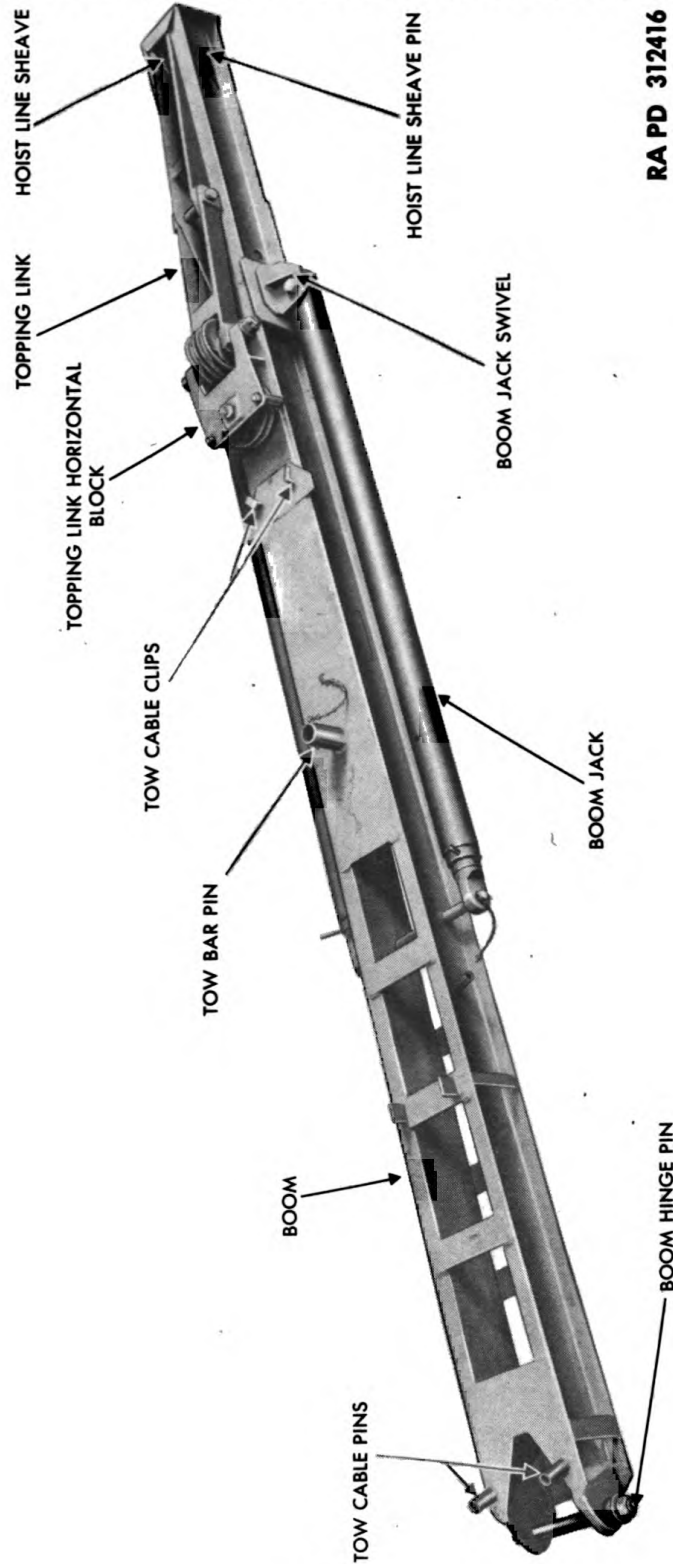

RA PD 312416

Figure 21 – Boom Assembly

**CRANE**

c. **Install Boom Sheave.** Set sheaves in center member, install sheave pin and install sheave pin anchor pin.

d. **Install Topping Link Assembly.** Insert the horizontal sheave pin through sheave side member and install washer on pin. Install sheave and another flat washer on pin and run sheave pin through horizontal block side member. Install cotter pin in the sheave pin. Install two flat washers under head of the vertical link sheave pin and run the pin through block, topping link and sheaves and install two flat washers. Install castellated nut and cotter pin. With the topping link and horizontal block connected, position them on the boom, install topping link pin and install cotter pin (fig. 20).

**Section V**

**MAIN DRIVE SHAFT DISASSEMBLY, INSPECTION, REPAIR, AND ASSEMBLY**

**30. MAIN DRIVE SHAFT.**

**a. Disassembly.**

(1) **REMOVE SELF-ALINING BEARING** (fig. 22). Back out the set screws in the self-aligning bearing lock collars. Hold the inner race of the self-aligning bearing, and turn the lock collar one-quarter turn in either direction until it is free on the bearing inner race. Slide collar and bearing assembly off shaft. Tip the bearing at 90 degrees to its normal operating position and, using a soft hammer, drive the bearing out through the recesses in the bearing housing.

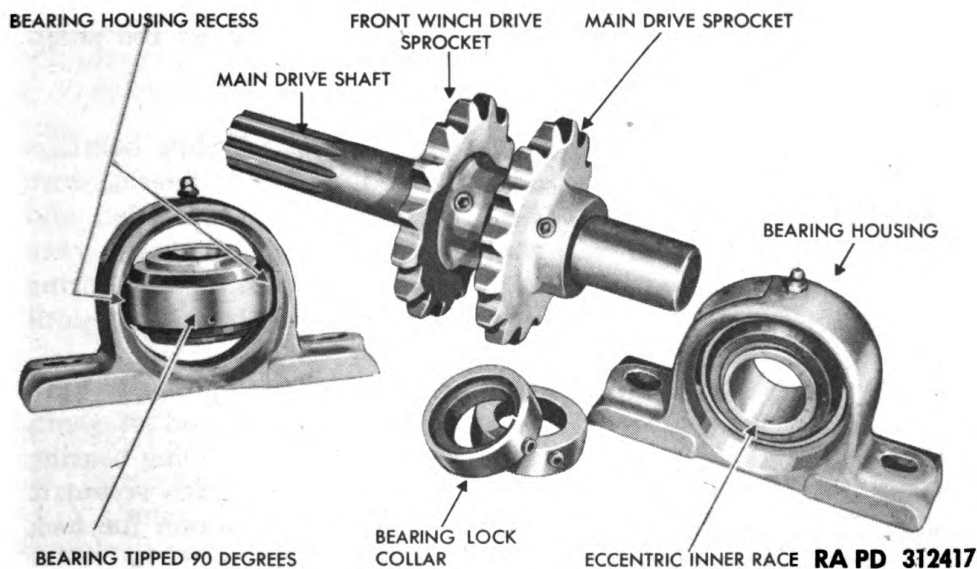

**Figure 22 – Main Drive Shaft – Disassembled**

**ORDNANCE MAINTENANCE — CRANE FOR HEAVY WRECKING  
TRUCK M1A1 (WARD LA FRANCE AND KENWORTH)**

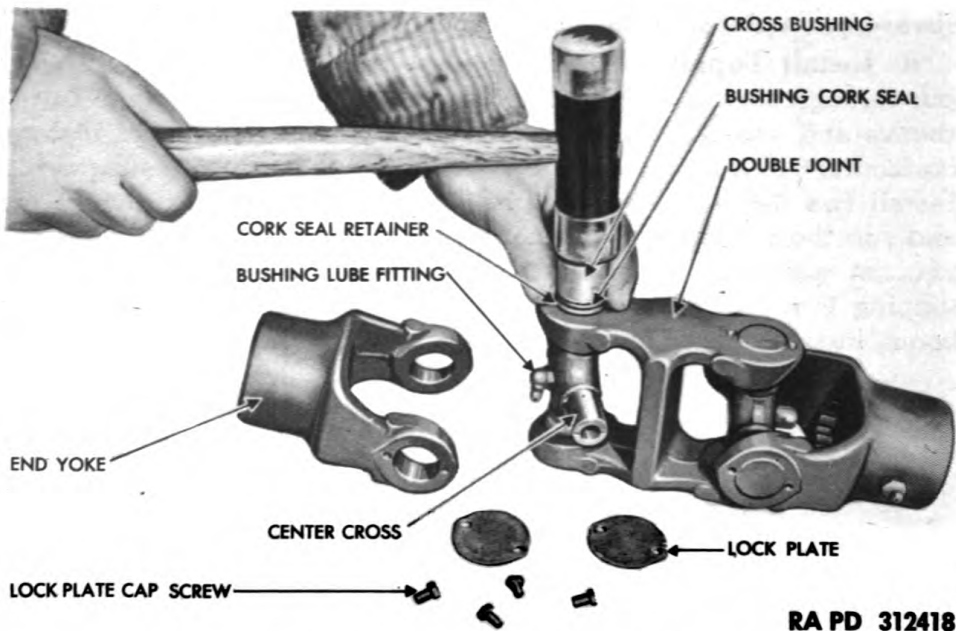

**Figure 23 — Installing Double Joint Bushing**

(2) **REMOVE SPROCKET.** Remove socket head set screws in sprocket hubs, place sprocket and hub assembly in a press, and press the sprockets off the main drive shaft. Remove the shaft keys.

**b. Cleaning, Inspection, and Repair.** Inspect the sprocket teeth for excessive wear. Inspect self-aligning bearings for free rotation. Inspect splined end of main drive shaft for excessive wear, evidence of sprocket looseness, or bearing inner races rotating on the shaft. Replace parts as indicated.

**c. Assembly.**

(1) **ASSEMBLE SELF-ALIGNING BEARINGS** (fig. 22). Slide bearings into the housings through recesses provided, and turn bearing into its normal running position. The bearings should be installed and rotated in the housing so that the eccentric side of the inner race faces toward the bearing lock collar. The recess side of the bearing lock collar fits over the inner bearing race and must be rotated until it locks against the inner bearing race.

(2) **INSTALL SELF-ALIGNING BEARINGS.** Press the sprockets onto shaft with the hubs of sprockets away from splined end of shaft. Install and tighten set screws. Install splined end self-aligning bearing lock collar on shaft, and slide self-aligning bearing on with eccentric side of inner race toward the sprockets (fig. 22). Position the lock collar on the inner race of the self-aligning bearing, turn the collar until it locks on the inner bearing race, and tighten bearing lock collar

## CRANE

set screw. The set screws in the sprocket hubs and center bearing lock collar will have to be loosened when the main drive shaft assembly is installed in the vehicle, to secure alinement of the center bearing and the chain sprocket. Lubricate self-alining bearings through lubricant fittings.

### 31. DOUBLE JOINT.

a. **Disassemble.** Remove 16 cap screws securing double joint bushing lock plates and remove the lock plates. Using a bronze drift drive the center cross in one direction as far as possible, and remove the center cross bushing. Drive the cross in the opposite direction until the opposite bearing is removed. Tilt the cross to clear the yoke lug and remove yoke. Repeat the same operation on each set of opposite cross bushings until the double joint assembly is completely disassembled. Remove the cork seals and cork retainers from the center cross.

b. **Clean, Inspect, and Repair.** Inspect yoke bearing bores for excessive wear or looseness. Inspect bushings for wear; inspect center cross for wear and lack of lubrication. Replace parts that show excessive wear. Inspect yoke splines for wear or evidence of loosening.

c. **Assemble** (fig. 23). Tipping the center cross, place it in position in the end yoke lugs. Install new cork seals on ends of cross with cup side up, place new cork retainers in retainer cups, set bearings in position on center cross and, using the soft hammer, drive retainer, cork seal, and bushing assembly onto cross. Repeat this operation until all the bushings, retainers, and seals are installed and double joint assembly is completely assembled. Install the lock plates and lock plate cap screws. Lubricate the double joint bushing assemblies through the lubricating fitting in the center of the universal joint cross.

---

## Section VI

### CRANE CONTROL DISASSEMBLY, INSPECTION, REPAIR, AND ASSEMBLY

#### 32. GEAR CASE CONTROL LINKAGE.

##### a. Spring Rods.

(1) **UPPER SPRING ROD.** Inspect spring rod for broken springs, worn clevis yoke eyes, or worn threads in the clevis yoke and on the spring rod. Replace broken springs, worn clevis yoke, or spring rods (fig. 71).

**ORDNANCE MAINTENANCE – CRANE FOR HEAVY WRECKING  
TRUCK M1A1 (WARD LA FRANCE AND KENWORTH)**

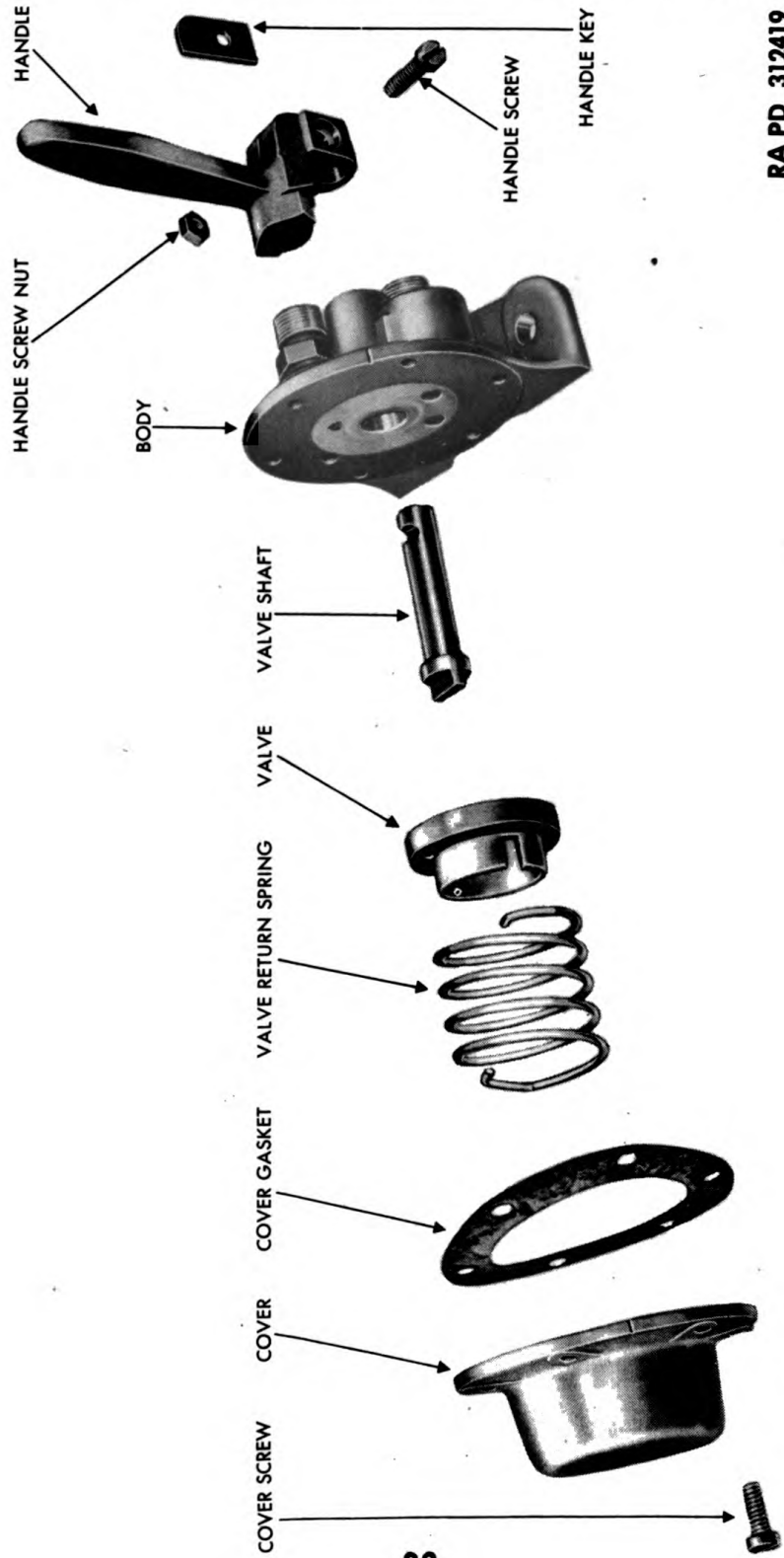

RA PD 312419

**Figure 24 – Clutch Control Valve – Disassembled**

## CRANE

(2) **LOWER SPRING ROD.** Remove spring rod adjusting nut and lock nut, flat washer, and spring; slide spring rod out of inboard lever trunnion. Remove inner spring flat washer, and adjusting lock nuts. Remove lever positioning sleeve nut. Clean all parts in dry-cleaning solvent and examine for broken springs, worn clevis yoke eyes, and worn spring rod threads.

b. **Cross Shafts and Hand Control Lever.** Inspect for bent cross shafts and hand control levers and loose keyways. Straighten or replace as indicated. Inspect cross shaft bearing holes for wear and distortion. If worn or distorted, fill with weld as indicated and redrill.

### 33. CLUTCH CONTROL VALVE.

a. **Disassemble** (fig. 24). Mark the cover and body by filing a notch across the sides to assure assembly in the same position. Remove six clutch control valve cover screws. Lift off cover and return spring. Turn valve over, and remove handle clamping screw and nut. Pry handle off valve stem, being careful not to lose handle key. Lift valve off and remove valve shaft.

b. **Inspect and Repair.** Wash all parts in dry-cleaning solvent, and examine mating surfaces of valve and valve seat. If valve or seat shows any evidence of wear, resurface the valve by lapping the valve surfaces together until all evidences of scoring or pitting are removed. Use fine lapping compound for the lapping operation, and after completion again wash the valve and seat until all traces of the lapping compound have been removed. Inspect valve stem for scoring, and replace as indicated.

c. **Assemble.** Lubricate valve surfaces with general purpose grease. Install valve stem, and place handle in position so that notch in valve stem and handle are in alignment. Install handle key, and install screw and nut. Place valve on valve stem lug in position so that the oblong recess in the valve, when the body and cover markings are in alignment, is directly over the two openings in valve body. Coat cover side only of cover gasket with joint and thread compound, and set in position. Care must be taken to insure that none of the compound gets inside the valve assembly. Place return spring in valve notch and in cover notch. Aline markings on valve body and cover to assure that proper spring tension is maintained and install six cover screws (fig. 24).

### 34. BOOM SWINGER CUT-OUT.

a. **Disassembly.**

(1) **REMOVE VALVE.** Remove three 1/4-inch cap screws attaching cut-out valve to swinger linkage. Using an offset screwdriver,



**ORDNANCE MAINTENANCE — CRANE FOR HEAVY WRECKING  
TRUCK M1A1 (WARD LA FRANCE AND KENWORTH)**

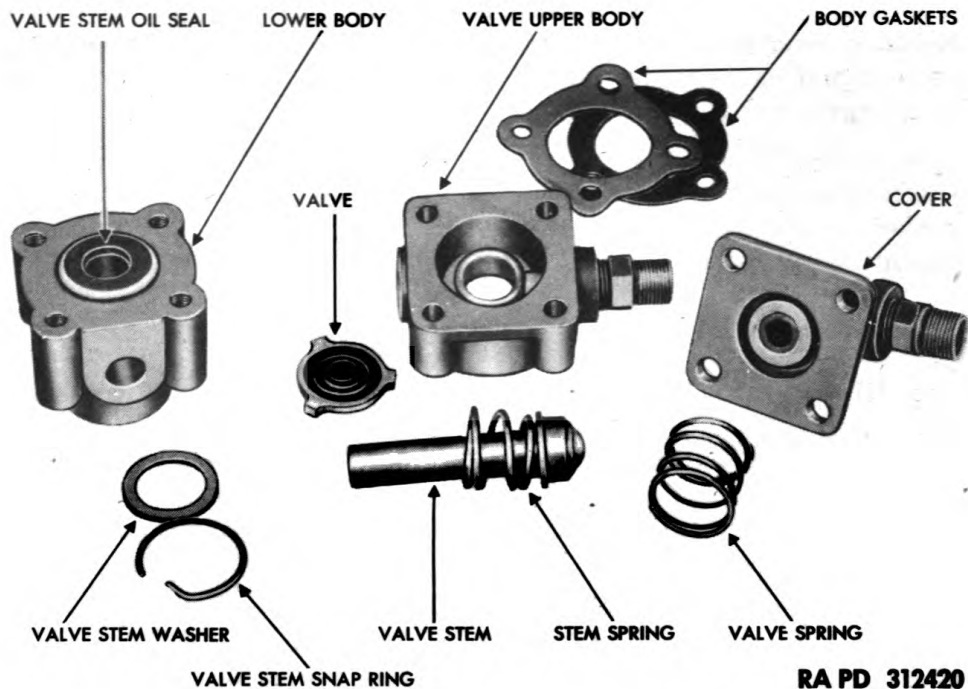

RA PD 312420

**Figure 25 — Swinger Cut-out Valve — Disassembled**

remove the 1/4-inch fillister-head screw attaching the valve to the swinger linkage, and remove valve.

(2) **DISASSEMBLE LINKAGE.** Remove two 1/4-inch bolts, nuts, and lock washers attaching linkage shaft upper bearing to swinger cut-out bracket. Pull bearing free of bracket, and lift out cut-out shaft. Remove two stove bolts and nuts attaching return spring to swinger valve bracket, and remove spring. Remove cotter pin and clevis pin, and lift out linkage roller. Remove 3/8-inch nut from outside of linkage bracket, and pry roller links and stud free of bracket (fig. 26).

(3) **DISASSEMBLE VALVE.** Mark valve upper and lower bodies and cover by means of a punch, to insure parts are returned to their correct relative position. Remove four 1/4-inch cap screws and lock washers, and lift off cover. Lift out valve spring. Remove gasket, and clean cover and upper body gasket surfaces. Lift out valve. Separate upper and lower body, remove gasket, and clean gasket surfaces. Turn valve lower body over, remove snap ring and washer, and remove valve stem and spring from bottom of body. Pry out valve stem seal from lower body (fig. 25).

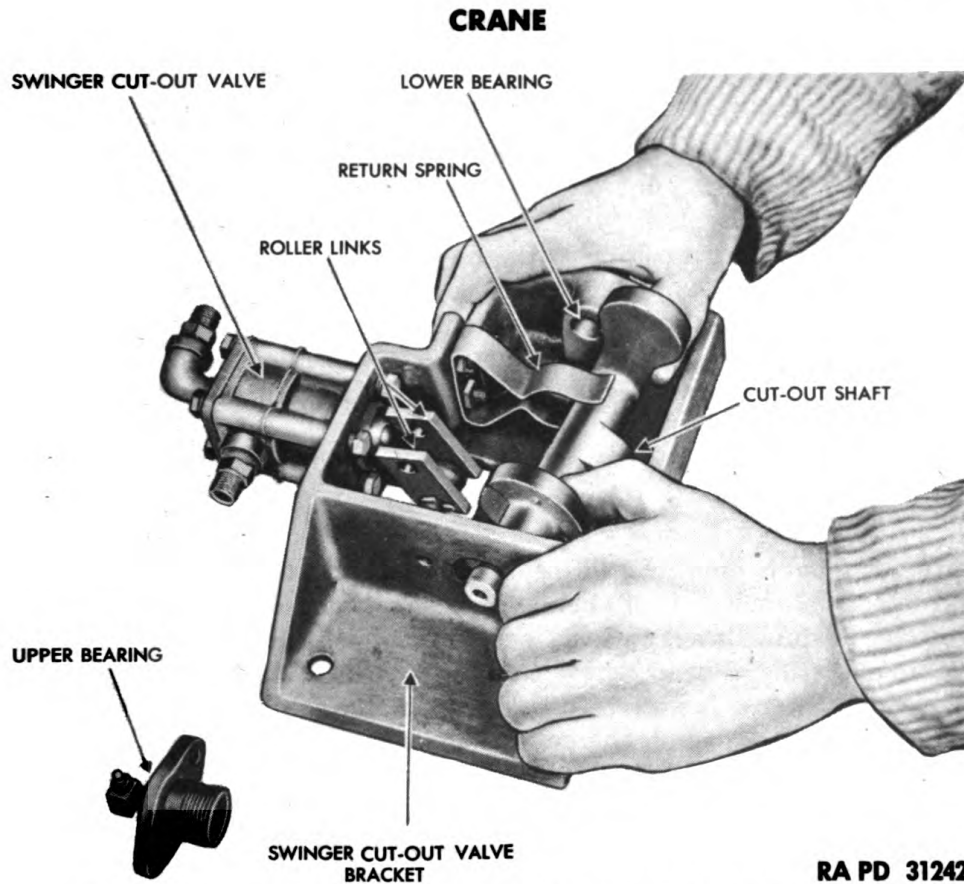

**Figure 26 – Installing Shaft in Swinger Cut-out Bracket**

**b. Cleaning, Inspection, and Repair.**

(1) **LINKAGE.** Wash all parts in dry-cleaning solvent, blow off with compressed air, and inspect for worn bearing surfaces and linkage eyes. Inspect return spring for tension and cracks, and replace parts as indicated.

(2) **VALVE.** Clean all parts in dry-cleaning solvent, and dry thoroughly with compressed air. Inspect for scored valve stem, and collapsed stem and valve springs. Inspect condition of flapper valve and flapper valve seat (fig. 25). If either show any evidence of roughness, do not attempt to reseal, but replace. Inspect valve for presence of foreign matter in air passages, and blow out to make sure that all air passages are open.

**c. Assembly.**

(1) **ASSEMBLE VALVE.** Using a wood block, tap the lower seal into the valve stem body until it seats. This seal is installed with the lip pointed up, or toward the valve upper body (fig. 25). Place a small amount of general purpose grease on the valve stem, and install

**TM 9-1796**  
**34-35**

**ORDNANCE MAINTENANCE – CRANE FOR HEAVY WRECKING  
TRUCK M1A1 (WARD LA FRANCE AND KENWORTH)**

the valve spring with the small end down. Install the lower body, and the stem retaining washer and snap ring. Using a new gasket, coat both sides with joint and thread compound. Place the upper and lower body together with the punch marks in alignment. Set the flapper valve in position with the rubber side toward the valve seat (fig. 25). Use another new gasket coated on both sides with joint and thread compound. Set flapper valve spring in position, and install cover with punch marks in alignment. Install four 1/4-inch cap screws and lock washers, and tighten securely. Test the valve for leaks by applying air pressure to the inlet opening, and check for leaks at the exhaust. Inspect for free operation of valve pin.

(2) **ASSEMBLE LINKAGE.** Install roller link on stud, and install cotter and clevis pin. Install inside nut on stud, run through bracket, and install 3/8-inch nut on outside of bracket. Place cut-out valve in position, install three 1/4-inch cap screws and lock washers, and install one fillister-head screw and lock washer attaching valve to swinger bracket. Install return spring, and install attaching stove bolts and nuts. Position the cut-out shaft through the upper bearing opening in bracket, and slide the shaft into the return spring (fig. 26). Push the shaft into lower bearing, and install the upper bearing. Install upper bearing bolts, nuts, and lock washers. Place valve operating roller in links, and install roller pin and cotter pin. Lubricate cut-out shaft bearings through lubrication fitting. The shaft is drilled its entire length for lubrication of the lower bearing. Loosen roller link eye nuts, and aline roller between cut-out shaft and valve stem button. Tighten roller link nut securely.

---

**Section VII**

**TOPPING PIVOT DISASSEMBLY, INSPECTION,  
REPAIR, AND ASSEMBLY**

**35. DISASSEMBLY.**

a. **Remove Base Cap.** Place a bar through the topping pivot sheave pin openings to prevent rotation of the pivot. With a punch and hammer bend down the lock washer tangs, and using a spanner wrench, turn off the bearing lock nut (fig. 30). Lift off the lock washer (fig. 27). Remove six 3/8-inch cap screws and lock washers attaching the base cap to the pivot base. Slide off the base cap. Remove the base felt (fig. 27).

## CRANE

b. **Remove Pivot.** Invert the topping pivot on blocking, and using a piece of hardwood and hammer, drive the pivot out of its bearings and base (fig. 28). Pull pivot free of base. Lift spacer off pivot, and also bronze pivot thrust washer. Using a soft drift, tap the ball bearing and roller bearings out of the pivot base (fig. 27).

### 36. CLEANING, INSPECTION, AND REPAIR.

a. Clean all parts thoroughly in dry-cleaning solvent. As soon as removed, put bearing in a container of dry-cleaning solvent. Bearings which are filled with hardened grease or heavy oil sludge may be difficult to clean in dry-cleaning solvent unless subjected to a thorough soaking. In such a case, soaking in hot light oil (160° to 180°F) is often advantageous, as it tends to soften the hardened material, making it more easily removed. Clean the bearings of all the old lubricant by revolving by hand in the dry-cleaning solvent to remove all dirt, chips, or solids of any nature. The use of compressed air is sometimes an advantage in cleaning bearings, but if used, do not allow the rotating members to turn freely, as this may cause scoring of the bearing parts. **CAUTION:** *In no case should the air contain foreign matter or moisture.* The condition of the bearings may then be judged by spinning or rotating by hand. After bearings have been cleaned and inspected, lubricate them, and either install or cover until they are ready for use. Wherever possible spin the bearing in clean new oil until the dry-cleaning solvent has been completely removed. This is important as oil has a tendency to slip from wet surfaces, leaving the surface unprotected and susceptible to corrosion. Dry all parts with compressed air, and when blowing out the bearings do not allow them to rotate, but direct the air directly across the bearing.

b. Remove felt from pivot cap and use a new felt in the cap. Inspect the thrust washer for any evidence of scoring, and replace if indicated (fig. 27).

c. Inspect the pivot roller bearing inner race for evidence of wear. If there is any evidence of wear or roughness, remove the inner race with a cold chisel and hammer until clearance permits installing a bearing puller (fig. 29). Remove the inner race and press a new bearing race into position until it shoulders against its seat.

d. Inspect ball bearings for excessive looseness, wear, or distress and renew as indicated. Inspect pivot base and pivot for cracks and wear at bearing seats, sheave pin holes, and mounting hole bolts. Renew worn or broken parts, or fill sheave pin holes or mounting holes by welding and redrilling.

TM 9-1796  
36

**ORDNANCE MAINTENANCE – CRANE FOR HEAVY WRECKING  
TRUCK M1A1 (WARD LA FRANCE AND KENWORTH)**

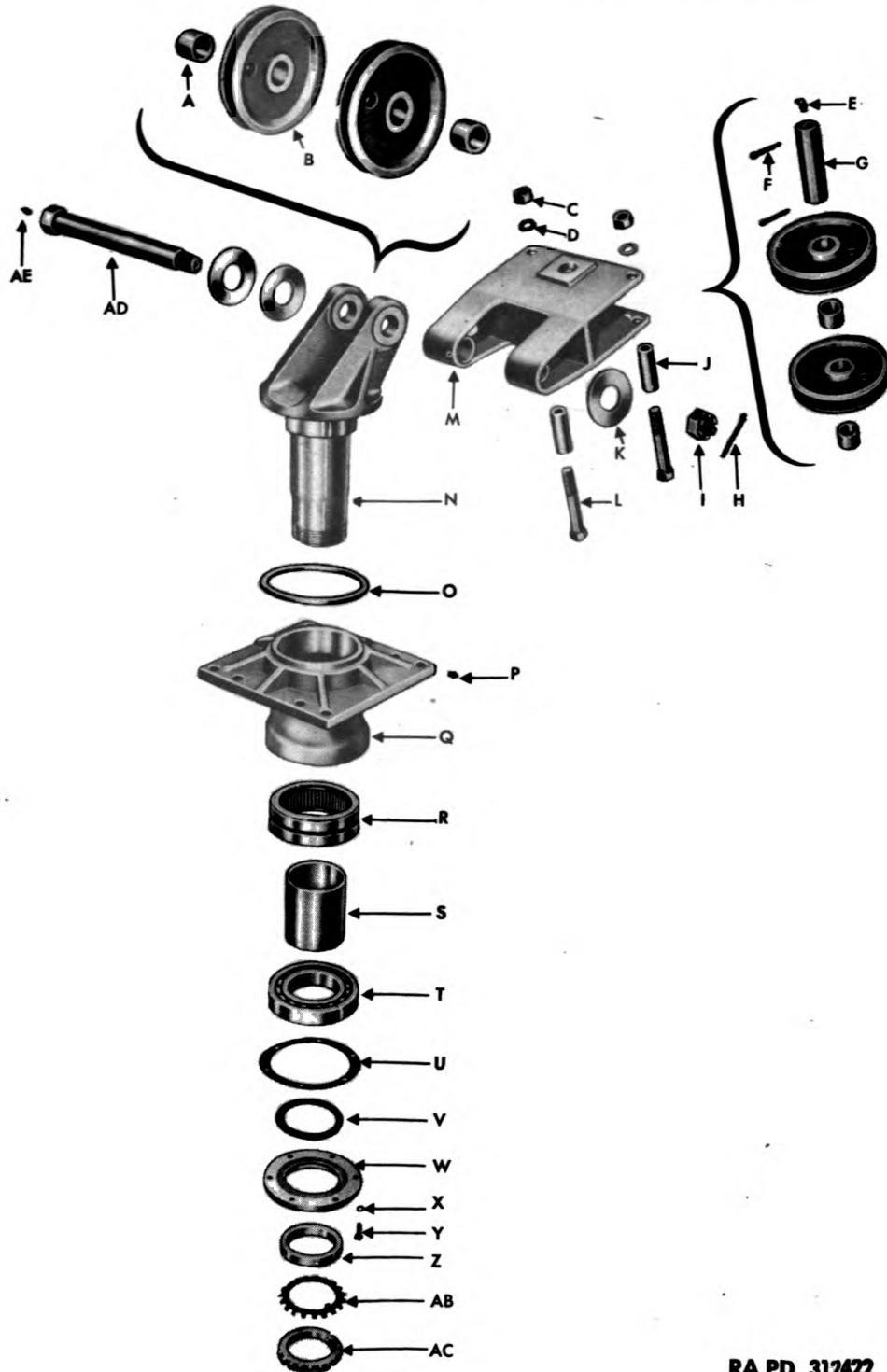

RA PD 312422

**Figure 27 – Topping Pivot – Disassembled**

CRANE

|        |                           |         |                                |
|--------|---------------------------|---------|--------------------------------|
| A..... | SHEAVE BUSHING (4)        | P.....  | PIVOT BASE LUBRICATING FITTING |
| B..... | TOPPING PIVOT SHEAVE (4)  | Q.....  | TOPPING PIVOT BASE             |
| C..... | FRAME CAP SCREW NUT (2)   | R.....  | PIVOT ROLLER BEARING           |
| D..... | SHEAVE FRAME WASHER (2)   | S.....  | PIVOT BEARING SPACER           |
| E..... | PIN LUBRICATING FITTING   | T.....  | PIVOT BALL BEARING             |
| F..... | SHEAVE PIN COTTER PIN (2) | U.....  | BASE CAP GASKET                |
| G..... | SHEAVE PIN                | V.....  | BASE FELT                      |
| H..... | SHEAVE PIN COTTER PIN     | W.....  | PIVOT BASE CAP                 |
| I..... | SHEAVE PIN NUT            | X.....  | BASE CAP LOCK WASHER (6)       |
| J..... | SHEAVE FRAME SPACER (2)   | Y.....  | BASE CAP SCREW (6)             |
| K..... | SHEAVE WASHER (3)         | Z.....  | BEARING CLAMP SLEEVE           |
| L..... | FRAME CAP SCREW (2)       | AB..... | BEARING LOCK WASHER            |
| M..... | SHEAVE FRAME              | AC..... | BEARING LOCK NUT               |
| N..... | TOPPING PIVOT             | AD..... | SHEAVE PIN (INNER)             |
| O..... | PIVOT THRUST WASHER       | AE..... | PIN LUBRICATING FITTING        |

RA PD 31242D

**Legend for Figure 27 – Topping Pivot – Disassembled**

**37. ASSEMBLY.**

**a. Install Topping Pivot.** Tap the ball and roller bearings into the base. Install the pivot thrust washer on the pivot base with a small amount of general purpose grease on both sides of the thrust washer. Pack both the ball and roller bearings with general purpose grease, set the bearing spacer on the topping pivot, and drive the topping pivot into the base and bearings (fig. 27).

**b. Install Base Cap.** Place the cap base felt in the cap and set the cap and felt; using a new gasket, position the cap on the pivot base. Install the six  $\frac{3}{8}$ -inch cap screws and lock washers and tighten securely. Install lock washer on boom pivot with washer tang located in topping pivot keyway. Tighten down the bearing lock nut by means of a spanner wrench (41-W-3250). Use a bar through the topping pivot sheave pin eyes to prevent the topping pivot from rotating while the nut is tightened. With a punch and hammer bend two lock washer tangs into the slots of the bearing lock nut (fig. 30). Inspect the topping pivot for excessive end play and free rotation.

ORDNANCE MAINTENANCE – CRANE FOR HEAVY WRECKING  
TRUCK M1A1 (WARD LA FRANCE AND KENWORTH)

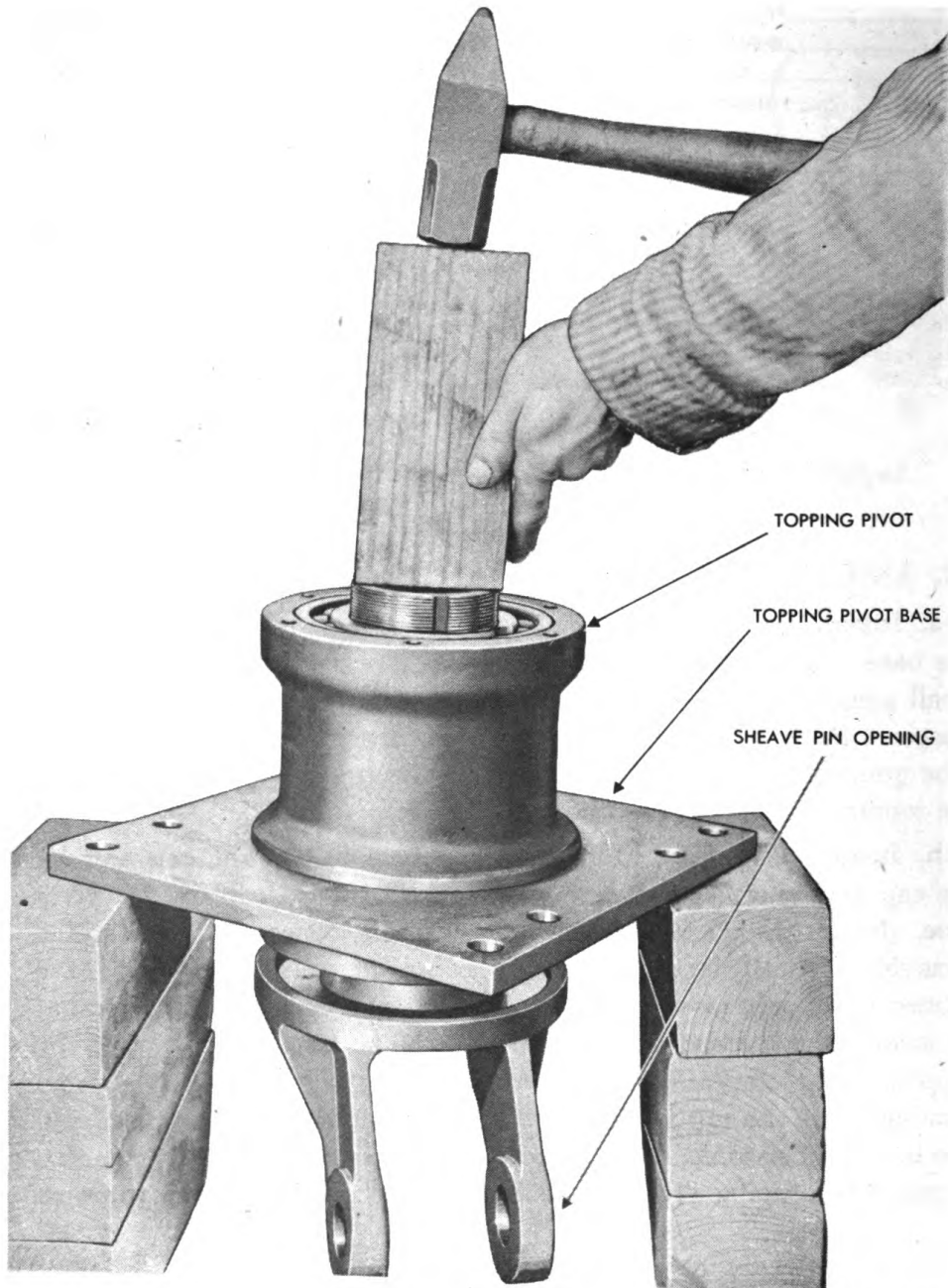

RA PD 312423

Figure 28 – Removing Pivot

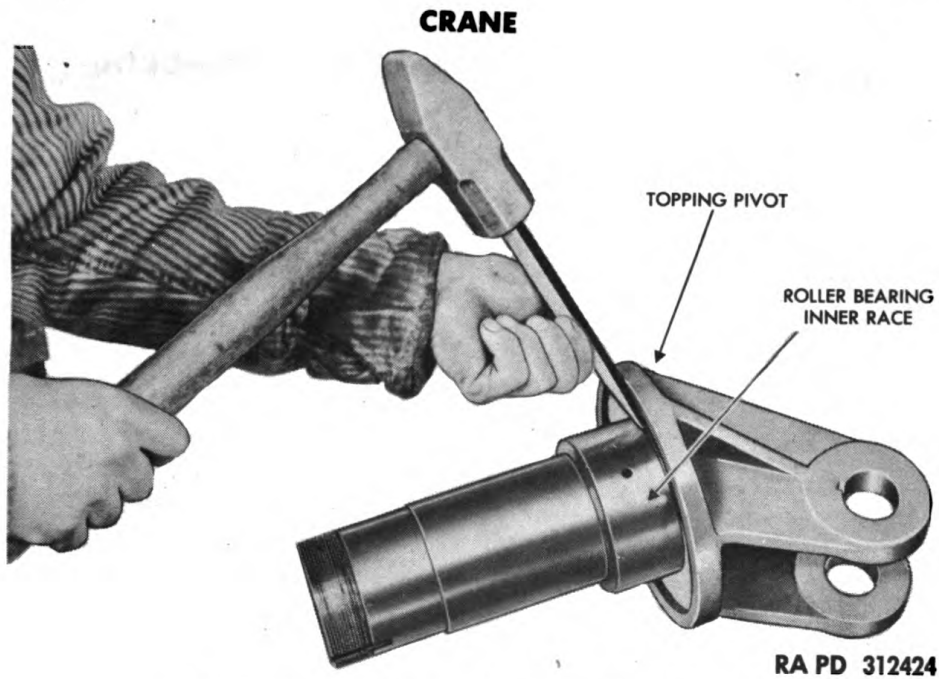

Figure 29 – Removing Bearing Race

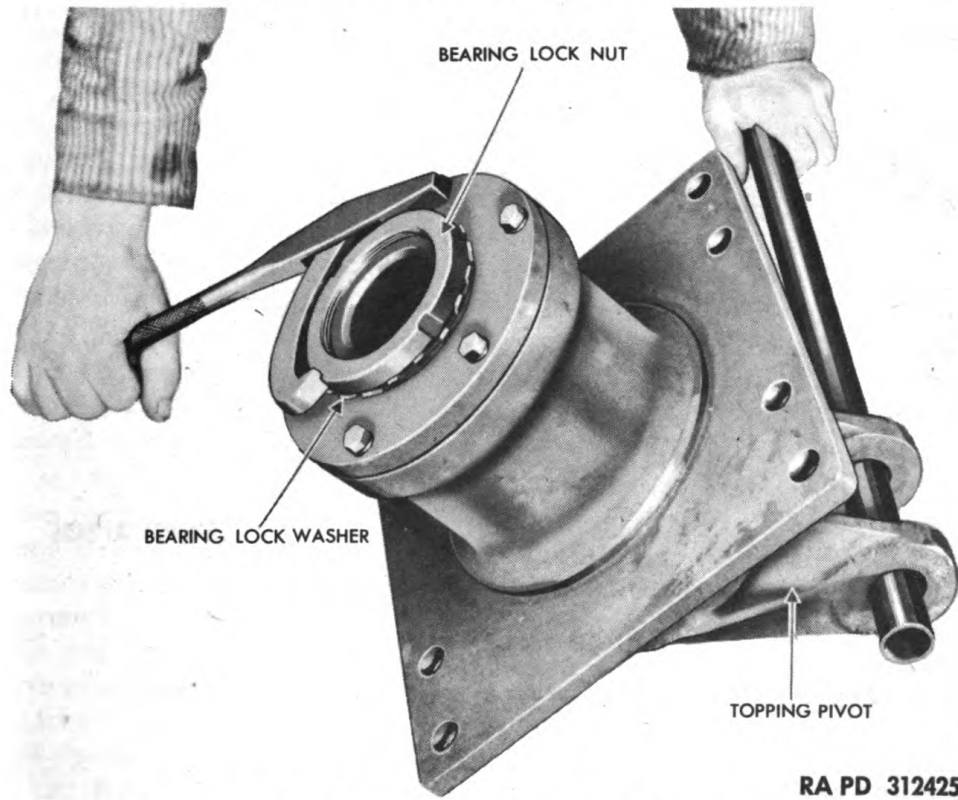
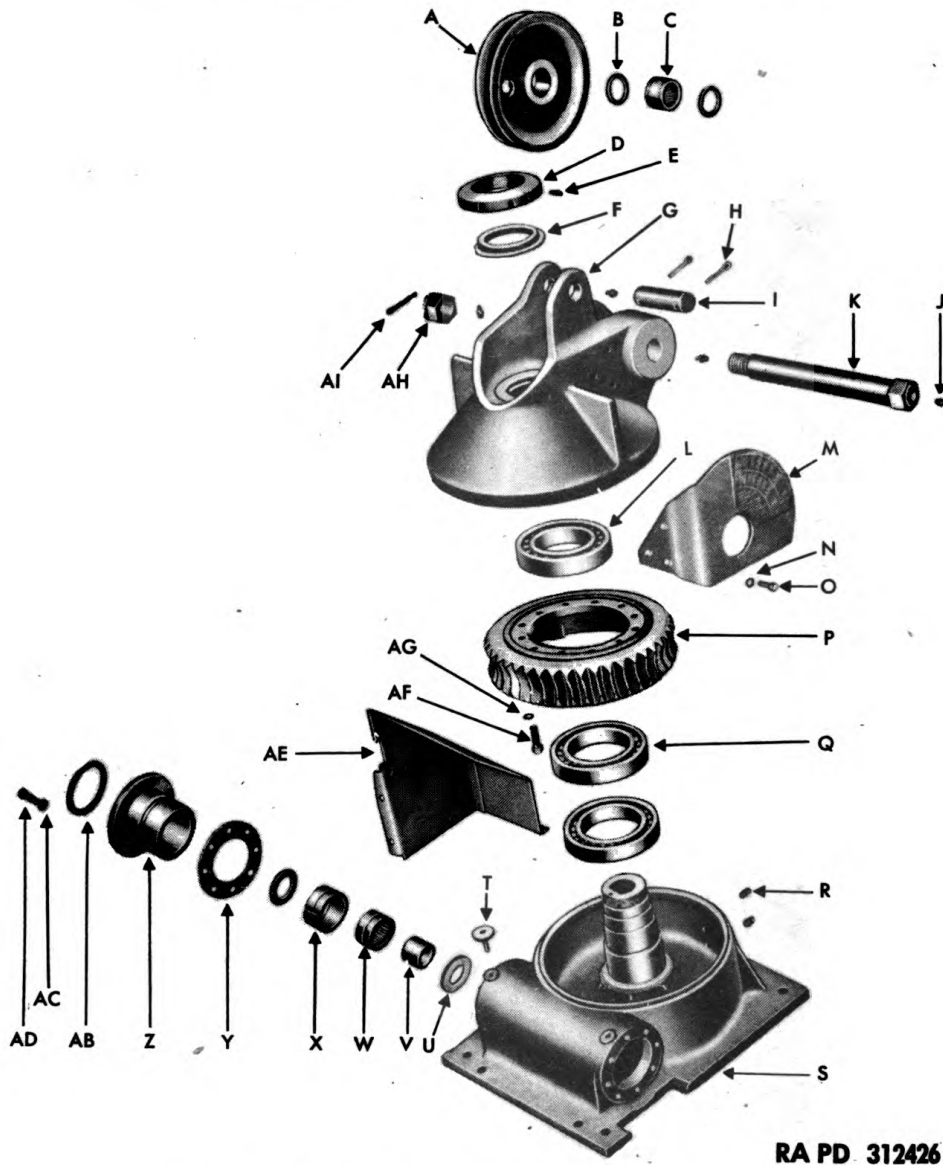

Figure 30 – Installing Bearing Lock Nut With Wrench 41-W-3250



**ORDNANCE MAINTENANCE — CRANE FOR HEAVY WRECKING  
TRUCK M1A1 (WARD LA FRANCE AND KENWORTH)**



RA PD. 312426

**Figure 31 — Boom Pivot — Disassembled**

**Section VIII**

**BOOM PIVOT DISASSEMBLY, INSPECTION,  
REPAIR, AND ASSEMBLY**

**38. DISASSEMBLY.**

**a. Remove Thrust Cage Nut.** Drain lubricant from boom pivot. Remove cotter pin and shear pin from the drive coupling, and set a piece of 1/2-inch cold rolled steel in shear pin opening long enough

## CRANE

|        |   |         |                                   |
|--------|---|---------|-----------------------------------|
| A..... | BOOM PIVOT SHEAVE                             | R.....  | BASE PIPE PLUG (2)                |
| B..... | SHEAVE FELT WASHER (2)                        | S.....  | BOOM PIVOT BASE                   |
| C..... | SHEAVE ROLLER BEARING                         | T.....  | GUIDE PIN (2)                     |
| D..... | RETAINER NUT                                  | U.....  | THRUST WASHER (2)                 |
| E..... | RETAINER SET SCREW                            | V.....  | WORM SHAFT BEARING RACE (OUTER)   |
| F..... | PIVOT BEARING FELT                            | W.....  | WORM SHAFT ROLLER BEARING (INNER) |
| G..... | BOOM PIVOT                                    | X.....  | BEARING SLEEVE (OUTER)            |
| H..... | SHEAVE PIN COTTER PIN (2)                     | Y.....  | END COVER GASKET                  |
| I..... | SHEAVE PIN                                    | Z.....  | WORM SHAFT END COVER              |
| J..... | BOOM PIVOT SHEAVE PIN LUBRICATING FITTING (4) | AB..... | INNER BEARING FELT                |
| K..... | BOOM HINGE PIN                                | AC..... | COVER LOCK WASHER (8)             |
| L..... | PIVOT BALL BEARING (UPPER SPINDLE)            | AD..... | END COVER CAP SCREW (8)           |
| M..... | LOAD INDICATOR                                | AE..... | SWINGER SPROCKET GUARD            |
| N..... | LOCK WASHER (3)                               | AF..... | WORM GEAR BOLT (12)               |
| O..... | CAP SCREW (3)                                 | AG..... | WORM GEAR LOCK WASHER (12)        |
| P..... | BOOM PIVOT WORM GEAR (LH)                     | AH..... | BOOM HINGE PIN NUT                |
| Q..... | PIVOT BALL BEARING (LOWER SPINDLE) (2)        | AI..... | HINGE PIN COTTER PIN              |

RA PD 312426 B

**Legend for Figure 31 – Boom Pivot – Disassembled**

to lock the worm shaft against rotation (fig. 42). Using a 6½-inch spanner wrench 41-W-3249 with a ¼-inch dowel pin and at least an 8-foot length of heavy tubing, turn the thrust cage nut counter-clockwise (when viewed from the driven end of the boom pivot worm). This nut will remove extremely hard, due to the spring-tension load on the nut and thrust cage threads.

**b. Remove Adjusting Nut.** Remove the socket head set screw from boom pivot adjusting nut (fig. 32). Back off nut carefully and slowly until the tension in the boom pivot worm spring is relieved, and continue turning until nut is removed.

**c. Remove Thrust Cage.** The outer spring thrust retainer has two tapped holes for ½-inch-20 cap screws (fig. 41). Screw in two cap screws and use as handles for pulling out retainer. This will remove the outer thrust ball bearing. Lift out thrust spring and thrust spring stop (fig. 32). Again using two ½-inch-20 cap screws, lift out the inner spring thrust retainer (fig. 33). Using a 10-inch extension and socket, remove eight 7/16-inch cap screws and lock washers attaching the thrust cage to the boom pivot base. Lift off spring cage.

**d. Remove Bearing Carrier.** Using a long-nosed punch, drive thrust bearing locating dowel out of worm. Loosen two socket head set screws from worm shaft collar, and slide collar off worm shaft. Slide bearing carrier assembly off worm (fig. 34).



CRANE

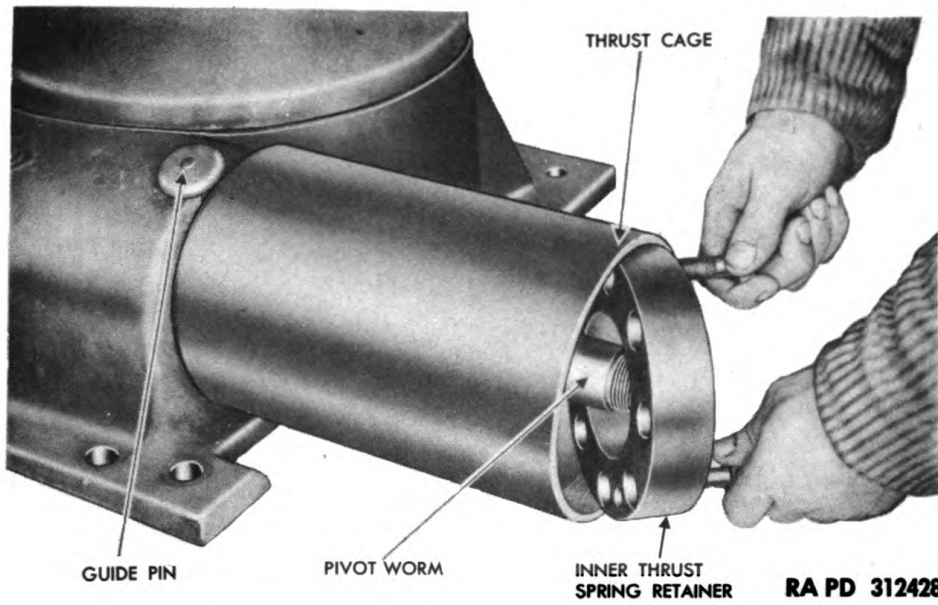

Figure 33 – Removing Inner Thrust Spring Retainer

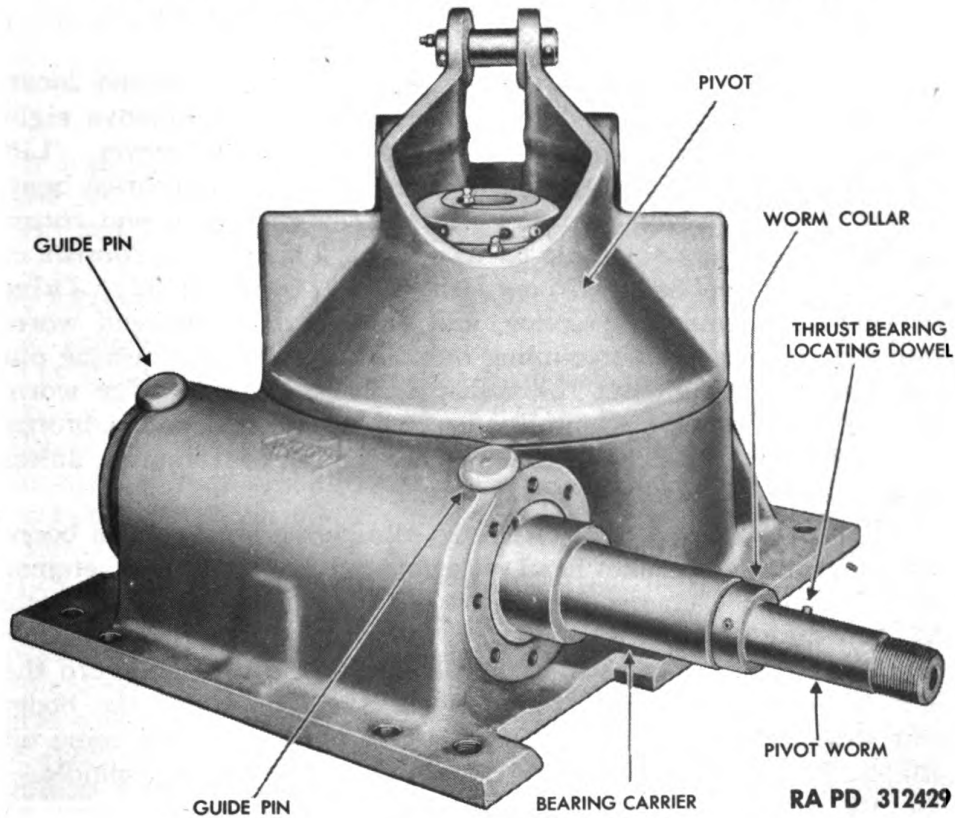
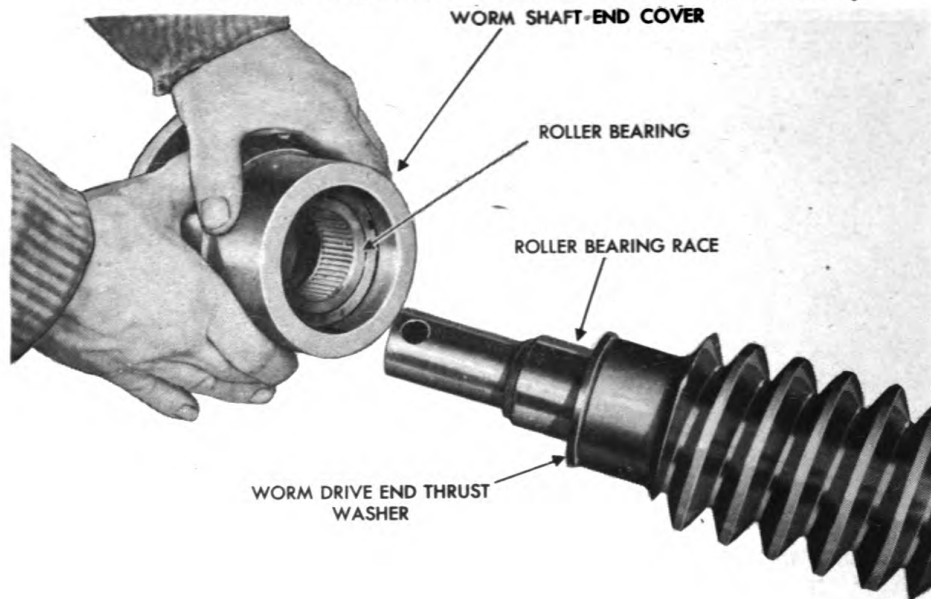

Figure 34 – Boom Pivot Worm Installed

**ORDNANCE MAINTENANCE – CRANE FOR HEAVY WRECKING TRUCK M1A1 (WARD LA FRANCE AND KENWORTH)**



RA PD 312430

**Figure 35 – Removing Worm Shaft End Cover**

e. **Disassemble Bearing Carrier.** Remove bearing carrier locating dowel cotter pins, and lift out locating dowels. Remove eight  $\frac{7}{16}$ -inch cap screws from drive end worm shaft end cover. Lift worm shaft with coupling and worm shaft end cover and thrust bearing out of boom pivot (fig. 35). *NOTE: The driven end thrust bearing may or may not come off as a unit. This bearing consists of 2 races and 10 steel balls. Do not lose the steel balls (fig. 32).* Drive the worm shaft out of coupling, and remove the drive end worm shaft end cover from the coupling hub. Slide the roller bearing out of end cover, and lift out the thrust washer (fig. 35). The worm shaft bearing carrier has a roller bearing in one end and a bronze bushing in the other, neither of which should be removed unless replacement is necessary (fig. 32).

f. **Remove Boom Pivot.** Remove lubricating fittings from boom pivot. Remove the socket head set screw out of boom pivot retainer nut. Using two C-clamps secure the boom pivot base to the bench. Place a length of  $\frac{3}{8}$ -inch round cold rolled rod in the pivot retainer nut. Place a bar through the boom hinge pin opening and turn the pivot to remove the pivot retainer nut (fig. 36). Pry the boom pivot straight up off the pivot base. The worm gear will come off with the pivot and the bearings remain on the pivot base spindle.

g. **Remove Worm Gear.** Using a bearing puller and pulling on the inner race of the bearing remove the bearings from the pivot spindle (fig. 31). Invert the boom pivot and remove 12 special  $\frac{1}{2}$ -

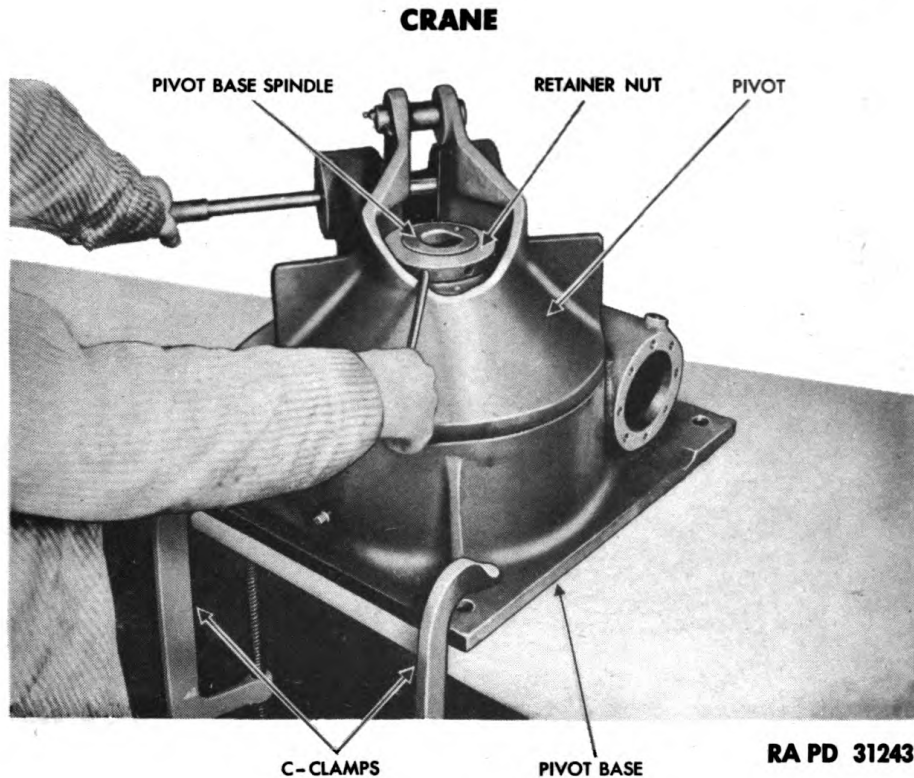

**Figure 36 – Removing Retainer Nut**

inch ream bolts and lock washers attaching the worm gear to the boom pivot, being careful not to damage gear teeth (fig. 37). Pry worm gear off the boom pivot.

### **39. CLEANING, INSPECTION, AND REPAIR.**

#### **a. Inspection.**

(1) Clean all parts thoroughly in dry-cleaning solvent, and dry with compressed air. When blowing out the bearings do not allow the bearings to rotate, but direct the air directly across the bearing. The bearings may require additional soaking in clean dry-cleaning solvent to soften any foreign material lodged in the bearings or bearing retainers. See paragraph 36 a.

(2) Inspect all ball and roller bearings for any evidence of excessive wear. Inspect all felt grease seals for signs of leakage and wear. Inspect boom hinge pin. Clean out drilled lubrication passages. Replace the pin if it shows any signs of wear or scoring. Inspect the worm gear tooth surfaces for wear, pitting, or chipped teeth. Inspect the gear bolt mounting holes for any evidence of being out-of-round. Replace the gear as indicated. The special ream bolts mounting the gear to the boom pivot must be tight. Inspect condition of ream bolts. If they show any evidence of wear or looseness, replace them.

ORDNANCE MAINTENANCE — CRANE FOR HEAVY WRECKING  
TRUCK M1A1 (WARD LA FRANCE AND KENWORTH)

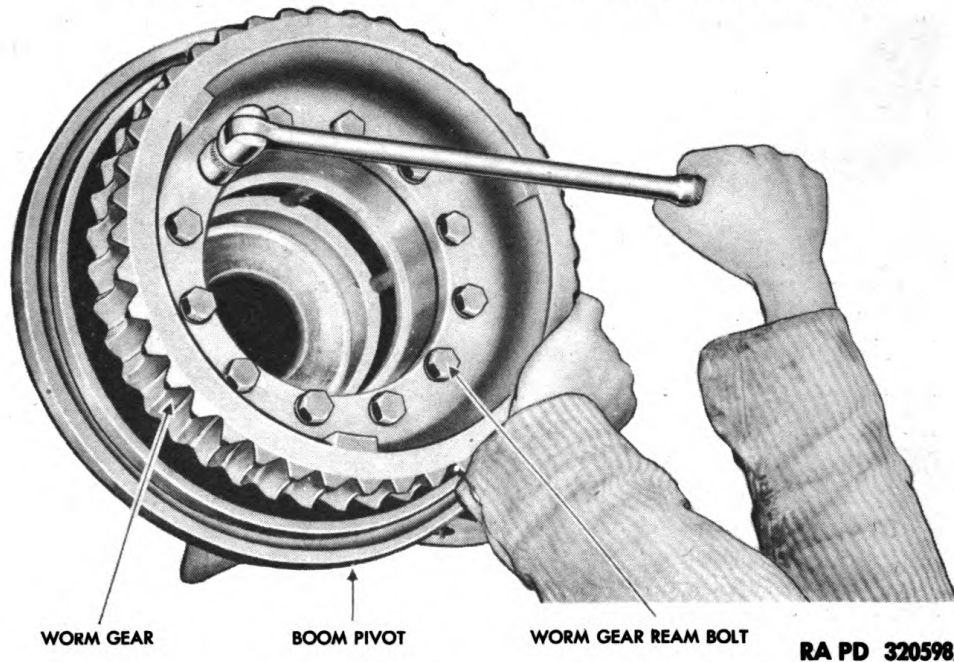

**Figure 37 — Installing Pivot Worm Gear**

(3) Inspect the condition of the worm thread surfaces, and if they show any signs of excessive wear or scoring, replace the worm. Inspect the worm for straightness; replace if bent. Inspect the roller bearing and the inner race sleeve; if they show any signs of wear, replace the sleeve. Inspect thrust surfaces of washers and worm; if they show signs of wear or scoring, replace as indicated. Inspect thrust bearing races and balls, and replace any races or balls that show wear. Inspect condition of roller bearings on the worm shaft and bushing in the bearing carrier. If the roller bearings or bushing show excessive wear or scoring, replace them. Inspect the spring retainers for wear, and replace if necessary (fig. 32). Inspect the drive coupling for looseness on the worm, or loose spline.

**b. Boom Pivot Repair.**

(1) If the thrust cage or worm shaft end cover cap screws twist off, or are broken due to misoperation, file the face of the stud (if possible) until it is flat; center-punch the stud, and drill for a stud remover. Remove the broken end and inspect the threads for damage; if damaged, retap threads.

(2) If the boom pivot pin openings or the mounting plate bolt holes become egg-shaped, weld them up and redrill the boom hinge pin opening to 1.500 inches, or the mounting plate openings to 0.7812 inch.

(3) Each time the boom pivot is disassembled, and inasmuch as the boom only operates through 180 degrees, the boom pivot worm

CRANE

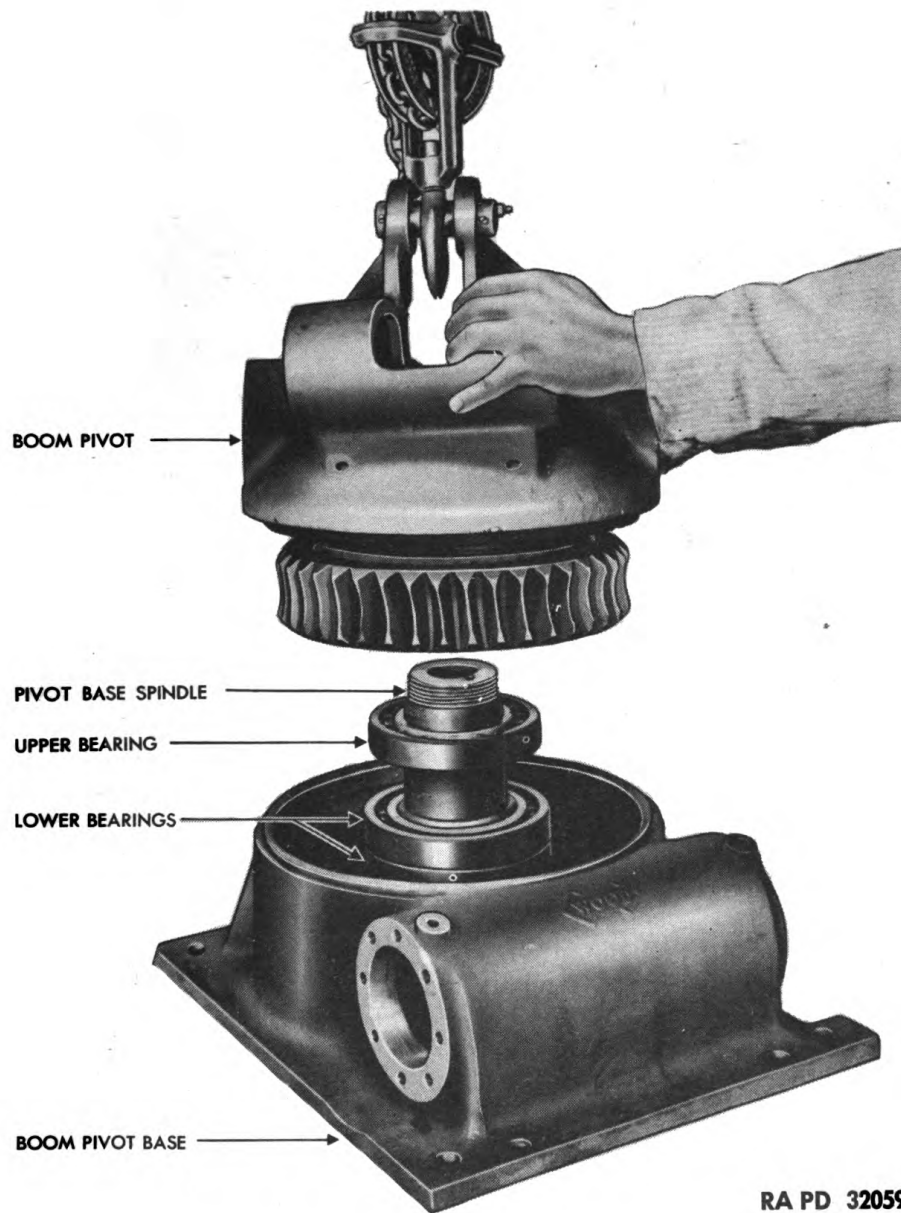

RA PD 320599

Figure 38 – Installing Pivot



**ORDNANCE MAINTENANCE — CRANE FOR HEAVY WRECKING  
TRUCK M1A1 (WARD LA FRANCE AND KENWORTH)**

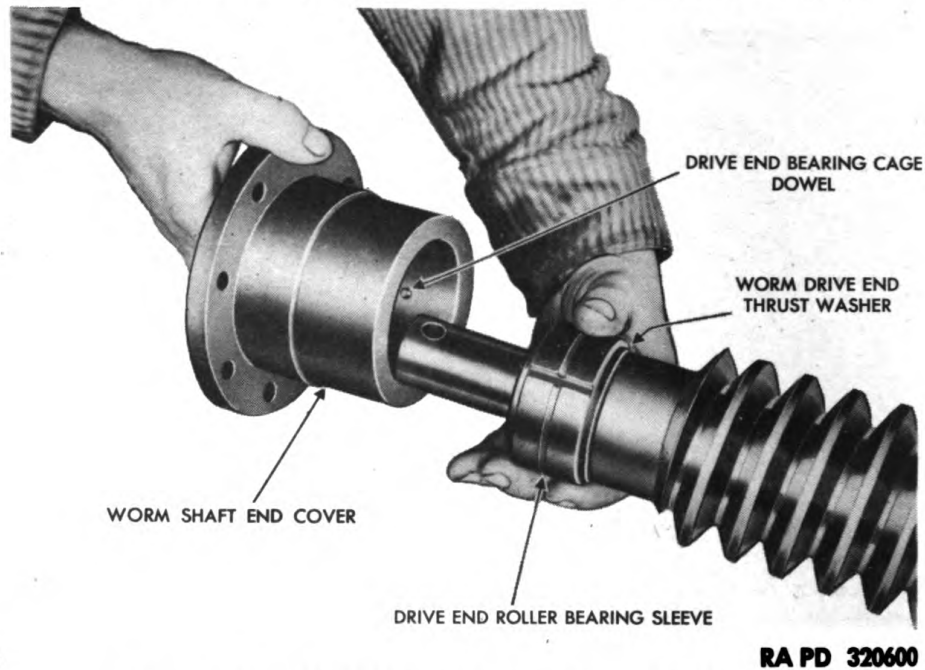

**Figure 39 — Installing Worm Shaft End Cover**

gear should be rotated 180 degrees in order to bring the unused portion of the worm gear in contact with the worm.

(4) If the worm bearing carrier bushing requires replacement, the bushing will have to be destroyed to be removed. Drive the bushing out and press a new bushing in position until it shoulders against its bearing carrier seat. Ream the bushing after installation to 1.500 inches.

**40. ASSEMBLY.**

**a. Install Spindle Bearings.** With the boom pivot inverted, place the worm gear on the pivot and, using new ream bolts and lock washers, bolt the worm gear to the boom pivot securely (fig. 37). Install the bearings on the boom pivot base spindle, keeping in mind that the two lower spindle bearings are mated in pairs; if one is renewed, the other must be renewed. When installing the bearings on the spindle, either press them on, or drive them on by applying pressure or driving on the inner race only. Install the upper spindle bearing in the same manner as described above (fig. 38).

**b. Install Pivot.** Mark the location of the set screw hole in the spindle. Set the pivot in position on the pivot spindle, and lower into position. **NOTE:** *Keep the pivot bearing bores in alignment (fig. 38).* Use a hardwood block and a heavy hammer to drive the pivot into position. Install the pivot retainer nut as soon as it is

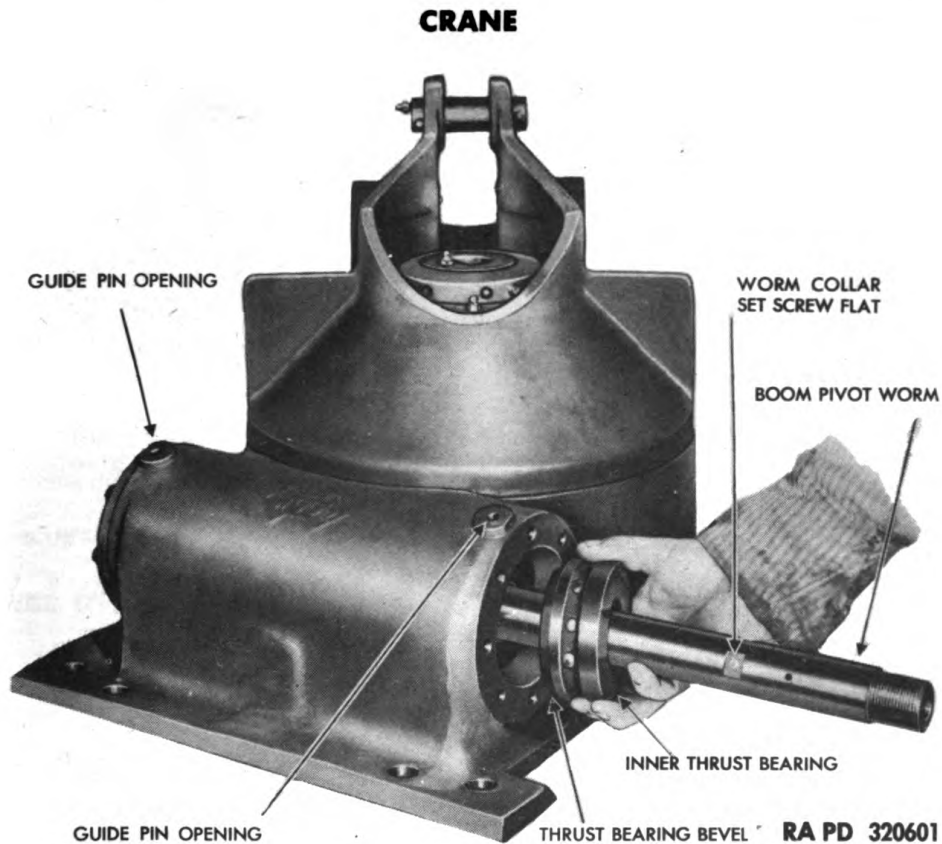

**Figure 40 – Installing Inner Thrust Bearing**

possible to do so, and pull the nut up tight. A small amount of lubricant on the nut threads will keep them from pulling. Tighten the pivot retainer nut (fig. 36) until it comes up solid; then back off the nut until the set screw hole is in alignment, and install the set screw. Install lubricating fittings in pivot and the pivot spindle.

**c. Install Worm Shaft End Cover** (fig. 39). Slide the thrust washer onto drive end of worm with beveled edge toward the worm. Press on the drive and driven end roller bearing races. Set the drive end roller bearing in position on worm, and install the thrust washer with beveled edge and grooved side toward the drive end of the worm. Install the worm shaft end cover with bearing and thrust washer installed on the drive end of the worm.

**d. Install Worm.** Enter worm through from drive end with worm shaft end cover installed. Use a new gasket between the cover and pivot base on the worm. The drive end of the boom pivot can be determined by noting the sides of the base plate, one side being notched, which is opposite the drive side and is provided for thrust cage clearance (fig. 40). Install eight cap screws and lock washers, securing worm shaft end cover to pivot base.

ORDNANCE MAINTENANCE – CRANE FOR HEAVY WRECKING  
TRUCK M1A1 (WARD LA FRANCE AND KENWORTH)

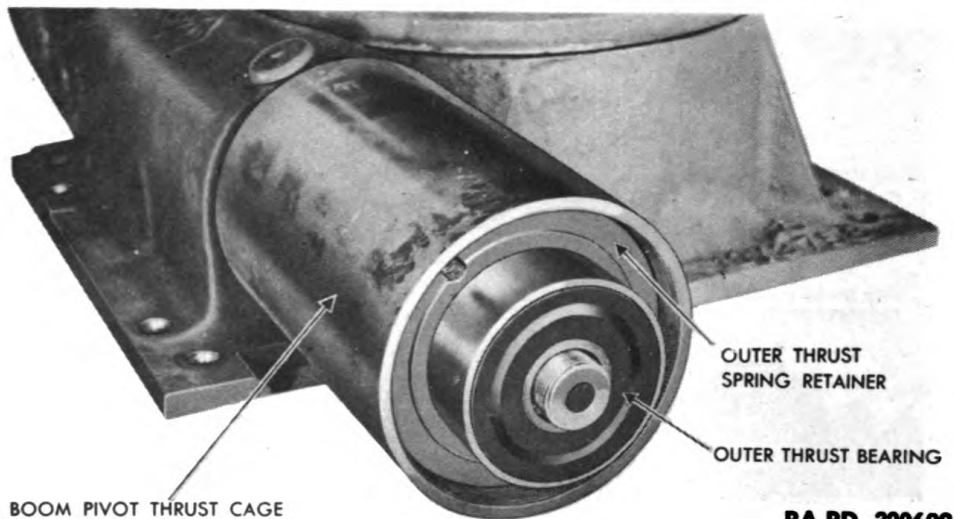

RA PD 320602

**Figure 41 – Boom Pivot Outer Thrust Retainer and Bearing Installed**

e. **Install Thrust Bearing Carrier** (fig. 40). Coat the balls and bearing races of the inner thrust bearing with heavy grease to hold the bearings together. Slide the bearing onto the driven end of the worm with the beveled edge of the thrust bearing toward the worm (fig. 40). Install guide pins through boom pivot base. The boom pivot is constructed for both right- and left-hand use and only one guide pin is long enough to contact the bearing carrier. The guide pin must be used on the driven end (fig. 40). (The other merely serves as a plug.) Slide the worm bearing carrier onto the worm and align keyway; using a soft hammer, drive it up against its seat (fig. 34). Slide the inner worm collar onto the worm, and tighten the socket head set screws onto the flats on the worm shaft (fig. 40). Drive the thrust bearing locating dowel into the worm.

f. **Install Thrust Cage and Spring.** Use a new gasket between the boom pivot and boom pivot thrust cage. Install cage and eight  $\frac{7}{16}$ -inch spring cage cap screws and lock washers, and tighten securely. Install two  $\frac{1}{2}$ -inch-20 cap screws on the smooth side of the inner thrust spring retainer to use as handles for installing the retainer (fig. 33). The counterbored side of the retainer enters the thrust cage first (fig. 33). Set the inner thrust spring retainer on its locating dowel. Slide the thrust spring stop onto the worm, and install the thrust spring. Set the outer thrust spring retainer into position with the smooth side of the retainer toward the spring, and the relieved side toward the driven end of the worm (fig. 41). Install the outer thrust bearing and slide it onto the shaft, aligning the keyway in the bearing with the locating dowel on the worm (fig. 41).

CRANE

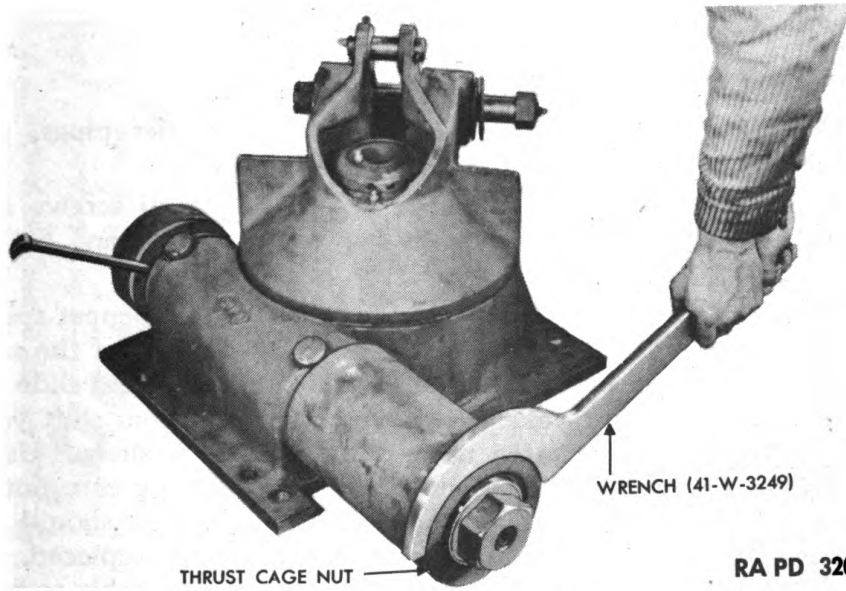
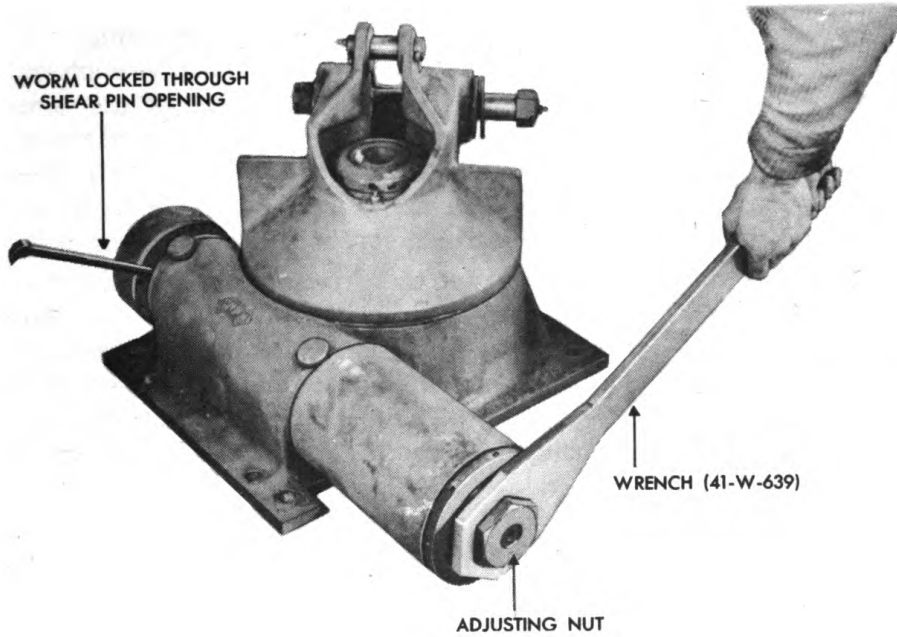

Figure 42 – Tightening Adjusting and Thrust Cage Nuts

**ORDNANCE MAINTENANCE — CRANE FOR HEAVY WRECKING  
TRUCK M1A1 (WARD LA FRANCE AND KENWORTH)**

**g. Install Adjusting and Thrust Cage Nuts.** Install adjusting nut and run up finger-tight. Install thrust cage nut, and run it up finger-tight. Alternately tighten the adjusting nut and thrust cage nut by means of two special wrenches. The adjusting nut wrench 41-W-639 is a 3¼-inch hexagon box wrench 26 inches long. The thrust cage nut wrench 41-W-3249 is a special spanner wrench suitable for use with a length of pipe (fig. 42). Because of the heavy tension of the boom pivot spring the nuts should be tightened alternately a little at a time until both nuts seat against their shoulders. Center-punch the thrust cage and thrust cage nut to lock in position, and install the socket head set screw in the adjusting nut.

**h. Install Drive Coupling.** Enter the drive coupling on shaft and drive into position. *NOTE: Make sure that the shear pin holes in the coupling and worm are in alignment before installing coupling on the worm.* Tap the coupling shear pin bushings into position, install the shear pin and cotter pin. The boom sheave pin should be installed in position to facilitate handling and installation of the boom (fig. 42).

---

**Section IX**

**SWINGER GEAR CASE DISASSEMBLY, INSPECTION,  
REPAIR, AND ASSEMBLY**

**41. DISASSEMBLY.**

**a. Drain Lubricant.** Remove drain plug and filler plugs, and drain lubricant from gear case. Replace the plugs.

**b. Remove Shift Cover.** Remove six 7/16-inch cap screws and lock washers attaching shift cover to swinger gear case, and lift off cover (fig. 43).

**c. Disassemble Shift Cover.** Remove the shift rod poppet spring and pawl. Remove the 3/8-inch cap screw from the end of the shift rod, lift off the lock washers, pull out the shift rod tube, and slide the shift rod out of the shift yoke. Remove cotter pins from shift yoke rollers, and remove castellated nuts. Lift off lock washers. Using a soft hammer drive the rollers out of shift yoke, taking care not to lose needle bearings out of roller (fig. 43). These rollers should not be removed unless the rollers or the yoke are to be replaced. A screwdriver slot is provided in the end of the bearing assembly to hold the bearing against rotation while removing the castellated nut. Loosen the lock nut on the shift rod eye and turn eye and links out of shift rod. Remove cotter and clevis pins securing links to shift rod eye.

CRANE

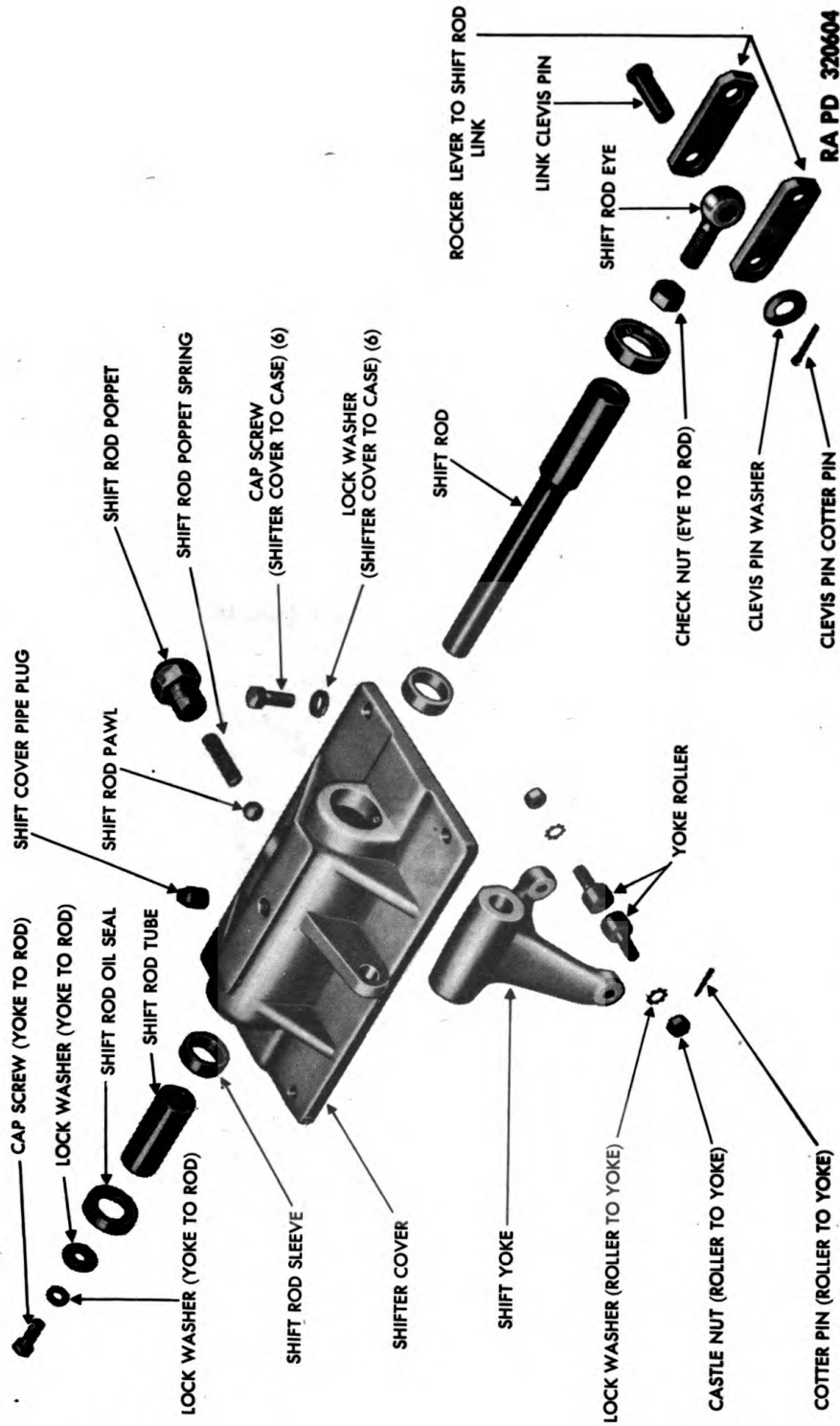
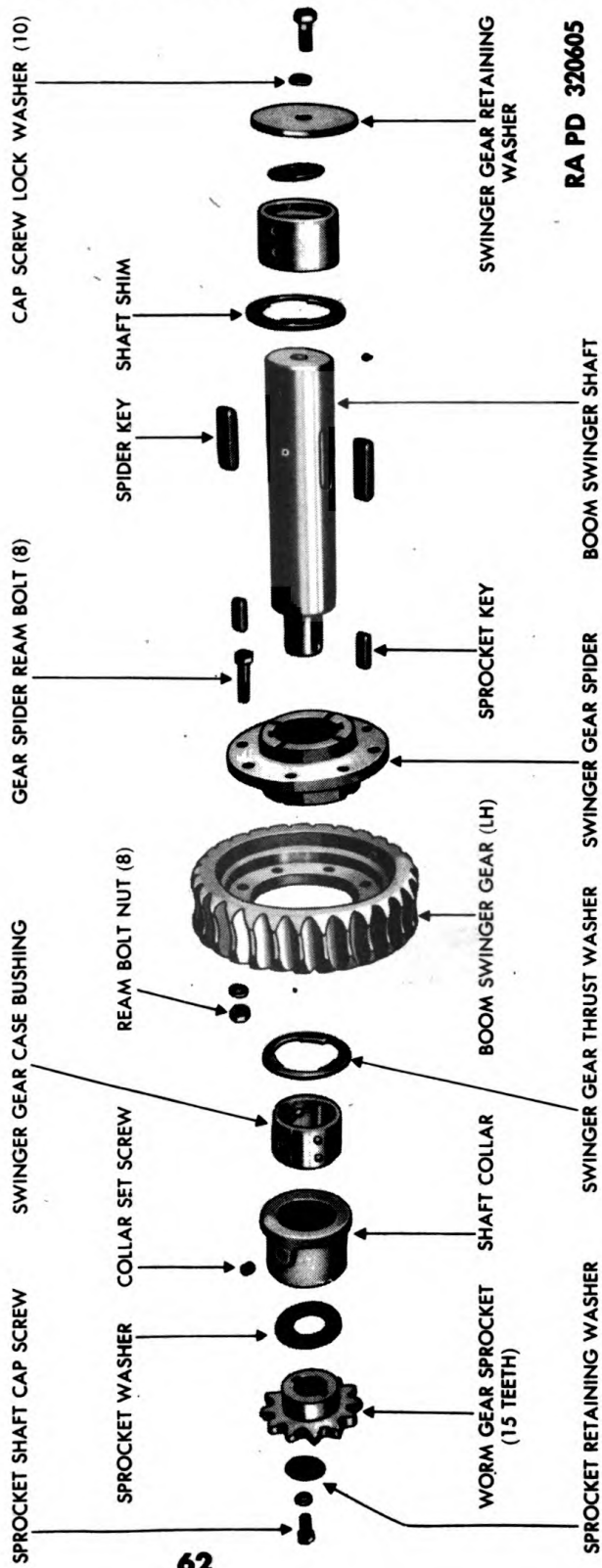

Figure 43 — Gear Case Shift Cover — Disassembled

**ORDNANCE MAINTENANCE – CRANE FOR HEAVY WRECKING  
TRUCK M1A1 (WARD LA FRANCE AND KENWORTH)**



**Figure 44 – Boom Swinger Gear and Shaft – Disassembled**

**CRANE**

**d. Remove Swing Gear and Shaft.** Remove six 1/2-inch cap screws and lock washers securing gear case upper half to the lower half of the gear case. Lift off the upper gear case half. Remove the gear shaft cap screw, lock washer, retainer plate, and shims. Lift out swinger gear and shaft, bushings, and sprocket.

**e. Disassemble Swinger Gear and Shaft.** Remove sprocket shaft cap screw, lock washer, and retaining washer. Remove the gear shaft retaining cap screw, plate, and adjusting pin. Place the gear and sprocket assembly in a hydraulic press, and press the sprocket off the gear shaft. Lift out the two sprocket keys, and slide the sprocket washer off the shaft. Remove the set screw from the shaft collar, and slide the collar off the shaft. Remove the swinger gear case bushing. Remove eight 1/2-inch special ream bolts securing swinger gear to spider. Place the shaft and spider in a hydraulic press, press the spider off the shaft, and lift out the spider keys (fig. 44).

**f. Remove Reverse Idler.** Remove the cotter pin from the end of the reverse idler pin, and remove the castellated nut. Using a soft hammer drive the reverse idler pin into the gear case and reaching down through the swinger gear opening lift the reverse idler pin, gear, bearing, and thrust washers out through the gear case opening (fig. 59). Slide off the thrust washer, idler gear and bearing, and inner thrust washer and tap out the reverse idler bearing.

**g. Remove Input Shaft.** Remove the 3/8-inch sprocket retaining cap screw and retaining washer, and drive sprocket off the input shaft (fig. 46). Remove five 7/16-inch cap screws and lock washers attaching gear case sprocket end cover to the case. Lift the cover free of input shaft and case. Remove five 7/16-inch cap screws and lock washers from gear case cover, remove 3/4-inch end cover blanking stud nut and lock washer, and lift off the end cover (fig. 63). Remove the set screw lock wires from the driven clutch gear hubs, and remove two set screws (fig. 46). Pull the input shaft toward the sprocket end; using a soft punch, drive the input shaft bearings off the shaft and out of the gear case. Move the input shaft assembly toward the front of the gear case until the rear of the shaft can be tilted out of the gear case through the shift cover opening, and lift the input shaft assembly free of the gear case (fig. 63).

**h. Disassemble Input Shaft.** Slide off the clutch spacer, thrust washer, and rear clutch gear assembly. Remove the thrust washer from the front end of the input shaft, and slide off the clutch gear. Tap the clutch gear bushings out of the clutch gears, remove bearing spacer, and slide the input shaft out of the sliding clutch (fig. 46).

**i. Remove Worm.** Drive boom swinger worm assembly through the front of the gear case until clear of the bearing bores, and then lift the worm assembly until the forward 28-tooth gear is centered in the gear case. Install puller 41-P-2911 through the worm and input shaft



**TM 9-1796  
41-42**

**ORDNANCE MAINTENANCE — CRANE FOR HEAVY WRECKING  
TRUCK M1A1 (WARD LA FRANCE AND KENWORTH)**

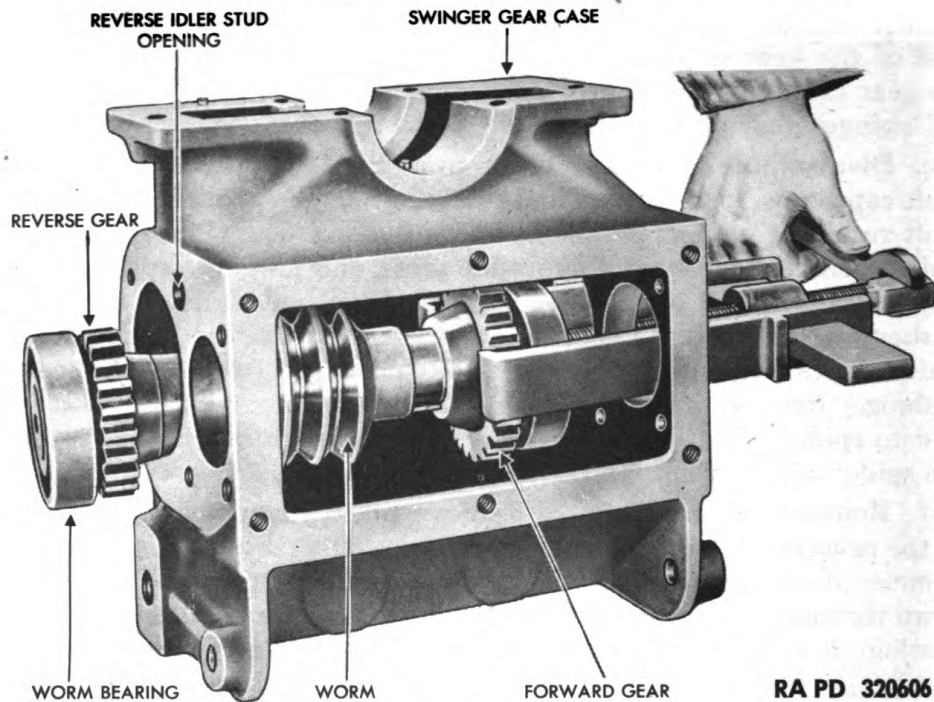

**Figure 45 — Removing Worm Forward Gear and Bearing  
With Puller 41-P-2911**

bearing bores, and pull the forward gear and bearing free of the worm (fig. 45). Lift out the bearing and forward gear, and slide the worm with the rear bearing and reverse gear through front end of the gear case. Install a puller on the reverse gear, pull gear and bearing off the worm, and lift out the gear keys.

**42. CLEANING, INSPECTION, AND REPAIR.**

a. Clean all parts of the swing gear case assembly in dry-cleaning solvent, and blow off with compressed air. Inspect the retaining washers on both ends of the worm gear shaft and input shaft; if they are cut or scored, replace them. Inspect the thrust washers between the swing gear spider and gear case; if worn or scored, replace. Clean and blow out with compressed air all drilled oil passages in the top and bottom halves of the worm gear case.

b. Inspect the swing gear case bushings for wear; if found to have more than a  $\frac{1}{64}$ -inch clearance, replace them. Inspect the swing gear teeth for distortion, scoring, and wear. If worn more than  $\frac{1}{32}$  inch, scored, or distorted, replace the gear. Inspect the clutch gears and sliding clutch. Examine the clutch contact surfaces. If the corners have been worn off, or if when fully engaged they do not

## CRANE

form a line contact, replace both gears and sliding clutch. **NOTE:** *Except in an emergency, do not replace one member without replacing all three.*

c. Inspect the shift cover oil seals and end cover oil seals; if they show evidence of wear or leaking, replace them. If oil seals are replaced, soak them in neat's-foot oil or engine oil for 1 hour before installation. The lips of the seals go toward the inside of the cover and gear case. The seals can be tapped into position until they seat in the cover (fig. 61). Do not drive the seals any more than necessary, once the seal has reached its seat. Inspect shift yoke rollers for free rotation and wear.

### 43. ASSEMBLY.

a. **Assemble and Install Worm.** Press the reverse gear and front bearing onto worm. Place worm in the gear case, and set forward gear onto worm; using a punch and hammer drive the forward gear onto the worm. Install the worm rear bearing on worm and in case. **NOTE:** *The hubs of the forward and reverse gear face the center of the worm. Keep in mind that the worm is assembled with the reverse gear in the same end of the gear case as the reverse idler gear. The blanking stud in the gear case, which is not removed in the disassembly, controls the location of the reverse idler and reverse gear. NOTE: This is the only means of identifying the one which the forward gear on the worm is located. The blanking stud and forward gear are on the same end of the gear case and worm (fig. 63).*

b. **Assemble Input Shaft.** Slide the sliding clutch onto the input shaft spline, and install the bearing collars with the lubricating groove toward the clutch gear (fig. 46). Tap the bushing assemblies into the clutch gears, and slide the clutch gear onto the input shaft. Install the set screw in the clutch gear opposite the drive end, and install the lock wire. The slot in the set screw should be in alignment with the circumferential groove machined in the hub of the clutch gear. Do not install the set screw in the drive end clutch gear. Install thrust washers with grooves toward clutch gear on both ends of the shaft, and install the space washer on the forward gear end.

c. **Install Input Shaft.** Set the drive end of the input shaft through the gear case cover opening and the input shaft bearing bore (fig. 63). Straighten the input shaft into position, install the single row bearing on the forward gear end, and the double row bearing on the drive or reverse gear end of the input shaft. Aline the holes in the clutch gear and clutch gear bushing, and install the set screw and lock wire as described in subparagraph b, above.

d. **Assemble Case.** Using a piece of light shim stock over the end of the input shaft, set the drive end gear cover in position on the gear case, using the shim stock as a guide and protector for the input shaft

ORDNANCE MAINTENANCE – CRANE FOR HEAVY WRECKING  
TRUCK M1A1 (WARD LA FRANCE AND KENWORTH)

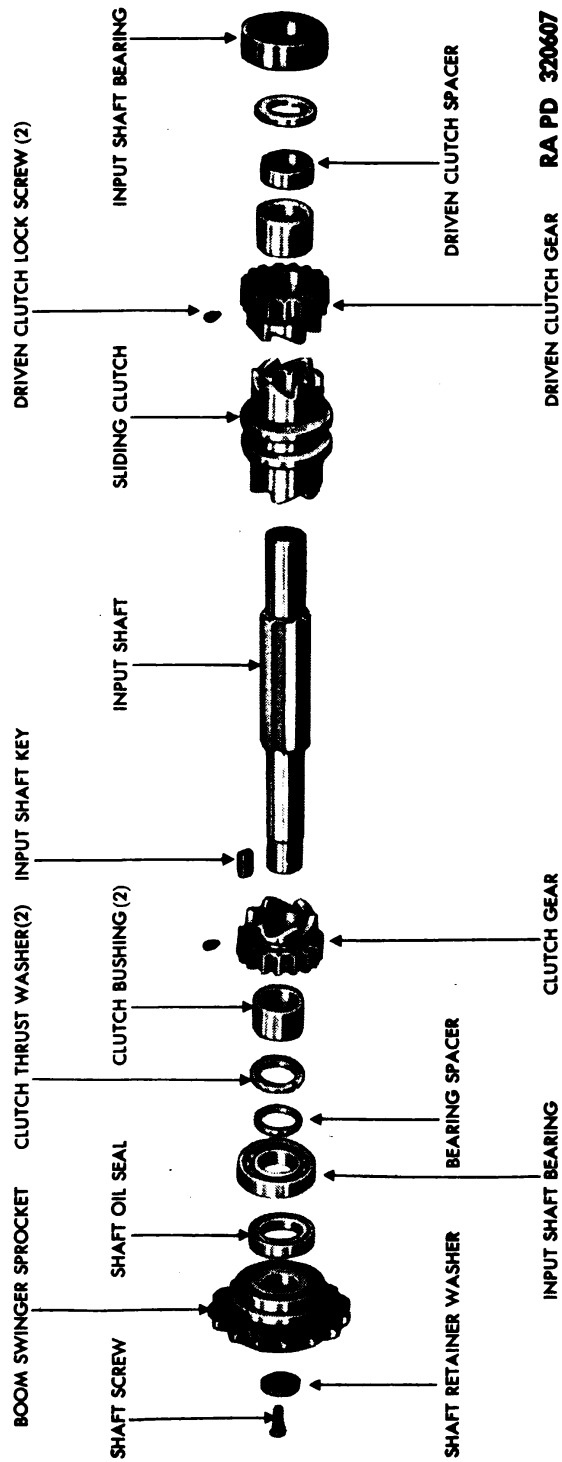

Figure 46 — Boom Swinger Input Shaft — Disassembled

**CRANE**

oil seal. Install the five  $\frac{7}{16}$ -inch cap screws and lock washers, and pull the shim stock off the input shaft. Install the rear gear case end plate, cap screws, and lock washers; install the blanking stud lock washer and nut. Use new gaskets between the gear case and end covers.

**e. Install Reverse Idler.** Assemble the reverse idler gear and thrust washers with the lubrication grooves toward the gear on the reverse idler gear pin. Enter the gear pin through the swinger gear opening and using a soft punch and hammer drive the gear pin into position (fig. 59). Make sure that the idler gear thrust washers remain in position to prevent interference between the stud shoulder and gear case. Install idler gear stud lock washer, castellated nut, and cotter pin.

**f. Assemble and Install Cover.** Enter shift rod through opening in cover, being careful not to damage the oil seals. Set the shift yoke in position, and continue sliding the rail through the cover. Install the shift rod tube, and install the retaining lock washers and cap screw (fig. 56). Drop the pawl through the poppet opening, and install the spring and poppet. Install the lock nut on the shift rod eye, and install the eye. Install the shift rod rocker links, clevis, and cotter pins (figs. 43 and 56). Use a new gasket and set the shift cover in position on the gear case, making certain that the sliding clutch is centered; enter the shift yoke into the groove on the sliding clutch. (The rocker links point away from the sprocket end of the gear case.) Install the six cap screws and lock washers securing the shift cover to the gear case.

**g. Assemble and Install Swinger and Shaft Gear.** Install the keys in the swinger shaft. Press the spider on the shaft until spider thrust faces are flush with ends of shaft keys. Set the swinger gear onto the spider and install the eight special ream bolts, nuts, and lock washers (fig. 44). Slide the thrust washers onto the shaft, and place shaft bushings on the shaft with the annular groove toward the shaft ends. Set the shaft and gear assembly in the gear case, and locate bushings on the case dowel pins. The sprocket end of the shaft is opposite the shift cover. Using new gaskets between the upper and lower gear case halves, set the upper case half in position and install six  $\frac{7}{16}$ -inch cap screws and lock washers. Slide gear shaft collar on the gear shaft, and allow  $\frac{1}{32}$  inch between the collar and gear case. Install the collar set screw. Install swinger gear retaining washer and lock washer on a retainer plate cap screw, and add or subtract spacer shims between the shaft and retaining washer until  $\frac{1}{32}$ -inch clearance exists between the retaining washer and the gear case. Install sprocket thrust washer on shaft, and install the sprocket key. Drive the sprocket onto the shaft until it shoulders against the retaining collar. Install the sprocket retaining washer, cap

**ORDNANCE MAINTENANCE — CRANE FOR HEAVY WRECKING  
TRUCK M1A1 (WARD LA FRANCE AND KENWORTH)**

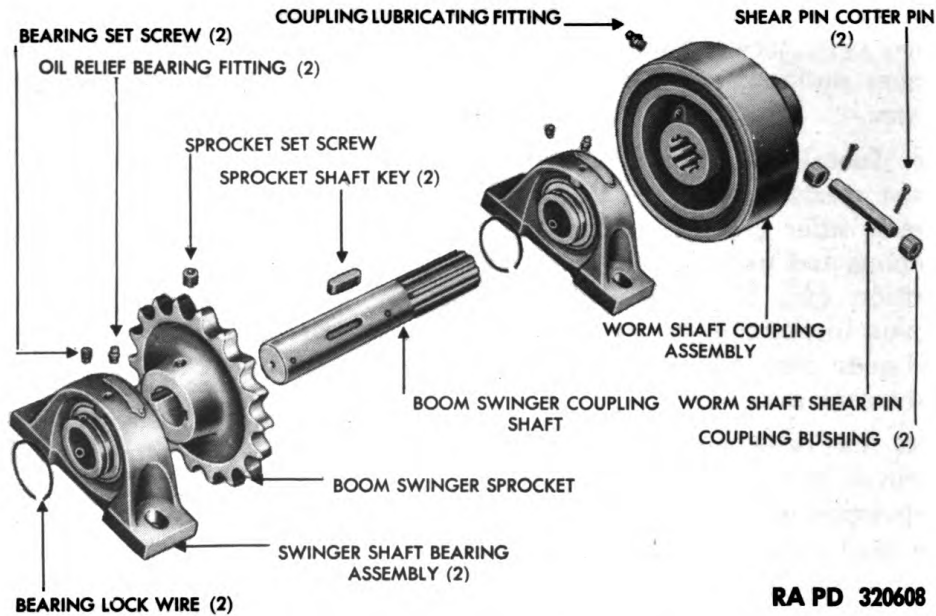

RA PD 320608

**Figure 47 — Boom Swinger Drive — Disassembled**

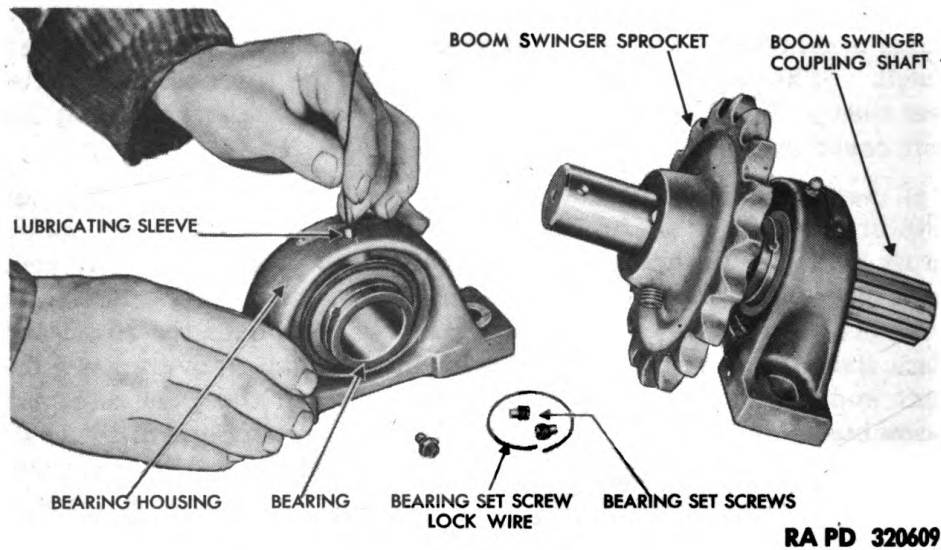

RA PD 320609

**Figure 48 — Removing Bearing Lubrication Sleeve**

screw, and lock washer. Install the input shaft coupling key, and install the input shaft sprocket coupling with the counterbore in the hub pointed toward the end of the shaft. Install sprocket retainer plate cap screw and lock washer. Install the grease drain and filler plug.

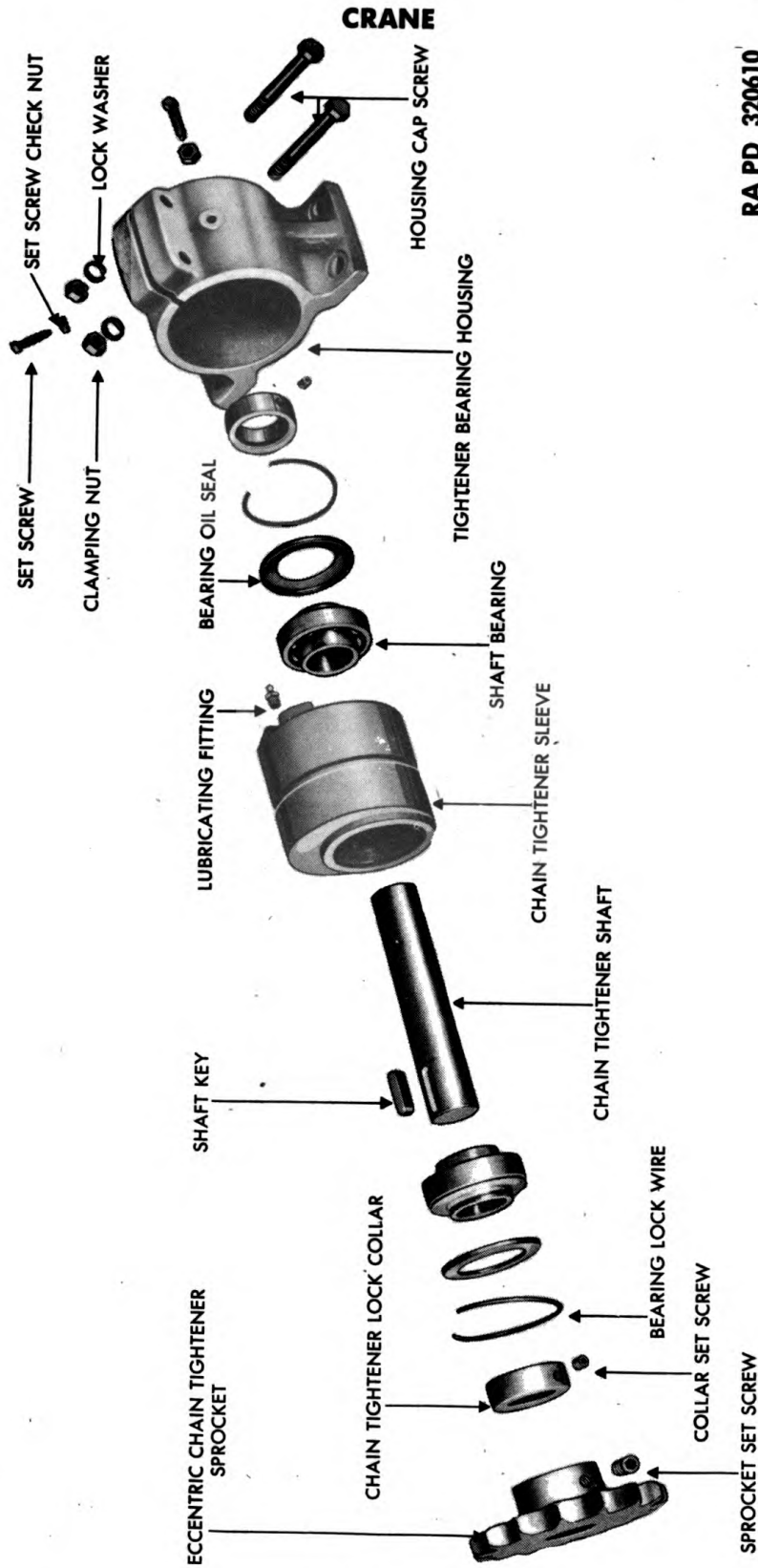
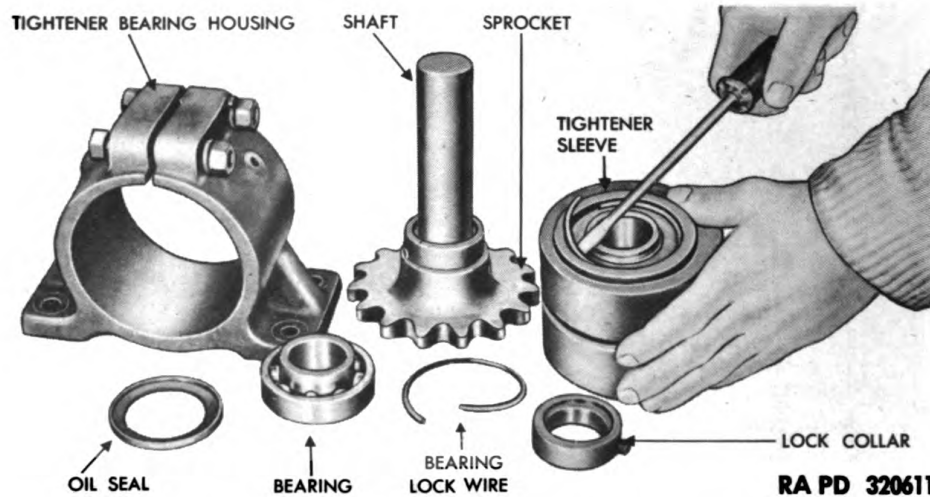

Figure 49 — Eccentric Chain Tightener — Disassembled

**ORDNANCE MAINTENANCE – CRANE FOR HEAVY WRECKING  
TRUCK M1A1 (WARD LA FRANCE AND KENWORTH)**



**Figure 50 – Removing Bearing Lock Wire**

**44. SWINGER DRIVE DISASSEMBLY, REPAIR, AND ASSEMBLY.**

**a. Disassemble.** Remove the bearing set screw lock wires on the bearing inner race, and remove set screw and slide bearing assemblies off the swinger coupling shaft. Remove the socket head set screw in the sprocket hub, press the sprocket off the shaft, and lift out sprocket keys (fig. 47). Remove the bearing lubrication fitting; reach into the lubrication fitting opening with a short piece of wire and lift out the small lubrication sleeve (fig. 48). Turn the bearings in their housing 90 degrees, and tap the bearing assemblies out through the grooves in one side of the bearing housing (fig. 22).

**b. Clean, Inspect, and Repair.** Clean all the parts thoroughly in dry-cleaning solvent, and inspect the bearings for free rotation. Inspect the sprocket for wear and the sprocket shaft for spline wear or looseness. Replace any worn or broken parts. Inspect the shaft for straightness and replace if bent.

**c. Assemble.** Install the shaft keys and press the sprocket onto the keys and shaft until the keys are flush with the extended end of the sprocket hub. The hub extended end points away from the splined end of the shaft (fig. 47). Slide the bearing assemblies through the grooves in the sides of the bearing housing, and turn 90 degrees into their operating position (fig. 22). Set the bearing assemblies onto the shaft, and install the set screws in the inner race of the bearings with the holes in alignment in the shaft. Install the set screw lock wires, and install the sprocket set screw.

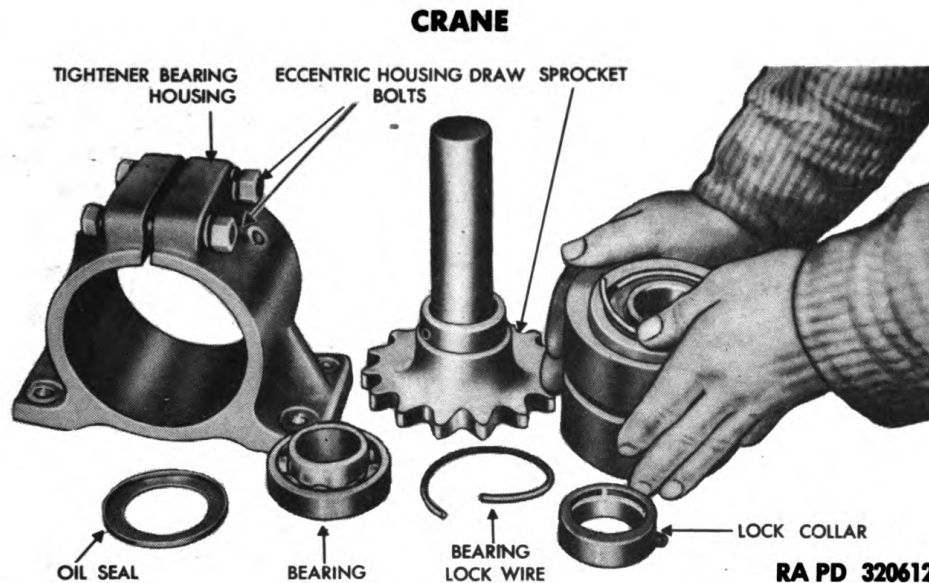

**Figure 51 – Installing Bearing Lock Wire**

**45. ECCENTRIC CHAIN TIGHTENER DISASSEMBLY, REPAIR, AND ASSEMBLY.**

**a. Disassemble.** Loosen the set screw check nuts, and remove the set screws from the chain tightener housing. Slide the chain tightener assembly out of the housing. Remove the set screw from the rear chain tightener collar, rotate the collar slightly until it is free, and slide it off the shaft. Loosen the set screw in the sprocket end chain tightener collar, and rotate the collar until it is free on the shaft. Slide the shaft out of the chain tightener sleeve. Remove the snap rings from either side of the chain tightener sleeve, and tap out the bearings (fig. 50). Remove set screw from the sprocket hub, press the sprocket off the shaft, and lift out the sprocket key (fig. 47).

**b. Clean, Inspect, and Repair.** Clean all parts thoroughly in dry-cleaning solvent. Inspect bearings for free rotation and wear. Inspect the chain tightener sleeve and tightener bearing housing for wear. Inspect the shaft for wear and straightness, and replace all parts that are excessively worn.

**c. Assemble.** Install the shaft key, and press the sprocket on the shaft until the shaft end and the face of the sprocket are flush. Install the sprocket set screw. Set the bearings in the chain tightener sleeve and tap in until they shoulder against their seats. Install the oil seals with the flange in, and install the bearing lock wires (fig. 51). Set one chain tightener lock collar on the sprocket shaft with the counterbore toward the bearing. Slide the shaft through the bearings, and set the outer lock collar on the shaft with the counterbore toward the bearing inner race (fig. 51). Turn the lock collars in either direction until they lock on the bearing inner race, and tighten the lock



**TM 9-1796**  
**45-48**

**ORDNANCE MAINTENANCE — CRANE FOR HEAVY WRECKING  
TRUCK M1A1 (WARD LA FRANCE AND KENWORTH)**

collar set screws. Slide the chain tightener sleeve into the housing, and install the set screws. Adjust finger-tight, as the eccentric chain tightener will have to be adjusted when installed on the crane.

---

**Section X**

**DOUBLE DRUM DISASSEMBLY, INSPECTION,  
REPAIR, AND ASSEMBLY**

**46. DISASSEMBLY.**

a. Remove the drum shaft retainer washer cap screws, lock washers, retainer washer, and shims. Slide off the worm gear case bushings and the worm gear spider outer thrust washers (fig. 52). Remove the lubricating fitting from the end frame sleeve, and slide the sleeve out of the support. Press off the worm gear spider and boom and hoist cable drums, and lift out the keys for the worm gear spiders and drums. Remove the eight special ream bolts, nuts, and lock washers that attach each worm gear to its spider. These bolts must fit tight, and care should be taken not to damage the threads or upset the ends of the bolts when they are driven out. Remove the rope clamp nuts and lock washers, and slide the rope clamps out of the drums (fig. 53).

**47. CLEANING, INSPECTION, AND REPAIR.**

a. Clean all parts thoroughly in dry-cleaning solvent. Inspect worm gears for pitting, and distorted or excessively worn teeth. If worn over  $\frac{1}{32}$  of an inch, replace the gears. Inspect the worm gear bolt holes for wear. If worn, replace the gears. Inspect the drum and gear shaft for straightness and wear; if worn or bent, replace the shafts. Inspect the hoist and boom drums for broken flanges and replace as indicated. Inspect the drum shaft thrust washers and bushings for excessive wear; if worn excessively, replace. Press a new bushing into the hoist drum, and install the dowel screws. Ream the drum bushing to 2.442 inches (fig. 53).

**48. ASSEMBLY.**

a. Set the worm gears on the spiders and install the ream bolts, nuts, and lock washers. Install the worm gear keys in the drum shaft, and press the spider onto the shaft until the spider hubs are flush with the ends of the keys (fig. 54). Install the inner thrust washer on the shaft, and install the drum keys and then press the

CRANE

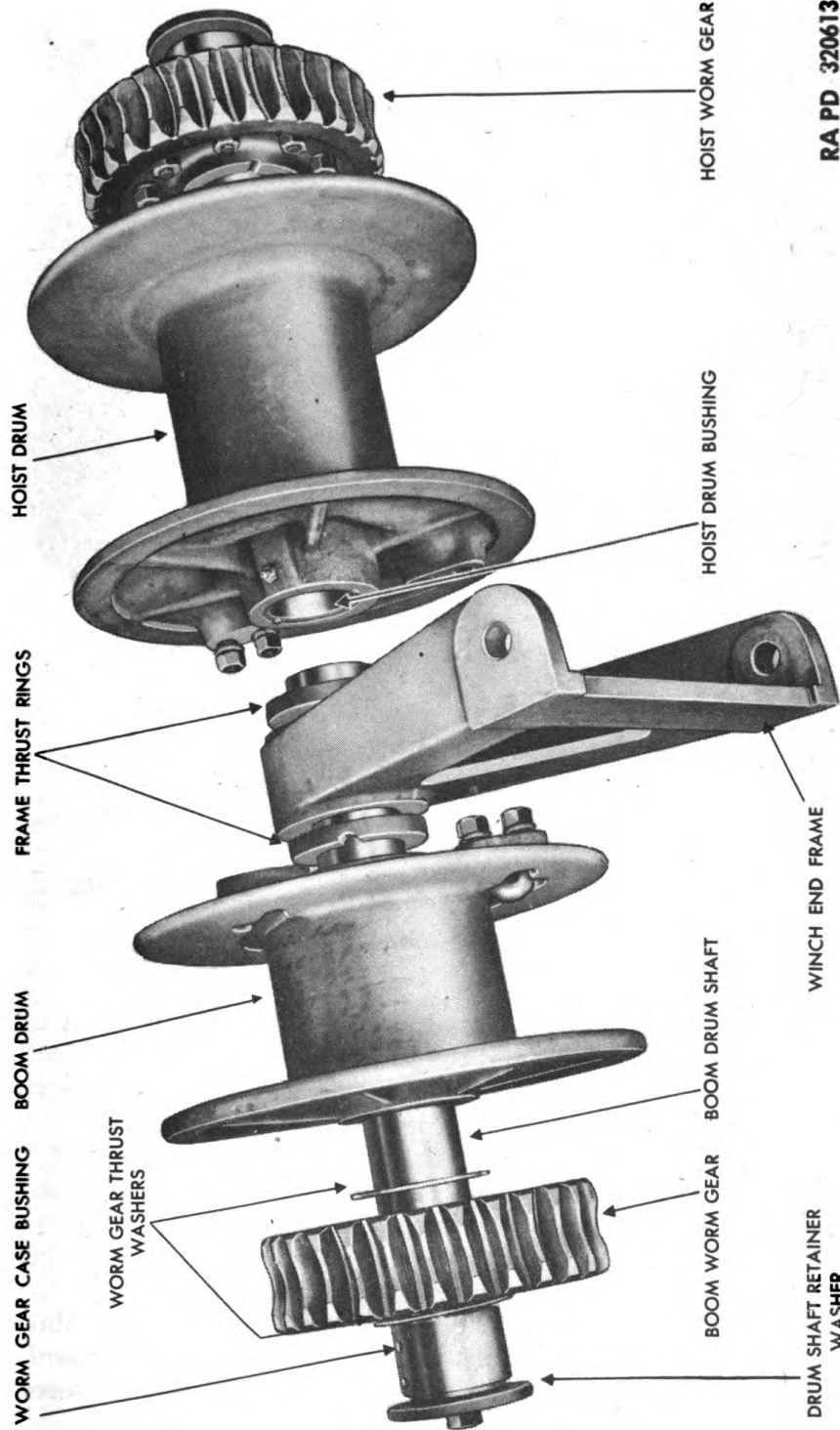

RA PD 320613

Figure 52 - Double Drum Assembly

TM 9-1796  
48

**ORDNANCE MAINTENANCE – CRANE FOR HEAVY WRECKING  
TRUCK M1A1 (WARD LA FRANCE AND KENWORTH)**

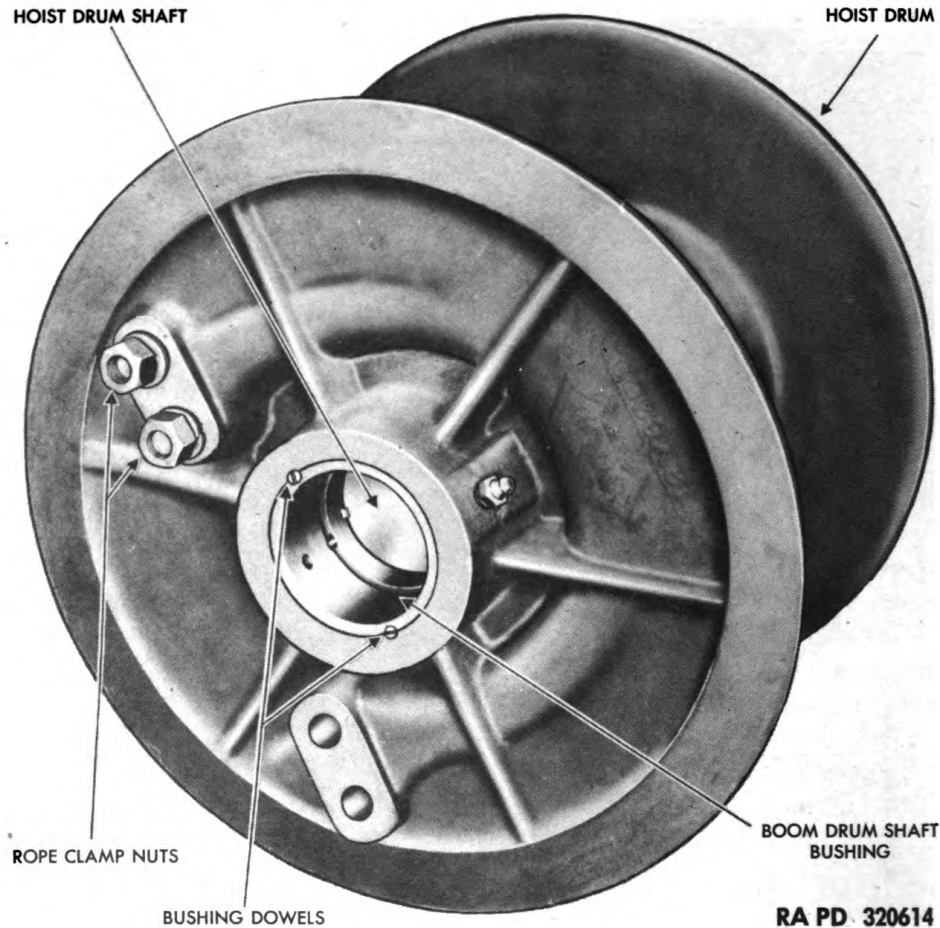

RA PD 320614

**Figure 53 – Hoist Drum**

drum onto the shaft until a distance of  $2\frac{17}{32}$  inches is obtained between the face of the drum and the thrust washer (fig. 55). Slide the outer thrust washer onto the shaft, and install the shaft bushings. Install the drum shaft shims, retainer washer, and lock washer under the head of the retainer washer cap screw. Install in the end of the drum shaft, but do not tighten the cap screws (fig. 52). Slide the end frame sleeve into the end frame, install the drum thrust washer on the boom drum shaft, and then slide the center support onto the shaft. Install the remaining frame ring. The lubrication grooves in both frame rings go toward the boom and hoist drums. Slide the boom drum shaft into the hoist drum (fig. 52). This assembly is installed in the hoist and boom gear cases at this stage of assembly.

CRANE

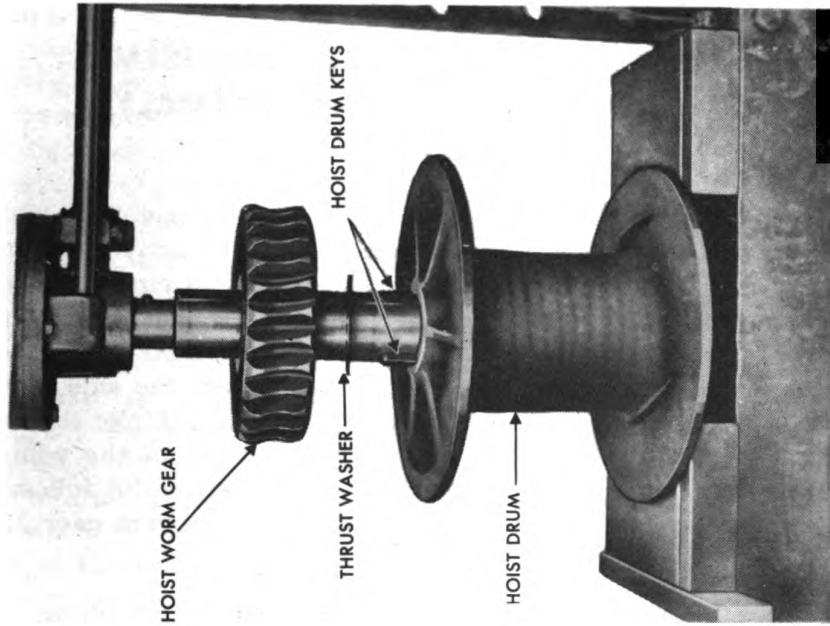

RA PD 320616

Figure 55 — Installing Hoist Drum

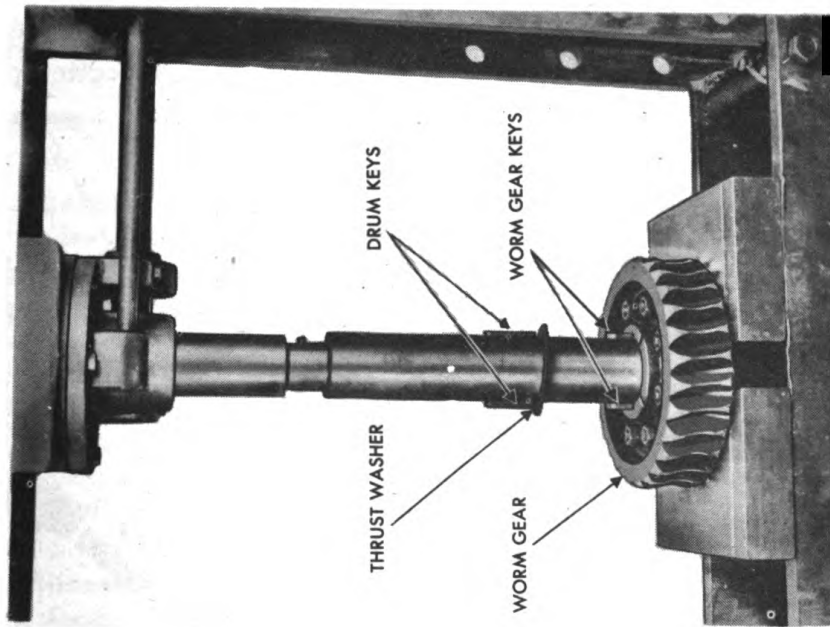

RA PD 320615

Figure 54 — Installing Worm Gear

ORDNANCE MAINTENANCE — CRANE FOR HEAVY WRECKING  
TRUCK M1A1 (WARD LA FRANCE AND KENWORTH)

Section XI

HOIST AND BOOM GEAR CASE DISASSEMBLY,  
INSPECTION, REPAIR, AND ASSEMBLY

49. GENERAL.

a. The hoist and boom gear cases in so far as disassembly, cleaning, inspection, and assembly are concerned, are exactly the same. They vary only in the location of the shift cover assembly in relation to their installed position. The brake cases are on the forward end of the gear cases, and the input shaft sprockets are on the rear end of the gear cases. The shift covers are mounted on the side of the gear case facing the right- and left-hand sides of the vehicle; the shift rod linkage in both instances points toward the front of the vehicle. The disassembly, repair, and assembly instructions in the following paragraphs can be applied to either the hoist or the boom gear case.

50. DISASSEMBLY.

a. **Drain Lubricant.** Remove drain plug and filler plugs, and drain lubricant from gear case. Replace the plugs.

b. **Remove Shift Cover.** Remove six  $\frac{7}{16}$ -inch cap screws and lock washers attaching shift cover to gear case, and lift off cover.

c. **Disassemble Shift Cover.** Remove the shift cover poppet spring and pawl. Remove the  $\frac{3}{8}$ -inch cap screw from the end of the shift rod and lift off lock washer. Pull out shift rod tube, and slide the shift rod out of the shift yoke (fig. 56). Remove cotter pins

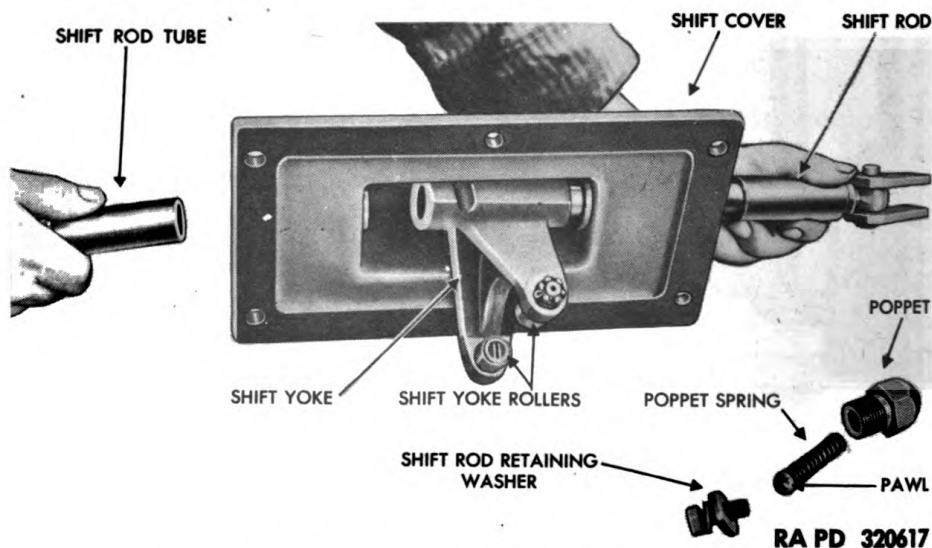

Figure 56 — Installing Gear Case Shift Rod and Yoke

## CRANE

from shift yoke roller studs, and remove castellated nuts. Lift off lock washers. Using a soft hammer, drive rollers out of shift yoke, using care not to lose needle bearings out of roller. These rollers should not be removed unless the rollers or the yoke are to be replaced (fig. 43). A screwdriver slot is provided in the end of the bearing assembly to hold the bearing against rotation while removing the castellated nut. Loosen the check nut on shift rod eye, and turn eye and links out of the shift rod. Remove cotter and clevis pins securing rocker arm links to shift rod eye (fig. 43).

**d. Disassemble Brake Case.** Remove two wing nuts and lock washers securing brake case cover to the brake case, and lift off the cover. Remove the brake band end adjusting nut and lock nut, and lift off the brake band spring and washer (fig. 57). Remove outer brake band anchor nut, and drive anchor end of the brake band into the brake case. Then lift the closed end of the brake band off the disk, tilt the band up, and pull the band free of the brake case (fig. 64). Remove the brake disk retaining cap screw, lock washer and retaining washer from the end of the drum shaft. Replace the cap screw to form a puller screw base. Position puller 41-P-2905-60 back of the brake disk, and with this base under the puller screw to prevent damaging the retainer cap screw threads, pull the disk off the shaft. Remove five  $\frac{7}{16}$ -inch cap screws and lock washers, the blanking stud nut and lock washer, and tap brake case off gear case (fig. 58).

**e. Remove Reverse Idler Gear.** Remove the cotter pin from the end of the reverse idler gear pin, and remove the castellated nut. Using a soft hammer, drive the reverse idler gear pin into the gear case, and reaching down through the worm gear opening, lift the reverse idler gear pin, gear, bearing, and thrust washers out through the gear case opening (fig. 59). Slide off the thrust washer, idler gear, bearing, and inner thrust washer, and tap out the reverse idler bearing.

**f. Remove Input Shaft.** Remove the  $\frac{3}{8}$ -inch sprocket retaining cap screw and retaining washer, and drive the sprocket off the input shaft. Remove five  $\frac{7}{16}$ -inch cap screws and lock washers attaching the gear case sprocket end cover to case. Lift the cover free of the input shaft and case. Remove the set screw lock wires from the driven clutch gear hubs, and remove two set screws. Pull input shaft toward the sprocket end, and using a soft punch, drive input shaft bearings off the shaft and out of the gear case (fig. 46). Move input shaft assembly toward the front of the gear case until the rear of the shaft can be tilted out of the gear case through the shift cover opening, and lift input shaft assembly free of the gear case (fig. 63).

**g. Disassemble Input Shaft.** Slide off rear end bearing spacer, thrust washer, and rear clutch gear assembly. Remove thrust washer from front end of input shaft, and slide off the clutch gear. Tap



CRANE

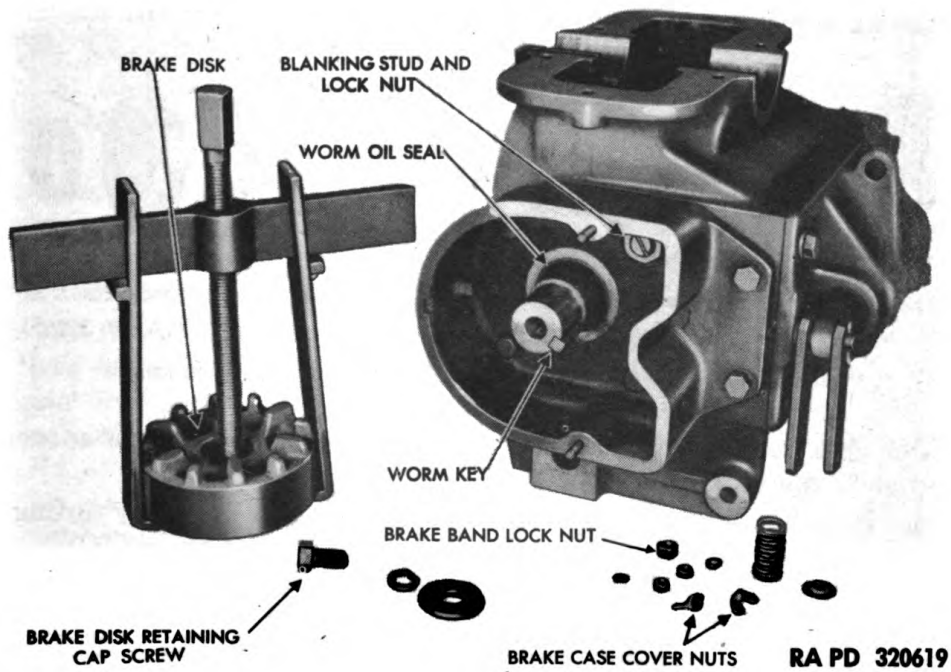
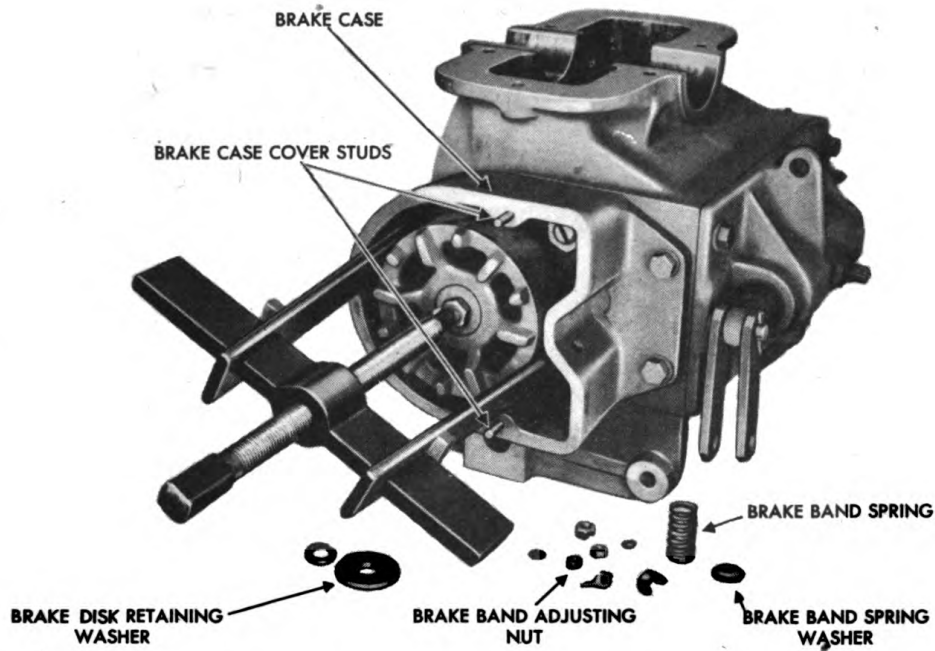
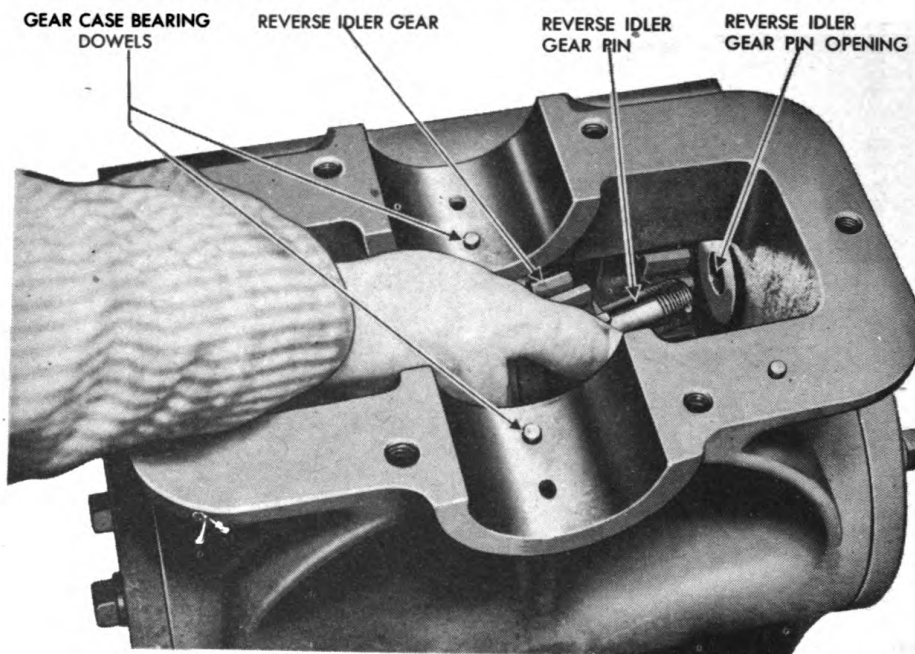

Figure 58 - Removing Brake Disk With Puller 41-P-2905-60



**ORDNANCE MAINTENANCE – CRANE FOR HEAVY WRECKING  
TRUCK M1A1 (WARD LA FRANCE AND KENWORTH)**



RA PD 320620

**Figure 59 – Installing Reverse Idler**

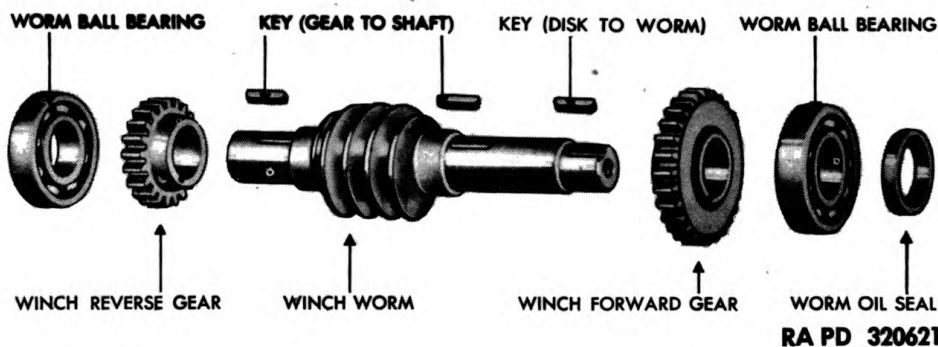

RA PD 320621

**Figure 60 – Hoist Gear Case Worm – Disassembled**

clutch gear bushings out of clutch gears, remove clutching gear spacer, and slide the input shaft out of the sliding clutch (fig. 46).

**h. Remove Worm.** Drive the worm and gear assembly through front of gear case until clear of bearing bores, and then lift worm assembly until the forward 28-tooth gear is centered in the gear case. Install a puller through the worm and input shaft bearing bores, and pull the forward gear and bearing free of worm (fig. 45). Lift out bearing and the forward gear, and slide the worm with rear bearing and reverse gear through front end of the gear case. Install puller on reverse gear, pull gear and bearing off the worm, and lift out the gear keys.

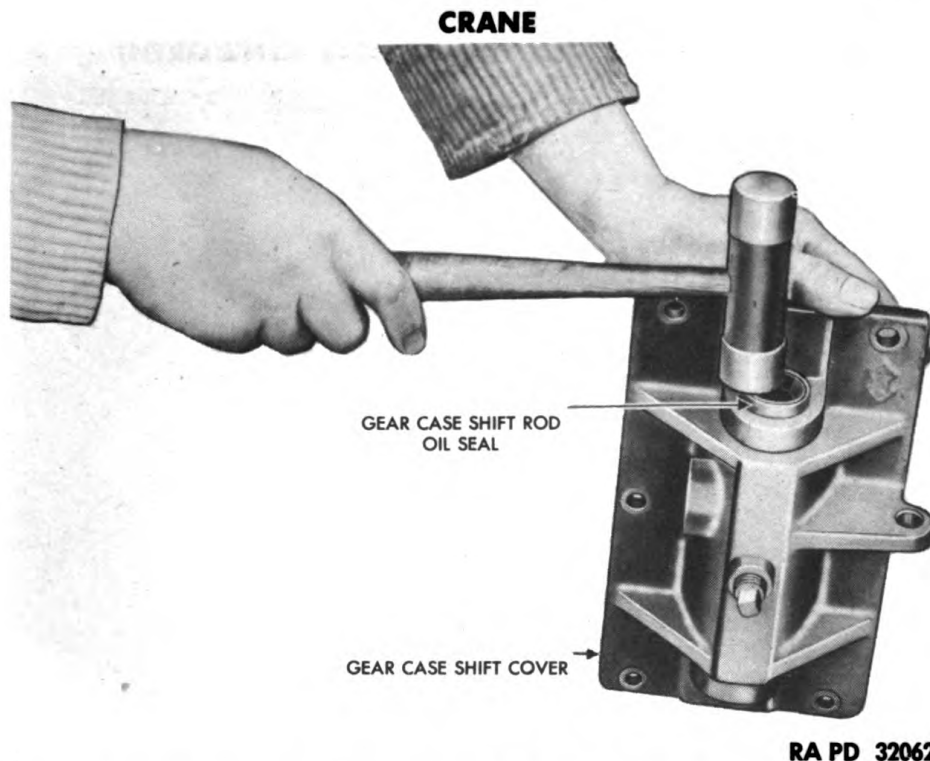

**Figure 61 – Installing Gear Case Shift Cover Oil Seal**

### 51. CLEANING, INSPECTION, AND REPAIR.

a. Clean all parts of the gear case assembly in dry-cleaning solvent and blow off with compressed air. Inspect the retaining washers on both ends of the worm shaft and input shaft; if they are cut or scored, replace them. Inspect the thrust washers between the worm gear spider and gear case, and if worn or scored, replace. Clean and blow out with compressed air all drilled oil passages in the top and bottom halves of the worm gear case.

b. Inspect the worm gear case bushings for wear, and if found to have more than  $\frac{1}{64}$ -inch clearance, replace them. Inspect the worm gear teeth for distortion, scoring, and wear. If worn more than  $\frac{1}{32}$  inch, scored, or distorted, replace the gear. Inspect the clutch gears and sliding clutch. Examine the clutch contact surfaces. If the corners have been worn off, or if when fully engaged they do not form a line contact, replace both gears and sliding clutch. Do not, except in an emergency, replace one member without replacing all three.

c. Inspect the shift cover and end cover oil seals; if they show evidence of wear or leaking, replace them. If oil seals are replaced soak them in neat's-foot oil or engine oil for 1 hour before installation. The lips of the seals go toward the inside of the cover and gear case. The seals can be tapped into position until they seat in the cover (fig. 61). Do not drive the seals any more than necessary once the

ORDNANCE MAINTENANCE — CRANE FOR HEAVY WRECKING  
TRUCK M1A1 (WARD LA FRANCE AND KENWORTH)

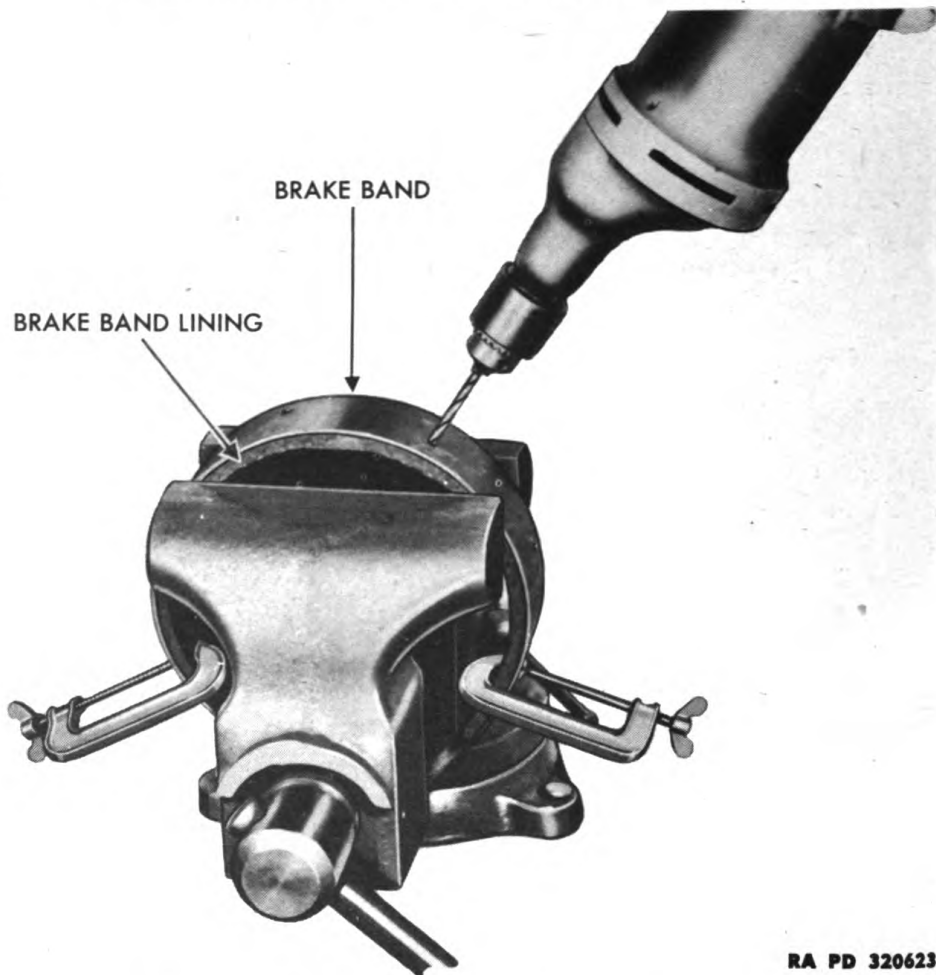

RA PD 320623

**Figure 62 — Relining Gear Case Brake Band**

seal has reached its seat. Inspect shift yoke rollers for free rotation and wear.

d. Inspect condition of brake band and see that it is properly curved to fit the brake disk. If the lining is worn down close to the rivets, replace the lining. Drill out the six brake lining rivets, and lift off the lining (fig. 62). *NOTE: This is special lining and ordinary brake lining must not be substituted.* Set lining in the brake band, install six rivets, and upset the ends of the rivets against the brake band. Recheck the curvature of the band.

**52. ASSEMBLY.**

a. **Assemble Worm.** Press the reverse gear and front bearing onto the worm. Place the worm in the gear case, set forward gear onto the worm and, using a punch and hammer, drive the forward gear onto

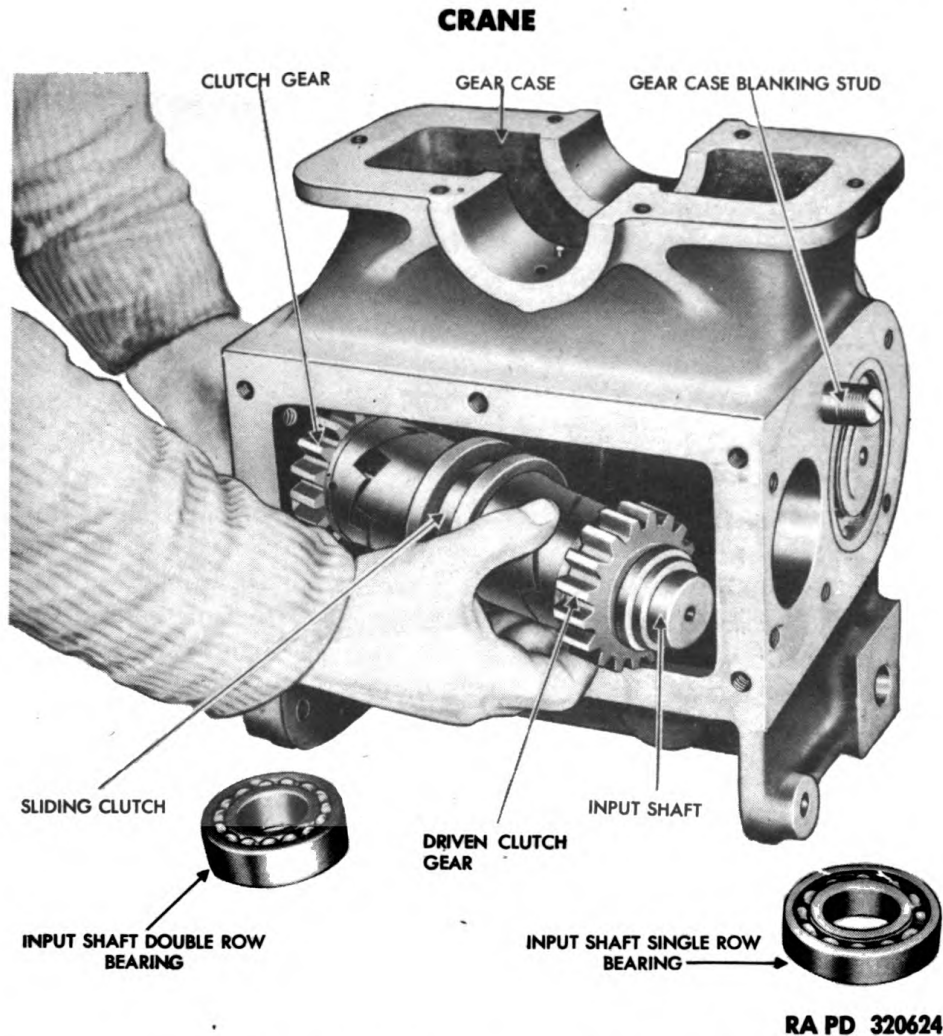
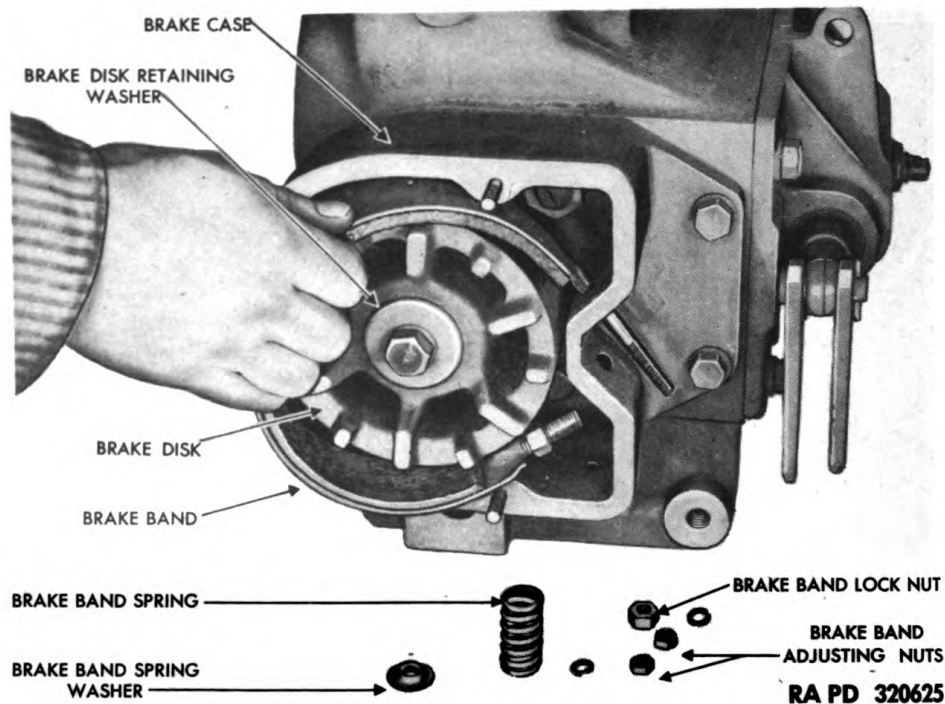

**Figure 63 – Installing Gear Case Input Shaft**

the worm. Install worm rear bearing on worm and in case. **NOTE:** The hubs of the forward and reverse gear face the center of the worm. The worm is assembled with the reverse gear in the same end of the gear case as the reverse idler gear (fig. 60). The blanking stud in the gear case which is not removed in the disassembly controls the location of the reverse idler and reverse gear. This is the only means of identifying the end of the worm on which the forward gear is located. The blanking stud and forward gear are on the same end of the gear case and worm (fig. 63).

**b. Assemble Input Shaft.** Slide the sliding clutch onto the input shaft spline, and install the spacers with the lubrication groove toward the clutch gear. Tap the bushings into the clutch gears, and slide the clutch gears onto the input shaft (fig. 46). Install the set screw in the clutch gear opposite the drive end, and install the lock wire.

**ORDNANCE MAINTENANCE — CRANE FOR HEAVY WRECKING TRUCK M1A1 (WARD LA FRANCE AND KENWORTH)**



**Figure 64 — Installing Gear Case Brake Band**

The slot in the set screw should be in alignment with the circumferential groove machined in the hub of the clutch gear. Do not install the set screw in the drive end clutch gear. Install the thrust washers with the grooves toward the clutch gear on both ends of the shaft, and install the bearing spacer on the forward gear end (fig. 46).

**c. Install Input Shaft.** Set the drive end of the input shaft through the gear case cover opening and the input shaft bearing bore. Straighten the input shaft into position, install the single-row bearing on the forward gear end, and the double-row bearing on the drive or reverse gear end of the input shaft (fig. 63). Align the holes in the clutch gear and clutch gear bushing, and install the set screw and lock wire as described in subparagraph b above.

**d. Assemble Case.** Using a piece of light shim stock over the end of the input shaft, set the drive end gear cover in position on the gear case, using the shim stock as a guide and protector for the input shaft oil seal. Install the five  $\frac{7}{16}$ -inch cap screws and lock washers, and pull the shim stock off the input shaft.

**e. Assemble and Install Brake.** Place a piece of light shim stock over the end of the worm, and set the brake case in position on the gear case, using the shim stock as a guide and protector for the worm shaft oil seal (fig. 58). Install five  $\frac{7}{16}$ -inch cap screws and lock

## CRANE

washers securing the gear case to the brake case, and slide the shim stock from between the oil seal and worm. Install the blanking stud lock washer and nut (fig. 58). Install worm brake disk key, and drive disk onto the worm until it shoulders on the shaft. Install the disk retaining washer lock washer and 1/2-inch disk retaining cap screw. Set the brake band anchor and adjusting ends through the gear case cover, and slide the band over the disk (fig. 64). Install the adjusting spring, spring washer, and adjusting nuts. Install the brake band anchor nut. Install the brake case cover, lock washers, and wing nuts.

### f. Brake Band Anchor End and Adjusting End Positions.

The brake band adjusting nut on the hoist gear case is positioned so that the adjusting end comes through the top opening in the brake case, and the anchor end through the bottom. The brake band adjusting nut on the boom gear case is positioned so that the adjusting end comes through the bottom opening in the brake case, and the anchor end through the top. Do not attempt to adjust boom or hoist brakes until they are installed and a load can be placed on the hoist line to check the adjustment.

---

## Section XII

### ASSEMBLY OF CRANE

#### 53. GEAR CASE SUPPORT INSTALLATION.

a. Set the gear case mounting bolts into the forward base angle, and position the base angle in the crane frame with the inside angle toward the rear of the frame. These bolts must be installed in the base angle before it is positioned because of the interference at the crane frame (fig. 15). Position the gear case rear base angle in the A-frame with the inside angle toward the front of the crane. Do not secure the gear case base angle to the crane frame until the hoist and boom gear cases have been installed and bolted to the base angles. Leaving the base angles loose facilitates the installation of the gear cases.

#### 54. BOOM AND HOIST GEAR CASE INSTALLATION.

a. **Install Boom Gear Case.** Run a bridal chain through the opening in the top of the crane A-frame, install two 7/16-inch cap screws in the lower gear case, attach the chain hooks to the gear case, and hoist it into position with the brake case pointed toward the front of the crane (fig. 15). Install the boom gear case front mounting and pivot bolts, lock washers, and nuts and leave loose. Install the rear pivot and mounting bolts, lock washers, and nuts and leave these loose to facilitate installation of the hoist gear case.

**ORDNANCE MAINTENANCE – CRANE FOR HEAVY WRECKING  
TRUCK M1A1 (WARD LA FRANCE AND KENWORTH)**

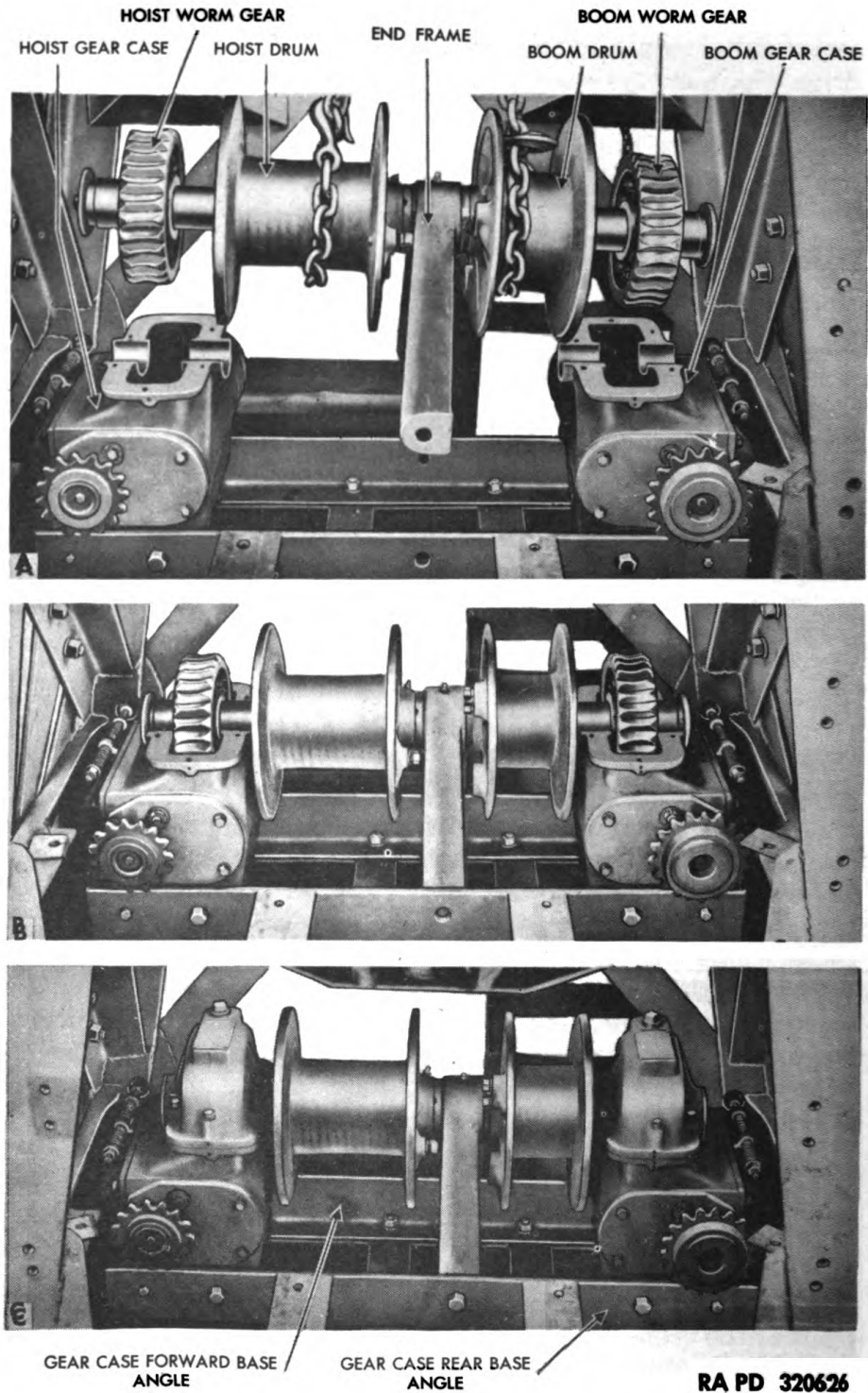

**Figure 65 – Installing Double Drum, Hoist, and Boom Gear Cases**

## CRANE

**b. Install Hoist Gear Case.** Using the same procedure as outlined in subparagraph a above, set the hoist gear case in position and install the gear case front mounting and pivot bolts, and leave them loose. Install the gear case rear mounting and pivot bolts, lock washers, and nuts and leave them loose.

**c. Install Base Angle Bolts.** Install the eight gear case base angle bolts, nuts, and lock washers and leave them loose until the last one has been installed. Tighten the eight base angle bolts, and then the gear case mounting and pivot bolts. Openings are provided in crane A-frame to facilitate base angle bolt installation.

### 55. WORM GEAR AND DOUBLE DRUM INSTALLATION.

**a. Position Double Drum.** Place worm gear and double drum in position. Set the boom drum shaft and worm gear on the boom pivot base plate. Set the end frame assembly and the hoist drum, shaft, and worm gear also on the boom pivot base plate, and assemble as outlined in paragraph 48 a (fig. 52). Using a bridal sling in the top of the crane A-frame, hook onto the two drums; with a chain hoist, raise the double drum and shaft assembly and lower into position in the bearing bores of the hoist and boom gear cases (A, fig. 65). When lowering the double drum assembly align the sleeve bearing dowel holes with the dowels in the gear cases. Make certain that the worm gear thrust washers are over against the worm gear spiders, and are not bent or damaged when the double drum assembly is lowered into the gear cases (B, fig. 65). Enter the end frame into the gear case base angles, and continue lowering the double drum assembly until it is in position (C, fig. 65). Slight rotation of the worm may be necessary to mesh the threads of the worms with the hoist and boom worm gears.

**b. Install Hoist and Boom Gear Case Upper Halves.** Install the hoist and boom gear case upper halves, using new gaskets. Install the gear case upper halves so that the punch marks on the upper and lower gear case halves are in alignment, and agree. Install six gear case cap screws and lock washers (C, fig. 65). Tighten down drum shaft retaining washer cap screws, and check clearance between the retaining washers and the gear cases. This clearance should be  $\frac{1}{32}$  inch; if there is any variation in this dimension, subtract or add shims under the retaining washers as necessary. Install the end frame mounting bolts, nuts, and lock washers. Remove the gear case filler plugs, and fill with gear oil to the level plug located on the sides of the gear cases. Capacity is 2 quarts each.

### 56. BOOM GEAR CASE CONTROL INSTALLATION.

**a. Install Cross Shaft and Inboard Lever.** The boom gear case cross shaft is the longest of the three control rods. Slide the rod through the front hole in the control lever outboard bracket, and



TM 9-1796  
56

ORDNANCE MAINTENANCE — CRANE FOR HEAVY WRECKING  
TRUCK M1A1 (WARD LA FRANCE AND KENWORTH)

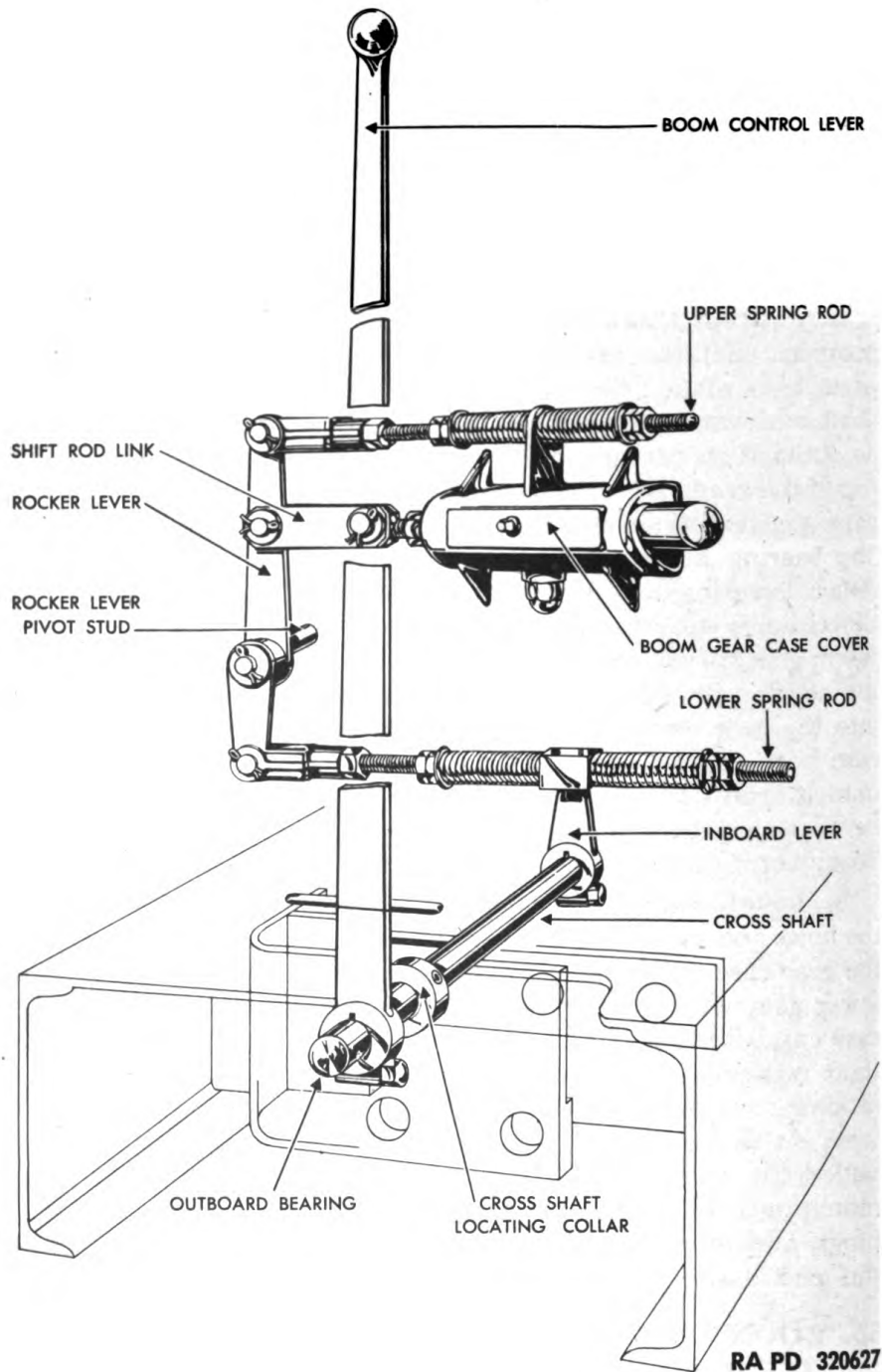

Figure 66 — Boom Gear Case Controls

CRANE

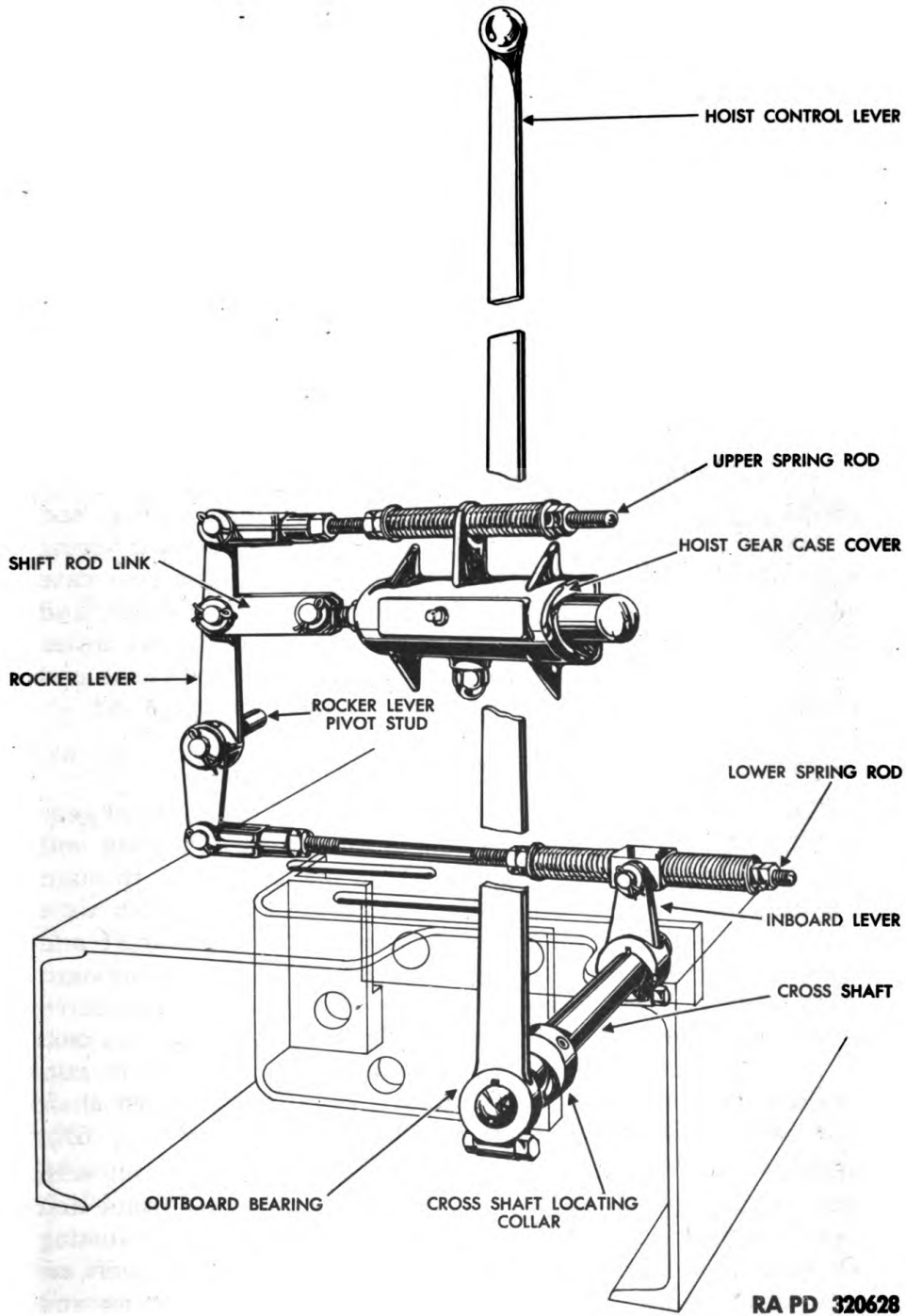

Figure 67 – Hoist Gear Case Controls

**ORDNANCE MAINTENANCE – CRANE FOR HEAVY WRECKING**  
**TRUCK M1A1 (WARD LA FRANCE AND KENWORTH)**

continue sliding through the A-frame base channel and beyond the outboard bracket. Install the cross shaft locating collar on the cross shaft. Enter the hand control lever in the opening of the crane operator's platform, and slide it onto the control cross shaft. Assemble the lower spring rod onto the inboard lever, and slide the lever onto the cross shaft with the end yoke of the spring rod extending to the front face of the crane A-frame. Aline keyway in cross shaft and lever, and drive the key into the shaft lever. Locate the lever so that the cross shaft and lever are flush, and tighten the cross shaft lever draw bolt nut (fig. 66).

**b. Install Hand Control Lever.** Aline the keyways in the hand control lever and cross shaft, and drive the key into position. Slide the cross shaft locating collar up against the crane base channel, and tighten the socket head set screw in the positioning collar, making sure that the hand control lever is centered in the operator's platform lever opening. Tighten hand control draw bolt.

**c. Install Upper Spring Rod.** Insert the upper spring rod through the front face of the crane A-frame with the forward spring and nut installed on the spring rod, and run it through the gear case shift cover trunnion. Install the spring rod rear spring, washer, and adjusting and lock nuts. Install the rocker lever pivot and cotter pins. Install the upper and lower spring rod and shift rod clevis and cotter pins. For adjustment of the spring rod see paragraph 82.

**57. HOIST GEAR CASE CONTROL INSTALLATION.**

**a. Install Cross Shaft and Inboard Lever.** Slide the hoist gear case cross shaft through the rear opening in the outboard bracket and through the inboard lever. Continue to slide the cross shaft through the crane base channel. Position the hand control lever flush with the end of the cross shaft, aline the keyways in the cross shaft and hand control lever, and drive the key into position. Drive the inboard lever over to the crane frame base channel. Aline the keyways, drive the key into position, and tighten the draw bolt. Leaving  $\frac{1}{32}$ -inch clearance between the hand control lever and cross shaft lever outboard bracket, slide the cross shaft locating collar on the cross shaft inside the base angle channel, and tighten the set screw (fig. 67).

**b. Install Upper Spring Rod.** Slide the upper spring rod with the forward spring in position through the front of the crane frame and shift cover trunnion. Install the rear spring, washer, and adjusting and lock nuts. Set the rocker arm in position, and with washers on either side of the arm, tap the pivot pin through the trunnion and install the cotter pin. Install the spring rod and shift rod link clevis and cotter pins. For adjustment of the spring rods see paragraph 82 **a.**

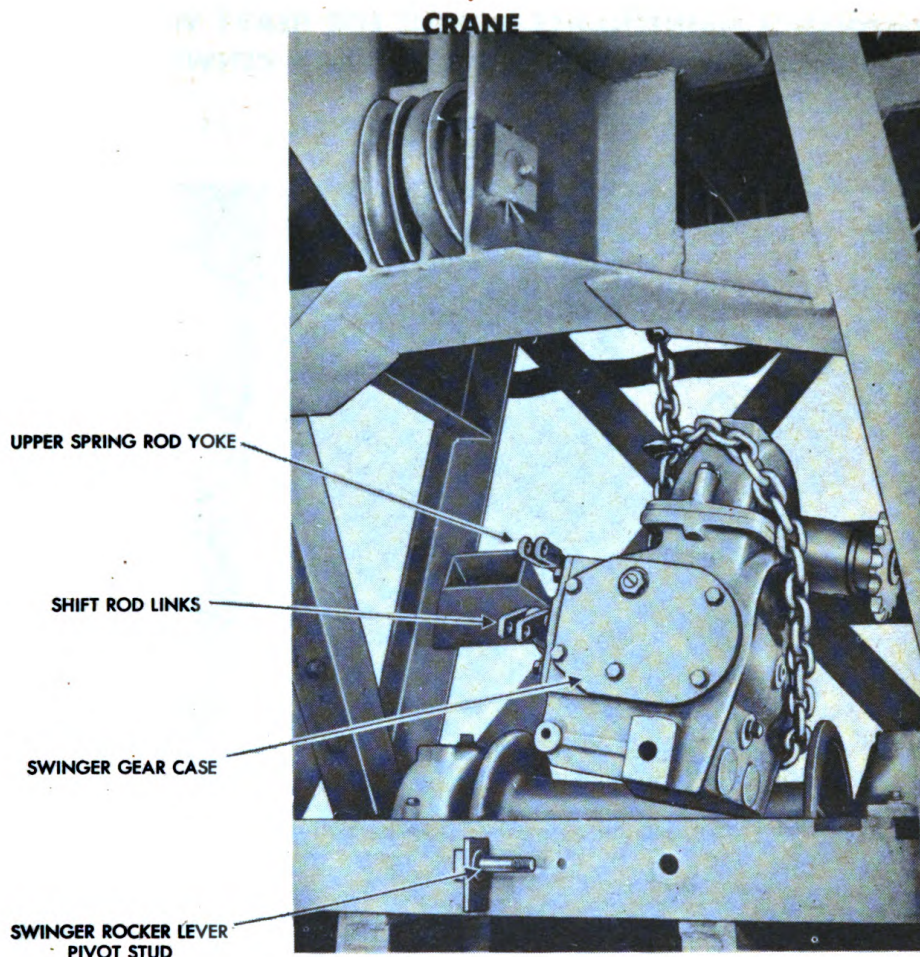

RA PD 320629

**Figure 68 – Installing Swinger Gear Case**

### 58. SWINGER GEAR CASE INSTALLATION.

**a. Install Main Drive Chain Eccentric Tightener.** The main drive chain eccentric tightener must be installed before the swinger base angle and gear case are installed. Position the eccentric chain tightener on the crane A-frame with the sprocket toward the front of the vehicle (fig. 11). Install four  $\frac{1}{2}$ -inch bolts through the frame and chain tightener, and install the lock washers and nuts on top. Adjustment of the chain tightener is made following the installation of the chain and crane.

**b. Install Base Angle.** Position the gear case base channels on the crane frame with the channel flanges pointing toward the center of the vehicle; install the four  $\frac{5}{8}$ -inch base channel bolts, nuts, and lock washers, but leave them loose. Set the base angles in position on the base channels with the eccentric chain tightener base to the right side of the vehicle; install the eight base angle attaching bolts,

**ORDNANCE MAINTENANCE — CRANE FOR HEAVY WRECKING  
TRUCK M1A1 (WARD LA FRANCE AND KENWORTH)**

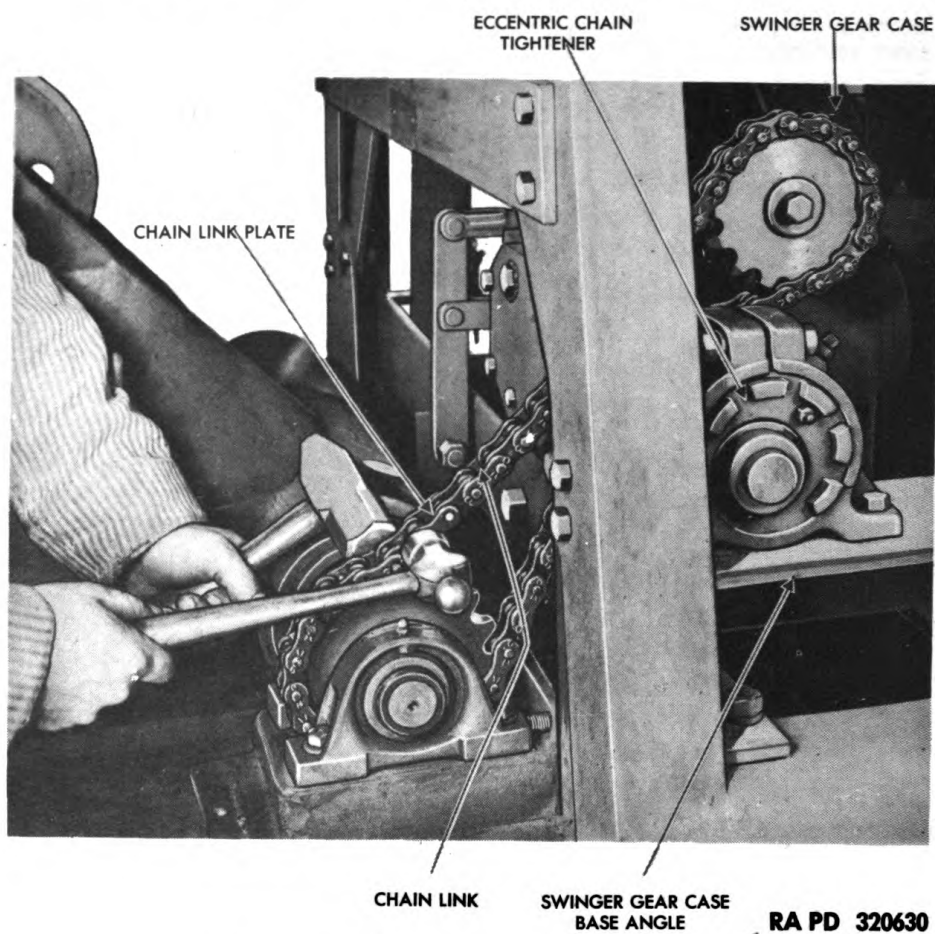
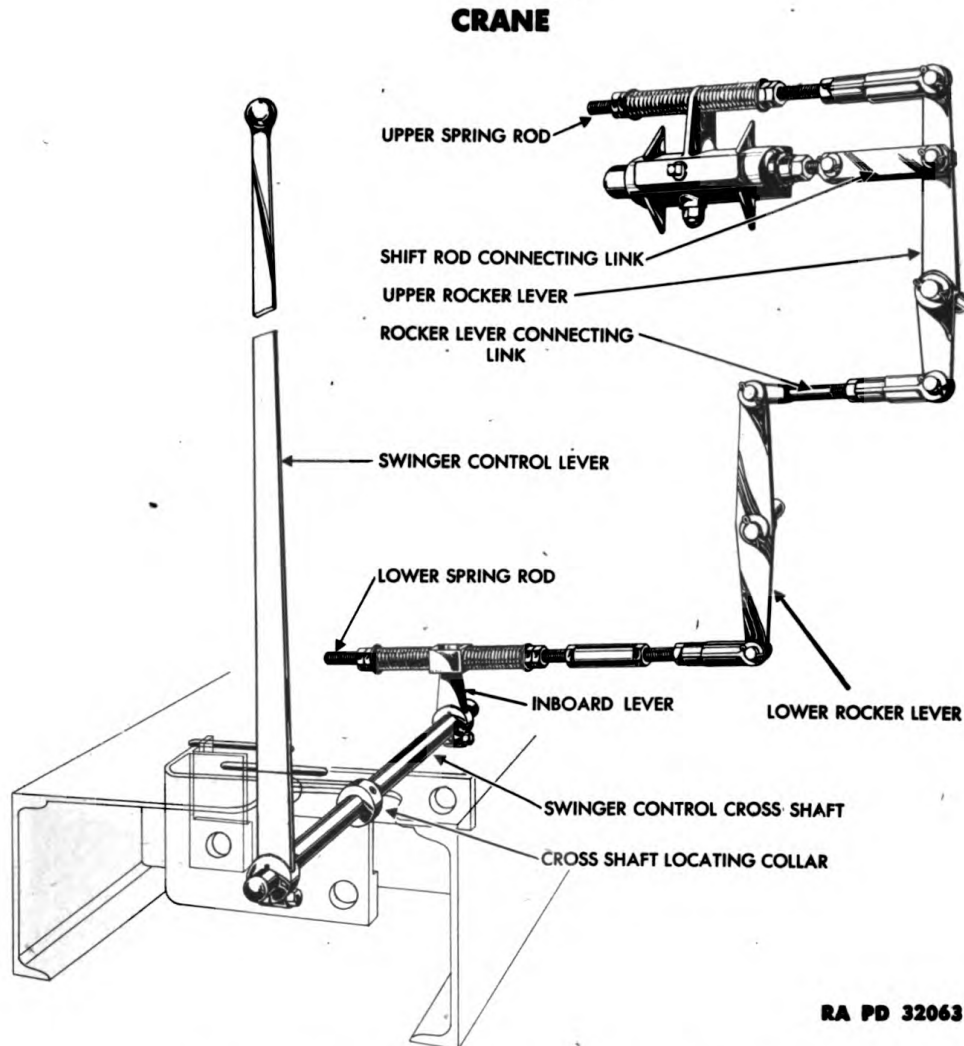

**Figure 69 — Breaking Drive Chain**

nuts, and lock washers. The alining shims were wired to the crane frame when the base was removed, and must be under the base angles at the corners of the A-frame in the quantity and thickness originally installed (fig. 13). Tighten all base channel and angle bolts.

**c. Install Swinger Drive Chain Eccentric Tightener.** Position the eccentric chain tightener on the base angle mounting plate and install four ½-inch bolts, nuts, and lock washers attaching the chain tightener to its base plate.

**d. Install Swinger Lower Rocker Arm and Spring Rod.** Place flat washers on either side of the lower rocker arm, slide it on the pivot pin, and install the cotter pin (fig. 71). Slide the lower spring rod assembly through the crane A-frame, and install the clevis yoke pin and cotter pin attaching the spring rod to the lower end of the lower rocker lever.



**Figure 70 – Swinger Gear Case Controls**

**e. Install Gear Case.** With a chain hoist and bridal chain run through the center opening of the crane A-frame. Lift the gear case into position on its mounting base angles with the pivot drive sprocket pointed toward the right of the vehicle (fig. 68). Install two gear case pivot studs and two mounting bolts attaching the gear case to the gear case base angles. Install pivot and mounting bolt lock washers and nuts.

### **59. SWINGER GEAR CASE CONTROL INSTALLATION.**

**a. Install Upper Rocker Lever.** Position the upper rocker lever on its pivot stud and install the clevis and cotter pins attaching the upper spring rod shift rod links and upper and lower rocker arm connecting link. Install pivot bolt and self-locking nut, and run the nut up until  $\frac{1}{32}$ -inch clearance is obtained on either side of upper rocker arm (fig. 71).

**ORDNANCE MAINTENANCE – CRANE FOR HEAVY WRECKING  
TRUCK M1A1 (WARD LA FRANCE AND KENWORTH)**

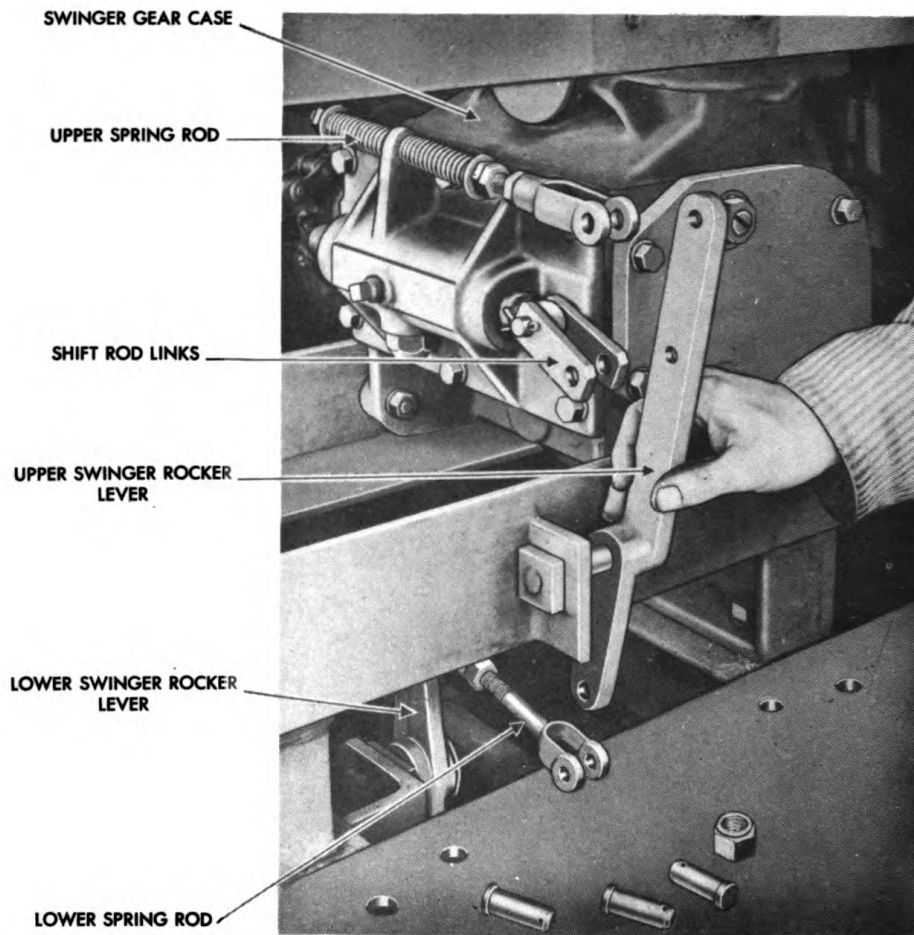

RA PD 320632

**Figure 71 – Installing Swinger Upper Rocker Lever**

**b. Install Cross Shaft and Levers.** Slide cross shaft through shift lever outboard bracket and through crane frame base channel, and install the positioning collar on the cross shaft. Continue to slide the cross shaft into the crane frame and into the inboard lever, and slide the cross shaft through until it clears the hand control lever bracket; then install the hand control lever on the cross shaft. Align the keyways in the cross shaft and hand control lever, and drive the key into position. With the hand control lever centered in the operating lever slot and the cross shaft flush with the outboard bracket, slide the locating collar up against the crane base angle and tighten the socket head set screw. Align the keyways in the inboard lever and cross shaft, and drive the key into position. Tighten the draw bolts on the inboard lever and hand control lever (fig. 70).

CRANE

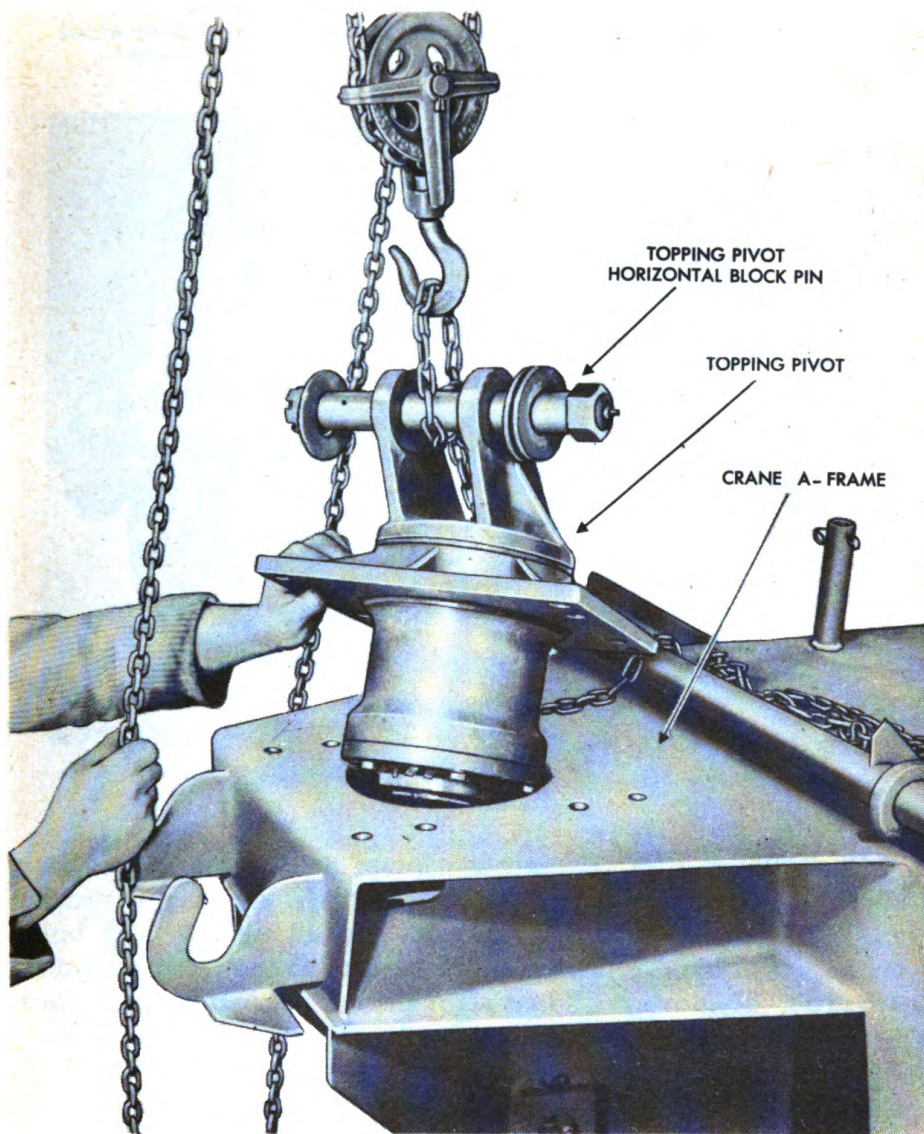

RA PD 320633

**Figure 72 – Installing Topping Pivot**

**60. BOOM PIVOT INSTALLATION.**

**a. Install Swinger Drive.** Set the swinger drive base in position on the boom pivot mounting base, and drive in the two dowels. Position the boom swinger coupling shaft and bearing assemblies on its mounting bracket, install flat washers under the head of the four mounting bolts, and install the bolts, lock washers, and nuts; tighten securely. Shims were wired at disassembly to the boom drive mounting base, and must be between the bearing assemblies and the base (fig. 10).



TM 9-1796  
60-62

**ORDNANCE MAINTENANCE — CRANE FOR HEAVY WRECKING  
TRUCK M1A1 (WARD LA FRANCE AND KENWORTH)**

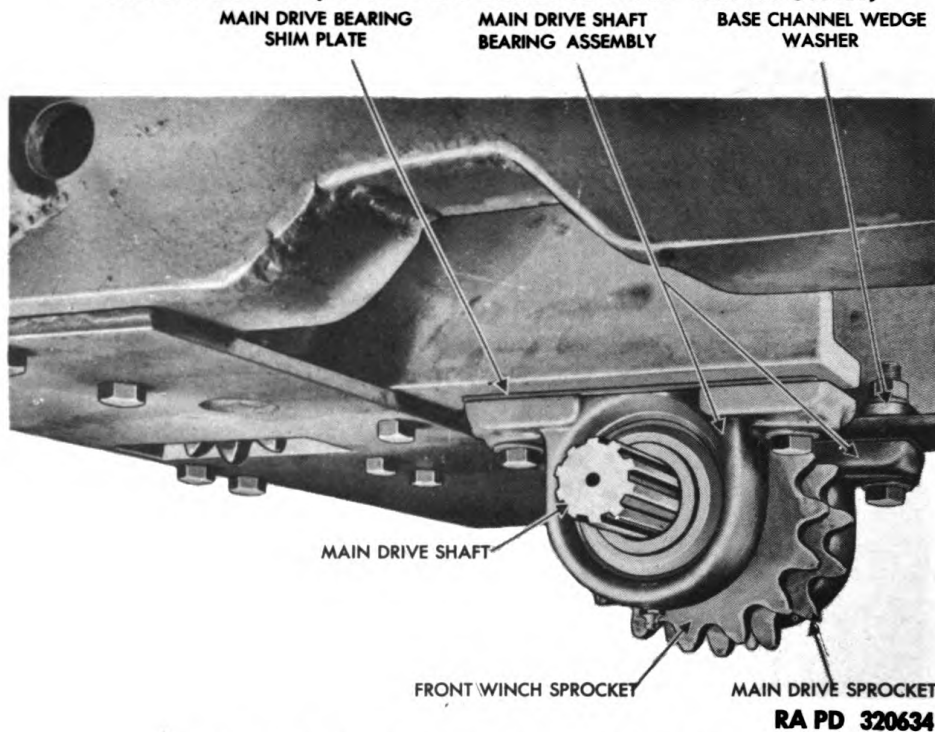

**Figure 73 — Main Drive Shaft Installed**

**b. Install Pivot.** Hoist the boom pivot onto its mounting base, and slide the pivot to the right of the vehicle entering the drive coupling onto the swinger coupling shaft. Install eight  $\frac{3}{4}$ -inch bolts, lock washers, and nuts securing the boom pivot to the pivot mounting base (fig. 10). Remove the boom pivot sheave pin, install the sheave, and replace the sheave pin and cotter pin. The boom pivot sheave is the only sheave on the crane that is equipped with a needle bearing. All other sheaves have bronze bushings.

**61. CRANE A-FRAME BRACE INSTALLATION.**

**a. Install Diagonal A-frame Braces.** Position the diagonal braces inside the A-frame corner angles and on back of guide sheave support angle. Install twelve  $\frac{1}{2}$ -inch bolts, lock washers, and nuts.

**b. Install Horizontal Brace.** Set the horizontal brace on the rear face of the A-frame corner angles with the swinger cut-out mounting holes to the lower side of the cross brace. Install four  $\frac{1}{2}$ -inch bolts, lock washers, and nuts.

**62. SWINGER CUT-OUT BRACKET INSTALLATION.**

**a.** Position the cut-out bracket on the A-frame horizontal brace and install two  $\frac{3}{8}$ -inch bolts, nuts, and lock washers.

CRANE

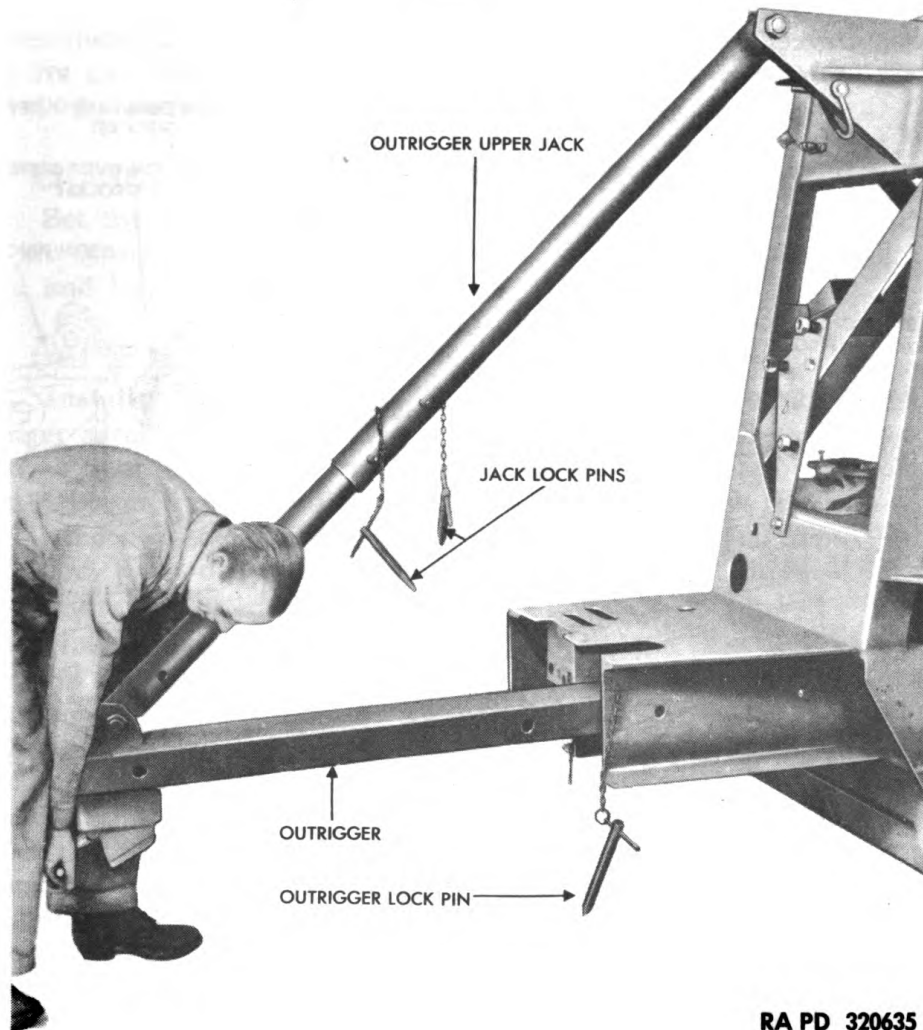

RA PD 320635

**Figure 74 – Installing Outrigger and Upper Jack**

**63. TOPPING PIVOT INSTALLATION.**

a. Using a chain hoist raise the topping pivot into position, install eight  $\frac{3}{4}$ -inch bolts through openings in side of crane frame, and install lock washers and nuts (fig. 72). Lubricate topping pivot through lubrication fitting. Set the topping cable horizontal sheave block in position; place two washers under the head of the block bolt; run the bolt through the block, topping pivot, and topping pivot vertical sheaves. Install one washer on the bolt, and install the castellated nut and cotter pin (fig. 8). Position the horizontal sheaves in the sheave block, and install the sheave and cotter pins.

**64. MAIN DRIVE SHAFT INSTALLATION.**

a. Set the main drive shaft in position on its mounting angles with two shim plates between the bearing assemblies and mounting angles.

**TM 9-1796**  
**64-65**

**ORDNANCE MAINTENANCE – CRANE FOR HEAVY WRECKING**  
**TRUCK M1A1 (WARD LA FRANCE AND KENWORTH)**

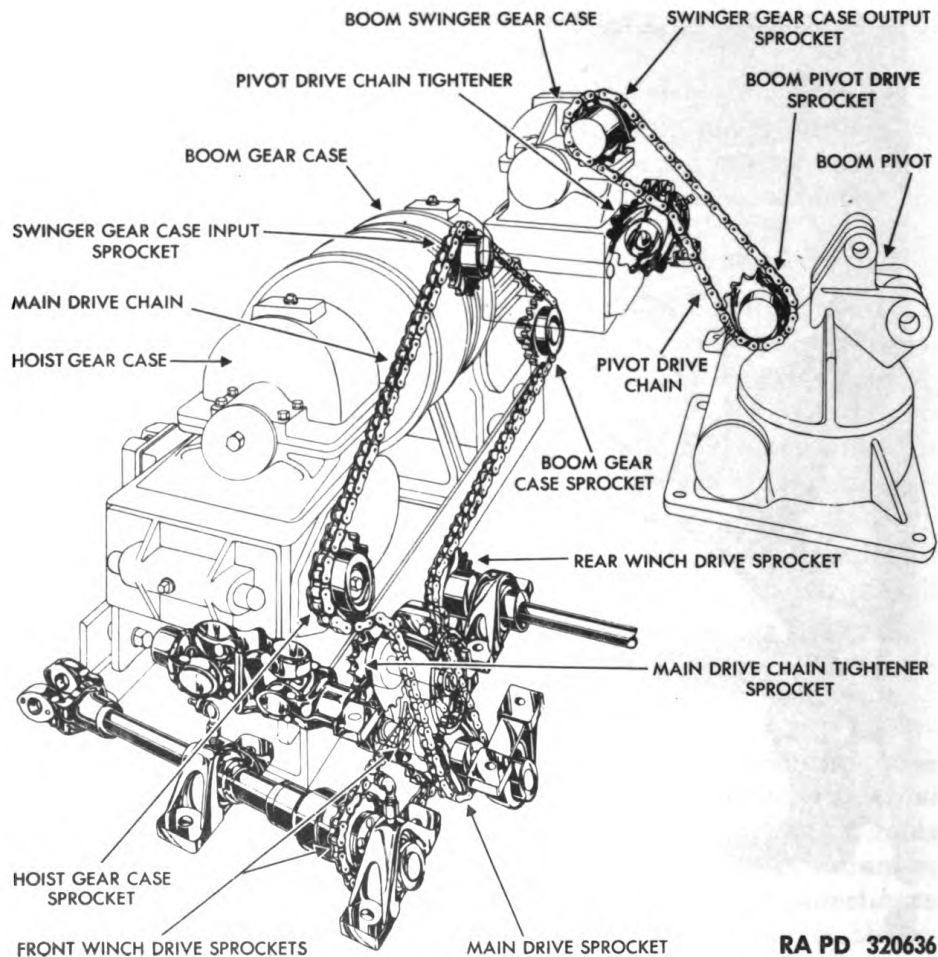

**Figure 75 – Main Drive Chain**

Install the four  $\frac{7}{16}$ -inch bolts through the bearing and mounting angles. Place wedge washers on each bolt on the rear mounting angle to compensate for the channel angle, and install the lock washers and nuts (fig. 73).

**65. OUTRIGGER INSTALLATION.**

a. Place the outrigger in its slide pocket in the crane A-frame, and slide the outrigger 2 feet into its pocket. Place the outrigger upper jack inner casing in the outrigger lugs; install the outrigger bolt, nut, and lock washer. Slide the outrigger upper jack outer tube onto

## CRANE

the lower tube, and swing the outrigger upper jack onto the crane frame; install the jack bolt, nut, and lock washer. Slide the outrigger into its carrying position, and install the lock pin and cotter pin. Install the outrigger upper jack tube pins (fig. 74).

### 66. CRANE CLUTCH CONTROL VALVE INSTALLATION.

a. Set the crane clutch control valve on the crane A-frame with the air connection fitting pointing down. Install two  $\frac{5}{16}$ -inch bolts, nuts, and lock washers.

### 67. DRIVE CHAIN INSTALLATION.

a. **Install Swinger Drive Chain.** Thread the chain under boom swinger sprocket over eccentric chain tightener, and under and over swinger gear case drive sprocket. The eccentric chain tightener should be in its released position. Join ends of drive chain, and install the connecting link side plate and cotter pins (fig. 69). Set the boom pivot drive chain guard in position; install three  $\frac{3}{8}$ -inch bolts, nuts, and lock washers.

b. **Install Main Drive Chain.** Lay the chain out and pick a point on the chain that divides it two-thirds and one-third. Keeping this point, set the chain on the swinger gear case input shaft sprocket with the one-third end to the left of the crane. Run this end around the hoist gear case sprocket and over the rear winch lay shaft sprocket, and then down and around the main drive sprocket. Taking the opposite end of the chain at the swinger gear case sprocket, run it around the boom gear case sprocket, then left and over the chain tightener sprocket, and then through the crane frame base and around the main drive shaft sprocket. Join the ends of the chain, and install the link plate and cotter pins (fig. 75).

---

## Section XIII

## INSTALLATION

### 68. CRANE INSTALLATION.

a. **Lift Crane Into Position.** Using lifting eye 41-E-610 through the topping pivot opening, raise the crane assembly with the rear winch installed directly above the chassis, and then center the chassis under the crane assembly (fig. 7). The crane throttle control cable must be laid over the fuel tank, and the rear winch throttle control nested in position inside the frame rail. The air tanks were removed when the crane was removed. Lower the crane assembly onto the vehicle.

**TM 9-1796**  
**68-73**

**ORDNANCE MAINTENANCE – CRANE FOR HEAVY WRECKING**  
**TRUCK M1A1 (WARD LA FRANCE AND KENWORTH)**

b. **Secure Crane to Vehicle.** Install sixteen  $\frac{5}{8}$ -inch and four  $\frac{3}{4}$ -inch bolts, nuts, and lock washers securing the crane to the vehicle frame. Locate lower outrigger jack hangers, and install the hangers under the heads of the crane attaching bolts.

**69. BODY INSTALLATION.**

a. **Lift Body Into Position.** The center of gravity of the body is  $38\frac{1}{2}$  inches ahead of the rear face of the body base. Using a bridle chain and chain hoist, hoist the body over the vehicle. Tilt the front end of the body down in order to clear the boom pivot and permit the rear winch cable roller brackets to enter the opening formed by the rear bumperettes (fig. 5).

b. **Secure Body.** Install four  $\frac{5}{8}$ -inch bolts, nuts, and lock washers attaching the body to the crane frame.

**70. AIR TANK INSTALLATION.**

a. Refer to TM 9-796 for air tank installation.

**71. SWINGER CUT-OUT INSTALLATION.**

a. **Install Swinger Cut-out Valve Assembly.** Position the swinger cut-out valve assembly on side of the crane A-frame, and install two  $\frac{3}{8}$ -inch nuts and lock washers.

b. **Install Swinger Cut-out Air Line.** Connect the air line to the upper connection on the swinger cut-out valve and the rear connection on the clutch control valve. Install the air line between the lower connection on the swinger cut-out valve and the tee in the air supply line.

**72. CRANE CONTROL INSTALLATION.**

a. **Install Control Valve.** Position the clutch control valve on the crane A-frame, and install two  $\frac{5}{16}$ -inch bolts, nuts, and lock washers.

b. **Install Air Lines.** The rear air line on the control valve is connected to the upper connection on the swinger cut-out valve. The front air line connects the clutch control valve with the double check valve between the control valve and clutch cylinder.

**73. FRONT WINCH DRIVE AND CONTROL INSTALLATION.**

a. **Install Front Winch Drive Shaft.** When the crane assembly was removed the front winch drive shaft universal joint was disconnected and slid to the front. Slide the universal joint assembly to the rear of the vehicle, and position it on the front winch jaw clutch shaft. Tighten the socket head set screw in the front winch drive shaft end yoke (fig. 6).

b. **Install Front Winch Jaw Clutch Control.** Enter the rear of the jaw clutch control rod through the opening in the crane frame

## CRANE

base angle and through the front winch jaw clutch yoke. Install clevis and cotter pins connecting the rod to the control. Install a  $\frac{3}{8}$ -inch nut on the rear of the front winch clutch shaft yoke and tighten.

### 74. BOOM INSTALLATION.

a. Using a chain hoist with an 84-inch bridle chain, hook onto the cross bars in the topping link and boom proper. Position the chain hoist hook 34 inches from the topping link connection, and raise the boom into position. The location of the chain hoist hook will balance the boom for safe and easy installation (fig. 4). Install the  $1\frac{1}{2}$ -inch pivot bolt, castellated nut, and cotter pin. The hinge pin bushings must be installed in the side members with their flanges out (fig. 19).

### 75. REAR WINCH CONTROL INSTALLATION.

a. Refer to TM 9-796 for installation of the rear winch controls.

### 76. MAIN DRIVE SHAFT DOUBLE JOINT INSTALLATION.

a. Install power take-off shaft end yoke, nut, and cotter pin (fig. 6). Slide the double joint assembly toward the rear of the vehicle onto the main drive shaft spline. Tilt the center cross into the end yoke boss; tip the center cross into position; install the center cross bushings, lock plates, and cap screws.

### 77. CABLE INSTALLATION.

#### a. Install Boom Cable.

(1) Place the topping link horizontal block with line dead-end eye on top in position, and insert pin and cotter pin. Taking free end of line and entering right side of the upper horizontal sheave on topping pivot, thread through sheave and pull all the cable through. Continue with the free end to the left side of the horizontal boom block, thread through sheave and pull cable tight. Enter cable in right side of the lower horizontal topping pivot block, thread through sheave, and pull cable tight (fig. 76).

(2) Enter lower side of the left vertical block on boom, thread through sheave, and pull cable tight. Continue over top of the left vertical block at topping pivot, thread through sheave, and pull cable tight. Enter lower side of the right sheave in vertical block on boom, thread through sheave, and pull cable tight (fig. 77).

(3) Thread cable over top of the right vertical block, down through opening in topping pivot, under the right crane frame guide sheave, over top of the right fleeting sheave, directly above boom topping drum. Clamp end of line under the cable clamp on drum, and engage the boom winch to "BOOM UP," holding cable tight on drum until boom lifts. The cable is underwound on the drum (fig. 78).

ORDNANCE MAINTENANCE – CRANE FOR HEAVY WRECKING  
TRUCK M1A1 (WARD LA FRANCE AND KENWORTH)

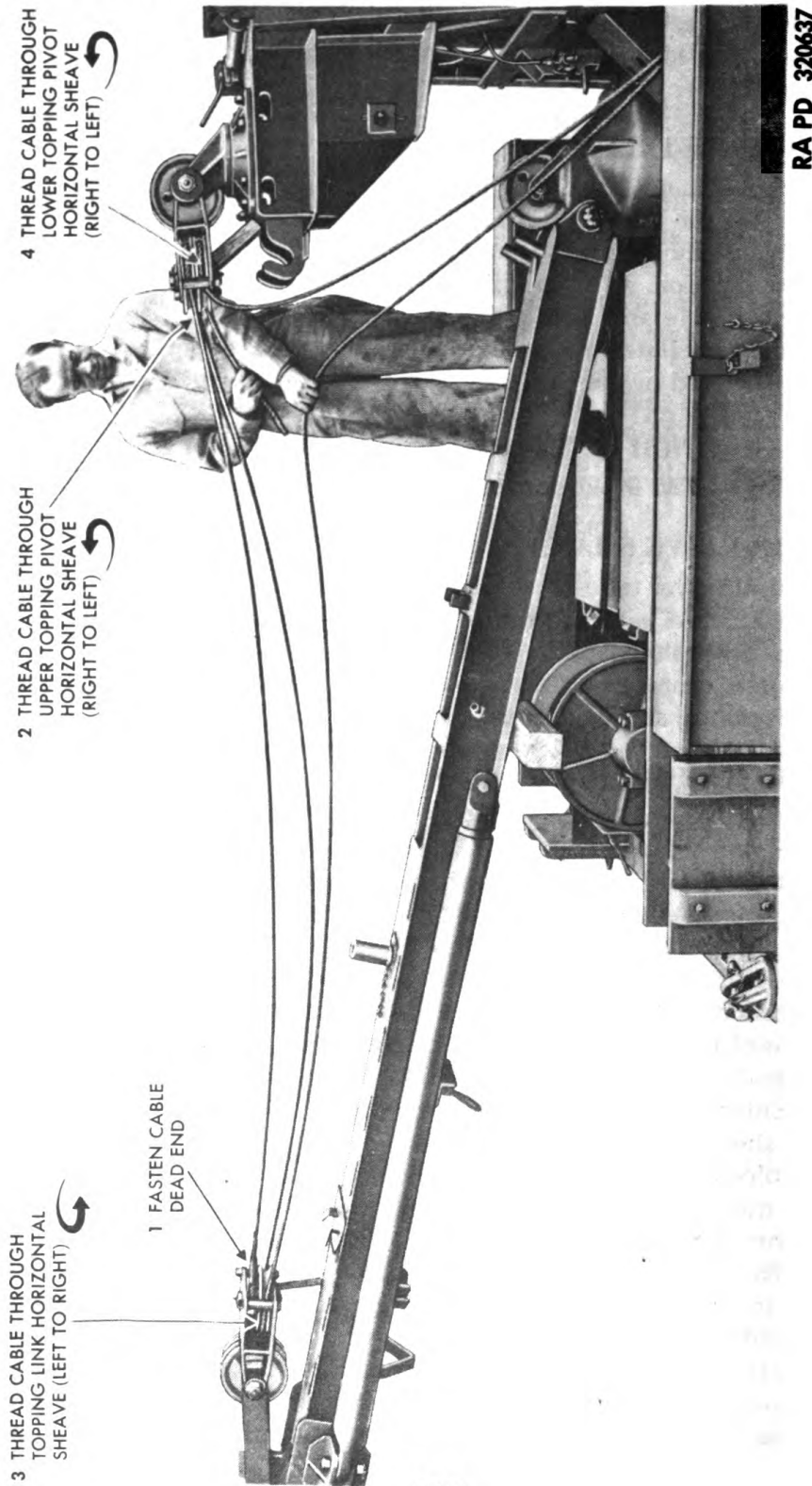
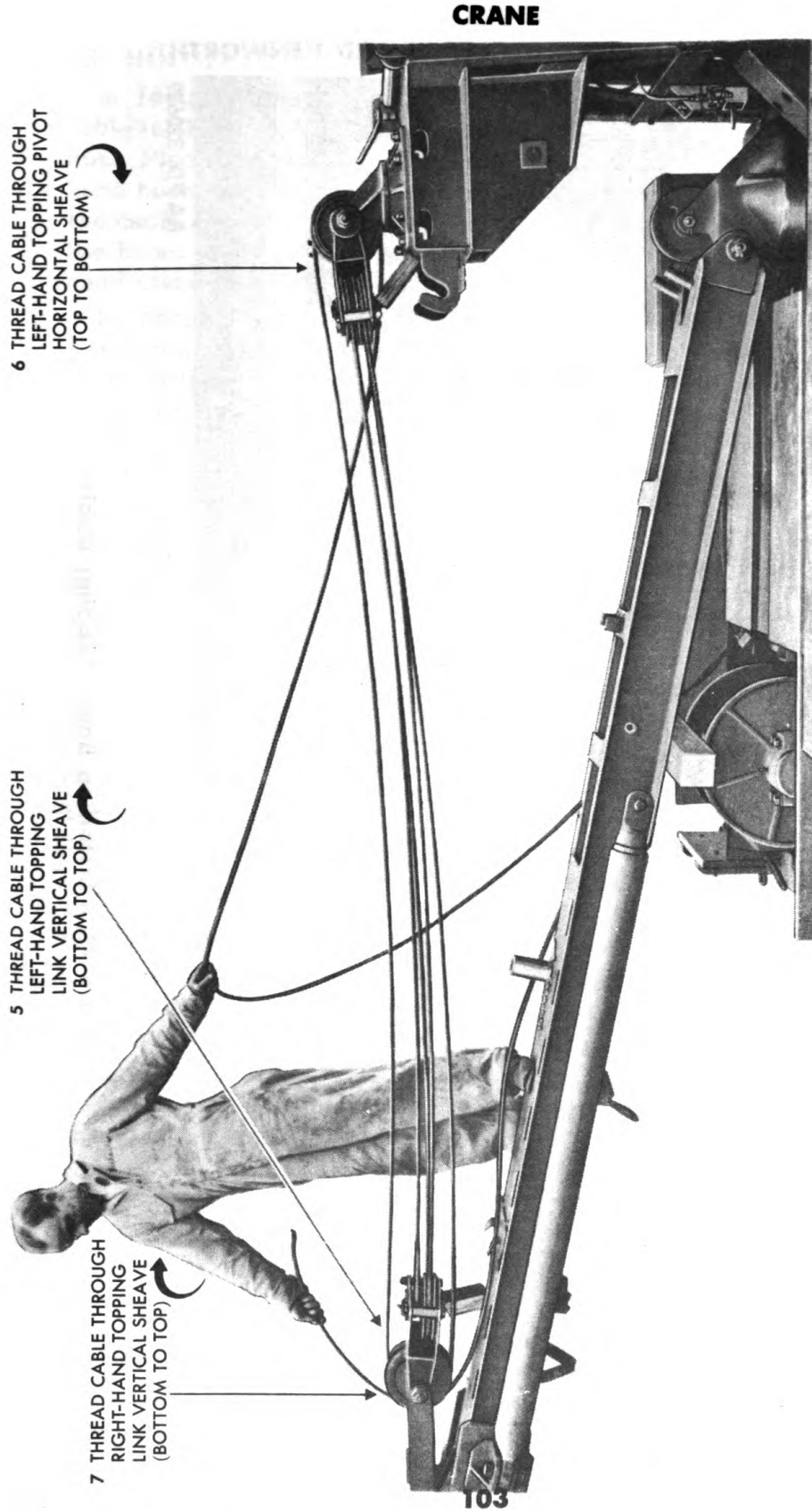

Figure 76 – Installing Boom Topping Cable



RA PD 320638

Figure 77 — Installing Boom Topping Cable



TM 9-1796  
77

ORDNANCE MAINTENANCE — CRANE FOR HEAVY WRECKING  
TRUCK M1A1 (WARD LA FRANCE AND KENWORTH)

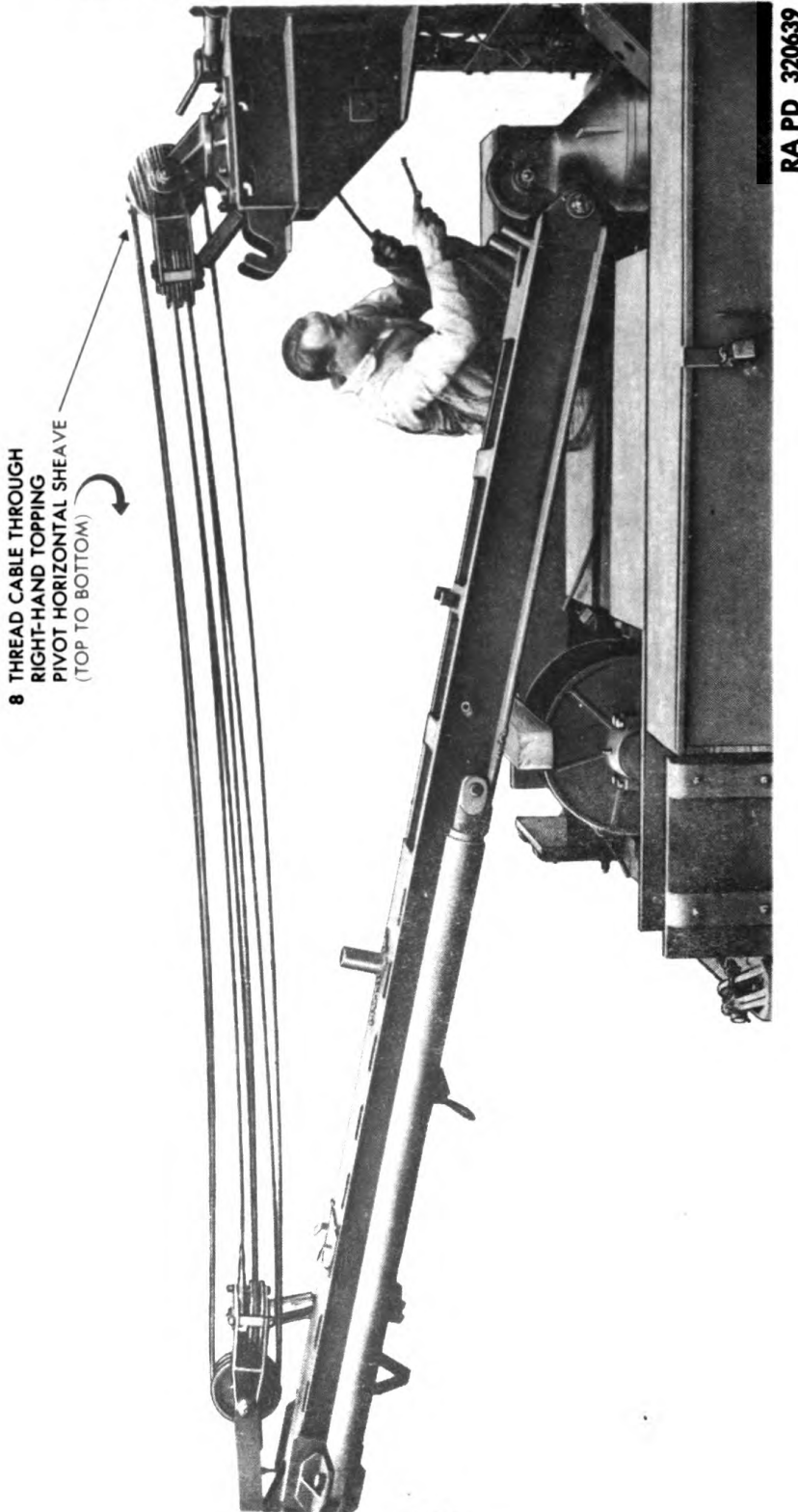

Figure 78 — Installing Boom Topping Cable

## CRANE

### 78. BOOM CABLE LOAD LINE INSTALLATION.

a. **Install Cable in Block and Boom.** Install dead-end eye of the cable in the hoist line block and install cap screws, lock washer, and nut. Place the free end of cable over and around rear of the right-hand boom end sheave, and through the hook line block. Then place the cable over the left-hand boom end sheave, and thread it through the boom and under the boom pivot sheave. Thread over the left-hand crane frame guide sheave and over the fleeting sheave.

b. **Secure and Wind Cable on Drum.** The hoist line is underwound on the hoist winch drum. Install end of cable under hoist winch drum U-bolt, and tighten U-bolt securely. Start the engine. Place the transmission in first speed and engage the power take-off; holding tension on the hoist line, slowly and carefully wind the cable on the hoist drum.

### 79. EQUIPMENT INSTALLATION.

a. **Install Anchor Stake and Ground Anchor.** Locate the ground anchors on the pins welded to the top of the crane frame, and set the 14 ground anchor stakes in the brackets on either side of the crane frame.

b. **Install Snatch Block.** Stow two single snatch blocks on the hooks provided at the rear of the crane frame.

c. **Install Tow Cable.** Position the tow cable over the welded clips on the boom, and hook the tow cable eyes over the welded pins. Set the tow bar in the opening formed between tow cable and welded pins provided on the top of the boom.

d. **Install Accessory Equipment.** The installation procedures for the searchlight, lower outrigger jacks, taillights, body jacks, and directional pulley beams are covered in TM 9-796.

e. **Install Oxygen and Acetylene Tanks.** Using a chain hoist, position the tanks on the forward end of the crane frame. Position the bracket and install bracket nuts.

f. **Install Spare Tires.** Hoist the tires in position on either side of the crane frame, and install the three wheel nuts attaching the spare tire to either side of the crane.

---

## Section XIV

### TEST AND ADJUSTMENT

#### 80. SPROCKET ALINEMENT.

a. **Boom Swinger Sprocket Alinement.** Loosen the set screws and set screw nuts on the front side of the boom pivot mounting base

**ORDNANCE MAINTENANCE – CRANE FOR HEAVY WRECKING  
TRUCK M1A1 (WARD LA FRANCE AND KENWORTH)**

(fig. 10) and by adjustment of the set screws, with the mounting bolts loose, aline the sprockets. Tighten the mounting bolts and set screw check nuts.

**b. Main Drive Sprocket Alinement.** Loosen the socket head set screws in the bearing and chain tightener lock collar. Turn the lock collars to the right or left until they are loose on the shaft, and tap the shaft fore and aft until the sprockets on the main drive shaft are in alinement with the gear case sprockets. Position the chain tightener lock collars on the bearing inner races, turn until they lock the shaft and bearing, and tighten the socket head set screws in the lock collars.

**81. DRIVE CHAIN ADJUSTMENT.**

**a. General.** The drive chains should be inspected once a month for lubrication and adjustment if necessary. If the chains are too tight the chains and sprockets will wear excessively. If the chains are too loose they will jump the sprockets. If the proper amount of slack cannot be taken out of the chain by adjustment, first examine the chain to see if there is an offset or half-link in the chain; if so, remove the half-link and adjust the chain by means of the eccentric tightener. If there is no half-link, remove a whole link.

**b. Swinger Drive Chain Adjustment.** Adjustment of the swinger drive chain is made at the eccentric chain tightener mounted between the swinger gear case and boom swinger drive. Loosen the chain tightener housing draw bolts and set screws, and turn the eccentric within the housing until  $\frac{1}{4}$ -inch to  $\frac{1}{2}$ -inch deflection is obtained at the center of the chain between the gear case and boom swinger sprockets. Hold the eccentric in this position and tighten the housing draw bolts securely. Tighten the eccentric set screws and set screw check nuts (fig. 69).

**c. Main Drive Chain Adjustment.** The adjustment of the main drive chain is made by an eccentric chain tightener located directly under the swinger gear case. Loosen the chain tightener housing draw bolts and set screws, and turn the eccentric within the housing until  $\frac{1}{4}$ -inch to  $\frac{1}{2}$ -inch deflection is obtained at the center of the chain between the swinger gear case and the hoist gear case sprocket. Hold the eccentric in this position, and tighten the housing draw bolts securely. Tighten the eccentric set screws and set screw check nuts.

**d. Front Winch Single Clutch Chain Adjustment.**

(1) **GENERAL.** The front winch sprocket chain and the main drive chain adjustments are interrelated. It is necessary to adjust the front winch sprocket chain first, and then adjust or readjust the main drive chain. The main drive chain eccentric chain tightener must be in

## CRANE

its fully released position before attempting to adjust the front winch clutch sprocket chain.

(2) **ADJUSTMENT.** Loosen the four  $\frac{1}{2}$ -inch bolts securing the main drive shaft to the crane frame base angles, and slide the main drive assembly to the right or left in the elongated holes in the base channels until  $\frac{1}{4}$ -inch to  $\frac{1}{2}$ -inch deflection is obtained in the center of the chain between the front winch and main drive sprockets. Tighten the main drive shaft attaching bolts. Readjust the main drive chain as outlined in subparagraph c above.

### 82. CONTROL SPRING ROD ADJUSTMENT.

a. **Upper Spring Rod Adjustment.** Loosen spring rod lock nut and position hand control lever for full engagement of the sliding clutch in either the forward or reverse positions. Examine the position of the shift rod to make certain that the sliding clutch is fully engaged, hold it in this position, and run up the adjusting nuts until there is  $\frac{1}{16}$ -inch clearance remaining in the spring before it is completely compressed. Perform the same procedure with the gear case in the opposite direction, and adjust the spring to the same clearance as described above. Secure the adjusting nut lock nut.

b. **Lower Spring Rod Adjustment.** Loosen spring rod adjusting nut and lock nut, and adjust the spring rod sleeve nut until the hand control lever is centered in its operating slot. Move the lever in one direction as far as it will go, and adjust the spring rod adjusting nuts until the spring is within  $\frac{1}{16}$  inch of being collapsed. Tighten the spring rod adjusting nut lock nuts.

### 83. HOIST AND BOOM CASE BRAKE ADJUSTMENT AND TEST.

a. **Test.** Place a maximum load of 16,000 pounds on the hoist line, and lift it free of the ground. Position the gear cases in neutral and ascertain whether the load is held in this position. If it is held, the brake may be too tight, or properly adjusted. If it lowers the hoist line or boom line by its own weight, the brake assembly is too loose and must be tightened.

b. **Adjustment.** As indicated, tighten or loosen the adjusting nut on the brake band by half turns until the tightness of the brake will just suspend the load. To be sure that the brake is not too tight, slack off the brake adjustment by half turns, and when the load on the boom starts to slip, tighten the adjusting nut until the desired condition is obtained. The boom and hoist brake adjustment are performed in the same manner, but independently of each other. When proper adjustment is obtained, tighten the adjusting nut lock nut.

**TM 9-1796  
84-86**

**ORDNANCE MAINTENANCE — CRANE FOR HEAVY WRECKING  
TRUCK M1A1 (WARD LA FRANCE AND KENWORTH)**

**84. SWINGER CUT-OUT VALVE TEST AND ADJUSTMENT.**

a. **Test.** Swing the boom to the right or left to its full arc. When it approaches 90 degrees, be alert in case the cut-out valve is out of adjustment, as the boom will continue to swing, and damage the crane frame; therefore, the lever must be turned to "NEUTRAL" immediately. If the cut-out valve releases the clutch before the boom has swung 90 degrees, the linkage and valve will have to be adjusted.

b. **Adjustment.** The only adjustment of the swinger cut-out assembly is the alinement of the linkage roller. Loosen the roller eye stud, and position the roller to contact the cam on the cut-out shaft and the valve stem. Tighten the eye stud nut in position. Failure to open the valve will indicate worn shaft bearings, roller or valve stem. These items will have to be replaced if indicated.

**85. SWINGER CUT-OUT CLUTCH VALVE TEST AND ADJUSTMENT.**

a. **Test.** Swing the boom until the swinger cut-out valve comes into operation and releases the engine clutch. Move the swinger control hand lever to swing the boom in the opposite direction, and open the clutch control valve to ascertain whether the clutch will engage.

b. **Adjustment.** If the boom fails to swing in the opposite direction, first inspect the clutch control valve and double check valve for proper operation and line installation. If the clutch cylinder appears to operate properly but does not engage the clutch, readjust the clutch air cylinder linkage as outlined in TM 9-796.

**86. CRANE TEST AND ADJUSTMENT.**

a. Inspect the crane air lines for air leaks, lubricate the chains, and check the grease level in the gear cases and boom pivot. Lubricate all sheave bushings, control linkage, eccentric chain tighteners, main drive shaft, boom swinger drive, topping pivot, and front winch jaw clutch.

CHAPTER 3  
SPECIAL TOOLS

87. SPECIAL TOOLS.

a. The tool list below is for information only and must not be used as a basis for requisition.

| <b>Tool</b>  | <b>Federal Stock Number</b> | <b>Manufacturer's<br/>Tool Number</b> |
|--|-----------------------------|---------------------------------------|
| Eye, lifting, boom assembly  | 41-W-610                    | MAS 8-2003                            |
| Wrench, box, single-end, hex,<br>straight, carbon steel, 3 1/4-in.<br>opening, 22 3/8 in. long       | 41-W-639                    | MAS 8-2002                            |
| Wrench, spanner, hook boom pivot<br>nut  | 41-W-3249                   | MAS 8-2001                            |
| Wrench, spanner, hook, solid,<br>4 1/16-in. circle diam, 13 1/2 in.<br>long (topping pivot lock nut) | 41-W-3250                   | MAS 8-2004                            |

**ORDNANCE MAINTENANCE — CRANE FOR HEAVY WRECKING TRUCK M1A1 (WARD LA FRANCE AND KENWORTH)**

**REFERENCES**

**PUBLICATIONS INDEXES.**

The following publications indexes should be consulted frequently for latest changes or revisions of references given in this section and for new publications relating to materiel covered in this manual:

- a. Introduction to Ordnance Catalog (explaining SNL system) . . . . . ASF Cat. ORD 1 IOC
- b. Ordnance Publication for Supply Index (index to SNL's) . . . . . ASF Cat. ORD 2 OPSI
- c. Index to Ordnance Publications (listing FM's, TM's, TC's, and TB's of interest to ordnance personnel, OPSR, MWO's, BSD, S of SR's, OSSC's, and OFSB's; and includes Alphabetical List of Major Items with Publications Pertaining Thereto) . . . . . OFSB 1-1
- d. List of Publications for Training (listing MR's, MTP's, T/BA's, T/A's, FM's, TM's, and TR's concerning training) . . . . . FM 21-6
- e. List of Training Films, Film Strips and Film Bulletins (listing TF's, FS's, and FB's by serial number and subject) . . . . . FM 21-7
- f. Military Training Aids (listing Graphic Training Aids, Models, Devices, and Displays) . . . . . FM 21-8

**STANDARD NOMENCLATURE LISTS.**

- Cleaning, preserving and lubrication materials, recoil fluids, special oils, and miscellaneous related items . . . . . SNL K-1
- General tools, and supplies, ordnance base automotive maintenance company engine rebuild Ordnance maintenance sets . . . . . SNL N-327  
SNL N-21
- Soldering, brazing and welding materials, gases and related items . . . . . SNL K-2
- Tools, maintenance for repair of automotive vehicles . . . . . SNL G-27
- Tool-sets, for ordnance service command automotive shops . . . . . SNL N-30
- Tool-sets, Motor transport . . . . . SNL N-19
- Truck, wrecking, heavy, M1 . . . . . SNL G-116

**EXPLANATORY PUBLICATIONS.**

**Fundamental Principles.**

- Automotive electricity . . . . . TM 10-580
- Basic maintenance manual . . . . . TM 38-250
- Electrical fundamentals . . . . . TM 1-455

REFERENCES

|  |            |
|--|------------|
| Lubrication of ordnance materiel .....   | TM 9-2835  |
| Military motor vehicles .....  | AR 850-15  |
| Motor vehicle inspections and preventive maintenance service .....   | TM 9-2810  |
| Precautions in handling gasoline .....   | AR 850-20  |
| Standard military motor vehicles .....   | TM 9-2800  |
| The internal combustion engine .....   | TM 10-570  |
| The machinist .....  | TM 10-445  |
| <b>Operation of Materiel.</b>  |            |
| Heavy wrecking truck M1A1 (Ward La France and Kenworth) .....  | TM 9-796   |
| <b>Maintenance and Repair.</b>   |            |
| Cleaning, preserving, lubricating and welding materials and similar items issued by the Ordnance Department .....  | TM 9-850   |
| Cold weather lubrication and service of combat vehicles and automotive materiel .....  | OFSB 6-11  |
| Ordnance maintenance: Body and chassis for heavy wrecking truck M1 .....   | TM 9-1795D |
| Ordnance maintenance: Engine for heavy wrecking truck M1 .....   | TM 9-1795B |
| Ordnance maintenance: Power train for heavy wrecker M1 .....   | TM 9-1795A |
| <b>Protection of Materiel.</b>   |            |
| Camouflage .....   | FM 5-20    |
| Chemical decontamination, materials and equipment .....  | TM 3-220   |
| Decontamination of armored force vehicles .....  | FM 17-59   |
| Defense against chemical attack .....  | FM 21-40   |
| Explosives and demolitions .....   | FM 5-25    |
| <b>Storage and Shipment.</b>   |            |
| Ordnance storage and shipment chart, group G — Major items .....   | OSSC-G     |
| Registration of motor vehicles .....   | AR 850-10  |
| Rules governing the loading of mechanized and motorized equipment also major caliber guns, for the United States Army and Navy, on open top equipment published by Operations and Maintenance Department of Association of American Railroads. |            |
| Storage of motor vehicle equipment .....   | AR 850-18  |



ORDNANCE MAINTENANCE — CRANE FOR HEAVY WRECKING  
TRUCK M1A1 (WARD LA FRANCE AND KENWORTH)

INDEX

| A                               | Page |                                     | Page |
|---------------------------------|------|-------------------------------------|------|
| Acetylene tanks                 |      | disassembly .....                   | 35   |
| installation .....              | 105  | Bearing carrier (boom pivot),       |      |
| removal .....                   | 11   | thrust                              |      |
| Adjustments and tests .....     | 105  | disassembly .....                   | 52   |
| Air lines                       |      | installation .....                  | 58   |
| installation .....              | 100  | removal .....                       | 49   |
| removal .....                   | 18   | Block, sheave, removal .....        | 19   |
| Air tank                        |      | Blocks, snatch (See Snatch blocks)  |      |
| installation .....              | 100  | Body                                |      |
| removal .....                   | 18   | installation .....                  | 100  |
| Alinement of sprockets .....    | 105  | removal                             |      |
| Anchor, ground                  |      | body .....                          | 13   |
| installation .....              | 105  | body jacks .....                    | 11   |
| removal .....                   | 11   | Boom                                |      |
| Anchor end and adjusting end,   |      | assembly .....                      | 33   |
| brake, positions of .....       | 85   | cleaning, inspection, and repair .. | 31   |
| Anchor stakes                   |      | disassembly .....                   | 29   |
| installation .....              | 105  | installation .....                  | 101  |
| removal .....                   | 11   | removal .....                       | 13   |
| Assembly                        |      | Boom line, removal .....            | 13   |
| boom .....                      | 33   | Brace, crane A-frame                |      |
| boom pivot .....                | 56   | installation .....                  | 96   |
| boom swinger cut-out .....      | 41   | removal .....                       | 23   |
| clutch control valve .....      | 39   | Brake, assembly and installation .. | 84   |
| crane .....                     | 85   | Brake band                          |      |
| double drum .....               | 72   | positions of anchor end and         |      |
| double joint .....              | 37   | adjusting end .....                 | 85   |
| eccentric chain tightener ..... | 71   | relocate for frame clearance ..     | 27   |
| hoist and boom gear cases ..... | 82   | Brake case, disassembly .....       | 77   |
| main drive shaft .....          | 36   |                                     |      |
| swinger drive assembly .....    | 70   |                                     |      |
| swinger gear case .....         | 65   |                                     |      |
| topping pivot .....             | 45   |                                     |      |
|                                 |      | <b>C</b>                            |      |
|                                 |      | Cable, boom                         |      |
|                                 |      | installation                        |      |
|                                 |      | cable .....                         | 101  |
|                                 |      | load line .....                     | 105  |
|                                 |      | removal of cable and load line ..   | 13   |
|                                 |      | Cage, thrust (See Thrust cage)      |      |
|                                 |      | Cap, topping pivot base (See Base   |      |
|                                 |      | cap, topping pivot)                 |      |
|                                 |      | Chain, winch single clutch,         |      |
|                                 |      | adjustment .....                    | 106  |
|                                 |      | Chain tightener, eccentric (See     |      |
|                                 |      | Eccentric chain tightener)          |      |
|                                 |      | Chain tightener, swinger drive,     |      |
|                                 |      | removal .....                       | 23   |
|                                 |      | Chains, drive (See Drive chains)    |      |

**B**

|                                   |    |
|-----------------------------------|----|
| Base angle (swinger gear case),   |    |
| installation .....                | 92 |
| Base angle bolts (hoist and boom  |    |
| gear cases), installation .....   | 87 |
| Base cap, topping pivot           |    |
| installation .....                | 45 |
| removal .....                     | 42 |
| Beam, directional, removal .....  | 11 |
| Bearing (main drive shaft), self- |    |
| alining                           |    |
| assembly and installation .....   | 36 |

INDEX

| C—Cont'd                           | Page | Page  |
|------------------------------------|------|---|
| Cleaning                           |      |   |
| boom                               | 31   | removal . . . . . 18                          |
| boom pivot                         | 53   | (See also Valve, swinger cut-out)             |
| boom swinger cut-out               | 41   | <b>D</b>                                      |
| double drum                        | 72   | Description and data . . . . . 8              |
| double joint                       | 37   | Disassembly                                   |
| eccentric chain tightener          | 71   | boom . . . . . 29                             |
| hoist and boom gear cases          | 81   | boom swinger cut-out . . . . . 39             |
| main drive shaft                   | 36   | clutch control valve . . . . . 39             |
| swinger drive assembly             | 70   | double drum . . . . . 72                      |
| swinger gear case                  | 64   | double joint . . . . . 37                     |
| topping pivot                      | 43   | eccentric chain tightener . . . . . 71        |
| Clutch control removal             |      | hoist and boom gear cases . . . . . 76        |
| air lines                          | 18   | main drive shaft . . . . . 35                 |
| clutch control                     | 16   | swinger drive assembly . . . . . 70           |
| Control lever, hand                |      | swinger gear case . . . . . 60                |
| inspection and repair              | 39   | topping pivot . . . . . 42                    |
| installation                       | 90   | Double drum                                   |
| removal                            | 27   | disassembly, cleaning, inspection,            |
| Control lever, swinger, removal of |      | assembly, and repair . . . . . 72             |
| cross shaft                        | 23   | installation . . . . . 87                     |
| Control linkage, gear case,        |      | removal of drum shaft and end                 |
| inspection and repair              | 37   | frame . . . . . 25                            |
| Control valve (See Valve, clutch   |      | Double joint                                  |
| control)                           |      | disassembly, assembly, cleaning,              |
| Crane                              |      | inspection, and repair . . . . . 37           |
| assembly                           |      | installation . . . . . 101                    |
| crane                              | 85   | Drive assembly, swinger                       |
| crane control                      | 37   | assembly, disassembly, and                    |
| description and data               | 8    | repair . . . . . 70                           |
| disassembly                        |      | removal . . . . . 20                          |
| crane control                      | 37   | Drive chains                                  |
| into subassemblies                 | 18   | adjustments . . . . . 106                     |
| inspection and repair (crane       |      | installation . . . . . 99                     |
| control)                           | 37   | removal . . . . . 20, 23, 29                  |
| installation                       |      | Drive coupling (boom pivot),                  |
| crane                              | 99   | installation . . . . . 60                     |
| crane control                      | 100  | Drive shaft, main                             |
| removal                            |      | assembly, cleaning, inspection,               |
| crane                              | 18   | and repair . . . . . 36                       |
| crane assembly                     | 9    | disassembly . . . . . 35                      |
| crane control                      | 16   | installation                                  |
| test and adjustments               | 108  | double joint . . . . . 101                    |
| Cut-out, swinger                   |      | drive shaft . . . . . 97                      |
| assembly, cleaning, inspection,    |      | removal                                       |
| and repair . . . . . 41            |      | double joint . . . . . 16                     |
| disassembly . . . . . 39           |      | drive shaft . . . . . 29                      |
| installation                       |      | Drive shaft, winch                            |
| bracket . . . . . 96               |      | installation . . . . . 100                    |
| cut-out . . . . . 100              |      | removal . . . . . 16                          |
|                                    |      | Drive sprocket, main, alinement . . . . . 106 |

**ORDNANCE MAINTENANCE — CRANE FOR HEAVY WRECKING  
TRUCK M1A1 (WARD LA FRANCE AND KENWORTH)**

| <b>E</b>                  | <b>Page</b> | <b>Page</b>                               |
|---------------------------|-------------|---|
| Eccentric chain tightener |             | disassembly . . . . . 60                  |
| disassembly, repair, and  |             | installation                              |
| assembly . . . . .        | 71          | cover . . . . . 67                        |
| installation . . . . .    | 91, 92      | gear case . . . . . 91                    |
| removal . . . . .         | 23, 25      | removal                                   |
| Equipment                 |             | gear case . . . . . 23                    |
| installation . . . . .    | 105         | support . . . . . 24                      |
| removal . . . . .         | 11          |   |
|                           |             | <b>I</b>                                  |
|                           |             | Idler, reverse                            |
|                           |             | installation . . . . . 67                 |
|                           |             | removal . . . . . 63                      |
|                           |             | Idler gear, reverse, removal . . . . . 77 |
|                           |             | Inboard lever, installation               |
|                           |             | boom gear case control . . . . . 87       |
|                           |             | hoist gear case control . . . . . 90      |
|                           |             | Input shaft (boom and hoist gear          |
|                           |             | case)                                     |
|                           |             | assembly . . . . . 83                     |
|                           |             | installation . . . . . 84                 |
|                           |             | removal and disassembly . . . . . 77      |
|                           |             | Input shaft (swinger gear case)           |
|                           |             | assembly and installation . . . . . 65    |
|                           |             | removal and disassembly . . . . . 63      |
|                           |             | Inspection and repair                     |
|                           |             | boom . . . . . 31                         |
|                           |             | boom pivot . . . . . 53                   |
|                           |             | boom swinger cut-out . . . . . 41         |
|                           |             | clutch control valve . . . . . 39         |
|                           |             | double drum . . . . . 72                  |
|                           |             | double joint . . . . . 37                 |
|                           |             | eccentric chain tightener . . . . . 71    |
|                           |             | hoist and boom gear cases . . . . . 81    |
|                           |             | main drive shaft . . . . . 36             |
|                           |             | swinger drive assembly . . . . . 70       |
|                           |             | swinger gear case . . . . . 64            |
|                           |             | topping pivot . . . . . 43                |
|                           |             | <b>J</b>                                  |
|                           |             | Jack, boom                                |
|                           |             | inspection and repair . . . . . 33        |
|                           |             | installation . . . . . 33                 |
|                           |             | removal . . . . . 30                      |
|                           |             | Jack swivel, boom                         |
|                           |             | installation . . . . . 33                 |
|                           |             | removal . . . . . 30                      |
|                           |             | repair . . . . . 33                       |



**ORDNANCE MAINTENANCE — CRANE FOR HEAVY WRECKING  
TRUCK M1A1 (WARD LA FRANCE AND KENWORTH)**

| <b>T—Cont'd</b>                          | <b>Page</b> |                                       | <b>Page</b> |
|--|-------------|---------------------------------------|-------------|
| Tests and adjustments .....              | 105         | Valves, swinger cut-out               |             |
| Throttle control, removal .....          | 16          | cleaning, inspection, repair, and     |             |
| Thrust cage                              |             | assembly .....                        | 41          |
| installation                             |             | disassembly .....                     | 40          |
| cage and spring .....                    | 58          | removal                               |             |
| nuts .....                               | 60          | valve assembly .....                  | 18          |
| removal                                  |             | valves .....                          | 39          |
| cage .....                               | 49          | test and adjustment .....             | 108         |
| nuts .....                               | 48          |                                       |             |
| Tire, spare                              |             | <b>W</b>                              |             |
| installation .....                       | 105         | Winch                                 |             |
| removal .....                            | 11          | adjustment of single clutch chain     | 106         |
| Tool box, removal .....                  | 9           | disconnect, (rear) roller brackets    | 13          |
| Topping link                             |             | installation                          |             |
| installation of assembly .....           | 35          | drive shaft and jaw clutch            |             |
| removal and disassembly .....            | 29          | control .....                         | 100         |
| repair of assembly .....                 | 33          | (rear) control .....                  | 101         |
| Topping pivot                            |             | removal                               |             |
| assembly and installation .....          | 45          | (front) drive, and control .....      | 16          |
| cleaning, inspection, and repair         | 43          | (rear) control .....                  | 13          |
| disassembly .....                        | 42          | (rear) control, air lines .....       | 18          |
| installation .....                       | 97          | (rear) layshaft .....                 | 25          |
| removal .....                            | 19, 43      | (rear) winch .....                    | 18          |
| Tow bar, removal .....                   | 11          | Worm (boom pivot), installation ..... | 57          |
| Tow cable                                |             | Worm (hoist and boom gear cases)      |             |
| installation .....                       | 105         | assembly .....                        | 82          |
| removal .....                            | 11          | removal .....                         | 80          |
| <b>V</b>                                 |             | Worm (swinger gear case)              |             |
| Valve, clutch control                    |             | assembly and installation .....       | 65          |
| disassembly, assembly, inspec-           |             | removal .....                         | 63          |
| tion, and repair .....                   | 39          | Worm gear (boom pivot), removal       | 52          |
| installation .....                       | 99          | Worm gear (crane), installation ..... | 87          |
| Valve, crane control, installation ..... | 100         | Worm shaft (boom pivot), instal-      |             |
|  |             | lation of end cover .....             | 57          |

