

TM 9-1582

U/13  
TM 1962  
WAR DEPARTMENT

TECHNICAL MANUAL

ORDNANCE MAINTENANCE

PANORAMIC TELESCOPE M8

August 15, 1942

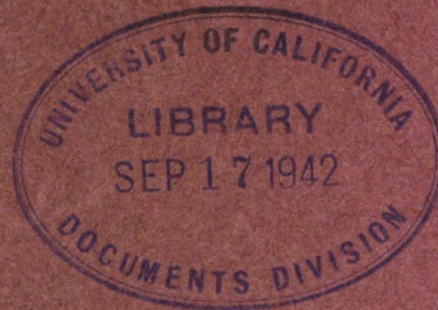



TECHNICAL MANUAL }  
No. 9-1582

U 113  
-2  
TM 9-1582  
1942

WAR DEPARTMENT,  
WASHINGTON, August 15, 1942.

★ ★  
ORDNANCE MAINTENANCE

PANORAMIC TELESCOPE M8

SECTION I. General.	Paragraph
Scope.....	1
II. Description.	
General.....	2
Optical system.....	3
Mechanical construction.....	4
Illumination.....	5
III. Operation.	
General.....	6
Leveling and adjusting.....	7
Pointing in direction.....	8
IV. Inspection.	
Procedure.....	9
V. Maintenance and repair.	
Tools.....	10
Disassembly and assembly.....	11
Adjustment.....	12
VI. Care and preservation.	
Care in handling.....	13
Optical parts.....	14
Lubrication.....	15
VII. Accessories.	
Packing chest.....	16
Electrical equipment.....	17
APPENDIX. List of references.....	Page 27

SECTION I  
GENERAL

Scope.....	Paragraph 1
------------	-------------

1. Scope.—*a.* This manual supplements the Technical Manuals on the panoramic telescope prepared for the using arm. It contains general descriptive matter and detailed instructions for the maintenance and repair of the instrument by ordnance personnel. Figures

\*This manual together with TM 9-1554, July 24, 1942, supersedes TM 9-2554, August 20, 1941.

1 to 12, inclusive, show the position and construction of each component part of the instrument.

b. The panoramic telescope M8 is the sighting element of the fire-control system used for laying in direction the 155-mm gun on the

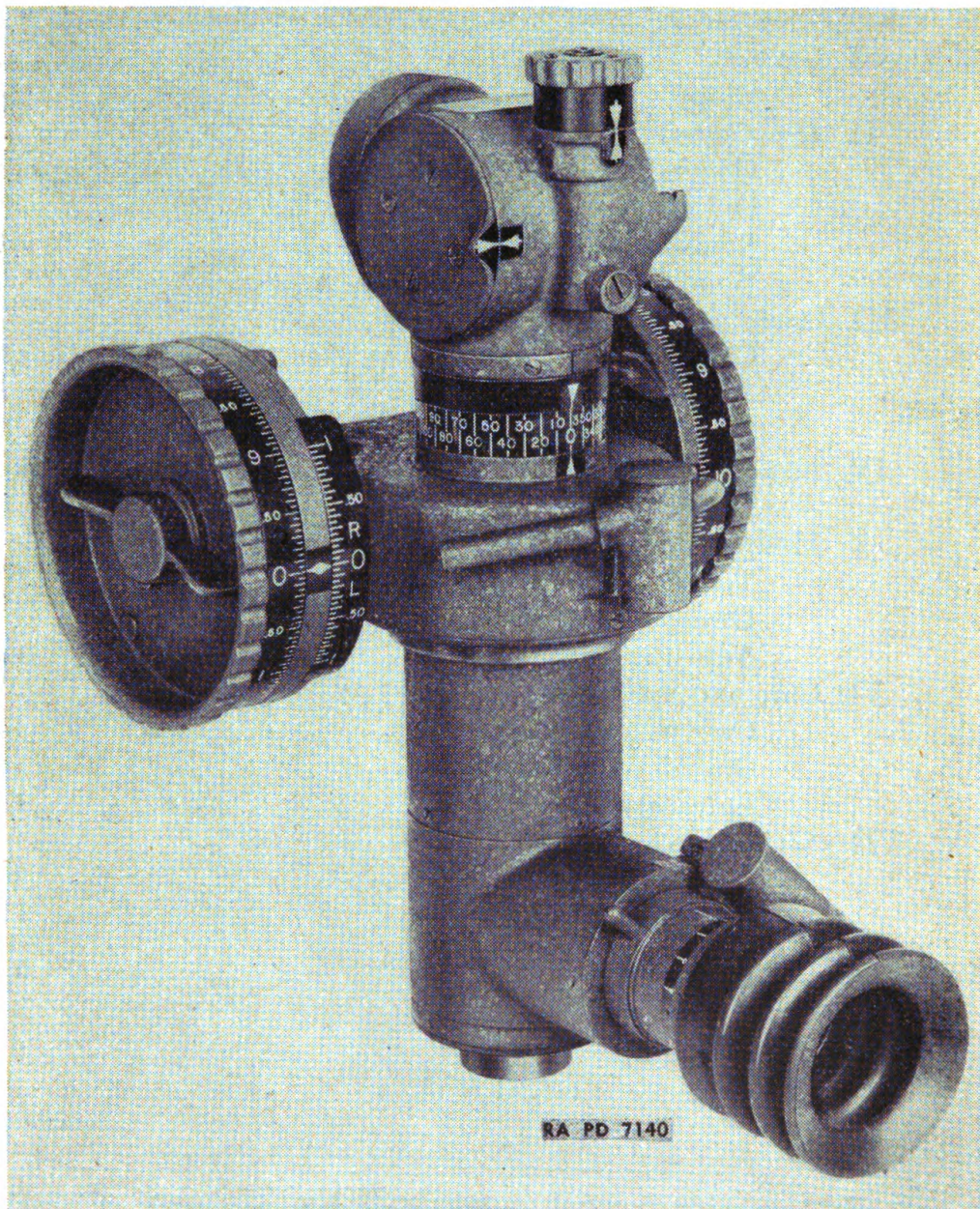

FIGURE 1.—Panoramic telescope M8.

155-mm gun carriage M3, and is mounted in telescope mount M6A1. It is also used for laying in direction the 8-inch railway gun on the 8-inch railway mount M1A1, and is mounted on this carriage in tele-



scope mount M20. The telescope is designed for use in case II and case III pointing, and is fastened in the telescope mount on the respective gun mount.

SECTION II

DESCRIPTION

	Paragraph
General.....	2
Optical system.....	3
Mechanical construction.....	4
Illumination.....	5

**2. General.**—Panoramic telescope M8 has a movable head graduated for 360° azimuth rotation. Adjustment in elevation is provided to bring the cross lines to bear on a target. The erecting prisms, which take the place of the dove reflecting prism usually used in panoramic telescopes are in the lower horizontal leg of the telescope. Two large micrometer knobs and the 90° elbow are distinguishing characteristics of this instrument.

**3. Optical system.**—*a.* This optical system includes window (A48091); 90° rotating prism (A46089); objective (A48092); Amici prism (B173197); erecting prism assembly consisting of two prisms (A45499 and A45500); reticle (A48093); field lens (A48095); eye lens (A48096); and amber filter (A179217), or neutral filter (A179218). (See fig. 8.)

*b.* The optical characteristics are as follows:

Power .....	6X
Field of view.....	6°40'
Diameter of exit pupil.....	.20 inch
Effective focal length of objective.....	7.58 inches
Effective focal length of eyepiece.....	1.263 inches
Apparent field of view.....	4°

**4. Mechanical construction.**—*a. General.*—Panoramic telescope M8 consists primarily of the rotating head assembly, the azimuth mechanism, and the elbow telescope assembly. A lighting system provides necessary illumination (fig. 1).

*b. Rotating head assembly.*—(1) The 90° rotating head prism (A46089) and prism holder (C69671) rotate in a vertical plane within the rotating head assembly (D28722) when the knob (A48097) is operated (figs. 5 and 8). The elevating worm knob stop rings (A49929 and A49930) limit the range of elevation or depression

(fig. 3). When both sets of indexes are alined (fig. 2) the rotating head assembly is in normal position.

(2) The window (A48091) mounted in front of the 90° rotating head prism seals the upper end of the telescope against dust and moisture.

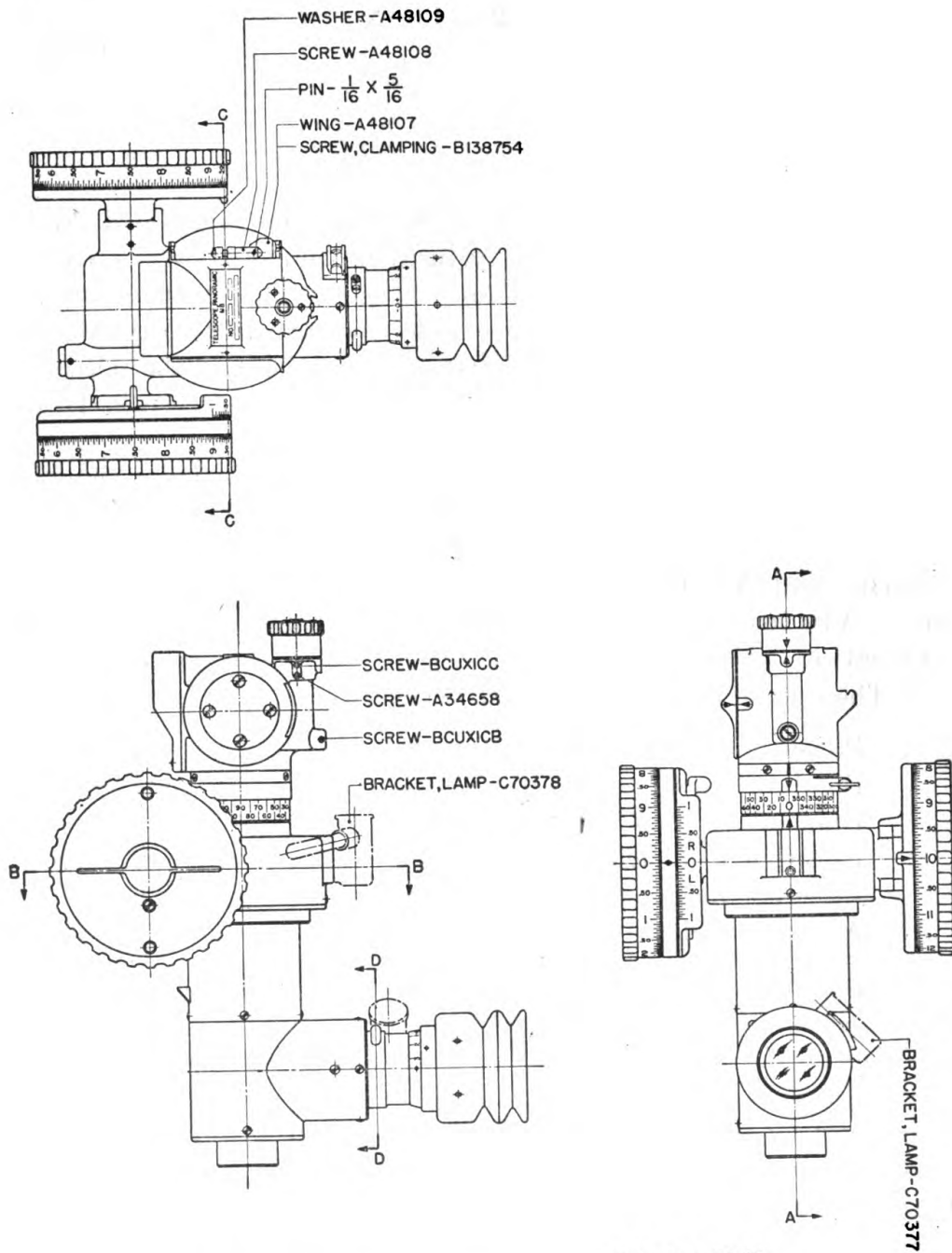

RA PD 7141

FIGURE 2.—Panoramic telescope M8—assembled views.

(3) The open sight (fig. 2) used for rough sighting, is parallel to the line of sight through the telescope when the  $90^\circ$  rotating head prism is in the normal position.

*c. Azimuth mechanism.*—(1) Two micrometer knobs (fig. 6) are provided to direct the panoramic telescope M8. The left knob (B138643) is used for case III pointing, and the right knob (B138644) for case II pointing (fig. 6). Both micrometers are graduated at

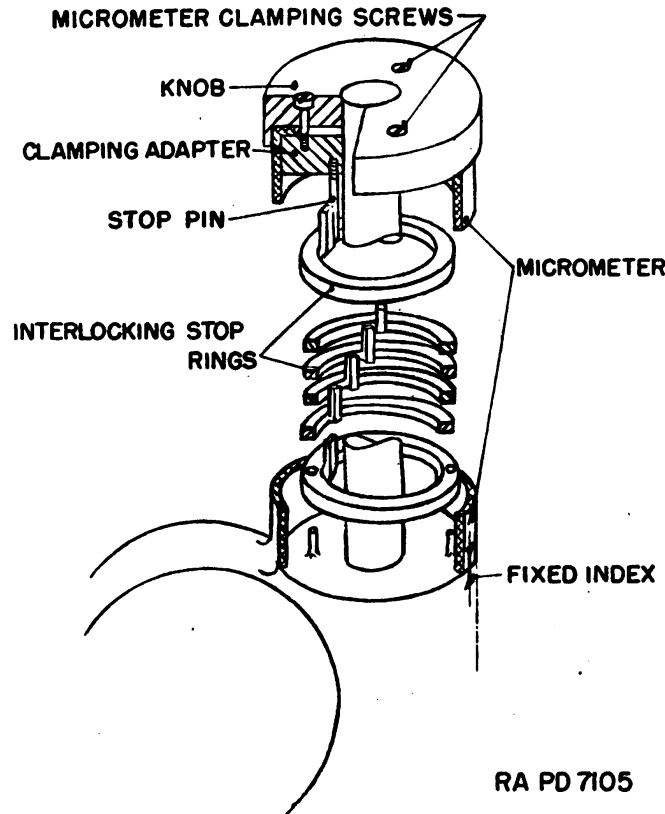

FIGURE 3.—Elevating micrometer, schematic diagram.

intervals of  $0.05^\circ$  and numbered at intervals of  $0.5^\circ$ . A complete revolution of the micrometer represents  $10^\circ$ .

(a) The left micrometer (fig. 1), used for case III pointing is numbered from 0–9 with 0 as normal. The right micrometer used in case II pointing for setting corrections by reference numbers is numbered from 5–14 with 10 as normal.

(b) The correction scale etched on worm shoe (B138705) is graduated at  $.05^\circ$  intervals and permits  $1^\circ$  correction on each side of normal (figs. 2 and 6).

(2) The azimuth scale (B138703, figs. 2 and 8) is graduated and numbered at  $10^\circ$  intervals from  $0^\circ$  to  $350^\circ$ , clockwise. It is clamped

to the lower shank of the rotating head by an adjustable azimuth index assembly (B138762).

(3) The ratchet (B138704) of the azimuth index assembly (B138753) and the detent (A179197) riveted to the worm shoe (B138705) cause the adjustable micrometer index to stop in coincidence with a graduation on the correction scale. The ratchet also prevents slipping of the index with respect to the correction scale (fig. 4).

(4) The knobs (B138643 and B138644, fig. 6) operate a train of bevel gears which turn the rotating head assembly (D28722, fig. 8) and rotate the erecting prism assembly (B136669), keeping the image erect at all times.

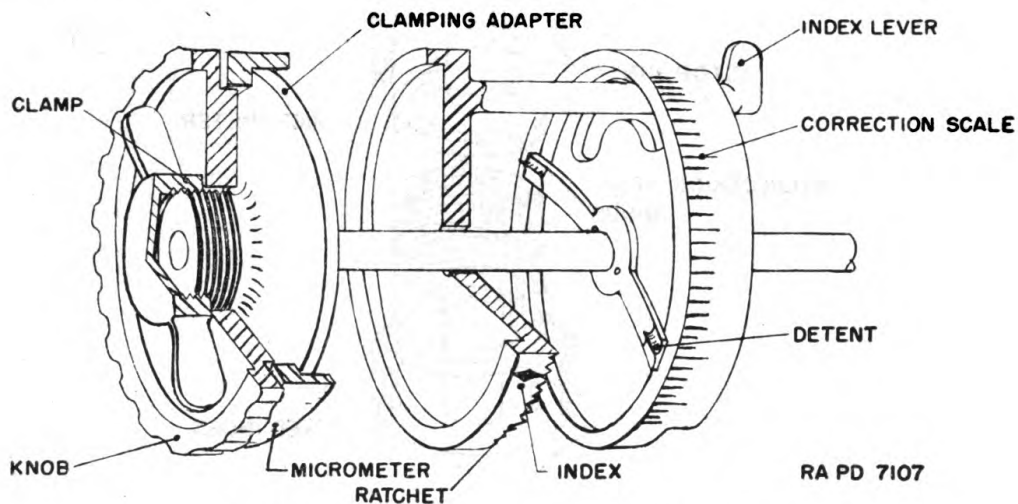

FIGURE 4. Azimuth micrometer, schematic diagram.

(a) The bevel gear (B138655) which is press-fitted to the worm gear (C70153) meshes with bevel pinion (B138656).

(b) The bevel pinion (B138656) rotating on a stud which is integral with the miter gear (C56884) turns the miter gear through one-half the angle traveled by the bevel gear (B138655). The bevel pinion (B138656) also meshes with the bevel gear (B138654).

(c) The bevel gear (B138654) is press-fitted to the support (D29291) and does not rotate.

(d) The miter gear (C56884) of the miter gear assembly (B138760) turns the miter gear (C70151) which is secured to the erecting prism assembly (B136669). Thus, the erecting prisms are rotated through half the angular distance traveled by the rotating head assembly.

(e) The spring washer (A48110) bears against the worm gear assembly (B138759), removing axial play of the worm gear assembly. The tubular spring (B138684) bears against the worm gear as-

sembly (B138759) and the miter gear assembly (B138760), removing axial play of the miter gear assembly.

d. *Elbow telescope assembly.*—The elbow telescope assembly (D28721, fig. 8) includes the objective assembly, Amici prism, erecting prisms assembly, and the reticle and eyepiece assembly.

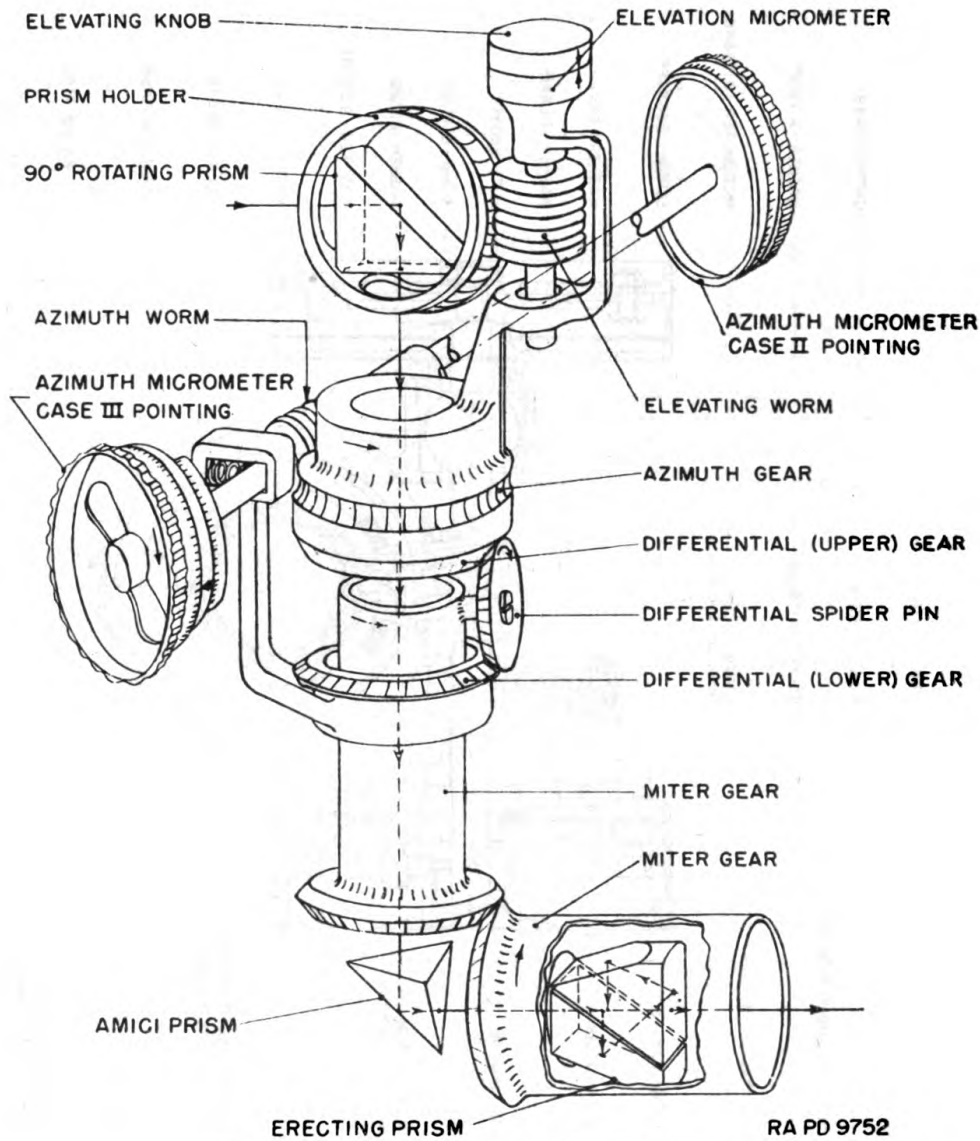

FIGURE 5. —Prism and gear, schematic diagram.

(1) The objective assembly (B138707, fig. 8), including the objective (A48092), cell (B137170), and ring (A48111), is screwed into the top of the elbow telescope tube (B137168) which in turn is screwed into the telescope elbow (D29373).

(2) The telescope elbow (D29373) contains the Amici prism (A36234), two-piece holder (C69674), diaphragm (A48114), and the



erecting prisms. The cover (B138607) seals the bottom of the telescope and serves as a locating surface for centering the telescope on the mount.

(3) The erecting prism assembly (A136669, fig. 8), rotated by the train of gears through one-half the angle traveled in azimuth by

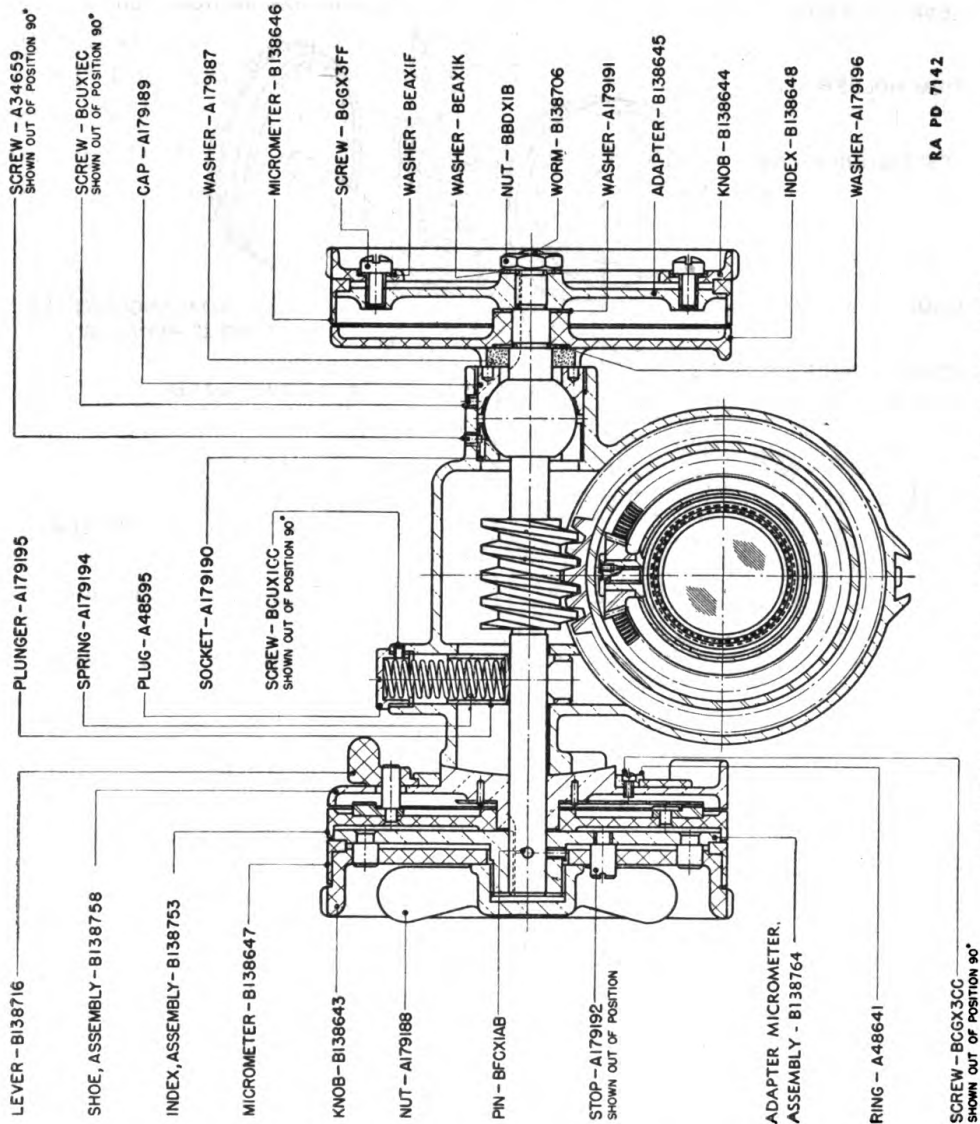

RA PD 7142

FIGURE 6.—Panoramic telescope, M8—section B-B.

the rotating head, contains the erecting prisms located in the prism support (C79326). Adjusting screws center this support on the spherical surface of miter gear (C70151). The spring washer (A185299) presses the prism against this surface and maintains the alignment. Access holes for the adjusting screws are sealed by screws (A185498).

(4) The eyepiece adapter (C70152) is secured to the telescope elbow and contains the reticle (B138756) and window (A178192) through which the reticle is illuminated. The adapter is threaded at the end to receive the eyepiece assembly (C56978), composed of eyelens, cell, sleeve, field lens, and retaining ring.

(5) The reticle (B138756, figs. 7 and 8) has a pattern consisting of a vertical and horizontal cross line.

(6) The eyepiece assembly (C56978), besides field lens (A48095) and eyelens (A48096), contains the diopter scale (B137176), graduated from +3 to -3 diopters. The setting for normal vision is zero.

(7) Two filter assemblies (B138670, amber, and B138671, neutral) are provided to shield the observer's eye from those light rays which would prevent a clear image because of certain light wave intensities producing a blurring effect.

(8) A soft rubber bellows-shaped eyeshield (B138699) cuts off stray light and protects the observer's eye from harmful light rays.

**5. Illumination.**—The telescope has two lamps for illumination of the reticle and one for the micrometers and scales. The reticle illuminating window cover assembly (B138701, fig. 7) protects the reticle window (A178192) and affords adjustment of the illumination. (See par. 17.)

SECTION III

OPERATION

	Paragraph
General .....	6
Leveling and adjusting.....	7
Pointing in direction.....	8

**6. General.**—The panoramic telescope M8 is used with telescope mount M6A1 and telescope mount M20. These mounts have different operating characteristics. Detailed operating instructions for the panoramic telescope M8 with each telescope mount are included in Technical Manuals pertaining to the particular telescope mount. Operating instructions applying to the panoramic telescope M8 only are included in this manual.

**7. Leveling and adjusting.**—The telescope mount must be kept properly cross-leveled at all times and leveled longitudinally, when required, to insure that true horizontal and vertical angles will be measured and that proper azimuth corrections will be automatically applied. Both the mount and the telescope must be in adjustment before operation. (See par. 12.)

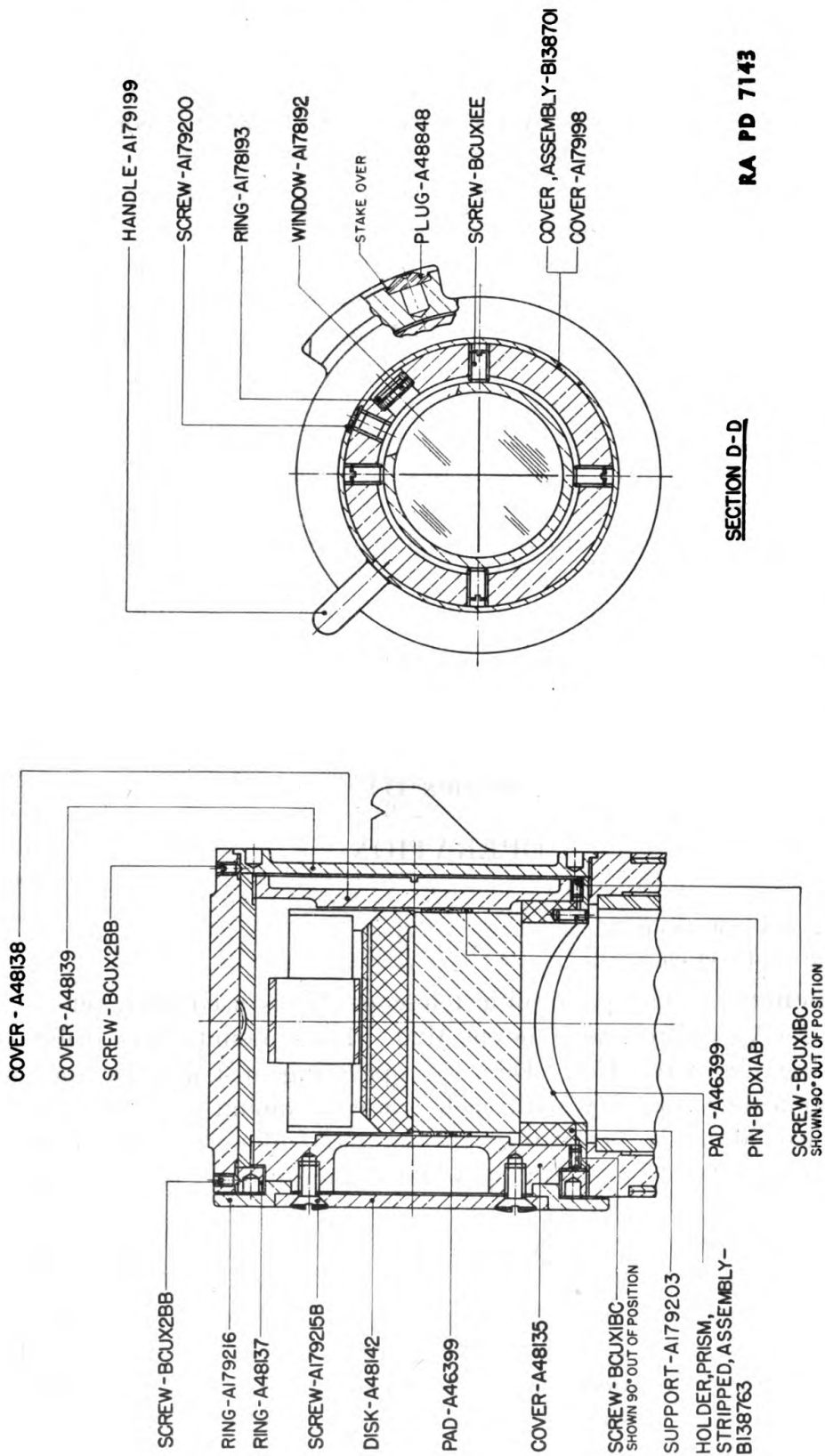

RA PD 7143

FIGURE 7.—Telescope M8, panoramic—sections C-C and D-D.



**8. Pointing in direction.**—*a. Applying lateral correction to individual gun.*—To set off a constant small correction of 1° or less, rotate case III azimuth index (D138653) in direction until the correction is indicated on the correction scale. Set the zero of the azimuth micrometer (D138647) opposite this index. This establishes the initial or zero correction. Subsequent deflections in azimuth may be set in either direction by rotating the azimuth setting or deflection setting knobs.

*b. Setting deflections for case II pointing.*—Deflections of 5° or less can be set by rotating the knob of the deflection micrometer (B138646) until the deflection is indicated opposite the case II index.

*c. Setting azimuths for case III pointing.*—Set off the announced azimuth of the set-forward point to the nearest 10° on the azimuth scale (B138703) and to the exact fraction of degree on the azimuth micrometer (B138647) of the panoramic telescope (fig. 6). The vertical line of the telescope is brought to bear on the aiming point by operating the traversing handwheel of the gun carriage.

SECTION IV

INSPECTION

Procedure ----- Paragraph  
 9

**9. Procedure.**—Inspections are made to determine the condition of the panoramic telescope, whether repairs or adjustments are required, and the remedies necessary to insure serviceability and proper functioning.

*Parts to be inspected*

*Points to be observed*

*a.* Exposed mechanical parts.

*a.* Observe general appearance. Note any bent or missing parts. Locating surfaces must be free of nicks and burs. Graduations should be clearly legible.

*b.* Optical system.

*b.* Note if checks or frost marks appear in the field of view. Such defects are evidence of loosening of the balsam used in cementing lenses and, if severe, require the return of the telescope to an arsenal or base shop. Note presence of objectionable scratches on lenses. Windows should be clean.

- | <i>Parts to be inspected</i> | <i>Points to be observed</i>   |
|------------------------------|--|
| <i>c.</i> Open sight.        | <i>c.</i> The line of sight should be parallel to the optical line of sight within $0.5^\circ$ (8.9 mils) in the horizontal and vertical planes. A testing target graduated in degrees or mils may be used.  |
| <i>d.</i> Erecting prisms.   | <i>d.</i> With the telescope clamped on a stable leveled surface, operate the azimuth knobs to rotate the head while viewing a fairly distant object. Observe whether the target remains erect as the head is rotated. If the target appears to depart from an erect position, the erecting prisms or mechanism require adjustment. For this test, the azimuth testing fixture (fig. 9) may be used. |
| <i>e.</i> Elevating indexes. | <i>e.</i> When the optical line of sight is horizontal and parallel to the azimuth locating surfaces of the telescope, the fixed and movable indexes of the elevation micrometer and coarse elevation index should exactly match.  |
| <i>f.</i> Reticle.           | <i>f.</i> Test for vertical and horizontal positioning of the reticle cross lines by sighting on a vertical line, such as a plumb line, with the telescope level. Test for alignment with optical axis.  |
| <i>g.</i> Eyepiece assembly. | <i>g.</i> While sighting on the cross lines of the collimating telescope, focus the eyepiece for sharpness and clarity of definition. The reading at optimum focus should be zero. The rubber eyeshield should be clean and in good condition.   |
| <i>h.</i> Objective.         | <i>h.</i> The objective should be in adjustment so that there is no parallax between the image and the lines at the center of the reticle when a suitable target is viewed at a distance of 275 yards $\pm$ 40 yards.  |

*Parts to be inspected*

*Points to be observed*

- i.* Azimuth mechanism. *i.* Operate micrometers throughout the entire range, checking for binding or excessive play. Backlash due to excessive play should not exceed  $0.05^\circ$ . Azimuth scale graduations should align exactly with the index when the zero of the azimuth micrometer aligns with the micrometer index.
- j.* Azimuth throw-out. *j.* Check the throw-out mechanism to make sure the azimuth worm and worm gear may be disengaged at any point.
- k.* Azimuth adjustable index. *k.* The azimuth adjustable index should clamp the azimuth scale when the thumbscrew is tightened and should allow the scale to rotate when the thumbscrew is unclamped. The detent and ratchet should align with each graduation on the correction scale within  $0.01^\circ$  ( $\frac{1}{5}$  of the space between graduations).
- l.* Reticle window cover. *l.* Turn the reticle window cover. There should be no binding or play.
- m.* Lamps. *m.* Try the lamp brackets in their clips for looseness or jamming. Lamps and sockets should be in good condition.

SECTION V

MAINTENANCE AND REPAIR

	Paragraph
Tools.....	10
Disassembly and assembly .....	11
Adjustment.....	12

**10. Tools.**—*a. Instrument repair kit.*—An optical repair kit containing necessary tools, cements, oils, etc., for use with this instrument is furnished ordnance maintenance personnel. Most of the items, such as screw drivers, require no description as their uses are self-explanatory. An ordinary nonerecting collimating telescope is furnished with the kit.

*b. Other tools.*—(1) No tools are supplied with the panoramic telescope M8 but it is recommended that a pair of strap wrenches be used for unscrewing the large-diameter threaded sections. The strap



wrenches should be not more than 8 to 12 inches long to avoid use of excessive force. Caution is recommended to avoid stripping threads or denting surfaces.

(2) The azimuth testing fixture (fig. 9), fitted with an adapter to accommodate the panoramic telescope, may be used where available. (An illustration of the azimuth testing fixture adapter is not included in this manual.)

(3) Other items of equipment used in inspection and readily available to the ordnance maintenance company are: a sensitive spirit level; a V-block for holding the collimating telescope; a sturdy workbench, affording a long space in front of the telescope to carry out optical tests; and a suitable testing target.

**11. Disassembly and assembly.**—Disassembly of the instrument may be required for cleaning or repair. Disassembly and assembly of the panoramic telescope M8 should be performed in a warm, dry, dust-free room whenever possible. For repairs that cannot be made with the facilities available, the instrument will be turned in to the base shop or arsenal. Assembly may be made by reversing steps taken in disassembly except where indicated. Before disassembling parts of the panoramic telescope M8, carefully mark their location with respect to each other to aid in realignment. Take note of any original markings. Reference to illustrations will indicate relationship of parts. Careful study of the illustrations should be made before attempting any disassembly or assembly.

*a. Rotating head assembly.*—To disassemble the rotating head assembly from the telescope, remove the two-piece clamping ring (B137159) secured by four screws. Remove the three screws (BCLX3CD) which fasten the rotating head assembly to the worm gear (C70153). Unscrew the rotating head from the gear hub. The azimuth scale (B138703) and the adjustable index assembly (B138762) are removed at this point.

(1) *Window.*—To remove window (A48091, fig. 8) remove window frame (B138702) and the six securing screws (A49945D). Push the window out of its seat in the frame. Before reassembly, seal the rim of the window with compound, sealing (black, Navy).

(2) *Elevation worm mechanism.*—To disassemble the elevation worm mechanism (fig. 8)—

(a) Withdraw plug (A34654) and locking screw spring (A33526) and plunger (A48657). Remove elevation worm knob (A48097) secured by three screws (BCGX3CC).

(b) Drive out taper pin (BFCX1A) and remove the nine stop rings (A49929) and the stop ring (A49930).

(c) Unscrew ball cap (A32115) and pull out worm (A179206) and socket (A32120), turning the worm if required to clear the prism holder teeth.

(d) In reassembly, make sure that all perceptible play and backlash have been eliminated. Before reassembly, coat the worm lightly with grease (see par. 15). After reassembly, the stop ring mechanism should permit rotation through eight or nine revolutions of the micrometer, half above and half below the micrometer index.

(3) *Prism holder assembly.*—(a) To withdraw prism holder assembly (C56977, figs. 7 and 8) after the elevation worm has been withdrawn, remove disk (A48142) and index ring (A179216) with the four retaining screws (A179215B) and unscrew ring (A48137). Pull out the prism holder assembly.

(b) To disassemble the prism holder assembly, unscrew cover (A48138) and two locking screws (BCUX1BC). Compress and withdraw prism spring (A48102) and withdraw prism support (A48103) and prism (A46089). Leave prism supports (A179203) in place. In reassembly, make sure that the prism seats exactly on prism supports (A179203) and that prism support (A48103) seats exactly on the prism. Cork pads (A46399) should be shellacked if necessary.

b. *Azimuth worm housing assembly.*—(1) To remove azimuth worm housing assembly (D28723, fig. 8) from the panoramic telescope after the rotating head has been removed and locating lines have been scribed, remove the three retaining screws (A49945D) and unscrew azimuth worm housing (D43243). In reassembling, seat spring (B138684) and carefully screw the housing on support (D29291) until the original scribed locating lines are reached. Make sure that pinion (B138656) meshes with bevel gears (B138655 and B138654) as the housing is screwed up against the spring washer (A48110). If the tops of the gear and pinion teeth come into contact and the gears later slip into mesh, the force exerted by the spring may damage the teeth.

(2) To remove the azimuth worm and worm mechanism—

(a) Unscrew stop (A179192, fig. 6) and azimuth knob nut (A179188). Remove knob (B138643) and micrometer (B138647).

(b) Remove taper pin (BFCX1AB) and slide micrometer adapter assembly (B138764) off the worm shaft to which it is keyed.

(c) Slide index assembly (B138753) and worm shoe assembly (B138758) off the worm shaft.

(d) Unscrew nut (BBDX1B), remove washer (BEAX1K), and slide adapter (B138645) and washers (BEAX1F and A179191) off the worm shaft.

(e) Slide index (B138648) and washer (A179196) off the worm shaft. Remove the felt washer (A179187).

(f) Remove plug (A48595) and retaining screw. Withdraw plunger spring (A179194).

(g) Remove ball cap (A179189) and lock screw (BCUX1EC). Remove the screw (A34659) which locks the ball socket.

(h) Disengage the azimuth worm (B138706) from the azimuth worm gear and pull it out of the housing at the ball socket end. Withdraw plunger (A179195).

(i) Pull gears (C70153 and B138655) out of housing (D43243) and slip spring washer (A48110) off worm gear (C70153, fig. 8).

c. *Support assembly.*—To disassemble support assembly (B138757) after disassembly in *a* and *b* above has been accomplished, proceed as follows:

(1) Mark location of support (D29291) with respect to the elbow.

(2) Remove miter gear (C56884) lifting it out of the support.

(3) Remove locking screws (A49945B) and unscrew support assembly (B138757) from elbow assembly (D28720).

d. *Elbow telescope assembly.*—After elbow telescope assembly (D28721) has been disassembled from the support assembly (see *o*(3) above), further disassembly may be accomplished as follows:

(1) *Objective assembly.*—Unscrew objective assembly (B138707) after removing lock screw (BCUX1CB) and marking the location of the objective assembly in the tube (B137168), using the screw hole as reference.

(2) *Amici prism.*—Unscrew elbow cover (B138607) and retaining screw. Withdraw screws (BCUX1EG) to release any pressure on the prism. Unscrew plug (A48113) and withdraw two-piece prism holder (C69674) and Amici prism (B173197).

(3) *Tube.*—To remove tube (B137168) withdraw lock screw (BCUX1EF) and unscrew the tube from the elbow after marking its location.

(4) *Eyepiece assembly.*—(a) To withdraw eyepiece assembly (C56978) and cell (B138700), remove rubber eyeshield (B138699) by stretching it over the flange of sleeve (A179201). Unscrew diopter scale (B137176) after removing the three lock screws (BCUX2BA). Unscrew eyepiece assembly from adapter assembly (B138752).

(b) To disassemble eyepiece assembly (C56978) withdraw screws (BCUX1CH and BCGX3CD) and slide sleeve (A179201) off cell (B138700). Unscrew ring (A48124) after marking its location, and withdraw eyelens (A48096), separator (A48123), and field lens doublet (A48095). In reassembly, refer to figure 8 for relationship of parts.



(5) *Adapter assembly.*—(a) Unscrew adapter assembly (B138752) after removing locking screws (A49945B). Spread the split ring (A48122, fig. 8) slightly and remove from slot.

(b) Remove window cover assembly (B138701, fig. 7) at this point by removing screw (A179200) and slipping the cover assembly over the adapter.

(c) To remove reticle assembly (B138756, fig. 8) unscrew the four adjusting screws (BCUX1EE, fig. 7) and lock ring (A48119, fig. 8). To disassemble reticle assembly, unscrew ring (A48117) and lock screw (BCUX1BA).

(d) The reticle window (A178192, fig. 7) is secured by the retaining ring (A178193), which is staked.

(6) *Erecting prism housing assembly.*—(a) After removing the adapter assembly (B138752), mark the position of the erecting prism housing assembly (C56976), and then withdraw it. (See fig. 8.)

(b) Loosen the screw (BCUX2CA) and unscrew the retainer (B173995). Remove the spring washer (A185299). Loosen the four screws (A185296) and withdraw the prism support assembly (C79327) after marking its location in the housing (B173993).

(c) Before removing the erecting prisms from the prism support assembly (C79237), mark the parts to preserve their relationship. Remove the four screws (A185295) which secure the cover (B173994) to the support and remove the cover and cork pad (A185298). The prisms may then be carefully withdrawn, care being taken to avoid damaging the prisms or the cork spacing pads.

**12. Adjustment.**—*a. Erecting prisms.*—(1) *General.*—It is possible for the erecting prisms to be out of adjustment in several respects.

(a) The prisms may be improperly mated or improperly seated in the prism support assembly. This will cause deviation of the image with respect to the optical axis. (See (2) and (4) below.)

(b) The prism support assembly may be improperly meshed with respect to the rotating head. This will cause the image to lean, or depart from the erect position. (See (3) below.)

(c) The prism support assembly may be improperly positioned on its spherical seat. This will cause the image to travel in a circle around the reticle center as the rotating head is turned in azimuth. (See (4) below.)

(2) *Deviation of prism support assembly.*—(a) To save time in adjustment, the prism support assembly (C79327) may be checked for deviation of the optical path before assembling the unit in the telescope. To check, fix the collimating telescope so that a clearly de-

finned, distant aiming point is centered on the telescope reticle. Interpose the erecting prism close to the collimating telescope and in the line of sight. If there is no prism deviation the aiming point will still

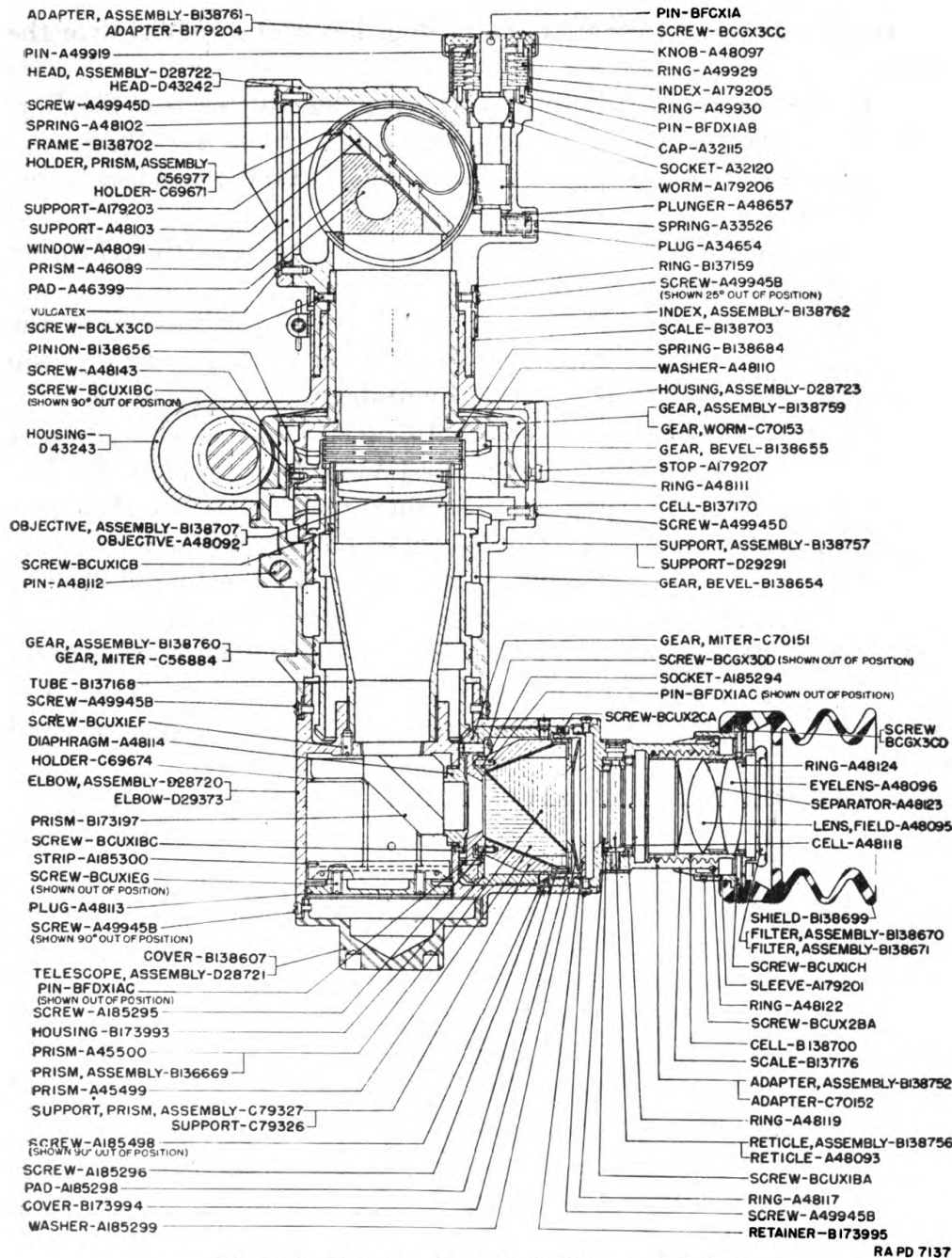

FIGURE 8.—Panoramic telescope M8—section A-A.

appear to be centered. Deviation should be not more than 3 minutes.

(b) A target may be set up for this check, consisting of a horizontal and a vertical cross line inclosed in a circle 17¼ inches in diameter,

at a distance of 275 yards from the prism support assembly. Center the collimating telescope reticle on the center of the target. When the prism support assembly is interposed in the line of sight, the reticle center will remain within the target circle if the deviation is less than 3 minutes.

(c) Deviation may be due to improper seating of the prisms in the support. Further sources of error are: nonuniform clamping, uneven spacing pads, prisms not mated.

(d) Where error is located in the seating or the clamping, the parts should be carefully reassembled. Where error is due to uneven padding or unmatched prisms, replacement of the prism assembly is required. Erecting prisms are furnished in matched pairs.

(3) *Erection of prism support assembly.*—With the telescope assembled, test for erection of the image by placing the panoramic telescope on the azimuth testing fixture which has been leveled and fitted with an adapter for the panoramic telescope M8. Set up a target some distance away. (The target described in (2) (b) above may be utilized. This arrangement may also be used for further tests.) Sight on the target. If the image leans, one of the following adjustments is to be made:

(a) Unscrew the adapter assembly (B138752) and disengage the prism housing assembly from its meshing with the gear assembly (B138760). Move the prism housing assembly clockwise or counterclockwise one tooth, or more if necessary, to bring the image to erection. If adjustment of less than one tooth spacing appears to be required, loosen two adjacent screws of the four adjusting screws (A185296), insert a thin rod into one of the two small holes in the face of retainer (B173995) and push the prism support assembly in the desired direction. Reassemble. Recheck for erection and for possible play or binding.

(b) An alternate method may be employed. Remove the spring pressure on the azimuth worm and gear by withdrawing plug (A48595) and spring (A179194). Unscrew the housing assembly (D28723) from the support assembly (B138757), after withdrawing the locking screws (A49945D). Separate the housing assembly sufficiently from the support assembly to draw the bevel gear (B138655) out of mesh with the pinion (B138656). With telescope erect, turn the rotating head until the field of view is erect. A plumb line or some vertical or horizontal line may be used as a target. Reassemble. Recheck for erection and for possible play or binding.

(4) *Eccentric rotation of prism support assembly.*—To test the adjustment of the prism support assembly (fig. 10②) on the spherical

surface of the miter gear use the arrangement described in (3) above.

(a) In order to determine whether the target remains stationary or travels in a circle around the reticle center of the field of view, rotate the telescope in regular intervals of  $45^\circ$ . At the same time, rotate the azimuth testing fixture  $45^\circ$  in the opposite direction. The position of the reticle cross lines and the image should be sighted at  $45^\circ$  intervals for two complete revolutions of the rotating head. Two revolutions of

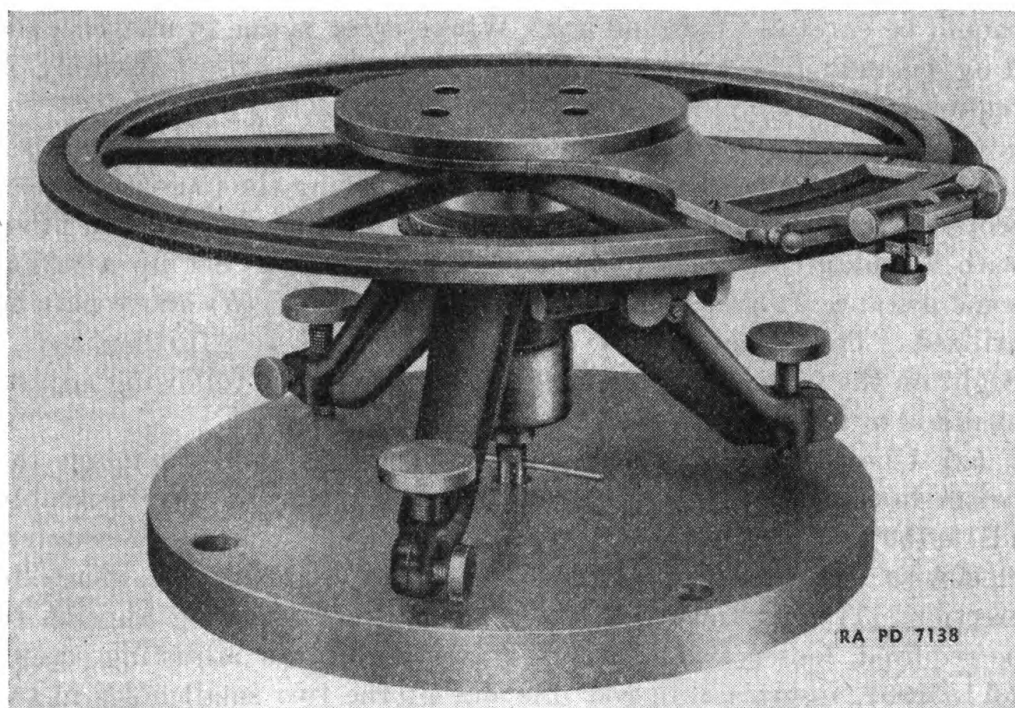

FIGURE 9.—Azimuth testing fixture.

the rotating head equal one revolution of the erecting prisms. On beginning the second revolution of the rotating head, move the telescope through  $22\frac{1}{2}^\circ$  for the first interval to avoid duplication.

(b) If the target does not remain stationary, remove the four plugging screws (A185498) in the elbow. Adjust the four adjusting screws (A185296) (through the plugging screw holes) so as to reduce the circle traveled by the image.

(c) If the circle of travel is not concentric with the center of the reticle adjust as in *b*(2) below.

(d) If the circle of travel cannot be reduced to a point but appears to diminish to a small circle and then on further adjustment in the same direction to increase, the prism support assembly may require adjustment. (See (2)(b) above.)



*b. Reticle.*—(1) *General.*—The reticle may be out of adjustment in two respects:

(a) The reticle may not be centered in the optical axis (fig. 10③). (See (2) below.)

(b) The reticle may be tilted with respect to the horizontal and vertical axes of the telescope. (See (3) below.)

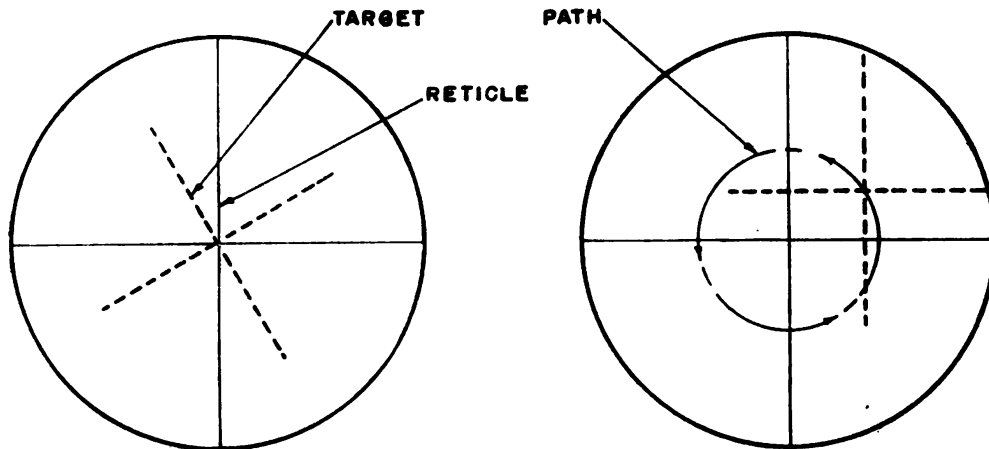

① Prism not erect but centered on reticle (par. 12b(3)).

② Prism deviates and path is centered on reticle (par. 12a(4)).

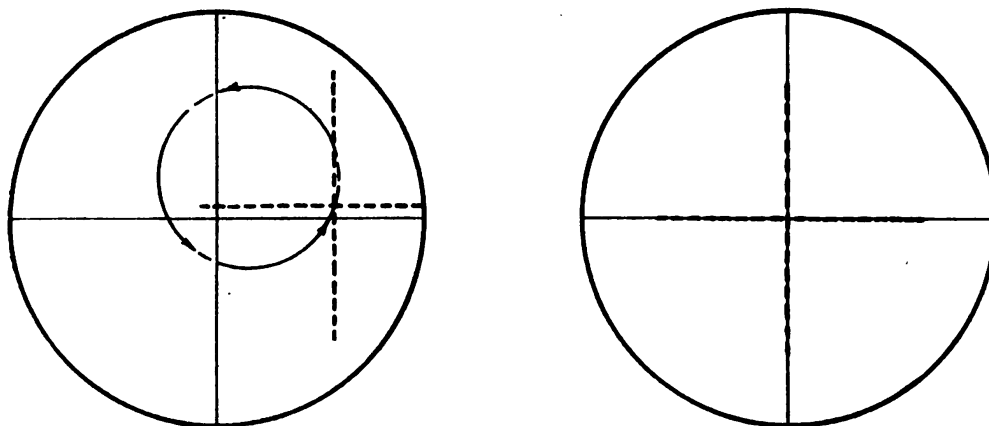

③ Prism deviates and path is not centered on reticle (par. 12b(2)).

④ Prism erect, reticle erect—satisfactory.

RA PD 7139

FIGURE 10. Views through eyepiece for various errors.

(2) *Centering reticle.*—To center the reticle with respect to the optical axis use the azimuth testing fixture as described in *a* above. Rotate the telescope in regular intervals with corresponding opposite rotation of the azimuth testing fixture. Eight intervals per revolution ( $45^\circ$ ) should suffice. On beginning the second revolution move the telescope through  $22\frac{1}{2}^\circ$  for the first interval to avoid duplication.

(a) Note if the target or the circle of travel of the target remains centered on the reticle center. If the centers are not in line the reticle requires adjustment.

(b) Remove the screw which retains the reticle window cover and slide the cover off the seat. Adjust the four reticle adjusting screws (BCUX1EE) to center the article.

(c) Check the new setting by rotating again, and then replace the cover and retaining screw.

(3) *Erecting reticle.*—(a) To check the cross lines of the reticle, clamp a collimating telescope to a V-block and block it up to the height of the axis of the eyepiece. Erect the collimating telescope reticle by alining it with a plumb line. Slide the collimating telescope and V-block to the rear of the panoramic telescope. Focus the collimating telescope on the reticle of the panoramic telescope. If the reticles are alined or parallel no adjustment is required (fig. 10① and ④).

(b) If the panoramic telescope reticle is not alined with, or parallel to, the collimating telescope it will be necessary to remove the eyepiece by unscrewing the sleeve (A179201) and its locking screw, and unscrewing the eyepiece completely. Loosen the ring (A48119). Rotate the reticle cell (A48118) to the erect position and replace the parts. It may be necessary to loosen the reticle clamping screws which are exposed by unlocking the reticle window cover and sliding it off its seat. Check for alinement on reassembly.

c. *Diopter scale.*—If the reading on the diopter scale is not approximately zero when the eyepiece is focused with the aid of the collimating telescope, loosen the set screw (BCUX2BA, fig. 8) and shift the diopter scale to read zero.

d. *Objective (parallax).*—Parallax is the apparent displacement of an object (or difference in apparent direction) when viewed from two points, and occurs when there is angular displacement between alined images. With the panoramic telescope leveled and aimed at a target set up at a distance of 275 yards, focus the eyepiece carefully on the reticle. The presence of parallax is noted by the displacement, in any direction, of the image with respect to the reticle, while the eye is moved from right to left or from top to bottom across the eyelens. If parallax is observed, remove the four screws (A49945B) which hold support assembly (B138757) to the elbow assembly (D28720), and unscrew the support assembly (B138757) from the elbow assembly. Focus the elbow of the telescope on the target and release the objective cell clamping screw (BCUX1CB). Screw the objective cell in or out to obtain the sharpest focus. Lock the cell in place and reassemble the telescope. This adjustment may disturb the mesh-

ing of the miter gears and throw the image out of the erect position. To correct this proceed as in *a*(3) above.

*e. Elevation indexes.*—Mount the panoramic telescope M8 on a level plate and set up a target a short distance away, which bears a horizontal line at the same height above ground as the line of sight of the telescope. Turn the elevation knob (A48097) (see fig. 5) until the reticle horizontal line coincides with the target.

(1) If the coarse adjustable index disk (A48142, fig. 7) does not coincide with its fixed index, loosen the four screws (A179215B) and slip the disk to match indexes. Tighten screws.

(2) If the fine adjustable index (A179205, fig. 8) does not coincide with its fixed index, loosen the three screws (BCGX3CC) on the elevation worm knob and slip the index (A179205) until both indexes match. Tighten screws.

## SECTION VI

### CARE AND PRESERVATION

	Paragraph
Care in handling.....	13
Optical parts.....	14
Lubrication.....	15

**13. Care in handling.**—*a.* The panoramic telescope contains highly accurate mechanisms and precise optical parts. Careful handling is imperative to avoid damage caused by unnecessary shocks, etc.

*b.* Avoid forcing the mechanisms against the stops provided for limiting motion of the mechanism.

*c.* Avoid nicking or denting the locating surfaces.

*d.* If the telescope has been exposed to rain, etc., it should be carefully dried, cleaned, and returned to its packing chest.

*e.* When the panoramic telescope M8 is not in use it should be kept in the wooden case provided.

*f.* The rubber eyeshield should be washed periodically in lukewarm water.

**14. Optical parts.**—*a.* To obtain satisfactory vision it is necessary to keep the exposed surfaces of the lenses and other parts clean and dry. Corrosion and etching of the glass surfaces can thus be prevented or retarded.

*b.* Moisture due to condensation may collect on the optical parts of the instrument when the temperature of the instrument is below that of the surrounding air. This may be removed by placing the instrument in a warm place. Heat from strongly concentrated sources should

never be applied directly as it may cause unequal expansion of parts with resulting inaccuracies in observation.

*c.* For dusting optical parts, use only a clean brush, camel's-hair. For wiping, use only clean paper, lens, tissue, for cleaning optical glass.

*d.* To remove oil or grease from optical surfaces, apply ethyl alcohol with a clean brush, camel's-hair, and rub gently with clean lens tissue. If alcohol is not available, breathe on the glass and wipe with clean lens tissue; repeat this operation several times until clean.

*e.* To remove dust, brush the glass lightly with a clean brush, camel's hair. Rap the handle of brush against a hard body in order to knock out dust particles clinging to the hairs. Repeat until dust is removed.

*f.* Do not wipe lenses or windows with the fingers.

*g.* Polishing liquids, pastes, or abrasives are not to be used for polishing lenses or windows.

**15. Lubrication.**—*a.* The panoramic telescope M8 should be lubricated on assembly with the following lubricants furnished by the Ordnance Department:

(1) Grease, lubricating, special (grease, special, low-temperature).

(2) Oil, lubricating, for aircraft instruments and machine guns.

*b.* The elevating worm (A179206, fig. 8), prism holder (C69671), azimuth worm gear, bevel gears, and miter gears should be lubricated with a thin film of grease.

*c.* External contact surfaces should be lightly oiled. Excess lubricant should be wiped off to avoid accumulation of grit and dirt.

*d.* Avoid bringing oil or grease into contact with the glass of optical parts.

*e.* Lubricants for fire-control instruments also function as rust preventives. It is important that they be applied carefully and sparingly. Too much grease applied to delicate mechanisms may cause stiffness of operation in cold weather.

## SECTION VII

### ACCESSORIES

	Paragraph
Packing chest.....	16
Electrical equipment.....	17

**16. Packing chest.**—A packing chest is provided for the telescope. Details of this chest are not available.

**17. Electrical equipment.**—*a.* Two lamp brackets furnish illumination for which electrical current is supplied.



PANORAMIC TELESCOPE M8

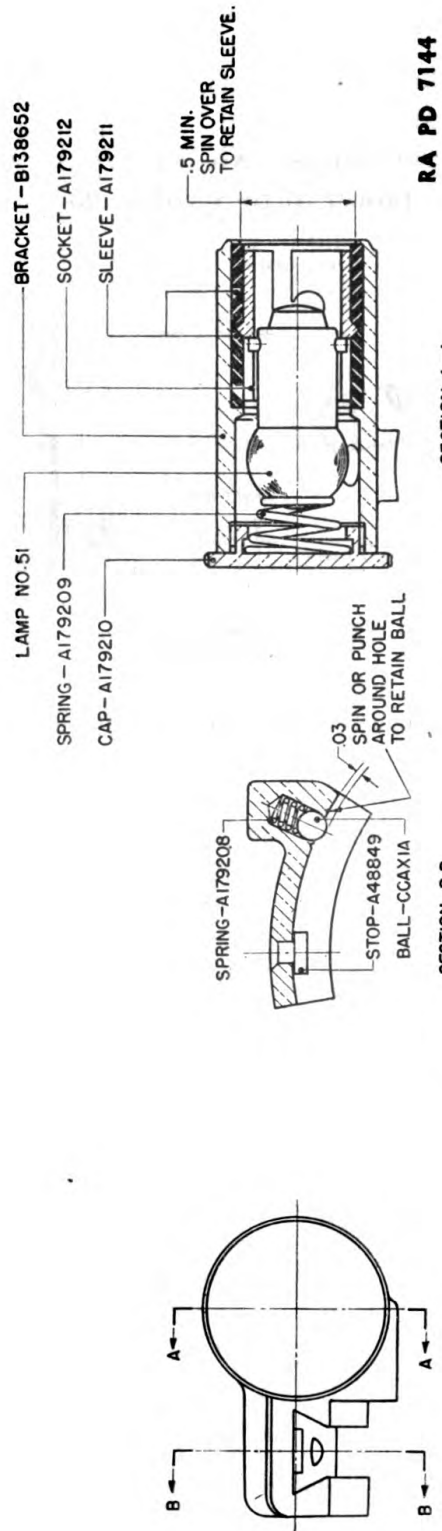

SECTION A-A

SECTION B-B

FIGURE 11.—Panoramic telescope M8, reticle lamp bracket.

(1) Lamp bracket assembly (C70378, figs. 2 and 12) clips to the azimuth housing (D43243, fig. 8) and illuminates the azimuth micrometer and scales.

(2) The lamp bracket assembly (C70377, figs. 2 and 11) clips to the elbow and illuminates the reticle.

b. Four spare electric lamps (No. 51 type), with bayonet base, single contact, 1 candlepower, 6 to 8 volts, .25-ampere, are included.

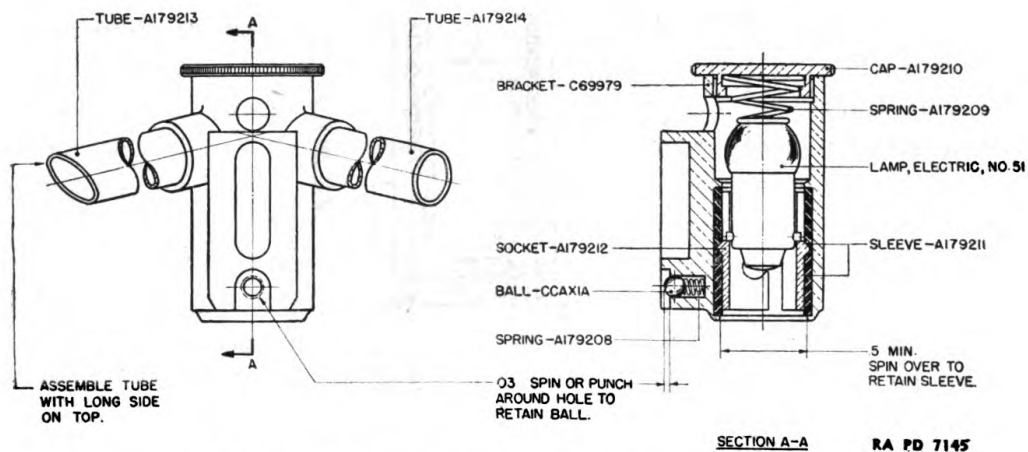

FIGURE 12. Panoramic telescope M8, scale lamp bracket.

## APPENDIX

## LIST OF REFERENCES

1. **Standard Nomenclature Lists.**

- a. Mount, telescope, M6A1..... SNL F-156  
 b. Mount, telescope, M20..... SNL F-186  
 c. Telescope, panoramic, M8..... SNL F-196  
 d. Instrument repair kit..... SNL F-206  
 e. Current Standard Nomenclature Lists are as tabulated here.  
 An up-to-date list of SNL's is maintained as the Ordnance Publications for Supply Index (OPSI).

2. **Explanatory publications.**

- a. Cleaning, preserving, and lubricating materials.. TM 9-850  
 b. *Gun matériel.*  
     155-mm gun matériel, M1917, M1918..... TM 9-345  
     8-inch railway matériel..... TM 9-463  
 c. *Maintenance and instruction guides.*  
     Instrument repairman..... TM 9-2602  
     Telescope mount M6A1..... TM 9-1554  
     Telescope mount M6A1, panoramic telescope M8 TM 9-2554  
     Telescope mount M20, panoramic telescope  
     M8, elevation quadrant M1..... TM 9-2674  
 d. *Miscellaneous.*  
     Fire control and position finding..... FM 4-15  
     Gunnery..... FM 4-10

[A. G. 062.11 (5-5-42).]

BY ORDER OF THE SECRETARY OF WAR:

G. C. MARSHALL,  
*Chief of Staff.*

OFFICIAL:

J. A. ULIO,  
*Major General,  
 The Adjutant General.*

DISTRIBUTION:

R 9 (2); IBn 9 (1); IC 9 (3).  
 (For explanation of symbols see FM 21-6.)



