

TECHNICAL MANUAL

**TRANSPORTABILITY GUIDANCE
REDEYE AIR DEFENSE GUIDED MISSILE SYSTEM**

**GUIDED MISSILE SYSTEM, INTERCEPT-AERIAL, M41
IN UNIPAK CONTAINER, M585 AND MONOPAK CONTAINER, M571
(FSN 1425-183-5990 AND FSN 1425-930-9923)**

**SHIPPING AND STORAGE CONTAINERS,
GUIDED MISSILE, UNIPAK, M585 AND MONOPAK, M571
(FSN 8140-880-7285 AND FSN 8140-937-1340)**

**MAINTENANCE EQUIPMENT SHELTER, GMS S-408 (XO-1) TSM
(FSN 4935-087-3227)**

TECHNICAL MANUAL }
 No. 55-1400-425-15-1 }

HEADQUARTERS
 DEPARTMENT OF THE ARMY
 WASHINGTON, D.C., 1 May 1973

**TRANSPORTABILITY GUIDANCE
 REDEYE AIR DEFENSE GUIDED MISSILE SYSTEM
 GUIDED MISSILE SYSTEM, INTERCEPT-AERIAL, M41
 IN UNIPAK CONTAINER, M585 AND MONOPAK CONTAINER, M571
 (FSN 1425-183-5990 AND FSN 1425-930-9923)
 SHIPPING AND STORAGE CONTAINERS,
 GUIDED MISSILE, UNIPAK, M585 AND MONOPAK, M571
 (FSN 8140-880-7285 AND FSN 8140-937-1340)
 MAINTENANCE EQUIPMENT SHELTER, GMS S-408 (XO-1) TSM
 (FSN 4935-087-3227)**

		Paragraph	Page
CHAPTER	1. INTRODUCTION	1-1-1-5	1-1
	2. TRANSPORTABLE DATA		
Section	I. General.....	2-2, 2-2	2-1
	II. Characteristics and Related Data of Items .	2-3, 2-4	2-6
CHAPTER	3. SAFETY	3-1, 3-2	3-1
	4. AID TRANSPORTABILITY GUIDANCE		
	5. HIGHWAY TRANSPORTABILITY GUIDANCE		
Section	I. General.....	5-1, 5-2	5-1
	II. Movement by Motor Vehicle	5-3-5-5	5-1
CHAPTER	6. MARINE AND TERMINAL TRANSPORTABILITY GUIDANCE	6-1-6-4	6-1
	7. RAIL TRANSPORTABILITY GUIDANCE		
Section	I. General	7-1, 7-2	7-1
	II. Transport on CONUS Railways.....	7-3-7-5	7-1
	III. Transport on Foreign Railways.....	7-6-7-8	7-35
APPENDIX.	REFERENCES		A-1

CHAPTER 1

INTRODUCTION

1-1. Purpose and Scope

This manual provides transportability guidance for logistic handling and movement of the major end items comprising the Redeye Air Defense Guided Missile System. It provides transportation officers down to division level and other personnel engaged in or responsible for movement or providing transportation services with information considered appropriate to insure safe transport. Significant technical and physical characteristics as well as safety considerations required for worldwide movement by various modes of transportation are included. For transportation purposes, the M585 and M571 shipping and storage containers are considered similar. Where differences occur, each model is listed separately in paragraph 2-3. When considered necessary, metric equivalents are given in parentheses following the dimensions or other measurements.

1-2. Reporting of Recommendations and Comments

The reporting of errors, omissions, and recommendations for improving this manual by the individual user is encouraged. Reports should be submitted on DA Form 2028 (Recommended Changes to Publications) and forwarded to Director, US Army Transportation Engineering Agency, Military Traffic Management and Terminal Service, ATTN: MTT-GDP, P.O. Box 6276, Newport News, Va. 23606.

1-3. Safety

Appropriate precautionary measures required during movement of the items are contained in chapter 3.

1-4. Definitions of Warnings, Cautions, and Notes

Throughout this manual, warnings, cautions, and notes emphasize important or critical guidance. They are used for the following conditions:

a. *Warning.* An operating procedure or practice that, if not correctly followed, could result in personal injury or loss of life.

b. *Caution.* An operating procedure or practice that, if not strictly observed, could result in damage to or destruction of equipment.

c. *Note.* An operating procedure or condition that must be emphasized.

1-5. Procedural Drawings

All Redeye missile system items, in addition to those identified in this manual, are listed in the *Master Ready Reference Index for Outloading and Storage Drawings Applicable to Guided Missile and Rocket Systems*, AMSMI-SP-1300. This index, and the drawings identified therein, may be obtained from the Director, US Army Materiel Command Ammunition Center, ATTN: AMXAC-DEO, Savanna, Illinois 61074.

CHAPTER 2

TRANSPORTABILITY DATA

Section I. GENERAL

2-1. Scope

This chapter provides a general description of the items, identification photographs, and tabulated transportability characteristics and data that are necessary for the movement of the items.

2-2. Descriptions

a. The Redeye weapon consists of the missile sealed inside its launcher. The launcher with its missile is stored in a shipping and storage container. Two types of shipping and storage containers are used for the weapon and launcher battery/gas units. The M586 container (fig. 21) consists of a two-piece polystyrene foam unit with a capacity for one weapon and three battery/gas units. The other container, M571 (fig. 22), is an

aluminum, two-piece shell with a capacity of one weapon and three battery gas units. This container is fungus-and moisture-resistant.

b. The maintenance equipment shelter, GMS S-408 (XO-1) TSM (fig. 2-3), is airtight and environmentally controlled by a heater/air conditioner. It contains the necessary tools and test equipment for operator and organizational maintenance of the Redeye Air Defense Guided Missile System. The all-metal shelter has lifting and tiedown provisions located on the four top corners, and towing and tiedown provisions are located on the four lower corners.

c. Palletized loads of the shipping and storage containers are shown in figures 2-4 and 2-5.

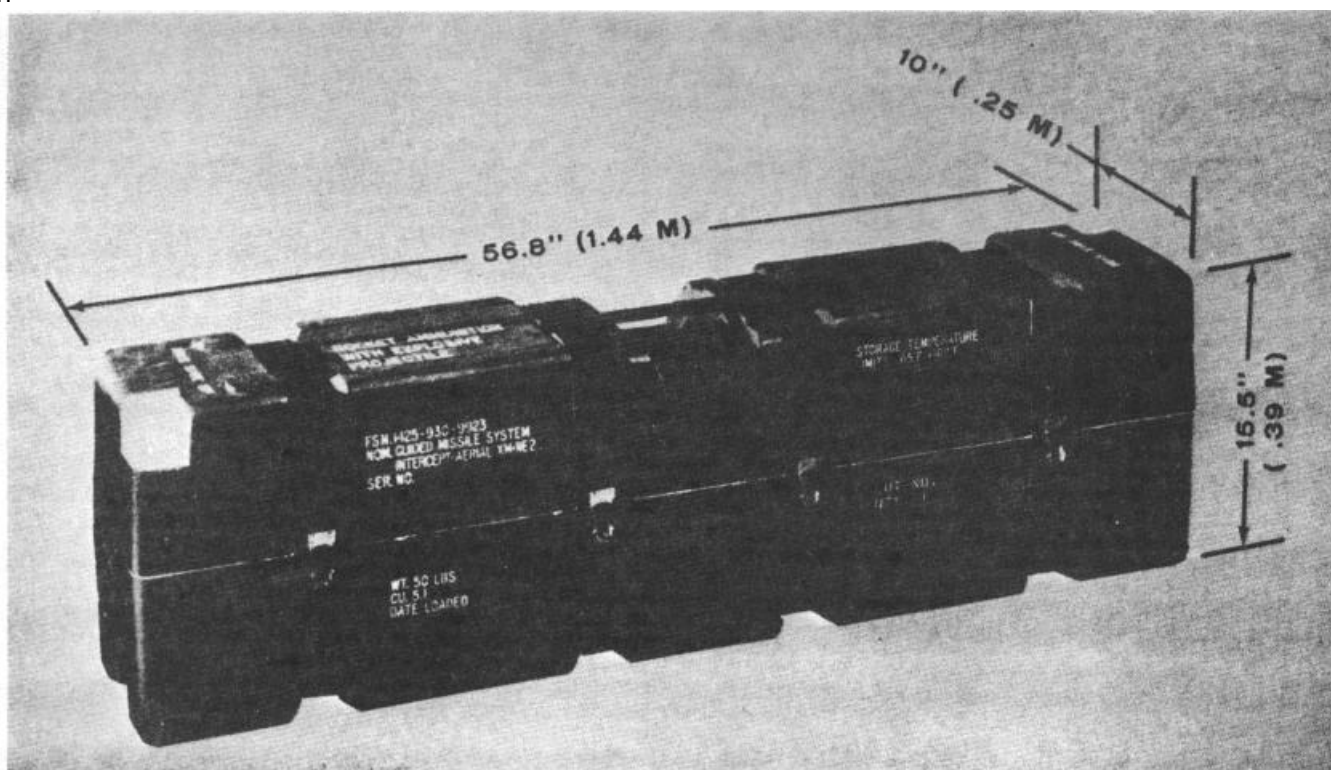

Figure 2-1. Shipping and storage container, M585.

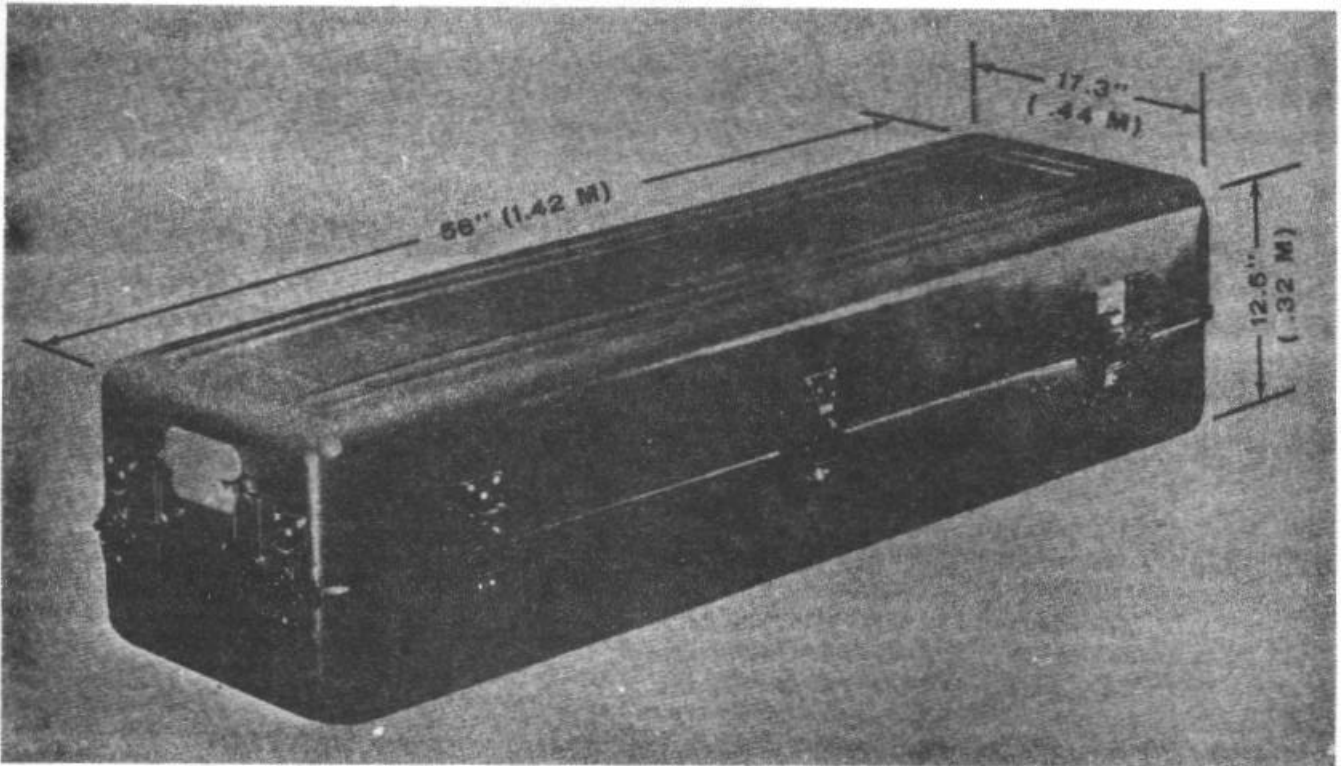

Figure 2-2. Shipping and storage container, M571.

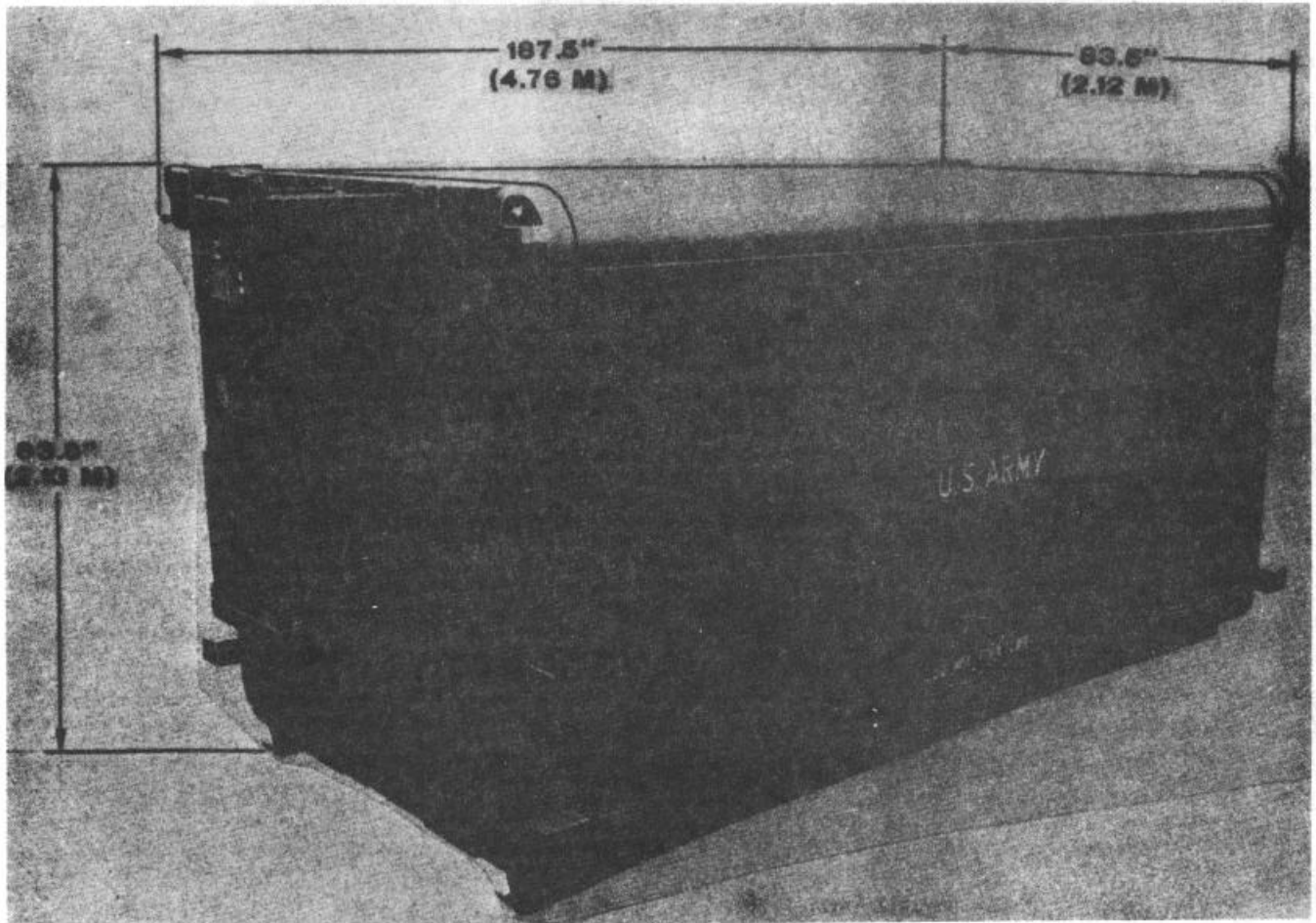

Figure 2-3. Uncrated maintenance equipment shelter, GMS S-408 (XO-1) TSM.

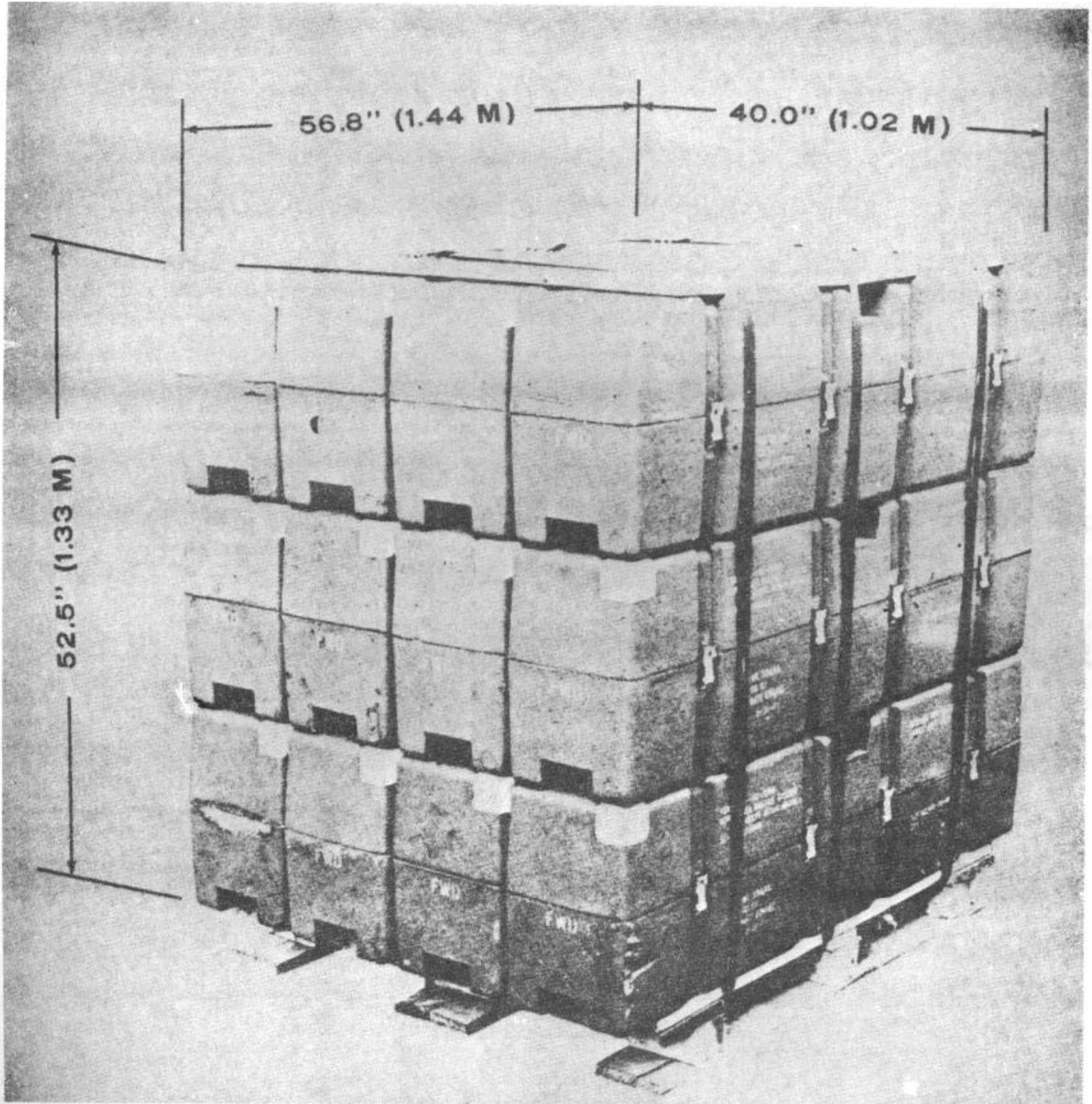

Figure 2-4. Palletized load of 12 shipping and storage containers, M585 (Unipak).

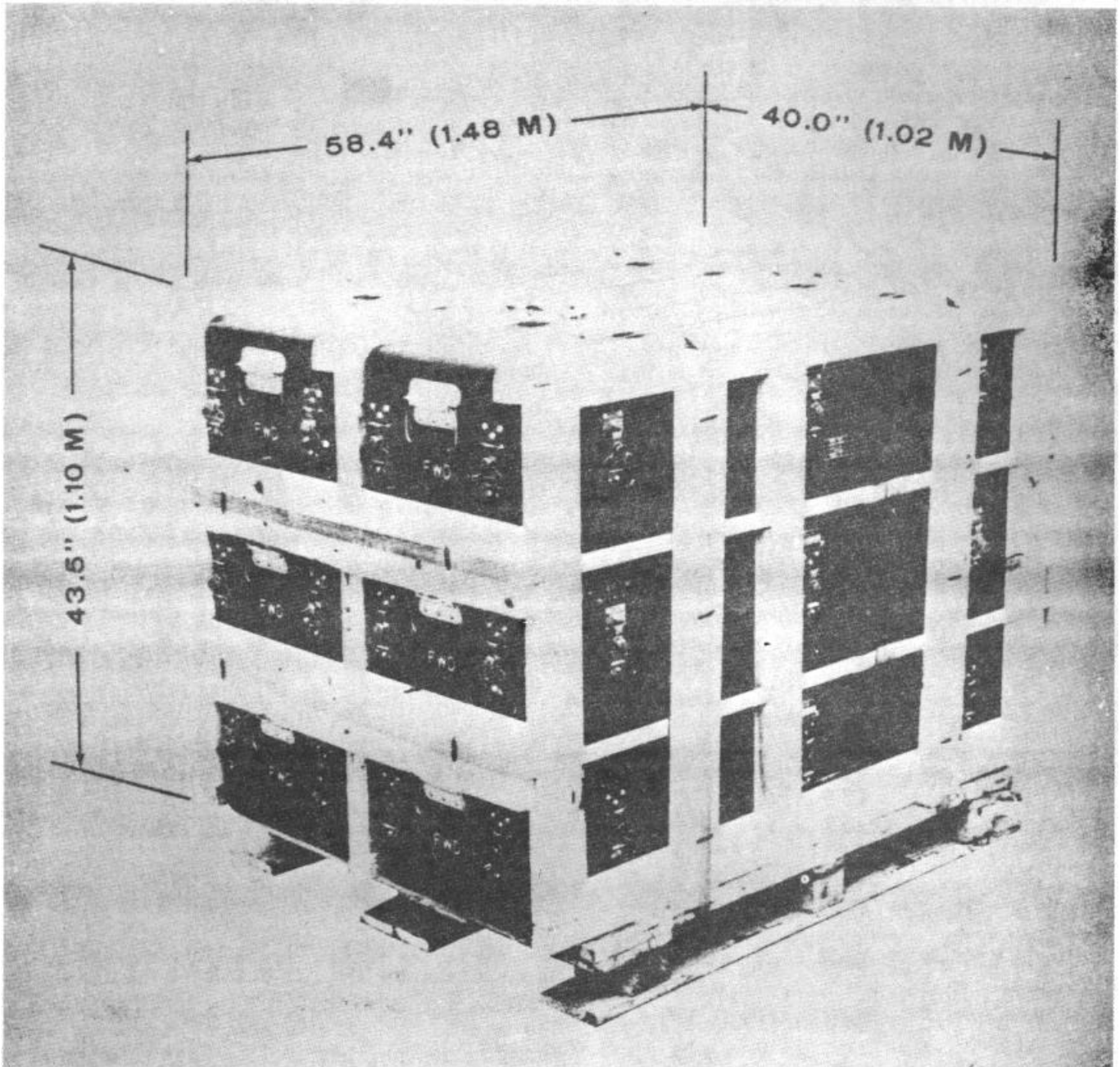

Figure 2-5. Palletized load of 6 shipping and storage containers, M571 (Monopak).

Section II. CHARACTERISTICS AND RELATED DATA OF ITEMS

2-3. General

The following data pertain to the identified basic items. Subsequent chapters show, where appropriate, dimensional data and weight for the items when configured for movement by a particular mode of transportation. Data are the latest available; weights and measurements are approximate.

Note. Data contained herein are applicable to model number or Federal Stock Number (FSN) shown. Changes in model number or FSN affect the loadability of the item as related to the guidance shown in this manual.

Note. Whenever weights and/or measurements are critical factors for transportability purposes, each item should be weighed and measured.

- a. M585 Shipping and Storage Container (Unipak).

Federal Stock Number: 8140-880-7285

Measurements (single container):

Length	56.8 in. (1.44 m)
Width	10.0 in. (0.25 m)
Height	15.5 in. (0.39 m)
Area	3.9 sq ft (0.37 sq m)
Volume	5.1 cu ft (0.41 cu m)
Weight	50 lb (23 kg) (loaded)
	19 lb (9 kg) (empty)

Measurements (12 containers, palletized):

Length	56.8 in. (1.44 m)
Width	40.0 in. (1.02 m)
Height	52.5 in. (1.33 m)
Area	15.7 sq ft (1.64 sq m)
Volume	68.7 cu ft (1.94 cu m)
Weight	686 lb (311 kg)

- b. M571 Shipping and Storage Container (Monopak).

Federal Stock Number: 8140-937-1340

Measurements (single container):

Length	56.0 in. (1.42 m)
Width	17.8 in. (0.44 m)
Height	12.5 in. (0.32 m)
Area	6.7 sq ft (0.62 sq m)

Volume	7.0 cu ft (0.20 cu ft)
Weight	72 lb (33 kg) (loaded)
	45 lb (21 kg) (empty)
Measurements (6 containers, palletized):	
Length	58.4 in. (1.48 m)
Width	40.0 in. (1.02 m)
Height	43.5 in. (1.10 m)
Area	16.2 sq ft (1.50 sq m)
Volume	58.8 cu ft (1.66 cu m)
Weight	662 lb (300 kg)

- c. Maintenance Equipment Shelter, GMS S-408 (XO-1) TSM.

Federal Stock Number: 4935-087-3227

Measurements (crated):

Length	202.0 in. (5.13 m)
Width	97.0 in. (2.46 m)
Height	99.0 in. (2.51 m)
Area	136.1 sq ft (12.63 sq m)
Volume	1,122.6 cu ft (31.77 cum)

Weight 6,600 lb (approx) (2994 kg)

Measurements (uncrated):

Length	187.5 in. (4.76 m)
Width	83.5 in. (2.12 m)
Height	83.8 in. (2.18 m)
Area	108.7 sq ft (10.09 sq m)
Volume	778.4 cu ft (22.02 cu m)
Weight	4,200 lb (approx) (1905 kg)

2-4. CONUS Freight Classification

Rail and motor freight classification descriptions and item numbers will be determined in accordance with chapter 211, AR 55-855 and the Freight Classification Guide System. Proper classification and/or description of articles must be determined and provided on the bill of lading before the shipment is released to the carrier.

CHAPTER 3

SAFETY

3-1. General

General safety considerations and precautions for movement are as follows:

- a. Do not walk under any items while they are being lifted by crane or other means.
- b. Insure that appropriate fire extinguishers (foam, soda acid, CO², dry chemical) are readily available during all loading and unloading operations.
- c. Insure that all lifting gear is in good order prior to lifting any of the items.

3-2. Hazardous Materials

Shipment of hazardous materials by all modes of commercial transportation within CONUS will be made in accordance with the requirements outlined in chapter 216, AR 55-355. It is mandatory that the utmost care and prudence be exercised by everyone engaged in the handling and transport of explosives, ammunition, and ammunition components for transport of the system's ammunition items.

a. When the missiles are transported by the various modes of transportation, the missile shipping and storage container will provide adequate shock and vibration protection provided the containers are securely tied down and braced in accordance with prescribed procedures (app).

b. The temperature limits on missile or ammunition containers must not be exceeded.

Warning. The intercept-aerial guided missile system, M41 (Redeye Air Defense Guided Missile System), contains explosives. All applicable safety regulations (app) will be strictly enforced. Explosive components containing electrical wiring must be protected at all times from stray voltages or induced electrical currents. Handling operations should not be performed during electrical storms. Explosives are contained in the warhead section, M221, and the rocket motor, M115. Insure that the explosives class A items and other hazardous materials on the system are shipped with compatible cargo when mixed in the same transport vehicle (app)

CHAPTER 4

AIR TRANSPORTABILITY GUIDANCE

The Redeye Air Defense Guided Missile System has not been test-loaded in US Army or Air Force aircraft. When the Redeye components are test-loaded, they will be included in this chapter.

CHAPTER 5

HIGHWAY TRANSPORTABILITY GUIDANCE

Section I. GENERAL

5-1. Scope

This chapter provides highway transportation guidance for the M41 Redeye missile in M585 and M571 shipping and storage containers, and for the GMS S-408 (XO-1) TSM maintenance equipment shelter. It covers significant technical and physical characteristics and prescribes the materials and guidance to prepare, load, and unload the items.

5-2. Safety

When the guided missile is shipped in a military vehicle over public highways in CONUS, movement is subject to all the safety laws, rules, and regulations applicable to commercial carriers, in addition to safety precautions contained in chapter 3. In oversea areas such movements are governed by theater regulations.

Section II. MOVEMENT BY MOTOR VEHICLE

5-3. General

The items can be transported over highways by various types of motor vehicles. When the missile is transported by motor vehicle, four reflectorized "Explosive A" placards must be conspicuously displayed on the front, rear, and on each side of the vehicle. The lettering on these placards will not be less than 6 inches high and will be series B letters of the Standard Highway Alphabet of the Federal Highway Administration. (It should be noted that California prohibits reflectorized placards on the front of truck trailers). The shipping name for the weapon is "Rocket Ammunition With Explosive Projectile." Shipping hazard classification DOT is Class A (app).

5-4. Preparation of Items

The degree of preparation for the items prior to being transported by vehicles is dependent upon the operational commitment.

5-5. Transport by Semitrailer*a. Loading.*

(1) The GMS S-408 (XO-1) TSM maintenance equipment shelter may be placed in the

tiedown position on flatbed or open-top semitrailers by crane.

(2) Palletized loads of missiles may be loaded with forklifts.

(3) After placement at the tiedown position, the items will be secured in accordance with figures 5-1, 5-2, 5-3, 5-4, and 5-6.

Note. The following figures were extracted from US Army Materiel Command missile drawings. Reference to page numbers in the notes within the figures refer to the number listed in the lower right or left-hand corner of each figure.

Note. Plus or minus tolerances reflected on figures for height of cross members above trailer or car floors are due to varying heights of wall members in different types of equipment. These tolerances have been predetermined as the maximum and minimum distances that may be used to provide adequate bearing on the load. These must not be exceeded.

Note. For lifting diagrams for each item, see chapter 6.

b. Unloading. Unloading is the reverse of loading.

GENERAL NOTES

- A. LOAD AS SHOWN IS BASED ON A CLOSED VAN TYPE TRAILER 40'-0" LONG X 7'-6" WIDE (INSIDE DIMENSION) WITH WOOD, BOARD AND METAL, OR METAL FLOOR.
- B. SELECTION OF VEHICLE TO BE USED TO TRANSPORT GUIDED MISSILE ABORTION AND/OR COMPONENTS THEREOF MUST COMPLY WITH AF 55-399, CHAPTER 213, FOR EXPLOSIVES OR OTHER DANGEROUS ARTICLES IN FULL.
- C. UNLESS A SHIPMENT WILL BE POSITIONED IN THE TRAILER CONSISTENT WITH STATE WEIGHT LAWS, THE NUMBER OF UNITS MAY BE ADJUSTED TO FIT THE DIMENSIONS OF THE VEHICLE CONCERNED OR THE QUANTITY TO BE SHIPPED; HOWEVER, THE APPROVED METHODS CONTAINED HEREIN FOR FULL OR PARTIAL TRUCKLOAD MUST BE FOLLOWED FOR BLOCKING, BRACING AND STAYING OF THIS ITEM.
- D. FOR DETAIL OF CONTAINER SEE DRAWING NO. X10212531.
 CONTAINER DIMENSIONS - 36-1/2" LONG X 17-1/2" WIDE X 12-1/2" HIGH.
 GROSS WEIGHT - 74 POUNDS (APPROX)
 TARE WEIGHT - 45 POUNDS (APPROX)
- E. FOR TRAILERS NOT EQUIPPED WITH REAR CORNER POSTS, REAR BLOCKING MUST CONTACT CLOSED DOORS.
- F. THIS ITEM IS AN IFC CLASS "A" EXPLOSIVE. SPECIFIED OUTLOADING PROCEDURES CAN ALSO BE UTILIZED FOR THE SHIPMENT OF THE DEPICTED CONTAINERS WHEN THEY ARE EMPTY OR LOADED WITH AN ITEM WHICH IS IDENTIFIED DIFFERENTLY BY NOMENCLATURE THAN THE ITEM DESIGNATED WITHIN THE DRAWING TITLE.

MATERIAL SPECIFICATIONS

- LAMBS: FED SPEC 88-L-791.
- NAILS: CORNER, CORNER COATED, FED SPEC FF-A-105.
 ALT: SQUARE-HEAD TYPE NAIL OF SAME SIZE.

Figure 5-1. Leading and bracing (TL & LTL) in van-type trailer of complete round, with three launcher batteries, packed in monopak container (sheet 1 of 4).

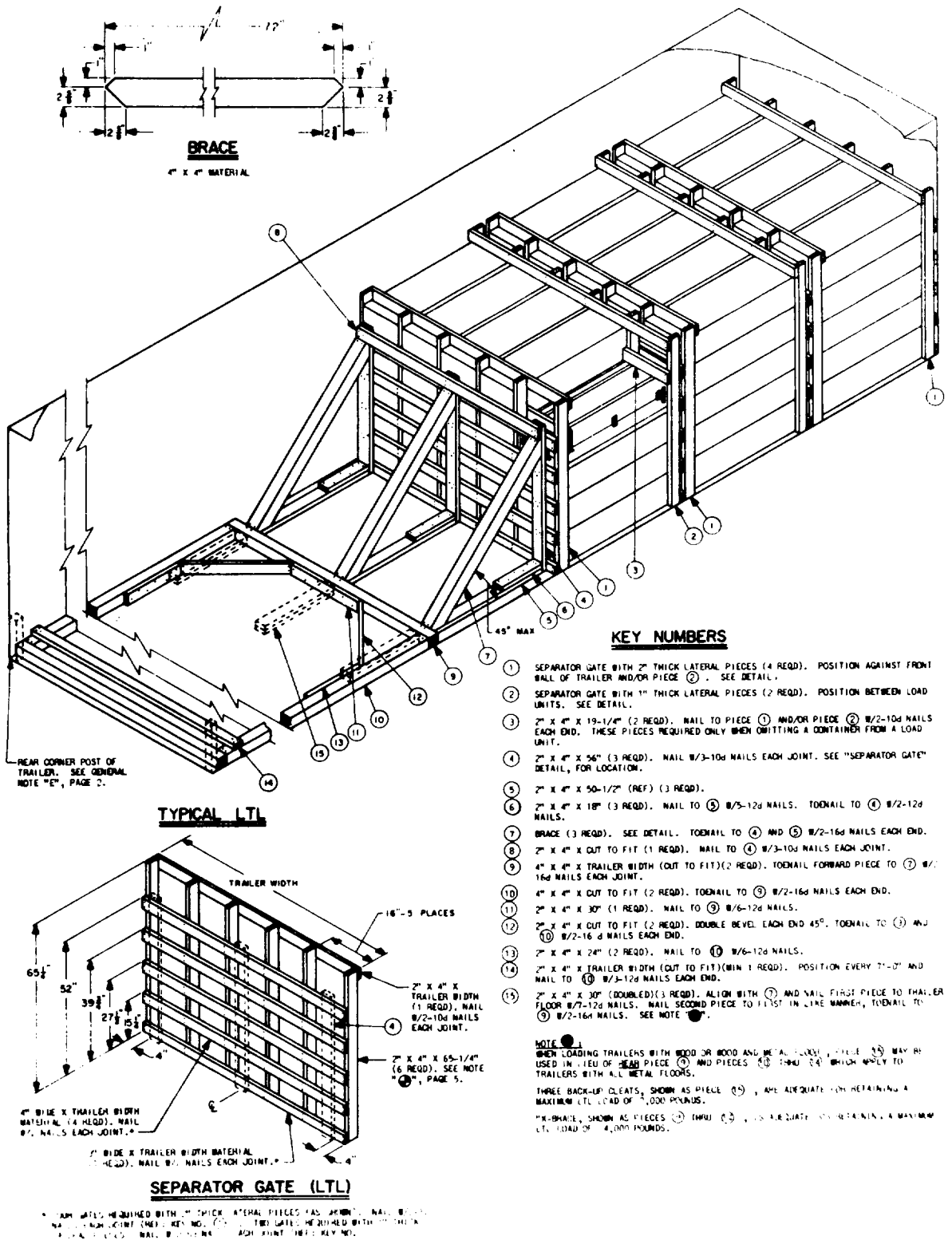

KEY NUMBERS

- 1 SEPARATOR GATE WITH 2" THICK LATERAL PIECES (4 REQD.). POSITION AGAINST FRONT WALL OF TRAILER AND/OR PIECE 2. SEE DETAIL.
- 2 SEPARATOR GATE WITH 1" THICK LATERAL PIECES (2 REQD.). POSITION BETWEEN LOAD UNITS. SEE DETAIL.
- 3 2" X 4" X 19-1/4" (2 REQD.). NAIL TO PIECE 1 AND/OR PIECE 2. 1/2-10d NAILS EACH END. THESE PIECES REQUIRED ONLY WHEN OMITTING A CONTAINER FROM A LOAD UNIT.
- 4 2" X 4" X 56" (3 REQD.). NAIL 1/3-10d NAILS EACH JOINT. SEE "SEPARATOR GATE" DETAIL, FOR LOCATION.
- 5 2" X 4" X 50-1/2" (REF.) (3 REQD.).
- 6 2" X 4" X 18" (3 REQD.). NAIL TO 5. 1/3-12d NAILS. TOENAIL TO 4. 1/2-12d NAILS.
- 7 BRACE (3 REQD.). SEE DETAIL. TOENAIL TO 4 AND 5. 1/2-16d NAILS EACH END.
- 8 2" X 4" X CUT TO FIT (1 REQD.). NAIL TO 4. 1/3-10d NAILS EACH JOINT.
- 9 4" X 4" X TRAILER WIDTH (CUT TO FIT)(2 REQD.). TOENAIL FORWARD PIECE TO 7. 1/2-16d NAILS EACH JOINT.
- 10 4" X 4" X CUT TO FIT (2 REQD.). TOENAIL TO 9. 1/2-16d NAILS EACH END.
- 11 2" X 4" X 30" (1 REQD.). NAIL TO 9. 1/6-12d NAILS.
- 12 2" X 4" X CUT TO FIT (2 REQD.). DOUBLE BEVEL EACH END 45°. TOENAIL TO 3 AND 10. 1/2-16d NAILS EACH END.
- 13 2" X 4" X 24" (2 REQD.). NAIL TO 10. 1/6-12d NAILS.
- 14 2" X 4" X TRAILER WIDTH (CUT TO FIT)(MIN 1 REQD.). POSITION EVERY 21-0" AND NAIL TO 10. 1/3-12d NAILS EACH END.
- 15 2" X 4" X 30" (DOUBLED)(3 REQD.). ALIGN WITH 7 AND NAIL FIRST PIECE TO TRAILER FLOOR 1/7-12d NAILS. NAIL SECOND PIECE TO FIRST IN LIKE MANNER, TOENAIL TO 9. 1/2-16d NAILS. SEE NOTE 1.

NOTE 1
 WHEN LOADING TRAILERS WITH WOOD OR WOOD AND METAL FLOOR, PIECE 15 MAY BE USED IN LIEU OF HEAD PIECE 8 AND PIECES 6, 9 AND 14 WHICH APPLY TO TRAILERS WITH ALL METAL FLOORS.
 THREE BACK-UP CLEATS, SHOWN AS PIECE 15, ARE ADEQUATE FOR RETAINING A MAXIMUM LTL LOAD OF 2,000 POUNDS.
 1" X 6" BRACE, SHOWN AS PIECES 7 THRU 9, IS ADEQUATE FOR RETAINING A MAXIMUM LTL LOAD OF 2,000 POUNDS.

* GATE UNITS REINFORCED WITH 1" THICK LATERAL PIECES (AS SHOWN) NAIL WITH 1/2-10d NAILS EACH JOINT (SEE KEY NO. 1). TWO GATES REINFORCED WITH 1" THICK LATERAL PIECES NAIL WITH 1/3-10d NAILS EACH JOINT (SEE KEY NO. 2).

Figure 5-1—Continued (sheet 2 of 4).

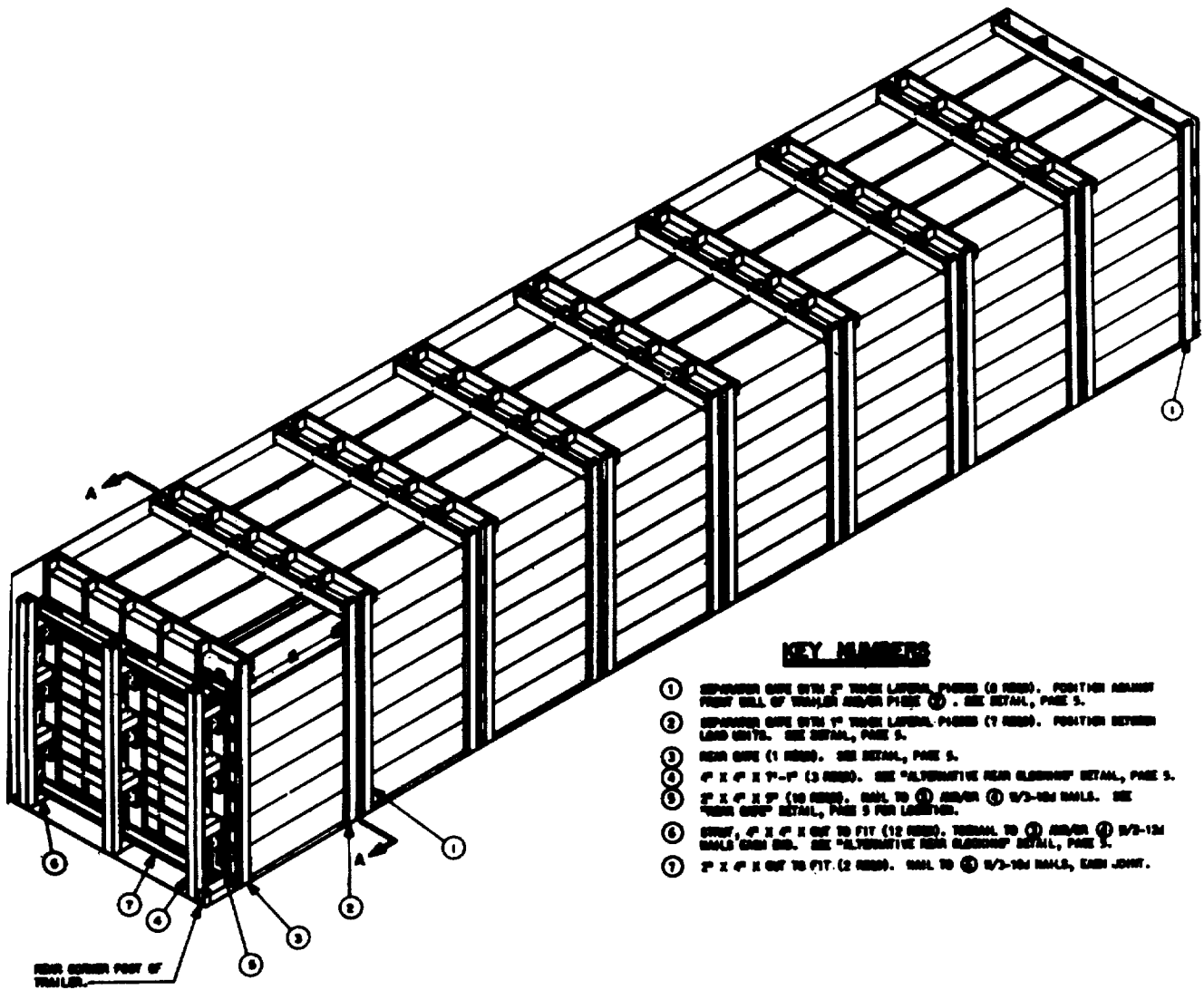

REAR CORNER PORT OF TRAILER.
ISOMETRIC VIEW

KEY NUMBERS

- ① SEPARATOR GATE WITH 2" THICK LATERAL PIPES (3 NEED). POSITION AGAINST FRONT BELL OF TRAILER AND/OR PIECE ②. SEE DETAIL, PAGE 5.
- ② SEPARATOR GATE WITH 1" THICK LATERAL PIPES (7 NEED). POSITION BETWEEN LOAD UNITS. SEE DETAIL, PAGE 5.
- ③ REAR GATE (1 NEED). SEE DETAIL, PAGE 5.
- ④ 4" X 4" X 7'-0" (3 NEED). SEE "ALTERNATIVE REAR BLOSSOM" DETAIL, PAGE 5.
- ⑤ 2" X 4" X 8" (10 NEED). SEAL TO ① AND/OR ④ 1/2"-10d NAILS. SEE "REAR GATE" DETAIL, PAGE 5 FOR LIGHTING.
- ⑥ GUYOT, 4" X 4" X 8" TO FIT (12 NEED). TYPICAL TO ① AND/OR ④ 1/2"-12d NAILS OVER END. SEE "ALTERNATIVE REAR BLOSSOM" DETAIL, PAGE 5.
- ⑦ 2" X 4" X 8" TO FIT (2 NEED). SEAL TO ④ 1/2"-10d NAILS, EACH JOINT.

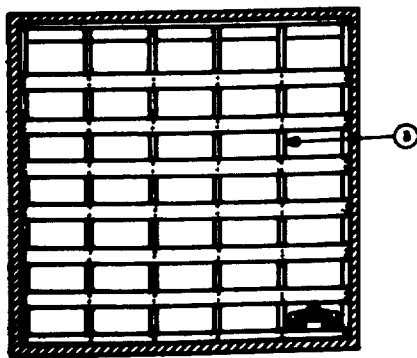

SECTION A-A

BILL OF MATERIAL		
LENGTH	LINEAL FEET	BOARD FEET
1" X 4" X 8"	30	14
2" X 4" X 8"	60	123
2" X 4" X 7"	1217	34
2" X 4" X 8"	31	612
2" X 4" X 8"	31	20
2" X 4" X 8"	31	42
NAILS		POUNDS
6d (2")	572	4
10d (3")	500	15-1/2
12d (3-1/4")	60	1

LOAD AS SHOWN

LINE	CAPACITY	WEIGHT (APPROX)
CONTAINER	200	20,700 LBS
BRIDGE		2,431 LBS
TOTAL WEIGHT		23,131 LBS

Figure 5-1—Continued (sheet 3 of 4).

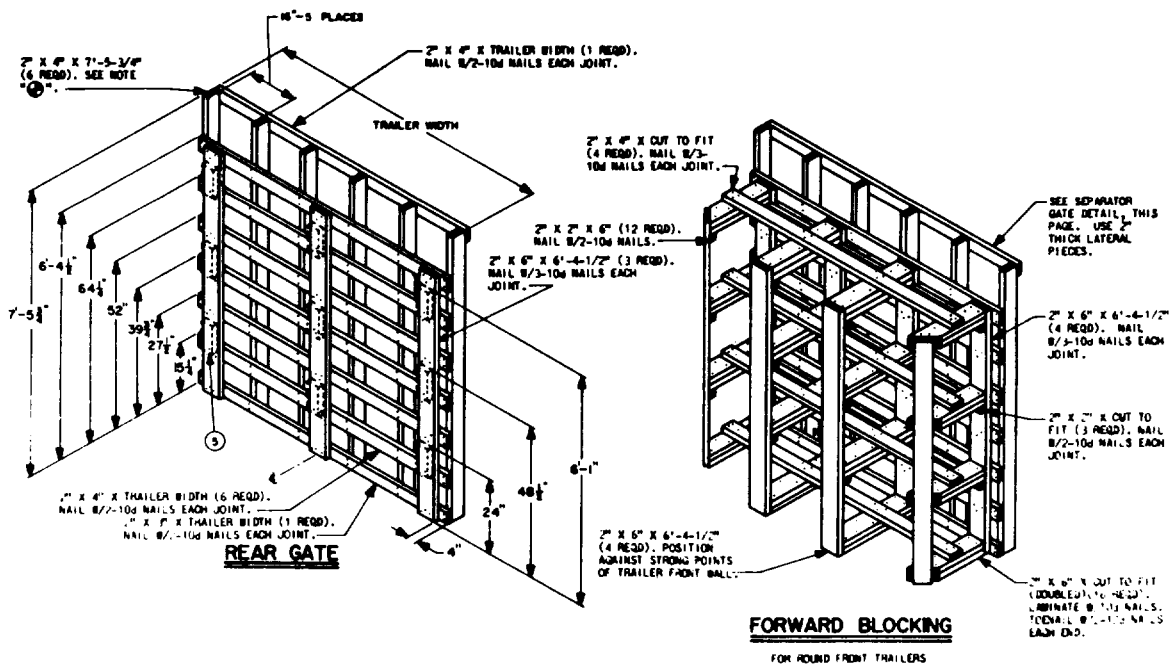
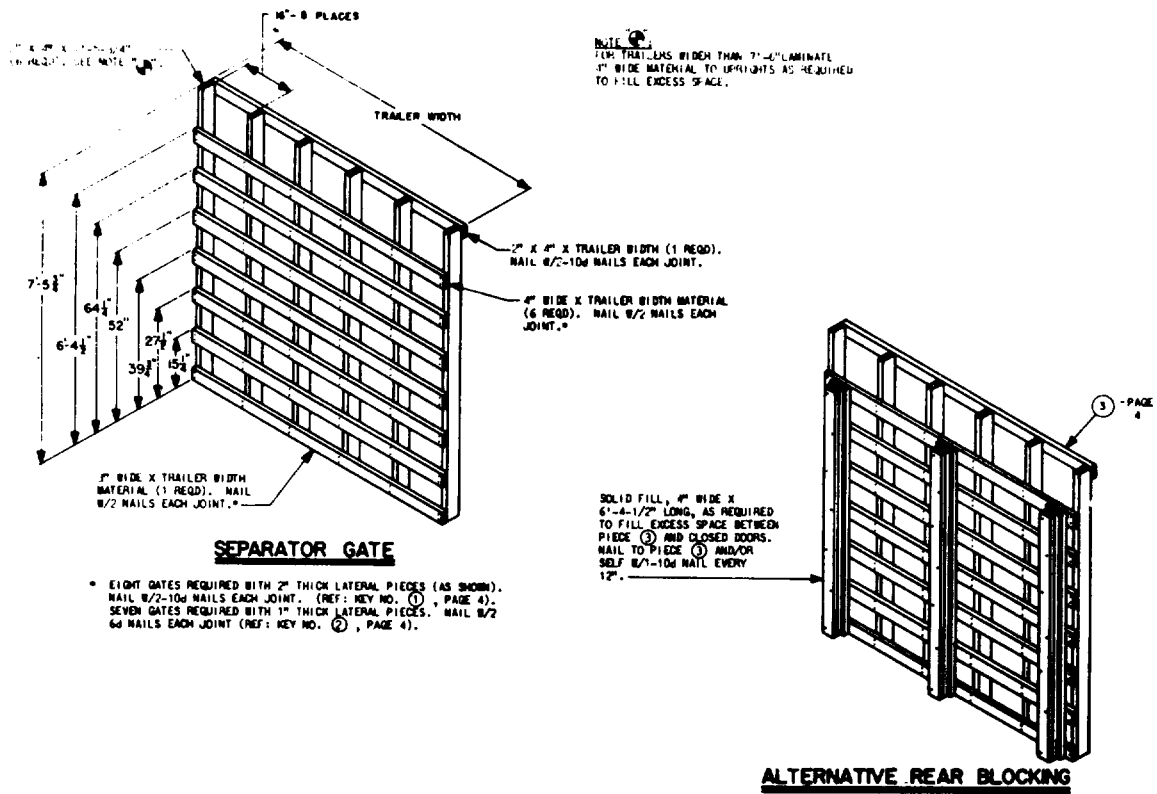
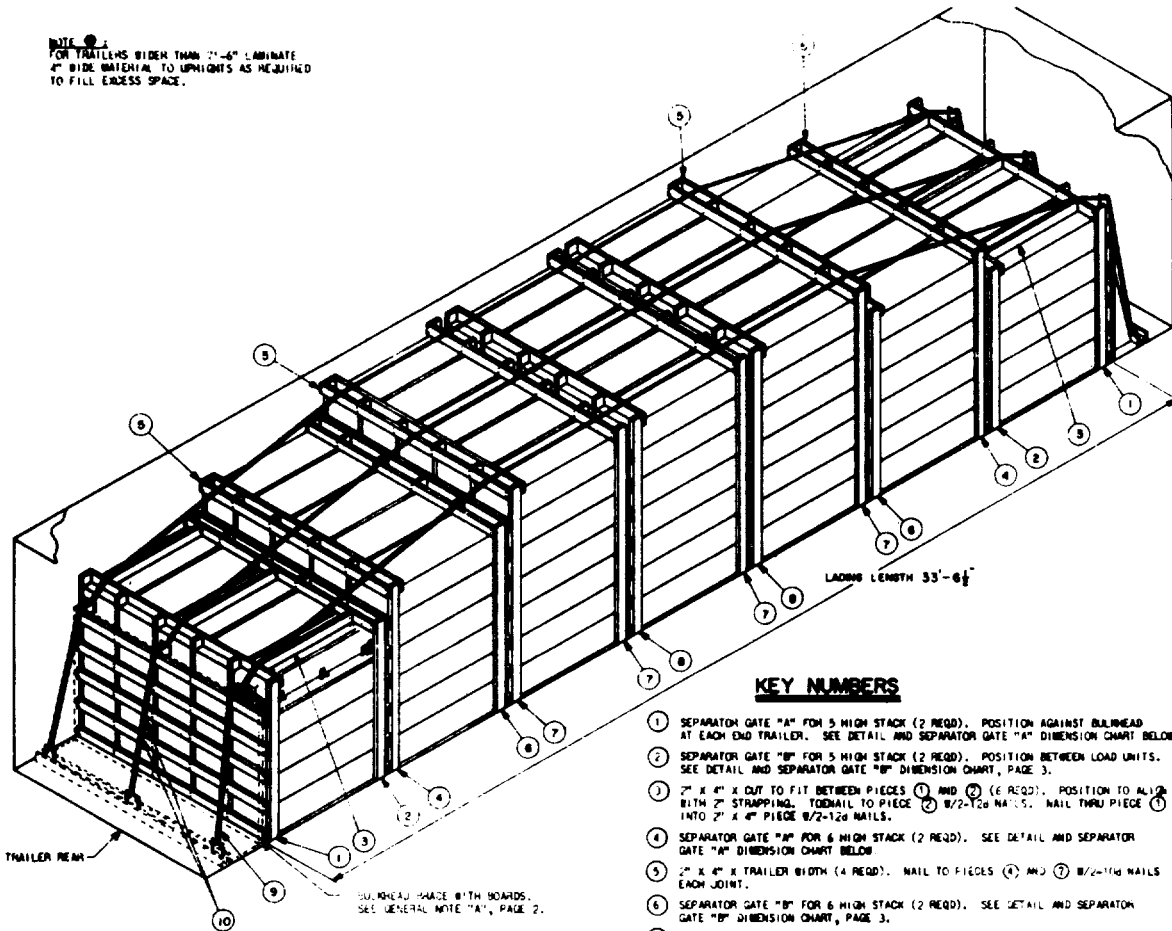

Figure 5-1—Continued (sheet 4 of 4).

NOTE
 FOR TRAILERS WIDER THAN 2'-6" LAMINATE
 2" WIDE MATERIAL TO UPRIGHTS AS REQUIRED
 TO FILL EXCESS SPACE.



ISOMETRIC VIEW

2" X 4" X TRAILER WIDTH
 (1 REQD). NAIL 8/2-10d
 NAILS EACH JOINT.

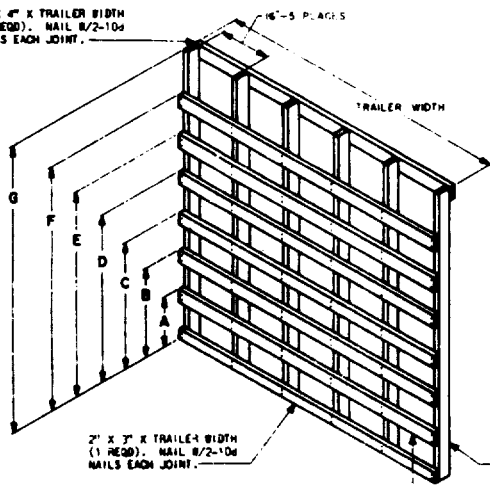

SEPARATOR GATE "A"

SEE CHART AT RIGHT FOR DIMENSIONS.

KEY NUMBERS

- 1 SEPARATOR GATE "A" FOR 5 HIGH STACK (2 REQD). POSITION AGAINST BULKHEAD AT EACH END TRAILER. SEE DETAIL AND SEPARATOR GATE "A" DIMENSION CHART BELOW.
- 2 SEPARATOR GATE "B" FOR 5 HIGH STACK (2 REQD). POSITION BETWEEN LOAD UNITS. SEE DETAIL AND SEPARATOR GATE "B" DIMENSION CHART, PAGE 3.
- 3 2" X 4" X CUT TO FIT BETWEEN PIECES 1 AND 2 (6 REQD). POSITION TO ALIGN WITH 2" STRAPPING. TORNAIL TO PIECE 2 8/2-12d NAILS. NAIL THRU PIECE 1 INTO 2" X 4" PIECE 8/2-12d NAILS.
- 4 SEPARATOR GATE "A" FOR 6 HIGH STACK (2 REQD). SEE DETAIL AND SEPARATOR GATE "A" DIMENSION CHART BELOW.
- 5 2" X 4" X TRAILER WIDTH (4 REQD). NAIL TO PIECES 4 AND 7 8/2-10d NAILS EACH JOINT.
- 6 SEPARATOR GATE "B" FOR 6 HIGH STACK (2 REQD). SEE DETAIL AND SEPARATOR GATE "B" DIMENSION CHART, PAGE 3.
- 7 SEPARATOR GATE "A" FOR 7 HIGH STACK (4 REQD). SEE DETAIL AND SEPARATOR GATE "A" DIMENSION CHART BELOW.
- 8 SEPARATOR GATE "B" FOR 7 HIGH STACK (2 REQD). SEE DETAIL AND SEPARATOR GATE "B" DIMENSION CHART, PAGE 3.
- 9 STEEL STRAPPING, 2" X .050" X 60"-0" (3 REQD). SEE GENERAL NOTE "F", PAGE 3.
- 10 SEALS FOR 2" STRAPPING (18 REQD).

SEPARATOR GATE "A" DIMENSION CHART			
DIMENSION	5 HIGH STACK	6 HIGH STACK	7 HIGH STACK
A	15-1/4"	15-1/4"	15-1/4"
B	27-1/2"	27-1/2"	27-1/2"
C	39-3/4"	39-3/4"	39-3/4"
D	52"	52"	52"
E	64-1/4"	64-1/4"	64-1/4"
F	81-41/2"	81-41/2"	81-41/2"
G	65-1/4"	61-5/8"	57-5/8"

Figure 5-2. Loading and bracing in van-type trailer for trailer-on-flatcar (TOFC) shipment of complete round with three launcher batteries, packed in monopak container (sheet 1 of 3).

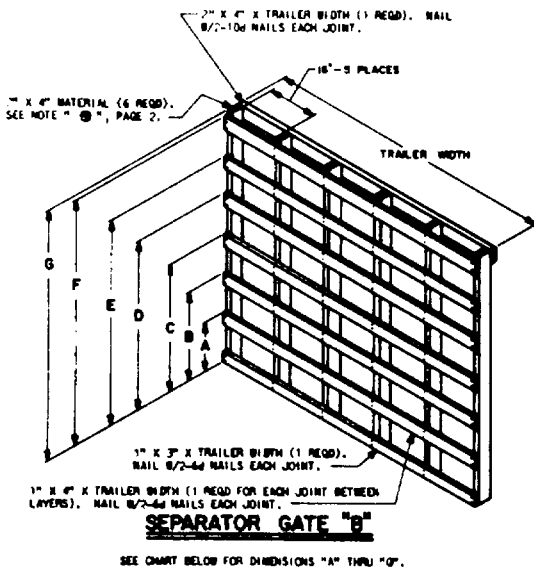

SEPARATOR GATE "B" DIMENSION CHART

DIMENSION	5 HIGH STACK	6 HIGH STACK	7 HIGH STACK
A	15-1/4"	15-1/4"	15-1/4"
B	27-1/2"	27-1/2"	27-1/2"
C	39-3/4"	39-3/4"	39-3/4"
D	52"	52"	52"
E	64-1/4"	64-1/4"	64-1/4"
F	61-4-1/2"	61-4-1/2"	61-4-1/2"
G	65-1/4"	61-5-1/2"	71-5-3/4"

BILL OF MATERIAL

LUMBER	LINEAL FEET	BOARD FEET
1" X 3"	45	12
1" X 4"	255	85
2" X 3"	60	30
2" X 4"	1027	685
NAILS	NO. REQD	POUNDS
6d (2")	480	3
10d (3")	816	12-3/4
12d (3-1/4")	24	1/2
STEEL STRAPPING, 2" X .050"	180' REQD	60 LBS
SEALS FOR 2" STRAPPING	18 REQD	4 LBS

MATERIAL SPECIFICATIONS

- LUMBER ----- 1 - FED SPEC 84-L-751.
- NAILS ----- 1 - COMMON, CORROSION COATED, FED SPEC FF-8-189.
ALT: ANNEALING TYPE NAIL OF SAME SIZE.
- STRAPPING, STEEL ----- 1 - TYPE 1, CLASS "A" OR "C", FED SPEC 88-6-701.
FOR FRI SEE 88-38-180.

GENERAL NOTES

- A. LOADING AND BRACING PROCEDURES SHOWN HEREIN ARE APPLICABLE TO TRAILER EQUIPPED WITH SPECIAL BULKHEAD BRACES AS PER ORDNANCE CORPS DRAWING 19-48-D-ORDJG-1440. TRAILER LOADS WILL BE SHIPPED ONLY ON THE APPROVED TYPE OF RAILROAD EQUIPMENT LISTED THEREIN.
- B. LOAD AS SHOWN IS BASED ON A VAN TYPE TRAILER HAVING 33'-4-1/2" CLEARANCE BETWEEN INSTALLED BULKHEAD BRACES X 7'-6" WIDE (INSIDE DIMENSION). SEE GENERAL NOTE "K".
- C. SELECTION OF VEHICLES TO BE USED TO TRANSPORT CONTAINERS MUST COMPLY WITH AR 95-295, CHAPTER 213, FOR EXPLOSIVES OR OTHER DANGEROUS ARTICLES, IN FULL.
- D. **SHIELDS:** A SHIELD WILL BE POSITIONED IN THE TRAILER CONSISTENT WITH THE HEIGHT LAW OF THE STATES THROUGH WHICH THE TRAILER WILL BE TRANSPORTED VIA HIGHWAY.
- E. FOR DETAIL OF CONTAINER SEE DRAWING NO. X10212531.
CONTAINER DIMENSIONS - 56-1/2" LONG X 17-1/2" WIDE X 12-1/2" HIGH.
GROSS WEIGHT ----- 74 POUNDS (APPROX).
TARE WEIGHT ----- 45 POUNDS (APPROX).
- F. WHEN STEEL STRAPPING IS SEALED AT AN END-OVER-END LAP JOINT OR AT A LAPPED-BACK-ON-SELF JOINT, A MINIMUM OF TWO (2) SEALS WITH TWO (2) CRUMPS PER SEAL MUST BE USED TO SEAL THE JOINT.
- G. THIS ITEM IS IN 100 CLASS "A" EXPLOSIVE. PROCEDURES SHOWN HEREIN ARE ALSO APPLICABLE FOR THE SHIPMENT OF THE DEPICTED CONTAINERS WHEN THEY ARE EMPTY OR LOADED WITH AN ITEM WHICH IS IDENTIFIED DIFFERENTLY BY NOMENCLATURE THAN THE ITEM DESIGNATED WITHIN THE DRAWING TITLE.
- H. DO NOT NAIL BLOCKING SHOWN HEREIN TO TRAILER BULKHEADS, SIDE BARS OR FLOOR. ALL NAILING WILL BE WITHIN THE SHIPMENT.
- J. THE STACKS ADJACENT TO BULKHEAD BRACE AND "TYPICAL END BLOCKING" ARE LIMITED TO FIVE (5) LAYERS IN HEIGHT.
- K. WHEN LOADING SIX (6) LOAD UNITS LONG IN A TRAILER HAVING APPROXIMATELY 33'-0" CLEARANCE BETWEEN INSTALLED BULKHEAD BRACES, THE VERTICAL 2" X 4" PIECES OF REAR SEPARATOR GATES "A", PIECES (1) AND (2), MUST BE INCREASED IN HEIGHT 6" AND 3" RESPECTIVELY. APPLY PIECE (3) AT TOP OF SEPARATOR GATE, PIECE (4) AND ADD ONE ADDITIONAL PIECE (5) AT TOP OF REAR SEPARATOR GATE, PIECE (1), TO PROVIDE CONTACT WITH 2" STEEL STRAPPING, PIECE (6), FOR HOLD BORN OF GATES AND LADING. **NOTE:** AT LEAST ONE SEPARATOR GATE BETWEEN EACH LOAD UNIT MUST BE CONTACTED BY STEEL STRAPPING, PIECE (6), AFTER INSTALLATION.
- L. FOR THE SHIPMENT OF A SMALLER LOAD, THE LOAD AS SHOWN MAY BE DECREASED BY MULTIPLES OF FIVE CONTAINERS BY OMITTING A LAYER FROM ONE OR MORE LOAD UNITS. FOR A QUANTITY OF FIVE OR LESS IN ONE LAYER, USE PROCEDURE SHOWN IN "TYPICAL FILL" DETAIL, PAGE 4.

LOAD AS SHOWN

ITEM	QUANTITY	WEIGHT (APPROX)
CONTAINERS	215	15,910 LBS
SHIPPING		2,111 LBS
TOTAL WEIGHT		18,021 LBS

Figure 5-2—Continued (sheet 2 of 3).

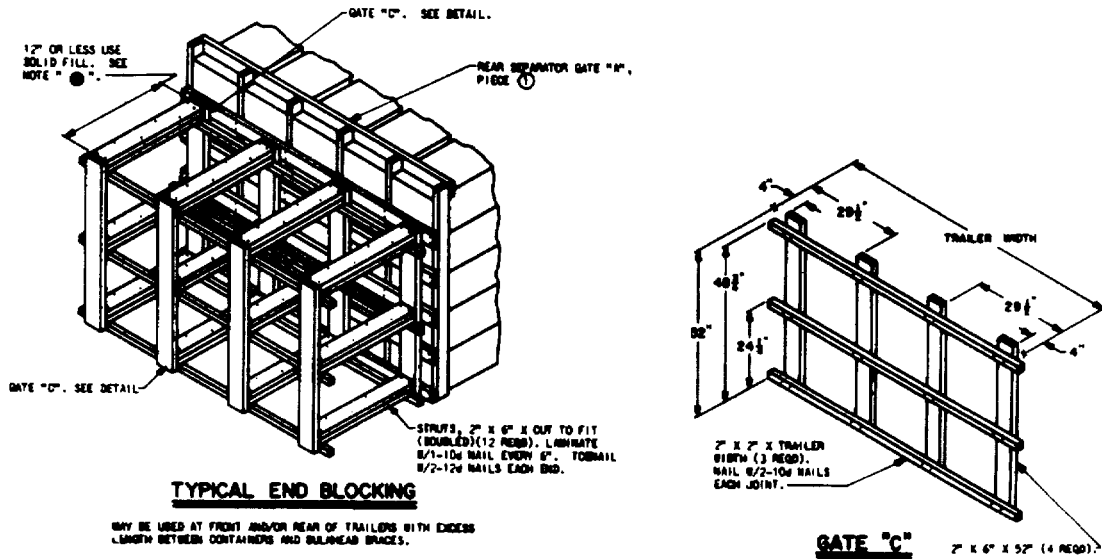

NOTE 1
MAY BE USED AT FRONT AND/OR REAR OF TRAILERS WITH EXCESS LENGTH BETWEEN CONTAINERS AND BULKHEAD BRACES.

NOTE 2
AS APPLICABLE, 6" WIDE VERTICAL SOLID FILL (POSITIONED IN LOCATION SHOWN FOR VERTICAL PIECES OF GATE "C") MAY BE SUBSTITUTED FOR THE TWO GATES "C" AND STRUPS. USE SOLID FILL FOR AN EXCESS SPACE WHICH IS LESS THAN 12". LAMINATE FIRST PIECE OF FILL INTERNAL TO REAR SEPARATOR GATE "A" 8/1-10d NAIL EACH JOINT. LAMINATE ADDITIONAL PIECES 8/3-10d NAILS.

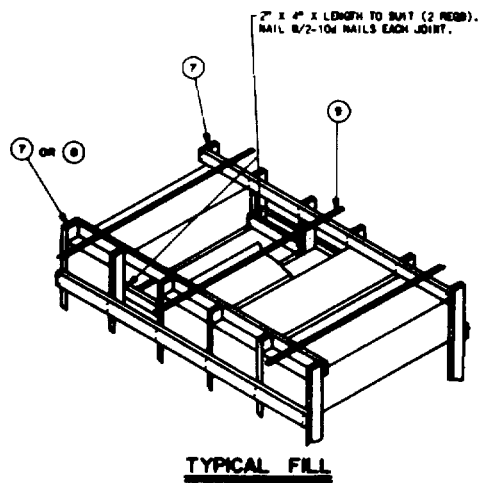

PROCEDURE SHOWN FOR THE ORIBACK OF ONE CONTAINER FROM A STACK. METHOD IS APPLICABLE FOR ANY QUANTITY FROM ONE TO FIVE AND MUST BE USED WHEN HEIGHT OF STACK IS LESS THAN HEIGHT OF SEPARATOR GATE, I.E., SIX HIGH STACK REQUIRES A SEPARATOR GATE PER SEVEN HIGH STACK IN ORDER TO PROVIDE CONTACT WITH 2" STRAPPING.

Figure 5-2—Continued (sheet 3 of 3).

GENERAL NOTES

- A. Not applicable.
- B. THE OUTLOADING PROCEDURES SPECIFIED HEREIN ARE APPLICABLE TO THE REDEYE MISSILE WHEN IT IS PACKED IN THE UNIPAK CONTAINER. SUBSEQUENT REFERENCE TO CONTAINER HEREIN MEANS THE UNIPAK CONTAINER WITH CONTENTS.
- C. FOR DETAIL OF THE XM585 CONTAINER (UNIPAK) SEE DRAWING NO. H826P9, AND "XM585 CONTAINER (UNIPAK)" VIEW ON PAGE 3.
CONTAINER DIMENSIONS --- 56-1/2" LONG X 10" WIDE X 15-1/2" HIGH.
GROSS WEIGHT ----- 48 POUNDS (APPROX).
- D. FOR DETAIL OF THE PALLETIZED UNIT SEE U.S. ARMY MATERIEL COMMAND DRAWING NO. 19-48-5232-GM00P3, AND "PALLET UNIT" VIEW ON PAGE 3.
PALLET UNIT DIMENSIONS --- 56-1/2" LONG X 40" WIDE X 32-1/2" HIGH.
GROSS WEIGHT ----- 486 POUNDS (APPROX).
- E. THIS ITEM IS A DOT CLASS "A" EXPLOSIVE. THE OUTLOADING PROCEDURES SPECIFIED HEREIN CAN ALSO BE UTILIZED FOR THE SHIPMENT OF THE DEPICTED CONTAINERS WHEN THEY ARE LOADED WITH AN ITEM WHICH IS IDENTIFIED DIFFERENTLY BY NOMENCLATURE THAN THE ITEM DESIGNATED WITHIN THE DRAWING TITLE.
- F. THE LOADS AS SHOWN HEREIN ARE FOR CLOSED OR OPEN TOP VAN TRAILERS WHICH ARE 80" TO 92" WIDE (INSIDE DIMENSION) AND OF VARIOUS LENGTHS, AND THEY ARE LIMITED TO HIGHWAY MOVEMENTS ONLY. THE DEPICTED LOADS ARE BASED ON TRAILERS OF THE CONVENTIONAL TYPE OR ARE BASED ON TRAILERS WHICH ARE EQUIPPED WITH SELF-CONTAINED MECHANICAL BRACING DEVICES (CROSS MEMBERS AND WALL MEMBERS) AND APPLY TO TRAILERS HAVING WOOD, WOOD AND METAL, OR METAL FLOORS.
- G. THE OUTLOADING PROCEDURES SPECIFIED ON PAGES 4 THROUGH 31 ARE FOR CONVENTIONAL TYPE VAN TRAILERS.
- H. THE OUTLOADING PROCEDURES SPECIFIED ON PAGES 22 THROUGH 30 ARE FOR TRAILERS EQUIPPED WITH VARIOUS TYPES OF SELF-CONTAINED MECHANICAL BRACING DEVICES. HOWEVER, CROSS MEMBER ATTACHMENT FACILITIES WITHIN THESE TRAILERS MUST PROVIDE FOR THE INSTALLATION OF LOAD BLOCKING CROSS MEMBERS AT THE HEIGHTS SPECIFIED HEREIN. CAUTION: TRAILERS EQUIPPED WITH FACILITIES WHICH DO NOT MEET THE LOCATION REQUIREMENTS MUST NOT BE USED. THE HEIGHT DIMENSIONS SPECIFIED WITHIN THIS DRAWING FOR INSTALLATION OF CROSS MEMBERS ARE IDENTICAL WITH THOSE RECOMMENDED BY THE BUREAU OF EXPLOSIVES PAMPHLET 6C, AND APPENDICES THERETO.
 - 1. VOIDS LENGTHWISE WITHIN THE LOAD MUST BE HELD TO A MINIMUM. CROSS MEMBERS MUST BE PLACED AGAINST THE LADING AS THOUGHTLY AS THE HOLE SPACING IN THE CROSS MEMBER ATTACHMENT FACILITY PERMITS. EACH CROSS MEMBER WILL BE INSTALLED WITH THE ENDS ATTACHED AS NEARLY AS POSSIBLE IN "MATED" POSITIONS (AT EQUAL HEIGHTS AND AT EQUAL DISTANCES FROM THE END OF THE TRAILER).
 - 2. CROSS MEMBERS IN EMPTY TRAILERS AND THOSE NOT USED IN LOADED TRAILERS MUST BE SECURED FOR SHIPMENT. COMPONENTS ASSIGNED TO EACH TRAILER MUST REMAIN THEREWITH EVEN THOUGH UNUSED DURING SOME SHIPMENTS.
 - 3. A CROSS MEMBER WILL NOT BE RELIED UPON TO RETAIN MORE CONTAINERS THAN SHOWN IN THE LOAD VIEWS.
- J. GROSS WEIGHT AND AXLE DISTRIBUTION OF WEIGHT FOR A LOAD WILL BE THE RESPONSIBILITY OF THE CARRIER. THE CARRIER WILL ADVISE THE SHIPPER OF THE APPLICABLE LOADING REQUIREMENTS AND THE SHIPPER WILL LOAD ACCORDINGLY.

(CONTINUED AT RIGHT)

(GENERAL NOTES CONTINUED)

- K. THE APPROVED BLOCKING, BRACING, AND STAYING METHODS FOR THE LOADS SPECIFIED HEREIN MUST BE FOLLOWED. THE NUMBER OF UNITS MAY BE ADJUSTED TO FIT THE SIZE OF THE VEHICLE TO BE LOADED OR THE QUANTITY TO BE SHIPPED. FOR A LOAD QUANTITY OTHER THAN SPECIFIED, THE APPROVED METHODS MUST BE FOLLOWED AS CLOSELY AS POSSIBLE.
- L. OTHER TYPES OF LADING ITEMS MAY BE LOADED INTO TRAILERS WHICH ARE PARTIALLY LOADED WITH THE DESIGNATED ITEM, PROVIDED THE TOTAL LOAD IS COMPATIBLE, EXISTING RESTRICTIONS ARE NOT VIOLATED, AND THE OTHER LADING ITEMS ARE BLOCKED AND BRACED TO EQUAL THE BLOCKING AND BRACING CRITERIA SPECIFIED HEREIN.
- M. DUNNAGE LUMBER SPECIFIED THROUGHOUT THIS PROCEDURAL DRAWING IS OF NOMINAL SIZE. FOR EXAMPLE, 2" X 4" MATERIAL IS ACTUALLY 1-5/8" THICK BY 3-5/8" WIDE AND 2" X 6" MATERIAL IS ACTUALLY 1-5/8" THICK BY 5-5/8" WIDE.
- N. FOR CONVENTIONAL TYPE TRAILERS NOT EQUIPPED WITH REAR CORNER POSTS, REAR BLOCKING MUST BE EXTENDED TO CONTACT THE REAR DOORS OF THE TRAILER WHEN THEY ARE CLOSED.
- P. NOTICE: A STAGGERED NAILING PATTERN WILL BE USED WHEREVER POSSIBLE WHEN NAILS ARE DRIVEN INTO JOINTS OF DUNNAGE ASSEMBLIES. ALSO, A STAGGERED NAILING PATTERN WILL BE USED WHEN DUNNAGE IS NAILED TO THE FLOOR OF THE TRANSPORTING VEHICLE, OR WHEN LAMINATING DUNNAGE. ADDITIONALLY, THE NAILING PATTERN FOR AN UPPER PIECE OF LAMINATED DUNNAGE WILL BE ADJUSTED AS REQUIRED SO THAT A NAIL FOR THAT PIECE WILL NOT BE DRIVEN THROUGH ONTO OR BOWE BESIDE A NAIL IN A LOWER PIECE.
- Q. PORTIONS OF THE TRAILER BODY DEPICTED WITHIN THIS PROCEDURAL DRAWING, SUCH AS ONE OF THE SIDE WALLS, HAVE NOT BEEN SHOWN IN THE LOAD VIEWS FOR CLARITY PURPOSES.
- R. FOR ADDITIONAL GUIDANCE, ATTENTION IS DIRECTED TO THE "CONTAINER AND PALLET UNIT DETAILS" ON PAGE 3 AND TO THE "SPECIAL NOTES" SECTION WHICH IS IMMEDIATELY ADJACENT TO A DEPICTED OUTLOADING METHOD.
- S. WHEN 1-1/4" STEEL STRAPPING IS SEALED AT AN END-OVER-END LAP JOINT FOR A STRAP APPLICATION OTHER THAN FOR PALLETIZING, A MINIMUM OF TWO (2) SEALS, BUTTED TOGETHER, WITH TWO (2) PAIR OF CRAMPS PER SEAL MUST BE USED.

MATERIAL SPECIFICATIONS

- LUMBER** --- SEE TM 743-300-1, DUNNAGE LUMBER, FED SPEC MM-1-751.
- NAILS** --- COMMON, CEMENT COATED OR CHEMICALLY ETCHED, FED SPEC FF-N-105.
ALT: ANNULAR-RING TYPE NAIL OF THE SAME SIZE.
- WIRE** --- FED SPEC QQ-W-461.
- PLYWOOD**: GROUP B OR C, GRADE * C-D (EXTERIOR); FED SPEC MM-P-328.
FSN 5330-051-1198.
- STRAPPING STEEL**: TYPE I OR IV, CLASS A OR B FOR PALLETIZING AND CLASS A, B, OR C FOR OUTLOADING, FED SPEC QQ-S-704.
- STRAP SEAL, STAPLE** --- COMMERCIAL GRADE.

* IF SPECIFIED GRADE IS NOT AVAILABLE, A BETTER GRADE MAY BE USED.

Figure 5-3. Loading and bracing in vehicle equipped with mechanical bracing system of complete round, with three launcher batteries packed in unipak container, unpalletized and palletized for container/trailer-on-flatcar (C/TOFC) shipment (sheet 1 of 13).

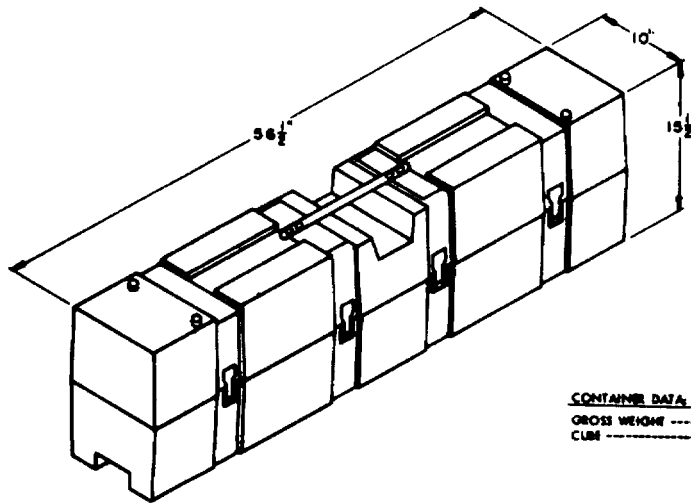

CONTAINER DATA
 GROSS WEIGHT ----- 48 POUNDS (APPROX).
 CUBIC ----- 5.67 CUBIC FEET.

XM 585 CONTAINER (UNIPAK)

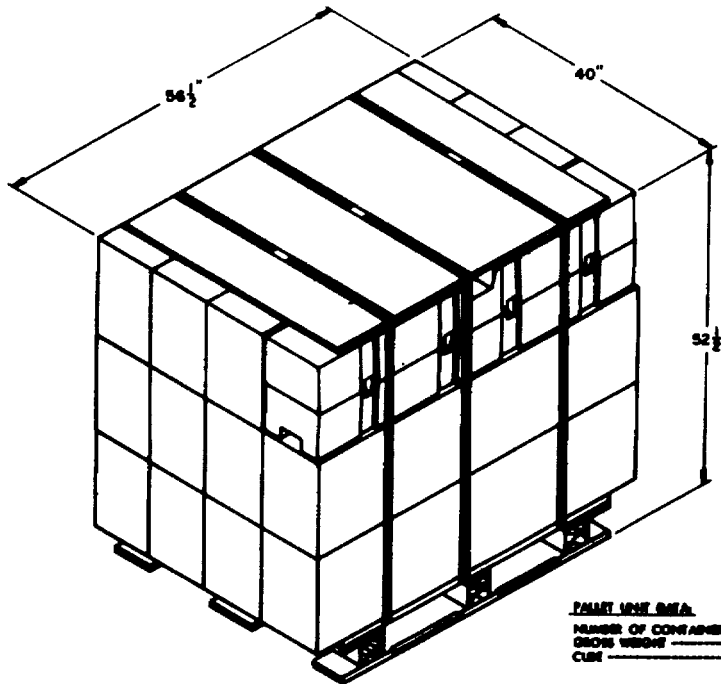

PALLET UNIT DATA
 NUMBER OF CONTAINERS ----- TWELVE (12).
 GROSS WEIGHT ----- 624 POUNDS (APPROX).
 CUBIC ----- 68.7 CUBIC FEET.

PALLET UNIT

FOR THE FABRICATION OF THIS PALLET UNIT, SEE U.S. ARMY MATERIAL
 COMMAND DRAWING NO. 19-48-3722-0-00001.

DETAILS OF CONTAINER AND PALLET UNIT

Figure 5-3—Continued (sheet 2 of 13).

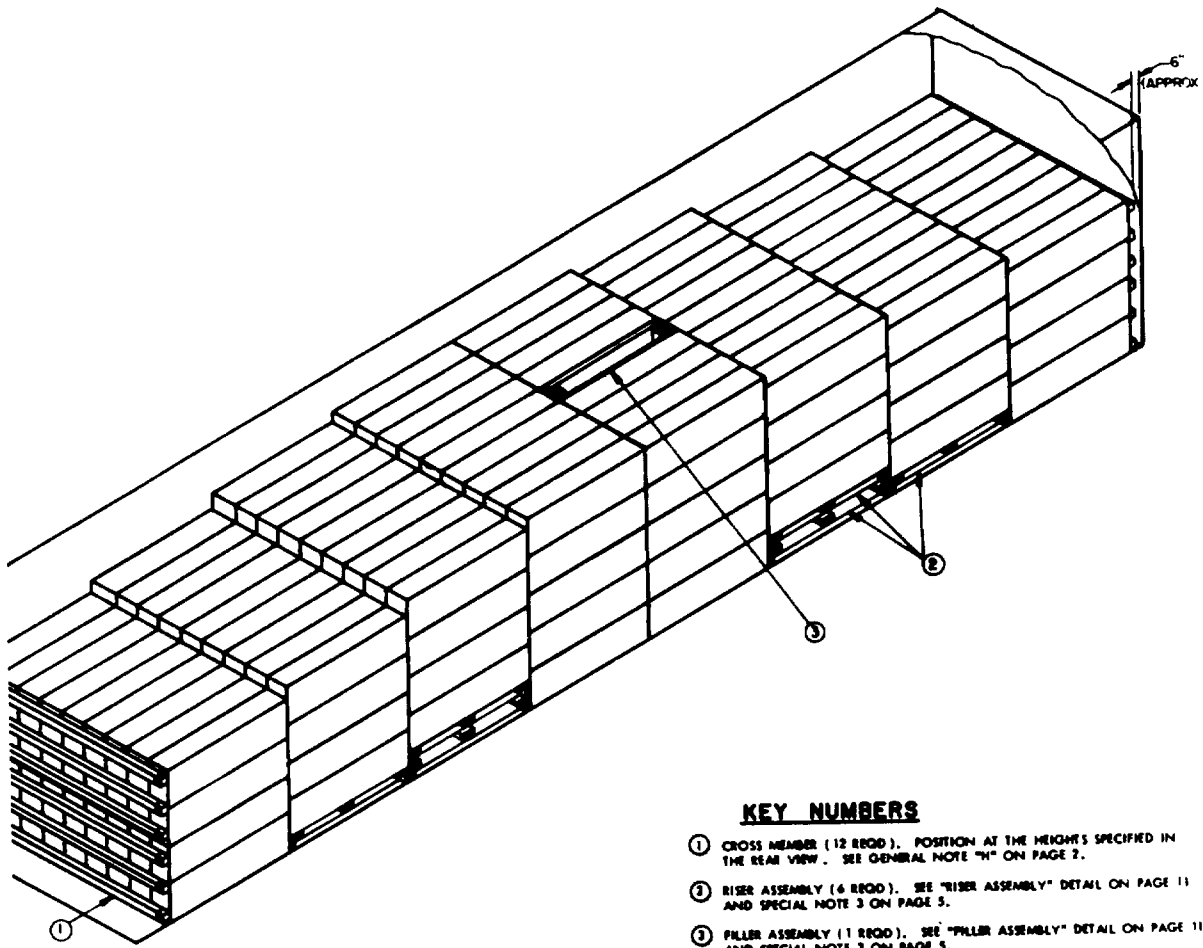

ISOMETRIC VIEW

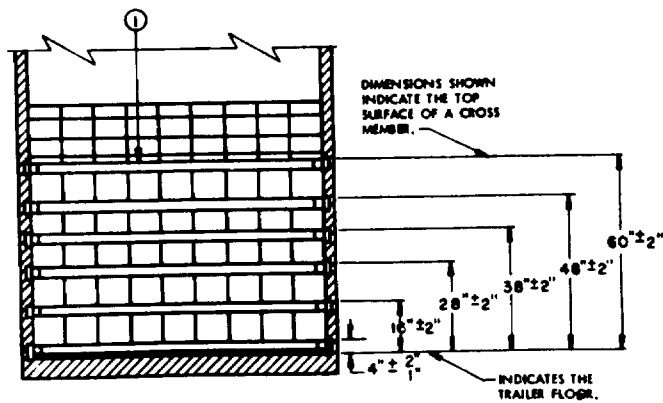

REAR VIEW

306-UNIT LOAD (UNPALLETIZED)

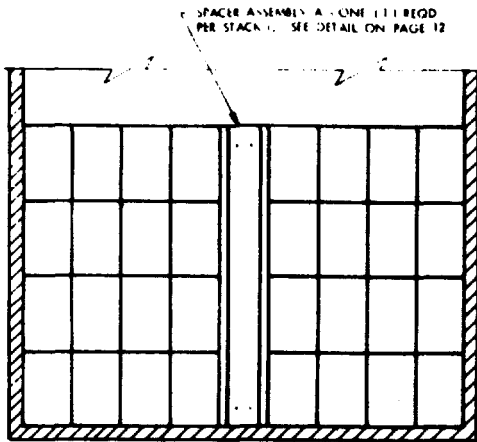

ALTERNATIVE SECTION

THE ABOVE SECTION VIEW DEPICTS AN EIGHT (8) CONTAINER-WIDE LOAD IN A TRAILER WITH AN INSIDE WIDTH DIMENSION OF LESS THAN 7'-6", IN WHICH A NINE (9) CONTAINER-WIDE LOAD WILL NOT FIT ACROSS THE WIDTH OF THE TRAILER. A "SPACER ASSEMBLY" WILL BE REQUIRED TO FILL THE EXCESS SPACE ACROSS THE WIDTH OF THE TRAILER. ADJUST THE WIDTH OF THE "SPACER ASSEMBLY" AS REQUIRED.

SPECIAL NOTES:

1. A 306-UNIT LOAD IS SHOWN IN A 40'-0" LONG BY 7'-6" (MIN.) DIMENSION 1 TRAILER WHICH IS EQUIPPED WITH A MECHANICAL LIFT BLOCKING SYSTEM THAT HAS A SYSTEM LENGTH OF 38'-0".
2. FOR A TRAILER WITH AN INSIDE WIDTH OF LESS THAN 7'-6" (OR WHEN NINE (9) CONTAINERS WILL NOT FIT ACROSS THE WIDTH OF THE TRAILER, REDUCE THE CONTAINER STACKS TO EIGHT CONTAINERS AND USE A "SPACER ASSEMBLY" AS SHOWN IN THE "ALTERNATIVE SECTION" VIEW AT LEFT.
3. THE USE OF THE "FILLER ASSEMBLY" IS SPECIFIED FOR THE DEPICTED LOAD ONLY TO SHOW A TYPICAL APPLICATION. THE USE OF THE "RISER ASSEMBLIES" IS SPECIFIED FOR THE DEPICTED LOAD TO SHOW A MAXIMUM QUANTITY LOAD. "RISER ASSEMBLIES" AND "FILLER ASSEMBLIES" MAY BE USED IN THE LOAD AS REQUIRED TO ADJUST THE LOADING PATTERN FOR THE NUMBER OF CONTAINERS TO BE SHIPPED. THE "FILLER ASSEMBLY" MUST BE USED IN THE TOP LAYER ONLY WHEN IT IS USED. **CAUTION:** CONTAINERS IN THE FRONT AND REAR STACKS CANNOT BE STACKED MORE THAN FOUR LAYERS IN HEIGHT.

BILL OF MATERIAL

LUMBER	LINEAR FEET	BOARD FEET
2" X 4"	250	167
2" X 6"	135	133
NAILS	NO. REQD	POUNDS
10d (3")	356	5-1/2

LOAD AS SHOWN

ITEM	QUANTITY	WEIGHT (APPROX)
CONTAINER	306	14,656 LBS
DUNNIAGE		761 LBS
TOTAL WEIGHT		15,417 LBS

306-UNIT LOAD (UNPALLETIZED)

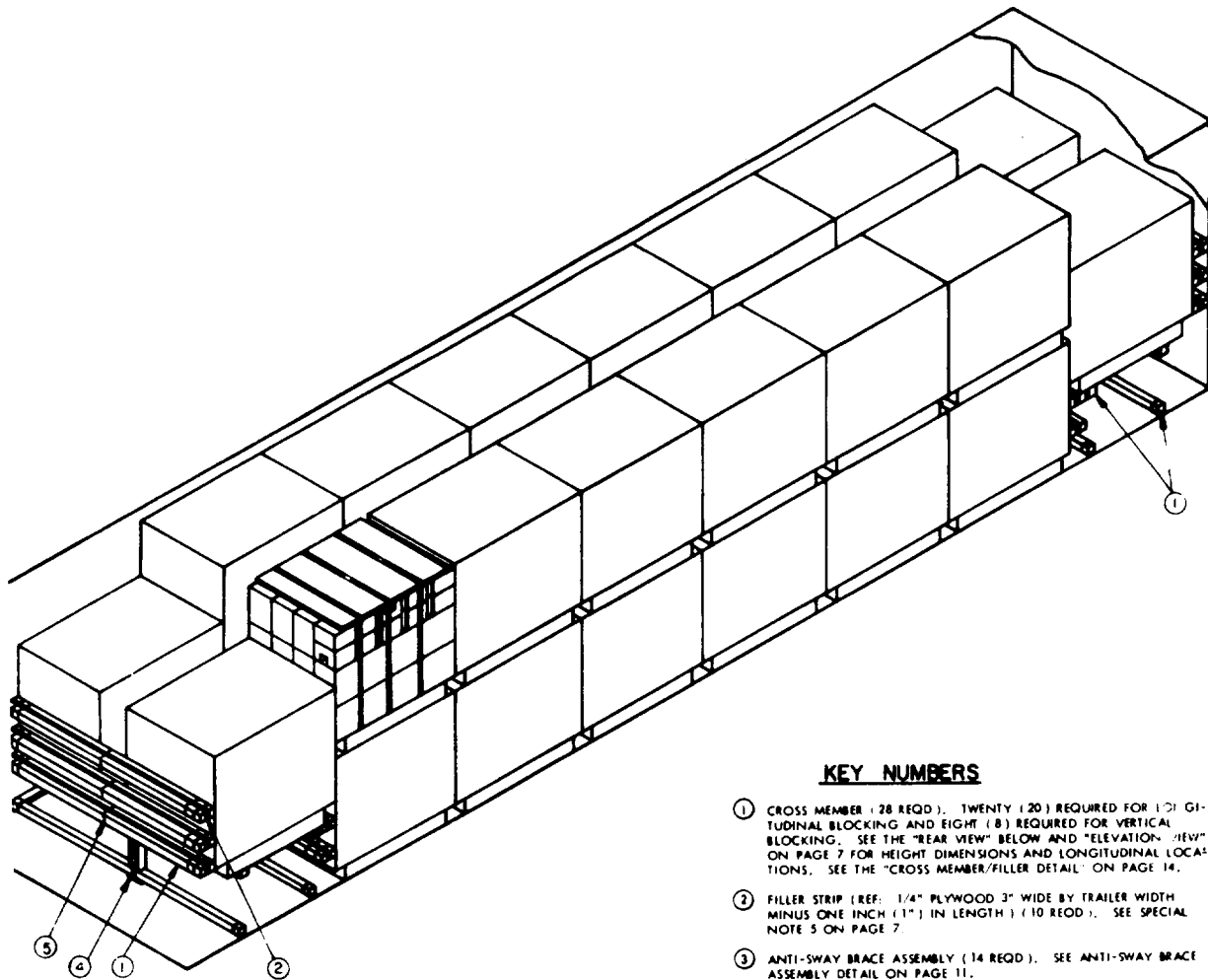

ISOMETRIC VIEW

KEY NUMBERS

- ① CROSS MEMBER (28 REQD.). TWENTY (20) REQUIRED FOR LONGITUDINAL BLOCKING AND EIGHT (8) REQUIRED FOR VERTICAL BLOCKING. SEE THE "REAR VIEW" BELOW AND "ELEVATION VIEW" ON PAGE 7 FOR HEIGHT DIMENSIONS AND LONGITUDINAL LOCATIONS. SEE THE "CROSS MEMBER/FILLER DETAIL" ON PAGE 14.
- ② FILLER STRIP (REF. 1/4" PLYWOOD 3" WIDE BY TRAILER WIDTH MINUS ONE INCH (1") IN LENGTH) (10 REQD.). SEE SPECIAL NOTE 5 ON PAGE 7.
- ③ ANTI-SWAY BRACE ASSEMBLY (14 REQD.). SEE ANTI-SWAY BRACE ASSEMBLY DETAIL ON PAGE 11.
- ④ SUPPORT ASSEMBLY (4 REQD.). SEE DETAIL ON PAGE 14 AND SPECIAL NOTE 3 ON PAGE 7.
- ⑤ TIE WIRE, NO. 14 GAGE BLACK ANNEALED WIRE (30 REQD., 1-REF. PER FILLER STRIP). USE TO SECURE PLYWOOD FILLER STRIPS TO CROSS MEMBERS. INSTALL THREE (3) COMPLETE WRAPS AROUND THE CROSS MEMBERS AND A FILLER STRIP. BRING ENDS TOGETHER AND TWIST TAUT. SEE "CROSS MEMBER/FILLER DETAIL" ON PAGE 14 FOR ADDITIONAL GUIDANCE.

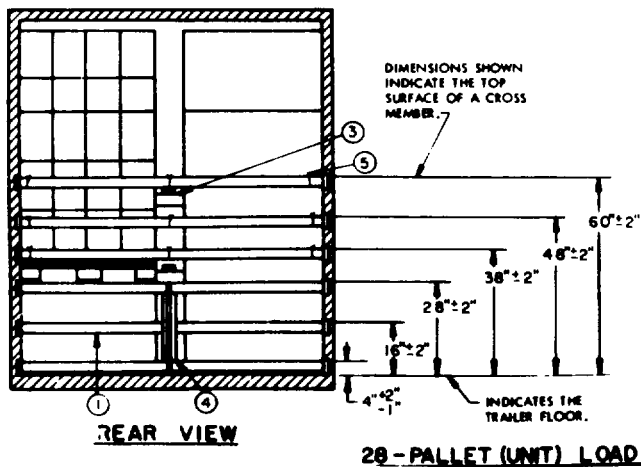

REAR VIEW

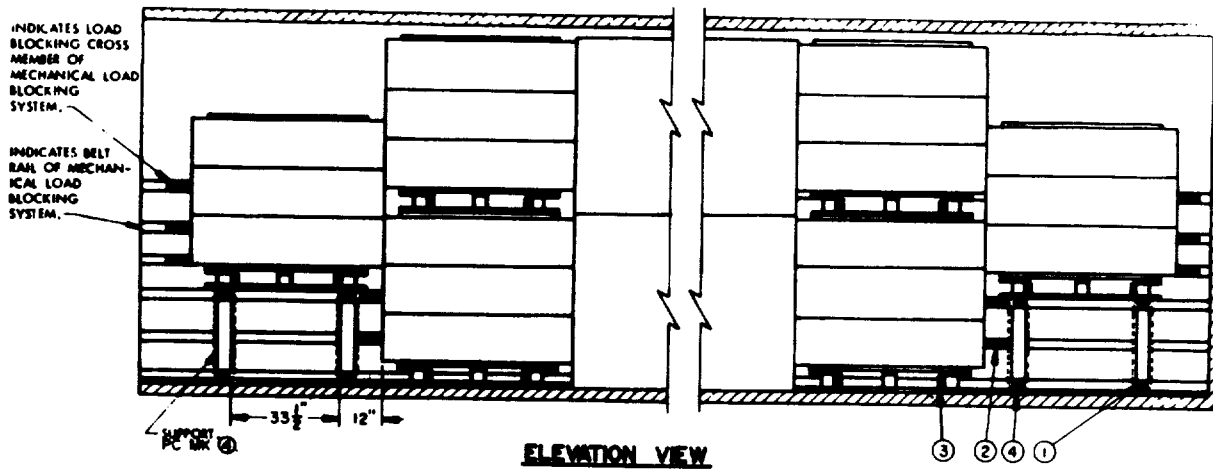

ELEVATION VIEW

SPECIAL NOTES:

1. A 28-PALLET UNIT LOAD IS SHOWN IN A 40'-0" LONG BY 7'-6" WIDE (INSIDE DIMENSION) TRAILER WHICH IS EQUIPPED WITH A MECHANICAL LOAD BLOCKING SYSTEM THAT HAS A SYSTEM LENGTH OF 38'-8" AND A INSIDE HEIGHT OF AT LEAST 8'-11".
2. IF IT IS NECESSARY TO OMIT ONE (1) PALLET UNIT FROM THE LOAD AS DEPICTED ON PAGE 6 TO SATISFY A LOAD QUANTITY REQUIREMENT SEE THE PROCEDURES DEPICTED ON PAGE 13 WHICH MUST BE USED.
3. IF IT IS NECESSARY TO OMIT TWO (2) PALLET UNITS FROM THE LOAD TO SATISFY A LOAD QUANTITY REQUIREMENT, OMIT TWO (2) PALLET UNITS FROM THE SECOND STACK FROM THE FRONT OR TWO (2) PALLET UNITS FROM THE SECOND STACK FROM THE REAR OF THE LOAD. THE TWO (2) REMAINING CROSS MEMBER IN THE SAME MANNER AS THE 28" HEIGHT DIMENSIONED PALLET UNITS WILL BE POSITIONED ON THE 28" HEIGHT DIMENSIONED CROSS MEMBERS IN THE SAME MANNER AS THE MOST FORWARD AND THE MOST REAR STACKS ARE NOW SHOWN. MOVE THE LONGITUDINALLY BLOCKING CROSS MEMBERS TO CONTACT THE PALLET UNITS ON THE FLOOR OF THE TRAILER. THE TWO (2) 28" HEIGHT DIMENSIONED CROSS MEMBERS USED TO ELEVATE THESE TWO PALLET UNITS WILL REQUIRE A "SUPPORT ASSEMBLY, PRICE MARKED 4," UNDER EACH CROSS MEMBER AS SHOWN IN THE "ELEVATION VIEW" ABOVE.
4. IF IT IS NECESSARY TO OMIT THREE (3) PALLET UNITS FROM THE LOAD TO SATISFY A LOAD QUANTITY REQUIREMENT, OMIT ONE (1) STACK OF FOUR (4) PALLET UNITS. BLOCK THE REMAINING PALLET UNITS AS SHOWN ABOVE. SEE PAGE 10 FOR THE PROCEDURE THAT MUST BE USED FOR BLOCKING THE ONE REMAINING PALLET UNIT.
5. A ONE-QUARTER INCH (1/4") FILLER STRIP HAS BEEN SPECIFIED FOR THE DEPICTED LOAD. HOWEVER, IF THE VOID BETWEEN A PAIR OF LONGITUDINALLY ADJACENT CROSS MEMBERS IS GREATER THAN 1/4", FILLER MATERIAL OF A THICKNESS WHICH WILL COMPLETELY OCCUPY THE VOID SPACE BETWEEN THE TWO (2) CROSS MEMBERS MUST BE USED.

BILL OF MATERIAL		
LUMBER	LINEAR FEET	BOARD FEET
1" X 2"	2	112
1" X 4"	14	5
2" X 3"	27	19
2" X 4"	149	99
4" X 4"	30	40
NAILS	NO. REQD	POUNDS
6d (2")	20	1/4
10d (3")	112	2
12d (3-1/4")	112	2
STEEL STRAPPING, 3/4" X .080"	24' REQD	2 LBS
SEALS FOR 3/4" STRAPPING	4 REQD	NIL
WIRE, NO. 14 GAGE	AS REQD	NIL

LOAD AS SHOWN

ITEM	QUANTITY	WEIGHT (APPROX)
PALLET UNIT	28	19,708 LBS
DUNNAGE		465 LBS
TOTAL WEIGHT		19,873 LBS

28 - PALLET (UNIT) LOAD

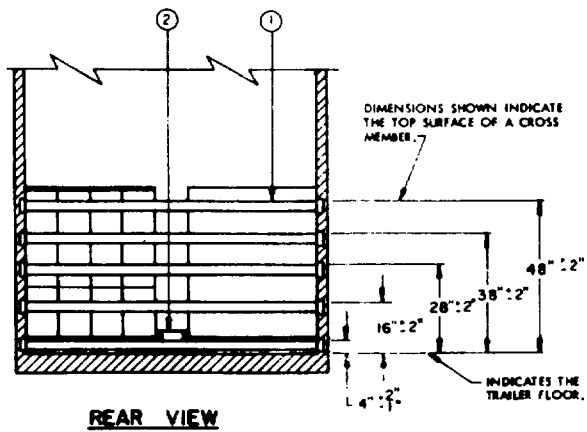
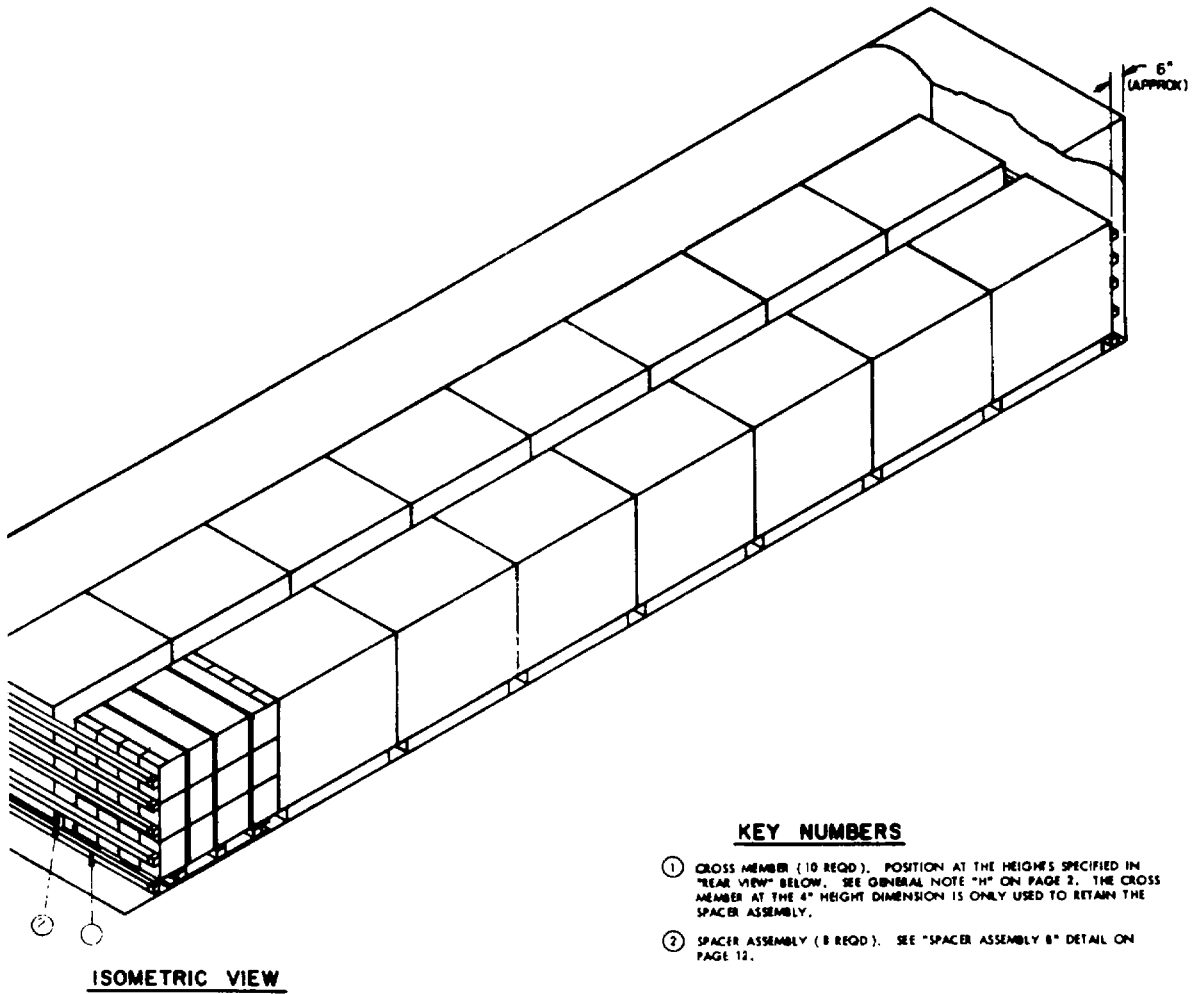

16 - PALLET (UNIT) LOAD

Figure 5-3—Continued (sheet 7 of 13).

SPECIAL NOTES

1. A 16-PALLET UNIT LOAD IS SHOWN IN A 48'-0" LONG BY 7'-4" WIDE (INSIDE DIMENSION) TRAILER WHICH IS EQUIPPED WITH A MECHANICAL LOAD BLOCKING SYSTEM THAT HAS A SYSTEM LENGTH OF 38'-3".
2. WHEN SHIPPING AN ODD NUMBER OF PALLET UNITS, SUCH AS 11, 13, OR 15, REFER TO PAGE 10 FOR PROCEDURES WHICH MUST BE USED.

BILL OF MATERIAL		
LUMBER	LINEAR FEET	BOARD FEET
2" X 4"	14	10
2" X 6"	85	85
NAILS	NO. REQD	POUNDS
10d (3")	128	2

LOAD AS SHOWN

ITEM	QUANTITY	WEIGHT (APPROX)
PALLET UNIT	16	10,976 LBS
DUNNAGE		240 LBS
TOTAL WEIGHT		11,216 LBS

16-PALLET (UNIT) LOAD

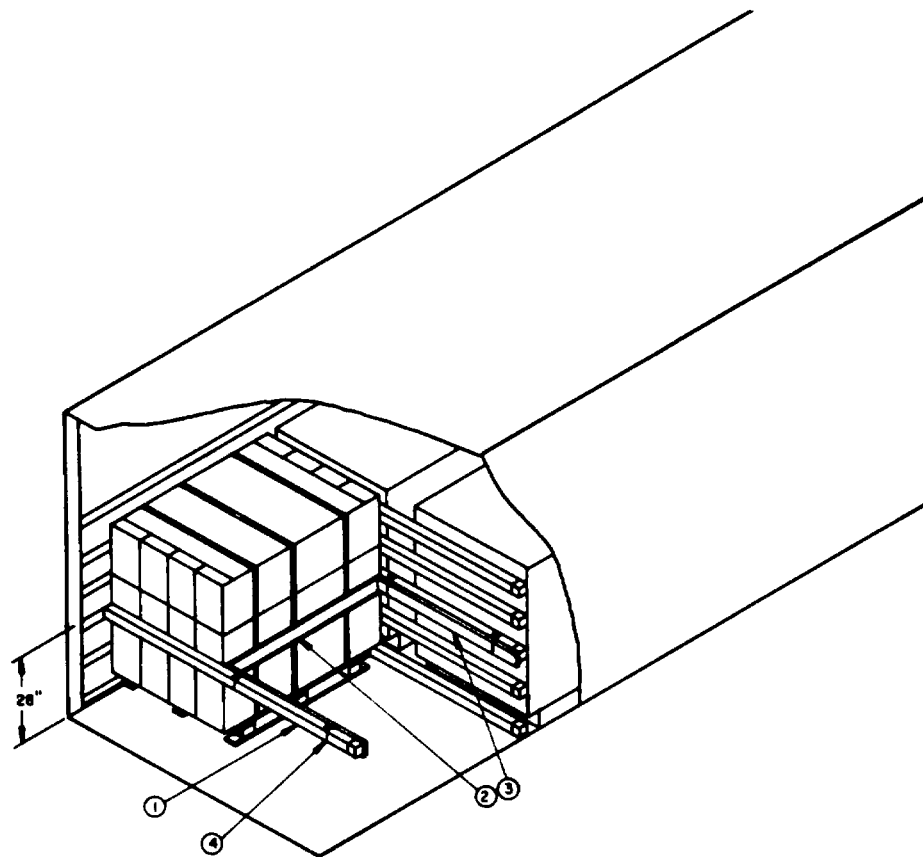

ISOMETRIC VIEW

THE PROCEDURES ABOVE DEPICT THE METHOD FOR SHIPPING AN ODD NUMBER OF PALLET UNITS, SUCH AS 15, 13, ETC. THE FORWARD PORTION OF THE LOAD WILL BE AS SHOWN ON PAGE 8. ONE ADDITIONAL CROSS MEMBER WILL BE REQUIRED TO BLOCK AND BRACE THE ODD PALLET UNIT. SEE PAGE 8 FOR DUNNAGE AND DIMENSIONS FOR THE FORWARD PORTION OF THE LOAD.

KEY NUMBERS

- ① CROSS MEMBER (1 REQD). POSITION AT THE 28" HEIGHT DIMENSION. SEE GENERAL NOTE "H" ON PAGE 2.
- ② BUFFER BOARD, 2" X 4" X 38-1/4" (1 REQD). NAIL TO THE SUPPORT PIECES W/2-13d NAILS AT EACH JOINT.
- ③ SUPPORT PIECE, 2" X 4" BY CUT TO FIT BETWEEN BUFFER BOARD AND THE TRAILER SIDE (2 REQD).
- ④ TIE WIRE, NO. 14 GAGE BLACK ANNEALED WIRE 60" LONG (4 REQD). INSTALL THREE COMPLETE LOOPS AROUND THE CROSS MEMBER AND THE SUPPORT PIECE, BRING THE ENDS TOGETHER AND TWIST TIGHT. IF NO. 14 GAGE WIRE IS NOT AVAILABLE, TWO (2) COMPLETE LOOPS OF NO. 8 GAGE WIRE MAY BE SUBSTITUTED.

OMMITTED PALLET PROCEDURES

Figure 5-3—Continued (sheet 9 of 13).

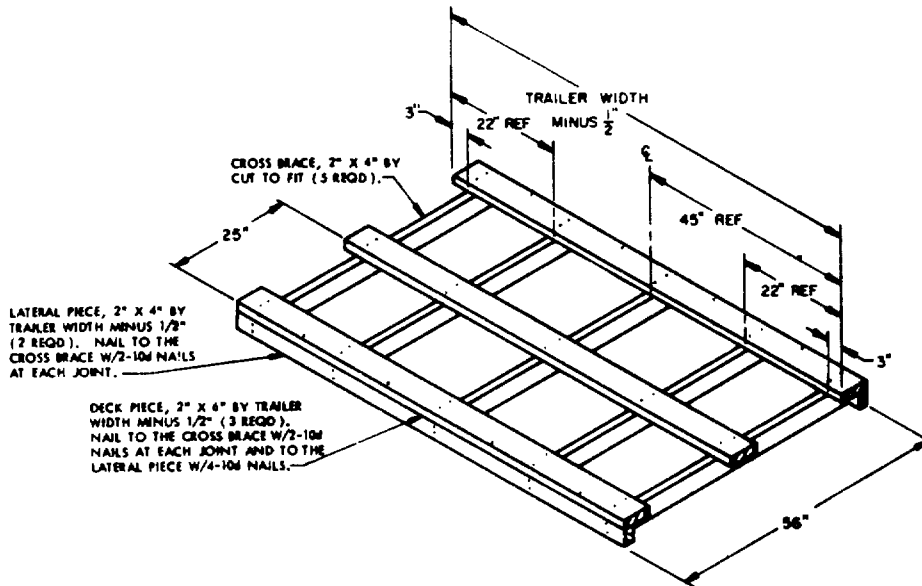
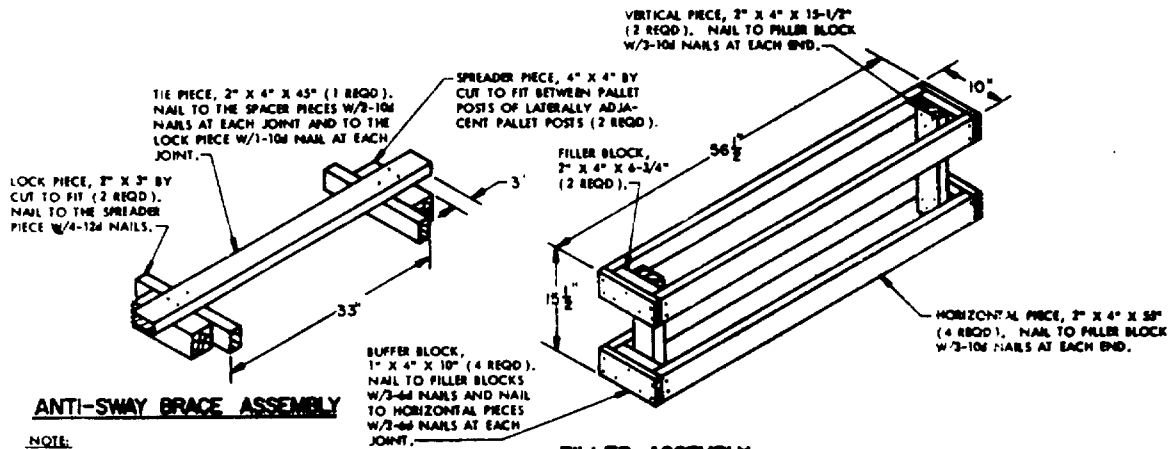

RISER ASSEMBLY

THE ASSEMBLY AS DEPICTED IS DESIGNED FOR STEPPING-UP OR STEPPING-DOWN A LOAD UNIT THAT IS NINE CONTAINERS WIDE. THE WIDTH MAY BE ADJUSTED AS REQUIRED FOR THE NUMBER OF CONTAINERS TO BE SHIPPED.

DETAILS

Figure 5-3—Continued (sheet 10 of 13).

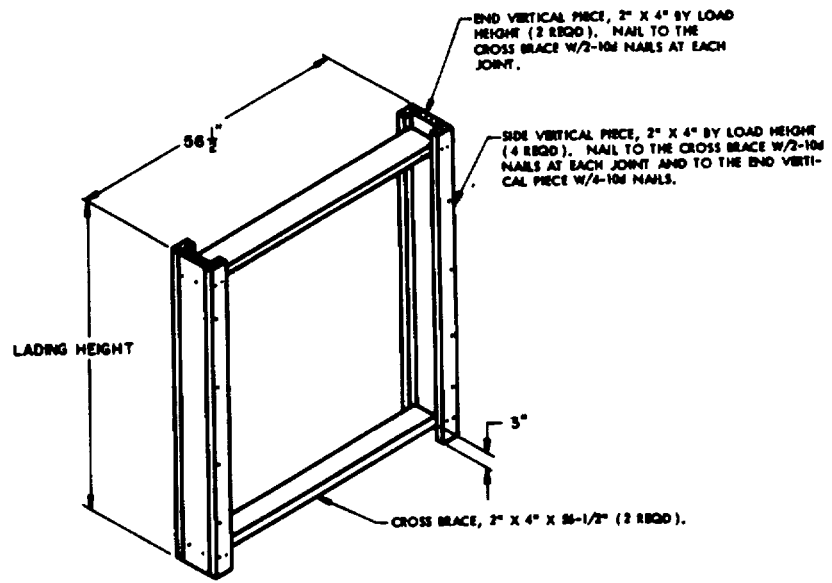

SPACER ASSEMBLY A

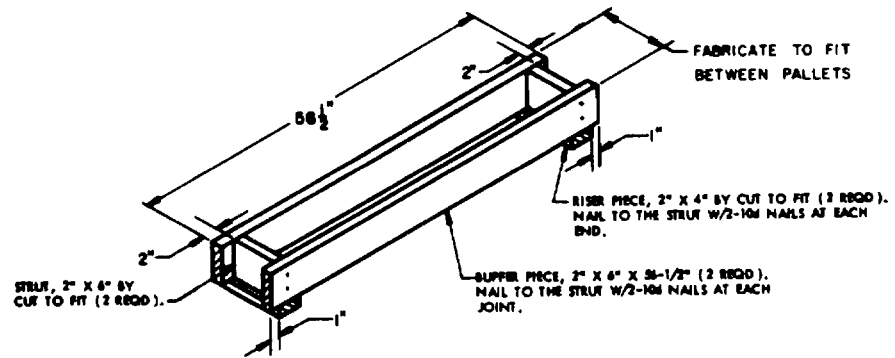

SPACER ASSEMBLY B

DETAILS

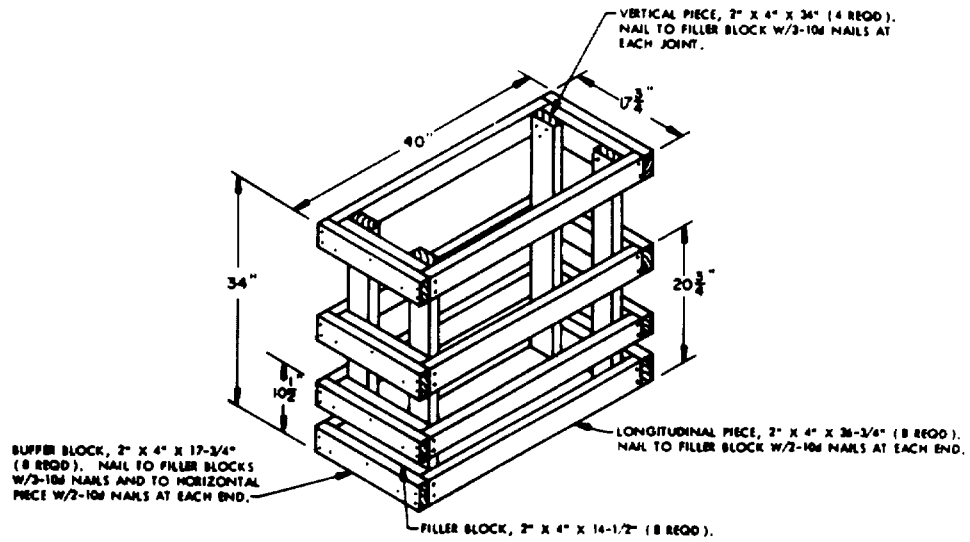

FILLER ASSEMBLY

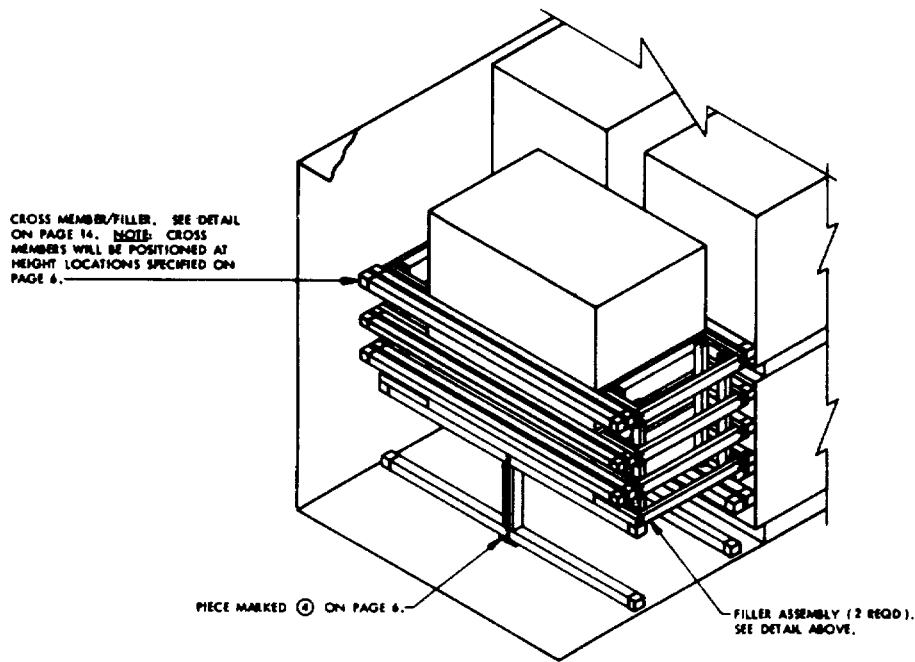

OMITTED-PALLET DETAIL

DETAILS

Figure 5-3—Continued (sheet 12 of 13).

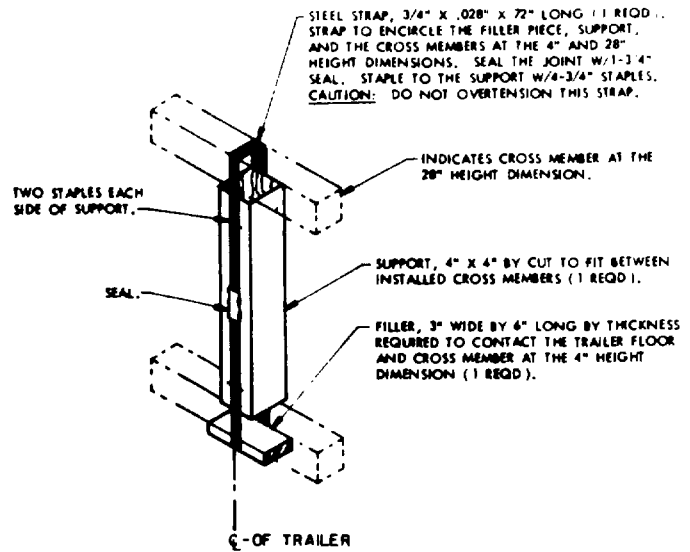

SUPPORT

THE SUPPORT PIECE AND FILLER PIECE ARE USED TO SUPPORT THE 28" HIGH CROSS MEMBERS WHEN USED TO SUPPORT THE PALLET UNITS AT THE REAR AND FRONT OF THE LOAD. THE SUPPORT ASSEMBLY SHOULD BE INSTALLED PRIOR TO POSITIONING THE UNITS ON THE CROSS MEMBERS. THE SUPPORT AND FILLER PIECES SHOULD BE SIZED FOR A SNUG FIT, NOT A WEDGE FIT.

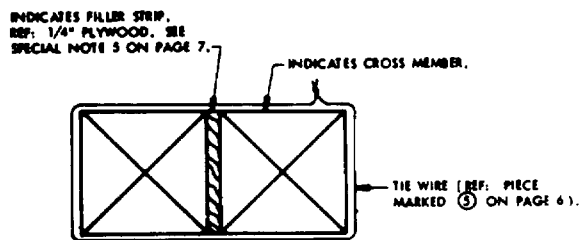

CROSS MEMBER / FILLER DETAIL

DETAILS

Figure 5-3—Continued (sheet 13 of 13).

GENERAL NOTES

(GENERAL NOTES CONTINUED)

- A. Not applicable.
- B. THE LOADING PROCEDURES SPECIFIED HEREIN ARE APPLICABLE TO THE REDUVE MISSILE WHEN IT IS PACKED IN THE UNIPAK CONTAINER, SUBSEQUENT REFERENCE TO CONTAINER HEREIN MEANS THE DUNNAGE CONTAINER (UNIPAK) WITH CONTENTS.
- C. FOR DETAIL OF THE DUNNAGE CONTAINER (UNIPAK) SEE DRAWING NO. 18B579N AND "DUNNAGE CONTAINER (UNIPAK)" VIEW ON PAGE 2.
CONTAINER DIMENSIONS ---- 28-1/2" LONG X 36" WIDE X 15-1/2" HIGH.
GROSS WEIGHT ---- 45 POUNDS (APPROX).
- D. FOR DETAIL OF THE PALLET UNIT SEE U.S. ARMY MATERIAL COMMAND DRAWING NO. 1P-46-822-0AM89S AND "PALLET UNIT" VIEW ON PAGE 2.
PALLET UNIT DIMENSIONS ---- 28-1/2" LONG X 48" WIDE X 28-1/2" HIGH.
GROSS WEIGHT ---- 85 POUNDS (APPROX).
- E. THIS ITEM IS A DOT CLASS "A" EXPLOSIVE. THE UNLOADING PROCEDURES SPECIFIED HEREIN CAN ALSO BE UTILIZED FOR THE SHIPMENT OF THE DESIGNATED CONTAINER WHEN THEY ARE LOADED WITH AN ITEM WHICH IS IDENTIFIED DIFFERENTLY BY NOMENCLATURE THAN THE ITEM DESIGNATED WITHIN THE DRAWING TITLE.
- F. THIS PROCEDURAL DRAWING IS APPLICABLE TO A TRAILER OR CONTAINER WHICH IS EQUIPPED WITH A MECHANICAL LOAD BRACING SYSTEM AS SPECIFIED WITHIN THE BUREAU OF EXPLOSIVES PAMPHLET NO. 6C AND APPENDICES THERETO. SUBSEQUENT REFERENCE TO A TRAILER THROUGHOUT THIS DOCUMENT MEANS A TRAILER OR CONTAINER. FOR TOPC AND/OR COPC SHIPMENTS, ONLY BAILEYS WHICH ARE SPECIFIED BY THE BUREAU OF EXPLOSIVES PAMPHLET NO. 6C, OR THE ABOVE MENTIONED APPENDICES, WILL BE USED.
- G. THE LOADS AS SHOWN ARE BASED ON TRAILERS WHICH ARE 89'-0" LONG BY 7'-0" WIDE (INSIDE DIMENSION) WITH A WOOD OR A WOOD AND METAL, OR A METAL FLOOR. THE DETAILED UNLOADING PROCEDURES ARE ALSO APPLICABLE TO TRAILERS WHICH ARE EIGHTY-NINE INCHES (89") THROUGH NINETY-THREE (93") IN WIDTH.
- H. THE HEIGHT LOCATIONS SPECIFIED WITHIN THIS DRAWING FOR THE INSTALLATION OF CROSS MEMBERS ARE IDENTICAL WITH THAT RECOMMENDED WITHIN THE BUREAU OF EXPLOSIVES PAMPHLET NO. 6C AND APPENDICES THERETO. CAUTION: TRAILERS EQUIPPED WITH FACILITIES WHICH DO NOT MEET THE LOCATION REQUIREMENT SPECIFIED HEREIN MUST NOT BE USED.
 - 1. WORDS WITHIN THE LENGTH OF A LOAD MUST BE HELD TO A MINIMUM. CROSS MEMBERS MUST BE PLACED AGAINST THE LADING AS TIGHTLY AS THE HOLE SPACING IN THE CROSS MEMBER ATTACHMENT FACILITY PERMITS. ALSO, EACH CROSS MEMBER WILL BE INSTALLED WITH THE ENDS ATTACHED AS NEARLY AS POSSIBLE IN "MATED" POSITIONS (AT EQUAL HEIGHTS AND AT EQUAL DISTANCES FROM THE END OF THE TRAILER).
 - 2. CROSS MEMBERS IN EMPTY TRAILERS AND THOSE NOT USED IN LOADED TRAILERS MUST BE SECURED FOR SHIPMENT. COMPONENTS ASSIGNED TO EACH TRAILER MUST REMAIN THEREWITH EVEN THOUGH UNUSED DURING SOME SHIPMENTS.
 - 3. A CROSS MEMBER WILL NOT BE RELIED UPON TO RETAIN MORE LADING ON EITHER SIDE THAN AS SHOWN WITHIN THE LOAD.
- J. SELECTION OF A VEHICLE TO BE USED TO TRANSPORT THE DESIGNATED ITEM MUST COMPLY WITH AR 55-265, CHAPTER 212, FOR EXPLOSIVES AND OTHER DANGEROUS ARTICLES, IN FULL.
- K. THE GROSS WEIGHT AND AXLE DISTRIBUTION OF WEIGHT FOR A LOAD WILL BE THE RESPONSIBILITY OF THE CARRIER. THE CARRIER WILL ADVISE THE SHIPPER OF THE APPLICABLE LOADING REQUIREMENTS, AND THE SHIPPER WILL LOAD ACCORDINGLY. NOTE: A SHIPMENT WILL BE POSITIONED IN A TRAILER CONSISTENT WITH THE WEIGHT LAWS OF THE STATES THROUGH WHICH THE TRAILER WILL BE TRANSPORTED BY HIGHWAY (MOTOR CARRIER).
- L. THE APPROVED BLOCKING, BRACING, AND STAYING METHODS FOR THE LOADS SPECIFIED HEREIN MUST BE FOLLOWED. THE NUMBER OF UNITS MAY BE ADJUSTED TO FIT THE SIZE OF VEHICLE TO BE LOADED OR THE QUANTITY TO BE SHIPPED. FOR A LOAD QUANTITY OTHER THAN SPECIFIED, THE APPROVED METHODS MUST BE FOLLOWED AS CLOSELY AS POSSIBLE.
- M. OTHER TYPES OF LADING ITEMS MAY BE LOADED INTO TRAILERS WHICH ARE PARTIALLY LOADED WITH THE DESIGNATED ITEM, PROVIDED THE TOTAL LOAD IS COMPATIBLE, DESIGNATED DIRECTIVES ARE NOT VIOLATED, AND THE OTHER LADING ITEMS ARE BLOCKED AND BRACED TO EQUAL THE BLOCKING AND BRACING CRITERIA SPECIFIED HEREIN.
- N. IN SOME INSTANCES CONTAINERS WILL ALREADY BE PALLETIZED WHEN OFFERED FOR LOADING. THESE PALLET UNITS SHOULD BE INSPECTED AND, AS REQUIRED, LOOSE UNITIZING STEEL STRAPPING MUST BE REPLACED.
- O. DUNNAGE LUMBER SPECIFIED THROUGHOUT THIS PROCEDURAL DRAWING IS OF NOMINAL SIZE. FOR EXAMPLE, 2" X 4" MATERIAL IS ACTUALLY 1-5/8" THICK BY 3-5/8" WIDE AND 4" X 4" MATERIAL IS ACTUALLY 3-5/8" THICK BY 3-5/8" WIDE.
- P. DO NOT NAIL BLOCKING SHOWN HEREIN TO THE TRAILER WALLS OR FLOOR. ALL NAILING WILL BE WITHIN THE DUNNAGE.
- Q. POSITIONS OF THE TRAILER BODY DESIGNATED WITHIN THIS PROCEDURAL DRAWING, SUCH AS ONE OF THE SIDE WALLS, HAVE NOT BEEN SHOWN IN THE LOAD VIEWS FOR CLARITY PURPOSES.
- R. FOR ADDITIONAL GUIDANCE, ATTENTION IS DIRECTED TO THE "DETAILS OF CONTAINER AND PALLET UNIT" ON PAGE 2 AND TO THE "SPECIAL NOTES" SECTION WHICH IS IMMEDIATELY ADJACENT TO THE DESIGNATED UNLOADING METHOD.

(CONTINUED AT RIGHT)

MATERIAL SPECIFICATIONS

LUMBER: SEE TM 783-280-1, DUNNAGE LUMBER; FED SPEC MM-L-751.

SHAKES: COMMON, CEMENT COATED OR CHEMICALLY ETCHED;
FED SPEC FF-N-185.
NAIL: ANNULAR-RING TYPE NAIL OF SAME SIZE.

WIRE: ANNEALED, BLACK, FED SPEC QQ-W-461.

Figure 5-4. Loading and bracing (TL & LTL) in closed or open-top van trailers of complete round, with three launcher batteries, packed in unipak container, unpalletized and palletized (sheet 1 of 27).

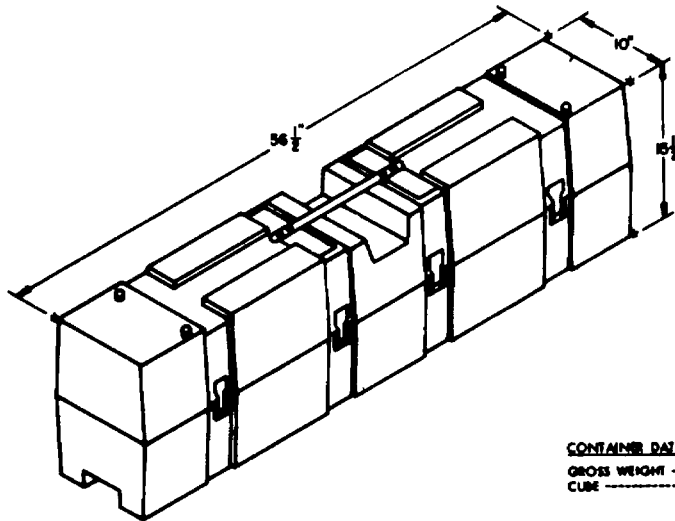

CONTAINER DATA
 GROSS WEIGHT ----- 48 POUNDS (APPROX).
 CUBE ----- 5.07 CUBIC FEET.

XM595 CONTAINER (UNPAK)

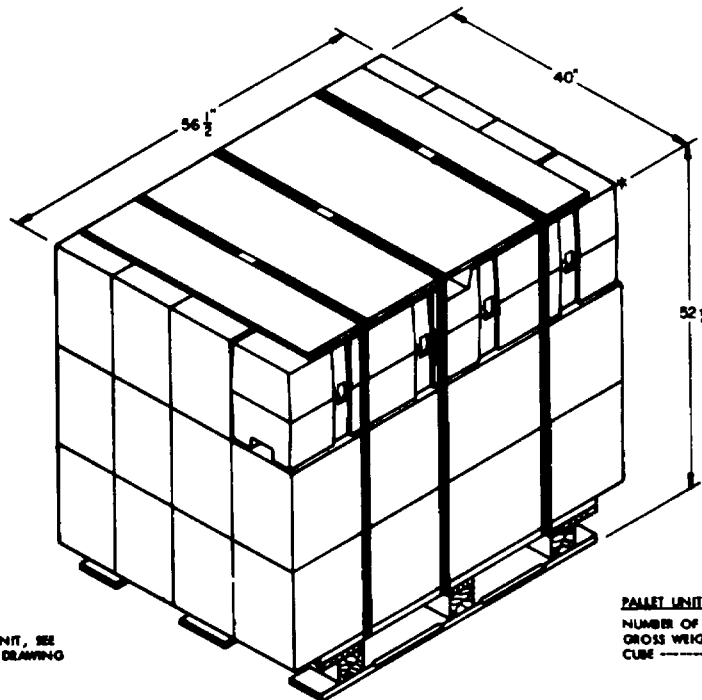

NOTE 1
 FOR THE FABRICATION OF THIS UNIT, SEE
 U.S. ARMY MATERIEL COMMAND DRAWING
 NO. 19-48-2832-GAG893.

PALLET UNIT DATA
 NUMBER OF CONTAINERS -- TWELVE (12).
 GROSS WEIGHT ----- 480 POUNDS (APPROX).
 CUBE ----- 61.7 CUBIC FEET.

PALLET UNIT
 SEE "NOTE 1" AT LEFT.
CONTAINER AND PALLET UNIT DETAILS

Figure 5-4—Continued (sheet 2 of 27).

SEE SPECIAL NOTE 4 ON PAGE 5.

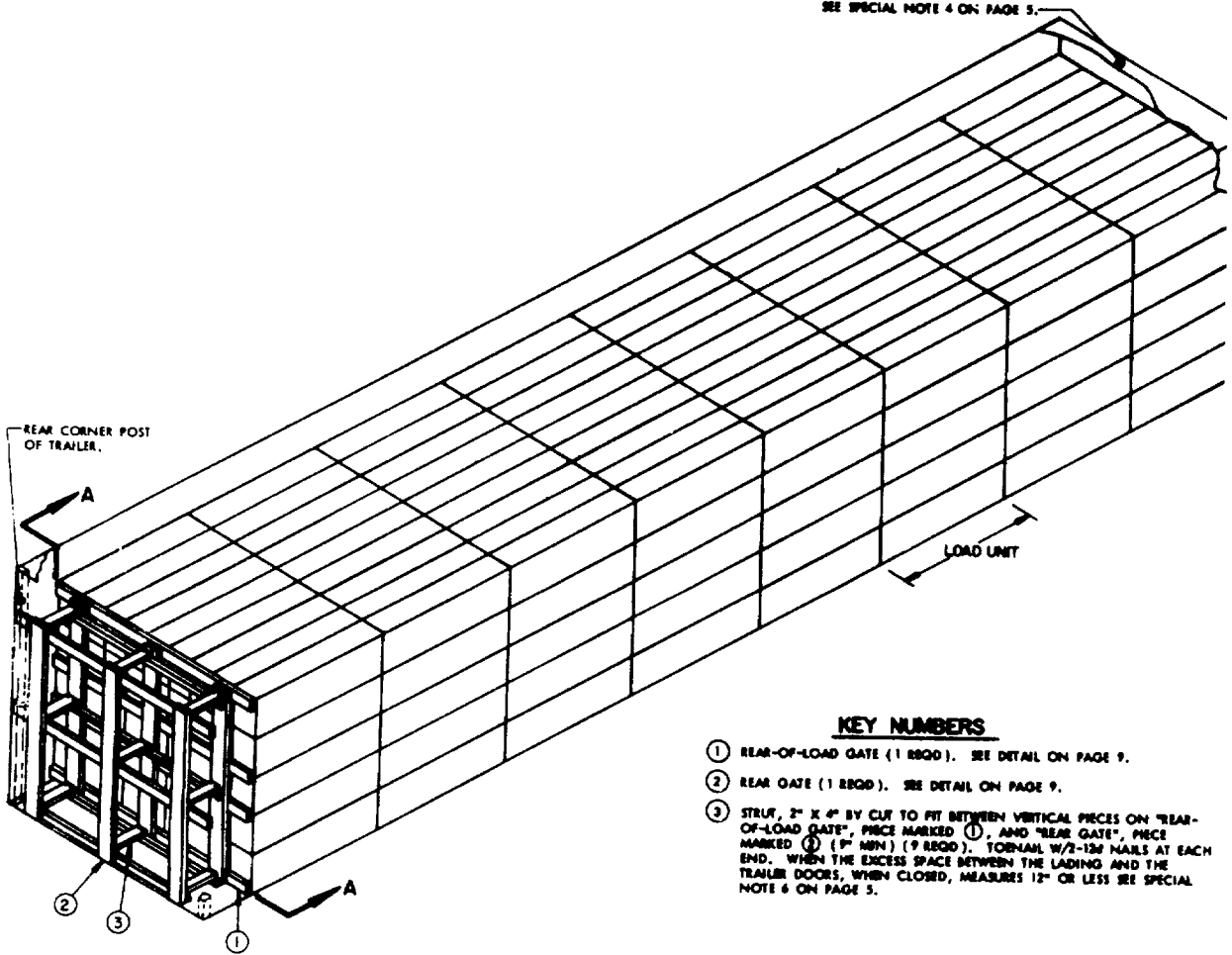

ISOMETRIC VIEW

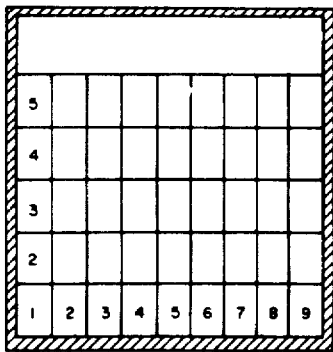

SECTION A-A
SEE SPECIAL NOTE 5 ON PAGE 5.

UNPALLETED LOAD IN A 40'-0" LONG TRAILER

SPECIAL NOTES

1. A 360-UNIT LOAD IS SHOWN IN A SQUARE-FRONT TRAILER WHICH IS 7'-6" WIDE (INSIDE DIMENSION) BY 40'-0" LONG. A 360-UNIT LOAD CAN BE LOADED IN A 39'-0" LONG TRAILER BY USING THE PROCEDURES OUTLINED IN SPECIAL NOTE 6 BELOW.
2. IF THE INSIDE HEIGHT OF THE VAN BEING USED PERMITS, SUCH AS WILL BE THE CASE WITH A HIGH-VOLUME VAN, ONE OF THE TWO PROCEDURES OUTLINED BELOW MAY BE USED:
 - A. THE CONTAINERS CAN BE STACKED SIX (6) LAYERS HIGH THROUGHOUT THE FORWARD PORTION OF THE VAN. THE TWO REARWARD LOAD UNITS WILL BE STACKED FIVE (5) LAYERS IN HEIGHT, WITH A "RISER" ASSEMBLY UNDER THE SECOND FROM THE REAR STACK. A MAXIMUM SIZE LOAD OF 414 CONTAINERS CAN BE LOADED BY THE PROCEDURES JUST DESCRIBED. REAR BLOCKING FOR THE INCREASED LOAD WILL BE AS SPECIFIED FOR THE LOAD SHOWN ON PAGE 4.
 - B. THE CONTAINERS CAN BE STACKED SIX (6) LAYERS HIGH THROUGHOUT THE LENGTH OF THE VAN IF THE INSIDE HEIGHT OF THE VAN PERMITS. INCREASE THE HEIGHT OF THE REAR-OF-LOAD GATE AND THE REAR GATE AS OUTLINED IN THE CHART ON PAGE 9. A MAXIMUM SIZE LOAD OF 422 CONTAINERS CAN BE LOADED BY THE PROCEDURES JUST DESCRIBED. REAR BLOCKING FOR THE INCREASED LOAD WILL BE AS SPECIFIED FOR THE LOAD SHOWN ON PAGE 4.
3. ADDITIONALLY, TO SATISFY THE NUMBER OF ITEMS TO BE SHIPPED, A RISER AS DEPICTED ON PAGE 8, MAY BE USED TO STEP UP A LOAD UNIT AND/OR TO DOWN A LOAD UNIT IN MULTIPLES OF NINE (9) BY ADJUSTING THE LOCATION OF THE "RISER" ASSEMBLY. ALSO, A "FILLER" ASSEMBLY MAY BE USED TO FILL THE VOID LATERALLY IN THE TRAILER FOR AN OMITTED CONTAINER, AS SHOWN IN "ISOMETRIC VIEW" ON PAGE 7 AND DETAILED ON PAGE 12.
4. IF THE TRAILER BEING LOADED HAS A ROUND-FRONT OR HALF-ROUNDED CORNERS AT THE FORWARD END, REFER TO PAGE 10 FOR "FORWARD BLOCKING" SPECIFICATIONS WHICH MUST BE USED. A SEVEN (7) LOAD UNIT LOAD IS THE MAXIMUM LOAD THAT CAN BE SHIPPED IN A 40'-0" LONG ROUND-FRONT TRAILER. A 39'-0" LONG TRAILER IS THE MINIMUM LENGTH ROUNDED-CORNER TRAILER THAT CAN BE USED TO SHIP AN EIGHT (8) LOAD UNIT LOAD, IF THE RADIUS OF THE CORNERS IS LESS THAN 3'.
5. IF THE TRAILER BEING LOADED HAS INSIDE WIDTH OF LESS THAN 90" OR IF NINE (9) CONTAINERS WILL NOT FIT ACROSS THE TRAILER AS DEPICTED WITHIN "SECTION A-A" THE PROCEDURES DEPICTED ON PAGE 13 WILL HAVE TO BE USED. A 320-CONTAINER LOAD CAN BE LOADED INTO A 39'-0" TO 40'-0" LONG TRAILER, IF LOAD IS 8-WIDE BY 5-HIGH.
6. WHEN THE EXCESS SPACE BETWEEN THE REAR OF THE LADING AND THE TRAILER DOORS, WHEN CLOSED, MEASURES 12" OR LESS SOLID FILL WILL BE USED IN LIEU OF REAR GATE AND STRUTS. DELETE THE 2" X 2" STRUT LEAGERS FROM THE REAR-OF-LOAD GATE. SOLID FILL, 6" WIDE BY 6'-4" LONG MATERIAL BY THICKNESS REQUIRED TO CONTACT REAR DOORS WHEN CLOSED (REQUIRED AT THREE LOCATIONS). NAIL TO REAR-OF-LOAD GATE OR SELF W/5-10d NAILS AT EACH JOINT.

BILL OF MATERIAL		
LUMBER	LINEAR FEET	BOARD FEET
2" X 2"	24	8
2" X 4"	58	39
2" X 6"	38	36
NAILS	NO. REQD	POUNDS
10d (3")	79	1-1/4
12d (3-1/4")	36	3-4

LOAD AS SHOWN

ITEM	QUANTITY	WEIGHT (APPROX)
CONTAINER	360	17,280 LBS
DUNNAGE		215 LBS
TOTAL WEIGHT		17,495 LBS

UNPALLETIZED LOAD IN A 40'-0" LONG TRAILER

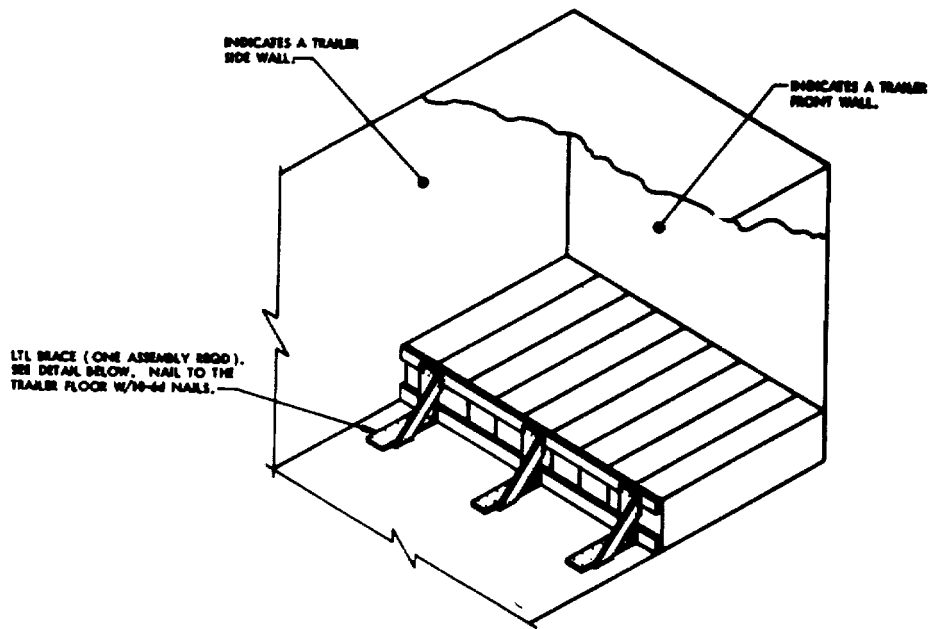

ISOMETRIC VIEW
(NINE CONTAINER LTL LOAD)

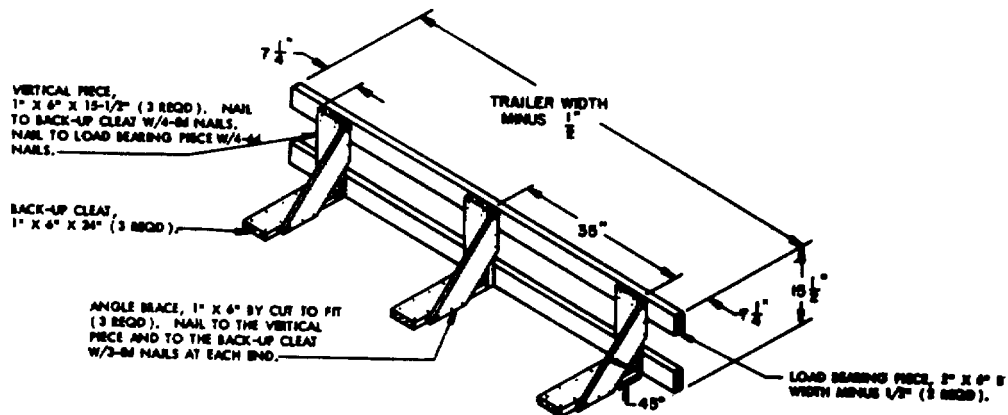

SPECIAL NOTES

1. THESE UNLOADING PROCEDURES DEPICT THE UNLOADING OF A ONE (1) CONTAINER HIGH LOAD IN A TRAILER WHICH HAS A NAILABLE FLOOR. TRAILERS WITH A NON-NAILABLE FLOOR CANNOT BE USED. CONTAINERS WILL NOT BE MORE THAN ONE (1) HIGH WHEN USING THE LTL BRACE.
2. IF THE TRAILER BEING LOADED HAS A ROUND-FRONT OR ROUNDED CORNERS AT THE FORWARD END, AN ADDITIONAL LTL BRACE ASSEMBLY AS DETAILED ABOVE MAY BE USED AT THE FORWARD END OF THE LADING. ALSO TWO (2) LTL BRACES WITH LOAD BEARING PICES MAY BE USED FOR LATERAL BLOCKING.
3. EACH ONE OF THE THREE (3) LTL BRACES AS APPLIED FOR LONGITUDINAL BRACING WILL SUPPORT 2,000 POUNDS OF LADING AND A MINIMUM OF TWO (2) BRACES WILL BE REQUIRED FOR LONGITUDINAL AND/OR LATERAL BLOCKING. THE WIDTH OF THE ASSEMBLY MAY BE ADJUSTED TO SUIT THE NUMBER OF CONTAINERS TO BE SHIPPED.

(CONTINUED AT PAGE)

LTL BRACE DETAIL

THIS DETAIL DEPICTS THREE (3) LTL BRACES SECURED TO THE LOAD BEARING PICES AS SHOWN IN THE ISOMETRIC VIEW ABOVE.

(SPECIAL NOTES CONTINUED)

4. THE LTL BRACE ASSEMBLY MAY BE USED IN CONJUNCTION WITH "SEMI ASSEMBLY" AND "FULL ASSEMBLY" AS LONG AS THE CONTAINER STACK ADJACENT TO THE LTL BRACE IS ONE CONTAINER HIGH.

TYPICAL LTL (UNPALLETIZED)

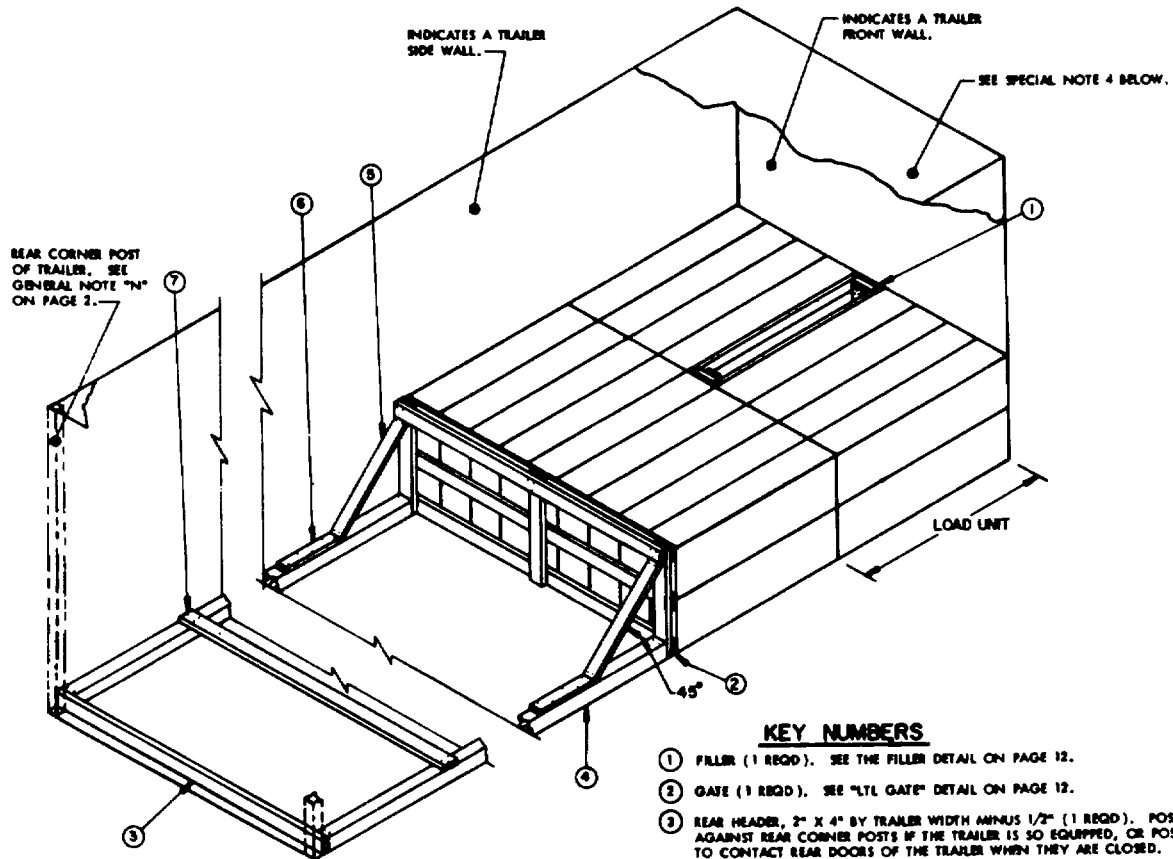

ISOMETRIC VIEW
(25-CONTAINER LTL LOAD)

KEY NUMBERS

- ① FILLER (1 REQD). SEE THE FILLER DETAIL ON PAGE 12.
- ② GATE (1 REQD). SEE "LTL GATE" DETAIL ON PAGE 12.
- ③ REAR HEADER, 2" X 4" BY TRAILER WIDTH MINUS 1/2" (1 REQD). POSITION AGAINST REAR CORNER POSTS IF THE TRAILER IS SO EQUIPPED, OR POSITION TO CONTACT REAR DOORS OF THE TRAILER WHEN THEY ARE CLOSED.
- ④ SIDE STRUT, 4" X 4" BY CUT TO FIT BETWEEN PIECES MARKED ① AND ③ (2 REQD). TOENAIL TO PIECES MARKED ② AND ⑤ W/3-12d NAILS AT EACH END.
- ⑤ KNEE BRACE, 2" X 4" BY CUT TO FIT (REF. 32°) (2 REQD). DOUBLE BEVEL EACH END WITH 45° CUTS. INSTALL AT 45° ANGLE AS SHOWN AND TOENAIL TO PIECES MARKED ② AND ④ W/3-12d NAILS AT EACH END.
- ⑥ BACK-UP CLEAT, 2" X 4" X 18" (2 REQD). NAIL TO PIECES MARKED ④ W/3-12d NAILS.
- ⑦ STRUT BRACING, 2" X 4" BY TRAILER WIDTH (CUT TO FIT) (MINIMUM OF 1 REQD). INSTALL ONE (1) NEAR REAR END OF STRUTS MARKED ④ AS SHOWN. ONE (1) ADDITIONAL PIECE REQUIRED FOR EVERY 7'-0" OF STRUT LENGTH. NAIL TO PIECES MARKED ④ W/3-12d NAILS AT EACH END.

SPECIAL NOTES

1. THESE LTL UNLOADING PROCEDURES ARE SHOWN DEPICTING THE USE OF "KNEE-BRACE" BLOCKING IN A 7'-6" WIDE TRAILER. WIDER TRAILERS CAN BE USED BUT 7'-6" IS THE MINIMUM WIDTH TRAILER FOR SHIPPING THE LOAD AS SHOWN. IF A NARROWER TRAILER IS USED SEE THE PROCEDURES DEPICTED ON PAGE 13 WHICH MUST BE USED.
2. THE "KNEE BRACE" BLOCKING SHOWN ABOVE IS ADEQUATE FOR RETAINING A MAXIMUM TWO (2) CONTAINER HIGH LOAD.
3. IF DESIRED, A THIRD LAYER MAY BE ADDED TO THE DEPICTED LOAD. AN ADDITIONAL HORIZONTAL PIECE MUST BE POSITIONED TO THE GATE AND THE VERTICAL PIECES OF THE GATE EXTENDED TO 45°. A REAR LOAD UNIT WILL NOT BE STACKED MORE THAN THREE (3) CONTAINERS IN HEIGHT.
4. IF THE TRAILER BEING LOADED HAS A BOUND-FRONT OR ROUNDED CORNERS AT THE FORWARD END, REFER TO PAGE 10 FOR "FORWARD BLOCKING" SPECIFICATIONS WHICH MUST BE USED.
5. THE USE OF THE "FILLER ASSEMBLY" IS SPECIFIED FOR THE DEPICTED LOAD ONLY TO SHOW A TYPICAL APPLICATION. "FILLER ASSEMBLIES" AND "RISER ASSEMBLIES" MAY BE USED IN THE LOAD AS REQUIRED TO ADJUST THE LOADING PATTERN FOR THE NUMBER OF CONTAINERS TO BE SHIPPED.

TYPICAL LTL (UNPALLETIZED)

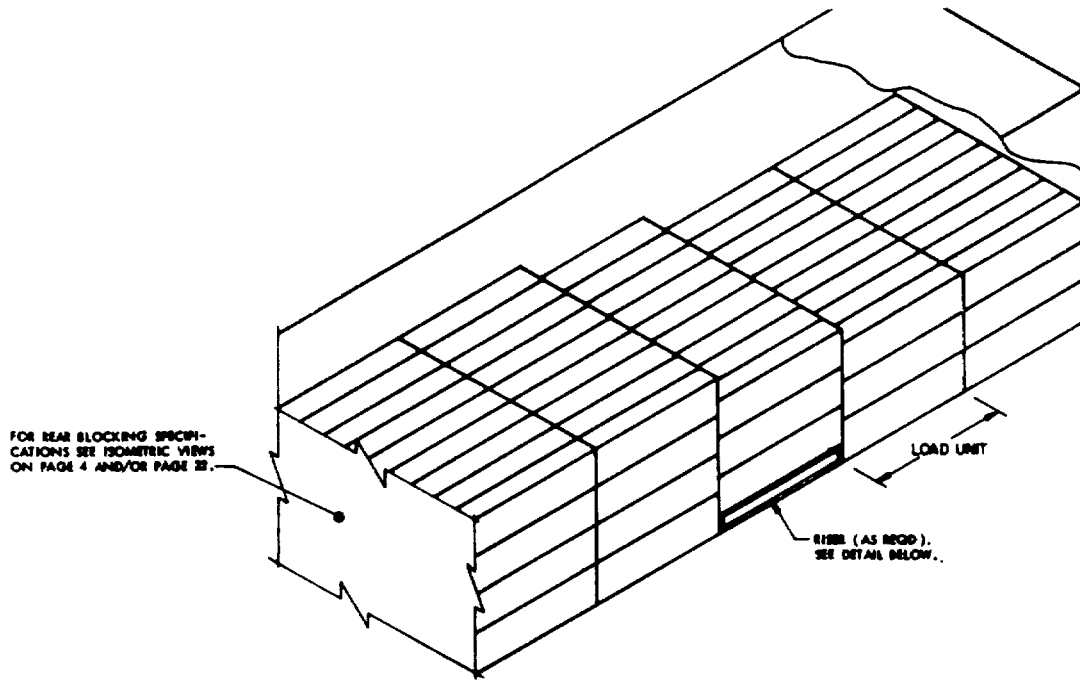

ISOMETRIC VIEW

THE ISOMETRIC VIEW ABOVE DEPICTS THE POSITIONING OF A "RISER ASSEMBLY" TO ADJUST THE NUMBER OF CONTAINERS TO BE SHIPPED. THE "RISER ASSEMBLY" MAY BE USED TO STEP-UP OR STEP-DOWN A LOAD UNIT. THE LOCATION AND/OR WIDTH OF THE "RISER ASSEMBLY" MAY ALSO BE ADJUSTED AS REQUIRED.

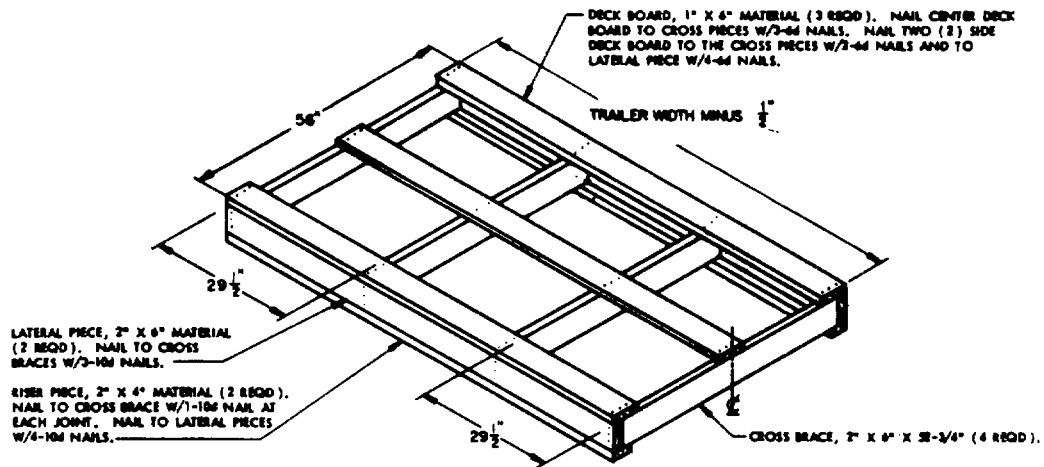

RISER

THE ASSEMBLY AS DEPICTED IS DESIGNED FOR STEPPING-UP OR STEPPING-DOWN A LOAD UNIT OF NINE CONTAINERS WIDE. THE WIDTH MAY BE ADJUSTED AS REQUIRED FOR THE NUMBER OF CONTAINERS TO BE SHIPPED.

DETAILS

NOTE ④:

IF DESIRED, 1/2" PLYWOOD MAY BE SUBSTITUTED FOR THE 2" X 4" HORIZONTAL PIECES. THE PLYWOOD IS REQUIRED TO COVER THE ENTIRE REAR SURFACE OF THE LADING, TRAILER WIDTH MINUS 1/2" BY 6'-4" HIGH. SECURE THE PLYWOOD TO THE VERTICAL PIECES W/1-1/4" NAIL EVERY 12". THE BUTTED JOINTS OF THE PLYWOOD MUST BE CENTERED ON THE CENTER VERTICAL OF THE GATE.

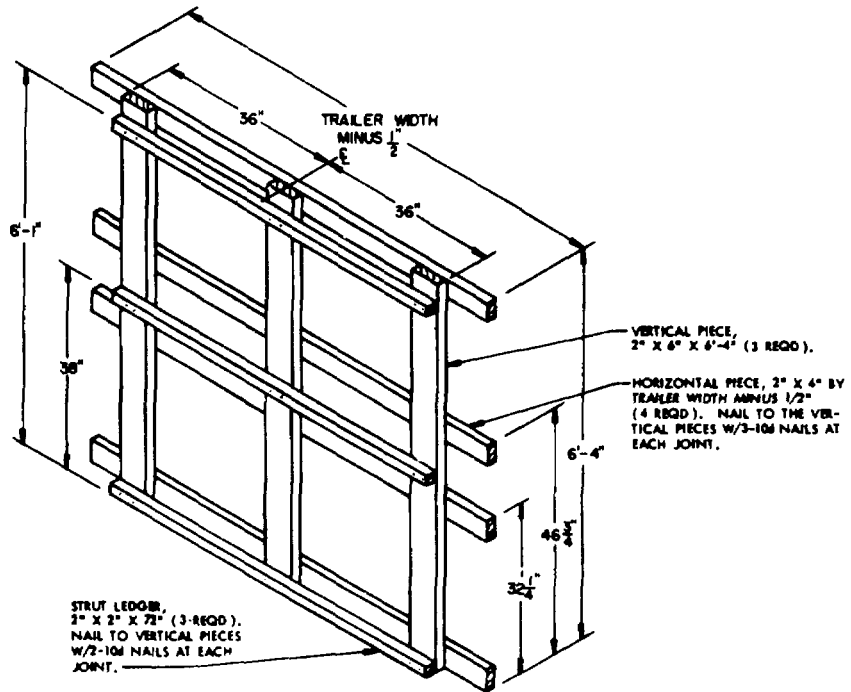
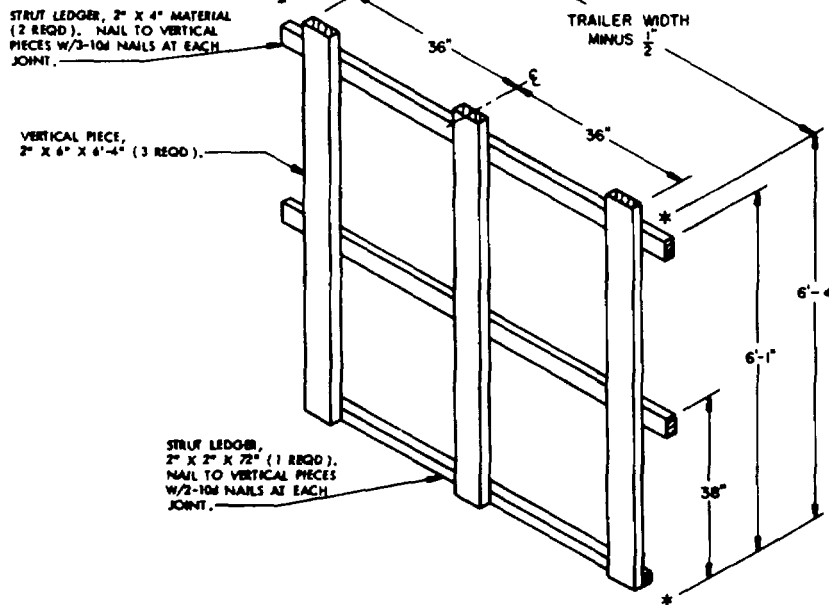

CHART			
NO. OF LAYERS	VARIABLE GATE DIMENSIONS		
	6	5	4
TOP HORIZONTAL	7'-8"	6'-4"	61"
M HORIZONTAL	63"	46-3/4"	X
M HORIZONTAL	32-1/4"	32-1/4"	32-1/4"
TOP STRUT LEDGER	7'-5"	6'-1"	58"
INTERMEDIATE STRUT LEDGER	46"	38"	30"

REAR-OF-LOAD GATE

THIS GATE IS DESIGNED FOR USE AT THE REAR END OF A FIVE (5) LAYER UNPALLETIZED LOAD. SEE "VARIABLE GATE DIMENSIONS" CHART ABOVE FOR GUIDANCE IN FABRICATING GATES FOR USE WITH OTHER HEIGHT LOADS.



NOTE ⑤:

THIS GATE IS DESIGNED FOR USE AT THE REAR END OF A FIVE (5) LAYER UNPALLETIZED LOAD AS DEPICTED ON PAGE 4. THIS GATE IS ALSO APPLICABLE TO OTHER HEIGHT LOADS; REFER TO THE "VARIABLE GATE DIMENSIONS" CHART ABOVE, FOR ADDITIONAL GUIDANCE.

REAR GATE

SEE "NOTE ④" * AT LEFT.

DETAILS

Figure 5-4--Continued (sheet 8 of 27).

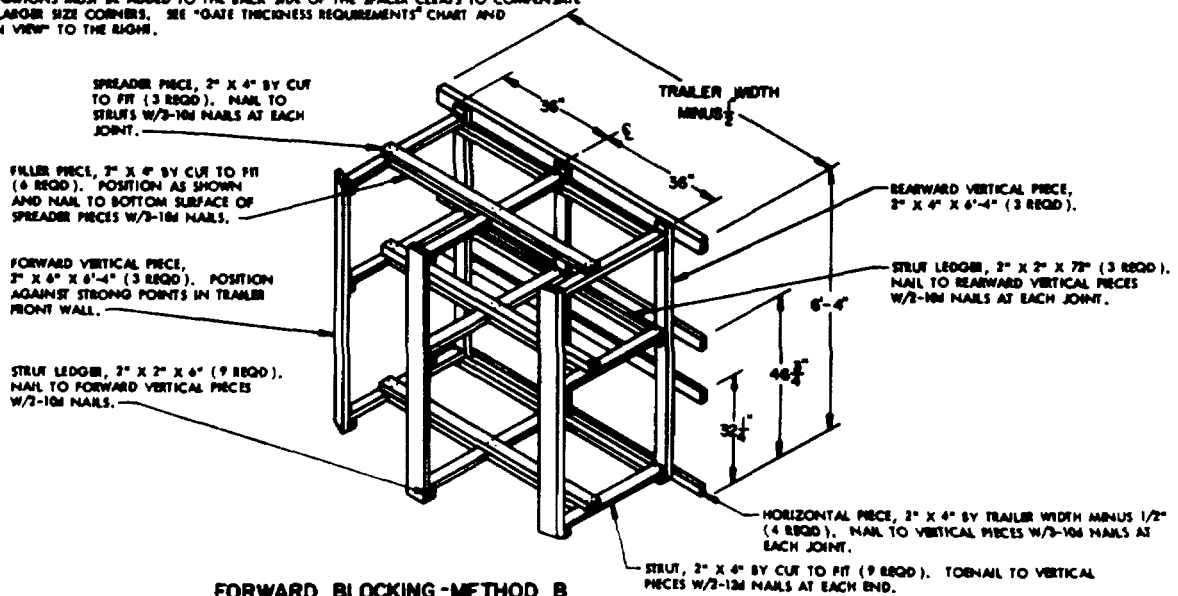
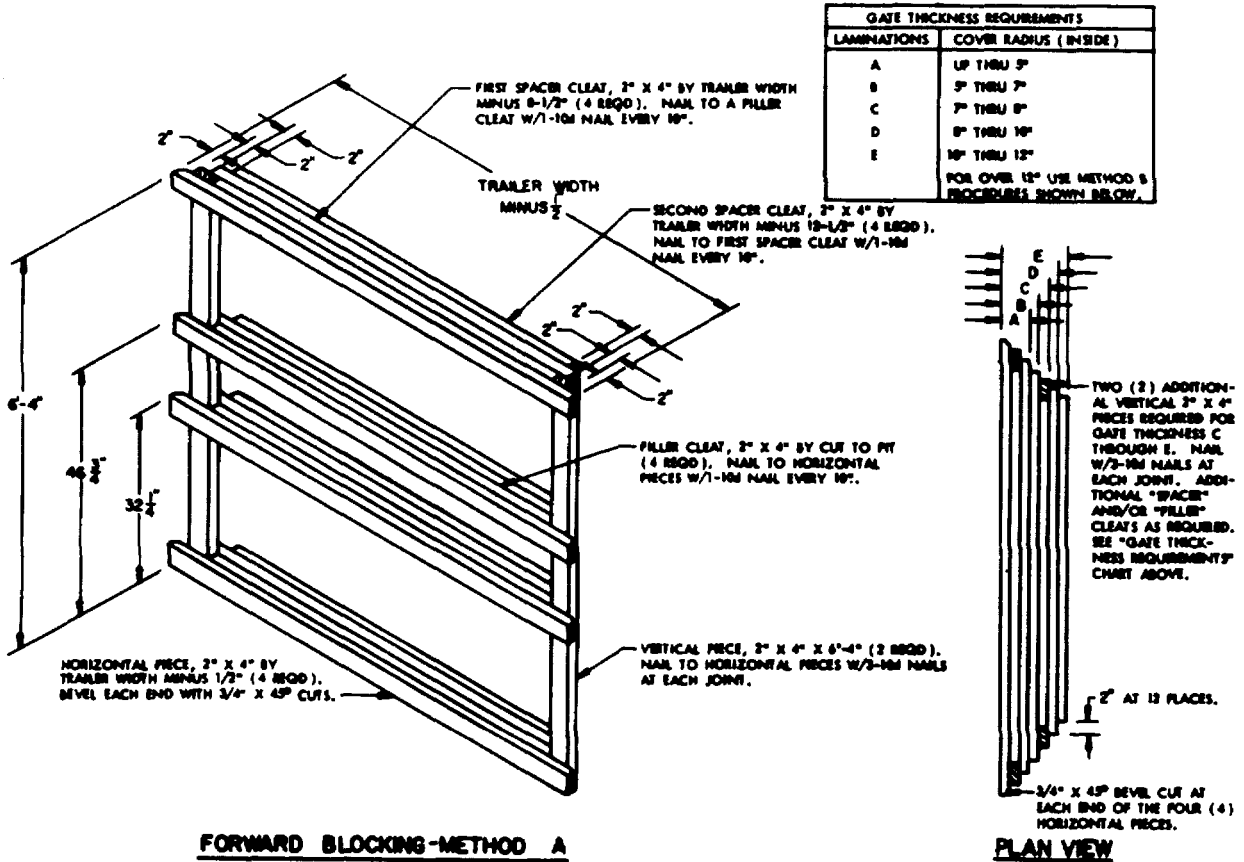
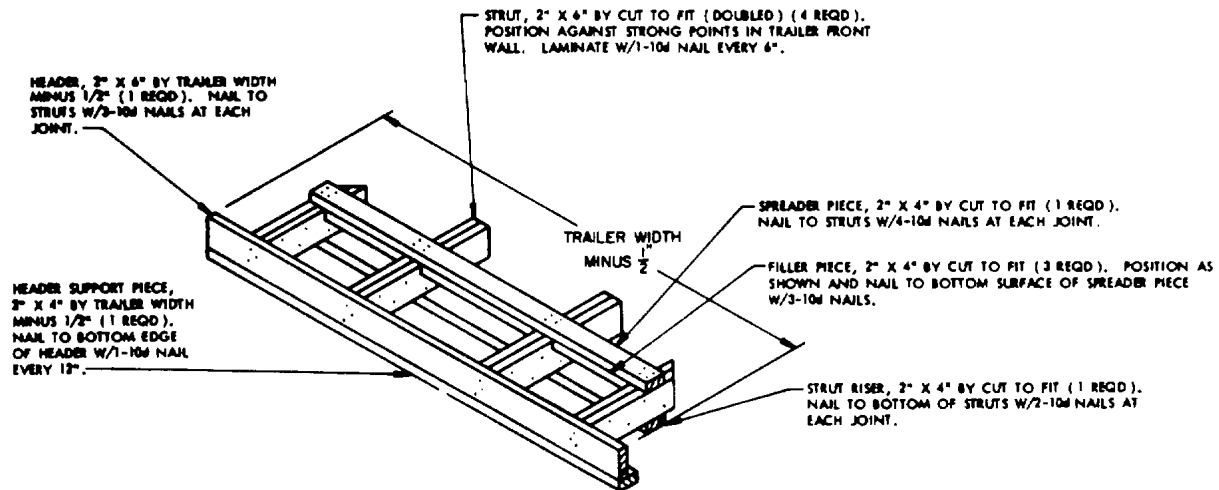
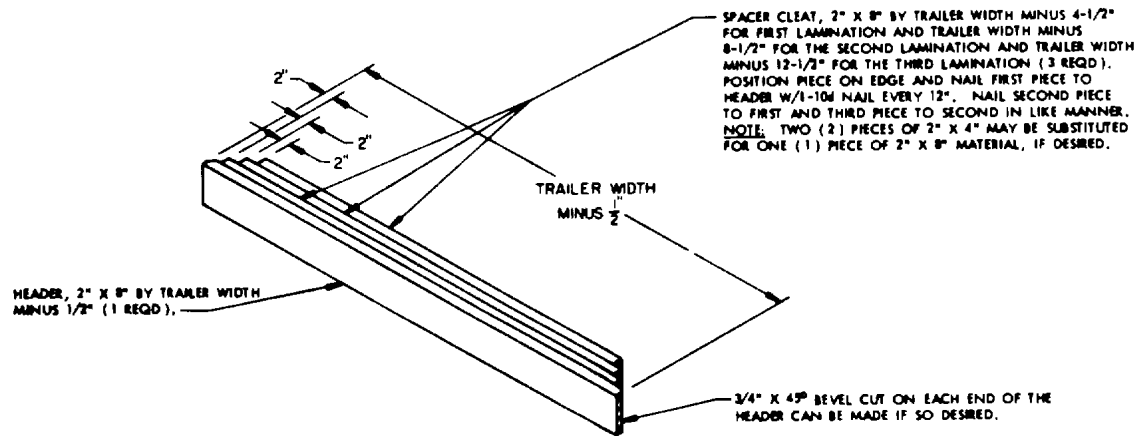

Figure 5-4--Continued (sheet 9 of 27).



FORWARD BLOCKING-METHOD C

THIS "FORWARD BLOCKING" ASSEMBLY IS DESIGNED FOR USE AT THE FORWARD END OF A PALLETIZED LOAD WHICH IS TO BE SHIPPED IN A TRAILER HAVING A ROUND-FRONT.



FORWARD BLOCKING-METHOD D

THIS "FORWARD BLOCKING" ASSEMBLY IS DESIGNED FOR USE AT THE FORWARD END OF A PALLETIZED LOAD WHICH IS TO BE SHIPPED IN A TRAILER HAVING ROUNDED CORNERS OF AN INSIDE RADIUS OF 7" OR LESS. ADDITIONAL LAMINATIONS MUST BE ADDED TO THE BACK SIDE OF THE SPACER CLEATS TO COMPENSATE FOR LARGER SIZE CORNERS. ADD ONE THICKNESS FOR A RADIUS OF 7" TO 8", TWO THICKNESSES FOR A RADIUS OF 8" TO 10", AND THREE THICKNESSES FOR A 10" THRU 12" RADIUS. NOTE: FOR TRAILERS WHICH HAVE LARGER CORNERS, USE "METHOD C" PROCEDURES SHOWN ABOVE.

Figure 5-4-Continued (sheet 10 of 27).

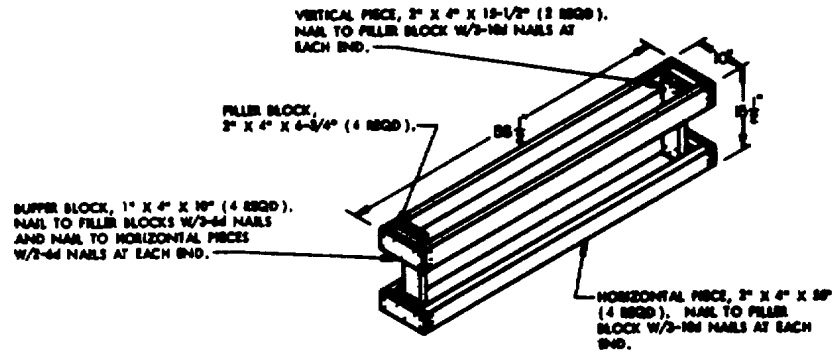

FILLER

THE FILLER ASSEMBLY AS SHOWN IS TO BE USED WITHIN LOADS TO TAKE THE PLACE OF AN OMITTED CONTAINER. IT MUST BE USED IN THE TOP LAYER ONLY.

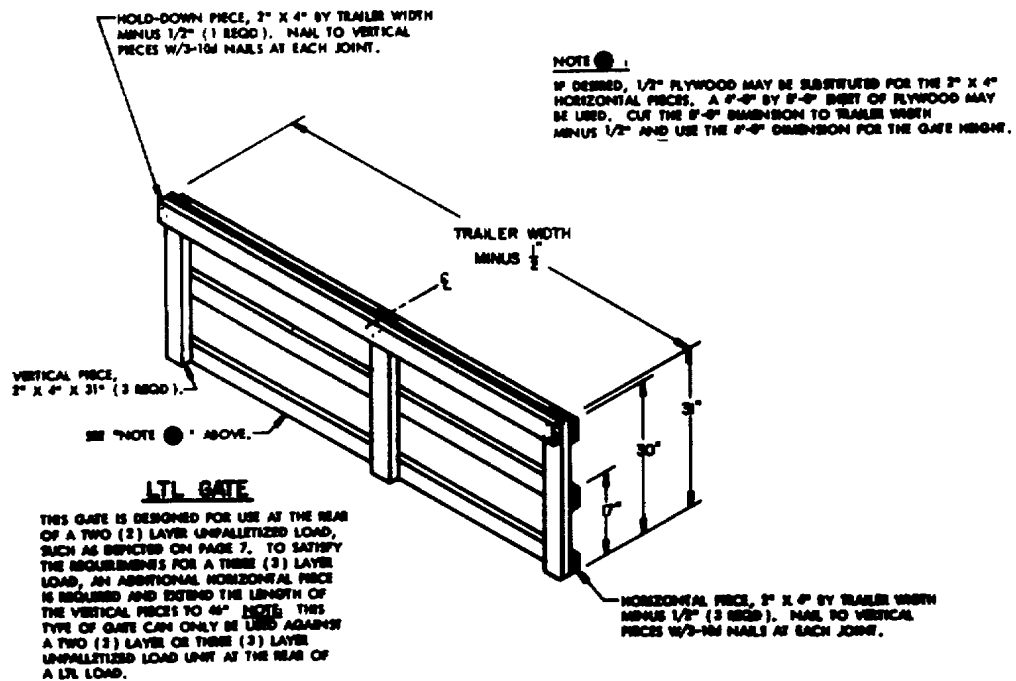

DETAILS

Figure 5--Continued (sheet 11 of 27).

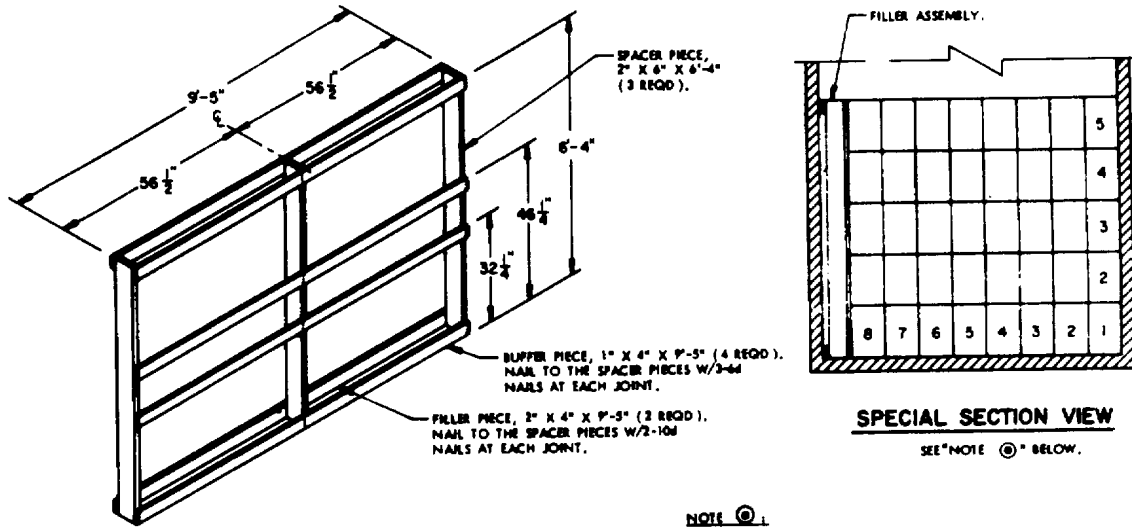

FILLER ASSEMBLY

THE FILLER ASSEMBLY DEPICTED IS FOR A TWO (2) CONTAINER-LONG LOAD UNIT. THE ASSEMBLY CAN ALSO BE FABRICATED FOR A ONE (1) CONTAINER-LONG LOAD UNIT, BY OMITTING THE CENTER SPACER PIECE. THE ASSEMBLY AS SHOWN ABOVE IS DESIGNED FOR A FIVE-CONTAINER HIGH LOAD. THE HEIGHT MAY BE ADJUSTED AS REQUIRED WHEN SHIPPING A DIFFERENT NUMBER OF LAYERS. BUFFER PIECES WILL BE USED AS REQUIRED SO THAT EACH LAYER IS CONTACTED AS TYPICALLY SHOWN WITHIN "SPECIAL SECTION VIEW".

NOTE (C)

IF A TRAILER IS OFFERED FOR LOADING AND THE INSIDE WIDTH IS LESS THAN 10' THE ABOVE ALTERNATIVE LOADING PROCEDURE WILL BE REQUIRED. A LOAD UNIT WILL CONSIST OF EIGHT CONTAINERS WIDE BY FIVE CONTAINERS HIGH BY TWO CONTAINERS LONG AS DEPICTED BY THE "SPECIAL SECTION VIEW" ABOVE, WITH A "FILLER ASSEMBLY" POSITIONED AGAINST ONE SIDE OF THE TRAILER WALL. THE FILLER ASSEMBLY WILL BE OF A THICKNESS TO PROVIDE NOT MORE THAN 1" VOID ACROSS THE WIDTH OF THE TRAILER. THE WIDTH OF THE "FILLER ASSEMBLY" CAN BE ADJUSTED BY ADDING LAMINATIONS TO THE 2" X 4" FILLER PIECES OR BY DECREASING THE THICKNESS OF THE FILLER PIECES. THE "FILLER ASSEMBLY" MAY BE USED AT EITHER SIDE OF THE TRAILER, AS LONG AS ALL ASSEMBLIES ARE ON THE SAME SIDE OF THE TRAILER. THE "FORWARD BLOCKING" AND "REAR BLOCKING" DUNNAGE AND/OR CROSS MEMBERS WILL BE AS SHOWN ON THE LOAD VIEWS.

Figure 5--Continued (sheet 12 of 27).

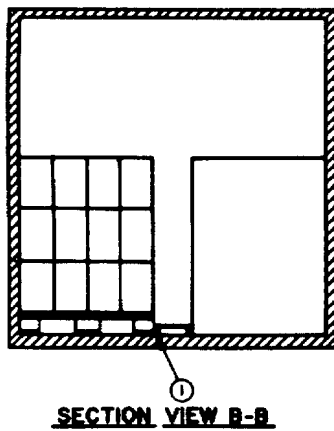
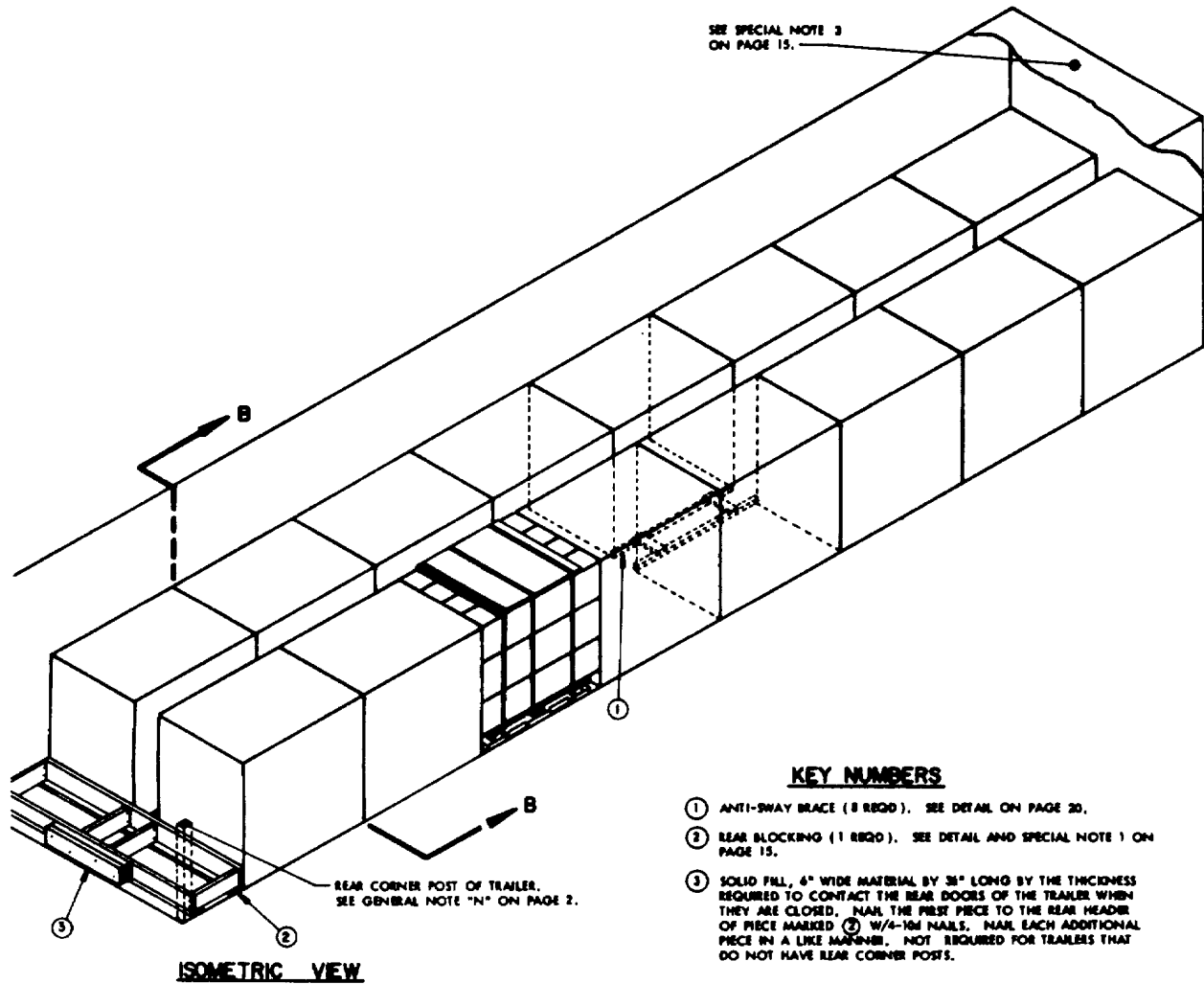
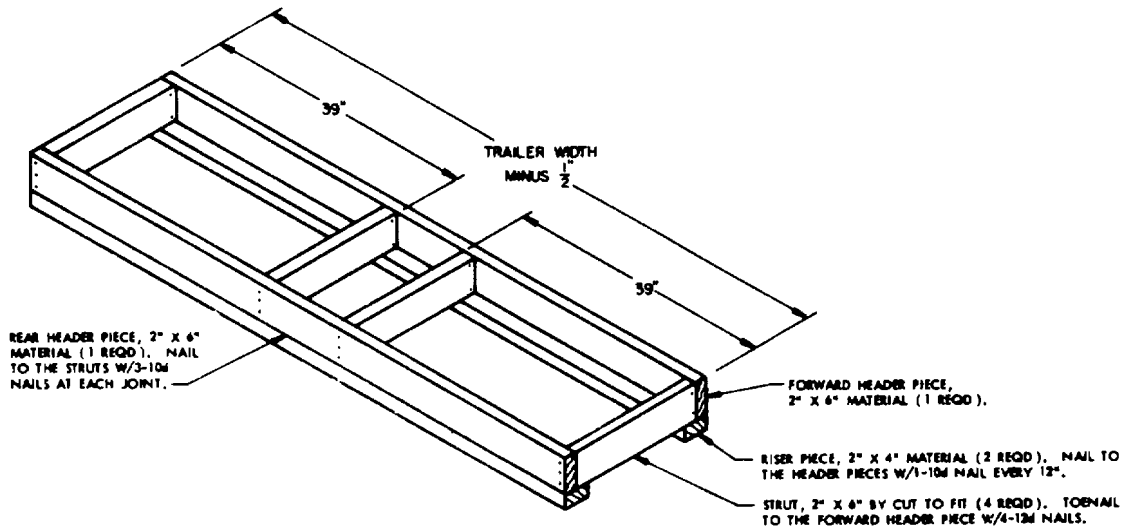

Figure 5--Continued (sheet 13 of 27).



REAR BLOCKING

THIS "REAR BLOCKING" ASSEMBLY IS DESIGNED FOR USE AT THE REAR END OF A PALLETIZED LOAD WHEN THE DISTANCE BETWEEN THE REAR OF THE LOAD AND THE REAR DOORS OF THE TRAILER WHEN THEY ARE CLOSED MEASURES 9' OR MORE. CAUTION: STRUTS LONGER THAN 40" WILL NOT BE USED; USE A "K-BRACE" TYPE OF REAR BLOCKING AS DEPICTED ON PAGE 18 TO FACILITATE COMPLIANCE WITH THIS RULE. WHEN THE DISTANCE BETWEEN THE REAR OF THE LOAD AND THE REAR DOORS MEASURES LESS THAN 9' SEE "ALTERNATIVE REAR BLOCKING" DETAIL ON PAGE 21.

SPECIAL NOTES:

1. A 16-UNIT LOAD IS SHOWN IN A SQUARE FRONT TRAILER WHICH IS 7'-6" WIDE (INSIDE DIMENSION) BY 40'-0" LONG AND WHICH IS EQUIPPED WITH REAR CORNER POSTS. A 16-UNIT LOAD CAN BE LOADED IN A 39'-0" LONG TRAILER BY USING THE "ALTERNATIVE REAR BLOCKING" PROCEDURES DEPICTED ON PAGE 21.
2. A NARROWER OR A WIDER TRAILER THAN SHOWN MAY BE USED FOR SHIPPING THE DEPICTED LOAD.
3. IF THE TRAILER BEING LOADED HAS ROUNDED CORNERS AT THE FORWARD END OR IF THE TRAILER HAS A ROUND FRONT, REFER TO PAGE 11 FOR BLOCKING SPECIFICATIONS WHICH MUST BE USED. A 16-UNIT LOAD MAY BE THE MAXIMUM NUMBER OF UNITS THAT CAN BE LOADED IN A 40'-0" LONG TRAILER THAT HAS A ROUND FRONT.

BILL OF MATERIAL

LUMBER	LINEAR FEET	BOARD FEET
1" X 4"	14	5
2" X 2"	84	28
2" X 4"	15	10
2" X 6"	22	22
NAILS	NO. REQD	POUNDS
6d (2")	96	3/4
10d (3")	58	1
12d (3-1/4")	16	1/2

LOAD AS SHOWN

ITEM	QUANTITY	WEIGHT (APPROX)
PALLET UNIT	16	10,976 LBS
DUNNAGE		166 LBS
TOTAL WEIGHT		11,142 LBS

PALLETIZED LOAD IN A 40'-0" LONG TRAILER (ONE UNIT HIGH)

PAGE 15

Figure 5-4--Continued (sheet 14 of 27).

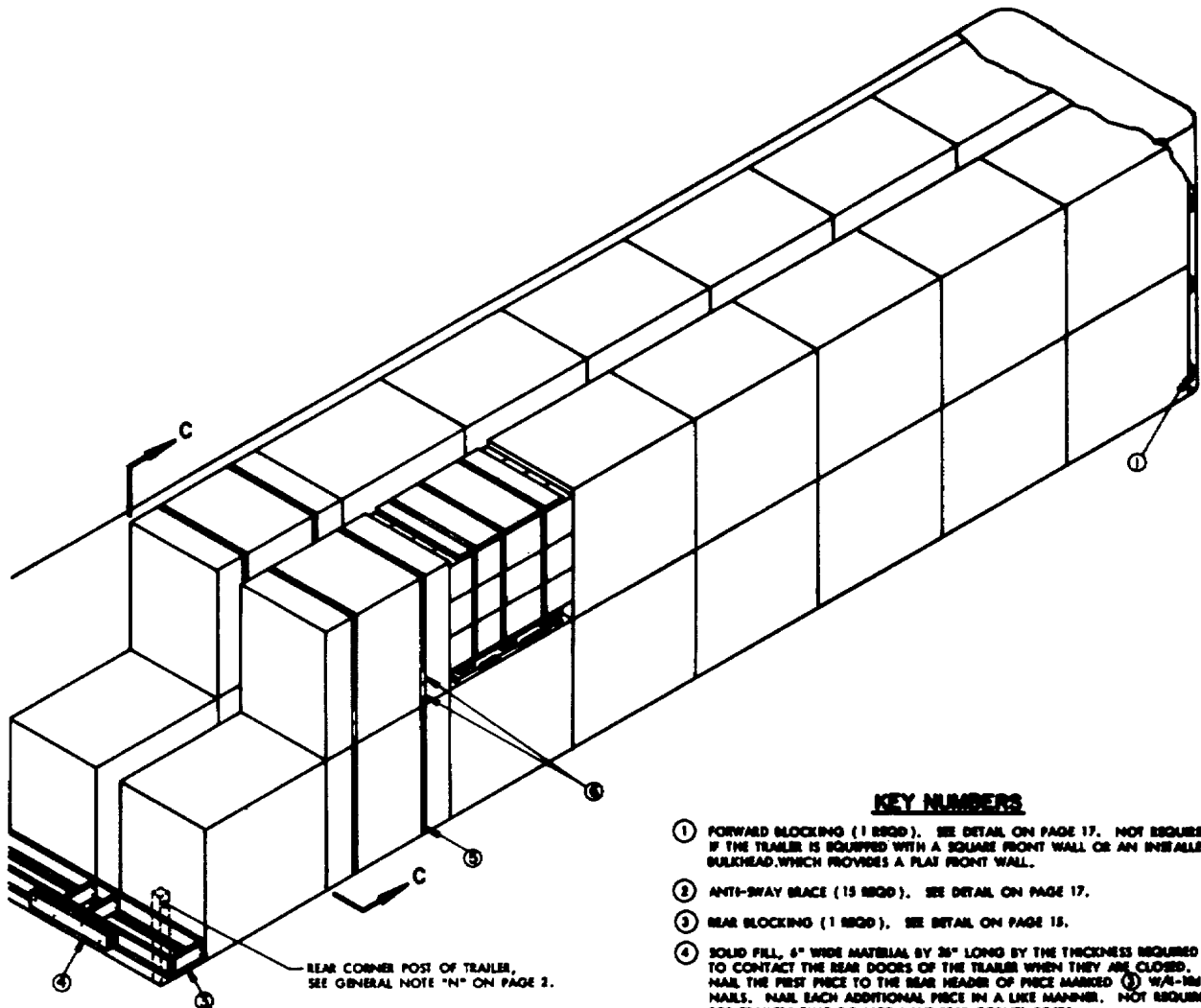

ISOMETRIC VIEW

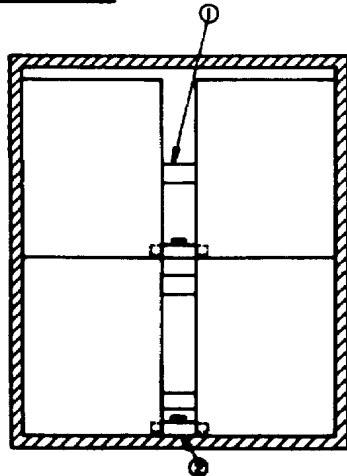

SECTION C-C

UNITIZING STRAP, PIECE MARKED ⑤, HAS BEEN OMITTED FOR CLARITY.

KEY NUMBERS

- ① FORWARD BLOCKING (1 BIDD). SEE DETAIL ON PAGE 17. NOT REQUIRED IF THE TRAILER IS EQUIPPED WITH A SQUARE FRONT WALL OR AN INSTALLED BULKHEAD, WHICH PROVIDES A FLAT FRONT WALL.
- ② ANTI-SWAY BRACE (15 BIDD). SEE DETAIL ON PAGE 17.
- ③ REAR BLOCKING (1 BIDD). SEE DETAIL ON PAGE 15.
- ④ SOLID FILL, 6" WIDE MATERIAL BY 26" LONG BY THE THICKNESS REQUIRED TO CONTACT THE REAR DOORS OF THE TRAILER WHEN THEY ARE CLOSED. NAIL THE FIRST PIECE TO THE REAR HEADER OF PRICE MARKED ① 1/4-IN. NAILS. NAIL EACH ADDITIONAL PIECE IN A LIKE MANNER. NOT REQUIRED FOR TRAILERS THAT DO NOT HAVE REAR CORNER POSTS.
- ⑤ UNITIZING STRAP, 1-1/4" X .026" X 17'-0" LONG STEEL STRAPPING (4 BIDD). SEE GENERAL NOTE "3" ON PAGE 3 AND SPECIAL NOTE 3 ON PAGE 17.
- ⑥ SEAL FOR 1-1/4" STEEL STRAPPING (8 BIDD). DOUBLE COMP. SEALS WILL NORMALLY BE INSTALLED TOWARD THE CENTER OF THE LOAD, SEALS HAVE BEEN SHOWN TOWARD THE SIDE OF THE TRAILER IN THE ISOMETRIC VIEW FOR CLARITY PURPOSES.

Figure 5-4-Continued (sheet 15 of 27).

SPECIAL NOTES

1. A 30-UNIT LOAD IS SHOWN IN A 7'-4" WIDE BY 8'-11" HIGH (INSIDE DIMENSIONS) BY 40'-0" LONG TRAILER, EQUIPPED WITH ROUNDED CORNERS AT THE FORWARD END AND REAR CORNER POSTS. WIDER OR NARROWER TRAILERS MAY BE USED FOR THE DEPICTED LOAD. **NOTICE:** 8'-11" IS THE MINIMUM HEIGHT TRAILER THAT CAN BE USED TO SHIP A 7-UNIT HIGH LOAD.
2. A 30-UNIT LOAD CAN BE LOADED IN A 39'-0" LONG TRAILER BY USING THE "ALTERNATIVE REAR BLOCKING" PROCEDURES DEPICTED ON PAGE 21.
3. IF THE TRAILER BEING LOADED HAS A SQUARE FRONT WALL OR AN INSTALLED BULK-HEAD AT THE FORWARD END, DELETE THE "FORWARD BLOCKING ASSEMBLY". IF THE TRAILER HAS ROUNDED CORNERS AT THE FORWARD END WITH A RADIUS OF BETWEEN 7" AND 12", ADD ADDITIONAL LATERAL PIECES TO THE FORWARD BLOCKING ASSEMBLY. IF THE TRAILER IS EQUIPPED WITH A ROUND-FRONT SEE THE "FORWARD BLOCKING-METHOD C" ON PAGE 11 FOR SPECIFICATIONS WHICH MUST BE USED. ALSO, IF "FORWARD BLOCKING-METHOD C" IS USED THE MOST FORWARD LOAD UNITS MUST BE UNITIZED IN THE SAME MANNER AS THE MOST REARWARD TWO-HIGH LOAD UNITS ARE UNITIZED IN THE ISOMETRIC VIEW.
4. IF THE DOOR OPENING HEIGHT PERMITS, THE REAR STACK MAY BE STACKED TWO (2) PALLET UNITS HIGH. THE UNITIZING STRAPS WILL THEN BE POSITIONED AROUND THE PALLET UNITS IN THE MOST REARWARD STACK.
5. THE TWO-HIGH STACKS AT THE REAR SHOULD BE UNITIZED IN THE REAR OF THE TRAILER AND THEN MOVED INTO FINAL POSITION.

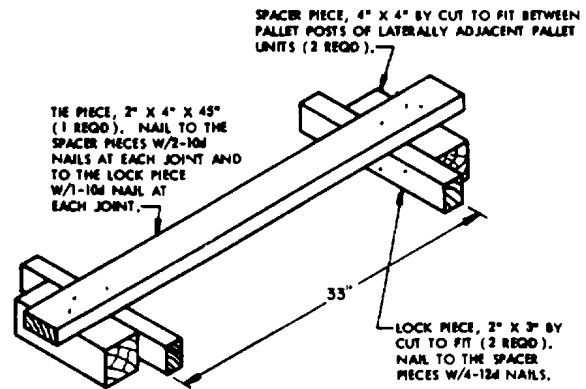

ANTI-SWAY BRACE

NOTE:

THE 4" X 4" SPACER PIECES ARE TO BE CUT TO FIT BETWEEN THE OUTWARD PALLET POSTS ON LATERALLY ADJACENT UNITS SO THAT THE INSTALLED ASSEMBLY WILL PROVIDE FOR A SNUG FIT. THIS ASSEMBLY CANNOT BE COMPLETELY ASSEMBLED PRIOR TO INSTALLING WITHIN A LOAD. THE TRICE WILL HAVE TO BE NAILED AFTER THE OTHER PIECES ARE IN PLACE.

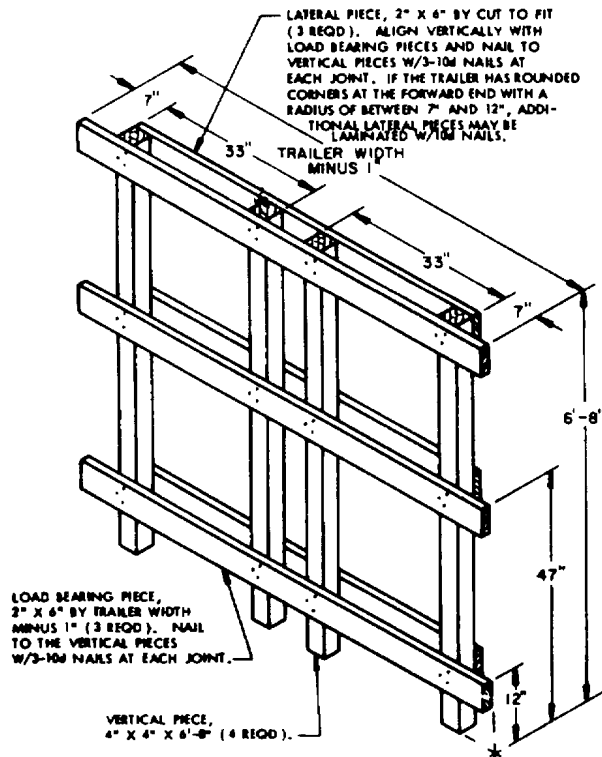

FORWARD BLOCKING

SEE SPECIAL NOTE 3 ABOVE.

PALLETIZED LOAD IN A 40'-0" LONG TRAILER (TWO UNITS HIGH)

BILL OF MATERIAL		
LUMBER	LINEAR FEET	BOARD FEET
2" X 3"	55	28
2" X 4"	69	46
2" X 6"	66	66
4" X 4"	52	69
NAILS	NO. REQD	POUNDS
10d (3")	198	3
12d (3-1/4")	16	1/4
STEEL STRAPPING, 1-1/4" X .035" ----- 64' REQD -----		10 LBS
SEALS FOR 1-1/4" STRAPPING ----- 8 REQD -----		NIL

LOAD AS SHOWN

ITEM	QUANTITY	WEIGHT (APPROX)
PALLET UNIT -----	20 -----	20,800 LBS
DUNNAGE -----	-----	536 LBS
TOTAL WEIGHT -----		21,336 LBS

Figure 5-4--Continued (skeet 16 of 27).

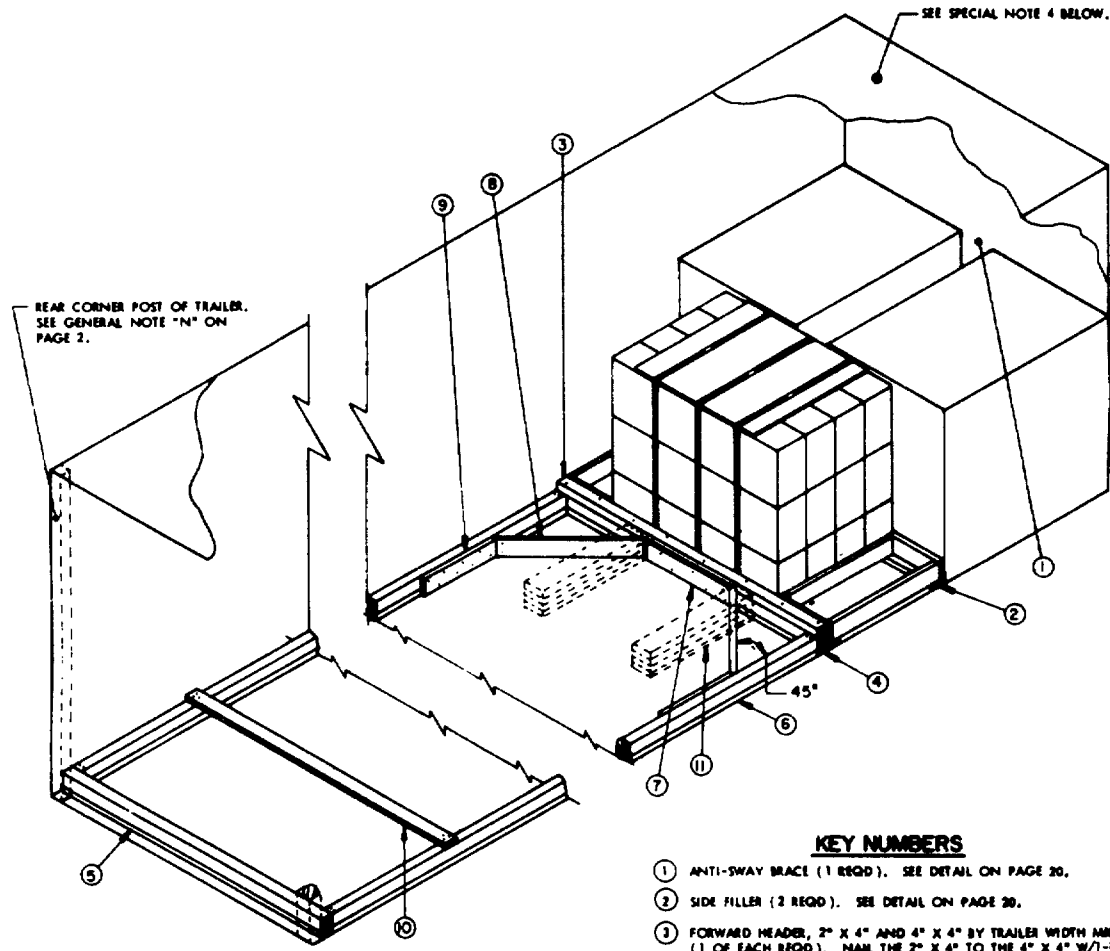

ISOMETRIC VIEW

SPECIAL NOTES

1. THESE OUTLOADING PROCEDURES ARE SHOWN DEPICTING THE USE OF TWO METHODS OF BLOCKING, THE USE OF A "K-BRACE" AND "NAILED FLOOR LINE" BLOCKING IN A 7'-4" WIDE TRAILER. A WIDER OR NARROWER TRAILER CAN ALSO BE USED.
2. THE "K-BRACE" BLOCKING, SHOWN AS PIECES MARKED ⑤ THRU ⑩ IS ADEQUATE FOR RETAINING A MAXIMUM LTL LOAD.
3. PIECES MARKED ⑪ ARE FOR USE IN A TRAILER WHICH HAS A NAILABLE FLOOR AND SHOULD BE USED, IF POSSIBLE, IN LIEU OF PIECES MARKED ⑤ THRU ⑩ WHICH APPLY TO TRAILERS HAVING NON-NAILABLE FLOORS. TWO (2) BACK-UP CLEATS, SHOWN AS PIECES MARKED ⑪, ARE ADEQUATE FOR RETAINING AN LTL LOAD OF NOT MORE THAN 7,000 POUNDS.
4. A TRAILER HAVING A SQUARE FRONT IS SHOWN; HOWEVER, IF A TRAILER IS OFFERED FOR SHIPMENT HAVING ROUNDED CORNERS AT THE FORWARD END OR A ROUND FRONT REFER TO PAGE 11 FOR BLOCKING SPECIFICATIONS WHICH MUST BE USED. ALSO, FOR A TRAILER EQUIPPED WITH ROUNDED CORNERS AT THE FORWARD END THE LOADING PATTERN MAY BE REVERSED, THAT IS, THE ONE UNIT COULD BE POSITIONED AGAINST THE FORWARD WALL AND THE OTHER TWO UNITS POSITIONED AGAINST THE FIRST UNIT. THE LENGTH OF THE SIDE FILLER WOULD BE REDUCED SO AS TO NOT CONTACT THE ROUNDED CORNERS OF THE TRAILER.

KEY NUMBERS

- ① ANTI-SWAY BRACE (1 REQD). SEE DETAIL ON PAGE 20.
- ② SIDE FILLER (2 REQD). SEE DETAIL ON PAGE 20.
- ③ FORWARD HEADER, 2" X 4" AND 4" X 4" BY TRAILER WIDTH MINUS 1/2" (1 OF EACH REQD). NAIL THE 2" X 4" TO THE 4" X 4" W/1-10d NAIL EVERY 12".
- ④ FORWARD HEADER RISER, 2" X 4" BY TRAILER WIDTH MINUS 1/2" (1 REQD). NAIL TO THE 4" X 4" OF PIECE MARKED ③ W/1-10d NAIL EVERY 12".
- ⑤ REAR HEADER, 2" X 4" AND 4" X 4" BY TRAILER WIDTH MINUS 1/2" (1 OF EACH REQD). LAMINATE THE 2" X 4" PIECE TO THE 4" X 4" W/1-10d NAIL EVERY 12". SEE SPECIAL NOTE 3 AT LEFT.
- ⑥ SIDE STRUT, 2" X 4" AND 4" X 4" BY CUT TO FIT (2 REQD). LAMINATE THE 2" X 4" PIECE TO THE 4" X 4" W/1-10d NAIL EVERY 12". TOENAIL TO THE HEADERS W/2-10d NAILS AT EACH JOINT.
- ⑦ CENTER CLEAT, 2" X 6" X 30" (1 REQD). NAIL TO PIECE MARKED ⑤ W/6-12d NAILS.
- ⑧ DIAGONAL BRACE, 2" X 4" BY CUT TO FIT (2 REQD). DOUBLE BEVEL EACH END WITH 45° CUTS. INSTALL AT A 45° ANGLE AS SHOWN AND TOENAIL TO PIECES MARKED ① AND ④ W/2-10d NAILS AT EACH JOINT.
- ⑨ SIDE CLEAT, 2" X 6" X 24" (2 REQD). NAIL TO PIECES MARKED ⑤ W/3-12d NAILS.
- ⑩ STRUT BRACING, 2" X 4" BY TRAILER WIDTH (CUT TO FIT) (MINIMUM OF 1 REQD). INSTALL ONE (1) NEAR REAR END OF STRUTS MARKED ⑥ AS SHOWN. ONE (1) ADDITIONAL PIECE IS REQUIRED FOR EVERY 7'-0" OF STRUT LENGTH. NAIL TO PIECE MARKED ④ W/3-12d NAILS AT EACH END.
- ⑪ BACK-UP CLEAT, 2" X 6" X 24" (QUADRUPLED) (2 REQD). ALIGN AS SHOWN IN "ISOMETRIC VIEW" ABOVE. NAIL FIRST PIECE TO TRAILER FLOOR W/3-12d NAILS. NAIL THE SECOND PIECE TO THE FIRST, THE THIRD PIECE TO THE SECOND AND THE FOURTH PIECE TO THE THIRD IN A LIKE MANNER. SEE SPECIAL NOTE 3 AT LEFT.

Figure 5-4--Continued (sheet 17 of 27).

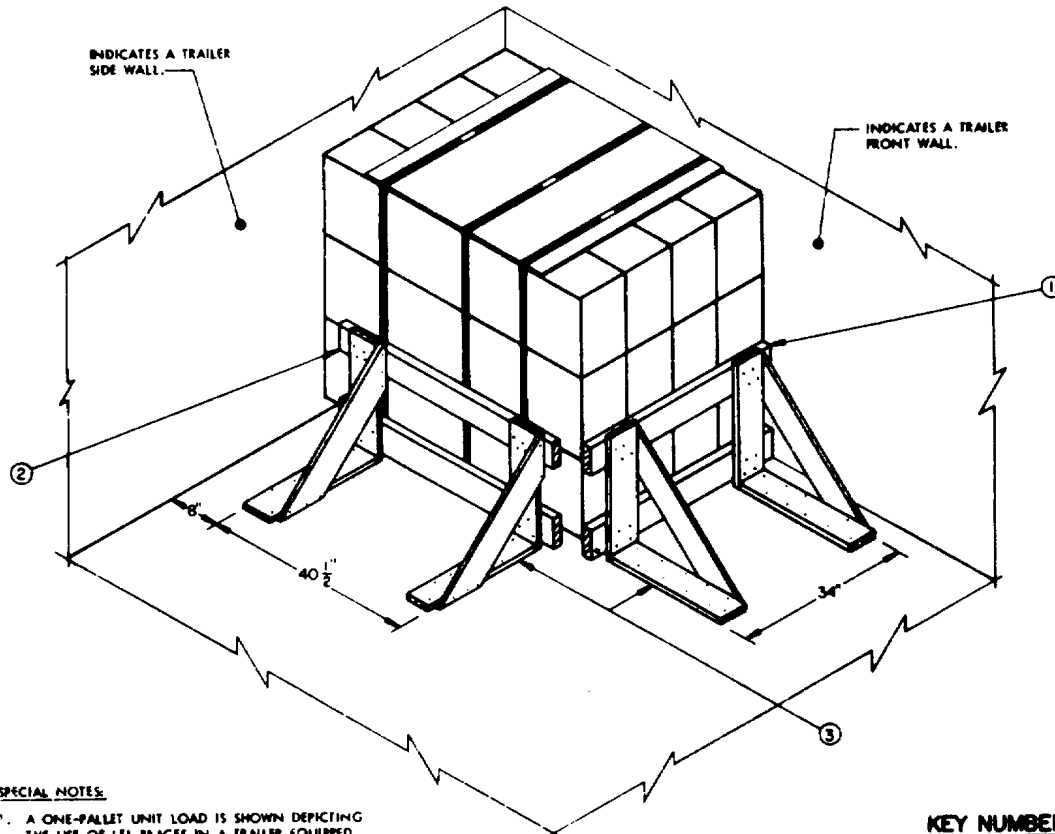

SPECIAL NOTES:

1. A ONE-PALLET UNIT LOAD IS SHOWN DEPICTING THE USE OF LTL BRACES IN A TRAILER EQUIPPED WITH A NAILABLE FLOOR. TRAILERS WITH ALL METAL FLOORS CANNOT BE USED.
2. THIS OUTLOADING PROCEDURE IS ALSO APPLICABLE FOR LTL LOADS OF MORE THAN ONE UNIT, PROVIDING THE CRITERIA OF "NOTE ④" BELOW IS OBSERVED. UNITS SHOULD BE LOADED SIDE BY SIDE WITH ANTI-SWAY BRACES BETWEEN LATERALLY ADJACENT UNITS.
3. IF DESIRED, LTL BRACES MAY ALSO BE INSTALLED AT THE FORWARD END OF THE LADING.

ISOMETRIC VIEW

KEY NUMBERS

- ① LOAD BEARING PIECE, 2" X 6" X 40" (2 REQD). LOCATE AT HEIGHTS SPECIFIED IN DETAIL BELOW.
- ② LOAD BEARING PIECE, 2" X 6" X 40" (2 REQD). LOCATE AT HEIGHTS SPECIFIED IN DETAIL BELOW.
- ③ LTL BRACE (4 REQD). SEE DETAIL BELOW. NAIL TO PIECES MARKED ① AND ② W/4-6d NAILS AT EACH JOINT. NAIL EACH LTL BRACE TO TRAILER FLOOR W/10-6d NAILS.

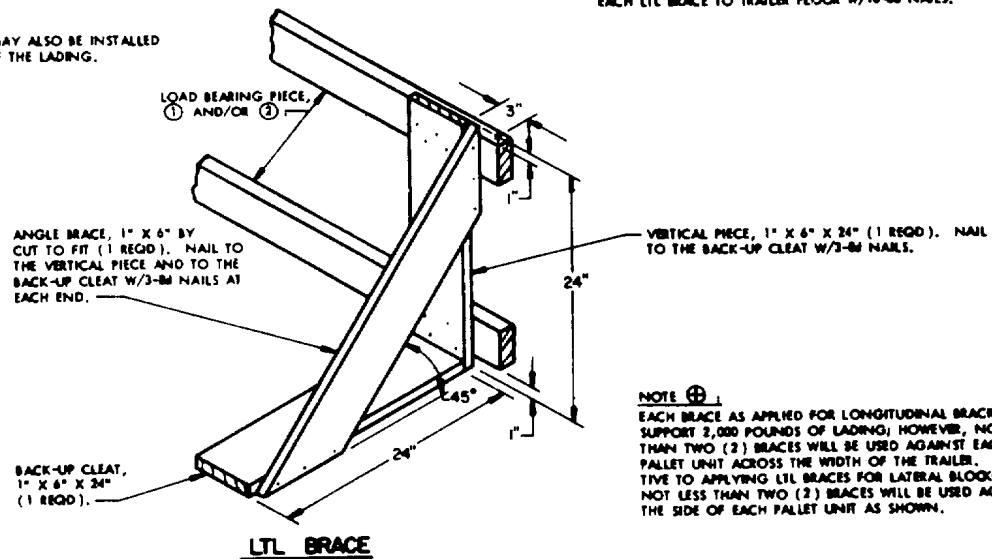

NOTE ④

EACH BRACE AS APPLIED FOR LONGITUDINAL BRACING WILL SUPPORT 2,000 POUNDS OF LADING; HOWEVER, NOT LESS THAN TWO (2) BRACES WILL BE USED AGAINST EACH PALLET UNIT ACROSS THE WIDTH OF THE TRAILER. RELATIVE TO APPLYING LTL BRACES FOR LATERAL BLOCKING, NOT LESS THAN TWO (2) BRACES WILL BE USED AGAINST THE SIDE OF EACH PALLET UNIT AS SHOWN.

TYPICAL LTL (PALLETIZED)

Figure 5-4--Continued (sheet 18 of 27).

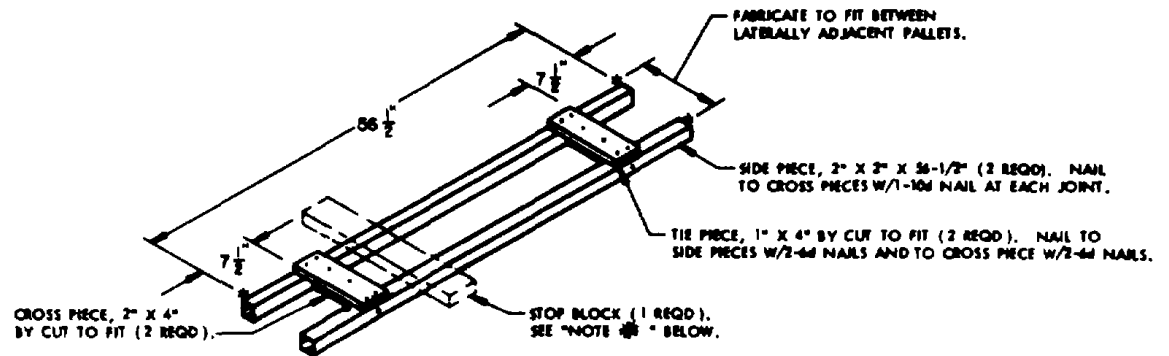

ANTI-SWAY BRACE

NOTE ❸ :

STOP BLOCK, 2" X 4" X 18" (1 REQD). THIS BLOCK IS TO BE USED TO PREVENT LONGITUDINAL MOVEMENT OF THE ANTI-SWAY BRACE WHEN USED ADJACENT TO A CROSS MEMBER IN A TRAILER EQUIPPED WITH MECHANICAL BRACING DEVICES. POSITION BEHIND PALLET POSTS OF LATERALLY ADJACENT PALLETS, AND NAIL TO SIDE PIECES W/7-10# NAILS AT EACH JOINT. ONLY REQUIRED ON THE ANTI-SWAY BRACE ADJACENT TO A CROSS MEMBER.

❷ WHEN USED IN A TRAILER WITH ROUNDED CORNERS AT THE FORWARD END REDUCE THIS DIMENSION SO THAT THE FILLER DOES NOT CONTACT THE RADIUS OF THE CORNERS.

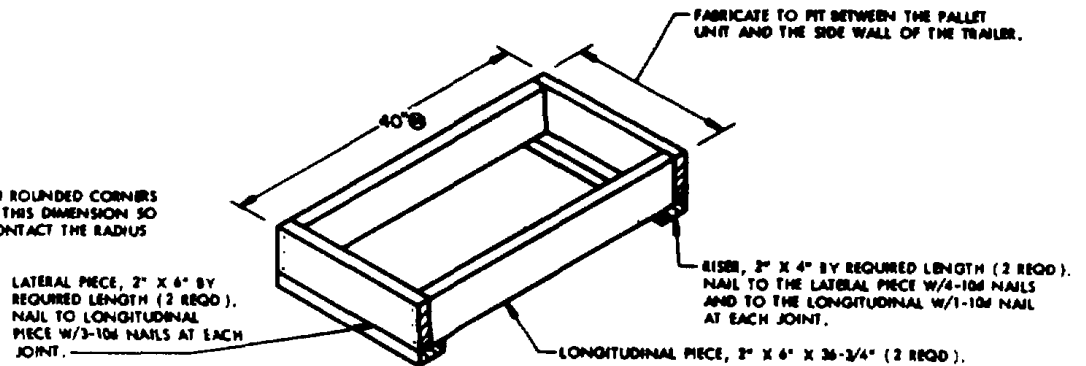

SIDE FILLER

Figure 5-4-Continued (sheet 19 of 27).

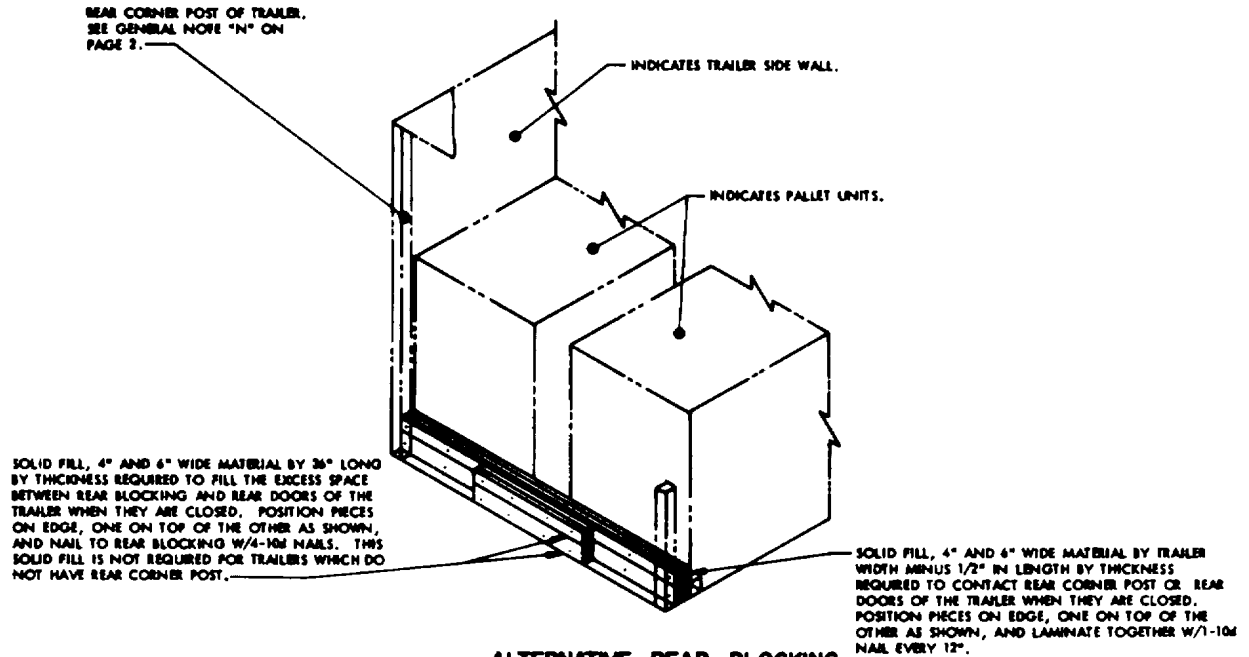

ALTERNATIVE REAR BLOCKING

NOTE. THIS TYPE OF REAR BLOCKING IS REQUIRED WHEN THE EXCESS SPACE BETWEEN THE REAR OF THE LADING AND TRAILER REAR DOORS MEASURES LESS THAN 12".

Figure 5-4--Continued (sheet 20 of 27).

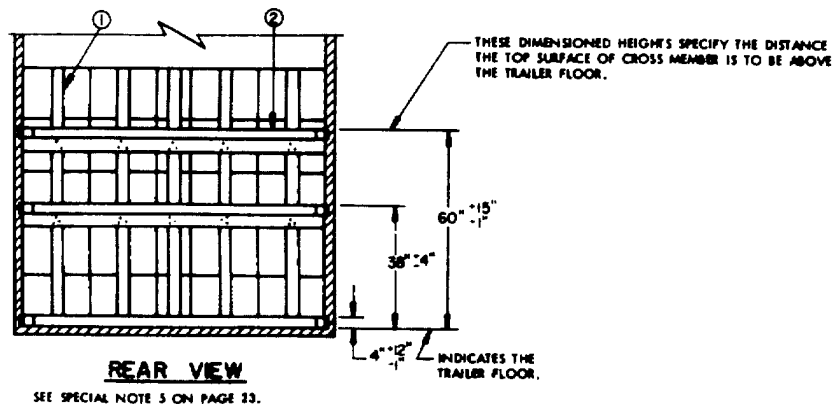
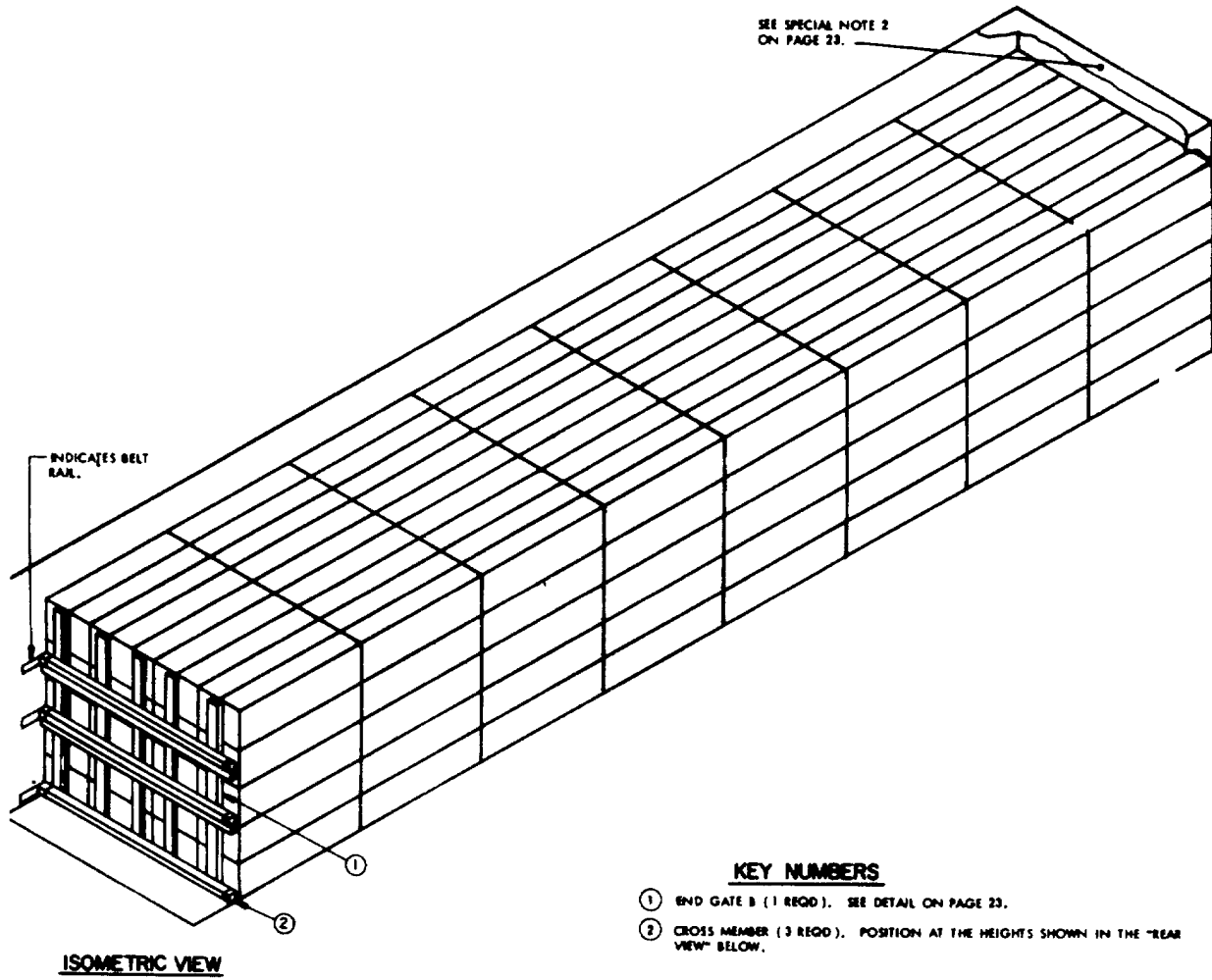

UNPALLETIZED LOAD IN A 40'-0" LONG TRAILER (MECHANICAL)

Figure 5-4--Continued (sheet 21 of 27).

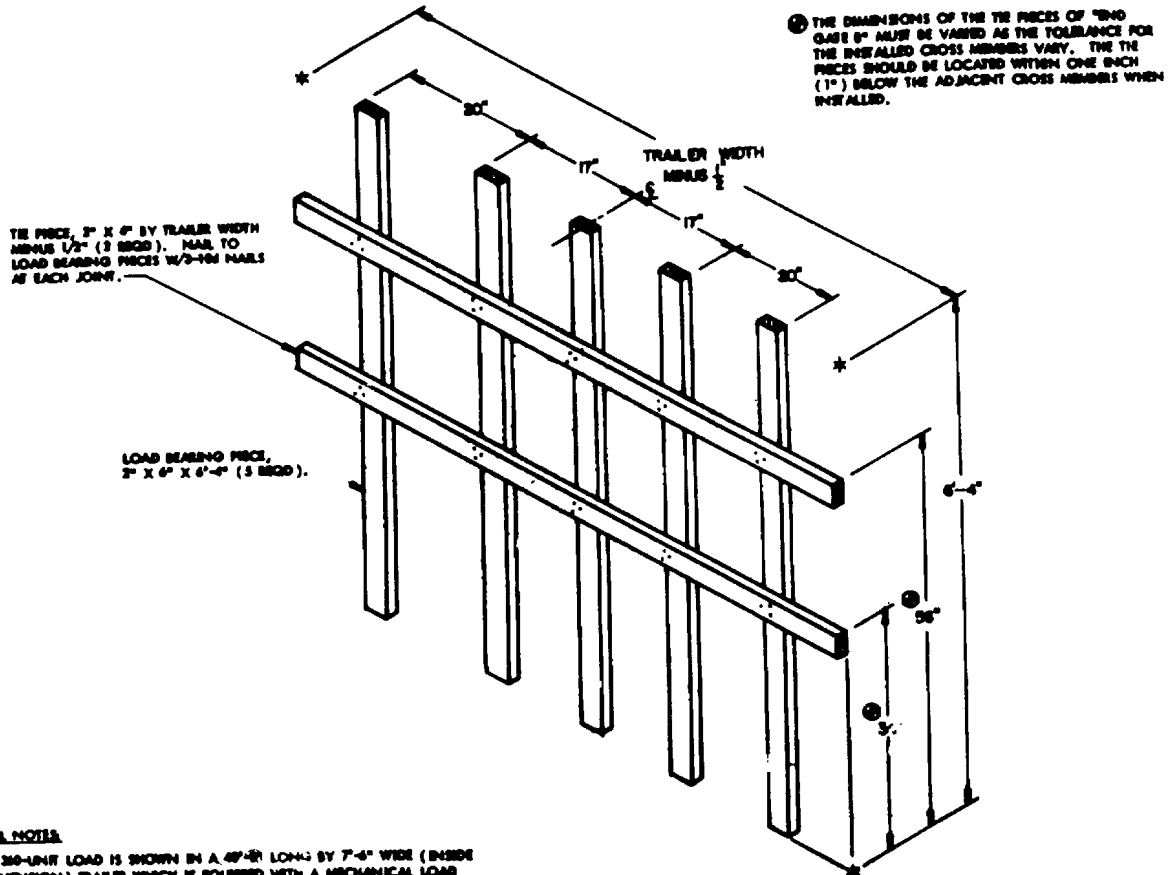

THE DIMENSIONS OF THE TIE PIECES OF "END GATE 8" MUST BE VARIED AS THE TOLERANCE FOR THE INSTALLED CROSS MEMBERS VARY. THE TIE PIECES SHOULD BE LOCATED WITHIN ONE INCH (1") BELOW THE ADJACENT CROSS MEMBERS WHEN INSTALLED.

TIE PIECE, 2" X 4" BY TRAILER WIDTH MINUS 1/2" (3 BKGD). NAIL TO LOAD BEARING PIECES W/3-6d NAILS AT EACH JOINT.

LOAD BEARING PIECE, 2" X 6" X 6'-4" (5 BKGD).

END GATE 8

SEE SPECIAL NOTE 3 BELOW.

SPECIAL NOTE

1. A 300-LBMT LOAD IS SHOWN IN A 48'-0" LONG BY 7'-6" WIDE (INSIDE DIMENSION) TRAILER WHICH IS EQUIPPED WITH A MECHANICAL LOAD BLOCKING SYSTEM THAT CONTAINS AT LEAST THREE (3) CROSS MEMBERS, AND IS AT LEAST 39'-0" IN LENGTH AS MEASURED FROM THE FRONT WALL OF THE TRAILER. A TRAILER WITH AN INSIDE WIDTH DIMENSION OF LESS THAN 7'-6" CANNOT BE USED FOR A 3-WIDE LOAD. SEE SPECIAL NOTE 5 BELOW.
2. A SQUARE-FRONT TRAILER IS SHOWN IN THE LOAD VIEW. IF THE TRAILER HAS ROUNDED-CORNERS AT THE FORWARD END, THREE (3) ADDITIONAL CROSS MEMBERS MAY BE POSITIONED AT THE FRONT OF THE TRAILER AT THE SAME HEIGHTS AS SPECIFIED IN THE "REAR VIEW" ON PAGE 25. AN ADDITIONAL "END GATE 8" WILL BE REQUIRED BETWEEN THE CROSS MEMBER AND THE LADING AT THE FRONT END. A TRAILER WITH ROUNDED CORNERS AT THE FORWARD END MUST HAVE A MECHANICAL LOAD BLOCKING SYSTEM LENGTH OF AT LEAST 39'-6".
3. IF DESIRED, 1/2" PLYWOOD MAY BE SUBSTITUTED FOR THE "END GATE 8". THE PLYWOOD MUST BE 6'-0" HIGH BY TRAILER WIDTH MINUS 1/2". IF TWO PIECES OF PLYWOOD ARE USED, THE PLYWOOD MUST HAVE A BUTTED JOINT NEAR THE CENTER OF THE WIDTH OF THE TRAILER. THREE (3) PIECES OF 1" X 4" X 12" BUSHINGS MUST BE USED TO KEEP THE PLYWOOD IN POSITION. POSITION THESE PIECES NEAR THE TOP, CENTER, AND BOTTOM OF THE PLYWOOD GATE ON THE CROSS MEMBER SIDE OF THE GATE. NAIL EACH OF THE PLYWOOD PIECES TO THESE 1" X 4" PIECES W/3-6d NAILS AT EACH JOINT. CLINCH.
4. IF THE INSIDE HEIGHT OF THE VAN BEING USED PERMITS, SUCH AS WILL BE THE CASE WITH A HIGH-VOLUME VAN, THE CONTAINERS CAN BE STACKED SIX (6) LAYERS HIGH THROUGHOUT THE FORWARD PORTION OF THE VAN. THE TWO SHIPPED LOAD UNITS WILL BE LIMITED TO FIVE (5) LAYERS IN HEIGHT, WITH A "SEAL" ASSEMBLY UNDER THE SECOND FROM THE SEAL STACK. A MAXIMUM SIZE LOAD OF 414 CONTAINERS CAN BE LOADED BY THE PROCEDURES JUST DESCRIBED. SEAL BLOCKING FOR THE INCREASED LOAD WILL BE AS SPECIFIED FOR THE LOAD SHOWN ON PAGE 25.
5. IF THE TRAILER BEING LOADED HAS AN INSIDE WIDTH OF LESS THAN 10" OR IF NINE (9) CONTAINERS WILL NOT FIT ACROSS THE TRAILER AS DEPICTED WITHIN THE "REAR VIEW" THE PROCEDURES SPECIFIED ON PAGE 13 WILL HAVE TO BE USED. A 200-CONTAINER LOAD CAN BE LOADED INTO A 39'-0" TO 48'-0" LONG TRAILER WHICH IS 8-WIDE BY 5-HEIGHT.

BILL OF MATERIAL		
LUMBER	LINEAR FEET	BOARD FEET
2" X 4"	15	30
2" X 6"	28	32
NAILS	NO. BKGD	POUNDS
1/2" (2")	30	1/2

LOAD AS SHOWN

ITEM	QUANTITY	WEIGHT (APPROX)
CONTAINER	250	17,250 LBS
MERCHANDISE		100 LBS
TOTAL WEIGHT		17,350 LBS

Figure 5-4--Continued (sheet 22 of 27).

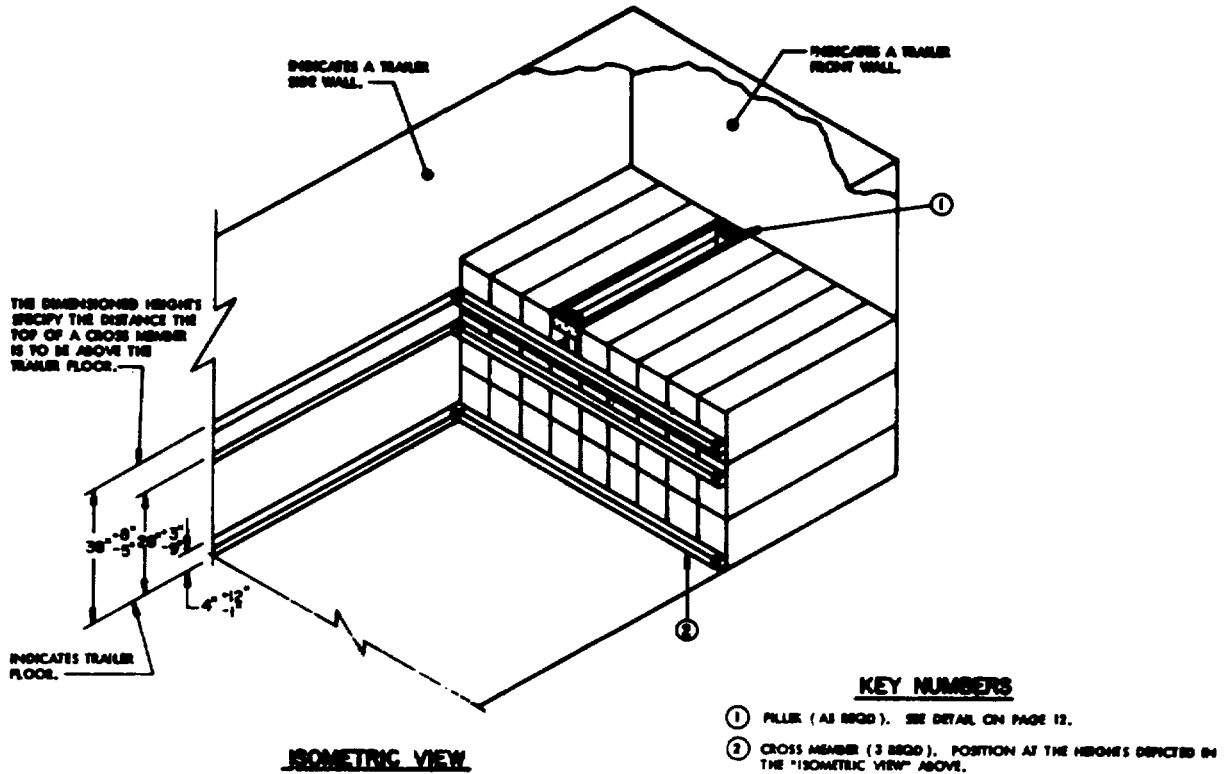

SPECIAL NOTES:

1. A 24-CONTAINER LOAD IS SHOWN IN A TRAILER EQUIPPED WITH MECHANICAL BRACING DEVICES.
2. IF DESIRED, THE METHOD FOR BLOCKING THE REAR OF THE LOAD, MAY ALSO BE UTILIZED FOR BLOCKING THE FRONT OF THE LOAD.
3. IF MORE THAN ONE (1) CONTAINER IS OMITTED FROM THE DEPICTED LOAD SHOWN ABOVE, THE METHOD USED IN THE "ISOMETRIC VIEW" SHOWN ON PAGE 23 FOR BLOCKING FROM THE SIDE OF THE CONTAINER TO THE TRAILER SIDE WALL SHOULD BE USED.
4. A FOUR (4) HIGH STACK MAY BE SHIPPED AS DEPICTED ABOVE WITH THE USE OF AN ADDITIONAL CROSS MEMBER POSITIONED AT THE 48" HEIGHT DIMENSION AGAINST THE FOURTH LAYER OF CONTAINERS.
5. THE USE OF THE "FILLER ASSEMBLY" IS SPECIFIED FOR THE DEPICTED LOAD ONLY TO SHOW A TYPICAL APPLICATION. "FILLER ASSEMBLIES" AND "RISER ASSEMBLIES" MAY BE USED IN THE LOAD AS REQUIRED TO ADJUST THE LOADING PATTERN FOR THE NUMBER OF CONTAINERS TO BE SHIPPED.

Figure 5-4--Continued (sheet 23 of 27).

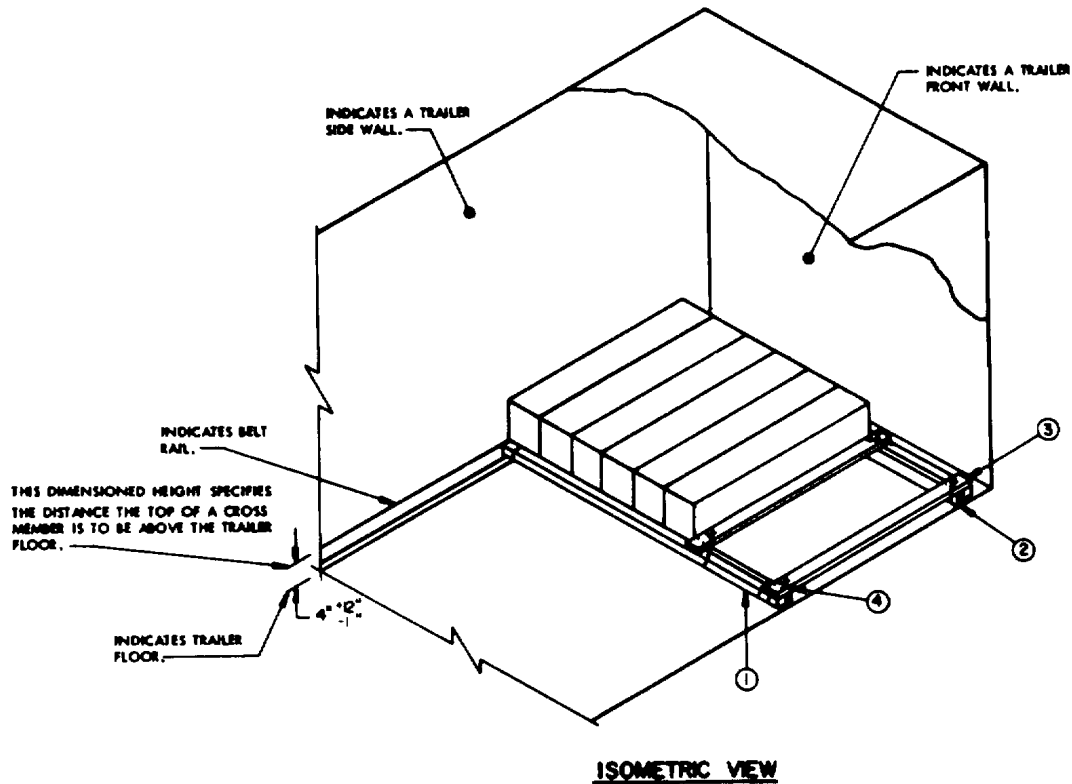

SPECIAL NOTES

1. A 4-UNIT LOAD IS SHOWN IN A TRAILER EQUIPPED WITH MECHANICAL BRACING DEVICES.
2. THE METHOD SHOWN IN THE "ISOMETRIC VIEW" FOR SIDE BLOCKING MAY BE USED FOR OTHER QUANTITY UNIT LOAD BY ADJUSTING THE LENGTH OF THE CROSS BRACE, PIECE MARKED ②.
3. FOUR (4) PIECES OF NO. 14 GAGE WIRE MAY BE USED IN LIEU OF THE NO. 8 GAGE WIRE. WHEN USING THE NO. 14 GAGE WIRE, INSTALL TWO (2) COMPLETE LOOPS AROUND THE TIE PIECE, CROSS PIECE, AND THE CROSS MEMBER.
4. THE USE OF THE SIDE BLOCKING ASSEMBLY, PIECES MARKED ①, ②, AND ④, IS SPECIFIED FOR THE DEPICTED LOAD ONLY TO SHOW A TYPICAL APPLICATION. SIDE BLOCKING ASSEMBLIES OR "FILLER ASSEMBLIES" MAY BE USED IN THE LOAD AS REQUIRED TO ADJUST THE LOADING PATTERN FOR THE NUMBER OF CONTAINERS TO BE SHIPPED.

KEY NUMBERS

- ① CROSS MEMBER (2 REQD). POSITION AT THE HEIGHT SHOWN IN THE "ISOMETRIC VIEW" ABOVE.
- ② CROSS BRACE, 2" X 4" BY CUT TO FIT BETWEEN THE CONTAINER AND THE TRAILER SIDE WALL MINUS 1/2" (2 REQD).
- ③ TIE PIECE, 2" X 4" X 42" (2 REQD). POSITION ONE AGAINST THE TRAILER SIDE WALL AND ONE AGAINST THE CONTAINER. NAIL TO THE CROSS BRACE, PIECE MARKED ②, W/2-10D NAILS AT EACH JOINT.
- ④ TIE WIRE, NO. 8 GAGE BLACK ANNEALED WIRE 24" LONG (4 REQD). INSTALL TO FORM A COMPLETE LOOP AROUND THE CROSS BRACE, THE TIE PIECE, AND THE CROSS MEMBER. BRING THE ENDS TOGETHER AND TWIST TIGHT. SEE SPECIAL NOTE 3. AT LEFT.

Figure 5-4--Continued (sheet 24 of 27).

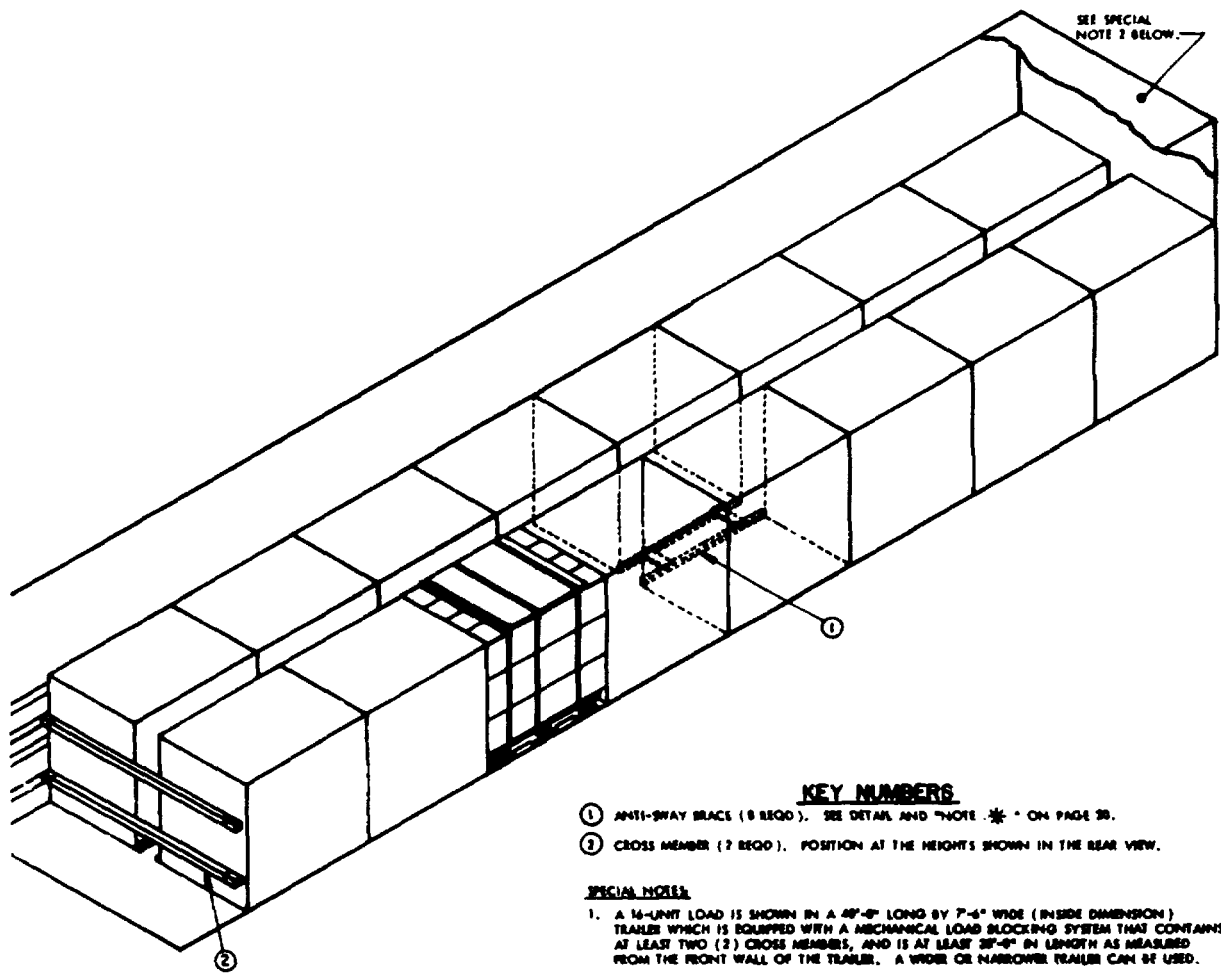

ISOMETRIC VIEW

THESE DIMENSIONED HEIGHTS SPECIFY THE DISTANCE THE TOP OF THE CROSS MEMBER IS TO BE ABOVE THE TRAILER FLOOR.

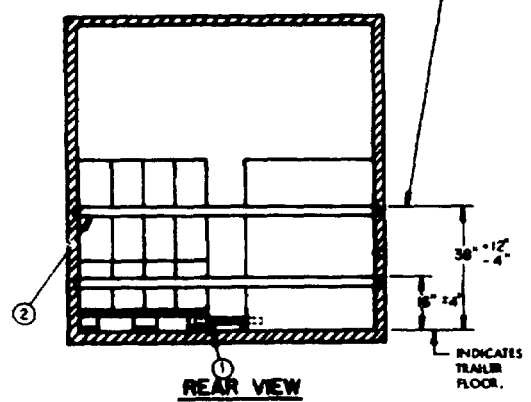

REAR VIEW

KEY NUMBERS

- ① ANTI-SWAY BRACE (8 REQ.). SEE DETAIL AND "NOTE 2" ON PAGE 26.
- ② CROSS MEMBER (2 REQ.). POSITION AT THE HEIGHTS SHOWN IN THE REAR VIEW.

SPECIAL NOTES

1. A 16-UNIT LOAD IS SHOWN IN A 40'-0" LONG BY 7'-6" WIDE (INSIDE DIMENSION) TRAILER WHICH IS EQUIPPED WITH A MECHANICAL LOAD BLOCKING SYSTEM THAT CONTAINS AT LEAST TWO (2) CROSS MEMBERS, AND IS AT LEAST 30'-0" IN LENGTH AS MEASURED FROM THE FRONT WALL OF THE TRAILER. A WIDER OR NARROWER TRAILER CAN BE USED.
2. A SQUARE-FRONT TRAILER IS SHOWN IN THE LOAD VIEW. IF THE TRAILER HAS ROUNDED-CORNERS AT THE FORWARD END, TWO (2) ADDITIONAL CROSS MEMBERS MAY BE POSITIONED AT THE FRONT OF THE TRAILER AT THE SAME HEIGHTS AS SPECIFIED IN THE "REAR VIEW" BELOW. A TRAILER WITH ROUNDED-CORNERS AT THE FORWARD END MUST HAVE A MECHANICAL LOAD BLOCKING SYSTEM OF AT LEAST 30'-2".
3. IF THE INSIDE HEIGHT OF THE VAN BEING LOADED IS 8'-11" OR MORE, THE UNITS CAN BE STACKED TWO (2) LAYERS HIGH AS SHOWN BY THE "SPECIAL ELEVATION" VIEW ON PAGE 27. THE FOLLOWING PROCEDURE WILL BE USED:
 - STEP - A. POSITION SEVEN (7) STACKS, TWO (2) UNITS HIGH BY TWO (2) UNITS WIDE, INTO TRAILER WITH ANTI-SWAY BRACES INSTALLED BETWEEN EACH PAIR OF LATEROALLY ADJACENT PALLET UNITS. SEE "ANTI-SWAY BRACE" DETAIL ON PAGE 17.
 - STEP - B. INSTALL TWO (2) CROSS MEMBERS, ONE (1) AT THE 16" HEIGHT DIMENSION AND ONE (1) AT THE 36" HEIGHT DIMENSION, TO BEAR AGAINST THE BOTTOM UNIT OF THE TWO (2) UNIT HIGH PORTION OF THE LOAD.
 - STEP - C. POSITION TWO (2) CROSS MEMBERS AT THE 4" HEIGHT DIMENSION AND TWO (2) CROSS MEMBERS AT THE 36" HEIGHT DIMENSION AS DIMENSIONED IN THE "SPECIAL ELEVATION" VIEW ON PAGE 27.
 - STEP - D. INSTALL A SUPPORT ASSEMBLY BETWEEN THE 4" AND THE 36" INSTALLED CROSS MEMBERS. SEE "SUPPORT" DETAIL ON PAGE 27.
 - STEP - E. INSTALL A CROSS MEMBER AT EACH OF THE 36", 48", AND 60" HEIGHT LOCATIONS DIRECTLY AGAINST THE TWO (2) ELEVATED PALLET UNITS.
4. IF THE TRAILER HAS ROUNDED-CORNERS AT THE FORWARD END, EITHER THE PROCEDURES JUST DESCRIBED ABOVE WILL ALSO BE REQUIRED AT THE FORWARD END OF THE TRAILER, OR FORWARD BLOCKING AS DETAILED ON PAGE 17 WILL BE REQUIRED.

PALLETIZED LOAD IN A 40'-0" LONG TRAILER (MECHANICAL)

Figure 5-4- Continued (Sheet 25 of 27).

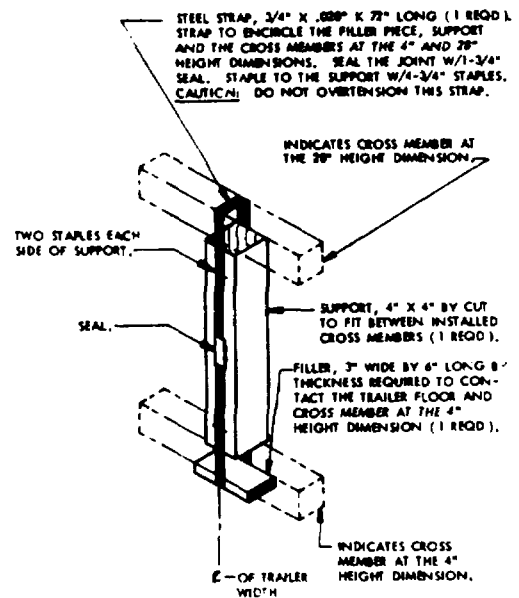
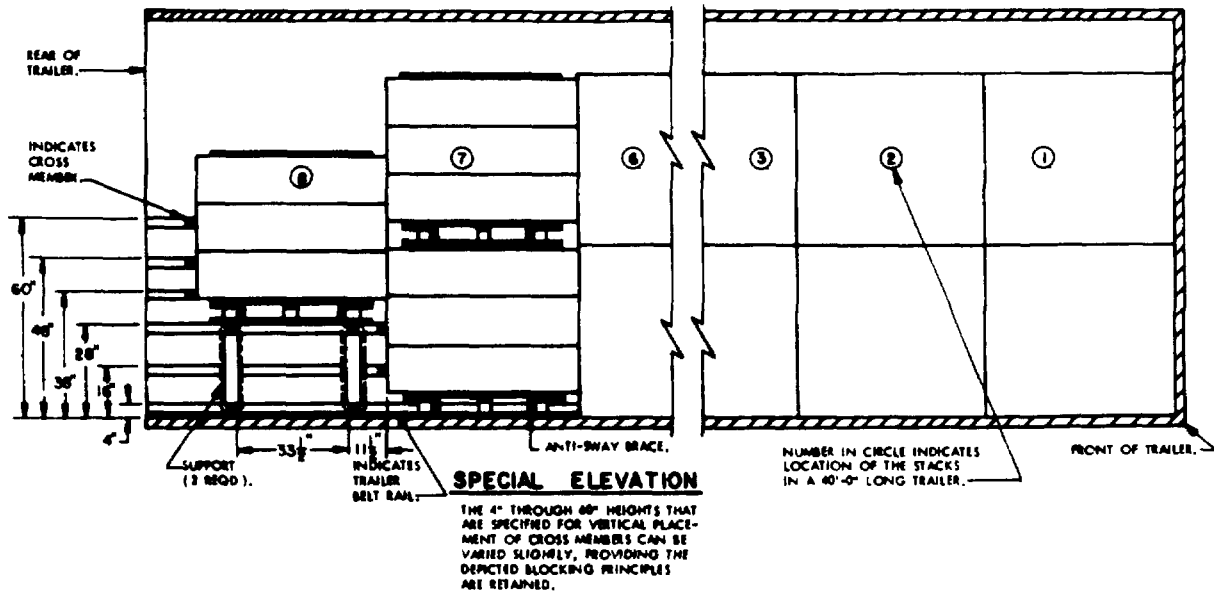

BILL OF MATERIAL		
LUMBER	LINEAR FEET	BOARD FEET
1" X 4"	14	5
2" X 2"	85	29
NAILS		POUNDS
4d (2")	88	1/2
10d (3")	32	1/2

SUPPORT
(2 REQ.)

THE SUPPORT PIECE AND FILLER PIECE ARE USED TO SUPPORT THE 28" HIGH CROSS MEMBERS WHEN USED TO SUPPORT THE PALLET UNITS AT THE REAR OF THE LOAD. THE SUPPORT ASSEMBLY SHOULD BE INSTALLED PRIOR TO POSITIONING THE UNITS ON THE CROSS MEMBERS. THE SUPPORT AND FILLER PIECES ARE TO BE SIZED FOR A SNUG FIT, NOT A WEDGE FIT.

LOAD AS SHOWN

ITEM	QUANTITY	WEIGHT (APPROX)
PALLET UNIT	16	10,976 LBS
DUNNAGE		88 LBS
TOTAL WEIGHT		11,064 LBS

Figure 5-4--Continued (sheet 26 of 27).

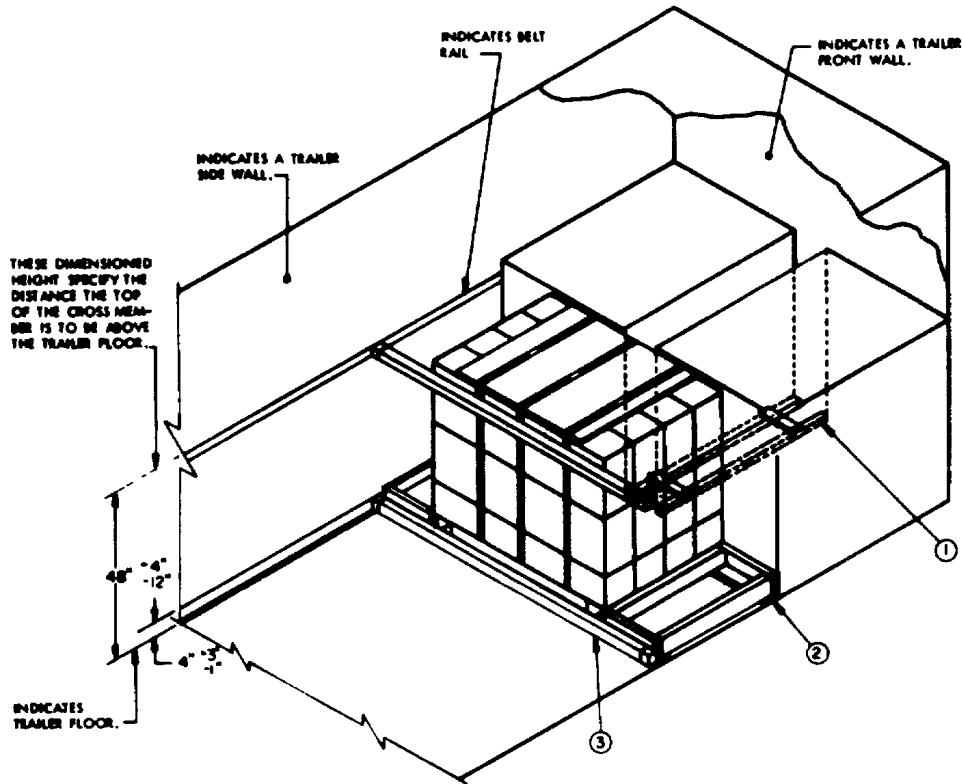

ISOMETRIC VIEW

SPECIAL NOTES

1. A THREE PALLET UNIT LOAD IS SHOWN IN A TRAILER EQUIPPED WITH MECHANICAL BRACING DEVICES.
2. IF DESIRED, CROSS MEMBERS MAY BE USED AT THE TRAILER FRONT BY USING THE PROCEDURES OUTLINED IN SPECIAL NOTE 2 ON PAGE 26.
3. IF AN EVEN NUMBER OF PALLET UNITS (SUCH AS 2, 4, 6, ETC) ARE BEING OUTLOADING, USE THE BLOCKING METHODS DEPICTED ON PAGE 26 FOR BLOCKING THE REAR LOAD UNITS. IF THE TRAILER BEING OFFERED FOR SHIPMENT HAS ROUNDED-CORNERS AT THE FORWARD END SEE SPECIAL NOTE 2 ON PAGE 26.
4. THE USE OF THE "SIDE FILLER" IS SPECIFIED FOR THE DEPICTED LOAD ONLY TO SHOW A TYPICAL APPLICATION. THEY ARE ONLY REQUIRED FOR SHIPPING AN UNEVEN NUMBER OF UNITS (SUCH AS 1, 3, 5, ETC).

KEY NUMBERS

- ① ANTI-SWAY BRACE (1 REQD). SEE THE DETAIL ON PAGE 20.
- ② SIDE FILLER (2 REQD). SEE THE DETAIL ON PAGE 20.
- ③ CROSS MEMBER (2 REQD). POSITION AT THE HEIGHTS SHOWN IN THE ISOMETRIC VIEW.

Figure 5-4--Continued (sheet 27 of 27).

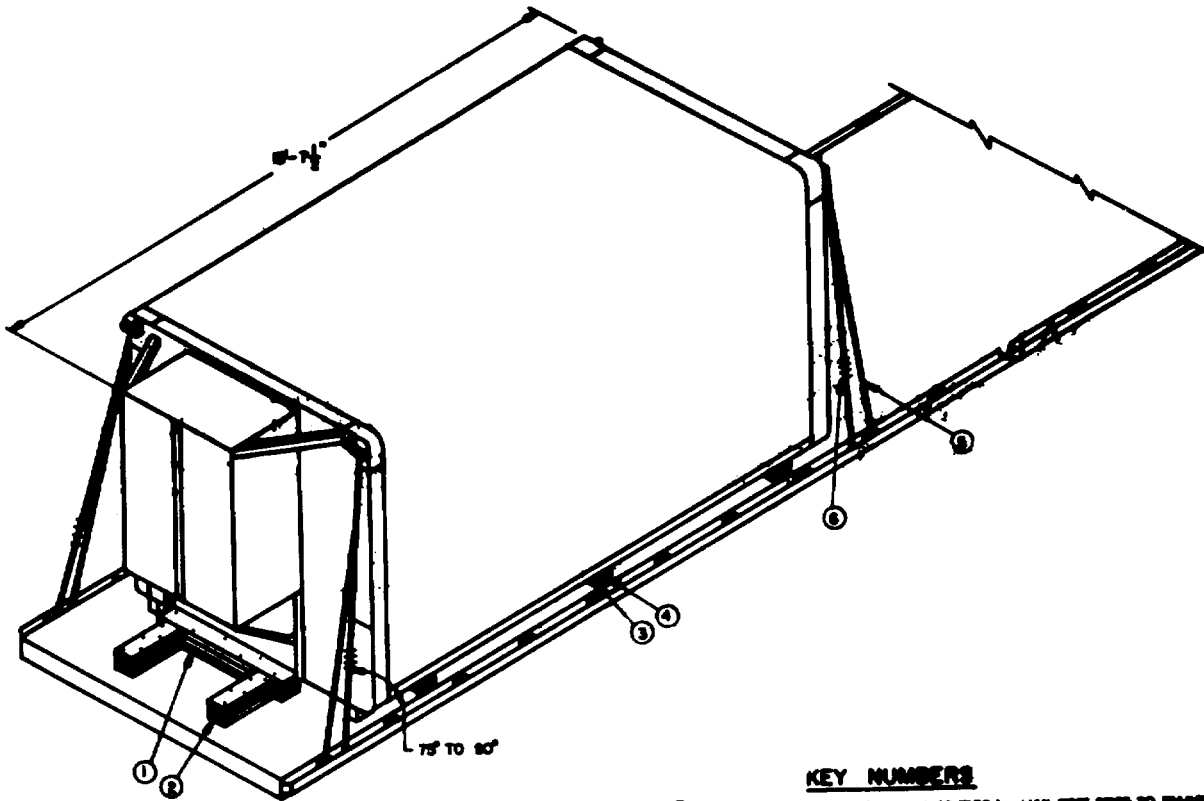

ISOMETRIC VIEW

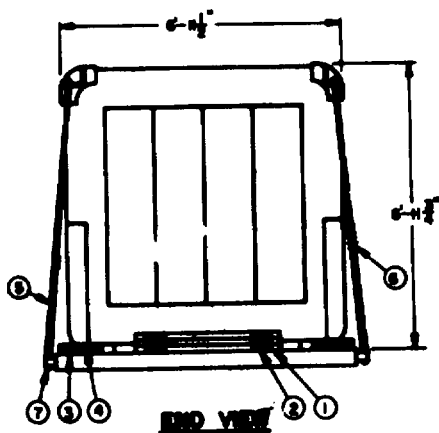

END VIEW

KEY NUMBERS

- ① BEAMER, 2" X 4" X 44" (TRIPLED) (2 REQD). NAIL FIRST PIECE TO TRAILER FLOOR W/3-12# NAILS. NAIL EACH ADDITIONAL PIECE W/3-8# NAILS. SEE GENERAL NOTE "L" ON PAGE 2.
- ② BACK-UP CLEAT, 2" X 4" X 18" (TRIPLED) (4 REQD). POSITION 3" FROM END OF PIECE MARKED ① AND NAIL FIRST PIECE TO TRAILER FLOOR W/3-12# NAILS. NAIL EACH ADDITIONAL PIECE W/3-8# NAILS.
- ③ SIDE BLOCKING, 1" X 4" X 12" (4 REQD). POSITION AGAINST SID AS SHOWN.
- ④ SIDE BLOCKING, 2" X 4" X 12" (4 REQD). POSITION ON TOP OF PIECE MARKED ③ AND AGAINST SID AS SHOWN. NAIL THIS PIECE MARKED ④ TO TRAILER FLOOR W/3-8# NAILS.
- ⑤ STEEL WIRE ROPE, 1/2" DIAMETER, 11.5 TONS (4 REQD). INSTALL CABLE TO APPROXIMATE THE ANGLE SHOWN AND TO FORM A COMPLETE LOOP FROM TIE DOWN FACILITY ON TRAILER THRU LASHING TIE DOWN DEVICE AND BACK TO TRAILER TIE DOWN FACILITY. SEE GENERAL NOTES "C", "D", AND "F".
- ⑥ CLIP, SIZE 1/2" (20 REQD). FOUR (4) PER CABLE AND ONE (1) PER THIMBLE. SEE GENERAL NOTE "E".
- ⑦ THIMBLE, STANDARD, SIZE 1/2" (4 REQD). ONE (1) PER TRAILER TIE DOWN FACILITY. SECURE TO WIRE ROPE MARKED ⑤ W/1-CLIP PER THIMBLE. SEE GENERAL NOTE "E".

PAGE 2

Figure 5-5. Loading and bracing on flatbed or low-boy trailer of maintenance equipment shelter, GMS S-408(XO-1) TSM (sheet 1 of 3).

GENERAL NOTES

- A. EACH LEG OF SHROUD TO BE SECURED TO RIGGING OR TO "LOCK-ON" TRAILER 2" x 4" WIRE WITH A WOOD OR A WOODEN SHIP METAL FLOOR. TRAILER WITH ALL METAL FLOORS WILL NOT BE USED. ONLY ONE UNIT OF LADING IS SHOWN. HOWEVER, MULTIPLES OF UNITS, AS SHOWN OR DIS-SIMILAR IN MATERIAL, MAY BE LOADED ON A TRAILER. THE NUMBER OF UNITS TO BE LOADED ON A TRAILER WILL BE DEPENDENT ON THE SIZE OF THE TRAILER USED OR THE QUANTITIES OF UNITS TO BE SHIPPED WITH THE VIEW OF FULL UTILIZATION OF CARRIER EQUIPMENT. CAUTION: THE LOAD AS SHOWN ON PAGE 4, CRATED, MAY REQUIRE "CLEARANCE" CONSIDERATION BECAUSE OF EXCESSIVE LADING SIZE.
- B. ONLY TRAILERS CAPABLE OF SAFELY TRANSPORTING THE LADING TO DESTINATION WITHOUT DAMAGE WILL BE SELECTED. TRAILERS SELECTED MUST HAVE "SOUND" FLOORS WHICH PROVIDE MAJ. RETENTION PROPERTIES EQUAL TO OR BETTER THAN SPECIFIED DUNNAGE LUMBER, AND A SUFFICIENT NUMBER OF THE DOWN FACILITIES OF A STRENGTH EQUAL TO OR BETTER THAN SPECIFIED LADING TIE DOWN ASSEMBLIES.
- C. SHIPMENT GROSS WEIGHT, AXLE DISTRIBUTION OF LADING WEIGHT AND OVERALL DIMENSIONS MUST MEET STATE LAW REQUIREMENTS.
- D. LADING DATA (UNCRATED):
ITEM DIMENSIONS ----- 12'-7-1/2" LONG X 6'-11-1/2" WIDE X 6'-11-3/4" HIGH.
ITEM GROSS WEIGHT --- 4,300 POUNDS (APPROX).

LADING DATA (CRATED):
ITEM DIMENSIONS ----- 14'-10" LONG X 8'-1" WIDE X 8'-1" HIGH.
ITEM GROSS WEIGHT --- 6,400 POUNDS (APPROX).
- E. REFER TO ORD DWG 19-40-C-ORDJ-288, "WIRE ROPE AND ANNEALED WIRE APPLICATION METHODS FOR SECURING LADING ON RAIL & MOTOR CARRIER EQUIP", FOR PROPER TIE DOWN APPLICATION, EXCEPT NUTS ON 1/2" CABLE CLIPS WILL BE TIGHTENED TO A TORQUE OF 85 TO 95 FOOT POUNDS.
- F. LADING WILL NOT BE SECURED BY CHAINS AND/OR LOAD BINDERS IN LIEU OF SPECIFIED DUNNAGE.
- G. CAUTION: IT IS RECOMMENDED THAT CABLE BE INSTALLED TO APPROXIMATE ANGLE SHOWN; HOWEVER, IF PLACEMENT OF TRANSPORTER TIE DOWN FACILITIES PREVENTS THIS, CARE MUST BE EXERCISED TO ENSURE THAT CABLES ON THE SAME SIDE OF LADING ARE INSTALLED SO THEIR RETENTION FORCES ACT IN OPPOSITE LONGITUDINAL DIRECTIONS -- CONTACT OF CABLE WITH EDGE OF LADING IS PROHIBITED.
- H. TO ACHIEVE PROPER CABLE TENSION, EMPLOY TWO (2) CABLE "GRIPPERS" AND AN APPLICABLY SIZED "COME-A-LONG" TYPE MECHANICAL HOIST.
- J. WHEN ANY STRAP IS SEALED AT AN END-OVER-END LAP JOINT, A MINIMUM OF TWO (2) SEALS (BUTTED TOGETHER) WITH TWO (2) PAIRS OF CRAMPS PER SEAL MUST BE USED TO SEAL THE JOINT.
- K. DUNNAGE LUMBER SPECIFIED THROUGHOUT THIS PROCEDURAL DRAWING IS OF NOMINAL SIZE. FOR EXAMPLE, 1" X 4" MATERIAL IS ACTUALLY 3/4" THICK BY 3-5/8" WIDE AND 2" X 4" MATERIAL IS ACTUALLY 1-5/8" THICK BY 3-5/8" WIDE.
- L. A STAGGERED NAILING PATTERN WILL BE USED WHEN DUNNAGE IS NAILED TO THE FLOOR OF THE TRANSPORTING VEHICLE, OR WHEN LAMINATING DUNNAGE. ADDITIONALLY, THE NAILING PATTERN FOR AN UPPER PIECE OF LAMINATED DUNNAGE WILL BE ADJUSTED AS REQUIRED SO THAT A NAIL FOR THAT PIECE WILL NOT BE DRIVEN THROUGH ONTO OR RIGHT BESIDE A NAIL IN A LOWER PIECE.

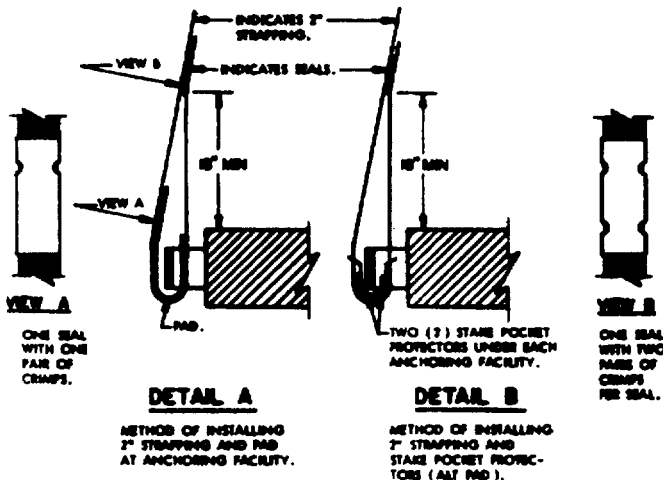

BILL OF MATERIAL		
LUMBER	LINEAR FEET	BOARD FEET
1" X 4"	6	3
2" X 4"	46	46
NAILS		
12d (3-1/4")	28	275
3d (4")	82	3
ROPE, STEEL WIRE, 1/2" DIA ----- 95 FT EQD ----- 48 LBS		
CLIP, 1/2" ----- 20 EQD ----- 9 LBS		
THIMBLE, STANDARD, 1/2" ----- 4 EQD ----- 1 LB		

MATERIAL SPECIFICATIONS

- LUMBER ----- : DOUGLAS FIR OR COMPARABLE LUMBER WITH STRAIGHT GRAIN AND FREE OF MATERIAL DEFECTS. REF: FED SPEC MMA-1-731.
- NAILS ----- : COMMON, CEMENT COATED OR CHEMICALLY ETCHED. REF: FED SPEC FF-40-105. ALT: ANNULAR-RING TYPE NAIL OF SAME SIZE.
- ROPE ----- : STEEL WIRE, PLAIN, PREFORMED, REGULAR LAY, 11.5 TONS, 6 X 19, FLEXIBLE RWIC, MACWHYTE WIRE ROPE CO (OR EQUAL). REF: FED SPEC MI-W-410.
- CLIPS ----- : 1/2" BOLT, CROSBY, HEAVY DUTY (OR EQUAL).
- STRAPPING, STEEL ----- : TYPE I OR IV, CLASS A OR C. REF: FED SPEC QQ-5-781. (FOR FIN SEE 35-38-100).
- STRAP SEAL, STRAP STAPLE, STAKE POCKET PROTECTOR ----- : COMMERCIAL GRADE.

LOAD AS SHOWN

ITEM	QUANTITY	WEIGHT (APPROX)
MAINTENANCE EQUIP.	1	4,300 LBS
SHELTER (UNCRATED)		
DUNNAGE		177 LBS
TOTAL WEIGHT		4,377 LBS

Figure 5-5--Continued (sheet 2 of 3).

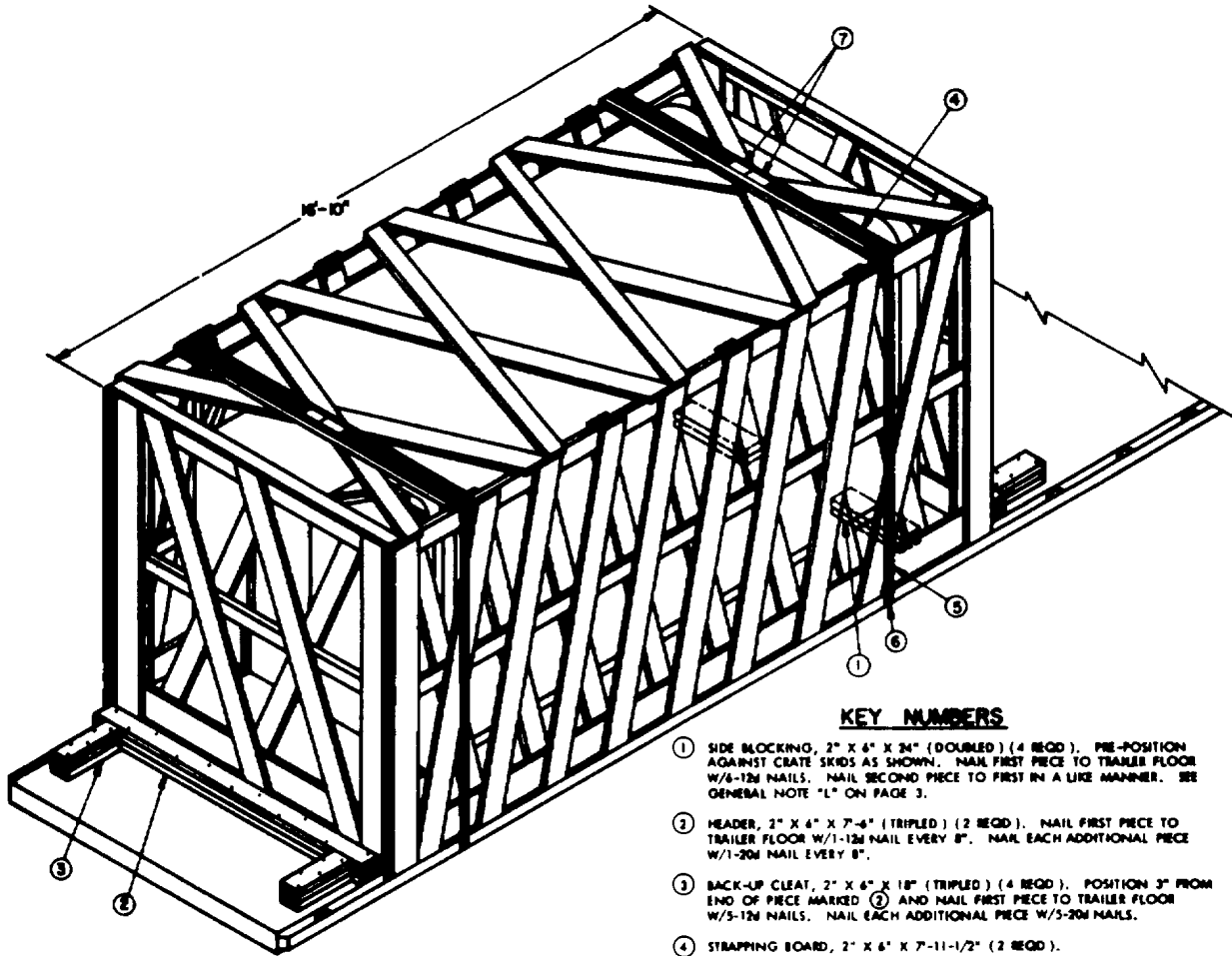

ISOMETRIC VIEW

KEY NUMBERS

- ① SIDE BLOCKING, 2" X 4" X 34" (DOUBLED) (4 REQ.). PRE-POSITION AGAINST CRATE SKIDS AS SHOWN. NAIL FIRST PIECE TO TRAILER FLOOR W/6-12M NAILS. NAIL SECOND PIECE TO FIRST IN A LIKE MANNER. SEE GENERAL NOTE "L" ON PAGE 3.
- ② HEADER, 2" X 4" X 7'-4" (TRIPLED) (2 REQ.). NAIL FIRST PIECE TO TRAILER FLOOR W/1-12M NAIL EVERY 8". NAIL EACH ADDITIONAL PIECE W/1-20M NAIL EVERY 8".
- ③ BACK-UP CLEAT, 2" X 4" X 18" (TRIPLED) (4 REQ.). POSITION 3" FROM END OF PIECE MARKED ② AND NAIL FIRST PIECE TO TRAILER FLOOR W/5-12M NAILS. NAIL EACH ADDITIONAL PIECE W/5-20M NAILS.
- ④ STRAPPING BOARD, 2" X 4" X 7'-11-1/2" (2 REQ.).
- ⑤ STEEL STRAPPING, 2" X .050" X 33'-0" (2 REQ.). STAPLE TO PIECE MARKED ④ W/4 STAPLES.
- ⑥ PAD, 2" X .050" STRAP 18" LONG (4 REQ.). POSITION UNDER AND SEAL TO PIECE MARKED ④. SEE "DETAIL A" ON PAGE 3. ALT. STAKE POCKET PROTECTOR (8 REQ.). TWO (2) USED UNDER EACH TIE DOWN FACILITY WITH PIECE MARKED ④. SEE "DETAIL B" ON PAGE 3.
- ⑦ SEAL FOR 2" STRAPPING (12 REQ.). SEE GENERAL NOTE "J" ON PAGE 3.

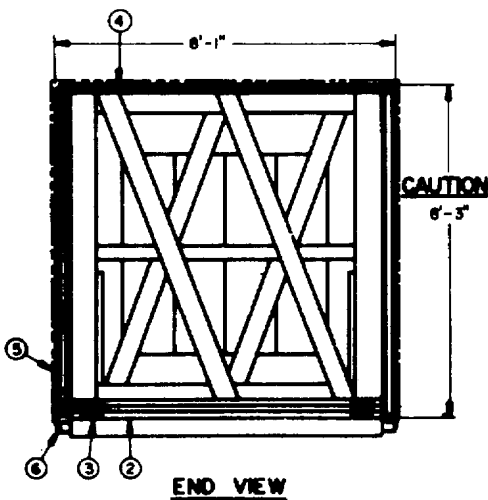

END VIEW

BILL OF MATERIAL

LUMBER	LINEAR FEET	BOARD FEET
2" X 4"	95	95
NAILS	NO. REQ.	POUNDS
12M (3-1/4")	90	1-1/2
20M (4")	84	3
STEEL STRAPPING, 2" X .050"	72 FT REQ.	24 LBS
SEAL FOR 2" STRAPPING	12 REQ.	3 LBS
STAPLE FOR 2" STRAPPING	8 REQ.	NIL

LOAD AS SHOWN

ITEM	QUANTITY	WEIGHT (APPROX)
MAINTENANCE EQUIP.	1	4,600 LBS
SHELTER (CRATED)		
DUNNAGE		270 LBS
TOTAL WEIGHT		4,870 LBS

Figure 5-5--Continued (sket 3 of 3).

CHAPTER 6

MARINE AND TERMINAL TRANSPORTABILITY GUIDANCE

6-1. Scope

This chapter provides marine and terminal transportability guidance for movement of the M41 Redeye missile in M585 and M571 containers and for the GMS S-408(XO-1) TSM maintenance equipment shelter.

It covers significant technical and physical characteristics and prescribes the materials and guidance required to prepare, load, and unload the items. Unloading is the reverse of loading.

Note. The methods described in this chapter for lifting and securing items are suggested procedures. Other methods of handling and stowage may be used, providing they will insure safe delivery without damage.

6-2. General Rules for Stowing Large, Crated, Heavy Equipment or Palletized Load

Crated, heavy equipment or palletized loads are blocked, braced, shored, lashed, and tommed as required to prevent movement. When loading a full hold of large pieces, it is advantageous to leave wire-rope slings attached to the last piece loaded for ease in unloading.

6-3. Safety

In addition to the safety precautions contained in chapter 3, the following are applicable:

a. Missiles will be handled and stowed in accordance with provisions contained in 46 Code of Federal Regulations (CFR) 146 or in Water Carrier Tarrif No. 24 or reissues thereof (app).

b. Vessel cargo equipment will be inspected as required by 46 CFR 146. Lifting devices, figures 6-1 and 6-2, must be included in the inspection.

6-4. Lifting and Loading

Figure 6-1 is a lifting diagram for palletized loads of M571 or M585 shipping and storage containers; figure 6-2 is a lifting diagram for the crated maintenance equipment shelter, GMS S-408(XO-1) TEM. Figure 6-3 (sheets 1 through 5) shows the minimum requirements for the handling, stowage, and bracing aboard ships of the crated maintenance equipment shelter, GMS S-408 (XO-1) TSM.

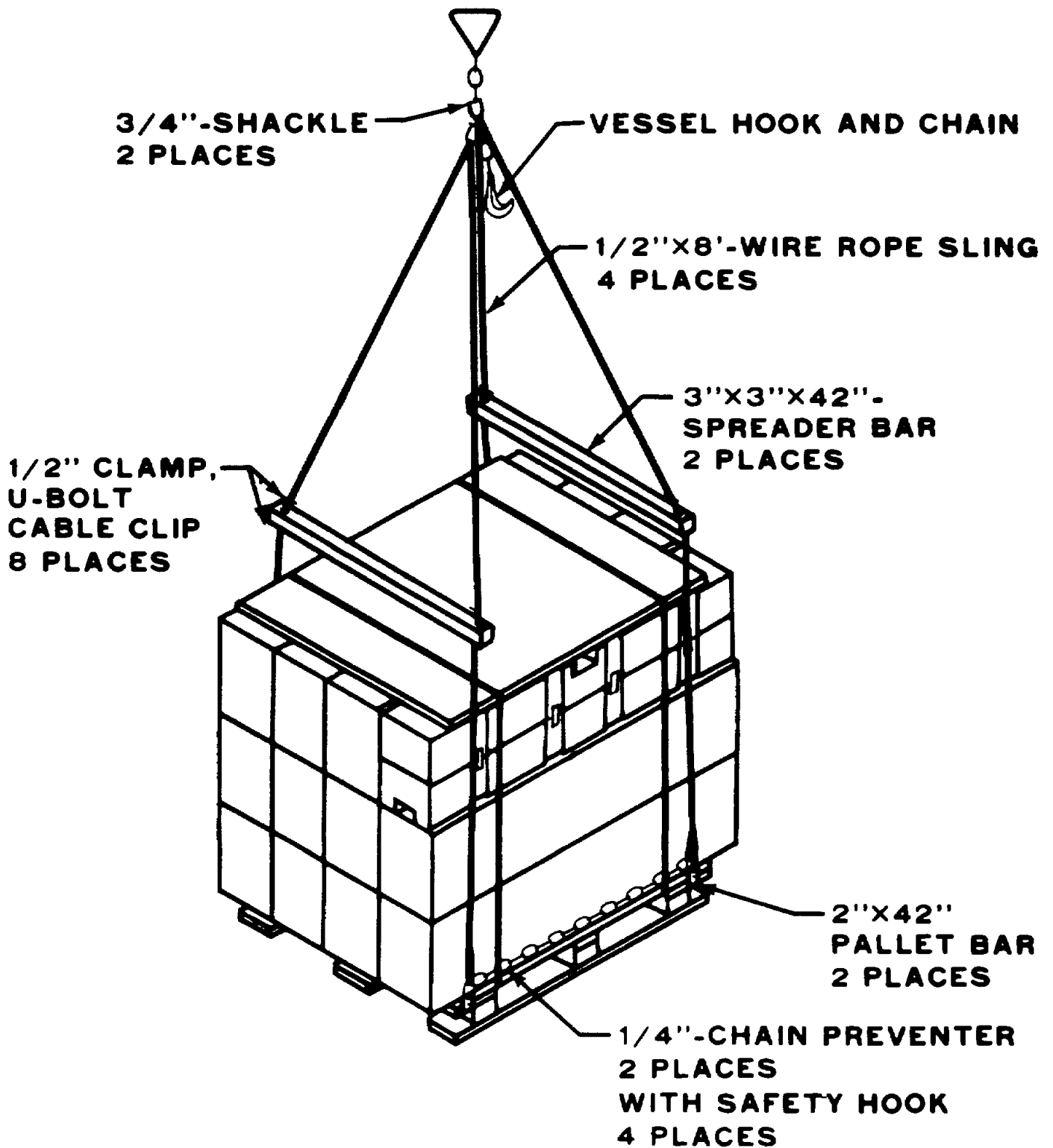

Figure 6-1. Lifting diagram for palletized M585 or M571 shipping and storage containers.

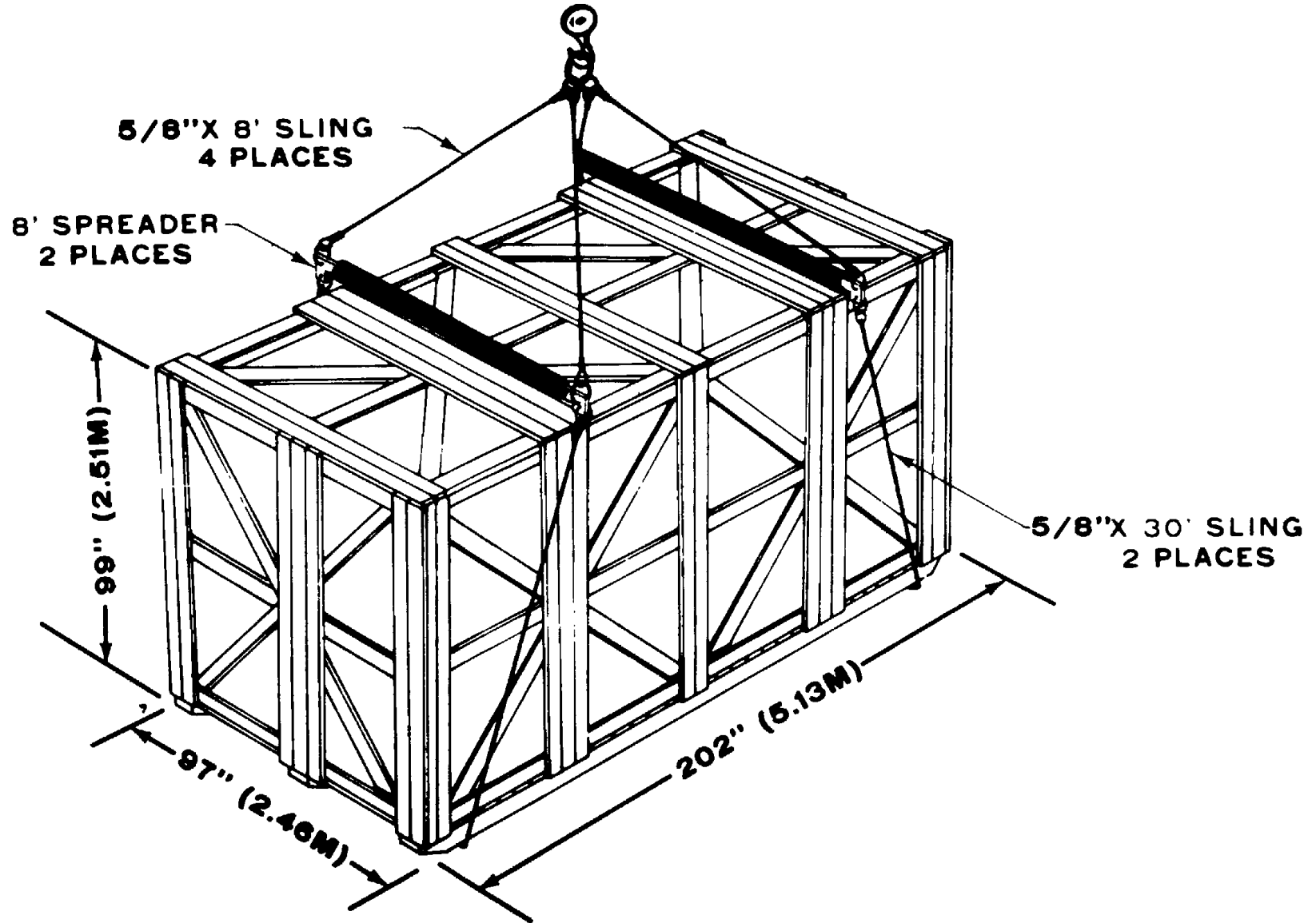

Figure 6-2. Lifting diagram for crated maintenance equipment shelter, GMS S-408(XO-1) TSM, using wire-rope slings with spreader bar.

GENERAL NOTES
 A. *NA*

- B. THIS DRAWING DEPICTS MINIMUM PROCEDURES APPLICABLE TO THE HANDLING, STOWAGE, AND BRACING ABOARD SHIPS OF THE MAINTENANCE EQUIPMENT SHELTER, GMS S-408 (XO-1) TSM (CRATED), FOR THE REDEYE MISSILE SYSTEM.
- C. OTHER TYPES OF CARGO MAY BE STOWED IN THE SAME HOLD OR TWEEN DECK WITH THE MAINTENANCE EQUIPMENT SHELTER SHOWN HEREIN.

D. LADING DATA

DIMENSIONS OF CRATE (TYPICAL) --- 16'-10" LONG BY 8'-1" WIDE BY 8'-1" HIGH.

GROSS WEIGHT ----- 6,600 LBS (APPROX).

CUBE ----- 1,100 CU. FT.

HANDLING

- A. PERTINENT PROVISIONS OF TITLE 46 CODE OF FEDERAL REGULATIONS APPLY.
- B. HANDLING OF THE SHELTER (CRATED) SHOULD BE ACCOMPLISHED BY USING SLING EXTENSIONS SECURELY POSITIONED IN THE NOTCHES OF THE CRATE SKIDS AS SHOWN.
- C. EACH CRATED ITEM SHALL BE HANDLED INDIVIDUALLY. STACKING OF CRATED ITEMS IS NOT PERMITTED.
- D. THE HANDLING SLING SHALL BE OF A DESIGN AND CONFIGURATION TO LIFT THE ITEM IN SUCH A MANNER THAT THE CABLE LEGS DO NOT APPLY EXCESSIVE PRESSURE WHICH MAY DAMAGE THE CRATE.
- E. ALTHOUGH DESIRABLE, A LEVEL LIFT IS NOT MANDATORY. THE CENTER OF GRAVITY OF THIS ITEM IS SHOWN TO ASSIST IN DETERMINING CABLE LENGTHS TO ASSURE A SAFE LIFT.

STOWAGE AND BRACING

- A. STOWAGE OF THIS ITEM IS RESTRICTED TO ONE (1) LAYER HIGH. HOWEVER, OTHER CARGO ITEMS MAY BE OVER-STOWED BY CONSTRUCTING A DUNNAGE FLOOR ON TOP OF THE DEPICTED CRATES. CAUTION THE WEIGHT OF OVER-STOWED CARGO MUST NOT CRUSH OR OTHERWISE DAMAGE THE CRATE OF THE SHELTER.
- B. SPECIES, GRADE AND SIZE OF LUMBER TO BE USED WILL COMPLY WITH REQUIREMENTS OF CURRENT SHIPWRIGHT-CARPENTRY AND RELATED SERVICES CONTRACTS. BRACING METHODS AND LUMBER SIZES DEPICTED IN THIS DRAWING ARE CONSIDERED MINIMUM AND ARE NOT INTENDED TO CONFLICT WITH CONTRACT REQUIREMENTS.
- C. A TYPICAL TIE DOWN PROCEDURE FOR THE CRATED ITEM IS SHOWN ON PAGE 4 AND DEPICTS THE PREFERRED METHOD OF USING CABLES AND TURNBUCKLES. IF USED, A TURNBUCKLE MUST BE OF A SIZE EQUAL IN STRENGTH TO THE MINIMUM SIZE CABLE REQUIRED TO SECURE THE ITEM. IN LIEU OF CABLES AND TURNBUCKLES, SECUREMENT MAY BE ACCOMPLISHED BY OTHER ACCEPTED METHODS.

Figure 6-3. Minimum required for the handling, stowage, and bracing aboard ships of the rated maintenance equipment shelter, GMS S-408(XO-1) TSM (sheet 1 of 5).

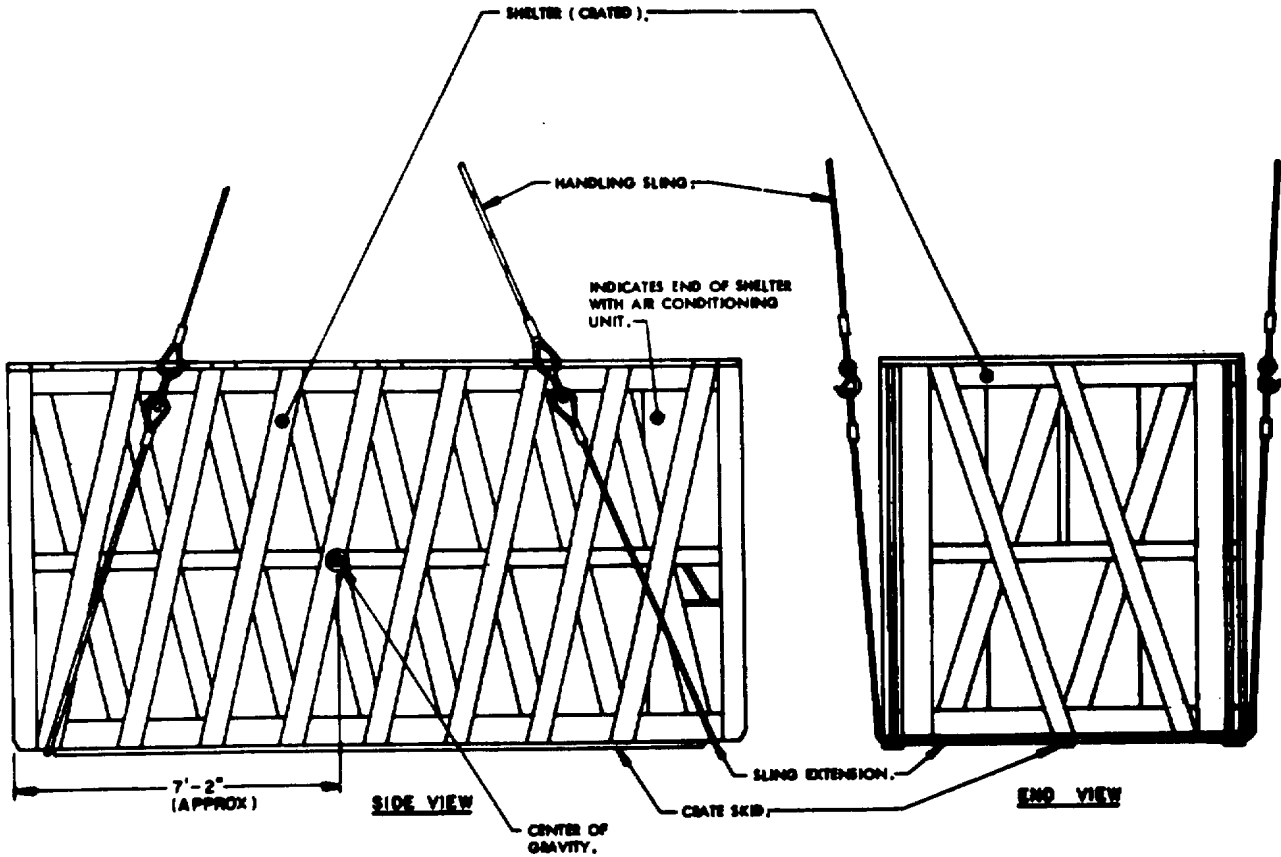

PRECAUTIONARY PROVISIONS FOR HANDLING, STORAGE AND BRACING AS SPECIFIED IN THE NOTES ON PAGE 2 MUST BE OBSERVED.

ATTACHMENT OF HANDLING SLING TO SHELTER CRATE

15 2 5

Figure 6-3--Continued (sheet 2 of 5).

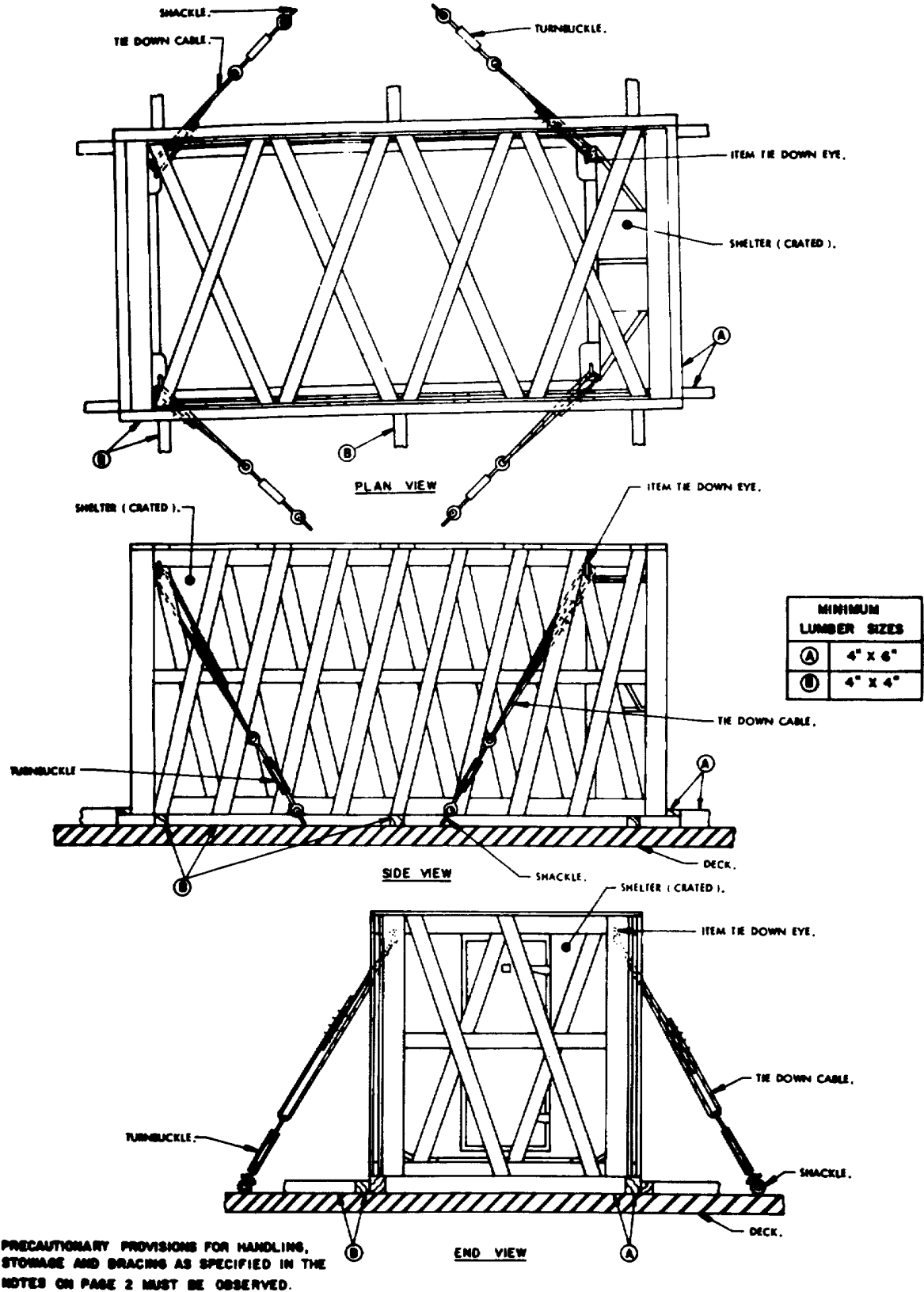
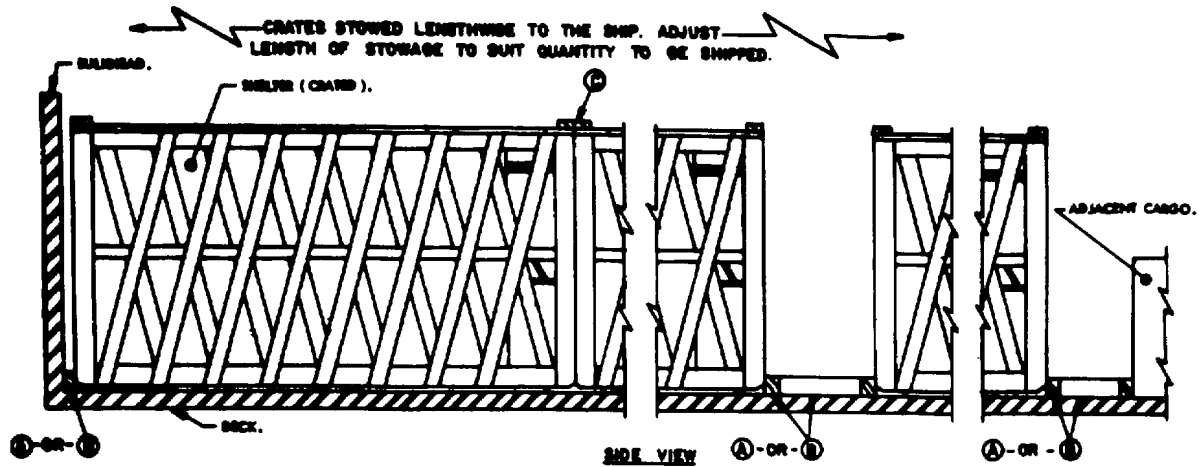

Figure 6-3—Continued (sheet 3 of 5).



THIS VIEW SHOWS BRACING AGAINST END OF CRATE AND USING FLOOR LINE BRACING MATERIAL (A) (4" X 6", 6" VERTICAL). WHEN BRACING AGAINST CRATE SIDE, USE FLOOR LINE BRACING MATERIAL (B) IN LIEU OF (A) MATERIAL.

MINIMUM LUMBER SIZES	
(A)	4" X 6"
(B)	4" X 4"
(C)	2" X 6"
(D)	2" X 4"

BRACING METHOD II, W/O CABLE

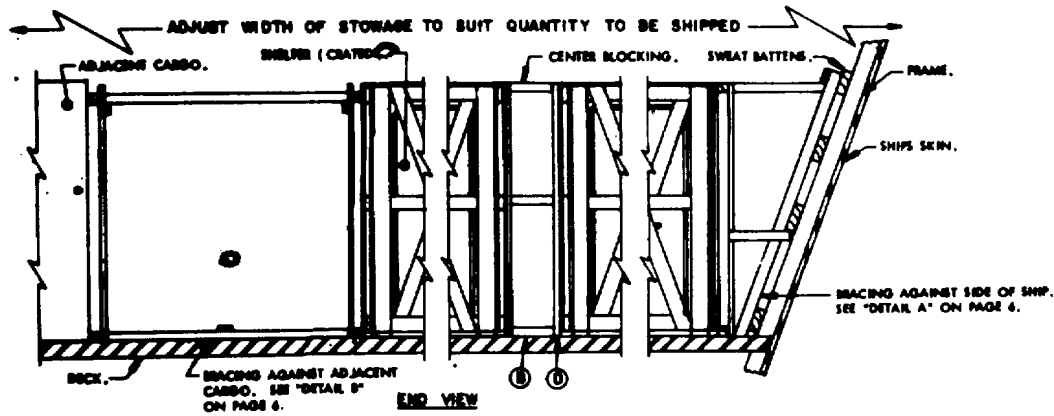

NOTE 1:
THIS VIEW SHOWS BRACING AGAINST SIDE OF CRATE AND USING FLOOR LINE BRACING MATERIAL (B) (4" X 4"). WHEN BRACING AGAINST CRATE END, USE FLOOR LINE BRACING MATERIAL (A) (4" X 6", 6" VERTICAL) IN LIEU OF (B) MATERIAL.

PRECAUTIONARY PROVISIONS FOR HANDLING, STORAGE AND BRACING AS SPECIFIED IN THE NOTES ON PAGE 2 MUST BE OBSERVED.

BRACING METHOD III, W/O CABLE

Figure 6-4--Continued (sheet 4 of 5).

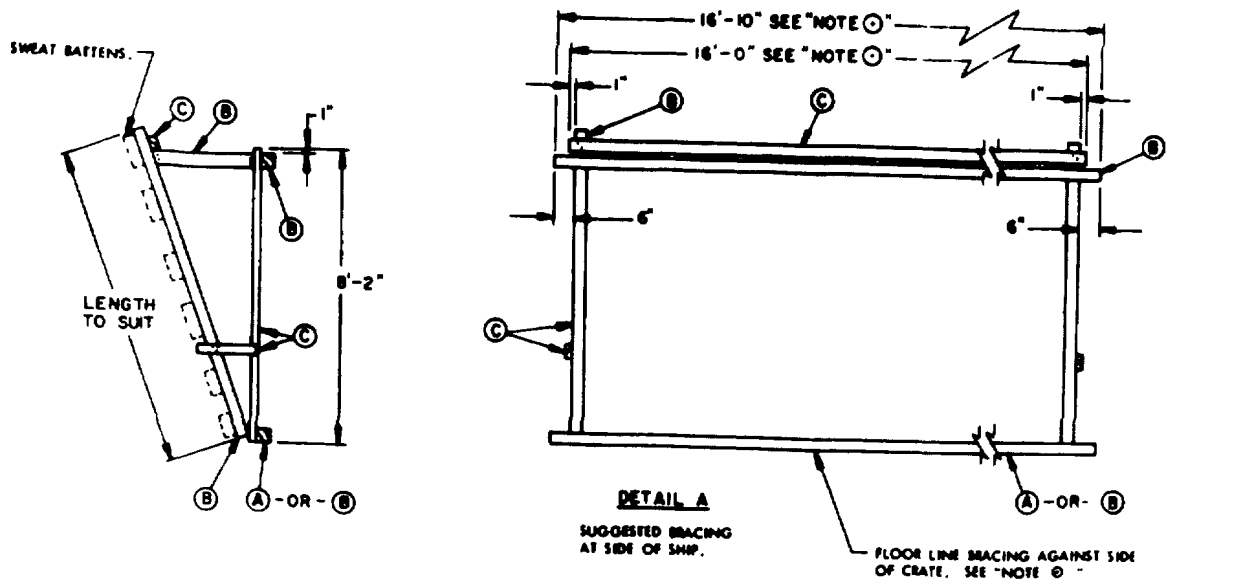

NOTE 1

DIMENSIONS SHOWN ARE FOR BRACING AGAINST SIDE OF CRATE AND USING FLOOR LINE BRACING MATERIAL (A). WHEN BRACING AGAINST CRATE ENDS, CHANGE THE DIMENSIONS OF THE BRACING ASSEMBLY, USE 8'-1" IN LIEU OF 16'-10" AND 7'-3" IN LIEU OF 16'-0". ALSO, USE FLOOR LINE BRACING MATERIAL (A) (4" X 6", 6" VERTICAL) AGAINST CRATE ENDS IN LIEU OF (B) MATERIAL.

MINIMUM LUMBER SIZES	
(A)	4" X 6"
(B)	4" X 4"
(C)	2" X 4"

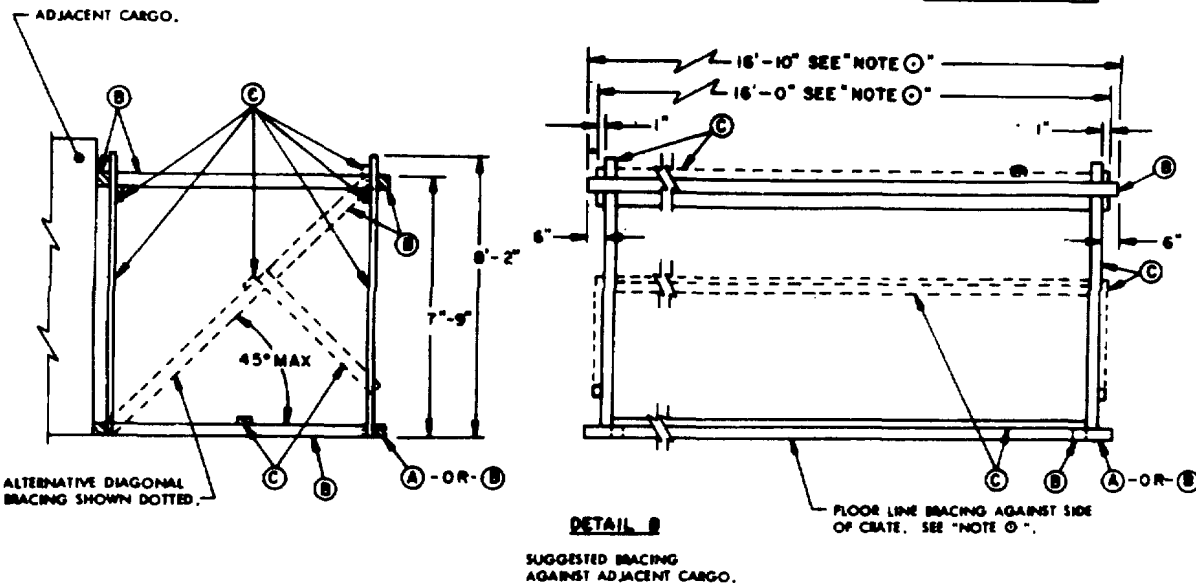

PRECAUTIONARY PROVISIONS FOR HANDLING, STOWAGE AND BRACING AS SPECIFIED IN THE NOTES ON PAGE 2 MUST BE OBSERVED.

Figure 6-3--Continued (sheet 5 of 5).

CHAPTER 7 RAIL TRANSPORTABILITY GUIDANCE

Section I. GENERAL

7-1. Scope

This chapter provides rail transportability guidance for movement of the M41 Redeye missile in M585 and M571 shipping and storage containers and the GMS S-408(XO-1) TSM maintenance equipment shelter. It covers significant technical and physical characteristics

and prescribes the materials and guidance required to prepare, load, tie down, and unload the items.

7-2. Maximum Utilization of Railcars

Additional cargo, as approved by the activity offering the items for transport, may be transported with the items.

Section II. TRANSPORT ON CONUS RAILWAYS

7-3. General

The transportability guidance contained in this section is applicable when the items are transported on CONUS railways. All items, when loaded on suitable railcars, can be transported without sectionalization or major disassembly within the Association of American Railroads Outline Diagram for Single Loads, Without End Overhang, on Open Top Cars as shown in both the *Railway Live Clearance Publications* and the *Official Railway Equipment Register*.

Note. Figures 7-1, 7-2, and 7-3 were extracted from US Army Materiel Command missile drawing. References to page numbers in the notes within the figures refer to the number listed in the lower right- or left-hand corner of each figure.

7-4. Preparation of Items

The degree of preparation for the items prior to being transported by railcar is dependent upon the operational commitment.

Note. A staggered nailing pattern will be used when lumber is nailed to the floor of the railcar, or when laminating lumber. Additionally, the nailing patterns for an upper piece of laminated lumber will be adjusted a required so that a nail for that piece will not be driven through, onto, or right beside a nail in the lower piece of lumber.

7-5. Loading

a. The M41 Redeye missile in M585 and M571 shipping and storage containers may be loaded into boxcars by use of a forklift.

b. The GMS S-408(XO-1) TSM maintenance equipment shelter may be placed in the tiedown position on the railcar by a crane.

c. After placement at the securing position, the items will be secured in accordance with the following figures:

Note. For lifting diagram for the GM 8-408(XO-1) TSM maintenance equipment shelter, see figure 6-2.

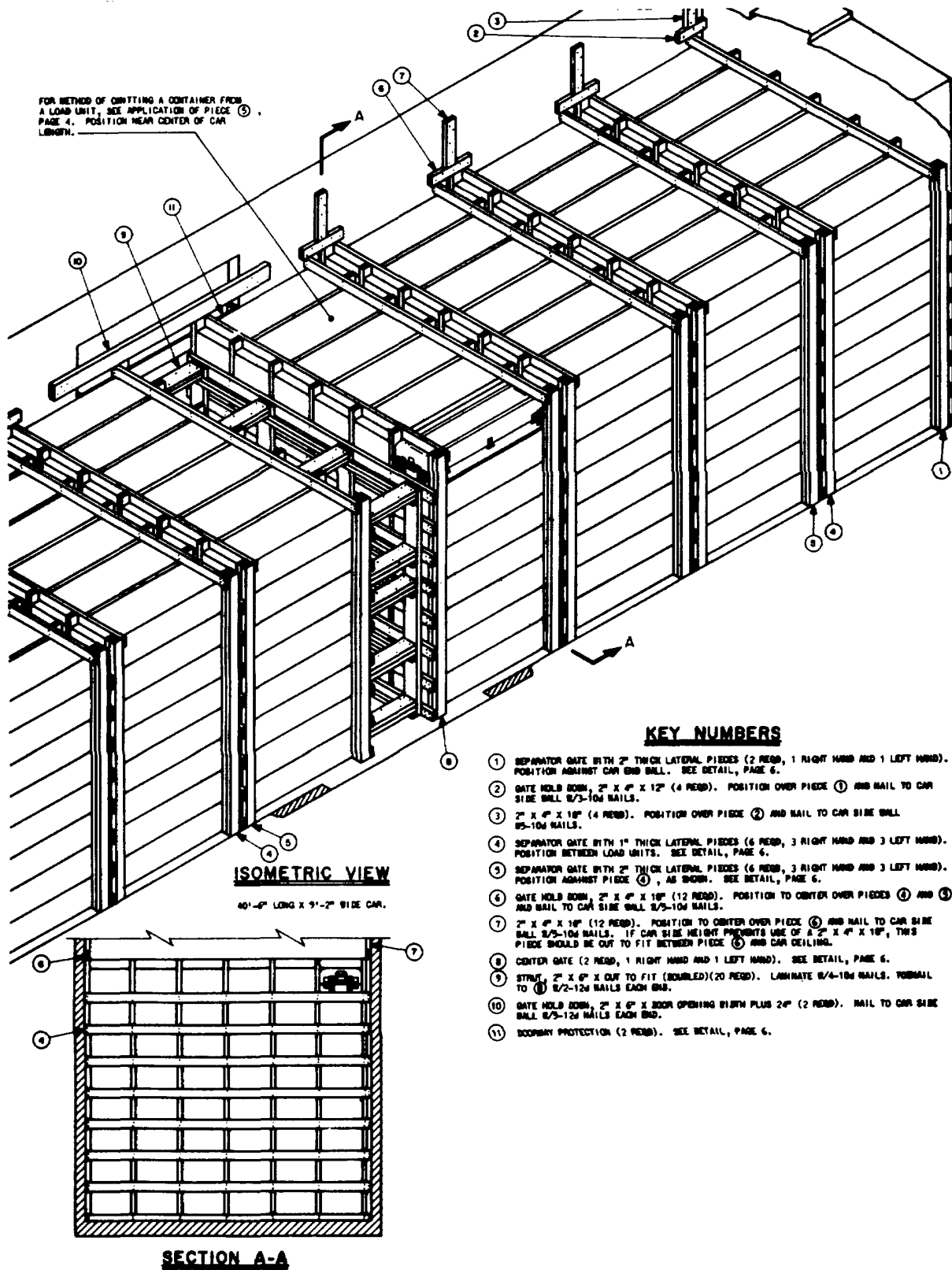

PAGE 2

Figure 7-1. Loading and bracing (CL & LCL) in boxcar of complete round, with three launcher batteries, packed in monopak container (sheet 1 of 5).

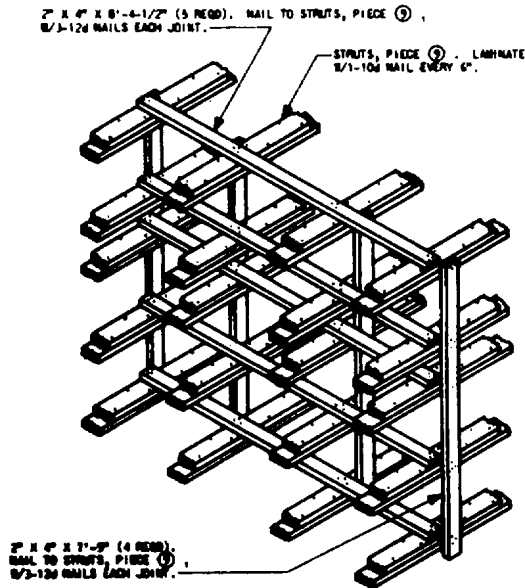

STRUT BRACING

FOR STRUTS 4\"/>

BILL OF MATERIAL		
LUMBER	LINEAL FEET	BOARD FEET
2\"/>	110	20
2\"/>	385	129
2\"/>	36	10
2\"/>	94	35
2\"/>	69	35
2\"/>	1923	1382
2\"/>	191	191
NAILS	NO. REQD	POUNDS
6d (2\"/>	804	4-3/4
16d (2\"/>	1976	38-1/2
12d (3-1/4\"/>	132	2-1/4

FOR 50'-0\"/>

GENERAL NOTES

- A. LOAD AS SHOWN IS BASED ON A BOX CAR 40'-0\"/>
- B. SELECTION OF RAIL CARS FOR THE TRANSPORT OF THIS ITEM WILL BE IN ACCORDANCE WITH AECDA-283-224, PARAGRAPHS 2110 AND 2111.
- C. UNLESS A SHIPMENT WILL BE POSITIONED IN THE RAIL CAR IN COMPLIANCE WITH THE WEIGHT DISTRIBUTION REQUIREMENTS OF THE AECDA, THE NUMBER OF UNITS MAY BE ADJUSTED TO FIT THE RAIL CAR CONCERNED OR THE QUANTITY TO BE SHIPPED; HOWEVER, THE APPROVED METHODS CONTAINED HEREIN FOR FULL OR PARTIAL CAVELOAD MUST BE FOLLOWED FOR BLOCKING, BRACING AND STAYING OF THIS ITEM.
- D. FOR DETAIL OF CONTAINER SEE BRACING NO. K16212531.
 CONTAINER DIMENSIONS - 56-1/2\"/>
- E. THIS ITEM IS AN 100 CLASS \"A\" EXPLOSIVE. SPECIFIED OUTLOADING PROCEDURES CAN ALSO BE UTILIZED FOR THE SHIPMENT OF THE DEPICED CONTAINERS WHEN THEY ARE EMPTY OR LOADED WITH AN ITEM WHICH IS IDENTIFIED DIFFERENTLY BY NOMENCLATURE THAN THE ITEM DESIGNATED WITHIN THE BRACING TITLE.
- F. SPECIFIED CENTER BLOCKING IS ADEQUATE TO RETAIN A FULL CAVELOAD OF 400 CONTAINERS IN A 50'-0\"/>

MATERIAL SPECIFICATIONS

LUMBER: FED SPEC 68-L-751.
 NAILS: COMMON, CORROSIVE COATED, FED SPEC FF-N-105.
 ALT: ANGLE-POIN TYPE NAIL OF SAME SIZE.

LOAD AS SHOWN

ITEM	QUANTITY	WEIGHT (APPROX)
CONTAINER	304	20,416 LBS
BARRAGE		8,215 LBS
TOTAL WEIGHT		28,631 LBS

Figure 7-1--Continued (sheet 2 of 5).

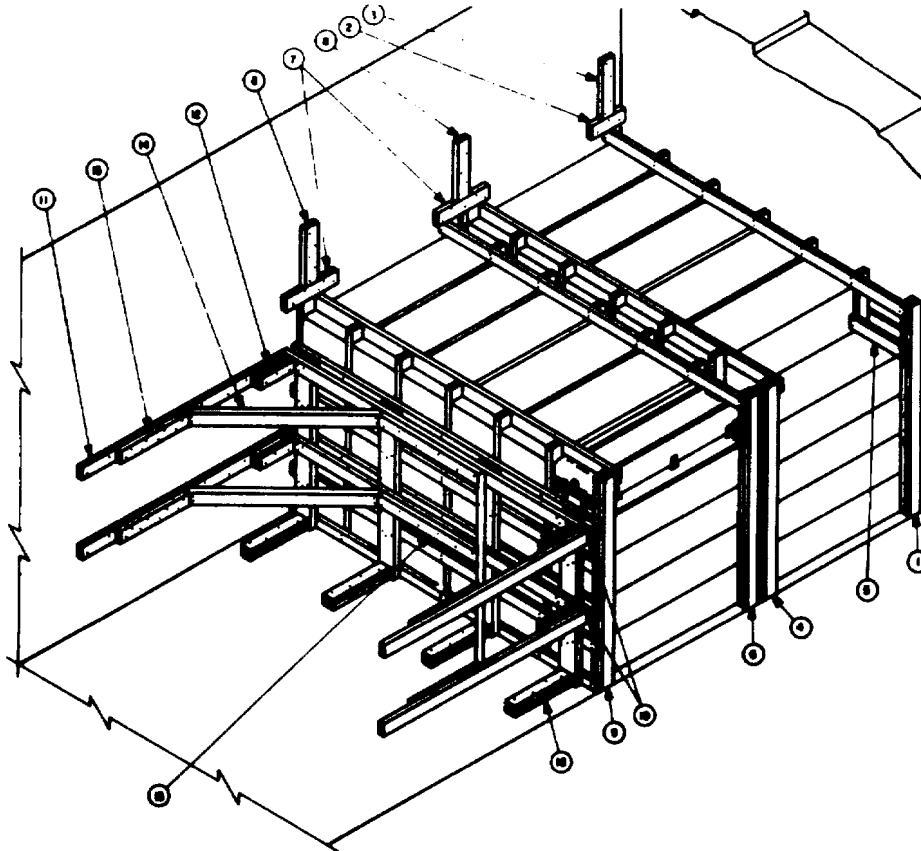

ISOMETRIC VIEW

50 UNIT LOAD IN A 9'-2" WIDE CAR

KEY NUMBERS

- ① SEPARATOR GATE WITH 2" THICK LATERAL PIECES (1 RIGHT HAND REEB). POSITION AGAINST CAR END WALL. SEE DETAIL, PAGE 5.
- ② GATE HOLD DOWN, 2" X 4" X 12" (2 REEB). POSITION OVER PIECE ① AND NAIL TO CAR SIDE WALL 8/3-10d NAILS.
- ③ 2" X 4" X 18" (2 REEB). POSITION OVER PIECE ② AND NAIL TO CAR SIDE WALL 8/5-10d NAILS.
- ④ SEPARATOR GATE WITH 1" THICK LATERAL PIECES (1 LEFT HAND REEB). POSITION BETWEEN LOAD UNITS. SEE DETAIL, PAGE 5.
- ⑤ 2" X 4" X 19-1/2" (2 REEB). NAIL TO PIECE ① AND/OR PIECE ④ 8/2-10d NAILS EACH END. THESE PIECES ONLY REQUIRED WHEN CONTAINING A CONTAINER FROM A LOAD UNIT.
- ⑥ SEPARATOR GATE WITH 2" THICK LATERAL PIECES (1 RIGHT HAND REEB). POSITION AGAINST PIECE ④, AS SHOWN. SEE DETAIL, PAGE 5.
- ⑦ GATE HOLD DOWN, 2" X 4" X 18" (4 REEB). POSITION TO CENTER OVER PIECES ③ AND ④ AND/OR PIECE ⑤ AND NAIL TO CAR SIDE WALL 8/5-10d NAILS.
- ⑧ 2" X 4" X 18" (4 REEB). POSITION TO CENTER OVER PIECE ① AND NAIL TO CAR SIDE WALL 8/5-10d NAILS.
- ⑨ GATE (1 REEB). SEE DETAIL, PAGE 5.
- ⑩ 2" X 4" X CAR BIRTH (2 REEB). POSITION AT 27-1/2" AND 32" HEIGHTS ABOVE THE CAR FLOOR AND NAIL TO PIECE ① 8/3-10d NAILS EACH JOINT. SEE NOTE "C".
- ⑪ 2" X 4" X 72" (4 REEB). ALIGN WITH PIECE ① AND NAIL TO CAR SIDE WALL 8/6-10d NAILS.
- ⑫ 2" X 4" X 12" (DOUBLED)(4 REEB). NAIL FIRST PIECE TO PIECE ① 8/3-16d NAILS. NAIL SECOND PIECE TO FIRST IN LINE THEREAFTER.
- ⑬ 2" X 4" X 36" (2 REEB). NAIL TO PIECE ① 8/6-10d NAILS.
- ⑭ BRACE, 2" X 4" X 58-1/2" (4 REEB). TONNAIL TO PIECES ① AND ④ 8/2-16d NAILS EACH END. SEE DETAIL, PAGE 5, FOR BEVEL CUTS REQUIRED.
- ⑮ 2" X 4" X 24" (4 REEB). NAIL TO PIECE ① 8/6-16d NAILS.
- ⑯ 2" X 4" X 28" (DOUBLED)(4 REEB). POSITION TO ALIGN WITH VERTICALS OF GATE, PIECE ③, AND NAIL FIRST PIECE TO CAR FLOOR 8/4-16d NAILS. NAIL SECOND PIECE TO FIRST 8/4-40d NAILS.

NOTE:

"C-BRACE", SHOWN AS PIECES ① THRU ④, AND PIECES ⑤ ARE ADEQUATE FOR RETAINING A MAXIMUM LOL LOAD OF 12,000 POUNDS.

Figure 7-1—Continued (sheet 3 of 5).

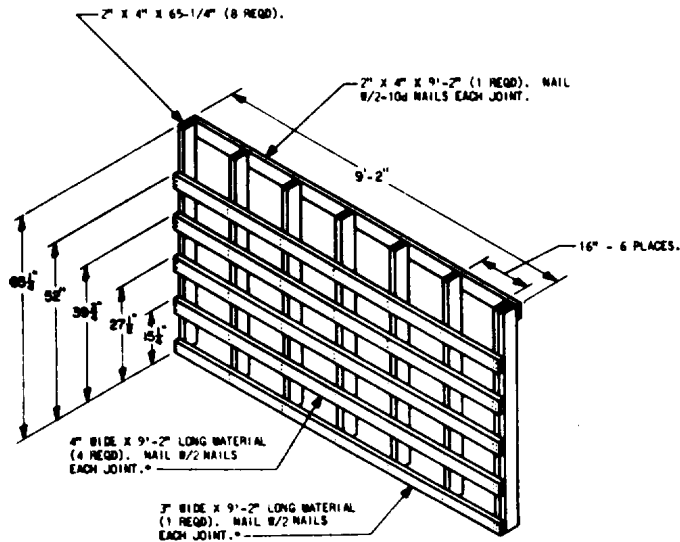

SEPARATOR GATE (LCL)

TWO RIGHT HAND REQUIRED WITH 2" THICK LATERAL PIECES (AS SHOWN). NAIL 8/2-10d NAILS EACH JOINT. (REF: KEY NOS. ① AND ②, PAGE 4).

ONE LEFT HAND REQUIRED WITH 1" THICK LATERAL PIECES. NAIL 8/2-6d NAILS EACH JOINT. (REF: KEY NO. ③, PAGE 4).

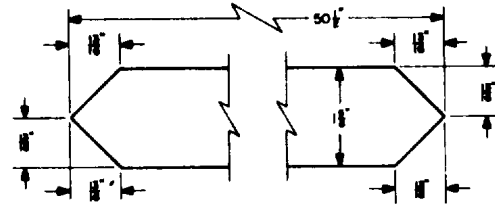

BRACE

2" X 4" MATERIAL

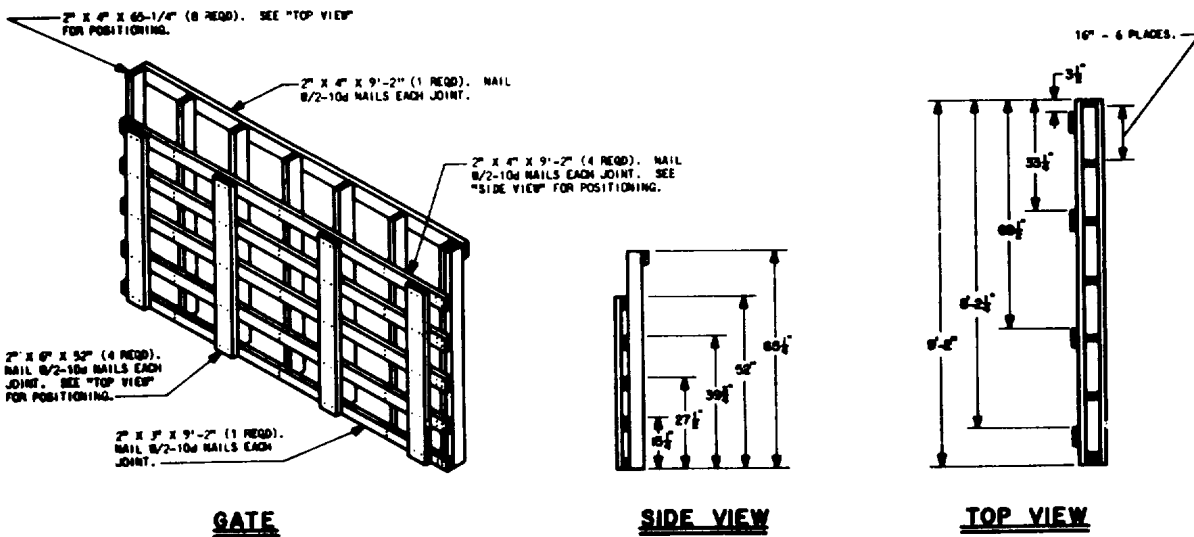

Figure 7-1--Continued (sheet 4 of 5).

GENERAL NOTES

- A. Not applicable.
- B. THE OUTLOADING PROCEDURES SPECIFIED HEREIN ARE APPLICABLE TO THE REDUZE MISSILE WHEN IT IS PACKED IN THE UNIPAK CONTAINER. SUBSEQUENT REFERENCE TO CONTAINER HEREIN MEANS THE XMAS88 CONTAINER (UNIPAK) WITH CONTENTS.
- C. FOR DETAIL OF THE XMAS88 CONTAINER (UNIPAK) SEE DRAWING NO. 1826496 AND "XMAS88 CONTAINER (UNIPAK)" VIEW ON PAGE 3. CONTAINER DIMENSIONS -- 36-1/2" LONG X 18" WIDE X 13-1/2" HIGH. GROSS WEIGHT ----- 40 POUNDS (APPROX).
- D. FOR DETAIL OF THE PALLET UNIT SEE U.S. ARMY MATERIAL COMMAND DRAWING NO. 18-48-3230-048093 AND "PALLET UNIT" VIEW ON PAGE 3. PALLET UNIT DIMENSIONS -- 36-1/2" LONG X 40" WIDE X 32-1/2" HIGH. GROSS WEIGHT ----- 486 POUNDS (APPROX).
- E. THIS ITEM IS A DOT CLASS "A" EXPLOSIVE. THE OUTLOADING PROCEDURES SPECIFIED HEREIN CAN ALSO BE UTILIZED FOR THE SHIPMENT OF THE DESIGNATED CONTAINERS WHEN THEY ARE LOADED WITH AN ITEM WHICH IS IDENTIFIED DIFFERENTLY BY NOMENCLATURE THAN THE ITEM DESIGNATED WITHIN THE DRAWING TITLE.
- F. OUTLOADING PROCEDURES SPECIFIED IN THIS DRAWING ARE FOR CONVENTIONAL TYPE BOX CARS OF VARIOUS LENGTH AND WIDTH COMBINATIONS.
- G. THE LOADS AS SHOWN ARE BASED ON CARS WHICH HAVE VARIOUS WIDTH DOORS OF THE CONVENTIONAL SLIDING TYPE. THE DEPICTED OUTLOADING PROCEDURES ARE ALSO APPLICABLE TO CARS WHICH ARE EQUIPPED WITH PLUG DOORS. CAUTION: DUNNAGE MATERIAL MUST NOT BE NAILED TO ANY PLUG DOOR, WHETHER AUXILIARY OR MAIN, EXCEPT TO A NAILING STRIP IF A DOOR IS SO EQUIPPED, FOR SECURING SUCH ITEMS AS GATE HOLD DOWN OR DOORWAY SPANNER DUNNAGE. ALSO, SPECIAL PROVISIONS MUST BE IMPLEMENTED AS DIRECTED WITHIN THE "SPECIAL NOTES" SECTION WHICH APPLIES TO THE BASIC LOAD INVOLVED. ALSO, AFTER THE PLUG DOORS ON A CAR ARE CLOSED AND READY FOR THE INSTALLATION OF "CAR SEALS", A PIECE OF WIRE OF SUITABLE SIZE WILL BE USED IN ADDITION TO, AND IN CONJUNCTION WITH, EACH CAR SEAL USED TO "SEAL" THE CAR. THE WIRE WILL BE THREADED THROUGH THE HOLES IN THE DOOR LATCH ASSEMBLY ONE OR MORE TIMES, AND THE WIRE ENDS WILL BE TWISTED TOGETHER.
- H. NOTICE: A SHIPMENT WILL BE POSITIONED IN THE RAIL CAR IN COMPLIANCE WITH THE WEIGHT DISTRIBUTION REQUIREMENTS OF THE AAR. THE APPROVED BLOCKING, BRACING AND STAYING METHODS FOR THE LOADS SPECIFIED HEREIN MUST BE FOLLOWED. THE NUMBER OF UNITS MAY BE ADJUSTED TO FIT THE SIZE OF THE CAR TO BE LOADED, OR THE QUANTITY TO BE SHIPPED. FOR A LOAD QUANTITY OTHER THAN SPECIFIED, THE APPROVED METHODS MUST BE FOLLOWED AS CLOSELY AS POSSIBLE.
- J. OTHER TYPES OF LADING ITEMS MAY BE LOADED IN THE CARS WHICH ARE PARTIALLY LOADED WITH THE DESIGNATED ITEM, PROVIDING THE LOAD IS COMPATIBLE, EXISTING DIRECTIVES ARE NOT VIOLATED, AND THE OTHER LADING ITEMS ARE BLOCKED AND BRACED TO EQUAL THE BLOCKING AND BRACING CRITERIA SPECIFIED HEREIN.
- K. THE SELECTION OF RAILCARS FOR THE TRANSPORT OF THE DESIGNATED ITEMS WILL BE IN ACCORDANCE WITH HAZARDOUS MATERIALS REGULATIONS OF DOT AND MR 55-355, CHAPTER 213, FOR EXPLOSIVES OR OTHER DANGEROUS ARTICLES, IN FULL.
- L. WHEN STEEL STRAPPING IS SEALED AT AN END-OVER-END LAP JOINT FOR A STRAP APPLICATION OTHER THAN FOR PALLETIZING, A MINIMUM OF TWO (2) SEALS, BUTTED TOGETHER, WITH TWO (2) PAIR OF CHAMPS PER SEAL MUST BE USED.
- M. DUNNAGE LUMBER SPECIFIED THROUGHOUT THIS PROCEDURAL DRAWING IS OF NOMINAL SIZE. FOR EXAMPLE, 2" X 4" MATERIAL IS ACTUALLY 1-5/8" THICK BY 3-5/8" WIDE AND 2" X 6" MATERIAL IS ACTUALLY 1-5/8" THICK BY 5-5/8" WIDE.

(CONTINUED AT RIGHT)

MATERIAL SPECIFICATIONS

- LUMBER ----- : SEE TM 713-200-1, DUNNAGE LUMBER, FED SPEC MM-1-751.
- NAILS ----- : COMMON, ZINC COATED OR CHEMICALLY ETCHED, FED SPEC FF-N-105. ALT: ANNULAR-RING TYPE NAIL OF THE SAME SIZE.
- STRAPPING, STEEL: TYPE I OR IV, CLASS B FOR PALLETIZING AND CLASS A, B, OR C FOR OUTLOADING, FED SPEC QQ-5-761.
- PLYWOOD ----- : GROUP B OR C, GRADE * C-D (EXTERIOR); FED SPEC MM-P-520. PSN 5230-051-1198.
- STRAP SEALS, SEALS ----- : COMMERCIAL GRADE.

* IF SPECIFIED GRADE IS NOT AVAILABLE, A BETTER EXTERIOR GRADE MAY BE USED.

Figure 7-2. Loading and bracing (CL & LCL) in boxcars of complete round, with three launcher batteries, packed in unipak container, unpalletized and palletized (sheet 1 of 25).

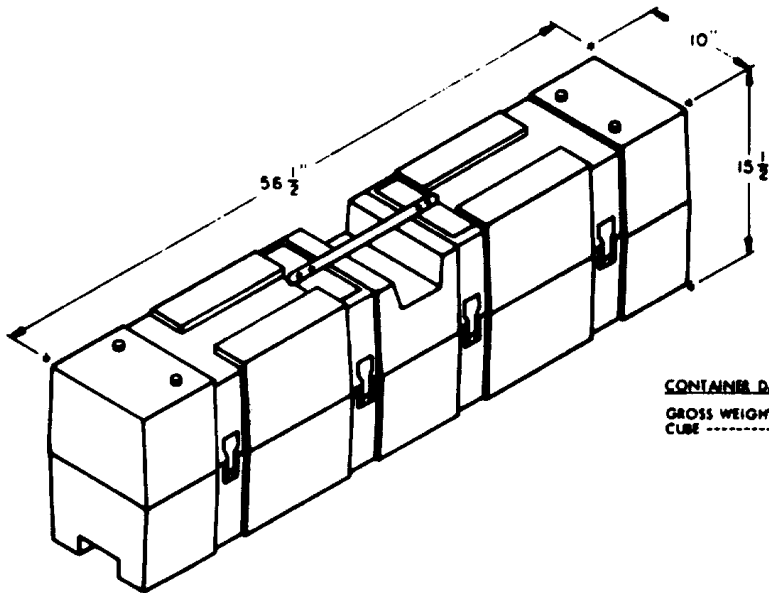

CONTAINER DATA:

GROSS WEIGHT --- 48 POUNDS (APPROX).
 CUBE ----- 5.07 CUBIC FEET.

XM585 CONTAINER (UNIPAK)

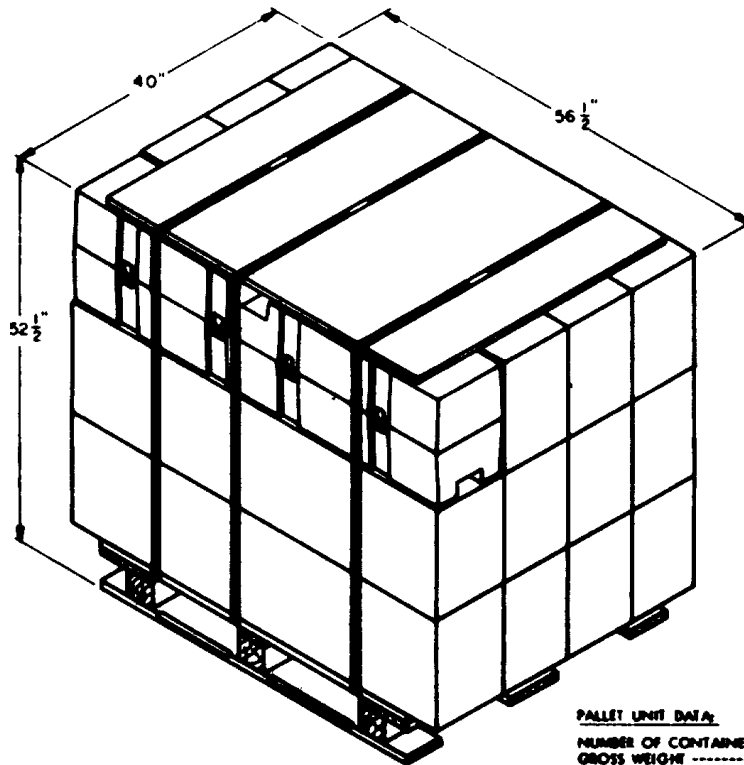

PALLET UNIT DATA:

NUMBER OF CONTAINERS --- TWELVE (12).
 GROSS WEIGHT ----- 686 POUNDS (APPROX).
 CUBE ----- 68.7 CUBIC FEET.

PALLET UNIT

FOR THE FABRICATION OF THIS PALLET UNIT, SEE U.S. ARMY
 MATERIEL COMMAND DRAWING NO. 19-48-5232-GM20P5.

CONTAINER AND PALLET UNIT DETAILS

Figure 7-2--Continued (sheet 2 of 25).

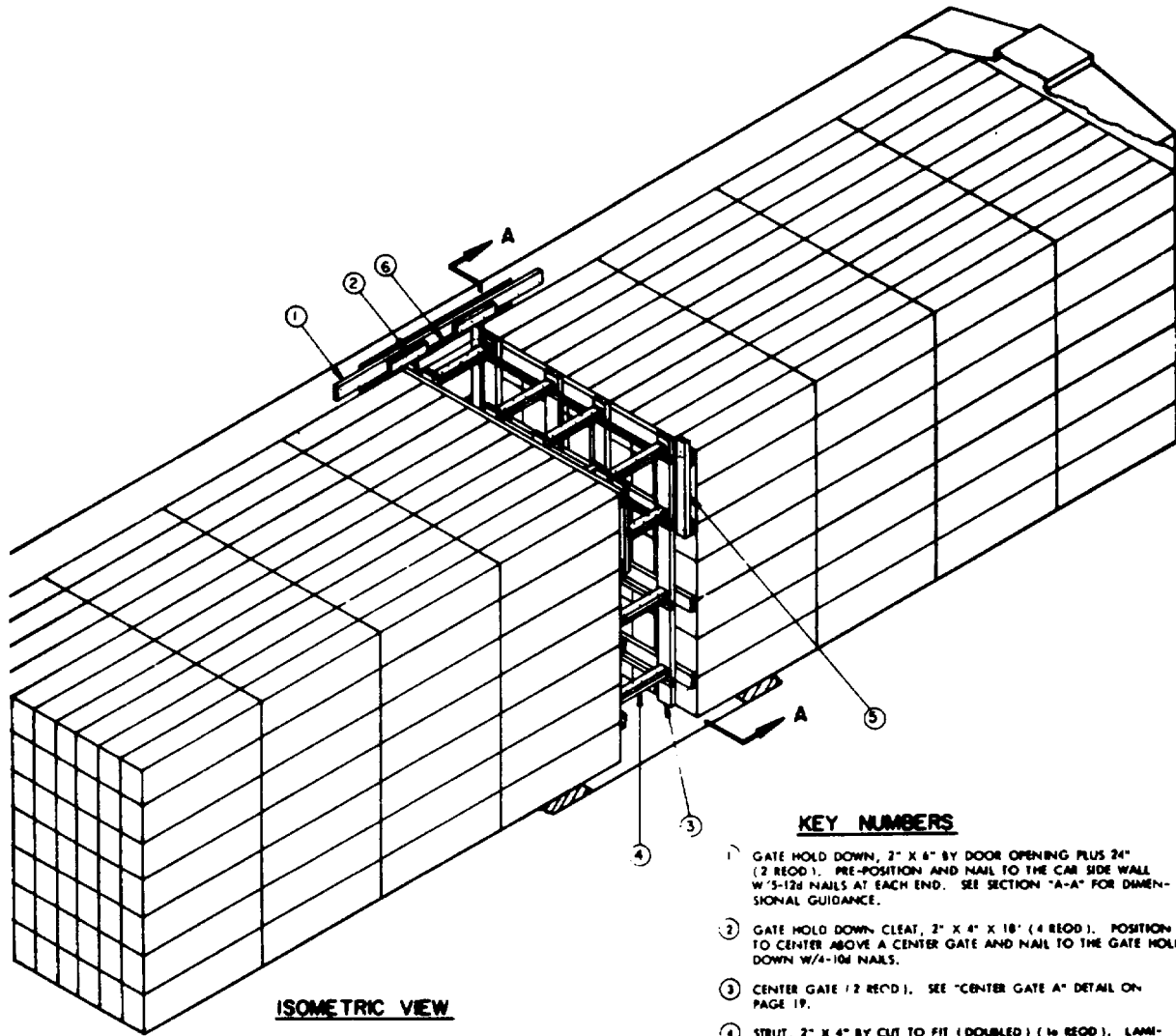

ISOMETRIC VIEW

KEY NUMBERS

- 1 GATE HOLD DOWN, 2" X 4" BY DOOR OPENING PLUS 24" (2 RECD). PRE-POSITION AND NAIL TO THE CAR SIDE WALL W/3-12d NAILS AT EACH END. SEE SECTION "A-A" FOR DIMENSIONAL GUIDANCE.
- 2 GATE HOLD DOWN CLEAT, 2" X 4" X 18" (4 RECD). POSITION TO CENTER ABOVE A CENTER GATE AND NAIL TO THE GATE HOLD DOWN W/4-10d NAILS.
- 3 CENTER GATE (2 RECD). SEE "CENTER GATE A" DETAIL ON PAGE 19.
- 4 STRUT, 2" X 4" BY CUT TO FIT (DOUBLED) (1/2 RECD). LAMINATE W/1-10d NAIL EVERY 4". TOENAIL TOP PIECE TO CENTER GATE W/2-12d NAILS AT EACH END. FOR STRUTS 5" OR GREATER IN LENGTH!! SEE "STRUT BRACING" DETAIL ON PAGE 24. SEE SPECIAL NOTE # ON PAGE 5.
- 5 VERTICAL BRACE, 2" X 4" 8' LENGTH TO SUIT (1 RECD). POSITION TO CONTACT GATE HOLD DOWN AND GATE HOLD DOWN CLEAT AND NAIL TO CENTER GATE W/3-18d NAILS AT EACH JOINT.
- 6 DOORWAY PROTECTION (2 RECD). SEE "DOORWAY PROTECTION GATE A" DETAIL ON PAGE 21. SEE SPECIAL NOTE 1 ON PAGE 5.

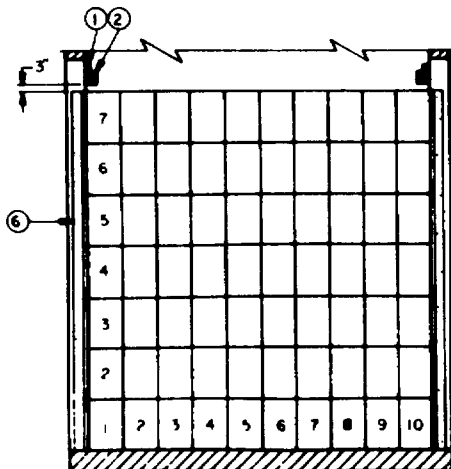

SECTION A-A

**UNPALLETIZED LOAD
IN A 40'-6" LONG BY 6'-6" WIDE CAR**

Figure 7-2--Continued (sheet 3 of 25).

SPECIAL NOTES

1. A 40'-6" LONG BY 8'-6" WIDE (INSIDE CLEARANCE) CONVENTIONAL TYPE BOX CAR EQUIPPED WITH 6'-0" WIDE DOOR OPENINGS IS SHOWN. THE LOAD AS SHOWN MAY ALSO BE SHIPPED IN CARS WHICH HAVE WIDER OR STAGGERED DOOR OPENINGS.
2. A WIDER CAR MAY BE USED FOR SHIPPING THE DEPICTED LOAD. WHEN A WIDER CAR IS USED SEE "TYPICAL CROSS SECTION" VIEW AND SPECIAL NOTE 3 ON PAGE 7.
3. IF THE DELINEATED UNLOADING METHOD IS USED FOR THE SHIPMENT OF A LOAD WHICH CONTAINS LESS CONTAINERS THAN SHOWN, "RISER ASSEMBLIES" MUST BE USED. SEE THE "RISER ASSEMBLY" DETAIL ON PAGE 23, AND "TYPICAL LCL" PROCEDURES ON PAGE 8 FOR PROPER APPLICATION. **CAUTION:** RISER ASSEMBLIES SHOULD ONLY BE USED WHEN THE QUANTITY TO BE SHIPPED CANNOT BE SATISFIED BY THE OMISSION OF A STACK OF 30 CONTAINERS AND/OR THE OMISSION OF A COMPLETE LAYER FROM THE LOADING CONFIGURATION SHOWN.
4. IF A CAR BEING LOADED HAS PLUG DOORS, THE ONLY CHANGE TO THE SPECIFIED PROCEDURES, IN ADDITION TO THE CRITERIA SET FORTH WITHIN GENERAL NOTE "G" ON PAGE 2, IS TO DELETE "DOORWAY PROTECTION GATE A" AND USE "DOORWAY PROTECTION FOR CARS HAVING PLUG DOORS" AS SHOWN ON PAGE 21. **NOTE:** NO DOORWAY PROTECTION IS REQUIRED IN A CAR HAVING PLUG DOORS IF LESS THAN ONE-HALF OF THE CONTAINER LENGTH PROJECTS INTO THE DOORWAY AREA. SEE GENERAL NOTE "S" ON PAGE 2.
5. IF DESIRED, 4" X 4" MATERIAL STRUT MAY BE SUBSTITUTED FOR EACH DOUBLED 2" X 4" STRUT THAT IS SPECIFIED.

BILL OF MATERIAL		
LUMBER	LINEAR FEET	BOARD FEET
1" X 6"	48	24
2" X 2"	43	21
2" X 3"	37	19
2" X 4"	91	61
2" X 6"	158	158
NAILS	NO. NEEDED	POUNDS
6d (2")	48	1/2
10d (3")	290	4-1/2
12d (3-1/4")	124	2-1/4

LOAD AS SHOWN

ITEM	QUANTITY	WEIGHT (APPROX)
CONTAINER	360	26,000 LBS
DUNNAGE		715 LBS
TOTAL WEIGHT		27,595 LBS

**UNPALLETIZED LOAD
IN A 40'-6" LONG BY 8'-6" WIDE CAR**

Figure 7-2—Continued (sheet 4 of 25)

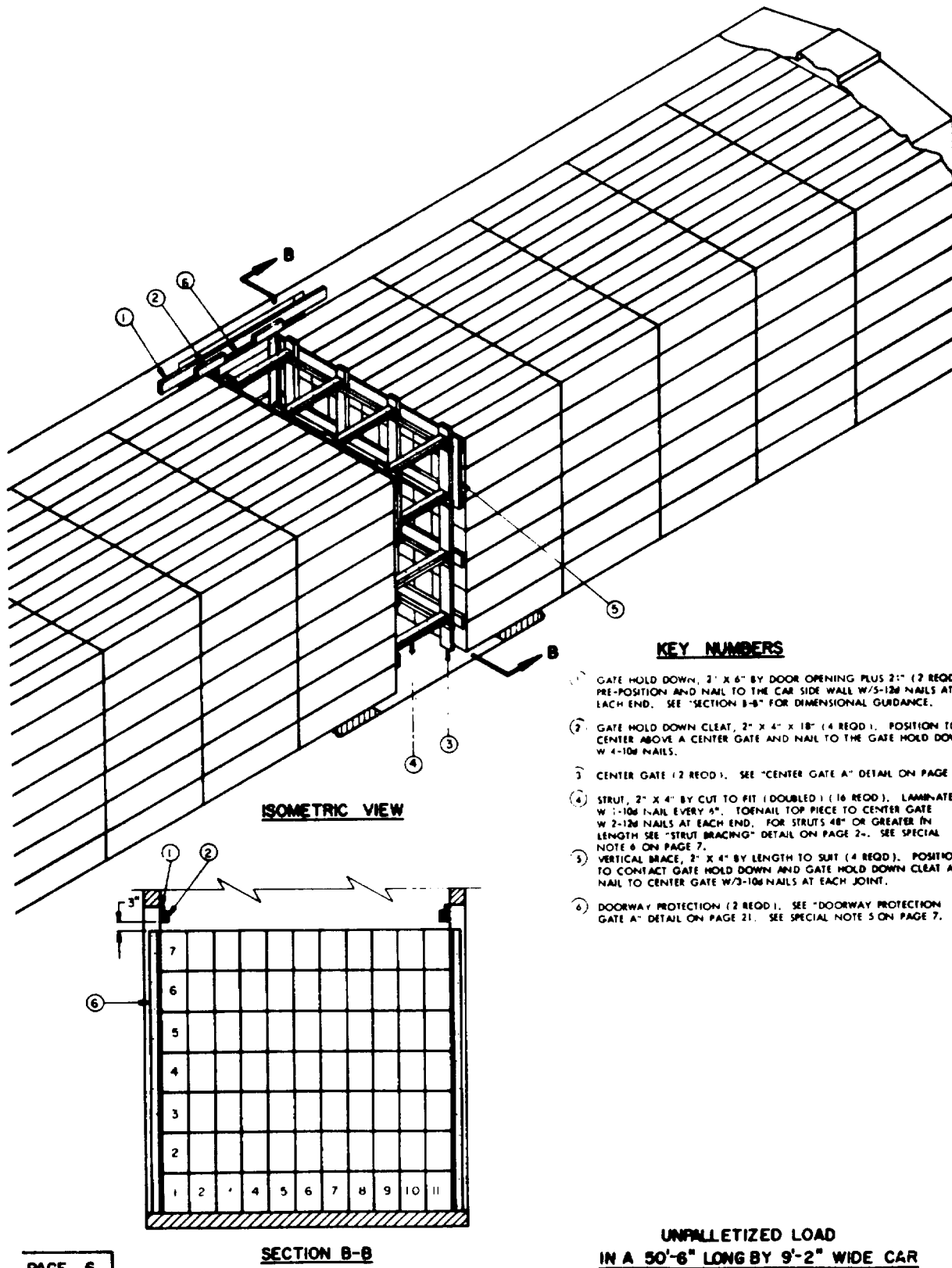
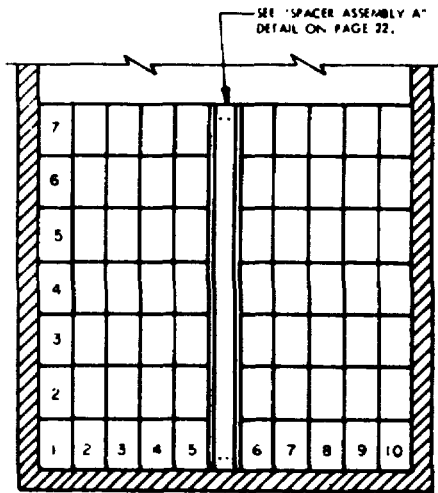

Figure 7-2-Continued (sheet 5 of 25).

SPECIAL NOTES:

1. A 50'-0" LONG BY 9'-2" WIDE (INSIDE CLEARANCE) CONVENTIONAL TYPE BOX CAR EQUIPPED WITH 6'-0" WIDE DOOR OPENINGS IS SHOWN. THE LOAD AS SHOWN MAY ALSO BE SHIPPED IN CARS WHICH HAVE WIDER OR STAGGERED DOOR OPENINGS.
2. A WIDER CAR CAN BE USED FOR SHIPPING THE DEPICTED LOAD.
3. IF A CAR WITH AN INSIDE DIMENSION OF LESS THAN 9'-2" IS USED FOR OUTLOADING THIS ITEM, ONE "SPACER ASSEMBLY" WILL BE REQUIRED FOR EACH CONTAINER STACK. SEE "TYPICAL CROSS SECTION" VIEW AT LEFT.
4. IF THE DESIGNATED OUTLOADING METHOD IS USED FOR THE SHIPMENT OF A LOAD WHICH CONTAINS LESS CONTAINERS THAN SHOWN, "RISER ASSEMBLIES" MUST BE USED. SEE THE "RISER ASSEMBLY" DETAIL ON PAGE 23, AND "TYPICAL LCL" PROCEDURES ON PAGE 8 FOR PROPER APPLICATION. **CAUTION:** RISER ASSEMBLIES SHOULD ONLY BE USED WHEN THE QUANTITY TO BE SHIPPED CANNOT BE SATISFIED BY THE OMISSION OF A STACK OF 77 CONTAINERS AND/OR THE OMISSION OF A COMPLETE LAYER FROM THE LOADING CONFIGURATION SHOWN.
5. IF A 9'-2" WIDE BOX CAR, LOADED AS DEPICTED ON PAGE 6, IS EQUIPPED WITH PLUG DOORS AND LESS THAN ONE-HALF OF THE CONTAINER LENGTH PROJECTS INTO THE DOORWAY AREA DOORWAY PROTECTION IS NOT REQUIRED. IF A 9'-2" WIDE CAR HAS PLUG DOORS AND MORE THAN ONE-HALF OF THE CONTAINER LENGTH PROJECTS INTO THE DOORWAY AREA, SEE "SPECIAL PROVISIONS FOR 9'-2" WIDE BOX CAR EQUIPPED WITH PLUG DOORS" DETAIL ON PAGE 26. SEE GENERAL NOTE "1" ON PAGE 2.
6. IF DESIRED, 4" X 4" MATERIAL STRUT MAY BE SUBSTITUTED FOR EACH DOUBLED 2" X 4" STRUT THAT IS SPECIFIED.



TYPICAL CROSS SECTION

THE ABOVE SECTION VIEW DEPICTS A TEN (10) CONTAINER WIDE LOAD IN A BOX CAR WITH AN INSIDE WIDTH DIMENSION OF LESS THAN 9'-2", IN WHICH AN ELEVEN (11) CONTAINER-WIDE LOAD WILL NOT FIT ACROSS THE WIDTH OF THE CAR. A "SPACER ASSEMBLY" WILL BE REQUIRED TO FILL THE EXCESS SPACE ACROSS THE WIDTH OF THE CAR. A TWO INCH (2") VOID ACROSS THE WIDTH OF THE CAR IS THE MAXIMUM ALLOWABLE VOID PERMITTED. ADJUST THE WIDTH OF THE "SPACER ASSEMBLY" AS REQUIRED.

BILL OF MATERIAL

LUMBER	LINEAR FEET	BOARD FEET
1" X 6"	48	24
2" X 2"	68	23
2" X 3"	37	19
2" X 4"	112	75
2" X 6"	164	164
NAILS	NO. REQD	POUNDS
6d (2")	48	1/2
10d (3")	76	4-3/4
12d (3-1/4")	124	2-1/4

LOAD AS SHOWN

ITEM	QUANTITY	WEIGHT (APPROX)
CONTAINER	770	36,900 LBS
ORIGINAGE		770 LBS
TOTAL WEIGHT		37,730 LBS

**UNPALLETIZED LOAD
IN A 50'-0" LONG BY 9'-2" WIDE CAR**

PAGE 7

Figure 7-2-Continued (sheet 6 of 25).

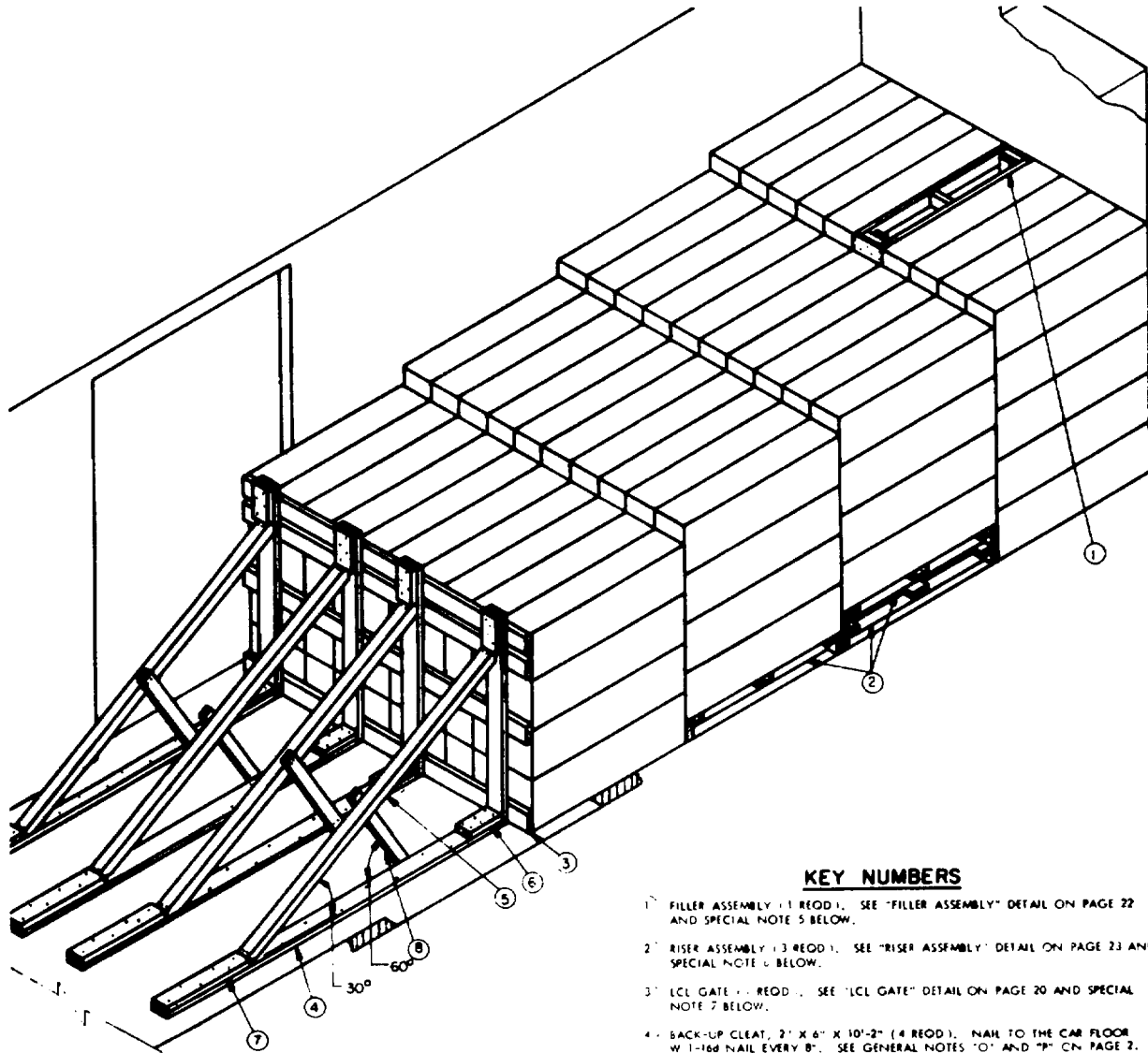

ISOMETRIC VIEW
DEPICTING A 169 UNIT LCL LOAD.

SPECIAL NOTES

1. AN 8'-6" WIDE (INSIDE CLEARANCE) CONVENTIONAL (TYPE BC) CAR IS SHOWN.
2. IF THE LADING EXTENDS INTO A DOORWAY AREA USE DOORWAY PROTECTION AS SPECIFIED IN LOADS SHOWN ON PAGES 4 THROUGH 7.
3. FOUR KNEE BRACE ASSEMBLIES AS SHOWN ABOVE ARE ADEQUATE FOR RETAINING A MAXIMUM SIZE LCL LOAD.
4. KNEE BRACE ASSEMBLIES MAY BE USED IN EACH END OF THE CAR.
5. FILLER ASSEMBLY, SHOWN AS PIECE MARKED ①, MAY BE USED AS REQUIRED. IT MUST BE USED IN THE TOP LAYER ONLY.
6. IF RISER ASSEMBLY SHOWN AS PIECE MARKED ② IS USED TO STEP DOWN CONTAINERS IT MUST BE USED AS DEPICTED ABOVE TO INSURE THAT SUFFICIENT BEARING SURFACES OF ADJACENT CONTAINERS ARE IN CONTACT.
7. MAXIMUM STACK HEIGHT ADJACENT TO AN LCL GATE IS FOUR (4) CONTAINERS HIGH.
8. THE USE OF THE "RISER ASSEMBLIES" AND "FILLER ASSEMBLY" ARE SPECIFIED FOR THE DEPICTED LOAD ONLY TO SHOW A TYPICAL APPLICATION. "RISER ASSEMBLIES" AND "FILLER ASSEMBLIES" MAY BE OMITTED IN THE LOAD AS REQUIRED TO ADJUST THE LASHING PATTERN FOR THE NUMBER OF CONTAINERS TO BE SHIPPED.

KEY NUMBERS

1. FILLER ASSEMBLY (1 REOD). SEE "FILLER ASSEMBLY" DETAIL ON PAGE 22 AND SPECIAL NOTE 5 BELOW.
2. RISER ASSEMBLY (3 REOD). SEE "RISER ASSEMBLY" DETAIL ON PAGE 23 AND SPECIAL NOTE 6 BELOW.
3. LCL GATE (1 REOD). SEE "LCL GATE" DETAIL ON PAGE 20 AND SPECIAL NOTE 7 BELOW.
4. BACK-UP CLEAT, 2" X 6" X 10'-2" (4 REOD). NAIL TO THE CAR FLOOR W/ 1-16d NAIL EVERY 8". SEE GENERAL NOTES "O" AND "P" ON PAGE 2.
5. DIAGONAL BRACE, 4" X 4" X 8'-9" (4 REOD). SEE "DIAGONAL BRACE" DETAIL ON PAGE 23. TOENAIL TO LCL GATE AND BACK-UP CLEAT W/2-16d NAILS AT EACH END.
6. SUPPORT PIECE, 2" X 6" X 12" (4 REOD). NAIL TO THE BACK-UP CLEAT W/ 4-16d NAILS AND TOENAIL TO LCL GATE W/2-12d NAILS.
7. BACK-UP CLEAT, 2" X 6" X 30" (4 REOD). POSITION AGAINST DIAGONAL BRACE AND NAIL TO BACK-UP CLEAT W/8-40d NAILS.
8. DIAGONAL BRACE SUPPORT, 2" X 4" X 37" (4 REOD). BEVEL THE BOTTOM END WITH 40° CUTS. CENTER ON THE DIAGONAL BRACE AND NAIL TO THE DIAGONAL BRACE AND BACK-UP CLEAT W/2-12d NAILS AT EACH LOCATION.

Figure 7-2--Continued (sheet 7 of 25).

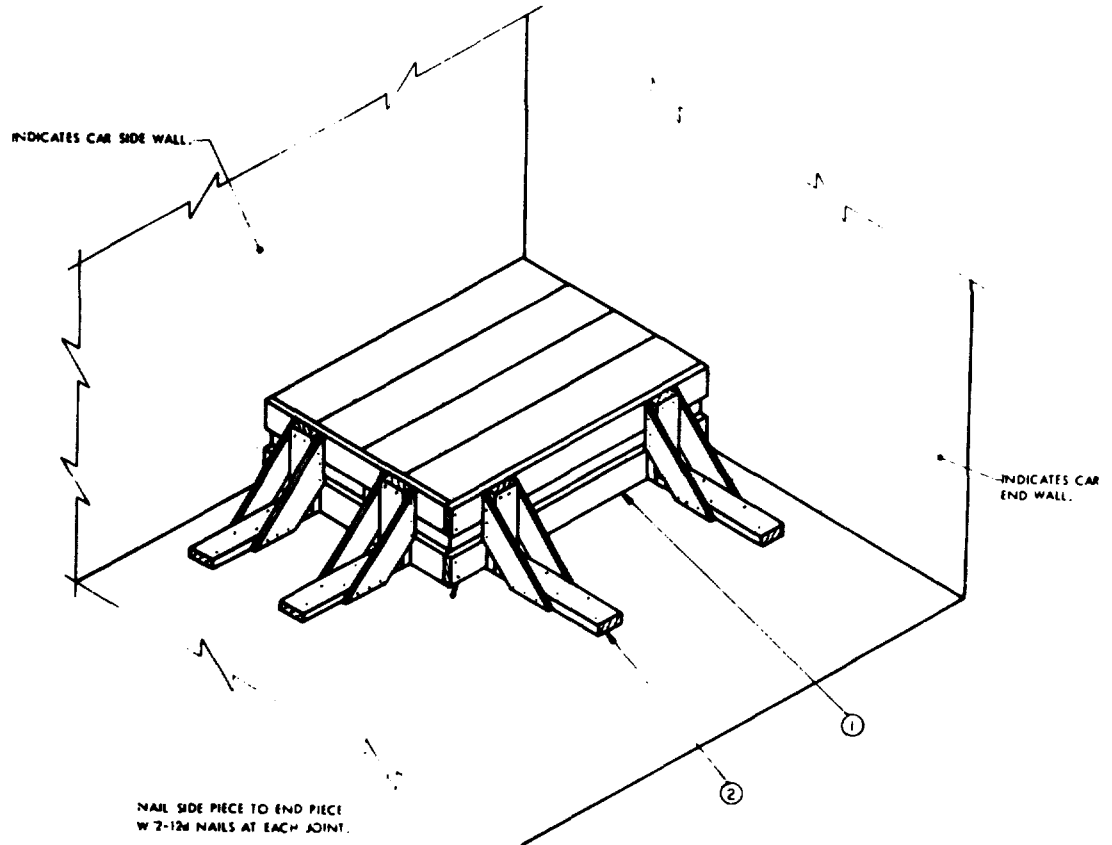

ISOMETRIC VIEW
 DEPICTING A FOUR-UNIT LCL LOAD.

SPECIAL NOTES:

1. PROCEDURES SHOWN DEPICT THE USE OF LCL BRACES.
2. CONTAINERS MUST NOT BE STACKED IF THESE BLOCKING PROCEDURES ARE USED.
3. IF DESIRED LCL BRACES AND 2" MATERIAL MAY BE INSTALLED AT EACH END OF THE LOAD.

KEY NUMBERS

- 1 2" MATERIAL, (FOUR PIECES OF 2" X 6" MATERIAL DEPICTED). POSITION AT THE TOP AND BOTTOM OF THE CONTAINERS AS SHOWN.
- 2 LCL BRACE (4 REED). SEE "LCL BRACE" DETAIL AND "NOTE ▲" ON PAGE 23. NAIL TO THE 2" MATERIAL W/ 2-10d NAILS AT EACH JOINT. NAIL TO THE CAR FLOOR W/ 2-10d NAILS. SEE GENERAL NOTES "C" AND "D" ON PAGE 2.

TYPICAL LCL (UNPALLETIZED)

Figure 7-2. Continued (sheet 8 of 25).

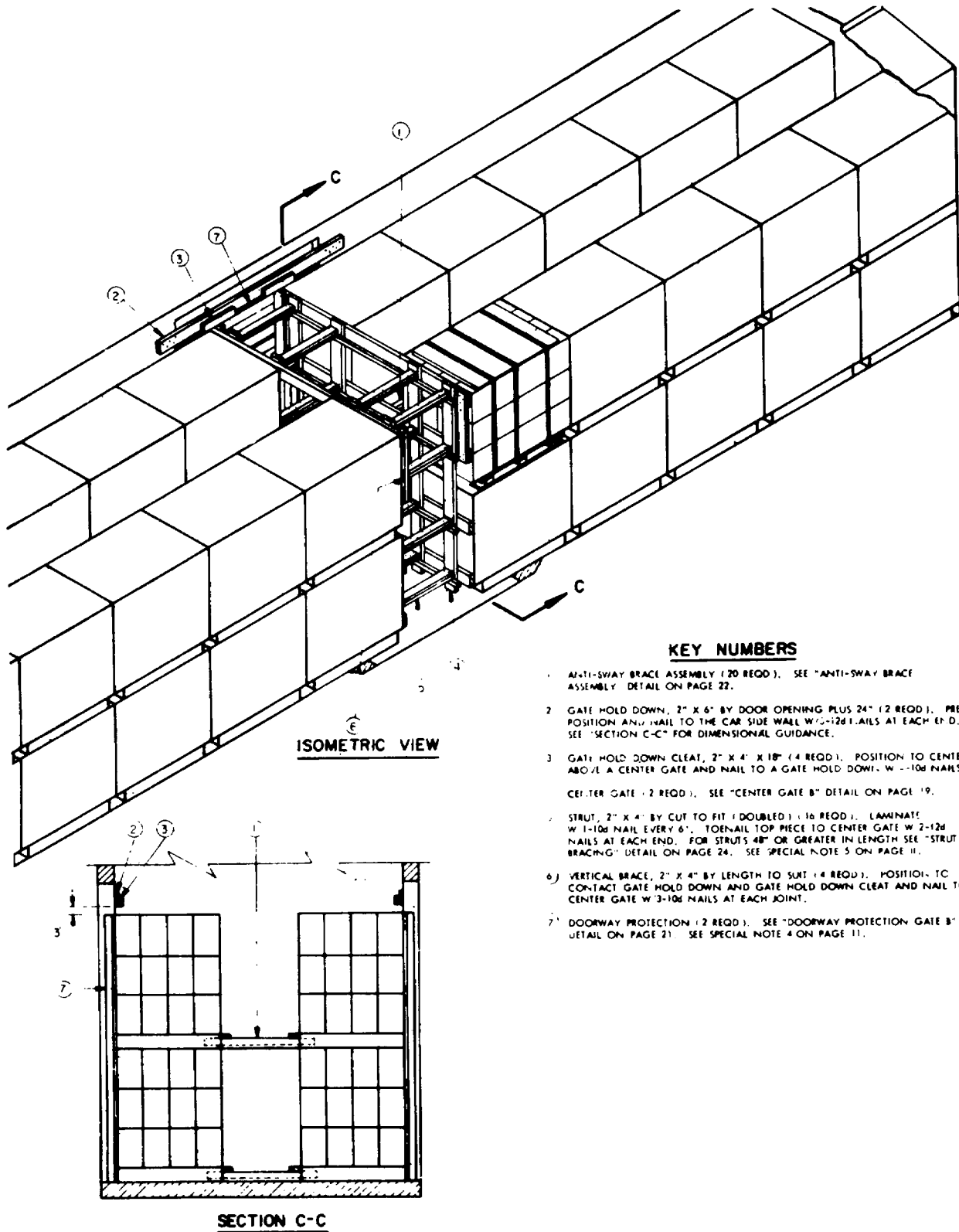

KEY NUMBERS

- 1 ANTI-SWAY BRACE ASSEMBLY (20 REQD.). SEE "ANTI-SWAY BRACE ASSEMBLY" DETAIL ON PAGE 22.
- 2 GATE HOLD DOWN, 2" X 6" BY DOOR OPENING PLUS 24" (2 REQD.). PRE-POSITION AND NAIL TO THE CAR SIDE WALL W/3-12d NAILS AT EACH END. SEE "SECTION C-C" FOR DIMENSIONAL GUIDANCE.
- 3 GATE HOLD DOWN CLEAT, 2" X 4" X 18" (4 REQD.). POSITION TO CENTER ABOVE A CENTER GATE AND NAIL TO A GATE HOLD DOWN W/3-10d NAILS. CENTER GATE (2 REQD.). SEE "CENTER GATE B" DETAIL ON PAGE 19.
- 4 STRUT, 2" X 4" BY CUT TO FIT (DOUBLED) (16 REQD.). LAMINATE W/1-10d NAIL EVERY 6". TOENAIL TOP PIECE TO CENTER GATE W/2-12d NAILS AT EACH END. FOR STRUTS 48" OR GREATER IN LENGTH SEE "STRUT BRACING" DETAIL ON PAGE 24. SEE SPECIAL NOTE 5 ON PAGE 11.
- 5 VERTICAL BRACE, 2" X 4" BY LENGTH TO SUIT (4 REQD.). POSITION TO CONTACT GATE HOLD DOWN AND GATE HOLD DOWN CLEAT AND NAIL TO CENTER GATE W/3-10d NAILS AT EACH JOINT.
- 6 DOORWAY PROTECTION (2 REQD.). SEE "DOORWAY PROTECTION GATE B" DETAIL ON PAGE 21. SEE SPECIAL NOTE 4 ON PAGE 11.

**PALLETIZED LOAD
IN A 50'-6" LONG BY 9'-2" WIDE CAR**

Figure 7-2--Continued (sheet 9 of 25).

SPECIAL NOTES:

1. A 50'-6" LONG BY 9'-2" WIDE INSIDE CLEARANCE CONVENTIONAL TYPE BOX CAR EQUIPPED WITH 7'-0" WIDE DOOR OPENING IS SHOWN. THE LOAD AS SHOWN MAY ALSO BE SHIPPED IN CARS WHICH HAVE RIDER OR STAGGERED DOOR OPENINGS. NOTE: A CAR HAVING 6'-0" WIDE DOOR OPENINGS MAY BE USED. HOWEVER, IT MAY BE NECESSARY TO DELETE A STACK OF FOUR (4) UNITS IN THE DOORWAY AREA DUE TO INSUFFICIENT LOADING CLEARANCE.
2. A WIDER OR NARROWER WIDTH CAR CAN BE USED FOR SHIPPING THE DEPICTED LOAD BY ADJUSTING THE WIDTH OF ANTI-SWAY BRACE ASSEMBLY AND THE WIDTH OF THE CENTER GATES.
3. IF THE DELINEATED OUTLOADING METHOD IS USED FOR THE SHIPMENT OF A LOAD WHICH CONTAINS LESS UNITS THAN SHOWN FOLLOW THE METHODS DEPICTED ON PAGES 14 AND 15.
4. IF THE CAR BEING LOADED HAS PLUG DOORS AND LESS THAN ONE-HALF OF A UNIT EXTENDS INTO THE DOORWAY AREA, NO DOORWAY PROTECTION IS REQUIRED. IF MORE THAN ONE-HALF OF A UNIT EXTENDS INTO THE DOORWAY AREA, DOORWAY PROTECTION AS SHOWN BY PIECES MARKED (3), (8) AND (9) ON PAGES 12 AND 13 MUST BE USED. SEE GENERAL NOTE "5" ON PAGE 2.
5. IF DESIRED, 4" X 4" MATERIAL STRUT MAY BE SUBSTITUTED FOR EACH DOUBLED 2" X 4" STRUT THAT IS SPECIFIED.

BILL OF MATERIAL		
LUMBER	LINEAR FEET	BOARD FEET
1" X 6"	36	28
2" X 2"	67	23
2" X 3"	175	88
2" X 4"	262	175
2" X 6"	163	163
4" X 4"	100	134
NAILS	NO. REQD	POUNDS
6d (2")	48	1.2
10d (3")	586	9
12d (3-1/4")	364	6-1/4

LOAD AS SHOWN

ITEM	QUANTITY	WEIGHT - APPROX.
PALLET UNIT	40	27,440 LBS
DUNNAGE		1,544 LBS
TOTAL WEIGHT		28,984 LBS

**PALLETIZED LOAD
IN A 50'-6" LONG BY 9'-2" WIDE CAR**

Figure 7-2--Continued (sheet 10 of 25).

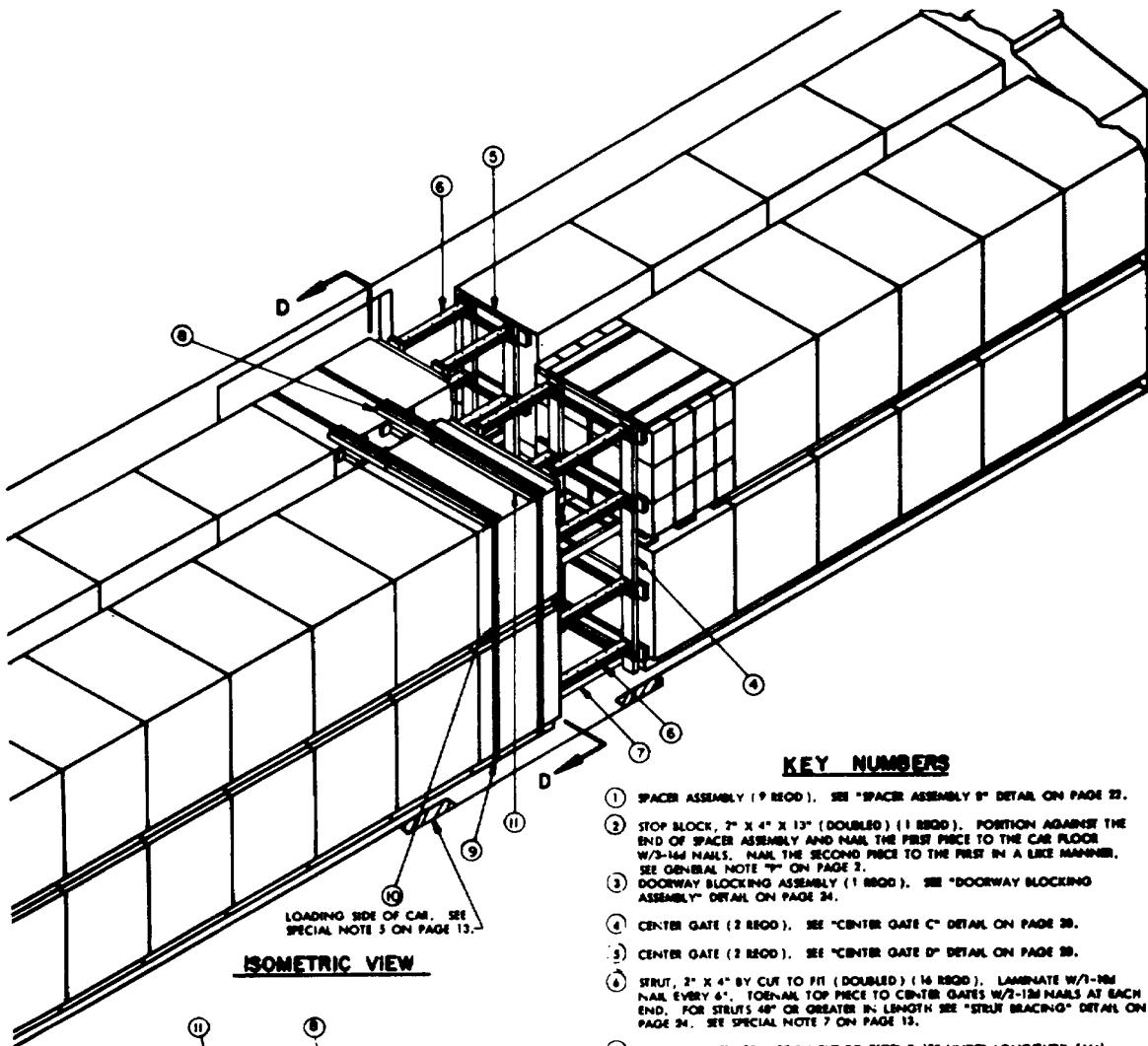

KEY NUMBERS

- ① SPACER ASSEMBLY (1 REQD.). SEE "SPACER ASSEMBLY" DETAIL ON PAGE 22.
- ② STOP BLOCK, 2" X 4" X 13" (DOUBLED) (1 REQD.). POSITION AGAINST THE END OF SPACER ASSEMBLY AND NAIL THE FIRST PIECE TO THE CAR FLOOR W/3-1/4" NAILS. NAIL THE SECOND PIECE TO THE FIRST IN A LIKE MANNER. SEE GENERAL NOTE "M" ON PAGE 2.
- ③ DOORWAY BLOCKING ASSEMBLY (1 REQD.). SEE "DOORWAY BLOCKING ASSEMBLY" DETAIL ON PAGE 24.
- ④ CENTER GATE (2 REQD.). SEE "CENTER GATE C" DETAIL ON PAGE 28.
- ⑤ CENTER GATE (2 REQD.). SEE "CENTER GATE D" DETAIL ON PAGE 28.
- ⑥ STRUT, 2" X 4" BY CUT TO FIT (DOUBLED) (16 REQD.). LAMINATE W/3-1/4" NAIL EVERY 6". TOENAIL TOP PIECE TO CENTER GATES W/2-1/2" NAILS AT EACH END. FOR STRUTS 48" OR GREATER IN LENGTH SEE "STRUT BRACING" DETAIL ON PAGE 24. SEE SPECIAL NOTE 7 ON PAGE 13.
- ⑦ GATE RETAINER, 2" X 3" BY CUT TO EXTEND 12" UNDER LONGITUDINALLY ADJACENT PALLET UNITS (8 REQD.). POSITION TO EXTEND UNDER PALLET UNITS AS SHOWN IN "SECTION D-D" AND "PLAN VIEW" AND NAIL TO CENTER GATES W/2-1/2" NAILS AT EACH JOINT.
- ⑧ STRAPPING BOARD (2 REQD.). SEE "STRAPPING BOARD" DETAIL ON PAGE 24.
- ⑨ DOORWAY PROTECTION, 1-1/4" X .035" X 28'-0" LONG STEEL STRAPPING (2 REQD.). INSTALL AS SHOWN TO ENIRCLE THOSE LOAD UNITS WHICH PROTRUDE INTO THE DOORWAY AREA. STAPLE TO STRAPPING BOARD W/2-1-1/4" STAPLES AND TO AUXILIARY STRAPPING BOARD W/3-1-1/4" STAPLES. SEE SPECIAL NOTE 4 ON PAGE 13.
- ⑩ SEAL FOR 1-1/4" STRAPPING (4 REQD., 2 PER STRAP). DOUBLE CRIMP EACH SEAL. SEE GENERAL NOTE "L" ON PAGE 2.
- ⑪ AUXILIARY STRAPPING BOARD, 2" X 4" BY CUT TO FIT FROM STRAPPING BOARD TO EDGE OF PALLETIZED CONTAINERS (2 REQD.). ALONG WITH STRAPPING BOARD, PRICE MARKED (E). THIS PIECE IS REQUIRED TO PROTECT THE CONTAINER ENDS FROM THE DOORWAY PROTECTION STRAPPING AND IS REQUIRED WHENEVER A STRAP PASSES OVER A CONTAINER NOT PROTECTED BY THE PLYWOOD COVER.

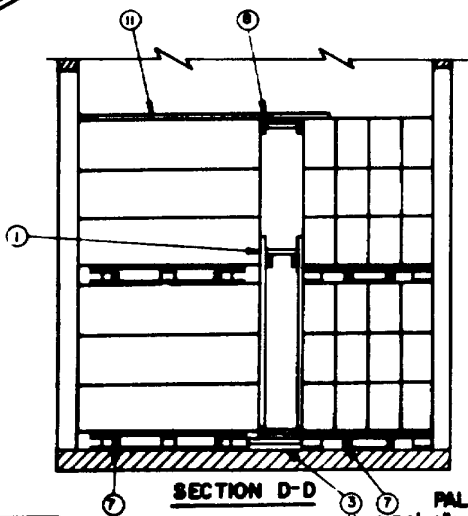
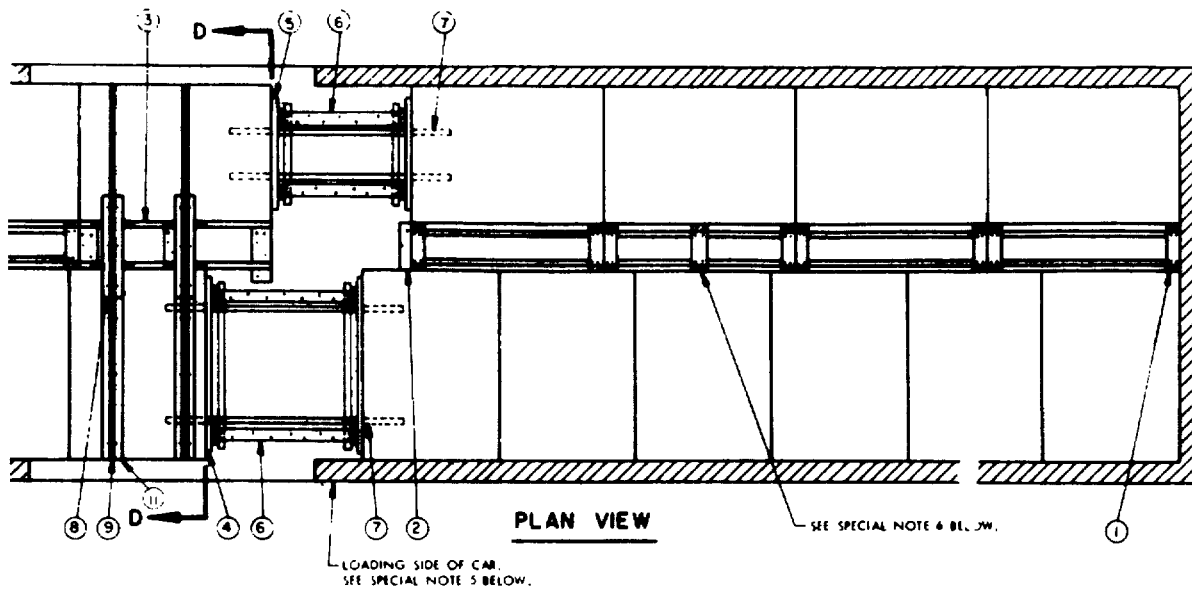

Figure 7-2--Continued (sheet 11 of 25).



SPECIAL NOTES

1. A 50'-6" LONG BY 9'-2" WIDE (INSIDE CLEARANCE) CONVENTIONAL TYPE BOX CAR EQUIPPED WITH 7'-0" WIDE DOOR OPENINGS IS SHOWN. THE LOAD AS SHOWN MAY ALSO BE SHIPPED IN CARS WHICH HAVE WIDER OR STAGGERED DOOR OPENINGS. **NOTE:** A CAR HAVING 8'-0" WIDE DOOR OPENINGS MAY BE USED, HOWEVER, IT MAY BE DIFFICULT TO INSTALL CENTER GATES AND STRUTS.
2. A WIDER OR NARROWER WIDTH CAR CAN BE USED FOR SHIPPING THE DEPICTED LOAD.
3. IF THE DELINEATED UNLOADING METHOD IS USED FOR THE SHIPMENT OF A LOAD WHICH CONTAINS LESS UNITS THAN SHOWN USE "OMITTED-UNIT GATE" AS SHOWN ON PAGE 14 AND DETAILED ON PAGE 23 AND/OR OMIT UNIT STACKS AS REQUIRED.
4. IF THE CAR BEING LOADED HAS PLUG DOORS AND LESS THAN ONE-HALF OF A UNIT EXTENDS INTO THE DOORWAY AREA, NO DOORWAY PROTECTION IS REQUIRED. IF MORE THAN ONE-HALF OF A UNIT EXTENDS INTO THE DOORWAY AREA, DOORWAY PROTECTION AS SHOWN BY PIECES MARKED (3), (8), (9), AND (11) MUST BE USED. SEE GENERAL NOTE "5" ON PAGE 2.
5. IF THE CAR BEING LOADED HAS THROUGH DOORWAYS AS SHOWN ABOVE AND THEY ARE LESS THAN 9'-0" WIDE A LOADING AND UNLOADING SIDE MUST BE DESIGNATED, AS SHOWN.
6. TO PROVIDE FOR LATERAL BLOCKING OF PALLET UNITS, EACH UNIT MUST CONTACT A VERTICAL PIECE OF THE SPACER ASSEMBLY. ADDITIONAL PIECES MUST BE INSTALLED ON THE SPACER ASSEMBLY AS DEPICTED IN THE PLAN VIEW ABOVE. ALSO, STRUTS MUST BE INSTALLED BETWEEN EACH PAIR OF VERTICAL PIECES AS SHOWN ON THE DETAILED VIEW ON PAGE 22.
7. IF DESIRED, 4" X 4" MATERIAL STRUT MAY BE SUBSTITUTED FOR EACH DOUBLED 2" X 4" STRUT THAT IS SPECIFIED.

BILL OF MATERIAL		
LUMBER	LINEAR FEET	BOARD FEET
1" X 4"	2	1
2" X 2"	56	19
2" X 3"	46	23
2" X 4"	539	260
2" X 6"	146	146
NAILS	NO. REQD	POUNDS
10d (3")	664	10-1/2
12d (3-1/4")	76	1-1/4
16d (3-1/2")	36	3/4
STEEL STRAPPING 1-1/4" X .035" -----	76' REQD -----	11 LBS
SEAL FOR 1-1/4" STRAPPING -----	4 REQD -----	NIL
STAPLE FOR 1-1/4" STRAPPING -----	10 REQD -----	NIL

LOAD AS SHOWN

ITEM	QUANTITY	WEIGHT - APPROX
PALLET UNIT -----	48 -----	32,928 LBS
DUNNAGE -----	-----	1,574 LBS
TOTAL WEIGHT ---		34,502 LBS

**PALLETIZED LOAD
IN A 50'-6" LONG BY 9'-2" WIDE CAR**

Figure 7-2-Continued (sheet 12 of 25).

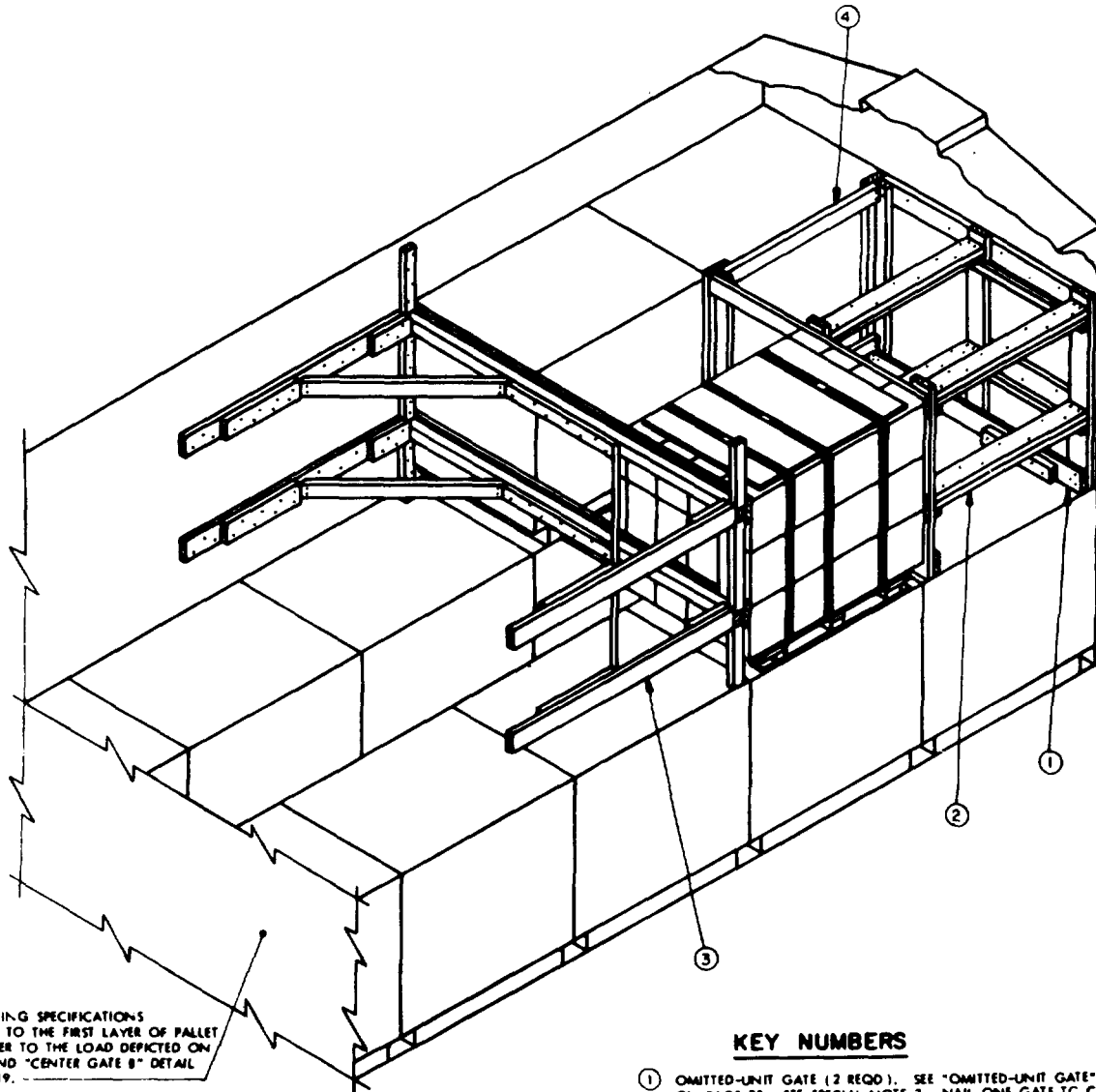

FOR BLOCKING SPECIFICATIONS APPLICABLE TO THE FIRST LAYER OF PALLET UNITS, REFER TO THE LOAD DEPICTED ON PAGE 10 AND "CENTER GATE 8" DETAIL ON PAGE 19.

ISOMETRIC VIEW

SPECIAL NOTES:

1. A 9'-2" WIDE (INSIDE CLEARANCE) CONVENTIONAL TYPE BOX CAR IS SHOWN.
2. A K-BRACE ASSEMBLY AS SHOWN IS ADEQUATE FOR RETAINING A MAXIMUM PARTIAL LAYER LOAD OF 14,000 POUNDS. CAUTION: SOME CARS ARE NOT SUITED FOR THE APPLICATION OF "PARTIAL LAYER BRACING" BECAUSE THE LENGTH OF THE PARTIAL LAYER TO BE SHIPPED AND/OR THE SIZE OR CONFIGURATION OF THE CAR DOORS WILL NOT PERMIT PROPER INSTALLATION OF THE SPECIFIED K-BRACE DUNNAGE. PIECES MARKED (A), (B), (C), (D) AND (E) MUST BE SUPPORTED AT THE SIDES OF A CAR BY A CAR SIDE WALL. IT IS ALRIGHT FOR THE END OF A DIAGONAL BRACE TO BEAR IN FRONT OF A DOOR OPENING; HOWEVER, THE ADJACENT PIECE MARKED (E) MUST BE DOUBLED AND EXTENDED ACROSS AND FAR ENOUGH PAST THE DOOR OPENING TO PROVIDE FOR THE SPECIFIED NAILING OF EACH PIECE.
3. THE USE OF THE "OMITTED-UNIT GATES" AND "STRUTS" ARE SPECIFIED FOR THE DEPICTED LOAD ONLY TO SHOW A TYPICAL APPLICATION. IF AN EVEN NUMBER OF UNITS ARE LOADED IN A CAR THE "OMITTED-UNIT GATES" AND "STRUTS" WILL NOT BE REQUIRED. WHEN ONE PALLET UNIT IS OMITTED FROM A LOAD AS SHOWN ON PAGES 10 AND 12, THE LOCATION OF THE OMITTED-UNIT DUNNAGE ABOVE SHOULD BE POSITIONED NEAR THE CENTER OF THE CAR AND DELETE THE NAILING TO THE CAR END WALL.

KEY NUMBERS

- ① OMITTED-UNIT GATE (2 REQD). SEE "OMITTED-UNIT GATE" DETAIL ON PAGE 23. SEE SPECIAL NOTE 3. NAIL ONE GATE TO CAR END WALL W/8-10# NAILS.
- ② STRUT, 2" X 4" BY CUT TO FIT (DOUBLED) (4 REQD). LAMINATE W/1-10# NAIL EVERY 6". TOENAIL TOP PIECE TO OMITTED-UNIT GATE W/2-12# NAILS AT EACH END.
- ③ K-BRACE (1 REQD). SEE "K-BRACE ASSEMBLY" DETAIL ON PAGE 15 AND SPECIAL NOTE 2.
- ④ SIDE STRUT, 2" X 4" BY CUT TO FIT (2 REQD). TOENAIL TO BUFFER PIECE OF "OMITTED-UNIT GATE" W/2-12# NAILS AT EACH END.

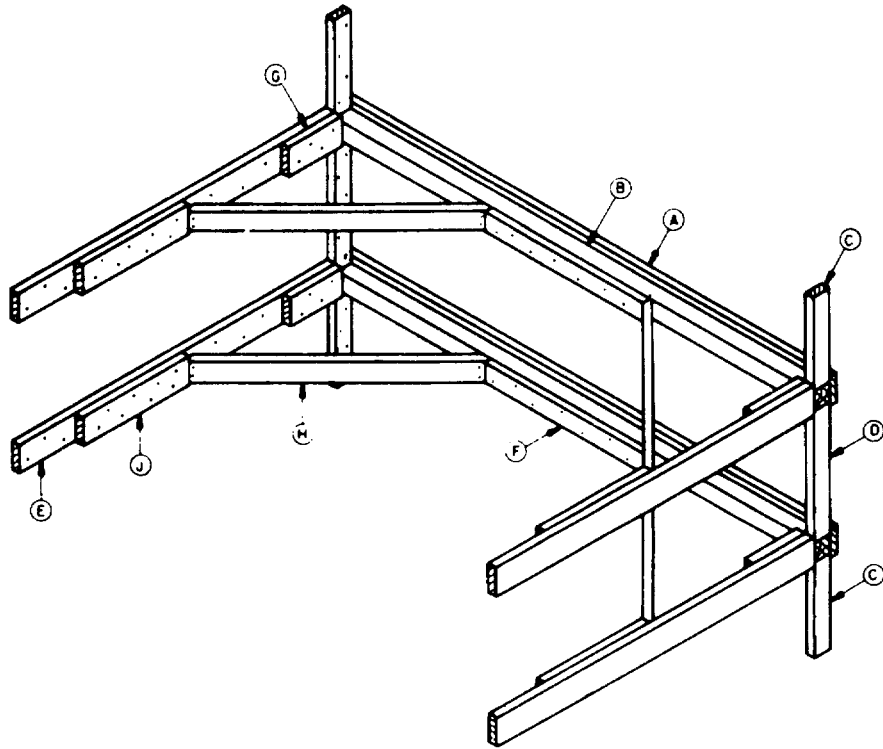

K- BRACE ASSEMBLY

SEE SPECIAL NOTE 2 OF PAGE 14

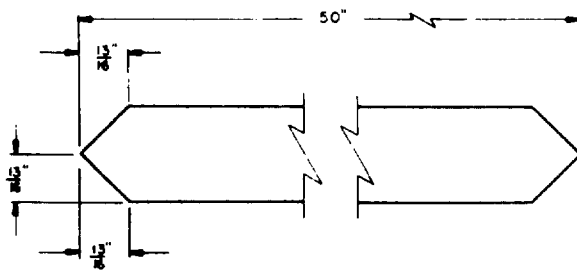

DIAGONAL BRACE

PIECE MARKED (H)

LUMBER AND NAILING CHART				
PC MK	LUMBER SIZE	NO. REQD	NAIL TO	NUMBER AND SIZE OF NAILS
A	2" X 6" BY CAR WIDTH (SEE "NOTE 2" BELOW)	2	B	1-12d EVERY 12"
B	4" X 4" BY CAR WIDTH	2	-	-----
C	2" X 4" X 18-12	4	CAR WALL	4-12d
D	2" X 4" X 26"	2	CAR WALL	6-12d
E	2" X 6" X 72"	4	CAR WALL	16-12d
F	2" X 4" X 36" FOR A 9'-2" CAR OR 2" X 4" X 28" FOR A 8'-6" CAR	2	B	7-12d
G	2" X 6" X 12"	4	E	4-16d
H	2" X 4" MATERIAL SEE DIAGONAL BRACE DETAIL	4	B & E	2-16d AT EACH END
J	2" X 6" X 24"	4	(E)	8-16d

NOTE 2: 1/2" PLYWOOD MAY BE SUBSTITUTED FOR PIECE MARKED A. THE PLYWOOD MUST BE OF A SIZE TO COVER THE AREA OF THE PALLET UNIT ADJACENT TO THE "K-BRACE". SECURE THE PLYWOOD TO PIECE MARKED B W/ 1-6d NAIL EVERY 12".

PARTIAL LAYER BRACE

Figure 7-2--Continued (.sheet 14 of 25).

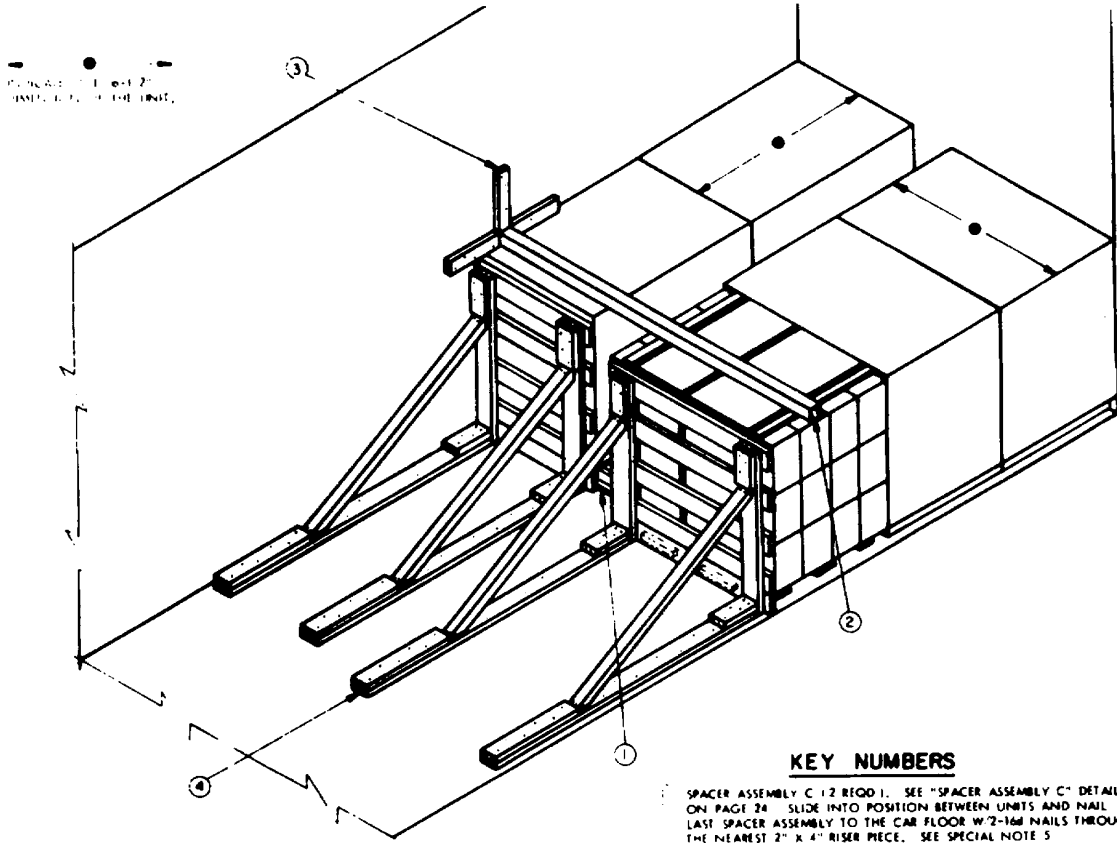

ISOMETRIC VIEW

FIVE PALLET UNITS SHOWN DEPICTING USE OF KNEE BRACE BLOCKING.

KEY NUMBERS

- 1 SPACER ASSEMBLY C (2 REQ'D). SEE "SPACER ASSEMBLY C" DETAIL ON PAGE 24. SLIDE INTO POSITION BETWEEN UNITS AND NAIL LAST SPACER ASSEMBLY TO THE CAR FLOOR W/ 2-16d NAILS THROUGH THE NEAREST 2" X 4" RISER PIECE. SEE SPECIAL NOTE 5.
- 2 HOLD DOWN, 4" X 4" BY CAR WIDTH (CUT TO FIT) (1 REQ'D). INSTALL ACROSS UNITS WHICH ARE ADJACENT TO PIECES MARKED 2. SEE SPECIAL NOTES 2 AND 3.
- 3 POCKET CLEAT, 2" X 4" X 18" (6 REQ'D). NAIL TO THE CAR SIDE WALL W/ 5-10d NAILS. SEE SPECIAL NOTES 2 AND 3.
- 4 KNEE BRACE ASSEMBLY (2 REQ'D). SEE "KNEE BRACE ASSEMBLY" DETAIL ON PAGE 17. SEE SPECIAL NOTE 4.

SPECIAL NOTES:

- 1 A 9'-2" WIDE (INSIDE CLEARANCE) CONVENTIONAL TYPE BOX CAR IS SHOWN, A NARROWER CAR MAY BE USED.
- 2 IF THE LADING EXTENDS INTO A DOORWAY AREA USE TWO (2) PIECES OF DOOR-SPANNING 2" X 4" MATERIAL ACROSS EACH DOORWAY INVOLVED FOR SECUREMENT OF THE PIECES MARKED 2 AND 3. A PIECE MARKED 2 WILL BE CUT FOR A SNUG FIT AGAINST THE DOOR-SPANNING PIECES AND THE VERTICAL POCKET CLEATS MARKED 3 WILL BE INSTALLED IN A HORIZONTAL POSITION INSTEAD OF A VERTICAL POSITION AS SHOWN.
- 3 **CAUTION:** IF A UNIT EXTENDS MORE THAN ONE HALF OF ITS WIDTH OR LENGTH PAST A DOOR POST INTO THE DOORWAY AREA IN A CONVENTIONAL OR PLUG DOOR CAR, A PIECE OF DOOR-SPANNING DUNNAGE OF 2" X 6" MATERIAL BY DOOR-OPENING WIDTH PLUS 24" IN LENGTH WILL BE POSITIONED ACROSS THE DOOR OPENING APPROXIMATELY 24" ABOVE THE CAR FLOOR AND NAILED TO THE CAR SIDE WALL W/ 5-12d NAILS AT EACH END.
- 4 SPECIFIED KNEE BRACE ASSEMBLIES ARE ADEQUATE FOR RETAINING A MAXIMUM LCL LOAD.
- 5 A SPACER ASSEMBLY IS ONLY REQUIRED WHEN THE VOID BETWEEN LATERALLY ADJACENT UNITS IS SIX INCHES (6") OR GREATER.

Figure 7-2--Continued (sheet 15 of 25)

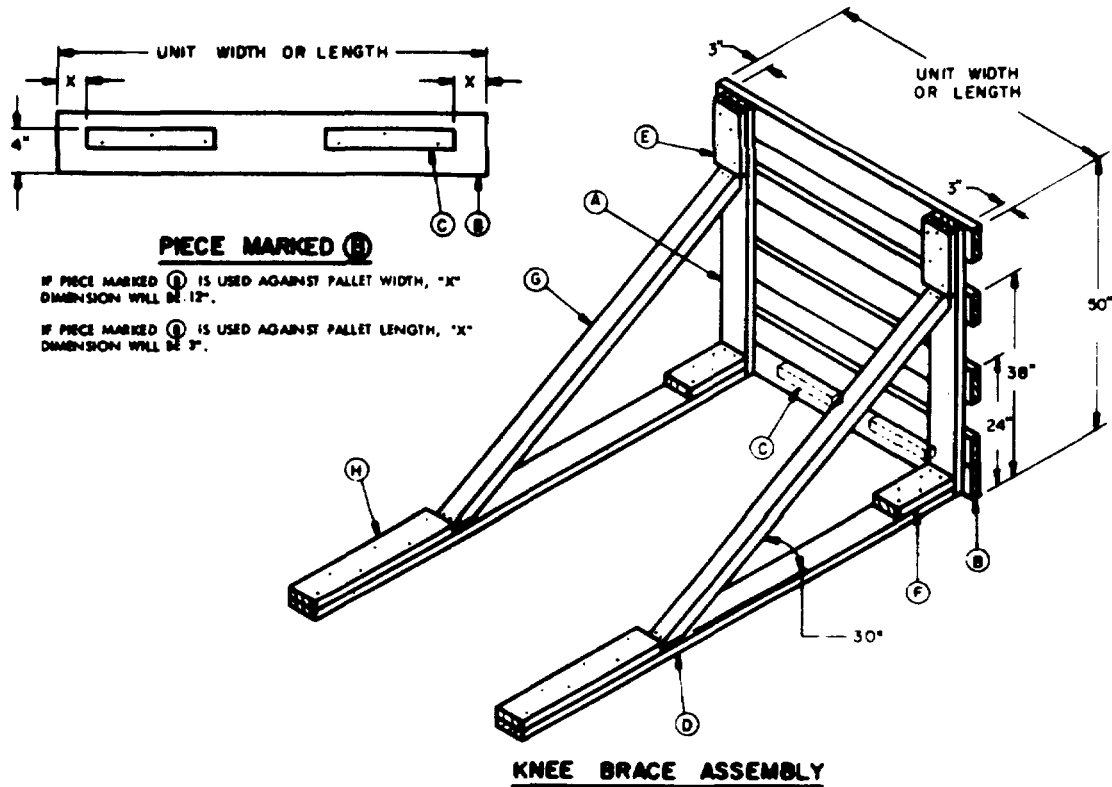

LUMBER AND NAILING DATA				
PC MK	LUMBER SIZE	NO. REQD	NAIL TO	NUMBER AND SIZE OF NAILS
(A)	2" X 6" X 36"	2	-	-----
(B)	2" X 6" MATERIAL (C)	5	(A)	3-16d AT EACH JOINT
(C)	2" X 2" X 12"	2	(B)	3-16d
(D)	2" X 6" X 7'-9" (D)	2	CAR FLOOR	1-16d EVERY 8"
(E)	2" X 3" X 12"	2	(A)	4-16d
(F)	2" X 6" X 12"	2	(A)	TOENAIL W/2-12d
(G)	4" X 4" X 72" SEE "BRACE" DETAIL	2	(A) AND (D)	2-16d AT EACH END
(H)	2" X 6" X 36"	2	(B)	6-6d

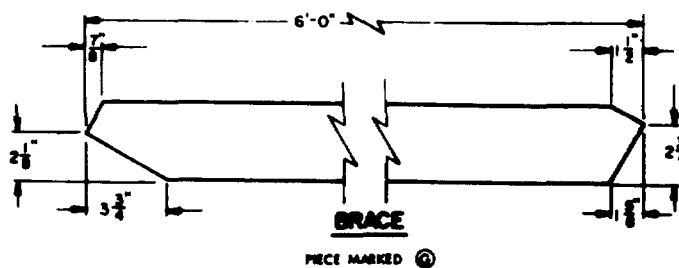

- (C) 36-1/2" FOR USE AGAINST THE WIDTH OF THE UNIT.
48" FOR USE AGAINST THE LENGTH OF THE UNIT.
- (D) SEE DETAIL OF PIECE MARKED (D) ABOVE FOR DIMENSIONAL GUIDANCE.
- (E) SEE GENERAL NOTES "O" AND "Y" ON PAGE 2.

NOTE (E): ONE PIECE OF 1/2" PLYWOOD MAY BE SUBSTITUTED FOR THE PIECES MARKED (C). ONE PIECE UNIT WIDTH BY 48" AND ONE PIECE UNIT LENGTH BY 48" WILL BE REQUIRED FOR THE VIEW DEPICTED ON PAGE 16. SECURE THE PLYWOOD TO EACH PIECE MARKED (A) W/3-6d NAILS. ALSO, NAIL TO HOLD DOWN BLOCKS, PIECE MARKED (B), W/2-6d NAILS AT EACH JOINT.

TYPICAL LCL (PALLETIZED)

Figure 7-2--Continued (sheet 16 of 25)

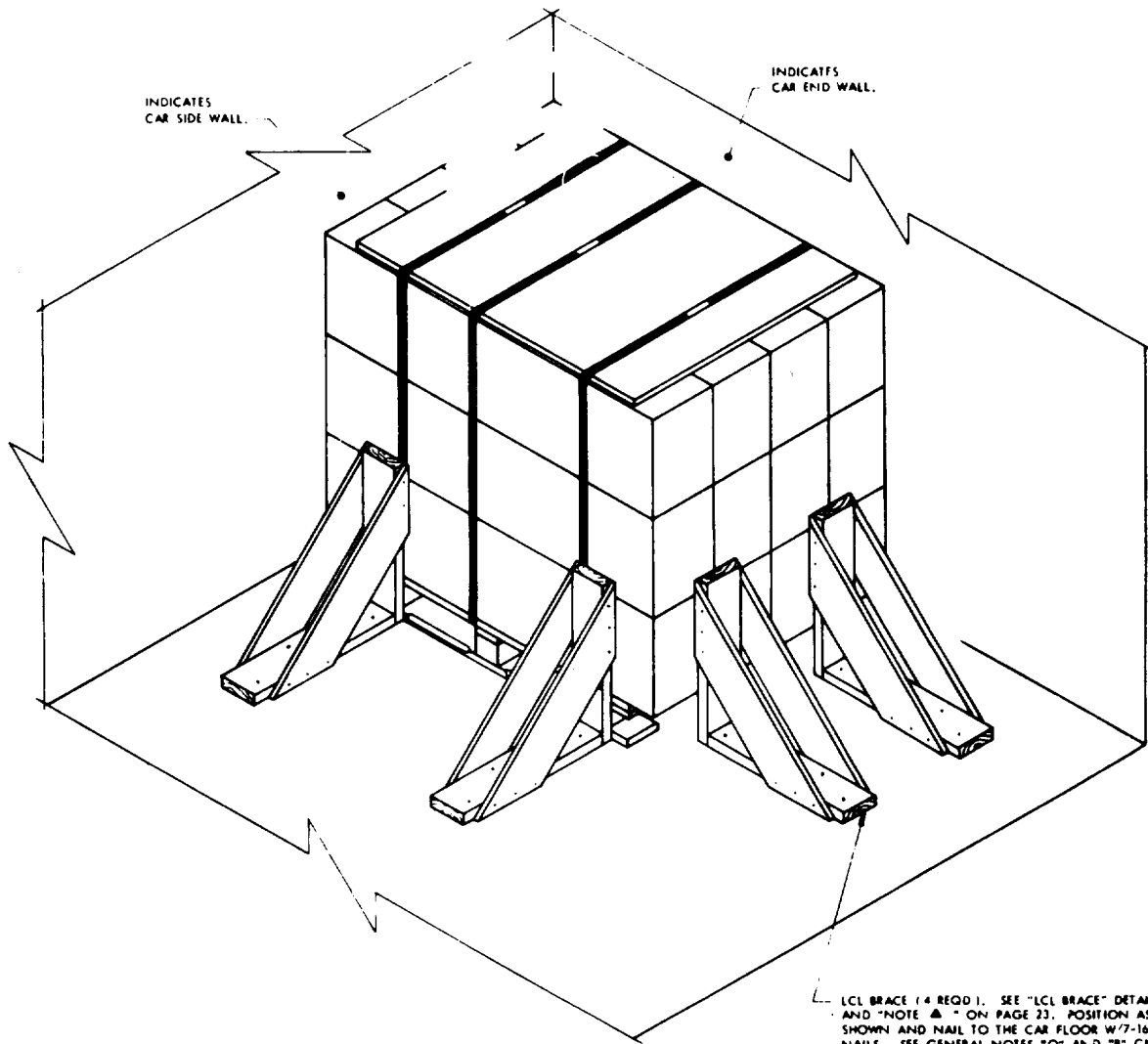

ISOMETRIC VIEW

ONE PALLET UNIT SHOWN DEPICTING USE OF LCL BRACE.

TYPICAL LCL (PALLETIZED)

Figure 7-2--Continued (sheet 17 of 25)

LOAD BEARING PIECE, 2" X 6" BY CAR WIDTH MINUS 1/2" (4 REQD.). NAIL TO THE STRUT BEARING PIECES W/3-10d NAILS AT EACH JOINT. SEE "NOTE ①" BELOW.

STRUT BEARING PIECE, 2" X 6" X 9'-6" (4 REQD.).

STRUT LEDGER, 2" X 2" BY CAR WIDTH MINUS 8" (4 REQD.). NAIL TO THE STRUT BEARING PIECES W/2-10d NAILS AT EACH JOINT.

NOTE ①:

1/2" PLYWOOD MAY BE SUBSTITUTED FOR THE 2" X 4" LOAD BEARING PIECES. THE PLYWOOD IS REQUIRED TO COVER THE ENTIRE FACE OF THE CENTER GATE, CAR WIDTH MINUS 1/2" BY 9'-2". SECURE THE PLYWOOD TO THE STRUT BEARING PIECES W/1-6d NAIL EVERY 12". ALL LATERAL JOINTS OF PLYWOOD MUST CENTER ON A CENTRALLY LOCATED STRUT BEARING PIECE.

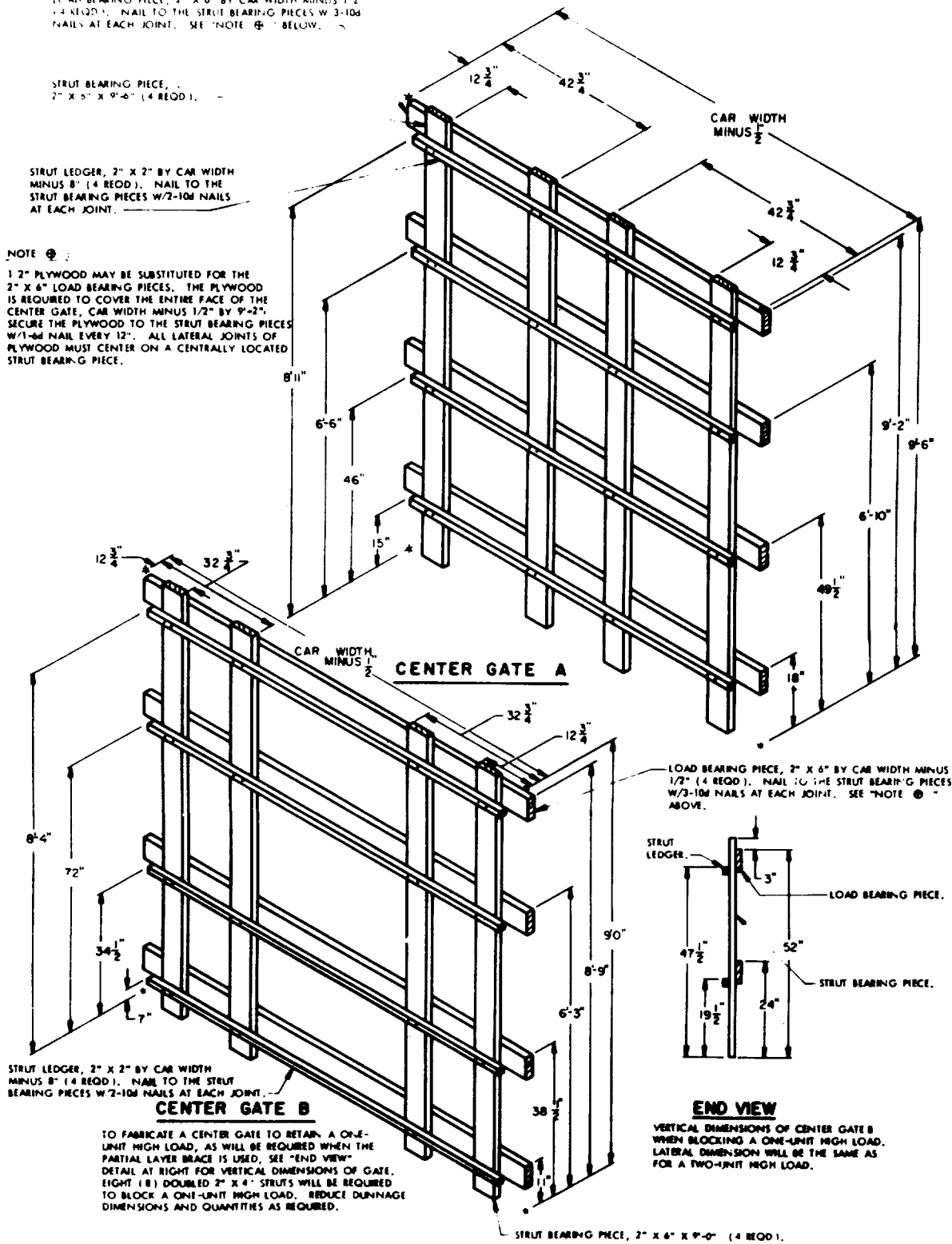

DETAILS

Figure 7-2--Continued (sheet 18 of 25)

LOAD BEARING PIECE, 2" X 6" X 52" (4 REQD).
NAIL TO THE STRUT BEARING PIECES W/3-10d
NAILS AT EACH JOINT.

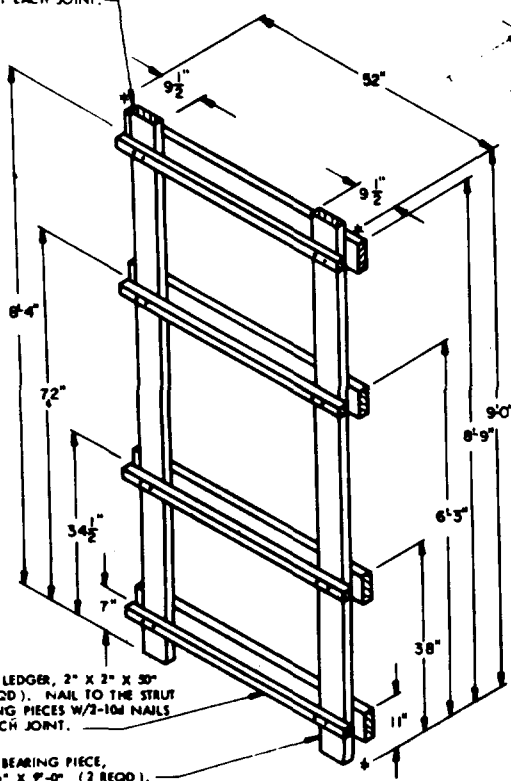

CENTER GATE C

LOAD BEARING PIECE, 2" X 6" X 33" (4 REQD).
NAIL TO THE STRUT BEARING PIECES W/3-10d
NAILS AT EACH JOINT.

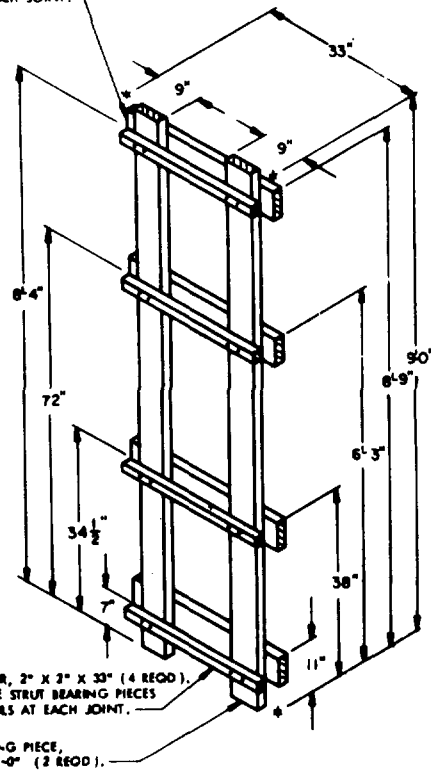

CENTER GATE D

STOP BLOCK, 2" X 6" X 12" (4 REQD).
NAIL TO THE VERTICAL PIECES W/3-10d NAILS.

BRACE BEARING PIECE,
2" X 6" X 46-1/2" (4 REQD).

LOAD BEARING PIECE, 2" X 6" BY CAR WIDTH
MINUS 1/2" (4 REQD). NAIL TO THE BRACE
BEARING PIECES W/3-10d NAILS AT EACH
JOINT. SEE "NOTE @" BELOW.

NOTE @

1/2" PLYWOOD MAY BE SUBSTITUTED FOR THE 2" X 6" LOAD BEARING PIECES. THE PLYWOOD IS REQUIRED TO COVER THE ENTIRE FACE OF THE GATE, THE WIDTH AND HEIGHT OF THE GATE. SECURE THE PLYWOOD TO THE BRACE BEARING PIECES W/1-4d NAIL EVERY 12". ALL LATERAL JOINTS MUST CENTER ON A CENTRALLY LOCATED BRACE BEARING PIECE.

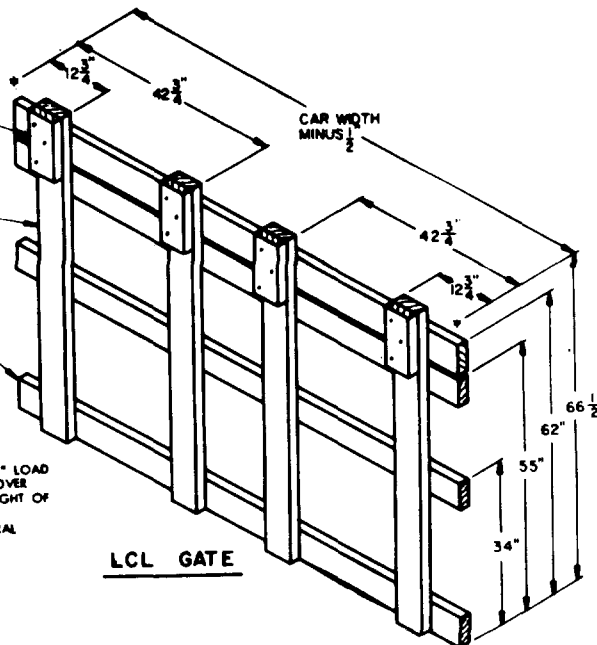

LCL GATE

DETAILS

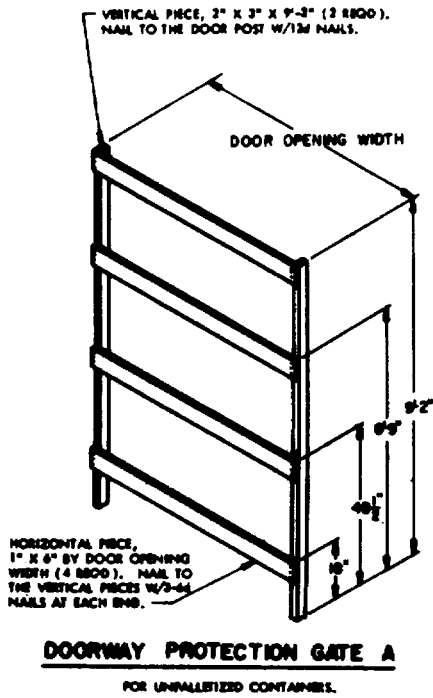

DOORWAY PROTECTION GATE A
FOR UNPALETTEZED CONTAINERS.

NOTE:
WHEN A CAR HAS DOOR POSTS WHICH DO NOT PROVIDE FOR ADEQUATE SECUREMENT OF THE GATE BY THE SPECIFIED NAILING METHOD, REFER TO DRAWING 19-48-1436-6A29 OF "BUREAU OF EXPLOSIVES PAMPHLET NO 6" FOR ALTERNATIVE GATE SECURING METHODS OR DOORWAY PROTECTION SPECIFICATIONS. DOORWAY PROTECTION DUNNAGE AS SHOWN IS NOT REQUIRED IF ALL OF THE DOORS IN A CAR ARE OF THE PLUG TYPE. REFER TO THE "SPECIAL NOTES" SECTION IMMEDIATELY ADJACENT TO THE BASIC LOADING DIAGRAM BEING FOLLOWED FOR SPECIAL DOOR PROTECTION PROVISIONS WHICH MUST BE IMPLEMENTED.

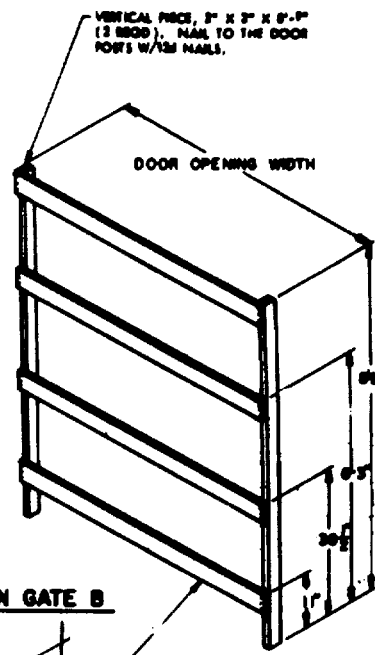

DOORWAY PROTECTION GATE B
FOR PALLET UNITS.

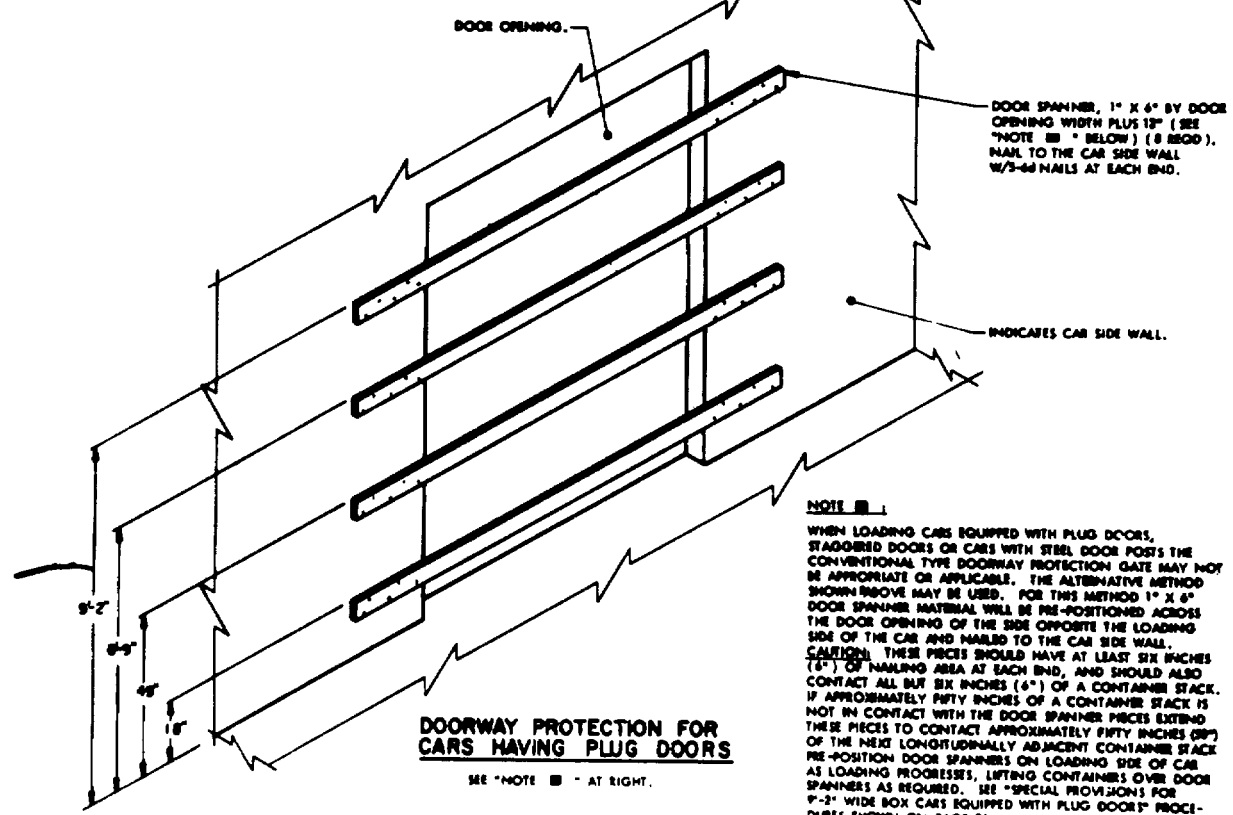

DOORWAY PROTECTION FOR CARS HAVING PLUG DOORS

SEE "NOTE B" - AT RIGHT.

DETAILS

NOTE B:
WHEN LOADING CARS EQUIPPED WITH PLUG DOORS, STAGGERED DOORS OR CARS WITH STEEL DOOR POSTS THE CONVENTIONAL TYPE DOORWAY PROTECTION GATE MAY NOT BE APPROPRIATE OR APPLICABLE. THE ALTERNATIVE METHOD SHOWN ABOVE MAY BE USED. FOR THIS METHOD 1" X 6" DOOR SPANNER MATERIAL WILL BE PRE-POSITIONED ACROSS THE DOOR OPENING OF THE SIDE OPPOSITE THE LOADING SIDE OF THE CAR AND NAILED TO THE CAR SIDE WALL. **CAUTION:** THESE PIECES SHOULD HAVE AT LEAST SIX INCHES (6") OF NAILING AREA AT EACH END, AND SHOULD ALSO CONTACT ALL BUT SIX INCHES (6") OF A CONTAINER STACK, IF APPROXIMATELY FIFTY INCHES OF A CONTAINER STACK IS NOT IN CONTACT WITH THE DOOR SPANNER EXTENDING THESE PIECES TO CONTACT APPROXIMATELY FIFTY INCHES (50") OF THE NEXT LONGITUDINALLY ADJACENT CONTAINER STACK PRE-POSITION DOOR SPANNERS ON LOADING SIDE OF CAR AS LOADING PROGRESSES, LIFTING CONTAINERS OVER DOOR SPANNERS AS REQUIRED. SEE "SPECIAL PROVISIONS FOR 9'-2" WIDE BOX CARS EQUIPPED WITH PLUG DOORS" PROCEDURES SHOWN ON PAGE 26.

Figure 7-2--Continued (sheet 20 of 25)

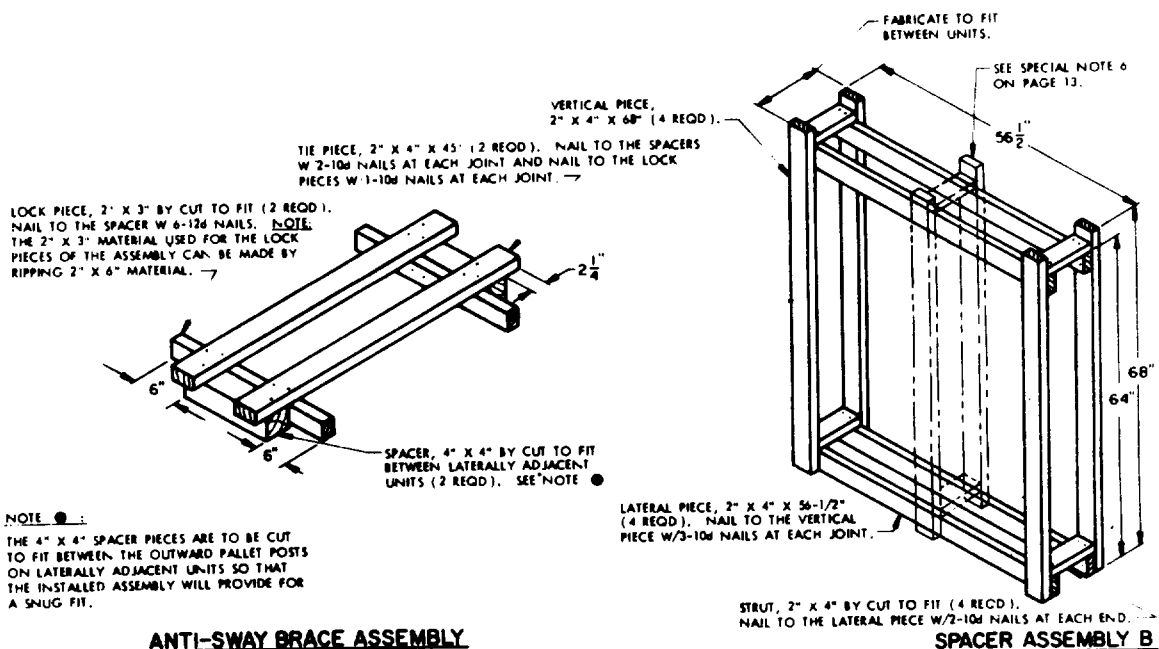
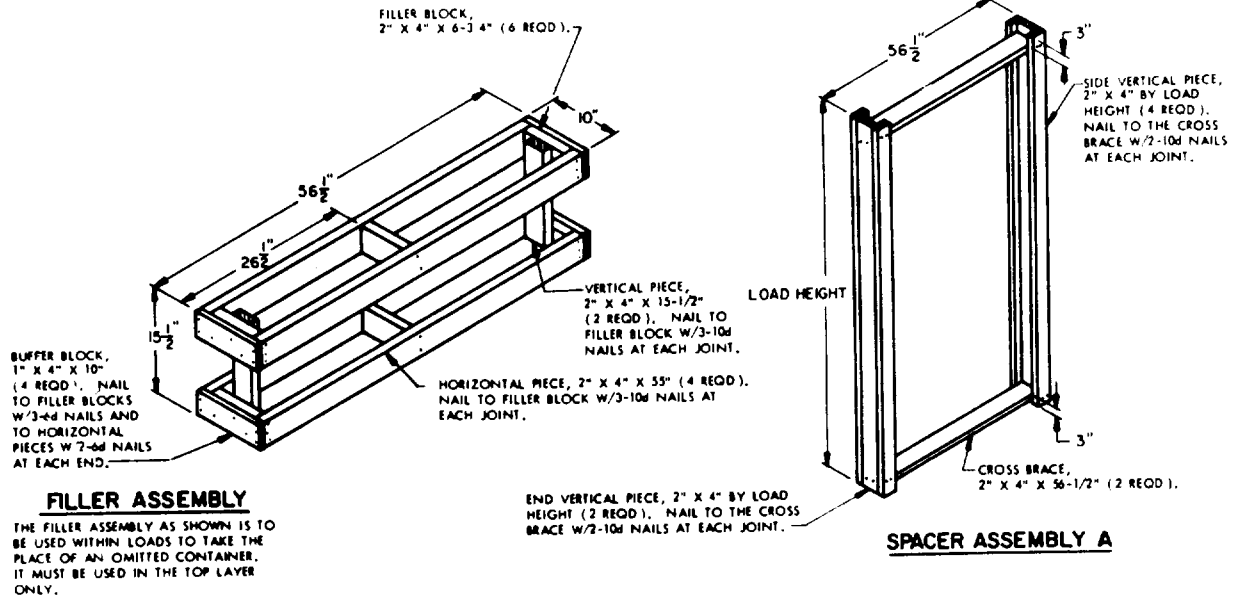
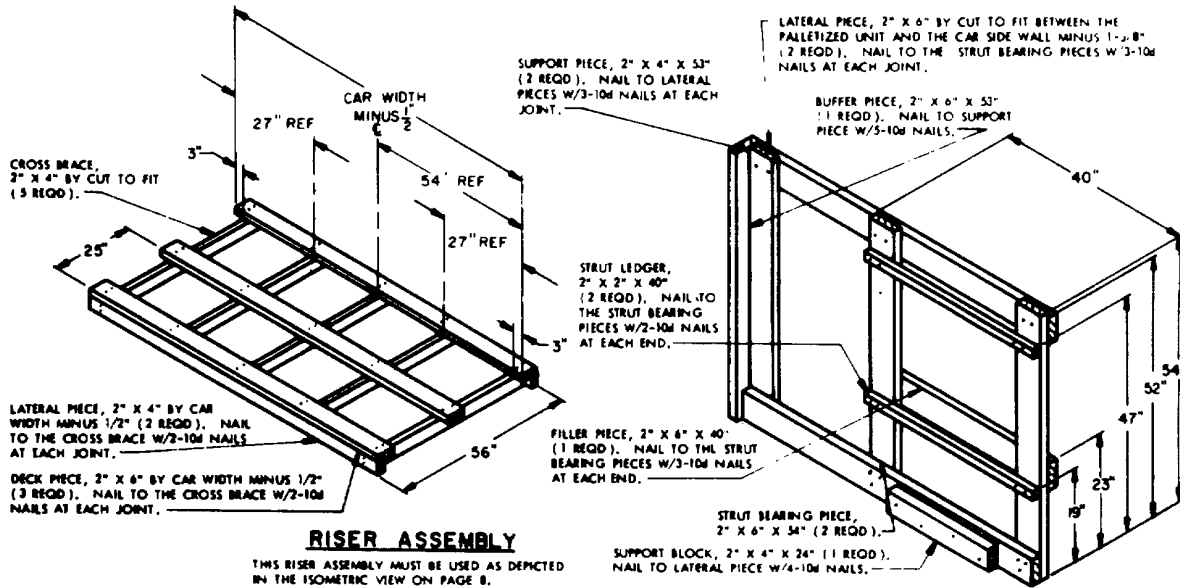
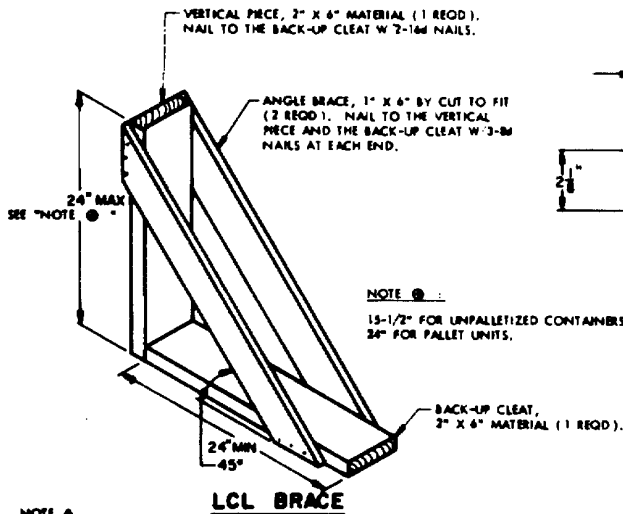

Figure 7-2--Continued (sheet 21 of 25).



ONE (1) GATE REQUIRED AS SHOWN ABOVE AND ONE (1) GATE REQUIRED WITH LATERAL PIECES, STRUT LEDGERS AND FILLER PIECE ON OPPOSITE SIDE OF THE VERTICAL PIECES.



NOTE ①:
15-1/2" FOR UNPALLETIZED CONTAINERS.
24" FOR PALLET UNITS.

NOTE ②:
EACH BRACE AS APPLIED FOR LONGITUDINAL OR LATERAL BRACING WILL SUPPORT 2,000 OR 8,000 POUNDS OF LOADING, RESPECTIVELY. ALSO RESPECTIVELY, A BRACE MUST BE USED FOR EACH 30" OR 48" INCREMENT OF LOAD DIMENSION; ADDITIONALLY, A MINIMUM OF TWO (2) BRACES MUST BE USED IN THEIR RESPECTIVE DIRECTIONS IF THE LOAD IS MORE THAN TWO (2) CONTAINERS LONG OR WIDE.

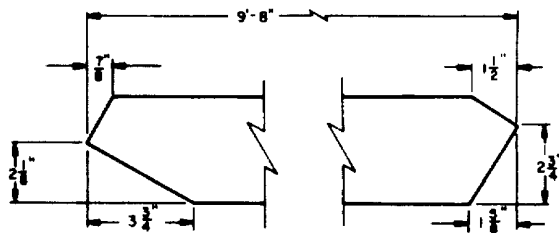

PIECE MARKED ③ ON PAGE 8.

Figure 7-2--Continued (sheet 22 of 25)

WHEN USED IN THE LOAD DEPICTED ON PAGE 10, THE "RISER PIECES" WILL BE CUT TO FIT BETWEEN LATERALLY ADJACENT PALLETS.

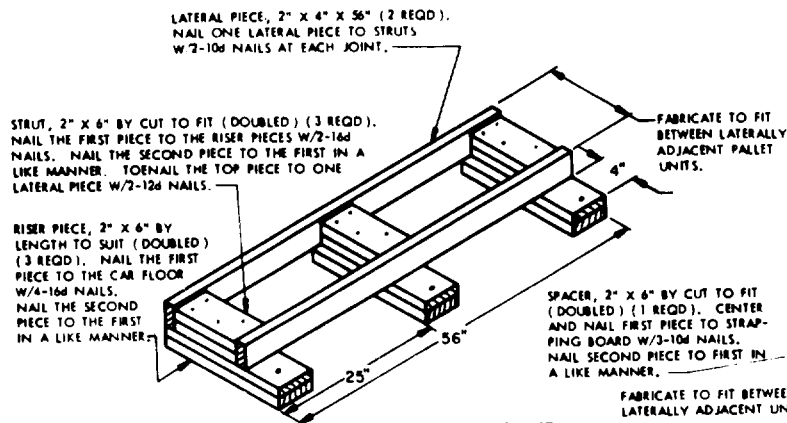

DOORWAY BLOCKING ASSEMBLY

TO BE FABRICATED IN POSITION. SEE GENERAL NOTES "O" AND "P" ON PAGE 2.

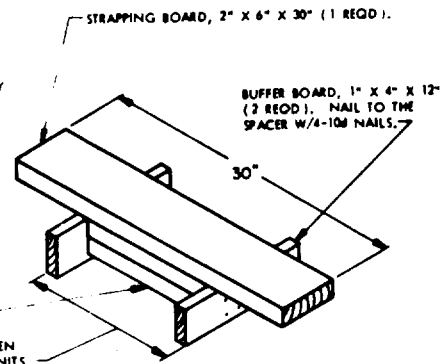

STRAPPING BOARD

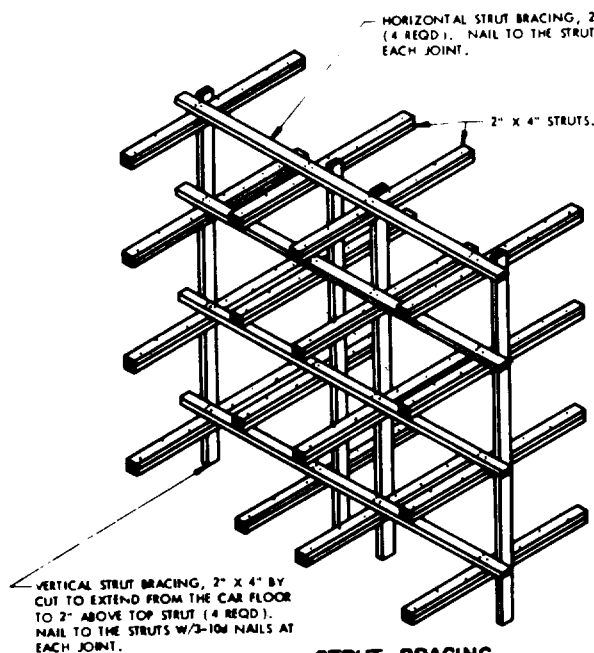

STRUT BRACING

STRUT BRACING IS REQUIRED WHEN STRUTS ARE 48" OR GREATER IN LENGTH. ONE (1) SET AS SHOWN ABOVE IS REQUIRED FOR EVERY 48" OF STRUT LENGTH.

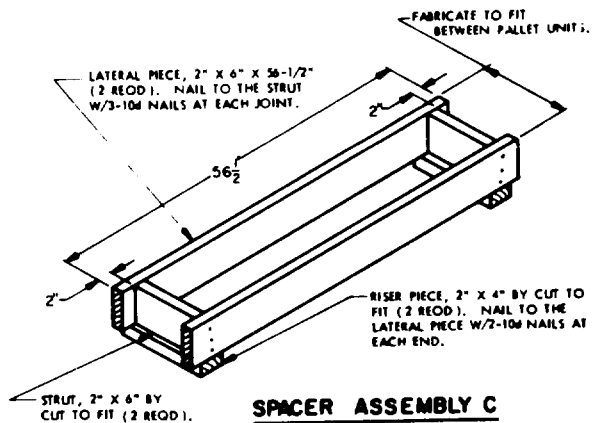

SPACER ASSEMBLY C

Figure 7-2--Continued (sheet 23 of 25).

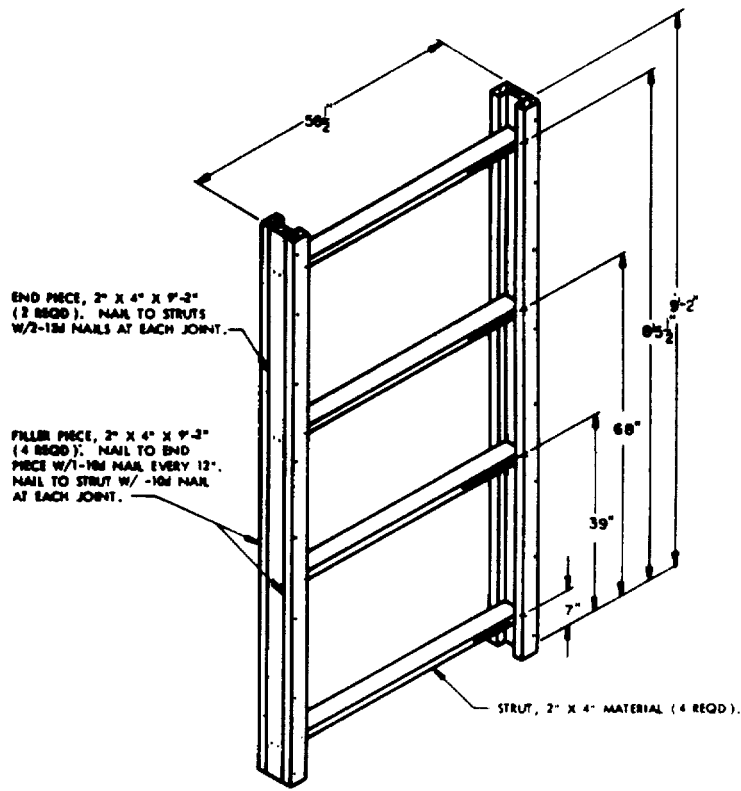

SPACER ASSEMBLY D

DETAIL

PAGE 25

Figure 7-2--Continued (sheet 24 of 25)

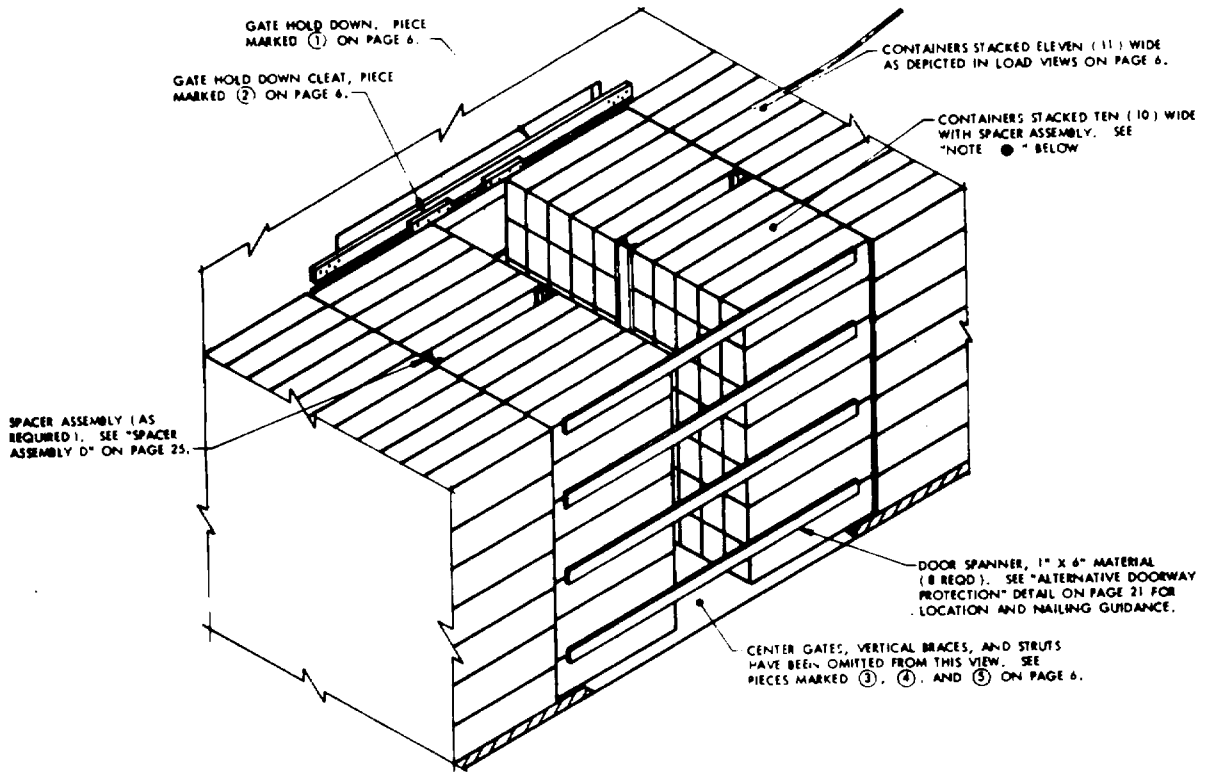

ISOMETRIC VIEW

NOTE 1

IF A 9'-2" WIDE BOX CAR IS EQUIPPED WITH PLUG DOORS THE SPECIAL PROVISIONS AS DEPICTED ABOVE WILL BE REQUIRED. ALL CONTAINER STACKS NOT ADJACENT TO A PLUG DOOR WILL BE STACKED SEVEN (7) CONTAINERS HIGH BY ELEVEN (11) CONTAINERS WIDE AS DEPICTED IN SECTION B-B ON PAGE 6. ALL CONTAINER STACKS THAT EXTEND ONE-HALF OF THE CONTAINER LENGTH OR MORE INTO THE DOORWAY AREA OF A PLUG DOOR WILL BE STACKED SEVEN (7) CONTAINERS HIGH BY TEN (10) CONTAINERS WIDE AS DEPICTED ABOVE. THE TEN (10) CONTAINER-WIDE STACK WILL REQUIRE A "SPACER ASSEMBLY" AS SHOWN. DOOR SPANNER PIECES (4 EACH SIDE OF CAR) OF 1" X 6" MATERIAL AS DEPICTED IN "ALTERNATIVE DOORWAY PROTECTION" DETAIL ON PAGE 21 WILL BE INSTALLED ON EACH SIDE OF CAR. DOOR SPANNER PIECES ON SIDE OPPOSITE LOADING SIDE OF CAR MAY BE PRE-POSITIONED. PIECES ON LOADING SIDE OF CAR WILL BE INSTALLED AS LOADING PROGRESSES. CAUTION: ADJUST THE CENTER GATE WIDTH TO CAR WIDTH MINUS TWO INCHES (2"). ALSO, CENTER GATES MUST BE IN THE CAR PRIOR TO INSTALLING DOOR SPANNER PIECES ON LOADING SIDE OF CAR. STRUTS AND VERTICAL BRACES WILL BE INSTALLED AS NOTED IN KEY NUMBERS ON PAGE 6. DELETE DOORWAY PROTECTION, PIECE MARKED (4), ON PAGE 6. SEE "NOTE 2" AND "CAUTION" ON PAGE 21 AND GENERAL NOTE "5" ON PAGE 2.

**SPECIAL PROVISIONS FOR
9'-2" WIDE BOX CARS EQUIPPED WITH PLUG DOORS**

Figure 7-2--Continued (sheet 25 of 25).

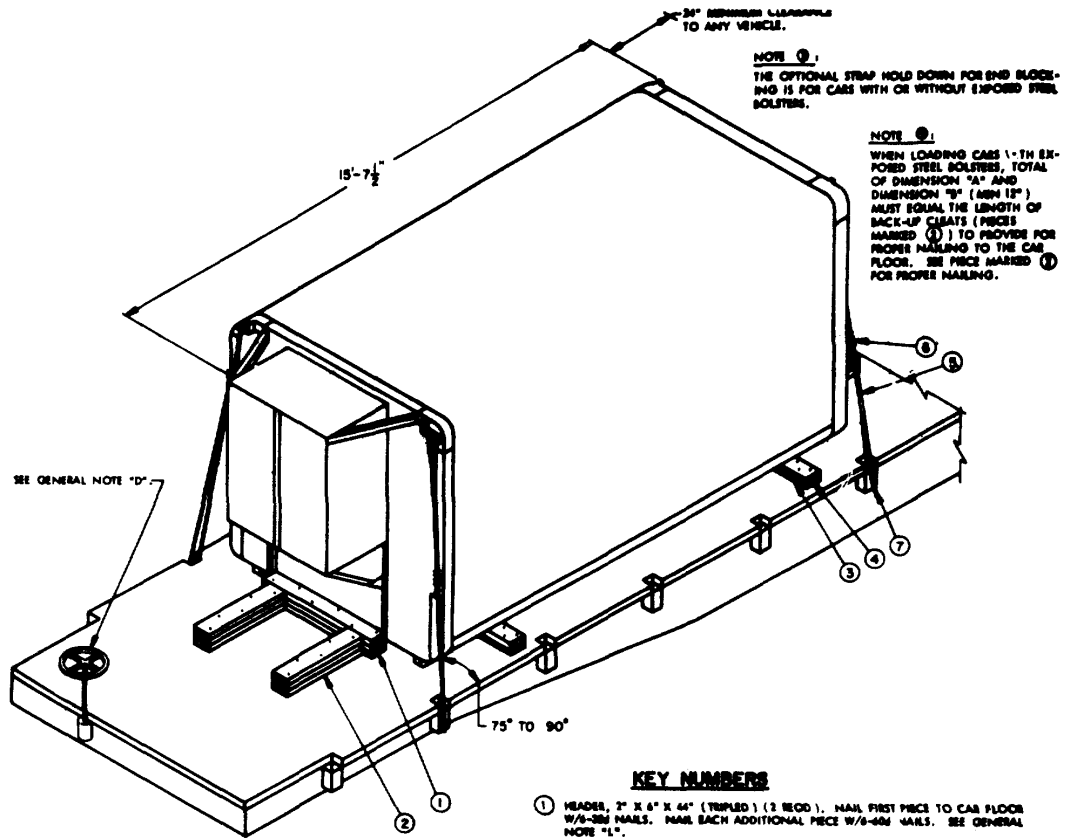

SEE GENERAL NOTE "D"

ISOMETRIC VIEW

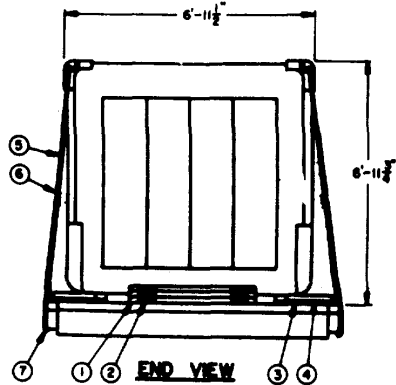

END VIEW

PAGE 2

KEY NUMBERS

- ① HEADER, 2" X 6" X 44" (TRIPLED) (2 REQ.). NAIL FIRST PIECE TO CAR FLOOR W/5-32# NAILS. NAIL EACH ADDITIONAL PIECE W/6-48# NAILS. SEE GENERAL NOTE "L".
- ② BACK-UP CLEAT, 2" X 6" X 20" (TRIPLED) (4 REQ.). POSITION 3" FROM END OF PIECE MARKED ① AND NAIL FIRST PIECE TO CAR FLOOR W/5-32# NAILS. NAIL EACH ADDITIONAL PIECE W/5-48# NAILS.
- ③ SIDE BLOCKING, 1" X 6" X 18" (4 REQ.). POSITION AGAINST SKID AS SHOWN.
- ④ SIDE BLOCKING, 2" X 6" X 18" (4 REQ.). POSITION ON TOP OF PIECE MARKED ③ AND AGAINST SKID AS SHOWN. NAIL THRU PIECE MARKED ③ TO CAR FLOOR W/5-32# NAILS.
- ⑤ STEEL WIRE ROPE, 1/2" DIAMETER, 11.5 TONS (4 REQ.). INSTALL CABLE TO APPROXIMATE THE ANGLE SHOWN AND TO FORM A COMPLETE LOOP FROM STAKE POCKET ON CAR THRU LADING TIE DOWN DEVICE AND BACK TO STAKE POCKET. SEE GENERAL NOTES "C", "E", AND "F".
- ⑥ CLIP, SIZE 1/2" (20 REQ.). FOUR (4) PER CABLE AND ONE (1) PER THIMBLE. SEE GENERAL NOTE "C".
- ⑦ THIMBLE, STANDARD, SIZE 1/2" (4 REQ.). ONE (1) PER STAKE POCKET. SECURE TO WIRE ROPE MARKED ⑤ W/1 CLIP PER THIMBLE. SEE GENERAL NOTE "C".

Figure 7-3. Loading and bracing on flatcar of maintenance equipment shelter, GMS S-408(XO-1) TSM (sheet 1 of 3).

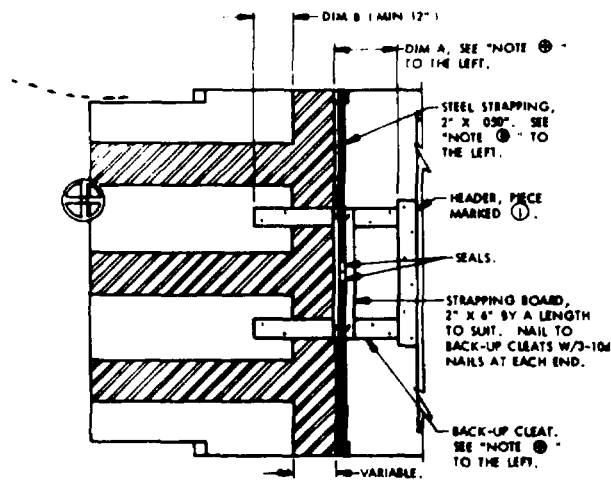

END BLOCKING FOR CARS WITH EXPOSED STEEL BOLSTERS

SEE GENERAL NOTE "G". THE BLOCKING AS SHOWN IS APPLICABLE FOR THE UNCRATED CONFIGURATION. ADJUST AS NECESSARY FOR THE CRATED LOAD ON PAGE 4.

(GENERAL NOTES CONTINUED)

- K. DUNNAGE LUMBER SPECIFIED THROUGHOUT THIS PROCEDURAL DRAWING IS OF NOMINAL SIZE. FOR EXAMPLE, 1" X 6" MATERIAL IS ACTUALLY 3/4" THICK BY 5-5/8" WIDE AND 2" X 6" MATERIAL IS ACTUALLY 1-5/8" THICK BY 5-5/8" WIDE.
- L. A STAGGERED NAILING PATTERN WILL BE USED WHEN DUNNAGE IS NAILED TO THE FLOOR OF THE TRANSPORTING VEHICLE, OR WHEN LAMINATING DUNNAGE. ADDITIONALLY, THE NAILING PATTERN FOR AN UPPER PIECE OF LAMINATED DUNNAGE WILL BE ADJUSTED AS REQUIRED SO THAT A NAIL FOR THAT PIECE WILL NOT BE DRIVEN THROUGH ONTO OR RIGHT BESIDE A NAIL IN A LOWER PIECE.

- GENERAL NOTES**
- A. THE LOAD AS SHOWN ON PAGE 2 IS BASED ON A FLAT CAR 8'-6" WIDE (PLATFORM) AND THE LOAD AS SHOWN ON PAGE 4 IS BASED ON A FLAT CAR 9'-2" WIDE (PLATFORM). WIDER CARS CAN BE USED. ONLY ONE UNIT OF LADING IS SHOWN, HOWEVER, MULTIPLES OF UNITS, AS SHOWN OR DISSIMILAR IN NATURE, MAY BE LOADED ON A CAR. THE NUMBER OF UNITS TO BE LOADED ON A CAR WILL BE DEPENDENT ON THE SIZE OF THE CAR USED OR THE QUANTITIES OF UNITS TO BE SHIPPED WITH THE VIEW OF FULL UTILIZATION OF CARRIER EQUIPMENT.
 - B. LADING DATA (UNCRATED):
ITEM DIMENSIONS ----- 15'-7-1/2" LONG X 6'-11-1/2" WIDE X 8'-11-3/4" HIGH
ITEM GROSS WEIGHT ---- 4,200 POUNDS (APPROX).
 - LADING DATA (CRATED):
ITEM DIMENSIONS ----- 16'-10" LONG X 8'-1" WIDE X 8'-1" HIGH
ITEM GROSS WEIGHT ---- 8,600 POUNDS (APPROX).
 - C. REFER TO OMD DWG 18-48-C-ORD-JU-588, "WIRE ROPE AND ANNEALED WIRE APPLICATION METHODS FOR SECURING LADING ON RAIL & MOTOR CARRIER EQUIP", FOR PROPER TIE DOWN APPLICATION, EXCEPT NUTS ON 1/2" CABLE CLIPS WILL BE TIGHTENED TO A TORQUE OF 85 TO 95 FOOT POUNDS.
 - D. REFER TO ASSOCIATION OF AMERICAN RAILROADS MANUAL, "GENERAL RULES GOVERNING THE LOADING OF COMMODITIES ON OPEN TOP CARS", FOR APPLICABLE LOADING RULES: PREFACE, 1-A, 2, 3, 4, 5, 9, 14, AND 15.
 - E. TO ACHIEVE PROPER CABLE TENSION, EMPLOY TWO (2) CABLE "GRIPPERS" AND AN APPLICABLY SIZED "COME-A-LONG" TYPE MECHANICAL HOIST.
 - F. **CAUTION:** IT IS RECOMMENDED THAT CABLE BE INSTALLED TO APPROXIMATE ANGLE SHOWN; HOWEVER, IF PLACEMENT OF CAR STAKE POCKETS PREVENTS THIS, CABLE MUST BE EXERCISED TO ENSURE THAT CABLES ON THE SAME SIDE OF LADING ARE INSTALLED SO THEIR RETENTION FORCES ACT IN OPPOSITE LONGITUDINAL DIRECTIONS --- CONTACT OF CABLE WITH EDGE OF LADING IS PROHIBITED.
 - G. ONLY CARS WITH "SOUND" FLOORS WILL BE USED. CARS WITH STEEL FLOOR ENDS AND/OR EXPOSED STEEL BOLSTERS WHICH INTERFERE WITH PROPER POSITIONING OR NAILING OF THE DUNNAGE WILL NOT BE USED. SEE "END BLOCKING FOR CARS WITH EXPOSED STEEL BOLSTERS" DETAIL ON THIS PAGE.
 - H. WHEN ANY STRAP IS SEALED AT AN END-OVER-END LAP JOINT, OR AS SHOWN IN DETAILS "A" AND "B" BELOW, A MINIMUM OF TWO (2) SEALS (BUTTED TOGETHER) WITH TWO (2) PAIRS OF CRIMPS PER SEAL MUST BE USED.
 - J. **CAUTION:** STAKE POCKETS WILL BE USED FOR ALL THE DOWN STRAPPING WHENEVER POSSIBLE. DO NOT USE SWIVEL RING TYPE ANCHOR DEVICES. IF OTHER TYPES ARE USED, THEY MUST BE OF SUFFICIENT WIDTH TO RECEIVE 2" STRAP.

(GENERAL NOTES CONTINUED AT LEFT)

BILL OF MATERIAL		
LUMBER	LINEAR FEET	BOARD FEET
1" X 6"	6	3
2" X 6"	58	58
NAILS		
30d (4-1/2")	44	2-1/4
60d (6")	64	6-1/2
ROPE, STEEL WIRE, 1/2" DIA	100 FT REQD	44 LBS
CLIP, 1/2"	20 REQD	9 LBS
THIMBLE, STANDARD, 1/2"	4 REQD	1 LB

MATERIAL SPECIFICATIONS

- LUMBER** ----- DOUGLAS FIR OR COMPARABLE LUMBER WITH STRAIGHT GRAIN AND FREE OF MATERIAL DEFECTS. REF: PED SPEC MM-L-731
- NAILS** ----- COMMON, CEMENT COATED OR CHEMICALLY ETCHED. REF: PED SPEC FF-N-105. ALT: ANNULAR-RING TYPE NAIL OF SAME SIZE.
- ROPE** ----- STEEL WIRE, PLAIN, PREFORMED, REGULAR LAY, 11.5 TONS, 6 X 19, FLEXIBLE TWIC, MACHWYTE WIRE ROPE CO (OR EQUAL). REF: PED SPEC BR-W-410.
- CLIPS** ----- "U" BOLT, CROSBY, HEAVY DUTY (OR EQUAL).
- STRAPPING, STEEL** ----- TYPE I OR IV, CLASS A OR C. REF: PED SPEC QO-S-781. (FOR FSN SEE 58-28-100).
- STRAP SEAL, STRAP STAPLE, STAKE POCKET PROTECTOR** ----- COMMERCIAL GRADE.

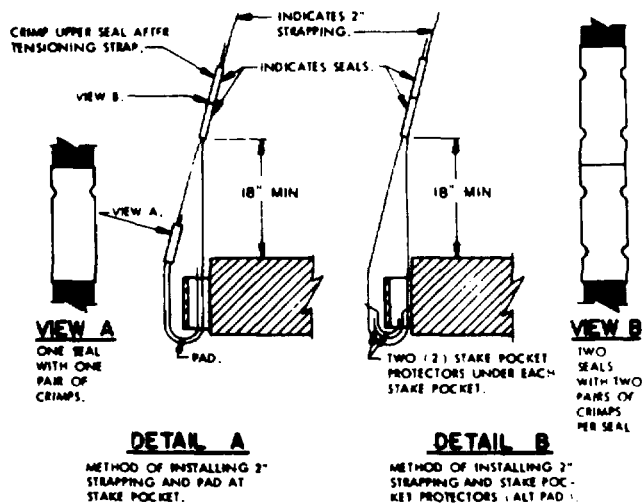

DETAIL A

METHOD OF INSTALLING 2" STRAPPING AND PAD AT STAKE POCKET.

DETAIL B

METHOD OF INSTALLING 2" STRAPPING AND STAKE POCKET PROTECTORS (ALT PAD).

LOAD AS SHOWN

ITEM	QUANTITY	WEIGHT (APPROX)
MAINT. EQUIPMENT	1	4,200 LBS
SHELTER (UNCRATED)		
DUNNAGE		215 LBS
TOTAL WEIGHT		4,415 LBS

Figure 7-3--Continued (sheet 2 of 3).

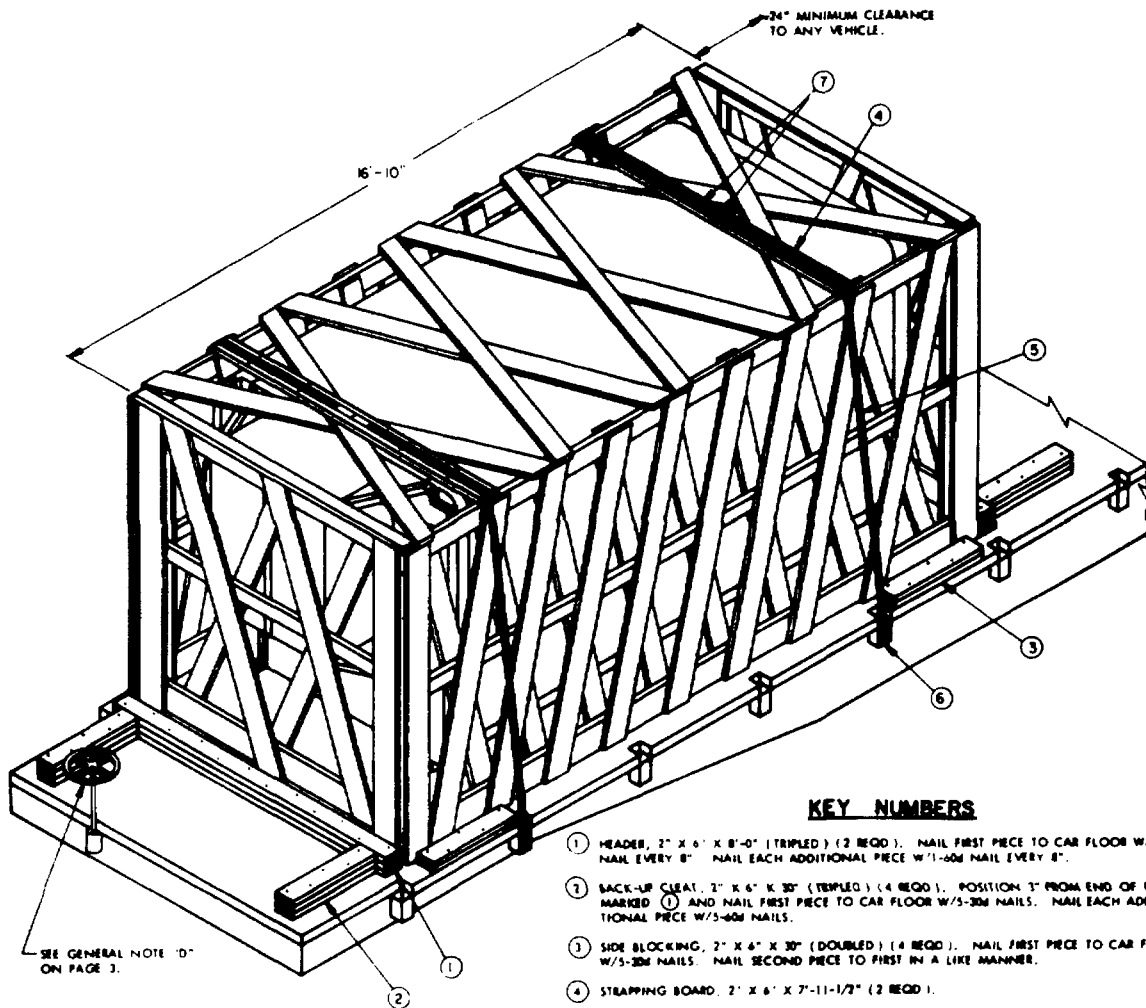

ISOMETRIC VIEW

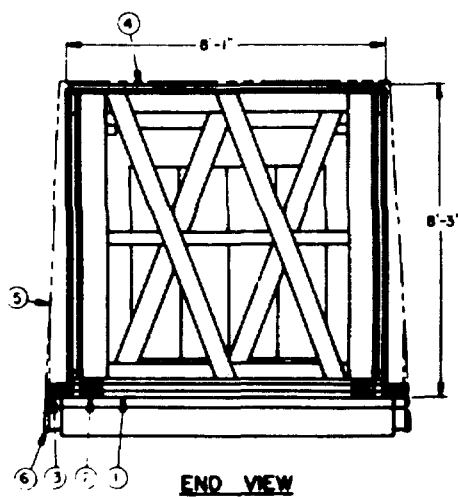

END VIEW

KEY NUMBERS

- ① HEADER, 2" X 6" X 8'-0" (TRIPLED) (2 REQ.). NAIL FIRST PIECE TO CAR FLOOR W/1-30# NAIL EVERY 8" NAIL EACH ADDITIONAL PIECE W/1-60# NAIL EVERY 8".
- ② BACK-UP CLEAT, 2" X 6" X 30" (TRIPLED) (4 REQ.). POSITION 3" FROM END OF PIECE MARKED ① AND NAIL FIRST PIECE TO CAR FLOOR W/3-30# NAILS. NAIL EACH ADDITIONAL PIECE W/3-60# NAILS.
- ③ SIDE BLOCKING, 2" X 4" X 30" (DOUBLED) (4 REQ.). NAIL FIRST PIECE TO CAR FLOOR W/3-30# NAILS. NAIL SECOND PIECE TO FIRST IN A LIKE MANNER.
- ④ STRAPPING BOARD, 2" X 6" X 7'-11-1/2" (2 REQ.).
- ⑤ STEEL STRAPPING, 2" X .050" X 37'-0" (2 REQ.) STAPLE TO PIECE MARKED ④ W/4 STAPLES.
- ⑥ PAD, 2" X .050" STRAP 24" LONG (4 REQ.). POSITION UNDER AND SEAL TO PIECE MARKED ⑤. SEE "DETAIL A" ON PAGE 3. ALL STAKE POCKET PROTECTOR (8 REQ.) TWO (2) USED UNDER EACH STAKE POCKET WITH PIECE MARKED ⑤. SEE "DETAIL B" ON PAGE 3.
- ⑦ SEAL FOR 2" STRAPPING (16 REQ.). SEE GENERAL NOTE "H" ON PAGE 3.

BILL OF MATERIAL

LUMBER	LINEAR FEET	BOARD FEET
2" X 6"	114	114
NAILS	NO. REQD	POUNDS
30# (4-1/2")	84	4-1/4
60# (6")	88	9
STEEL STRAPPING, 2" X .050"	82 FT REQD	36 LBS
SEAL FOR 2" STRAPPING	16 REQD	4 LBS
STAPLE FOR 2" STRAPPING	8 REQD	NIL

LOAD AS SHOWN

ITEM	QUANTITY	WEIGHT (APPROX)
MARINE EQUIPMENT	1	6,600 LBS
SHELTER (CRATED)		
DUNNAGE		331 LBS
TOTAL WEIGHT		6,931 LBS

Figure 7-3-Continued (sheet 3 of 3).

Section III. TRANSPORT ON FOREIGN RAILWAYS

7-6. General

The transportability guidance contained in this section is applicable when the Redeye maintenance equipment shelter, GMS S-408(XO-1) TSM, is transported on foreign railways. Consideration is given to single and multiple shelter movements on the types of rail cars normally used for the movement of these shelters. The shelters, when loaded on a suitable railcar, can be transported without restrictions within European countries complying with the International Loading Gauge (formerly Berne International); the majority of the countries in the Middle East and South America; and Australia, India, and Pakistan. In the Middle East and South America, the clearances vary by country, and each country will require a separate check. In Australia, India, and Pakistan, wide- or broad-gauge railways provide adequate clearances. Because of the various designation systems used by different countries, foreign railcars are not easily classified. In addition, clearances vary, in many cases, from one country to the next and within one country; consequently, evaluation of transportability capability must be made on an individual basis. The M571 and

M585 shipping and storage containers can be loaded into foreign railroad boxcars. The methods for securing both shelters and containers are similar to those used for securing the items on American railroad cars.

7-7. Transport on US Army Foreign Service

a. General. The Redeye maintenance equipment shelter, GMS S-408 (XO-1) TSM can be transported on a number of US Army-owned foreign service flatcars. These flatcars are exclusively for the transport of US military materiel. Table 7-1 represents a few of the flatcars available in Europe that are suitable for transportation of these shelters.

b. Materials. The materials required for blocking and tiedown of the shelters on US Army foreign service flatcars are essentially the same as those used for transporting the items within CONUS. For general guidance, refer to figure 7-3, sheets 1 through 3. For more detail and illustrations of these cars, refer to TM 55-208.

Table 7-1. Characteristics of US Army-Owned European Flatcars Available for Transportation of the GMS S-408(XO-1) TSM Shelter

Flatcar designation	Capacity	Length	Width	Platform height*
FF	50-ton (45.36 MT)	40-ft. 9-in. (12.42 m)	8-ft. 7 1/8-in. (2.62 m)	4-ft. 1 1/8-in. (1.25 m)
SSY	55-ton (49.90 MT)	31-ft. 2-in. (9.50 m)	10-ft. 4-in. (3.15 m)	4-ft. 2 3/4-in. (1.29 m)
SSYS	66-ton (59.88 MT)	31-ft. 2-in. (9.50 m)	10-ft. 4-in. (3.15 m)	4-ft. 2 3/4-in. (1.29 m)
SSYM	88-ton (79.83 MT)	39-ft. 1/2-in. (11.90 m)	10-ft. 4-in. (3.15 m)	4-ft. 3 1/2-in. (1.31 m)
FFLM	90-ton (81.65 MT)	46-ft. 8-in. (14.42 m)	10-ft. 3-in. (3.12 m)	4-ft. 2 3/4-in. (1.29 m)

*Above top of rail.

7-8. Unloading

The unloading is the reverse of loading.

APPENDIX REFERENCES

1. Field Manuals (FM)

FM 5-36 Route Reconnaissance and Classification
FM 55-15 Transportation Reference Data

2. Supply Bulletins (SB)

SB 700-20 Army Adopted and Other Items of Materiel Selected for Authorization

3. Technical Bulletins (TB)

TB 55-46-1 Standard Characteristics (Dimensions, Weight, and Cube) for Transport-
ability of Military Vehicles and Other Outsize/Overweight Equipment

4. Army Regulations (AR)

AR 746-1 Color, Marking, and Preparation of Equipment for Shipment
AR 55-355 Military Traffic Management Regulation (Joint)

5. Technical Manuals (TM)

TM 5-330 Planning and Design of Roads (Vehicle Cone Index)
TM 5-725 Rigging
TM 9-1400-425-12 Operator and Organizational Maintenance Manual. Intercept-Aerial Guided
Missile System M41 and Training Intercept-Aerial Guided Missile Sys-
tem M46A1 and M46A2 (Redeye Air Defense Guided Missile System)
TM 55-208 Railway Equipment and Characteristics Data
TM 65-500 Marine Equipment Characteristics and Data
TM 55-513 Military Stevedoring

6. Other Publications and Source of Procurement

Association of American Railroads Rules Governing the Loading of Commodities on Open Top Cars

Section No. 1-General Rules

Section No. 6-Rules Governing the Loading of Department of Defense Material

Mr. R. C. Reber, Secretary

Mechanical Division

Association of American Railroads

1920 L Street, N.W.

Washington, D.C. 20036

Rail Carrier's Tariff No. 25 or reissues thereof-Hazardous Materials Regulations of the Department
of Transportation Including Specifications for Shipping Containers.

R. M. Graziano, Agent

American Railroad Building

1920 L Street N.W.

Washington, D.C. 20036

Commodities in Closed Cars. Association of American Railroads Circular No. 42-D or reissues
thereof-General Rules Covering Loading of Carload Shipments of Commodities in Closed Cars.

Mr. B. Williams

Freight Loading and Container Section

The Association of American Railroads

59 East Van Buren Street

Chicago, Illinois 60605

Water Carrier Tariff No. 24 of reissues thereof-Regulations Governing the Transportation or Storage of Explosives or Other Dangerous Articles or Substances, and Combustible Liquids on Board Vessels.

R. M. Graziano, Agent
American Railroad Building
1920 L Street N.W.
Washington, D.C. 20036

46 Code of Federal Regulations (CFR) 146 Motor Carriers' Explosives and Dangerous Articles Tariff No. 14 or reissues thereof-Department of Transportation Regulations Governing Transportation of Explosives and Other Dangerous Articles by Motor, Rail and Water Including Specifications for Shipping Containers.

Richard H. Hinchcliff, Issuing Officer
1616 P Street, N.W.
Washington, D.C. 20036

Bureau of Explosives Pamphlet No. 6C Trailer on Flatcars

Bureau of Explosives
Association of American Railroads
American Railroads Building
1920 L Street N.W.
Washington, D.C. 20036

By Order of the Secretary of the Army:

Official:

VERNE L. BOWERS
Major General, United States Army
The Adjutant General

CREIGHTON W. ABRAMS
General, United States Army
Chief of Staff

Distribution:

To be distributed in accordance with DA Form 12-32, (qty rqr block No. 617) Organizational maintenance requirements for Redeye Missile System.

*U.S. GOVERNMENT PRINTING OFFICE: 1990 - 262-912/30362

RECOMMENDED CHANGES TO EQUIPMENT TECHNICAL PUBLICATIONS



THEN...JOT DOWN THE DOPE ABOUT IT ON THIS FORM. CAREFULLY TEAR IT OUT, FOLD IT AND DROP IT IN THE MAIL.

SOMETHING WRONG WITH PUBLICATION

FROM: (PRINT YOUR UNIT'S COMPLETE ADDRESS)

DATE SENT

PUBLICATION NUMBER

PUBLICATION DATE

PUBLICATION TITLE

BE EXACT PIN-POINT WHERE IT IS

PAGE NO.	PARA-GRAPH	FIGURE NO.	TABLE NO.

IN THIS SPACE, TELL WHAT IS WRONG AND WHAT SHOULD BE DONE ABOUT IT.

PRINTED NAME, GRADE OR TITLE AND TELEPHONE NUMBER

SIGN HERE

PIN: 013795-000