

Generated on 2017-02-21 15:26 GMT / http://hdl.handle.net/2027/uc1.b3243911
Public Domain, Google-digitized / http://www.hathitrust.org/access_use#pd-google

62
W13
.2
TM
1942

TM 9-1545

WAR DEPARTMENT

U.S. Dept. of Army

TECHNICAL MANUAL

ORDNANCE MAINTENANCE

TELESCOPE MOUNT M25

(FOR 4.5-INCH GUN CARRIAGE M1 AND
155-MM HOWITZER CARRIAGE M1)

July 6, 1942



U 113
12

TM 9-1545
1-2

TM 9:1545
1942

TECHNICAL MANUAL }
No. 9-1545



WAR DEPARTMENT,
WASHINGTON, July 6, 1942.

ORDNANCE MAINTENANCE

TELESCOPE MOUNT M25

(FOR 4.5-INCH GUN CARRIAGE M1 AND 155-MM HOWITZER
CARRIAGE M1)

	Paragraphs
SECTION I. General	1-2
II. Description	3-6
III. Care and preservation	7-10
IV. Basic inspection	11-14
V. Detailed inspection and correction	15-22
VI. Disassembly and assembly	23-24
VII. Cleaning and painting	25-27
APPENDIX. References	Page 30

SECTION I

GENERAL

	Paragraph
Scope	1
Characteristics	2

1. **Scope.**—*a.* This manual is published for the information and guidance of ordnance maintenance personnel. It contains detailed instructions for inspection, disassembly, assembly, maintenance, and repair of the telescope mount M25. These instructions are supplementary to those in the Field and Technical Manuals prepared for the using arm. Additional descriptive matter and illustrations are included to aid in providing a complete working knowledge of the matériel. Since the panoramic telescopes M5A5 and M12 and the instrument light M5 are used with this mount, enough information is included to identify them.

b. Information on packing, storage, and shipment, also on preparation of matériel for use in cold climates, at extreme temperatures, or under unusual conditions is not available at this time, but will be included in a revision of this manual.

2. **Characteristics.**—*a.* The telescope mount M25 (fig. 1) is of the azimuth compensating type. It corrects the error in azimuth resulting from elevation of the gun with trunnions out of level. The various motions of this telescope mount with respect to the gun carriage and functional parts of the telescope mount are shown in figures 2, 6, 7,

467072°—42—1

M558454

Generated on 2017-02-21 15:26 GMT / http://hdl.handle.net/2027/uc1.b3243911
Public Domain, Google-digitized / http://www.hathitrust.org/access_use#pd-google

and 8. The M5A5 or M12 panoramic telescope fits into the socket secured to the upper part of the mount.

b. The telescope mount M25 and panoramic telescope M12 constitute the standard on-carriage sighting equipment for the 4.5-inch gun carriage M1 and the 155-mm howitzer carriage M1. The panoramic telescope M5A5 is the substitute standard item for the telescope requirement of this matériel. This sighting equipment is used for laying the gun or howitzer in azimuth and elevation.

SECTION II

DESCRIPTION

	Paragraph
Mount, telescope, M25-----	3
Telescope, panoramic, M5A5-----	4
Telescope, panoramic, M12-----	5
Light, instrument, M5-----	6

3. Mount, telescope, M25.—The telescope mount M25 (fig. 1) consists essentially of the cross-leveling mechanism, the elevating mechanism, the actuating arm with bracket, and the telescope socket.

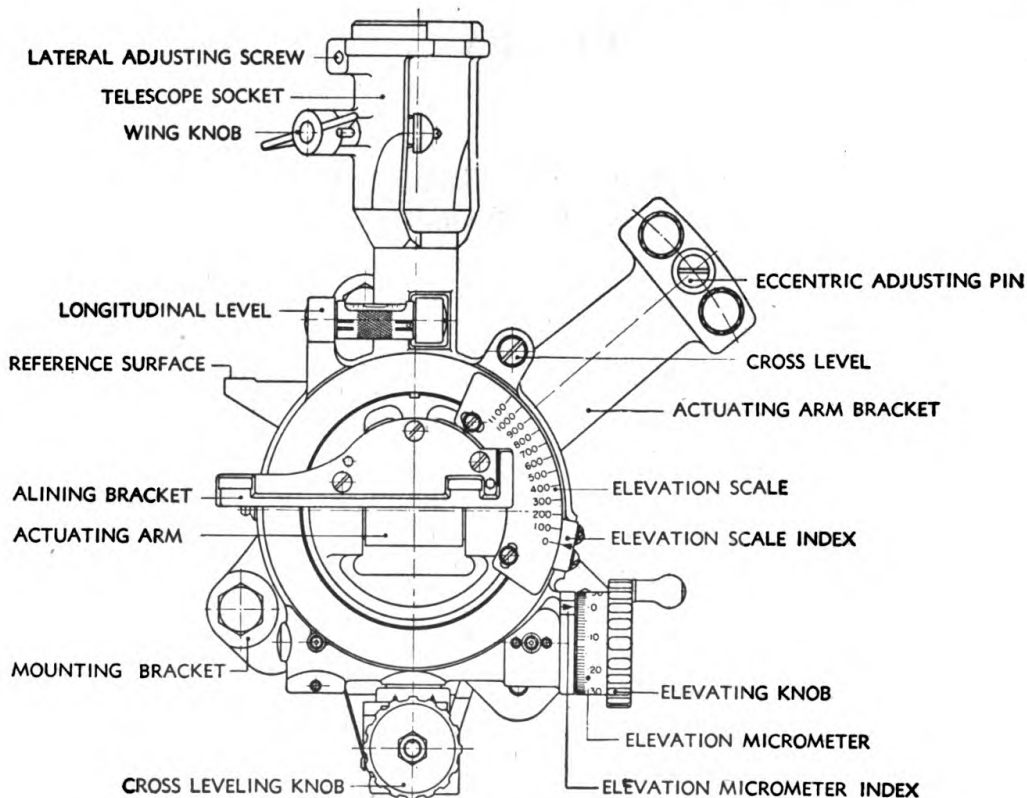

RA PD 8414

FIGURE 1.—Telescope mount M25.

a. The cross-leveling mechanism is contained in the cross level worm housing. When the cross-leveling knob is rotated, the mount tilts about the pivot in the mount-actuating arm assembly (fig. 2). The cross-leveled position is indicated on the cross level vial. Stops limit the tilt of the telescope mount.

b. The elevating mechanism (fig. 1) is housed in the telescope mount body and is actuated by the elevating worm. (This is often referred to as the longitudinal-leveling mechanism.) The worm meshes with the teeth on the gear assembly (fig. 2). When the elevating worm knob is rotated, the body assembly and rocker rotate about the actuating arm. The telescope socket is secured to the telescope body assembly and tilts either forward or backward as the elevating knob assembly is rotated. A longitudinal level indicates the horizontal datum plane. An elevation scale with index is on the left side of the instrument. The elevation scale is graduated in 100-mil divisions from 0 to 1,100 mils, the zero graduation indicating "normal." A micrometer is on the elevation worm shaft. Provision is made for adjusting the elevation scale and the elevation micrometer. An alining bracket (fig. 1) is screwed to the elevating gear to place the pivot on the end of the actuating arm parallel to the axis of the gun.

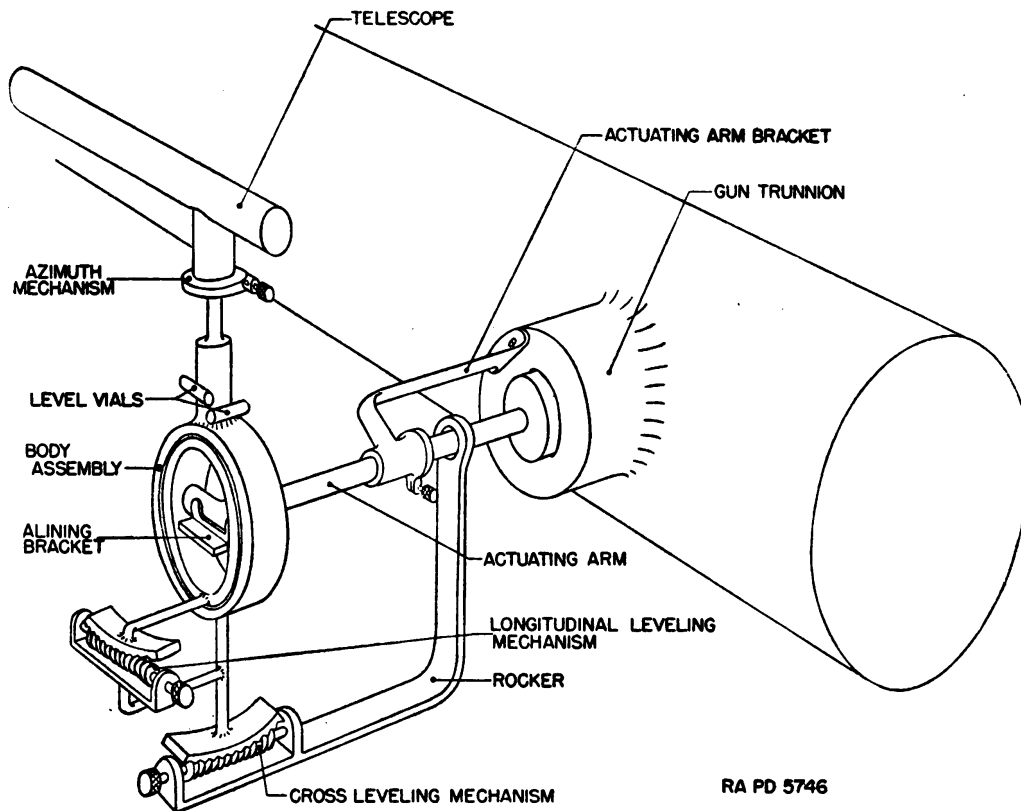

FIGURE 2.—Telescope mount M25—schematic diagram.

c. The actuating arm bracket (fig. 1) supports the pivot for the cross-leveling mechanism. This bracket, accurately located on the actuating arm by a dowel pin and clamping screw has two elongated holes and an adjusting pin to be used for alining the telescope mount with the bore of the gun. The telescope mount bracket supports the actuating arm and rocker. It is bolted to the gun carriage.

d. The telescope socket is pinned to the upper part of the telescope mount body assembly (fig. 1). This socket has accurately machined surfaces for locating the panoramic telescope. The telescope retaining shaft with torsion spring, located on the upper part of the socket, holds the telescope in position. Two tangent adjusting screws with locking screw make possible a small lateral adjustment for the telescope. In the lower part of the socket is a cylindrical hole for the collar of the panoramic telescope. Figures 3, 4, and 5 are assembled and sectioned views of the telescope mount.

e. When the gun is elevated with trunnions out of level, compensation for deviation in azimuth of the axis of the gun occurs as follows:

(1) When the gun is elevated with its trunnions canted as shown in figure 6②, there is an accompanying deflection of the line of fire or deviation in azimuth.

(2) The pivot in the left end of the actuating arm of the mount is fixed with its axis parallel to the bore of the gun (fig. 7). By cross-leveling the mount about the pivot (fig. 8①), a vertical plane of the mount through the axis of pivot will be parallel to the bore of the gun. As the axis of the telescope in its *zero position* is parallel to the axis of the bore, true azimuths of the gun may be read on the telescope. The only requirements are that the cross level and longitudinal level bubbles be centered.

4. Telescope, panoramic, M5A5, (fig. 9).—*a. General.*—This telescope is a 4-power telescope of the fixed-focus type. It is divided into three groups to facilitate description; the rotating head and related mechanism; dove prism and related mechanism; and the elbow, including the parts which it supports.

b. Rotating head and related mechanism.—The elevation worm, housed in the rotating head, engages the teeth cut on the prism holder, which contains the field prism. Rotation of the worm by means of the elevation worm knob causes the field prism to rotate in the vertical plane through the line of sighting. A window in front of the prism excludes dust and moisture from the optical system and internal mechanism. An open sight is attached to the rotating head cover in such a position that when the mount is leveled the line of sighting through it will be horizontal. The rotating head is fastened to the azimuth

TELESCOPE MOUNT M25

TM 9-1545
4

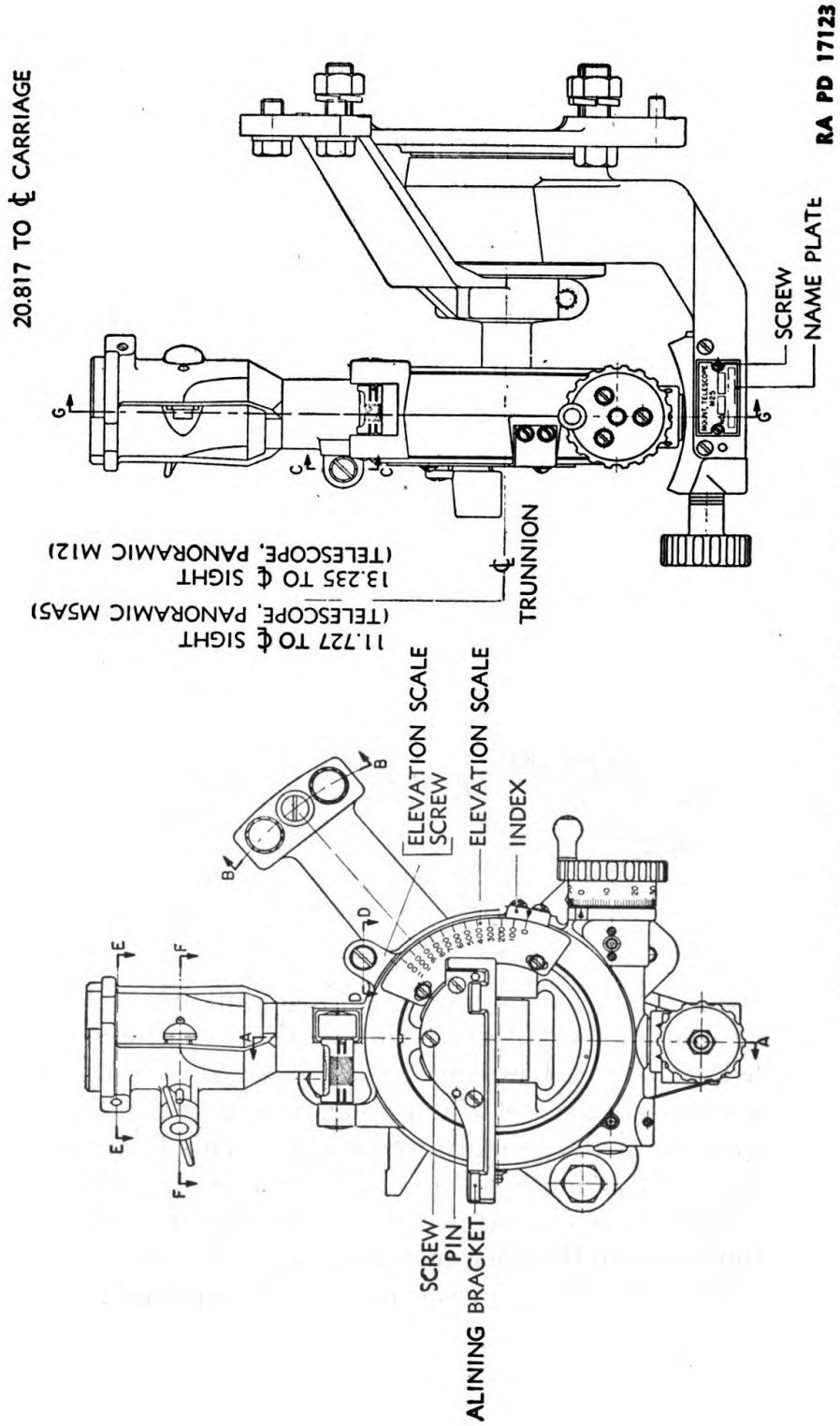

FIGURE 3.—Telescope mount M25—assembled views.

worm gear which engages the azimuth worm in the azimuth worm housing. The azimuth scale is a circular scale divided into two consecutive semicircles, each graduated in intervals of 100 mils. The graduations on each semicircle read from 0 to 3,200 mils. The scale is engraved on the azimuth worm gear in such a position that when the 0 is opposite its index, the rotating head is turned 45° counterclockwise in reference to the axis of the eyepiece. Lateral motion of the rotating head is accomplished by means of the azimuth worm knob which is pinned to the azimuth worm. An azimuth micrometer index is mounted on the opposite end of the azimuth worm shaft. The azimuth setting is indicated by the micrometer engraved on the azimuth micrometer knob. The azimuth micrometer index is graduated in 100 spaces, each

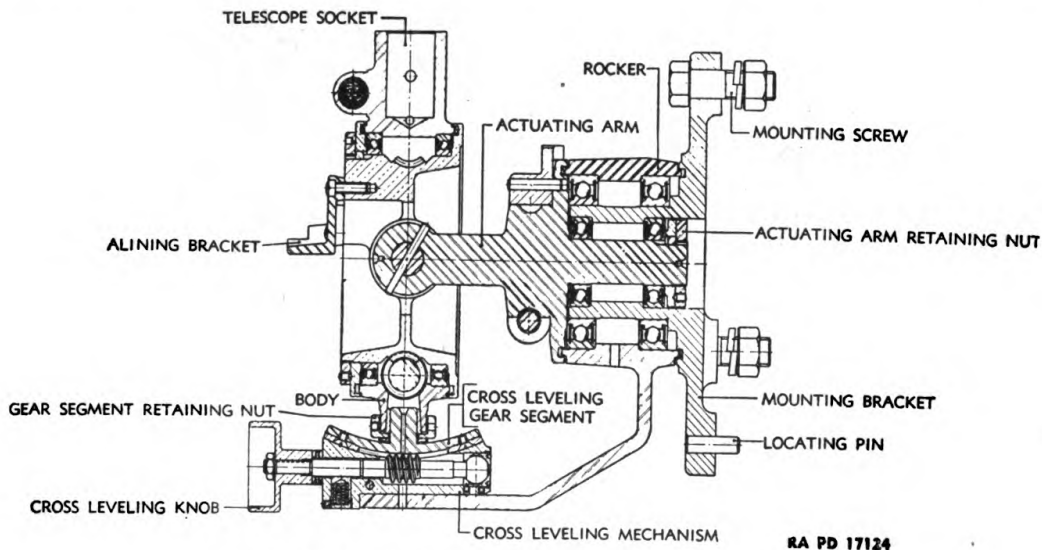

FIGURE 4.—Telescope mount M25—section A-A.

one representing 1 mil, and is numbered at 10-mil intervals in both clockwise and counterclockwise directions. The two groups of numbers are filled in with contrasting colors to avoid confusion. The worm release lever actuates a cam and plunger arrangement, disengaging the azimuth worm and azimuth worm gear. This feature permits rapid adjustment of azimuth settings. The worm and gear will re-engage only at points of 100-mil increase or decrease in azimuth, leaving the relation between the micrometer and azimuth scale unchanged.

c. Dove prism.—The dove prism (fig. 9) is supported within a sleeve by its holder, and is geared to the field prism so that the former is rotated about the vertical axis through one-half the angle of rotation of the latter. This gearing consists of a spur gear cut on the inner

TELESCOPE MOUNT M25

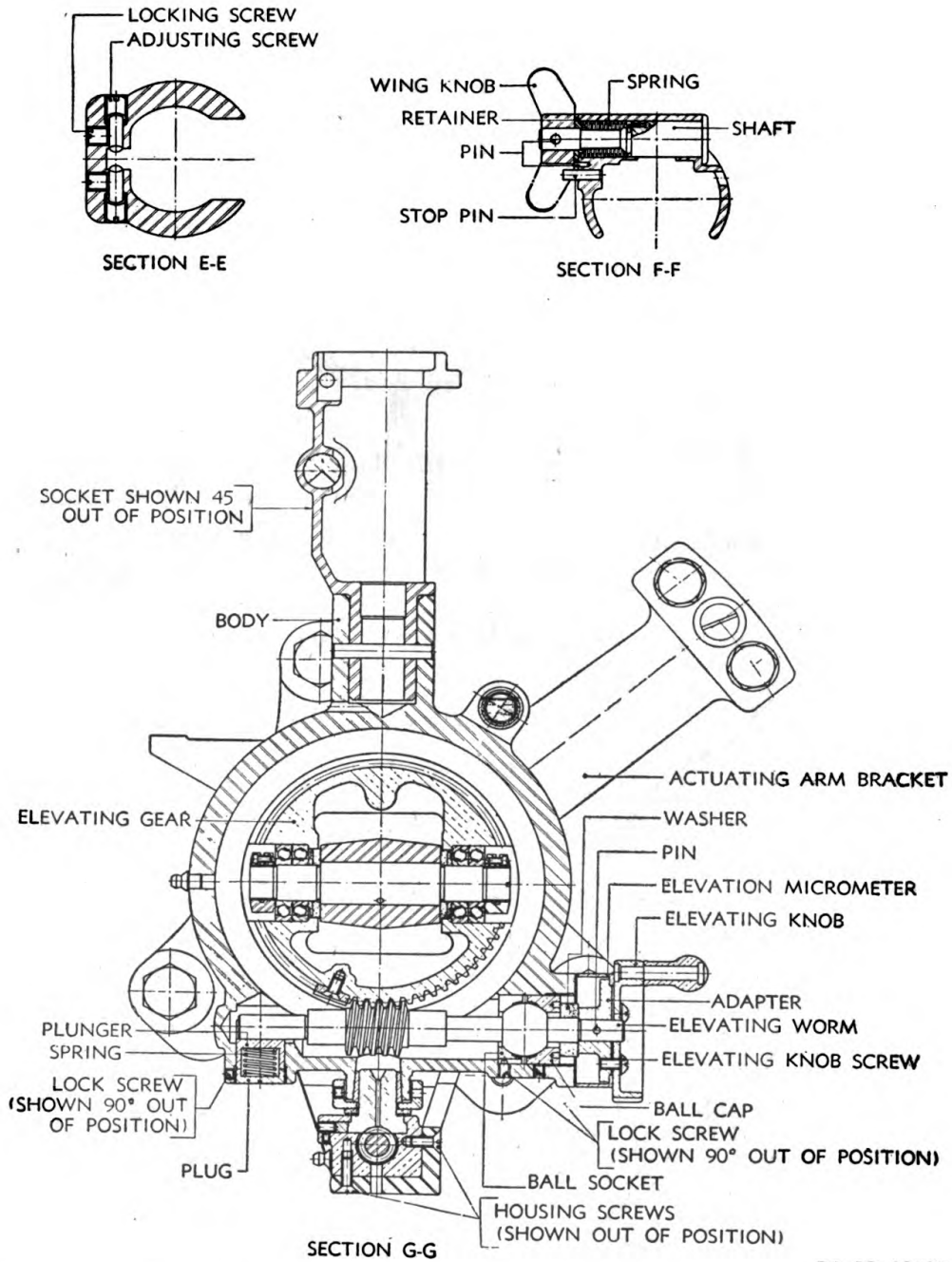

FIGURE 5.—Telescope mount M25—sections E-E, F-F, G-G.

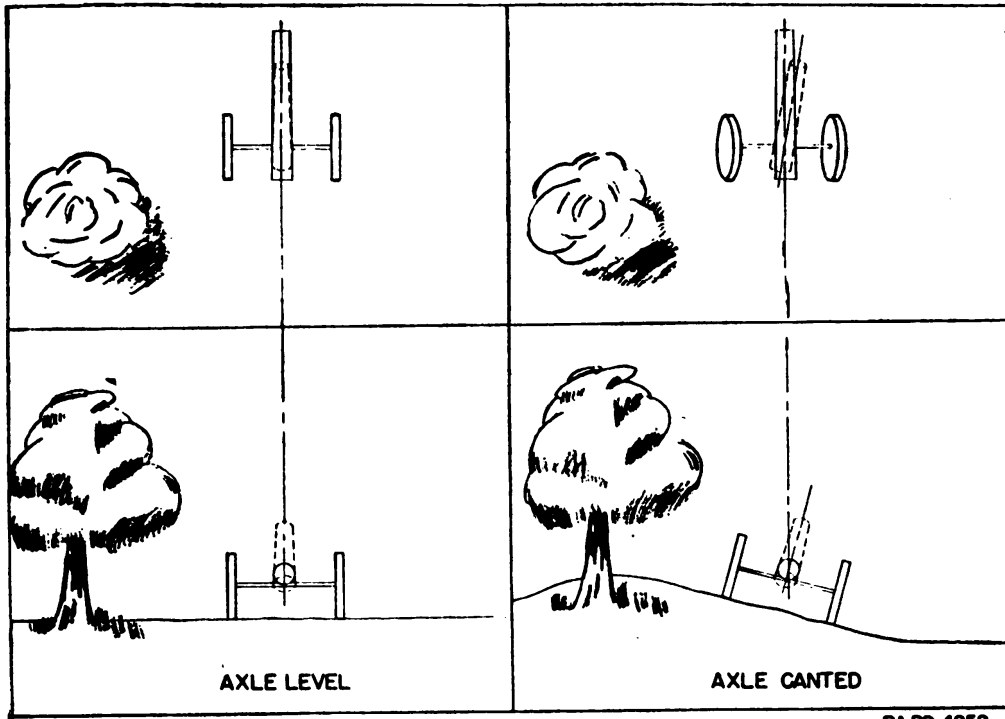

FIGURE 6.—Change in azimuth due to axle cant.

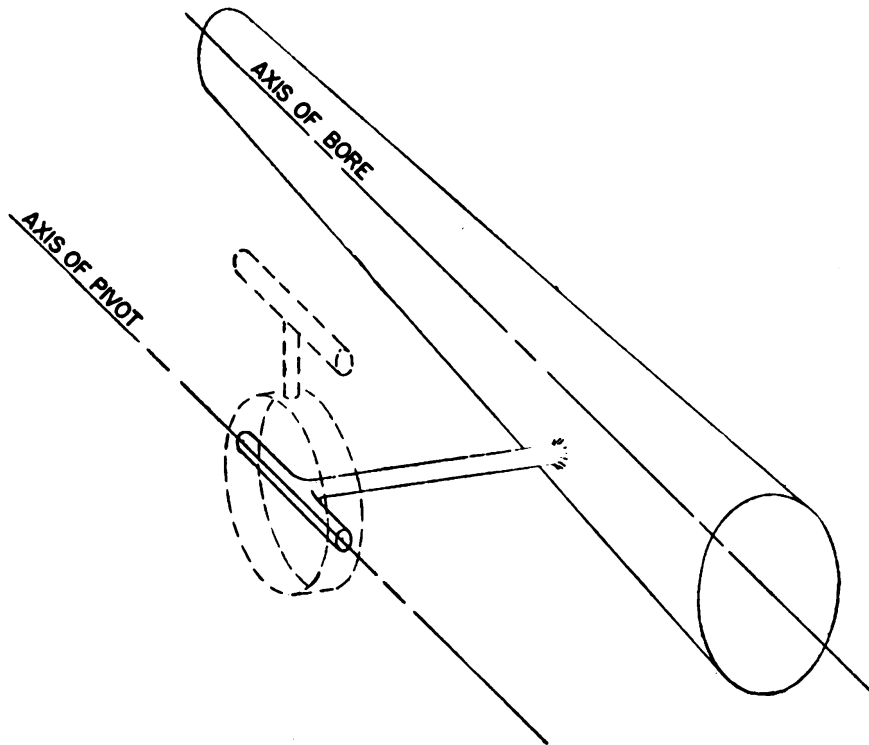
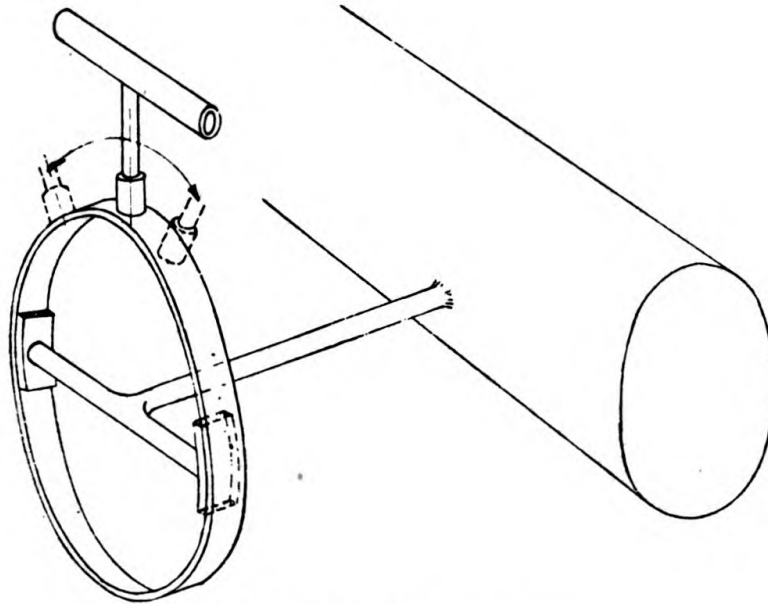

FIGURE 7.—Axis of pivot is parallel to axis of bore.

RAPD 4254

TELESCOPE MOUNT M25



① Longitudinal leveling motion.

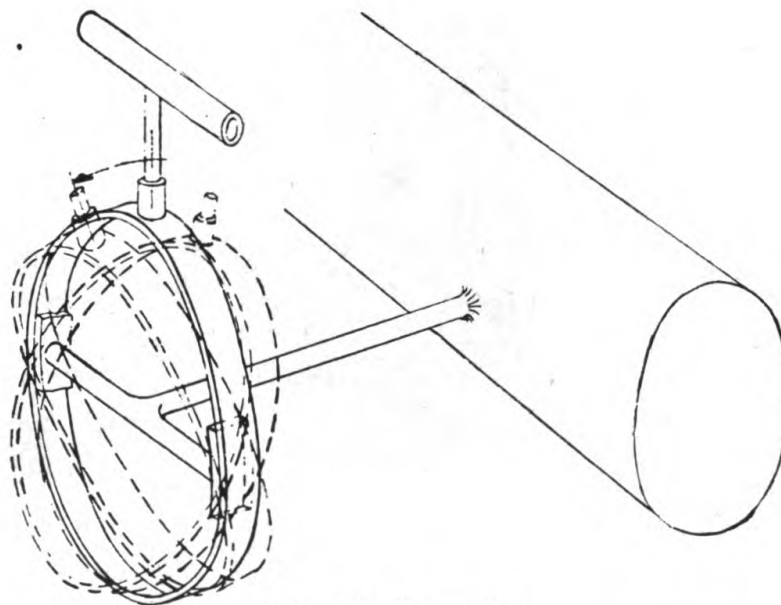

② Cross-leveling motion.

FIGURE 8.—Cross-leveling and longitudinal-leveling motions.

Generated on 2017-02-21 19:53 GMT / http://hdl.handle.net/2027/uc1.b3243911
Public Domain, Google-digitized / http://www.hathitrust.org/access_use#pd-google

hub of the azimuth worm gear, two spur pinions, and the spur gear cut on the sleeve near its upper end.

5. **Telescope, panoramic, M12.**—This telescope, also a 4-power, erect-image instrument, is similar to the M5A5. Physically the M12 is

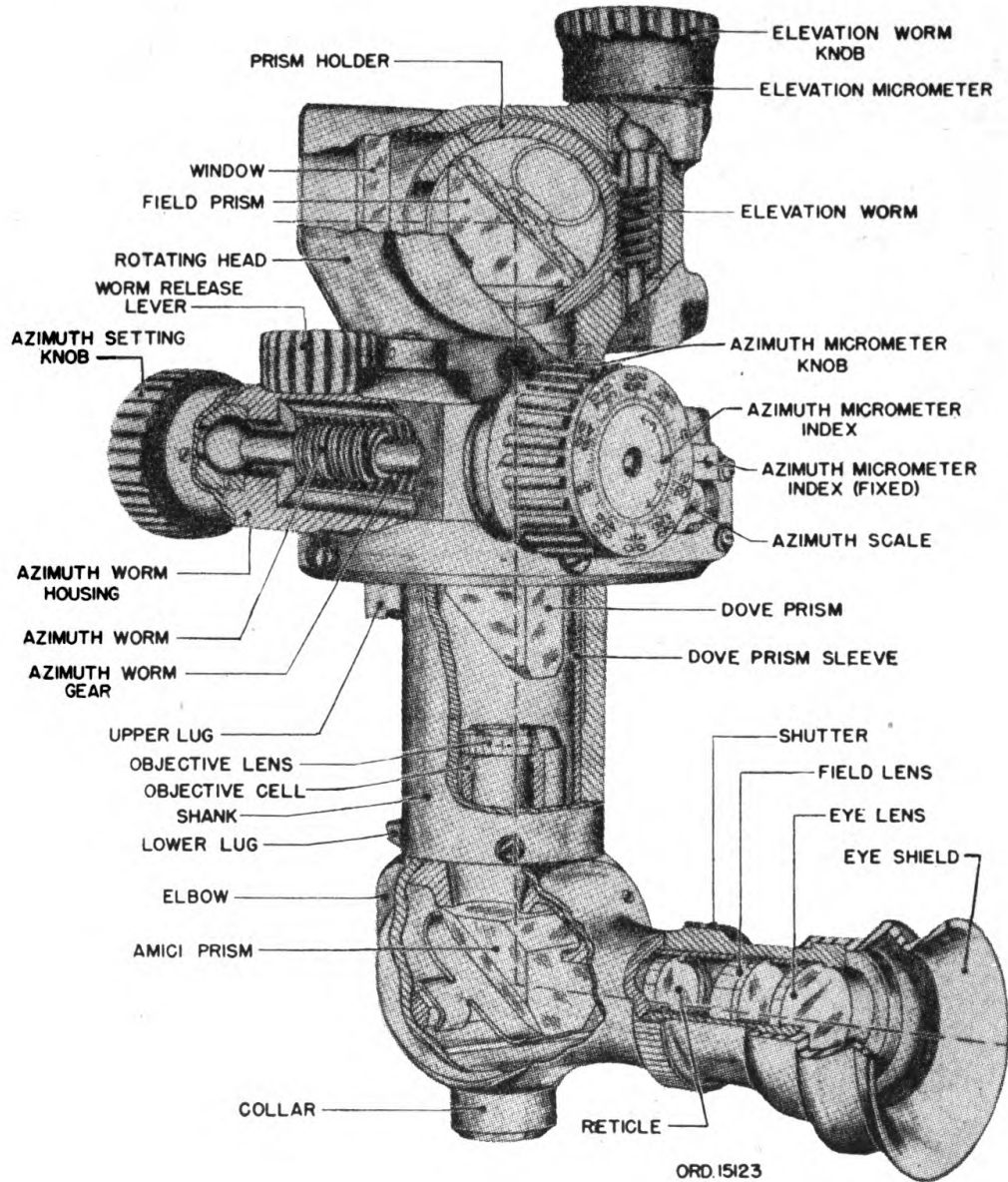

FIGURE 9.—Panoramic telescope M5A5—arrangement of internal parts.

larger. The reticle is graduated in the same manner as in the M5A5 telescope and the eyepiece is offset similarly. The azimuth scale differs,

however. Its graduations are engraved at 100-mil intervals, numbered every 400 mils on the outside of the rotating head. The azimuth scale of the M5A5 telescope is contained inside the telescope body, with a window for vision. The azimuth micrometers are of a different design on the two instruments.

6. Light, instrument, M5.—This light (fig. 10) consists essentially of the body assembly and battery tube.

a. The body assembly constitutes the framework of the instrument light. Two clamps, held in place by thumbnuts, hold the light in place on the telescope mount M25. Rods of clear plastic, inclosed in tubes, transmit the light to various parts of the instrument.

b. The battery tube is cylindrical to accommodate two standard flashlight cells. A toggle switch is on the lower end of this tube and a removable cap on the other end.

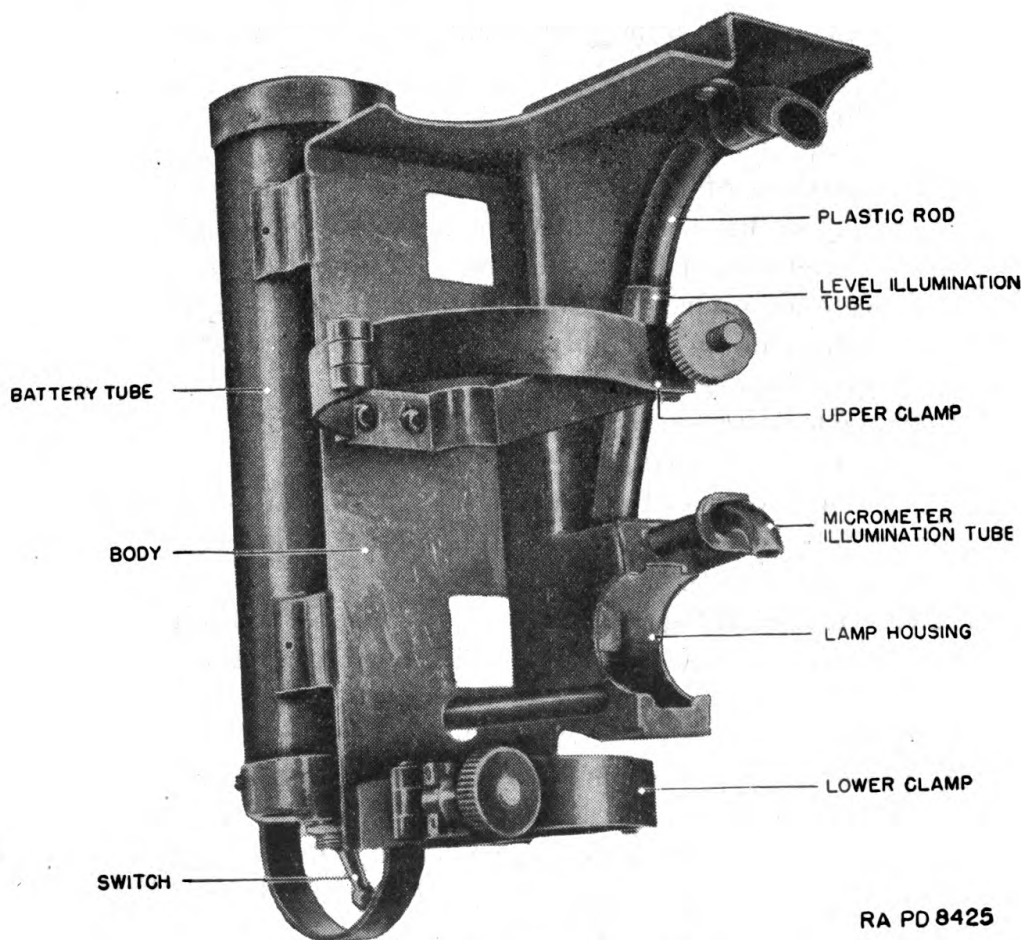

FIGURE 10.—Instrument light M5.

SECTION III

CARE AND PRESERVATION

	Paragraph
Cleaning and preserving materials.....	7
Lubrication of telescope mount.....	8
Care in handling.....	9
Care of optical parts.....	10

7. Cleaning and preserving materials.—*a.* The authorized lubricants are—

Oil, lubricating, for aircraft instruments and machine guns (for all lubrication where oil is required).

Grease, special, low temperature (for all lubrication where grease is required).

b. Materials used for cleaning are—

Alcohol, ethyl (for cleaning optical parts).

Solvent, dry-cleaning (for cleaning metal components).

Paper, lens, tissue.

Brush, camel's-hair.

Bulb, air.

8. Lubrication of telescope mount.—*a.* Lubricants should be used sparingly on fire-control instruments. Too much grease applied to delicate movements may cause stiffness of operation in cold weather.

b. Lubricate all internal sliding surfaces, gears, and bearings with a thin film of grease on assembly. This greasing operation is usually sufficient to last between servicing operations.

c. Coat the locating surfaces on the telescope socket with a light coat of grease to prevent rusting.

d. Place a few drops of oil on the telescope retaining shaft and on the various felt washers. This should be done at intervals dependent upon service conditions.

9. Care in handling.—*a.* Stops are provided to limit the motion of various mechanisms. Avoid any attempt to operate mechanisms past these stops.

b. Keep level vials covered when the levels are not being used.

c. Wipe off all oil that seeps from the bearings, to prevent accumulation of dust and grit.

d. Exercise care to avoid nicking or denting the locating surfaces of the telescope socket. These are accurately machined surfaces and may be dented easily through improper care or usage.

e. Care should be exercised to prevent bumping the instrument light. The clamp screws should be kept tight. Vibration will damage the lamp.

f. Remove battery cells from the battery tube when the instrument light is not being used. Chemical reaction set up in the cells may in time cause the cells to swell. This will damage the battery tube and make removal of the cells difficult.

10. Care of optical parts.—*a.* To obtain satisfactory vision it is necessary that exposed surfaces of the lenses and other optical parts be kept clean and dry. Corrosion and etching of the surface of the glass, which greatly interferes with the good optical qualities of the instrument, can be prevented or greatly retarded in this way.

b. Under no conditions will polishing liquids, pastes, or abrasives be used for polishing lenses and windows.

c. For cleaning optical glass use only paper, lens, tissue. To remove dust, brush the glass lightly with a clean camel's-hair brush and rap the brush against a hard body to knock out small particles of dust that cling to the hairs. Repeat until all dust is removed.

d. Moisture due to condensation may collect on the optical parts of the instrument when the temperature of the parts is lower than that of surrounding air. This moisture may be removed by application of gentle warmth. Heat from strongly concentrated sources should never be applied directly as it may cause unequal expansion of parts resulting in breakage of optical elements or inaccuracies in observation.

e. Exercise particular care to keep optical parts free from oil or grease. Do not wipe the lenses or windows with the fingers. To remove oil or grease from optical surfaces apply alcohol, ethyl, with a clean camel's-hair brush, and rub gently with clean lens paper. If alcohol is not available, breathe heavily on the glass and wipe off with clean lens paper. Repeat this operation several times until the glass is clean.

SECTION IV

BASIC INSPECTION

	Paragraph
Purpose.....	11
Facilities needed.....	12
Inspection requirements of the instrument.....	13
Basic inspection.....	14

11. Purpose.—Inspection is for the purpose of determining the condition of the instrument, whether repairs or adjustments are re-

quired, and remedies necessary to insure serviceability and proper functioning.

a. The first inspection performed on an instrument is to determine the condition of the instrument and to locate basic faults. As a result of this inspection, proper disposition of the instrument can be made and necessary action taken or recommended. Inspection Forms Nos. O. O. F. 7228 and O. O. F. 7229 are provided for recording results of the inspection. Instructions concerning entries to be made are printed on the back of the form.

b. The detailed inspection is performed by the instrument repairman. The purpose of this inspection is to determine the specific repair required to place the instrument in serviceable condition. Inspection procedure may vary with each instrument, depending on the faults indicated by the basic inspection. Inspection forms and methods used in connection with the detailed inspection are described in TM 9-2602. Section V contains detailed inspection instructions for the telescope mount.

12. Facilities needed.—The following tools and fixtures are necessary for the inspection:

- a.* A sensitive level.
- b.* Several screw drivers (small and medium size).
- c.* Several wrenches.
- d.* A telescope mount testing fixture.
- e.* A sturdy bench on which to work.
- f.* A plumb line target.

13. Inspection requirements of the instrument.—The following inspections of the telescope mount should be made:

- a.* Longitudinal and cross level assemblies.
- b.* Elevating mechanism.
- c.* Cross-leveling mechanism.
- d.* Telescope socket lateral adjustments.
- e.* Actuating arm bracket and support bracket adjustment.
- f.* Plumb travel.

14. Basic inspection.—*a.* Examine the instrument and accessories for completeness, appearance, condition and legibility of scales, and for loose, broken, or bent parts. No tools are required for this phase of the inspection. Record the serial number of the instrument.

b. Operate the cross-leveling and elevating mechanisms to the limit of their motion in each direction. This motion should be smooth without excessive friction or undue looseness.

c. Rotate the telescope retaining shaft (fig. 5, sec. F-F). Note the torsion in the torsion spring.

d. Uncover both level vials. Note whether the level vials are unbroken and free from smudge, so that the bubble and vial graduations can be seen easily.

SECTION V

DETAILED INSPECTION AND CORRECTION

	Paragraph
Longitudinal level assembly.....	15
Elevating mechanism.....	16
Cross-leveling mechanism.....	17
Telescope socket lateral adjustment.....	18
Telescope horizontal reticle line.....	19
Actuating arm bracket and support bracket.....	20
Plumb travel.....	21
Instrument light M5.....	22

15. Longitudinal level assembly.—a. Inspection.—(Procedure for inspecting the cross level assembly is similar.) For this inspection the telescope mount may be either in a testing fixture or on the gun carriage. Inspect setting of the level tube and level vial in the following manner:

(1) Uncover the level tube. Center the bubble and press down alternately on each end of the level tube. Note whether the bubble remains stationary during this procedure. If the bubble does not remain stationary, an adjustment of the level tube adjusting screws is necessary.

(2) Place a test level on the top surface of the telescope socket, parallel to the axis of the level tube being tested. If the bubble in the level tube on the mount is not centered when the test level bubble is centered, adjustment is necessary. (One level vial graduation error is allowable.)

b. Adjustment (fig. 11).—(1) Remove the pins from both ends of the level tube. Unscrew the right and left tube plugs.

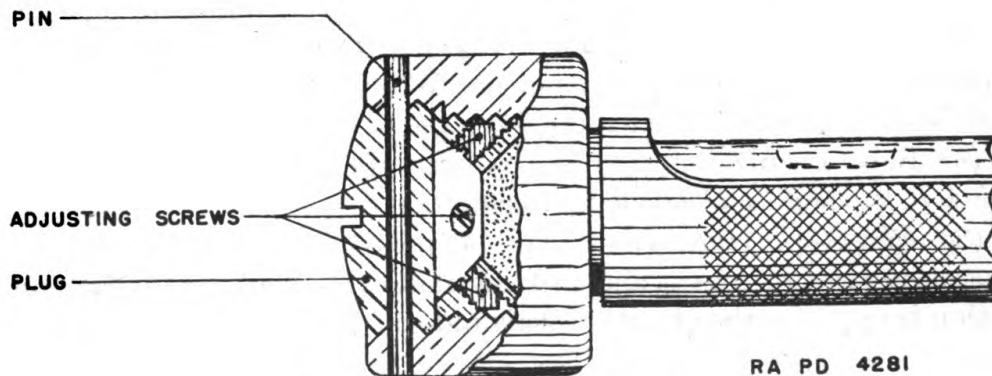

FIGURE 11.—Level vial adjustment.

(2) Loosen the four adjusting screws. Jack up or lower the level tube by means of these screws. As one screw is screwed in, the opposite one should be backed out. After desired adjustment has been obtained see that all adjusting screws are tight. Replace plugs and pins.

16. Elevating mechanism.—a. Inspection.—(1) Scale and micrometer.—Place a sensitive level on the pads of the actuating arm. Rotate the arm until the bubble is centered. Secure the actuating arm in this position. As a check, place the level also on the machined surfaces of the alining bracket and note whether the bubble is centered. With the longitudinal-leveling knob center the bubble in the longitudinal level vial. The elevation scale index and the elevation micrometer index should be opposite the zeros on their respective scales. If this is not the case, the elevation scale or elevation micrometer is out of alinement, assuming that the longitudinal level vial has been checked for adjustment.

(2) *Backlash.*—(a) Displace the actuating arm bracket (fig. 2) from its normal position so that the bubble in the longitudinal level vial is centered when the elevation scale index indicates approximately 200 on the elevation scale.

(b) Center the bubble in the longitudinal level by rotating the longitudinal leveling in one direction. Record the readings opposite the elevation scale index and the elevation micrometer index. Rotate the knob in the same direction about one revolution further. Center the bubble again by rotating the knob assembly in the opposite direction. Again record the readings opposite the elevation scale index and the elevation micrometer index. The difference between the initial and final readings is the backlash. If the backlash exceeds 0.5 mil, replacement or adjustment of the wearing parts is necessary.

b. Adjustments.—(1) Backlash.—(a) Remove the knob by first removing the three screws with washers. Remove the elevation micrometer. Remove the adapter by first driving out the adapter pin. Remove the washer.

(b) Loosen the locking screw. Tighten the ball cap sufficiently to eliminate all longitudinal play but not to cause any binding. If backlash is still excessive, replace the worn parts.

(c) Before replacing the various parts, put a few drops of oil on the felt washer and elevating worm.

(2) *Elevation scale* (fig. 12).—Adjustment is accomplished by loosening the two screws and shifting the scales until the desired indication is opposite the elevation scale index. Tighten the screws.

(3) *Elevation micrometer* (fig. 1).—Loosen the three roundhead screws. Hold the elevating knob assembly stationary and shift the micrometer the desired amount. Tighten screws securely.

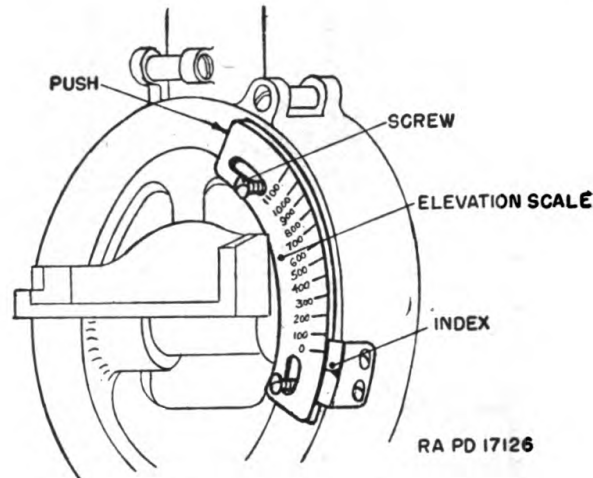

FIGURE 12.—Elevation scale adjustment.

17. **Cross-leveling mechanism.**—*a. Inspection.*—(1) *Gib.*—Rotate the cross-leveling knob until this rotation is stopped by the right stop. With one hand, attempt to shake the segment in its housing. If any perceptible lateral play is noticed, an adjustment of the segment gib is indicated.

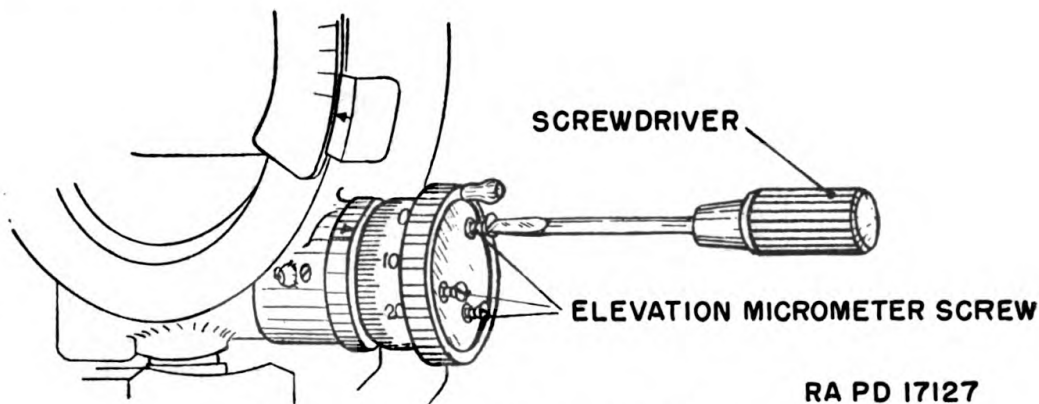

FIGURE 13.—Elevation micrometer adjustment.

(2) *Backlash.*—Inspection and adjustment for backlash in the cross-leveling mechanism is the same as for the elevating mechanism.

b. Gib adjustment.—Loosen the retaining nut (fig. 14) by first loosening the locking screw. Loosen the locking screw (1, fig. 15) and adjust the screws (2) so that the segment can be moved in the cross

level worm housing without excessive friction or undue looseness. Tighten the nut and all locking screws.

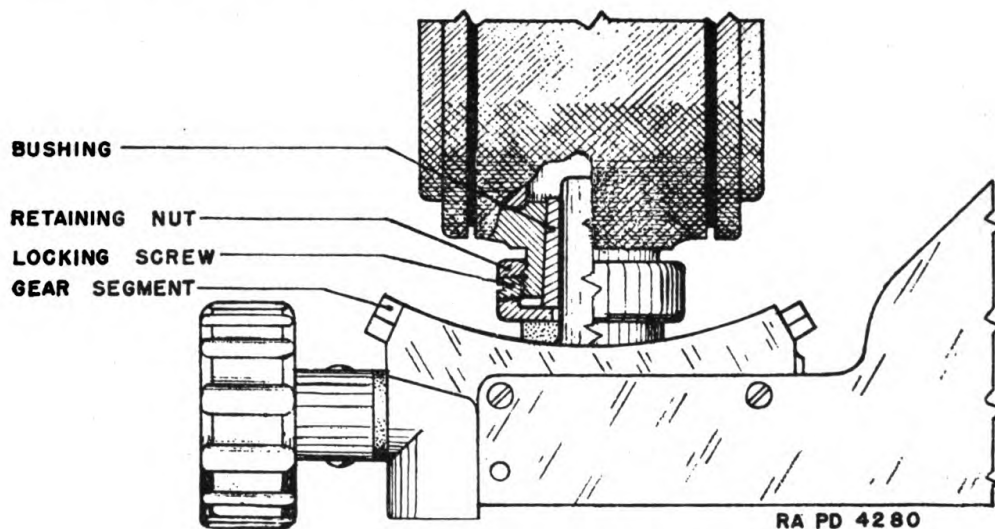

FIGURE 14.—Cross level gear segment and associated bushing adjustment.

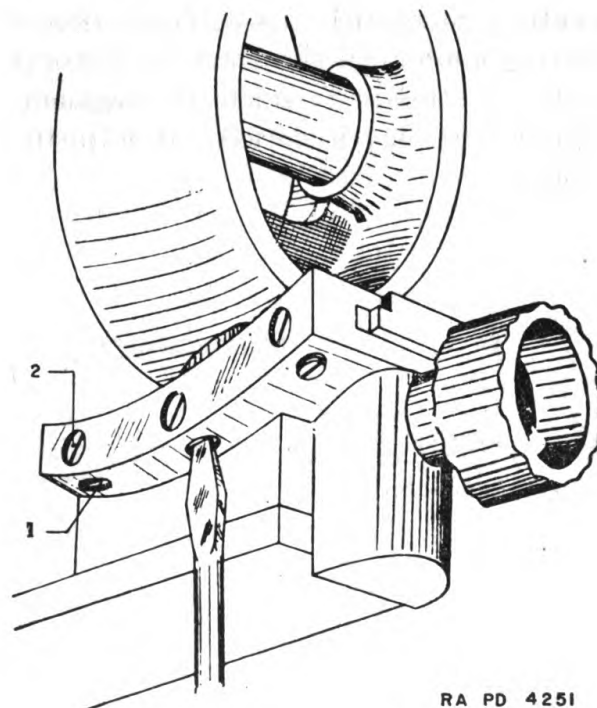

FIGURE 15.—Adjustment of gib screws.

18. Telescope socket lateral adjustment.—a. Inspection.—(1) Set the telescope mount so that both level vials are centered. Place the panoramic telescope M5A5 or M12 in the telescope socket and lock

TELESCOPE MOUNT M25

in position by means of the wing knob. Set the telescope azimuth scale index and associate micrometer index to zero.

(2) Set up a test target about 50 feet away from the telescope mount. Bore sight on the test target and observe whether the vertical cross line of the telescope reticle falls on the proper vertical line of the test target. If it does not, an adjustment of the socket adjusting screws is necessary.

b. Adjustment (fig. 16).—(1) Set the azimuth micrometer knob to zero against the fixed index. The azimuth micrometer index should be

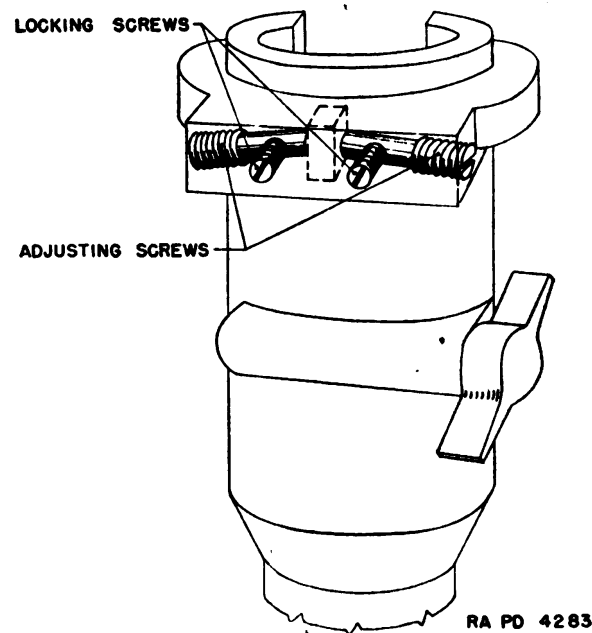

FIGURE 16.—Telescope lateral adjusting screws.

opposite zero on the azimuth micrometer scale. If this is not the case, temporarily loosen the micrometer screw and shift the micrometer index until this indication is obtained.

(2) Loosen the telescope socket locking screws (fig. 16) and adjust the adjusting screws until the vertical reticle line falls on the vertical line of the test target. Tighten the locking screws. The adjusting screw must be set snugly against the upper lug of the telescope but not tight enough to lock in the socket.

19. Telescope horizontal reticle line.—*a. Inspection.*—With the elevation scale and elevation micrometer scale on the telescope mount set to zero, bore sight on a test target. If the horizontal reticle line does not fall on the proper horizontal line on the target, adjustment is necessary.

b. Adjustment.—Rotate the elevation worm knob (fig. 9) on the panoramic telescope until the horizontal reticle line falls on the horizontal line on the target. If the elevating micrometer index does not coincide with zero, loosen the micrometer screws temporarily and shift the micrometer.

20. Actuating arm bracket and support bracket.—*a. Inspection.*—Remove the telescope mount from the gun carriage (see par. 23a) and place it on a bench. Grasp the support bracket and the actuating arm bracket and rotate the two brackets with respect to each other. Note any end play, undue looseness, or excessive friction in these parts. If any of these are noticed, an adjustment is necessary.

b. Adjustment.—Loosen the headless locking screw (2, fig. 19) and tighten the nut (3) until all play is removed and the support bracket can be rotated without undue looseness or excessive friction. Firmly tighten the locking screw.

21. Plumb travel.—*a. Inspection.*—(1) With the telescope mount assembled to the gun carriage, elevate or depress the gun so that the bore of the gun is horizontal. Center the bubbles in the cross level and longitudinal level vials by means of the respective mechanisms of the telescope mount.

(2) Place the panoramic telescope M5A5 or M12 in the telescope socket, and lock in position by means of the wing knob. Place a plumb line target in front of the telescope at a distance so that the line of sight can be elevated from zero to 1,100 mils (approximately 62°) with the plumb line in view. Rotate the telescope azimuth knob until the vertical reticle line coincides with the plumb line target. By means of the elevating knob assembly elevate the line of sight until the elevation scale index and elevation micrometer index indicate 1,100 mils elevation. The vertical reticle line should follow the plumb line during this elevating procedure within plus or minus 0.75 mil. If deviation is excessive, worn or untrue parts are indicated and replacement of those parts is necessary.

b. Adjustment.—This may require complete disassembly of the telescope mount and thorough examination of each component part for wear and trueness, although only one defective part may be the cause of the malfunctioning.

(1) In disassembling follow the procedure given in paragraph 23a and *g*. Replace worn or defective parts.

(2) Clean all parts of grease and grit. Lubricate bearings and gears sparingly with a few drops of oil. Place a few drops of oil on the felt washer and strips. Reassemble the mechanisms.

22. Instrument light M5.—The instrument light should furnish adequate illumination for the instrument. Operate the switch to see if it functions properly. Examine the electrical connections and insulation on the wires. Weak or corroded batteries and burned-out lamps should be replaced. Loose connections should be tightened.

SECTION VI

DISASSEMBLY AND ASSEMBLY

Disassembly and assembly-----	Paragraph 23
Inspection-----	24

23. Disassembly and assembly.—*a. To remove telescope mount from gun or howitzer carriage (fig. 17).*—(1) Remove the actuating arm mounting screws which secure the actuating arm bracket to the trunnion bracket. Remove the nuts and washers from the two lower screws in the mount bracket.

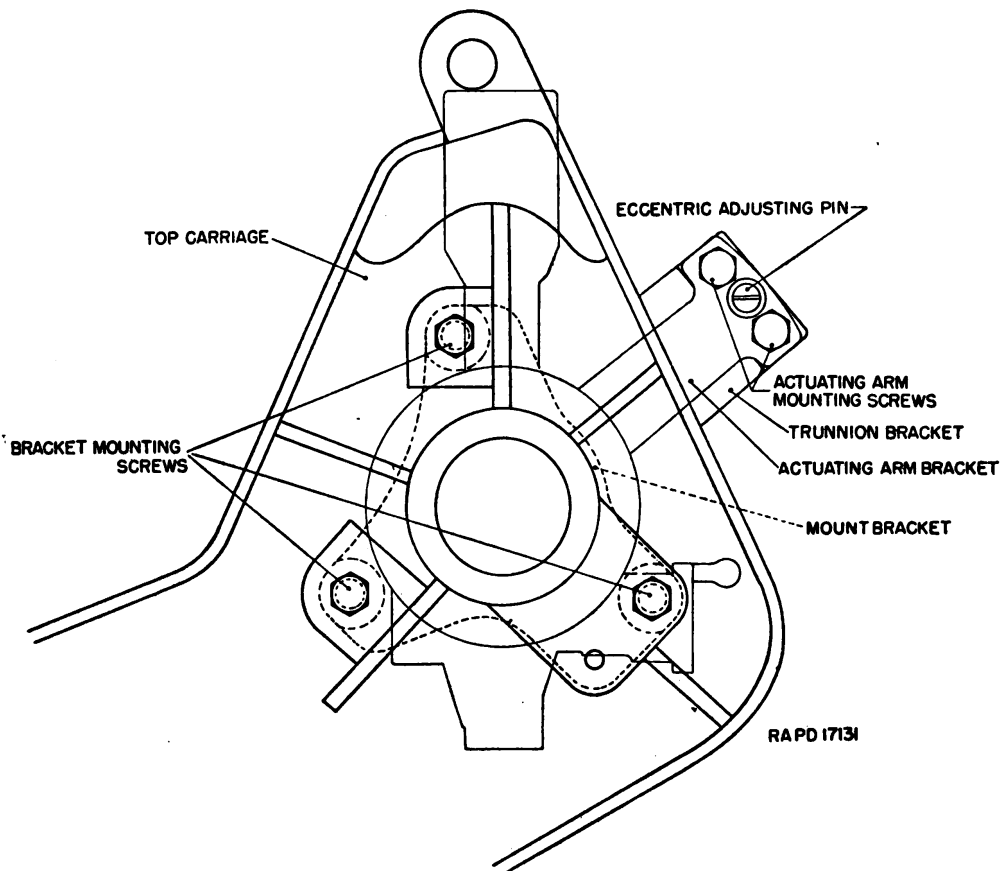

FIGURE 17.—Location of mounting screws in top carriage and trunnion bracket.

(2) With one hand on the telescope mount, remove the nut from the upper screw. Carefully remove the telescope mount from the gun carriage, pulling it straight out from the mounting holds.

b. To reassemble telescope mount to carriage.—(1) Slide the locating pin into its hold and aline the screw holes in the mount bracket with associated holes on the top carriage. Insert the three bracket mounting screws in the holes, slip on the washers, and tighten the nuts.

(2) Place the actuating arm bracket in its proper position on the trunnion bracket and insert the two actuating arm bracket screws with washers. Tighten the screws just enough to permit movement of the actuating arm bracket by rotating the eccentric adjusting pin.

(3) Elevate or depress the gun so that the bore of the gun is horizontal (as determined by a gunner's quadrant or sensitive level). Place a sensitive level on the pads of the actuating arm bracket. Turn the eccentric adjusting pin with a screw driver until the bubble in the sensitive level is centered, indicating that the pads are horizontal. Firmly tighten the actuating arm mounting screws.

c. To disassemble longitudinal level assembly.—(Procedure for disassembling the cross level assembly, being similar, is not given.)

(1) With a punch and a light hammer drive out the pins (fig. 11) which secure the level vial plugs. Unscrew both level vial plugs.

(2) Loosen the four adjusting screws. Extract the level tube assembly from its housing by sliding it out toward the right. Care should be exercised that the tube cover does not slide from its proper position and hinder the disassembling procedure.

(3) Clean out the calcined gypsum (plaster of paris) setting from each end of the level tube by means of a small screw driver or knife blade. Extract the level vial and thoroughly clean out the remaining plaster of paris.

d. To reassemble longitudinal level assembly.—(1) Place the level vial in the level tube and locate it so that the graduations are centered in the tube opening. Pack the tube with calcined gypsum (plaster of paris) which has been mixed to medium consistency.

(2) Hold the tube cover in the proper position and slide the level tube into place. Replace the pin and plug on the right side of the tube. Adjust the level tube by means of the four adjusting screws as explained in paragraph 15. Replace the left pin and plug.

e. To disassemble elevating mechanism.—(1) *Elevating worm.*—In connection with disassembling this mechanism, reference should be made to figure 18.

TELESCOPE MOUNT M25

(a) Remove the three screws (and washers) which secure the elevating knob. Lift off the knob and the elevation micrometer.

(b) Drive out the taper pin which secures the elevation micrometer adapter, and remove the adapter. Also remove the felt washer.

(c) Loosen or remove the locking screws which secure the ball caps and ball socket.

(d) Unscrew the ball cap.

(e) Loosen the locking screw which secures the worm plunger plug. Unscrew the plunger plug and remove the plunger together with spring from the telescope mount.

(f) Unthread the elevating worm and remove it, together with the ball socket.

(2) *Elevating worm gear.*—(a) With the elevating mechanism disassembled as described above, further disassemble the telescope mount as illustrated in figure 19. The numbers on the illustration indicate the order of disassembly.

(b) To remove the elevating worm gear from the telescope mount body (see fig. 20), remove the three flathead screws (1) and the alining bracket (2). Remove the two screws (3) with washer, and the elevation scale (4) and unscrew the nut (6) after loosening the locking screw (5). Extract the washer (7) from the telescope mount body. Slide the body from the elevating worm (8). The two bearings (9 and 10) can then be removed.

(c) To disassemble the elevating worm gear from the actuating arm, extract the tapered pivot pin (fig. 21). Remove the pivot locking screw and unscrew the pivot nut. The actuating arm bracket can now be removed, thus disengaging the actuating arm from the elevating worm gear. The two pivot bearings and felt washer can also be removed if necessary.

f. To reassemble elevating mechanism.—(1) *Elevating worm gear.*—Clean all bearings and gear teeth. Place a few drops of oil on the felt washers, strip, bearings, and gear teeth. Follow the same procedure for reassembling as for disassembling, except in the reverse order. (See figs. 19, 20, and 21.) Adjust the adjusting nuts so that the parts affected operate smoothly without undue friction or looseness.

(2) *Elevating worm.*—Clean all parts thoroughly and place a few drops of oil on the wearing parts of the elevating worm and on the felt washer. Follow the procedure given for disassembling, except in reverse order. (See fig. 18.) Adjust the ball cap so the worm may be rotated without undue looseness or excessive friction.

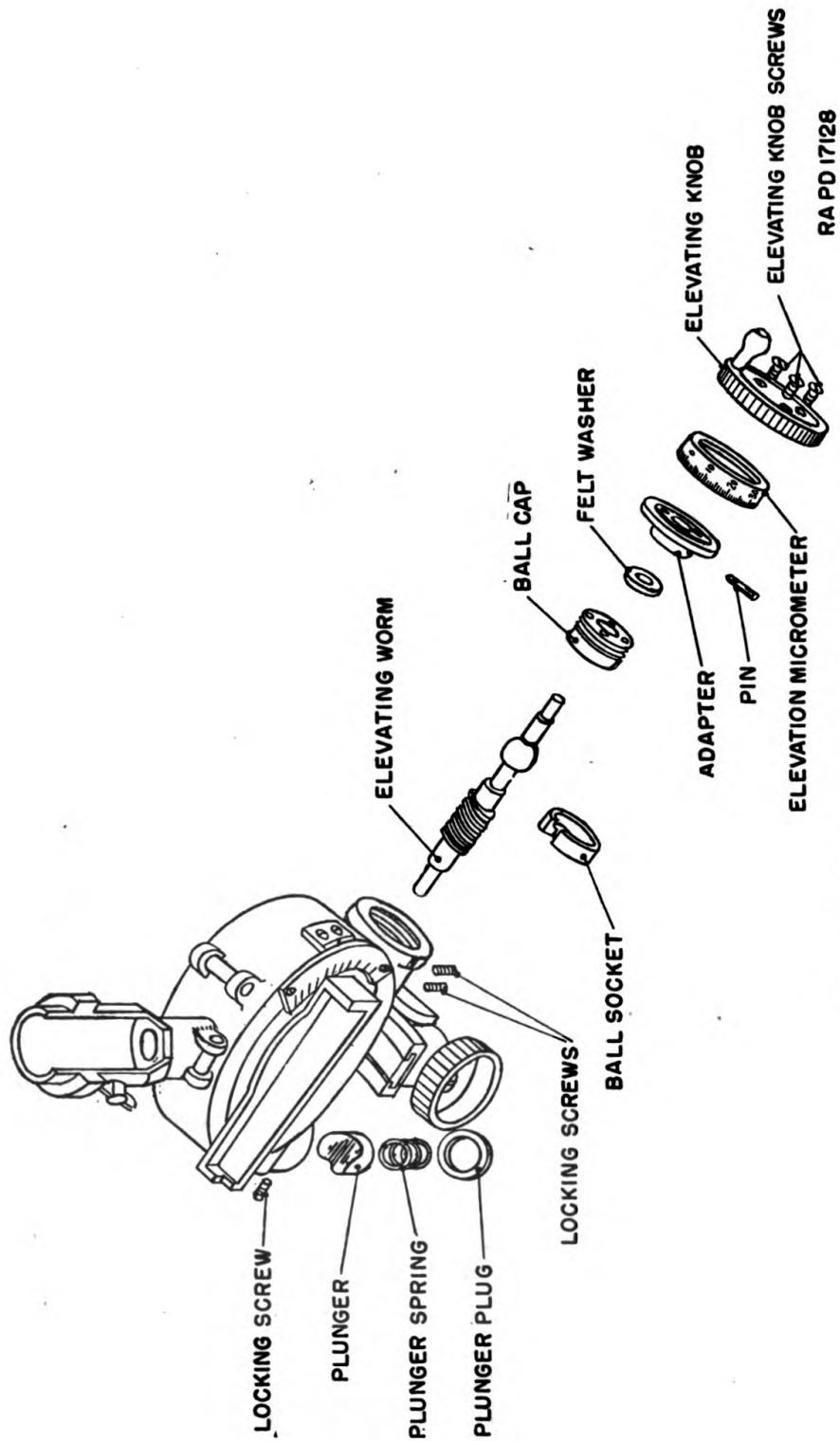

FIGURE 18.—Exploded view of elevating mechanism.

TELESCOPE MOUNT M25

RA PD 8411

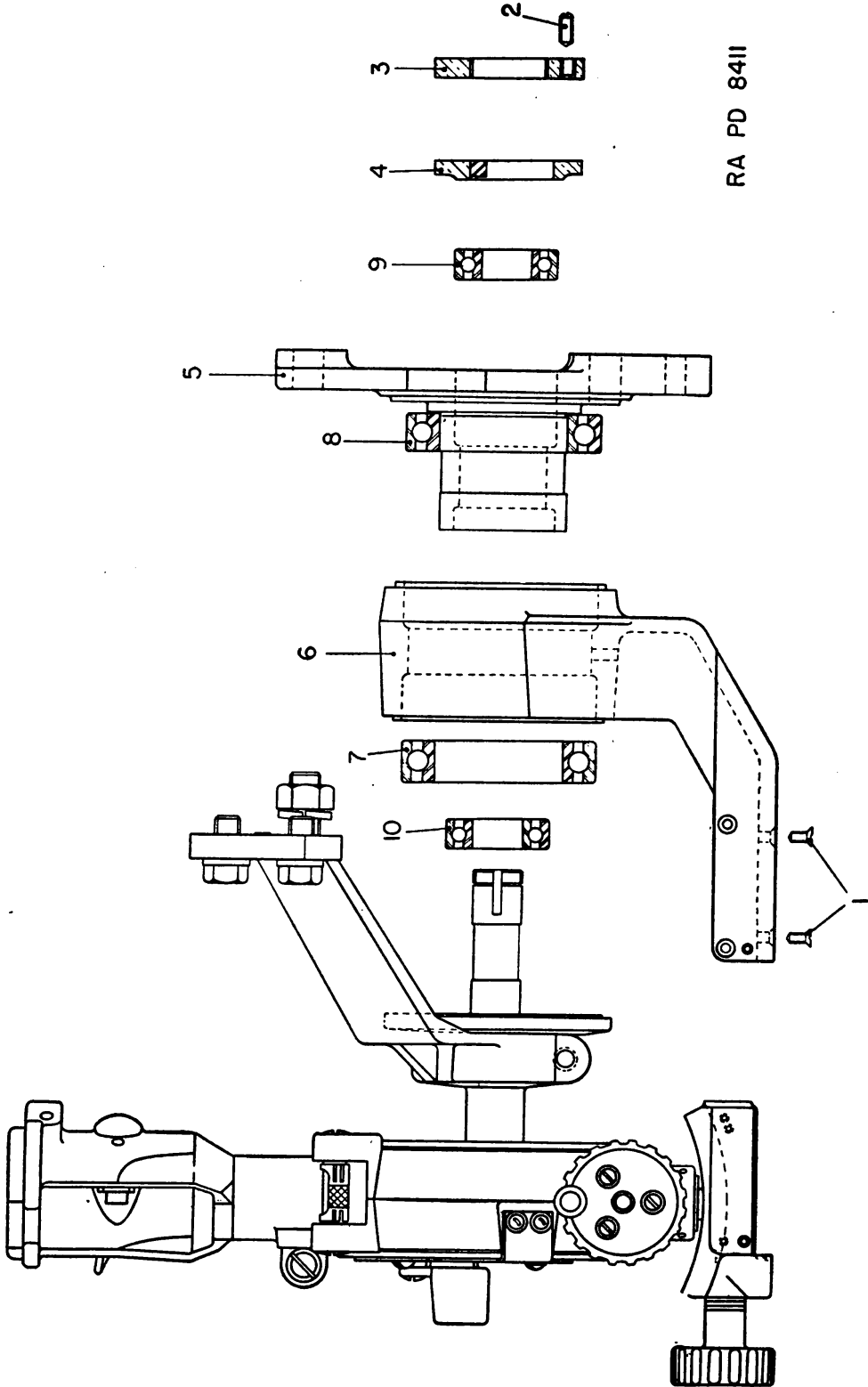
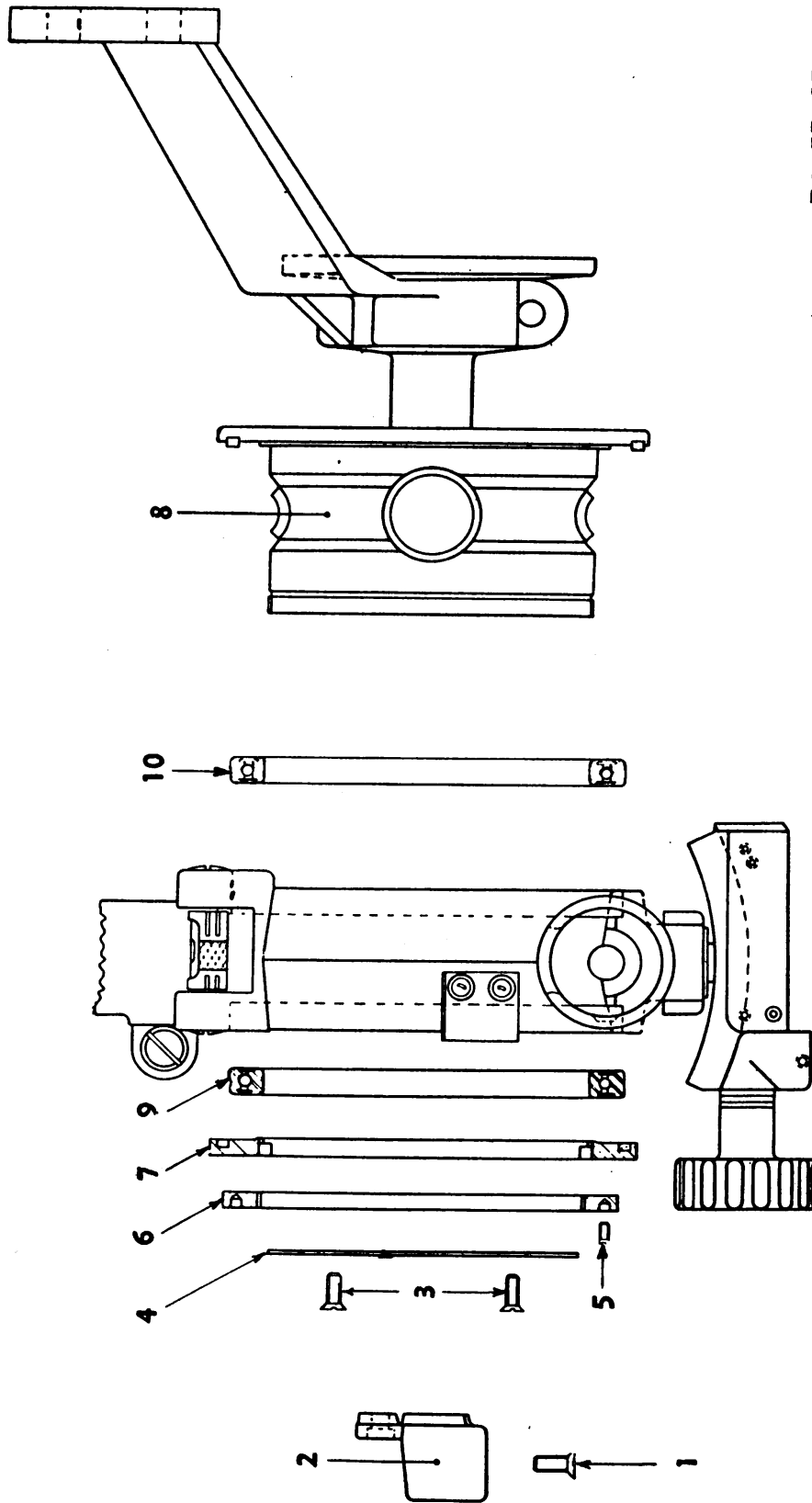

Figure 19.—Exploded view of rocker and bearings.



RA PD 17129

FIGURE 20.—Exploded view of actuating arm and bearings.

g. To disassemble cross-leveling mechanism.—Reference should be made to figure 22 in regard to disassembling procedure for this mechanism.

(1) With the telescope mount body and actuating arm removed from the rocker (fig. 19) as described above, proceed to disassemble the cross-leveling mechanism.

(2) Remove the plug (fig. 22) by first loosening the locking screw. Unscrew the cross-leveling retainer knob and remove the washer and knob. Slide off the felt washer. Unscrew the ball cap after first loosening the headless locking screws. Remove the cross level worm together with the ball socket from the housing.

(3) Slide the worm housing from the cross level segment by first loosening the locking screws (1, fig. 15) and gib adjusting screws

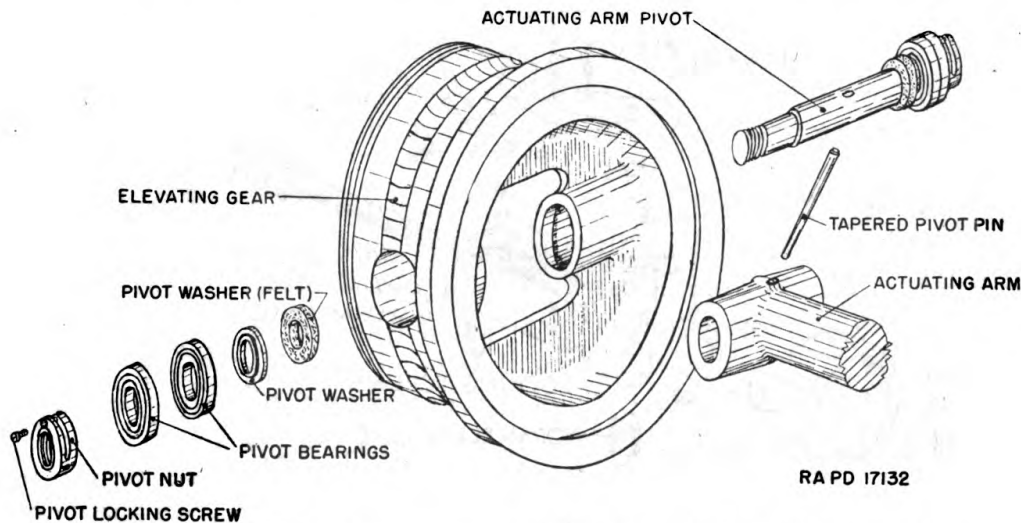

FIGURE 21.—Exploded view of elevating worm gear pivot and related parts.

(2, fig. 15). Loosen the retaining nut (fig. 22) by first loosening the locking screw. Extract the cross level segment together with washer from the telescope body. The disassembly may be carried out further if necessary.

h. To reassemble cross-leveling mechanism.—(1) Follow the same procedure as for disassembling, except in reverse order.

(2) Thoroughly clean all bearings and gear teeth. Place a few drops of oil on the felt washers, bearings, and gear teeth. Adjust the ball cap and the gib adjusting screws so that the parts affected may be moved without undue friction or looseness.

i. To disassemble telescope retaining shaft (fig. 5, sec. F-F).—Remove the wing knob by first driving out the pin. Extract the retainer. Remove the retaining shaft from the telescope socket. Slide the torsion spring out toward the left.

j. To reassemble telescope retaining shaft.—Place a few drops of oil on the retaining shaft. Follow the same procedure for reassembling as for disassembling, except in reverse order. When assembling, see that the torsion spring is in proper position in relation to the pin before replacing any of the other parts.

k. To replace battery cells in instrument light M5.—Remove the instrument light from the telescope mount by loosening both thumb-nuts and sliding the clamps away from the associate eyebolt. Remove the cap from the battery tube by turning the cap to the right. Slide out both old battery cells and replace with fresh cells. See that the cells

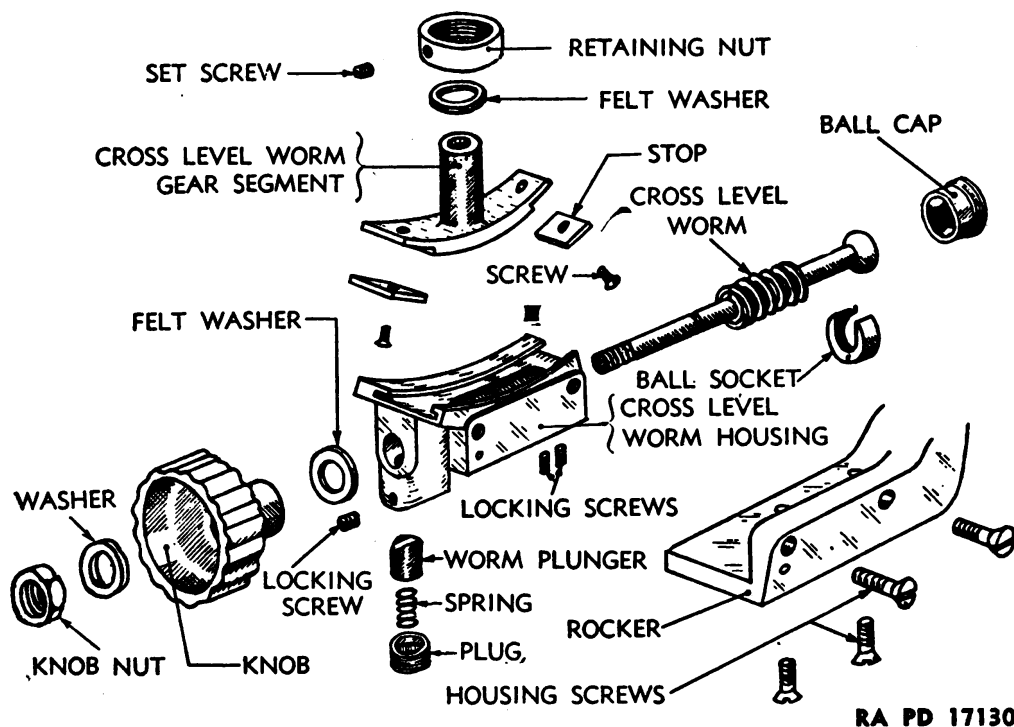

FIGURE 22.—Exploded view of cross-leveling mechanism.

are placed in the tube with the proper end toward the tube cap. Replace the tube cap and assemble the instrument light to the telescope mount.

24. Inspection.—*a. General.*—Note general appearance, loose or missing parts on screws and nuts, and legibility of scales. Operate the cross-leveling and longitudinal-leveling mechanisms to the limit of motion in each direction. Observe whether these parts function properly.

b. Detail.—The various parts and mechanisms should be inspected according to the procedure given in section V.

SECTION VII

CLEANING AND PAINTING

	Paragraph
Cleaning optical elements.....	25
Cleaning mechanical parts.....	26
Painting.....	27

25. Cleaning optical elements.—Lenses and windows of the telescope should be cleaned periodically, depending upon service conditions. Corrosion and etching of the surface of the glass can be prevented or greatly retarded by keeping the glass clean and dry.

a. To remove dust, brush the glass lightly with a clean camel's-hair brush and rap the brush against a hard body in order to knock out small particles of dust that cling to the hairs.

b. To remove oil or grease from optical surfaces, apply ethyl alcohol with a clean camel's-hair brush, and rub gently with clean lens paper. In case alcohol is not available, breathe heavily on the glass and wipe off with clean lens paper; repeat this operation several times until clean.

26. Cleaning mechanical parts.—*a.* Use solvent, dry-cleaning, to clean ordinary metal parts. Clean with a stiff bristled brush. Do not allow the solvent to become saturated with grease and dirt. Change it frequently. As this cleaning solvent is inflammable, proper precautions should be taken when using or handling it.

b. Use compound, cleaning, for removing old grease and grit from the larger parts of this equipment. This cleaning compound should not be used for small and delicate parts. See SNL K-1 and TM 9-850.

27. Painting.—*a. General.*—Painting of instruments must be supervised by some one familiar with functioning of the instruments. Care should be exercised that no paint comes in contact with scales, level vials, gear teeth bearings, bearing surfaces, and locating surfaces. The effect of paint on bearings and bearing surfaces is obvious. Removal of paint from scales and level vials will result in scratching the scales and level vials. Ordnance matériel is painted before issue and from time to time depending upon the service conditions and climatic conditions to which the matériel is subjected.

b. Preparing for painting.—(1) *To clean.*—All surfaces to be painted must be dry and free from dirt, oil, grease, and rust. For cleaning use solvent, dry-cleaning, and rinse with hot water. Dry in an air stream. It must be remembered that frequent washing of metal components in the same batch of solvent will soon render it

unfit for further use, since it easily becomes saturated with grease, oil, and dirt. The solvent must be changed frequently. Rough, sand-cast surfaces to be finished should be filed or ground to remove all projections that will result in a poor finish.

(2) *To remove old paint.*—(a) Remove loose paint around marred parts by means of paper, flint, No. 1. Dust off all loose sand.

(b) Use remover, paint and varnish, if the paint is in bad condition and necessitates removal in entirety before paint is applied.

(c) Apply paint remover as it comes from the can. Allow the remover to stay on until the paint can be scraped or wiped off. Keep it out of finished joints or bearings. As the remover is *very inflammable*, proper precautions should be taken when using or handling it.

c. Painting.—(1) Apply the paint with a brush or spray gun. Exercise care to avoid splashing or spraying paint on parts which are not to be painted. Finished colors must conform to authorized or prescribed hues. Minor deviations of pigment proportions are permissible, if necessary to match colors.

(2) Use filler, white scale, for painting scales. Thoroughly clean out the graduation marks. Apply a thin coat of white filler. Wash off surplus filler with soap, castile, and water; rinse in clean water, and dry.

APPENDIX

REFERENCES

1. Standard Nomenclature Lists.

Mount, telescope, M25 (for 4.5-inch gun carriage M1 and 155-mm howitzer carriage M1)-----	SNL F-216
Telescope, panoramic, M5A5-----	SNL F-22
Telescope, panoramic, M12 (for 155-mm gun carriage M1 and 8-inch howitzer carriage M1)-----	SNL F-214
Gun and carriage, 4.5-inch, M1-----	SNL C-38
Carriage, howitzer, 155-mm, M1-----	SNL C-39
Kit, repair, instrument-----	SNL F-206
Truck, instrument, repair, M1-----	SNL G-92
Material, cleaning and preserving, and tools and equipment used therewith-----	SNL K-1
Current Standard Nomenclature Lists are tabulated here. An up-to-date list of SNL's is maintained as the "Ordnance Publications for Supply Index"-----	OPSI

TELESCOPE MOUNT M25

2. Technical Manuals.

Telescopes, panoramic, M1917M1, M2A1, M3A1,
 M4, M5A2, M5A3, M5A4, M5A5, M5A6, and M6_ TM 9-1583
 Carriage, howitzer, 155-mm, M1----- TM 9-331
 Carriage, gun, 4.5-inch, M1----- TM 9-328
 Cleaning and preserving materials----- TM 9-850
 Instruction Guide, The Instrument Repairman--- TM 9-2602
 Telescope, panoramic, M12, M12A1, M12A2,
 M12A3, and M12A4----- TM 9-1584

[A. G. 062.11 (5-1-42).]

BY ORDER OF THE SECRETARY OF WAR :

G. C. MARSHALL,
Chief of Staff.

OFFICIAL :

J. A. ULIO,
*Major General,
 The Adjutant General.*

DISTRIBUTION :

R 9(2) ; IBn 9(1) ; IC 9(3).
 (For explanation of symbols see FM 21-6.)

