

End 4113
TM
1945

TM 11-434

WAR DEPARTMENT TECHNICAL MANUAL

U.S. Dept. of Army

SPOTTING SETS

PH-32-B, PH-32-C,

PH-32-D, and PH-32-E,

AND

SPOTTING SET

AN / TVQ-1



WAR DEPARTMENT · DECEMBER 1945

WAR DEPARTMENT TECHNICAL MANUAL
TM 11-434

*This manual supersedes TM 11-434, 12 May 1942; TM 11-434D, 25 June 1943;
and TM 11-434F, 14 March 1944.*

SPOTTING SETS
PH-32-B, PH-32-C,
PH-32-D, and PH-32-F
AND
SPOTTING SET AN/TVQ-1



WAR DEPARTMENT · DECEMBER 1945

*United States Government Printing Office
Washington: 1945*

WAR DEPARTMENT

Washington 25, D. C., 7 December, 1945

TM 11-434, Spotting Sets PH-32-B, PH-32-C, PH-32-D, and PH-32-F, and Spotting Set AN/TVQ-1, is published for the information and guidance of all concerned.

[AG 300.7 (5 Aug 45).]

BY ORDER OF THE SECRETARY OF WAR:

OFFICIAL:

EDWARD F. WITSELL

Major General

Acting The Adjutant General

DWIGHT D. EISENHOWER

Chief of Staff

DISTRIBUTION:

AAF (5); AGF (5); ASF (2); T of Opns (5); Dept (2); Base Comd (2); Island Comd (2); Arm & Sv Bd (1); S Div ASF (1); Tech Sv (2); Sv C (2); Air Tech Sv C (2); Dep 11 (2); Lab 11 (2); 4th Ech Maint Shops 11 (2); 5th Ech Maint Shops 11 (2); T/O & E 11-107(3); 11-127(3); 11-587(3); 11-592(3); 11-597(3).

Refer to FM 21-6 for explanation of distribution formula

Operating spotting components of Spotting Set PH-32-(*)	31	39
Performance check list	32	40

PART THREE. MAINTENANCE INSTRUCTIONS FOR SPOTTING COMPONENTS OF SPOTTING SET PH-32-(*).

<i>Section IV.</i> Preventive maintenance techniques.		
Meaning of preventive maintenance	33	43
Description of preventive maintenance techniques....	34	43
Switch and relay contacts	35	45
Wiring and connecting cables	36	46
Bakelite, glass, rubber, painted metal, and painted wood surfaces	37	46
Hardware	38	46
V. Itemized preventive maintenance of spotting components of Spotting Set PH-32-(*).		
Introduction	39	46
Materials needed	40	47
Maintenance of phototheodolites	41	47
Maintenance of Junction Box JB-40 and Cord CD-407	42	47
Maintenance of Exposure Meter PH-252-(*).....	43	48
Maintenance of Time Interval Device PH-103.....	44	48
Maintenance of Time Interval Multiplier PH-264-(*)	45	49
Maintenance of Line Connector Unit EE-87.....	46	49
Maintenance of Time Interval Signal BE-65.....	47	49
Maintenance of Battery BB-46	48	49
Maintenance of Axle RL-27-(*).....	49	49
Maintenance of Reel Unit RL-31-(*).....	50	50
Preventive maintenance check list for spotting components	51	50
VI. Lubrication of spotting sets.		
War Department Lubrication Orders	52	51
Compliance with War Department Lubrication Orders	53	52
War Department Lubrication Orders for Spotting Sets	54	52
VII. Moistureproofing and fungiproofing of spotting components of Spotting Set PH-32-(*).		
General	55	52
Treatment	56	53
Spotting components requiring treatment	57	53
Junction Box JB-40	58	54
Time Interval Device PH-103	59	55
Time Interval Multiplier PH-264-(*)	60	57

PART FOUR. AUXILIARY EQUIPMENT (not used).

PART FIVE. REPAIR INSTRUCTIONS.

<i>Section VIII.</i> Theory of operation of spotting components.		
Group functioning of spotting components of Spotting Set PH-32-(*)	61	61
Individual functioning of spotting components.....	62	62

	<i>Paragraph</i>	<i>Page</i>
Functioning of Time Interval Device PH-103.....	63	62
Functioning of Time Interval Multiplier PH-264-(*)	64	65
IX. Trouble shooting spotting components.		
General trouble-shooting information	65	67
Trouble shooting Time Interval Device PH-103.....	66	67
Trouble shooting Time Interval Multiplier PH-264-(*)	67	70
Unsatisfactory equipment report	68	72

SPOTTING SET AN/TVQ-1

PART ONE. INTRODUCTION.

Section I. Description.

General	69	75
Application	70	75
Table of major components of Spotting Set AN/TVQ-1	71	79
Table of power requirements for Spotting Set AN/TVQ-1	72	86
Descriptions of components of Spotting Set AN/TVQ-1	73	87
Theodolite MX-194/TVQ-1	74	87
Cover CW-95/TVQ-1	75	88
Cords CX-227/TVQ-1 and CX-228/TVQ-1.....	76	88
Cord CX-229/TVQ-1	77	89
Power Unit PE-75-()	78	90

II. Installation and assembly of spotting components of Spotting Set AN/TVQ-1.

Siting	79	90
Locating phototheodolite supports	80	91
Wiring between battery and flank stations.....	81	92
Preparing spotting components for distribution to stations	82	92
Distributing spotting components to stations.....	83	92
Installing Theodolite MX-194/TVQ-1	84	93
Electrical connections of spotting components.....	85	93
Repacking spotting components.....	86	96

PART TWO. OPERATING INSTRUCTIONS FOR SPOTTING COMPONENTS OF SPOTTING SET AN/TVQ-1.

Section III. Technical operation.

Operating Time Interval Device PH-103.....	87	98
Operating Time Interval Multiplier PH-264-(*)	88	98
Preparing Theodolite MX-194/TVQ-1 for operation..	89	98
Operating spotting components of Spotting Set AN/TVQ-1	90	100
Performance check list	91	101

v

PART THREE. MAINTENANCE INSTRUCTIONS FOR SPOTTING COMPONENTS OF SPOTTING SET AN/TVQ-1.

	<i>Paragraph</i>	<i>Page</i>
<i>Section IV. General.</i>		
Preventive maintenance techniques	92	102
Preventive maintenance procedures	93	102
Lubrication	94	102
Moistureproofing and fungiproofing.....	95	102

PART FOUR. AUXILIARY EQUIPMENT (not used).

PART FIVE. REPAIR INSTRUCTIONS.

<i>Section V. Theory of operation of spotting components.</i>		
Group functioning of spotting components of Spotting Set AN/TVQ-1	96	104
Individual functioning of spotting components.....	97	106
<i>VI. Trouble shooting spotting components of Spotting Set AN/TVQ-1.</i>		
Trouble shooting	98	106

FILM DEVELOPING COMPONENTS OF SPOTTING SETS PH-32-B, PH-32-C, PH-32-D, AND PH-32-F; AND SPOTTING SET AN/TVQ-1

PART ONE. INTRODUCTION.

<i>Section I. Description.</i>		
Film Developing Components	99	109
Developing Equipment PH-41	100	109
Drying Rack PH-42	101	112
Bottles PH-22 and PH-136	102	113
Paddle PH-80	103	113
Funnel PH-175	104	114
Developer chemical	105	114
Fixing powder	106	114
<i>II. Installation and assembly of film developing components.</i>		
Location	107	114
Unpacking and checking	108	114
Assembling Developing Equipment PH-41	109	115
Assembling Drying Rack PH-42	110	115
Preparing developer solution	111	116
Preparing fixing solution	112	116
Disassembling and repacking film developing components	113	117

PART TWO. OPERATING INSTRUCTIONS FOR FILM DEVELOPING COMPONENTS.

<i>Section III. Technical operation.</i>		
General	114	119
Preparing tanks for processing operations.....	115	119

	<i>Paragraph</i>	<i>Page</i>
Processing exposed film	116	120
Precautions	117	124
Performance check list	118	126

PART THREE. MAINTENANCE INSTRUCTIONS FOR FILM DEVELOPING COMPONENTS.

<i>Section IV.</i> Preventive maintenance techniques.		
Meaning of preventive maintenance.....	119	129
Description of preventive maintenance.....	120	129
Hardware	121	129
Metal parts	122	129
Glass and wood parts	123	130
V. Itemized preventive maintenance of film developing components.		
Materials needed	124	130
Maintenance of Developing Equipment PH-41.....	125	130
Maintenance of Drying Rack PH-42	126	131
Maintenance of Bottles PH-22 and PH-136	127	131
Preventive maintenance check list	128	131
VI. Lubrication of film developing components.		
Lubrication	129	132
VII. Moistureproofing and fungiproofing of film developing components.		
Moistureproofing and fungiproofing	130	133

PART FOUR. AUXILIARY EQUIPMENT (not used).

PART FIVE. REPAIR INSTRUCTIONS.

<i>Section VIII.</i> Theory of operation of developing components.		
Functioning of film developing components.....	131	135
IX. Repairs to film developing components.		
General	132	136
Developing Equipment PH-41	133	136
Drying Rack PH-42	134	136
Unsatisfactory equipment report	135	137

**FILM VIEWING COMPONENTS OF SPOTTING SETS
PH-32-B, PH-32-C, PH-32-D, AND PH-32-F;
AND SPOTTING SET AN/TVQ-I**

PART ONE. INTRODUCTION.

<i>Section I.</i> Description.		
Film Viewing Components	136	141
Film Viewer PH-97-(*)	137	141
Rewinder PH-92	138	151
Splicer PH-91-(*)	139	152
Film cement	140	155

VII

	<i>Paragraph</i>	<i>Page</i>
II. Installation and assembly of film viewing components.		
Location	141	155
Film Viewer PH-97-(*)	142	155
Installing Rewinder PH-92	143	156
Installing Splicer PH-91-(*)	144	157
Repacking film viewing components	145	157
 PART TWO. OPERATING INSTRUCTIONS FOR FILM VIEWING COMPONENTS.		
<i>Section III. Technical operation.</i>		
Operating Rewinder PH-92	146	159
Operating Splicer PH-91-(*)	147	160
Operating Film Viewer PH-97-(*)	148	161
Performance check list	149	166
 PART THREE. MAINTENANCE INSTRUCTIONS FOR FILM VIEWING COMPONENTS.		
<i>Section IV. Preventive maintenance techniques.</i>		
Lenses	150	168
Batteries	151	168
V. Itemized preventive maintenance of film viewing components.		
Materials needed	152	169
Maintenance of Film Viewer PH-97-(*)	153	169
Maintenance of Rewinder PH-92	154	170
Maintenance of Splicer PH-91-(*)	155	170
Preventive maintenance check list for film viewing components	156	171
VI. Lubrication of film viewing components.		
Key to lubrication order abbreviations	157	172
Lubricating film viewing components	158	172
VII. Moistureproofing and fungiproofing film viewing components.		
Moistureproofing and fungiproofing	159	172
 PART FOUR. AUXILIARY EQUIPMENT (not used).		
 PART FIVE. REPAIR INSTRUCTIONS.		
<i>Section VIII. Theory of operation of film viewing components.</i>		
Functioning of Film Viewer PH-97-(*)	160	174
IX. Repairs to film viewing components.		
Repair of Film Viewer PH-97-(*)	161	175
Adjustments on Viewing Attachment PH-98-(*)	162	176
Adjustment of Splicer PH-91-(*)	163	177
 APPENDIX I. MAINTENANCE PARTS FOR SPOTTING SETS PH-32-(*) AND AN/TVQ-1		
		179
II. REFERENCES		
		181
INDEX		182

VIII

DESTRUCTION NOTICE

WHY —To prevent the enemy from using or salvaging this equipment for his benefit.

WHEN—When ordered by your commander.

HOW —1. Smash—Use sledges, axes, handaxes, pickaxes, hammers, crowbars, heavy tools.
2. Cut—Use axes, handaxes, machetes.
3. Burn—Use gasoline, kerosene, oil, flame throwers, incendiary grenades.
4. Explosives—Use firearms, grenades, TNT.
5. Disposal—Bury in slit trenches, fox holes, other holes. Throw in streams. Scatter.

USE ANYTHING IMMEDIATELY AVAILABLE FOR DESTRUCTION OF THIS EQUIPMENT

WHAT—1. Smash—Phototheodolite frame, camera, telescope, film, etc., junction box, time interval device, time interval multiplier, line connector unit, film viewer, developing equipment, batteries, and power unit.
2. Cut—Cords, cable of junction box, film, and wire.
3. Burn—Film, drying rack, carrying cases, wire cords, manuals, and photographic chemicals.
4. Bend—Axle RL-27.
5. Bury or scatter—Any or all of the above pieces after breaking.

DESTROY EVERYTHING

SPOTTING SETS
PH-32-B, PH-32-C, PH-32-D, and PH-32-F

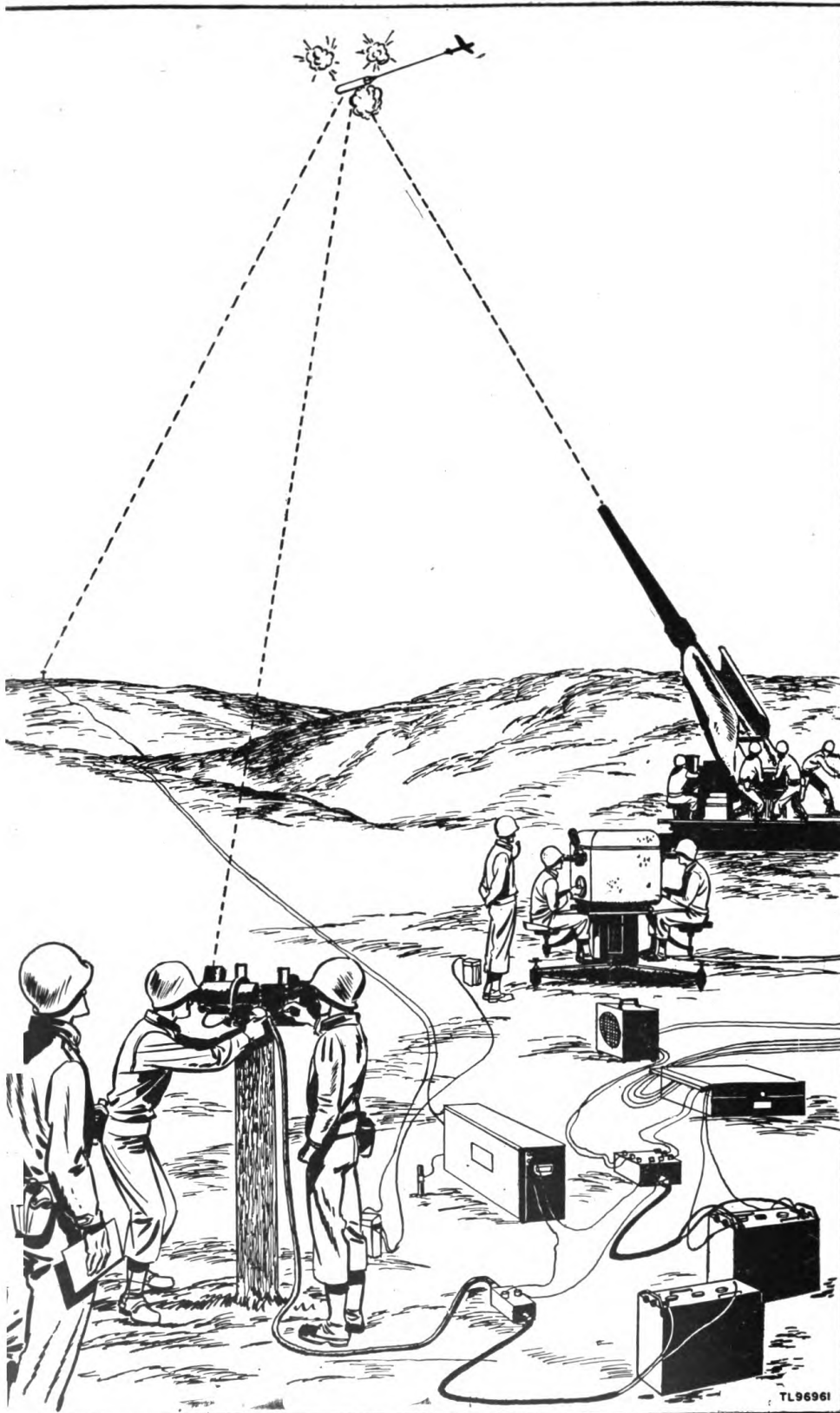

Figure 1. Spotting Set PH-32-B, PH-32-C, PH-32-D, or PH-32-F in use. The battery station phototheodolite with associated equipment is shown in the foreground, with the gun director and anti-aircraft gun shown in the middle right. The flank station, 4,000 to 5,000 yards distant, is shown in the left background. The broken lines indicate the theodolite lines of sight and the gun line of fire to the target.

This manual supersedes TM 11-434, 12 May 1942; TM 11-434D, 25 June 1943; and TM 11-434F, 14 March 1944.

PART ONE

INTRODUCTION

Section 1. DESCRIPTION

I. General

a. Spotting Sets PH-32-B, PH-32-C, PH-32-D, and PH-32-F are portable assemblies of equipment each of which is capable of measuring the vertical and horizontal angles of a point from two positions, and making motion picture records of that point with the angular measurements and a time identification included in each picture. The sets also contain equipment for processing the exposed films and exhibiting the finished films to be viewed for plotting purposes.

b. Basic type nomenclature including the symbol (*) instead of a suffix letter indicates any one or all of the models of that particular equipment which are covered in this manual. For example:

(1) Spotting Set PH-32-(*) indicates any one or all of Spotting Sets PH-32-B, PH-32-C, PH-32-D, and PH-32-F.

(2) Theodolite PH-(*)-33 indicates any one or all of Theodolites PH-BC-33, PH-BD-33, PH-BE-33, PH-BF-33, PH-BG-33, and PH-BH-33.

(3) Exposure Meter PH-252-(*) indicates any one or all of Exposure Meters, PH-252, PH-252-A, PH-252-B, PH-252-C, and PH-252-E.

(4) Time Interval Multiplier PH-264-(*) indicates any one or all of Time Interval Multipliers PH-264-A, PH-264-B, and PH-264-C.

(5) Axle RL-27-(*) indicates any one or all of Axles RL-27, RL-27-A, and RL-27-B.

(6) Reel Unit RL-31-(*) indicates any one or all of Reel Units RL-31, RL-31-B, and RL-31-C.

(7) Film Viewer PH-97-(*) indicates any one or all of Film Viewers PH-97, PH-97-A, PH-97-B, PH-97-C, and PH-97-D.

(8) Splicer PH-91-(*) indicates either Splicer PH-91 or PH-91-A or both.

(c) In use, one phototheodolite, the timed-signal generating equipment, and some of the equipment which reproduces audibly the timed signals, are electrically connected and are located in the immediate vicinity of the anti-aircraft battery. The other phototheodolite and the remaining signal reproducing equipment are electrically connected to the group at the battery station, but are located some distance away on the flank. Both phototheodolites are aimed directly on the target on which the anti-aircraft guns are trained, the phototheodolites simultaneously taking motion pictures of the target and shellbursts from different positions. Figure 2 is a block diagram of the usual installation of the spotting components of Spotting Set PH-32-(*).

(2) The *film developing components* include equipment and supplies for developing and drying the motion picture film exposed in the phototheodolites.

(3) The *film viewing components* include equipment for rewinding and splicing, and a special machine for examining the finished film. The data obtained from examination of two pictures of the same target, taken at the same moment but from different positions, permit determination in all dimensions of the absolute position of the target and any shellbursts shown. Also, the path and speed of the target can be plotted from the results of a series of such determinations.

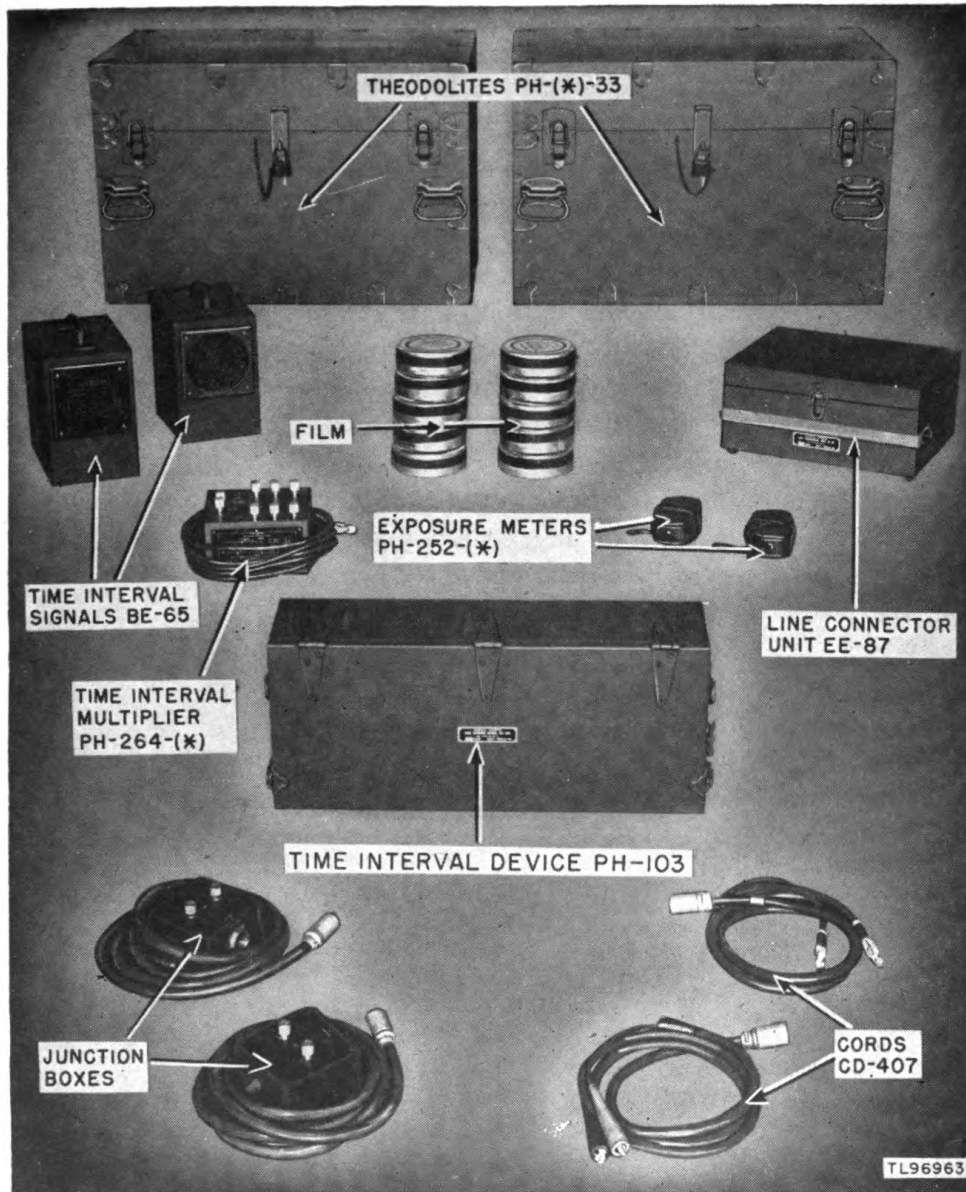

Figure 3. Spotting components of Spotting Set PH-32-(*). (Other components shown in figures 4, 5, and 6.)

3. Table of Major Components of Spotting Set PH-32-(*)

a. SPOTTING COMPONENTS (fig. 3). The spotting components (par. 2b(1)) of Spotting Set PH-32-(*) are:

Quan	Component	Dimensions (in.)			Volume (cu ft)	Weight (lb)
		Length	Width	Height		
2	Theodolite PH-(*)-33 in carrying case.	30 to 36	20 to 24	18 to 21	6.9 to 9.4	160 to 230
2	Junction Box JB-40 (packed one in each theodolite carrying case).	120 (cord)	4.5 x 4.5 x 2.5 (box)		.05	7.5
2	Cord CD-407 (packed one in each theodolite carrying case).	84	-----		.01	1.5
2	Exposure Meter PH-252-(*) (usually packed one in each theodolite carrying case).	4.25	2.75	1.75	.01	.75
10 rolls	Film, 35-mm motion picture, 200 feet long.	5.5	5.5	1.75	.03	1.25
1	Time Interval Device PH-103.	27	12	7	1.3	23
1	Time Interval Multiplier PH-264-(*).	84 (cord)	6.5 x 5.75 x 4		.23	6
1	Line Connector Unit EE-87..	14.25	11.25	6.875	.64	25
2	Time Interval Signal BE-65..	10.875	11.5	6.5	.47	18

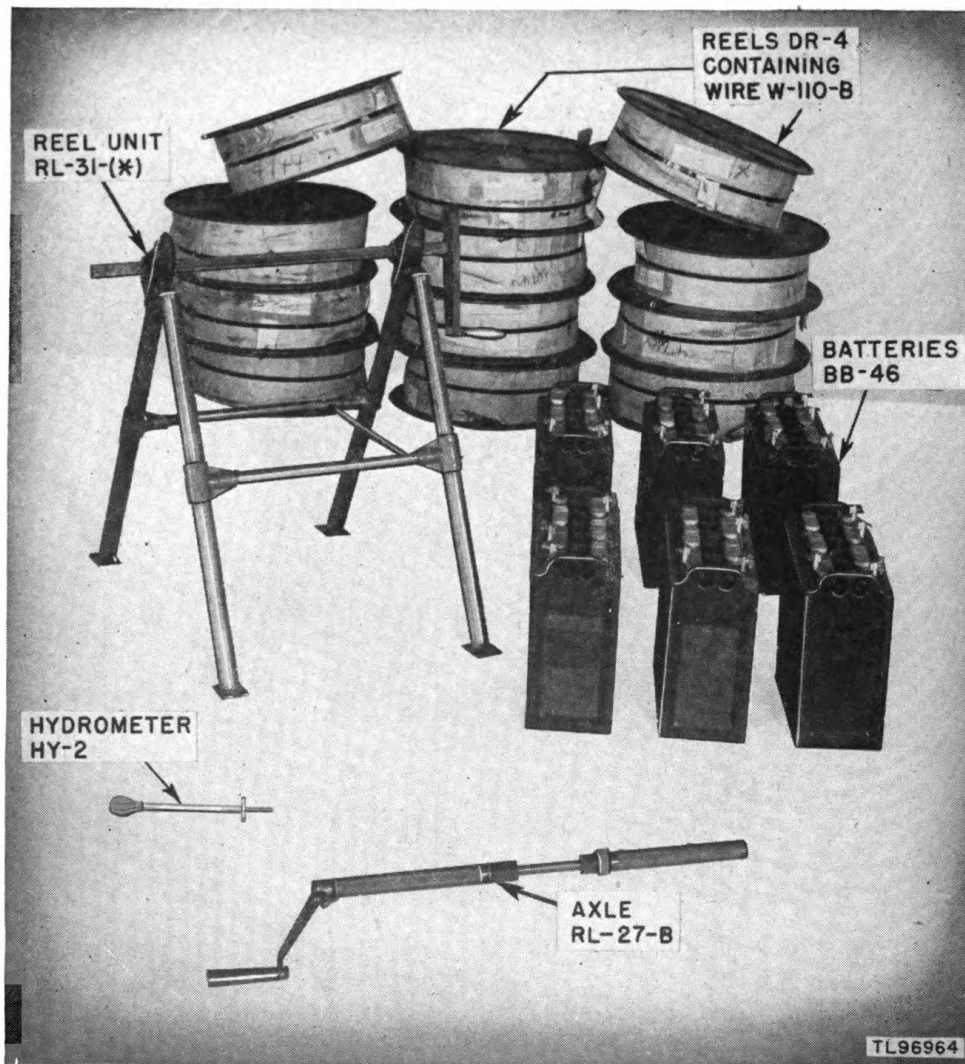

Figure 4. Wire and power components of Spotting Set PH-32-(*). (Other components shown in figures 3, 5, and 6.)

b. WIRE AND POWER COMPONENTS (fig. 4). The wire and power components (par. 2b(1)(b)) of Spotting Set PH-32-(*) are:

Quan	Component	Dimensions (in.)				Volume (cu ft)	Weight (lb)
		Length	Width	Height	Diam		
6	Battery BB-46.....	21	12	20	-----	2.9	122
1	Hydrometer HY-2..	12	-----	-----	2	.02	0.5
1	*Axle RL-27-(*)....	27.25 to 29	4.5 (crank)	-----	1.75	.035 to .185	5 to 9
1	*Reel Unit RL-31-(*)	2.5	32	30.5	-----	1.4	33.6 to 55.5
	Installation Kit (for above).	30.5	8.5	4	-----	0.51	22.5
12	Reel DR-4 contain- ing ½ mile Wire W-110-B.	-----	-----	7	22.25	1.5	82

* Specific information about the weight and dimensions of each model of these components is given in the reference indicated below:

Axle RL-27-(*), paragraph 13.

Reel Unit RL-31-(*), TM 11-362.

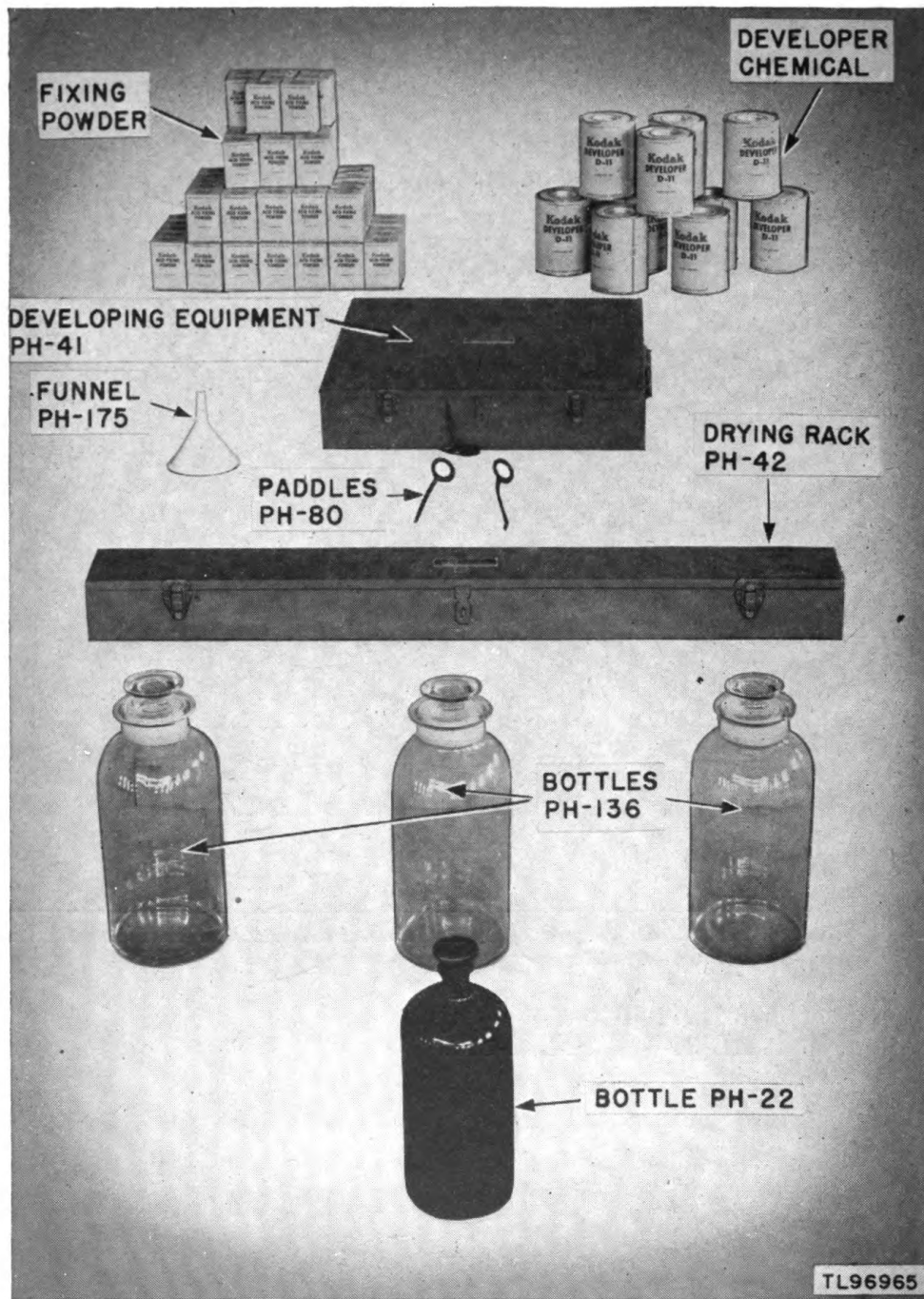

Figure 5. Film developing components of Spotting Set PH-32-(*). (Other components shown in figures 3, 4, and 6.)

c. FILM DEVELOPING COMPONENTS (fig. 5). The film developing components (par. 2b(2)) of Spotting Set PH-32-(*) are:

Quan	Component	Dimensions (in.)				Volume (cu ft)	Weight (lb)
		Length	Width	Height	Diam		
1	Developing Equipment PH-41 in carrying case.	26	26	5	-----	1.9	50
1	Drying Rack PH-42 in carrying case.	50	5	4	-----	.57	12
10 cans	Chemical, developer (Eastman Kodak Co. D-11).	-----	-----	8	5.5	.12	6
40 cans	Chemical, acid fixing powder, 1-gal size.	-----	-----	4.5	3.5	.025	2
or 40 jars	Chemical, acid fixing powder, 1-gal size.	-----	-----	6	3.5	.033	2.5
or 80 pkgs	Chemical, acid fixing powder, 1/2-gal size.	3	1.5	5	-----	.013	1
1	Bottle PH-22	-----	-----	14	6	.22	4
3	Bottle PH-136	-----	-----	18	8	.52	7.5
1	Funnel PH-175	-----	-----	7	4	.05	.5
2	Paddle PH-80	12	2.5	-----	-----	.02	.25

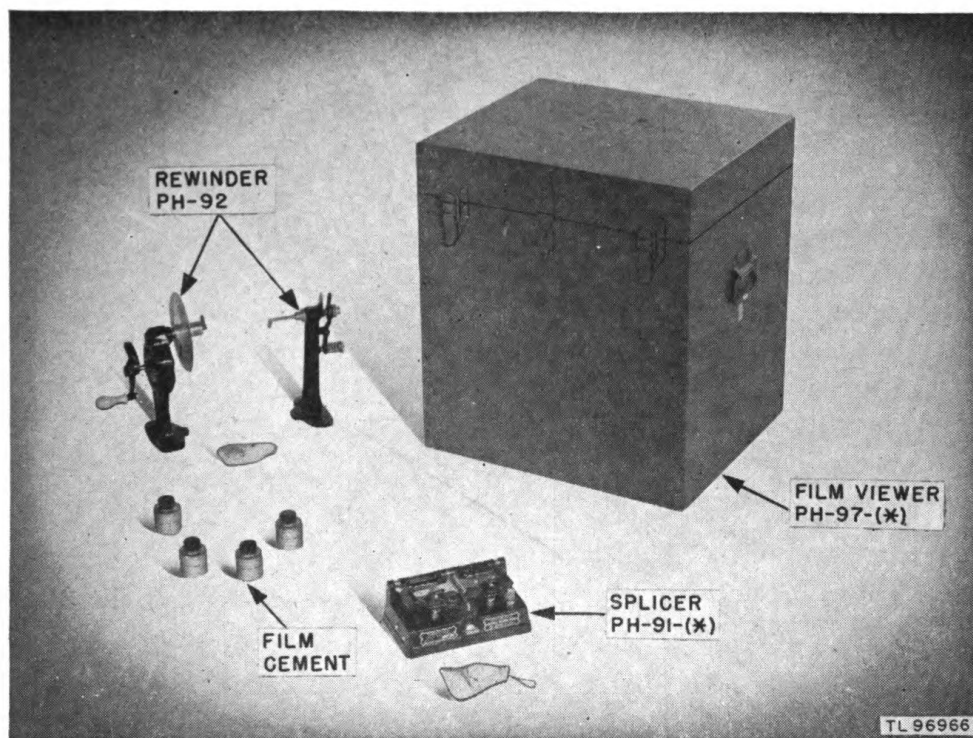

Figure 6. Film viewing components of Spotting Set PH-32-(*). (Other components shown in figures 3, 4, and 5.)

d. FILM VIEWING COMPONENTS (fig. 6). The film viewing components (par. 2b(3)) of Spotting Set PH-32-(* are:

Quan	Component	Dimensions (in.)				Volume (cu ft)	Weight (lb)
		Length	Width	Height	Diam		
1	*Film Viewer PH-97-(*), in carrying case.	20 to 22	17 to 19	20 to 24	-----	3.5 to 5.5	100 to 125
1	Rewinder PH-92	12	9	8	-----	.5	10
1	*Splicer PH-91-(*)	8.25	5 to 5.5	3.25 to 3.75	-----	.08 to .1	6 to 8
2 bots	Cement, nitrate film splicing, 4 oz.	-----	-----	5	2	.009	.5
or 4 cans	Cement, nitrate film splicing, 2 oz.	-----	-----	2.5	2	.004	.25

* Specific information about the weight and dimensions of each model of these components is given in the following appropriate reference:

Film Viewer PH-97-(*), paragraph 137a(2).

Splicer PH-91-(*), paragraph 139a(2).

4. Table of Power Requirements for Spotting Set PH-32-(*)

The power requirement of each type of component of Spotting Set PH-32-(*) is given in the following table:

Component	Volts (d-c)	Source			
		Quan	Type	Volts	Remarks
Theodolite PH-(*)-33---	12	1	Battery BB-46	12	Supplied with spotting set but without electrolyte, which must be procured separately.
Time Interval Device PH-103 interval circuit.	45	1	Battery BA-26	45	Not supplied with spotting set. Must be procured separately.
Time counter circuit	45	1	Battery BA-26	45	
Time Interval Multiplier PH-264-(*).	12	1	Battery BB-46	12	Supplied with spotting set but without electrolyte, which must be procured separately.
Time Interval Signal BE-65.	3	2	Battery BA-23	1.5	Not supplied with spotting set. Must be procured separately.
Line Connector Unit EE-87.	12	-----	(Same source as Time Interval Multiplier PH-264-(*).)		
Film Viewer PH-97-(*)	-----	-----	(Any available 110-v, 60-cycle, a-c, or 110-v, d-c, circuit installation.)		

5. Descriptions of Components of Spotting Set PH-32-(*)

a. SPOTTING AND WIRE AND POWER COMPONENTS (figs. 3 and 4). Descriptions of the spotting and wire and power components of Spotting Set PH-32-(*) are contained in succeeding paragraphs of this section.

b. FILM DEVELOPING COMPONENTS (fig. 5). Descriptions of the film developing components of Spotting Set PH-32-(*) are contained in section I, "Film Developing Components of Spotting Sets PH-32-(*) and Spotting Set AN/TVQ-1."

c. FILM VIEWING COMPONENTS (fig. 6). Descriptions of the film viewing components of Spotting Set PH-32-(*) are contained in section I, "Film Viewing Components of Spotting Sets PH-32-(*) and Spotting Set AN/TVQ-1."

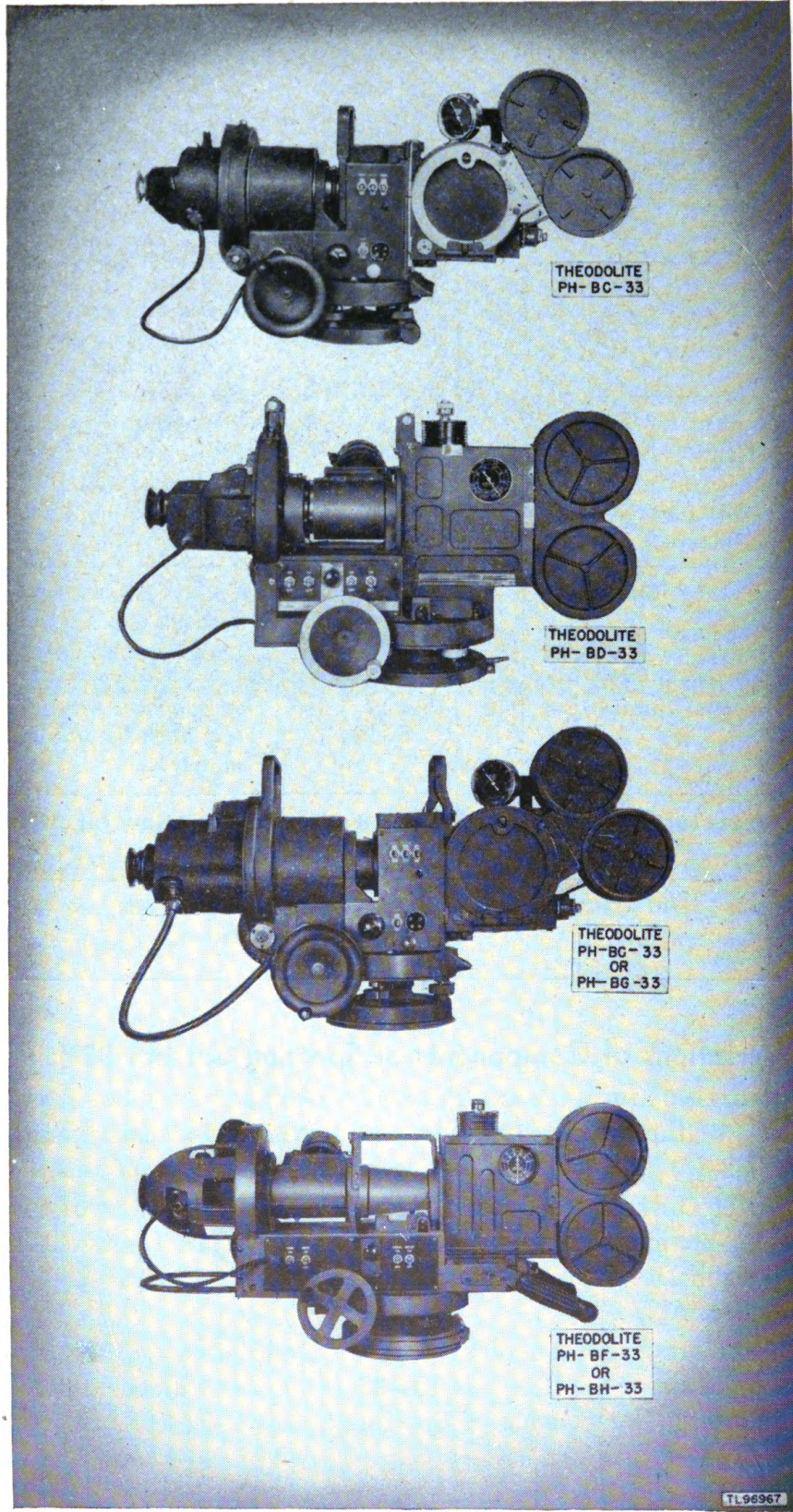

Figure 7. Various models of Theodolite PH-(*)-33.

6. Theodolite PH-(*)-33 (fig 7)

a. Two Theodolites PH-(*)-33 are the instruments provided with Spotting Set PH-32-(*) to make angular measurements of a target from two different points and obtain motion picture records of the target and its measurements (par. 2).

b. There are six models of Theodolite PH-(*)-33: Theodolites PH-BC-33, PH-BD-33, PH-BE-33, PH-BF-33, PH-BG-33, and PH-BH-33. Each model consists essentially of a telescope and a motion picture camera mounted together on a frame so that when the telescope is manually directed on a target, the camera is trained on the same target.

c. Detailed description and instructions on the use and maintenance of Theodolite PH-(*)-33 are contained in TM 11-2534.

7. Junction Box JB-40 and Cord CD-407 (fig. 8)

a. Two Junction Boxes JB-40 and two Cords CD-407 are the means provided with Spotting Set PH-32-(*) to connect the two Theodolites PH-(*)-33 (par. 6) to the required electrical power supply. One Junction Box JB-40 and one Cord CD-407 are packed in each theodolite carrying case.

Note. Theodolite PH-BD-33 uses a junction box similar in appearance and for the same purpose as Junction Box JB-40, but its internal wiring is different and consequently they are not interchangeable. (For additional data see TM 11-2534.)

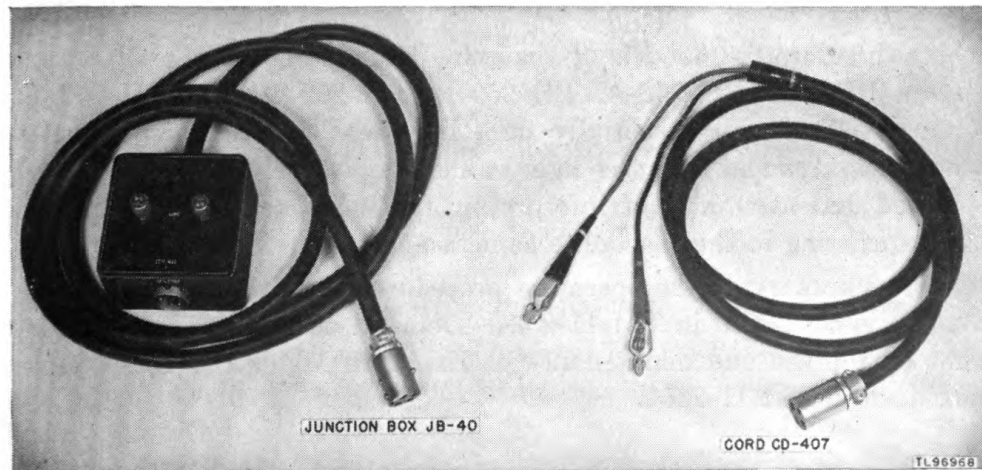

Figure 8. Junction Box JB-40 and Cord CD-407.

b. Junction Box JB-40 consists of a small connection box with a socket and two binding posts and an attached four-conductor cable and plug.

c. Cord CD-407 consists of a length of two-conductor cable terminated at one end in a plug and at the other end with alligator clips.

8. Exposure Meter PH-252-(*) (fig. 9)

a. Exposure Meter PH-252-(*) is the instrument provided with Spotting Set PH-32-(*) for measuring the prevailing light intensity (brightness) to determine the proper adjustment of the theodolite camera lens aperture.

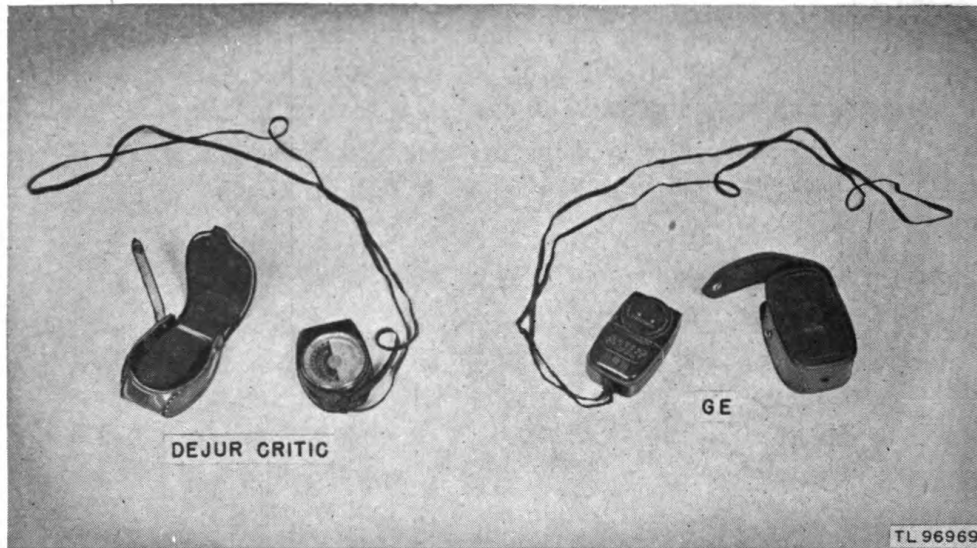

Figure 9. Latest types of Exposure Meter PH-252-(*) furnished with Spotting Set PH-32-(*) .

b. There are five models of Exposure Meter PH-252-(*) : Exposure Meters PH-252, PH-252-A, PH-252-B, PH-252-C, and PH-252-E. Each model consists essentially of a light-sensitive cell and a meter which measures and indicates light values, respectively, and a manually operated dial assembly for interpreting the value according to certain factors existing in the theodolite camera at the time.

c. A summary of the operating procedure for Exposure Meter PH-252-(*) is contained in TM 11-2534. Detailed description and instructions on the use and maintenance of Exposure Meter PH-252-(*) are contained in TM 11-2351.

9. Time Interval Device PH-103 (fig. 10)

a. GENERAL. Time Interval Device PH-103 is a portable apparatus designed to provide a 45-volt, d-c impulse at 1-second intervals for intermittent operation of other electrical apparatus. Circuits for making continuity and ground tests on associated wire lines are included in the device. The timing and test circuits are assembled on a panel which is mounted in a wooden case which contains space for operating batteries.

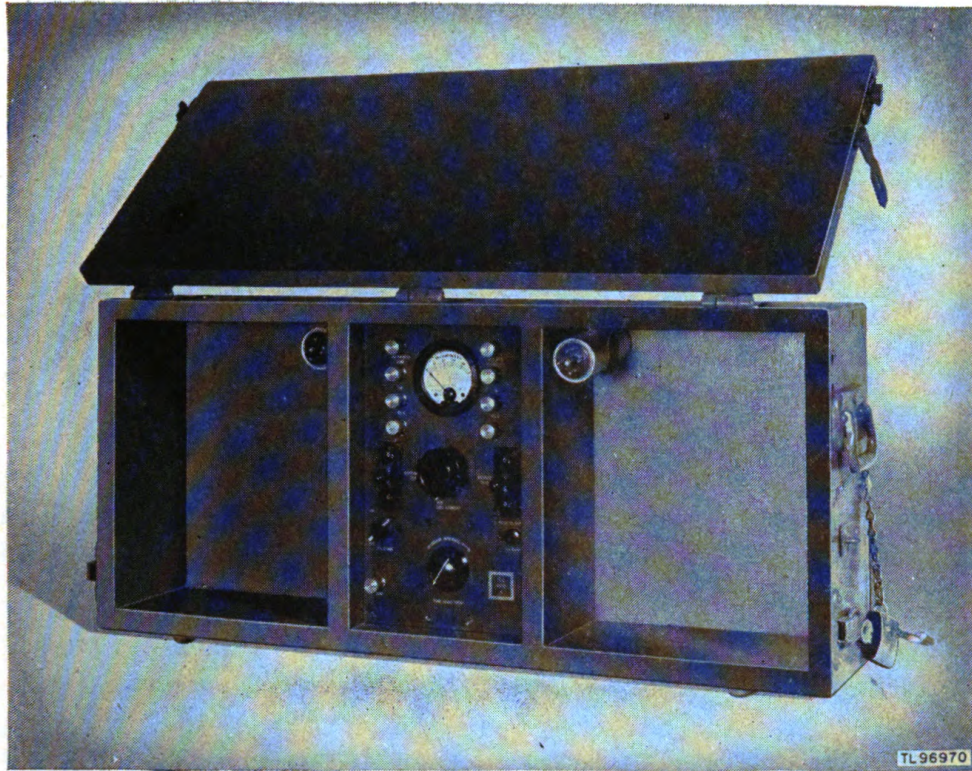

Figure 10. Time Interval Device PH-103, front open.

b. APPLICATION. Time Interval Device PH-103 is the device provided with Spotting Set PH-32-(*) to supply the timed 45-volt impulse of direct current required by the time counters of the spotting set theodolites, and also required by Time Interval Multiplier PH-264-(*) (par. 9).

c. COMPONENTS (fig. 11). Time Interval Device PH-103 consists of the following major components:

- 1 case.
- 1 panel assembly.
- 2 can type capacitors (running spares).

d. CASE. (1) The case of Time Interval Device PH-103 is a wooden box provided with a hinged front which has trunk catches and a hasp and staple with padlock for closing. Two carrying handles also are provided, and the bottom of the case is fitted with resilient bumpers.

(2) The inside of the case is divided into three compartments. Each of the two end compartments provides space for a Battery BA-26, and each of these compartments is provided with a strap (clip) for holding one of the two spare can type capacitors in the upper inside corner. The middle compartment contains the panel assembly (*e* below), fastened in place with four corner screws. The wiring diagram of Time Interval Device PH-103 is pasted on the inside back of this compartment.

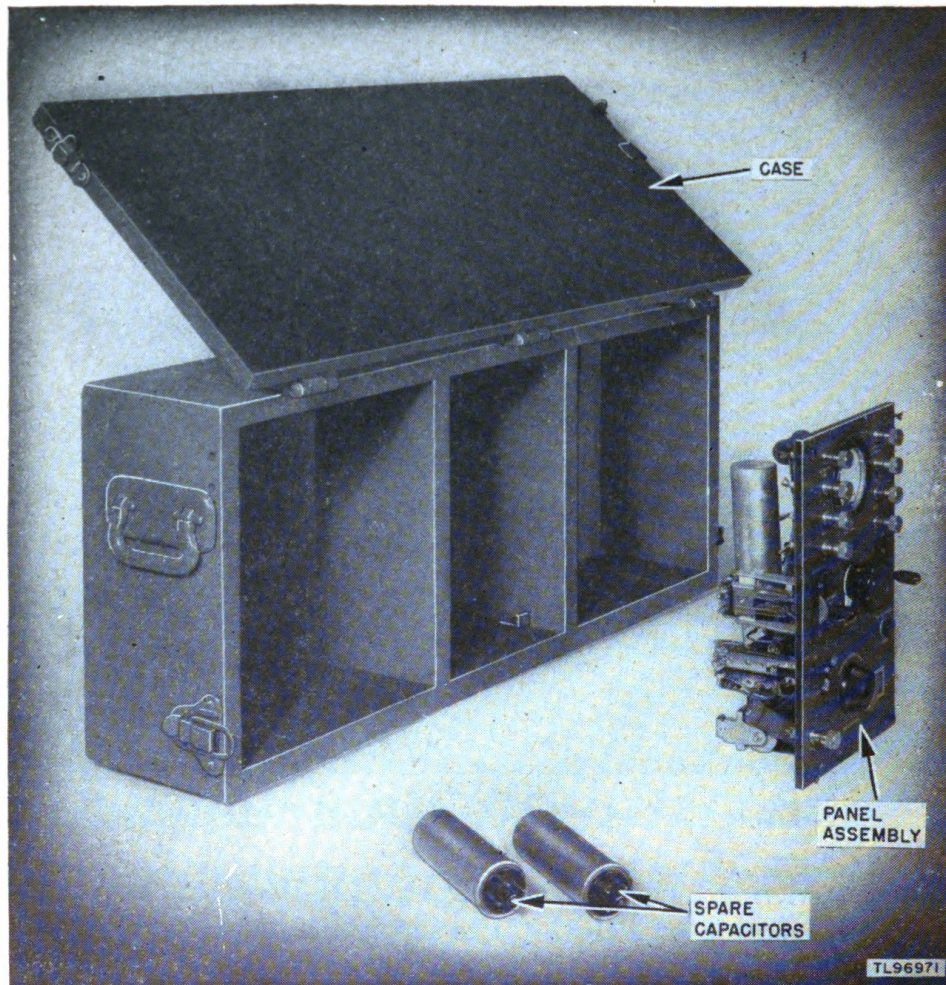

Figure 11. Component parts of Time Interval Device PH-103.

(3) The end pieces and partitions of the case are provided with holes near the top front edge for running connecting wires to the panel without interfering with the closing of the hinged front of the case.

e. **PANEL ASSEMBLY.** The panel assembly of Time Interval Device PH-103 is a bakelite panel with certain control and connection fixtures mounted on the front, and with other fixtures and the wiring for the whole assembly mounted on the back.

- (1) The following are mounted and labeled on the front of the panel:
- 1 milliammeter.
 - 2 nonlocking key switches, one labeled CONTINUITY TEST and one labeled GROUND TEST.
 - 1 push-button switch labeled T.I. SHORT.
 - 1 rotating switch labeled T.I. START.
 - 1 rheostat labeled MIN. LINE CURRENT.

1 potentiometer labeled TIME ADJUSTMENT.

9 binding posts; one pair labeled O₂ CAMERA LINE, one pair labeled JCT. BOX O₁ CAMERA, two pair each labeled 45V with polarity of each post designated, and a single post labeled GRD.

(2) The following are mounted on the back of the panel:

2 relays.

1 can type capacitor.

2 fixed resistors.

Wiring which connects all the various fixtures of the panel assembly.

f. ORIGINAL PACKAGING. Time Interval Device PH-103 sometimes is originally shipped with the panel assembly removed from the case. Once assembled by fastening the panel assembly in the middle compartment, the time interval device is ready for use.

10. Time Interval Multiplier PH-264-(*) (fig. 12)

a. GENERAL. Time Interval Multiplier PH-264-(*) is a portable apparatus designed to multiply an input of a timed 1-second, 45-v, d-c impulse into an output of two 12-v, d-c impulses timed at 5- and 10-second intervals, respectively, for intermittent operation of other electrical apparatus. The circuits are assembled in a small wooden box which is covered by a panel and provided with a connecting cable.

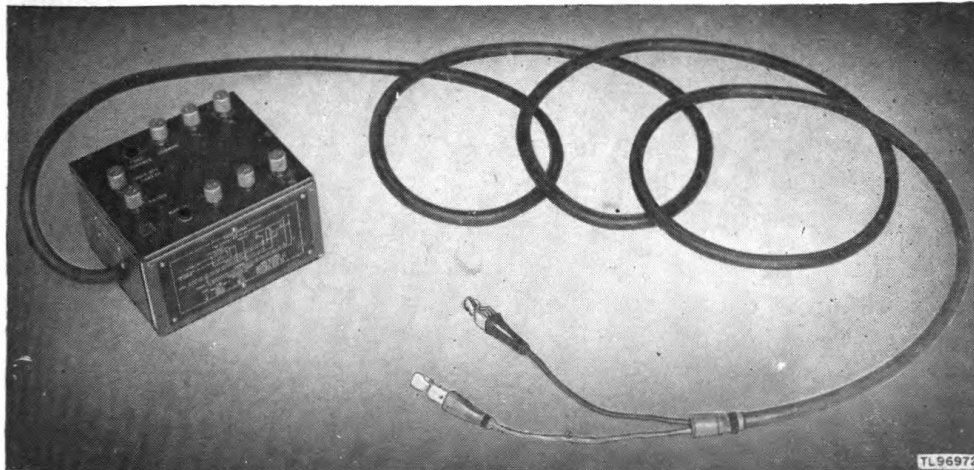

Figure 12. Time Interval Multiplier PH-264-(*).

b. APPLICATION. Time Interval Multiplier PH-264-(*) is the device provided with Spotting Set PH-32-(*) to supply the timed 12-volt impulses of direct current required by Line Connector Unit EE-87 (par. 11) and Time Interval Signals BE-65 (par. 12).

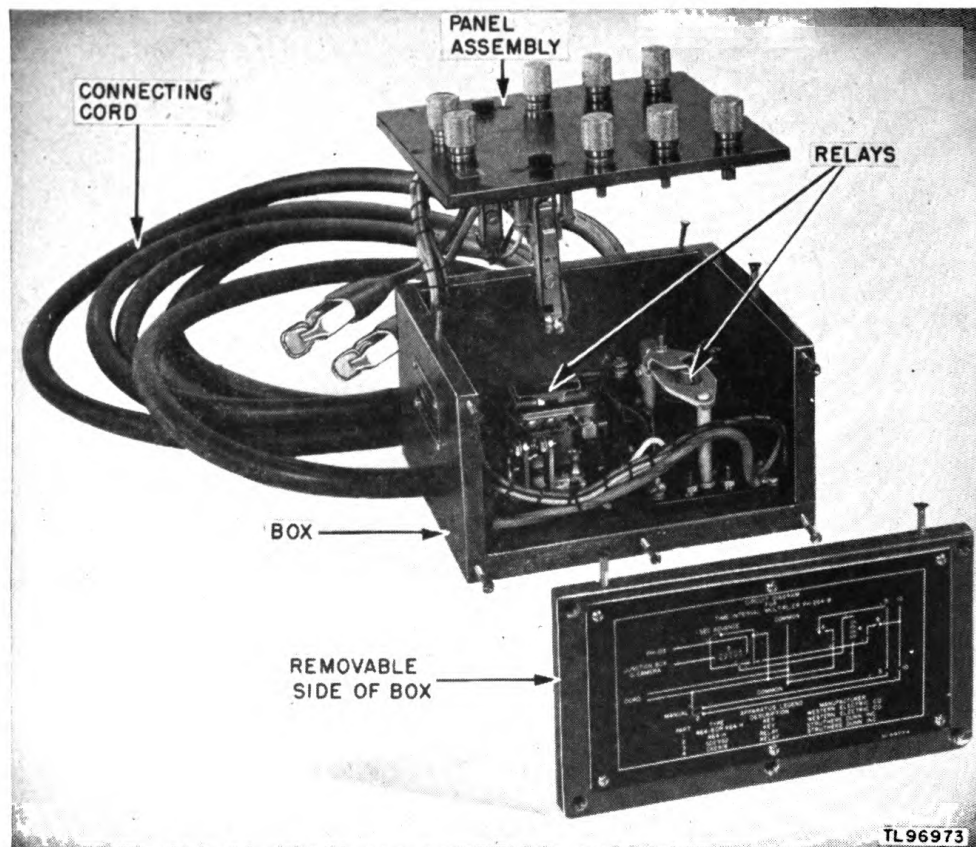

Figure 13. Component parts of Time Interval Multiplier PH-264-(*).

c. COMPONENTS (fig. 13). Time Interval Multiplier PH-264-(*) consists of the following major components:

- 1 box.
- 2 relays.
- 1 panel assembly.
- 1 connecting cable.

d. Box. The box of Time Interval Multiplier PH-264-(*) is wooden and is closed at the top by a panel (*f* below) which is fastened on by six screws. One side of the box is removable, being held in place by corner screws. A diagram of the multiplier circuit is fastened to the outside face of the removable side of the box.

e. RELAYS. The two relays of Time Interval Multiplier PH-264-(*) are mounted inside the box (*d* above). One relay is a line relay controlling a single contact. The other relay is a stepping relay operating a ratchet wheel which controls two cam-operated contacts.

f. PANEL ASSEMBLY. The panel assembly of Time Interval Multiplier PH-264-(*) is a bakelite panel bearing eight binding posts and two push-button switches.

- (1) The binding posts are marked as follows:
 - 2 posts each labeled with the numeral 10.
 - 2 posts each labeled with the numeral 5.
 - 2 posts each labeled COMMON.
 - 1 post labeled PH-103.
 - 1 post labeled JUNCT. BOX O₁ CAMERA.
- (2) The push-button switches are marked as follows:
 - 1 button labeled 1 SEC. ADVANCE.
 - 1 button labeled MANUAL.

g. **CONNECTING CABLE.** The connecting cable of Time Interval Multiplier PH-264-(*) is a two-conductor synthetic-rubber-covered cable about 12½ feet long. One end is fastened by a clamp inside the box (*d* above). The other end is separated into the two conductors and the end of each conductor is provided with an alligator clip for connection to the terminals of a battery.

II. Line Connector Unit EE-87 (fig. 14)

a. Line Connector Unit EE-87 is the electrical device provided with Spotting Set PH-32-(*) to produce a tone on telephone lines used by



Figure 14. Line Connector Unit EE-87.

the visual record section of the anti-aircraft battery. Line Connector Unit EE-87 is used in conjunction with Time Interval Multiplier PH-264 (par. 10).

b. Line Connector Unit EE-87 is composed essentially of a multiple relay and a tone producing circuit connected to a panel on which are mounted and labeled sixteen binding posts and two key switches. This equipment is contained in a portable wooden case with a hinged cover.

c. Detailed description and instructions on the use and maintenance of Line Connector Unit EE-87 are contained in TM 11-433.

12. Time Interval Signal BE-65 (fig. 15)

a. Two Time Interval Signals BE-65 are the electrical devices provided with Spotting Set PH-32-(*) to supply audible signals at regular intervals. Time Interval Signal BE-65 is used in conjunction with Time Interval Multiplier PH-264-(*) (par. 10).



Figure 15. Time Interval Signal BE-65.

b. Time Interval Signal BE-65 consists essentially of a relay and an electric vibrator horn housed in a heavy metal case provided with a carrying handle. The carrying case has a hinged back giving access to a terminal panel and to a space for two Batteries BA-23.

c. Detailed description and instructions on the use and maintenance of Time Interval Signal BE-65 are contained in TM 11-433.

13. Axle RL-27-(*) (fig. 16)

a. Axle RL-27-(*) is one of the means provided with Spotting Set PH-32-(*) for handling the reels of Wire W-110-B (par. 16). Reel Unit RL-31-(*) (par. 14) is the other means.

b. There are three models of Axle RL-27-(*): Axles RL-27, RL-27-A, and RL-27-B. The weights and dimensions of each model are as follows:

Model	Dimensions (in.)			Volume (cu ft)	Weight (lb)
	Length	Width	Diam		
Axle RL-27	27.25	1.75	.035	5
Axle RL-27-A	27.25	1.75	.035	5
Axle RL-27-B	29	4.5 (crank)	1.75	.185	9

c. Except for the types of bearings and the use of a crank, all models are constructed essentially as follows:

(1) A solid round metal bar is mounted so that it will rotate in bearings contained in two tubular metal handles which inclose the bar for the greater portion of its length at each end.

(a) Axle RL-27 has solid bronze bearings in the handles.

(b) Axles RL-27-A and RL-27-B have pin type roller bearings in the handles.

(2) The uninclosed middle section of the bar is provided with two squared sections of metal which are pinned integral with the bar. These sections are positioned so they will fit the squared holes in the hub of Reel DR-4 (par. 15).

(3) The inside end of one of the handles is provided with a knurled ring which actuates a spring catch to permit removal of this handle from the bar.

(4) The removable handle end of the bar is tapered to facilitate insertion through the hub of Reel DR-4 and back into place in the handle, which then locks the reel on the axle.

(5) In Axle RL-27-B one end of the bar extends through the *non-removable* handle about 1¼ inches and is squared to receive Crank GC-15 which is a component of this model. The hub of the crank is provided with a spring catch which fits a hole in the squared end of the bar. Axles RL-27 and RL-27-A do not have the squared end and crank.

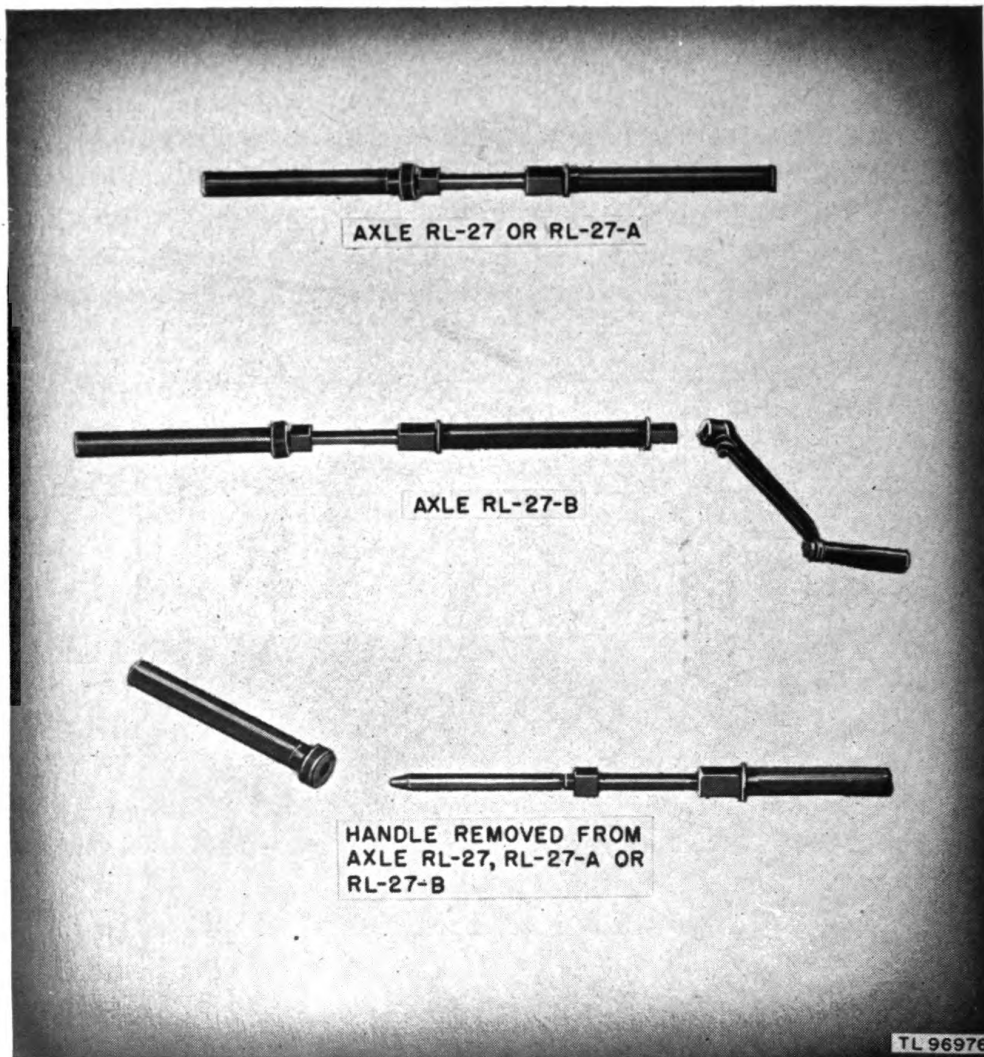

Figure 16. Axle RL-27-(*).

14. Reel Unit RL-31-(*). (fig. 17)

a. Reel Unit RL-31-(*). is one of the means provided with Spotting Set PH-32-(*). for handling the reels of Wire W-110-B (par. 15). Axle RL-27-(*). (par. 13) is the other means.

b. There are three models of Reel Unit RL-31-(*): Reel Units RL-31, RL-31-B, and RL-31-C. All models consist of the following components:

- (1) A collapsible, H-type metal frame equipped with a bearing assembly to support an axle.
- (2) A brake unit and crank to control the rotation of the axle.
- (3) Canvas shoulder straps to facilitate in hand-carrying the assembly.

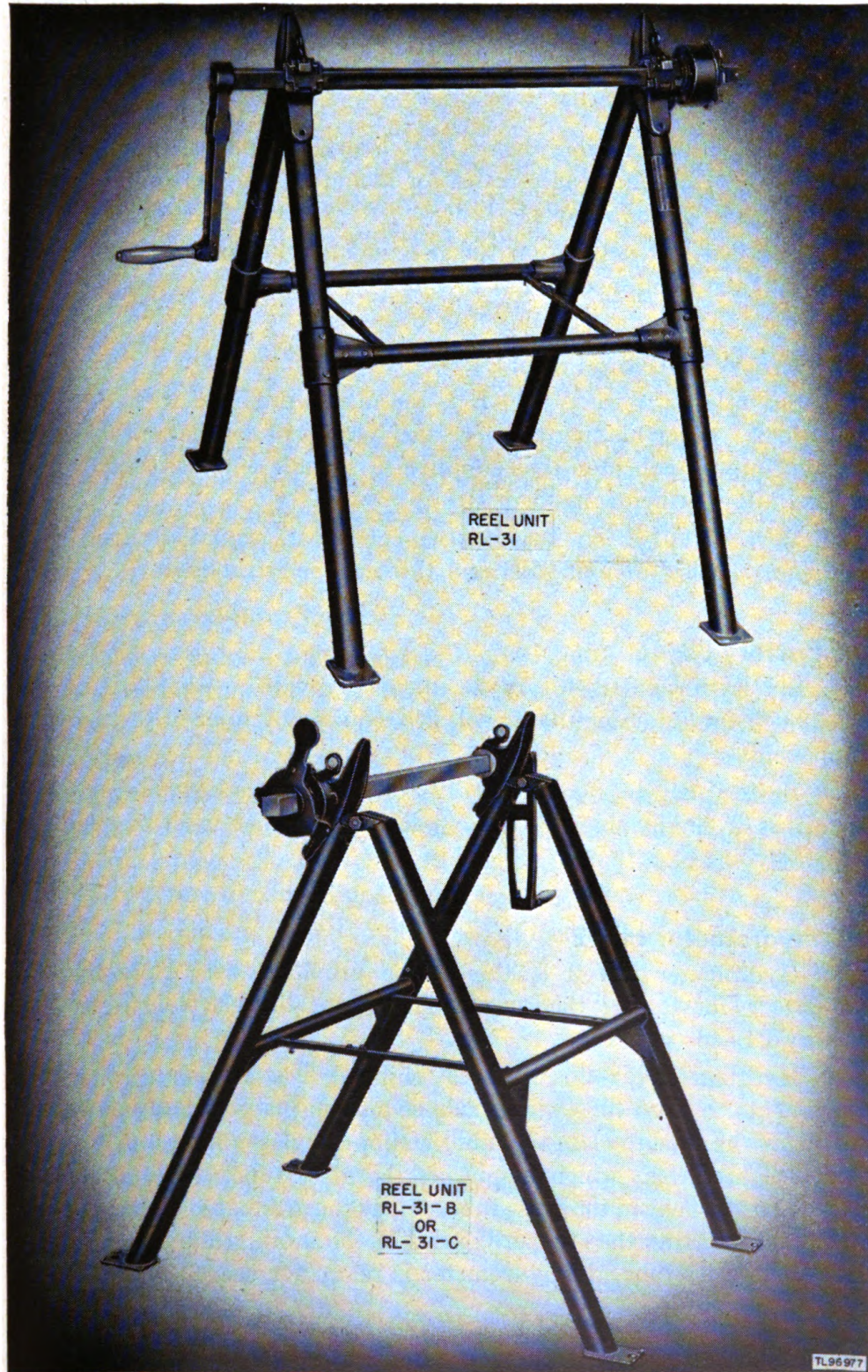

Figure 17. Reel Unit RL-31-(*).

(4) Tail gate hangers for mounting the reel unit on a "station wagon" type of vehicle and toe clamps for mounting the reel unit on the floor of a truck.

(5) The necessary nuts, bolts, and washers for mounting the reel unit.

(6) In addition to the above, Reel Unit RL-31-C also includes a mounting kit containing accessories for mounting the reel unit on back of an O-truck, 1/4-ton, 4 by 4.

c. Detailed instructions on the use and maintenance of Reel Unit RL-31-(*) are contained in TM 11-362.

15. Wire W-110-B on Reel DR-4

a. Six miles of Wire W-110-B is the means provided with Spotting Set PH-32-(*) for making the necessary electrical connections between the spotting components. It is supplied in 1/2-mile lengths, each wound on Reel DR-4, which is made of steel.

b. Wire W-110-B is a twisted, two-conductor, insulated wire. Each conductor consists of four steel and three copper strands.

16. Battery BB-46

a. Six Batteries BB-46 are the means provided with Spotting Set PH-32-(*) for obtaining the 12-volt d-c required by some of the spotting components.

b. Battery BB-46 is a six-cell, 12-volt, 75 ampere-hour storage battery. It is originally shipped without electrolyte which must be procured separately.

17. Hydrometer HY-2

a. Hydrometer HY-2 is the means provided with Spotting Set PH-32-(*) for testing the specific gravity of the electrolyte used in Battery BB-46 (par. 16).

b. Hydrometer HY-2 is originally shipped disassembled into its three components: a glass tube with a rubber bulb in place at one end; a soft rubber intake tube to close the other end of the glass tube; and a graduated, weighted float which fits inside the glass tube. Once assembled by placing the float in the glass tube so that the graduated stem is uppermost, and inserting the stopperlike end of the intake tube into the open end of the glass tube, the hydrometer is ready for use.

18. Film

a. The 200-foot rolls of film provided with Spotting Set PH-32-(*) are for use in the film magazines of the theodolite cameras.

b. The film is a commercial shellburst panchromatic, perforated, 35-mm, safety, motion-picture film. Each roll is supplied wrapped in lightproof paper and packed in 1½ in. cardboard boxes, or in a metal can, to exclude all light.

Section II. INSTALLATION AND ASSEMBLY OF SPOTTING COMPONENTS OF SPOTTING SET PH-32-(*)

19. Siting

Two outdoor sites are required for installation of the spotting components of Spotting Set PH-32-(*). One site is located in the vicinity of the antiaircraft battery and is called the *battery* or O_1 station, and the other is located out on the flank and is called the *flank* or O_2 station. Each site must be provided with a special support for a phototheodolite, and these supports must be located exactly with respect to each other, to the antiaircraft battery, and to the path of the target.

20. Phototheodolite Support

The standard support for a spotting set theodolite should be a combination steel and concrete pier constructed as described in *a* below. A wooden support, such as described in *b* below, can be used if a concrete-steel support is not available.

a. CONCRETE-STEEL SUPPORT (fig. 18). The concrete-steel support for a phototheodolite consists of a ¼-inch steel plate welded to the end of a 3-inch steel pipe which extends 12 inches from the smaller end of a tapered concrete pedestal 7 feet long.

(1) The concrete pedestal measures 16 inches square at the base and tapers to 8 inches square at the top.

(2) The steel pipe is 30 inches long with 18 inches of its length embedded into the concrete.

(3) The steel plate is about 7¾ inches in diameter and is drilled for mounting the base ring of the phototheodolite.

b. WOODEN SUPPORT (fig. 19). A satisfactory wooden support for a phototheodolite is an 8- by 8-inch post, 8 feet long, which is provided with ground braces consisting of several 2- by 4-inch boards nailed across the sides of the post near one end.

(1) The top surface of the post must be squared to provide a flat surface for mounting the base ring of the phototheodolite with lag screws.

(2) Eight 2-foot lengths of 2- by 4-inch boards must be used at the other end of the post to provide a substantial base when the post is em-

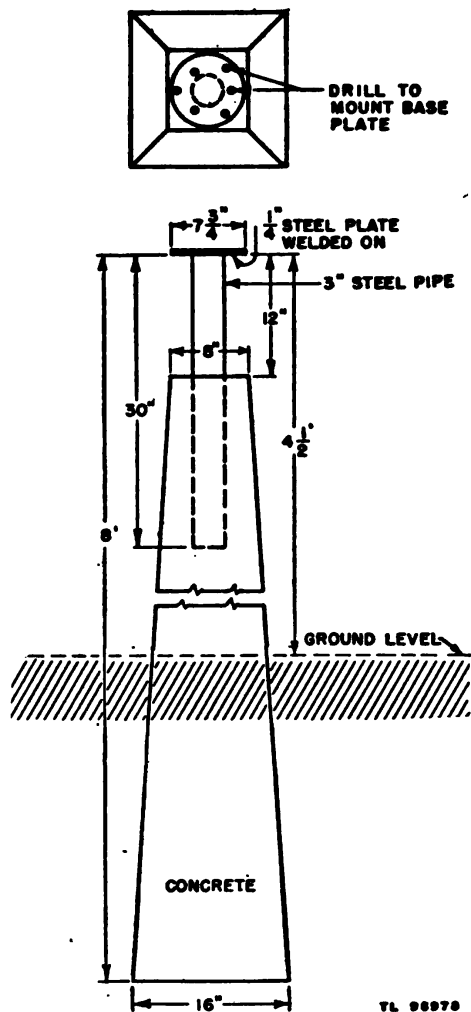

Figure 18. Concrete-steel support for phototheodolite.

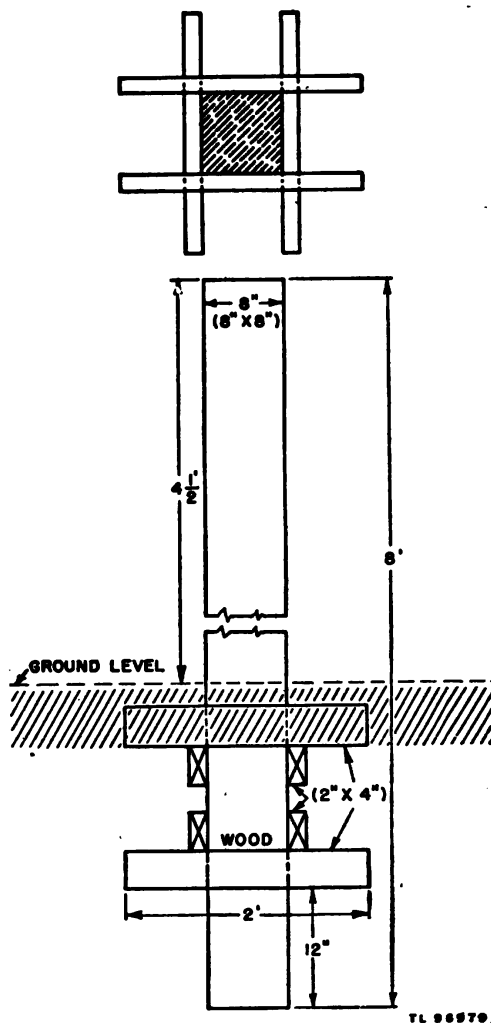

Figure 19. Wooden support for phototheodolite.

bedded in the ground. Starting at about 12 inches from the lower end, pairs of these boards are nailed across alternate opposite sides of the post as shown in figure 19.

21. Locating Phototheodolite Supports

a. GENERAL. Two considerations which apply alike to the supports at both stations of a Spotting Set PH-32-(*) installation are:

- (1) The support must be located so that the theodolite will have an unobstructed view of the entire field of fire.
- (2) The support (par. 19) must be embedded securely into the ground to a depth of 3 1/2 feet, with 4 1/2 feet extending above the ground (fig. 18 or 19) to obtain the proper height for the phototheodolites.

b. BATTERY STATION. The special consideration which must be given the location of the support at the battery station of a Spotting Set

PH-32-(*) installation is that it be located within 35 yards of the director or tracking head of the antiaircraft battery installation on a line roughly perpendicular to the path of the target.

c. **FLANK STATION.** The special considerations which must be given the location of the support at the flank station of a Spotting Set PH-32-(*) installation are:

(1) The support must be located 4,000 to 5,000 yards from the battery station phototheodolite support, at the end of a surveyed base line which is approximately parallel to the path of the target.

(2) See TM 44-225, 5-235, and 5-236 for instruction in the standard surveying methods to use in locating the flank support, and conform to the following survey accuracy specifications.

(a) The *distance* between the battery station phototheodolite support and the flank station support must be obtained to an accuracy of 1 part in 5,000.

(b) The *elevations* of the two stations must be determined to plus or minus 1 foot.

(c) The *azimuths* of the base line, and of the supports-to-orienting-target lines, must be determined to plus or minus 0.2 mil.

22. Wiring Between Battery and Flank Stations

a. **REQUIREMENTS.** At least two lines of field wire are required between the two stations of a spotting set installation.

(1) One line is required for time-counter operation of the phototheodolites.

(2) One line is required for telephone communication between the phototheodolite operators and any visual observers that may be located at these stations.

b. **EQUIPMENT.** Sufficient Wire W-110-B (wound in 1/2-mile lengths on Reels DR-4) and Reel Unit RL-31-(*) and Axle RL-27-(*) (both for handling the reels of wire) are supplied with the spotting set.

(1) *Reel Unit RL-31-(*)*. Reel Unit RL-31-(*) can be used to handle two Reels DR-4 at a time. It can be set up on the ground; mounted in, or secured to the tailboard of, a vehicle; used by two men litter fashion as a carrying frame; or used by one man as a rolling frame, wheelbarrow fashion. (See TM 11-362 for detailed instructions.)

(2) *Axle RL-27-(*)*. Axle RL-27-(*) is supplied with the spotting set to lay the required lines where conditions do not permit the use of Reel Unit RL-31-(*). It can be used by two men to handle one Reel DR-4 of Wire W-110-B at a time. Proceed as follows to mount a reel on the axle:

(a) Grasp the knurled ring of the removable handle of the axle and twist it to unlock the handle, and pull the handle from the shaft.

(b) Insert the shaft through the hub of Reel DR-4 until the squared sections on the shaft fit the square holes in the hub.

(c) Replace the removable handle on the shaft and make sure the knurled ring locks in position.

c. **SPLICING.** The 1/2-mile lengths of field wire between the stations must be spliced in the approved manner. (See FM-24-5 for instructions is making field wires splices.)

23. Preparing Spotting Components for Distribution to Stations

Before distributing the spotting components to the battery and flank stations, certain components must be prepared as follows:

a. **THEODOLITE PH-(*)-33.** Load the four film magazines of each Theodolite PH-(*)-33 with film as instructed in TM 11-2534.

b. **TIME INTERVAL DEVICE PH-103.** Install one Battery BA-26 in each side compartment of Time Interval Device PH-103. Connect each battery terminal to the appropriate binding post of the adjacent pair marked 45V on the panel, first running each connecting wire through the hole provided for it in the adjacent partition.

c. **TIME INTERVAL SIGNAL BE-65.** Install two Batteries BA-23 in place in each Time Interval Signal BE-65. Connect the batteries as instructed in TM 11-433.

d. **BATTERY BB-46.** Test each Battery BB-46 with Hydrometer HY-2 to make sure that it is charged and in proper operating condition. (See TM 11-430 for specific instructions.)

24. Distributing Spotting Components to Stations

After the phototheodolite supports have been installed (par. 21), field wire laid between the stations (par. 22), and certain of the spotting components specially prepared (par. 23), distribute the spotting components to the stations as follows:

a. **BATTERY STATION.**

- 1 Theodolite PH-(*)-33 in carrying case.
- 1 Time Interval Device PH-103.
- 1 Time Interval Multiplier PH-264-(*).
- 1 Line Connector Unit EE-87.
- 1 Time Interval Signal BE-65.
- 2 Battery BB-46.

b. **FLANK STATION.**

- 1 Theodolite PH-(*)-33.
- 1 Time Interval Signal BE-65 (if directed).
- 1 Battery BB-46.

25. Installing Theodolite PH-(*)-33

Install the phototheodolite in place at each station by referring to the instructions in TM 11-2534 to perform the following steps in the order given:

- a. Mount the phototheodolite's separate base ring on the support.
- b. Mount the phototheodolite on the base ring.
- c. Level the phototheodolite.
- d. Focus the telescope of the phototheodolite.
- e. Orient the phototheodolite.
- f. Connect the phototheodolite's junction box to the phototheodolite, and connect Cord CD-407 to the junction box.

26. Electrical Connection of Spotting Components

a. BATTERY STATION (fig. 20). (1) Place one Battery BB-46 within reach of Cord CD-407 from the phototheodolite's junction box. Check that the MOTOR switch on the phototheodolite's control panel is OFF and then connect each of the alligator clips of Cord CD-407 to a

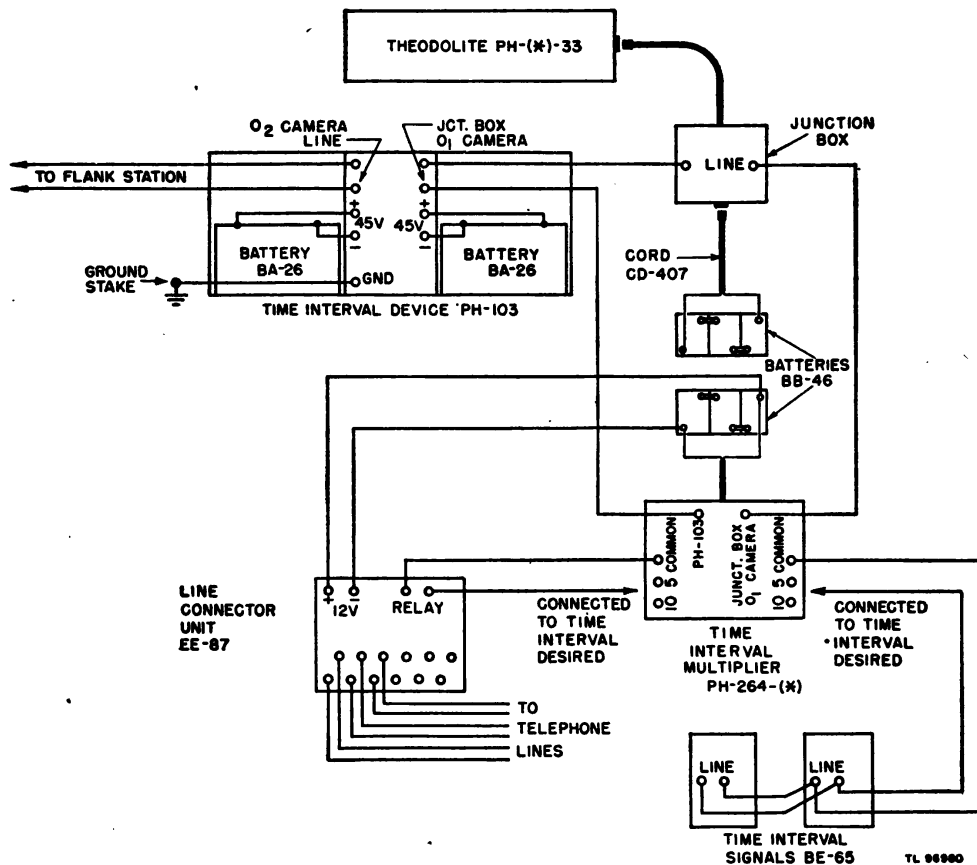

Figure 20. Cording diagram of battery station components of spotting components of Spotting Set PH-32-(*).

terminal on the battery, taking care that the clip marked + is connected to the positive (+) terminal of the battery.

(2) Place Time Interval Device PH-103 bottom side (the one with the bumpers) on the ground near the phototheodolite's junction box, and open the hinged front of the case. Insert a single conductor wire through the holes provided near the bottom of the sides of the left-hand compartment, and connect it to the binding post marked GRD at the lower left-hand corner of the panel. Use a ground clamp to connect the other end of this wire to a metal rod driven into the ground near the time interval device.

(3) Place Time Interval Multiplier PH-264-(*) near Time Interval Device PH-103, and place the remaining Battery BB-46 within reach of the alligator clips on the end of the cable from Time Interval Multiplier PH-264-(*). Connect each of these clips to a terminal on the battery.

(4) Untwist enough of the paired wires of one of the previously laid lines (par. 22) to the flank station, and insert the separated conductors through the holes provided in the sides of the left-hand compartment of the time interval device. Connect each of these wires to an O₂ CAMERA LINE binding post at the top left side of the panel.

(5) Take a separate length of field wire and untwist enough of the paired wires at one end so that the conductors can be inserted separately through the holes provided in the sides of the right-hand compartment of the time interval device. Connect this end of each of these wires to a JCT. BOX O₁ CAMERA binding post at the top right side of the panel.

(6) Connect the other ends of the pair of conductors from the JCT. BOX O₁ CAMERA binding posts of the time interval device, as follows:

(a) Connect one conductor to one of the LINE binding posts on the phototheodolite's junction box.

(b) Connect the other conductor to the binding post marked PH-103 on Time Interval Multiplier PH-264-(*).

(7) Check that the T.I. START switch on Time Interval Device PH-103 is OFF. Then use a length of single conductor wire and connect it as follows:

(a) Connect one end to the unused LINE binding post on the phototheodolite junction box.

(b) Connect the other end to the JUNCT. BOX O₁ CAMERA binding post on Time Interval Multiplier PH-264-(*).

(8) Locate Line Connector Unit EE-87 and Time Interval Signal BE-65, and connect them to Time Interval Multiplier PH-264-(*), in accordance with special instructions given at the time by the person in charge.

(a) Connect the two binding posts marked 12V (on Line Connector Unit EE-87) by field wire to the appropriate terminals of the same

Battery BB-46 to which the cable of Time Interval Multiplier PH-264- (*) is connected. Connect the two binding posts marked RELAY by field wire to Time Interval Multiplier PH-264- (*), one to a COMMON binding post and the other to either a binding post marked 5 or to one marked 10, depending upon whether a 5- or a 10-second interval impulse is desired.

(b) Connect the two binding posts marked LINE (on each Time Interval Signal BE-65) by field wire to Time Interval Multiplier PH-264- (*); one to a COMMON binding post and the other to either a binding post marked 5, or to one marked 10, depending upon whether a 5- or a 10-second interval impulse is desired.

(9) The battery station end of the remaining field wire line previously laid to the flank station is available for the connection of a field telephone.

b. FLANK STATION (fig. 21). (1) Place Battery BB-46 within reach of Cord CD-407 from the phototheodolite's junction box. Check that the MOTOR SWITCH on the phototheodolite control panel is OFF, and then connect each of the alligator clips of Cord CD-407 to a terminal on the battery, taking care that the positive (+) clip is connected to the positive (+) terminal of the battery.

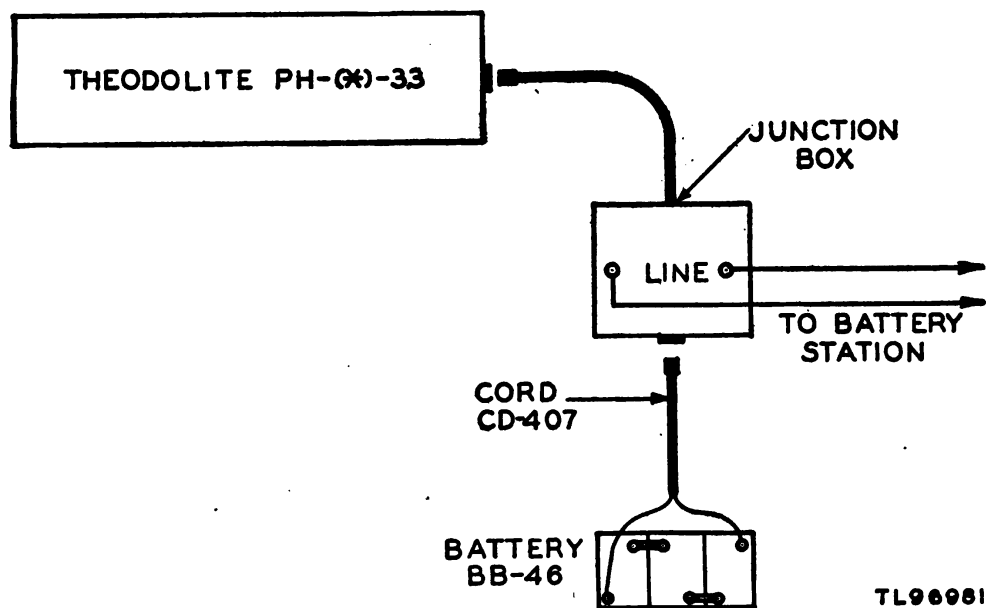

Figure 21. Cording diagram of flank station spotting components of Spotting Set PH-32-(*).

(2) Determine which of the two lines from the battery station is the line connected to Time Interval Device PH-103 (a(4) above). Connect the flank station end of this line to the LINE binding posts of the flank phototheodolite's junction box.

(3) The remaining field wire line from the battery station is available for the connection of a field telephone.

27. Repacking Spotting Components

a. THEODOLITE PH-(*)-33. (1) Disconnect Cord CD-407 from Battery BB-46 and from the phototheodolite junction box.

(2) Disconnect the two conductors from the LINE binding posts of the phototheodolite junction box, and disconnect the junction box from the phototheodolite.

(3) Dismount the phototheodolite and the base ring from the support, and repack them and the connecting cords in the carrying case as instructed in TM 11-2534.

b. LINE CONNECTOR UNIT EE-87. If the line connector unit is not to be used again for some time, disconnect all wires from the unit's binding posts and close the lid and fasten the trunk catch. If the unit will be used again soon, it may be more convenient to leave some wires connected as follows:

(1) Leave the wires connected to the 12V binding posts but disconnect them from the terminals of Battery BB-46.

(2) Leave the wires connected to the RELAY binding posts but disconnect them from Time Interval Multiplier PH-264-(*).

(3) Disconnect all telephone lines from the line connector unit's binding posts.

(4) Close the lid, fasten the trunk catch, and wind the connected wires around the case.

c. TIME INTERVAL SIGNAL BE-65. If the Time Interval Signals BE-65 are not to be used again for some time, remove the two Batteries BA-23 from each, and disconnect the wires from the LINE binding posts. If they will be used again within a couple of days, leave the batteries in place, and it may be more convenient to leave the wires connected to the LINE binding posts but disconnect them from Time Interval Multiplier PH-264-(*). and wrap them around the case of each Time Interval Signal BE-65.

d. TIME INTERVAL MULTIPLIER PH-264-(*). (1) Disconnect the cable from Battery BB-46.

(2) If the multiplier will be used again soon, it may be more convenient to leave the wires connected to the JUNCT. BOX O₁ CAMERA and PH-103 binding posts but disconnect the other end of one of the wires from Time Interval Device PH-103. (The other end of the other wire already has been disconnected (a(2) above) from the phototheodolite junction box.)

e. TIME INTERVAL DEVICE PH-103. (1) Disconnect the two wires connected to the O₂ CAMERA LINE binding posts, and pull the wires from the holes in the case.

(2) If the device is not to be used again within a couple of days, proceed as follows:

(a) Disconnect the wires from the terminals of the two Batteries BA-26 and remove the batteries from the case.

(b) Disconnect the wires from the JCT. BOX O₁ CAMERA binding posts and pull the wires from the holes in the case.

(c) Close the hinged front and lock the case.

(3) If the device is to be used again within a couple of days, the batteries can be left connected. It also may be more convenient to leave the wires connected to the JCT. BOX O₁ CAMERA binding posts—simply wind the wires around the case after closing and fastening the hinged front.

f. **VOLUMES AND WEIGHTS.** The following table lists the volumes and weights of the spotting components of Spotting Set PH-32-(*):

Table of Volumes and Weights

Model	Volume (cu ft)	Weight (lb)
* Theodolite Ph-(*)-33 in carrying case.....	6.9 to 9.4	160 to 230
Time Interval Device PH-103.....	1.3	23
Time Interval Multiplier PH-264-(*).09	6
Time Interval Signal BE-65.....	.47	18
Line Connector Unit EE-87.....	.64	25
Battery BB-46	2.9	122

* Specific information about the volume and weight of each model of this component is given in TM 11-2534.

PART TWO

OPERATING INSTRUCTIONS FOR SPOTTING COMPONENTS OF SPOTTING SET PH-32-(*)

Note. For information on destroying this equipment to prevent enemy use, see the destruction notice at the front of this manual.

Section III. TECHNICAL OPERATION

28. Operating Time Interval Device PH-103

a. PRELIMINARY. (1) Check the following on Time Interval Device PH-103:

(a) That the LINE CURRENT rheostat is in the MIN. position (counterclockwise to stop).

(b) That the T.I. START switch is turned to OFF.

(2) Throw the SIGNAL switch of each phototheodolite to ON.

b. LINE TESTING. Use Time Interval Device PH-103 to test the lines to the phototheodolites for grounds and then for continuity, as follows:

(1) *Testing for grounds.* Check that the GRD binding post is connected to a ground stake, and then proceed as follows:

(a) Operate the GROUND TEST key switch to the O₁ position. Observe milliammeter on the panel:

1. If the meter needle is deflected, a ground on the line to the battery station phototheodolite is indicated.

2. If the meter needle is not deflected, the line is clear of grounds.

(b) Operate the GROUND TEST key switch to the O₂ position and observe the milliammeter ((a) 1 and 2 above) to determine the condition of the line to the flank station phototheodolite.

(c) If the line to either station is grounded, locate and clear the trouble; then retest.

(2) *Testing for continuity.* (a) Operate the CONTINUITY TEST key switch to the O₁ position. Observe the milliammeter on the panel:

1. If the meter needle is deflected, it indicates that the line to the battery station phototheodolite is properly closed; however, a full scale deflection indicates a short circuit which must be repaired.
2. If the meter needle is not deflected, an open line is indicated which must be repaired.

(b) Operate the CONTINUITY TEST key switch to the O₂ position and observe the milliammeter ((a) 1 and 2 above), to determine the condition of the line to the flank station phototheodolite.

Note. The milliammeter reading does not necessarily have to be the same when indicating properly closed circuits for both positions of the CONTINUITY TEST key switch, as the reading depends on circuit length and construction which varies for the two stations.

c. ADJUSTING LINE CURRENT. Use Time Interval Device PH-103 to adjust the current in the lines to the phototheodolites as follows:

(1) Press the T.I. SHORT push button and keep it depressed during the following operation.

(2) Observe the milliammeter and turn the LINE CURRENT rheostat knob clockwise until the milliammeter needle indicates a value between 25 and 30 milliamperes (ma).

(3) Release the T.I. SHORT push button.

d. ADJUSTING TIME INTERVAL. Adjust the time interval period of Time Interval Device PH-103 as follows:

(1) Turn the TIME ADJUSTMENT knob in the direction indicated by the INCREASE INTERVAL arrow marked on the panel, until the arrow marked on the knob indicates the midpoint in the knob's range.

(2) Turn the T.I. START switch to ON. The click of the operating relays will be clearly audible.

(3) Use a stop watch to time a certain number of clicks, depending upon the interval desired. The standard period for spotting set operation is 1 second, which is set as follows:

(a) Carefully measure the elapsed time for 30 clicks. It should be exactly 30 seconds for correct adjustment.

(b) If the interval needs adjusting, rotate the TIME ADJUSTMENT knob in the correct direction to increase or decrease the time interval, as the need may be, and repeat the measurement of the elapsed time for 30 clicks.

(c) Repeat the adjustment until 30 clicks occur in exactly 30 seconds.

Note. After the above adjustment once is made, it is not necessary to repeat it each time the equipment is used, provided the TIME ADJUSTMENT knob is kept at the same position. However, the time interval period should be checked frequently.

e. **ADVANCING PHOTOTHEODOLITE TIME COUNTERS.** Time Interval Device PH-103 can be used to advance the time counters of both the battery station and the flank station phototheodolites simultaneously, or to advance one station's set independently of the other's. First check that the T.I. START switch of Time Interval Device PH-103 is in the OFF position, and that the SIGNAL switches of the phototheodolites are in the ON positions. Then proceed as follows:

(1) *Advancing time counters at both stations.* Depress and release the T.I. SHORT push button of Time Interval Device PH-103. Each time it is depressed the time counters of the phototheodolites at both stations will advance one unit simultaneously.

(2) *Advancing time counters at battery station.* Operate the CONTINUITY TEST key switch to the O₁ position and then release it. Each time it is operated to O₁, the battery station time counters will advance one unit.

(3) *Advancing time counters at flank station.* Operate the CONTINUITY TEST key switch to the O₂ position. Each time it is operated to O₂, the flank station time counters will advance one unit.

29. Operating Time Interval Multiplier PH-264-(*)

a. The MANUAL push button on Time Interval Multiplier PH-264-(*) can be used as follows to test the audible signal equipment lines connected to the multiplier:

(1) Press the MANUAL push button.

(2) If the connected signals do not respond, then open or shorted lines, or inoperative equipment, is indicated.

b. The 1 SEC. ADVANCE push button on Time Interval Multiplier PH-264-(*) can be used as follows to set the beginning of the sequence of impulses to be sent out over the lines connected to the multiplier:

(1) Press the 1 SEC. ADVANCE push button and release it.

(2) Each time the push button is depressed the stepping relay can be heard to click as it advances the ratchet one step. The ratchet, which controls the 5- and 10-second contacts, thus can be set at any one of the ten steps in its rotation.

30. Preparing Theodolite PH-(*)-33 for Operation

a. Prepare Theodolite PH-(*)-33 at each station for operation by following the instructions in TM 11-2534 to perform the following steps in the order given:

(1) Load the camera.

(2) Adjust the camera speed.

(3) Select and mount the filters (daylight operation only).

(4) Set the camera lens aperture.

- (5) Set the film footage counter to zero.
- (6) Make an adjustment check filming (daylight operation only).
 - b. Reset the time counters of both phototheodolites to the same setting by using the mechanical means provided on each phototheodolite (TM 11-2534), or by using Time Interval Device PH-103 as instructed in paragraph 28e.
 - c. Throw the SIGNAL switch of the flank phototheodolite to ON.
 - d. Throw the SIGNAL switch of the battery phototheodolite to OFF. This switch will be used as the control switch for the time counter circuit in which the time counters of both phototheodolites are connected in series.

31. Operating Spotting Components of Spotting Set PH-32-(*)

a. BATTERY STATION. After testing the time counter lines (par. 28b); adjusting the current in the lines (par. 28c); checking the time interval period of impulses (par. 28d); synchronizing the battery station time counter with the time counter at the flank station (par. 28e); testing the lines to the audible signal equipment (par. 29a) and presetting the sequence of impulses to be sent over those lines (par. 29b); and preparing Theodolite PH-(*)-33 (par. 30); the battery station spotting components of Spotting Set PH-32-(*) are ready for operation, as follows:

- (1) Turn the T.I. START switch on Time Interval Device PH-103 to ON.
- (2) When the target comes into view, aim the phototheodolite on it as instructed in TM 11-2534.
- (3) At the proper command, throw the SIGNAL switch of the phototheodolite to ON.
- (4) At the next proper command, start the camera by throwing the MOTOR switch of the phototheodolite to ON. Stop the camera, when ordered, by throwing the MOTOR switch of the phototheodolite to OFF. Repeat operating the camera as often as directed.
- (5) At the end of a target run, do the following:
 - (a) Throw the SIGNAL switch of the phototheodolite to OFF.
 - (b) Traverse the phototheodolite *back* to the approximate starting point of the course.
 - (c) Turn the T.I. START switch on Time Interval Device PH-103 to OFF.
 - (6) Repeat steps (1) through (5) above as often as directed.

b. FLANK STATION. After synchronizing the flank station time counter with the time counter at the battery station (par. 28e) and preparing Theodolite PH-(*)-33 for operation (par. 30), the flank station spotting components of Spotting Set PH-32-(*) are ready for operation as follows:

(1) When the target comes into view, aim the phototheodolite on it as instructed in TM 11-2534.

(2) At the proper command, start the camera by throwing the MOTOR switch of the phototheodolite to ON. Stop the camera, when ordered, by throwing the MOTOR switch of the phototheodolite to OFF. Repeat operating the camera as often as directed.

(3) At the end of a target run, traverse the phototheodolite *back* to the approximate starting point of the course.

(4) Repeat steps (1), (2), and (3) above as often as directed.

c. COMPLETION OF PRACTICE. (1) Immediately after the completion of a practice run, follow the instructions given in TM 11-2534 to perform the following operations with each phototheodolite:

(a) Make a second adjustment-check filming.

(b) Unthread the film from the camera.

(c) Remove the film magazine from the phototheodolite.

(2) Repack the spotting components at each station (par. 27).

(3) Store the spotting components from both stations together under cover.

32. Performance Check List

Use the following check sheet as a guide in checking the performance of the spotting components of a spotting set installation:

	Item No.	Item	Action or condition	Normal indication	Corrective measure	
PREPARATORY	Phototheodolite	1	Refer to performance check list in TM 11-2534			
		2				
		3				
		4				
		5				
		6				
		7				
		8				
		9				
	Time Interval Device PH-103	10	Battery station time counter line.	Throw GROUND TEST key switch to O ₁ position.	No reading on milliammeter.	Locate and clear ground.
		11	Flank station time counter line.	Throw GROUND TEST key switch to O ₂ position.	No reading on milliammeter.	Locate and clear ground.
		12	Battery station time counter line.	Throw CONTINUITY TEST key switch to O ₁ position.	A reading (less than full scale) on milliammeter. (A full scale reading indicates short circuit.)	Locate and repair open or short circuit.
		13	Flank station time counter line.	Throw CONTINUITY TEST key switch to O ₂ position.	A reading (less than full scale) on milliammeter. (A full scale reading indicates short circuit.)	Locate and repair open or short circuit.
		14	Time counters line current.	Press T.I. SHORT push button.	Milliammeter reading between 25 and 30 ma.	Adjust current by turning LINE CURRENT rheostat.
		15	Time interval period.	Time audible clicks with stop watch.	Thirty clicks in exactly 30 seconds.	Adjust interval by turning TIME ADJUSTMENT knob.
	Time Interval Multiplier PH-204(*)	16	Lines to audible signal equipment.	Press M A N U A L push button.	Audible signal equipment responds.	Check lines to equipment.
		17	Presetting beginning of impulse sequence to audible signal equipment.	Press 1 SEC. ADVANCE push button.	Click of relay actuating ratchet.	Check connection to Battery BB-46.

(Continued on next page)

		Item No.	Item	Action or condition	Normal indication	Corrective measure
START	Spotting Set	18	Phototheodolite.	Aim telescope on target.	Telescope cross-hairs bisect target image.	Refer to TM 11-2534.
		19	Time Interval Device PH-103.	Turn T.I. START switch to ON.	Audible click of relays.	Par. 66.
		20	Time counter circuit.	Throw SIGNAL switch of control phototheodolite to ON.	Signal lamp on each phototheodolite flashes intermittently.	Refer to TM 11-2534.
		21	Camera.	Throw the MOTOR switch to ON.	Camera motor operating.	Refer to TM 11-2534.
PERFORMANCE	Spotting Set	22	Time Interval Device PH-103.	Milliammeter reading.	25 to 30 ma.	Par. 66.
		23	Phototheodolite.	(1) Signal Lamp. (2) Tachometer.	(1) Flashes intermittently. (2) Registers speed of film through camera.	Refer to TM 11-2534.
		24	Time Interval Signal BE-65.	Horn.	Sounds at regular intervals.	Refer to TM 11-2534.
		25	Line Connector Unit EE-87.	Tone on telephone lines.	Intermittently impresses tone on connected lines.	Refer to TM 11-2534.
STOP	Spotting Set	26	Camera.	Turn MOTOR switch to OFF.	Camera motor stops operating.	Refer to TM 11-2534.
		27	Time counter circuit.	Throw the SIGNAL switch of the control phototheodolite to OFF.	Signal lamps stop flashing.	Refer to TM 11-2534.
		28	Time Interval Device PH-103.	Turn T.I. START switch to OFF.	Relay stops clicking.	Par. 66.

PART THREE
MAINTENANCE INSTRUCTIONS FOR SPOTTING
COMPONENTS OF SPOTTING SET
PH-32-(*)

Section IV. PREVENTIVE MAINTENANCE TECHNIQUES

33. Meaning of Preventive Maintenance

Preventive maintenance is a systematic series of operations performed at regular intervals on equipment in order to maintain top efficiency in performance, to minimize unwanted interruptions in service, and to eliminate major break-downs. To understand what is meant by preventive maintenance, it is necessary to distinguish preventive maintenance from trouble shooting and repair. The prime function of preventive maintenance is to *prevent* break-downs, and the consequent necessity for repair. On the other hand, the prime function of trouble shooting and repair is to locate and correct *existing* defects. The importance of preventive maintenance cannot be overemphasized. The usefulness of an entire spotting set depends upon each spotting component, each film developing component, and each film viewing component, being ready to operate at peak efficiency when needed. Consequently, it is vitally important that operators and repairmen of spotting set equipment maintain their equipment properly.

Note. The operations in sections IV, V, and VI, in each of the four divisions of this manual are first and second echelon (organization operators and repairmen) maintenance. Some operations in section VII of each division are higher echelon maintenance.

34. Description of Preventive Maintenance Techniques

a. Most of the components of a spotting set require routine preventive maintenance. Those requiring maintenance differ in the amount and kind required. Because hit-or-miss maintenance techniques must not be applied, definite and specific instructions are needed. This section contains this type of specific instructions and serves as a guide for

personnel assigned to perform the six basic maintenance operations: **FEEL, INSPECT, TIGHTEN, CLEAN, ADJUST, and LUBRICATE.** Throughout the manual the lettering system for the six operations will be as follows:

F—Feel
I—Inspect
T—Tighten
C—Clean
A—Adjust
L—Lubricate

The first two operations establish the need for the other four. The selection of operations is based on a general knowledge of field requirements. Field use without continuous inspection and the continuous performance of necessary tightening, cleaning, and lubricating will result in most equipment becoming operationally erratic, undependable, and subject to break-down when it is needed.

b. The Feel operation is used most often to check rotating parts and to determine if electrical connections, bushings, etc., are overheated. The Feel operation indicates the need for lubrication or the existence of similar types of defects requiring correction. The maintenance man must become familiar with the normal operating temperatures of motors, etc.; in order to recognize signs of overheating.

Note. It is important that the Feel operation be performed as soon as possible after shut-down and always before any other maintenance is done.

c. Inspection is the most important operation in the preventive maintenance program. A careless observer will overlook the evidence of minor trouble. Although these defects may not interfere with the performance of the equipment, valuable time and effort can be saved if they are corrected before they lead to major break-downs. Make every effort to become thoroughly familiar with the indications of normal functioning, in order to be able to recognize the signs of a defection. Inspection consists of carefully observing all parts of the equipment, noticing their appearance, placement, state of cleanliness, etc. Inspect for the following conditions:

(1) Overheating, as indicated by discoloration, blistering, or bulging of the parts or surface of the container; leakage of insulating compounds; and oxidation of metal contact surfaces.

(2) Placement, by observing that all leads and cabling are in their original position.

(3) Cleanliness, by carefully examining all recesses in the unit for accumulation of dust, especially between contact terminals. Parts, connections, and joints should be free of dust, corrosion, and other foreign

matter. In tropical and high-humidity locations, look for fungus growth and mildew.

(4) Tightness, by testing any connection or mounting which appears to be loose.

d. The Tighten, Clean, and Adjust operations are self-explanatory. Specific procedures to be followed in performing these operations wherever they are necessary are given in part three in each chapter in this manual. When a loose connection is tightened, it should be moisture-proofed and fungiproofed again by the application of varnish with a small brush. See section VII below for details of moistureproofing and fungiproofing for spotting components.

e. The Lubricate operation refers to the application of grease or oil to bearings of motors or other rotating shafts. Lubrication may also mean the application of a light oil to door hinges or other sliding surfaces of the equipment.

f. The remainder of this section does not deal with individual components of a spotting set. Rather it combines all instructional material on the major classes of parts found *only* in the *spotting components*, excepting the phototheodolites, of a spotting set. The instructional material on the major classes of parts found in a phototheodolite are contained in TM 11-2534. The instructional material on the major classes of parts found in the film developing components and in the film viewing components of a spotting set are contained in section IV, "Film Developing Components, etc.," and section IV, "Film Viewing Components, etc." Section V of each of the four divisions of this manual treats the maintenance to be performed on the individual items of the particular type of components covered in that division.

35. Switch and Relay Contacts

a. GENERAL. Preventive maintenance work on the contacts of the switches and relays of the spotting components of a spotting set consists of Inspect (I) and Clean (C).

b. INSPECT (I). Inspect for contacts that have become stuck, pitted, or dirty.

c. CLEAN (C). (1) Use a burnishing tool essentially as follows:

(a) Place the blade between the contacts and press the contacts together with slight pressure.

(b) Move the blade back and forth between the contacts until the contacts are smooth and bright.

(2) When contacts are sufficiently dirty to require further cleaning, flush with carbon tetrachloride applied with a toothpick, and clean with the flat side of a clean, dry toothpick or similar material. Again burnish ((1) above) using a clean blade of the burnishing tool.

36. Wiring and Connecting Cables

a. **GENERAL.** Preventive maintenance work on the wiring and connecting cables of the spotting components of a spotting set consists of Inspect (I), Tighten (T), Clean (C), and Adjust (A).

b. **INSPECT (I).** Check the condition of wiring connections for frayed insulation or broken strands of wire, and for loose or corroded connections. Inspect connecting cables, sockets, and plugs, for frayed insulation, corroded terminals, and loose connections.

c. **TIGHTEN (T).** Tighten loose connections by resoldering, first cleaning the old connections of all dirt and corrosion.

d. **CLEAN (C).** Clean dirty and corroded contacts in the cable sockets, and prongs of connecting plugs, by rubbing with fine sandpaper.

e. **ADJUST (A).** Use the fingers or a pair of long-nose pliers to bend socket contacts and springs which do not make adequate contact.

37. Bakelite, Glass, Rubber, Painted Metal, and Painted Wood Surfaces

a. **GENERAL.** Preventive maintenance work on the bakelite, glass, rubber, painted metal, and painted wood surfaces of spotting components of a spotting set consists solely of Clean (C).

b. **CLEAN (C).** Use a soft, dry cloth or a brush to wipe off dust. Use a damp cloth to wash off dirt.

38. Hardware

a. **GENERAL.** Preventive maintenance work of the hardware (fastening screws and nuts, hinges, catches, etc.) of spotting components of a spotting set consists of Inspect (I), Tighten (T), Lubricate (L).

b. **INSPECT (I).** Inspect screws for looseness. Inspect hinges and other fastenings for rust and dirt.

c. **TIGHTEN (T).** Use a screw driver on loose slotted-head screws. Make them moderately handtight.

d. **LUBRICATE (L).** Lubricate the moving parts of hinges, catches, and locks with Oil, Engine (OE).

Section V. ITEMIZED PREVENTIVE MAINTENANCE OF SPOTTING COMPONENTS OF SPOTTING SET PH-32-(*)

39. Introduction

For ease and efficiency of performance, it is suggested that preventive maintenance on spotting components of a spotting set be broken down into operations, or items, that can be performed at different time in-

tervals. The general techniques involved and the application of FITCAL operations in performing preventive maintenance on *general classes* of parts included in the spotting components are discussed in section IV above. Those general instructions are not repeated in this section. See section IV above if more information is required when performing the following preventive maintenance items.

40. Materials Needed

a. MAINTENANCE MATERIALS. Have the following items on hand before beginning preventive maintenance work on the spotting components of a spotting set:

- (1) Screw driver.
- (2) Burnishing tool.
- (3) Fine sandpaper.
- (4) Cleaning fluid (see Note below).
- (5) Clean cloths.

Note. Gasoline will not be used as a cleaning fluid for any purpose. Solvent, Dry-Cleaning, is available as a cleaning fluid through established supply channels. Oil, Fuel, Diesel, may be used for cleaning purposes when dry-cleaning solvent (SD) is not on hand. Carbon tetrachloride will be used as a cleaning fluid only in the following cases: where inflammable solvents cannot be used because of the fire hazard, and for cleaning electrical contacts including relay contacts, plugs, commutators, etc.

b. RUNNING SPARES. The only spotting components which have running spares are the phototheodolites and Time Interval Device PH-103.

(1) *Phototheodolite.* Information about the running spares of a phototheodolite is contained in TM 11-2534.

(2) *Time Interval Device PH-103* (fig. 11). The running spares of Time Interval Device PH-103 are two can type, plug-in capacitors for replacement of the capacitor in the time interval circuit when it becomes defective. The spare capacitors are packed in the side compartments of the case of the time interval device.

41. Maintenance of Phototheodolites

Instructions for the maintenance of the spotting set phototheodolites are contained in TM 11-2534.

42. Maintenance of Junction Box JB-40 and Cord CD-407

a. JUNCTION Box JB-40. (1) Keep the connection box clean (par. 37b).

(2) Keep the panel fastening screws tight.

(3) Keep the socket, and the cable and plug, in good condition (par. 36).

b. CORD CD-407. Keep the cable and plug in good condition (par. 36).

43. Maintenance of Exposure Meter PH-252-(*)

Instructions for the maintenance of Exposure Meter PH-252-(*) are contained in TM 11-2351.

44. Maintenance of Time Interval Device PH-103

a. CASE. (1) Keep the case clean (par. 37).

(2) Keep the fastening screws of the hinges, catches, handles, hasp and staple, tight.

(3) Lubricate the hardware (par. 38d).

b. PANEL ASSEMBLY. (1) Keep the panel clean (par. 37).

(2) Keep the corner mounting screws tight.

(3) Keep the contacts of the switches and relays clean (par. 35).



Figure 22. Replacing defective capacitor of Time Interval Device PH-103.

c. **REPLACING CAPACITOR** (fig. 22). Whenever the output of Time Interval Device PH-103 becomes erratic, and it is certain that fresh batteries are being used, replace the capacitor in the time interval circuit, as follows:

- (1) Disconnect all leads from the panel binding posts.
- (2) Remove the four corner screws which hold the panel in the case.
- (3) Grasp the binding post in the upper right-hand corner of the panel with one hand, and grasp the binding post in the lower left-hand corner with the other hand, and carefully lift the panel assembly straight out from the case.
- (4) Remove the old capacitor from the socket, and insert one of the spare capacitors (par. 40b(2)) in its place. Be sure that the new capacitor is seated firmly in the socket.
- (5) Carefully replace the panel assembly in the case and fasten it with the four corner screws. Reconnect the leads to the proper binding posts (par. 23b).

45. Maintenance of Time Interval Multiplier PH-264-(*)

- a. Keep the box and the panel clean (par. 37).
- b. Keep the panel fastening screws, and the screws holding the removable side of the box, tight.
- c. Keep the connecting cord in good condition (par. 36).
- d. Keep the contacts of the switches and relays clean (par. 35).

46. Maintenance of Line Connector Unit EE-87

Instructions for the maintenance of Line Connector Unit EE-87 are contained in TM 11-433.

47. Maintenance of Time Interval Signal BE-65

Instructions for the maintenance of Time Interval Signal BE-65 are contained in TM 11-433.

48. Maintenance of Battery BB-46

Keep Battery BB-46 fully charged; keep its cells filled to the proper level; and keep its terminals clean of corrosion. Detailed instructions for the maintenance of storage batteries are contained in TM 11-430.

49. Maintenance of Axle RL-27-(*)

- a. Keep the removable handle, and the portion of the bar which engages this handle, free from dirt and grit.
- b. Do not use the axle as a lever, crowbar, or hammer, and keep it free from nicks, scratches, or bends.

c. Lubricate Axle RL-27-(*) after every 3 days of continuous use, or whenever required, as follows:

(1) Take off the removable handle and use Solvent, Dry Cleaning (SD) to clean the lock and flush out the bearings. Allow parts to dry thoroughly. Clean dirt from handle shaft.

(2) In temperatures above 0° F., use Oil, Engine (OE), as follows:

(a) Apply liberally at opening between shaft and inner end of fixed handle.

(b) Apply liberally to bearings and lock of removable handle.

(3) In temperatures below 0° F., use Oil, Lubricating, Preservative, Special (PS) in the same manner as instructed in (2) (a) and (b) above.

50. Maintenance of Reel Unit RL-31-(*)

Instructions for the maintenance of Reel Unit RL-31-(*) are contained in TM 11-362.

51. Preventive Maintenance Check List for Spotting Components

The following check list is a summary of the preventive maintenance to be performed on the spotting components of a spotting set. It includes the FITCAL operations described previously in this section. The suggested time intervals for performing the FITCAL operations may be varied by the local commander. However, for best performance of the equipment, perform operations at least as frequently as called for in the check list. The echelon column indicates which items are first echelon maintenance, and which are second echelon maintenance.

Item	Operation	Description	When performed				Echelon
			Daily	Weekly	Monthly	Every 3 months	
1	ITCAL	Phototheodolite.....	(Refer to TM 11-2534)				
2	ITC	Junction Box JB-40.....	X				First
3	IT	Cord CD-407.....	X				First
4	IC	Exposure Meter PH-252-(*).	(Refer to TM 11-2351)				
5	ITC	Case of Time Interval Device PH-103.	X				First
6	L	Case of Time Interval Device FH-103.			X		First
7	ITC	Panel assembly of Time Interval Device PH-103.	X				First
8	ITC	Time Interval Multiplier PH-264-(*).	X				First
9	ITCL	Line Connector Unit EE-87.	(Refer to TM 11-433)				
10	ITCL	Time Interval Signal BE-65.					
11	IC	Battery BB-46.....	X				First
12	IC	Axle RL-27-(*).	X				First
13	L	Axle RL-27-(*).			X		Second
14	ITCL	Recl Unit RL-31-(*).	(Refer to TM 11-362)				

Note. "X" indicates when operations are to be performed.

F I T C A L
 Feel Inspect Tighten Clean Adjust Lubricate

Section VI. LUBRICATION OF SPOTTING SETS

52. War Department Lubrication Orders

War Department Lubrication Orders are waterproof, illustrated, numbered and dated cards or decalcomania labels which prescribe approved first and second echelon lubrication instructions for mechanical equipment which requires lubrication by using organizations. Current War Department Lubrication Orders which are available are listed in the latest edition of FM 21-6. Lubrication orders should be requisitioned

in conformance with instructions and lists in FM 21-6, which is published quarterly by The Adjutant General.

53. Compliance with War Department Lubrication Orders

Instructions contained in War Department Lubrication Orders are mandatory and supersede all conflicting lubrication instructions of an earlier date. Applicable War Department Lubrication Orders which are available will be obtained, carried with the equipment at all times, and fully complied with. Difficulties experienced in obtaining and complying with such orders will be reported through technical channels to the Commanding General, Army Service Forces, Attention: Maintenance Division.

54. War Department Lubrication Orders for Spotting Sets

Two War Department Lubrication Orders are issued on the spotting sets covered in this manual, as follows:

a. WAR DEPARTMENT LUBRICATION ORDER No. 3107. War Department Lubrication Order No. 3107, Spotting Sets PH-32 and AN/TVQ-1 (Theodolite PH-(BD, BF, & BH)-33), is furnished on both sides of a 10- by 15-inch card which should accompany the spotting set at all times. Facsimiles of both sides of a temporary version of Lubrication Order No. 3107 are contained in TM 11-2534.

b. WAR DEPARTMENT LUBRICATION ORDER No. 3107A. War Department Lubrication Order No. 3107A is furnished on both sides of a 10- by 15-inch card.

(1) One side is entitled Spotting Sets PH-32 and AN/TVQ-1 (Theodolite PH-(BC, BE, & BG)-33 and Theodolite MX-194/TVQ-1), and a facsimile of a temporary version of this side of Lubrication Order No. 3107A is contained in TM 11-2534.

(2) The other side is entitled Spotting Sets PH-32 and AN/TVQ-1 (Viewing Attachment PH-98-(*), Rewinder PH-92, and Splicer PH-91-(*)); figure 61 is a facsimile of this side.

Section VII. MOISTUREPROOFING AND FUNGIPROOFING OF SPOTTING COMPONENTS OF SPOTTING SET PH-32-(*)

55. General

When operated in tropical areas where temperature and relative humidity are extremely high, Signal Corps equipment requires special attention. These are some of the problems met:

- a. Resistors, capacitors, coils, chokes, transformer windings, etc., fail because of the effects of fungus growth and excessive moisture.
- b. Electrolytic action, often visible in the form of corrosion, takes place in resistors, coils, chokes, transformer windings, etc., causing eventual break-down.
- c. Hook-up wire insulation and cable insulation break down. Fungus growth accelerates deterioration.
- d. Moisture forms electrical leakage paths on terminal boards and insulating strips.
- e. Moisture provides leakage paths between battery terminals.

56. Treatment.

A moistureproofing and fungiproofing treatment has been devised which, if properly applied, provides a reasonable degree of protection against fungus growth, insects, corrosion, salt-spray, and moisture. The treatment involves the use of a moisture- and fungus-resistant varnish applied with a spray gun or brush. See TB SIG 13, Moistureproofing and Fungiproofing Signal Corps Equipment, for information about the supplies and equipment required in this treatment.

Caution: Varnish spray may have poisonous effects if inhaled. To avoid inhaling the spray, use respirator if available; otherwise, fasten cheesecloth or other cloth material over nose and mouth. Never spray varnish or lacquer near an open flame. Do not smoke in a room where varnish or lacquer is being sprayed. The spray may be highly explosive.

57. Spotting Components Requiring Treatment

a. The spotting components of a spotting set which require moisture-proofing and fungiproofing treatment are:

- (1) The phototheodolites.
- (2) Junction Box JB-40.
- (3) Time Interval Device PH-103.
- (4) Time Interval Multiplier PH-264-(*).
- (5) Line Connector Unit EE-87.
- (6) Time Interval Signal BE-65.

b. The step-by-step instructions for treating some of the above components are given in other Technical Manuals as follows:

- (1) Phototheodolites, TM 11-2534.
- (2) Line Connector Unit EE-87 and Time Interval Signal BE-65, TM 11-433.

c. The step-by-step instructions for treating Junction Box JB-40, Time Interval Device PH-103, and Time Interval Multiplier PH-264-(*), are given in succeeding paragraphs.

58. Junction Box JB-40

a. PREPARATION. (1) Make any repairs that are necessary for proper operation of the equipment.

(2) Screw down the two LINE binding posts.

b. DISASSEMBLY. (1) Remove the four corner screws which hold the panel to the connection box.

(2) Grasp the binding posts and lift the panel from the box.

c. CLEANING. Clean all dirt, dust, rust, and fungus from the inside and outside of the connection box. Clean all oil and grease from the surfaces.

d. MASKING (fig. 23). (1) Mask the contact points of the socket on one side of the connection box.

(2) Starting from the box, mask about 8 inches of the cable.

e. DRYING. Dry the connection box in an oven or under heat lamps for 2 or 3 hours at 160° F.

f. VARNISHING. (1) Apply varnish (Lacquer, Fungus-resistant, spec No. 71-2202 (stock No. 6G1005.3), or equal) immediately after drying (e above). If the varnish is not applied immediately, moisture condenses

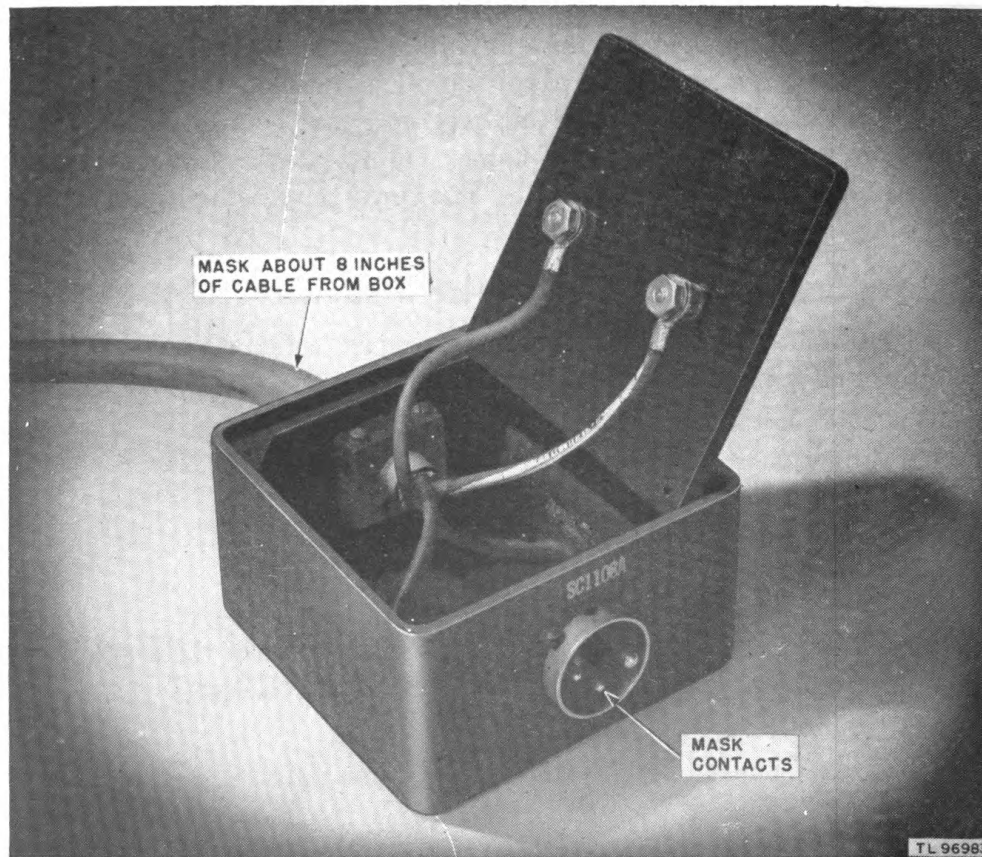

Figure 23. Masking Junction Box JB-40 for moistureproofing and fungiproofing treatment.

on the equipment. Varnish applied over moisture peels off readily after the varnish has dried.

(2) Use a spray gun and apply the varnish to the inside and outside of the connection box. *Do not spray the cable.* Apply three coats, allowing each coat to air-dry for 15 to 20 minutes before applying the next.

g. REASSEMBLY. (1) Remove all masking tape, being careful not to peel varnish from nearby areas.

(2) Replace the panel on the connection box and fasten it with the four corner screws.

h. MARKING. Mark the letters MFP and the date of treatment on an unlabeled portion of the panel.

Example: MFP—1 May 45.

59. Time Interval Device PH-103

a. PREPARATION. (1) Make all repairs and adjustments necessary for proper operation of the equipment.

(2) Screw down all binding posts.

b. DISASSEMBLY. (1) Remove the four corner screws which hold the panel assembly in the case.

(2) Grasp the binding post in the upper right-hand corner of the panel with one hand, grasp the binding post in the lower left-hand corner with the other hand, then carefully lift the panel assembly straight out from the case.

(3) Remove the capacitor from the socket at the back of the panel.

(4) Detach the mounting bracket of the bottom relay from the panel, and carefully lay the relay and bracket to the side. *Do not disconnect the wires.* The bracket is held by two screw-lockwasher-nut assemblies.

c. CLEANING. Clean all dirt, dust, rust, and fungus from the equipment. Clean all oil and grease from the surfaces to be varnished.

d. MASKING (fig. 24). (1) Wrap masking tape around the following points on the back of the panel:

(a) Contact springs of the GROUND TEST key switch.

(b) Contact springs of the CONTINUITY TEST key switch.

(c) Contact springs of the T.I. START switch.

(d) Contact springs of the T.I. SHORT push button.

(e) Hub and contact portion of the LINE CURRENT rheostat.

(f) Hub and contact portion of TIME ADJUSTMENT potentiometer.

(g) Contact springs, armature, hinges, and core contact points of both relays.

(h) Both resistors, one at the top near the milliammeter and another at the bottom near the potentiometer.

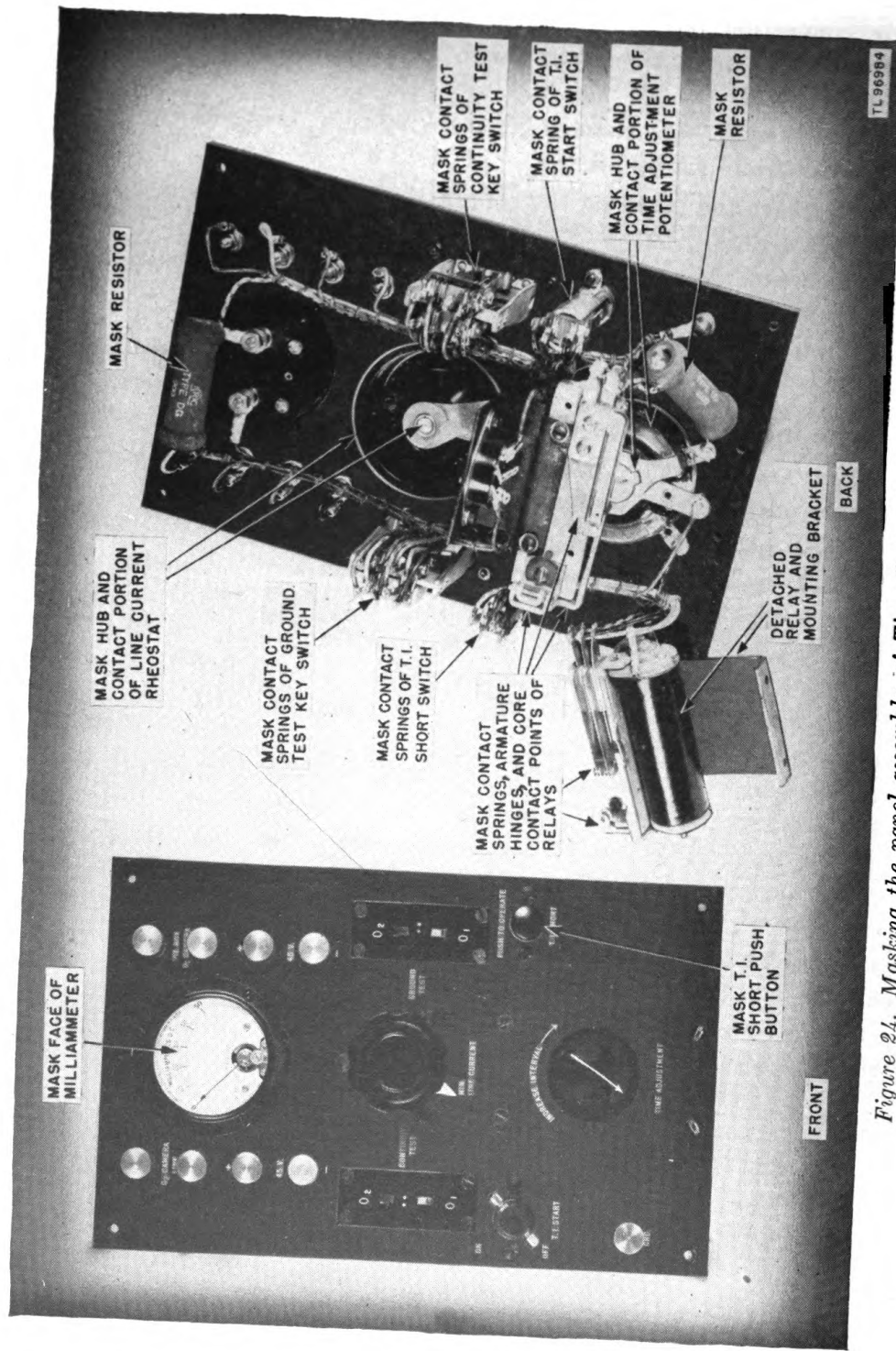

Figure 24. Masking the panel assembly of Time Interval Device PH-103 for moistureproofing and fungiproofing treatment.

(2) Mask the following points on the front of the panel:

(a) Face of the milliammeter.

(b) T.I. SHORT push button.

e. DRYING. Dry the panel assembly, with the exception of the capacitor, in an oven or under heat lamps for 2 or 3 hours at 160° F. *Do not heat the capacitor.*

f. VARNISHING. (1) Replace the capacitor into the socket at the back of the panel.

(2) Apply varnish (Lacquer, Fungus-resistant, spec No. 71-2202 (stock No. 6G1005.3), or equal) immediately after drying (e above). If varnish is not applied immediately, moisture condenses on the equipment. Varnish applied over moisture peels off readily after the varnish has dried.

(3) Use a spray gun and apply the varnish to all exposed parts on both sides of the panel assembly. Apply three coats, allowing each coat to air-dry for 15 to 20 minutes before applying the next. Between each application of varnish, move the capacitor in its socket, and actuate the GROUND TEST key switch, the CONTINUITY TEST key switch, and the T.I. START switch, to prevent sealing.

g. REASSEMBLY. (1) Remove all masking tape.

(2) Use a small brush and varnish to touch up the front of the milliammeter as follows:

(a) Seal the edge of the dial glass in its frame.

(b) Seal the zero adjusting screw.

(3) Replace the bottom relay and bracket and secure it to the panel with the screws, lockwashers, and nuts.

(4) Replace the panel assembly in the case and fasten it with the four corner screws.

(5) Test the operation of the device (par. 28).

h. MARKING. Mark the letters MFP and the date of treatment on an unlabeled portion of the panel.

Example: MFP—1 May 45.

60. Time Interval Multiplier PH-264-(*).

a. PREPARATION. (1) Make any repairs or adjustments that are necessary for proper operation of the equipment.

(2) Screw down all binding posts.

b. DISASSEMBLY. (1) Remove the six screws which hold the panel assembly to the box.

(2) Lift the panel assembly from the box and lay it to one side. *Do not disconnect the wires.*

(3) Remove the five screws which hold the removable side to the box and remove the side.

c. CLEANING. Clean all dirt, dust, rust, and fungus from the box and panel assembly. Clean all oil and grease from the surfaces.

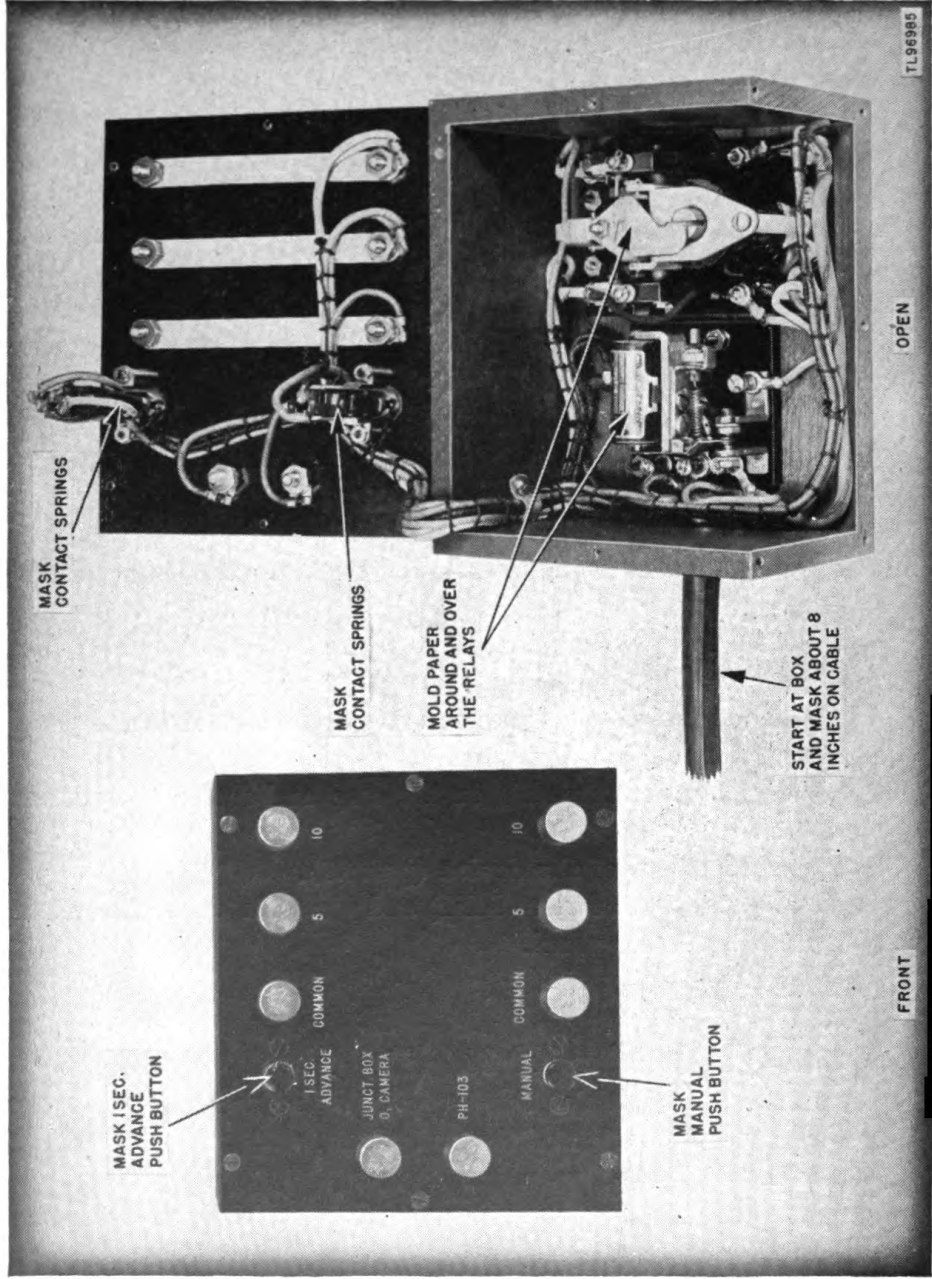

Figure 25. Masking Time Interval Multiplier PH-264-(*) for moistureproofing and fungiproofing treatment.

d. MASKING (fig. 25). (1) Mold paper around and over the relays, allowing leads and terminals to remain exposed, inside the box.

(2) Mask the following on the back of the panel assembly:

(a) Contact springs of the MANUAL push button.

(b) Contact springs of the 1 SEC. ADVANCE push button.

(3) Mask the MANUAL and the 1 SEC. ADVANCE push buttons on the front of the panel assembly.

(4) Starting at the box, mask about 8 inches of the cable.

e. DRYING. Dry the equipment in an oven or under heat lamps for 2 or 3 hours at 160° F.

f. VARNISHING. (1) Apply varnish (Lacquer, Fungus-resistant, spec No. 71-2202 (stock No. 6G1005.3) or equal), immediately after drying (e above). If the varnish is not applied immediately, moisture condenses on the equipment. Varnish applied over moisture peels off readily after the varnish has dried.

(2) Use a spray gun and apply the varnish to all exposed parts inside the box, and to both sides of the panel assembly. *Do not spray the cable.* Apply three coats, allowing each coat to air-dry for 15 to 20 minutes before applying the next.

(3) After the last coat of varnish has dried, remove the paper from around the relays, remove all the masking tape, and apply varnish with a brush as follows:

(a) Touch up each relay, taking care that no varnish gets on the contacts or on the pivot points of the movable parts of the relays.

(b) Touch up the contact springs and fiber spacers of the MANUAL and 1 SEC. ADVANCE push-button keys, taking care that no varnish gets on the contacts of the switches.

g. REASSEMBLY. (1) Replace the side of the box and fasten it with the five screws.

(2) Replace the panel assembly and fasten it with the six screws.

(3) Test the operation of the equipment (par. 29).

h. MARKING. Mark the letters MFP and the date of treatment on an unlabeled portion of the panel.

Example: MFP—1 May 45.

Note. If, during repairs, the coating of protective varnish has been punctured or broken, and if complete treatment is not needed to reseal the equipment, apply a brush coat to the affected parts. Be sure the break is completely sealed.

PART FOUR
AUXILIARY EQUIPMENT

(NOT USED)

PART FIVE

REPAIR INSTRUCTIONS

Note. Failure or unsatisfactory performance of equipment used by Army Ground Forces and Army Service Forces will be reported on WD AGO Form 468 (Unsatisfactory Equipment Report). For particulars see paragraph 68. If this form is not available, prepare letter containing the data elicited by the sample form shown in figure 60 without reproducing copies of the form.

Section VIII. THEORY OF OPERATION OF SPOTTING COMPONENTS

61. Group Functioning of Spotting Components of Spotting Set PH-32-(*)

a. The equipment is arranged as follows:

(1) A phototheodolite is located at each end of a long baseline.
(2) There is a *junction box* for each phototheodolite, providing means for connecting power separately to the phototheodolite's time counter and to its camera motor.

(3) A 12-volt *storage battery* is provided for each phototheodolite to supply the power for the camera motor, and a *special cord* is provided to connect the battery to the phototheodolite's junction box.

(4) There is a *time interval device* which is powered by two self-contained 45-volt dry cell batteries. This device produces a 45-volt d-c impulse regularly at 1-second intervals, which is used for two purposes, as follows:

(*a*) To power the two phototheodolites' time counters, which are connected in series with each other and with the device by long lines of field wire connected to the junction boxes so that, for all practical purposes, the time counters of both phototheodolites are powered simultaneously by the intermittent impulse.

(*b*) To supply intermittent power to the device referred to in (5) below.

(5) A *time interval multiplier* is provided which produces 12-volt, d-c impulses at 5- and 10-second intervals. It is powered separately by the intermittent 1-second, 45-v, d-c impulse from the time interval device ((4) above) and by a 12-volt storage battery.

(6) There is a *line connector unit* which produces audible tone intermittently on connected telephone lines. It is powered separately by

either the 5- or the 10-second, 45-v, d-c impulse from the time interval multiplier ((5) above), and by the same 12-volt storage battery used by the multiplier.

(7) *Time interval signals*, each of which has a loudspeaker which howls intermittently, are provided. Each is powered separately by two self-contained, 3-volt, dry cell batteries, and by either the 5- or the 10-second, 45-v, d-c impulse from the time interval multiplier.

b. The group functioning of the equipment is as follows:

(1) Each phototheodolite is manually operated and is kept trained on the same target. The cameras of the two phototheodolites are synchronized so that they take motion pictures of the target area at the same speed, and each records the elevation and azimuth measurements and the time counter indication on each frame of film. The time counters of the two phototheodolites initially are synchronized and thereafter are simultaneously advanced one unit per second by impulses from the time interval device, so that the frames of film exposed by the two phototheodolites at identical moments can be identified.

(2) The time interval multiplier is operated simultaneously with the phototheodolites' time counters, since it is operated by the same 1-second impulse. However, the line connector unit and the time interval signals horns are operated by the multiplier so that they supply either a single full-second audible signal once every 5 seconds, or three $\frac{1}{2}$ -second audible signals for 3 consecutive seconds within a period of 10 seconds. These signals are used to coordinate the making of visual records and the performance of other duties.

62. Individual Functioning of Spotting Components

a. The functioning of each of the following spotting components of Spotting Set PH-32-(*) is contained in the Technical Manuals indicated below:

(1) Phototheodolites, TM 11-2534.

(2) Line Connector Unit EE-87 and Time Interval Signal BE-65, TM 11-433.

b. The functioning of Time Interval Device PH-103 and of Time Interval Multiplier PH-264 are contained in succeeding paragraphs.

63. Functioning of Time Interval Device PH-103 (figs. 26 and 27)

a. GENERAL. The circuit of Time Interval Device PH-103 consists basically of four circuits:

- (1) Time interval circuit.
- (2) Theodolite circuit.
- (3) Continuity test circuit.
- (4) Ground test circuit.

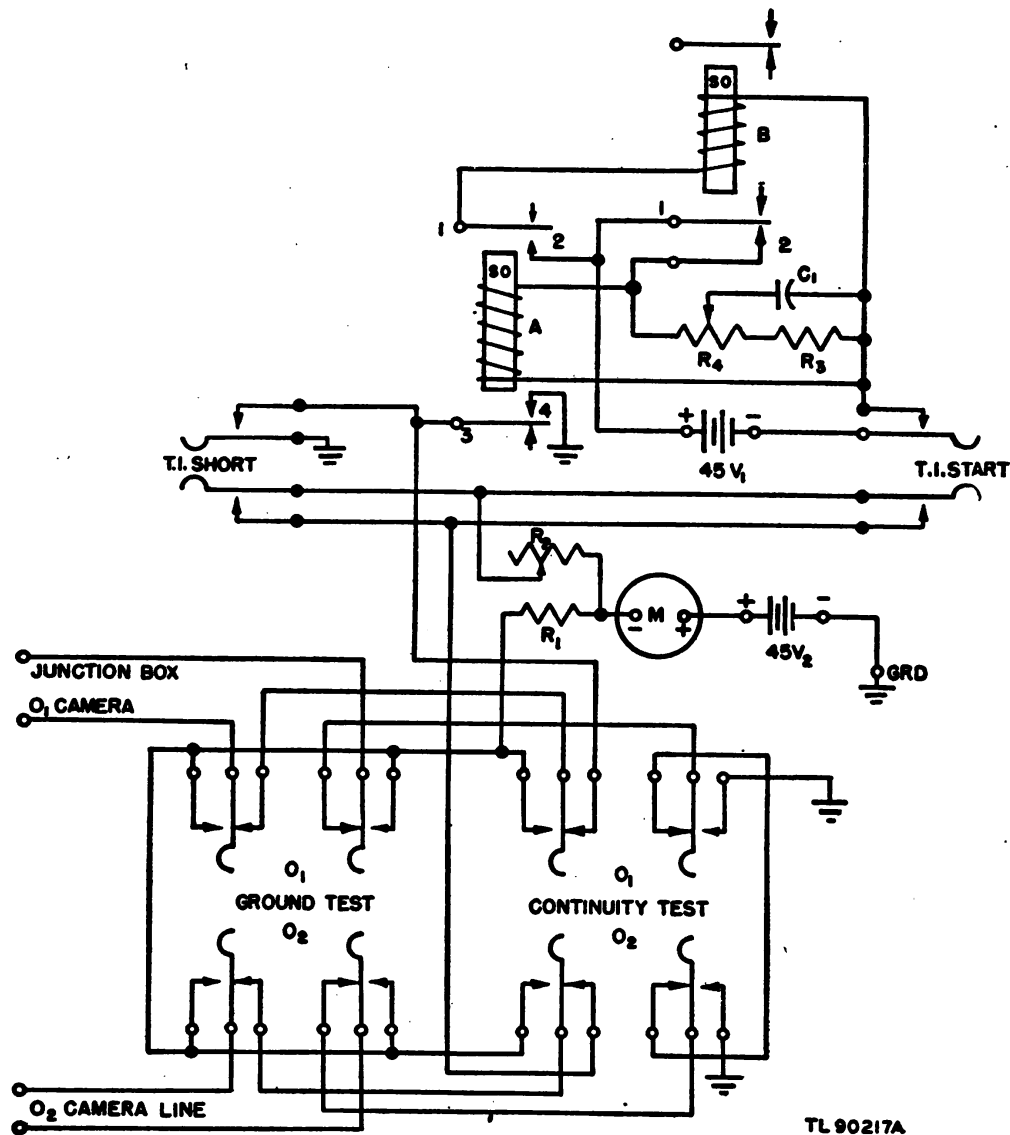

Figure 26. Schematic diagram of Time Interval Device PH-103.

b. TIME INTERVAL CIRCUIT ((1), fig. 27). (1) The time interval device circuit consists of two slow-operating relays A and B, resistor R_3 , potentiometer R_4 , capacitor C_1 , and one contact of the T.I.START switch. It draws power for operation from battery V_1 . The circuit is designed to provide an adjustable range in pulsing rate of one cycle per second, plus or minus 20 percent.

(a) When the T.I.START switch is closed, relay A operates through contacts 1 and 2 on relay B.

(b) As soon as relay A has operated, relay B operates through contacts 1 and 2 on relay A, and causes relay A to release.

(c) Release of relay A opens the operating circuit of relay B, and relay B releases. This completes the cycle of operation; both relays are released, and relay A again operates to repeat the cycle.

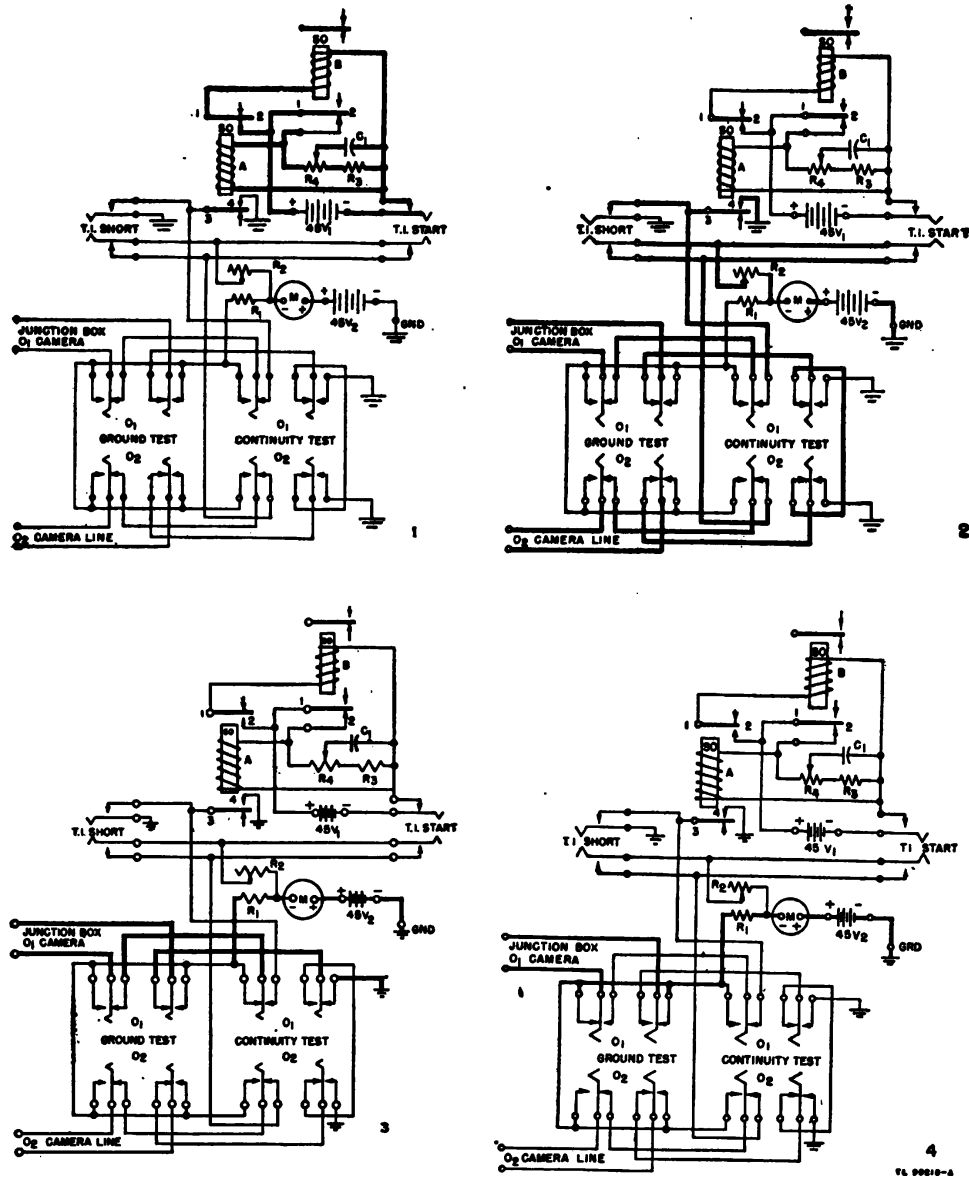

Figure 27. Functional schematic diagrams of Time Interval Device PH-103.

(2) The time interval is controlled by the values of resistor R_3 , potentiometer R_4 , and capacitor C_1 .

(a) While relay B is in a nonoperated condition, capacitor C_1 is charged. The rate of charge is controlled by setting potentiometer R_4 .

(b) When relay B operates, the capacitor stops charging and starts discharging through two paths, one path through resistor R_3 and a part

of potentiometer R_4 , and the other path through the remainder of the potentiometer and relay A.

(c) Relay A will not release until the voltage impressed by capacitor C_1 drops below the "hold" value of the voltage for the relay. This delay in the releasing time of relay A lengthens the time per cycle of operation of the two relays and thus controls the time interval.

c. THEODOLITE CIRCUIT ((2), fig. 27). (1) This circuit consists of one contact of the T.I.START switch, a T.I.SHORT switch, rheostat R_2 , meter M (common to several circuits), 45-volt battery V_2 , and contacts 3 and 4 of relay A.

(2) With the T.I.START switch closed, each time that relay A operates, contacts 3 and 4 close the circuit containing rheostat R_2 , meter M, the theodolite circuits, and battery V_2 .

(3) The current in this circuit is adjusted with the rheostat. Pressing the T.I. SHORT switch closes this circuit and holds it closed as long as the switch is pressed, regardless of the position of the T.I.START switch or the operated or nonoperated condition of the relay A.

(4) With the SIGNAL switches of both phototheodolites closed, their signal lamps light and the time counters advance one unit each time this switch is pressed or each time that relay A operates during normal operation. This switch is used to close the circuit for adjusting line current from 25 to 30 ma.

d. CONTINUITY TEST CIRCUIT ((3), fig. 27). (1) The basic function of this circuit is to place battery V_2 in series with meter M, resistor R_1 , and each theodolite line, one at a time.

(2) This is done by operating the CONTINUITY TEST key to the O_1 or O_2 position to test either the O_1 or O_2 line, respectively. Either line may be tested at any time, but the SIGNAL switch of the phototheodolite whose line is being tested must be closed at the time the test is being made.

(3) Each time the key is operated, the signal lamp of the phototheodolite on the line being tested lights and its time counter advances one unit.

e. GROUND TEST CIRCUIT ((4), fig. 27). The basic function of this circuit is to place both sides, paralleled, of either the O_1 or O_2 line in series with resistor R_1 , meter M, battery V_2 , and ground. The ground connection is supplied by a ground rod connected to a ground terminal at the lower left corner of the panel. It is not necessary for the SIGNAL switches of the phototheodolites to be closed for this test. The circuit testing the O_1 line is shown in (4), figure 27.

64. Functioning of Time Interval Multiplier PH-264-(*) (fig. 28)

The multiplier circuit consists of two relays and two nonlocking push-button type keys.

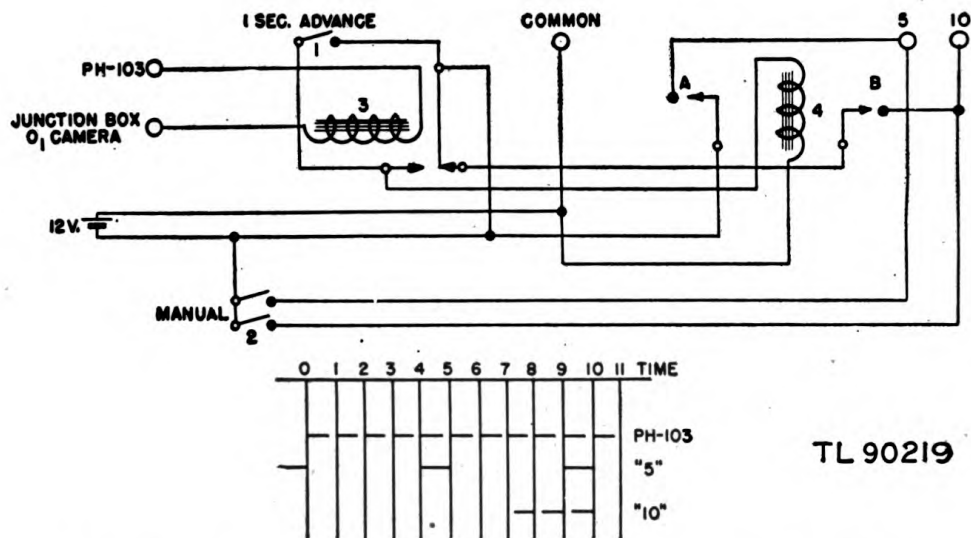

TL 90219

Figure 28. Schematic diagram of Time Interval Multiplier PH-264-(*).

a. In use, the winding of relay 3 is in series with the line from the time interval device to the O₁ junction box; therefore, relay 3 is operated once each second by the time interval device. Each operation of relay 3 causes relay 4 to be energized.

b. Relay 4 has two contacts moved by two cams on a shaft with a 10-tooth ratchet wheel. The driving pawl is the armature of relay 4, and each time it is operated it advances the ratchet wheel one tooth.

(1) Contacts A are closed by the A cam once for each of two diametrically opposite teeth on the ratchet. As the cams rotate, contacts A are closed by the two projections on the A cam once every five operations of relays 3 and 4. Each time contacts A are closed, 12-volt battery pulses appear between the COMMON binding post and the binding post marked 5 until the ratchet is advanced again, opening contacts A. This will occur every fifth second when relay 3 receives an impulse once per second.

(2) Contacts B are closed once each 10 seconds continuously for three consecutive teeth on the ratchet, closing the path from the binding post marked 10 to the back contact of relay 3. When relay 3 releases after being operated, 12-volt battery pulses appear between the COMMON binding post and the binding post marked 10. Contact B remains closed for two more operations of relays 3 and 4 so that three battery pulses will appear between binding posts marked COMMON and 10.

c. The time chart in figure 28 illustrates the sequence of battery pulses obtained. Pressing the manual key impresses battery between the COMMON and both the 5 and 10 binding posts. The 1 SEC. ADVANCE key operates stepping relay 4 once each time the key is pressed.

Section IX. TROUBLE SHOOTING SPOTTING COMPONENTS

65. General Trouble-Shooting Information

No matter how well equipment is designed and manufactured, faults occur in service. When such faults occur, the repairman must locate and correct them as rapidly as possible. This section contains general information to aid personnel engaged in the important duty of trouble shooting.

a. TROUBLE-SHOOTING DATA. Take advantage of the component illustrations and circuit diagrams supplied in this manual and in other manuals referred to, in order to help in the rapid location of faults.

b. TROUBLE-SHOOTING PROCEDURE. (1) The first step in servicing a defective spotting component is to analyze the fault. This is done by thinking about the possible causes for the abnormal operation of the equipment.

(2) The second step is to localize the fault. This is done by the process of elimination. That is, start testing for battery or ground at any point up to which the circuit is functioning properly, and then test a step at a time toward the trouble until it is located.

(3) Some faults, such as burned-out resistors, arcing, and shorted coils, can be located by sight, smell, or hearing. The majority of faults, however, must be located by making continuity or ground tests.

c. TROUBLE-SHOOTING SPOTTING COMPONENTS. (1) The trouble-shooting procedure for each of the following spotting components is given in the Technical Manual indicated below:

(*a*) Phototheodolites, TM 11-2534.

(*b*) Line Connector Unit EE-87 and Time Interval Signal BE-65, TM 11-433.

(2) The trouble-shooting procedures for Time Interval Device PH-103 and Time Interval Multiplier PH-264(*) are given in succeeding paragraphs.

66. Trouble-shooting Time Interval Device PH-103 (fig. 29)

a. PROCEDURE. After the trouble has been analyzed and localized, remove the panel assembly (par. 25*b*(1) and (2)) and carefully inspect the back of the panel for apparent defects, such as:

- (1) Badly soldered connections.
- (2) Loose connections.
- (3) Broken wires.
- (4) Bulged resistors.
- (5) Worn insulation.
- (6) Stuck or spread switch contacts.
- (7) Stuck or spread relay contacts.
- (8) Capacitor loose in socket.

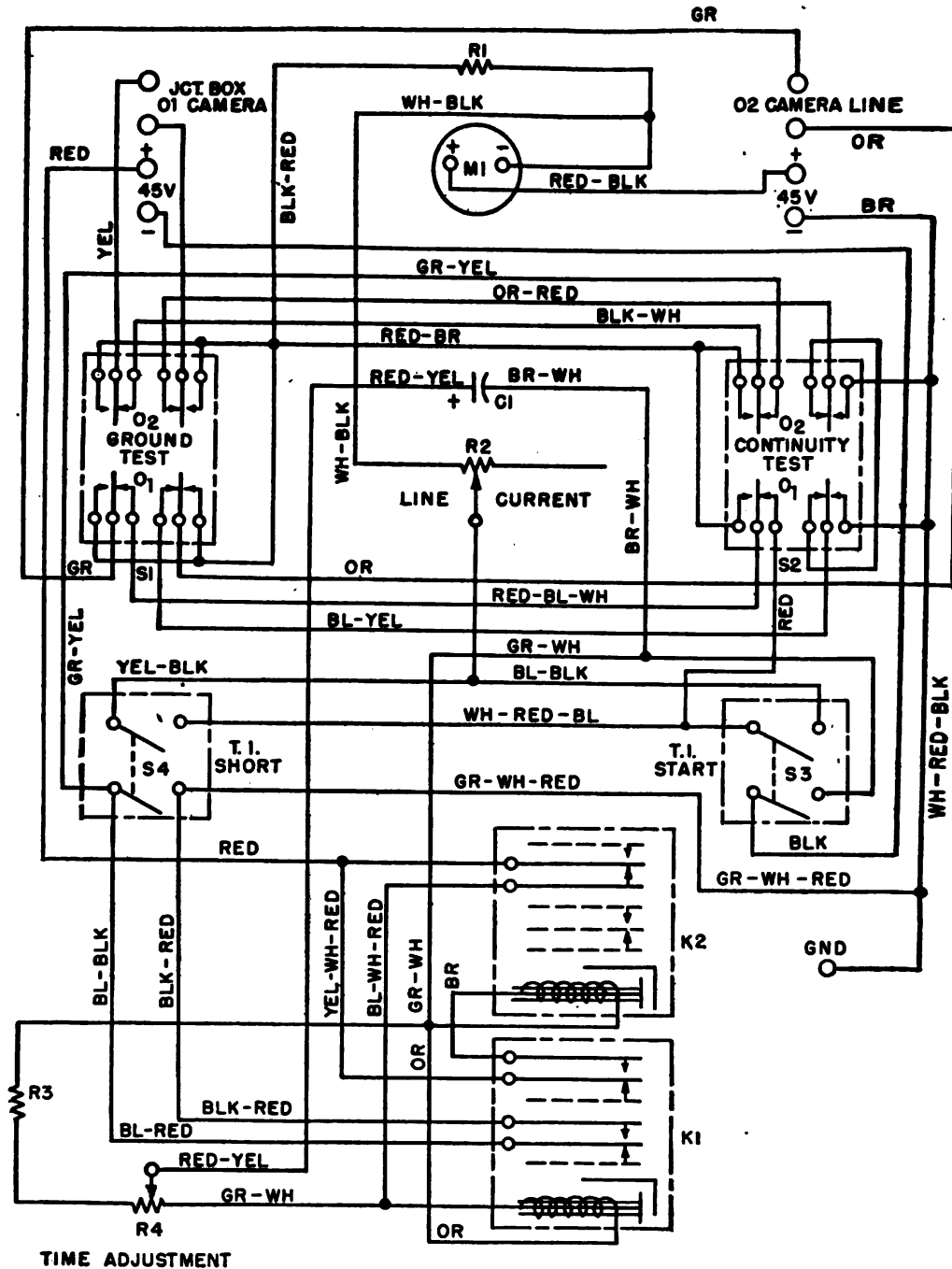

LEGEND

- | | |
|--------------------------|---------------------------------------|
| K1 } SLOW ACTING RELAYS | R1- RESISTOR, 900 OHMS |
| K2 } SLOW ACTING RELAYS | R2- LINE CURRENT ADJ RHEO, 2,500 OHMS |
| C1- CAPACITOR, 200 M M F | R3- RESISTOR, 4,000 OHMS |
| S1- CONTINUITY TEST KEY | R4- POTENTIOMETER, 1,000 OHMS |
| S2- GROUND TEST KEY | S3- T.I. START SWITCH |
| MI- MILLIAMMETER | S4- T.I. SHORT SWITCH |

TL 97296

Figure 29. Circuit diagram of Time Interval Device PH-103.

b. TROUBLE-SHOOTING CHART. The chart below lists some of the troubles that may occur in Time Interval Device PH-103, and give suggestions about the probable causes of such troubles.

Trouble	Probable cause
<p>(1) Milliammeter needle does not deflect when the following conditions exist:</p> <p>(a) The T.I.SHORT push button is depressed.</p> <p>(b) A 45-volt battery is connected to the 45V binding posts on the left side of the panel.</p> <p>(c) JCT. O₁ CAMERA LINE binding posts are shorted.</p> <p>(d) O₂ CAMERA LINE binding posts are shorted.</p>	<p>(a) Milliammeter M₁ burned out or has loose connection.</p> <p>(b) Contacts of switch S₄ are dirty or out of adjustment.</p> <p>(c) Contacts of switches S₁ and S₂ are dirty or out of adjustment.</p> <p>(d) Rheostat R₂ is defective or has dirty contacts.</p> <p>(e) Defective wiring between any of the above items.</p>
<p>(2) No voltage at one pair of O₁ or O₂ binding posts when the other pair is shorted and the following conditions exist:</p> <p>(a) The T.I.SHORT push button is depressed.</p> <p>(b) A 45-volt battery is connected to the 45V binding posts on the left side of the panel.</p>	<p>Any one of the items listed in (1) above.</p>
<p>(3) Line current in excess of 30 ma with LINE CURRENT rheostat turned all the way clockwise.</p>	<p>Rheostat R₂ is defective or short circuited.</p>
<p>(4) Relays do not operate when T.I. START switch is turned to ON and a 45-volt battery is connected to the 45V binding post on the right side of the panel.</p>	<p>(a) Contacts of switch S₃ are dirty or out of adjustment.</p> <p>(b) Open winding of relay K₁.</p> <p>(c) Contacts on relay K₂ are dirty or out of adjustment.</p> <p>(d) Run-down battery.</p>
<p>(5) Relay K₁ does not release.</p>	<p>(a) Contacts on relay K₁ are dirty or out of adjustment.</p> <p>(b) Contacts on relay K₂ are stuck in the nonoperated position.</p> <p>(c) Armature on relay K₁ sticks.</p>
<p>(6) Relay K₁ operates, but relay K₂ does not operate.</p>	<p>(a) Contacts of relay K₁ are dirty or out of adjustment.</p> <p>(b) Defective winding on relay K₂.</p>
<p>(7) Relay K₂ does not release.</p>	<p>(a) Armature on relay K₂ sticks.</p> <p>(b) Contacts of relay K₁ stick in the operated position.</p>

Trouble	Probable cause
(8) Erratic timing.	(a) Run-down battery in the right side compartment. (b) Defective capacitor C_1 .
(9) Interval cannot be adjusted within the desired limits.	(a) Defective capacitor C_1 . (b) Defective or open resistor R_a . (c) Defective potentiometer R_4 .
(10) No impulse at JCT. BOX O_1 CAMERA binding post or O_2 CAMERA LINE post.	(a) Contacts of relay K_1 are dirty or out of adjustment. (b) Contacts on switch S_2 are dirty or out of adjustment. (c) Open winding of relay K_1 .
(11) Continuous impulse.	(a) Contacts of relay K_1 stick in the operated position. (b) Ground contact of switch S_2 in the operated position.

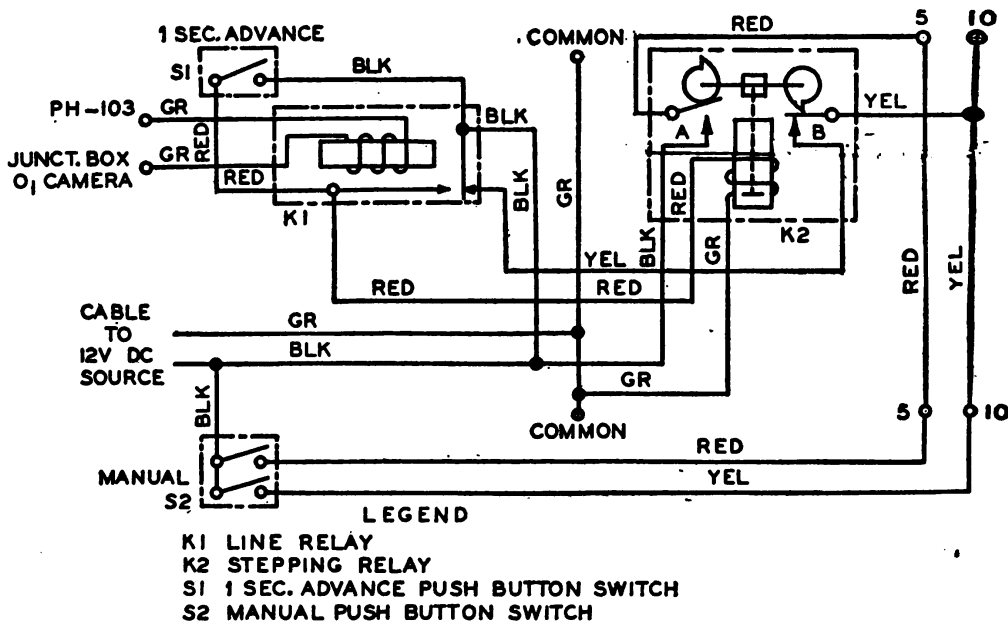

TL97267

Figure 30. Circuit diagram of Time Interval Multiplier PH-264-(*).

67. Trouble Shooting Time Interval Multiplier PH-264-(*)(fig. 30)

a. PROCEDURE. After the trouble has been analyzed and localized, remove the panel assembly (par. 60b) and carefully inspect the inside of the box and the back of the panel assembly for apparent defects, such as:

- (1) Badly soldered connections.
- (2) Loose connections.

- (3) Broken wires.
- (4) Worn insulation.
- (5) Defective springs or movable parts on relays.
- (6) Stuck or spread switch contacts.

b. **TROUBLE-SHOOTING CHART.** The following chart lists some of the troubles that may occur in Time Interval Multiplier PH-264-(*) and gives suggestions about the probable causes of such troubles.

Trouble	Probable cause
(1) Relay K_1 will not operate when a 45-volt battery is intermittently connected to the JUNCT. BOX O_1 CAMERA and PH-103 binding posts.	(a) Defective or open winding on relay K_1 . (b) Loose or broken connection between the binding posts and the relay.
(2) Relay K_2 will not operate when a 45-volt battery is intermittently connected to the JUNCT. BOX O_1 CAMERA and PH-103 binding posts, and the cable of the multiplier connected to a 12-volt battery.	(a) Defective or open winding on relay K_2 . (b) Relay K_1 contacts dirty or out of adjustment. (c) Run-down battery or defective connecting cable connected to the multiplier.
(3) Relay K_2 does not operate when the 1 SEC. ADVANCE push button is depressed with the multiplier cable connected to a 12-volt battery.	(a) Run-down battery or defective connecting cable. (b) Defective winding on relay K_2 . (c) Switch S_1 contacts dirty or out of adjustment.
(4) No voltage between the COMMON and 5 and 10 binding posts when the MANUAL push button is depressed, with the multiplier cable connected to 12-volt battery.	(a) Run-down battery or defective connecting cable. (b) Switch S_2 contacts dirty or out of adjustment. (c) Poor connections at the 5, 10, and COMMON binding posts.
(5) No voltage between the COMMON and 5 or 10 binding posts when an intermittent 45-volt impulse is applied to the JUNCT. BOX O_1 CAMERA and PH-103 posts, with the multiplier cable connected to a 12-volt battery.	(a) Open winding on relay K_1 . (b) Contacts of relay K_1 are dirty or out of adjustment. (c) Open winding on relay K_2 . (d) Defective cams on relay K_2 . (e) Defective springs of relay K_2 . (f) Contacts dirty or out of adjustment on relay K_2 .
(6) Continuous 12-volt output between 5 and COMMON binding posts with the multiplier connected to batteries as in (5) above.	(a) Contacts A on relay K_2 stuck in operated position or shorted out of the circuit. (b) Switch S_2 contacts stuck in operated position.

Trouble	Probable cause
(7) Continuous 12-volt output between 10 and COMMON binding posts with multiplier connected as in (5) above.	(a) Relay K_1 contacts stuck in non-operated position and contacts B or relay K_2 stuck in operated position. (b) Switch S_2 contacts stuck in operated position.
(8) Relay K_2 will not release.	(a) Contacts on switch S_1 stuck in operated position. (b) Contacts on relay K_1 stuck in operated position.

68. Unsatisfactory Equipment Report

a. When trouble with Spotting Set PH-320-(*) occurs more often than repair personnel consider normal, fill out War Department Unsatisfactory Equipment Report WD AGO Form 468 and forward it in duplicate, through channels, to the Office of the Chief Signal Officer, Washington 25, D. C.

b. If this form is not available, prepare letter containing the data elicited by the sample form shown in figure 60 without reproducing copies of the form.

SPOTTING SET AN/TVQ-1

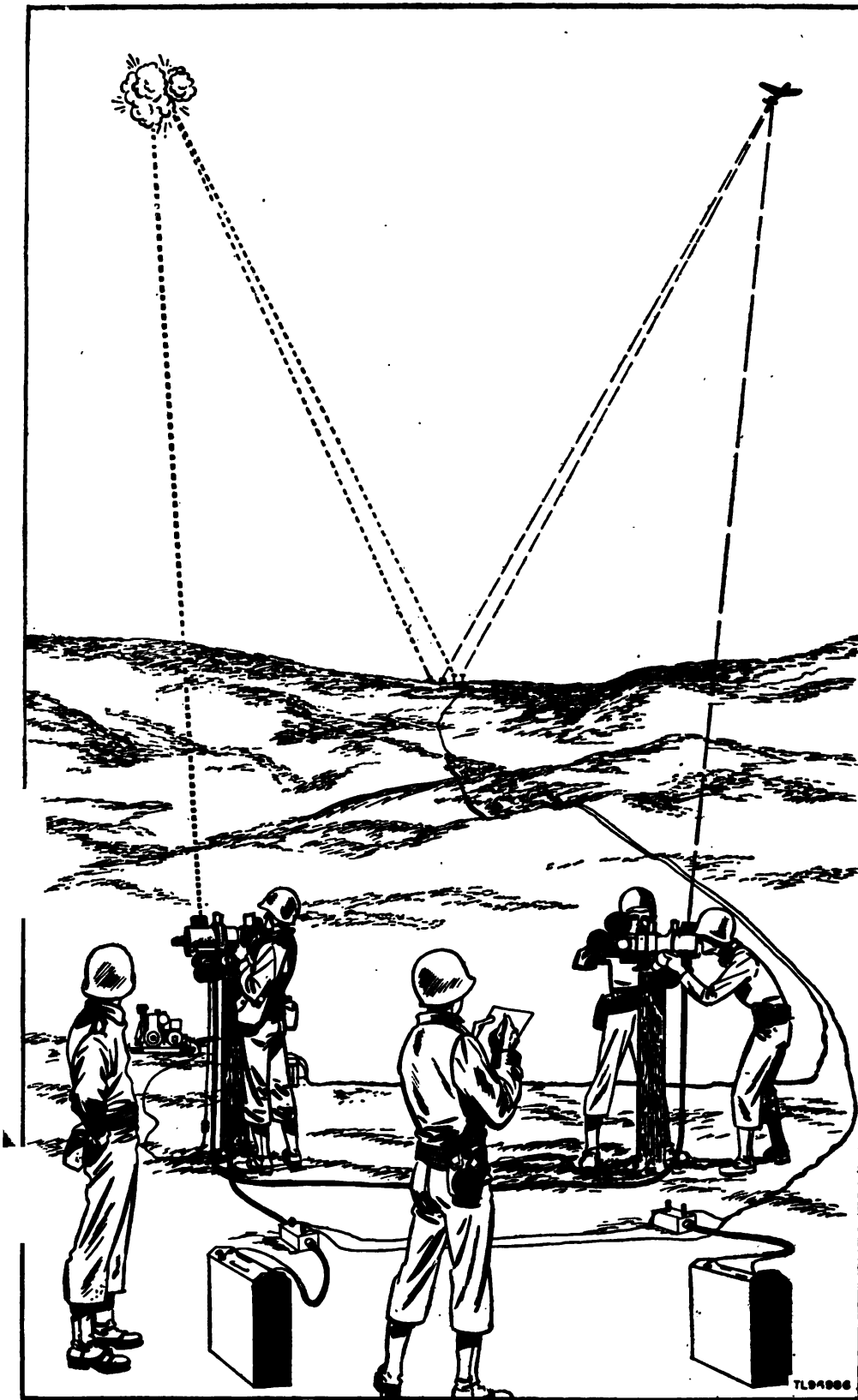

Figure 31. Spotting components of Spotting Set AN/TVQ-1 in use. (The flank station pair of phototheodolites and associated equipment are shown in the foreground. The battery station 4,000 to 8,000 yards distant is shown in the background. The broken lines indicate the lines of sight from the gun director and one phototheodolite at each station to the target; the dotted lines indicate the lines of sight from the other theodolite at each station, and the line of fire of the gun, to a point in space which has the same elevation but the opposite azimuth as the target.)

PART ONE

INTRODUCTION

Section I. DESCRIPTION

69. General

a. Spotting Set AN/TVQ-1 is a portable assembly of equipment which is capable of measuring the vertical and horizontal angles of two points, each from two positions, and making motion-picture records of those points with the angular measurements and a time identification included in each picture. The set also includes equipment for processing the exposed films, and exhibiting the finished films to be viewed for plotting purposes.

b. Basic type nomenclature including the symbol (*) instead of a suffix letter, indicates any one or all of the models of that particular equipment which are covered in this manual. For example:

(1) Exposure Meter PH-252-(*) indicates any one or all of Exposure Meters PH-252, PH-252-A, PH-252-B, PH-252-C, and PH-252-E.

(2) Time Interval Multiplier PH-264-(*) indicates any one or all of Time Interval Multipliers PH-264-A, PH-264-B, and PH-264-C.

(3) Axle RL-27-(*) indicates any one or all of Axles RL-27, RL-27-A, and RL-27-B.

(4) Reel Unit RL-31-(*) indicates any one or all of Reel Units RL-31, RL-31-B, and RL-31-C.

(5) Film Viewer PH-97-(*) indicates any one or all of Film Viewers PH-97, PH-97-A, PH-97-B, PH-97-C, and PH-97-D.

(6) Splicer PH-91-(*) indicates either Splicer PH-91 or PH-91-A.

c. The symbol (), used throughout this manual in connection with Power Unit PE-75-(), indicates any or all existing models of that equipment.

70. Application (fig. 31)

a. Spotting Set AN/TVQ-1 is used in the *equiangular* method of antiaircraft practice where the guns fire at a point in space instead of directly at the target. The purpose of Spotting Set AN/TVQ-1 is to

photograph the target, and the shellbursts at the point in space, to obtain scoring records which can be compared to analyze the effectiveness of the gunfire.

b. Spotting Set AN/TVQ-1 includes *spotting* components; *wire and power* components; *film developing* components; and *film viewing* components.

(1) The spotting components and the wire and power components are used together.

(a) The spotting components include two pairs of selsyn-motor-equipped phototheodolites which take motion pictures of the points they measure; some devices for generating regulated intermittent electric signals; equipment for audibly reproducing the timed signals; and a special cable for use in the gun data system of the antiaircraft battery.

(b) The wire and power components include a power unit; storage batteries; hydrometers for testing the batteries; wire for interconnecting the spotting components; and equipment for handling the wire.

(c) In use, one pair of selsyn-motor-connected phototheodolites and the timed signal generating equipment and some of the equipment which audibly reproduces the timed signals, are electrically connected and located in the immediate vicinity of the antiaircraft battery.

(d) The other pair of selsyn-motor-connected phototheodolites and some signal reproducing equipment are electrically connected to the group at the battery station, but are located some distance away on the flank. The power unit also is located on the flank to furnish power for the selsyn motors of the pair of phototheodolites there.

(e) A base line is laid between the battery and flank stations, and the target moves along one side of this base line. One phototheodolite at the battery station and the gun director of the antiaircraft battery, and one phototheodolite at the flank station, are manually aimed at the target, the phototheodolites taking motion pictures of the target from different positions. The antiaircraft guns, because of a reversal of data which is accomplished between the gun director and the guns, do not fire at the target but place their fire at the point in space which corresponds to the position of the target *on the other side of the base line between the stations*. The range, altitude, and elevation of the point being fired at are the same as those of the target, only the *azimuth* being changed; for example, if the target lies 300 miles to the *left* of the base line, fire will be directed 300 miles to the *right* of the base line. Likewise the remaining phototheodolite at each station is automatically aimed at this point in space which has the same elevation angle but is on the other side of the base line from the target, these phototheodolites taking motion pictures of the shellbursts from different positions so that deviations of the bursts can be measured in much the same way that deviations from a target would be determined. Figure 32 is a block

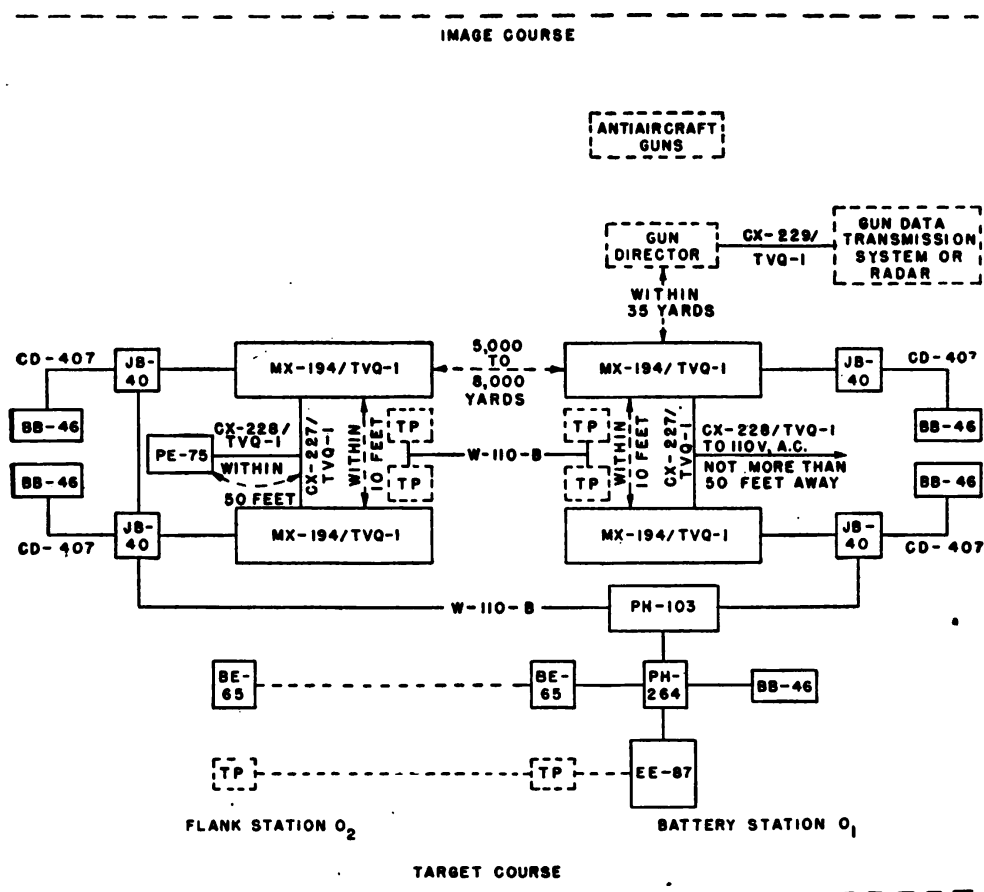

- | | |
|------------------------------|-----------------------------------|
| BB-46, Battery. | JB-40, Junction Box. |
| BE-65, Time Interval Signal. | MX-194/TVQ-1, Theodolite. |
| CD-407, Cord. | PE-75, Power Unit. |
| CX-227/TVQ-1, Cord. | PH-103, Time Interval Device. |
| CX-228/TVQ-1, Cord. | PH-264, Time Interval Multiplier. |
| CX-229/TVQ-1, Cord. | TP, Telephone. |
| EE-87, Line Connector Unit. | |

Figure 32. Block diagram of installation of spotting components of Spotting Set AN/TVQ-1.

diagram of the usual installation of the spotting components of Spotting Set AN/TVQ-1.

(2) The *film developing* components include equipment and supplies for developing and drying the motion-picture film exposed in the photo-theodolites.

(3) The *film viewing* components include equipment for rewinding and splicing, and a special machine for examining the finished film. The data obtained from examination of two pictures of the target, and of two pictures of the point in space at which the guns were fired, all taken at the same moment but from different positions, can be used to calculate

71. Table of Major Components of Spotting Set AN/TVQ-1

a. SPOTTING COMPONENTS (fig. 33). The spotting components (par. 70b(1)(a)) of Spotting Set AN/TVQ-1 are:

Quan	Component	Dimensions (in.)			Volume (cu ft)	Weight (lb)
		Length	Width	Height		
4	Theodolite MX-194/TVQ-1 in carrying case.	36	25	24	12.5	265
4	Junction Box JB-40 (packed one in each theodolite carrying case).	120 (cord)	4.5 x 4.5 x 2.5 (box)		.05	7.5
4	Cover CW-95/TVQ-1 (packed one in each theodolite carrying case).	36	24	24	1.2	1
4	Cord CD-407 (packed one in each theodolite carrying case).	84			.01	1.5
2	Cord CX-227/TVQ-1 (packed one in each of two theodolite carrying cases).	300				7
2	Cord CX-228/TVQ-1 (packed one in each of the two theodolite carrying cases which do not contain Cord CX-227/TVQ-1).	600				5
1	Cord CX-229/TVQ-1 (packed in one of the theodolite carrying cases).	60				8
4	Exposure Meter PH-252- (*) (usually packed one in each theodolite carrying case).	4.25	2.75	1.75	.01	.75
20 rolls	Film, 35-mm motion-picture, 200 feet long.	5.5	5.5	1.75	.03	1.25
2	Time Interval Device PH-103.	27	12	7	1.3	23
2	Time Interval Multiplier PH-264- (*) .	7	6	4	.09	6
2	Line Connector Unit EE-87.	14.25	11.25	6.875	.64	25
4	Time Interval Signal BE-65.	10.875	11.5	6.5	.47	18

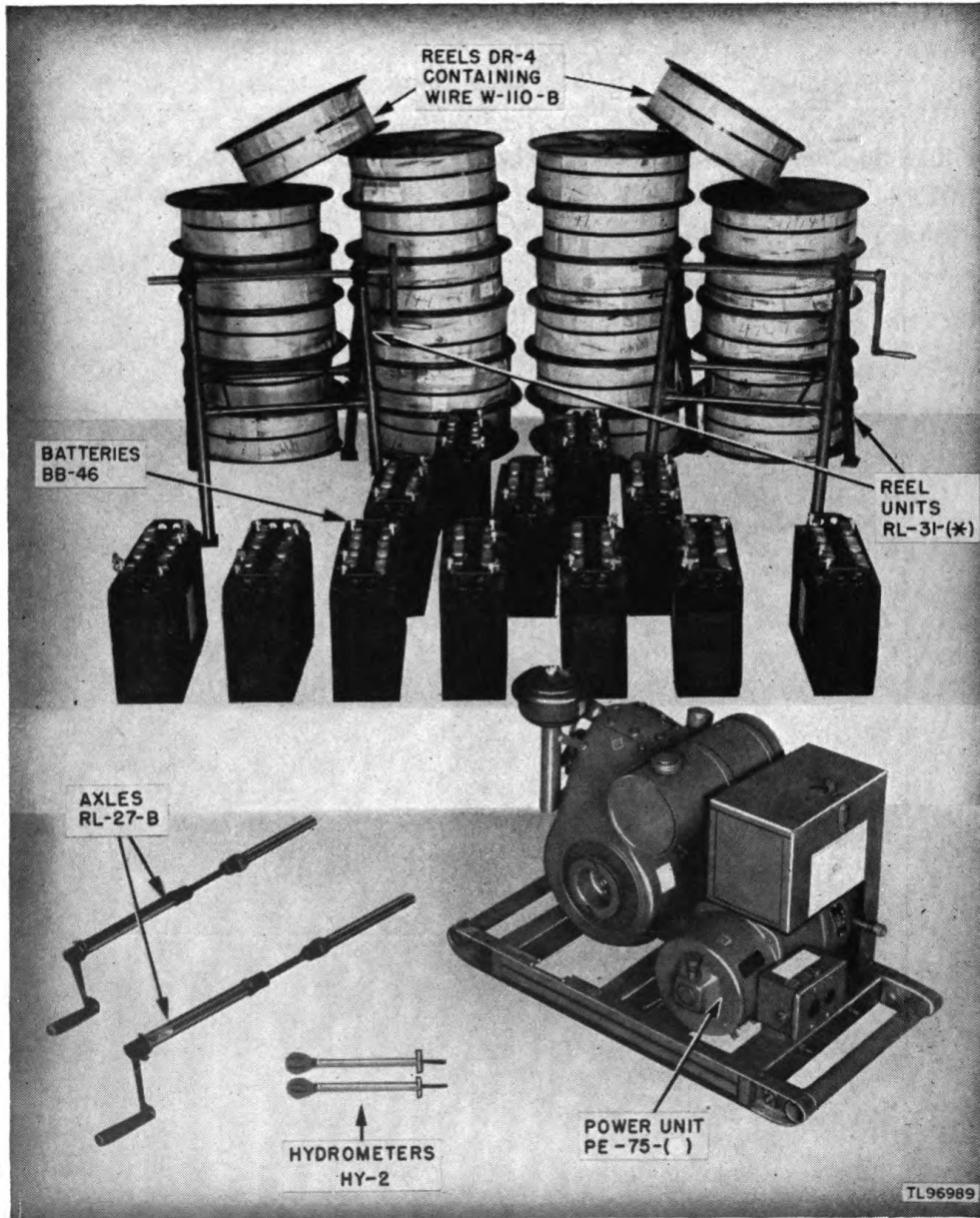

Figure 34. Wire and power components of Spotting Set AN/TVQ-1. (Other components shown in figures 33, 35, and 36.)

b. WIRE AND POWER COMPONENTS (fig. 34). The wire and power components (par. 70b(1)(b)) of Spotting Set AN/TVQ-1 are:

Quan	Component	Dimensions (in.)				Volume (cu ft)	Weight (lb)
		Length	Width	Height	Diam		
1	*Power Unit PE-75-()	36	20	24	-----	10	319
2	Hydrometer HY-2	12	-----	-----	2	.02	.5
12	Battery BB-46	21	12	20	-----	2.9	122
2	*Axle RL-27-(*)-	37.25 to 29	-----	-----	1.75	.035 to .185	5 to 9
	Crank	-----	4.5	-----	-----	-----	-----
2	*Reel Unit RL-31-(*)-	2.58	32	30.5	-----	1.4	33.6 to 55.5
2	Installation kit (for above).	30.5	8.5	4	-----	0.51	22.25
24	Reel DR-4 containing ½ mile Wire W-110-B.	-----	-----	7	22.25	1.5	82

* Specific information about the weight and dimensions of each model is given in the references indicated below.

Axle RL-27-(*), paragraph 13.
 Reel Unit RL-31-(*), TM 11-362.
 Power Unit PE-75- (), TM 11-900.

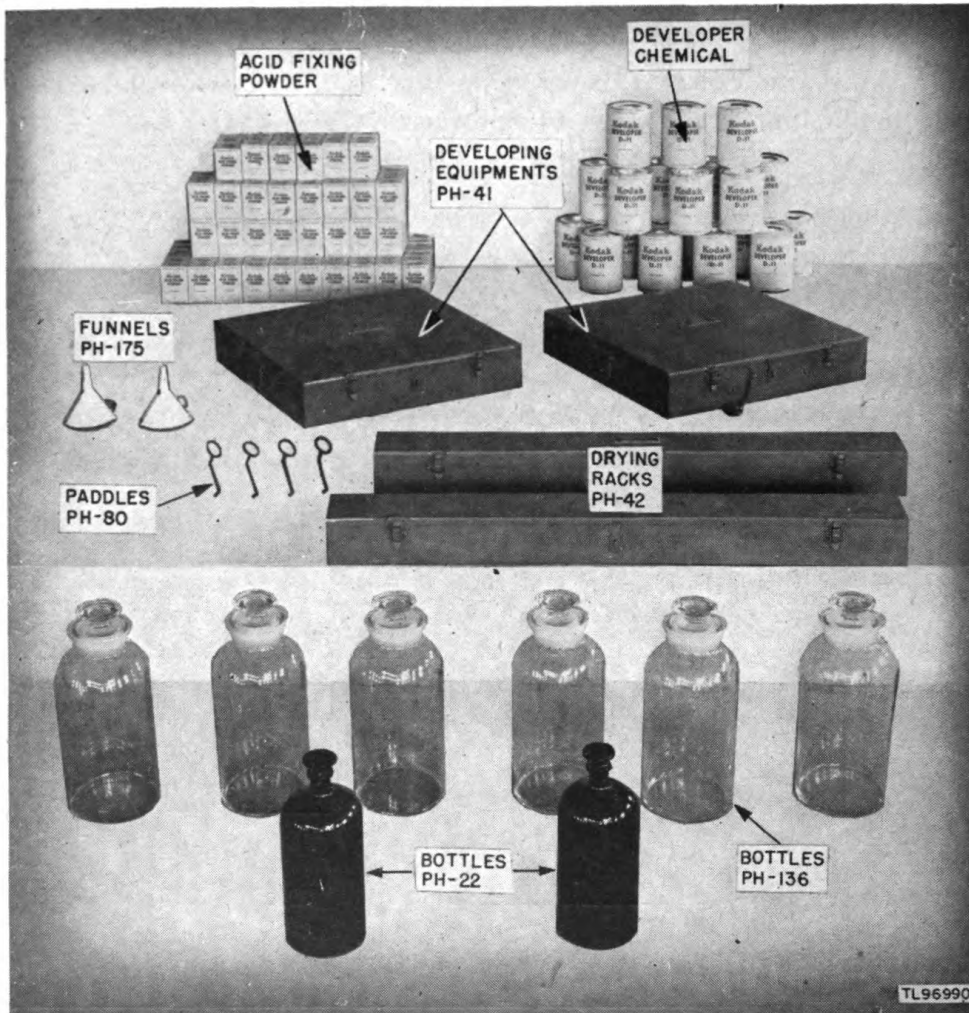

Figure 35. Film developing components of Spotting Set AN/TVQ-1. (Other components shown in figures 33, 34, and 36.)

c. FILM DEVELOPING COMPONENTS (fig. 35). The film developing components (par. 70b(2)) of Spotting Set AN/TVQ-1 are:

Quan	Componen	Dimensions (in.)				Volume (cu ft)	Weight (lb)
		Length	Width	Height	Diam		
2	Developing Equipment PH-41 in carrying case.	26	26	5		1.9	50
2	Drying Rack PH-42 in carrying case.	50	5	4		.57	12
20 cans	Chemical, developer (Eastman Kodak Co. D-11).			8	5.5	.12	6
80 cans or	Chemical, acid fixing powder, 1-gal size.			4.5	3.5	.025	2
80 jars	Chemical, acid fixing powder, 1-gal size.			6	3.5	.033	2.5
or 160 pkgs	Chemical, acid fixing powder, 1/2-gal size.	3	1.5	5		.013	1
2	Bottle PH-22			14	6	0.22	4
6	Bottle PH-136			18	8	0.52	7.5
2	Funnel PH-175			7	4	.05	.5
4	Paddle PH-80	12	2.5	1.5		.02	.25

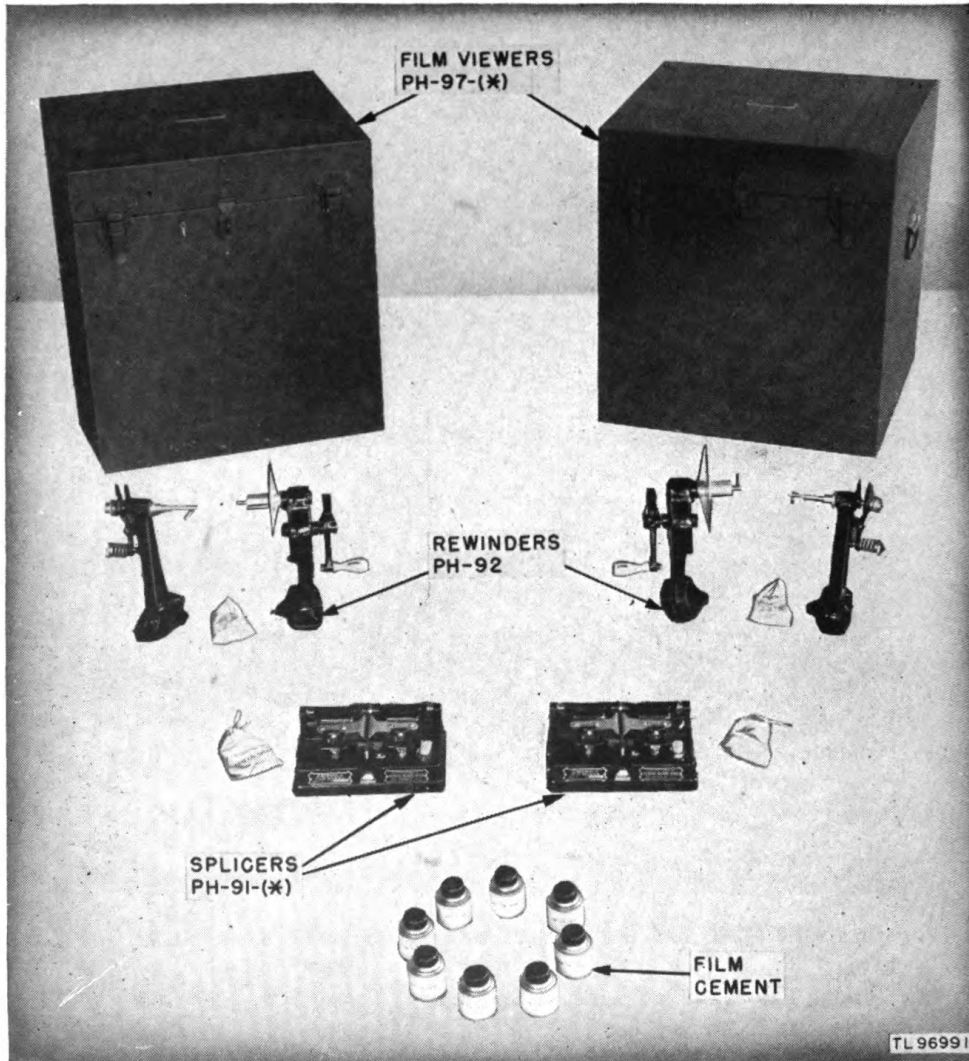

Figure 36. Film viewing components of Spotting Set AN/TVQ-1. (Other components shown in figs. 33, 34, and 35.)

d. **FILM VIEWING COMPONENTS** (fig. 36). The film viewing components (par. 70b(3)) of Spotting Set AN/TVQ-1 are:

Quan	Component	Dimensions (in.)				Volume (cu ft)	Weight (lb)
		Length	Width	Height	Diam		
2	*Film Viewer PH-97-(*) in carrying case.	20 to 22	17 to 19	20 to 24	-----	3.5 to 5.5	100 to 125
2	Rewinder PH-92	12	9	8	-----	0.5	10
2	*Splicer PH-91-(*)	8.375	5 to 5.5	3.25 to 3.75	-----	.08 to .1	6 to 8
4 bots or 8 cans	Cement, nitrate film splicing, 4 oz.	-----	-----	5	2	.009	0.5
	Cement, nitrate film splicing, 2 oz.	-----	-----	2.5	2	.004	0.25

* Specific information about the weight and dimensions of each model of these components is given in the following appropriate references:

Film Viewer PH-97-(*), paragraph 137a(2).
 Splicer PH-91-(*), paragraph 139a(2)

72. Table of Power Requirements for Spotting Set AN/TVQ-1

The power requirements of each type of component of Spotting Set AN/TVQ-1 is given in the following table:

Component	Volts			Source	Volts	Remarks
	a-c	d-c	Quan.	Type		
Theodolite MX-194/ TVQ-1: Camera circuit.....		12	1	Battery BB-46	12	Supplied with spotting set but without electrolyte which must be procured separately.
Selsyn motor circuit: flank station.....	110		1	Power Unit PE-75-()	110	Supplied with spotting set.
battery station.....	110					No means supplied with spotting set. Must be obtained from standard 110-v, a-c supply available at antiaircraft battery.
Time Interval Device PH-103: interval circuit.....		45	1	Battery BA-26	45	Not supplied with spotting set. Must be procured separately.
time counter circuit.....		45	1	Battery BA-26	45	
Time Interval Multiplier PH-264-(*).		12	1	Battery BB-46	12	Supplied with spotting set but without electrolyte which must be procured separately.
Time Interval Signal BE-65.		3	2	Battery BA-23	1.5	Not supplied with spotting set. Must be procured separately.
Line Connector Unit EE-87.		12		(Same source as Time Interval Multiplier PH-264-(*).)		
Film Viewer PH-97-(*).		110		(Any available 110-v, 60-cycle, a-c, or 110-v, d-c, circuit installation.)		

73. Descriptions of Components of Spotting Set AN/TVQ-1

a. SPOTTING AND WIRE AND POWER COMPONENTS (figs. 33 and 34). The descriptions of the spotting and wire and power components of Spotting Set AN/TVQ-1 are contained in two places in this manual:

(1) The following spotting and wire and power components are common to Spotting Set AN/TVQ-1 and Spotting Set PH-32-(*) and are described in the indicated paragraphs:

<i>Component</i>	<i>Paragraph</i>
Axle RL-27-(*)	13
Battery BB-46	16
Cord CD-407	7
Exposure Meter PH-252-(*)	8
Film	18
Hydrometer HY-2	17
Junction Box JB-40	7
Line Connector Unit EE-87	11
Reel Unit RL-31-(*)	14
Time Interval Device PH-103	9
Time Interval Multiplier PH-264-(*)	10
Time Interval Signal BE-65	12
Wire W-110-B	15

(2) The following spotting and power components are peculiar to Spotting Set AN/TVQ-1 and are described in the succeeding paragraphs in this section:

- Theodolite MX-194/TVQ-1
- Cover CW-95/TVQ-1
- Cords CX-227/TVQ-1 and CX-228/TVQ-1
- Cord CX-229/TVQ-1
- Power Unit PE-75-()

b. FILM DEVELOPING COMPONENTS (fig. 35). The descriptions of the film developing components of Spotting Set AN/TVQ-1 are contained in section I, "Film Developing Components, etc."

c. FILM VIEWING COMPONENTS (fig. 36). The descriptions of the film viewing components of Spotting Set AN/TVQ-1 are contained in section I, "Film Viewing Components, etc."

74. Theodolite MX-194/TVQ-1 (fig. 37)

a. Four Theodolites MX-194/TVQ-1 are the instruments provided with Spotting Set AN/TVQ-1 to make angular measurements and take motion pictures of a target and of a point in space (par. 70a).

b. Theodolite MX-194/TVQ-1 consists essentially of a telescope and a motion picture camera mounted together on a frame which is provided

both with manual and selsyn-motor means of controlling the theodolite's motions.

c. Detailed description and instruction on the use and maintenance of Theodolite MX-194/TVQ-1 are contained in TM 11-2534.

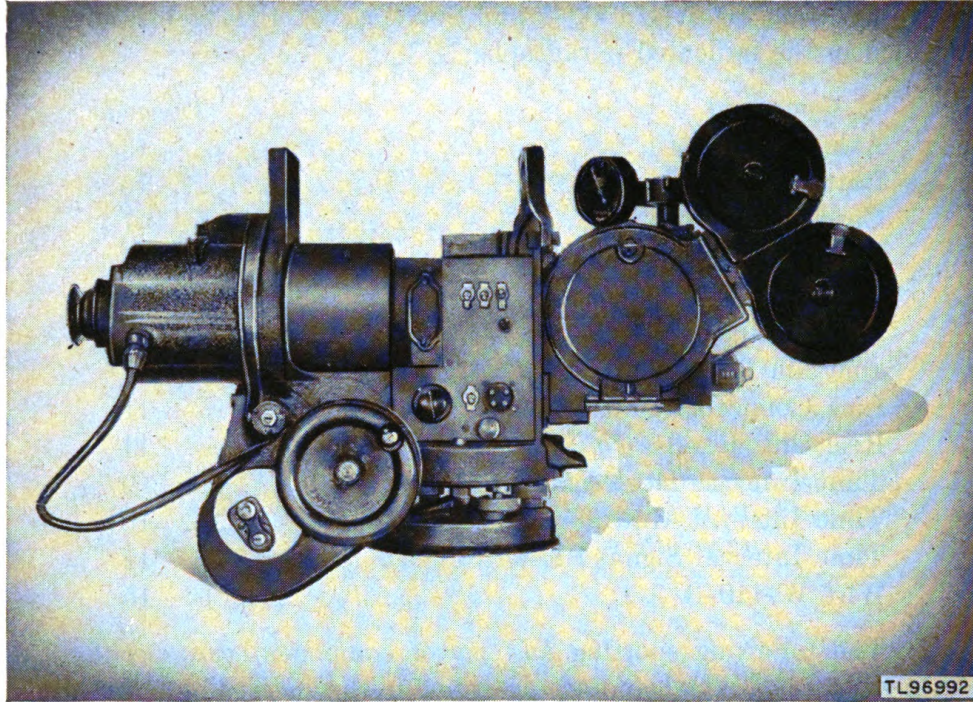

Figure 37. Theodolite MX-194/TVQ-1.

75. Cover CW-95/TVQ-1

a. Four Covers CW-95/TVQ-1 are provided with Spotting Set AN/TVQ-1 for protection of Theodolites MX-194/TVQ-1 when they are allowed to remain outdoors, unused.

b. Cover CW-95/TVQ-1 is a five-sided heavy cotton duck (canvas) cover measuring 2 by 2 by 3 feet. One cover is packed in each Theodolite MX-194/TVQ-1 carrying case.

76. Cords CX-227/TVQ-1 and CX-228/TVQ-1 (fig. 38)

a. Two Cords CX-227/TVQ-1 and two Cords CX-228/TVQ-1 are the means provided with Spotting Set AN/TVQ-1 to interconnect the selsyn motors of each pair of Theodolites MX-194/TVQ-1, and to connect each selsyn combination to the required power source.

b. Cord CX-227/TVQ-1 consists of two cables; one an eight-conductor cable, 25 feet long; the other a two-conductor cable, 4 feet long. One end of both cables is terminated in the same eight-contact receptacle

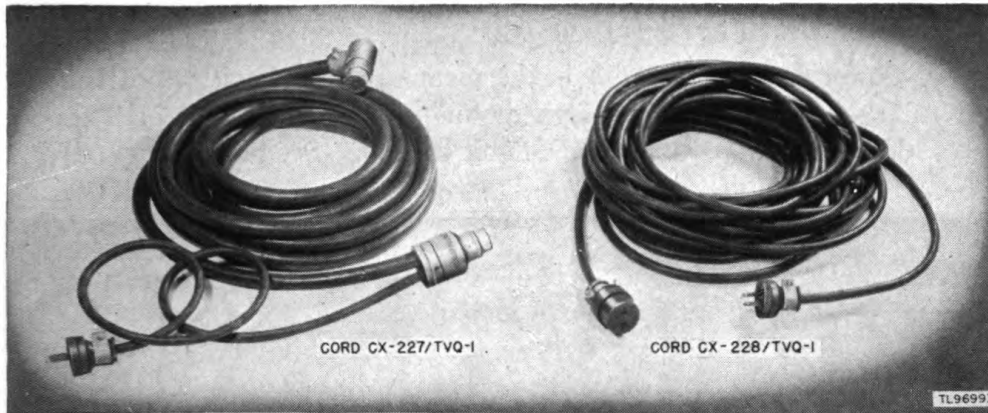

Figure 38. Cords CX-227/TVQ-1 and CX-228/TVQ-1.

plug. The other end of the eight-conductor cable is terminated in another eight-contact receptacle plug, and the other end of the two-conductor cable is terminated in a standard two-pin plug.

c. Cord CX-228/TVQ-1 is a two-conductor cable, 50 feet long. One end of the cable is terminated in a standard two-contact receptacle, and the other end is terminated in a standard two-pin plug.

77. Cord CX-229/TVQ-1 (fig. 39)

a. Cord CX-229/TVQ-1 is the means provided with Spotting Set AN/TVQ-1 for reversing the direction of the azimuth angle between the director and the main junction box of the data transmission system, or between the radar and the director, of the antiaircraft battery, so that the guns will fire at a point in space instead of at the target at which the director or radar is aimed.

b. Cord CX-229/TVQ-1 is a twenty-conductor cable, 5 feet long. One end of the cable is terminated in a male plug and the other end is terminated in a female receptacle.

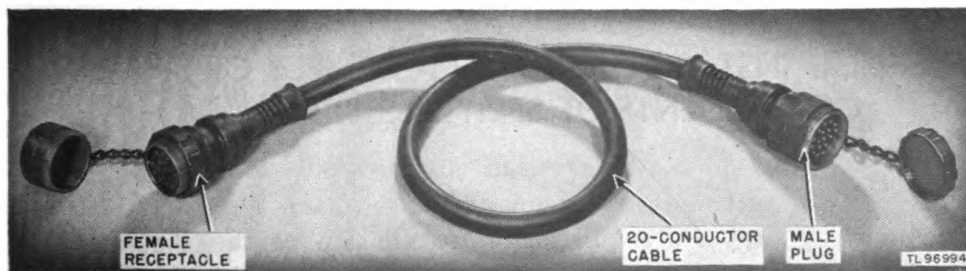

Figure 39. Cord CX-229/TVQ-1.

78. Power Unit PE-75-() (fig. 40)

a. Power Unit PE-75-() is the means provided with Spotting Set AN/TVQ-1 to furnish the selsyn motor power requirement of Theodolites MX-194/TVQ-1 used at the flank station. (See par. 70b(1)(d).)

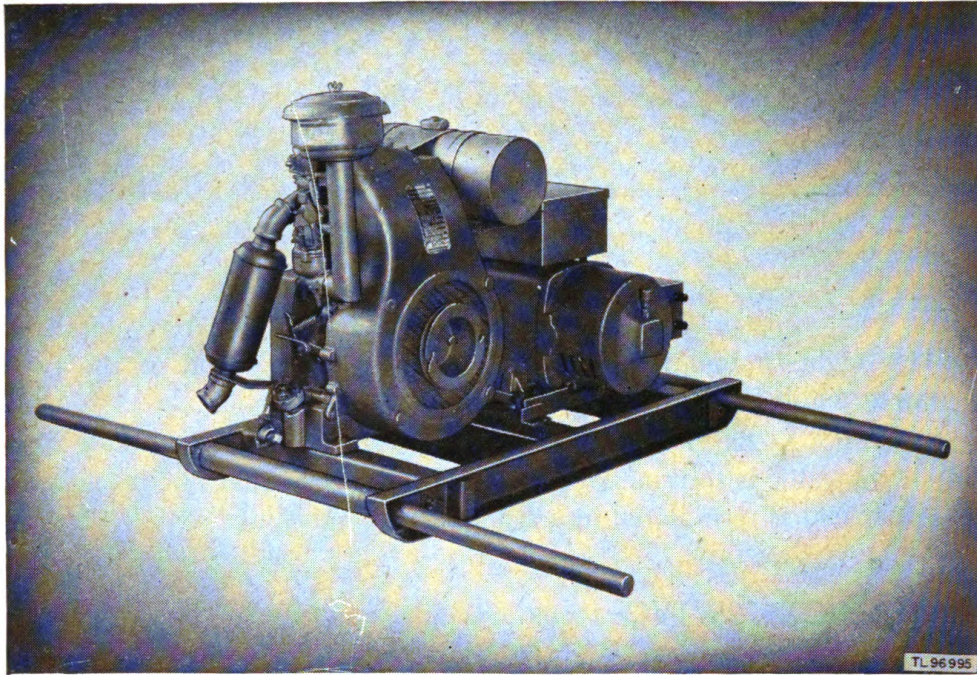

Figure 40. Power Unit PE-75-().

b. There are numerous models of Power Unit PE-75-(). Each of the models essentially is a portable, gasoline-engine-driven, 2.5 kw electric generator delivering a 120-v, 60-cycle, single-phase, alternating current.

c. Detailed description and instructions on the use and maintenance of Power Unit PE-75-() are contained in TM 11-900.

Section II. INSTALLATION AND ASSEMBLY OF SPOTTING COMPONENTS OF SPOTTING SET AN/TVQ-1

79. Siting

Two outdoor sites are required for installation of the spotting components of Spotting Set AN/TVQ-1. One site is located in the vicinity of the anti-aircraft battery and is called the *battery* or O_1 station, and the other is located out on the flank and is called the *flank* or O_2 station. Each site must be provided with two special supports (par. 20) for phototheodolites, and each pair of these supports must be located exactly

with respect to each other, to the antiaircraft battery, and to the path of the target.

80. Locating Phototheodolite Supports

a. GENERAL. Two considerations which apply alike to the supports at both stations are:

(1) Each pair of supports must be located so that one phototheodolite at each station will have an unobstructed view of the target course, and the other phototheodolite at each station will have an unobstructed view of the field of fire which is opposite the target course.

(2) Each support (par. 20) must be embedded securely into the ground to a depth of $3\frac{1}{2}$ feet, with $4\frac{1}{2}$ feet extending above ground (fig. 18 or 19) to obtain the proper height for the phototheodolite.

b. BATTERY STATION. The special considerations which must be given the location of the two supports at the battery station are:

(1) One support must be located within 35 yards of the director or tracking head of the antiaircraft battery installation on a line roughly perpendicular to the path of the target.

(2) The second support must be located within 10 feet of the first and on the opposite side of the base line (c(1) below). The line connecting the two supports should be approximately perpendicular to the base line.

c. FLANK STATION. The special considerations which must be given the location of the two supports at the flank station are:

(1) The flank station must be located 4,000 to 8,000 yards from the battery station at the end of a surveyed base line which is approximately parallel to the path of the target. The supports must not be more than 10 feet apart and on a line approximately perpendicular to the base line.

Note. An 8,000-yard base line is desirable so that the target angles (battery theodolite—target—flank theodolite), on which the accuracy of Spotting Set AN/TVQ-1 mainly depends, will be as large as possible. Small target angles give very uncertain results.

(2) See TM 44-225, 5-235, and 5-236 for instruction in the standard methods to use in locating flank supports, and conform to the following survey accuracy specifications:

(a) The *distance* between the battery station phototheodolite supports and the flank station supports must be obtained to an accuracy of 1 part in 5,000.

(b) The *elevations* of the two stations must be determined to plus or minus 1 foot.

(c) The *azimuths* of the base line, and of the supports-to-orienting-target lines, must be determined to plus or minus 0.2 mil.

81. Wiring between Battery and Flank Stations

The same requirements and equipment as described in paragraph 22 for laying wire between the stations of a Spotting Set PH-32-(*) installation apply to Spotting Set AN/TVQ-1.

82. Preparing Spotting Components for Distribution to Stations

Before distributing the spotting set components to the battery and flank stations, certain components must be prepared as follows:

a. THEODOLITE MX-194/TVQ-1. Load the four film magazines of each of the four Theodolites MX-194/TVQ-1 with film as instructed in TM 11-2534.

b. TIME INTERVAL DEVICE PH-103. Install one Battery BA-26 in each side compartment of one Time Interval Device PH-103. (See Note below.) Connect each battery terminal to the appropriate binding posts of the adjacent pair marked 45V on the panel, first running each connecting wire through the hole provided for it in the adjacent partition.

c. TIME INTERVAL SIGNAL BE-65. Install two Batteries BA-23 in place in each of two Time Interval Signals BE-65. (See Note below.) Connect the batteries as instructed in TM 11-433.

d. BATTERY BB-46. Test each of five Batteries BB-46 (see Note below) with Hydrometer HY-2 to make sure that it is charged and in proper operating condition. (See TM 11-430 for specific instructions.)

e. POWER UNIT PE-75-(). Make sure that there is a sufficient supply of gasoline and oil for operation of Power Unit PE-75-().

Note. It is necessary to prepare only one of the two Time Interval Devices PH-103, only two of the four Time Interval Signals BE-65, and only five of the 12 Batteries BB-46 for use in a Spotting Set AN/TVQ-1 installation. The extra items are spares which make it possible to divide the components of Spotting Set AN/TVQ-1 into two spotting sets of the other type (par. 70c).

83. Distributing Spotting Components to Stations

After the phototheodolite supports have been installed (par. 80), field wire laid between the stations (par. 22), and certain of the spotting components specially prepared (par. 82), distribute the spotting components as follows:

- a. BATTERY STATION.
 - 2 Theodolites MX-194/TVQ-1 in carrying cases.
 - 1 Time Interval Device PH-103.
 - 1 Time Interval Multiplier PH-264-(*).
 - 1 Line Connector Unit EE-87.
 - 1 Time Interval Signal BE-65.
 - 3 Batteries BB-46.

b. FLANK STATION.

- 2 Theodolites MX-194/TVQ-1.
- 1 Time Interval Signal BE-65 (if directed).
- 2 Batteries BB-46.
- 1 Power Unit PE-75-().

Note. The following *duplicate* spotting components are not distributed: One Time Interval Device PH-103; One Time Interval Multiplier PH-264-(*); One Line Connector Unit EE-87; Two Time Interval Signals BE-65; and Seven Batteries BB-46. These are some of the extra items which make it possible to divide the components of Spotting Set AN/TVQ-1 into two spotting sets of the other type (par. 70c).

84. Installing Theodolite MX-194/TVQ-1

Install each of the phototheodolites in place at each station by referring to the instructions in TM 11-2534 to perform the following steps in the order given:

- a. Mount the phototheodolite's separate base ring on the support.
- b. Mount the phototheodolite on the base ring.
- c. Level the phototheodolite.
- d. Focus the telescope of the phototheodolite.
- e. Orient the phototheodolite.
- f. Connect one Junction Box JB-40 to each phototheodolite, and connect one Cord CD-407 to each junction box.
- g. Connect the selsyn motors to a pair of phototheodolites with Cord CX-227/TVQ-1.

85. Electrical Connections of Spotting Components

a. BATTERY STATION (fig. 41). (1) Connect the phototheodolites as follows:

- (a) Place one Battery BB-46 within reach of each Cord CD-407.
- (b) Check that the MOTOR switch on each phototheodolite is OFF and then connect the alligator clips of each Cord CD-407 to the terminals on the adjacent Battery BB-46, taking care that the clip marked + is connected to the positive (+) terminal of the battery.

(c) Connect a single-conductor wire between one LINE binding post of one Junction Box JB-40 and one LINE binding post of the other Junction Box JB-40.

(d) Connect the plug end of Cord CX-228/TVQ-1 to a source of 110-v alternating current, and lay the receptacle end of the cord near the two-pin plug extending from Cord CX-227/TVQ-1. *Do not insert the plug into the receptacle.*

(2) Place the bottom side of Time Interval Device PH-103 (the side with the bumpers) on the ground near the phototheodolites' junc-

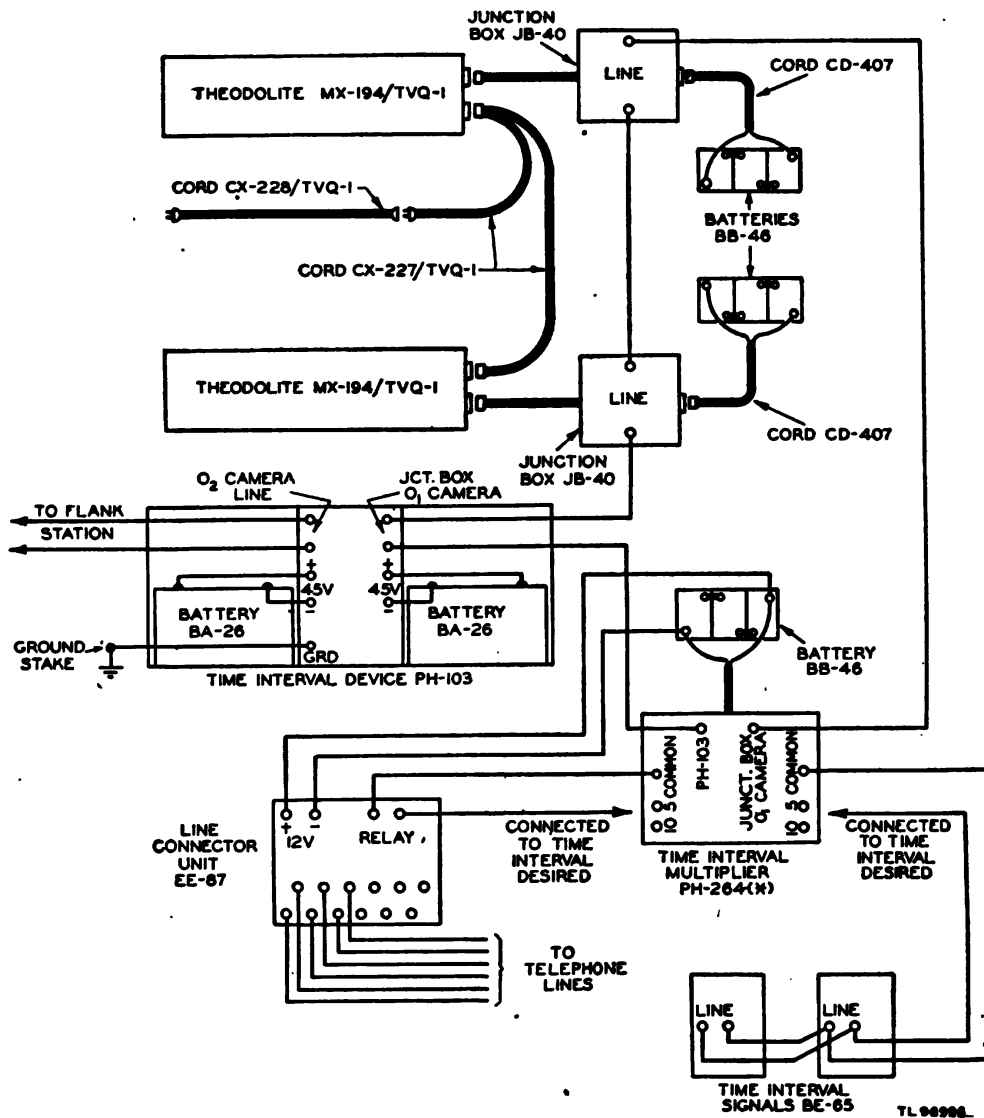

Figure 41. Cording diagram of battery station spotting components of Spotting Set AN/TVQ-1.

tion boxes, and open the hinged front of the case. Insert a single-conductor wire through the holes provided near the bottom of the sides of the left-hand compartment, and connect it to the binding post marked GRD at the lower left-hand corner of the panel. Use a ground clamp to connect the other end of this wire to a metal rod driven into the ground near the time interval device.

(3) Place Time Interval Multiplier PH-264-(*), near Time Interval Device PH-103, and place the remaining Battery BB-46 within reach of the alligator clips on the end of the cable from Time Interval Multiplier PH-264-(*). Connect each of these clips to a terminal on the battery.

(4) Untwist enough of the paired wires of one of the previously laid lines (par. 22) to the flank station, and insert the separated conductors through the holes provided in the sides of the left-hand compartment of the time interval device. Connect each of these wires to an O₂ CAMERA LINE binding post at the top left side of the panel.

(5) Take a separate length of field wire and untwist enough of the paired wires at one end so that the conductors can be inserted separately through the holes provided in the sides of the right-hand compartment of the time interval device. Connect this end of each of these wires to a JCT. BOX O₁ CAMERA binding post at the top right side of the panel.

(6) Connect the other ends of the pair of conductors from the JCT. BOX O₁ CAMERA binding posts of the time interval device as follows:

(a) Connect one conductor to the unused LINE binding post on one Junction Box JB-40.

(b) Connect the other conductor to the binding post marked PH-103 on Time Interval Multiplier PH-264-(*).

(7) Check that the T.I.START switch on Time Interval Device PH-103 is OFF. Then use a length of single-conductor wire and connect it as follows:

(a) Connect one end to the LINE binding post still unused on one Junction Box JB-40.

(b) Connect the other end to the JUNCT. BOX O₁ CAMERA binding post on Time Interval Multiplier PH-264-(*).

(8) Locate Line Connector Unit EE-87 and Time Interval Signals BE-65 and connect them to Time Interval Multiplier PH-264-(*). in accordance with special instructions given at the time by the person in charge.

(a) Connect the two binding posts marked + 12V — (on panel of Line Connector Unit EE-87) by field wire to the appropriate terminals of the same Battery BB-46 to which the cable of Time Interval Multiplier PH-264-(*). is connected. Connect the two binding posts marked RELAY by field wire to Time Interval Multiplier PH-264-(*); one to a COMMON binding post and the other to either a binding post marked 5 or to one marked 10, depending upon whether a 5- or a 10-second interval impulse is desired.

(b) Connect the two binding posts marked LINE (on panel of each Time Interval Signal BE-65) by field wire to Time Interval Multiplier PH-264-(*); one to a COMMON binding post and the other to either a binding post marked 5, or to one marked 10, depending upon whether a 5- or a 10-second interval impulse is desired.

(9) The battery station end of the remaining field wire line previously laid to the flank station is available for connection of a field telephone.

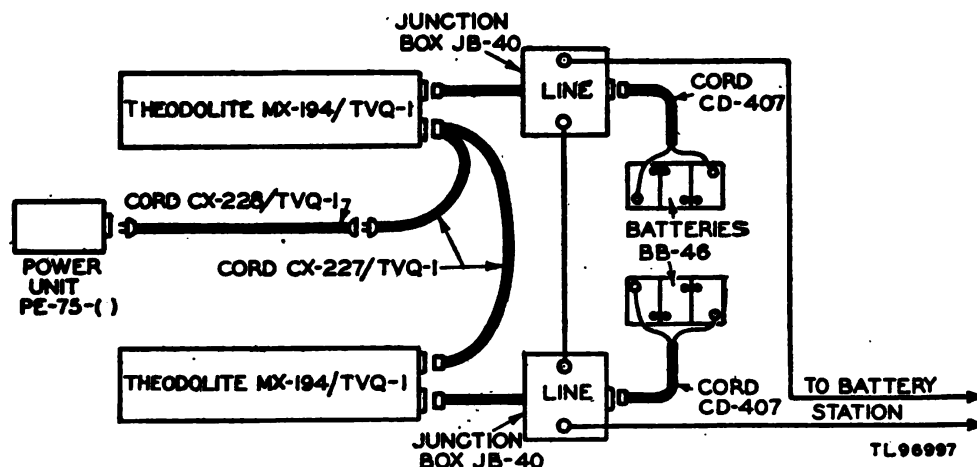

Figure 42. Cording diagram of flank station spotting components of Spotting Set AN/TVQ-1.

b. FLANK STATION (fig. 42). (1) Connect the phototheodolites as follows:

(a) Place one Battery BB-46 within reach of each Cord CD-407.

(b) Check that the MOTOR switch on each phototheodolite is OFF and then connect the alligator clips of each Cord CD-407 to the terminals on the adjacent Battery BB-46, taking care that the clip marked + is connected to the positive (+) terminal of the battery.

(c) Connect a single-conductor wire between one LINE binding post of one Junction Box JB-40 and one LINE binding post of the other Junction Box JB-40.

(d) Connect the plug end of Cord CX-228/TVQ-1 to Power Unit PE-75-(), and lay the receptacle end of the cord near the two-pin plug extending from Cord CX-227/TVQ-1. Do not insert the plug into the receptacle.

(2) Determine which of the two lines from the battery station is the line connected to Time Interval Device PH-103 (a(4) above). Untwist enough of the paired wires of this line and connect one conductor to the unused LINE binding post of one Junction Box JB-40 and connect the other conductor to the unused LINE binding post of the other Junction Box JB-40.

(3) The remaining field wire line from the battery station is available for connection of a field telephone.

86. Repacking Spotting Components

a. THEODOLITE MX-194/TVQ-1. (1) Disconnect Cord CD-407 from Battery BB-46, and from Junction Box JB-40.

(2) Disconnect the conductors from the LINE binding posts of Junction Box JB-40 and disconnect the junction box from the phototheodolite.

(3) Disconnect Cord CX-227/TVQ-1 from the phototheodolite and disconnect Cord CX-228/TVQ-1 from the source of alternating current.

(4) Dismount the phototheodolite and the base ring from the support, and repack them and the connecting cords in the carrying case as instructed in TM 11-2534.

b. OTHER COMPONENTS. Paragraph 27b through e gives instructions for repacking Line Connector Unit EE-87, Time Interval Signal BE-65, Time Interval Multiplier PH-264-(*), and Time Interval Device PH-103.

c. VOLUMES AND WEIGHTS. The following table lists the volumes and weights of the spotting components of Spotting Set AN/TVQ-1:

Table of Volumes and Weights

Component	Volume (cu ft)	Weight (lb)
Theodolite MX-194/TVQ-1 in carrying case.....	12.5	265
Time Interval Device PH-103.....	1.3	23
Time Interval Multiplier PH-264-(*).09	6
Time Interval Signal BE-65.....	.47	18
Line Connector Unit EE-87.....	.64	25
Power Unit PE-75-().....	10	319
Battery BB-46	2.9	122

PART TWO

OPERATING INSTRUCTIONS FOR SPOTTING COMPONENTS OF SPOTTING SET AN/TVQ-1

Note. For information on destroying this equipment to prevent enemy use, see the destruction notice at the front of this manual.

Section III. TECHNICAL OPERATION

87. Operating Time Interval Device PH-103

The operation of Time Interval Device PH-103 in a Spotting Set AN/TVQ-1 installation is the same as given in paragraph 28, for Spotting Set PH-32-(*). However, when adjusting line current (par. 28c), it will be necessary to add battery as follows if 25 to 30 ma cannot be obtained when the LINE CURRENT rheostat is in the maximum position:

- a. Turn the LINE CURRENT rheostat to the MIN. position.
- b. Connect a 22½- or a 45-volt battery in series with Battery BA-26 in the left-hand compartment.
- c. Adjust the current (par. 28c).

88. Operating Time Interval Multiplier PH-264-(*)

The operation of Time Interval Multiplier PH-264-(*) in a Spotting Set AN/TVQ-1 installation is the same as given in paragraph 29, for Spotting Set PH-32-(*).

89. Preparing Theodolite MX-194/TVQ-1 for Operation

a. Prepare each Theodolite MX-194/TVQ-1 at each station for operation by following the instructions given in TM 11-2534 to perform the following steps in the order given:

- (1) Load the camera.
- (2) Adjust the camera speed.
- (3) Select and mount the filters (daylight operation only).
- (4) Set the camera lens aperture.

(5) Set the film footage counter to zero.

(6) Make an adjustment check filming (daylight operation only).

b. Before powering the selsyn motors (*d* below), photographs of the orientation point should be taken with each Theodolite MX-194/TVQ-1 so that errors in orienting can be checked when viewing the film for plotting purposes. This is necessary with Spotting Set AN/TVQ-1 to obtain results which closely approximate the results obtained with Spotting Set PH-32-(*), where both target and burst are photographed on the same film. Proceed as follows:

(1) With the theodolite set at the elevation of the orienting point, and a little behind it in azimuth, throw the MOTOR switch to ON and turn the azimuth handwheel slowly clockwise (increasing azimuth) while peering through the telescope until the orienting point is passed over by the telescope cross hairs. Throw the MOTOR switch to OFF.

(2) Change the time counter number for identification purposes. Then throw the MOTOR switch to ON and turn the azimuth handwheel slowly counterclockwise (decreasing azimuth) until the orienting point is passed over again, but in the opposite direction, by the telescope cross hairs. Throw the MOTOR switch to OFF.

c. Reset the time counters of all four Theodolites MX-194/TVQ-1 to the same setting by using the mechanical means provided on each theodolite (TM 11-2534), or by using Time Interval Device PH-103 as instructed in paragraph 28*e*.

d. Synchronize the selsyn motors of the pair of Theodolites MX-194/TVQ-1 at each station, as follows:

(1) Use the idler gear knobs and put both selsyn motors of one Theodolite MX-194/TVQ-1 in the *unmeshed* position.

(2) Put the selsyn motors of the other Theodolite MX-194/TVQ-1 of the pair in the *meshed* position.

(3) *Only after checking that both selsyns of one theodolite of the pair are in the unmeshed position*, apply power to the selsyn motors circuit by inserting the two-pin plug of Cord CX-227/TVQ-1 into the nearby receptacle of Cord CX-228/TVQ-1. (See par. 85*a*(1)(*d*).)

(4) After the power is applied, put the unmeshed selsyns of the one theodolite into mesh, and check to see that—

(*a*) The azimuth setting of both Theodolites MX-194/TVQ-1 of the pair agree, within 0.2 mil, with the desired settings for the base line position.

(*b*) The elevation angle of both theodolites agree within the limits of following for clockwise and counterclockwise rotation of the handwheels.

e. Set the SIGNAL switches of the theodolites as follows:

(1) Throw the SIGNAL switch of each theodolite at the flank station to ON.

(2) Throw the SIGNAL switch of one theodolite at the battery station to ON, and throw the SIGNAL switch of the other battery theodolite to OFF. Use this SIGNAL switch as the control switch for the time counter circuit in which the time counters of the four theodolites are connected in series.

90. Operating Spotting Components of Spotting Set AN/TVQ-1

a. BATTERY STATION. After testing the time counter lines (par. 28b); adjusting the current in the lines (par. 28c); checking the time interval period of impulses (par. 28d); synchronizing the battery station theodolites' time counters with the time counters at the flank station (par. 28e); testing the lines to the audible signal equipment (par. 29a) and pre-setting the sequence of impulses to be sent over those lines (par. 29b); and preparing each Theodolite MX-194/TVQ-1 (par. 89); the battery station spotting components of Spotting Set AN/TVQ-1 are ready for operation, as follows:

(1) Turn the T.I.START switch on the time interval device to ON.

(2) When the target comes into view, aim the target phototheodolite on it as instructed in TM 11-2534.

(3) At the proper command, throw the SIGNAL switch on the control phototheodolite to ON.

(4) At the next proper command, start the cameras by throwing the MOTOR switch of each phototheodolite to ON. Stop the cameras when ordered, by throwing the MOTOR switch of each phototheodolite to OFF. Repeat operating the cameras as often as directed.

(5) At the end of the target run, do the following:

(a) Throw the SIGNAL switch of the control phototheodolite to OFF.

(b) Traverse the target phototheodolite *back* to the approximate starting point of the course.

(c) Turn the T.I.START switch of Time Interval Device PH-103 to OFF.

(6) Repeat steps (1) through (5) above as often as directed.

b. FLANK STATION. After synchronizing the flank station time counters with the battery station time counters (par. 28e), and preparing each Theodolite MX-194/TVQ-1 (par. 89), the flank station spotting components of Spotting Set AN/TVQ-1 are ready for operation, as follows:

(1) When the target comes into view, aim the target phototheodolite on it as instructed in TM 11-2534.

(2) At the proper command, start the cameras by throwing the MOTOR switch of each phototheodolite to ON. Stop the cameras, when ordered, by throwing the MOTOR switch of each phototheodolite to OFF. Repeat operating the cameras as often as directed.

(3) At the end of the target run, traverse the target phototheodolite *back* to the approximate starting point of the course.

(4) Repeat steps (1), (2), and (3) above as often as directed.

91. Performance Check List

Use the performance check list given in paragraph 32 as a guide in checking the performance of the spotting components of Spotting Set AN/TVQ-1.

PART THREE
**MAINTENANCE INSTRUCTIONS FOR SPOTTING
COMPONENTS OF SPOTTING SET
AN/TVQ-1**

Section IV. GENERAL

92. Preventive Maintenance Techniques.

The information given in section IV, "Spotting Set PH-32-(*)," on preventive maintenance techniques is applicable to the spotting components of Spotting Set AN/TVQ-1.

93. Preventive Maintenance Procedures

The information given in section V, "Spotting Sets PH-32-(*)," on itemized preventive maintenance is applicable to the spotting components of Spotting Set AN/TVQ-1.

94. Lubrication

The information given in section VI, "Spotting Sets PH-32-(*)," on lubrication is applicable to the spotting components of Spotting Set AN/TVQ-1.

95. Moistureproofing and fungiproofing

The information given in section VII, "Spotting Sets PH-32-(*)," on moistureproofing and fungiproofing is applicable to the spotting components of Spotting Set AN/TVQ-1.

PART FOUR
AUXILIARY EQUIPMENT

(NOT USED)

PART FIVE
REPAIR INSTRUCTIONS FOR SPOTTING
COMPONENTS OF SPOTTING
SET AN/TVQ-1

Section V. THEORY OF OPERATION OF SPOTTING
COMPONENTS

96. Group Functioning of Spotting Components of Spotting Set AN/TVQ-1

a. The equipment is arranged as follows:

(1) A pair of *phototheodolites* is located at each end of a long base line. Each of these phototheodolites is equipped with two selsyn motors, one geared to the elevation mechanism and the other geared to the azimuth mechanism.

(2) There is a *junction box* for each phototheodolite, providing means for connecting power separately to the phototheodolite's time counter and to its camera motor.

(3) A 12-volt *storage battery* is provided for each phototheodolite to supply the power for the camera motor, and a *special cord* is provided to connect the battery to the phototheodolite's junction box.

(4) A *special cable* is provided for interconnecting the selsyn motors of each pair of phototheodolites, so that the elevation and azimuth selsyns of one phototheodolite are respectively connected to the elevation and azimuth selsyns of the other phototheodolite of the pair. In addition, there is a long extension cable for connecting the selsyn motor cable of each pair of phototheodolites to a source of 110 volt alternating current for the selsyns.

(5) A portable, gasoline-engine-driven *electric generator* is provided to supply the power for the selsyn motors of the one pair of phototheodolites located where the required power is not otherwise available.

(6) There is a *time interval device* which is powered by two self-contained, 45-volt dry cell batteries. This device produces a 45-volt, d-c impulse regularly at 1-second intervals, which is used for two purposes as follows:

(a) To power the four phototheodolites' time counters, which are connected in series with each other and with the device by long lines of field wire connected to the junction boxes so that, for all practical purposes, the time counters of all four phototheodolites are powered simultaneously by the intermittent impulse.

(b) To supply intermittent power to the device referred to in (7) below.

(7) A *time interval multiplier* is provided which produces 12-volt, d-c impulses at 5- and 10-second intervals. It is powered separately by the intermittent 1-second, 45-v, d-c impulse from the time interval device ((6) above) and by a 12-volt storage battery.

(8) There is a *line connector unit* which produces audible tone intermittently on connected telephone lines. It is powered separately by either the 5- or 10-second, 45-v, d-c impulse from the time interval multiplier ((7) above) and by the same 12-volt storage battery used by the multiplier.

(9) *Time interval signals*, each of which has a loudspeaker which howls intermittently, are provided. Each is powered separately by two self-contained 3-volt, dry cell batteries, and by either the 5- or 10-second, 45-v, d-c impulse from the time interval multiplier.

b. The group functioning of the equipment is as follows:

(1) One phototheodolite of each pair is *manually operated* and is kept trained on the same target. The selsyn motors of each manually-operated phototheodolite drive the selsyn motors of the other phototheodolite to which they are connected (a(4) above), so that the latter phototheodolite is *automatically operated* as follows:

(a) The connection between the elevation selsyns is such that the elevation selsyn of the manually operated phototheodolite drives the elevation selsyn of the other phototheodolite of the pair so that the latter automatically *duplicates* the elevation movements of the manually driven phototheodolite.

(b) The connection between the azimuth selsyns is such that the azimuth selsyn of the manually operated phototheodolite drives the azimuth selsyn of the other phototheodolite of the pair so that the latter automatically moves in azimuth *opposite* to the azimuth movements of the manually operated phototheodolite.

(2) The cameras of the four phototheodolites are synchronized so that they take motion pictures at the same speed, one camera of each pair of phototheodolites taking pictures of the target area, and the other camera in each pair of phototheodolites taking pictures of the area around a point in space which has the *same elevation* but the *reverse azimuth* as the target. In addition, each camera records the elevation and azimuth measurements and the time counter indication of its phototheodolite on each frame of film. The time counters of the four

phototheodolites are initially synchronized and thereafter are simultaneously advanced one unit per second by impulses from the time interval device, so that the frame of film exposed in the four phototheodolites at identical moments can be identified.

(3) The time interval multiplier is operated simultaneously with the phototheodolites' time counters, since it is operated by the same 1-second impulse. However, the line connector unit and the time interval signal horns are operated by the multiplier so that they supply either a single full-second audible signal once every 5 seconds, or three $\frac{1}{2}$ -second audible signals for 3 consecutive seconds within a period of 10 seconds. These signals are used to coordinate the making of visual records and the performance of other duties.

97. Individual Functioning of Spotting Components

a. The functioning of each of the following spotting and power components of Spotting Set AN/TVQ-1 is contained in the Technical Manual indicated below:

(1) Phototheodolites, TM 11-2534.

(2) Line Connector Unit EE-87 and Time Interval Signal BE-65, TM 11-433.

(3) Power Unit PE-75-(), TM 11-900.

b. The functioning of Time Interval Device PH-103 and of Time Interval Multiplier PH-264-(*) is contained in paragraphs 63 and 64.

Section VI. TROUBLE SHOOTING SPOTTING COMPONENTS OF SPOTTING SET AN/TVQ-1

98. Trouble Shooting

Trouble-shooting information in section IX, "Spotting Set PH-32-(*)," applies likewise to the spotting components of Spotting Set AN/TVQ-1.

FILM DEVELOPING COMPONENTS OF
SPOTTING SETS PH-32-B, PH-32-C,
PH-32-D, AND PH-32-F; AND
SPOTTING SET AN/TVQ-I

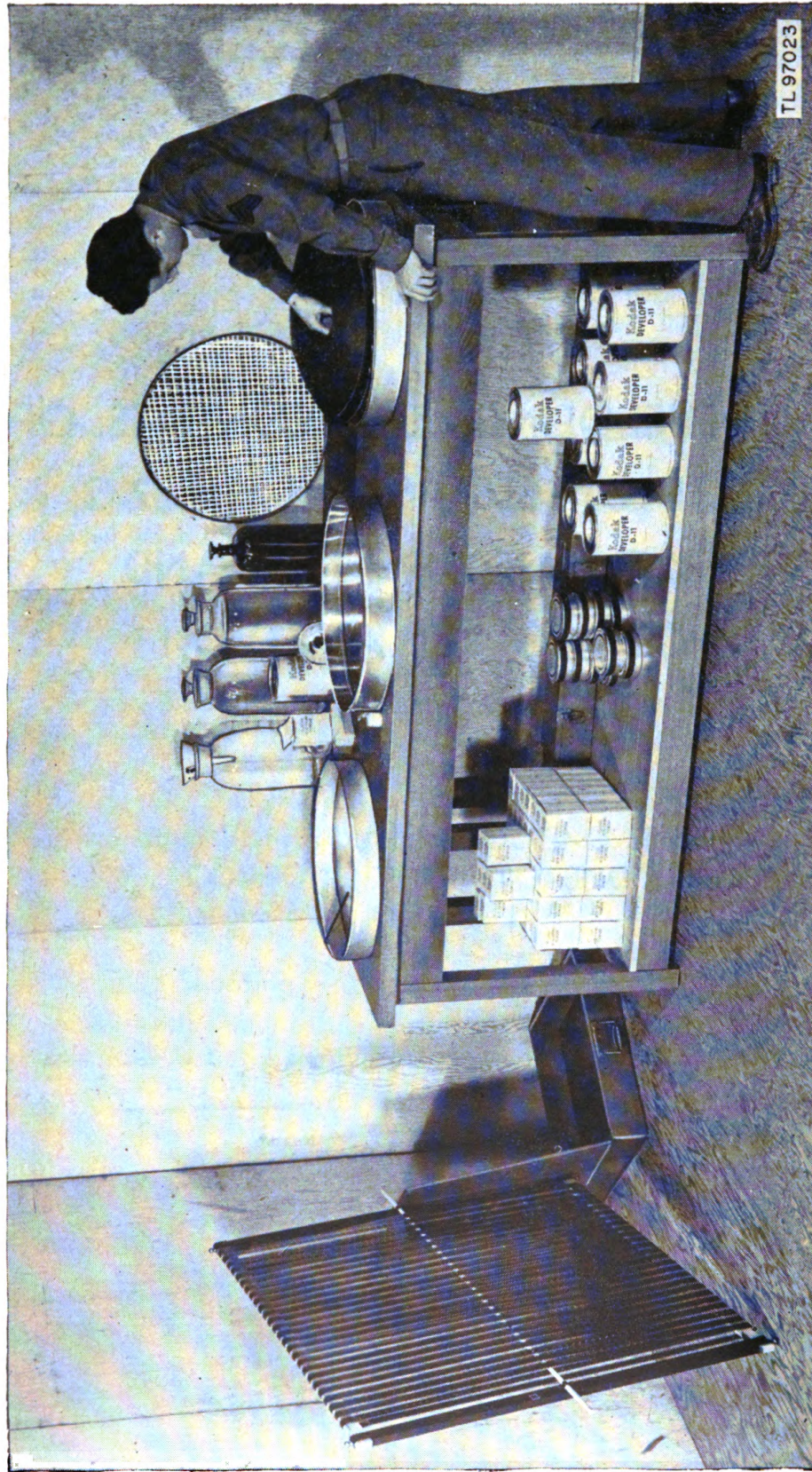

Figure 43. Film developing components of Spotting Sets PH-32-B, PH-32-C, PH-32-D, or PH-32-F, or Spotting Set AN/TVQ-1, in use.

PART ONE

INTRODUCTION

Section I. DESCRIPTION

99. Film Developing Components

a. The film developing components of Spotting Sets PH-32-B, PH-32-C, PH-32-D, or PH-32-F, or of Spotting Set AN/TVQ-1 consist of the following items which are described in succeeding paragraphs:

Developing Equipment PH-41.

Drying Rack PH-42.

Bottles PH-22 and PH-136.

Paddle PH-80.

Funnel PH-175.

Developer chemical.

Fixing powder.

b. The quantity, weight, and dimensions of each item are given in paragraph 3*c* for Spotting Set PH-32-(*) or in paragraph 71*c* for Spotting Set AN/TVQ-1.

100. Developing Equipment PH-41

a. GENERAL. Developing Equipment PH-41 is a portable assembly of equipment for processing 35-mm motion-picture film. The equipment includes three tanks capable of handling 200 feet of film for containing the processing solutions, a developing reel and screen for handling the film, a changing bag for loading film magazines, and a case into which the equipment is packed for transportation or storage.

b. APPLICATION (fig. 43). Film Developing Equipment PH-41 is provided with Spotting Sets PH-32-B, PH-32-C, PH-32-D, or PH-32-F, or Spotting Set AN/TVQ-1 to develop and fix the film used in the cameras of the phototheodolites.

c. COMPONENTS (fig. 44). Film Developing Equipment PH-41 consists of the following components:

1 case.

3 tanks.

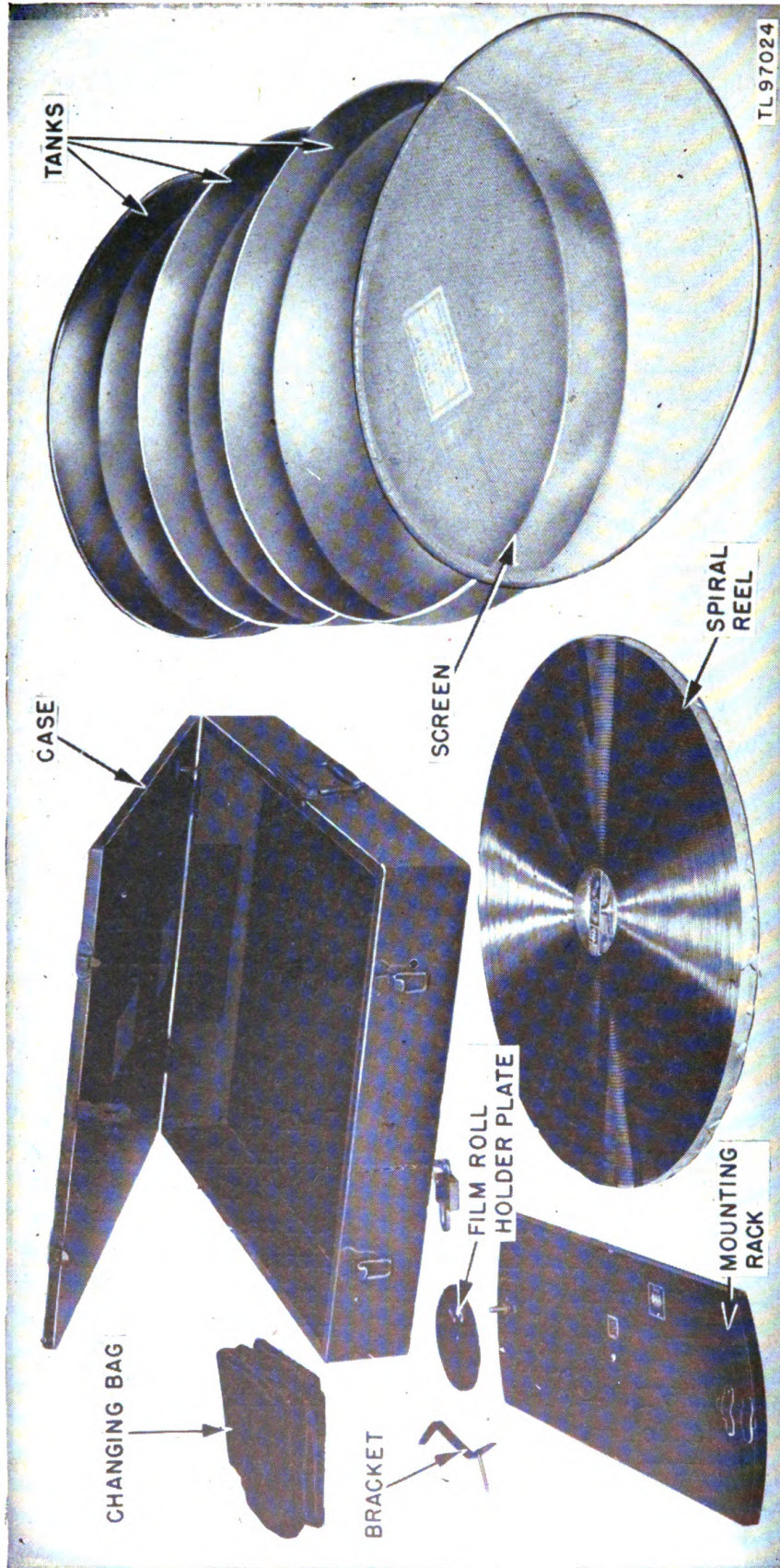

Figure 44. Components of Developing Equipment PH-41.

1 developing reel assembly consisting of—

- 1 spiral reel.
- 1 mounting rack.
- 1 bracket.
- 1 film roll holder plate.

1 screen.

1 changing bag.

d. CASE. The carrying case for Developing Equipment PH-41 is a wooden case equipped with two carrying handles and a hinged lid held closed by two trunk catches and by a hasp and staple with a padlock. Inside the case, the four sides of the bottom section are provided with strips of felt to protect the tanks and developing reel assembly against vibration and damage.

e. TANKS. A nest of three tanks is provided with the developing equipment for mixing and holding the developing and fixing solutions and the washing water required for processing motion picture film. Each tank is a shallow, circular, metal pan. The tanks vary just enough in size to permit them to be packed one inside the other in the case (*d* above), the largest tank measuring 24 inches in diameter and 3½ inches in height. The largest tank is monel metal with double soldered seams; the two smaller tanks are spun metal.

f. DEVELOPING REEL ASSEMBLY. The developing reel assembly serves two functions. It holds the film so that the entire surface of the film is exposed to the processing solutions and also provides a means of immersing the film into the processing solutions without touching the film with the hands.

(1) The mounting rack is a wooden board provided with an upright spindle near one end and a clamp at the other end.

(2) The spiral reel is a stainless steel tape spirally wound on a frame so that a maximum of 200 feet of motion-picture film can be exposed simultaneously to the processing solutions. The center of the reel is provided with a handle and with a hub which fits the spindle of the mounting rack.

(3) The bracket is metal bent to shape. The lower end fits into the clamp on the mounting rack, and the elevated end is provided with an upright spindle.

(4) The film roll holder plate is circular and is provided with a center hole to fit over the bracket spindle.

g. SCREEN. The screen is supplied to aid in the removal of the film from the spiral reel (*f*(2) above). The screen is a circular wire frame covered with wire screening.

h. CHANGING BAG. (1) The changing bag is used to reload the film magazines of the spotting set phototheodolites when a darkroom is not available.

(2) Essentially, the changing bag is a weatherproof, lightproof, black, cloth bag provided with a large opening at one end and two small openings, one on each side, near the other end. The large opening is closed by means of a flap which is equipped with snap buttons or a hookless fastener. The edge of each of the small openings is provided with elastic.

101. Drying Rack PH-42 (fig. 45)

a. GENERAL. Drying Rack PH-42 is a portable assembly of equipment for drying motion-picture film. It includes a disassembled rack and a case into which the rack is placed for transportation or storage.

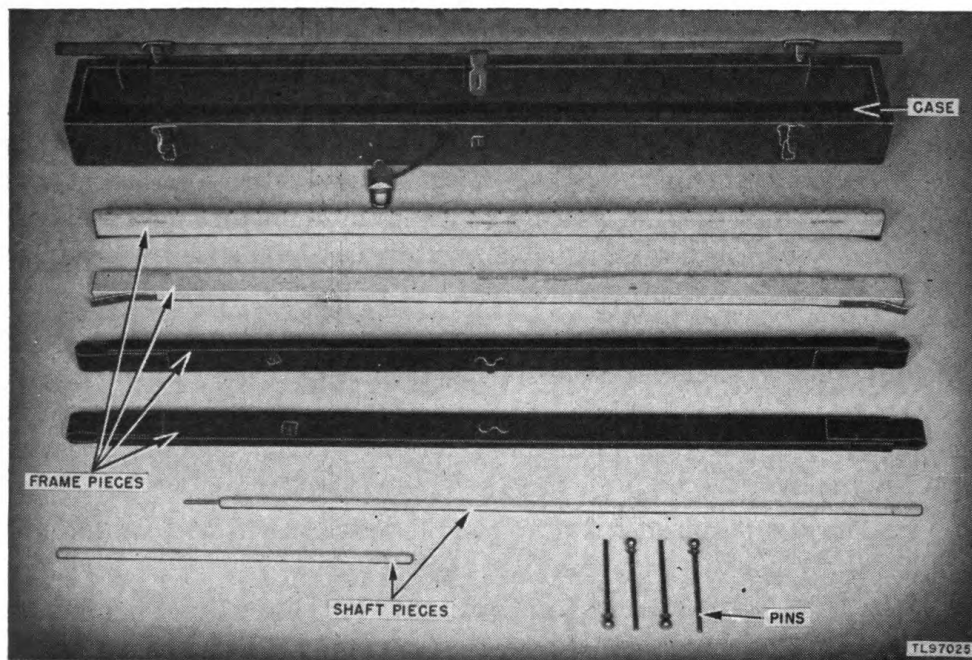

Figure 45. Component parts of Drying Rack PH-42.

b. APPLICATION. Drying Rack PH-42 is provided with Spotting Sets PH-32-B, PH-32-C, PH-32-D, or PH-32-F, or Spotting Set AN/TVQ-1 for drying the film processed with Developing Equipment PH-41 (par. 100).

c. COMPONENTS. Drying Rack PH-42 consists of the following components:

- 1 case.
- 1 disassembled rack, consisting of—
 - 4 frame pieces (2 uprights and 2 crosspieces).
 - 4 pins.
 - 2 shaft pieces.

d. CASE. The case of Drying Rack PH-42 is wooden. It has a hinged lid provided with trunk catches and a hasp and staple with padlock.

e. FRAME PIECES. The uprights and crosspieces of Drying Rack PH-42 are assembled to form the frame of the rack. The pieces are wooden, two painted and two unpainted.

(1) The two painted pieces are the uprights of the rack. Each is provided with a looped metal strap at each end. Each strap has a hole directly in line with a hole running into the end of the piece. The middle of one of the wide sides of each piece is provided with a strap hanger for supporting the shaft (*g* below).

(2) The two unpainted pieces are the crosspieces of the rack. Each has one of its narrow sides rounded the entire length and provided with metal pins evenly spaced along the center. At each end, on the flat narrow side, there is a flat spring to provide tension when the end is inserted and pinned (*f* below) into one of the looped straps of the uprights. The free end of each spring has a hole which is directly in line with a hole running through the narrow sides.

f. PINS. The four pins are the means provided with Drying Rack PH-42 to interlock the ends of the assembled uprights and crosspieces. The pins are steel and fit the holes in the ends of the frame pieces (*e* above).

g. SHAFT PIECES. The two shaft pieces are the means supplied with Drying Rack PH-42 to form a shaft on which the assembled rack can revolve. The pieces are wooden, one slightly longer than the other. The longer piece has a metal dowel extending from one end which fits a hole in one end of the shorter piece. The assembled shaft is supported by the strap holders on the upright pieces (*e*(1) above).

102. Bottles PH-22 and PH-136 (figs. 5 and 35)

Bottles PH-22 and PH-136 are provided with Spotting Set PH-32-B, PH-32-C, PH-32-D, or PH-32-F, or Spotting Set AN/TVQ-1 for storing photographic solutions.

a. Bottle PH-22 is a 1-gallon, dark glass bottle with a glass stopper.

b. Bottle PH-136 is a 2-gallon, clear glass, wide-mouthed bottle with a glass mushroom stopper.

103. Paddle PH-80 (figs. 5 and 35)

Paddle PH-80 is a slender stirring rod with a small hook at one end and shaped into a loop of approximately 2 inches diameter at the other end. The paddle is 12 inches long and is made of hard rubber. It is used to stir photographic solutions when they are being mixed.

104. Funnel PH-175 (figs. 5 and 35)

Funnel PH-175 is supplied with Spotting Set PH-32-B, PH-32-C, PH-32-D, or PH-32-F, or Spotting Set AN/TVQ-1 to aid in pouring photographic solutions into bottles. It is a 1-pint, enamel-finish funnel, 6¼ inches in diameter, and is provided with a handle.

105. Developer Chemical

The developer chemical provided with Spotting Set PH-32-B, PH-32-C, PH-32-D, or PH-32-F, or Spotting Set AN/TVQ-1 is the prepared commercial product, Kodak Developer D-11. It is supplied in a two-part container, each part holding chemicals that are necessary in the preparation of the developer. The contents of the whole container are sufficient when mixed with water to make 5 gallons of developing solution.

106. Fixing Powder

The fixing powder provided with Spotting Set PH-32-B, PH-32-C, PH-32-D, or PH-32-F, or Spotting Set AN/TVQ-1 is the prepared commercial product Kodak Acid Fixing Powder. The chemical may be supplied in any of the following forms:

a. In a can in sufficient quantity to make 1 gallon of fixing solution. When the chemical is so supplied, the hardener is contained in a separate package within the can.

b. In a package in sufficient quantity to make ½ gallon of fixing solution. When the chemical is so supplied, the hardener is contained in a separate package within the larger package.

c. In a jar in sufficient quantity to make 1 gallon of fixing solution. When the chemical is so supplied, the hardener is mixed with the fixing agent.

Section II. INSTALLATION AND ASSEMBLY OF FILM DEVELOPING COMPONENTS

107. Location

Most of the procedures necessary to process exposed film (loading the developing reel, developing, rinsing, fixing) must be performed in total darkness. A source of running water is desirable. Drying Rack PH-42 may be used in the presence of light, but not in direct sunlight.

108. Unpacking and Checking

a. DEVELOPING EQUIPMENT PH-41. (1) Open the case containing Developing Equipment PH-41 by opening the lock and releasing the two trunk catches.

(2) Remove and check the contents of the case against the list given in paragraph 100c. Two Paddles PH-80 are packed in the case, but are not components of the developing equipment.

(3) Place the three tanks and the complete developing reel assembly in convenient locations on the table in the darkroom. (See fig. 43.) Set the wire screen on the table near the washing tank. Place one Paddle PH-80 in the fixing tank and the other paddle in the developing tank; engage the hook on each paddle with the rim of the tank to prevent the paddle from slipping into the tank. Place Bottles PH-22 and PH-136, and Funnel PH-175 in convenient locations.

b. DRYING RACK PH-42. (1) Open the case containing Drying Rack PH-42 by opening the lock and releasing the two trunk catches.

(2) Remove and check the contents of the case against the list given in paragraph 101c.

(3) Place the various components of the drying rack at the site where the drying rack is to be assembled.

(4) Close the case and store it in a convenient place.

c. CHEMICALS. Remove the packaged chemicals from their packing cases and store the packages in a cool, dry place. Use the individual packages as needed.

109. Assembling Developing Equipment PH-41

a. Place the spiral reel on the mounting rack by lowering the reel until the spindle on the mounting rack fits through the hole in the hub of the reel.

b. Slide the entire length of the lower end of the metal bracket under the clamp on the mounting rack.

c. Lower the film roll holder plate over the bracket spindle until the holder plate is supported by the elevated end of the bracket.

110. Assembling Drying Rack PH-42

a. Hold one of the painted upright pieces vertically and in position to receive an unpainted crosspiece. Be careful not to bend the lower looped metal strap of the upright against the floor.

b. Insert one end of the crosspiece through the top looped metal strap of the upright. The metal pins on the rounded side of the crosspiece must point up.

c. Line up the holes through the top of the looped strap, through the crosspiece and its tension spring, and in the end of the upright.

d. Interlock the upright and crosspiece by passing a steel pin through the aligned holes. Be sure that the pin passes into the hole in the upright.

e. Position the second upright so that the shaft strap holders on the two uprights face the same way.

f. Insert the crosspieces into the top looped metal strap on the second upright and then secure them together with a steel pin (*b*, *c*, and *d* above).

g. Insert and securely pin the remaining crosspiece in the metal straps at the other ends of the two uprights, taking care that the metal pins on the second crosspiece also extend outward from the frame.

h. Fit each section of the shaft through one of the shaft strap holders so that the dowel pin on the longer section and the hole in one end of the shorter section point toward the center of the drying rack.

i. Assemble the shaft by inserting the dowel into the hole. The two ends of the shaft should now extend about 5 inches on either side of the assembled rack.

111. Preparing Developer Solution

a. Insert a screw driver in the large outer rim slot at the top of the can containing the Kodak Developer D-11, and pry open the cover.

b. Use the screw driver and pry up the cover of the small can (containing the developing agent) which is part of the larger cover removed in *a* above.

c. Dissolve the contents of the small can in 2½ gallons of warm water (about 125° F. or 50° C.).

d. Add the contents of the large can to the solution prepared in *c* above.

e. Stir with Paddle PH-80 until both the chemicals are completely dissolved.

f. Add enough water to the solution to make 5 gallons of the developer solution. Five gallons of developer solution are sufficient to develop 1,000 feet of film.

g. If the developer solution is not to be used immediately, store the developer solution in the three Bottles PH-136. (See par. 116i(1).)

112. Preparing Fixing Solution

The acid fixing powder may be supplied either in a 1-gallon size container or in a ½-gallon size container. Also the acid fixing powder may contain the hardener already mixed in it or may be packed in the container with a separate package of the hardener.

a. PREPARING FIXING SOLUTION WITH ACID FIXING POWDER WITH HARDENER. (1) While stirring rapidly and continuously with Paddle PH-80, slowly pour the acid fixing powder with hardener into 3 quarts of water. The water must not be above 80° F. (27° C.) in temperature.

(2) Continue to stir until the powder with hardener is completely dissolved.

(3) Add enough water to the solution to make 1 gallon of acid fixing solution.

Note. If the solution is not prepared as recommended, it may turn milky in appearance, but it will usually clear on standing.

(4) Repeat the procedures described in (1) through (3) above, until 4 gallons of fixing powder are prepared. A 4-gallon lot of fixing solution may be used as long as two 5-gallon lots of developer.

b. PREPARING FIXING SOLUTION WITH ACID FIXING POWDER. (1) Loosen the chemical (fixing agent) in its container (1-gallon size), and pour about one-half of the chemical slowly into 3 quarts of water. Stir rapidly while pouring it into the water. The water should not be above 80° F. (27° C.) in temperature.

(2) Remove the package of hardener from the container. The package of hardener is revealed when about half of the fixing agent is removed from the container.

(3) Pour the remainder of the fixing agent into the solution (*a* above), while stirring the solution rapidly with Paddle PH-80. Continue to stir until all of the fixing agent is completely dissolved.

(4) While stirring the fixing solution rapidly, add the hardener slowly.

(5) Continue to stir the solution until the hardener is dissolved.

(6) Add sufficient cold water to the solution to make 1 gallon of solution.

Note. The directions given in *b* above for preparing the fixing solution apply to 1-gallon size containers. The same directions apply to the ½-gallon size containers except that the contents of two of the containers must be used to obtain a 1-gallon lot of the fixing solution.

(7) Repeat the procedures described in (1) through (6) above, until 4 gallons of the fixing solution are prepared.

113. Disassembling and Repacking Film Developing Components

a. DEVELOPING EQUIPMENT PH-41. (1) Thoroughly rinse the three tanks with clean water, allow them to drain, and then dry. Use a clean, lint-free cloth if necessary.

(2) Allow the developing reel to drain, and then dry. Use a clean, lint-free cloth if necessary. Be careful not to bend the spirally wound steel tape.

(3) Clean and dry the two Paddles PH-80.

(4) Remove the film roll holder plate from the bracket spindle.

(5) Disengage the bracket from the mounting rack clamp.

(6) Nest the three tanks so that the medium tank fits inside the largest tank, and the smallest tank, in turn, fits inside the medium tank.

- (7) Place the nest of three tanks on the bottom of the carrying case.
- (8) Place the developing reel inside the case by fitting the reel inside the smallest tank. Be sure that the reel is dry.
- (9) Place the wire screen over the developing reel.
- (10) Place the mounting rack, film roll holder plate, bracket, changing bag, and two Paddles PH-80 in convenient positions on top of the wire screen.
- (11) Close the cover of the case, fasten the two trunk catches, and snap the lock shut.

b. DRYING RACK PH-42. (1) Disengage the two sections of the shaft of the drying rack, and then release the two sections from the shaft strap holders on the two uprights.

(2) Pull out the two steel pins which interlock one crosspiece with the uprights.

(3) Disengage the crosspiece from the two uprights.

(4) Disengage the remaining crosspiece from the uprights ((2) and (3) above).

(5) If necessary, clean and wipe dry with a lint-free cloth the various components of the drying rack.

(6) Place the two uprights, the two crosspieces, the four steel pins, the two sections of the shaft in convenient positions in the case.

(7) Fasten the two trunk catches and snap the lock shut.

c. TABLE OF WEIGHTS AND VOLUMES.

Item	Volume (cu ft)	Weight (lb)
Developing Equipment PH-41 in carrying case.....	1.9	50
Drying Rack PH-42 in carrying case.....	0.57	12
Bottle PH-22	0.22	4
Bottle PH-136	0.52	7.5
Funnel PH-175	0.05	0.5

PART TWO

OPERATING INSTRUCTIONS FOR FILM DEVELOPING COMPONENTS

Note. For information on destroying this equipment to prevent enemy use, see the destruction notice at the front of this manual.

Section III. TECHNICAL OPERATION

114. General

Careful and proper processing of the exposed film determines the success with which the data on the film can be interpreted, analyzed, and made useful. Scratches or water spots on film, for example, may render the photographs useless. All instructions and cautions given in this section therefore, must be observed with extreme care.

115. Preparing Tanks for Processing Operations

a. The tanks are used in the order in which they are removed from the carrying case. The medium tank, however, is used for a second time (after the fixing operation) for the washing operation. The table which follows lists the uses of the three different-sized tanks supplied as part of Developing Equipment PH-41. Never use a tank for any purpose other than the one specified for it in the table.

<i>Tank Size</i>	<i>Use</i>
Smallest	Developing
Medium	Water rinse and water wash
Largest	Fixing

b. Pour the developer solution (par. 105) into the smallest tank to a depth of approximately 3 inches. Never use a developing solution which *has turned dark brown in color or which is more than 1 week old.*

c. Pour clear water into the medium-sized tank to a depth of about 3 inches.

d. Pour the fixing solution (hypo) into the largest tank to a depth of approximately 3 inches.

116. Processing Exposed Film

a. **LOADING FILM ONTO DEVELOPING REEL** (fig. 46). Load the exposed film onto the developing reel in *total* darkness as follows:

(1) Remove the exposed film from the can.

(2) Determine which side of the film has the emulsion on it by pressing the film between moistened fingers or between the lips. The wet fingers or lips stick to the emulsion side of the film. Then rewind the film with the emulsion side *in*. Rewinding the film before placing it on the film holder insures that the counter edge of the film and not the target portion will touch the spiral reel. This greatly lessens the possibility of scratching the target portion of the film.

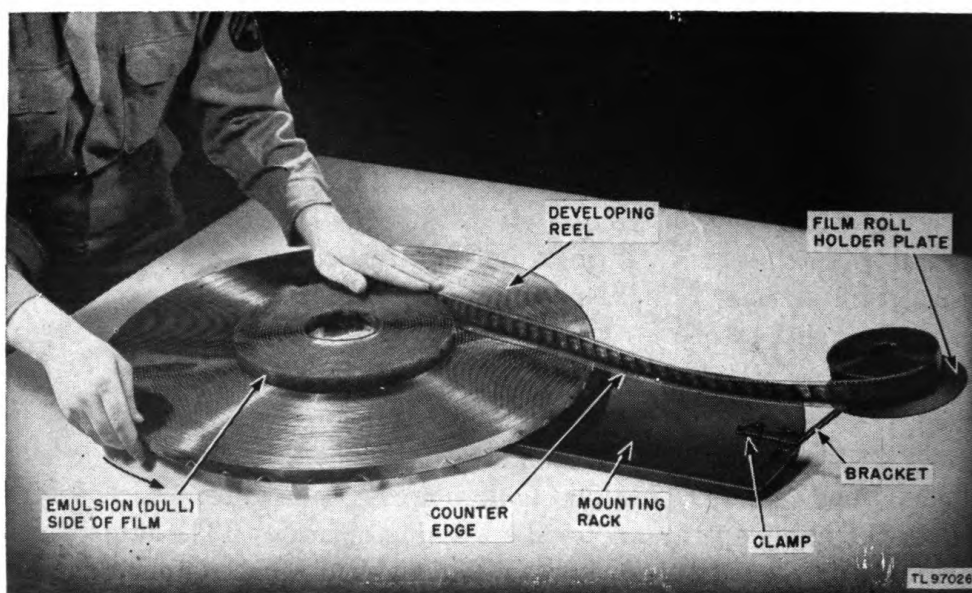

Figure 46. Loading film on developing reel.

(3) Place the roll of film on the film roll holder plate. Secure the free end of the film by one of its perforations to the hook on the inner end of the reel spiral. *The reel must be absolutely dry before use.*

(4) Rotate the reel with the right hand in a counterclockwise direction, guiding the film into the reel spaces with the left hand.

(5) Continue to rotate the reel in a counterclockwise direction until all of the film is wound tightly on the reel, *emulsion side out and counter edge down.*

(6) When all of the film is wound on the reel, double back about $\frac{1}{2}$ inch of the outer end and insert the doubled portion in the spiral to hold this end securely in place in the reel. To fill a reel with two or more short pieces before developing, double back the free ends of the short pieces and then hook them together in the reel.

b. DEVELOPING FILM. The film must be developed in *total* darkness.

(1) Grasp the reel by its hand hold, and lower it into the tank of developer.

(2) Move the reel quickly up and down about $\frac{1}{2}$ inch. Do this several times to drive out any air bubbles that may stick to the film. Do not rotate the reel while it is in the developer solution.

(3) Set the reel on the bottom of the tank so that the film and reel are completely immersed in the developing solution.

(4) Allow the film to develop according to the following time-temperature relationship.

<i>Developer temperature</i>	<i>Time of Development (minutes)</i>
65° F.	5
70° F.	4 $\frac{1}{2}$
75° F.	4

Note. The fixing solution and water rinse and wash should be kept as near in temperature to that of the developing solution as possible.

c. RINSING FILM. After the film has been developed for the required length of time, it must be rinsed in clear water. The rinsing of the film must be done in *total* darkness.

(1) Grasp the reel by its handle and lift the reel out of the developing tank.

(2) Allow the reel to drain for about 15 or 20 seconds.

(3) Immerse the reel in the rinsing tank. This tank contains clear water at a temperature approximately the same as that of the developer.

(4) Remove any air bubbles by moving the reel quickly up and down about $\frac{1}{2}$ inch in the water. Do not rotate the reel in the rinsing tank.

(5) Allow the reel to remain immersed in the water rinse for about 1 minute.

d. FIXING FILM. After the film has been rinsed, it must be fixed. The film must be fixed in *total* darkness.

(1) Grasp the reel by its handle and lift the reel out of the rinsing tank.

(2) Allow the reel to drain, and then immerse it in the fixing solution (hypo) in the fixing tank.

(3) Remove any air bubbles on the film by quickly moving the reel several times up and down about $\frac{1}{2}$ inch.

(4) Immerse the reel and film in the fixing solution and allow the reel to remain immersed in the fixing tank for 10 to 15 minutes. The fixing solution should be nearly the same temperature as the developer and rinse.

e. WASHING FILM. The film is washed after the fixing operation. The washing of the film and all further operations may be done in the presence of light, but not in direct sunlight.

(1) Empty the water rinse tank (medium-sized tank), rinse thoroughly, and then fill it to a depth of about 3 inches with clear water.

(2) After the film has been in the hypo for the required length of time, lift the reel by the handle and allow the reel to drain for 15 to 20 seconds.

(3) Place the reel in the tank of washing water, and move the reel up and down in the wash water for 15 to 20 seconds.

(4) Lift the reel out of the water, allow the reel to drain for a few seconds, and then shake off the surplus water.

(5) Change the water in the tank and repeat the washing operation ((3) and (4) above).

(6) Repeat the washing operation for five to eight changes of water.

f. REMOVING FILM FROM REEL. (1) After the film is thoroughly washed, lift the reel by its handle out of the water and allow it to drain for a few seconds.

(2) Release both ends (and any joints) of the film so that the film lies free in the reel.

(3) Place the wire screen over the film wound in the reel.

(4) Grasp the rims of both the screen and the reel firmly with both hands and turn the complete assembly upside down.

(5) Lower the screen and reel in this position into the medium-sized tank until they are immersed in the washing water.

(6) Agitate the reel slightly to release the film, and then lift the reel out of the water, leaving the film on the screen in the tank.

(7) Shake the excess water out of the reel, and then locate it where it can drain and dry.

g. WINDING FILM ON DRYING RACK (fig. 47). Three operators are required to wind the film on the Drying Rack PH-42. The first operator manipulates the drying rack, the second carefully wipes the film between two viscose sponges (or cotton), and the third holds the roll of wet film after it has been rolled into a compact roll ((1) below). Use Drying Rack PH-42 in a fairly cool, well-ventilated room of even temperature.

(1) Wind the film carefully by hand under water into a compact roll so that the film will not scratch when handled. This can be done by operator three.

(2) Wet two viscose sponges (or cotton) in clear water and then squeeze them as dry as possible. This can be done by operator two.

(3) Rest one end of the assembled drying rack (par. 110) on the developing equipment case, and hold the other end with the hands (fig. 47). This can be done by operator one.

(4) Loop the free end of the film over the crosspiece between the two pins next to operator one. Pin or clip the free end of the film back

on itself so that the film securely engages the crosspiece. Fasten the film on the rack so that the film will *wind with the emulsion side out*.

(5) Operator one winds the film loosely on the drying rack, carefully guiding the film between two adjacent pins on the crosspieces. While operator one is winding the film on the rack, operator two carefully wipes the film with the sponges to remove as much loose water from the film as possible without scratching or sliding the emulsion on the film. If the film shrinks tight on the drying rack as it dries, loosen the film to prevent it from stretching or breaking.

(6) When the film is completely wound on the drying rack, pin or clip the free end of the film so that it will not unwind during the drying period.

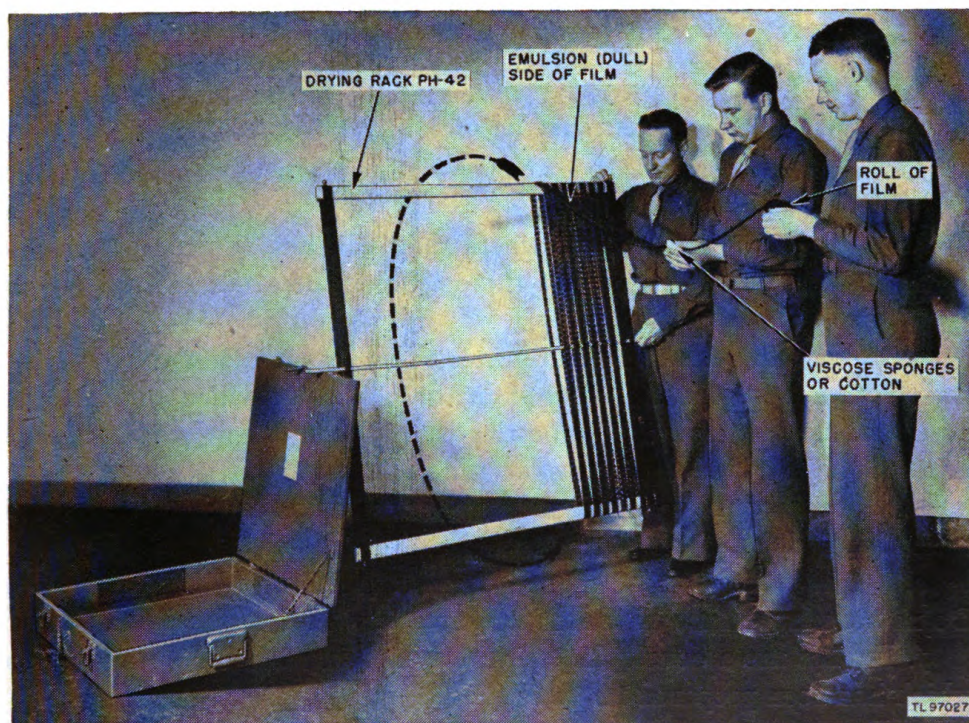

Figure 47. Winding film on drying rack.

h. REMOVING FILM FROM DRYING RACK. When the film is dry (after approximately 5 to 10 minutes), use Rewinder PH-92 and wind the film into a roll or on one of the reels of the film viewer (par. 146).

i. STORAGE OF DEVELOPING AND FIXING SOLUTIONS. (1) *Developing solution.* Developing solution deteriorates in contact with air and is also affected by light. When no more developing is to be done, store the developing solution immediately in bottles.

(a) Use Funnel PH-175 and pour the developing solution into bottles.

(b) To exclude air from a bottle which is not completely full, drop clean pebbles into the bottle or bottles to raise the surface of the developer into the neck of the bottle.

(c) Cork the bottle tightly with the mushroom stopper.

(d) Store the bottles for future use in a cool dark place.

(e) Thoroughly rinse and clean the developer tank, and place it where it will completely drain and dry.

(2) *Fixing solution.* (a) Use Funnel PH-175 and pour the fixing solution into bottles.

(b) Cork the bottle and store it conveniently for reuse.

(c) Thoroughly rinse the tank, and allow it to drain and dry. Also rinse the tank of washing water, and allow it and the wire screen to drain and dry.

117. Precautions

The following precautions must be carefully observed:

a. Keep the chemicals dry. Never expose them to moisture or store them in moist places.

b. Store chemical solutions where they will not be exposed to temperatures of 40° F. or less. At these temperatures the chemicals may crystallize out of solution.

c. Developing solution deteriorates when in contact with air. When the solution is not in use, store it in the bottles provided for this purpose. Eliminate any air in the bottles by dropping clean pebbles into it until the level of the liquid rises to the neck of the bottle.

d. Do not pour too much solution or water into the tanks. If the water is too deep, it will float the film out of the reel.

e. When processing the film in the reel, hold the reel by its handle. Do not touch the face of the film at any time during the processing.

f. Do not use a developing solution which has turned dark brown or which has been prepared for more than 1 week.

g. Do not use a tank for any purpose other than the one for which it is provided.

h. Be absolutely certain that the developing reel is dry before film is wound on it. If the reel is not dry, the film will stick to the reel.

i. Always use the wire screen as an aid in removing the film from the reel after the washing process. This prevents the film from slipping haphazardly out of the reel and becoming entangled.

j. Wind the film loosely on the drying rack. If the film should shrink tight on the drying rack as it dries, loosen the film to prevent stretching or breaking.

k. Always perform the following operations in a completely dark room: loading the film on the reel, developing the film, rinsing the film, and fixing the film.

- l.* Do not try to remove the film from the reel except by turning the reel upside down (with the aid of the wire screen) in water.
- m.* Do not rotate the reel while it is immersed in solution.
- n.* Never try to dry the film in the reel. Use Drying Rack PH-42 for this purpose.
- o.* Wash and dry the reel thoroughly before replacing it in the carrying case for Developing Equipment PH-41.
- p.* Do not leave chemical solutions in the tanks after the film has been processed and no more processing is to be done immediately.

118. Performance Check List

Item No.	Item	Action or condition	Normal indication	Corrective measure
1	Developing Equipment PH-41.	Assemble developing reel assembly (par. 109).	Reel rotates freely on spindle; bracket is held securely in mounting rack clamp.	
2	Developer.	Dissolve contents of one can of Kodak Developer D-11 in warm water (par. 111).	Chemical is completely dissolved; 5 gallons of solution prepared.	Stir with Paddle PH-80 until all of chemical is dissolved; add sufficient water to make 5 gallons.
3	Acid forming powder.	Dissolve acid forming powder and hardener in water (par. 112).	Chemical completely dissolved; 1 gallon of solution prepared.	Stir with Paddle PH-80 until all of chemical is dissolved; add sufficient water to make 5 gallons.
4	Drying Rack PH-42.	Assemble drying rack (par. 110).		
5	Tanks.	Pour fixing and developer solutions and water into their respective tanks (par. 115).	Each tank contains a liquid to a depth of 3 inches.	Add or remove liquid as necessary. Do not use a developing solution which has turned dark brown in color or which is more than 1 week old.
6	Site.	Put out all lights.	Condition of total darkness exists.	

PREPARATORY

EQUIPMENT PERFORMANCE

7	Developing reel and film.	Load film on reel (par. 116a). Reel must be dry.	Wind film on reel with emulsion side out. Counter edge and not target portion of film touches spiral reel.	Rewind film with emulsion side in.
8	Developing tank and solution.	Develop film in developing solution (par. 116b). Do not touch face of film.		
9	Rinsing tank.	Rinse the developed film in clear water (par. 116c). Do not touch the face of the film.		
10	Fixing tank and solution.	Fix the film in hypo (par. 116d). Do not touch the face of the film.		
11	Washing tank.	Wash the film in approximately eight changes of water (par. 116e).		
12	Wire screen.	Place screen on top of film in reel, turn all upside down, and remove film from reel (par. 116f).	Film lies on screen in water when reel is removed.	Release ends (or joints) of film in reel.
13	Drying rack.	Wind film on drying rack. Three operators are required (par. 116g).	Film winds loosely on rack with all surplus water removed from film.	Loosen film on drying rack. Wipe film with viscose sponge or cotton.
14	Rewinder PH-92.	Rewind film on one of reels of Film Viewer PH-97, or into roll for storage (par. 146).	Film winds on reel with emulsion side in and with the leading end on the outside of the reel, or into roll with emulsion side in and with trailing end on outside of roll.	

Item No.	Item	Action or condition	Normal indication	Corrective measure
15	Bottles and Funnel PH-175.	Pour the developing solution into the bottles (par. 116i(1)).	Surface of developer rises to neck of bottle.	Drop clean pebbles into bottle until surface of liquid does rise to the neck of the bottle.
16	Bottles and Funnel PH-175.	Pour the fixing solution into the bottles (par. 116i(2)).		
17	Tanks.	Rinse and wash all tanks. Allow to drain and dry.		
18	Wire screen.	Rinse and wash the screen and allow to drain and dry.		

STOP

PART THREE

MAINTENANCE INSTRUCTIONS FOR FILM DEVELOPING COMPONENTS

Section IV. PREVENTIVE MAINTENANCE TECHNIQUES

119. Meaning of Preventive Maintenance

For complete information on the meaning of preventive maintenance, see paragraph 33.

120. Description of Preventive Maintenance

a. For a complete description of preventive maintenance techniques, see paragraph 34*a* through *e*.

b. The remaining paragraphs in this section do not deal with individual film developing components. Rather they combine all instructional material on the major *classes* of parts of the film developing components. Section V below treats the maintenance to be performed on the individual items of the film developing components.

121. Hardware

a. GENERAL. Preventive maintenance work on hardware (fastening screws and nuts, hinges, catches, clamps, pins, etc.) of the film developing components consists of Inspect (I), Tighten (T), and Lubricate (L).

b. INSPECT (I). Inspect all screws, nails, and pins for looseness. Inspect hinges and other fastenings for rust and dirt.

c. TIGHTEN (T). Use a screw driver on loose slotted-head screws. Make them moderately handtight. Cement or wedge loose pins in place.

d. LUBRICATE (L). Lubricate the moving parts of hinges, catches, and locks with Oil, Engine, (OE).

122. Metal Parts

a. GENERAL. Preventive maintenance work on metal parts of the film developing components consists of Inspect (I), Clean (C), and Adjust (A).

b. INSPECT (I). Inspect all metal parts for dirt, dents, and bends.

PART THREE

MAINTENANCE INSTRUCTIONS FOR FILM DEVELOPING COMPONENTS

Section IV. PREVENTIVE MAINTENANCE TECHNIQUES

119. Meaning of Preventive Maintenance

For complete information on the meaning of preventive maintenance, see paragraph 33.

120. Description of Preventive Maintenance

a. For a complete description of preventive maintenance techniques, see paragraph 34*a* through *e*.

b. The remaining paragraphs in this section do not deal with individual film developing components. Rather they combine all instructional material on the major *classes* of parts of the film developing components. Section V below treats the maintenance to be performed on the individual items of the film developing components.

121. Hardware

a. GENERAL. Preventive maintenance work on hardware (fastening screws and nuts, hinges, catches, clamps, pins, etc.) of the film developing components consists of Inspect (I), Tighten (T), and Lubricate (L).

b. INSPECT (I). Inspect all screws, nails, and pins for looseness. Inspect hinges and other fastenings for rust and dirt.

c. TIGHTEN (T). Use a screw driver on loose slotted-head screws. Make them moderately handtight. Cement or wedge loose pins in place.

d. LUBRICATE (L). Lubricate the moving parts of hinges, catches, and locks with Oil, Engine, (OE).

122. Metal Parts

a. GENERAL. Preventive maintenance work on metal parts of the film developing components consists of Inspect (I), Clean (C), and Adjust (A).

b. INSPECT (I). Inspect all metal parts for dirt, dents, and bends.

c. **CLEAN (C)**. Use a soft, dry, lint-free cloth or brush to wipe off dust. Use a damp cloth to remove dirt. If the dirt is difficult to remove, moisten the cloth with Solvent, Dry Cleaning, spec P-S-661a.

d. **ADJUST (A)**. Use the fingers or a pair of long-nose pliers to bend back any metal part into proper shape.

123. Glass and Wood Parts

a. **GENERAL**. Preventive maintenance work on the glass and wood parts of the film developing components consists of Inspect (I) and Clean (C).

b. **INSPECT (I)**. Inspect all wood and glass parts for chips, breaks, cracks, and accumulations of dust and dirt.

c. **CLEAN (C)**. Use a soft, dry, lint-free cloth or brush to wipe off dust. Use a damp cloth to wipe off dirt. If the dirt is difficult to remove, moisten the cloth with Solvent, Dry Cleaning (SD).

Section V. ITEMIZED PREVENTIVE MAINTENANCE OF FILM DEVELOPING COMPONENTS

124. Materials Needed

Have the following items on hand before beginning preventive maintenance work on the film developing components of Spotting Sets PH-32-(*) and Spotting Set AN/TVQ-1:

- Screwdriver.
- Clean cloths.
- Long-nose pliers.
- Cleaning fluid (see note).
- Oil, Engine (OE).
- Soldering iron and solder.

Note. Gasoline will not be used as a cleaning fluid for any purpose. Solvent, Dry Cleaning, is available as a cleaning fluid through established supply channels. Oil, Fuel, Diesel, may be used for cleaning purposes when dry-cleaning solvent (SD) is not on hand. Carbon tetrachloride will be used as a cleaning fluid only in the following cases: where inflammable solvents cannot be used because of the fire hazard, and for cleaning electrical contacts including relay contacts, plugs, commutators, etc.

125. Maintenance of Developing Equipment PH-41

a. **CASE**. (1) Keep the case clean (par. 123c).

(2) Keep the fastening screws of the hinges, catches, handles and hasp and staple tight (par. 121c).

(3) Lubricate the hardware (par. 121d).

b. **DEVELOPING REEL ASSEMBLY.** (1) *Developing Reel.* Keep the developing reel clean and dry. Bend any dented or deformed part of the reel (spiral tape, handle, hook) back into shape (par. 122d).

(2) *Film Roll Holder Plate and Bracket.* Keep these items clean and free of all dents and bends (par. 122c and d).

(3) *Mounting Rack.* Keep the mounting rack clean (par. 122c).

c. **WIRE SCREEN.** Examine the wire screen to check whether the rim is misshapen. If it is, bend it back into shape. Examine the screen for tears and rips. Solder torn pieces of the screen together.

d. **TANKS.** Bend back into shape any dented part of the tanks (par. 122d). Keep the tanks clean and dry whenever they are not in use (par. 122c).

126. Maintenance of Drying Rack PH-42.

a. **CASE.** Preventive maintenance work on the carrying case for Drying Rack PH-42 is identical with the maintenance instructions given for the carrying case for Developing Equipment PH-41 (par. 125a).

b. **UPRIGHTS.** Keep the uprights free from accumulations of dirt and other foreign matter. Never use the upright as a lever, crowbar, or hammer. Examine the looped metal straps and the shaft strap holders, and be sure that they are not dented or bent out of shape (par. 122d). Be certain that the hole in the looped strap lines up with the hole in the wooden portion of the upright. If the holes are not in line, bend the metal strap until they are. Keep tight all nails and screws which hold the metal straps and shaft strap holders in place.

c. **CROSSPIECES AND SHAFT.** Keep the crosspieces and two-piece shaft clean (par. 123c). Tighten all loose pins and nails in place (par. 121c). Examine the springs on the crosspiece; if they are deformed, bend them back into place (par. 122d).

d. **PINS.** Never use the pins as levers or crowbars. If a pin is deformed and cannot be bent back into shape, requisition a new one.

127. Maintenance of Bottles PH-22 and PH-136.

Keep all bottles clean (par. 123c), especially the bottle stoppers which come in contact with the processing solutions.

128. Preventive Maintenance Check List

The following check list is a summary of the preventive maintenance to be performed on the film developing components of the spotting set. Suggested time intervals for performing preventive maintenance may be varied at any time by the local commander. However, for best performance of the equipment, perform operations at least as frequently as called for in the check list. The last column indicates whether the operation is first or second echelon maintenance.

Item No.	Operation	Item	When performed			Echelon
			Daily	Weekly	Monthly	
1	IC	Developing reel (par. 125b)---	*			First
2	IC	Tanks (par. 125d)-----	*			First
3	IC	Drying rack (par. 126)-----		*		First
4	A	Uprights of drying rack (par. 126b).		*		First
5	ICA	Holder plate and bracket (par. 125b(2)).		*		First
6	ITCL	Cases (par. 125a)-----			*	First
7	A	Developing reel (par. 125b(1)).			*	First
8	IT	Uprights of drying rack (par. 126b).			*	First
9	ITA	Crosspieces (par. 126c)-----			*	First
10	IT	Shaft (par. 126c)-----			*	First
11	IA	Screen (par. 125c)-----			*	Second
12	IA	Tanks (par. 125d)-----			*	First
13	IC	Bottles PH-22 and PH-136 (par. 127).			*	First

F * I T C A L
 Feel Inspect Tighten Clean Adjust Lubricate

* The feel operation is inapplicable to this equipment.

Section VI. LUBRICATION OF FILM DEVELOPING COMPONENTS

129. Lubrication.

None of the film developing components is covered by the War Department Lubrication Orders issued on Spotting Sets PH-32-(*) and AN/TVQ-1, which are referred to in section VI, "Spotting Set PH-32-(*)." Lubrication instructions for the film developing components of a spotting set are contained in paragraph 121d.

Section VII. MOISTUREPROOFING AND FUNGI- PROOFING OF FILM DEVELOPING COMPONENTS

130. Moistureproofing and Fungiproofing

Moistureproofing and fungiproofing procedures are not required for the film developing components of Spotting Sets PH-32- (*) and AN/TVQ-1.

PART FOUR
AUXILIARY EQUIPMENT

(NOT USED)

PART FIVE

REPAIR INSTRUCTIONS

Note. Failure or unsatisfactory performance of equipment used by Army Ground Forces and Army Service Forces will be reported on WD, AGO Form 468 (Unsatisfactory Equipment Report). For particulars see paragraph 128. If Form 468 is not available, prepare letter containing the data elicited by the sample form shown in figure 60 without reproducing copies of the form.

Section VIII. THEORY OF OPERATION OF FILM DEVELOPING COMPONENTS

131. Functioning of Film Developing Components

a. DEVELOPING EQUIPMENT PH-41 AND DRYING RACK PH-42. Developing Equipment PH-41 and Drying Rack PH-42 are designed to develop 35-mm film in lengths up to 200 feet. The developing reel holds the film without slack, emulsion side out, so that the processing solution have free access to the emulsion, and the emulsion side will not be scratched during processing.

b. DEVELOPING. During development the silver bromide of the grains, which have been affected by light during the exposure of the film in the phototheodolites, is converted into black metallic silver which constitutes the final image. The developer is thus a reducing mixture. The developer consists of a reducing or oxidizing agent (elon and hydroquinone), a preservative (sodium sulphite), an accelerator (sodium carbonate), and a restrainer (potassium bromide). The functions of the developer solution ingredients are as follows:

(1) *Reducing agent.* The reducing agent reduces the silver in the silver compound to black metallic silver.

(2) *Preservative.* The preservative prevents the too rapid oxidation of the reducing agent and thereby preserves the developing power of the solution for the length of time required.

(3) *Accelerator.* The accelerator is an alkali which energizes the developing agent.

(4) *Restrainer.* The restrainer adds a surplus of bromide and prevents free silver from causing chemical fog. The restrainer regulates the rate of development and controls the action of the developing solution.

(5) *Water*. Water acts as a solvent for the solid chemicals used.

c. **RINSING**. The developer solution contains an alkali and the fixing solution an acid. Rinsing prevents the transfer of alkali from the developing tank to the fixing bath. This transfer of alkali is undesirable because it can neutralize the acid in the fixing bath.

d. **FIXING**. The purpose of the fixing process is the removal of all silver compound unaffected by light during exposure. The fixing solution consists of water, hyposulphite of soda, a preservative (sodium sulphite), a hardener (potassium alum), and acid (acetic acid), and boric acid. The functions of the various ingredients of the fixing solution are as follows:

(1) *Water*. The water acts as a solvent for the other chemicals used.

(2) *Hyposulphite of soda*. The hyposulphite of soda acts as a solvent for the silver compound on the film.

(3) *Sodium sulphite*. The sodium sulphite acts as a preservative to maintain the strength of the hypo.

(4) *Potassium alum*. The potassium alum serves to harden the gelatin on the film.

(5) *Acetic acid*. The acetic acid serves to neutralize any alkali which may have carried over from the developer.

(6) *Boric acid*. The boric acid prevents sludge formation.

e. **WASHING**. Thorough washing removes all remaining soluble substances on the film and leaves only the silver and the gelatin.

f. **DRYING**. The film is passed through the wet viscose sponges or through cotton to remove any particles of grit or foreign matter and to remove surplus water. Drying Rack PH-42 permits a maximum exposure of the emulsion side of the film during drying.

Section IX. REPAIRS TO FILM DEVELOPING COMPONENTS

132. General

If properly used and maintained, Developing Equipment PH-41 and Drying Rack PH-42 will require very little repair.

133. Developing Equipment PH-41

a. To repair open seams and holes in the tanks, solder the tank leaks from the outside. Be sure to wash away all flux.

b. Repair a broken handle on the developing reel by soldering it back in place. Wash away all flux.

134. Drying Rack PH-42

A broken or badly cracked upright, crosspiece, or shaft may be repaired by taping, or by stapling the two broken pieces with a metal holder.

Such repair, however, is for emergency use only; every precaution should usually be taken to prevent foreign matter from coming in contact with the film. Replace a broken or cracked wooden piece as soon as possible.

135. Unsatisfactory Equipment Report

a. When trouble in equipment used by Army Ground Forces or Army Service Forces occurs more often than repair personnel feel is normal, War Department Unsatisfactory Equipment Report, WD AGO Form 468 should be filled out and forwarded through channels to the Office of the Chief Signal Officer, Washington 25, D. C.

b. If Form 468 is not available, prepare letter containing the data elicited by the sample form shown in figure 60 without reproducing copies of the form.

FILM VIEWING COMPONENTS OF
SPOTTING SETS PH-32-B, PH-32-C,
PH-32-D, AND PH-32-F; AND
SPOTTING SET AN/TVQ-I

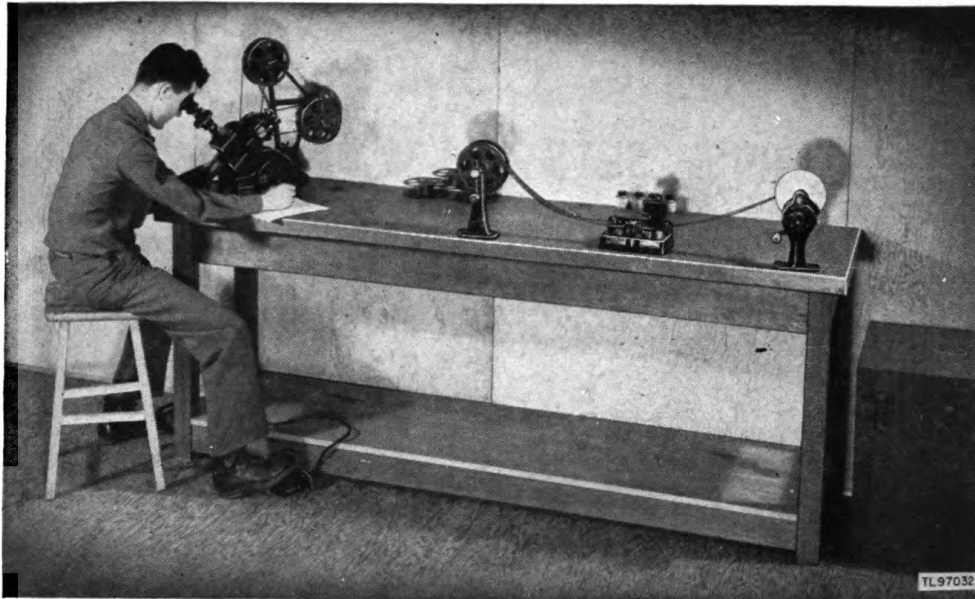

Figure 48. Film Viewing Components of Spotting Set PH-32-B, PH-32-C, PH-32-D, or PH-32-F or Spotting Set AN/TVQ-1, in use.

PART ONE

INTRODUCTION

Section I. DESCRIPTION

136. Film Viewing Components

a. The film viewing components of Spotting Set PH-32-B, PH-32-C, PH-32-D, or PH-32-F, or Spotting Set AN/TVQ-1, consist of the following items which are described in succeeding paragraphs:

Film Viewer PH-97, PH-97-A, PH-97-B, PH-97-C, or PH-97-D.

Rewinder PH-92.

Splicer PH-91 or PH-91-A.

Film cement.

b. The quantity, weight, and dimensions of each item are given in paragraph 3*d* for Spotting Set PH-32-(*), or paragraph 71*d* for Spotting Set AN/TVQ-1.

c. Basic type nomenclature including the symbol (*), instead of a suffix letter, indicates any one or all of the models of that particular equipment which are covered in this manual. For example:

(1) Film Viewer PH-97-(*) indicates any one or all of Film Viewers PH-97, PH-97-A, PH-97-B, PH-97-C, and PH-97-D.

(2) Splicer PH-91-(*) indicates either one or both of Splicers PH-91 and PH-91-A.

137. Film Viewer PH-97-(*)

a. GENERAL.

(1) Film Viewer PH-97-(*) is portable equipment designed for viewing 35-mm motion-picture film which has been used in a photo-theodolite. The equipment includes an electrically operated machine in which the film can be handled as stills or as moving pictures; a special optical attachment which superimposes a special circular scale onto the film; and a case into which the equipment is packed for transport or storage.

(2) The five models of Film Viewer PH-97-(*) and the weight and dimensions of each model are as follows:

Model	Dimensions (in.)			Volume	Weight
	Length	Width	Height	(cu ft)	(lb)
Film Viewer PH-97	17	20	20	3.9	106
Film Viewer PH-97-A	17	20	20	3.9	106
Film Viewer PH-97-B	21	19	24	5.5	125
Film Viewer PH-97-C	23	19	22	5.5	100
Film Viewer PH-97-D	21	19	24	5.5	125

(3) Except for the differences in weights and dimensions as listed above, all models of Film Viewer PH-97-(*) essentially are the same, differing in suffix letter designation mainly because of their use with different models of spotting sets.

b. APPLICATION. Film Viewer PH-97-(*) is the equipment used for viewing and measuring (for the purpose of extracting data) the pictures taken by the spotting set phototheodolites during antiaircraft artillery practice.

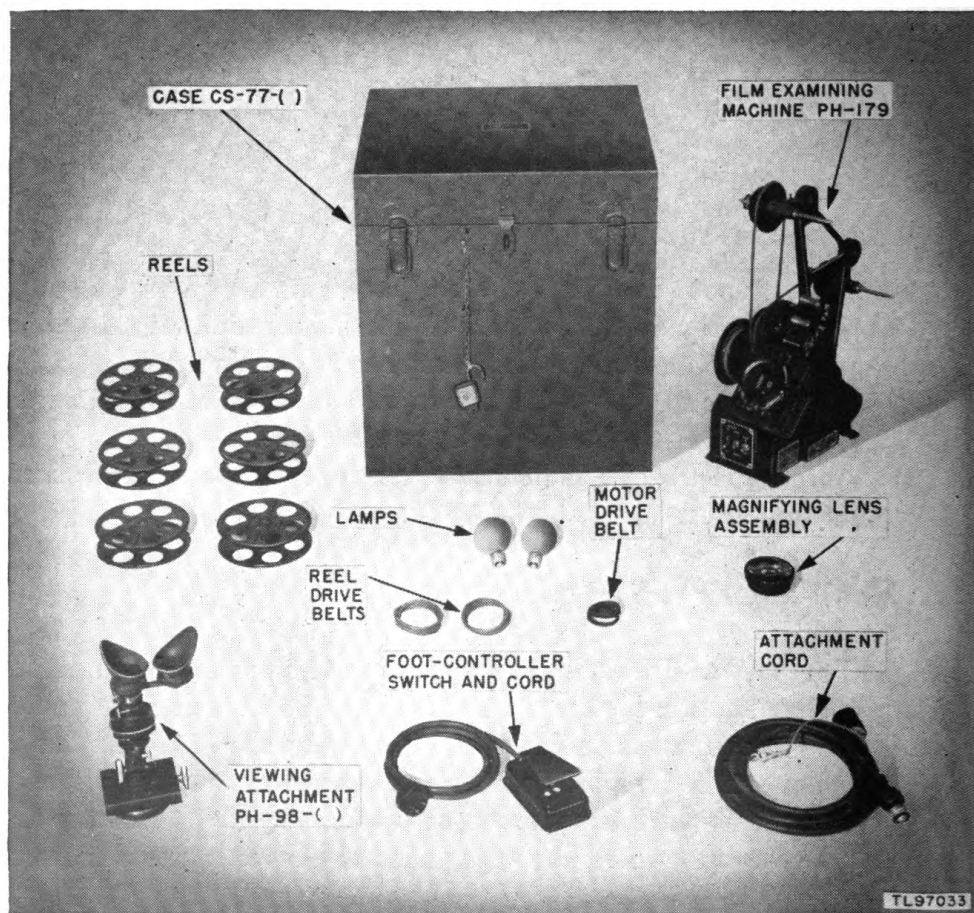

Figure 49. Components of Film Viewer PH-97-(*).

c. COMPONENTS (fig. 49). Film Viewer PH-97-(*) consists of the following major components:

- 1 Film Examining Machine PH-179, which includes—
 - 1 magnifying lens assembly, with clamping ring.
 - 1 attachment cord with plug.
 - 1 foot controller switch with cord.
 - 1 set of running spares, consisting of—
 - 1 motor drive belt.
 - 2 reel drive belts.
 - 2 lamps, 25-watt.
- 6 reels, 400-foot capacity.
- 1 Viewing Attachment PH-98-(*) .
- 1 Case CS-77-(*) .

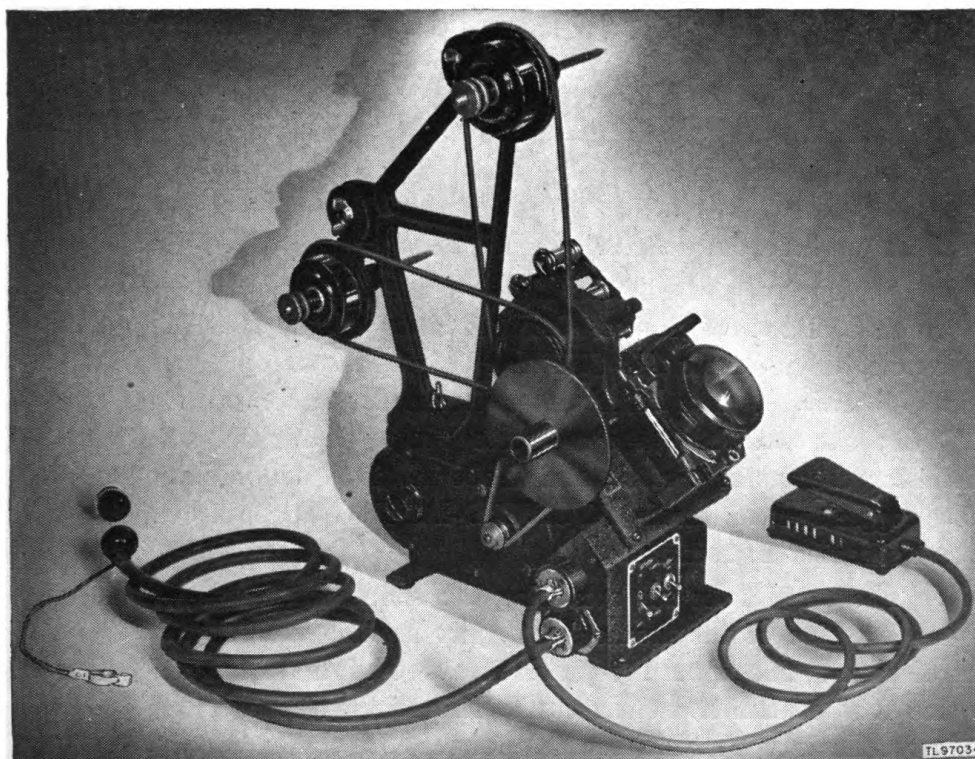

Figure 50. Film Examining Machine PH-179.

d. FILM EXAMINING MACHINE PH-179 (fig. 50). (1) Film Examining Machine PH-179 is the means provided with Film Viewer PH-97-(*) to handle 35-mm motion-picture film and to furnish illumination for viewing it.

(2) Essentially, Film Examining Machine PH-179 is a frame body containing a film transportation assembly, a film gate assembly, an electric lamp, an electric motor, and a control panel and receptacles for attaching connecting cords.

(a) The film transportation assembly includes brackets for supporting reels of film, and sprockets for engaging and moving film in the track provided.

(b) The film gate consists of a lower portion and an upper portion.

1. The lower portion is side-hinged in place over a part of the film transportation track, and is held closed by a catch.

2. The upper portion is movably mounted on the lower portion, which is provided with a lever by which the upper portion can be shifted parallel to the direction of film movement. A hinged ring threaded to receive either Viewing Attachment PH-98- (*) (c below) or the magnifying lens which is part of Film Examining Machine PH-179, is mounted on the upper portion.

(c) The electric lamp is mounted behind a diffusing opal glass located below an opening in the film transportation track, opposite the film gate.

(d) The electric motor is a $\frac{1}{8}$ -horsepower universal motor which will operate on 100 to 120 volts, d-c or 60-cycle a-c. It is mounted inside the frame body and drives the film sprockets and the reel bracket spindles by belts and pulleys. A hand rheostat for controlling the speed of the motor is located on the left side of the frame body.

(e) The control panel is located at the lower front of the frame body and consists of three switches. One switch is labeled LIGHT and is a single-pole, single-throw ON-OFF toggle switch controlling the electric lamp ((c) above). The other two switches are under the single label MOTOR; one switch is a single-pole, single-throw ON-OFF trigger switch for the motor circuit, and the other is a double-pole, double-throw toggle switch (marked FORW'D-BACKW'D) for reversing the motor's direction of rotation.

(f) The receptacles for attaching the connecting cords are located on the left side of the frame body, just around the corner from the control panel. The upper receptacle is a two-contact female receptacle for the foot controller switch cord. The lower receptacle is a three-prong twistlock type male receptacle for the cord connecting the machine to the power supply.

(g) The foot controller cord is a two-conductor cable, 6 feet long. One end is terminated in a two-prong twistlock type male plug. The foot controller at the other end of the cable essentially is a foot-operated rheostat.

(h) The attachment cord is a three-conductor cable, 10 feet long. One end is terminated in a three-contact female plug. The other end is terminated in a two-prong male plug which has a single loose lead provided with an alligator clip for grounding the third conductor in the cable.

(3) A detailed description of Film Examining Machine PH-179 will be found in TM 11-2388 (when published).

e. REELS. Six empty reels are the means provided with Film Viewer PH-97- (*) for containing the film on the spindles of the reel brackets of Film Examining Machine PH-179. The film capacity of each reel is 400 feet.

f. VIEWING ATTACHMENT PH-98- (*). (1) Viewing Attachment PH-98- (*) is the means provided with Film Viewer PH-97- (*) for pre-

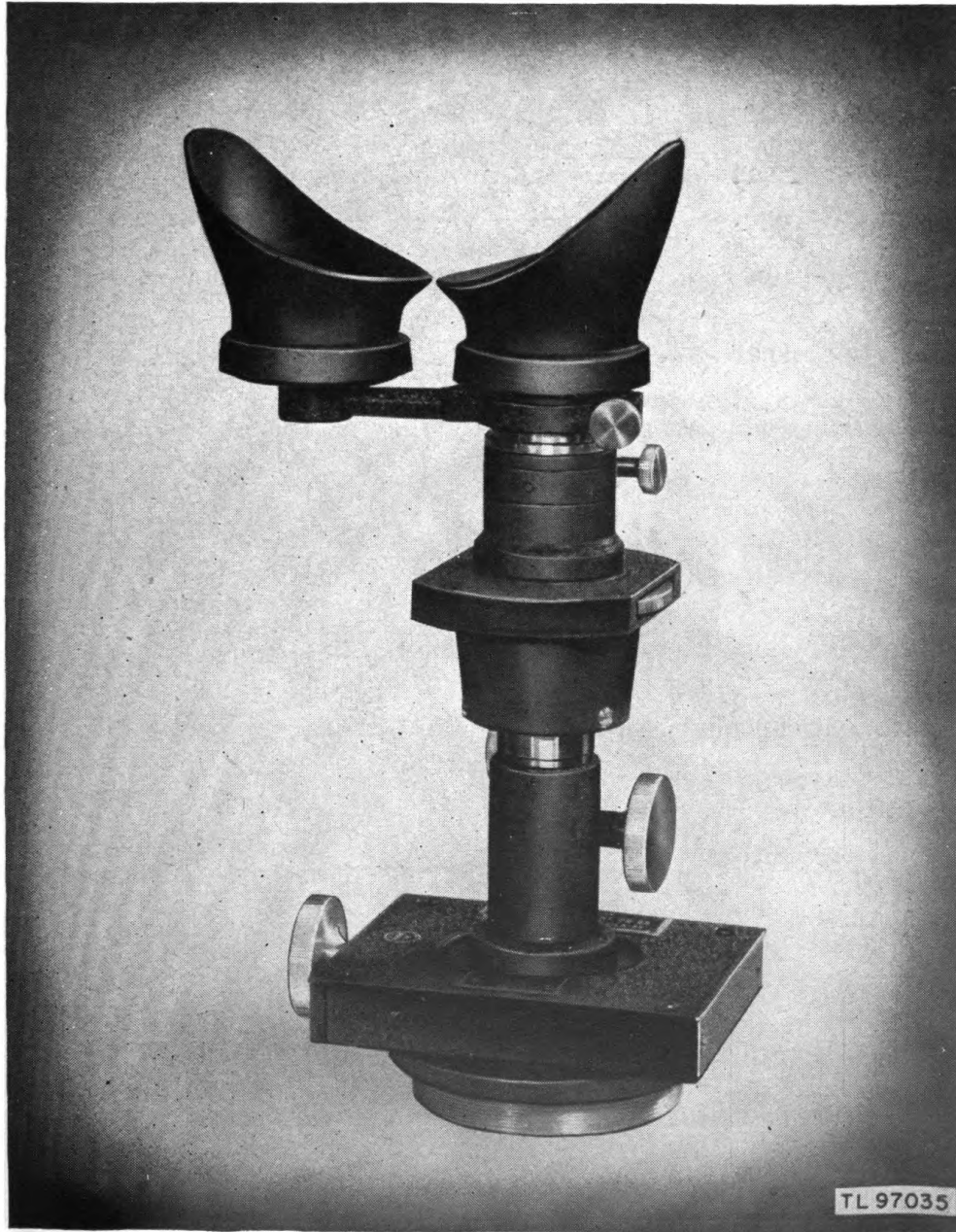

Figure 51. Viewing Attachment PH-98-().*

cise examination of each frame of film run through Film Examining Machine PH-179.

(2) There are five models of Viewing Attachment PH-98-(*): Viewing Attachments PH-98, PH-98-A, PH-98-B, PH-98-C, and PH-98-D.

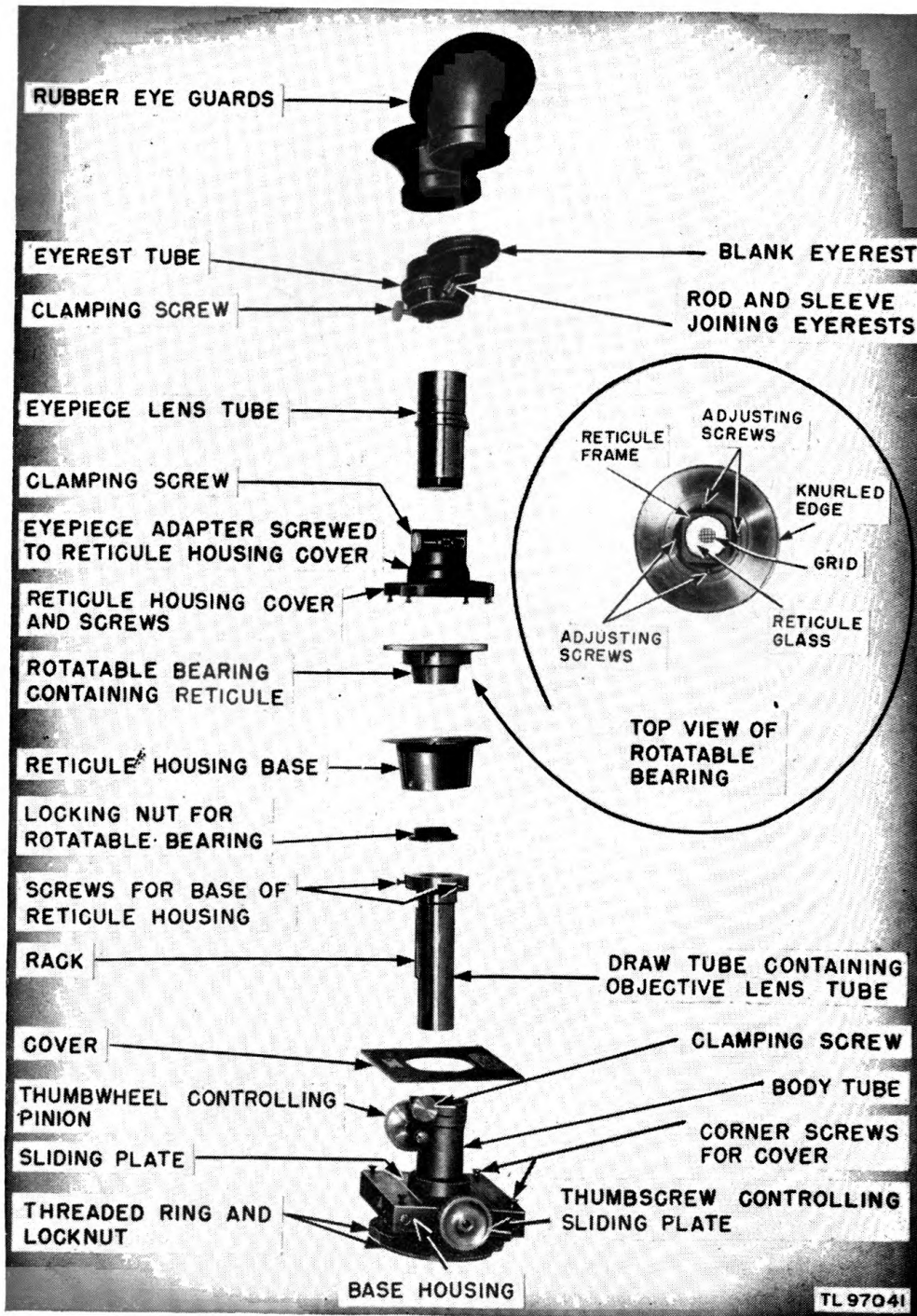

Figure 52. Viewing Attachment PH-98-(*), exploded view of construction.

All models are essentially the same, differing in suffix letter designation because of their use with different models of Film Viewer PH-97-(*), (a(2) above).

(3) Essentially, Viewing Attachment PH-98-(*) is a compound microscope with a fixed over-all magnification of three diameters and a field of view on the film of 33 millimeters. It consists of a *base assembly*, an *objective lens assembly*, a *reticule assembly*, an *eyepiece assembly*, and an *eyerest assembly*. (See fig. 52.)

(a) The *base assembly* consists of a base housing and cover, and a sliding plate and body tube.

1. The base housing is a heavy metal rectangular body with a large circular opening through the center. The under side is provided with a threaded ring and locknut for screwing into the hinged mounting ring on the film gate of Film Examining Machine PH-179 (d(2) above).
2. The sliding plate has a smaller circular opening over which the upright body tube is mounted. The plate is contained within the base housing, which is provided with a cover fastened by four corner screws. The cover has an oblong opening in the center through which the body tube extends. The base housing is provided with a knurled thumbscrew at one side to move the sliding plate perpendicular to the edge of the film.
3. The inside of the upright body tube is provided with a longitudinal groove and with a pinion controlled by a large knurled thumbwheel on the outside of the tube. The top of the body tube is partially split and fitted with a smaller knurled-head clamping screw and a locking screw and slotted nut.

(b) The *objective lens assembly* consists of a lens tube and a draw tube.

1. The draw tube is fitted into the body tube of the base assembly. The outside of the draw tube is provided with a rack which fits the groove and engages the pinion in the body tube.
2. The objective lens is mounted in the lower end of a tube which is fitted inside the draw tube. The lens tube is held in position by a small, recessed-head setscrew in the flange at the top end of the draw tube. A light diaphragm for the objective lens is fitted in the lower end of the draw tube.

(c) The *reticule assembly* consists of a two-piece housing, a rotatable bearing, and a reticule.

1. The housing base is a cone-shaped hollow casting with a wide flange at the upper end. The inside surface is

machined to provide a bearing surface for the rotatable bearing. The lower end of the housing base fits on the flange at the top of the draw tube ((b) above), and is fastened by three screws.

2. The rotatable bearing is hollow and the outside is tapered and machined to fit inside the housing base. The top is provided with a large ring having a knurled edge. The inside of the lower end of the bearing is threaded and is provided with a locking nut which secures it in the housing base but permits rotation.
3. The reticule is a piece of glass with plane surfaces. A graduated circular grid with cross ruling is engraved in the center of one of the plane surfaces, and the glass is mounted in a special circular frame (inset, fig. 52). The reticule frame is mounted in the upper end of the rotatable bearing, and is centered and held in place by four screws through the side of the rotatable bearing. The four screws can be lined up with four holes in the housing base for adjustment purposes.
4. The housing cover is shaped like the top flange of the housing base, and has an opening in the center. It fits over the large knurled ring of the rotatable bearing and fastens to the housing base by four corner screws. Opposite sides of both the cover and the base flange are straight to permit the knurled ring to extend enough to handle for rotating the reticule. A threaded ring is provided around the opening on the top surface of the housing cover.

(d) The *eyepiece assembly* consists of an adapter and a lens tube.

1. The adapter is a short tubular piece which screws on the threaded ring around the opening in the cover of the reticule assembly. The side of the adapter tube is partially split near the top, and is provided with a clamping ring controlled by a knurled thumbscrew.
2. The lens tube slides inside the adapter tube. The assembly of lenses forming the eyepiece are mounted in the lens tube.

(e) The *eyerest assembly* is two eyerests joined by a rod and provided with rubber eyeguards.

1. One of the eyerests is a short tube which fits on the eyepiece lens tube. The lower end of the eyerest tube is partially split and is provided with a clamping knurled thumbscrew. A short rod extending to the side is screwed into the lower end of the tube opposite the clamping screw.
2. The other eyerest is a blank, and is provided with a sleeve extending to the side. The sleeve slides over the rod ex-

tending from the other eyerest, and is fastened by a pin through a slot in the sleeve which permits the distance between the eyerests to be adjusted to suit the user's eyes.

g. CASE CS-77-(*) (fig. 53). (1) Case CS-77-(*) is the means provided with Film Viewer PH-97-(*) for safe storage of the other components.

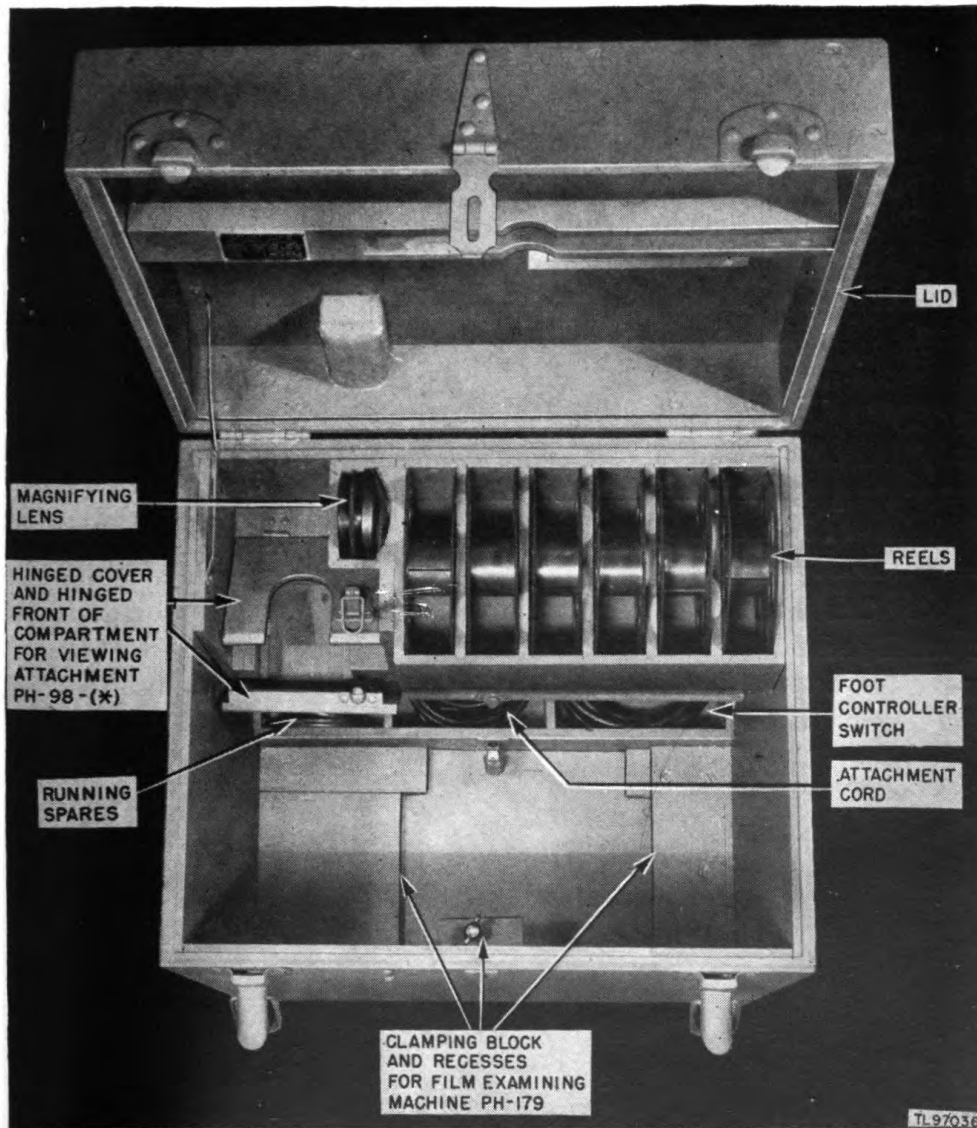

Figure 53. Case CS-77-(*) of Film Viewer PH-97-(*).

(2) There are five models of Case CS-77-(*): Cases CS-77, CS-77-A, CS-77-B, CS-77-C, and CS-77-D. All models are essentially the same, differing in suffix letter designation because of their use with different models of Film Viewer PH-97-(*) (a(2) above).

(3) Case CS-77-(*) is wooden and has a hinged lid which is equipped with trunk catches and a hasp and staple with padlock.

(4) The inside of Case CS-77-(*) is partitioned and provided with special means for securing Film Examining Machine PH-179 and Viewing Attachment PH-98-(*).

(a) The floor of the case is provided with wooden blocks to form a recess for the base of Film Examining Machine PH-179, and has an elevated block and screw with a clamping nut to hold the machine in place.

(b) The floor of the case also is provided with a partitioned compartment which has a hinged lid with a trunk catch. This compartment provides space for the cords and the running spares of Film Examining Machine PH-179.

(c) An open compartment partitioned to hold the six reels, a small cloth-padded compartment shaped to hold the magnifying lens of Film Examining Machine PH-179, and a special compartment to hold Viewing Attachment PH-98-(*), are provided along the back inside wall near the top of the case.

(d) The special compartment for Viewing Attachment PH-98-(*) is provided with a hinged front and a hinged cover. The inside of the compartment is recessed and the cover is notched, and both are padded, to hold the base of the viewing attachment. A trunk catch fastens the hinged front and cover closed to secure the viewing attachment in place.

(e) The inside of the hinged lid of Case CS-77-(*) is provided with a small padded block to hold the magnifying lens down in its compartment and a large block which fits the top of Film Examining Machine PH-179 when the lid is closed.

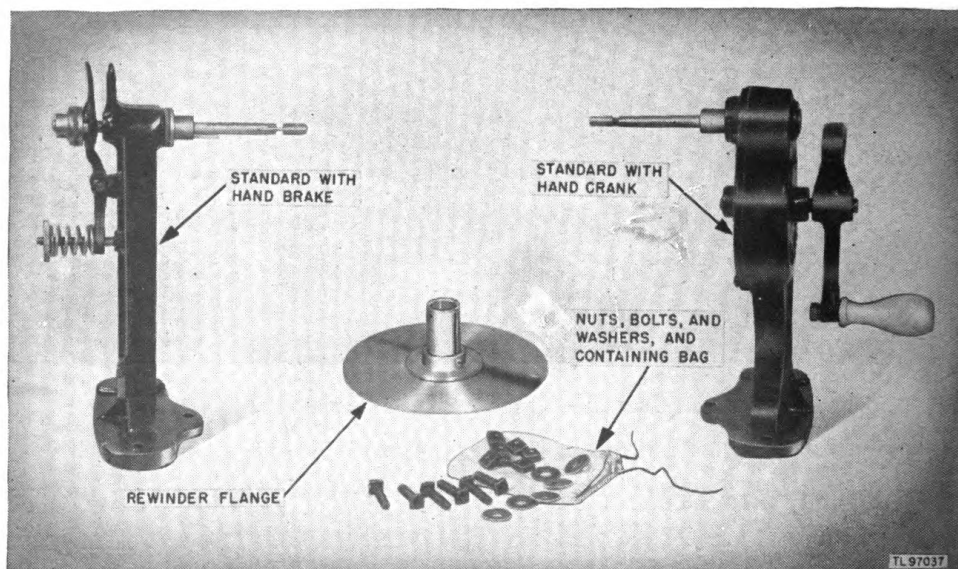

Figure 54. Rewinder PH-92.

138. Rewinder PH-92 (fig. 54)

a. GENERAL. Rewinder PH-92 is a portable assembly of equipment designed for manual rewinding of motion-picture film from one reel to another. It includes two reel-holding standards with separate bolts, nuts, and washers for mounting the standards on a support, and a special rewinding flange from which the roll of film can be removed readily.

b. APPLICATION. Rewinder PH-92 is used for the purpose of winding dry film from Drying Rack PH-42 (par. 101) into a roll for storage or onto one of the reels of Film Viewer PH-97-(*) (par. 137).

c. COMPONENTS. Rewinder PH-92 consists of the following major components:

- 2 standards.
- 1 rewinding flange.
- 1 bag containing—
 - 6 bolts.
 - 6 nuts.
 - 6 washers.

d. STANDARDS. The two standards of Rewinder PH-92 are metal castings, each having a flat base provided with mounting holes. The upper end of each standard is provided with a bearing carrying a reel-holding shaft which has a locking key and a pivoted tip. The reel-holder shaft of one standard is geared to a counterbalanced hand crank, and the shaft of the other standard is provided with a hand brake.

(1) The hand crank of the one standard is pinned on the outside end of a sliding shaft mounted in the center of a gear housing. A large spur gear is mounted on this shaft inside the housing. The end of the reel-holder shaft inside the housing is provided with a pinion gear with which the spur gear can be made to mesh by sliding the crank handle shaft. The gear housing is provided with a cover fastened on by screws.

(2) The hand brake of the other standard consists of a metal disk and leather washer fitted on the reel-holder shaft on one side of the standard; and a lever, and two metal disks separated by a leather washer, fitted on the shaft on the other side of the standard. A bolt fitted into the side of the standard extends through a hole in the lower end of the lever and is provided with a coil spring and thumbnut to adjust the braking tension. The top of the standard is provided with an extension which matches the top of the lever to provide finger control of the brake.

e. REWINDING FLANGE. The rewinding flange to Rewinder PH-92 consists of two parts: a hub and a disk.

(1) The hub is a metal cylinder, with its center hole grooved to fit the key on the reel-holding shaft of either standard (*d* above). The outside surface of the hub is provided with a groove, a threaded hole, and a slit, the latter to receive the end of a length of film.

(2) The disk also is metal, and has a center opening which fits over the hub. The opening is provided with a setscrew which holds the disk on the hub, either by the screw fitting into the groove in the hub and thus permitting the disk to slide from side to side, or by screwing into the threaded hole in the hub and thus fastening the disk stationary at one side.

139. Splicer PH-91-(*) (figs. 55, 56, and 57)

a. GENERAL. (1) Splicer PH-91-(*) is equipment designed for splicing 35-mm motion-picture film.

(2) There are two models of Splicer PH-91-(*) : Splicer PH-91 and Splicer PH-91-A. The weight and dimensions of each model are as follows:

Model	Dimensions (inches)			Volume	Weight
	Length	Width	Height	(cu ft)	(lb)
Splicer PH-91	8.25	5	3.25	.08	6
Splicer PH-91-A	8.25	5.5	3.75	.1	8

(3) Splicers PH-91 and PH-91-A each include a frame containing facilities for holding, cutting, and splicing film; and a felt pad for moistening, and a scraper for removing, the film emulsion preparatory to splicing. In addition, the frame of Splicer PH-91-A includes a lamp and switch, and space for batteries, for illumination; and a bottle and applicator for film cement.

b. APPLICATION. The function of Splicer PH-91-(*) is to cut and splice film for use in Film Viewer PH-97-(*) (par. 137).

c. COMPONENTS. (1) *Splicer PH-91*. The major components of Splicer PH-91 are:

- 1 frame.
- 1 scraper.
- 1 felt pad.
- Spare scraper blades.

(2) *Splicer PH-91-A*. The major components of Splicer PH-91-A are:

- 1 frame.
- 1 bottle and applicator.
- 1 scraper.
- 1 felt pad.
- Spare scraper blades.

d. FRAME. The frame of Splicer PH-91 and of Splicer PH-91-A (figs. 55 and 56) consists essentially of a base on which two hinged sets

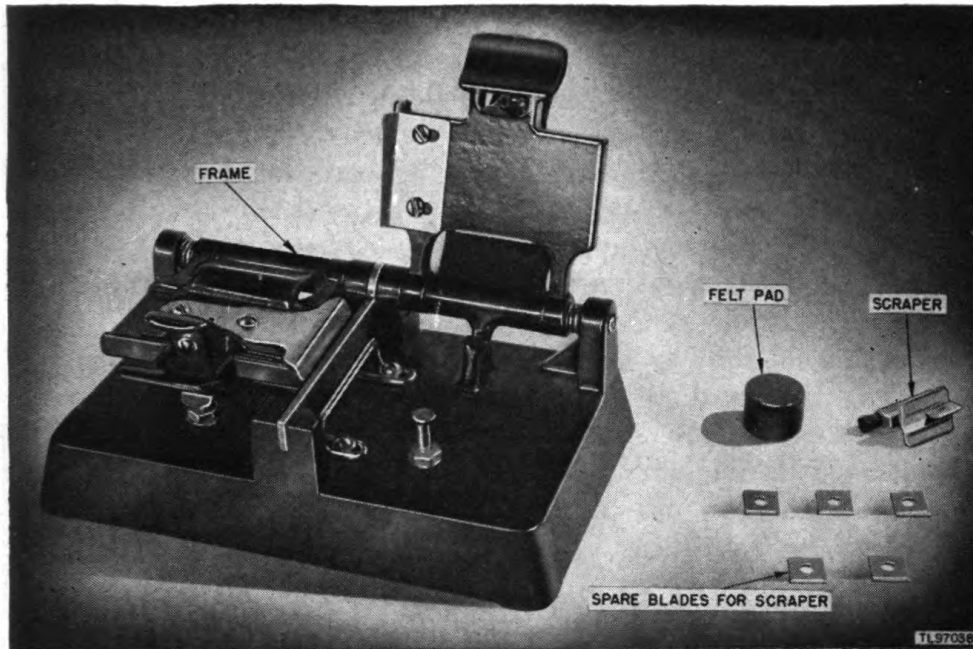

Figure 55. Splicer PH-91.

of arms and a stationary shearing bar are mounted. The frame of Splicer PH-91-A is additionally equipped with a built-in flashlight and contains a bottle and applicator for film cement.

(1) The base is constructed of heavy cast metal with three short standards spaced along the back edge and a single short standard

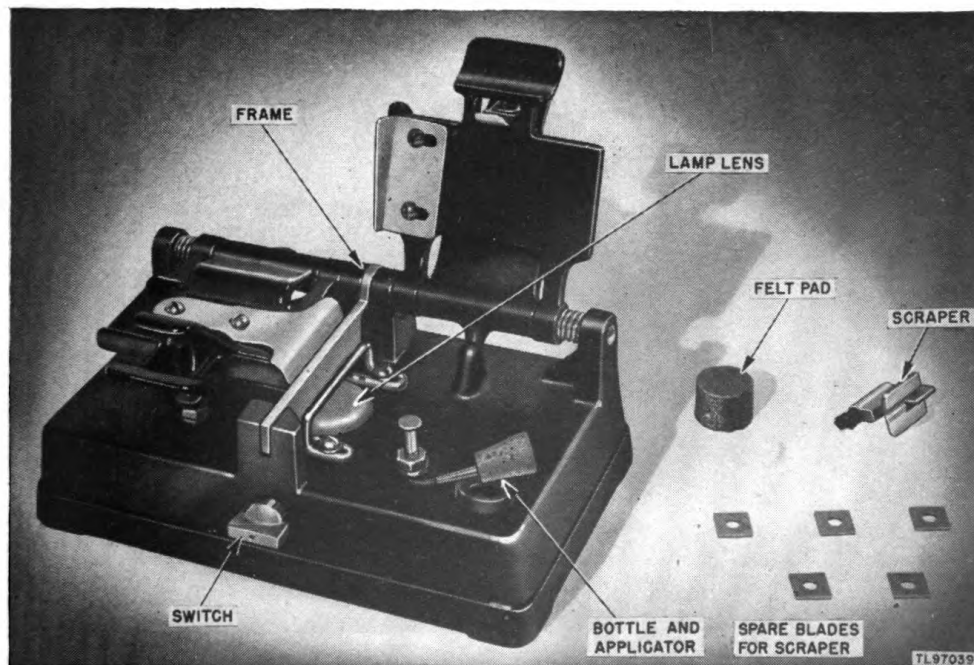

Figure 56. Splicer PH-91-A.

located at the middle of the front edge. The hinge rod for the arms is supported by the three back standards, and the shear bar is supported between the middle back standard and the front standard. Two latch pins and a scraper guide also are mounted on the base.

(2) The two sets of arms are located one on each side of the shear bar. Each set consists of two hinged jaws, one above the other. The upper jaw of each set is equipped with a latch spring assembly which engages the lower jaw so that the pair of jaws can be latched together when required. The same latch assembly also engages one of the latch pins on the base to hold the set of arms in the lowered position. The top side of the lower jaw of each set is indented the width of 35-mm film and is provided with pins to engage the film perforations. The under side of the lower jaw of each set is equipped with a shearing blade which contacts one of the cutting edges of the shearing bar mounted on the base. The top side of the upper jaw of the right-hand set of arms is equipped with two pressure plates which are bent down to contact the top surface of the shearing bar on the base. The upper jaw of the left-hand set of arms is equipped with a similar plate which acts as a cement guard.

(3) The additional equipment of the frame of Splicer PH-91-A (figs. 56 and 57) consists of the following, which are contained in the base:

(a) An assembly of a reflector, a lamp, and a frosted glass lens which shows through an opening in the top surface of the base immediately below the shearing blade.

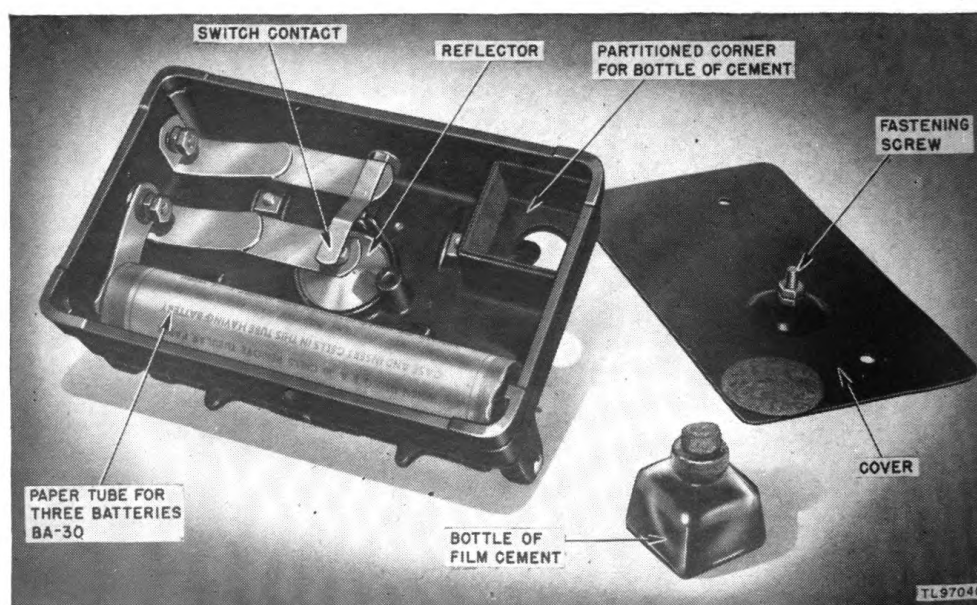

Figure 57. Splicer PH-91-A, bottom view, with cover and bottle of film cement removed.

(b) A switching arrangement with a knob extending through an opening in the middle of the front side of the base.

(c) A long paper tube located between two contacts. The tube is for insertion of three Batteries BA-30 for the lighting circuit.

(d) A partitioned corner provided with felt cushioning and a bottle with applicator which extends through an opening in the front right-hand corner of the top surface of the base.

(e) A bottom cover which holds the battery tube and the bottle in place in the base. The cover is fastened by a single screw.

e. **SCRAPER.** The scraper of Splicer PH-91 and PH-91-A consists of a small metal fitting equipped with a brush and provided with a slot and clamping screw which hold a special blade.

140. Film Cement

a. The film cement supplied is suitable for splicing the nitrate film used in a phototheodolite camera.

b. The cement is supplied either in 2-ounce quantities in cans, or in 4-ounce quantities in bottles.

Section II. INSTALLATION AND ASSEMBLY OF FILM VIEWING COMPONENTS

141. Location (fig. 48)

An indoor location with 110-volt, a-c or d-c electric power available is required for installation of the film viewing components. A table or other firm, level surface, and a stool are necessary for the convenient use of the film viewer, and additional table space is needed for mounting the film rewinder and film splicer.

142. Film Viewer PH-97-(*)

a. **UNPACKING AND ASSEMBLING FILM EXAMINING MACHINE PH-179.**

(1) Place Carrying Case CS-77-(*) near the table or other firm level surface on which the film examining machine will be mounted.

(2) Open the carrying case and remove Film Examining Machine PH-179 as follows:

(a) Loosen the clamping nut of the elevated clamping block and screw at the lower front inside the case.

(b) Raise the clamping block and turn it away from the film examining machine so that the length of the block is parallel with the front side of the case.

(c) Grasp the reel bracket of the film examining machine (fig. 58) and tilt the machine toward the right and then slide it to the left to

release it from the recesses provided on the floor of the case, and then lift the machine straight up and out of the case. Place the machine on the firm, level surface selected for its use.

(3) Open the compartment provided on the floor along the back of the case. Remove the attachment cord and the foot-controller switch (fig. 53) and connect them to the film examining machine as follows:

(a) Insert the plug of the foot-controller switch cord into the upper receptacle at the left front corner of the machine, and twist the plug clockwise to lock it in place. Lay the foot-controller switch on the floor.

(b) Attach the alligator clip of the loose lead from the two-prong plug of the attachment cord to grounded conduit, a water pipe, or any suitable grounded object in the vicinity of the available 110-volt outlet. Then insert the two-prong plug into the outlet. Check that the MOTOR trigger switch on the machine is thrown to OFF, and then insert the three-contact female plug at the other end of the attachment cord into the lower receptacle at the left front corner of the machine. Twist the plug clockwise to lock it in place. Set the hand rheostat on the left side of the machine to a point midway in its range.

b. UNPACKING AND INSTALLING VIEWING ATTACHMENT PH-98-(*).

(1) Unfasten the trunk catch of the compartment holding the viewing attachment. Swing the hinged front all the way down, and swing the hinged cover up enough to permit the removal of the attachment.

(2) Grasp the base of the attachment firmly and carefully pull it out of the compartment. *Do not handle the attachment by the eyerest assembly at the top.*

(3) Screw the base of the viewing attachment three or four turns into the threaded hinged mounting ring on the film gate of the film examining machine. Position the attachment so that the large thumb-screw on its base is toward the left side of the film examining machine. Then tighten the large locking nut on the threaded portion of the base to lock the attachment in position on the machine.

143. Installing Rewinder PH-92

a. Mount the two standards of Rewinder PH-92 (fig. 48) to the top of a table, desk, or to a separate board of suitable thickness, using the bolts, washers, and nuts supplied with the equipment. Observe the following specifications:

(1) Mount the standards 3 to 4 feet apart so that one operator simultaneously can operate both the crank on one standard and the hand brake on the other.

(2) Align the standards carefully so that the film will wind smoothly from one to the other.

(3) Mount each standard with its crank or brake side toward the using edge of the table or whatever surface the equipment will be used.

b. Put the rewinding flange on the reel-holding shaft of one of the standards.

144. Installing Splicer PH-91-(*)

Normally, Splicer PH-91-(*) is used between the two standards of Rewinder PH-92 (par. 143), so that film to be cut and spliced can be handled conveniently from reels mounted on the rewinder. Splicer PH-91 does not require any assembly or special preparation for use. Proceed as follows to prepare Splicer PH-91-A:

a. Loosen the cover screw on the bottom of the splicer and remove the cover.

b. Remove the paper tube and insert three Batteries BA-30 in it. Replace the tube between the contacts provided.

c. Remove the bottle and fill it with film cement.

d. Replace the bottle and then the bottom cover of the splicer, fastening the cover in place with the screw provided.

145. Repacking Film Viewing Components

a. FILM VIEWER PH-97-(*).

(1) Replace empty reels in the compartment provided in Case CS-77-(*).

(2) Loosen the locknut on the threaded portion of the base of Viewing Attachment PH-98-(*). Carefully unscrew the attachment from the film examining machine and replace it in the special compartment in Case CS-77-(*) as follows:

(a) Check that the hinged front of the compartment is swung all the way down.

(b) Grasp the viewing attachment by its base, on the side opposite the large thumbwheel. Carefully slide the attachment, thumbwheel first, all the way into the recesses provided in the compartment.

(c) Swing the hinged front of the compartment up into place, and lower the hinged cover. Interlock the front and the cover with the trunk catch provided.

(3) Disconnect the attachment cord and the foot controller switch cord from the film examining machine. Each must be twisted counterclockwise to unlock it from the machine. Unplug the other end of the attachment cord from the power outlet, and disconnect the alligator clip at that end. Coil each cord and place it in one of the sections of the compartment provided on the floor of Case CS-77-(*). The foot-controller switch fits the larger section. Close the lid of the compartment and fasten the trunk catch.

(4) Replace Film Examining Machine PH-179 in Case CS-77- (*) as follows:

(a) Check that the elevated clamping block at the lower front inside the case is turned with its length parallel to the front of the case.

(b) Stand at the left side of the machine (the side with the receptacles for the connecting cords). Grasp the film examining machine by the reel bracket (fig. 58) to lift it, and carefully lower it into the case. Tip the machine so that its lower front edge fits under the recess provided at the right side of the floor of the case. Then lower the rear edge of the machine all the way to fit in the recess provided at the left side of the floor of the case.

(c) Lift and turn the clamping block until it rests on the flat surface of the frame of the machine, and then tighten the clamping nut to hold the machine securely in place.

b. **REWINDER PH-92.** Remove the bolts, nuts, and washers which hold the two standards to the table or board on which they are used. Put the bolts, nuts, and washers in a bag or other container in which they can be kept together with the two standards and the rewinding flange which constitute Rewinder PH-92.

c. **SPLICER PH-91-(*).** (1) Put the felt pad and the scraper with its spare blades in a bag or container in which they can be kept together with the splicer.

(2) If Splicer PH-91-A is not to be used for some time, proceed as follows:

(a) Remove the bottom cover of the splicer.

(b) Remove the bottle and empty it of film cement. Clean the applicator brush before replacing it in the bottle.

(c) Remove the paper tube containing Batteries BA-30 and remove the batteries. Replace the tube.

(d) Replace the bottom cover of the splicer.

(3) Keep the spare cans of film cement with Splicer PH-91-(*).

d. **VOLUMES AND WEIGHTS.**

Component	Volume (cu ft)	Weight (lb)
Film Viewer PH-97-() in Case CS-77-(*).	3.5 to 5.5	100 to 125
Rewinder PH-925	10
**Splicer PH-91-(*).08 to .1	6 to 8

* Paragraph 137a(2).

** Paragraph 139a(2).

PART TWO

OPERATING INSTRUCTIONS FOR FILM VIEWING COMPONENTS

Section III. TECHNICAL OPERATION

146. Operating Rewinder PH-92

Rewinder PH-92 is used to wind film on to a reel suitable for use in Film Viewer PH-97-(*) (par. 148), and to unwind film from a reel to a roll suitable for storage in a can.

a. FROM DRYING RACK PH-42 TO A ROLL. Proceed as follows to use Rewinder PH-92 to wind dried film from Drying Rack PH-42 (par. 116*h*) into a roll for storage:

- (1) Put the rewinding flange on the reel-holding shaft of the hand-crank standard of the rewinder.
- (2) Select the leading end (lowest time counter numbers) of the film on the drying rack and insert it into the slot on the hub of the rewinding flange.
- (3) Turn the crank of the rewinder to wind the film so that the emulsion (dull) side is toward the *inside* of the roll, and wind all the film from the drying rack.
- (4) Remove the rewinding flange and slide the roll of film from the hub of the flange.
- (5) Place the roll in a can, properly labeled, for storage.

b. FROM DRYING RACK PH-42 TO REEL. Proceed as follows to use Rewinder PH-92 to wind the dried film from Drying Rack PH-42 (par. 116*h*) on to a reel for viewing in Film Viewer PH-97-(*) :

- (1) Put one of the empty reels provided with Film Viewer PH-97-(*) on the reel-holding shaft of the hand-crank standard of the rewinder.
- (2) Select the trailing end (highest time counter numbers) of the film on the drying rack and insert it into the slot in the hub of the reel.
- (3) Turn the crank of the rewinder to wind the film so that the emulsion (dull) side is toward the *inside* of the reel, and wind all the film from the drying rack.
- (4) Remove the reel of film, which now is ready for use on the film viewer (par. 148).

c. **FROM ROLL TO REEL.** Proceed as follows to use Rewinder PH-92 to wind film from a storage roll onto a reel for use in Film Viewer PH-97-(*):

(1) Check to see that the trailing end (highest time counter numbers) is on the outside of the roll. If not, the roll must be rewound to meet this requirement.

(2) Put the roll directly on the reel-holding shaft, or on the hub of the rewinding flange if possible, of the hand-brake standard of the rewinder.

(3) Put one of the empty reels provided with Film Viewer PH-97-(*) on the reel-holding shaft of the hand-crank standard of the rewinder.

(4) Insert the trailing end of the film into the slot in the hub of the reel.

(5) Turn the rewinder crank to wind the film so that the emulsion (dull) side is toward the *inside* of the reel, and wind all the film onto the reel.

(6) Remove the reel, which now is ready for use in the film viewer.

d. **FROM REEL TO ROLL.** Proceed as follows to use Rewinder PH-92 to wind film from a reel into a roll for storage:

(1) Check to see that the leading end (lowest time counter numbers) is on the outside end of the reel. If not, the reel must be rewound to meet this requirement.

(2) Put the rewinding flange on the reel-holding shaft of the hand-crank standard of the rewinder.

(3) Put the reel of film on the reel-holding shaft of the hand-crank standard of the rewinder.

(4) Insert the leading end into the slot in the hub of the rewinding flange.

(5) Turn the rewinder crank to wind the film so that the emulsion (dull) side is toward the *inside* of the roll, and wind all the film from the reel.

(6) Remove the rewinding flange and slide the roll of film from the hub of the flange.

(7) Place the roll in a can, properly labeled, for storage.

147. Operating Splicer PH-91-(*)

While facing the front (the nameplate side) of Splicer PH-91-(*), proceed as follows to use the slicer to cut and splice film:

a. Swing *both* jaws of the left set of arms back against its stop.

b. Swing the *upper* jaw of the right set of arms up and back against its stop, leaving the lower jaw down in place.

c. Place the film emulsion (dull) side up in the track of the lower jaw of the right set of arms, fitting the film perforations over the track

pins so that the dividing line between film frames is over the center of the stationary shearing bar. Clamp the upper jaw down on the film.

d. Bring the left set of arms down, cutting the film in the right set of arms with the shearing blade. Raise the right set of arms which hold the cut film.

e. Swing the upper jaw of the left set of arms back against the stop. Place the opposite end of the film to be spliced emulsion (dull) side up in the track, fitting the film perforations over the track pins so that the dividing line between the film frames is over the center of the stationary shearing bar. Clamp the upper left jaw down on the film.

f. Bring the right set of arms down, cutting the film in the left set of arms with the shearing blade. Swing the right set of arms back against its stop.

g. Use the felt pad to moisten the section of film which extends from the left set of arms. The moistening process is not absolutely necessary but is recommended, especially for old film.

h. Place the notch of the scraper on the scraper guide which is on the right side of the shearing bar. Start from the center and scrape the emulsion from the film toward each edge. *Incline the scraper in the direction of travel and be careful not to bear too hard on the film.* Use the brush on the scraper to remove any particles of emulsion after scraping.

i. To avoid getting cement on the shearing bar, raise the left set of arms so that the film is about $\frac{1}{4}$ inch above the shearing bar. Apply cement with one stroke of the brush and swing the left set of arms back down in position. Immediately swing the right set of arms, carrying the opposite end of film, all the way down in position so that its end of film is pressed against the cemented end.

j. Allow a few minutes for the cement to set. Raise the upper jaws of both right and left sets of arms and wipe off the surplus cement from the film with a dry cloth. The film now is spliced.

Note. Thin cement does not give as satisfactory results as cement having a little body. If splices fail to hold, try thickening the cement by dissolving a small quantity of celluloid film in the cement to give it the desired consistency.

148. Operating Film Viewer PH-97-(*)

a. **THREADING FILM** (fig. 58). A reel of film properly prepared for threading in Film Viewer PH-97-(*) will be wound emulsion (dull) side toward the inside of the reel and the leading end (lowest time counter numbers) on the outside of the reel (par. 146b and c). Proceed as follows:

(1) Place the reel on the upper spindle of Film Viewer PH-97-(*) so that the film feeds off the top of the reel and toward the front of the

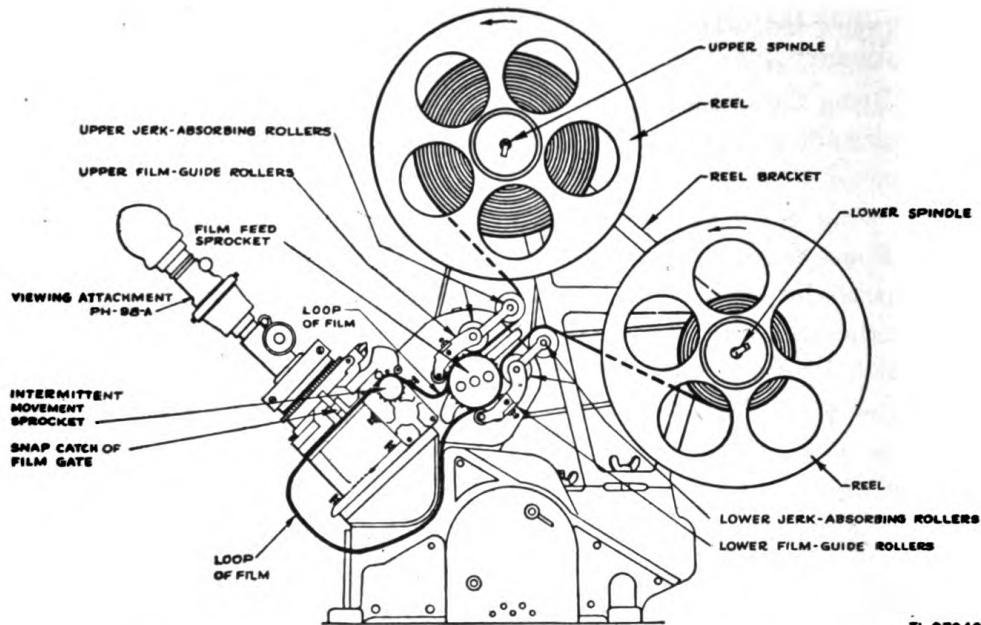

Figure 58. Threading the film in Film Viewer PH-97-(*).

viewer. Fit the keyway of the reel over the key on the spindle and bend the pivoted tip of the spindle to hold the reel in place.

(2) Place an empty reel on the lower spindle and lock it on in the same manner as described in (1) above.

(3) Throw the MOTOR toggle switch on the control panel to BACKW'D.

(4) Open the upper and lower film guide rollers (which contact the film feed sprocket) by pulling up on the handle of the upper film guide roller and pressing down on the handle of the lower film guide roller.

(5) Open the film gate by depressing the snap catch which allows the gate to swing over to the left.

(6) Unwind about 2 feet of film from the upper reel. Work from the right side of the machine and thread the film as follows:

(a) Slide the film under the upper jerk-absorbing rollers, between the film feed sprocket and the opened upper film guide rollers and into the track below the opened film gate.

(b) Engage the film perforations on the teeth of the film feed sprocket and then close the upper film guide rollers.

(c) Put a small loop of film between the film feed sprocket and the intermittent movement sprocket as shown in figure 58. Then engage the teeth of the intermittent movement sprocket on the film perforations and close the film gate, taking care that the film lies straight in the track.

(7) Operate the viewer by hand (using the smooth handwheel on the left-hand side) to make sure that the loop between the film feed sprocket

and the intermittent movement sprocket is large enough so that the film does not pull tight between the two sprockets.

(8) Check that the MOTOR toggle switch is thrown to BACKW'D, then operate the viewer by pressing the foot controller switch until a free end of about 3 feet of film is obtained. Then proceed as follows:

(a) Loop the film back and slide it into the slot in the right side of the machine, between the film feed sprocket and the opened lower film guide rollers, and over the lower jerk-absorbing rollers.

(b) Leave a sizable loop (fig. 58) below the film gate and then engage the film perforations on the teeth of the film feed sprocket and close the lower film guide rollers.

(9) Feed the end of the film under the lower reel and insert it into the slot in the reel hub. Wind up the slack film by turning the lower reel by hand.

b. ADJUSTING OPTICAL SYSTEM (fig. 52). (1) Throw the LIGHT toggle switch to ON. This turns on the light below the film gate to illuminate the film.

(2) Loosen the eyerest clamping screw on the viewing attachment and adjust the eyerest as follows:

(a) Turn the eyerest for observing with either the right or the left eye.

(b) Move the blank eyerest sideways to adjust the distance between the eyerests for convenient observing.

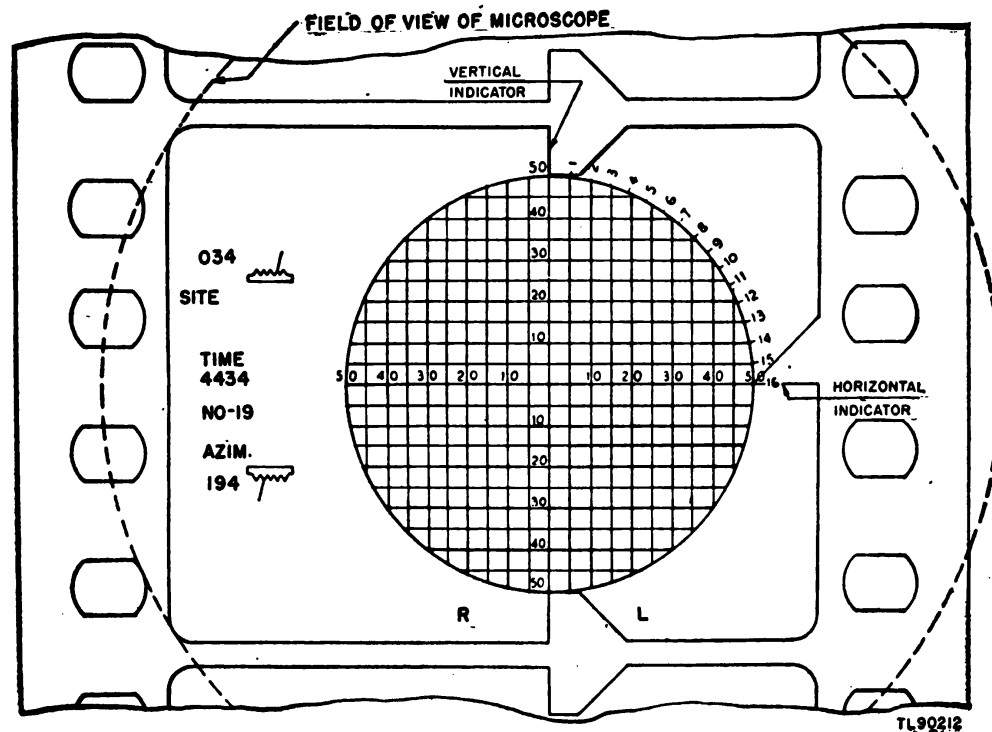

Figure 59. Single frame of film showing reticule image.

(c) Slide the eyerest on the eyepiece lens tube to the lower position for operators wearing glasses; for others use the upper position.

(d) Tighten the eyerest clamping screw.

(3) Loosen the eyepiece clamping screw on the eyepiece adapter and, while looking into the eyepiece, shift the lens tube until the grid engraved on the reticule is focused clearly. Tighten the clamping screw, but do not use force.

(4) Check that the MOTOR toggle switch of the film examining machine is thrown to BACKW'D, and then use the foot-controller switch to operate the machine until a frame of film with the vertical and horizontal indicator marks comes into the field of view of the viewing attachment.

(5) Turn the film examining machine by hand (using the smooth handwheel on the left side) to a position where slight back-and-forth movement of the handwheel does not move the film.

(6) Loosen the clamping screw at the top of the body tube of the viewing attachment and use the large thumbwheel on the side of the body tube to focus the objective lens on the film.

(7) Align the grid with the indicator shadow on the film, as follows (fig. 59):

(a) Use the knurled edge of the reticule ring to turn the grid until the numbers on the horizontal and vertical center lines are viewed in the upright position.

(b) Use the framing lever on the top of the film gate to align the horizontal indicator shadow on the film with the center horizontal line on the grid.

(c) Use the knurled thumbscrew on the side of the base housing to align the vertical indicator shadows on the film with the vertical center line on the grid.

c. **READING THE FILM.** The detailed method of obtaining data from the film observed in Film Viewer PH-97-(*) will be prescribed by the using arm. The following is pertinent supplementary information:

(1) *Appearance of bursts on film.* Gun bursts will appear on the film either as a light spot on a dark background or as a dark spot on a light background.

(2) *Elevation and azimuth readings.* The elevation (site) and azimuth (azim) readings on the film each are composed of three digits and a saw-tooth scale with a line touching it (fig. 59):

(a) The three digits indicate, from left to right, thousands hundreds, and tens.

(b) The point where the line touches the saw-tooth scale indicates units, as follows:

1. The crests of the saw-teeth represent, from left to right, 1, 3, 5, 7, and 9.

2. The troughs of the saw-teeth represent, from left to right, 2, 4, 6, 8, and 0.
3. When the line touches the slope of a tooth instead of the crest or the trough, the correct fractional unit reading is obtained by judging where the line would touch an imaginary line joining all the crests of the teeth, and then dropping an imaginary perpendicular line to the slope below and judging what fraction of the slope it includes.

(c) The readings of the SITE and AZIM indications in figure 59 are: SITE, 347 mils; AZIM, 1943 mils.

(3) *Reticule markings.*

(a) The reticules of some Film Viewers PH-97-(*), but not all of them, are provided with the letters R and L at the bottom to indicate reel right and left which are reversed on the film because of the mirror or prism in the phototheodolite camera optical system. *Remember this reversal of right and left when reading the film.*

(b) The equivalent distance in mils between parallel grid lines of the reticule vary with the model of phototheodolite in which the film being viewed was exposed, as follows:

1. The camera of Theodolite PH-BC-33 has a field of view of 100 mils, and when viewing film from this phototheodolite the reticule grid lines will be 5 mils apart.
2. The cameras of Theodolites PH-BD-33, PH-BE-33, PH-BF-33, PH-BG-33, PH-BH-33, and MX-194/TVQ-1, have a field of view of 50 mils, and when viewing film from any of these phototheodolites the reticule grid lines will be 2.5 mils apart.

d. REWINDING FILM FROM LOWER REEL. When a reel of film has been run through Film Viewer PH-97-(*) and is wound all on the lower reel, the trailing end (highest time counter numbers) will be on the outside of the reel. To get it into a roll for storage properly wound for future reviewing, it must be rewound twice. The following is the most convenient method of doing this:

(1) Leave both reels in place on the machine and insert the end of the film from the lower reel directly into the slot of the empty upper reel. *Do not feed the film through the film transportation assembly of the machine.*

(2) Throw the MOTOR toggle switch to FORW'D.

(3) Use the foot-controller switch, or throw the MOTOR trigger switch to ON, and wind the film emulsion (dull) side in onto the upper reel.

(4) Remove the upper reel, and use one of the following methods to wind the film into a roll for storage:

(a) Use Rewinder PH-92 as instructed in paragraph 146*d*.

(b) Use the flange fastened to the large motor drive belt pulley on the left front side of the film examining machine, as follows:

1. Throw the MOTOR toggle switch to BACKW'D.
2. Insert a pencil through the hub of the reel of film and use it as a shaft to support the reel in front of the flange.
3. Pull the end of the film off the top side of the reel and over the top of the hub of the flange of the machine. Wind several turns on the hub by hand to secure that end.
4. Use the foot-controller switch to wind the film *very slowly* emulsion (dull) side in from the reel onto the hub of the flange.
5. Grasp the roll of film and slide it from the hub with a rotational motion. Place the roll in a can, properly labeled, for storage.

149. Performance Check List

Use the following check list as a guide in checking the performance of Film Viewer PH-97-(*) of Spotting Sets PH-32-(*) and AN/TVQ-1:

	Item No.	Item	Action or condition	Normal condition	Corrective measures
REVERSE STOP START	1	MOTOR trigger switch	Throw to OFF		
	2	Attachment cord	Connect to machine and to 110-volt source with ground clip connected		
	3	Foot-controller switch	Connect to machine		
	4	Rheostat	Set at a point mid-way in its range		
	5	Viewing Attachment PH-98-(*)	Mount on film gate of machine	Large thumbwheel of base, toward left side of machine; locking nut tight	Par. 142b(3)
	6	Empty reel	Place on lower spindle		
	7	Roll of film	Place on upper spindle	Film wound on reel, emulsion (dull) side in, with leading end (lowest time counter numbers) on outside	Par. 146
	8	MOTOR toggle switch	Throw to BACKWARD		
	9	Film	Threaded through film transportation assembly of machine	Film feeds through machine without binding	Increase size of loops (par. 148a)
	10	LIGHT switch	Thrown to ON	Lamp lights illuminating film	Check lamp
	11	Viewing Attachment PH-98-(*)	Focused on film	Grid lines clearly superimposed, and lined up with the indicator shadows on the film	Par. 148b
	12	Foot-controller switch	Pressed with foot	Film runs through machine from upper to lower reel	
	13	Foot-controller switch	Release foot pressure	Motion of film stops	
	14	MOTOR toggle switch	Throw to FORWARD		
	15	Foot-controller switch	Pressed with foot	Film runs through machine from lower to upper reel	

PART THREE

MAINTENANCE INSTRUCTIONS FOR FILM VIEWING COMPONENTS

The information in section IV, "Spotting Sets PH-32-(*)," on preventive maintenance techniques applies likewise to the film viewing components of Spotting Sets PH-32-(*), and AN/TVQ-1. In addition, the paragraphs below apply to classes of parts found only in the film viewing components.

Section IV. PREVENTIVE MAINTENANCE TECHNIQUES

150. Lenses

a. GENERAL. Preventive maintenance work on the lenses of the film viewing components of a spotting set consists of Inspect (I) and Clean (C).

b. INSPECT (I). Inspect lenses for cracked or chipped places. A cracked or chipped lens must be replaced as soon as possible. Inspect lenses for accumulation of dust or a film of dirt. Dusty or dirty lenses must be cleaned.

c. CLEAN (C). (1) Use a camel's-hair brush to lightly brush off dust or loose dirt.

(2) Wipe off any film of dirt, or greasy finger marks, with special lens tissue slightly moistened with alcohol, if that fluid is available. If special tissue is not available, use absorbent cotton, a clean linen cloth, a clean chamois, or soft toilet tissue. *Do not use a cotton or silk cloth.* It is very easy to ruin a lens surface by scratching, so be extremely careful when wiping it. *Do not wipe hard.*

151. Batteries

a. GENERAL. Preventive maintenance work on batteries of film viewing components of a spotting set consist of Inspect (I) and Clean (C).

b. INSPECT (I). Inspect a battery for wet, dirty, or corroded contacts. Wet contacts must be dried with a clean cloth. Dirty or corroded contacts must be cleaned.

c. **CLEAN (C).** Clean the bottom of each battery (where it makes contact with the spring or contact of another battery) by scraping the zinc surface with a knife. Be careful to remove the dull white zinc oxide without gouging into the metal itself. Polish the scraped surface with sandpaper until it is bright.

Section V. ITEMIZED PREVENTIVE MAINTENANCE OF FILM VIEWING COMPONENTS

152. Materials Needed

a. **MAINTENANCE MATERIALS.** Have the following items on hand before beginning preventive maintenance work on the film viewing components of a spotting set:

- Screwdriver.
- Clean cloths.
- Camel's-hair brush.
- Alcohol, if available.
- Lens tissue, absorbent cotton, chamois, or soft toilet tissue.
- Lubricants (par. 157).
- Knife.
- Fine sandpaper.

Note. Gasoline will not be used as a cleaning fluid for any purpose. Solvent, Dry-cleaning, is available as a cleaning fluid through established supply channels. Oil, Fuel, Diesel, may be used as a substitute for dry-cleaning solvent when the solvent is not at hand. Carbon tetrachloride will be used as a cleaning fluid only in the following cases: where inflammable solvents cannot be used because of the fire hazard, and for cleaning electrical contacts including relay contacts, plugs, commutators, etc.

b. **RUNNING SPARES.** (1) *Film Viewer PH-97-(*)*. The running spares supplied with Film Viewer PH-97-(*) are packed in the carrying case (par. 137g), and consist of—

- 2 belts as spares for the reel-drive belt.
- 1 belt as a spare for the motor-drive belt.
- 2 lamps (25w, 120v) as spares for the electric lamp.

(2) *Splicer PH-91-(*)*. The running spares supplied with Splicer PH-91-(*) are five spare blades for the scraper.

153. Maintenance of Film Viewer PH-97-(*)

- a. **CASE CS-77-(*)**. (1) Keep the case clean (par. 37).
- (2) Keep the fastening screws of hinges, catches, hasp and staple, and handles tight.
- (3) Lubricate the hardware as instructed in paragraph 38d.

b. **FILM EXAMINING MACHINE PH-179.** Instructions for the maintenance of Film Examining Machine PH-179 will be contained in TM 11-2388.

c. **VIEWING ATTACHMENT PH-98-(*).** (1) Clean (par. 150) the exposed surface of the eyepiece lens.

(2) If dust gets on the top surface of the reticule, loosen the clamping screw of the eyepiece adapter (fig. 52) and remove the eyepiece lens tube to gain access to the reticule. Remove the dust with a camel's-hair brush. *Do not disassemble the viewing attachment further.*

(3) Keep the rubber eyerests clean (par. 37).

(4) Keep the metal surface clean and free from dust (par. 37).

(5) Keep the clamping thumbscrews of the body tube, the eyepiece adapter, and the eyerest adapter, *hand tight. Do not force.*

(6) Keep the fastening screws of the various parts tight.

154. Maintenance of Rewinder PH-92

a. **STANDARDS.** (1) Keep the metal surfaces clean and free from dust (par. 37).

(2) Keep the mounting bolts tight.

(3) Keep the fastening screws of the gear housing of the hand-crank standard tight.

(4) Lubricate as instructed in figure 61.

b. **REWINDING FLANGE.** (1) Keep the metal surfaces clean (par. 37).

(2) Keep the setscrew of the disk tight.

155. Maintenance of Splicer PH-91-(*).

a. Keep the metal surfaces clean and free from dust (par. 37).

b. Keep the shearing bar clean of dried cement, which is easily softened by painting with fresh cement. It then can be wiped off with a dry cloth.

c. Keep the blade in the scraper clean, and frequently change its scraping edge, or replace with a new blade. There are eight positions in which to place the blade in the holder, each position presenting a new scraping edge. The blade is held in the holder by a screw. Before inserting a new blade in the holder see that the blade and slot for receiving it are perfectly clean so that the blade will go back against the stop provided. Any foreign substance will cause the blade to protrude, thereby causing the blade to remove too much emulsion, which will leave a transparent line beyond the splice. Hold the blade firmly against the stop while tightening the screw to hold it.

d. On Splicer PH-91-A the following additional parts require maintenance:

- (1) Keep the frosted glass lens clean (par. 37).
- (2) Keep the battery contacts clean (par. 151).
- (3) Keep the cement bottle clean and tightly stoppered when not in use.

e. Lubricate Splicer PH-91-(*) as instructed in figure 61.

156. Preventive Maintenance Check List for Film Viewing Components

The following check list is a summary of the preventive maintenance to be performed on the film developing components of a spotting set. It includes the FITCA operations described previously in this section and the L operation described in figure 61. The suggested time intervals for performing the FITCAL operations may be varied by the local commander. However, for the best performance of the equipment, it is recommended that the operations be performed at least as frequently as called for in the check list. The echelon column indicates which items are first echelon maintenance and which are second echelon maintenance.

Item No.	Operation	Description	When performed				Echelon
			Daily	Weekly	Monthly	Every 3 months	
1	ITC	Case CS-77-(*)	X				First
2	ITCAL	Film Examining Machine PH-179	(Refer to TM 11-2388)				
3	ITC	Viewing Attachment PH-98-(*)	X				First
4	ITC	Rewinder PH-92	X				First
5	ITC	Splicer PH-91-(*)	X				First
6	L	Rewinder PH-92 (fig. 61)		X			First
7	L	Splicer PH-91-(*) (fig. 61)		X			First
8	L	Case CS-77-(*) (par. 38d)			X		First
9	L	Rewinder PH-92 (fig. 61)				X	First

Section VI. LUBRICATION OF FILM VIEWING COMPONENTS

The War Department Lubrication Orders issued on Spotting Sets PH-32-(*) and AN/TVQ-1 are referred to in section VI, "Spotting Sets PH-32-(*)." They include an order (par. 54b(2)) covering the film viewing components of a spotting set.

157. Key to Lubrication Order Abbreviations

The following is the key to the abbreviations used in the War Department Lubrication Order reproduced in figure 61:

LUBRICANTS	LOWEST EXPECTED AIR TEMPERATURE			INTERVALS
	above + 32° F.	+ 32° to 0° F.	below 0° F.	
OE—OIL, engine..	OE SAE 10	PS	PS	W—Weekly
PS—OIL, lubricating, preservative, special. All air temperatures...				M—Monthly
GL—GREASE, lubricating, special. All air temperatures.				3M—3 months

158. Lubricating Film Viewing Components

a. See figure 61 for instructions on lubricating the following film viewing components:

- (1) Viewing Attachment PH-98-(*).
- (2) Rewinder PH-92.
- (3) Splicer PH-91-(*).

b. Lubrication instructions for Film Examining Machine PH-179 are contained in War Department Lubrication Order No. 3813, a facsimile of which will be contained in TM 11-2388.

Section VII. MOISTUREPROOFING AND FUNGIPROOFING FILM VIEWING COMPONENTS

159. Moistureproofing and fungiproofing

This treatment is not required on any of the film viewing components, except Film Examining Machine PH-179 which is one of the components of Film Viewer PH-97-(*). The treatment for Film Examining Machine PH-179 will be given in TM 11-2388.

PART FOUR
AUXILIARY EQUIPMENT

(NOT USED)

PART FIVE

REPAIR INSTRUCTIONS

Section VIII. THEORY OF OPERATION OF FILM VIEWING COMPONENTS

160. Functioning of Film Viewer PH-97-(*)

Film Viewer PH-97-(*) consists basically of two parts: Film Examining Machine PH-179 which provides means for moving motion-picture film intermittently past a lighted aperture; and Viewing Attachment PH-98-(*) which is a microscope with a special reticule for viewing the film at the lighted aperture of the film examining machine.

a. The film is carried on two reels on the film examining machine, winding from either one to the other through a film guide which includes the lighted aperture. Two sprockets, one driven intermittently and the other continuously, move the film through the machine; the intermittent sprocket moving the film one frame at a time past the lighted aperture and the continuous sprocket keeping the film feeding steadily to or away from the intermittent sprocket. Each sprocket is provided with rollers which hold the film against the sprocket so that its teeth engage in the film perforations to obtain positive motion. A loop of film between the two sprockets supplies the slack necessary to permit steady and intermittent movement in the same length of film.

b. The viewing attachment is a compound microscope which screws into a mount over the lighted aperture of the film examining machine. It consists of a two-lens eyepiece and an objective lens between which is a reticule on which is engraved a circular grid specially graduated for making measurements on motion pictures of antiaircraft artillery practice. The reticule is located a fixed distance from the objective, and the eyepiece is movable to focus on the reticule. The microscope is moved vertically by means of a rack and pinion to focus the objective lens on the film, and the objective produces a reduced image of the film on the reticule. The reticule is rotatable, the microscope is movable perpendicular to the film, and the viewing attachment mounting on the film examining machine is movable parallel to the film, so that the film image can be positioned exactly with respect to the grid lines on the reticule.

Section IX. REPAIRS TO FILM VIEWING COMPONENTS

161. Repair of Film Viewer PH-97-(*)

a. FILM EXAMINING MACHINE PH-179. Repair instructions for Film Examining Machine PH-179 will be contained in TM 11-2388.

b. VIEWING ATTACHMENT PH-98-(*). (1) *Disassembly* (fig. 52).

(a) Loosen the eyerest clamping screw and pull the eyerest assembly from the eyepiece lens tube.

(b) Loosen the clamping screw on the eyepiece adapter and pull the eyepiece lens tube from the adapter.

(c) Unscrew the eyepiece adapter from the reticule housing cover.

(d) Remove the three screws holding the reticule assembly to the top of the draw tube, and lift the assembly off. Disassemble the reticule assembly as follows:

1. Remove the four corner screws on the under side of the flange at the top of the reticule housing base, and lift off the reticule housing cover.
2. Use a spanner wrench to unscrew the locking nut of the rotatable bearing, and lift the bearing from the housing.

(e) Remove the draw tube as follows:

1. Loosen the clamping screw on the body tube and lower the draw tube all the way.
2. Remove the screw at the end of the shaft opposite the large thumbwheel on the body tube.
3. Remove the thumbwheel and shaft, turning it slightly to disengage the pinion from the rack.
4. Pull straight up on the draw tube to remove it from the body tube.

(f) The sliding plate with attached body tube can be removed from the base housing as follows:

1. Remove the four corner screws holding the cover to the base housing, and remove the cover.
2. Remove the two screws from either end piece and turn the thumbscrew until the sliding plate clears the end of the screw.
3. Slide the plate from the housing, taking care not to lose the two springs recessed in the end of the plate.

(2) *Lubrication before reassembly.* Clean the following parts with Solvent, Dry Cleaning (SD), and then apply Grease, Lubricating, Special (GL), as indicated below:

(a) Clean the bearing surfaces of the reticule housing base and the rotatable bearing. Apply a light coat of grease (GL).

(b) Clean the tongue on the underside of the reticule housing cover and the dust trap groove on the top of the rotatable bearing. Apply a light coat of grease (GL) to the tongue and to the groove.

(c) Clean the machined surfaces of the sliding plate and of the base housing. Apply a coat of grease (GL).

(3) *Reassembly.* Reassemble the viewing attachment parts in the reverse order of disassembly ((1) above), taking care that—

(a) The springs are replaced in the sliding plate and are positioned correctly in the holes provided in the end piece.

(b) The base housing cover is replaced so that the Signal Corps nameplate is on the same side as the clamping screw on the body tube.

(c) The locking nut is replaced in the rotatable bearing.

162. Adjustments on Viewing Attachment PH-98-(*)

a. **BODY TUBE ROTATIONAL SHAKE.** Rotational shake is caused by the draw tube (fig. 52) fitting too loosely in the body tube. Correct this condition by tightening the screw and nut controlling the lower half of the partially split top of the body tube, the top half of which is controlled by a thumbscrew.

b. **CENTERING RETICULE.** Two small screw drivers and a piece of 35-mm film with a fine cross scratched on it are required for centering the reticule. With the viewing attachment mounted in place on Film Examining Machine PH-179 (par. 142) proceed as follows:

(1) Open the film gate of the film examining machine and insert the prepared piece of film.

(2) Focus the viewing attachment eyepiece on the reticule, and then focus the objective on the film.

(3) Use the framing lever, the thumbwheel controlling the sliding plate, and the knurled ring of the reticule, to adjust the grid until its center lines coincide with the intersection of the crossline on the film.

(4) Rotate the reticule 180°.

(a) If the reticule is centered properly there will be no apparent movement of the crossed lines with respect to the center of the reticule.

(b) If there is apparent movement, note the amount and then proceed as follows:

1. Rotate the reticule until a small screw appears under the hole (just below the reticule ring) on *each* side of the reticule housing.

2. Engage the screw drivers in these opposite screws, and turn the screws simultaneously to move the center of the reticule about *one-half* the apparent movement noticed after rotating the reticule 180°. Move the reticule in the direction *toward* the intersection of the crosslines on the film.

3. Rotate the reticule until the other pair of screws appear under the holes, and repeat step 2 above.
4. Check the centering ((3) and (4) above), and repeat the screw adjustment until no relative movement is observed on rotation of the reticule.

c. **MAGNIFICATION.** The graduations on the grid of the reticule indicate correctly *only* when the magnification of the objective is so adjusted that the outer circle of the grid is accurately inscribed in the vertical and horizontal indicator shadows on a frame of film, as shown in figure 59. If the grid does not do this, note the amount that it varies, and then adjust the objective lens as follows:

(1) Mark two lines exactly 0.588 inch apart (the correct distance that should exist between the vertical indicators) on a piece of film. Insert the film in place in the film guide of the film examining machine.

(2) Remove the three screws holding the reticule assembly to the top of the draw tube of the viewing attachment, and remove the reticule assembly.

(3) The tube in which the objective lens is mounted is fitted inside the draw tube and is held in place by a small recessed-head setscrew in the draw tube flange to which the reticule assembly was screwed. Adjust the objective lens tube as follows:

(a) Loosen the setscrew and slide the tube in either one of the following directions as required:

1. Push it toward the film to increase the size of the image.
2. Pull it away from the film to decrease the size of the image.

(b) Tighten the setscrew to hold the tube in the new position.

(c) Replace the reticule assembly without its screws.

(d) Carefully focus the eyepiece on the reticule, and focus the objective on the film so that there is no apparent motion of the grid across the film when the observer's eye is moved slightly from side to side and up and down.

(e) Check the relation of the outer circle of the grid with the lines on the film, and repeat the adjustment until the grid is accurately inscribed in the lines on the film.

(4) Carefully remove all dust particles from the reticule assembly before finally replacing and fastening it on the draw tube.

163. Adjustment of Splicer PH-91-(*)

The cement guard attached to the top side of the upper jaw of the left set of arms must not protrude below the lower face of that jaw, and should be spaced a full 1/64 inch from the left edge of the stationary shearing bar. The cement guard prevents applying cement where it is not needed.

WAR DEPARTMENT UNSATISFACTORY EQUIPMENT REPORT					
FOR	TECHNICAL SERVICE Signal Corps	MATERIEL	DATE 15 July 44		
FROM	ORGANIZATION 00th AAA Training Battalion,	STATION Fort Blank, Ia		TECHNICAL SERVICE	
TO	NEXT SUPERIOR HEADQUARTERS Signal Officer,	STATION Fort Blank, Ia	TECHNICAL SERVICE Signal Corps		
COMPLETE MAJOR ITEM					
NOMENCLATURE Theodolite FH-00-33		TYPE	MODEL		
MANUFACTURER X, Y, Z Company	U. S. A. REG. NO.	SERIAL NO. 0000	DATE RECEIVED 10 June 44		
EQUIPMENT WITH WHICH USED (if applicable) Spotting Set FH-32-00					
DEFECTIVE COMPONENT—DESCRIPTION AND CAUSE OF TROUBLE					
PART NO. 40000/A0	TYPE Motor, 12r	MANUFACTURER A. B. C. Company		DATE INSTALLED 10 June 44	
DESCRIPTION OF FAILURE AND PROBABLE CAUSE (if additional space is required, see back of form) Field coils failed (probably because of humid conditions)					
DATE OF INITIAL TROUBLE 30 June 44	TOTAL TIME INSTALLED		TOTAL PERIOD OF OPERATION BEFORE FAILURE		
	YEARS	MONTHS	DAYS	YEARS	MONTHS
	---	---	20	---	---
				HOURS	MILES
				60	---
BRIEF DESCRIPTION OF UNUSUAL SERVICE CONDITIONS AND ANY REMEDIAL ACTION TAKEN Operation in extremely humid climate. Unit oven dried 30 June 44					
TRAINING OR SKILL OF USING PERSONNEL		RECOMMENDATIONS (if additional space is required, see back of form)			
POOR	FAIR	GOOD			
		<input checked="" type="checkbox"/>	Moistureproofing treatment for motor coils.		
ORIGINATING OFFICER					
TYPED NAME, GRADE, AND ORGANIZATION John A. Doe, Capt., AAA, Supply Officer			SIGNATURE John A. Doe.		
FIRST ENDORSEMENT					
TO CHIEF	TECHNICAL SERVICE	OFFICE		DATE	
NAME, GRADE, AND STATION			STATION	DATE	
Instructions					
<ol style="list-style-type: none"> It is imperative that the chief of technical service concerned be advised at the earliest practical moment of any constructional, design, or operational defect in material. This form is designed to facilitate such reports and to provide a uniform method of submitting the required data. This form will be used for reporting manufacturing, design, or operational defects in material, petroleum fuels, lubricants, and preserving materials with a view to improving and correcting such defects, and for use in recommending modifications of material. This form will not be used for reporting failures, isolated material defects or malfunctions of material resulting from fat-wear-and-tear or accidental damage nor for the replacement, repair or the issue of parts and equipment. It does not replace currently authorized operational or performance records. Reports of malfunctions and accidents involving ammunition will continue to be submitted as directed in the manner described in A.R. 710-10 (change No. 2). It will not be practicable or desirable in all cases to fill all blank spaces of the report. However, the report should be as complete as possible in order to expedite necessary corrective action. Additional pertinent information not provided for in the blank spaces should be submitted as inclosure to the form. Photographs, sketches, or other illustrative material are highly desirable. When cases arise where it is necessary to communicate with a chief of service in order to assure safety to personnel, more expeditious means of communication are authorized. This form should be used to confirm reports made by more expeditious means. This form will be made out in triplicate by using or service organization. Two copies will be forwarded direct to the technical service; one copy will be forwarded through command channels. Necessity for using this form will be determined by the using or service troops. 					

Figure 60. Sample Filled-out Unsatisfactory Equipment Report.

APPENDIX I

MAINTENANCE PARTS FOR SPOTTING SETS PH-32-(*) AND AN/TVQ-1

Note. The information below was compiled on 10 July 1945.

1. Spotting Set PH-32-(*)

The appropriate pamphlets of the ASF Signal Supply Catalog for Spotting Sets PH-32-B, C, D and F are:

Higher Echelon Spare Parts

SIG 8-PH-32.
SIG 8-BE-65.
SIG 8-EE-87.
SIG 8-PH-33.
SIG 8-PH-97.
SIG 8-PH-103.
SIG 8-PH-264 (when published).
SIG 8-RL-27.
SIG 8-RL-31.

2. Spotting Set AN/TVQ-1.

The appropriate pamphlets of the ASF Signal Supply Catalog for Spotting Set AN/TVQ-1 are:

Organizational Spare Parts

SIG 7-AN/TVQ-1.
SIG 7-PE-75.

Higher Echelon Spare Parts

SIG 8-AN/TVQ-1.
SIG 8-BE-65.
SIG 8-EE-87.
SIG 8-MX-194/TVQ-1.
SIG 8-PE-75.
SIG 8-PH-97.
SIG 8-PH-264 (when published).

SIG 8-PH-103.
 SIG 8-RL-27.
 SIG 8-RL-31.

Note. For an index of available catalog pamphlets, see the latest issue of ASF Signal Supply Catalog SIG 2.

3. First, Second, and Third Echelon Parts

a. The following list covers first, second, and third echelon maintenance parts of Spotting Sets PH-32-(*) and AN/TVQ-1:

Ref symbol	Signal Corps stock No.	Name
TM 11-433	3A23	Battery BA-23
Fig. 26, V ₁ and V ₂ ..	3A26	Battery BA-26
Figs. 4 and 34	3A46	Battery BB-46

b. The following list covers first, second, and third echelon maintenance parts of Axle RL-27-(*):

Ref symbol	Signal Corps stock No.	Name
	6H870	Cover, shaft end (grease retainer and dirt protection)
	6H227A/12-1	Spring, lock (tension for handle locking key)

c. First, second, and in most cases, third echelon parts of other components are covered in the Technical Manuals published on those equipments. (See App. II.)

APPENDIX II

REFERENCES

The following is a list of other War Department publications referred to in this manual:

FM 21-6, List and Index of War Department Publications.

FM 24-5, Basic Field Manual, Signal Communication.

TB SIG 13, Moistureproofing and Fungiproofing Signal Corps Equipment.

TB SIG 123, Preventive Maintenance Practices for Ground Signal Equipment.

TM 5-235, Surveying.

TM 5-236, Surveying Tables.

TM 11-362, Reel Units RL-31, RL-31-B, and RL-31-C.

TM 11-430, Batteries for Signal Communication Except Those Pertaining to Aircraft.

TM 11-433, Time Control Equipment RC-133.

TM 11-900, Power Units PE-75-C through PE-75-T.

TM 11-2388, Film Examining Machine PH-179 (when published).

TM 11-2351, Exposure Meters PH-77, PH-77-A & PH-252-A.

TM 11-2534, Theodolites PH-BC-33, PH-BD-33, PH-BF-33, PH-BG-33, and Theodolite MX-194/TVQ-1.

TM 44-225, Orientation For Artillery.



SPOTTING SETS PH-32 and AN/TVQ-1

Viewing Attachment PH-98-(), Rewinder PH-92-() & Splicer PH-91-()

References: TM 11-434 & TM 11-2534. This equipment covered by 3 Lubrication Orders, No. 3107, No. 3107A & No. 3813.

NOTE For Lubrication Instructions on Film Examining Machine PH-97-(1), with which this Viewing Attachment is used, see Lubrication Order No. 3813.

VIEWING ATTACHMENT PH-98-()

NOTE For Lubrication Instructions on Film Examining Machine PH-97-(1), with which this Viewing Attachment is used, see Lubrication Order No. 3813.

<p>Eyepiece Clamp Screw PS M Lubricate threads sparingly</p> <p>Eyepiece Tube Clamp Screw PS M Lubricate threads sparingly</p> <p>Draw Tube Clamp Screw PS M Lubricate threads sparingly</p> <p>Mounting Base and Locking Ring GL M Clean and lubricate threads sparingly, remove excess</p>	<p>Eye Guard Adjusting Arm and Sleeve M PS Clean and coat sliding surface sparingly, remove excess</p> <p>Eyepiece Tube M GL Remove tube and clean surface. Apply very light film of lubricant to tube, then wipe off excess.</p> <p>Draw Tube, Rack and Pinion M OE Clean and coat exposed surface of tube. Apply 1 or 2 drops to rack teeth. Rack tube in and out to spread lubricant.</p> <p>Cross Motion Control Screw and Slides M OE Remove cover plate. Apply lubricant sparingly to 2 slides. Also, apply 1 drop to control screw bearing and sparingly lubricate control screw threads. Operate to spread lubricant.</p>
--	---

Toggle Joints OE W
1 drop, each

Tension Arm Pivot Pin OE W
1 drop

Tension Control Screw OE W
Lubricate threads sparingly

REWINDER PH-92-()

Spindle Shaft Bearings W OE
2 or 3 drops, each

Drive Gear and Pinion 3M GL
Remove cover, clean and coat teeth

Cranking Shaft W OE
Move hand crank away from gear housing. Apply 1 or 2 drops of lubricant in housing bore and on exposed surface of shaft.

Splicing Clamp Shafts PS W
Lubricate shafts sparingly, then remove excess lubricant. To expose shafts for proper lubrication, force clamps side-wise to compress spring. NOTE: Be sure film track is free of any lubricant.

SPLICER PH-91-()

Splicing Clamp Shafts W PS
Lubricate shafts sparingly, then remove excess lubricant. To expose shafts for proper lubrication, force clamps side-wise to compress spring. NOTE: Be sure film track is free of any lubricant.

OIL CAN POINTS—Monthly, lubricate Viewing Attachment Eyepiece Detent Spring and Ball sparingly with PS. Wipe off excess lubricant. Also, lubricate Carrying Chest Hinges, Locks and Fasteners with OE.
LUBRICATED BY MAINTENANCE PERSON.

NEL — Viewing Attachment Reticle Housing Bearing and Rotating Ring Tongue and Groove Dust Trap.
Copy of this Lubrication Order will remain with the equipment at all times. Instructions contained therein are mandatory and supersede all

conflicting lubrication instructions dated prior to 27 January 1945.
BY ORDER OF THE SECRETARY OF WAR:
G. C. MARSHALL,
Chief of Staff.

OFFICIAL:
J. A. ULIO,
Major General,
The Adjutant General.

TL 97285

No. 3107A

Figure 61. Facsimile of one side of War Department Lubrication Order No. 3107A for Spotting Sets PH-32 and AN/TVQ-1. (See par. 54.)

INDEX

	<i>Paragraph</i>	<i>Page</i>
Abbreviations, War Department Lubrication Orders	157	172
Adjusting—		
Theodolite line current	28	36
Time interval	28	36
Adjustments:		
Operating, Film Viewer PH-97-(*)	148	161
Repair, Viewing Attachment PH-98-(*)	162	176
Splicer PH-91-(*)	163	177
Advancing theodolite time counters	28	36
Application:		
Spotting Set AN/TVQ-1	70	75
Spotting Set PH-32-(*)	2	4
Assembly:		
Developing Equipment PH-41	109	115
Drying Rack PH-42	110	115
Film Viewer PH-97-(*)	142	155
Axle RL-27-(*):		
Description	13	23
Lubrication	49	49
Maintenance, preventive	49	49
Using	22	29
Bakelite surfaces, preventive maintenance	37	46
Battery BB-46:		
Description	16	26
Maintenance	48	49
Battery and flank stations, wiring between	22	29
Batteries, preventive maintenance	151	168
Bottles PH-22 and PH-136:		
Description	97	106
Maintenance	127	131
Capacitor, replacing in Time Interval Device PH-103	44	48
Case CS-77-(*), description	137	141
Cement, film, description	140	155
Chart, trouble-shooting for—		
Time Interval Device PH-103	66	67
Time Interval Multiplier PH-264-(*)	67	70
Components:		
Spotting Set AN/TVQ-1	71	79
Spotting Set PH-32-(*)	3	7
		183

	<i>Paragraph</i>	<i>Page</i>
Connecting cables, preventive maintenance	36	46
Continuity, theodolite lines, testing	28	36
Cord CD-407, description	7	15
Cord CX-227/TVQ-1, description	76	88
Cord CX-228/TVQ-1, description	76	88
Cord CX-229/TVQ-1, description	77	89
Cover CW-95/TVQ-1, description	75	88

Description:

Axle RL-27-(*)	13	23
Battery BB-46	16	26
Bottles PH-22 and PH-136	97	106
Case CS-77-(*)	137	141
Cord CD-407	7	15
Cord CX-227/TVQ-1	76	88
Cord CX-228/TVQ-1	76	88
Cord CX-229/TVQ-1	77	89
Developer, chemical	105	114
Developing Equipment PH-41	95	102
Drying Rack PH-42	96	104
Exposure Meter PH-252-(*)	8	16
Film	18	26
Film cement	140	155
Film Examining Machine PH-179	137	141
Film Viewer PH-97-(*)	137	141
Fixing powder	106	114
Funnel PH-175	99	109
Hydrometer HY-2	17	26
Junction Box JB-40	7	15
Line Connector Unit EE-87	11	21
Paddle PH-80	98	106
Power Unit PE-75-()	78	90
Reel DR-4	15	26
Reel Unit RL-31-(*)	14	24
Rewinder PH-92	138	151
Spotting Set AN/TVQ-1	69	75
Spotting Set PH-32-(*)	1	3
Splicer PH-91-(*)	139	152
Theodolite MX-194/TVQ-1	74	87
Theodolite PH-(*)-33	6	15
Time Interval Device PH-103	9	16
Time Interval Multiplier PH-264-(*)	10	19
Time Interval Signal BE-65	12	22
Viewing Attachment PH-98-(*)	137	131
Wire W-110-B	15	26
Developer, chemical, description	105	114
Developer, solution, preparation	111	116
Developing Equipment PH-41:		
Assembly	109	115
Description	95	102
Maintenance	125	130
Repacking	113	117

	<i>Paragraph</i>	<i>Page</i>
Repairs	133	136
Unpacking and checking	108	114
Developing reel, use	116	120
Dimensions of Components:		
Spotting Set PH-32-(*)	3	7
Spotting Set AN/TVQ-1	71	79
Distribution of spotting components to stations:		
Spotting Set AN/TVQ-1	83	92
Spotting Set PH-32-(*)	24	30
Drying Rack PH-42:		
Assembly	110	115
Description	96	104
Maintenance	126	131
Repacking	113	117
Repairs	134	136
Unpacking and checking	108	114
Use	116	120
Electrical connections, spotting components:		
Spotting Set AN/TVQ-1	85	93
Spotting Set PH-32-(*)	26	31
Exposed film, processing	116	120
Exposure Meter PH-252-(*), description	8	16
Film:		
Description	18	26
Processing	116	120
Winding on developing reel	116	120
Film cement	140	155
Film developing components:		
Description	94	102
Functioning	131	135
Location	107	114
Performance check list	118	126
Preventive maintenance	121-123	129
Preventive maintenance check list	128	131
Repacking	113	117
Unpacking and checking	108	114
Unsatisfactory equipment report	135	137
Volume and weights	113	117
Film Examining Machine PH-179, description	137	141
Film Viewer PH-97-(*):		
Application	137	141
Description	137	141
Dimensions	137	141
Functioning	160	174
Installation	142	155
Lubrication	158	172
Maintenance	153	169
Operation	148	161
Performance check list	149	166

	<i>Paragraph</i>	<i>Page</i>
Repacking	145	157
Repairs	161	175
Running spares	152	169
Weight	137	141
Film viewing components:		
Description	136	141
Location	141	155
Performance check list	149	166
Preventive maintenance check list	156	171
Repacking	145	157
Volumes and weights	145	157
FITCAL, description	34	43
Fixing powder, description	106	114
Fixing solution, preparation	112	116
Flank and battery stations, wiring between	22	29
Funnel PH-175, description	99	109
Functioning:		
Film developing components	131	135
Film Viewer PH-97-(*)	160	174
Group functioning, spotting components:		
Spotting Set AN/TVQ-1	92	102
Spotting Set PH-32-(*)	61	61
Line connector unit (<i>See</i> TM 11-433.)		
Phototheodolite (<i>See</i> TM 11-2534.)		
Time Interval Device PH-103	63	62
Time Interval Multiplier PH-264-(*)	64	65
Time Interval Signal BE-65 (<i>See</i> TM 11-433.)		
Fungiproofing and moistureproofing	55-57	52
Glass surfaces, preventive maintenance	37,123	46,130
Grounds, theodolite lines, testing	28	36
Hardware, preventive maintenance	38	46
Hydrometer HY-2, description	17	26
Installation:		
Developing Equipment PH-41	109	115
Drying Rack PH-42	110	115
Film Viewer PH-97-(*)	142	155
Rewinder PH-92	143	156
Splicer PH-91-(*)	144	157
Theodolite MX-194/TVQ-1	84	93
Theodolite PH-(*)-33	25	31
Interval, time, adjusting	28	36
Itemized preventive maintenance on spotting components	39	46
Junction Box JB-40:		
Description	7	15
Maintenance	42	47
Moistureproofing and fungiproofing	58	54

	<i>Paragraph</i>	<i>Page</i>
Lenses, preventive maintenance	150	168
Line Connector Unit EE-87:		
Description	11	21
Maintenance (<i>See</i> TM 11-433.)		
Repacking	27	34
Location:		
Film developing components	107	114
Film viewing components	141	155
Phototheodolite supports:		
Spotting Set AN/TVQ-1	80	91
Spotting Set PH-32-(*)	21	28
Lubrication:		
Axle RL-27-(*)	49	49
Film viewing components	158	172
Hardware	38	46
Orders, War Department	52-54	51
Lubrication Order abbreviations	157	172
Magnification, adjusting Viewing Attachment PH-98-(*)	162	176
Maintenance, preventive:		
Axle RL-27-(*)	49	49
Bakelite surfaces	37	46
Battery BB-46	48	49
Batteries (dry cell)	151	168
Bottles PH-22 and PH-136	127	131
Connecting cables	36	46
Cord CD-407	42	47
Developing Equipment PH-41	125	130
Drying Rack PH-42	126	131
Exposure Meter PH-252-(*) (<i>See</i> TM 11-2388.)		
Film Viewer PH-97-(*)	153	169
FITCAL operations	34	43
Glass surfaces	37	46
Hardware	38	46
Itemized	39	46
Junction Box JB-40	42	47
Lenses	150	168
Line Connector Unit EE-87. (<i>See</i> TM 11-433.)		
Materials needed:		
Spotting components	40	47
Film developing components	124	130
Film viewing components	152	169
Meaning	33	43
Metal surfaces	37	46
Phototheodolites. (<i>See</i> TM 11-2534.)		
Reel Unit RL-31-(*) (<i>See</i> TM 11-362.)		
Rewinder PH-92	154	170
Rubber	37	46
Splicer PH-91-(*)	155	170
Switch and relay contacts	35	45
Techniques	34	43
Time Interval Device PH-103	44	48

	<i>Paragraph</i>	<i>Page</i>
Time Interval Multiplier PH-264-(*)	45	49
Time Interval Signal BE-65. (See TM 11-433.)		
Wiring	36	46
Wood surfaces	37	46
Maintenance parts, Spotting Sets PH-32-(*) and AN/TVQ-1.....	App. I	179
Metal surfaces, preventive maintenance	37, 122	46, 129
Moistureproofing and fungiproofing:		
General information	55, 56, 57	52, 53
Junction Box JB-40	58	54
Time Interval Device PH-103	59	55
Time Interval Multiplier PH-264-(*)	60	57
Operation:		
Film Viewer PH-97-(*)	148	161
Rewinder PH-92	146	159
Splicer PH-91-(*)	147	160
Spotting components:		
Spotting Set AN/TVQ-1	90	100
Spotting Set PH-32-(*)	31	39
Time Interval Device PH-103	28	36
Time Interval Multiplier PH-264-(*)	29	38
Paddle PH-80, description	98	106
Performance check list:		
Film developing components	118	126
Film viewing components	149	166
Spotting components	32	40
Photographic solutions:		
Preparing	111, 112	116
Storage	116	120
Phototheodolite:		
Description	6, 74	15, 87
Maintenance. (See TM 11-2534.)		
Support	20	27
Power requirements:		
Spotting Set AN/TVQ-1	72	86
Spotting Set PH-32-(*)	4	13
Power Unit PE-75-(), description	78	90
Preparation of—		
Developer solution	111	116
Fixing solution	112	116
Spotting components:		
Spotting Set AN/TVQ-1	82	92
Spotting Set PH-32-(*)	23	30
Tanks for film processing	115	119
Theodolite MX-194/TVQ-1 for operation	89	98
Theodolite PH-(*)-33 for operation	30	38
Preventive maintenance. (See Maintenance, preventive.)		
Preventive maintenance check list:		
Film developing components	128	131
Film viewing components	156	171
Spotting components	51	50
Processing film	116	120

	<i>Paragraph</i>	<i>Page</i>
Reel DR-4, description	15	26
Reel Unit RL-31-(*):		
Description	14	24
Maintenance. (See TM 11-362.)		
Using	22	29
References, technical publications	App. II	181
Repacking:		
Developing Equipment PH-41	113	117
Drying Rack PH-42	113	117
Film Viewer PH-97-(*)	145	157
Line Connector Unit EE-87	27	34
Rewinder PH-92	145	157
Splicer PH-91-(*)	145	157
Theodolite MX-194/TVQ-1	86	96
Theodolite PH-(*)-33	27	34
Time Interval Device PH-103	27	34
Time Interval Multiplier PH-264-(*)	27	34
Time Interval Signal BE-65	27	34
Repairs:		
Developing Equipment PH-41	133	136
Drying Rack PH-42	134	136
Film Viewer PH-97-(*)	161	175
Rewinder PH-92:		
Description	138	151
Installation	143	156
Maintenance, preventive	153	169
Operation	146	159
Repacking	145	157
Rubber, preventive maintenance	37	46
Running spares:		
Film Viewer PH-97-(*)	152	169
Time Interval Device PH-103	40	47
Siting of spotting components:		
Spotting Set AN/TVQ-1	79	90
Spotting Set PH-32-(*)	19	27
Splicer PH-91-(*):		
Adjustment	163	177
Application	139	152
Installation	144	157
Maintenance	155	170
Operation	147	160
Repacking	145	157
Spotting Set AN/TVQ-1:		
Application	70	75
Components, table	71	79
Description	69	75
Distribution of components to stations	83	92
Electrical connections of spotting components	85	93
Group functioning of spotting components	92	102
Maintenance parts	App. I	179
Operation of spotting components	90	100

	<i>Paragraph</i>	<i>Page</i>
Performance check list	91	101
Power requirements	72	86
Preparing components for distribution to stations	82	92
Repacking	86	96
Siting	79	90
Volume	71	79
War Department Lubrication Orders	54	52
Weight	71	79
Spotting Set PH-32-(*):		
Application	2	4
Components, table	3	7
Description	1	3
Dimensions	3	7
Distribution of spotting components to stations	4	30
Electrical connections of spotting components	6	31
Group functioning of spotting components	61	61
Maintenance parts	App. I	179
Operation of spotting components	31	39
Power requirements	4	13
Preparing spotting components for distribution to stations	23	30
Preventive maintenance check list	51	50
Repacking	27	34
Siting, spotting components	19	27
Volume	3	7
War Department Lubrication Orders	54	52
Weight	3	7
Storage, photographic solution	116	120
Support, phototheodolite:		
Description	20	27
Location:		
Spotting Set AN/TVQ-1	80	91
Spotting Set PH-32-(*).	21	28
Tanks, preparing for film processing	115	119
Technical publications, references	App. II	181
Testing theodolite lines	28	36
Theodolite MX-194/TVQ-1:		
Description	74	87
Installation	84	93
Preparation for operation	89	98
Repacking	86	96
War Department Lubrication Order	54	52
Theodolite PH-(*)-33:		
Description	6	15
Installation	25	31
Preparation for operation	30	38
Repacking	27	34
War Department Lubrication Order	54	52
Theodolite lines:		
Adjusting current	28	36
Testing for continuity	28	36
Testing for grounds	28	36

	<i>Paragraph</i>	<i>Page</i>
Theodolite time counters, advancing	28	36
Time counters, theodolite, advancing	28	36
Time interval, adjusting	28	36
Time Interval Device PH-103:		
Description	9	16
Functioning	63	62
Maintenance	44	48
Moistureproofing and fungiproofing	59	55
Operation	28	36
Repacking	27	34
Replacing capacitor	44	48
Trouble shooting	66	67
Time Interval Multiplier PH-264-(*):		
Description	10	19
Functioning	64	65
Maintenance	45	49
Moistureproofing and fungiproofing	60	57
Operation	29	38
Repacking	27	34
Trouble shooting	67	70
Time Interval Signal BE-65, description	12	22
Trouble shooting:		
General information	65	67
Line Connector Unit EE-87. (<i>See</i> TM 11-433.)		
Phototheodolites. (<i>See</i> TM 11-2534.)		
Time Interval Device PH-103	66	67
Time Interval Multiplier PH-264-(*).	67	70
Time Interval Signal BE-65. (<i>See</i> TM 11-433.)		
Unsatisfactory equipment report	68	72
Viewing Attachment PH-98-(*):		
Description	137	141
Lubrication	158	172
Magnification, adjusting	162	176
Repair adjustments	162	176
Volumes of components:		
Spotting Set AN/TVQ-1	71	79
Spotting Set PH-32-(*).	3	7
War Department Lubrication Orders	52-54	51
Weights of components:		
Spotting Set AN/TVQ-1	71	79
Spotting Set PH-32-(*).	3	7
Wire W-110-B, description	15	26
Wiring between battery and flank stations	22	29

☆ U. S. GOVERNMENT PRINTING OFFICE: 1945—1945—672752

