

**ARMY TM 9-6115-756-13&P  
AIR FORCE TO 35C2-3-532-11  
NAVY TM 7610-LL-L1A-0023**

---

**TECHNICAL MANUAL**

**OPERATOR AND FIELD MAINTENANCE MANUAL  
INCLUDING REPAIR PARTS AND SPECIAL TOOLS LIST**

**FOR**

**POWER UNIT, DIESEL ENGINE DRIVEN,  
LIGHT TACTICAL TRAILER MOUNTED, AMMPS 10KW,  
50/60 HZ, PU-2002 (NSN: 6115-01-562-4010) (EIC: N/A)**

**POWER UNIT, DIESEL ENGINE DRIVEN,  
LIGHT TACTICAL TRAILER MOUNTED, AMMPS 10KW,  
400 HZ, PU-2012 (NSN: 6115-01-562-3907) (EIC: N/A)**

**POWER PLANT, DIESEL ENGINE DRIVEN,  
M200A1 TRAILER MOUNTED, AMMPS 10KW,  
50/60 HZ, PP-3102 (NSN: 6115-01-562-6480) (EIC: N/A)**

---

DISTRIBUTION STATEMENT A — Approved for public release; distribution is unlimited.

**HEADQUARTERS, DEPARTMENTS OF THE ARMY,  
AIR FORCE, AND NAVY**

**1 JUNE 2011**



## WARNING SUMMARY

### FIRST AID

For First Aid information, refer to Field Manual (FM) 4-25.11.



**5**

#### 5 SAFETY STEPS TO FOLLOW IF SOMEONE IS THE VICTIM OF ELECTRICAL SHOCK:

**1**

Do not try to pull or grab the individual.

**2**

If possible, turn off the electrical power.

**3**

If you cannot turn off the electrical power, pull, push, or lift the person to safety using a dry wooden pole, dry rope, or some other insulating material.

**4**

Send for help as soon as possible.

**5**

After the injured person is free of contact with the source of electrical shock, move the person a short distance away. Immediately start artificial respiration if necessary.

The Warning Summary summarizes critical safety and hazardous material warnings that must be understood and applied during operation and maintenance of the Advanced Medium Mobile Power Sources (AMMPS) generator sets.

- These warnings are important.
- Study and understand all warnings.
- These warnings can save your life and the lives of personnel with whom you work.
- Some general warnings found in the Warning Summary will not be repeated within the Technical Manual (TM).
- Specific warnings will be listed above the task or paragraph to which they apply.

Operation and maintenance of the AMMPS generator set contains many possibilities for injury or death to personnel. Be sure to be familiar with general first aid procedures as referenced in FM 4-25.11, First Aid.

## WARNING ICONS

The following icons are used in conjunction with warnings so that you do not miss important information. They are not meant to be a substitute for reading the warnings, but they give graphic descriptions of danger.



EAR PROTECTION — Headphones over ears shows that noise level will harm ears.



ELECTRICAL — Electrical wire to arm with electricity symbol running through human body shows that life-threatening shock hazard is present.



ELECTRICAL — Electrical wire to hand with electricity symbol running through hand shows that shock hazard is present.



FLYING PARTICLES — Objects striking person shows that the material presents a danger to life or health.



HEAVY OBJECT — Human figure stooping over heavy object shows physical injury potential from improper lifting technique.



HEAVY PARTS — Hand with heavy object on top shows that heavy parts can crush and harm.



HEAVY PARTS — Foot with heavy object on top shows that heavy parts can crush and harm.



HEAVY PARTS — Heavy object on human figure shows that heavy parts present a danger to life or limb.



HEAVY PARTS — Heavy object pinning human figure against a wall shows that heavy, moving parts present a danger to life or limb.



HOT AREA — Hand over object radiating heat shows that equipment is hot and can burn.



MOVING PARTS — Human figure with an arm caught between the gears shows that the larger moving parts of the equipment present a danger to life or limb.



MOVING PARTS — Hand with fingers caught between gears shows that the smaller moving parts of the equipment present a danger to life or limb.



SHARP OBJECT — Human hand being punctured shows equipment presents a danger to life or limb.

**WARNING DESCRIPTIONS**

**WARNING**



**Electrical**

- Direct Current (DC) voltages are present at generator set electrical components even with generator set shut down. Avoid shorting any positive with ground/negative. Do not ground yourself in standing water. Failure to comply may cause injury or death to personnel and damage to equipment.
- North Atlantic Treaty Organization (NATO) slave receptacle is electrically live at all times and is not protected by a fuse. Disconnecting main DC circuit breaker does not ensure the circuit is dead. This circuit is only dead when the batteries are fully disconnected. Disconnect both batteries before performing maintenance on the slave receptacle. Failure to comply may cause injury or death to personnel.
- Ensure generator sets are shut down and output terminal board has no voltage prior to making any connections for parallel operation or moving a generator set that has been operating in parallel. Operating generator sets always contain the risk of electrocution. Failure to comply may cause injury or death to personnel.
- High voltage is produced when this generator set is in operation. Ensure engine control and DEAD CRANK switches are set to OFF, negative battery cable is disconnected, and unit is completely shut down and free of any power source before attempting any troubleshooting or maintenance on unit. Failure to comply may cause injury or death to personnel.
- High voltage is produced when this generator set is in operation. Do not contact output cables when operating this generator set. Failure to comply may cause injury or death to personnel.
- High-voltage power is available when the main contactor is closed. Avoid accidental contact with live components. Ensure load cables are properly connected and the load cable door is shut before closing main contactor. Ensure that personnel working with/on loads connected to the generator set are aware that main contactor is about to be closed before closing main contactor. Failure to comply may cause injury or death to personnel.
- Shut down generator sets before performing inspection of load cables. Failure to comply may cause injury or death to personnel by electrocution.
- Ensure equipment/vehicles being used to jump-start the generator set are not touching. Touching of metal surfaces can cause improper grounding. Do not allow the cable ends to touch each other or any part of the generator set/vehicle/equipment other than the NATO slave receptacle. Failure to comply may cause injury or death to personnel.
- High voltage is produced when generator set is in operation. Never attempt to start the generator set unless it is properly grounded. Do not ground yourself in standing water. Never attempt to connect or disconnect load cables while the generator sets are running. Failure to comply may cause injury or death to personnel.

## WARNING



### Heat

- Allow engine to cool from normal operating temperature prior to draining engine oil and removing oil filter. Failure to comply may cause injury or death to personnel.
- When operating, generator set engine has hot metal surfaces that will burn flesh on contact. Shut down generator set and allow engine to cool before checks, services, and maintenance. Wear gloves and additional protective clothing as required. Failure to comply may cause injury or death to personnel.

## WARNING



### Jewelry/Clothing

- Metal jewelry can conduct electricity and become entangled in generator set components. Remove all jewelry and do not wear loose clothing when working on equipment. Failure to comply may cause injury or death to personnel.
- While inspecting the operation of the generator set, do not inadvertently reach into the generator set. Failure to comply may cause injury or death to personnel.

## WARNING



### Lifting

- Support components when removing/installing the attaching hardware or component may fall. Failure to comply may cause injury or death to personnel and damage to equipment.
- Comply with all lifting requirements. Observe the decals on equipment and parts that identify the weight and determine if an assistant is needed. Maximum lift is 37 pounds (lb) (16.8 kilograms (kg)) for one person, 74 lb (33.6 kg) for two persons, and 101 lb (45.8 kg) for three persons. Failure to comply may cause injury or death to personnel.
- The components being lifted weigh greater than 40 lb (18.14 kg). Two personnel or a suitable lifting device are necessary to lift component. Failure to comply may cause injury or death to personnel.
- When lifting generator set, use lifting equipment with minimum lifting capacity of 1000 lb (453.6 kg). Do not stand or put arms, legs, or any body part under hoisted load. Do not permit generator set to swing. Failure to comply may cause injury or death to personnel.

## WARNING



### Trailer

- Trailers must be secured to prohibit movement prior to performing Preventive Maintenance Checks and Services (PMCS) or connecting ground and output cables. Failure to comply may cause injury or death to personnel.
- Be sure brakes are operating properly before driving at normal speeds. Failure to comply may cause injury or death to personnel.



HAZARDOUS MATERIALS ICONS



BIOLOGICAL — Abstract symbol bug shows that a material may contain bacteria or viruses that present a danger to life or health.



CHEMICAL — Drops of liquid on hand shows that the material will cause burns or irritation to human skin or tissue.



CRYOGENIC — Hand in block of ice shows that the material is extremely cold and can injure human skin or tissue.



EXPLOSION — Rapidly expanding symbol shows that the material may explode if subjected to high temperatures, source of ignition or high pressure.



EYE PROTECTION — Person with goggles shows that the material will injure the eyes.



FIRE — Flame shows that a material may ignite and cause burns.



HIGH PRESSURE — Human hand being penetrated by high pressure shows system pressures present a danger to life or limb.



POISON — Skull and crossbones shows that a material is poisonous or is a danger to life.



RADIATION — Three circular wedges shows that the material emits radioactive energy and can injure human tissue.



VAPOR — Human figure in a cloud shows that material vapors present a danger to life or health.

## HAZARDOUS MATERIALS WARNINGS DESCRIPTIONS

There is a potential risk that soldiers and other users may be exposed to chemical substances and diesel engine exhaust during the operation, maintenance, and repair of the AMMPS generator sets.

Potential sources of chemical substances include fuels, oils, lubricants, paints, cleaners/solvents, engine coolant fluids, cold start fluid, fire extinguishing agents, battery acid/chemicals, and miscellaneous chemicals used during the setup/operation/maintenance and sustainment throughout the life-cycle of the AMMPS generator sets.

### WARNING



This manual describes physical and chemical processes that may require the use of chemicals, solvents, paints, and/or other commercially available material. Users of the manual should obtain the Material Safety Data Sheets (MSDS), Occupational Safety and Health Act (OSHA) Form 20, or the equivalent from the manufacturers or suppliers of materials to be used. Failure to comply with all procedures, recommendations, warnings and cautions for safe use, handling, storage, and disposal of these materials may result in serious injury or death to personnel.

### WARNING



#### Cleaning

Cleaning solvent is combustible and toxic to eyes, skin, and respiratory tract. Skin and eye protection is required. Avoid repeated or prolonged contact. Work in ventilated area only. Failure to comply may cause injury or death to personnel.

### WARNING



#### Cold

In extremely cold weather, skin can stick to metal. Avoid contacting metal items with bare skin in extremely cold weather. Failure to comply may cause injury or death to personnel.

**WARNING**



**Exhaust**

- Exhaust discharge contains deadly gases, including carbon monoxide. Exhaust gases are most dangerous in places with poor ventilation. Do not operate generator set in an enclosed area unless exhaust discharge is properly vented. Failure to comply may cause injury or death to personnel.
- Hot exhaust gases can ignite combustible materials. Allow room for safe discharge of hot gases. Failure to comply may cause injury or death to personnel.
- Exhaust gases are most dangerous in places with poor ventilation. The best defense against exhaust gas poisoning is very good ventilation. To protect yourself and others, always obey the following rules:
  - Do not run engine indoors unless you have very good ventilation.
  - Do not idle engine for a long time unless there is very good ventilation.
  - Be alert at all times. Check for smell of exhaust fumes.
  - Failure to comply may cause injury or death to personnel.
- Exhaust gas poisoning causes dizziness, headache, loss of muscle control, sleepiness, coma, and death. If anyone shows signs of exhaust gas poisoning, get all personnel clear of AMMPS. Make sure they have lots of fresh air. Keep them warm, calm, and inactive. Get medical help. If anyone stops breathing, give artificial respiration. Failure to comply may cause injury or death to personnel.

**WARNING**



**Eye**

Flying debris or material may enter eyes or strike the face. Wear appropriate eye/face protection while performing maintenance tasks. Failure to comply may cause injury or death to personnel.

**WARNING**



**Fuel**

- Fuel is combustible and toxic to eyes, skin, and respiratory tract. Skin and eye protection are required when working in contact with fuel. Avoid repeated or prolonged contact. Provide adequate ventilation. Operators are to wash exposed skin and change soaked clothing promptly if exposed to fuel. Failure to comply may cause injury or death to personnel.

**WARNING**



**Fuel — Continued.**

- Fuels used in the generator set are combustible. Do not smoke or use open fire when performing maintenance. Fire and possible explosion may result. Failure to comply may cause injury or death to personnel and damage to equipment.
- Fuels used in the generator set are combustible. Ensure fuel source grounding strap is connected to unit fuel fill grounding stud (fuel fill static ground). When filling the fuel tank, maintain metal-to-metal contact between filler nozzle and fuel tank opening to eliminate Electrostatic Discharge (ESD). Fire and possible explosion can result. Failure to comply may cause injury or death to personnel.
- Do not operate generator set if any fuel leaks are present. Fuel is combustible. Always perform PMCS before operation. Failure to comply may cause injury or death to personnel.
- Hot engine surfaces from engine and generator circuitry are possible sources of ignition. When refueling during unit operation with Diesel Fuel (DF)-1, DF-2, Jet Petroleum (JP)5, or JP8, avoid fuel splash and fuel spill. Do not smoke or use open flame when performing refueling. Remember PMCS are still required. Flames and possible explosion may result. Failure to comply may cause injury or death to personnel.

**WARNING**



**Noise**

- Hearing protection required during maintenance or repair with engine running. Failure to comply can cause hearing loss.

## LIST OF EFFECTIVE PAGES/WPs

NOTE: Zero in the "Change No." column indicates an original page or work package.

Date of issue for the original manual is:

Original 1 June 2011

**TOTAL NUMBER OF PAGES FOR FRONT MATTER AND REAR MATTER IS 54 AND TOTAL NUMBER OF WORK PACKAGES IS 60, CONSISTING OF THE FOLLOWING:**

Page/WP No.	Change No.	Page/WP No.	Change No.
Front cover	0	Chp 6 index	0
Blank	0	WP 0013 (6 pgs)	0
Warning summary (10 pgs)	0	WP 0014 (4 pgs)	0
i – xvi	0	WP 0015 (2 pgs)	0
Chp 1 title page	0	WP 0016 (4 pgs)	0
Chp 1 index	0	WP 0017 (4 pgs)	0
WP 0001 (8 pgs)	0	WP 0018 (4 pgs)	0
WP 0002 (6 pgs)	0	WP 0019 (4 pgs)	0
WP 0003 (2 pgs)	0	WP 0020 (10 pgs)	0
Chp 2 title page	0	WP 0021 (12 pgs)	0
Chp 2 index	0	WP 0022 (4 pgs)	0
WP 0004 (2 pgs)	0	WP 0023 (4 pgs)	0
WP 0005 (26 pgs)	0	WP 0024 (6 pgs)	0
WP 0006 (4 pgs)	0	WP 0025 (6 pgs)	0
Chp 3 title page	0	WP 0026 (6 pgs)	0
Chp 3 index	0	WP 0027 (18 pgs)	0
WP 0007 (2 pgs)	0	WP 0028 (6 pgs)	0
WP 0008 (8 pgs)	0	WP 0029 (4 pgs)	0
Chp 4 title page	0	WP 0030 (6 pgs)	0
Chp 4 index	0	WP 0031 (10 pgs)	0
WP 0009 (4 pgs)	0	WP 0032 (4 pgs)	0
WP 0010 (6 pgs)	0	WP 0033 (4 pgs)	0
Chp 5 title page	0	WP 0034 (2 pgs)	0
Chp 5 index	0	Chp 7 title page	0
WP 0011 (4 pgs)	0	Chp 7 index	0
WP 0012 (18 pgs)	0	WP 0035 (6 pgs)	0
Chp 6 title page	0	WP 0036 (6 pgs)	0

<b>Page/WP No.</b>	<b>Change No.</b>	<b>Page/WP No.</b>	<b>Change No.</b>
WP 0037 (4 pgs)	0	FP 1	0
WP 0038 (4 pgs)	0	FP 2 BLANK	0
WP 0039 (4 pgs)	0	FP 3	0
WP 0040 (4 pgs)	0	FP 4 BLANK	0
WP 0041 (6 pgs)	0	Inside back cover	0
WP 0042 (4 pgs)	0	Back cover	0
WP 0043 (4 pgs)	0		
WP 0044 (4 pgs)	0		
WP 0045 (6 pgs)	0		
WP 0046 (4 pgs)	0		
WP 0047 (4 pgs)	0		
WP 0048 (10 pgs)	0		
WP 0049 (4 pgs)	0		
WP 0050 (6 pgs)	0		
WP 0051 (2 pgs)	0		
WP 0052 (2 pgs)	0		
WP 0053 (2 pgs)	0		
WP 0054 (4 pgs)	0		
Chp 8 title page	0		
Chp 8 index	0		
WP 0055 (2 pgs)	0		
WP 0056 (4 pgs)	0		
WP 0057 (4 pgs)	0		
WP 0058 (8 pgs)	0		
WP 0059 (2 pgs)	0		
WP 0060 (2 pgs)	0		
Glossary-1 – Glossary-2	0		
INDEX-1 –INDEX-12	0		

HEADQUARTERS,  
DEPARTMENTS OF THE ARMY,  
AIR FORCE, AND NAVY  
WASHINGTON, D.C., 1 JUNE 2011

TECHNICAL MANUAL  
OPERATOR AND FIELD MAINTENANCE MANUAL  
INCLUDING REPAIR PARTS AND SPECIAL TOOLS LIST

FOR

POWER UNIT, DIESEL ENGINE DRIVEN, LIGHT TACTICAL TRAILER MOUNTED, AMMPS 10KW, 50/60 HZ,  
PU-2002 (NSN: 6115-01-562-4010) (EIC: N/A)

POWER UNIT, DIESEL ENGINE DRIVEN, LIGHT TACTICAL TRAILER MOUNTED, AMMPS 10KW, 400 HZ,  
PU-2012 (NSN: 6115-01-562-3907) (EIC: N/A)

POWER PLANT, DIESEL ENGINE DRIVEN, M200A1 TRAILER MOUNTED, AMMPS 10KW, 50/60 HZ,  
PP-3102 (NSN: 6115-01-562-6480) (EIC: N/A)

**REPORTING ERRORS AND RECOMMENDING IMPROVEMENTS**

You can help improve this manual. If you find any mistakes or if you know of a way to improve the procedures, please let us know. Reports, as applicable by the requiring service, should be submitted as follows:

- (a) (A) Army - Mail your letter or DA Form 2028 (Recommended Changes to Publications and Blank Forms) located in the back of this manual, directly to: Commander, U.S. Army CECOM Life Cycle Management Command (LCMC), ATTN: AMSEL-LCL-ECM, Aberdeen Proving Ground, MD 21005-1846. You may also send in your recommended changes via electronic mail or by fax. Our fax number is 443-861-5521, DSN 848-5521. Our e-mail address is [MONM-AMSELLEOPUBSCHG@conus.army.mil](mailto:MONM-AMSELLEOPUBSCHG@conus.army.mil). Our online web address for entering and submitting DA Form 2028s is <http://edm.apg.army.mil/pubs/2028.html>.
- (b) (N) Navy — By letter directly to Commander, Space and Naval Warfare Systems Command, ATTN: SPAWAR 8122, Washington, DC 20363-5100.
- (c) (F) Air Force — By Air Force AFTO Form 22 TM Change Recommendation and Reply in accordance with paragraph 6-5, Section VI, TO 00-5-1 directly to prime ALC/MST.

A reply will be furnished to you.

## TABLE OF CONTENTS

	<b>Page No.</b>
	<b><u>WP Sequence No.</u></b>
How to Use This Manual	
<b>Chapter 1 — General Information, Equipment Description, and Theory of Operation</b>	
General Information .....	WP 0001
Scope .....	WP 0001-1
Type of Manual .....	WP 0001-1
Model Number(s) and Equipment Name(s) .....	WP 0001-1
Table 1. Model Number(s) and Equipment Name(s) .....	WP 0001-1
Purpose of Equipment .....	WP 0001-1
Figure 1. PU-2002 and PU-2012 Roadside and Curbside View .....	WP 0001-2
Figure 2. PP-3102 Roadside and Curbside View .....	WP 0001-3
Maintenance Forms, Records, and Reports .....	WP 0001-4
Reporting Equipment Improvement Recommendations (EIR) .....	WP 0001-4
Corrosion Prevention and Control (CPC) .....	WP 0001-4
Ozone-Depleting Substances (ODS) .....	WP 0001-5
Destruction of Army Materiel to Prevent Enemy Use .....	WP 0001-5
Preparation for Storage or Shipment .....	WP 0001-5
Warranty Information .....	WP 0001-5
Nomenclature Cross Reference List .....	WP 0001-5
List of Abbreviations/Acronyms .....	WP 0001-6
Equipment Description And Data .....	WP 0002
Equipment Characteristics, Capabilities, and Features .....	WP 0002-1
Table 1. AMMPS 10 kW PU and PP Models .....	WP 0002-1
Location and Description of Major Components .....	WP 0002-1
Generator Sets (MEP 1040 and MEP 1041) .....	WP 0002-1
Switch Box Assembly P/N 04-21329 .....	WP 0002-2
Figure 1. PU-2002 and PU-2012 Curbside View .....	WP 0002-2
Figure 2. PP-3102 Roadside and Curbside View .....	WP 0002-3
Trailers .....	WP 0002-4
LTT .....	WP 0002-4
M200A1 Trailer .....	WP 0002-4
Accessory Box .....	WP 0002-4
Differences Between Models .....	WP 0002-4
Table 2. Differences Between Models .....	WP 0002-4
Equipment Data .....	WP 0002-5
Table 3. Equipment Data .....	WP 0002-5
Theory Of Operation .....	WP 0003
Operation .....	WP 0003-1
Technical Principles of Operation .....	WP 0003-1
PU Functional Description .....	WP 0003-1
PP Functional Description .....	WP 0003-1



**TABLE OF CONTENTS — CONTINUED.**

	<b>Page No.</b>
	<b>WP Sequence No.</b>
<b>Chapter 2 — Operator Instructions</b>	
Description And Use Of Operator Controls And Indicators .....	WP 0004
Introduction .....	WP 0004-1
Generator Set MEP 1040 and MEP 1041 .....	WP 0004-1
LTT .....	WP 0004-1
M200A1 .....	WP 0004-1
Switch Box Assembly .....	WP 0004-1
Figure 1. Switch Box Indicators .....	WP 0004-2
Table 1. Switch Box Indicators .....	WP 0004-2
Operation Under Usual Conditions.....	WP 0005
Siting Requirements .....	WP 0005-2
Assembly and Preparation for Use.....	WP 0005-3
Unpacking the PU and PP .....	WP 0005-3
Grounding (PU-2002 and PU-2012).....	WP 0005-4
Figure 1. Grounding Cables Installation for PU-2002 and PU-2012 .....	WP 0005-4
Figure 2. Install Ground Rod with Slide Hammer .....	WP 0005-6
Figure 3. Install Ground Rod with Sledge Hammer.....	WP 0005-7
Grounding (PP-3102) .....	WP 0005-9
Figure 4. Grounding PP-3102.....	WP 0005-9
Removal of Ground Rod.....	WP 0005-10
Connection to Load (PU-2002 and PU-2012) .....	WP 0005-11
Table 1. Load Terminal Selection.....	WP 0005-11
Connection to Load (PP-3102).....	WP 0005-12
Figure 5. Installation of Load and Ground Cables.....	WP 0005-12
Initial Adjustments .....	WP 0005-13
Figure 6. Rear Leg Prop .....	WP 0005-13
Operating Procedures .....	WP 0005-14
Generator Set Operating Procedures.....	WP 0005-14
Trailer Operating Procedures .....	WP 0005-14
Switch Box Operating Procedures .....	WP 0005-14
Decals and Instruction Plates .....	WP 0005-15
Figure 7. Location of Plates and Labels — PU-2002 and PU-2012.....	WP 0005-15
Table 2. Decals and Instruction Plates — PU-2002 and PU-2012.....	WP 0005-15
Figure 8. Location of Plates and Labels — PP-3102 Curbside .....	WP 0005-16
Table 3. Decals and Instruction Plates — PP-3102 .....	WP 0005-17
Figure 9. Location of Plates and Labels — PP-3102 Roadside .....	WP 0005-17
Table 4. Decals and Instruction Plates — PP-3102 .....	WP 0005-17
Figure 10. Plate, PU Identification, PU-2002.....	WP 0005-18
Figure 11. Plate, PU Identification, PU-2012.....	WP 0005-18
Figure 12. Plate, ID LTT Trailer.....	WP 0005-19
Figure 13. Plate, Name Identification, Chassis, LTT Trailer.....	WP 0005-19
Figure 14. Plate, PU Identification (IUID), PU-2002.....	WP 0005-20
Figure 15. Plate, PU Identification (IUID), PU-2012.....	WP 0005-20
Figure 16. Plate, Status, Switch Box .....	WP 0005-21

**TABLE OF CONTENTS — CONTINUED.**

	<b>Page No.</b>
	<b>WP Sequence No.</b>
Figure 17. Plate, Switch Box Schematic .....	WP 0005-21
Figure 18. Plate, Switch Box Identification .....	WP 0005-22
Figure 19. Plate, Operating Procedures .....	WP 0005-22
Figure 20. Plate, On Line, Switch Box.....	WP 0005-23
Figure 21. Plate, Name Identification, M200A1 Chassis, Trailer.....	WP 0005-23
Figure 22. Plate, Tie Down Instruction, M200A1 Trailer.....	WP 0005-23
Figure 23. Plate, ID M200A1 Trailer .....	WP 0005-24
Figure 24. Plate, PP Identification, PP-3102 .....	WP 0005-24
Figure 25. Plate, PP Identification (IUID), PP-3102 .....	WP 0005-25
Preparation for Movement .....	WP 0005-25
Operation Under Unusual Conditions .....	WP 0006
Unusual Environment/Weather.....	WP 0006-1
Operation in Extreme Cold (Below-25°F (-31°C)) .....	WP 0006-1
Operation in Extreme Heat (Above 120°F (49°C)) .....	WP 0006-2
Operation in Sandy or Dusty Areas .....	WP 0006-3
Operation in Snow .....	WP 0006-3
Operation in Saltwater Areas.....	WP 0006-3
Operation in Mud .....	WP 0006-3
Fording.....	WP 0006-4

**Chapter 3 — Operator Troubleshooting Procedures**

Troubleshooting Index .....	WP 0007
General Troubleshooting Information .....	WP 0007-1
10 kW Generator Set Troubleshooting .....	WP 0007-1
LTT Troubleshooting .....	WP 0007-1
M200A1 Trailer Troubleshooting .....	WP 0007-1
Malfunction/Symptom Index .....	WP 0007-1
DCS Fault and Warning Codes .....	WP 0007-1
Indications from Manual Troubleshooting Techniques .....	WP 0007-1
After Corrective Action.....	WP 0007-2
Specific Troubleshooting Procedures.....	WP 0007-2
Troubleshooting Procedures .....	WP 0008

**Chapter 4 — Operator Maintenance Instructions**

Operator PMCS Introduction .....	WP 0009
Introduction .....	WP 0009-1
General .....	WP 0009-1
Explanation of the Columns Found in PMCS Table .....	WP 0009-1
Corrosion Prevention and Control (CPC) .....	WP 0009-1
Rust Definition .....	WP 0009-2
Deterioration Definition .....	WP 0009-2
Cracking Definition.....	WP 0009-2
Inspection .....	WP 0009-2
Cleaning and Lubrication.....	WP 0009-3

**TABLE OF CONTENTS — CONTINUED.**

	<b>Page No.</b>
	<b>WP Sequence No.</b>
Oil Filters.....	WP 0009-3
AOAP Sampling.....	WP 0009-3
Warranty Hardtime .....	WP 0009-3
Fuel Leakage .....	WP 0009-3
Operator PMCS .....	WP 0010
Table 1. PMCS for the AMMPS 10 kW PU and PP.....	WP 0010-1
Lubrication Instructions.....	WP 0010-6
 <b>Chapter 5 — Field Troubleshooting Procedures</b>	
Troubleshooting Index .....	WP 0011
General Troubleshooting Information .....	WP 0011-1
10 kW Generator Set Troubleshooting .....	WP 0011-1
LTT Troubleshooting .....	WP 0011-1
M200A1 Trailer Troubleshooting .....	WP 0011-1
Malfunction/Symptom Index .....	WP 0011-1
DCS Fault and Warning Codes .....	WP 0011-1
Indications from Manual Troubleshooting Techniques.....	WP 0011-2
After Corrective Action.....	WP 0011-2
Specific Troubleshooting Procedures.....	WP 0011-2
Troubleshooting Procedures .....	WP 0012
 <b>Chapter 6 — Field Maintenance Instructions</b>	
Service Upon Receipt.....	WP 0013
Siting.....	WP 0013-2
Service Upon Receipt of Materiel.....	WP 0013-2
Unpacking.....	WP 0013-2
Packing .....	WP 0013-2
Checking Unpacked Equipment.....	WP 0013-3
Installation Instructions .....	WP 0013-3
Installation of Ground Rod.....	WP 0013-3
Installation of Auxiliary Fuel Drum Adapter .....	WP 0013-4
Figure 1. Fuel Drum Adapter Assembly .....	WP 0013-5
Preliminary Checks and Adjustment of Equipment .....	WP 0013-6
Field PMCS Introduction.....	WP 0014
Introduction .....	WP 0014-1
General .....	WP 0014-1
Explanation of the Columns Found in PMCS Table .....	WP 0014-1
CPC .....	WP 0014-1
Rust Definition .....	WP 0014-2
Deterioration Definition .....	WP 0014-2
Cracking Definition .....	WP 0014-2
Inspection .....	WP 0014-2
Cleaning and Lubrication.....	WP 0014-3
Oil Filters.....	WP 0014-3

**TABLE OF CONTENTS — CONTINUED.**

	<b>Page No.</b>
	<b>WP Sequence No.</b>
AOAP Sampling.....	WP 0014-3
Warranty Hardtime.....	WP 0014-3
Fluid Leakage.....	WP 0014-4
Field PMCS.....	WP 0015
Field PMCS Instructions.....	WP 0015-1
Lubrication Instructions.....	WP 0015-1
Drain Generator Set Engine Oil.....	WP 0016
Drain Generator Set Engine Oil.....	WP 0016-2
Figure 1. PU-2002 and PU-2012 Engine Oil Drain Port — Location.....	WP 0016-2
Figure 2. PP-3102 Engine Oil Drain Port — Location.....	WP 0016-3
Figure 3. Engine Oil Drain Hose — Installation.....	WP 0016-3
Drain Generator Set Fuel.....	WP 0017
Drain Generator Set Fuel.....	WP 0017-1
Figure 1. PU-2002 and PU-2012 Fuel Drain Port — Location.....	WP 0017-2
Figure 2. PP-3102 Fuel Drain Port — Location.....	WP 0017-2
Figure 3. Fuel Drain Hose — Installation.....	WP 0017-3
Remove/Install Generator Set.....	WP 0018
Remove Generator Set.....	WP 0018-1
Figure 1. PU-2002 or PU-2012 Generator Set — Location.....	WP 0018-2
Figure 2. PP-3102 Generator Set — Location.....	WP 0018-2
Figure 3. Generator Set — Removal.....	WP 0018-3
Inspect Generator Set Mounting Location.....	WP 0018-4
Install Generator Set.....	WP 0018-4
Replace Mounting Rail.....	WP 0019
Replace Mounting Rail (PU-2002 and PU-2012).....	WP 0019-2
Figure 1. Mounting Rail PU-2002 and PU-2012 — Location.....	WP 0019-2
Replace Mounting Rail (PP-3102).....	WP 0019-3
Figure 2. Mounting Rail PP-3102 — Location.....	WP 0019-3
Figure 3. Rail Assembly PP-3102 — Detail.....	WP 0019-4
Replace Trailer Fender.....	WP 0020
Replace Fender (PU-2002 and PU-2012).....	WP 0020-2
Figure 1. Fender (PU-2002 and PU-2012) — Location.....	WP 0020-2
Figure 2. Fender (PU-2002 and PU-2012) — Detail.....	WP 0020-3
Figure 3. Curbside Fender ID Labels — Location.....	WP 0020-4
Figure 4. Rear Tail Light and Electrical Wiring — Detail.....	WP 0020-4
Figure 5. Reflector and Rear Marker Light and Electrical Wiring — Detail.....	WP 0020-5
Replace Fender (PP-3102).....	WP 0020-7
Figure 6. Fender (PP-3102) — Location.....	WP 0020-7
Figure 7. Fender (PP-3102) — Detail.....	WP 0020-8
Remove/Install Trailer Floor Plates, Platform, and Step.....	WP 0021
Remove Center Floor Plate (PU-2002 and PU-2012).....	WP 0021-2
Figure 1. Trailer PU-2002 and PU-2012 Floor Plates — Location.....	WP 0021-2
Inspect Center Floor Plate (PU-2002 and PU-2012).....	WP 0021-3
Install Center Floor Plate (PU-2002 and PU-2012).....	WP 0021-3
Remove Inner Side Floor Plate (PU-2002 and PU-2012).....	WP 0021-3
Inspect Inner Side Floor Plate (PU-2002 and PU-2012).....	WP 0021-4
Install Inner Side Floor Plate (PU-2002 and PU-2012).....	WP 0021-4
Remove Side Floor Plate (PU-2002 and PU-2012).....	WP 0021-4

**TABLE OF CONTENTS — CONTINUED.**

	<b>Page No.</b>
	<b>WP Sequence No.</b>
Inspect Side Floor Plate (PU-2002 and PU-2012) .....	WP 0021-4
Install Side Floor Plate (PU-2002 and PU-2012).....	WP 0021-4
Remove Platform (PP-3102) .....	WP 0021-5
Figure 2. Trailer PP-3102, Platform and Step — Location.....	WP 0021-5
Figure 3. Trailer Lights Cable and Plug Clamp — Detail .....	WP 0021-6
Figure 4. Platform, Step, and Chassis — Detail.....	WP 0021-7
Inspect Platform (PP-3102) .....	WP 0021-7
Install Platform (PP-3102) .....	WP 0021-8
Remove Step (PP-3102) .....	WP 0021-8
Figure 5. Brake Cable Bracket — Detail .....	WP 0021-9
Figure 6. ID Plates — Detail .....	WP 0021-10
Inspect Step (PP-3102) .....	WP 0021-10
Install Step (PP-3102) .....	WP 0021-11
Remove/Install Fire Extinguisher Bracket .....	WP 0022
Remove Fire Extinguisher Bracket.....	WP 0022-2
Figure 1. Fire Extinguisher Bracket PU-2002 and PU-2012 — Location .....	WP 0022-2
Figure 2. Fire Extinguisher Bracket PP-3102 — Location.....	WP 0022-2
Figure 3. Fire Extinguisher Bracket — Detail .....	WP 0022-3
Install Fire Extinguisher Bracket.....	WP 0022-4
Remove/Install Ground Terminal.....	WP 0023
Remove Ground Terminal .....	WP 0023-2
Figure 1. Ground Terminal PU-2002 and PU-2012 — Location .....	WP 0023-2
Figure 2. Ground Terminal PP-3102 — Location .....	WP 0023-3
Figure 3. Ground Terminal — Detail .....	WP 0023-4
Install Ground Terminal .....	WP 0023-4
Remove/Install Accessory Box.....	WP 0024
Remove Accessory Box (PU-2002 and PU-2012) .....	WP 0024-1
Figure 1. Accessory Box PU-2002 and PU-2012 — Location.....	WP 0024-2
Figure 2. Accessory Box PU-2002 and PU-2012 — Detail .....	WP 0024-2
Install Accessory Box (PU-2002 and PU-2012) .....	WP 0024-3
Remove Accessory Box (PP-3102).....	WP 0024-4
Figure 3. Accessory Box PP-3102 — Location .....	WP 0024-4
Figure 4. Accessory Box PP-3102 — Detail.....	WP 0024-5
Install Accessory Box (PP-3102).....	WP 0024-5
Remove/Install Switch Box Assembly .....	WP 0025
Remove Switch Box Assembly.....	WP 0025-1
Figure 1. Switch Box (PP-3102) — Location.....	WP 0025-2
Figure 2. Removal of Wiring Harness from Generator .....	WP 0025-2
Figure 3. Switch Box — Removal.....	WP 0025-3
Inspect Switch Box Assembly.....	WP 0025-4
Install Switch Box Assembly.....	WP 0025-4
Repair Switch Box Housing .....	WP 0026
Replace Switch Box Cover .....	WP 0026-1
Figure 1. Switch Box Cover — Removal .....	WP 0026-2
Replace Latch.....	WP 0026-3
Figure 2. Replace Latch .....	WP 0026-3
Replace Output Terminal Cover .....	WP 0026-4
Figure 3. Replace Output Terminal Cover.....	WP 0026-4

**TABLE OF CONTENTS — CONTINUED.**

	<b>Page No.</b>
	<b>WP Sequence No.</b>
Replace Switch Box Components .....	WP 0027
Test Contactor .....	WP 0027-2
Figure 1. Switch Box Components — Location .....	WP 0027-3
Figure 2. Contactor — Terminals .....	WP 0027-4
Replace Output Terminal Stud and Output Terminal Board .....	WP 0027-6
Figure 3. Output Terminal Stud and Output Terminal Board — Removal.....	WP 0027-6
Replace Contactor .....	WP 0027-9
Figure 4. Contactor — Removal.....	WP 0027-9
Figure 5. Contactor — Labels.....	WP 0027-10
Figure 6. Contactor Wiring — Removal.....	WP 0027-11
Replace Control Cable .....	WP 0027-12
Figure 7. Control Cable — Removal.....	WP 0027-13
Replace Control Card .....	WP 0027-14
Figure 8. Control Card — Removal .....	WP 0027-15
Replace Indicator Light.....	WP 0027-16
Figure 9. Indicator Light — Removal .....	WP 0027-16
Figure 10. Indicator Light Wiring — Removal.....	WP 0027-17
Remove/Install Switch Box Wiring Harness .....	WP 0028
Remove Switch Box Wiring Harness.....	WP 0028-1
Figure 1. Wiring Harnesses PP-3102 — Location.....	WP 0028-2
Figure 2. Wiring Harness Removal from Contactor.....	WP 0028-3
Figure 3. Wiring Harness Removal from Output Terminal Studs .....	WP 0028-3
Figure 4. Wiring Harness — Removal.....	WP 0028-4
Inspect Switch Box Wiring Harness.....	WP 0028-5
Install Switch Box Wiring Harness.....	WP 0028-5
Replace Trailer Leg Prop Assembly .....	WP 0029
Replace Trailer Leg Prop Assembly .....	WP 0029-1
Figure 1. Trailer Leg Prop Assembly — Location.....	WP 0029-2
Figure 2. Leg Prop Assembly — Detail 1 .....	WP 0029-3
Figure 3. Leg Prop Assembly — Detail 2 .....	WP 0029-4
Remove/Install Hand Brake Modification.....	WP 0030
Remove Hand Brake Bracket (PP-3102) .....	WP 0030-2
Figure 1. Hand Brake Bracket — Location.....	WP 0030-2
Figure 2. Hand Brake Bracket and Hand Brake — Detail .....	WP 0030-3
Figure 3. Brake Cable Connection to Hand Brake — Detail .....	WP 0030-4
Install Hand Brake Bracket (PP-3102) .....	WP 0030-4
General Maintenance .....	WP 0031
Using a Fire Extinguisher .....	WP 0031-1
General Fuel Requirements .....	WP 0031-2
Table 1. Diesel Fuel.....	WP 0031-2
Using a Multimeter.....	WP 0031-2
Repair Electrical Connectors .....	WP 0031-4
Figure 1. Simple Crimp-On Ring Connector.....	WP 0031-4
Figure 2. Multipin Connector Repair.....	WP 0031-5
Remove/Install P-Clamps .....	WP 0031-6
Remove P-Clamps.....	WP 0031-6
Figure 3. P-Clamp — Removal.....	WP 0031-6
Install P-Clamps.....	WP 0031-7

**TABLE OF CONTENTS — CONTINUED.**

	<b>Page No.</b>
	<b>WP Sequence No.</b>
Jump Starting a Generator Set on PU and PP.....	WP 0031-7
Figure 4. NATO Slave Receptacle — Location.....	WP 0031-8
Install Clinch Nut.....	WP 0031-9
Figure 5. Clinch Nut to Rivet Tool.....	WP 0031-9
Figure 6. Install Clinch Nut to Panel.....	WP 0031-10
Figure 7. Remove Rivet Nut Tool.....	WP 0031-11
Figure 8. Installed Clinch Nut.....	WP 0031-12
Lubrication Instructions.....	WP 0032
Table 1. Lubrication Order.....	WP 0032-2
Lubricate Hinges and Latches.....	WP 0032-2
Figure 1. Hinge and Latch Locations (PU-2002 and PU-2012) — Curbside.....	WP 0032-2
Figure 2. Hinge and Latch Locations (PP-3102).....	WP 0032-3
Table 2. Table of Lubricant — Hinges and Latches.....	WP 0032-3
Torque Limits.....	WP 0033
Scope.....	WP 0033-1
Table 1. Special Torque Limits.....	WP 0033-2
How to Use Torque Table.....	WP 0033-3
Figure 1. Screw/Bolt Measurement.....	WP 0033-3
Table 2. Standard Torque Limits.....	WP 0033-4
Wiring Diagrams.....	WP 0034
Introduction.....	WP 0034-1
Scope.....	WP 0034-1
Wire Identification.....	WP 0034-1
Abbreviations.....	WP 0034-1
Wiring Diagrams.....	WP 0034-1

**Chapter 7 — Parts Information**

RPSTL Introduction.....	WP 0035
Introduction.....	WP 0035-1
Scope.....	WP 0035-1
General.....	WP 0035-1
Explanation of Columns in the Repair Parts List and Special Tools List WPs.....	WP 0035-1
Table 1. SMR Code Explanation.....	WP 0035-2
Source Code Application/Explanation.....	WP 0035-2
Explanation of Cross Reference Indexes Work Packages Formats and Columns.....	WP 0035-5
Special Information.....	WP 0035-5
How to Locate Repair Parts.....	WP 0035-6
Abbreviations.....	WP 0035-6
GROUP 00 Power Unit/Power Plant Repair Parts List.....	WP 0036
Figure 1. Power Unit/Power Plant.....	WP 0036-1
GROUP 01 Trailer Chassis Repair Parts List.....	WP 0037
Figure 2. Trailer Chassis.....	WP 0037-2
GROUP 0101 Fire Extinguisher Bracket Repair Parts List.....	WP 0038
Figure 3. Fire Extinguisher Bracket.....	WP 0038-2
GROUP 0102 Fenders Repair Parts List.....	WP 0039
Figure 4. Fenders.....	WP 0039-1
GROUP 0103 Floors, Rails, and Spacers Repair Parts List.....	WP 0040

**TABLE OF CONTENTS — CONTINUED.**

	<b>Page No.</b>	<b>WP Sequence No.</b>
GROUP 0103 Floors, Rails, and Spacers Repair Parts List .....	WP 0040	
Figure 5. Floors, Rails, and Spacers .....	WP 0040-1	
GROUP 0104 Brakes UOC 99D Repair Parts List.....	WP 0041	
Figure 6. Brakes UOC 99D.....	WP 0041-2	
GROUP 0105 LTT Lights Installation UOC 98Z and 99A Repair Parts List .....	WP 0042	
Figure 7. LTT Lights Installation UOC 98Z and 99A .....	WP 0042-2	
GROUP 0106 LTT Leveling Support Jack UOC 98Z and 99A Repair Parts List.....	WP 0043	
Figure 8. LTT Leveling Support Jack UOC 98Z and 99A.....	WP 0043-2	
GROUP 0107 Accessory Box Repair Parts List.....	WP 0044	
Figure 9. Accessory Box.....	WP 0044-2	
GROUP 0108 Accessories Repair Parts List.....	WP 0045	
Figure 10. Accessories .....	WP 0045-1	
GROUP 0109 M200 Identification Plates UOC 99D Repair Parts List .....	WP 0046	
Figure 11. M200 Identification Plates UOC 99D .....	WP 0046-2	
GROUP 02 Switch Box Installation Repair Parts List .....	WP 0047	
Figure 12. Switch Box Installation .....	WP 0047-2	
GROUP 0201 Switch Box Components Repair Parts List .....	WP 0048	
Figure 13. Switch Box Components .....	WP 0048-2	
GROUP 0202 Switch Box Leads Repair Parts List.....	WP 0049	
Figure 14. Switch Box Leads.....	WP 0049-1	
GROUP 0203 Switch Box Wiring Harnesses Repair Parts List .....	WP 0050	
Figure 15. Switch Box Wiring Harnesses .....	WP 0050-1	
Bulk Item.....	WP 0051	
Special Tools List.....	WP 0052	
National Stock Number (NSN) Index.....	WP 0053	
Part Number Index.....	WP 0054	

**Chapter 8— Supporting Information**

References .....	WP 0055
Scope.....	WP 0055-1
Field Manuals .....	WP 0055-1
Forms.....	WP 0055-1
Technical Manuals.....	WP 0055-2
Miscellaneous Manuals .....	WP 0055-2
Maintenance Allocation Chart (MAC) Introduction .....	WP 0056
Introduction .....	WP 0056-1
The Army Maintenance System MAC .....	WP 0056-1
Maintenance Functions .....	WP 0056-2
Explanation of Columns in the MAC.....	WP 0056-3
Explanation of Columns in the Tools and Test Equipment Requirements.....	WP 0056-4
Explanation of Columns in the Remarks .....	WP 0056-4
Maintenance Allocation Chart (MAC) .....	WP 0057
Table 1. MAC for AMMPS 10 kW PU and PP .....	WP 0057-1
Table 2. Tools and Test Equipment for AMMPS 10 kW PU and PP .....	WP 0057-3
Table 3. Remarks for the AMMPS 10 kW PU and PP.....	WP 0057-4



**TABLE OF CONTENTS — CONTINUED.**

	<b>Page No.</b>
	<b>WP Sequence No.</b>
Components of End Item (COEI) and Basic Issue Items (BII) Lists.....	WP 0058
Introduction .....	WP 0058-1
Scope.....	WP 0058-1
General .....	WP 0058-1
Explanation of Columns in the COEI List and BII List .....	WP 0058-1
Figure 1. Power Unit — PU-2002 and PU-2012.....	WP 0058-2
Figure 2. Power Plant — PP-3102 .....	WP 0058-2
Figure 3. AMMPS 10 kW 50/60 Hz and AMMPS 10 kW 400 Hz .....	WP 0058-3
Figure 4. Trailer Chassis Light Tactical (LTT) .....	WP 0058-3
Figure 5. Chassis Trailer M200A1 1 1/2 Ton.....	WP 0058-4
Figure 6. Switch Box.....	WP 0058-4
Table 1. Components of End Item (COEI) .....	WP 0058-5
Figure 7. Basic Issue Items (BII) .....	WP 0058-6
Table 2. Basic Issue Items .....	WP 0058-8
Additional Authorization List (AAL).....	WP 0059
Introduction .....	WP 0059-1
Scope.....	WP 0059-1
General .....	WP 0059-1
Explanation of Columns in the AAL .....	WP 0059-1
Table 1. Additional Authorization List .....	WP 0059-1
Expendable and Durable Items List.....	WP 0060
Introduction .....	WP 0060-1
Scope.....	WP 0060-1
Explanation of Columns in the Expendable/Durable Items List .....	WP 0060-1
Table 1. Expendable and Durable Items .....	WP 0060-1
Glossary	
Alphabetical Index	
Foldout Pages	

## HOW TO USE THIS MANUAL

This manual contains operator and field maintenance instructions with Repair Parts and Special Tools List for the AMMPS 10 kW trailer-mounted Power Units (PU): PU-2002 and PU-2012; and Power Plants (PP): PP-3102.

This operator and field maintenance manual shall be used in conjunction with AMMPS 10 kW generator set operator maintenance manual (TM 9-6115-750-10), field maintenance manual with Repair Parts and Special Tools List (RPSTL) (TM 9-6115-750-24&P), two-wheel Light Tactical Trailer (LTT) chassis operator and field service manual (TM-9-2330-392-14&P), two-wheel trailer generator chassis (M200A1) operator and field service manual (TM-9-2330-205-14&P), and a National Maintenance Work Requirement (NMWR) manual (NMWR 9-6115-750).

### NOTE

Throughout this manual, trailer orientation is described from the point of the trailer tongue facing forward. From this perspective, the left side of the trailer will be referred to as “roadside” and the right side of the trailer will be referred to as “curbside”.

### Manual Overview

This operator and field maintenance manual provides troubleshooting, PMCS, maintenance, parts information, and supporting information required to maintain and repair the AMMPS 10 kW PU and PP. Listed below are some of the features included in this TM to help locate and use the provided information.

### WORK PACKAGES (WPs)

This TM has been organized using the WP concept. Each chapter contains a series of WP rather than sections and paragraphs. Each WP is designed to stand alone as a complete information module. If you keep your section(s) of this TM in a loose-leaf binder, you will be able to remove just the WP needed to complete a specific task.

Each WP is numbered using a four-digit number beginning with WP 0001. WPs are numbered sequentially throughout the TM (e.g. WP 0022, WP 0023, etc.). The Table of Contents lists each chapter and WP title, as well as all figures and tables contained within each WP. Figures and tables are numbered sequentially within each WP.

The WP number is located at the top right of each page. It is also located at the bottom of the page with the WP page number included (0001-2 would be page 2 of the General Information WP (WP 0001, General Information)).

Each WP starts on a right-hand page. This is done so you can remove a single WP from the paper TM if needed for a task. Blank pages are assigned a number, but it appears on the preceding or following page. For example, if page 0001-10 of a WP is blank, page 0001-9 will have the number 0001-9/10 blank; or if page 0001-1 of a WP is blank, page 0001-2 will have the number 0001-1 blank/2.

Each task within a maintenance or troubleshooting WP contains step-by-step procedures and will end with the words END OF TASK, and each WP ends with the statement END OF WORK PACKAGE.

References to equipment placarding are printed as they appear on the equipment whenever possible. On-screen text is shown in brackets in the manual (i.e. [Ready to Crank]). References to equipment data and description plates (WP 0005, Operation Under Usual Conditions) are printed as they appear on the equipment.

Typographical conventions are as follows:

[Unload] indicates a soft key or a switch.

[Previous] + [Next] indicates two simultaneous key presses.

[ + ] [ - ] indicates two sequential key presses.

### **Warnings, Cautions, and Notes Definitions**

Warning, caution, and note headings, chapter titles, and paragraph headings are printed in bold type. Multiple warning, caution, or note paragraphs may appear above a procedure, task, or step with one warning, caution, or note heading. Prior to starting a WP, all warnings included in the WP should be reviewed, understood, and followed. Review the materials/parts in the initial setup of the WP for any hazardous materials used during maintenance of the equipment. Then refer to the detailed warnings for hazardous materials in the Warning Summary. Make sure to read all warnings within references WP that are required to complete tasks.

### **WARNING**

Warning highlights an essential operating or maintenance procedure, practice, condition, statement, etc., which, if not strictly observed, could result in injury to, or death of, personnel or long-term health hazards.

### **CAUTION**

Caution highlights an essential operating or maintenance procedure, practice, condition, statement, etc., which, if not strictly observed, could result in damage to, or destruction of, equipment or loss of mission effectiveness.

### **NOTE**

Note highlights an essential operating or maintenance procedure, condition, or statement.

## **TM CONTENT**

### **Front Matter**

The front cover of the manual identifies the exact model(s) covered by this manual. Be certain the generator set you are working on is covered by the information in the manual. Additional manuals will be required to provide information on models not covered by this manual.

The List of Effective Pages/Work Packages provides a list of pages/WPs that have been modified from a previous edition of the manual.

The Table of Contents will help you understand the organization of the manual. The overall Table of Contents in the front of the manual directs you to chapters and lists all WPs in the manual with tables and figures identified for each WP. The chapters contain descriptive information, maintenance procedures organized by maintenance level, and supporting data. Each chapter is divided into WPs with titles that describe the information or procedure in the WP. Each chapter contains its own chapter index that lists all the WPs within the chapter to help you find information.

## **Chapter 1 — General Information, Equipment Description, and Theory of Operation**

The General Information WP (WP 0001, General Information) provides general information about this manual and the related forms and records. Instructions are provided for making equipment improvement and recommendations. Coverage includes a reference to the manual that contains instructions on destruction of materiel to prevent enemy use. Also, the General Information WP contains a list of abbreviations and acronyms used in this TM and a nomenclature cross-reference list when official nomenclature differs from its common usage.

The Equipment Description and Data WP (WP 0002, Equipment Description and Data) describes the characteristics, capabilities, and features of the AMMPS 10 kW PU and PP and provides information on location and description of major components.

The Theory of Operation WP (WP 0003, Theory of Operation) provides you with an overview of the operation of the AMMPS 10 kW PU and PP.

## **Chapter 2 — Operator Instructions**

Chapter 2 provides the detailed instructions for safe operation of the AMMPS 10 kW PU and PP. Specific instructions for operation of the AMMPS 10 kW generator set are found in TM 9-6115-750-10.

## **Chapter 3 — Operator Troubleshooting Procedures**

A reference index (WP 0007, Troubleshooting Index) is organized by system linking potential problems unique to AMMPS 10 kW PU and PP to a troubleshooting procedures WP (WP 0008, Troubleshooting Procedures). Refer to TM 9-6115-750-10 for operator troubleshooting information specific to the AMMPS 10 kW generator set. Refer to TM 9-2330-392-14&P (LTT) and TM 9-2330-205-14&P (M200A1) for operator troubleshooting related to the base trailer configurations.

The operator troubleshooting procedures WP (WP 0008, Troubleshooting Procedures) gives a step-by-step procedure to troubleshoot service problems unique to AMMPS 10 kW PU and PP.

## **Chapter 4 — Operator Maintenance Instructions**

Chapter 4 provides an index (WP 0009, Operator PMCS Introduction) and necessary operator PMCS procedures (WP 0010, Operator PMCS) to service and maintain the AMMPS 10 kW PU and PP. Refer to TM 9-6115-750-10 for operator maintenance information specific to the AMMPS 10 kW generator set. Refer to TM 9-2330-392-14&P (LTT) and TM 9-2330-205-14&P (M200A1) for operator maintenance related to the base trailer configurations.

## **Chapter 5 — Field Maintenance Troubleshooting**

A reference index (WP 0011, Troubleshooting Index) is organized by system linking potential problems unique to AMMPS 10 kW PU and PP to a troubleshooting procedures WP (WP 0012, Troubleshooting Procedures). Refer to TM 9-6115-750-24&P for field troubleshooting information specific to the AMMPS 10 kW generator set. Refer to TM 9-2330-392-14&P (LTT) and TM 9-2330-205-14&P (M200A1) for field troubleshooting related to the base trailer configurations.

The field troubleshooting procedures WP (WP 0012, Troubleshooting Procedures) provides a step-by-step procedure to troubleshoot service problems unique to AMMPS 10 kW PU and PP.

The 10 kW trailer-mounted PU and PP provides electronic troubleshooting of the PP switch boxes and load cable connections through the Digital Control System (DCS). If a malfunction occurs or is about to occur to a component monitored by the DCS, a fault or warning code is displayed on the DCS screen at the rear of the generator set. This provides a comprehensive level of information to identify problems that may occur with the PU and PP switch boxes and/or load cable connections and also minimize downtime for repair.

Detailed information on the electronic troubleshooting data available through the DCS, fault and warning code lists and information, and manual troubleshooting guidelines for the AMMPS 10 kW generator set are found in TM 9-6115-750-24&P.

## **Chapter 6 — Field Maintenance Instructions**

The service procedures required to be performed when a generator set is first received in the field are described in the Service Upon Receipt WP (WP 0013, Service Upon Receipt).

Every generator set requires some periodic scheduled maintenance. The theory of the scheduled maintenance or PMCS is outlined in Field PMCS Introduction WP (WP 0014, Field PMCS Introduction). A detailed table to guide through the scheduled maintenance tasks is provided by Field PMCS WP (WP 0015, Field PMCS).

Detailed instructions for removal, installation, test, and adjustment of critical components (Line Replaceable Units (LRUs)) of the AMMPS 10 kW PU and PP are the subject of WP 0016 through 0030. See the Table of Contents for specific WP numbers and titles for each LRU. Refer to TM 9-6115-750-10 for field maintenance information specific to the AMMPS 10 kW generator set. Refer to TM 9-2330-392-14&P (LTT) and TM 9-2330-205-14&P (M200A1) for field maintenance related to the base trailer configurations.

Each field maintenance WP begins with an initial setup table that contains information about the tools and equipment conditions, parts and supplies, reference WPs and manuals, and personnel required to perform each task.

Maintenance tasks not specific to AMMPS 10 kW PU and PP but common to many types of equipment may be listed in the General Maintenance WP (WP 0031, General Maintenance).

Specific lubrication instructions for the AMMPS 10 kW PU and PP are found in Lubrication Instructions WP (WP 0032, Lubrication Instructions).

If the design engineers responsible for the AMMPS 10 kW PU and PP have specified a critical torque value for tightening fasteners, that value will be stated in the field maintenance WP for the appropriate LRU. Otherwise, information for nominal torque values of common United States (U.S.) standard units and metric hardware is provided in the Torque Limits WP (WP 0033, Torque Limits).

Single page and large size electrical diagrams and drawings, such as schematics, are found in the Foldout Pages (Foldout Pages) section in Rear Matter.

## **Chapter 7 — Parts Information**

The Repair Parts and Special Tools List (RPSTL) contains parts that support both field and sustainment maintenance. This chapter covers WP 0035 through 0054. The repair parts list (WP 0036 – WP 0050) itemizes all available parts required to maintain and repair the AMMPS 10 kW PU and PP.

Bulk items (WP 0051, Bulk Item), special tools (WP 0052, Special Tools List), National Stock Numbers (NSN) (WP 0053, National Stock Number (NSN) Index), and Part Number (P/N) (WP 0054, Part Number Index) indexes are included in the other WPs in this chapter.

## **Chapter 8 — Supporting Information**

The supporting information chapter provides the Maintenance Allocation Chart (MAC) (WP 0057, Maintenance Allocation Chart (MAC)) that lists the proper level of maintenance where critical tasks are to be performed. The MAC also provides a list of all tools, kits, and test equipment, both special and common, required to maintain the AMMPS 10 kW generator set.

Chapter 8 also provides Components of End Item (COEI) and Basic Issue Items (BII) lists (WP 0058, Components of End Item (COEI) and Basic Issue Items (BII) Lists) to help inventory items for safe and efficient operation of the 10 kW trailer-mounted PU and PP. It also contains the Additional Authorization List (AAL) (WP 0059, Additional Authorization List (AAL)) for the support of 10 kW trailer-mounted PU and PP that will be needed to operate and maintain the 10 kW trailer-mounted PU and PP. Other WPs in this chapter list commonly used

supplies (WP 0060, Expendable and Durable Items List) and list referenced materials (WP 0055, References) used throughout this TM.

**Rear Matter**

Rear Matter includes a Glossary containing the list of terms and definitions which are uncommon and not identified within the manual or within a standard dictionary. An Alphabetical Index is included to list WP topic in alphabetical order.

The Department of Army (DA) Form 2028, Recommended Changes to Publications and Blank Forms is the document to be submitted to correct errors found in the manual or to make recommended changes that will improve the manual.

Large size electrical diagrams and drawings, such as schematics, are located in the Foldout Pages section at the rear of this manual.

Rear Matter also provides a conversion chart between U.S standard units and metric values.

**CHAPTER 1**

**GENERAL INFORMATION, EQUIPMENT DESCRIPTION, AND  
THEORY OF OPERATION**

**FOR**

**AMMPS 10KW TRAILER-MOUNTED POWER UNITS AND POWER PLANTS**

CHAPTER 1

GENERAL INFORMATION, EQUIPMENT DESCRIPTION, AND THEORY OF OPERATION

**WORK PACKAGE INDEX**

---

<u>Title</u>	<u>WP Sequence No.</u>
GENERAL INFORMATION.....	0001
EQUIPMENT DESCRIPTION AND DATA.....	0002
THEORY OF OPERATION.....	0003



---

**OPERATOR AND FIELD MAINTENANCE  
AMMPS 10KW TRAILER-MOUNTED POWER UNITS AND POWER PLANTS  
GENERAL INFORMATION**

---

**SCOPE**

This operator and field maintenance TM with repair parts and special tools lists contains operator instructions and field maintenance requirements for the AMMPS 10 kW generator sets that are configured as PU and PP by mounting one or more generator sets on mobile trailers. A PU consists of one AMMPS 10 kW generator set on one trailer without a switch box. A PP consists of two AMMPS 10 kW generator sets on one trailer, interconnected through a switch box. The different models are shown in Figure 1 and Figure 2.

**Type of Manual**

Operator and field maintenance including repair parts and special tools list.

**Model Number(s) and Equipment Name(s)**

AMMPS 10 kW 50/60 and 400 hertz (Hz) generator sets, trailer mounted (Table 1):

**Table 1. Model Number(s) and Equipment Name(s).**

PU-2002 (Figure 1)	PU, diesel engine driven, LTT mounted, 10 kW, 50/60 Hz
PU-2012 (Figure 1)	PU, diesel engine driven, LTT mounted, 10 kW, 400 Hz
PP-3102 (Figure 2)	PP, diesel engine driven, M200A1 trailer mounted, 10 kW, 50/60 Hz

**Purpose of Equipment**

The AMMPS 10 kW PU and PP are designed to provide tactical, quiet, highly mobile Alternating Current (AC) power in a combat setting. The PU and PP generator sets are designed for ease of transportation, operation, and maintenance. PUs and PPs are configured for rapid mobility with a wide variety of towing units.

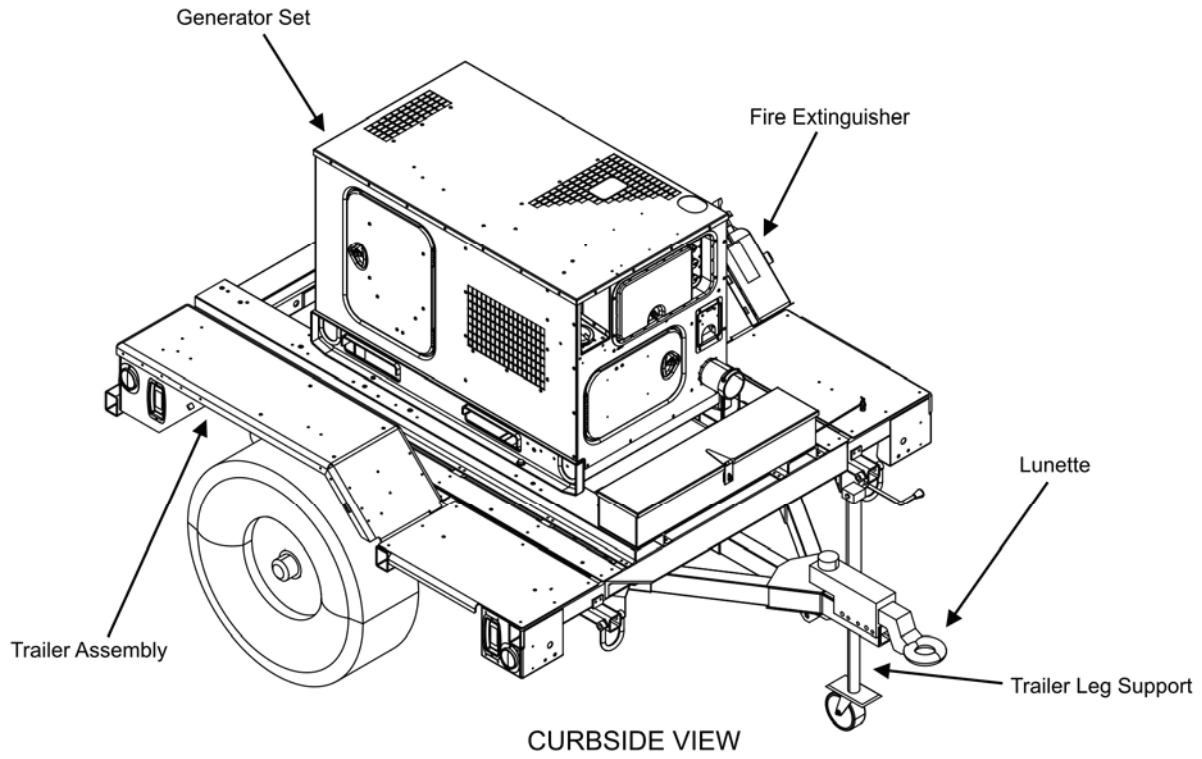

Figure 1. PU-2002 and PU-2012 Roadside and Curbside View.

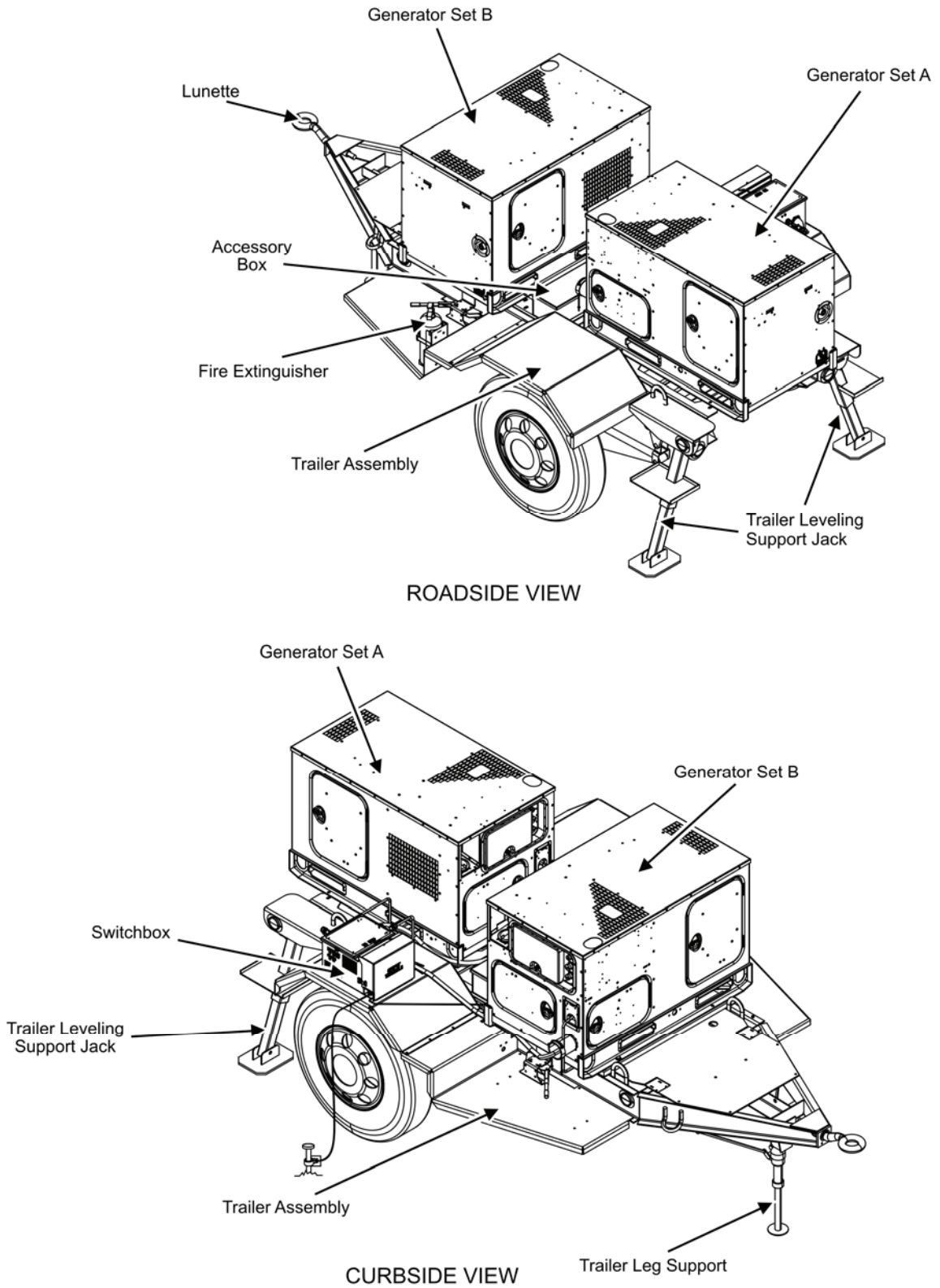

Figure 2. PP-3102 Roadside and Curbside View.

---

## MAINTENANCE FORMS, RECORDS, AND REPORTS

- (1) (Army). Department of the Army forms and procedures used for equipment maintenance will be those prescribed by (as applicable) DA PAM 750-8, The Army Maintenance Management System (TAMMS) Users Manual; DA PAM 738-751, Functional Users Manual for the Army Maintenance Management System – Aviation (TAMMS-A); or AR 700-138, Army Logistics Readiness and Sustainability.
- (2) (Air Force). Maintenance forms and records used by Air Force personnel are prescribed in AFI 21-101 and the applicable TO 00-20, Series of Technical Orders.
- (3) (Navy). Navy users should refer to their service peculiar directives to determine applicable maintenance forms and records to be used.

## REPORTING EQUIPMENT IMPROVEMENT RECOMMENDATIONS (EIR)

(1) (Army). If your equipment needs improvement, let us know. Send us an EIR. You, the user, are the only one who can tell us what you don't like about your equipment. Let us know why you don't like the design or performance. If you have Internet access, the easiest and fastest way to report problems or suggestions is to follow the instructions and links below:

If you have a user's account, you can submit the PQDR for ALL CECOM (B16) Warranty, EIR, and PQDRs (including those B16 Aviation related) through the Navy's Web Product Quality Deficiency Reporting (PQDR) site, <http://www.nslcptsmh.csd.disa.mil/webpqdr/webpqdr.htm>. If you do not, either go to EZPQDR, <http://www.nslcptsmh.csd.disa.mil/webpqdr/files/ezpqdr.htm> and input your PQDR there, or establish a new account. New accounts can be established at the following address: <http://www.nslcptsmh.csd.disa.mil/accessforms/uarform.htm>.

CECOM (B16) aviation PQDRs will not go to AMCOMs Joint Deficiency Reporting System (JDRS). If AMCOM should get a CECOM aviation PQDR, they will redirect it to the CECOM PQDR Team.

Use the PQDR for Warranties, EIRs, and PQDRs. There is a block on the PQDR that can be clicked if it is a Warranty. The originator can still put in the description that they want this investigated as an EIR and then enter what the issue is.

You may also submit your SF 368 (Product Quality Deficiency Report) via email (MONM-AMSELLEODCSCFO@CONUS.ARMY.MIL), facsimile (732-532-2929), or regular mail (call 732-532-8843 for the current mailing address).

We will send you a reply.

- (2) (Air Force). Air Force personnel are encouraged to submit EIRs IAW Air Force Regulation (AFR) 900-4.
- (3) (Navy). Navy personnel are encouraged to submit EIRs through their local Beneficial Suggestion Program.

## CORROSION PREVENTION AND CONTROL (CPC)

Corrosion Prevention and Control (CPC) of Army materiel is a continuing concern. It is important that any corrosion problems with this item be reported so that the problem can be corrected and improvements can be made to prevent the problem in future items.

Corrosion specifically occurs with metals. It is an electrochemical process that causes the degradation of metals. It is commonly caused by exposure to moisture, acids, bases, or salts. An example is the rusting of iron. Corrosion damage in metals can be seen, depending on the metal, as tarnishing, pitting, fogging, surface residue, and/or cracking.

Plastics, composites, and rubbers can also degrade. Degradation is caused by thermal (heat), oxidation (oxygen), solvation (solvents), or photolytic (light, typically Ultraviolet (UV)) processes. The most common exposures are excessive heat or light. Damage from these processes will appear as cracking, softening, swelling, and/or breaking. SF 368, Product Quality Deficiency Report, should be submitted to the address specified in DA PAM 750-8, The Army Maintenance Management System (TAMMS) Users Manual.

For aircraft TMs, this information shall include a reference to TM 1-1500-344-23, volumes 1 through 4 (Cleaning and Corrosion Control).

### **OZONE-DEPLETING SUBSTANCES (ODS)**

The use of Class 1 Ozone-Depleting Substances (ODS) for new acquisitions has been curtailed by Section 326 of the National Defense Authorization Act of Fiscal Year 1993 (Public Law 102, 484) and related Army policy. ODS are listed in Title VI of the Clean Air Act. For systems procured and fielded prior to the effectiveness of the above law (June 1993) that use a Class 1 ODS, a listing of those substances required to operate and maintain the system shall be included in the TM. This requirement applies to any system procured or fielded after June 1993 that requires the use of a Class 1 ODS, where the use of the ODS has been properly documented and waived. The procuring activity will provide a list of Class 1 ODS on request.

### **DESTRUCTION OF ARMY MATERIEL TO PREVENT ENEMY USE**

Destruction of Army electronics materiel to prevent enemy use shall be IAW TM 750-244-2.

Destruction of Air Force materiel to prevent enemy use shall be IAW AFI 33-201.

Destruction of Navy materiel to prevent enemy use shall be IAW Navy direction.

### **PREPARATION FOR STORAGE OR SHIPMENT**

Administrative storage of equipment issued to and used by Army activities will have Preventive Maintenance Checks and Services (PMCS) performed before storing. When removing the equipment from administrative storage, the PMCS checks should be performed to assure operational readiness.

### **WARRANTY INFORMATION**

The AMMPS 10 kW generator set is warranted for 1800 hours (hr) of operation or 36 months, whichever occurs first. The warranty starts on the date the equipment is accepted in the "Wide Area Work Flow" system. This warranty includes repair or replacement of any items that prove to be nonconforming and/or defective within the warranty period. Report all defects to your supervisor, who will take appropriate action.

### **NOMENCLATURE CROSS-REFERENCE LIST**

Shortened nomenclature is used in this manual to make procedures easier to read. A cross-reference between the shortened, common name used in this manual and the official nomenclature is provided in the list below.

<b>Common Name</b>	<b>Official Nomenclature</b>
LTT	Trailer, Light Tactical
M200A1	Chassis, trailer, 2 1/2 ton, 2 wheel
MEP 1040	Generator set, 10 kW, 50/60 Hz
MEP 1041	Generator set, 10 kW, 400 Hz
PP-3102	Power plant, diesel engine driven, M200A1 trailer mounted, 10 kW, 50/60 Hz
PU-2002	Power unit, diesel engine driven, LTT mounted, 10 kW, 50/60 Hz
PU-2012	Power unit, diesel engine driven, LTT mounted, 10 kW, 400 Hz

**LIST OF ABBREVIATIONS/ACRONYMS**

Acronyms and abbreviations used in this TM are provided and defined below.

<b>Abbreviation/Acronym</b>	<b>Definition</b>
°	Degree
°C	Degree Celsius
°F	Degree Fahrenheit
–	Negative
kΩ	Kilohm
Ω	Ohms
%	Percent
+	Positive
±	Plus or minus
A	After
AAL	Additional Authorization List
AC	Alternating Current
AFI	Air Force Instruction
AFR	Air Force Regulation
AFTO	Air Force Technical Order
AMMPS	Advanced Medium Mobile Power Sources
AR	Army Regulation
ASB	Aviation Support Battalion
B	Before
BII	Basic Issue Item
BOI	Basis of Issue
C	Crew (level of maintenance)
CAGEC	Commercial and Government Entity Code
cm	Centimeter
COEI	Components of End Item
CPC	Corrosion Prevention and Control
CTA	Common Table of Allowances
D	Depot (level of maintenance)
D	During
DA	Department of Army
DC	Direct Current
DCS	Digital Control System
DD	Department of Defense (forms only)
DF	Diesel Fuel
DOD	Department of Defense
E	Empty
EIR	Equipment Improvement Recommendation
e-mail	Electronic mail
EMP	Electromagnetic Pulse
ESC	Equipment Service Criteria
ESD	Electrostatic Discharge
F	Field (level of maintenance)
FGC	Functional Group Code
FM	Field Manual

---

<b>Abbreviation/Acronym</b>	<b>Definition</b>
ft	Foot
ft/lb	Foot/pound
gal	Gallon
GMTK	General Mechanic's Tool Kit
GND	Ground
H	Below Depot (level of maintenance)
HCI	Hardness Critical Item
HMMWV	High Mobility Multipurpose Wheeled Vehicle
hr	Hour
Hz	Hertz
IAW	In Accordance With
ID	Identification
in	Inch
in/lb	Inch/pound
IUID	Individual Unit Identification
JDRS	Joint Deficiency Reporting System
JP	Jet Petroleum
JTA	Joint Table of Allowances
kg	Kilogram
km/h	Kilometers per hour
kPa	KiloPascal
kW	Kilowatt
L	Liter
lb	Pound
LED	Light Emitting Diode
LRU	Line Replaceable Unit
LTT	Light Tactical Trailer
m	Meter
MAC	Maintenance Allocation Chart
MEP	Mobile Electric Power
min	Minute
mm	Millimeter
mph	Miles per hour
MSDS	Material Safety Data Sheets
MTOE	Modified Table of Organization and Equipment
MWO	Modification Work Orders
N	Neutral
NATO	North Atlantic Treaty Organization
NHA	Next Higher Assembly
NIIN	National Item Identification Number
Nm	Newton meter
NMWR	National Maintenance Work Requirement
NSN	National Stock Number
ODS	Ozone-Depleting Substances
OSHA	Occupational Safety and Health Act

---

<b>Abbreviation/Acronym</b>	<b>Definition</b>
PAM	Pamphlet
PDA	Personal Data Assistant
PMCS	Preventive Maintenance Checks and Services
P/N	Part number
PP	Power Plant
PQDR	Product Quality Deficiency Report
psi	Pounds per square inch
PU	Power Unit
QDR	Quality Deficiency Reports
rpm	Revolutions per minute
RPSTL	Repair Parts and Special Tools
SAE	Society of Automotive Engineers
sec	Second
SF	Standard Form
SMR	Source, Maintenance, and Recoverability
SOP	Standard Operating Procedure
SRA	Specialized Repair Activity
TAMMS	The Army Maintenance Management System
TAMMS-A	The Army Maintenance Management System — Aviation
TDA	Tactical Decision Aid
TDR	Transportation Discrepancy Report
TM	Technical Manual
TMDE	Test, Measurement, and Diagnostic Equipment
TO	Technical Order
TOE	Table of Organization and Equipment
UOC	Usable On Code
U.S.	United States
UUT	Unit Under Testing
UV	Ultraviolet
V	Volts
VAC	Volts Alternating Current
VDC	Volts Direct Current
WP	Work Package

**END OF WORK PACKAGE**



---

**OPERATOR AND FIELD MAINTENANCE**  
**AMMPS 10KW TRAILER-MOUNTED POWER UNITS AND POWER PLANTS**  
**EQUIPMENT DESCRIPTION AND DATA**

---

**EQUIPMENT CHARACTERISTICS, CAPABILITIES, AND FEATURES**

The AMMPS 10 kW PUs and PPs are trailer-mounted mobile suppliers of electrical energy to fielded equipment. The PUs and PPs consist of three configurations of trailer and generator set (Table 1).

The trailers have been modified to accommodate the AMMPS 10 kW generator sets. The modifications include adding generator mounting rails, special lifting rings, fenders, and changing the accessory box and fire extinguisher brackets positions. Each generator set is a liquid-cooled, diesel engine driven unit. Each generator set has a load capacity of 10 kW when operating at 60 Hz (Department of Defense (DOD) model Mobile Electric Power (MEP) 1040) or 400 Hz (MEP 1041). When operating at the 50 Hz setting (MEP 1040), the load capacity of the generator set is 8.3 kW. Refer to TM 9-6115-750-10 for detailed equipment characteristics about the generator set.

**Table 1. AMMPS 10 kW PU and PP Models.**

PU-2002 (Figure 1)	PU, diesel engine driven, LTT mounted, 10 kW, 50/60 Hz
PU-2012 (Figure 1)	PU, diesel engine driven, LTT mounted, 10 kW, 400 Hz
PP-3102 (Figure 2)	PP, diesel engine driven, M200A1 trailer mounted, 10 kW, 50/60 Hz

**LOCATION AND DESCRIPTION OF MAJOR COMPONENTS**

**GENERATOR SETS (MEP 1040 AND MEP 1041)**

The MEP 1040 AMMPS 10 kW generator set (Figure 1, Item 1 and Figure 2, Items 1 and 2) is designed to accommodate the continuing proliferation of electronics (computers, Personal Data Assistants (PDA), etc.), life support systems, and global communications necessary in today's battlefield that require a continuous, uninterrupted flow of electricity to accommodate all tactical situations. The MEP 1040 generator set can easily switch between 50 Hz and 60 Hz frequency output through the DCS adjustments screen. See TM 9-6115-750-10 for operating instructions.

The MEP 1041 AMMPS 10 kW generator set (Figure 1, Item 1) is designed to accommodate the continuing proliferation of electronics (computers, radar, and fire control systems) necessary in today's battlefield that require a continuous, uninterrupted flow of electricity to accommodate all tactical situations. The MEP 1041 generator set operates at a fixed 400 Hz frequency. See TM 9-6115-750-10 for operating instructions.

No easily discernable external differences exist between the MEP 1040 (Figure 1, Item 1 and Figure 2, Items 1 and 2) and MEP 1041 generator sets (Figure 1, Item 1). It is necessary to read the Identification (ID) labels on the generator sets to ensure the output frequency is available as requested. See TM 9-6115-750-10 for the location and description of the ID labels.

**SWITCH BOX ASSEMBLY P/N 04-21329 (Figure 2, Item 4)**

The PP-3102 utilizes a switch box assembly 04-21329 (Figure 2, Item 4). Each switch box assembly is mounted on the curbside fender of the M200A1 (Figure 2, Item 5) trailer. The switch box assembly (Figure 2, Item 4) is already connected to the output boxes of each generator set (Figure 2, Items 1 and 2) when delivered.

Each contactor in the switch box assembly (Figure 2, Item 4) is provided with a switch box control cable (Figure 2, Item 3) which is connected to the respective generator sets at the SWITCH BOX CONTROL RECEPTACLE (located below the convenience receptacle). See TM 9-6115-750-10 for the location and description of the convenience receptacle. The covers for the switch box and cover for the output terminals are secured by locking latches. Indicator lights show the status or power in and out of the two switch box contactors (one for each generator set in the PP). Connection from the PP to the load is made through the output terminals on the switch box.

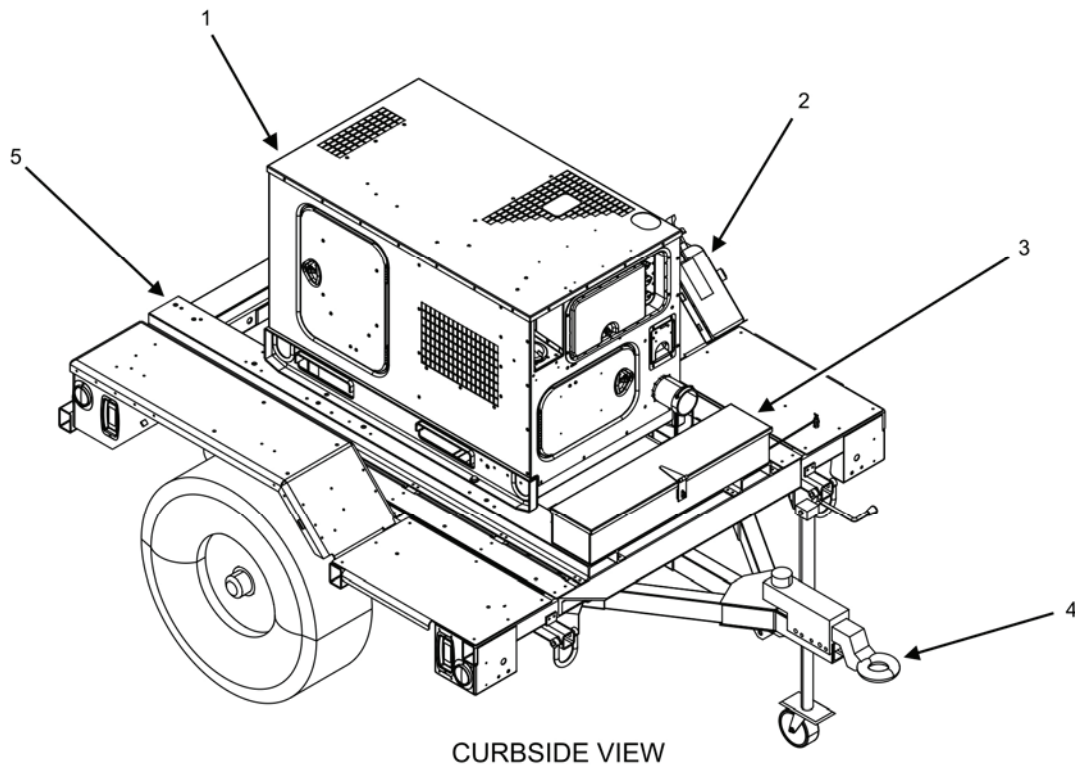

CURBSIDE VIEW

**Figure 1. PU-2002 and PU-2012 Curbside View.**

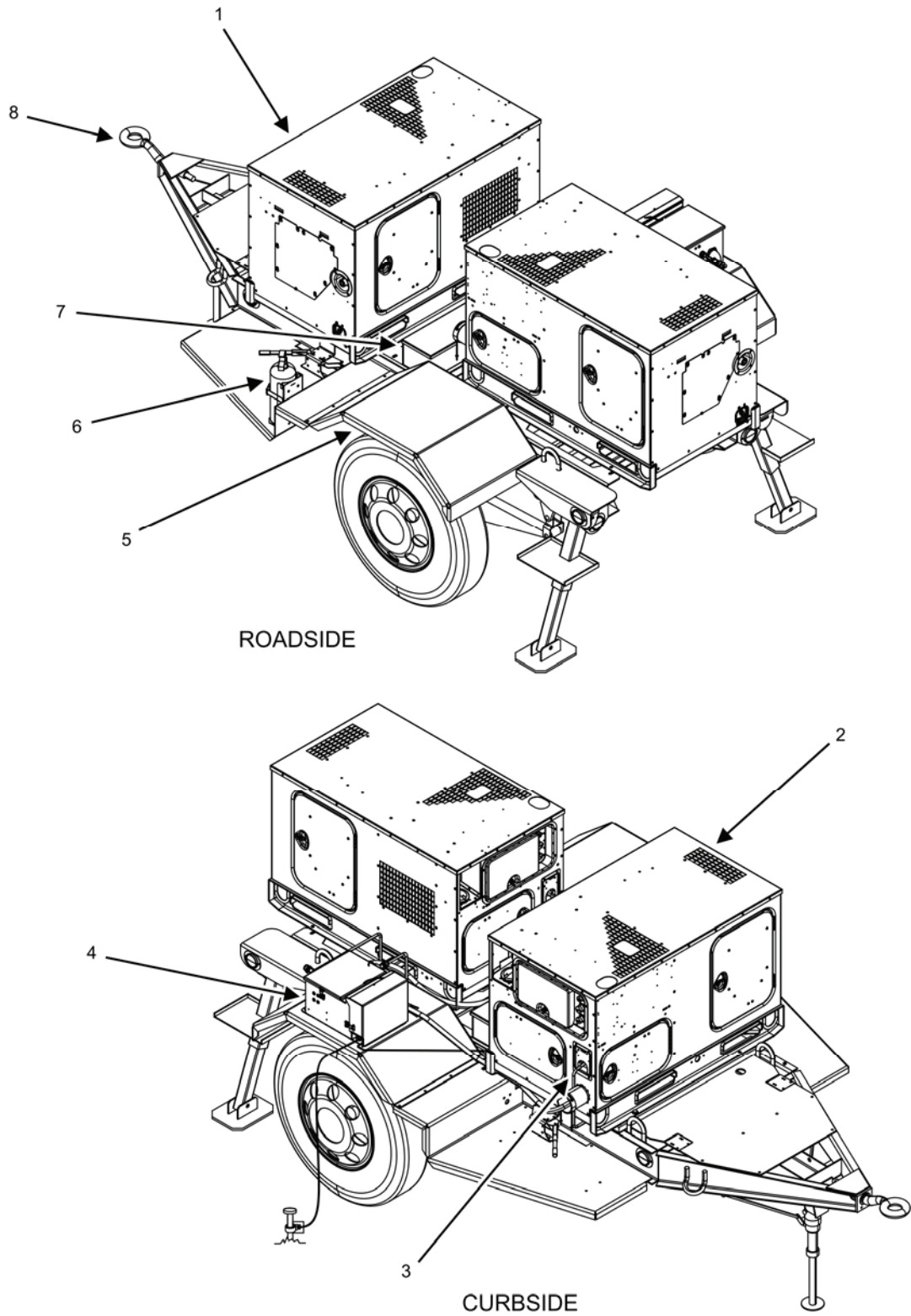

Figure 2. PP-3102 Roadside and Curbside View.

**TRAILERS**

**LTT (Figure 1, Item 5)**

The LTT is an open-frame, single-axle, two-wheeled trailer chassis. The LTT is designed to transport a variety of loads and can be configured in several ways. The LTT used in PU-2002 and PU-2012 has been modified to accommodate the MEP 1040 and MEP 1041 generator sets. The load capacity of the unit is 2740 lb (1242.8 kg) highway or cross country. The unit may be towed by a High Mobility Multipurpose Wheeled Vehicle (HMMWV) M1097/M1114 series or similar vehicle. Speed is restricted to 55 miles per hour (mph) (88.5 kilometers per hour (km/h)) on improved roads, 35 mph (56.3 km/h) on secondary roads, and 20 mph (32.2 km/h) on unimproved roads or cross country. The LTT is designed to be towed by a towing vehicle without airbrake connections. A handbrake lever and cable assembly located on each side of the trailer activates a service brake at each wheel. Control of each service brake is independent. In addition to handbrake-activated service brakes, the trailers are equipped with an inertia-actuated hydraulic brake system. Forging is not permitted at a depth which submerges any portion of the attached generator set(s). The trailer is able to ford hard-bottom water crossings up to 60 inch (in) (152.4 centimeter (cm)) deep. Connection between the trailer and the towing vehicle is by a lunette (Figure 1, Item 4) on the trailer. Each unit is provided with a fire extinguisher (Figure 1, Item 3). See TM 9-2330-392-14&P for operation and maintenance instructions.

**M200A1 Trailer (Figure 2, Item 5)**

The M200A1 is an open-frame, single-axle, two-wheeled trailer chassis designed to transport an electric generator. The M200A1 trailer is used in PP-3102. The load capacity of the unit is 5000 lb (2268 kg) highway or 3750 lb (1700 kg) cross country. The unit may be towed by a minimum of a 2 1/2-ton, 6 x 6, M35 cargo truck or vehicles with similar or greater towing capacity. Speed is restricted to 55 mph (88.5 km/h) on improved roads and 30 mph (48.3 km/h) on unimproved roads or cross country. Forging is not permitted at a depth which submerges any portion of the attached generator sets. The trailer is able to ford hard-bottom water crossings to any depth that can be negotiated by the towing vehicle. Connection between the trailer and the towing vehicle is by a lunette (Figure 2, Item 8) on the trailer. Each unit is provided with a fire extinguisher (Figure 2, Item 6). See TM 9-2330-205-14&P for operation and maintenance instructions.

**Accessory Box (Figure 1, Item 4 and Figure 2, Item 7)**

The accessory box is to provide space for needed equipment, such as the trailer TM, ground cable, slide hammer, grounding connections, fire extinguisher, and sledge hammer. PU-2002 and PU-2012 have the accessory box (Figure 1, Item 4) installed on the front of the LTT. PP-3102 has the accessory box (Figure 2, Item 7) mounted between the generator sets of the M200A1 trailer.

**DIFFERENCES BETWEEN MODELS**

Differences between the PU-2002, PU-2012, and PP-3102 are identified in Table 2. A quantity under the applicable PU or PP column heading indicates that the item is a component of that model.

**Table 2. Differences Between Models.**

COMPONENT	PU-2002	PU-2012	PP-3102
MEP-1040 AMMPS 50/60 Hz	1		2
MEP-1041 AMMPS 400 Hz		1	
Switch box			1
Trailer, LTT (2740 lb)	1	1	
Trailer, M200A1 (2 1/2 Ton)			1

**EQUIPMENT DATA**

**NOTE**

Refer to TM 9-6115-750-10, TM 9-2330-392-14&P, and TM 9-2330-205-14&P for specific data on the generator sets and trailers.

For a list of leading particulars, refer to Table 3.

**Table 3. Equipment Data.**

<b>PU and PP:</b>	
<b>DOD Model Numbers:</b>	
PU-2002	One LTT and one MEP 1040
PU-2012	One LTT and one MEP 1041
PP-3102	One M200A1 and two MEP 1040 with switch box assembly 04-21239
<b>NSN:</b>	
PU-2002	6115-01-562-4010
PU-2012	6115-01-562-3907
PP-3102	6115-01-562-6480
<b>Overall Length:</b>	
PU-2002	135 in (343 cm)
PU-2012	135 in (343 cm)
PP-3102	167.5 in (411 cm)
<b>Overall Width:</b>	
PU-2002	87.5 in (222.3 cm)
PU-2012	87.5 in (222.3 cm)
PP-3102	89 in (236 cm)
<b>Overall Height:</b>	
PU-2002	72.0 in (182.9 cm)
PU-2012	72.0 in (182.9 cm)
PP-3102	75.5 in (191.8 cm)
<b>Dry Weights (Less Bil):</b>	
PU-2002	2460 lb (1115.84 kg)
PU-2012	2470 lb (1120.37 kg)
PP-3102	4781 lb (2168.63 kg)
<b>Wet Weights:</b>	
PU-2002	2499 lb (1133.53 kg)
PU-2012	2514 lb (1140.33 kg)
PP-3102	4863 lb (2205.82 kg)

**END OF WORK PACKAGE**



---

**OPERATOR AND FIELD MAINTENANCE**  
**AMMPS 10KW TRAILER-MOUNTED POWER UNITS AND POWER PLANTS**  
**THEORY OF OPERATION**

---

**OPERATION**

The AMMPS 10 kW PUs and PPs are designed for deployment in the battlefield to provide the soldier with the continuous power generation necessary for today's fielded electronic devices and various electrical equipment demands. The AMMPS 10 kW PUs and PPs are mobile, trailer-mounted generator sets, in order to provide flexibility of movement to the commander. The generator sets are designed to accommodate parallel operation of generator sets, as well as additional and backup power generation.

**TECHNICAL PRINCIPLES OF OPERATION****PU Functional Description**

The PUs are readily mobile. The power source for PU-2002 is one AMMPS 10 kW, 50/60 Hz, model MEP 1040 generator set. The power source for PU-2012 is one AMMPS 10 kW, 400 Hz, model MEP 1041 generator set. The generator sets for PU-2002 and PU-2012 are mounted on a LTT.

Each generator set consists of a liquid-cooled diesel engine, brushless generator, excitation system, fuel system, 24-Volt Direct Current (VDC) starting system, and a DCS which contains a malfunction protection system. The generator set has a voltage selection switch that allows either of three output configurations: 120-volt (V), single phase, 2-wire; 120/240-V, single phase, 3-wire; or 120/208-V, three phase, 4-wire. Electrical power to the supported system or equipment is supplied through the output terminals of the generator set.

**PP Functional Description**

The PPs are readily mobile. The power sources for the PP-3102 are two AMMPS 10 kW, 50/60 Hz, model MEP-1040 generator sets. Generator sets for PP-3102 are mounted on a single M200A1 trailer.

Each generator set consists of a liquid-cooled diesel engine, brushless generator, excitation system, fuel system, 24-VDC starting system, and a DCS which contains a malfunction protection system. The generator set has a voltage selection switch that allows either of three output configurations: 120-V, single phase, 2-wire; 120/240-V, single phase, 3-wire; or 120/208-V, three phase, 4-wire. Electrical power to the supported system or equipment is supplied through a switch box assembly. The switch box assembly is connected between the two generator sets by factory-connected load cables. The switch box enables transfer of the load from one generator set to the other without interruption of power and facilitates parallel operation. The switch box detects the existence of power on the output terminals and communicates with the DCS. The supplied equipment is connected to the switch box by connecting load cables to the switch box output terminals. Each switch box has a controller cable which connects the switch box to the DCS. The cable must be attached in order for the switch box to open and close the switch box contactor and for the exchange of signals between the DCS and the switch box.

**END OF WORK PACKAGE**





**CHAPTER 2**  
**OPERATOR INSTRUCTIONS**  
**FOR**  
**AMMPS 10KW TRAILER-MOUNTED POWER UNITS AND POWER PLANTS**

CHAPTER 2  
OPERATOR INSTRUCTIONS

**WORK PACKAGE INDEX**

---

<u>Title</u>	<u>WP Sequence No.</u>
DESCRIPTION AND USE OF OPERATOR CONTROLS AND INDICATORS .....	0004
OPERATION UNDER USUAL CONDITIONS .....	0005
OPERATION UNDER UNUSUAL CONDITIONS .....	0006

---

**OPERATOR MAINTENANCE**  
**AMMPS 10KW TRAILER-MOUNTED POWER UNITS AND POWER PLANTS**  
**DESCRIPTION AND USE OF OPERATOR CONTROLS AND INDICATORS**

---

## **INTRODUCTION**

### **Generator Set MEP 1040 And MEP 1041**

See TM 9-6115-750-10 for information on controls and indicators used on these generator sets.

### **LTT**

See TM 9-2330-392-14&P for information on controls and indicators used on the LTT.

### **M200A1**

See TM 9-2330-205-14&P for information on controls and indicators used on the M200A1 trailer.

### **Switch Box Assembly**

The switch box assemblies are electromechanical devices that transfer the output of the generator set(s) to the load and facilitate parallel operation. They are attached to the curbside fender of the M200A1 trailers. The M200A1 trailer is supplied with switch box assembly 04-21329. The switch box is wired to the generator sets during the manufacturer's assembly.

A contactor for each generator set is contained within the switch box. Both contactors are connected to their respective generator sets by a switch box control cable. The switch box control cable connects to the generator sets at the SWITCH BOX CONTROL RECEPTACLE located below the generator set's convenience receptacle. The switch box contactors are controlled by the AC CIRCUIT INTERRUPT and UNIT PARALLEL switches on the generator sets. See TM 9-6115-750-10 for the location of these switches. Both generator sets are grounded to earth through the switch box using a common ground with the trailer they are mounted on. See WP 0005, Operation Under Usual Conditions for specific grounding instructions. For additional grounding information, consult FM 11-487-4, Installation Practices: Grounding, Bonding, and Shielding. Connection from the switch box to the load is through the switch box output terminals. See WP 0005, Operation Under Usual Conditions and TM 9-6115-750-10 for details of the connection procedure.

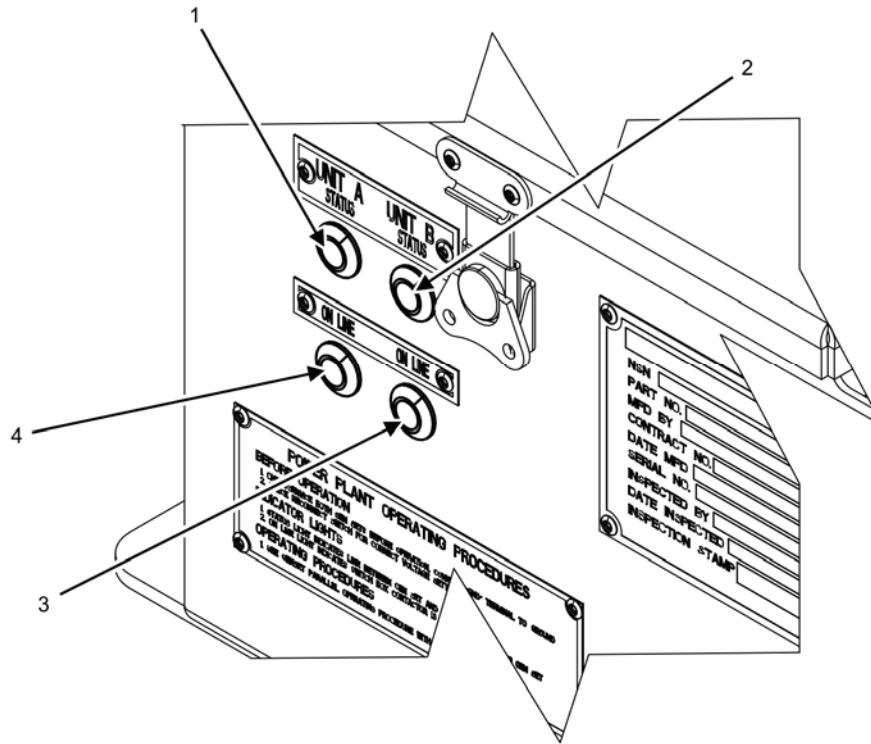

Figure 1. Switch Box Indicators.

Table 1. Switch Box Indicators.

KEY	CONTROL/INDICATOR	FUNCTION
1	UNIT A STATUS Indicator Light	Indicates the operational status of the rear generator set. When indicator light is on, the generator set is producing power and the general contactor is closed. When the light is off, the generator set is not operating or the generator set contactor is open.
2	UNIT B STATUS Indicator Light	Indicates the operational status of the front generator set. When indicator light is on, the generator set is producing power and the generator set contactor is closed. When the light is off, the generator set is not operating or not producing power.
3	UNIT B ON LINE Indicator Light	Indicates if the front generator set is providing power to the load. When the indicator light is on, the switch box contactor is closed and the generator set is providing power to the load. When the indicator light is off, the switch box contactor is open and the generator set is disconnected from the load.
4	UNIT A ON LINE Indicator Light	Indicates if the rear generator set is providing power to the load. When the indicator light is on, the switch box contactor is closed and the generator set is providing power to the load. When the indicator light is off, the switch box contactor is open and the generator set is disconnected from the load.

END OF WORK PACKAGE

---

**OPERATOR MAINTENANCE**  
**AMMPS 10KW TRAILER-MOUNTED POWER UNITS AND POWER PLANTS**  
**OPERATION UNDER USUAL CONDITIONS**

---

**INITIAL SETUP:****Test Equipment**

Not Applicable

**Tools and Special Tools**

Not Applicable

**Materials/Parts**

Not Applicable

**Personnel Required**

Operator (1)

Assistant (1)

**References**

FM 11-487-4

**References**

LTT – TM 9-2330-392-14&amp;P

M200A1 – TM 9-2330-205-14&amp;P

WP 0002, Equipment Description and Data

WP 0004, Description and Use of Operator Controls and Indicators

WP 0010, Operator PMCS

WP 0023, Remove/Install Ground Terminal

**Equipment Conditions**

Engine control switch OFF (TM 9-6115-750-10, WP 0005)

---

**OPERATION UNDER USUAL CONDITIONS****WARNING**

- DC voltages are present at generator set electrical components even with generator set shut down. Avoid shorting any positive with ground/negative. Do not ground yourself in standing water. Failure to comply may cause injury or death to personnel and damage to equipment.
- High voltage is produced when generator set is in operation. Never attempt to start the generator set unless it is properly grounded. Do not ground yourself in standing water. Never attempt to connect or disconnect load cables while the generator sets are running. Failure to comply may cause injury or death to personnel.
- Exhaust discharge contains deadly gases, including carbon monoxide. Exhaust gases are most dangerous in places with poor ventilation. Do not operate generator set in an enclosed area unless exhaust discharge is properly vented. Failure to comply may cause injury or death to personnel.
- Hot exhaust gases can ignite combustible materials. Allow room for safe discharge of hot gases. Failure to comply may cause injury or death to personnel.
- Metal jewelry can conduct electricity and become entangled in generator set components. Remove all jewelry and do not wear loose clothing when working on equipment. Failure to comply may cause injury or death to personnel.

## WARNING

- Exhaust gases are most dangerous in places with poor ventilation. The best defense against exhaust gas poisoning is very good ventilation. To protect yourself and others, always obey the following rules:
  - Do not run engine indoors unless you have very good ventilation.
  - Do not idle engine for a long time unless there is very good ventilation.
  - Be alert at all times. Check for smell of exhaust fumes.
  - Failure to comply may cause injury or death to personnel.
- Exhaust gas poisoning causes dizziness, headache, loss of muscle control, sleepiness, coma, and death. If anyone shows signs of exhaust gas poisoning, get all personnel clear of AMMPS. Make sure they have lots of fresh air. Keep them warm, calm, and inactive. Get medical help. If anyone stops breathing, give artificial respiration. Failure to comply may cause injury or death to personnel.
- When operating, generator set engine has hot metal surfaces that will burn flesh on contact. Shut down generator set and allow engine to cool before checks, services, and maintenance. Wear gloves and additional protective clothing as required. Failure to comply may cause injury or death to personnel.

## SITING REQUIREMENTS

### WARNING

Hot exhaust gases can ignite combustible materials. Allow room for safe discharge of hot gases. Failure to comply may cause injury or death.

### NOTE

Before the PU or PP is started and operated, it is towed to and positioned at the work site.

1. Select the site that provides the following features:
  - a. Ample space for maneuvering vehicles used to move generator set(s) or trailer-mounted generator set(s).
    - (1) The model PU-2002 and PU-2012 footprint dimensions are 136 x 86 in (345.4 x 218.4 cm).
    - (2) The model PP-3102 footprint dimensions are 162 x 96 in (411.5 x 243.8 cm).
    - (3) Allow for the dimensions and turning radius of the towing vehicle.
  - b. Firm, reasonably level (less than 15 degree slope on all axes), well-drained terrain that is not adjacent to low areas where exhaust fumes might collect.
  - c. Space on all sides for service and maintenance.
  - d. Generator set(s) positioned as far away as possible from occupied mobile shelters, vehicle cabs, and building ventilation system air intakes and/or other openings or duct the exhaust to a safe location.
  - e. Adequate ventilation to prevent recirculation of hot air exhausted from generator set.
  - f. Adequate open-air ventilation and exhaust exposure controls when the AMMPS is positioned in protected fighting positions or revetments (barriers/walls/embankments).
  - g. Adequate open-air ventilation and proper placement of exhaust when AMMPS is mounted on a flatbed truck chassis or used on a system in occupied shelters.

- 
2. Make use of natural protective barriers.
  3. Modify location as required.
    - a. Level an area larger than the footprint of the unit if a sufficiently level area is unavailable naturally.
      - (1) The model PU-2002 and PU-2012 footprint dimensions are 136 x 86 in (345.4 x 218.4 cm).
      - (2) The model PP-3102 footprint dimensions are 162 x 96 in (411.5 x 243.8 cm).
    - b. Remove combustible materials within 36 in (91.44 cm) of all sides of generator set.
  4. Ensure the following conditions are met if using an enclosure:
    - a. Meet minimum enclosure requirements of 36 in (91.44 cm) from all sides.
    - b. Install proper exhaust pipe extensions, ducts and vents to outside or use dilution ventilation or local exhaust ventilation when the AMMPS is operated in an enclosure or building to exhaust gas.
    - c. Make air inlet and outlet openings in enclosure same size as or larger than those on the generator set.
  5. Do not direct exhaust into area containing combustible materials.

**END OF TASK****ASSEMBLY AND PREPARATION FOR USE****WARNING**

Trailer(s) must be secured to prohibit movement prior to performing PMCS or connecting ground and output cables. Failure to comply may cause injury or death to personnel.

**Unpacking the PU and PP**

1. Ensure trailer(s) is secured to prohibit movement. See Initial Adjustments task.
2. Ensure packing materials are removed from PU and PP.
3. Remove packing material if present.

**END OF TASK**

**Grounding (PU-2002 and PU-2012)**

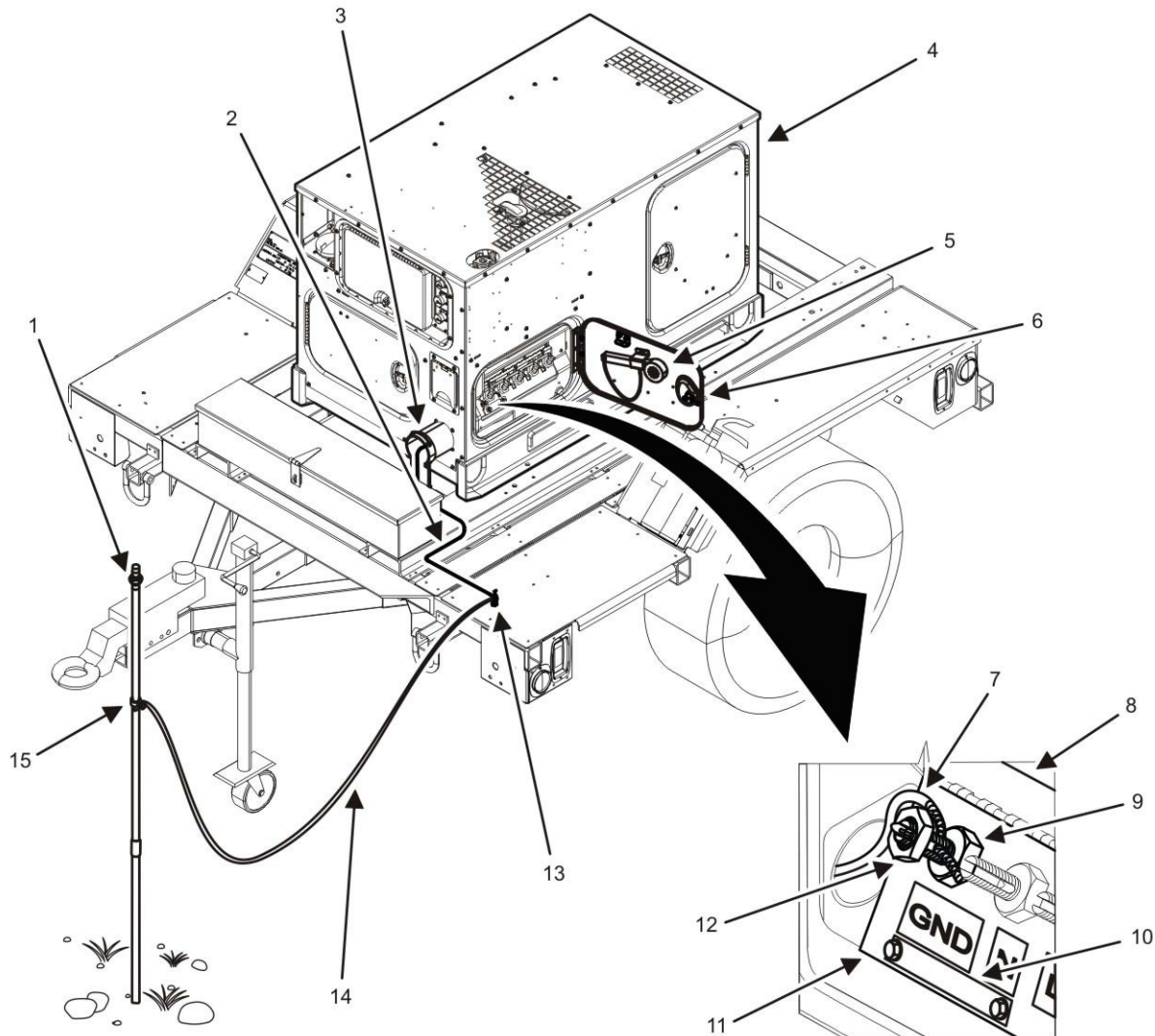

**Figure 1. Grounding Cables Installation for PU-2002 and PU-2012.**

1. Open output box door (Figure 1, Item 6).
2. Thread ground cable (Figure 1, Item 2) into output box through flexible sleeve (Figure 1, Item 3).
3. Lift protective cover (Figure 1, Item 8) from output terminal board (Figure 1, Item 11).

**WARNING**

Do not remove the bonding jumper between GND and N unless the weapon system requires an underground system. Refer to applicable weapon system TM for specific guidance on power and connection requirements. Failure to comply may cause injury or death to personnel.

4. Ensure the bonding jumper (neutral busbar) (Figure 1, Item 10) is securely fastened between N and ground.
5. Loosen terminal nut (Figure 1, Item 12) using provided terminal nut wrench (Figure 1, Item 5) located inside output box door (Figure 1, Item 6).



6. Insert ground cable (Figure 1, Item 7) through slot on terminal (Figure 1, Item 9) marked GND.
7. Tighten terminal nut (Figure 1, Item 12) using terminal nut wrench (Figure 1, Item 5).

### CAUTION

Excessive tightening of the clamp (Figure 1, Item 15) can sever copper conductors and weaken the connection to ground. Tighten the clamp (Figure 1, Item 15) only as much as will prevent the ground cable (Figure 1, Item 14) from being pulled from the clamp (Figure 1, Item 15) by hand. Failure to comply will cause damage to equipment.

8. Install trailer grounding terminal (Figure 1, Item 13) if not present using WP 0023, Remove/Install Ground Terminal and ground terminal assembly found in accessory box.
9. Attach ground cable (Figure 1, Item 2) from generator set (Figure 1, Item 4) to ground terminal (Figure 1, Item 13) at roadside front of trailer.

### NOTE

The accessory box contains two tools which can be used to drive the ground rod into the ground: a slide hammer assembly (Figure 2) and a sledge hammer (Figure 3). The slide hammer assembly provides the safest and easiest method of driving the ground rod and should be used whenever possible. Use of the slide hammer is described in steps 10 through 12. Use of the sledge hammer is described in step 13.

10. Install ground rod (Figure 1, Item 1) using slide hammer (Figure 2, Item 7) assembly (WP 0002, Equipment Description and Data).
  - a. Install impact disk (Figure 2, Item 3) on slide hammer rod (Figure 2, Item 1).
  - b. Tighten impact disk (Figure 2, Item 3) to end of threads on slide hammer rod (Figure 2, Item 1).
  - c. Install lock washer and nut (Figure 2, Item 4).
  - d. Tighten lock washer and nut (Figure 2, Item 4) securely against impact disk (Figure 2, Item 3).
  - e. Remove nut (Figure 2, Item 2) if installed.

### NOTE

Ground rod (Figure 1, Item 1) must be installed within 5 feet (ft) (1.52 meter (m)) of PU ground terminal (Figure 1, Item 13). Ground cable (Figure 1, Item 14) is 6 ft (1.83 m) in length.

For additional grounding information, consult FM 11-487-4, Installation Practices: Grounding, Bonding, and Shielding.

- f. Position slide hammer (Figure 2, Item 7) on slide hammer rod (Figure 2, Item 1).
- g. Install nut (Figure 2, Item 2), and tighten to end of threads on slide hammer rod (Figure 2, Item 1).
- h. Install ground rod coupling (Figure 2, Item 6) to ground rod (Figure 2, Item 5) and screw slide hammer rod (Figure 2, Item 1) into coupling (Figure 2, Item 6).
- i. Ensure slide hammer rod (Figure 2, Item 1) seats on ground rod (Figure 2, Item 5).
- j. Drive ground rod (Figure 2, Item 5) into ground until coupling (Figure 2, Item 6) is just above surface.
- k. Remove slide hammer (Figure 2, Item 7) and install another section of ground rod (Figure 2, Item 5).
- l. Install another coupling (Figure 2, Item 6) to ground rod (Figure 2, Item 5) and screw slide hammer rod (Figure 2, Item 1) into coupling (Figure 2, Item 6).
- m. Drive ground rod (Figure 2, Item 5) down until new coupling (Figure 2, Item 6) is just above ground surface.

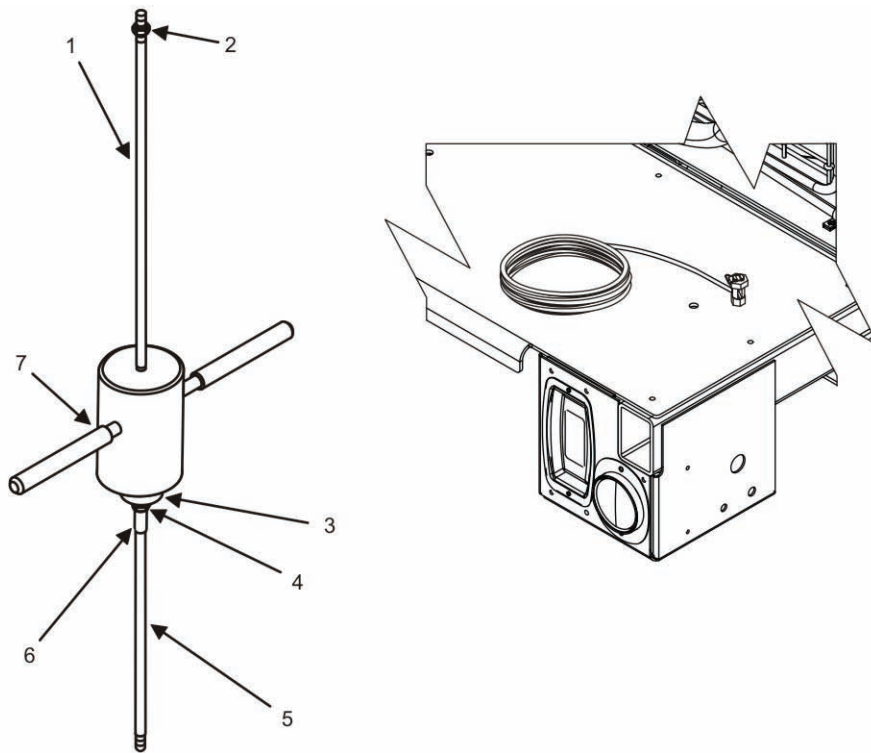

**Figure 2. Install Ground Rod With Slide Hammer.**

### NOTE

Avoid driving the third or final ground rod coupling too close to ground level. Allow enough clearance to easily attach the grounding cable (Figure 1, Item 14).

- n. Repeat steps 10 k – m until ground rod (Figure 2, Item 5) has been driven 8 ft (2.44 m) or deeper, providing an effective ground.

### CAUTION

Excessive tightening of the clamp (Figure 1, Item 15) can sever copper conductors and weaken the connection to ground. Tighten the clamp (Figure 1, Item 15) only as much as will prevent the ground cable (Figure 1, Item 14) from being pulled from the clamp (Figure 1, Item 15) by hand. Failure to comply will cause damage to equipment.

- o. Connect clamp (Figure 1, Item 15) and ground cable (Figure 1, Item 14) to ground rod (Figure 1, Item 1) and tighten clamp (Figure 1, Item 15).
  - p. Install trailer grounding terminal if not present using WP 0023, Remove/Install Ground Terminal and ground terminal assembly found in accessory box.
  - q. Connect ground cable (Figure 1, Item 14) to ground terminal (Figure 1, Item 13) on trailer.
11. Ensure all grounding connections are secure.
12. Disassemble slide hammer.
- a. Remove and retain nut (Figure 2, Item 2) from end of slide hammer rod (Figure 2, Item 1).
  - b. Remove slide hammer (Figure 2, Item 7) from slide hammer rod (Figure 2, Item 1).
  - c. Reinstall nut (Figure 2, Item 2) on end of slide hammer rod (Figure 2, Item 1) to prevent loss.

- d. Store slide hammer (Figure 2, Item 7) and slide hammer rod (Figure 2, Item 1) in accessory box.

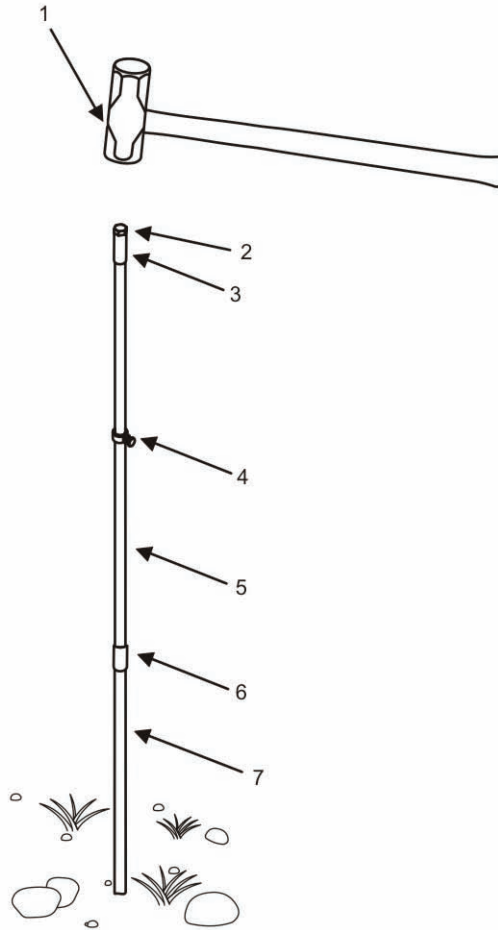

**Figure 3. Install Ground Rod With Sledge Hammer.**

**NOTE**

The accessory box contains two tools which can be used to drive the ground rod into the ground: a slide hammer assembly (Figure 2) and a sledge hammer (Figure 3). If the slide hammer assembly is not available, use the sledge hammer as described in step 13.

13. Install ground rod (Figure 3, Item 7) from accessory box using sledge hammer (Figure 3, Item 1) if slide hammer (Figure 2, Item 7) is not available.

**NOTE**

Ground rod (Figure 3, Item 7) must be installed within 5 ft (1.52 m) of PU ground terminal (Figure 1, Item 13). Ground cable (Figure 1, Item 14) is 6 ft (1.83 m) in length.

- Connect coupling (Figure 3, Item 6) to first section of ground rod (Figure 3, Item 7).
- Screw driving stud (Figure 3, Item 2) into coupling (Figure 3, Item 6).

**CAUTION**

Ensure that driving stud (Figure 3, Item 2) seats completely on couplings (Figure 3, Items 3 and 6) as shown. Failure to comply will cause damage to equipment.

**NOTE**

The driving stud (Figure 3, Item 2) is illustrated in Figure 3 as it would appear after being attached to the second coupling (Figure 3, Item 3) after completing step 13 e.

- c. Drive first section of ground rod (Figure 3, Item 7) into ground until coupling (Figure 3, Item 6) is just above surface.
- d. Remove driving stud (Figure 3, Item 2) and install second section of ground rod (Figure 3, Item 5) to first coupling (Figure 3, Item 6).
- e. Install second coupling (Figure 3, Item 3) and driving stud (Figure 3, Item 2) to second section of ground rod (Figure 3, Item 5).
- f. Drive second section of ground rod (Figure 3, Item 5) down until second coupling (Figure 3, Item 3) is just above the surface.

**NOTE**

Avoid driving the ground rod driving stud and coupling too close to ground level on last section of rod. Allow enough clearance to easily attach the grounding cable.

- g. Repeat steps 13 a – f until ground rod assembly has been driven 8 ft (2.44 m) or deeper.

**CAUTION**

Excessive tightening of the clamp (Figure 3, Item 4) can sever copper conductors and weaken the connection to ground. Tighten the clamp (Figure 3, Item 4) only as much as will prevent the cable from being pulled from the clamp (Figure 3, Item 4) by hand. Failure to comply will cause damage to equipment.

- h. Connect clamp (Figure 1, Item 15) and ground cable (Figure 1, Item 14) to ground rod (Figure 1, Item 1) and tighten clamp (Figure 1, Item 15).
  - i. Install trailer grounding terminal (Figure 1, Item 13) if not present using WP 0023, Remove/Install Ground Terminal and ground terminal assembly found in accessory box.
  - j. Connect ground cable (Figure 1, Item 14) to ground terminal (Figure 1, Item 13) on trailer.
14. Ensure all grounding connections are secure.

**END OF TASK**

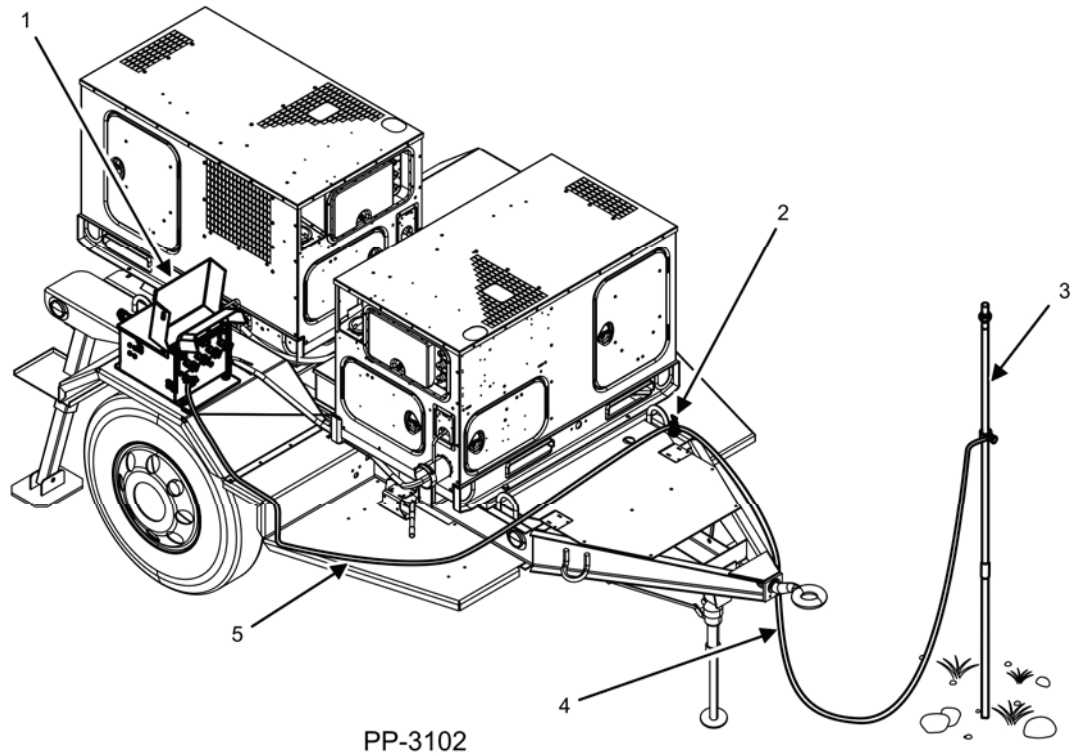
**Grounding (PP-3102)****Figure 4. Grounding PP-3102.**

1. Ensure ground cable (Figure 4, Item 5) from switch box (Figure 4, Item 1) is attached to trailer ground terminal (Figure 4, Item 2).
2. Attach ground cable (Figure 4, Item 5) from switch box (Figure 4, Item 1) to trailer ground terminal (Figure 4, Item 2) if ground cable is not attached.
  - a. Open switch box (Figure 4, Item 1) output terminal board cover.
  - b. Remove terminal nut wrench (Figure 5, Item 5) from brackets on the outside of switch box (Figure 5, Item 4).
  - c. Lift protective cover (Figure 5, Item 3) from switch box output terminal board (Figure 5, Item 2).
  - d. Loosen terminal nut (Figure 5, Item 8) using terminal nut wrench (Figure 5, Item 5).
  - e. Insert end of ground cable (Figure 4, Item 4) into slot in ground terminal (Figure 5, Item 6) on right side of output terminal board (Figure 5, Item 2).
  - f. Tighten terminal nut (Figure 5, Item 8) using terminal nut wrench (Figure 5, Item 5).
  - g. Secure terminal nut wrench (Figure 5, Item 5) on the brackets outside of the switch box (Figure 5, Item 4).
  - h. Lower protective cover (Figure 5, Item 3) over switch box output terminal board (Figure 5, Item 2).
  - i. Secure switch box (Figure 4, Item 1) output terminal board cover.
3. Install ground rod from accessory box. See Grounding PU-2002 and PU-2012 task, steps 10, 11, and 12, or Grounding PU-2002 and PU-2012 task, step 13.

## CAUTION

Excessive tightening of the clamp (Figure 3, Item 4) can sever copper conductors and weaken the connection to ground. Tighten the clamp (Figure 3, Item 4) only as much as will prevent the cable from being pulled from the clamp (Figure 3, Item 4) by hand. Failure to comply will cause damage to equipment.

## NOTE

Ground rod (Figure 1, Item 1) must be installed within 5 ft (1.52 m) of PP ground terminal (Figure 4, Item 2). Ground cable (Figure 4, Item 4) is 6 ft (1.83 m) in length.

4. Attach ground cable (Figure 4, Item 4) from earth ground (Figure 4, Item 3) to ground terminal (Figure 4, Item 2) at roadside front of trailer.
5. Ensure all grounding connections are secure.

## END OF TASK

### Removal of Ground Rod

## NOTE

Removing ground rod (Figure 2, Item 5) requires the reverse action of the slide hammer (Figure 2, Item 7). The slide hammer will be installed with the slide hammer (Figure 2, Item 7) between the end of the grounding rod (Figure 2, Item 5) and the impact disk (Figure 2, Item 3) so that the slide hammer (Figure 2, Item 7) strikes the impact disk (Figure 2, Item 3) with an upward stroke.

1. Loosen clamp (Figure 1, Item 15) and remove ground cable (Figure 1, Item 14) and clamp (Figure 1, Item 15) from ground rod (Figure 1, Item 1).
2. Install impact disk (Figure 2, Item 3) on slide hammer rod (Figure 2, Item 7).
3. Tighten impact disk (Figure 2, Item 3) to end of threads on slide hammer rod (Figure 2, Item 1).
4. Install lock washer and nut (Figure 2, Item 4).
5. Tighten lock washer and nut (Figure 2, Item 4) securely against impact disk (Figure 2, Item 3).
6. Remove nut (Figure 2, Item 2) if installed.
7. Position slide hammer (Figure 2, Item 7) on slide hammer rod (Figure 2, Item 1) under impact disk (Figure 2, Item 3).
8. Install nut (Figure 2, Item 2) and thread to top of slide hammer rod (Figure 2, Item 1) thread.
9. Screw slide hammer rod (Figure 2, Item 1) into end of ground rod (Figure 2, Item 5).
10. Tighten nut (Figure 2, Item 2) until it meets coupling (Figure 2, Item 6).
11. Ensure slide hammer rod (Figure 2, Item 1) seats on coupling (Figure 2, Item 6).
12. Strike impact disk (Figure 2, Item 3) with slide hammer (Figure 2, Item 7) using an upward motion.
13. Remove ground rod (Figure 2, Item 5) section and coupling (Figure 2, Item 6) just above surface.
14. Install slide hammer rod (Figure 2, Item 1) into end of next section of ground rod (Figure 2, Item 5) and repeat steps 10 – 13.
15. Install slide hammer rod (Figure 2, Item 1) into end of third section of ground rod (Figure 2, Item 5) and repeat step 10 – 13 until ground rod is removed.
16. Disassemble slide hammer (Figure 2, Item 7).
17. Inspect three sections of ground rod (Figure 1, Item 1) for damage and replace as required.

18. Store ground rod (Figure 1, Item 1) sections in generator set.

**END OF TASK**

**Connection to Load (PU-2002 and PU-2012)**

1. Secure load requirements from higher command.
2. Connect load cables to generator set output box. See TM 9-6115-750-10 and Table 1.

**Table 1. Load Terminal Selection.**

GENERATOR OUTPUT	OUTPUT TERMINALS	VOLTAGE READING	CURRENT READING TERMINAL
120/208 V 3 PH	L1, L2, L3, N	208 V (L1-L2) 208 V (L2-L3) 208 V (L3-L1) 120 V (L1-N)	L1 L2 L3 L1
120 V 1 PH	L1-N	120 V	L1
120/240 V 1 PH	L3-L1 L3-N L1-N	240 V 120 V 120 V	L3 L3 L1

**CAUTION**

When using single phase connections, always attempt to balance loads between terminals (do not connect all loads between one terminal and neutral). Failure to comply may result in damage to equipment.

3. Ensure ground cable remains secure.

**END OF TASK**

**Connection to Load (PP-3102)**

1. Secure load requirements from higher command.

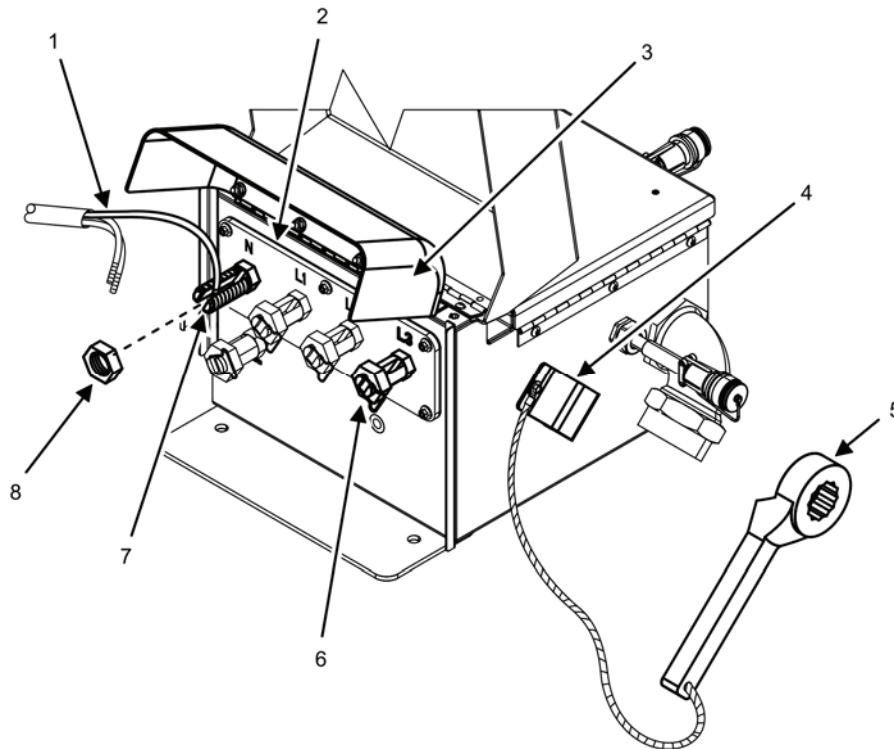

**Figure 5. Installation of Load and Ground Cables.**

2. Connect load cables to switch box output box. See Table 1 and TM 9-6115-750-10.
  - a. Open switch box (Figure 4, Item 1) output terminal board cover.
  - b. Remove terminal nut wrench (Figure 5, Item 5) from brackets on the outside switch box (Figure 5, Item 4).
  - c. Lift protective cover (Figure 5, Item 3) from switch box output terminal board (Figure 5, Item 2).
  - d. Loosen terminal nuts (shown removed for clarity) (Figure 5, Item 8) using terminal nut wrench (Figure 5, Item 5)
  - e. Insert end of required load cables (Figure 5, Item 1) into slots in switch box output terminals (Figure 5, Item 7).
  - f. Tighten terminal nuts (shown removed for clarity) (Figure 5, Item 8).
  - g. Secure terminal nut wrench (Figure 5, Item 5) on the brackets outside of the switch box (Figure 5, Item 4).
  - h. Lower protective cover (Figure 5, Item 3) over switch box output terminal board (Figure 5, Item 2).
  - i. Secure switch box (Figure 4, Item 1) output terminal board cover.
3. Ensure ground cable remains secure.

**END OF TASK**



**INITIAL ADJUSTMENTS****WARNING**

Trailer(s) must be secured to prohibit movement prior to performing PMCS or connecting ground and output cables. Failure to comply may cause injury or death to personnel.

**NOTE**

Steps 1 through 5 apply to LTT trailer only. Follow instructions in TM 2330-205-14&P to secure M200A1 trailer from movement.

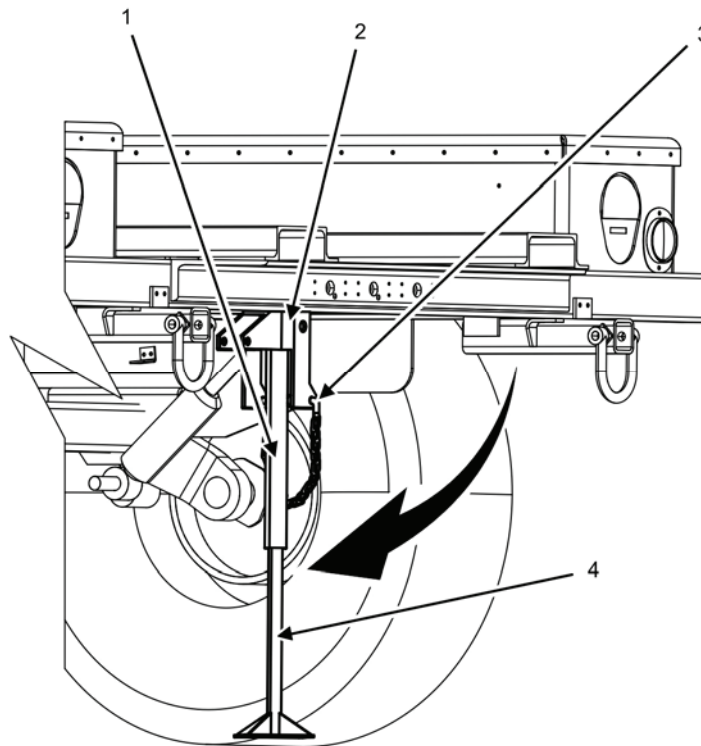

**Figure 6. Rear Leg Prop.**

1. Grasp rear leg prop (Figure 6, Item 1) to support it during locking pin (Figure 6, Item 3) removal.
2. Remove locking pin (Figure 6, Item 3) securing rear leg prop (Figure 6, Item 1) to trailer bracket (Figure 6, Item 2).
3. Lower rear leg prop (Figure 6, Item 1).
4. Replace locking pin (Figure 6, Item 3).
5. Turn lower portion (Figure 6, Item 4) of rear leg prop (Figure 6, Item 1) clockwise to extend lower portion (Figure 6, Item 4) of rear leg prop (Figure 6, Item 1) until it contacts the ground.
6. Perform all generator set PMCS (TM 9-6115-750-10).
7. Perform all trailer PMCS. See TM 9-2330-392-14&P for PMCS of the LTT or see TM 9-2330-205-14&P for PMCS of the M200A1 trailer.
8. Perform all PU and PP PMCS (WP 0010, Operator PMCS).

- 
9. See TM 9-6115-750-10 for generator set initial adjustments.
  10. See TM 9-2330-392-14&P for initial adjustment of the LTT or see TM 9-2330-205-14&P for initial adjustment of the M200A1 trailer.
  11. Remove fire extinguisher from trailer bracket and position on ground nearby the PU and PP.

**END OF TASK****OPERATING PROCEDURES****Generator Set Operating Procedures**

1. See TM 9-6115-750-10 for operation procedures as PU.
2. See TM 9-6115-750-10 for operation procedures in parallel as PP.

**END OF TASK****Trailer Operating Procedures**

1. See TM 9-2330-392-14&P for operation procedures as PU-2002 and PU-2012.
2. See TM 9-2330-205-14&P for operation procedures as PP-3102.

**END OF TASK****Switch Box Operating Procedures****NOTE**

No controls exist for the switch box. Its operation is autonomous.

1. Monitor indicator lights on switch box.
2. See WP 0004, Description and Use of Operator Controls and Indicators for description of indicators on switch box.

**END OF TASK**

**DECALS AND INSTRUCTION PLATES**

Identification and instructions plates are mounted on the trailers. Figure 7 through Figure 25 show the location and contents of each plate on each PU or PP. Table 2 through Table 4 identify the plates illustrated in Figure 7 through Figure 9.

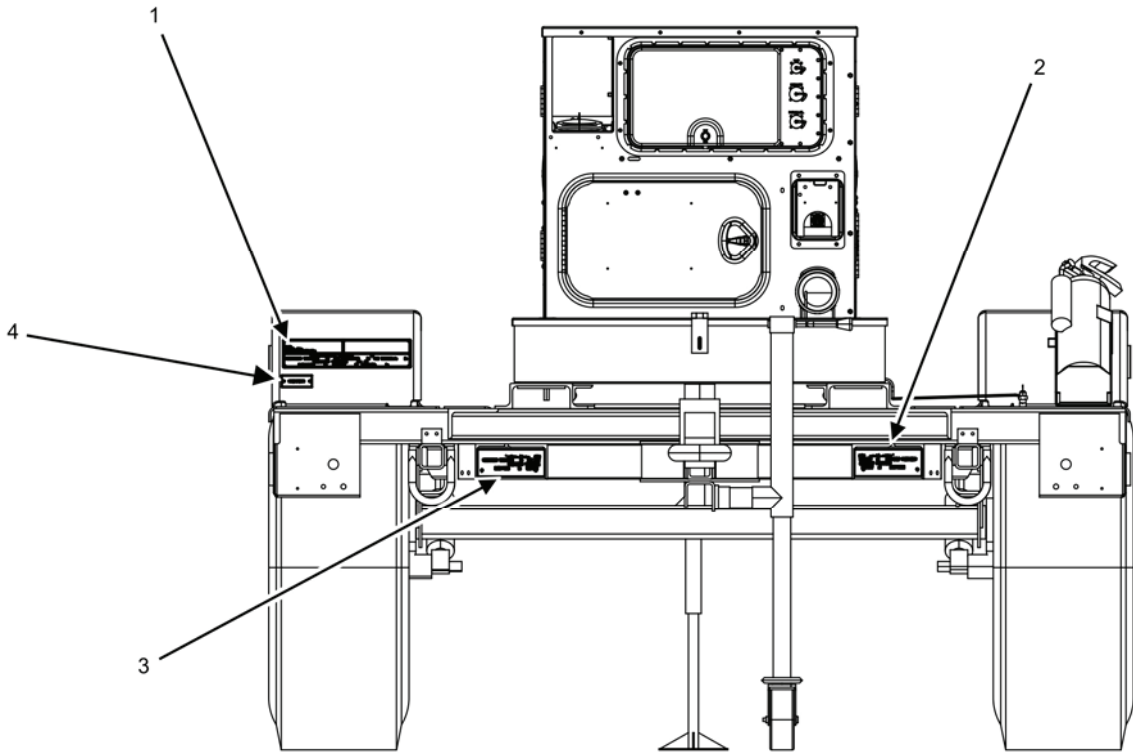

**Figure 7. Location of Plates and Labels — PU-2002 and PU-2012.**

**Table 2. Decals and Instruction Plates — PU-2002 and PU-2012.**

<b>ITEM NUMBER</b>	<b>NAME</b>	<b>MODEL PU-2002 FIGURE NUMBER</b>	<b>MODEL PU-2012 FIGURE NUMBER</b>
1	Name Plate, PU	Figure 10	Figure 11
2	Plate, ID Trailer	Figure 12	Figure 12
3	Plate, Name Identification, Chassis, Trailer	Figure 13	Figure 13
4	Plate, Individual Unit Identification (IUID)	Figure 14	Figure 15

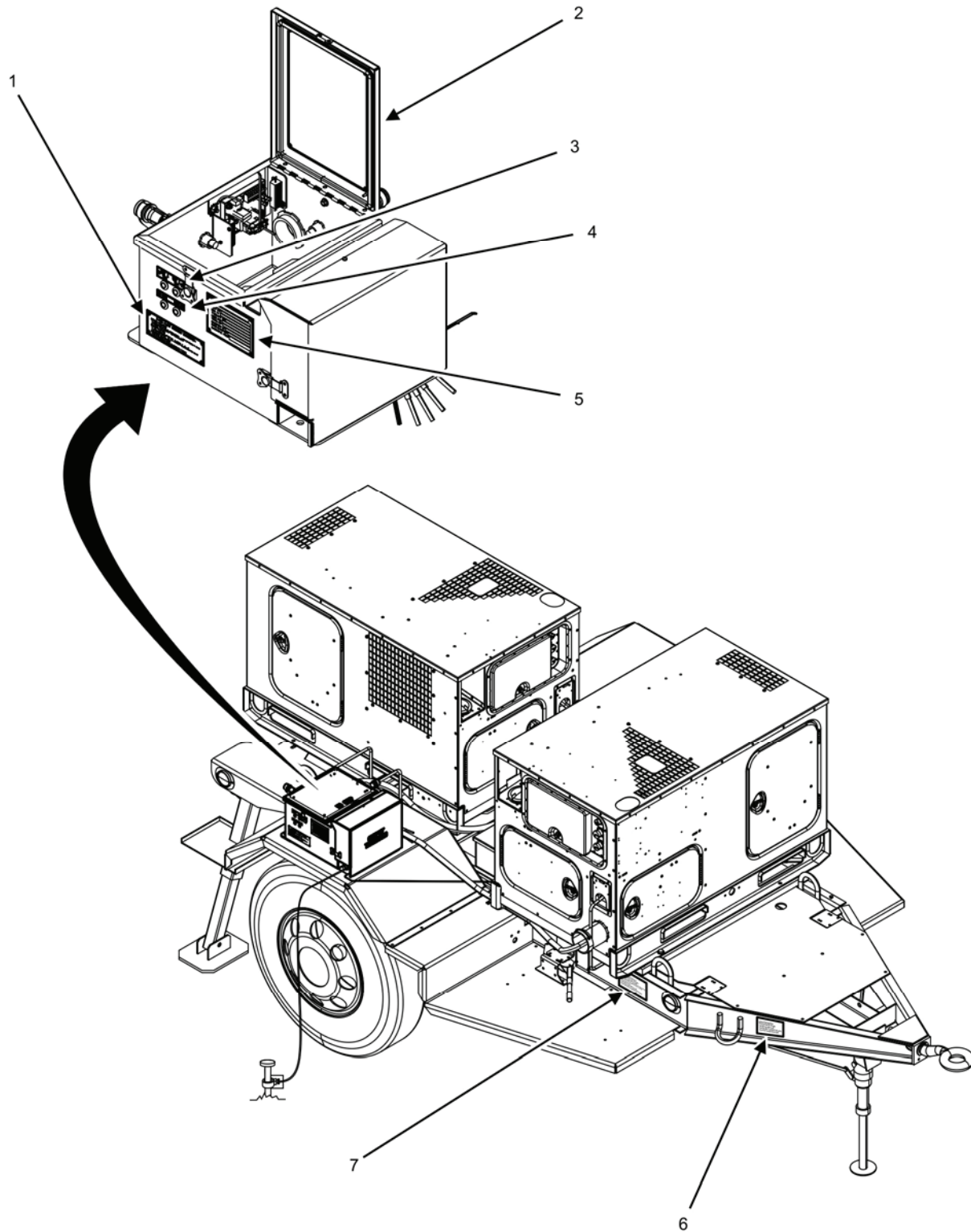

Figure 8. Location of Plates and Labels — PP-3102 Curbside.

Table 3. Decals and Instruction Plates — PP-3102.

ITEM NUMBER	NAME	MODEL PP-3102 FIGURE NUMBER
1	Plate, Operating Procedures	Figure 19
2	Plate, Schematic	Figure 17
3	Plate, Status, Switch Box	Figure 16
4	Plate, On Line, Switch Box	Figure 20
5	Plate, Switch Box Identification	Figure 18
6	Plate, Name Identification, Chassis, Trailer	Figure 21
7	Plate, Tie Down Instruction, Trailer	Figure 22

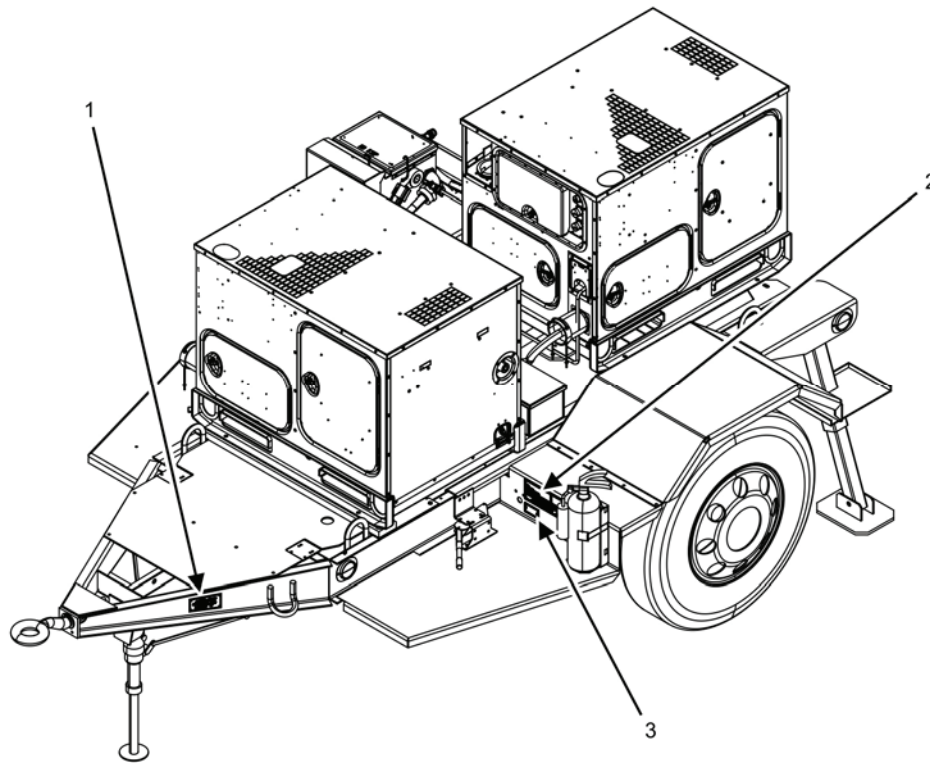

Figure 9. Location of Plates and Labels — PP-3102 Roadside.

Table 4. Decals and Instruction Plates — PP-3102.

ITEM NUMBER	NAME	MODEL PP-3102 FIGURE NUMBER
1	Plate, ID Trailer	Figure 23
2	Name Plate, PP	Figure 24
3	Plate, PP IUID Identification	Figure 25

POWER UNIT PU-2002 1-AMMPS 10KW 50/60 HZ NSN: 6115-01-562-4010 SERIAL NO: 1213454321 TECHNICAL MANUAL: TM 9-6115-756-13	
OPERATIONAL WEIGHT: 2499 lb SHIPPING WEIGHT: 2460 lb ON LUNETTE: 300 lb ON WHEELS: 2160 lb SHIPPING CUBAGE: 630 cu ft. LENGTH: 135 in WIDTH: 86 in HEIGHT: 71 in	

Figure 10. Plate, PU Identification, PU-2002.

POWER UNIT PU-2012 1-AMMPS 10KW 400 HZ NSN: 6115-01-562-3907 SERIAL NO: 5432112345 TECHNICAL MANUAL: TM 9-6115-756-13	
OPERATIONAL WEIGHT: 2514 lb SHIPPING WEIGHT: 2470 lb ON LUNETTE: 300 lb ON WHEELS: 2170 lb SHIPPING CUBAGE: 477 cu ft. LENGTH: 135 in WIDTH: 86 in HEIGHT: 71 in	

Figure 11. Plate, PU Identification, PU-2012.

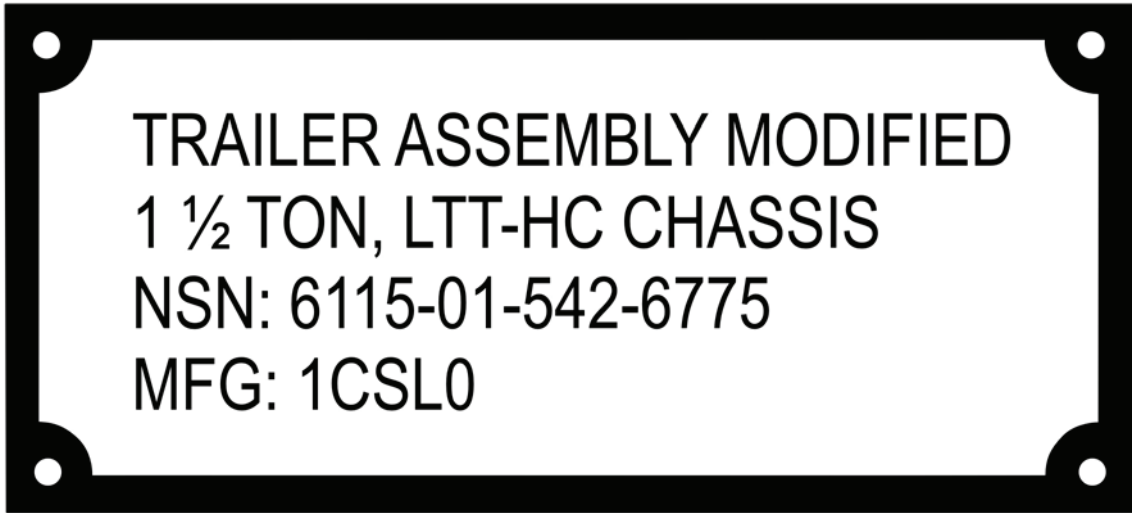

Figure 12. Plate, ID LTT Trailer.

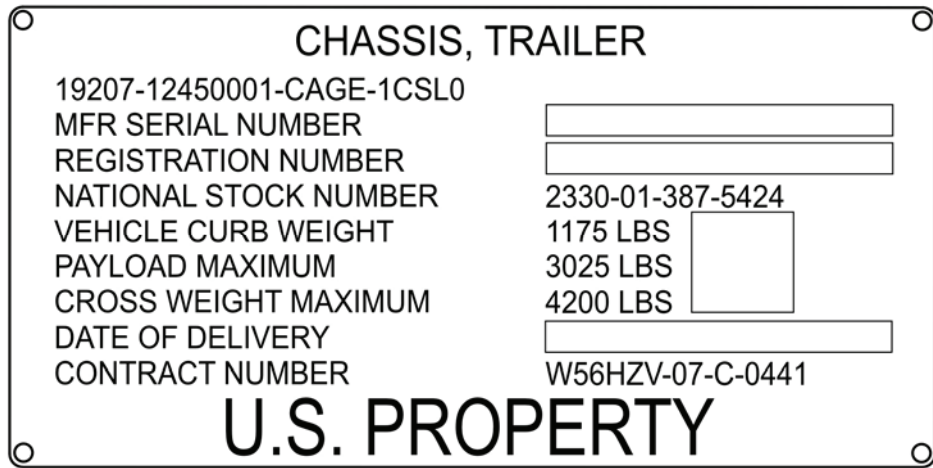

Figure 13. Plate, Name Identification, Chassis, LTT Trailer.

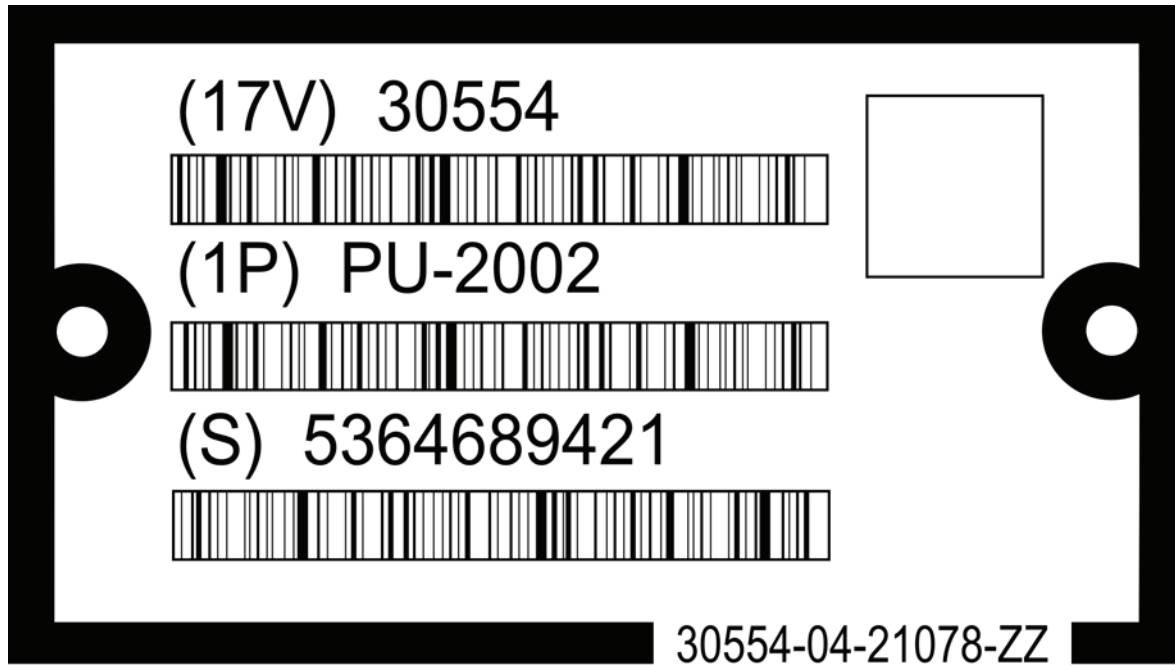

Figure 14. Plate, PU Identification (IUID), PU-2002.

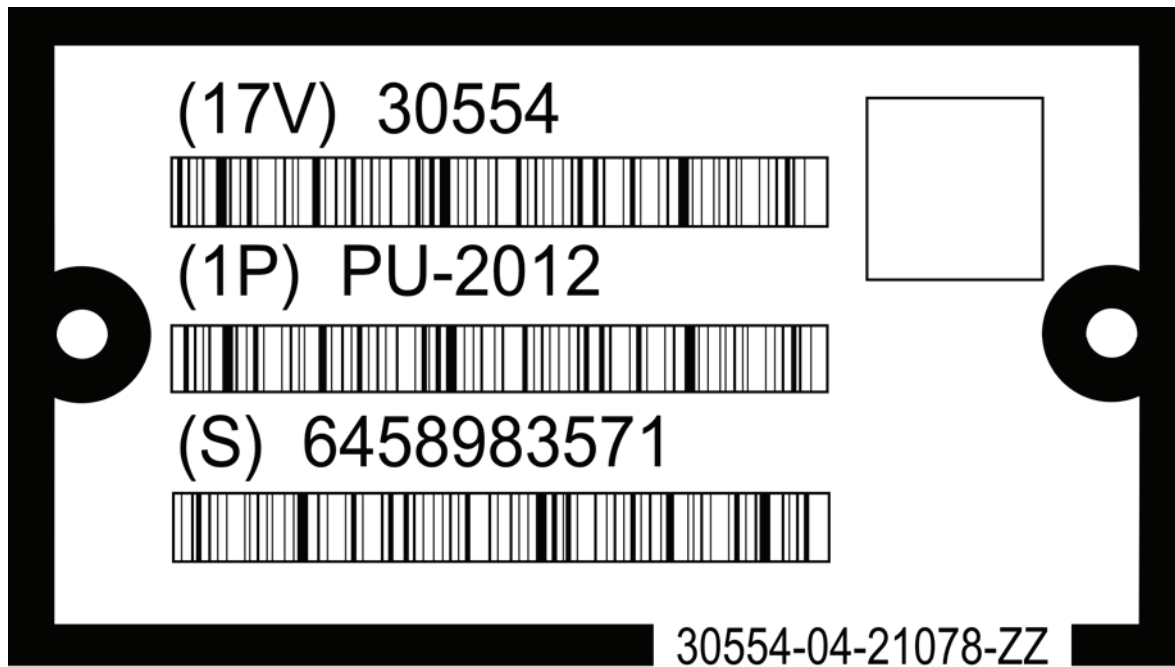

Figure 15. Plate, PU Identification (IUID), PU-2012.



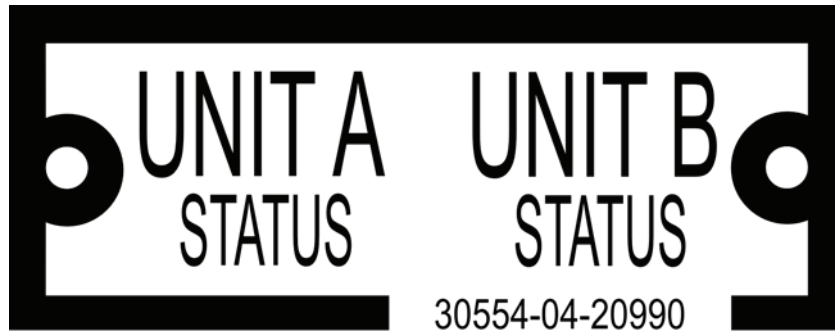

Figure 16. Plate, Status, Switch Box.

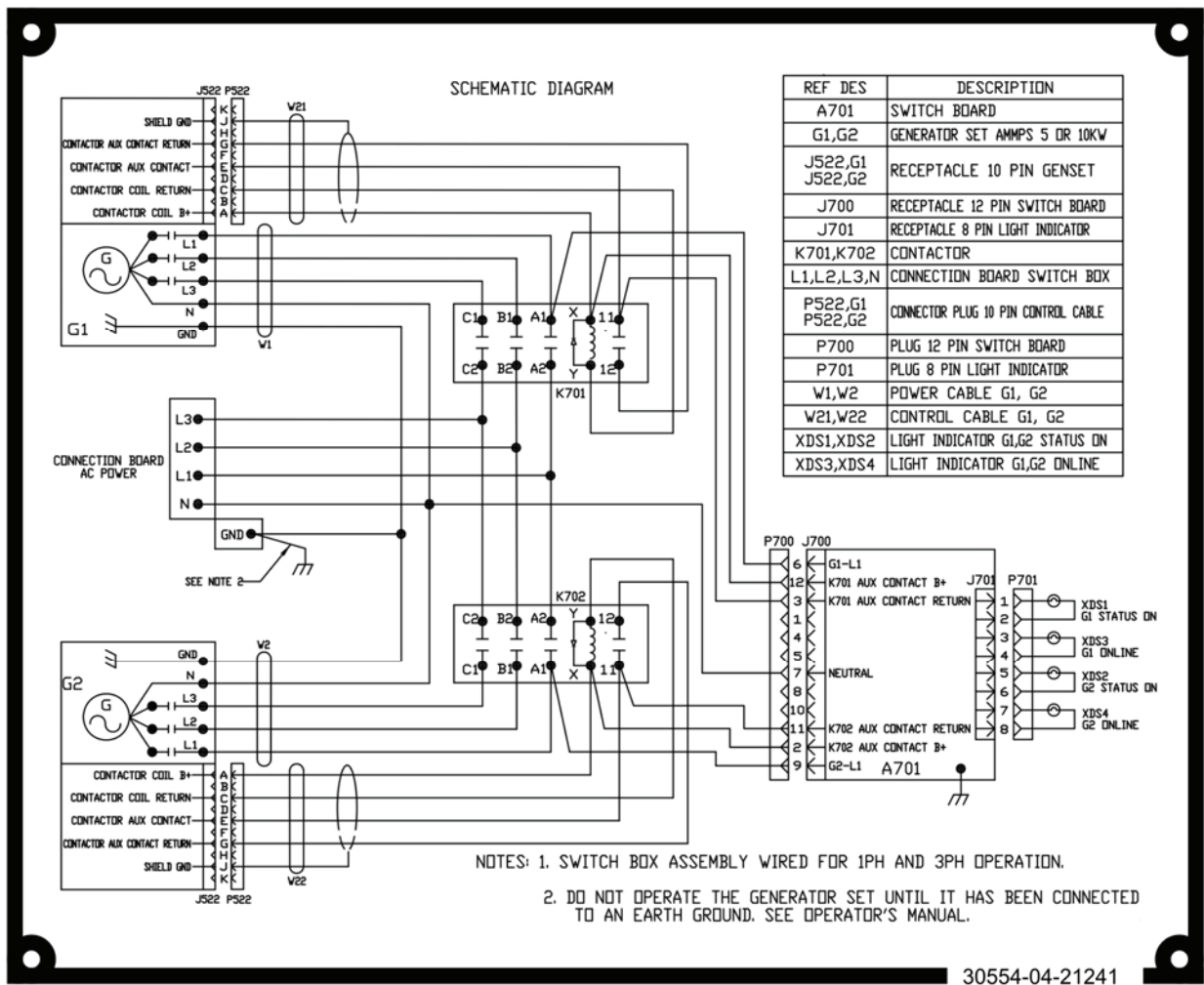

Figure 17. Plate, Switch Box Schematic.

SWITCH BOX 5kW AND 10kW 50/60 Hz OR 400 Hz - LTT	
NSN	6115-01-542-6775
PART NO.	04-20835
MFD BY	CUMMINS POWER GENERATION
CONTRACT NO.	W15P7T-04-D-A003
DATE MFD	08/01/2009
SERIAL NO.	1234554321
INSPECTED BY	JNM
DATE INSPECTED	08/02/2009
INSPECTION STAMP	
30554-04-21077-XX	

Figure 18. Plate, Switch Box Identification.

<b>POWER PLANT OPERATING PROCEDURES</b>	
<b>BEFORE OPERATION</b>	
1. CHECK SERVICE BOTH GEN SETS BEFORE OPERATION, CONNECT -GND- TERMINAL TO GROUND	
2. CHECK RECONNECT SWITCH FOR CORRECT VOLTAGE SETTING	
<b>INDICATOR LIGHTS</b>	
1. STATUS LIGHT INDICATES LINE BETWEEN GEN SET AND SW BOX IS HOT	
2. ON LINE LIGHT INDICATES SWITCH BOX CONTACTOR IS CLOSED FOR INDICATED GEN SET	
<b>OPERATING PROCEDURES</b>	
1. SEE GENSET PARALLEL OPERATING PROCEDURE WITH SWITCH BOX	

Figure 19. Plate, Operating Procedures.



Figure 20. Plate, On Line, Switch Box.

<p><b>CHASSIS, TRAILER GENERATOR, 2 1/2 TON 2W, M200A1</b>  <b>NATIONAL STOCK NO. 2330-00-331-2307</b>                  MANUFACTURED BY: SCHUTT INDUSTRIES, INC                  CLINTONVILLE, WI 54929</p> <p>VEHICLE INDET. NO. <input type="text" value="090520070760"/></p> <p>CONTRACT NO. <input type="text" value="W56HZV-06-D-0203"/></p>		<p><b>WEIGHT AND DIMENSION DATA</b></p>																
<p><b>PUBLICATIONS</b>                  Technical Manual                  TM9-2330-205-14&amp;P</p> <p>Cage Code: 1CSL0                  Original PN: 8358998 </p>		<table border="1"> <thead> <tr> <th>WEIGHTS</th> <th>EMPTY</th> <th>LOADED</th> </tr> </thead> <tbody> <tr> <td>LOADED</td> <td></td> <td>5000</td> </tr> <tr> <td>ON WHEELS</td> <td>1755</td> <td></td> </tr> <tr> <td>ON LUNETTE</td> <td>260</td> <td></td> </tr> <tr> <td>TOTAL</td> <td>2015</td> <td>7015</td> </tr> </tbody> </table>		WEIGHTS	EMPTY	LOADED	LOADED		5000	ON WHEELS	1755		ON LUNETTE	260		TOTAL	2015	7015
WEIGHTS	EMPTY	LOADED																
LOADED		5000																
ON WHEELS	1755																	
ON LUNETTE	260																	
TOTAL	2015	7015																
<p>DELIVERY DATE <input type="text"/></p> <p>INSPECTED <input type="text"/></p>		<p>SHIPPING CUBAGE 355 CU. FT.</p>																

Figure 21. Plate, Name Identification, M200A1 Chassis, Trailer.

<p><b>TIE-DOWN DATA</b></p> <p><b>NOTE: REAR TIEDOWN LUGS ARE LOCATED ABOVE REAR SPRING HANGER AND BELOW REAR LIFT LUG. DO NOT USE LIFT LUG FOR TIEDOWN.</b></p> <p>PROVIDE SUPPORT BLOCKS BETWEEN TRAILER AND DESK AS SHOWN (4) LOCATIONS                  MIN CAPACITY OF ALL TIEDOWN CHAINS IS 10,000 LBS.</p>		<p><b>M200A1 LIFTING DATA</b></p> <table border="1"> <thead> <tr> <th></th> <th>FRONT EYE</th> <th>FRONT EYE</th> </tr> </thead> <tbody> <tr> <td>CAPACITY/EYE</td> <td>4290 LBS.</td> <td>8250 LBS.</td> </tr> <tr> <td>CABLE SIZE *</td> <td>.75 MIN.</td> <td>.75 MIN.</td> </tr> <tr> <td>SHIPPING WEIGHT</td> <td colspan="2">2410 LBS.</td> </tr> <tr> <td>SHIPPING CUBAGE</td> <td colspan="2">331.3 CuFt</td> </tr> </tbody> </table> <p>* TYPE I OR II PER. FED SPEC RR-W-410</p>			FRONT EYE	FRONT EYE	CAPACITY/EYE	4290 LBS.	8250 LBS.	CABLE SIZE *	.75 MIN.	.75 MIN.	SHIPPING WEIGHT	2410 LBS.		SHIPPING CUBAGE	331.3 CuFt	
	FRONT EYE	FRONT EYE																
CAPACITY/EYE	4290 LBS.	8250 LBS.																
CABLE SIZE *	.75 MIN.	.75 MIN.																
SHIPPING WEIGHT	2410 LBS.																	
SHIPPING CUBAGE	331.3 CuFt																	

Figure 22. Plate, Tie Down Instruction, M200A1 Trailer.



Figure 23. Plate, ID M200A1 Trailer.

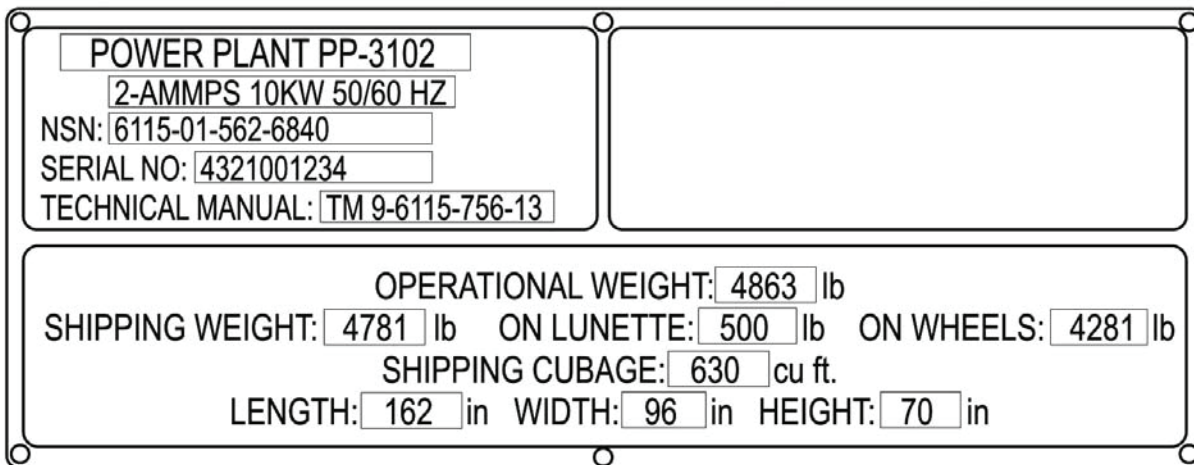

Figure 24. Plate, PP Identification, PP-3102.

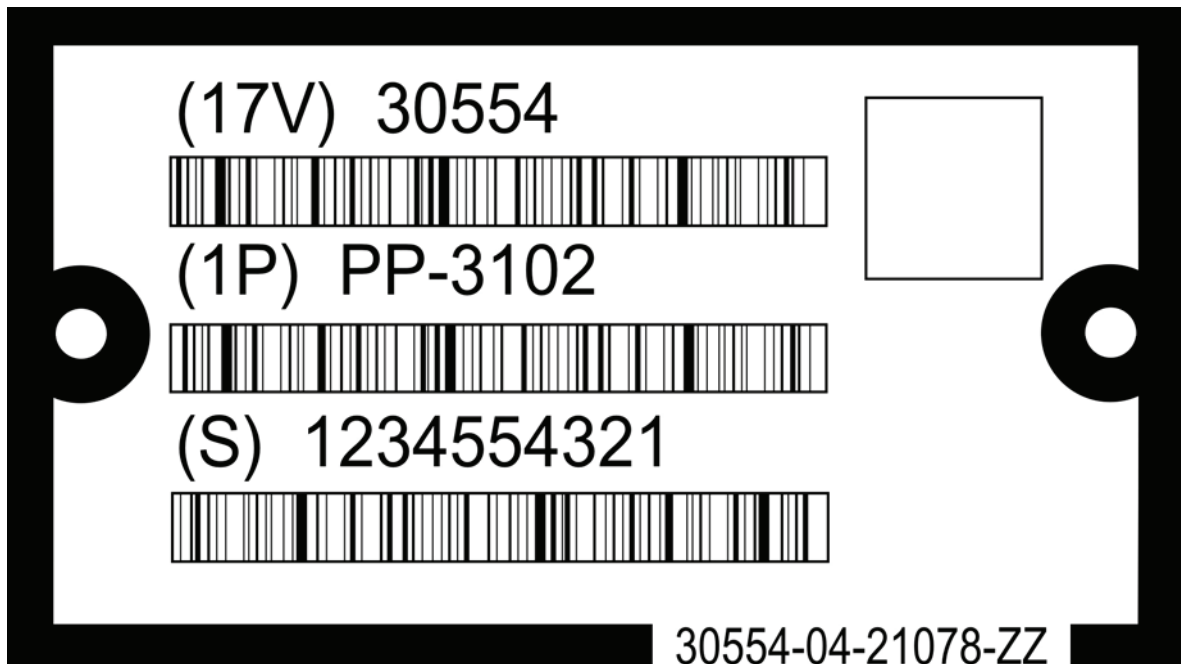

Figure 25. Plate, PP Identification (IUID), PP-3102.

#### END OF TASK

#### PREPARATION FOR MOVEMENT

#### WARNING

Ensure all generator sets are shut down and disconnected from the load (TM 9-6115-750-10). Ensure auxiliary fuel (if used) has been disconnected (TM 9-6115-750-10). Failure to comply may cause injury or death to personnel.

1. Open all contactors, turn generator set(s) engine control switch to OFF, and disconnect output cables from generator set(s) (TM 9-6115-750-10).
2. Disconnect auxiliary fuel source (if used) (TM 9-6115-750-10).
3. Remove ground cable (Figure 1, Item 14) from ground rod (Figure 1, Item 1).
4. Disconnect ground cable (Figure 1, Item 14) from trailer ground terminal (Figure 1, Item 13).
5. Remove and disassemble ground rod (Figure 1, Item 1).
6. Stow ground rod (Figure 1, Item 1) and ground cable (Figure 1, Item 14) in accessory box (WP 0002, Equipment Description and Data).
7. Replace fire extinguisher in bracket.

**NOTE**

Steps 8 – 11 apply to LTT only. Follow instructions in TM 9-2330-205-14&P to prepare M200A1 trailer for movement.

8. Turn lower portion (Figure 6, Item 4) of rear leg prop (Figure 6, Item 1) counterclockwise to raise lower portion (Figure 6, Item 4) of rear leg prop (Figure 6, Item 1) until it is completely retracted.
9. Remove locking pin (Figure 6, Item 3) securing rear leg prop (Figure 6, Item 1) in lowered position.
10. Raise rear leg prop (Figure 6, Item 1) to horizontal/travel position.
11. Replace locking pin (Figure 6, Item 3) to secure rear leg prop (Figure 6, Item 1) in horizontal/travel position.

**END OF TASK**

**END OF WORK PACKAGE**

**OPERATOR MAINTENANCE**  
**AMMPS 10KW TRAILER-MOUNTED POWER UNITS AND POWER PLANTS**  
**OPERATION UNDER UNUSUAL CONDITIONS**

**INITIAL SETUP:**

**Test Equipment**

Not Applicable

**Tools and Special Tools**

Not Applicable

**Materials/Parts**

Not Applicable

**Personnel Required**

Operator (1)

91D Assistant (1)

**References**

FM 21-305

FM 9-207

TM 9-238

TM 9-6115-750-24&P

**Equipment Conditions**

Engine control switch OFF (TM 9-6115-750-10, WP 0005)

Unit sited (WP 0005, Operation Under Usual Conditions)

Wheels chocked, brakes applied (LTT – TM 9-2330-392-14&P), (M200A1 – TM 9-2330-205-14&P)

Front trailer supports deployed (LTT – TM 9-2330-392-14&P), (M200A1 – TM 9-2330-205-14&P)

Rear leg prop assembly deployed (WP 0005, Operation Under Usual Conditions)

Rear step jacks deployed (M200A1 – TM 9-2330-205-14&P)

**OPERATION UNDER UNUSUAL CONDITIONS**

**UNUSUAL ENVIRONMENT/WEATHER**

**Operation In Extreme Cold (Below-25°F (-31°C))**

**WARNING**

In extremely cold weather, skin can stick to metal. Avoid contacting metal items with bare skin in extremely cold weather. Failure to comply may cause injury or death to personnel.

1. Refer to the lubrication charts in TM 9-6115-750-24&P, TM 9-2330-392-14&P, and TM 9-2330-205-14&P for proper lubricants to use in extreme cold.

**NOTE**

Extreme cold can cause insulation material on electrical wire to crack and cause short circuits, and other construction materials to become hard, brittle, and easily damaged or broken.

2. Inspect all parts and wiring frequently for damage, loose hardware, or missing parts.
3. Inspect tire-to-ground contact for indications of tires frozen to ground.
4. Notify field maintenance if tires are frozen to ground.

**NOTE**

Flat spots on tires are often an indication of being under-inflated. Tires lose air pressure in cold weather.

5. Inspect tires for flat spots.
6. Notify field maintenance if flat spots are found.

**CAUTION**

Brake shoes may freeze to brake drum and will need to be heated to prevent damage to mating surfaces. Failure to comply will cause damage to equipment.

**NOTE**

Notify field maintenance for step 7.

7. Inspect brake shoe to brake drum contact prior to movement.
8. Refer to FM 9-207, Operation and Maintenance of Ordnance Material In Cold Weather, and FM 21-305, Manual for the Wheeled Vehicle Driver, for special instructions on driving hazards in extreme cold.
9. Park in a sheltered area out of the wind when parking short term.
10. Place footing of planks or brush under trailer wheels, landing gear, and step jack for long term parking.
11. Remove all built-up ice, snow, and mud as soon as possible after use.
12. Shield the trailer with canvas covers, if available. Keep cover ends off the ground to prevent covers from freezing to the ground.
13. Refer to TM 9-6115-750-24&P, TM 9-2330-392-14&P, and TM 9-2330-205-14&P for additional precautions in extreme cold.

**END OF TASK****Operation In Extreme Heat (Above 120°F (49°C))**

1. Refer to the lubrication charts in TM 9-6115-750-24&P, TM 9-2330-392-14&P, and TM 9-2330-205-14&P for proper lubricants to use in extreme heat.

**CAUTION**

Do not park the trailer in sunlight for long periods of time. Heat and sunlight shorten tire life. Failure to comply will cause damage to equipment.

2. Shelter or cover the trailer with canvas if available.
3. Refer to TM 9-6115-750-24&P, TM 9-2330-392-14&P, and TM 9-2330-205-14&P for additional precautions in extreme heat.

**END OF TASK**



---

**Operation In Sandy Or Dusty Areas**

1. Clean, inspect, and lubricate more often in dusty or sandy areas.

**NOTE**

Notify field maintenance for step 2.

2. Reduce tire pressure during emergency operation on beach or desert sand to 15 pounds per square inch (psi) (103 kiloPascal (kPa)) for LTT trailers and 62 psi (430 kPa) for M200A1 trailers.

**NOTE**

Notify field maintenance for step 3.

3. Return tire pressure to 17 psi (117 kPa) for LTT trailers and 70 psi (482 kPa) for M200A1 trailers after emergency operation in sand.
4. Refer to TM 9-6115-750-10 for additional precautions for the generator set in sandy or dusty areas.

**END OF TASK****Operation In Snow**

1. See FM 21-305 for special instructions on operating in snow.
2. Keep generator set intake and exhaust grates free of ice and snow.

**END OF TASK****Operation In Saltwater Areas****NOTE**

Saltwater causes rust and corrosion to develop rapidly.

1. Clean, inspect, and lubricate trailers more often than scheduled. See TM 9-2330-392-14&P and TM 9-2330-205-14&P.
2. See TM 9-6115-750-10 for additional precautions for generator sets.

**END OF TASK****Operation In Mud**

1. Clean thoroughly and lubricate all parts contaminated by mud as soon as possible after operating in mud.
2. Pack wheel bearings if necessary. See TM 9-2330-392-14&P and TM 9-2330-205-14&P for instructions.
3. Clear mud from generator set intake and exhaust grates.

**END OF TASK**

**Fording****CAUTION**

Fording water deeper than deck level of the trailer is not permitted. Generator sets must not be submerged. Failure to comply will cause damage to equipment.

1. Check bottom surface of stream or river. Ford across only if bottom is firm.
2. Apply the brakes a few times after fording to dry out the brake lining.

**WARNING**

Be sure brakes are operating properly before driving at normal speeds. Failure to comply may cause injury or death to personnel.

3. Lubricate all unpainted surfaces with lubricating oil prior to fording.

**NOTE**

Notify field maintenance for step 4.

4. Lubricate trailers IAW the lubrication charts in TM 9-2330-392-14&P and TM 9-2330-205-14&P.
5. Refer to TM 9-238, Deep Water Fording of Ordnance Material, for deepwater fording information.

**END OF TASK**

**END OF WORK PACKAGE**

**CHAPTER 3**

**OPERATOR TROUBLESHOOTING PROCEDURES**

**FOR**

**AMMPS 10KW TRAILER-MOUNTED POWER UNITS AND POWER PLANTS**

CHAPTER 3

OPERATOR TROUBLESHOOTING PROCEDURES

**WORK PACKAGE INDEX**

---

<u>Title</u>	<u>WP Sequence No.</u>
TRUBLESHOOTING INDEX .....	0007
TRUBLESHOOTING PROCEDURES .....	0008

---

**OPERATOR MAINTENANCE**  
**AMMPS 10KW TRAILER-MOUNTED POWER UNITS AND POWER PLANTS**  
**TROUBLESHOOTING INDEX**

---

**GENERAL TROUBLESHOOTING INFORMATION**

Operator troubleshooting procedures are designed to isolate and correct AMMPS faults and warnings so that electrical power is provided to end users with the least possible service interruption. Troubleshooting techniques apply to all AMMPS components as indicated.

Troubleshooting procedures list the symptoms, malfunctions, and corrective actions required to correct system faults and warnings. Perform all steps in the order they appear in the WP. Troubleshooting procedures are listed according to symptom, followed by the malfunction, and then any corrective action(s). All necessary references to procedures/instructions can be found within the Troubleshooting WP (WP 0008, Troubleshooting Procedures).

The DCS constantly monitors the engine sensors for abnormal conditions, such as low oil pressure and high coolant temperature. If any of these conditions occur, the DCS panel will display a message indicating a fault or warning code. The system will shut down if a fault is indicated. If a warning is indicated but not addressed, it will frequently become a fault. If a malfunction or failure occurs during operation or performance check, perform troubleshooting IAW the Malfunction/Symptom Index and any displayed fault or warning codes (TM 9-6115-750-10).

Do not begin a task until you understand the task.

**10 kW Generator Set Troubleshooting**

Refer to TM 9-6115-750-10.

**LTT Troubleshooting**

Refer to TM 9-2330-392-14&P.

**M200A1 Trailer Troubleshooting**

Refer to TM 9-2330-205-14&P.

**MALFUNCTION/SYMPPTOM INDEX**

The malfunction/symptom index is a quick reference for locating troubleshooting procedures. Troubleshooting procedures are arranged based upon the location of the malfunction (i.e., switch box) and the presence of a DCS code.

**DCS Fault and Warning Codes**

Refer to TM 9-6115-750-10 for a complete list of DCS fault and warning codes.

**Indications from Manual Troubleshooting Techniques**

Field maintenance is responsible for performing manual troubleshooting techniques, including continuity tests and voltage checks, maintenance actions that require the use of tools, and DCS function activities other than routine operator adjustments.

**After Corrective Action**

After the corrective action is completed, the equipment must be tested to verify that a fault or warning has been corrected. Locate the malfunction in the troubleshooting procedures and perform the test or inspection. If the correct response is not obtained, continue troubleshooting all suspected malfunctions and performing corresponding corrective actions until the equipment is operational or is replaced with operational equipment.

**Specific Troubleshooting Procedures**

This TM cannot list all malfunctions that may occur or all tests or inspections and corrective actions. If a malfunction is not listed or is not corrected by the listed corrective action, notify field maintenance.

**Malfunction/Symptom Troubleshooting Procedure WP and Page**

**SWITCH BOX TROUBLESHOOTING**

- 1. [Fault 1459: Reverse Power] displayed on DCS screen .....WP 0008, Page 2  
 Mechanical paralleling instability .....WP 0008, Page 2
- 2. [Fault 1461: Loss of Field] displayed on DCS screen .....WP 0008, Page 2  
 Electrical paralleling instability .....WP 0008, Page 2
- 3. [Fault 3659: Switch Box Fail To Open] displayed on DCS screen .....WP 0008, Page 3  
 Contactor or wiring problem .....WP 0008, Page 3
- 4. [Warning 1456: Bus Out Of Synchronization Range] displayed on DCS screen .....WP 0008, Page 4  
 Voltage or frequency mismatch between generator sets .....WP 0008, Page 4
- 5. [Warning 1457: Fail To Synchronize] displayed on DCS screen .....WP 0008, Page 4  
 Synchronization problem .....WP 0008, Page 4
- 6. [Warning 1458: Sync Phase Rotation Mismatch] displayed on DCS screen .....WP 0008, Page 5  
 Load cables improperly connected .....WP 0008, Page 5
- 7. [Warning 3658: Switch Box Fail To Close] displayed on DCS screen .....WP 0008, Page 6  
 Improper connections or malfunctioning switch box contactor .....WP 0008, Page 6
- 8. One of the indicator lights fails to light .....WP 0008, Page 7  
 Wiring, connection, or Light Emitting Diode (LED) problem .....WP 0008, Page 7

**END OF WORK PACKAGE**

**OPERATOR MAINTENANCE  
AMMPS 10KW TRAILER-MOUNTED POWER UNITS AND POWER PLANTS  
TROUBLESHOOTING PROCEDURES**

**INITIAL SETUP:**

<b>Test Equipment</b>	<b>Equipment Conditions</b>
Not Applicable	Engine control switch OFF (TM 9-6115-750-10, WP 0005)
<b>Tools and Special Tools</b>	Engine cool
Not Applicable	Wheels chocked, brakes applied (LTT – TM 9-2330-392-14&P), (M200A1 – TM 9-2330-205-14&P)
<b>Materials/Parts</b>	Front trailer supports deployed (LTT – TM 9-2330-392-14&P), (M200A1 – TM 9-2330-205-14&P)
Not Applicable	Rear leg prop assembly deployed (WP 0005, Operation Under Usual Conditions)
<b>Personnel Required</b>	Rear step jacks deployed (M200A1 – TM 9-2330-205-14&P)
Operator (1)	
<b>References</b>	
WP 0010, Operator PMCS	

**TROUBLESHOOTING PROCEDURES**

**WARNING**

- Shut down generator sets before performing inspection of load cables. Failure to comply may cause injury or death to personnel by electrocution.
- Ensure generator sets are shut down and output terminal board has no voltage prior to making any connections for parallel operation or moving a generator set that has been operating in parallel. Operating generator sets always contain the risk of electrocution. Failure to comply may cause injury or death to personnel.
- High voltage is produced when generator set is in operation. Never attempt to start the generator set unless it is properly grounded. Do not ground yourself in standing water. Never attempt to connect or disconnect load cables while the generator sets are running. Failure to comply may cause injury or death to personnel.
- High voltage is produced when this generator set is in operation. Do not contact output cables when operating this generator set. Failure to comply may cause injury or death to personnel.
- High-voltage power is available when the main contactor is closed. Avoid accidental contact with live components. Ensure load cables are properly connected and the load cable door is shut before closing main contactor. Ensure that personnel working with/on loads connected to the generator set are aware that main contactor is about to be closed before closing main contactor. Failure to comply may cause injury or death to personnel.

---

**NOTE**

Always perform PMCS prior to beginning any troubleshooting procedure (WP 0010, Operator PMCS). Follow all procedures for operating the PU or PP (WP 0005, Operation Under Usual Conditions).

Read the entire corrective action sequence before beginning steps to complete corrective action for a malfunction.

**SYMPTOM**

[Fault 1459: Reverse Power] displayed on DCS screen.

**NOTE**

Reverse power occurs when two generator sets are operating in parallel. A generator set may not accept a load when the unloaded generator set operating speed is less than the loaded generator set operating speed. The loaded generator set will motorize, or reverse power, the unloaded generator set. This situation creates an undue load on the loaded generator and may damage the unloaded generator set.

**MALFUNCTION**

Mechanical paralleling instability.

**CORRECTIVE ACTION****WARNING**

- Ensure generator sets are shut down and output terminal board has no voltage prior to making any connections for parallel operation or moving a generator set that has been operating in parallel. Operating generator sets always contain the risk of electrocution. Failure to comply may cause injury or death to personnel.
- Shut down generator sets before performing inspection of load cables. Failure to comply may cause injury or death to personnel by electrocution.
  - STEP 1. Examine load cables and load demands and ensure generator sets are proper size for load requirements.
  - STEP 2. Remove connections and reconnect IAW paralleling instructions (TM 9-6115-750-10).
  - STEP 3. If symptom continues, contact field maintenance.

**SYMPTOM**

[Fault 1461: Loss of Field] displayed on DCS screen.

**MALFUNCTION**

Electrical paralleling instability.



---

**CORRECTIVE ACTION****WARNING**

- Ensure generator sets are shut down and output terminal board has no voltage prior to making any connections for parallel operation or moving a generator set that has been operating in parallel. Operating generator sets always contain the risk of electrocution. Failure to comply may cause injury or death to personnel.
- Shut down generator sets before performing inspection of load cables. Failure to comply may cause injury or death to personnel by electrocution.
  - STEP 1. Examine load cables and load demands and ensure generator sets are proper size for load requirements.
  - STEP 2. Remove connections and reconnect IAW paralleling instructions (TM 9-6115-750-10).
  - STEP 3. If symptom continues, contact field maintenance.

**SYMPTOM**

[Fault 3659: Switch Box Fail To Open] displayed on DCS screen.

**MALFUNCTION**

Contactor or wiring problem.

**CORRECTIVE ACTION****WARNING**

- Shut down generator sets before performing inspection of load cables. Failure to comply may cause injury or death to personnel by electrocution.
- Ensure generator sets are shut down and output terminal board has no voltage prior to making any connections for parallel operation or moving a generator set that has been operating in parallel. Operating generator sets always contain the risk of electrocution. Failure to comply may cause injury or death to personnel.
- High voltage is produced when generator set is in operation. Never attempt to start the generator set unless it is properly grounded. Do not ground yourself in standing water. Never attempt to connect or disconnect load cables while the generator sets are running. Failure to comply may cause injury or death to personnel.
- High voltage is produced when this generator set is in operation. Do not contact output cables when operating this generator set. Failure to comply may cause injury or death to personnel.
  - STEP 1. Ensure all generator sets attached to switch box are shut down.
  - STEP 2. Ensure control cable is connected from switch box to generator set switch box control receptacle. Tighten/reconnect cable as necessary.
  - STEP 3. If symptom continues, contact field maintenance.

**SYMPTOM**

[Warning 1456: Bus Out Of Synchronization Range] displayed on DCS screen.

**MALFUNCTION**

Voltage or frequency mismatch between generator sets.

**CORRECTIVE ACTION**

- STEP 1. Verify that both sets have same voltage, frequency, and number of phases.
- STEP 2. Use voltage selection switch or DCS [Adjustments] screens one or two to set to desired setting (TM 9-6115-750-10) if adjustments are required.
- STEP 3. If symptom continues, contact field maintenance.

**SYMPTOM**

[Warning 1457: Fail To Synchronize] displayed on DCS screen.

**MALFUNCTION**

Synchronization problem.

**CORRECTIVE ACTION****WARNING**

- Shut down generator sets before performing inspection of load cables. Failure to comply may cause injury or death to personnel by electrocution.
- Ensure generator sets are shut down and output terminal board has no voltage prior to making any connections for parallel operation or moving a generator set that has been operating in parallel. Operating generator sets always contain the risk of electrocution. Failure to comply may cause injury or death to personnel.
- High voltage is produced when generator set is in operation. Never attempt to start the generator set unless it is properly grounded. Do not ground yourself in standing water. Never attempt to connect or disconnect load cables while the generator sets are running. Failure to comply may cause injury or death to personnel.
- High voltage is produced when this generator set is in operation. Do not contact output cables when operating this generator set. Failure to comply may cause injury or death to personnel.
  - STEP 1. Ensure both generator sets being used are at the same operating temperature (TM 9-6115-750-10).
  - STEP 2. If one generator is cold, allow it to warm to operating temperature (TM 9-6115-750-10) and retry paralleling.
  - STEP 3. If symptom continues, ensure all generator sets attached to switch box are shut down.
  - STEP 4. Ensure parallel cable is connected between generator sets (TM 9-6115-750-10).
  - STEP 5. Ensure control cable is connected from switch box to generator set switch box control receptacle. Tighten/reconnect cable as necessary.

- STEP 6. Examine output terminal board connections visually at each generator to determine that output cables are connected to the correct terminals (TM 9-6115-750-10). Adjust as required.
- STEP 7. Check switch box load cable attachments and ensure generator sets are able to meet load demands (WP 0005, Operation Under Usual Conditions).
- STEP 8. Replace PP with larger PP or reduce load as required.
- STEP 9. If symptom continues, contact field maintenance.

**SYMPTOM**

[Warning 1458: Sync Phase Rotation Mismatch] displayed on DCS screen.

**MALFUNCTION**

Load cables improperly connected.

**CORRECTIVE ACTION****WARNING**

- High voltage is produced when generator set is in operation. Never attempt to start the generator set unless it is properly grounded. Do not ground yourself in standing water. Never attempt to connect or disconnect load cables while the generator sets are running. Failure to comply may cause injury or death to personnel.
- High voltage is produced when this generator set is in operation. Do not contact output cables when operating this generator set. Failure to comply may cause injury or death to personnel.
- High-voltage power is available when the main contactor is closed. Avoid accidental contact with live components. Ensure load cables are properly connected and the load cable door is shut before closing main contactor. Ensure that personnel working with/on loads connected to the generator set are aware that main contactor is about to be closed before closing main contactor. Failure to comply may cause injury or death to personnel.
- Ensure generator sets are shut down and output terminal board has no voltage prior to making any connections for parallel operation or moving a generator set that has been operating in parallel. Operating generator sets always contain the risk of electrocution. Failure to comply may cause injury or death to personnel.
- Shut down generator sets before performing inspection of load cables. Failure to comply may cause injury or death to personnel by electrocution.
  - STEP 1. Examine output terminal board connections visually at each generator to determine that output cables are connected to the correct terminals (TM 9-6115-750-10).
  - STEP 2. If output cables are connected incorrectly, verify that off-line generator cables are de-energized.
  - STEP 3. Disconnect off-line generator cables at output terminal board and reconnect to match operating generator output cables.

## WARNING

High-voltage power is available when the main contactor is closed. Avoid accidental contact with live components. Ensure load cables are properly connected and the load cable door is shut before closing main contactor. Ensure that personnel working with/on loads connected to the generator set are aware that main contactor is about to be closed before closing main contactor. Failure to comply may cause injury or death to personnel.

STEP 4. Operate generators in parallel (TM 9-6115-750-10).

STEP 5. If symptom continues, contact field maintenance.

## SYMPTOM

[Warning 3658: Switch Box Fail To Close] displayed on DCS screen.

## MALFUNCTION

Improper connections or malfunctioning switch box contactor.

## CORRECTIVE ACTION

## WARNING

- Shut down generator sets before performing inspection of load cables. Failure to comply may cause injury or death to personnel by electrocution.
- Ensure generator sets are shut down and output terminal board has no voltage prior to making any connections for parallel operation or moving a generator set that has been operating in parallel. Operating generator sets always contain the risk of electrocution. Failure to comply may cause injury or death to personnel.
- High voltage is produced when generator set is in operation. Never attempt to start the generator set unless it is properly grounded. Do not ground yourself in standing water. Never attempt to connect or disconnect load cables while the generator sets are running. Failure to comply may cause injury or death to personnel.
- High voltage is produced when this generator set is in operation. Do not contact output cables when operating this generator set. Failure to comply may cause injury or death to personnel.
  - STEP 1. Ensure all generator sets attached to switch box are shut down.
  - STEP 2. Ensure control cable is connected from switch box to generator set switch box control receptacle. Tighten/reconnect cable as necessary.
  - STEP 3. If symptom continues, contact field maintenance.

**SYMPTOM**

One of the indicator lights fails to light.

**NOTE**

STATUS indicator lights show that the load cables between the generator set and the switch box are energized (i.e. generator set contactor is closed). ON LINE indicator lights show that the switch box contactor is closed for indicated generator set.

**MALFUNCTION**

Wiring, connection, or Light Emitting Diode (LED) problem.

**CORRECTIVE ACTION**

STEP 1. Ensure contactor(s) are closed (TM 9-6115-750-10).

**WARNING**

- Ensure generator sets are shut down and output terminal board has no voltage prior to making any connections for parallel operation or moving a generator set that has been operating in parallel. Operating generator sets always contain the risk of electrocution. Failure to comply may cause injury or death to personnel.
- Shut down generator sets before performing inspection of load cables. Failure to comply may cause injury or death to personnel by electrocution.

STEP 2. Ensure load cables are connected from switch box to generator set output box terminal board correctly (TM 9-6115-750-10).

STEP 3. If symptom continues, contact field maintenance.

**END OF WORK PACKAGE**



**CHAPTER 4**  
**OPERATOR MAINTENANCE INSTRUCTIONS**  
**FOR**  
**AMMPS 10KW TRAILER-MOUNTED POWER UNITS AND POWER PLANTS**

CHAPTER 4

OPERATOR MAINTENANCE INSTRUCTIONS

**WORK PACKAGE INDEX**

---

<u>Title</u>	<u>WP Sequence No.</u>
OPERATOR PMCS INTRODUCTION.....	0009
OPERATOR PMCS.....	0010



---

**OPERATOR MAINTENANCE**  
**AMMPS 10KW TRAILER-MOUNTED POWER UNITS AND POWER PLANTS**  
**OPERATOR PMCS INTRODUCTION**

---

**INTRODUCTION**

This section contains information that you will need to perform operator PMCS. Steps are included to help you perform these procedures easily and quickly. PMCS consists of scheduled maintenance items used to make sure the 10 kW PUs and PPs are ready for operation at all times. Inspect the system regularly and carefully so that you can find, correct, or prevent any defects.

**GENERAL**

PMCS is performed to keep the equipment in operating condition. The checks are used to find, correct, or report problems. Pay attention to warning and caution statements. A warning indicates the possibility of injury or death to personnel. A caution means the equipment could be damaged.

- Before operation of the equipment, perform Before (B) PMCS.
- During operation, perform During (D) PMCS.
- After operation, perform After (A) PMCS.

**EXPLANATION OF THE COLUMNS FOUND IN PMCS TABLE**

Column (1) – Item No. The item number lists the checks and services in the order they are to be performed. This column will be used as a source of item for the TM Number Column on DA Form 2404, Equipment Inspection and Maintenance Worksheet; or DA Form 5988E (electronic version), Equipment Inspection and Maintenance Worksheet, in recording the result of the PMCS.

Column (2) – Interval. References when the PMCS should be performed.

Column (3) – Item to be checked or serviced. Identifies the portion of the system to be inspected.

Column (4) – Procedure. Provides the procedures for performing the checks.

Column (5) – Equipment Not Ready/Available If. Contains the criteria that will render the system incapable of performing its primary mission. If the system does not perform as required, refer to Chapter 3, Operator Maintenance Troubleshooting (WP 0007, Troubleshooting Index). If equipment appears to be malfunctioning and the problem cannot be fixed, immediately report it to your supervisor and report it on DA Form 2404, Equipment Inspection and Maintenance Worksheet.

**CORROSION PREVENTION AND CONTROL (CPC)**

CPC of Army materiel is a continuing concern. It is important that any corrosion problems with this item be reported so that the problem can be corrected and improvements can be made to prevent the problem in future items.

Corrosion specifically occurs with metals. It is an electrochemical process that causes the degradation of metals. It is commonly caused by exposure to moisture, acids, bases, or salts. An example is the rusting of iron. Corrosion damage in metals can be seen, depending on the metal, as tarnishing, pitting, fogging, surface residue, and/or cracking.

Plastics, composites, and rubbers can also degrade. Degradation is caused by thermal (heat), oxidation (oxygen), solvation (solvents), or photolytic (light, typically Ultraviolet (UV)) processes. The most common exposures are excessive heat or light. Damage from these processes will appear as cracking, softening, swelling, and/or breaking. SF 368, Product Quality Deficiency Report, should be submitted to the address specified in DA PAM 750-8, The Army Maintenance Management System (TAMMS) Users Manual.

For aircraft TMs, this information shall include a reference to TM 1-1500-344-23, volumes 1 through 4 (Cleaning and Corrosion Control).

### **Rust Definition**

Rust is defined as any various scaly or powdery reddish-brown or reddish-yellow materials that form on iron and iron-coated materials in the presence of moisture, deteriorating as a result of disuse or neglect.

### **Deterioration Definition**

Deterioration is defined as any condition that causes material to be impaired or lessens the quality or value of the material.

### **Cracking Definition**

Cracking is defined as when material is found to be split or broken, either completely or partially.

## **INSPECTION**

Look for signs of problems or trouble. Most problems can be detected by sight, touch, smell, or sound. Be alert when around the 10 kW PUs and PPs.

Inspect to ensure that all components are in good condition. Are they correctly assembled, stowed, or secured? Are any components worn, corroded, or rusty? Correct any problems found or notify your immediate supervisor.

There are common items on the generator set that should be checked. These include the following:

**Bolts, clamps, screws, and nuts:** Continuously inspect for looseness. Inspect for chipped paint, bare metal, rust, and corrosion around bolt and screw heads and nuts. Replace as necessary. Tighten hardware as required. If tools are required, notify field maintenance.

**Welds:** Some components of the 10 kW PUs and PPs are welded. To inspect welds, look for chipped paint, rust, corrosion, and gaps. When these conditions are found, notify field maintenance.

## **WARNING**

- NATO slave receptacle is electrically live at all times and is not protected by a fuse. Disconnecting main DC circuit breaker does not ensure the circuit is dead. This circuit is only dead when the batteries are fully disconnected. Disconnect both batteries before performing maintenance on the slave receptacle. Failure to comply may cause injury or death to personnel.
- High voltage is produced when generator set is in operation. Never attempt to start the generator set unless it is properly grounded. Do not ground yourself in standing water. Never attempt to connect or disconnect load cables while the generator set is operating. Failure to comply may cause injury or death to personnel.

**Electrical wires, connectors, and harnesses:** Tighten loose connections. Inspect for cracked or broken insulation, bare wires, and broken connectors. If any are found, notify field maintenance.

**Hoses and fluid lines:** Inspect for wear, damage, and leaks. Ensure clamps and fittings are tight. Wet spots indicate a leak. A stain by a fitting or connector can also mean a leak. When this is found, notify field maintenance.

---

## CLEANING AND LUBRICATION

Proper cleaning and lubrication can aid in avoiding possible problems or trouble. Make it a habit to do the following:

### CAUTION

Follow all cleaning and lubrication instructions carefully. Failure to comply may cause damage to equipment.

Under harsh environmental conditions, conduct PMCS more frequently.

Use only the recommended cleaning solutions and lubricants found in the Expendable and Durable Items List (WP 0060, Expendable and Durable Items List).

### Oil Filters

Oil filters shall be serviced/cleaned/changed by field maintenance personnel, as applicable, when:

They are known to be contaminated or clogged.

At prescribed hardtime intervals.

### AOAP Sampling

The PU-2002, PU-2012, and PP-3102 models are not enrolled in the Army Oil Analysis Program. Hardtime intervals apply.

### Warranty Hardtime

For equipment under manufacturer's warranty, hardtime oil service intervals shall be followed. Intervals shall be shortened if lubricants are known to be contaminated or if operation is under adverse conditions (such as longer-than-usual operating hours, extended idling periods, extreme dust).

## FLUID LEAKAGE

### WARNING

- Do not operate generator set if any fuel leaks are present. Fuel is combustible. Always perform PMCS before operation. Failure to comply may cause injury or death to personnel.
- Fuel is combustible and toxic to eyes, skin, and respiratory tract. Skin and eye protection are required when working in contact with fuel. Avoid repeated or prolonged contact. Provide adequate ventilation. Operators are to wash skin and change clothing promptly if in contact with fuel. Failure to comply may cause injury or death to personnel.

### CAUTION

When operating with Class I or II leaks, continue to check fluid level as required by PMCS. Class III leaks should be reported to your supervisor immediately. Any Class I, II, or III fuel leak requires equipment shut down. Failure to comply may cause damage to equipment.

It is necessary to know how fluid leakage affects the status of the 10 kW generator set. Following are types/classes of leakage that determine the status of the 10 kW generator set. Learn these leakage definitions and remember: when in doubt, notify your supervisor. Equipment operation is allowed with minor leakage (Class I or II). Consideration must be given to fluid capacity in the item/system being checked/inspected. When in doubt, notify your supervisor.

Any Class I, II, or III fuel leak requires equipment shut down.

Class III leaks should be reported immediately to your supervisor.

- (1) Class I: Seepage of fluid (as indicated by wetness or discoloration) not great enough to form drops.
- (2) Class II: Leakage of fluid great enough to form drops but not enough to cause drops to drip from item being checked/inspected.
- (3) Class III: Leakage of fluid great enough to form three drops that fall from item being checked/inspected within 5 sec.

**END OF WORK PACKAGE**

**OPERATOR MAINTENANCE**  
**AMMPS 10KW TRAILER-MOUNTED POWER UNITS AND POWER PLANTS**  
**OPERATOR PMCS**

**INITIAL SETUP:**

**Test Equipment**

Not Applicable

**Tools and Special Tools**

Not Applicable

**Materials/Parts**

Not Applicable

**Personnel Required**

Operator (1)

**References**

Not Applicable

**Equipment Conditions**

Engine control switch OFF (TM 9-6115-750-10, WP 0005)

Engine cool

Equipment grounded (WP 0005, Operation Under Usual Conditions)

Wheels chocked, brakes applied (LTT – TM 9-2330-392-14&P), (M200A1 – TM 9-2330-205-14&P)

Front trailer supports deployed (LTT – TM 9-2330-392-14&P), (M200A1 – TM 9-2330-205-14&P)

Rear leg prop assembly deployed (WP 0005, Operation Under Usual Conditions)

Rear step jacks deployed (M200A1 – TM 9-2330-205-14&P)

**Table 1. PMCS for the AMMPS 10 kW PU and PP.**

ITEM NO.	INTERVAL	ITEM TO BE CHECKED OR SERVICED	PROCEDURE	EQUIPMENT NOT READY/AVAILABLE IF:
<b>WARNING</b>				
<ul style="list-style-type: none"> <li>• Exhaust discharge contains deadly gases, including carbon monoxide. Exhaust gases are most dangerous in places with poor ventilation. Do not operate generator set in an enclosed area unless exhaust discharge is properly vented. Failure to comply may cause injury or death to personnel.</li> <li>• While inspecting the operation of the generator set, do not inadvertently reach into the generator set. Failure to comply may cause injury or death to personnel.</li> <li>• Flying debris or material may enter eyes or strike the face. Wear appropriate eye/face protection while performing maintenance tasks. Failure to comply may cause injury or death to personnel.</li> <li>• Hearing protection is required during maintenance or repair with engine running. Failure to comply can cause hearing loss.</li> <li>• High voltage is produced when generator set is in operation. Never attempt to start the generator set unless it is properly grounded. Do not ground yourself in standing water. Never attempt to connect or disconnect load cables while the generator sets are operating. Failure to comply may cause injury or death to personnel.</li> </ul>				

**Table 1. PMCS for the AMMPS 10 kW PU and PP — Continued.**

ITEM NO.	INTERVAL	ITEM TO BE CHECKED OR SERVICED	PROCEDURE	EQUIPMENT NOT READY/AVAILABLE IF:
<b>WARNING</b>				
<ul style="list-style-type: none"> <li>• Fuel is combustible and toxic to eyes, skin, and respiratory tract. Skin and eye protection are required when working in contact with fuel. Avoid repeated or prolonged contact. Provide adequate ventilation. Operators are to wash skin and change clothing promptly if in contact with fuel. Failure to comply may cause injury or death to personnel.</li> <li>• Do not operate generator set if any fuel leaks are present. Fuel is combustible. Always perform PMCS before operation. Failure to comply may cause injury or death to personnel.</li> <li>• Shut down generator sets before performing inspection of load cables. Failure to comply may cause injury or death to personnel by electrocution.</li> <li>• Fuels used in the generator set are combustible. Do not smoke or use open fire when performing maintenance. Fire and possible explosion may result. Failure to comply may cause injury or death to personnel and damage to equipment.</li> </ul>				
<b>CAUTION</b>				
<p>PMCS for PU or PP cannot be done until PMCS for generator set and PMCS for trailer have been performed. Operator PMCS for the 10 kW generator set are contained in TM 9-6115-750-10. When performing trailer PMCS, note interval and perform appropriate Before or After based on when the trailer was moved or will be moved. Operator level PMCS for the LTT are contained in TM 9-2330-392-14&amp;P and for the M200A1 in TM 9-2330-205-14&amp;P. Failure to comply may cause damage to equipment.</p>				
			<b>Trailer</b>	
1	Before	Ground rod, clamp, and wire	<ol style="list-style-type: none"> <li>1. Inspect ground rod and wire for missing parts, loose connection, corrosion, or damage.</li> <li>2. Notify field maintenance of corroded parts.</li> </ol>	Ground rod, clamp, or wire missing or damaged, or loose connection.
2	Before	Ground terminal and ground wire to switch box	<ol style="list-style-type: none"> <li>1. Inspect ground terminal on trailer and connection to switch box for missing parts, loose connections, corrosion, or damage.</li> <li>2. Notify field maintenance of damaged parts, loose connections, or corrosion.</li> </ol>	Ground terminal or wiring missing or damaged, or connection loose.
3	Before	Trailer fenders, rails, and floor plates	<ol style="list-style-type: none"> <li>1. Inspect trailer fenders, rails, and plates for damage that interferes with proper operation.</li> <li>2. Notify field maintenance of damaged parts that need to be replaced.</li> </ol>	Damage that interferes with proper operation.

Table 1. PMCS for the AMMPS 10 kW PU and PP — Continued.

ITEM NO.	INTERVAL	ITEM TO BE CHECKED OR SERVICED	PROCEDURE	EQUIPMENT NOT READY/AVAILABLE IF:
4	Before	Fire extinguisher and bracket	1. Ensure fire extinguisher is nearby the PP or PU or is secured in bracket on trailer. If fire extinguisher is in bracket, remove and set beside trailer for use when necessary.	Fire extinguisher is missing.
			2. Ensure fire extinguisher bracket latch opens and fire extinguisher is accessible.	Bracket is damaged or extinguisher is unable to be removed from bracket.
			3. Inspect fire extinguisher for damage and proper charge.	Fire extinguisher is damaged or discharged.
			4. Notify field maintenance of damaged parts or discharged fire extinguisher.	
5	Before	Accessory box	1. Inspect accessory box lid and latch for damage.	Accessory box lid and latch is unable to be opened or closed or is severely damaged.
			2. Notify field maintenance of damage.	
<p><b>NOTE</b></p> <p>Ground rods and wires should be installed into ground and attached to trailer grounding terminal. If present in switch box confirm that trailer is properly grounded to ground rods installed into the ground (WP 0005, Operation Under Usual Conditions).</p>				
			3. Ensure accessory box components are present if not being used: fuel drum adapter, driver/puller, sledge hammer, pipe elbow, hose clamp, and hose.	Necessary component is missing from accessory box.
			4. Notify field maintenance of missing components.	
6	Before	ID plates	1. Ensure ID plates are present, secure, and legible. Five are required (WP 0005, Operation Under Usual Conditions).	
			2. Notify field maintenance of missing, loose, or illegible ID plates.	
<p><b>Switch Box (For PP Only)</b></p>				
7	Before	Switch box cover	1. Check cover, latch, hinge, and seal for damage and loose or corroded parts.	
			2. Open switch box cover and inspect switch box cover for ground wire running from cover to inside of switch box. Ensure connections are tight.	Ground wire is missing or loose.

Table 1. PMCS for the AMMPS 10 kW PU and PP — Continued.

ITEM NO.	INTERVAL	ITEM TO BE CHECKED OR SERVICED	PROCEDURE	EQUIPMENT NOT READY/AVAILABLE IF:
			3. Ensure schematic plate is located inside cover and is legible.	
			4. Close and latch cover.	
			5. Notify field maintenance of damaged, loose, corroded parts; missing or loose ground wire or schematic plate; or cover that cannot be secured.	
8	Before	Terminal lug wrench	1. Inspect switch box for damaged or missing terminal lug wrench.	No terminal lug wrench available for use.
			2. Notify field maintenance of damaged or missing terminal lug wrench.	
9	Before	Switch box housing	1. Inspect switch box housing for damage or corrosion.	Switch box housing damage or corrosion that interferes with proper operation.
			2. Ensure ID plates are present and legible. Five are required (WP 0005, Operation Under Usual Conditions).	
			3. Notify field maintenance of damaged, corroded, or missing ID plates.	
10	Before	LED indicators	1. Inspect LED indicators for cracks or damage.	LED indicators are cracked or damaged.
			2. Notify field maintenance of damage.	
11	Before	Output terminal board covers	1. Unlatch switch box terminal board metal cover and inspect for proper operation and damage.	Cover or latch is damaged or will not open and close properly.
			2. Inspect for ground wire attached to metal cover and switch box housing. Inspect fasteners for looseness.	Ground wire is loose or not attached to switch box housing or metal cover.
			3. Inspect output terminal board plastic protective cover for cracks, corroded hinge, or damage.	Output terminal board protective cover missing or punctured.
			4. Notify field maintenance of corroded hinge, loose fasteners, missing or unattached ground wire, or damage to metal or plastic cover.	
12	Before	Output terminals, connections, and ground.	1. Inspect ground and load cable connections for tightness to output load board by pulling gently.	
			2. Tighten as required (WP 0005, Operation Under Usual Conditions).	Cable cannot be secured.
			3. Inspect terminals and terminal nuts for damage or corrosion.	



Table 1. PMCS for the AMMPS 10 kW PU and PP — Continued.

ITEM NO.	INTERVAL	ITEM TO BE CHECKED OR SERVICED	PROCEDURE	EQUIPMENT NOT READY/AVAILABLE IF:
			4. Notify field maintenance of damage or corrosion to terminals or terminal nuts.	
13	Before	Fuel drum adapter (if used)	1. Inspect the auxiliary fuel connections at fuel drum adapter for damage, missing parts, corrosion, or improper installation.	Damaged, corroded, or missing parts or improper installation.
			2. Notify field maintenance of damage, missing parts, corrosion, or improper installation.	
			3. Start generator set (TM 9-6115-749-10).	
14	During	Ground rod and connections	1. Inspect for arcing, damage, corrosion, and loose connections.	Arcing, damaged, corroded, or loose connections.
			2. Notify field maintenance of corroded parts, damage, arcing, or loose connections.	
15	During	Fuel drum adapter (if used)	1. Inspect fuel drum adapter for proper operation and leaks.	Fuel drum adapter is not extracting fuel properly or is leaking.
			2. Contact field maintenance if leaks are found or fuel drum adapter is not operating properly.	
			<b>Switch Box (For PP Only)</b>	
16	During	LED indicators	1. Inspect LED indicators for desired operation (proper ON LINE or STATUS indicators illuminated).	STATUS or ON LINE is not at desired setting.
			2. Contact field maintenance if indicators do not illuminate consistent with generator settings.	
17	After	Generator set	Ensure generator set operator After PMCS are completed (TM 9-6115-750-10).	
18	After	Fire extinguisher	Ensure fire extinguisher is secured in bracket on trailer.	

**LUBRICATION INSTRUCTIONS**

There are no scheduled lubrication intervals for external components (i.e. hinges and latches).

Lubrication instructions for the 10 kW generator sets are contained in TM 9-6115-750-10. Lubrication instructions for the LTTs are contained in TM 9-2330-392-14&P and for the M200A1 in TM 9-2330-205-14&P.

**END OF WORK PACKAGE**

**CHAPTER 5**  
**FIELD TROUBLESHOOTING PROCEDURES**  
**FOR**  
**AMMPS 10KW TRAILER-MOUNTED POWER UNITS AND POWER PLANTS**

CHAPTER 5

FIELD TROUBLESHOOTING PROCEDURES

WORK PACKAGE INDEX

---

<u>Title</u>	<u>WP Sequence No.</u>
TROUBLESHOOTING INDEX .....	0011
TROUBLESHOOTING PROCEDURES .....	0012

---

**FIELD MAINTENANCE**  
**AMMPS 10KW TRAILER-MOUNTED POWER UNITS AND POWER PLANTS**  
**TROUBLESHOOTING INDEX**

---

**GENERAL TROUBLESHOOTING INFORMATION**

Troubleshooting procedures are designed to isolate AMMPS faults to the LRU level. Troubleshooting techniques apply to all AMMPS components as indicated.

Troubleshooting procedures list the symptoms, malfunctions, and corrective actions required to resolve the problem(s). Perform all steps in the order they appear in the WP. Troubleshooting procedures are listed according to symptom, followed by the malfunction, and then any corrective action(s). All necessary references to procedures/instructions can be found within the applicable Troubleshooting WP (see the Malfunction/Symptom Index below).

The DCS constantly monitors the generator set for abnormal conditions, such as low oil pressure and high coolant temperature. If any of these conditions occur, the DCS control panel display screen will display a message indicating a fault or warning code. The system will shut down if a fault code is indicated. The system will not normally shut down from warning codes. If a warning is indicated but not addressed, it may become a fault. If a malfunction or failure occurs during an operation or performance check, perform troubleshooting IAW the Malfunction/Symptom Index and any displayed fault or warning codes (TM 9-6115-750-24&P).

DO NOT BEGIN A TASK UNTIL:

- You understand the task.
- You have the tools and equipment you need.

**10 kW Generator Set Troubleshooting**

Refer to TM 9-6115-750-24&P.

**LTT Troubleshooting**

Refer to TM 9-2330-392-14&P.

**M200A1 Trailer Troubleshooting**

Refer to TM 9-2330-205-14&P.

**MALFUNCTION/SYMPTOM INDEX**

The Malfunction/Symptom Index is a quick reference for locating troubleshooting procedures. Troubleshooting procedures are arranged based on the location of the malfunction (i.e., switch box) and the presence of a DCS code.

**DCS Fault/Warning Codes**

Refer to TM 9-6115-750-24&P for a detailed description of each fault and warning code with applicable troubleshooting reference. Specific switch box faults are covered in the troubleshooting procedures (WP 0012, Troubleshooting Procedures).

**Indications from Manual Troubleshooting Techniques**

Field maintenance is responsible for performing manual troubleshooting techniques, including continuity tests and voltage checks.

**After Corrective Action**

After the corrective action is completed, the equipment must be tested to verify that the problem is corrected. Locate the malfunction in the troubleshooting procedures and perform the test or inspection. If the correct response is not obtained, continue troubleshooting all suspected malfunctions and performing corresponding corrective actions until the equipment is operational or is replaced with operational equipment.

**Specific Troubleshooting Procedures**

This TM cannot list all malfunctions that may occur or all tests or inspections and corrective actions. If the malfunction encountered is not listed or is not corrected by the listed corrective action, replace the lowest level LRU component that will remedy the malfunction.

**Malfunction/Symptom**

**Troubleshooting Procedure WP and Page**

**SWITCH BOX TROUBLESHOOTING**

1. [Fault 1459: Reverse Power] displayed on DCS screen .....	WP 0012, Page 2
Mechanical paralleling instability .....	WP 0012, Page 2
2. [Fault 1461: Loss of Field] displayed on DCS screen .....	WP 0012, Page 3
Electrical paralleling instability .....	WP 0012, Page 3
3. [Fault 3659: Switch Box Fail To Open] displayed on DCS screen .....	WP 0012, Page 3
a. Malfunctioning switch box contactor .....	WP 0012, Page 3
b. Control cable has bad connections or is shorted .....	WP 0012, Page 4
c. Generator set failure .....	WP 0012, Page 5
4. [Warning 1456: Bus Out Of Synchronization Range] displayed on DCS screen .....	WP 0012, Page 6
Voltage or frequency mismatch between generator sets .....	WP 0012, Page 6
5. [Warning 1457: Fail To Synchronize] displayed on DCS screen .....	WP 0012, Page 7
Synchronization failure .....	WP 0012, Page 7
6. [Warning 1458: Sync Phase Rotation Mismatch] displayed on DCS screen .....	WP 0012, Page 8
Load cables improperly connected .....	WP 0012, Page 8
7. [Warning 3658: Switch Box Fail To Close] displayed on DCS screen .....	WP 0012, Page 11
a. Malfunctioning switch box contactor .....	WP 0012, Page 11
b. Control cable has bad connections or is shorted .....	WP 0012, Page 11
c. Generator set failure .....	WP 0012, Page 12
8. STATUS indicator light fails to light .....	WP 0012, Page 12
a. Power not available at switch box input .....	WP 0012, Page 13
b. Improper or malfunctioning paralleling procedures .....	WP 0012, Page 13
c. Loose or damaged connector or wires .....	WP 0012, Page 14
d. Defective indicator light .....	WP 0012, Page 14

- 
- 9. ON LINE indicator light fails to light..... WP 0012, Page 15
    - a. Improper connection of control cable..... WP 0012, Page 15
    - b. Improper or malfunctioning paralleling procedures..... WP 0012, Page 16
    - c. Loose or damaged connector or wires..... WP 0012, Page 16
    - d. Defective indicator light..... WP 0012, Page 17

**END OF WORK PACKAGE**





---

**FIELD MAINTENANCE**  
**AMMPS 10KW TRAILER-MOUNTED POWER UNITS AND POWER PLANTS**  
**TROUBLESHOOTING PROCEDURES**

---

**INITIAL SETUP:****Test Equipment**

Not Applicable

**Tools and Special Tools**

Tool Kit, General Mechanic's (GMTK) (WP 0057, Table 2, Item 10)

**Materials/Parts**

Not Applicable

**Personnel Required**

91D (1)

Assistant (1)

**References**

TM 9-6115-750-24&amp;P

WP 0015, Field PMCS

WP 0027, Replace Switch Box Components

**References**

WP 0031, General Maintenance

**Equipment Conditions**

Engine control switch OFF (TM 9-6115-750-10, WP 0005)

Engine cool

Wheels chocked and brakes applied (LTT – TM 9-2330-392-14&amp;P), (M200A1 – TM 9-2330-205-14&amp;P)

Front trailer support deployed (LTT – TM 9-2330-392-14&amp;P), (M200A1 – TM 9-2330-205-14&amp;P)

Rear leg prop assembly deployed (WP 0005, Operation Under Usual Conditions)

Rear step jacks deployed (M200A1 – TM 9-2330-205-14&amp;P)

**TROUBLESHOOTING****WARNING**

- Ensure generator sets are shut down and output terminal board has no voltage prior to making any connections for parallel operation or moving a generator set that has been operating in parallel. Operating generator sets always contain the risk of electrocution. Failure to comply may cause injury or death to personnel.
- Shut down generator sets before performing inspection of load cables. Failure to comply may cause injury or death to personnel by electrocution.
- High voltage is produced when generator set is in operation. Never attempt to start the generator set unless it is properly grounded. Do not ground yourself in standing water. Never attempt to connect or disconnect load cables while the generator sets are running. Failure to comply may cause injury or death to personnel.
- High voltage is produced when this generator set is in operation. Do not contact output cables when operating this generator set. Failure to comply may cause injury or death to personnel.
- DC voltages are present at generator set electrical components even with generator set shut down. Avoid shorting any positive with ground/negative. Do not ground yourself in standing water. Failure to comply may cause injury or death to personnel and damage to equipment.

---

## WARNING

- High-voltage power is available when the main contactor is closed. Avoid accidental contact with live components. Ensure load cables are properly connected and the load cable door is shut before closing main contactor. Ensure that personnel working with/on loads connected to the generator set are aware that main contactor is about to be closed before closing main contactor. Failure to comply may cause injury or death to personnel.

## NOTE

Always perform PMCS prior to beginning any troubleshooting procedure (WP 0015, Field PMCS).

Read the entire corrective action sequence before beginning steps to complete corrective action for a malfunction.

FAULT RESET switch must be pushed to clear each fault code as it is addressed.

This troubleshooting WP is applicable to switch box (PP) applications only. For PU and other generator set troubleshooting, see TM 9-6115-750-24&P. For trailer troubleshooting, see TM 9-2330-392-14&P for the LTT or see TM 9-2330-205-14&P for the M200A1.

## SYMPTOM

[Fault 1459: Reverse Power] displayed on DCS screen.

## NOTE

Reverse power occurs when two generator sets are operating in parallel. A generator set may not accept a load when the unloaded generator set operating speed is less than the loaded generator set operating speed. The loaded generator set will motorize, or reverse power, the unloaded generator set. This situation creates an undue load on the loaded generator and may damage the unloaded generator set.

## MALFUNCTION

Mechanical paralleling instability.

## CORRECTIVE ACTION

## WARNING

- Ensure generator sets are shut down and output terminal board has no voltage prior to making any connections for parallel operation or moving a generator set that has been operating in parallel. Operating generator sets always contain the risk of electrocution. Failure to comply may cause injury or death to personnel.
- Shut down generator sets before performing inspection of load cables. Failure to comply may cause injury or death to personnel by electrocution.
  - STEP 1. Examine load cables and load demands and ensure generator sets are proper size for load requirements.
  - STEP 2. Remove connections and reconnect IAW paralleling instructions (TM 9-6115-750-10).
  - STEP 3. If symptom continues, troubleshoot engine of unloaded generator set for poor engine performance (TM 9-6115-750-24&P).

**SYMPTOM**

[Fault 1461: Loss of Field] displayed on DCS screen.

**MALFUNCTION**

Electrical paralleling instability.

**CORRECTIVE ACTION****WARNING**

- Ensure generator sets are shut down and output terminal board has no voltage prior to making any connections for parallel operation or moving a generator set that has been operating in parallel. Operating generator sets always contain the risk of electrocution. Failure to comply may cause injury or death to personnel.
- Shut down generator sets before performing inspection of load cables. Failure to comply may cause injury or death to personnel by electrocution.
  - STEP 1. Examine load cables and load demands and ensure generator sets are proper size for load requirements. Increase size of generator sets or decrease load demands as required.
  - STEP 2. If cables and generator sets are proper size, remove connections and reconnect IAW paralleling instructions (TM 9-6115-750-10).
  - STEP 3. If symptom continues, check circuit breakers CB10 ALT QUAD 1 and CB11 ALT QUAD 2 of generator experiencing DCS fault code to see if tripped (TM 9-6115-750-24&P).
  - STEP 4. Reset circuit breaker(s) if tripped. If circuit breaker(s) will not reset, replace circuit breaker(s) (TM 9-6115-750-24&P).
  - STEP 5. If circuit breaker(s) trips again, replace circuit breakers (TM 9-6115-750-24&P).
  - STEP 6. If symptom continues, test rectifiers and replace as required (TM 9-6115-750-24&P).
  - STEP 7. If symptom continues, replace AC generator (TM 9-6115-750-24&P).

**SYMPTOM**

[Fault 3659: Switch Box Fail To Open] displayed on DCS screen.

**MALFUNCTION**

Malfunctioning switch box contactor.

**CORRECTIVE ACTION****WARNING**

- High voltage is produced when generator set is in operation. Never attempt to start the generator set unless it is properly grounded. Do not ground yourself in standing water. Never attempt to connect or disconnect load cables while the generator sets are running. Failure to comply may cause injury or death to personnel.
- High voltage is produced when this generator set is in operation. Do not contact output cables when operating this generator set. Failure to comply may cause injury or death to personnel.
  - STEP 1. Ensure there is no power to the switch box from the generator sets by confirming that all sets supplying power to the switch box have been shut down.
  - STEP 2. Test switch box contactor (WP 0027, Replace Switch Box Components) to determine if contactor opens once power is removed.
  - STEP 3. If contactor is defective (shows continuity when power is removed), replace as required (WP 0027, Replace Switch Box Components).
  - STEP 4. If contactor is not defective (opens when power is removed), then cable, wiring, or DCS is applying 24 VDC to contactor when it should not be. Proceed to next malfunction.

**MALFUNCTION**

Control cable has bad connections or is shorted.

**CORRECTIVE ACTION****WARNING**

Shut down generator sets before performing inspection of load cables. Failure to comply may cause injury or death to personnel by electrocution.

- STEP 1. Ensure control cable is connected properly to each generator set and to the switch box (WP 0027, Replace Switch Box Components).
- STEP 2. Reconnect control cables that are connected improperly (WP 0027, Replace Switch Box Components). If symptom continues, proceed to STEP 3.
- STEP 3. Inspect pins and connectors for recessed pins, damaged or missing pins, moisture, or any damage that prevents good connections.
- STEP 4. Replace control cable as required (WP 0027, Replace Switch Box Components).

**NOTE**

Wire K701-X corresponds to pin A on connector end of control cable, wire K701-Y corresponds to pin C, wire K701-11 corresponds to pin E, and wire K701-12 corresponds to pin G. The same orientation applies to all K702 wires and pins.

- STEP 5. Open switch box lid and check wires into contactor from control cable for a short using a multimeter set to test continuity (WP 0031, General Maintenance).
- STEP 6. If continuity is not found between a wire and a corresponding pin or is found between a wire and the wrong pin (e.g. K701-Y to pin E), control cable is shorted.

STEP 7. Replace control cable or wiring, as applicable (WP 0027, Replace Switch Box Components).

STEP 8. If symptom continues, proceed to next malfunction.

### **MALFUNCTION**

Generator set failure.

#### **CORRECTIVE ACTION**

STEP 1. Check generator set wiring from SWITCH BOX CONTROL RECEPTACLE to printed circuit board module for proper connections using wiring diagrams (TM 9-6115-750-24&P).

STEP 2. Inspect connector and pins for damage, corrosion, breakage, moisture, or other damage that could cause a poor electrical connection.

STEP 3. Check each pin in SWITCH BOX CONTROL RECEPTACLE to each corresponding sleeve pin in connector on wire for continuity using a multimeter set to test continuity (WP 0031, General Maintenance).

STEP 4. Connect wiring or connectors in generator set or replace wiring or connectors in generator set as required (TM 9-6115-750-24&P).

STEP 5. Inspect PP contactor connector on printed circuit board module (TM 9-6115-750-24&P) for damage to pins, corrosion, breakage, or moisture.

STEP 6. Find and troubleshoot wiring connections from printed circuit board module to DCS using wiring diagrams (TM 9-6115-750-24&P) and a multimeter set to test continuity (WP 0031, General Maintenance).

STEP 7. If all conditions are good, turn on DCS while leaving generator set off.

### **WARNING**

DC voltages are present at generator set electrical components even with generator set shut down. Avoid shorting any positive with ground/negative. Do not ground yourself in standing water. Failure to comply may cause injury or death to personnel and damage to equipment.

### **NOTE**

Terminals X and Y on contactor are for the wires that energize the contactor coil.

STEP 8. Test contactor coil for 24 VDC using a multimeter set to test voltage (WP 0031, General Maintenance).

STEP 9. If 24 VDC is detected on contactor coil, DCS is faulty. Replace DCS (TM 9-6115-750-24&P).

**SYMPTOM**

[Warning 1456: Bus Out Of Synchronization Range] displayed on DCS screen.

**MALFUNCTION**

Voltage or frequency mismatch between generator sets.

**CORRECTIVE ACTION**

- STEP 1. Observe DCS and confirm both generator sets are using the same number of phases (TM 9-6115-750-10).
- STEP 2. Adjust using voltage selection switch as required (TM 9-6115-750-10).
- STEP 3. Observe generator set voltage of operating generator DCS display and compare to generator set voltage of off-line generator.
- STEP 4. If voltages are unequal, adjust voltage as required to meet ordered parameters (TM 9-6115-750-10).
- STEP 5. Push FAULT RESET switch to clear [Warning 1456: Bus Out Of Synchronization Range].
- STEP 6. Parallel generators (TM 9-6115-750-10).
- STEP 7. If generators will not parallel and/or [Warning 1456: Bus Out Of synchronization Range] reappears, continue to STEP 8.
- STEP 8. Observe generator set frequency of operating generator DCS screen and compare to generator set frequency of off-line generator.
- STEP 9. If frequencies are unequal, adjust frequency as required to meet ordered parameters (TM 9-6115-750-10).
- STEP 10. Push FAULT RESET switch to clear [Warning 1456: Bus Out Of Synchronization Range].
- STEP 11. Parallel generators (TM 9-6115-750-10).
- STEP 12. If generators will not parallel and/or [Warning 1456: Bus Out Of Synchronization Range] reappears, continue to STEP 13.

**WARNING**

- High voltage is produced when generator set is in operation. Never attempt to start the generator set unless it is properly grounded. Do not ground yourself in standing water. Never attempt to connect or disconnect load cables while the generator sets are running. Failure to comply may cause injury or death to personnel.
- High-voltage power is available when the main contactor is closed. Avoid accidental contact with live components. Ensure load cables are properly connected and the load cable door is shut before closing main contactor. Ensure that personnel working with/on loads connected to the generator set are aware that main contactor is about to be closed before closing main contactor. Failure to comply may cause injury or death to personnel.

STEP 13. Use a multimeter selected for the appropriate scale to measure voltage of the output terminals on the off-line generator (WP 0031, General Maintenance).

STEP 14. If actual voltage measured with the multimeter is equal to the voltage displayed on the off-line generator DCS display, continue to STEP 16.

STEP 15. If actual voltage measured with the multimeter is greater or less than 10 percent (%) of voltage indicated on DCS display, replace DCS (TM 9-6115-750-24&P).

STEP 16. Observe generator set frequency of both generator sets (TM 9-6115-750-10).

STEP 17. Use InPower AMMPS tool to measure the engine speed (revolutions per minute (rpm)) of generator sets or use frequency of generator sets as a reference for engine speed if InPower AMMPS tool is not available.

### NOTE

Generator set engine speed for 50 Hz is 1500 rpm, for 60 Hz is 1800 rpm, and for 400 Hz is 2000 rpm.

STEP 18. If generator frequency or engine speed is more or less than 10% of rated speed, adjust or replace engine speed sensor (TM 9-6115-750-24&P).

STEP 19. If generator frequency or engine speed of generator set is within specification, test and replace DCS (TM 9-6115-750-24&P).

STEP 20. If MEP-1041 is at 400 Hz (+/- 10%) and MEP-1040 is at 50 Hz or 60 Hz (+/- 10%), test and replace DCS (TM 9-6115-750-24&P). If either value is outside of 10% range, adjust or replace engine speed sensors (TM 9-6115-750-24&P).

STEP 21. If symptom continues, troubleshoot engine for poor performance or fuel problems (TM 9-6115-750-24&P).

### SYMPTOM

[Warning 1457: Fail To Synchronize] displayed on DCS screen.

### MALFUNCTION

Synchronization failure.

### CORRECTIVE ACTION

### WARNING

- Shut down generator sets before performing inspection of load cables. Failure to comply may cause injury or death to personnel by electrocution.
- Ensure generator sets are shut down and output terminal board has no voltage prior to making any connections for parallel operation or moving a generator set that has been operating in parallel. Operating generator sets always contain the risk of electrocution. Failure to comply may cause injury or death to personnel.
- High voltage is produced when generator set is in operation. Never attempt to start the generator set unless it is properly grounded. Do not ground yourself in standing water. Never attempt to connect or disconnect load cables while the generator sets are running. Failure to comply may cause injury or death to personnel.
- High voltage is produced when this generator set is in operation. Do not contact output cables when operating this generator set. Failure to comply may cause injury or death to personnel.

STEP 1. Ensure both generator sets are at the same ambient or operating temperature by checking coolant temperature on DCS (TM 9-6115-750-10).

STEP 2. Allow cold generator set to warm up and attempt paralleling again.

- STEP 3. If symptom continues, ensure all generator sets attached to switch box are shut down.
- STEP 4. Ensure parallel cable between generator sets is attached (TM 9-6115-750-10).
- STEP 5. Ensure control cable is connected from switch box to generator set SWITCH BOX CONTROL RECEPTACLE. Tighten/reconnect cable as necessary.
- STEP 6. Examine output terminal board connections visually at each generator to determine that output cables are connected to the correct terminals (TM 9-6115-750-10). Adjust as required.
- STEP 7. Examine DCS screen visually and confirm that generator sets are operating at same frequency and voltage settings and that generator sets are of the same kilowatt size (TM 9-6115-750-10).
- STEP 8. Check switch box load cable attachments and ensure generator sets are able to meet load demands (WP 0005, Operation Under Usual Conditions).
- STEP 9. Replace PP with larger PP or reduce load as required.

## SYMPTOM

[Warning 1458: Sync Phase Rotation Mismatch] displayed on DCS screen.

## MALFUNCTION

Load cables improperly connected.

## CORRECTIVE ACTION

## WARNING

- High voltage is produced when generator set is in operation. Never attempt to start the generator set unless it is properly grounded. Do not ground yourself in standing water. Never attempt to connect or disconnect load cables while the generator sets are running. Failure to comply may cause injury or death to personnel.
- High voltage is produced when this generator set is in operation. Do not contact output cables when operating this generator set. Failure to comply may cause injury or death to personnel.
- High-voltage power is available when the main contactor is closed. Avoid accidental contact with live components. Ensure load cables are properly connected and the load cable door is shut before closing main contactor. Ensure that personnel working with/on loads connected to the generator set are aware that main contactor is about to be closed before closing main contactor. Failure to comply may cause injury or death to personnel.
- Ensure generator sets are shut down and output terminal board has no voltage prior to making any connections for parallel operation or moving a generator set that has been operating in parallel. Operating generator sets always contain the risk of electrocution. Failure to comply may cause injury or death to personnel.
- Shut down generator sets before performing inspection of load cables. Failure to comply may cause injury or death to personnel by electrocution.
  - STEP 1. Examine output terminal board connections visually at each generator to determine that output cables are connected to the correct terminals (TM 9-6115-750-10).
  - STEP 2. If output cables are connected incorrectly, verify that off-line generator cables are de-energized.



---

## WARNING

High-voltage power is available when the main contactor is closed. Avoid accidental contact with live components. Ensure load cables are properly connected and the load cable door is shut before closing main contactor. Ensure that personnel working with/on loads connected to the generator set are aware that main contactor is about to be closed before closing main contactor. Failure to comply may cause injury or death to personnel.

- STEP 3. Disconnect off-line generator cables at output terminal board and reconnect to match operating generator output cables.
- STEP 4. Attempt to parallel generator sets (TM 9-6115-750-10).
- STEP 5. If [Warning 1458: Synchronization Phase Rotation Mismatch] reappears, stop the off-line generator.
- STEP 6. After the off-line generator has stopped, verify that off-line generator cables are de-energized.
- STEP 7. Disconnect off-line generator cables at output terminal board.

## WARNING

- When operating, generator set engine has hot metal surfaces that will burn flesh on contact. Shut down generator set and allow engine to cool before checks, services, and maintenance. Wear gloves and additional protective clothing as required. Failure to comply may cause injury or death to personnel.
- Exhaust discharge contains deadly gases, including carbon monoxide. Exhaust gases are most dangerous in places with poor ventilation. Do not operate generator set in an enclosed area unless exhaust discharge is properly vented. Failure to comply may cause injury or death to personnel.
- High voltage is produced when generator set is in operation. Never attempt to start the generator set unless it is properly grounded. Do not ground yourself in standing water. Never attempt to connect or disconnect load cables while the generator sets are running. Failure to comply may cause injury or death to personnel.

## CAUTION

Operating generator set with doors open or with panels removed for an extended length of time will cause engine to overheat. Do not operate generator with doors open or panels removed for longer than necessary to complete your task. Monitor DCS temperature indicator to prevent engine overheating. Failure to comply will cause damage to equipment.

- STEP 8. Start off-line generator set (TM 9-6115-750-10).
- STEP 9. Examine DCS display to verify that off-line generator has developed voltage.

## WARNING

- High voltage is produced when generator set is in operation. Never attempt to start the generator set unless it is properly grounded. Do not ground yourself in standing water. Never attempt to connect or disconnect load cables while the generator sets are running. Failure to comply may cause injury or death to personnel.
- High voltage is produced when this generator set is in operation. Do not contact output cables when operating this generator set. Failure to comply may cause injury or death to personnel.
- High-voltage power is available when the main contactor is closed. Avoid accidental contact with live components. Ensure load cables are properly connected and the load cable door is shut before closing main contactor. Ensure that personnel working with/on loads connected to the generator set are aware that main contactor is about to be closed before closing main contactor. Failure to comply may cause injury or death to personnel.

STEP 10. Open both generator set terminal board access doors.

## NOTE

The aid of an assistant is required to perform the step 11. Generator sets must be physically located so terminal board access doors are within arm's reach of each other prior to performing step 11.

STEP 11. Lift the clear plastic entry guards of each generator set with the aid of an assistant to gain access to output terminals of both generator sets.

STEP 12. Use a multimeter selected for the appropriate scale to measure voltage of the output terminals (WP 0031, General Maintenance).

STEP 13. Place one multimeter probe at terminal L1 of operating generator set and the second multimeter probe at terminal L1 of off-line generator set.

STEP 14. Note if a voltage is or is not indicated.

STEP 15. Repeat STEPS 13 and 14 for terminals L2 and L3 of both generators.

STEP 16. Note which terminals indicated a voltage and apply a temporary mark on the clear plastic cable entry guard at those terminal locations.

STEP 17. If voltage was detected between any of the terminals, wire connections are incorrect in one of the generator sets.

STEP 18. Check output terminal boards, AC generator wiring, and voltage selection switch wiring for proper wiring in both generator sets using wiring diagrams (TM 9-6115-750-24&P). Adjust as required (TM 9-6115-750-24&P).

## WARNING

Ensure generator sets are shut down and output terminal board has no voltage prior to making any connections for parallel operation or moving a generator set that has been operating in parallel. Operating generator sets always contain the risk of electrocution. Failure to comply may cause injury or death to personnel.

STEP 19. Attempt to parallel generators (TM 9-6115-750-10).

STEP 20. If [Warning 1458: Synchronization Phase Rotation Mismatch] reappears, stop the off-line generator.

STEP 21. After off-line generator set has stopped, verify that the off-line generator set cables are de-energized.

STEP 22. Disconnect off-line generator set cables at output terminal board.

STEP 23. Replace DCS (TM 9-6115-750-24&P).

### **SYMPTOM**

[Warning 3658: Switch Box Fail To Close] displayed on DCS screen.

### **MALFUNCTION**

Malfunctioning switch box contactor.

### **CORRECTIVE ACTION**

### **WARNING**

High voltage is produced when generator set is in operation. Never attempt to start the generator set unless it is properly grounded. Do not ground yourself in standing water. Never attempt to connect or disconnect load cables while the generator sets are running. Failure to comply may cause injury or death to personnel.

- STEP 1. Before checking wires or testing, ensure there is no power to the switch box from the generator sets by confirming that all generator sets supplying power to the switch box have been shut down.
- STEP 2. Ensure control cable is connected properly to each generator set and to the switch box (WP 0027, Replace Switch Box Components).
- STEP 3. Reconnect control cables that are connected poorly or improperly (WP 0027, Replace Switch Box Components). If symptom continues, proceed to STEP 4.
- STEP 4. Test switch box contactor (WP 0027, Replace Switch Box Components).
- STEP 5. Replace switch box contactor as required (WP 0027, Replace Switch Box Components).
- STEP 6. If symptom continues, proceed to next malfunction.

### **MALFUNCTION**

Control cable has bad connections or is shorted.

### **CORRECTIVE ACTION**

- STEP 1. Inspect pins and connectors for recessed pins, damaged or missing pins, moisture, or damage that prevents good connections.
- STEP 2. Replace control cable as required (WP 0027, Replace Switch Box Components).

### **NOTE**

Wire K701-X corresponds to pin A on connector end of control cable, wire K701-Y corresponds to pin C, wire K701-11 corresponds to pin E, and wire K701-12 corresponds to pin G. The same orientation applies to all K702 wires.

- STEP 3. Open switch box lid and check wires into contactor from control cable for a short using a multimeter set to test continuity (WP 0031, General Maintenance).
- STEP 4. If continuity is not found between a lead and a pin, control cable is shorted.

STEP 5. Replace control cable or wiring as applicable (WP 0027, Replace Switch Box Components).

STEP 6. If symptom continues, proceed to next malfunction.

### **MALFUNCTION**

Generator set failure.

#### **CORRECTIVE ACTION**

STEP 1. Check generator set wiring from SWITCH BOX CONTROL RECEPTACLE to printed circuit board module for proper connections using wiring diagrams (TM 9-6115-750-24&P).

STEP 2. Inspect connector and pins for damage, corrosion, breakage, moisture, or other damage that could cause a poor electrical connection.

STEP 3. Check each pin in SWITCH BOX CONTROL RECEPTACLE to each corresponding sleeve pin in connector on wire for continuity using a multimeter set to test continuity (WP 0031, General Maintenance).

STEP 4. Connect wiring or connectors in generator set or replace wiring or connectors in generator set as required (TM 9-6115-750-24&P).

STEP 5. Inspect PP contactor connector on printed circuit board module (TM 9-6115-750-24&P) for damage to pins, corrosion, breakage, or moisture.

STEP 6. Find and troubleshoot wiring connections from printed circuit board module to DCS using wiring diagrams (TM 9-6115-750-24&P) and a multimeter set to test continuity (WP 0031, General Maintenance).

STEP 7. If all conditions are good, turn on DCS while leaving generator set off.

### **WARNING**

DC voltages are present at generator set electrical components even with generator set shut down. Avoid shorting any positive with ground/negative. Do not ground yourself in standing water. Failure to comply may cause injury or death to personnel and damage to equipment.

STEP 8. Test contactor coil for 24 VDC using a multimeter set to test voltage (WP 0031, General Maintenance).

STEP 9. If 24 VDC is detected on contactor coil, DCS is faulty. Replace DCS (TM 9-6115-750-24&P).

### **SYMPTOM**

STATUS indicator light fails to light.

## NOTE

Indicator lights are LEDs. Testing is done IAW standard diode testing rather than standard light bulb testing.

STATUS indicator lights show that the load cables between the generator set and the switch box are energized (i.e. generator set contactor is closed and AC voltage at the switch box is approximately >50 Volts Alternating Current (VAC)). ON LINE indicator lights show that the switch box contactor is closed for indicated generator set and power is available at the bus of the switch box.

## MALFUNCTION

Power not available at switch box input.

### CORRECTIVE ACTION

## WARNING

- High voltage is produced when generator set is in operation. Never attempt to start the generator set unless it is properly grounded. Do not ground yourself in standing water. Never attempt to connect or disconnect load cables while the generator sets are running. Failure to comply may cause injury or death to personnel.
- High voltage is produced when this generator set is in operation. Do not contact output cables when operating this generator set. Failure to comply may cause injury or death to personnel.
  - STEP 1. Test load cables on contactor of switch box (WP 0027, Replace Switch Box Components) of malfunctioning generator set for power at switch box input using a multimeter set to test AC voltage (WP 0031, General Maintenance).
  - STEP 2. If there is no power at switch box input, output box contactor is open or not supplying power to switch box. Proceed to STEP 4.
  - STEP 3. If there is power at switch box input, output box contactor is closed. Troubleshoot IAW Loose or damaged connector or wires malfunction.
  - STEP 4. Check generator set for proper operation and ensure [CONTACTOR] is [CLOSED] (TM 9-6115-750-10).

## WARNING

Shut down generator sets before performing inspection of load cables. Failure to comply may cause injury or death to personnel by electrocution.

- STEP 5. If generator set is operating properly, check load cables between generator set and switch box for improper connections.
- STEP 6. If connections are correct, test load cable for shorts using a multimeter set to test continuity (WP 0031, General Maintenance).
- STEP 7. If symptom continues, proceed to next malfunction.

## MALFUNCTION

Improper or malfunctioning paralleling procedures.

**CORRECTIVE ACTION****WARNING**

- Ensure generator sets are shut down and output terminal board has no voltage prior to making any connections for parallel operation or moving a generator set that has been operating in parallel. Operating generator sets always contain the risk of electrocution. Failure to comply may cause injury or death to personnel.
- Shut down generator sets before performing inspection of load cables. Failure to comply may cause injury or death to personnel by electrocution.
  - STEP 1. Shut down generator sets and disconnect load cables IAW paralleling instructions (TM 9-6115-750-10).
  - STEP 2. Reconnect generator sets and attempt parallel operation (TM 9-6115-750-10).
  - STEP 3. If symptom continues but paralleling is successful, continue to Loose or damaged connector or wires malfunction.
  - STEP 4. If symptom continues and paralleling is unsuccessful, troubleshoot IAW [Warning 1457: Fail To Synchronize] displayed on DCS screen symptom.

**MALFUNCTION**

Loose or damaged connector or wires.

**CORRECTIVE ACTION****WARNING**

- High voltage is produced when generator set is in operation. Never attempt to start the generator set unless it is properly grounded. Do not ground yourself in standing water. Never attempt to connect or disconnect load cables while the generator sets are running. Failure to comply may cause injury or death to personnel.
- Shut down generator sets before performing inspection of load cables. Failure to comply may cause injury or death to personnel by electrocution.
  - STEP 1. Check connector end at control card for proper connection and replace as required.
  - STEP 2. Inspect connector for damage and replace as required.
  - STEP 3. Check wires at connector end for proper connection and tighten any loose wires.
  - STEP 4. Inspect wires for fraying, splits in insulation, or other damage that may prevent proper use.
  - STEP 5. If symptom continues, proceed to next malfunction.

**MALFUNCTION**

Defective indicator light.

**CORRECTIVE ACTION**

- STEP 1. Disconnect indicator light wires from wiring connector at control card (WP 0027, Replace Switch Box Components).

---

**NOTE**

Multimeter may need to be set to test diodes, if feature is available. Depending on multimeter available, forward voltage may not be high enough to test diode.

STEP 2. Test LED with multimeter set to Ohms by holding red lead to red wire and black lead to black wire (WP 0031, General Maintenance).

STEP 3. Record resistance value.

STEP 4. Reverse leads (red to black, black to red) and record resistance.

**NOTE**

If the diode is functional, Ohms reading will indicate high resistance in one direction and low resistance with leads reversed. If the diode is shorted, multimeter will read zero Ohms ( $\Omega$ ) or full scale with the leads in either direction. If the diode is open, multimeter will read infinite resistance with leads in either direction, indicating a faulty diode.

STEP 5. Replace LED as required (WP 0027, Replace Switch Box Components).

STEP 6. If symptom continues, replace control card (WP 0027, Replace Switch Box Components).

**SYMPTOM**

ON LINE indicator light fails to light.

**NOTE**

Indicator lights are LEDs. Testing is done IAW standard diode testing rather than standard light bulb testing.

STATUS indicator lights show that the load cables between the generator set and the switch box are energized (i.e. generator set contactor is closed and AC voltage at the switch box is approximately >50 VAC). ON LINE indicator lights show that the switch box contactor is closed for indicated generator set and power is available at the bus of the switch box.

**MALFUNCTION**

Improper connection of control cable.

**CORRECTIVE ACTION****WARNING**

- High voltage is produced when generator set is in operation. Never attempt to start the generator set unless it is properly grounded. Do not ground yourself in standing water. Never attempt to connect or disconnect load cables while the generator sets are running. Failure to comply may cause injury or death to personnel.
- High voltage is produced when this generator set is in operation. Do not contact output cables when operating this generator set. Failure to comply may cause injury or death to personnel.

STEP 1. Test output terminals of switch box for power using a multimeter set to test AC voltage (WP 0031, General Maintenance).

STEP 2. If power is available, proceed to Defective indicator light malfunction.

STEP 3. If power is not available, troubleshoot IAW [Warning 3658: Switch Box Fail To Close] displayed on DCS screen symptom.

STEP 4. If symptom continues, proceed to next malfunction.

### **MALFUNCTION**

Improper or malfunctioning paralleling procedures.

### **CORRECTIVE ACTION**

### **WARNING**

- Ensure generator sets are shut down and output terminal board has no voltage prior to making any connections for parallel operation or moving a generator set that has been operating in parallel. Operating generator sets always contain the risk of electrocution. Failure to comply may cause injury or death to personnel.
- Shut down generator sets before performing inspection of load cables. Failure to comply may cause injury or death to personnel by electrocution.
  - STEP 1. Shut down generator sets and disconnect load cables IAW paralleling instructions (TM 9-6115-750-24&P).
  - STEP 2. Reconnect generator sets and attempt parallel (TM 9-6115-750-24&P).
  - STEP 3. If symptom continues but paralleling is successful, troubleshoot IAW Loose or damaged connector or wires malfunction.
  - STEP 4. If symptom continues and paralleling is unsuccessful, troubleshoot IAW [Warning 1457: Fail To Synchronize] displayed on DCS screen symptom.

### **MALFUNCTION**

Loose or damaged connector or wires.

### **CORRECTIVE ACTION**

### **WARNING**

- High voltage is produced when generator set is in operation. Never attempt to start the generator set unless it is properly grounded. Do not ground yourself in standing water. Never attempt to connect or disconnect load cables while the generator sets are running. Failure to comply may cause injury or death to personnel.
- Shut down generator sets before performing inspection of load cables. Failure to comply may cause injury or death to personnel by electrocution.
  - STEP 1. Check connector end at control card for proper connection and replace as required.
  - STEP 2. Inspect connector for damage and replace as required.
  - STEP 3. Check wires at connector end for proper connection and tighten any loose wires.
  - STEP 4. Inspect wires for fraying, splits in insulation, or other damage that may prevent proper use.
  - STEP 5. If symptom continues, proceed to next malfunction.



---

**MALFUNCTION**

Defective indicator light.

**CORRECTIVE ACTION**

STEP 1. Disconnect indicator light wires from wiring connector at control card (WP 0027, Replace Switch Box Components).

**NOTE**

Multimeter may need to be set to test diodes, if feature is available. Depending on multimeter available, forward voltage may not be high enough to test diode.

STEP 2. Test LED with multimeter set to Ohms (WP 0031, General Maintenance) by holding red lead to red wire and black lead to black wire.

STEP 3. Record resistance value.

STEP 4. Reverse leads (red to black, black to red) and record resistance.

**NOTE**

If the diode is functional, Ohms reading will indicate high resistance in one direction and low resistance with leads reversed. If the diode is shorted, multimeter will read zero  $\Omega$  or full scale with the leads in either direction. If the diode is open, multimeter will read infinite resistance with leads in either direction, indicating a faulty diode.

STEP 5. Replace LED as required (WP 0027, Replace Switch Box Components).

STEP 6. If symptom continues, replace control card (WP 0027, Replace Switch Box Components).

**END OF WORK PACKAGE**



**CHAPTER 6**  
**FIELD MAINTENANCE INSTRUCTIONS**  
**FOR**  
**AMMPS 10KW TRAILER-MOUNTED POWER UNITS AND POWER PLANTS**

CHAPTER 6

FIELD MAINTENANCE INSTRUCTIONS

**WORK PACKAGE INDEX**

<u>Title</u>	<u>WP Sequence No.</u>
SERVICE UPON RECEIPT .....	0013
FIELD PMCS INTRODUCTION .....	0014
FIELD PMCS.....	0015
DRAIN GENERATOR SET ENGINE OIL .....	0016
DRAIN GENERATOR SET FUEL .....	0017
REMOVE/INSTALL GENERATOR SET .....	0018
REPLACE MOUNTING RAIL.....	0019
REPLACE TRAILER FENDER .....	0020
REMOVE/INSTALL TRAILER FLOOR PLATES, PLATFORM, AND STEP.....	0021
REMOVE/INSTALL FIRE EXTINGUISHER BRACKET .....	0022
REMOVE/INSTALL GROUND TERMINAL.....	0023
REMOVE/INSTALL ACCESSORY BOX.....	0024
REMOVE/INSTALL SWITCH BOX ASSEMBLY.....	0025
REPAIR SWITCH BOX HOUSING .....	0026
REPLACE SWITCH BOX COMPONENTS.....	0027
REMOVE/INSTALL SWITCH BOX WIRING HARNESS .....	0028
REPLACE TRAILER LEG PROP ASSEMBLY .....	0029
REMOVE/INSTALL HAND BRAKE BRACKET .....	0030
GENERAL MAINTENANCE.....	0031
LUBRICATION INSTRUCTIONS.....	0032
TORQUE LIMITS .....	0033
WIRING DIAGRAMS.....	0034

---

**FIELD MAINTENANCE**  
**AMMPS 10KW TRAILER-MOUNTED POWER UNITS AND POWER PLANTS**  
**SERVICE UPON RECEIPT**

---

**INITIAL SETUP:****Test Equipment**

Not Applicable

**Tools and Special Tools**

Tool Kit, General Mechanic's (GMTK) (WP 0057, Table 2, Item 10)

**Materials/Parts**

Not Applicable

**Personnel Required**

91D (1)

**References**

DA PAM 750-8

MIL-PRF-22191F

SF 361

WP 0002, Equipment Description and Data

**References**

WP 0010, Operator PMCS

WP 0015, Field PMCS

**Equipment Conditions**

Engine control switch OFF (TM 9-6115-750-10, WP 0005)

Engine cool

Wheels chocked, brakes applied (LTT – TM 9-2330-392-14&amp;P), (M200A1 – TM 9-2330-205-14&amp;P)

Front trailer support(s) deployed (LTT – TM 9-2330-392-14&amp;P), (M200A1 – TM 9-2330-205-14&amp;P)

Rear leg prop assembly deployed (WP 0005, Operation Under Usual Conditions)

Rear step jacks deployed (M200A1 – TM 9-2330-205-14&amp;P)

**SERVICE UPON RECEIPT****WARNING**

- Exhaust discharge contains deadly gases, including carbon monoxide. Exhaust gases are most dangerous in places with poor ventilation. Do not operate generator set in an enclosed area unless exhaust discharge is properly vented. Failure to comply may cause injury or death to personnel.
- High voltage is produced when generator set is in operation. Never attempt to start the generator set unless it is properly grounded. Do not ground yourself in standing water. Never attempt to connect or disconnect load cables while the generator sets are running. Failure to comply may cause injury or death to personnel.
- High voltage is produced when this generator set is in operation. Do not contact output cables when operating this generator set. Failure to comply may cause injury or death to personnel.
- Hearing protection required during maintenance or repair with engine running. Failure to comply can cause hearing loss.

---

## CAUTION

Operating generator set with doors open or with panels removed for an extended length of time will cause engine to overheat. Do not operate generator with doors open or panels removed for longer than necessary to complete your task. Monitor DCS temperature indicator to prevent engine overheating. Failure to comply will cause damage to equipment.

This WP provides information and guidance for service upon receipt of the AMMPS 10 kW PUs and PPs. These procedures ensure the AMMPS unit is adequately sited, unpacked, inspected, serviced, and operationally tested before being subjected to use. All applicable service upon receipt instructions for the generator sets and trailers must be performed before performing the PU or PP service upon receipt. See TM 9-6115-750-24&P for service upon receipt of generator sets, TM 9-2330-392-14&P for service upon receipt of LTT, and TM 9-2330-205-14&P for service upon receipt of M200A1.

## SITING

## WARNING

Hot exhaust gases can ignite combustible materials. Allow room for safe discharge of hot gases. Failure to comply may cause injury or death to personnel

## NOTE

Before the PU or PP is started and operated, it is towed to and positioned at the work site.

Select a site IAW instructions in WP 0005, Operation Under Usual Conditions.

## END OF TASK

## SERVICE UPON RECEIPT OF MATERIEL

### Unpacking

## NOTE

The PU or PP should take approximately half an hour to unpack.

1. Remove polyethylene wrap and paperboard protectors.
2. Remove fire extinguisher from accessory box or bracket on trailer and position near trailer (see WP 0002, Equipment Description and Data for location of fire extinguisher bracket).
3. Dispose of all packaging materials for the 10 kW PU or PP IAW local SOP.

## END OF TASK

### Packing

1. Ensure fuel drum adapter is stowed in accessory box on trailer and paralleling cable is stored in the proper generator set accessory box (TM 9-6115-750-10).
2. Check accessory box for the following items: driver/puller, sledge hammer, ground rods (three parts, if removed), and ground wire, pipe elbow, hose clamp, and hose used to drain oil.
3. Ensure technical publications are sealed into plastic bags IAW MIL-PRF-22191F, Performance Specification, Barrier Materials, Transparent, Flexible, Heat-Sealable and stowed in accessory box of trailer.
4. Ensure fire extinguisher is removed from bracket on trailer or removed from location beside trailer and stowed in accessory box on trailer.

- 
5. Perform remaining packing instructions for trailer (TM 9-2330-392-14&P for LTT or TM 9-2330-205-14&P for M200A1) and generator set (TM 9-6115-750-24&P).

**END OF TASK****Checking Unpacked Equipment**

1. Open switch box output terminal board cover and check output terminals and cover for damage.
2. Check output terminal board for damage.
3. Inspect load cables, control wires, and any visible connections for damage.
4. Inspect the equipment for damage incurred during shipment. If the equipment has been damaged, report the damage on SF 361, Transportation Discrepancy Report.
5. Open accessory box and ensure grounding rods (three), ground wire, driver/puller, sledge hammer, fuel drum adapter, hose, hose clamp, and elbow fitting (for oil drain) are included.
6. Check the equipment against the packing slip to see if the shipment is complete. Report all discrepancies in accordance with applicable service instructions (e.g., for Army instructions, see DA PAM 750-8, The Army Maintenance Management System (TAMMS) Users Manual).
7. Check to see whether the equipment has been modified.
8. Check identification plates on trailer and switch box for positive identification (WP 0005, Operation Under Usual Conditions).

**END OF TASK****INSTALLATION INSTRUCTIONS****Installation of Ground Rod**

Ground the PU or PP IAW WP 0005, Operation Under Usual Conditions.

**END OF TASK**

---

### Installation of Auxiliary Fuel Drum Adapter

Each PU or PP has provisions for obtaining fuel from an external source, such as a 5-gallon (gal) (18.9-liter (L)) fuel can or a 55-gal (208.14-L) diesel fuel container (TM 9-6115-750-10).

### WARNING

- Do not operate generator set if any fuel leaks are present. Fuel is combustible. Always perform PMCS before operation. Failure to comply may cause injury or death to personnel.
  - Fuel is combustible and toxic to eyes, skin, and respiratory tract. Skin and eye protection are required when working in contact with fuel. Avoid repeated or prolonged contact. Provide adequate ventilation. Operators are to wash skin and change clothing promptly if in contact with fuel. Failure to comply may cause injury or death to personnel.
  - Fuels used in the generator set are combustible. Ensure fuel source grounding strap is connected to unit fuel fill grounding stud (fuel fill static ground). When filling the fuel tank, maintain metal-to-metal contact between filler nozzle and fuel tank opening to eliminate ESD. Fire and possible explosion can result. Failure to comply may cause injury or death to personnel.
  - Hot engine surfaces from engine and generator circuitry are possible sources of ignition. When refueling during unit operation with DF-1, DF-2, JP5, or JP8, avoid fuel splash and fuel spill. Do not smoke or use open flame when performing refueling. Remember PMCS are still required. Flames and possible explosion may result. Failure to comply may cause injury or death to personnel.
1. Place external fuel source (Figure 1, Item 2) several feet, but no more than 20 ft (6.09 m), away from generator set and no more than 6 ft (1.83 m) above or below auxiliary fuel connection.
  2. Remove auxiliary fuel drum adapter assembly from accessory box (components consist of fuel drum adapter (Figure 1, Item 4), fuel pickup tube (Figure 1, Item 5), and extension pipe (Figure 1, Item 6)).



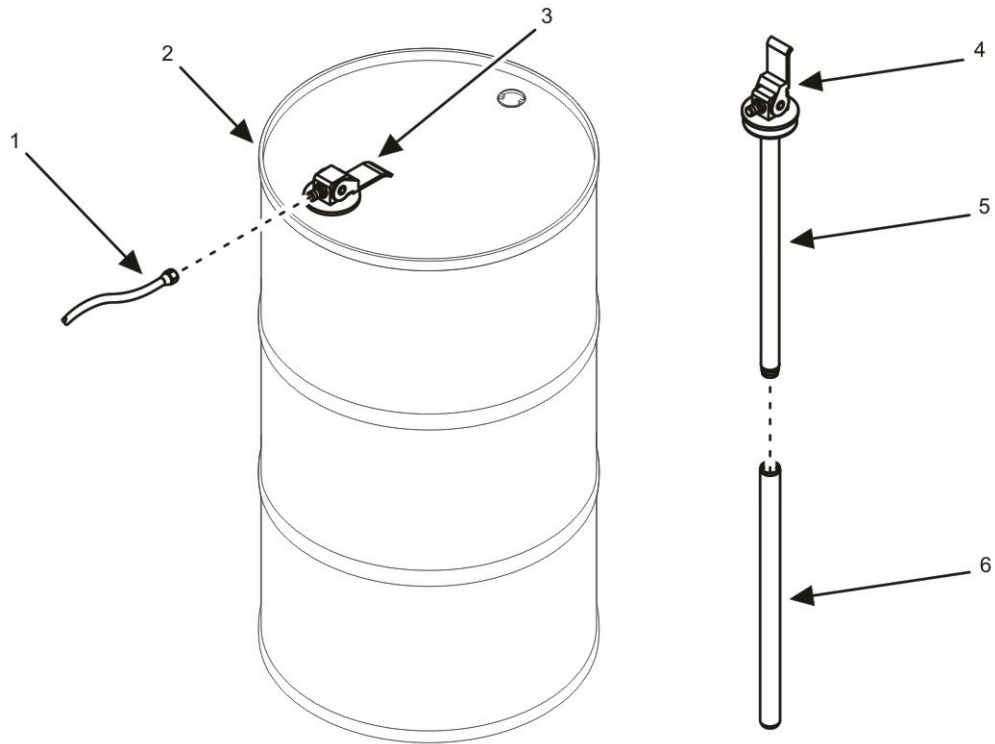

**Figure 1. Fuel Drum Adapter Assembly.**

3. Thread fuel pickup tube (Figure 1, Item 5) into the fuel drum adapter (Figure 1, Item 4).

**NOTE**

Step 4 is performed when using fuel drum adapter assembly with a 55-gal (208.14-L) diesel fuel container.

4. Thread extension pipe (Figure 1, Item 6) onto fuel pickup tube (Figure 1, Item 5).
5. Attach auxiliary fuel line(s) (Figure 1, Item 1) to fuel drum adapter assembly (Figure 1, Item 3) and to generator set(s) (TM 9-6115-750-10). Tighten the connections.
6. Insert fuel drum adapter assembly (Figure 1, Item 3) into external fuel source (Figure 1, Item 2).

**NOTE**

Fuel drum adapter assembly is secured into external fuel source by pressing down on the handle of the clamp.

7. Secure fuel drum adapter assembly (Figure 1, Item 3) to external fuel source (Figure 1, Item 2).

**END OF TASK**

---

**PRELIMINARY CHECKS AND ADJUSTMENT OF EQUIPMENT**

Checks and adjustments shall be made on all newly installed AMMPS 10 kW PUs and PPs. Information on the location of items such as controls and components is located in individual WPs. Before any equipment is put into use, checks are required to ensure proper operation of the equipment.

**WARNING**

High voltage is produced when this generator set is in operation. Ensure engine control and DEAD CRANK switches are set to OFF, negative battery cable is disconnected, and unit is completely shut down and free of any power source before attempting any troubleshooting or maintenance on unit. Failure to comply may cause injury or death to personnel.

**NOTE**

Perform all field maintenance monthly PMCS procedures (WP 0015, Field PMCS).

To conduct some of these preliminary checks and adjustments, it is necessary to run the AMMPS 10 kW PU or PP under load.

1. Perform before PMCS (WP 0010, Operator PMCS).
2. Check for grounding, including earth ground circuits and earth conditioning (soil/terrain) for conduction, as well as a check of the grounding circuit for negligible resistance using a multimeter set to Ohms.
3. Check for firm seating and connection of all plug-in parts, mating connectors, jacks, and plugs.
4. Check cable and wiring harness routing, dressing, and fastening.
5. Start generator set A (TM 9-6115-750-10).
6. Start generator set B (TM 9-6115-750-10).
7. Check for proper parallel operation (TM 9-6115-750-10).
8. Repair as required.
9. Perform after PMCS (WP 0010, Operator PMCS) on AMMPS 10 kW PUs and PPs.

**END OF TASK****END OF WORK PACKAGE**

---

**FIELD MAINTENANCE**  
**AMMPS 10KW TRAILER-MOUNTED POWER UNITS AND POWER PLANTS**  
**FIELD PMCS INTRODUCTION**

---

## **INTRODUCTION**

This section contains information you will need to perform field PMCS. Steps are included to help you perform these procedures easily and quickly. PMCS consist of scheduled maintenance items used to make sure the AMMPS PUs and PPs are ready for operation at all times. Inspect the system regularly and carefully so you can find, correct, and prevent any defects.

## **GENERAL**

PMCS are performed to keep the equipment in operating condition. The checks are used to find, correct, or report problems. Pay attention to warning and caution statements. A warning indicates the possibility of injury or death to personnel. A caution means the potential for equipment damage.

Intervals are given in operating hours.

- First 50 hours.
- Every 250 hours.
- Every 500 hours.
- Every 1000 hours.
- Every 1500 hours.
- Under harsh environmental conditions, PMCS should be conducted more frequently.

## **EXPLANATION OF THE COLUMNS FOUND IN THE PMCS TABLE**

Column (1) – Item No. The item number lists the checks and services in the order they are to be completed. This column will be used as a source of item for the TM Number Column on DA Form 2404, Equipment Inspection and Maintenance Worksheet, or DA Form 5988E (electronic version), Equipment Inspection and Maintenance Worksheet, in recording the result of the PMCS.

Column (2) – Interval. References when the PMCS should be performed.

Column (3) – Item to be Checked or Serviced. Identifies the portion of the system to be inspected.

Column (4) – Procedure. Provides the procedures for performing the checks.

Column (5) – Equipment is not Ready/Available if. Contains the criteria that will render the system incapable of performing its primary mission. If the system does not perform as required, refer to Chapter 5, Field Maintenance Troubleshooting (WP 0011, Troubleshooting Index). If equipment appears to be malfunctioning and the problem cannot be fixed, immediately report it to your supervisor and report it on DA Form 2404, Equipment Inspection and Maintenance Worksheet.

## **CPC**

CPC of Army materiel is a continuing concern. It is important that any corrosion problems with this item be reported so that the problem can be corrected and improvements can be made to prevent future problems.

Corrosion specifically occurs with metals. It is an electrochemical process that causes the degradation of metals. It is commonly caused by exposure to moisture, acids, bases, or salts. An example is the rusting of iron. Corrosion damage in metals can be seen, depending on the metal, as tarnishing, pitting, fogging, surface residue, and/or cracking.

Plastics, composites, and rubbers can also degrade. Degradation is caused by thermal (heat), oxidation (oxygen), solvation (solvents), or photolytic (light, typically Ultraviolet (UV)) processes. The most common exposures are excessive heat or light. Damage from these processes will appear as cracking, softening, swelling, and/or breaking. SF 368, Product Quality Deficiency Report, should be submitted to the address specified in DA PAM 750-8, The Army Maintenance Management System (TAMMS) Users Manual.

For aircraft TMs, this information shall include a reference to TM 1-1500-344-23, volumes 1 through 4 (Cleaning and Corrosion Control).

### **Rust Definition**

Rust is defined as any various scaly or powdery reddish-brown or reddish-yellow materials that form on iron and iron-coated materials in the presence of moisture, deteriorating as a result of disuse or neglect.

### **Deterioration Definition**

Deterioration is defined as any condition that causes material to be defective or lessens the quality or value of the material.

### **Cracking Definition**

Cracking is defined as when material is found to be split or broken, either completely or partially.

## **INSPECTION**

Look for signs of problems or troubles. Most problems can be detected by sight, touch, smell, or sound. Be alert when around the 10 kW PUs and PPs.

Inspect to ensure that all components are in good condition. Are they correctly assembled, stowed, or secured? Are any components worn, corroded, or rusty? Correct any problems found or notify your immediate supervisor.

There are common items that should be checked. These include the following:

**Bolts, clamps, screws, and nuts:** Continuously inspect for looseness. Inspect for chipped paint, bare metal, rust, or corrosion around bolt and screw heads and nuts. Replace as necessary. Tighten hardware as required.

**Welds:** Some components of the 10 kW PUs and PPs are welded. To inspect welds, look for chipped paint, rust, corrosion, or gaps. When these conditions are found, repair or replace as required.

## **WARNING**

- NATO slave receptacle is electrically live at all times and is not protected by a fuse. Disconnecting main DC circuit breaker does not ensure the circuit is dead. This circuit is only dead when the batteries are fully disconnected. Disconnect both batteries before performing maintenance on the slave receptacle. Failure to comply may cause injury or death to personnel.
- Metal jewelry can conduct electricity and become entangled in generator set components. Remove all jewelry and do not wear loose clothing when working on equipment. Failure to comply may cause injury or death to personnel.
- High voltage is produced when generator set is in operation. Never attempt to start the generator set unless it is properly grounded. Do not ground yourself in standing water. Never attempt to connect or disconnect load cables while the generator sets are operating. Failure to comply may cause injury or death to personnel.

**Electrical wires, connectors, and harnesses:** Tighten loose connections. Inspect for cracked or broken insulation, bare wires, and broken connectors. If any are found, repair or replace as required.

---

**Hoses and fluid lines:** Inspect for wear, damage, and leaks. Ensure clamps and fittings are tight. Wet spots indicate a leak. A stain by a fitting or connector can also mean a leak. When this is found, repair or replace as required.

## **CLEANING AND LUBRICATION**

Proper cleaning and lubrication can aid in avoiding possible problems or trouble. Make it a habit to do the following:

### **CAUTION**

Follow all cleaning and lubrication instructions carefully. Failure to comply may cause damage to equipment.

Under harsh environmental conditions, conduct PMCS more frequently.

Use only the recommended cleaning solutions and lubricants found in the Expendable and Durable Items List (WP 0060, Expendable and Durable Items List).

### **Oil Filters**

Oil filters shall be serviced/cleaned/changed by field maintenance personnel, as applicable, when:

They are known to be contaminated or clogged.

At prescribed hardtime intervals.

### **AOAP Sampling**

The PU-2002, PU-2012, and PP-3102 models are not enrolled in the Army Oil Analysis Program. Hardtime intervals apply.

### **Warranty Hardtime**

For equipment under manufacturer's warranty, hardtime oil service intervals shall be followed. Intervals shall be shortened if lubricants are known to be contaminated or if operation is under adverse conditions (such as longer-than-usual operating hours, extended idling periods, extreme dust).

---

**FLUID LEAKAGE****WARNING**

- Do not operate generator set if any fuel leaks are present. Fuel is combustible. Always perform PMCS before operation. Failure to comply may cause injury or death to personnel.
- Fuel is combustible and toxic to eyes, skin, and respiratory tract. Skin and eye protection are required when working in contact with fuel. Avoid repeated or prolonged contact. Provide adequate ventilation. Operators are to wash skin and change clothing promptly if in contact with fuel. Failure to comply may cause injury or death to personnel.

**CAUTION**

When operating with Class I or II leaks, continue to check fluid level as required by PMCS. Class III leaks should be noted and repaired immediately. Any Class I, II, or III fuel leak requires equipment shut down. Failure to comply may cause damage to equipment.

It is necessary to know how fluid leakage affects the status of the 10 kW generator sets. Following are types/classes of leakage that determine the status of the 10 kW generator sets. Learn these leakage definitions, and remember: when in doubt, notify your supervisor. Equipment operation is allowed with minor leakage (Class I or II). Consideration must be given to fluid capacity in the item/system being checked/inspected. When in doubt, notify your supervisor.

Any Class I, II, or III fuel leak requires equipment shut down.

Class III leaks should be reported immediately to your supervisor.

- (1) Class I: Seepage of fluid (as indicated by wetness or discoloration) not great enough to form drops.
- (2) Class II: Leakage of fluid great enough to form drops but not enough to cause drops to drip from item being checked/inspected.
- (3) Class III: Leakage of fluid great enough to form three drops that fall from item being checked/inspected within 5 sec.

**END OF WORK PACKAGE**

---

**FIELD MAINTENANCE**  
**AMMPS 10KW TRAILER-MOUNTED POWER UNITS AND POWER PLANTS**  
**FIELD PMCS**

---

**INITIAL SETUP:****Test Equipment**

Not Applicable

**Tools and Special Tools**

Not Applicable

**Materials/Parts**

Not Applicable

**Personnel Required**

91D (1)

**References**

TM 9-6115-750-24&amp;P

WP 0010, Operator PMCS

WP 0032, Lubrication Instructions

**Equipment Conditions**

Engine control switch OFF (TM 9-6115-750-10, WP 0005)

Engine cool

Wheels chocked, brakes applied (LTT – TM 9-2330-392-14&amp;P), (M200A1 – TM 9-2330-205-14&amp;P)

Front trailer supports deployed (LTT – TM 9-2330-392-14&amp;P), (M200A1 – TM 9-2330-205-14&amp;P)

Rear leg prop assembly deployed (WP 0005, Operation Under Usual Conditions)

Rear step jacks deployed (M200A1 – TM 9-2330-205-14&amp;P)

**NOTE**

Ensure operator level PMCS (WP 0010, Operator PMCS) has been performed before performing field maintenance level PMCS.

**FIELD PMCS INSTRUCTIONS**

There are no specific field level PMCS instructions for the switch box. For field level generator set PMCS, see TM 9-6115-750-24&P. For field level trailer PMCS, see TM 9-2330-392-14&P for the LTTs and see TM 9-2330-205-14&P for the M200A1.

**LUBRICATION INSTRUCTIONS**

There are no scheduled lubrication intervals for external components (i.e. hinges and latches). Lubrication instructions are contained in WP 0032, Lubrication Instructions.

Lubrication instructions for the 10 kW generator sets are contained in TM 9-6115-750-24&P. Lubrication instructions for the LTTs are contained in TM 9-2330-392-14&P and for the M200A1 are contained in TM 9-2330-205-14&P.

**END OF WORK PACKAGE**





---

**FIELD MAINTENANCE**  
**AMMPS 10KW TRAILER-MOUNTED POWER UNIT AND POWER PLANT**  
**DRAIN GENERATOR SET ENGINE OIL**

---

**INITIAL SETUP:****Test Equipment**

Not Applicable

**Personnel Required**

91D (1)

**Tools and Special Tools**

Tool Kit, General Mechanic's (GMTK) (WP 0057, Table 2, Item 10)

**References**

TM 9-6115-750-24&amp;P

**Materials/Parts**

Elbow, pipe (WP 0058, Components of End Item (COEI) and Basic Issue Items (BII) Lists, Table 2, Item 2)

Hose, drain (WP 0058, Table 2, Item 5)

Cleaning compound, solvent (WP 0060, Expendable and Durable Items List, Item 1)

Pan, drain (WP 0060, Item 4)

Rag, wiping (WP 0060, Item 5)

Sealant (WP 0060, Item 6)

**Equipment Conditions**

Engine control switch OFF (TM 9-6115-750-10, WP 0005)

Engine cool

Wheels chocked, brakes applied (LTT – TM 9-2330-392-14&amp;P), (M200A1 – TM 9-2330-205-14&amp;P)

Front trailer support(s) deployed (LTT – TM 9-2330-392-14&amp;P), (M200A1 – TM 9-2330-205-14&amp;P)

Rear leg prop assembly deployed (WP 0005, Operation Under Usual Conditions)

Rear step jacks deployed (M200A1 – TM 9-2330-205-14&amp;P)

**DRAIN GENERATOR SET ENGINE OIL****WARNING**

- Allow engine to cool from normal operating temperature prior to draining engine oil and removing oil filter. Failure to comply may cause injury or death to personnel.
- Cleaning solvent is combustible and toxic to eyes, skin, and respiratory tract. Skin and eye protection is required. Avoid repeated or prolonged contact. Work in ventilated area only. Failure to comply may cause injury or death to personnel.

**NOTE**

Tasks to replace the generator set engine oil filter and fill the lubrication system oil are located in TM 9-6115-750-24&P.

### Drain Generator Set Engine Oil

1. Ensure equipment conditions are met in order presented at initial setup.
2. Start engine and run for 5 minutes (min) to warm engine oil.
3. Turn engine off.

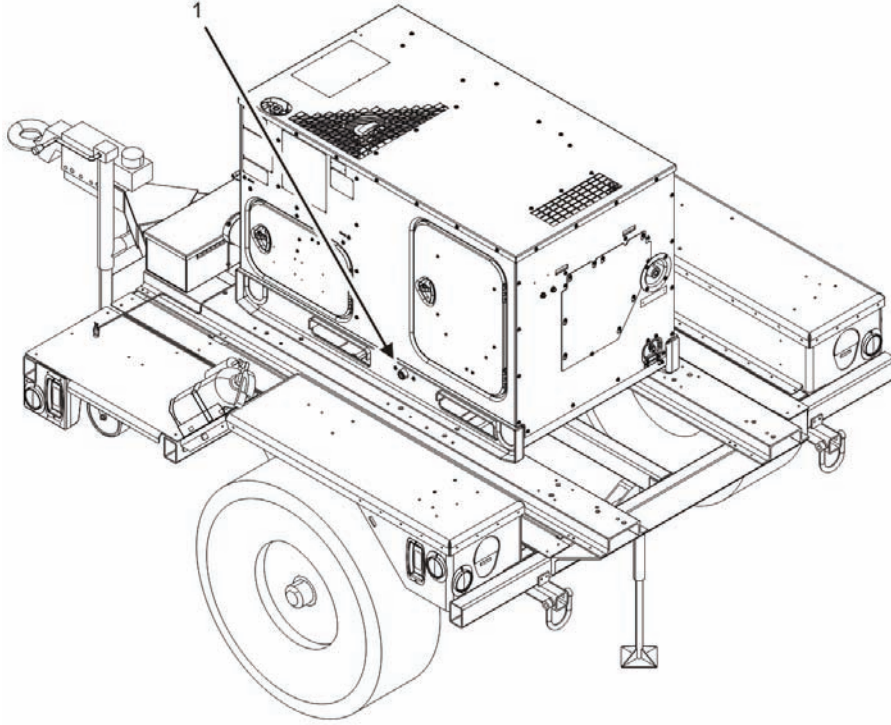

**Figure 1. PU-2002 and PU-2012 Engine Oil Drain Port — Location.**

4. Locate generator set engine oil drain port (Figure 1, Item 1 or Figure 2, Item 1) on generator skid.

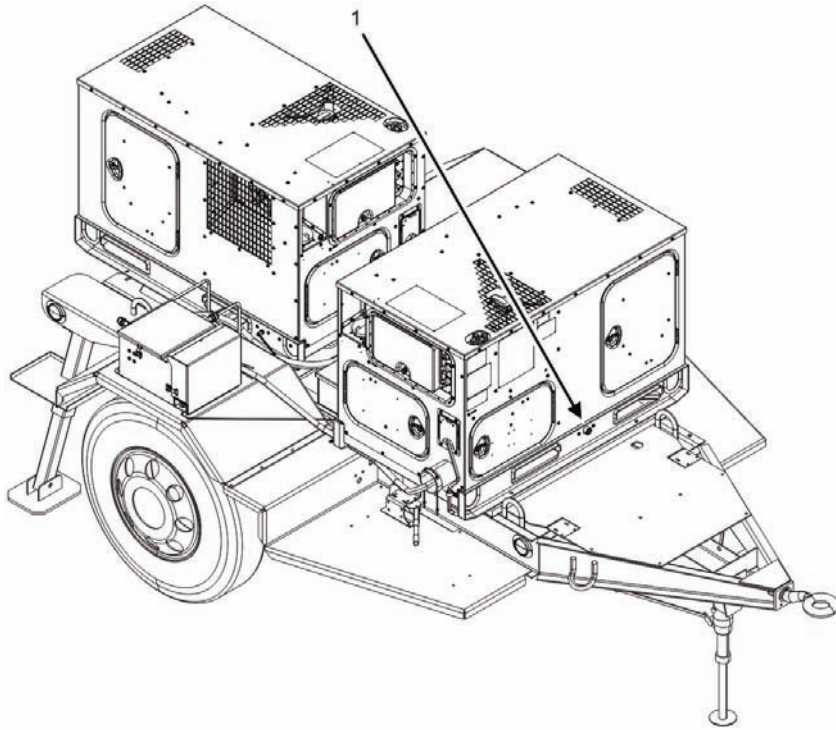

Figure 2. PP-3102 Engine Oil Drain Port — Location.

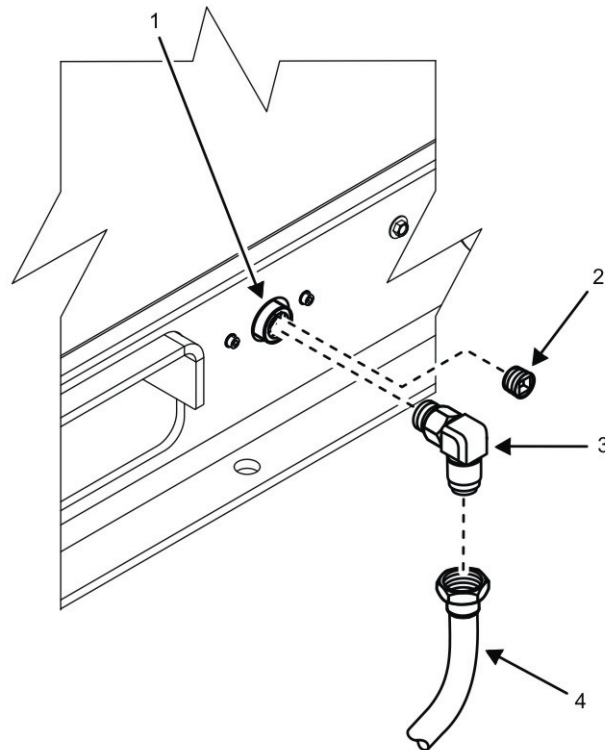

Figure 3. Engine Oil Drain Hose — Installation.

- 
5. Remove elbow (Figure 3, Item 3) and drain hose (Figure 3, Item 4) from trailer accessory box.
  6. Clean plug (Figure 3, Item 2) and drain port (Figure 3, Item 1) of generator set using cleaning solvent and wiping rags.
  7. Open right-side door of generator set and ensure ball valve is in the closed position (TM 9-6115-750-24&P).
  8. Remove plug (Figure 3, Item 2) from engine oil drain port (Figure 3, Item 1).
  9. Install elbow (Figure 3, Item 3) to engine oil drain port (Figure 3, Item 1).
  10. Install drain hose (Figure 3, Item 4) to elbow (Figure 3, Item 3).
  11. Allow drain hose (Figure 3, Item 4) to hang down below trailer.
  12. Position a suitable drain pan under drain hose (Figure 3, Item 4).
  13. Drain engine oil and replace oil filter (TM 9-6115-750-24&P).
  14. Ensure ball valve is in the closed position (TM 9-6115-750-24&P) once flow of oil has stopped.
  15. Remove drain hose (Figure 3, Item 4) from elbow (Figure 3, Item 3).
  16. Remove elbow (Figure 3, Item 3) from engine oil drain port (Figure 3, Item 1).
  17. Apply pipe thread sealant to threads of plug (Figure 3, Item 2) prior to installation into engine oil drain port (Figure 3, Item 1).
  18. Wipe residual engine oil from engine oil drain port (Figure 3, Item 1), and install plug (Figure 3, Item 2).
  19. Close right-side generator set door.
  20. Clean elbow (Figure 3, Item 3) and drain hose (Figure 3, Item 4) using cleaning solvent and wiping rags.
  21. Stow elbow (Figure 3, Item 3) and drain hose (Figure 3, Item 4) in trailer accessory box.
  22. Dispose of used engine oil and soiled rags IAW local Standard Operating Procedure (SOP).
  23. Fill engine oil (TM 9-6115-750-24&P).

**END OF TASK**

**END OF WORK PACKAGE**

---

**FIELD MAINTENANCE**  
**AMMPS 10KW TRAILER-MOUNTED POWER UNITS AND POWER PLANTS**  
**DRAIN GENERATOR SET FUEL**

---

**INITIAL SETUP:****Test Equipment**

Not Applicable

**References**

TM 9-6115-750-24&amp;P

**Tools and Special Tools**

Tool Kit, General Mechanic's (GMTK) (WP 0057, Table 2, Item 10)

**Equipment Conditions**

Engine control switch OFF (TM 9-6115-750-10, WP 0005)

**Materials/Parts**

Cleaning compound, solvent (WP 0060, Expendable and Durable Items List, Item 1)

Pan, drain (WP 0060, Item 4)

Rag, wiping (WP 0060, Item 5)

Wheels chocked, brakes applied (LTT – TM 9-2330-392-14&amp;P), (M200A1 – TM 9-2330-205-14&amp;P)

Front trailer support deployed (LTT – TM 9-2330-392-14&amp;P), (M200A1 – TM 9-2330-205-14&amp;P)

Rear leg prop assembly deployed (WP 0005, Operation Under Usual Conditions)

**Personnel Required**

91D (1)

Rear step jacks deployed (M200A1 – TM 9-2330-205-14&amp;P)

---

**DRAIN GENERATOR SET FUEL****WARNING**

- Fuel is combustible and toxic to eyes, skin, and respiratory tract. Skin and eye protection are required when working in contact with fuel. Avoid repeated or prolonged contact. Provide adequate ventilation. Operators are to wash skin and change clothing promptly if in contact with fuel. Failure to comply may cause injury or death to personnel.
- Fuels used in the generator set are combustible. Do not smoke or use open fire when performing maintenance. Fire and possible explosion may result. Failure to comply may cause injury or death to personnel and damage to equipment.
- Cleaning solvent is combustible and toxic to eyes, skin, and respiratory tract. Skin and eye protection is required. Avoid repeated or prolonged contact. Work in ventilated area only. Failure to comply may cause injury or death to personnel.

**Drain Generator Set Fuel**

1. Ensure equipment conditions are met in order presented at initial setup.
2. Locate generator set fuel drain port (Figure 1, Item 1 or Figure 2, Item 1) on generator skid.

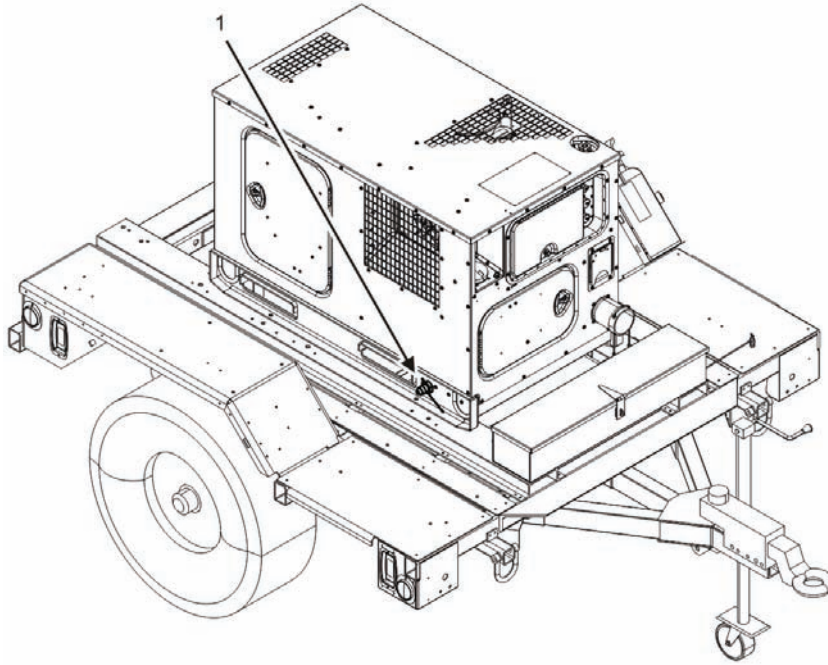

Figure 1. PU-2002 and PU-2012 Fuel Drain Port — Location.

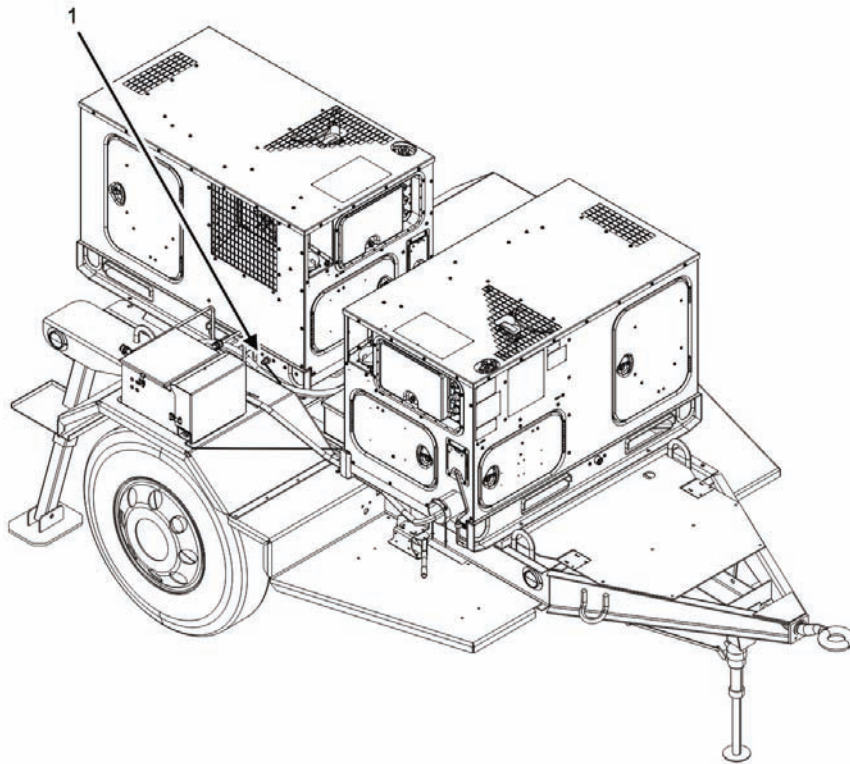
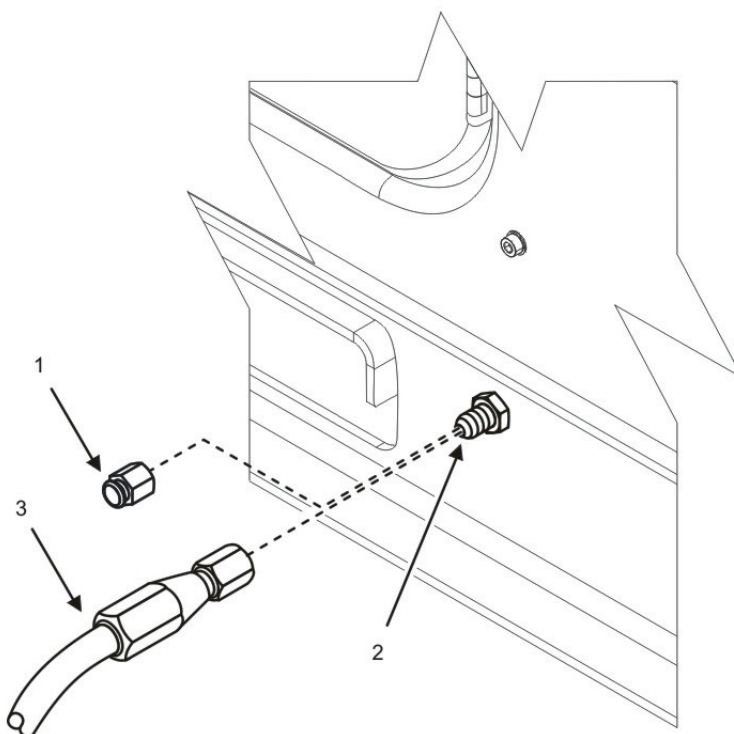

Figure 2. PP-3102 Fuel Drain Port — Location.



**Figure 3. Fuel Drain Hose — Installation.**

3. Remove auxiliary fuel hose (Figure 3, Item 3) from trailer accessory box or from generator set accessory box.
4. Clean outside of cap (Figure 3, Item 1) and fuel drain port (Figure 3, Item 2) using cleaning solvent and wiping rags.
5. Open left-side door of generator set and ensure ball valve is in the closed position (TM 9-6115-750-24&P).
6. Remove cap (Figure 3, Item 1) from fuel drain port (Figure 3, Item 2).
7. Install auxiliary fuel hose (Figure 3, Item 3) to fuel drain port (Figure 3, Item 2). Allow auxiliary fuel hose (Figure 3, Item 3) to hang down between the generator set mounting rails below trailer floor.
8. Position a suitable container with a capacity of at least 5.0 gal (20.0 L) under fuel hose (Figure 3, Item 3).
9. Drain fuel (TM 9-6115-750-24&P).
10. Ensure ball valve is in the closed position (TM 9-6115-750-24&P) once flow of fuel has stopped.
11. Remove auxiliary fuel hose (Figure 3, Item 3) from fuel drain port (Figure 3, Item 2).
12. Wipe residual fuel from fuel drain port (Figure 3, Item 2) and install cap (Figure 3, Item 1).
13. Close left-side generator set door.
14. Clean auxiliary fuel hose (Figure 3, Item 3) using cleaning solvent and wiping rags.
15. Stow auxiliary fuel hose (Figure 3, Item 3) in trailer accessory box or generator set accessory box.
16. Dispose of used fuel and soiled rags IAW local SOP.
17. Fill fuel (TM 9-6115-750-24&P).

**END OF TASK**

**END OF WORK PACKAGE**





---

**FIELD MAINTENANCE**  
**AMMPS 10KW TRAILER-MOUNTED POWER UNITS AND POWER PLANTS**  
**REMOVE/INSTALL GENERATOR SET**

---

**INITIAL SETUP****Test Equipment**

Not Applicable

**Tools and Special Tools**

Tool Kit, General Mechanic's (GMTK) (WP 0057 Table 2, Item 10)

Wrench, Torque, Click, Ratcheting, 1/2" Drive, 250 FT-LB (WP 0057, Table 2, Item 13)

**Materials/Parts**

Generator set, diesel (1) (WP 0036, Repair Parts List, Figure 1, Item 2)

Generator set, diesel (1) (WP 0036, Figure 1, Item 13)

Generator set, diesel (2) (WP 0036, Figure 1, Item 24)

Nut, self-locking, hexagon (4) (WP 0036, Figure 1, Item 9)

Nut, self-locking, hexagon (4) (WP 0036, Figure 1, Item 20)

Nut, self-locking, hexagon (8) (WP 0036, Figure 1, Item 28)

Cleaning compound, solvent (WP 0060, Expendable and Durable Items List, Item 1)

Pad, scouring (WP 0060, Item 3)

Rag, wiping (WP 0060, Item 5)

**Personnel Required**

91D (1)

Assistant (1)

Lift equipment operator (1)

**References**

WP 0019, Replace Mounting Rail

**Equipment Conditions**

Engine control switch OFF (TM 9-6115-750-10, WP 0005)

Wheels chocked and brakes applied (LTT – TM 9-2330-392-14&P), (M200A1 – TM 9-2330-205-14&P)

Front trailer support deployed (LTT – TM 9-2330-392-14&P), (M200A1 – TM 9-2330-205-14&P)

Rear leg prop assembly deployed (WP 0005, Operation Under Usual Conditions)

Rear step jacks deployed (M200A1 – TM 9-2330-205-14&P)

Load cables removed from generator set (if attached) (TM 9-6115-750-10)

Ground cable removed from generator set (if attached) (TM 9-6115-750-10)

**REMOVE/INSTALL GENERATOR SET****WARNING**

When lifting generator set, use lifting equipment with minimum lifting capacity of 1,500 lb (680 kg). Do not stand or put arms, legs, or any body part under hoisted load. Do not permit generator set to swing. Failure to comply may cause injury or death to personnel.

**Remove Generator Set**

1. Ensure equipment conditions are met in order presented at initial set up.
2. Locate generator set to be removed (Figure 1, Item 1 or Figure 2, Item 1).

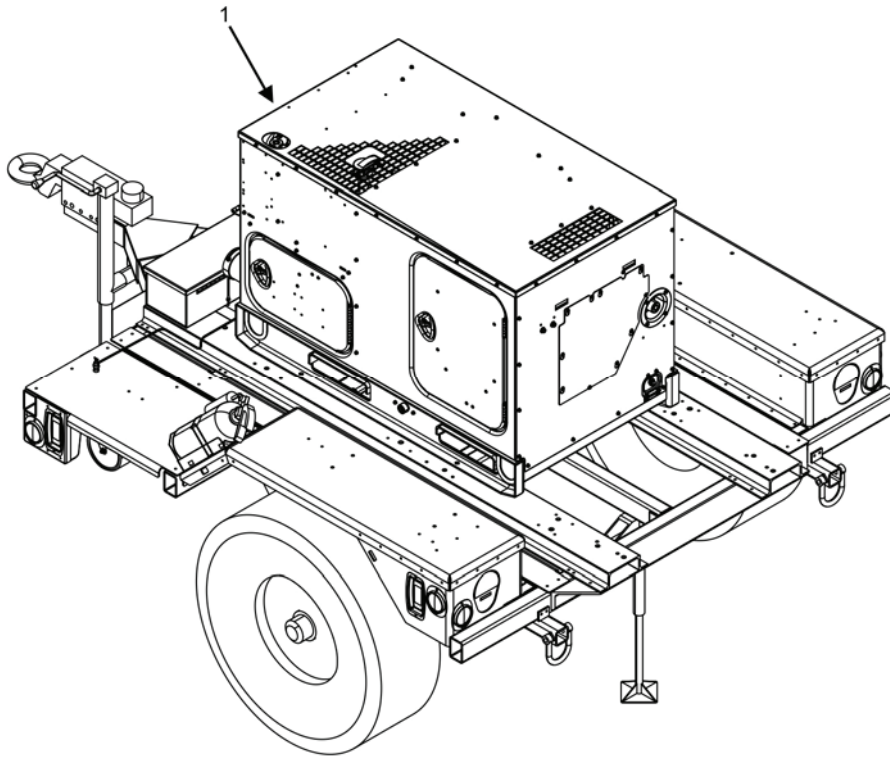

Figure 1. PU-2002 or PU-2012 Generator Set — Location.

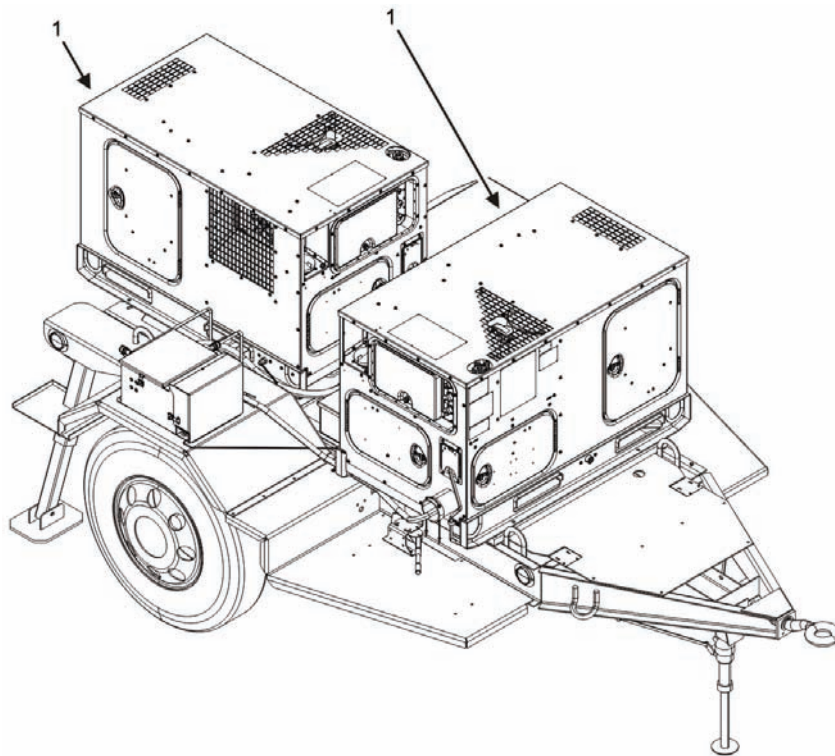
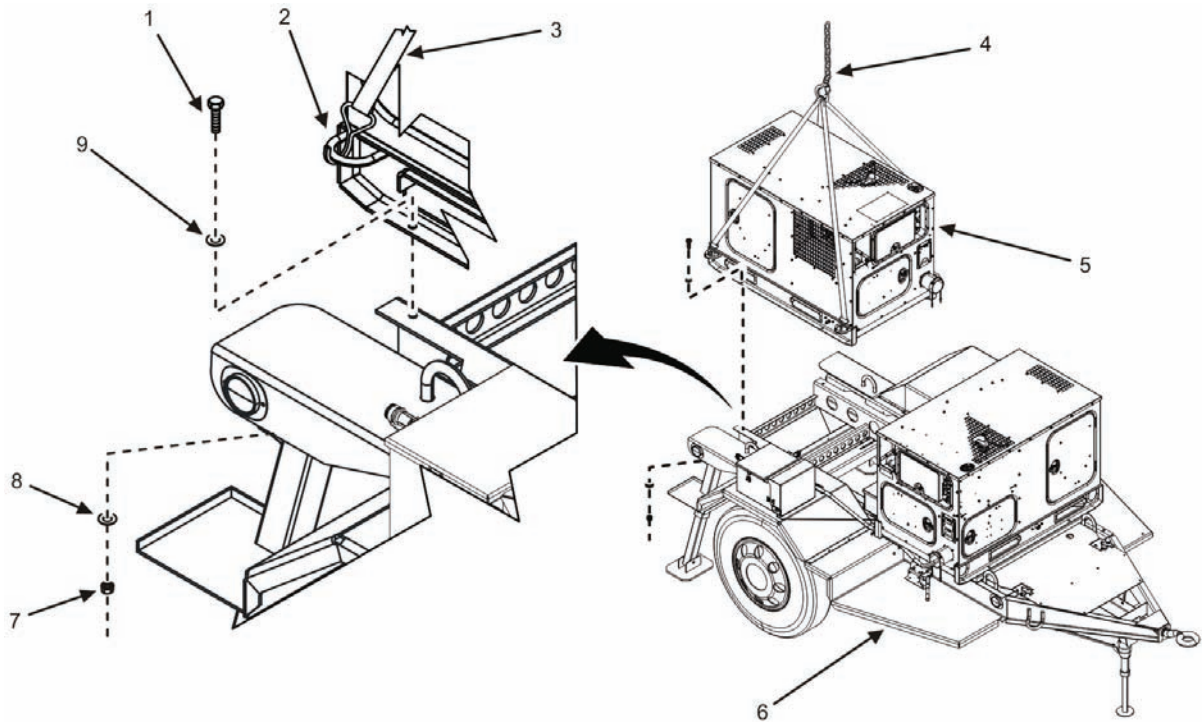

Figure 2. PP-3102 Generator Set — Location.

**NOTE**

Figure 3 shows a generator set being removed from an M200A1 trailer. The removal procedure of a single generator set (Figure 3, Item 5) from its trailer mounting is the same regardless of the PU or PP model involved.



**Figure 3. Generator Set — Removal.**

3. Remove four lock nuts (Figure 3, Item 7) and four flat washers (Figure 3, Item 8) that secure generator set (Figure 3, Item 5) to trailer (Figure 3, Item 6).
4. Attach four hooks (Figure 3, Item 3) of lifting equipment (Figure 3, Item 4) with a minimum capacity of 1,500 lb (680 kg) to each of four lifting rings (Figure 3, Item 2) of generator set (Figure 3, Item 5).
5. Remove four bolts (Figure 3, Item 1) and four flat washers (Figure 3, Item 9) that secure generator set (Figure 3, Item 5) to trailer (Figure 3, Item 6).
6. Lift generator set (Figure 3, Item 5) carefully from trailer (Figure 3, Item 6).
7. Steady generator set (Figure 3, Item 5) with help of an assistant to prevent generator set (Figure 3, Item 5) from swinging while suspended from the lifting equipment (Figure 3, Item 4).
8. Move generator set (Figure 3, Item 5) and lower to a suitable, stable landing area.
9. Remove lifting equipment (Figure 3, Item 4) from generator set (Figure 3, Item 5).

**END OF TASK**

---

**Inspect Generator Set Mounting Location**

1. Inspect mounting rails on trailer (Figure 3, Item 6) for corrosion, dents, or cracks.
2. Remove surface corrosion from mounting rails on trailer (Figure 3, Item 6) using cleaning solvent, an abrasive pad, and wiping rags.
3. Replace mounting rails on trailer (Figure 3, Item 6) that are badly corroded, bent, or cracked (WP 0019, Replace Mounting Rails).
4. Clean mounting rails on trailer (Figure 3, Item 6) using cleaning solvent and wiping rags.

**END OF TASK****Install Generator Set****NOTE**

The installation procedure of a single generator set from its trailer mounting is the same regardless of the PU or PP model involved. Instructions for deployment of trailer equipment are dependant upon trailer model being used.

1. Attach four hooks (Figure 3, Item 3) of lifting equipment (Figure 3, Item 4) with a minimum capacity of 1,500 lb (680 kg) to each of four lifting rings (Figure 3, Item 2) of generator set (Figure 3, Item 5).
2. Lift generator set (Figure 3, Item 5) carefully.
3. Steady generator set (Figure 3, Item 5) with the help of an assistant to prevent generator set from swinging while suspended from the lifting equipment (Figure 3, Item 4).
4. Move generator set over trailer (Figure 3, Item 6) using the lifting equipment (Figure 3, Item 4).
5. Lower generator set (Figure 3, Item 5) carefully to align mounting holes in trailer (Figure 3, Item 6) and generator set (Figure 3, Item 5).
6. Install four bolts (Figure 3, Item 1) and four flat washers (Figure 3, Item 9) through generator set skid and into trailer (Figure 3, Item 6).
7. Install four new lock nuts (Figure 3, Item 7) and four flat washers (Figure 3, Item 8) to secure generator set (Figure 3, Item 5) to trailer (Figure 3, Item 6).
8. Tighten four bolts (Figure 3, Item 1) to 80 – 88 ft/lb (109 – 120 Newton meters (Nm)).
9. Remove lifting equipment (Figure 3, Item 4) from generator set (Figure 3, Item 5).
10. Install ground cable to generator set (if originally attached) (TM 9-6115-750-10).
11. Install load cables to generator set (if originally attached) (TM 9-6115-750-10).
12. Start generator set (TM 9-6115-750-10).
13. Check for proper operation (TM 9-6115-750-10).
14. Repair as required.

**END OF TASK****END OF WORK PACKAGE**

---

**FIELD MAINTENANCE**  
**AMMPS 10KW TRAILER-MOUNTED POWER UNITS AND POWER PLANTS**  
**REPLACE MOUNTING RAIL**

---

**INITIAL SETUP:****Test Equipment**

Not Applicable

**Tools and Special Tools**

Riveter Kit, Blind, Hand (WP 0057, Table 2, Item 7)

Tool Kit, Blind, Fastener, Installation (WP 0057, Table 2, Item 9)

Tool Kit, General Mechanic's (GMTK) (WP 0057, Table 2, Item 10)

Wrench, Torque, Dial, 3/8" Drive, 300 IN-LB (WP 0057, Table 2, Item 15)

**Materials/Parts**

Frame, spacer (1) (WP 0040, Repair Parts List, Figure 5, Item 17)

Nut, self-locking, head (4) (WP 0040, Figure 5, Item 20)

Pin, quick release (40) (WP 0040, Figure 5, Item 5)

Rail, mounting, (curbside) (1) (WP 0040, Figure 5, Item 1)

Rail, mounting, (roadside) (1) (WP 0040, Figure 5, Item 4)

Rivet, blind, (4) (WP 0040, Figure 5, Item 2)

**Personnel Required**

91D (1)

**References**

WP 0018, Remove/Install Generator Set

WP 0021, Remove/Install Trailer Floor Plates, Platform, and Step

WP 0024, Remove/Install Accessory Box

**Equipment Conditions**

Engine control switch OFF (TM 9-6115-750-10, WP 0005)

Wheels chocked, brakes applied (LTT – TM 9-2330-392-14&amp;P), (M200A1 – TM 9-2330-205-14&amp;P)

Front trailer support(s) deployed (LTT – TM 9-2330-392-14&amp;P), (M200A1 – TM 9-2330-205-14&amp;P)

Rear leg prop assembly deployed (WP 0005, Operation Under Usual Conditions)

Rear step jacks deployed (M200A1 – TM 9-2330-205-14&amp;P)

## REPLACE MOUNTING RAIL

### Replace Mounting Rail (PU-2002 and PU-2012)

#### NOTE

Generator set roadside mounting rail (Figure 1, Item 3) and curbside mounting rail (Figure 1, Item 1) use the same hardware and procedure to replace. Either or both can be replaced during this procedure.

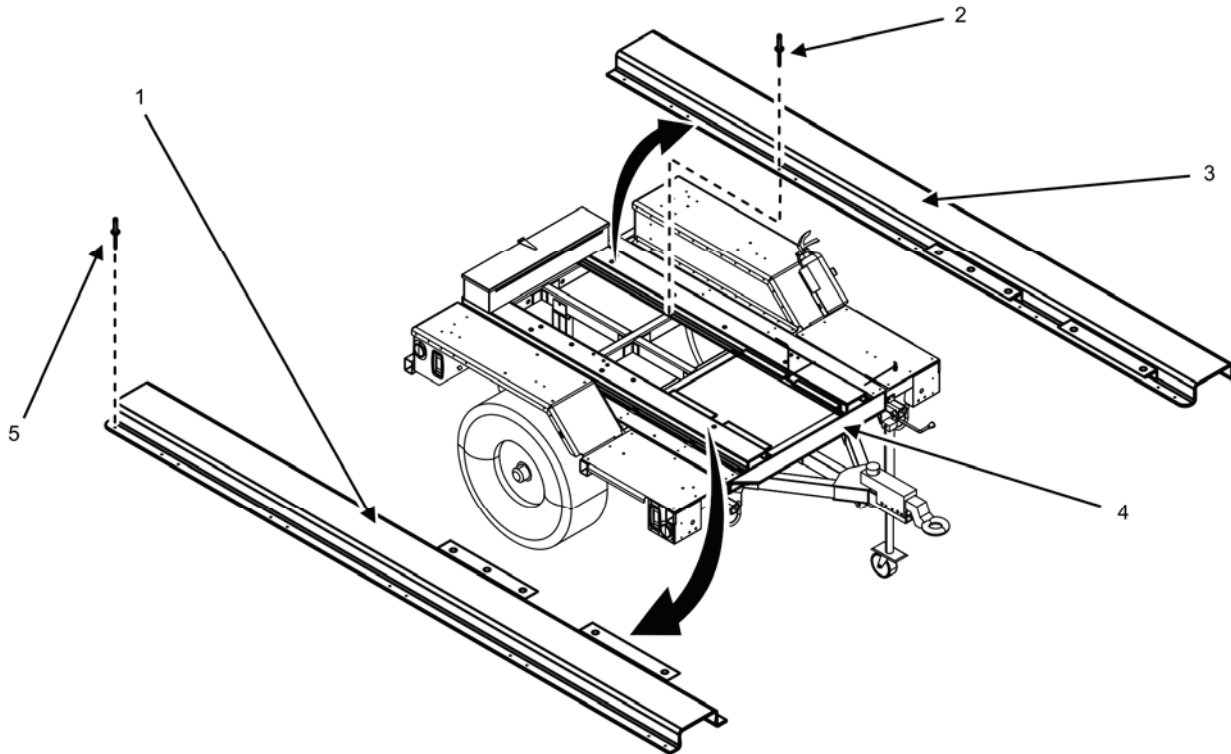

**Figure 1. Mounting Rail PU-2002 and PU-2012 — Location.**

1. Ensure equipment conditions are met in order presented in initial setup.
2. Remove accessory box (WP 0024, Remove/Install Accessory Box).
3. Remove center floor plate (WP 0021, Remove/Install Trailer Floor Plates, Platform, and Step).
4. Remove generator(s) (WP 0018, Remove/Install Generator Set).
5. Locate mounting rail assembly (Figure 1, Items 1 and/or 3).
6. Remove 22 rivets (Figure 1, Items 2 and 5) from mounting rail assembly (Figure 1, Items 1 and/or 3).
7. Discard 22 rivets (Figure 1, Items 2 and 5).
8. Remove mounting rail assembly (Figure 1, Items 1 and/or 3).
9. Inspect trailer chassis (Figure 1, Item 4) where mounting rail assembly (Figure 1, Items 1 and/or 3) was attached for any sign of damage. Repair or replace as required.
10. Align holes in replacement mounting rail assembly (Figure 1, Items 1 and/or 3) with matching holes in trailer chassis (Figure 1, Item 2).

**NOTE**

Two different gripping strength blind rivets are used to install mounting rail assemblies (Figure 1, Items 1 and/or 3). Two rivets (Figure 1, Item 5) on each mounting rail are different than the other 20 rivets (Figure 1, Item 2) that attach each mounting rail (Figure 1, Items 1 and/or 3) to trailer chassis (Figure 1, Item 4). Verify that rivets with correct part number have been installed in appropriate locations.

11. Install 20 rivets (Figure 1, Item 2) into each aligned hole of mounting rail assembly (Figure 1, Items 1 and/or 3) before any rivets (Figure 1, Items 2 and 5) are cinched.
12. Install two rivets (Figure 1, Item 5) into each aligned hole of mounting rail assembly (Figure 1, Items 1 and/or 3).
13. Cinch 22 rivets (Figure 1, Items 2 and 5) to firmly attach mounting rail assembly (Figure 1, Items 1 and/or 3) to trailer chassis (Figure 1, Item 4).
14. Install generator set(s) (WP 0018, Remove/Install Generator Set).
15. Install center floor plate (WP 0021, Remove/Install Trailer Floor Plates, Platform, and Step).
16. Install accessory box (WP 0024, Remove/Install Accessory Box).

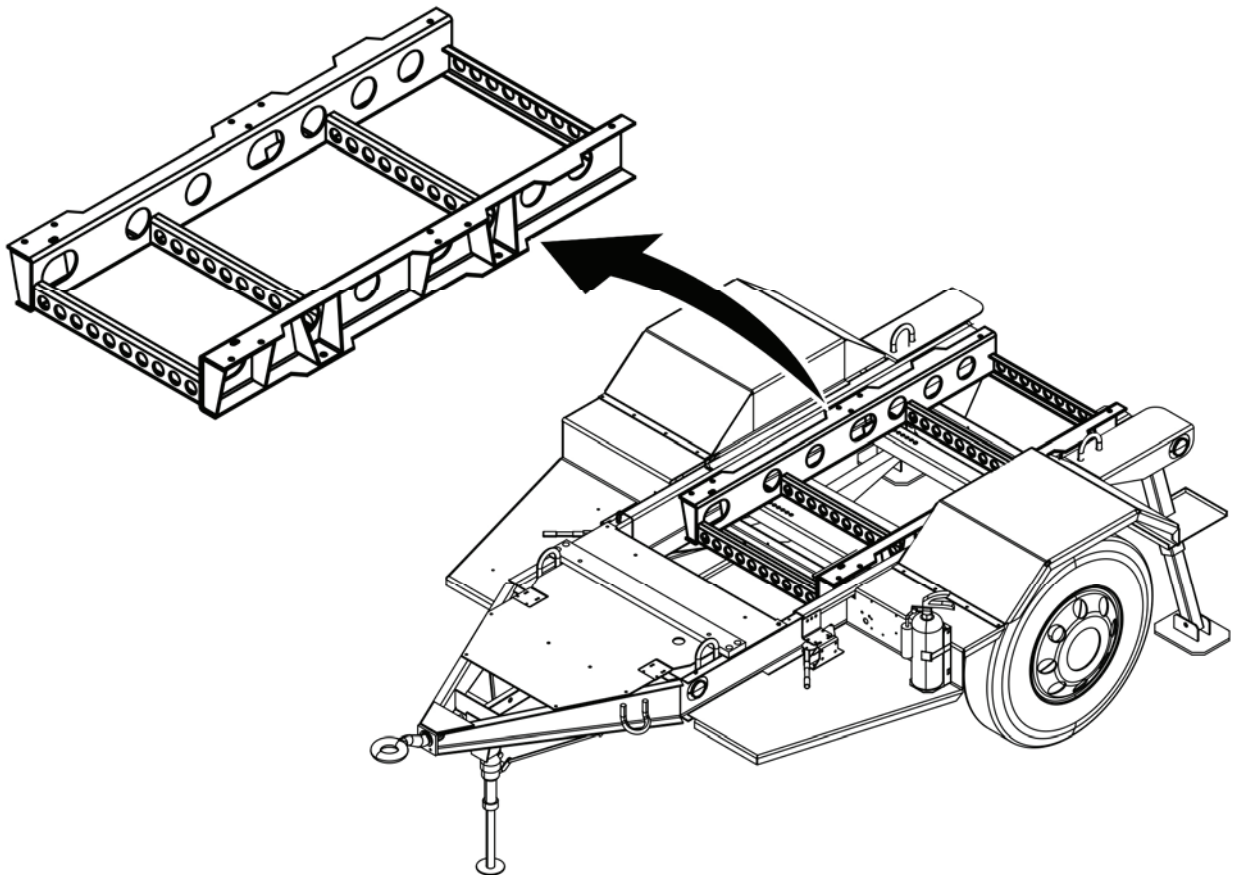
**END OF TASK****Replace Mounting Rail (PP-3102)**

**Figure 2. Mounting Rail PP-3102 — Location.**

1. Ensure equipment conditions are met in order presented in initial setup.
2. Remove generator sets (WP 0018, Remove/Install Generator Set).
3. Remove accessory box (WP 0024, Remove/Install Accessory Box).
4. Locate mounting rail (Figure 2).
5. Remove four bolts (Figure 3, Item 2), eight flat washers (Figure 3, Item 3), and four nylon lock nuts (Figure 3, Item 5) from mounting rail (Figure 3, Item 1).
6. Discard six nylon lock nuts (Figure 3, Item 5).
7. Remove mounting rail (Figure 3, Item 1).
8. Inspect trailer chassis (Figure 3, Item 4) where mounting rail (Figure 3, Item 1) was attached for any sign of damage. Repair or replace as required.
9. Align holes in replacement mounting rail (Figure 3, Item 1) with matching holes in trailer chassis (Figure 2, Item 2).
10. Install four bolts (Figure 3, Item 2), eight flat washers (Figure 3, Item 3), and four new nylon lock nuts (Figure 3, Item 5) at each aligned hole of the mounting rail (Figure 3, Item 1).

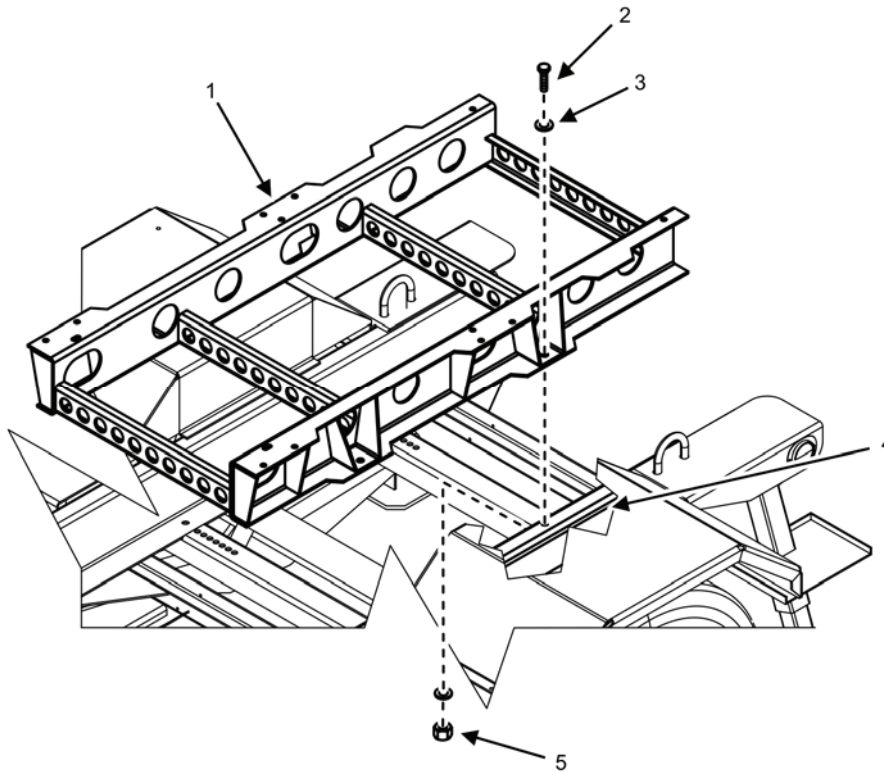

**Figure 3. Rail Assembly PP-3102 — Detail.**

11. Secure four nylon lock nuts (Figure 3, Item 5) to torque value of 191 – 233 ft/lb (259 – 316 Nm).
12. Install generator sets (WP 0018, Remove/Install Generator Set).
13. Install accessory box (WP 0024, Remove/Install Accessory Box).

**END OF TASK**

**END OF WORK PACKAGE**



---

**FIELD MAINTENANCE**  
**AMMPS 10KW TRAILER-MOUNTED POWER UNITS AND POWER PLANTS**  
**REPLACE TRAILER FENDER**

---

**INITIAL SETUP:****Test Equipment**

Not Applicable

**Tools and Special Tools**

Riveter Kit, Blind, Hand (WP 0057, Table 2, Item 7)

Tool Kit, Blind, Fastener, Installation (WP 0057, Table 2, Item 9)

Tool Kit, General Mechanic's (GMTK) (WP 0057, Table 2, Item 10)

Wrench, Torque, Click, Ratcheting, 3/8" Drive, 75 FT-LB (WP 0057, Table 2, Item 14)

**Materials/Parts**

Fender assembly (curbside) (1) (WP 0039, Figure 4, Item 1)

Fender assembly (roadside) (1) (WP 0039, Repair Parts List, Figure 4, Item 3)

Fender, vehicular (curbside) (1) (WP 0039, Figure 4, Item 4)

Fender, vehicular (roadside) (1) (WP 0039, Figure 4, Item 10)

Nut, self-locking, hexagon (18) (WP 0039, Figure 4, Item 17)

Rivet, blind, (6) (WP 0036, Figure 1, Item 17)

Rivet, blind, (2) (WP 0036, Figure 1, Item 19)

Rivet, blind (24) (WP 0039, Figure 4, Item 2)

**Materials/Parts**

Rivet, blind (8) (WP 0042, Figure 7, Item 2)

Rivet, blind, (12) (WP 0042, Figure 7, Item 4)

Strap, tiedown, electrical (4) (WP 0042, Figure 7, Item 1)

Washer, lock (2) (WP 0039, Figure 4, Item 9)

**Personnel Required**

91D (1)

Assistant (1)

**References**

WP 0022, Remove/Install Fire Extinguisher Bracket

WP 0024, Remove/Install Accessory Box

WP 0025, Remove/Install Switch Box Assembly

**Equipment Conditions**

Engine control switch OFF (TM 9-6115-750-10, WP 0005)

Wheels chocked, brakes applied (LTT – TM 9-2330-392-14&P), (M200A1 – TM 9-2330-205-14&P)

Front trailer support(s) deployed (LTT – TM 9-2330-392-14&P), (M200A1 – TM 9-2330-205-14&P)

Rear leg prop assembly deployed (WP 0005, Operation Under Usual Conditions)

Rear step jacks deployed (M200A1 – TM 9-2330-205-14&P)

---

**REPLACE TRAILER FENDER****WARNING**

Support components when removing/installing the attaching hardware or component may fall. Failure to comply may cause injury or death to personnel and damage to equipment.

**Replace Fender (PU-2002 and PU-2012)****NOTE**

Both roadside fender (Figure 2, Item 1) and curbside fender (Figure 2, Item 4) are removed and installed using the same procedure. Steps will vary according to which side fender will be removed/installed.

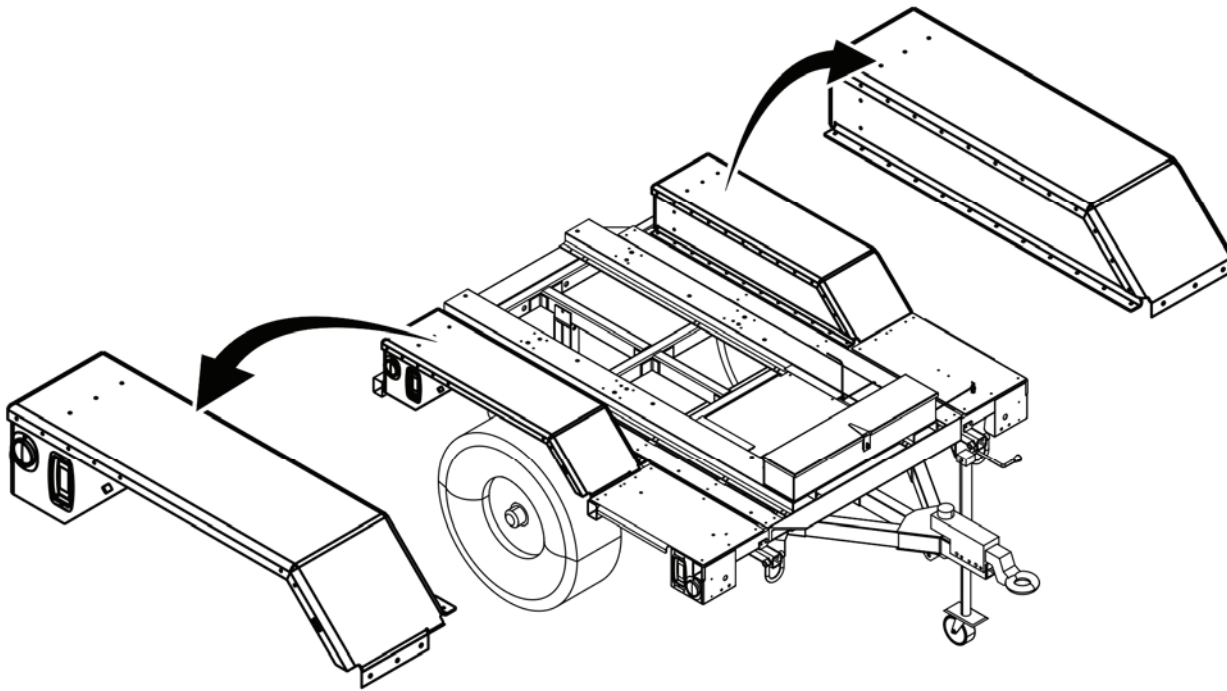

**Figure 1. Fender (PU-2002 and PU-2012) — Location.**

1. Ensure equipment conditions are met in order presented in initial setup.
2. Locate fender(s) (Figure 1).

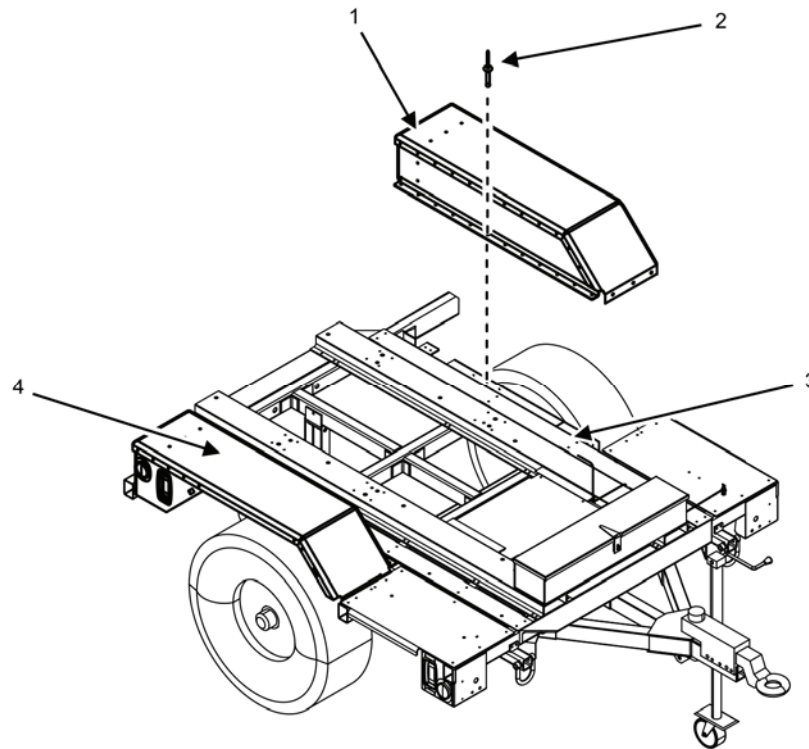

**Figure 2. Fender (PU-2002 and PU-2012) — Detail.**

**NOTE**

Step 3 only applies to the roadside fender (Figure 2, Item 1) for PU-2002 and PU-2012. Steps 4 – 6 only apply to the curbside fender (Figure 2, Item 4).

3. Remove fire extinguisher bracket (WP 0022, Remove/Install Fire Extinguisher Bracket) from roadside fender (Figure 2, Item 1) for PU-2002 or PU-2012.

**NOTE**

Steps 4 through 6 only apply to the curbside fender (Figure 3, Item 1). Proceed to step 7 if replacing roadside fender (Figure 2, Item 1).

4. Locate curbside fender (Figure 3, Item 1) ID labels (Figure 3, Items 2 and 4).
5. Remove six rivets (Figure 3, Item 3) from ID label (Figure 3, Item 2) and two rivets (Figure 3, Item 3) from ID label (Figure 3, Item 4).
6. Remove ID labels (Figure 3, Items 2 and 4) and set aside for installation.

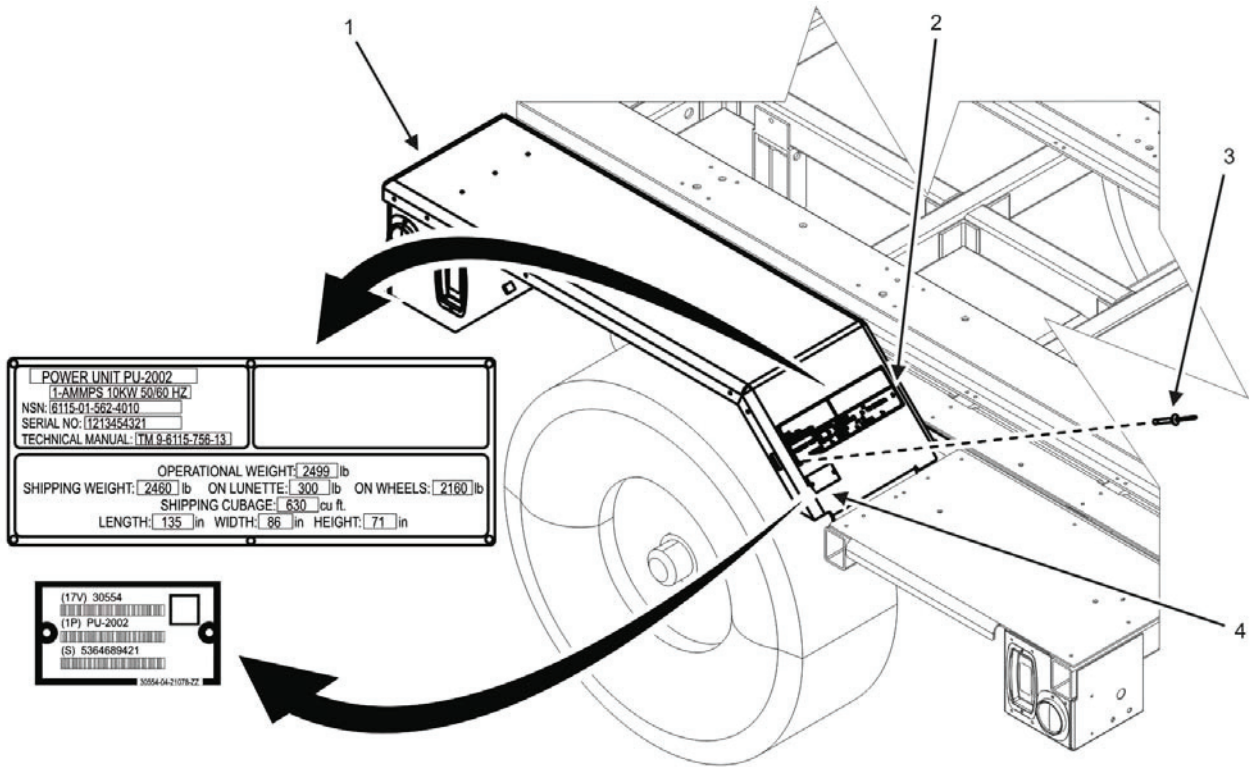

Figure 3. Curbside Fender ID Labels — Location.

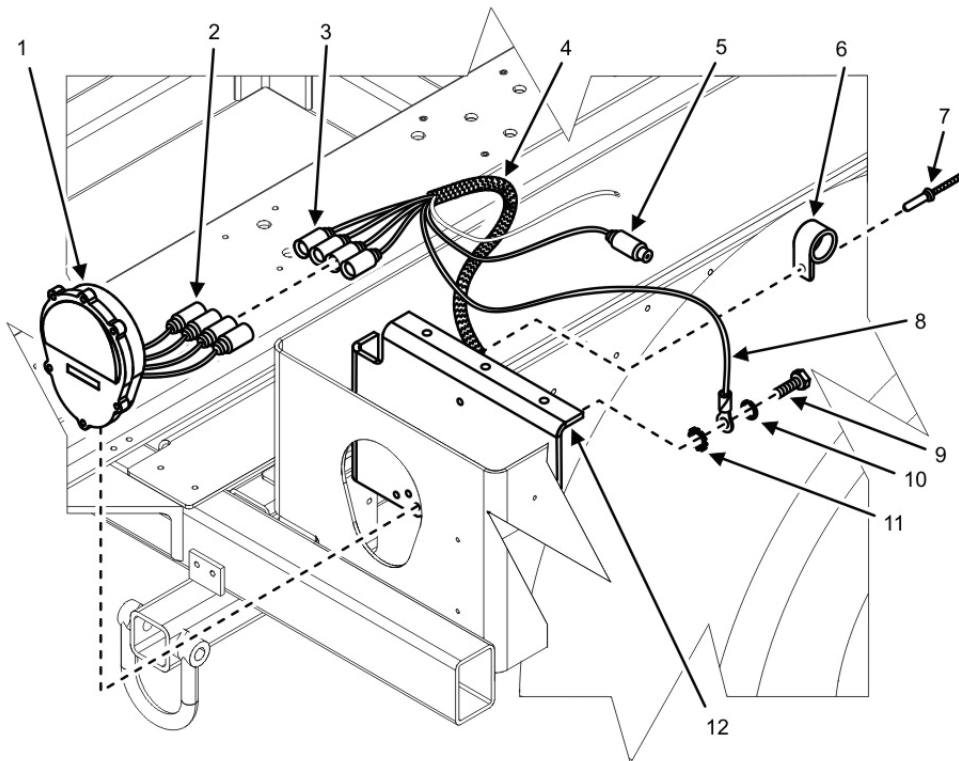
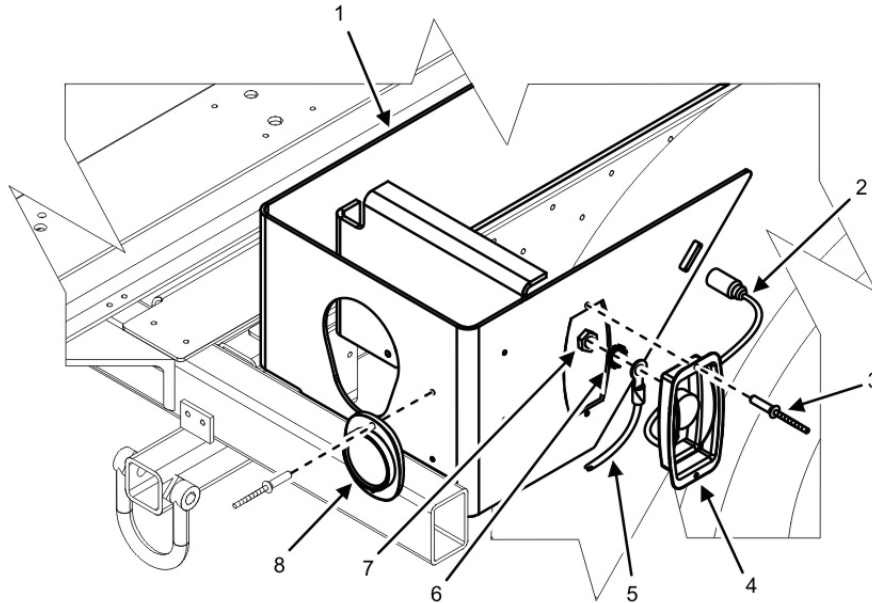

Figure 4. Rear Tail Light and Electrical Wiring — Detail.

**NOTE**

To assist during installation, tag or mark all electrical wires and connectors prior to removal.

7. Disconnect rear tail light connectors (Figure 4, Item 2) and rear marker light connector (Figure 5, Item 2) from trailer wiring harness connectors (Figure 4, Items 3 and 5).
8. Remove bolt (Figure 4, Item 9), lock washer (Figure 4, Item 10), ground terminal wire (Figure 4, Item 8), and external tooth lock washer (Figure 4, Item 11) that attach ground terminal wire (Figure 4, Item 8) to rear tail light (Figure 4, Item 1).
9. Detach ground terminal wire (Figure 4, Item 8) from bolt (Figure 4, Item 9).
10. Remove nut (Figure 5, Item 7) and external tooth lock washer (Figure 5, Item 6) that attach ground terminal wire (Figure 5, Item 5) to rear marker light (Figure 5, Item 4).
11. Detach ground terminal wire (Figure 5, Item 5) from rear marker light (Figure 5, Item 4).
12. Discard lock washers and external tooth lock washer (Figure 4, Items 10 and 11) (Figure 5, Item 6).
13. Remove two rivets (Figure 4, Item 7) from two clamps (Figure 4, Item 6) that attach trailer wiring harness (Figure 4, Item 4) to fender (Figure 4, Item 12).



**Figure 5. Reflector and Rear Marker Light and Electrical Wiring — Detail.**

**NOTE**

Assistance must be secured for step 14 and step 15.

14. Remove 18 rivets that attach fender (Figure 2, Items 1 and/or 4) to trailer chassis (Figure 2, Item 3).
15. Remove fender (Figure 2, Items 1 and/or 4) from trailer chassis (Figure 2, Item 3) and place on a suitable work surface.
16. Support rear tail light (Figure 4, Item 1).
17. Remove bolt without ground terminal wire (Figure 4, Item 8), lock washer (Figure 4, Item 10), and external tooth lock washer (Figure 4, Item 11) that attach rear tail light (Figure 4, Item 1) to fender (Figure 4, Item 12). Note orientation of bolt for installation.

18. Inspect rear tail light (Figure 4, Item 1) for damage. Repair or replace as required.
19. Remove six rivets (Figure 5, Item 3) that attach two reflectors (Figure 5, Item 8) and rear marker light (Figure 5, Item 4) to fender (Figure 5, Item 1).
20. Inspect two reflectors (Figure 5, Item 8) and rear marker light (Figure 5, Item 4) for damage. Repair or replace as required.
21. Inspect trailer chassis (Figure 2, Item 3) where fender (Figure 2, Items 1 and/or 4) was attached for any sign of damage. Repair or replace as required.
22. Place replacement fender (Figure 4, Item 12) on a suitable work surface.
23. Align holes of one reflector (Figure 5, Item 8) with matching holes on fender (Figure 5, Item 1).
24. Install one rivet (Figure 5, Item 3) into each aligned hole of first reflector (Figure 5, Item 8) before any rivets (Figure 5, Item 3) are cinched.
25. Cinch two rivets (Figure 5 item 3) to firmly attach reflector (Figure 5, Item 8) to fender (Figure 5, Item 1).
26. Repeat steps 23 – 25 for second reflector (Figure 5, Item 8).
27. Align holes of rear marker light (Figure 5, Item 4) with matching holes on fender (Figure 5, Item 1).
28. Install one rivet (Figure 5, Item 3) into each aligned hole of rear marker light (Figure 5, Item 4) before any rivets (Figure 5, Item 3) are cinched.
29. Cinch two rivets (Figure 5, Item 3) to firmly attach rear marker light (Figure 5, Item 4) to fender (Figure 5, Item 1).
30. Align holes of rear tail light (Figure 4, Item 1) with holes on fender (Figure 4, Item 12).
31. Install bolt (Figure 4, Item 9), new lock washer (Figure 4, Item 10), and new external tooth lock washer (Figure 4, Item 11) into aligned hole IAW orientation noted in step 17.
32. Position and align holes in fender (Figure 2, Items 1 and/or 4) with matching holes in trailer chassis (Figure 2, Item 3).
33. Install 18 rivets (Figure 2, Item 2) into each aligned hole of the fender (Figure 2, Items 1 and/or 4) before any rivets are cinched.
34. Cinch 18 rivets (Figure 2, Item 2) to firmly attach fender (Figure 2, Items 1 and/or 4) to trailer chassis (Figure 2, Item 3).
35. Install and cinch one rivet (Figure 4, Item 7) for each of two clamps (Figure 4, Item 6) that attach trailer wiring harness (Figure 4, Item 4) to fender (Figure 4, Item 12).
36. Connect rear marker light ground terminal wire (Figure 5, Item 5) to rear marker light (Figure 5, Item 4) with new external tooth lock washer (Figure 5, Item 6) and nut (Figure 5, Item 7).
37. Install new lock washer (Figure 4, Item 10), ground terminal wire (Figure 4, Item 8), new external tooth lock washer (Figure 4, Item 11), and bolt (Figure 4, Item 9) IAW sequence shown in Figure 4 into aligned hole of rear tail light (Figure 4, Item 1) and fender (Figure 4, Item 12).
38. Connect rear tail light connectors (Figure 4, Item 2) and rear marker light connector (Figure 5, Item 2) to trailer wiring harness connectors (Figure 4, Items 3 and 5).

## NOTE

Steps 39 – 44 only apply to the curbside fender (Figure 3, Item 1).

39. Align holes of ID label (Figure 3, Item 2) with matching holes on curbside fender (Figure 3, Item 1).
40. Install one rivet (Figure 3, Item 3) into each aligned hole before any rivets (Figure 3, Item 3) are cinched.
41. Cinch six rivets (Figure 3, Item 3) to firmly attach ID label (Figure 3, Item 2) to curbside fender (Figure 3, Item 1).

42. Align holes of ID label (Figure 3, Item 4) with matching holes on curbside fender (Figure 3, Item 1).
43. Install one rivet (Figure 3, Item 3) into each aligned hole before any rivets (Figure 3, Item 3) are cinched.
44. Cinch two rivets (Figure 3, Item 3) to firmly attach ID label (Figure 3, Item 4) to curbside fender (Figure 3, Item 1).

### NOTE

Step 45 only applies to the roadside fender (Figure 2, Item 1).

45. Install fire extinguisher bracket (WP 0022, Remove/Install Fire Extinguisher Bracket) on roadside fender (Figure 2, Item 1) for PU-2002 or PU-2012.

### END OF TASK

### Replace Fender (PP-3102)

### NOTE

Both roadside fender (Figure 7, Item 2) and curbside fender (Figure 7, Item 1) are removed and installed using the same procedure.

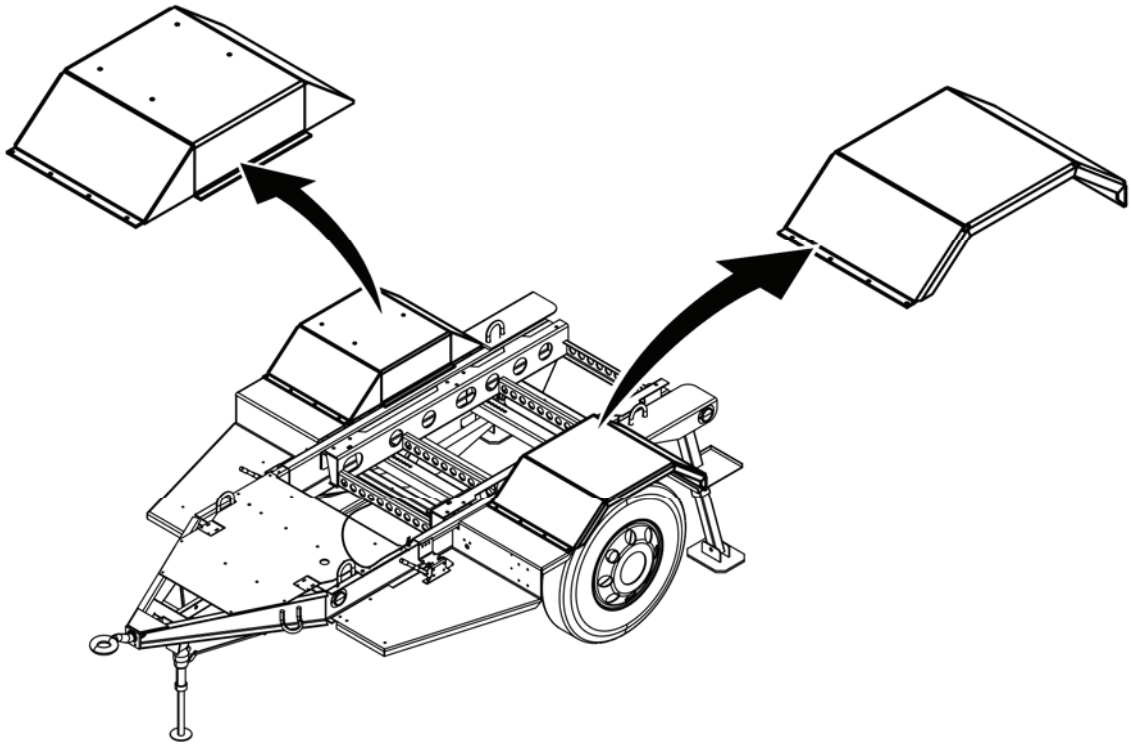
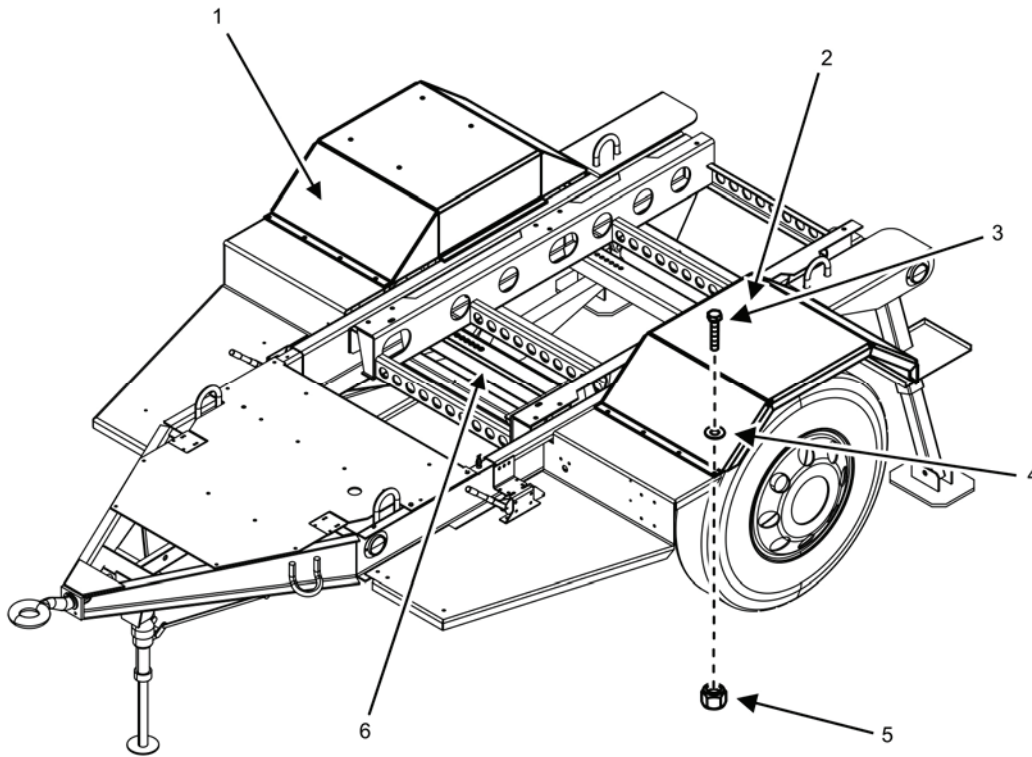

Figure 6. Fender (PP-3102) — Location.



**Figure 7. Fender (PP-3102) — Detail.**

1. Ensure equipment conditions are met in order presented in initial setup.
2. Locate fender(s) (Figure 6).

### NOTE

Assistance must be secured for steps 3 through 5 and steps 7 through 9.

Step 3 only applies to curbside fender (Figure 7, Item 1). Proceed to step 4 if replacing roadside fender (Figure 7, Item 2).

3. Remove switch box assembly (WP 0025, Remove/Install Switch Box Assembly) from curbside fender (Figure 7, Item 1).
4. Remove 10 bolts (Figure 7, Item 3), 20 flat washers (Figure 7, Item 4), and 10 nylon lock nuts (Figure 7, Item 5) that attach fender (Figure 7, Items 1 and/or 2) to trailer chassis (Figure 7, Item 6).
5. Discard 10 nylon lock nuts (Figure 7, Item 5).
6. Remove fender (Figure 7, Items 1 and/or 2) from trailer chassis (Figure 7, Item 6).
7. Inspect trailer chassis (Figure 7, Item 6) where fender (Figure 7, Items 1 and/or 2) was attached for any sign of damage. Repair or replace as required.
8. Align holes in replacement fender (Figure 7, Items 1 and/or 2) with matching holes in trailer chassis (Figure 7, Item 6).
9. Install 10 bolts (Figure 7, Item 3), 20 flat washers (Figure 7, Item 4), and 10 new nylon lock nuts (Figure 7, Item 5) at each aligned hole.



10. Secure 10 nylon lock nuts (Figure 7, Item 5) to torque value of 22 – 27 ft/lb (30 – 37 Nm).
11. Install switch box (WP 0025, Remove/Install Switch Box Assembly) if removed.

**END OF TASK**

**END OF WORK PACKAGE**



---

**FIELD MAINTENANCE**  
**AMMPS 10KW TRAILER-MOUNTED POWER UNITS AND POWER PLANTS**  
**REMOVE/INSTALL TRAILER FLOOR PLATES, PLATFORM, AND STEP**

---

**INITIAL SETUP:****Test Equipment**

Not Applicable

**Tools and Special Tools**

Riveter Kit, Blind, Hand (WP 0057, Table 2, Item 7)  
 Tool Kit, Blind, Fastener, Installation (WP 0057, Table 2, Item 9)  
 Tool Kit, General Mechanic's (GMTK) (WP 0057, Table 2, Item 10)  
 Wrench, Torque, Dial, 3/8" Drive, 300 IN-LB (WP 0057, Table 2, Item 15)

**Materials/Parts**

Floor, center (1) (WP 0040, Repair Parts List, Figure 5, Item 6)  
 Floor, side, inner (curbside) (1) (WP 0040, Figure 5, Item 7)  
 Floor, side, inner (roadside) (1) (WP 0040, Figure 5, Item 12)  
 Nut, self-locking, hexagon (32) (WP 0040, Figure 5, Item 21)  
 Platform, front (1) (WP 0040, Figure 5, Item 14)  
 Pin, quick release (42) (WP 0040, Figure 5, Item 5)  
 Rail, mounting (curbside) (1) (WP 0040, Figure 5, Item 1)  
 Rail, mounting (roadside) (1) (WP 0040, Figure 5, Item 4)  
 Rivet, blind (6) (WP 0036, Repair Parts List, Figure 1, Item 31)

**Materials/Parts**

Rivet, blind (2) (WP 0036, Figure 1, Item 32)  
 Rivet, blind (4) (WP 0040, Figure 5, Item 2)  
 Step, front, curbside (1) (WP 0040, Figure 5, Item 13)  
 Step, front, roadside (1) (WP 0040, Figure 5, Item 22)

**Personnel Required**

91D (1)  
 Assistant (1)

**References**

WP 0018, Remove/Install Generator Set  
 WP 0022, Remove/Install Fire Extinguisher Bracket  
 WP 0023, Remove Install Ground Terminal  
 WP 0024, Remove/Install Accessory Box  
 WP 0030, Remove/Install Hand Brake Modification

**Equipment Conditions**

Engine control switch OFF (TM 9-6115-750-10, WP 0005)  
 Wheels chocked, brakes applied (LTT – TM 9-2330-392-14&P), (M200A1 – TM 9-2330-205-14&P)  
 Front trailer support(s) deployed (LTT – TM 9-2330-392-14&P), (M200A1 – TM 9-2330-205-14&P)  
 Rear leg prop assembly deployed (WP 0005, Operation Under Usual Conditions)  
 Rear step jacks deployed (M200A1 – TM 9-2330-205-14&P)

---

**REMOVE/INSTALL TRAILER FLOOR PLATES, PLATFORM, AND STEP****WARNING**

- The component being lifted weighs greater than 40 lb (18.14 kg). Two personnel or a suitable lifting device are necessary to lift component. Failure to comply may cause injury or death to personnel.
- Support components when removing/installing the attaching hardware or component may fall. Failure to comply may cause injury or death to personnel and damage to equipment.

**Remove Center Floor Plate (PU-2002 and PU-2012)**

Figure 1. Trailer PU-2002 and PU-2012 Floor Plates — Location.

1. Ensure equipment conditions are met in order presented in initial setup.
2. Locate center floor plate (Figure 1, Item 5).
3. Remove accessory box (WP 0024, Remove/Install Accessory Box) from PU-2002 or PU-2012.
4. Remove eight rivets (Figure 1, Item 3) that attach center floor plate (Figure 1, Item 5) to trailer chassis (Figure 1, Item 1).
5. Remove center floor plate (Figure 1, Item 5).

**END OF TASK****Inspect Center Floor Plate (PU-2002 and PU-2012)**

1. Inspect center floor plate (Figure 1, Item 5) for cracks or other signs of weakness. Replace as required.
2. Inspect trailer chassis (Figure 1, Item 1) for any sign of damage where center floor plate (Figure 1, Item 5) was attached. Repair or replace as required.

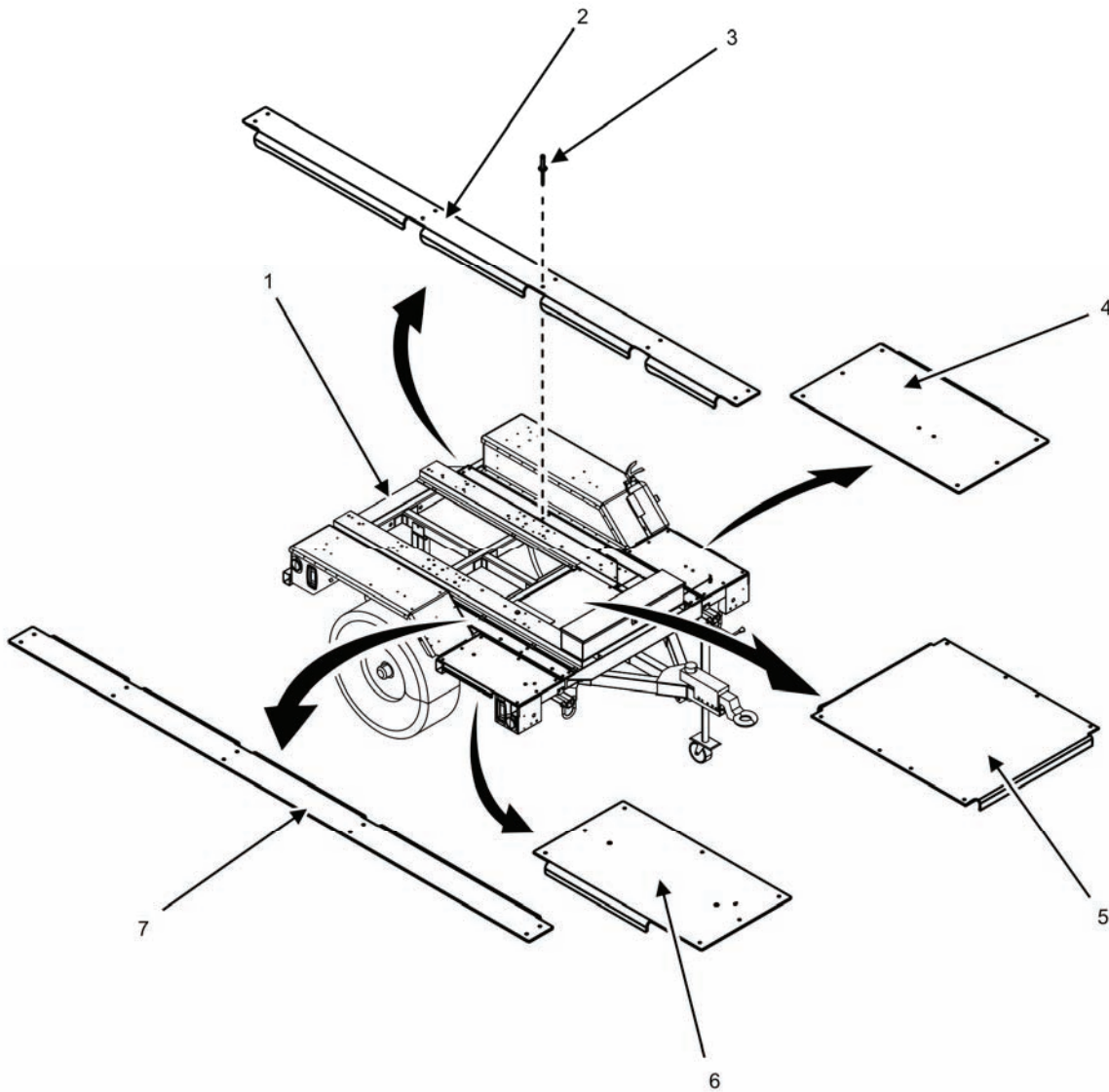
**END OF TASK****Install Center Floor Plate (PU-2002 and PU-2012)**

1. Align holes in center floor plate (Figure 1, Item 5) with matching holes on trailer chassis (Figure 1, Item 1).
2. Install eight rivets (Figure 1, Item 3) into each aligned hole before any rivets (Figure 1, Item 3) are cinched.
3. Cinch eight rivets (Figure 1, Item 3) to center floor plate (Figure 1, Item 5) and trailer chassis (Figure 1, Item 1).
4. Install accessory box (WP 0024, Remove/Install Accessory Box) to PU-2002 or PU-2012.

**END OF TASK****Remove Inner Side Floor Plate (PU-2002 and PU-2012)****NOTE**

Both the roadside inner side floor plate (Figure 1, Item 2) and curbside inner side floor plate (Figure 1, Item 7) use the same procedure to remove and install.

1. Ensure equipment conditions are met in order presented in initial setup.
2. Locate inner side floor plate (Figure 1, Items 2 and/or 7).
3. Remove 10 rivets (Figure 1, Item 3) that attach inner side floor plate (Figure 1, Items 2 and/or 7) to trailer chassis (Figure 1, Item 1).
4. Remove inner side floor plate (Figure 1, Items 2 and/or 7).

**END OF TASK**

**Inspect Inner Side Floor Plate (PU-2002 and PU-2012)**

1. Inspect inner side floor plate (Figure 1, Items 2 and/or 7) for cracks or other signs of weakness. Replace as required.
2. Inspect trailer chassis (Figure 1, Item 1) where inner side floor plate (Figure 1, Items 2 and/or 7) was attached for any sign of damage. Repair or replace as required.

**END OF TASK****Install Inner Side Floor Plate (PU-2002 and PU-2012)**

1. Align holes in inner side floor plate (Figure 1, Items 2 and/or 7) with matching holes in trailer chassis (Figure 1, Item 1).
2. Install 10 rivets (Figure 1, Item 3) into each aligned hole before any rivets (Figure 1, Item 3) are cinched.
3. Cinch 10 rivets (Figure 1, Item 3) to inner side floor plate (Figure 1, Items 2 and/or 7) and trailer chassis (Figure 1, Item 1).

**END OF TASK****Remove Side Floor Plate (PU-2002 and PU-2012)****NOTE**

Both the roadside side floor plate (Figure 1, Item 4) and curbside side floor plate (Figure 1, Item 6) use the same procedure to remove and install.

1. Ensure equipment conditions are met in order presented in initial setup.
2. Locate side floor plate (Figure 1, Items 4 and/or 6).
3. Remove fire extinguisher bracket (WP 0022, Remove/Install Fire Extinguisher Bracket).
4. Remove ground terminal (WP 0023, Remove/Install Ground Terminal).
5. Remove seven rivets (Figure 1, Item 3) that attach side floor plate (Figure 1, Items 4 and/or 6) to trailer chassis (Figure 1, Item 1).
6. Remove side floor plate (Figure 1, Items 4 and/or 6).

**END OF TASK****Inspect Side Floor Plate (PU-2002 and PU-2012)**

1. Inspect side floor plate (Figure 1, Items 4 and/or 6) for cracks or other signs of weakness. Replace as required.
2. Inspect trailer chassis (Figure 1, Item 1) where side floor plate (Figure 1, Items 4 and/or 6) was attached for any sign of damage. Repair or replace as required.

**END OF TASK****Install Side Floor Plate (PU-2002 and PU-2012)**

1. Align holes in replacement side floor plate (Figure 1, Items 4 and/or 6) with matching holes in trailer chassis (Figure 1, Item 1).
2. Install seven rivets (Figure 1, Item 3) into each aligned hole before any rivets (Figure 1, Item 3) are cinched.

3. Cinch seven rivets (Figure 1, Item 3) to side floor plate (Figure 1, Items 4 and/or 6) and trailer chassis (Figure 1, Item 1).
4. Install fire extinguisher bracket (WP 0022, Remove/Install Fire Extinguisher Bracket).
5. Install ground terminal (WP 0023, Remove/Install Ground Terminal).

**END OF TASK**

**Remove Platform (PP-3102)**

1. Ensure equipment conditions are met in order presented in initial setup.

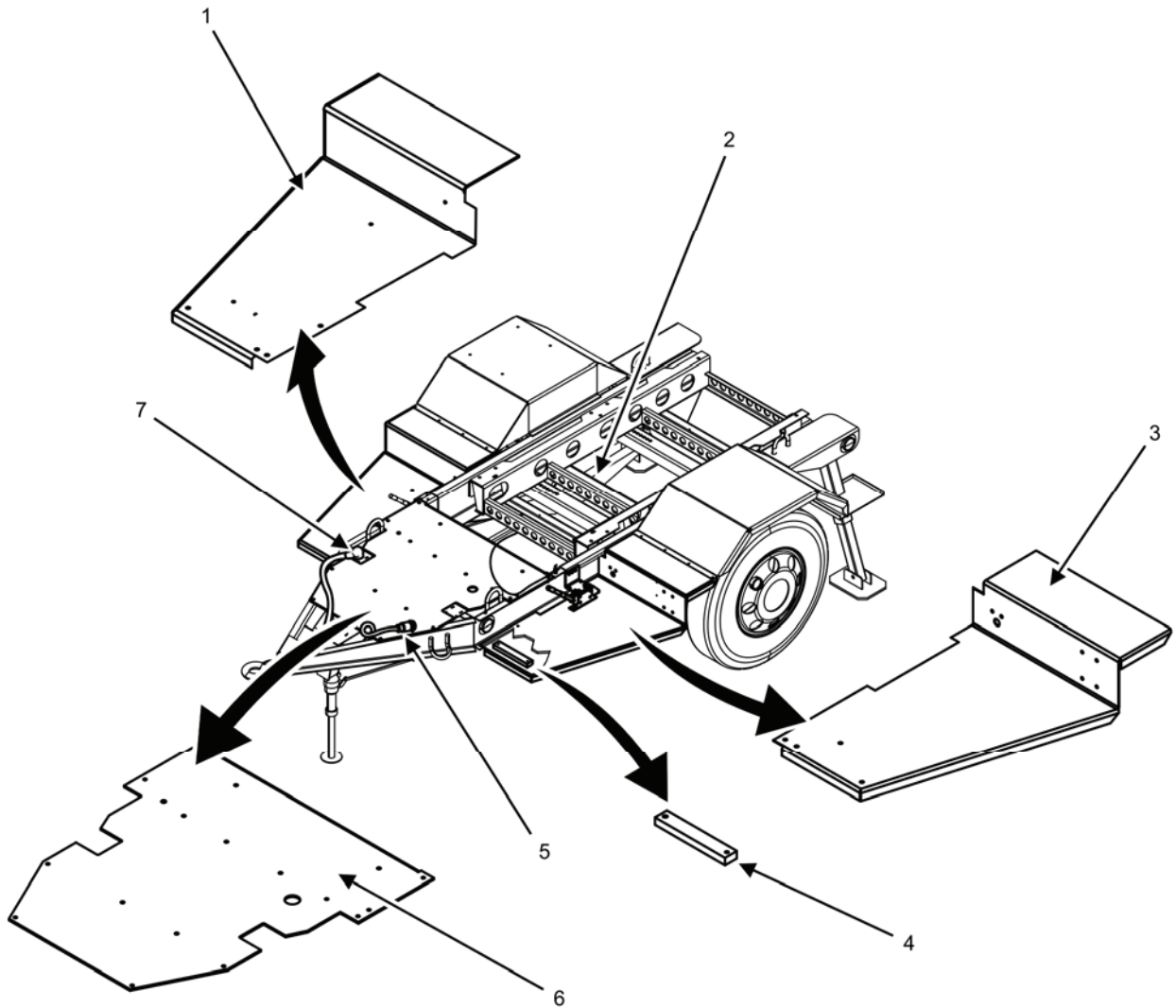

**Figure 2. Trailer PP-3102, Platform and Step — Location.**

2. Remove UNIT B generator (WP 0018, Remove/Install Generator Set).
3. Locate platform (Figure 2, Item 6).
4. Locate trailer lights cable and plug clamp (Figure 2, Item 5).

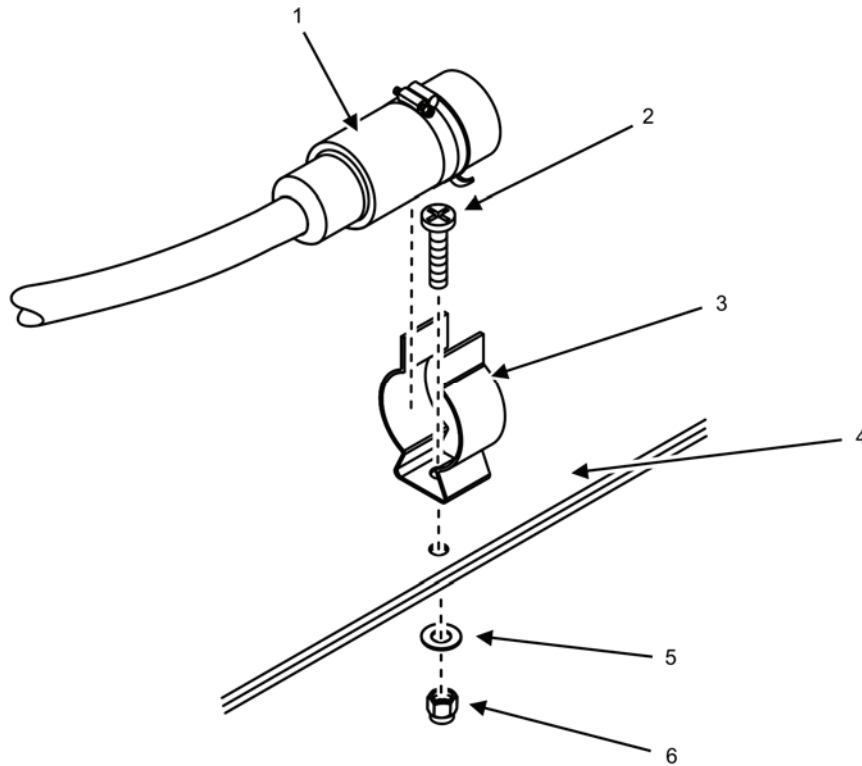

**Figure 3. Trailer Lights Cable and Plug Clamp — Detail.**

5. Remove trailer lights cable and plug (Figure 3, Item 1) from clamp (Figure 3, Item 3).
6. Set trailer lights cable and plug (Figure 3, Item 1) aside to protect from damage and to prevent interference.
7. Remove screw (Figure 3, Item 2), flat washer (Figure 3, Item 5), nylon lock nut (Figure 3, Item 6), and clamp (Figure 3, Item 3) from front platform/chassis mounting location (Figure 3, Item 4).
8. Set clamp (Figure 3, Item 3) aside for reuse.
9. Discard nylon lock nut (Figure 3, Item 6).



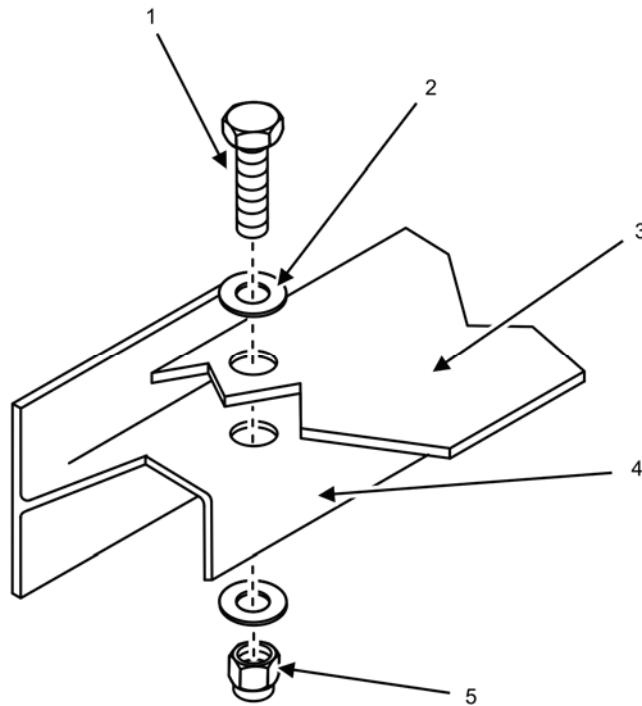

**Figure 4. Platform, Step, and Chassis — Detail.**

10. Remove curbside air brake line fitting (Figure 2, Item 7) from storage bracket.
11. Cover open air brake line fitting (Figure 2, Item 7) to prevent entry of contamination.
12. Set air brake line fitting (Figure 2, Item 7) aside to protect from damage and to prevent interference.
13. Remove 8 bolts (Figure 4, Item 1), 16 flat washers (Figure 4, Item 2), and 8 nylon lock nuts that attach platform (Figure 2, Item 6) (Figure 4, Item 3) to trailer chassis (Figure 2, Item 2) (Figure 4, Item 4).
14. Discard nylon lock nuts (Figure 4, Item 5).
15. Remove platform (Figure 2, Item 6).
16. Set platform spacer (Figure 2, Item 4) aside for reuse.

**END OF TASK**

**Inspect Platform (PP-3102)**

1. Inspect platform (Figure 2, Item 6) for cracks or other signs of weakness. Replace as required.
2. Inspect trailer chassis (Figure 2, Item 2) where platform (Figure 2, Item 6) was attached for any sign of damage. Repair or replace as required.

**END OF TASK**

---

**Install Platform (PP-3102)**

1. Align holes in platform (Figure 2, Item 6) with matching holes in trailer chassis (Figure 2, Item 2).
2. Install 8 bolts (Figure 4, Item 1), 16 flat washers (Figure 4, Item 2), and 8 new nylon lock nuts (Figure 4, Item 5) into each aligned hole.
3. Secure eight new nylon lock nuts to torque value of 22 – 27 ft/lb (30 – 37 Nm).
4. Remove cover placed on air brake line fitting (Figure 2, Item 7).
5. Return curbside air brake line fitting (Figure 2, Item 7) to storage bracket.
6. Install clamp (Figure 3, Item 3) with screw (Figure 3, Item 2), flat washer (Figure 3, Item 5), and nylon lock nut (Figure 3, Item 6) at platform/chassis mounting location (Figure 3, Item 4).
7. Install trailer lights cable and plug (Figure 3, Item 1) to clamp (Figure 3, Item 3).

**END OF TASK****Remove Step (PP-3102)****NOTE**

Both roadside step (Figure 2, Item 3) and curbside step (Figure 2, Item 1) use the same procedure to remove and install. Steps will vary according to which step will be removed or installed.

1. Ensure equipment conditions are met in order presented in initial setup.
2. Locate step (Figure 2, Items 1 and/or 3).

**NOTE**

Step 3 applies only to roadside step (Figure 2, Item 3) for PP-3102 configuration. Step 4 applies only to curbside step (Figure 2, Item 1) for PP-3102 configuration.

3. Remove fire extinguisher bracket (WP 0022, Remove/Install Fire Extinguisher Bracket) from roadside step.
4. Remove P-clamp that attaches switch box wiring harness to trailer (WP 0028, Remove/Install Switch Box Wiring Harness) from curbside step.
5. Remove hand brake bracket (WP 0030, Remove/Install Hand Brake Modification).

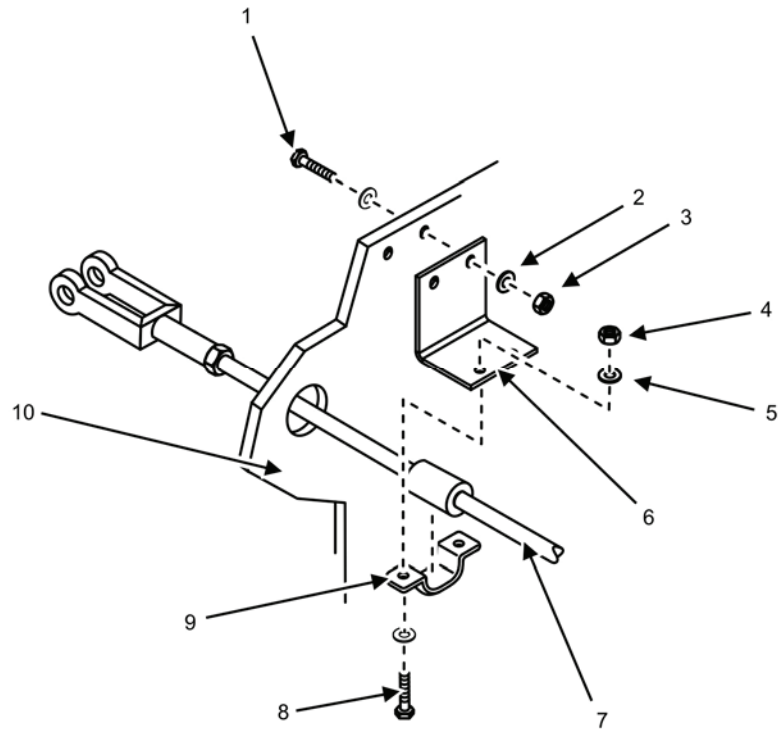

**Figure 5. Brake Cable Bracket — Detail.**

6. Remove two bolts (Figure 5, Item 8), four washers (Figure 5, Item 5), two nylon lock nuts (Figure 5, Item 4), and brake cable clamp (Figure 5, Item 9) that attach brake cable (Figure 5, Item 7) to brake cable bracket (Figure 5, Item 6).
7. Discard two nylon lock nuts (Figure 5, Item 4).
8. Set brake cable clamp (Figure 5, Item 9) aside for reuse.
9. Remove any restraining object that was applied to prevent brake cable (Figure 5, Item 7) from being withdrawn through step (Figure 5, Item 10).
10. Withdraw brake cable (Figure 5, Item 7) through step (Figure 5, Item 10).
11. Set brake cable (Figure 5, Item 7) aside to protect from damage and to prevent interference.
12. Remove two bolts (Figure 5, Item 1), four washers (Figure 5, Item 2), and two nylon lock nuts (Figure 5, Item 3) that attach brake cable bracket (Figure 5, Item 6) to step (Figure 5, Item 10).
13. Discard two nylon lock nuts (Figure 5, Item 3).
14. Set brake cable bracket (Figure 5, Item 6) aside for reuse.

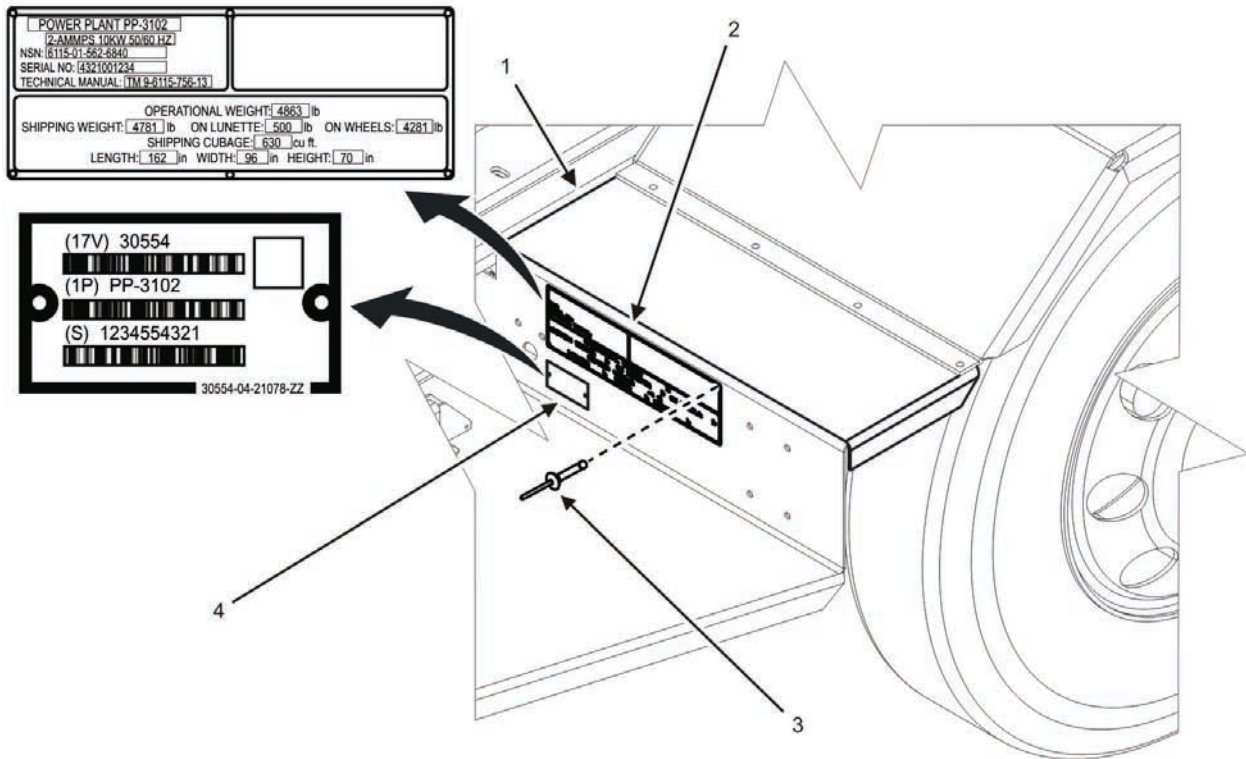

Figure 6. ID Plates — Detail.

### NOTE

Steps 15 through 17 apply only to roadside step (Figure 6, Item 1) for PP-3102 configuration when roadside step (Figure 6, Item 1) will be replaced.

15. Remove eight rivets (Figure 6, Item 3) that attach identification plates (Figure 6, Items 2 and 4) to roadside step (Figure 2, Item 3).
16. Remove identification plates (Figure 6, Items 2 and 4) from roadside step (Figure 2, Item 3).
17. Set identification plates (Figure 6, Items 2 and 4) aside for installation of roadside step (Figure 2, Item 3).
18. Remove 10 bolts (Figure 4, Item 1), 20 flat washers (Figure 4, Item 2), and 10 nylon lock nuts (Figure 4, Item 5) that attach step (Figure 2, Items 1 and/or 3) to trailer chassis (Figure 2, Item 2).
19. Discard 10 nylon lock nuts (Figure 4, Item 5).
20. Remove step (Figure 2, Items 1 and/or 3).

### END OF TASK

#### Inspect Step (PP-3102)

1. Inspect step (Figure 2, Items 1 and/or 3) for cracks or other signs of weakness. Replace as required.
2. Inspect trailer chassis (Figure 2, Item 2) where step (Figure 2, Items 1 and/or 3) was attached for any sign of damage. Repair or replace as required.

### END OF TASK

---

**Install Step (PP-3102)**

1. Align holes in step (Figure 2, Items 1 and/or 3) with matching holes in trailer chassis (Figure 2, Item 2).
2. Install 10 bolts (Figure 4, Item 1), 20 flat washers (Figure 4, Item 2), and 10 new nylon lock nuts (Figure 4, Item 5) into each aligned hole.
3. Secure 10 new nylon lock nuts (Figure 4, Item 5) to torque value of 22 – 27 ft/lb (30 – 37 Nm).

**NOTE**

Steps 4 through 9 apply only to roadside step (Figure 6, Item 1) for PP-3102 configuration if the roadside step (Figure 6, Item 1) has been replaced.

4. Align holes in identification plate (Figure 6, Item 2) with matching holes in roadside step (Figure 6, Item 1).
5. Install six rivets (Figure 6, Item 3) into aligned holes before cinching any rivets (Figure 6, Item 3).
6. Cinch six rivets (Figure 6, Item 3) to identification plate (Figure 6, Item 2) and roadside step (Figure 6, Item 1).
7. Align holes in identification plate (Figure 6, Item 4) with matching holes in roadside step (Figure 6, Item 1).
8. Install two rivets (Figure 6, Item 3) into aligned holes before cinching any rivet (Figure 6, Item 3).
9. Cinch rivets (Figure 6, Item 3) to identification plate (Figure 6, Item 4) and roadside step (Figure 6, Item 1).
10. Align holes in brake cable bracket (Figure 5, Item 6) with matching holes in step (Figure 5, Item 10).
11. Install two bolts (Figure 5, Item 1), four washers (Figure 5, Item 2), and two new nylon lock nuts (Figure 5, Item 3) that attach brake cable bracket (Figure 5, Item 6) to step (Figure 5, Item 10).
12. Secure two new nylon lock nuts (Figure 5, Item 3) to torque value of 22 – 27 ft/lb (30 – 37 Nm).
13. Insert brake cable (Figure 5, Item 7) through step (Figure 5, Item 10).
14. Position brake cable clamp (Figure 5, Item 9) onto brake cable (Figure 5, Item 7) and align holes in brake cable clamp (Figure 5, Item 9) with matching holes in brake cable bracket (Figure 5, Item 6).
15. Install two bolts (Figure 5, Item 8), four washers (Figure 5, Item 5), and two new nylon lock nuts (Figure 5, Item 4) that attach brake cable (Figure 5, Item 7) to brake cable bracket (Figure 5, Item 6).
16. Secure two new nylon lock nuts (Figure 5, Item 4) to torque value of 22 – 27 ft/lb (30 – 37 Nm).
17. Install hand brake bracket (WP 0030, Remove/Install Hand Brake Bracket).

**NOTE**

Step 18 applies only to curbside step (Figure 2, Item 1) for PP-3102 configuration. Step 19 applies only to roadside step (Figure 2, Item 3) for PP-3102 configuration.

18. Install P-clamp that attaches switch box wiring harness to trailer (WP 0028, Remove Switch Box Wiring Harness) on curbside step.
19. Install fire extinguisher bracket (WP 0022, Remove/Install Fire Extinguisher Bracket) on roadside step.

**END OF TASK****END OF WORK PACKAGE**



---

**FIELD MAINTENANCE**  
**AMMPS 10KW TRAILER-MOUNTED POWER UNITS AND POWER PLANTS**  
**REMOVE/INSTALL FIRE EXTINGUISHER BRACKET**

---

**INITIAL SETUP:****Test Equipment**

Not Applicable

**Tools and Special Tools**

Tool Kit, General Mechanic's (GMTK) (WP 0057, Table 2, Item 10)

Wrench, Torque, Dial, 3/8" Drive, 300 IN-LB (WP 0057, Table 2, Item 15)

**Materials/Parts**

Bracket, fire extinguisher (1) (WP 0038, Repair Parts List, Figure 3, Item 1)

Nut, self-locking, hexagon (4) (WP 0038, Figure 3, Item 4)

**Personnel Required**

91D (1)

**References**

Not Applicable

**Equipment Conditions**

Engine control switch OFF (TM 9-6115-750-10, WP 0005)

Wheels chocked, brakes applied (LTT – TM 9-2330-392-14&amp;P), (M200A1 – TM 9-2330-205-14&amp;P)

Front trailer support deployed (LTT – TM 9-2330-392-14&amp;P), (M200A1 – TM 9-2330-205-14&amp;P)

Rear leg prop assembly deployed (WP 0005, Operation Under Usual Conditions)

Rear step jacks deployed (M200A1 – TM 9-2330-205-14&amp;P)

---

**REMOVE/INSTALL FIRE EXTINGUISHER BRACKET****NOTE**

PU-2002, PU-2012, and PP-3102 trailer fire extinguisher brackets use the same procedure and hardware to remove and install. The location difference is shown in Figure 1 and Figure 2.

**Remove Fire Extinguisher Bracket**

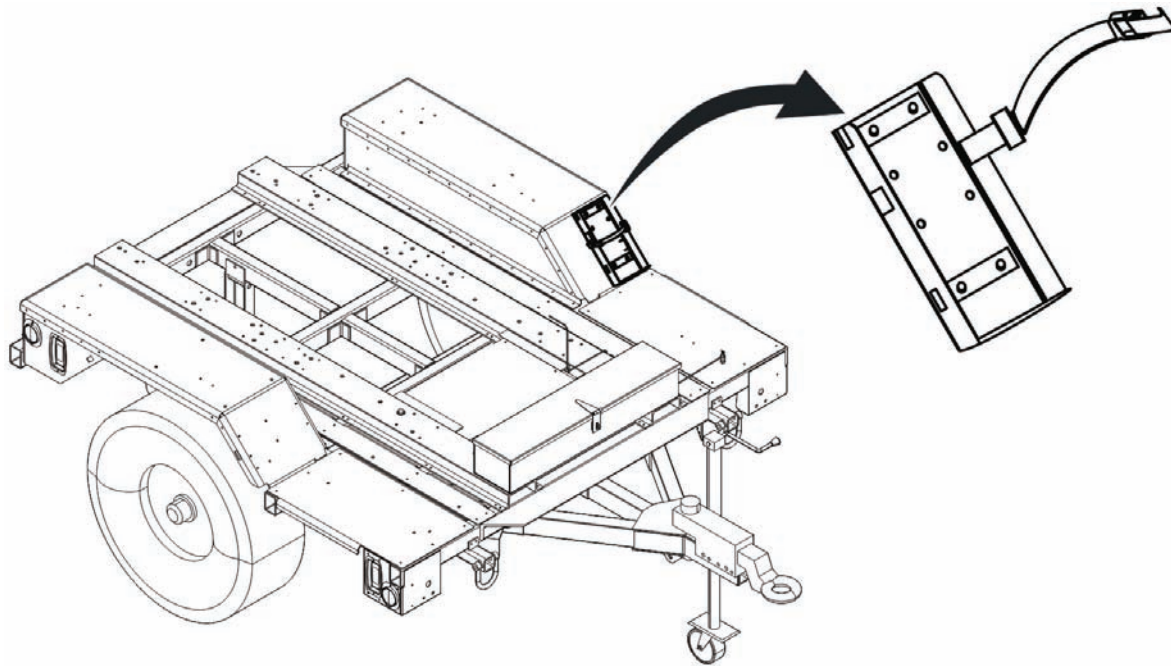

**Figure 1. Fire Extinguisher Bracket PU-2002 and PU-2012 — Location.**

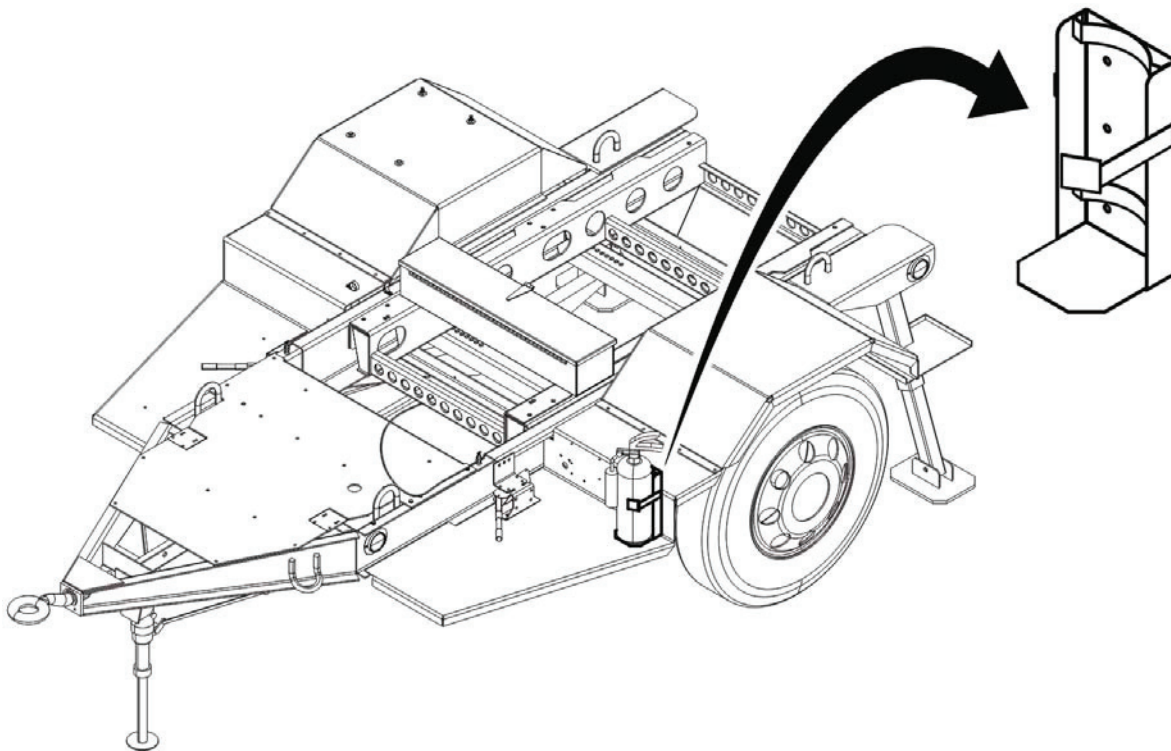

**Figure 2. Fire Extinguisher Bracket PP-3102 — Location.**



1. Ensure equipment conditions are met in order presented in initial setup.
2. Locate fire extinguisher bracket (Figure 1 or Figure 2).
3. Open latch (Figure 3, Item 4) on strap (Figure 3, Item 3) that secures fire extinguisher (Figure 3, Item 5) to bracket (Figure 3, Item 2).

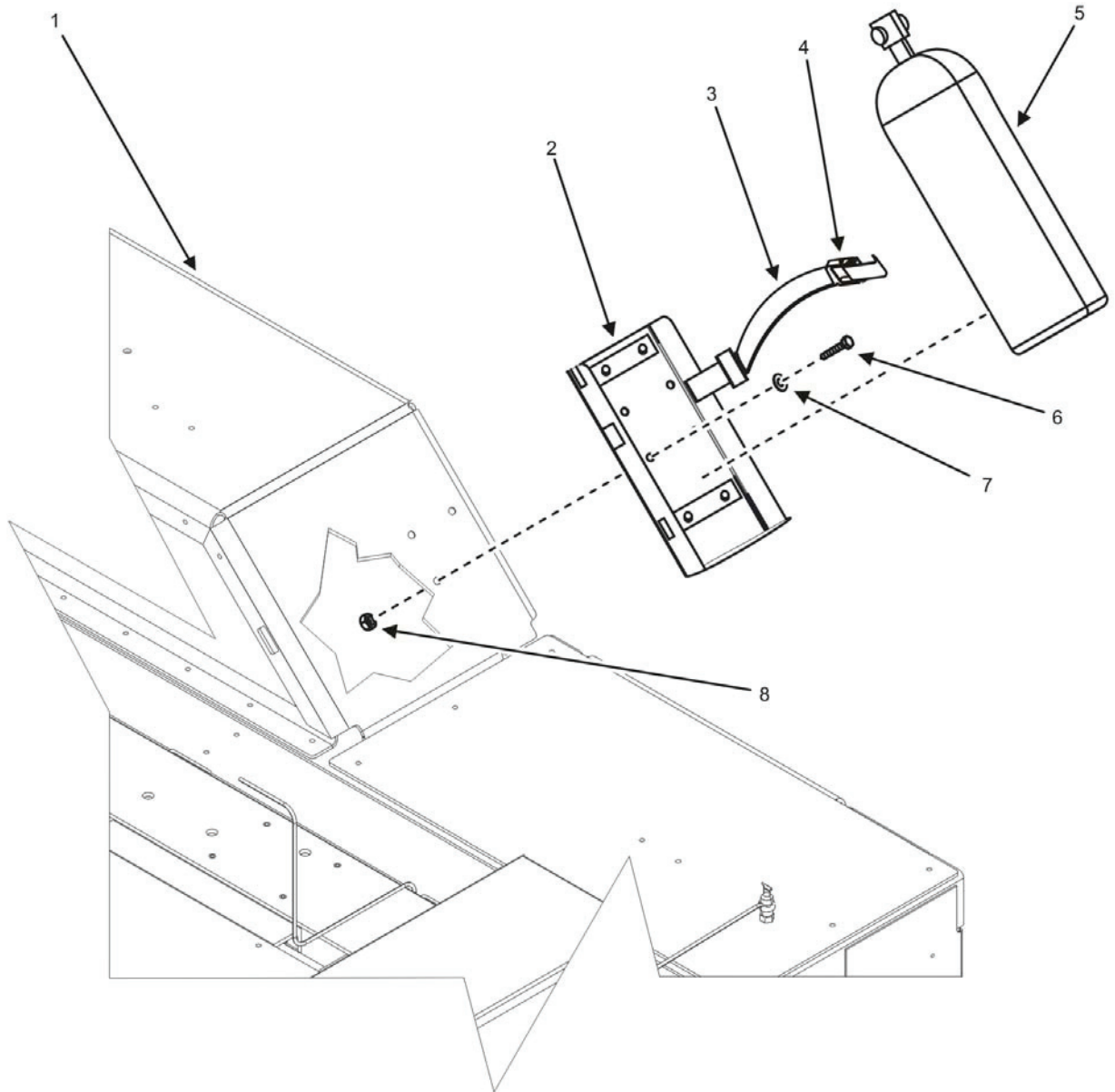

**Figure 3. Fire Extinguisher Bracket — Detail.**

**NOTE**

Mounting location varies. Fender mount shown in Figure 3.

4. Remove fire extinguisher (Figure 3, Item 5) from bracket (Figure 3, Item 2).

- 
5. Remove four bolts (Figure 3, Item 6), eight flat washers (Figure 3, Item 7), and four nylon lock nuts (Figure 3, Item 8) from trailer fender (Figure 3 Item 1).
  6. Remove fire extinguisher bracket (Figure 3, Item 2) from trailer fender (Figure 3, Item 1).
  7. Inspect bracket (Figure 3, Item 2) for damaged or missing components. Replace as required.
  8. Inspect bolts (Figure 3, Item 6) for damaged and/or worn threads. Replace as required.
  9. Discard nylon lock nuts (Figure 3, Item 8).

**END OF TASK****Install Fire Extinguisher Bracket**

1. Align fire extinguisher bracket (Figure 3, Item 2) holes with matching holes on trailer fender (Figure 3, Item 1).
2. Install four bolts (Figure 3, Item 6), eight flat washers (Figure 3, Item 7), and four new nylon lock nuts (Figure 3, Item 8) that secure bracket (Figure 3, Item 2) to trailer fender (Figure 3, Item 1).
3. Secure nylon lock nuts (Figure 3, Item 8) to torque of 22 – 27 ft/lb (30 – 37 Nm).
4. Install fire extinguisher (Figure 3, Item 5).
5. Close latch (Figure 3, Item 4) on strap (Figure 3, Item 3) that secures fire extinguisher (Figure 3, Item 5) to bracket (Figure 3, Item 2).

**END OF TASK****END OF WORK PACKAGE**

**FIELD MAINTENANCE**  
**AMMPS 10KW TRAILER-MOUNTED POWER UNITS AND POWER PLANTS**  
**REMOVE/INSTALL GROUND TERMINAL**

**INITIAL SETUP:**

**Test Equipment**

Not Applicable

**Tools and Special Tools**

Tool Kit, General Mechanic's (GMTK) (WP 0057, Table 2, Item 10)

Wrench, Torque, Dial, 3/8" Drive, 300 IN-LB (WP 0057, Table 2, Item 15)

**Materials/Parts**

Terminal, stud (1) (WP 0045, Repair Parts List, Figure 10, Item 2)

Washer, lock (1) (WP 0045, Figure 10, Item 5)

**Personnel Required**

91D (1)

**References**

Not Applicable

**Equipment Conditions**

Engine control switch OFF (TM 9-6115-750-10, WP 0005)

Wheels chocked and brakes applied (LTT – TM 9-2330-392-14&P), (M200A1 – TM 9-2330-205-14&P)

Front trailer support deployed (LTT – TM 9-2330-392-14&P), (M200A1 – TM 9-2330-205-14&P)

Rear leg prop assembly deployed (WP 0005, Operation Under Usual Conditions)

Rear step jacks deployed (M200A1 – TM 9-2330-205-14&P)

**REMOVE/INSTALL GROUND TERMINAL**

**NOTE**

PU-2002, PU-2012, and PP-3102 ground terminals use the same hardware and the same procedure to remove and install. The location difference is shown in Figure 1 and Figure 2.

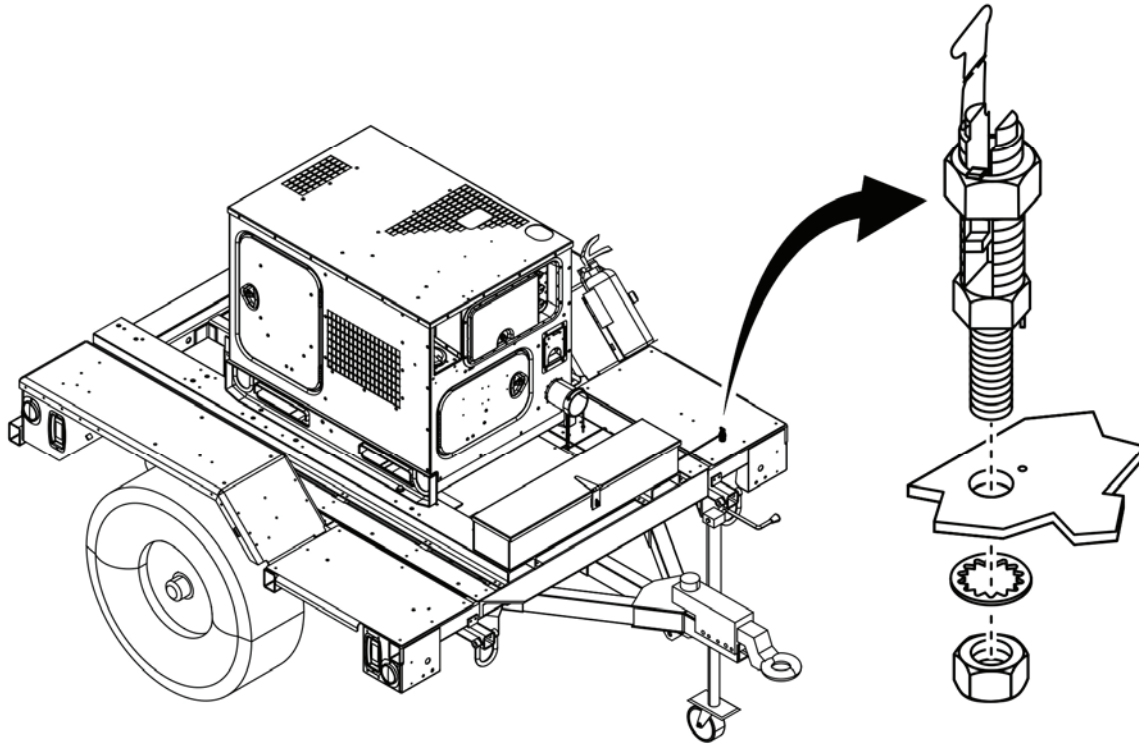
**Remove Ground Terminal**

**Figure 1. Ground Terminal PU-2002 and PU-2012 — Location.**

1. Ensure equipment conditions are met in order presented in initial setup.

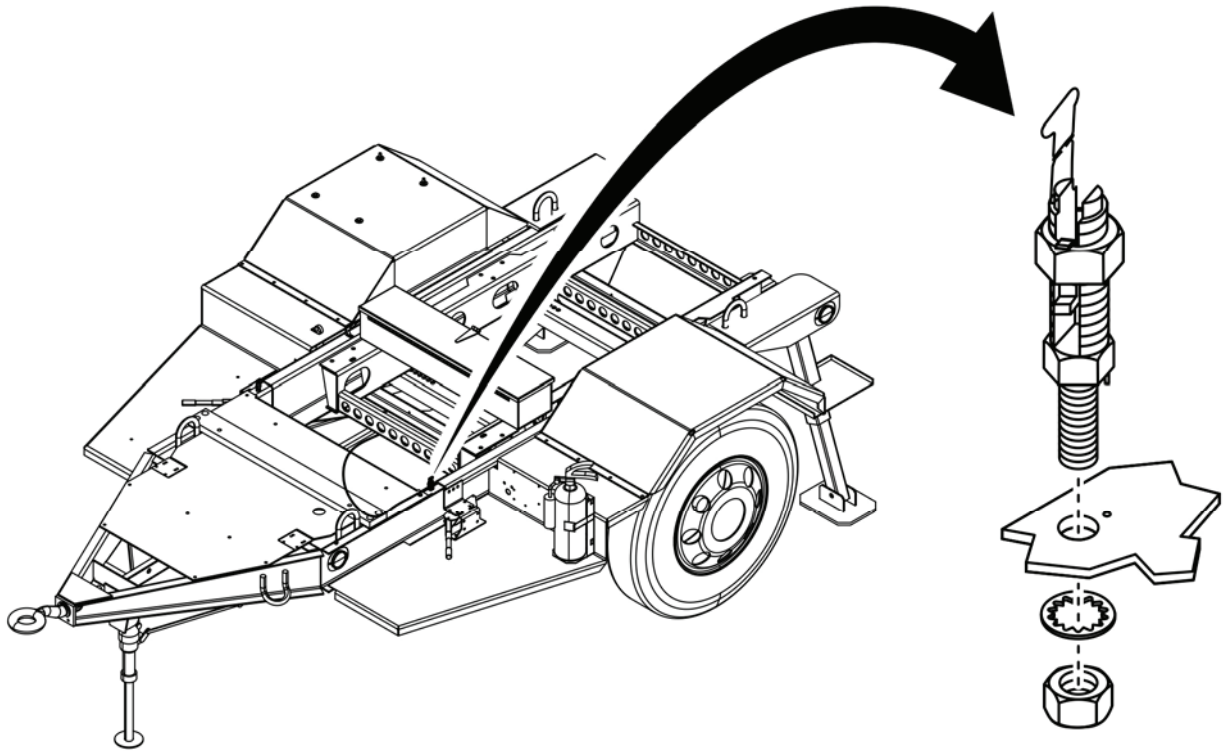

**Figure 2. Ground Terminal PP-3102 — Location.**

2. Locate ground terminal (Figure 3, Item 2) on trailer (Figure 1 or Figure 2).

**NOTE**

Step 3 applies only when ground wire(s) is connected to ground terminal (Figure 3, Item 2).

3. Disconnect ground wire(s) from ground terminal (Figure 3, Item 2) (WP 0005, Operation Under Usual Conditions).
4. Remove nut (Figure 3, Item 7) and internal tooth lock washer (Figure 3, Item 6) that secures ground terminal (Figure 3, Item 2) to trailer floor/step plate (Figure 3, Item 5).

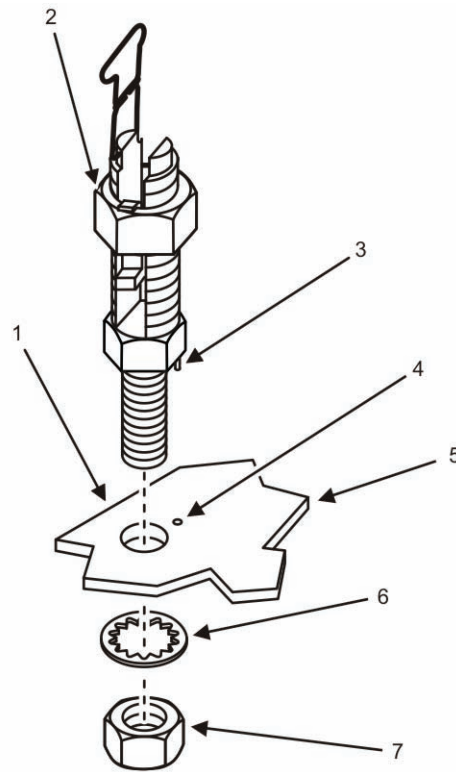

**Figure 3. Ground Terminal — Detail.**

5. Discard internal tooth lock washer (Figure 3, Item 6).
6. Remove ground terminal (Figure 3, Item 2) from trailer floor/step plate (Figure 3, Item 5).
7. Inspect ground terminal (Figure 3, Item 2) for missing hardware. Replace as required.
8. Inspect threads of ground terminal (Figure 3, Item 2) for damage. Replace as required.

#### **END OF TASK**

#### **Install Ground Terminal**

1. Locate ground terminal stud hole (Figure 3, Item 1) on trailer floor/step plate (Figure 3, Item 5) according to Figure 1, Figure 2, or Figure 3.
2. Insert ground terminal (Figure 3, Item 2) into ground terminal stud hole (Figure 3, Item 1) with alignment pin (Figure 3, Item 3) in line with alignment hole (Figure 3, Item 4).
3. Install internal tooth lock washer (Figure 3, Item 6) and nut (Figure 3, Item 7) onto ground terminal (Figure 3, Item 2).
4. Secure nut (Figure 3, Item 7) to torque value of 65 in/lb (7 Nm).
5. Install ground wire(s) as directed (WP 0005, Operation Under Usual Conditions).

#### **END OF TASK**

#### **END OF WORK PACKAGE**

---

**FIELD MAINTENANCE**  
**AMMPS 10KW TRAILER-MOUNTED POWER UNITS AND POWER PLANTS**  
**REMOVE/INSTALL ACCESSORY BOX**

---

**INITIAL SETUP:****Test Equipment**

Not Applicable

**Tools and Special Tools**

Tool Kit, General Mechanic's (GMTK) (WP 0057, Table 2, Item 10)

Wrench, Torque, Dial, 3/8" Drive, 300 IN-LB (WP 0057, Table 2, Item 15)

**Materials/Parts**

Box, accessories (1) (WP 0044, Repair Parts List, Figure 9, Item 1)

Nut, self-locking, hexagon (4) (WP 0044, Figure 9, Item 11)

**Personnel Required**

91D (1)

**References**

Not Applicable

**Equipment Conditions**

Engine control switch OFF (TM 9-6115-750-10, WP 0005)

Wheels chocked, brakes applied (LTT – TM 9-2330-392-14&amp;P), (M200A1 – TM 9-2330-205-14&amp;P)

Front trailer support deployed (LTT – TM 9-2330-392-14&amp;P), (M200A1 – TM 9-2330-205-14&amp;P)

Rear leg prop assembly deployed (WP 0005, Operation Under Usual Conditions)

Rear step jacks deployed (M200A1 – TM 9-2330-205-14&amp;P)

**REMOVE/INSTALL ACCESSORY BOX****NOTE**

PU-2002 and PU-2012 accessory boxes use the same hardware and the same procedure to remove and install.

**Remove Accessory Box (PU-2002 and PU-2012)**

1. Ensure equipment conditions are met in order presented in initial setup.
2. Locate accessory box (Figure 1).

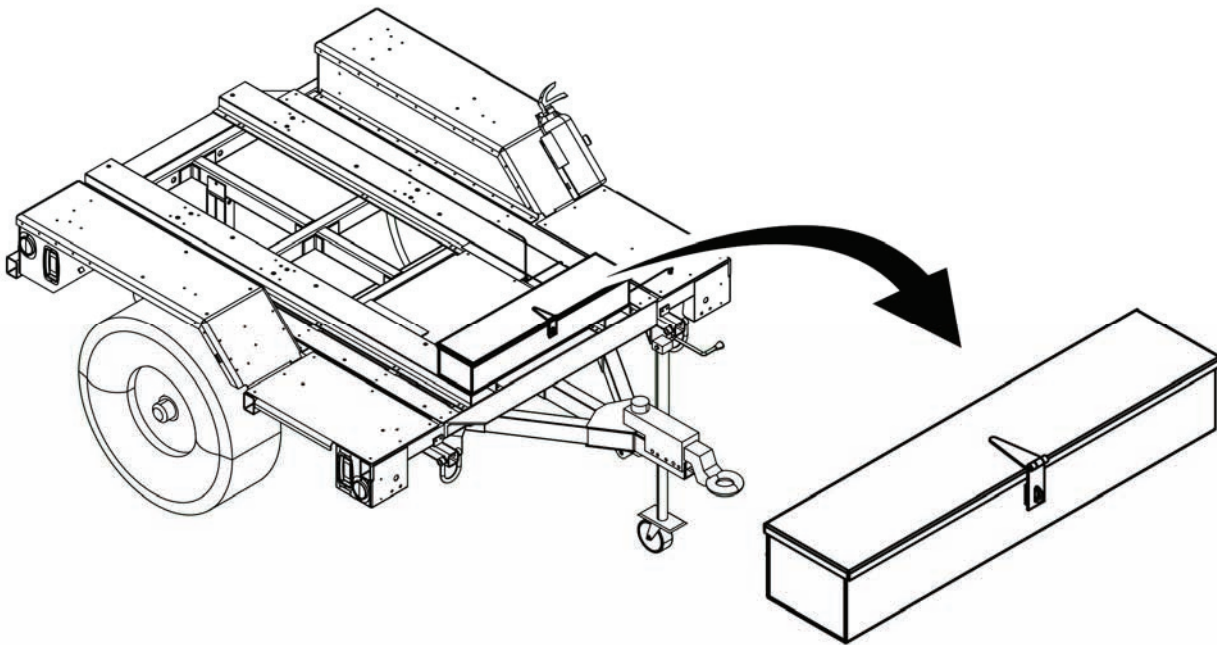

Figure 1. Accessory Box PU-2002 and PU-2012 — Location.

**NOTE**

Mounting location varies. Frame mount is shown in Figure 2.

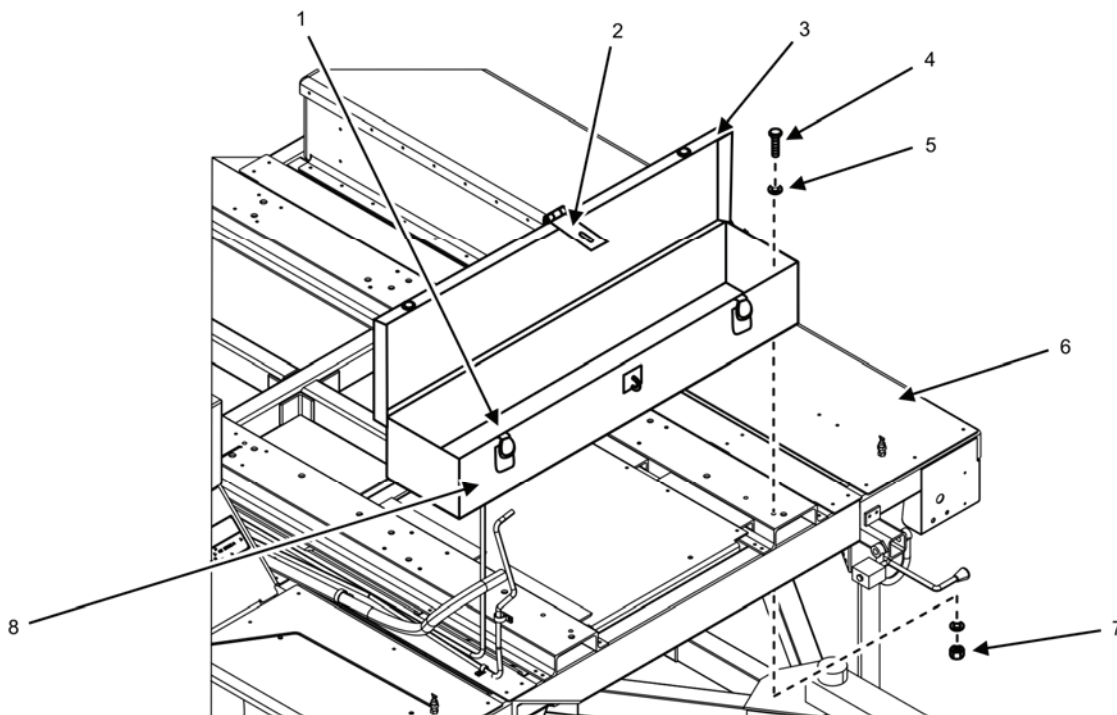

Figure 2. Accessory Box PU-2002 and PU-2012 — Detail.



- 
3. Release box catches (Figure 2, Item 1).
  4. Release box hasp (Figure 2, Item 2).
  5. Open box cover (Figure 2, Item 3).
  6. Remove accessories from accessory box (Figure 2, Item 8).
  7. Place accessories in a safe location.
  8. Remove four bolts (Figure 2, Item 4), eight flat washers (Figure 2, Item 5), and four nylon lock nuts (Figure 2, Item 7) that attach accessory box (Figure 2, Item 8) to trailer (Figure 2, Item 6).
  9. Remove accessory box (Figure 2, Item 8) from trailer (Figure 2, Item 6).
  10. Inspect accessory box (Figure 2, Item 8) for damage and damaged or missing components. Replace as required.
  11. Discard four nylon lock nuts (Figure 2, Item 7).

**END OF TASK****Install Accessory Box (PU-2002 and PU-2012)**

1. Align holes in accessory box (Figure 2, Item 8) with matching holes in trailer (Figure 2, Item 6).
2. Install four bolts (Figure 2, Item 4), eight flat washers (Figure 2, Item 5), and four new nylon lock nuts (Figure 2, Item 7) that attach accessory box (Figure 2, Item 8) to trailer (Figure 2, Item 6).
3. Secure four nylon lock nuts (Figure 2, Item 7) to torque value of 22 – 27 ft/lb (30 – 37 Nm).
4. Return accessories to accessory box (Figure 2, Item 8).
5. Close box cover (Figure 2, Item 3).
6. Close box hasp (Figure 2, Item 2).
7. Close box catches (Figure 2, Item 1).

**END OF TASK**

### Remove Accessory Box (PP-3102)

1. Ensure equipment conditions are met in order presented in initial setup.
2. Locate accessory box (Figure 3).

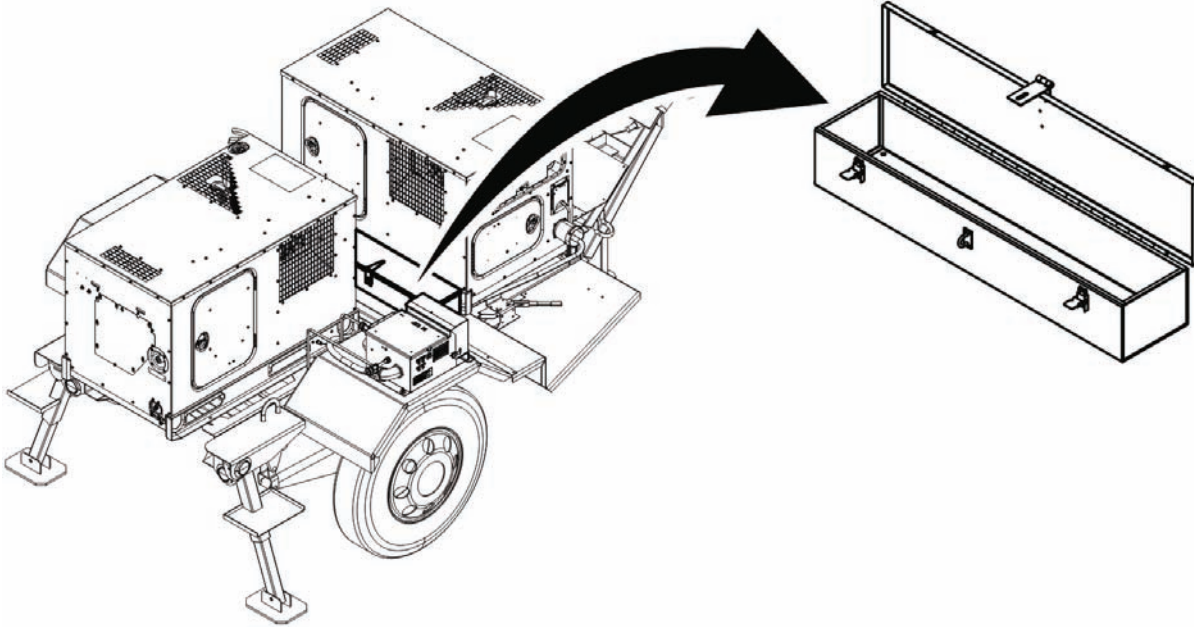

**Figure 3. Accessory Box PP-3102 — Location.**

3. Release box catches (Figure 4, Item 4).
4. Release box hasp (Figure 4, Item 5).
5. Open box cover (Figure 4, Item 6).
6. Remove accessories from accessory box (Figure 4, Item 7).
7. Place accessories in a safe location.
8. Remove four bolts (Figure 4, Item 3), 16 flat washers (Figure 4, Item 2), and four nylon lock nuts (Figure 4, Item 8) that attach accessory box (Figure 4, Item 7) to trailer (Figure 4, Item 1).
9. Remove accessory box (Figure 4, Item 7) from trailer (Figure 4, Item 1).

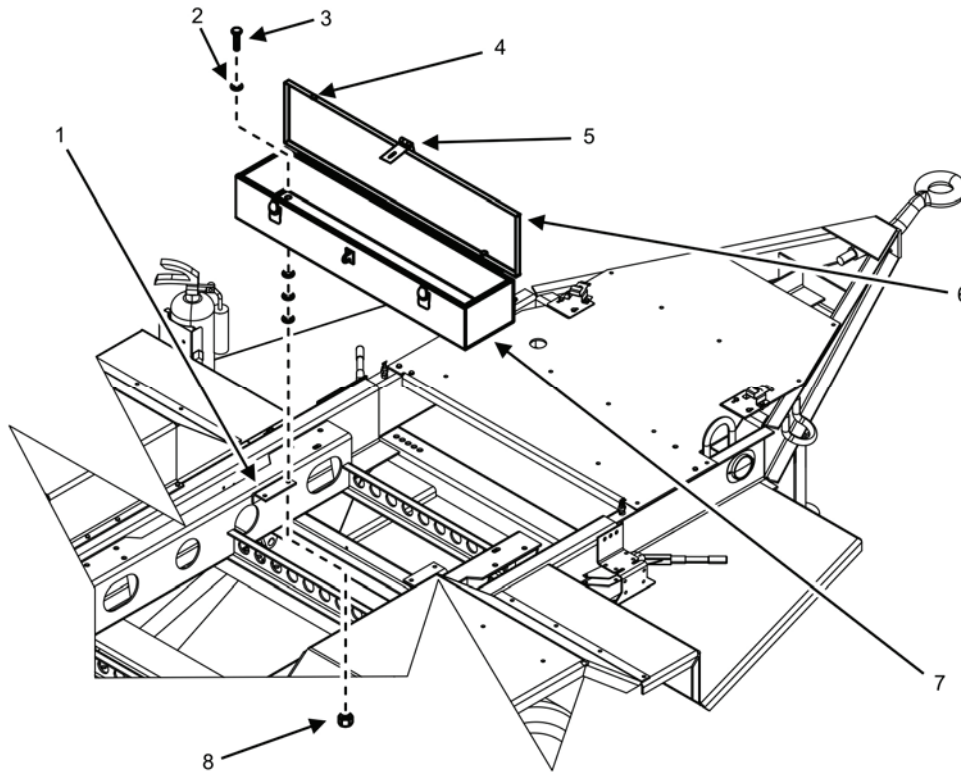

**Figure 4. Accessory Box PP-3102 — Detail.**

10. Inspect accessory box (Figure 4, Item 7) for damage and damaged or missing components. Replace as required.
11. Discard four nylon lock nuts (Figure 4, Item 8).

**END OF TASK**

**Install Accessory Box (PP-3102)**

1. Align holes in accessory box (Figure 4, Item 7) with matching holes in trailer (Figure 4, Item 1).
2. Install four bolts (Figure 4, Item 3), 16 flat washers (Figure 4, Item 2), and four new nylon lock nuts (Figure 4, Item 8) that attach accessory box (Figure 4, Item 7) to trailer (Figure 4, Item 1).
3. Secure four nylon lock nuts (Figure 4, Item 8) to torque value of 22 – 27 ft/lb (30 – 37 Nm).
4. Return accessories to accessory box (Figure 4, Item 7).
5. Close box cover (Figure 4, Item 6).
6. Close box hasp (Figure 4, Item 5).
7. Close box catches (Figure 4, Item 4).

**END OF TASK**

**END OF WORK PACKAGE**



---

**FIELD MAINTENANCE**  
**AMMPS 10KW TRAILER-MOUNTED POWER UNITS AND POWER PLANTS**  
**REMOVE/INSTALL SWITCH BOX ASSEMBLY**

---

**INITIAL SETUP:****Test Equipment**

Not Applicable

**Tools and Special Tools**

Tool Kit, General Mechanic's (GMTK) (WP 0057, Table 2, Item 10)

Wrench, Torque, Click, Ratcheting, 3/8" Drive, 75 FT-LB (WP 0057, Table 2, Item 14)

**Materials/Parts**

Nut, self-locking, hexagon (7)(WP 0047, Repair Parts List, Figure 12, Item 4)

Switch box assembly (WP 0047, Figure 12, Item 1)

**Personnel Required**

91D (1)

**References**

WP 0026, Repair Switch Box Housing

WP 0027, Replace Switch Box Components

WP 0028, Remove/Install Switch Box Wiring Harness

WP 0031, General Maintenance

**Equipment Conditions**

Engine control switch OFF (TM 9-6115-750-10, WP 0005)

Engine cool

Wheels chocked, brakes applied (M200A1 – TM 9-2330-205-14&P)

Front trailer supports deployed (M200A1 – TM 9-2330-205-14&P)

Rear step jacks deployed (M200A1 – TM 9-2330-205-14&P)

---

**REMOVE/INSTALL SWITCH BOX ASSEMBLY****Remove Switch Box Assembly**

1. Ensure equipment conditions are met in order presented in initial setup.
2. Locate switch box (Figure 1).

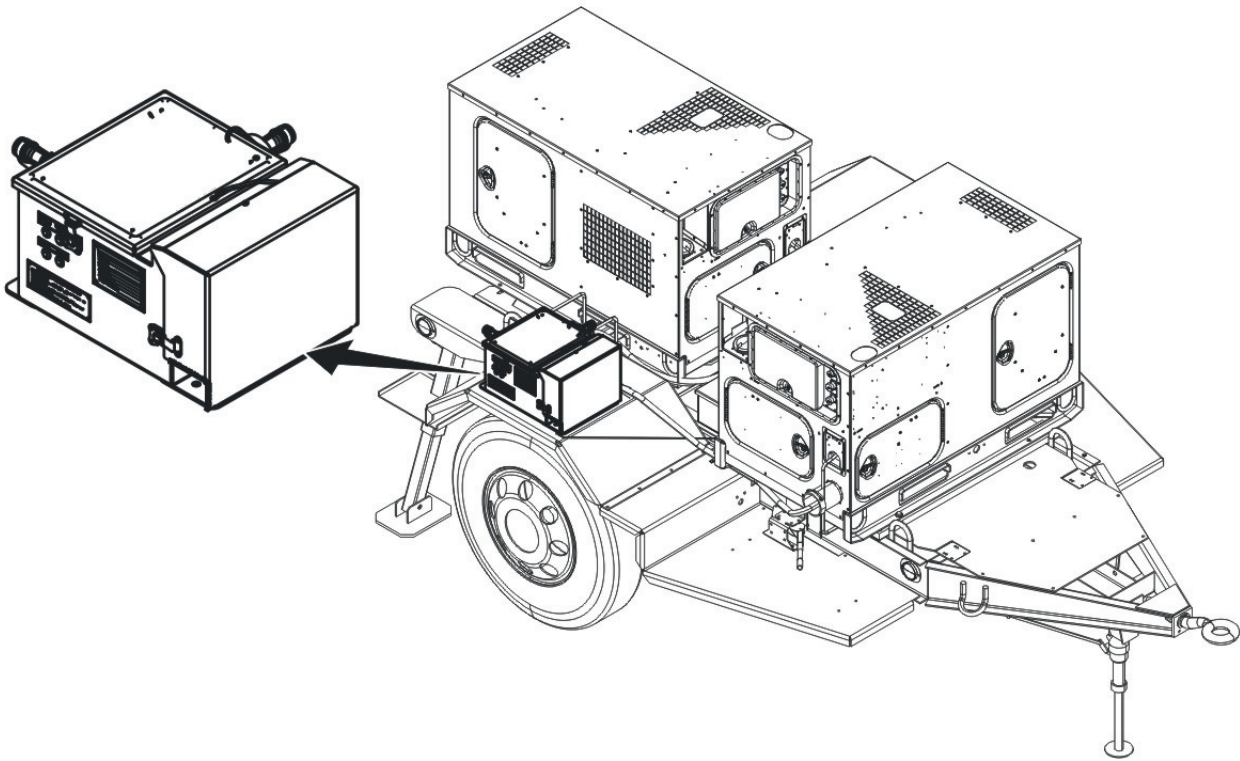

Figure 1. Switch Box (PP-3102) — Location.

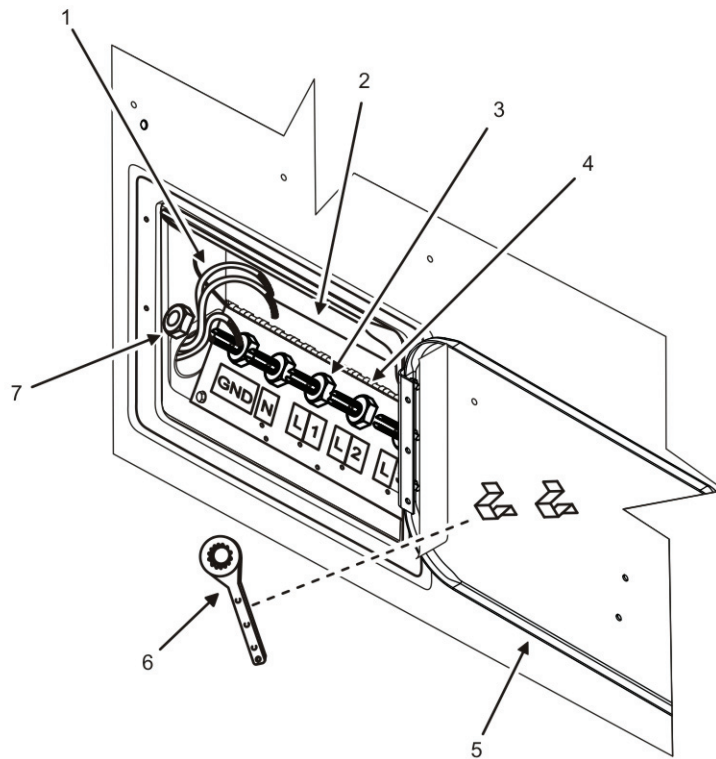
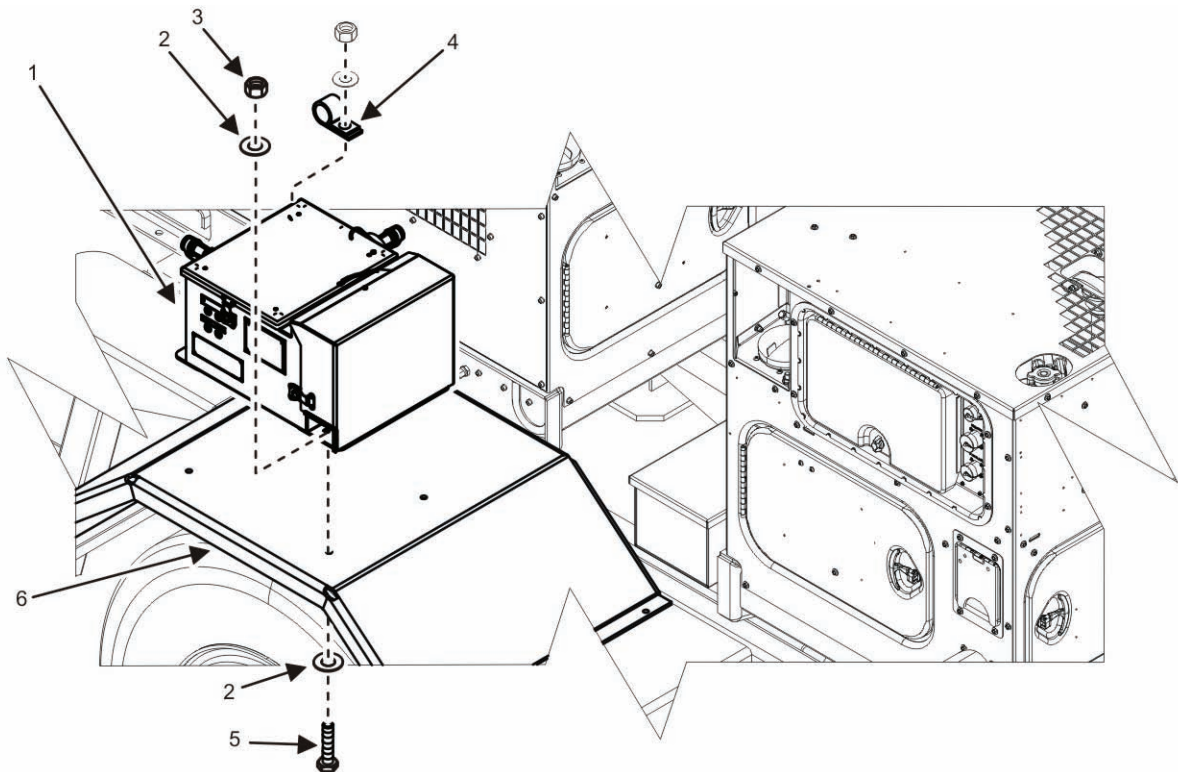

Figure 2. Removal of Wiring Harness from Generator.

3. Remove wiring harnesses from output terminal boards (Figure 2, Item 4) of generator sets A and B.
  - a. Open output terminal board access door (Figure 2, Item 5).
  - b. Lift protective cover (Figure 2, Item 2) from output terminal board (Figure 2, Item 4).
  - c. Remove terminal nut wrench (Figure 2, Item 6) from brackets on the inside of output terminal board access door (Figure 2, Item 5).
  - d. Loosen terminal nuts (Figure 2, Item 7) (shown removed for clarity) using terminal nut wrench (Figure 2, Item 6) on output terminals (Figure 2, Item 3).
  - e. Remove ends of wiring harness (Figure 2, Item 1) from output terminals (Figure 2, Item 3).
  - f. Remove ends of wiring harness (Figure 2, Item 1) through flexible sleeve.
  - g. Tighten terminal nuts (Figure 2, Item 7).
  - h. Secure terminal nut wrench (Figure 2, Item 6) on the brackets inside of the output terminal board access door (Figure 2, Item 5).
  - i. Lower protective cover (Figure 2, Item 2) over output terminal board (Figure 2, Item 4).
  - j. Secure output terminal board access door (Figure 2, Item 5).
  - k. Repeat steps 3 a – j for other parallel generator set.



**Figure 3. Switch Box — Removal.**

4. Disconnect control cables from SWITCH BOX CONTACTOR RECEPTACLE of generator sets A and B (TM 9-6115-750-10).

**NOTE**

Note orientation of bolts (Figure 3, Item 5) securing switch box assembly (Figure 3, Item 1) to curbside fender (Figure 3, Item 6) to aid in installation.

5. Remove four bolts (Figure 3, Item 5), eight washers (Figure 3, Item 2), and four nuts (Figure 3, Item 3) securing switch box assembly (Figure 3, Item 1) to curbside fender (Figure 3, Item 6).

**NOTE**

PP-3102 contains numerous clamps at various locations on the trailers, generator sets, and switch box. Note location of removed P-clamps for installation. One of the four bolts (Figure 3, Item 5) removed in step 5 also secures P-clamp (Figure 3, Item 4).

6. Remove remaining P-clamps (Figure 3, Item 4) from wiring harness and control cable (WP 0031, General Maintenance).
7. Remove switch box assembly (Figure 3, Item 1) from curbside fender (Figure 3, Item 6) and place on a suitable work surface.

**END OF TASK****Inspect Switch Box Assembly**

1. Inspect switch box cover, output terminal cover, and latches for damage. Repair switch box housing as required (WP 0026, Repair Switch Box Housing).
2. Open switch box cover and inspect wiring harness for damage. Replace wiring harness as required (WP 0028, Remove/Install Switch Box Wiring Harness).
3. Inspect switch box assembly components for damage and replace components as required (WP 0027, Replace Switch Box Components).
4. Inspect switch box housing. Replace switch box assembly (Figure 3, Item 1) as required.
5. Close switch box cover.

**END OF TASK****Install Switch Box Assembly**

1. Position switch box assembly (Figure 3, Item 1) to mounting location on curbside fender (Figure 3, Item 6).
2. Install wiring harness to generator set A and B load terminals (Figure 2, Item 3).
  - a. Open output terminal board access door (Figure 2, Item 5).
  - b. Lift protective cover (Figure 2, Item 2) from output terminal board (Figure 2, Item 4).
  - c. Remove terminal nut wrench (Figure 2, Item 6) from brackets on the inside of output terminal board access door (Figure 2, Item 5).
  - d. Loosen terminal nuts (Figure 2, Item 7) (shown removed for clarity) using terminal nut wrench (Figure 2, Item 6) on load terminals (Figure 2, Item 3).
  - e. Insert ends of wiring harness (Figure 2, Item 1) through flexible sleeve.
  - f. Insert ends of wiring harness (Figure 2, Item 1) into load terminal (Figure 2, Item 3).
  - g. Tighten terminal nuts (Figure 2, Item 7).
  - h. Check ground cable connection to load terminal (Figure 2, Item 3). Tighten as necessary.



- 
- i. Secure terminal nut wrench (Figure 2, Item 6) on the brackets inside of the output terminal board access door (Figure 2, Item 5).
  - j. Lower protective cover (Figure 2, Item 2) over output terminal board (Figure 2, Item 4).
  - k. Secure output terminal board access door (Figure 2, Item 5).
3. Install control cables to SWITCH BOX CONTACTOR RECEPTACLE in convenience receptacles of generators A and B (TM 9-6115-750-10).
  4. Install P-clamps (Figure 3, Item 4) of wiring harness and control cable at noted locations on PP (WP 0031, General Maintenance).

### NOTE

One of the four bolts installed in step 5 also secures P-clamp (Figure 3, Item 4). Install four bolts (Figure 3, Item 5) according to orientation noted in removal.

5. Install four bolts (Figure 3, Item 5), eight washers (Figure 3, Item 2), and four nuts (Figure 3, Item 3) that secure switch box assembly (Figure 3, Item 1) to curbside fender (Figure 3, Item 6).
6. Tighten four bolts (Figure 3, Item 5) to 24 ft/lb (33 Nm).
7. Start generator set A (TM 9-6115-750-10).
8. Start generator set B (TM 9-6115-750-10).
9. Confirm proper parallel operation (TM 9-6115-750-10).
10. Repair as required.

**END OF TASK**

**END OF WORK PACKAGE**



---

**FIELD MAINTENANCE**  
**AMMPS 10KW TRAILER-MOUNTED POWER UNITS AND POWER PLANTS**  
**REPAIR SWITCH BOX HOUSING**

---

**INITIAL SETUP:****Test Equipment**

Not Applicable

**Personnel Required**

91D (1)

**Tools and Special Tools**

Drill-Driver, Battery Operated, Rechargeable (WP 0057, Table 2, Item 3)

Drill, Set, Twist (WP 0057, Table 2, Item 4)

Strap, Wrist, Electrostatic Discharge (WP 0057, Table 2, Item 8)

Tool Kit, Blind, Fastener, Installation (WP 0057, Table 2, Item 9)

Tool Kit, General Mechanic's (GMTK) (WP 0057, Table 2, Item 10)

Wrench, Torque, Dial, 3/8" Drive, 300 IN-LB (WP 0057, Table 2, Item 15)

**References**

Not Applicable

**Equipment Conditions**

Engine control switch OFF (TM 9-6115-750-10, WP 0005)

Engine cool

Wheels chocked, brakes applied (M200A1 – TM 9-2330-205-14&amp;P)

Front trailer supports deployed (M200A1 – TM 9-2330-205-14&amp;P)

Rear step jacks deployed (M200A1 – TM 9-2330-205-14&amp;P)

**Materials/Parts**

Catch, clamping (WP 0048, Repair Parts List, Figure 13, Item 3)

Cover, box (WP 0048, Figure 13, Item 20)

Cover, terminal (WP 0048, Figure 13, Item 27)

Rivet, blind (2 per latch) (WP 0048, Figure 13, Item 1)

Strike, catch (WP 0048, Figure 13, Item 4)

---

**REPAIR SWITCH BOX HOUSING****CAUTION**

Printed circuit boards/cards contain components that are sensitive to static electricity. Always wear an antistatic wrist strap connected to a metal surface to channel static electricity to ground when handling printed circuit boards/cards. Failure to comply may cause damage to equipment.

**Replace Switch Box Cover**

1. Ensure equipment conditions are met in order presented in initial setup.
2. Remove switch box cover (Figure 1, Item 2).
  - a. Open switch box cover (Figure 1, Item 2).

**NOTE**

One of the three flange nuts (Figure 1, Item 6) removed in step 2b secures ground strap (Figure 1, Item 1) to switch box interior.

- b. Remove three flange nuts (Figure 1, Item 6) and screws (Figure 1, Item 4) securing hinge (Figure 1, Item 5) of switch box cover (Figure 1, Item 2) to switch box.

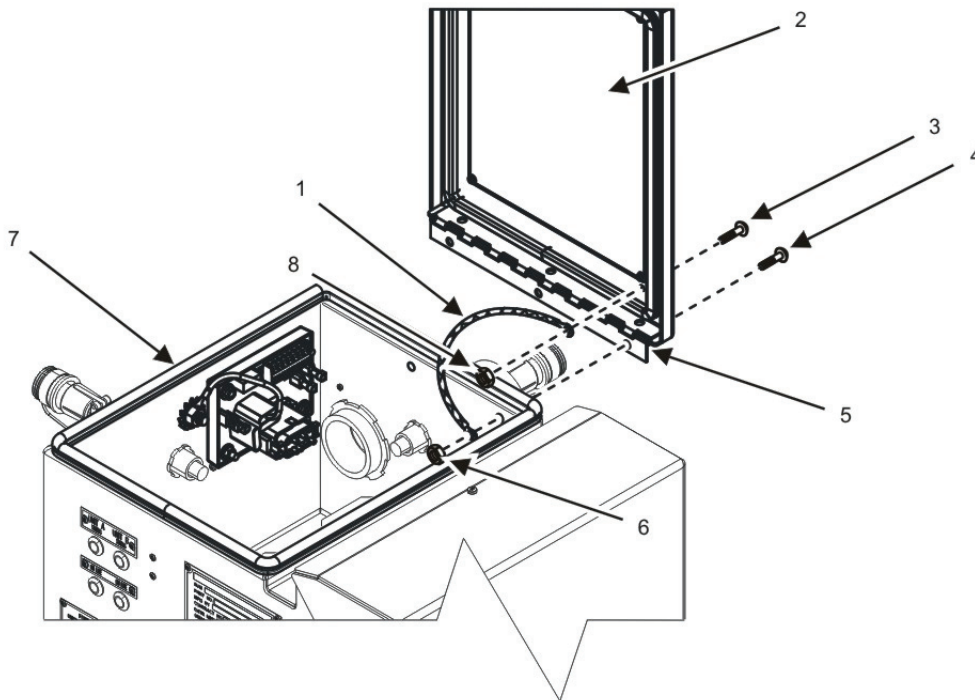

**Figure 1. Switch Box Cover — Removal.**

- c. Remove switch box cover (Figure 1, Item 2) from switch box and place on a suitable work surface.
  - d. Remove screw (Figure 1, Item 3) and flange nut (Figure 1, Item 8) that secures opposite end of ground strap (Figure 1, Item 1) to inside switch box cover (Figure 1, Item 2).
  - e. Inspect edging (Figure 1, Item 7) in switch box for tears, corrosion, and other obvious signs of damage. Replace edging (Figure 1, Item 7) as required.
3. Inspect switch box cover (Figure 1, Item 2).
    - a. Inspect switch box cover (Figure 1, Item 2) for dents, cracks, corrosion, and other obvious signs of damage. Replace switch box cover (Figure 1, Item 2) as required.
    - b. Inspect hinge (Figure 1, Item 5) for dents, obstruction of movement, and other obvious signs of damage. Replace switch box cover (Figure 1, Item 2) if hinge (Figure 1, Item 5) is damaged or malfunctioning.
  4. Install switch box cover (Figure 1, Item 2).
    - a. Install ground strap (Figure 1, Item 1) to inside switch box cover (Figure 1, Item 2) with screw (Figure 1, Item 3) and flange nut (Figure 1, Item 8).
    - b. Position hinge (Figure 1, Item 5) of switch box cover (Figure 1, Item 2) to mounting location on switch box.

**NOTE**

One of the three flange nuts (Figure 1, Item 6) installed in step 4c secures other end of ground strap (Figure 1, Item 1) to switch box interior.

- c. Position ground strap (Figure 1, Item 1) to mounting position in switch box interior.
- d. Secure hinge (Figure 1, Item 5) of switch box cover (Figure 1, Item 2) to switch box with three screws (Figure 1, Item 4) and flange nuts (Figure 1, Item 6). Ensure screw (Figure 1, Item 4) supports ground strap (Figure 1, Item 1).
- e. Tighten flange nuts (Figure 1, Item 6) to 87 – 105 in/lb (10 – 12 Nm).

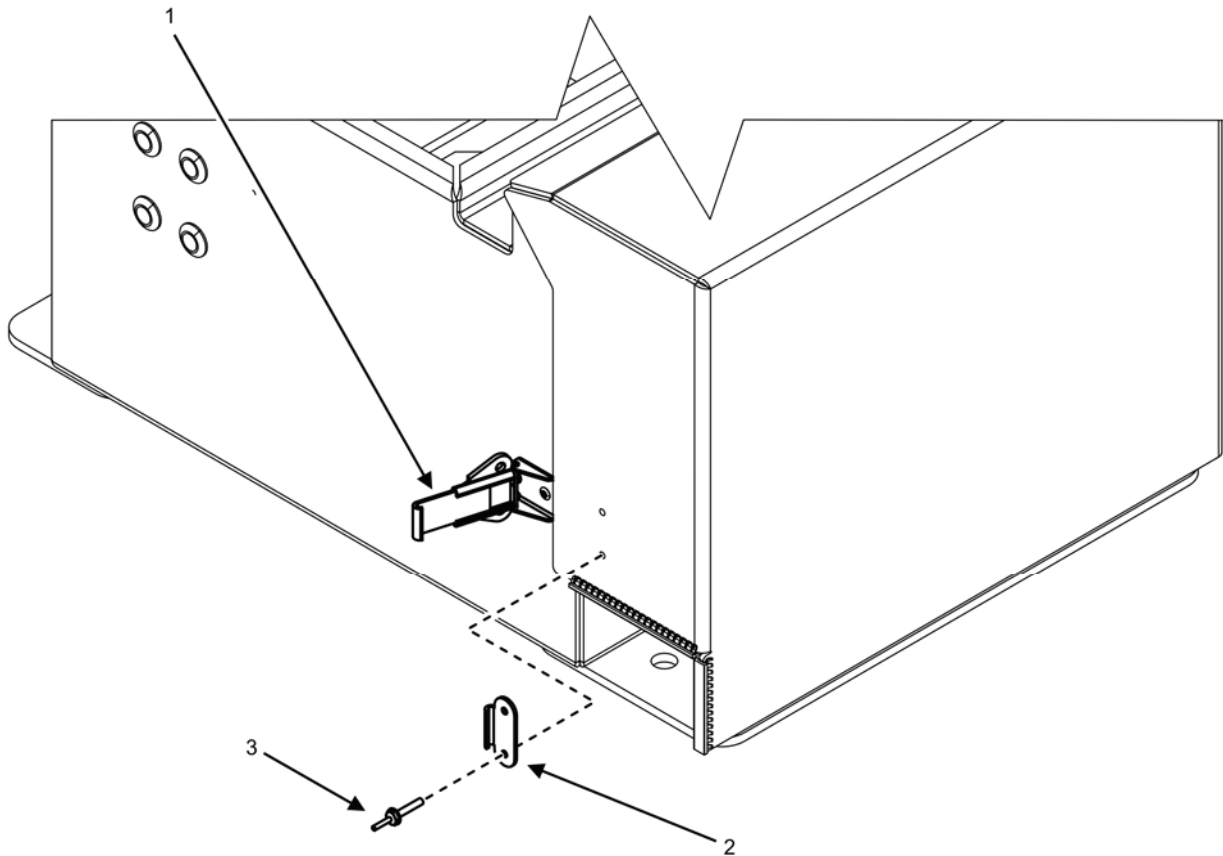
**END OF TASK****Replace Latch**

**Figure 2. Replace Latch.**

1. Ensure equipment conditions are met in order presented in initial setup.
2. Release latch (Figure 2, Items 1 and 2).
3. Drill out rivets (Figure 2, Item 3) of latch component (Figure 2, Items 1 or 2) to be replaced.
4. Remove latch component (Figure 2, Items 1 or 2) to be replaced.
5. Position new latch component (Figure 2, Items 1 or 2) onto switch box cover, terminal cover, or switch box and align riveting holes.

6. Secure new latch component (Figure 2, Items 1 or 2) with two new rivets (Figure 2, Item 3).
7. Check latch (Figure 2, Items 1 and 2) for proper operation.
8. Repeat steps 1 through 7 as necessary.

## END OF TASK

### Replace Output Terminal Cover

1. Ensure equipment conditions are met in order presented in initial setup.

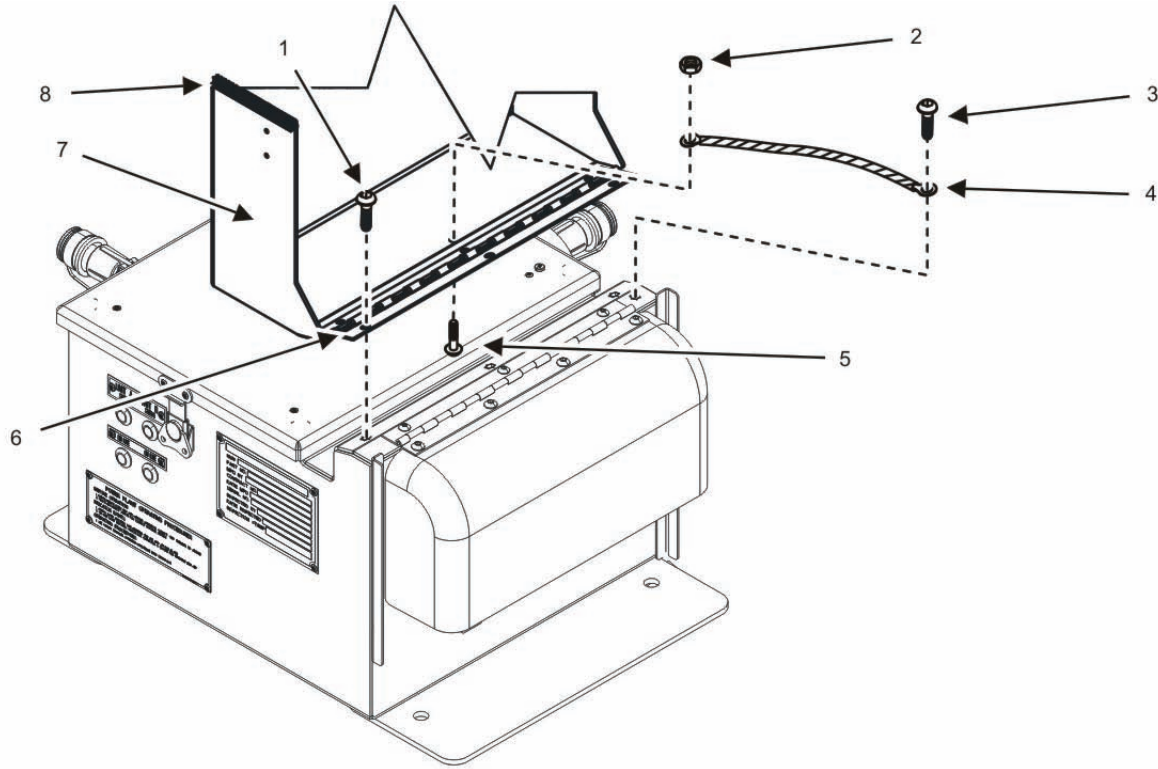

**Figure 3. Replace Output Terminal Cover.**

2. Remove output terminal cover (Figure 3, Item 7).
  - a. Open output terminal cover (Figure 3, Item 7).
  - b. Remove three screws (Figure 3, Item 1) securing hinge (Figure 3, Item 6) of output terminal cover (Figure 3, Item 7) to switch box.
  - c. Remove screw (Figure 3, Item 5) and nut (Figure 3, Item 2) securing ground strap (Figure 3, Item 4) to inside output terminal cover (Figure 3, Item 7).
  - d. Remove output terminal cover (Figure 3, Item 7) from switch box.
  - e. Remove screw (Figure 3, Item 3) securing other end of ground strap (Figure 3, Item 4) to switch box.
  - f. Inspect ground strap (Figure 3, Item 4) for tears, corrosion, and other obvious signs of damage. Replace as required.

- 
3. Inspect output terminal cover (Figure 3, Item 7).
    - a. Inspect output terminal cover (Figure 3, Item 7) for dents, cracks, corrosion, and other obvious signs of damage. Replace output terminal cover (Figure 3, Item 7) as required.
    - b. Inspect hinge (Figure 3, Item 6) for dents, obstruction of movement, and other obvious signs of damage. Replace output terminal cover (Figure 3, Item 7) if hinge is damaged or malfunctioning.
    - c. Inspect edging (Figure 3, Item 8) on output terminal cover (Figure 3, Item 7) for cracks, deterioration, and other obvious signs of damage. Replace edging (Figure 3, Item 8) as required.
  4. Install output terminal cover (Figure 3, Item 7).
    - a. Position ground strap (Figure 3, Item 4) to mounting location inside of output terminal cover (Figure 3, Item 7).
    - b. Secure ground strap (Figure 3, Item 4) to inside output terminal cover (Figure 3, Item 7) with screw (Figure 3, Item 5) and nut (Figure 3, Item 2).
    - c. Position hinge (Figure 3, Item 6) of output terminal cover (Figure 3, Item 7) to mounting location on switch box.
    - d. Secure hinge (Figure 3, Item 6) to switch box with three screws (Figure 3, Item 1).
    - e. Tighten three screws (Figure 3, Item 1) to 51 – 62 in/lb (6 – 7 Nm).
    - f. Position ground strap (Figure 3, Item 4) to mounting location on switch box.
    - g. Secure ground strap (Figure 3, Item 4) to switch box with screw (Figure 3, Item 3).

**END OF TASK**

**END OF WORK PACKAGE**





---

**FIELD MAINTENANCE**  
**AMMPS 10KW TRAILER-MOUNTED POWER UNITS AND POWER PLANTS**  
**REPLACE SWITCH BOX COMPONENTS**

---

**INITIAL SETUP:****Test Equipment**

Not Applicable

**Tools and Special Tools**

Strap, Wrist, Electrostatic Discharge (WP 0057, Table 2, Item 8)

Tool Kit, General Mechanic's (GMTK) (WP 0057, Table 2, Item 10)

Wrench, Torque, Click, Ratcheting, 1/2" Drive, 250 FT-LB (WP 0057, Table 2, Item 13)

Wrench, Torque, Click, Ratcheting, 3/8" Drive, 75 FT-LB (WP 0057, Table 2, Item 14)

Wrench, Torque, Dial, 3/8" Drive, 300 IN-LB (WP 0057, Table 2, Item 15)

**Materials/Parts**

Board, connection (WP 0048, Repair Parts List, Figure 13, Item 36)

Cable, electrical (1) (WP 0050, Repair Parts List, Figure 15, Item 12)

Cable, electrical (1) (WP 0050, Figure 15, Item 28)

Card, control switch (1) (WP 0048, Figure 13, Item 42)

Contact, magnetic (WP 0048, Figure 13, Item 33)

Diode, light emitting (WP 0048, Figure 13, Item 47)

Gasket (WP 0048, Figure 13, Item 35)

Terminal, stud (WP 0048, Figure 13, Item 38)

Washer, lock 1/4 (1) (WP 0048, Figure 13, Item 46)

**Materials/Parts**

Cleaning compound, solvent (WP 0060, Expendable and Durable Items List, Item 1)

Tag, marker (WP 0060, Item 7)

**Personnel Required**

91D (1)

**References**

WP 0026, Repair Switch Box Housing

WP 0028, Remove/Install Switch Box Wiring Harness

WP 0031, General Maintenance

Foldout Pages

**Equipment Conditions**

Engine control switch OFF (TM 9-6115-750-10, WP 0005)

Engine cool

Wheels chocked, brakes applied (M200A1 –TM 9-2330-205-14&P)

Front trailer supports deployed (M200A1 –TM 9-2330-205-14&P)

Rear leg prop assembly deployed (WP 0005, Operation under Usual Conditions)

Rear step jacks deployed (M200A1 –TM 9-2330-205-14&P)

**REMOVE/INSTALL SWITCH BOX COMPONENTS****CAUTION**

Printed circuit boards/cards contain components that are sensitive to static electricity. Always wear an antistatic wrist strap connected to a metal surface to channel static electricity to ground when handling printed circuit boards/cards. Failure to comply may cause damage to equipment.

**Test Contactor****WARNING**

- Ensure generator sets are shut down and output terminal board has no voltage prior to making any connections for parallel operation or moving a generator set that has been operating in parallel. Operating generator sets always contain the risk of electrocution. Failure to comply may cause injury or death to personnel.
  - Shut down generator sets before performing inspection of load cables. Failure to comply may cause injury or death to personnel by electrocution.
1. Ensure equipment conditions are met in order presented in initial setup.
  2. Open switch box cover.
  3. Locate contactor (Figure 1).

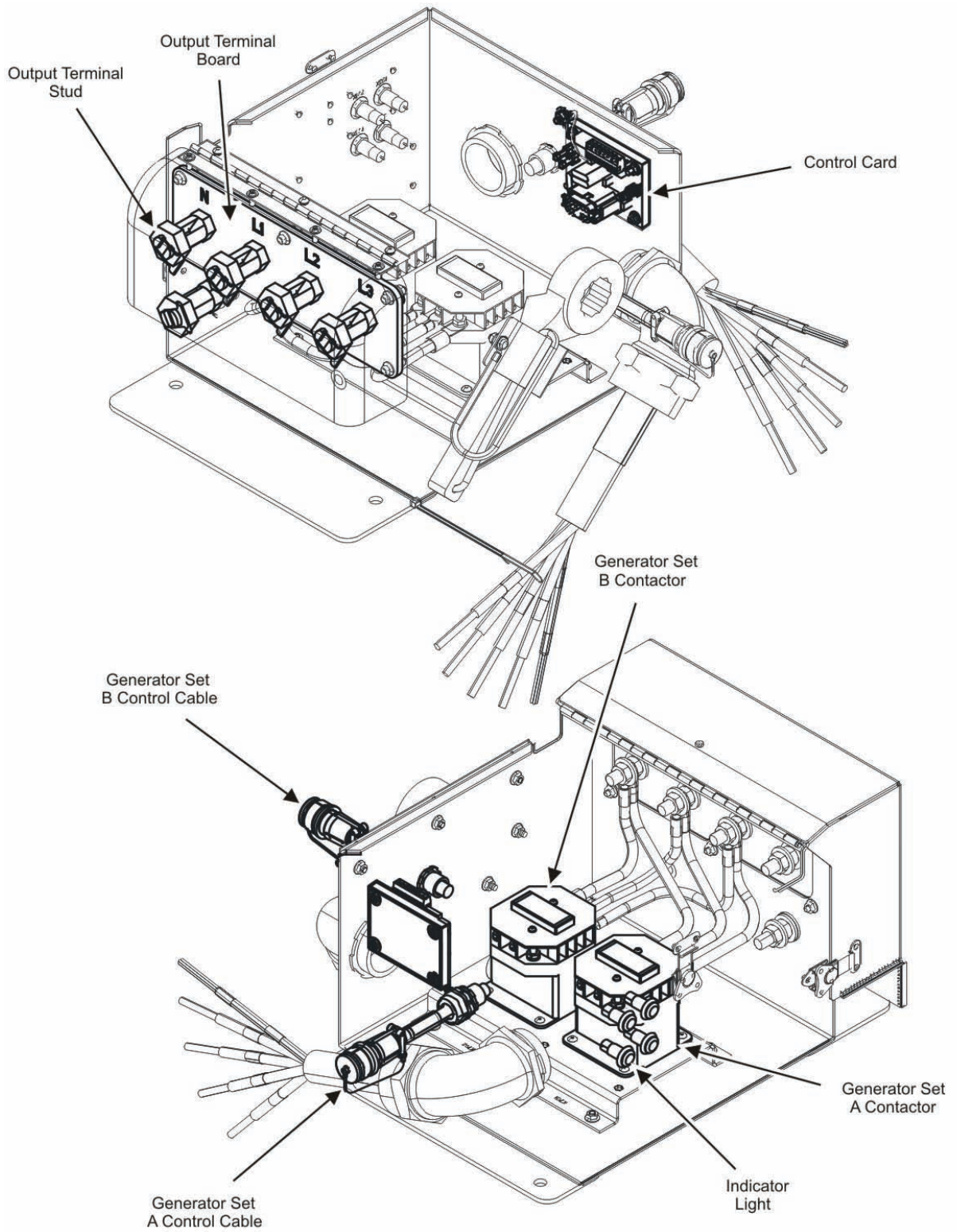
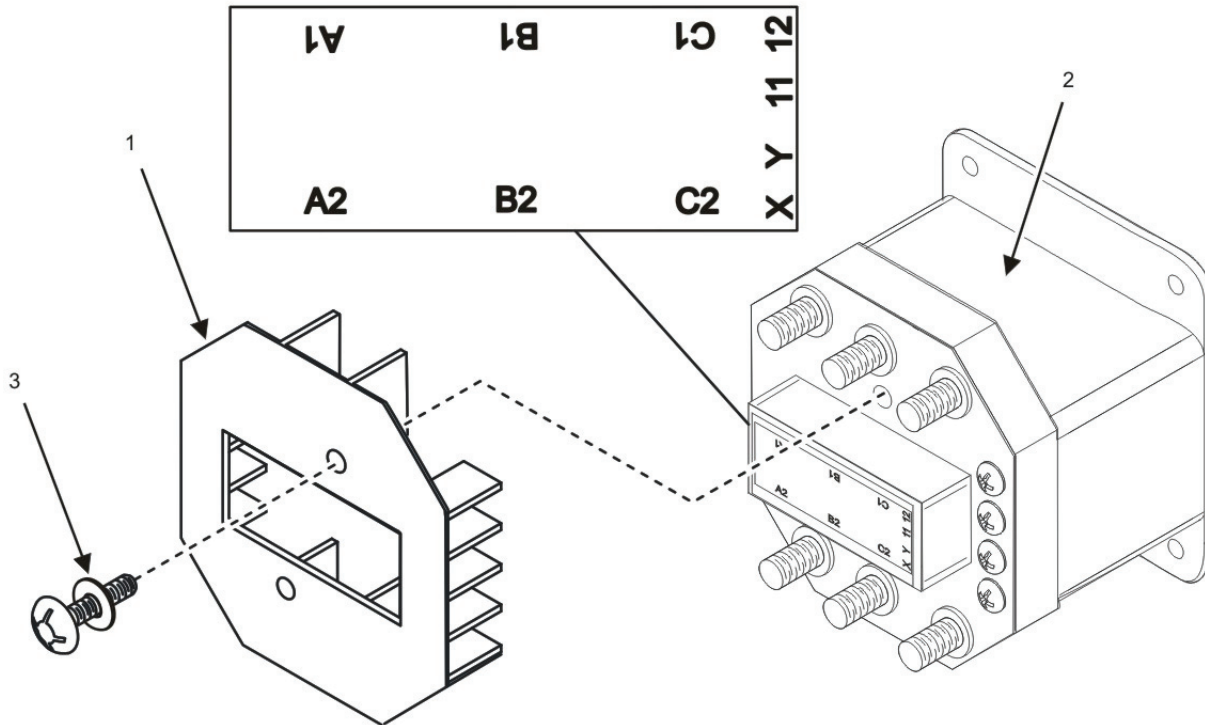

Figure 1. Switch Box Components — Location.

4. Remove two screws and captive washers (Figure 2, Item 3) securing contactor cover (Figure 2, Item 1) to contactor (Figure 2, Item 2).
5. Remove contactor cover (Figure 2, Item 1).



**Figure 2. Contactor — Terminals.**

**NOTE**

Contactor (Figure 2, Item 2) is shown removed and with wires disconnected for clarity (Figure 2). Test can be done with contactor (Figure 2, Item 2) installed in switch box and all wires connected.

Terminals A1 through C1 (Figure 2) are for the generator set wiring harness and A2 through C2 (Figure 2) are for the output terminal wires. Terminals X and Y (Figure 2) are for the wires that energize the contactor coil. Terminals 11 and 12 (Figure 2) are for wires for the auxiliary contact.

6. Measure the resistance between each terminal of the input side of contactor (Figure 2, Item 2) (Terminals A1 through C1) and output side of contactor (Figure 2, Item 2) (Terminals A2 through C2). Ensure resistance between any two terminals is infinite or high (approximately 100,000 Ohms ( $\Omega$ ) or more).
7. Replace contactor (Figure 2, Item 2) if a low ( $10 \Omega$  or less) or zero  $\Omega$  value is obtained. See Replace Contactor task.

**NOTE**

Resistance reading between terminals X and Y should be  $47 \Omega \pm 10\%$ .

8. Measure the resistance between terminals X and Y (Figure 2) using a multimeter set to test resistance.
9. Replace contactor (Figure 2, Item 2) if reading is outside of specification. See Replace Contactor task.

- 
10. Measure for continuity between terminals 11 and 12 (Figure 2) and between each terminal and ground using a multimeter set to test continuity.
  11. Replace contactor (Figure 2, Item 2) if continuity is found. See Replace Contactor task.
  12. Measure resistance between each contactor terminal (11, 12, A1, A2, B1, B2, C1, and C2) (Figure 2) using a multimeter set to test resistance. Ensure resistance between any two terminals is infinite or high.
  13. Replace contactor (Figure 2, Item 2) if a low or zero  $\Omega$  value is obtained. See Replace Contactor task.
  14. Measure resistance between terminal X and each terminal (11, 12, A1, A2, B1, B2, C1, and C2) (Figure 2) using a multimeter set to test resistance. Ensure resistance between X and any other terminal is infinite or high.
  15. Replace contactor (Figure 2, Item 2) if resistance is low or zero  $\Omega$ . See Replace Contactor task.
  16. Measure resistance between terminal Y and each terminal (11, 12, A1, A2, B1, B2, C1, and C2) (Figure 2) using a multimeter set to test resistance. Ensure resistance between Y and any other terminal is infinite or high.
  17. Replace contactor (Figure 2, Item 2) if resistance is low or zero  $\Omega$ . See Replace Contactor task.
  18. Position contactor cover (Figure 2, Item 1) over contactor (Figure 2, Item 2).
  19. Secure contactor cover (Figure 2, Item 1) with two screws with captive washers (Figure 2, Item 3).
  20. Close switch box cover.
  21. Start generator set A (TM 9-6115-750-10).
  22. Start generator set B (TM 9-6115-750-10).
  23. Check for proper parallel operation (TM 9-6115-750-10).
  24. Repair as required.

**END OF TASK**

**Replace Output Terminal Stud and Output Terminal Board**

**NOTE**

Repair of output terminal studs (Figure 3, Item 3) and output terminal board (Figure 3, Item 4) by replacing damaged output terminal stud(s) (Figure 3, Item 3) and/or output terminal board (Figure 3, Item 4) as needed.

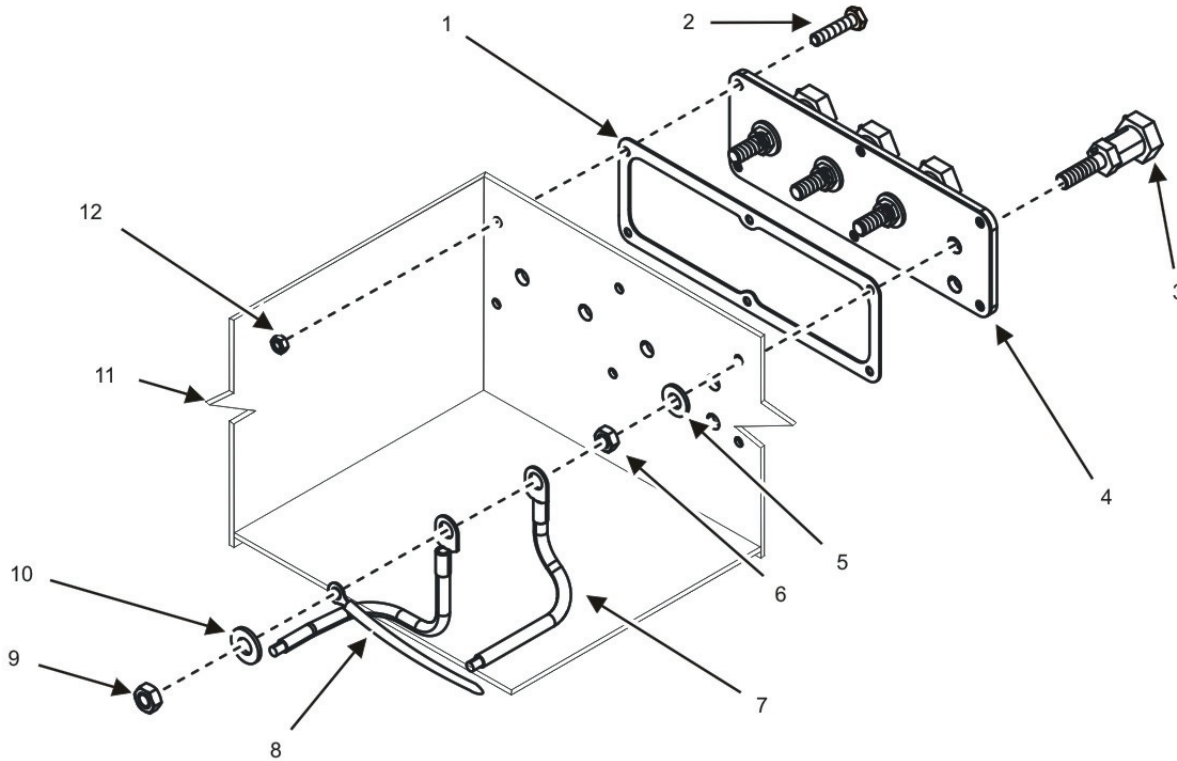

**Figure 3. Output Terminals Studs and Output Terminal Board — Removal.**

1. Ensure equipment conditions are met in order presented in initial setup.
2. Open switch box and output terminal covers.
3. Locate output terminal stud to be removed (Figure 1).

**NOTE**

Output terminal cover may be removed to better access output terminal studs (Figure 3, Item 3) and output terminal board (Figure 3, Item 4) (WP 0026, Repair Switch Box Housing).

N, L1, L2, and L3 output terminal studs (Figure 3, Item 3) are positioned on the output terminal board. Ground (GND) output terminal stud is located below neutral (N) output terminal stud (Figure 3, Item 3) on the switch box housing (Figure 3, Item 11). All output terminal wires (Figure 3, Item 7) are removed and installed with the same procedure, except for N terminal, which has the control-card-to-N wire (Figure 3, Item 8).

4. Remove output terminal stud (Figure 3, Item 3).

- a. Ensure all output terminal wires (Figure 3, Item 7) (generator set A: K701-A2, K701-B2, K701-C2, N, and GND) (generator set B: K702-A2, K702-B2, K702-C2, N, and GND) and control-card-to-N wire (N) (Figure 3, Item 8) are clearly labeled according to their output terminal stud (Figure 3, Item 3) location. Tag output terminal wires (Figure 3, Items 7) as needed.
- b. Remove hex nut (Figure 3, Item 9) and flat washer (Figure 3, Item 10) from rear of output terminal stud (Figure 3, Item 3) to be removed.

### NOTE

L1, L2, and L3 output terminal studs (Figure 3, Item 3) secure two wires, one from each contactor. N output terminal stud secures three wires, one N wire from each wiring harness, and one control-card-to-N wire (Figure 3, Item 8). GND terminal stud (not shown) secures two GND wires, one from each wiring harness. Prior to removal, tag and identify all wires. Tags will be used as a guide during reassembly.

- c. Remove appropriately tagged wires (Figure 3, Items 7 and 8) from rear of output terminal stud (Figure 3, Item 3) to be removed.
- d. Inspect wires (Figure 3, Items 7 and 9) for damaged ring connectors. Repair ring connectors as required (WP 0031, General Maintenance).
- e. Remove hex nut (Figure 3, Item 6) and flat washer (Figure 3, Item 5) securing output terminal stud (Figure 3, Item 3) to output terminal board (Figure 3, Item 4).
- f. Remove output terminal stud (Figure 3, Item 3) from output terminal board (Figure 3, Item 4) and place on a suitable work surface.
- g. Repeat steps 4a – f for any remaining output terminal stud (Figure 3, Item 3) to be replaced.
- h. Repeat steps 4a – f if replacing the output terminal board (Figure 3, Item 4) and then continue to step 5

### NOTE

If replacing the output terminal board (Figure 3, Item 4), continue with step 5. Otherwise, proceed to step 6.

5. Remove output terminal board (Figure 3, Item 4).
  - a. Remove six bolts (Figure 3, Item 2) and nuts (Figure 3, Item 12) securing output terminal board (Figure 3, Item 4) to switch box housing (Figure 3, Item 11).
  - b. Remove output terminal board (Figure 3, Item 4) and gasket (Figure 3, Item 1) from switch box housing (Figure 3, Item 11) and place on a suitable work surface.

### WARNING

Cleaning solvent is combustible and toxic to eyes, skin, and respiratory tract. Skin and eye protection is required. Avoid repeated or prolonged contact. Work in ventilated area only. Failure to comply may cause injury or death to personnel.

- c. Remove any remaining gasket (Figure 3, Item 1) material from switch box housing (Figure 3, Item 11) and output terminal board (Figure 3, Item 4) with cleaning solvent.
  - d. Discard gasket (Figure 3, Item 1).
6. Inspect output terminal stud (Figure 3, Item 3) and output terminal board (Figure 3, Item 4).
    - a. Inspect output terminal stud (Figure 3, Item 3) for worn or damaged threads, cracks, corrosion, and other obvious signs of damage. Replace output terminal stud (Figure 3, Item 3) as required.
    - b. Inspect output terminal board (Figure 3, Item 4) for cracks and other obvious signs of damage and replace as required.

**NOTE**

If replacing the output terminal board (Figure 3, Item 4), continue with step 7. Otherwise, proceed to step 8.

7. Install output terminal board (Figure 3, Item 4).
  - a. Position new gasket (Figure 3, Item 1) and output terminal board (Figure 3, Item 4) to mounting location on switch box housing (Figure 3, Item 11).
  - b. Secure new gasket (Figure 3, Item 1) and output terminal board (Figure 3, Item 4) to mounting location with six bolts (Figure 3, Item 2) and nuts (Figure 3, Item 12).
  - c. Tighten nuts (Figure 3, Item 12) to 86.7 – 105.3 in/lb (9.8 – 11.9 Nm).
8. Install output terminal stud (Figure 3, Item 3).
  - a. Position output terminal stud (Figure 3, Item 3) so that alignment pin fits in hole provided.
  - b. Secure output terminal stud (Figure 3, Item 3) to position with flat washer (Figure 3, Item 5) and hex nut (Figure 3, Item 6).
  - c. Tighten hex nut (Figure 3, Item 6) to 35 ft/lb (47 Nm).

**NOTE**

N output terminal stud also secures control-card-to-N wire (N) (Figure 3, Item 8). Output terminal wires (Figure 6, Item 7) have the heaviest terminal lug and shall be installed closest to hex nut (Figure 3, Item 6).

- d. Install appropriately tagged output terminal wires (generator set A: K701-A2, K701-B2, K701-C2, N, and GND) (generator set B: K702-A2, K702-B2, K702-C2, N, and GND) to rear of output terminal stud (Figure 3, Item 3).
- e. Secure output terminal wires (Figure 3, Item 7) with flat washer (Figure 3, Item 10) and hex nut (Figure 3, Item 9).
- f. Tighten hex nut (Figure 3, Item 9) to 35 ft/lb (47 Nm).
- g. Repeat steps 8a – f for any remaining output terminal studs (Figure 3, Item 3) to be installed.

**NOTE**

Output terminal cover may have been removed to aid in output terminal stud and output terminal board removal. Cover must be installed if removed (WP 0026, Repair Switch Box Housing).

9. Install output terminal cover (if removed) (WP 0026, Repair Switch Box Housing).
10. Close and secure switch box and output terminal covers.
11. Start generator set A (TM 9-6115-750-10).
12. Start generator set B (TM 9-6115-750-10).
13. Confirm proper parallel operation (TM 9-6115-750-10).
14. Repair as required.

**END OF TASK**



## Replace Contactor

### NOTE

Repair contactor(s) (Figure 4, Item 3) by replacing faulty contactor (Figure 4, Item 3).

1. Ensure equipment conditions are met in order presented in initial setup.

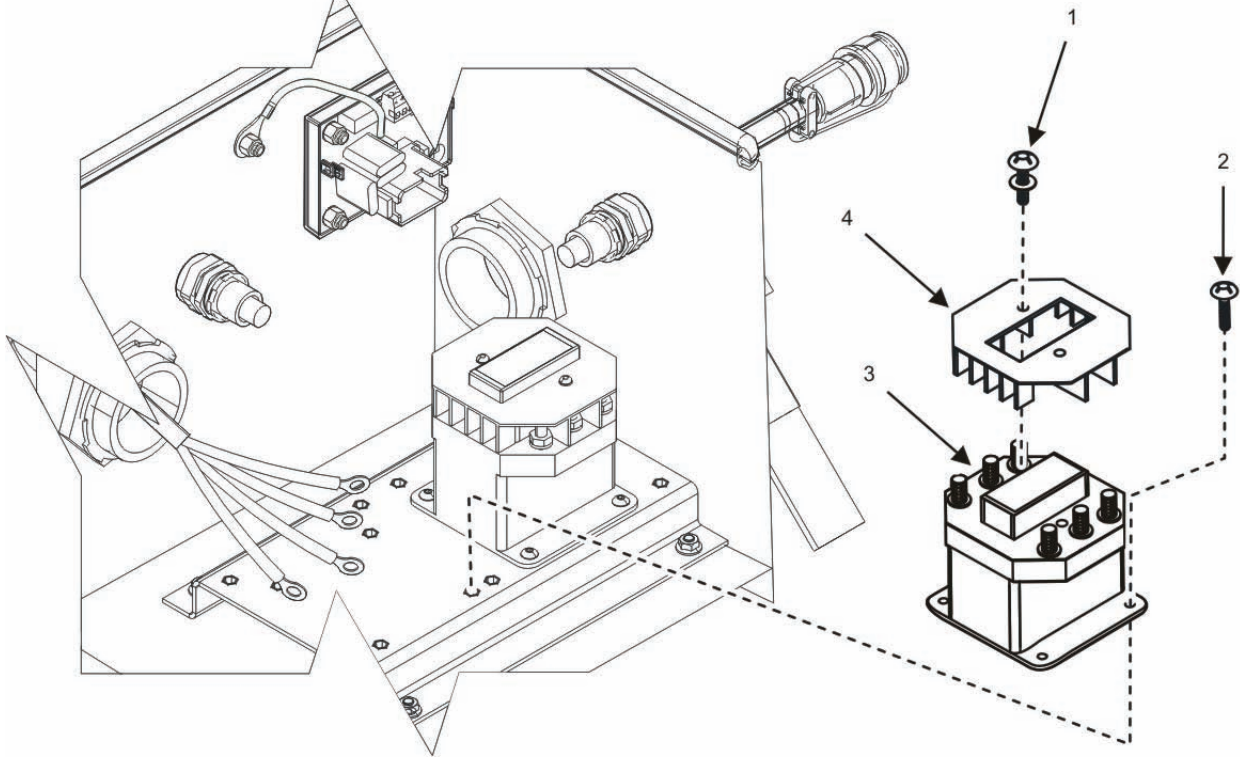

**Figure 4. Contactor — Removal.**

2. Open switch box cover.
3. Locate contactor(s) (Figure 1).
4. Remove contactor (Figure 4, Item 3).
  - a. Remove two screws and captive washers (Figure 4, Item 1) securing contactor cover (Figure 4, Item 4).
  - b. Remove contactor cover (Figure 4, Item 4).

**NOTE**

Prior to disassembly, tag all wires for identification. Tags will be used as a guide during reassembly.

Contactor (Figure 4, Item 3) is labeled (Figure 5). Label each wire according to the location label on the contactor (Figure 4, Item 3) to aid in installation.

All wires are removed from contactor studs in the same method. A1 contactor stud (Figure 6, Item 6) also secures control-card-to-N wire (Figure 6, Item 8).

- c. Ensure wiring harness wires (generator set A wiring harness: K701-A1, K701-B1, and K701-C1) (generator set B wiring harness: K702-A1, K702-B1, and K702-C1) and output terminal wires (generator set A: K701-A2, K701-B2, and K701-C2) (generator set B: K702-A2, K702-B2, and K702-C2) attached to contactor studs (Figure 6, Item 6) are clearly and appropriately labeled. Tag or label wires (Figure 4, Item 7) as needed.

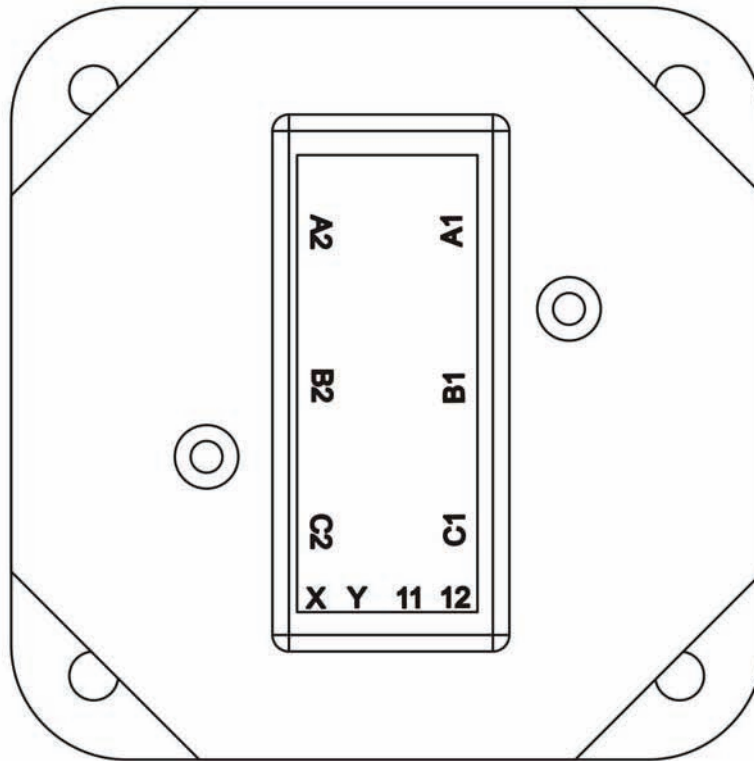

**Figure 5. Contactor — Labels.**

- d. Remove nuts (Figure 6, Item 1) and lock washers (Figure 6, Item 9) securing wires (Figure 6, Item 7) to contactor studs (Figure 6, Item 6).
- e. Remove wires (Figure 6, Item 7) and control-card-to-N wire (Figure 6, Item 8) from contactor studs (Figure 6, Item 6).
- f. Tag four control cable wires (Figure 6, Item 4) (from generator set A: K701-12, K701-11, K701-Y, and K701-X) (from generator set B: K702-12, K702-11, K702-Y, and K702-X) and two control-card-to-N wires (Figure 6, Item 3) (generator set A: K701-A1) (generator set B: K702-A1).
- g. Remove four screws with washers (Figure 6, Item 2) securing four control cable wires (Figure 6, Item 4) and two control-card-to-N wires (Figure 6, Item 3) to contactor (Figure 4, Item 3).

- h. Remove four control cable wires (Figure 6, Item 4) and two control-card-to-N wires (Figure 6, Item 3) from contactor terminals (Figure 6, Item 5).
- i. Remove four screws (Figure 4, Item 2) securing contactor (Figure 4, Item 3) to switch box.
- j. Remove contactor (Figure 4, Item 3) and place on suitable work surface.

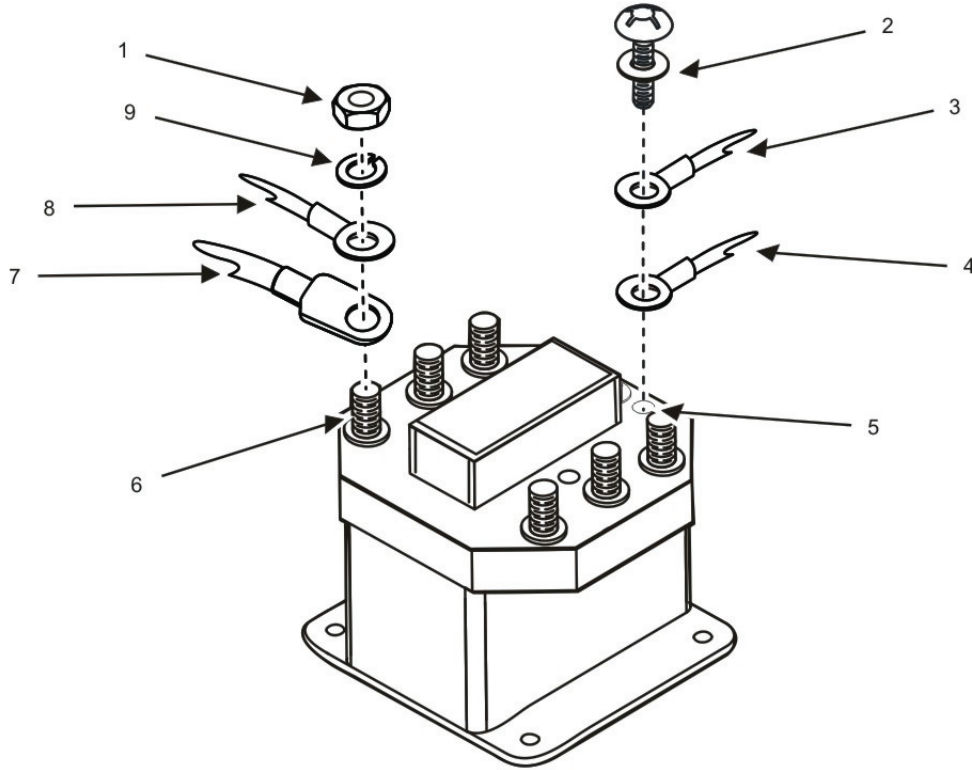

**Figure 6. Contactor Wiring — Removal.**

5. Inspect contactor (Figure 4, Item 3).
  - a. Inspect contactor cover (Figure 4, Item 4) for cracks and other obvious signs of damage. Replace contactor (Figure 4, Item 3) as required.
  - b. Inspect contactor (Figure 4, Item 3) for cracks and other obvious signs of damage. Replace contactor (Figure 4, Item 3) as required.
  - c. Inspect wires (Figure 6, Item 7) for damage. Replace wiring harness or output terminal wires (Figure 6, Item 7) as required (WP 0028, Remove/Install Switch Box Wiring Harness or Repair Output Terminals and Output Terminal Board task).
  - d. Inspect two control-card-to-N wires (Figure 6, Item 3) for cracked insulation, corrosion, and other obvious signs of damage. Replace control-card-to-N connector as required. See Replace Control Card task and Output Terminals and Output Terminal Board task.
  - e. Inspect four control cable wires (Figure 6, Item 4) for cracked insulation, corrosion, and other obvious signs of damage. Replace control cable as required. See Replace Control Cable task.
  - f. Inspect wires (Figure 6, Item 7), control-card-to-N wires (Figure 6, Items 3 and 8), control cable wires (Figure 6, Item 4) for damaged ring connectors. Repair ring connectors as required (WP 0031, General Maintenance).
6. Install contactor (Figure 4, Item 3).
  - a. Position contactor (Figure 4, Item 3) to mounting location on switch box.

- b. Secure contactor (Figure 4, Item 3) to switch box with four screws (Figure 4, Item 2). Tighten screws (Figure 4, Item 2) to 62 – 51 in/lb (6 – 7 Nm).
- c. Position four appropriately tagged control cable wires (Figure 6, Item 4) (from generator set A: K701-12, K701-11, K701-Y, and K701-X) (from generator set B: K702-12, K702-11, K702-Y, and K702-X) and two control-card-to-N wires (Figure 6, Item 3) (generator set A: K701-A1) (generator set B: K702-A1) to matching locations on contactor terminals (Figure 6, Item 5).
- d. Install four control cable wires (Figure 6, Item 4) and two control-card-to-N wires (Figure 6, Item 3) to contactor terminals (Figure 6, Item 5) and screws with washers (Figure 6, Item 2).

### NOTE

A1 contactor stud (Figure 6, Item 6) also secures control-card-to-N wire (Figure 6, Item 8). Wire (Figure 6, Item 7) that has the larger terminal lug shall be installed closest to the contactor (Figure 4, Item 3).

- e. Position six appropriately tagged wires (generator set A wiring harness: K701-A1, K701-B1, and K701-C1) (generator set B wiring harness: K702-A1, K702-B1, and K702-C1) (generator set A: K701-A2, K701-B2, and K701-C2) (generator set B: K702-A2, K702-B2, and K702-C2) to matching location on contactor studs (Figure 6, Item 6).
  - f. Secure wires (Figure 6, Item 7) with six lock washers (Figure 6, Item 9) and hex nuts (Figure 6, Item 1).
  - g. Tighten six hex nuts (Figure 6, Item 1) to a torque value of 18 – 22 ft/lb (24 – 30 Nm).
  - h. Position contactor cover (Figure 4, Item 4) over contactor (Figure 4, Item 3).
  - i. Secure contactor cover (Figure 4, Item 4) with two screws with captive washers (Figure 4, Item 1).
7. Close switch box cover.
  8. Start generator set A (TM 9-6115-750-10).
  9. Start generator set B (TM 9-6115-750-10).
  10. Confirm proper parallel operation (TM 9-6115-750-10).
  11. Repair as required.

### END OF TASK

### Replace Control Cable

### NOTE

Repair control cable(s) (Figure 7, Item 8) by replacing faulty control cable(s) (Figure 7, Item 8).

Switch box is equipped with two control cables (Figure 7, Item 8) with different part numbers. Each control cable (Figure 7, Item 8) attaches to one contactor. The procedure for removing each control cable (Figure 7, Item 8) is the same. If replacing control cable (Figure 7, Item 8), be sure to replace damaged control cable with matching replacement part.

1. Ensure equipment conditions are met in order presented in initial setup.
2. Open switch box cover.
3. Locate control cable (Figure 1) to be removed.

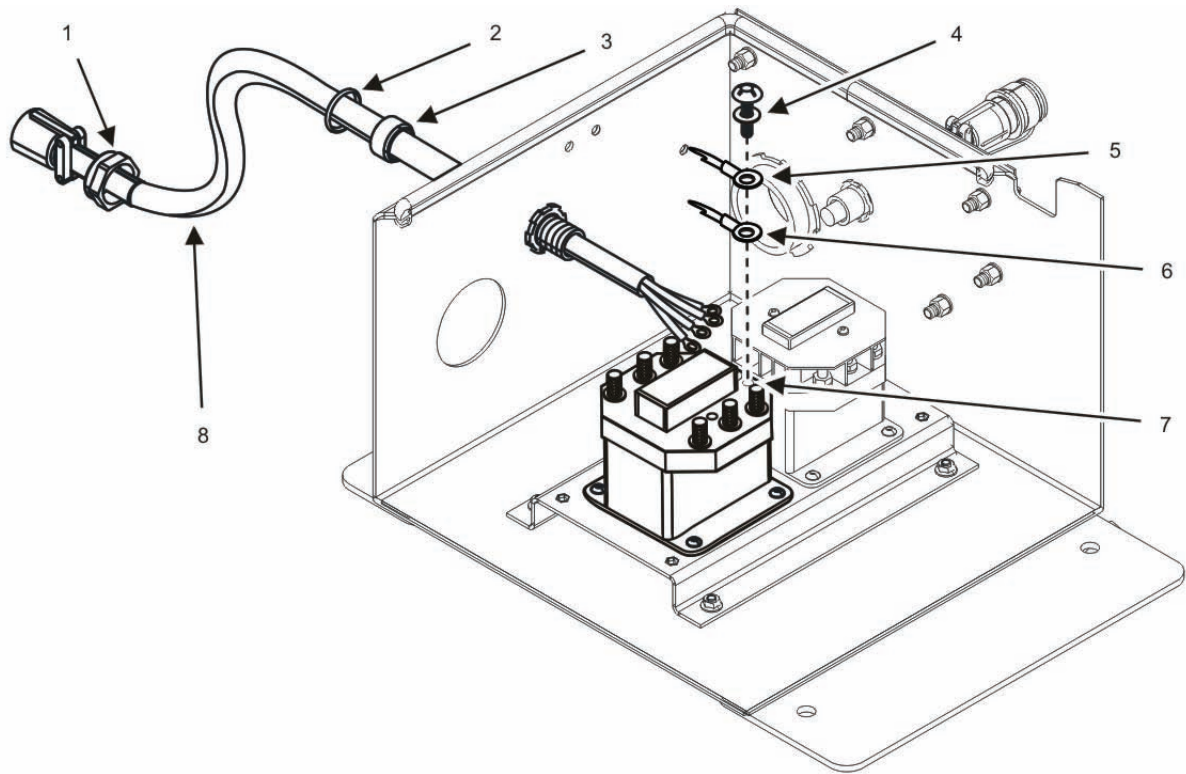

**Figure 7. Control Cable — Removal.**

4. Remove control cable (Figure 7, Item 8).
  - a. Remove contactor cover. See Replace Contactor task.
  - b. Cut cable ties securing control cable wires (Figure 7, Item 6) to other wiring harnesses in switch box assembly.

#### **NOTE**

- Two contactor terminals (Figure 7, Item 7) secure two control-card-to-N wires (Figure 7, Item 5).
- c. Tag four control cable wires (Figure 7, Item 6) and two control-card-to-N wires (Figure 7, Item 5) according to labels (Figure 5) on contactor.
  - d. Remove four screws (Figure 7, Item 4) securing control cable wires (Figure 7, Item 6) and control-card-to-N wires (Figure 7, Item 5) to contactor terminals (Figure 7, Item 7).
  - e. Loosen and slide compression nut (Figure 7, Item 1), compression ring (Figure 7, Item 2), and isolator (Figure 7, Item 3) from strain relief and onto control cable (Figure 7, Item 8).
  - f. Remove control cable (Figure 7, Item 8) from switch box assembly.
  - g. Remove control cable (Figure 7, Item 8) from SWITCH BOX CONTROL RECEPTACLE (TM 9-6115-750-10).
  - h. Install compression nut (Figure 7, Item 1), compression ring (Figure 7, Item 2), and isolator (Figure 7, Item 3) onto strain relief at switch box housing.
5. Inspect control cable (Figure 7, Item 8).
    - a. Inspect control cable wires (Figure 7, Item 6) for corrosion and cracks in insulation.

- b. Inspect ring connectors of control cable wires (Figure 7, Item 6) for corrosion, cracks, and other obvious signs of damage. Repair ring connectors as required (WP 0031, General Maintenance).
  - c. Inspect multipin pin connector of control cable (Figure 7, Item 8) for damage. Repair as required (WP 0031, General Maintenance).
  - d. Inspect control cable (Figure 7, Item 8) strain relief for cracks and other obvious signs of damage.
  - e. Replace control cable (Figure 7, Item 8) if any irreparable damage is found.
6. Test control cable (Figure 7, Item 8).

### NOTE

Use Foldout Pages in Rear Matter to locate connections between ring connector and multipin socket.

- a. Test four control cable wires (Figure 7, Item 6) for continuity between ring connector and appropriate multipin connector socket using multimeter see (WP 0031, General Maintenance).
  - b. Test two control-card-to-N wires for continuity using multimeter see (WP 0031, General Maintenance).
  - c. Replace control cable (Figure 7, Item 8) if continuity is not found.
7. Install control cable (Figure 7, Item 8).
- a. Slide compression nut (Figure 7, Item 1), compression ring (Figure 7, Item 2), and isolator (Figure 7, Item 3) onto control cable (Figure 7, Item 8).
  - b. Insert control cable wires (Figure 7, Item 6) through strain relief hole in switch box housing.
  - c. Position four appropriately tagged control cable wires (Figure 7, Item 6) and two control-card-to-N wires (Figure 7, Item 5) to noted positions on contactor terminals (Figure 7, Item 7).
  - d. Install control cable wires (Figure 7, Item 6) and control-card-to-N wires (Figure 7, Item 5) to contactor terminals (Figure 7, Item 7) with four screws (Figure 7, Item 4).
  - e. Install contactor cover. See Replace Contactor task.
  - f. Position isolator (Figure 7, Item 3) and compression ring (Figure 7, Item 2) to strain relief.
  - g. Install compression nut (Figure 7, Item 1) onto strain relief to secure control cable (Figure 7, Item 8) to switch box housing.
  - h. Install control cable to SWITCH BOX CONTROL RECEPTACLE (TM 9-6115-750-10).
8. Close switch box cover.
9. Start generator set A (TM 9-6115-750-10).
10. Start generator set B (TM 9-6115-750-10).
11. Confirm proper parallel operation (TM 9-6115-750-10).
12. Repair as required.

### END OF TASK

#### Replace Control Card

### NOTE

Repair control card (Figure 8, Item 2) by replacing damaged control card (Figure 8, Item 2).

1. Ensure equipment conditions are met in order presented in initial setup.
2. Open switch box cover.

3. Locate control card (Figure 1).

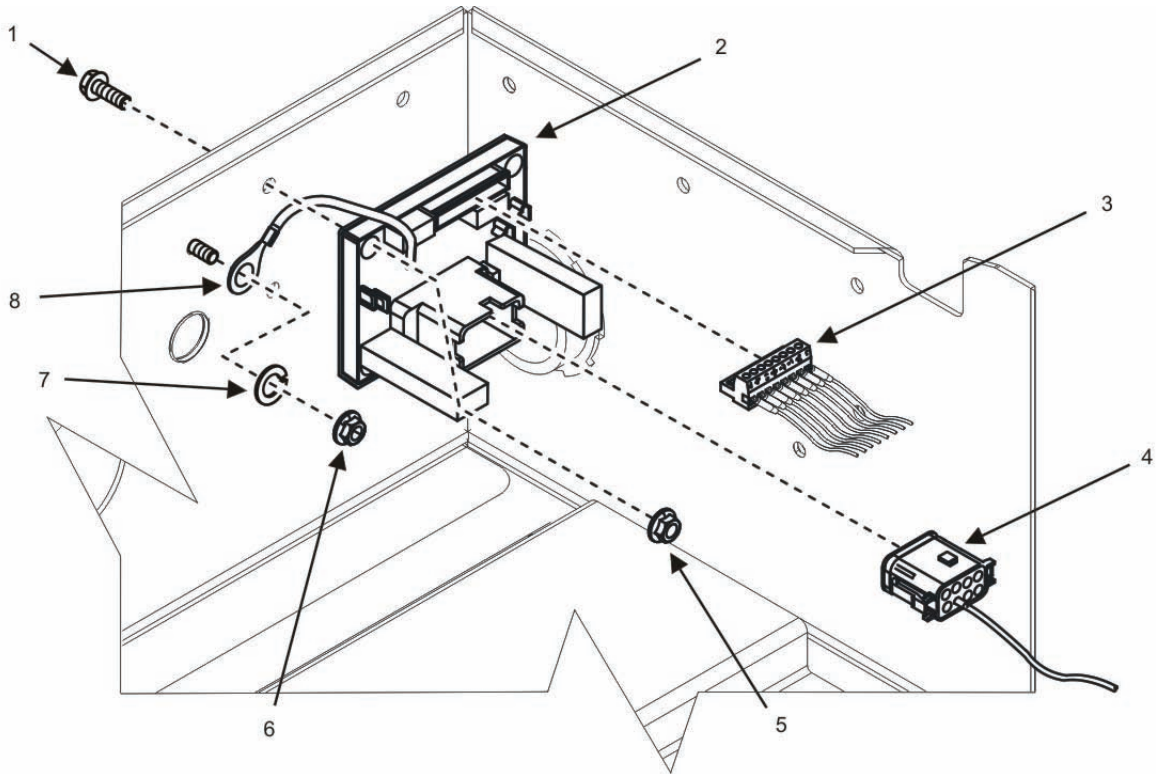

**Figure 8. Control Card — Removal.**

4. Remove control card (Figure 8, Item 2).
  - a. Remove nut (Figure 8, Item 6) and lock washer (Figure 8, Item 7) securing wire (Figure 8, Item 8) to interior switch box housing.
  - b. Discard lock washer (Figure 8, Item 7).
  - c. Tag control-card-to-N connector (Figure 8, Item 4) and control-card-to-indicator-lights connector (Figure 8, Item 3).
  - d. Disconnect control-card-to-N connector (Figure 8, Item 4).
  - e. Inspect wires of control-card-to-N connector (Figure 8, Item 4) for damage or corrosion. Repair control-card-to-N connector (Figure 8, Item 4) as required (WP 0031, General Maintenance).
  - f. Disconnect control-card-to-indicator-lights connector (Figure 8, Item 3).
  - g. Remove four flange nuts (Figure 8, Item 5) and screws (Figure 8, Item 1) securing control card (Figure 8, Item 2) to interior switch box housing.
5. Inspect control card (Figure 8, Item 2).
  - a. Inspect control card (Figure 8, Item 2) for cracks, corrosion, and other obvious signs of damage.
  - b. Inspect wire (Figure 8, Item 8) for obvious signs of damage.
  - c. Replace control card (Figure 8, Item 2) if damage is found.
  - d. Inspect ring connector of wire (Figure 8, Item 8) for cracks, corrosion, and other obvious signs of damage. Repair ring connector as required (WP 0031, General Maintenance).
6. Install control card (Figure 8, Item 2).

- a. Place control card (Figure 8, Item 2) to mounting location on interior switch box housing.
  - b. Secure to interior switch box housing with four screws (Figure 8, Item 1) and flange nuts (Figure 8, Item 5) to secure control card (Figure 8, Item 2).
  - c. Connect control-card-to-indicator-lights connector (Figure 8, Item 3) to control card (Figure 8, Item 2).
  - d. Connect control-card-to-N connector (Figure 8, Item 4) to control card (Figure 8, Item 2).
  - e. Attach wire (Figure 8, Item 8) from control card to interior switch box housing with nut (Figure 8, Item 6) and new lock washer (Figure 8, Item 7).
  - f. Tighten nut (Figure 8, Item 6) to 86.7– 105.3 in/lb (9.8 – 11.9 Nm).
7. Close switch box cover.
  8. Start generator set A (TM 9-6115-750-10).
  9. Start generator set B (TM 9-6115-750-10).
  10. Confirm proper parallel operation (TM 9-6115-750-10).
  11. Repair as required.

**END OF TASK**

**Replace Indicator Light**

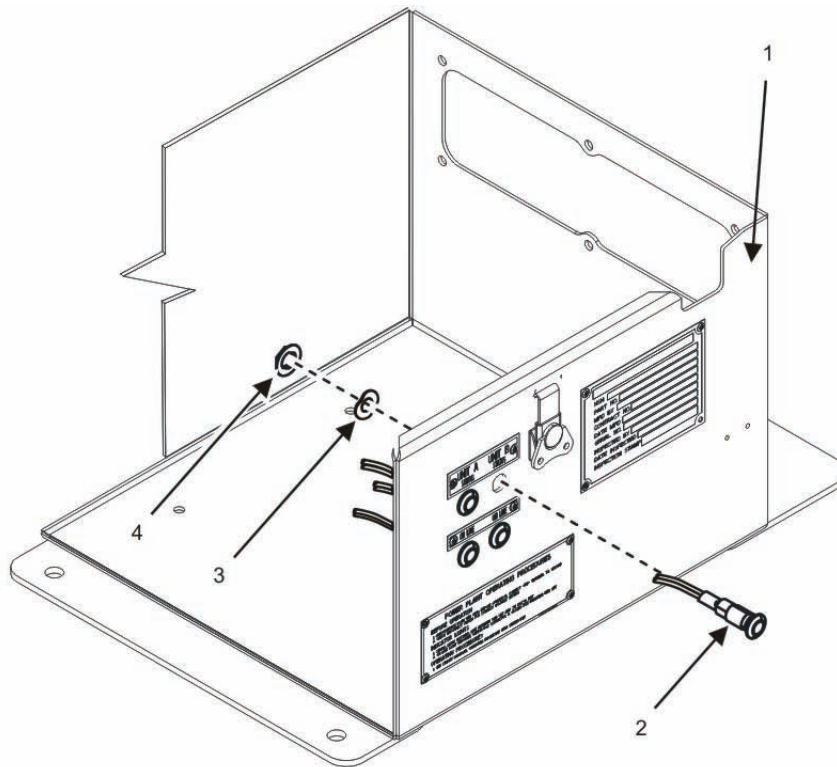

**Figure 9. Indicator Light — Removal.**

**NOTE**

Repair indicator light(s) (Figure 9, Item 2) by replacing faulty indicator light (Figure 9, Item 2).

1. Ensure equipment conditions are met in order presented in initial setup.



2. Open switch box cover.
3. Locate indicator light (Figure 1) to be removed.
4. Remove indicator light (Figure 9, Item 2).
  - a. Cut any cable ties on indicator light wires (Figure 10, Item 2).

### NOTE

Indicator light terminals (Figure 10, Item 3) are labeled on the connector (Figure 10, Item 4). If removing more than one indicator light (Figure 9, Item 2) at the same time, note which labeled terminals (Figure 10, Item 3) apply to each light. Black wires connect to negative numbers, and red wires connect to positive numbers.

- b. Tag black and red wires (Figure 10, Item 2) according to labeled terminals (Figure 10, Item 3).
- c. Remove screws (Figure 10, Item 1) securing black and red wires (Figure 10, Item 2) from indicator light (Figure 9, Item 2) to be removed.
- d. Remove black and red wires (Figure 10, Item 2) from terminals (Figure 10, Item 3).
- e. Remove nut (Figure 9, Item 4) and washer (Figure 9, Item 3) securing indicator light (Figure 9, Item 2) to switch box housing (Figure 9, Item 1).
- f. Remove indicator light (Figure 9, Item 2) through front of switch box housing (Figure 9, Item 1).
- g. Repeat steps 4b – e as needed for other indicator lights (Figure 9, Item 2) to be removed.

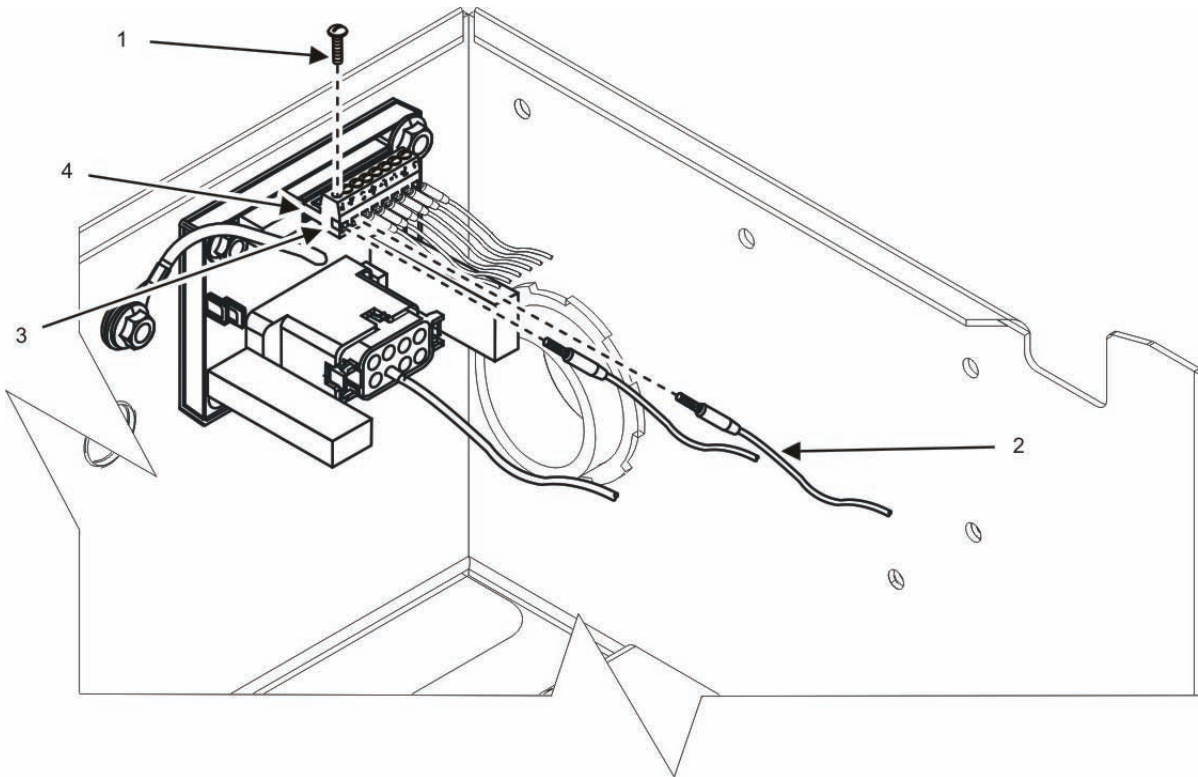

Figure 10. Indicator Light Wiring — Removal.

- 
5. Inspect indicator light (Figure 9, Item 2).
    - a. Inspect indicator light (Figure 9, Item 2) for broken lens, torn wires, and other obvious signs of damage. Replace indicator light (Figure 9, Item 2) as required.
    - b. Inspect indicator light connector (Figure 10, Item 4) for cracks and other obvious signs of damage. Replace connector (Figure 10, Item 4) as required.
  6. Install indicator light (Figure 9, Item 2).
    - a. Position indicator light (Figure 9, Item 2) through front of switch box housing (Figure 9, Item 1).
    - b. Secure indicator light (Figure 9, Item 2) to switch box housing (Figure 9, Item 1) with washer (Figure 9, Item 3) and nut (Figure 9, Item 4).
    - c. Position black and red wires (Figure 10, Item 2) to tagged terminals (Figure 10, Item 3) on indicator light connector (Figure 10, Item 4).
    - d. Install wires (Figure 10, Item 2) to indicator light connector (Figure 10, Item 4) with screws (Figure 10, Item 1).
    - e. Repeat steps 6a – d for remaining indicator lights (Figure 9, Item 2) to be installed, as needed.
    - f. Secure wires (Figure 10, Item 2) of all indicator lights (Figure 9, Item 2) together with new cable ties.
  7. Close switch box cover.
  8. Start generator set A (TM 9-6115-750-10).
  9. Start generator set B (TM 9-6115-750-10).
  10. Confirm proper parallel operation (TM 9-6115-750-10).
  11. Repair as required.

**END OF TASK**

**END OF WORK PACKAGE**

---

**FIELD MAINTENANCE**  
**AMMPS 10KW TRAILER-MOUNTED POWER UNITS AND POWER PLANTS**  
**REMOVE/INSTALL SWITCH BOX WIRING HARNESS**

---

**INITIAL SETUP:****Test Equipment**

Not Applicable

**Tools and Special Tools**

Strap, Wrist, Electrostatic Discharge (WP 0057, Table 2, Item 8)

Tool Kit, General Mechanic's (GMTK) (WP 0057, Table 2, Item 10)

Wrench, Torque, Click, Ratcheting, 1/2" Drive, 250 FT-LB (WP 0057, Table 2, Item 13)

Wrench, Torque, Dial, 3/8" Drive, 300 IN-LB (WP 0057, Table 2, Item 15)

**Materials/Parts**

Cable, power (WP 0050, Repair Parts List, Figure 15, Item 23)

Cable, power (WP 0050, Figure 15, Item 30)

**Personnel Required**

91D (1)

**References**

WP 0025, Remove/Install Switch Box Assembly

WP 0027, Replace Switch Box Components

WP 0031, General Maintenance

**Equipment Conditions**

Engine control switch OFF (TM 9-6115-750-10, WP 0005)

Engine cool

Wheels chocked, brakes applied (M200A1 – TM 9-2330-205-14&P)

Front trailer supports deployed (M200A1 – TM 9-2330-205-14&P)

Rear step jacks deployed (M200A1 – TM 9-2330-205-14&P)

**REMOVE/INSTALL SWITCH BOX WIRING HARNESS****CAUTION**

Printed circuit boards/cards contain components that are sensitive to static electricity. Always wear an antistatic wrist strap connected to a metal surface to channel static electricity to ground when handling printed circuit boards/cards. Failure to comply may cause damage to equipment.

**Remove Switch Box Wiring Harness****NOTE**

Switch boxes are equipped with two wiring harnesses. Generator set A wiring harness has a different part number than generator set B wiring harness. Procedure for removing wiring harnesses is the same. If replacing wiring harness, be sure to replace damaged wiring harness with appropriate replacement part.

1. Ensure equipment conditions are met in order presented in initial setup.
2. Open switch box cover.
3. Locate wiring harness(s) (Figure 1) to be removed.

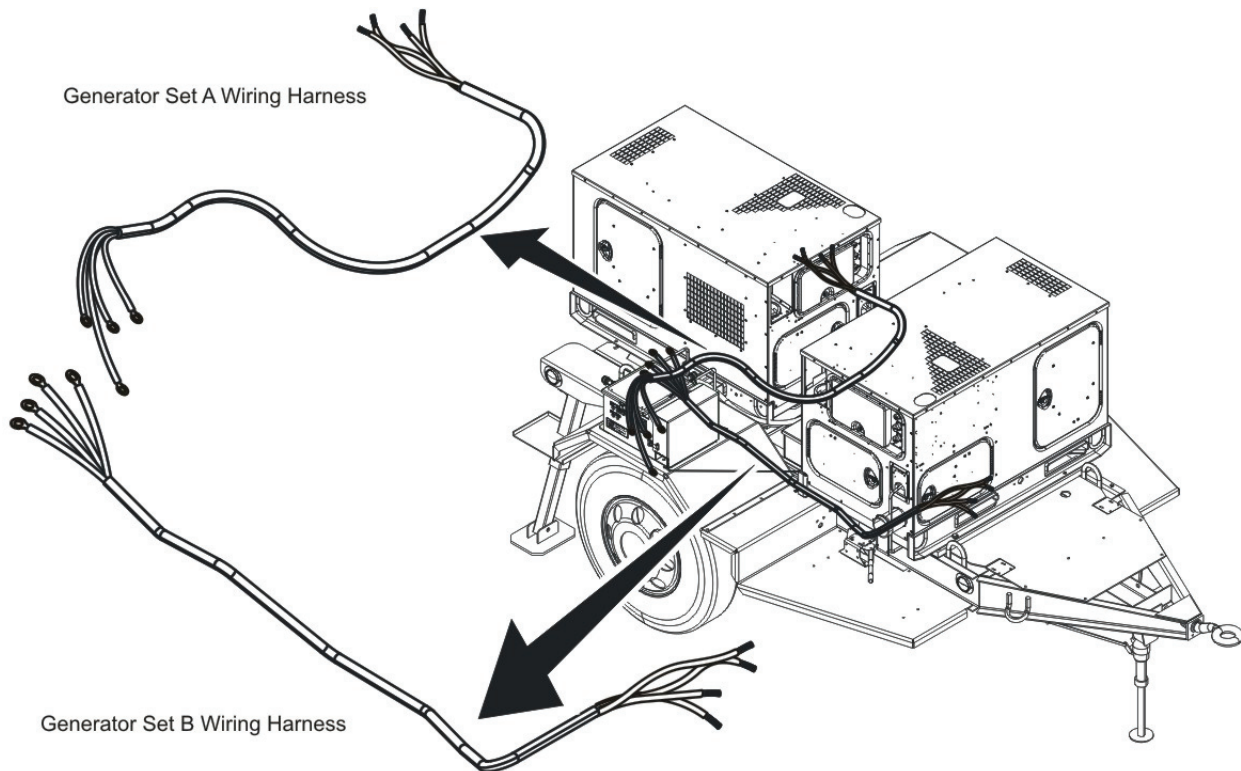

**Figure 1. Wiring Harnesses PP-3102 — Location.**

4. Remove wiring harness (Figure 2, Item 7) from output box of generator (WP 0025, Remove/Install Switch Box Assembly).

#### **NOTE**

PP-3102 contains numerous clamps at various locations on the trailer, generator sets, and switch box. Note location of removed P-clamps for installation.

5. Remove bolt securing wiring harness (Figure 2, Item 7) P-clamps to PP (WP 0031, General Maintenance).
6. Cut any cable ties that attach wiring harness (Figure 2, Item 7) to other wires in switch box assembly.
7. Remove contactor cover (WP 0027, Replace Switch Box Components).

#### **NOTE**

Figure 2 shows generator set A wiring harness (Figure 2, Item 7). Removal procedure is the same for removal of generator set B wiring harness.

8. Ensure wiring harness wires (Figure 2, Item 4) (generator set A wiring harness: K701-A1, K701-B1, and K701-C1) (generator set B wiring harness: K702-A1, K702-B1, and K702-C1) attached to contactor (Figure 2, Item 6) are clearly and appropriately labeled. Tag or label wiring harness wires (Figure 2, Item 4) as needed.
9. Remove nuts (Figure 2, Item 1) and lock washers (Figure 2, Item 2) securing wiring harness wires (Figure 2, Item 4) to contactor studs (Figure 2, Item 5).

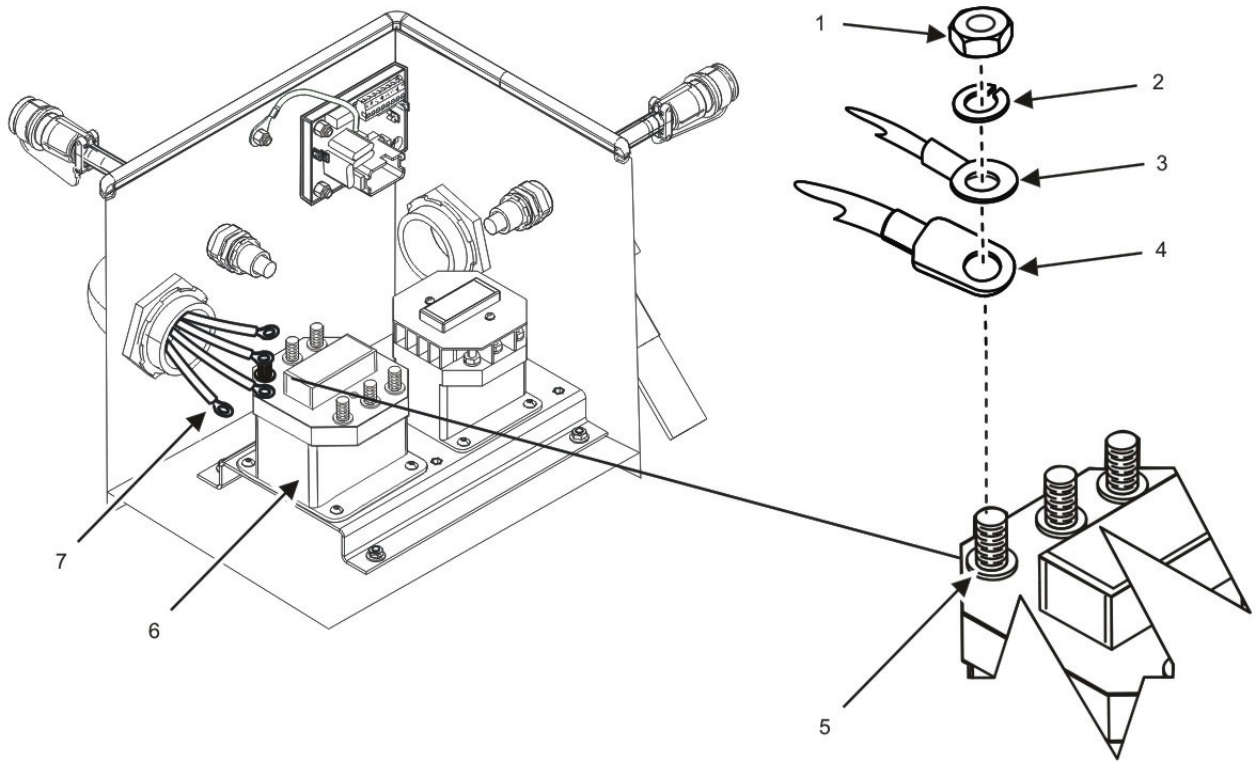

Figure 2. Wiring Harness Removal from Contactor.

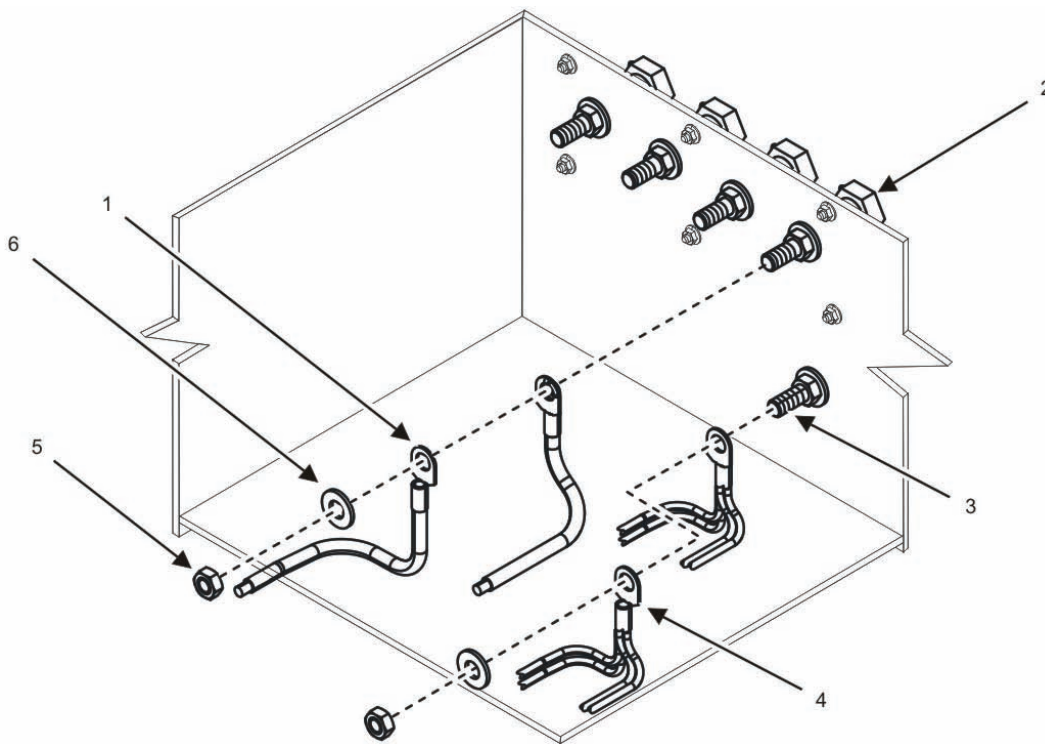
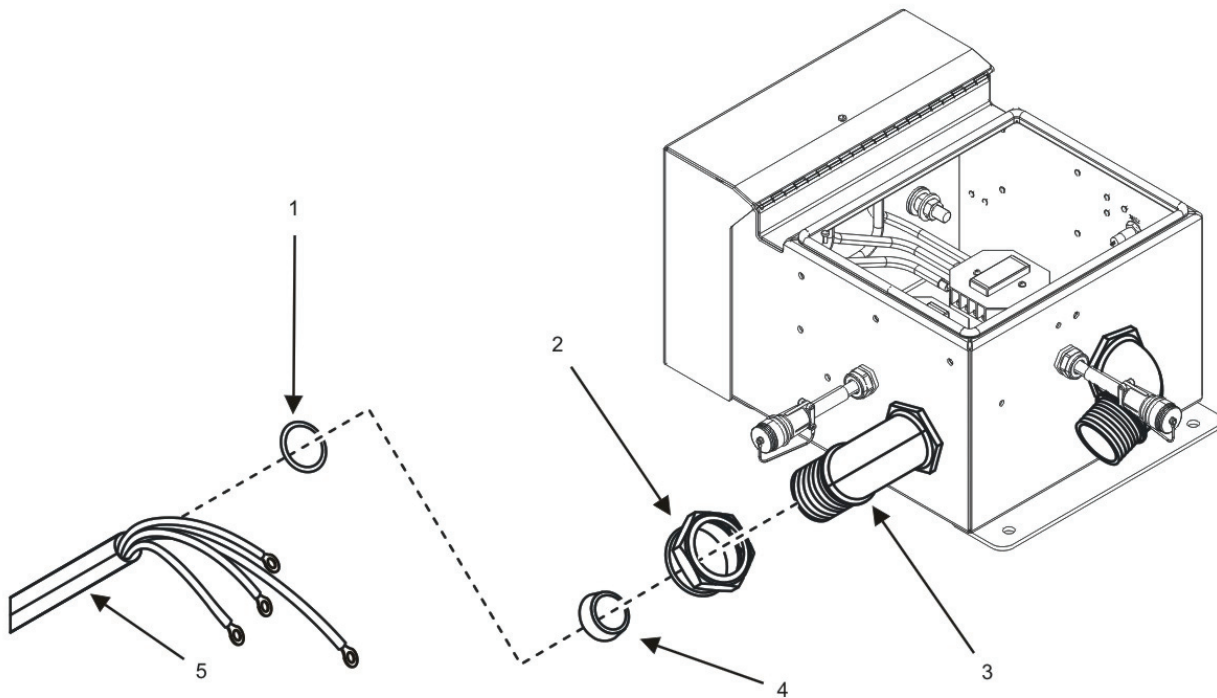

Figure 3. Wiring Harness Removal from Output Terminal Studs.

**NOTE**

A1 contactor stud (Figure 2, Item 5) also secures control-card-to-N wire (Figure 2, Item 3) (generator set A wire K701-A1) (generator set B wire K702-A1) (WP 0027, Replace Switch Box Components).

10. Remove wiring harness wires (Figure 2, Item 4) and control-card-to-N wire (Figure 2, Item 3) from contactor (Figure 2, Item 6).



**Figure 4. Wiring Harness — Removal.**

11. Ensure N wire (Figure 3, Item 1) and GND wire (Figure 3, Item 4) of wiring harness (Figure 4, Item 5) attached to the back of N (Figure 3, Item 2) and GND (Figure 3, Item 3) output terminal studs are clearly and appropriately labeled. Tag or label N wire (Figure 3, Item 1) and GND wire (Figure 3, Item 4) as needed.
12. Remove nuts (Figure 3, Item 5) and flat washers (Figure 3, Item 6) securing N wire (Figure 3, Item 1) and GND wire (Figure 3, Item 4) from back of N (Figure 3, Item 2) and GND (Figure 3, Item 3) output terminal studs.
13. Remove N wire (Figure 3, Item 1) and GND wire (Figure 3, Item 4) from rear of N (Figure 3, Item 2) and GND (Figure 3, Item 3) output terminal studs.

**NOTE**

Generator set B wiring harness (Figure 4, Item 5) is shown in Figure 4. Removal of generator set A wiring harness is the same as generator set B wiring harness (Figure 4, Item 5).

14. Loosen compression nut (Figure 4, Item 2) from strain relief (Figure 4, Item 3).
15. Slide compression nut (Figure 4, Item 2), compression ring (Figure 4, Item 1), and isolator (Figure 4, Item 4) off strain relief (Figure 4, Item 3) and onto wiring harness (Figure 4, Item 5).
16. Remove wiring harness (Figure 4, Item 5) from switch box assembly through strain relief (Figure 4, Item 3).

17. Place wiring harness (Figure 4, Item 5) on a suitable work surface.
18. Install compression nut (Figure 4, Item 2), compression ring (Figure 4, Item 1), and isolator (Figure 4, Item 4) onto strain relief (Figure 4, Item 3).

#### **END OF TASK**

#### **Inspect Switch Box Wiring Harness**

1. Inspect wiring harness wires (Figure 2, Item 4) for corrosion and cracks in insulation. Replace wiring harness (Figure 2, Item 7) as required.
2. Inspect ring connectors of wiring harness wires (Figure 2, Item 4) for corrosion, cracks, and other obvious signs of damage. Repair ring connectors as required (WP 0031, General Maintenance).
3. Inspect strain relief (Figure 4, Item 3), compression nut (Figure 4, Item 2), compression ring (Figure 4, Item 1), and isolator (Figure 4, Item 4) for cracks, corrosion, and other obvious signs of damage. Replace strain relief (Figure 4, Item 3) as required.

#### **END OF TASK**

#### **Install Switch Box Wiring Harness**

1. Slide compression nut (Figure 4, Item 2), compression ring (Figure 4, Item 1), and isolator (Figure 4, Item 4) over wiring harness (Figure 4, Item 5).
2. Insert wiring harness (Figure 4, Item 5) through strain relief (Figure 4, Item 3) into switch box assembly.
3. Position appropriately tagged N wire (Figure 3, Item 1) and GND wire (Figure 3, Item 4) to N (Figure 3, Item 2) and GND (Figure 3, Item 3) output terminal studs.
4. Secure N wire (Figure 3, Item 1) to N (Figure 3, Item 2) output terminal stud and GND wire (Figure 3, Item 4) to GND (Figure 3, Item 3) output terminal stud with nuts (Figure 3, Item 5) and flat washers (Figure 3, Item 6).
5. Tighten nuts (Figure 3, Item 5) to 35 ft/lb (47 Nm).

#### **NOTE**

A1 contactor stud (Figure 2, Item 5) also secures control card N wire (Figure 2, Item 3). Wiring harness wire (Figure 2, Item 4) has the larger terminal lug and shall be installed closest to the contactor (Figure 2, Item 6).

6. Position appropriately tagged wiring harness wires (Figure 2, Item 4) (generator set A wiring harness: K701-A1, K701-B1, and K701-C1) (generator set B wiring harness: K702-A1, K702-B1, and K702-C1) and control-card-to-N wire (Figure 2, Item 3) (generator set A: K701-A1) (generator set B: K702-A1) to matching location on contactor studs (Figure 2, Item 5).
7. Secure wiring harness wires (Figure 2, Item 4) and control-card-to-N wire to contactor studs (Figure 2, Item 5) with lock washer (Figure 2, Item 2) and nut (Figure 2, Item 1).
8. Tighten nut (Figure 2, Item 1) to 69 – 85 in/lb (8 – 10 Nm).
9. Install contactor cover over contactor (WP 0027, Replace Switch Box Components).
10. Close switch box cover.
11. Position compression ring (Figure 4, Item 1) and isolator (Figure 4, Item 4) to strain relief (Figure 4, Item 3) gap.
12. Tighten compression nut (Figure 4, Item 2) on strain relief (Figure 4, Item 3).
13. Install bolts that secure wiring harness P-clamps to PP (WP 0031, General Maintenance).

14. Install wiring harness to output box of generator (WP 0025, Remove/Install Switch Box Assembly).
15. Start generator set A (TM 9-6115-750-10).
16. Start generator set B (TM 9-6115-750-10).
17. Confirm proper parallel operation (TM 9-6115-750-10).
18. Repair as required.

**END OF TASK**

**END OF WORK PACKAGE**



---

**FIELD MAINTENANCE**  
**AMMPS 10KW TRAILER-MOUNTED POWER UNITS AND POWER PLANTS**  
**REPLACE TRAILER LEG PROP ASSEMBLY**

---

**INITIAL SETUP:****Test Equipment**

Not Applicable

**References**

Not Applicable

**Tools and Special Tools**

Riveter Kit, Blind, Hand (WP 0057, Table 2, Item 7)

Tool Kit, Blind, Fastener, Installation (WP 0057, Table 2, Item 9)

Tool Kit, General Mechanic's (GMTK) (WP 0057, Table 2, Item 10)

**Equipment Conditions**

Engine control switch OFF (TM 9-6115-750-10, WP 0005)

Wheels chocked, brakes applied (LTT – TM 9-2330-392-14&amp;P), (M200A1 – TM 9-2330-205-14&amp;P)

Front trailer support(s) deployed (LTT – TM 9-2330-392-14&amp;P), (M200A1 – TM 9-2330-205-14&amp;P)

**Materials/Parts**

Jack, leveling support (1) (WP 0043, Repair Parts List, Figure 8, Item 1)

Pin, cotter (2) (WP 0043, Figure 8, Item 10)

Rivet, blind (3) (WP 0043, Figure 8, Item 11)

Rear leg prop assembly deployed (WP 0005, Operation Under Usual Conditions)

Rear step jacks deployed (M200A1 – TM 9-2330-205-14&amp;P)

Generator set removed (WP 0018, Remove/Install Generator Set)

**Personnel Required**

91D (1)

---

**REPLACE LEG PROP ASSEMBLY****Replace Trailer Leg Prop Assembly**

1. Ensure equipment conditions are met in order presented in initial setup.
2. Locate trailer leg prop assembly (Figure 1).
3. Support trailer chassis (Figure 1, Item 1) to prevent trailer from tipping when lower leg prop (Figure 2, Item 5) is raised.

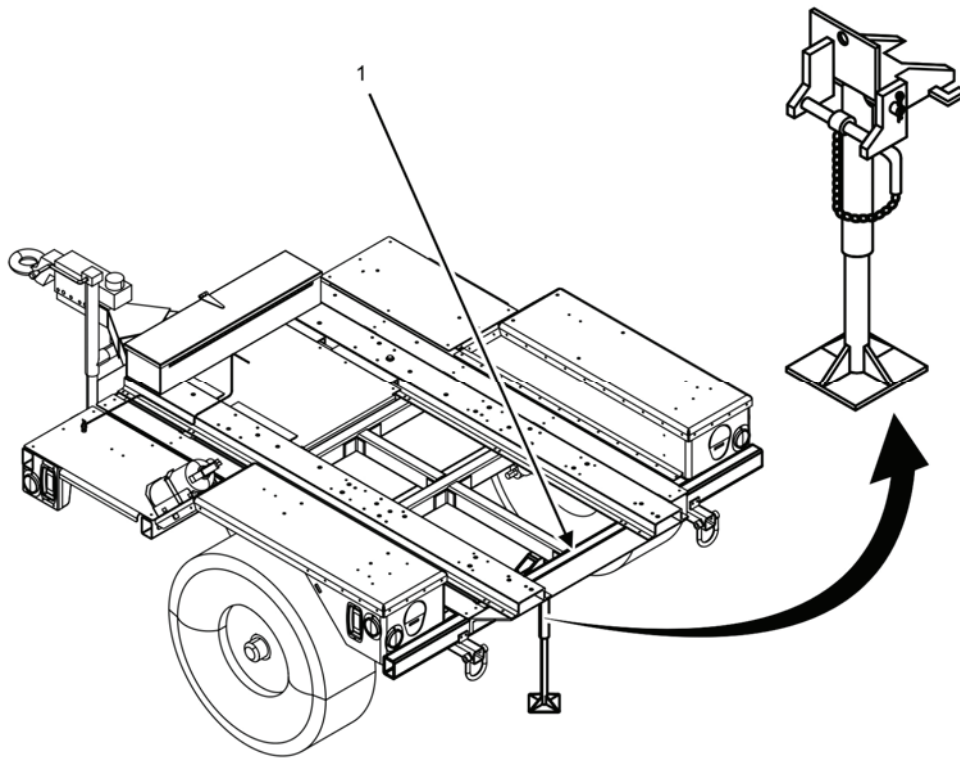

**Figure 1. Trailer Leg Prop Assembly — Location.**

4. Remove locking pin (Figure 2, Item 4) from leg prop bracket (Figure 2, Item 3).
5. Turn lower leg prop (Figure 2, Item 5) counterclockwise to raise lower leg prop (Figure 2, Item 5) until it is completely retracted.
6. Straighten cotter pins (Figure 2, Item 2) on each end of pivot rod (Figure 2, Item 1).
7. Remove cotter pins (Figure 2, Item 2) from pivot rod (Figure 2, Item 1).
8. Discard used cotter pins (Figure 2, Item 1).
9. Support leg prop assembly (Figure 2, Item 6).
10. Remove pivot rod (Figure 3, Item 1) from leg prop bracket (Figure 3, Item 3).
11. Remove leg prop assembly (Figure 2, Item 6) from leg prop bracket (Figure 3, Item 3).
12. Remove three rivets (Figure 3, Item 4) from leg prop bracket (Figure 3, Item 3).
13. Remove leg prop bracket (Figure 3, Item 3) from trailer chassis (Figure 1, Item 1).
14. Align holes in new leg prop bracket (Figure 3, Item 3) with matching holes on trailer chassis (Figure 1, Item 1).
15. Install three rivets (Figure 3, Item 4) into each aligned hole before any rivets (Figure 3, Item 4) are cinched.

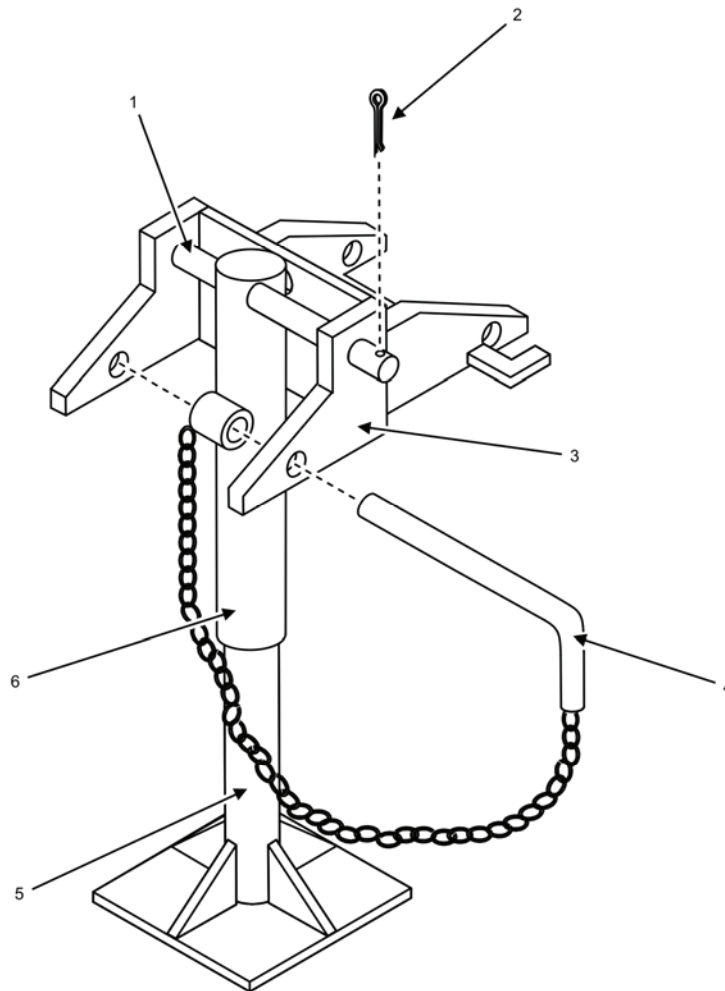

**Figure 2. Leg Prop Assembly — Detail 1.**

16. Cinch three rivets (Figure 3, Item 4) to firmly attach leg prop bracket (Figure 3, Item 3) to trailer chassis (Figure 1, Item 1).
17. Proceed to step 20 if one end of pivot rod (Figure 3, Item 1) contains an inserted and bent cotter pin (Figure 3, Item 2). Otherwise, proceed to step 18.
18. Insert cotter pin (Figure 3, Item 2) into one end of pivot rod (Figure 3, Item 1) if neither end of the pivot rod (Figure 3, Item 1) contains a cotter pin (Figure 3, Item 2).
19. Bend end of cotter pin (Figure 3, Item 1) to retain within the pivot rod (Figure 3, Item 2) end.
20. Position leg prop assembly (Figure 2, Item 6) to align with holes in leg prop bracket (Figure 2, Item 3).
21. Insert the pivot rod (Figure 2, Item 1) end without a cotter pin (Figure 2, Item 2) into aligned holes until second cotter pin hole is visible beyond the leg prop bracket (Figure 2, Item 3).
22. Insert second cotter pin (Figure 2, Item 2).

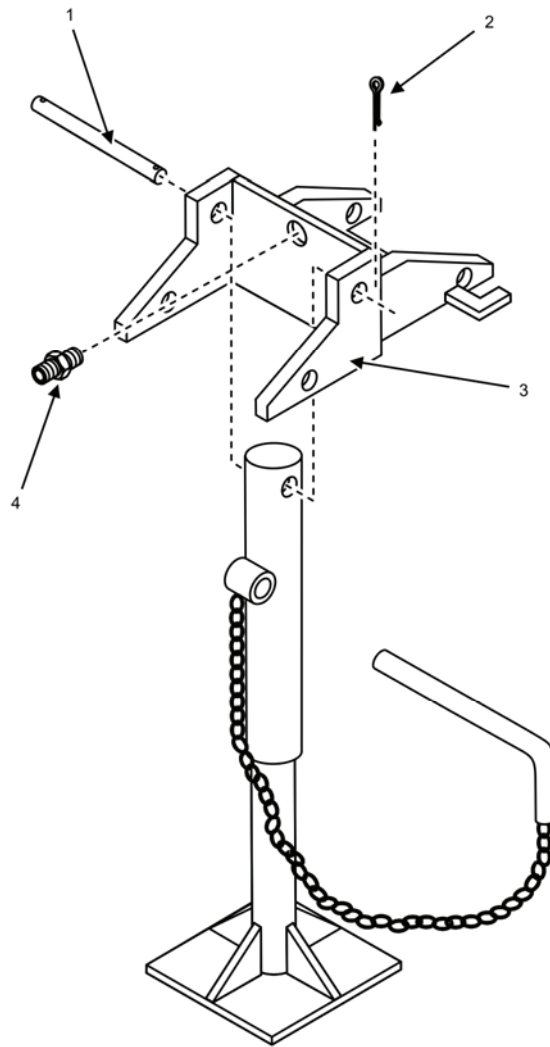

**Figure 3. Leg Prop Assembly — Detail 2.**

23. Bend end of second cotter pin (Figure 2, Item 2) to retain within the pivot rod (Figure 2, Item 1) end.
24. Raise leg prop assembly (Figure 2, Item 6) from vertical/extended position to horizontal/travel position to test freedom of movement and repair as required.
25. Lower leg prop assembly (Figure 2, Item 6) to vertical/extended position.
26. Insert locking pin (Figure 2, Item 4).
27. Turn lower leg prop (Figure 2, Item 5) clockwise until it makes firm contact with surface.
28. Install generator set if removed (WP 0018, Remove/Install Generator Set).
29. Remove temporary trailer support.

**END OF TASK**

**END OF WORK PACKAGE**

---

**FIELD MAINTENANCE**  
**AMMPS 10KW TRAILER-MOUNTED POWER UNITS AND POWER PLANTS**  
**REMOVE/INSTALL HAND BRAKE MODIFICATION**

---

**INITIAL SETUP:****Test Equipment**

Not Applicable

**Tools and Special Tools**

Tool Kit, General Mechanic's (GMTK) (WP 0057, Table 2, Item 10)

Wrench, Torque, Click, Ratcheting 1/2" Drive, 250 FT-LB (WP 0057, Table 2, Item 13)

**Materials/Parts**

Bracket, brake cable (2) (WP 0041, Repair Parts List, Figure 6, Item 7)

Nut, self-locking, hexagonal (16) (WP 0041, Figure 6, Item 6)

Spacer, sleeve (4) (WP 0041, Figure 6, Item 5)

**Personnel Required**

91D (1)

**References**

Not Applicable

**Equipment Conditions**

Engine control switch OFF (TM 9-6115-750-10, WP 0005)

Wheels chocked, brakes applied (M200A1 – TM 9-2330-205-14&amp;P)

Front trailer support deployed (M200A1 – TM 9-2330-205-14&amp;P)

Rear step jacks deployed (M200A1 – TM 9-2330-205-14&amp;P)

**REMOVE/INSTALL HAND BRAKE BRACKET****Remove Hand Brake Bracket (PP-3102)****NOTE**

Generator set roadside hand brake bracket (Figure 2, Item 1) and curbside hand brake bracket use the same hardware and procedure to remove and install. Either or both can be removed and installed using this procedure.

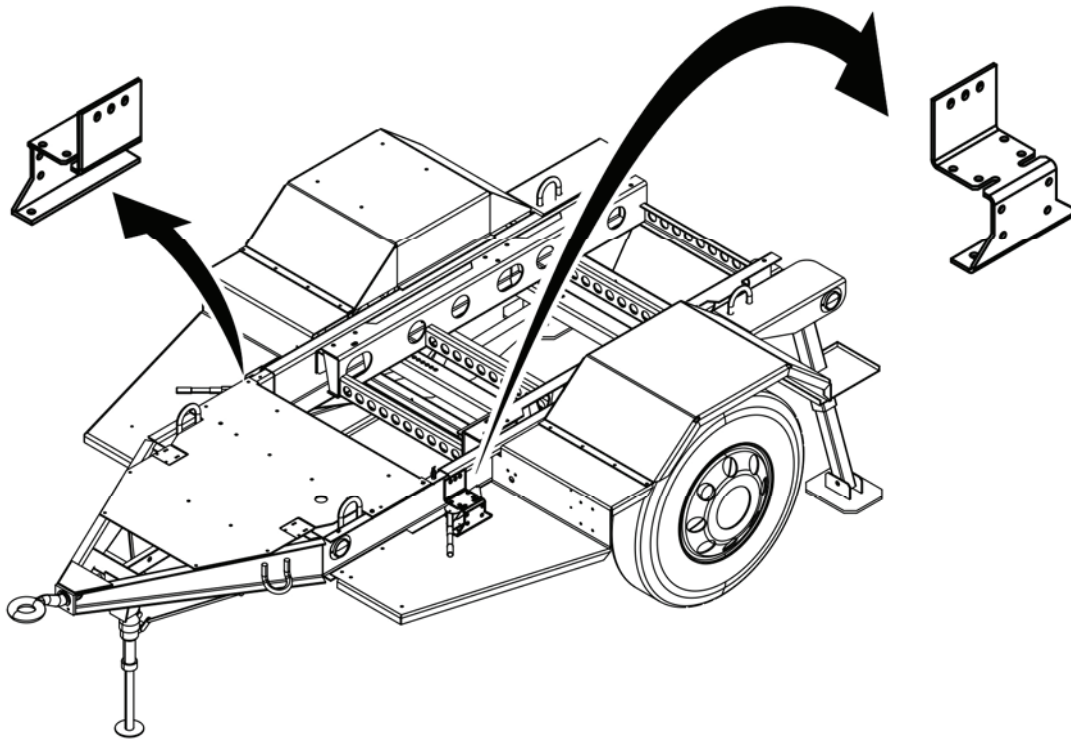

**Figure 1. Hand Brake Bracket — Location.**

1. Ensure equipment conditions are met in order presented in initial setup.
2. Locate hand brake bracket (Figure 1).
3. Release brake tension by moving hand brake lever (Figure 2, Item 7) toward trailer wheels.
4. Straighten ends of cotter pin (Figure 3, Item 2).
5. Remove cotter pin (Figure 3, Item 2) from clevis pin (Figure 3, Item 5).
6. Discard cotter pin (Figure 3, Item 2).
7. Remove clevis pin (Figure 3, Item 5) from brake cable clevis yoke (Figure 3, Item 3) and hand brake pivot plate (Figure 3, Item 1).
8. Set clevis pin (Figure 3, Item 5) aside for reuse.

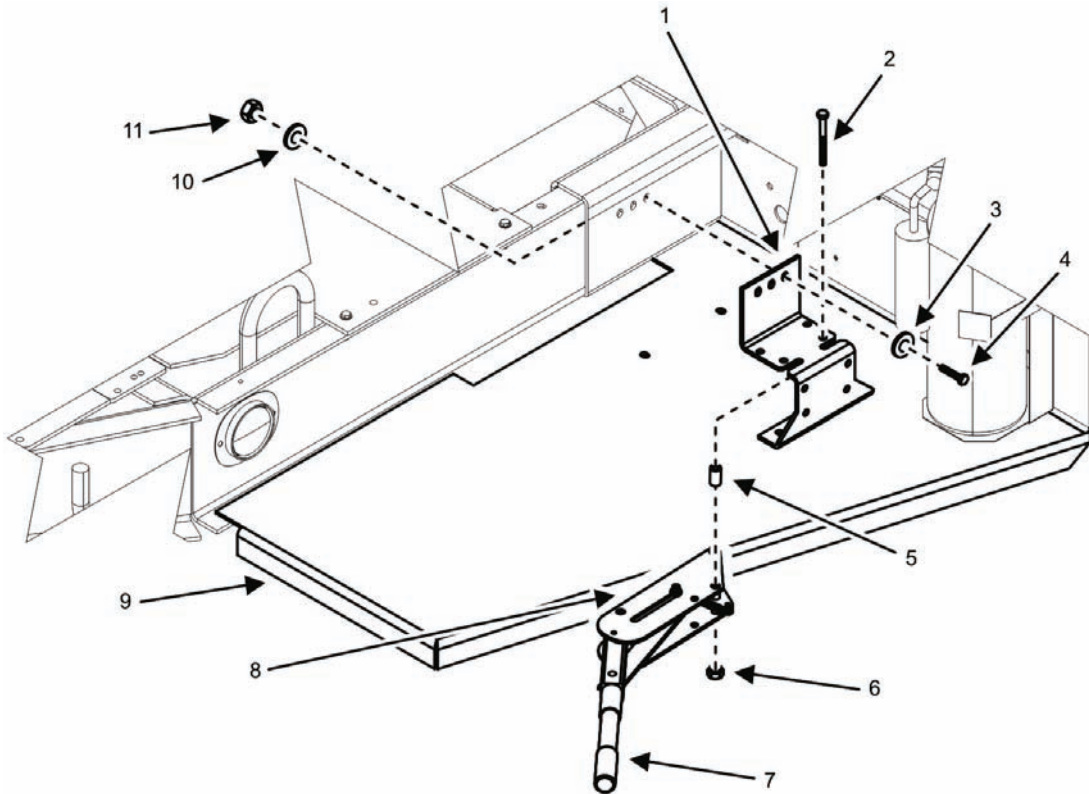

**Figure 2. Hand Brake Bracket and Hand Brake — Detail.**

9. Separate brake cable clevis yoke (Figure 3, Item 3) from brake assembly pivot plate (Figure 3, Item 1).
10. Attach restraint to brake cable clevis yoke (Figure 3, Item 3) to prevent from being withdrawn through step (Figure 3, Item 4).
11. Remove two bolts (Figure 2, Item 2), two spacers (Figure 2, Item 5), and two nylon lock nuts (Figure 2, Item 6) that attach hand brake (Figure 2, Item 8) to hand brake bracket (Figure 2, Item 1).
12. Set two spacers (Figure 2, Item 5) aside for reuse.
13. Discard two nylon lock nuts (Figure 2, Item 6).
14. Remove hand brake (Figure 2, Item 8) from hand brake bracket (Figure 2, Item 1).
15. Inspect hand brake (Figure 2, Item 8) for any sign of damage. Replace as required.
16. Remove four bolts (Figure 2, Item 4), eight flat washers (Figure 2, Items 3 and 10), and four nylon lock nuts (Figure 2, Item 11) that attach hand brake bracket (Figure 2, Item 1) to trailer chassis and step (Figure 2, Item 9).
17. Discard four nylon lock nuts (Figure 2, Item 11).
18. Inspect hand brake bracket (Figure 2, Item 1) for any sign of damage. Replace as required.

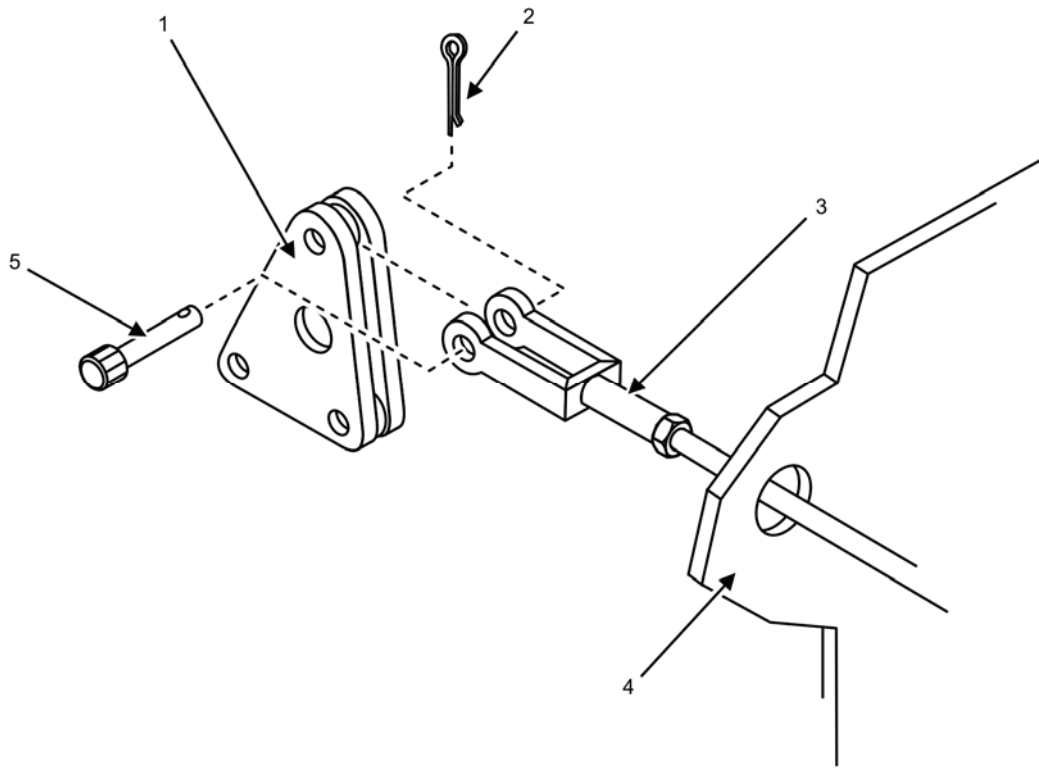

**Figure 3. Brake Cable Connection to Hand Brake — Detail.**

19. Inspect trailer chassis and step (Figure 2, Item 9) where hand brake bracket (Figure 2, Item 1) was attached for any sign of damage. Repair or replace as required.

#### END OF TASK

#### Install Hand Brake Bracket (PP-3102)

1. Position and align holes in hand brake bracket (Figure 2, Item 1) with matching holes in trailer chassis and step (Figure 2, Item 9).
2. Install four bolts (Figure 2, Item 4), eight flat washers (Figure 2, Items 3 and 10), and four new nylon lock nuts (Figure 2, Item 11) into each aligned hole of the hand brake bracket (Figure 2, Item 1).
3. Secure four new nylon lock nuts (Figure 2, Item 11) to torque value of 22 – 27 ft/lb (30 – 37 Nm).
4. Position and align holes in hand brake (Figure 2, Item 8) with matching holes in hand brake bracket (Figure 2, Item 1).
5. Install two bolts (Figure 2, Item 2), two spacers (Figure 2, Item 5), and two new nylon lock nuts (Figure 2, Item 6) into each aligned hole of the hand brake (Figure 2, Item 8) and hand brake bracket (Figure 2, Item 1).
6. Tighten two new nylon lock nuts (Figure 2, Item 6) to torque value of 42 – 45 ft/lb (57 – 61 Nm).
7. Position and align brake cable clevis yoke (Figure 3, Item 3) onto hand brake pivot plate (Figure 3, Item 1).
8. Insert clevis pin (Figure 3, Item 5) into holes of brake cable clevis yoke (Figure 3, Item 3) and hand brake pivot plate (Figure 3, Item 1).
9. Insert cotter pin (Figure 3, Item 2) into clevis pin (Figure 3, Item 5).



10. Bend ends of cotter pin (Figure 3, Item 2) to retain within clevis pin (Figure 3, Item 5).
11. Apply brake tension by moving hand brake lever (Figure 2, Item 7) toward the front of the trailer.

**END OF TASK**

**END OF WORK PACKAGE**



**FIELD MAINTENANCE**  
**AMMPS 10KW TRAILER-MOUNTED POWER UNITS AND POWER PLANTS**  
**GENERAL MAINTENANCE**

**INITIAL SETUP:**

<b>Test Equipment</b>	<b>Personnel Required</b>
Not Applicable	91D (1)
<b>Tools and Special Tools</b>	<b>References</b>
Crimping, Tool, Terminal (WP 0057, Table 2, Item 1)	A-A-52557A
Crimping, Tool, Terminal, Hand (WP 0057, Table 2, Item 2)	MIL-DLT-83133G
Remover, Electrical Contact (WP 0057, Table 2, Item 6)	TB SIG 222
Tool Kit, General Mechanic's (GMTK) (WP 0057, Table 2, Item 10)	TM 9-6115-750-10
Tool, Rivet Nut (WP 0057, Table 2, Item 12)	TM 9-6115-750-24&P
<b>Materials/Parts</b>	WP 0010, Operator PMCS
Not Applicable	WP 0015, Field PMCS
	Foldout Pages
	<b>Equipment Conditions</b>
	Not Applicable

**GENERAL MAINTENANCE**

This section provides general maintenance procedures for using a fire extinguisher, understanding general fuel requirements, using a multimeter, repairing wiring, and jump starting a generator set.

**Using a Fire Extinguisher**

Do not use a fire extinguisher without reading the instructions and receiving proper training. When using a fire extinguisher, choose the proper type of fire extinguisher for the class of fire. Be sure to use a type "A" on ordinary materials (paper, cardboard, and most plastics), type "B" on combustible or combustibles (diesel, gas, grease, and oil), type "C" on electrical fires, type "D" on combustible metal/chemical fires, or a multipurpose extinguisher designated with the proper letter for the class fire. For example, an "ABC" extinguisher will handle class "A," "B," and "C" fires. Using the improper fire extinguisher can result in spreading of the fire and failure to extinguish. Failure to comply may cause injury or death to personnel. Do not attempt to extinguish a fire that is large in size. Do not attempt to extinguish a fire when there is no clear exit visible. Be sure building is evacuated. Call for help IAW local SOP. Stay low to avoid smoke. Failure to comply may cause injury or death to personnel.

1. Determine the class of fire ("A," "B," "C," or "D").
2. Choose the correct type of extinguisher.
3. Pull the pin of the extinguisher.
4. Aim the extinguisher at the base of the fire.
5. Sweep back and forth toward the fire.
6. Continue until fire is extinguished.

7. Recharge or dispose of extinguisher IAW local SOP.

**END OF TASK**

**General Fuel Requirements**

**WARNING**

- Fuel is combustible and toxic to eyes, skin, and respiratory tract. Skin and eye protection are required when working in contact with fuel. Avoid repeated or prolonged contact. Provide adequate ventilation. Operators are to wash skin and change clothing promptly if in contact with fuel. Failure to comply may cause injury or death to personnel.
- Fuels used in the generator set are combustible. Ensure fuel source grounding strap is connected to unit fuel fill grounding stud (fuel fill static ground). When filling the fuel tank, maintain metal-to-metal contact between filler nozzle and fuel tank opening to eliminate ESD. Fire and possible explosion can result. Failure to comply may cause injury or death to personnel.
- Fuels used in the generator set are combustible. Do not smoke or use open flames when performing maintenance. Fire and possible explosion may result. Failure to comply may cause injury or death to personnel and damage to equipment.
- Hot engine surfaces from the engine and generator circuitry are possible sources of ignition. When hot refueling with DF-1, DF-2, JP5, or JP8, avoid fuel splash and fuel spill. Do not smoke or use open flame when performing refueling. Remember all PMCS (WP 0010, Operator PMCS and WP 0015, Field PMCS) is still required. Flames and possible explosion may result. Failure to comply may cause injury or death to personnel.

**NOTE**

See Table 1 for the types of fuel required for the AMMPS generator set.

**Table 1. Diesel Fuel.**

<b>AMBIENT TEMPERATURE</b>	<b>DIESEL FUEL</b>
-50 degrees Fahrenheit (°F) to +135°F (-45.6 degrees Celsius (°C) to 57.2°C)	MIL-DLT-83133G <sup>a</sup> JP8
+20°F to +135°F (-6.7°C to -57.2°C)	A-A-52557A <sup>b</sup> GR 2-D
-50°F to +135°F (-45.6°C to 57.2°C)	A-A-52557A GR 1-D

<sup>a</sup> Turbine Fuel, Aviation, Kerosene Type, JP-8 (NATO F-34), NATO F-35, and JP-8+100 (NATO F-37).

<sup>b</sup> Fuel Oil, Diesel; for Posts, Camps and Stations.

**END OF TASK**

**Using a Multimeter**

1. Select turn dial for option to be used:
  - a. Ohms for resistance, continuity, and short circuit.
  - b. Volts for voltage.
  - c. Amperes for current.

---

**WARNING**

High voltage is produced when this generator set is in operation. Ensure engine control and DEAD CRANK switches are set to OFF, negative battery cable is disconnected, and unit is completely shut down and free of any power source before attempting any troubleshooting or maintenance on unit. Failure to comply may cause injury or death to personnel.

2. Measure resistance value.
  - a. Connect multimeter leads to leads of item being checked.
  - b. Use red lead for positive terminal.
  - c. Use black lead for negative terminal.
  - d. Observe display for reading.
  - e. Compare reading to specifications.
3. Check continuity.
  - a. Connect multimeter leads to wiring circuit being checked.
  - b. Observe display for reading.
  - c. Consult specifications for maximum permissible reading.
4. Check for short circuit, wire to wire.
  - a. Connect multimeter leads to wires being checked.
  - b. Observe display for reading.
  - c. Reading must be greater than 100 kilohms ( $k\Omega$ ) wire to wire or short exists.
5. Check for short circuit to ground.
  - a. Connect one multimeter lead to wire being checked.
  - b. Touch multimeter probe to bare metal, such as engine block.
  - c. Observe display for reading.
  - d. Repeat steps 5a through c for remaining wires in circuit.
  - e. Reading must be greater than 100  $k\Omega$  or short to ground exists.
6. Place proper lead on proper terminal to check voltage:
  - a. Use red lead for positive terminal.
  - b. Use black lead for negative terminal.
  - c. Observe display for reading.
  - d. Compare reading to specifications.
7. Place proper lead on proper terminal to check current:
  - a. Use red lead for positive terminal.
  - b. Use black lead for negative terminal.
  - c. Observe display for reading.
  - d. Compare reading to specifications.

**END OF TASK**

## Repair Electrical Connectors

### NOTE

Two primary types of connector are used on the AMMPS switch box wiring harness. Each type of electrical connector can be replaced without removing the entire wiring harness from the unit. Repair of components is done by replacement of parts in step 1 and step 2.

1. Ensure the engine control switch on the generator set is OFF (TM 9-6115-750-10).
2. Remove negative ground cable from right-hand battery (TM 9-6115-750-24&P).
3. Replace simple crimp-on ring connector.
  - a. Identify failed electrical component connector (Figure 1, Item 4).
  - b. Cut and discard old connector (Figure 1, Item 4) from wire lead (Figure 1, Item 2) at base of old connector.
  - c. Install a length of new shrink wrap (Figure 1, Item 1) long enough to cover the crimp area of new connector (Figure 1, Item 4) onto wire lead (Figure 1, Item 2).
  - d. Strip insulation from wire lead (Figure 1, Item 2) equal to depth of new connector well.
  - e. Place bare wire of wire lead (Figure 1, Item 2) into new connector (Figure 1, Item 4) well and crimp to secure connector (Figure 1, Item 4) to wire lead (Figure 1, Item 2) using a crimping tool (Figure 1, Item 3).
  - f. Test new connector (Figure 1, Item 4) using a multimeter to verify continuity is present using wire diagram (Foldout Pages) as a guide to identify the correct circuit.
  - g. Slide shrink wrap (Figure 1, Item 1) over newly crimped connection and heat to form a tight seal.
  - h. Install new connector (Figure 1, Item 4) to electrical component.
  - i. Check operation of electrical component for proper operation. Repair as required.

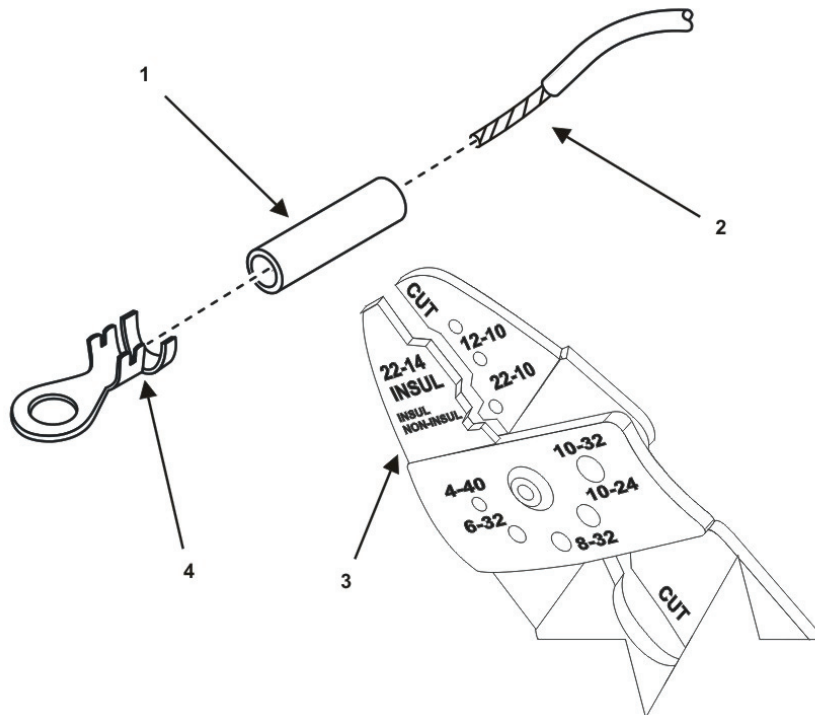
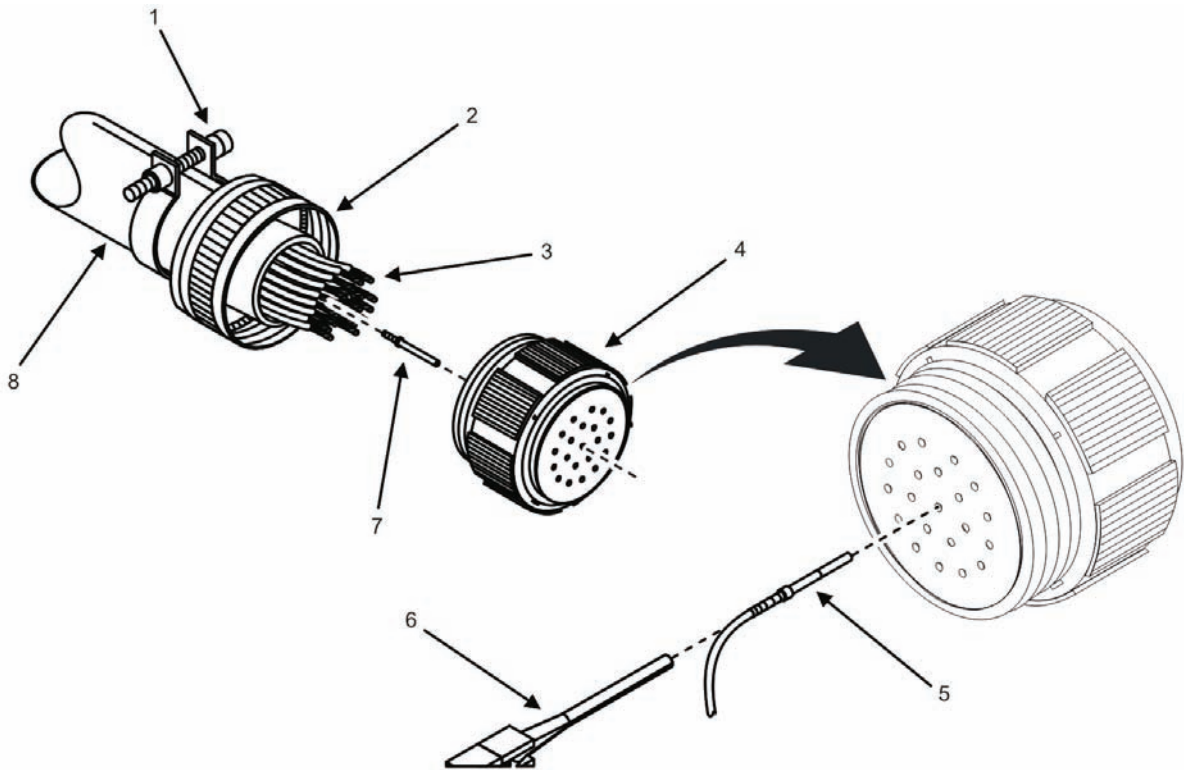

Figure 1. Simple Crimp-on Ring Connector.

## NOTE

Step 4 contains typical repair instructions for the multipin connectors (Figure 2) used on the AMMPS switch box wiring harness and unit B output cable assembly. Each one varies in the number of pins/sockets used in the connector. Repair of each multipin connector (Figure 2) uses the same procedure.

4. Repair multipin connector (Figure 2).
  - a. Disconnect cable connector from generator set component.
  - b. Test wire/socket connections (Figure 2, Item 5) of electrical connector using a multimeter to determine failed socket(s) (Figure 2, Item 7) within the connector.
  - c. Loosen two screws (Figure 2, Item 1) that secure strap of shell (Figure 2, Item 2) to cable (Figure 2, Item 8).
  - d. Unscrew shell (Figure 2, Item 2) from connector housing (Figure 2, Item 4).
  - e. Slide shell (Figure 2, Item 2) down cable (Figure 2, Item 8) to access back of connector housing (Figure 2, Item 4).
  - f. Tag and mark each wire/socket connection (Figure 2, Item 5).



**Figure 2. Multipin Connector Repair.**

- g. Remove every wire/socket connection (Figure 2, Item 5) from rear of connector housing (Figure 2, Item 4) using extractor tool (Figure 2, Item 6).
- h. Inspect all individual wire/socket connections (Figure 2, Item 5) for signs of obvious damage. Replace all damaged sockets (Figure 2, Item 7) while accessible
- i. Inspect cable (Figure 2, Item 8), shell (Figure 2, Item 2), and connector housing (Figure 2, Item 4) for signs of obvious damage. Replace all damaged components as required.

- j. Unsolder (see TB SIG 222, Solder and Soldering) broken/damaged socket(s) (Figure 2, Item 7) and remove socket (Figure 2, Item 7) from cable wire (Figure 2, Item 3).
  - k. Solder (see TB SIG 222) new socket(s) (Figure 2, Item 7) to cable wire (Figure 2, Item 3).
  - l. Test new socket/wire connection(s) (Figure 2, Item 5) to ensure proper electrical flow.
  - m. Insert all individual socket/wire connections (Figure 2, Item 5) into rear of connector housing (Figure 2, Item 4) using tags/markings applied during removal as a guide. Push socket/wire connections (Figure 2, Item 5) into connector housing (Figure 2, Item 4) locations by hand until each socket (Figure 2, Item 7) is fully seated and will not pull out.
  - n. Slide shell (Figure 2, Item 2) over cable (Figure 2, Item 8) to its mounting location on connector housing (Figure 2, Item 4) and secure by screwing shell (Figure 2, Item 2) onto connector housing (Figure 2, Item 4).
  - o. Tighten two screws (Figure 2, Item 1) to secure strap of shell (Figure 2, Item 2) to cable (Figure 2, Item 8) and relieve strain on cable (Figure 2, Item 8).
5. Install negative ground cable to right-hand battery (TM 9-6115-750-24&P).
  6. Set engine control switch to PRIME & RUN (TM 9-6115-750-10).
  7. Start engine and check for proper operation (TM 9-6115-750-10).

**END OF TASK**

**REMOVE/INSTALL P-CLAMPS**

**Remove P-Clamps**

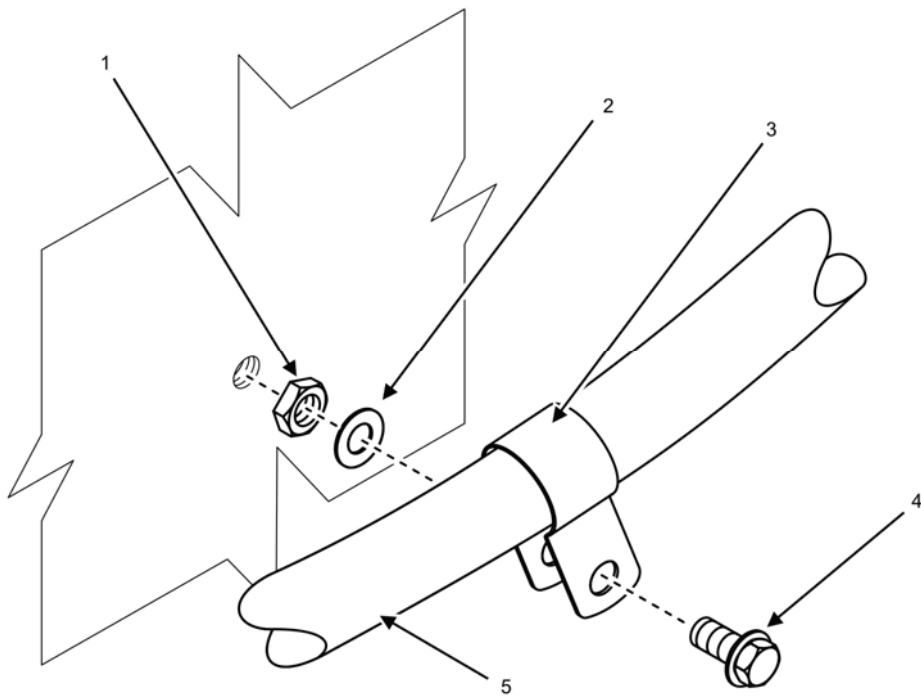

**Figure 3. P-Clamp — Removal.**



---

## NOTE

Wiring harnesses are secured to unit, trailer, and switch box in several places by P-clamps. P-clamps must be removed to remove or reposition wiring harnesses or to remove components. Instructions below apply to all P-clamps encountered during maintenance procedures.

1. Ensure the engine control switch on the generator set is OFF (TM 9-6115-750-10).
2. Remove negative ground cable from right-hand battery (TM 9-6115-750-24&P).
3. Remove and retain screw (Figure 3, Item 4) that secures P-clamp (Figure 3, Item 3) to mounting location.
4. Remove and retain any washer(s) (Figure 3, Item 2) and nut(s) (Figure 3, Item 1).
5. Note orientation of P-clamp (Figure 3, Item 3) to wiring harness (Figure 3, Item 5) to assist installation.
6. Remove and retain P-clamp (Figure 3, Item 3) from wiring harness (Figure 3, Item 5) for reuse.
7. Inspect P-clamp (Figure 3, Item 3) and fasteners for damage or severe corrosion. Replace as required.

### END OF TASK

#### Install P-Clamps

1. Install P-clamp (Figure 3, Item 3) on wiring harness (Figure 3, Item 5) in orientation noted in Remove P-clamps, step 3.
2. Position wiring harness (Figure 3, Item 5) and P-clamp (Figure 3, Item 3) on mounting location.
3. Install screw (Figure 3, Item 4).
4. Install washer(s) (Figure 3, Item 2) and nut(s) (Figure 3, Item 1) as required.
5. Tighten fasteners.
6. Install negative ground cable from right-hand battery (TM 9-6115-750-24&P).
7. Set engine control switch to PRIME & RUN (TM 9-6115-750-10).
8. Start engine and check for proper operation (TM 9-6115-750-10).

### END OF TASK

#### Jump Starting a Generator Set on PU and PP

Jump starting requires the use of the NATO slave receptacle. NATO slave cables are required to jump start a 24-V system. The generator set cannot be jump started with a 12-V system. Ensure the vehicle/equipment being used to jump start the generator set is a 24-V system.

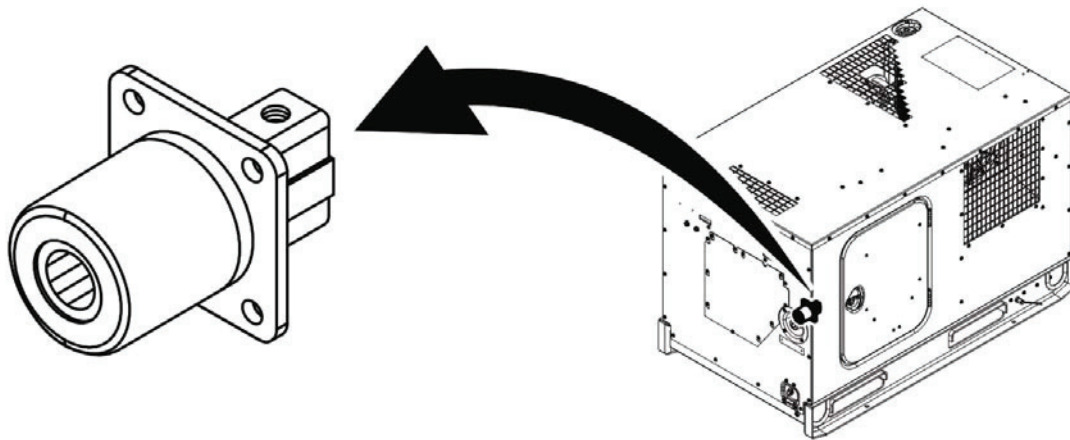

**Figure 4. NATO Slave Receptacle — Location.**

### **WARNING**

- NATO slave receptacle is electrically live at all times and is not protected by a fuse. Disconnecting main DC circuit breaker does not ensure the circuit is dead. This circuit is only dead when the batteries are fully disconnected. Disconnect both batteries before performing maintenance on the slave receptacle. Failure to comply may cause injury or death to personnel.
- Ensure equipment/vehicles being used to jump-start the generator set are not touching. Touching of metal surfaces can cause improper grounding. Do not allow the cable ends to touch each other or any part of the generator set/vehicle/equipment other than the NATO slave receptacle. May result in damage to the electrical system of the generator set/vehicle/equipment. Failure to comply may cause injury or death to personnel.
- High voltage is produced when generator set is in operation. Never attempt to start the generator set unless it is properly grounded. Do not ground yourself in standing water. Never attempt to connect or disconnect load cables while the generator sets are running. Failure to comply may cause injury or death to personnel.

1. Move the vehicle/equipment being used to jump start close enough to the generator set that the cables reach.
2. Ensure the engine control switch on the generator set is OFF.
3. Ensure the vehicle/equipment being used to jump start is OFF.
4. Locate the NATO slave receptacle (Figure 4) on the front panel of the generator set.
5. Remove the NATO slave receptacle cover.
6. Ensure NATO slave cable ends are free of dirt and debris.
7. Ensure NATO slave receptacles are free of dirt and debris.
8. Connect the NATO slave cable to the generator set at NATO slave receptacle.
9. Turn on the vehicle/equipment being used to jump start the generator set.
10. Connect the other end of the NATO slave cable to the vehicle/equipment being used to jump start.
11. Allow the generator set to charge for 10 min.

**CAUTION**

Do not crank engine in excess of 15 sec. Allow starter to cool for at least 15 sec between attempted starts. Failure to comply may cause damage to equipment.

12. Set engine control switch to PRIME & RUN (TM 9-6115-750-10).
13. Start engine and check for proper operation (TM 9-6115-750-10).
14. Ensure proper operation of the generator set.
15. Remove the NATO slave cable from the vehicle/equipment being used to jump start.
16. Remove the NATO slave cable from the generator set.
17. Replace the cover on the NATO slave receptacle.

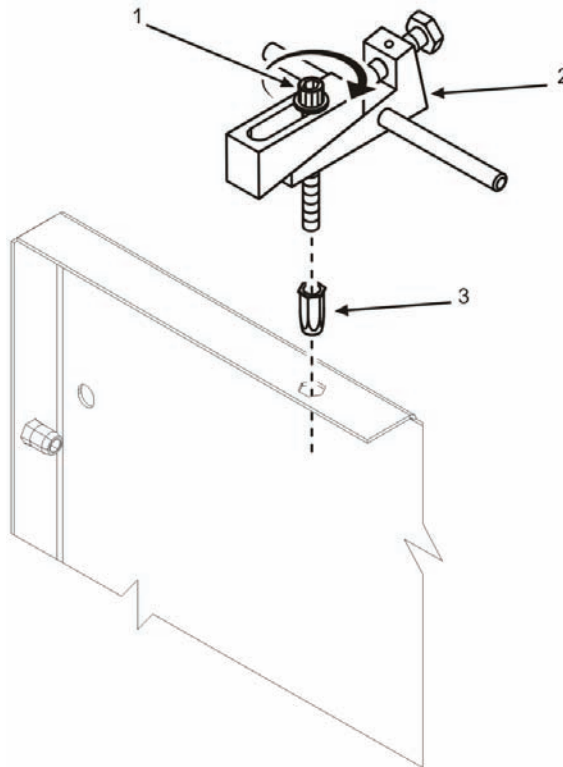
**END OF TASK****Install Clinch Nut**

**Figure 5. Clinch Nut to Rivet Tool.**

1. Install new clinch nut (Figure 5, Item 3) to rivet nut tool (Figure 5, Item 2) by turning socket head screw (Figure 5, Item 1) clockwise until clinch nut (Figure 5, Item 3) is fully installed on tool.

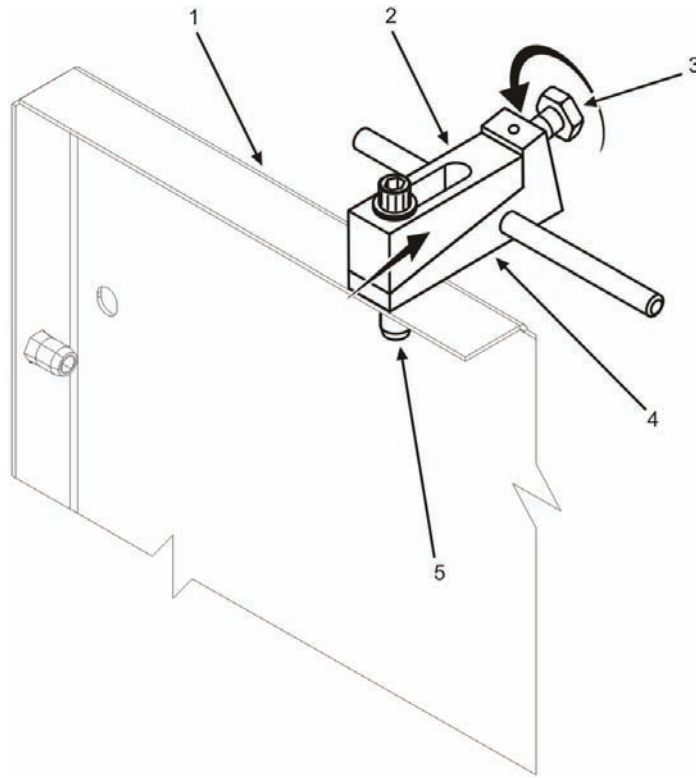
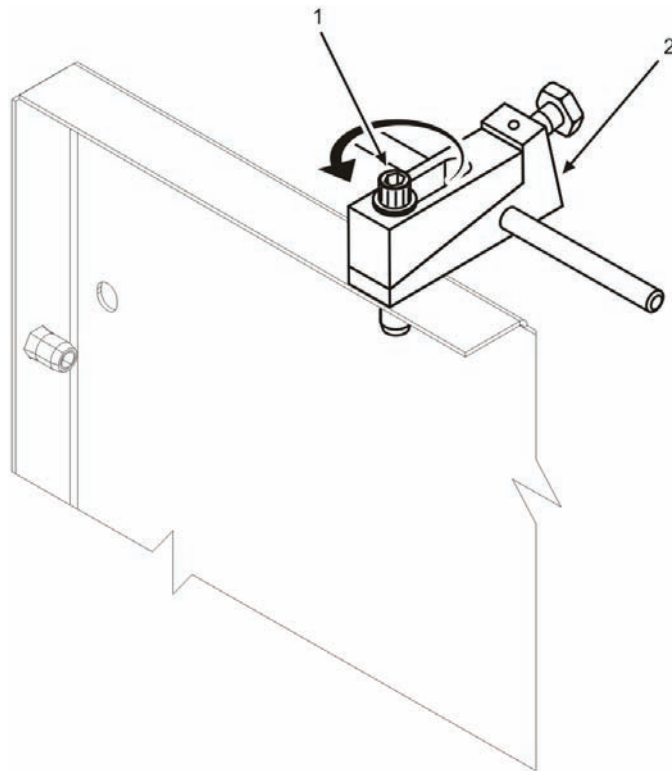

**Figure 6. Install Clinch Nut to Panel.**

### **CAUTION**

Prior to tightening hex head screw (Figure 6, Item 3), position rivet nut tool (Figure 5, Item 2) flush with panel (Figure 6, Item 1) surface. Failure to comply may result in damage to equipment.

2. Install clinch nut (Figure 6, Item 5) into opening in panel (Figure 6, Item 1) with bottom surface of tool (Figure 6, Item 4) flush with panel (Figure 6, Item 1).
3. Turn hex head screw (Figure 6, Item 3) clockwise to draw top wedge (Figure 6, Item 2) of tool toward hex head screw (Figure 6, Item 3).
4. Continue to tighten hex head screw (Figure 6, Item 3) until top wedge (Figure 6, Item 2) is fully seated on bottom wedge of tool (Figure 6, Item 4).



**Figure 7. Remove Rivet Nut Tool.**

5. Turn socket head screw (Figure 7, Item 1) counter-clockwise to remove tool (Figure 7, Item 2) from panel.

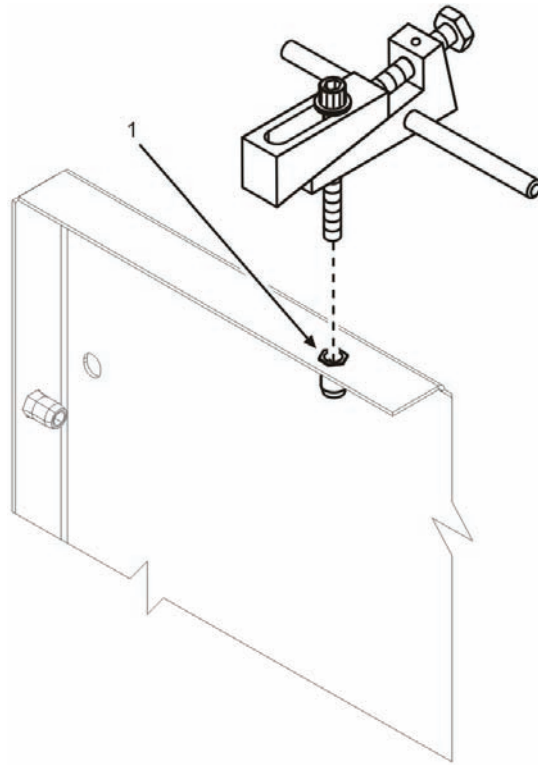

**Figure 8. Installed Clinch Nut.**

6. Use installed clinch nut (Figure 8, Item 1) to secure panel as required.

**END OF TASK**

**END OF WORK PACKAGE**

---

**FIELD MAINTENANCE**  
**AMMPS 10KW TRAILER-MOUNTED POWER UNITS AND POWER PLANTS**  
**LUBRICATION INSTRUCTIONS**

---

**INITIAL SETUP:****Test Equipment**

Not Applicable

**Tools and Special Tools**

Tool Kit, General Mechanic's (GMTK) (WP 0057, Table 2, Item 10)

**Materials/Parts**

Lubricating oil, engine (WP 0060, Expendable and Durable Items List, Item 2)

Rag, wiping (WP 0060, Item 5)

**Personnel Required**

91D (1)

**References**

MIL-PRF-2104H

TM 9-6115-750-24&amp;P

**Equipment Conditions**

Wheels chocked and brakes applied (LTT – TM 9-2330-392-14&amp;P), (M200A1 – TM 9-2330-205-14&amp;P)

Front trailer support deployed (LTT – TM 9-2330-392-14&amp;P), (M200A1 – TM 9-2330-205-14&amp;P)

Rear leg prop assembly deployed (WP 0005, Operation Under Usual Conditions)

Rear step jacks deployed (M200A1 – TM 9-2330-205-14&amp;P)

---

**LUBRICATION INSTRUCTIONS****WARNING**

When operating, generator set engine has hot metal surfaces that will burn flesh on contact. Shut down generator set and allow engine to cool before checks, services, and maintenance. Wear gloves and additional protective clothing as required. Failure to comply may cause injury or death to personnel.

**CAUTION**

Ensure the lubrication and cooling systems of AMMPS 10 kW generator set have been filled to capacity before operating the unit (TM 9-6115-750-24&P). Failure to comply may cause damage to equipment.

Ensure the components of trailer have been properly lubricated before operating the unit (LTT – TM-9-2330-392-14&P or M200A1 – TM-9-2330-205-14&P). Failure to comply may cause damage to equipment.

**NOTE**

Refer to Table 1 for lubricating fluids used on the AMMPS 10 kW PU and PP models and their applications.

**Table 1. Lubrication Order.**

USAGE	FLUID/LUBRICANT	CAPACITIES	EXPECTED TEMPERATURES
Hinge/latch lubrication MIL-PRF-2104H <sup>a</sup>	Society of Automotive Engineers (SAE) 15W40	Not applicable	Not applicable

<sup>a</sup> Performance Specification, Lubrication Oil, Internal Combustion Engine, Combat/Tactical Service.

**Lubricate Hinges and Latches**

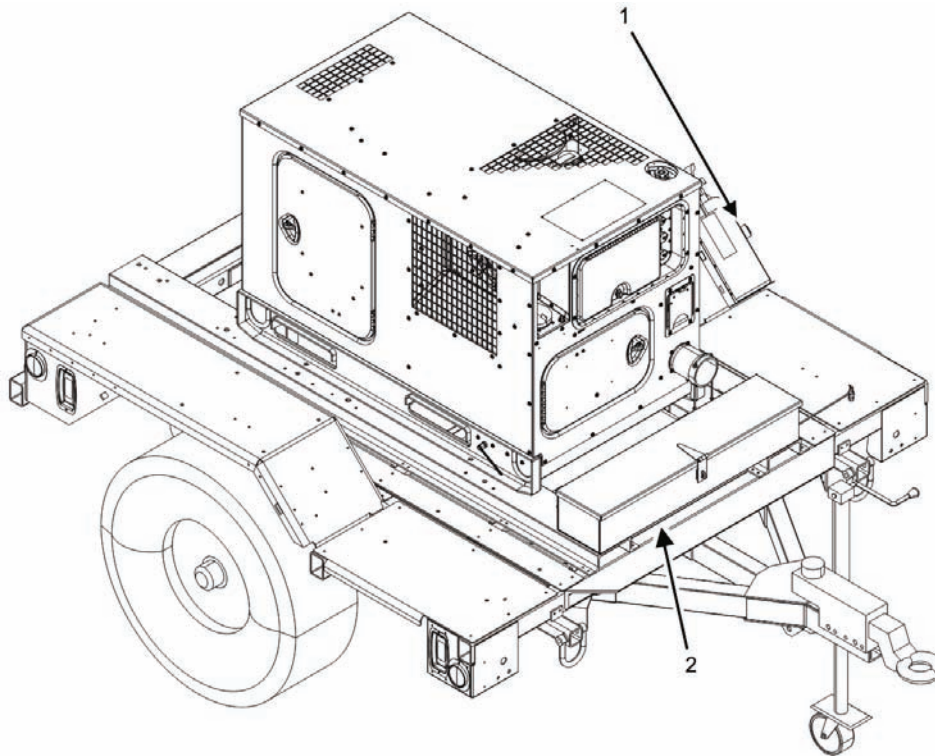

**Figure 1. Hinge and Latch Locations (PU-2002 and PU-2012) — Curbside.**

1. Open cover to accessory box (Figure 1, Item 2 and Figure 2, Item 1).
2. Apply one drop of lubrication oil (Table 2) to hinge and latch on accessory box cover.
3. Cycle accessory box cover through three open-close sequences.
4. Close and secure accessory box cover.



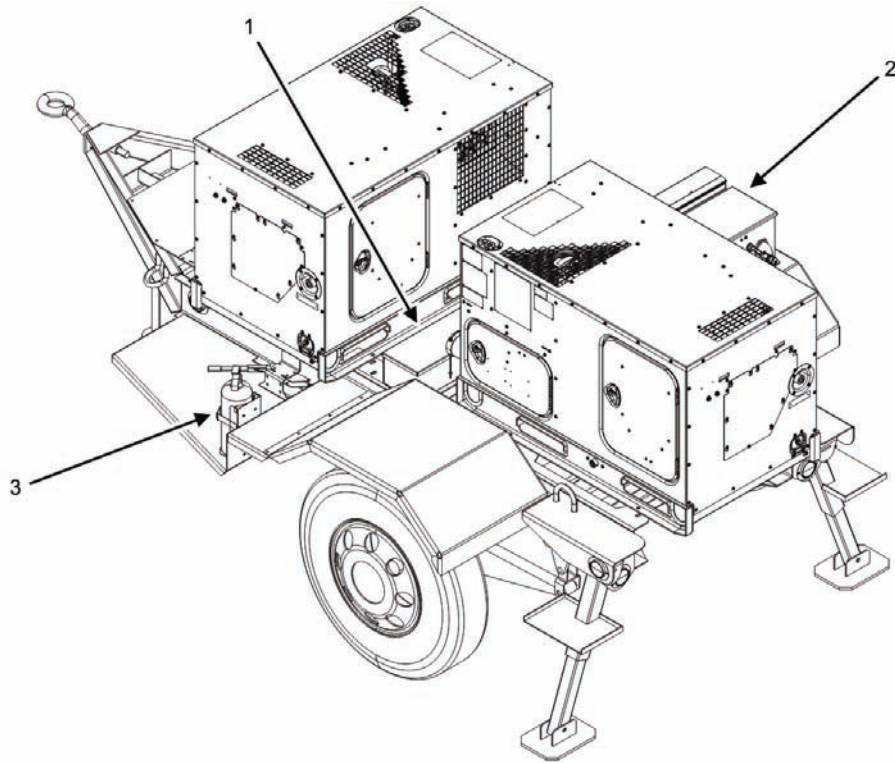

**Figure 2. Hinge and Latch Locations (PP-3102).**

5. Release latch on fire extinguisher bracket (Figure 1, Item 1 and Figure 2, Item 3).
6. Apply one drop of lubrication oil (Table 2) to fire extinguisher bracket strap hinge and latch.
7. Cycle fire extinguisher bracket strap hinge and latch through three open-close sequences.
8. Close and secure fire extinguisher bracket strap.
9. Open cover to switch box (Figure 2, Item 2) on PP only.
10. Apply one drop of lubrication oil (Table 2) to each hinge/latch on switch box cover.
11. Cycle switch box cover through three open-close sequences.
12. Close and secure switch box cover.
13. Wipe excess oil from all hinges/latches using a wiping rag.
14. Dispose of soiled rags IAW local SOP.

**Table 2. Table of Lubricant — Hinges and Latches.**

SPECIFICATION	TYPE OF LUBRICANT	FREQUENCY	METHOD OF APPLICATION
MIL-PRF-2104H	MIL-PRF-2104H	500 hr	Oil can, mechanic's flexible

**END OF TASK**

**END OF WORK PACKAGE**



---

**FIELD MAINTENANCE**  
**AMMPS 10KW TRAILER-MOUNTED POWER UNITS AND POWER PLANTS**  
**TORQUE LIMITS**

---

**SCOPE**

This WP provides general torque limits for fasteners used on the 10 kW trailer-mounted PU and PP. Special torque limits are indicated in Table 1. Table 2 provides nominal torque limits to be used when they are not indicated in Table 1.

The following formula should be used to determine the setting used on the torque wrench when using a crowfoot extension: (SOCKET, CROWFOOT WRENCH HEAD 17105)  $M1 = M2 \times L1 / L2$ . The values from the formula are defined in the list below.

<b><u>Term</u></b>	<b><u>Definition</u></b>
M1	The torque setting of the wrench (this is what is being calculated).
M2	The desired torque to be applied to the nut.
L1	The normal length of the torque wrench (from center of grip to center of drive).
L2	The length of the torque wrench plus the length of crowfoot adapter (measured from the center of crowfoot drive to center of wrench drive).

The example shows the calculation of the torque to be set on an 18-in wrench with a 4-in crowfoot adapter to obtain 80 ft/lb of torque.

$$M1 (65.45) = 80 \times 18/22.$$

When any extension is 90 degrees from the torque wrench, no adjustment is necessary.

These general and special torque limits shall not be applied to fasteners that retain rubber components. The rubber components may be damaged before the correct torque limit is reached. If a special torque limit is not given in the maintenance instructions for rubber components, tighten the fastener until it touches the metal, and then tighten it one more turn.

Table 1. Special Torque Limits.

COMPONENT	THREAD DIAMETER AND PITCH	TORQUE	LUBRICATING OIL APPLICATION
Generator to trailer mounting bolts	0.500 X 13 UNC	80 – 88 ft/lb 109 – 119 Nm	Not applied
Mounting rails to chassis nuts PP-3102	5/8-11, UNC 3B	191 – 233 ft/lb 259 – 316 Nm	Not applied
Brake bracket to chassis nuts PP-3102	5/16-18, UNC 3B	22 – 27 ft/lb 30 – 37 Nm	Not applied
Accessory box to chassis nuts PU-2002, PU-2012, and PP-3102	5/16-18, UNC 3B	22 – 27 ft/lb 30 – 37 Nm	Not applied
Fire extinguisher bracket to fender nuts PU-2002, PU-2012, and PP-3102	5/16-18, UNC 3B	22 – 27 ft/lb 30 – 37 Nm	Not applied
Fender to chassis PP-3102 nuts	5/16-18, UNC 3B	22 – 27 ft/lb 30 – 37 Nm	Not applied
Floor plate to chassis PU-2002 and PU-2012 nuts	5/16-18, UNC 3B	22 – 27 ft/lb 30 – 37 Nm	Not applied
Platform and step to chassis PP-3102 nuts	5/16-18, UNC 3B	22 – 27 ft/lb 30 – 37 Nm	Not applied
Ground terminal nut	1/4-20, brass	65 in/lb 7 Nm	Not applied
Switch box mounting bolts PP-3102	1.5 X 3/8-16 UNC	24 ft/lb 33 Nm	Not applied

### How to Use Torque Table

1. Measure the distance between the thread ridges in millimeter to determine pitch (Figure 1, Item 1).
2. Measure the diameter of the fastener (Figure 1, Item 2).
3. Look down the left-hand column under the Diameter heading to find the diameter of the fastener.
4. To locate torque value, look across to column matching description and size of fastener.

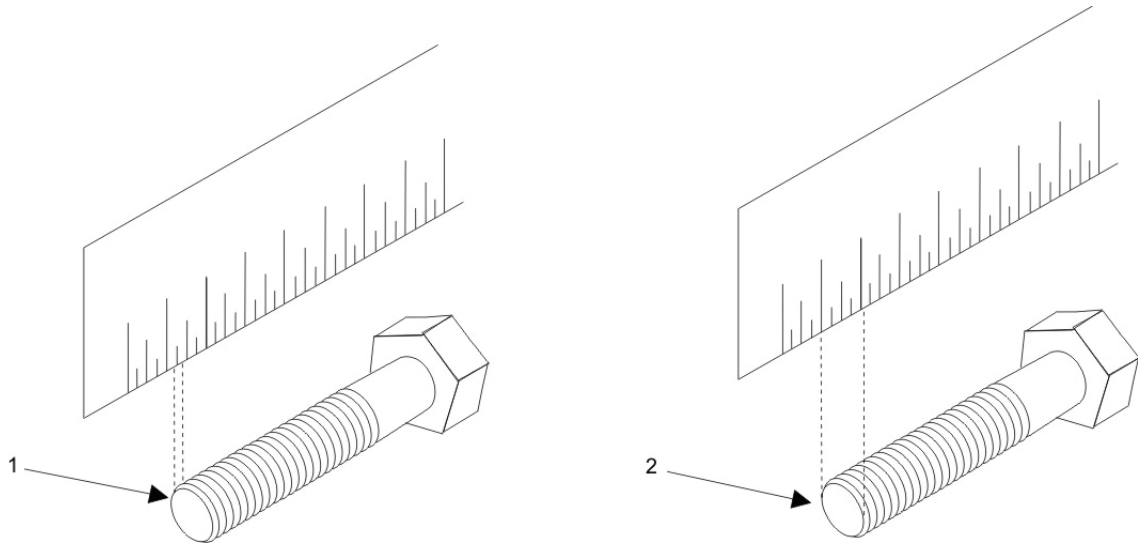

**Figure 1. Screw/Bolt Measurement.**

**CAUTION**

The torque values in Table 2 should be applied only to bolts marked 7 (7T strength). Failure to comply will cause damage to equipment.

**NOTE**

Apply 80% of listed torque value to fasteners tightened to aluminum alloys. Apply 60% of listed torque value to fasteners of 4T strength and all lock nuts.

**Table 2. Standard Torque Limits.**

ITEM	THREAD DIAMETER AND PITCH	TORQUE
Cap screw (7T) and nut	M6 – 1.0 millimeter (mm)	7 – 9 ft/lb 10 – 12 Nm
Cap screw (7T) and nut	M8 – 1.25 mm	17 – 21 ft/lb 23 – 28 Nm
Cap screw (7T) and nut	M10 – 1.5 mm	33 – 40 ft/lb 44 – 54 Nm
Cap screw (7T) and nut	M12 – 1.75 mm	58 – 72 ft/lb 78 – 98 Nm
Cap screw (7T) and nut	M14 – 1.5 mm	94 – 108 ft/lb 128 – 147 Nm
Cap screw (7T) and nut	M16 – 1.5 mm	159 – 174 ft/lb 216 – 235 Nm
PT plug	0.125 mm – NA	7 ft/lb 10 Nm
PT plug	0.25 mm – NA	14 ft/lb 20 Nm
PT plug	0.375 mm – NA	22 ft/lb 29 Nm
PT plug	0.500 mm – NA	43 ft/lb 59 Nm
Pipe joint plug	M8 – NA	9 – 12 ft/lb 13 – 17 Nm
Pipe joint plug	M10 – NA	14 – 19 ft/lb 19 – 26 Nm
Pipe joint plug	M12 – NA	18 – 25 ft/lb 25 – 34 Nm
Pipe joint plug	M14 – NA	29 – 36 ft/lb 39 – 49 Nm
Pipe joint plug	M16 – NA	36 – 43 ft/lb 49 – 59 Nm

**END OF TASK****END OF WORK PACKAGE**

**FIELD MAINTENANCE  
 AMMPS 10KW TRAILER-MOUNTED POWER UNITS AND POWER PLANTS  
 WIRING DIAGRAMS**

**INITIAL SETUP:**

**Test Equipment**

Not Applicable

**Personnel Required**

Not Applicable

**Tools and Special Tools**

Not Applicable

**References**

ASME Y14.38

**Materials/Parts**

Not Applicable

Foldout Pages

**Equipment Conditions**

Not Applicable

**INTRODUCTION**

**Scope**

All diagrams and essential wiring information are provided for the electrical circuits of the AMMPS 10 kW trailer-mounted PU and PP.

**WIRE IDENTIFICATION**

Identification of wires is done in the FO-1, Schematic Plate and FO-2, Wiring Diagram in the Rear Matter of this manual.

**ABBREVIATIONS**

Any abbreviations in the wiring information conform to ASME Y14.38, Abbreviations and Acronyms: An American National Standard unless the wires are marked as shown in the respective diagrams.

**WIRING DIAGRAMS**

Schematics plate and wiring diagram to support the AMMPS 10 kW trailer-mounted PU and PP are provided in the FO-1, Schematic Plate and FO-2, Wiring Diagram located in the Rear Matter of this manual.

**END OF WORK PACKAGE**





**CHAPTER 7**  
**PARTS INFORMATION**  
**FOR**  
**AMMPS 10KW TRAILER-MOUNTED POWER UNITS AND POWER PLANTS**

CHAPTER 7  
PARTS INFORMATION

**WORK PACKAGE INDEX**

<u>Title</u>	<u>WP Sequence No.</u>
RPSTL INTRODUCTION .....	0035
POWER UNIT/POWER PLANT REPAIR PARTS LIST .....	0036
TRAILER CHASSIS REPAIR PARTS LIST .....	0037
FIRE EXTINGUISHER BRACKET REPAIR PARTS LIST .....	0038
FENDERS REPAIR PARTS LIST .....	0039
FLOORS, RAILS, AND SPACERS REPAIR PARTS LIST .....	0040
BRAKES UOC 99D REPAIR PARTS LIST .....	0041
LTT LIGHTS INSTALLATION UOC 98Z AND 99A REPAIR PARTS LIST .....	0042
LTT LEVELING SUPPORT JACK UOC 98Z AND 99A REPAIR PARTS LIST .....	0043
ACCESSORY BOX REPAIR PARTS LIST .....	0044
ACCESSORIES REPAIR PARTS LIST .....	0045
M200 IDENTIFICATION PLATES UOC 99D REPAIR PARTS LIST .....	0046
SWITCH BOX INSTALLATION REPAIR PARTS LIST .....	0047
SWITCH BOX COMPONENTS REPAIR PARTS LIST .....	0048
SWITCH BOX LEADS REPAIR PARTS LIST .....	0049
SWITCH BOX WIRING HARNESES REPAIR PARTS LIST .....	0050
BULK ITEM .....	0051
SPECIAL TOOLS LIST .....	0052
NATIONAL STOCK NUMBER (NSN) INDEX .....	0053
PART NUMBER INDEX .....	0054

---

**OPERATOR AND FIELD MAINTENANCE**  
**AMMPS 10KW TRAILER-MOUNTED POWER UNITS AND POWER PLANTS**  
**RPSTL INTRODUCTION**

---

## **INTRODUCTION**

### **SCOPE**

This RPSTL lists and authorizes spares and repair parts; special tools; special test, measurement, and diagnostic equipment (TMDE); and other special support equipment required for performance of operator and field maintenance of the AMMPS 10 kW PU and PP. It authorizes the requisitioning, issue, and disposition of spares, repair parts, and special tools as indicated by the source, maintenance, and recoverability (SMR) codes.

### **GENERAL**

In addition to the Introduction work package, this RPSTL is divided into the following work packages.

1. **Repair Parts List Work Packages.** Work packages containing lists of spares and repair parts authorized by this RPSTL for use in the performance of maintenance. These work packages also include parts which must be removed for replacement of the authorized parts. Parts lists are composed of functional groups in ascending alphanumeric sequence, with the parts in each group listed in ascending figure and item number sequence. Sending units, brackets, filters, and bolts are listed with the component they mount on. Bulk materials are listed by item name in FIG. BULK at the end of the work packages. Repair parts kits are listed separately in their own functional group and work package. Repair parts for reparable special tools are also listed in a separate work package. Items listed are shown on the associated illustrations.
2. **Special Tools List Work Packages.** Work packages containing lists of special tools, special TMDE, and special support equipment authorized by this RPSTL (as indicated by Basis of Issue (BOI) information in the DESCRIPTION AND USABLE ON CODE (UOC) column). Tools that are components of common tool sets and/or Class VII are not listed.
3. **Cross-Reference Indexes Work Packages.** There are two cross reference indexes work packages in this RPSTL: the National Stock Number (NSN) Index work package and the Part Number (P/N) Index work package. The National Stock Number (NSN) Index work package refers you to the figure and item number. The Part Number (P/N) Index work package refers you to the figure and item number.

### **EXPLANATION OF COLUMNS IN THE REPAIR PARTS LIST AND SPECIALTOOLS LIST WPS**

**ITEM NO. (Column (1)).** Indicates the number used to identify items called out in the illustration.

**SMR CODE (Column (2)).** The SMR code containing supply/requisitioning information, maintenance level authorization criteria, and disposition instruction, as shown in the following breakout. This entry may be subdivided into four subentries, one for each service.

**Table 1. SMR Code Explanation.**

<u>Source Code</u> <u>XX</u>	<u>Maintenance Code</u> <u>XX</u>	<u>Recoverability Code</u> <u>X</u>
1st two positions: How to get an item.	3rd position: Who can install, replace, or use the item.	4th position: Who can do complete repair* on the item.
		5th position: Who determines the disposition action on unserviceable items.

\*Complete Repair: Maintenance capacity, capability, and authority to perform all corrective maintenance tasks of the "Repair" function in a use/user environment in order to restore serviceability to a failed item.

Source Code. The source code tells you how you get an item needed for maintenance, repair, or overhaul of an end item/equipment. Explanations of source codes follow:

<u>Source Code</u>	<u>Application/Explanation</u>
PA PB PC PD PE PF PG PH PR PZ	<b>NOTE</b>  Items coded PC are subject to deterioration. Stock items; use the applicable NSN to requisition/request items with these source codes. They are authorized to the level indicated by the code entered in the third position of the SMR code.
KD KF KB	Items with these codes are not to be requested/requisitioned individually. They are part of a kit which is authorized to the maintenance level indicated in the third position of the SMR code. The complete kit must be requisitioned and applied.
MF-Made at field level MH-Made at below depot/sustainment level ML-Made at SRA MD-Made at depot MG-Navy only	Items with these codes are not to be requisitioned/requested individually. They must be made from bulk material which is identified by P/N in the DESCRIPTION AND UOC column and listed in the bulk material group work package of the RPSTL. If the item is authorized to you by the third position code of the SMR code, but the source indicates it is made at a higher level, order the item from the higher level of maintenance.
AF-Assembled by field level AH-Assembled by below depot/sustainment level AL-Assembled by SRA AD-Assembled by depot AG-Navy only	Items with these codes are not to be requested/requisitioned individually. The parts that make up the assembled item must be requisitioned or fabricated and assembled at the level of maintenance indicated in the source code. If the third position of the SMR code authorizes you to replace the item, but the source code indicates the item is assembled at a higher level, order the item from the higher level of maintenance.
XA	Do not requisition an "XA" coded item. Order the next higher assembly. (Refer to NOTE below.)
XB	If an item is not available from salvage, order it using the CAGEC and part number.
XC	Installation drawings, diagrams, instruction sheets, field service drawings; identified by manufacturer's part number.

**Source Code**

**Application/Explanation**

XD Item is not stocked. Order an XD-coded item through local purchase or normal supply channels using the CAGEC and part number given, if no NSN is available.

**NOTE**

Cannibalization or controlled exchange, when authorized, may be used as a source of supply for items with the above source codes except for those items source coded "XA" or those aircraft support items restricted by requirements of AR 750-1.

Maintenance Code. Maintenance codes tell you the level(s) of maintenance authorized to use and repair support items. The maintenance codes are entered in the third and fourth positions of the SMR code as follows:

Third Position. The maintenance code entered in the third position tells you the lowest maintenance level authorized to remove, replace, and use an item. The maintenance code entered in the third position will indicate authorization to the following levels of maintenance:

**Maintenance**

**Code**

**Application/Explanation**

- F - Field maintenance can remove, replace, and use the item.
- H - Below Depot Sustainment maintenance can remove, replace, and use the item.
- L - Specialized repair activity can remove, replace, and use the item.
- G - Afloat and ashore intermediate maintenance can remove, replace, and use the item (Navy only).
- K - Contractor facility can remove, replace, and use the item.
- Z - Item is not authorized to be removed, replaced, or used at any maintenance level.
- D - Depot can remove, replace, and use the item.

\*NOTE - Army may use C in the third position. However, for joint service publications, Army will use O.

Fourth Position. The maintenance code entered in the fourth position tells you whether or not the item is to be repaired and identifies the lowest maintenance level with the capability to do complete repair (perform all authorized repair functions).

**NOTE**

Some limited repair may be done on the item at a lower level of maintenance, if authorized by the Maintenance Allocation Chart (MAC) and SMR codes.

**Maintenance**

**Code**

**Application/Explanation**

- F - Field is the lowest level that can do complete repair of the item.
- H - Below Depot Sustainment is the lowest level that can do complete repair of the item.
- L - Specialized repair activity (*enter specialized repair activity or TASMG designator*) is the lowest level that can do complete repair of the item.
- D - Depot is the lowest level that can do complete repair of the item.
- G - Both afloat and ashore intermediate levels are capable of complete repair of item (Navy only).
- K - Complete repair is done at contractor facility.

- Z - Nonreparable. No repair is authorized.
- B - No repair is authorized. No parts or special tools are authorized for maintenance of "B" coded item. However, the item may be reconditioned by adjusting, lubricating, etc., at the user level.

Recoverability Code. Recoverability codes are assigned to items to indicate the disposition action on unserviceable items. The recoverability code is shown in the fifth position of the SMR code as follows:

Recoverability Code	Application/Explanation
Z -	Nonreparable item. When unserviceable, condemn and dispose of the item at the level of maintenance shown in the third position of the SMR code.
F -	Reparable item. When uneconomically repairable, condemn and dispose of the item at the field level.
H -	Reparable item. When uneconomically repairable, condemn and dispose of the item at the below depot sustainment level.
D -	Reparable item. When beyond lower level repair capability, return to depot. Condemnation and disposal of item are not authorized below depot level.
L -	Reparable item. Condemnation and disposal not authorized below Specialized Repair Activity (SRA).
A -	Item requires special handling or condemnation procedures because of specific reasons (such as precious metal content, high dollar value, critical material, or hazardous material). Refer to appropriate manuals/directives for specific instructions.
G -	Field level repairable item. Condemn and dispose at either afloat or ashore intermediate levels (Navy only).
K -	Reparable item. Condemnation and disposal to be performed at contractor facility.

NSN (Column (3)). The NSN for the item is listed in this column.

CAGEC (Column (4)). The Commercial and Government Entity Code (CAGEC) is a five-digit code which is used to identify the manufacturer, distributor, or Government agency/activity that supplies the item.

PART NUMBER (Column (5)). Indicates the primary number used by the manufacturer (individual, company, firm, corporation, or Government activity), which controls the design and characteristics of the item by means of its engineering drawings, specifications, standards, and inspection requirements to identify an item or range of items.

**NOTE**

When you use an NSN to requisition an item, the item you receive may have a different part number from the number listed.

DESCRIPTION AND UOC (Column (6)). This column includes the following information:

1. The federal item name and, when required, a minimum description to identify the item.
2. Part numbers of bulk materials are referenced in this column in the line entry to be manufactured or fabricated.
3. Hardness Critical Item (HCI). A support item that provides the equipment with special protection from electromagnetic pulse (EMP) damage during a nuclear attack.
4. The statement END OF FIGURE appears just below the last item description in column (6) for a given figure in both the repair parts list and special tools list work packages.

QTY (Column (7)). The QTY (quantity per figure) column indicates the quantity of the item used in the breakout shown on the illustration/figure, which is prepared for a functional group, sub-functional group, or an assembly. A

"V" appearing in this column instead of a quantity indicates that the quantity is variable and quantity may change from application to application.

**EXPLANATION OF CROSS-REFERENCE INDEXES WORK PACKAGES FORMAT AND COLUMNS**

1. National Stock Number (NSN) Index Work Package. NSNs in this index are listed in National Item Identification Number (NIIN) sequence.

STOCK NUMBER Column. This column lists the NSN in NIIN sequence. The NIIN consists of the last nine digits of the NSN. When using this column to locate an item, ignore the first four digits of the NSN. However, the complete NSN should be used when ordering items by stock number.

For example, if the NSN is 5385-01-574-1476, the NIIN is 01-574-1476.

FIG. Column. This column lists the number of the figure where the item is identified/located. The figures are in numerical order in the repair parts list and special tools list work packages.

ITEM Column. The item number identifies the item associated with the figure listed in the adjacent FIG. column. This item is also identified by the NSN listed on the same line.

2. Part Number (P/N) Index work package. Part numbers in this index are listed in ascending alphanumeric sequence (vertical arrangement of letter and number combinations which places the first letter or digit of each group in order A through Z, followed by the numbers 0 through 9 and each following letter or digit in like order).

PART NUMBER Column. Indicates the part number assigned to the item.

FIG. Column. This column lists the number of the figure where the item is identified/located in the repair parts list and special tools list work packages.

ITEM Column. The item number is the number assigned to the item as it appears in the figure referenced in the adjacent figure number column.

**SPECIAL INFORMATION**

UOC. The UOC appears in the lower left corner of the Description Column heading. Usable on codes are shown as "UOC:..." in the Description Column (justified left) on the first line under the applicable item/nomenclature. Uncoded items are applicable to all models. Identification of the UOCs used in the RPSTL are:

<u>Code</u>	<u>Used On</u>
98Z	Model PU-2002
98A	Model PU-2012
99D	Model PP-3102

Fabrication Instructions. Bulk materials required to manufacture items are listed in the bulk material functional group of this RPSTL. Part numbers for bulk material are also referenced in the Description Column of the line item entry for the item to be manufactured/fabricated. Detailed fabrication instructions for items source coded to be manufactured or fabricated are found in applicable TM.

Index Numbers. Items which have the word BULK in the figure column will have an index number shown in the item number column. This index number is a cross-reference between the NSN / Part Number (P/N) Index work packages and the bulk material list in the repair parts list work package.

---

## HOW TO LOCATE REPAIR PARTS

### 1. When NSNs or Part Numbers Are Not Known.

First. Using the Table of Contents, determine the assembly group to which the item belongs. This is necessary since figures are prepared for assembly groups and subassembly groups, and lists are divided into the same groups.

Second. Find the figure covering the functional group or the subfunctional group to which the item belongs.

Third. Identify the item on the figure and note the number(s).

Fourth. Look in the repair parts list work package for the figure and item numbers. The NSNs and part numbers are on the same line as the associated item numbers.

### 2. When NSN Is Known.

First. If you have the NSN, look in the STOCK NUMBER column of the NSN Index work package. The NSN is arranged in NIIN sequence. Note the figure and item number next to the NSN.

Second. Turn to the figure and locate the item number. Verify that the item is the one you are looking for.

### 3. When Part Number Is Known.

First. If you have the part number and not the NSN, look in the PART NUMBER column of the part number index WP. Identify the figure and item number.

Second. Look up the item on the figure in the applicable repair parts list work package.

## ABBREVIATIONS

Not applicable.

## END OF WORK PACKAGE



**OPERATOR AND FIELD MAINTENANCE**  
**AMMPS 10KW TRAILER-MOUNTED POWER UNITS AND POWER PLANTS**  
**POWER UNIT/POWER PLANT REPAIR PARTS LIST**

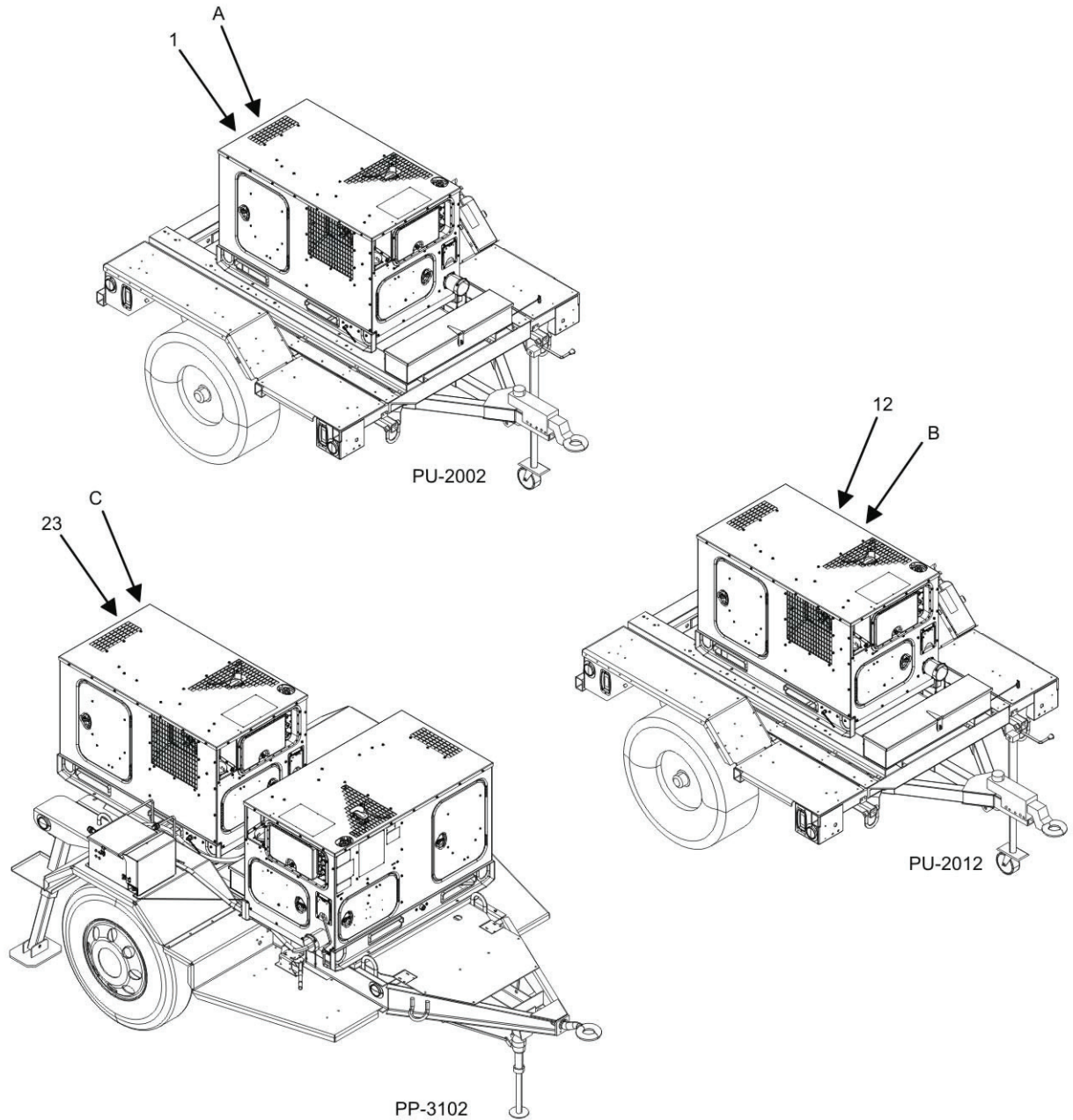

**Figure 1. Power Unit/Power Plant (Sheet 1 of 4).**

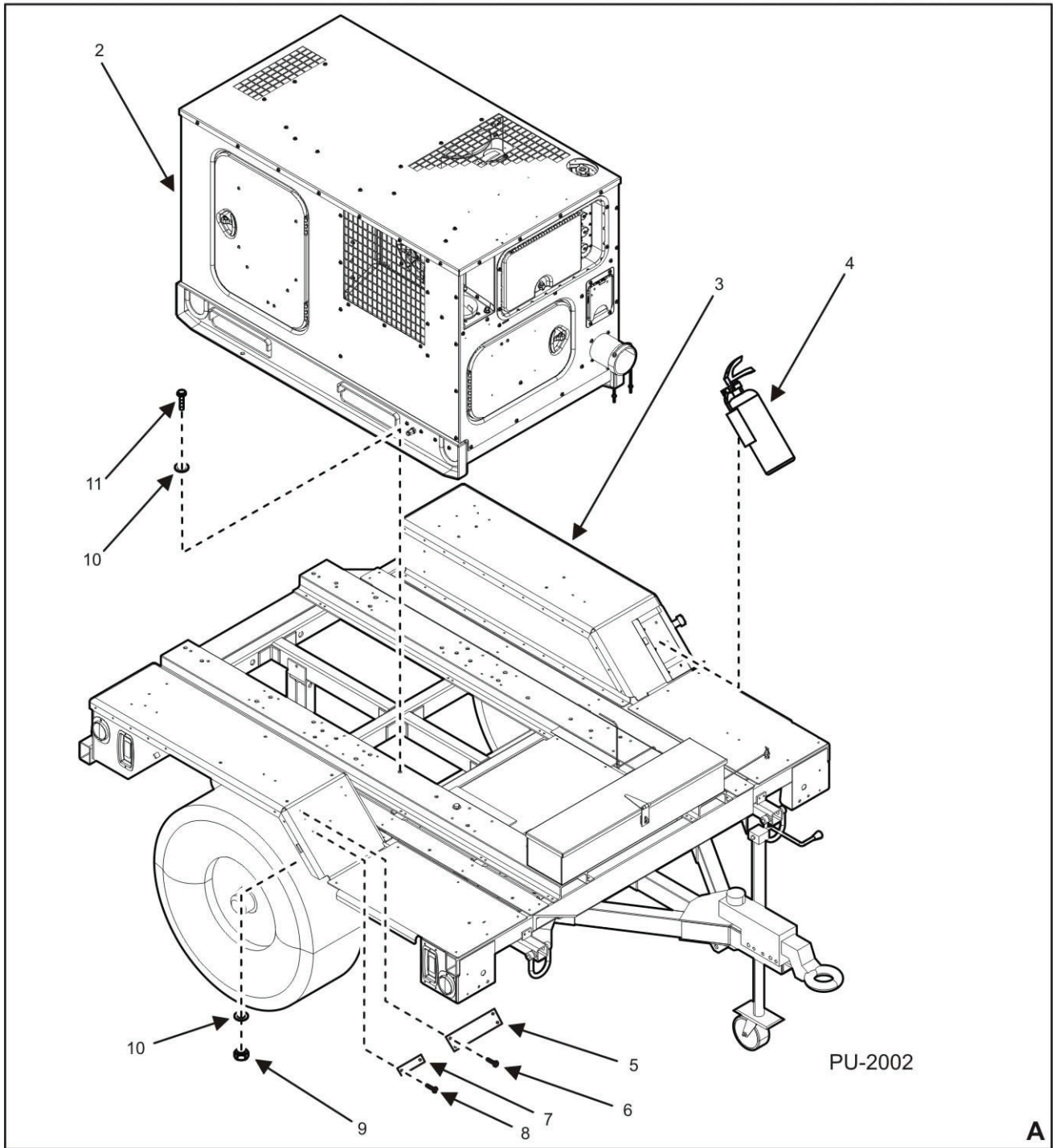

Figure 1. Power Unit/Power Plant (Sheet 2 of 4).

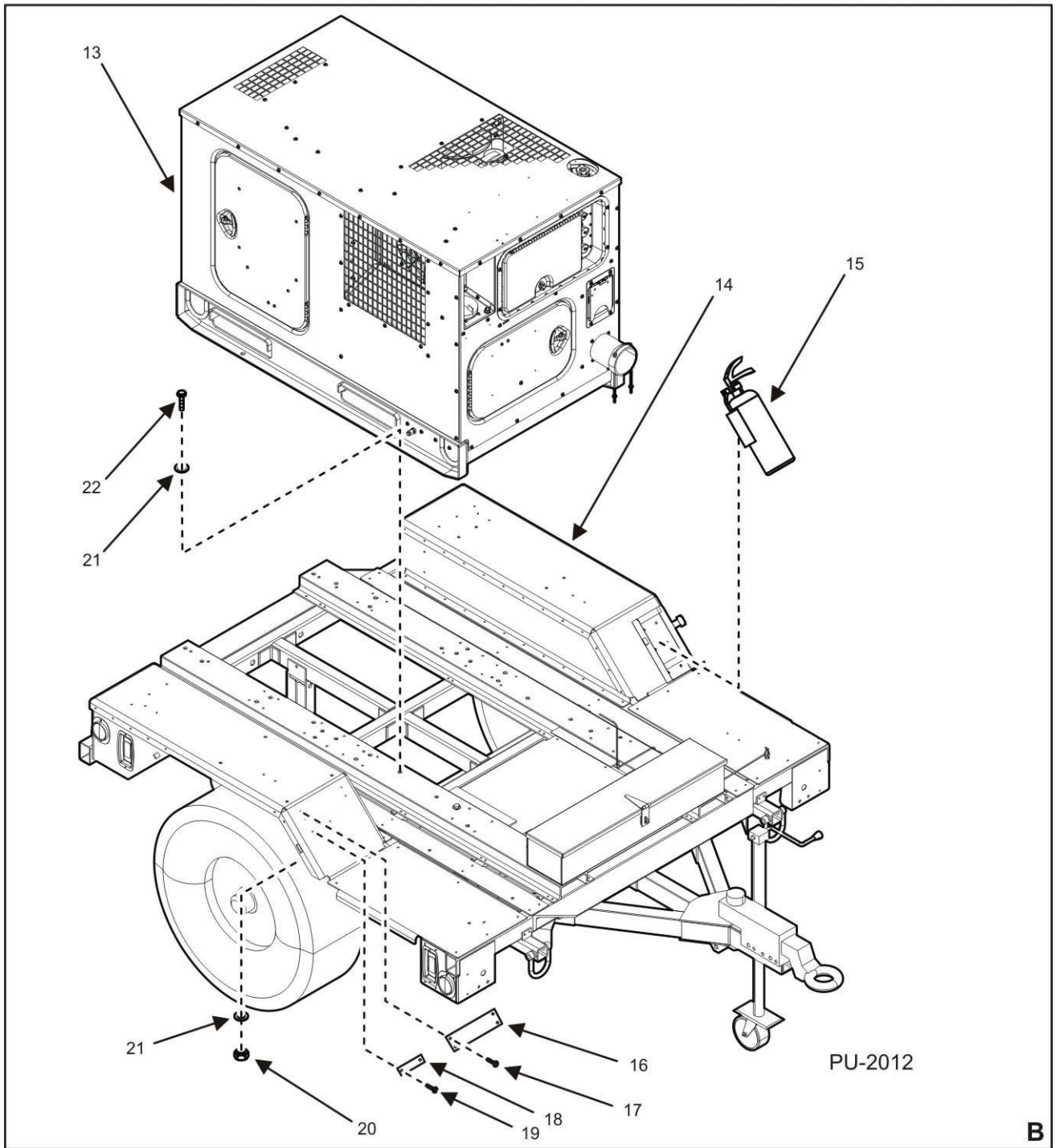

Figure 1. Power Unit/Power Plant (Sheet 3 of 4).

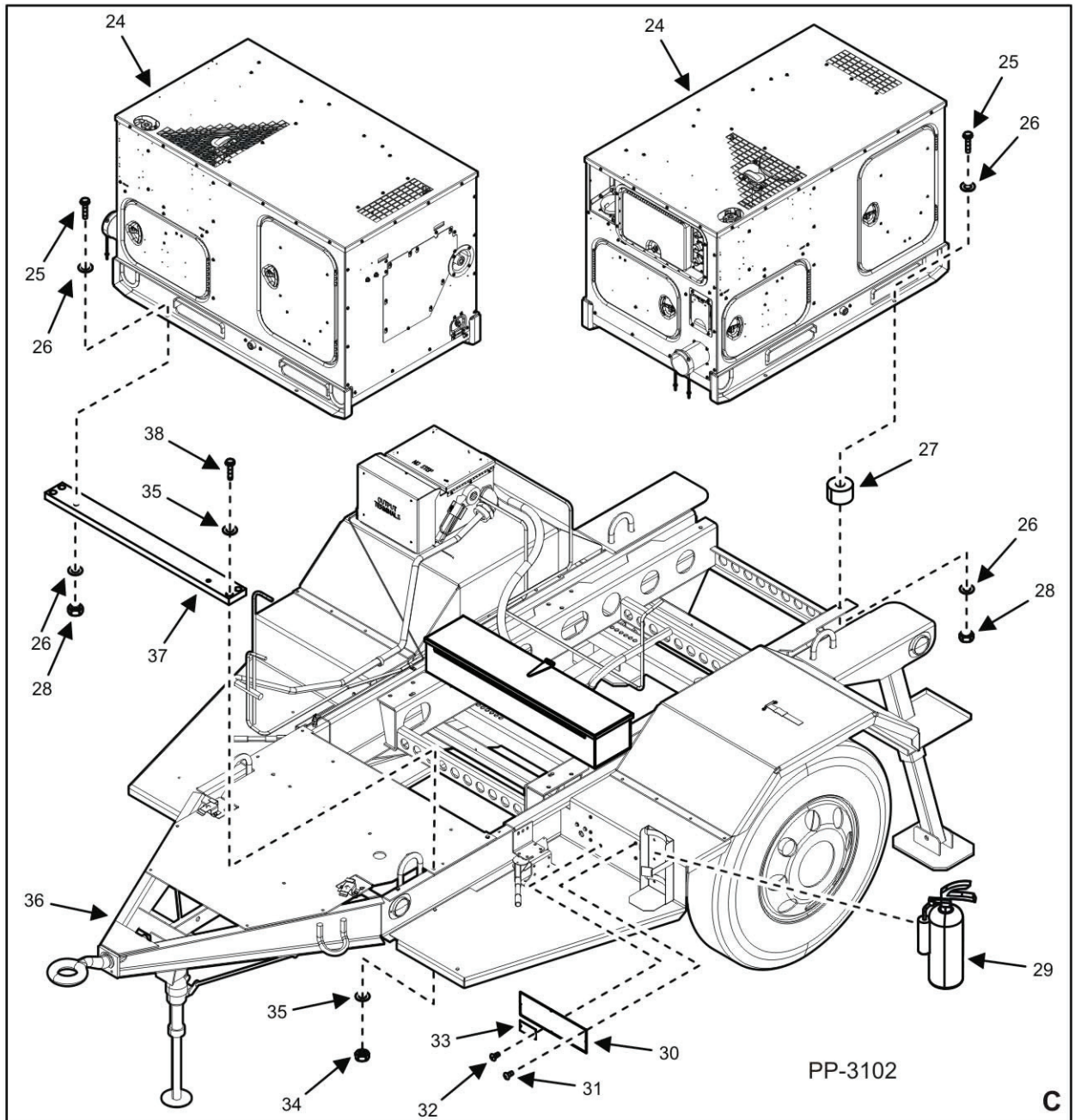

Figure 1. Power Unit/Power Plant (Sheet 4 of 4).

(1) ITEM NO.	(2) SMR CODE	(3) NSN	(4) CAGEC	(5) P/N	(6) DESCRIPTION AND UOC	(7) QTY.
					GROUP 00	
					FIG. 1 POWER UNIT/POWER PLANT	
1	PAFHH	6115015624010	30554	PU-2002	GENERATOR SET, DIESEL, POWER UNIT (SEE SHEET 2 FOR PARTS BREAKDOWN) UOC: 98Z	1
2	PAFHH	6115015617455	30554	MEP-1040	.GENERATOR SET, DIESEL UOC: 98Z	1
3	PAFFF	6115015426775	97403	13230E6565	.MODIFIED TRAILER UOC: 98Z	1
4	PAFZZ	4210015527734	97403	13230E6831	..EXTINGUISHER, FIRE UOC: 98Z	1
5	XBFZZ		30554	04-21180-3	.NAMEPLATE, SHIPPING UOC: 98Z	1
6	PAFZZ	5320010863593	96906	MS20604AD6C4	.RIVET, BLIND UOC: 98Z	6
7	XBFZZ		30554	04-21078-12	.PLATE, UID IDENTIFICATION UOC: 98Z	1
8	PAFZZ	5320009572514	80205	MS20604AD4W4	.RIVET, BLIND UOC: 98Z	2
9	PAFZZ	5310015531219	27687	F51N7582-813	..NUT, SELF-LOCKING, HEXAGON UOC: 98Z	4
10	PAFZZ		30554	88-20033-40A	..WASHER, FLAT UOC: 98Z	8
11	PAFZZ	5305000712071	80204	B1821BH050C200N	..SCREW, CAP, HEXAGON HEAD UOC: 98Z	4
12	PAFHH	6115015623907	30554	PU-2012	GENERATOR SET, DIESEL, POWER UNIT (SEE SHEET 3 FOR PARTS BREAKDOWN) UOC: 99A	1
13	PAFHH	6115015617466	30554	MEP-1041	.GENERATOR SET, DIESEL UOC: 99A	1
14	PAFFF	6115015426775	97403	13230E6565	.MODIFIED TRAILER UOC: 99A	1
15	PAFZZ	4210015527734	97403	13230E6831	..EXTINGUISHER, FIRE UOC: 99A	1
16	XBFZZ		30554	04-21180-4	.NAMEPLATE, SHIPPING UOC: 99A	1
17	PAFZZ	5320010863593	96906	MS20604AD6C4	.RIVET, BLIND UOC: 99A	6
18	XBFZZ		30554	04-21078-17	.PLATE, UID IDENTIFICATION UOC: 99A	1
19	PAFZZ	5320009572514	80205	MS20604AD4W4	.RIVET, BLIND UOC: 99A	2
20	PAFZZ	5310015531219	27687	F51N7582-813	..NUT, SELF-LOCKING, HEXAGON UOC: 99A	4
21	PAFZZ		30554	88-20033-40A	.WASHER, FLAT UOC: 99A	8
22	PAFZZ	5305000712071	80204	B1821BH050C200N	..SCREW, CAP, HEXAGON HEAD UOC: 99A	4

(1) ITEM NO.	(2) SMR CODE	(3) NSN	(4) CAGEC	(5) P/N	(6) DESCRIPTION AND UOC	(7) QTY.
23	PAFHH	6115015626480	30554	PP-3102	POWER PLANT, ELECTRIC (SEE SHEET 4 FOR PARTS BREAKDOWN) UOC: 99D	1
24	PAFHH	6115015617455	30554	MEP-1040	.GENERATOR SET, DIESEL UOC: 99D	2
25	PAFZZ	5305000712075	80204	B1821BH050C300N	..SCREW, CAP, HEXAGON HEAD UOC: 99D	8
26	PAFZZ		30554	88-20033-40A	..WASHER, FLAT UOC: 99D	16
27	PAFZZ		44940	04-21721	.SPACER, MOUNTING UOC: 99D	6
28	PAFZZ	5310015531219	27687	F51N7582-813	..NUT, SELF-LOCKING, HEXAGON UOC: 99D	8
29	PAFZZ	4210015527734	97403	13230E6831	..EXTINGUISHER, FIRE UOC: 99D	1
30	XBFZZ		30554	04-21180-22	.NAMEPLATE, SHIPPING UOC: 99D	1
31	PAFZZ	5320010863593	96906	MS20604AD6C4	.RIVET, BLIND UOC: 99D	6
32	PAFZZ	5320009572514	80205	MS20604AD4W4	.RIVET, BLIND UOC: 99D	2
33	XBFZZ		30554	04-21078-33	.PLATE, UID IDENTIFICATION UOC: 99D	1
34	PAFZZ	5310002453424	80205	MS17829-5C	..NUT, SELF-LOCKING, HEXAGON UOC: 99D	4
35	PAFZZ	5310000446477	96906	MS51412-25	..WASHER, FLAT UOC: 99D	8
36	PAFFF		30554	04-21234	.MODIFIED TRAILER UOC: 99D	1
37	PAFZZ		44940	04-21300	.SPACER, MOUNTING UOC: 99D	1
38	PAFZZ	5306002264829	80204	B1821BH031C125N	..BOLT, MACHINE UOC: 99D	4
<b>END OF FIGURE</b>						

---

**OPERATOR AND FIELD MAINTENANCE  
AMMPS 10KW TRAILER-MOUNTED POWER UNITS AND POWER PLANTS  
TRAILER CHASSIS REPAIR PARTS LIST**

---

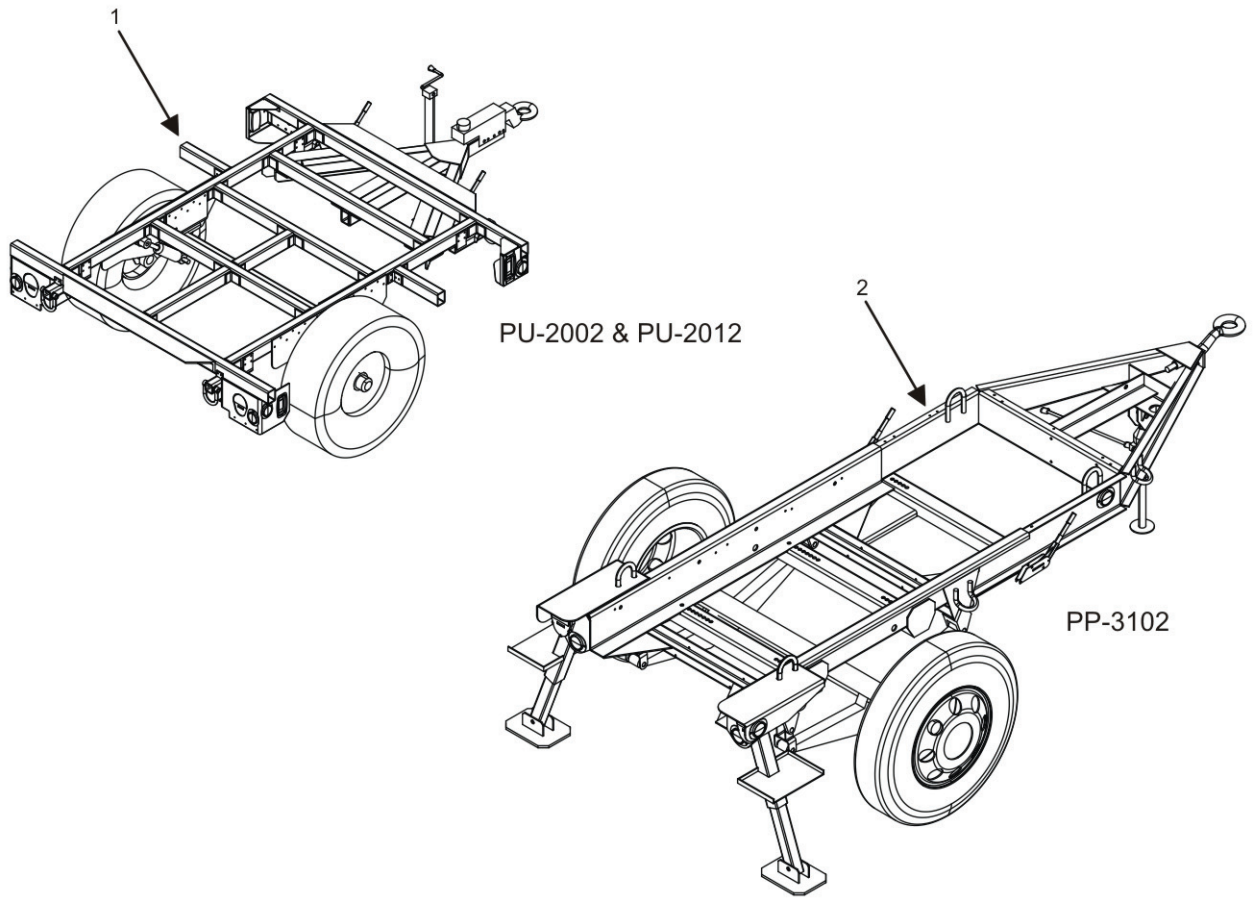

Figure 2. Trailer Chassis (Sheet 1 of 1).



(1) ITEM NO.	(2) SMR CODE	(3) NSN	(4) CAGEC	(5) P/N	(6) DESCRIPTION AND UOC	(7) QTY.
					GROUP 01	
					FIG. 2 TRAILER CHASSIS	
1	PAFFF		19207	12450001	.CHASSIS, TRAILER- LTT	
2	PAFFF	2330003312307	19207	8358998	UOC: 98Z, 99A .CHASSIS, TRAILER- M200	1
					UOC: 99D	1
					<b>END OF FIGURE</b>	



---

**OPERATOR AND FIELD MAINTENANCE  
AMMPS 10KW TRAILER-MOUNTED POWER UNITS AND POWER PLANTS  
FIRE EXTINGUISHER BRACKET REPAIR PARTS LIST**

---

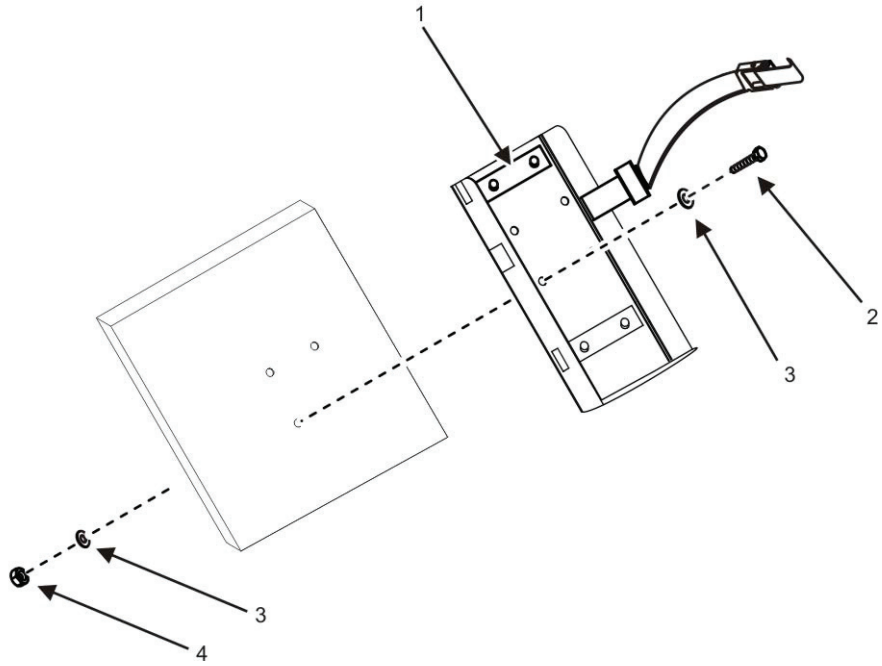

Figure 3. Fire Extinguisher Bracket (Sheet 1 of 1).

(1) ITEM NO.	(2) SMR CODE.	(3) NSN	(4) CAGEC	(5) P/N	(6) DESCRIPTION AND UOC	(7) QTY.
					GROUP 0101	
					FIG. 3 FIRE EXTINGUISHER BRACKET	
1	PAFZZ	4210015351439	0J0S5	270191	.BRACKET, FIRE EXTINGUISHER	1
2	PAFZZ	5306002264827	80204	B1821BH031C100N	..BOLT, MACHINE	4
3	PAFZZ	5310000446477	96906	MS51412-25	..WASHER, FLAT	8
4	PAFZZ	5310002453424	80205	MS17829-5C	..NUT, SELF-LOCKING, HEXAGON	4
					<b>END OF FIGURE</b>	



---

**OPERATOR AND FIELD MAINTENANCE**  
**AMMPS 10KW TRAILER-MOUNTED POWER UNITS AND POWER PLANTS**  
**FENDERS REPAIR PARTS LIST**

---

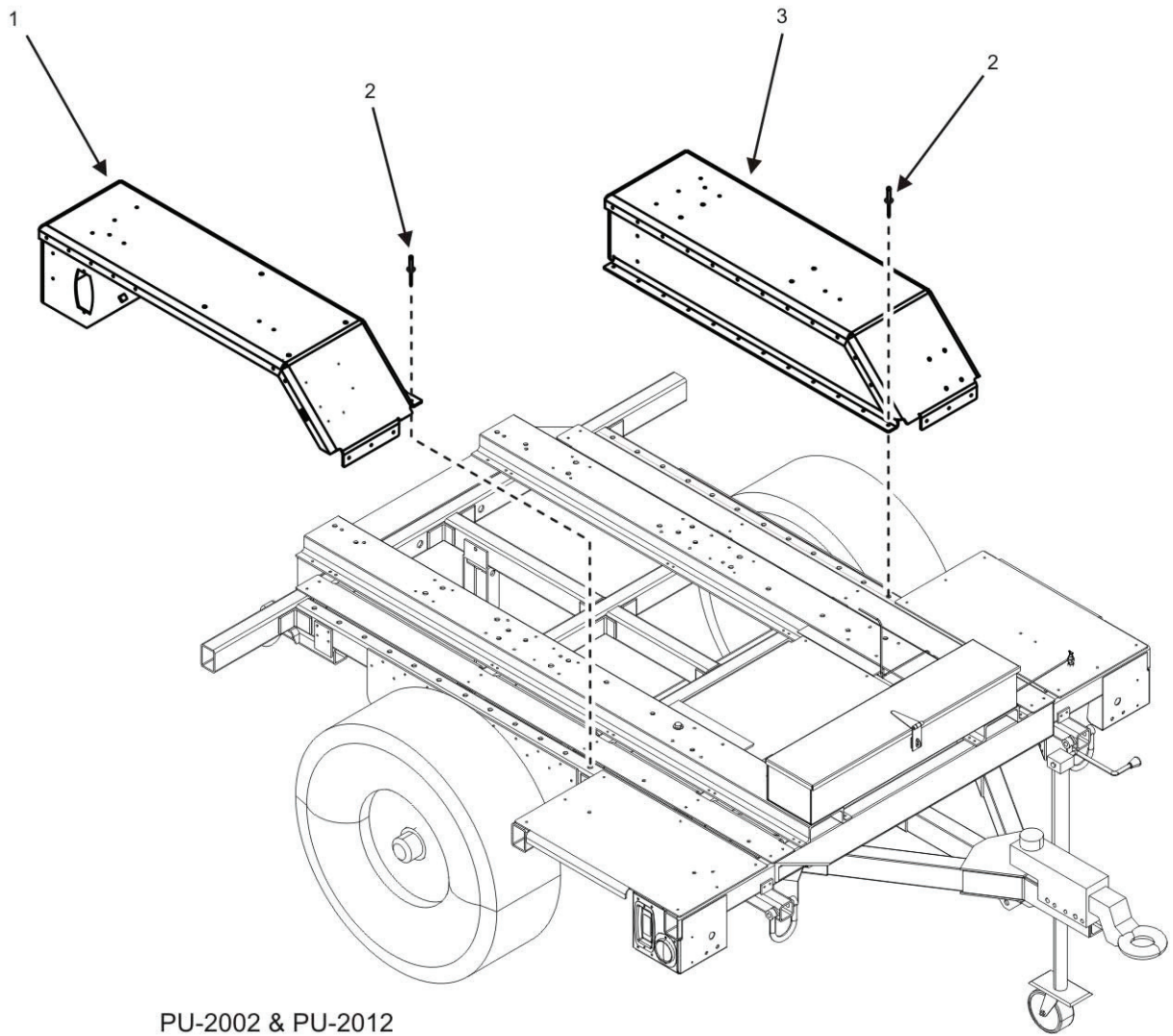

**Figure 4. Fenders (Sheet 1 of 2).**

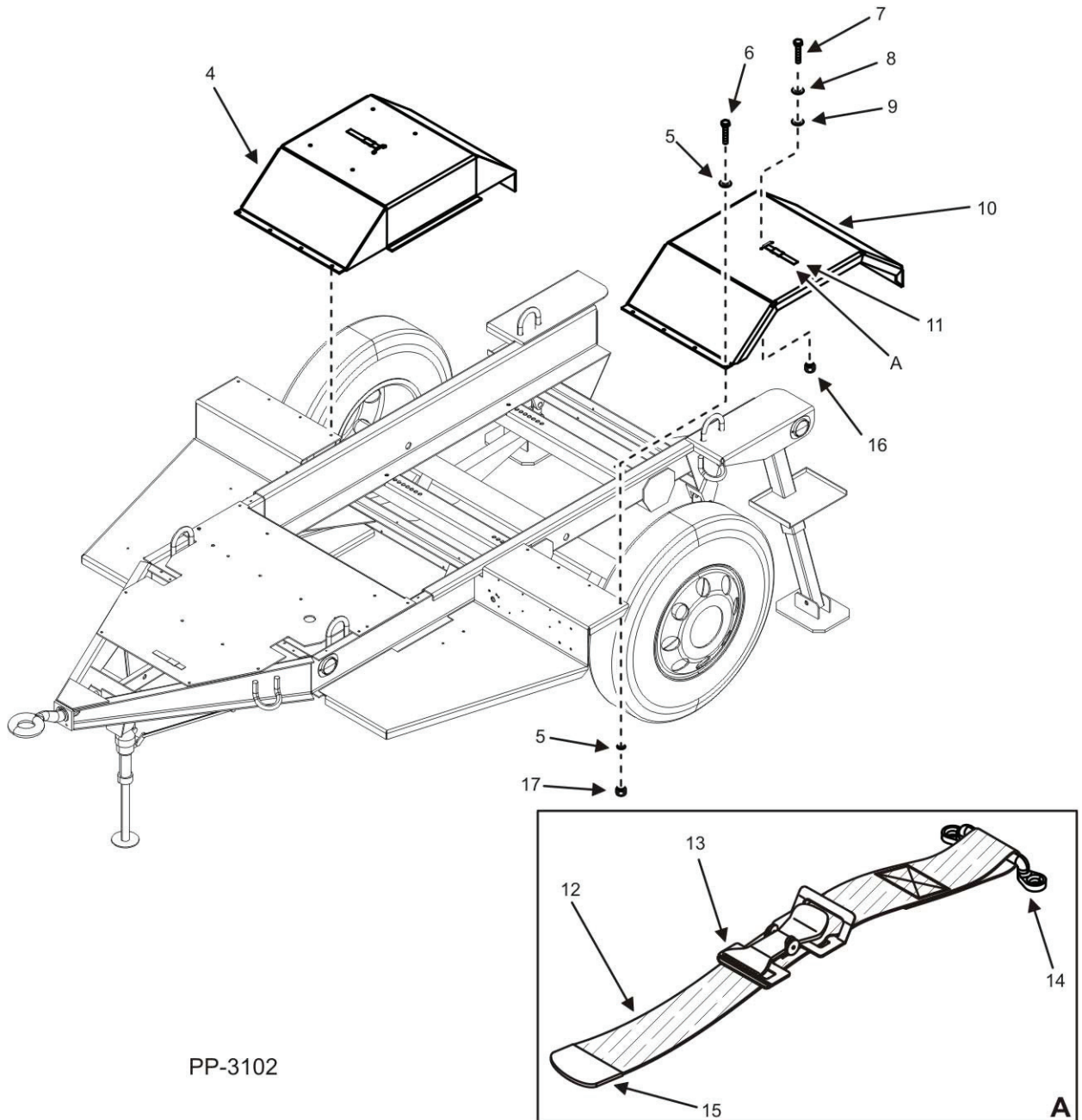

PP-3102

Figure 4. Fenders (Sheet 2 of 2).



(1) ITEM NO.	(2) SMR CODE	(3) NSN	(4) CAGEC	(5) P/N	(6) DESCRIPTION AND UOC	(7) QTY.
					GROUP 0102	
					FIG. 4 FENDERS	
1	XBFZZ		97403	13230E6571-1	.FENDER ASSEMBLY (CURBSIDE) (USE COATING COMPOUND P/N AA59166-2-03H (58536) AS REQUIRED FROM BULK ITEMS LIST) UOC: 98Z, 99A	1
2	PAFZZ	5320014856915	9K475	MGLP-R8-6	..RIVET, BLIND UOC: 98Z, 99A	24
3	XBFZZ		97403	13230E6571-2	..FENDER ASSEMBLY (ROADSIDE) (USE COATING COMPOUND P/N AA59166-2-03H (58536) AS REQUIRED FROM BULK ITEMS LIST) UOC: 98Z, 99A	1
4	PAFZZ	2510011954273	97403	13214E1263	..FENDER, VEHICULAR (CURBSIDE) (USE COATING COMPOUND P/N AA59166-2-001G- 34088 (58536) AS REQUIRED FROM BULK ITEMS LIST) UOC: 99D	1
5	PAFZZ	5310000446477	96906	MS51412-25	..WASHER, FLAT UOC: 99D	36
6	PAFZZ	5306002264829	80204	B1821BH031C125N	..BOLT, MACHINE UOC: 99D	18
7	PAFZZ	5305014791214	97403	13230E6673-66A	..SCREW, MACHINE UOC: 99D	2
8	PAFZZ	5310015002482	30554	88-20033-11A	..WASHER, FLAT UOC: 99D	2
9	PAFZZ	5310015002428	97403	13230E6744-43	..WASHER, LOCK UOC: 99D	2
10	PAFZZ	2510015351092	97403	13214E1264	..FENDER, VEHICULAR (ROADSIDE) (USE COATING COMPOUND P/N AA59166-2-001G- 34088 (58536) AS REQUIRED FROM BULK ITEMS LIST) UOC: 99D	1
11	PAFFF	6115012800063	97403	13218E5091	.TIEDOWN, STRAP UOC: 99D	1
12	PAFZZ	5340013988680	97403	13214E9975-1	..STRAP, WEBBING UOC: 99D	1
13	PAFZZ	5340000576956	80205	MS51929-2	..BUCKLE UOC: 99D	1
14	PAFZZ	5340002290340	96906	MS51939-3	..LOOP, STRAP, FASTENER UOC: 99D	1
15	PAFZZ	5340000787029	96906	MS51926-3	..CLIP, END, STRAP UOC: 99D	1
16	PAFZZ	5310014989981	97403	13218E0320-89	..NUT, PLAIN, HEXAGON UOC: 99D	2
17	PAFZZ	5310002453424	80205	MS17829-5C	..NUT, SELF-LOCKING, HEXAGON UOC: 99D	18

---

(1) ITEM NO.	(2) SMR CODE	(3) NSN	(4) CAGEC	(5) P/N	(6) DESCRIPTION AND UOC	(7) QTY.
END OF FIGURE						

**OPERATOR AND FIELD MAINTENANCE**  
**AMMPS 10KW TRAILER-MOUNTED POWER UNITS AND POWER PLANTS**  
**FLOORS, RAILS, AND SPACERS REPAIR PARTS LIST**

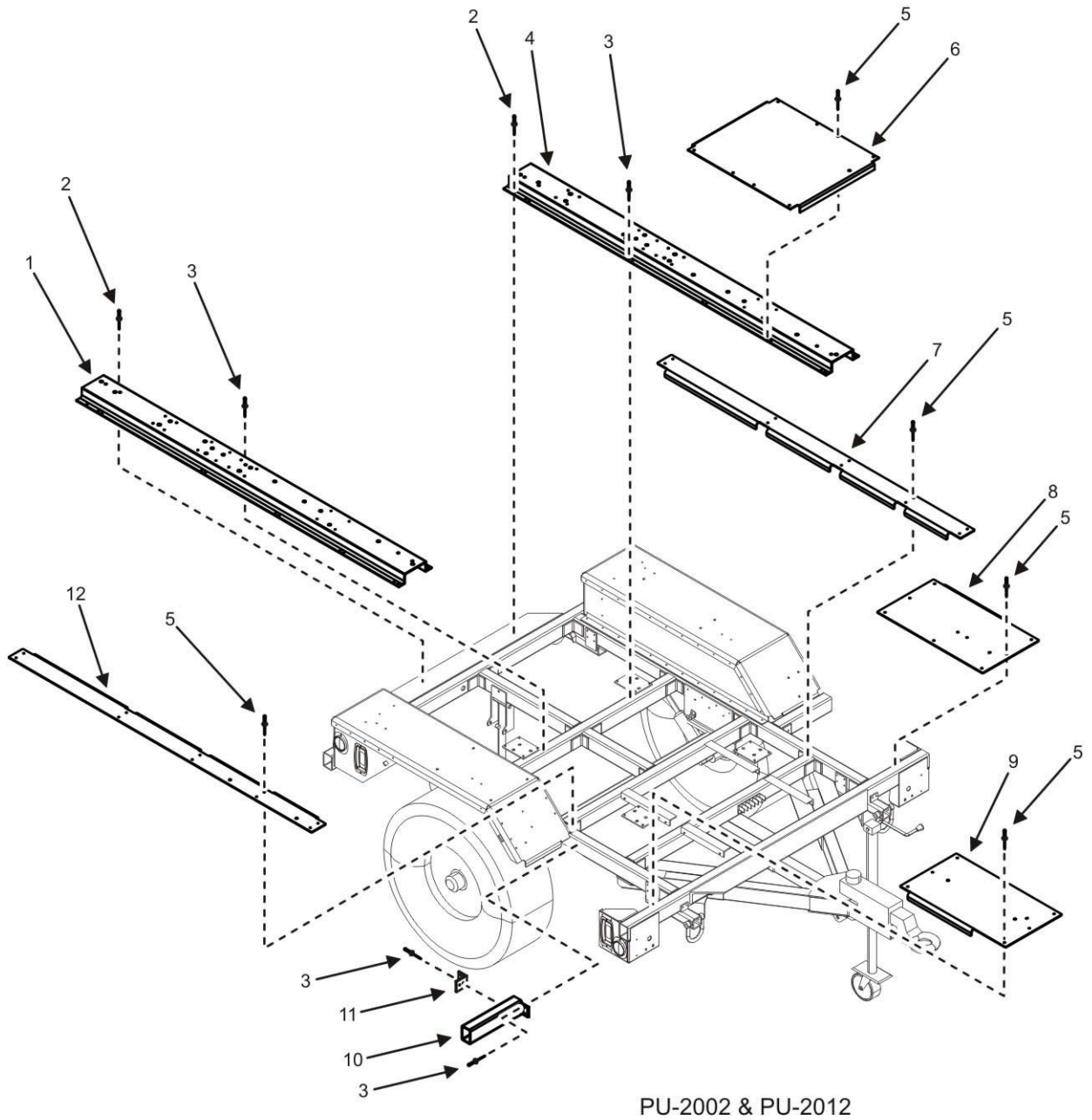

**Figure 5. Floors, Rails, and Spacers (Sheet 1 of 2).**

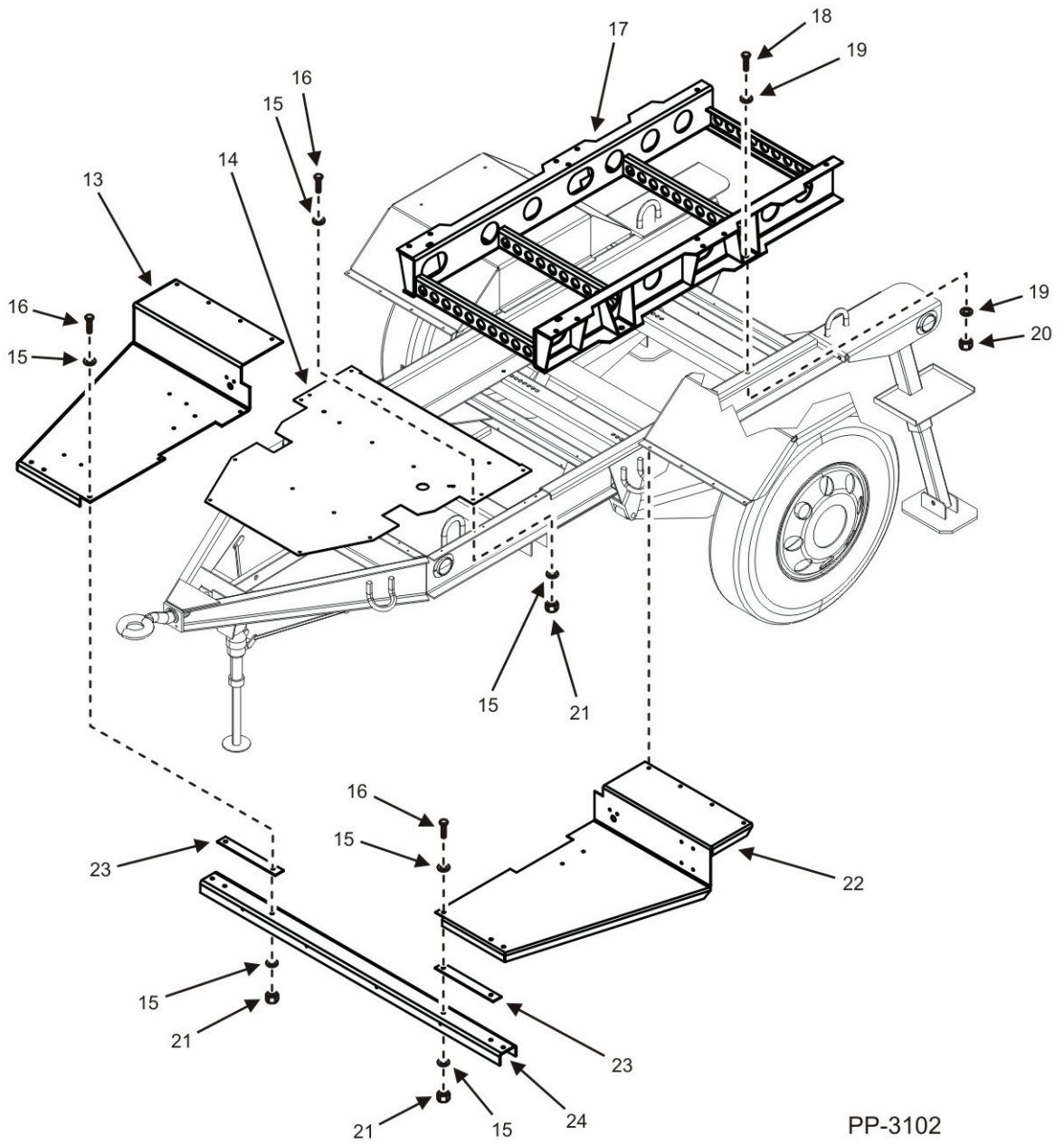

PP-3102

Figure 5. Floors, Rails, and Spacers (Sheet 2 of 2).

(1) ITEM NO.	(2) SMR CODE	(3) NSN	(4) CAGEC	(5) P/N	(6) DESCRIPTION AND UOC	(7) QTY.
					GROUP 0103	
					FIG. 5 FLOORS, RAILS, AND SPACERS	
1	XBFFF		97403	13230E6569-1	.RAIL, MOUNTING (CURBSIDE) UOC: 98Z, 99A	1
2	PAFZZ	5320011401479	9K475	B0M-R8-10	.RIVET, BLIND UOC: 98Z, 99A	4
3	PAFZZ	5320004830558	9K475	B0M-R8-8	.RIVET, BLIND UOC: 98Z, 99A	56
4	XBFFF		97403	13230E6569-2	.RAIL, MOUNTING (ROADSIDE) UOC: 98Z, 99A	1
5	XBFZZ	5315014664174	9K475	MGLP-R8-10	.PIN, QUICK RELEASE UOC: 98Z, 99A	42
6	XBFZZ		97403	13230E6568	.FLOOR, CENTER UOC: 98Z, 99A	1
7	PAFZZ		97403	13230E6564-2	.FLOOR, SIDE, INNER (ROADSIDE) (USE COATING COMPOUND P/N AA59166-2-001G- 34088 (58536) AS REQUIRED FROM BULK ITEMS LIST) UOC: 98Z, 99A	1
8	XBFZZ		97403	13230E6567-2	.FLOOR, SIDE (ROADSIDE) (USE COATING COMPOUND P/N AA59166-2-001G- 34088 (58536) AS REQUIRED FROM BULK ITEMS LIST) UOC: 98Z, 99A	1
9	XBFZZ		97403	13230E6567-1	.FLOOR, SIDE (CURBSIDE) (USE COATING COMPOUND P/N AA59166-2-001G- 34088 (58536) AS REQUIRED FROM BULK ITEMS LIST) UOC: 98Z, 99A	1
10	PAFZZ		19207	12450056-1	.TUBE, RECTANGULAR, RND CORNER UOC: 98Z, 99A	1
11	XBFZZ		97403	13230E6524	.CLIP, FRAME UOC: 98Z, 99A	2
12	XBFZZ		97403	13230E6564-1	.FLOOR, SIDE, INNER (CURBSIDE) (USE COATING COMPOUND P/N AA59166-2-001G- 34088 (58536) AS REQUIRED FROM BULK ITEMS LIST) UOC: 98Z, 99A	4
						1

(1) ITEM NO.	(2) SMR CODE	(3) NSN	(4) CAGEC	(5) P/N	(6) DESCRIPTION AND UOC	(7) QTY.
13	XBFFF	2540011509864	97403	13214E1461	.STEP, FRONT, CURBSIDE (USE COATING COMPOUND P/N AA59166-2-001G- 34088 (58536) AS REQUIRED FROM BULK ITEMS LIST) UOC: 99D	1
14	PAFZZ		97403	13229E6108	.PLATFORM, FRONT (USE COATING COMPOUND P/N AA59166-2-001G-34088 (58536) AS REQUIRED FROM BULK ITEMS LIST) UOC: 99D	1
15	PAFZZ	5310000446477	96906	MS51412-25	.WASHER, FLAT UOC: 99D	1
16	XBFFZ	5306002264829	80204	B1821BH031C125N	.BOLT, MACHINE UOC: 99D	64
17	PAFZZ		44940	04-21716	.FRAME, SPACER UOC: 99D	32
18	PAFZZ	5305015519219	80204	B1821BH062C175N	.SCREW, CAP, HEXAGON HEAD UOC 99D	1
19	PAFZZ	5310015316074	30554	88-20033-45A	.WASHER, FLAT UOC: 99D	4
20	XBFFF	5310015524574	97403	13230E6382-14	.NUT, SELF-LOCKING, HEAD UOC: 99D	8
21	PAFZZ	5310002453424	80205	MS17829-5C	.NUT, SELF-LOCKING, HEXAGON UOC: 99D	4
22	PAFZZ	2510011964682	97403	13214E1462	.STEP, FRONT, ROADSIDE (USE COATING COMPOUND P/N AA59166-2-001G- 34088 (58536) AS REQUIRED FROM BULK ITEMS LIST) UOC: 99D	32
23	PAFZZ	5365009442682	97403	13214E1267-1	.SPACER, PLATE UOC: 99D	1
24	XBFFZ		97403	13214E1268	.CHANNEL UOC: 99D	2
					<b>END OF FIGURE</b>	1

---

**OPERATOR AND FIELD MAINTENANCE  
AMMPS 10KW TRAILER-MOUNTED POWER UNITS AND POWER PLANTS  
BRAKES UOC 99D REPAIR PARTS LIST**

---

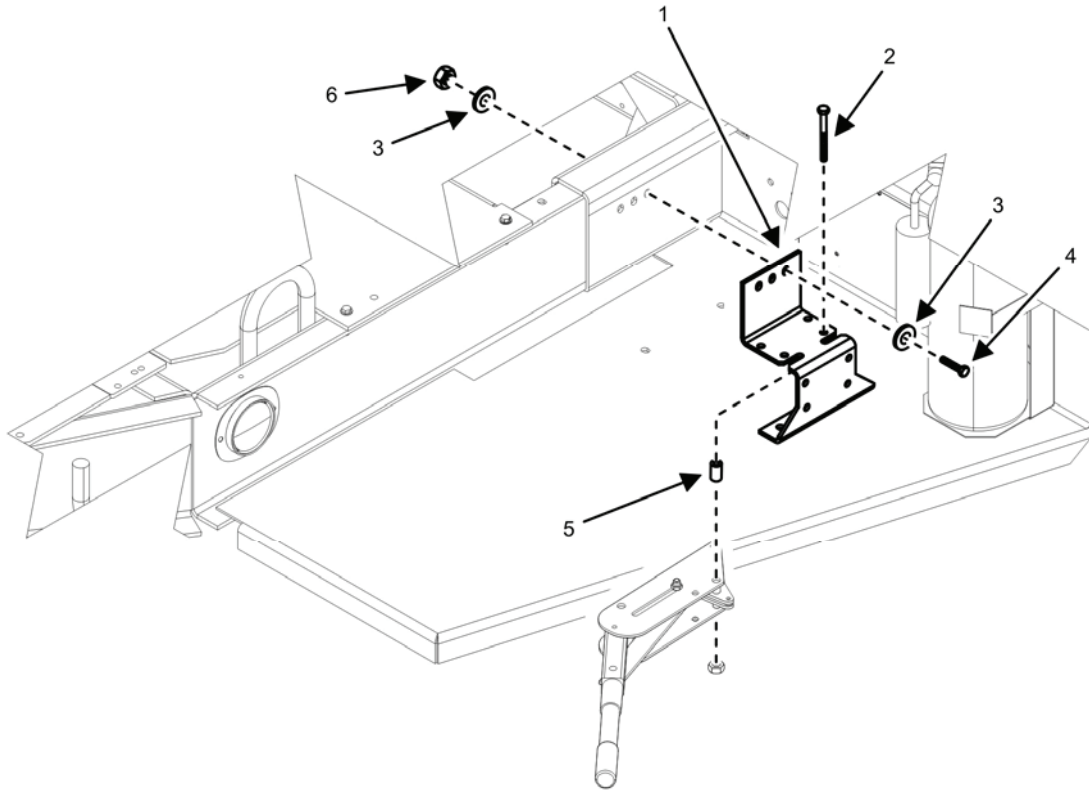

Figure 6. Brakes UOC 99D (Sheet 1 of 3).



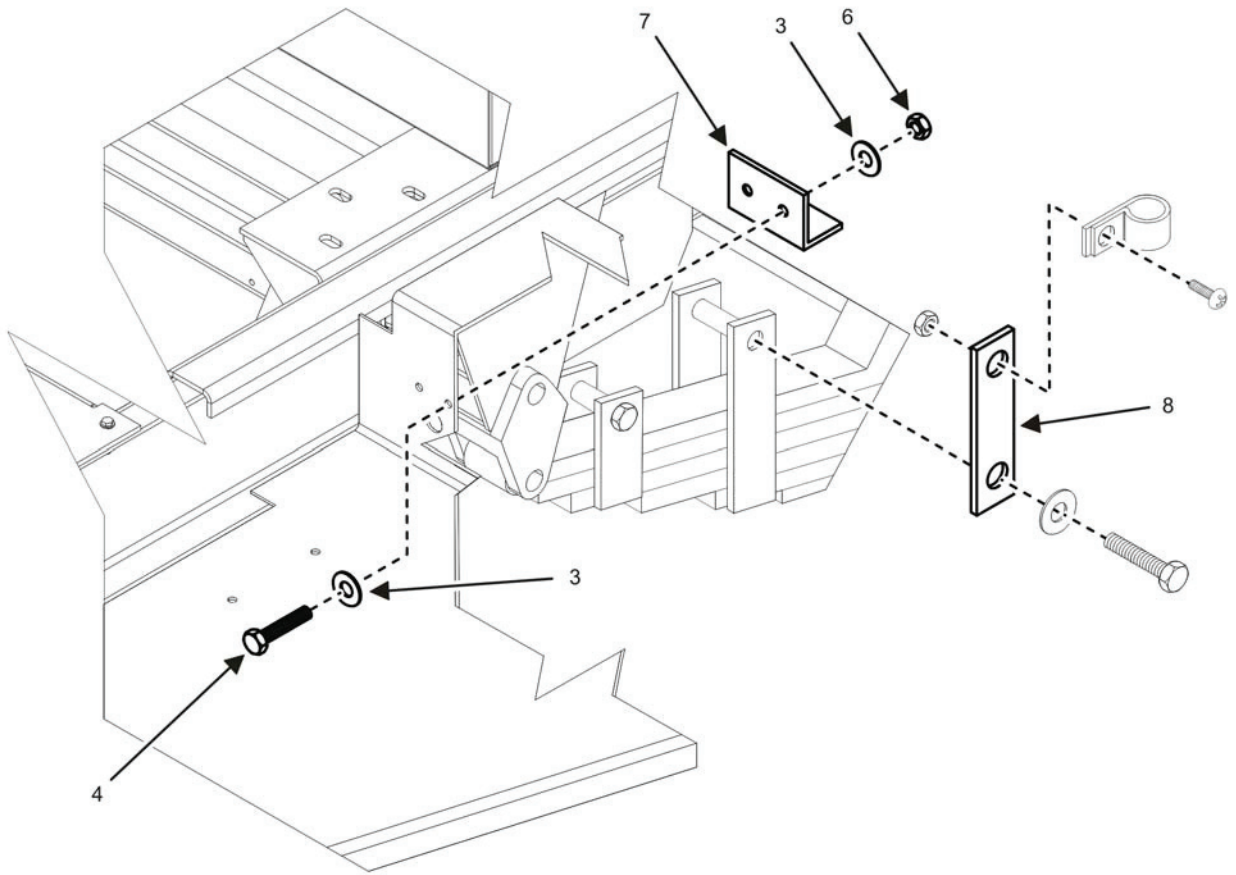

Figure 6. Brakes UOC 99D (Sheet 2 of 3).

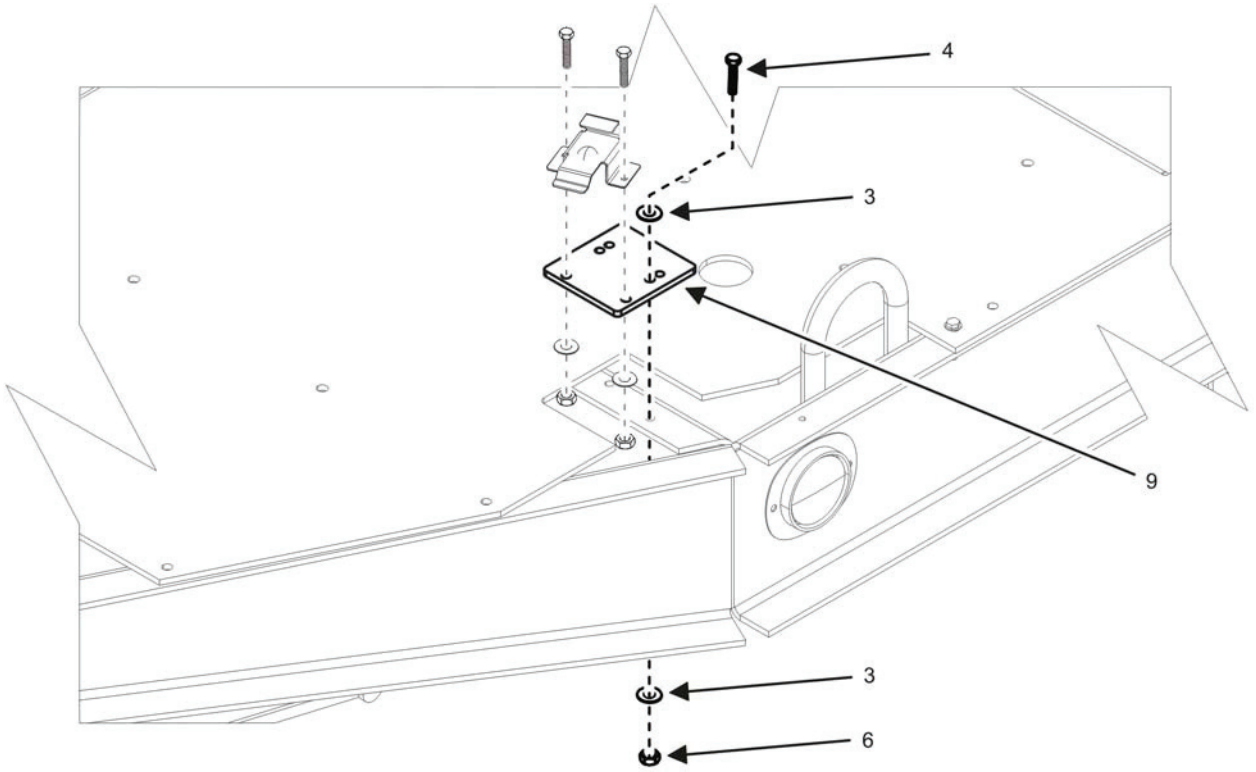

Figure 6. Brakes UOC 99D (Sheet 3 of 3).

(1) ITEM NO.	(2) SMR CODE	(3) NSN	(4) CAGEC	(5) P/N	(6) DESCRIPTION AND UOC	(7) QTY.
					GROUP 0104	
					FIG. 6 BRAKES UOC 99D	
1	XBFZZ		44940	04-21233	.BRACKET, BRAKE UOC: 99D	2
2	PAFZZ	5306002264832	80204	B1821BH031C175N	.BOLT, MACHINE UOC: 99D	6
3	PAFZZ	5310000446477	96906	MS51412-25	.WASHER, FLAT UOC: 99D	32
4	PAFZZ	5306002264829	80204	B1821BH031C125N	.BOLT, MACHINE UOC: 99D	16
5	PAFZZ	5365009893304	97403	13214E1272	.SPACER, SLEEVE UOC: 99D	4
6	PAFZZ	5310002453424	80205	MS17829-5C	.NUT, SELF-LOCKING, HEXAGON UOC: 99D	16
7	PAFZZ	2510015351092	97403	13214E1270	.BRACKET, BRAKE CABLE UOC: 99D	2
8	XBFZZ		97403	13214E1271	.STRAP, BRAKE CABLE UOC: 99D	2
9	XBFZZ		44940	04-21362	.PLATE, MOUNTING UOC: 99D	2
					<b>END OF FIGURE</b>	



---

**OPERATOR AND FIELD MAINTENANCE  
AMMPS 10KW TRAILER-MOUNTED POWER UNITS AND POWER PLANTS  
LTT LIGHTS INSTALLATION UOC 98Z AND 99A REPAIR PARTS LIST**

---

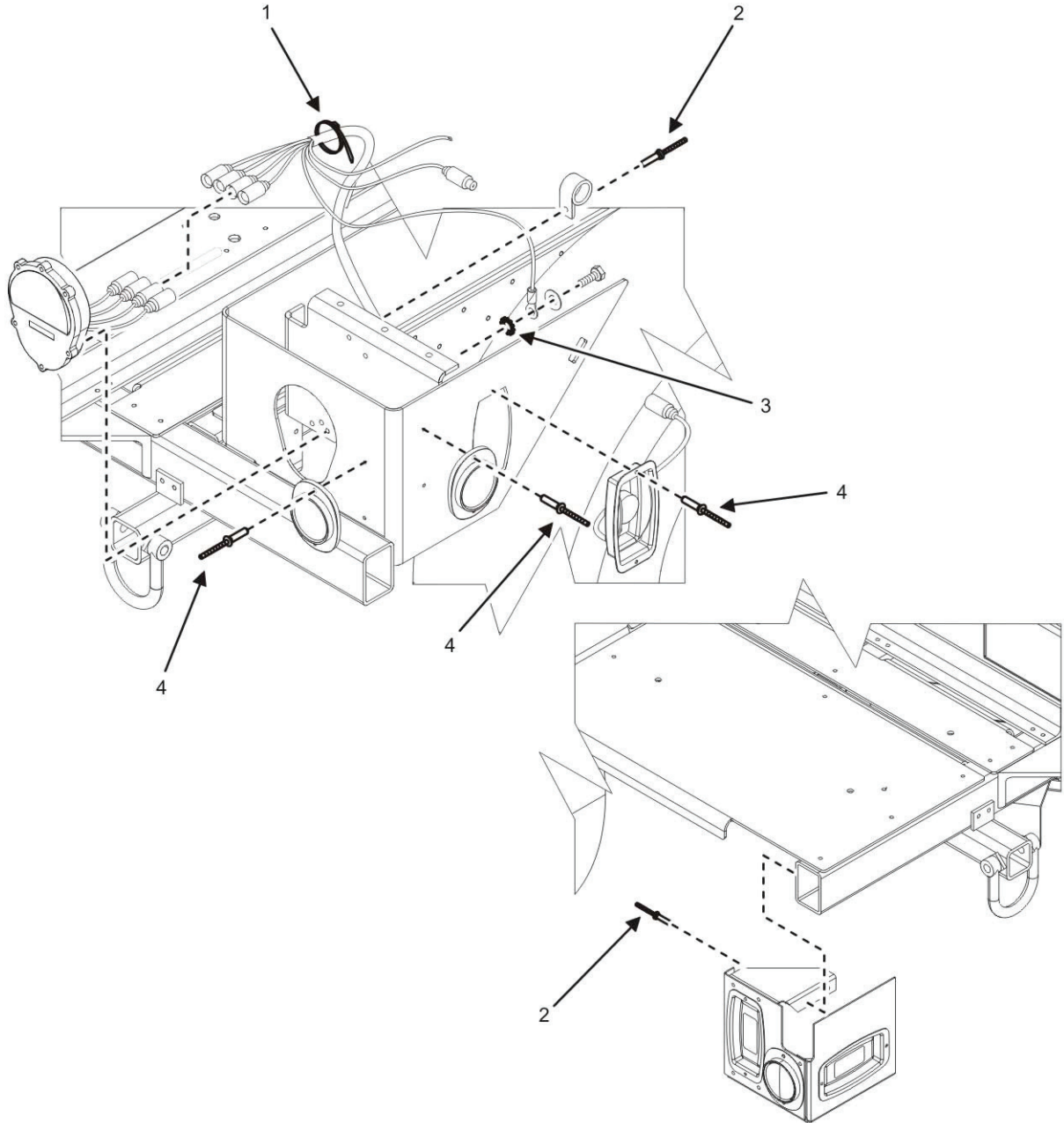

Figure 7. LTT Lights Installation UOC 98Z and 99A (Sheet 1 of 1).

(1) ITEM NO.	(2) SMR CODE	(3) NSN	(4) CAGEC	(5) P/N	(6) DESCRIPTION AND UOC	(7) QTY.
					GROUP 0105	
					FIG. 7 LTT LIGHTS INSTALLATION UOC 98Z AND 99A	
1	PAFZZ	5975000742072	81343	MS3367-1-9	.STRAP, TIEDOWN, ELECTRICAL UOC: 98Z, 99A	4
2	PAFZZ	5320014856915	9K475	MGLP-R8-6	.RIVET, BLIND UOC: 98Z, 99A	18
3	PAFZZ	5310014785703	97403	13230E6744-46	.WASHER, LOCK UOC: 98Z, 99A	4
4	PAFZZ	5320014142171	11815	BAPK-69	.RIVET, BLIND UOC: 98Z, 99A	12
					<b>END OF FIGURE</b>	





---

**OPERATOR AND FIELD MAINTENANCE  
AMMPS 10KW TRAILER-MOUNTED POWER UNITS AND POWER PLANTS  
LTT LEVELING SUPPORT JACK UOC 98Z AND 99A REPAIR PARTS LIST**

---

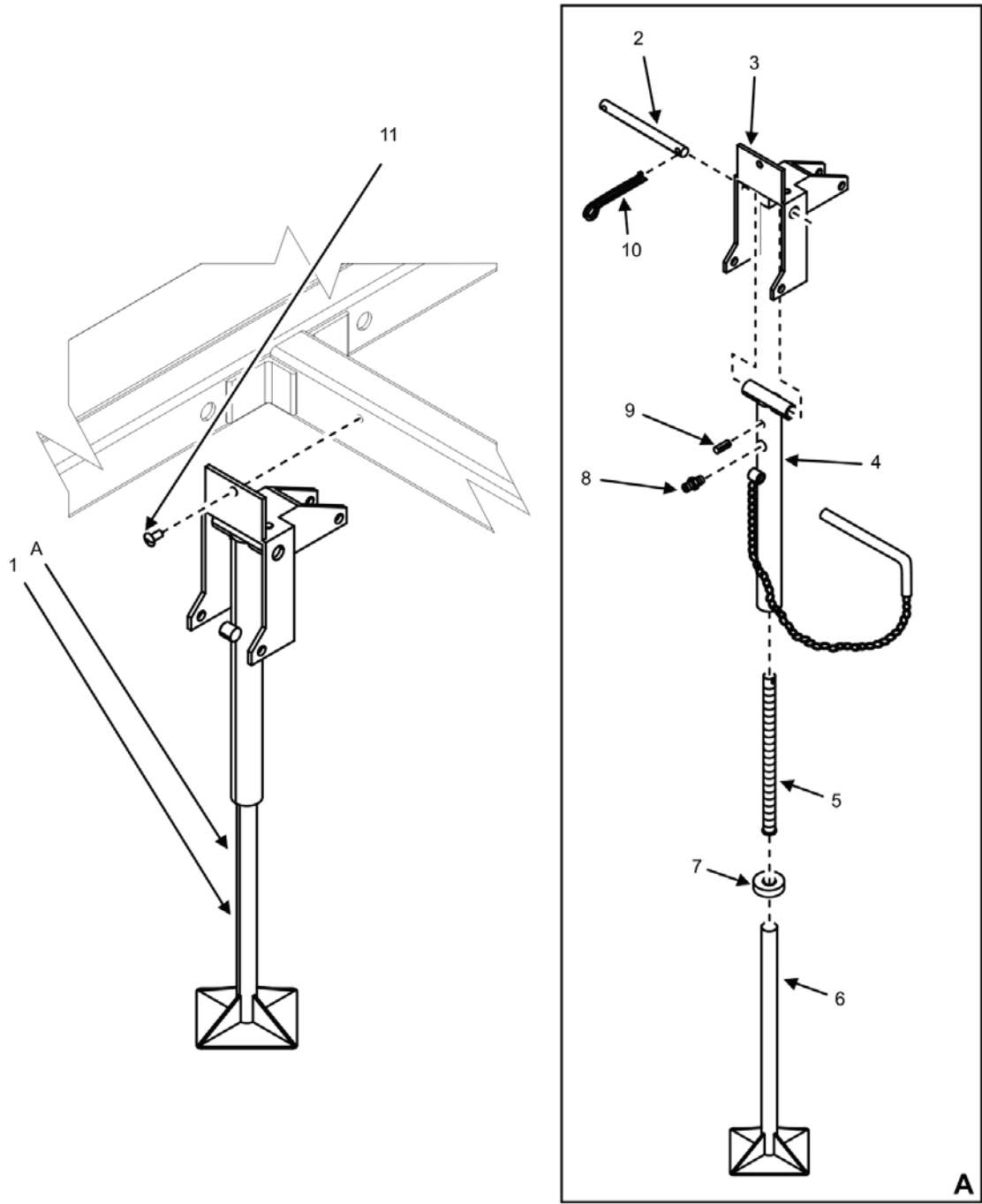

Figure 8. LTT Leveling Support Jack UOC 98Z and 99A (Sheet 1 of 1).

(1) ITEM NO.	(2) SMR CODE	(3) NSN	(4) CAGEC	(5) P/N	(6) DESCRIPTION AND UOC	(7) QTY.
					GROUP 0106	
					FIG. 8 LTT LEVELING SUPPORT JACK UOC 98Z AND 99A	
1	PAFZZ	2590004208929	97403	13214E1206-1	..JACK, LEVELING SUPPORT UOC: 98Z, 99A	1
2	PAFZZ	5315011620143	97403	13214E1209	..PIN, STRAIGHT, HEAD UOC: 98Z, 99A	1
3	PAFZZ	5342012201548	97403	13214E1207	..BRACKET UOC: 98Z, 99A	1
4	PAFZZ	2590004538977	97403	13214E1208-1	..LEG, UPPER UOC: 98Z, 99A	1
5	PAFZZ		97403	13214E1210	..SCREW UOC: 98Z, 99A	1
6	XAFZZ		97403	13214E1212-1	..SUPPORT BASE, LEG UOC: 98Z, 99A	1
7	PAFZZ	5310011490869	97403	13214E1211	..NUT, SLEEVE UOC: 98Z, 99A	1
8	PAFZZ	4730001720049	81343	AS15006-1	..FITTING, LUBRICATION UOC: 98Z, 99A	1
9	PAFZZ	5315008384584	80205	MS16562-66	..PIN, SPRING UOC: 98Z, 99A	1
10	PAFZZ	5315008395822	80205	MS24665-353	..PIN, COTTER UOC: 98Z, 99A	2
11	PAFZZ		9K475	B0M-R12-8	..RIVET, BLIND UOC: 98Z, 99A	3
					<b>END OF FIGURE</b>	



---

**OPERATOR AND FIELD MAINTENANCE  
AMMPS 10KW TRAILER-MOUNTED POWER UNITS AND POWER PLANTS  
ACCESSORY BOX REPAIR PARTS LIST**

---

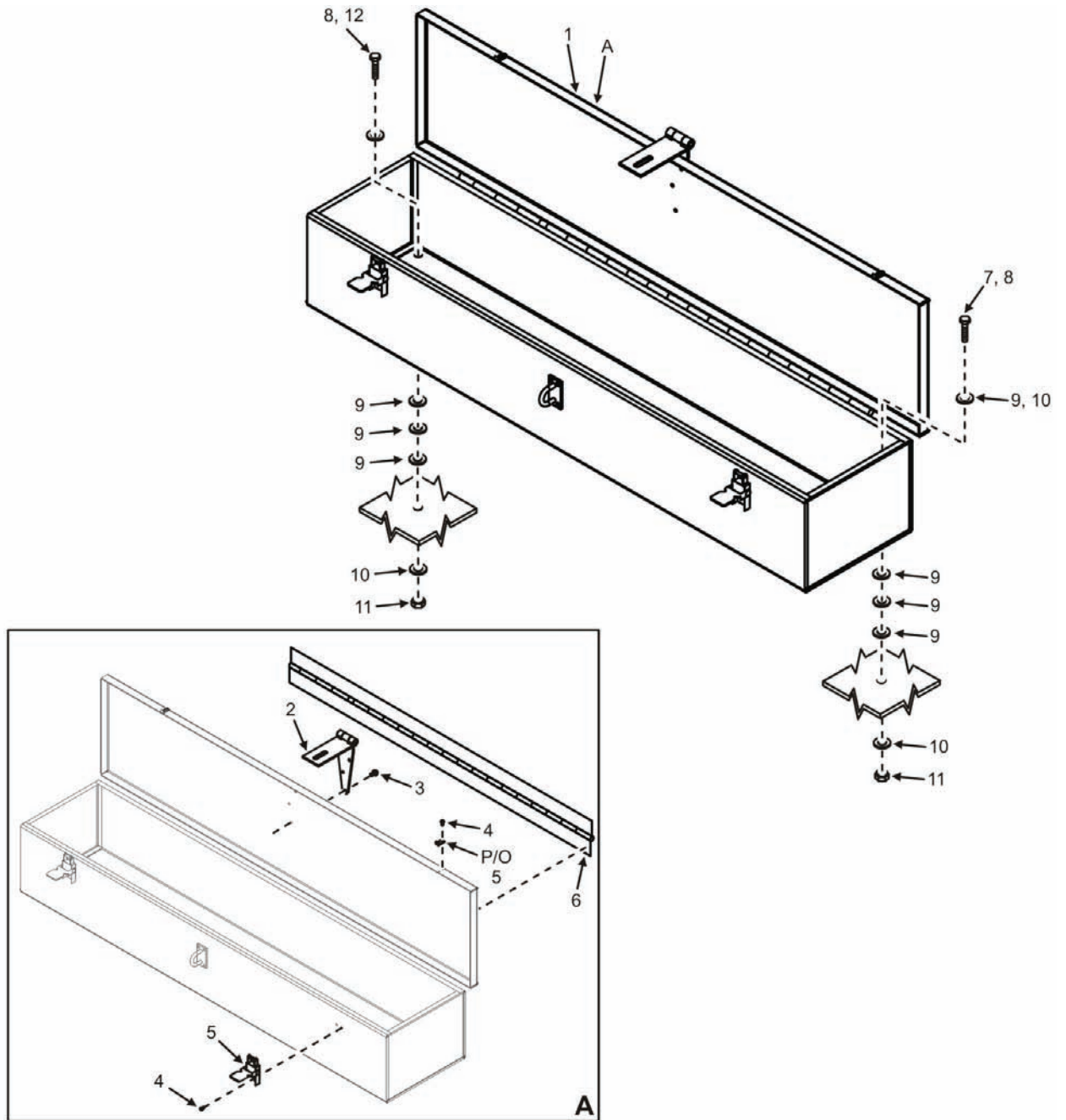

Figure 9. Accessory Box (Sheet 1 of 1).

(1) ITEM NO.	(2) SMR CODE	(3) NSN	(4) CAGEC	(5) P/N	(6) DESCRIPTION AND UOC	(7) QTY.
					GROUP 0107	
					FIG. 9 ACCESSORY BOX	
1	PAFFF	2540014178036	97403	13229E7946	.BOX, ACCESSORIES	1
2	PAFZZ	5340002348422	96906	MS27969-4	..HASP, HINGED	1
3	PAFZZ	5320013360710	11815	CR4622-4-3	..RIVET, BLIND	6
4	PAFZZ	5320007533830	80205	MS20613-4P5	..RIVET, SOLID	8
5	PAFZZ	5340015435523	96906	MS18015-12	..CATCH, CLAMPING	2
6	PAFZZ	5340010880489	96906	MS35823-6D	..HINGE, BUTT	1
7	PAFZZ	5305002264831	80204	B1821BH031C150N	.SCREW, CAP, HEXAGON HEAD UOC: 98Z, 99A	2
8	PAFZZ	5306002264829	80204	B1821BH031C125N	.BOLT, MACHINE UOC: 99D	4
9	PAFZZ	5310000446477	96906	MS51412-25	.WASHER, FLAT UOC: 99D	16
10	PAFZZ	5310000446477	96906	MS51412-25	.WASHER, FLAT UOC: 98Z, 99A	8
11	PAFZZ	5310002453424	80205	MS17829-5C	.NUT, SELF-LOCKING, HEXAGON	4
12	PAFZZ	5306002264827	80204	B1821BH031C100N	.BOLT, MACHINE UOC: 98Z, 99A	2
					<b>END OF FIGURE</b>	





**OPERATOR AND FIELD MAINTENANCE  
AMMPS 10KW TRAILER-MOUNTED POWER UNITS AND POWER PLANTS  
ACCESSORIES REPAIR PARTS LIST**

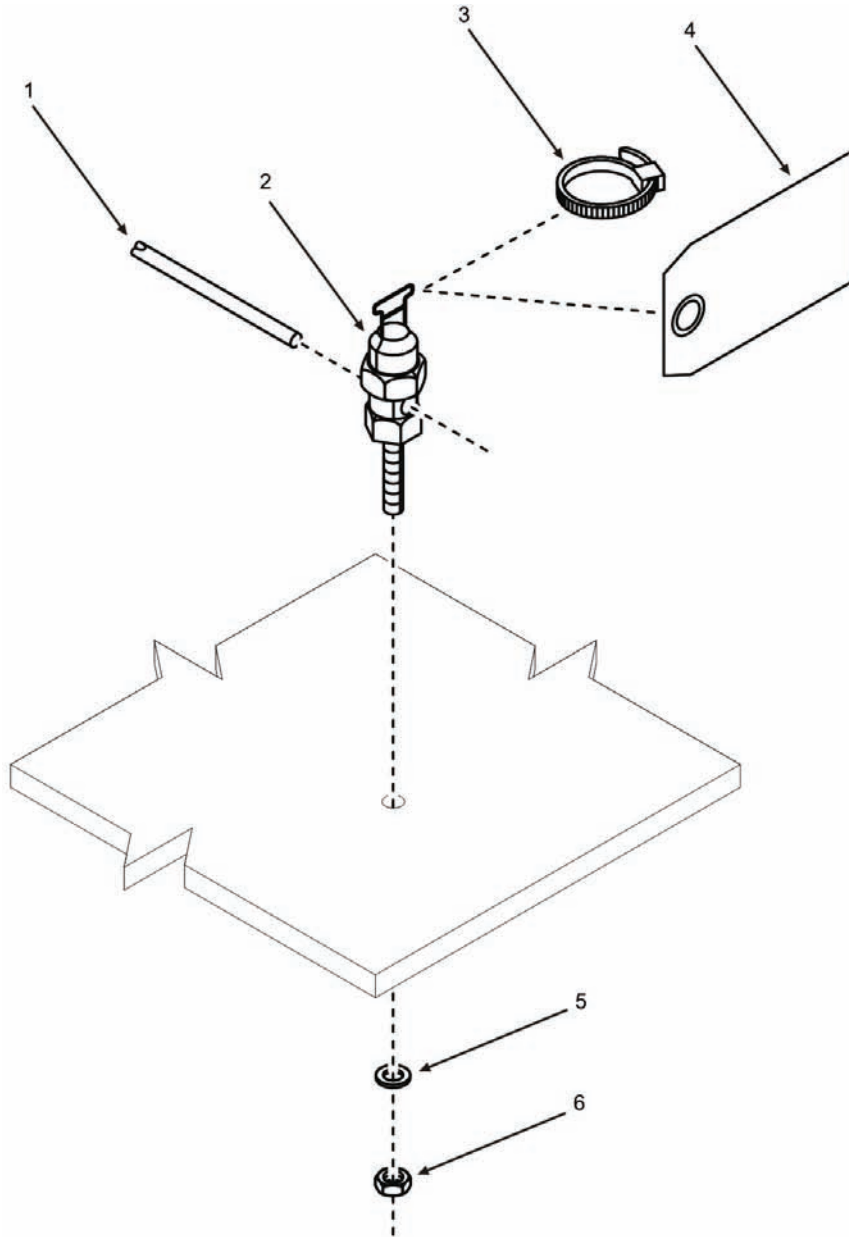

Figure 10. Accessories (Sheet 1 of 4).

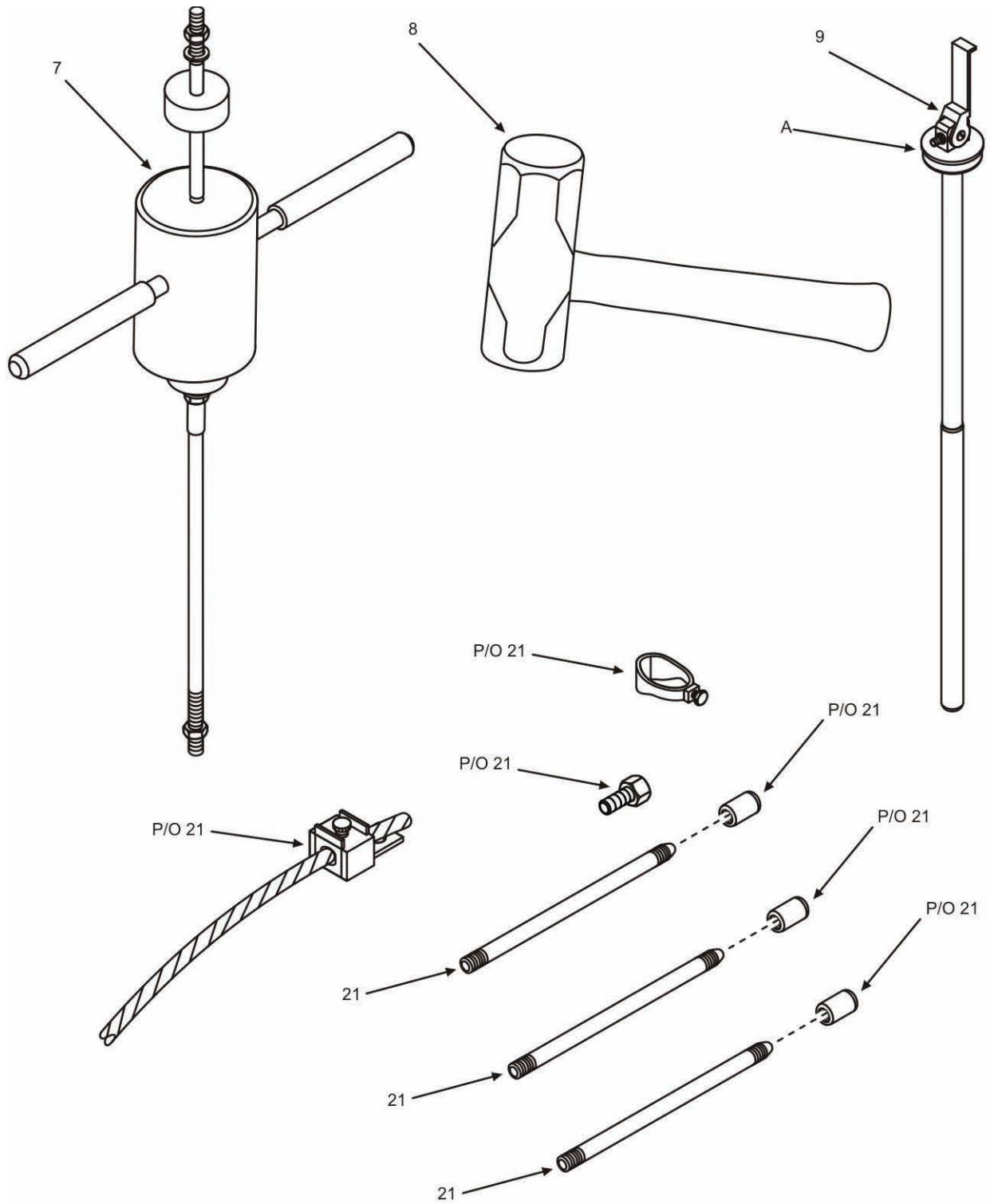

Figure 10. Accessories (Sheet 2 of 4).

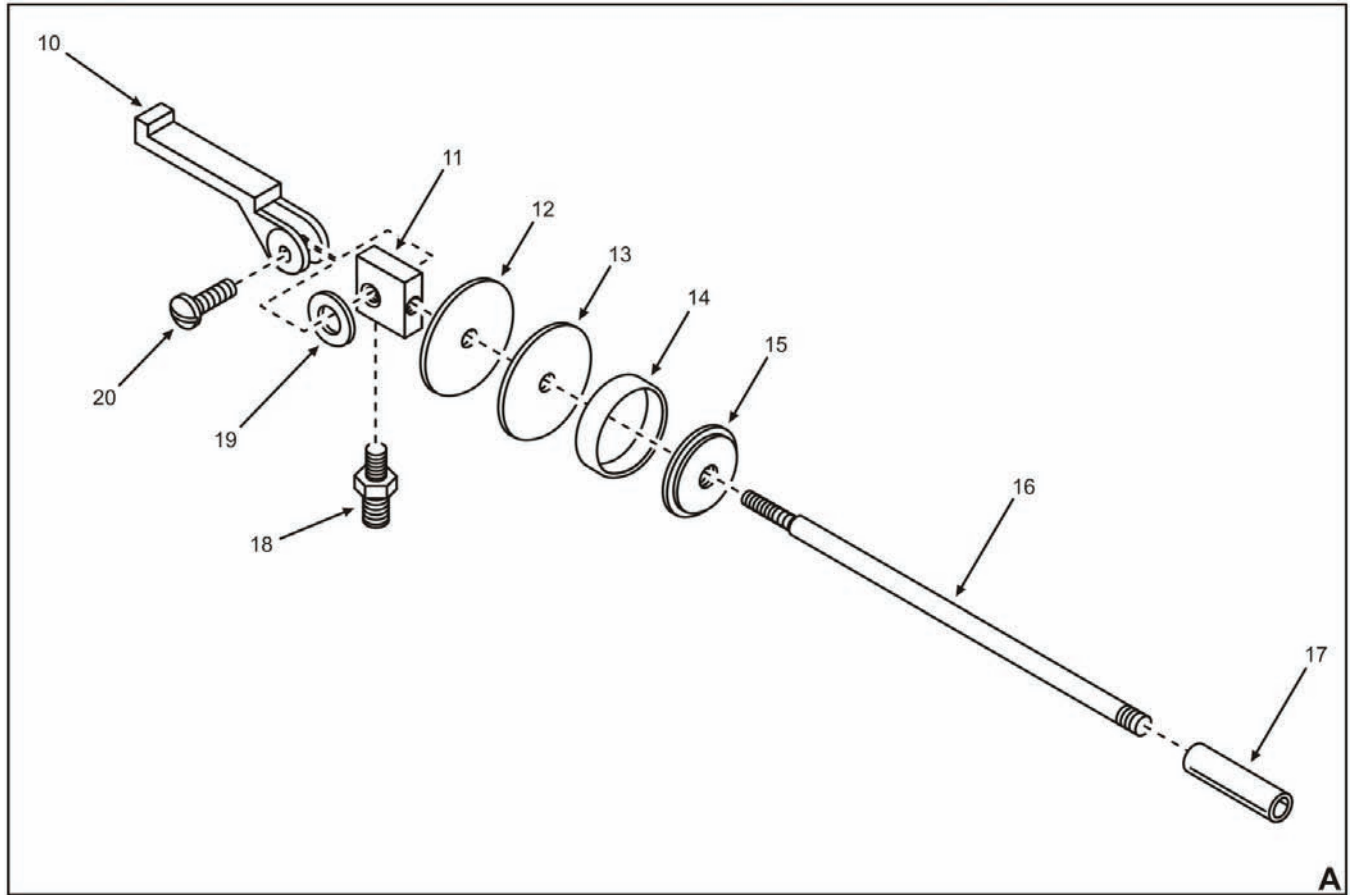

Figure 10. Accessories (Sheet 3 of 4).

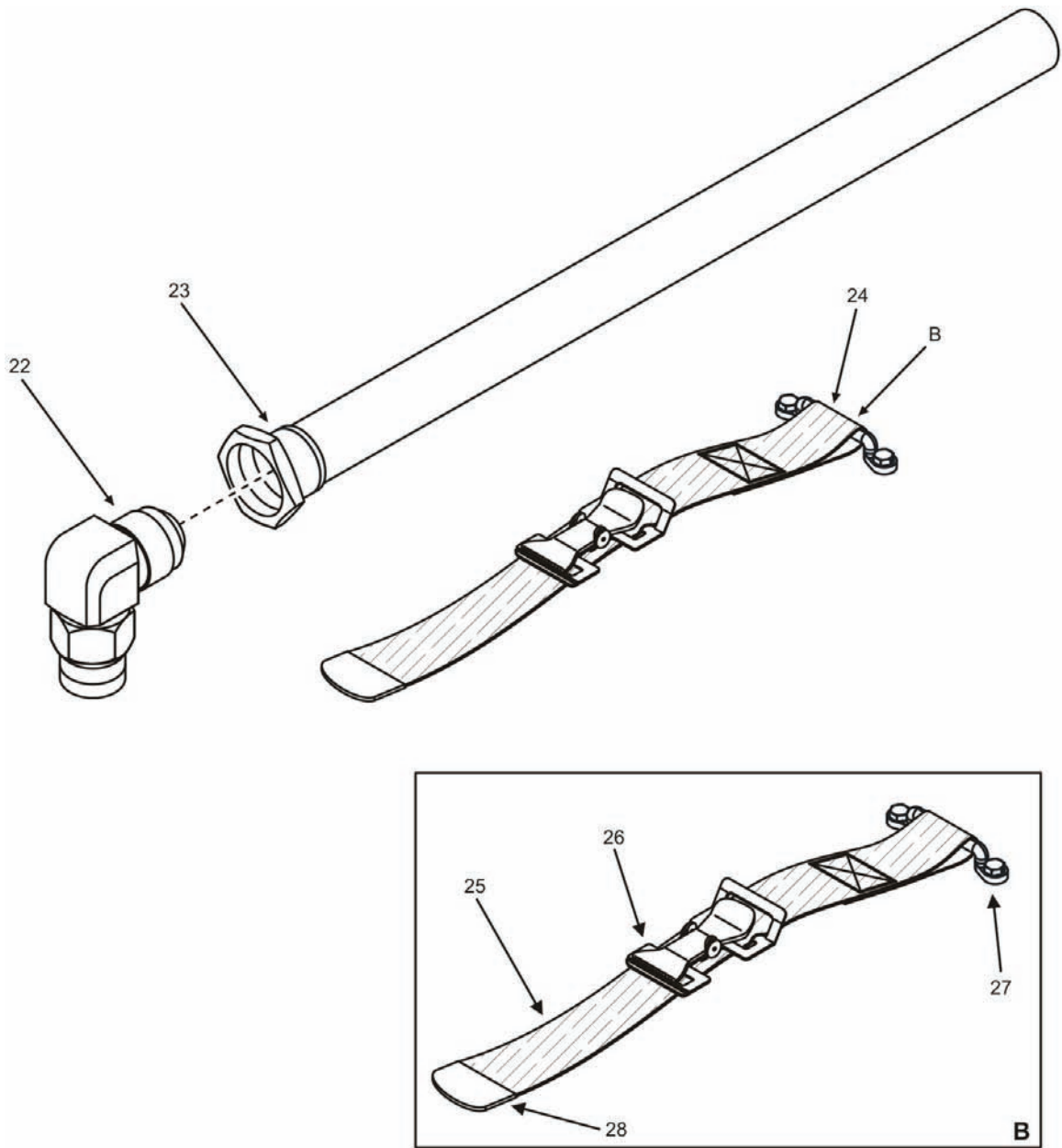

Figure 10. Accessories (Sheet 4 of 4).

(1) ITEM NO.	(2) SMR CODE	(3) NSN	(4) CAGEC	(5) P/N	(6) DESCRIPTION AND UOC	(7) QTY.
					GROUP 0108	
					FIG. 10 ACCESSORIES	
1	MFFZZ	6145012269164	58536	AA59551-C06B1B	.WIRE, ELECTRICAL (MAKE FROM AA59551- C06B1B ON BULK ITEMS LIST, CUT TO LENGTH AS REQUIRED) UOC: 98Z, 99A	1
2	PAFZZ	5940000213321	96906	MS39347-2	.TERMINAL, STUD	1
3	PAFZZ	5975007275153	30554	88-20018-2	.STRAP, TIEDOWN, ELECTRICAL	1
4	XBFZZ		30554	02-23013	.TAG, INSTRUCTIONAL, GROUND	1
5	PAFZZ	5310015675809	97403	13230E6743-108	.WASHER, LOCK	1
6	PAFZZ	5310015675817	97403	13218E0320-331	.NUT, PLAIN, HEXAGON	1
7	PAFZZ	5120010131676	45225	P74-144	.SLIDE HAMMER, GROUND	1
8	PAFZZ	5120002514489	39428	5877A246	.HAMMER, HAND	1
9	PAFFF	5342000661235	97403	13211E7541	.ADAPTER, CONTAINER (SEE SHEET 3 FOR PARTS BREAKDOWN)	1
10	PAFZZ	3740009021481	97403	13200E6363	..CLAMP, STRAINER	1
11	PAFZZ		97403	13211E7548	..HEAD	1
12	PAFZZ	5310005715090	97403	13200E6361	..WASHER, FLAT	1
13	PCFZZ	5310004082561	97403	13211E7547	..WASHER, FLAT	1
14	PCFZZ	5330004025125	97403	13211E7546	..GASKET	1
15	PAFZZ	5310005669502	97403	13211E7544	..WASHER, RECESSED	1
16	PAFZZ	4710001856948	97403	13211E7543	..PIPE, METALLIC (LENGTH OF 15.688 IN)	1
17	PAFZZ	4710005978731	97403	13211E7542	..PIPE, METALLIC (55 GAL DRUM)	1
18	PAFZZ	4730002775115	81343	AS5194-0504	..ADAPTER, STRAIGHT, PIPE	1
19	PAFZZ	5310002091239	96906	MS35335-60	..WASHER, LOCK	2
20	PAFZZ	5305008412681	18876	10277113	..SCREW, SHOULDER	2
21	PAFZZ	5975008783791	58536	AA55804-3B 9FT	.ROD, GROUND (SET)	1
22	PAFZZ	4730011484531	01276	2249-12-12S	.ELBOW, PIPE	1
23	PCFZZ		44940	04-21619	.HOSE, DRAIN	1
24	PAFFF	6115012800063	97403	13218E5091	.TIEDOWN, STRAP UOC: 99D	1
25	PAFZZ	5340013988680	97403	13214E9975-1	..STRAP, WEBBING UOC: 99D	1
26	PAFZZ	5340000576956	80205	MS51929-2	..BUCKLE UOC: 99D	1
27	PAFZZ	5340002290340	96906	MS51939-3	..LOOP, STRAP, FASTENER UOC: 99D	1
28	PAFZZ	5340000787029	96906	MS51926-3	..CLIP, END, STRAP UOC: 99D	1
					<b>END OF FIGURE</b>	



---

**OPERATOR AND FIELD MAINTENANCE  
AMMPS 10KW TRAILER-MOUNTED POWER UNITS AND POWER PLANTS  
M200 IDENTIFICATION PLATES UOC 99D REPAIR PARTS LIST**

---

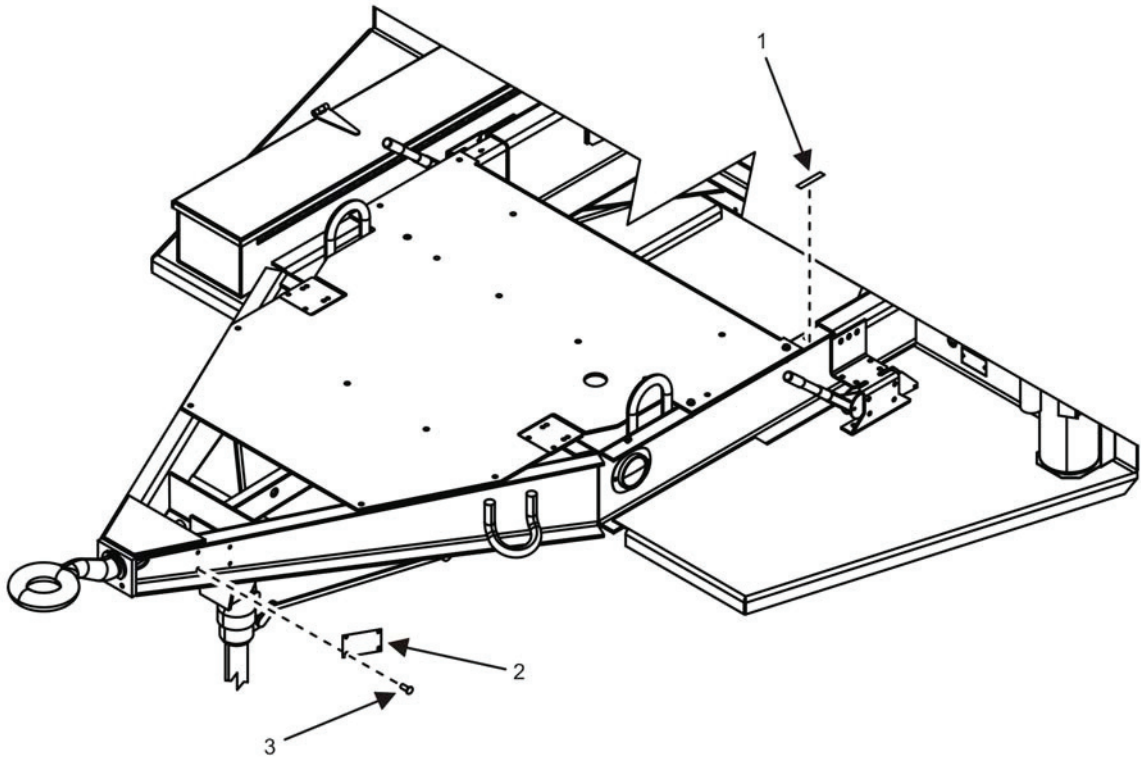

Figure 11. M200 Identification Plates UOC 99D (Sheet 1 of 1).



(1) ITEM NO.	(2) SMR CODE	(3) NSN	(4) CAGEC	(5) P/N	(6) DESCRIPTION AND UOC	(7) QTY.
					GROUP 0109	
					FIG. 11 M200 IDENTIFICATION PLATES UOC 99D	
1	XBFZZ		97403	13230E6796	.PLATE, IDENTIFICATION UOC: 99D	2
2	XBFZZ		97403	13230E6797	.PLATE, IDENTIFICATION UOC: 99D	1
3	PAFZZ	5320010863593	96906	MS20604AD6C4	.RIVET, BLIND UOC: 99D	4
					<b>END OF FIGURE</b>	



---

**OPERATOR AND FIELD MAINTENANCE  
AMMPS 10KW TRAILER-MOUNTED POWER UNITS AND POWER PLANTS  
SWITCH BOX INSTALLATION REPAIR PARTS LIST**

---

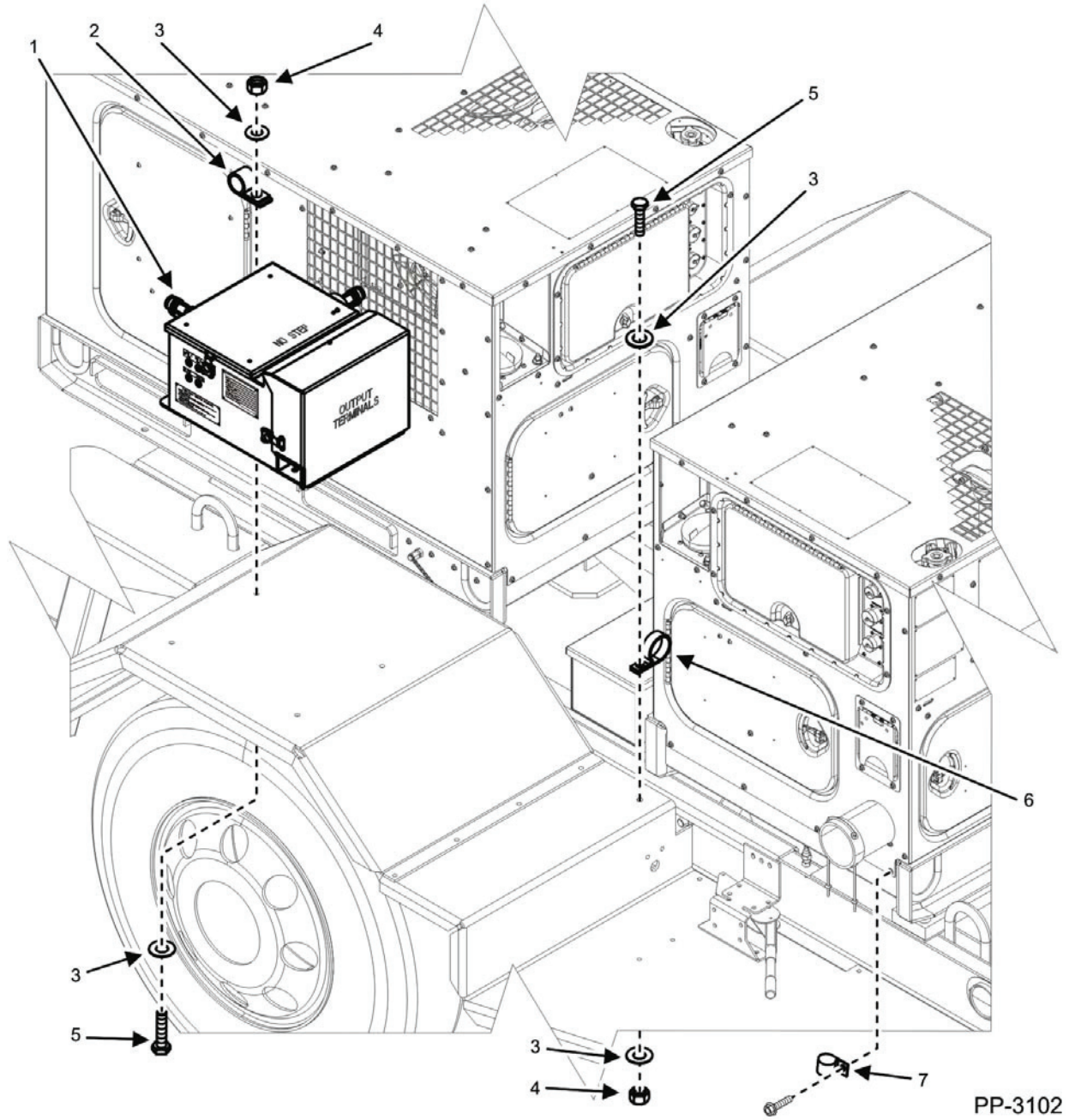

PP-3102

Figure 12. Switch Box Installation (Sheet 1 of 1).

(1) ITEM NO.	(2) SMR CODE	(3) NSN	(4) CAGEC	(5) P/N	(6) DESCRIPTION AND UOC	(7) QTY.
					GROUP 02	
					FIG. 12 SWITCH BOX INSTALLATION	
1	PAFZZ		44940	04-21329	.SWITCH BOX ASSEMBLY (SEE FIGURE 13 FOR PARTS BREAKDOWN)	
2	PAFZZ	5340011231556	75272	COV-0813	UOC: 99D ..CLAMP, LOOP	1
3	PAFZZ	5310015320321	30554	88-20033-31A	UOC: 99D ..WASHER, FLAT	1
4	PAFFF	5310000874652	81349	M45913/1-6CG5C	UOC: 99D ..NUT, SELF- LOCKING, HEXAGON	11
5	PAFZZ		44940	AEB02C375A50WA6F Y1	UOC: 99D ..SCREW	7
6	PAFZZ	5340004044100	75272	COV2113	UOC: 99D ..CLAMP, LOOP	7
7	PAFFF		75272	COV-0809	UOC: 99D ..CLAMP, LOOP	2
					UOC: 99D	2
					<b>END OF FIGURE</b>	



---

**OPERATOR AND FIELD MAINTENANCE  
AMMPS 10KW TRAILER-MOUNTED POWER UNITS AND POWER PLANTS  
SWITCH BOX COMPONENTS REPAIR PARTS LIST**

---

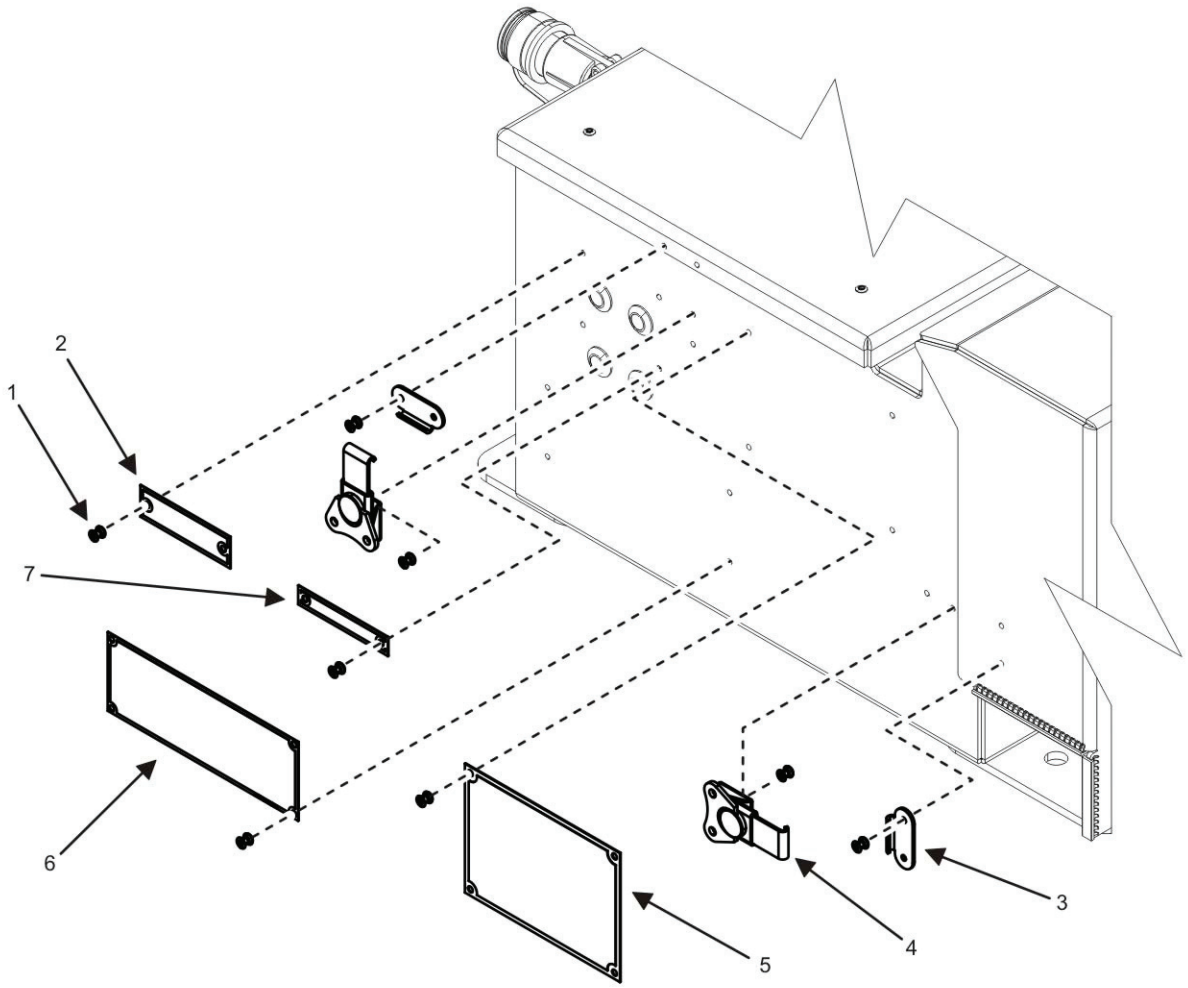

Figure 13. Switch Box Components (Sheet 1 of 7).



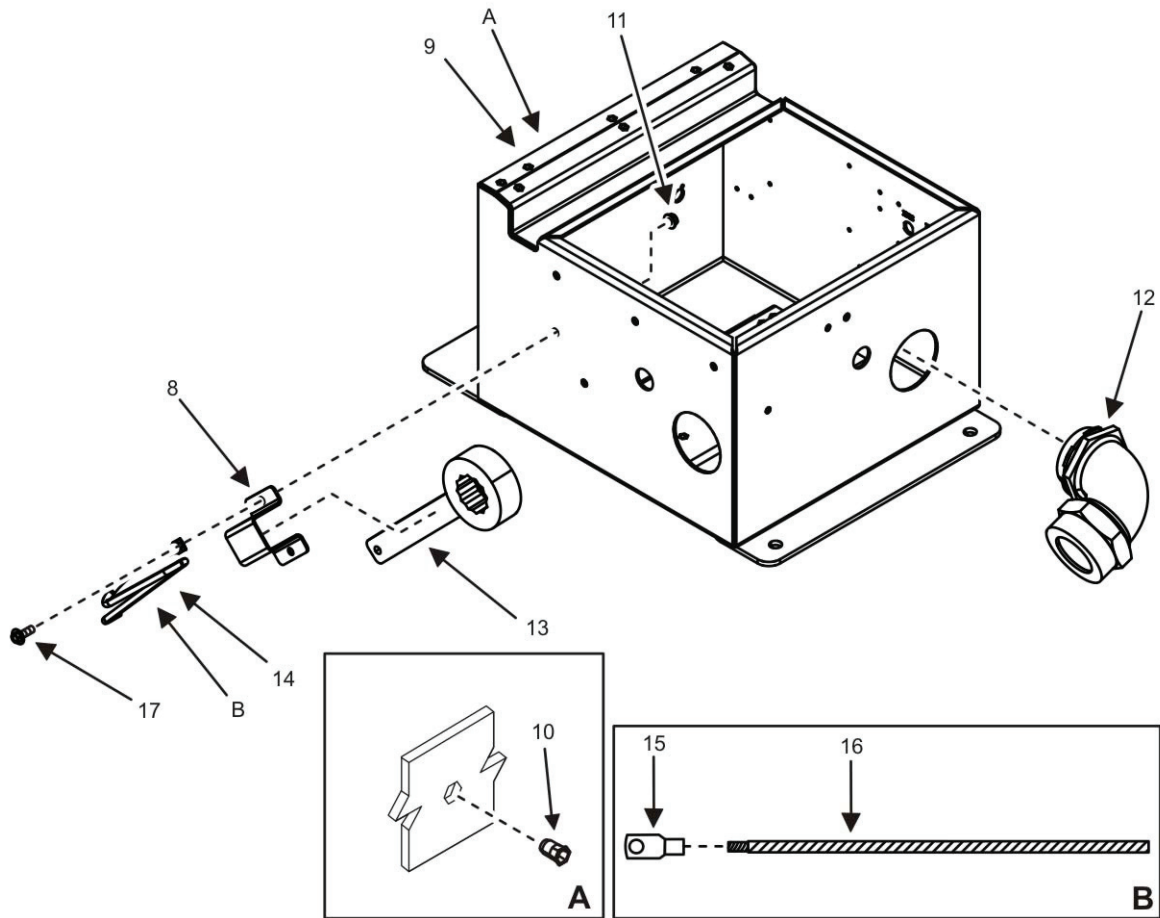

Figure 13. Switch Box Components (Sheet 2 of 7).

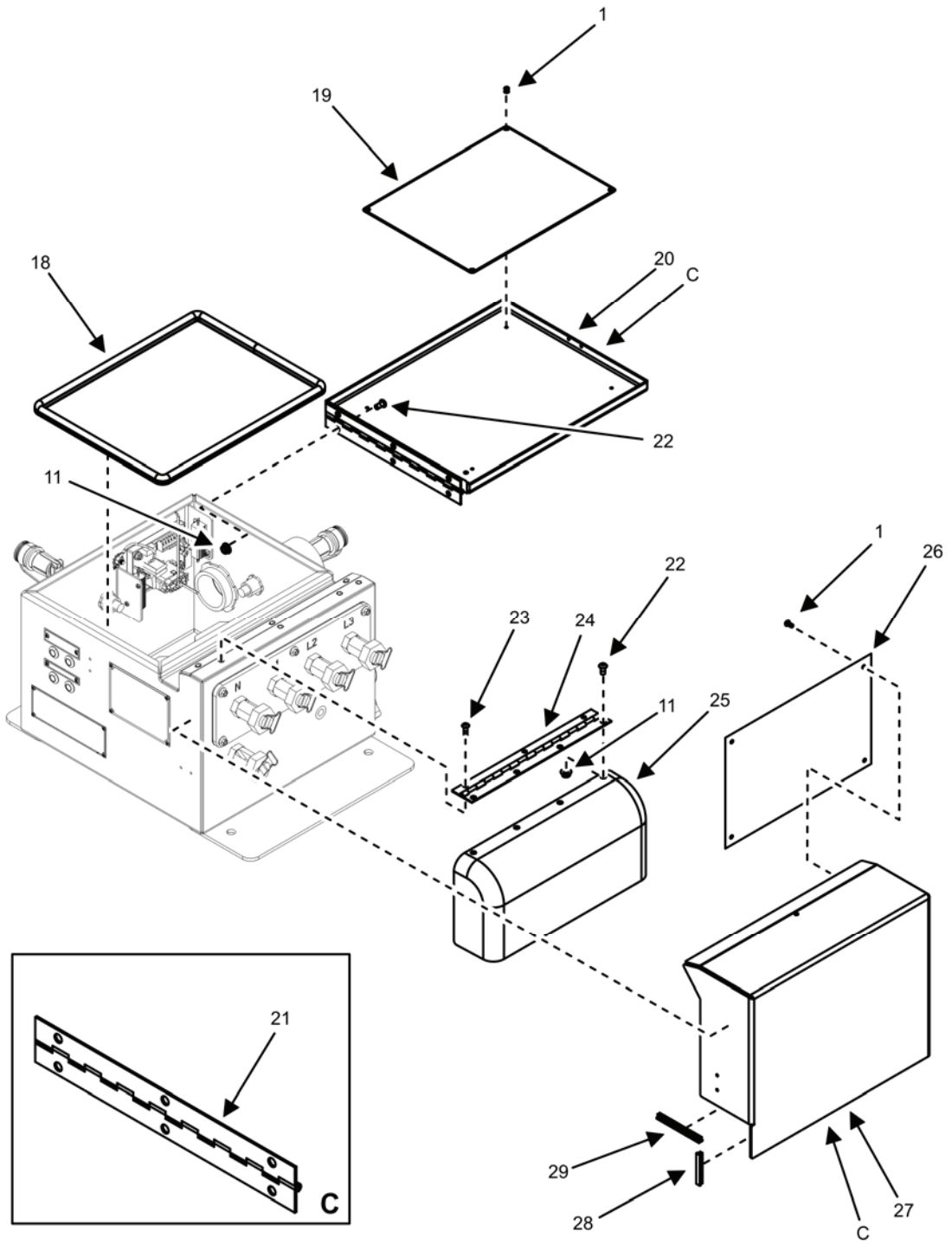

Figure 13. Switch Box Components (Sheet 3 of 7).

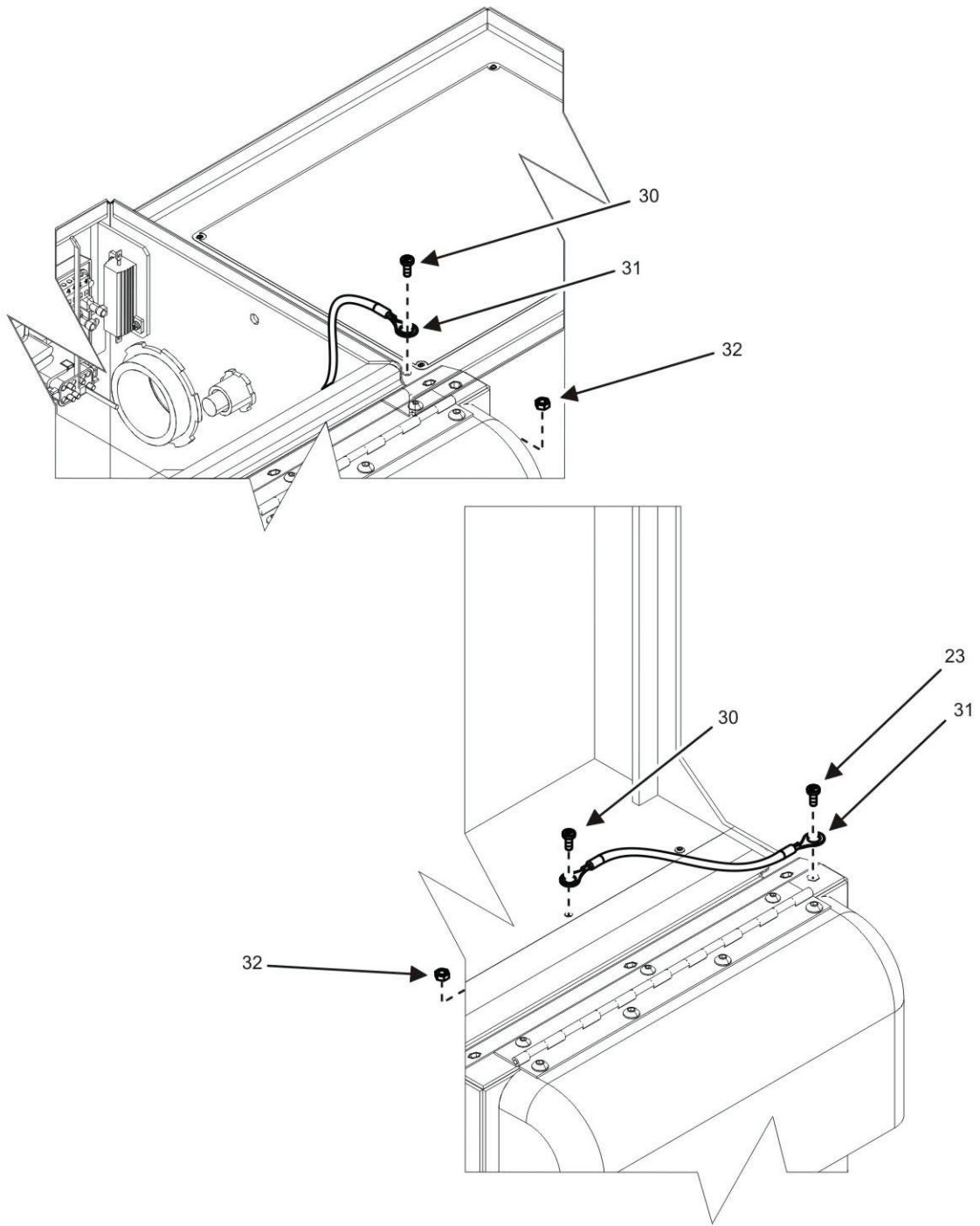

Figure 13. Switch Box Components (Sheet 4 of 7).

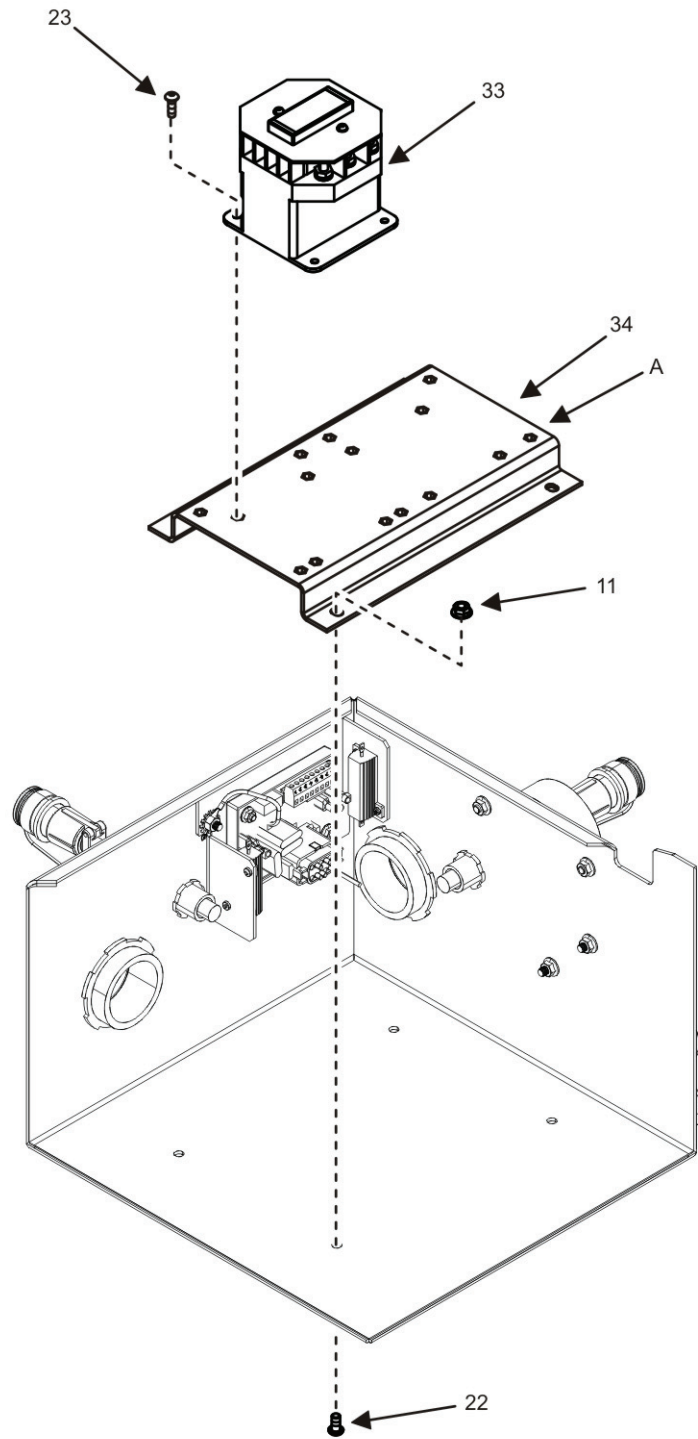

Figure 13. Switch Box Components (Sheet 5 of 7).

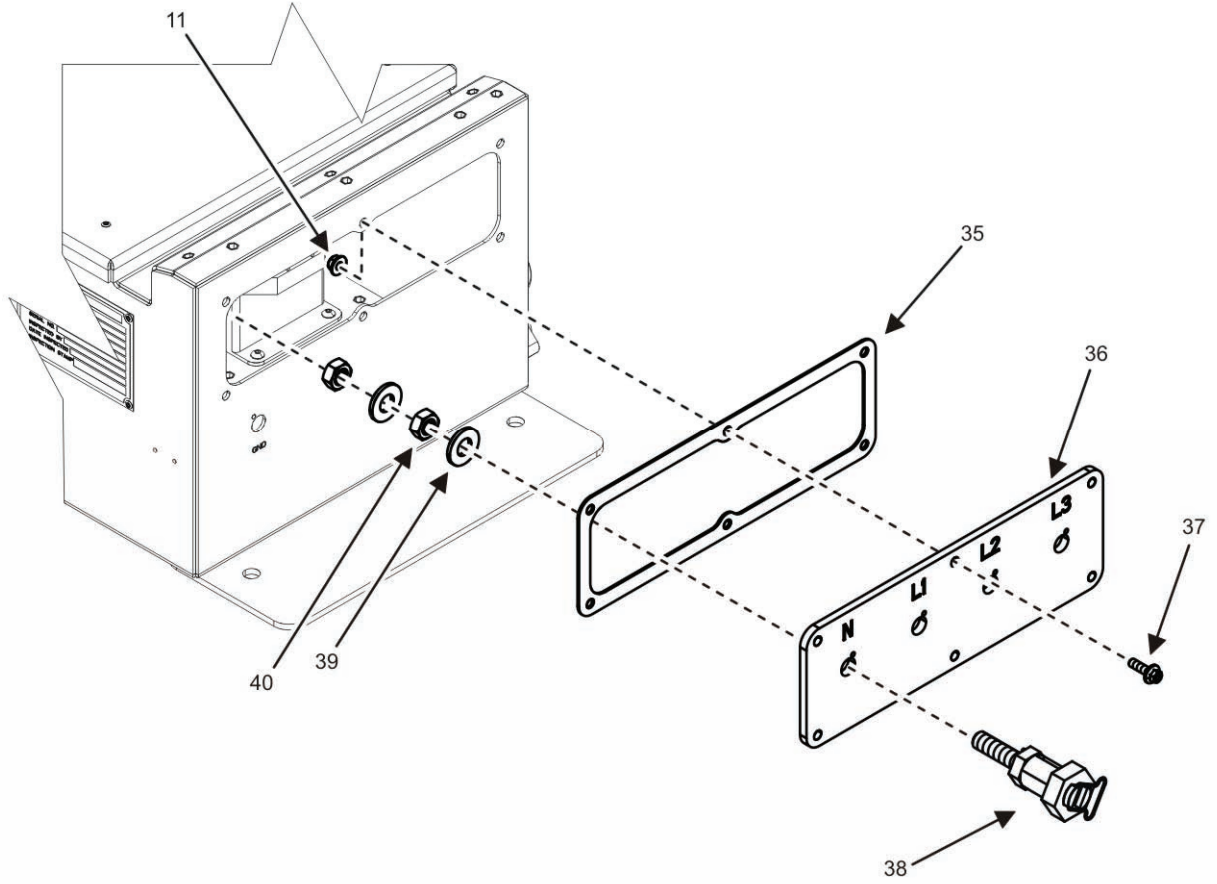

Figure 13. Switch Box Components (Sheet 6 of 7).

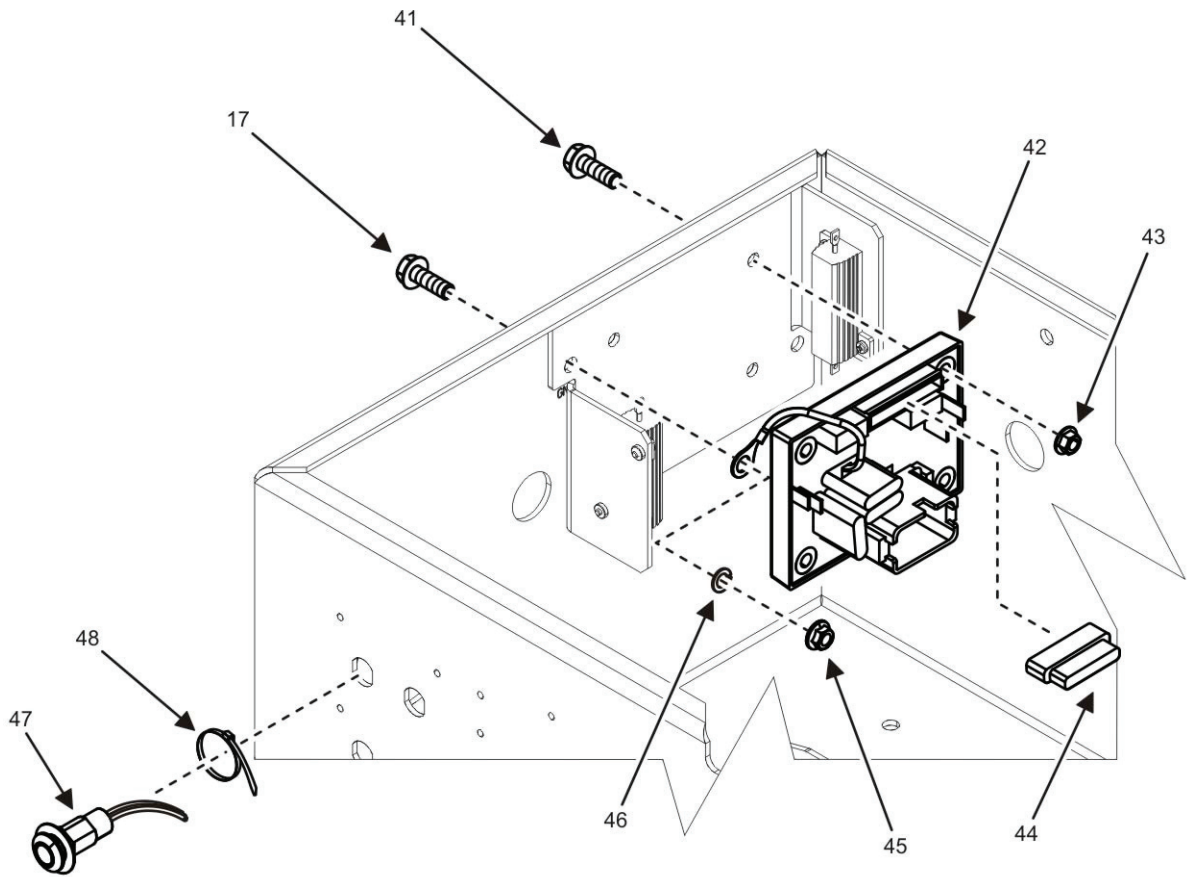

Figure 13. Switch Box Components (Sheet 7 of 7).

(1) ITEM NO.	(2) SMR CODE	(3) NSN	(4) CAGEC	(5) P/N	(6) DESCRIPTION AND UOC	(7) QTY.
					GROUP 0201	
					FIG. 13 SWITCH BOX COMPONENTS	
1	PAFZZ	5320009321972	81349	M24243/6-A402H	.RIVET, BLIND	28
2	XBFZZ		30554	04-20990	.PLATE INDICATOR (STATUS)	1
3	PAFZZ	5340014681767	94222	K3-2347-07	. CATCH, CLAMPING	2
4	PAFZZ	5340006855899	94222	K3-0334-52	.STRIKE, CATCH	2
5	XBFZZ		30554	04-21138-4	.PLATE, IDENTIFICATION, SWITCH BOX	1
6	XBFZZ		30554	04-21098	.PLATE, POWER PLANT, OPERATING INSTRUCTIONS	1
7	XBFZZ		30554	04-20991	.PLATE, INDICATOR (ON LINE)	1
8	XBFZZ		44940	04-20285	.BRACKET, MOUNTING	1
9	XBFFF		44940	04-20809	.SWITCH BOX	1
10	PAFZZ		3A2G6	39101-75030	.NUT, PLAIN, CLINCH	7
11	PAFZZ		44940	DIN6923-M6	.NUT, PLAIN, EXTENDED	19
12	XBFZZ		1GLC4	55013	.RELIEF, STRAIN	2
13	PAFZZ	5120013738976	30554	88-21146	.WRENCH, BOX	1
14	XBFFF		44940	04-21322	.CORD	1
15	PAFZZ	5940006553318	96906	MS20659-41	.TERMINAL, LUG	1
16	PAFZZ	4020014769072	30554	98-19724	.FIBER ROPE ASSEMBLY	1
17	PAFZZ		93907	A026G000	.SCREW, FLANGE HEAD	3
18	MFFZZ		44940	04-20822-1	.EDGING (MAKE FROM A2533 ON BULK ITEMS LIST AND CUT TO LENGTH 691 MM +/- 4 MM )	1
19	XBFZZ		30554	04-21241	.PLATE, SCHEMATIC	1
20	XBFFF		44940	04-20820	.COVER, BOX	1
21	PAFZZ	5340010541766	58536	AA55592-10A	.HINGE, BUTT	2
22	PAFZZ		44940	DIN7380A2-M6X12	.SCREW, CAP, SOCKET HEAD BUTTON M6 X 1 X 12	11
23	PAFZZ		44940	AES46M508016CH2A 31	HEAD SOCKET M5 Z 0.8 X 16	15
24	PAFZZ		44940	04-20816	.HINGE, CONTINUOUS	1
25	PAFZZ		44940	04-20823	.COVER, TERMINAL	1
26	XBFZZ		30554	04-21315	.PLATE, WIRING	1
27	XBFFF		44940	04-20815	.COVER, TERMINAL	1
28	MFFZZ		44940	04-20827-1	.EDGING	1
29	MFFZZ		44940	04-20827-2	.EDGING	1
30	PAFZZ		44940	DIN7985-M4X10	.SCREW, PAN HEAD M4 X 10	2
31	PAFZZ		44940	04-21318-1	.STRAP, GROUNDING	2
32	PAFZZ	5310015006541	3L891	40CNFHS	.NUT, PLAIN, HEXAGON	2
33	PAFZZ		01XDA	CT150E24E2S	.CONTACTOR, MAGNETIC	2
34	XBFFF		44940	04-20845	.BRACKET, MOUNTING	1
35	PCFZZ		44940	04-20824	.GASKET	1
36	XBFZZ		44940	04-20825	.BOARD, CONNECTION	1
37	PAFZZ		44940	AES10M06A020WB4K 42	.SCREW, HEX FLANGE HEAD M6 X 1 X 20	6
38	PAFZZ	5940009581214	82168	DG3M6F-S-RPC	.TERMINAL, STUD	5

(1) ITEM NO.	(2) SMR CODE	(3) NSN	(4) CAGEC	(5) P/N	(6) DESCRIPTION AND UOC	(7) QTY.
39	PAFZZ		3A054	95395A250	.WASHER, FLAT 1/2 INCH FLAT	10
40	PAFZZ	5310001898467	30554	88-22336-1	.NUT, PLAIN, HEXAGON	10
41	PAFZZ		44940	DIN7380A2-M5X25	.SCREW, CAP, SOCKET HEAD M5 X 0.8 X 25	2
42	PAFZZ		44940	A028T645	.CARD, CONTROL SWITCH	1
43	PAFZZ		44940	DIN6923-M5	.NUT, PLAIN, HEXAGON M5 X 0.8	2
44	PAFZZ		IUX99	395300108	.CONNECTOR, PLUG	1
45	PAFZZ		44940	AEN15M06A50MCH2A 31	.NUT, HEX M6 X 1.0	1
46	PAFZZ		44940	AEW22X250000EA1A A1	.WASHER, LOCK 1/4	1
47	PAFZZ		U7832	699-532-54-50	.DIODE, LIGHT EMITTING	4
48	PAFZZ	5975001113208	81343	MS3367-5-9	.STRAP, TIEDOWN, ELECTRICAL	12
<b>END OF FIGURE</b>						



**OPERATOR AND FIELD MAINTENANCE  
 AMMPS 10KW TRAILER-MOUNTED POWER UNITS AND POWER PLANTS  
 SWITCH BOX LEADS REPAIR PARTS LIST**

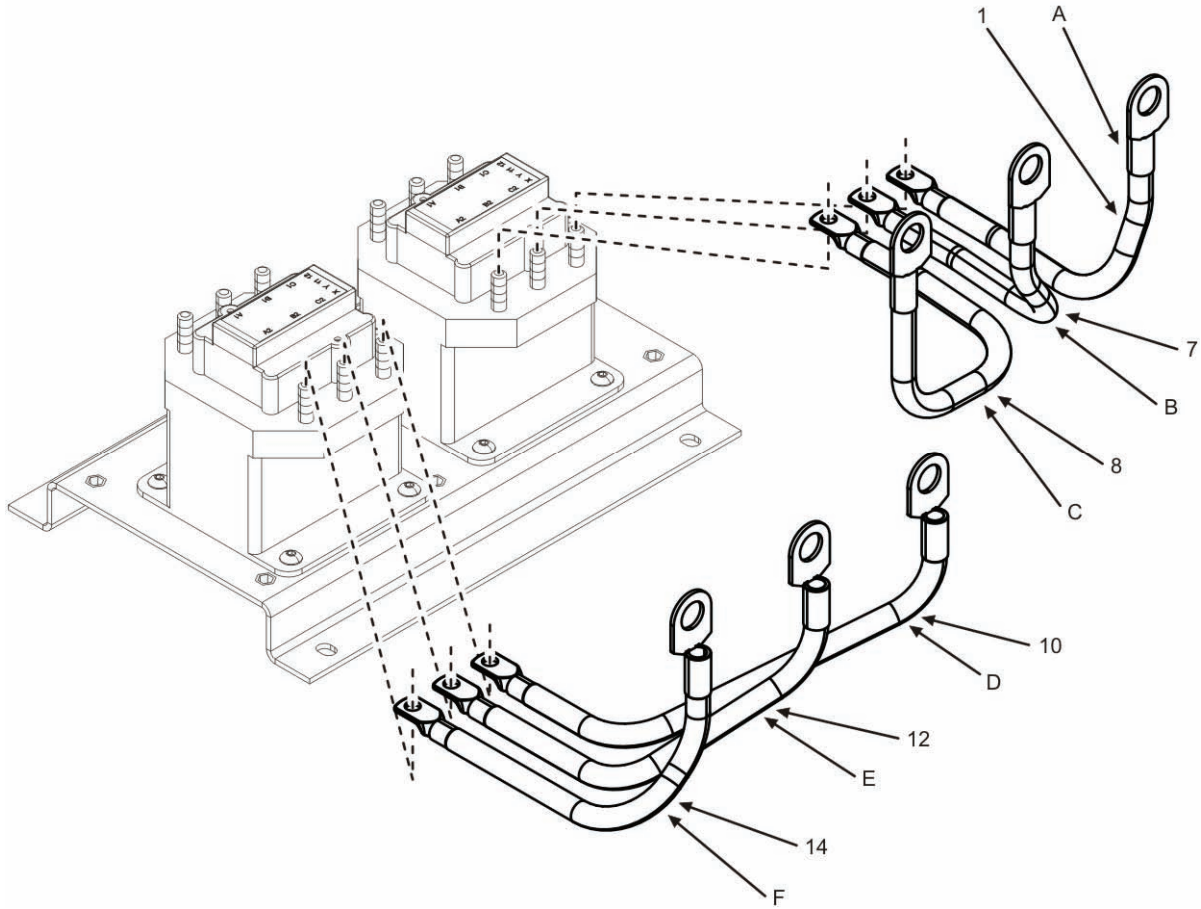

**Figure 14. Switch Box Leads (Sheet 1 of 2).**

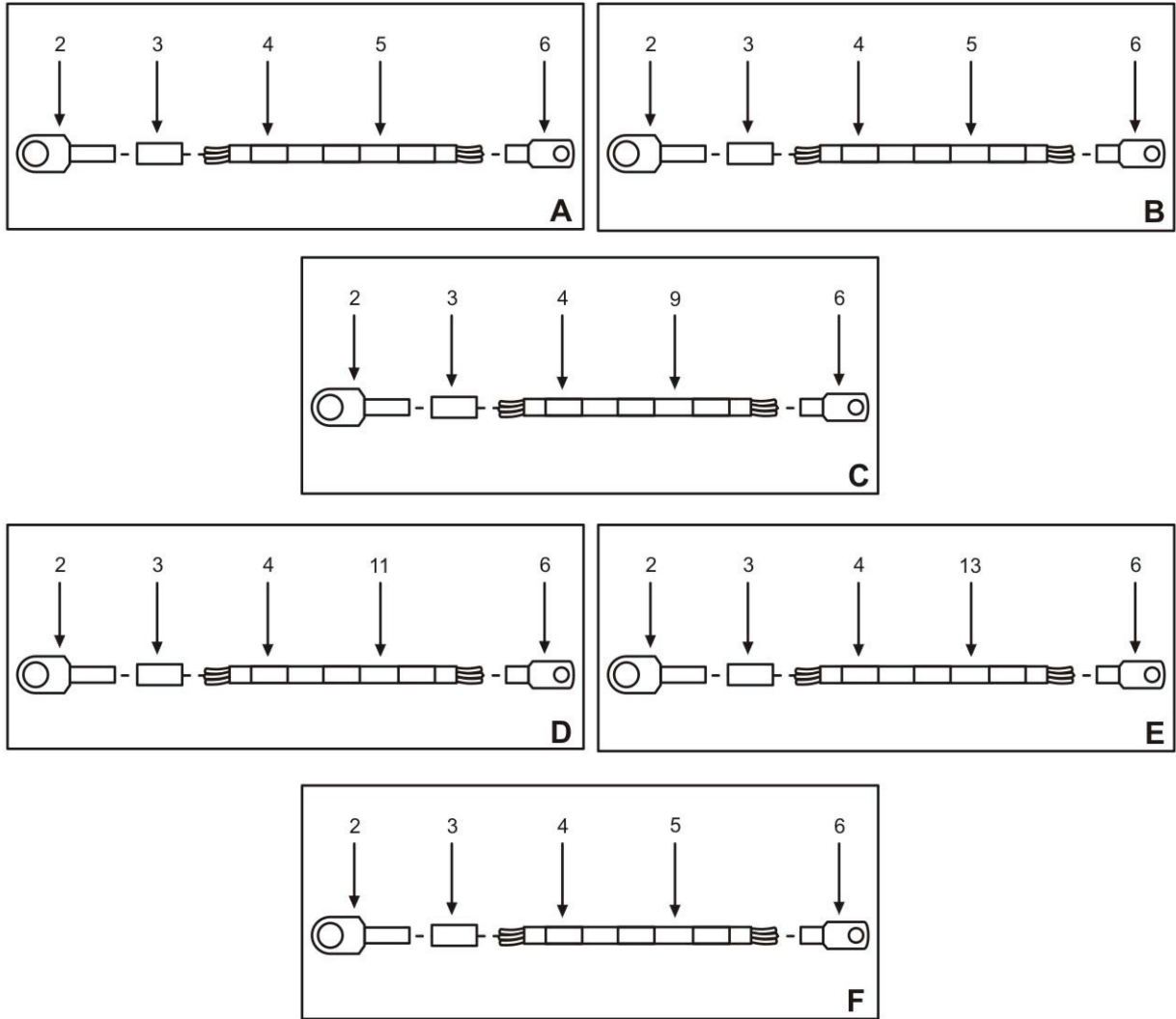

Figure 14. Switch Box Leads (Sheet 2 of 2).

(1) ITEM NO.	(2) SMR CODE	(3) NSN	(4) CAGEC	(5) P/N	(6) DESCRIPTION AND UOC	(7) QTY.
					GROUP 0202	
					FIG. 14 SWITCH BOX LEADS	
1	XBFFF		44940	04-20819-6	.LEAD, ELECTRICAL K702-C2 (SEE SHEET 2 FOR PARTS BREAKDOWN)	1
2	PAFZZ	5940010558403	00779	324114	..TERMINAL, LUG	6
3	MFFZZ		30554	88-20541-16	..INSULATION SLEEVING MAKE FROM 88-20541-16ON BULK ITEMS LIST, CUT TO LENGTH AS REQUIRED)	6
4	XBFZZ		53421	TAG9T3-100B	..LAMINATE, LABEL COVER	18
5	MFFZZ		0X4C9	3271-4-133	.. WIRE, STRANDED (MAKE FROM 3271-4- 133 ON BULK ITEMS LIST, CUT TO LENGTH 180 +/- 3 MM)	1
6	PAFZZ		00779	2-31811-4	..TERMINAL, LUG	6
7	XBFFF		44940	04-20819-5	.LEAD, ELECTRICAL K702-B2 (SEE SHEET 2 FOR PARTS BREAKDOWN)	1
8	XBFFF		44940	04-20819-4	.LEAD, ELECTRICAL K702-A2 (SEE SHEET 2 FOR PARTS BREAKDOWN)	1
9	MFFZZ		0X4C9	3271-4-133	.. WIRE, STRANDED (MAKE FROM 3271-4- 133 ON BULK ITEMS LIST, CUT TO LENGTH 210 +/- 3 MM)	1
10	XBFFF		44940	04-20819-3	.LEAD, ELECTRICAL K701-C2 (SEE SHEET 2 FOR PARTS BREAKDOWN)	1
11	MFFZZ		0X4C9	3271-4-133	.. WIRE, STRANDED (MAKE FROM 3271-4- 133 ON BULK ITEMS LIST, CUT TO LENGTH 225 +/- 3 MM)	1
12	XBFFF		44940	04-20819-2	.LEAD, ELECTRICAL K701-B2 (SEE SHEET 2 FOR PARTS BREAKDOWN)	1
13	MFFZZ		0X4C9	3271-4-133	.. WIRE, STRANDED (MAKE FROM 3271-4- 133 ON BULK ITEMS LIST, CUT TO LENGTH 200 +/- 3 MM)	1
14	XBFFF		44940	04-20819-1	.LEAD, ELECTRICAL K701-A2 (SEE SHEET 2 FOR PARTS BREAKDOWN)	1
					<b>END OF FIGURE</b>	



OPERATOR AND FIELD MAINTENANCE  
AMMPS 10KW TRAILER-MOUNTED POWER UNITS AND POWER PLANTS  
SWITCH BOX WIRING HARNESSES REPAIR PARTS LIST

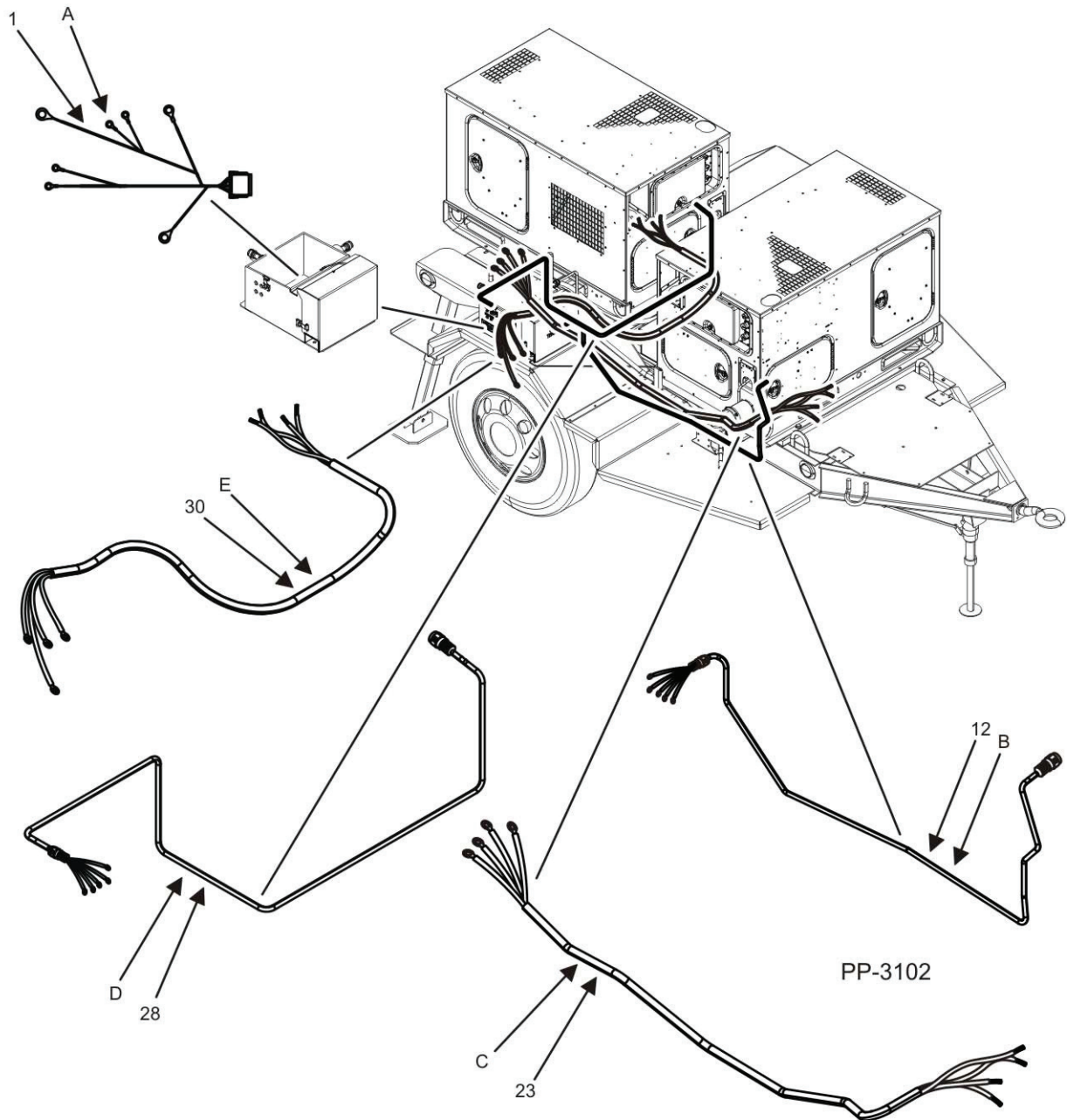

Figure 15. Switch Box Wiring Harnesses (Sheet 1 of 4).

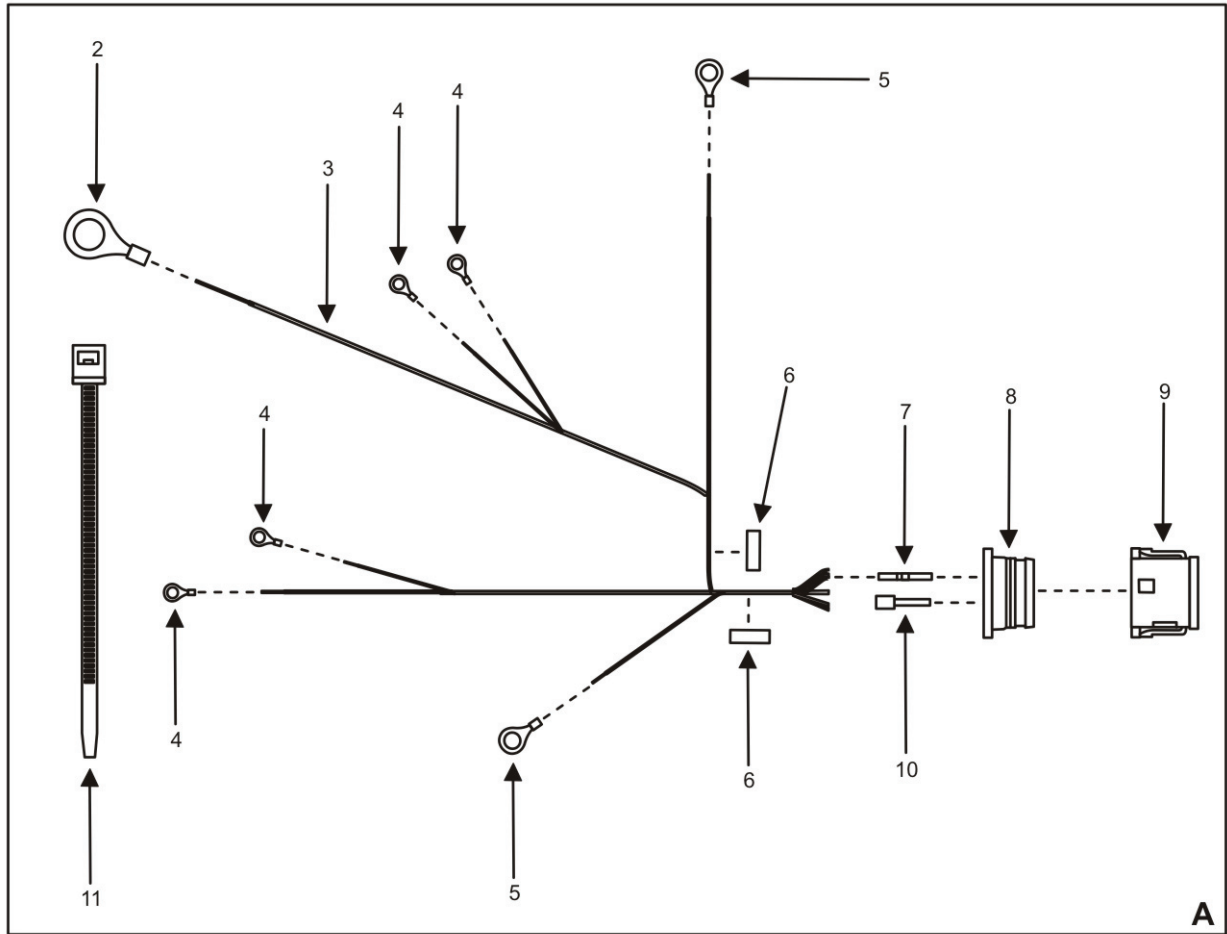

Figure 15. Switch Box Wiring Harnesses (Sheet 2 of 4).

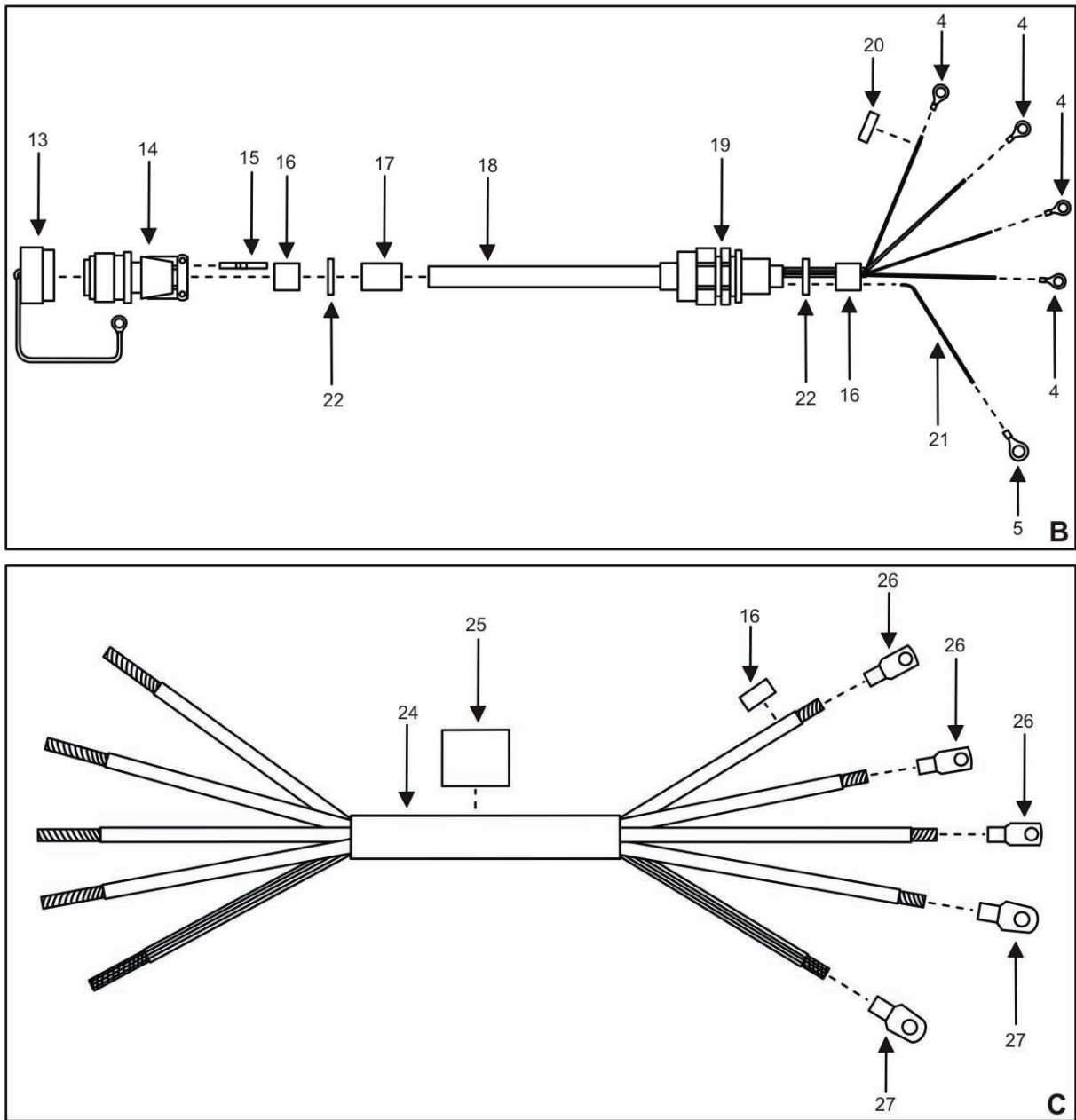

Figure 15. Switch Box Wiring Harnesses (Sheet 3 of 4).

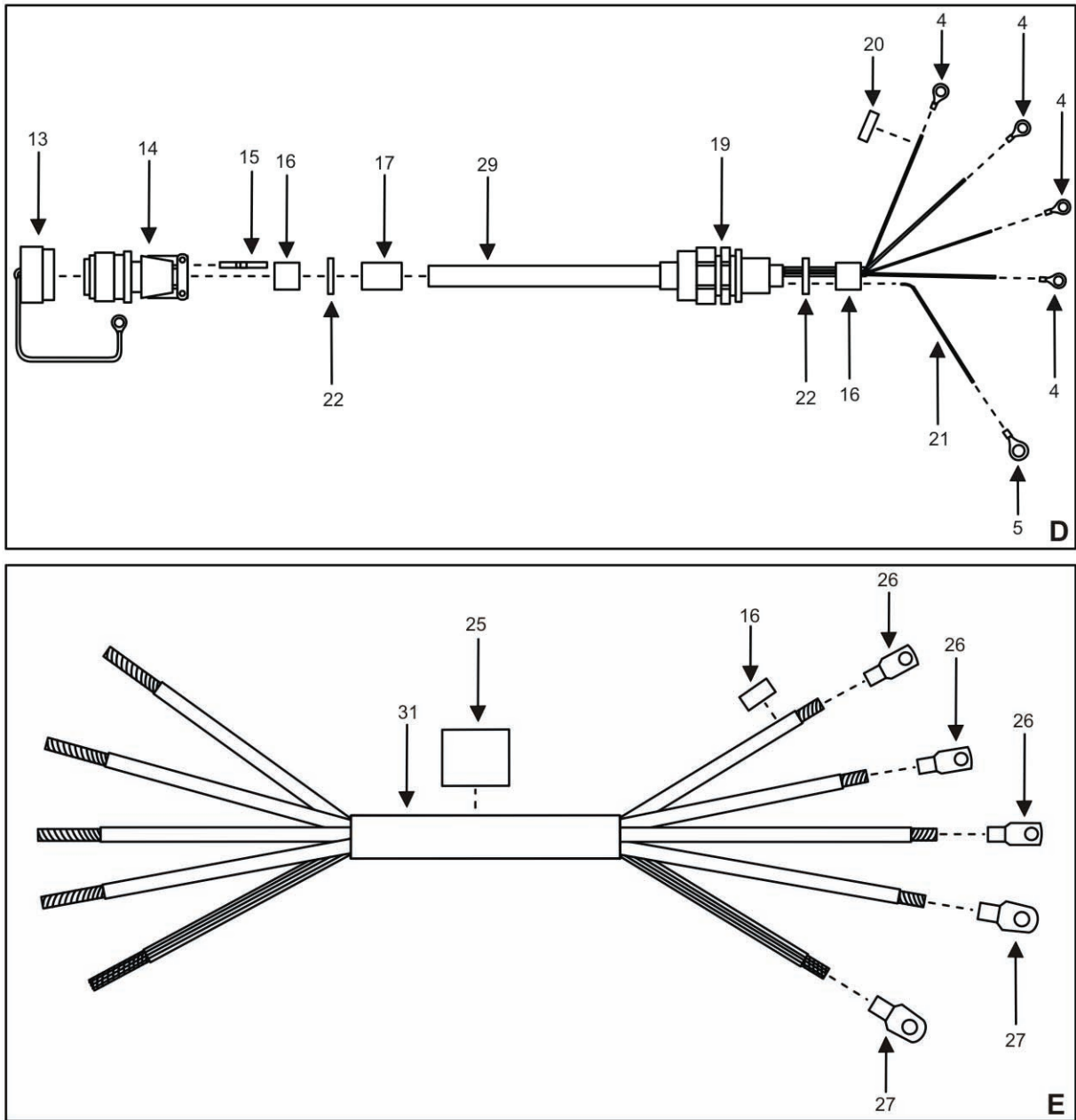

Figure 15. Switch Box Wiring Harnesses (Sheet 4 of 4).



(1) ITEM NO.	(2) SMR CODE	(3) NSN	(4) CAGEC	(5) P/N	(6) DESCRIPTION AND UOC	(7) QTY.
					GROUP 0203	
					FIG. 15 SWITCH BOX WIRING HARNESES	
1	PBFFF		44940	04-21290	.HARNESS, WIRING P700 TO K701-K702 (SEE SHEET 2 FOR PARTS BREAKDOWN) UOC: 99D	1
2	PAFZZ	4210015628664	00779	50981	..TERMINAL UOC: 99D	1
3	MFFZZ		0X4C9	3271-16-26	..STRAND, WIRE (CUT TO LENGTH AS REQUIRED FROM BULK ITEMS LIST) UOC: 99D	1
4	PAFZZ	5940002582074	00779	34105	..TERMINAL, LUG UOC: 99D	12
5	PAFZZ		00779	2-34113-2	..TERMINAL, LUG UOC: 99D	4
6	XBFZZ		53421	TAG9T3-100B	..LAMINATE, LABEL COVER UOC: 99D	20
7	PAFZZ	5999012036687	11139	0462-201-16141	..CONTACT, ELECTRICAL UOC: 99D	7
8	PAFZZ	5935014541789	11139	W12S	..RETAINER, ELECTRICAL UOC: 99D	1
9	PAFZZ		11139	DT06-12SA-P012	..CONNECTOR, PLUG UOC: 99D	1
10	PAFZZ	5935011741235	11139	114017	..PLUG, END SEAL, ELECT UOC: 99D	5
11	PAFZZ	5975001113208	81343	MS3367-5-9	..STRAP, TIEDOWN ELECTRICAL UOC: 99D	1
12	PBFFF		44940	04-20981-2	..CABLE, ELECTRICAL (SEE SHEET 3 FOR PARTS BREAKDOWN) UOC: 99D	1
13	PAFZZ		076Z5	RT25042-18DF	..COVER, PROTECTIVE UOC: 99D	2
14	PAFZZ		076Z5	RT3106F18-19P	..CONNECTOR, PLUG, ELECTRICAL UOC: 99D	2
15	PAFZZ	4730007176207	30554	88-20550-2	..PLUG, GROMMET, SEALING UOC: 99D	12
16	MFFZZ		30554	88-20541-16	..INSULATION SLEEVING (MAKE FROM 88-20541-16 ON BULK ITEMS LIST, CUT TO LENGTH AS REQUIRED) UOC: 99D	37
17	PAFZZ		30554	88-20554-1	..ADAPTER, CABLE UOC: 99D	2
18	MFFZZ		0X4C9	31285820-54	..CABLE, POWER (MAKE FROM 31285820-54 ON BULK ITEMS LIST, CUT TO LENGTH 2380 MM +/- 35 MM) UOC: 99D	1

(1) ITEM NO.	(2) SMR CODE	(3) NSN	(4) CAGEC	(5) P/N	(6) DESCRIPTION AND UOC	(7) QTY.
19	XBFZZ		1GLC4	55004	..RELIEF, STRAIN UOC: 99D	2
20	PAFZZ		30554	88-20541-6	..INSULATION SLEEVING (MAKE FROM 88-20541-6 ON BULK ITEMS LIST, CUT TO LENGTH AS REQUIRED) UOC: 99D	10
21	MFFZZ		0X4C9	3271-16-26	..STRAND, WIRE (MAKE FROM 3271-16- 26 ON BULK ITEMS LIST, CUT TO LENGTH 2600 MM +/- 15) UOC: 99D	2
22	PAFZZ		1JX75	L-C-6	..SLEEVE, SOLDER TERMINATION UOC: 99D	4
23	XBFFF		44940	04-20826-4	..CABLE, POWER (SEE SHEET 3 FOR PARTS BREAKDOWN) UOC: 99D	1
24	MFFZZ		0X4C9	38300	..CABLE, POWER (MAKE FROM 38300 ON BULK ITEMS LIST, CUT TO LENGTH 2915 MM +/- 9 MM) UOC: 99D	1
25	PAFZZ		30554	88-20541-23	..INSULATION SLEEVING (MAKE FROM 88-20541-23 ON BULK ITEMS LIST, CUT TO LENGTH AS REQUIRED) UOC: 99D	2
26	PAFZZ		00779	2-31811-4	..TERMINAL, LUG UOC: 99D	6
27	PAFZZ	5940001154996	96906	MS20659-145	..TERMINAL, LUG UOC: 99D	4
28	PBFFF		44940	04-20981-1	..CABLE, ELECTRICAL (SEE SHEET 4 FOR PARTS BREAKDOWN) UOC: 99D	1
29	MFFZZ		0X4C9	31285820-54	..CABLE, POWER (MAKE FROM 31285820-54 ON BULK ITEMS LIST, CUT TO LENGTH 2450 MM +/- 35 MM) UOC: 99D	1
30	XBFFF		44940	04-20826-3	..CABLE, POWER (SEE SHEET 4 FOR PARTS BREAKDOWN) UOC: 99D	1
31	MFFZZ		0X4C9	38300	..CABLE, POWER (MAKE FROM 38300 ON BULK ITEMS LIST, CUT TO LENGTH 2965 MM +/- 9 MM) UOC: 99D	1
<b>END OF FIGURE</b>						

**OPERATOR AND FIELD MAINTENANCE**  
**AMMPS 10KW TRAILER-MOUNTED POWER UNITS AND POWER PLANTS**  
**BULK ITEM**

(1) ITEM NO.	(2) SMR CODE	(3) NSN	(4) CAGEC	(5) PART NUMBER	(6) DESCRIPTION AND UOC	(7) QTY
					GROUP 99 BULK MATERIAL	
					FIG. BULK	
1	PCFZZ		0HZU1	MA 212	ADHESIVE, RUBBER BASIC	1
2	PAFZZ		0X4C9	31285820-54	CABLE, POWER	1
3	PAFZZ		0X4C9	38300	CABLE, POWER 4 CONDUCTOR	1
4	PCFZZ	8010001417838	58536	AA59166-2-001G-34088	COATING COMPOUND, NONSLIP	1
5	PCFZZ		C4643	A2533	EDGING	1
6	PCFZZ		0HES0	BAP5-0100-ER0201	EDGING	1
7	PAFZZ		30554	88-20541-16	INSULATION SLEEVING	1
8	PAFZZ		30554	88-20541-23	INSULATION SLEEVING	1
9	PAFZZ		30554	88-20541-6	INSULATION SLEEVING	1
10	PAFZZ		0X4C9	3271-16-26	STRAND, WIRE	1
11	PAFZZ	6145012269164	58536	AA59551-C06B1B	WIRE, ELECTRICAL	1
12	PAFZZ		0X4C9	3271-4-133	WIRE, STRANDED	1
					<b>END OF FIGURE</b>	



**OPERATOR AND FIELD MAINTENANCE  
AMMPS 10KW TRAILER-MOUNTED POWER UNITS AND POWER PLANTS  
SPECIAL TOOLS LIST**

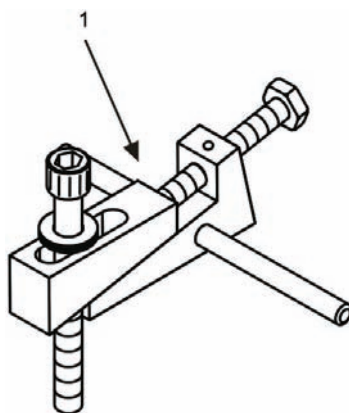

**Figure 16. Special Tools List (Sheet 1 of 1).**

(1) ITEM NO	(2) SMR CODE	(3) NATIONAL STOCK NUMBER (NSN)	(4) CAGEC	(5) PART NUMBER (P/N)	(6) DESCRIPTION AND USABLE ON CODE (UOC)	(7) QTY
1	PAFZZ		0J1H4	01METRIC	SPECIAL TOOLS FIG. 16 TOOL, RIVET NUT	
					<b>END OF FIGURE</b>	



**OPERATOR AND FIELD MAINTENANCE**  
**AMMPS 10KW TRAILER MOUNTED POWER UNITS AND POWER PLANTS**  
**NATIONAL STOCK NUMBER (NSN) INDEX**

STOCK NUMBER	FIG.	ITEM	STOCK NUMBER	FIG.	ITEM
5940000213321	10	2	5120002514489	10	8
5310000446477	1	35	5940002582074	15	4
	3	3	4730002775115	10	18
	4	5	2330003312307	2	2
	5	15	5330004025125	10	14
	6	3	5340004044100	12	6
	9	9	5310004082561	10	13
	9	10	2590004208929	8	1
5340000576956	4	13	2590004538977	8	4
	10	26	5320004830558	5	3
5342000661235	10	9	5310005669502	10	15
5305000712071	1	11	5310005715090	10	12
	1	22	4710005978731	10	17
5305000712075	1	25	5940006553318	13	15
5975000742072	7	1	5340006855899	13	4
5340000787029	4	15	4730007176207	15	15
	10	28	5975007275153	10	3
5310000874652	12	4	5320007533830	9	4
5975001113208	13	48	5315008384584	8	9
	15	11	5315008395822	8	10
5940001154996	15	27	5305008412681	10	20
8010001417838	BULK	4	5975008783791	10	21
4730001720049	8	8	3740009021481	10	10
4710001856948	10	16	5320009321972	13	1
5310001898467	13	40	5365009442682	5	23
5310002091239	10	19	5320009572514	1	8
5306002264827	3	2		1	19
	9	12		1	32
5306002264829	1	38	5940009581214	13	38
	4	6	5365009893304	6	5
	5	16	5120010131676	10	7
	6	4	5340010541766	13	21
	9	8	5940010558403	14	2
5305002264831	9	7	5320010863593	1	6
5306002264832	6	2		1	17
5340002290340	4	14		1	31
	10	27		11	3
5340002348422	9	2	5340010880489	9	6
5310002453424	1	34	5340011231556	12	2
	3	4	5320011401479	5	2
	4	17	4730011484531	10	22
	5	21	5310011490869	8	7
	6	6	2540011509864	5	13
	9	11	5315011620143	8	2

STOCK NUMBER	FIG.	ITEM	STOCK NUMBER	FIG.	ITEM
5935011741235	15	10		1	28
2510011954273	4	4	6115015617455	1	2
2510011964682	5	22		1	24
5999012036687	15	7	6115015617466	1	13
5342012201548	8	3	6115015623907	1	12
6145012269164	10	1	6115015624010	1	1
	BULK	11	6115015626480	1	23
6115012800063	4	11	4210015628664	15	2
	10	24	5310015675809	10	5
5320013360710	9	3	5310015675817	10	6
5120013738976	13	13			
5340013988680	4	12			
	10	25			
5320014142171	7	4			
2540014178036	9	1			
5935014541789	15	8			
5315014664174	5	5			
5340014681767	13	3			
4020014769072	13	16			
5310014785703	7	3			
5305014791214	4	7			
5320014856915	4	2			
	7	2			
5310014989981	4	16			
5310015002428	4	9			
5310015002482	4	8			
5310015006541	13	32			
5310015316074	5	19			
5310015320321	12	3			
2510015351092	4	10			
	6	7			
4210015351439	3	1			
6115015426775	1	3			
	1	14			
5340015435523	9	5			
5305015519219	5	18			
5310015524574	5	20			
4210015527734	1	4			
	1	15			
	1	29			
5310015531219	1	9			
	1	20			

END OF WORK PACKAGE



**OPERATOR AND FIELD MAINTENANCE**  
**AMMPS 10KW TRAILER MOUNTED POWER UNITS AND POWER PLANTS**  
**PART NUMBER (P/N) INDEX**

<b>PART NUMBER</b>	<b>FIG.</b>	<b>ITEM</b>	<b>PART NUMBER</b>	<b>FIG.</b>	<b>ITEM</b>
A026G000	13	17	DIN7985-M4X10	13	30
A028T645	13	42	DT06-12SA-P012	15	9
A2533	BULK	5	F51N7582-813	1	9
AA55592-10A	13	21		1	20
AA55804-3B 9FT	10	21		1	28
AA59166-2-001G-34088	BULK	4	K3-0334-52	13	4
AA59551-C06B1B	10	1	K3-2347-07	13	3
	BULK	11	L-C-6	15	22
AEB02C375A50WA6F Y1	12	5	M24243/6-A402H	13	1
AEN15M06A50MCH2A 31	13	45	M45913/1-6CG5C	12	4
AES10M06A020WB4K 42	13	37	MA 212	BULK	1
AES46M508016CH2A 31	13	23	MEP-1040	1	2
AEW22X250000EA1A A1	13	46		1	24
AS15006-1	8	8	MEP-1041	1	13
AS5194-0504	10	18	MGLP-R8-10	5	5
B0M-R12-8	8	11	MGLP-R8-6	4	2
B0M-R8-10	5	2		7	2
B0M-R8-8	5	3	MS16562-66	8	9
B1821BH031C100N	3	2	MS17829-5C	1	34
	9	12		3	4
B1821BH031C125N	1	38		4	17
	4	6		5	21
	5	16		6	6
	6	4		9	11
	9	8	MS18015-12	9	5
B1821BH031C150N	9	7	MS20604AD4W4	1	8
B1821BH031C175N	6	2		1	19
B1821BH050C200N	1	11		1	32
	1	22	MS20604AD6C4	1	6
B1821BH050C300N	1	25		1	17
B1821BH062C175N	5	18		1	31
BAP5-0100-ER0201	BULK	6		11	3
BAPK-69	7	4	MS20613-4P5	9	4
COV-0809	12	7	MS20659-145	15	27
COV-0813	12	2	MS20659-41	13	15
COV2113	12	6	MS24665-353	8	10
CR4622-4-3	9	3	MS27969-4	9	2
CT150E24E2S	13	33	MS3367-1-9	7	1
DG3M6F-S-RPC	13	38	MS3367-5-9	13	48
DIN6923-M5	13	43		15	11
DIN6923-M6	13	11	MS35335-60	10	19
DIN7380A2-M5X25	13	41	MS35823-6D	9	6
DIN7380A2-M6X12	13	22	MS39347-2	10	2

PART NUMBER	FIG.	ITEM	PART NUMBER	FIG.	ITEM
MS51412-25	1	35	04-20823	13	25
	3	3	04-20824	13	35
	4	5	04-20825	13	36
	5	15	04-20826-3	15	30
	6	3	04-20826-4	15	23
	9	9	04-20827-1	13	28
	9	10	04-20827-2	13	29
MS51926-3	4	15	04-20845	13	34
	10	28	04-20981-1	15	28
MS51929-2	4	13	04-20981-2	15	12
	10	26	04-20990	13	2
MS51939-3	4	14	04-20991	13	7
	10	27	04-21078-12	1	7
P74-144	10	7	04-21078-17	1	18
PP-3102	1	23	04-21078-33	1	33
PU-2002	1	1	04-21098	13	6
PU-2012	1	12	04-21138-4	13	5
RT25042-18DF	15	13	04-21180-22	1	30
RT3106F18-19P	15	14	04-21180-3	1	5
TAG9T3-100B	14	4	04-21180-4	1	16
	15	6	04-21233	6	1
W12S	15	8	04-21234	1	36
34105	15	4	04-21241	13	19
38300	15	24	04-21290	15	1
	15	31	04-21300	1	37
	BULK	3	04-21315	13	26
50981	15	2	04-21318-1	13	31
55004	15	19	04-21322	13	14
55013	13	12	04-21329	12	1
114017	15	10	04-21362	6	9
270191	3	1	04-21619	10	23
324114	14	2	04-21716	5	17
8358998	2	2	04-21721	1	27
10277113	10	20	0462-201-16141	15	7
12450001	2	1	12450056-1	5	10
395300108	13	44	13200E6361	10	12
02-23013	10	4	13200E6363	10	10
04-20285	13	8	13211E7541	10	9
04-20809	13	9	13211E7542	10	17
04-20815	13	27	13211E7543	10	16
04-20816	13	24	13211E7544	10	15
04-20819-1	14	14	13211E7546	10	14
04-20819-2	14	12	13211E7547	10	13
04-20819-3	14	10	13211E7548	10	11
04-20819-4	14	8	13214E1206-1	8	1
04-20819-5	14	7	13214E1207	8	3
04-20819-6	14	1	13214E1208-1	8	4
04-20820	13	20	13214E1209	8	2
04-20822-1	13	18	13214E1210	8	5

PART NUMBER	FIG.	ITEM	PART NUMBER	FIG.	ITEM
13214E1211	8	7		15	29
13214E1212-1	8	6		BULK	2
13214E1263	4	4	3271-16-26	15	3
13214E1264	4	10		15	21
13214E1267-1	5	23		BULK	10
13214E1268	5	24	3271-4-133	14	5
13214E1270	6	7		14	9
13214E1271	6	8		14	11
13214E1272	6	5		14	13
13214E1461	5	13		BULK	12
13214E1462	5	22	39101-75030	13	10
13214E9975-1	4	12	40CNFHS	13	32
	10	25	5877A246	10	8
13218E0320-331	10	6	699-532-54-50	13	47
13218E0320-89	4	16	88-20018-2	10	3
13218E5091	4	11	88-20033-11A	4	8
	10	24	88-20033-31A	12	3
13229E6108	5	14	88-20033-40A	1	10
13229E7946	9	1		1	21
13230E6382-14	5	20		1	26
13230E6524	5	11	88-20033-45A	5	19
13230E6564-1	5	7	88-20541-16	14	3
13230E6564-2	5	12		15	16
13230E6565	1	3		BULK	7
	1	14	88-20541-23	15	25
13230E6567-1	5	9		BULK	8
13230E6567-2	5	8	88-20541-6	15	20
13230E6568	5	6		BULK	9
13230E6569-1	5	1	88-20550-2	15	15
13230E6569-2	5	4	88-20554-1	15	17
13230E6571-1	4	1	88-21146	13	13
13230E6571-2	4	3	88-22336-1	13	40
13230E6673-66A	4	7	95395A250	13	39
13230E6743-108	10	5	98-19724	13	16
13230E6744-43	4	9			
13230E6744-46	7	3			
13230E6796	11	1			
13230E6797	11	2			
13230E6831	1	4			
	1	15			
	1	29			
2249-12-12S	10	22			
2-31811-4	14	6			
	15	26			
2-34113-2	15	5			
31285820-54	15	18			

END OF WORK PACKAGE



**CHAPTER 8**  
**SUPPORTING INFORMATION**  
**FOR**  
**AMMPS 10KW TRAILER MOUNTED POWER UNITS AND POWER PLANTS**

**CHAPTER 8**  
**SUPPORTING INFORMATION**

**WORK PACKAGE INDEX**

---

<b><u>Title</u></b>	<b><u>WP Sequence No.</u></b>
REFERENCES.....	0055
MAINTENANCE ALLOCATION CHART (MAC) INTRODUCTION .....	0056
MAINTENANCE ALLOCATION CHART (MAC) .....	0057
COMPONENTS OF END ITEM (COEI) AND BASIC ISSUE ITEMS (BII) LISTS .....	0058
ADDITIONAL AUTHORIZATION LIST (AAL) .....	0059
EXPENDABLE AND DURABLE ITEMS LIST.....	0060

---

**OPERATOR AND FIELD MAINTENANCE  
AMMPS 10KW TRAILER-MOUNTED POWER UNITS AND POWER PLANTS  
REFERENCES**

---

**SCOPE**

This WP lists all the FM, forms, TMs, and miscellaneous publications referenced in this TM.

**FIELD MANUALS**

FM 4-25.11	First Aid
FM 11-487-4	Installation Practices: Grounding, Bonding, and Shielding
FM 5-424	Theater of Operations Electrical Systems
FM 9-207	Operation and Maintenance of Ordnance Material In Cold Weather
FM 21-305	Manual for the Wheeled Vehicle Driver

**FORMS**

AFI 21-101	Aircraft and Equipment Maintenance Management
AFI 33-201	Air Force Instruction, Communications Security
AFR 900-4	Product Quality Deficiency Report (PQDR)
Air Force Technical Order (AFTO) Form 22	Technical Manual (TM) Change Recommendation and Reply
AR 25-30	The Army Publishing Program
AR 700-138	Army Logistics Readiness and Sustainability
AR 750-1	Army Materiel Maintenance Policy
CTA 50-909	Field and Garrison Furnishings and Equipment
CTA 50-970	Expendable/Durable Items (Except Medical Class V Repair Parts, and Heraldic Items)
CTA 8-10	Army Medical Department Expendable/Durable Items
DA Form 2028	Recommended Changes to Publications and Blank Forms
DA Form 2404	Equipment Inspection and Maintenance Worksheet
DA Form 5988E	Equipment Inspection and Maintenance Worksheet (electronic version)
DA PAM 738-751	Functional Users Manual for The Army Maintenance Management System — Aviation (TAMMS-A)
DA PAM 750-8	The Army Maintenance Management System (TAMMS) Users Manual
DD Form 250	Material Inspection and Receiving Report
MCO P4855.10	Product Quality Deficiency Report (PQDR)
NAVMC Form 10772	Recommended Changes to Technical Publications
SF 361	Transportation Discrepancy Report (TDR)
SF 368	Product Quality Deficiency Report (PQDR)
TO 00-20	Technical Order, series 20

**TECHNICAL MANUALS**

NMWR-9-6115-750	National Maintenance Works Requirement manual for the 10 kW AMMPS Generator Sets
TB SIG 222	Solder and Soldering
TM 1-1500-344-23	Aircraft Weapon Systems Cleaning and Corrosion Control
TM 4700-15/1	Preventive Maintenance Checks and Services (PMCS) Roster (4700)
TM 750-244-2	Procedures for Destruction of Equipment to Prevent Enemy Use
TM 9-238	Deep Water Fording of Ordnance Material
TM 9-6115-750-24&P	Field and Sustainment Maintenance Manual for Generator Set Including Repair Parts and Special Tools List (RPSTL), Skid Mounted 10 kW Advanced Medium Mobile Power Sources (AMMPS)
TM 9-6115-750-10	Operator's Manual for Generator Set, Skid Mounted 10 kW Advanced Medium Mobile Power Sources (AMMPS)
TM 9-2330-392-14&P	Operator and Field Maintenance Manual Light Tactical Trailer
TM 9-2330-205-14&P	Operator and Field Maintenance Manual M200A1 Trailer

**MISCELLANEOUS DOCUMENTS**

A-A-52557A	Fuel Oil, Diesel; for Posts, Camps and Stations
ASME Y 14.38	Abbreviations and Acronyms: An American National Standard
MIL-DLT-83133G	Turbine Fuel, Aviation, Kerosene Type, JP-8 (NATO F-34), NATO F-35, and JP-8+100 (NATO F-37)
MIL-PRF-2104H	Performance Specification, Lubrication Oil, Internal Combustion Engine, Combat/Tactical Service
MIL-PRF-21260E	Performance Specification, Lubrication Oil, Internal Combustion Engine, Preservative Break-In
MIL-PRF-22191F	Performance Specification, Barrier Materials, Transparent, Flexible, Heat-Sealable
MIL-PRF-46167D	Performance Specification, Lubrication Oil, Internal Combustion Engine, Arctic

**END OF WORK PACKAGE**



---

**OPERATOR AND FIELD MAINTENANCE**  
**AMMPS 10KW TRAILER-MOUNTED POWER UNITS AND POWER PLANTS**  
**MAINTENANCE ALLOWOCATION CHART (MAC) INTRODUCTION**

---

## INTRODUCTION

### The Army Maintenance System MAC

This introduction provides a general explanation of all maintenance and repair functions authorized at the two maintenance levels under the Two-Level Maintenance System concept.

This MAC (immediately following the introduction) designates overall authority and responsibility for the performance of maintenance functions on the identified end item or component. The application of the maintenance functions to the end item or component shall be consistent with the capacities and capabilities of the designated maintenance levels, which are shown on the MAC in column (4) as:

Field – includes two subcolumns, Crew (C) and Maintainer (F)

Sustainment – includes two subcolumns, Below Depot (H) and Depot (D)

The maintenance to be performed at field and sustainment levels is described as follows:

1. Crew maintenance. The responsibility of a using organization to perform maintenance on its assigned equipment. It normally consists of inspecting, servicing, lubricating, adjusting, and replacing parts, minor assemblies, and subassemblies. The replace function for this level of maintenance is indicated by the letter "C" in the third position of the SMR code. A "C" appearing in the fourth position of the SMR code indicates complete repair is possible at the crew maintenance level.
2. Maintainer maintenance. Maintenance accomplished on a component, accessory, assembly, subassembly, plug-in unit, or other portion either on the system or after it is removed. The replace function for this level of maintenance is indicated by the letter "F" appearing in the third position of the SMR code. An "F" appearing in the fourth position of the SMR code indicates complete repair is possible at the field maintenance level. Items are returned to use after maintenance is performed at this level.
3. Below depot sustainment. Maintenance accomplished on a component, accessory, assembly, subassembly, plug-in unit, or other portion either on the system or after it is removed. The replace function for this level of maintenance is indicated by the letter "H" appearing in the third position of the SMR code. An "H" appearing in the fourth position of the SMR code indicates complete repair is possible at the below depot sustainment maintenance level. Items are returned to the supply system after maintenance is performed at this level.
4. Depot sustainment. Maintenance accomplished on a component, accessory, assembly, subassembly, plug-in unit, or other portion either on the system or after it is removed. The replace function for this level of maintenance is indicated by the letter "D" or "K" appearing in the third position of the SMR code. Depot sustainment maintenance can be performed by either depot personnel or contractor personnel. A "D" or "K" appearing in the fourth position of the SMR code indicates complete repair is possible at the depot sustainment maintenance level. Items are returned to the supply systems after maintenance is performed at this level.

The tools and test equipment requirements table (immediately following the MAC) list the tools and test equipment (both special tools and common tool sets) required for each maintenance function as referenced from the MAC.

The remarks table (immediately following the tools and test equipment requirements) contain supplemental instructions and explanatory notes for a particular maintenance function.

---

## Maintenance Functions

Maintenance functions are limited to and defined as follows:

1. **Inspect.** To determine the serviceability of an item by comparing its physical, mechanical, and/or electrical characteristics with established standards through examination (e.g., by sight, sound, or feel). This includes scheduled inspection and gaugings and evaluation of cannon tubes.
2. **Test.** To verify serviceability by measuring the mechanical, pneumatic, hydraulic, or electrical characteristics of an item and comparing those characteristics with prescribed standards on a scheduled basis, i.e., load testing of lift devices and hydrostatic testing of pressure hoses.
3. **Service.** Operations required periodically to keep an item in proper operating condition, e.g., to clean (includes decontaminate, when required), to preserve, to drain, to paint, or to replenish fuel, lubricants, chemical fluids, or gases. This includes scheduled exercising and purging of recoil mechanisms. The following are examples of service functions:
  - a. **Unpack.** To remove from the packing box for service or when required for the performance of maintenance operations.
  - b. **Repack.** To return item to the packing box after service and other maintenance operations.
  - c. **Clean.** To rid the item of contamination.
  - d. **Touch up.** To spot paint scratched or blistered surfaces.
  - e. **Mark.** To restore obliterated identification.
4. **Adjust.** To maintain or regulate, within prescribed limits, by bringing into proper position or by setting the operating characteristics to specified parameters.
5. **Align.** To adjust specified variable elements of an item to bring about optimum or desired performance.
6. **Calibrate.** To determine and cause corrections to be made or to be adjusted on instruments of test, measuring, and diagnostic equipment used in precision measurement. Consists of comparisons of two instruments, one of which is a certified standard of known accuracy, to detect and adjust any discrepancy in the accuracy of the instrument being compared.
7. **Remove/Install.** To remove and install the same item when required to perform service or other maintenance functions. Install may be the act of emplacing, seating, or fixing into position a spare, repair part, or module (component or assembly) in a manner to allow the proper functioning of an equipment or system.
8. **Paint (ammunition only).** To prepare and spray color coats of paint so that the ammunition can be identified and protected. The color indicating primary use is applied, preferably, to the entire exterior surface as the background color of the item. Other markings are to be repainted as original so as to retain proper ammunition identification.
9. **Replace.** To remove an unserviceable item and install a serviceable counterpart in its place. "Replace" is authorized by the MAC, and the assigned maintenance level is shown as the third position code of the Source, Maintenance, and Recoverability (SMR) code.
10. **Repair.** The application of maintenance services, including fault location/troubleshooting, removal/installation, disassembly/assembly procedures, and maintenance actions to identify troubles and restore serviceability to an item by correcting specific damage, fault, malfunction, or failure in a part, subassembly, module (component or assembly), end item, or system.

## NOTE

The following definitions are applicable to the “repair” maintenance function:

Services. Inspect, test, service, adjust, align, calibrate, and/or replace.

Fault location/troubleshooting. The process of investigating and detecting the cause of equipment malfunction; the act of isolating a fault within a system or Unit Under Testing (UUT).

Disassembly/assembly. The step-by-step breakdown (taking apart) of a spare/functional group coded item to the level of its least component that is assigned a SMR code for the level of maintenance under consideration (i.e., identified as maintenance significant).

Actions. Welding, grinding, riveting, straightening, facing, machining, and/or resurfacing.

11. Overhaul. That maintenance effort (service/action) prescribed to restore an item to a completely serviceable/operational condition as required by maintenance standards in appropriate technical publications. Overhaul is normally the highest degree of maintenance performed by the Army. Overhaul does not normally return an item to like-new condition.
12. Rebuild. Consists of those services/actions necessary for the restoration of unserviceable equipment to a like-new condition in accordance with original manufacturing standards. Rebuild is the highest degree of material maintenance applied to Army equipment. The rebuild operation includes the act of returning to zero those age measurements (e.g., hr/miles) considered in classifying Army equipment/components.

### Explanation of Columns in the MAC

Column (1) Group Number. Column (1) lists Functional Group Code (FGC) numbers, the purpose of which is to identify maintenance-significant components, assemblies, subassemblies, and modules with the Next Higher Assembly (NHA).

Column (2) Component/Assembly. Column (2) contains the item names of components, assemblies, subassemblies, and modules for which maintenance is authorized.

Column (3) Maintenance Function. Column (3) lists the functions to be performed on the item listed in column (2). (For a detailed explanation of these functions, refer to “Maintenance Functions” outlined above.)

Column (4) Maintenance Level. Column (4) specifies each level of maintenance authorized to perform each function listed in column (3) by indicating work time required (expressed as man hours in whole hours or decimals) in the appropriate subcolumn. This work time figure represents the active time required to perform that maintenance function at the indicated level of maintenance. If the number or complexity of the tasks within the listed maintenance function varies at different maintenance levels, appropriate work time figures are to be shown for each level. The work time figure represents the average time required to restore an item (assembly, subassembly, component, module, end item, or system) to a serviceable condition under typical field operating conditions. This time includes preparation time (including any necessary disassembly/assembly time), troubleshooting/fault location time, and quality assurance time in addition to the time required to perform the specific tasks identified for the maintenance functions authorized in the MAC. The symbol designations for the various maintenance levels are as follows:

Field:

- C Crew maintenance
- F Maintainer maintenance

Sustainment:

- L Specialized Repair Activity (SRA)
- H Below depot maintenance
- D Depot maintenance

---

## NOTE

The "L" maintenance level is not included in column (4) of the MAC. Functions to this level of maintenance are identified by work time figure in the "H" column of column (4), and an associated reference code is used in the REMARKS column (6). This code is keyed to the remarks, and the SRA complete repair application is explained there.

Column (5) Tools and Equipment Reference Code. Column (5) specifies, by code, those common tool sets (not individual tools), common Test, Measurement, and Diagnostic Equipment (TMDE), and special tools, special TMDE, and special support equipment required to perform the designated function. Codes are keyed to the entries in the tools and test equipment table.

Column (6) Remarks Code. When applicable, this column contains a letter code, in alphabetical order, which is keyed to the remarks table entries.

### Explanation of Columns in the Tools and Test Equipment Requirements

Column (1) Tool or Test Equipment Reference Code. The tool or test equipment reference code correlates with a code used in column (5) of the MAC.

Column (2) Maintenance Level. The lowest level of maintenance authorized to use the tool or test equipment.

Column (3) Nomenclature. Name or identification of the tool or test equipment.

Column (4) National Stock Number (NSN). The NSN of the tool or test equipment.

Column (5) Tool Number. The manufacturer's part number.

### Explanation of Columns in the Remarks

Column (1) Remarks Code. The code recorded in column (6) of the MAC.

Column (2) Remarks. This column lists information pertinent to the maintenance function being performed as indicated in the MAC.

### END OF WORK PACKAGE

**OPERATOR AND FIELD MAINTENANCE  
AMMPS 10KW TRAILER-MOUNTED POWER UNITS AND POWER PLANTS  
MAINTENANCE ALLOCATION CHART (MAC)**

**Table 1. MAC for AMMPS 10 kW PU and PP.**

(1) GROUP NUMBER	(2) COMPONENT/ASSEMBLY	(3) MAINTENANCE FUNCTION	(4) MAINTENANCE LEVEL				(5) TOOLS & EQUIP REF CODE	(6) REMARKS CODE
			FIELD		SUSTAINMENT			
			CREW	MAINTAINER	BELOW DEPOT	DEPOT		
			C	F	H	D		
00	POWER UNIT/POWER PLANT	Inspect	2.4	0.2			A, B, C	
		Service		0.75		10	B, C	
		Repair		1.0		9, 10, 13	D	
01	TRAILER CHASSIS	Inspect		0.4			A, E, F	
0101	FIRE EXTINGUISHER BRACKET	Inspect	0.1	0.1			A, E, F	
		Remove/Install		0.2		10, 14		
		Replace		0.2		10, 14		
0102	FENDERS	Inspect	0.1	0.1			A	
		Remove/Install		0.8		7, 9, 10		
		Replace		0.8		7, 9, 10		
0103	FLOOR, RAILS, AND SPACERS	Inspect	0.1	0.2			A	
		Remove/Install		1.0		7, 9, 10, 13, 14		
		Replace		1.0		7, 9, 10, 13, 14		
0104	BRAKES	Inspect	0.1	0.1			A, F, G	
		Remove/Install		0.5		10, 13	G	
		Replace		0.5		10, 13	G	
0105	LTT LIGHTS INSTALLATION	Inspect	0.1	0.1			A, E, H	
		Remove/Install		0.5		7	H	
		Replace		0.5		7	H	
0106	LTT LEVELING SUPPORT JACK	Inspect	0.1	0.1			A, E, H	
		Remove/Install		0.5		7, 10	H	
		Repair		0.3		7, 10	H	
		Replace		0.5		7, 10	H	
0107	ACCESSORY BOX	Inspect	0.1	0.1			A	
		Remove/Install		0.2		10, 14		
		Repair		0.5		10, 14		
		Replace		0.2		10, 14		

Table 1. MAC for AMMPS 10 kW PU and PP — Continued.

(1) GROUP NUMBER	(2) COMPONENT/ASSEMBLY	(3) MAINTENANCE FUNCTION	(4) MAINTENANCE LEVEL				(5) TOOLS & EQUIP REF CODE	(6) REMARK S CODE
			FIELD		SUSTAINMENT			
			CREW	MAINTAINER	BELOW DEPOT	DEPOT		
			C	F	H	D		
0108	ACCESSORIES	Inspect	0.1	0.1			A	
		Repair		0.3		10, 15		
0109	M200 IDENTIFICATION PLATES	Inspect	0.1				A, G	
		Remove/Install		0.1		9	G	
		Replace		0.1		9	G	
02	SWITCH BOX INSTALLATION	Inspect	0.1	0.1			A, G	
		Remove/Install		0.5		9, 10, 13, 15	G	
		Repair		0.3		3, 4, 9, 10, 13, 15	G	
		Replace		0.5		9, 10, 13, 15	G	
0201	SWITCH BOX COMPONENTS	Inspect		0.1			A, G	
		Remove/Install		0.7		8, 10, 13, 14, 15	G	
		Repair		0.4		8, 10, 12, 13, 14, 15	G, I	
		Test		0.2		8, 10	G	
		Replace		0.7		8, 10, 13, 14, 15	G	
0202	SWITCH BOX LEADS	Inspect	0.1	0.1			A, G	
		Remove/Install		0.4		8, 10, 13, 15	G	
		Repair		0.6		1, 2, 6, 8, 10, 13, 15	G	
		Test		0.3		8, 10	G	
		Replace		0.4		8, 10, 13, 15	G	
0203	SWITCH BOX WIRING HARNESS	Inspect	0.1	0.1			A, G	
		Remove/Install		0.5		10, 13, 15	G	
		Repair		0.4		1, 2, 6, 10, 13, 15	G	
		Test		0.3		10	G	
		Replace		0.5		10, 13, 15	G	

Table 2. Tools and Test Equipment for AMMPS 10 kW PU and PP.

TOOL OR TEST EQUIPMENT REF CODE	MAINTENANCE LEVEL	NOMENCLATURE	NSN	TOOL NUMBER
1	F	Crimping, Tool, Terminal		KTC S0159
2	F	Crimping, Tool, Terminal, Hand	5120013748936	J-38852
3	F	Drill-Driver, Battery Operated, Rechargeable		KTC S0188
4	F	Drill, Set, Twist		KTC S0194
5	F	Forward Repair System	4940015331621	SC 4940-95-E42
6	F	Remover, Electrical Contact	5120011584707	114010
7	F	Riveter Kit, Blind, Hand	5180012014978	D-100-MIL-1
8	F	Strap, Wrist, Electrostatic Discharge	5920014913509	4720
9	F	Tool Kit, Blind, Fastener, Installation		KTC S0700
10	F	Tool Kit, General Mechanic's (GMTK)	5180015487634	SC 5180-95-B48
11	F	Tool Set, SATS, Base	4910014906453	SC 4910-95-A81
12	F	Tool, Rivet Nut		01METRIC
13	F	Wrench, Torque, Click, Ratcheting, 1/2" Drive, 250 FT-LB		KTC S0991
14	F	Wrench, Torque, Click, Ratcheting, 3/8" Drive, 75 FT-LB		KTC S0989
15	F	Wrench, Torque, Dial, 3/8" Drive, 300 IN-LB		KTC S0987

**Table 3. Remarks for the AMMPS 10 kW PU and PP.**

REMARKS CODE	REMARKS
A	Preventive Maintenance Checks and Services (PMCS)
B	Refer to TM 9-6115-750-10 for generator set operator maintenance.
C	Refer to TM 9-6115-750-24&P for generator set field and sustainment maintenance.
D	Power Unit/Power Plant repair function includes replacement of identification plates.
E	Refer to TM 9-2330-392-14&P for LTT maintenance.
F	Refer to TM 9-2330-205-14&P for M200A1 trailer maintenance.
G	PP-3102 only.
H	PU-2002 and PU-2012 only.
I	Switch Box Components repair function includes the replacement of the connection board, magnetic contactor, control switch card, and clinch nuts.

**END OF WORK PACKAGE**



**OPERATOR AND FIELD MAINTENANCE  
 AMMPS 10KW TRAILER-MOUNTED POWER UNITS AND POWER PLANTS  
 COMPONENTS OF END ITEM (COEI) AND BASIC ISSUE ITEMS (BII) LISTS**

**INTRODUCTION**

**Scope**

This work package provides COEI and BII lists for the AMMPS 10 kW PU and PP to help you inventory items for safe and efficient operation of the equipment.

**General**

The COEI and BII information is divided into the following lists:

Components of End Item (COEI). This list is for information purposes only and is not authority to requisition replacements. These items are part of the AMMPS. As part of the end item, these items must be with the end item whenever it is issued or transferred between property accounts. Items of COEI are removed and separately packaged for transportation or shipment only when necessary. Illustrations are furnished to help you find and identify the items.

Basic Issue Item (BII). These essential items are required to place the AMMPS in operation, operate it, and to do emergency repairs. Although shipped separately packaged, BII must be with the AMMPS during operation and when it is transferred between property accounts. Listing these items is your authority to request/requisition them for replacement based on authorization of the end item by the TOE/MTOE. Illustrations are furnished to help you find and identify the items.

**Explanation of Columns in the COEI List and BII List**

Column (1) Illus. Number. Gives you the number of the item illustrated.

Column (2) National Stock Number (NSN). Identifies the stock number of the item to be used for requisitioning purposes.

Column (3) Description, Part Number/(CAGEC). Identifies the Federal item name (in all capital letters) followed by a minimum description when needed. The stowage location of COEI and BII is also included in this column. The last line below the description is the part number and the Commercial and Government Entity Code (CAGEC) (in parentheses).

Column (4) Usable On Code. When applicable, gives you a code if the item you need is not the same for different models of equipment. These codes are identified below.

<u>Code</u>	<u>Used on</u>
98Z	Model PU-2002
99A	Model PU-2012
99D	Model PP-3102

Column (5) U/I. Unit of Issue (U/I) indicates the physical measurement or count of the item as issued per the National Stock Number shown in column (2).

Column (6) Qty Rqr. Indicates the quantity required.

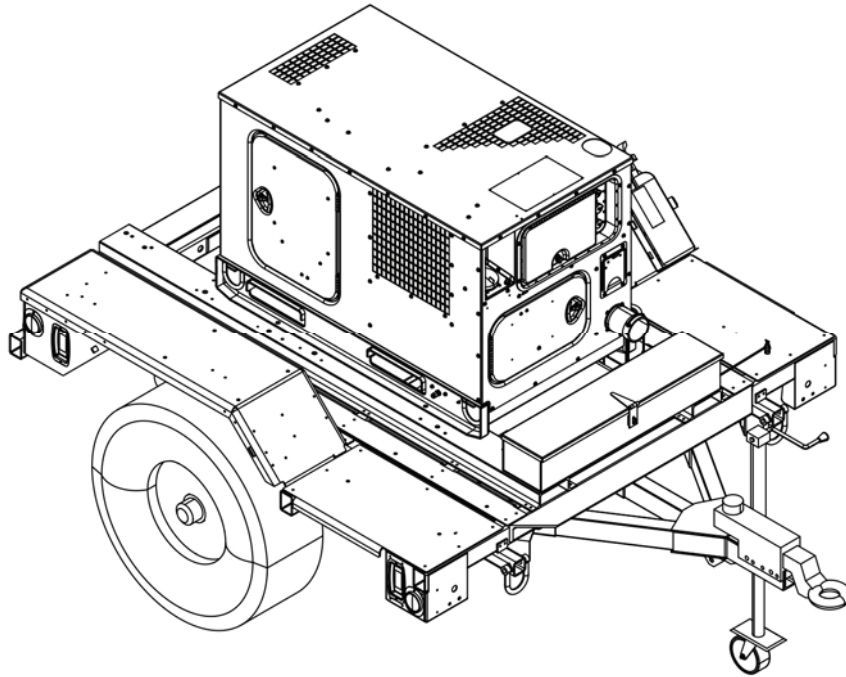

Figure 1. Power Unit — PU-2002 and PU-2012.

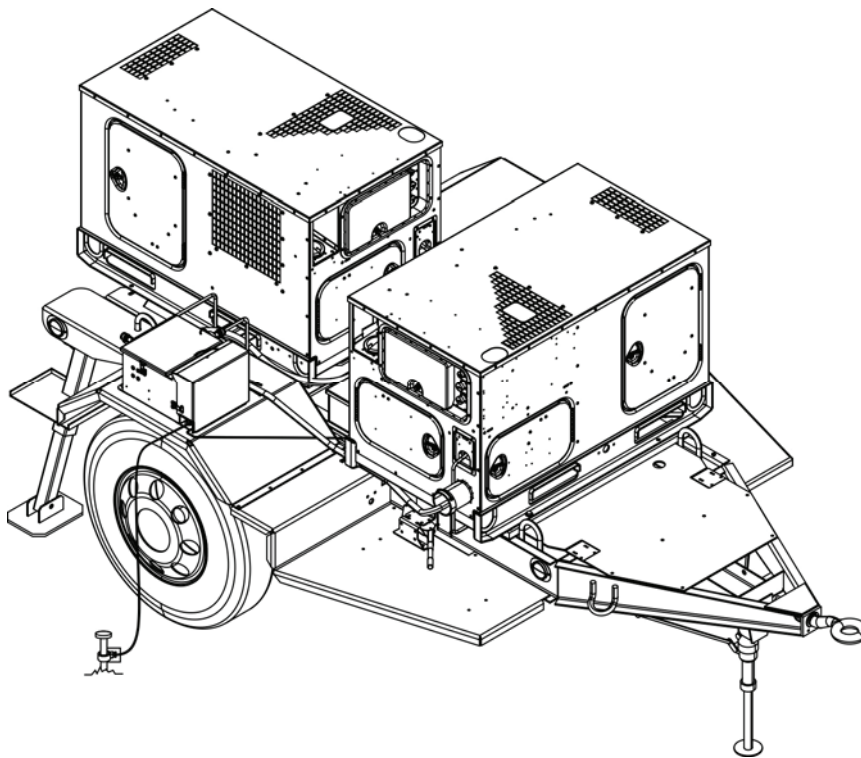

Figure 2. Power Plant — PP-3102.

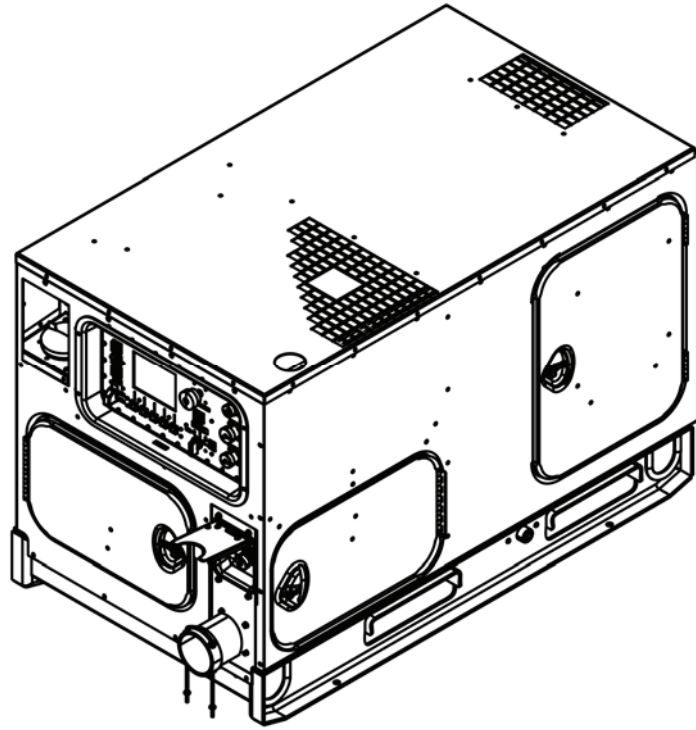

Figure 3. AMMPS 10 kW 50/60 Hz and AMMPS 10 kW 400 Hz.

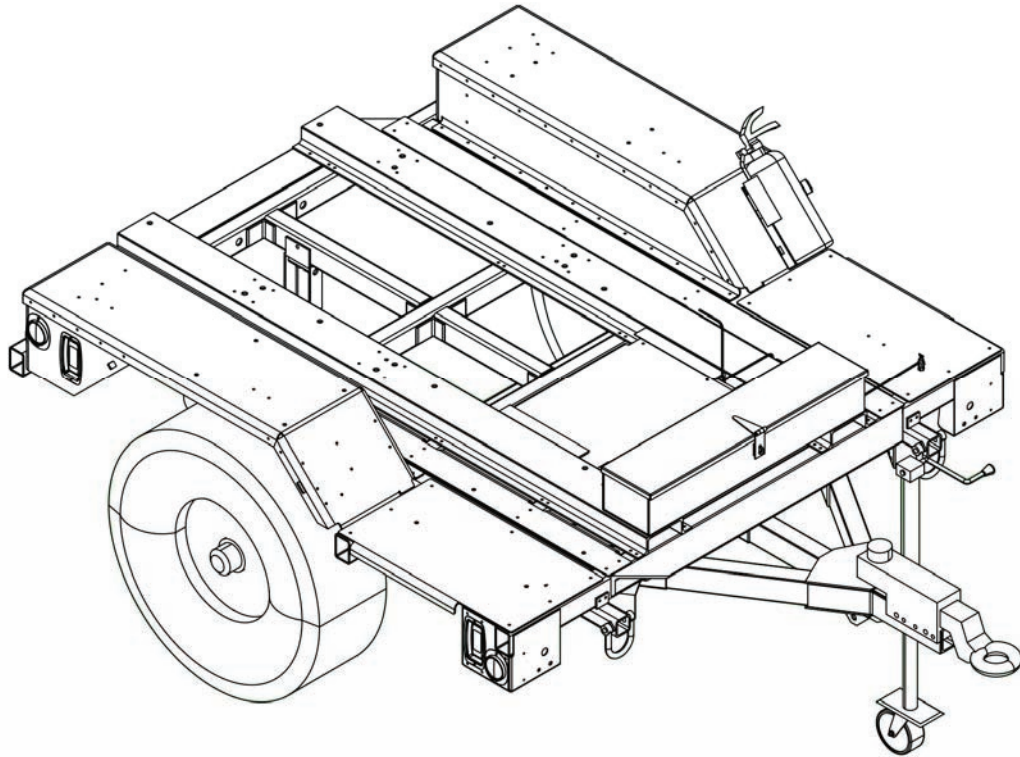

Figure 4. Trailer Chassis, Light Tactical (LTT).

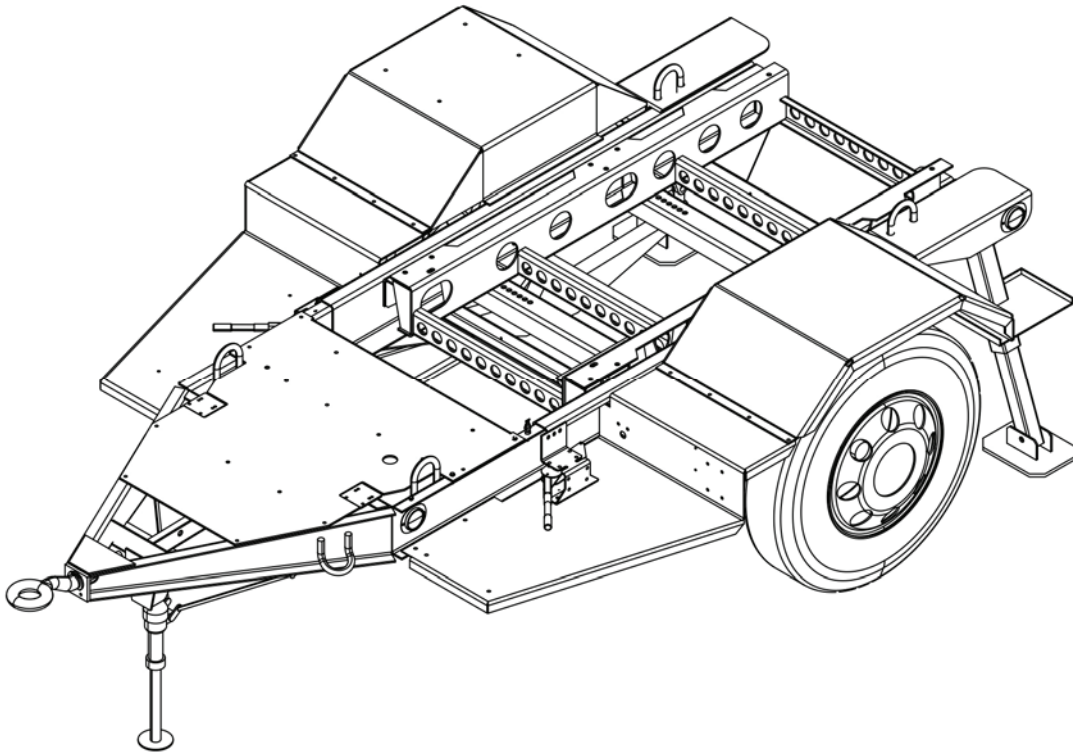

Figure 5. Chassis Trailer, M200A1 1 1/2 Ton.

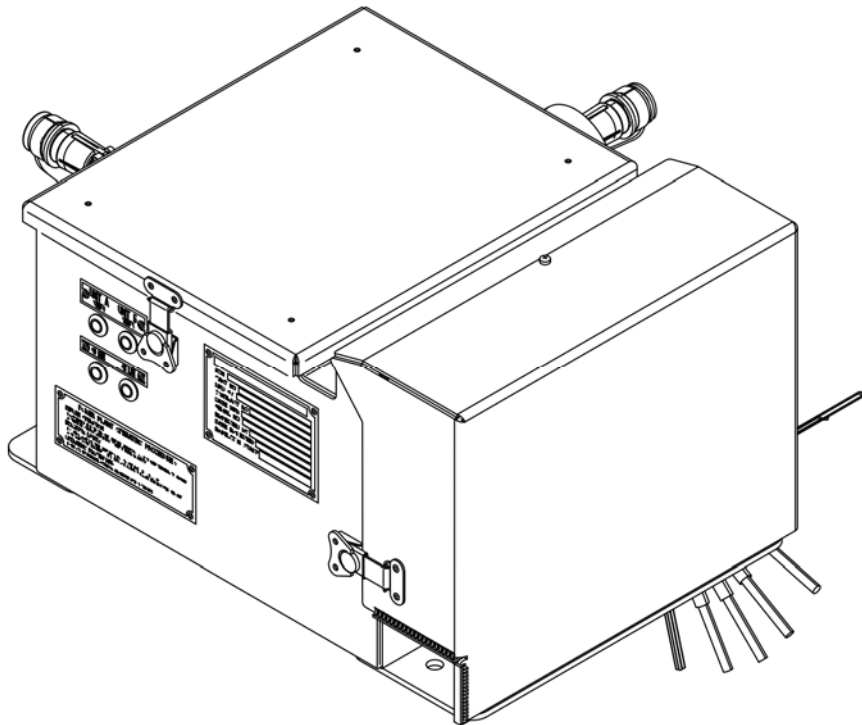

Figure 6. Switch Box.

Table 1. Components of End Item (COEI).

(1) ILLUS. NUMBER	(2) NATIONAL STOCK NUMBER (NSN)	(3) DESCRIPTION, PART NUMBER/(CAGEC)	(4) USABLE ON CODE	(5) U/I	(6) QTY RQR
1	6115-01-562-4010	POWER UNIT PU-2002, PU-2002 (30554)	98Z	EA	1
3	6115-01-561-7455	AMMPS 10 kW 50/60 Hz, MEP- 1040 (30554)	98Z, 99D	EA	1
4	2330-01-387-5424	CHASSIS, TRAILER, LIGHT TACTICAL, 2 WHEEL, 13230E6565 (97403)	98Z, 99A	EA	1
1	6115-01-562-3907	POWER UNIT PU-2012, PU-2012 (30554)	99A	EA	1
3	6115-01-561-7466	AMMPS 10 kW 400 Hz, MEP- 1041 (30554)	99A	EA	1
4	2330-01-387-5424	CHASSIS, TRAILER, LIGHT TACTICAL, 2 WHEEL, 13230E6565 (97403)	98Z, 99A	EA	1
2	6115-01-562-6480	POWER PLANT PP-3102, PP-3102 (30554)	99D	EA	1
3	6115-01-561-7455	AMMPS 10 kW 50/60 Hz, MEP- 1040 (30554)	98Z, 99D	EA	2
5	2330-00-331-2307	CHASSIS, TRAILER 1 1/2 TON, M200A1, 04-21234 (30554)	99D	EA	1
6		SWITCH BOX, 04-21329 (44940)	99D	EA	1

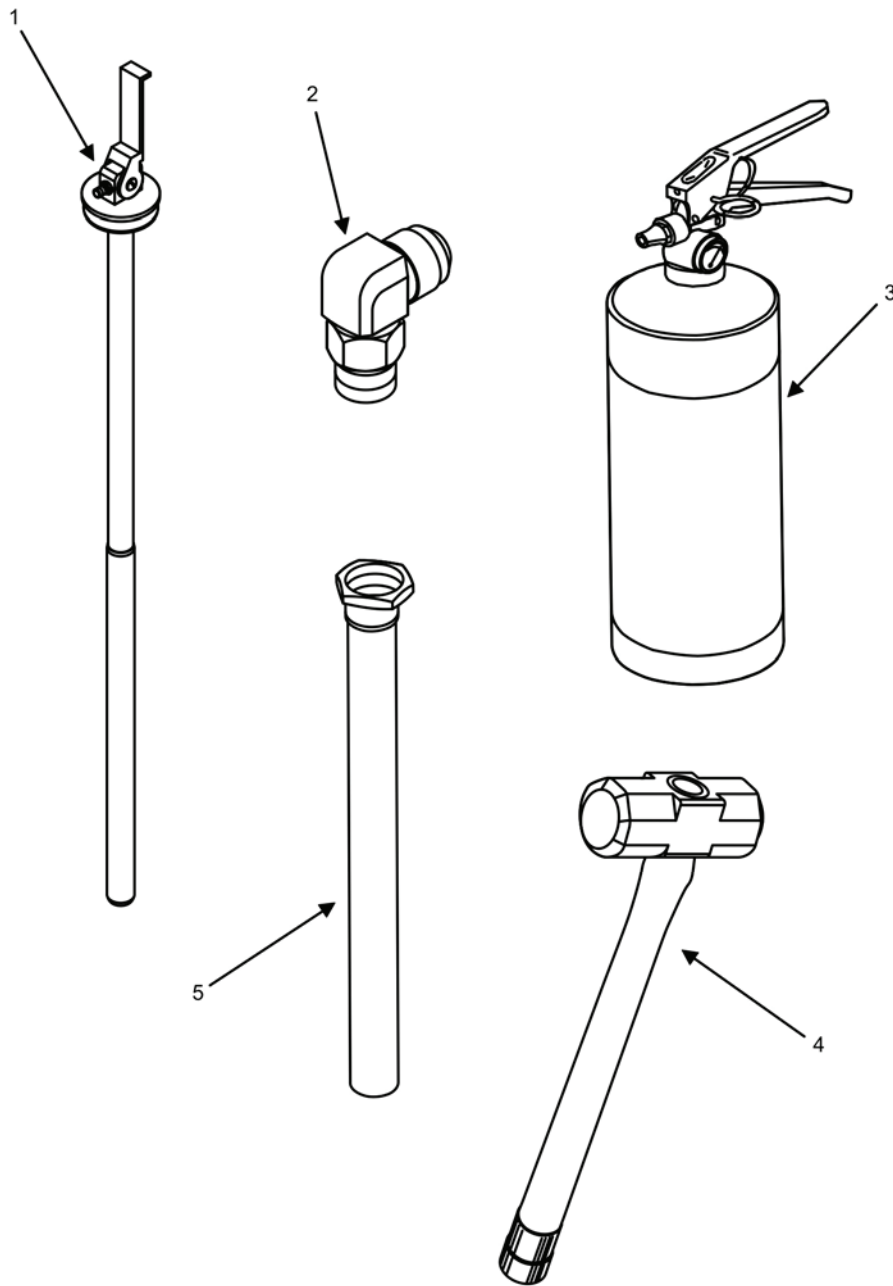

Figure 7. Basic Issue Items (BII) (Sheet 1 of 2).

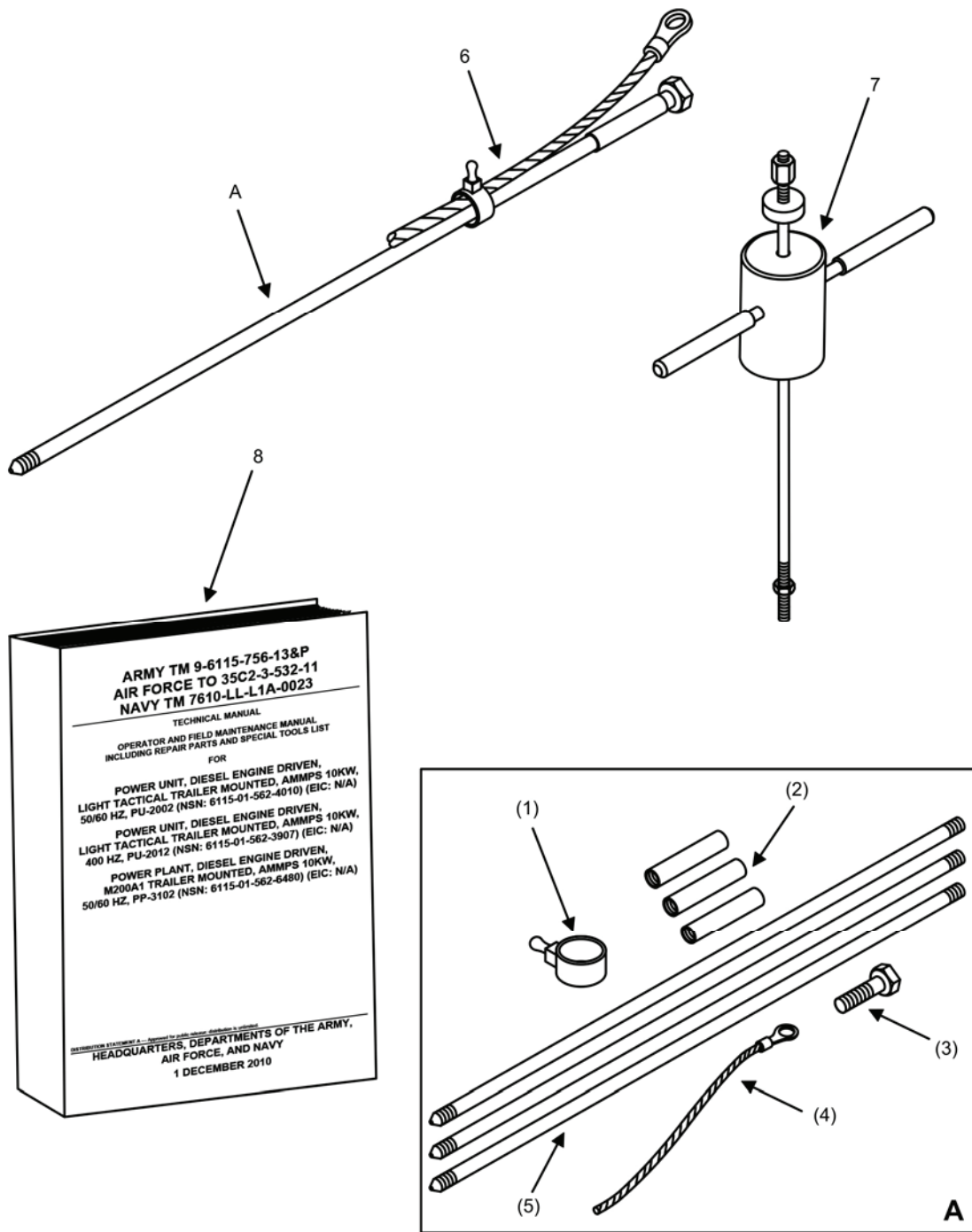

Figure 7. Basic Issue Items (BII) (Sheet 2 of 2).

Table 2. Basic Issue Items (BI).

(1) ILLUS. NUMBER	(2) NATIONAL STOCK NUMBER (NSN)	(3) DESCRIPTION, PART NUMBER/(CAGEC)	(4) USABLE ON CODE	(5) U/I	(6) QTY RQR
1	5342-00-066-1235	ADAPTER, CONTAINER, FUEL, 13211E7541 (97403)	ALL	EA	1
2	4730-01-148-4531	ELBOW, PIPE, 2249-12-12S (01276)	ALL	EA	1
3	4210-01-361-6921	EXTINGUISHER, FIRE, CARBON DIOXIDE, 13230E6831 (97403)	ALL	EA	1
4	5120-00-251-4489	HAMMER, HAND, ENGINEERS, DOUBLE, 8#, 5877A246 (39428)	ALL	EA	1
5		HOSE, DRAIN, 04-21619 (44940)	ALL	EA	1
6	5975-00-296-5324	ROD, GROUNDING, ASSY., AA55804-3B 9FT (58536)	ALL	EA	1
		(1) CLAMP (2) COUPLING (3) (3) DRIVING STUD (4) GROUND CABLE (5) GROUND ROD (3)			
7	5120-01-013-1676	SLIDE HAMMER, GROUND ROD, P74-144 (45225)	ALL	EA	1
8		TM 9-6115-756-13&P	ALL	EA	1

END OF WORK PACKAGE



**OPERATOR AND FIELD MAINTENANCE  
AMMPS 10KW POWER UNITS AND POWER PLANTS  
ADDITIONAL AUTHORIZATION LIST (AAL)**

**INTRODUCTION**

**Scope**

This work package lists additional items you are authorized for the support of AMMPS PU and PP.

**General**

This list identifies items that do not have to accompany the AMMPS PU and PP and that do not have to be turned in with it. These items are all authorized to you by CTA, MTOE, TDA, or JTA.

**Explanation of Columns in the AAL**

Column (1) National Stock Number (NSN). Identifies the stock number of the item to be used for requisitioning purposes.

Column (2) Description, Part Number/(CAGEC). Identifies the Federal item name (in all capital letters) followed by a minimum description when needed. The last line below the description is the part number and the Commercial and Government Entity Code (CAGEC) (in parentheses).

Column (3) Usable On Code. When applicable, gives you a code if the item you need is not the same for different models of equipment. These codes are identified below.

<u>Code</u>	<u>Used on</u>
98Z	Model PU-2002
99A	Model PU-2012
99D	Model PP-3102

Column (4) U/I. Unit of Issue (U/I) indicates the physical measurement or count of the item as issued per the National Stock Number shown in column (1).

Column (5) Qty Recom. Indicates the quantity recommended.

**Table 1. Additional Authorization List.**

(1) NATIONAL STOCK NUMBER (NSN)	(2) DESCRIPTION, PART NUMBER/(CAGEC)	(3) USABLE ON CODE	(4) U/I	(5) QTY RECOM.
5120-01-373-8976	TM 9-6115-750-10	ALL	EA	1
	TM 9-6115-750-24&P	ALL	EA	1
	WRENCH, NONMETALLIC	ALL	EA	1

**END OF WORK PACKAGE**



**OPERATOR AND FIELD MAINTENANCE  
AMMPS 10KW TRAILER-MOUNTED POWER UNITS AND POWER PLANTS  
EXPENDABLE AND DURABLE ITEMS LIST**

**INTRODUCTION**

**Scope**

This work package lists expendable and durable items that you will need to operate and maintain the AMMPS 10 kW PU and PP. This list is for information only and is not authority to requisition the listed items. These items are authorized to you by CTA 50-970, Expendable/Durable Items (Except Medical, Class V, Repair Parts, and Heraldic Items), CTA 50-909, Field and Garrison Furnishings and Equipment, or CTA 8-10, Army Medical Department Expendable/Durable Items.

**Explanation of Columns in the Expendable/Durable Items List**

Column (1) Item No. This number is assigned to the entry in the list and is referenced in the narrative instructions to identify the item (e.g., Use brake fluid (WP 0098, Item 5)).

Column (2) Level. This column identifies the lowest level of maintenance that requires the listed item (F = Maintainer or ASB).

Column (3) National Stock Number (NSN). This is the NSN assigned to the item which you can use to requisition it.

Column (4) Item Name, Description, Part Number/(CAGEC). This column provides the other information you need to identify the item. The last line below the description is the part number and the Commercial and Government Entity Code (CAGEC) (in parentheses).

Column (5) U/I. Unit of Issue (U/I) code shows the physical measure or count of an item, such as gallon, dozen, gross, etc.

**Table 1. Expendable and Durable Items.**

(1) ITEM NO.	(2) LEVEL	(3) NATIONAL STOCK NUMBER (NSN)	(4) ITEM NAME, DESCRIPTION, PART NUMBER/(CAGEC)	(5) U/I
1	F	6850-01-474-2317	Cleaning compound, solvent, BT05 (0K209)	CO
2	F	9150-01-518-9477	Lubricating oil, engine, 1 qt MIL-PRF-2104H OE/HDO-15/40, MIL-PRF-2104 (81349)	QT
3	F	7920-01-430-5028	Pad, scouring, 048011-04028 gray 6" X 9" (27293)	EA
4	F	4910-01-490-6453	Pan, drain, KTC S0255 (00NS2)	EA
5	F	7920-00-205-3571	Rag, wiping, DDD-R-0030 (81348)	BX
6	F	8030-01-465-1390	Sealant, 56507 (05972)	EA
7	F	9905-00-537-8954	Tag, marker, 50 each bundle, 9905-00-537- 8954 (81349)	BD

**END OF WORK PACKAGE**



## GLOSSARY

### SCOPE

This WP defines uncommon terms used in the 10 kW trailer-mounted PU and PP TM.

<b>TERM</b>	<b>DEFINITION</b>
Adjustment Hints Indicator	Portion of the DCS display which shows functional soft keys to use during adjustment.
Automatic Voltage Regulator (AVR)	Electrical regulator designed to automatically maintain a constant voltage level. Important component in synchronous generators, it controls the output voltage of the generator by controlling its excitation.
Exciter	A device that supplies DC to the field coils of a synchronous generator, producing the magnetic flux required for inducing output voltage in the armature coils (stator).
Ground Fault Protection (GFP) Generator set A	Circuitry designed to protect personnel from line-to-ground fault currents. Generator set directly wired to the switch box in a PP. It is an alternative term for UNIT A.
Generator set B	Generator set directly wired to a connecting cable assembly in a PP. It is an alternative term for UNIT B.
Line-to-Line Voltage	The voltage between any two phases of an AC generator.
Line-to Neutral Voltage	The voltage between a phase and the common neutral where the three phases are tied together in a 3-phase, 4-wire, Y-connected generator.
Load factor	The ratio of the average load to the generator set power rating.
Parallel operation	The operation of two or more AC power sources whose output leads are connected to a common load.
Permanent Magnet Generator (PMG)	A generator whose field is a permanent magnet as opposed to an electro-magnet (wound field).
Power Plant (PP)	Two AMMPS generator sets hooked up in parallel with the use of a switch box.
Power Unit (PU)	A single AMMPS generator set.
Switch box	Device utilized for joining two AMMPS in parallel for additional electricity production.
Switch box control cable	Cable connection from DCS to switch box contactor controller that opens and closes the contactor while communicating the contactor status with the DCS
Switch box wiring harness	Cable connection from load terminals of parallel generator sets to switch box.
Synchronization	Status obtained when an incoming generator set is matched with and in step to the same frequency, voltage, and phase sequence as the operating power source in parallel application.
Unit A	Generator set directly wired to the switch box in a PP. UNIT A is the first set to be placed on line. This is also called generator set A.
Unit B	Generator set directly wired to a connecting cable assembly in a PP. UNIT B is the second set to be placed on line. This is also called generator set B.

### END OF WORK PACKAGE



## ALPHABETICAL INDEX

**SUBJECT**

**WP SEQUENCE NO.-PAGE NO.**

**A**

Accessories Repair Parts List .....	WP 0045
Accessory Box Repair Parts List.....	WP 0044
Additional Authorization List (AAL) .....	WP 0058

**B**

Brakes UOC 98D Repair Parts List.....	WP 0041
Bulk Item .....	WP 0051

**C**

Components of End Item (COEI) And Basic Issue Items (BI) List.....	WP 0057
--	---------

**D**

Description and Use of Operator Controls and Indicators .....	WP 0004
Drain Generator Set Engine Oil .....	WP 0016
Drain Generator Set Fuel.....	WP 0017

**E**

Equipment Description and Data .....	WP 0002
Expendable and Durable Items List.....	WP 0060

**F**

Fenders Repair Parts Lists.....	WP 0039
Field PMCS .....	WP 0015
Field PMCS Introduction .....	WP 0014

**INDEX — Continued.**

Fire Extinguisher Bracket Repair Parts List ..... WP 0038  
 Floors, Rails, and Spacers Repair Parts List ..... WP 0040

**G**

General Information ..... WP 0001  
 General Maintenance ..... WP 0031  
     Using a Fire Extinguisher ..... WP 0031-1  
     General Fuel Requirements ..... WP 0031-2  
     Using a Multimeter ..... WP 0031-2  
     Repair Electrical Connectors ..... WP 0031-4  
     Remove P-Clamps ..... WP 0031-6  
     Install P-Clamps ..... WP 0031-7  
     Jump Starting a Generator Set on PU and PP ..... WP 0031-8  
     Install Clinch Nut ..... WP 0031-10

**L**

LTT Leveling Support Jack UOC 98Z and 99A Repair Parts List ..... WP 0043  
 LTT Lights Installation UOC 98Z and 99A Repair Parts List ..... WP 0042  
 Lubrication Instructions ..... WP 0032  
     Lubricate Hinges and Latches ..... WP 0032-2

**M**

Maintenance Allocation Chart (MAC) ..... WP 0057  
 Maintenance Allocation Chart (MAC) Introduction ..... WP 0056  
 M200 Identification Plates UOC 99D Repair Parts List ..... WP 0046

**N**

National Stock Number (NSN) Index ..... WP 0053

**O**

Operation Under Unusual Conditions ..... WP 0006  
     Unusual Environment/Weather ..... WP 0006-1  
     Operation in Extreme Cold (Below -25°F (-31°C)) ..... WP 0006-1  
     Operation in Extreme Heat (Above 120°F (49°C)) ..... WP 0006-2  
     Operation in Sandy or Dusty Areas ..... WP 0006-3  
     Operation in Snow ..... WP 0006-3  
     Operation in Saltwater Areas ..... WP 0006-3



**INDEX — Continued.**

Operation in Mud .....	WP 0006-3
Fording.....	WP 0006-4
Operation Under Usual Conditions .....	WP 0005
Siting Requirements .....	WP 0005-2
Assembly and Preparation for Use.....	WP 0005-3
Unpacking the PU and PP .....	WP 0005-3
Grounding (PU-2002 and PU-2012).....	WP 0005-4
Grounding (PP-3102) .....	WP 0005-9
Removal of Ground Rod.....	WP 0005-10
Connection to Load (PU-2002 and PU-2012) .....	WP 0005-11
Connection to Load (PP-3102).....	WP 0005-12
Initial Adjustments .....	WP 0005-13
Operating Procedures .....	WP 0005-14
Generator Set Operating Procedures.....	WP 0005-14
Trailer Operating Procedures .....	WP 0005-14
Switch Box Operating Procedures.....	WP 0005-14
Decals and Instruction Plates.....	WP 0005-15
Preparation for Movement .....	WP 0005-25
Operator PMCS.....	WP 0010
Operator PMCS Introduction.....	WP 0009
<b>P</b>	
Part Number Index .....	WP 0054
Power Unit/Power Plant Repair Parts List .....	WP 0036
<b>R</b>	
References .....	WP 0055
Remove/Install Accessory Box .....	WP 0024
Remove Accessory Box (PU-2002 and PU-2012) .....	WP 0024-1
Install Accessory Box (PU-2002 and PU-2012) .....	WP 0024-3
Remove Accessory Box (PP-3102).....	WP 0024-4
Install Accessory Box (PP-3102).....	WP 0024-5
Remove/Install Fire Extinguisher Bracket.....	WP 0022
Remove Fire Extinguisher Bracket.....	WP 0022-2
Install Fire Extinguisher Bracket.....	WP-0022-4
Remove/Install Generator Set.....	WP 0018
Remove Generator Set.....	WP 0018-1
Inspect Generator Set Mounting Location.....	WP-0018-4
Install Generator Set.....	WP-0018-4

**INDEX — Continued.**

Remove/Install Ground Terminal .....	WP 0023
Remove Ground Terminal .....	WP 0023-2
Install Ground Terminal .....	WP-0023-4
Remove/Install Hand Brake Modification .....	WP 0030
Remove Hand Brake Bracket .....	WP 0030-2
Install Hand Brake Bracket (PP-3102).....	WP-0030-4
Remove/Install Switch Box Assembly .....	WP 0025
Remove Switch Box.....	WP 0025-1
Inspect Switch Box Assembly.....	WP-0025-4
Install Switch Box Assembly .....	WP-0025-4
Remove/Install Switch Box Wiring Harness.....	WP 0028
Remove Switch Box Wiring Harness.....	WP 0028-1
Inspect Switch Box Wiring Harness.....	WP-0028-5
Install Switch Box Wiring Harness.....	WP-0028-5
Remove/Install Trailer Floor Plates, Platform, and Step.....	WP 0021
Remove Center Floor Plate (PU-2002 and PU-2012).....	WP 0021-2
Inspect Center Floor Plate (PU-2002 and PU-2012).....	WP-0021-3
Install Center Floor Plate (PU-2002 and PU-2012).....	WP-0021-3
Remove Inner Side Floor Plate (PU-2002 and PU-2012).....	WP 0021-3
Inspect Inner Side Floor Plate (PU-2002 and PU-2012).....	WP-0021-4
Install Inner Side Floor Plate (PU-2002 and PU-2012).....	WP-0021-4
Remove Side Floor Plate (PU-2002 and PU-2012).....	WP 0021-4
Inspect Side Floor Plate (PU-2002 and PU-2012).....	WP-0021-4
Install Side Floor Plate (PU-2002 and PU-2012).....	WP-0021-4
Remove Platform (PP-3102) .....	WP 0021-5
Inspect Platform (PP-3102) .....	WP-0021-7
Install Platform (PP-3102) .....	WP-0021-8
Remove Step (PP-3102) .....	WP 0021-8
Inspect Step (PP-3102) .....	WP-0021-10
Install Step (PP-3102).....	WP-0021-11
Repair Switch Box Housing.....	WP 0026
Replace Switch Box Cover .....	WP 0026-1
Replace Latch.....	WP-0026-3
Replace Output Terminal Cover .....	WP-0026-4
Replace Mounting Rail .....	WP 0019
Replace Mounting Rail (PU-2002 and PU-2012) .....	WP 0019-2
Replace Mounting Rail (PP-3102).....	WP-0019-3

**INDEX — Continued.**

Replace Switch Box Components..... WP 0027

    Test Contactor ..... WP 0027-2

    Replace Output Terminal Stud and Output Terminal Board ..... WP-0027-6

    Replace Contactor..... WP-0027-9

    Replace Control Cable ..... WP-0027-12

    Replace Control Card ..... WP-0027-14

    Replace Indicator Light..... WP-0027-16

Replace Trailer Fender ..... WP 0020

    Replace Fender (PU-2002 and PU-2012) ..... WP 0020-2

    Replace Fender (PP-3102)..... WP-0020-7

Replace Trailer Leg Prop Assembly ..... WP 0029

    Replace Trailer Leg Prop Assembly ..... WP 0029-1

RPSTL Introduction..... WP 0035

**S**

Service Upon Receipt .....WP 0013

    Siting ..... WP 0013-2

    Service Upon Receipt of Materiel ..... WP 0013-2

    Unpacking..... WP 0013-2

    Packing ..... WP 0013-2

    Checking Equipment ..... WP 0013-3

    Installation Instructions ..... WP 0013-3

    Installation of Ground Rod..... WP 0013-3

    Installation of Auxiliary Fuel Drum Adapter ..... WP 0013-3

    Preliminary Checks and Adjustment of Equipment ..... WP 0013-5

Special Tools List.....WP 0052

Switch Box Components Repair Parts List .....WP 0048

Switch Box Installation Repair Parts List .....WP 0047

Switch Box Leads Repair Parts List.....WP 0049

Switch Box Wiring Harnesses Repair Parts List .....WP 0050

**T**

Theory of Operation .....WP 0003

Trailer Chassis Repair Parts List .....WP 0037

Torque Limits ..... WP 0033

**INDEX — Continued.**

Troubleshooting Index..... WP 0007

Troubleshooting Index..... WP 0011

Troubleshooting Procedures..... WP 0008

Troubleshooting Procedures..... WP 0012

**W**

Wiring Diagrams..... WP 0034

**END OF WORK PACKAGE**

<b>RECOMMENDED CHANGES TO PUBLICATIONS AND BLANK FORMS</b> For use of this form, see AR 25-30; the proponent agency is OAASA				Use Part II (reverse) for Repair Parts and Special Tool Lists (RPSTL) and Supply Catalogs/Supply Manuals (SC/SM).		DATE 30 August 2002
<b>TO:</b> (Forward to proponent of publication or form) (Include ZIP Code) Commander, US Army CECOM LCMC ATTN: AMSEL-LCL-ECM Aberdeen Proving Ground, MD 21005-1846				<b>FROM:</b> (Activity and location) (Include ZIP Code) Jane Q. Doe, SFC 1234 Any Street Anytown, AL 34565		
<b>PART I - ALL PUBLICATIONS (EXCEPT RPSTL AND SC/SM) AND BLANK FORMS</b>						
PUBLICATION/FORM NUMBER TM 11-1234-567-14			DATE 16 Sep 2001		TITLE Operator, Field and Sustainment Support Maintenance Manual for Radio, AN/ABC-123	
ITEM	PAGE	PARA-GRAPH	LINE	FIGURE NO.	TABLE	RECOMMENDED CHANGES AND REASON
1	WP0005 PG 3		2			Test or Corrective Action column should identify a different WP number.
TYPED NAME, GRADE OR TITLE Jane Q. Doe, SFC				TELEPHONE EXCHANGE/AUTOVON, PLUS EXTENSION 123-4567		SIGNATURE

EXAMPLE

<b>TO</b> (Forward direct to addressee listed in publication)	<b>FROM</b> (Activity and location) (Include ZIP Code)	<b>DATE</b>
---	--	-------------

**PART II – REPAIR PARTS AND SPECIAL TOOL LISTS AND SUPPLY CATALOGS/SUPPLY MANUALS**

<b>PUBLICATION NUMBER</b> TB 9-2590-528-13&P	<b>DATE</b>	<b>TITLE</b> INTERROGATION ARM ASSEMBLY (IAA)
---	-------------	--

PAGE NO.	COLM NO.	LINE NO.	NATIONAL STOCK NUMBER	REFERENCE NO.	FIGURE NO.	ITEM NO.	TOTAL NO. OF MAJOR ITEMS SUPPORTED	RECOMMENDED ACTION

**PART III – REMARKS** (Any general remarks, recommendations, or suggestions for improvement of publications and blank forms. Additional blank sheets may be used if more space is needed.)

<b>TYPED NAME, GRADE OR TITLE</b> Jane Q. Doe, SPC	<b>TELEPHONE EXCHANGE/AUTOVON, PLUS EXTENSION</b> 123-4567	<b>SIGNATURE</b>
---	---	------------------

<b>RECOMMENDED CHANGES TO PUBLICATIONS AND BLANK FORMS</b>						Use Part II (reverse) for Repair Parts and Special Tool Lists (RPSTL) and Supply Catalogs/Supply Manuals (SC/SM).	<b>DATE</b>
For use of this form, see AR 25-30; the proponent agency is OAASA							
<b>TO</b> (Forward to proponent of publication or form) (Include ZIP Code)						<b>FROM</b> (Activity and location) (Include ZIP Code)	
<b>PART I – ALL PUBLICATIONS (EXCEPT RPSTL AND SC/SM) AND BLANK FORMS</b>							
<b>PUBLICATION/FORM NUMBER</b>						<b>DATE</b>	<b>TITLE</b>
<b>ITEM</b>	<b>PAGE</b>	<b>PARA-GRAPH</b>	<b>LINE</b>	<b>FIGURE NO.</b>	<b>TABLE</b>	<b>RECOMMENDED CHANGES AND REASON</b>	
* Reference to line numbers within the paragraph or subparagraph.							
<b>TYPED NAME, GRADE OR TITLE</b>				<b>TELEPHONE EXCHANGE/AUTOVON, PLUS EXTENSION</b>		<b>SIGNATURE</b>	

<b>TO</b> <i>(Forward direct to addressee listed in publication)</i>	<b>FROM</b> <i>(Activity and location) (Include ZIP Code)</i>	<b>DATE</b>
--	---	-------------

**PART II – REPAIR PARTS AND SPECIAL TOOL LISTS AND SUPPLY CATALOGS/SUPPLY MANUALS**

PUBLICATION NUMBER			DATE	TITLE				
PAGE NO.	COLM NO.	LINE NO.	NATIONAL STOCK NUMBER	REFERENCE NO.	FIGURE NO.	ITEM NO.	TOTAL NO. OF MAJOR ITEMS SUPPORTED	RECOMMENDED ACTION

**PART III – REMARKS** *(Any general remarks, recommendations, or suggestions for improvement of publications and blank forms. Additional blank sheets may be used if more space is needed.)*

<b>TYPED NAME, GRADE OR TITLE</b>	<b>TELEPHONE EXCHANGE/AUTOVON, PLUS EXTENSION</b>	<b>SIGNATURE</b>
-----------------------------------	---	------------------



<b>RECOMMENDED CHANGES TO PUBLICATIONS AND BLANK FORMS</b>						Use Part II (reverse) for Repair Parts and Special Tool Lists (RPSTL) and Supply Catalogs/Supply Manuals (SC/SM).	<b>DATE</b>
For use of this form, see AR 25-30; the proponent agency is OAASA							
<b>TO</b> (Forward to proponent of publication or form) (Include ZIP Code)						<b>FROM</b> (Activity and location) (Include ZIP Code)	
<b>PART I – ALL PUBLICATIONS (EXCEPT RPSTL AND SC/SM) AND BLANK FORMS</b>							
<b>PUBLICATION/FORM NUMBER</b>						<b>DATE</b>	<b>TITLE</b>
<b>ITEM</b>	<b>PAGE</b>	<b>PARA- GRAPH</b>	<b>LINE</b>	<b>FIGURE NO.</b>	<b>TABLE</b>	<b>RECOMMENDED CHANGES AND REASON</b>	
* Reference to line numbers within the paragraph or subparagraph.							
<b>TYPED NAME, GRADE OR TITLE</b>				<b>TELEPHONE EXCHANGE/AUTOVON, PLUS EXTENSION</b>		<b>SIGNATURE</b>	

<b>TO</b> <i>(Forward direct to addressee listed in publication)</i>	<b>FROM</b> <i>(Activity and location) (Include ZIP Code)</i>	<b>DATE</b>
--	---	-------------

**PART II – REPAIR PARTS AND SPECIAL TOOL LISTS AND SUPPLY CATALOGS/SUPPLY MANUALS**

PUBLICATION NUMBER			DATE	TITLE				
PAGE NO.	COLM NO.	LINE NO.	NATIONAL STOCK NUMBER	REFERENCE NO.	FIGURE NO.	ITEM NO.	TOTAL NO. OF MAJOR ITEMS SUPPORTED	RECOMMENDED ACTION

**PART III – REMARKS** *(Any general remarks, recommendations, or suggestions for improvement of publications and blank forms. Additional blank sheets may be used if more space is needed.)*

<b>TYPED NAME, GRADE OR TITLE</b>	<b>TELEPHONE EXCHANGE/AUTOVON, PLUS EXTENSION</b>	<b>SIGNATURE</b>
-----------------------------------	---	------------------

<b>RECOMMENDED CHANGES TO PUBLICATIONS AND BLANK FORMS</b>						Use Part II (reverse) for Repair Parts and Special Tool Lists (RPSTL) and Supply Catalogs/Supply Manuals (SC/SM).	<b>DATE</b>
For use of this form, see AR 25-30; the proponent agency is OAASA							
<b>TO</b> (Forward to proponent of publication or form) (Include ZIP Code)						<b>FROM</b> (Activity and location) (Include ZIP Code)	
<b>PART I – ALL PUBLICATIONS (EXCEPT RPSTL AND SC/SM) AND BLANK FORMS</b>							
<b>PUBLICATION/FORM NUMBER</b>						<b>DATE</b>	<b>TITLE</b>
<b>ITEM</b>	<b>PAGE</b>	<b>PARA-GRAPH</b>	<b>LINE</b>	<b>FIGURE NO.</b>	<b>TABLE</b>	<b>RECOMMENDED CHANGES AND REASON</b>	
* Reference to line numbers within the paragraph or subparagraph.							
<b>TYPED NAME, GRADE OR TITLE</b>				<b>TELEPHONE EXCHANGE/AUTOVON, PLUS EXTENSION</b>		<b>SIGNATURE</b>	

<b>TO</b> <i>(Forward direct to addressee listed in publication)</i>	<b>FROM</b> <i>(Activity and location) (Include ZIP Code)</i>	<b>DATE</b>
--	---	-------------

**PART II – REPAIR PARTS AND SPECIAL TOOL LISTS AND SUPPLY CATALOGS/SUPPLY MANUALS**

PUBLICATION NUMBER			DATE	TITLE				
PAGE NO.	COLM NO.	LINE NO.	NATIONAL STOCK NUMBER	REFERENCE NO.	FIGURE NO.	ITEM NO.	TOTAL NO. OF MAJOR ITEMS SUPPORTED	RECOMMENDED ACTION

**PART III – REMARKS** *(Any general remarks, recommendations, or suggestions for improvement of publications and blank forms. Additional blank sheets may be used if more space is needed.)*

<b>TYPED NAME, GRADE OR TITLE</b>	<b>TELEPHONE EXCHANGE/AUTOVON, PLUS EXTENSION</b>	<b>SIGNATURE</b>
-----------------------------------	---	------------------

TM 9-6115-756-13&P

By Order of the Secretary of the Army:

**MARTIN E. DEMPSEY**  
*General, United States Army*  
*Chief of Staff*

Official:



**JOYCE E. MORROW**  
*Administrative Assistant to the*  
*Secretary of the Army*  
1109012

By Order of the Secretary of the Air Force:

**NORTON A. SCHWARTZ**  
*General, USAF*  
*Chief of Staff, USAF*

Official:

**DONALD J. HOFFMAN**  
*General, USAF*  
*Commander, AFMC*

By Order of the Secretary of the Navy:

**NAVAL FACILITIES ENGINEERING  
COMMAND (NAVFAC)**

**NAVAL FACILITIES EXPEDITIONARY  
LOGISTICS CENTER (NFELC)  
CODE EXP 21**

Army Distribution: To be distributed IAW the Initial Distribution Number (IDN) 360028 requirements for TM 9-6115-756-13&P.



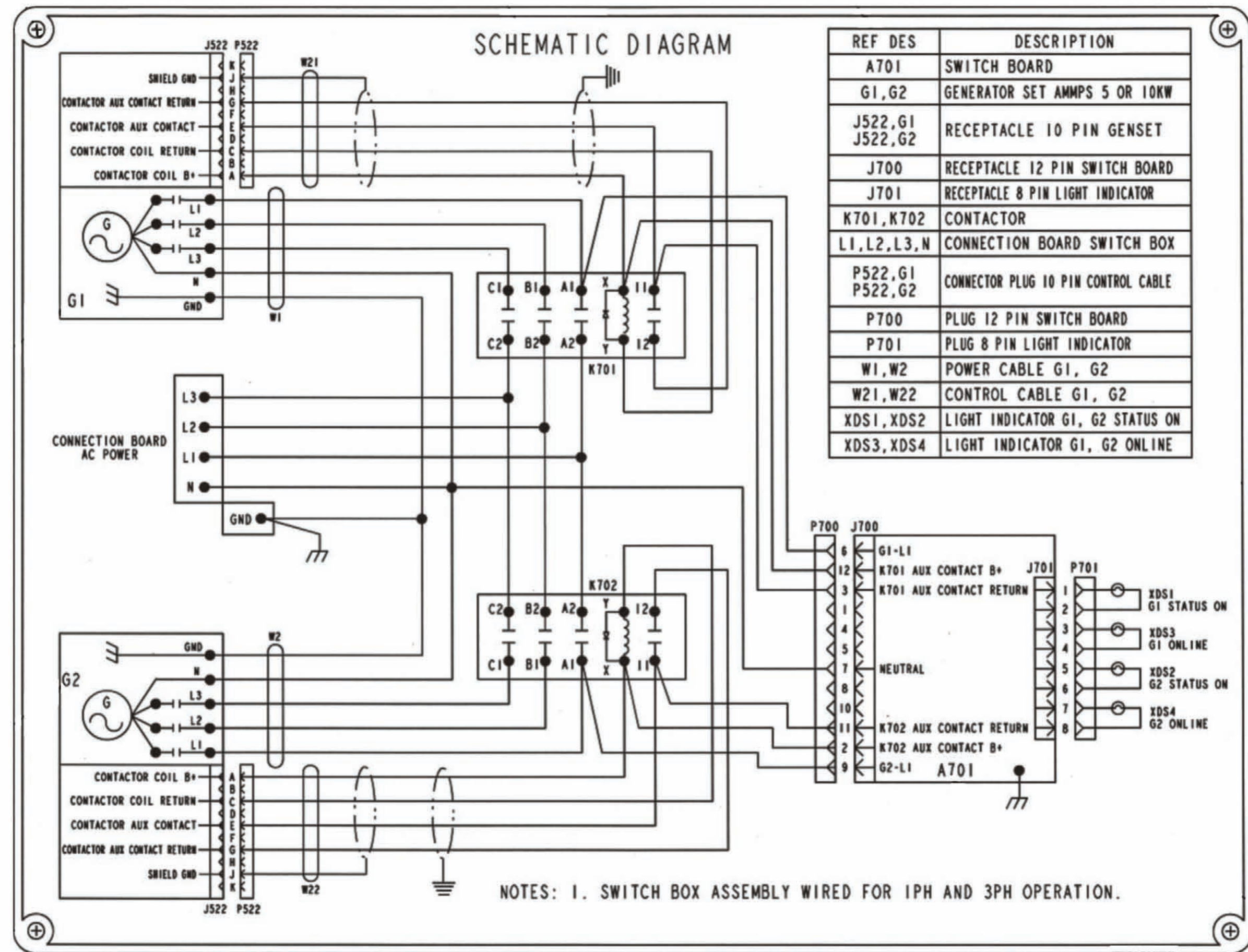





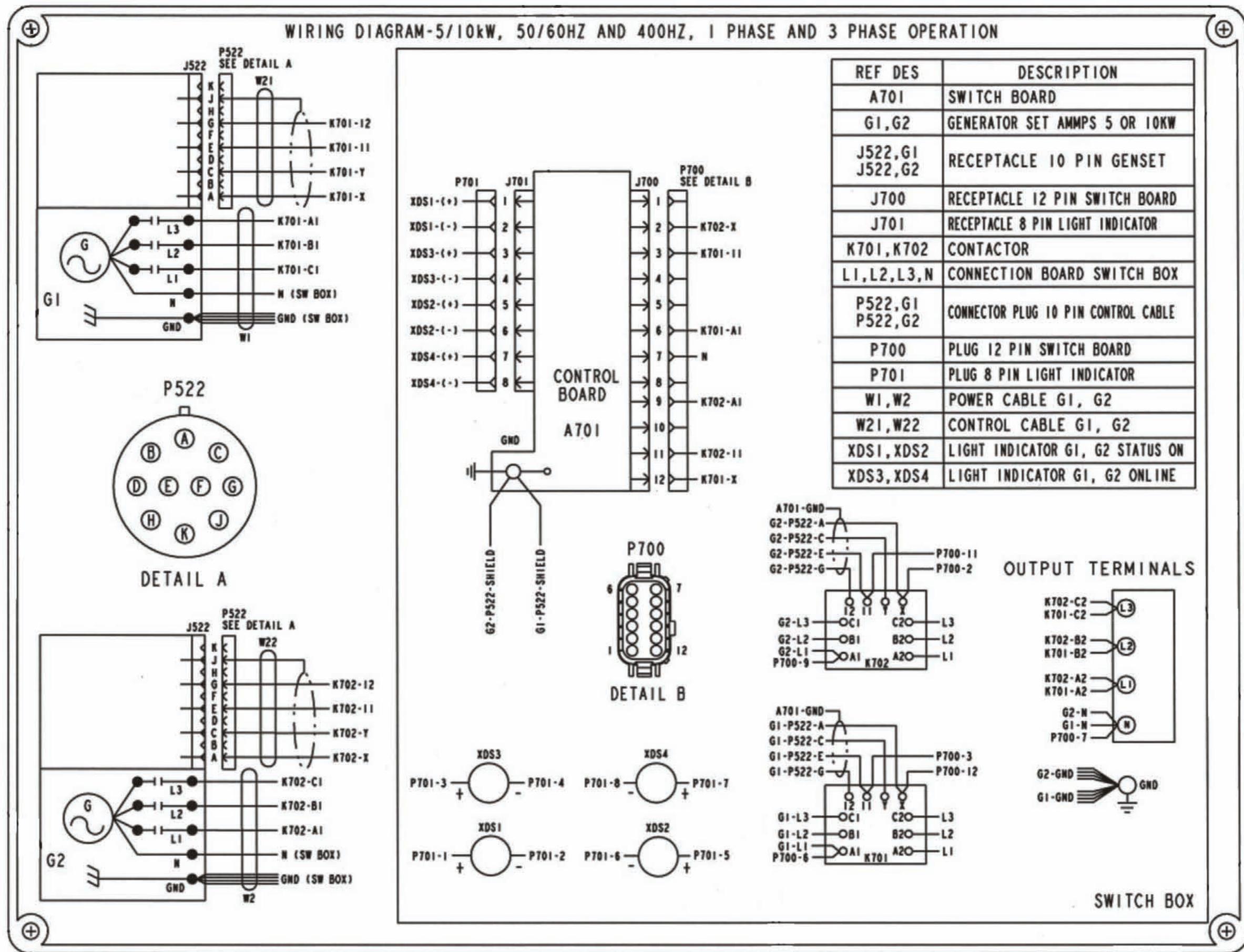



## THE METRIC SYSTEM AND EQUIVALENTS

### LINEAR MEASURE

1 Centimeter = 10 Millimeters = 0.01 Meters = 0.3937 Inches  
 1 Meter = 100 Centimeters = 1000 Millimeters = 39.37 Inches  
 1 Kilometer = 1000 Meters = 0.621 Miles

### WEIGHTS

1 Gram = 0.001 Kilograms = 1000 Milligrams = 0.035 Ounces  
 1 Kilogram = 1000 Grams = 2.2 Lb.  
 1 Metric Ton = 1000 Kilograms = 1 Megagram = 1.1 Short Tons

### LIQUID MEASURE

1 Milliliter = 0.001 Liters = 0.0338 Fluid Ounces  
 1 Liter = 1000 Milliliters = 33.82 Fluid Ounces

### SQUARE MEASURE

1 Sq. Centimeter = 100 Sq. Millimeters = 0.155 Sq. Inches  
 1 Sq. Meter = 10,000 Sq. Centimeters = 10.76 Sq. Feet  
 1 Sq. Kilometer = 1,000 Sq. Meters = 0.386 Sq. Miles

### CUBIC MEASURE

1 Cu. Centimeter = 1000 Cu. Millimeters = 0.06 Cu. Inches  
 1 Cu. Meter = 1,000,000 Cu. Centimeters = 35.31 Cu. Feet

### TEMPERATURE

$5/9 (^{\circ}\text{F} - 32) = ^{\circ}\text{C}$   
 212° Fahrenheit is equivalent to 100° Celsius  
 90° Fahrenheit is equivalent to 32.2° Celsius  
 32° Fahrenheit is equivalent to 0° Celsius  
 $9/5 (^{\circ}\text{C} + 32) = ^{\circ}\text{F}$

### APPROXIMATE CONVERSION FACTORS

TO CHANGE	TO	MULTIPLY BY
Inches .....	Centimeters .....	2.540
Feet .....	Meters .....	0.305
Yards .....	Meters .....	0.914
Miles .....	Kilometers .....	1.609
Square Inches .....	Square Centimeters .....	6.451
Square Feet.....	Square Meters.....	0.093
Square Yards.....	Square Meters.....	0.836
Square Miles.....	Square Kilometers.....	2.590
Acres .....	Square Hectometers .....	0.405
Cubic Feet .....	Cubic Meters .....	0.028
Cubic Yards .....	Cubic Meters .....	0.765
Fluid Ounces .....	Milliliters.....	29.573
Pints.....	Liters.....	0.473
Quarts.....	Liters.....	0.946
Gallons .....	Liters.....	3.785
Ounces .....	Grams.....	28.349
Pounds .....	Kilograms .....	0.454
Short Tons .....	Metric Tons .....	0.907
Pound-Feet.....	Newton-Meters .....	1.356
Pounds per Square Inch.....	Kilopascals .....	6.895
Miles per Gallon.....	Kilometers per Liter .....	0.425
Miles per Hour .....	Kilometers per Hour .....	1.609

TO CHANGE	TO	MULTIPLY BY
Centimeters .....	Inches.....	0.394
Meters.....	Feet .....	3.280
Meters.....	Yards .....	1.094
Kilometers.....	Miles .....	0.621
Square Centimeters.....	Square Inches .....	0.155
Square Meters .....	Square Feet.....	10.764
Square Meters .....	Square Yards .....	1.196
Square Kilometers .....	Square Miles .....	0.386
Square Hectometers.....	Acres .....	2.471
Cubic Meters .....	Cubic Feet.....	35.315
Cubic Meters .....	Cubic Yards.....	1.308
Milliliters.....	Fluid Ounces .....	0.034
Liters.....	Pints.....	2.113
Liters.....	Quarts.....	1.057
Liters.....	Gallons .....	0.264
Grams.....	Ounces .....	0.035
Kilograms.....	Pounds .....	2.205
Metric Tons.....	Short Tons.....	1.102
Newton-Meters .....	Pound-Feet.....	0.738
Kilopascals .....	Pounds per Square Inch.....	0.145
Kilometers per Liter .....	Miles per Gallon .....	2.354
Kilometers per Hour.....	Miles per Hour .....	0.621

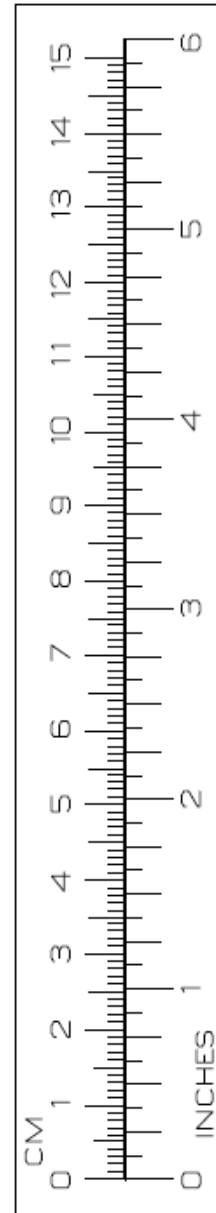

**PIN: 086808-000**