

450 U113
12
TM
1944

TM 11-251

WAR DEPARTMENT TECHNICAL MANUAL

L4.5.0 set of army

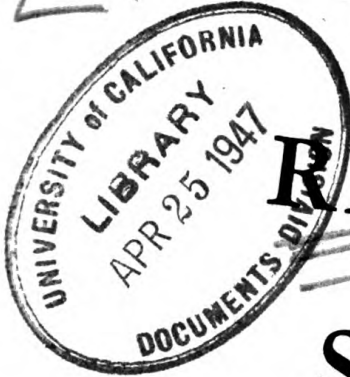

RADIO SET

SCR-555-A

RESTRICTED

Dissemination of Restricted Matter.

The information contained in restricted documents and the essential characteristics of restricted material may be given to any person known to be in the service of the United States and to persons of undoubted loyalty and discretion who are cooperating in Government work, but will not be communicated to the public or to the press except by authorized military public relations agencies. (See also par. 23b, AR 380-5, 15 Mar. 1944.)

WAR DEPARTMENT

SEPTEMBER 1944

Digitized by



UNIVERSITY OF CALIFORNIA

WAR DEPARTMENT TECHNICAL MANUAL
TM 11-251

RADIO SET
SCR-555-A



WAR DEPARTMENT

SEPTEMBER 1944

RESTRICTED. DISSEMINATION OF RESTRICTED MATTER.
The information contained in restricted documents and the essential characteristics of restricted materiel may be given to any person known to be in the service of the United States and to persons of undoubted loyalty and discretion who are cooperating in Government work, but will not be communicated to the public or to the press except by authorized military public relations agencies. (See also par. 23b, AR 380-5, 15 Mar 1944.)

WAR DEPARTMENT,
WASHINGTON 25, D. C., 25 SEPTEMBER 1944.

TM 11-251, Radio Set SCR-555-A, is published for the information and guidance of all concerned.

[A. G. 300.7 (13 Dec. 1943).]

BY ORDER OF THE SECRETARY OF WAR:

G. C. MARSHALL,
Chief of Staff.

OFFICIAL:

J. A. ULIO,
*Major General,
The Adjutant General.*

DISTRIBUTION:

Armies (Sig) (5); Sv C (Sig) (5); Dept (Sig) (5); Def Comd (Sig) (2); D (2); IBn 1 (5); IC 11 (5); Tech Sv (2); Arm & Sv Boards (2); Post, Camp, Sta (2); ROTC (5); Sv Sv Sch (10); T of Opns (5); Base Comd (5); Sig C Dep (2); Gen Overseas, SOS Dep (Sig Sec) (2); Sig C Labs (2); Sig C Rep Shops (2); PE (Sig) (2).

IBn 1: T/O & E 1-1027.

IC 11: T/O & E 11-7; 11-47; 11-57; 11-107; 11-127; 11-237; 11-287; 11-587; 11-592; 11-597; 11-500, Direction Finder Team (IC), FCC-Intercept and direction Finding Team (ID).

For explanation of symbols see FM 21-6.

U113
 .2
 TM11:251
 1944

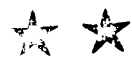

TABLE OF CONTENTS

	<i>Paragraph</i>	<i>Page</i>
SECTION I. Description.		
General	1	1
Radio Set SCR-555-A, components with weights and dimensions	2	2
Frequency coverage	3	6
Power source	4	6
Power input	5	6
Power output'	6	6
Description of main components	7	6
Description of auxiliary components ...	8	10
 II. Installation and operation.		
Selection of site	9	13
Initial procedure	10	15
Installation	11	15
Orientation	12	39
Radio Transmitter BC-655-A	13	41
Operation of Radio Set SCR-555-A	14	43
Initial adjustment of radio direction finder	15	43
Operation as figure-8 aural-null radio direction finder	16	45
Operation as switched-cardioid left-right radio direction finder	17	46
Operation of headsets and microphone ..	18	47
Operation precautions	2	48
 III. Functioning of parts.		
Principle of switched-cardioid radio direction finder	20	49
Antenna system	21	56
Adcock r-f amplifiers	22	57
Vertical amplifiers	23	58
Square wave oscillator	24	58
Negative pulse rectifiers	25	59

TABLE OF CONTENTS

Section III. Functioning of parts (contd).	<i>Paragraph</i>	<i>Page</i>
Synchronous voltmeter	26	60
R-f oscillator and mixer	27	60
I-f amplifier	28	61
C-w oscillator	29	62
Second detector, automatic volume control, and bearing amplifier	30	62
Output stage	31	63
Controls	32	64
Meters	33	66
Power Unit PE-155-A	34	66
Telephone equipment	35	67
Radio Transmitter BC-655-A	36	67
 IV. Maintenance.		
Servicing	37	69
Trouble and remedy chart	38	70
Alignment procedure	39	71
Replacement of coils	40	74
Balancing adcock antenna transformers.	41	74
Dynamotor unit	42	75
Antenna system	43	79
Performance data	44	80
Normal voltage readings	45	80
Parts location detail	46	80
Operational inspection of		
Radio Transmitter BC-655-A	47	80
Disassembly of Radio Transmitter		
BC-655-A	48	81
Routine inspection and overhaul of		
Radio Transmitter BC-655-A	49	82
Location and remedy of faults in		
Radio Transmitter BC-655-A	50	83
Typical vacuum-tube socket		
measurements	51	83
Replacing defective components of		
Radio Transmitter BC-655-A	52	84
Over-all performance test of		
Radio Transmitter BC-655-A	53	85
Moistureproofing and fungiproofing		
Radio Set SCR-555-A	54	85
 V. Supplementary data.		
Maintenance parts list for		
Radio Set SCR-555-A	55	93

LIST OF ILLUSTRATIONS

<i>Fig. No.</i>	<i>Title</i>	<i>Page</i>
1	Radio Set SCR-555-A, complete assembly, in operation	ix
2	Radio Set SCR-555-A, close-up view, in operation	x
3	Radio Set SCR-555-A, crated	4
4	Radio Set SCR-555-A, miscellaneous components	5
5	Chest CH-128-A, components	7
6	Radio Transmitter BC-655-A, with cover	11
7	Correct placement of antenna for coastal installation	14
8	Tower TR-25-A, outline dimensions	16
9	Floor section and sills	17
10	Sills assembled to floor, tower legs, and apex block	18
11	Assembly of two tower legs to floor and apex block	20
12	Assembly of third tower leg to floor and apex block	21
13	Assembly of roof to tower	22
14	Antenna AN-105-A, outline dimensions	23
15	Assembly of antenna mast to crossarm	24
16	Assembly of both mast sections and of antenna rods	25
17	Method of using strap wrench	26
18	Mounting FT-365-A, outline dimensional drawing	27
19	Method of making telephone connection between mounting and floor	27
20	Assembly of Mounting FT-365-A to floor	28
21	Cabinet CS-155-A, outline dimensional detail	29
22	Cabinet CS-155-A, mounted	30
23	Writing shelf assembly	31
24	Assembly of azimuth scale	32
25	Ground connection	34
26	Chest CH-137-A, packed	36
27	Chest CH-105-A, packed	37
28	Chest CH-202-A, packed	38
29	Mounting of telescope	39
30	Compass calibration	42
31	Orientation example	42
32	Radio Transmitter BC-655-A placed for operation	44
33	Adcock and vertical antenna diagrams	50

LIST OF ILLUSTRATIONS

<i>Fig. No.</i>	<i>Title</i>	<i>Page</i>
34	Adcock and vertical antenna field patterns	51
35	Cardioid field patterns	52
36	Simplified form, switched-cardioid radio direction finder	53
37	Cardioid field patterns obtained by switching	54
38	Electronic switching, circuit diagram	55
39	Antenna AN-105-A, circuit diagram	77
40	Antenna AN-105-A, crossarm details	78
41	Figure-8 and vertical field patterns measured at 33 megacycles	111
42	Cardioid field patterns measured at 33 megacycles	112
43	Radio Receiver BC-1005-A, selectivity curve, 4.2 megacycles	113
44	Radio Receiver BC-1005-A, sensitivity curves	114
45	Typical radio direction finder performance data	115
46	Blank chart for recording radio direction finder performance data	116
47	Radio Receiver BC-1005-A, top view, tube socket layout and voltages	117
48	Radio Receiver BC-1005-A, bottom view, tube socket layout and voltages	118
49	Radio Receiver BC-1005-A, front view	119
50	Radio Receiver BC-1005-A, top view, coil shields in place ..	120
51	Radio Receiver BC-1005-A, top view, coil shields removed ..	121
52	Radio Receiver BC-1005-A, bottom view	123
53	Power Unit PE-155-A, top view	125
54	Power Unit PE-155-A, bottom view	126
55	Battery cable and power cable, wiring diagram	127
56	Power Unit PE-155-A, connection diagram	128
57	Power Unit PE-155-A, schematic diagram	129
58	Radio Receiver BC-1005-A, connection diagram, top view ...	131
59	Radio Receiver BC-1005-A, connection diagram, bottom view	133
60	Radio Transmitter BC-655-A, front view	135
61	Radio Transmitter BC-655-A, top view of chassis	136
62	Radio Transmitter BC-655-A, bottom view of chassis	137
63	Radio Transmitter BC-655-A, side view of chassis	138
64	Radio Transmitter BC-655-A, battery compartment	138
65	Radio Transmitter BC-655-A, schematic diagram	139
66	Block diagram of Radio Receiver BC-1005-A	141
67	Antenna system, schematic diagram	141
68	Adcock r-f amplifiers, schematic diagram	141
69	Vertical amplifiers, schematic diagram	141
70	Square-wave oscillator, schematic diagram	143

LIST OF ILLUSTRATIONS

<i>Fig. No.</i>	<i>Title</i>	<i>Page</i>
71	Negative pulse rectifiers, schematic diagram	143
72	Synchronous voltmeter, schematic diagram	143
73	R-f oscillator and mixer, schematic diagram	143
74	I-f amplifier, schematic diagram	145
75	C-w oscillator, schematic diagram	145
76	Second detector, automatic volume control, and bearing amplifier, schematic diagram	145
77	Output stage, schematic diagram	145
78	Radio Receiver BC-1005-A, schematic diagram	145

DESTRUCTION NOTICE

WHY —To prevent the enemy from using or salvaging this equipment for his benefit.

WHEN—When ordered by your commander.

- HOW** —1. Smash — Use sledges, axes, handaxes, pickaxes, hammers, crowbars, heavy tools, etc.
2. Cut — Use axes, handaxes, machetes, etc.
 3. Burn — Use gasoline, kerosene, oil, flame throwers, incendiary grenades, etc.
 4. Explosives — Use firearms, grenades, TNT, etc.
 5. Disposal — Bury in slit trenches, fox holes, or other holes. Throw in streams. Scatter.

USE ANYTHING IMMEDIATELY AVAILABLE FOR DESTRUCTION OF THIS EQUIPMENT.

- WHAT**—1. Smash — Meters, tuning capacitors, vacuum tubes, dynamotor, batteries, receiver controls, castings, top of antenna mast, and ends of crossarm.
2. Cut — R-f cables from antenna to receiver, battery and power cables, telephone line, antenna mast, and crossarm.
 3. Bend and/or break — Antenna mast at joints and connectors inside joints, antenna mast itself, antenna rods, tower, and shelter.
 4. Burns — Technical manuals: tear out circuit diagrams and burn; then burn the pictures, last the text. Burn schematic diagrams on receiver cabinet.
 5. Bury — Any or all of the above pieces after breaking.

DESTROY EVERYTHING

SAFETY NOTICE

This equipment uses dangerously high voltages which may be fatal if contacted by operating personnel. These high-voltage points are not exposed during normal operation procedures. Do not move any tubes, power cable, or component unit from its normal position without first disconnecting the primary power source. Before touching any part in a chassis that has been removed for servicing, carefully ground the part.

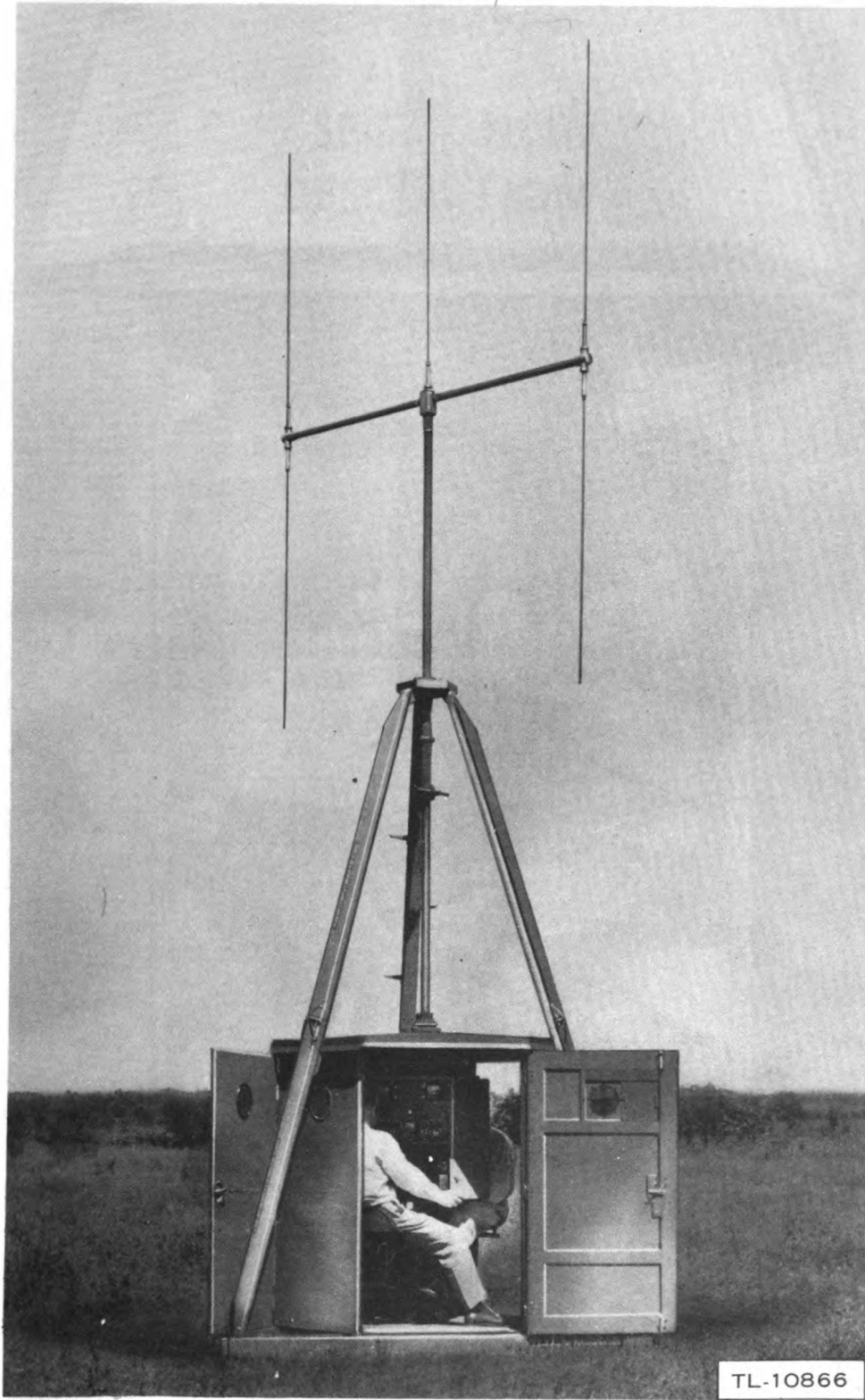

Figure 1. . Radio Set SCR-555-A, complete assembly in operation.

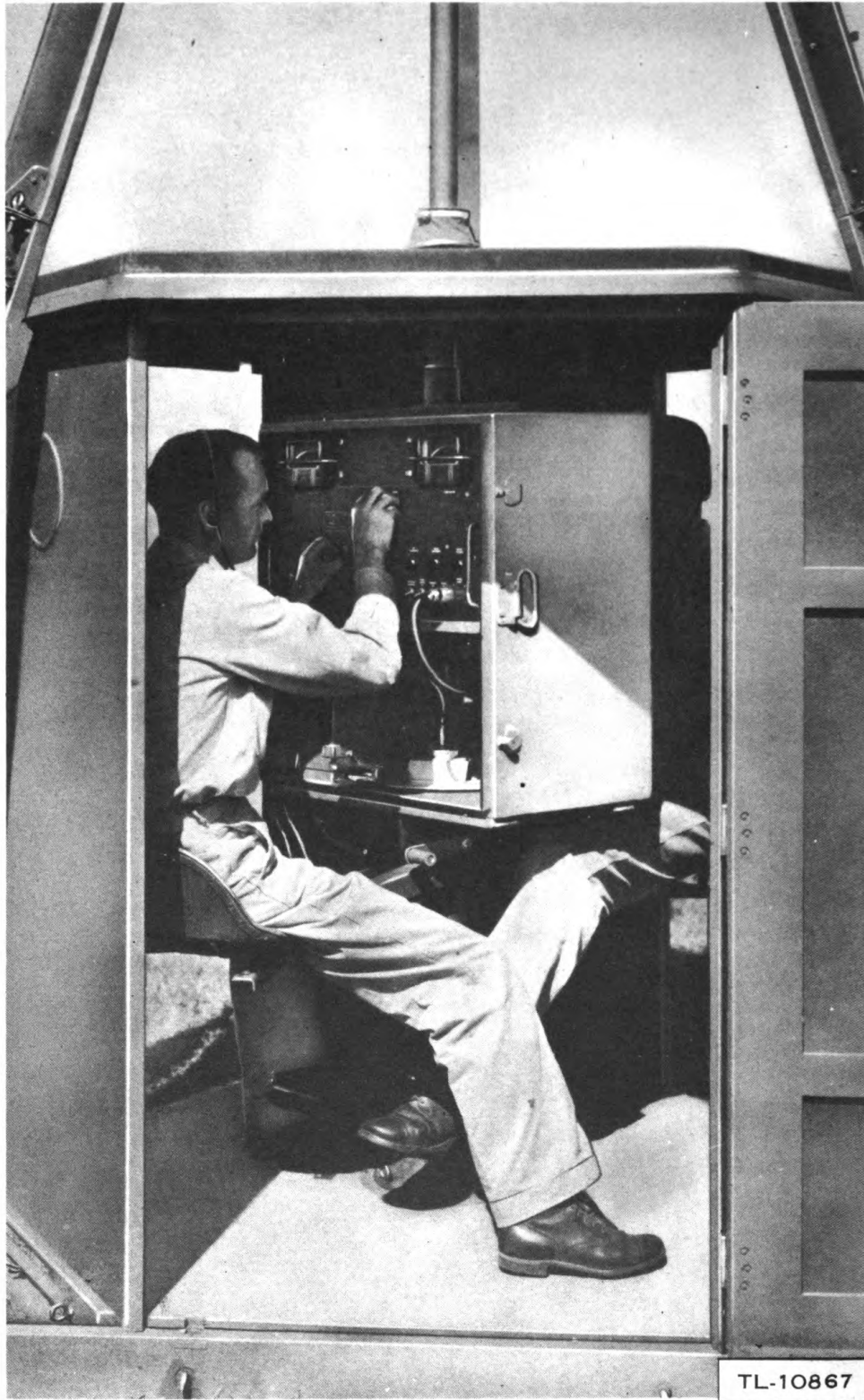

Figure 2. Radio Set SCR-555-A, close-up view, in operation.

x

RESTRICTED

SECTION I DESCRIPTION

1. GENERAL.

Radio Set SCR-555-A (figs. 1 and 2) is a self-contained, semiportable, ground, radio direction finder (RDF) station. The equipment has a frequency range of 18 to 65 megacycles, covered in two bands, and provides for the reception of amplitude-modulated (a-m) or continuous-wave (c-w) signals. The RDF can be used to determine the direction of radio transmitters located on the ground or in aircraft. A rotatable adcock antenna is used and signal nulls (a condition of minimum or no signal which exists at that position of the adcock when its plane is at right angles to the direction of arrival of the radio wave) are indicated both visually and aurally. The visual indicator (BEARING METER) is a microammeter, while headsets are used for aural operation. The radio operator rotates the adcock, radio equipment, and the telephone operator by moving his own body. After the RDF has been oriented to some reference line, using the compass and telescopic sight, the direction of the incoming signal with respect to the reference line is indicated in degrees on the azimuth scale. The radio set can be dismantled and packed in 13 chests and crates (fig. 3).

2. RADIO SET SCR-555-A, COMPONENTS WITH WEIGHTS AND DIMENSIONS.

Quantity	Description	Weight (pounds)		Over-all dimensions (inches)
		Unit only (net)	In shipping chest (gross)	
1	Tower TR-25-A packed in five chests:	220	329	69 ⁷ / ₈ x 63 ⁷ / ₈ x 2
	Chest CH-135-A; three shelter door and side sections.			
	Chest CH-136-A; roof section.			
	Chest CH-137-A; three lower tower legs, three upper tower legs, one apex block, three wedges.			
	Chest CH-201-A; floor section.			
	Chest CH-202-A; three base sills.			
	Radio Transmitter BC-655-A and Antenna AN-103-A packed in Chest CH-128-A.			
1	Tripod LG-23-B packed in Chest CH-202-A.	120	251	60 x 68 x 5 ¹ / ₄
	Tripod LG-14-B packed in Chest CH-202-A.			
	Ground Rod GP-28 packed in Chest CH-202-A.			
1		69	200	96 x 8 ¹ / ₂ x 4 ¹ / ₂
1		12		10 ¹ / ₂ x 9 x 6 ³ / ₄
1		8		58 ⁵ / ₈ x 4 ¹ / ₂ diam
1		8		40 ⁵ / ₈ x 5 ⁷ / ₁₆ diam
1		3		60 x 1 ¹ / ₂ diam

2. RADIO SET SCR-555-A, COMPONENTS WITH WEIGHTS AND DIMENSIONS (Contd).

Quantity	Description	Weight (pounds)		Over-all dimensions (inches)
		Unit only (net)	In shipping chest (gross)	
1	Antenna AN-105-A packed in one Chest CH-105-A, containing: one lower mast section, one upper mast section, one crossarm assembly, five antenna rods.	23 28 1/2 28 1/2 7	225	85 3/8 x 4 80 3/8 x 4 3/4 95 x 5 1/2 x 4 1/8 75 x 1 1/4 diam
1	Mounting FT-365-A packed in one Chest CH-126-A.	69	194	55 1/2 x 32 5/8 x 16 1/2
1	Radio Receiver BC-1005-A, Power Unit PE-155-A, and Cord CD-1028, one of each, packed in Cabinet CS-155-A.		170	29 3/4 x 28 1/2 x 17 3/8
1	Miscellaneous parts packed in Chest CH-128-A.	57	115	15 1/4 x 21 3/8 x 25
4	12-volt storage battery, shipped without electrolyte, one in each Chest CH-139-A.	52	66	7 1/8 x 10 1/2 x 13
1	Carboy of electrolyte sufficient for four batteries listed above.	64	98	21 x 11 diam
1	Nest of three boxes: Box-47-A, Box-45-A, and Box-46-A.	75	-	30 x 18 x 16

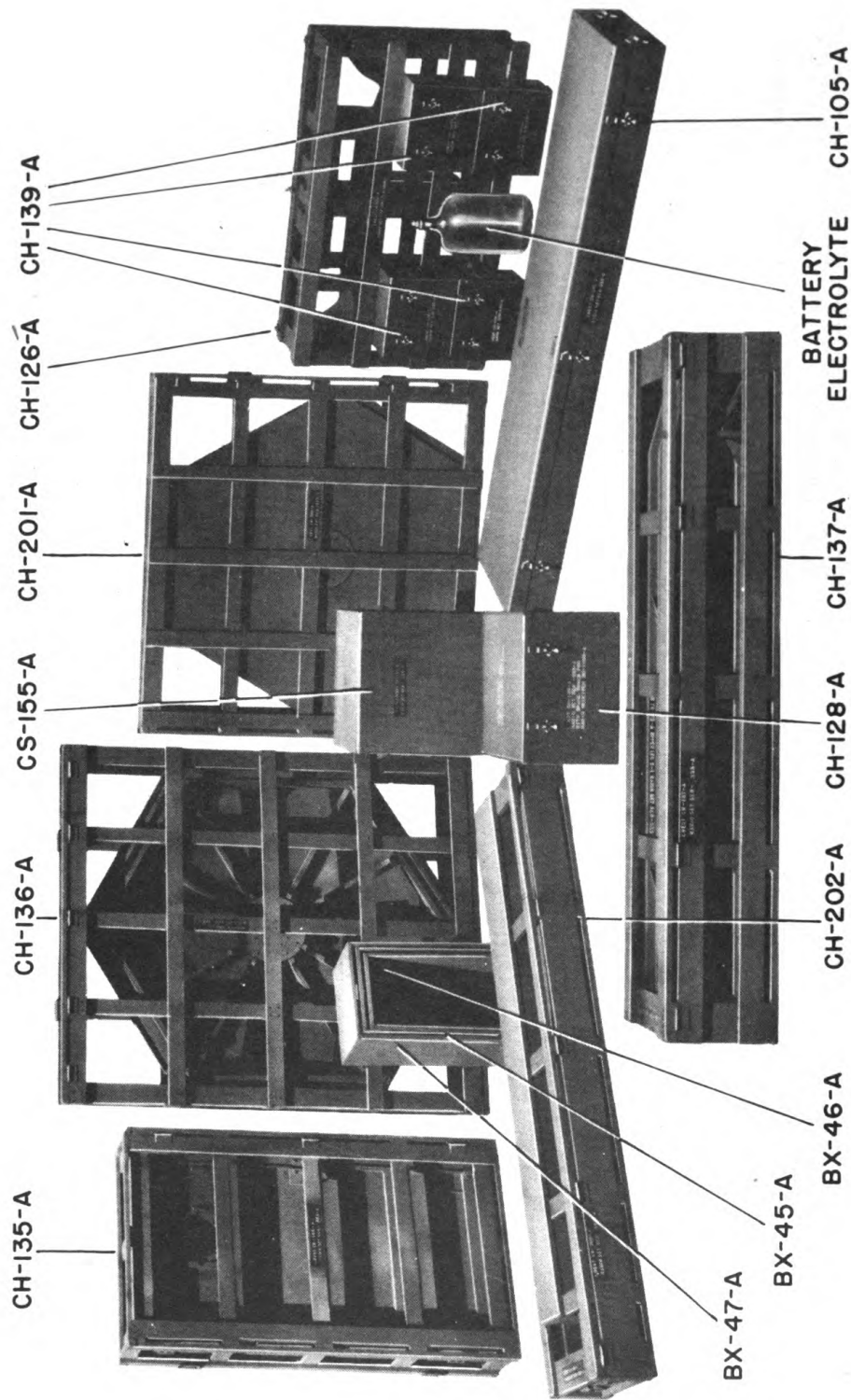

TL-10868

Figure 3. Radio Set SCR-555-A, crated.

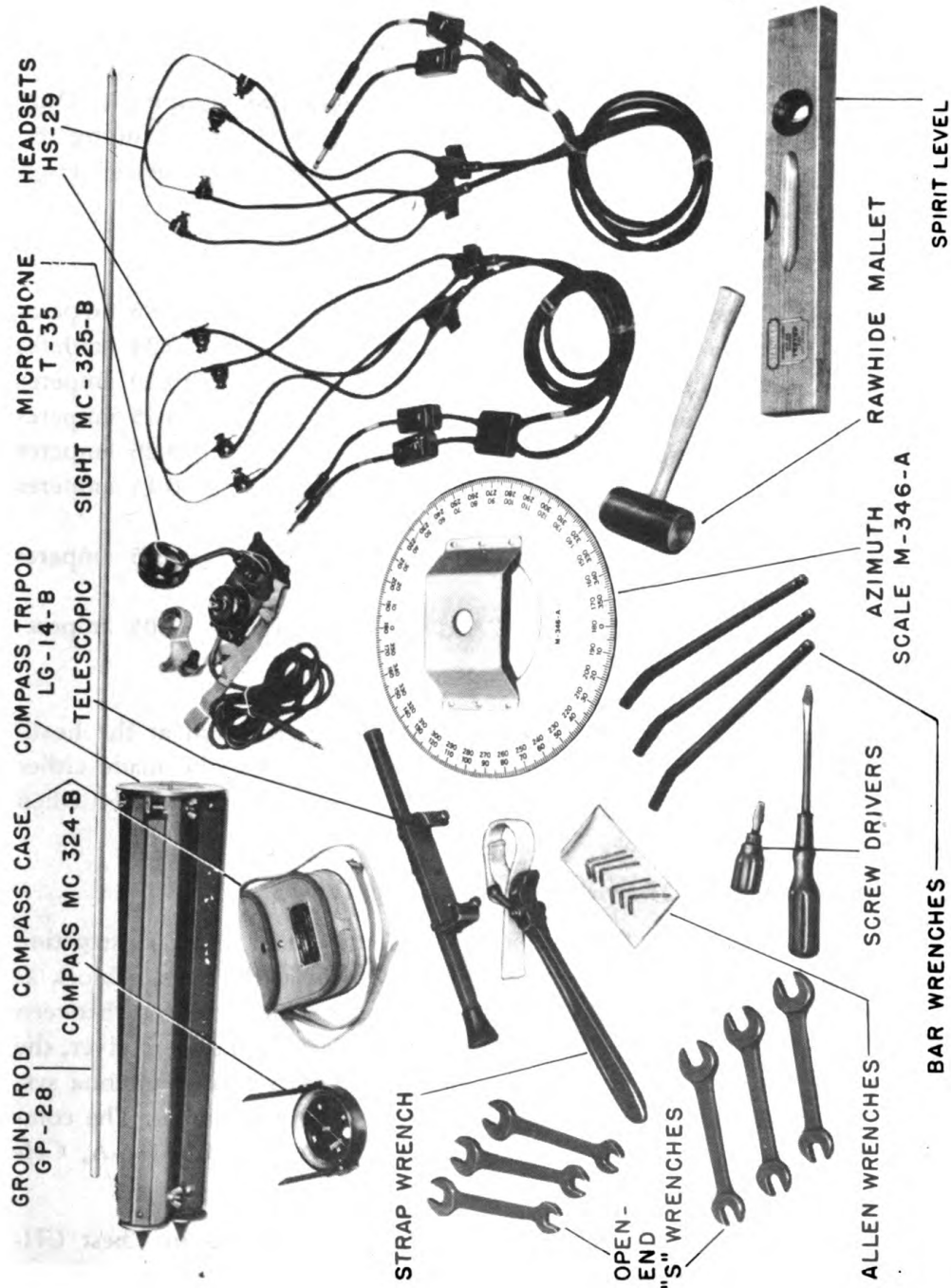

Figure 4. Radio Set SCR-555-A, miscellaneous components.

3. FREQUENCY COVERAGE.

Band No. 1: 18 to 34 megacycles. Band No. 2: 34 to 65 megacycles.

4. POWER SOURCE.

Four 12-volt storage batteries are supplied with this equipment. Only one battery is needed to furnish all voltages for the RDF, including the low-voltage side of the dynamotor unit. The other three are spares. High voltages are furnished by the dynamotor unit.

5. POWER INPUT.

12 volts, 15 vacuum-tube heaters	2.85 amperes
12 volts, 1 dial lamp	0.24 amperes
12 volts, 6 meter lamps	0.50 amperes
12 volts, 4 heater lamps	0.75 amperes
12 volts, 2 azimuth scale lamps	0.26 amperes
12 volts, microphone current	0.15 amperes
12 volts, dynamotor primary, switch 333-2 at FIG-8 position	2.65 amperes
12 volts, dynamotor primary, switch 333-2 at SWITCHED CARDIOID position	3.05 amperes

6. POWER OUTPUT.

The maximum undistorted audio power output measured at the head-phone jack is 300 milliwatts. The output impedance can be made either 4,000 or 250 ohms. The 4,000-ohm tap is connected in the set when shipped from the factory.

7. DESCRIPTION OF MAIN COMPONENTS.

a. Tower TR-25-A. This is a semiportable tower of wood construction and tripod design. It is made stable by a platform at the base, a block at the apex, and the shelter roof at a point approximately midway between the platform and the apex. The tower, which houses the radio receiver, the power unit, and battery, serves as a support for the rotating antenna system, and provides shelter for the operators and the equipment. The complete tower is packed in five chests: Chests CH-135-A, CH-136-A, CH-137-A, CH-201-A, and CH-202-A.

b. Antenna AN-105-A. The antenna system, packed in Chest CH-105-A, consists of the upper and lower mast sections, the crossarm assembly, and the five antenna rods (four for the adcock and one for the vertical sense antenna). A bearing is provided on the upper mast section which seats in the hole in the center of the apex block. A telescope mounting bracket is attached to the lower mast section, and a drip flange assembly to prevent rain and snow from entering the shelter through the opening in the roof is provided for the antenna mast. Canvas hoods are provided

DESCRIPTION

TRANSMITTER
 JNA FOR RADIO TRANSMITTER
 BATTERY
 BATTERY
 ET
 PHONE
 RY CABLE
 2 CABLE
 ASS
 JTH SCALE
 JTH SCALE SPINDLE KNOB
 TOPIC SIGHT
 CAN WATERPROOF GREASE
 JAR OF ROSIN
 WRENCH
 IDE MALLET
 ID ROD CLAMP
 LEVEL
 VRENCH
 END "S" WRENCH
 ALLEN WRENCH
 /DRIVER
 FOR TRANSMITTER
 UT $\frac{3}{8}$ " - 16
 DLT $\frac{3}{8}$ " - 16 X 3"
 DLT $\frac{3}{8}$ " - 16 X 5"
 DLT $\frac{3}{8}$ " - 16 X $\frac{3}{4}$ "
 LEAD CAP SCREW $\frac{3}{8}$ " - 16 X 1"
 LEAD CAP SCREW $\frac{1}{2}$ " - 20 X $1\frac{1}{2}$ "
 LEAD CAP SCREW $\frac{3}{8}$ " - 16 X $1\frac{3}{4}$ "
 LIGHT MAZDA NO. 44
 R LAMP MAZDA NO. 55
 SET FOR DYNAMOTOR
 T FOR ANTENNA ROD
 ATOR GASKET
 T FOR CROSS ARM END PLATE
 T FOR MAST FLANGE
 OR SHELTER DOOR LOCK
 IICAL MANUAL
 JM TUBES FOR RADIO TRANSMITTER BC-655-A
 JAN-1A5GT/G
 JAN-958
 JM TUBES FOR RADIO RECEIVER BC-1005-A
 JAN-6AC7
 JAN-12SG7
 JAN-12SA7
 JAN-12SK7
 JAN-12SR7
 JAN-12SN7GT
 JAN-12H6
 JAN-12A6
 JAN-12J5GT

TL-10889

for covering the ends of the masts and the center of the crossarm when they are not assembled. This prevents dirt and water from entering these parts. When not in use, these hoods are stored in Chest CH-128-A. Dirt and water must be kept out of the antenna system. For this reason, the seats of the antenna rods are provided with gaskets and the rods must be securely tightened. The access plates at the ends of the crossarm also have watertight gaskets and the junctions of the masts, and the mast and crossarm, are so fashioned that rain will not enter. These junctions are also indexed so that they can be assembled in only one way.

c. Cabinet CS-155-A. The cabinet is made of plywood and houses Radio Receiver BC-1005-A, Power Unit PE-155-A, and one 12-volt storage battery. Space is also provided for the installation of the azimuth scale and its associated hairline indicators. Lamps mounted on the two hairline indicators make it possible to illuminate the azimuth scale. The writing shelf for the telephone operator mounts in back of the cabinet.

d. Radio Receiver BC-1005-A. This is a special high-frequency superheterodyne RDF receiver, designed to cover the frequency range of 18 to 65 megacycles in two bands. It has two separate antenna input connections. One connection is for the vertical sense antenna, the other for the adcock. The receiver obtains power from Power Unit PE-155-A and a 12-volt storage battery. The receiver consists of an r-f oscillator, mixer, three-stage i-f amplifier, c-w oscillator, detector, and output stage which are conventional in design. A two-stage r-f amplifier for the vertical antenna, used in conjunction with a balanced r-f amplifier, 130-cycle multivibrator, synchronous rectifier, and microammeter, provides means of visual indication of the direction of arrival of received signals and at the same time eliminates 180° ambiguity of the adcock antenna. All controls except those marked TEST SWITCH and ADCOCK BALANCE are located on the front panel and are plainly marked. TEST SWITCH and ADCOCK BALANCE controls are located on the top rear of the chassis.

e. Mounting FT-365-A. This is a rotatable mounting which fastens to the floor of the shelter and supports the receiver cabinet and antenna mast assembly. The mounting has two saddle seats, one for the radio operator and one for the telephone operator. It has a hand brake for locking the rotating system in any position, and a foot rest for the telephone operator to keep his feet off the floor while the radio operator turns the assembly. The two seats on the mounting are adjustable. Either seat may be moved one notch nearer to or one notch farther from the center support, if necessary, by removing the seat mounting bolts and sliding the seat to the required position.

f. Chest CH-128-A. This is a plywood chest containing Radio Transmitter BC-655-A, Antenna AN-103-A, spare tubes and batteries, Telescopic Sight MC-325-B, Compass MC-324-B, Azimuth Scale M-346-A, spare

brushes for the dynamotor, power and battery cables, microphones and headsets, technical manuals, tools, bolts, and miscellaneous items necessary for the installation and operation of the equipment. A detailed list of each item contained in this chest is shown on the label inside the lid, and in figure 5.

g. Chest CH-139-A. This is a wooden chest housing one 12-volt storage battery. Four of these chests with batteries, less electrolyte, are supplied. A sufficient quantity of electrolyte for the four batteries is provided in a carboy shipped with the equipment. The inside walls of the battery chests and the battery compartment are painted with an acid-proof paint to resist the deteriorating effects of the electrolyte on the wood.

h. Chests CH-135-A, CH-136-A, CH-137-A, CH-201-A, and CH-202-A. These chests are all of lattice or open construction, made of wood, and designed to hold all sections and pieces of Tower TR-25-A when it is knocked down for shipping. In addition, space is provided in Chest CH-202-A for Tripods LG-23-B and LG-14-B used to support the target transmitter and the compass, respectively. The tower sections and pieces are divided among the chests as follows:

CH-135-A houses the three shelter door and side sections.

CH-136-A houses the roof section.

CH-137-A houses the three lower and three upper mast legs, the apex block, and the three mast Wedges M-345-A.

CH-201-A houses the floor section.

CH-202-A houses the three base sills of Tower TR-25-A, Tripods LG-14-B and LG-23-B, and Ground Rod GP-28.

i. Boxes BX-45-A, BX-46-A, and BX-47-A. A nest of three boxes without lids, of which BX-47-A is the largest and BX-46-A the smallest, is used to provide support for various members of the tower and antenna during assembly. These three boxes may also be used to hold miscellaneous equipment.

8. DESCRIPTION OF AUXILIARY COMPONENTS.

a. General. Radio Transmitter BC-655-A (fig. 6), is a battery-operated portable transmitter with a frequency range from 17.5 to 162 megacycles, and with Antenna AN-103-A, and Tripod LG-23-B can be used to test the operation of Radio Set SCR-555-A. The radio transmitter and antenna are packed in Chest CH-128-A. The tripod is packed in Chest CH-202-A.

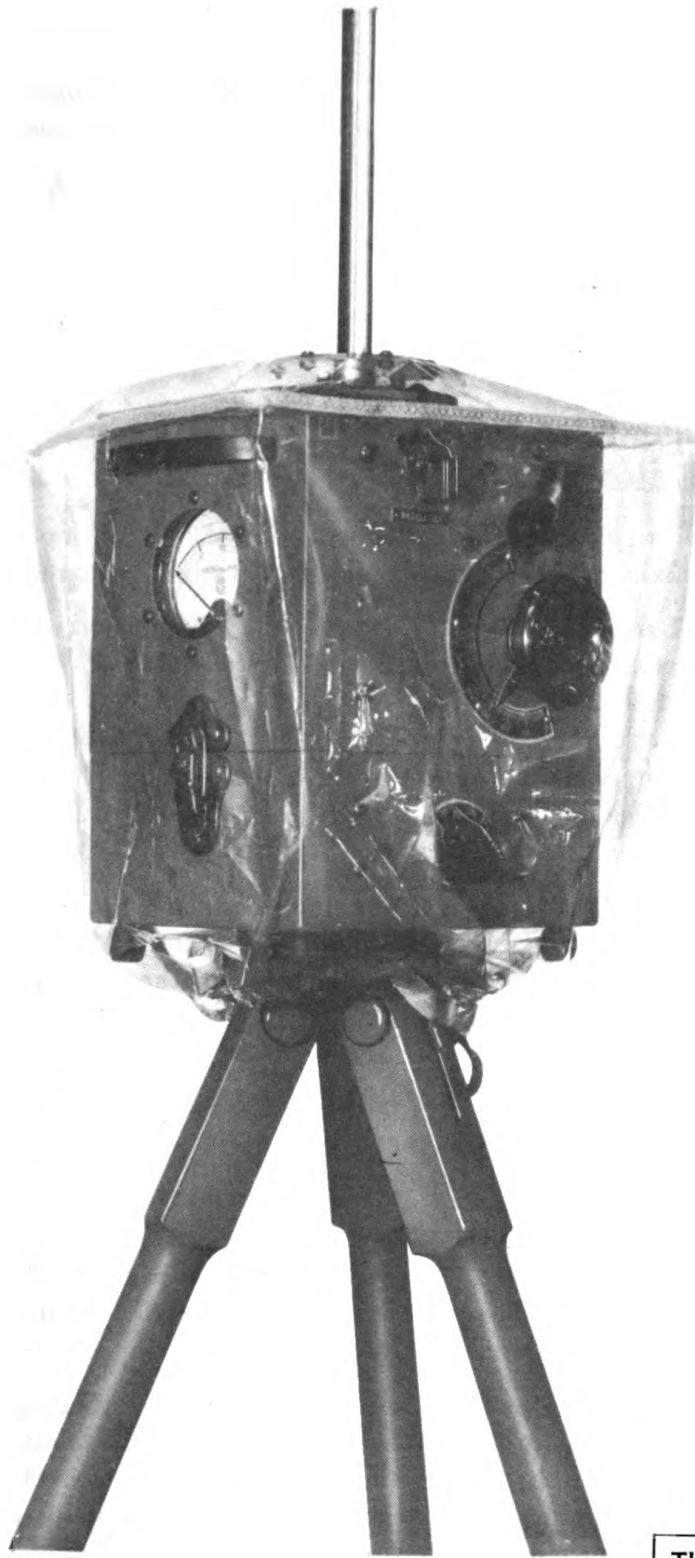

TL-10970

Figure 6. Radio Transmitter BC-655-A, with cover.

b. Dimensions and Weights.

<i>Description</i>	<i>Over-all size in inches (including projections)</i>	<i>Weight in pounds</i>
1 Radio Transmitter BC-655-A complete with tubes, batteries, and cover; packed in Chest CH-128-A.	10 $\frac{1}{2}$ x 9 x 6 $\frac{3}{4}$	12.00
1 Antenna AN-103-A packed in Chest CH-128-A.	7 $\frac{3}{16}$ to 31	0.25
1 Tripod LG-23-B packed in Chest CH-202-A.	59 x 4 diameter	6.50

c. Frequency Range. The frequency range of the transmitter is continuously variable from 17.5 to 162 megacycles in three bands as follows:

Band	Frequency (mc)
1	17.5 to 40
2	34 to 80
3	71 to 162

The power output of the transmitter is ample to permit a good signal to be received when the transmitter is set up at 100-yard radial points from the RDF antenna.

d. Antenna Requirements. The transmitter utilizes a vertical collapsible radiator 7 $\frac{3}{16}$ inches long when collapsed, and 31 inches long when extended. The antenna screws to the top of the case and is readily demountable.

e. Vacuum Tubes. Radio Transmitter BC-655-A uses two vacuum tubes. One Tube VT-212 (JAN 958) is used as an r-f oscillator, and the other Tube VT-124 (JAN 1A5GT) generates a 1,000-cycle audio tone which modulates the r-f oscillator.

f. Power Requirements. The transmitter operates directly from one Battery BA-65 (1.5 volts) and two Batteries BA-63 (45 volts). The two tubes draw 150 milliamperes filament current and a total of 8.1 milliamperes of plate and screen current.

g. Physical Description. A surveyor-type Tripod LG-23-B is provided to support the transmitter when set up in the field. The unit is composed of two separate cases held together with two snap clamps. The upper case contains the transmitter chassis and the lower case contains the batteries. Access to the transmitter and batteries is possible by opening the snap clamps and separating the two cases. A cover is provided to permit operation of the transmitter during rain or snow.

SECTION II

INSTALLATION AND OPERATION

9. SELECTION OF SITE.

It is not always feasible or possible to calibrate an RDF site because of the time involved. For this reason, the best possible location for the installation should be chosen to insure optimum performance of the equipment without calibration. The following factors should govern the choice of the site:

a. Terrain.

- (1) The area should be substantially flat for at least 100 yards from the RDF antenna and should not have more than a gentle slope for several times that distance.
- (2) The area should be the highest level area in the vicinity. A site in a valley is generally unsatisfactory.
- (3) Mountains or hilly country should be avoided whenever possible.
- (4) The area should be removed as far as possible from the coastline of large bodies of water. If the installation must be made on or near the coast, the flattest area should be selected and the antenna erected in such a position that the azimuth arc to be serviced is as nearly perpendicular to the coastline as possible (fig. 7).
- (5) The earth at and around the site should have uniformly high conductivity and moisture content. Areas uniformly covered with grass or vegetation usually meet this requirement. Rocky or sandy soil is poor as a site; however, areas having uniformly low conductivity are preferable to areas having high conductivity spotted with rock formations, sand, or varying moisture content.
- (6) Regions where there are abrupt discontinuities of the earth's surface should be avoided as this usually indicates the presence of rock or mineral outcroppings, or underground streams.

b. Objects to be Avoided. The site should be removed from tall trees, buildings, wire fences, power or telephone lines, radio antennas, railroad tracks, sharp ground contours (mountains, cliffs, and ravines), buried

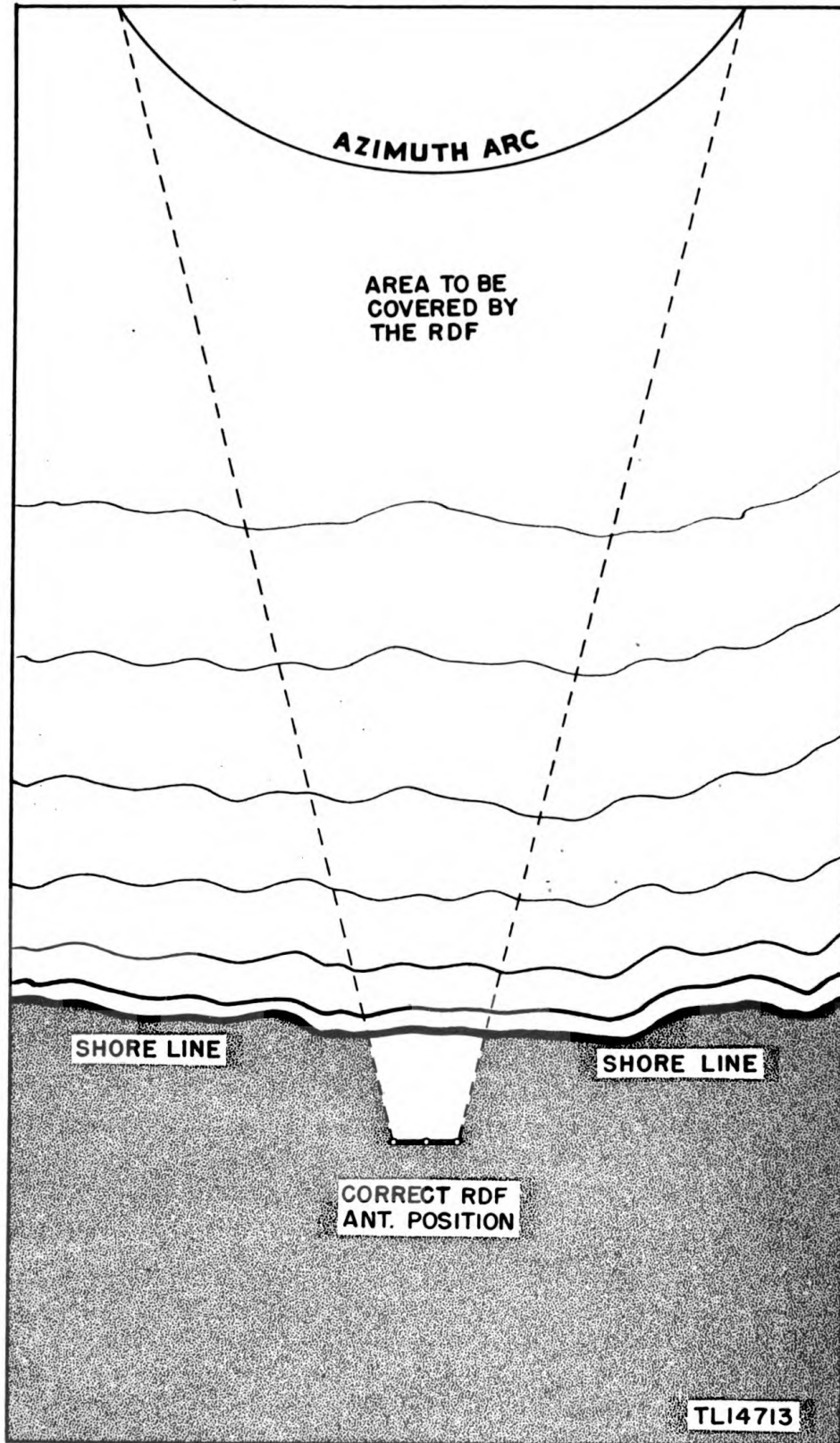

Figure 7. Correct placement of antenna for coastal installation.

metal conductors (cables and pipe lines), chimney stacks, water towers, rivers, lakes, and streams.

c. Distances to be Observed. The distances listed in the following table should be maintained between the RDF antenna and the obstructions given, to minimize their effect on the accuracy of the azimuths:

<i>Obstruction</i>	<i>Distance</i>
Scattered trees and single small wooden buildings.	150 yards
Wire fences.	150 yards
High cliffs and deep ravines.	150 yards
Buried metallic conductors (other than lines to RDF).	300 yards
Chimney stacks and water towers.	300 yards
Overhead conductors (power lines, telephone lines, and antennas) and railroad tracks.	500 yards
Rivers, streams, and lakes.	150 to 500 yards
Forests and metal structures.	500 to 1,000 yards
Mountains.	5 to 25 miles.

10. INITIAL PROCEDURE.

Unpack the equipment carefully from the shipping crates and check against the list of components in paragraph 2.

11. INSTALLATION.

a. Erection of Tower TR-25-A. The tower is packed in five chests, as listed in paragraph 7h. Two different lengths of eyebolts are used in erecting the tower and shelter. Take the $\frac{3}{8}$ "-16 x 3" eyebolts from Chest CH-128-A, and the three bar wrenches for tightening the eyebolts. Apply a small quantity of waterproof grease, stored in the Chest CH-128-A, to the threads of the bolts before using them.

- (1) Remove the floor section (5-1) from Chest CH-201-A and place it on the ground with the smooth side up.
- (2) Remove the three sills (3-1, 3-2, and 3-3) from Chest CH-202-A and place them on the ground (fig. 9). Secure the sills to the floor, using two 3-inch eyebolts in each sill. Do not tighten the eyebolts.
- (3) Install two $\frac{3}{4}$ -inch eyebolts at each of the three points where the sills meet, but do not tighten.
- (4) Tighten the eyebolts securing the sills to the floor. After this has been done, tighten the eyebolts at the junctions of the sills.

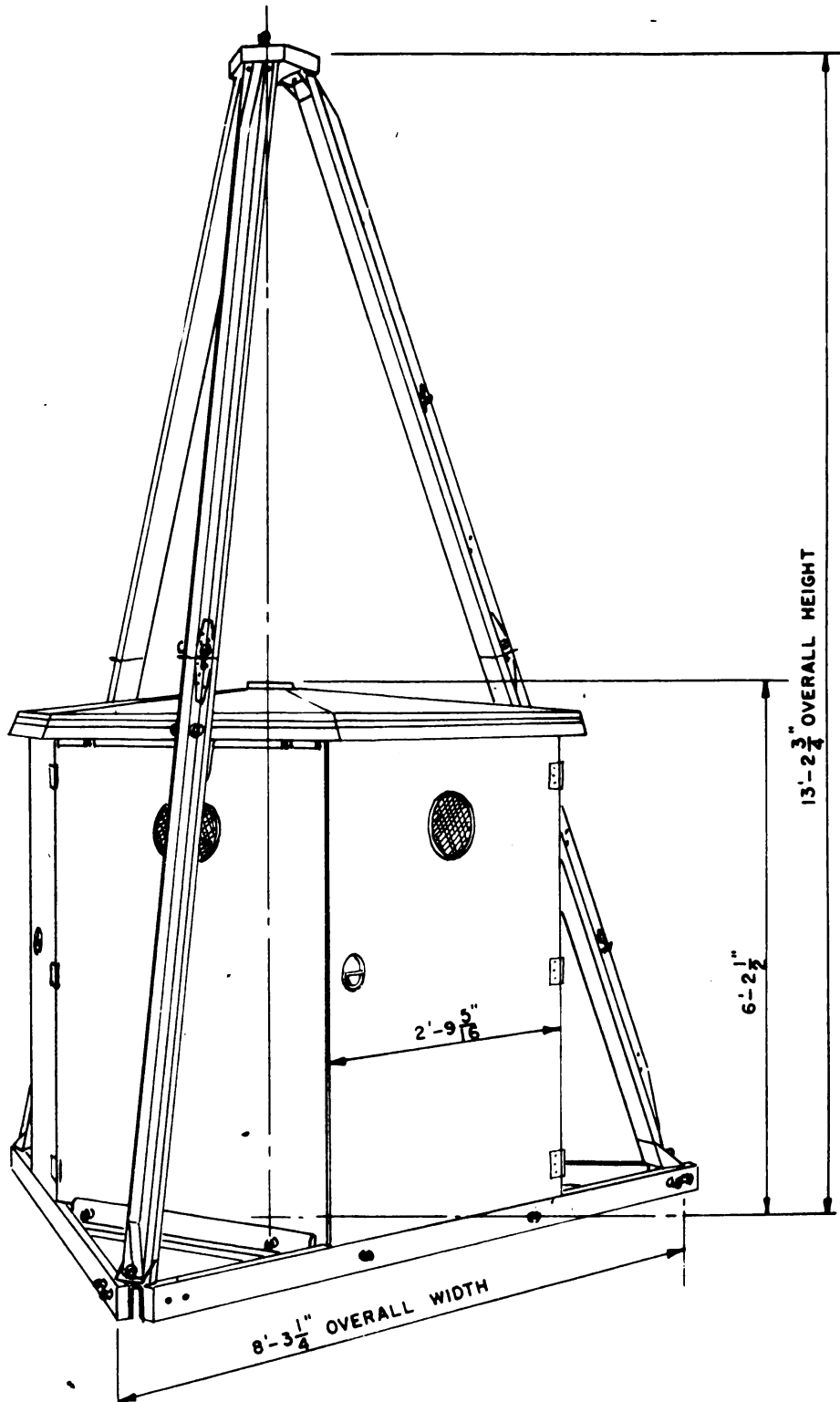

TL-10957

Figure 8. Tower TR-25-A, outline dimensions.

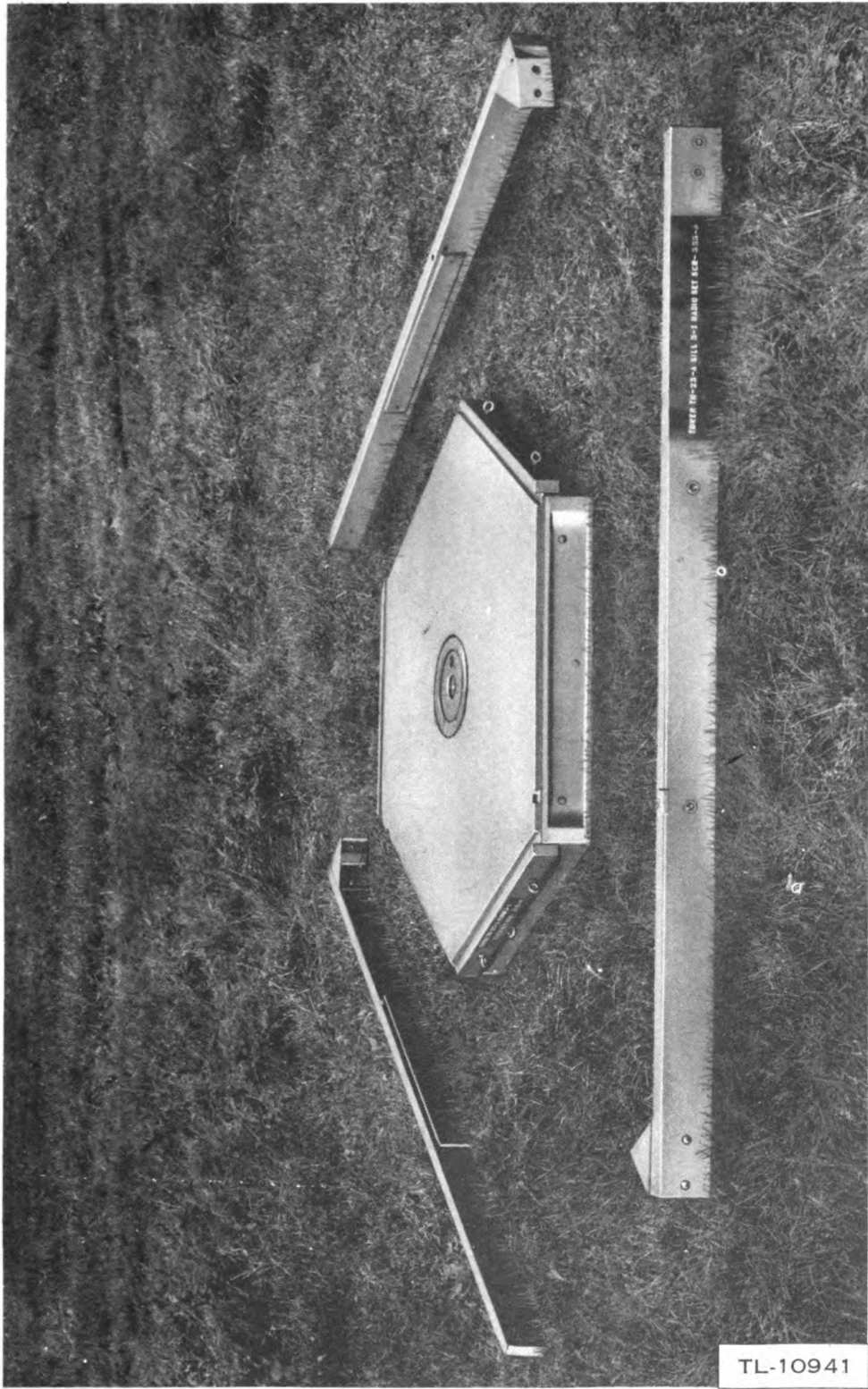

Figure 9. Floor section and sills.

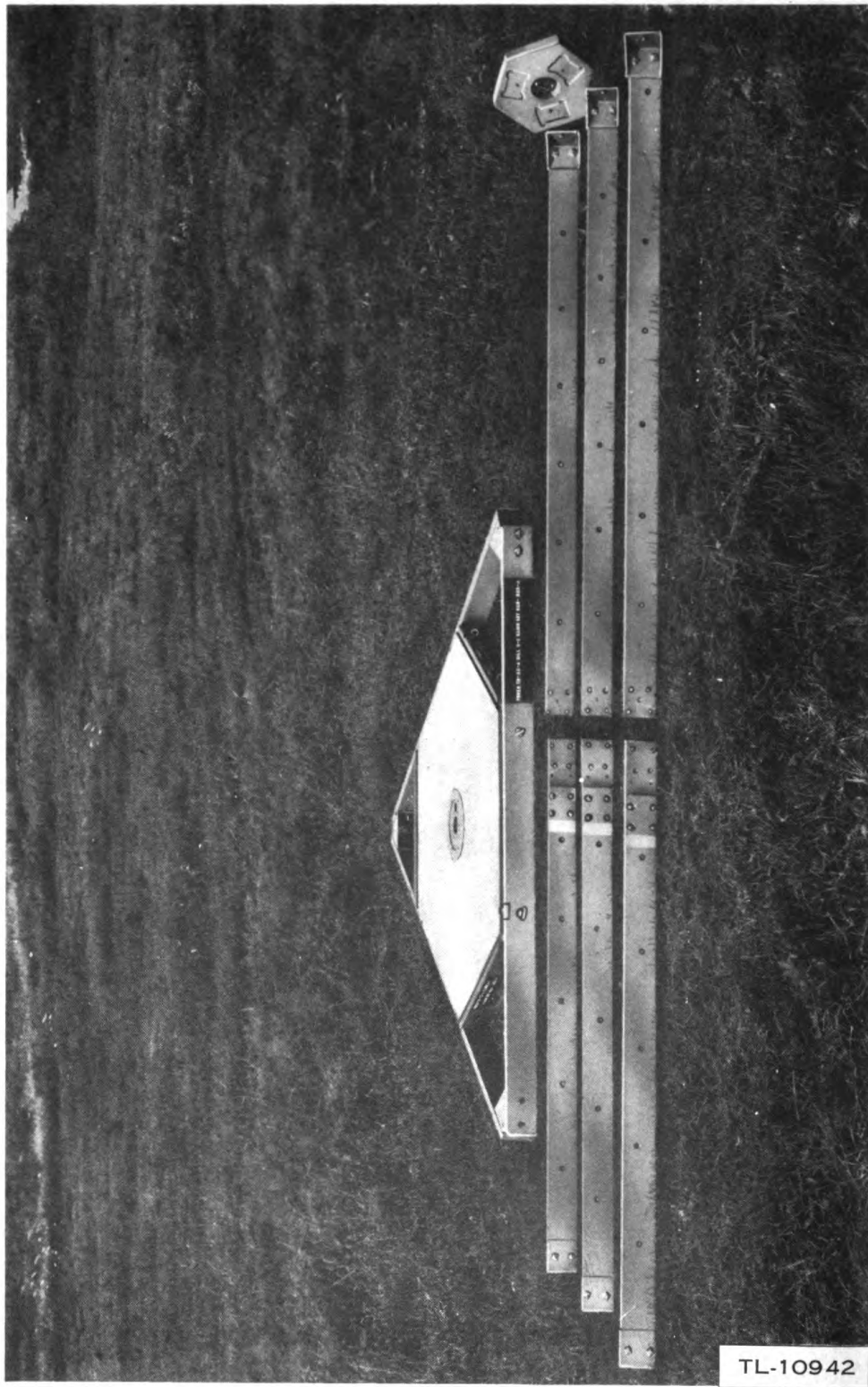

Figure 10. Sills assembled to floor, tower legs, and apex block.

(5) Remove the three lower tower legs (1-1, 1-2, and 1-3) and the three upper tower legs (2-1, 2-2, and 2-3), the apex block (4-1), and three Wedges M-345-A from Chest CH-137-A (fig. 10). Bolt each of the lower tower legs to the corresponding upper legs (1-1 to 2-1, 1-2 to 2-2, and 1-3 to 2-3) using $\frac{3}{4}$ -inch eyebolts. Tighten these bolts.

(6) Bolt two of the tower leg assemblies to the lower side of the apex block. The lower side of the apex block has three cutouts to prevent the tower legs from turning after they are secured in place. Do not tighten the bolts securing the tower legs to the apex block at this time. During this assembly, the tower legs should lie on the ground. Lift the floor to a vertical position (fig. 11), and fasten the lower ends of two of the tower legs to the floor sills with $\frac{3}{4}$ -inch eyebolts. Install the third tower leg in place, bolting the ends to the apex block and the floor (fig. 12). Do not tighten these bolts.

(7) Raise the tower to its normal upright position. Remove the roof (6-1) from Chest CH-136-A and stand it right side up on the floor inside the tower. Make sure that the two holes in each of the three sides of the roof are in line with the tower legs. Lift the roof upward until two of the sides are over the resting blocks (fig. 13). The roof should now be levelled so that the remaining side snaps in position over the resting block. Line up the holes in the sides of the roof with the corresponding holes in the tower and fasten with 3-inch eyebolts. Do not tighten.

(8) Return the tower to the horizontal position. Tighten the three eyebolts at the apex block. Rest the apex block on Box BX-47-A. Apply a coat of waterproof grease around the inside of the tapered hole in the apex block. This grease permits free movement of the bearing on the antenna mast in this block.

b. Antenna AN-105-A (fig. 14). The antenna is packed in Chest CH-105-A.

(1) Remove the lower mast section and the drip flange. Place the drip flange over the opening in the center of the roof, with the larger opening in the drip flange sliding over the wooden ring on the roof. Place the end of the lower mast section in which there are three jacks through the drip flange and the opening in the top of the roof (fig. 15).

(2) Remove the crossarm assembly from the chest and place over two Boxes BX-45-A and BX-46-A (fig. 15).

(3) Remove the upper mast section from its chest and place it over the crossarm section so that the mounting holes are aligned. Fit these pieces together so that the plugs and jacks are engaged, and bolt with $\frac{3}{8}$ "-16 x 1" hexagonal head cap screws. Wrenches for tightening these screws are

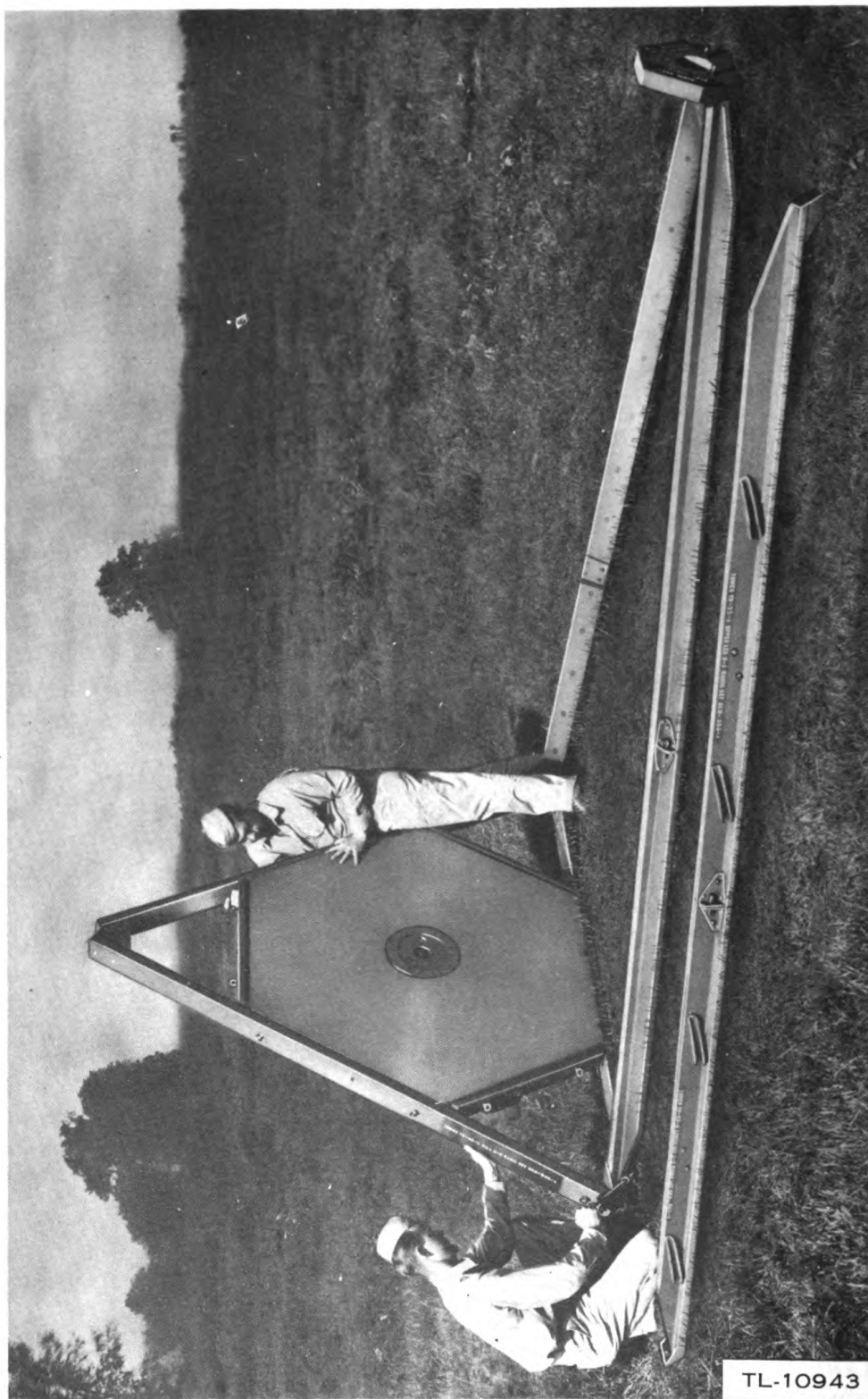

Figure 11. Assembly of two tower legs to floor and apex block.

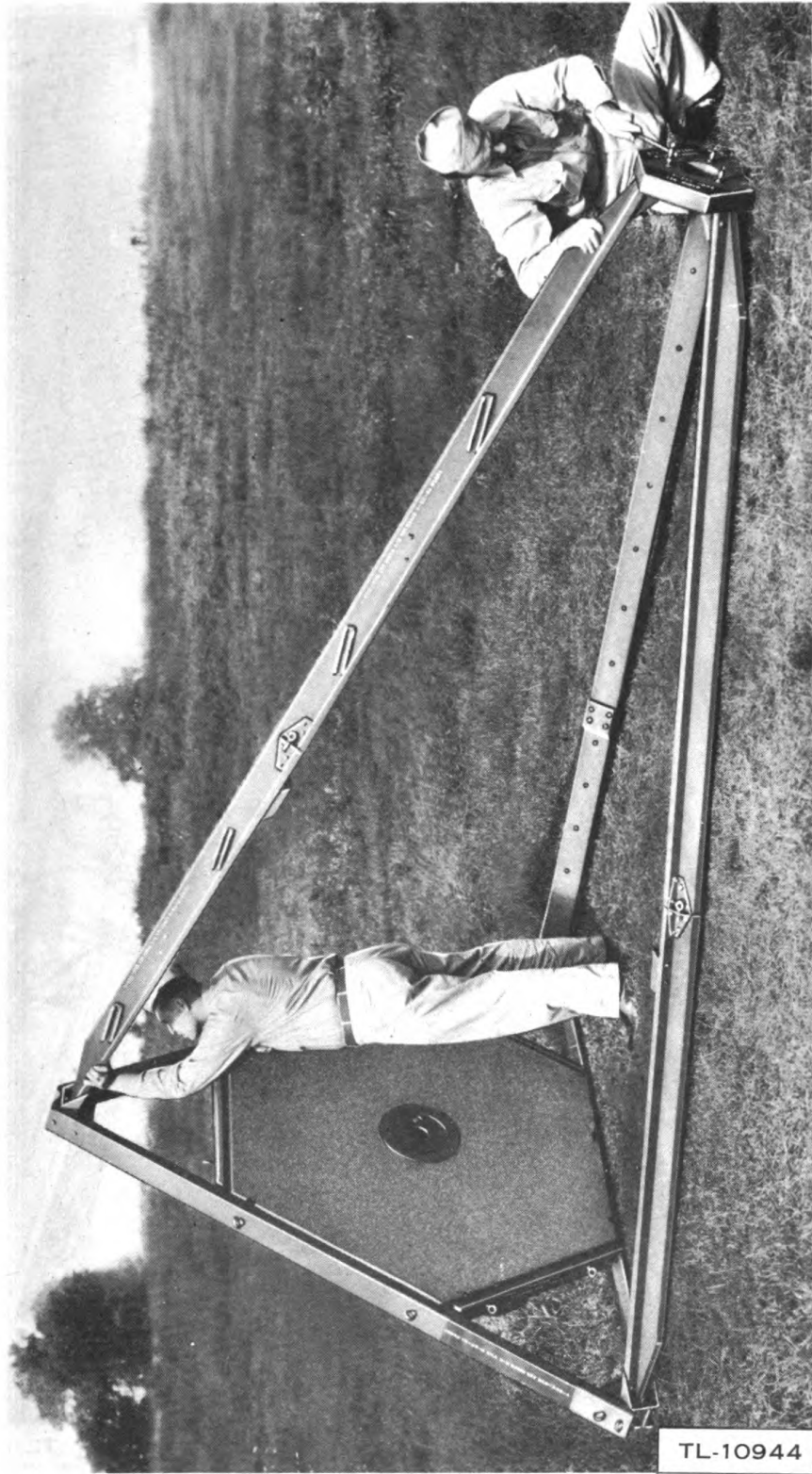

Figure 12. Assembly of third tower leg to floor and apex block.

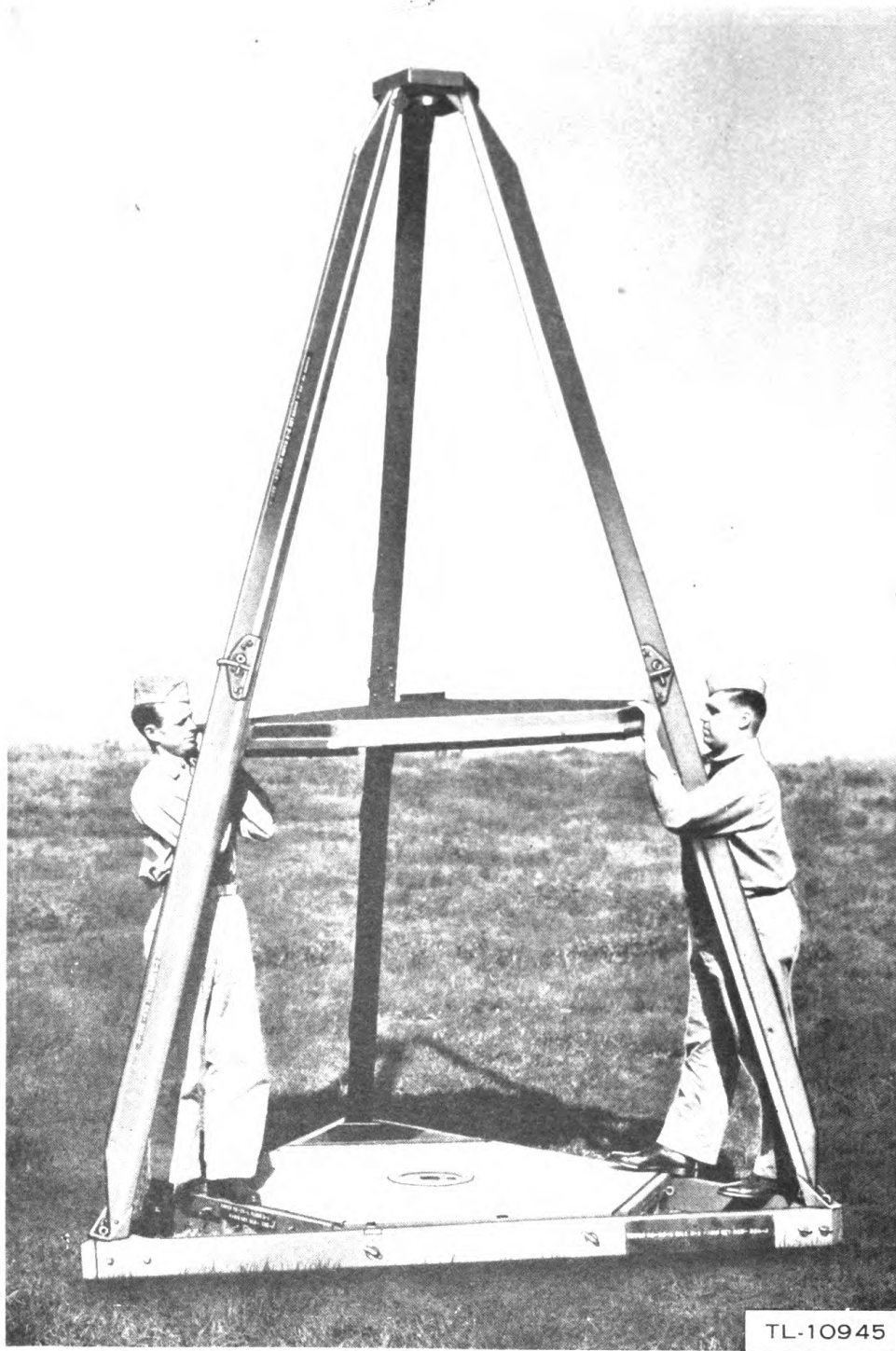

Figure 13. Assembly of roof to tower.

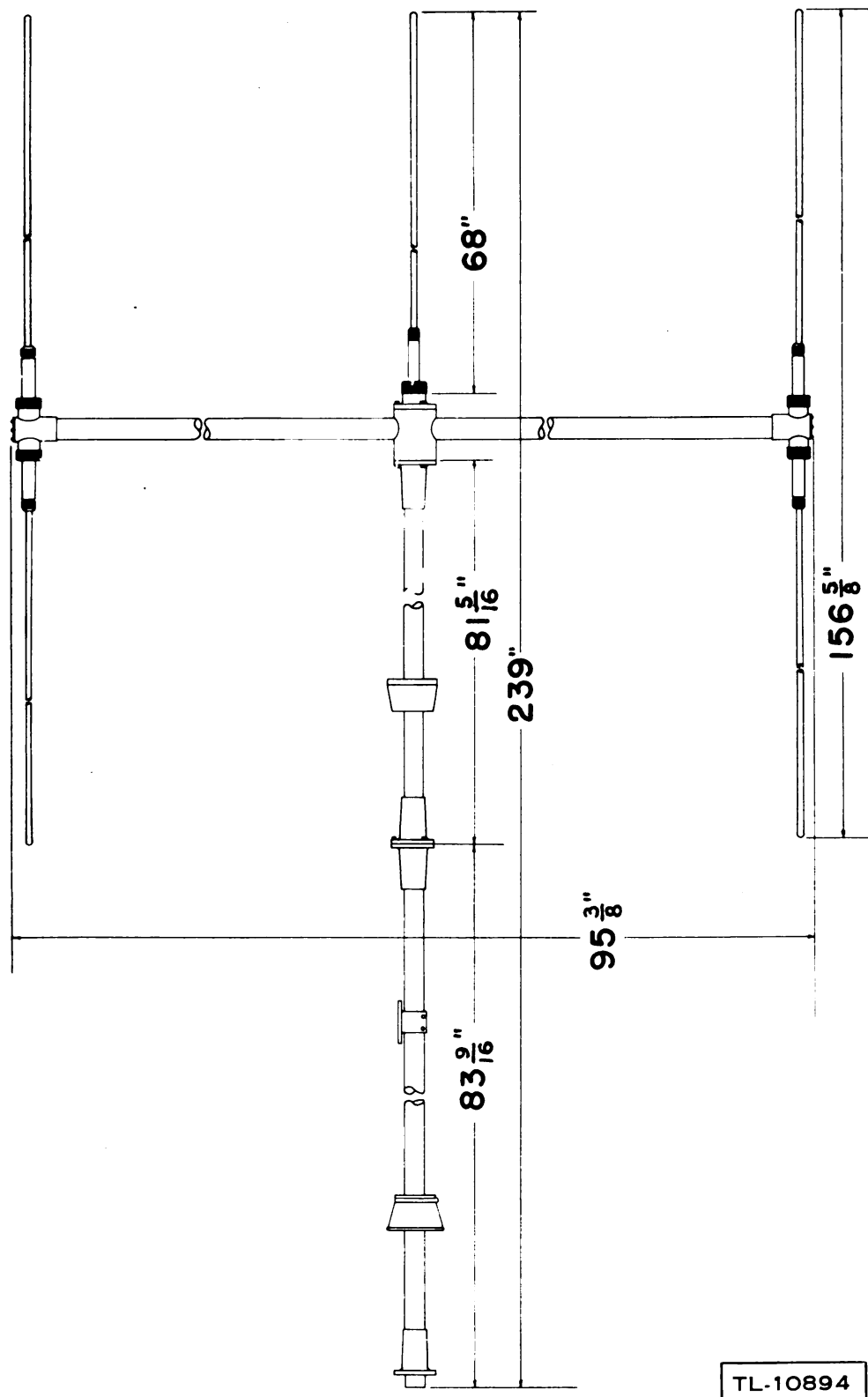

Figure 14. Antenna AN-105-A, outline dimensions.

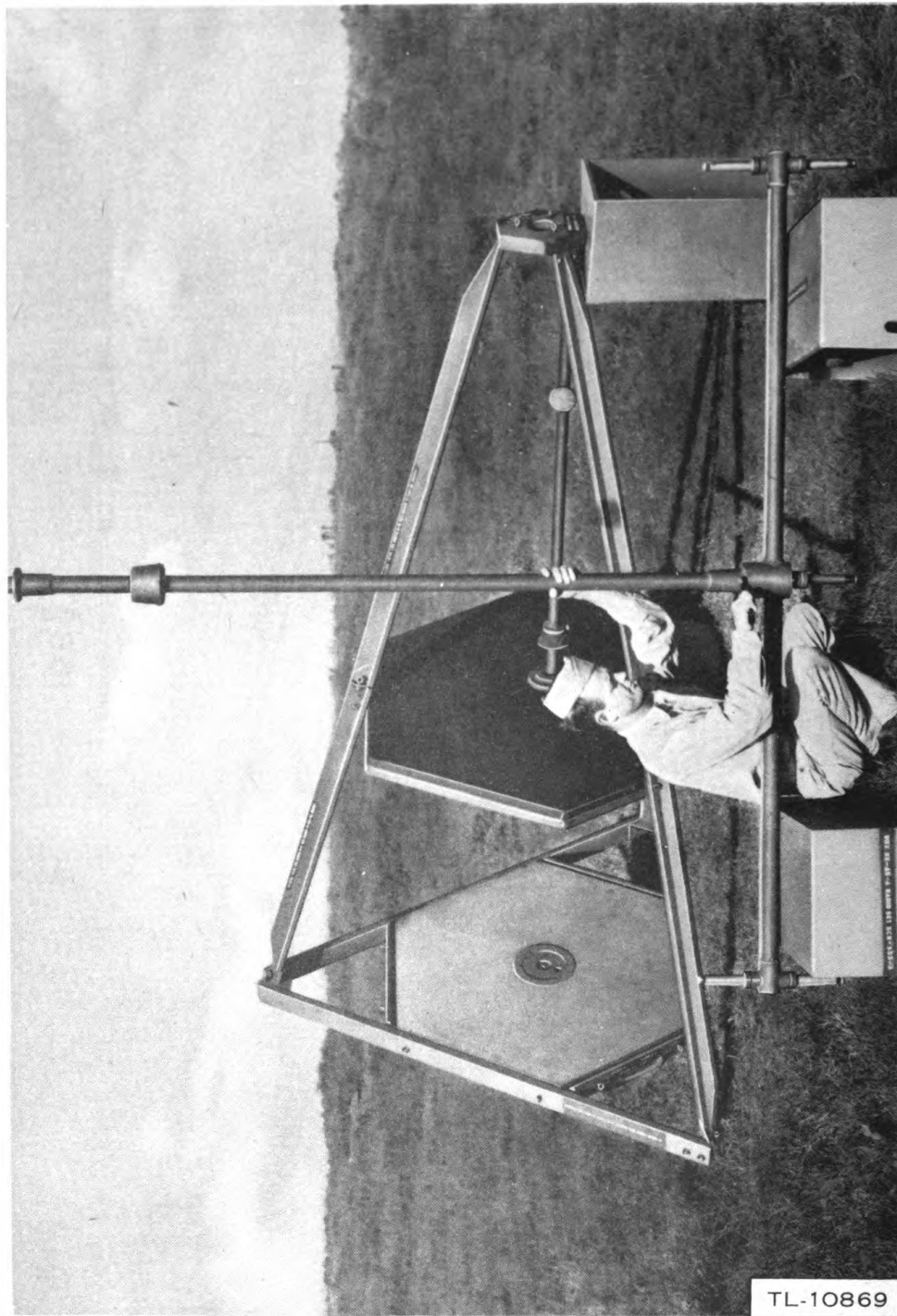

Figure 15. Assembly of antenna mast to crossarm.

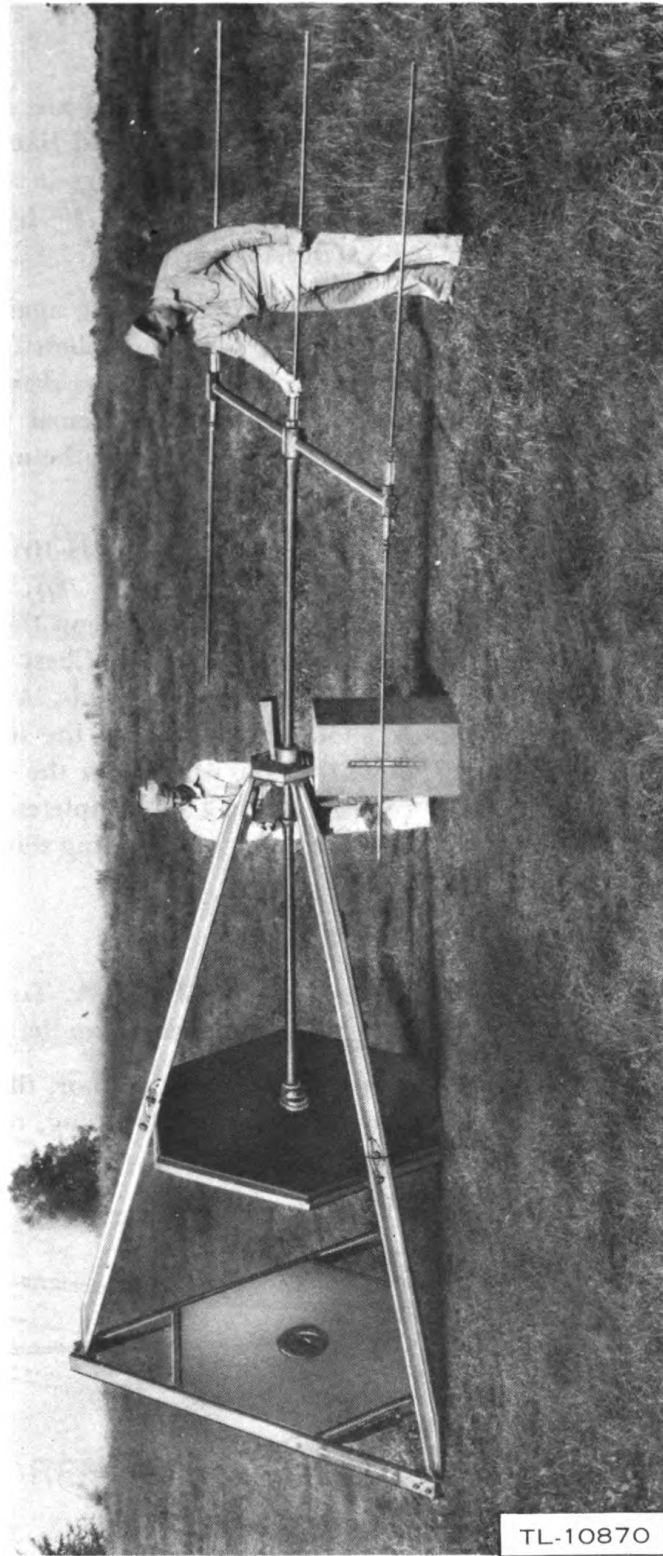

Figure 16. Assembly of both mast sections and of antenna rods.

stored in Chest CH-128-A. Refer to figure 14 for illustration of this assembly.

(4) After the upper mast and crossarm sections are assembled, put the mast through the opening in the apex block and line up the mounting holes and jacks with the mounting holes and plugs in the lower mast section. Bolt the sections together with $\frac{3}{8}$ "-16 x 1" hexagonal head cap screws from Chest CH-128-A (fig. 16).

(5) With the bottom surface of the apex bearing against the top of the apex block, place one of the wedges, packed in Chest CH-137-A, through the opening in the apex block, forcing the antenna mast to one side. This wedge prevents the mast from falling to its normal position when the tower is placed upright, and the receiver chest can be moved into position in a later operation.

(6) Remove the five antenna rods from Chest CH-105-A and plug them into the sockets on the crossarm assembly (fig. 16). The five rods are interchangeable and are secured by knurled nuts on the rods. These nuts are tightened with the strap wrench stored in Chest CH-128-A. Figure 17 illustrates the procedure for tightening the nuts. A quantity of rosin, packed in Chest CH-128-A, should be applied to the strap of the wrench before use. By sighting down the rods and down the crossarm, check to see that the rods have not been bent. This completes the antenna mast assembly. The tower may be set upright, but in doing this, keep the antenna rods clear to prevent damage.

c. Mounting FT-365-A (fig. 18).

(1) Remove the mounting from Chest CH-126-A. To prevent the seats from turning, set the brake by pulling the brake handle.

(2) Hold the mounting over the center of the floor, tilting it to one side at an angle of approximately 45° . Remove the plug, to which a cable is attached, from the jack in the mounting, and insert it in the jack in the center of the floor (fig. 19).

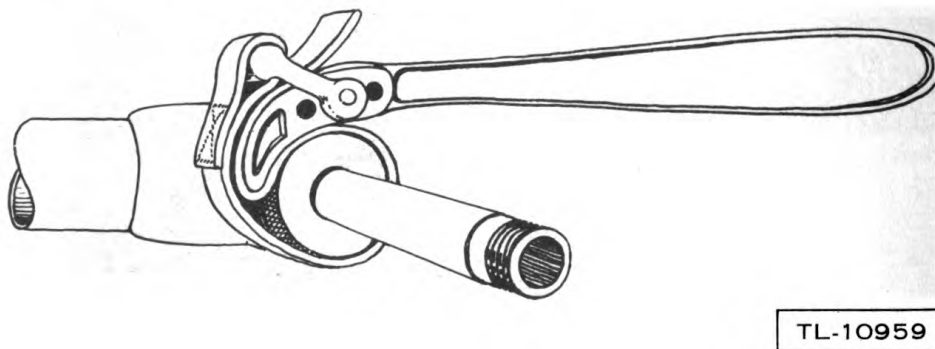

Figure 17. Method of using strap wrench.

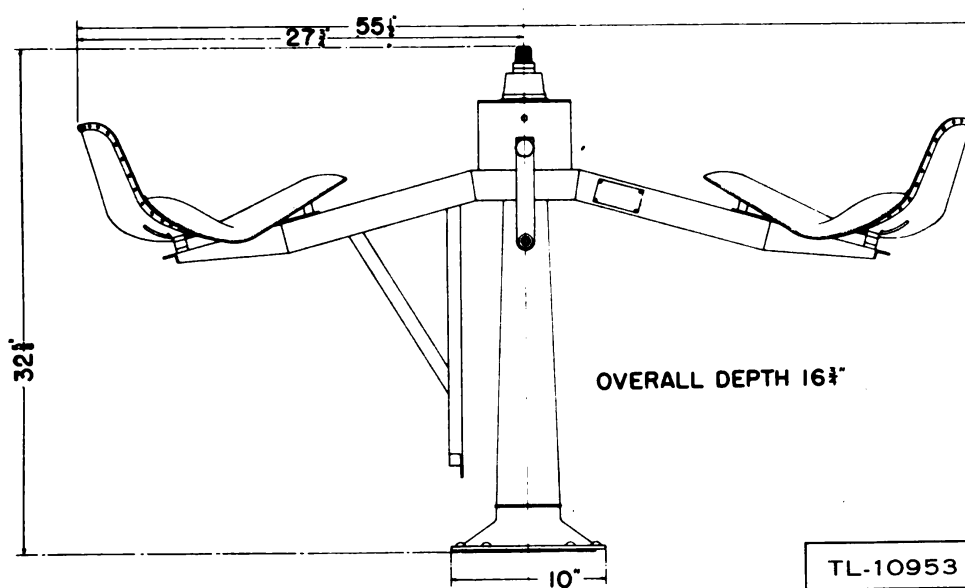
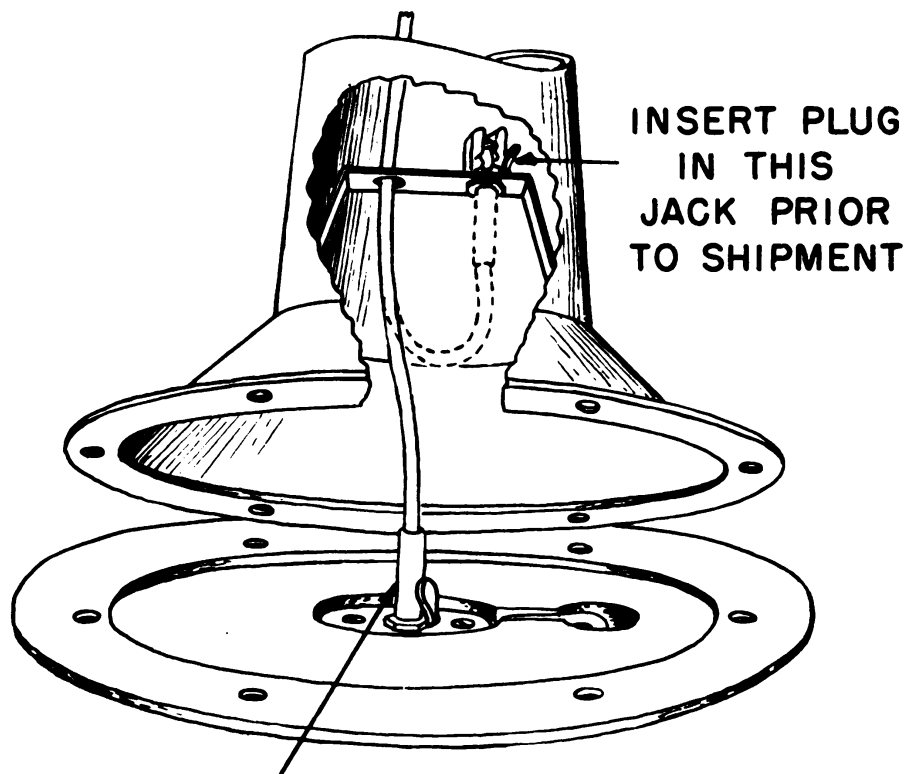

Figure 18. Mounting FT-365-A, outline dimensional drawing.



USE CARE IN REMOVING
PLUG BEFORE PEDESTAL
IS MOVED TO SIDE

Figure 19. Method of making telephone connection between mounting and floor.

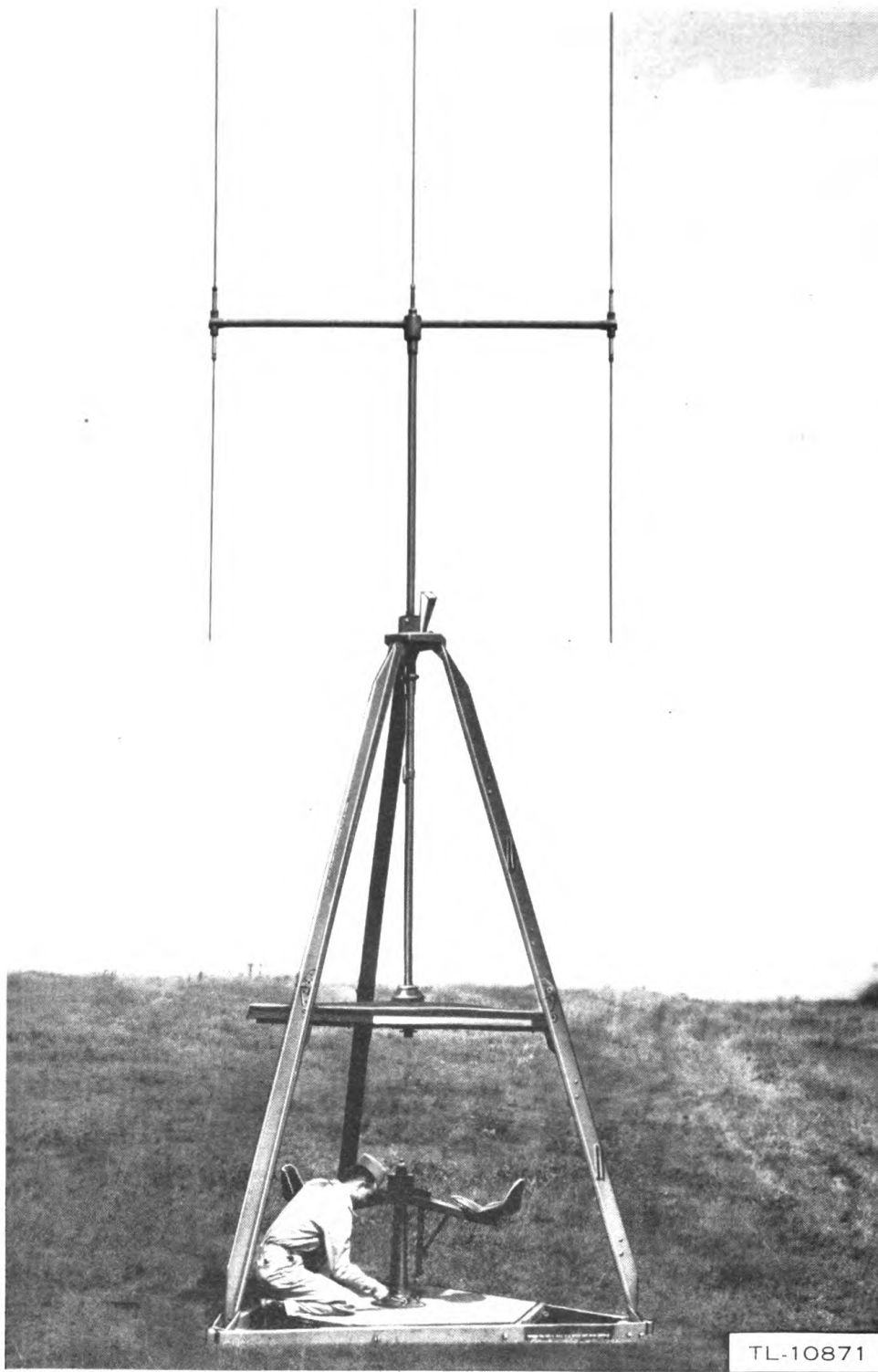

Figure 20. Assembly of Mounting FT-365-A to floor.

(3) Set the mounting in an upright position, and align the six holes in its base with the six holes in the floor of the shelter. Fasten the mounting to the floor with six 5-inch eyebolts, located in Chest CH-128-A, and tighten securely (fig. 20).

d. Cabinet CS-155-A (fig. 21).

(1) Place the cabinet on the ground with the door facing upward. Metal plates on the two ends of the receiver cabinet keep dust and dirt out during shipment. Loosen the three screws holding each plate, slide the plate around one-half turn, and tighten the three screws. Only one screw holds the plate when it is in this position. Use the larger of the two screwdrivers from the Chest CH-128-A for this operation.

(2) Remove the front cover from the receiver cabinet and lift the chest

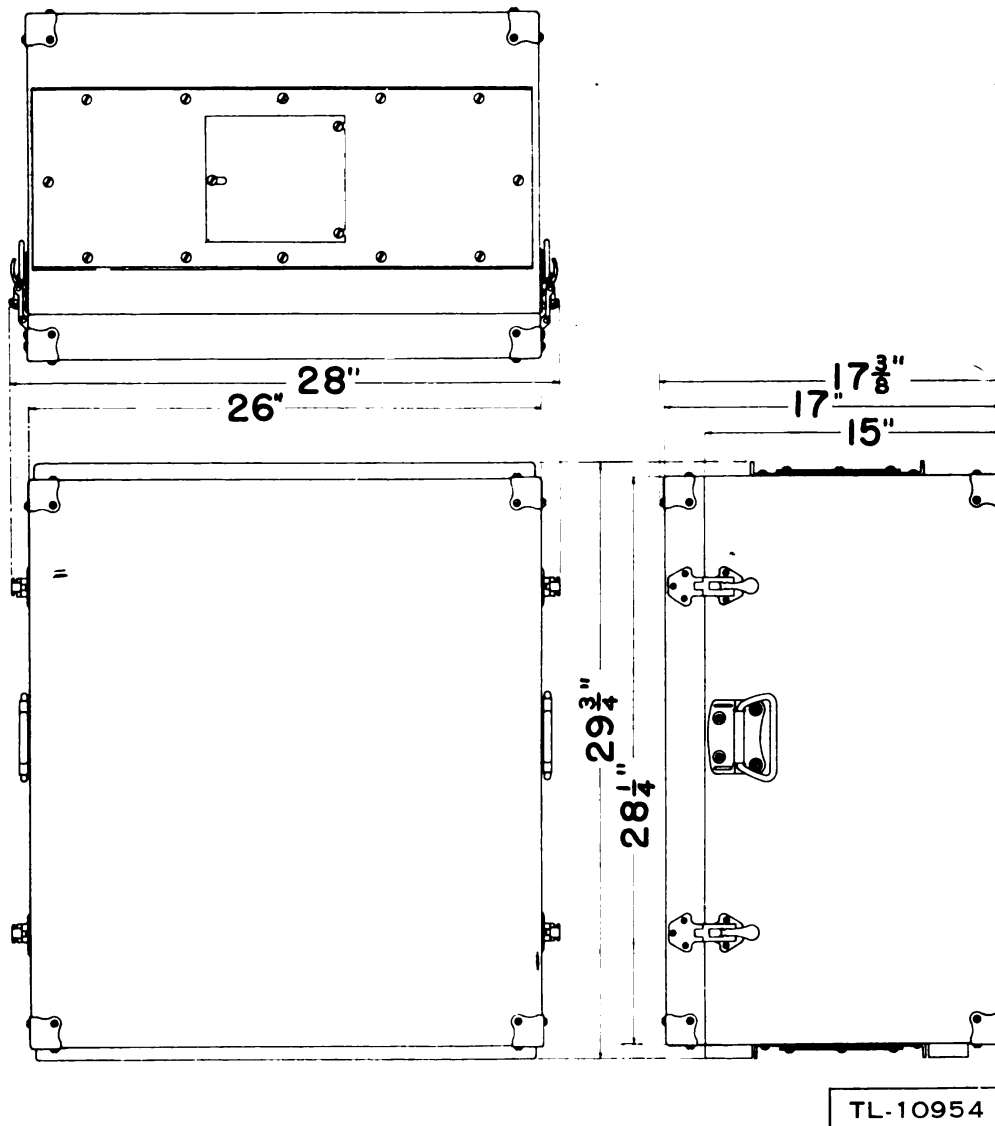

Figure 21. Cabinet CS-155-A, outline dimensional detail.



Figure 22. Cabinet CS-155-A, mounted.

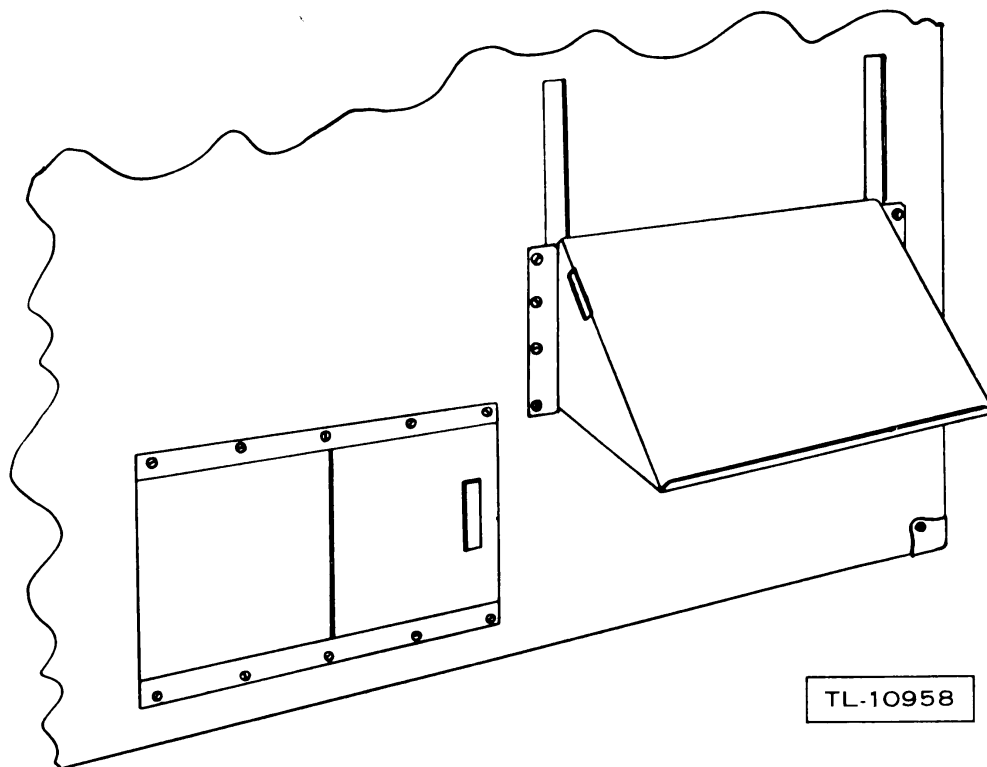

Figure 23. Writing shelf assembly.

onto the mounting so that the receiver panel faces the seat under which the foot rest is mounted. The threaded spindle on the mounting should pass through the large opening in the bottom of the receiver cabinet, and the five holes in the bottom of the chest should line up with the threaded holes in the top of the mounting. A pin in the top of the mounting will fit into an opening provided in the bottom of the receiver cabinet, if the assembly is installed properly.

(3) Secure the cabinet to the mounting with five $\frac{1}{2}$ "-20 x $1\frac{1}{2}$ " hexagonal head cap screws. These screws and the wrenches for tightening them are stored in Chest CH-128-A. Do not tighten these screws with a wrench until they are all in place and have been tightened by hand. While one man removes the wedge in the apex block, a second man standing on the roof lowers the antenna. A third man loosens the brake and rotates the receiver chest to align it with the connector plugs in the mast. The man on the roof then lowers the assembly as far as it will go. Set the brake and secure the mast to the receiver chest with $\frac{3}{8}$ "-16 x $1\frac{3}{4}$ " hexagonal head cap screws before attempting to rotate either one. Release the brake on the mounting and check for freedom of rotation. If required, the apex bearing should be moved up or down. Be sure that setscrews in the apex bearing are tight after making this adjustment.

(4) Install the writing shelf, stored in the azimuth scale compartment of Cabinet CS-155-A, on the back of the cabinet (fig. 23).

e. Shelter Sides.

(1) Turn the door handle on each section to free the three shelter sides and door sections; then slide each section out of Chest CH-135-A. The three sections are identical and any one may be installed first. Slide the side stencilled TOWER TR-25-A SIDE into the groove provided in the underside of the roof and at the edge of the floor. The smooth surface must be on the outside and the windows near the top. Repeat this procedure to install the remaining two side sections.

(2) Close the three doors so that they are latched at the top and bottom. Tighten the wingnuts on the inner side of the roof, after the ends of the hookbolts have been engaged in the holes in the top of each shelter side.

(3) With the three doors closed and latched at top and bottom, tighten the eyebolts in each of the clamp rails along three sides of the floor; also tighten the six eyebolts which secure the roof to the tower. Every eyebolt in the entire assembly should now be checked for tightness and, when necessary, tightened securely. That is, they are turned as far as possible without exerting extra pressure. **IF THE BOLTS ARE TIGHTENED BEYOND THIS POINT, THEIR THREADS OR THE THREADS IN THE TAPPED HOLES MAY BE STRIPPED.**

f. Levelling of Tower. Use the spirit level, located in Chest CH-128-A, to determine whether the floor is level. Place wedges under the corners of the tower where required. Three wedges are packed in Chest CH-137-A for levelling purposes.

g. Azimuth Scale M-346-A (fig. 24). Remove the azimuth scale from Chest CH-128-A and place the scale over the mounting spindle that projects through the bottom of the receiver chest. It is necessary to angle this azimuth scale under the battery compartment in order to locate it on the spindle. After the scale is in position, secure it with the knurled nut provided for this purpose. This knurled nut is stored in Chest

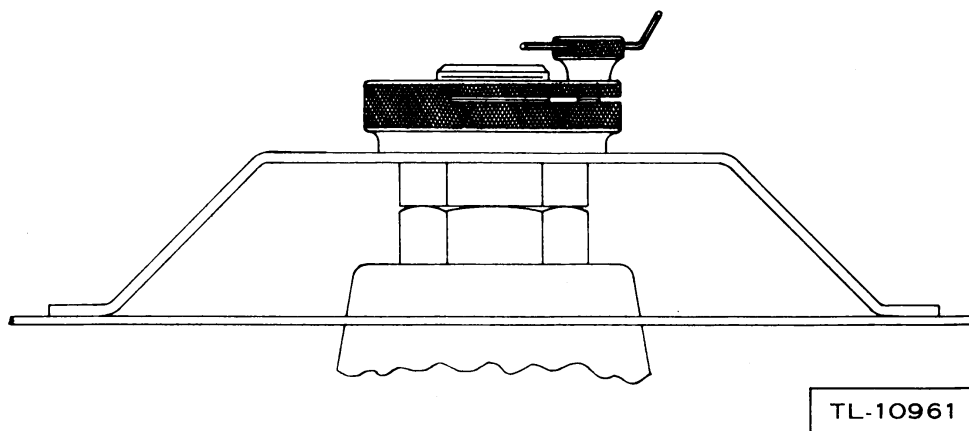

Figure 24. Assembly of azimuth scale.

CH-128-A. Release the catches securing the two hairline indicators and lower them into position directly over the scale. Instructions for setting the azimuth scale are given in paragraph **12c**.

h. Initial Servicing of Storage Batteries. Four 12-volt batteries are packed in individual Chests CH-139-A. Electrolyte for the batteries is shipped in a carboy. These batteries are shipped dry and before they are placed in operation for the first time they must be serviced as indicated. This servicing applies only to the initial use of the batteries.

(1) Remove the four batteries from their chests, unscrew the filler plugs, and remove and discard the tubes; never replace these tubes.

(2) Fill each cell with electrolyte from the carboy until the plates are covered. Replace the filler plugs on one of the batteries if it must be put to immediate use. In this condition, it will operate the RDF for approximately 8.5 hours before charging is necessary. This is about 80 percent of the discharge life of a fully charged battery. A fully charged battery will operate Radio Set SCR-555-A for 11 hours before it drops to 10 volts and requires recharging.

(3) The batteries not being used immediately after filling should be allowed to stand for AT LEAST TWO HOURS with filler plugs removed. After this time, restore the electrolyte level, replace the filler plugs, and charge the batteries according to instructions given in paragraph **37b**.

i. Electrical Connections.

(1) Place one of the batteries on the floor of the tower near the front of the receiver cabinet.

(2) Remove the battery cable from Chest CH-128-A. Connect the terminal lug on the white lead under the wingnut on the battery terminal marked P, and tighten the nut securely. Connect the terminal lug on the black lead under the wingnut of the battery terminal marked N.

(3) Open the door of the battery compartment in the lower left-hand corner of the receiver cabinet and slide the battery into the compartment so that the battery terminal connections are to the right.

(4) Lay the cable in the slot in the upper right-hand corner of the compartment and close the door.

(5) Insert the plug on the opposite end of this cable into the three-prong receptacle on the power supply chassis. The power supply is mounted on a shelf in the right side of the receiver cabinet, and the power receptacles are located on the front of the chassis. The slack in the battery cable is taken up by the clip located directly beneath the radio receiver.

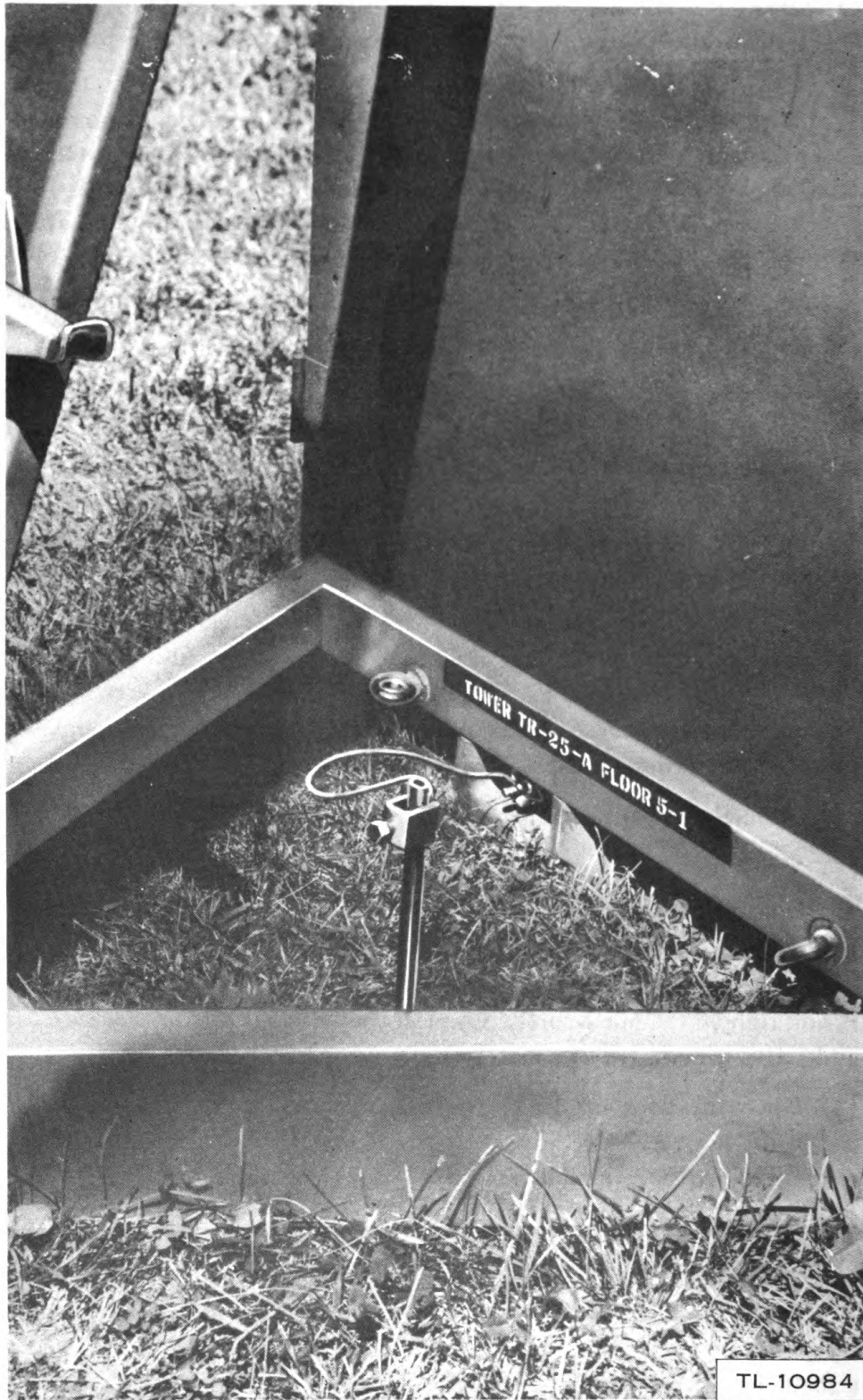

Figure 25. Ground connection.

(6) Remove the power cable from Chest CH-128-A and connect the four-prong plug to the receptacle in the power supply. Connect the plug on the other end of the cable to the receptacle at the lower right-hand corner of the radio receiver panel.

(7) Plug the headsets and the microphone into their respective jacks on the receiver panel. Two microphones (Microphone T-35) and two headset assemblies (Headset HS-29) are stored in Chest CH-128-A (fig. 4). Only one microphone and one headset assembly can be used at a time; the others are spares. The two headsets of the assembly accommodate both the radio operator and the telephone operator. One phone of each headset is connected to the receiver output; the other phone is connected to the telephone line. Headset plugs are inserted in the jacks marked A PHONES and B PHONES. The microphone jack is designated MIC.

(8) Insert the phone plug, mounted on a hinged bracket at the left side of the azimuth scale compartment, in the jack at the center of the mounting spindle. This provides the telephone line connection between the top of the mounting and the receiver telephone line terminals.

(9) If a field telephone line is used, connect the line to the two terminals on one side of the shelter near the ground. Make sure that these knurled nuts are tightened against the skinned ends of the telephone line after the connections have been made.

(10) Drive Ground Rod GP-28, packed in Chest CH-202-A, into the ground near one of the shelter sides (fig. 25). A ground connection is provided on each of three sides of the shelter, and the rod may be driven near any of these terminals. Allow at least 6 inches of the ground rod to project above the ground and fasten the ground clamp near the top of the rod. The ground clamp is packed in Chest CH-128-A. Connect a length of No. 14, or larger, copper wire between the ground clamp and the ground connection on the tower base.

j. Disassembly. Disassemble the tower and shelter in the reverse order of assembly.

k. Repacking Tower and Shelter. Whenever the tower and shelter parts are to be replaced in their packing chests, fold the shelter doors and sides with their outer surfaces together, and slide into the chest, hinges first. Turn the door handle while sliding these sections into the chest until they touch the opposite side. Release the handle and the bolts at the top and the bottom of the door should catch in the openings in the chest. If the door and side sections do not slide into the chest easily, apply a small amount of waterproof grease to the grooves.

CAUTION: When removing the mounting from the floor of the tower, BE SURE TO WITHDRAW THE TELEPHONE LINE

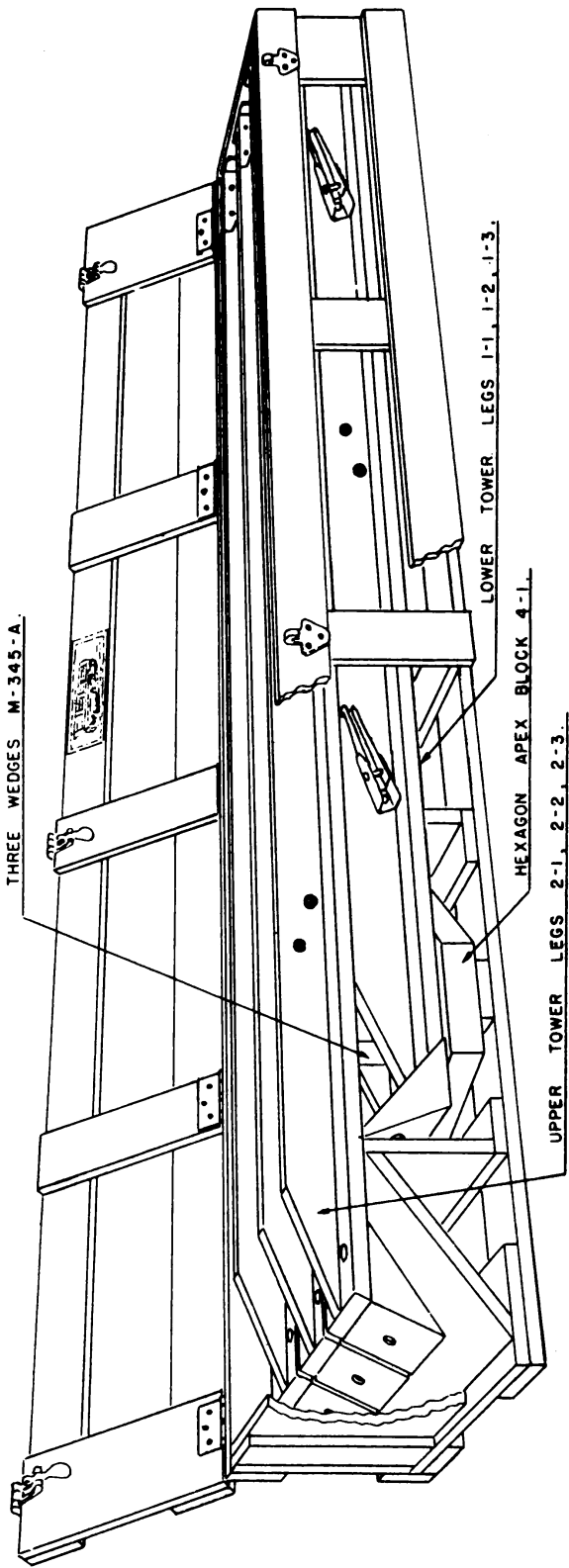

TL-10993

Figure 26. Chest CH-137-A, packed.

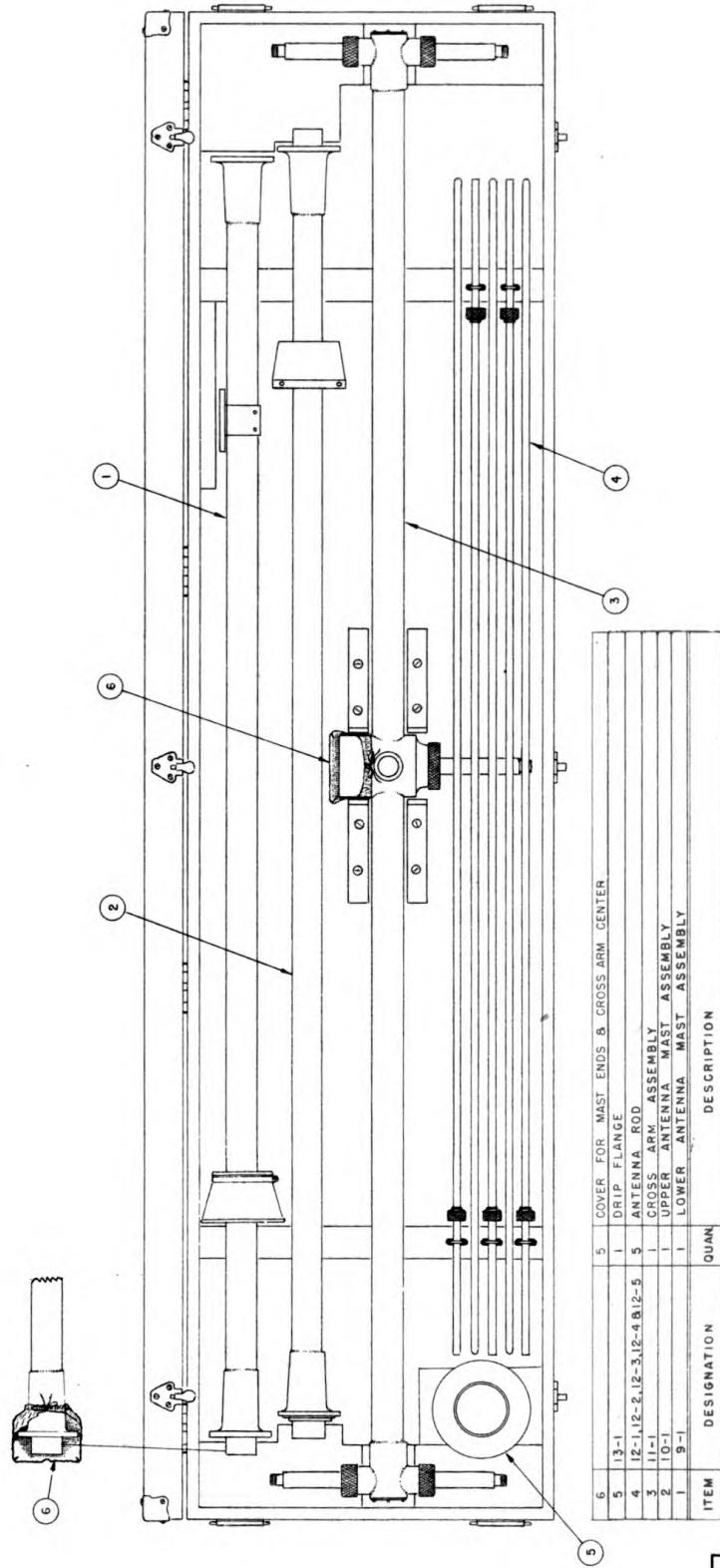

ITEM	DESIGNATION	QUAN	DESCRIPTION
6	13-1	5	COVER FOR MAST ENDS & CROSS ARM CENTER
5	12-1,12-2,12-3,12-4 & 12-5	1	DRIP FLANGE
4	11-1	5	ANTENNA ROD
3	10-1	1	CROSS ARM ASSEMBLY
2	9-1	1	UPPER ANTENNA MAST ASSEMBLY
1	8-1	1	LOWER ANTENNA MAST ASSEMBLY

TL-10892

Figure 27. Chest CH-105-A, packed.

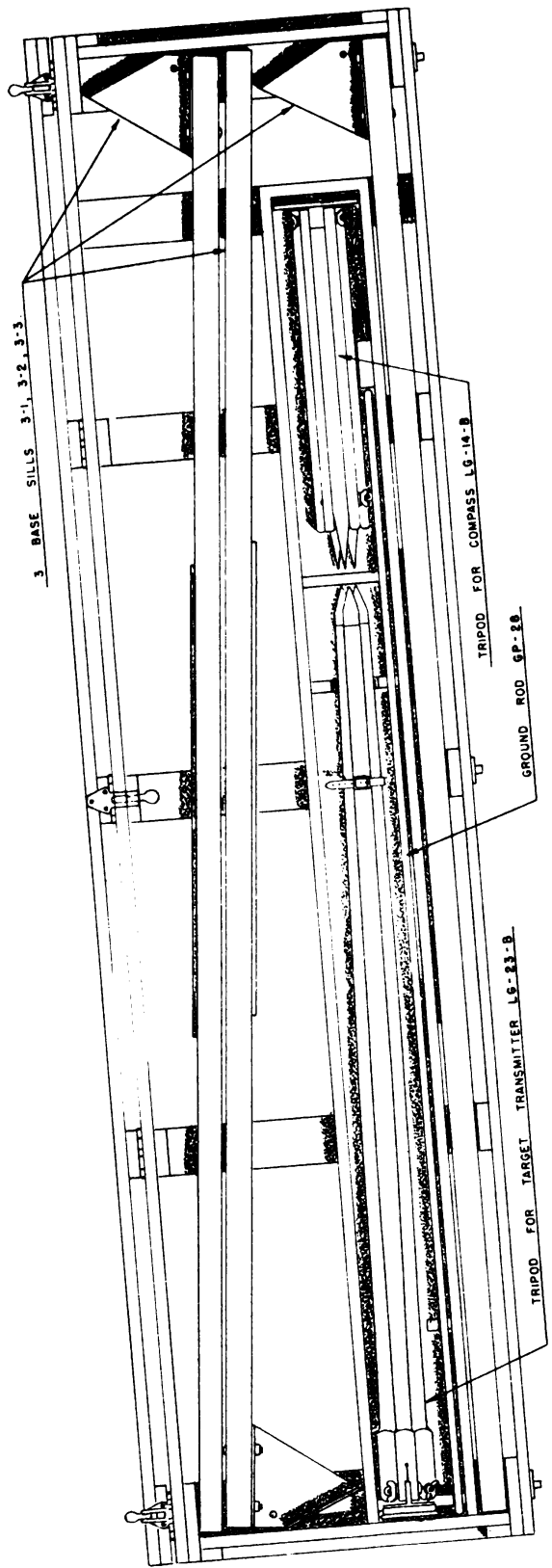

TL-10995

Figure 28. Chest CH-202-A, packed.

PLUG FROM THE JACK IN THE FLOOR, otherwise permanent damage to the plug, jack, or both will result. Also be sure to insert the plug in the jack located in the mounting, when the equipment is dismantled, to prevent damage to these parts in transit. Pack all other components in the chests just as they were originally packed. For the location of each part in its chest, refer to the labels attached to the respective chests, or figures 26, 27, and 28.

12. ORIENTATION.

a. Telescopic Sight MC-325-A. Remove the sight from Chest CH-128-A and attach it to the telescope mounting bracket (fig. 29), located on the lower antenna mast section slightly above the midpoint between the shelter roof and the apex block. For accurate orientation, the telescopic sight must be exactly 90° to the plane of the adcock antenna. The mounting bracket is correctly set at the time of manufacture, and adjustments are seldom required. However, should any adjustment be necessary, provision is made for it in the following instructions. Variations can be made in any plane, if desired.

- (1) Remove Compass MC-324-B from the Chest CH-128-A and attach it to Tripod LG-14-B stored in Chest CH-202-A.
- (2) Move the tripod to any point, preferably north of the set as determined by a rough compass reading, approximately 300 feet from the RDF.
- (3) Use the compass as a sighting device, without regard to compass indication, and sight upon the center of the vertical antenna mast.
- (4) Rotate the antenna system until the left and right dipoles fall in the line of sight of the compass.
- (5) With the antenna in this position, note the azimuth scale reading.
- (6) Rotate the RDF EXACTLY 90° from this position, in the direction that will place the line of sight of the telescope toward the compass.
- (7) Lock the RDF in this position and adjust the telescopic sight, if nec-

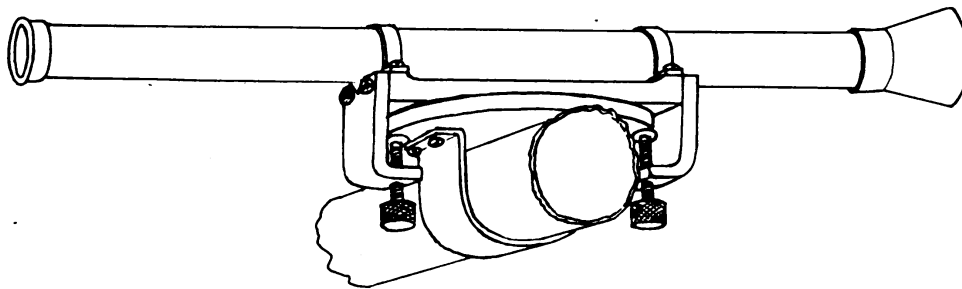

TL-10960

Figure 29. Mounting of telescope.

essary, until the line of sight falls on the center of the compass. To adjust the telescopic sight, loosen the four Allen head setscrews (wrenches for these screws are carried in Chest CH-128-A) and shift the assembly until perfect alignment is obtained. Tighten the four setscrews securely. The telescopic sight is now aligned with the adcock antenna.

(8) To check this adjustment, unlock the RDF and rotate it exactly 90° . In this position, the dipole antenna should fall in the line of sight of the compass to the center antenna mast, and only the dipole nearest the compass should be seen. If more than one dipole can be seen through the compass sights, the above alignment is incorrect and should be repeated.

b. Orientation of the RDF with Respect to a Fixed Azimuth. It is possible to orient the set with respect to magnetic north or true north in several ways. The recommended method and one alternate or check method are described in paragraphs **12c** and **12d**.

(1) Compass MC-324-B is equipped with two folding sights and a counterclockwise 360° scale so calibrated that the azimuth sighted may be read directly from the compass scale. This reading is the actual great circle azimuth from magnetic or true north, depending upon the initial calibration of the compass.

(2) To calibrate the compass for direct reading from magnetic north, rotate the scale by means of the small adjustment at the bottom of the compass, until the 0° point on the scale coincides with the reference line or pointer beneath the center of the front sight. When so calibrated, the angle from magnetic north to any object sighted will be indicated directly on the compass scale when read from the end of the needle bearing the letter N.

(3) To calibrate the compass for direct reading from true north, rotate the compass scale from east or west by the amount of magnetic declination at that particular geographic location. This can be obtained from any approved military map of the region. That is, if the declination is 10° west, the compass scale should be rotated until the 350° graduation coincides with the indicator. When so calibrated, the compass readings will indicate true azimuths.

(4) Examples of compass calibrations for magnetic north and true north with declinations of 10° east and 10° west are shown in figure 30.

c. Orientation, Recommended Method.

(1) After the telescopic sight is aligned as described in paragraph **12a**, correct the compass to read either true north or magnetic north, depending upon whether the orientation of the RDF is to be made with respect to true north or magnetic north.

(2) With the compass mounted on the tripod and placed approximately 300 feet north of the RDF, sight the compass upon the center mast of the antenna. Record the compass azimuth so obtained.

(3) Rotate the RDF until the cross hairs of the telescope fall on the center of the compass or a plumb line attached to the center of the tripod. Clamp the RDF in this position.

(4) Loosen the knurled head setscrew and the large knurled nut above the azimuth scale and when it is free, rotate the scale until the azimuth indicated on the RED scale at the radio operator's position is exactly the same as the compass reading obtained in paragraph 12c(2).

(5) Tighten the knurled nut with the strap wrench; tighten the knurled head setscrew. If a fine adjustment is required to make this reading coincide with the compass reading, the position of the hairline on the azimuth scale may be shifted. Tighten the hairline securely after this adjustment.

(6) Recheck the azimuth scale reading when the telescope is sighted on the center of the compass. If this azimuth and the compass reading do not agree, repeat the above procedure.

(7) Adjust the position of the hairline pointer for the telephone operator (opposite side from radio operator) until the azimuth indicated from this position on the BLACK scale is the same as that indicated from the radio operator's position on the RED scale.

(8) Figure 31 shows the correct orientation with respect to true north for a site with a 10° west declination.

d. Orientation, Check Method.

(1) Calibrate the compass to the correct declination and place it on the tripod approximately 30 feet from the RDF. If the compass is closer, it will be influenced by the magnetic field of the RDF; if it is farther away, the angular distance from it to the RDF will be sufficiently large to introduce errors. For minimum error, place the compass on the line between the RDF and the object.

(2) Sight the compass on an object such as a tree, tower, building, etc., which is at least a mile away. Record the azimuth obtained.

(3) Sight the same object through the telescopic sight and observe the reading on the BLACK calibrations on the azimuth scale.

(4) If the equipment has been correctly oriented, the two azimuths obtained will be identical. If they are not, proceed as explained in subparagraph c above.

13. RADIO TRANSMITTER BC-655-A.

a. Installation. Open the snap clamps on the case of Radio Transmitter BC-655-A, allowing the two sections of the case to be separated. Check the two tubes and the battery plugs for tightness in their sockets.

COMPASS CALIBRATION FOR MAGNETIC NORTH
AND TRUE NORTH WITH 10 DEGREE WEST DECLINATION &
10 DEGREE EAST DECLINATION

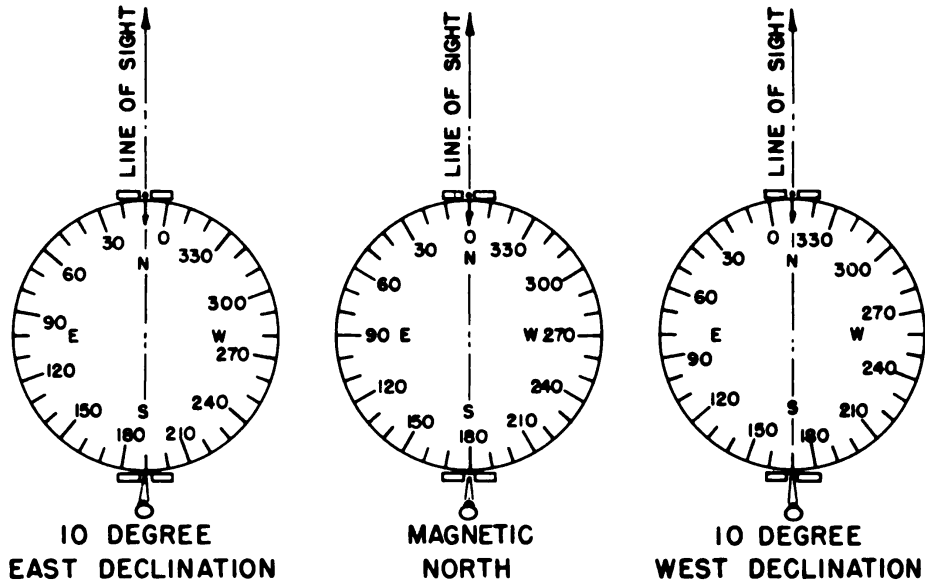

TL-10963

Figure 30 *Compass calibration.*

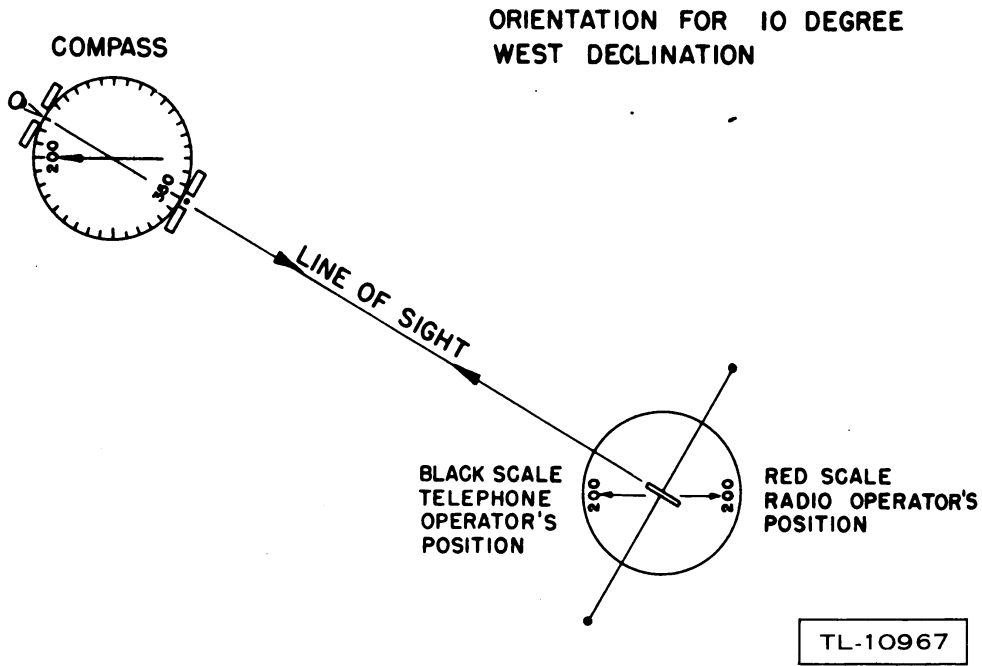

TL-10967

Figure 31. *Orientation example.*

The two 45-volt batteries have three-prong connectors and the 1.5-volt battery has a two-prong connector, so that it is impossible to connect them improperly. Fasten Antenna AN-103-A securely to the transmitter. Mount the transmitter and antenna on Tripod LG-23-B.

b. Location of Test Points. Using the compass and telescope, locate eight points, using stakes 100 yards from the RDF, starting with true or magnetic north and spacing the stakes 45° apart around the RDF. These are the points where the transmitter will be placed to test the operation of Radio Set SCR-555-A.

c. Operation. Proper operation of Radio Set SCR-555-A consists of getting approximately correct azimuths ($\pm 2^\circ$ or 3°) for each stake point of the transmitter. It also consists of getting a good response on the RDF at all frequencies with the transmitter placed at a distance of 100 yards from the adcock.

(1) Turn on the transmitter.

(2) Set the frequency.

(3) Take an azimuth on the transmitter. The difference between this azimuth and the true azimuth is the apparent error. If errors larger than 3° are observed, move the RDF to a new location rather than attempt to calibrate the site. This test equipment may be used to calibrate for certain types of site errors, but such calibrations should not be undertaken by inexperienced operating personnel.

NOTE: If the pointer of the BEARING METER on the RDF vibrates or moves slowly back and forth when the target transmitter is used for testing, turn the MODULATION ON-OFF switch, located on the transmitter, to OFF.

14. OPERATION OF RADIO SET SCR-555-A.

This radio set can be used as a figure-8 or switched-cardioid RDF. Both visual and aural indications are given for either method; however, the set is slightly more accurate on FIG.-8. FIG.-8 must be used for keyed c-w signals. SWITCHED CARDIOID must be used if sense determination is required.

15. INITIAL ADJUSTMENT OF RADIO DIRECTION FINDER.

To balance adcock amplifiers, proceed as follows:

a. Set the radio transmitter 50 yards from the RDF and tune it to 34 megacycles (fig. 32).

b. Record the azimuth obtained on the transmitter using the procedure outlined in paragraph 17.

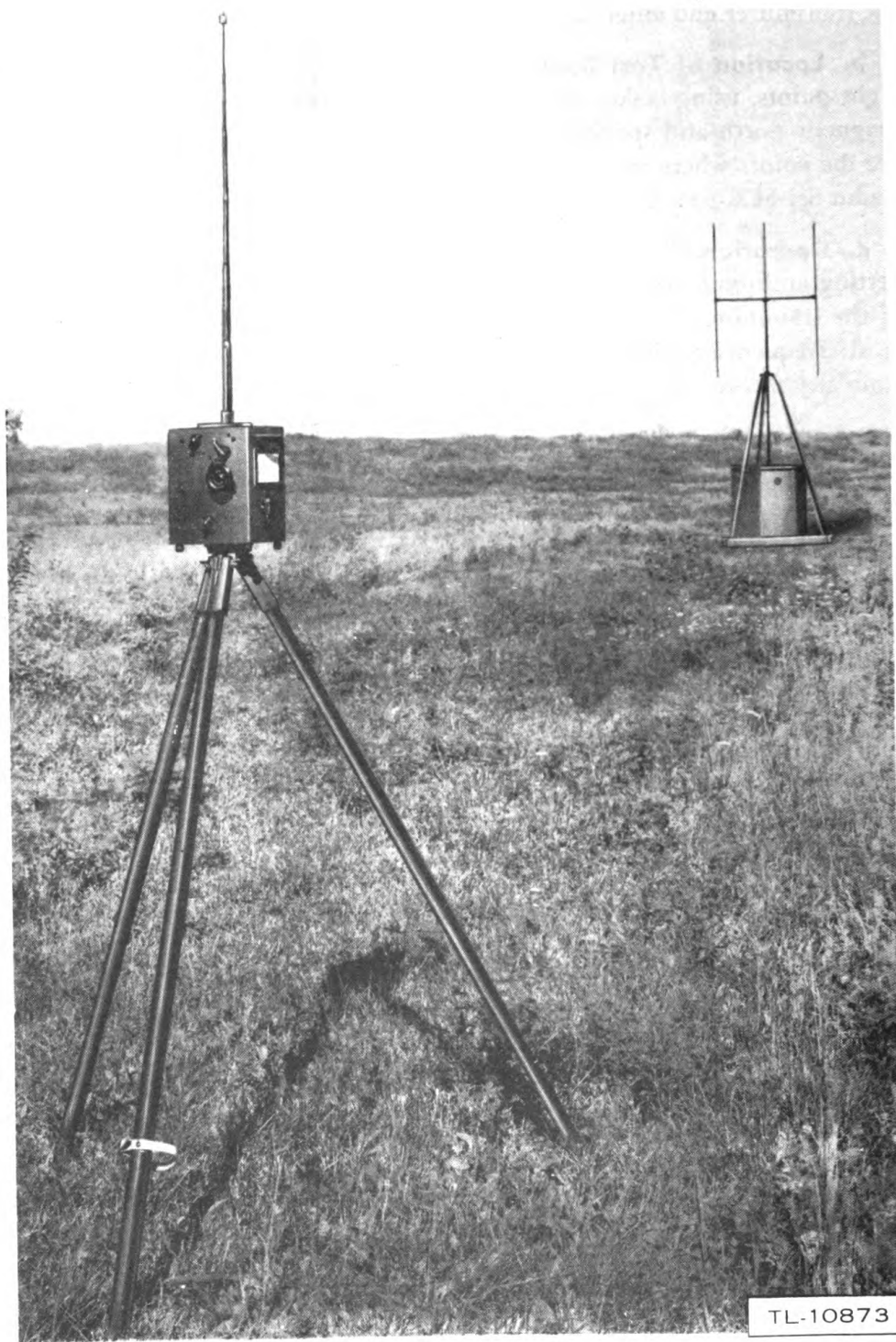

Figure 32. Radio Transmitter BC-655-A placed for operation.

- c. Turn the RDF off the azimuth about 90°.
- d. Remove the access door on the front panel of the receiver and set the TEST SWITCH to its extreme right or BALANCE position. The TEST SWITCH is located near the left rear corner of the receiver and can be reached with the right hand (fig. 50).
- e. Turn the METER SENSITIVITY control to the extreme clockwise position.
- f. With the RF SENSITIVITY control set at minimum, reach in the panel opening, and with a screwdriver set the ADCOCK BALANCE control at one extreme or the other. This control, provided with a slotted shaft, is mounted on the chassis immediately behind the tuning drum (fig. 50).
- g. Set the SWITCHED CARDIOID — FIG.-8 switch at SWITCHED CARDIOID and slowly advance the RF SENSITIVITY control clockwise, while watching the BEARING METER. The meter will deflect to one side and then start to reverse, which indicates overload of the third i-f stage. Turn the RF SENSITIVITY control to slightly below this overload point.
- h. Adjust the ADCOCK BALANCE control until the BEARING METER indicates zero. The adcock amplifiers are now balanced. If balance cannot be obtained, interchange the adcock amplifier tubes or replace one.

16. OPERATION AS FIGURE-8 AURAL-NULI RADIO DIRECTION FINDER.

For step-by-step instructions, proceed as follows:

- a. Set the switch marked SWITCHED CARDIOID — FIG-8 to FIG-8 position.
- b. Turn the receiver on by setting the POWER switch to ON.
- c. When the receiver has become warm, turn the RF SENSITIVITY control left to AVC.
- d. Turn the AUDIO VOLUME control to a high level.
- e. Select the desired frequency band with the BAND switch and tune the receiver to the desired frequency with the TUNING knob.
- f. When the signal is located, tune for minimum reading on the tuning meter marked TUNE FOR DIP, or until a maximum signal is heard in the phones.
- g. Having made these adjustments, rotate the RDF until a signal null (minimum signal) is heard in the phones, or until the tuning meter indicates a maximum reading.

- h.** The exact center of this null is the true azimuth.
- i.** Rotate the RDF approximately 180° and check the reciprocal azimuth. This should be exactly 180° from the direct azimuth. If it is not, repeat the operation.
- j.** When used in this manner, the RDF gives a bidirectional azimuth and sense indication is impossible.

17. OPERATION AS SWITCHED-CARDIOID LEFT-RIGHT RADIO DIRECTION FINDER.

For step-by-step instructions, proceed as follows:

- a.** Set the SWITCHED CARDIOID — FIG-8 switch to FIG-8 position.
- b.** Turn the receiver on by turning the POWER switch to ON.
- c.** When the receiver has become operative, turn the RF SENSITIVITY control left to AVC.
- d.** Set the BAND switch to the correct position for the frequency to be tuned, and tune the receiver to the desired frequency with the TUNING knob.
- e.** When the signal is located, accurately tune for minimum reading on the tuning meter.
- f.** Turn the METER SENSITIVITY control to the extreme counterclockwise position.
- g.** Set the SWITCHED CARDIOID—FIG-8 switch to the SWITCHED CARDIOID position.
- h.** Adjust the METER BALANCE control until the BEARING METER reads zero.
- i.** Turn the METER SENSITIVITY control approximately one-half turn or until the BEARING METER shows a deflection to either right or left of zero.
- j.** Rotate the RDF until the BEARING METER reads zero. Greater sensitivity at the null may be obtained by turning the METER SENSITIVITY control clockwise.
- k.** The sense or direction of the signal is checked by rotating the RDF off null position and noting the direction in which the BEARING METER indicator swings.
- l.** A DIRECT AZIMUTH IS INDICATED WHEN THE BEARING METER INDICATOR SWINGS TO THE RIGHT AS THE ANTENNA IS ROTATED COUNTERCLOCKWISE (OPERATOR'S BODY MOVES RIGHT). The exact azimuth is indicated when the antenna is in such a

position that the BEARING METER indicates zero. On a direct azimuth the signal source is in front of the radio operator and is indicated by the BLACK azimuth scale in front of the radio operator, and by the RED azimuth scale in front of the telephone operator.

m. Rotate the RDF through 180° and check the reciprocal azimuth. This should be exactly 180° from the direct azimuth.

n. A RECIPROCAL AZIMUTH IS INDICATED WHEN THE BEARING METER INDICATOR SWINGS LEFT AS THE ANTENNA IS ROTATED COUNTERCLOCKWISE (OPERATOR'S BODY MOVES RIGHT). The exact azimuth is indicated when the BEARING METER reads zero. On a reciprocal azimuth, the signal source is in back of the radio operator and is read on the BLACK scale. He may, however, obtain the direct azimuth by reading the RED scale.

o. A direct azimuth is also obtained when the BEARING METER swings left as the antenna is rotated clockwise (operator's body moves left).

p. A reciprocal azimuth is also obtained when the BEARING METER swings right as the antenna is rotated clockwise (operator's body moves left).

q. In addition to the BEARING METER, the operator has an aural indication of a null position. When the RDF is tuned to the null position, the low-frequency hum of the cardioid-switching voltage disappears.

18. OPERATION OF HEADSETS AND MICROPHONE.

a. **Headset HS-29.** This headset assembly supplied with the RDF consists of two headsets. Each headset has split phones so that one ear hears the RDF circuit while the other ear is hearing the telephone circuit. Headset HS-29 has two plugs, one for each circuit.

(1) Insert phone plugs in A PHONES jack and B PHONES jack.

(2) The following chart indicates what will be heard in the A PHONES and in the B PHONES with the RADIO switch and the A PHONES switch in different positions. The volume control referred to is that marked VOLUME A — PHONES ON LINE.

<i>RADIO switch</i>	<i>OFF LINE</i>		<i>ON LINE</i>	
	<i>ON RADIO</i>	<i>ON LINE</i>	<i>ON RADIO</i>	<i>ON LINE</i>
<i>A-PHONES switch</i>				
A PHONES	radio	(weak) telephone volume control operates	radio and telephone	(weak) radio and telephone volume control operates
B PHONES	radio	radio and telephone	radio and telephone	radio and telephone

When the RADIO switch is in the ON LINE position, the output of the radio receiver is heard at the other end of the telephone line. Where *weak* is shown in the above chart, it indicates that the signal is not as loud as when other switch combinations are used. This is due to the use of the high-impedance headsets; provision is made for conversion to the use of low-impedance headsets (par. 35f).

b. Microphone T-35. The microphone is plugged into the jack marked MIC and is operative when the switch on the microphone breast plate is ON. When not in continuous use, the switch should be OFF.

19. OPERATION PRECAUTIONS.

a. Adcock Balance. Check the adcock amplifiers every 2 weeks or oftener to see that a balance is maintained. If a balance cannot be made with the ADCOCK BALANCE control, interchange the two adcock tubes or replace one tube.

b. Overload. When operating as a switched-cardioid RDF on very strong signals, it is best practice to set the METER SENSITIVITY control at the approximate maximum setting and then use RF SENSITIVITY as the master control. This eliminates the possibility of overloading the last i-f amplifier tube.

c. C-w Operation. When copying code signals, a sharper signal will be heard if the AUDIO VOLUME control is nearly at maximum, the AVC switched OFF, and the RF SENSITIVITY control is used. Operation as a switched-cardioid RDF on keyed signals is not satisfactory although an indication of sense is sometimes possible. For the most accurate readings, use the equipment as a figure-8 aural-null RDF when receiving keyed c-w signals.

d. Nearby Objects. When Radio Set SCR-555-A is being used as an RDF, no persons other than the two operators should be within 50 feet of the set. The area immediately surrounding the RDF (25-foot radius) must be free of all metallic objects which are 18 inches or more in length, or errors will be introduced.

SECTION III

FUNCTIONING OF PARTS

20. PRINCIPLE OF SWITCHED-CARDIOID RADIO DIRECTION FINDER.

a. Antenna AN-105-A. This radio set uses both a vertical H-type adcock antenna and a centrally located vertical antenna (fig. 33). The adcock antenna consists of two spaced doublets connected in opposition by a cross-connection (fig. 33 ①). The adcock antenna by itself has a horizontal field pattern (fig. 34). This figure-8 field pattern represents the horizontal directivity of the adcock portion of the antenna. The vertical antenna portion (fig. 33 ②) is equally sensitive in all horizontal directions and its field pattern is circular (fig. 34). If the figure-8 output of the adcock antenna is combined with the equisignal output of the vertical antenna under proper phase conditions, the field pattern will be a cardioid (fig. 35 ①). If the connections from the adcock antenna are reversed before it is joined with the vertical antenna, the cardioid pattern will reverse and take the form shown in figure 35 ②.

b. Switching. The operation of a switched-cardioid RDF requires the rapid switching of the adcock antenna output to produce first one and then the reverse cardioid. Figure 36 illustrates the simplest form of the switched-cardioid RDF. In this simple form, the signal from the adcock antenna is reversed by a reversing switch. Synchronized with this is another switch which reverses connections to a zero-center galvanometer which indicates the output of the radio receiver. When the reversing switches are at position A, cardioid A is formed, and the meter connection is such that the signal causes the meter to deflect to the right. When the switches are at position B, cardioid B is formed, and a signal will deflect the meter to the left. If the switches are operated rapidly enough, the meter will deflect to the right only an amount proportional to the difference in output from the two cardioid patterns.

c. Azimuths. If a radio transmitter is located as shown in figure 37 ①, the BEARING METER tends to deflect to the right by the amount "a" and to the left by the amount "b". With the transmitter still located at the same position and the antenna system rotated 180°, the condition shown

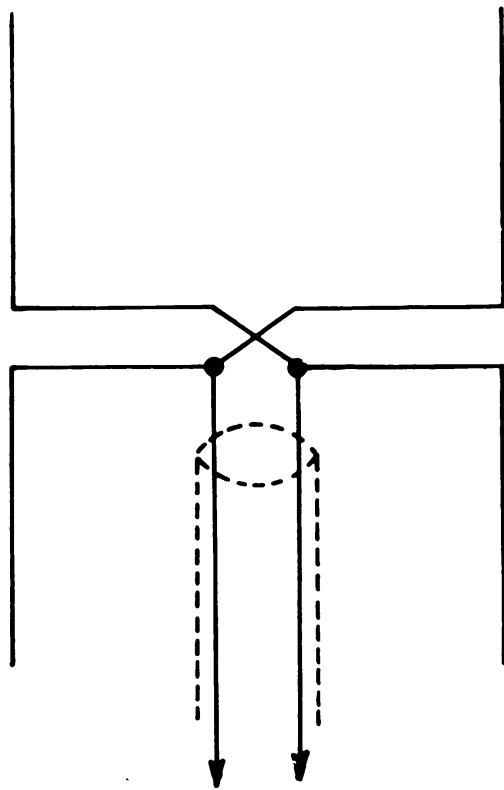

ADCOCK ANTENNA

①

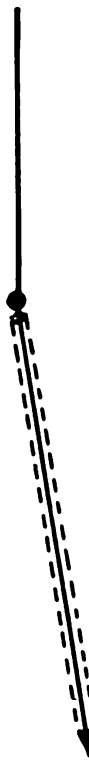

VERTICAL ANTENNA

②

TL-10964

Figure 33. Adcock and vertical antenna diagrams.

in figure 37 ② will exist and it will be noted that the amount "b" now exceeds the amount "a", and the meter will deflect to the left by the amount "b" minus "a". Therefore, the system is said to have *sense*, as it is possible to determine whether a direct or a reciprocal azimuth is being observed by noting the direction in which the meter deflects when the antenna is rotated off the null position. When the adcock antenna is rotated to a null position, the signal which is heard is that from the vertical antenna alone, because the adcock antenna is at a null and is not contributing any signal. Therefore, there are no pulses of signal from the adcock antenna to deflect the meter one way or the other, or to be heard in the phones. This gives the operator an aural indication as well as a visual indication of the null position.

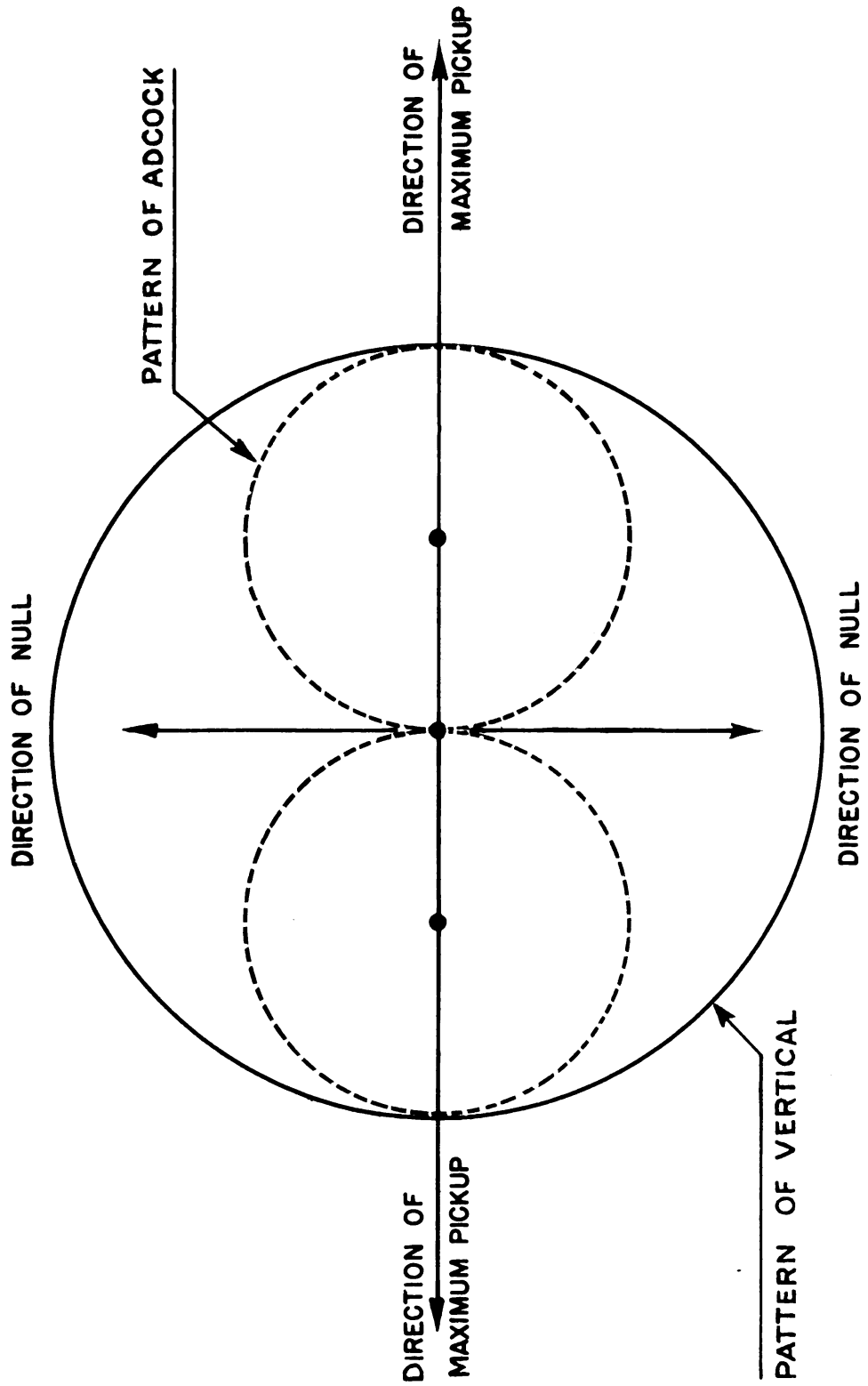

TL-10966

Figure 34. Adcock and vertical antenna field patterns.

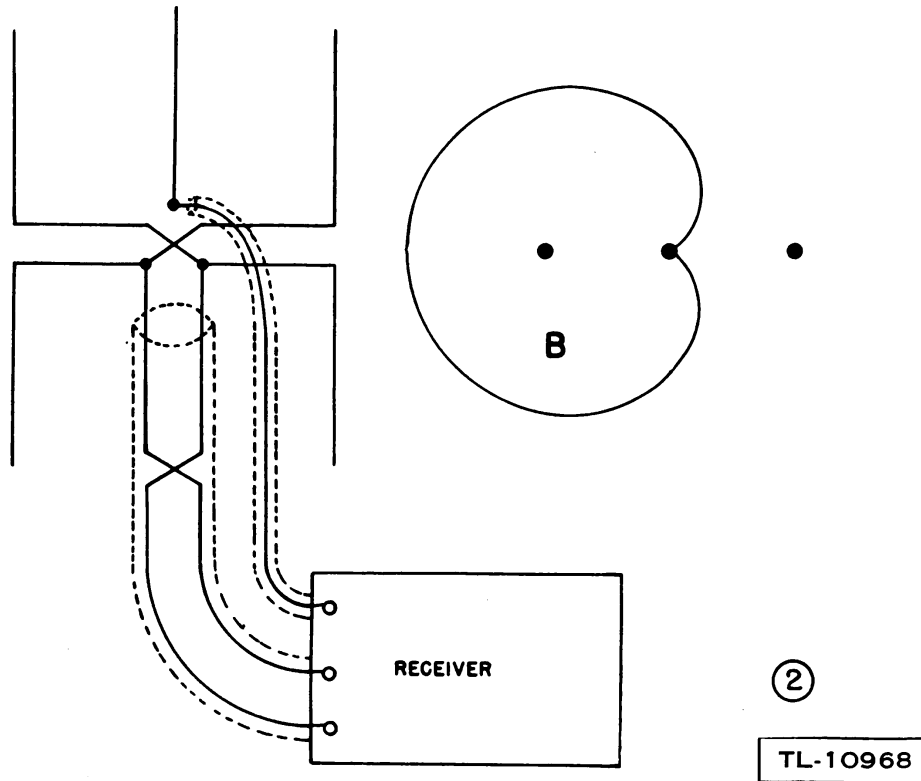
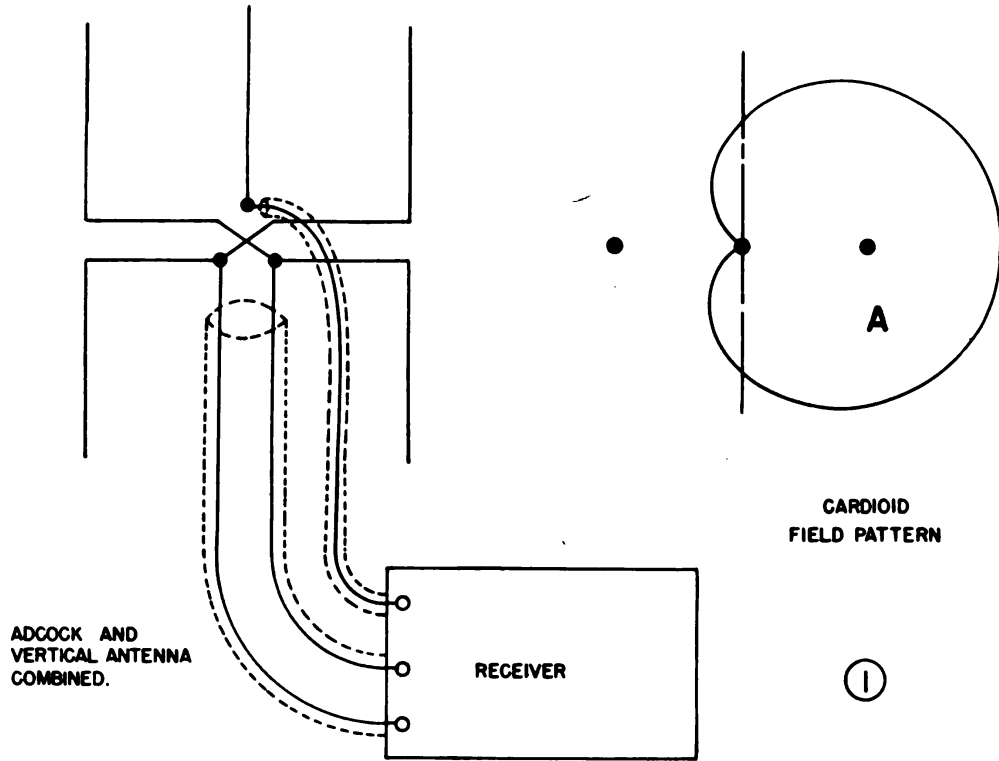

Figure 35. Cardioid field patterns.

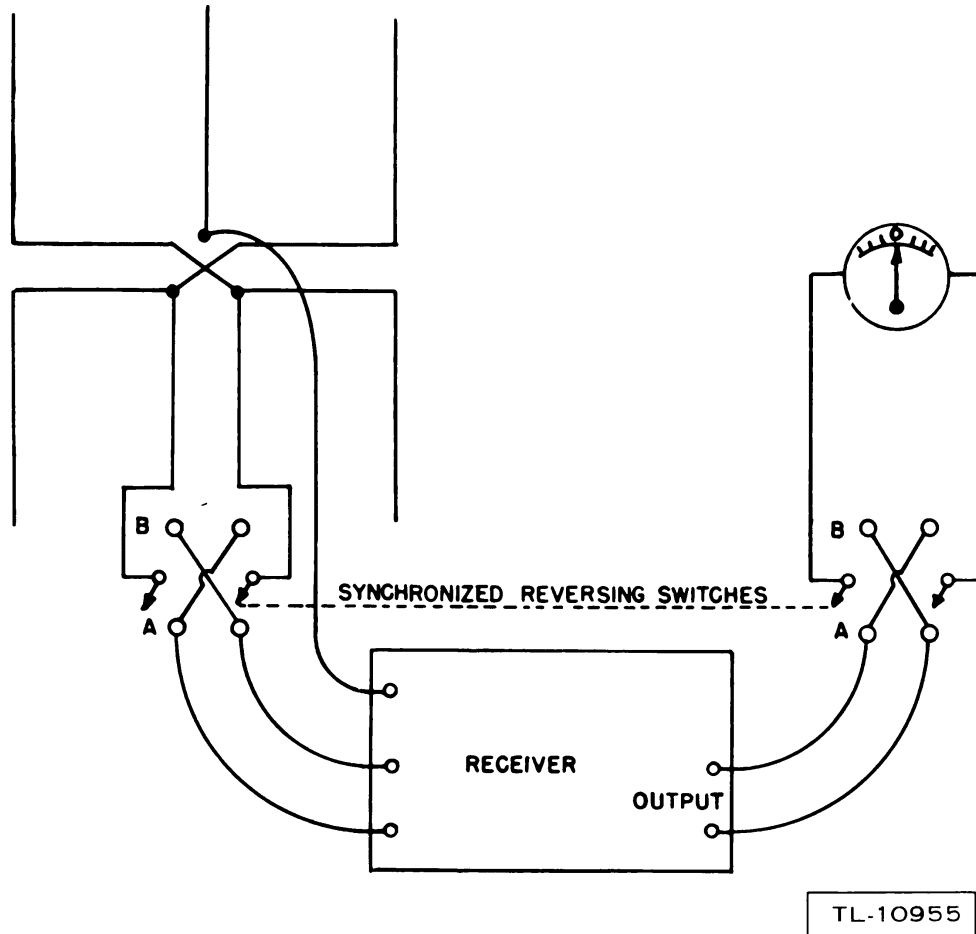
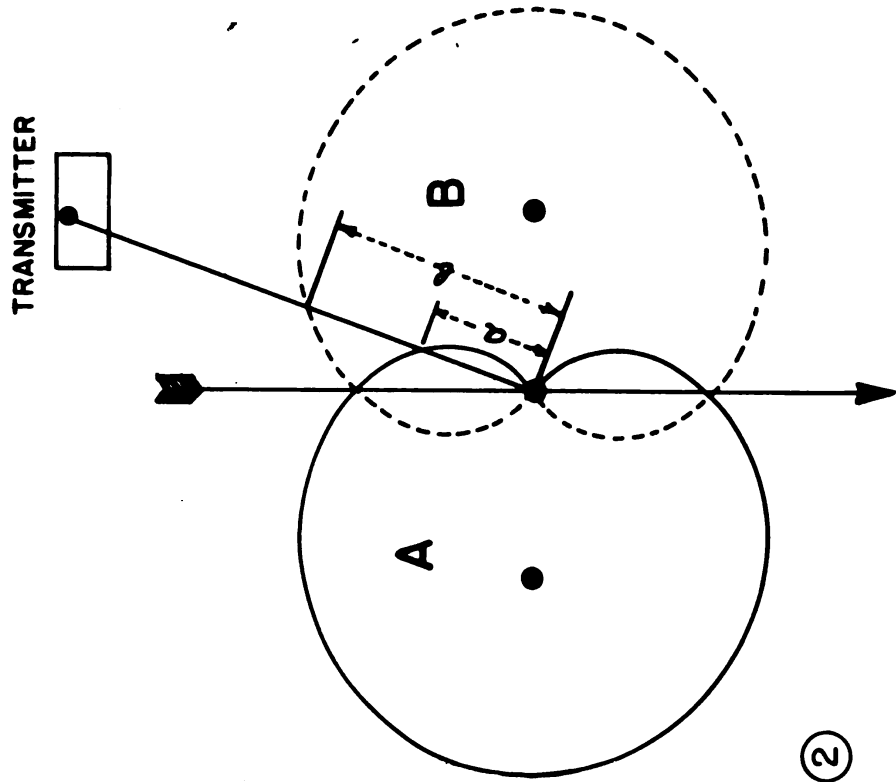
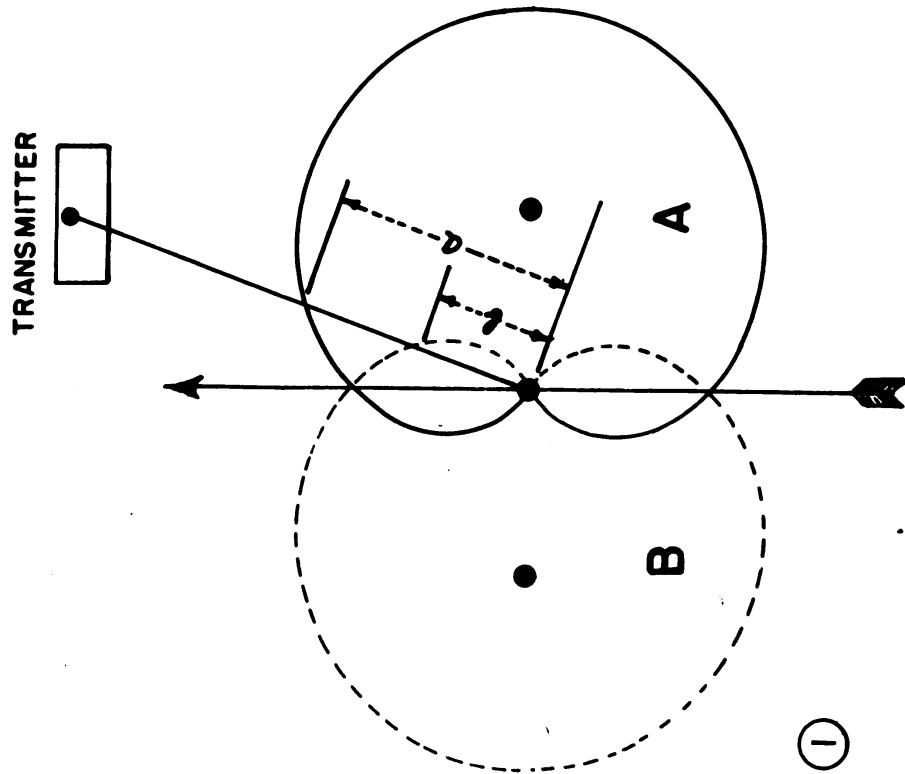

Figure 36. Simplified form, switched-cardioid radio direction finder.

d. Electronic Switching. In the receiver, the adcock antenna connections and the meter connections are reversed by an electronic switching circuit (fig. 38). A square wave oscillator operating at 130 cycles feeds two negative pulse rectifiers which pass only negative pulses. These negative pulses are fed to the grids of the adcock amplifier tubes and alternately cut off one tube and then the other. Since the grids of the adcock amplifiers are in push-pull and the plates are connected in parallel, the signal at the plate is reversed in phase at a rate of 130 cycles per second. This signal is combined with the signal from the vertical amplifier and fed to the mixer tube of a superheterodyne receiver. When tube A is operating, cardioid A is formed, and when tube B is operating, cardioid B is formed. The output of the detector is fed to the bearing amplifier which amplifies the pulses. The negative pulses which cut off the adcock amplifiers are also fed to the grids of the synchronous voltmeter. With no signal fed to the plates of the synchronous voltmeter (METER SENSITIVITY control off), the plate currents are balanced by the METER BALANCE control so that the indicator meter shows no deflection. If the pulses as shown from the



2



1

TL-10956

Figure 37. Cardioid field patterns obtained by switching.

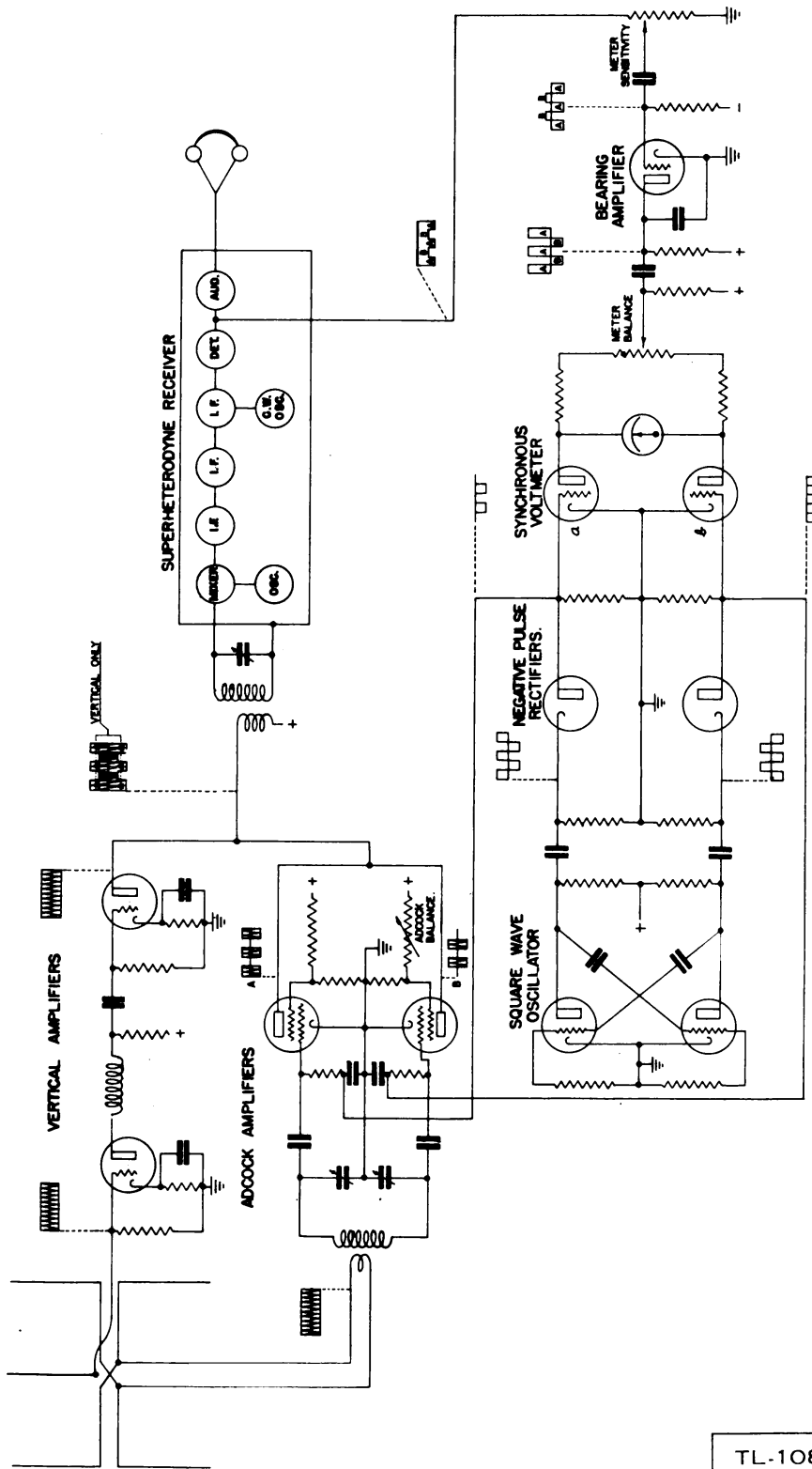

TL-10874

Figure 38. Electronic switching, circuit diagram.

bearing amplifier are now fed to the plates of the synchronous voltmeter, the plate voltage is increased when tube B is working, which gives an unbalance in the plate currents and causes the BEARING METER to deflect to the right. When a station to the left of null is received, the 130-cycle waveform at the superheterodyne input is reversed since the r-f output of the adcock antenna is now changed 180°. The plate voltage of tube A is now increased when the tube is conducting, resulting in an unbalanced condition which causes the meter to deflect to the left. It is essential that the adcock amplifiers be balanced to have the same gain. This is done by adjusting the screen voltage on one tube. When an adcock amplifier tube is not cut off by a negative pulse on its grid, the grid receives as its normal operating bias the voltage developed in the negative pulse rectifier load resistor by the space current of the rectifier. This same voltage also serves as the bias for the grids of the synchronous voltmeter. A functional block diagram of Radio Receiver BC-1005-A is shown in figure 66.

21. ANTENNA SYSTEM (fig. 67).

The antenna system is the most critical part of the entire radio set. The adcock antenna uses a closely-balanced twin transmission line which is shielded from the single coaxial transmission line of the vertical antenna. Four 100-ohm resistors 233-1, 233-2, 233-3, and 233-4 are connected, one in series with each antenna rod of the adcock antenna. These series resistors in conjunction with 270-ohm resistors 235-5 and 235-6, tend to make the antenna aperiodic.

NOTE: An antenna is aperiodic when it exhibits no resonant characteristics in the frequency band for which it is designed.

The resistor bridge system prevents any resonant condition which would otherwise occur between the upper rod at one end of the crossarm and the lower rod at the other end. Resonance is avoided as it would magnify the ill effect of slight unbalances. The twin transmission lines within the crossarm meet at the center and are cross-connected through four 47-ohm resistors 234-1, 234-2, 234-3, and 234-4. This cross-connecting network maintains a balance, matches the three pairs of coaxial transmission lines, connects the adcock dipoles in opposition to each other, and prevents resonance. A 68-ohm resistor 201 is located within the crossarm at the center and is connected in series with the vertical antenna. This tends to make this antenna aperiodic. Reflections in the transmission line from the vertical antenna are damped by the 270-ohm shunt resistors 235-3 and 235-4 and the 12-ohm series resistors 237-1 and 237-2, at the top and bottom of the mast. The adcock and vertical antennas have separate transmission lines. One transmission line consists of a twin coaxial cable terminated with banana-plug connectors. The second line, a single coaxial cable, is also terminated with a banana-plug connector and both lines are plugged into

their respective sockets on top of the receiver chassis. The base of the mast connects to a junction box in the top of the receiver cabinet. The box contains two 270-ohm resistors 235-1 and 235-2, one connected from each side of the twin line to ground. These resistors, in combination with the antenna transformer 311 in the receiver and its primary series-resistors 212-1 and 212-2, provide the proper termination impedance over the tuning range of 18-65 megacycles. The vertical connector cable from the junction box to the receiver is longer than the adcock connector cable by about half the length of the crossarm. This maintains a constant phase angle between the adcock and vertical antennas at all frequencies. All resistors in the adcock antenna system have been stabilized by temperature cycling and adjusted to the close tolerances indicated. The twin transmission line has a characteristic impedance of 155 ohms, 77.5 ohms from each side to ground. The characteristic impedance of the single coaxial line is 70 ohms.

22. ADCOCK R-F AMPLIFIERS (fig. 68).

The adcock r-f amplifiers consist of a balanced modulator circuit in which the adcock and vertical antenna signals are combined to form a cardioid pattern which is switched 130 times per second. Switching is accomplished by alternately driving the grids of tubes V3 and V4 type 12SG7 pentodes, to cut-off by applying negative pulses from the negative pulse rectifiers. Since the grids are connected in push-pull and the plates in parallel, the adcock antenna signal voltage appearing across the plate load is reversed in phase at a 130-cycle rate. The vertical amplifier output is combined with the modulator output since a common plate load is utilized. When an r-f signal is present at the grids of the modulator (adcock antenna off null), the adcock and vertical antenna signals will combine across the common plate load to form a square wave r-f signal pattern as the adcock and vertical signals alternately add and subtract across the common plate load. The amplitude of this r-f envelope will depend upon the angle of the adcock antenna with respect to the null position, and the phase of the r-f envelope will change 180° when the adcock antenna is rotated through a null position. The adcock antenna signal is fed through series resistors 212-1 and 212-2 to the antenna transformer 311. The resistors, in combination with the transformer primary and shunt resistors 235-1 and 235-2, terminate the transmission line from the adcock antenna. The split stator capacitor 126-1 is adjustable and provides means for accurately balancing the transformer primary to ground. Capacitors 120 are ganged with the tuning control and, together with aligning capacitor 119-1, resonate the secondary to transformer 311. The signal is applied in push-pull to the grids of tubes V3 and V4 through capacitors 103-1 and 103-2, and appears across the primary of the mixer input coil in greater amplitude. The pulsed bias voltages from the pulse rectifiers are applied through an r-f decoupling network (consisting of resistors 208-1, 208-2 and capacitors 104-1, 104-2), and alternately drive the grids to cut-off. Capacitors 103-1 and 103-2

have a value of 100 micromicrofarads and therefore present a low-impedance path to the adcock antenna r-f signals; however their reactance at 130 cycles is very high and they effectively isolate the switching pulses from the tuned grid circuit. The screen voltage for tube V3 is supplied through a voltage dividing network consisting of resistors 209-1 and 210-1. Capacitor 101-8 places the screen at ground potential. Tube V4 screen potential is supplied by a voltage dividing network consisting of variable resistor 227 and resistor 209-2. The variable resistor provides means for regulating the screen potential of tube V4 so that the cathode currents of both tubes can be balanced. Capacitor 101-9 places the screen of tube V4 at ground potential.

23. VERTICAL AMPLIFIERS (fig. 69).

The vertical amplifiers increase the amplitude of the vertical or *sense* antenna signals before they are combined with the adcock r-f amplifier output. The vertical antenna coaxial line is properly terminated by resistor 218, which also serves as the grid load of the first amplifier tube, V1, a type 6AC7 pentode. Resistor 202-1, bypassed by capacitor 101-1, provides self-bias. Resistor 203-1 drops the high-voltage supply to the proper screen potential, and decoupling is provided by capacitor 101-2. The output of vertical amplifier tube V1 is coupled to amplifier tube V2, also a type 6AC7 pentode, by inductance 316 and coupling capacitor 102-1. Inductance 316, the plate capacity of tube V1, and the grid input capacity of tube V2 form a filter network to equalize gain and phase shift. Resistor 204 also forms part of this filter network and plate load, and resistor 203-2 and capacitor 101-3 form a decoupling network. Resistor 205-1 forms the grid load for tube V2, which is self-biased by resistor 202-2 and bypassed by capacitor 101-4. Proper screen potential is provided by dropping resistor 203-3 bypassed by capacitor 101-5. The output of the vertical amplifiers is combined with the adcock r-f amplifier output and applied to the mixer stage input.

24. SQUARE WAVE OSCILLATOR (fig. 70).

The square wave oscillator dual-triode tube V15, a type 12SN7GT twin triode, is used as a two-stage resistance-coupled amplifier in which the output of one section is coupled to the input of the other section. Each section of the tube gives a phase inversion which is equivalent to a 180° phase shift. Thus a total phase shift of 360° is obtained; the output of one section is in phase with the input of the other section, and the conditions for an oscillatory circuit are satisfied. Although the circuit is balanced externally, there will be enough unbalance between the two sections of the tube to start its operation. Assume a point in one cycle of operation at which the voltage at plate 5 is increasing and has reached a value just above that for plate 2. The instant the voltage at plate 5 exceeds that at plate 2, capacitor 104-5 charges and causes the voltage on grid 1 to become

positive. This voltage rise on grid 1 causes an increase in current through plate resistor 222-1 and causes the voltage at plate 2 to decrease. The decreasing voltage at plate 2 causes capacitor 104-4 to discharge through grid resistor 221-2 causing the voltage at grid 4 to become negative. The current through plate resistor 222-2 now decreases and the voltage at plate 5 increases, charging capacitor 104-5 still further. The action described continues until grid 4 is well beyond cut-off and there is no further change in voltage at plate 5. The instant the voltage at plate 5 reaches maximum value, capacitor 104-5 starts to discharge through resistor 221-1, causing the voltage at grid 1 to become negative. The current through plate resistor 222-1 now decreases, and the voltage at plate 2 increases charging capacitor 104-4 and causing grid 4 to become positive. When this happens, the current through plate resistor 222-2 increases causing the voltage to decrease at plate 5, thereby causing a further discharge of capacitor 104-5 through grid resistor 221-1, driving grid 1 more negative. The negative voltage on grid 1 causes less current through plate resistor 222-1 and an increase in voltage at plate 2, charging capacitor 104-4 still further. The action just described continues until there is no further change in voltage at plate 2. The instant the voltage at plate 2 reaches maximum value, capacitor 104-4 starts to discharge through grid resistor 221-2 making grid 4 negative, less current flows through plate resistor 222-2, the voltage at plate 5 increases, and capacitor 104-5 starts to charge. This completes one cycle of operation. The frequency of the square wave oscillator is determined by the values of the grid and plate resistors and the feedback capacitors. A negative pulse is produced at each plate during the time it is conducting. Capacitors 113-1 and 113-2 couple the oscillator output to the negative pulse rectifier.

25. NEGATIVE PULSE RECTIFIERS (fig. 71).

The negative pulse rectifiers are driven by negative pulses from the square wave oscillator, and alternately generate d-c voltages in synchronism with the negative portion of the applied pulses. The bias voltage thus developed is utilized to alternately switch the adcock r-f amplifiers and the synchronous voltmeter bias. The negative pulse rectifiers are contained in one envelope (tube V14), a type 12H6 twin diode. The output of the square wave generator is applied to the cathodes of tube V14 through coupling capacitors 113-1, 113-2 and series cathode resistors 220-4 and 220-5. When a negative pulse is applied to the cathode of the first or A section of tube V14, the diode will conduct, as its cathode is driven negative with respect to the anode, and a voltage will be developed across resistor 220-2. At the same instant, a positive pulse is applied to the second or B section of tube V14, but this diode will not conduct as its cathode is being driven positive. When the applied pulse polarity is reversed, the action of A and B will be reversed, developing a negative voltage across diode load resistor 220-3. The negative voltages which are alternately

developed across the diode load resistors are applied to the synchronous voltmeter and adcock amplifier control grids.

26. SYNCHRONOUS VOLTMETER (fig. 72).

The synchronous voltmeter circuit provides visual indication of the adcock antenna null position and direction sense of received signals. A zero-center 75-0-75 microammeter and tube V13, a 12SN7GT twin triode, form the main circuit components. The two triode sections are connected in push-pull and the output from the negative pulse rectifier is applied to the grids across grid resistors 220-2 and 220-3. Resistors 219-2 and 219-3, and potentiometer 230 form a balanced plate load circuit. BEARING METER 377, in conjunction with the balanced plate load, indicates the potential difference between plates. In the absence of a signal from the bearing amplifier, the pulsed voltage from the pulse rectifiers alternately drives the grids to cut-off and a balanced condition exists. When the adcock antenna is off null, the square wave output of the bearing amplifier appearing across resistor 221-7 will be applied to the plates of tube V13. For purposes of analysis, assume triode A is conducting and B is driven to cut-off by a negative pulse from the pulse rectifier. At the same instant that the above action is occurring, assume a positive pulse from the bearing amplifier appears at the plates of tube V13 through potentiometer 230. Since triode A is conducting, the positive pulse from the bearing amplifier will instantaneously increase its plate voltage and an unbalanced condition will exist. The BEARING METER will then deflect off-center in proportion to the pulse amplitude from the bearing amplifier. Next consider triode A biased to cut-off by a negative pulse from the pulse rectifier and triode B conducting. At this instant triode B will not receive a positive pulse from the bearing amplifier and its plate current will not increase. When the adcock antenna is rotated to a null position, the pulsed voltage input to tube V13 plates is effectively removed as the 130-cycle r-f envelope is no longer present across the adcock and vertical amplifier plate loads. Assume that the above events, occurring at a rate of 130 cycles per second, occurred when the received signals arrived from the right side of the adcock antenna null. If a station is now received to the left side of null, the above cycle of events will be repeated but in opposite sequence. Since the square wave r-f envelope at the mixer stage has now reversed or shifted in effect 180°, the bearing amplifier output waveform has also reversed and an unbalanced condition which will deflect the BEARING METER in the opposite direction exists. The above cycle of events, occurring 130 times per second, causes BEARING METER indicator deflection to left or right until the adcock antenna is rotated to a null position.

27. R-F OSCILLATOR AND MIXER (fig. 73).

The r-f oscillator and mixer converts the incoming signal to an i-f frequency of 4.2 megacycles. The r-f oscillator operates at a frequency 4.2

megacycles higher than the incoming signal, and its output is applied to the mixer stage resulting in a 4.2-megacycle signal at the mixer output which is applied to the i-f amplifier input. Tube V10, a type 12J5GT triode, is used in the r-f oscillator circuit. Coil assembly 315 is resonated by tracking capacitor 123-2, series padding capacitor 118, and ganged tuning capacitor 121B. Capacitor 101-6 and resistor 206-2 form the plate feedback coil decoupling network. Resistor 206-1 and capacitor 102-2 serve to equalize the amplitude of oscillations on the low-frequency band. When plate voltage is applied, the grid and cathode are at the same potential and plate current increases, resulting in a feedback voltage through coil assembly 315. As oscillations build up, the grid is driven positive, charging grid capacitor 108-1. During negative half-cycles, the capacitor tends to discharge through parallel resistor 207. Capacitor 108-1 acquires an average negative charge on the grid side, providing bias. As the triode is alternately driven to saturation and cut-off, oscillations are produced in the parallel resonant circuit at a frequency determined by the circuit components. The r-f output is applied through coupling capacitor 114-3 and appears across mixer grid load resistor 213. The received signal from the adcock and vertical amplifiers is induced across the secondary of transformer 313, and resonated by tracking capacitor 122 and ganged capacitor 121A. The signal is then applied to the mixer tube through blocking capacitor 105-1 and appears across grid load resistor 211-1. Tube V5, a 12SA7 pentagrid converter, is self-biased by resistor 214-1 which is bypassed by capacitor 101-11. The r-f oscillator frequency, 4.2 megacycles above the incoming signal, is injected in grid 1, and the 4.2-megacycle component is applied to the i-f amplifier input. Resistor 203-4, capacitors 101-12 and 106-2, and resistor 215-1 form decoupling networks.

28. I-F AMPLIFIER (fig. 74).

The mixer signal output is applied to the three-stage i-f amplifier, which selects and amplifies the 4.2-megacycle i-f signal component. Tubes V6, V7, and V8, three type 12SK7 tubes, together with permeability-tuned i-f transformers, form the main circuit components. The i-f signal appearing across the primary of tuned input transformer 317-1 is induced across the tuned secondary winding and applied to tube V6 input. Resistor 205-2 damps the tuned input circuit, and resistor 216-1 and capacitors 106-3 and 106-5 form the grid circuit decoupling network. Self-bias is provided by resistors 214-2 and 217-1, and degeneration is introduced since resistor 214-2 is not bypassed. Capacitor 106-4 and resistor 215-2 form the plate load decoupling network. Tuning meter 375, a 0-50 milliammeter, indicates the cathode current of tubes V6 and V7 and since the cathode current varies inversely with the amplitude of the received signal a minimum reading on the meter indicates maximum signal. A single-pole double-throw switch, mounted on the r-f sensitivity control 288, selects either AVC or manual sensitivity control. In AVC position, control 288 is effectively

removed from the circuit, and the gain of the first two i-f stages is controlled by the automatic volume control circuit. In manual position (AVC off) the avc line is grounded, and the gain is controlled by sensitivity control 288 which varies the cathode-grid fixed potential of the first two i-f stages. Resistor 216-2 and capacitors 106-7 and 106-9 form the grid circuit decoupling network for tube V7. Self-bias is obtained by cathode resistors 214-3 and 217-2, and degeneration is introduced since resistor 214-3 is not bypassed. Resistor 215-3 and capacitor 106-8 form the plate load decoupling network. The 4.2-megacycle i-f signal induced across transformer 317-3 is applied to the input circuit of the third i-f amplifier tube V8. The selectivity of the tuned input-circuit is broadened by resistor 205-4 to give the required over-all i-f amplifier bandwidth. Self-bias is provided by cathode resistor 214-4, bypassed by capacitor 106-11. A continuous-wave (c-w) oscillator provides means of reception of c-w signals by applying an audio tone to the suppressor grid of tube V8 which imposes a 1,500-cycle audio voltage on the i-f signal. Capacitor 106-10 and resistor 215-4 form the plate load decoupling network for tube V8. The i-f amplifier output is applied to the second detector, demodulated, and applied to the bearing amplifier and output stages.

29. C-W OSCILLATOR (fig. 75).

The c-w oscillator generates a 1,500-cycle audio signal which, when applied to the third i-f tube suppressor grid, modulates the i-f component at a 1,500-cycle audio rate. One section of tube V12, a type 12SN7GT twin triode, is used in a phase-shifting oscillator circuit and the second section acts as a buffer-amplifier. A three-mesh, resistance-capacity phase-shifting network is connected between the output and the input of the oscillator section. This network comprises capacitors 112-1, 112-2, and 101-13, resistors 209-3, 208-3, 221-3, and the resistance-capacitance network 104-3 and 208-4. The network is proportioned to give a 180° phase shift between plate and grid at the desired frequency of 1,500 cycles, since each resistor-capacitor combination is designed to shift the applied voltage approximately 60° . The oscillator output is applied to the second half-section of tube V12 through coupling capacitor 101-14 and decoupling resistor 221-4 to the buffer-amplifier input. Resistor 220-8 forms the grid load, the tube is self-biased by cathode resistor 223, and degeneration is introduced since resistor 223 is unbypassed. The 1,500-cycle output appearing across load resistor 220-7 is applied to the third i-f suppressor grid through coupling capacitor 111-3, and appears across the i-f suppressor grid load resistor 205-5 and r-f decoupling capacitor 124. A small portion of the output is fed through stabilizing capacitor 108-4 to the oscillator input.

30. SECOND DETECTOR, AUTOMATIC VOLUME CONTROL, AND BEARING AMPLIFIER (fig. 76).

The i-f amplifier output is applied to the second detector which removes

the audio carrier components. The detected i-f signal component is also utilized to develop avc voltage to control the gain of the first two i-f amplifier stages. The i-f signal component appearing across the secondary of transformer 317-4 is applied across the detector diodes and cathode of tube V9, a type 12SR7 duo-diode triode. Resistor 219-1 and capacitors 108-2 and 108-3 form an r-f decoupling network. An audio voltage in proportion to the average i-f carrier envelope is produced across diode load resistor 221-5. At the same time an avc voltage is developed across resistor 221-6 in proportion to the i-f carrier amplitude and is utilized to regulate the gain of i-f amplifier tubes V6 and V7. Audio volume and meter sensitivity potentiometers 229-1 and 229-2 are connected in shunt with the signal diode load resistor and are used to regulate the audio signal amplitude applied to the audio output stage and bearing amplifier. Capacitor 111-2 isolates the avc voltage, and jack 353 provides means for a low-level signal output. The METER SENSITIVITY potentiometer arm is connected through coupling capacitor 111-1 to the grid of bearing amplifier triode V9, and the signal appears in greater amplitude across plate load resistor 210-2. Resistor 211-2 is the triode grid load and resistors 220-6 and 222-3 bypassed by capacitor 110-1, form a voltage dividing network which supplies fixed bias to the triode from a minus 12-volt source. When the equipment is operated in SWITCHED CARDIOID position and the adcock antenna is off null position, a 130-cycle audio waveform and the received station's modulation are present at the output of the bearing amplifier. Since it is desirable to apply only the 130-cycle signal to the synchronous voltmeter circuit, capacitor 109-1 greatly attenuates the higher audio components but does not materially affect the 130-cycle signal since its reactance is quite high at 130 cycles. Capacitor 110-2, however, presents a low-impedance path for the 130-cycle signal which is applied to the synchronous voltmeter circuit.

31. OUTPUT STAGE (fig. 77).

Tube V11, a type 12A6 beam-power amplifier, together with its associated circuit components, increases the second detector signal output to a satisfactory operating level. The detector output is applied to the control grid of tube V11 through coupling capacitor 111-4 and appears across grid load resistor 211-3. Bypass capacitor 110-3 places the lower end of grid load resistor 211-3 at ground potential, and fixed bias is applied through resistor 220-1 from a fixed minus 12-volt source. Capacitor 111-5 attenuates the higher audio frequencies; tone control 231 and capacitor 109-2 vary the audio response curve. The tone control, when set to the desired position, is useful for improving the signal-to-noise-ratio since attenuation of the higher audio frequencies minimizes static and interference. Resistor 224 and capacitor 116A form a decoupling network for the plate load.

Terminals 3 and 5 of output transformer 302 provide an output impedance of 4,000 ohms, and tap 4 is available for a 250-ohm output to match low-impedance phones. Switch 335 provides means for disconnecting the radio equipment from the telephone line, and phone jack 351-2 may be switched from radio output to line by switch 334-1. When jack 351-2 is operated in line position, phone volume may be controlled by potentiometer 232. Transformer 301 output impedance matches a 600-ohm telephone line whose connections are made to terminal strip 354. A microphone connection to the line is provided by a third winding on transformer 301, resistor 225-1 provides microphone current from a minus 12-volt source, and capacitor 117 bypasses the lower end of the microphone winding.

32. CONTROLS.

a. **TEST SWITCH.** This switch controls the screen voltage to the vertical amplifier and the adcock amplifier. Its function is outlined in the chart that follows:

<i>TEST SWITCH position</i>	<i>FIG-8 SWITCHED CARDIOID switch position</i>	<i>Vertical amplifier and adcock amplifier tubes in operation</i>	<i>Purpose</i>
NORMAL	FIG-8	Adcock amplifier V3.	To take azimuths by aural nulls with figure-8 pattern.
NORMAL	SWITCHED CARDIOID	Adcock amplifier V3, V4. Vertical amplifiers V1 and V2.	To take azimuths with left-right meter indicator.
CARDIOID A	FIG-8	Adcock amplifier V3. Vertical amplifiers V1 and V2.	To check shape of cardioid A pattern.
CARDIOID A	SWITCHED CARDIOID	Not used.	Not used.
CARDIOID B	FIG-8	Adcock amplifier V4. Vertical amplifier V1 and V2.	To check shape of cardioid B pattern.
CARDIOID B	SWITCHED CARDIOID	Not used.	Not used.
BALANCE	FIG-8	Not used.	Not used.
BALANCE	SWITCHED CARDIOID	Adcock amplifier V3, V4.	To allow balancing of gain between adcock amplifiers V3 and V4.

b. ADCOCK BALANCE. This rheostat is part of a voltage divider and controls the screen voltage on adcock amplifier V4. This permits balancing its gain with that of adcock amplifier V3.

c. FIG-8 — SWITCHED CARDIOID Switch. This switch controls plate voltage of the bearing amplifier, square wave oscillator, and synchronous voltmeter. It also controls screen voltage to the vertical amplifiers when the test switch is in the NORMAL position. Its function is outlined in the preceding chart.

d. BAND Switch. This switch permits selection of either band. When the knob is turned to the left, 18-34 megacycles reception is obtained; when turned to the right, 34-65 megacycles reception is obtained.

e. POWER Switch. This switch turns battery power on or off to both receiver and power units.

f. HEATERS Switch. This switch turns power on or off to the heater lamps only when POWER switch is OFF. The heater lamps are provided to keep the receiver components dry in humid climates.

g. PANEL LIGHTS Switch. This switch turns power on or off to all panel lights, including those used to illuminate meter scales.

h. C-W Switch. This switch turns the audio oscillator on or off. The audio oscillator modulates the third i-f amplifier at a frequency of 1,500 cycles per second for c-w reception.

i. R-F SENSITIVITY. This control is a variable resistor through which the cathode current of tubes V6 and V7 flows. It is used to vary the bias and gain of the first and second i-f tubes.

j. AUDIO VOLUME. This control is a potentiometer for varying the intensity of the audio signal to the grid of V11 when using headphones for aural reception or when feeding the radio output to the line.

k. TONE CONTROL. This is a variable resistor for changing the audio response curve of the system for aural reception. It is quite useful in improving the signal-to-noise ratio and is particularly effective in minimizing the effect of heavy static in the phones.

l. METER BALANCE. This control is a potentiometer which serves to balance the plate currents in the synchronous voltmeter V13 so that the BEARING METER reads zero with the square wave oscillator operating, but with no signal fed to the synchronous voltmeter from the bearing amplifier V9.

m. METER SENSITIVITY. This control is a potentiometer which varies the amount of signal to the bearing amplifier. It is used to prevent the BEARING METER from going off scale when maximum signal is

realized. This occurs when the antenna is 90° off a null. To avoid the possibility of overloading the last i-f stage, the control is usually set nearly full on and sensitivity is then controlled by the R-F SENSITIVITY control.

n. VOLUME A PHONES ON LINE. This control is a potentiometer for controlling the volume in the phones when they are connected to the telephone line.

o. A PHONES Switch. This control is used for switching A PHONES to either ON LINE or ON RADIO.

p. RADIO ON-LINE—OFF-LINE. This switch applies the radio output to or away from the primary of transformer 301 whose secondary is connected to the telephone line.

33. METERS.

a. BAT. VOLTAGE. This is a d-c voltmeter with a range of 0-15 volts. The meter indicates the terminal voltage of the storage battery.

b. TUNE FOR DIP. This is a d-c milliammeter with a range of 0-50 milliamperes. It indicates the cathode current of the first and second i-f stages and therefore serves as a tuning meter when AVC is used.

c. BEARING METER. This is a zero-center galvanometer with a range of 75-0-75 microamperes. It is operated by the synchronous voltmeter and is the visual null indicator.

d. Illumination. Each meter is illuminated by two 6-volt lamps connected in series. This combination is in series with a resistor to decrease the illumination and eliminate glare.

34. POWER UNIT PE-155-A.

a. Dynamotor. The dynamotor is of the polarized plug-in type secured in place by snap slides. *A spare dynamotor is carried on the power supply chassis at the rear.* Spare brushes are provided in Chest CH-128-A. The dynamotor rating is as follows: input 12 volts — 3.0 amperes, output 170 volts — 0.1 ampere.

b. Fuses. The primary is fused with a 10-ampere fuse and the secondary with a 1/4-ampere fuse. Three spares of each are carried underneath the swivel cover carrying the fuse nameplate.

c. Filters. R-F hash is filtered from the primary by r-f choke 318-1 and capacitors 113-3 and 111-6 (fig. 57). The r-f filter in the secondary is formed by r-f choke 318-2 and capacitor 111-7. The main filter for the power supply is in the radio receiver.

d. Receptacles. Receptacle 363 is a connection for the battery cable. Receptacle 362 provides for the power cable connection to the receiver;

receptacles 361-1 and 361-2 are connected in series and provide for connections of the azimuth scale lamps. These are 6-volt lamps and both plugs must be connected to light the series lamps.

e. Diagrams. For schematic circuits of Radio Receiver BC-1005-A, refer to figures 67 to 78. For battery cable and power cable wiring diagram, refer to figure 55.

35. TELEPHONE EQUIPMENT.

a. The field telephone line enters the tower through terminals at one side of the tower, and then goes to the telephone junction box under the floor. This box has two r-f filter chokes, one in each side of the line, to prevent any radio signal from entering the receiver through the telephone line, as this would introduce bearing errors.

b. From the junction box, the line extends to a jack at the center of the floor which provides for connection to the line within the mounting. Whenever the mounting is removed from the floor, do not damage the jack or plug.

c. A jack at the top of the mounting provides connections to the telephone line from the receiver. The jack is stationary and the plug rotates with the receiver cabinet.

d. In addition to the binding posts on the radio receiver panel, LINE jack 351-3 is provided for connection to the telephone line.

e. For the schematic diagram of the telephone circuit within the receiver, refer to figure 77.

f. The output of the radio receiver (terminals 3 and 5 on transformer 302) is 4,000 ohms for matching Headset HS-29. The output of the radio receiver to the telephone line (terminals 3 and 5 on transformer 301) is 600 ohms. Transformers 301 and 302 have a terminal 4 provided, which in combination with terminal 3 is 250 ohms. If it is desired to use headsets with lower impedance than those furnished, then instead of terminal 5 on transformer 302 and terminal 2 on transformer 301, terminal 4 is to be used. If low-impedance headsets are so used, there will no longer be a drop in volume when the A PHONES are switched to ON LINE.

36. RADIO TRANSMITTER BC-655-A (fig. 65).

Radio Transmitter BC-655-A employs a type 958 acorn triode (V1) in the r-f oscillator circuit which is an Armstrong plate feedback type. Tube V2, a type IA5GT power amplifier pentode, is used in an audio oscillator circuit to generate a 1,000-cycle audio signal which modulates the r-f oscillator. Separate coils for each band are selected in the grid and antenna circuits by switches S1 and S3. Switch S2, ganged to the same shaft, connects the filament return lead to the pre-adjusted tap as the coils to be used

are selected. One tickler coil provides suitable feedback to maintain oscillations over the entire frequency range of the transmitter, and no switching is necessary in the tickler circuit. Capacitor C4 is the grid tuning capacitor and together with the grid coil selected determines the frequency of oscillations. Resistor R1 and capacitors C1 and C8 form a decoupling network for the tickler coil. The lower grid coils are shunted by damping resistors R4 and R5 which broaden the band of frequencies generated. Microammeter M1 bypassed by capacitor C3 is connected in series with grid leak R2 and indicates grid current, thus visually indicating oscillator circuit operation. The antenna coil delivers energy from the grid tank circuit to the vertical antenna mounted on top of the case; this circuit is untuned and the only adjustment required is to extend the antenna sufficiently to provide a satisfactory signal at the RDF receiver antenna. When the power switch S5 is turned on, the grid and filament of tube V1 are at the same potential and plate current is maximum, causing energy to be fed from the plate coil to the grid coil. The grid will be biased negative by grid current flowing through resistor R2 charging capacitor C7 negative on the grid side. The plate current will then drop, reducing the feedback energy in the tickler coil and tapped portion of the grid coil. The amplitude of oscillations will become stable when conditions of least loss occur, which will be at the resonant frequency of the tuned grid circuit. Capacitor C2 together with a series choke L5 isolates the filament of tube V1 from the rest of the circuit. The modulator tube V2 is a type 1A5 GT pentode with plate and screen tied together. Oscillations occur in the manner described above except that energy from the plate circuit of this tube is returned to the control grid through the primary and secondary of modulation transformer T1. The frequency of oscillation in this circuit is determined by the circuit constants, and is adjusted by altering the capacity of capacitor C5. This circuit is adjusted at the factory to operate at 1,000 cycles and no external adjustment is provided. Should adjustment become necessary the frequency may be varied by adjusting capacitor C5 with an insulated screwdriver. The frequency should be set at 1,000 cps by zero-beating the output of Radio Transmitter BC-655-A with a known 1,000 cps source. The audio frequency power generated in the plate circuit of tube V2 is combined with the oscillator plate current through modulation transformer T1 and modulates the amplitude of the high-frequency oscillator at 1,000 cps. Capacitors C6 and C9 bypass the plate and lower end of transformer T1.

SECTION IV

MAINTENANCE

NOTE: *Failure or unsatisfactory performance of equipment will be reported on W.D., A.G.O. Form No. 468. If this form is not available see TM 38-250.*

37. SERVICING.

a. Radio Set.

CAUTION: BE CAREFUL IN MAINTAINING AND SERVICING THIS EQUIPMENT. OPERATORS WILL MAKE ONLY MINOR REPAIRS OR REPLACEMENTS. SERVICING AND REPAIR IS AUTHORIZED ONLY BY COMPETENT PERSONNEL SUPPLIED WITH ADEQUATE TOOLS AND INSTRUMENTS. AN INEXPERIENCED OPERATOR, IN ATTEMPTING TO LOCATE AND REPAIR TROUBLES WHICH A COMPETENT MAN COULD SERVICE IN A FEW MOMENTS, MAY DAMAGE THE EQUIPMENT TO SUCH AN EXTENT AS TO REQUIRE SHIPMENT TO A DEPOT FOR REPAIR. THIS APPLIES PARTICULARLY TO INDISCRIMINATE TUBE REPLACEMENT AND ALIGNMENT.

b. Storage Batteries. The storage batteries should be charged when required in the initial servicing procedure or whenever the terminal voltage of a battery drops to 10 volts.

(1) Connect the positive terminals of the batteries to be charged to positive (+) of the charging source and the negative terminals to negative (—) of the charging source.

(2) Charge the batteries at a rate of approximately 6 amperes until the specific gravity stops rising. If the temperature of the electrolyte exceeds 90° F, reduce the charging rate and increase the time.

(3) At completion of the charge, the specific gravity of the electrolyte should be 1.275 in a temperate climate or 1.200 in a tropical climate. These measured values may be slightly higher but will usually drop to the limits stated after 5 minutes of operation load. If not, adjust by removing some of the solution and replace with approved water or electrolyte as required.

38. TROUBLE AND REMEDY CHART.

Check these items in the order given.

<i>Trouble</i>	<i>Probable cause</i>	<i>Remedy</i>
Dynamotor fails to start.	Blown fuse. Loose battery terminal. Low battery voltage. Defective power switch. Open power cable. Defective dynamotor.	Replace. Replace. Replace or recharge. Replace. Replace. Replace.
Receiver inoperative.	Headset plugged into improper jack. Test switch in BALANCE position. Telephone line shorted and radio switch is in ON LINE position. Antenna cables not connected to receiver. Cord CD-1028 open. Defective tube. Defective headset.	See paragraph 18. Turn to NORMAL position. Check telephone line. Connect plugs to proper receptacles. Replace. Replace. Replace.
Faulty vertical antenna pattern.	Loose antenna. Dirty, wet, or broken antenna insulators. Water in mast or cross-arm. Bent antenna rod. Defective resistors in antenna attenuator. Defective transmission lines in mast.	Check all plug connections from receiver through antenna rods. Wipe off, clean, or replace if broken. Dry out. Straighten or replace. Replace crossarm. Replace mast.
Faulty figure-8 field pattern.	Loose antenna connections. Dirty, wet, or broken antenna insulators. Water in mast or cross-arm. Bent antenna rods.	Check all plug connections from receiver through antenna rods. Wipe off, clean, or replace if broken. Dry out. Straighten or replace.

<i>Trouble</i>	<i>Probable Cause</i>	<i>Remedy</i>
	Defective resistors in antenna attenuator. Defective transmission lines in mast or crossarm.	Replace crossarm. Replace mast or crossarm.
Faulty switched-cardioid bearing indications.	Faulty figure-8 pattern. Faulty vertical pattern. Adcock amplifier tubes improperly balanced. Defective tubes in vertical or adcock amplifier stages V3, V4.	Go through figure-8 pattern routine above. Go through vertical pattern routine above. Balance tubes (subpar. 15a). Replace.
Impossible to balance bearing meter.	Defective tubes in square wave oscillator, negative pulse rectifier, or synchronous voltmeter.	Replace defective tube or tubes.
Impossible to balance adcock amplifiers.	Test switch not in BALANCE position. Faulty adcock amplifier tubes V3, V4. Defective bearing amplifier tube V9.	Check. Interchange or replace. Check.
Telephone inoperative.	Open circuit between terminal box under floor and line binding posts on receiver or circuit grounded or shorted. Damaged jack under Mounting FT-365-A.	Locate fault with continuity tester and repair. Repair or replace.

39. ALIGNMENT PROCEDURE.

a. Equipment Required. (1) OUTPUT INDICATOR.

(a) The preferred indicator is a 0-100 microammeter, connected to DETECTOR OUTPUT connection 353. This will indicate current in the second detector diode load resistor. When using this meter, keep the indication at 100 microamperes or less, with RF SENSITIVITY control at maximum.

(b) The second choice for an output indicator is a rectifier-type voltmeter connected across the audio output or phone jack. With this type of indicator, keep the output at 15 volts or less with the RF SENSITIVITY and AUDIO VOLUME controls at maximum.

(c) The third choice for an output indicator is to use the tuning meter on the front panel of the radio receiver. This serves as a tuning meter when the RF SENSITIVITY control is at SWITCH TO AVC. When using this meter as an indicator, keep the test signal at such a level that the meter shows a change of 5 to 15 milliamperes.

(2) ALIGNMENT TOOLS. A small insulated screwdriver is used for making trimmer adjustments. The insulated end of the screwdriver should be about $\frac{1}{4}$ -inch or $\frac{3}{8}$ -inch in diameter and about 4-inches to 6-inches long.

(3) DUMMY ANTENNA. Dummy antenna consisting of a 0.005-microfarad capacitor and a 75-ohm resistor, both to be connected in series with the high side of the output cable from the signal generator should be used.

(4) SIGNAL GENERATOR. Any signal generator capable of producing a stable frequency of 4.2 megacycles and all frequencies between 18 and 65 megacycles will be satisfactory.

b. Preliminary for All Alignment Procedures.

- (1) Put a fully charged storage battery in the set.
- (2) Allow the receiver and the signal generator to warm up for at least 15 minutes.
- (3) Connect a microammeter to connection 353, designated DETECTOR OUTPUT at left rear corner of the receiver chassis.
- (4) During all alignment procedure, the SWITCHED CARDIOID — FIG-8 switch should be kept in the FIG-8 position.

c. Alignment of I-f Stages.

- (1) Set the band switch to the 18-34 megacycle band.
- (2) Set the TUNING dial at 18 megacycles.
- (3) Set the signal generator at 4.2 megacycles and connect it to the control grid (pin 4) of the third i-f stage vacuum tube V8.
- (4) Turn adjustment screws on i-f transformer 317-4 for maximum output on the output indicator.
- (5) Connect the signal generator to the control grid of the second i-f tube V7 and adjust trimmers on transformer 317-3.
- (6) Connect the signal generator to the control grid of the first i-f tube V6 and adjust transformer 317-2.

(7) Set TEST SWITCH to CARDIOID A.

(8) Connect the signal generator to the grid (pin 5) of the mixer tube V5 and adjust transformer 317-1. With the signal generator so connected, a signal of at least 20 microvolts is required.

(9) As an alternate method of feeding i-f signal to the mixer tube V5 without removing the shield can covering the bottom of this socket, it is satisfactory to remove the tube shield and wrap several turns of wire around the glass bulb. If the high side of the signal generator is connected to this wire, there is enough capacity coupling to the tube so that a signal of about 8,000 microvolts will permit adjusting transformer 317-1.

d. Oscillator Calibration (18- to 34-Megacycle Band).

(1) Connect the signal generator to the socket for the vertical antenna, and leave test switch at CARDIOID A position.

(2) Set signal generator at 34 megacycles.

(3) Set receiver dial at 34 megacycles.

(4) Adjust oscillator trimmer 123-2 for maximum signal.

e. Oscillator Calibration (34- to 65-Megacycle Band).

(1) Set receiver band switch to the 34- to 65-megacycle band.

(2) Set signal generator at the 65-megacycle band.

(3) Set receiver dial at 65 megacycles.

(4) Adjust oscillator trimmer 123-3 for maximum signal.

f. R-f Stage Alignment (18- to 34-Megacycle Band).

(1) Leave the signal generator connected to the socket for the vertical antenna and leave the test switch at CARDIOID A position.

(2) Set the signal generator at 34 megacycles.

(3) Set the receiver band switch to the 18- to 34-megacycle band.

(4) Set receiver dial at 34 megacycles, and carefully tune in the signal to maximum.

(5) Adjust the r-f trimmer 122 for maximum signal.

g. R-f Stage Alignment (34- to 65-Megacycle Band).

(1) Set signal generator at 65 megacycles.

(2) Set receiver band switch to the 34- to 65-megacycle band.

(3) Set receiver dial at 65 megacycles, and carefully tune in the signal to maximum.

(4) Adjust the r-f trimmer 123-1 for maximum signal.

h. Adcock Antenna Stage Alignment (18- to 34-Megacycle Band).

(1) Leave test switch at CARDIOID A position.

(2) Connect signal generator between chassis and one terminal of the adcock input socket. Ground the other terminal of the adcock input socket through 75 ohms.

(3) Set the signal generator at 34 megacycles.

(4) Set receiver band switch to the 18- to 34-megacycle band.

(5) Set the receiver dial at 34 megacycles and tune in the signal for maximum.

(6) Adjust the antenna trimmer 119-1 for maximum signal.

i. Adcock Antenna Stage Alignment (34- to 65-Megacycle Band).

(1) Set signal generator at 65 megacycles.

(2) Set receiver band switch to the 34- to 65-megacycle band.

(3) Set the receiver dial at 65 megacycles and tune in the signal maximum.

(4) Adjust the antenna trimmer 119-2 for maximum signal.

40. REPLACEMENT OF COILS.

Should it be necessary to replace antenna, r-f, or oscillator coils, great care must be used in checking that all leads are put back in EXACTLY the same physical location. Final adjustment of coils for tracking and calibration is accomplished by a slight bending of these leads. Polarity of the primary on the antenna transformer must be maintained. Note that the form for this primary is silver plated and grounded to serve as an electrostatic shield. Resistors 212-1-2 must be located exactly as found.

41. BALANCING ADCOCK ANTENNA TRANSFORMERS.

The primary circuits of the adcock antenna transformer are carefully balanced by means of variable differential ceramic capacitors assembled to the transformers and accessible from above. The holes that provide access for this adjustment are labeled BAL. These adjustments are critical and should not be tampered with unless the antenna coils 310 or 311 have been replaced or series resistors 212-1 or 212-2 replaced. To adjust for balance, solder a jumper between the tips of the prongs of adcock input receptacle 350. Connect the high or output side of the signal generator to the EXACT center of the jumper; the low or grounded side of the generator is connected to chassis. Switches and controls must be the same as indicated in paragraph 15. Adjust the differential capacitor for minimum sensitivity in the receiver. It is advisable to make this adjustment at the

high-frequency end of each band, approximately 63 megacycles and 33 megacycles. However, it may be done at the low-frequency end of each band with approximately the same results, if the frequency range of the generator does not permit following the suggested frequency setting.

42. DYNAMOTOR UNIT.

If the power unit operates satisfactorily, with the dynamotor noise at a low level, it should require little attention; however periodic lubrication and cleaning accumulated dust, dirt, and grease from the commutators and brushes are required. For access to the commutators, brushes, and bearings, remove the end covers. These covers are held in place by fillister-head screws that have their heads cross-drilled for safety wiring.

a. Lubrication. Grease-sealed ball bearings are used. They are lubricated for approximately 1,000 hours of operation. An occasional inspection will reveal when it is necessary to relubricate. To inspect the bearings or to add grease, remove the end covers and the bearing plates from the dynamotor. A sufficient amount of clean grease should be added so that the bearings are covered. Too much grease should not be packed around the bearings as it will work out through the bearing seals when the dynamotor is running, and cause excessive heating. Recommended for this use is General Purpose Grease No. 2, U. S. Army Specification No. 2-108. Other greases of comparable quality can be used, if the above is not available. A good grade of light ball-bearing mineral grease will do. Wash the ball bearings and clean out the old grease once a year. To clean, remove the armature from the dynamotor but do not remove the bearings from the shaft. Wash the bearings and bearing housings with clean naphtha or carbon tetrachloride, using a small stiff brush to remove the old grease. Do not allow the cleaning fluid to come in contact with the armature windings. Dry the bearings thoroughly and check for smooth and free operation before replacing the armature in the dynamotor. Reassemble the unit and lubricate.

b. Brushes. Periodic inspection of the brushes and brush holders is essential. The brushes are wearing parts and should be given a visual inspection approximately every 100 hours of operation. The wearing of the brushes causes carbon dust to form around the brush holders. Since this carbon dust may interfere with the free movement of the brushes in their holders, it must be blown out every time that the equipment is examined or serviced. Also wipe the commutators with a soft cloth saturated with carbon tetrachloride. Do not remove the brushes from their holders unless it is absolutely necessary to do so for replacement or major cleaning operations. If noise is present in the receiver, investigate other possible sources before tampering with the dynamotor brushes. However, if the brushes are removed and found to be in serviceable condition, replace them in the same respective holders, and in exactly the same direction as they originally

were placed. If this is not done, the brushes will have to be run in again, with a period of noisy operation while this is taking place. To facilitate replacement in servicing, each brush is stamped + and —, adjacent to the respective brush holders. Always insert the brushes in their respective holders with the polarity marks upward. This method consistently insures correct replacement at all times. In normal service, the low-voltage brushes last 400 to 500 operating hours. New brushes are 1/2-inch long; they should be replaced after 400 hours of service or when they have worn down to approximately 1/4 inch. Whenever new brushes are installed, the commutators should be sanded. The high-voltage brushes wear at a much slower rate and have a conservative life of 1,200 to 1,500 operating hours. These brushes are 1/2-inch long when new and should be replaced when they have worn down to approximately 1/4 inch. After new brushes are installed, check to make sure that the brush fits freely in the holder without binding, and run the dynamotor for 6 to 8 hours at normal load. Noisy and inefficient operation may be experienced until the brushes are properly worn in.

c. Commutators. The commutator copper, in normal operation turns a chocolate brown color with a darker film on the section which is in contact with the brushes. This film is not a cause of noise but is rather a desirable condition and indicates good commutation. The commutators should not be sanded to remove this film. Keep grease and oil off the commutators and brushes at all times. If any lubricant is present, wipe it off with a cloth saturated with carbon tetrachloride. In time, minute grooves will appear on the commutators from the action of the brushes. This is a normal condition of wear; however, if it gets serious, the commutators should be sanded smooth with grade 000 or finer sandpaper while the machine is running. Canvas or crocus cloth should be used for polishing or finishing.

CAUTION: DO NOT USE EMERY CLOTH ON COMMUTATORS AS THE ABRASIVE IS METALLIC AND MAY CAUSE SHORT CIRCUITS IN THE ARMATURE BY BECOMING IMBEDDED IN THE SLOTS BETWEEN THE BARS.

If the commutators become seriously worn or scored, as is quite possible after prolonged operation, it will be necessary to reface them. This requires removing the armature and turning it in a lathe. For finish turning of the commutator, the armature must be turned on centers at a speed of approximately 500 revolutions per minute, and a tool bit sharply ground for copper turning must be used. A 0.010-inch to 0.012-inch cut will usually be sufficient to clean up most commutator roughness. For this depth of cut, it is not necessary to undercut the commutator mica, but if the copper is turned down so far that the mica is also cut, it becomes necessary to file away the mica between the copper bars with a triangular or lozenge-shaped

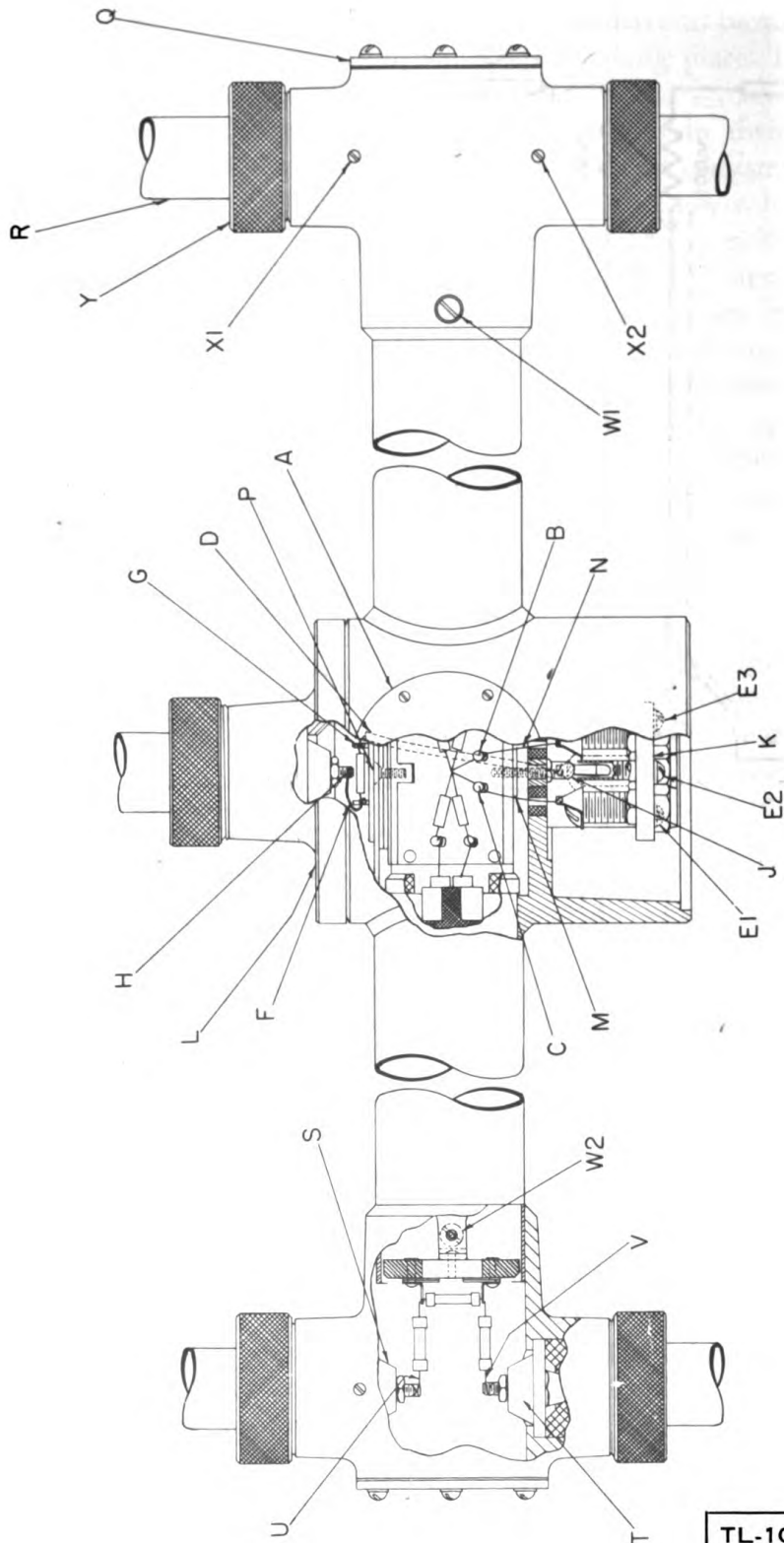

TL-10876

Figure 40. Antenna AN-105-A, crossarm details.

file to a cut of about 0.015 inch to 0.025 inch, so that brushes will not come in contact with the mica. Polish the commutators, as directed in the above paragraphs, after finish turning. Brush mica slots clean of all mica, copper, and sand particles before replacing the armature in the dynamotor.

43. ANTENNA SYSTEM.

a. Servicing. Before servicing the antenna system, study paragraph 21 thoroughly.

b. Equipment Required.

- (1) Resistance bridge with tolerance of 0.1 percent.
- (2) Capacity bridge capable of comparing 150-micromicrofarad (mmf) capacitors with a reset accuracy of 0.25 mmf.

c. Continuity and Resistance Check.

- (1) To gain access to the terminals for test, remove the plates at the ends of the crossarm and remove the coverplate over the center of the crossarm.
- (2) Refer to figure 39 for circuit and resistor values. For code numbers, refer to figure 67.
- (3) It is permissible for the absolute values of the resistors to vary as much as 15 percent, but all 100-ohm resistors must be within $\frac{1}{2}$ ohm of each other, all 47-ohm resistors in the attenuator must be within $\frac{1}{4}$ ohm of each other, and the 270-ohm resistors in the junction box at the base of the mast must be within $1\frac{1}{2}$ ohms of each other.
- (4) To check leakage, disconnect the junction box. Leakage of any transmission line to ground is normally above 1,000 megohms. If this checks below 100,000 ohms, locate the fault and correct it.

d. Removal of Transmission Line from Crossarm. Should it be necessary to remove the transmission lines from the crossarm, the following procedure is suggested. Refer to the drawing in figure 40 that shows a section view of the antenna crossarms.

- (1) Remove coverplate A and center flange L from the crossarm after antenna rods have been removed. Unsolder lead F disconnecting it from screw H.
- (2) Unsolder leads D, M, and N from lugs G, C, and B, respectively, removing the leads from their lugs.
- (3) Remove three screws E-1, E-2, and E-3 so that the connector plate K may be pulled from the assembly.
- (4) Banana plug J and the flathead screw P must now be removed.
- (5) Remove the end coverplate designated Q from both ends of the crossarm assembly. Unsolder resistor leads U and V from the connector plates

S and T at both ends of the assembly.

(6) Unscrew the two knurled nuts designated Y and pull the two insulators R from the assembly. This is to be done only at the left end of the crossarm, when facing the open side of the junction box at the center of the crossarm.

(7) Remove the two screws W-1 and W-2 from both ends of the crossarm assembly. Remove the two Allen head setscrews X-1 and X-2 from the left end only, and push connector plates S and T out of the open ends of the assembly.

(8) Pull the transmission line from the left end of the crossarm.

d. Capacity Check (Mast Sections). In a mast section, the capacity of each side of the twin line to ground will be in the order of 165 mmf. This is not critical but one side of the line must measure within 2 mmf of the other side.

44. PERFORMANCE DATA.

Figures 41 to 45 inclusive show measured field patterns, i-f selectivity, over-all sensitivity curves, and typical RDF performance data. Figure 46 provides a means for entering performance data on any RDF.

45. NORMAL VOLTAGE READINGS.

The tube-socket layout diagrams showing voltages to ground (figs. 47 and 48) are furnished for the information and guidance of servicing personnel. The values are approximate and will vary slightly with different units and different measuring equipment. The readings represent those to be found in normal operation.

46. PARTS LOCATION DETAIL.

Figures 49 to 59, inclusive, have been prepared to assist in locating and replacing mechanical and electrical parts. The reference numbers shown in these figures correspond to reference numbers shown on the schematic diagram.

47. OPERATIONAL INSPECTION OF RADIO TRANSMITTER BC-655-A.

The inspection of transmitter should be sufficiently thorough to determine whether the equipment is in proper working order. The operating test should be made with the station at which the target transmitter is to be used, or under conditions which approximate the terrain, operating conditions, and equipment set-up to be encountered.

a. Release the two snap clamps at the sides of the case and separate the upper and lower sections of the transmitter.

b. Make certain that battery plugs and vacuum tubes are securely inserted in their sockets.

c. Close the transmitter case and fasten the two snap clamps.

d. Attach collapsible antenna to its mounting on top of the case.

e. Turn the transmitter on and note whether it delivers a satisfactory signal both with and without modulation on all frequencies to be used. At no frequency setting should the meter indication drop to zero.

f. Turn the transmitter off.

48. DISASSEMBLY OF RADIO TRANSMITTER BC-655-A.

a. Power Supply. Release the two snap clamps at the sides of the case and separate the upper and lower sections of the transmitter case.

b. Testing Equipment Required.

(1) RCA Voltohmyst Jr. or equal.

(2) Supreme Instrument Corporation Set Tester, Model 504-A.

(3) Set of test leads and plugs.

(4) Receiving equipment covering the frequency range of the target transmitter, capable of c-w and mcw reception.

c. Procedure.

(1) Operate Radio Transmitter BC-655-A and observe the meter on the side of the chassis. This meter is in the grid circuit of the high-frequency oscillator Tube VT-212. Flow of current in this circuit indicates oscillation.

(2) If the meter indicates current flow when the transmitter is first turned on, but soon drops off to a low or zero current flow, the batteries are weak and should be replaced.

(3) If the meter fails to register when the transmitter is turned on, the batteries are dead; one or both tubes may be defective, or the meter may be defective. Check the voltage of each battery, and replace if the terminal voltage is 80 percent normal or less. If the meter still fails to register, short its terminals or substitute a meter known to be in good condition. Replace the meter, if substitution test proves it defective. Check the tubes on the set tester following the instructions furnished with that unit. Replace either or both tubes if defective.

(4) Remove the power cable plug from its receptacle.

(5) Remove the board over the batteries.

(6) Remove the plug from the receptacle in the top of each battery.

d. Transmitter Chassis.

- (1) Separate the two sections of the transmitter case as in subparagraph **a** above.
- (2) Note carefully the setting of tuning capacitor C4 when knob and pointer indicate 100 on the tuning scale, in order that calibration can be preserved in reassembly.
- (3) Remove knobs and tuning control from front panel.
- (4) Remove four screws holding chassis to front panel.
- (5) Remove retaining bracket, screw, lockwasher, and wingnut associated with V2 (Tube VT-124).
- (6) Remove the chassis from the case and place it on a flat surface.

NOTE: The banana plug connecting the output lead to the antenna base should withdraw without undue friction. Should it be tight, extract it with a hooked wire.

49. ROUTINE INSPECTION AND OVERHAUL OF RADIO TRANSMITTER BC-655-A.

a. General. Inspect all nuts, bolts, and screws for tightness. Do not tighten glyptal screws or nuts unless it is evident that they are loose. In the event any are loose, tighten and apply glyptal. Remove any loose solder, dirt, and metallic chips. Clean equipment thoroughly and touch up scratched paint. Remove all traces of corrosion. Inspect wiring and solder-joints. If more than two strands are broken at a soldered joint, resolder the connection. Clean all plug connectors if necessary.

b. Tubes. Check both tubes with a test set. Make these tests in accordance with the instruction pamphlet supplied with the test set. If the tubes do not pass this test, replace them. Replace any tube used over 500 hours. See that both tubes are securely mounted in their sockets.

c. Tuning Capacitor. Inspect for dirt or dust between plates, and remove with a pipe cleaner or soft cloth. Do not blow out with an air hose, as it may contain water or have sufficient pressure to bend the plates. Do not lubricate, as the unit is permanently lubricated when assembled.

d. Batteries. Measure the terminal voltages of the batteries with an accurate d-c voltmeter. Replace Battery BA-63, 45 volts, when its terminal voltage drops to 36 volts. Replace Battery BA-65, 1.5 volts, when its terminal voltage drops to 1.2 volts.

e. Reassembly. Reassemble the unit, reversing the procedure given in paragraph 48. The banana plug terminating the output lead must be reinserted in the antenna mounting base before the four chassis mounting

screws are replaced. The output lead is stranded wire of sufficient strength to hold the plug in approximately the position required for the insertion. By bending the output lead, position the plug so that by tilting the case, with chassis loosely inserted, the plug tip starts to enter the jack in the antenna mounting base. The plug can be easily seated with a lead pencil, using the rubber eraser, or any slender implement. Ample room for insertion of the pencil or other tool is provided between the tuning capacitor C4 and the modulation transformer T1.

CAUTION: DO NOT DAMAGE OR DISTURB THE FILAMENT R-F CHOKE, OTHER COMPONENTS, OR WIRING. BE CERTAIN THAT TUNING CAPACITOR ROTOR PLATES ARE FULLY MESHED BEFORE INSERTING ANY TOOL NEAR THE CAPACITOR.

50. LOCATION AND REMEDY OF FAULTS IN RADIO TRANSMITTER BC-655-A.

The location of open and short-circuit faults will be facilitated if an orderly procedure is followed instead of testing at random points. Using the schematic diagram for guidance, check one portion of the circuit at a time. Check each element contained in that portion for open circuits, short circuits, and ground, referring to the schematic diagram (fig. 65), and the data contained in paragraph 52. If these tests give normal readings, that particular portion of the circuit is probably not at fault and needs no further attention. Radio Transmitter BC-655-A customarily requires no maintenance except replacement of batteries and tubes.

NOTE: The acorn tube V1 (VT-212) is not held in place by a tube clamp since the socket is designed to hold the tube leads firmly. Exercise extreme care in replacing this tube to avoid injuring the tube seals. Make certain that all five leads are firmly clamped. Both tubes are removed by grasping firmly with the fingers and pulling up. No tools are required. DO NOT TWIST OR TURN TUBES.

51. TYPICAL VACUUM-TUBE SOCKET MEASUREMENTS.

a. Resistance Measurements. The resistance measurements in table A below, were made between tube-socket terminals and ground (chassis) with the RCA Voltohmyst Jr. Tubes must be in sockets with MODULATION switch S5 ON and the power switch OFF.

<i>Tube</i>	<i>Filament —</i>		<i>Filament +</i>		<i>Plate</i>	<i>Grid</i>		
V1(VT-212)	0		*8.25		infinite	47,000		
<i>Tube</i>	1	2	3	4	5	6	7	8
V2(VT-124)	ground	*8.5	infinite	infinite	680,000	no connec- tion	ground	no connec- tion

*Values read on RX1 scale.

NOTE: Values read on RX10,000 scale.

b. Voltage Measurements. The d-c voltage measurements in table B were made with tuning capacitor C4 turned for maximum reading, range selector switch set to band 1, battery switch ON, and MODULATION switch ON, using the Voltomyst Jr.

<i>Tube</i>	<i>Filament —</i>	<i>Filament +</i>	<i>Plate</i>	<i>Grid</i>	<i>Current</i>			
V1(VT-212)	0	0	78	—4	85 micro-amps			
<i>Tube</i>	1	2	3	4	5	6	7	8
V2(VT-124)	ground	1.45	78	78	—25	no connec- tion	ground	no connec- tion

52. REPLACING DEFECTIVE COMPONENTS OF RADIO TRANSMITTER BC-655-A.

When it has been determined that a component is defective, replace it with an identical component from the spare parts provided. Check with the data in the maintenance parts list to be certain that the new component is properly identified. The new part must comply in every respect with the data in the maintenance parts list.

a. Before removing a part from the unit, make a note of the leads connected to it and unsolder them. Bend the wires only as much as is absolutely necessary to remove the component. Apply the soldering iron just long enough to soften the soldered joint. Lengthy application of the soldering iron may loosen the terminal or other soldered connections on adjacent components.

b. Components can usually be removed with a small wrench and screw-

driver. Do not use pliers where a wrench can be used to loosen nuts. A lockwasher is provided directly beneath each nut, and a plain flat washer is located between the lockwasher and panel or chassis. Always replace washers and nuts in this order.

c. When new parts are installed, use same screws and bolts as used for old parts if they are in good condition. Do not tighten nuts or screws excessively.

d. Use only rosin core or special radio solder. NEVER USE PASTE OR ACID FLUX.

e. Clean and tin both terminal and wire before attempting to make the joint. Fasten the wire mechanically by twisting it around the terminal and clipping surplus before soldering. Heat wire and terminal so solder will flow into joint.

53. OVER-ALL PERFORMANCE TEST OF RADIO TRANSMITTER BC-655-A.

An over-all performance test can best be made in conjunction with the equipment with which Radio Transmitter BC-655-A is to be used. Operation will be considered satisfactory if a suitable signal is delivered under conditions comparable with actual use.

a. Since this equipment is designed for use in calibrating RDF antennas, a sufficiently powerful signal should be radiated to provide a narrow null on the azimuth scale at the receiver.

b. The transmitter should oscillate, both with and without modulation, at all frequencies for which it is calibrated. At no frequency setting should the meter reading drop to zero.

54. MOISTUREPROOFING AND FUNGIPROOFING RADIO SET SCR-555-A.

a. General.

(1) PROBLEMS ENCOUNTERED. Communication failures commonly occur when Signal Corps equipment is operated in tropical areas where the temperature and relative humidity are extremely high. The following problems are typical:

(a) Resistors and capacitors fail.

(b) Electrolytic action takes place in coils, chokes, and transformer windings, etc., causing eventual break-down.

(c) Hook-up wire and cable insulation break down. Fungus growth accelerates deterioration.

(d) Moisture forms electrical leakage paths on terminal boards and

insulating strips, causing flash-overs and crosstalk.

(e) Moisture provides leakage paths between battery terminals.

(2) TREATMENT. A moistureproofing and fungiproofing treatment has been devised which, if properly applied, provides a reasonable degree of protection against fungus growth, insects, corrosion, salt spray, and moisture. The treatment involves the use of a moisture-resistant and fungi-resistant varnish applied by means of a spray gun. A brief description of the method of application follows:

(a) Make all repairs and adjustments necessary for the proper operation of the equipment.

(b) Thoroughly clean equipment to be processed of all dirt, dust, rust, fungus, oil, grease, etc.

(c) Partially disassemble equipment and cover certain points, such as relay contacts, open switches, air capacitors, sockets, bearings, etc., with masking tape.

(d) Thoroughly dry equipment by heat to dispel moisture which the circuit elements have absorbed.

(e) Paint or spray all circuit elements and all parts of the equipment with three coats of moistureproofing and fungiproofing varnish. When the process is completed, mark MFP, followed by date of completion.

(f) Give the equipment a final operational check; radio sets should receive a 24- to 36-hour aging period, when time permits, before aligning.

CAUTION: Varnish spray may have toxic effects. Use respirator, if available. Otherwise fasten cheesecloth or other cloth material over nose and mouth.

b. Step-by-step Instructions for Radio Receiver BC-1005-A.

NOTE: Read and carefully study the instructions furnished with the moistureproofing and fungiproofing maintenance kit before processing the radio set.

(1) DISASSEMBLY.

(a) Remove Radio Receiver BC-1005-A from Cabinet CS-155-A in the following manner:

1. Disconnect the power cable from the receiver.
2. Remove the access door on the front panel and disconnect the two cables from the top of the receiver (adcock antenna cable and vertical-antenna cable).
3. Disconnect the two wires from the line terminal posts.

4. Loosen the 10 knurled screws around the edge of the front panel.

5. Grasp the two large handles on the front panel and pull the unit forward.

(b) Remove the six vacuum tubes from their sockets on the under side of the chassis. It is not necessary to remove the tubes located on top of the chassis.

(c) Remove the four shield cans from the adcock input, vertical input, r-f amplifier, and oscillator circuits.

(d) Rotate the capacitor dial until the capacitor plates are fully meshed.

(2) MASKING.

(a) Completely cover with masking tape the following components located on the bottom of the chassis:

1. The test switch.

2. The four jacks A-PHONES, B-PHONES, LINE, and MIC.

3. The DETECTOR OUTPUT pin jacks.

4. The six tube sockets that are used for the tubes located on the under side of the chassis.

5. The bottoms of all other tube sockets.

(b) Cover the rectangular opening, which normally provides clearance for the tuning dial, in the chassis.

(c) Cover the turned-under bottom edge of the chassis with masking tape. This is done to insure good ground contact when the set is replaced in the cabinet.

(3) DRYING. Bake chassis according to instructions furnished with the moistureproofing and fungiproofing maintenance kit.

(4) VARNISHING.

(a) Spray the under side of the chassis only according to instructions furnished with the kit.

(b) Apply varnish with a brush to the rear surfaces of the three meters (battery voltmeter, tuning meter, and bearing meter). Cover all joints and openings. Apply varnish in front and back of the joint between the receiver panel and each meter case, and to the joint between each meter case and the glass. Cover the zero adjustment screw but do not allow the varnish to cover more than $\frac{1}{4}$ inch of the outer edge of the glass.

(c) Apply varnish with a brush to all exposed wires, fixed capacitors, resistors, coils, etc., located on top of the chassis.

CAUTION: Apply varnish with a small brush, using a minimum of varnish on each component, so that the varnish will not drip or run. Avoid touching the tuning capacitors, the trimmer capacitors, the sockets of the tubes located on the under side of the chassis, and the moving parts and contacts of the band switch.

(d) Bake chassis for 10 minutes.

(e) Repeat steps in subparagraph (a), (b), (c), and (d) above for three coats of varnish.

(5) REASSEMBLY AND TEST.

CAUTION: Do not return Radio Receiver BC-1005-A to Cabinet CS-155-A until the antenna junction box has been moisture-proofed and fungiproofed according to instructions.

(a) After the third baking operation, remove masking tape from all components. Replace shield cans and vacuum tubes. This completes the processing of Radio Receiver BC-1005-A.

(b) The alignment of the set may be affected by this process. Check the operation carefully, preferably in a complete field set-up, using the target transmitter or signals of known frequency and bearing. With the sensitivity control in the AVC position, the tuning meter provides a rough indication of sensitivity, suitable for comparison with measurements made before moistureproofing and fungiproofing or with measurements made on other Receivers BC-1005-A in the same set-up. With the signal properly tuned in, a lower meter reading indicates higher sensitivity.

(c) If realignment is necessary, follow the procedure indicated in paragraph 39 of this manual.

c. Step-by-Step Instructions for Power Unit PE-155-A.

(1) DISASSEMBLY.

(a) Remove Power Unit PE-155-A from Cabinet CS-155-A in the following manner:

1. Disconnect the receiver power cable and battery cable from the front of the dynamotor unit.
2. Disconnect the two azimuth-scale light cords from the side of the unit.
3. Remove the four screws on the under side of the shelf supporting the power unit.

(b) Remove the two dynamotors by releasing the slide catches.

(c) Remove the bottom coverplate, which is held in place by four screws.

(2) **MASKING.** Cover with masking tape the bottom of the three-prong dynamotor plug and the azimuth-scale light pin jacks, on the inside of the chassis.

(3) **DRYING.** Bake the chassis and bottom coverplate according to instructions furnished with the kit.

(4) **VARNISHING.**

(a) Spray the under side of chassis and the inside surface of the bottom coverplate according to instructions furnished with kit.

(b) Bake the chassis and coverplate for 10 minutes.

(c) Repeat steps in subparagraphs (a) and (b) above for three coats of varnish.

(d) After the third baking operation, remove masking tape from all components.

(5) **REASSEMBLY AND TEST.** This completes the processing of Power Unit PE-155-A; it may now be reassembled for use.

d. Step-by-step Instructions for Antenna Mast Assembly.

(1) **DISASSEMBLY.**

(a) Antenna Mast Assembly AN-105-A, consists of the upper and lower mast sections, the crossarm assembly, and the five antenna rods. The five antenna rods are not to be treated.

CAUTION: If Radio Set SCR-555-A has been set up for operation, it is recommended that the antenna system be removed for treatment by carefully following in reverse the procedure outlined in paragraph 11b.

(b) Remove the two end coverplates and the center coverplate of the crossarm assembly.

(2) **DRYING.** If the upper and lower mast sections and the crossarm assembly will fit into the drying oven, they should be baked according to instructions furnished with the moistureproofing and fungiproofing maintenance kit. Otherwise dry these components as completely as possible by wiping and exposing them to sunlight.

(3) **VARNISHING.**

(a) Spray the interior of the compartments at the ends and center of the crossarm assembly.

(b) Apply varnish with a brush to the five bakelite insulators which are on the crossarm assembly and that are used to support the antenna rods.

(c) Apply varnish with a small brush to the phenolic insulators which are part of the connectors at the ends of the mast sections and are at the center of the crossarm assembly.

CAUTION: Avoid touching the banana plugs and jacks.

(*d*) Bake the mast sections and crossarm assembly for 10 minutes, or air-dry until the varnish is not wet.

(*e*) Repeat steps in subparagraph (*a*), (*b*), (*c*), and (*d*) above for three coats of varnish.

(*f*) After the last drying or baking operation, replace the three coverplates on the crossarm assembly. This completes the processing of the antenna mast assembly; it may be reassembled for use.

e. Step-by-step Instructions for Antenna Junction Box.

(1) DISASSEMBLY.

(*a*) The antenna junction box is located in the upper portion of Cabinet CS-155-A.

(*b*) Remove the coverplate, which is retained by a single screw, from the bottom of the junction box.

(2) DRYING. Do not bake Cabinet CS-155-A. Dry the junction box by wiping and air-drying.

(3) VARNISHING.

(*a*) Apply varnish with a brush to the resistors, terminals, and insulators inside the junction box.

(*b*) Apply varnish with a small brush to the insulator that is part of the antenna connector on top of the cabinet.

(*c*) Allow the varnish to air-dry.

(*d*) Repeat steps in subparagraphs (*a*), (*b*), and (*c*) above for three coats of varnish. This completes the processing of Radio Set SCR-555-A, with the exception of the target transmitter; it may be reassembled for use.

f. Step-by-step Instructions for Radio Transmitter BC-655-A.

(1) DISASSEMBLY.

(*a*) Follow the procedure indicated in paragraph 48 of this manual.

(*b*) Remove the chassis plate opposite the tuning controls. This is accomplished by removing the screws that hold the plate to the rest of the chassis, and the screws that are being used as grounding points and to support the terminal strips.

(*c*) Remove the two vacuum tubes.

(*d*) Remove the batteries from the battery case. Do not treat the batteries.

(2) MASKING.

(a) On the inside of the transmitter case, apply masking tape to the antenna banana-plug jack and to the meter window.

(b) On the inside of the battery case, apply masking tape to the battery switch, the power socket, and the battery plugs.

(c) It is not necessary to mask any components on the chassis as the varnish is to be applied only with a brush.

(3) DRYING. Bake the chassis, the transmitter case, and the battery case according to instructions furnished with the moistureproofing and fungi-proofing maintenance kit. Do not bake the batteries.

(4) VARNISHING.

(a) Spray the interior of the transmitter case and the battery case.

(b) Apply varnish with a brush to all accessible wires, fixed capacitors, resistors, coils, etc., located on the chassis.

CAUTION: Apply the varnish with a small brush, using a minimum of varnish on each component, so that the varnish will not drip or run. Avoid touching the tuning capacitors, the band-switch contacts, and the tube-socket contacts.

(c) Bake the chassis, the transmitter case, and the battery case for 10 minutes.

(d) Repeat steps in subparagraphs (a), (b), and (c) above for three coats of varnish.

(5) REASSEMBLY AND TEST.

(a) After the third baking operation, remove masking tape from all components. This completes the processing of Radio Transmitter BC-655-A; it may be reassembled for use.

(b) Check the operation of the transmitter as recommended in paragraph 53 of this manual.

SECTION V SUPPLEMENTARY DATA

55. MAINTENANCE PARTS LIST FOR RADIO SET SCR-555-A.

a. Complete Components List.

<i>Ref symbol</i>	<i>Signal Corps stock No.</i>	<i>Name of part and description</i>	<i>Quan per unit</i>	<i>Run-ning spares</i>	<i>Orgn stock</i>	<i>3d ech</i>	<i>4th ech</i>	<i>5th ech</i>	<i>Depot stock</i>
	3E1999-28	CORD, CD-1028.	1			*	*	*	*
	3E7182-1	CABLE: battery; (connects battery to power supply).	1			*	*	*	*
	3E7182-3	CABLE: power; (connects Radio Receiver BC-1005-A to power supply).	1			*	*	*	*
	3F2670-324-B	COMPASS MC-324.B.	1			*	*	*	*
	2Z3290.1	COUPLING: flexible; (couples dial drive to 2-gang variable capacitor).	2			*	*	*	*
	3H4600-155A	POWER UNIT PE-155-A.	1	1		*	*	*	*
	3B1500-5	ELECTROLYTE: 1.265 specific gravity.	1			*	*	*	*
	3Z1921	FUSE: type 3AG; 10-ampere; 25-volt.	1	3		*	*	*	*
	3Z2587.1	FUSE: type 3AG; 0.25-ampere; 250-volt; cartridge.	1	3		*	*	*	*
	2B829	HEADSET HS-29.	2			*	*	*	*
	2Z5850-11	KNOB: spindle; (secures azimuth scale to pedestal spindle).	1			*	*	*	*
	6Q63156	LEVEL: spirit.	1			*	*	*	*
	6R362	MALLET: rawhide.	1			*	*	*	*
	4G1335	MICROPHONE T-35.	2			*	*	*	*
	2Z6721-365A	PEDESTAL ASSEMBLY FT-365-A.	1			*	*	*	*

* Indicates stock available.

24 55. MAINTENANCE PARTS LIST FOR RADIO SET SCR-555-A (contd).

a. Complete Components List (contd).

Ref symbol	Signal Corps stock No.	Name of part and description	Quan per unit	Run-ning spares	Orgn stock	3d ech	4th ech	5th ech	Depot stock
	2Z7249.4	PLUG: banana; (used as antenna transmission line connector in antenna mast).	6			*	*	*	*
	2Z7249.6	PLUG: banana; (used as ground circuit connector in antenna mast).	3			*	*	*	*
	2C5005A	RECEIVER BC-1005-A.	1			*	*	*	*
	1F6C1-4.10	SHIELDING: 1/4" wide, No. 13 gauge; (used as ground connection for jack in tower floor).				*	*	*	*
	2C6530-655A	TARGET TRANSMITTER BC-655-A.	1				*	*	*
	2Z9L68-325B	TELESCOPE MC-325-B.	1			*			*
	2A3459-25A	TOWER AND SHELTER ASSEMBLY TR-25-A.	1						*
	6L58757	WASHER: flat; special.	30			*	*	*	*
	6R57400	WRENCH: Allen; No. 8.	7			*	*	*	*
	6R57400-6	WRENCH: Allen; No. 6.	1			*	*	*	*
	6Q3861	WRENCH: bar.	3			*	*	*	*
	6R59349	WRENCH: strap.	1			*	*	*	*
	6R57224-18	WRENCH: open-end; 7" L 3/4 x 9/16.	6			*	*	*	*
	6L106-1.5	BOLT: carriage; 3/8" — 16; 1 1/2" long.	12			*	*	*	*
	6L105-1.5	BOLT: carriage; 5/16" — 18; 1 1/2" long.	12			*	*	*	*

* Indicates stock available.

6L106-2.5	BOLT: carriage; $\frac{3}{8}$ "—16; 2 $\frac{1}{2}$ " long.	6	*	*	*	*
6Z1020	BOLT: door; surface type; $\frac{1}{4}$ " long; (to hold doors of tower open).	3	*	*	*	*
6Z1017-2	BOLT: hook; $1\frac{5}{16}$ "—18; (to clamp shelter side to roof).	6	*	*	*	*
6L804-1.5F	BOLT: stove; $\frac{1}{4}$ x 20 x 1 $\frac{1}{2}$ "; flathead.	6	*	*	*	*
6L804-1.5R	BOLT: stove; $\frac{1}{4}$ x 20 x 1 $\frac{1}{2}$ "; roundhead.	48	*	*	*	*
6L804-2R	BOLT: stove; $\frac{1}{4}$ "—20 x 2" long; roundhead.	12	*	*	*	*
6L306-7F	BOLT: eye; $\frac{3}{8}$ "-16 x $\frac{3}{4}$ " long.	18	*	*	*	*
6L306-3F	BOLT: eye; $\frac{3}{8}$ "-16 x 3" long.	27	*	*	*	*
6L306-5F	BOLT: eye; $\frac{3}{8}$ "-16 x 5" long.	6	*	*	*	*
6G670.1	GREASE: (lubricant for apex bearing and tower eyebolt threads).	1	*	*	*	*
6Z4860-4	GROMMET: fiber; No. 5 black; $\frac{1}{2}$ " OD, $\frac{3}{8}$ " ID.	4	*	*	*	*
6Z4860-3	GROMMET: fiber; No. 5 black; 0.437" OD, $\frac{3}{16}$ " ID.	3	*	*	*	*
6Z4860-5	GROMMET: fiber; No. 5 black; $\frac{5}{16}$ " OD, $\frac{1}{4}$ " ID.	3	*	*	*	*
6L3608-32	NUT: hex; No. 8-32.	222	*	*	*	*
6L3610-32	NUT: steel; hex; No. 10-32.	56	*	*	*	*
6L3505-18	NUT: jam; hex; $\frac{5}{16}$ "-18.	3	*	*	*	*
6Z2382-1	NUT: lock; 1"-20; AN-3066-10; (used with cable connector No. 368).	1	*	*	*	*
2Z3269-15	NUT: lock; $\frac{3}{4}$ "-20; AN-3066-6; (used with cable connector No. 370).	1	*	*	*	*
6L3804-20S	NUT: square; $\frac{1}{4}$ "-20.	54	*	*	*	*

* Indicates stock available.

55. MAINTENANCE PARTS LIST FOR RADIO SET SCR-555-A (contd).

a. Complete Components List (contd).

Ref symbol	Signal Corps stock No.	Name of part and description	Quan per unit	Ran-ning spares	Orgn stock	3d ech	4th ech	5th ech	Depot stock
	6L3805-18	NUT: square; $\frac{3}{16}$ " -18.	12			*	*	*	*
	6L3806-16	NUT: square; $\frac{3}{8}$ " -16.	18			*	*	*	*
	6L2706-16S	NUT: tee.	24			*	*	*	*
	6L3818-18E	NUT: wing; $\frac{3}{16}$ " -18.	3			*	*	*	*
	6G18054.1	ROSIN: (used on strap wrench).	1			*	*	*	*
	6L4906-16.5	SCREW: cap; $\frac{3}{8}$ " -16; 1" long.	4			*	*	*	*
	6L7032-16S	SCREW: machine; 10-32 x 1" long; flathead.	12			*	*	*	*
	6L6832-18E	SCREW: machine; No. 8-32 x $1\frac{1}{8}$ " long; flathead.	54			*	*	*	*
	6L6832-24S	SCREW: machine; No. 8-32 x $1\frac{1}{2}$ " long; flathead.	132			*	*	*	*
	6L7032-14S	SCREW: machine; No. 10-32 x $\frac{7}{8}$ " long; flathead.	40			*	*	*	*
	6L7032-24S	SCREW: machine; No. 10-32 x $1\frac{1}{2}$ " long; flathead.	16			*	*	*	*
	6L6832-24.1S	SCREW: machine; No. 8-32 x $1\frac{1}{2}$ " long; roundhead.	36			*	*	*	*
	6L7920-4.34S	SCREW: machine; $\frac{1}{4}$ "-20 x $2\frac{1}{4}$ "; roundhead.	2			*	*	*	*
	6L20910-14F	SCREW: jam; No. 10-32 x $\frac{7}{8}$ "; (locks spindle knob).	1			*	*	*	*
	6L71008	WASHER: flat; special; $\frac{1}{4}$ " OD, 0.406" ID, $\frac{1}{8}$ " thick.	290			*	*	*	*
	1B110B	WIRE: telephone; 64" long.	1			*	*	*	*
	6L72908	WASHER: lock; No. 8; external teeth.	222			*	*	*	*

* Indicates stock available.

58 55. MAINTENANCE PARTS LIST FOR RADIO SET SCR-555-A (contd).

b. Radio Receiver BC-1005-A.

Ref symbol	Signal Corps stock No.	Name of part and description	Quan per unit	Run-ning spares	Orgn stock	3d ech	4th ech	5th ech	Depot stock
375	3F905-13	AMMETER: d-c; 0-50 ma, G. E. DO-58.	1				*	*	*
377	3F2822	AMMETER: d-c; 75 microamps each side of center, G. E. DO-58.	1				*	*	*
120 121A 121B	3D9089VA1	CAPACITOR: variable; air; 2-gang.	3				*	*	*
122	3D9001VE5	CAPACITOR: variable; ceramic; 1.5 to 7 mmf; Erie type 8842D.	1			*	*	*	*
119-1 119-2	3D9001VE5-1	CAPACITOR: variable; ceramic; 1.5 to 7 mmf; Erie type 8842A.	2			*	*	*	*
123-1 123-2 123-3	3D9012V-2	CAPACITOR: variable; ceramic; 3 to 12 mmf; Erie type 88420.	3			*	*	*	*
114-1 114-2 114-3	3D9005-25	CAPACITOR: fixed; ceramic; 5-mmf ± 1 mmf; 500 v dc (working).	3			*	*	*	*
105-1 105-2	3D9005-23	CAPACITOR: fixed; ceramic; 15 mmf $\pm 5\%$; 500 v dc (working); Erie type B.	2			*	*	*	*
125	3D9035-10	CAPACITOR: fixed; ceramic; 35-mmf $+3\%$; 500 v dc (working); Erie type B.	1			*	*	*	*

* Indicates stock available.

107-1 107-2 107-3 107-4 107-5 107-6 107-7	3D9040-18.1	CAPACITOR: fixed; ceramic; 40-mmfm; 500 v dc (working); Centralab type D.	7	*	*	*	*	*
103-1 103-2	3D9100-57.2	CAPACITOR: fixed; ceramic; 100-mmfm $\pm 5\%$; 500 v dc (working); Centralab type C.	2	*	*	*	*	*
108-1 108-2 108-3 108-4	3D9100-119	CAPACITOR: fixed; ceramic; 100-mmfm $\pm 5\%$; 500 v dc (working); Erie type B.	4	*	*	*	*	*
102-1 102-2	3D9250-46.2	CAPACITOR: fixed; ceramic; 250-mmfm $\pm 5\%$; 500 v dc (working); Centralab type C.	2	*	*	*	*	*
124	3D9400-29	CAPACITOR: fixed; ceramic; 400-mmfm $\pm 5\%$; 500 v dc (working); Erie type B.	1	*	*	*	*	*
117	3DB40-33	CAPACITOR: electrolytic; metal cased; 40-mf; 40 v dc (working).	1	*	*	*	*	*
116A 116B	3DB80-4	CAPACITOR: electrolytic; metal cased; 80-80-mf; +100% -10%; 300 v dc (working).	1	*	*	*	*	*
118	3DK9750-13	CAPACITOR: mica; moulded; 750-mmfm $\pm 2\%$; 500 v dc (working).	1	*	*	*	*	*
112-1 112-2	3K3010212	CAPACITOR: mica; moulded; 1,000-mmfm $\pm 5\%$; 500 v dc (working).	2	*	*	*	*	*
104-1 104-2 104-3 104-4 104-5	3K3020212	CAPACITOR: mica; moulded; 2,000-mmfm $\pm 5\%$; 500 v dc (working).	5	*	*	*	*	*

* Indicates stock available.

55. MAINTENANCE PARTS LIST FOR RADIO SET SCR-555-A (contd).

b. Radio Receiver BC-1005-A (contd).

<i>Ref symbol</i>	<i>Signal Corps stock No.</i>	<i>Name of part and description</i>	<i>Quan per unit</i>	<i>Run-ning spares</i>	<i>Orgn stock</i>	<i>3d ech</i>	<i>4th ech</i>	<i>5th ech</i>	<i>Depot stock</i>
101-1 101-2 101-3 101-4 101-5 101-6 101-7 101-8 101-9 101-10 101-11 101-12 101-13 101-14	3D3551212	CAPACITOR: mica; moulded; 5,100-mmf $\pm 5\%$; 500 v dc (working).	14			*	*	*	*
111-1 111-2 111-3 111-4 111-5	3DA10-189.1	CAPACITOR: paper; oil filled; 10,000-mmf $\pm 20\%$; 600 v dc (working).	5			*	*	*	*
106-1 106-2 106-3 106-4 106-5 106-7	3DA20-81	CAPACITOR: paper; oil filled; 20,000-mmf $\pm 20\%$; 600 v dc (working).	13			*	*	*	*

* Indicates stock available.

55. MAINTENANCE PARTS LIST FOR RADIO SET SCR-555-A (contd).

b. Radio Receiver BC-1005-A (contd).

Ref symbol	Signal Corps stock No.	Name of part and description	Quan per unit	Run-ning spares	Orgn stock	3d ech	4th ech	5th ech	Depot stock
230	2Z7278.1	POTENTIOMETER: wire-wound; 10,000-ohm.	1			*	*	*	*
227	2Z7281.7	POTENTIOMETER: wire-wound; 20,000-ohm; slotted shaft.	1			*	*	*	*
202-1 202-2	3RC20BE151M	RESISTOR: carbon; insulated; 150-ohm $\pm 20\%$; $1/2$ -w.	2			*	*	*	*
217-1 217-2	3RC21BE330M	RESISTOR: carbon; insulated; 33-ohm $\pm 20\%$; $1/2$ -w.	2			*	*	*	*
218	3ZK6007E5-12	RESISTOR: carbon; insulated; 75-ohm $\pm 20\%$; $1/2$ -w.	1			*	*	*	*
214-1 214-2 214-3 214-4	3RC21BE221M	RESISTOR: carbon; insulated; 220-ohm $\pm 20\%$; $1/2$ -w.	4			*	*	*	*
206-1 206-2 206-3	3RC21BE102M	RESISTOR: carbon; insulated; 1,000-ohm $\pm 20\%$; $1/2$ -w.	3			*	*	*	*
203-1 203-2 203-3 203-4	3RC21BE152M	RESISTOR: carbon; insulated; 1,500-ohm $\pm 20\%$; $1/2$ -w.	4			*	*	*	*
215-1 215-2 215-3 215-4	3RC21BE222M	RESISTOR: carbon; insulated; 2,200-ohm $\pm 20\%$; $1/2$ -w.	4			*	*	*	*

* Indicates stock available.

223	3RC21BE332M	RESISTOR: carbon; insulated; 3,300-ohm $\pm 20\%$; 1/2-w.	1			*	*	*	*
219-1	3RC21BE472M	RESISTOR: carbon; insulated; 4,700-ohm $\pm 20\%$; 1/2-w.	3			*	*	*	*
219-2									
219-3									
207	3RC21BE682M	RESISTOR: carbon; insulated; 6,800-ohm $\pm 20\%$; 1/2-w.	1			*	*	*	*
210-1	3RC21BE103M	RESISTOR: carbon; insulated; 10,000-ohm $\pm 20\%$; 1/2-w.	2			*	*	*	*
210-2									
213	3RC21BE223K	RESISTOR: carbon; insulated; 22,000-ohm $\pm 10\%$; 1/2-w.	1			*	*	*	*
222-1	3RC21BE683M	RESISTOR: carbon; insulated; 68,000-ohm $\pm 20\%$; 1/2-w.	3			*	*	*	*
222-2									
222-3									
220-1	3RC21BE104M	RESISTOR: carbon; insulated; 100,000-ohm $\pm 20\%$; 1/2-w.	9			*	*	*	*
220-2									
220-3									
220-4									
220-5									
220-6									
220-7									
220-8									
220-9									
208-1	3RC21BE154M	RESISTOR: carbon; insulated; 150,000-ohm $\pm 20\%$; 1/2-w.	4			*	*	*	*
208-2									
208-3									
208-4									
216-1	3RC21BE224M	RESISTOR: carbon; insulated; 220,000-ohm $\pm 20\%$; 1/2-w.	2			*	*	*	*
216-2									
211-1	3RC21BE474M	RESISTOR: carbon; insulated; 470,000-ohm $\pm 20\%$; 1/2-w.	3			*	*	*	*
211-2									
211-3	3RC								

* Indicates stock available.

55. MAINTENANCE PARTS LIST FOR RADIO SET SCR-555-A (contd).

b. Radio Receiver BC-1005-A (contd).

Ref symbol	Signal Corps stock No.	Name of part and description	Quan per unit	Run-ning spares	Orgn stock	3d ech	4th ech	5th ech	Depot stock
221-1 221-2 221-3 221-4 221-5 221-6 221-7	3RC21BE105M	RESISTOR: carbon; insulated; 1 meg AWS; 1/2-w.	7			*	*	*	*
209-1 209-2 209-3	3RC21BE333M	RESISTOR: carbon; insulated; 33,000-ohm $\pm 20\%$; 1/2-w.	3			*	*	*	*
224	3RC31BE102K	RESISTOR: carbon; insulated; 1,000-ohm $\pm 10\%$; 1-w.	1			*	*	*	*
226	3RC41BE270K	RESISTOR: carbon; insulated; 27-ohm $\pm 10\%$; 2-w.	1			*	*	*	*
225-1 225-2 225-3 225-4	3RC41BE390K	RESISTOR: carbon; insulated; 39-ohm $\pm 10\%$; 2-w.	4			*	*	*	*
212-1 212-2	3Z6006H8-11	RESISTOR: carbon; non-insulated; 68-ohm; 1/4-w.	2			*	*	*	*
350	2Z8799-207	SOCKET: connector; 2-prong; tan mica-filled bakelite insulation; wall mounting type.	1			*	*	*	*
349	2ZK8671.12	SOCKET: connector; single-prong; tan mica-filled bakelite insulation.	1			*	*	*	*

* Indicates stock available.

359	2Z5883-102	SOCKET: lamp; single-contact; miniature bayonet; Cinch 99023 (modified).	1	*	*	*	*	*
361-1 361-2	2Z8673-37	SOCKET: lamp; polarized; bakelite insulation; 1/8" mounting centers; Cinch type F-82A (modified).	2	*	*	*	*	*
358	2Z5883-101	SOCKET: lamp; single-contact; miniature bayonet; Micarta Fabricators (special).	1	*	*	*	*	*
360	2Z8650.5	SOCKET: tube; 8-prong; mica-filled bakelite insulation; Cinch type 9950.	15	*	*	*	*	*
330	3Z9826-122	SWITCH: rotary; 4-position; 4-deck; wafer type.	1	*	*	*	*	*
331A 331B 331C 331D	3Z9826-12.1	SWITCH: rotary; 2-position; 4-deck; wafer type.	1	*	*	*	*	*
332A 332B 332C	3Z9826-123	SWITCH: rotary; 2 position; 3-deck; wafer type.	1	*	*	*	*	*
333-1 333-2 333-3 333-4	3ZK9845-19	SWITCH: toggle; spst; Cutler Hammer 8803K3.	4	*	*	*	*	*
334-1 334-2	3Z9849.60	SWITCH: toggle; dpdt; Cutler Hammer 8825K2.	2	*	*	*	*	*
335	3Z9845-11.1	SWITCH: toggle; dpdt; Cutler Hammer 8823K2.	1	*	*	*	*	*
302	2Z9632.172	TRANSFORMER: audio.	1	*	*	*	*	*
301	2Z9632.171	TRANSFORMER: audio.	1	*	*	*	*	*
317-1 317-2 317-3 317-4	2Z9643.105	TRANSFORMER: i-f.	4	*	*	*	*	*

* Indicates stock available.

55. MAINTENANCE PARTS LIST FOR RADIO SET SCR-555-A (contd).

b. Radio Receiver BC-1005-A (contd).

<i>Ref symbol</i>	<i>Signal Corps stock No.</i>	<i>Name of part and description</i>	<i>Quan per unit</i>	<i>Run-ning spares</i>	<i>Orgn stock</i>	<i>3d ech</i>	<i>4th ech</i>	<i>5th ech</i>	<i>Depot stock</i>
311	2C5005A/T4	TRANSFORMER: r-f; antenna; 18-34 mc.	1				*	*	*
315	2C5005A/T6	TRANSFORMER: r-f oscillator; 18-34 mc.	1				*	*	*
313	2C5005A/T2	TRANSFORMER: r-f mixer; 18-34 mc.	1				*	*	*
310	2C5005A/T1	TRANSFORMER: r-f; antenna; 34-65 mc.	1				*	*	*
312	2C5005A/T3	TRANSFORMER: r-f mixer; 34-65 mc.	1				*	*	*
314	2C5005A/T5	TRANSFORMER: r-f oscillator; 34-65 mc.	1				*	*	*
376	3F8015-15	VOLTMETER: d-c; 0-15 volts; G.E. DO-58.	1				*	*	*

c. Antenna Mast Assembly AN-105-A.

	2A275-15	ROD ASSEMBLY: cold drawn seamless steel tubing; 1/2" OD; 74 3/4" long.	5				*	*	*
	2A276-16	CROSSARM ASSEMBLY: welded-steel tubing; 2" diameter; over-all length 95 1/2".	1				*	*	*
	2A2029	MAST SECTION: lower; over-all length 84".	1				*	*	*
	2A2029-1	MAST SECTION: upper; over-all length 84".	1				*	*	*

d. Power Unit PE-155-A.

111-6	3DA10-189.1	CAPACITOR: fixed; paper; mineral oil-filled; 10,000-mmfd ±20%; 600 v dc (working).	2				*	*	*
111-7							*	*	*

* Indicates stock available.

113-3	3DA500-95	CAPACITOR: fixed; paper; 500,000-mmf $\pm 10\%$; 400 v dc (working).	1		*	*	*	*
318-1 318-2	2C6323-54C	COIL: choke; r-f; inductance 17 microhenries $\pm 20\%$.	2		*	*	*	*
389	2Z3600-19	CUSHION: rubber; strip: $3\frac{3}{8}$ " long, $1\frac{3}{32}$ " high, $1\frac{3}{64}$ " deep, with slot $1\frac{3}{64}$ " x $\frac{3}{32}$ ".	1		*	*	*	*
387-1	3H1512-5	DYNAMOTOR: input 12 volts at 3 amps; output 170 volts at 100 milliamps; Pioneer Gen-E-Motor type DS-12.	1	1	*	*	*	*
388-1	3Z2587.1	FUSE: cartridge; 250-milliamp, 250-volt; $1\frac{1}{4}$ " x $\frac{1}{4}$ " diam; Bussman 3AG type No. 1264.	1	3	*	*	*	*
	3Z1921	FUSE: cartridge; 10-amp, 250-volt; $1\frac{1}{4}$ " x $\frac{1}{4}$ " diam; Bussman 3A6 type No. 1081.	1	3	*	*	*	*
	3Z3275-1	FUSE HOLDER: extractor post; bakelite; single-hole, mounting; Magnavox No. A180244.	2		*	*	*	*
	2Z7113.43	PLUG: 3-prong; banana type; Magnavox No. XA180203.	1		*	*	*	*
	2Z7113.25	RECEPTACLE: 3-prong; contact current rating 30 amps.; Cannon Electric No. P4-13.	1		*	*	*	*
	2Z6684	SHOCK MOUNT: rubber.	4		*	*	*	*
	6Z8210	SNAP SLIDE ASSEMBLY: Magnavox dwgs No. A630638B and A101842G3N.	4		*	*	*	*
	2Z6873.37	SOCKET: 2-contact; polarized; Sheridan Electric Corp. No. F-82A (modified).	2		*	*	*	*
367	2Z8673.53	SOCKET: 3-prong; bakelite insulation; Magnavox No. XA180208 (for dynamotor input and output plug 364).	1		*	*	*	*
	3H1512-5/B10	BRUSH SET: replacement; Magnavox No. XB530011G2.	4	8	*	*	*	*

* Indicates stock available.

55. MAINTENANCE PARTS LIST FOR RADIO SET SCR-555-A (contd).

e. Radio Transmitter BC-655-A (contd).

Ref symbol	Signal Corps stock No.	Name of part and description	Quan per unit	Run-ning spares	Orgn stock	3d ech	4th ech	5th ech	Depot stock
C7	2A275-103	ANTENNA AN-103.	1						*
	3D9025-16	CAPACITOR: fixed; ceramic; 25-mmf $\pm 5\%$; 1,000 v dc (working); CD type O.	1						*
C1	3F2-22.3	ADAPTER: phenolic; for microammeter model 0221-T.	1			*	*	*	*
C2	3D9500-8	CAPACITOR: 1,000-mmf; made up of two, fixed; mica; 500-mmf $\pm 20\%$; 500 v dc (working); in parallel.	4			*	*	*	*
C3									
C8									
C6	3DA20-48	CAPACITOR: fixed; potted; 20,000-mmf; 200 v dc (working); Sprague No. 2532.	1			*	*	*	*
C9	3DA250-38	CAPACITOR: fixed; potted; 250,000-mmf; 200 v dc (working); Sprague No. 2532.	1			*	*	*	*
C4	3D9008VE5	CAPACITOR: variable; air dielectric; 7-mmf min to 97.5-mmf max; Automatic Winding Co. No. B-14M4-705.	1				*	*	*
C5	3DA1-89	CAPACITOR: variable; mica wafer dielectric; 1,000-mmf; 200 v dc (test); F. W. Sickles Co. type HC-5.	1			*	*	*	*
L5	3C371-2	COIL: filament r-f choke; Stromberg-Carlson No. D-4218.	1				*	*	*
	2Z8673-3	CONNECTOR: female; 3-prong; Amphenol type S3S.	1			*	*	*	*
	2Z4866.120	GASKET: antenna base ring; STC No. D-4171.	1			*	*	*	*
	2Z4885-5	GUIDE: wire; $\frac{1}{16}$ " "XX" formica; STC No. D-4327.	1			*	*	*	*

* Indicates stock available.

M1	3G1837-8.13 3G1837-2.4 2Z3400-123A 2Z5761.1 2ZK5822-26 2Z5822-87	INSULATOR: antenna base; STC No. D-4136. INSULATOR: rain cover; STC No. D-4137. COVER BG-123-A. KNOB: bar; black bakelite; Radolek No. C-10901. KNOB: standard bar; black bakelite; Kurz-Kasch. KNOB: round; black phenolic; Gordon Specialities Co. No. 301.	1 1 1 1 2 2	*	*	*	*	*	*	*	*	*	*
	3FS72	MICROAMMETER: d-c; 0-200 microamperes; Triplett Model 0221-T.	1	*	*	*	*	*	*	*	*	*	*
	2Z7112.13	PLUG: male; 2-prong; Cinch No. 2724.	1	*	*	*	*	*	*	*	*	*	*
	2Z3023-1	PLUG: male; 3-prong; Amphenol No. MPM3S.	1	*	*	*	*	*	*	*	*	*	*
	2Z7113.29	PLUG: male; 3-prong; Cinch No. 2726; BA63.	2	*	*	*	*	*	*	*	*	*	*
R1	3Z6010-36	RESISTOR: carbon; 100-ohm $\pm 10\%$; $1/2$ -w; Allen-Bradley type "E-B".	1	*	*	*	*	*	*	*	*	*	*
R2	3Z6647-5	RESISTOR: carbon; 47,000-ohm $\pm 10\%$; $1/2$ -w; Allen-Bradley type "E-B".	1	*	*	*	*	*	*	*	*	*	*
R3	3Z6768-6	RESISTOR: carbon; 680,000-ohm $\pm 10\%$; $1/2$ -w; Allen-Bradley type "E-B".	1	*	*	*	*	*	*	*	*	*	*
R4	3Z6947-6	RESISTOR: carbon; 470,000-ohm $\pm 10\%$; $1/2$ -w; Allen-Bradley type "E-B".	2	*	*	*	*	*	*	*	*	*	*
R5	2Z8795.1	SOCKET: tube; standard octal; Amphenol type RSS8.	1	*	*	*	*	*	*	*	*	*	*
S4	3Z9825-61	SWITCH: rotary; STC No. D-4143.	1	*	*	*	*	*	*	*	*	*	*
S5	3Z9825-61.4	SWITCH: rotary; SPST; STC No. D-4186.	1	*	*	*	*	*	*	*	*	*	*
S1	2C6530-655A/1	SWITCH AND COIL ASSEMBLY: 3-section; including L1 and L2; STC No. D-4202.	1	*	*	*	*	*	*	*	*	*	*

* Indicates stock available.

55. MAINTENANCE PARTS LIST FOR RADIO SET SCR-555-A (contd).

e. Radio Transmitter BC-655-A (contd).

Ref symbol	Signal Corps stock No.	Name of part and description	Quan per unit	Run-ning spares	Orgn stock	3d ecb	4th ecb	5th ecb	Depot stock
T1	2Z9636.6	TRANSFORMER: a-f; modulation; pri. 265-ohm, sec. 1,000-ohm; STC No. D-4190.	1				*	*	*
	2Z4880-52	WINDOW: meter viewing; STC No. D-4156.	1			*	*	*	*
	3A63	BATTERY BA-63.	2		*				
	3A65	BATTERY BA-65.	1		*				
V2	2J1A5GT	TUBE JAN-1A5GT/G.	1	1		*	*	*	*
V1	2J958	TUBE JAN-958.	1	1		*	*	*	*
f. Tower TR-25-A.									
	2A3459-25A/L1	LEGS: tower; lower.	3				*	*	*
	2A3459-25A/L2	LEGS: tower; upper.	3				*	*	*

3524-SCDL-43—13260—11-44

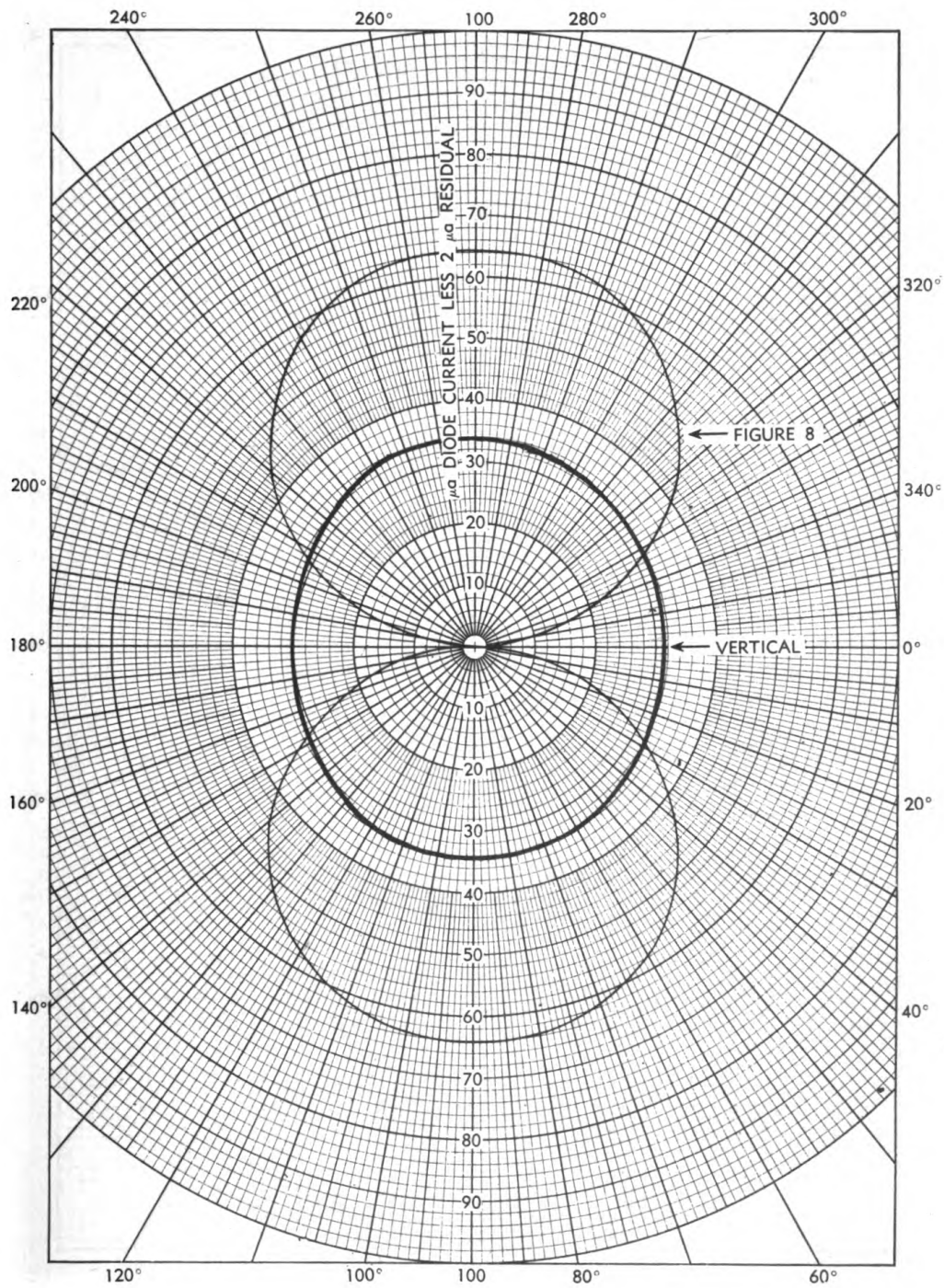

TL-10883

Figure 41. Figure-8 and vertical field patterns measured at 33 megacycles.

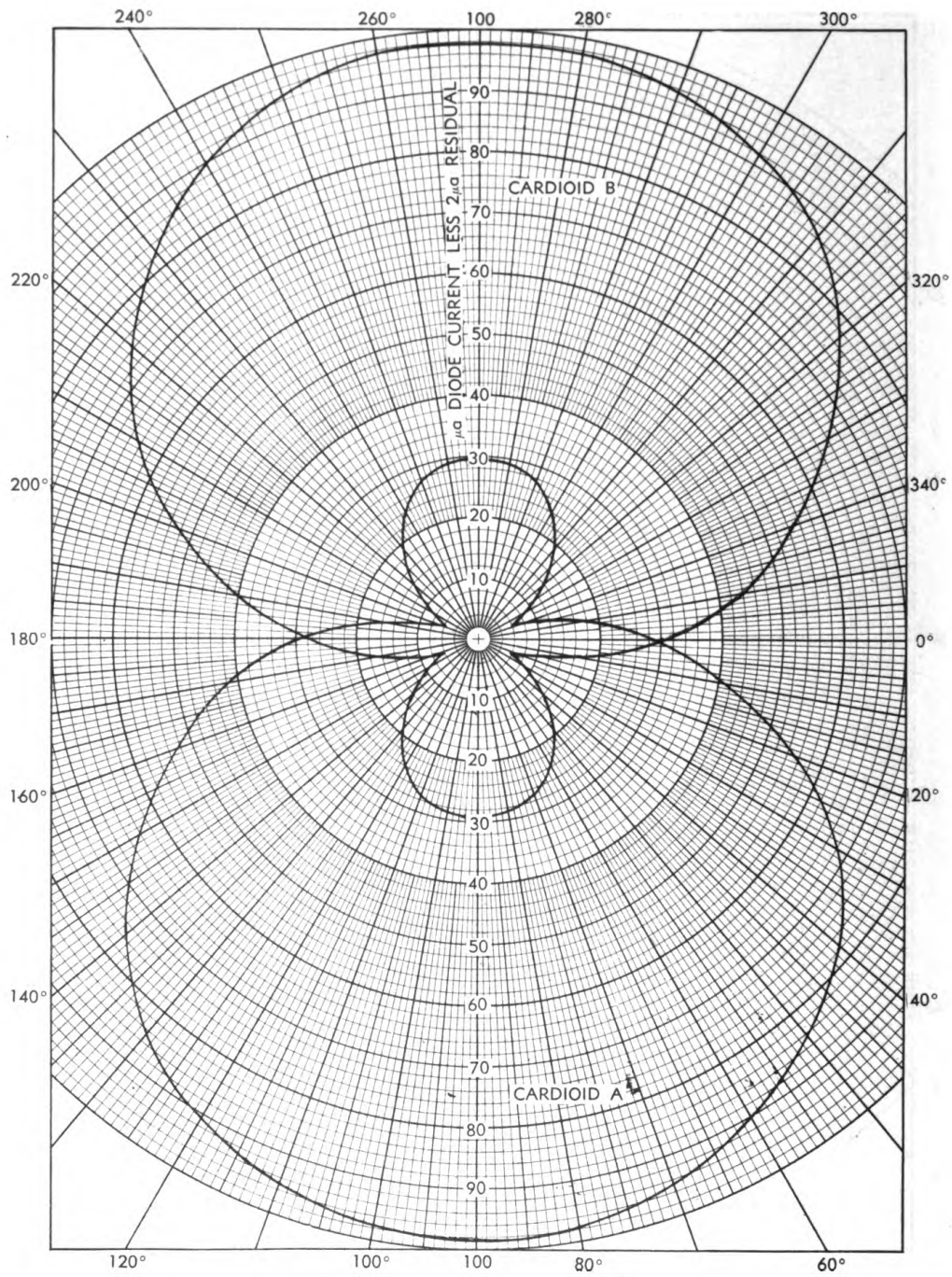

TL-10884

Figure 42. Cardioid field patterns measured at 33 megacycles.

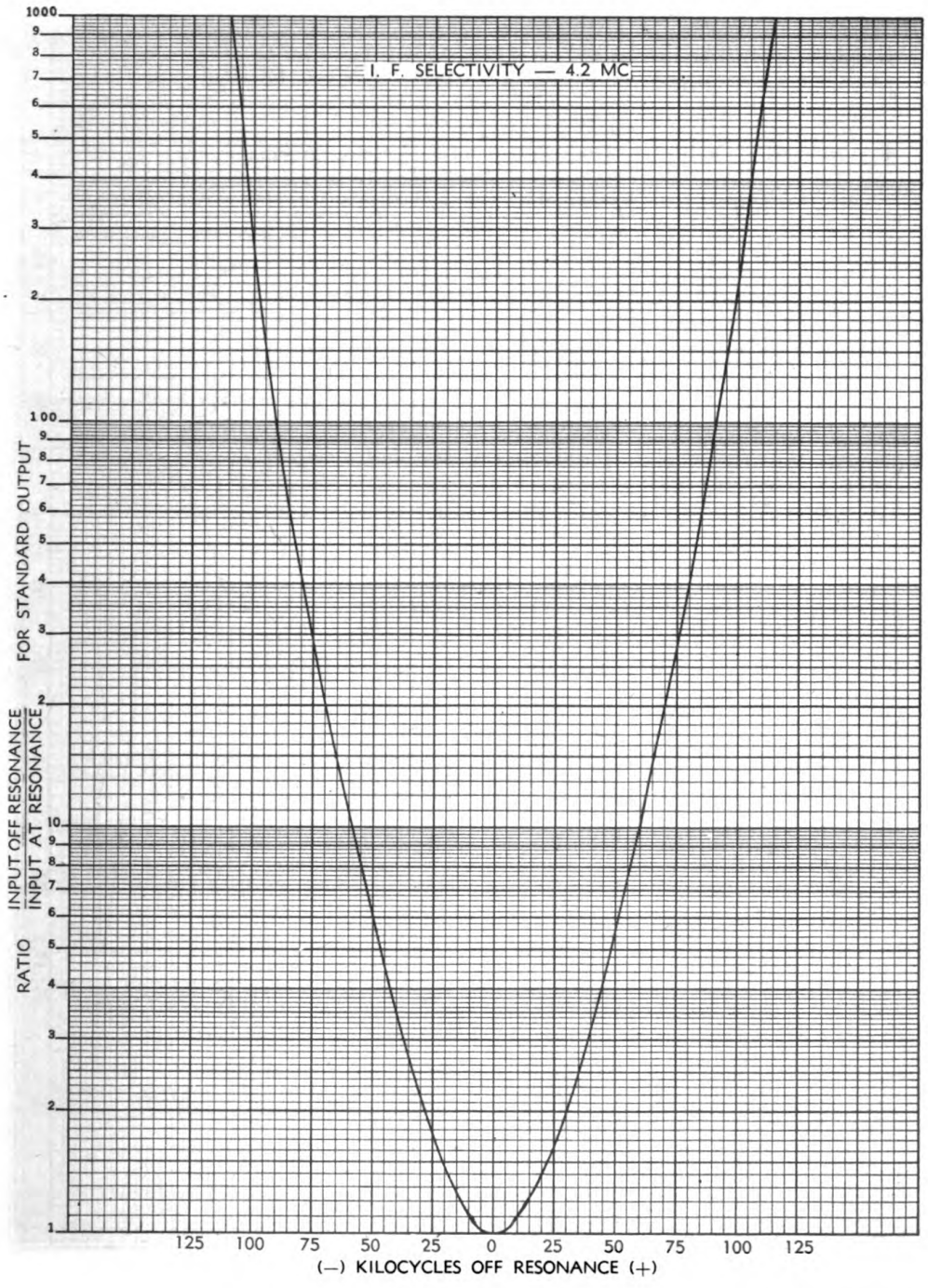

TL-10890

Figure 43. Radio Receiver BC-1005-A, selectivity curve, 4.2 megacycles.

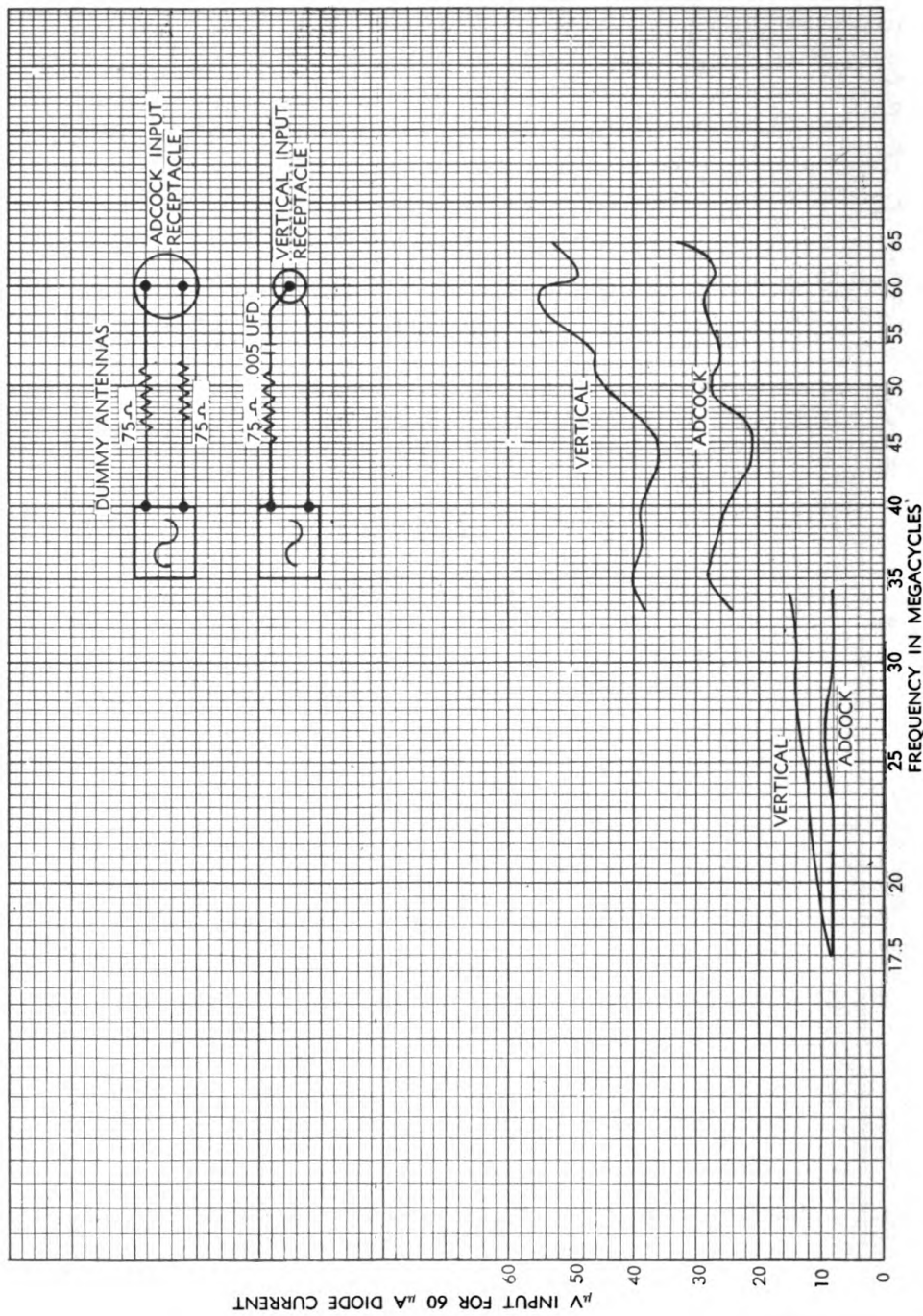

TL-10891

Figure 44. Radio Receiver BC-1005-A, sensitivity curves.

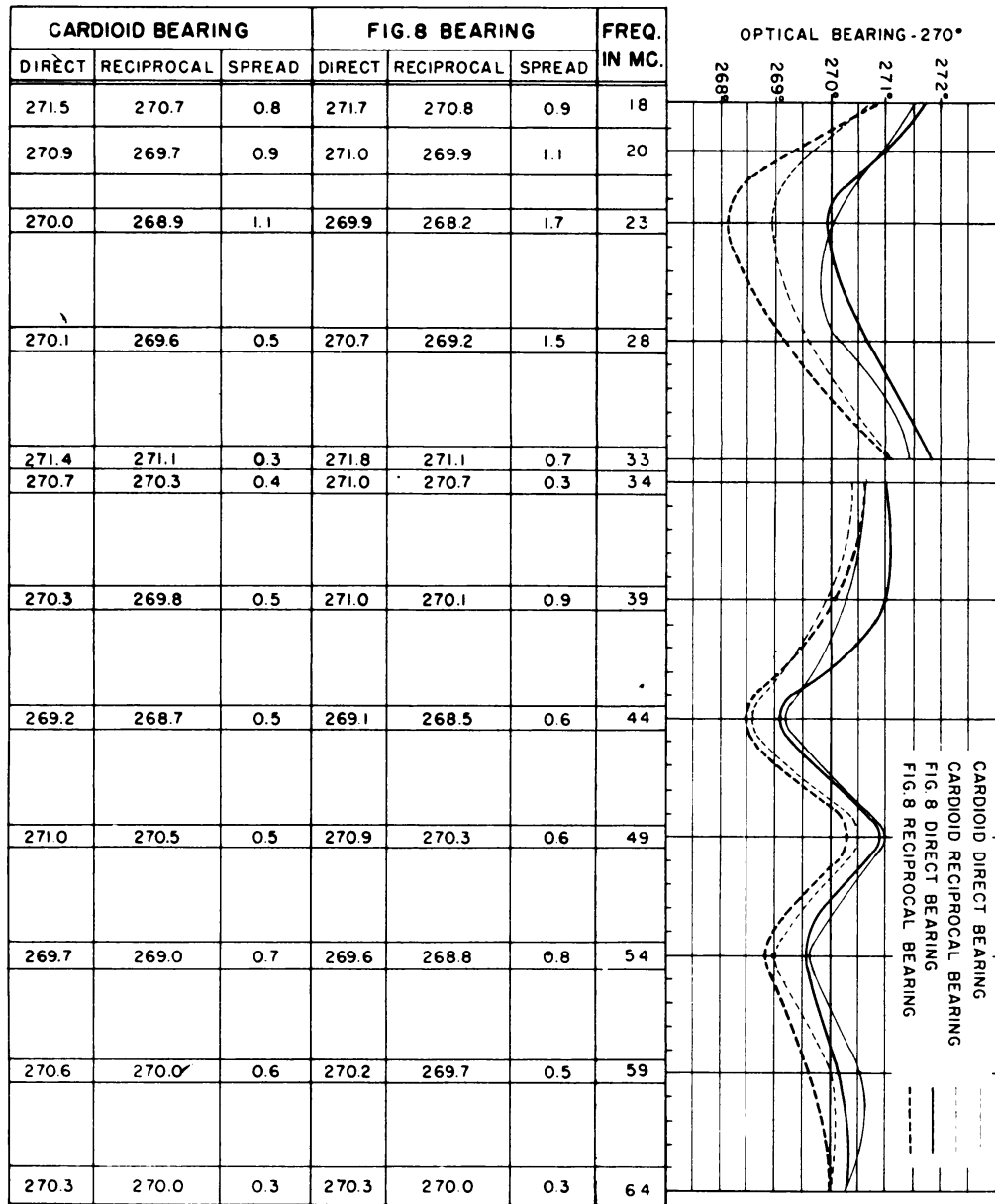

TL-10895

Figure 45. Typical radio direction finder performance data.

CARDIOID BEARING			FIG. 8 BEARING			FREQ. IN MC.
DIRECT	RECIPROCAL	SPREAD	DIRECT	RECIPROCAL	SPREAD	
						18
						20
						23
						28
						33
						34
						39
						44
						49
						54
						59
						64

TL-10896

Figure 46. Blank chart for recording radio direction finder performance data.

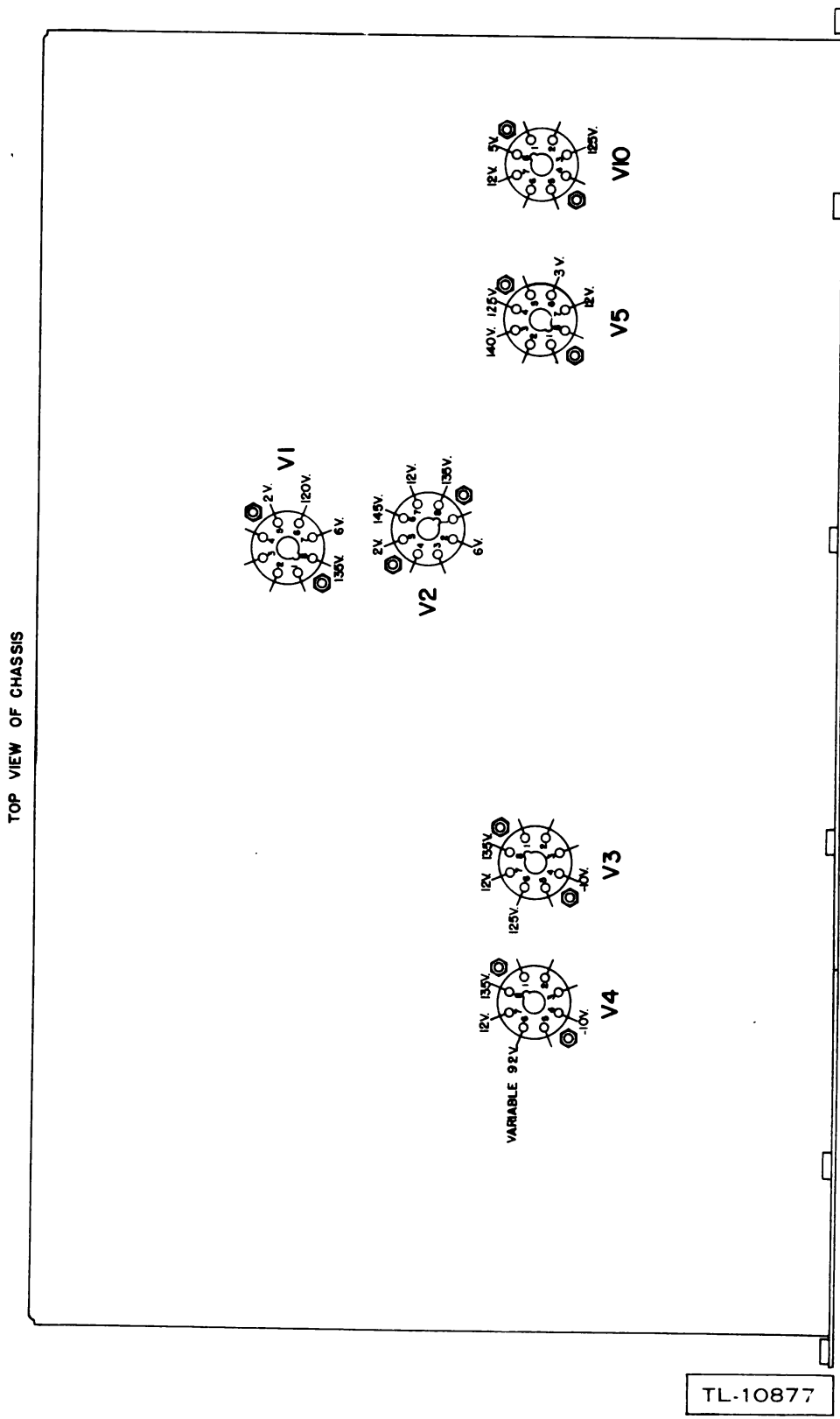
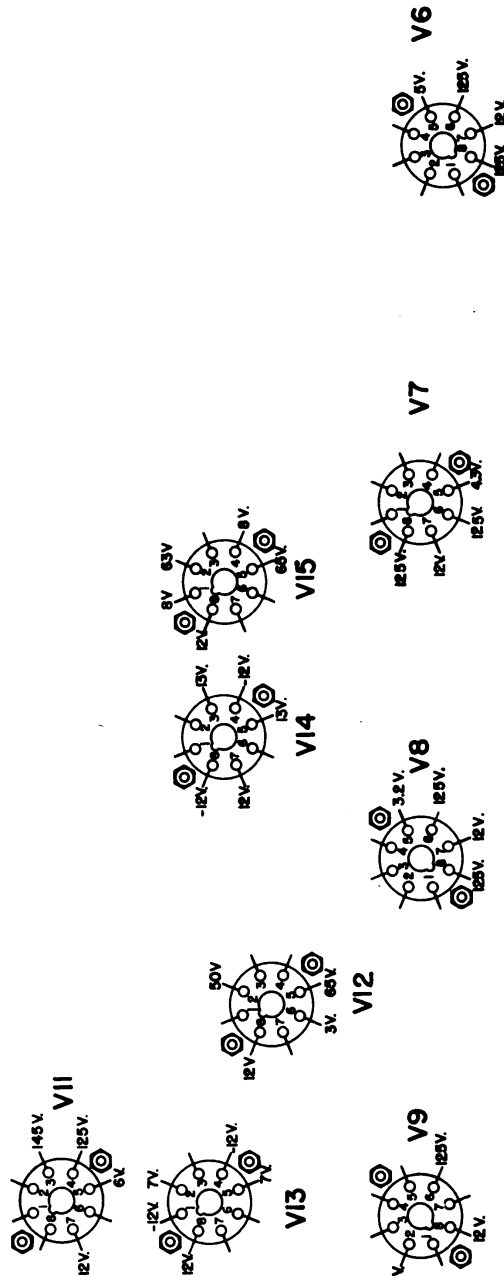

Figure 47. Radio Receiver BC-1005-A, top view, tube socket layout and voltages.

BOTTOM VIEW OF CHASSIS.



TL-10878

Figure 48. Radio Receiver BC-1005-A, bottom view, tube socket layout and voltages.

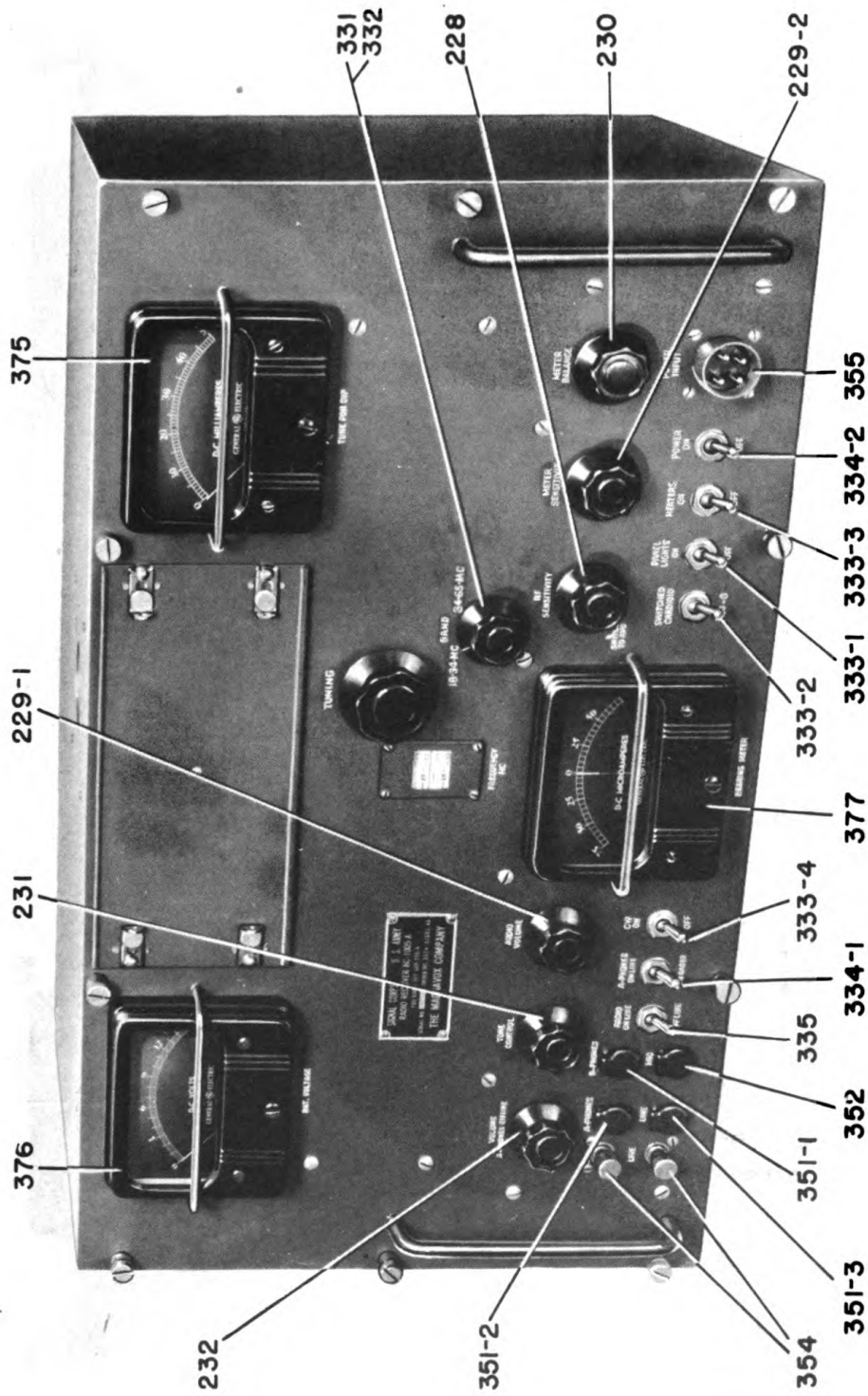

TL-10879

Figure 49. Radio Receiver BC-1005-A, front view.

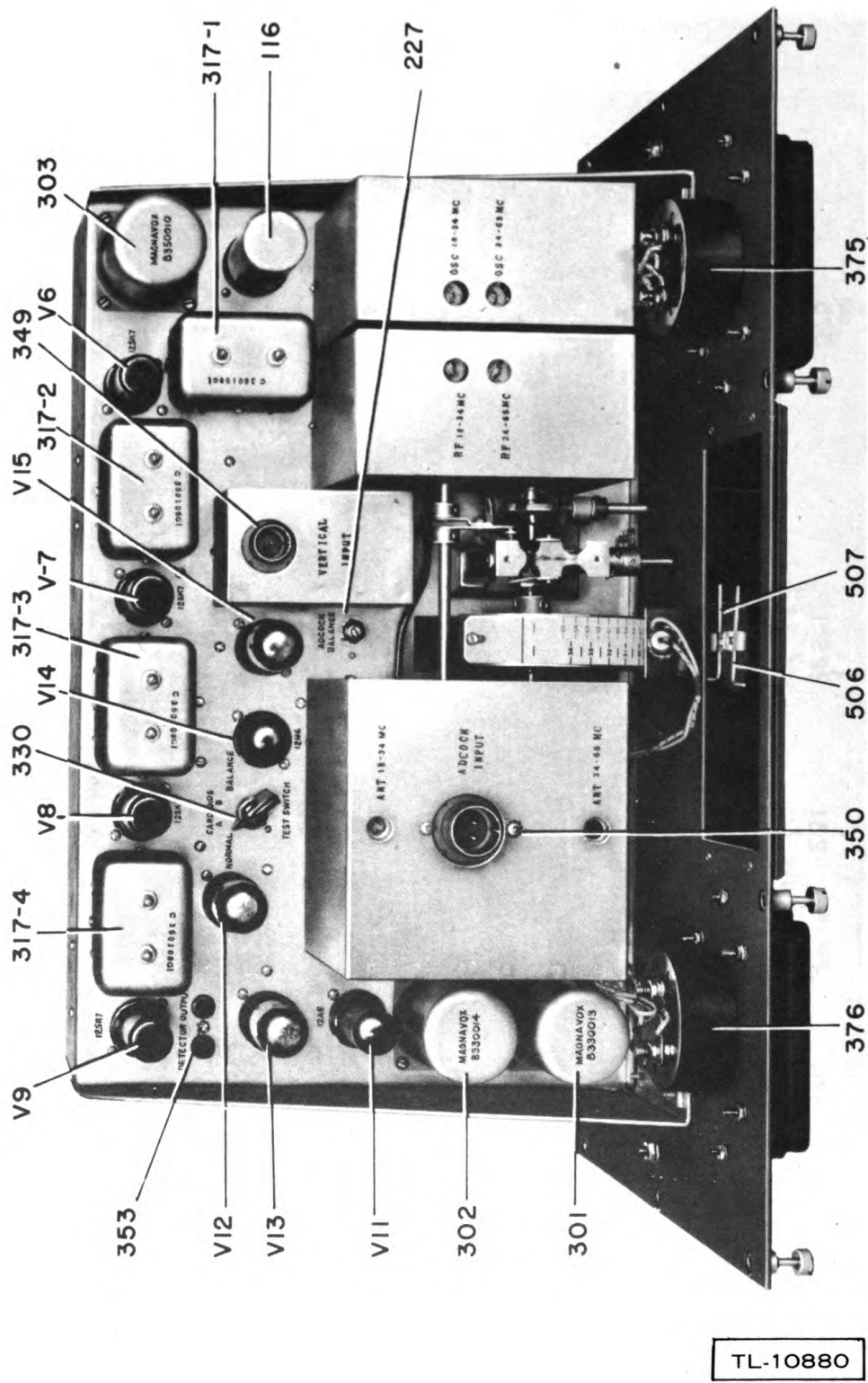

Figure 50. Radio Receiver BC-1005-A, top view, coil shields in place.

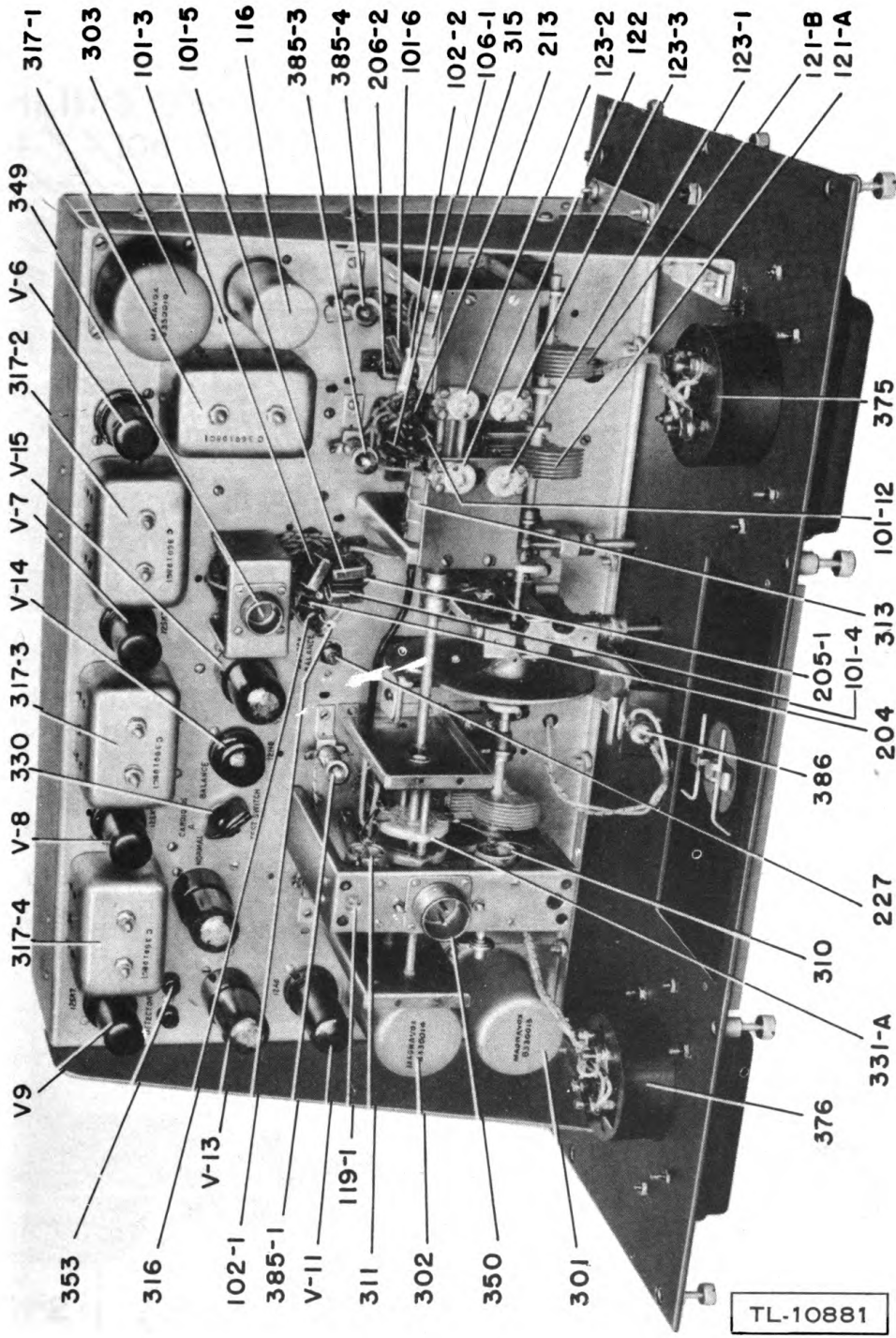

Figure 51. Radio Receiver BC-1005-A, top view, coil shields removed.

06-11
24

221
-5

BC-10