

This is a reproduction of a library book that was digitized by Google as part of an ongoing effort to preserve the information in books and make it universally accessible.

Google™ books

<https://books.google.com>

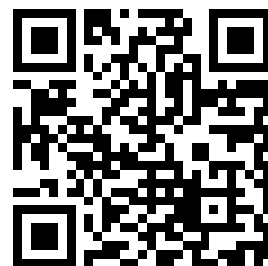

FED-DOCS

Digitized by Google

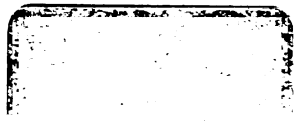

W1.35:11-2603

TM 11-2603

WAR DEPARTMENT TECHNICAL MANUAL



RADIO SET AN/TRC-2

RESTRICTED. DISSEMINATION OF RESTRICTED MATTER.
 The information contained in restricted documents and the essential characteristics of restricted materiel may be given to any person known to be in the service of the United States and to persons of undoubted loyalty and discretion who are cooperating in Government work, but will not be communicated to the public or to the press except by authorized military public relations agencies. (See also par. 28, AR 380-5, 15 Mar 1944.)

RADIO SET AN/TRC-2



WAR DEPARTMENT

1 APRIL 1944

~~RESTRICTED. DISSEMINATION OF RESTRICTED MATTER~~

The information contained in restricted documents and the essential characteristics of restricted materiel may be given to any person known to be in the service of the United States and to persons of undoubted loyalty and discretion who are cooperating in Government work, but will not be communicated to the public or to the press except by authorized military public relations agencies. (See also par. 28, AR 380-5, 15 Mar. 44.)

WAR DEPARTMENT,
WASHINGTON 25, D. C., 31 March 1944.

TM 11-2603, War Department Technical Manual, Radio Set AN/TRC-2, is published for the information and guidance of all concerned.

[A. G. 300.7 (1 Jan. 1944).]

BY ORDER OF THE SECRETARY OF WAR:

G. C. MARSHALL,
Chief of Staff.

OFFICIAL:

J. A. ULIO,
*Major General,
The Adjutant General.*

DISTRIBUTION:

X

(For explanation of symbol see FM 21-6.)

TABLE OF CONTENTS

	<i>Paragraph</i>	<i>Page</i>
PART ONE. Description.		
General	1	1
Frequency Range	2	1
Operating Range	3	1
Power Input	4	1
Power Output	5	1
Modes of Transmission and Reception	6	1
Components	7	2
Radio Receiver and Transmitter BC-1306	8	2
Receiver Transmitter RT-12/TRC-2	9	2
Power Unit PE-162	10	2
Engine GE-12-A	11	2
Generator GN-50	12	2
Filter FL-22	13	2
Generator GN-57	14	3
Antenna Equipment	15	3
Vibrator Power Supply PP-39/TRC-2	16	3
Accessories	17	3
Power Cables	18	3
Maintenance Kit	19	3
Gasoline Cans	20	3
TWO. Installation and Operation.		
Preparing Packboards for Carrying	21	7
Mounting Components to Packboards	22	7
Selecting Location	23	7
Erecting Antenna	24	8
Selecting Antenna	25	13
Connecting Receiver-Transmitter and Accessories	26	15
Preparing Power Unit PE-162	27	19
Mounting Generator GN-57	28	20
Preparing Vibrator Power Supply PP-39/TRC-2	29	20
Operating the Receiver	30	24
Operating the Transmitter	31	24
Operating Power Unit PE-162	32	26
Operating Generator GN-57	33	29
Charging Battery BB-54-A in Vibrator Power Unit PP-39/TRC-2	34	20
Quick Charging on Mounting FT-338-A	35	30
Quick Charging without Mounting Bracket	36	39
Charging from the Hand Generator or Power Unit PE-162	37	30
Side Tone Circuit	38	30

TABLE OF CONTENTS

	<i>Paragraph</i>	<i>Page</i>
Transmitter Dial Readings	39	35
Receiver Dial Readings	40	35
Operation of Microphone	41	35
Operation of Key	42	35
Crystal-Controlled Operation	43	35
Master-Oscillator Operation	44	35
Receiver Calibration	45	36
Transmitter Calibration	46	36
Battery Operation of Receiver Only	47	36
Precautions During Operation	48	36
Minimizing Indicator Glow	49	37

THREE. Functioning of Parts.

Section 1. Radio Receiver and Transmitter BC-1306.

General	50	39
Receiver Circuit Analysis	51	39
Receiver Antenna Circuit	52	39
R-F Amplifier	53	39
High Frequency Oscillator	54	39
First I-f Amplifier	55	41
Second I-f Amplifier	56	41
Crystal Calibration	57	41
Detector	58	41
Beat-Frequency Oscillator	59	41
First Audio Amplifier	60	42
Audio Output	61	42
Side Tone for Receiver	62	42
Transmitter	63	42
Master Oscillator-Crystal Oscillator	64	42
Modulator	65	47
Voltage Regulator	66	48
Antenna Loading	67	48

Section II. Receiver Transmitter RT-12/TRC-2.

Receiver	68	49
Transmitter	69	49
Power Unit PE-162	70	49
Operating Principle of Engine GE-12-A	71	49
Operating Principle of Generator GN-50 and Filter FL-22	72	50
Components of Generator and Filter FL-22	73	51
Generator GN-57	74	52
Circuit Analysis of Generator GN-57	75	52
Vibrator Power Supply PP-39/TRC-2	76	53
Storage Battery of Vibrator Power Supply	77	53
Charging Circuit of Vibrator Power Supply	78	54
Functioning of Relay when Charging	79	54
Charging from Hand Generator	80	55

TABLE OF CONTENTS

FOUR. Maintenance.

	<i>Paragraph</i>	<i>Page</i>
Section I. Receiver and Transmitter.		
General Instructions	81	59
Receiver, Failure to Operate	82	59
Receiver Tube Replacement	83	60
Transmitter, Failure to Operate	84	60
Voltage Regulator VT-200	85	65
Replacing Transmitter Tubes	86	65
Hand Generator GN-57—Failure to Operate	87	67
Interference from Generator GN-57	88	67
Voltage Regulator—Hand Generator	89	67
Power Amplifier Overload	90	67
Section II. Vibrator Power Supply PP-39.		
Failure to Operate	91	69
Failure to Charge	92	69
Excessive Charging Rate	93	71
Section III. Battery BA-54-A.		
General Care	94	71
Charging Battery	95	71
Section IV. General Service and Alignment Procedure.		
General Service Information	96	72
Receiver Alignment Equipment	97	74
Receiver Alignment Procedure	98	74
Transmitter Alignment Equipment	99	76
Transmitter Alignment Procedure	100	76
Section V. Power Unit PE-162.		
Failure to Operate	101	78
Lack of Power	102	78
Overheating	103	78
Spark Plug	104	78
Magneto	105	78
Generator GN-50	106	81
Engine GE-12	107	83
Section VI.		
Maintenance Groups	108	92
Operation of Soldering Iron	109	95
FIVE. Supplementary Data.		
Maintenance Parts List for Radio Set AN/TRC-2 (Part I.)	110	105
Maintenance Parts List for Radio Set AN/TRC-2 (Part II.)	111	107
Maintenance Parts List for Radio Receiver and Transmitter BC-1306. (Receiver Group)	112	108
Maintenance Parts List for Radio Receiver and Transmitter BC-1306. (Transmitter Group)	113	111
Maintenance Parts List for Receiver-Transmitter RT-12/TRC-2 (Receiver Group)	114	115
Maintenance Parts List for Receiver-Transmitter RT-12/TRC-2 (Trans- mitter Group)	115	118
Maintenance Parts List for Power Unit PE-162	116	121
Maintenance Parts List for Power Unit PE-162 (Generator Group)	117	121
Maintenance Parts List for Power Unit PE-162 (General Hardware Group)	118	121
Maintenance Parts List for Vibrator Power Supply PP-39/TRC-2	119	122
Maintenance Parts List for Generator GN-57	120	124

LIST OF ILLUSTRATIONS

<i>Fig. No.</i>	<i>Title</i>	<i>Page</i>
1	Radio Set AN/TRC-2 Components.....	x
2	Strapping Bags to Packboards.....	3
3	Gasoline Drum Unpacked.....	4
4	Antenna Equipment for Radio Set AN/TRC-2 (Section 1).....	5
5	Antenna Equipment for Radio Set AN/TRC-2 (Section 2).....	5
6	Generator GN-57 on Packboard.....	6
7	Generator GN-57 and Accessories.....	6
8	Maintenance Kit Unpacked.....	8
9	Radio Set BC-1306 or RT-12/TRC-2 on Packboard.....	9
10	Gasoline-Oil Mixing Can and Oil Container.....	10
11	Packboard Attachments for Power Unit PE-162.....	10
12	Field Operation—Radio Receiver and Transmitter BC-1306.....	11
13	Calibration Chart for Antenna AN-160.....	12
14	Maintenance Kit on Packboard.....	13
15	Field Operation—Receiver - Transmitter RT-12/TRC-2.....	14
16	Receiver of Radio Set BC-1306 Operating from Battery BA-48.....	15
17	Operating Radio Receiver and Transmitter BC-1306 or RT-12/TRC-2 with Generator GN-57 and Battery BA-48.....	16
18	Receiver-Transmitter RT-12/TRC-2 with Cover M-404.....	17
19	Receiver-Transmitter RT-12/TRC-2 with Cover M-404 on Back of Set.....	18
20	Power Unit PE-162 Mounted on Packboard.....	19
21	Power Unit PE-162, Rain Shield and Packboard.....	20
22	Vibrator Power Supply PP-39/TRC-2, Rear and Front View (Battery BB-54 Inside)...	21
23a,b	Installation of Battery BB-54-A into Battery Jacket.....	22
23c	Installation of Battery Assembly into Vibrator Power Unit.....	22
24	Vibrator Power Supply PP-39/TRC-2 on Packboard.....	23
25	Gasoline Drum on Packboard.....	23
26	Receiver - Transmitter RT-12/TRC-2.....	25
27	Radio Receiver and Transmitter BC-1306.....	27
28	Starting Controls, Power Unit PE-162.....	28
29	Cordage, Batteries and Nozzle Unpacked.....	29
30	Vibrator Power Unit PP-39/TRC-2 and Mounting FT-338-A.....	31
31	Vibrator Power Unit PP-39/TRC-2 Attached to Mounting FT-338-A.....	32
32	Charging Vibrator Power Supply PP-39/TRC-2 from Vehicular Storage Battery.....	33
33	Vibrator Power Supply PP-39/TRC-2.....	34
34	Accessory Bag on Packboard.....	37
35	Cordage, Batteries, and Nozzle on Packboard.....	37
36	Charging Battery of Vibrator Power Supply PE-39/TRC-2 with Power Unit PE-162.....	38
37	Operating Radio Receiver and Transmitter BC-1306 or RT-12/TRC-2 with Vibrator Power Supply PP-39/TRC-2 and Generator GN-57.....	40
38	Parts Symbols of Receiver of Radio Receiver and Transmitter BC-1306 or RT-12/TRC-2.....	43
39	Parts Symbols of Transmitter of Radio Receiver and Transmitter BC-1306 (Top View).....	45
40	Parts Location of Transmitter of Receiver-Transmitter RT-12/TRC-2 (Top View).....	48
41	Operation of Piston.....	50
42	Sectional View of Power Unit PE-162.....	51
43	Circuit Symbols, Generator GN-57.....	52
44	Circuit of Vibrator Power Supply PP-39/TRC-2.....	55

LIST OF ILLUSTRATIONS

<i>Fig. No.</i>	<i>Title</i>	<i>Page</i>
45	Circuit Symbols—Vibrator Power Supply.....	56
46	Transmitter Frequency Calibration Charts.....	57
47	Transmitter Tuning Capacitor Assembly—Circuit Symbols.....	58
48	Tuning Capacitor Shaft Packing and Mounting.....	58
49	Cord CX-75/TRC-2 and Cord CD-1086.....	58
50	Receiver Test Set-Up.....	61
51	Tuning Capacitor Rear Mounting.....	62
52	Circuit Voltages—Receiver.....	63
53	Voltage Test Points—Transmitter.....	64
54	Case (Receiver-Transmitter) Wiring Diagram.....	65
55	Circuit—Generator GN-57.....	66
56	Circuit Voltages—Generator GN-57.....	67
57	Circuit—Cord CD-1119.....	68
58	Circuit-Test Cable.....	68
59	Vibrator Power Supply—Voltage Check Points (Chassis).....	70
60	Vibrator Power Supply PP-39/TRC-2—Circuit Symbols (Chassis).....	72
61	Voltage Test Points—Vibrator Power Supply.....	73
62	Alignment of Receiver of Radio Receiver and Transmitter BC-1306 and RT-12/TRC-2 (Top View).....	75
63	Alignment Data, Transmitter.....	77
64	Magneto Assembly.....	79
65	Magneto Stator Plate Assembly.....	80
66	Brush Removal.....	81
67	Point Adjustment.....	82
68	Circuit of Power Unit PE-162.....	83
69	Replaceable Parts, Power Unit PE-162.....	84
70	Timing Engine.....	85
71	Dressing Commutator.....	86
72	Cross Section Drawing of Engine GE-12-A.....	87
73	Generator Assembly.....	87
74	Carburetor Parts.....	88
75	Fuel Tank Assembly.....	90
76	Carbon Removal—Exhaust Ports.....	90
77	Test for Spark Output.....	91
78	Carbon Removal—Intake Ports.....	91
79	Power Unit PE-162, Front View.....	91
80	Power Unit PE-162, Rear View.....	91
81	Accessories Unpacked.....	93
82	Tool Kit.....	94
83	Soldering Iron, Gasoline Operated.....	95
84	Operation of Soldering Iron.....	96
85	Operation of Soldering Iron.....	96
86	Operation of Soldering Iron.....	96
87	Operation of Soldering Iron.....	96
88	Schematic Diagram Receiver BC-1306.....	97
89	Schematic Diagram Receiver RT-12/TRC-2.....	99
90	Schematic Diagram Transmitter BC-1306.....	101
91	Schematic Diagram Transmitter RT-12/TRC-2.....	103

DESTRUCTION NOTICE

WHY —To prevent the enemy from using or salvaging this equipment for his benefit.

WHEN—When ordered by your commander.

- HOW**
1. **Smash**—Use sledges, axes, handaxes, pickaxes, hammers, crow-bars, heavy tools, etc.
 2. **Cut**—Use axes, handaxes, machetes, etc.
 3. **Burn**—Use gasoline, kerosene, oil, flame throwers, incendiary grenades, etc.
 4. **Explosives**—Use firearms, grenades, TNT, etc.
 5. **Disposal**—Bury in slit trenches, fox holes, other holes. Throw in streams. Scatter.

USE ANYTHING IMMEDIATELY AVAILABLE FOR DESTRUCTION OF THIS EQUIPMENT.

- WHAT**
1. **Smash**—Cabinet or case, chassis, tubes, tuning capacitor, instrument panel, and every electrical and mechanical part. Rip out all wiring in the unit. Destroy nameplates and circuit labels.
 2. **Cut**—Wire, cables, cords, and covers.
 3. **Burn**—Calibration book, technical manual, and other printed matter.
 4. **Bury or scatter**—Any or all of the above pieces after demolishing the equipment.

DESTROY EVERYTHING

SAFETY NOTICE

Operation of this equipment involves the use of high voltages which are dangerous to life. Operating personnel must at all times observe all safety regulations. Do not operate equipment when removed from case.

NOTE

**Refer to page 64 for lubrication data
on Generator GN-57**

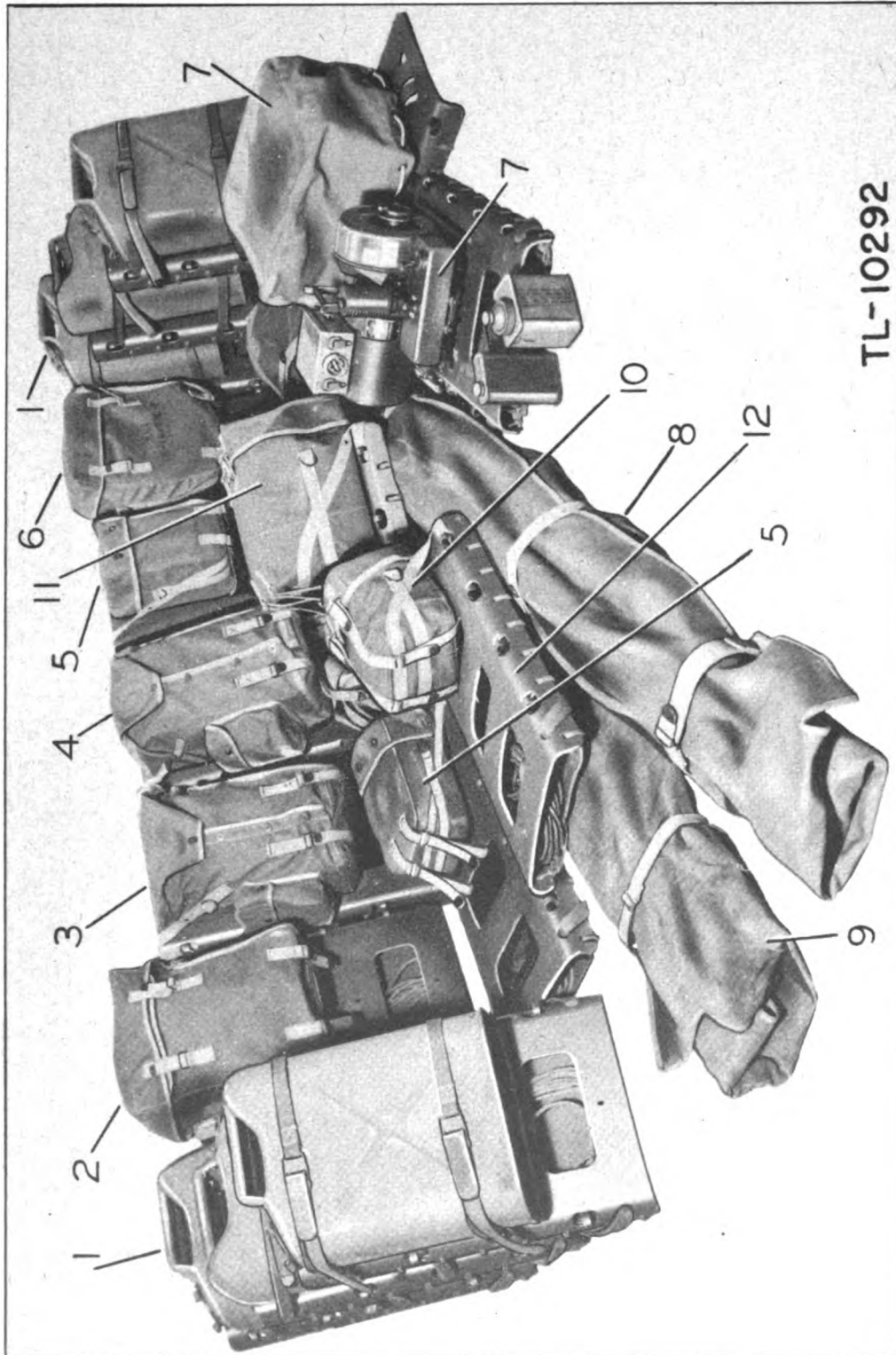

Figure 1—Radio Set AN/TRC-2 Components

- | | |
|--|---------------------------------------|
| 1. Drums, gasoline (6 each) | 7. Power Unit PE-162 (2 each) |
| 2. Accessory kit | 8. Antenna Equipment |
| 3. Radio Receiver and Transmitter BC-1306 | 9. Antenna Equipment |
| 4. Receiver-Transmitter RT-12/TRC-2 | 10. Vibrator Power Supply PP-39/TRC-2 |
| 5. Vibrator Power Supply PP-39/TRC-2 | 11. Maintenance kit |
| 6. Cords CX-75/TRC-2 (2 each) and Batteries BA-48 (2 each) | 12. Packboards (16 each) |

PART ONE

DESCRIPTION

1. GENERAL.

Radio Set AN/TRC-2 is a long-range man-packed two-way radio telephone (voice) and radio telegraph (CW) set, designed for field use. The set is divided into a number of individual loads to facilitate transportation of all components by man-pack. The entire radio set, ready for carrying, is shown in Figure 1. The individual loads ready for carrying, and the exploded view of each load, are shown in Figures 2, 3, 4, 5, 6, 7, 8, 9, 14, 16, 20, 21, 24, 25, 29, 34, 35 and 81.

2. FREQUENCY RANGE.

The radio set covers two frequency ranges: 2000 kc to 3400 kc, using Radio Receiver-Transmitter RT-12/TRC-2, and 3800 kc to 6500 kc, using Radio Receiver and Transmitter BC-1306. Crystals used in the transmitter operate at one-half of the transmitted frequency.

3. OPERATING RANGE.

Radio Set AN/TRC-2 will provide communication up to 75 miles on voice, and up to 125 miles on CW.

4. POWER INPUT.

a. Receiver-Transmitter.—The power necessary for operation of the receiver-transmitter is normally obtained from Power Unit PE-162, a gasoline-engine driven generator set of light weight, shown in Figures 79 and 80. Two such units form a part of the set to insure continued operation. Generator GN-57, a hand-cranked unit, is provided as part of the set to be used if no gasoline is available.

b. Receivers.—Power necessary to operate the receivers alone may be obtained from Vibrator Power Supply PP-39/TRC-2 or Battery BA-48. During periods of two-way communication, power for the receiver is normally obtained from Power Unit PE-162 or Generator GN-57, although power

for the receiver (and for the low-power stages of the transmitter) may be obtained from Vibrator Power Supply PP-39/TRC-2 or Battery BA-48.

(1) Vibrator Power Supply PP-39/TRC-2 (Fig. 22) is a storage battery operated vibrator unit which obtains its power from a self-contained 2-volt storage cell, Battery BB-54.

(2) Battery BA-48 is a dry battery which delivers necessary operating voltages to the receiver.

5. POWER OUTPUT.

a. Transmitter.—The power output of the transmitter varies over wide limits depending upon the position of the POWER switch and upon whether Power Unit PE-162 or Generator GN-57 is used. The normal power output under these varying conditions is given in the following table:

Power Switch Position	Power Unit PE-162		Generator GN-57	
	Phone	CW	Phone	CW
High	8.5 watts	25 watts	6 watts	17 watts
Medium	4.5 watts	21 watts	4 watts	14 watts
Low	2.2 watts	13 watts	2 watts	8.5 watts

b. Receiver.—Maximum power output of the receiver is sufficient to operate Loud Speaker LS-11, furnished with this equipment. The receiver is operated with one or two Headsets HS-30-D when weak signals must be received.

6. MODES OF TRANSMISSION AND RECEPTION.

a. Radio Set AN/TRC-2 will transmit and receive:

- (1) Continuous-wave radio telegraph;
- (2) Voice-modulated radio telephone (phone), amplitude-modulated;

(3) Tone-modulated radio telegraph, (mcw) amplitude-modulated.

b. All types of transmission are master-oscillator controlled or crystal-controlled.

(1) A calibration chart for master-oscillator operation is attached to the front of the transmitter.

(2) A 200-kc crystal in the receiver furnishes standard-frequency check points, against which to check and correct the calibration of the transmitter.

(3) Provision has been made for two crystals to be plugged into a receptacle on the front panel of the transmitter, to control frequency during crystal-controlled operation.

(4) A three-position switch selects the frequency-controlling element: MO, CRYSTAL A, or CRYSTAL B.

(5) A chart attached to the front of the crystal cover provides a convenient place to record the frequencies of the crystals inside and the corresponding dial settings.

7. COMPONENTS.

The complete list of component items of Radio Set AN/TRC-2 are shown in a distributed form in Figures 3, 4, 5, 7, 8, 16, 29 and 81. The main components are described below.

8. RADIO RECEIVER AND TRANSMITTER BC-1306.

(Fig. 27.) This component is a complete receiver and transmitter that operates from a separate power supply, operating in the frequency range 3800 kc to 6500 kc. It is light in weight, portable and watertight. Panel Cover M-404, a watertight cover for the front panel of the receiver-transmitter is provided to insure that no water can enter the set. With this cover in place, the set will float. This unit is carried in Bag CW-15/TRC-2, made of rainproof canvas. Additional items carried in the same bag are: Headset HS-30-D, Extension Cord CD-307-A, Battery BA-48 and Cord CD-1119 (battery cable).

a. Receiver Dial Calibration. — The receiver dial is calibrated in megacycles, with 20 kilocycle graduations.

b. Transmitter Dial Calibration. — The transmitter dial is calibrated 0 to 3000. A calibration chart is attached to the front panel, listing dial settings for every 20 kc from 3800 kc to 6500 kc.

9. RECEIVER-TRANSMITTER RT-12/TRC-2.

This component is identical in size and general arrangement to Radio Receiver and Transmitter BC-1306 described in paragraph 8, except that it covers the frequency range 2000 kc to 3400 kc. It has an additional output binding post for a counterpoise (Figure 26), and both dials are calibrated every 10 kc instead of every 20 kc. Bag CW-15/TRC-2 is used to carry this unit. Additional items carried in this bag are the same type and quantity as described in paragraph 8.

10. POWER UNIT PE-162.

(Figs. 79 and 80.) This unit is a compact, light weight, gasoline-engine driven generator, of the manual starting type, with an output of 250 watts. The components of this power unit are Engine GE-12-A, Generator GN-50 and Filter FL-22.

11. ENGINE GE-12-A.

The engine is a one-cylinder, two-cycle, air-cooled unit developing one horsepower at 3,000 revolutions per minute. The fuel is a mixture of oil and gasoline in the ratio of one part No. 10 SAE oil to 16 parts gasoline of any type. Each engine is furnished with a fuel-mixing can to facilitate measuring oil and gasoline to obtain the correct proportions. (Figure 10).

12. GENERATOR GN-50.

Generator GN-50 is a dual voltage unit developing 7.5 volts on the low-voltage commutator and 500 volts on the high-voltage commutator. These voltages are fed to Filter FL-22, mounted on the generator. The armature is directly coupled to the engine crankshaft by means of a female splined coupling.

13. FILTER FL-22.

The filter contains filter capacitors, chokes, dropping resistor, and a circuit breaker. The purpose of the filter is to reduce audio ripple and radio-frequency interference to a level that will give satisfactory operation of the receiver-transmitter, to furnish the proper output voltages

required, and to protect the generator against overload. A manually reset circuit breaker inside the filter gives the desired protection without the use of fuses.

14. GENERATOR GN-57.

Generator GN-57 is a hand-cranked generator which supplies all voltages required for operation of either Radio Receiver and Transmitter BC-1306 or Receiver-Transmitter RT-12/TRC-2. It does not deliver the same high voltage to the transmitter as the Power Unit PE-162 because of its light weight. Differences in power output of the transmitter caused by the difference in high-voltage output of the power sources are shown in paragraph 5.

a. The accessories required for the generator are:

- 1 Leg LG-2-A
- 2 Leg LG-3
- 2 Crank GC-7
- 1 Cord CD-1086

b. The legs are carried in one of the antenna equipment rolls, and the cranks in the bag with the generator and cords.

15. ANTENNA EQUIPMENT.

Antenna equipment is carried in two Antenna Equipment Rolls CW-9/TRC-2. Figures 4 and 5 show both antenna equipment rolls, unrolled to display their contents. These items constitute all of the necessary items to make the antenna installation shown in Figures 12 and 15. When erected, each mast is 30 feet high.

16. VIBRATOR POWER SUPPLY PP-39/TRC-2.

Vibrator Power Supply PP-39/TRC-2, shown in Figure 22 is a power source for the receiver and low-power stages of the transmitter. A self-contained 2-volt storage cell (Battery BB-54) is part of this unit.

17. ACCESSORIES.

The small accessories needed for operation of Radio Set AN/TRC-2 are shown in Figure 81. They are carried in Bag CW-16/TRC-2, shown in Figure 34.

18. POWER CABLES.

Two cables, each 50 feet long, are provided to allow placing the Power Unit PE-162 at a considerable distance from the radio set. These cables, together with the items shown in Figure 29 are carried in Bag CW-14/TRC-2, shown in Figure 35.

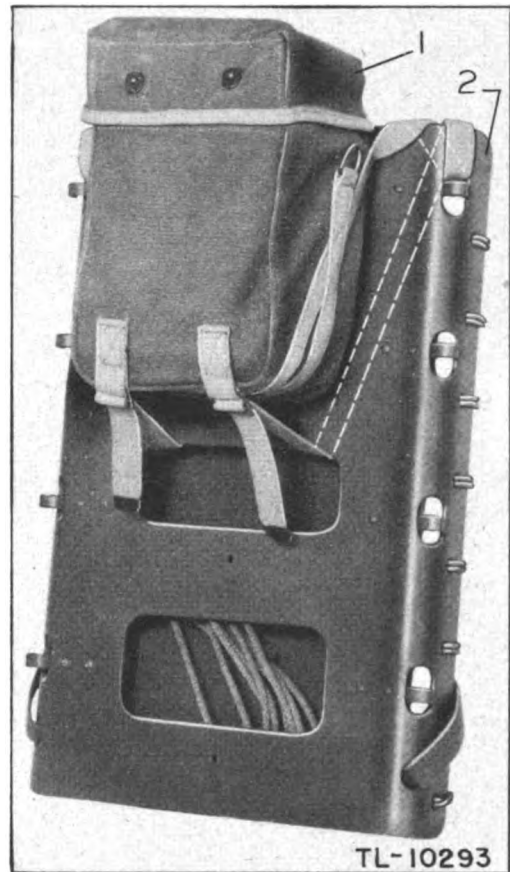

Figure 2—Strapping Bags to Packboards

19. MAINTENANCE KIT.

A complete maintenance kit, containing replacement tubes, electrical components, and engine parts, is carried in Bag CW-13/TRC-2, shown in Figures 8 and 14.

20. GASOLINE CANS.

Fuel for Power Unit PE-162 is carried in six 5-gallon cans (QMC No. 42-B-1280), as shown in Figures 3 and 25. The cans may be loaded with pre-mixed fuel; or oil may be carried in one container, and gasoline in the remaining containers.

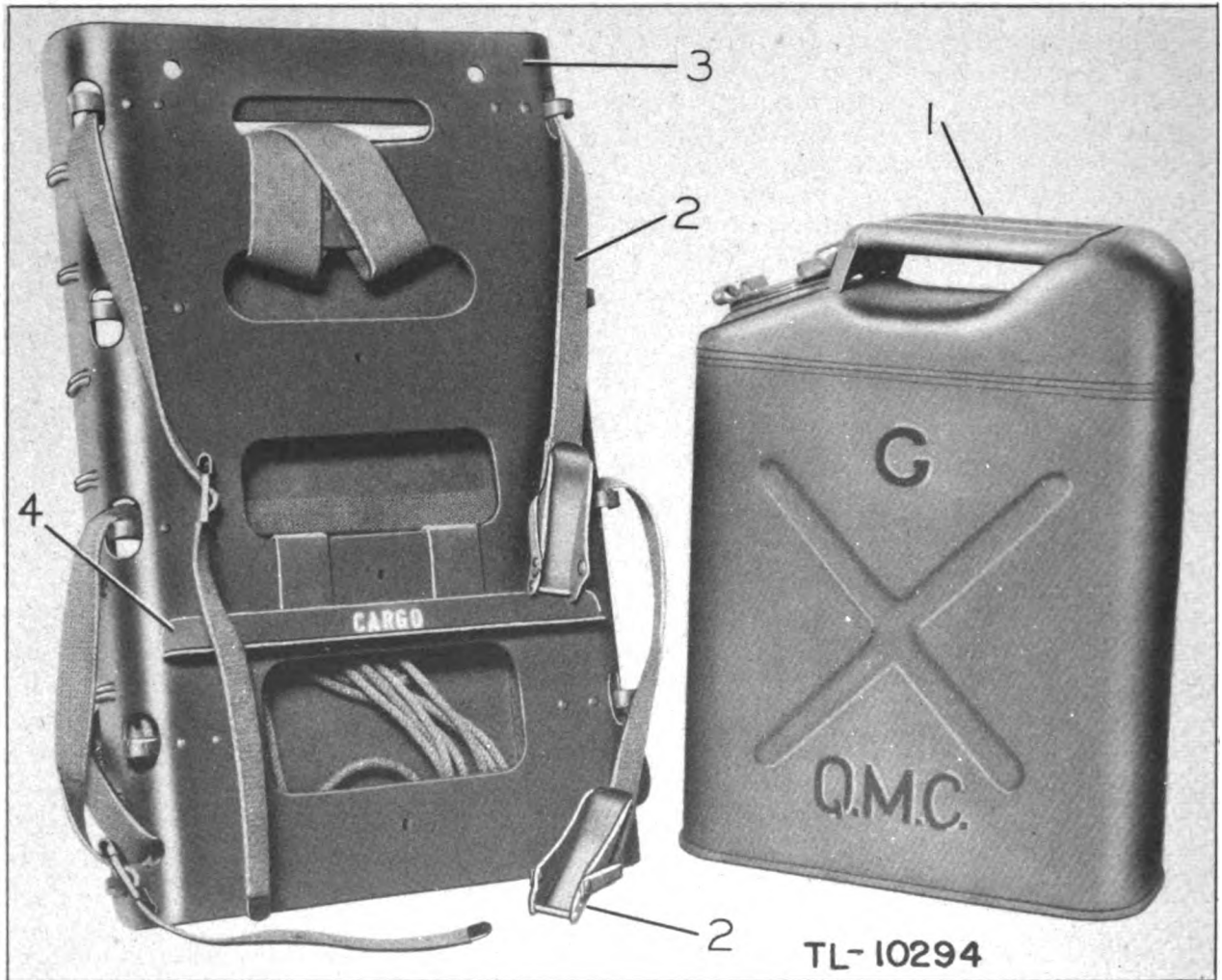

Figure 3—Gasoline Drum Unpacked.

- 1. Drum, gasoline
- 2. Strap, with quick release buckle.

- 3. Packboard
- 4. Attachment

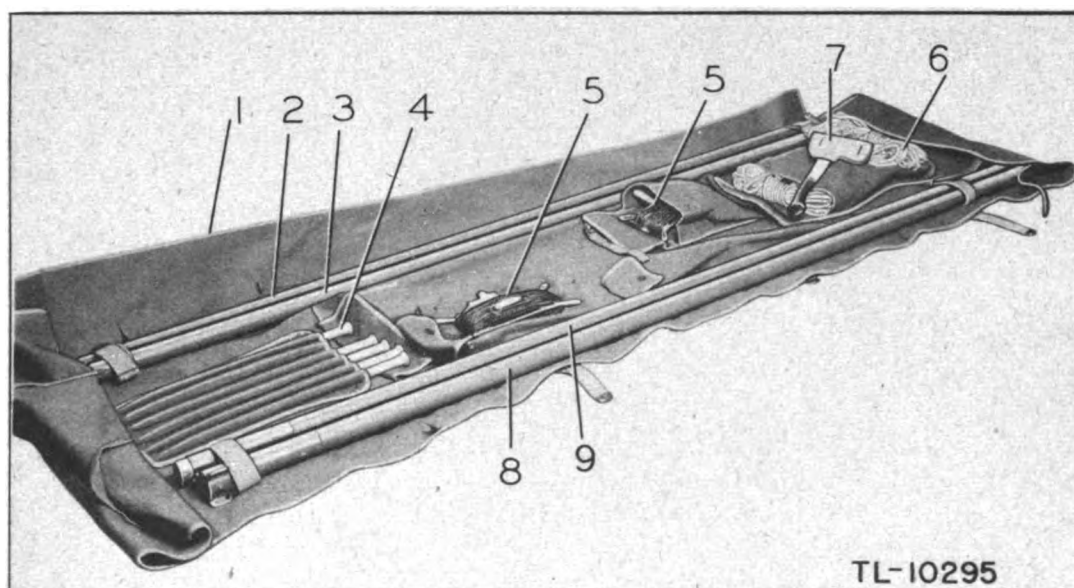

Figure 4—Antenna Equipment for Radio Set AN/TRC-2 (Section 1)

- | | | |
|---|---------------------|-----------------------|
| 1. Antenna Equipment Roll CW-9/TRC-2 | Guy GY-34 (3 each) | 7. Ax and Sheath |
| 2. Mast Section MS-91 | Guy GY-35 | 8. Mast Section M6-93 |
| 3. Mast Section MS-92 | 6. Halyard 65 ft. | 9. Mast Section MS-94 |
| 4. Stake GP-2 (5 each) | Halyard 15 ft. | |
| 5. Antenna AN-160, Wound on Reel RL-29 (2 each) | Guy 45 ft. (2 each) | |

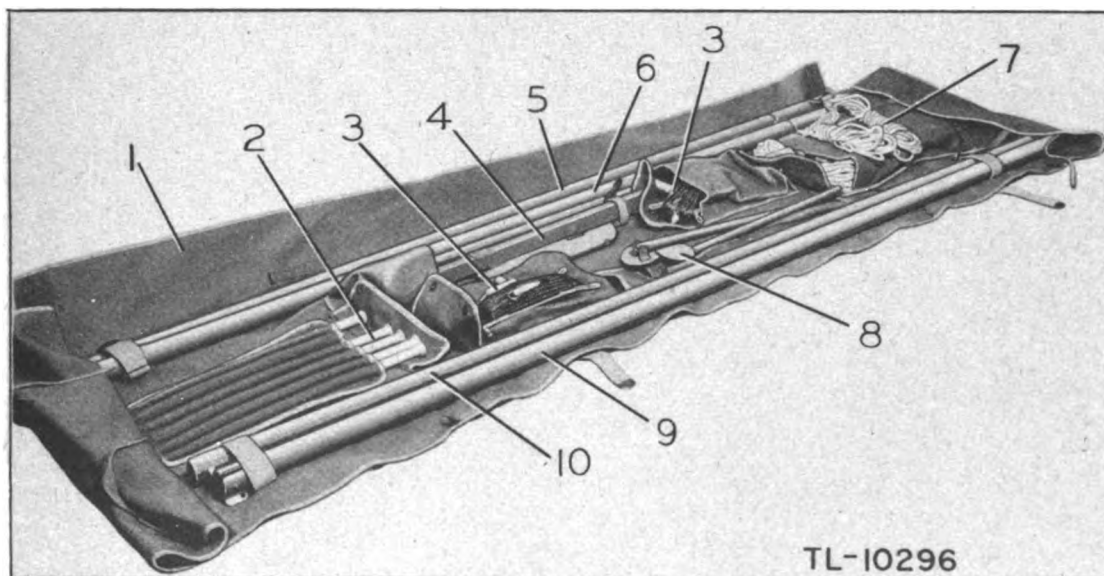

Figure 5—Antenna Equipment for Radio Set AN/TRC-2 (Section 2)

- | | | |
|---|-----------------------|------------------------|
| 1. Antenna Equipment Roll CW-9/TRC-2 | 6. Mast Section MS-92 | 8. Leg LG-3 (2 each) |
| 2. Stake GP-2 (5 each) | Guy GY-34 (3 each) | 9. Mast Section MS-93 |
| 3. Antenna AN-160, Wound on Reel RL-29 (2 each) | Guy GY-35 | 10. Mast Section MS-94 |
| 4. Leg LG-2-A | 7. Halyard 15 ft. | |
| 5. Mast Section MS-91 | Guy 45 ft. (2 each) | |
| | Halyard 10 ft. | |

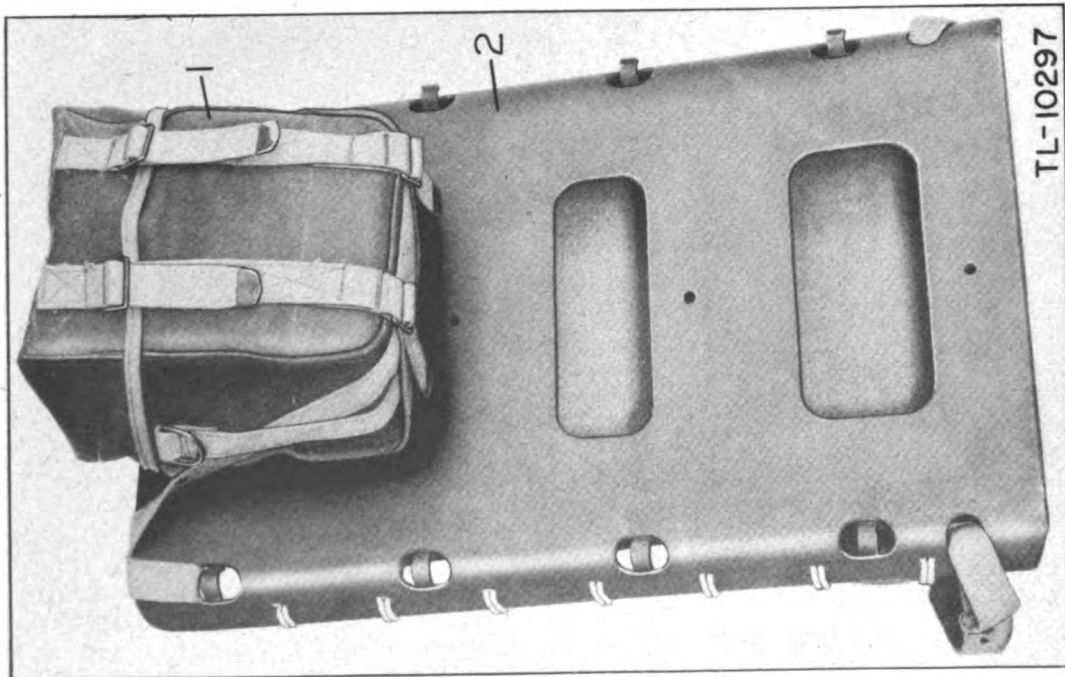

Figure 6—Generator GN-57 on Packboard
1. Generator GN-57 in Bag CW-11/TRC-2
2. Packboard

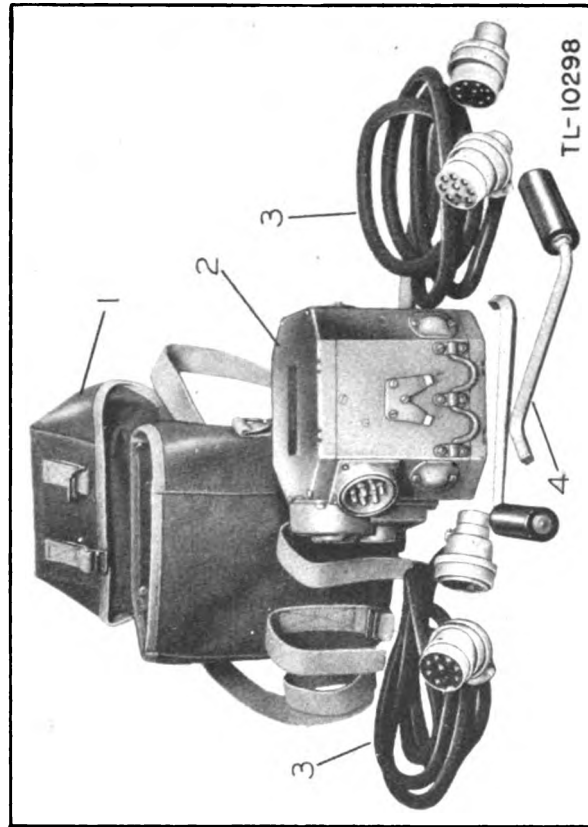

Figure 7—Generator GN-57 and Accessories
1. Bag CW-11/TRC-2
2. Generator GN-57
3. Cord CD-1086 (2 each)
4. Crank GC-7 (2 each)

PART TWO

INSTALLATION AND OPERATION

21. PREPARING PACKBOARDS FOR CARRYING.

Radio Set AN/TRC-2 is shipped in wooden crates. For field use, it is designed to be carried in 18 packboard loads. There are two procedures to be followed in loading a packboard:

a. Place the load as high up on the packboard as possible so that by bending the body forward slightly, the weight is distributed across the upper part of the back instead of being suspended entirely from the shoulder straps.

b. Secure the straps so that the load will not shift on the packboard. First wrap the mounting strap a complete turn around the top cross bar of the packboard. Then pass the strap down between the board and the canvas and pull it out through the hole at the bottom of the bag. Fasten with the buckles provided. Figure 2 illustrates how the straps should be arranged for one package. Location of each bag on its packboard is shown in Figures 6, 9, 14, 20, 21, 24, 25, 34 and 35.

22. MOUNTING COMPONENTS TO PACKBOARDS.

a. Open crate containing packboards.

b. Open the crate of gasoline cans and fasten each can to a packboard, as shown in Figure 25. Install attachment (Item 4, Fig. 3) to packboard if not already mounted. Fill cans as directed in paragraph 20. The mixed fuel method (par. 11) should be used to prevent the possibility of anyone using non-lubricated fuel in Power Unit PE-162.

c. Open the crate containing two Power Units PE-162 and remove the units. Attached to each power unit will be found a bag containing the accessories necessary for mounting the power units to the packboards. Mount as shown in Figures 11, 20 and 21.

d. Mount Radio Receiver-Transmitter BC-1306

and Radio-Transmitter RT-12/TRC-2, as shown in Figures 9 and 16.

e. Open the remaining small packages. All but one will be found to contain canvas bags with equipment inside. Distribute these bags to the remaining packboards and mount one bag on each board.

f. The one small package which does not contain a canvas carrying bag contains 4 Batteries BA-48 and 4 Batteries BB-54. These must be placed in the following bags:

(1) 1 Battery BA-48 in Bag CW-15/TRC-2 with Radio Receiver and Transmitter BC-1306.

(2) 1 Battery BA-48 in Bag CW-15/TRC-2 with Receiver-Transmitter RT-12/TRC-2.

(3) 2 ea. Battery BA-48 in Bag CW-14/TRC-2 inside coils of cable.

(4) 2 ea. Battery BB-54 in Bag CW-13/TRC-2 with maintenance kit.

(5) Battery BB-54 should be prepared for use in accordance with paragraph 29. The batteries in their cartons may be fastened to the packboards carrying the vibrator power supplies by using the rope which is attached to the packboards for that purpose.

g. Open the long package and remove the contents. The contents consist of two Antenna Equipment Rolls CW-9/TRC-2, containing the mast sections and all auxiliary equipment for the antenna. These packages are ready to be carried either by the hand straps provided, or on the shoulders of the men assigned. Each antenna equipment roll is designed as a two-man load.

23. SELECTING LOCATION.

Select a location satisfactory for operation. The location should afford some degree of concealment and permit the antenna to project up in a relatively open space. Do not allow the antenna or lead-in wire to touch branches of trees or shrubs.

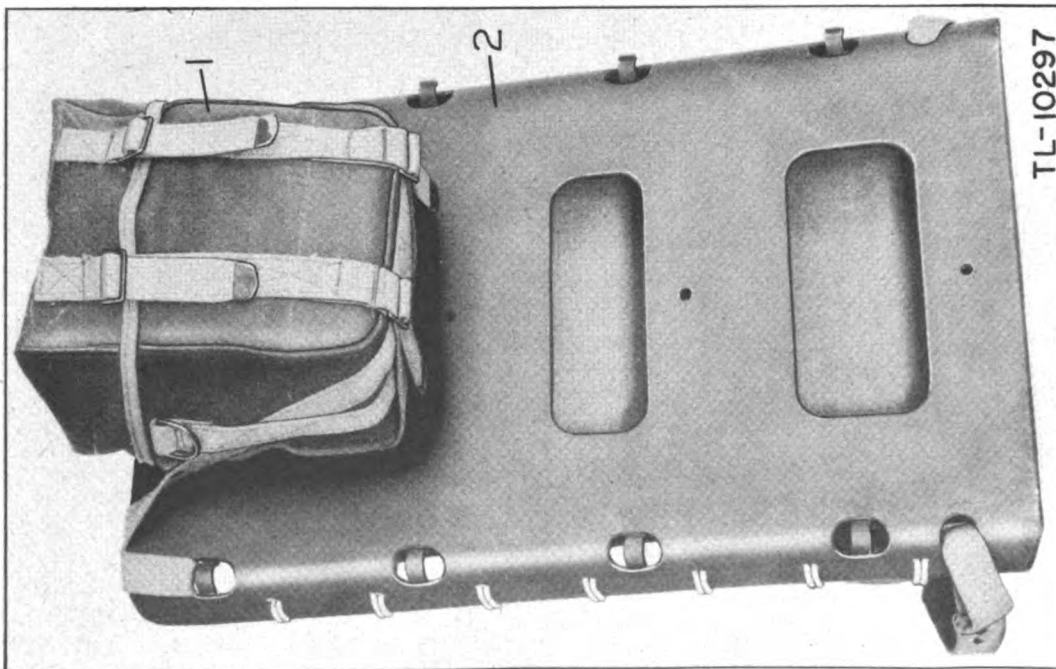

Figure 6—Generator GN-57 on Packboard
1. Generator GN-57 in Bag CW-11/TRC-2
2. Packboard

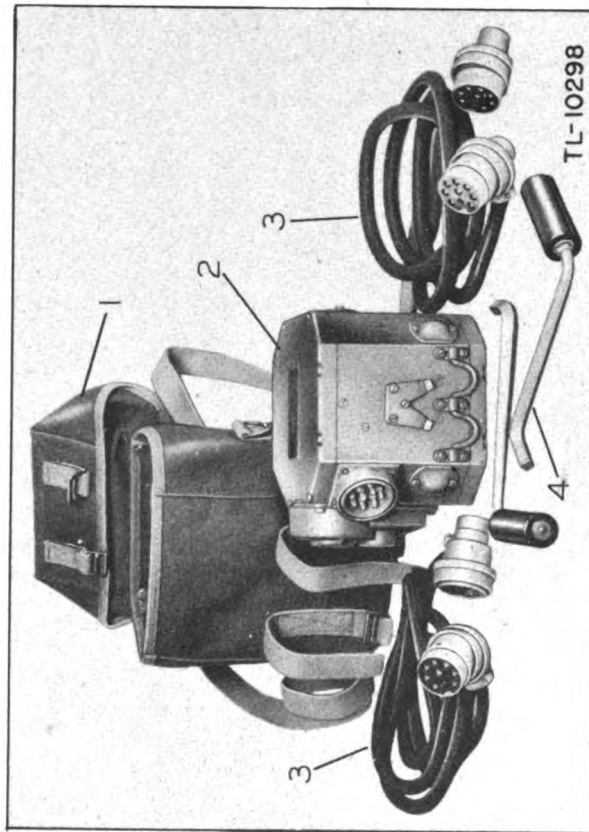

Figure 7—Generator GN-57 and Accessories
1. Bag CW-11/TRC-2
2. Generator GN-57
3. Cord CD-1086 (2 each)
4. Crank GC-7 (2 each)

PART TWO

INSTALLATION AND OPERATION

21. PREPARING PACKBOARDS FOR CARRYING.

Radio Set AN/TRC-2 is shipped in wooden crates. For field use, it is designed to be carried in 18 packboard loads. There are two procedures to be followed in loading a packboard:

a. Place the load as high up on the packboard as possible so that by bending the body forward slightly, the weight is distributed across the upper part of the back instead of being suspended entirely from the shoulder straps.

b. Secure the straps so that the load will not shift on the packboard. First wrap the mounting strap a complete turn around the top cross bar of the packboard. Then pass the strap down between the board and the canvas and pull it out through the hole at the bottom of the bag. Fasten with the buckles provided. Figure 2 illustrates how the straps should be arranged for one package. Location of each bag on its packboard is shown in Figures 6, 9, 14, 20, 21, 24, 25, 34 and 35.

22. MOUNTING COMPONENTS TO PACKBOARDS.

a. Open crate containing packboards.

b. Open the crate of gasoline cans and fasten each can to a packboard, as shown in Figure 25. Install attachment (Item 4, Fig. 3) to packboard if not already mounted. Fill cans as directed in paragraph 20. The mixed fuel method (par. 11) should be used to prevent the possibility of anyone using non-lubricated fuel in Power Unit PE-162.

c. Open the crate containing two Power Units PE-162 and remove the units. Attached to each power unit will be found a bag containing the accessories necessary for mounting the power units to the packboards. Mount as shown in Figures 11, 20 and 21.

d. Mount Radio Receiver-Transmitter BC-1306

and Radio-Transmitter RT-12/TRC-2, as shown in Figures 9 and 16.

e. Open the remaining small packages. All but one will be found to contain canvas bags with equipment inside. Distribute these bags to the remaining packboards and mount one bag on each board.

f. The one small package which does not contain a canvas carrying bag contains 4 Batteries BA-48 and 4 Batteries BB-54. These must be placed in the following bags:

(1) 1 Battery BA-48 in Bag CW-15/TRC-2 with Radio Receiver and Transmitter BC-1306.

(2) 1 Battery BA-48 in Bag CW-15/TRC-2 with Receiver-Transmitter RT-12/TRC-2.

(3) 2 ea. Battery BA-48 in Bag CW-14/TRC-2 inside coils of cable.

(4) 2 ea. Battery BB-54 in Bag CW-13/TRC-2 with maintenance kit.

(5) Battery BB-54 should be prepared for use in accordance with paragraph 29. The batteries in their cartons may be fastened to the packboards carrying the vibrator power supplies by using the rope which is attached to the packboards for that purpose.

g. Open the long package and remove the contents. The contents consist of two Antenna Equipment Rolls CW-9/TRC-2, containing the mast sections and all auxiliary equipment for the antenna. These packages are ready to be carried either by the hand straps provided, or on the shoulders of the men assigned. Each antenna equipment roll is designed as a two-man load.

23. SELECTING LOCATION.

Select a location satisfactory for operation. The location should afford some degree of concealment and permit the antenna to project up in a relatively open space. Do not allow the antenna or lead-in wire to touch branches of trees or shrubs.

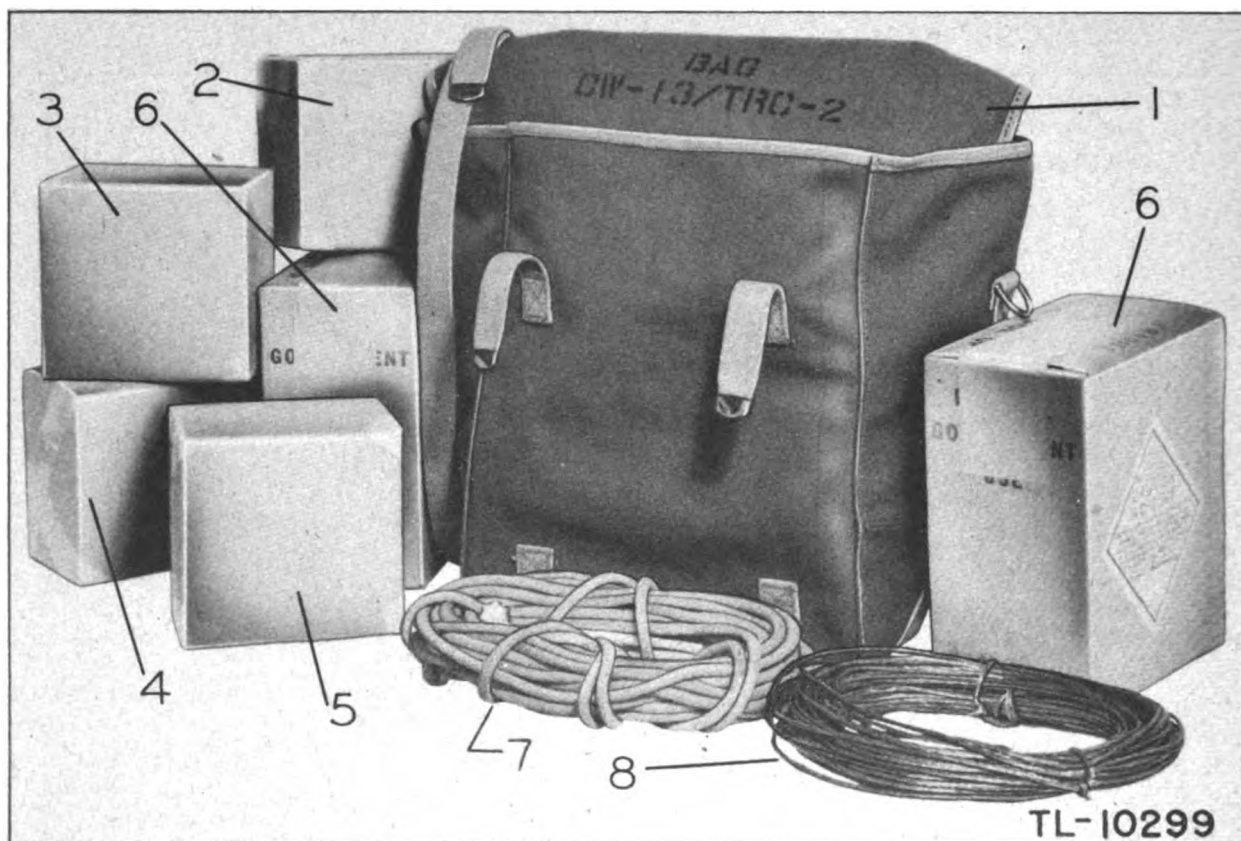

Figure 8—Maintenance Kit Unpacked

1. Bag CW-13/TRC-2
2. Spare parts for Engine GE-12-A and Generator GN-50
3. Same as item (2) above
4. Spare parts for Radio Receiver and Transmitter BC-1306 and RT-12/TRC-2, Vibrator Power Supply PP-39/TRC-2, Generator GN-57, and Filter FL-22.
5. Same as item (4) above
6. Battery BB-54-A (2 each)
7. Guy rope
8. Wire, antenna

24. ERECTING ANTENNA.

Unpack the two Antenna Equipment Rolls CW-9/TRC-2 and set up the antenna system as shown in Figure 12 for Radio Receiver and Transmitter BC-1306. To erect the mast sections, proceed as follows:

- a. Slide Mast Section MS-93 through the loops of Mast Section MS-92.
- b. Connect Mast Section MS-91 to Mast Section MS-92.
- c. Connect Mast Section MS-94 to Mast Section MS-93.

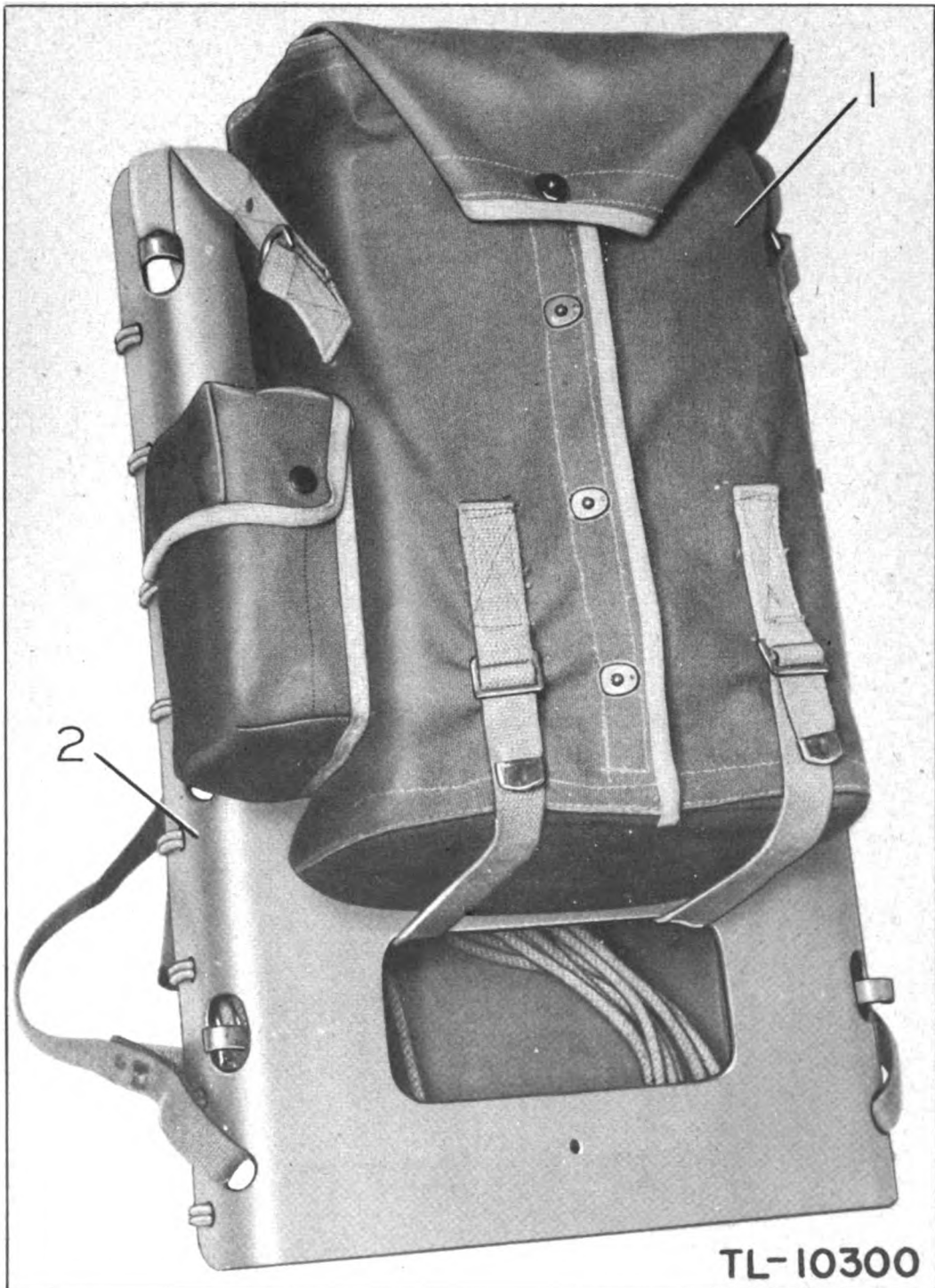

Figure 9—Radio Set BC-1306 or RT-12/TRC-2 on Packboard.

1. Radio Receiver and Transmitter BC-1306 or RT-12/TRC-2 inside Bag CW-15/TRC-2.
2. Packboard

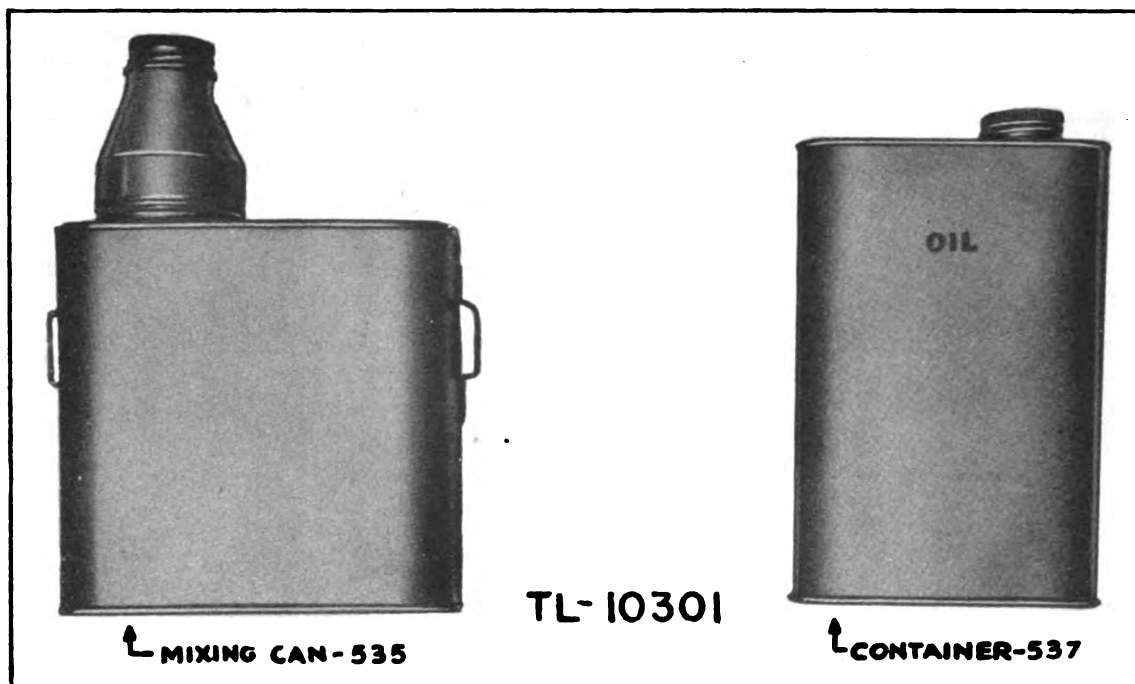

Figure 10—Gasoline-Oil Mixing Can and Oil Container

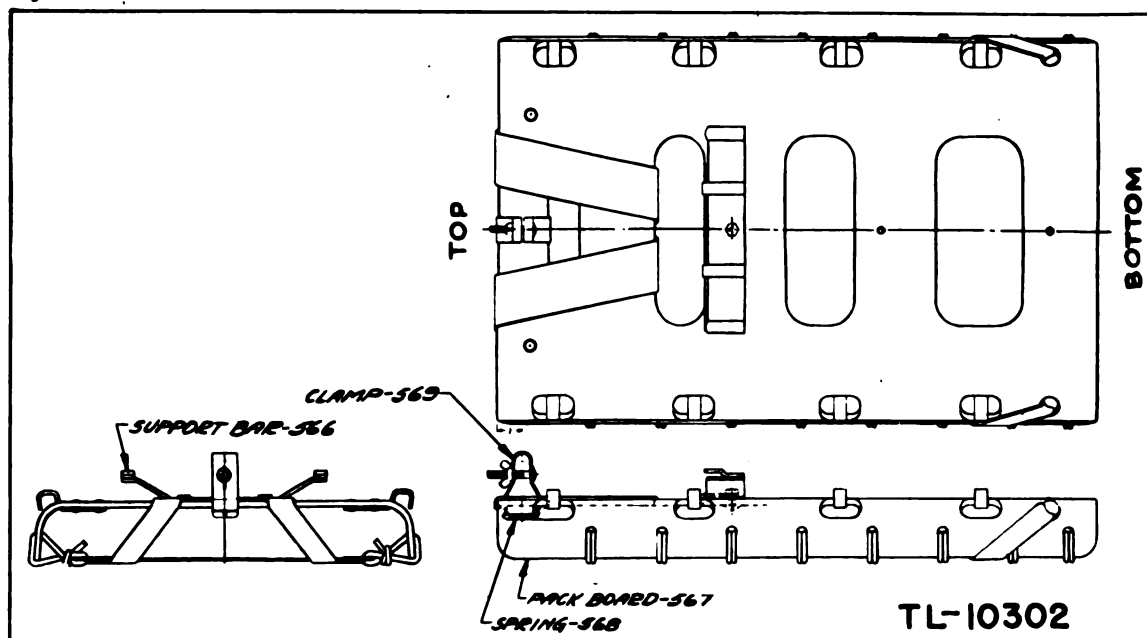
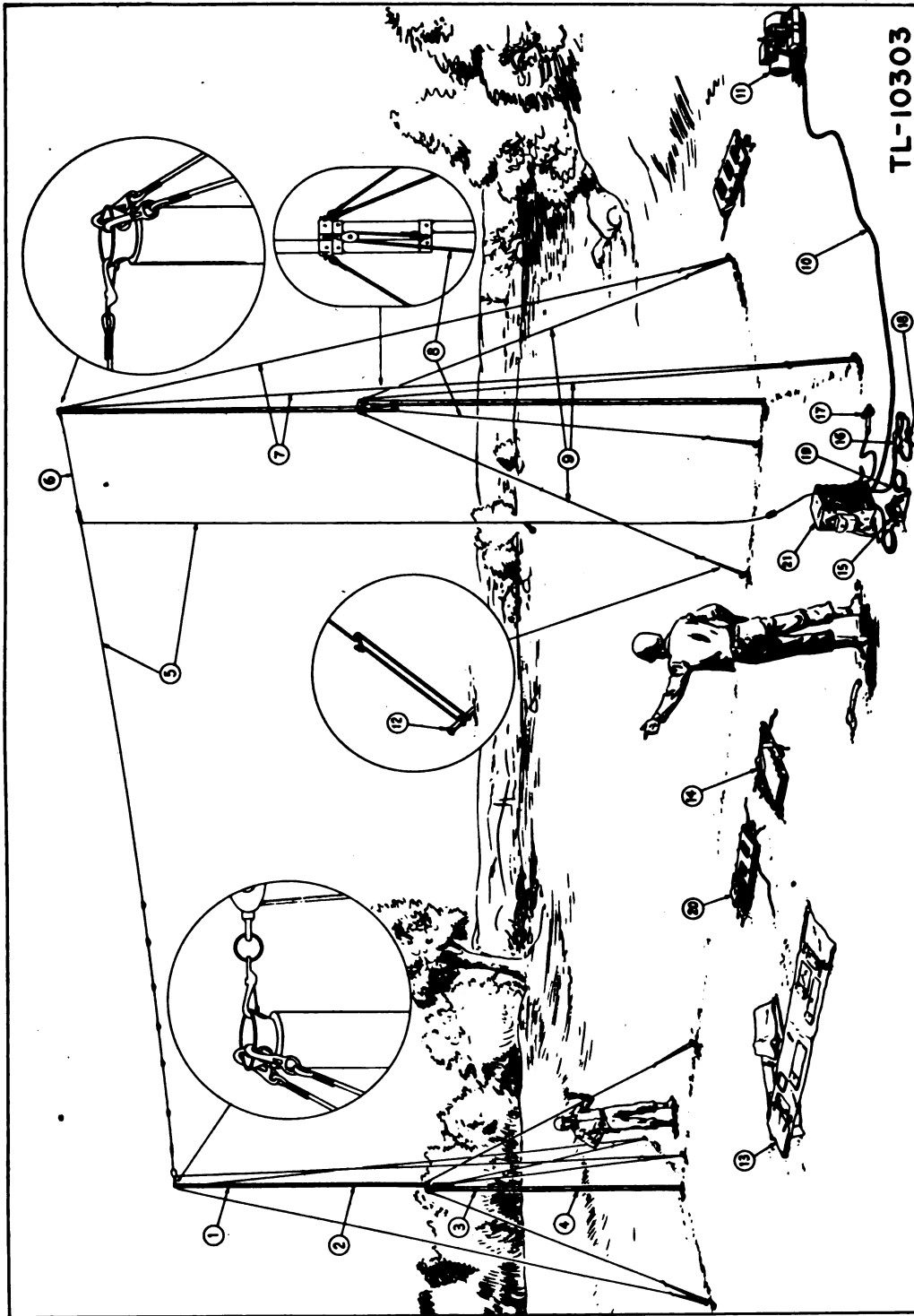

Figure 11—Packboard Attachments for Power Unit PE-162



- | | | |
|--------------------------------|---------------------------------------|---|
| 1. Mast Section MS-91 (2 each) | 8. Guy GY-35 (2 each) | 15. Key J-45 |
| 2. Mast Section MS-92 (2 each) | 9. Guy GY-34 (6 each) | 16. Cord CD-933 |
| 3. Mast Section MS-93 (2 each) | 10. Cord CX-75/TRC-2 | 17. Microphone T-17 |
| 4. Mast Section MS-94 (2 each) | 11. Power Unit PE-162 | 18. Headset HS-30 |
| 5. Antenna AN-160 | 12. Stake GP-2 | 19. Cord CD-307-A |
| 6. Halyard 10 ft. | 13. Antenna Equipment Roll CW-9/TRC-2 | 20. Bag CW-16/TRC-2 |
| 7. Halyard 45 ft. (4 each) | 14. Packboard | 21. Radio Receiver and Transmitter BC-1306 in Bag CW-15/TRC-2 |

Figure 12—Field Operation—Radio Receiver and Transmitter BC-1306

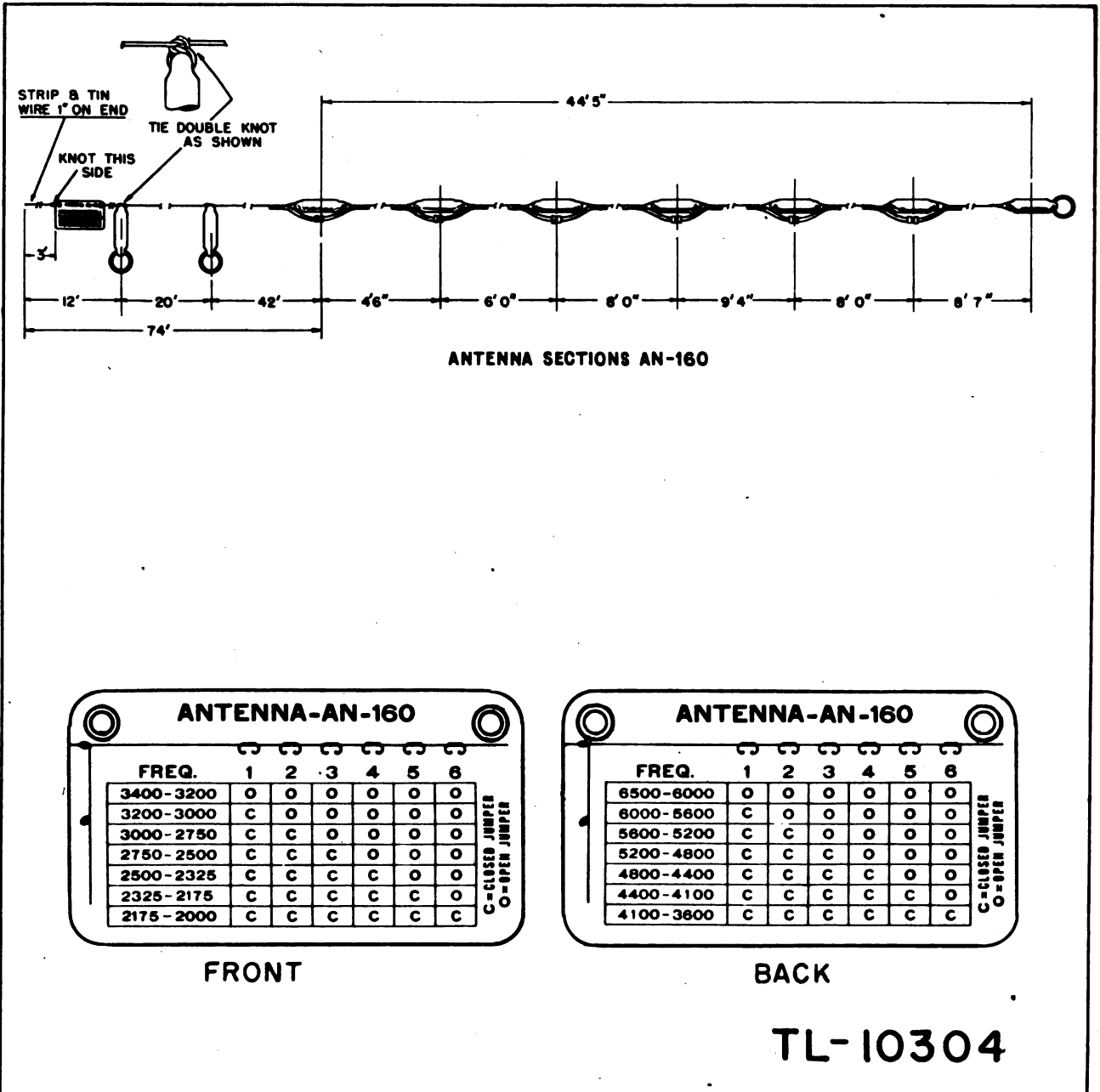

Figure 13—Calibration Chart for Antenna AN-160

d. Attach all the guys and halyards to the mast section located near the receiver-transmitter (lead-in end).

e. Connect Antenna AN-160 (lead-in end) to the 10-foot halyard attached to the top of the mast.

f. After attaching all the guys and halyards, erect the other mast.

i. Connect the loose end of the antenna to the 65-foot halyard and raise the antenna.

NOTE: To set up the antenna system for Radio Receiver and Transmitter RT-12/TRC-2, a counterpoise, (Antenna AN-160) is added, as shown in Figure 15.

j. Trees may be used in place of mast sections if more convenient.

25. SELECTING ANTENNA.

a. Radio Set AN/TRC-2 is issued with five Antenna AN-160. When using Receiver-Transmitter RT-12/TRC-2, two of these antennas are used: one as an antenna, the other as a counterpoise. The remaining three antennas are spares. When using Radio Receiver and Transmitter BC-1306, only one antenna is used; the others are spares. For satisfactory operation of the transmitter, antenna length is critical with respect to frequency. The antennas are divided into sections by insulators, fitted with jumpers designed to permit quick connection or disconnection of sections in order to change the length of the antenna. A calibration chart attached to each antenna shows which jumpers to open and close for each frequency range (Fig. 13).

b. When using Radio Receiver and Transmitter BC-1306 one Antenna AN-160 is employed, erected as shown in Figure 12. Connect the lead-in to the ANT binding post on Radio Receiver and Transmitter BC-1306. No ground connection is needed. The counterpoise should not remain suspended between the masts during operation of this set.

c. When operating Receiver-Transmitter RT-12/TRC-2, one antenna AN-160 is erected the same as it is for Radio Receiver and Transmitter BC-1306 except for another antenna AN-160 used as the counterpoise. The arrangement is shown in Figure 15. Note that the insulators at the ends of the antenna are not directly over the insulators at the end of the counterpoise. This allows for shortening of the counterpoise lead to the transmitter without cutting the wire or resorting to other methods of supporting the counterpoise. The counterpoise is supported from the insulator nearest the end of the lead-in, while the antenna is supported from the second insulator. The antenna lead is connected to the ANT binding post,

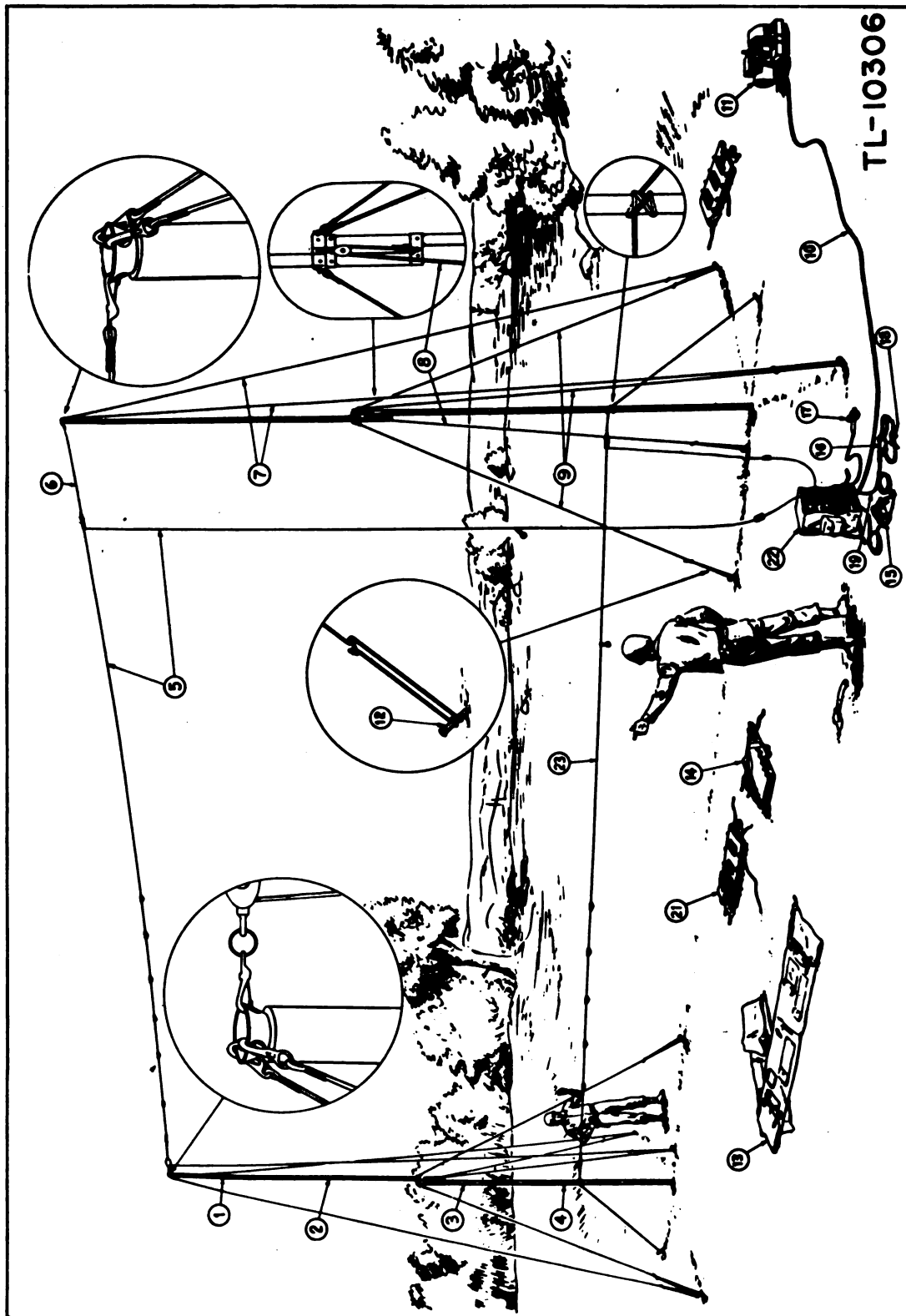

Figure 14—Maintenance Kit on Packboard

1. Maintenance kit in bag
2. Packboard

g. Pull both Guys GY-35 taut, thereby raising the masts to their extended height of 30 feet, and anchor the guys to stakes driven near the masts (Figs. 12 and 15).

h. Anchor the 45-foot halyards.



1 through 20—same as in Figure 12
22. Radio Receiver and Transmitter RT-12/TRC-2 in Bag CW-15/TRC-2
23. Antenna AN-160 (Counterpoise)
24. Halyard—15 Feet

Figure 15—Field Operation— Receiver-Transmitter RT-12/TRC-2.

and the counterpoise to the CPSE binding post on Receiver-Transmitter RT-12/TRC-2. When using Receiver-Transmitter RT-12/TRC-2, the length of counterpoise is changed to correspond to that of the antenna. Identical jumpers are closed in the counterpoise and the antenna. When frequency changes require a different antenna length, the counterpoise must be changed accordingly.

d. When portions of the antenna or counterpoise are not used, open all the jumpers in the unused portion.

26. CONNECTING RECEIVER-TRANSMITTER AND ACCESSORIES.

a. Unstrap Radio Receiver-Transmitter BC-

1306 or Receiver-Transmitter RT-12/TRC-2 and the accessory bag from the packboards.

b. Take the radio set out of the bag and remove Panel Cover M-404. Slip the cover on the back of the set and re-install into the bag, leaving the front flaps open to allow operation of the controls and entrance of the cables (Figs. 18 and 19).

c. Attach the female end of Power Cord CX-75/TRC-2 or CD-1086, depending upon which power supply is to be used.

d. For phone operation, insert the plug of the microphone into the MIKE jack, or, for CW or MCW, insert the plug of the Key J-45 into the KEY jack.



Figure 16—Receiver of Radio Set BC-1306 Operating from Battery BA-48

1. Battery BA-48
2. Cord CD-1119

3. Bag CW-15/TRC-2
4. Radio Receiver and Transmitter BC-1306

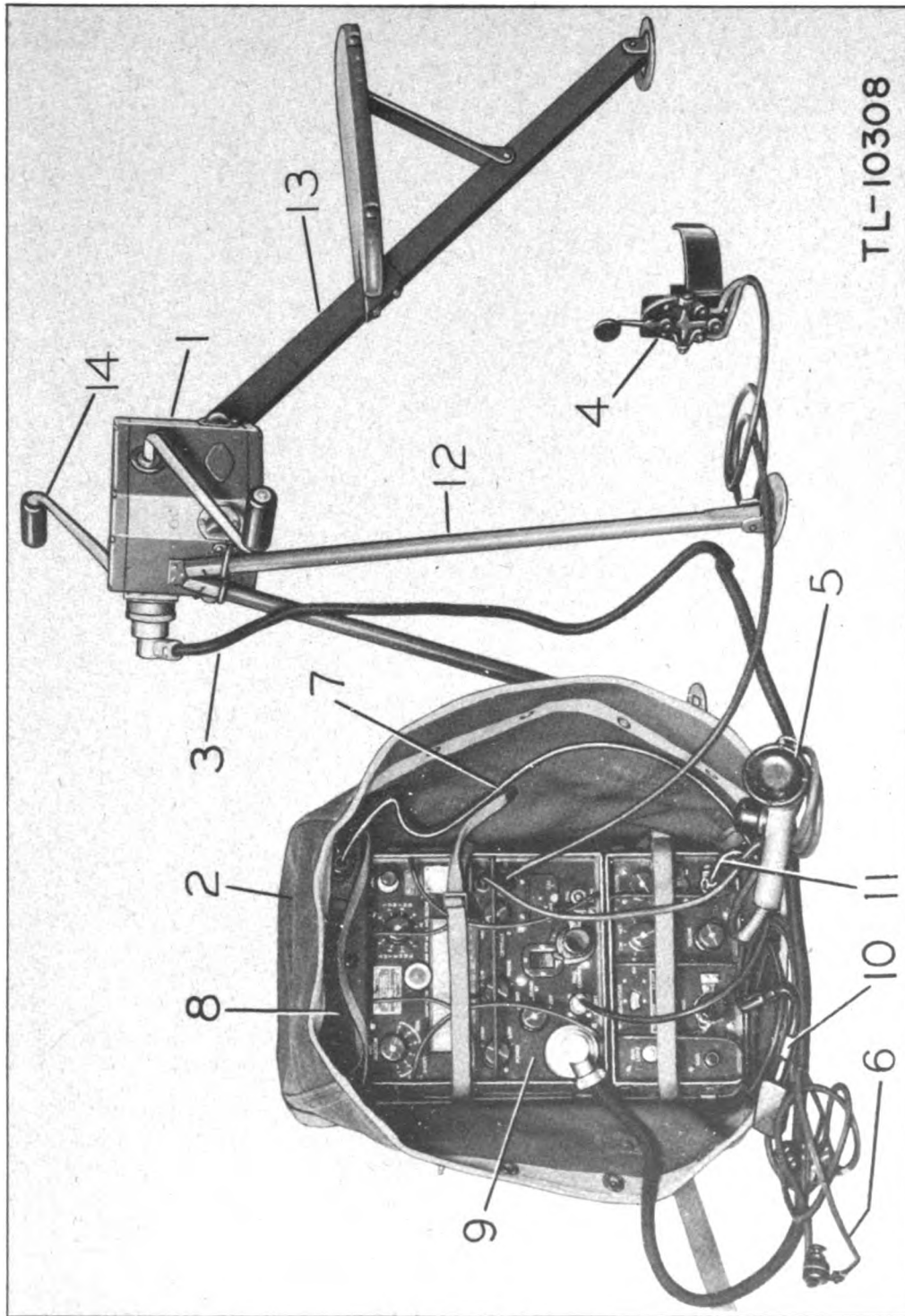

- | | | |
|--|--|--|
| <ul style="list-style-type: none"> 1. Generator GN-57 2. Bag CW-15/TRC-2 3. Cord CD-1086 4. Key J-45 5. Microphone T-17 | <ul style="list-style-type: none"> 6. Headset HS-30 7. Cord CD-1119 8. Battery BA-48 9. Radio Receiver and Transmitter | <ul style="list-style-type: none"> 10. Cord CD-933 11. Cord CD-307-A 12. Leg LG-3 (2 each) 13. Leg LG-2-A 14. Crank GC-7 (2 each) |
|--|--|--|

Figure 17—Operating Radio Receiver and Transmitter BC-1306 or RT-12/TRC-2 with Generator GN-57 and Battery BA-48



Figure 18—Receiver-Transmitter RT-12/TRC-2 with Cover M-404

1. Panel Cover M-404

2. Receiver-Transmitter RT-12/TRC-2.

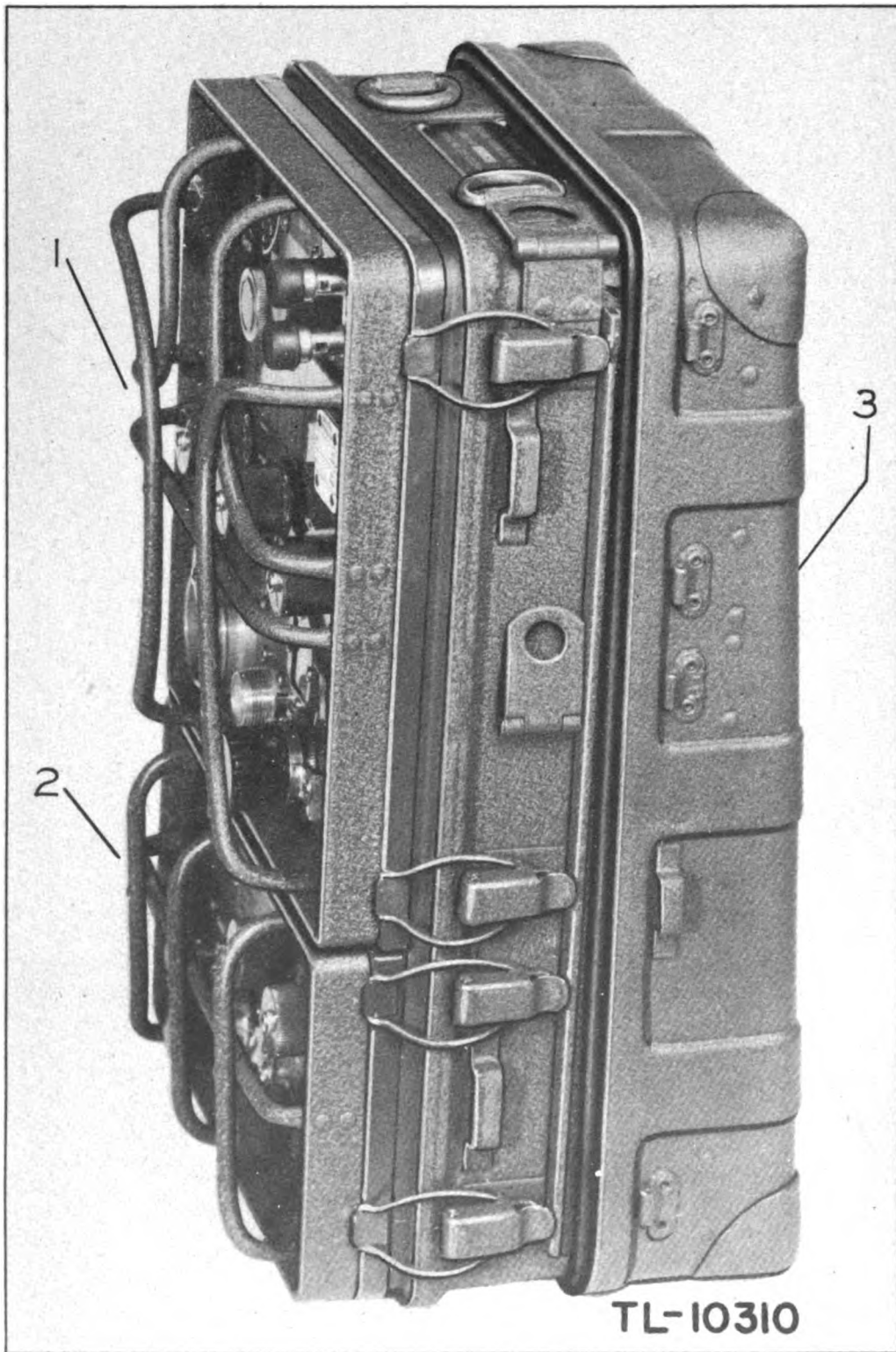

Figure 19—Receiver-Transmitter RT-12/TRC-2 with Cover M-404 on Back of Set.

1. Transmitter of RT-12/TRC-2

2. Receiver of RT-12/TRC-2

3. Cover M-404

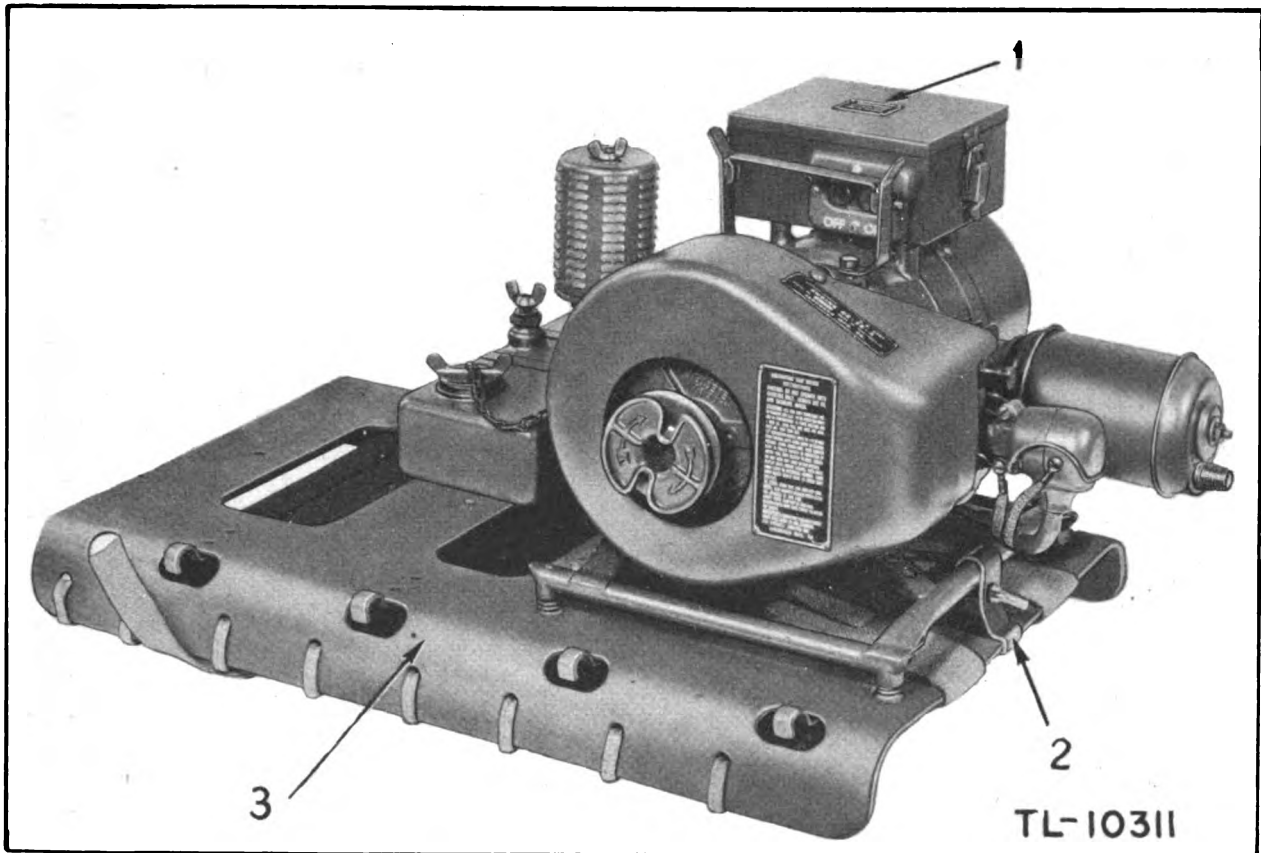

Figure 20—Power Unit PE-162 Mounted on Packboard

1. Power Unit PE-162

2. Clamp

3. Packboard

e. Insert the plug of the headset or loudspeaker cord into the PHONES jack.

f. Connect the power cables of Battery BA-48 or Vibrator Power Supply PP-39/TRC-2 to the BATTERY receptacle on the transmitter panel when operating with the hand generator.

NOTE: When Receiver-Transmitter RT-12/TRC-2 is used, connect the counterpoise lead to binding post CPSE. See Figures 15 and 26.

g. Connect the antenna lead-in to the ANT post on the transmitter.

27. PREPARING POWER UNIT PE-162.

- a.* Remove the power unit from the packboard.
- b.* Drain the crank-case of the rust-inhibiting oil.
- c.* Remove the blank washer between the air-cleaner cartridge and the cleaner base.
- d.* Remove the tape from the muffler outlet.
- e.* Remove the silica-gel plug from the spark plug hole and install the spark plug. Spark plug is connected on end of spark plug cable.

f. Connect Power Cord CX-75/TRC-2 to the power receptacle on the filter box.

g. Before placing the engine in operation, fill fuel tank with oil-gasoline mixture.

CAUTION: Never pour the oil and gasoline into the tank separately. Never attempt to fill the tank while the engine is operating.

h. Press the ON-OFF switch to the ON position and the power unit is ready for use.

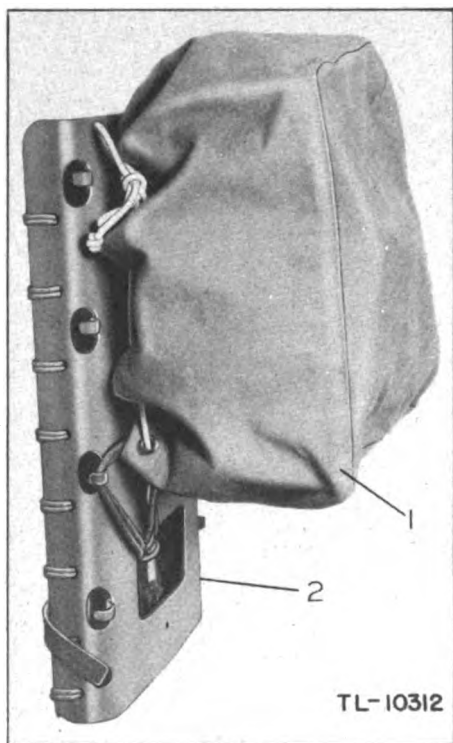

Figure 21—Power Unit PE-162, Rain Shield and Packboard

1. Cover CW-10/TRC-2 over Power Unit PE-162
2. Packboard

i. If pre-mixed fuel is not available, a single filling for the fuel tank is prepared as follows: Remove the large screw top from the fuel mixing can and use the screw top as a measuring cup. Fill it to the top with oil, then pour this amount of oil into the fuel mixing can. Fill the remaining space in the mixing can with gasoline, shake thoroughly, and pour into the fuel tank of the engine.

28. MOUNTING GENERATOR GN-57.

The hand generator is carried in Bag CW-11/TRC-2. The supporting legs are carried in Antenna Equipment Roll CW-9/TRC-2. To mount the generator on its legs proceed as follows:

a. Insert two Legs LG-3 upward through the metal loops on the front of the generator and under the retaining springs.

b. Rest the generator on the two legs and slip the bottom of the attachment of Leg LG-2-A into its retainer. Drop the metal loop over the top of the attachment on the back of the generator.

c. Insert two Cranks GC-7 into the sockets on the sides of the generator. The long shafts of the cranks should be at an angle of 180° to each other (Fig. 17).

d. Connect the male plug of Cord CD-1086 to the generator receptacle, and the female plug to the receiver-transmitter. **Do not use Cord CX-75/TRC-2.** Generator GN-57 may now be operated.

29. PREPARING VIBRATOR POWER SUPPLY PP-39/TRC-2.

Remove the vibrator power supply from Bag CW-12/TRC-2 (Fig. 24) and follow the steps outlined below.

a. **Filling Battery.** To fill Battery BB-54-A with electrolyte:

- (1) Remove filler cap from battery.
- (2) Insert funnel in filler cap opening in battery.
- (3) Using funnel, pour electrolyte into battery. Fill until level of electrolyte is approximately $\frac{1}{4}$ inch above the liquid level line on the side of the battery.
- (4) Remove funnel.
- (5) Replace filler cap on battery and *tighten securely.*
- (6) Allow the battery to stand not less than 3 hours nor longer than 16 hours before charging.
- (7) If the electrolyte is then below the level line, add more electrolyte until the level is at the level line.

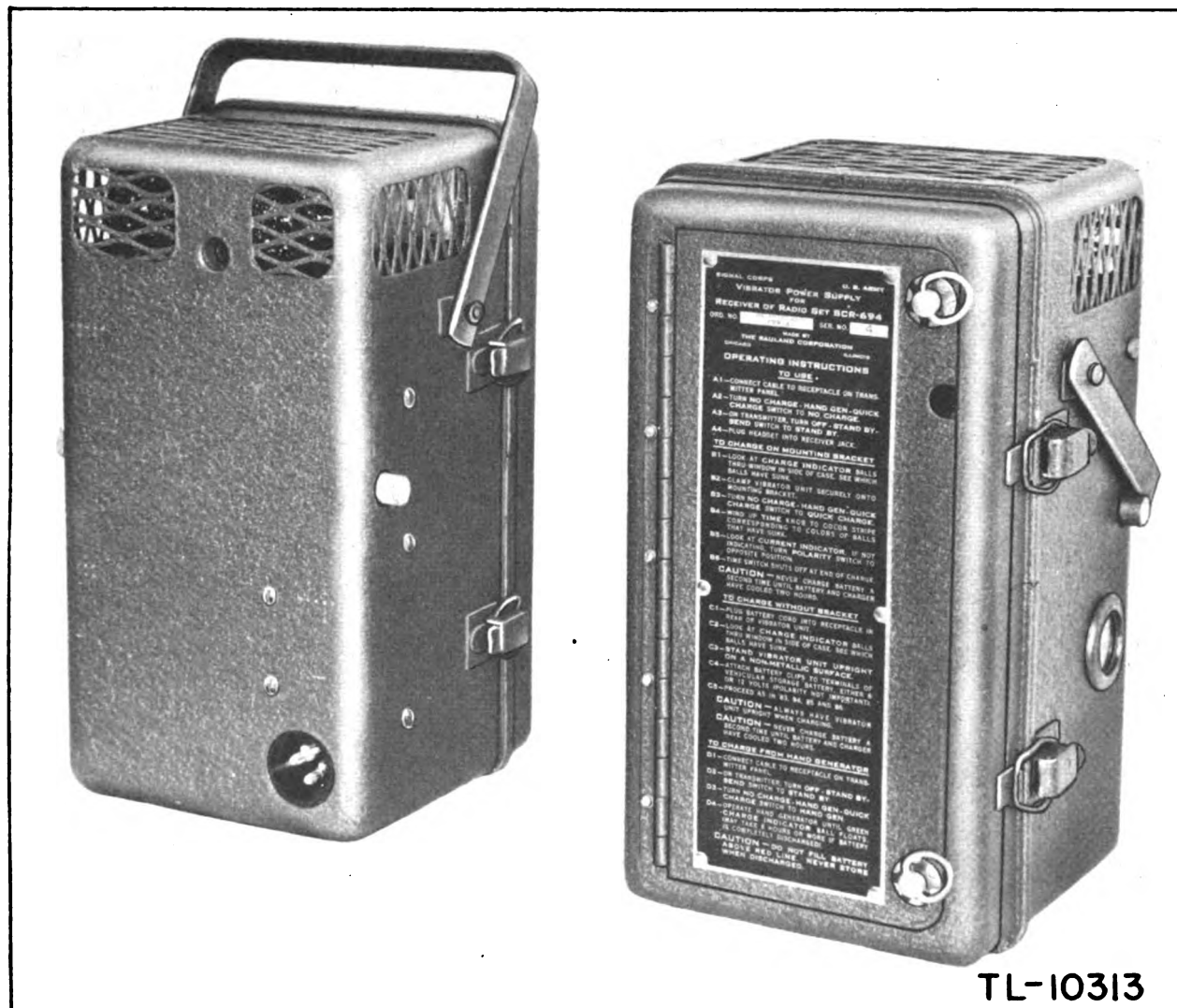

TL-10313

Figure 22—Vibrator Power Supply PP-39/TRC-2—Rear and Front View (Battery BB-54 Inside)

b. Assembling Battery (Fig. 23). To assemble battery in jacket and cover:

(1) Insert battery into jacket, with the charge indicator balls in the battery on the same side as the window in the battery jacket. Make sure that the battery is pushed all the way into the jacket.

(2) Connect leads on battery cover to terminals on battery. **OBSERVE PROPER POLARITY.** The positive battery cover lead is identified by a piece of yellow sleeving, and must be connected to the positive battery terminal.

(3) Assemble battery and jacket to battery retainer, sliding retainer into the depressed area on the jacket between the long pads.

(4) Bend strap on battery retainer around the top of the battery cover and the back surface of the jacket.

(5) Line up the screw hole in the bracket at the end of the strap with the corresponding bracket in the front surface of the retainer, and insert screw. Check to make sure that the lip on the battery jacket is within the inside wall of the

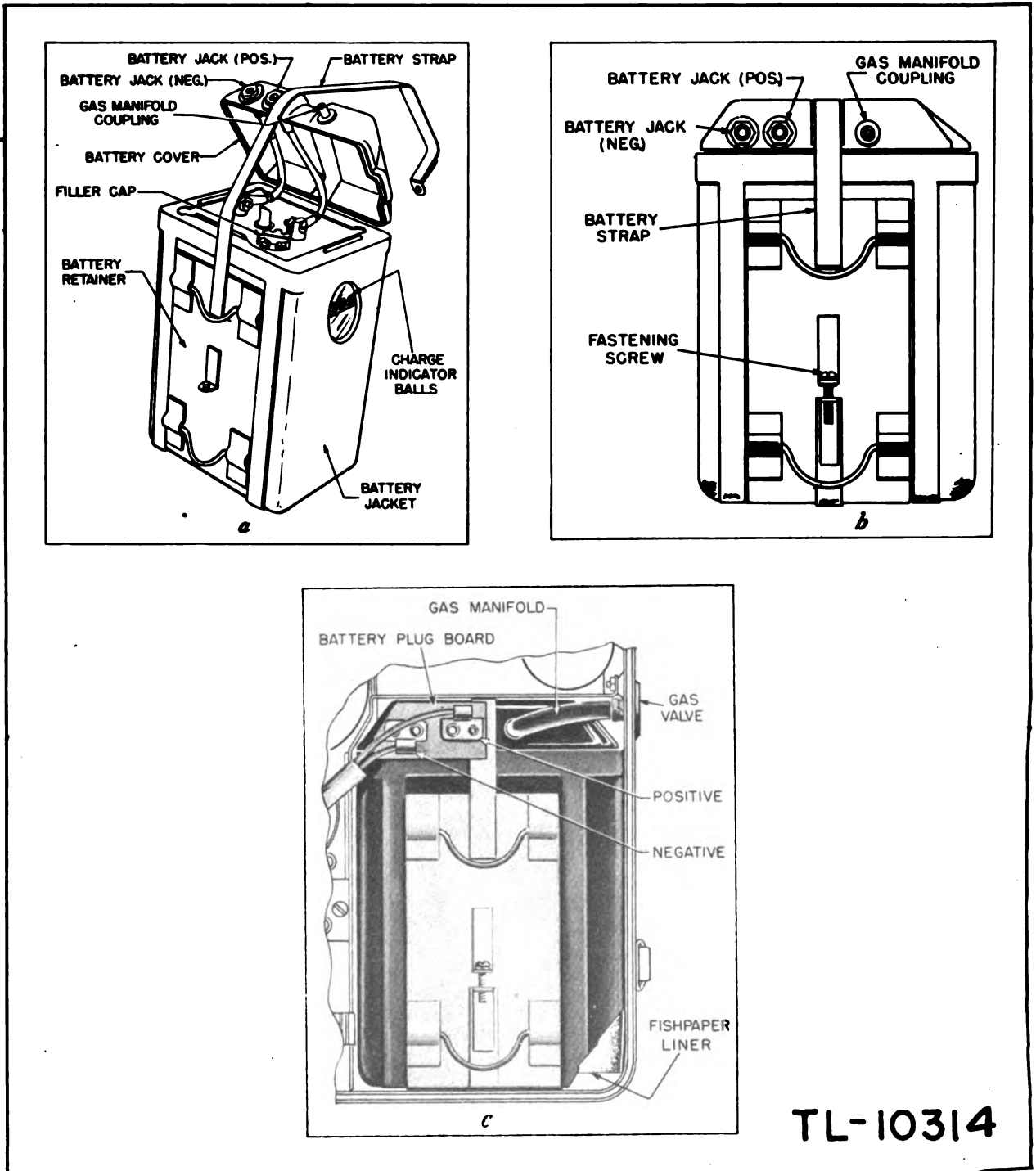

TL-10314

Figure 23-a, b, c

a and b—Installation of Battery BB-54-A into Battery Jacket
c—Installation of Battery Assembly into Vibrator Power Unit

battery cover at all points. Tighten screw until battery is secured onto the jacket.

c. **Installing Battery.**—To install battery into PP-39/TRC-2 case (Figure 23):

- (1) Wrap fibre liner around battery.
- (2) Slide battery assembly into case. BE CAREFUL not to bend the coupling on the gas valve on the case as the edge of the battery cover slides past the coupling.
- (3) Install gas manifold, attaching the short end to the coupling on the battery cover and the long end to the gas valve on the case.
- (4) Plug battery plug board into battery jacks in battery cover.
- (5) Clamp the front cover to case. The battery may then be charged. See paragraph 34.

(6) The storage battery contained in the vibrator can be recharged from the following sources:

- (a) A 12-volt storage battery.
- (b) A 6-volt storage battery.
- (c) Power Unit PE-162.
- (d) Generator GN-57.

When Battery BB-54 is charged from a 6- or 12-volt storage battery, the charging rate starts at 15 amperes and tapers gradually as the battery charges. Approximately 2½ hours are required to recharge the unit if the battery is completely discharged. If recharged from Power Unit PE-162 or Generator GN-57 the charging rate is approximately 1/3 as high and will consequently take approximately three times as long.

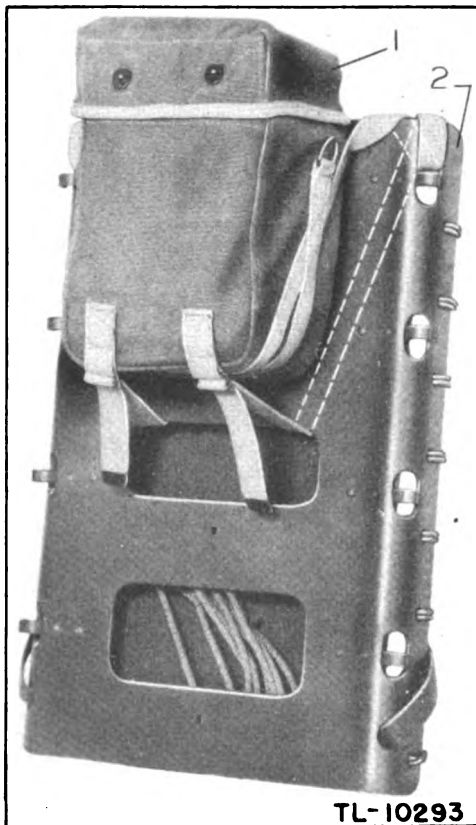

Figure 24—Vibrator Power Supply PP-39/TRC-2 on Packboard

1. Vibrator Power Supply PP-39/TRC-2 in Bag CW-12/TRC-2.
2. Packboard

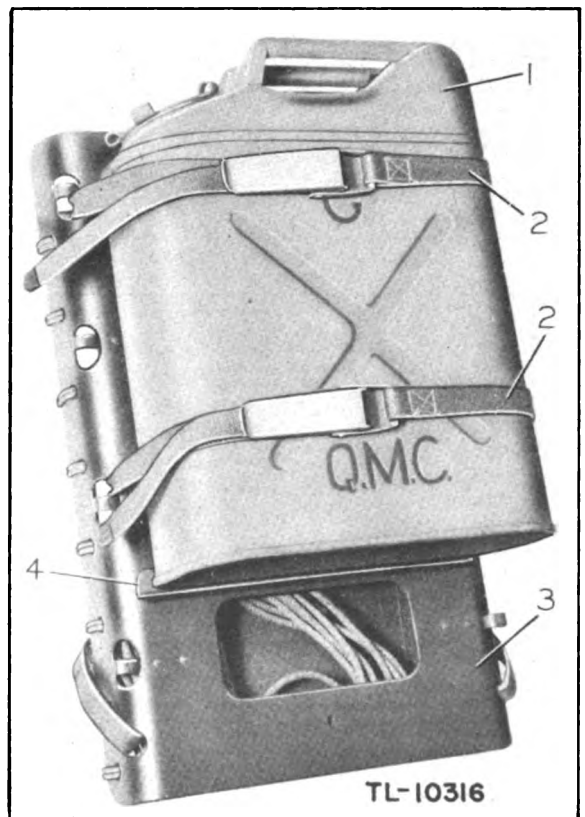

Figure 25—Gasoline Drum on Packboard

1. Drum, gasoline
2. Strap, with quick release buckle
3. Packboard
4. Attachment

30. OPERATING THE RECEIVER.

a. The receivers of this set may be operated from any one of the following four power sources.

- (1) Vibrator Power Unit PP-39/TRC-2.
- (2) Battery BA-48.
- (3) Power Unit PE-162.
- (4) Generator GN-57.

b. When operated from Vibrator Power Unit or from Battery BA-48, proceed as follows:

(1) Plug a headset cord into the PHONES jack. This closes the filament circuit of the receiver but power is not turned on. The output impedance of the receivers may be either 250 or 4000 ohms as selected by a switch on the receiver chassis. The switch on the receivers, when shipped, is set at 250 ohms. The headsets and loudspeaker will match 250-ohm impedances.

(2) Prepare Vibrator Power Supply PP-39/TRC-2 for operation as follows:

(a) Open the front door of the power unit, unroll the connecting cable and see that the NO CHARGE-HAND GEN-QUICK CHG switch is set at NO CHARGE; close the front door with the cable extending through the cut-out provided for that purpose in the door and connect the cable to the BATTERY receptacle on the front of the transmitter panel.

(3) Turn the OFF-STANDBY-SEND switch to STANDBY. If the headset is removed from the jack or the OFF-STANDBY-SEND switch turned to OFF or SEND, the vibrator stops.

(4) To operate only the receiver from Battery BA-48, connect Cable CD-1119 to the BATTERY receptacle on the front of the transmitter panel, plug in a headset, and turn the OFF-STANDBY-SEND switch to STANDBY.

CAUTION: Always plug the cable into the battery before connecting the other end to the transmitter.

(5) Turn the SENSITIVITY switch to the HIGH position. This will provide maximum sensitivity so that the weakest signals may be heard. If the signal is strong, the signal-to-noise ratio may be improved by using a lower sensitivity position.

(6) Turn the PHONE-CW-NET-CAL switch to either PHONE or CW, whichever type of signal it is desired to receive.

(7) Turn the receiver to the desired frequency or until the desired signal is heard. If the signal is strong, clear reception will be had if the SENSITIVITY switch is turned to a lower sensitivity position.

(8) A dial light has been provided to aid in tuning the receiver at night. The DIAL LIGHT button must be pushed to illuminate the dial. Push only long enough to locate the correct frequency on the dial, since the receiver will operate *less efficiently* while the lamp is burning.

(9) The use of the NET or CAL position of the PHONE-CW-NET-CAL switch is explained under paragraphs 44 and 45.

(10) Do not leave the PHONE-CW-NET-CAL switch on NET or CAL because the receiver sensitivity is then so low that few signals will be heard, and the modulator of the transmitter will not work.

31. OPERATING THE TRANSMITTER.

a. The transmitter may be operated from either of two power sources: Power Unit PE-162, or Generator GN-57 (Figs. 17 and 37).

(1) When operated from Power Unit PE-162 all power is supplied through the 50-foot power cord CX-75/TRC-2. When operated from Generator GN-57, all power is supplied through the 7-foot cord, CD-1086. If the generator is used in combination with the vibrator power supply or Battery BA-48, the "B" power for the low-power stages of the transmitter is supplied by either the vibrator power supply or the battery, and the high voltages and filament power are supplied by the hand generator. This combination of power supplies reduces the load on the hand generator approximately 25 per cent, thereby making it easier to crank.

b. When operating from Power Unit PE-162 proceed as follows:

(1) Connect main power cable from the power supply to the transmitter and prepare the power unit, or generator, for operation. (See paragraphs 27 and 28.)

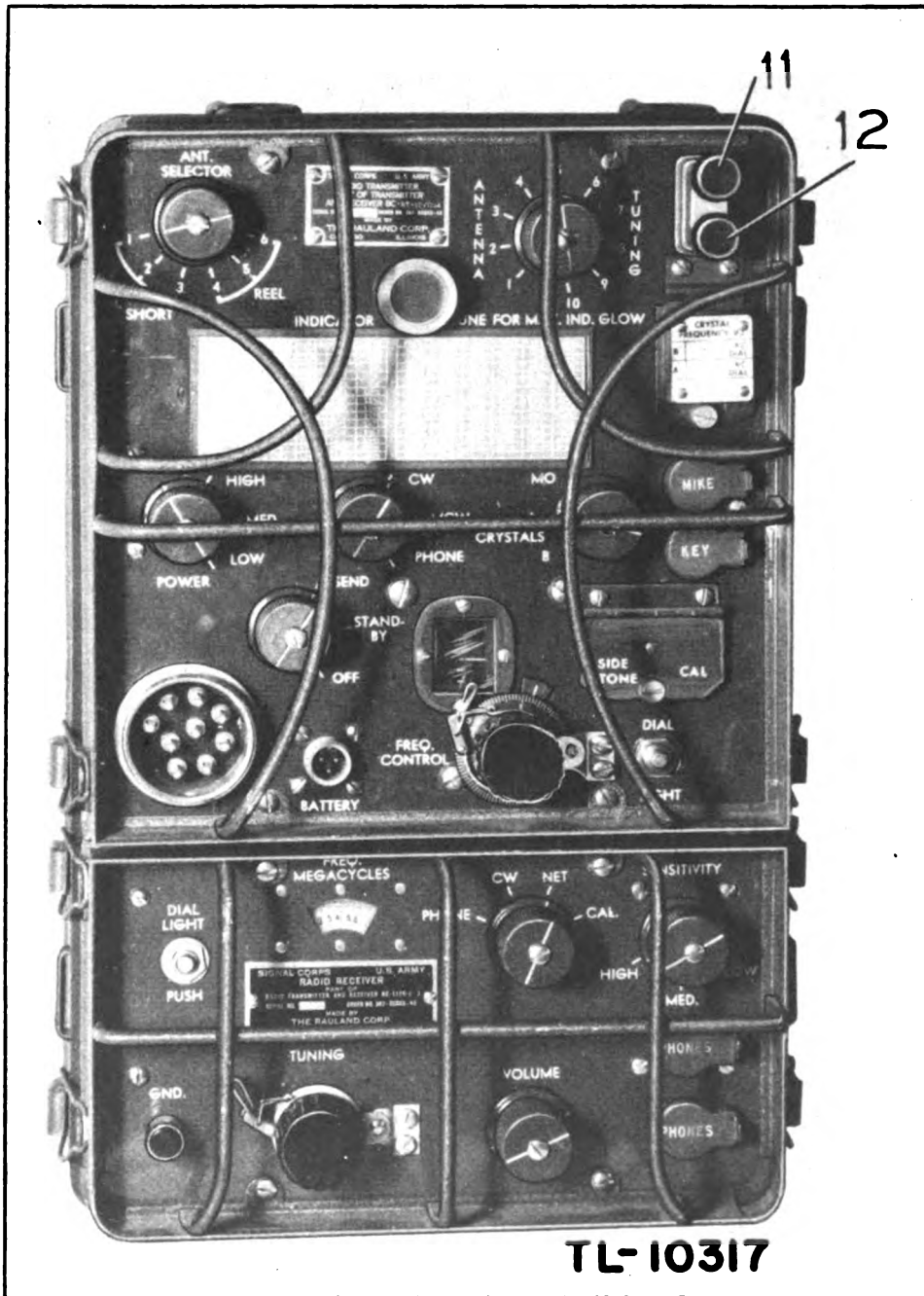

Figure 26—Receiver-Transmitter RT-12/TRC-2.

(Also see Figure 27.)

11. Antenna Post

12. Counterpoise

(2) Plug a microphone into the MIKE jack and the key into the KEY jack.

(3) Set SEND-STANDBY-OFF switch to the SEND position.

(4) Set ANT. SELECTOR switch to REEL position 5.

(5) Line up the two dots of the polaroid indicator jewel so that it will show maximum glow from lamp.

(6) Set the power switch to the HIGH position.

(7) Set the CW-MCW-PHONE switch to the CW position.

(8) Set PHONE-CW-NET-CAL switch to the PHONE or CW position, whichever type of operation is desired. Either position allows operation of the modulator stage of the transmitter.

(9) Set CRYSTALS switch to MO position and tune FREQUENCY CONTROL knob to proper dial setting. (Par. 39.) If crystal operation is desired, set CRYSTALS switch to A or B crystal position and proceed as follows:

(a) Set CW-MCW-PHONE switch to the CW or MCW position.

(b) Set PHONE-CW-NET-CAL switch to NET.

(c) Set HIGH-MED-LOW sensitivity switch to HIGH.

(d) Adjust the receiver tuning control knob to the transmitter frequency (twice the crystal frequency) and listen for a signal from the crystal oscillator as the receiver tuning dial is rocked.

(e) If no signal is heard, the crystal is probably defective, and operation should be transferred to MO.

(10) Connect Antenna AN-160 to ANT post (and the counterpoise to the CPSE post if Receiver-Transmitter RT-12/TRC-2 is used), and adjust to proper frequency of operation, as described in paragraphs 39 to 40.

(11) Press the microphone or key button and adjust the knob, TUNE FOR MAX. IND. GLOW until the indicator shows maximum brilliance.

(12) The power switch may then be set for the desired power output and the CW-MCW-PHONE switch to the type of transmission desired.

(13) A dial light is provided to aid in tuning the transmitter at night. The dial light button must be pushed when dial illumination is desired.

(14) When using Generator GN-57, operating procedure is the same as for Power Unit PE-162, except that the SEND-STANDBY-OFF switch is set to the STANDBY position. When using hand generator for sending and receiving place SEND-STANDBY-OFF switch to SEND position (Fig. 37).

32. OPERATING POWER UNIT PE-162.

a. Prepare the power unit for operation in accordance with directions given in paragraph 27.

b. Connect the plugs of the 50-foot cord to the receptacle on the filter box and on the transmitter panel, screwing the locking rings up tight. Turn the OFF-STANDBY-SEND switch on transmitter to OFF.

c. Check to make sure that the high tension lead is connected to the spark plug.

d. Open the air vent wing nut and fuel line shut-off (Fig. 80.)

e. Turn the carburetor needle valve and adjustment knob (Fig. 28) to number 5 on its scale which is the half-open position.

f. Move the choke lever (Fig. 28) to the vertical position.

g. Face the pulley. Slip the knotted end of the starting rope through the notch in the pulley. Leave the knot on the outside face of the pulley, and wind the starting rope in a clockwise direction in the groove, until all of the rope is used.

h. Pull the rope up sharply to the rear, meanwhile steadying the unit with the left hand, or foot on the fan housing. Repeat this operation until the engine starts.

NOTE: If the engine does not start after a reasonable number of attempts, refer to paragraph 101 for servicing.

i. When the engine starts, move the choke lever to the horizontal position. After the engine warms

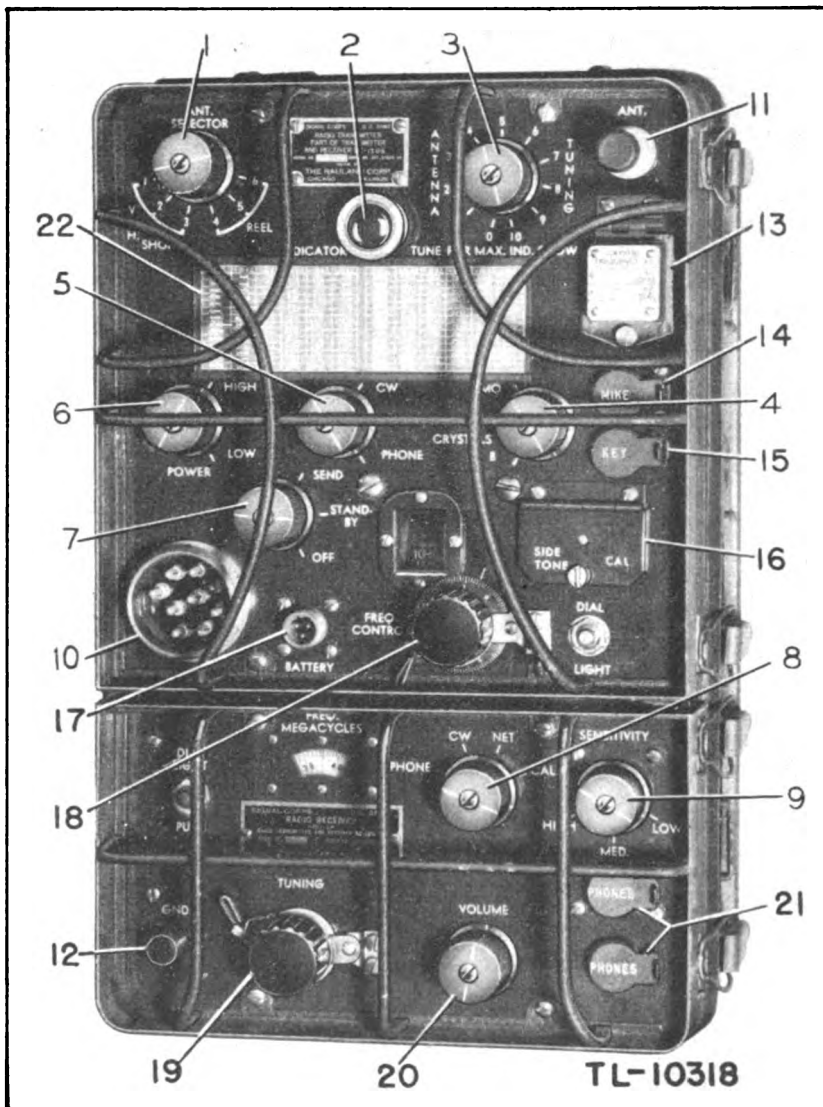

Figure 27—Radio Receiver and Transmitter BC-1306

(Also see Figure 26.)

1. **ANT. SELECTOR:** Set for type of antenna used and correct position for frequency of operation.
2. **Polaroid INDICATOR:** Line up two dots for maximum brilliancy.
3. **ANTENNA TUNING:** Tune for maximum INDICATOR glow for antenna power.
4. **CRYSTALS Switch:** Set to type frequency control desired.
5. **CW-MCW-PHONE Switch:** Set to type emission desired.
6. **POWER Switch:** Controls power input to the antenna and load on power supply.
7. **SEND-STANDBY-OFF Switch:** Set to proper position for type of power supply used.
8. **PHONE-CW-NET-CAL. Switch:** Set to PHONE or CW for reception and NET or CAL. for operation as described in Par. 30 and 31.
9. **SENSITIVITY Switch:** If signal is strong, set to MED. or LOW position for best signal to noise ratio.
10. **Main Power Receptacle.**

up and is placed under load, adjust the needle valve until the engine runs smoothly.

CAUTION: The first time the engine is started, check the output voltage of the generator with voltmeter provided in the tool box.

(2) With the engine running at the proper speed and the cable attached, push the ON button on the filter unit and turn the OFF-STANDBY-SEND switch on the transmitter to SEND. The transmitter may now be operated from the power unit.

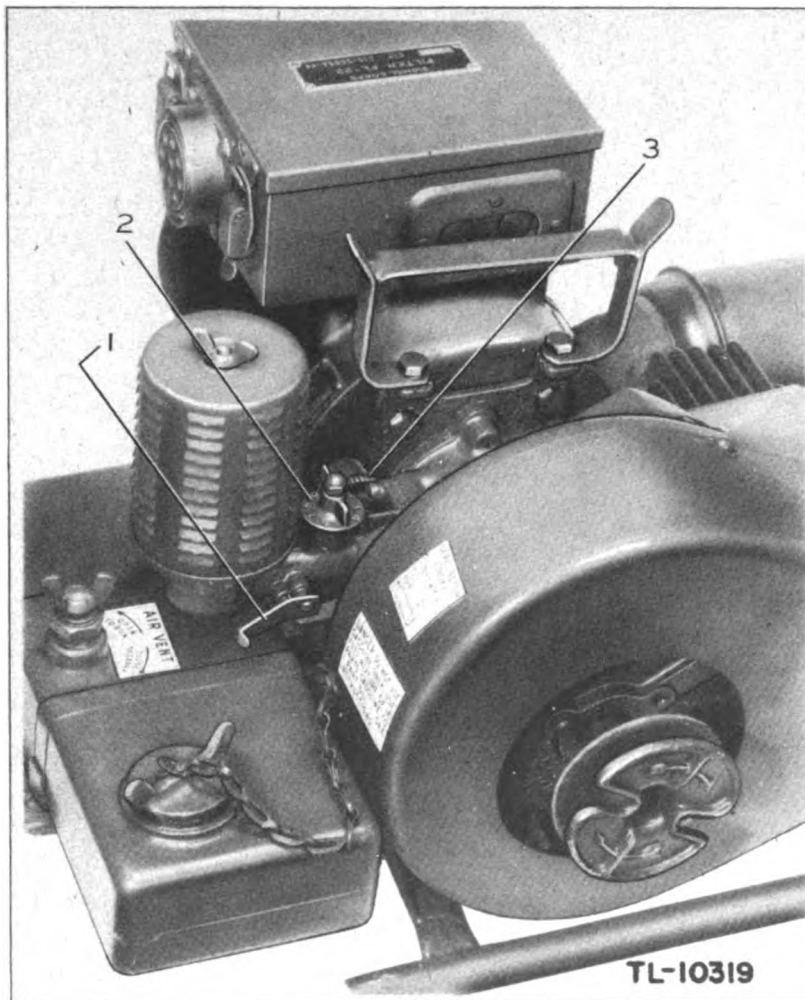

Figure 28—Starting Controls—Power Unit PE-162

1. Choke Lever

2. Mixture Control

3. Speed Control

j. Measure voltages as follows:

(1) Disconnect the cable, start the engine, push the ON button on the filter unit and measure the voltage between pins shown in Figure 68. If the voltage is not approximately 500 volts, adjust the speed regulator (Fig. 28) until that voltage is obtained. Push the OFF button on the filter unit, attach the cable and screw the retaining ring up right.

(3) For subsequent starting, the carburetor needle valve and the speed regulator ordinarily need not be changed unless the engine is extremely cold or the grade of fuel has been changed. It is usually sufficient to use only the choke for starting. In very cold climates, it will be necessary to open the needle valve for starting, readjusting it as the engine warms up.

(4) Sometimes the engine may refuse to start

due to excessive choking, particularly when warm. This results in a flooded engine. The remedy is as follows: Close the fuel line valve (Fig. 80), open the drain cock underneath the crankcase, and crank the engine a few times. When drained, close drain cock and open fuel line valve. Remove spark plug, dry and re-install plug, attach high tension lead, replace ignition shield, and start engine in the normal manner.

33. OPERATING GENERATOR GN-57.

Cord CD-1086 connects the generator to the radio set. Care should be exercised to see that the plugs and receptacles are clean and dry when connected, and that the retaining rings on the cable plugs are turned up tight. Turn the crank of the generator approximately 60 revolutions per minute. Direction of rotation is shown by arrows on

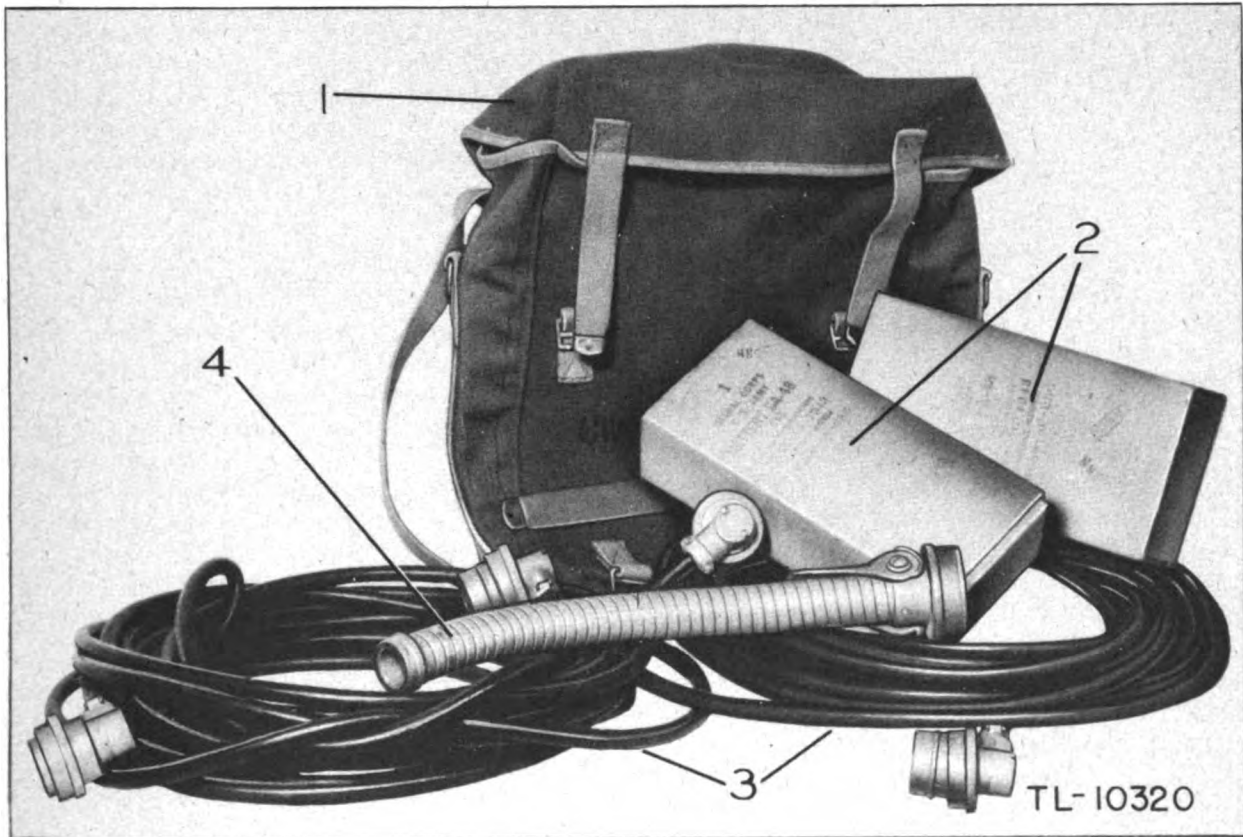

Figure 29—Cordage, Batteries, and Nozzle Unpacked

- | | |
|---------------------------|------------------------------|
| 1. Bag CW-14/TRC-2 | 3. Cord CX-75/TRC-2 (2 each) |
| 2. Battery BA-48 (2 each) | 4. Nozzle. |

k. A circuit breaker located in the filter box protects the generator against overloads. Power is connected to the transmitter by pressing the ON button on the side of the filter box. The power is turned off by pressing the OFF button, releasing the ON button. The circuit breaker is designed so that it will not lock in the ON position if the OFF-STANDBY-SEND switch on the transmitter is in the SEND position.

the side of the generator case. Satisfactory operation can be obtained at 50 to 70 turns per minute.

34. CHARGING BATTERY BB-54-A IN VIBRATOR POWER UNIT PP-39/TRC-2.

Battery BB-54-A (inside of the vibrator unit) can be charged at a high rate from any heavy-duty storage battery, either 6 or 12 volts, by means of Cord CD-618-A (Figs. 32 and 33).

35. QUICK CHARGING ON MOUNTING FT-338-A.

- a. Check CHARGE INDICATOR balls through window in the side of battery case.
- b. Clamp vibrator unit securely to mounting bracket on Mounting FT-338-A (Figs. 30 and 31).
- c. Turn NO CHARGE-HAND GEN-QUICK-CHARGE switch to QUICK CHARGE.
- d. Turn the switch to ON.
- e. Check CURRENT INDICATOR. If not indicating, turn POLARITY switch to opposite position.
- f. Leave the switch at ON for the periods indicated below:

Balls Sunk	Time
Green (only).....	20 minutes
Green and white.....	1¼ hours
Green, white and red.....	2½ hours

g. Turn the switch to OFF. The battery should then be completely charged. If all of the indicator balls are not floating (and a moderate jar or bump will not cause them to rise) then a slightly longer charging time may be required. DO NOT CONTINUE TO CHARGE WHEN THE GREEN BALL IS FLOATING.

36. QUICK CHARGING WITHOUT MOUNTING BRACKET.

- a. Plug Cord CD-618-A into receptacle (rear of vibrator unit).
- b. Check CHARGE INDICATOR balls through window in the side of case.
- c. Stand vibrator unit upright on a non-metallic surface (Fig. 32).
- d. Attach battery clips to terminals of a storage battery, either 6 or 12 volts. Either clip can be attached to the positive or negative terminal.
- e. Proceed as outlined in paragraph 35 above.

NOTE: When charging from a battery installed in a vehicle not having FT-338-A mounting connect yellow lead of Cable CD-618-A to post of battery that is not grounded or connected to chassis of vehicle. Black wire is connected to grounded side of battery in vehicle.

37. QUICK CHARGING FROM THE HAND GENERATOR OR POWER UNIT PE-162.

- a. Connect power cable of vibrator unit to BATTERY receptacle on transmitter panel.
- b. Turn SEND-STANDBY-OFF switch to OFF.
- c. Set the NO CHARGE-HAND GEN-QUICK CHG. switch to HAND GEN.
- d. Operate the hand generator or Power Unit PE-162 until the green charge indicator ball floats. This may take 6 to 8 hours if the battery was completely discharged. The CURRENT indicator on the vibrator unit should show about one-third as much deflection as when the unit is under quick charge.

38. SIDE TONE CIRCUIT.

- a. A side tone circuit in the transmitter permits the operator to monitor transmission, either PHONE or CW. The tone is not obtained directly from the transmitted signal. Side tone will be heard although the transmitter power stage fails. The INDICATOR glows when power is being transmitted. The volume of side tone is controlled by screwdriver adjustment of the slotted shaft beneath the waterproof cover marked SIDE TONE CAL. After adjustment, tighten the waterproof cover to prevent entrance of water.
- b. When the PHONE-CW-NET-CAL switch (receiver) is turned to NET or CAL, the side tone oscillator is made inoperative due to removal of screen voltage. This prevents side tone from interfering with zero beating of the transmitter to the receiver.

39. TRANSMITTER DIAL READINGS.

Dial settings for the transmitter are read from two dials. The drum dial, behind the window, is calibrated in thousands and hundreds, while the flat disc attached to the FREQUENCY CONTROL knob is calibrated in tens and units. Complete dial readings are the combined indications of both dials. A calibration chart, attached to the front of the transmitter, furnishes exact dial settings for frequencies within the tuning range of the transmitter (Fig. 46). To obtain unlisted frequency settings, proceed as follows:

- a. *Step 1.* From the desired frequency, subtract the first calibrated frequency below it.

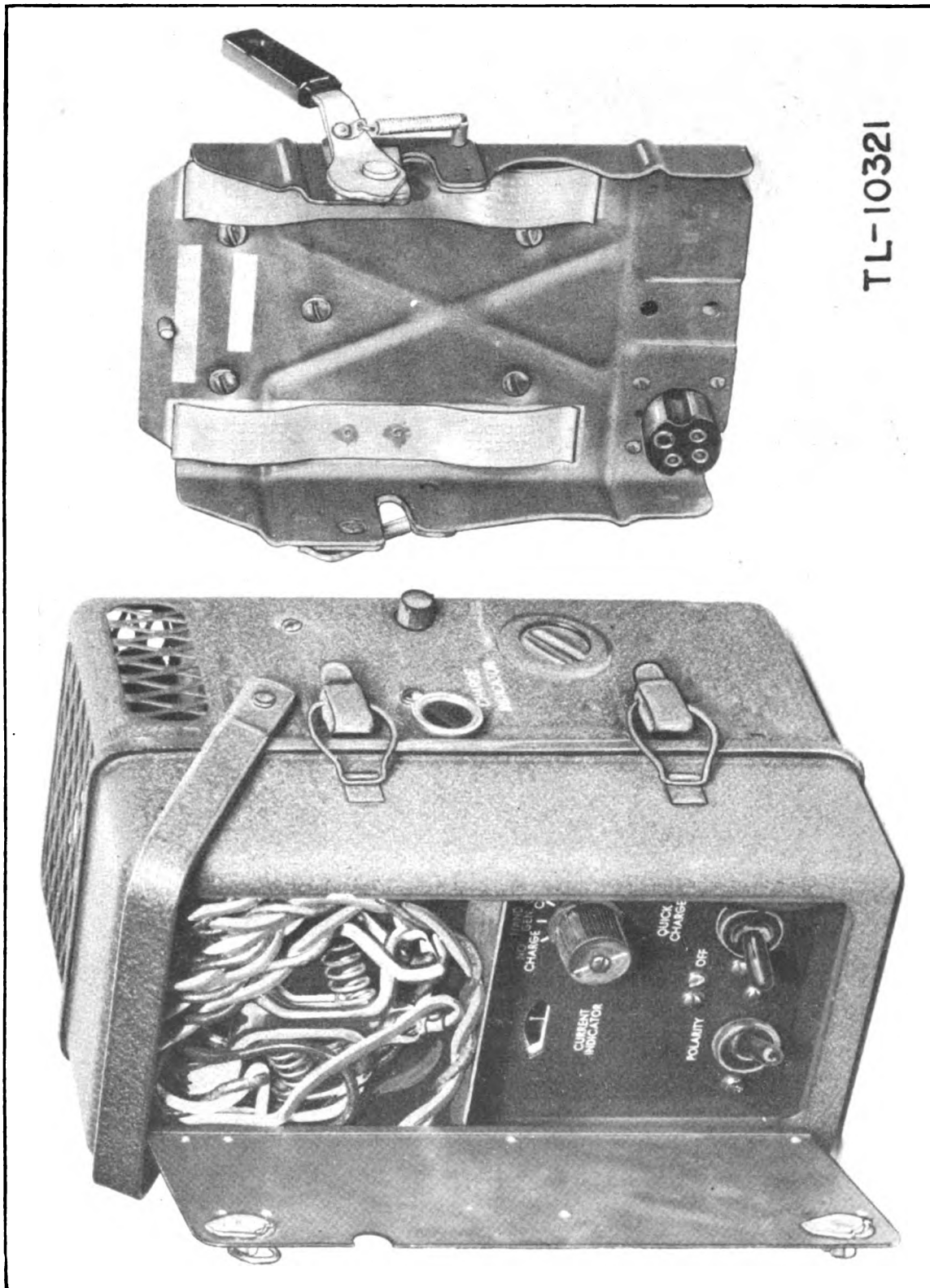

Figure 30—Vibrator Power Unit PP-39, TRC-2 and Mounting FT-338-A

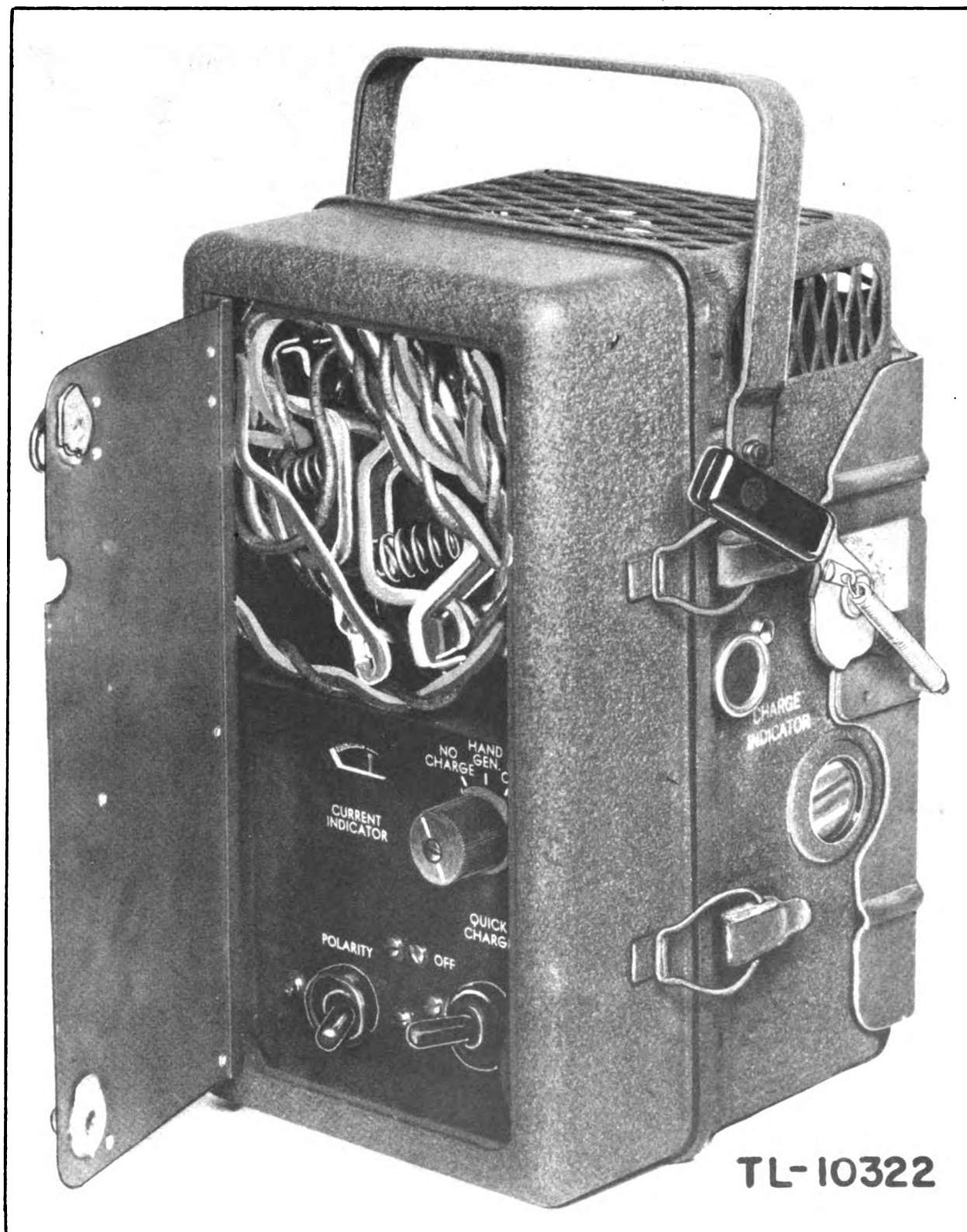

Figure 31—Vibrator Power Unit PP-39/TRC-2 Attached to Mounting FT-338-A

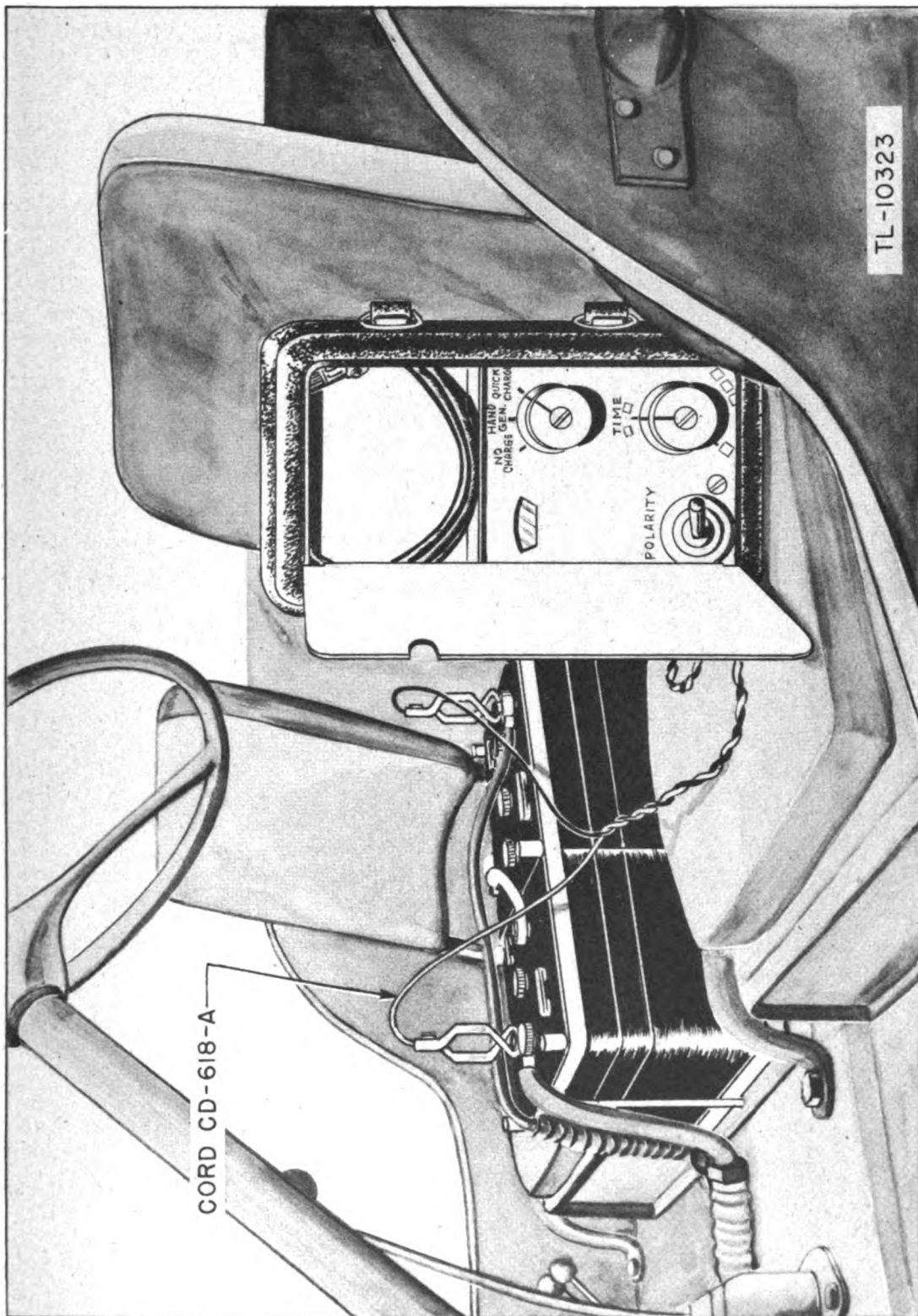

Figure 32—Charging Vibrator Power Supply PP-39/TRC-2 from Vehicular Storage Battery

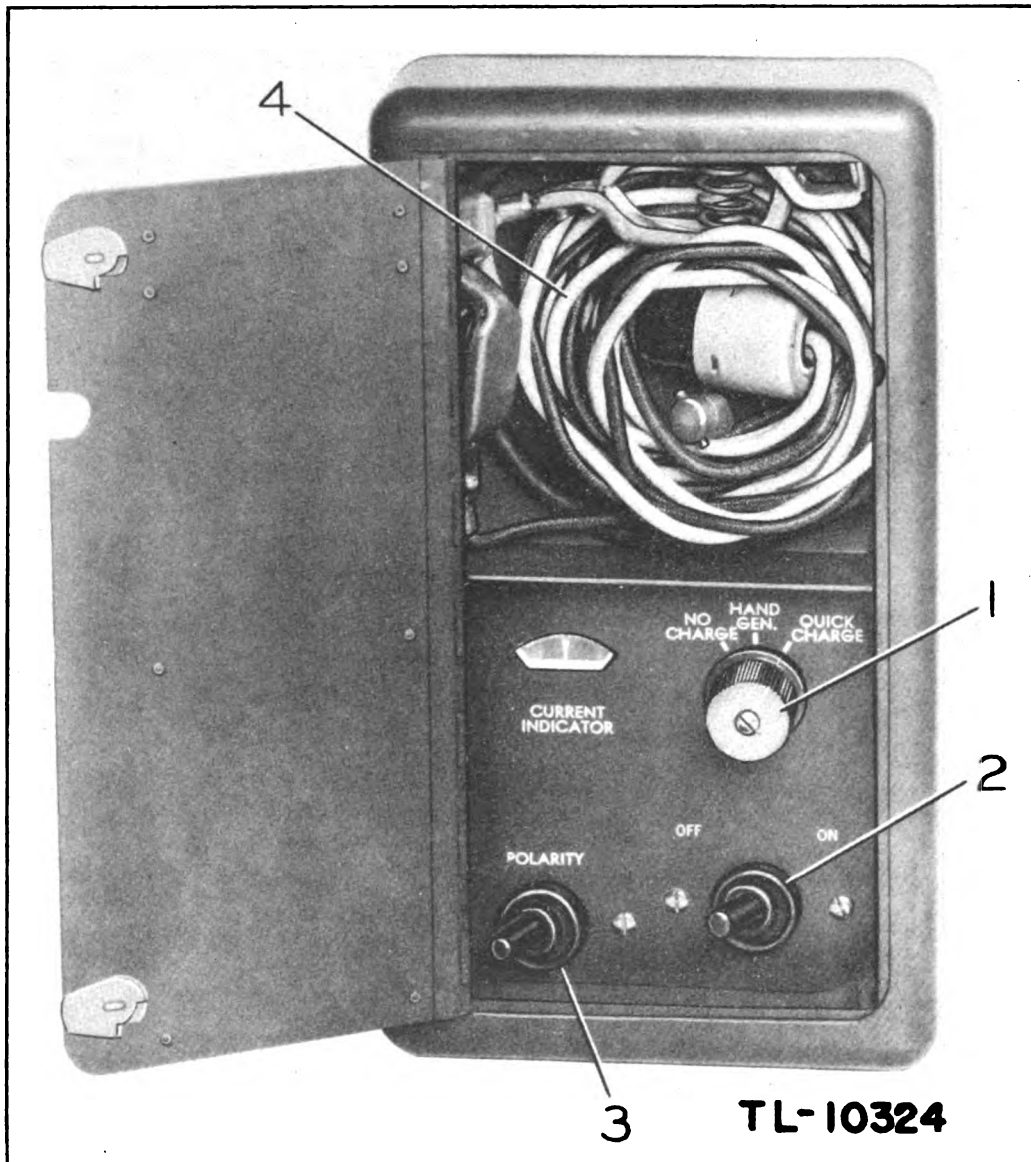

Figure 33—Vibrator Power Supply PP-39/TRC-2

1. **NO CHARGE-HAND GEN-QUICK CHARGE Switch:**
 1. Set to **NO CHARGE** when discharging.
 2. Set to **HAND GEN.** when charging from Power Unit or Hand Generator
 3. Set to **QUICK CHARGE** when charging from vehicular storage battery.
2. **OFF-ON Switch:** Set to **ON** when charging. Set to **OFF** when discharging.
3. **POLARITY Switch:** When charging set to position which shows "CHARGE" on **CURRENT INDICATOR**.
4. **Cord CD-618-A:** Quick Charge Cable.

b. Step 2. Find the difference between the dial readings for the calibrated frequencies just above and just below the desired frequency.

c. Step 3. For Radio Receiver and Transmitter BC-1306 multiply the value derived in Step 1 by that in Step 2 and divide the answer by 20.

d. Step 4. For Receiver-Transmitter RT-12/TRC-2, multiply the value derived in Step 1 by that in Step 2 and divide the answer by 10.

e. Step 5. Add the answer obtained in Step 3 or Step 4 to the dial setting corresponding to the frequency just below the desired frequency. This answer is the new dial setting.

40. RECEIVER DIAL READINGS.

a. Receiver-Transmitter BC-1306. — The receiver dial is calibrated in megacycles (mc). (1 mc = 1,000 kc). The receiver dial of Receiver-Transmitter BC-1306 is calibrated from 3.8 mc to 6.5 mc, with each division equal to 20 kc. In reading the dial, disregard the decimal point between the figures on the dial scale. Read in hundreds of kilocycles the pair of numbers to the left of the center line on the window. Then add 20 kilocycles for each division between those figures and the line on the window.

b. Receiver-Transmitter RT-12/TRC-2.—The receiver dial of Receiver-Transmitter RT-12/TRC-2 is calibrated from 2.0 mc to 3.4 mc with dial calibrations every 10 kc. Read the receiver dial the same as directed for Receiver-Transmitter BC-1306, except that each space represents 10 kc instead of 20 kc.

41. OPERATION OF MICROPHONE.

a. Hold Microphone T-17 close to the lips and speak loudly and clearly.

b. Microphone T-45 is suspended directly in front of the lips by means of the special harness. A separate switch, part of Cord CD-318-A, is suspended by a light strap hung around the operator's neck.

c. To talk, push down the button or switch, wait approximately two seconds for the tubes to heat, and begin the message. Releasing the button or switch stops the transmitter and permits the receiver to operate. The transmitter will not oper-

ate with the button or switch up, nor will the receiver operate with either down.

42. OPERATION OF KEY.

Plug the key into the KEY jack on the transmitter, and operate in conventional manner.

43. CRYSTAL-CONTROLLED OPERATION.

Adjust the receiver-transmitter for operation as instructed in paragraph 31.—B-(9).

44. MASTER-OSCILLATOR OPERATION.

a. Tune the receiver to the net control station. If the control station is using MCW, tune the receiver with the PHONE-CW-NET-CAL switch in the PHONE position, shift the switch to CW, and adjust the receiver to zero beat; thus establishing a reference frequency to which the transmitter will be tuned.

b. Determine the frequency of the control station from the receiver dial.

c. Connect the antenna jumpers for that frequency (Par. 25).

d. Set the CRYSTALS switch to MO.

e. Set the CW-MCW-PHONE switch to CW.

f. Set the SEND-STANDBY-OFF switch to SEND.

g. Set the transmitter **FREQ. CONTROL** knob to the frequency of the net control station.

h. Turn the PHONE-CW-NET-CAL switch to NET.

i. Turn the **FREQ. CONTROL** knob on the transmitter until a zero beat is heard in the headset.

45. RECEIVER CALIBRATION.

a. A 200-kc crystal is provided in the receiver for the purpose of supplying a series of crystal-controlled check points against which to check the calibration of the receiver and the transmitter. These frequencies are harmonics of 200 kc. On Receiver-Transmitter RT-12/TRC-2, these points are 2,000 kc, 2,200 kc, 2,400 kc, etc., up to 3,400 kc. On Receiver-Transmitter BC-1306, the calibration check points are 3,800 kc, 4,000 kc, 4,200 kc, etc., up to 6,400 kc.

b. To check the receiver calibration, proceed as follows:

(1) Turn the PHONE-CW-NET CAL switch to CAL.

(2) Turn the SEND-STANDBY-OFF switch to SEND.

(3) Turn the CW-MCW-PHONE switch to PHONE.

(4) Turn the receiver dial to the lowest frequency check point (3,800 kc on BC-1306) or 2,000 kc on RT-12/TRC-2) and adjust to zero beat on the strongest beat note in the vicinity of the crystal check point. The receiver is out of calibration to the extent that the index line fails to coincide with the exact frequency.

(5) Check the remaining crystal check point.

(6) Turn the PHONE-CW-NET-CAL switch to PHONE or CW. Always check the receiver calibration at the low-frequency end of the dial.

46. TRANSMITTER CALIBRATION.

Calibration of transmitter is made from the front panel without special tools or test equipment. Greatest accuracy is obtained if the calibration is adjusted at the NEAREST crystal check point. Proceed as follows:

a. Select the crystal check point nearest the assigned frequency.

b. Adjust the receiver to zero beat at the selected crystal check point.

c. Turn the CRYSTALS switch to MO.

d. From the calibration chart, determine the dial setting for the crystal check point selected. Set the **FREQ. CONTROL** knob to this dial setting.

e. Turn the CW-MCW-PHONE switch to CW.

f. Rotate the **FREQ. CONTROL** knob to both sides of the setting, until zero beat is heard in the phones. The degree of difference between the dial setting at zero beat and the dial setting specified on the calibration chart is the error in calibration.

g. To correct the calibration, set the **FREQ. CONTROL** knob to the frequency specified on the calibration chart, open the cover marked **SIDE TONE CAL.**, adjust the **CAL.** trimmer

until zero beat is heard in the headset, then securely tighten the door to prevent entry of water.

h. Turn the PHONE-CW-NET-CAL switch to PHONE or CW. The transmitter can now be tuned accurately to any frequency within 100 kc of the point of calibration. For frequencies more than 100 kc away from this setting, the transmitter must be recalibrated.

47. BATTERY OPERATION OF RECEIVER ONLY.

Operation of the receiver only is possible with Vibrator Power Supply PP-39/TRC-2 or Battery BA-48. When fully charged, the vibrator power supply will furnish approximately 10 hours continuous service without recharging. Battery BA-48 will furnish approximately 20 hours continuous operation. Intermittent operation of the receiver with Battery BA-48 will lengthen battery life.

48. PRECAUTIONS DURING OPERATION.

a. Never use gasoline only as fuel for Power Unit PE-162 since lubrication will be lacking.

b. Turn the OFF-STANDBY-SEND switch to OFF when pushing the ON button of Power Unit PE-162, otherwise the circuit breaker will not stay closed. After pushing the ON button on PE-162, turn the transmitter switch to SEND.

c. Never operate the transmitter with the OFF-STANDBY-SEND switch in STANDBY, unless Vibrator Power Supply PP-39/TRC-2 is connected, since there would be no excitation for the power tube.

d. Set the OFF-STANDBY-SEND switch to STANDBY when operating with Vibrator Power Supply PP-39/TRC-2 or Battery BA-48 for receiving.

e. Use the correct antenna length for the frequency of transmission, so that it will draw the proper power from the transmitter.

f. Adjust the knob **TUNE FOR MAX IND. GLOW** to produce maximum brilliance of the **INDICATOR**. Also, see item 2, Figure 27.

g. Never tune the transmitter for maximum indicator glow without an antenna connected, since this overloads the output tube and subjects the transmitter to excessive r-f voltage.

h. Set the CRYSTALS switch to MO when operating master-oscillator-controlled.

i. Test for crystal oscillation when operating crystal-controlled.

j. Never leave the PHONE-CW-NET-CAL switch on NET or CAL, because this reduces receiver sensitivity and weak signals may not be heard.

k. A short, positive ground connection is necessary for reducing the noise level in the receiver.

l. After pressing the microphone button, always wait two seconds to allow the tubes to warm up

before beginning to speak. Watch for INDICATOR glow, to be sure that the transmitter is functioning.

49. MINIMIZING INDICATOR GLOW.

To reduce the possibility of the INDICATOR being seen by the enemy at night, a polaroid cover is provided to limit the amount of light emitted. Maximum light is obtained when the spots on the barrel of the indicator and rim are lined up. Rotate the rim clockwise one-quarter turn for minimum light.

CAUTION: Always rotate the rim in a clockwise direction.



Figure 34—Accessory Bag on Packboard

- 1. Accessories in bag
- 2. Packboard



Figure 35—Cordage, Batteries, and Nozzle on Packboard

- 1. Cordage, batteries, and nozzle in bag
- 2. Packboard

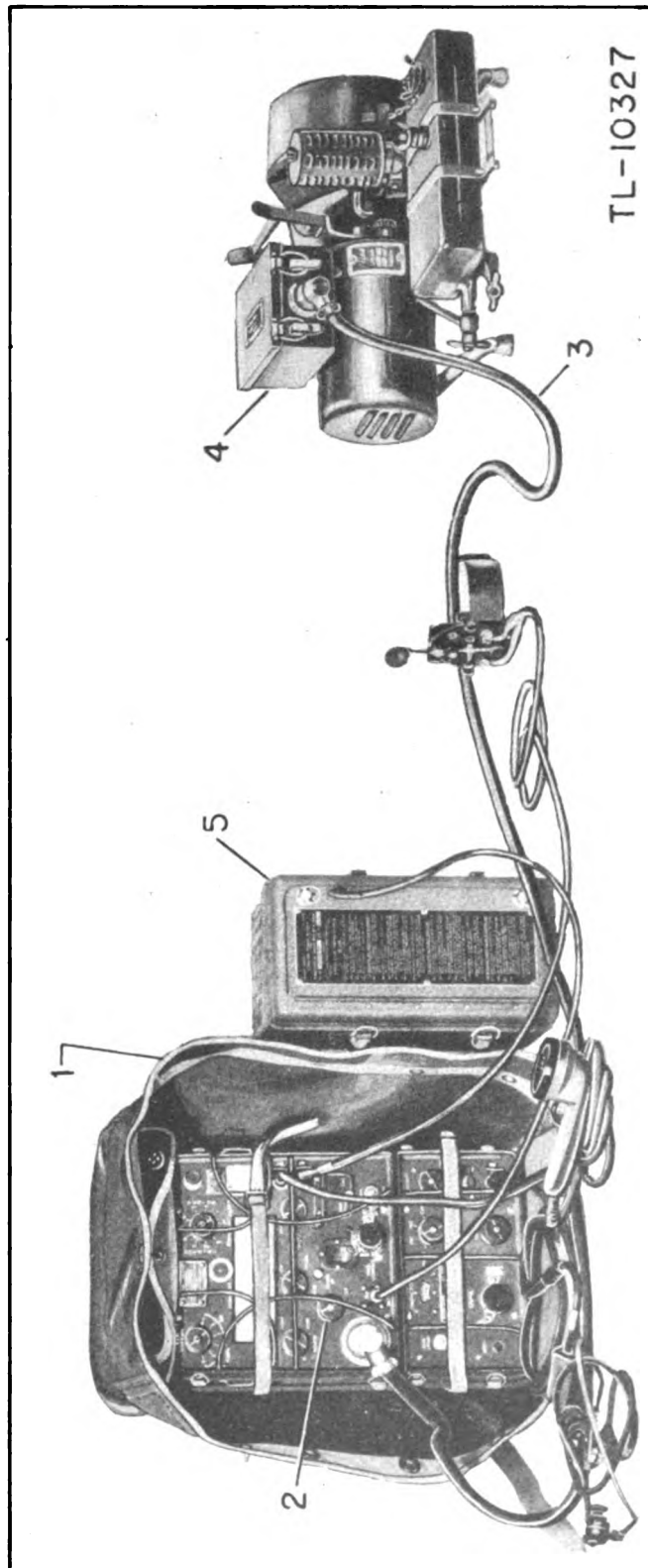

- 1. Bag CW-15/TRC-2
- 2. Switch in OFF position when charging
- 3. Cord CX-75/TRC-2
- 4. Power Unit PE-162
- 5. Vibrator Power Supply PP-39/TRC-2

Figure 36—Charging Battery of Vibrator Power Supply PP-39/TRC-2 with Power Unit PE-162

PART THREE

FUNCTIONING OF PARTS

SECTION I

RADIO RECEIVER AND TRANSMITTER BC-1306

50. GENERAL.

The two principal parts of Radio Receiver and Transmitter BC-1306 are the receiver and the transmitter. These two units are interconnected to facilitate simultaneous control of both units.

51. RECEIVER CIRCUIT ANALYSIS.

The receiver section of Radio Receiver and Transmitter BC-1306 is a 6-tube superheterodyne (Fig. 88) consisting of one stage of radio-frequency (r-f) amplification, a converter (mixer-oscillator), two stages of intermediate-frequency (i-f) amplification, a second-detector first audio stage, and an audio-frequency (a-f) power-output stage. Three multi-purpose tubes are used.

a. The first is the mixer tube 1R5 in socket 59. This tube combines the functions of oscillator and mixer, and at the same time furnishes bias to the audio-power stage.

b. The second multi-purpose tube 1R5 in socket 61 functions as the second i-f amplifier, and, during calibration is the crystal calibrating oscillator.

c. The third multi-purpose tube 1S5 in socket 62 functions as second detector, automatic volume control (avc), and first audio amplifier. An additional function of this tube is to act as beating oscillator for cw reception.

d. All power is cut off from the receiver-transmitter when the SEND-STANDBY-OFF switch is in the OFF position.

52. RECEIVER ANTENNA CIRCUIT.

The antenna is connected to the receiver through plug 52 to the wave trap in antenna transformer 40. The purpose of the wave trap is to reduce interference from stations within the frequency range of the image frequency of the receiver.

53. R-F AMPLIFIER.

Signals which pass the wave trap are coupled, both inductively and capacitively, to the first tuned grid circuit. Capacitor 1-A is the rear section of the main tuning capacitor and capacitor 2 is the trimmer mounted on the same section of the gang. These two capacitors in parallel tune this first circuit to resonance with the incoming signal. The signal is applied to the control grid of the 1L4 r-f amplifier tube in socket 58 where the signal is amplified. Capacitor 8-1 closes the first tuned circuit, but permits the application of avc voltage to the first grid, through the secondary winding of the antenna transformer. Resistor 28-1 passes the necessary avc voltage, and when used in combination with capacitor 8-1, attenuates any i-f or r-f that might accompany the avc voltage and which would produce undesirable feedback if not removed. Capacitor 9-1 bypasses the screen of the first amplifier tube to prevent oscillation in the tube. The output from this tube is coupled inductively and capacitively to the second tuned circuit consisting of the secondary (terminals 3 and 5) of coil 41, gang capacitor 1-B and trimmer 3. The voltage developed across this circuit is connected to the control grid of converter tube 1R5 in socket 59.

54. HIGH FREQUENCY OSCILLATOR.

The high-frequency oscillator (hfo) coil 42 is tuned by gang capacitor 1-C, trimmer 4 and padding capacitor 7. The function of the padding capacitor is to influence the tuning curve of the oscillator circuit to provide 456 kc tracking above the signal frequency. Bias for the audio output tube is obtained from the grid bias of the high-frequency oscillator through filter network 26-1, 25-1, 31-4, and 9-2. Screen-grid voltage for the tube is obtained through dropping resistor 27 and is bypassed by capacitor 8-2. The necessary feedback to make the tube oscillate is obtained by

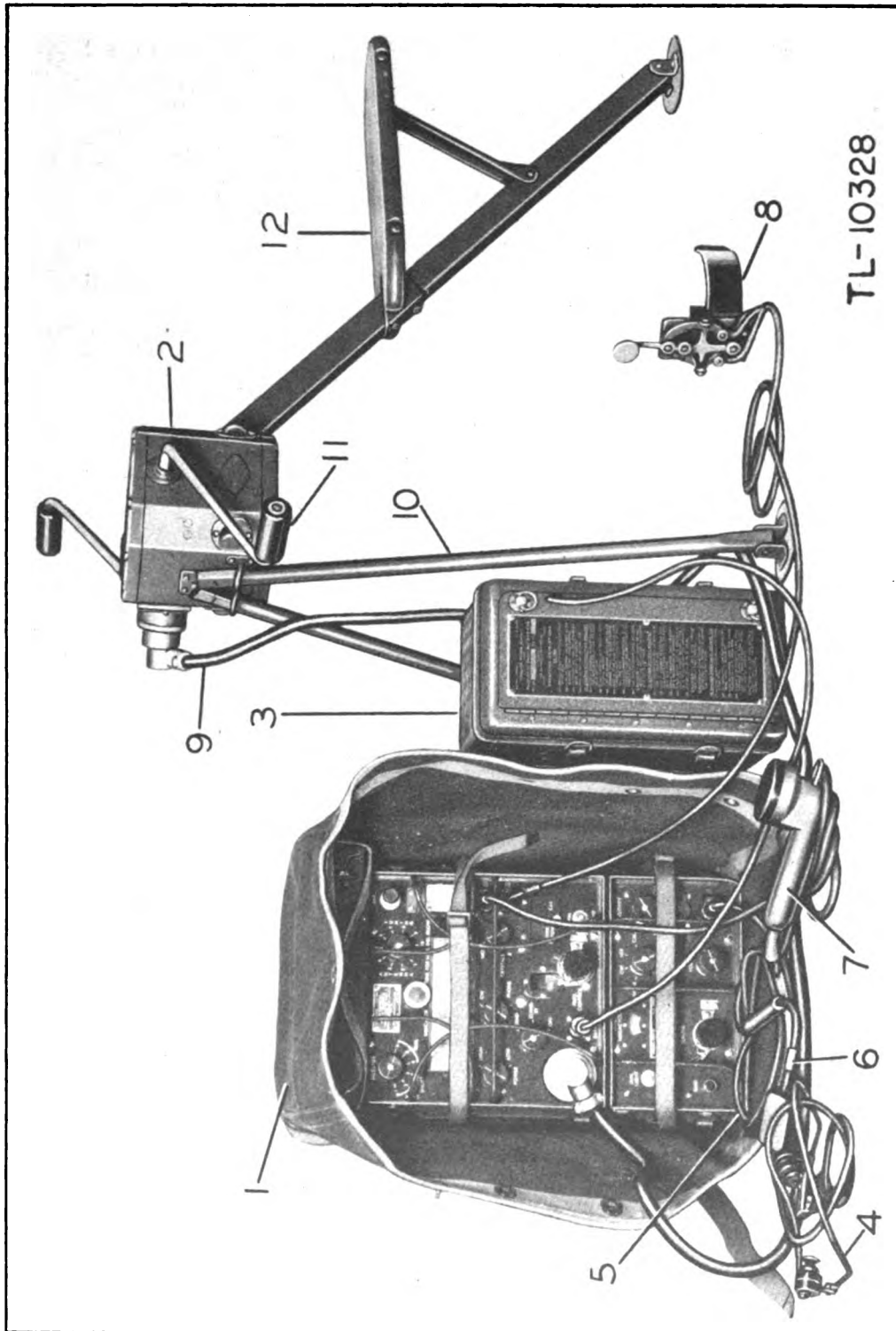

- | | | |
|--------------------------------------|--------------------|-------------------------|
| 1. Bag CW-15/TRC-2 | 5. Cord CD-307-A | 9. Cord CD-1086 |
| 2. Generator GN-57 | 6. Cord CD-933 | 10. Leg LG-3 (2 each) |
| 3. Vibrator Power Supply PP-39/TRC-2 | 7. Microphone T-17 | 11. Crank GC-7 (2 each) |
| 4. Headset HS-30 | 8. Key J-45 | 12. Leg LG-2-A |

Figure 37—Operating Radio Receiver and Transmitter BC-1306 or RT-12/TRC-2 with Vibrator Power Supply PP-39/TRC-2 and Generator GN-57

coupling the grid circuit through a bi-filar (two parallel wire) winding in the filament circuit. In oscillator coil 42, terminal 3 is grounded while terminal 4 is by-passed to ground. Terminals 1 and 2 are connected to the filament which is above ground potential with respect to r-f. The hfo also provides bias voltage for the output tube, through network 26-1, 25-1, 31-4 and 9-2. The screen voltage is obtained through resistor 36-1, by-passed by capacitor 9-3. Capacitor 18 by-passes the plate load of the output tube so that the load impedance does not increase at high audio frequencies. Plate voltage for the output tube is supplied through the primary of the output transformer.

55. FIRST I-F AMPLIFIER.

The output from the hfo tube is directly coupled to the primary of the first i-f transformer 43-1. This primary circuit consists of a fixed capacitor 15-1 and a variable inductance. Tuning is accomplished by moving a slug of compressed powdered iron in the field of the coil. This circuit is inductively coupled to the secondary, which is constructed and tuned in a similar fashion. The output voltage of the transformer is applied to the control grid of the first i-f amplifier tube 1L4 in socket 60. Screen voltage for this tube is obtained from resistor 32 through SENSITIVITY switch 47 and either resistor 29, 30 or 31-1, depending upon the position of switch 47. The sensitivity of the receiver is controlled by the variation in screen voltage which is brought about by changing the position of the SENSITIVITY switch. The output of the first i-f amplifier tube 60 is applied to the second i-f transformer 43-2. Transformers 43-2 and 43-3 are identical to transformer 43-1 and are tuned in precisely the same manner. By-pass for the avc voltage applied to number 4 terminal of transformer 43-1 is provided through capacitor 8-3.

56. SECOND I-F AMPLIFIER.

Plate voltage to the second i-f amplifier tube is supplied through resistor 39 and is by-passed by capacitor 8-9. The purpose of this filter is to prevent regeneration at the intermediate frequency.

57. CRYSTAL CALIBRATION.

A crystal calibrating circuit is included as part of the second i-f stage and consists of crystal 57,

a tuned circuit 44, resonant to 200 kc, a grid resistor 37, and frequency corrector capacitor 11. R-f by-passing is accomplished by capacitor 12. The output of the crystal calibrator circuit is derived from the oscillator grid and is coupled by capacitor 23 to the control grid of the r-f amplifier tube. Calibration of the receiver is obtained when this voltage fed into the r-f amplifier is considered as an incoming cw signal, and is tuned to zero beat in the usual manner for cw reception. Capacitor 8-4 by-passes the tuned circuit in transformer 44 when the PHONE-CW-NET-CAL switch is in all positions except CAL. The oscillator is prevented from working except when the switch is in that position.

58. DETECTOR.

The secondary output of the third i-f transformer 43-3 is applied to the diode section of tube 1S5 in socket 62. Resistor 28-3 and potentiometer 34-A constitute the diode load, across which is developed the avc voltage which is applied through resistors 28-1 and 26-2 to the grids of tubes 1L4 in sockets 58 and 60.

59. BEAT-FREQUENCY OSCILLATOR.

a. The beat-frequency oscillator (bfo) operation of the 1S5 is somewhat unconventional and a special circuit is necessary to accomplish the desired results. When this tube is not oscillating, the entire network associated with transformer 45 can be assumed to be merely a dropping resistor and by-pass capacitor for supplying screen voltage to the tube.

b. When the oscillator is working, this circuit becomes very different in its operation. Resistor 33 still supplies the screen voltage which is by-passed (for audio) by capacitor 8-6, but this capacitor also serves to bring terminal 4 to ground potential as far as r-f is concerned.

c. Point 2 of coil assembly 45 is connected to the screen of tube 62. Point 1 is coupled through blocking capacitor 17 to the control grid of the same tube.

d. This condition causes the tube to oscillate between its control and screen grids at a frequency determined by the inductance in transformer 45 and capacitance in item 16 plus tube and stray capacities.

NOTE: This oscillator operates at one-half of the

intermediate frequency to improve stability. The second harmonic produces the beat note.

e. The R-f voltage on the control grid is coupled through the tube to the plate circuit. Most of this voltage is by-passed to ground through capacitor 13-2 to prevent overloading the grid of the output tube. A small voltage remains, however, which is fed back through capacitor 24 to the grid of the second i-f amplifier tube in socket 61. Here it is amplified and passed on through coil 43-3 to the detector, to produce the required beat note for cw reception.

60. FIRST AUDIO AMPLIFIER.

The a-f component across potentiometer 34-A (volume control) is applied through capacitor 25-2 and resistor 31-3 to the control grid of tube 1S5 in socket 62. Resistors 31-3 and 31-2 provide a d-c return path for the grid of the amplifier section of the tube. The plate voltage of this tube is supplied through plate load resistor 35, across which the output voltage is developed.

61. AUDIO OUTPUT.

The output voltage of the first audio amplifier section of tube 1S5 in socket 62 is applied to the grid of output 3Q4 in socket 63 by means of capacitor 25-3 and potentiometer 34-B. Capacitor 13-2 is an r-f by-pass on the output of the first audio amplifier, to prevent overloading the grid of the output tube with r-f from the beat frequency oscillator portion of the 1S5.

62. SIDE TONE FOR RECEIVER.

a. A side tone signal, for monitoring purposes, is obtained from the transmitter through resistor 36-2 and blocking capacitor 8-8 and is conveyed to the headset by being applied to the primary of output transformer 46.

b. When transmitting cw or mcw, the modulator tube operates as an audio oscillator, furnishing the side tone. A small portion of this power is transmitted to the headset. The keying relay interrupts the plate voltage of the modulator tube, and at the same time it interrupts the plate circuit of the master oscillator and power amplifier. The relay thus keys the side tone oscillator in synchronism with the transmitted signals.

c. The secondary of the output transformer is connected through switch 49 to the headset jacks 51-1 and 51-2. The switch serves to select the out-

put impedance of the receiver, 250 or 4,000 ohms.

d. Capacitor 20 is a large electrolytic unit designed for suppressing hum and ripple in the filament circuit when the receiver is operated from sources other than batteries. Capacitor 8-7 is an r-f by-pass in the same circuit. Coupling in the "B" plus circuit is prevented by capacitors 21 and 22.

e. Switch 48 is the PHONE-CW-NET-CAL switch. In the PHONE position only, capacitor 8-5 by-passes the screen of tube 1S5 in socket 62 and stops the bfo action. In the PHONE or CW position, pins 4 and 6 of receptacle 54 are connected, supplying screen voltage to the modulator tube of the transmitter. In the NET or CAL positions, pins 1 and 4 are connected through switch 48, supplying screen voltage to the MO tube in the transmitter, permitting that tube to function in netting or calibrating operations. The 200 kc crystal oscillator operates only in the CAL position. In all other positions of the switch this oscillator is made inoperative by by-passing the screen grid of the second i-f tube in socket 62 through capacitor 8-4. The dial light in socket 56 is operated by switch 50.

63. TRANSMITTER.

a. The transmitter section of Radio Receiver and Transmitter BC-1306, consists of a master oscillator, a power amplifier and modulator (Fig. 90).

b. Switch 138 is the SEND-STANDBY-OFF switch. In SEND position all power is derived through power receptacle 144 from Power Unit PE-162 or Generator GN-57. Capacitors 99 and 100 by-pass power-supply hash. In STANDBY position the transmitter receives its power from Generator GN-57 with the exception of the 105 volt circuit. This is obtained from BATTERY receptacle 145 (Fig. 39).

64. MASTER OSCILLATOR-CRYSTAL OSCILLATOR.

The oscillator may be self-excited or crystal-controlled, and is used to supply r-f power to the grid circuit of the power amplifier tube. Tube 3A4 in socket 140, is an electron-coupled oscillator when the CRYSTAL switch 135 is in the MO position, and a crystal oscillator when the switch is in the CRYSTALS A or B position.

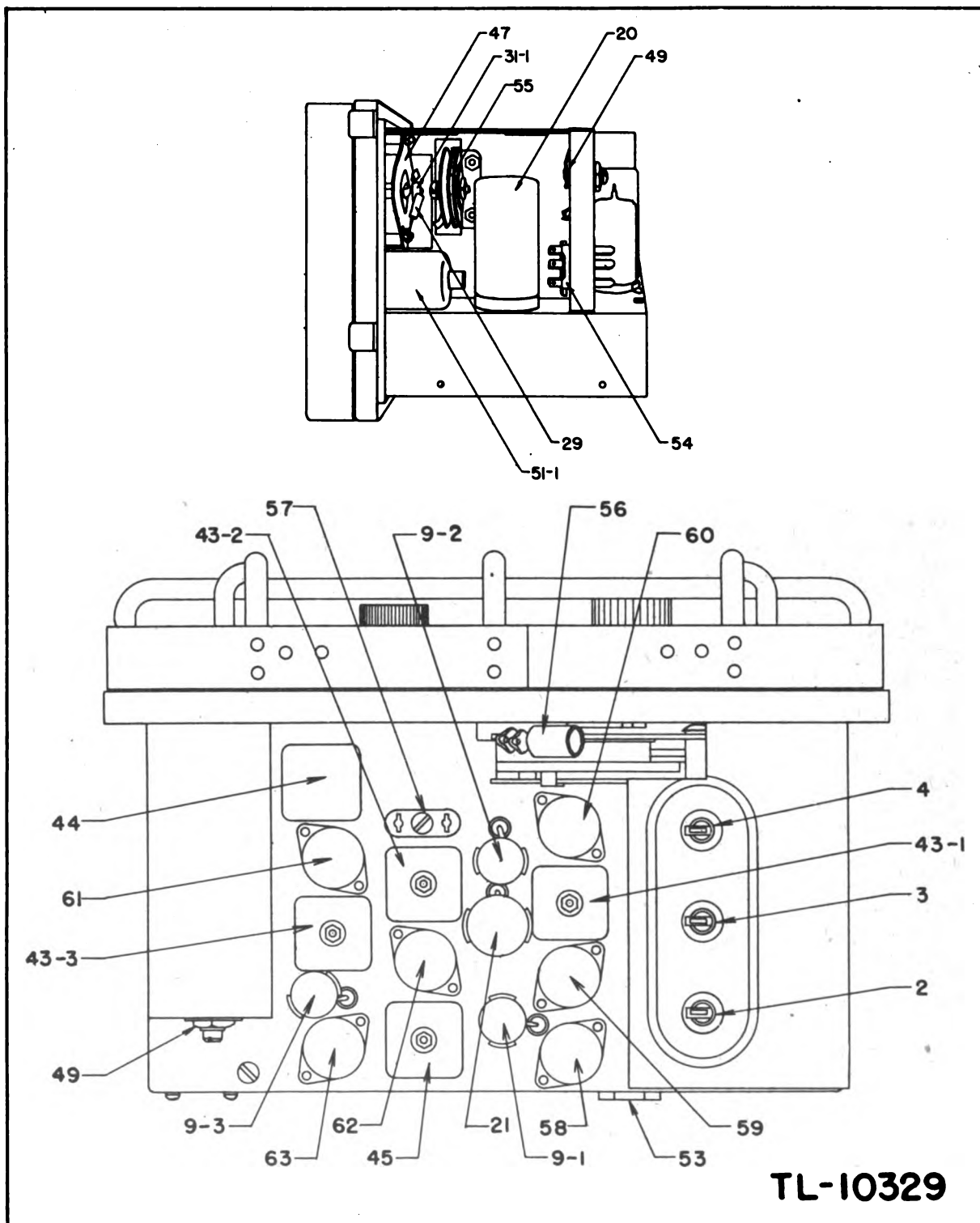

TL-10329

Figure 38—Parts Symbols of Receiver of Radio Receiver and Transmitter BC-1306 or RT-12/TRC-2

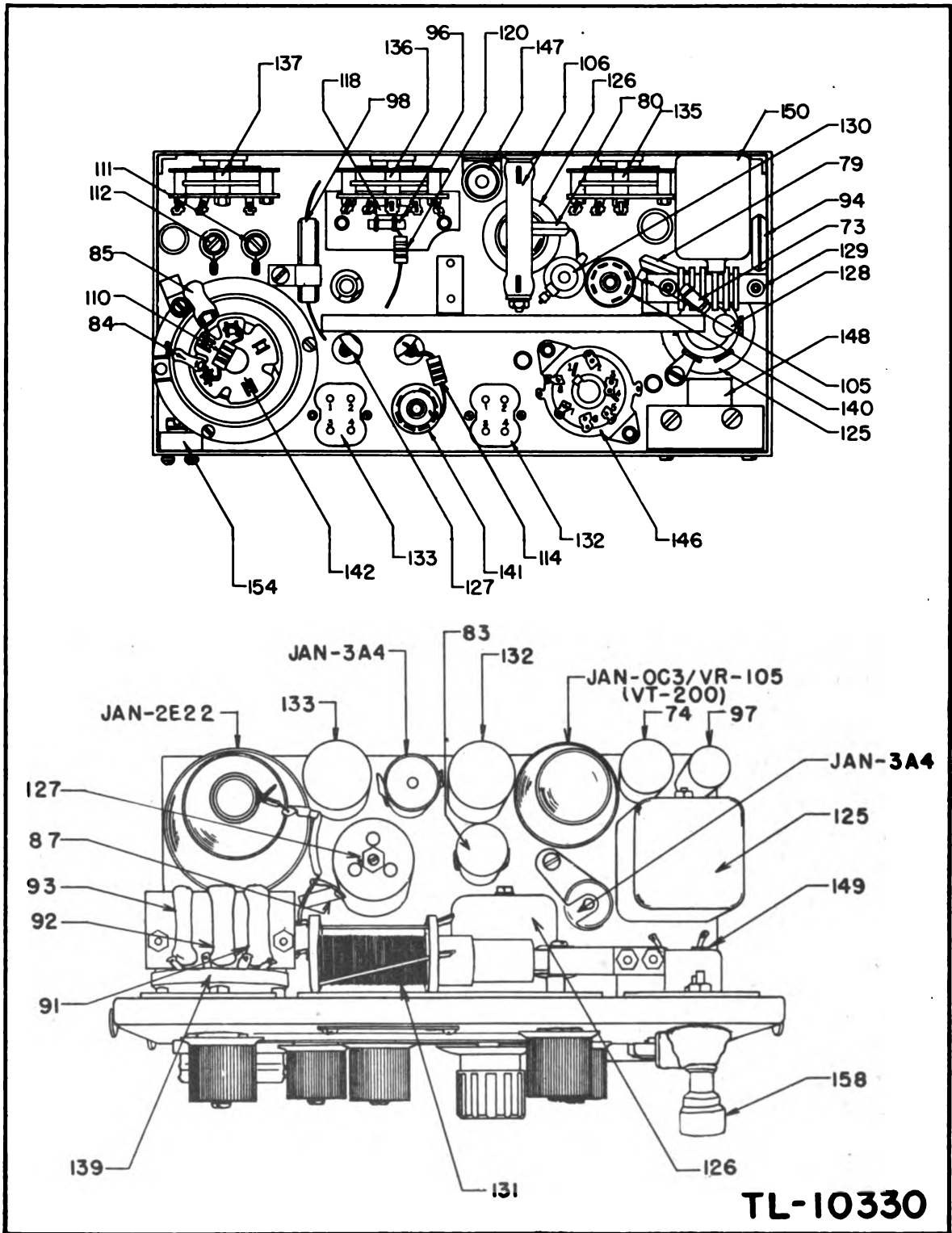

Figure 39—Parts Symbols of Transmitter of Radio Receiver and Transmitter BC-1305 (Top View)

STANFORD LIBRARIES

a. Master Oscillator.—Capacitors 75-A, 76-A, 76-B and 77 are used to resonate coil 125. Capacitor 78 is a ceramic unit having a negative temperature coefficient and is connected directly across the oscillator inductance 125. A slug of compressed iron on a bi-metallic strip is used in the coil to compensate for changes in inductance caused by changes in temperature. The oscillator is temperature compensated, both capacitively and inductively.

b. Crystal Oscillator.—The crystal circuit employed in these transmitters will function properly with crystals covering a wide range of frequencies. The circuit has been designed so that, if a crystal refuses to operate, the transmitter will oscillate with sufficient amplitude to bias the output tube enough to prevent excessive plate current from being drawn. The INDICATOR may show r-f output on crystal operation even though the crystal may be defective.

65. MODULATOR.

a. The modulator circuit supplies the a-f power necessary to modulate the suppressor grid of the power amplifier tube during phone or MCW operation. The modulator circuit is conventional consisting of MIKE jack 151, microphone transformer 132, modulator tube type 3A4 in socket 141, and audio output transformer 133.

b. The doubler circuit consists of capacitors 75-B (part of the main gang-tuning capacitor), capacitor 81, and coil 126. Capacitor 82 is the power-amplifier grid-return r-f by-pass. Resistor 107 is the power-amplifier grid leak. Resistor 108 is part of the power-amplifier suppressor-grid bias voltage divider and resistor 109 is the modulator (tube 3A4 in socket 141) bias resistor. Capacitor 83 is the suppressor-grid audio by-pass. Resistor 117 and capacitor 97 comprise the microphone filter. Resistor 114 is the modulator screen-grid dropping resistor and capacitor 95 is its by-pass.

c. The output of the doubler circuit is directly coupled from a tap on coil 126 to the grid of the power-amplifier tube (type 2E22) in socket 142. The screen grid is by-passed by capacitor 102. Resistor 110 is the grid return for the suppressor grid. The grid is by-passed by capacitor 84. Capacitor 85 is the amplifier-filament r-f by-pass. Coil 127 and capacitors 75-C (part of main tuning gang) and 86 form the power-amplifier plate tank circuit. Capacitor 87 is used for coupling the

power-amplifier output to the antenna loading coil through keying relay 156.

d. Capacitor 104 is a neutralizing capacitor which always prevents oscillation except when the grid circuit of the oscillator is tuned to approximately the selected crystal frequency.

e. Choke 128 is used to prevent r-f current from entering the filament circuit. Choke 129 provides a high impedance path for r-f current when using crystal operation. Capacitor 94 by-passes r-f current from the screen grid.

f. Socket 149 is used to hold the two crystals in use.

g. The signal is coupled from the plate of tube 3A4 to the frequency-doubling circuit through capacitor 80.

h. Choke 130 is used to prevent r-f power loss in resistor 106, which is the plate voltage-dropping resistor for the oscillator.

i. Potentiometer 115, located on the front panel, provides a means of adjusting the side tone output.

j. Jack 150 connects the key to keying relay 156, which is in receive position when the key is up. Jack 155 is used to ground the transmitter to the case and acts as the negative return circuit for the receiver.

k. CW-MCW-PHONE switch 136 is used to convert the modulator tube from an audio amplifier to an audio oscillator (in CW or MCW position). This is done by introducing feed-back from its plate to its grid circuit through capacitor 96. Resistor 120 is the audio oscillator grid leak.

l. In the MCW position resistor 119 loads the suppressor grid of tube 2E22, and capacitor 98 is the audio oscillator harmonic filter. Resistor 118 is used to equalize the side tone level between CW and MCW positions. In changing from CW to MCW or PHONE position, the power-amplifier suppressor-grid bias is changed from +6 to -60 volts through switch 136.

m. Metering socket 143 is used to check the circuit voltages of the transmitter during test. Resistor 113 provides a voltage drop in the plate circuit of the power-amplifier tube so that the plate current may be calculated from the voltage obtained (plate current in ma = volts x 50) across the resistor.

66. VOLTAGE REGULATOR.

a. A voltage regulator tube (VR105-30) is used to control the plate supply voltage to the master oscillator, modulator and receiver.

b. Voltage regulator 157 is identical to the voltage regulator in the receiver. It maintains the filament voltage on the oscillator and modulator constant. Resistor 122 is the common dropping resistor for the modulator and oscillator filaments. Receptacle 148 connects all operating voltages to the receiver. The dial light in socket 147 is operated by switch 134 through voltage dropping resistor 121.

c. Voltage regulator 146 is used to maintain a constant plate supply for the master oscillator, modulator and receiver. Capacitor 74 by-passes a-f from the receiver.

67. ANTENNA LOADING.

a. Switch 139 is used to select the proper capacitors 91, 92 or 93 and taps on antenna loading coil 131 for antenna loading, and to connect the output to antenna post 155. A neon bulb in socket 152 indicates when the antenna is tuned correctly and capacitor 88 represents the capacity of this socket to ground. Switch 137 governs the transmitter output by controlling the screen voltage.

b. In the HIGH position, Resistors 111 and 112 are in parallel, and the highest power output results.

c. In the MED. position, resistor 112 is in the circuit alone, resistor 111 being shorted out.

d. In the LOW position, the two resistors 111 and 112 are in series.

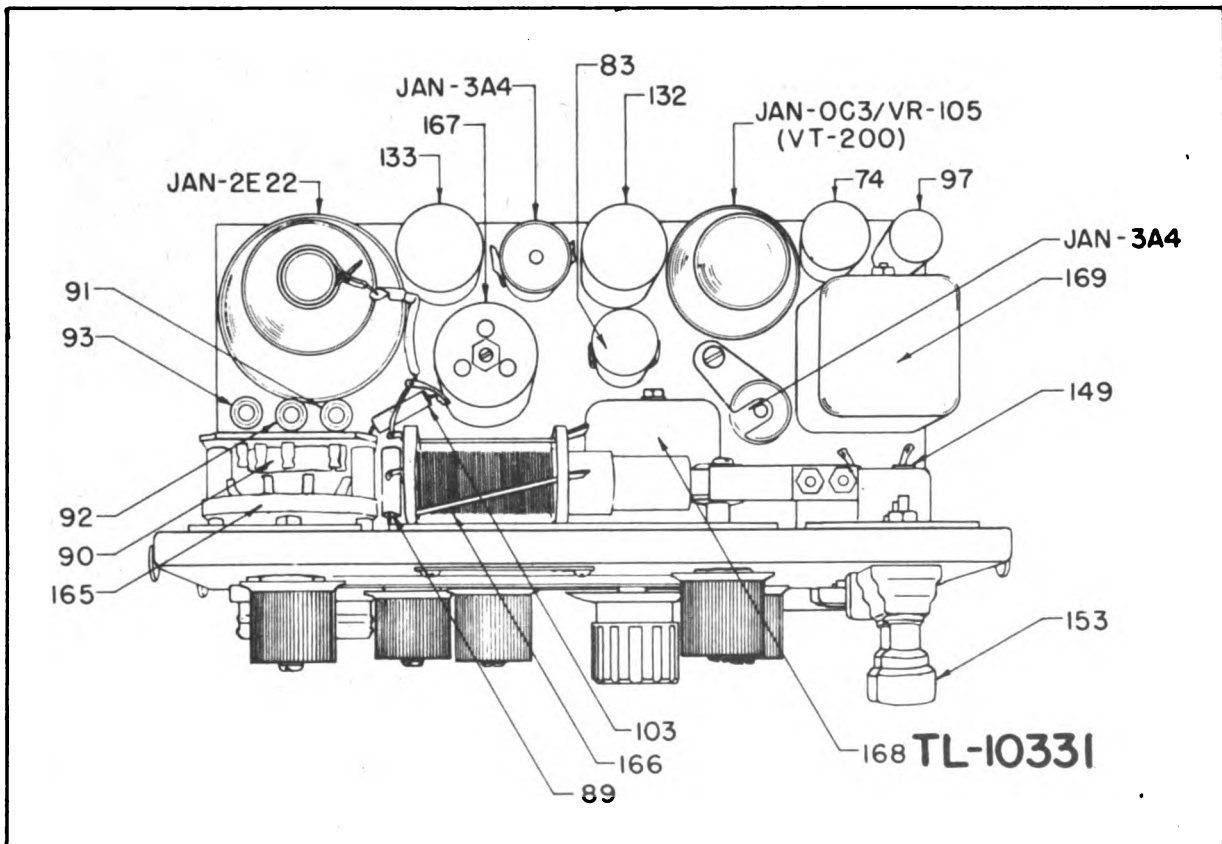

Figure 40—Parts Location of Transmitter of Receiver-Transmitter RT-12/TRC-2 (Top View)

SECTION II

RECEIVER-TRANSMITTER RT-12/TRC-2

68. RECEIVER.

The receiver section of Receiver-Transmitter RT-12/TRC-2 is exactly the same as the receiver of Radio Receiver and Transmitter BC-1306 except that the frequency band is lower and the antenna coil has no wave trap. The antenna coil, r-f coil, and oscillator coils are different from those used in the higher frequency receiver, but they serve the same respective purposes. The padding capacitor is also different for the same reason (Fig. 89).

69. TRANSMITTER.

The transmitter section of Receiver-Transmitter RT-12/TRC-2 is the same as the trans-

mitter of Radio Receiver and Transmitter BC-1306 except that the coils are of higher inductance and operate on a lower frequency. The coils in this transmitter perform the same relative functions as those in the higher frequency transmitter. The antenna circuits are slightly different. In the RT-12/TRC-2 transmitter, the output circuit is low-impedance, feeding the antenna and counterpoise at a low-impedance point; while the BC-1306 transmitter feeds the antenna at one end, a high-impedance point. Because of an appreciable drop in filament voltage in the oscillator feed-back winding, filament dropping resistor 116 in this set is tapped, whereas the corresponding resistor 122, in the high frequency set has no tap (Figs. 40 and 91).

SECTION III

ACCESSORY COMPONENTS

70. POWER UNIT PE-162.

Power Unit PE-162 consists of three essential units, Engine GE-12-A, Generator GN-50, and Filter FL-22. The engine rotates the armature of the generator, which furnishes electrical power. The filter eliminates hum, ripple or r-f interference from the power supplied by the generator.

71. OPERATING PRINCIPLE OF ENGINE GE-12-A.

- a. This engine employs a two-stroke cycle and is commonly known as a two-cycle engine.
- b. The piston, on its upward stroke, draws a charge of fuel into the crankcase through a reed

valve attached to the rear of the carburetor (Fig. 41). At the same time, a charge, previously drawn into the crankcase and subsequently passed into the cylinder, is being compressed.

c. The compressed charge is ignited when the piston is $\frac{1}{8}$ inch from the top dead center on the upward stroke. The speed of the piston is such that the piston travels up the remaining $\frac{1}{8}$ inch and starts down again by the time the burning gases build up pressure on the piston head, which forces it down on the power stroke. The descending piston compresses the charge previously drawn into the crankcase.

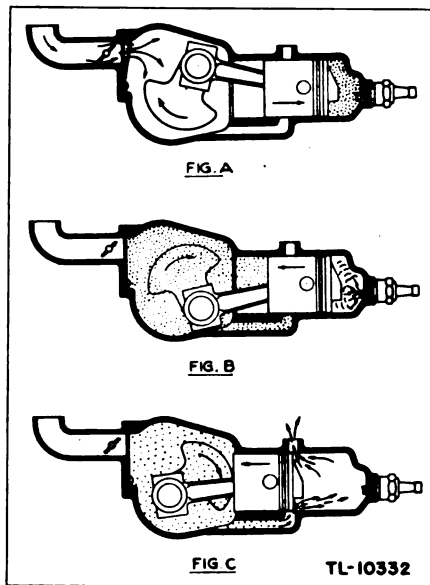

Figure 41—Operation of Piston

d. Near the bottom of its downward (power) stroke the piston uncovers the exhaust port of the cylinder, releasing the exhaust gases, most of which rush out as in Figure 41. As the piston continues down it then uncovers the intake ports, permitting the compressed fuel charge in the crankcase to rush into the combustion chamber, thus pushing the remainder of the exhaust gases out of the cylinder. The compressed fuel is prevented from crossing directly across the cylinder head and out the exhaust port by a baffle cast on top of the piston. By the time the incoming gas reaches the exhaust port, the piston has already started to move upward again, closing the port and starting a new compression stroke. A power stroke is thus accomplished once each revolution.

e. Ignition is supplied by a high tension flywheel type magneto. The principal parts of the system are: a coil, a set of breaker points, a capacitor, (all of which are shown in Figure 64), and a permanent magnet which is cast permanently into the flywheel. Power for the spark is generated by rotation of the magnet past the pole pieces associated with the coil. The opening of the breaker points determines the instant at which the spark-plug will fire. The mounting plate for the coil and breaker mechanism has mounting holes that permit considerable rotation of the assembly. This freedom of movement is provided purposely to permit proper timing of the engine. The screws holding the mounting plate to the engine should never be disturbed unless absolutely necessary and, if the assembly is moved for any reason, the engine must be retimed, in accordance with instructions in paragraph 105, Magneto.

f. The carburetor (500) is of the vacuum lift type, drawing fuel through a connecting line directly from the gasoline tank. No float is used.

g. The air cleaner (504) is of the replaceable cartridge type. Its function is to prevent the entry of foreign matter into the engine.

h. The governor is of the pneumatic type and is operated by an air blast created by the magneto rotor fins. The governor vane (435), located over the rotor fins, is moved by the flow of air and, in turn, moves the carburetor butterfly valve through a system of wires and levers.

72. OPERATING PRINCIPLE OF GENERATOR GN-50 AND FILTER FL-22.

a. *Generator GN-50.*—The generator is a four-pole shunt type having an armature containing two separate windings, one supplying high voltage, the other a low voltage. The two field coils (212-1 and 212-2, Fig. 68) are connected in series to the brushes on the low voltage commutator on the armature. The high voltage winding of the armature revolves in the same field as the low voltage winding and voltages are induced in both windings in proportion to the number of turns of wire in each. Output voltage varies directly with the speed of Engine GE-12-A. The voltage generated in the armature coils is taken off by the commutator brushes.

b. Filter FL-22.—The filter eliminates commutator ripple and r-f interference from the generator. Two independent filters are connected in series to eliminate both types of interference.

c. Chokes.—The series chokes smooth out the pulsating d-c and offer high impedance to the flow of the r-f currents generated by the commutator brushes. The capacitors by-pass to ground any a-c which gets past the chokes.

73. COMPONENTS OF GENERATOR GN-50 AND FILTER FL-22.

a. Choke 204 offers high impedance to the r-f interference generated by sparking at the brushes of commutator 213.

b. Capacitor 208A by-passes the r-f interference to ground and, at the same time, being of large capacity, reduces interference at the commutator ripple frequency. The inductance of the armature also forms a part of the high voltage filtering.

c. Resistor 201 reduces the voltage from 425 volts to 105 volts when the voltage regulator in the transmitter is connected. If the voltage regu-

lator is not connected, the voltage will vary, depending upon the current being drawn.

d. Capacitor 208B filters the "B" voltage to the receiver. Commutator 211 furnishes the low voltage.

e. Field coils 212-1 and 212-2 furnish the necessary magnetic field in which the armature revolves.

f. Choke 203 is a high current iron-core choke to eliminate ripple from the 6-volt circuit to the transmitter.

g. Capacitor 207 is an electrolytic type of high capacity to complete the 6-volt filter section.

h. Capacitor 209 suppresses r-f interference at the commutator.

i. Choke 202 serves the dual purpose of filtering the current for the receiver filaments and of reducing the voltage from 6 to 1.4 volts. Receptacle 200 carries all output voltages from the filter.

j. Circuit breaker 205 protects the generator against overload. Unusually high current through either winding will trip the circuit breaker, opening the load on both windings.

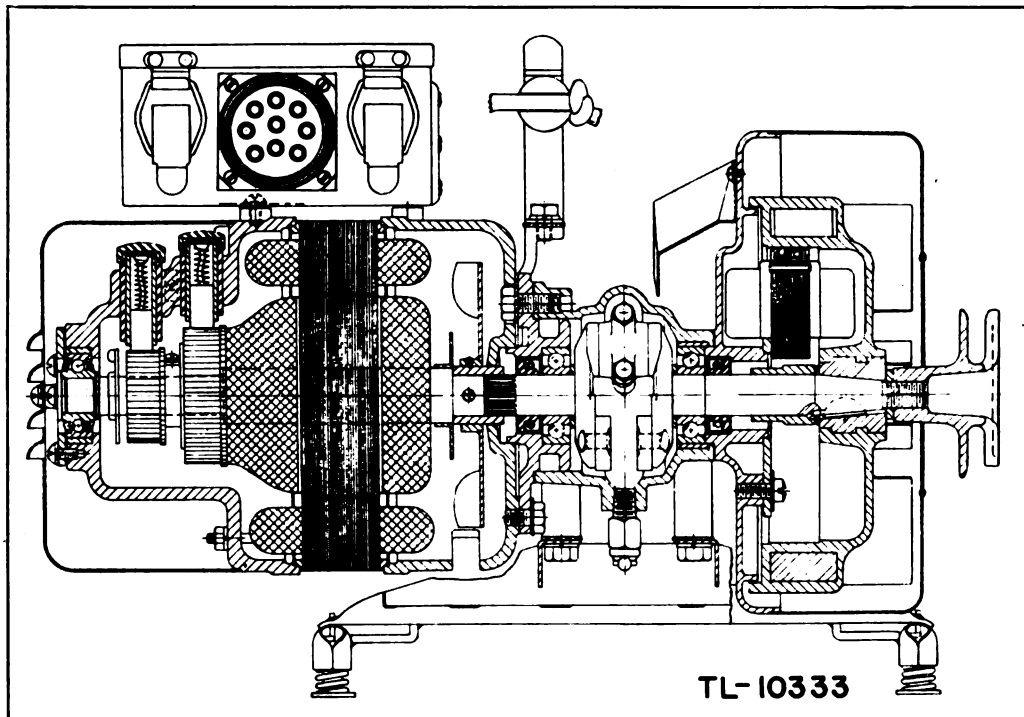

Figure 42—Sectional View of Power Unit PE-162

74. GENERATOR GN-57.

The hand generator is a dual-voltage unit driven through a step-up gear train from the cranks. Inside the generator housing is a voltage regulator which acts to keep the voltage constant. A filter is included to eliminate commutator ripple and r-f interference (Figs. 43 and 55).

75. CIRCUIT ANALYSIS OF GENERATOR GN-57.

a. The generator consists of an armature having two independent windings: a 6-volt winding connected to commutator 235 and a 425-volt winding connected to commutator 236. This armature rotates between field coils 237-1 and 237-2.

b. Voltage regulator 234 is connected across the low voltage commutator and acts on the voltage applied to the field to maintain constant output. Since both the high and low voltage armature windings revolve in the same field, controlling the voltage on the low-voltage com-

mutator also maintains the voltage constant on the high voltage commutator.

c. The high voltage output of commutator 236 is filtered by capacitor 232 to remove ripple. The r-f interference from this commutator is removed by the combination of choke 228 and capacitor 233. Resistor 229 drops the high voltage to 105 when the voltage regulator in the transmitter is connected. If the voltage at the low end of resistor 229 is measured without the voltage regulator being connected, the reading may vary up to the full voltage of the high voltage commutator, depending upon the load that is being drawn at the time of measurement.

d. The output of the 6-volt commutator 235 is filtered for ripple by choke 227 and capacitor 231. It is filtered for r-f interference by choke 226 and capacitor 230. Choke 225 serves a dual purpose: filtering the voltage to the receiver tube filaments and reducing the voltage from 6 to 1.4.

e. All of the output voltages of the filters are connected to receptacle 238.

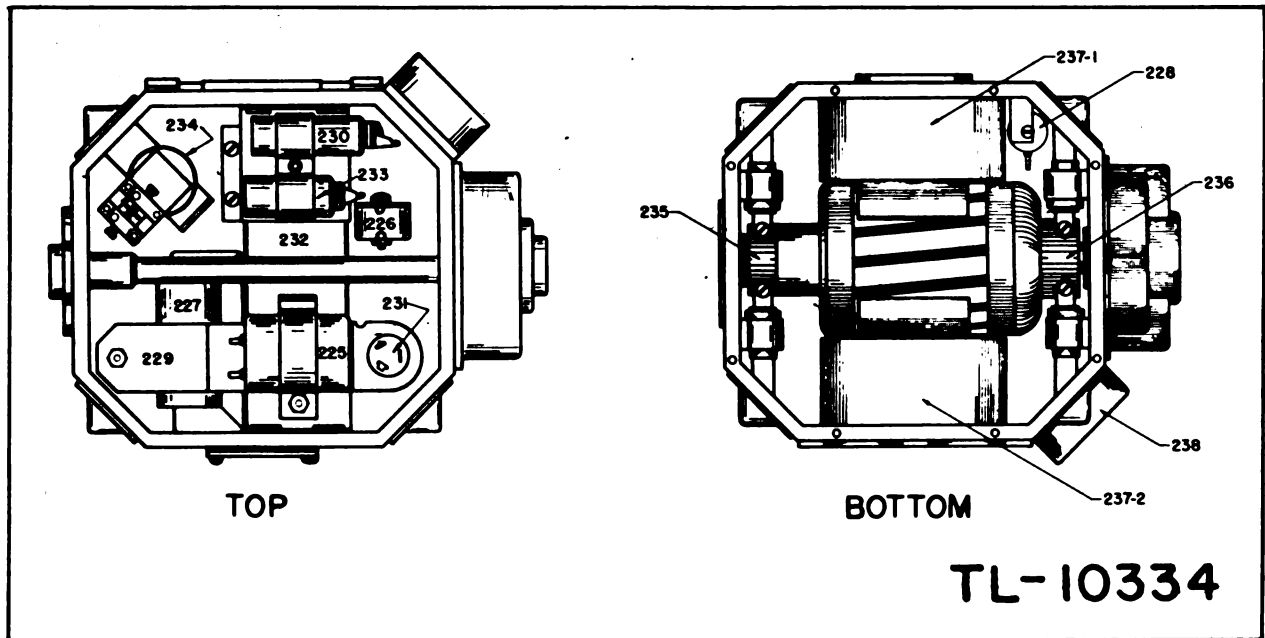

Figure 43—Circuit Symbols Generator GN-57

76. VIBRATOR POWER SUPPLY PP-39/TRC-2.

a. Vibrator Power Supply PP-39/TRC-2 (Figs. 44 and 45) can be divided into three principal parts:

(1) Storage battery, which furnishes power to the vibrator power supply proper, and to the tube filaments in the receiver.

(2) Charging circuit, through which the storage battery is charged from an external source.

(3) Vibrator power supply proper, which furnishes plate power to the receiver (Fig. 45).

b. The vibrator power supply employs a synchronous vibrator and associated power transformer, together with filter and control circuits. Power is furnished to the receiver through plug 325 and the attached cable (Fig. 60).

c. When the vibrator supply is functioning as a power source for the receiver, the NO CHARGE-HAND GEN-QUICK CHARGE switch 318 operates in the NO CHARGE position. In this position, the 2-volt battery negative return from the receiver is carried through plug 325 and the shield around the attached cable to the power supply chassis. The 2-volt battery positive lead is carried to the receiver filament circuit through choke 312, which, together with shunt capacitor 302, forms a vibrator interference filter. Also in series with the receiver filament circuit is the coil of relay 317. The resistance of this coil and choke 312 is sufficient to drop the receiver filament supply voltage to 1.4 volts at approximately 450 milliamperes drain.

d. Relay 317 is a single pole, normally open type. The contacts are wired in series with the positive lead to the vibrator. This relay controls the operation of the vibrator supply, the contacts closing only when the SEND-STANDBY-OFF switch on the transmitter is in the STANDBY position, and current flows in the receiver filament circuit. (NOTE: If the headphone plug is not in the PHONES jack the filament circuit is open and the relay cannot close.)

e. R. F. choke 311 and capacitor 303, in the positive battery supply circuit to the vibrator, together with resistor 309, serve as filter elements to remove vibrator interference from the receiver supply circuits.

f. The synchronous Vibrator VB-8-A, mounted in socket 323, operates in conjunction with power transformer 314. When current flows through the vibrator driving coil, the reed is set in motion, the action being similar to that of a doorbell buzzer. Attached to the reed are the moving elements of the vibrator contacts. These moving contacts may be regarded as forming a pair of polarity-reversal switches; one of the pair is connected to the battery supply circuit and operates to apply a voltage alternately to the two halves of a center-tapped primary, simulating ac, while the other is associated with the transformer secondary and serves to rectify the high voltage output. In order to insure proper wave-form and minimum contact arcing, capacitor 304 is connected across the secondary winding.

g. In order to remove any remaining a-c component, the high voltage output is carried through a filter system consisting of resistor 308, choke 313, and capacitors 301-A and 301-B.

h. Plate power is carried from the filter to the receiver through the power cable and plug 325.

77. STORAGE BATTERY OF VIBRATOR POWER SUPPLY.

a. The storage battery 324 is a 2-volt lead-acid cell with a rated capacity of 25 ampere-hours. Integral with the battery is a transparent housing which incloses three colored balls, each of different specific gravity. This housing is visible from the outside of the case, the position of the balls indicating the condition of the electrolyte, and the state of charge of the battery.

b. The battery is surrounded by a gas-tight rubber jacket, which protects the other components of the power supply from the corrosive action of acid and fumes which may be emitted during charging. The battery is capped by a plastic cover, completing a gas-tight seal. Attached to the cover is a gas coupling and manifold, through which the battery fumes are conveyed to an escape valve mounted in the side of the power supply case.

c. The battery circuit is carried through the plastic cover by two jacks 334. These jacks are engaged by the corresponding plugs in plugboard 333, attached to the leads which furnish power to the vibrator section and to the receiver filaments, and connect to the charging circuit.

78. CHARGING CIRCUIT OF VIBRATOR POWER SUPPLY.

a. Quick Charge.—(1) The storage battery may be recharged on QUICK CHARGE from either a 6- or 12-volt storage battery, or on HAND GEN. through the operation of Power Unit PE-162 or Generator GN-57 without removing Battery BB-54 from case.

(2) Charging from a battery requires the use of Cord CD-618-A. The cord socket 332 is engaged with power plug 326, located at the rear of the case. The charging cord is not polarized, and 330-1 and 330-2 may be attached to the terminals of the battery from which the charge is taken without regard for polarity. Cable 331 carries the charging current from the clips to the cord socket. When charging in a vehicle equipped with Mounting Bracket FT-338-A, the charging current is carried directly to the power plug 326 through the socket on the mounting.

(3) From the power plug, the charging current is carried through heavy leads to jack board 328. This jack board and the corresponding plug board 327 serve to connect the components in the power supply case with the controls mounted in the cover.

b. Several control elements mounted on the vibrator power supply are connected in series with the charging circuit, as follows:

(1) *Current Indicator 322.*—This indicator employs an automotive-type 30-0-30 ampere movement, and indicates current flow in the battery circuit. Half-scale deflection on the right hand side of the scale indicates approximately 15 amperes, the normal rate when charging from a 6- or 12-volt battery.

(2) *Polarity Switch 319.*—This switch incorporates a double-pole, double-throw action, and is wired to function as a polarity-reversing switch. It provides means of reversing polarity of the charging circuit.

NOTE. On certain equipments this switch is designated as 319-2.

(3) *NO CHARGE-HAND GEN.-QUICK CHARGE switch 318.* This switch performs the following functions:

(a) Connects the 2-volt storage battery

positive charging lead to the battery input circuit or to the hand generator charge input, depending upon the type of charge desired.

(b) Connects the 2-volt storage battery negative lead to the battery input circuit on QUICK CHARGE, or to the chassis on HAND GEN. or NO CHARGE.

(c) Connects the 2-volt storage battery positive lead to the battery charging circuit on QUICK CHARGE, or to the receiver-transmitter unit on HAND GEN. and on NO CHARGE.

79. FUNCTIONING OF RELAY WHEN CHARGING.

a. Connected in series with the battery charging circuit is relay 316, of the double pole, normally open type. The relay coil is wired in series with contact rectifier 321. The relay contacts close only when the charging circuit is correctly polarized with respect to the 2-volt storage battery.

b. The light-duty pair of relay contacts is in parallel with the contact rectifier, shunting this component out of the circuit when the relay closes.

c. The heavy-duty pair of contacts functions as a switch in series with the charging circuit, insuring that charging current is applied to the 2-volt battery only when the polarity is correct.

d. Resistor 305 is wired in series with the battery charging circuit. When charging from a 6-volt battery, the voltage drop across this resistor limits the charging current to 15 amperes.

e. Automatic introduction of additional dropping resistance in the charging circuit when the 2-volt battery is to be charged from a 12-volt source is provided by relay 315, of single pole, normally closed type.

f. The relay coil is connected in series across the battery charging circuit, the relay contacts opening when the voltage across the charging circuit exceeds 10 volts. Connected in series with the battery charging circuit are three resistors in parallel, 306-1, 306-2, 306-3. The resistors provide a voltage drop of 6 volts at the charging current of 15 amperes. The relay contacts are wired across these resistors, shunting them out of the circuit on 6-volt operation, and switching them into the circuit when charging from a 12-volt battery.

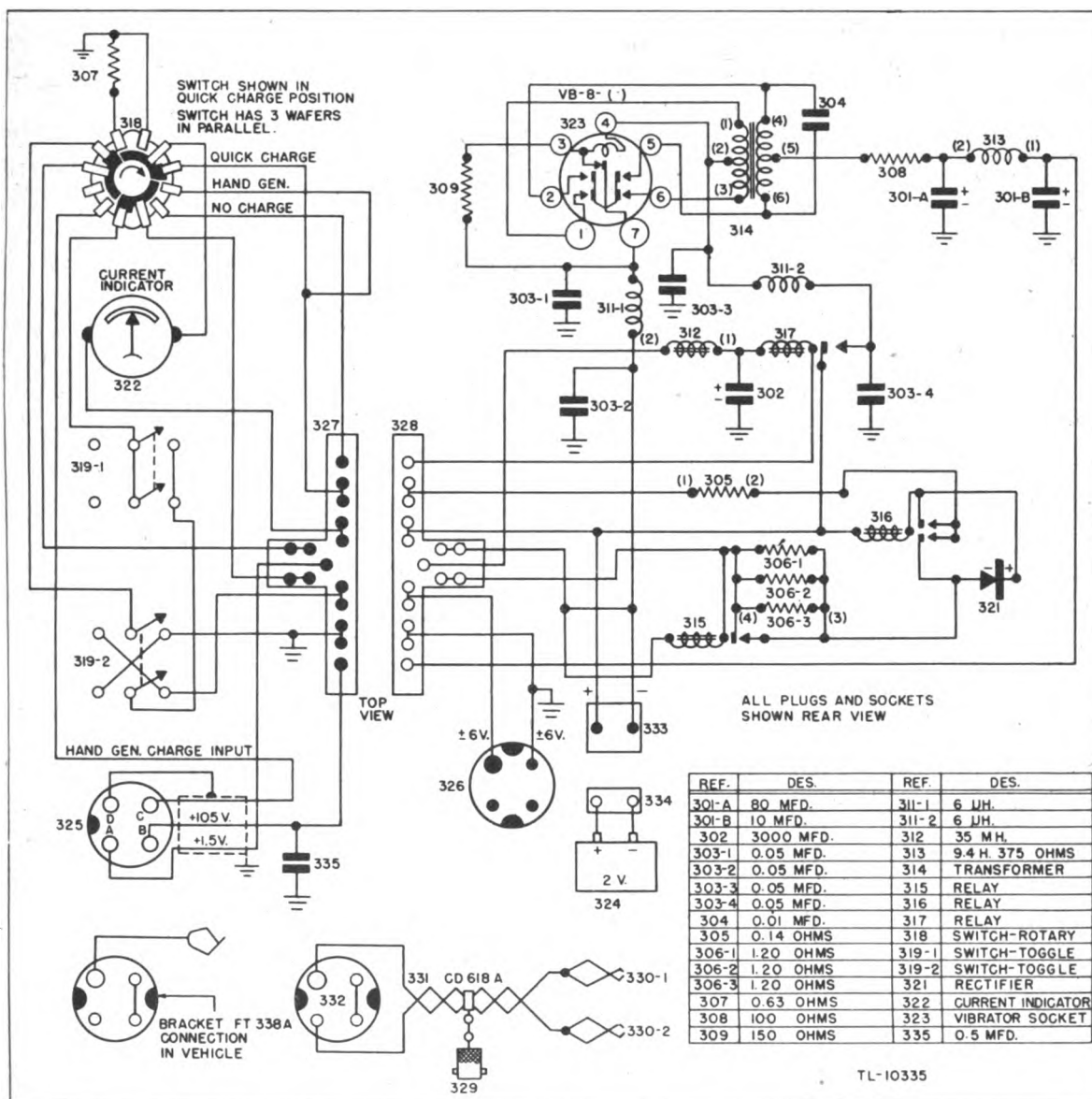

Figure 44—Circuit of Vibrator Power Supply PP-39/TRC-2

80. CHARGING FROM HAND GENERATOR.

a. When charging from Power Unit PE-162 or Generator GN-57, plug 325 is inserted into the battery receptacle on the transmitter and the charging current is carried through the attached cable to the vibrator power supply cover.

b. With the NO CHARGE-HAND GEN.-QUICK CHARGE switch 318 in the HAND

GEN. position, the positive battery charging lead is connected to the cable which terminates in plug 325. The negative battery charging circuit is completed through the chassis of the vibrator power supply and the cable shield. In addition, switch 318, in the HAND GEN. position, connects resistor 307 in series with the charging circuit, providing sufficient voltage drop to limit the current.

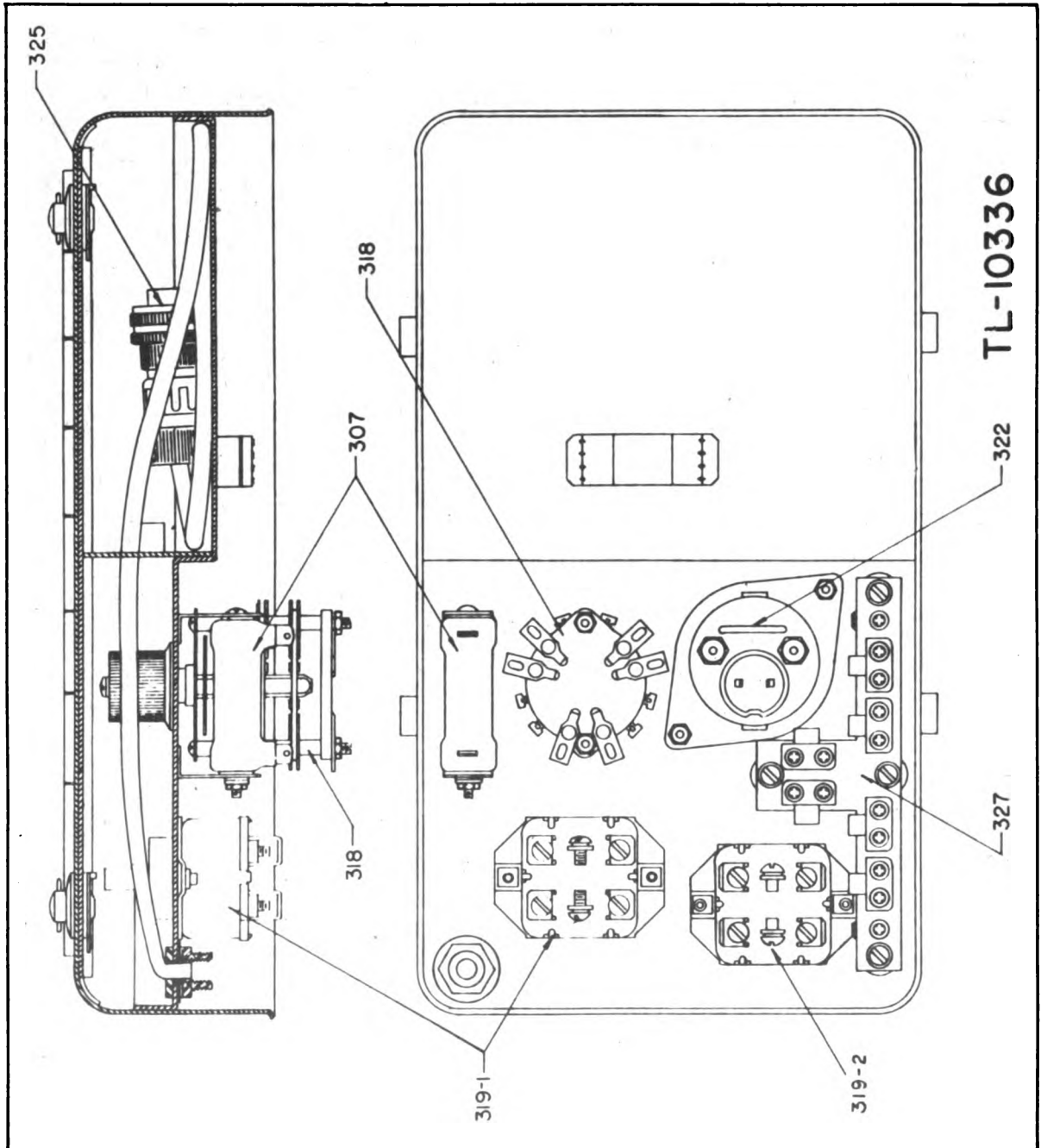

Figure 45—Circuit Symbols—Vibrator Power Supply

FREQ.	+00 K.C.	+10 K.C.	+20 K.C.	+30 K.C.	+40 K.C.	SERIAL NO. * 336	+50 K.C.	+60 K.C.	+70 K.C.	+80 K.C.	+90 K.C.	FREQ.
2000	257	292	328	363	397		432	465	497	530	563	2000
2100	594	626	657	686	716		746	774	803	831	860	2100
2200	888	915	942	968	994		1020	1046	1071	1095	1120	2200
2300	1145	1170	1192	1216	1240		1264	1286	1308	1330	1352	2300
2400	1374	1395	1416	1438	1458		1478	1498	1518	1538	1558	2400
2500	1577	1596	1615	1634	1653		1670	1688	1706	1723	1741	2500
2600	1758	1775	1793	1809	1826		1843	1860	1876	1892	1907	2600
2700	1923	1940	1955	1970	1986		2001	2016	2031	2046	2061	2700
2800	2077	2091	2106	2121	2136		2151	2166	2180	2194	2208	2800
2900	2223	2237	2251	2265	2278		2292	2305	2319	2332	2345	2900
3000	2359	2371	2384	2397	2409		2422	2436	2447	2460	2473	3000
3100	2485	2497	2509	2521	2534		2547	2558	2570	2582	2593	3100
3200	2606	2617	2629	2640	2652		2663	2675	2686	2697	2708	3200
3300	2720	2731	2743	2754	2766		2777	2789	2800	2813	2826	3300

FREQ.	+00 K.C.	+20 K.C.	+40 K.C.	+60 K.C.	+80 K.C.	SERIAL NO. * 336	FREQ.	+00 K.C.	+20 K.C.	+40 K.C.	+60 K.C.	+80 K.C.
3800	168	208	247	284	321		5200	1912	1929	1945	1962	1977
3900	358	393	429	463	497		5300	1993	2009	2025	2041	2057
4000	532	564	596	629	660		5400	2072	2088	2103	2119	2135
4100	691	722	752	781	811		5500	2150	2165	2180	2195	2210
4200	840	869	897	925	954		5600	2225	2240	2254	2269	2283
4300	979	1005	1032	1058	1084		5700	2297	2312	2326	2340	2355
4400	1109	1134	1159	1183	1207		5800	2369	2383	2397	2411	2425
4500	1231	1254	1277	1300	1323		5900	2439	2453	2466	2480	2494
4600	1345	1367	1389	1411	1432		6000	2509	2522	2535	2549	2562
4700	1453	1474	1494	1515	1535		6100	2576	2589	2603	2617	2630
4800	1555	1575	1593	1613	1632		6200	2643	2656	2670	2684	2695
4900	1650	1668	1686	1705	1723		6300	2709	2723	2736	2750	2763
5000	1741	1759	1776	1794	1811		6400	2777	2790	2804	2820	2836
5100	1829	1846	1863	1879	1895		6500	2854				

TL-10337

Figure 46—Transmitter Frequency Calibration Charts

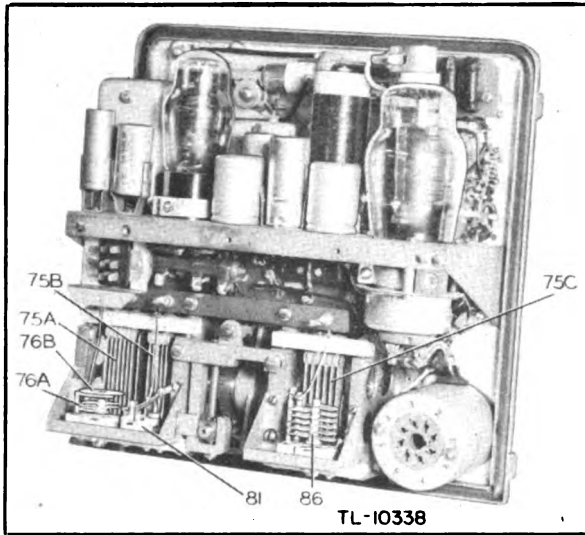

Figure 47—Transmitter Tuning Capacitor Assembly—
Circuit Symbols

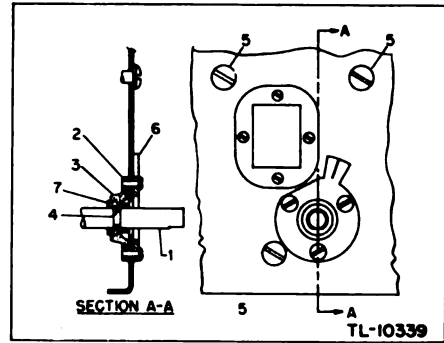

Figure 48—Tuning Capacitor Shaft Packing and
Mounting

1. Shaft, capacitor
2. Clamping ring
3. Neoprene sealing bushing
4. Graphite packing string
5. Mounting screws
6. Dial pointer
7. Capacitor mounting screws

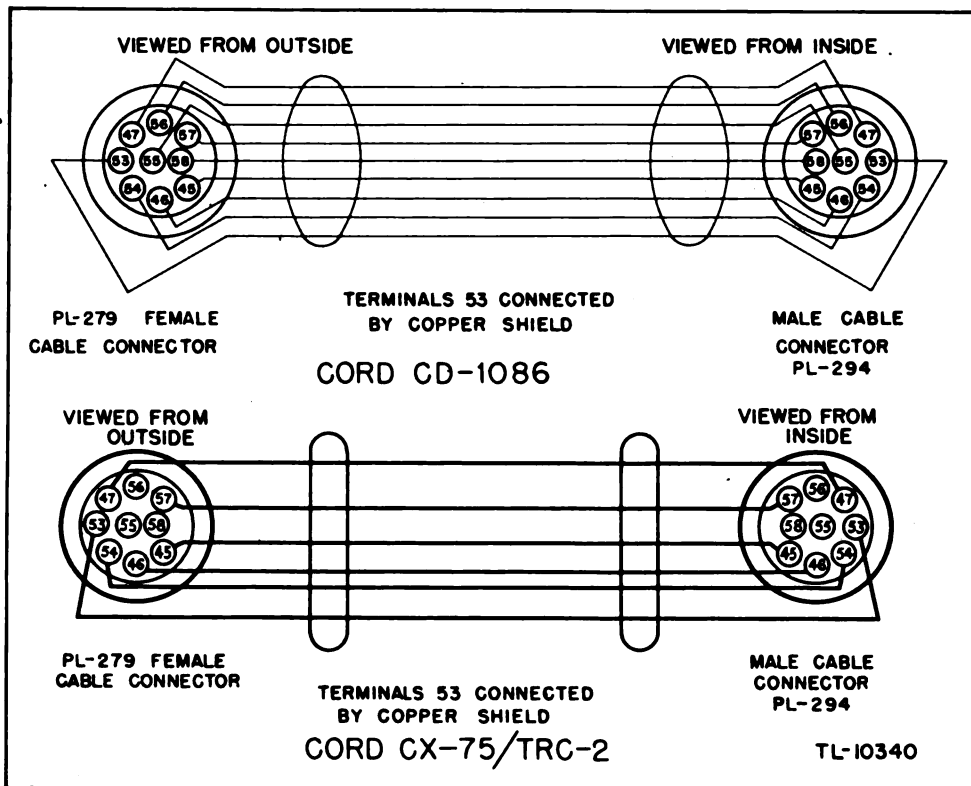

Figure 49—Cord CX-75/TRC-2 and Cord CD-1086

PART FOUR

MAINTENANCE

UNSATISFACTORY PERFORMANCE OF THIS EQUIPMENT WILL BE REPORTED IMMEDIATELY ON W.D., A.G.O. FORM No. 468. IF FORM IS NOT AVAILABLE, SEE TM 38-250

SECTION I

RECEIVER AND TRANSMITTER

81. GENERAL INSTRUCTIONS.

Radio Set AN/TRC-2 is issued with the necessary tools and equipment for making repairs and adjustments in the field. Tool Kit (Fig. 82) contains tools and equipment for making repairs necessary under most conditions. Do not attempt to make any adjustments or repairs to Radio Set AN/TRC-2 until the position of all switches has been checked, all cable connections tightened and determine that the radio receiver has been connected in accordance with instructions given in this manual. Do not attempt to change components such as resistors, condensers, and so forth, until all tubes have been checked, continuity tests made on all cables, and the trouble isolated to the particular unit that will not operate. Always use extreme care in replacing any defective component to insure that no additional damage will be caused by moving components adjacent to that which is being replaced or repaired.

82. RECEIVER, FAILURE TO OPERATE.

The receiver can fail to operate for any of the following reasons:

- a. The SEND-STANDBY-OFF switch can be in the STANDBY or OFF position.
- b. The phone plug is not pushed all the way in.
- c. The power cable from the power supply to the transmitter is not properly plugged in at both ends.
- d. The antenna can be disconnected.

NOTE: A moment's inspection of the equipment will serve to check the first four troubles listed.

e. There can be one or more defective tubes in the receiver. See paragraph 83.

f. The phones can be defective. They can be tested by ohmmeter in the following manner:

- (1) Touch one ohmmeter lead to one tip of the phone plug and the other ohmmeter lead to the sleeve of the plug. A distinct click should be heard in the phones.

g. There can be failure of some circuit component. Check and replace if necessary.

h. When used with Power Unit PE-162:

- (1) The ON-OFF switch on Power Unit PE-162 can be in the OFF position.

- (2) The Power Unit may not be delivering power. Push the dial light switch. The dial should be dimly illuminated. If no light appears when the button is pressed either no power is being delivered to the receiver or the dial light is burned out. In daylight or under other bright light, the dial must be shielded from the extraneous light to see the dim illumination of the dial.

i. When using Generator GN-57, the hand generator may not be delivering power. (Par. 33.)

j. When using Vibrator Power Supply PP-39/TRC-2:

- (1) The NO CHARGE-HAND GEN. QUICK CHARGE switch must be in the NO CHARGE position.

- (2) The vibrator unit may not be delivering power. See paragraph 30.

k. When used with Battery BA-48:

(1) The battery cable from Battery BA-48 may not be properly plugged into the transmitter or the retaining ring on the plug may not be tightened (Fig. 57).

(2) The batteries may be exhausted and require replacement.

83. RECEIVER TUBE REPLACEMENT.

The tubes in the receiver are connected in parallel, and operate at 1.4 volts through a common dropping resistor in the power unit. When operated from the hand generator, a resistor in the generator drops the voltage from 6 to 1.4. A selenium rectifier is connected across the filament circuit of the receiver as a voltage regulator to prevent damage to the filaments of tubes remaining in the receiver after several tubes are removed. When the receiver fails to operate, substitute tubes one at a time until the defective tube is discovered. To replace tubes proceed as follows:

a. Loosen four retainer clamps holding the receiver in the case.

b. Carefully pull the set out of the cabinet.

c. Push down on the tube shield holder and press the snap fasteners inward, holding the tube shield in place.

d. Remove the tube shields by pulling the tube assembly straight up.

e. Remove the tubes from the receiver, carefully pulling the tubes straight up.

f. Remove the spare tube box from the Accessory Bag CW-16/TRC-2.

g. As each tube is removed from the spare tube box, place it in the proper socket in the receiver. *Consult the TUBE LAYOUT DIAGRAM for the proper socket corresponding to each tube type.* Line up the blank spot on the socket with the place where there is no pin on the tube base, before attempting to insert the tube in the socket. *Do not attempt to force any tube into its socket because the glass base of the tube can be damaged easily. Forcing a tube into its socket can make a good tube bad immediately or within a few days.* (In the latter case a slow leak may develop which will allow air to enter. Leaky tubes usually show a milky or cloudy color on the inside of the bulb.)

CAUTION: Each spare tube box contains six tubes 3A4 which look exactly like the receiver tubes. These are used in the transmitter and should not be confused with the receiver tubes.

h. When all tubes have been installed in their proper sockets, push the tube shield down over the tubes until the catches snap in place.

(1) Push the set back in the cabinet and fasten retainer clamps.

84. TRANSMITTER, FAILURE TO OPERATE.

The transmitter may fail to operate for any one of the following reasons:

a. The SEND-STANDBY-OFF switch may be in the STANDBY or OFF position. (SEND position uses the hand generator as the only source of power. In the STANDBY position the hand generator furnishes the high voltage plate power and the filament power to the transmitter; the vibrator unit or battery furnishes the filament power to the receiver, the low voltage plate power to the receiver and the low power stages of the transmitter.)

b. The PHONE CW-NET-CAL switch may be in the NET or CAL. position.

c. The ON-OFF switch or power unit may be in the OFF position.

d. The plug of the microphone or key may not be pushed all the way into its proper jack.

e. The power cable from the power supply to the transmitter may not be properly plugged in at both ends and the retaining rings turned up tight.

f. The power cable may have one or more broken connections. Try substituting the spare cable (Fig. 49).

g. The antenna may not be connected.

h. When operated with Generator GN-57, the transmitter may actually be operating but the INDICATOR may be out of resonance either because the knob TUNE FOR MAX IND. GLOW has not been adjusted, or because the ANT switch is in the wrong position. Inspect switch setting and adjust the knob.

i. On crystal-controlled operation a crystal may be defective. Try operation on master oscillator.

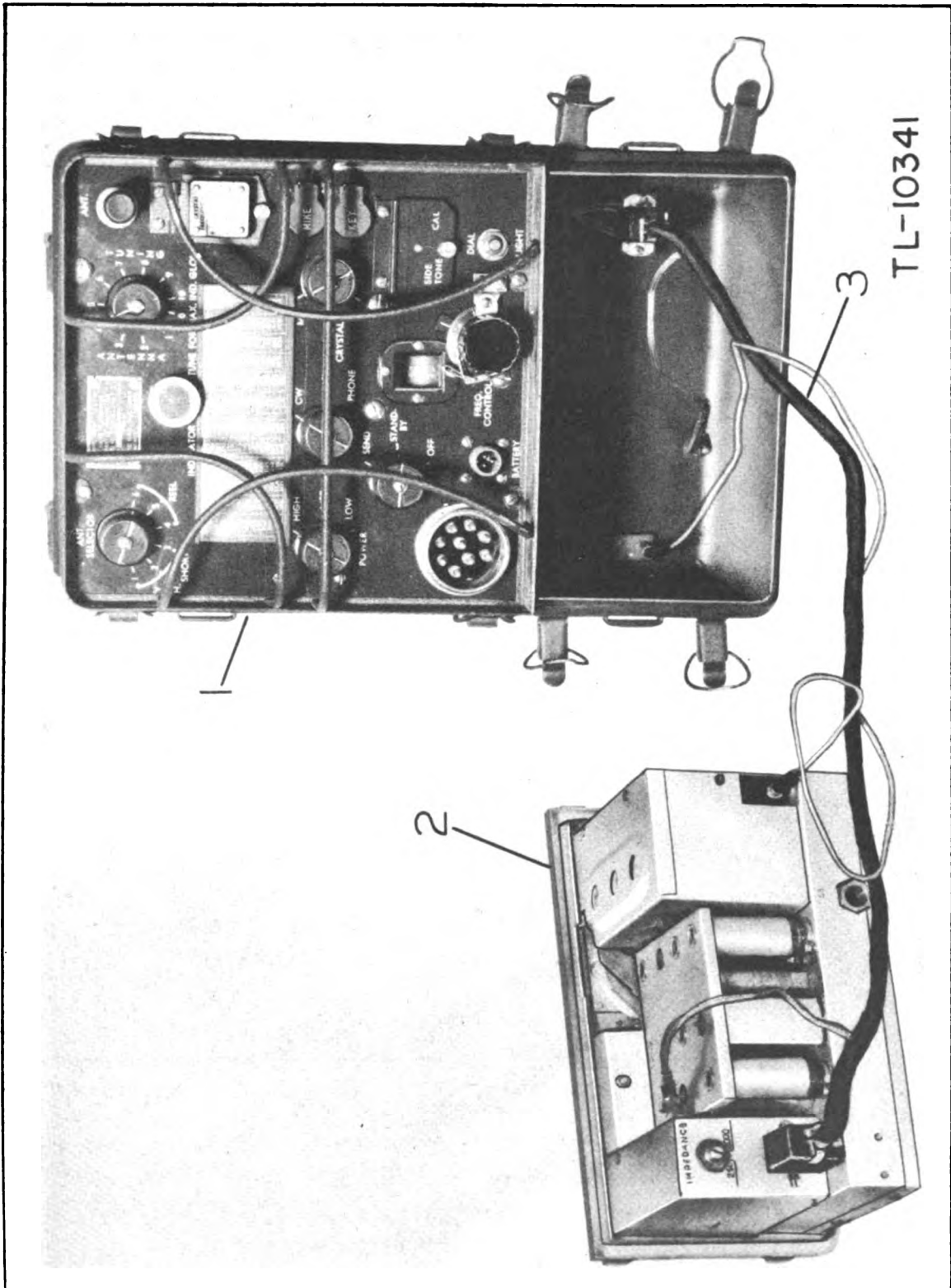

- 1. Transmitter
- 2. Receiver
- 3. Test Cable

Figure 50—Receiver Test Set-Up

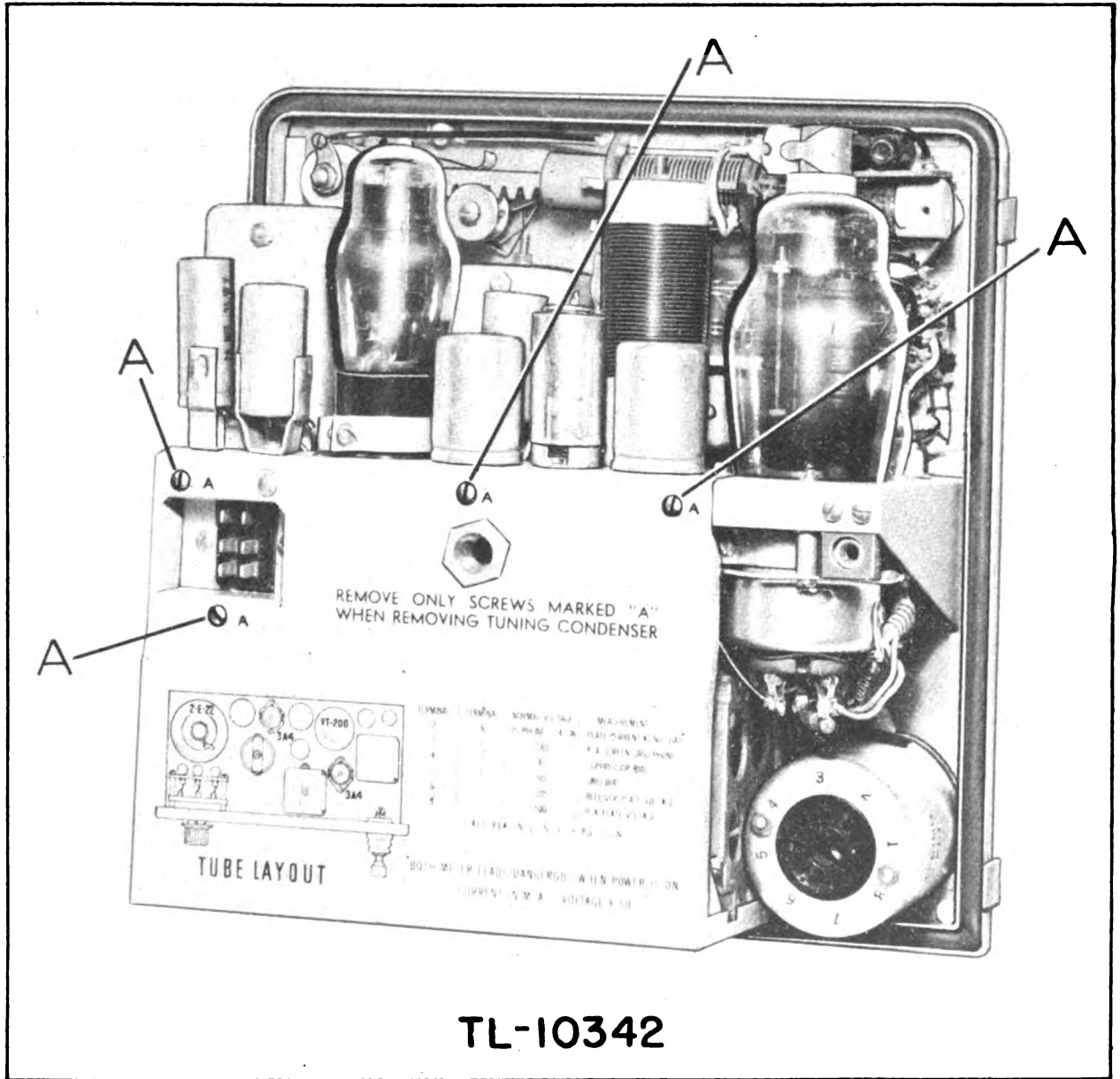

Figure 51—Tuning Capacitor Rear Mounting

Removal of main tuning capacitor

1. Remove frequency control knob assembly.
2. Remove only screw marked "A" from rear shield.
3. Remove 3 screws, item 5, holding shaft packing.
4. Remove 3 screws, item 7, mounting tuning capacitor to panel.

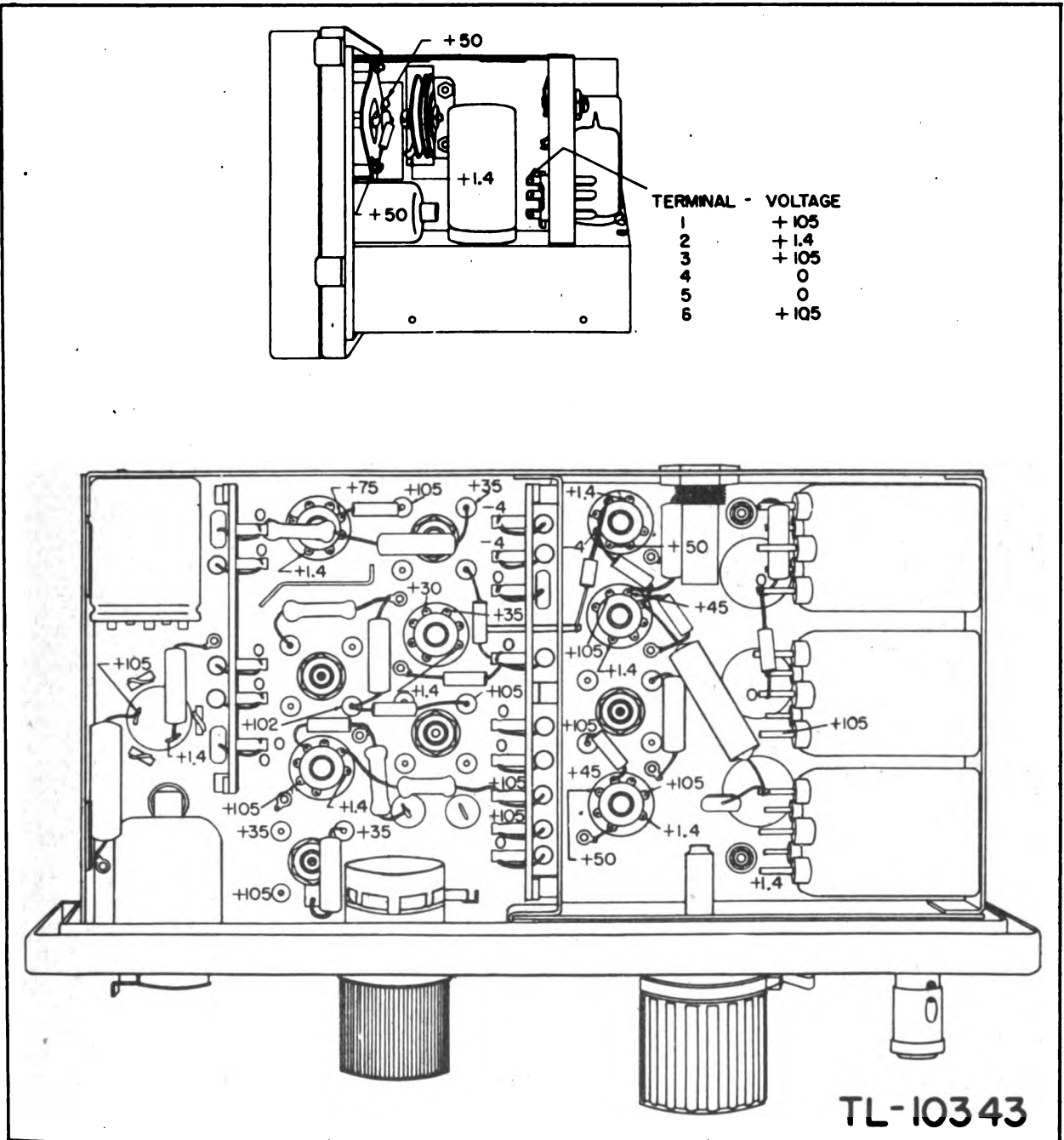
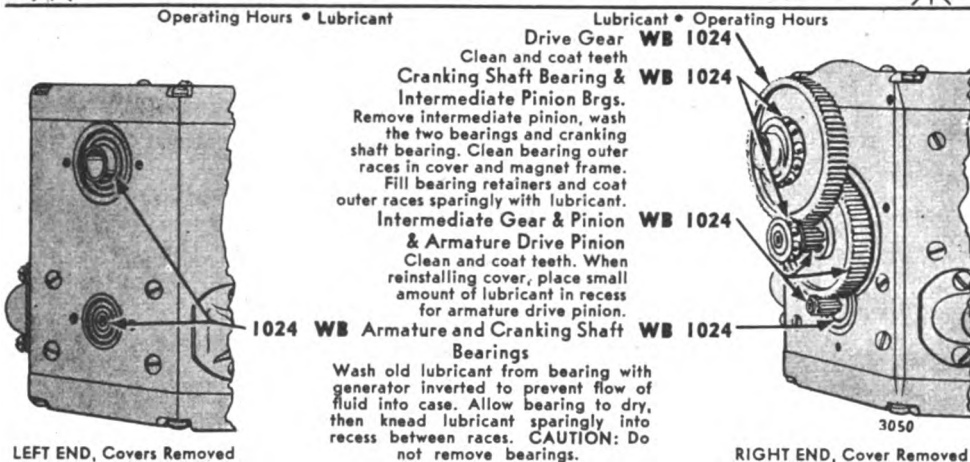

Figure 52—Circuit Voltages—Receiver

Voltage readings taken with switches in PHONE and HIGH SENSITIVITY positions.

HAND GENERATORS (Radio) GN-35, 37, 44, 45, 53, 54 AND 57



KEY: WB—GREASE, general purpose No. 2. All temperatures

CLEAN parts with SOLVENT, dry-cleaning, or OIL, fuel, Diesel. Allow parts to dry thoroughly before lubricating. CAUTION: Do not allow fluid to enter Requisite LUBRICATION ORDER from Philadelphia Signal Depot, or Utah ASF Depot, Ogden, Utah, by Signal Corps Stock No.

Generator Case.
OIL CAN POINTS—Every 44 hours, lubricate Hand Crank Bearings, Tripod Hinges with OE SAE 10. REFERENCE—Technical Manual.
By Order of the Secretary of War:
G. C. Marshall, Chief of Staff.

-3050

1 Apr 1944
Supersedes all previous lubrication instructions.

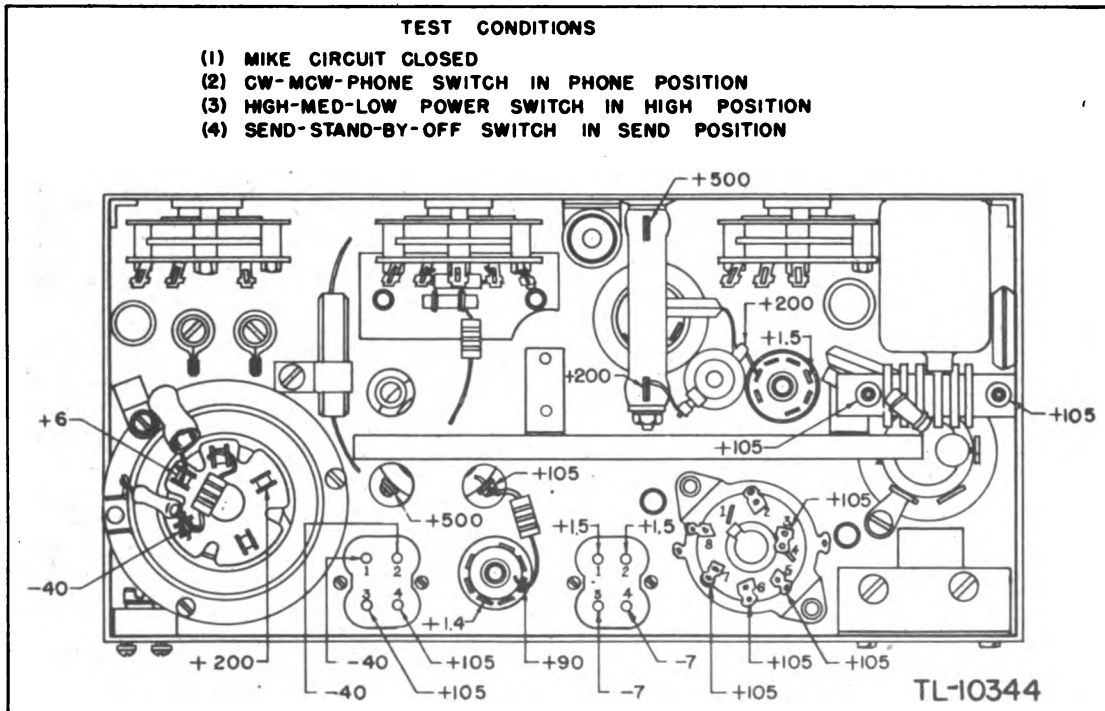

Figure 53—Voltage Test Points—Transmitter

j. There may be a defective tube in the transmitter. See paragraph 86.

k. When used with Power Unit PE-162, the power unit may not be working. See paragraph 32.

l. When operated with Generator GN-57, the hand generator may not be turned fast enough or may not be operating properly. Pushing the dial light button, when the CW-MCW-PHONE switch is in either MCW or CW position, should light up the dial if the generator is operating.

m. When using Generator GN-57 with Vibrator Power Supply PP-39/TRC-2:

(1) The power cable from the vibrator power supply to the transmitter may not be properly connected at the transmitter or the storage battery in the vibrator unit may be exhausted.

(2) The NO CHARGE-HAND GEN-QUICK CHARGE switch in the vibrator power supply must be in the NO CHARGE position.

(3) Hand generator is not being turned fast enough or may not be operating properly.

n. When using Generator GN-57 with Battery BA-48:

(1) The power cable from the battery to the transmitter may not be properly connected at the transmitter, or the battery may be exhausted. Check for voltage.

(2) Hand generator is not being turned fast enough or may not be operating properly.

o. There are three principal reasons why a crystal may fail to operate in the transmitter:

(1) The CRYSTALS switch may be in an incorrect position.

(2) The FREQ. CONTROL knob may not be adjusted to the proper dial setting.

(3) The crystal may be defective.

85. VOLTAGE REGULATOR VT-200.

Voltage regulator Tube VT-200 (VR-105-30) stabilizes the voltage applied to the transmitter master oscillator and to the receiver. If the voltage regulator tube is removed there will be no "B" voltage on the receiver or in the low power stages of the transmitter.

86. REPLACING TRANSMITTER TUBES.

a. Turn SEND-STANDBY-OFF switch to OFF.

b. Disconnect power cable at the transmitter.

c. Remove plugs, microphone and key.

d. Disconnect antenna.

e. Loosen the four retainer clamps on the side of the transmitter case.

f. Gradually work the transmitter loose and pull out the case, making sure that output tube in left corner of transmitter clears the cabinet.

g. To remove small tubes, remove the shield, then the tube. Spare tubes are carried in the spare tube box in Accessory Bag CW-16/TRC-2. Line up the blank space on the tube with the blank space in the socket before attempting to insert the tube into the socket. The tubes can be damaged easily. Do not force them into the sockets.

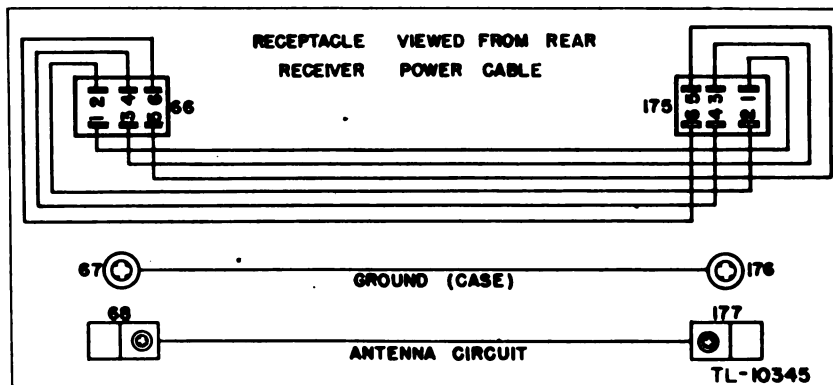

Figure 54—Case (Receiver-Transmitter) Wiring Diagram

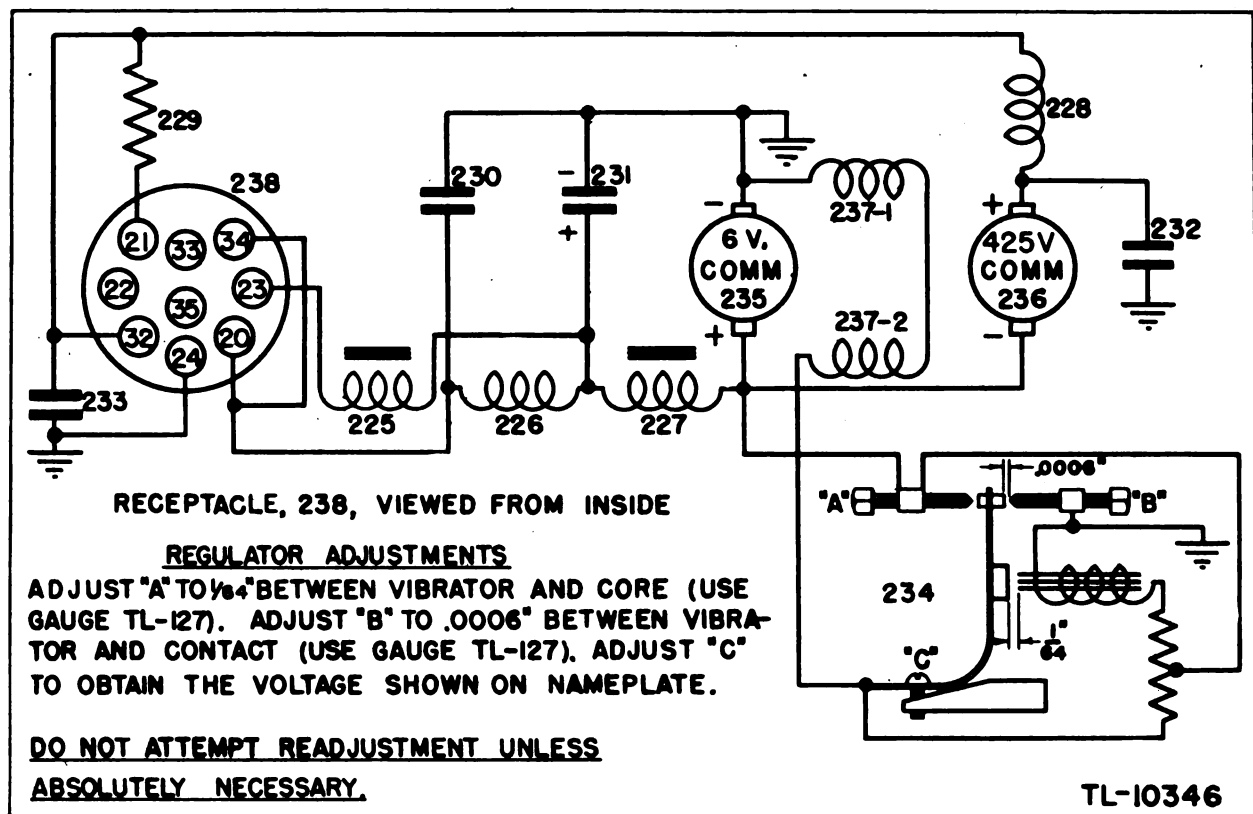

Figure 55—Circuit—Generator GN-57

- | | |
|---|---------------------------------|
| 225. Choke, 22 millihenries | 232. Cap., 4 μ f. 500 V. |
| 226. Choke, R.F. 7 microhenries | 233. Cap., 0.05 μ f. 800 V. |
| 227. Choke, 3.45 millihenries | 234. Regulator. |
| 228. Choke, R.F., 530 microhenries | 235. Commutator, low voltage |
| 229. Res., wire wound, 10,000 ohms | 236. Commutator, high voltage |
| 230. Cap., 0.5 μ f. 120 V. | 237-1. Coil, field |
| 231. Cap., Electrolytic, 500 μ f. 12 V. | 237-2. Coil, field |
| 238. Receptacle, power | |

A crack may be produced in the glass base which can make the tube inoperative immediately or a few days later. The latter case is caused by slow leaks.

h. To remove the large output tube, loosen the tube clamp around the base of the tube, then remove the top cap connection and pull the tube out.

CAUTION: The top cap in normal operation

carries approximately 500 volts. Be sure the power is OFF before touching this connection.

After inserting the new tube be sure to replace the top cap and to tighten the tube clamp.

i. The voltage regulator tube seldom fails unless physically damaged. To replace it, first loosen the tube clamp, then remove the tube.

87. HAND GENERATOR GN-57—FAILURE TO OPERATE.

The hand generator may fail to operate for any one of the following reasons:

- a. The cranks may be turned in the wrong direction. An arrow marked on the case indicates the proper direction.
- b. The crank is being turned too slowly. The proper speed is 50 to 70 turns per minute.
- c. The power cable may not be properly plugged in at both ends and the retainer rings on the cable plugs *turned up tight* on the receptacles. Tighten if necessary.
- d. The brushes may be worn down or may be stuck in the brush holders so that they do not make proper contact with the commutator. Replace if necessary.
- e. There may be a failure of some circuit element. Replace if necessary.

88. INTERFERENCE FROM GENERATOR GN-57.

If the hand generator produces static when the hands of the operator come in contact with the metal parts of the handles, the grounding springs at the ends of the shaft of the generator are not making good contact. An examination of the

generator will show a piece of thin metal at the outside ends of the shaft. (The cranks go through a hole in each.) These pieces can become worn or bent so that they no longer make good contact with the shaft bushing. The position of the bushing must be readjusted to improve or restore contact with the grounding spring.

89. VOLTAGE REGULATOR—HAND GENERATOR.

A vibrating contact type voltage regulator is incorporated in the hand generator to compensate for varying speeds of cranking. Adjust according to directions inside the cover of the generator, only when necessary.

90. POWER AMPLIFIER OVERLOAD.

a. The output circuit of the transmitter is so designed that any mistake in connecting the antenna, or any accidental short circuit of the antenna will not place an overload on the power amplifier tube. Maximum loading occurs when the transmitter and antenna circuits are matched. If the high voltage is applied to the power amplifier without r-f power on the grid, no grid bias will be developed to limit the plate current and the tube will draw excessive plate current.

CAUTION: This tube must not be operated under such conditions.

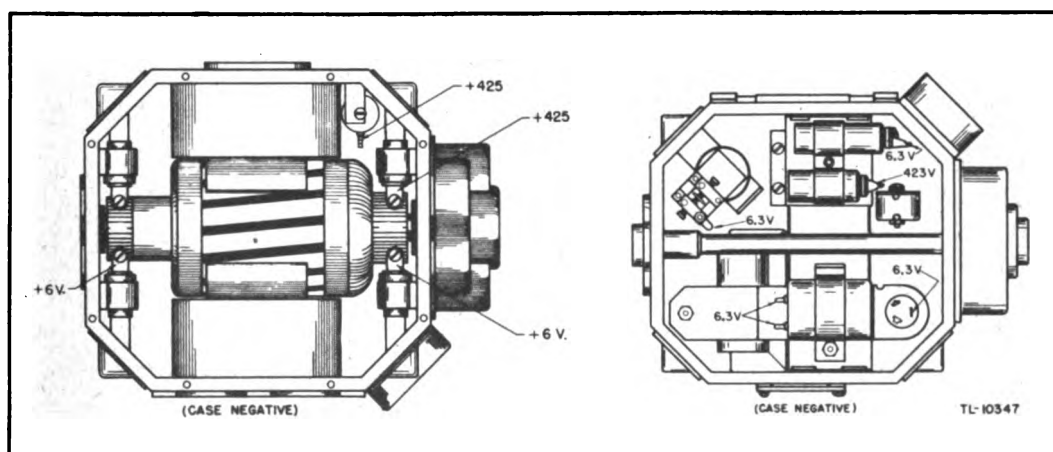

Figure 56—Circuit Voltages—Generator GN-57

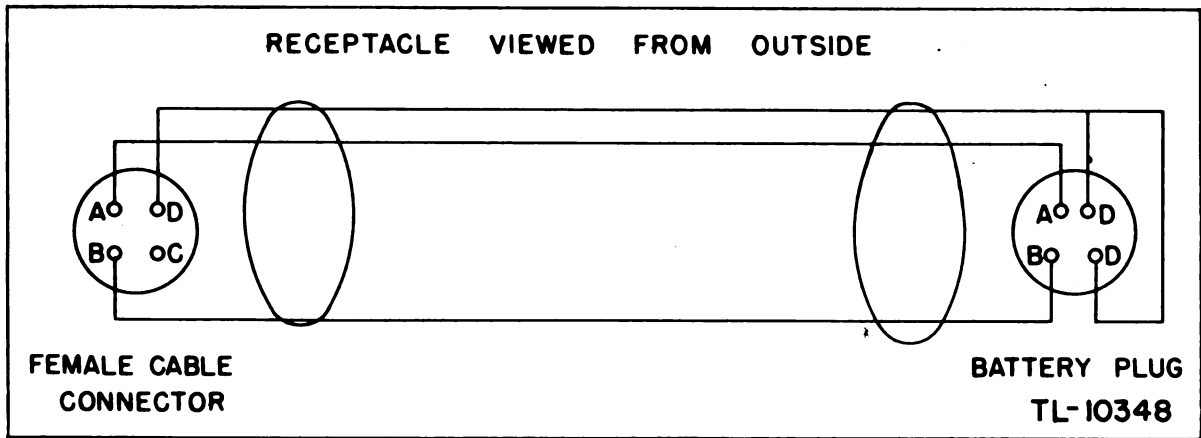

Figure 57—Circuit—Cord CD-1119

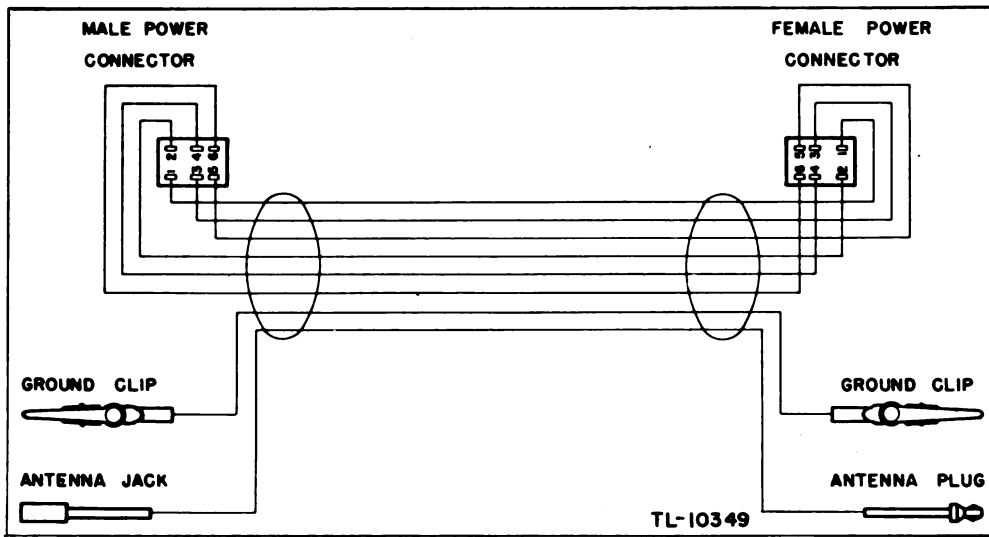

Figure 58—Circuit—Test Cable

The power amplifier has been designed and adjusted so that some r-f grid voltage will be developed if the oscillator fails to excite the p-a tube. This is accomplished by allowing the power amplifier to oscillate feebly if its grid-bias voltage drops too low. This self-oscillation builds up a limited bias on the grid of the p-a tube, thereby limiting its plate current. Under this condition, the power output to the antenna is low and erratic, and netting or calibrating cannot be accomplished.

b. Lack of r-f power on the grid of the power

amplifier usually results from failure of the oscillator tube, but it is possible for the same effect to be produced by other causes, such as the failure of a resistor or a defect in the keying relay which would prevent the B voltage from reaching the oscillator tube. When transmitting with the SEND-STANDBY-OFF switch in STANDBY position, the power amplifier will receive no excitation unless Vibrator Power Supply PP-39/TRC-2 or Battery BA-48 is operated in conjunction with the generator.

SECTION II

VIBRATOR POWER SUPPLY PP-39/TRC-2

91. FAILURE TO OPERATE.

If the vibrator power supply fails to deliver power to the receiver when the attachment cord is properly connected to the BATTERY receptacle on the transmitter panel and the NO-CHARGE - HAND GEN - QUICK CHARGE switch is on NO CHARGE, any one of the following defects may be the cause, and the suggested remedy should be applied:

a. The 2-volt battery may be discharged. Check CHARGE INDICATOR balls. Check to see if CURRENT INDICATOR shows discharge. Charge battery if necessary.

b. Ground spring, located on the inside of the cover below the circuit label, may not be contacting the chassis. Check to see if the contact arms have become flattened. If necessary, carefully bend the arms so that they will scrape the top of filament choke 312 when the cover is closed.

c. Vibrator may be defective. Place ear to case and listen for characteristic hum. If defective, replace the vibrator with spare.

d. Vibrator control relay 317 may not be operating. Move NO CHARGE-HAND GEN.-QUICK CHARGE switch back and forth between NO CHARGE and QUICK CHARGE positions, and listen for click of relay at NO CHARGE. If no click is heard, remove chassis from case and, with battery plug 333 connected to battery, move armature of vibrator control relay to close the circuit. Listen for hum of vibrator. If vibrator functions with relay contacts closed, check to see if contact arms on relay are dirty or bent. Repair if necessary. Check plug board on cover and jack board on case. Make sure that the plugs and jacks are clean. If relay still does not operate, disconnect the hot side of filament filter capacitor 302. If unit now functions, capacitor 302 is defective. Replace the capacitor.

e. B filter capacitors 301-A and 301-B may be defective. Remove chassis from case and disconnect the hot wires from these capacitors. Replace chassis and check for operation of receiver. If receiver functions, capacitors 301-A and 301-B are defective. Replace these capacitors.

92. FAILURE TO CHARGE.

a. If the vibrator unit fails to charge when properly connected to a 6- or 12-volt battery known to be well-charged, and the NO CHARGE-HAND GEN-QUICK CHARGE switch is on QUICK CHARGE, any one of the following defects may be the cause, and the suggested remedy should be applied:

(1) Clips on charging cable CD-618-A may be dirty or corroded. Clean if necessary.

(2) Cut-out relay 316 may not be operating. Remove cover from case and place a piece of non-conducting substance between the armature of this relay and the power resistor cable, to close the contacts on the relay. Replace cover and check for operation by observing the CURRENT INDICATOR. When charging properly, CURRENT INDICATOR should show half-deflection on the CHARGE side. If unit charges with relay 316 propped closed, check contacts to see if they have become dirty or bent. Repair if necessary.

b. If the unit fails to charge from the hand generator with the NO CHARGE-HAND GEN-QUICK CHARGE switch on HAND GEN, and with the vibrator power supply properly connected to the BATTERY receptacle on the transmitter panel and the hand generator or Power Unit PE-162 operating, the following defects may be the cause and the suggested remedies should be applied:

(1) The cutout relay may not be operating. Test and repair. See paragraph 92,*a* (2) above.

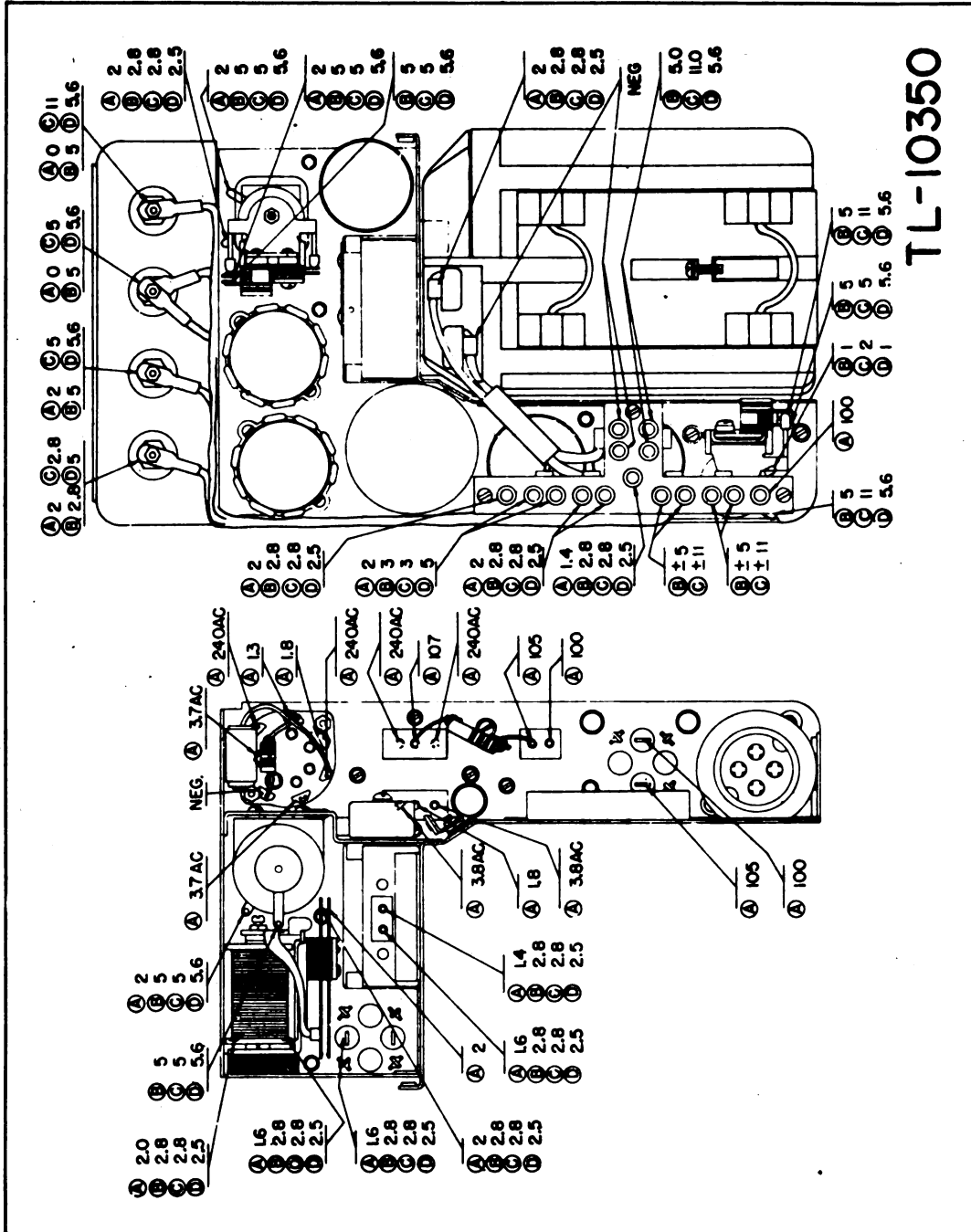

TEST CONDITIONS

- a. Voltage with receiver operating, and switch in NO CHARGE position.
- b. Voltage with switch in QUICK CHARGE position from 6-volt storage battery.
- c. Voltages in QUICK CHARGE position from 12-volt battery. (Receiver cannot operate.)
- d. Voltages in HAND GEN position from 12-volt battery. (Receiver cannot operate.)

Figure 59—Vibrator Power Supply—Voltage Check Points (Chassis).

(2) The SEND-STANDBY-OFF switch on the transmitter may not be at OFF, which is the only position in which the charging current is available to the vibrator unit.

(3) If Power Unit PE-162 is used, the circuit breaker in the filter may be open. Turn the NO CHARGE - HAND GEN - QUICK CHARGE switch to NO CHARGE, push the ON button on the filter, and turn the switch back to HAND GEN.

(4) The plugs on the cable from the generator or power unit to the transmitter may not be pushed in all the way and the retaining rings properly tightened.

93. EXCESSIVE CHARGING RATE.

If the charging rate is excessive (CURRENT INDICATOR near or beyond full scale) when connected to a 12-volt battery any one of the following defects may be the cause and the suggested remedy should be applied:

a. Voltage relay 315 may not be operating. Remove cover from case and place a piece of non-conducting material between the armature of the relay and the jack board, to open the relay contacts. Replace cover and check for proper charging. CURRENT INDICATOR should show half-scale deflection on the CHARGE side. If proper charging rate is shown with the relay contacts propped open, check contacts to see if they have become bent so that they never open. Repair if necessary.

SECTION III

BATTERY BB-54A

94. GENERAL CARE.

a. Keep liquid level up to level line by adding distilled water *AFTER THE BATTERY IS CHARGED*. To add water, remove the battery plug board and disconnect the gas manifold from the gas valve; then slide the battery out of the case by pulling upward on the rings on the battery retainer. *Be careful not to bend the gas valve coupling as the battery cover slides past this point.* Loosen the screw on the battery strap and open the battery cover. Remove filler cap from battery and add distilled water up to the level line. Replace battery cover and tighten screw on battery strap. Slide battery back into case and install gas manifold and plug board.

b. Recharge battery as soon as possible after discharge to prevent damage to plates.

c. When not in use, recharge when the white ball sinks.

95. CHARGING BATTERY.

a. For best results, the battery should first be charged using the Hand Generator GN-57 or

Power Unit PE-162, as the use of these power units will put a slow charge in the battery which lengthens the life of the battery. If time is an important factor, the battery may first be charged from a 6 or 12-volt storage battery as directed in INSTRUCTIONS FOR CHARGING BATTERY.

b. All specific gravity balls in the side of the battery should be floating at the electrolyte level line when the battery is fully charged.

CAUTION: During the charging period, the electrolyte level will rise up to $\frac{1}{4}$ " above the level line. This is an indication that the battery has taken the charge and the electrolyte will fall to the level line after the charging current has been disconnected. The rise of the electrolyte is caused by expansion from the heat of charging and, during the charge, when the electrolyte is warm, the charge indicator balls will not give a true reading until the electrolyte has cooled for about one half-hour or more. It is important that the charging rate be as directed under paragraph CHARGING BATTERY IN VIBRATOR POWER SUPPLY PP-39/TRC-2.

SECTION IV

GENERAL SERVICE AND ALIGNMENT PROCEDURE

96. GENERAL SERVICE INFORMATION.

Normal voltage charts are included in this manual to permit rapid discovery of trouble by locating abnormal voltages in the equipment. Where alignment or adjustments are described, two methods are usually given, one a complete technically correct procedure when adequate test equipment is available, the other a simple test method or touch-up method that can be applied

in the field without complete test equipment. *It is recommended that no adjustment be made to any circuit involving alignment unless absolutely necessary, and then only with extreme care being exercised to see that the "readjustment" does not make the equipment worse, because it is possible to so badly misadjust the alignment controls that it may be virtually impossible to restore the equipment to use unless test equipment not furnished with this set is available.*

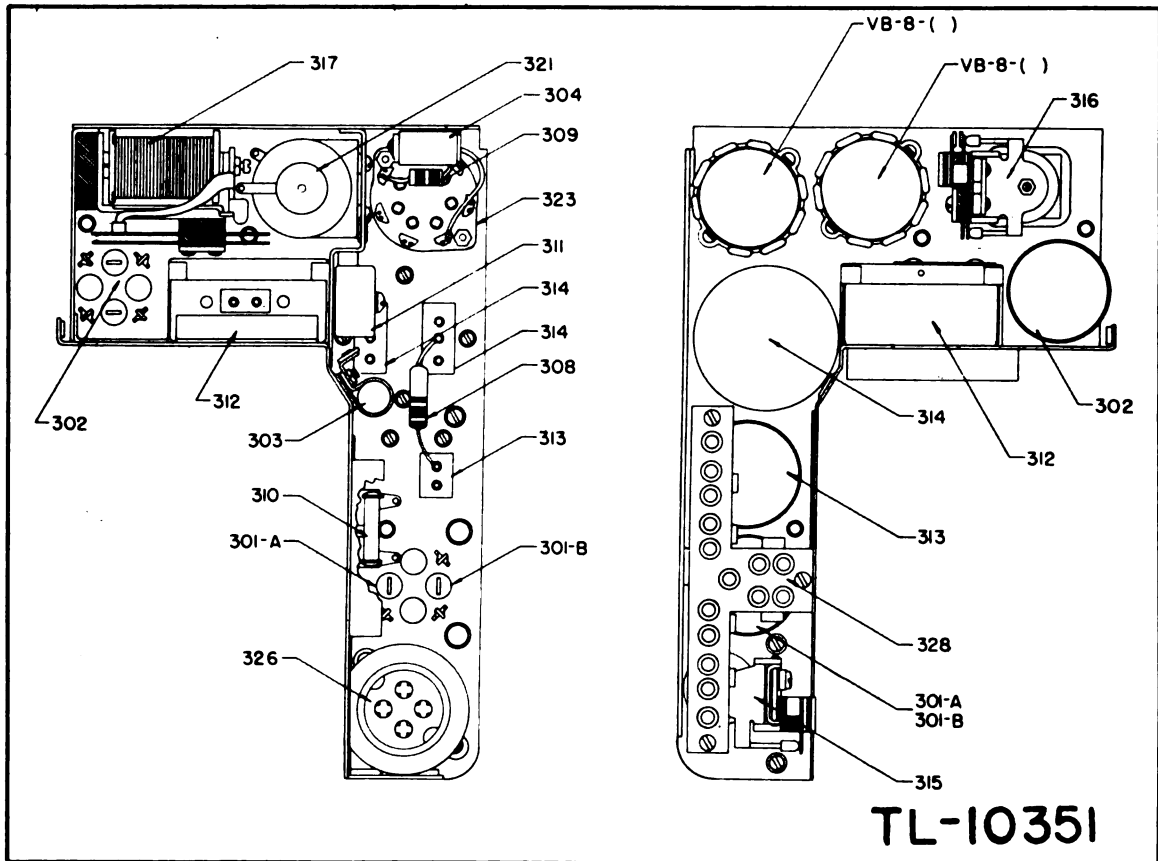

Figure 60—Vibrator Power Supply PP-39/TRC-2—Circuit Symbols (Chassis)

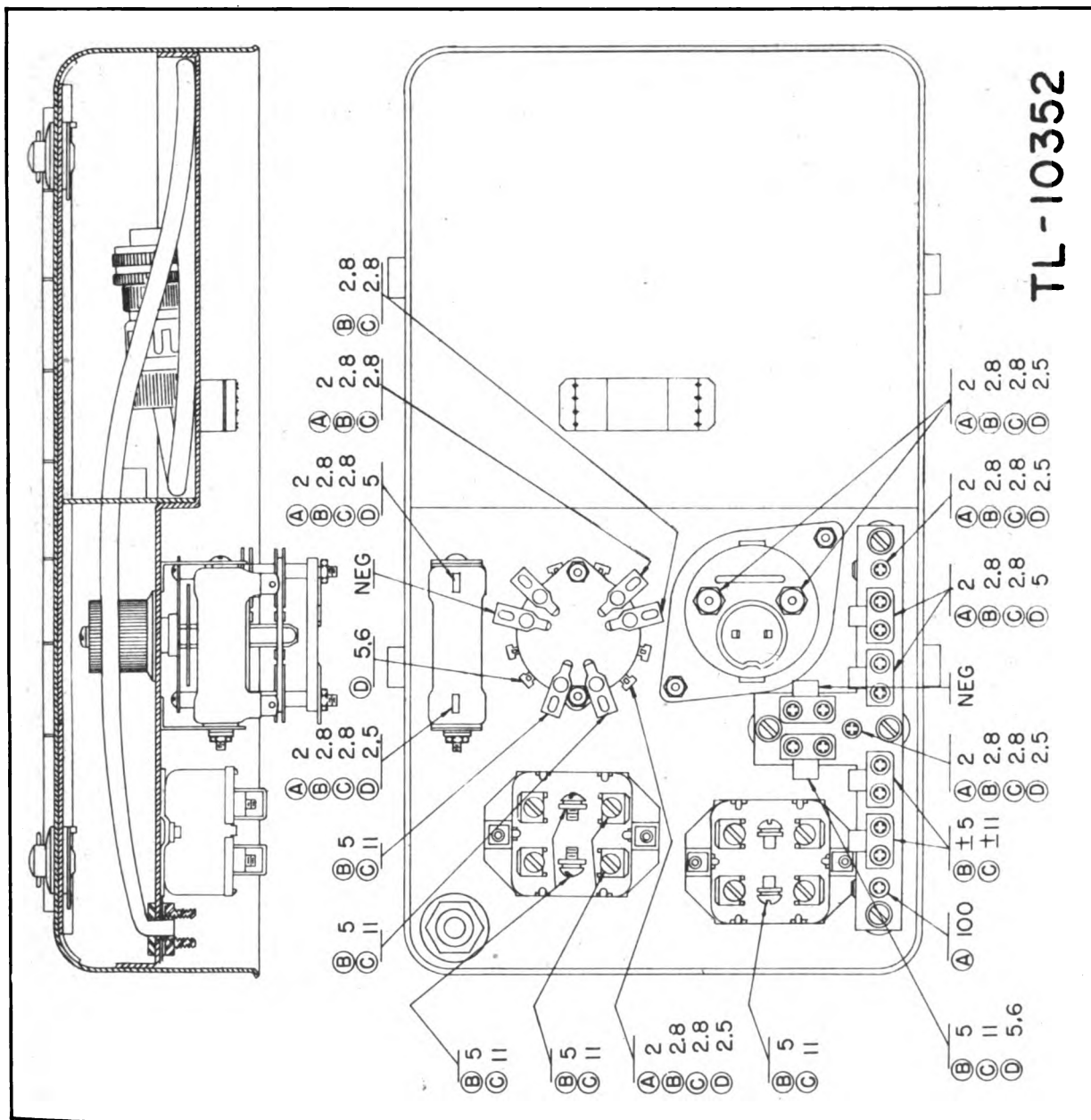

Figure 61—Voltage Test Points—Vibrator Power Supply
See Fig. 59 for Test Conditions.

97. RECEIVER ALIGNMENT EQUIPMENT.

The equipment needed for alignment of the receiver is as follows:

- a. A signal generator or service oscillator.
- b. An output meter.
- c. A dummy antenna consisting of a 250- μ f capacitor.
- d. A test cable to supply voltage to the receiver when removed from the cabinet. This cable is provided in the tool kit which forms a part of Radio Set AN/TRC-2.

98. RECEIVER ALIGNMENT PROCEDURE.

a. Loosen the clips which hold the receiver in the case and carefully remove the receiver.

b. Remove the bottom plate of the receiver.

c. Connect the receiver to the power plug, antenna plug, and ground plug, using the test cable provided in the tool box (Fig. 50).

d. Connect an output meter to a phone plug and insert it into one PHONES jack, while the headset is plugged into the other PHONES jack. The volt-ohmmeter provided with this set has a 0 to 6-volt a-c scale which may be used as an output meter.

e. Supply power to the receiver from one of the usual sources: Power Unit PE-162, Vibrator Unit PP-39/TRC-2, Generator GN-57, or Battery BA-48. Batteries will be found the most satisfactory supply for alignment purposes because of their steady voltage output to the receiver. Turn the SEND-STANDBY-OFF switch to SEND if receiver power is obtained from Power Unit PE-162 or Generator GN-57, or turn to STANDBY if receiver power is obtained from Vibrator Unit PP-39/TRC-2 or Battery BA-48.

f. Set the receiver on one end so that the aligning screws on both the top and bottom of the i-f transformer can be easily reached. Do not remove the tube shield.

g. Connect the ground side of the signal generator to the chassis of the receiver.

h. Connect the high potential or hot terminal of the signal generator to the grid of the second i-f tube.

i. Set the signal generator to exactly 456 kc, either by its own calibration or by means of Frequency Meter Set SCR-211.

j. Turn the VOLUME control clockwise, as far as possible, and set the SENSITIVITY-LOW-MED-HIGH switch to HIGH.

k. Using a modulated signal from the generator applied to the grid of the second i-f amplifier tube, adjust the screws in the top and bottom of the third i-f transformer for maximum indication on the output meter. As alignment progresses, reduce the output from the signal generator in order to secure most accurate alignment.

l. Move the signal generator output lead from the grid of the second i-f tube to the grid of the first i-f tube. Adjust the screws in the second i-f transformer for maximum indication on the output meter, reducing input from the generator as alignment progresses.

m. Move the generator output connection to the grid of the mixer tube, and adjust the screws in the first i-f transformer, again reducing output from the generator.

n. Set the PHONE-CW-NET-CAL switch to CW and adjust the beat frequency oscillator to zero beat. Lock all of the i-f adjustments by means of the lock nuts on the adjusting screws, taking care not to disturb the screw adjustments. Replace the bottom of the receiver and turn it right side up.

o. Set the signal generator at exactly 3.2 megacycles when aligning the receiver of Receiver-Transmitter RT-12/TRC-2, or at exactly 6.2 megacycles when aligning the receiver of Radio Receiver and Transmitter BC-1306.

p. Connect the hot lead of the signal generator to the antenna jack on the receiver through the dummy antenna.

q. Tune in the signal on the receiver by rotating the TUNING knob. If the signal is picked up when the dial indicates correct reading, the oscillator is properly aligned. If the dial does not indicate the proper frequency, the oscillator must be realigned as follows:

(1) Set the receiver dial to the correct frequency.

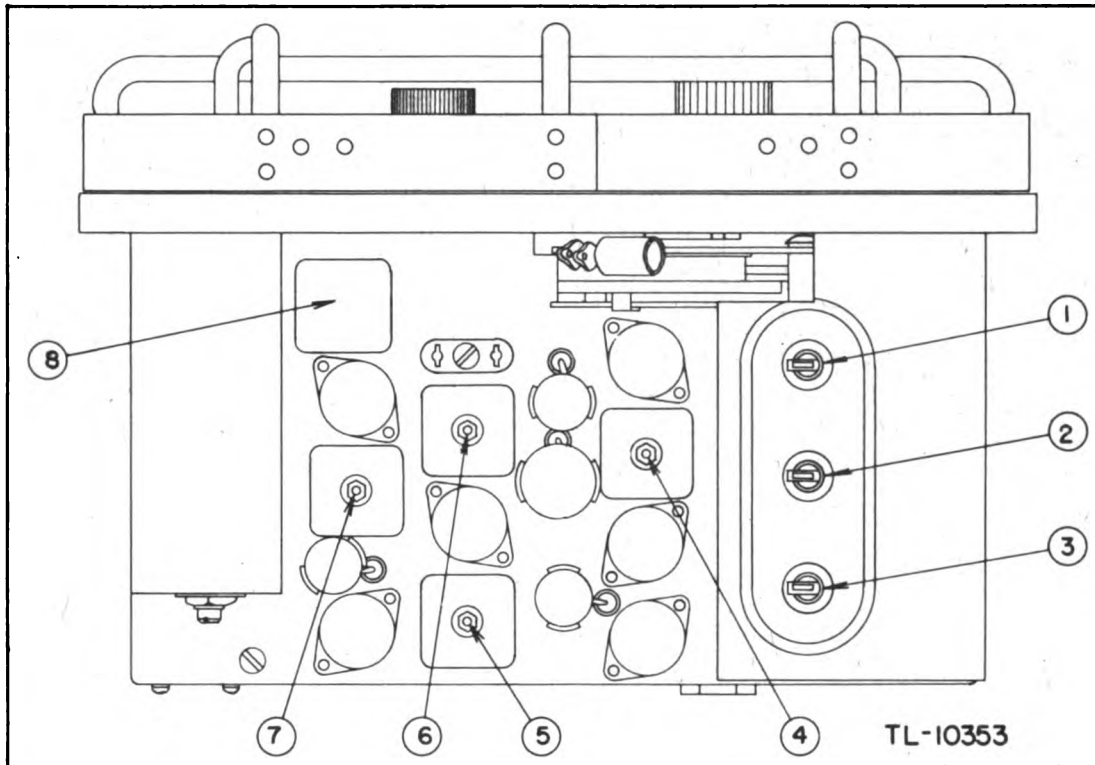

Figure 62—Alignment of Receiver of Radio Receiver and Transmitter BC-1036 and RT-12/TRC-2 (Top View)

- | | |
|---------------------------------------|--|
| 1. Oscillator trimmer | 5. Beat frequency Oscillator tuning |
| 2. R.F. trimmer | 6. Second I.F. (top and bottom tuning) |
| 3. Ant. trimmer | 7. Diode (output) I.F. (top and bottom tuning) |
| 4. First I.F. (top and bottom tuning) | 8. Crystal tank circuit (bottom tuning only) |

(2) Adjust the oscillator trimmer, which is located on the section of the gang capacitor nearest the panel of the receiver (Fig. 62).

(3) Adjust the remaining trimmer capacitors on the tuning capacitor gang for maximum reading on the output meter. Be careful not to move the TUNING control.

r. The receiver is now completely aligned and no further adjustments need be made.

s. If the receiver should become progressively less sensitive with the passage of time, and replacing tubes does not materially improve the sensitivity, recheck the alignment of the receiver while it is still possible to pick up signals or noise. If the headset is used as an output indicator, the trimming adjustments are loosened one at a time

and each (except the oscillator trimmer) turned slightly, first to one side of its former position, then to the other, to discover if any improvement in signal can be obtained. The i-f adjustment should be locked at the point of maximum response, and the antenna and r-f trimmer capacitors left at the positions of maximum response.

t. If the calibration of the receiver is off as judged by the crystal calibrating circuit in the receiver, the calibration can be restored to normal. Shift the oscillator a slight amount in the direction which improves calibration, then adjust the antenna and r-f trimmers until, by a series of small movements of these trimmers, the calibration has been restored and maximum sensitivity preserved.

99. TRANSMITTER ALIGNMENT EQUIPMENT.

The following equipment is recommended for alignment of the transmitter:

a. Frequency Meter Set SCR-211. If Frequency Meter Set SCR-211 is not available, the calibrating crystal in the receiver may be used.

b. A voltmeter with a resistance of 1000-ohms-per-volt and several scales reading up to 150 volts.

c. A 5000-ohm, 20-watt carbon or other non-inductive resistor (for BC-1306).

d. A 40-ohm, 20-watt carbon or other non-inductive resistor (for RT-12/TRC-2).

e. A stabilized power source. Power Unit PE-162 is recommended, although generator GN-57 may be used if necessary. It may be slightly more difficult to peak the adjustments, due to voltage variations occasioned by changes in cranking speed for which voltage regulator in the generator cannot completely compensate.

f. The volt-ohmmeter supplied with this set is satisfactory for alignment purposes.

100. TRANSMITTER ALIGNMENT PROCEDURE.

a. Remove the power cable from the transmitter.

b. Unfasten the clips and remove the transmitter from its case. Be careful not to damage the power amplifier tube.

c. Attach the power cable to the power receptacle on the front of the panel.

CAUTION: The top cap of the output tube and many other points carry approximately 500 volts when the power is on. Exercise extreme caution.

d. Set the CW-MCW-PHONE switch to PHONE.

e. Set the CRYSTALS switch to MO.

f. Turn the ANT. SELECTOR switch to SHORT position 1, and TUNE FOR MAX. IND. GLOW knob to any position between 5 and 10. Do not use any position lower than 5, as misalignment will result.

g. Set the frequency meter to 6,300 kc for the transmitter section of Radio Receiver and Transmitter BC-1306 or 3,300 kc for Receiver-Transmitter RT-12/TRC-2.

h. Set the **FREQ. CONTROL** knob on the transmitter to the setting indicated on the calibration chart for 6,300 kc for Radio Receiver and Transmitter BC-1306, or 3,300 kc for Receiver-Transmitter RT-12/TRC-2.

i. Press the microphone button and listen in the phones connected to the frequency meter for the signal from the transmitter. Adjust the master-oscillator trimmer to exact zero beat. If the 200-kc crystal in the receiver is used instead of the frequency meter proceed as instructed in paragraph 31(d).

NOTE: Since Frequency Meter Set SCR-211 can give beat notes between harmonics of the transmitter and the frequency meter, measurements of the transmitter frequency should be taken at several points on the dial to be sure that the transmitter has been aligned to the correct frequency and that it calibrates closely over its entire range. If a check is made at several points and it is found that only the one at which the adjustment has been made is closely on frequency, and that the other points checked are considerably in error, it is probable that the wrong beat note was used in the frequency meter, and that none of the frequencies is correct.

j. Connect the negative lead of the 1,000-ohm-per-volt meter to pin No. 5 on the metering socket, and connect the positive lead to the chassis.

k. Adjust the buffer-plate trimmer for maximum output indication on the meter (Fig. 63).

l. Using approximately a 3-volt scale of the meter, connect the positive lead of the meter to terminal No. 2 and the negative lead to terminal No. 8.

CAUTION: Both ends of the meter connected in this way are approximately 500 volts above chassis. Use extreme caution.

m. Adjust the power amplifier trimmer for *minimum* indication on the meter.

n. On the transmitter of Radio Receiver and Transmitter BC-1306, connect the 5000-ohm carbon resistor from the ANT post on the transmitter to the GND binding post of the receiver or to some bare metal part of the chassis of the transmitter. On the transmitter of Receiver-Transmitter RT-12/TRC-2 connect the 40-ohm

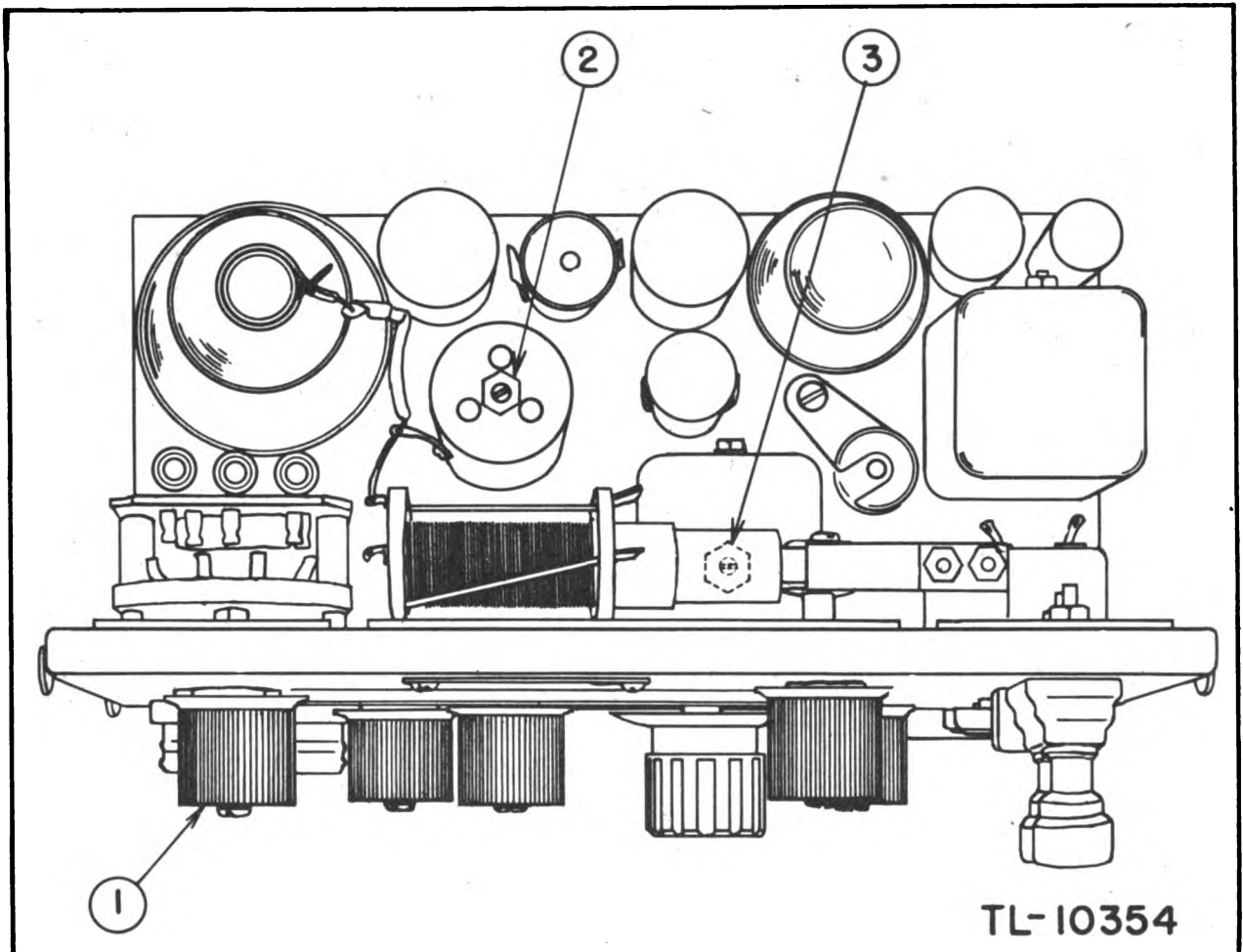

Figure 63—Alignment Data, Transmitter

Screws (2) and (3) are adjusted only when the main tuning capacitor (75A, 75B and 75C) or the coils tuned by this capacitor are removed from chassis and replaced with new parts.

carbon resistor between the ANT and CPSE binding posts. Turn the ANT. SELECTOR switch to position 5 on the REEL scale. Rotate knob TUNE FOR MAX. IND. GLOW until INDICATOR glows brightest.

o. As a final check to insure proper alignment, the transmitter should be tuned at one end of the frequency band and then at the other, at the same time adjusting the TUNE FOR MAX. IND. GLOW knob at each end. This is done to make

certain that the indicator glows at normal brilliance and can be tuned to resonance at each end of the band. Correct voltmeter readings are shown in the chart at the rear of the transmitter shield.

p. The alignment of the transmitter is now complete.

q. Remove the power cable as a safety measure.

r. Replace the transmitter in its case.

SECTION V

POWER UNIT PE-162

101. FAILURE TO OPERATE.

a. If the Engine GE-12 fails to operate properly, see list below for some of the most likely faults and their corresponding remedies:

Possible Cause	Check	Remedy
Fuel—none or too little	Fuel tank	Fill
Fuel line valve closed.	Fuel line valve	Open valve
Air vent closed	Air vent	Open vent
Choke lever not in position	Choke lever	Following directions for starting
Carburetor needle valve not adjusted correctly	Carburetor adjustment	Reset
Water or dirt in fuel	Fuel tank	Drain, clean, refill
Wet spark plug	Spark Plug	Dry
Engine flooded	Crankcase drain	Open and drain
Incorrect fuel mixture	Gas tank	Drain and refill
Broken high tension cable	Cable	Replace
Muffler plugged	Muffler	Clean out

b. If none of the above items is the cause of faulty operation, make further checks as follows:

Possible Cause	Check	Remedy
Defective spark plug	Spark plug	Replace
Carbonized spark plug	Spark plug	Clean or replace
Wrong gap on spark plug	Spark plug	Adjust to .030"
Defective coil	Spark	Check
Defective magneto capacitor	Spark	Replace
Magneto points out of adjustment	Spark	Adjust or replace
Obstruction under carburetor reed valve	Reed	Clean

102. LACK OF POWER.

If the engine lacks power look for the following troubles.

Possible cause	Check	Remedy
Choke lever in choke position	Choke lever	Move to horizontal
Carburetor needle valve out of adjustment	Needle valve	Adjust
Muffler plugged	Muffler	Clean out
Clogged air filter	Filter	Clean or replace

103. OVERHEATING.

If the engine overheats look for the following troubles:

Possible Cause	Check	Remedy
Wrong type of spark plug	Spark plug	Replace with Champion J5 or equivalent
Engine port holes clogged	Cylinder	Clean out
Piston and cylinder head carbonized	Cylinder and piston	Clean

104. SPARK PLUG.

a. *To Check Spark Plug.*—Remove from cylinder head and shield 400; first disconnect magneto high tension wire 450. Then reattach high tension wire to spark plug and lay plug on the cylinder. Spin motor to check spark. If no spark occurs at the spark plug points, clean out plug or install a new one.

b. *To Clean Carbonized Spark Plug.*—Remove and scrape thoroughly to eliminate all carbon, brownish lead deposits, and loose particles.

c. *To Replace Spark Plug.*—To locate engine trouble, first replace the spark plug. If this does not correct the difficulty, leave the new plug in place while checking further. For maximum operating efficiency it is important that the same type plug furnished with the equipment be used. Always use Champion J5 spark plug, or one in equivalent heat range. Point gap should be .030 inch. Check gap with feeler gauge provided in the tool box.

d. *Further Check.*—Failure of the spark plug may be due to improper point gap or cracked or dirty porcelain. Carbon or lead deposits on point will cause failure by shorting the spark plug.

105. MAGNETO.

a. *To Check Magneto.*—A weak spark is often due to improper adjustment of the magneto points. Check point adjustment as directed. When the magneto appears to be causing trouble, make the

following test before attempting a repair. When the engine fails to start, and the spark plug is known to be functioning properly, check magneto by holding high tension wire (450) $\frac{3}{16}$ inch away from a point on the engine (Fig. 77). When the engine is cranked in the usual manner, a properly performing magneto will produce a strong enough spark to jump the $\frac{3}{16}$ inch gap.

b. To Adjust Points.— The only adjustable part of the magneto is the breaker plate 457, which provides adjustment for the breaker points. To adjust breaker points, first remove housing 464. Then unscrew starter pulley 467 from the crankshaft. Screw on flywheel removal tool 531 and tap tool on the end to loosen flywheel 460, which should be removed to provide access to points. Turn engine clockwise (to the right) by hand, until breaker points are fully open. Check opening (Fig. 67) with feeler gauge 536. Correct opening is .020 inch.

NOTE: The contact points remain open only during the entire travel of cam 446 from the breaking edge. They are closed only while the flat section of the cam is passing the breaker arm fibre 445. The cam must be positioned so the breaker arm fibre rests on the highest point of cam when gauging the point opening.

c. To Reset Points.—If points need resetting, bend down contact plate lock 453 (Fig. 65), loosen locknut 456A which holds breaker plate 457 in position, and move plate up or down to obtain proper point opening. After setting is accomplished, tighten locknut 456 and bend ear of plate lock against flat of locknut so it cannot become loose. The fixed contact on plate 457 must never be loosened or breaker arm 445 bent to provide adjustment.

d. To Clean Points.—Uneven or pitted contact points may be restored to a true, even condition by using a smooth carborundum or dressing stone. Remove all dust particles. However, points in this condition should be replaced. For minor dressing, a fine grain sandpaper such as No. 00 can be used.

e. To Replace Points.—The moving contact is part of the breaker arm. In replacing breaker arm 445 make certain breaker arm bushing is in place. If one or other of contact points is badly worn, change both at same time to insure satisfactory operation. The breaker arm bearing is packed with a cam lubricant at the time of assembly and should not require additional lubrication. A small amount of this lubricant is also packed on the breaker arm cam wiper 462 and wipes off on cam

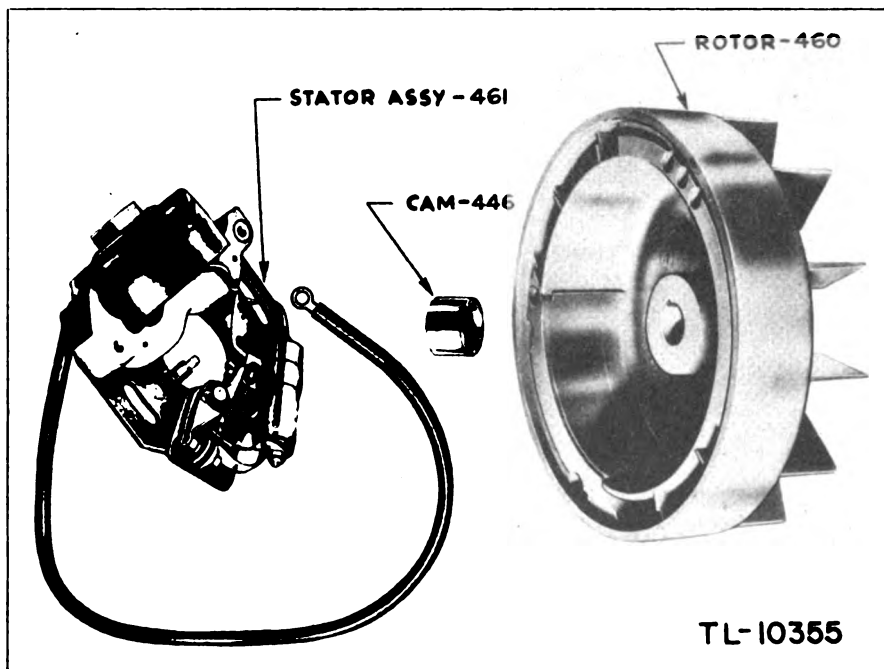

Figure 64—Magneto Assembly

surface. This provides permanent lubrication between rubbing surfaces.

f. To Adjust Magneto Timing.—If the magneto assembly is removed from the engine, retime as follows:

(1) Check point opening. Remove spark plug. Turn crankshaft 419 in direction of engine rotation (clockwise) until piston reaches top dead center.

(2) Insert a small rod through spark plug hole in cylinder head 406 until it touches top of piston. Scribe a line on the rod flush with top of spark plug hole. Then withdraw rod and scribe another line up $\frac{1}{8}$ inch from dead center mark (Fig. 70). Turn engine in opposite direction of rotation (counterclockwise) about one-quarter turn.

(3) Insert the rod again through spark plug hole until it touches top of piston. Then rotate the crankshaft (clockwise) until top mark on rod is flush with top of spark plug hole.

(4) Move stator plate 461 until points just begin to break. Tighten plate by means of the two round head screws, which lock plate in place. Recheck to determine if piston is $\frac{1}{8}$ inch from top dead center when points just begin to break. If setting is correct, a spark occurs when piston is $\frac{1}{8}$ inch from top dead center.

g. To Replace High Tension Wire.—A chafed or broken cable 450 which causes continuous or intermittent misfiring should be replaced. Strip back about $\frac{1}{2}$ inch on the magneto end of the cable, twist strands together and slip through hole in bracket attached to coil. Bend strand

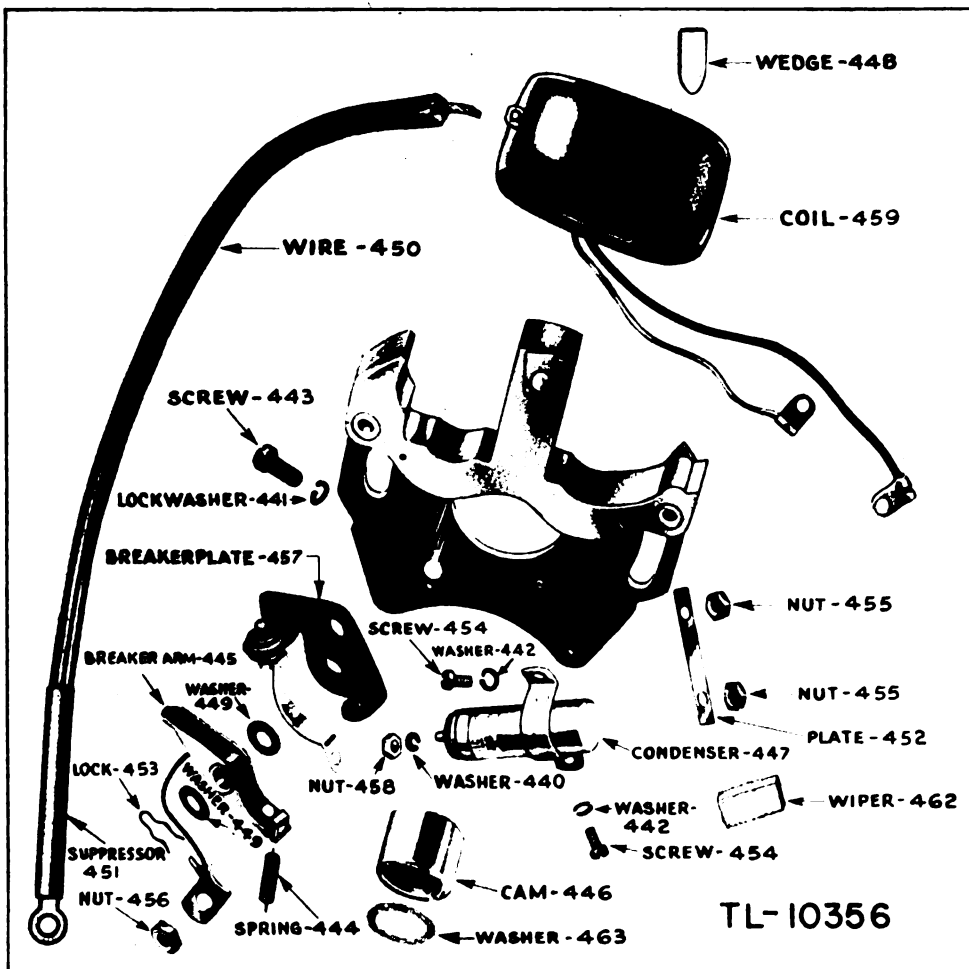

Figure 65—Magneto Stator Plate Assembly

around bracket so cable cannot work out (Fig. 65). Do not solder cable to coil.

h. Coil and Capacitor.—If no spark or a weak spark occurs after adjusting the contact points, the trouble is likely to be in the coil 459 or capacitor 447. Replace either one or both to obtain a strong spark only after checking the spark plug, high tension wire connection, and magneto contact points. In replacing the coil assembly, the three machined faces of the laminations must line up exactly with the three machined bosses of the stator. Tighten screws securely.

i. Magnet.—Integrally cast in the rim of rotor 460 is the magnetic unit, which concentrates a powerful magnetic charge within a small volume. No trouble should be experienced with the magnet.

j. To Lubricate Magneto.—For cam lubrication add a little vaseline or petrolatum to the cam wiper 462 after approximately 200 hours of operation. Never use oil or a fluid lubricant as either can short out the breaker points.

106. GENERATOR GN-50.

Generator GN-50 will require very little attention with the exception of replacement of the brush and spring assemblies 149 and 150, (Fig. 73) and occasional examination of the commutators to make sure there is a good electrical contact between them and the brushes. Oil, grease, or dirt will affect the output of the generator and also cause sparking at the brushes. The generator may be inspected simply by removing end cover 542 which is fastened to the generator frame by two machine screws 594.

a. To Clean Commutators.—Clean commutators by touching very lightly with a fine grain sandpaper (No. 000) or crocus cloth while the armature is rotating (Fig. 71). Stop the unit and use a knife or screwdriver to remove oil, dust or carbon from between bars of commutators.

b. To Replace Brushes.—The brush and spring assemblies can be removed by moving bakelite brush holder caps from holders. (Fig. 66). To install brush and spring assemblies reverse the

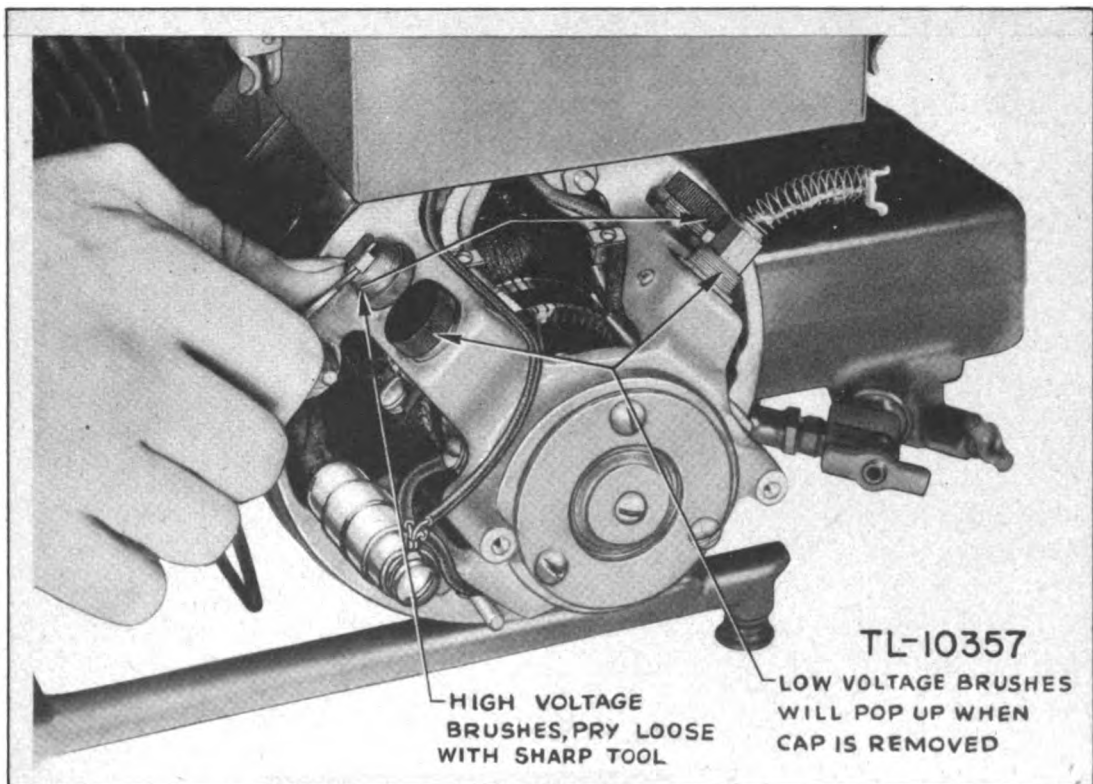

Figure 66—Brush Removal

above procedure, being careful that the brushes seat firmly against the commutators, and move freely in the holders. New brushes should be fitted to have 100 per cent effective surface contacting the commutator. To obtain this it is necessary to sand the brushes. This is accomplished by cutting a strip of No. 000 sandpaper or crocus cloth the exact width of the commutator. The strip is then wrapped around the commutator with the sanded side out, and the brushes are then dressed by turning the armature slowly in a clockwise direction. After dressing, blow carbon dust out of generator.

c. To Remove Commutator End Bearing.

- (1) Remove entire generator unit from engine by taking out three screws 570,
- (2) Take off filter box and disconnect four lead wires going to generator brush holders.
- (3) Remove end cover.

(4) Unscrew four brush holder caps 459 and remove brushes. Be sure to identify brushes so that when reinstalled they are placed in their original holders.

(5) Remove four nuts 574 from stud bolts 559.

(6) Tap end bell 545 on pulley end of shaft with wood mallet and pull away from field assembly.

(7) Remove three screws 594 holding washer 553 against bearing race.

(8) Remove screw 594 holding washer 554 to end of shaft.

(9) Lay generator assembly on its side and force armature shaft from bearing by placing a piece of brass rod or wood peg against shaft end and tapping same with hammer.

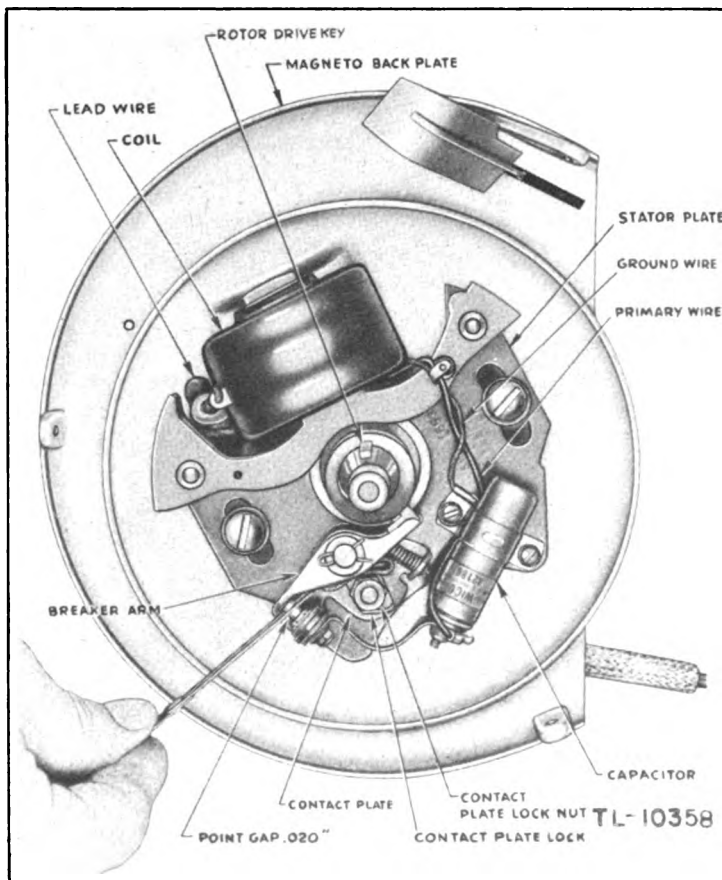

Figure 67—Point Adjustment

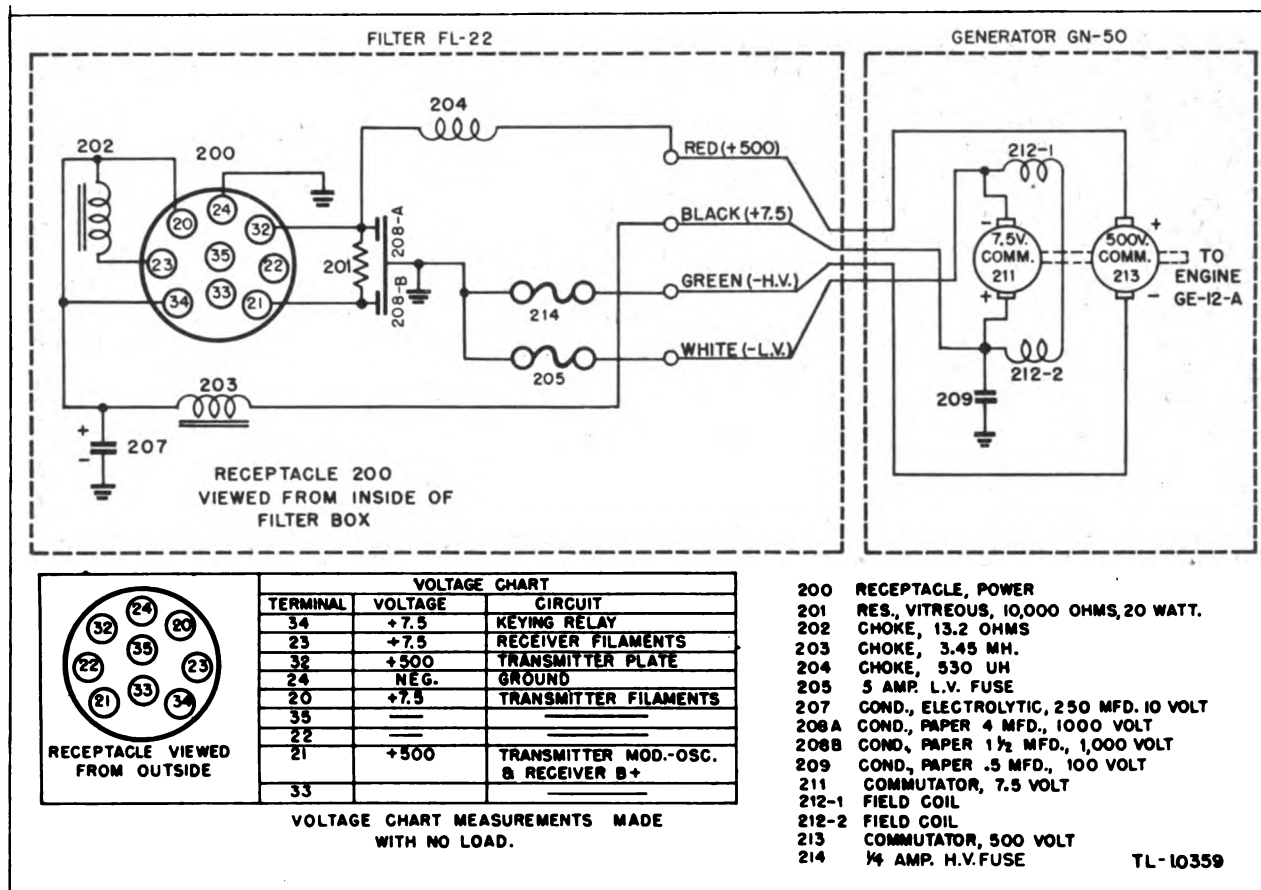

Figure 68—Circuit of Power Unit PE-162

(10) Remove end bell 545 on commutator end of shaft from field assembly.

(11) If remaining in the end bell, the bearing can be pulled out with fingers.

(12) To reassemble, reverse above procedure. When inserting bearing, press same on shaft by tapping pieces of wood which should just fit over inner race.

d. To Lubricate.—Lubrication of the generator is not required since the one bearing at the commutator end is of the double-seal type and does not require lubrication.

107. ENGINE GE-12.

CAUTION: Do not dismantle engine unless absolutely necessary. Be sure engine failure is not due to some simple cause before undertaking major repairs.

Follow instructions carefully. Incorrect procedures may cause permanent damage to the engine.

a. Dismantling.—To disassemble the engine for major repairs, first remove the generator. Then disassemble the engine as follows:

(1) Remove ground wires from spark plug shield 400 and take shield off. Remove magneto

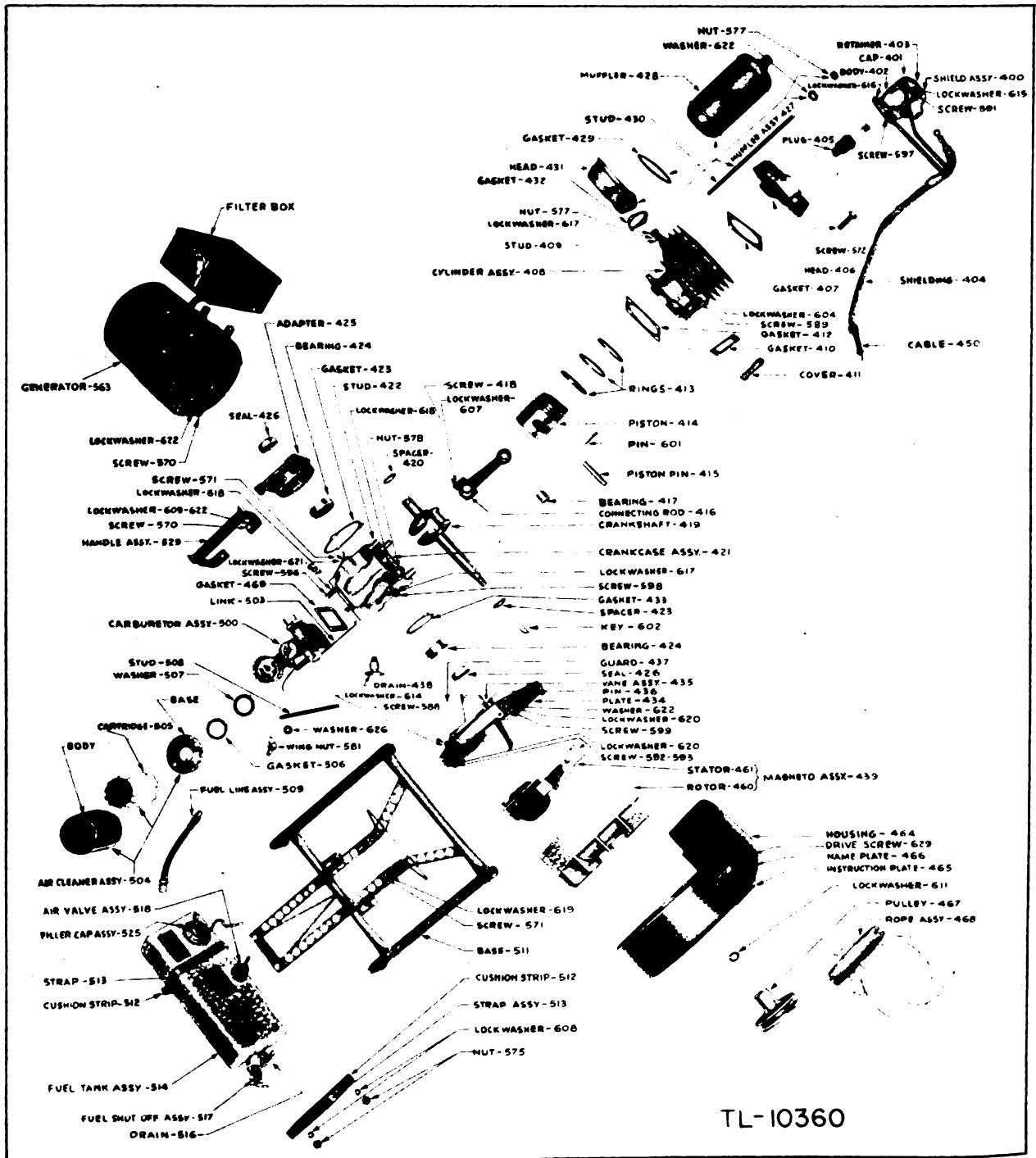

TL-10360

Figure 69—Replaceable Parts, Power Unit PE-162

high tension wire from spark plug 405. Next remove muffler assembly. Take out two screws holding governor link guard 437 to magneto back plate 434 (Fig. 69).

(2) Magneto housing 464 is removed and then starter pulley 467. Magneto rotor 460 is then removed by use of flywheel removal tool 531.

(3) Remove stator plate 461 and magneto back plate 434.

(4) Uncouple governor connecting link 503. Disconnect fuel line 509. Remove gas tank from mounting base. Take out four screws holding carburetor to engine crankcase and remove carburetor.

(5) Unscrew four cap screws 572 holding cylinder head in place. Then remove four nuts 578 holding cylinder 408 bolts to crankcase. Remove cylinder.

(6) Remove the piston and connecting rod assembly by taking off the two cap screws 418

from connecting rod bearing cap. This is done through the opening in crankcase where carburetor is attached.

(7) Remove cap screws 571, bolting adapter 425 to crankcase. Before proceeding further, remove balance of engine from mounting base 511. To remove adapter 425 from crankcase 421, turn assembly over, screw on flywheel puller 531 and tap puller lightly with a hammer. The adapter will then come off.

(8) The piston 414 is removed from connecting rod 416 by removing cotter pin 601 which holds piston in place. This cotter pin passes through the boss on the inside of the piston and through the piston pin. Piston pin 415 can then be tapped out from either end of piston.

b. Installation of Piston Rings.

(1) Replace piston rings when the ring end gap, with rings in cylinder, exceeds .020 inch, or when the rings are stuck tightly in the piston.

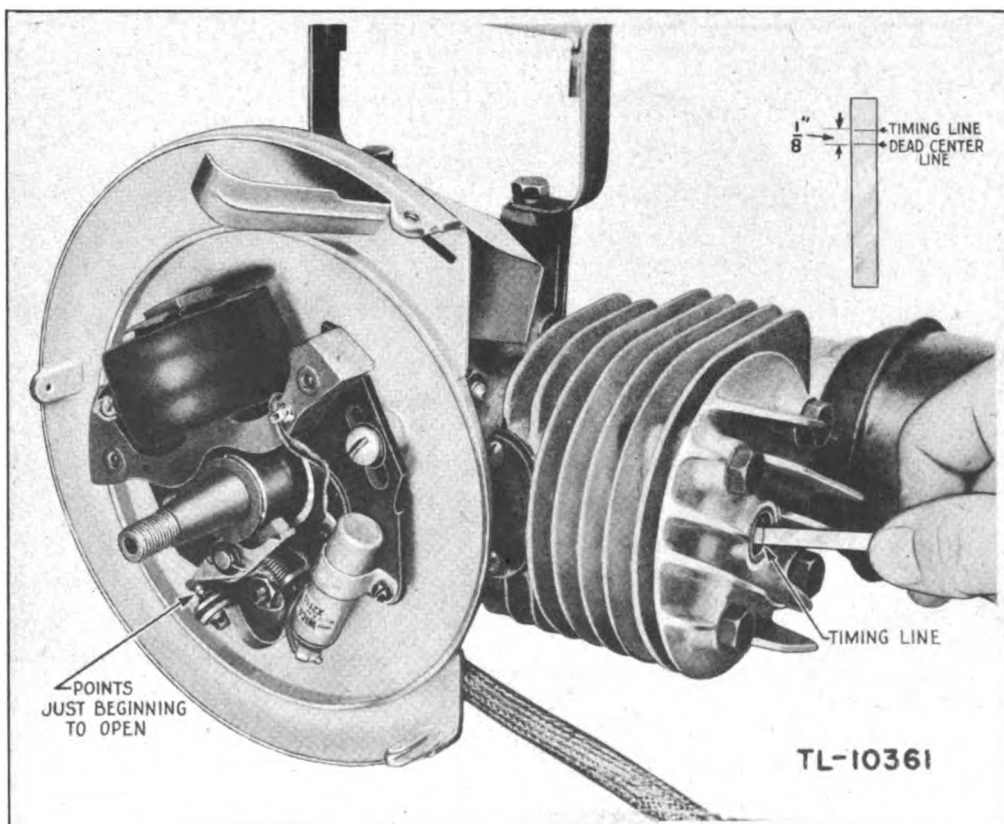

Figure 70—Timing Engine

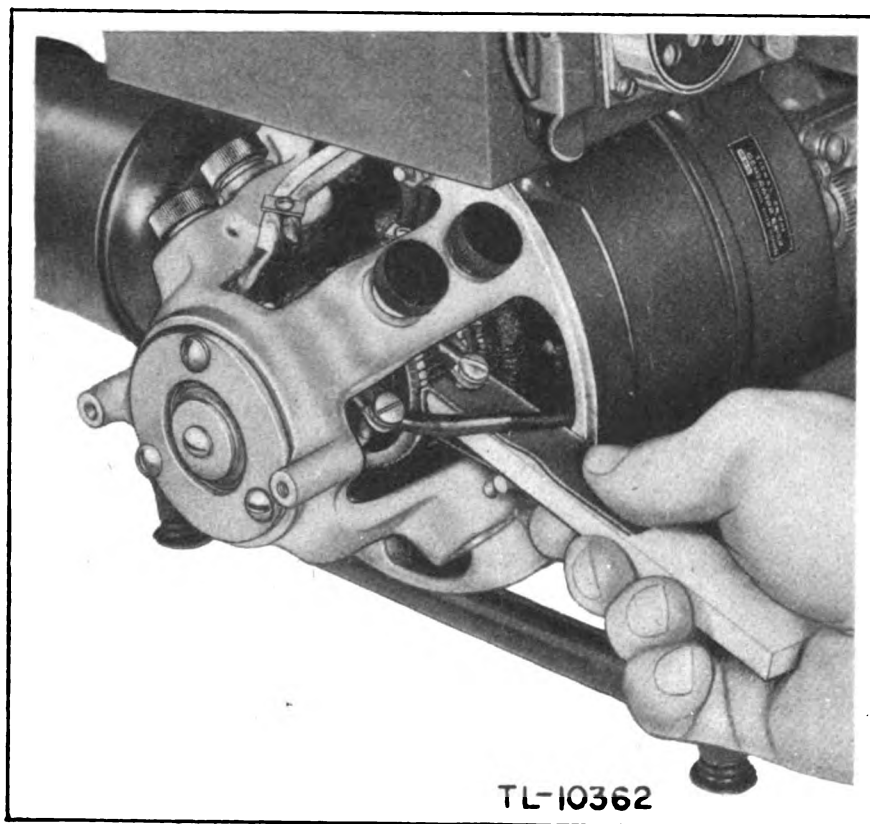

Figure 71—Dressing Commutator

Piston rings should make contact with the cylinder wall all around.

(2) Before installing new rings, be sure piston ring grooves are clean and free from carbon.

(3) End gap of new rings should be approximately .010 inch; side clearance in grooves for new rings should be .002 inch to .003 inch.

(4) To break in new piston rings, run the engine for at least one hour before applying any load.

c. Assembly of Piston to Connecting Rod.

(1) When installing piston to connecting rod, use a new cotter pin.

(2) The piston pin should be a tap fit in the piston. If the piston pin is loose, it will shear the cotter pin, which in turn will permit movement of the piston pin far enough to cut grooves in the cylinder liner.

d. Adjustment of Connecting Rod and Crank Shaft.—Should the connecting rod 416 ever become loose on the crankshaft pin and require taking up, it will be necessary to file the bearing cap. The connecting-rod bearing should be fitted to the crankshaft, just tight enough so that the piston and rod assembly will drop of its own weight when released from horizontal position. This bearing should be fitted before the crankshaft is installed in the crankcase.

e. Installation of Piston Assembly. — In reassembling piston assembly to cylinder, be sure the hump or intake side of the piston is on the same side as the intake port holes in the cylinder. This is the side opposite to that on which the muffler is attached.

f. Assembly of Engine and Generator.—To reassemble engine and generator, reverse sequence described in the instructions covering disassembly of each one.

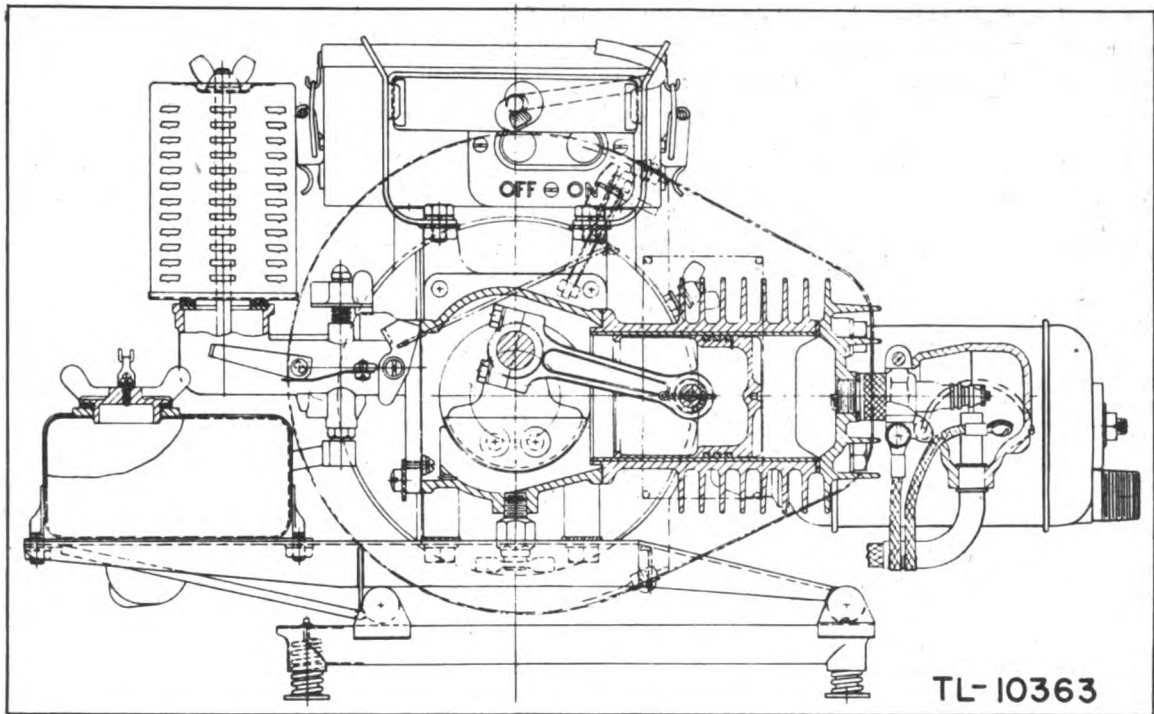

Figure 72—Cross Section Drawing of Engine GE-12-A

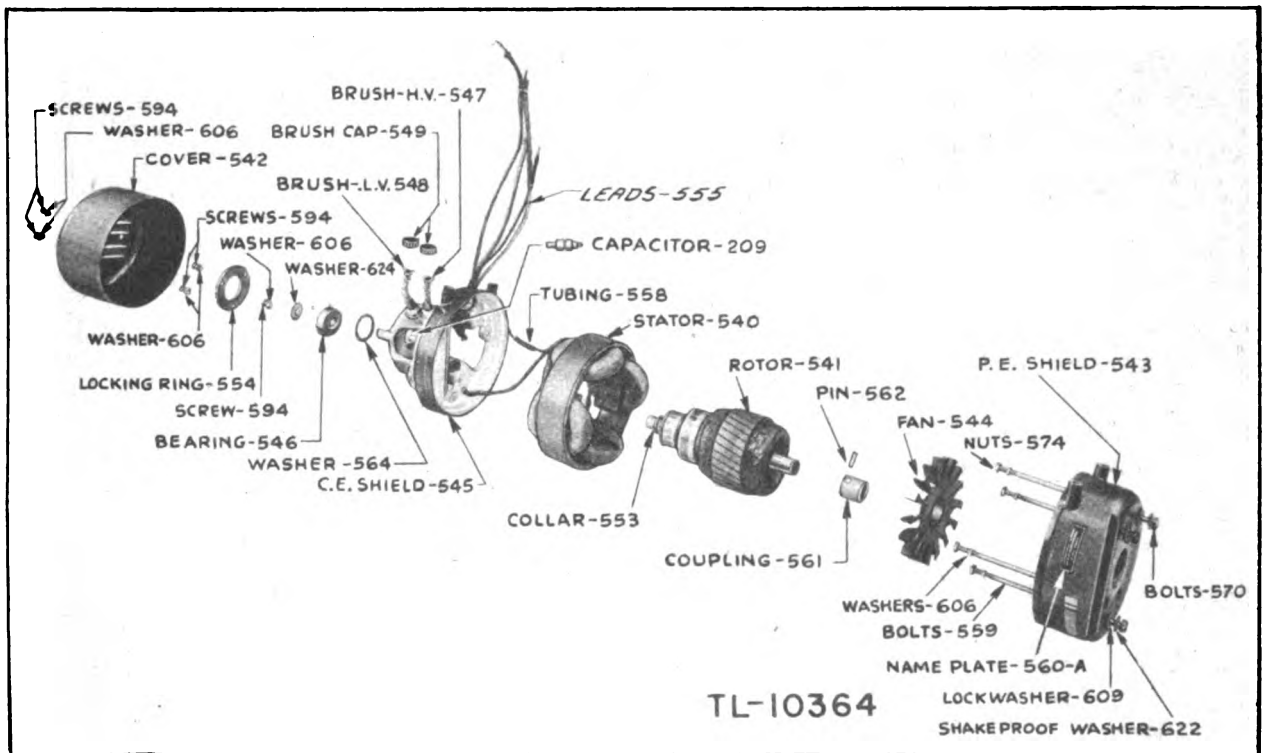

Figure 73—Generator Assembly

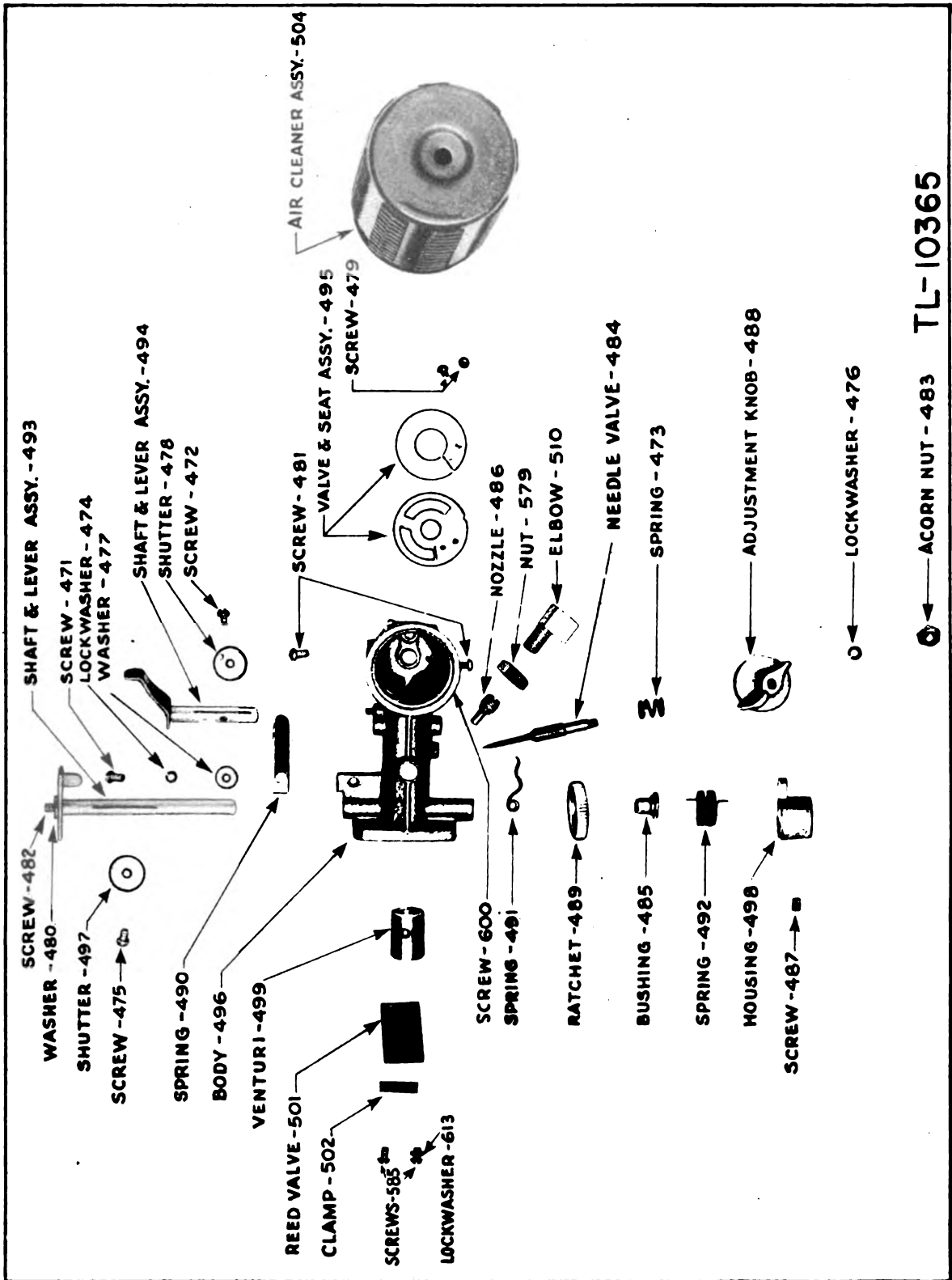

Figure 74—Carburetor Parts

g. Carburetor.

(1) **Adjustment of Needle Valve.**—The carburetor needle valve 484 is correctly set at the time of assembly. If the needle valve must be removed, follow these directions:

(a) Hold adjustment knob 488 with one hand, then loosen and remove acorn-nut 483 on top of the knob with a wrench. Unscrew adjustment valve by turning in a counter-clockwise direction (Fig. 74).

(b) When reassembling valve 484 to carburetor, turn it in a clockwise direction as far as it will go. Do not tighten fast against seat, or seat and valve will be damaged.

(c) With valve in seat as far as it will go, turn it back about one-quarter turn from this closed position. Replace spring 473 and valve adjustment knob with wing of knob against left-hand side of stop. Screw on acorn-nut and tighten, making sure valve does not move while this is being done.

(2) **Air Check Valve.**—If the engine fails to operate properly, and it is known that there is no restriction due to carbon, and the carburetor, spark plug, and magneto points are correctly adjusted, remove air cleaner 504 and clean any small particles of foreign matter out of air check valve 495 located in carburetor bowl.

(3) Reed Valve.

(1) When the engine still fails to operate satisfactorily after the air check valve has been cleaned, remove the carburetor and examine reed valve 501 attached to carburetor on the back. Make certain that no foreign matter prevents the valve from closing or seating properly.

CAUTION: Carburetor reed valve 501 is concaved about .002 of an inch. In order that it will function properly it is necessary, if the valve is removed or replaced, that the concave side seats against the back of the carburetor. The reed valve must close fully. If valve is bent out of shape, straighten or replace.

(2) In reattaching carburetor, make sure all connections are tight to prevent air leakage.

h. Air Cleaner.—Air cleaner 504 prevents dust and grit from entering the engine and causing wear to moving parts. If equipment is operated

under extremely severe and dusty conditions, felt core 505 should be removed and washed out in gasoline, naphtha or acetone after every 30 hours of operation or oftener if conditions permit. Filter core 505 should be dipped in oil after cleaning. Permit oil to drain off before assembling to cleaner. The filter core should also be examined periodically to see that no openings are present to permit entry of foreign matter. A leaky core must be replaced.

i. Governor.

(1) If engine speed requires changing, turn knurled speed regulator 489 toward cylinder counterclockwise to increase speed; turn clockwise to decrease speed.

(2) The governor should require no attention except when the governor housing 498 is removed for replacement of spring 492. To replace governor spring:

(a) Remove governor link guard 437 by taking out the two screws holding it to magneto back plate.

(b) Disconnect fuel line 509 and then remove gas tank from unit mounting base.

(c) Uncouple governor link 503 and remove carburetor from engine.

(d) Loosen headless set screw 487 in governor spring barrel with wrench 539 and slip assembly from throttle shaft 493.

(e) In replacing governor spring, insert one end of the spring into hole in governor housing. Slide the housing onto throttle shaft. Then line up other end of spring with hole in knurled speed adjusting wheel 489. Hold extension on governor in vertical position. Next throttle shaft 493 extension up against stop or in full throttle position. Then tighten headless screw in governor housing.

(f) Check governor housing to determine that no bind exists. It should move freely through entire range of travel.

j. Gasoline Line.—Gas-line packing nuts and all connections must be absolutely tight since an air leak will prevent a full charge of gasoline from entering the motor and affect carburetion. Check all connections, including fuel line shut-off. Period-

ically tighten all connections. Draw up the packing nuts of the fuel line and shut-off if necessary.

k. Lubrication.—Engine GE-12 requires no lubrication other than that supplied by the fuel mixture and occasional lubricating of magneto cam 446 with vaseline or petrolatum. *Do not use fluid lubricant.*

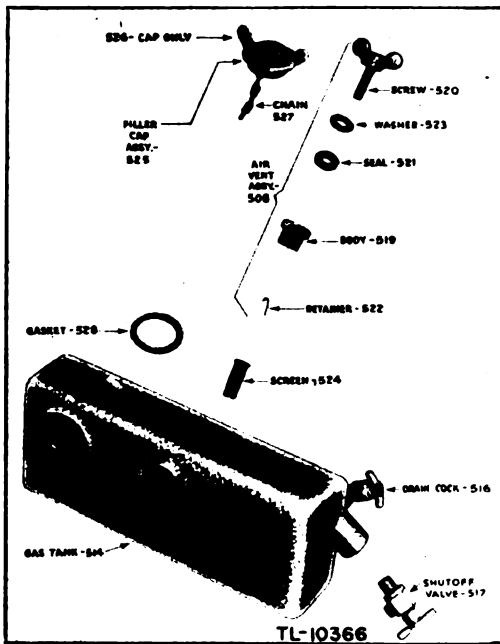

Figure 75—Fuel Tank Assembly

l. Carbon Removal.—Make a periodic check of the engine-exhaust-intake port holes, and muffler assembly, to determine that no carbon has built up at those points, to restrict scavenging of exhaust gases from the cylinder and reduce power output. To remove carbon:

- (1) Remove spark plug to avoid pulling against compression when turning engine over by hand.
- (2) Remove muffler.
- (3) Turn engine over by hand until piston reaches bottom dead center. Examine exhaust ports.
- (4) Remove carbon and lead deposits in exhaust ports with a screwdriver or similar instrument. See Figure 76. Be careful not to damage the piston when removing carbon from ports.

(5) If carbon is found in the exhaust ports, thoroughly check the piston, intake ports, and cylinder head as follows:

- (a) Remove fan housing 464.
- (b) Remove the cylinder head 406.
- (c) Scrape off carbon and lead deposits from cylinder head, inside of cylinder, and top of piston. Use a screwdriver or knife. (Fig. 78)
- (d) Remove carbon from intake ports.
- (e) Before reassembling the cylinder head, make sure all loose particles of carbon and lead are removed from the engine. Small particles of carbon and lead left in the engine may foul the spark plug.

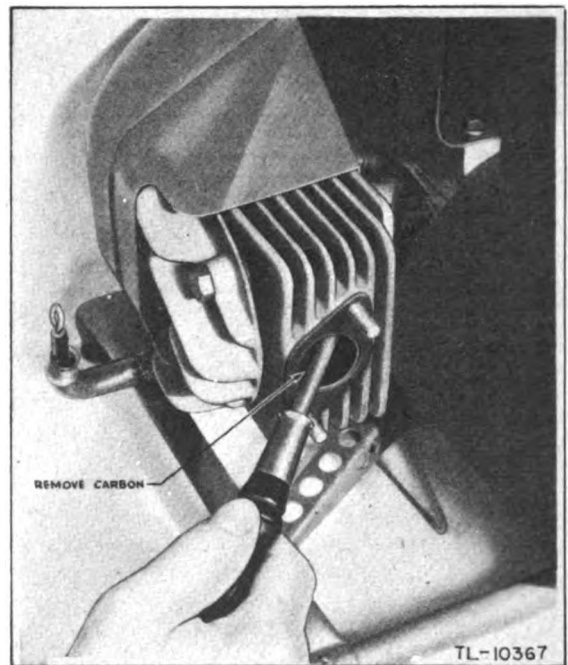

Figure 76—Carbon Removal—Exhaust Ports

- (6) Muffler 427 can be disassembled by removing nut 577, and separating muffler shell 428 from head 431. Scrape carbon from inside the head. Clean carbon out of all inner and outer holes of shell. Make certain gasket 429 is not damaged before reassembly of muffler.
- (7) Crank engine a few times before reinstalling muffler, to give carbon chips an opportunity to pass out of the engine.

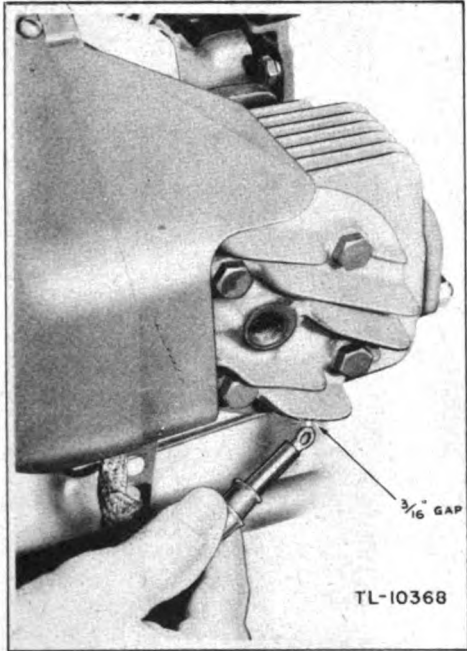

Figure 77—Test for Spark Output

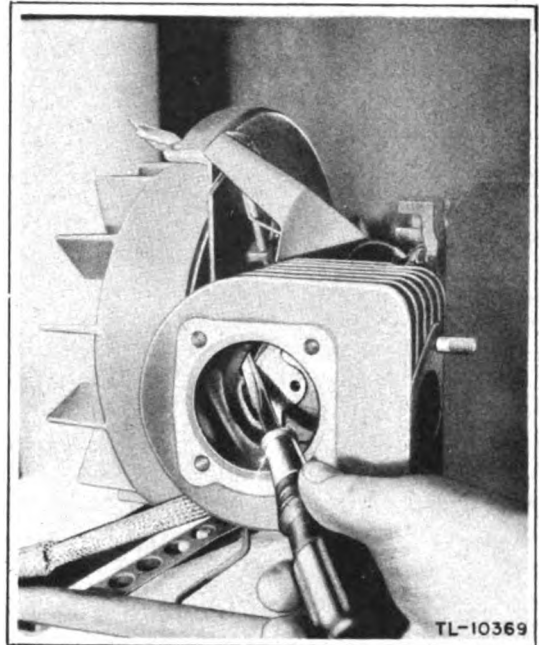

Figure 78—Carbon Removal—Intake Ports

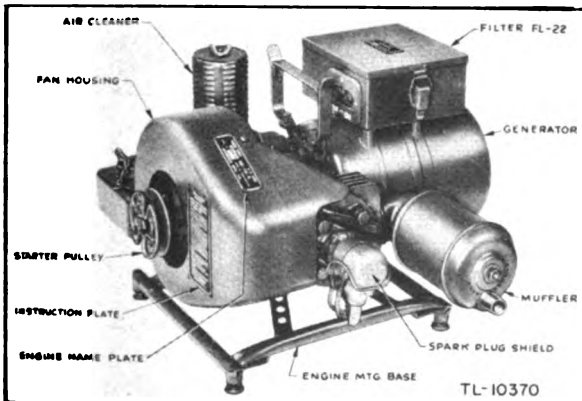

Figure 79—Power Unit PE-162, Front View

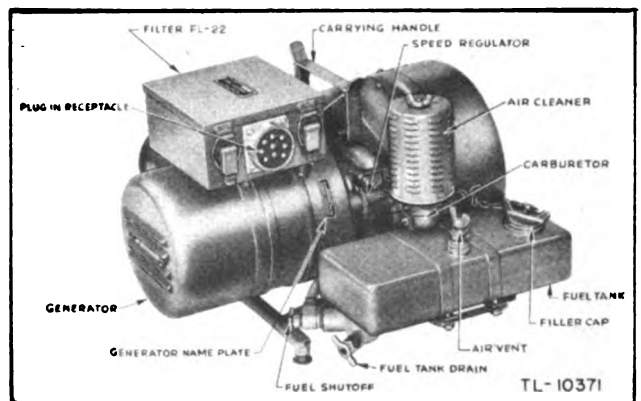

Figure 80—Power Unit PE-162, Rear View

SECTION VI

MAINTENANCE EQUIPMENT

108. MAINTENANCE GROUPS.

a. The maintenance kit supplied with this equipment contains necessary replacement components to facilitate making repairs in the field. Two maintenance equipment groups are provided, one set containing necessary spare parts for Radio Receiver and Transmitter BC-1306 and Receiver-Transmitter RT-12/TRC-2. The second maintenance group is comprised of necessary spare parts for making repairs to Power Unit PE-162. The tool kit, a part of maintenance parts for Receiver-Transmitter RT-12/TRC-2, contains tools and equipment for making repairs to any unit which is a part of Radio Set AN/TRC-2.

b. The following is a list of spare parts furnished in maintenance group for Receiver-Transmitter RT-12/TRC-2 and Radio Receiver and Transmitter BC-1306.

- 1 each Complete set of replacement resistors capacitors, and r. f. chokes for one Radio Receiver and Transmitter BC-1306, Vibrator Power Supply PP-39/TRC-2, and Generator GN-57.
- 1 each Set of replacement resistors, capacitors and r. f. chokes for one Receiver-Transmitter RT-12/TRC-2 of those values and ratings that are not common to Radio Receiver and Transmitter BC-1306.
- 2 each Battery BB-54, dry, with electrolyte in separate bottle.
- 4 each Funnel, plastic, for Battery BB-54.
- 12 each Inserts M-300 for Headset HS-30-D.
- 1 each Cord CD-1119.
- 1 each Cord, vibrator to receiver.
- 2 each Receptacle SO-125.
- 2 each Plug PL-279.

- 2 each Receptacle for Generator GN-57.
- 2 each Matching plugs for above.
- 50 ft. Guy rope, spare.
- 6 each Antenna insulators.
- 6 each Antenna jumpers.
- 200 ft. Wire, No. 14 stranded antenna.
- 50 ft. Wire No. 22 stranded Aeroglass.
- 2 each Spare tube kits, each containing:
 - 1 each 2E22
 - 1 each VR-105-30
 - 6 each 3A4
 - 6 each 1L4
 - 6 each 1R5
 - 3 each 1S5
 - 3 each 3Q4
 - 2 each Pilot Lamp
 - 3 each Neon bulb

c. *Running spare parts for Power Unit PE-162*

The following parts are furnished with each radio set for use in Power Unit PE-162.

- 2 each Piston and Connecting Rod Assembly.
- 1 each Crankcase & Fuel Tank Draincock.
- 1 each Shutoff Valve & Screen Assembly.
- 1 each Fuel Line Assembly.
- 1 each Air Cleaner Assembly.
- 4 each Air Filter Cartridge.
- 10 each Spark Plugs.
- 4 sets Every gasket.
- 2 each Magneto Breaker Point & Plate Assembly.
- 2 each Magneto Breaker Arm.

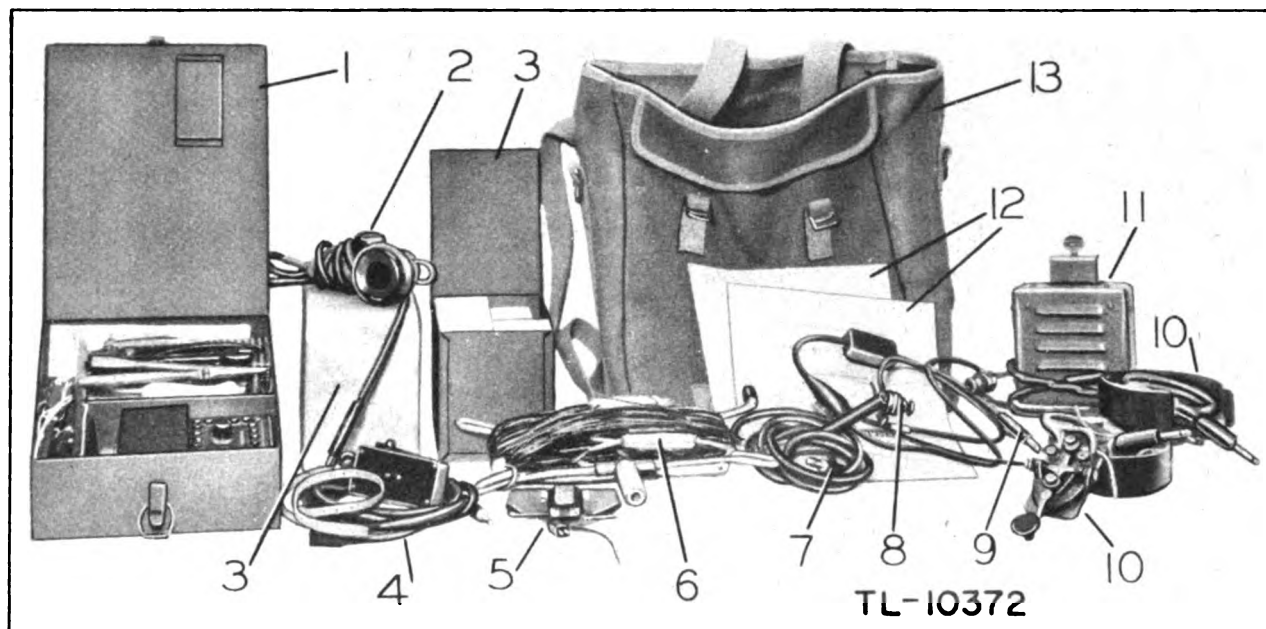

Figure 81—Accessories Unpacked

- | | |
|--------------------|--|
| 1. Tools in Box | 8. Headset HS-30-D |
| 2. Microphone T-17 | 9. Cord CD-933 |
| 3. Spare Tube Kit | 10. Key J-45 (2 each) |
| 4. Cord CD-318-A | 11. Loudspeaker LS-11 |
| 5. Microphone T-45 | 12. Technical Manual for
Radio Set AN/TRC-2 |
| 6. Antenna AN-160 | 13. Bag CW-16/TRC-2 |
| 7. Cord CD-307-A | |

- 4 each Capacitors, magneto.
 - 2 each High Tension Cable & Suppressor Assembly.
 - 4 each Carburetor Reed Valves.
 - 2 sets Piston Rings.
 - 2 each Wire Clip for Spark Plug Shield.
 - 1 each Muffler through bolt.
 - 1 set Every nut, bolt, screw, washer and lockwasher.
 - 1 set Resistors for Filter FL-22.
 - 1 set Coil and Chokes for Filter FL-22.
 - 1 set Capacitors for Filter FL-22.
 - 1 set Carburetor Springs.
 - 2 each Springs for voltage regulator assembly.
- d. Tool Kit* The tool kit supplied with this

equipment contains all equipment listed below. The ax and sheath are packed into Antenna Equipment Roll CW-9/TRC-2 (Fig. 82).

- 1 Hand ax with leather sheath for ax.
- 1 Knife TL-29.
- 1 Pliers TL-103, 5" diagonals.
- 1 Pliers TL-126, 6" longnose.
- 1 Screwdriver, $\frac{1}{8}$ " x 2" blade.
- 1 Screwdriver, $\frac{1}{4}$ " blade, 4" long.
- 1 Solder M-31, 1-lb. spool.
- 1 End Wrench $\frac{3}{8}$ x $\frac{7}{16}$ in.
- 1 End Wrench $\frac{1}{2}$ x $\frac{11}{16}$ in.
- 1 Gas Pliers.
- 1 Screwdriver-Socket Wrench.
- 1 File and Handle.
- 1 Feeler Gauge.

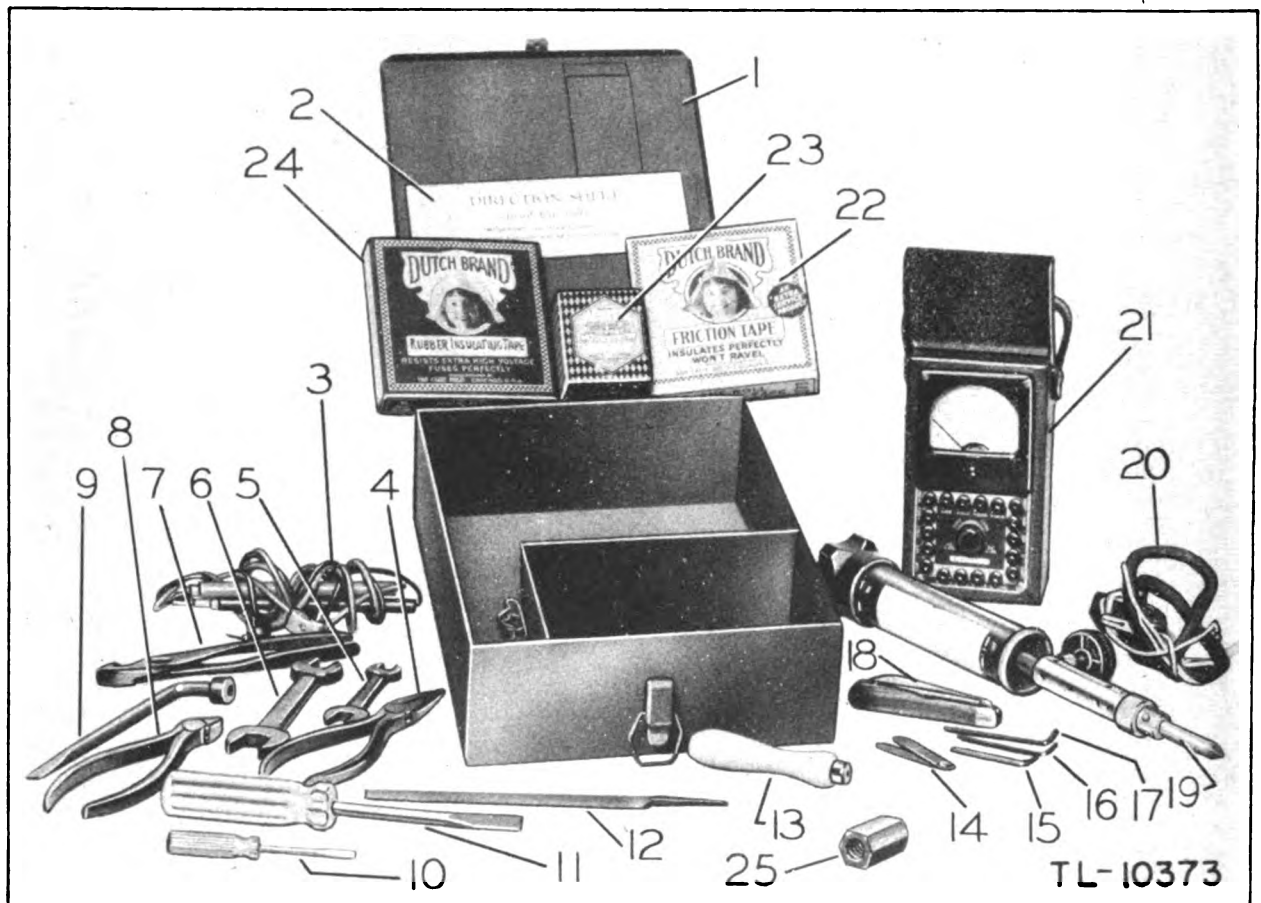

Figure 82—Tool Kit

- | | |
|--|--|
| 1. Tool box | 14. Feeler gauge |
| 2. Soldering iron instruction sheet | 15. Set screw wrench No. 6 |
| 3. Volt-ohmmeter test leads. | 16. Set screw wrench No. 8 |
| 4. Pliers TL-126, longnose | 17. Set screw wrench No. 10 |
| 5. Open end wrench $\frac{3}{8} \times \frac{1}{16}$ in. | 18. Knife TL-29 |
| 6. Open end wrench $\frac{1}{2} \times \frac{1}{16}$ in. | 19. Soldering iron, gasoline
operated |
| 7. Gas pliers | 20. Test cable |
| 8. Pliers TL-103, diagonals | 21. Volt-ohmmeter |
| 9. Screwdriver—socket wrench | 22. Tape TL-83, friction |
| 10. Screwdriver 2 in. blade | 23. Solder M-31 |
| 11. Screwdriver 4 in. blade | 24. Tape TL-93, rubber |
| 12. File | 25. Fly wheel puller |
| 13. File handle | |

- 1 Flywheel Puller.
- 1 Setscrew Wrench No. 6.
- 1 Setscrew Wrench No. 8.
- 1 Setscrew Wrench No. 10.
- 1 Test Cable.
- 1 Soldering iron, gasoline operated, with spare wick, spare tip, spare jet and jet cleaner.
- 1 Tape TL-83, Friction, $\frac{3}{4}$ " wide, $\frac{1}{2}$ -lb. roll.
- 1 Tape TL-93, Rubber, $\frac{3}{4}$ " wide, $\frac{1}{2}$ -lb. roll.
- 1 Volt-ohmmeter, with metal cover and two sets of Batteries, one in use, one spare.

109. OPERATION OF SOLDERING IRON.

The gasoline-operated soldering iron is operated in much the same manner as a conventional blow-torch and one filling of gasoline will operate the iron for approximately one-half hour (Fig. 83).

a. To fill chamber with fuel, unscrew handle base and fill tube with fuel, (Fig. 84). Screw handle base tightly so that the fuel will not leak out. *See that Regulating Valve is turned up tightly to the right (in a clockwise direction).*

b. Stand the iron upright and fill priming cup (Fig. 85) about one-half full with denatured alcohol, gasoline, benzine or naphtha and ignite. Shield the iron from the wind, so that the flame

envelopes the barrel, to provide proper preheating of this section.

c. When the priming liquid is burned out, immediately open the regulation valve and touch lighted match to large holes in burner tube under the copper point. The vapor in the tube will ignite, causing a hissing noise. Leave iron in this position for approximately three minutes after starting to heat copper point to soldering temperature. The iron may thereafter be held in any position.

d. If iron starts with weak flame, the flame will gradually increase a few minutes after iron becomes heated. In the event that the iron should sputter or go out after priming, this may be caused by the priming cup being over-filled, causing over-generation of gas. Reduce flame for a few minutes by turning regulating valve until proper pressure is obtained (Fig. 86).

110. USE OF SOLDERING IRON.

a. Clean surfaces are essential. File or scrape surfaces to be soldered, to provide good electrical connection.

b. Copper tip of iron must be well-tinned. Dip copper point in flux or paste, then work iron in small portion of solder until it adheres to copper point. The copper must be hot for tinning. After

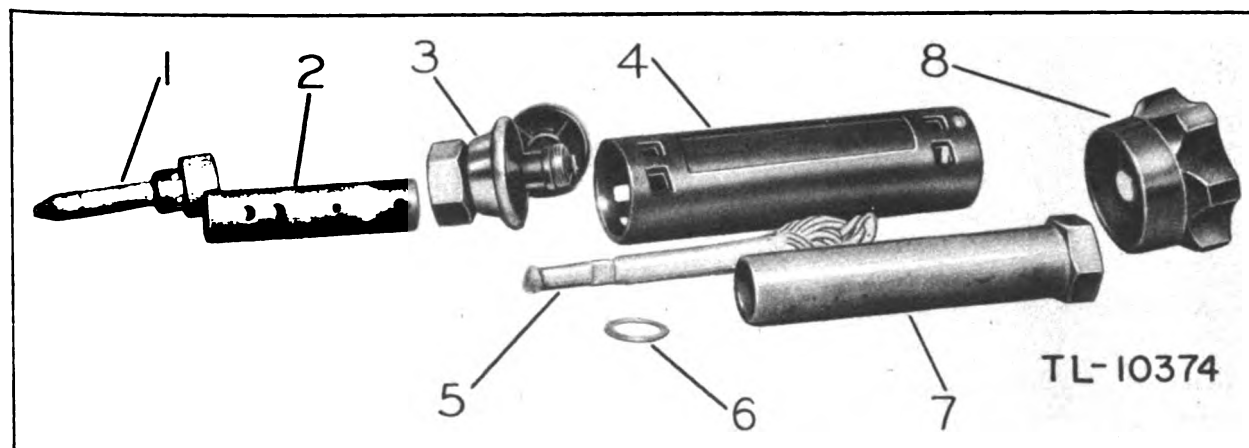

Figure 83—Soldering Iron, Gasoline Operated

- | | | | |
|------------------|-------------------------|-----------|---------------|
| 1. Soldering tip | 3. Burner tip and valve | 5. Wick | 7. Tank |
| 2. Burner body | 4. Handle | 6. Washer | 8. Filler cap |

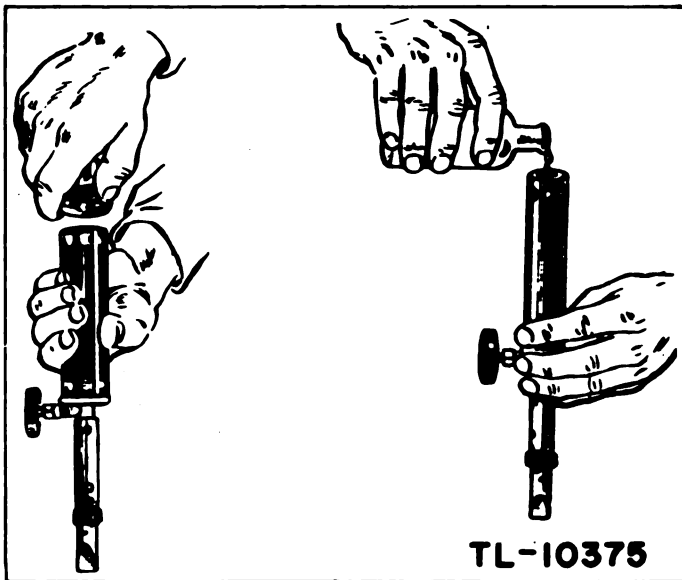

Figure 84
Filling Chamber

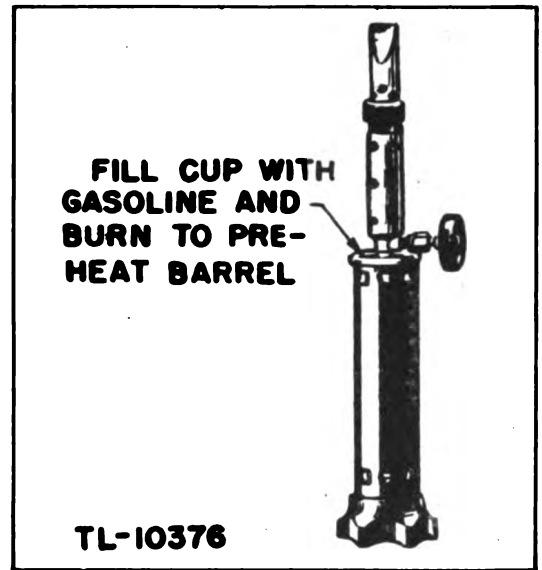

Figure 85
Filling priming cup

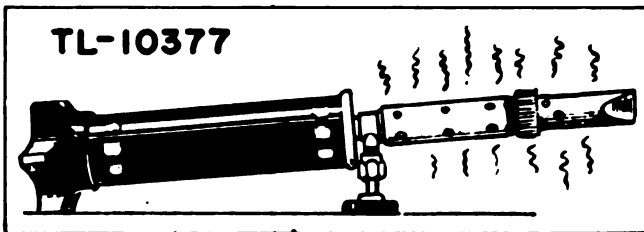

Figure 86
Regulating valve adj.

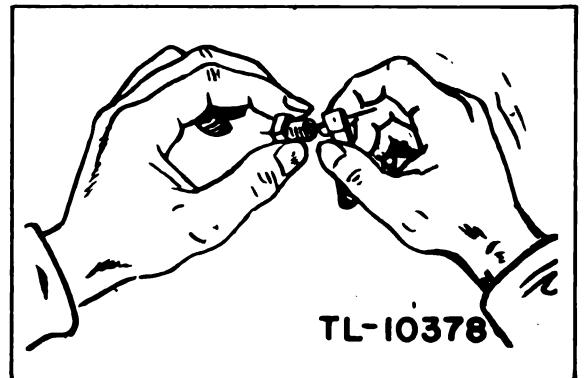

Figure 87
Cleaning burner tip

considerable use, file off copper point to keep in good condition.

c. Copper point must be hot enough to allow solder to flow freely. If the point is too hot, the solder point will be burned and it will be necessary to retard the flame valve or dip the copper point in water.

111. MAINTENANCE OF SOLDERING IRON.

a. After soldering iron has been used, it is possible that the burner will carbonize and require cleaning. Spare tips are contained in the handle, which also contains a cleaner for cleaning burner tip.

b. To clean burner tip, unscrew burner tube and unscrew burner tip from generating chamber. Insert tip cleaner in large opening of burner tip

so it will extend through the tip (Fig. 87). Always keep holes in burner tube clean. Soot may accumulate from priming.

c. Should leakage occur in regulating valve, tighten valve nut. Such leakage would cause gas pressure to reduce. Always fill fuel tube level full before starting.

d. It is recommended that plain gasoline, benzine or naphtha be used as iron will require less cleaning with this type of fuel. It can be operated with vehicular gasoline (Ethyl) but the use of this gasoline tends to cause carbonizing at the burner tip.

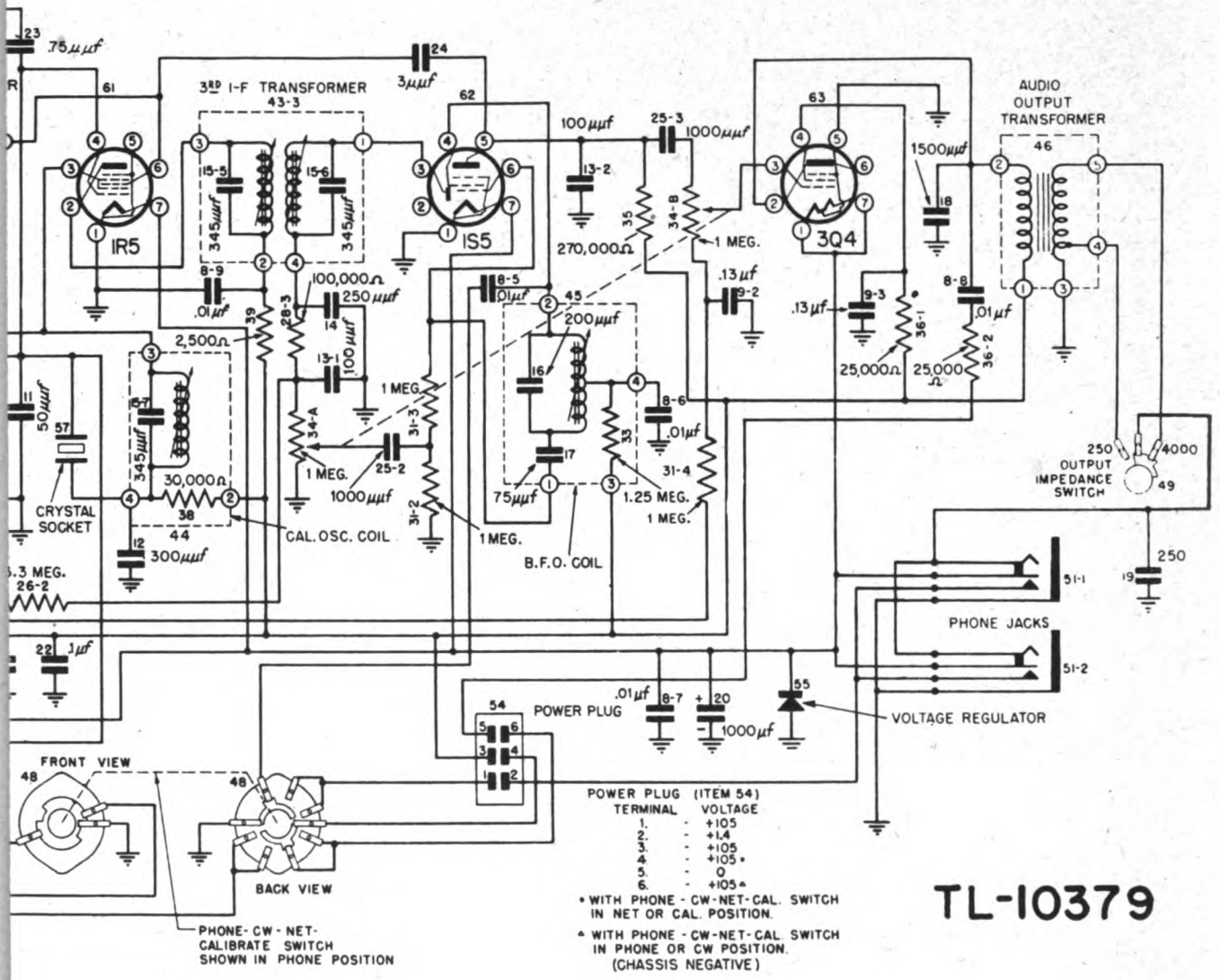

Fig. 88—Schematic Diagram Receiver BC-1306

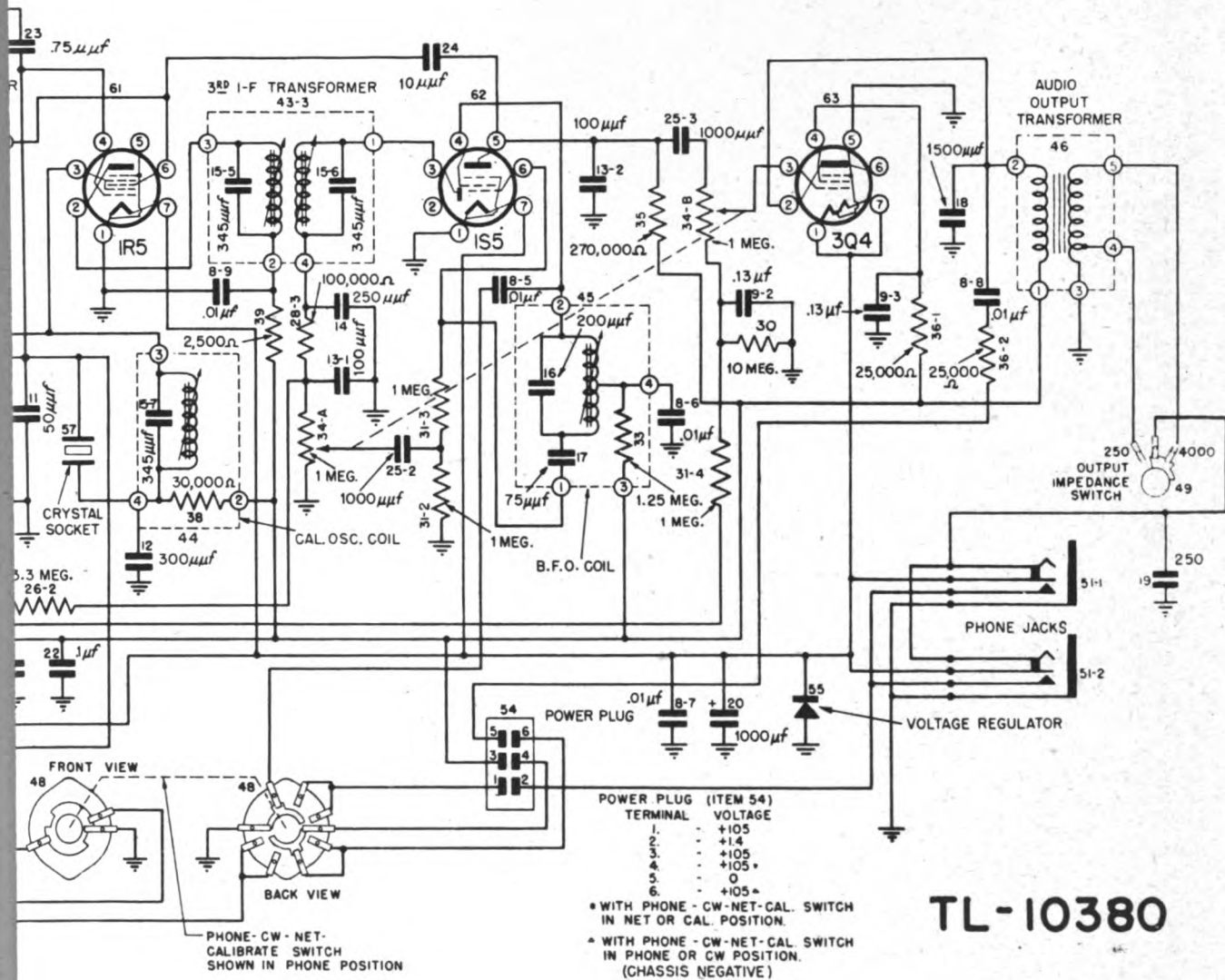
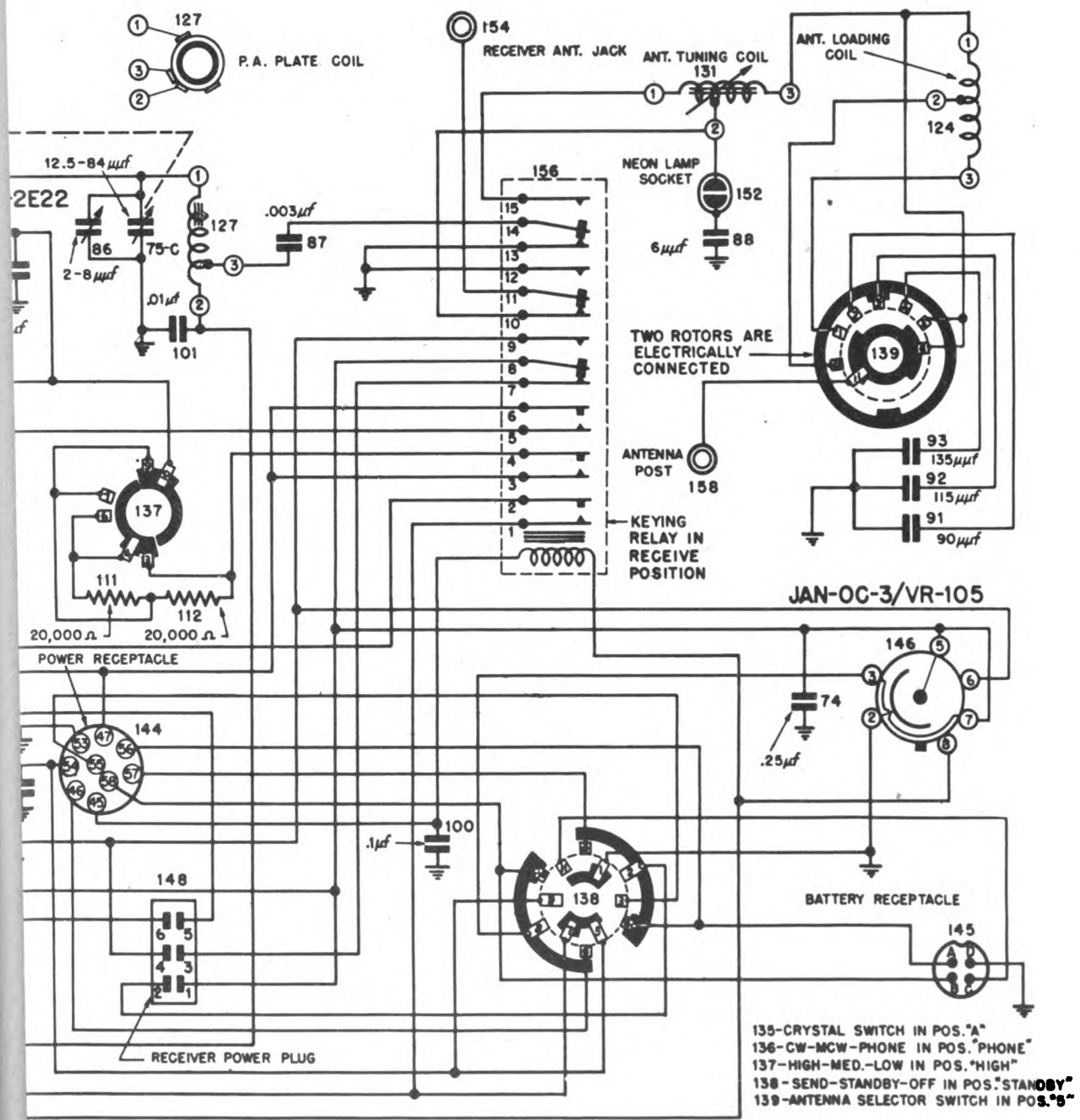

Fig. 89—Schematic Diagram Receiver RT-12/TRC-2



TL-10381

Fig. 90—Schematic Diagram Transmitter BC-1306

CRYSTAL SWITCH IN POS. "A"
 CW-MCW-PHONE IN POS. "PHONE"
 HIGH-MED-LOW IN POS. "HIGH"
 ON-OFF-STANDBY-OFF IN POS. "STANDBY"
 ANTENNA SELECTOR SWITCH IN POS. "2"

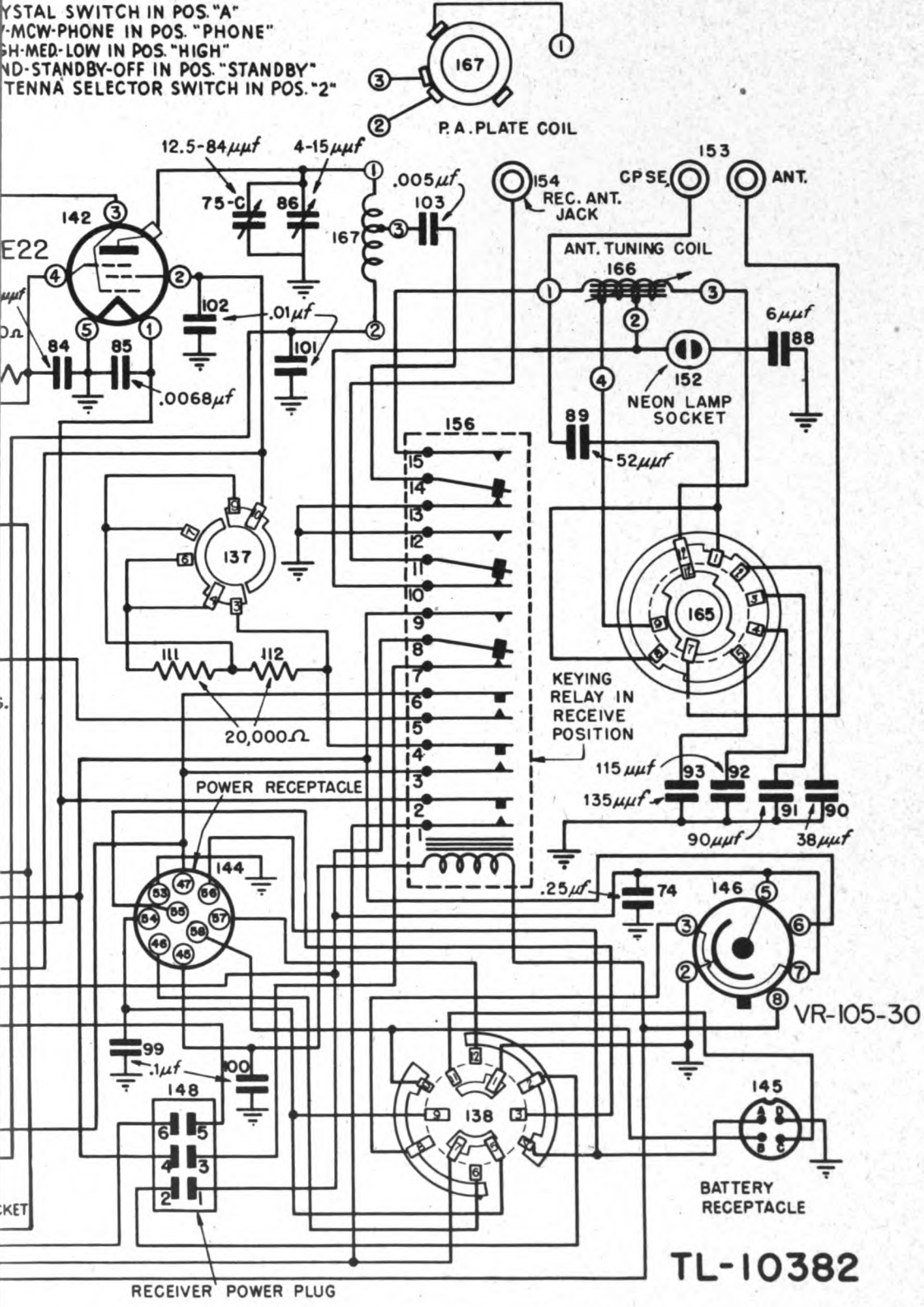

TL-10382

Fig. 91—Schematic Diagram Transmitter RT-12/TRC-2

PART FIVE. SUPPLEMENTARY DATA.

Par. 110 MAINTENANCE PARTS LIST FOR RADIO SET AN/TRC-2. (PART I.)

NOTE: Order maintenance parts by stock number, name, and description. Only maintenance parts can be requisitioned.

Ref symbol	Signal Corps stock No.	Name of part and description	Running spares	Orign stock	3d ech	4th ech	5th ech	Depot stock	Quan per AN/TRC-2
	2A275-160	ANTENNA AN-160			*	*	*	*	5
	3E1999-19	CORD CD-1119.			*	*	*	*	2
	3E1307A-15	CORD CD-307-A.			*	*	*	*	3
	3E1933	CORD CD-933.			*	*	*	*	3
	3E1318A	CORD CD-318-A.			*	*	*	*	1
	3E1618	CORD CD-618.			*	*	*	*	
	3E1999-86	CORD CD-1086 (7 ft.)			*	*	*	*	2
	3E6000-75	CORD CX-75/TRC-2.			*	*	*	*	2
	3H1407	CRANK GC-7.			*	*	*	*	2
	2Z3501-24()	CRYSTAL HOLDER FT-241-A (DC-24-A); 200 kc; 2 crystals in each set for receiver.			*	*	*	*	1
	2X5B-3150	CRYSTAL HOLDER FT-243; 1,900 kc-3,250 kc.			*	*	*	*	1
	3H2357	GENERATOR GN-57; hand (component).			*	*	*	*	1
		GENERATOR GN-57; hand (repair parts).							
	ZA1334	GUY GY-34.			*	*	*	*	6
	ZA1335	GUY GY-35.			*	*	*	*	2
	2A275-160/R2	GUY CORD; long (42 ft.).			*	*	*	*	4
		HALYARD; antenna; short (10 ft.).			*	*	*	*	1
	2A275-160/R4	HALYARD; (65 ft.).			*	*	*	*	1
	2A275-160/R3	HALYARD; counterpoise (18 ft.).			*	*	*	*	1
	2B830	HEADSET HS-30; (component).			*	*	*	*	3
		HEADSET HS-30; (repair parts).							
	2Z6102A	LEG LG-2-A.			*	*	*	*	1
	2Z6103	LEG LG-3.			*	*	*	*	2
	6013188	TECHNICAL MANUAL TM 11-2603.			*	*	*	*	2

*Indicates stock available.

Par. 110 MAINTENANCE PARTS LIST FOR RADIO SET AN/TRC-2. (PART I.)

NOTE: Order maintenance parts by stock number, name, and description. Only maintenance parts can be requisitioned.

Ref symbol	Signal Corps stock No.	Name of part and description	Running spares	Orgn stock	3d ech	4th ech	5th ech	Depot stock	Quan per AN/TRC-2
	3Z3445	KEY J-45.			*	*	*	*	2
	6C51	LOUDSPEAKER LS-11.			*	*	*	*	1
	2A2391	MAST SECTION MS-91: (same as SC-D-4983 Group One).			*	*	*	*	2
	2A2392	MAST SECTION MS-92.			*	*	*	*	2
	2A2393	MAST SECTION MS-93: (Group Three).			*	*	*	*	2
	2A2394	MAST SECTION MS-94: (Group Four).			*	*	*	*	2
	2B1617	MICROPHONE T-17: (component).			*	*	*	*	1
		MICROPHONE T-17: (repair parts).							
	2B1645	MICROPHONE T-45: (component).			*	*	*	*	1
		MICROPHONE T-45: (repair parts).							
	6Z8372	NOZZLE: flexible; QMC-42-7-1375.			*	*	*	*	1
	3H4600-162	POWER UNIT PE-162: (component).			*	*	*	*	2
		POWER UNIT PE-162: (repair parts).							
	2C5395-1306	RECEIVER-TRANSMITTER BC-1306: (component).			*	*	*	*	1
		RECEIVER-TRANSMITTER BC-1306: (repair parts).							
	2C5130-12	RECEIVER-TRANSMITTER RT-12/TRC-2: (component).			*	*	*	*	1
		RECEIVER-TRANSMITTER RT-12/TRC-2: (repair parts).							
	2A3129()	REEL RL-29-() .			*	*	*	*	5
	2Z8061-9	ROLL CW-9/TRC-2: antenna.			*	*	*	*	2
	2A3302	STAKE GP-2.			*	*	*	*	10
	6R37993	TOOL KIT.			*	*	*	*	1
	3H4497-39	VIBRATOR POWER SUPPLY PP-39/TRC-2: (component).			*	*	*	*	2
		VIBRATOR POWER SUPPLY PP-39/TRC-2: (repair parts).							

Par. 111 MAINTENANCE PARTS LIST FOR RADIO SET AN/TRC-2. (PART II.)

NOTE: Order maintenance parts by stock number, name, and description. Only maintenance parts can be requisitioned.

Ref symbol	Signal Corps stock No.	Name of part and description	Running spares	Orgn stock	3d ech	4th ech	5th ech	Depot stock	Quan per AN/TRC-2
3A48		BATTERY BA-48.			*	*	*	*	4
3854A		BATTERY BB-54-A.			*	*	*	*	2
2J2E22		TUBE JAN 2E22.			*	*	*	*	2
2JOC3/VR105		TUBE JAN 2JOC3/VR105.			*	*	*	*	2
2J1S5		TUBE JAN 1S5 (VT-172).			*	*	*	*	2
2J3A4		TUBE JAN 3A4.			*	*	*	*	4
2J1L4		TUBE JAN 1L4.			*	*	*	*	4
2J1R5		TUBE JAN 1R5 (VT-171).			*	*	*	*	4
2J3Q4		TUBE JAN 3Q4 (VT-264).			*	*	*	*	2
ZZ5971.1		NEON BULB: Sylvania T-4½.			*	*	*	*	2
ZZ5889-3		PILOT LAMP: Mazda S-47.			*	*	*	*	4

*Indicates stock available.

Par. 112 MAINTENANCE PARTS LIST FOR RADIO RECEIVER AND TRANSMITTER BC-1306. (RECEIVER GROUP).

NOTE: Order maintenance parts by stock number, name, and description. Only maintenance parts can be requisitioned.

Ref symbol	Signal Corps stock No.	Name of part and description	Running spares	Ordn stock	3d ech	4th ech	5th ech	Depot stock	Quan per BC-1306
23	309000.75-1	CAPACITOR: fixed; bakelite; $75\mu\text{mf} \pm 66.6\%$ -0.0%; 300 v. dc; Stackpole, Rauland CC-010.			•	•	•	•	1
24	3D9003-16.1	CAPACITOR: fixed; ceramic; $3\text{-}\mu\text{mf} \pm 10\%$ 500 v dc; Muter type A or types 11 & 12.			•	•	•	•	1
3	3DK9013V-3	CAPACITOR: variable; $3\text{-}13\text{-}\mu\text{mf} \pm 20\%$; Erie TS2A, type N300.			•	•	•	•	1
4	3D9030V-6	CAPACITOR: variable; $4\text{-}30\text{-}\mu\text{mf}$; 500 v dc; Erie TS2A-N500.			•	•	•	•	1
2	2D9020V-8	CAPACITOR: variable; ceramic; $5\text{-}20\text{-}\mu\text{mf}$; 500 v dc; Erie TS2A, type N300.			•	•	•	•	1
11	3D9050-79.2	CAPACITOR: fixed; ceramic; $50\text{-}\mu\text{mf} \pm 5\%$; 300 v dc; Muter type B.			•	•	•	•	1
10	3D9050-49.4	CAPACITOR: fixed; ceramic; $50\text{-}\mu\text{mf} \pm 10\%$; 300 v dc; Erie type M.			•	•	•	•	1
1A-1C	3D9097V	CAPACITOR: variable; air dielectric; $14\text{-}97\text{-}\mu\text{mf}$; 500 peak volts; Oak 904-3-24.			•	•	•	•	1
5	3D9090-10	CAPACITOR: fixed; ceramic; $90\text{-}\mu\text{mf} \pm 3\%$; 300 v dc; Centralab 813.			•	•	•	•	1
13	3D90100-126	CAPACITOR: fixed; ceramic; $100\text{-}\mu\text{mf} \pm 20\%$; 300 v dc; Muter type B.			•	•	•	•	1
19	3D9250-66	CAPACITOR: fixed; mica; $250\text{-}\mu\text{mf} \pm 20\%$; 300 v dc; Underwood CM-251E.			•	•	•	•	1
14	3D9250-65	CAPACITOR: fixed; ceramic; $250\text{-}\mu\text{mf} \pm 20\%$; 300 v dc; Muter type B.			•	•	•	•	1
12	3D9300-8	CAPACITOR: fixed; mica; $300\text{-}\mu\text{mf} \pm 10\%$; 300 v dc; Mica-mold OXM.			•	•	•	•	1
7	3D9600-19	CAPACITOR: fixed; mica; $600\text{-}\mu\text{mf} \pm 10\%$; 300 v dc; Mica-mold OXM.			•	•	•	•	1
25	3DA1-123	CAPACITOR: fixed; ceramic; $1,000\text{-}\mu\text{mf} \pm 10\%$; 500 v dc; Muter type B or 20.			•	•	•	•	1
20	3DB1000-3	CAPACITOR: fixed; electrolytic; $1,000\text{-}\mu\text{f} \pm 50\%$, -20%; 3 v dc; Magnavox 4376.			•	•	•	•	1
17	3DA1.500-18	CAPACITOR: fixed; ceramic; $1,500\text{-}\mu\text{mf} \pm 20\%$; 300 v dc; Muter type B or 20.			•	•	•	•	1

Par. 112 MAINTENANCE PARTS LIST FOR RADIO RECEIVER AND TRANSMITTER BC-1306. (RECEIVER GROUP).

NOTE: Order maintenance parts by stock number, name, and description. Only maintenance parts can be requisitioned.

Ref symbol	Signal Corps stock No.	Name of part and description	Running spraes	Orgn stock	3d ech	4th ech	5th ech	Depot stock	Quan per BC-1306
33	3RC10AE125K	RESISTOR: fixed; carbon; insulated; 1.25-meg ±10%; 1/4-watt; Stackpole type MB 1/4.			•	•	•	•	1
26	3RC-10AE335M	RESISTOR: fixed; carbon; insulated; 3.3-meg ±20%; 1/4-watt; ASA type RC10AE335M.			•	•	•	•	1
30	3RC10AE106K	RESISTOR: fixed; carbon; insulated; 10-meg ±10%; 1/4-watt; ASA type RC10AE106K.			•	•	•	•	1
57	2Z8672-28	SOCKET: crystal; 2-contact; Cinch 9816.			•	•	•	•	1
58-63	2Z8799-19	SOCKET: miniature tube; 7-contact; low-loss bakelite.			•	•	•	•	6
47	3Z9825-62.94	SWITCH: rotary; Oak type 26760-HI.			•	•	•	•	1
48	3Z9825-62.93	SWITCH: rotary; Oak type 26763-HI.			•	•	•	•	1
49	3Z9825-62.92	SWITCH: rotary; Oak type 26780-23.			•	•	•	•	1
50	3Z9824-42.1	SWITCH: push button; Stackpole type SM.			•	•	•	•	1
45	2C5395-1306/T4	TRANSFORMER: r-f; Monarch LU-0002.			•	•	•	•	1
40	2C5395-1306/T2	TRANSFORMER: r-f; antenna coil transformer; Standard Coil Products LV-0005.			•	•	•	•	1
41	2C5395-1306/T1	TRANSFORMER: r-f; Standard Coil Products LW-0007.			•	•	•	•	1
42	2C5395-1306/T3	TRANSFORMER: r-f; Standard Coil Products LL-0020.			•	•	•	•	1
43	2Z9641.80	TRANSFORMER: i-f; peaked at 456 kc; Rauland dwg LR-0002; special.			•	•	•	•	1
46	2Z9632.133	TRANSFORMER: audio; output; Rauland dwg LO-0072; special; Standard Transformer Corp. 234-A7.			•	•	•	•	1

*Indicates stock available.

Par. 113 MAINTENANCE PARTS LIST FOR RADIO RECEIVER AND TRANSMITTER BC-1306. (TRANSMITTER GROUP.)

NOTE: Order maintenance parts by stock number, name, and description. Only maintenance parts can be requisitioned.

Ref symbol	Signal Corps stock No.	Name of part and description	Running spares	Orgn stock	3d ech	4th ech	5th ech	Depot stock	Quan per BC-1306
75A-75-C	3D9145V-3	CAPACITOR: variable; air; 3-section; Rauland CV-331.			•	•	•	•	1
81	3D9001VE5-1	CAPACITOR: variable; ceramic; 1.5- μ mf minimum; 7- μ mf maximum.			•	•	•	•	1
77	3D9008V-6	CAPACITOR: variable; air; 2-8- μ mf; Oak 884-AT.			•	•	•	•	1
76A-76B	3D9010V-6	CAPACITOR: variable; air; 2-section; 2- μ mf minimum, 10- μ mf maximum.			•	•	•	•	1
73	3D9003-16.1	CAPACITOR: fixed; ceramic; 3- μ mf \pm 10%; 300 v dc; Muter type A.			•	•	•	•	1
86	3D9015V-19	CAPACITOR: variable; air; 4-15- μ mf; 4,000 peak volts; Oak 886-AT.			•	•	•	•	1
104	3D9006-11	CAPACITOR: fixed; ceramic; 6- μ mf \pm 5%; 500 v dc; Centralab.			•	•	•	•	1
78	3D9015-26	CAPACITOR: fixed; ceramic; 15- μ mf \pm 5%; 500 v dc; Centralab 667-A.			•	•	•	•	1
91	3D9090-9	CAPACITOR: fixed; ceramic; 90- μ mf \pm 5%; 500 v dc; Muter type 40 or 41 or type A.			•	•	•	•	1
92	3D9115	CAPACITOR: fixed; ceramic; 115- μ mf \pm 5%; 500 v dc; Muter type 40 or 41 or type A.			•	•	•	•	1
93	3D9135-6	CAPACITOR: fixed; ceramic; 135- μ mf \pm 5%; 500 v dc; Muter type 41.			•	•	•	•	1
84-96	3DA1-123	CAPACITOR: fixed; ceramic; 1,000- μ mf \pm 10%; 500 v dc; Muter type B or 20.			•	•	•	•	2
79-80	3DKA1-91.1	CAPACITOR: fixed; mica; 1,000- μ mf \pm 10%; 500 v dc; Dubilier 5W.			•	•	•	•	2
87	3DA3-5	CAPACITOR: fixed; mica; 3,000- μ mf \pm 10%; 750 v dc; Mica-mold "W."			•	•	•	•	1
103	3DA5-18	CAPACITOR: fixed; mica; 5,000- μ mf \pm 10%; 500 v dc; Dubilier type IR or Aerovox 1464.			•	•	•	•	1
85	3DA6.800-2	CAPACITOR: fixed; ceramic; 6,800- μ mf \pm 30% - 20%; 300 v dc; Muter type D.			•	•	•	•	1
101	3DA10-126.1	CAPACITOR: fixed; paper; 10,000- μ mf \pm 10%; 1,000 v dc; Micamold 345-25.			•	•	•	•	1

*Indicates stock available.

Par. 113 MAINTENANCE PARTS LIST FOR RADIO RECEIVER AND TRANSMITTER BC-1306. (TRANSMITTER GROUP.)

NOTE: Order maintenance parts by stock number, name, and description. Only maintenance parts can be requisitioned.

Ref symbol	Signal Corps stock No.	Name of part and description	Running spares	Org'n stock	3d ech	4th ech	5th ech	Depot stock	Quan per BC-1306
102	3DA10-124.1	CAPACITOR: fixed; paper; 10,000- μ mf \pm 20%; 600 v dc; Micamold 342.			•	•	•	•	1
94	3DA10-160.1	CAPACITOR: fixed; paper; 10,000- μ mf \pm 20%; 120 v dc; Micamold 338-10, Philco 305-1523.			•	•	•	•	1
98	3DA20-85	CAPACITOR: fixed; paper; 20,000- μ mf \pm 20%; 300 v dc; Micamold 340-27; Rauland CP-203F.			•	•	•	•	1
82	3DA100-209.1	CAPACITOR: fixed; paper; 100,000- μ mf \pm 10%; 120 v dc; Micamold 340-22.			•	•	•	•	1
95	3DA100-209	CAPACITOR: fixed; paper; 100,000- μ mf \pm 20%; 120 v dc; Micamold 340-22.			•	•	•	•	3
99									
100									
74-83	3DA250-88	CAPACITOR: fixed; paper; 250,000- μ mf \pm 20%; 200 v dc; Gudeman 7016.			•	•	•	•	2
97	3DB25-34	CAPACITOR: fixed; electrolytic; 25- μ f \pm 100% -10%; 25 v dc; Micamold 935-1.			•	•	•	•	1
130	2C5395-1306/C1	COIL: r-f; choke; S. W. Inductor Co. SW3467.			•	•	•	•	1
129	2C5395-1306/C5	COIL: r-f; choke; S. W. Inductor Co. SW3475.			•	•	•	•	1
128	3C323-34B	COIL: r-f; choke; Rauland LC-0080.			•	•	•	•	1
127	2C5395-1306/C10	COIL: power-amplifier; r-f plate; Monarch LX-0013.			•	•	•	•	1
126	2C5395-1306/C8	COIL: r-f; doubler; Monarch LX-0011.			•	•	•	•	1
131	2C5395-1306/C4	COIL: r-f; antenna tuning; Monarch VG-0579.			•	•	•	•	1
125	2C5395-1306/C11	COIL ASSEMBLY: osc. grid tuning; Rauland LL-0018.			•	•	•	•	1
124	2C5395-1306/C9	COIL: antenna r-f loading; Monarch LX-0007.			•	•	•	•	1
154	2C9401.35	JACK ASSEMBLY: banana type; Rauland VG-0631.			•	•	•	•	1
150-151	2Z5598.6	JACK AND CABLE ASSEMBLY: microphone and key; Rauland VG-0634; special.			•	•	•	•	2
155	2Z5598-4	JACK: large banana type; Rauland BG 0315.			•	•	•	•	1
158	3Z774-5.1	POST: binding; screw-type; Rauland VG-1003.			•	•	•	•	1
145	2Z8799-134	RECEPTACLE: Socket SO-134.			•	•	•	•	1
144	2Z7119.12	RECEPTACLE: plug; 9 male pins; Rauland VG-0838.			•	•	•	•	1

Supplementary Data

157	3H4858-7	RECTIFIER: selenium; dry disc; filament voltage regulator; 157 ma \pm 13% at 76°F; Fansteel Q10361.																	1
156	Z7594	RELAY: keying; Auto E. Co. Z11247; C. P. Clare A-16214.																	1
121	3Z6006-17	RESISTOR: fixed; carbon; 60-ohm \pm 10%; $\frac{1}{2}$ -watt; Stackpole MB $\frac{1}{2}$.																	1
117	3Z6030-76	RESISTOR: fixed; carbon; 300-ohm \pm 20%; $\frac{1}{2}$ -watt; Stackpole MB $\frac{1}{2}$.																	1
109	3Z6170-4	RESISTOR: fixed; carbon; 1,700-ohm \pm 10%; $\frac{1}{2}$ -watt; Stackpole MB $\frac{1}{2}$.																	1
113	3RC31AE200J	RESISTOR: fixed; carbon; 20-ohm \pm 5%; 1-watt; Stackpole MB-1.																	1
114	3Z6350-31	RESISTOR: fixed; carbon; 3,500-ohm \pm 10%; $\frac{1}{2}$ -watt; Stackpole MB $\frac{1}{2}$.																	1
108	3Z6570-19	RESISTOR: fixed; carbon; 7,000-ohm \pm 10%; $\frac{1}{2}$ -watt; Stackpole MB $\frac{1}{2}$.																	1
110 118 119	3RC21BE183K	RESISTOR: fixed; carbon; 18,000-ohm \pm 10%; $\frac{1}{2}$ -watt; ASA type RC21BE183K.																	3
115	3Z6801-17	RESISTOR, POTENTIOMETER: single-section; 1-meg \pm 20%; Chicago Tel type LM.																	1
105	3Z6624-3	RESISTOR: 24,000-ohm \pm 5%; $\frac{1}{2}$ -watt; Erie 504.																	1
107	3Z6614-5	RESISTOR: fixed; carbon; 14,000-ohm \pm 10%; 1-watt; Stackpole MB-1.																	1
122	3Z5999-3	RESISTOR: fixed; wirewound on ceramic tube; 9.3-ohms \pm 2.5%; 5 watt; Scientific Industries 282.																	1
111 112	3Z6620-71	RESISTOR: fixed; wirewound; 20,000-ohm \pm 5%; 10-watt; Scientific Industries 280.																	2
106	3Z6625-59	RESISTOR: fixed; wirewound; 25,000-ohm \pm 5%; 10-watt; Scientific Industries 279.																	1
152	2Z5885-8	SOCKET ASSEMBLY: neon; candalabra bayonet; Drake Lamp socket 628W, and Drake nut 60D.																	1
146	2Z8678.52	SOCKET: regulator tube; octal; Rauland ST-800-E.																	1
149	2Z8678	SOCKET: 4-contact (for 2 crystal units, marked A and B); center mounting hole; crystals each mount in two holes; Cinch Mfg. 9804; part of BC-650 of SCR-609-A and SCR-610-A.																	1
142	2Z8675.46	SOCKET: PA tube socket; 5-prong; Rauland VG-0109.																	1

*Indicates stock available.

Par. 113 MAINTENANCE PARTS LIST FOR RADIO RECEIVER AND TRANSMITTER BC-1306. (TRANSMITTER GROUP.)

NOTE: Order maintenance parts by stock number, name, and description. Only maintenance parts can be requisitioned.

Ref symbol	Signal Corps stock No.	Name of part and description	Running spares	Orgn stock	3d ech	4th ech	5th ech	Depot stock	Quan per BC-1306
148	2Z7227-2	SOCKET: male; 6-prong; polarized; Jones P-306-AB.			•	•	•	•	1
140	2Z8677.36	SOCKET: miniature tube; 7-pin; Cinch 9834.			•	•	•	•	1
141	2Z8677.37	SOCKET: miniature tube; 7-pin; Cinch CP-50103.			•	•	•	•	1
143	2Z8678.52	SOCKET: octal; 8-pin; Amphenol 74-8.			•	•	•	•	1
147	2Z5883-69	SOCKET ASSEMBLY: miniature bayonet; Rauland SL-0021.			•	•	•	•	1
134	3Z9824-42.1	SWITCH: push button; Stackpole type SM.			•	•	•	•	1
135	3Z9825-32.81	SWITCH: rotary; Oak 25629-HI.			•	•	•	•	1
136	3Z9825-62.82	SWITCH: rotary; Oak 25630-HI.			•	•	•	•	1
137	3Z9825-62.88	SWITCH: rotary; Oak 25618-HI.			•	•	•	•	1
138	3Z9825-62.84	SWITCH: rotary; Oak 26671-HI.			•	•	•	•	1
139	3Z9825-62.85	SWITCH: rotary; Oak 26636-HI-C.			•	•	•	•	1
132	2Z9631.95	TRANSFORMER: input; a-f microphone; Stancor 234-A5.			•	•	•	•	1
133	2Z9634.39	TRANSFORMER: modulation; Stancor 234-A6.			•	•	•	•	1

*Indicates stock available.

Supplementary Data

Par. 114 MAINTENANCE PARTS LIST FOR RECEIVER-TRANSMITTER RT-12/TRC-2 (RECEIVER GROUP).

NOTE: Order maintenance parts by stock number, name, and description. Only maintenance parts can be requisitioned.

Ref symbol	Signal Corps stock No.	Name of part and description	Running spares	Orgn stock	3d ech	4th ech	5th ech	Depot stock	Quan per RT-12/TRC-2
23	3D9000-75-1	CAPACITOR: fixed; 0.75- μ mf.			•	•	•	•	1
24	3D9003-16	CAPACITOR: fixed; 3- μ mf \pm 10%; 300 v dc.			•	•	•	•	1
3	3DK9013V-3	CAPACITOR: variable; 3-13- μ mf.			•	•	•	•	1
4	3D9030V-6	CAPACITOR: variable; 4-30- μ mf.			•	•	•	•	1
2	3D9020V-8	CAPACITOR: variable; 5-20- μ mf.			•	•	•	•	1
11	3D9050-79.2	CAPACITOR: fixed; 50- μ mf \pm 5%; 300 v dc.			•	•	•	•	1
10	3D9050-49.4	CAPACITOR: fixed; 50- μ mf \pm 10%; 300 v dc			•	•	•	•	1
1-A to 1-C	3D9097V	CAPACITOR: variable; air; 14-97 μ mf.			•	•	•	•	1
5	3D9002E5-1	CAPACITOR: variable; 2.5- μ mf.			•	•	•	•	1
13	3D9100-126	CAPACITOR: fixed; 100- μ mf \pm 20%; 300 v dc.			•	•	•	•	1
19	3D9250-66	CAPACITOR: fixed; mica; 250- μ mf \pm 20%; 300 v dc; special assembly.			•	•	•	•	1
14	3D9250-65	CAPACITOR: fixed; 250- μ mf \pm 20%; 300 v dc.			•	•	•	•	1
12	3D9300-8.1	CAPACITOR: fixed; silver-mica; 300- μ mf \pm 10%; 300 v dc.			•	•	•	•	1
7	3D9400-23	CAPACITOR: fixed; mica; 400- μ mf \pm 10%; 300 v dc; CM 25A391K.			•	•	•	•	1
25	3DA1-123	CAPACITOR: fixed; 1,000- μ mf \pm 10%; 300 v dc.			•	•	•	•	1
20	3DB1000-3	CAPACITOR: fixed; electrolytic; 1,000- μ f + 50% - 20%;			•	•	•	•	1
18	3DA1.500-18	CAPACITOR: fixed; 1,500- μ mf \pm 20%; 300 v dc.			•	•	•	•	1
8	3DA10-160.1	CAPACITOR: fixed; paper; 10,000- μ mf \pm 20%; 120 v dc.			•	•	•	•	1
22	3DA100-209	CAPACITOR: fixed; paper; 100,000- μ mf \pm 20%; 120 v dc.			•	•	•	•	1
9	3DA130-5	CAPACITOR: fixed; paper; 130,000- μ mf \pm 20%; 150 v dc.			•	•	•	•	1
21	3DA250-88	CAPACITOR: fixed; paper; 250,000- μ mf \pm 20%; 200 v dc.			•	•	•	•	1
44	2C5395-1306/C	COIL: r-f; oscillator; wound on bakelite tube.			•	•	•	•	1
52	2Z5998-5	JACK: banana type.			•	•	•	•	1

*Indicates stock available.

Par. 114 MAINTENANCE PARTS LIST FOR RECEIVER-TRANSMITTER RT-12/TRC-2 (RECEIVER GROUP).

NOTE: Order maintenance parts by stock number, name, and description. Only maintenance parts can be requisitioned.

Ref symbol	Signal Corps stock No.	Name of part and description	Running spares	Orgn stock	3d ech	4th ech	5th ech	Depot stock	Quan per RT-12/TRC-2
51	2Z5598-7	JACK: phone.			•	•	•	•	1
	2Z5816-21	KNOB: tuning; black bakelite.			•	•	•	•	1
54	2Z7227-2	PLUG: 6-pole; male.			•	•	•	•	1
53	2Z6721-237A/T1	POST: binding.			•	•	•	•	1
34-A 34-B	2Z7284-43	POTENTIOMETER: dual; 1-meg = 20%; carbon.			•	•	•	•	1
55	3H4858-7	RECTIFIER: selenium; 2-plate; dry disc.			•	•	•	•	1
39	3Z6250-74	RESISTOR: carbon; 2,500-ohm = 20%; 1/4-watt; RC10AE-242J.			•	•	•	•	1
29	3Z6620-117	RESISTOR: carbon; 20,000-ohm = 10%; 1/4-watt; RC10-AE203J.			•	•	•	•	1
36	3Z6625-102	RESISTOR: carbon; 25,000-ohm = 10%; 1/4-watt; RC10-AE243J.			•	•	•	•	1
27	3Z6633-3	RESISTOR: carbon; 33,000-ohm = 10%; 1/4-watt; RC10-AE333K.			•	•	•	•	1
32	3Z6660-24	RESISTOR: carbon; 60,000-ohm = 10%; 1/4-watt; RC10AE-623J.			•	•	•	•	1
28	3RC10AE104K	RESISTOR: carbon; 100,000-ohm = 10%; 1/4-watt; RC10-AE104K.			•	•	•	•	1
35	3RC10AE274K	RESISTOR: carbon; 270,000-ohm = 10%; 1/4-watt; RC10-AE274K.			•	•	•	•	1
37	3Z6750-56	RESISTOR: carbon; 500,000-ohm = 10%; 1/4-watt; RC10-AE514J.			•	•	•	•	1
31	3RC10AE105K	RESISTOR: carbon; 1-meg = 10%; 1/4-watt; RC10AE104K.			•	•	•	•	1
33	3RC10AE125K	RESISTOR: carbon; 1.25-meg = 20%; RC10AE135J.			•	•	•	•	1
26	3Z6803A3-2	RESISTOR: carbon; 3.3-meg = 20%; 1/4-watt; RC10AE335M.			•	•	•	•	1
30	3RC10AE106K	RESISTOR: carbon; 10-meg = 10%; 1/4-watt; RC10AE106K.			•	•	•	•	1
57	2Z8672-28	SOCKET: 2-pin; molded phenolic.			•	•	•	•	1
58 to 63	2Z8799-19	SOCKET: miniature tube; 7-pin; low-loss bakelite.			•	•	•	•	5
47	3Z9825-62.94	SWITCH: rotary; 1-pole; 3-position; single-section.			•	•	•	•	1

Par. 115 MAINTENANCE PARTS LIST FOR RECEIVER-TRANSMITTER RT-12/TRC-2 (TRANSMITTER GROUP).

NOTE: Order maintenance parts by stock number, name, and description. Only maintenance parts can be requisitioned.

Ref symbol	Signal Corps stock No.	Name of part and description	Running spares	Orgn stock	3d ech	4th ech	5th ech	Depot stock	Quan per RT-12/TRC-2
75-A to 75-C	3D9145V-3	CAPACITOR: variable; air; 3-section.			•	•	•	•	1
81	3D9001VE5-1	CAPACITOR: variable; min. capacity 1.5 μmf , max. capacity 7 μmf ; single-section; 2-plate.			•	•	•	•	1
77	3D9008V-6	CAPACITOR: variable; air; min. capacity 2 μmf , max. capacity 8 μmf ; single-section; 3-plate.			•	•	•	•	1
76-A to 76-B	3D9010V-6	CAPACITOR: variable; air; min. capacity 2 μmf , max. capacity 10 μmf ; 2-section; 4-plate.			•	•	•	•	1
86	3D9015V-19	CAPACITOR: variable; air; 4-15- μmf ; single-section; 11-plate.			•	•	•	•	1
104	3D9006-11	CAPACITOR: fixed; 6- μmf \pm 5%; 500 v dc.			•	•	•	•	1
78	3D9015-26	CAPACITOR: fixed; 15- μmf \pm 5%; 500 v dc.			•	•	•	•	1
91	3D9090-9	CAPACITOR: fixed; 90- μmf \pm 5%; 5,000 v dc.			•	•	•	•	1
92	3D9115	CAPACITOR: fixed; 115- μmf \pm 5%; 5,000 v dc.			•	•	•	•	1
93	3D9135-6	CAPACITOR: fixed; 135- μmf \pm 5%; 5,000 v dc.			•	•	•	•	1
84 to 96	3DA1-124	CAPACITOR: fixed; 1,000- μmf \pm 20%; 300 v dc.			•	•	•	•	2
79 to 80	3DA1-55	CAPACITOR: fixed; mica; 1,000- μmf \pm 10%; 500 v dc.			•	•	•	•	2
87	3DA3-5	CAPACITOR: fixed; mica; 3,000- μmf \pm 10%; 750 v dc.			•	•	•	•	1
85	3DA6.800-2	CAPACITOR: fixed; 6,800- μmf \pm 30% -20%; 300 v dc.			•	•	•	•	1
101	3DA10-126.1	CAPACITOR: fixed; paper; 10,000- μmf \pm 10%; 1,000 v dc.			•	•	•	•	1
94 to 102	3DA10-124.1	CAPACITOR: fixed; paper; 10,000- μmf \pm 10%; 600 v dc.			•	•	•	•	2
98	3DA20-85	CAPACITOR: fixed; paper; 20,000- μmf \pm 20%; 300 v dc.			•	•	•	•	1
82	3DA100-209.1	CAPACITOR: fixed; paper; 100,000 μmf \pm 10%; 120 v dc.			•	•	•	•	1
95 to 100	3DA100-68	CAPACITOR: fixed; paper; 100,000- μmf \pm 20%; 120 v dc.			•	•	•	•	3
74	3DA250-88	CAPACITOR: fixed; paper; 250,000- μmf \pm 20%; 200 v dc.			•	•	•	•	1
83	3DA250-88	CAPACITOR: fixed; paper; 250,000- μmf \pm 20%; 200 v dc.			•	•	•	•	1

Par. 115 MAINTENANCE PARTS LIST FOR RECEIVER-TRANSMITTER RT-12/TRC-2 (TRANSMITTER GROUP).

NOTE: Order maintenance parts by stock number, name, and description. Only maintenance parts can be requisitioned.

Ref symbol	Signal Corps stock No.	Name of part and description	Running spares	Orgn stock	3d ech	4th ech	5th ech	Depot stock	Quan per RT-12/TRC-2
107	3Z6614-5	RESISTOR: fixed; carbon; 14,000-ohm \pm 10%; $\frac{1}{2}$ -watt; AWS RC31BE133J.			•	•	•	•	1
122	3Z5999-3	RESISTOR: fixed; 9.3-ohm \pm 2.5%; 5-watt.			•	•	•	•	1
111 112	3Z6620-71	RESISTOR: fixed; 20,000-ohm \pm 5%; 10-watt.			•	•	•	•	2
106	3Z6625-59	RESISTOR: fixed; 25,000-ohm \pm 5%; 10-watt.			•	•	•	•	1
152	2Z5885-8	SOCKET: capacitor; bayonet type.			•	•	•	•	1
146	2Z8678-52	SOCKET: octal.			•	•	•	•	1
149	2Z8678	SOCKET: 4-pin; female.			•	•	•	•	1
142	2Z8675-46	SOCKET: tube; 5-pin; mica-filled insulation.			•	•	•	•	1
148	2Z7227-2	SOCKET: 6-pin; male.			•	•	•	•	1
140	2Z8677-36	SOCKET: miniature tube; 7-pin; ceramic.			•	•	•	•	1
143	2Z8678-52	SOCKET: octal; 8-pin.			•	•	•	•	1
141	2Z8677-37	SOCKET: miniature tube; 7-pin; low-loss phenolic.			•	•	•	•	1
147	2Z5883-69	SOCKET: miniature; bayonet type.			•	•	•	•	1
134	3Z9824-42.1	SWITCH: push button; SPST; normally open.			•	•	•	•	1
135	3Z9825-62.81	SWITCH: rotary selector; single-section; 3-position.			•	•	•	•	1
136	3Z9825-62.82	SWITCH: rotary selector; single-section; 3-position; bakelite insulation.			•	•	•	•	1
137	3Z9825-62.83	SWITCH: rotary; single-section; 3-position; bakelite insulation.			•	•	•	•	1
138	3Z9825-62.84	SWITCH: rotary; single-section; 3-position; bakelite insulation.			•	•	•	•	1
139	3Z9825-62.87	SWITCH: rotary; single-section; 6-position; ceramic insulation.			•	•	•	•	1
132	2Z9631-95	TRANSFORMER: audio; microphone in aluminum can.			•	•	•	•	1
133	2Z5334-39	TRANSFORMER: audio; modulation in aluminum can.			•	•	•	•	1

*Indicates stock available.

Par. 116 MAINTENANCE PARTS LIST FOR POWER UNIT PE-162.

NOTE: Order maintenance parts by stock number, name, and description. Only maintenance parts can be requisitioned.

Ref symbol	Signal Corps stock No.	Name of part and description	Running spares	Orgn stock	3d ech	4th ech	5th ech	Depot stock	Quan per Unit
	3H1912A	ENGINE GE-12-A: (component).				*		*	1
		ENGINE GE-12-A: (repair parts).							
	3H2350	GENERATOR GN-50: Leland 10511KJ9.				*		*	1

Par. 117 MAINTENANCE PARTS LIST FOR POWER UNIT PE-162 (GENERATOR GROUP).

3H2351A B10	BEARING: ball; alloy steel; New Departure 88502.				*	*	*	*	1
3H2350 B6	BRUSH: dc; carbon; low-voltage; C.G-65.				*	*	*	*	2
3H2350 B6	BRUSH: dc; carbon; high-voltage; 802H.				*	*	*	*	2
3H2350 C1	CAP: brush; bakelite.				*	*	*	*	4
3H1912A/C45	COUPLING: spline.				*	*	*	*	1
3H2351A G1	GASKET: outlet plate.				*	*	*	*	1
3H1912A/P21	PIN: spline coupling.				*	*	*	*	1

Par. 118 MAINTENANCE PARTS LIST FOR POWER UNIT PE-162 (GENERAL HARDWARE GROUP).

6L3610-34	NUT: steel; hex; No. 10-24.				*	*	*	*	1
6L2610-24S	PALNUT: No. 10.				*	*	*	*	4
6L968-3S	RIVETING BURR: steel; $\frac{3}{16}$ -inch.				*	*	*	*	4
6L4904-8	SCREW: cap; steel; hex; $\frac{1}{4}$ -20 x $\frac{1}{2}$ ".				*	*	*	*	3
6L7032-12.1P	SCREW: round head; steel; 10-32 x $\frac{3}{4}$ ".				*	*	*	*	2
6L73027	WASHER: brass; standard flat No. 8.				*	*	*	*	2
6L70010P	WASHER: lock; steel; No. 10.				*	*	*	*	2
6L71004C	WASHER: lock; steel; $\frac{1}{4}$ ".				*	*	*	*	3
6L58020	WASHER: lock; steel; $\frac{5}{16}$ ".				*	*	*	*	1

*Indicates stock available.

Par. 115 MAINTENANCE PARTS LIST FOR RECEIVER-TRANSMITTER RT-12/TRC-2 (TRANSMITTER GROUP).

NOTE: Order maintenance parts by stock number, name, and description. Only maintenance parts can be requisitioned.

Ref symbol	Signal Corps stock No.	Name of part and description	Running spares	Orgn stock	3d ech	4th ech	5th ech	Depot stock	Quan per RT-12/TRC-2
107	3Z6614-5	RESISTOR: fixed; carbon; 14,000-ohm \pm 10%; 1/2-watt; AWS RC31BE133J.			•	•	•	•	1
122	3Z5999-3	RESISTOR: fixed; 9.3-ohm \pm 2.5%; 5-watt.			•	•	•	•	1
111 112	3Z6620-71	RESISTOR: fixed; 20,000-ohm \pm 5%; 10-watt.			•	•	•	•	2
106	3Z6625-59	RESISTOR: fixed; 25,000-ohm \pm 5%; 10-watt.			•	•	•	•	1
152	2Z5885-8	SOCKET: capacitor; bayonet type.			•	•	•	•	1
146	2Z8678-52	SOCKET: octal.			•	•	•	•	1
149	2Z8678	SOCKET: 4-pin; female.			•	•	•	•	1
142	2Z8675-46	SOCKET: tube; 5-pin; mica-filled insulation.			•	•	•	•	1
148	2Z7227-2	SOCKET: 6-pin; male.			•	•	•	•	1
140	2Z8677-36	SOCKET: miniature tube; 7-pin; ceramic.			•	•	•	•	1
143	2Z8678-52	SOCKET: octal; 8-pin.			•	•	•	•	1
141	2Z8677-37	SOCKET: miniature tube; 7-pin; low-loss phenolic.			•	•	•	•	1
147	2Z5883-69	SOCKET: miniature; bayonet type.			•	•	•	•	1
134	3Z9824-42.1	SWITCH: push button; SPST; normally open.			•	•	•	•	1
135	3Z9825-62.81	SWITCH: rotary selector; single-section; 3-position.			•	•	•	•	1
136	3Z9825-62.82	SWITCH: rotary selector; single-section; 3-position; bakelite insulation.			•	•	•	•	1
137	3Z9825-62.83	SWITCH: rotary; single-section; 3-position; bakelite insulation.			•	•	•	•	1
138	3Z9825-62.84	SWITCH: rotary; single-section; 3-position; bakelite insulation.			•	•	•	•	1
139	3Z9825-62.87	SWITCH: rotary; single-section; 6-position; ceramic insulation.			•	•	•	•	1
132	2Z9631-95	TRANSFORMER: audio; microphone in aluminum can.			•	•	•	•	1
133	2Z9634-39	TRANSFORMER: audio; modulation in aluminum can.			•	•	•	•	1

*Indicates stock available.

Par. 116 MAINTENANCE PARTS LIST FOR POWER UNIT PE-162.

NOTE: Order maintenance parts by stock number, name, and description. Only maintenance parts can be requisitioned.

Ref symbol	Signal Corps stock No.	Name of part and description	Running spares	Orgn stock	3d ech	4th ech	5th ech	Depot stock	Quan per Unit
	3H1912A	ENGINE GE-12-A: (component).				*		*	1
	3H2350	ENGINE GE-12-A: (repair parts). GENERATOR GN-50: Leland 10511KJ9.				*		*	1

Par. 117 MAINTENANCE PARTS LIST FOR POWER UNIT PE-162 (GENERATOR GROUP).

3H2351A/B10	BEARING: ball; alloy steel; New Departure 88502.				*	*	*	*	1
3H2350/B6	BRUSH: dc; carbon; low-voltage; C.G-65.				*	*	*	*	2
3H2350/B6	BRUSH: dc; carbon; high-voltage; 802H.				*	*	*	*	2
3H2350/C1	CAP: brush; bakelite.				*	*	*	*	4
3H1912A/C45	COUPLING: spline.				*	*	*	*	1
3H2351A/G1	GASKET: outlet plate.				*	*	*	*	1
3H1912A/P21	PIN: spline coupling.				*	*	*	*	1

Par. 118 MAINTENANCE PARTS LIST FOR POWER UNIT PE-162 (GENERAL HARDWARE GROUP).

6L3610-34	NUT: steel; hex; No. 10-24.				*	*	*	*	1
6L2610-24S	PALNUT: No. 10.				*	*	*	*	4
6L968-3S	RIVETING BURR: steel; 3/16-inch.				*	*	*	*	4
6L4904-8	SCREW: cap; steel; hex; 1/4-20 x 1/2".				*	*	*	*	3
6L7032-12.1P	SCREW: round head; steel; 10-32 x 3/4".				*	*	*	*	2
6L73027	WASHER: brass; standard flat No. 8.				*	*	*	*	2
6L70010P	WASHER: lock; steel; No. 10.				*	*	*	*	2
6L71004C	WASHER: lock; steel; 1/4".				*	*	*	*	3
6L58020	WASHER: lock; steel; 5/16".				*	*	*	*	1

*Indicates stock available.

Par. 119 MAINTENANCE PARTS LIST FOR VIBRATOR POWER SUPPLY PP 39/TRC-2.

NOTE: Order maintenance parts by stock number, name, and description. Only maintenance parts can be requisitioned.

Ref symbol	Signal Corps stock No.	Name of part and description	Running spares	Orign stock	3d ech	4th ech	5th ech	Depot stock	Quan per PP-39/TRC-2
		BOARD: plug; terminal; 15-pin; banana type; polarized.			•	•	•	•	1
328	2Z9415.7	BOARD: jack ; terminal; 15-pin; banana type; polarized.			•	•	•	•	1
331	3E7173-3	CABLE: 2 conductors; insulated; twisted; 1 black, 1 white; #10 wire; stranded; 8 ft.			•	•	•	•	1
304	3DA10-114	CAPACITOR: fixed; paper; 10,000- μ f \approx 10%; 600 v dc.			•	•	•	•	1
303	3DA5-126	CAPACITOR: fixed; paper; 50,000- μ f + 14% - 6%; 120 v dc.			•	•	•	•	1
301-B	3DB80-3	CAPACITOR: electrolytic; 10- μ f \approx 15%; 250 v dc.			•	•	•	•	1
301-A	3DB80-3	CAPACITOR: electrolytic; 80- μ f \approx 15%; 250 v dc.			•	•	•	•	1
302	3DB3000-1	CAPACITOR: electrolytic; 2-section; 3,000-3,000- μ f \approx 15%; 3 v dc.			•	•	•	•	1
312	3C323-34J	CHOKE: filter; 35- μ h; 0.54 ohms; 0.45 amps. max. current.			•	•	•	•	1
313	3C323-34G	CHOKE: filter; 9.4-h; 375 ohms; 17 ma max. current.			•	•	•	•	1
320	3Z1087-3	CLIP: battery; 50 amps; (supplied with cord).			•	•	•	•	2
311	3C323-34H	COIL: r-f choke; 7- μ h.			•	•	•	•	1
325	3E7173-2	CORD AND PLUG ASSEMBLY: 3-conductor; shielded; rubber-covered; black.			•	•	•	•	1
322	3F1030-23	METER: current indicator; 30-0-30 amps. range.			•	•	•	•	1
332	2Z8674.81	PLUG: 4-pin; banana type; polarized; molded bakelite neck.			•	•	•	•	1
326	2Z7114.44	RECEPTACLE: male; 4-pin; banana type; polarized; molded bakelite.			•	•	•	•	1
321	3H4858-10	RECTIFIER: selenium; 2-plate; dry disc.			•	•	•	•	1
315	2Z7585-50	RELAY: SPST; normally open at 9.2 volts dc; 180 ohms.			•	•	•	•	1
316	2Z7588-42	RELAY: DPST; normally open at 4 v dc 60-ohm.			•	•	•	•	1
317	2Z9625-20	RELAY: SPST; normally open at 300 ma; 0.68-ohm.			•	•	•	•	1
305	3Z5971-6	RESISTOR: wire-wound on ceramic tube; 0.14-ohm \approx 10%; 35-watt.			•	•	•	•	1

Par. 120 MAINTENANCE PARTS LIST FOR GENERATOR GN-57.

NOTE: Order maintenance parts by stock number, name, and description. Only maintenance parts can be requisitioned.

Ref symbol	Signal Corps stock No.	Name of part and description	Running spares	Orgn stock	3d ech	4th ech	5th ech	Depot stock	Quan per GN-57
233	3DA50-118	CAPACITOR: fixed; oil paper; 50,000 μ f, \pm 20%; 800 v dc; Gudeman No. 7617.			*	*	*	*	1
230	3DA500-184	CAPACITOR: fixed; oil paper; 500,000 μ f, \pm 20%; 120 v dc; Gudeman No. 7193.			*	*	*	*	1
232	3DB4-123	CAPACITOR: fixed; oil paper; 4 μ f \pm 6%; 500 v dc; General Electric Co. No. ACE1A145, Navy type CG-48778.			*	*	*	*	1
231	3DB500-15	CAPACITOR: fixed; electrolytic; 500 μ f \pm 20%; 12 v dc; Magnavox No. 4382.			*	*	*	*	1
227	3C323-34M	COIL: choke; filter; resistance 210 ohms dc; 3.45 mh; Rauland type LC-0088.			*	*	*	*	1
226	3C323-34H	COIL: R-f choke; 7 mh; Ensign Coil Co. No. LC-0063.			*	*	*	*	1
225	3C323-34L	COIL: choke; filament; 22mh; dc resistance 10.6 ohms \pm 20%; Rauland type LC-0087.			*	*	*	*	1
228	3C323-34K	COIL: R-f choke; 530 mh \pm 5%; Rauland type LC-0086.			*	*	*	*	1
234	3H4963	REGULATOR: voltage; vibrating reed type; Burke Electric Co., Erie, Pa.			*	*	*	*	1
229	3Z6610-143	RESISTOR: fixed; wire wound; 100,000 ohm \pm 5%; 20 watt; vitreous enamel insulation.			*	*	*	*	1
	3H2345/AB10	BRUSH ASSEMBLY: carbon; high voltage; includes 2 brushes, 2 springs and 1 end plug; Burke Electric Co.			*	*	*	*	1
	3H2345A/B11	BRUSH ASSEMBLY: carbon; low voltage; includes 2 brushes, 2 springs and 1 end plug; Burke Electric Co.			*	*	*	*	1

*Indicates stock available.





3 6105 113 778 315



