

4 *U113*
12
TM
1943

TM 9-1777C
==

WAR DEPARTMENT
U.S. Dept. of Army
TECHNICAL MANUAL

ORDNANCE MAINTENANCE

**HEAVY TRACTOR MI (IHC TD-18) —
POWER TRAIN,
TRACK FRAME ASSEMBLY, AND SEATS**

FEBRUARY 25, 1943

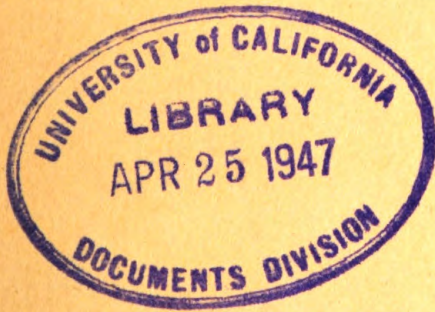

4113
2
TM 9-1777C
1943
★ ★

TECHNICAL MANUAL }
No. 9-1777C

WAR DEPARTMENT
Washington, February 25, 1943

ORDNANCE MAINTENANCE

**HEAVY TRACTOR M1 (IHC TD-18) —
POWER TRAIN,
TRACK FRAME ASSEMBLY, AND SEATS**

Prepared under the direction of the
Chief of Ordnance

CONTENTS

		Paragraphs	Pages
CHAPTER 1	Introduction.....	1- 4	3
CHAPTER 2	Description and tabulated data	5-12	4-15
CHAPTER 3	Trouble shooting.....	13-20	16-20
CHAPTER 4	Power train		
SECTION	I. Engine clutch.....	21-31	21-48
	II. Transmission and drive bevel gear	32-41	49-94
	III. Steering clutches and brakes....	42-62	95-158
	IV. Final drives and sprockets.....	63-73	159-180

*This manual supersedes TB 1786C-1, January 11, 1943.

7574681

ORDNANCE MAINTENANCE — HEAVY TRACTOR M1 (IHC TD-18) —
POWER TRAIN, TRACK FRAME ASSEMBLY, AND SEATS

CONTENTS — (Cont.)

	Paragraphs	Pages
CHAPTER 5	Track frame assembly	
SECTION	I. Description, inspection and trouble shooting	74-76 181-182
	II. Equalizer spring	77-82 183-191
	III. Track idlers	83-88 192-197
	IV. Bottom track rollers	89-94 198-209
	V. Front idler	95-100 210-218
	VI. Front idler springs	101-104 219-224
	VII. Track	105-112 225-245
	VIII. Track frame diagonal brace	113-118 246-249
	IX. Track frame guide, bracket with roller, and main frame side channels	119-127 250-258
	X. Track frame	128-132 259-269
CHAPTER 6	Metal parts	133-136 270-292
CHAPTER 7	Fits, tolerances, and special tools	
SECTION	I. Fits and tolerances	137-138 293
	II. Special tools	139 294-297
CHAPTER 8	References	140-141 298-299
INDEX		300-305

CHAPTER 1

INTRODUCTION

	Paragraph
Scope	1
Contents and arrangement of manual.....	2
References	3
Registration numbers	4

1. SCOPE.

a. This manual is published for the information and guidance of ordnance personnel. It contains detailed instructions for inspection, disassembly, assembly, maintenance, and repair of the power train, track frame assembly, and seats for Heavy Tractor M1 (IHC TD-18). These instructions are supplementary to those in the field and technical manuals prepared for the using arms. Additional descriptive matter and illustrations are included to aid in providing a working knowledge of the materiel.

2. CONTENTS AND ARRANGEMENT OF MANUAL

a. Separate chapters of this manual are devoted to introductory information, description and tabulated data, trouble shooting, inspection of the vehicle, the power train, brakes for drawn load, track frame assembly, odometer and odometer drive, general maintenance of metal parts, special instructions and data, and references. Chapters, as required, are divided into sections on major assemblies. Fits and tolerances and special tools are likewise included in individual sections.

b. Other ordnance maintenance manuals pertaining to the Heavy Tractor M1 (IHC TD-18) are TM 9-1777A, on the engine; TM 9-1777B, on engine accessories; and TM 9-1777D, on the equipment.

c. As indicated in paragraph 4, four lots of the tractor have been manufactured. Where differences in design and parts occur, the correct procedure for each lot is given in the manual.

3. REFERENCES.

a. Chapter VIII at the end of this manual gives all standard nomenclature lists, technical manuals, and other publications for the materiel described herein.

4. REGISTRATION NUMBERS.

a. At the date of issue of this manual, the Heavy Tractor M1 (IHC TD-18) has been produced in four lots, designated as lots 1, 2, 3, and 4.

ORDNANCE MAINTENANCE — HEAVY TRACTOR MI (IHC TD-18) —
POWER TRAIN, TRACK FRAME ASSEMBLY, AND SEATS

CHAPTER 2

DESCRIPTION AND TABULATED DATA

	Paragraph
Serial numbers.....	5
General	6
Power train.....	7
Steering	8
Track frame construction.....	9
Grouser boxes.....	10
Pack carriers.....	11
Seat and fenders.....	12

5. SERIAL NUMBERS.

a. The engine serial number is stamped on the left side of the crankcase on a milled surface near top of crankcase. No attempt has been made to have engine serial numbers conform with the tractor serial numbers. For engine serial numbers, refer to TM 9-1777A.

6. GENERAL.

a. Changes and improvements have been made in the successive four lots of tractors (par. 4). Where these changes affect the servicing of the tractor, instructions are given in this manual covering all operations. Major components of the tractor are replaceable and interchangeable on all four lots, with a few exceptions, the most important of which are as follows:

- (1) Sprocket drive pinion and gear.
- (2) Sprocket drive gear cover.
- (3) Drive bevel gear and pinion and related parts.

b. Reference must be made to SNL G-101 for list of parts involved in each change.

c. **Specifications.** Tractor dimensions, travel speeds, track data, and tractor weights are given in TM 9-777.

(1) ENGINE CLUTCH.

Single plate, over-center type, diameter..... 17 in.

(2) STEERING CLUTCHES.

Speed in high gear..... 290 rpm

Diameter 15 in.

Friction surfaces (each clutch)..... 39

Effective friction area (each clutch)..... 2,160 sq in.

DESCRIPTION AND TABULATED DATA

RA PD 14813

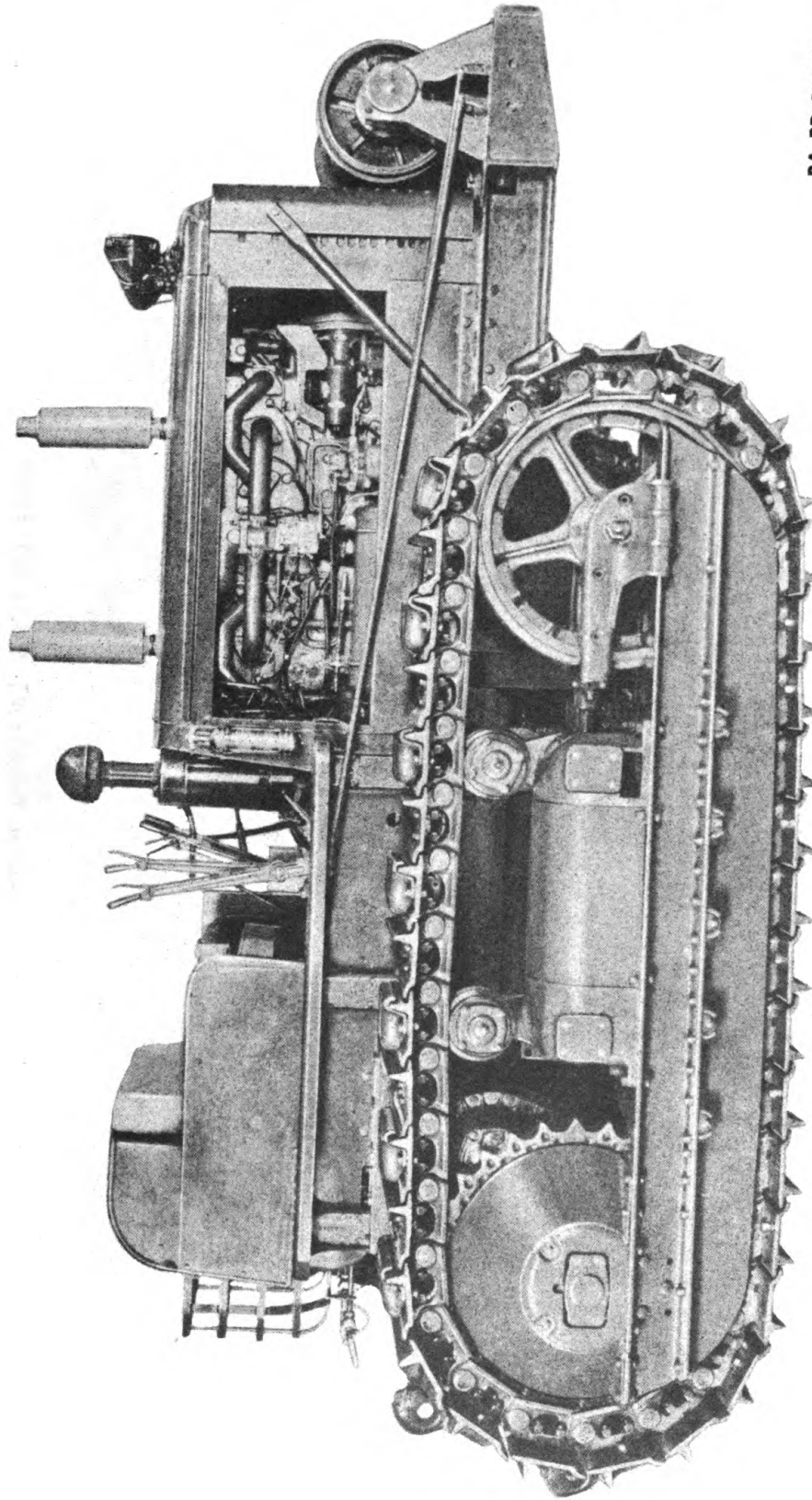
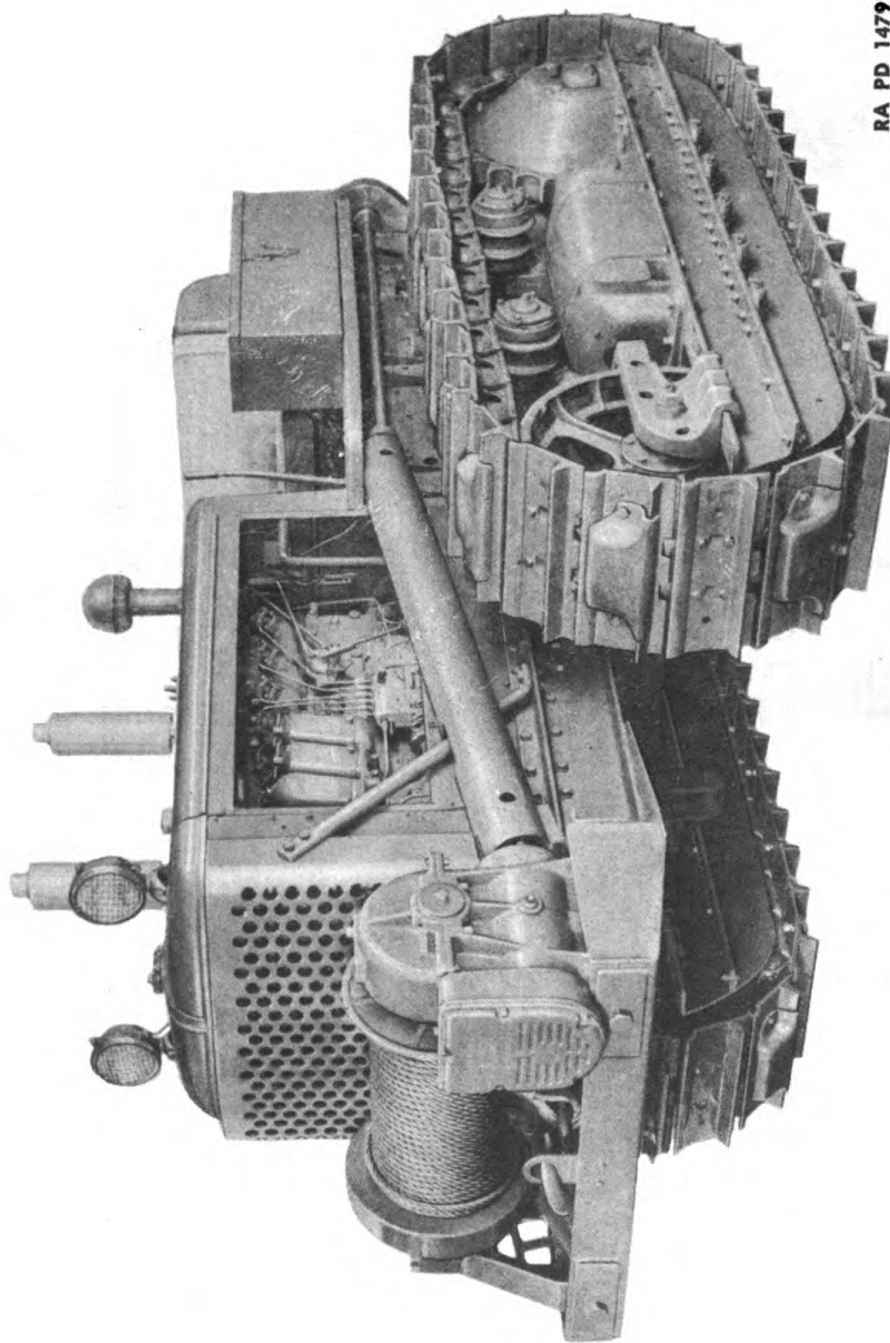

Figure 1 — Heavy Tractor M1 (Lot 1), Right Side

ORDNANCE MAINTENANCE — HEAVY TRACTOR M1 (IHC TD-18) —
POWER TRAIN, TRACK FRAME ASSEMBLY, AND SEATS



RA PD 14791

Figure 2 — Heavy Tractor M1 (Lot 1), Left Front

DESCRIPTION AND TABULATED DATA

RA PD 14789

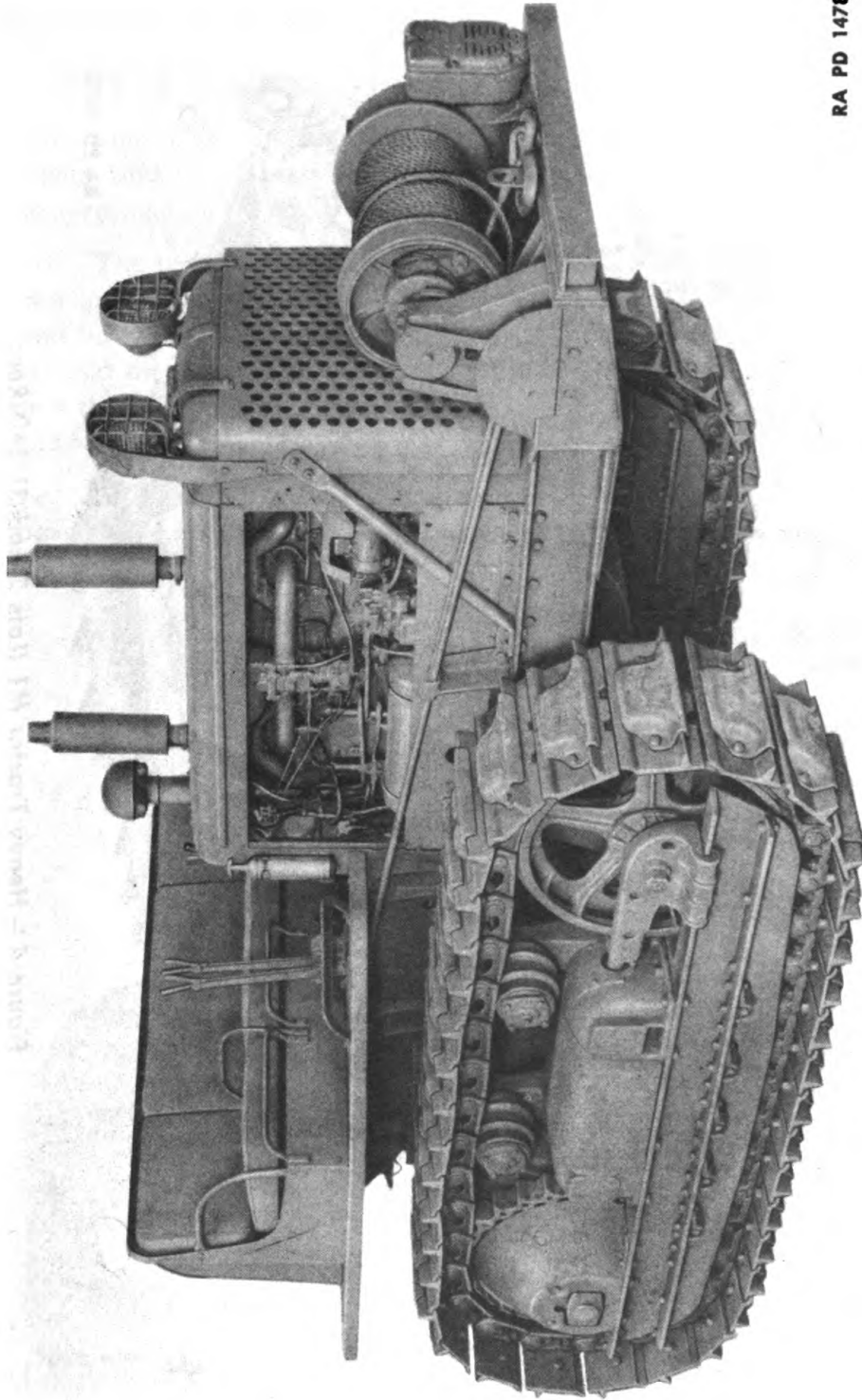
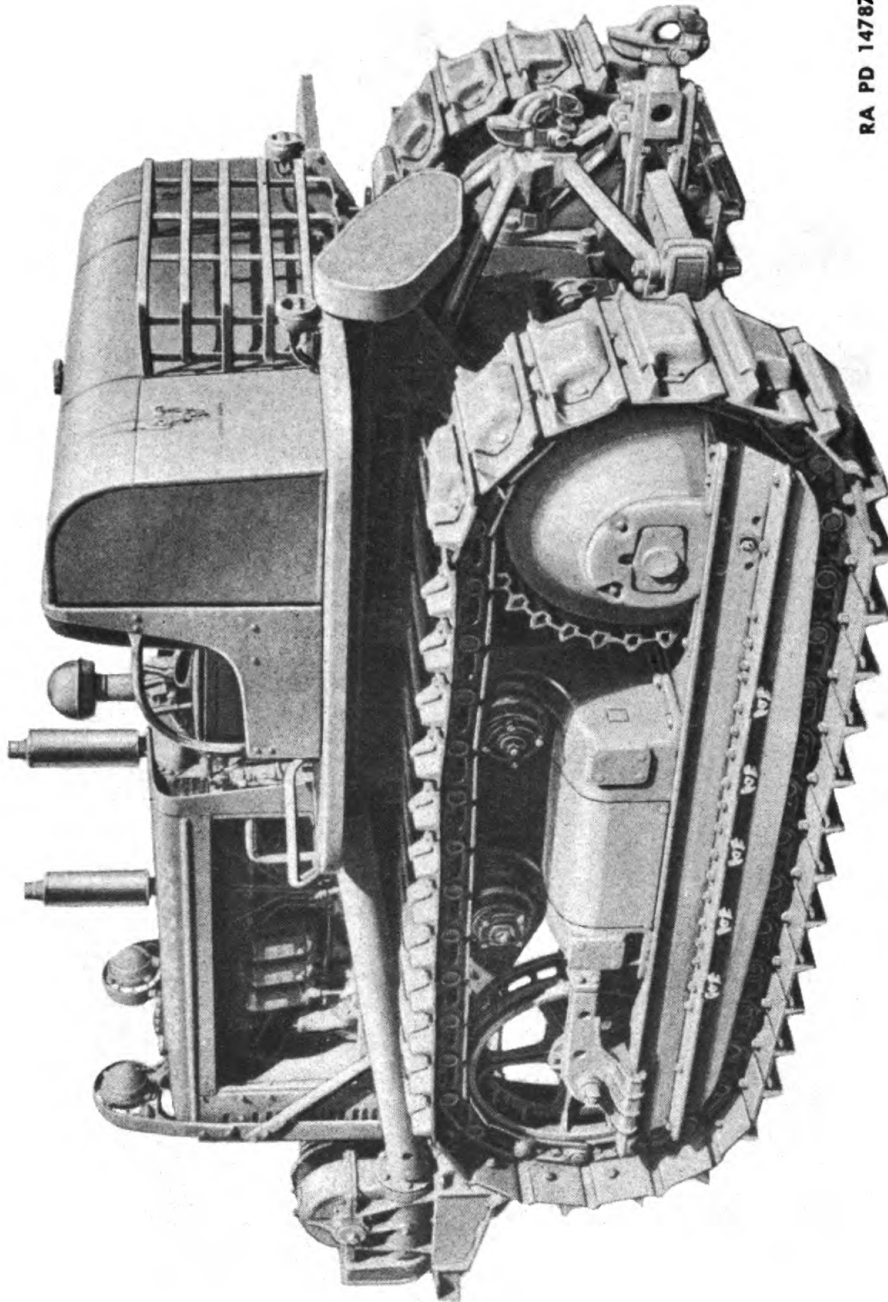

Figure 3 — Heavy Tractor M1 (Lots 2 and 3), Right Front

ORDNANCE MAINTENANCE — HEAVY TRACTOR M1 (IHC TD-18) —
POWER TRAIN, TRACK FRAME ASSEMBLY, AND SEATS



RA PD 14787

Figure 4 — Heavy Tractor M1 (Lots 2 and 3), Left Rear

DESCRIPTION AND TABULATED DATA

(3) STEERING BRAKES.

Diameter	17 in.
Friction area (each brake).....	180 sq in.

7. POWER TRAIN (fig. 9).

a. Line of power from engine is through flywheel and clutch, transmission and bevel gears, steering clutches, and sprocket drive gears to the sprockets on each side of tractor.

b. The transmission has two ranges, a high and a low. Control is by lever independent of regular shifter lever. It is left of left steering clutch hand lever. To shift from one range to the other, disengage engine clutch first and move lever to desired range. Down is the low range; back or up is the high range. In each position, tractor can be shifted by conventional shifter to any speed in that range after disengaging engine clutch.

c. Hi-Lo sliding gear has internal and external teeth. Internal teeth engage drive shaft gear in high range setting, driving transmission spline

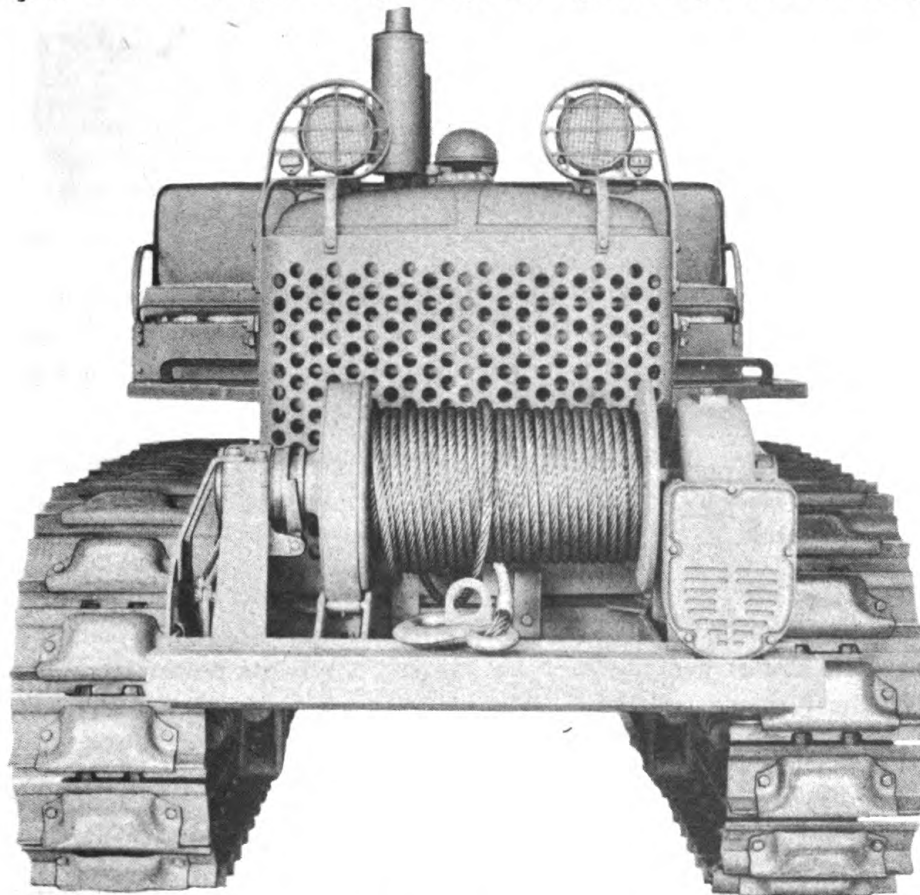

RA PD 14788

Figure 5 — Heavy Tractor M1 (Lots 2 and 3), Front

**ORDNANCE MAINTENANCE — HEAVY TRACTOR M1 (IHC TD-18) —
POWER TRAIN, TRACK FRAME ASSEMBLY, AND SEATS**

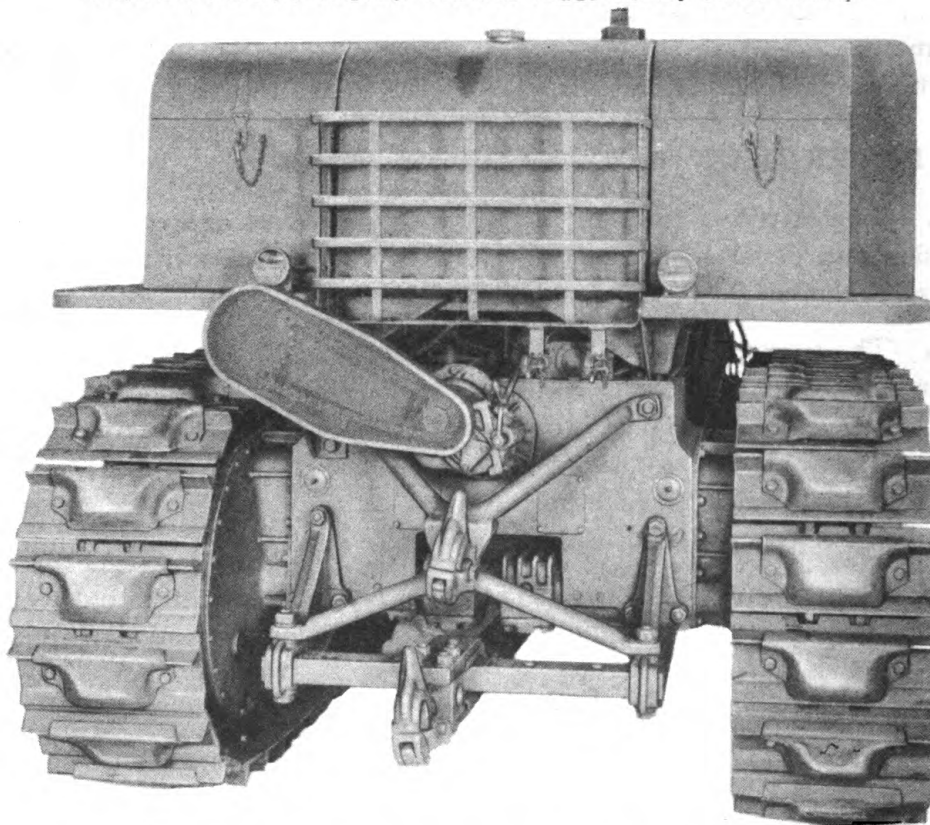

RA PD 14778

Figure 6 — Heavy Tractor M1 (Lots 2 and 3), Rear

shaft. External teeth engage low range gear in low range setting. Line of power is then from drive shaft gear to low range idlers to shifter gear to spline shaft. The low range gears are ball-bearing, mounted to shaft, and rotate constantly when clutch is engaged.

d. Tractor can be shifted from low to high reverse, first to third, second to fifth, fourth to sixth, or vice versa, by shifting only Hi-Lo range lever, using clutch.

e. Reverse idler on Hi-Lo shaft and reverse gear on the bevel pinion shaft are constantly meshed and are also running whenever tractor is moving. The shifter gear in the rear position transmits power to reverse idler. In the forward position it transmits power to the first and fourth speed gear. Reverse idler is mounted on two roller bearings.

f. Clutch brake operates automatically when clutch is disengaged, facilitating faster shifting of gears.

g. When both steering clutches are engaged, power is transmitted equally to each track. By disengaging one clutch all the power is applied to one track. If one steering clutch is disengaged and steering brake

DESCRIPTION AND TABULATED DATA

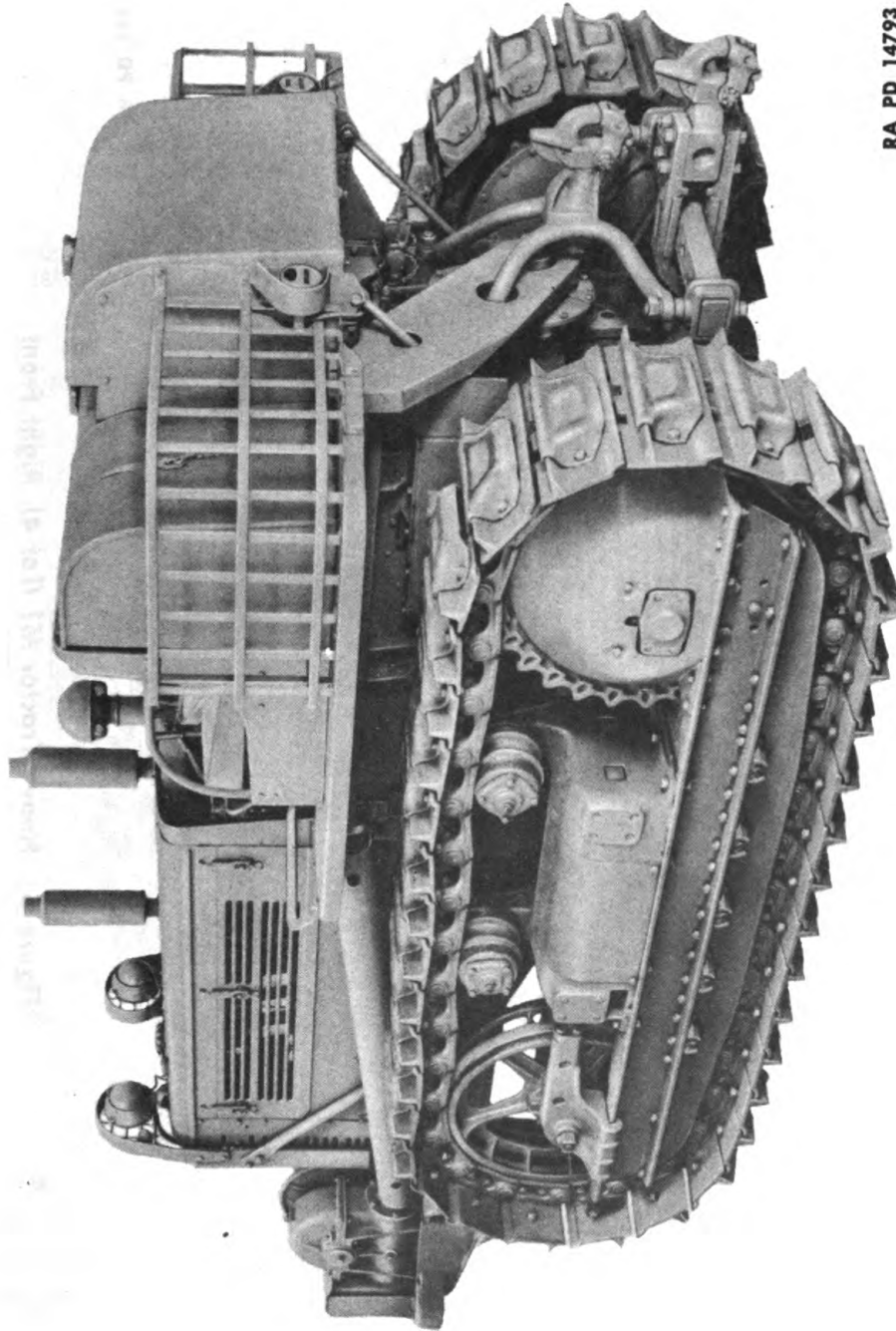

RA PD 14793

Figure 7 — Heavy Tractor M1 (Lot 4), Left Rear

ORDNANCE MAINTENANCE — HEAVY TRACTOR M1 (IHC TD-18) —
POWER TRAIN, TRACK FRAME ASSEMBLY, AND SEATS

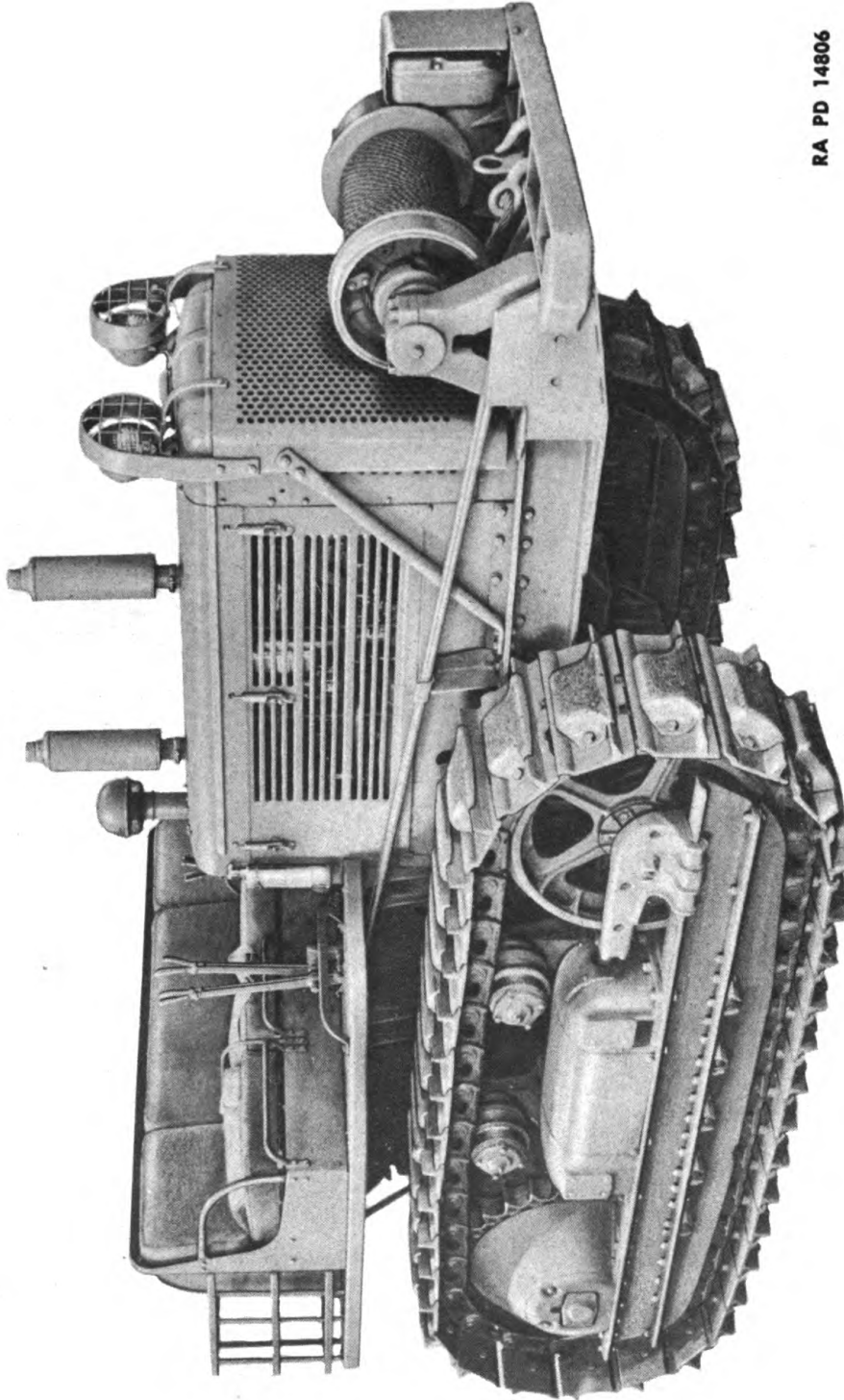

RA PD 14806

Figure 8 — Heavy Tractor M1 (Lot 4), Right Front

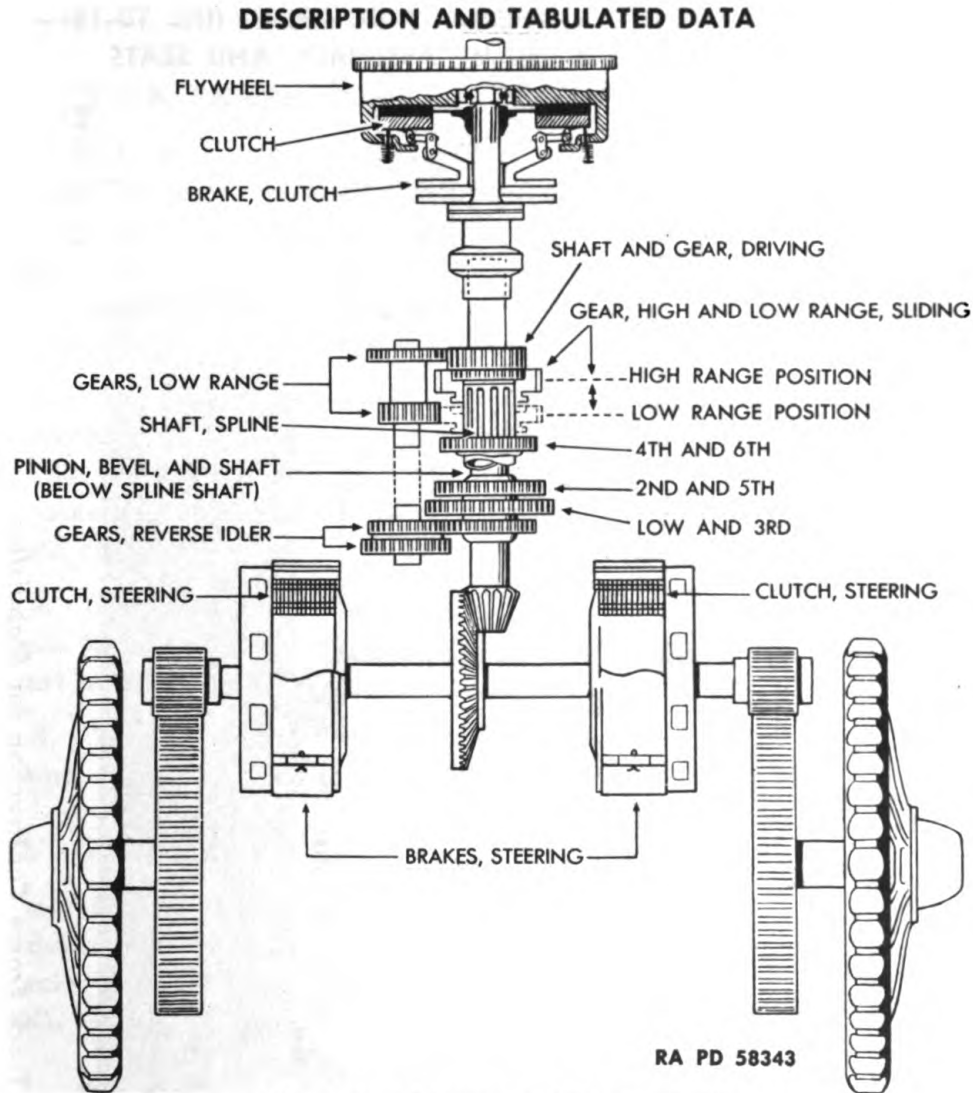

Figure 9 – Diagram of Power Train

applied on same side, the tractor pivots on its track. Disengaging both steering clutches at the same time, or disengaging engine clutch, stops the tractor.

8. STEERING.

a. The tractor is steered by means of clutches and brakes mounted in the main frame. To steer the tractor to the left, the left steering lever is pulled back. This operation disengages the left steering clutch, resulting in all the power being transmitted to the right sprocket and causing the tractor to turn to the left. The left track is now running free.

b. When the left steering brake is applied, the left track is locked, causing the tractor to pivot on that track. To turn to the right, the right steering clutch and brake are used.

ORDNANCE MAINTENANCE — HEAVY TRACTOR MI (IHC TD-18) —
POWER TRAIN, TRACK FRAME ASSEMBLY, AND SEATS

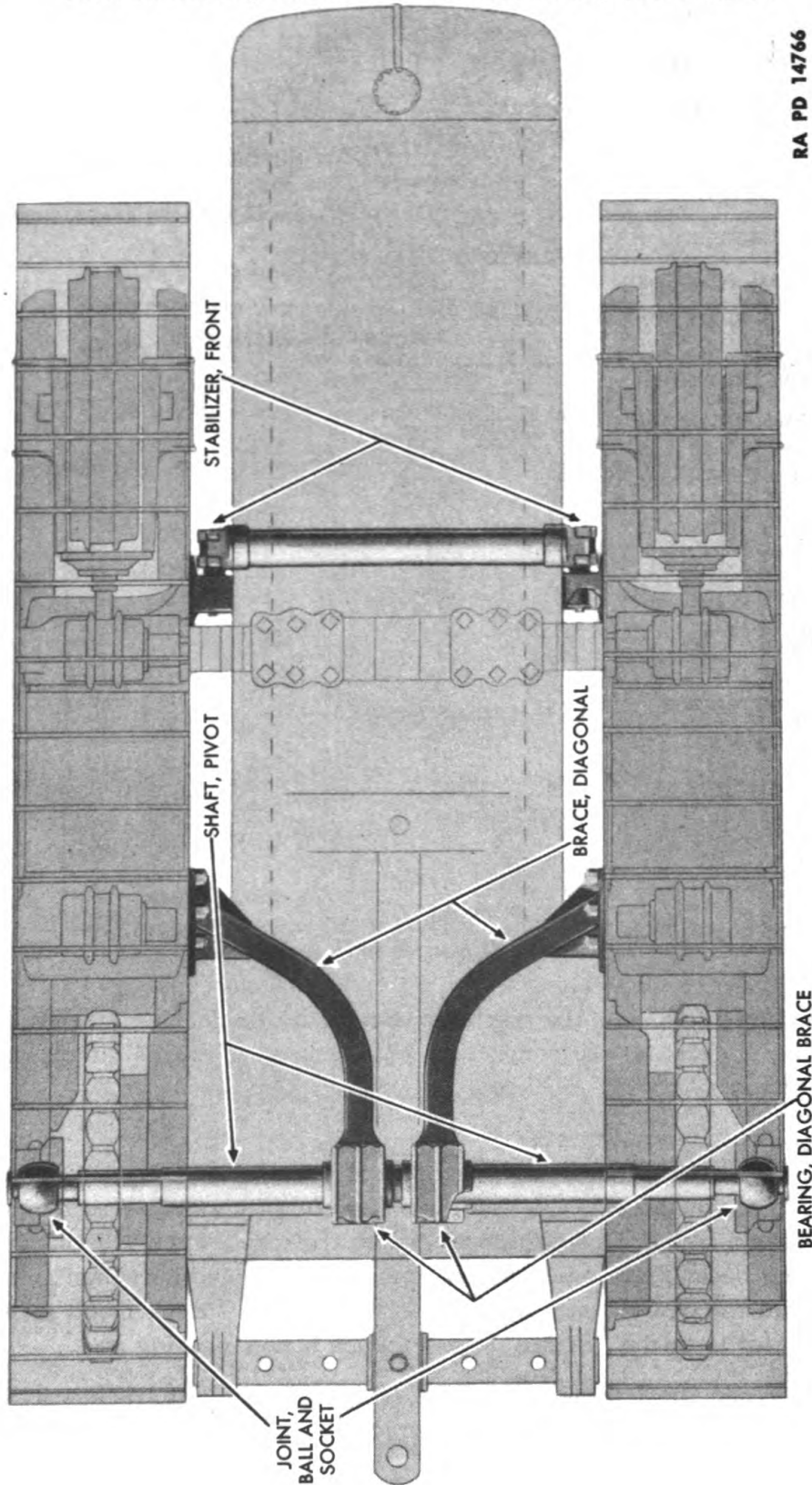

Figure 10 — Track Frame Construction for Stabilizing

DESCRIPTION AND TABULATED DATA

9. TRACK FRAME CONSTRUCTION (fig. 10).

a. The track frames are mounted and pivoted on ball and socket joints. The joints permit vertical movement of the tracks and relieve twisting strain on the pivot shaft. The front stabilizer ties the two tracks together, keeping them parallel, and yet permits up-and-down oscillation. The diagonal brace bearings on the pivot shaft permit the braces to oscillate with the track frame.

b. The weight of the tractor is carried on five track rollers mounted in each track frame. The weight is transferred from the track frames to the pivot shaft and equalizer spring. No weight is carried on the sprockets or front idlers, their purpose being to drive and cam the track chain.

c. The front idlers are equipped with recoil springs mounted on the track frames. These springs permit the idler to recoil under shock but exert no tension on the track when in normal operating position.

d. Two upper track idler rollers, mounted on brackets on each track frame, carry the track chains between the sprocket and front idlers.

10. GROUSER BOXES.

a. Grouser boxes are mounted on the fenders, back of the seat, to provide storage of street plates when they are not being used on the tracks. Grouser boxes on lots 2, 3 and 4 differ from lot 1. Refer to SNL G-101.

11. PACK CARRIERS.

a. All tractors are provided with pack carriers mounted back of the fuel tanks.

12. SEAT AND FENDERS.

a. Lot 1 tractors are provided with fenders and a one-man seat, the fenders carrying the grouser chest and winch control levers. Lots 2, 3, and 4 tractors are provided with four-man seats and extra wide fenders. Tool boxes are provided under the two outside seat cushions. The fenders carry the two outside seats, grouser boxes, and winch control levers.

ORDNANCE MAINTENANCE — HEAVY TRACTOR MI (IHC TD-18) —
POWER TRAIN, TRACK FRAME ASSEMBLY, AND SEATS

CHAPTER 3

TROUBLE SHOOTING

	Paragraph
Scope	13
Facilities	14
Engine clutch	15
Steering clutches and brakes	16
Gears	17
Track chain	18
Final drive and sprockets	19
Transmission	20

13. SCOPE.

a. The trouble shooting procedure outlined in this chapter covers the engine clutch, transmission and drive bevel gear, steering clutches and brakes, final drive and sprockets, track idlers, track rollers, front idlers, and track.

14. FACILITIES

a. The trouble shooting procedure outlined in this section should be followed on the completely assembled tractor, before any assemblies or components have been removed from the vehicle. Tools and equipment needed are included in the other paragraphs of this manual to which references are made.

15. ENGINE CLUTCH.

a. Clutch Slips.

Probable Cause	Probable Remedy
Clutch out of adjustment.	Adjust clutch (par. 31).
Clutch facings worn excessively.	Replace clutch facings (par. 28).
Pressure plate scored excessively, or broken.	Replace pressure plate (pars. 25, 26, 29, and 30).
Oil or grease on facing and pressure plate.	Wash with SOLVENT, dry-cleaning.
Pilot bearing worn excessively.	Remove clutch and replace pilot bearing (TM 9-1777A).

b. Clutch Noisy.

Release bearing worn excessively.	Replace release bearing (pars. 25, 26, 29, and 30).
-----------------------------------	---

TROUBLE SHOOTING

c. Clutch Difficult to Engage and Disengage.

Probable Cause	Probable Remedy
Camshafts and cam blocks worn.	Replace camshafts and cam blocks (pars. 25, 26, 27, 29, and 30).
Connecting links and pins worn.	Replace links and pins (pars. 25, 26, 29, and 30).

d. Transmission Gears Fail to Stop When Clutch is Disengaged.

Clutch brake facing worn.	Replace brake facings (par. 28).
Return springs weak or broken.	Replace return springs (pars. 25, 26, 29, and 30).
Pilot bearing worn excessively.	Replace pilot bearing (TM 9-1777A).

e. Clutch Lever Loose.

Sleeve bushings worn.	Replace bushings (pars. 25, 26, 29, and 30).
-----------------------	--

16. STEERING CLUTCHES AND BRAKES.

a. Steering Clutch Will Not Release Fully.

Steering clutch out of adjustment.	Adjust steering clutch controls (par. 57).
Disks warped.	Replace (pars. 52, 53, 55, and 56).
Teeth on clutch driving disks have worn grooves in clutch drum.	Replace disks and drum (pars. 52, 53, 55, and 56).
Pilot bearing worn excessively.	Replace bearing (pars. 52, 53, 55, and 56).

b. Steering Clutches Release with Difficulty.

Release thrust bearing inadequately lubricated or worn.	Lubricate bearing, and if this does not correct trouble, replace bearing (pars. 52, 53, 55, and 56). Inadequate lubrication will also cause release collar to bind on bearing cage cap.
Steering clutch release collar shifter links, link pins and release fork worn.	Replace worn parts (pars. 52, 53, 55, and 56).

TM 9-17,7C
16-17

**ORDNANCE MAINTENANCE — HEAVY TRACTOR MI (IHC TD-18) —
POWER TRAIN, TRACK FRAME ASSEMBLY, AND SEATS**

c. Steering Clutches Slip.

Probable Cause	Probable Remedy
Clutches out of adjustment.	Adjust (par. 57).
Clutch pressure spring weak or broken.	Replace spring (pars. 52, 53, 55, and 56).
Teeth on clutch driving disk have worn grooves in clutch drum, causing the disks to catch in grooves and not return to engage position.	Replace disks and drum (pars. 52, 53, 55, and 56).
Excessive oil or grease on clutch facings.	Wash with SOLVENT, dry-cleaning.

d. Clutches Will Not Release.

Out of adjustment.	Adjust controls (par. 57).
--------------------	----------------------------

e. Steering Brakes Will Not Hold.

Brakes out of adjustment.	Adjust (par. 51).
Brake lining worn out.	Replace lining (par. 45).
Linkage broken or disconnected.	Inspect operation of brakes by removing inspection covers in bottom of main frame.
Oil or grease on brake bands and drum.	Wash with SOLVENT, dry-cleaning.

17. GEARS.

a. Gears Noisy.

Lack of lubrication.	Check lubrication as outlined in TM 9-777.
Gears worn.	Remove main frame cover and inspect gears (par. 52 through step b (8)).
Bearings worn.	Remove main frame cover and inspect bearings for wear (par. 52 through step b (8)).

TROUBLE SHOOTING

18. TRACK CHAIN.

a. Track Chain Comes Off.

Probable Cause	Probable Remedy
Track chain out of adjustment.	Adjust track (par. 112).
Track link pins and bushings worn excessively.	Reverse pins and bushings or replace (par. 109).
Flanges on track rollers, idlers, or front idlers worn excessively.	To replace track idlers, see paragraphs 84 through 88. To replace bottom track rollers, see paragraph 90 through 94. To replace front idler, see paragraphs 96 through 100.
Track links worn so that roller and idler flanges are running on track link bushings.	Remove track (par. 106). Disassemble track (par. 107) and replace worn parts. Assemble track (par. 110) and install track on tractor (par. 112).

19. FINAL DRIVE AND SPROCKETS.

a. Sprocket Fails to Drive Track.

Sprocket worn excessively.	Replace sprocket (pars. 66 and 67).
Final drive gears worn excessively.	Replace gears (pars. 68 through 72).
See paragraph 16 c for other causes.	

20. TRANSMISSION.

a. Transmission Gear Will Not Stay Engaged.

Poppet springs weak or broken.	Replace springs (pars. 35, 36, 38, and 39).
Poppet balls worn or poppet ball slots in shifter rails worn.	Replace worn parts. Remove gear shifter housing with levers attached (par. 52 b (6)). Remove worn parts (par. 36). Install new parts (par. 38). Install gear shifter housing with levers attached (par. 56 b (13)).

**ORDNANCE MAINTENANCE — HEAVY TRACTOR MI (IHC TD-18) —
POWER TRAIN, TRACK FRAME ASSEMBLY, AND SEATS**

Probable Cause	Probable Remedy
Transmission gears worn.	Replace worn gears (pars. 35, 36, 38, and 39).
Bearings on spline shaft and drive shaft worn.	Replace worn bearings (pars. 35, 36, 38, and 39).

b. Transmission Gears Will Not Shift.

Forks on shifter rails broken.	Remove gear shifter housing with levers attached (par. 52 b (6)). Remove shifter rails from housing (par. 36 b (15)). Install new shifter rails (par. 38 b (18)). Install gear shifter housing with levers attached (par. 56 b (13)).
Forks not engaged with sliding gears.	Remove gear shifter housing with levers attached (par. 52 b (6)) to see if forks are properly engaged with sliding gears. Install correctly (par. 56 b (13)).

CHAPTER 4

POWER TRAIN

Section I

ENGINE CLUTCH

	Paragraph
Engine clutch, construction and operation	21
Allocation of maintenance duties by echelons	22
Engine clutch inspection in vehicle	23
Trouble shooting	24
Removal	25
Disassembly	26
Parts inspection	27
Engine clutch facings, installation	28
Assembly	29
Installation	30
Adjustment	31

21. ENGINE CLUTCH, CONSTRUCTION AND OPERATION (figs. 19 and 21).

a. A 17-inch single plate, over-center type engine clutch is used, which has a torque capacity of 1,488 foot-pounds. Throwout and pilot bearings are of the ball type. Lubrication fittings are provided for each release cam, which should be lubricated as outlined in TM 9-777. They should not be lubricated excessively; otherwise the efficiency of the clutch facing will be decreased. The release mechanism is furnished with a clutch brake which facilitates faster shifting of transmission gears. The clutch brake operates automatically when the clutch is disengaged. No adjustment of this brake is necessary. Pins on the release carrier have bushings which fit into the release fork to reduce friction and wear.

22. ALLOCATION OF MAINTENANCE DUTIES BY ECHELONS.

a. **Definitions.** Echelons and words as used in this list of maintenance allocations are defined as follows:

SECOND ECHELON: Line organization regiments, battalions, companies, detachments, and separate companies.

THIRD ECHELON: Ordnance light maintenance companies, ordnance medium maintenance companies, ordnance divisional maintenance battalions, and post ordnance shops.

**ORDNANCE MAINTENANCE — HEAVY TRACTOR MI (IHC TD-18) —
POWER TRAIN, TRACK FRAME ASSEMBLY, AND SEATS**

FOURTH ECHELON: Ordnance heavy maintenance companies, and service command shops.

FIFTH ECHELON: Ordnance base regiments, ordnance bases, arsenals, and manufacturers' plants.

SERVICE (Including preventive maintenance): Refer to AR 850-15, paragraph 23 a (1) and (2).
Consists of servicing, cleaning, lubricating, tightening bolts and nuts, and making external adjustments of subassemblies or assemblies and controls.

REPLACE: Refer to AR 850-15, paragraph 23 a (4).
Consists of removing the part, subassembly or assembly from the vehicles and replacing it with a new or reconditioned or rebuilt part, subassembly, or assembly, whichever the case may be.

REPAIR: Refer to AR 850-15, paragraph 23 a (3) and (5), in part.
Consists of making repairs to, or replacement of the part, subassembly or assembly that can be accomplished without completely disassembling the subassembly or assemblies, and does not require heavy welding, or riveting, machining, fitting and/or alining or balancing.

REBUILD: Refer to AR 850-15, paragraph 23 a (5), in part, and (6).
Consists of completely reconditioning and replacing in serviceable condition any unserviceable part, subassembly or assembly of the vehicle, including welding, riveting, machining, fitting, alining, balancing, assembling and testing.

CLUTCH	ECHELONS		
	2nd	3rd	4th
Clutch, assembly—replace or repair.....		X	
Clutch, assembly—rebuild.....			X
Clutch, assembly—adjust.....	X		

23. ENGINE CLUTCH INSPECTION IN VEHICLE.

a. Pilot Bearing. The pilot bearing, which is in the flywheel, cannot be directly inspected while the clutch is installed. However, if transmission gears continue to run when engine clutch lever is moved into its forward position, it is an indication that the pilot bearing may be worn. If clutch lever wobbles back and forth when engine is running, it is also an indication that pilot bearing is worn.

ENGINE CLUTCH

b. **Brake Disk with Facing.** Condition described in subparagraph a above may also indicate that facing of brake disk is worn or coated with grease and oil which impair its efficiency.

c. **Clutch Adjustment.** If tractor will not move when in gear, after shifting into gear and pulling back clutch lever (if the steering brakes are released), it is an indication of clutch slippage and need of clutch adjustment. Adjust clutch (par. 31).

d. **Backplate.** Remove engine clutch inspection cover (fig. 11) and check for looseness of cap screws which hold backplate to flywheel (fig. 15).

e. **Clutch Return Springs.** Inspect for broken return spring (fig. 13). Broken springs will let the pressure plate drag, causing the transmission to operate when clutch is disengaged.

f. **Clutch Operation.** When clutch lever is moved to engage or disengage the clutch, cams should snap smoothly over center. Roughness in this operation indicates that camshafts, cam plates, or linkage are worn.

24. TROUBLE SHOOTING.

a. Refer to paragraph 15.

25. REMOVAL.

a. Equipment.

BAR, steel	WRENCH, box, $\frac{7}{8}$ -in.
CHISEL	WRENCH, open-end, $\frac{1}{2}$ -in.
DRIFT, brass	WRENCH, open-end, $\frac{9}{16}$ -in. (2)
HAMMER	WRENCH, open-end, $\frac{5}{8}$ -in.
PUNCH	WRENCH, open-end, $\frac{3}{4}$ -in.
ROPE	WRENCH, open-end, $\frac{7}{8}$ -in. (2)
SCREWDRIVER	WRENCH, socket, $\frac{3}{4}$ -in.
WIRE	WRENCH, socket, 1-in.
WRENCH, box, 1-in.	WRENCH, socket, $1\frac{1}{8}$ -in.

b. Procedure.

(1) DISCONNECT TERMINALS FROM BATTERY.

(2) REMOVE AIR CLEANER BODY.

WRENCH, open-end, $\frac{3}{4}$ -in.

Use a $\frac{3}{4}$ -inch open-end wrench to remove 4 cap screws and lock washers which hold body to control housing and top.

ORDNANCE MAINTENANCE – HEAVY TRACTOR MI (IHC TD-18) –
POWER TRAIN, TRACK FRAME ASSEMBLY, AND SEATS

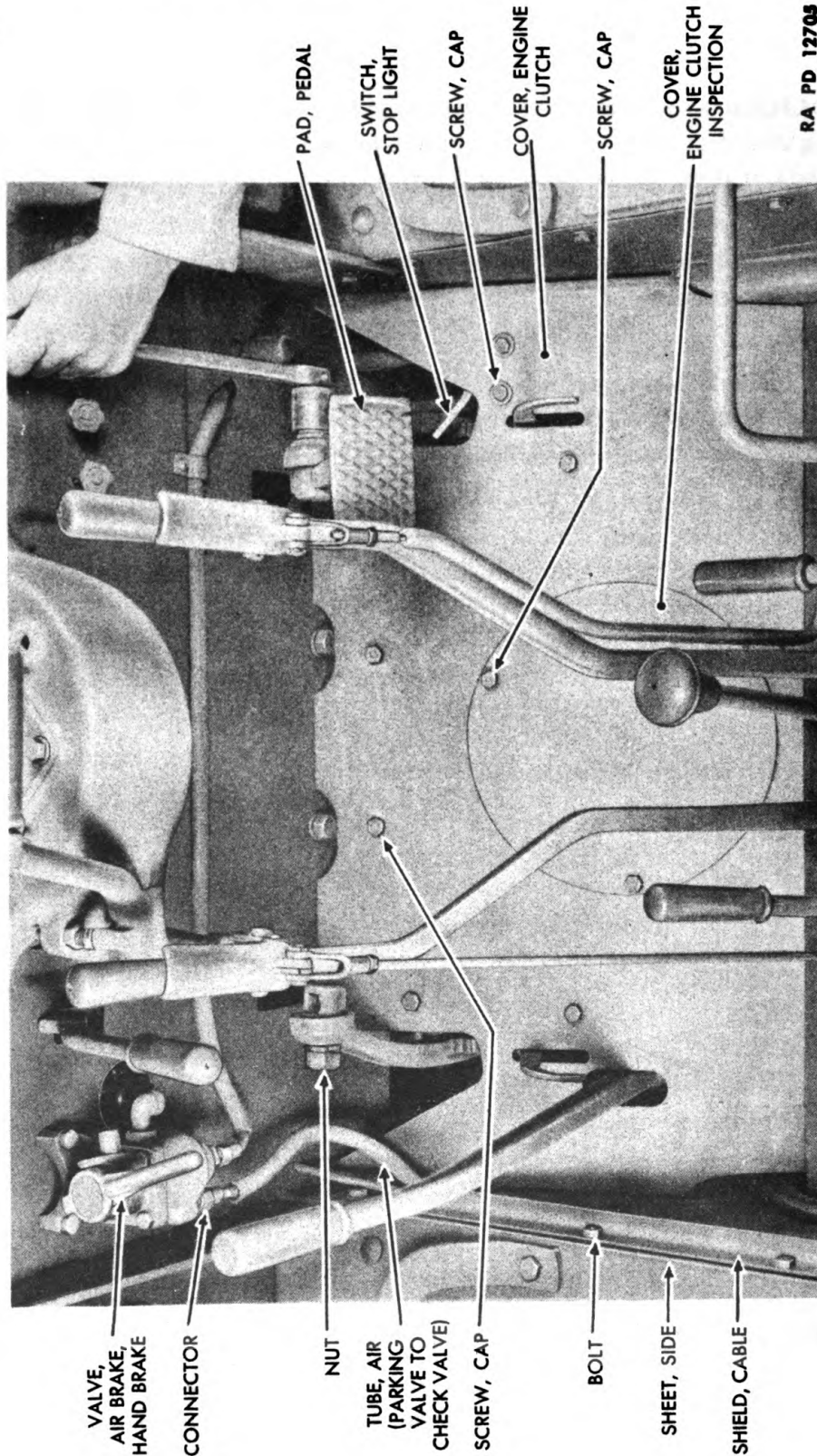

RA PD 12705

Figure 11 – Engine Clutch Cover Removal

ENGINE CLUTCH**(3) REMOVE PEDAL PADS (fig. 11).****WRENCH, socket, 1 1/8-in.**

Loosen nut which holds each pedal pad in position, using a 1 1/8-inch socket wrench, then remove pedal pads.

(4) REMOVE CAP SCREWS FROM ENGINE CLUTCH COVER (fig. 11).**WRENCH, open-end 1/2-in. WRENCH, open-end, 9/16-in.**

Use a 9/16-inch open-end wrench to remove 8 cap screws and lock washers from engine clutch cover and 3 cap screws and lock washers from engine clutch inspection cover. Also remove 2 cap screws, lock washers, and flat washers which hold stop light switch in place, using a 1/2-inch open-end wrench. Remove stop light switch.

(5) REMOVE AIR TUBE AND CABLE SHIELD FROM LEFT FENDER SIDE SHEET (fig. 11).**WRENCH, open-end, 9/16-in. (2)**

Use two 9/16-inch open-end wrenches to remove 3 bolts, nuts, and lock washers which hold shield to fender side sheet. Use one wrench to hold the nuts from outside of side sheet.

(6) DISCONNECT AIR TUBE (PARKING VALVE TO CHECK VALVE) FROM HAND BRAKE VALVE (fig. 11).**WRENCH, open-end, 5/8-in.**

Use a 5/8-inch open-end wrench to disconnect connector at air brake hand brake valve.

(7) REMOVE WINCH DRIVE SHAFT GUARD. NOTE: It is necessary to remove guard from winch drive shaft to gain access to 2 cap screws which hold engine clutch cover to left front fender bracket.**WRENCH, open-end, 9/16-in. WRENCH, open-end, 7/8-in.****WRENCH, open-end, 3/4-in. WRENCH, socket, 1-in.**

(a) Remove 6 bolts, nuts, lock washers, and flat washers and 2 cap screws and lock washers which hold guard to left side sheet. Use a 9/16-inch open-end wrench.

(b) Use a 1-inch socket wrench to remove cap screw and lock washer which hold guard to main frame left channel.

(c) Use a 7/8-inch open-end wrench to remove cap screw and lock washer which hold guard to winch.

(d) Using a 3/4-inch open-end wrench, remove bolt, spacer, lock washer and nut which hold winch guard to left front bracket.

(e) Remove guard.

**ORDNANCE MAINTENANCE — HEAVY TRACTOR MI (IHC TD-18) —
POWER TRAIN, TRACK FRAME ASSEMBLY, AND SEATS**

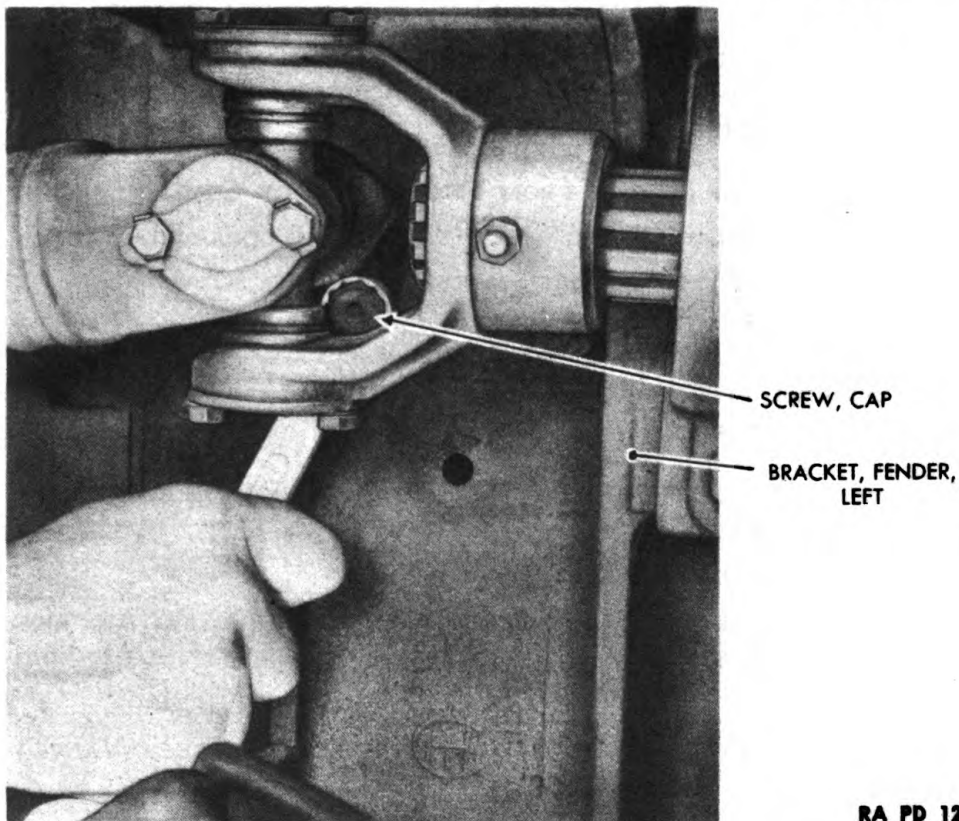

RA PD 12706

Figure 12 — Removal of Cap Screws Securing Engine Clutch Cover to Left Fender Bracket

(8) REMOVE 2 CAP SCREWS AND LOCK WASHERS WHICH SECURE ENGINE CLUTCH COVER TO LEFT FRONT FENDER BRACKET (fig. 12).

WRENCH, open-end, $\frac{3}{4}$ -in.

Use a $\frac{3}{4}$ -inch open-end wrench to remove 2 cap screws and lock washers from left fender bracket. Then use the same wrench to remove 2 cap screws and lock washers from right front fender bracket.

(9) REMOVE ENGINE CLUTCH COVER.

ROPE

Pull back steering clutch levers to their extreme rear position and tie them with rope. Lock steering brakes in forward position. Lift out engine clutch inspection cover, and then remove engine clutch cover.

(10) DISCONNECT CLUTCH RING FROM TRANSMISSION FLANGE (fig. 13).

SCREWDRIVER

WRENCH, open-end, $\frac{3}{4}$ -in.

Engage the engine clutch lever. Then use screwdriver to bend back locks which hold bolts in place. Using a $\frac{3}{4}$ -inch open-end wrench,

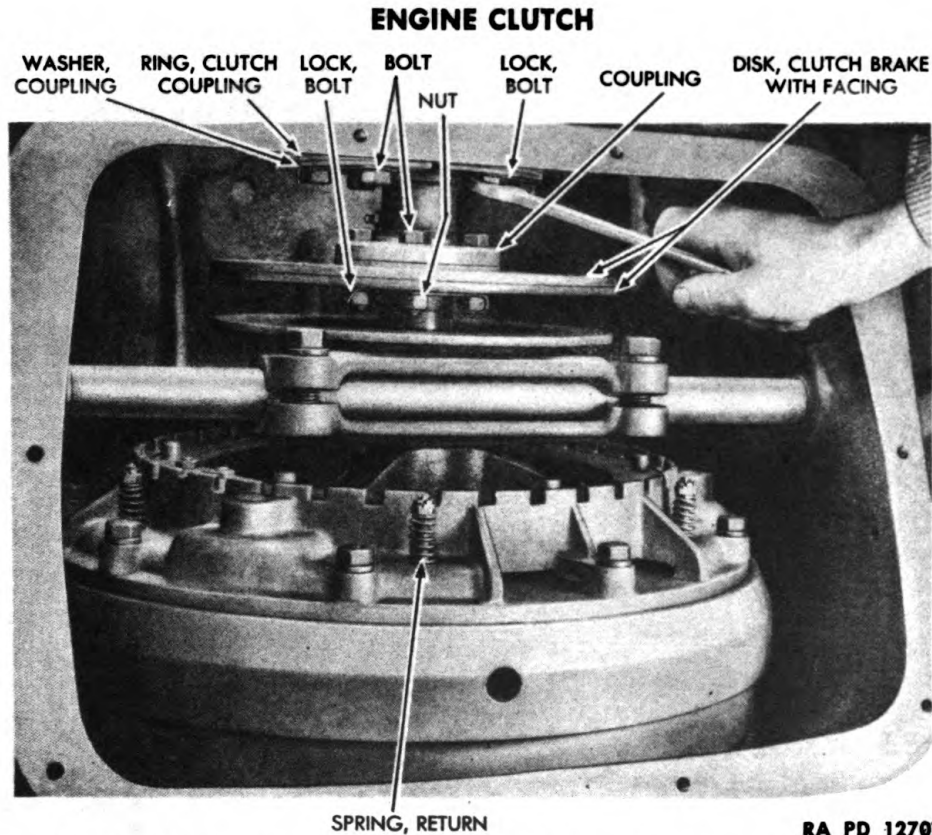

Figure 13 – Disconnecting Engine Clutch Ring from Transmission Flange

remove 6 nuts, locks, and bolts which hold clutch coupling washer and clutch ring to transmission flange. Remove coupling washer.

(11) DISCONNECT CLUTCH COUPLING FROM CLUTCH SHAFT AND CLUTCH DISK BRAKE WITH FACING (fig. 13).

SCREWDRIVER

WRENCH, open-end, $\frac{3}{4}$ -in.

Use screwdriver to bend back locks which hold nuts in place. Using a $\frac{3}{4}$ -inch open-end wrench, remove 6 nuts, locks, and bolts which hold clutch coupling to clutch shaft and to clutch disk with facing. Remove clutch ring and coupling.

(12) REMOVE CLUTCH FORK SHAFT (fig. 14).

DRIFT, brass

WRENCH, box, 1-in.

WRENCH, box or open-end,
 $\frac{7}{8}$ -in.

WRENCH, socket, 1-in.

WRENCH, socket, $1\frac{1}{8}$ -in.

(a) Using a $\frac{7}{8}$ -inch box or open-end wrench, loosen the 2 clutch fork cap screws and lock washers which hold fork to clutch shaft.

(b) Using a 1-inch box wrench, remove nut, lock washer and bolt which hold clutch lever on clutch fork shaft, then remove clutch lever. Remove Woodruff key from the end of the shaft.

(c) From left side of vehicle, use a drift to drive out clutch fork

ORDNANCE MAINTENANCE – HEAVY TRACTOR MI (IHC TD-18) –
POWER TRAIN, TRACK FRAME ASSEMBLY, AND SEATS

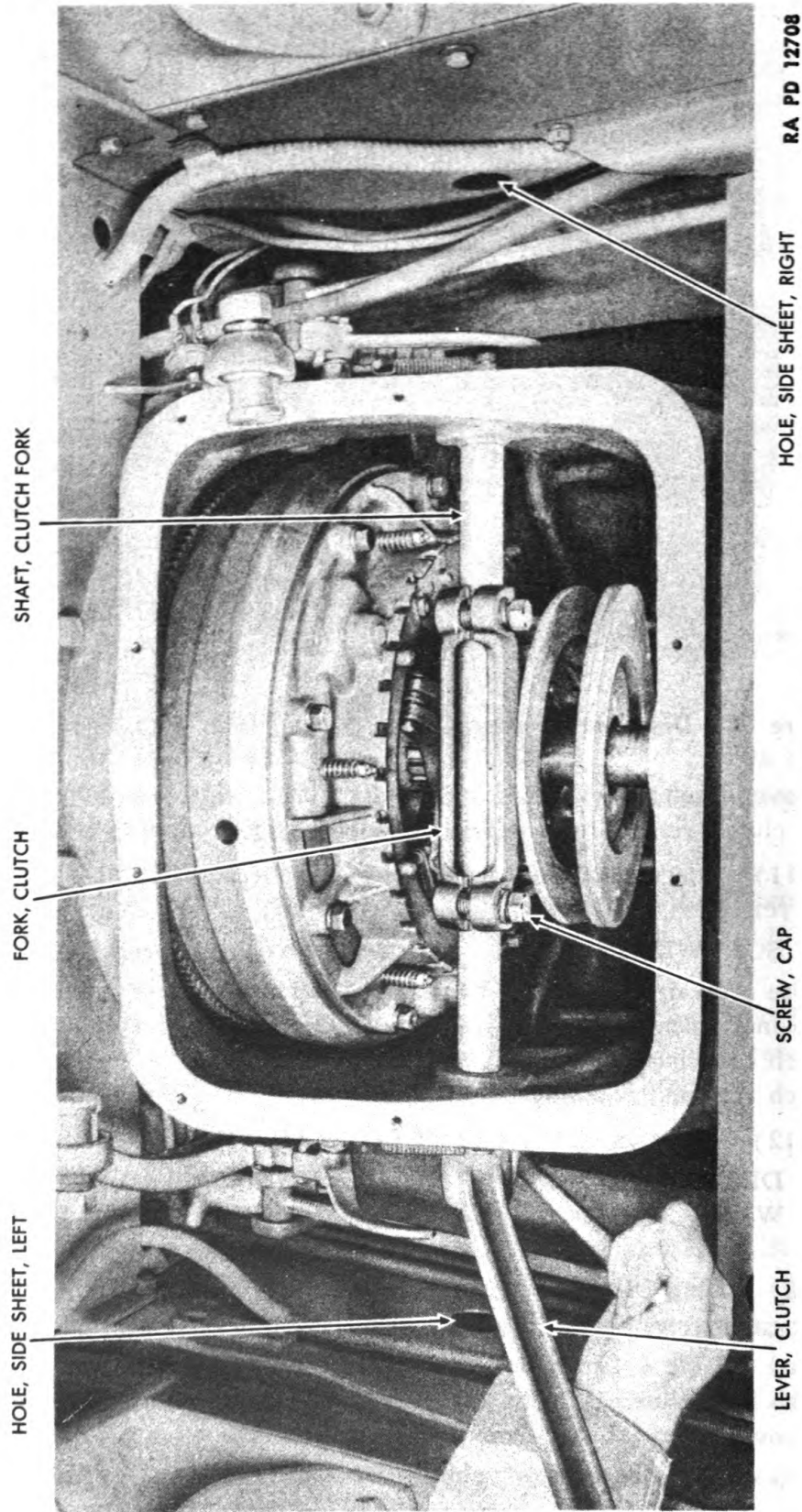

Figure 14 – Clutch Fork Shaft Removal

RA PD 12708

ENGINE CLUTCH

shaft, entering a drift through the hole in left fender side sheet. The shaft can then be removed through hole in right fender side sheet. Before driving shaft all of the way out, drive shaft through clutch fork until shaft can be rotated. The 2 Woodruff keys which engage the shaft on the fork can then be removed. NOTE: It is not necessary to remove the shaft entirely, providing it is removed through the hole in right fender side sheet sufficiently to provide access to the balance of the clutch assembly (fig. 15).

(d) Remove clutch fork and 2 pin bushings. NOTE: If a track lug is in the way when driving out shaft, it will be necessary to move tractor slightly, also, if street plates are installed, 1 plate will have to be removed to provide space to remove the shaft. To do this, remove the 2 bolts securing street plate to track, using a 1-inch socket wrench to hold the bolthead and a 1½-inch socket wrench to remove nut, then remove bolts and lock washers and plate.

(13) DISCONNECT CLUTCH BACKPLATE FROM FLYWHEEL (fig. 15).

WRENCH, socket, ¾-in.

Use a ¾-inch socket wrench to remove 9 cap screws and lock washers which hold backplate to flywheel.

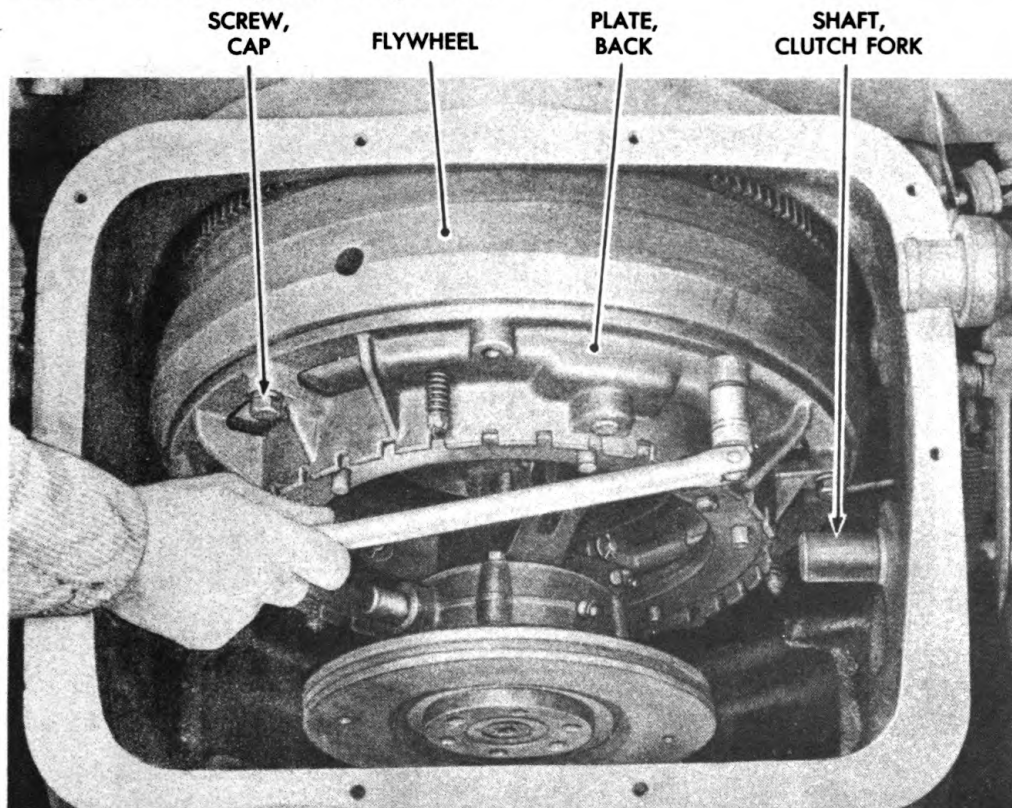

RA PD 12709

Figure 15 — Cap Screw, Removal from Clutch Back Plate

ORDNANCE MAINTENANCE — HEAVY TRACTOR MI (IHC TD-18) —
POWER TRAIN, TRACK FRAME ASSEMBLY, AND SEATS

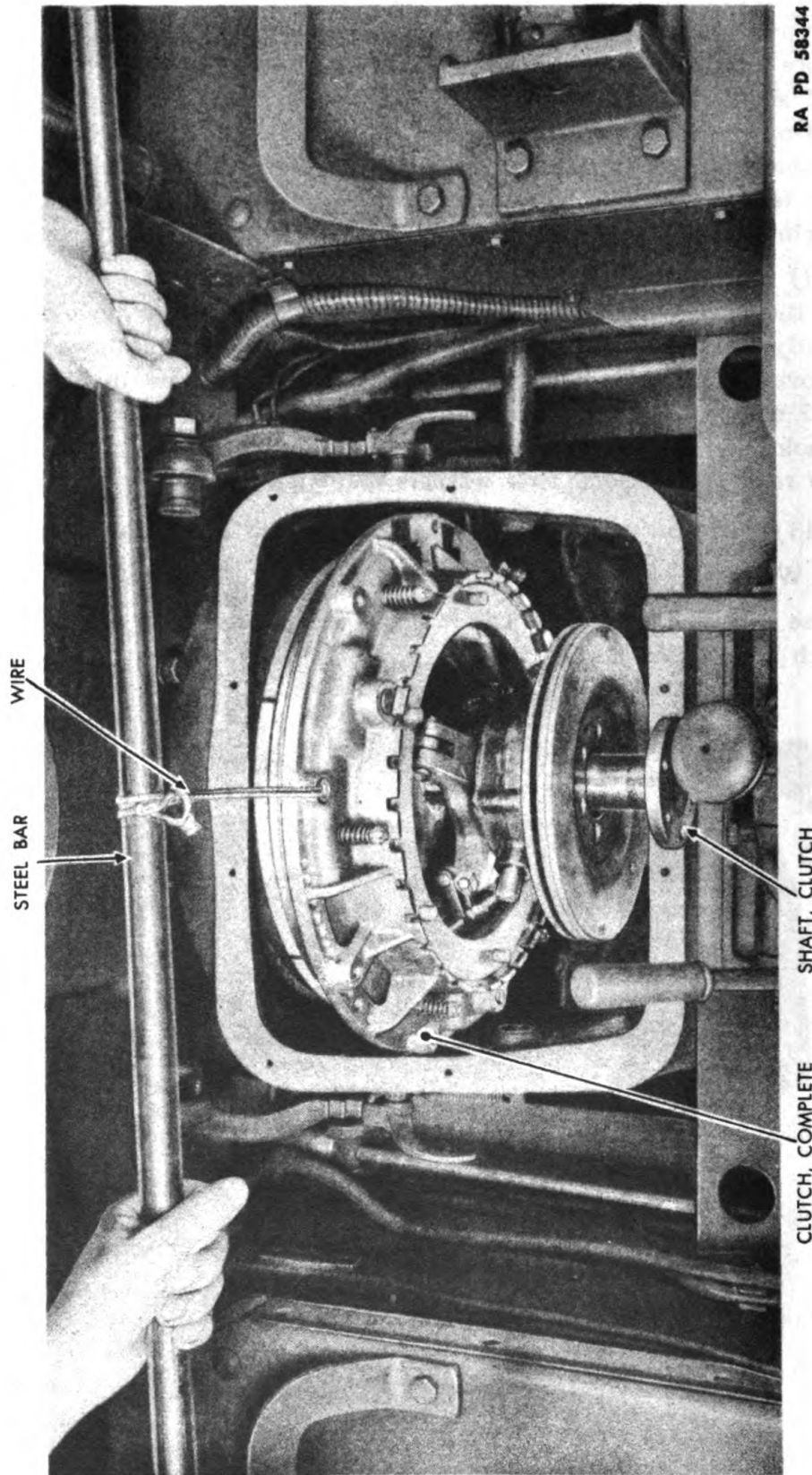

RA PD 58344

Figure 16 — Engine Clutch Assembly Removal

ENGINE CLUTCH

(14) REMOVE ENGINE CLUTCH, COMPLETE (fig. 16).

BAR, steel

WIRE

SCREWDRIVER

Use a screwdriver to pry clutch free from flywheel. Then support clutch on a steel bar by means of a strong wire attached to the bar and through one of the cap screw holes in clutch backplate. Use a screwdriver to pry clutch shaft outward so that it is free of pilot bearing. Lift complete clutch upward, tilting it so that clutch shaft can be pulled out still farther over edge of clutch compartment. The complete clutch can then be lifted out.

BUSHINGS, ENGINE CLUTCH FORK SHAFT

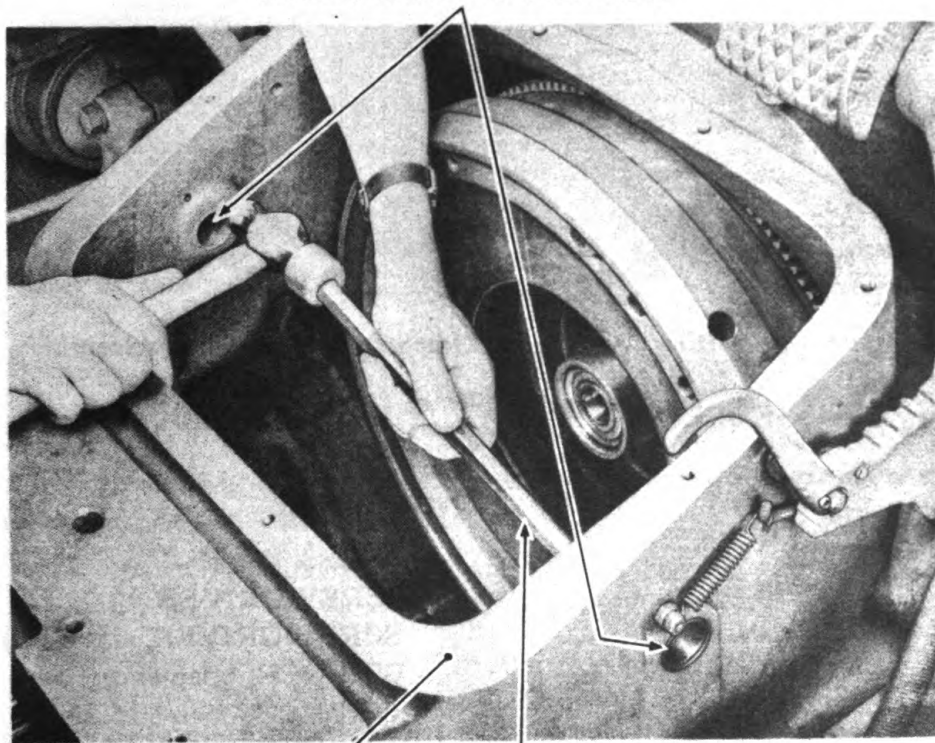

Figure 17 – Engine Clutch Fork Shaft Bushing Removal

(15) REMOVE ENGINE CLUTCH FORK SHAFT BUSHINGS (fig. 17).

NOTE: Do not remove fork shaft bushings unless they are worn and are to be replaced.

CHISEL

PUNCH

HAMMER

Use a hammer and chisel to pry up corner of bushing. Then use a punch and drive the bushing from the main frame. Remove the second bushing on the opposite side of frame in a similar manner.

**ORDNANCE MAINTENANCE — HEAVY TRACTOR MI (IHC TD-18) —
POWER TRAIN, TRACK FRAME ASSEMBLY, AND SEATS**

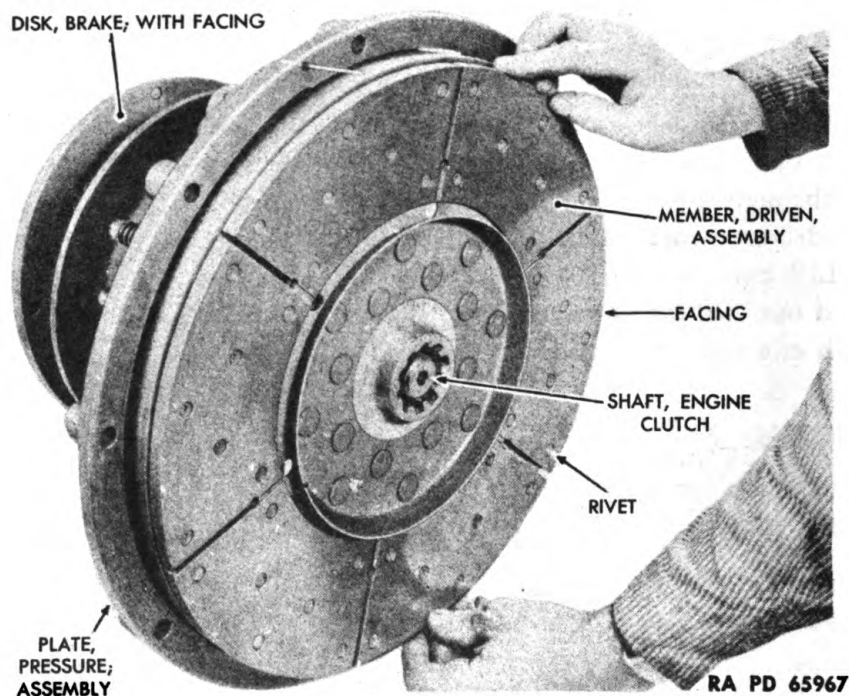

Figure 18 — Lifting Off Engine Clutch Driven Member Assembly

26. DISASSEMBLY.

a. Equipment.

BAR, steel
CHISEL
CUTTERS, diagonal
DRIFT, brass
HAMMER
HAMMER, rawhide
PLATE, steel

PLIERS
PRESS, arbor
SCREWDRIVER
SCREWDRIVER, small (2)
WRENCH, open-end, 3/8-in.
WRENCH, open-end, 1/2-in.
WRENCH, open-end, 9/16-in.

b. Procedure.

(1) LIFT OFF ENGINE CLUTCH DRIVEN MEMBER ASSEMBLY FROM COMPLETE ENGINE CLUTCH (fig. 18).

(2) REMOVE ENGINE CLUTCH SHAFT AND BRAKE DISK WITH FACING (fig. 18).

(3) REMOVE BRAKE DISK, BEARING CARRIER AND SLEEVE, AND BUSHING (fig. 19).

CUTTERS, diagonal

(a) Using diagonal cutters, remove cotter pin from each of 3 link pins which hold 3 connecting links to sleeve and bushing.

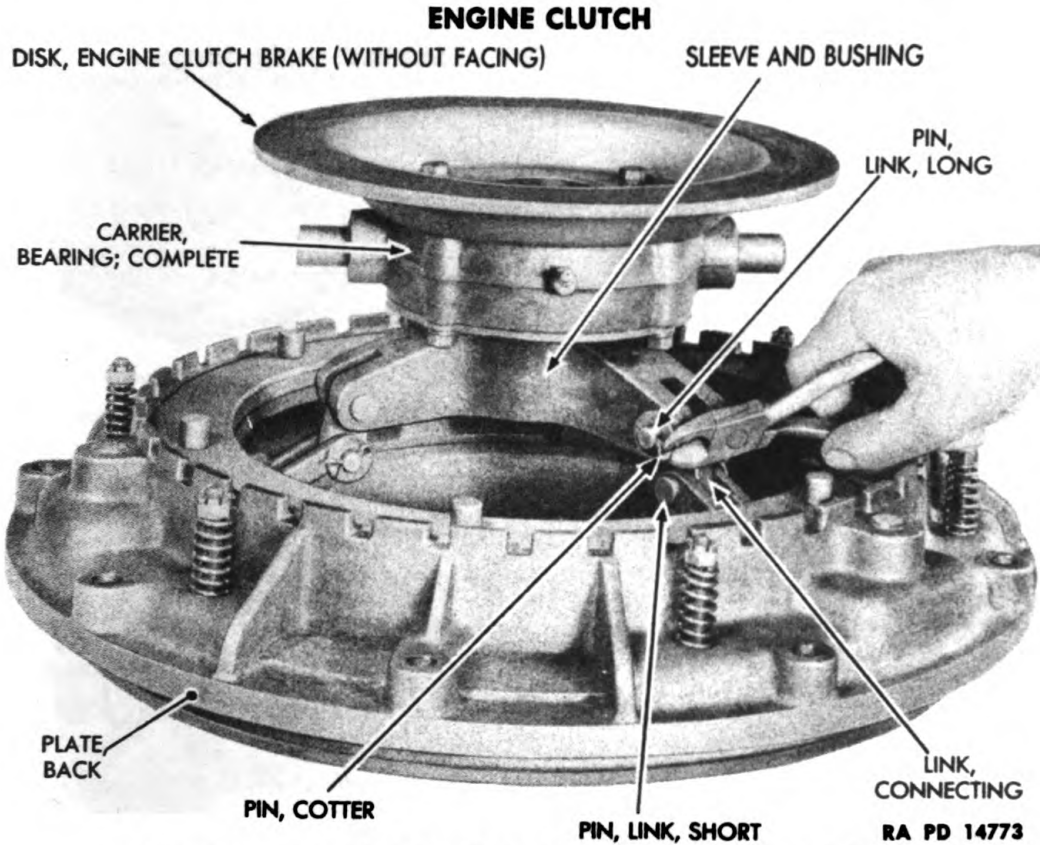

Figure 19 – Engine Clutch Brake Disk, Carrier and Sleeve, and Bushing; Removal

(b) Remove brake disk (without facing), bearing carrier and sleeve, and bushing.

(4) REMOVE ADJUSTING RING (fig. 20).

DRIFT, brass
HAMMER

WRENCH, open-end, $\frac{9}{16}$ -in.

(a) Using a $\frac{9}{16}$ -inch open-end wrench, loosen 2 nuts which hold adjusting lock in place. Then release lock.

(b) Use brass drift and hammer to tap adjusting ring in a counter-clockwise direction. When ring moves freely, unscrew it from backplate.

(c) Lift out ring plate.

(5) LIFT OUT CAMSHAFTS FROM BACKPLATE (fig. 21).

(6) REMOVE RETURN SPRING BOLTS AND RETURN SPRING (fig. 21).

CUTTERS, diagonal
SCREWDRIVER

WRENCH, open-end, $\frac{1}{2}$ -in.

Using diagonal cutters, remove 6 cotter pins from 6 castellated nuts which hold 6 return springs to return spring bolts. Hold boltheads with screwdriver and remove nuts, using a $\frac{1}{2}$ -inch open-end wrench.

ORDNANCE MAINTENANCE — HEAVY TRACTOR MI (IHC TD-18) —
POWER TRAIN, TRACK FRAME ASSEMBLY, AND SEATS

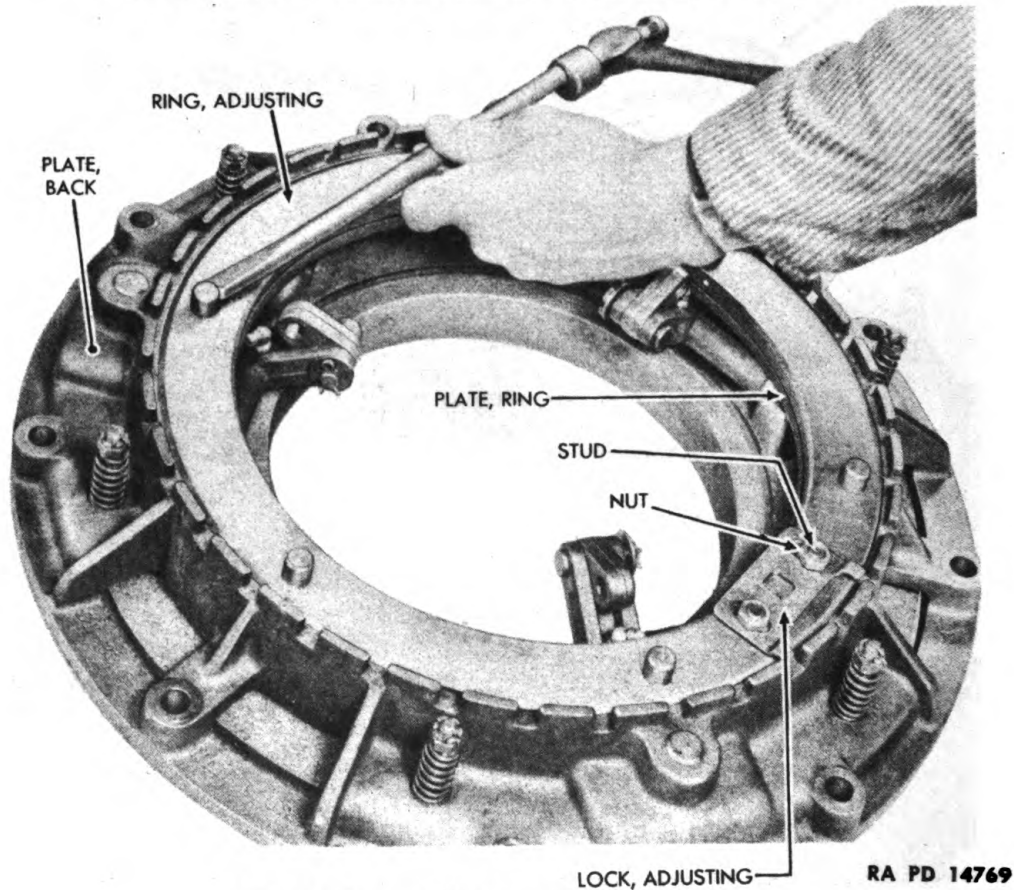

Figure 20 — Adjusting Ring Removal

- (7) LIFT BACKPLATE FROM PRESSURE PLATE ASSEMBLY (fig. 21).
- (8) REMOVE CAM BLOCKS FROM PRESSURE PLATE ASSEMBLY (fig. 22).

HAMMER

SCREWDRIVER

Do not remove unless new blocks are to be installed. To remove, use a hammer and screwdriver to tap cam block screw locks loose from 6 fillister head screws which hold 6 cam blocks on pressure plate cover. Then use screwdriver to remove screws. Lift out cam blocks.

- (9) REMOVE ADJUSTING LOCK FROM ADJUSTING RING (fig. 20).

WRENCH, open-end, $\frac{1}{16}$ -in.

Use a $\frac{1}{16}$ -inch open-end wrench to remove nuts from 2 studs, then remove adjusting lock.

- (10) DISASSEMBLE CAMSHAFTS (fig. 21).

PLIERS

WRENCH, open-end, $\frac{3}{8}$ -in.

- (a) Remove connecting link from each camshaft, using pliers to

ENGINE CLUTCH

remove cotter pin from short link pin. Remove flat washer and connecting link.

(b) Remove camshaft lubricator fittings. Use a $\frac{3}{8}$ -inch open-end wrench to remove the fitting from each camshaft.

(11) REMOVE ENGINE CLUTCH BRAKE DISK (fig. 23).

HAMMER, rawhide

WRENCH, open-end, $\frac{1}{2}$ -in.

Use a $\frac{1}{2}$ -inch open-end wrench to remove 4 cap screws and lock washers which hold engine clutch brake disk (without facing) to bearing carrier. Use rawhide hammer to tap disk from bearing carrier.

(12) REMOVE BEARING CARRIER FROM BEARING PLATE (fig. 24).

WRENCH, open-end, $\frac{3}{8}$ -in.

WRENCH, open-end, $\frac{1}{2}$ -in.

(a) Use a $\frac{1}{2}$ -inch open-end wrench to remove 4 cap screws and lock washers which hold bearing plate to bearing carrier. Then remove bearing carrier from release bearing and bearing plate.

(b) Remove lubricator fitting from bearing carrier, using a $\frac{3}{8}$ -inch open-end wrench.

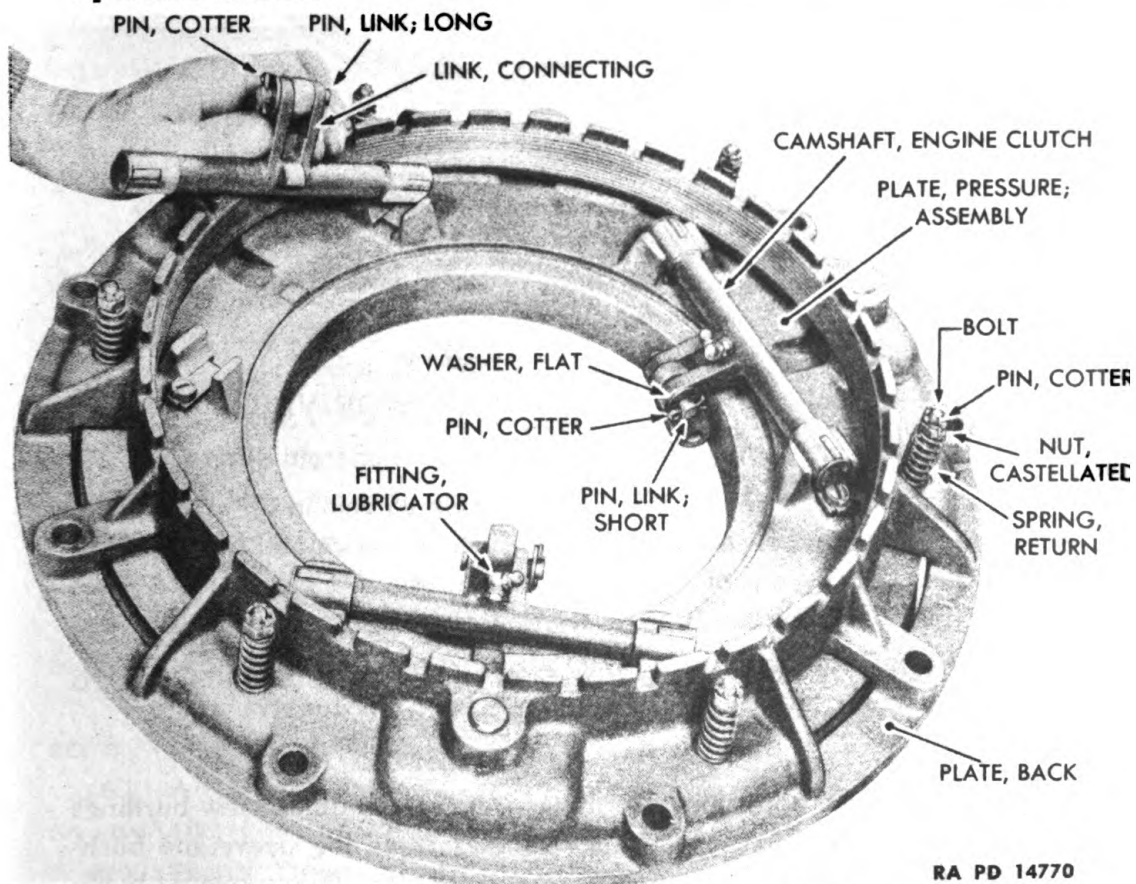

RA PD 14770

Figure 21 – Engine Clutch Camshaft Removal

ORDNANCE MAINTENANCE — HEAVY TRACTOR MI (IHC TD-18) —
POWER TRAIN, TRACK FRAME ASSEMBLY, AND SEATS

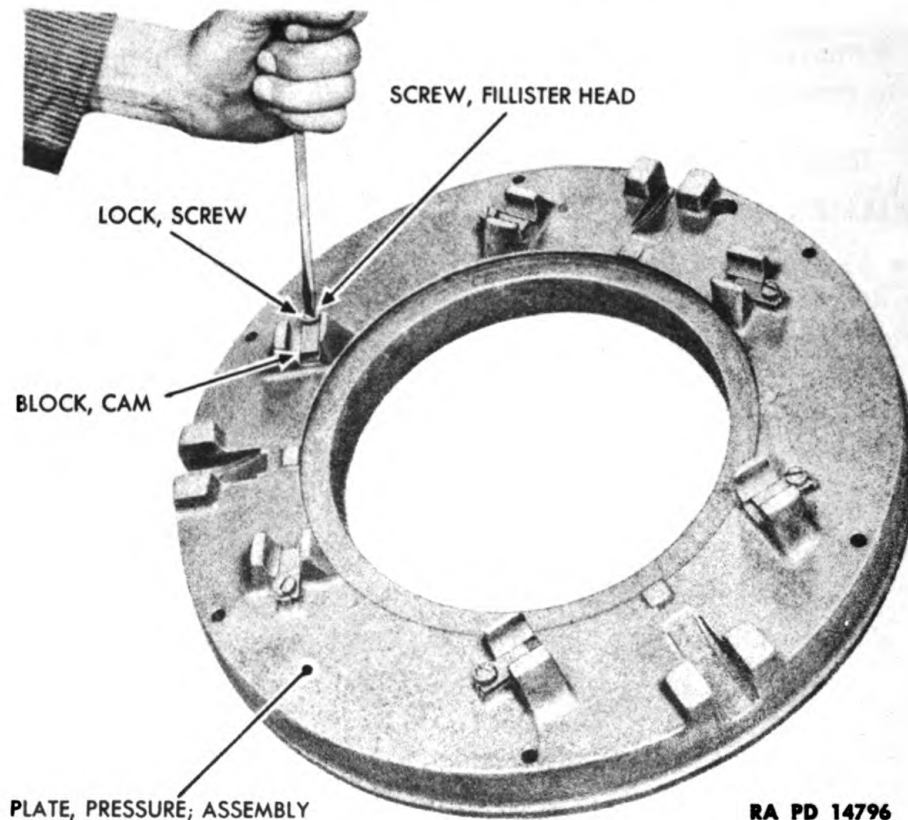

Figure 22 — Cam Block Removal from Pressure Plate Assembly

(13) REMOVE RELEASE BEARING FROM SLEEVE AND BUSHING (fig. 25).

BAR, steel (2)
PLATE, steel

PRESS, arbor
SCREWDRIVER, small (2)

(a) Use 2 small screwdrivers to pry snap ring from sleeve.

(b) Place sleeve and bushing and bearing carrier in an arbor press. Position 2 steel bars on bearing plate at sides of sleeve and bushing with a steel plate across top of bars. Use arbor press on steel plate to press bearing plate and release bearing from sleeve and bushing.

(14) REMOVE BUSHINGS FROM SLEEVE IF THE BUSHINGS ARE TO BE REPLACED (fig. 25).

CHISEL

HAMMER

CAUTION: Do not remove bushings from sleeve unless new bushings are to be installed. First inspect the bushings, replacing sleeve and bushings on clutch shaft and checking for excessive play. To remove oil bush-

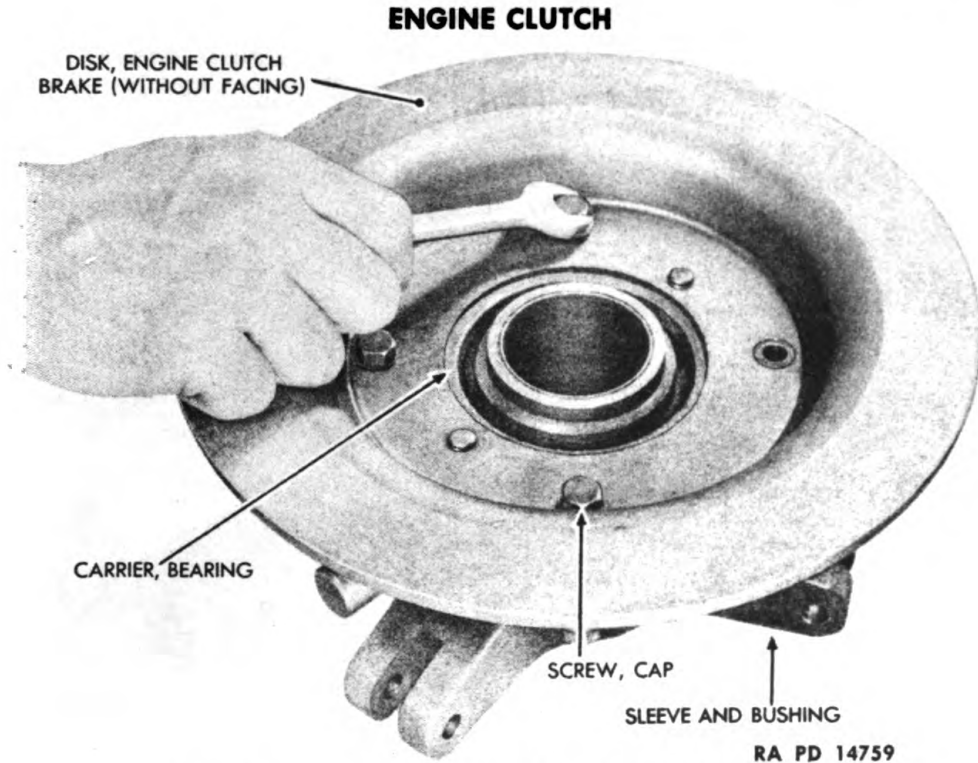

Figure 23 – Engine Clutch Brake Disk Removal

ings, use a hammer and chisel to cut them free from sleeve. Exercise care not to damage sleeve.

27. PARTS, INSPECTION.

a. Clean All Parts. Wash all components of the disassembled engine clutch thoroughly in SOLVENT, dry-cleaning.

b. Inspect All Parts.

(1) **ENGINE CLUTCH COUPLING RING.** Check for worn teeth on coupling. Replace, if worn.

(2) **ENGINE CLUTCH COUPLING.** Replace if teeth are worn or if coupling fits loose on coupling ring.

(3) **ENGINE CLUTCH SHAFT.** Replace if splines are worn or if driven member fits loosely on shaft.

(4) **ENGINE CLUTCH BRAKE DISK (WITH FACING).** Check to see if facing is worn down to rivets. If so, install new facing.

(5) **ADJUSTING RING ASSEMBLY.** Examine threads to see that they are free of grease or dirt.

(6) **ADJUSTING RING PLATE.** Place ring plate on a surface plate or on any other flat surface to check for excessive "dishing."

(7) **BRAKE DISK (WITHOUT FACING).** If facing is rough, replace.

**ORDNANCE MAINTENANCE – HEAVY TRACTOR MI (IHC TD-18) –
POWER TRAIN, TRACK FRAME ASSEMBLY, AND SEATS**

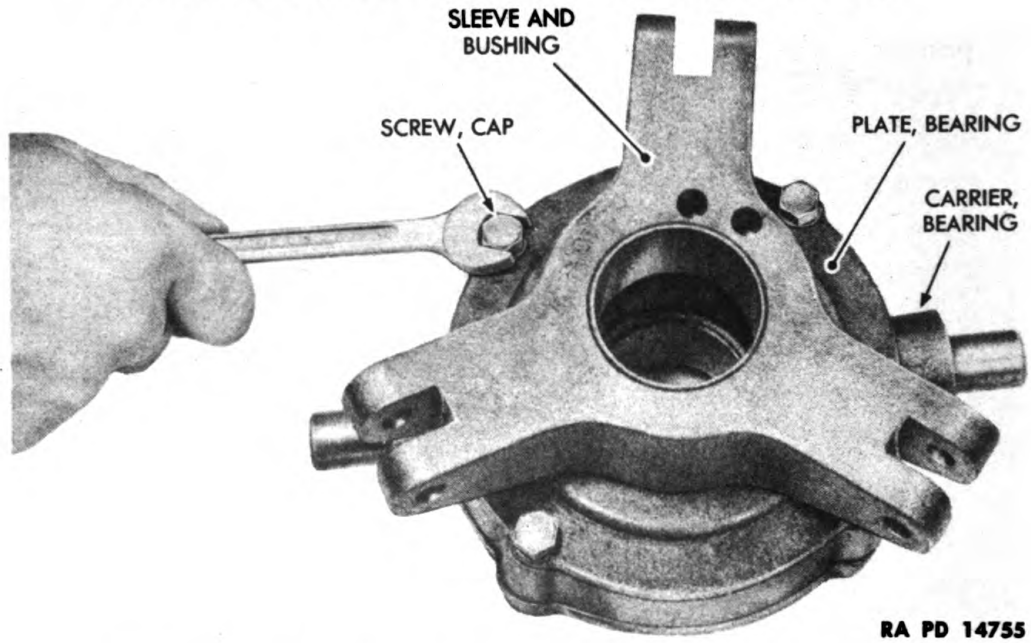

Figure 24 – Bearing Carrier Removal from Bearing Plate

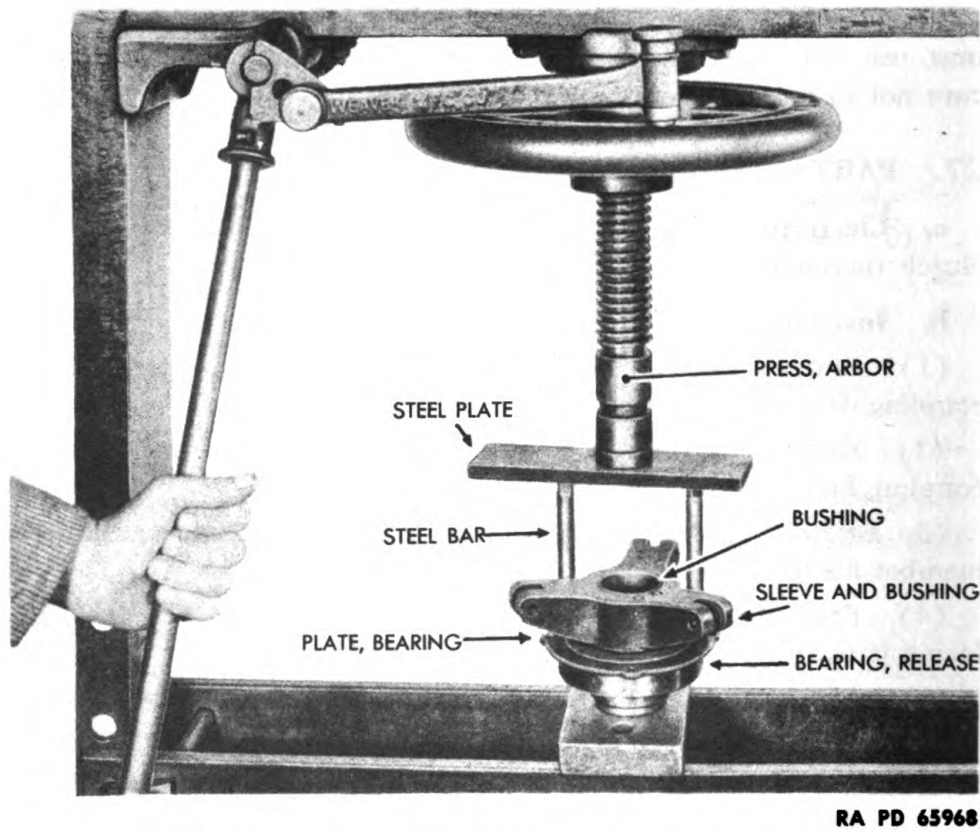

Figure 25 – Pressing Release Bearing from Sleeve and Bushing

ENGINE CLUTCH

- (8) **LUBRICATOR FITTING ON BRAKE DISK.** Check to see that the passage in the fitting is open and clean.
- (9) **BEARING CARRIER.** Inspect for loose fit of release bearing in bearing carrier. Replace if a bearing in good condition fits loosely in carrier.
- (10) **RELEASE BEARING.** Check bearing for loose running and for looseness on clutch shaft. Replace if these conditions exist.
- (11) **SLEEVE AND BUSHING.** Check for loose movement on clutch shaft. Replace if clearance is greater than 0.005 inch. Check all pinholes for wear. Test camshafts for loose operation of cams.
- (12) **CAMSHAFT.** Replace if rollers are worn or loose.
- (13) **BACKPLATE.** Examine for loose or worn pins. Replace if pins cannot be tightened or if they are worn.
- (14) **PRESSURE PLATE ASSEMBLY.** Examine pressure plate for score marks. Check for cracks or roughness of facing, and replace if these conditions exist. Replace cam blocks if worn.
- (15) **DRIVEN MEMBER ASSEMBLY.** If facings are worn to rivets, new facings must be installed.
- (16) **PILOT BEARINGS.** Examine pilot bearing for loose running, and wear. Also check for loose fit in flywheel. Replace if these conditions are found. Refer to TM 9-1777A.
- (17) **FACINGS.** Check facings on driven member and brake disk for wear.
- (18) **RETURN SPRINGS.** Check to see if springs are broken.

28. ENGINE CLUTCH FACINGS, INSTALLATION

a. To Install New Facings on Driven Member Assembly.

(1) EQUIPMENT.

KNIFE, putty

SOLVENT, dry-cleaning

MACHINE, riveting

(2) PROCEDURE.

(a) Remove engine clutch and disassemble clutch until the driven member assembly is removed (pars. 25 and 26).

(b) *Remove Rivets Which Hold Old Facing to Driven Member Assembly.*

MACHINE, riveting

Use standard post ordnance riveting machine as used for general automotive work to remove old facing and rivets.

ENGINE CLUTCH

pins can be inserted. Do not tighten further. Use diagonal cutters to insert cotter pins which lock nuts to bolts.

(3) INSTALL CAMSHAFTS (fig. 21).

CUTTERS, diagonal

WRENCH, open-end, $\frac{3}{8}$ -in.

(a) Attach connecting link to each of the 3 camshafts. Install short link pins and flat washers which hold connecting links to camshafts. Use diagonal cutters to install cotter pin in end of each short link pin.

(b) Install camshaft lubricator fitting on each camshaft. Use a $\frac{3}{8}$ -inch open-end wrench.

(c) Position the 3 camshafts on pressure plate assembly lubrication fittings up.

(d) Lubricate camshafts through fittings. Wipe off excess lubricant.

(4) PLACE ADJUSTING RING PLATE IN POSITION IN BACKPLATE, OVER CAMSHAFT (fig. 20).

(5) INSTALL ADJUSTING RING (fig. 20).

WRENCH, open-end, $\frac{9}{16}$ -in.

(a) Screw adjusting ring into backplate in a clockwise direction, tightening it as much as possible by hand.

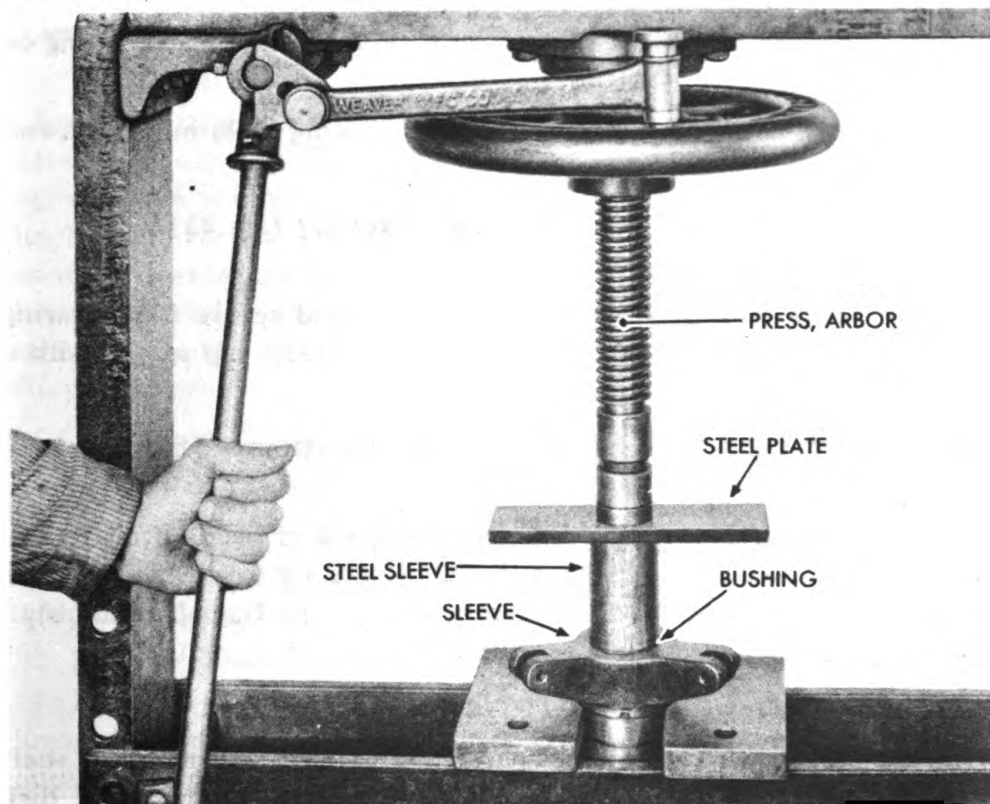

RA PD 65969

Figure 26 – Installing Bushing in Engine Clutch Sleeve

**ORDNANCE MAINTENANCE — HEAVY TRACTOR M1 (IHC TD-18) —
POWER TRAIN, TRACK FRAME ASSEMBLY, AND SEATS**

(b) Install adjusting lock, using $\frac{3}{16}$ -inch open-end wrench to tighten 2 nuts which hold lock to adjusting ring studs.

(6) **PRESS BUSHINGS INTO SLEEVE** (fig. 26).

PRESS, arbor

New bushings are to be installed when old bushings have been removed from sleeve. Use an arbor press to press 2 new bushings into sleeve.

(7) **INSTALL RELEASE BEARING ON SLEEVE AND BUSHING.**

PRESS, arbor

Install release bearing plate over sleeve and bushing. Position bearing on sleeve, the reverse of figure 25. Use an arbor press to press release bearing on sleeve and bushing.

(8) **INSTALL BEARING CARRIER** (fig. 24).

WRENCH, open-end, $\frac{3}{8}$ -in. **WRENCH**, open-end, $\frac{1}{2}$ -in.

(a) Place bearing carrier over release bearing and install snap ring. Secure carrier to release bearing plate with 4 cap screws and lock washers. Tighten cap screws with a $\frac{1}{2}$ -inch open-end wrench. **CAUTION:** The square on bottom of bearing plate must be opposite lubricator fitting on bearing carrier.

(b) Install lubricator to bearing carrier, using a $\frac{3}{8}$ -inch open-end wrench.

(9) **INSTALL BRAKE DISK (WITHOUT FACING)** (fig. 23).

WRENCH, open-end, $\frac{1}{2}$ -in.

Install brake disk over sleeve and bushing and secure it to bearing carrier with 4 cap screws and lock washers. Tighten cap screws with a $\frac{1}{2}$ -inch open-end wrench.

(10) **ATTACH SLEEVE AND BUSHING TO CAMSHAFTS** (fig. 19).

PLIERS

Place sleeve and bushing with attached parts in position over camshafts. Attach sleeve and bushing to camshafts by inserting long link pins through sleeve and bushing and connecting links. Use pliers to install cotter pins in ends of 3 long link pins.

(11) **INSTALL BRAKE DISK (WITH FACING)** (fig. 18).

Install brake disk (with facing) over clutch shaft; then install shaft with brake disk (with facing) into assembled parts from brake disk (without facing) side.

**ORDNANCE MAINTENANCE — HEAVY TRACTOR MI (IHC TD-18) —
POWER TRAIN, TRACK FRAME ASSEMBLY, AND SEATS**

(b) Place 2 halves of coupling washer in place and install 3 bolt locks and 6 bolts, with boltheads toward clutch. Hold bolt nuts with a 3/4-inch open-end wrench and tighten boltheads with another 3/4-inch open-end wrench. Use a screwdriver to lock bolt locks on the boltheads.

(c) Tighten coupling front nuts with a 3/4-inch open-end wrench and use a screwdriver to lock bolt locks on bolt nuts.

(5) INSTALL THE CLUTCH FORK (fig. 27).

(a) Place the 2 pin bushings on the bearing carrier, with the shoulders of the pin bushings next to the carrier. **CAUTION:** When the clutch fork is installed, the carrier must be positioned with the lubrication fitting at the top.

(b) Install the clutch fork with the cap screw heads facing the rear of the clutch.

(6) INSTALL THE CLUTCH FORK SHAFT (fig. 14).

WRENCH, box, 7/8-in.

WRENCH, open-end, 7/8-in.

WRENCH, box, 1-in.

(a) Enter the clutch fork shaft through the right side sheet hole into the engine clutch compartment. Center the shaft into the clutch fork with keyways facing up, then install the 2 Woodruff keys which engage

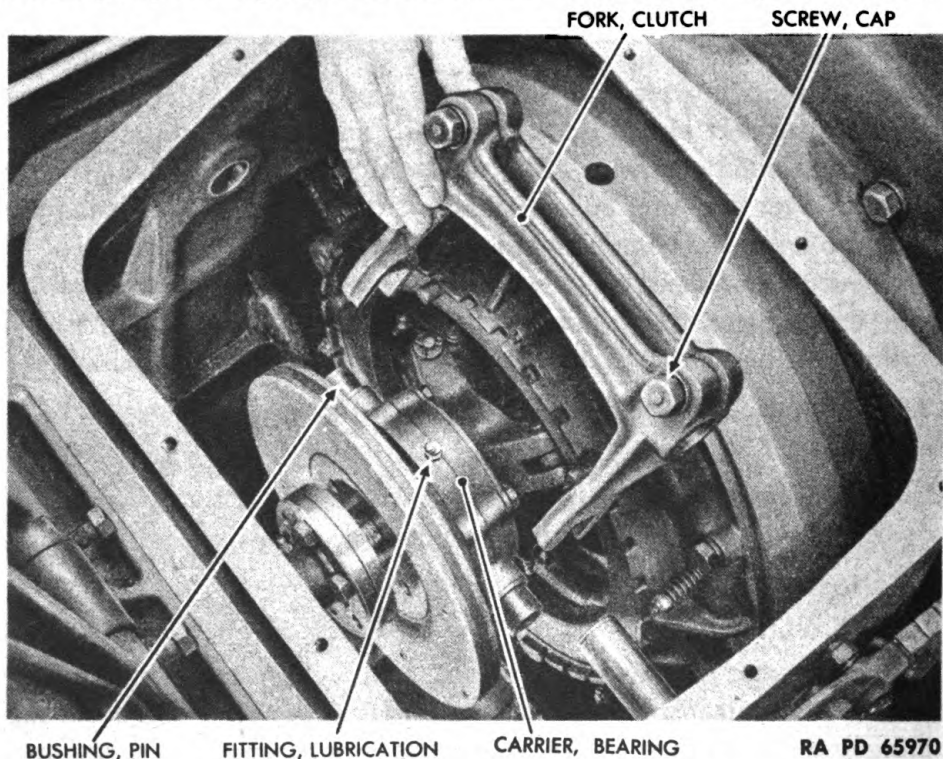

Figure 27 — Clutch Fork Installation

ENGINE CLUTCH

the shaft on the fork. Rotate the shaft 90 degrees and slide the shaft and keys into position.

(b) Use a $\frac{7}{8}$ -inch box or open-end wrench to tighten the 2 clutch fork cap screws and lock washers which hold the fork to the clutch shaft.

(c) Insert the Woodruff key in position on the end of the shaft and attach clutch lever. Use a one-inch box wrench to install and tighten bolt, nut, and lock washer which hold clutch lever on clutch fork shaft.

(7) ADJUST THE CLUTCH (par. 31).

(8) PLACE THE ENGINE CLUTCH COVER IN POSITION.

With steering clutch levers tied with rope in their extreme rear position, and steering brakes locked in forward position, place engine clutch cover in position.

(9) INSTALL CAP SCREWS AND LOCK WASHERS WHICH SECURE THE ENGINE CLUTCH COVER TO THE FENDER BRACKETS (fig. 12).

WRENCH, open-end, $\frac{3}{4}$ -in.

Install 2 cap screws and lock washers to left fender bracket. Also install 2 cap screws and lock washers in right fender bracket. Tighten cap screws with a $\frac{3}{4}$ -inch open-end wrench.

(10) INSTALL WINCH DRIVE SHAFT GUARD.

The winch drive shaft guard will have been removed when removing the clutch in order to gain access to 2 cap screws which hold engine clutch cover to left fender bracket. Install it as follows:

WRENCH, open-end, $\frac{9}{16}$ -in.

WRENCH, socket, 1-in.

WRENCH, open-end, $\frac{7}{8}$ -in.

(a) Place guard in position.

(b) Install bolt, spacer, lock washer, and nut which hold the winch guard to the left front fender bracket.

(c) Use a $\frac{7}{8}$ -inch open-end wrench to install cap screw and lock washer which hold guard to winch.

(d) Use a 1-inch socket wrench to install cap screw and lock washer which hold guard to left frame channel.

(e) Install 6 bolts, nuts, lock washers, and flat washers and 2 cap screws and lock washers which hold guard to left fender side sheet. Tighten bolts and cap screws with a $\frac{9}{16}$ -inch open-end wrench.

(11) CONNECT AIR TUBE (PARKING VALVE TO CHECK VALVE) TO THE HAND BRAKE VALVE (fig. 11).

WRENCH, open-end, $\frac{5}{8}$ -in.

Use a $\frac{5}{8}$ -inch open-end wrench to connect connector to valve.

**ORDNANCE MAINTENANCE — HEAVY TRACTOR MI (IHC TD-18) —
POWER TRAIN, TRACK FRAME ASSEMBLY, AND SEATS**

(12) CONNECT AIR TUBE AND CABLE SHIELD TO LEFT FENDER SIDE SHEET (fig. 11).

WRENCH, open-end, $\frac{9}{16}$ -in. (2)

Use two $\frac{9}{16}$ -inch open-end wrenches to install 3 bolts, nuts, and lock washers which hold shield to fender side sheet. Use one wrench to hold nuts from underneath side sheet.

(13) INSTALL CAP SCREWS IN ENGINE CLUTCH COVER (fig. 11).

WRENCH, open-end, $\frac{9}{16}$ -in.

Install 8 cap screws and lock washers in engine clutch cover, tightening them with a $\frac{9}{16}$ -inch open-end wrench.

(14) INSTALL THE STOP LIGHT SWITCH (fig. 11).

WRENCH, open-end, $\frac{1}{2}$ -in.

Place the stop light switch in position and install 2 cap screws, lock washers, and flat washers which hold switch in place. Tighten the cap screws with a $\frac{1}{2}$ -inch open-end wrench.

(15) INSTALL ENGINE CLUTCH INSPECTION COVER (fig. 11).

WRENCH, open-end, $\frac{9}{16}$ -in.

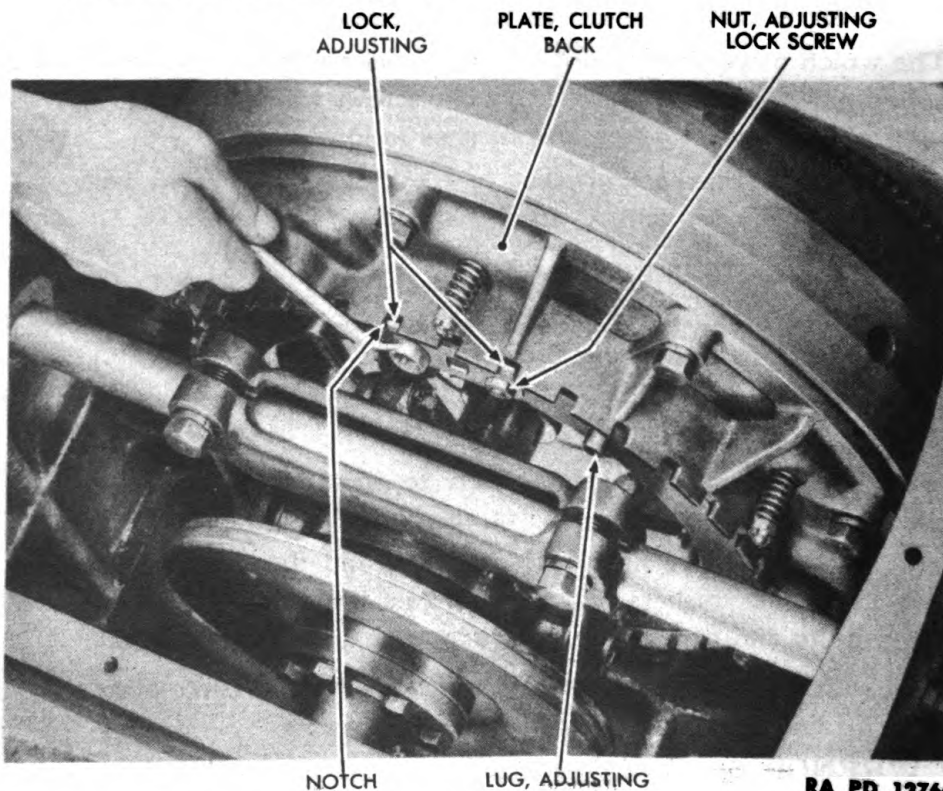

RA PD 12764

Figure 28 — Engine Clutch Adjustment (Lots 2, 3, and 4 Tractors)

ENGINE CLUTCH

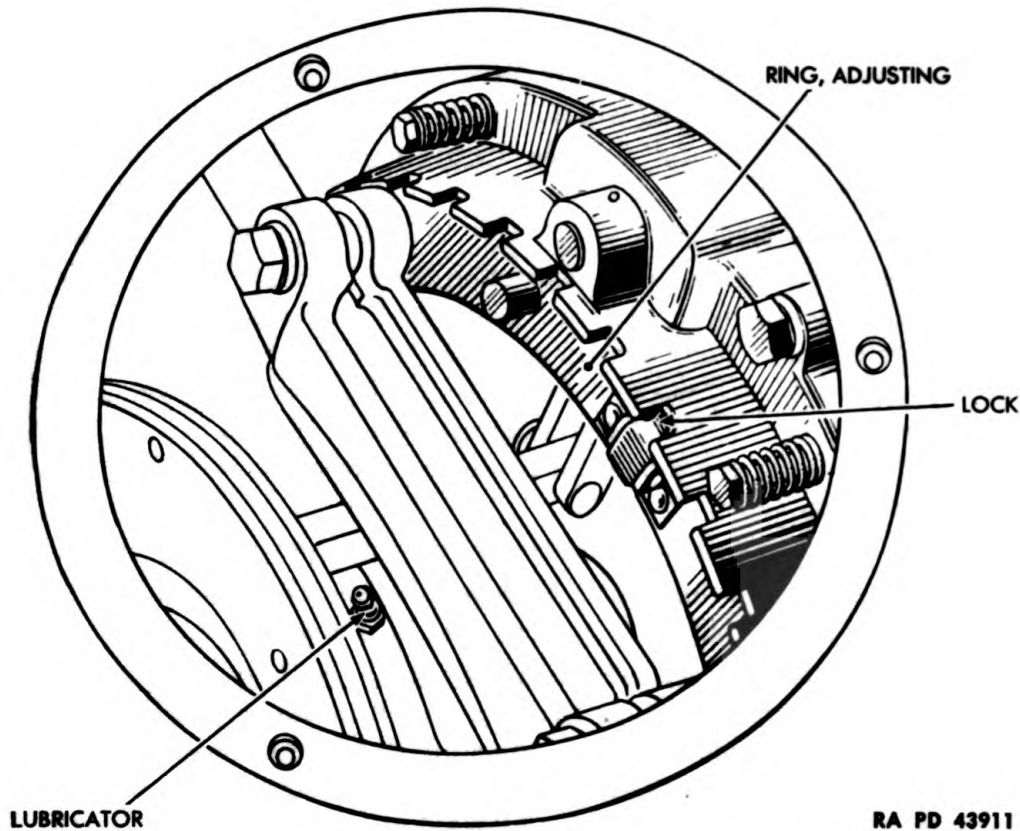

RA PD 43911

Figure 29 – Engine Clutch Adjustment (Lot 1 Tractors)

Place inspection cover in position and install 3 cap screws and lock washers, tightening the cap screws with a $\frac{9}{16}$ -inch open-end wrench.

(16) **INSTALL PEDAL PADS** (fig. 11).

WRENCH, socket, $1\frac{1}{8}$ -in.

Place each pedal pad in position and use a $1\frac{1}{8}$ -inch open-end wrench, to tighten the nut which holds each pedal pad in place.

(17) **INSTALL THE AIR CLEANER BODY ASSEMBLY** (fig. 32).

WRENCH, open-end, $\frac{3}{4}$ -in.

Place air cleaner body assembly in position on control housing and top. Insert 4 cap screws and lock washers and tighten them with a $\frac{3}{4}$ -inch open-end wrench.

31. ADJUSTMENT.

a. Equipment.

ROD, small steel

WRENCH, open-end, $\frac{9}{16}$ -in.

b. Procedure.

(1) **LUBRICATION.** Before adjustment, lubricate clutch cams, clutch

**ORDNANCE MAINTENANCE — HEAVY TRACTOR M1 (IHC TD-18) —
POWER TRAIN, TRACK FRAME ASSEMBLY, AND SEATS**

release, clutch pilot bearing; also clutch coupling on early models. Use GREASE, general purpose (seasonal grade).

(2) ADJUSTMENT OF ENGINE CLUTCH FOR LOTS 2, 3, AND 4 TRACTORS.

ROD, small steel

WRENCH, open-end, $\frac{9}{16}$ -in.

(a) Remove engine clutch inspection cover (fig. 11). Use a $\frac{9}{16}$ -inch open-end wrench to remove 3 cap screws and lock washers which hold engine clutch inspection cover in position. Remove cover. **NOTE:** The clutch can be adjusted in the field by removing inspection cover as outlined above, however, when clutch adjustment is made when installing clutch, this adjustment should be made before the engine clutch cover is installed (fig. 28).

(b) Check to make sure that clutch lever is disengaged.

(c) Use a $\frac{9}{16}$ -inch open-end wrench to loosen the 2 adjusting lock screw nuts so that adjusting lock drops out of notches in clutch backplate.

(d) Use a small steel rod on the adjusting ring lugs to adjust ring, moving the ring clockwise to take up clutch or move adjusting ring counterclockwise to loosen. When adjusting clutch in the field, adjusting ring should be moved no more than one or two notches to compensate for wear. Otherwise, clutch will be adjusted too tightly.

(e) Pull hand lever back to determine if over-center engagement is felt. If a full over-center engagement is not obtained, adjusting ring should be backed up one notch in a counterclockwise direction. When the correct adjustment is reached, replace adjusting lock in notches on adjusting ring. The adjusting lock must line up with these notches in backplate. Install adjusting lock screw nuts, tightening them with a $\frac{9}{16}$ -inch open-end wrench.

(f) Install clutch inspection cover. Install the 3 cap screws and nuts and tighten them with a $\frac{9}{16}$ -inch open-end wrench.

(3) CLUTCH ADJUSTMENT FOR LOT 1 TRACTORS.

(a) Remove inspection cover (1) (a) above.

(b) Check to make sure clutch lever is disengaged.

(c) Pull the adjusting lock free of the notch in the adjusting ring.

(d) See step (1) (d) above.

(e) Pull back hand lever to determine if the over-center engagement is felt. If a full over-center engagement is not obtained, the adjusting ring should be backed up one notch in a counterclockwise direction. When correct adjustment is reached, replace adjusting lock in a notch on adjusting ring. The adjusting lock must line up with a notch in the back plate.

(f) See step (1) (f) above.

Section II

TRANSMISSION AND DRIVE BEVEL GEAR

	Paragraph
Allocation of maintenance duties by echelons	32
Inspection in the vehicle	33
Trouble shooting	34
Removal	35
Disassembly	36
Parts, cleaning, inspection and repair	37
Assembly	38
Installation	39
Drive bevel gear, assembly and adjustment	40
Check after installation	41

32. ALLOCATION OF MAINTENANCE DUTIES BY ECHELONS.

a. Description. Transmission is of the selective spur gear type, having 6 speeds forward and 2 reverse. Standard shifting is controlled by one lever, while change from high to low range is controlled by another lever. Gears are assembled on 3 shafts which are mounted in rear main frame. Bevel pinion and shaft revolves on a straight roller bearing in bearing cage next to pinion. Ball bearings take end thrust, and bearing cage of bevel pinion shaft is shimmed from transmission and cover for cone setting of bevel gear. Upper shaft or spline shaft revolves on 2 ball bearings in cages. It is hollow to admit power take-off shaft, thus driving direct from drive gear assembly. The Hi-Lo and reverse shaft is stationary in main frame and transmission end cover. Reverse gear revolves on 2 roller bearings. Hi-Lo range gear revolves on 2 ball bearings. Lubrication is provided by splash from constant running oiler gear. Reservoir capacity is 7½ gallons. Several changes have been made in transmission and bevel gear. These changes do not affect the removal and reassembly; however, many of the parts that have been changed are not interchangeable among tractors in various lots. Reference must be made to the standard nomenclature list to determine the parts that are changed and the serial number of the tractor on which the change went into effect.

b. Allocation of Maintenance Duties by Echelons.

(1) DEFINITIONS. Refer to paragraph 22.

	TRANSMISSION		
	ECHELONS		
	2nd	3rd	4th
Transmission, assembly—repair or rebuild			X
Transmission gear shift, assembly—replace	X		
Transmission gear shift, assembly—repair		X	
Transmission gear shift, assembly—rebuild			X

ORDNANCE MAINTENANCE — HEAVY TRACTOR MI (IHC TD-18) —
POWER TRAIN, TRACK FRAME ASSEMBLY, AND SEATS

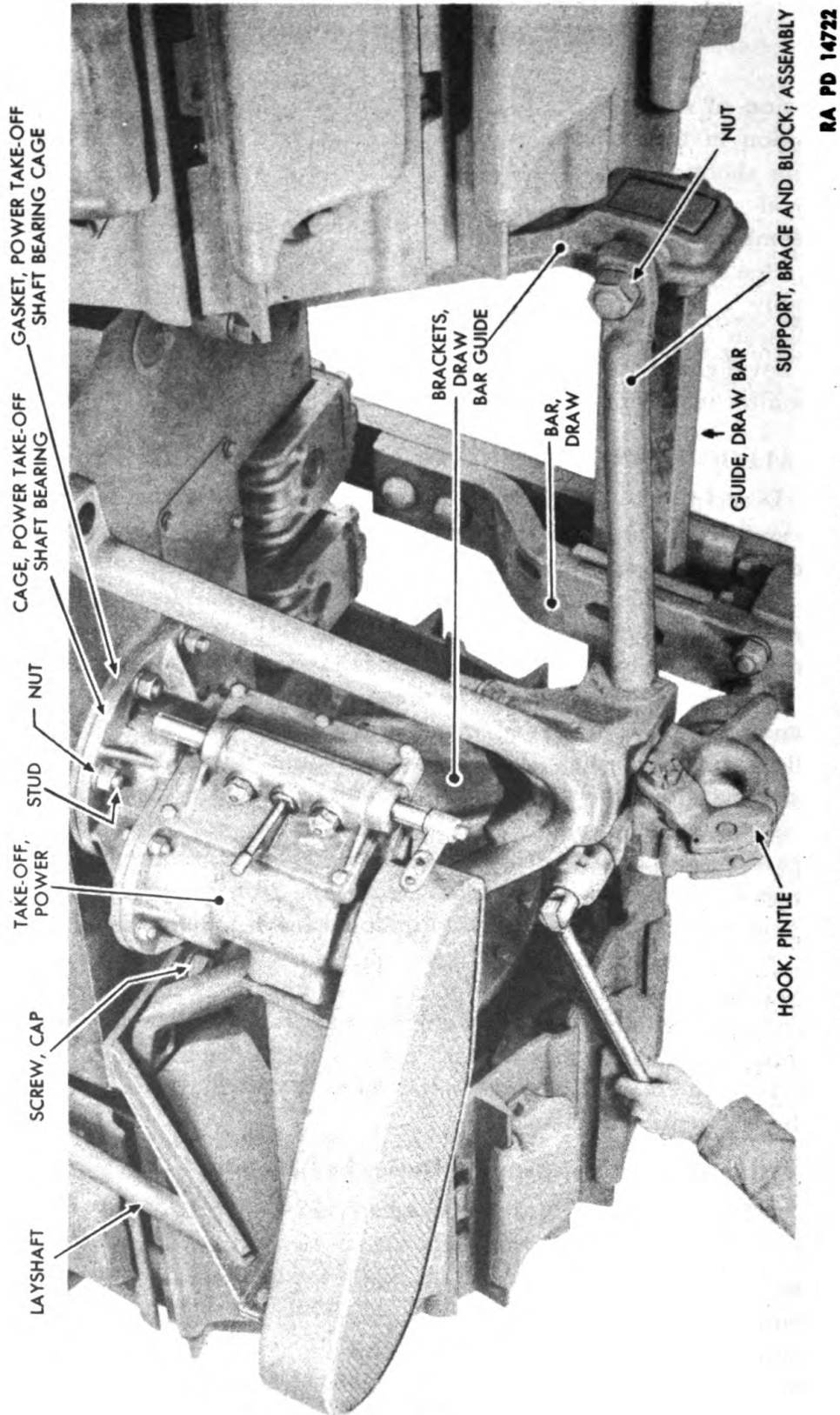

RA PD 14722

Figure 30 — Brace and Block Support Assembly Removal

TRANSMISSION AND DRIVE BEVEL GEAR

33. INSPECTION IN THE VEHICLE.

a. Except for noisy gear operation or for an inoperative transmission, which is an obvious indication of transmission or drive bevel gear trouble, the transmission and drive bevel gear cannot be inspected in the vehicle without removing seat, fenders, etc., and main frame cover, which is outlined in removal procedure (par. 35).

34. TROUBLE SHOOTING.

a. Transmission and drive bevel gear trouble shooting procedure is treated in paragraphs 17 and 20.

35. REMOVAL.

a. Equipment.

BAR, long steel	SLEEVE, steel
BLOCK, wood	WRENCH, open-end, $\frac{9}{16}$ -in. (2)
CROWBAR	WRENCH, open-end, $\frac{3}{4}$ -in.
HAMMER	WRENCH, open-end, 1-in.
HOIST	WRENCH, socket, $\frac{9}{16}$ -in. (2)
PLATE, steel	WRENCH, socket, $\frac{3}{4}$ -in.
PLIERS	WRENCH, socket, $1\frac{1}{16}$ -in.
PRESS, arbor	WRENCH, socket, $1\frac{1}{8}$ -in.
SCREW, cap $\frac{3}{8}$ -in. (3)	WRENCH, socket, $1\frac{5}{16}$ -in.
SCREW, cap, $\frac{1}{2}$ -in. (3)	WRENCH, socket, $1\frac{5}{8}$ -in.
SCREWDRIVER	WRENCH, socket, $1\frac{7}{8}$ -in.

b. Procedure.

(1) REMOVE SEAT, FENDERS, GROUSER BOXES, PACK CARRIER, DIESEL FUEL TANK, AND FENDER SIDE SHEETS AS A UNIT.

Follow procedure outlined in paragraph 52 h (1).

(2) REMOVE MAIN FRAME COVER AND ATTACHED PARTS.

Follow procedure outlined in paragraph 52 h (2), (3), (4), (5), (6), (7), and (8).

(3) REMOVE BRACE AND BLOCK SUPPORT ASSEMBLY WITH PINTLE HOOK ATTACHED (fig. 30).

WRENCH, socket, $1\frac{5}{8}$ -in.

WRENCH, socket, $1\frac{7}{8}$ -in.

Remove cap screw and lock washer which hold brace and block support assembly to left corner of main frame ($1\frac{5}{8}$ -in. socket wrench). Also remove 2 nuts and lock washers which hold brace and block support assembly to guide brackets ($1\frac{7}{8}$ -in. socket wrench). Lift off the brace and block support assembly.

**ORDNANCE MAINTENANCE — HEAVY TRACTOR MI (IHC TD-18) —
POWER TRAIN, TRACK FRAME ASSEMBLY, AND SEATS**

(4) REMOVE POWER TAKE-OFF WITH LAYSHAFT ATTACHED ON LOT 1 AND 4 TRACTORS (fig. 30). NOTE: The power take-off is removed without removing the layshaft. The layshaft is removed as a separate unit.

WRENCH, socket, $1\frac{1}{8}$ -in.

WRENCH, socket, $1\frac{5}{8}$ -in.

(a) Remove 6 nuts and lock washers which hold power take-off to main frame studs.

(b) Disconnect rear pillow block support from main frame. Use a $1\frac{5}{8}$ -inch socket wrench to remove cap screws and lock washers.

(c) Remove front layshaft pillow block with shims.

(d) Then lift off power take-off with layshaft attached. Use a $1\frac{1}{8}$ -inch socket wrench. Two men are required to lift it off, unless a hoist is available. Remove power take-off shaft bearing cage gasket.

(5) REMOVE POWER SHAFT BEARING CAGE, COMPLETE, AND POWER TAKE-OFF SHAFT (fig. 31).

WRENCH, open-end, $\frac{9}{16}$ -in.

FRAME, MAIN

SCREW, CAP ($\frac{3}{8}$ -IN.)

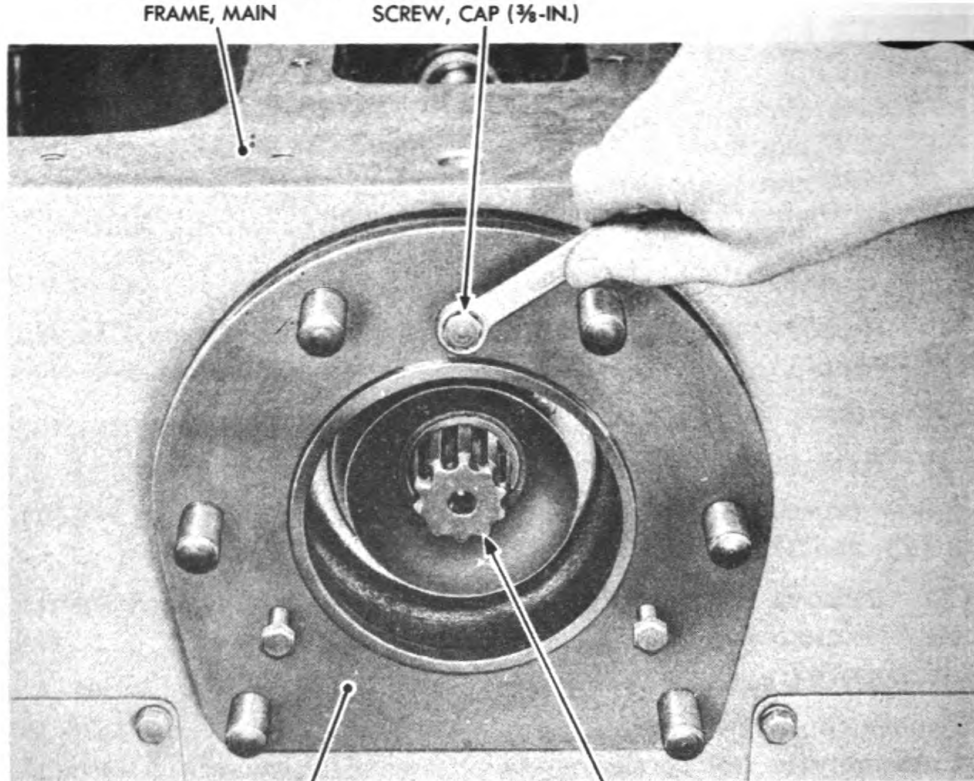

CAGE, POWER SHAFT BEARING; COMPLETE

SHAFT, POWER TAKE-OFF

RA PD 14621

**Figure 31 — Pulling Power Shaft Bearing Cage, Complete,
from Main Frame**

TRANSMISSION AND DRIVE BEVEL GEAR

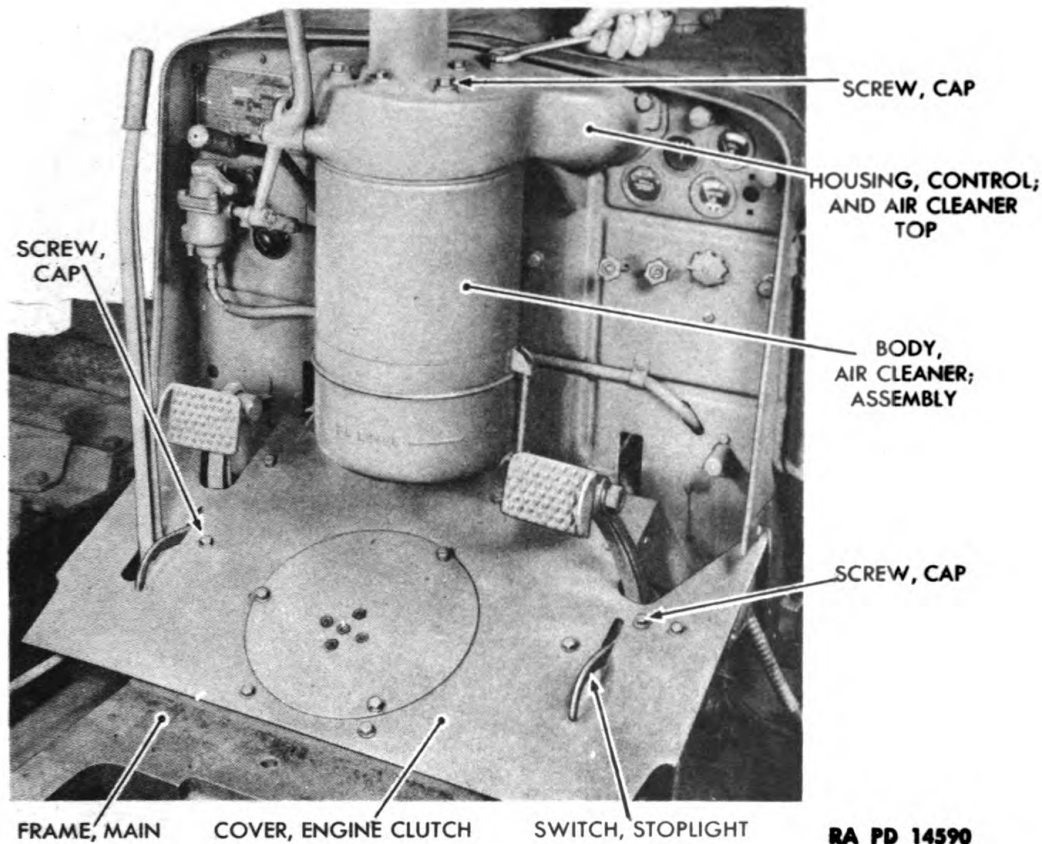

Figure 32 – Air Cleaner Body and Engine Clutch Cover Removal

(a) Insert three $\frac{3}{8}$ -inch cap screws in tapped holes in power shaft bearing cage and tighten with a $\frac{9}{16}$ -inch open-end wrench until cage is pulled loose from main frame.

(b) Pull power shaft bearing cage and power take-off shaft out from rear of main frame.

(6) REMOVE AIR CLEANER BODY ASSEMBLY (fig. 32).

WRENCH, open-end, $\frac{3}{4}$ -in.

Remove 4 cap screws and lock washers which hold air cleaner body assembly to control housing and air cleaner top. Use a $\frac{3}{4}$ -inch open-end wrench; then lift off the body assembly.

(7) REMOVE ENGINE CLUTCH COVER (fig. 32).

WRENCH, socket, $\frac{9}{16}$ -in.

Using a $\frac{9}{16}$ -inch socket, remove 8 cap screws and lock washers which hold engine clutch cover to main frame and 2 cap screws and lock washers which hold stop light switch to cover; then lift off the cover.

(8) REMOVE ENGINE CLUTCH.

Follow procedure outlined in paragraph 25 b (10) through (14).

**ORDNANCE MAINTENANCE — HEAVY TRACTOR M1 (IHC TD-18) —
POWER TRAIN, TRACK FRAME ASSEMBLY, AND SEATS**

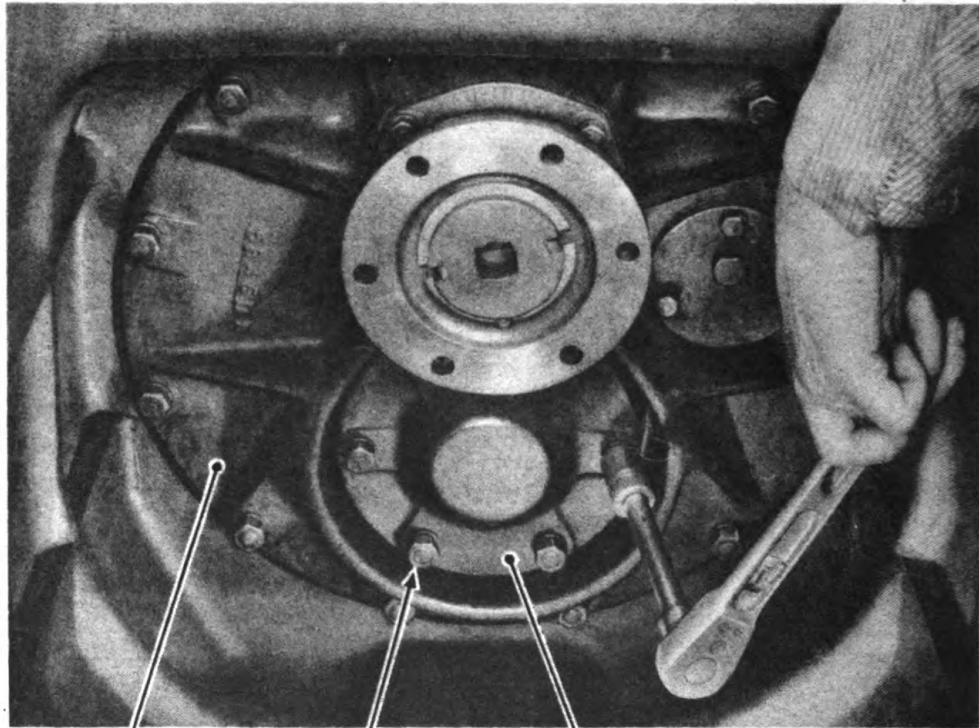

COVER, TRANSMISSION END SCREW, CAP RETAINER, BEVEL PINION SHAFT BEARING, FRONT RA PD 14824

Figure 33 — Transmission Bevel Pinion Shaft Front Bearing Retainer Removal

(9) REMOVE FRONT RETAINER (fig. 33).

WRENCH, socket, $\frac{3}{4}$ -in.

Use a $\frac{3}{4}$ -inch socket wrench to remove 4 cap screws and lock washers and 2 nuts and lock washers. Lift off front retainer and remove gasket.

(10) REMOVE BEVEL PINION SHAFT FRONT RETAINER WASHER (fig. 34).

WRENCH, socket, $\frac{3}{4}$ -in.

Use a $\frac{3}{4}$ -inch socket wrench to remove 2 cap screws and lock washers; then remove washer.

(11) REMOVE FRONT BEVEL PINION SHAFT BEARING CAGE (fig. 35).

SCREWS, cap, $\frac{3}{8}$ -in. (3) WRENCH, socket, $\frac{9}{16}$ -in.

Insert three $\frac{3}{8}$ -inch cap screws in tapped holes of bearing cage. Tighten cap screws with $\frac{9}{16}$ -inch socket wrench until bearing cage is pulled from bevel pinion and shaft. Remove cage and shims.

(12) DISCONNECT IDLER SHAFT RETAINER FROM IDLER SHAFT (fig. 35).

WRENCH, socket, $\frac{3}{4}$ -in.

TRANSMISSION AND DRIVE BEVEL GEAR

Use a $\frac{3}{4}$ -inch socket wrench to remove the cap screw and lock washer which hold idler shaft retainer to idler shaft.

(13) REMOVE TRANSMISSION END COVER (fig. 36).

SCREW, cap, $\frac{1}{2}$ -in. (3)

WRENCH, socket, $\frac{1}{8}$ -in.

WRENCH, socket, $\frac{3}{4}$ -in.

(a) Use a $\frac{3}{4}$ -inch socket wrench and remove 6 cap screws and lock washers which hold end cover to main frame. Then use a $\frac{1}{8}$ -inch socket wrench to remove 4 nuts and lock washers from the 4 studs which hold the end cover to main frame.

(b) Insert three $\frac{1}{2}$ -inch cap screws in tapped holes (fig. 37), and tighten with a $\frac{3}{4}$ -inch socket wrench until end cover and attached parts are pulled from transmission spline shaft and idler shaft; then lift out end cover and attached parts. Remove end cover gasket.

(14) REMOVE CAP SCREWS FROM REAR TRANSMISSION SPLINE SHAFT BEARING CAGE (fig. 38).

WRENCH, open-end, $\frac{9}{16}$ -in.

COVER, TRANSMISSION END

SCREW, CAP

**WASHER, BEVEL PINION
SHAFT FRONT RETAINER**

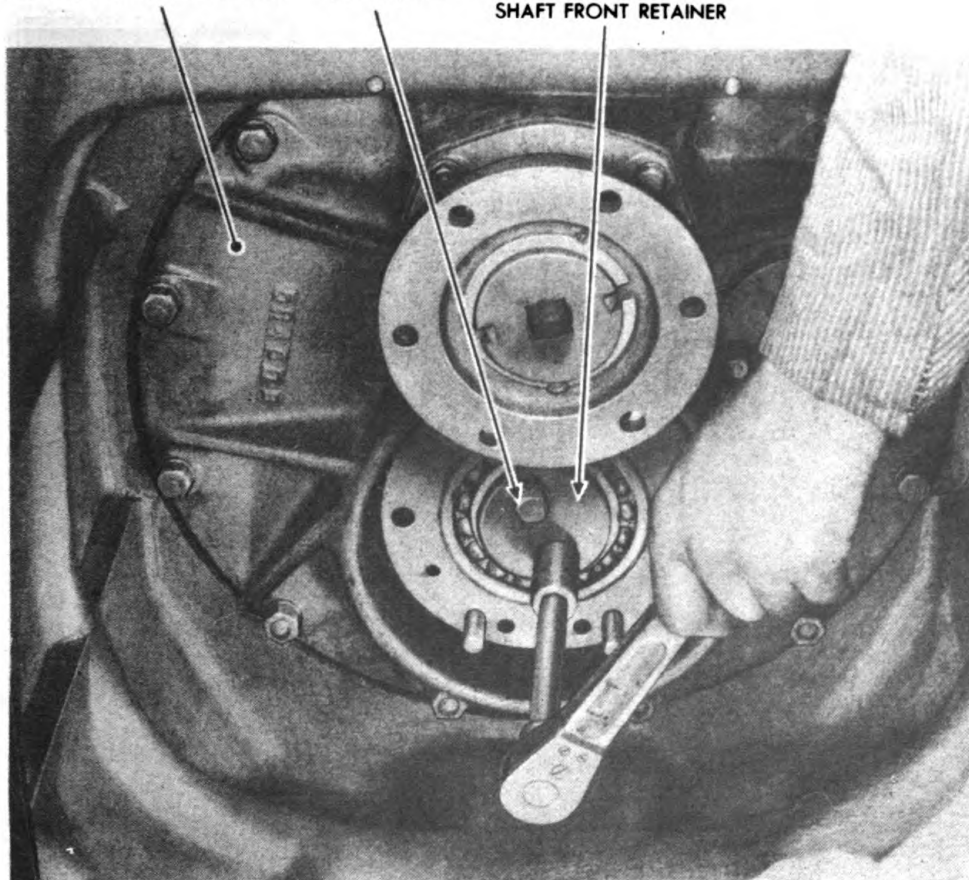

RA PD 14825

Figure 34 — Bevel Pinion Shaft Front Retainer Washer Removal

ORDNANCE MAINTENANCE — HEAVY TRACTOR MI (IHC TD-18) —
POWER TRAIN, TRACK FRAME ASSEMBLY, AND SEATS

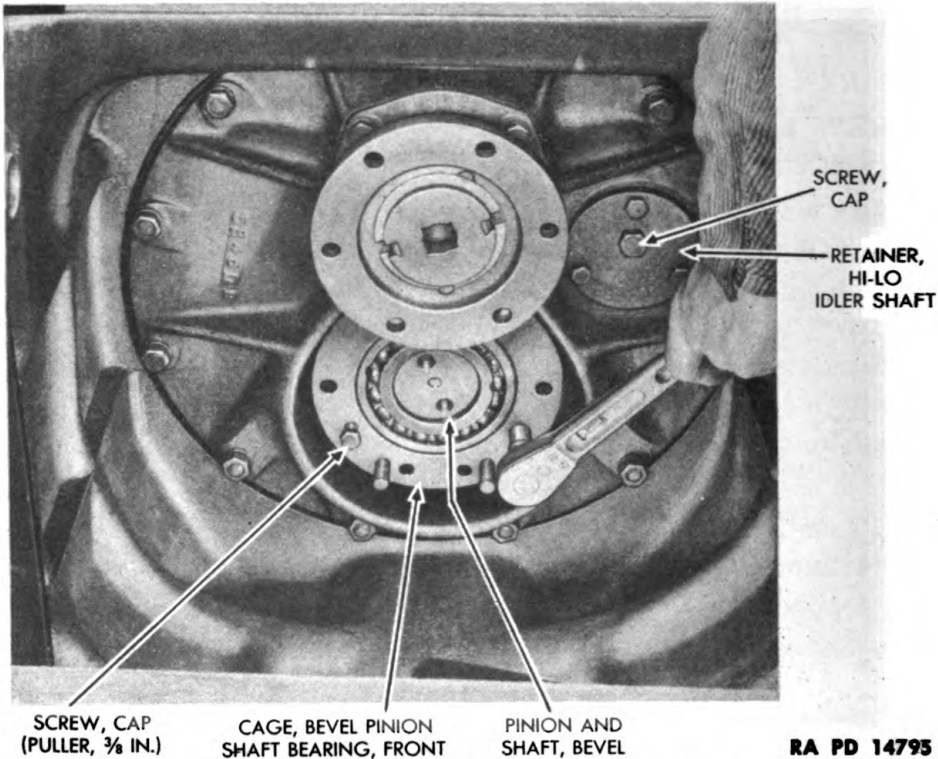

Figure 35 — Front Bevel Pinion Shaft Bearing Cage Removal

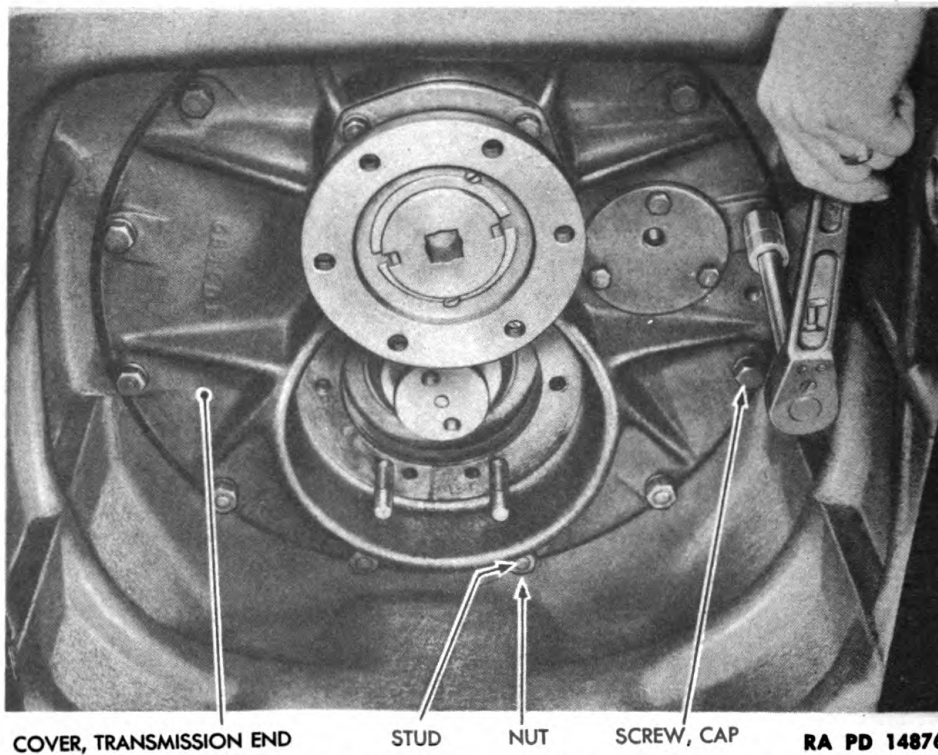
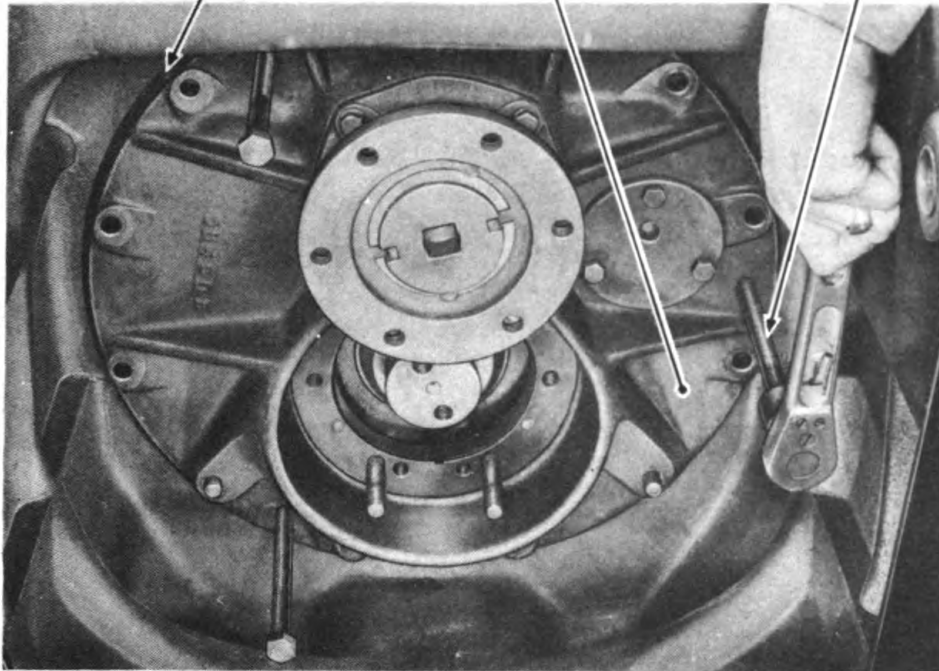

Figure 36 — Removal of Cap Screws from Transmission End Cover

TRANSMISSION AND DRIVE BEVEL GEAR

GASKET, END COVER COVER, TRANSMISSION END SCREW, CAP (1/2 IN.)



RA PD 14879

Figure 37 — Transmission End Cover Removal

CAGE, TRANSMISSION SPLINE SHAFT BEARING, REAR

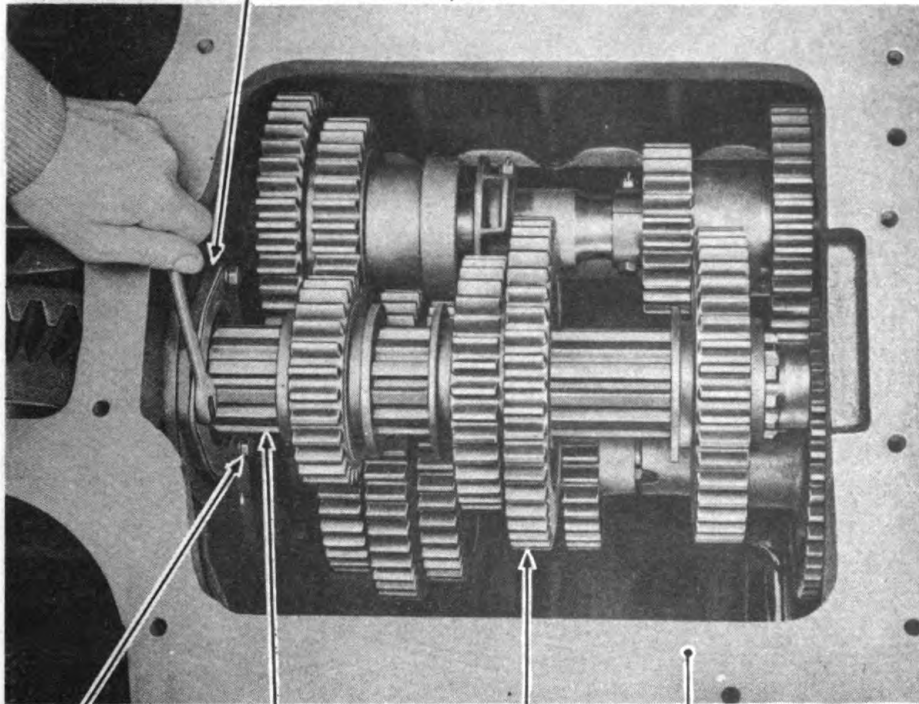

SCREW, CAP SHAFT, TRANSMISSION SPLINE; WITH BUSHING TRANSMISSION FRAME, MAIN

RA PD 43657

Figure 38 — Removing the Cap Screws from Rear Transmission Spline Shaft Bearing Cage

ORDNANCE MAINTENANCE — HEAVY TRACTOR MI (IHC TD-18) —
POWER TRAIN, TRACK FRAME ASSEMBLY, AND SEATS

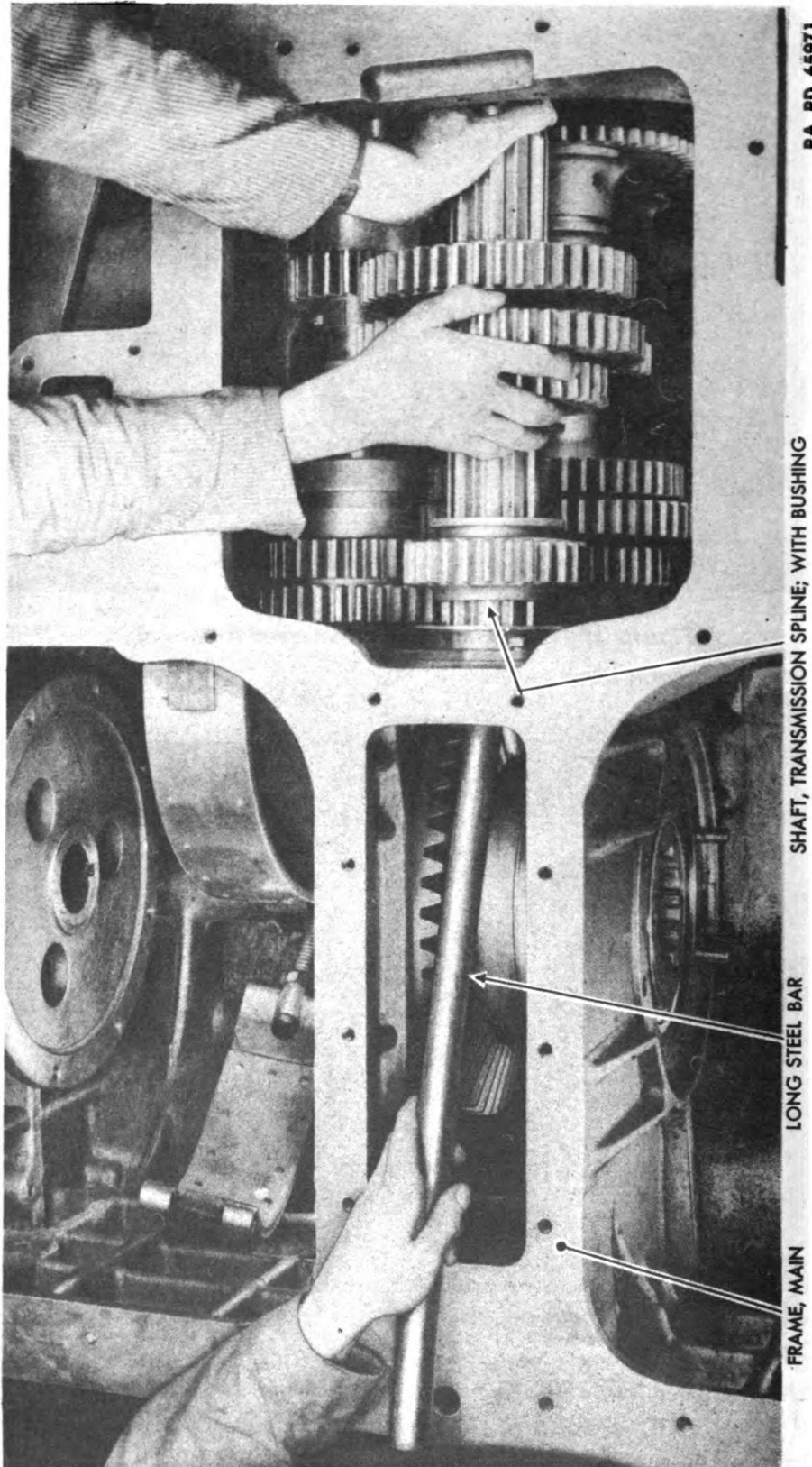

RA PD 65971

SHAFT, TRANSMISSION SPLINE; WITH BUSHING

LONG STEEL BAR

FRAME, MAIN

Figure 39 — Transmission Spline Shaft with Bushing Removal

TRANSMISSION AND DRIVE BEVEL GEAR

Use a $\frac{9}{16}$ -inch open-end wrench to remove 3 cap screws and lock washer which hold bearing cage to main frame.

(15) REMOVE TRANSMISSION SPLINE SHAFT WITH BUSHING (fig. 39).

BAR, long steel

With another mechanic holding front end of shaft, use a long steel bar from rear of main frame to tap rear end of shaft until it is free from main frame; then lift the shaft with gears attached from the vehicle.

(16) REMOVE REAR HI-LO RANGE IDLER BEARING RETAINER (fig. 40).

PLIERS

WRENCH, open-end, $\frac{9}{16}$ -in.

(2)

Use pliers to remove cotter pin from castellated nut. Use two $\frac{9}{16}$ -inch open-end wrenches to remove retainer bolt; then remove bearing retainer.

(17) REMOVE HIGH AND LOW RANGE IDLER SHAFT AND ATTACHED GEARS (fig. 41).

CROWBAR

Place crowbar between main frame and transmission reverse idler

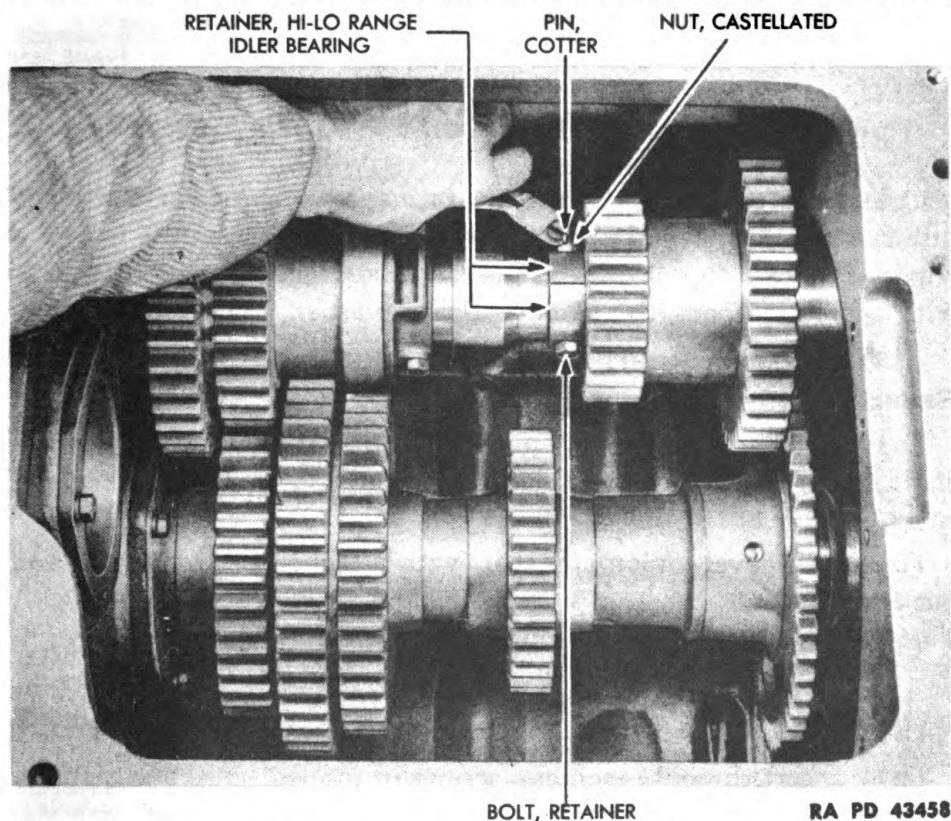

Figure 40 — Rear Hi-Lo Range Idler Bearing Retainer Removal

**ORDNANCE MAINTENANCE — HEAVY TRACTOR MI (IHC TD-18) —
POWER TRAIN, TRACK FRAME ASSEMBLY, AND SEATS**

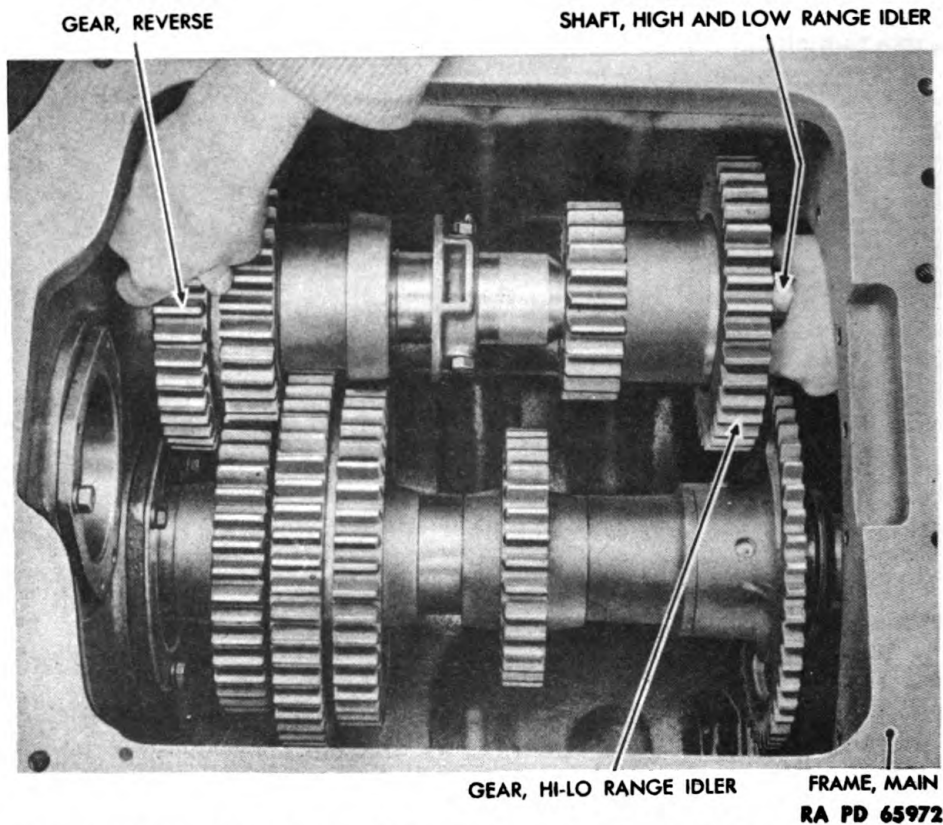

Figure 41 — Hi-Lo Range Idler Shaft and Attached Gears Removal

gear and pry gear away from main frame, toward rear of tractor. Then pull shaft with attached gears forward, until rear of shaft is free of main frame, but still supporting Hi-Lo range idler gear; then lift out shaft with gears attached. Also remove thrust washer.

(18) REMOVE FRONT BEVEL PINION SHAFT BEARING SPACER FROM BEVEL PINION AND SHAFT (fig. 42).

(a) Remove front bevel pinion shaft bearing spacer from end of shaft. Then remove transmission oiler gear and transmission oiler gear sleeve.

(b) Pull bevel pinion and shaft with attached parts forward and lift out from main frame.

(19) REMOVE REAR SPLINE SHAFT BEARING CAGE (fig. 43).

SCREW, cap, 3/8-in. (3)

WRENCH, open-end, 1 1/8-in.

(a) Remove 3 cap screws holding bearing cage to main frame.

(b) Insert three 3/8-inch cap screws in tapped holes and tighten cap screws until cage is pulled from frame. Tighten cap screws with 1 1/8-inch open-end wrench.

TRANSMISSION AND DRIVE BEVEL GEAR

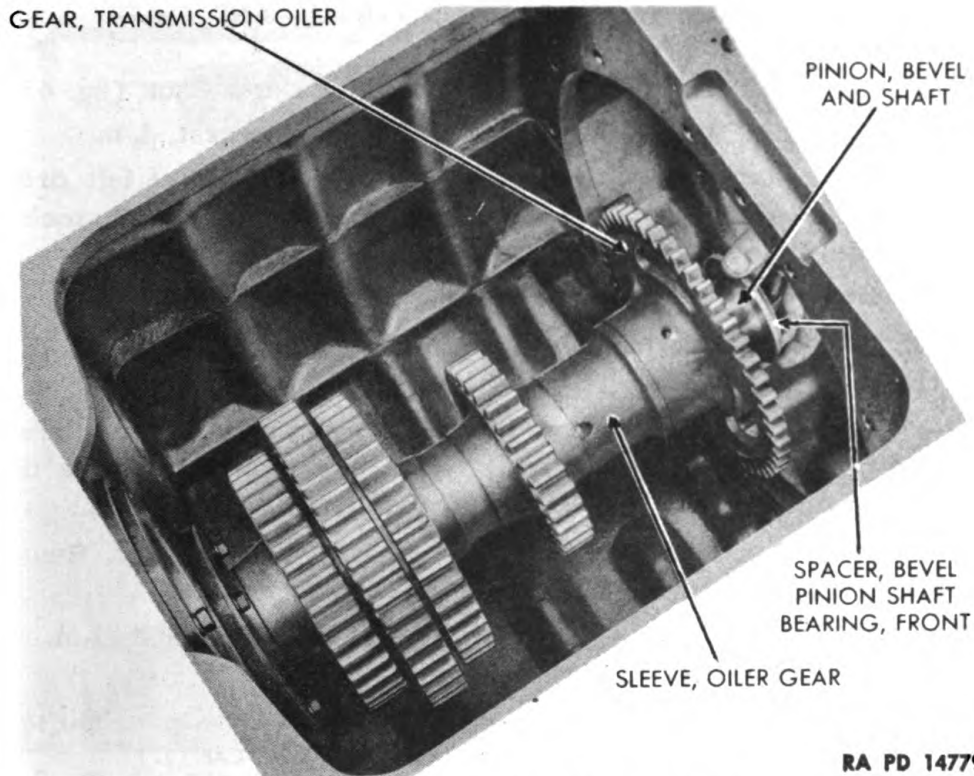

RA PD 14779

Figure 42 – Bevel Pinion and Shaft with Attached Parts Removal

(20) REMOVE REAR BEVEL PINION AND SHAFT BEARING CAGE (fig. 43).

CAUTION: Do not remove rear bevel pinion and shaft bearing cage unless the bearing is loose in the bearing race. Then it is necessary to remove cage to remove race, which is always replaced whenever a new bearing is installed.

PLATE, steel

SLEEVE, steel

PRESS, arbor

WRENCH, open-end, $\frac{9}{16}$ -in.

SCREW, cap, $\frac{3}{8}$ -in. (3)

(a) Use a $\frac{9}{16}$ -inch open-end wrench to remove 3 cap screws and lock washers which secure cage to main frame. Remove rear bevel pinion and shaft bearing retainer.

(b) Insert three $\frac{3}{8}$ -inch cap screws in tapped holes and tighten cap screws with a $\frac{9}{16}$ -inch open-end wrench until cage is pulled from main frame.

(c) Use an arbor press and steel plate or sleeve to press bearing race from cage (fig. 44). **NOTE:** If drive bevel gear does not have to be removed, the removal of the transmission is complete at this point.

(21) REMOVE STEERING CLUTCHES (par. 52).

**ORDNANCE MAINTENANCE — HEAVY TRACTOR MI (IHC TD-18) —
POWER TRAIN, TRACK FRAME ASSEMBLY, AND SEATS**

(22) REMOVE LEFT DRIVE BEVEL GEAR BEARING CAGE (fig. 45).

SCREW, cap, $\frac{3}{8}$ -in. (3) WRENCH, socket, $\frac{9}{16}$ -in.

(a) Insert three $\frac{3}{8}$ -inch cap screws in tapped holes of left drive bevel gear bearing cage. Tighten cap screws with a $\frac{9}{16}$ -inch socket wrench until cage is pulled out; then remove puller screws.

(b) Remove drive bevel gear bearing cage gasket.

(23) REMOVE RIGHT DRIVE BEVEL GEAR BEARING CAGE (fig. 45).

BLOCK, wood

Wedge a block of wood between bevel gear and main frame to keep assembly from moving toward right. Then remove cage following the same procedure outlined in (22) above; then remove wood block.

(24) REMOVE DRIVE BEVEL GEAR SPACER FROM DRIVE BEVEL GEAR (fig. 46).

HAMMER

WRENCH, open-end, 1-in.

SCREWDRIVER

Use a screwdriver and hammer to pry back drive bevel gear bolt nut CAGE, SPLINE SHAFT BEARING, REAR SCREW, PULLER SCREW, CAP

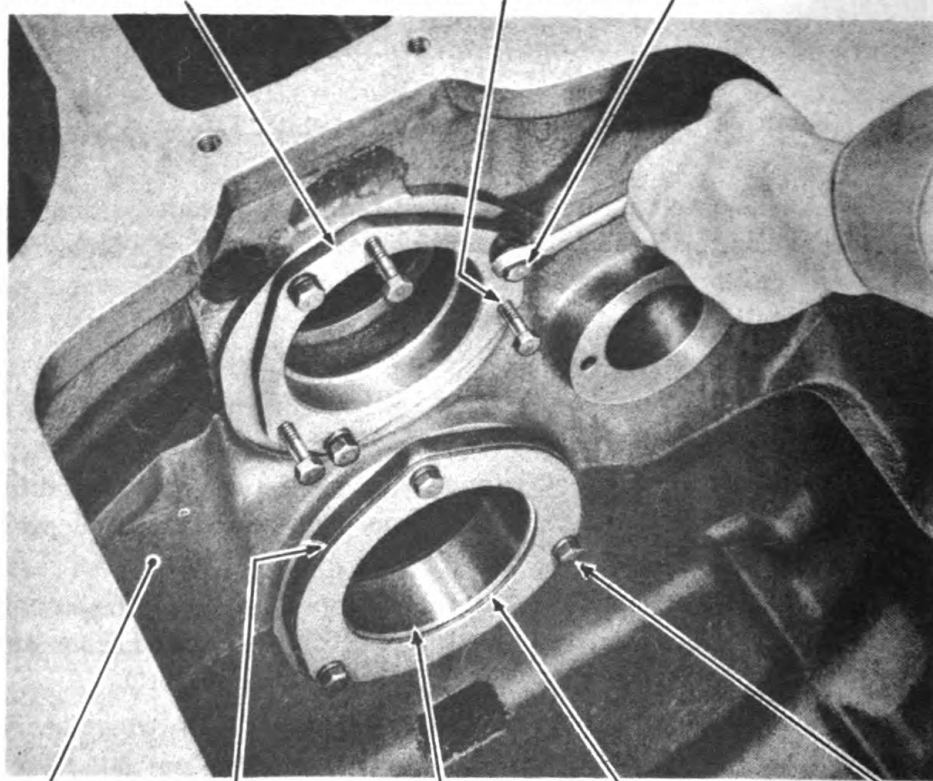

FRAME, MAIN CAGE, BEVEL PINION AND SHAFT BEARING, REAR RACE, BEARING RETAINER, BEVEL PINION AND SHAFT BEARING, REAR SCREW, CAP
RA PD 14777

Figure 43 — Rear Spline Shaft Bearing Cage Removal

TRANSMISSION AND DRIVE BEVEL GEAR

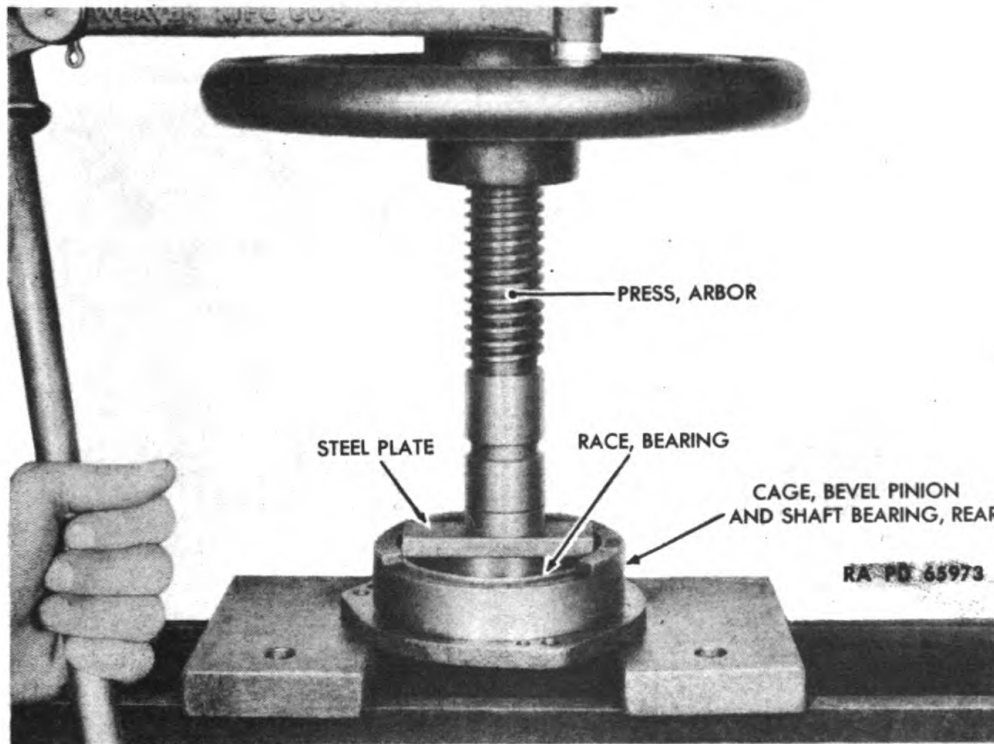

Figure 44 — Pressing Bearing Race from Rear Bevel Pinion and Shaft Bearing Cage

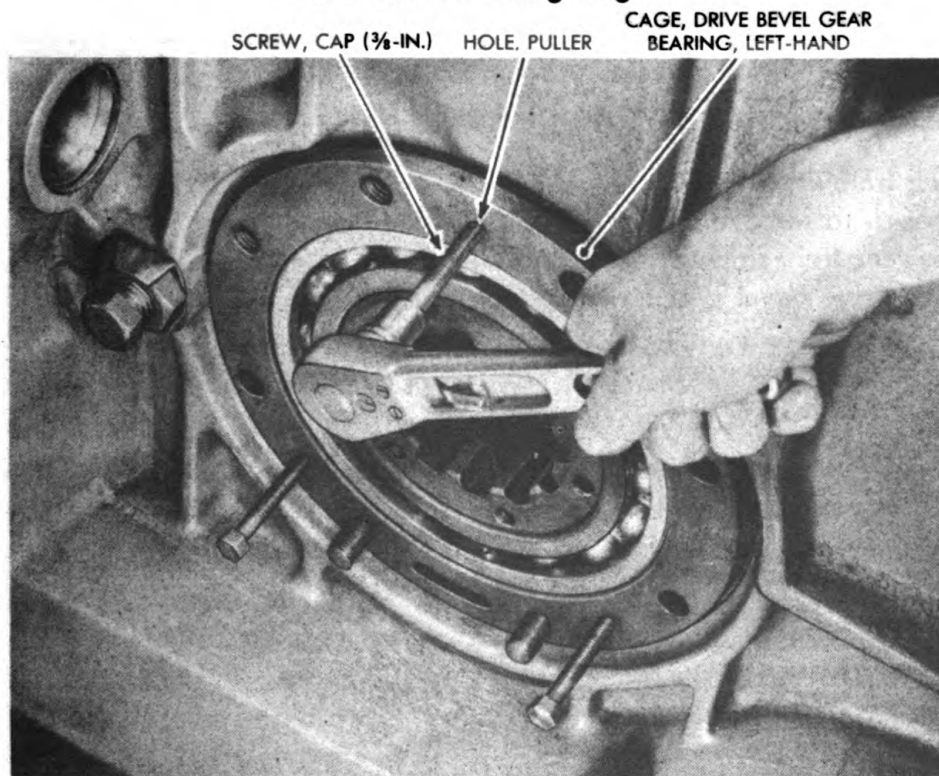

Figure 45 — Left-Hand Drive Bevel Gear Bearing Cage Removal

ORDNANCE MAINTENANCE — HEAVY TRACTOR MI (IHC TD-18) —
POWER TRAIN, TRACK FRAME ASSEMBLY, AND SEATS

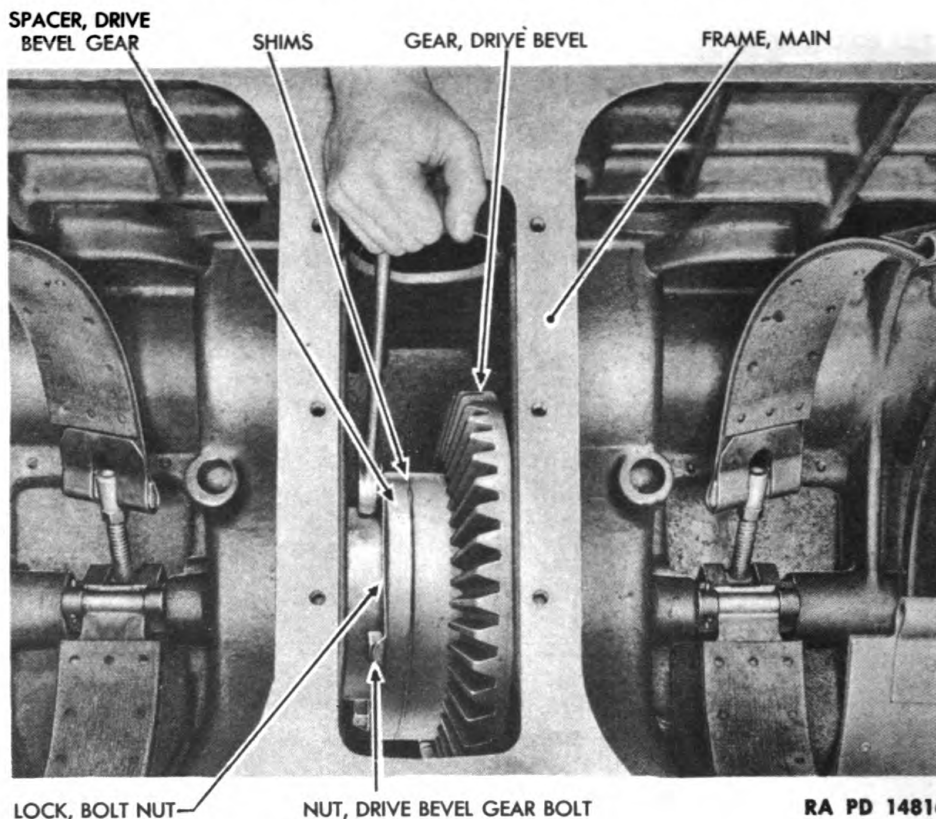

Figure 46 — Removing Cap Screws Which Hold Drive Bevel Gear Spacer to Drive Bevel Gear

lock from each of 4 drive bevel gear cap screws. Use a 1-inch open-end wrench to remove nuts from bolts. It will be necessary to lift and turn the gear from time to time to provide access to nuts. Then lift off spacer with drive bevel gear ball bearing attached. Remove shims.

(25) LIFT DRIVE BEVEL GEAR FROM MAIN FRAME.

36. DISASSEMBLY.

a. Perform the following operations to the extent necessary to inspect all parts and replace defective parts.

(1) EQUIPMENT.

BAR, steel
BLOCK, wood
CHISEL, cold
CUTTERS, diagonal
DRIFT, brass
HAMMER, rawhide

PLUG, 3/4-in. sq
PRESS, arbor
PULLER, gear OTC-938,
with attachment OTC-952,
or equivalent
PUNCH, brass

TRANSMISSION AND DRIVE BEVEL GEAR

- | | |
|---------------------------------------|-------------------------------------|
| SCREWDRIVER | WRENCH , open-end, 3/4-in. |
| VICE | WRENCH , socket, 1/8-in. (2) |
| WRENCH , box, 1/8-in. (2) | WRENCH , socket, 3/4-in. |
| WRENCH , open-end, 1/2-in. | WRENCH , socket, 3/4-in. sq |
| WRENCH , open-end, 1/8-in. (2) | |

(2) **PROCEDURE.**

(a) *Remove Driving Flange Nut* (fig. 48).

- | | |
|--------------------------|------------------------------------|
| HAMMER | VICE |
| PLUG , 3/4-in. sq | WRENCH , socket, 3/4-in. sq |
| SCREWDRIVER | |

1. Use a screwdriver and hammer to drive nut lock free from driving flange nut.

2. To keep driving flange from turning, place assembled parts between copper jaws of vise. Then use 3/4-inch square plug in a 3/4-inch square socket wrench to remove driving flange nut. Lift off nut lock.

3. Lift off driving flange.

(b) *Remove Drive Shaft Front Bearing Retainer* (fig. 48.)

- | | |
|----------------------|------------------------------|
| PRESS , arbor | WRENCH , box, 1/8-in. |
|----------------------|------------------------------|

1. Use a 1/8-inch box wrench to remove 4 cap screws and lock washers.

2. Lift off drive shaft front bearing retainer with oil seal and gasket.

3. Place bearing retainer in arbor press and press out oil seal (reverse of fig. 63).

(c) *Remove Drive Shaft and Gear* (fig. 48).

- HAMMER**, rawhide

1. Use a rawhide hammer to force drive shaft out of end cover.

2. Remove bearing spacer.

(d) *Remove Bearings from Drive Shaft Gear* (fig. 49).

- | | |
|---------------------|----------------------|
| BLOCK , wood | PUNCH , brass |
| HAMMER | |

Tap sharply, shaft and gear against wood block to remove spline shaft bearing. Use a brass punch and hammer from inside gear to drive out rear drive shaft bearing.

(e) *Remove Front Drive Shaft Bearing* (fig. 50).

- | | |
|---------------|----------------------|
| HAMMER | PUNCH , brass |
|---------------|----------------------|

Use brass punch and hammer to force bearing out of end cover.

ORDNANCE MAINTENANCE — HEAVY TRACTOR MI (IHC TD-18) —
POWER TRAIN, TRACK FRAME ASSEMBLY, AND SEATS

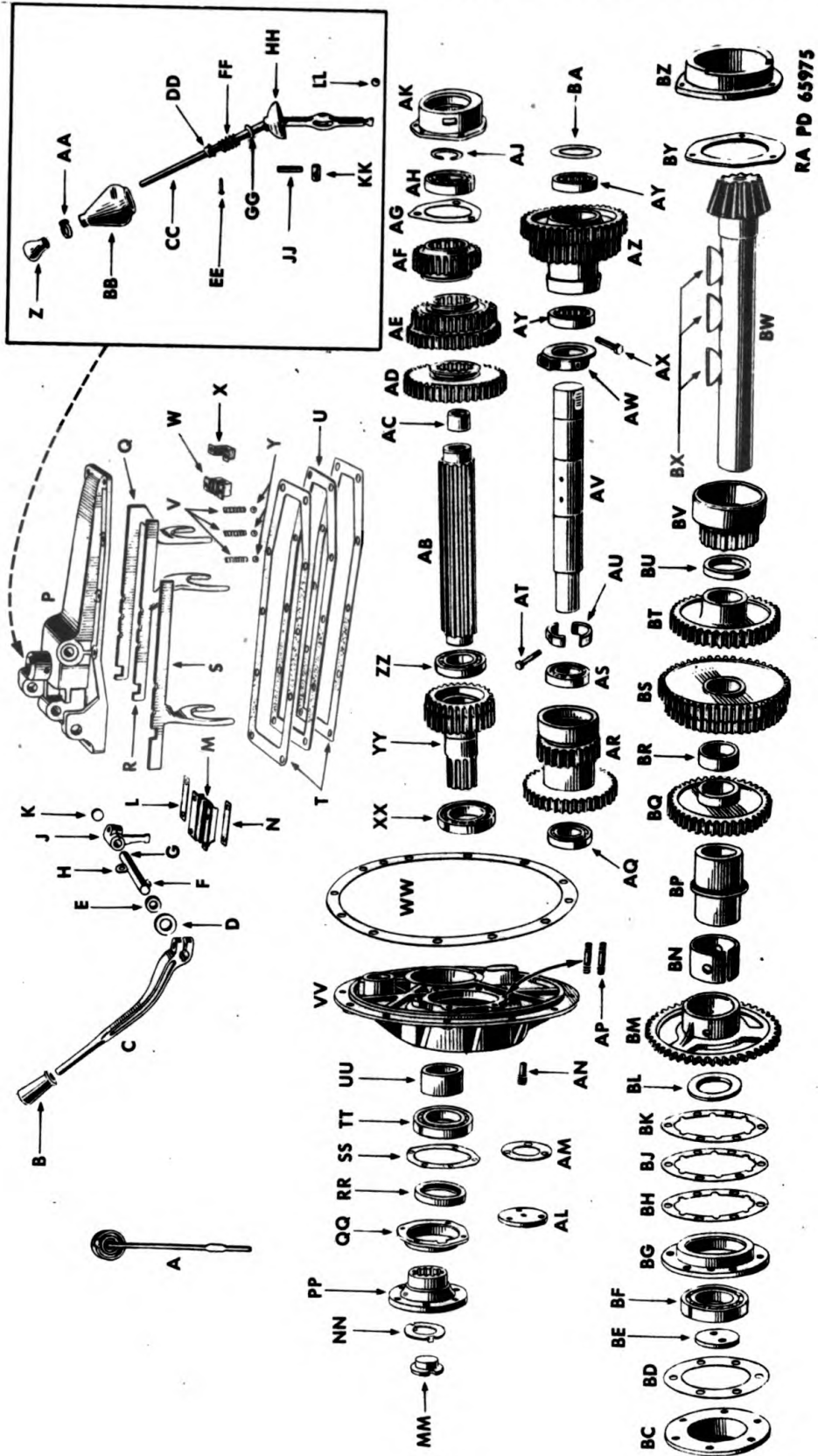

Figure 47 — Transmission Parts

TRANSMISSION AND DRIVE BEVEL GEAR

- A—ROD, OIL LEVEL
- B—HANDLE, LEVER, HI-LO GEAR SHIFTER
- C—LEVER, HI-LO GEAR SHIFTER
- D—WASHER, OIL SEAL
- E—SEAL, OIL, GEAR SHIFTER SHAFT
- F—KEY, LEVER, GEAR SHIFTER
- G—SHAFT, HI-LO GEAR SHIFTER ARM
- H—KEY, HI-LO GEAR SHIFTER
- J—ARM, HI-LO GEAR SHIFTER
- K—PLUG, HI-LO GEAR SHIFTER ARM SHAFT
- L—LOCK, LEFT
- M—GUIDE, RAIL, GEAR SHIFTER
- N—LOCK, RIGHT
- P—HOUSING, GEAR SHIFTER
- Q—RAIL WITH FORK, SHIFT, LOW AND REVERSE
- R—RAIL WITH FORK, SHIFT, SECOND AND THIRD
- S—RAIL WITH FORK, SHIFT, HI-LO
- T—GASKET, HOUSING, GEAR SHIFTER
- U—SPACER, HOUSING, GEAR SHIFTER
- V—SPRING, POPPET BALL
- W—GUIDE, GEAR SHIFTER RAIL; REAR
- X—LOCK
- Y—BALL, POPPET
- Z—BALL, LEVER, GEAR SHIFTER
- AA—CLAMP, BOOT, GEAR SHIFTER
- BB—BOOT, GEAR SHIFTER
- CC—LEVER, GEAR SHIFTER
- DD—STOP, SPRING; UPPER
- EE—RIVET
- FF—SPRING, SHIELD, GEAR SHIFTER SWIVEL HOUSING
- GG—STOP, SPRING; LOWER
- HH—SHIELD, SWIVEL HOUSING
- JJ—SHAFT, SWIVEL, GEAR SHIFTER LEVER; SMALL
- KK—SHAFT, SWIVEL, GEAR SHIFTER LEVER; LARGE
- LL—PLUG, EXPANSION, SWIVEL SHAFT
- MM—NUT, DRIVING FLANGE
- NN—LOCK, NUT, DRIVING FLANGE
- PP—FLANGE, DRIVING
- QQ—RETAINER, BEARING, DRIVING SHAFT; FRONT
- RR—SEAL, OIL, DRIVING SHAFT
- SS—GASKET, RETAINER
- TT—BEARING, DRIVING SHAFT, FRONT
- UU—SPACER, BEARING, DRIVING SHAFT
- VV—COVER, END, TRANSMISSION
- WW—GASKET, END COVER
- XX—BEARING, DRIVING SHAFT, REAR
- YY—SHAFT AND GEAR, DRIVING, TRANSMISSION
- ZZ—BEARING, SPLINE SHAFT
- AB—SHAFT, SPLINE
- AC—BUSHING, SHAFT, POWER TAKE-OFF
- AD—GEAR, SLIDING, HI-LO RANGE
- AE—GEAR, SLIDING, 2ND, 4TH, 5TH, AND 6TH SPEED
- AF—GEAR, SLIDING, REVERSE, 1ST AND 3RD SPEED
- AG—RETAINER, BEARING, SPLINE SHAFT; REAR
- AH—BEARING, SPLINE SHAFT; REAR
- AJ—RING, SNAP, SPLINE SHAFT BEARING
- AK—CAGE, BEARING, SPLINE SHAFT; REAR
- AL—RETAINER, SHAFT, HI-LO RANGE IDLER
- AM—GASKET, SHAFT RETAINER
- AN—PIN, DOWEL, END COVER
- AP—STUD, BEVEL PINION SHAFT BEARING CAGE FRONT
- AQ—BEARING, HI-LO RANGE IDLER GEAR; FRONT
- AR—GEAR, IDLER, HI-LO RANGE
- AS—BEARING, HI-LO RANGE IDLER GEAR; REAR
- AT—BOLT, RETAINER, BEARING
- AU—RETAINER, BEARING, REAR
- AV—SHAFT, IDLER
- AW—SCOOP, OIL, REVERSE IDLER GEAR
- AX—BOLT, OIL SCOOP
- AY—BEARING, GEAR, REVERSE IDLER
- AZ—GEAR, IDLER REVERSE
- BA—WASHER, THRUST, REVERSE IDLER
- BC—RETAINER, BEARING, BEVEL PINION SHAFT
- BD—GASKET, BEARING RETAINER
- BE—WASHER, RETAINER, BEVEL PINION SHAFT BEARING FRONT
- BF—BEARING, BEVEL PINION SHAFT; FRONT
- BG—CAGE, BEARING, BEVEL PINION AND SHAFT; FRONT
- BH—SHIM, BEARING CAGE, BEVEL PINION SHAFT; HEAVY
- BJ—SHIM, BEARING CAGE, BEVEL PINION SHAFT; MEDIUM
- BK—SHIM, BEARING CAGE, BEVEL PINION SHAFT; LIGHT
- BL—SPACER, BEARING, BEVEL PINION SHAFT; FRONT
- BM—GEAR, OILER, TRANSMISSION
- BN—BUSHING, GEAR, TRANSMISSION OILER
- BP—SLEEVE, GEAR, TRANSMISSION OILER
- BQ—GEAR, TRANSMISSION, 4TH AND 6TH SPEED
- BR—SPACER, SHAFT, BEVEL PINION
- BS—GEAR, TRANSMISSION; 1ST, 2ND, 3RD AND 5TH SPEED
- BT—GEAR, REVERSE, TRANSMISSION
- BU—SPACER, REVERSE GEAR
- BV—BEARING, SHAFT, BEVEL PINION; REAR
- BW—SHAFT, BEVEL PINION
- BX—KEY
- BY—RETAINER, BEARING, BEVEL PINION AND SHAFT; REAR
- BZ—CAGE, BEARING, BEVEL PINION AND SHAFT; REAR

RA PD 659758

Legend for Figure 47 — Transmission Parts

**ORDNANCE MAINTENANCE — HEAVY TRACTOR MI (IHC TD-18) —
POWER TRAIN, TRACK FRAME ASSEMBLY, AND SEATS**

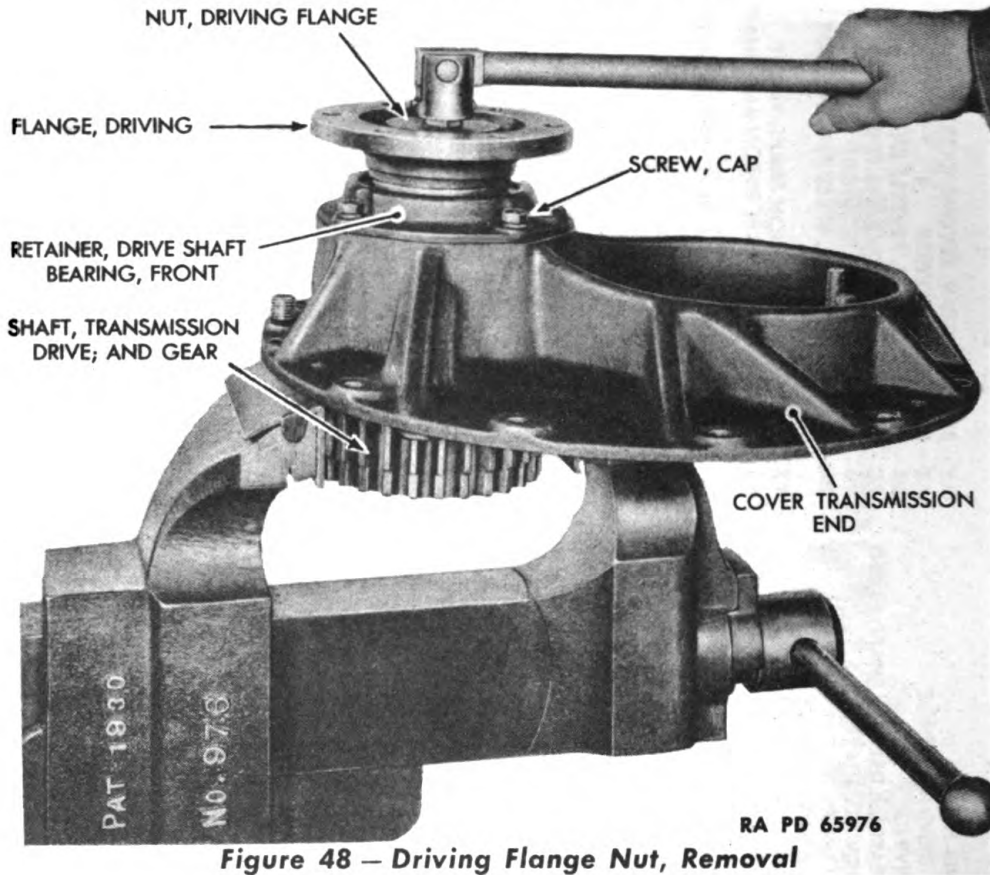

Figure 48 — Driving Flange Nut, Removal

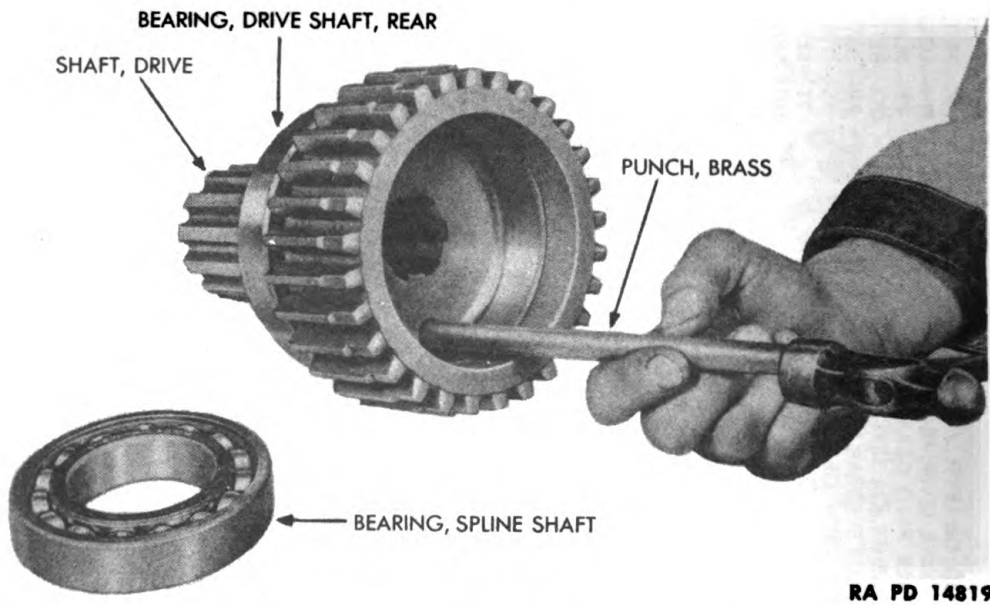

Figure 49 — Transmission Drive Shaft Bearing Removal

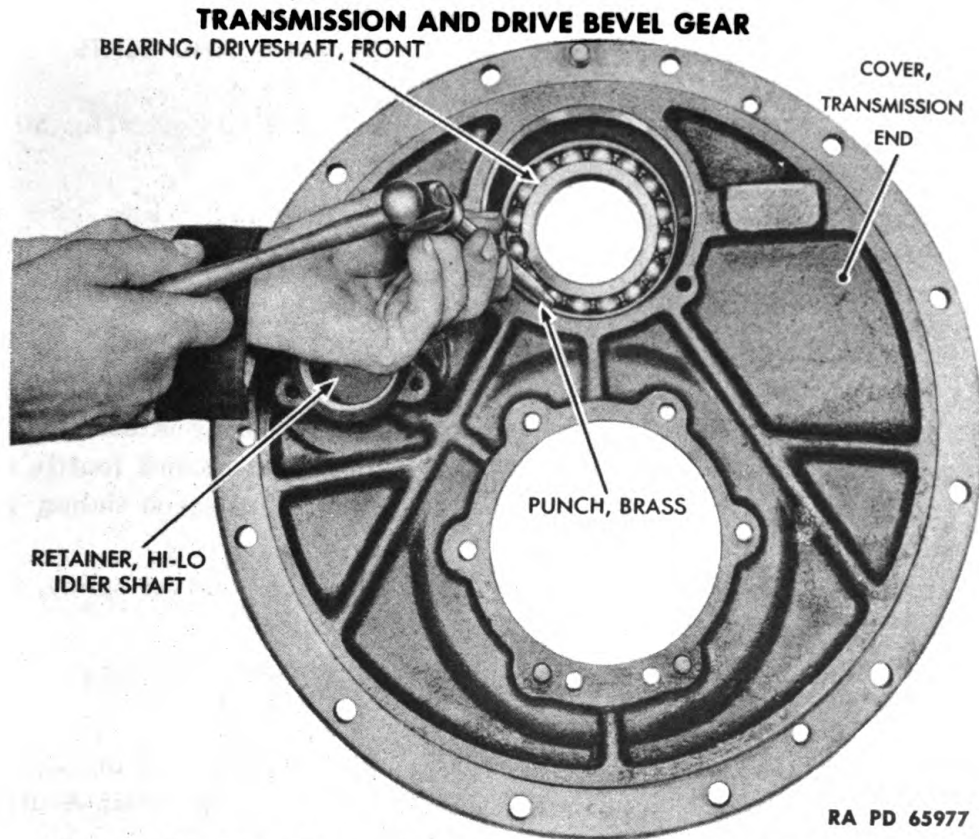

Figure 50 – Front Transmission Drive Shaft Bearing Removal

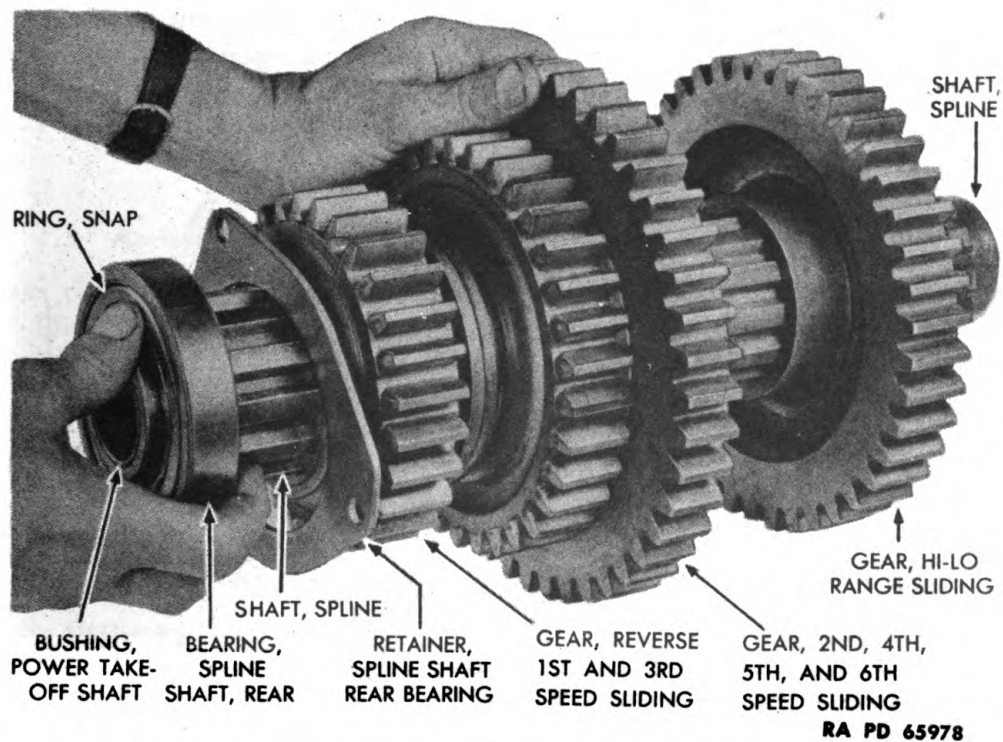

Figure 51 – Transmission Spline Shaft Gear Removal

**ORDNANCE MAINTENANCE — HEAVY TRACTOR MI (IHC TD-18) —
POWER TRAIN, TRACK FRAME ASSEMBLY, AND SEATS**

(f) *Remove Hi-Lo Idler Shaft Retainer from End Cover (fig. 50).*

WRENCH, box, $\frac{9}{16}$ -in.

Use $\frac{9}{16}$ -inch box wrench to remove 3 cap screws and lock washers. Lift off retainer.

(g) *Remove Spline Shaft Gears (fig. 51).*

CHISEL
HAMMER

PUNCH, brass
SCREWDRIVER

1. Pull spline shaft with rear spline shaft bearing attached out of gears, removing in order: Hi-Lo range sliding gear; second, fourth, fifth, and sixth speed sliding gear; reverse, first, and third speed sliding gear, and spline shaft rear bearing retainer.

2. Use screwdriver to remove snap ring from end of spline shaft. Drive off bearing with a brass punch and hammer.

3. Use chisel and hammer to remove power take-off bushing.

(h) *Remove Idler Gears (fig. 52).*

CUTTERS, diagonal
HAMMER, rawhide

WRENCH, box, $\frac{9}{16}$ -in. (2)
WRENCH, open-end, $\frac{9}{16}$ -in. (2)

1. Use rawhide hammer to drive Hi-Lo range idler gear and reverse idler gear from idler shaft.

2. Use diagonal cutters to remove cotter pin from bolt which holds oil scoop to idler shaft. Then use two $\frac{9}{16}$ -inch box or open-end wrenches to remove castellated nut on reverse idler gear oil scoop bolt. Take out bolt and remove oil scoop.

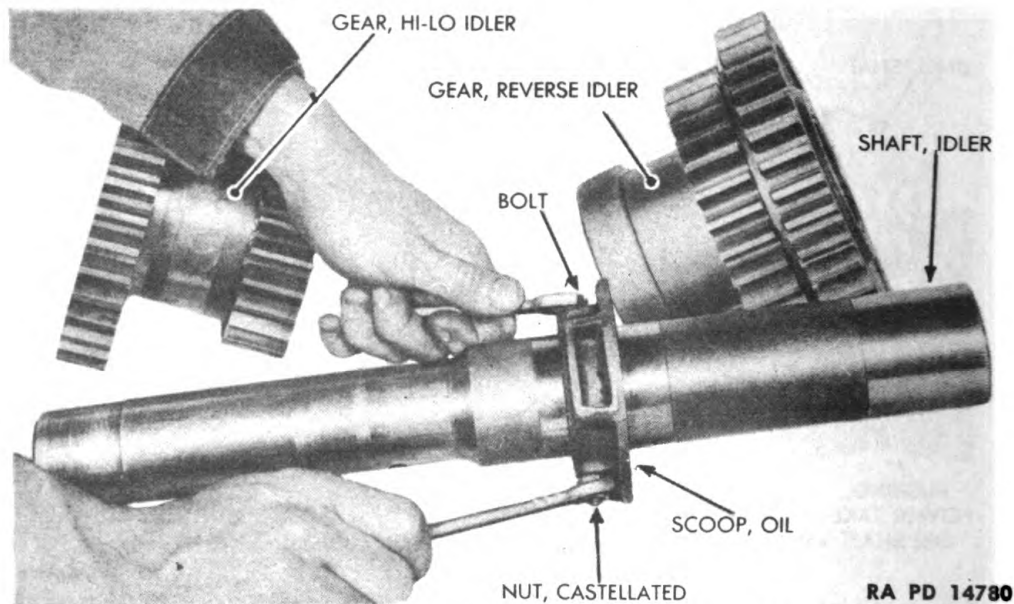
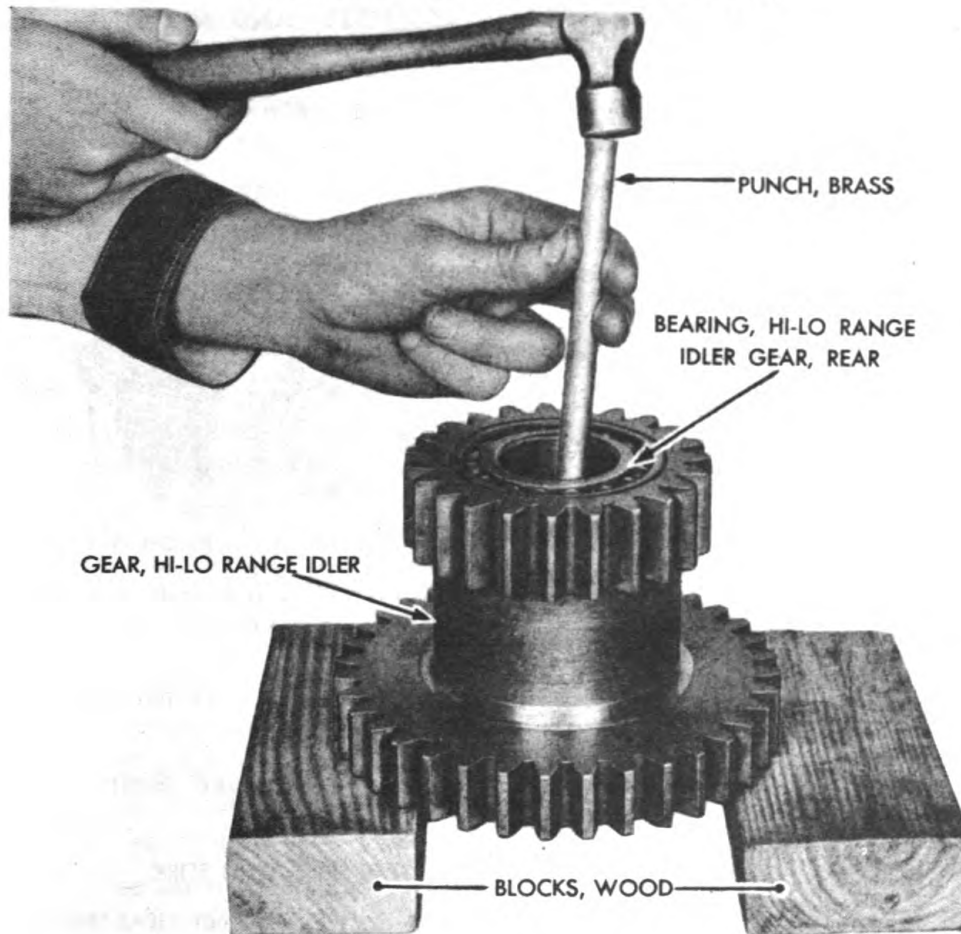

Figure 52 — Transmission Idler Shaft Oil Scoop Removal

TRANSMISSION AND DRIVE BEVEL GEAR



RA PD 65979

Figure 53 – Removal of Bearings from Transmission Hi-Lo Range Idler Gear

(i) Remove Both Bearings from Hi-Lo Range Idler Gear (fig. 53).

HAMMER

PUNCH, brass

Drive out front and rear Hi-Lo range idler gear bearings with hammer and brass punch.

(j) Remove Both Bearings from Reverse Idler Gear.

HAMMER

PUNCH, brass

In a similar manner to (i) above, use brass punch and hammer to drive out 2 transmission reverse idler gear bearings.

(k) Remove Fourth and Sixth Speed Gear (fig. 54).

PULLER, gear OTC-938, with attachment OTC-952, or equivalent

1. Install attachment OTC-952 and gear puller OTC-938, or equivalent.

**ORDNANCE MAINTENANCE — HEAVY TRACTOR MI (IHC TD-18) —
POWER TRAIN, TRACK FRAME ASSEMBLY, AND SEATS**

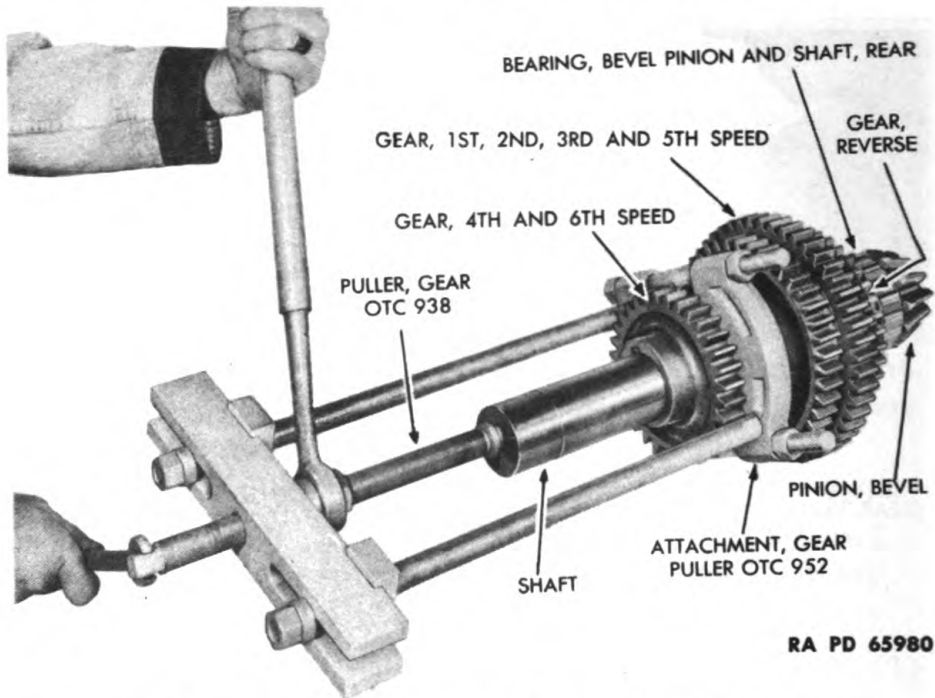

Figure 54 — Removal of Gears from Bevel Pinion and Shaft

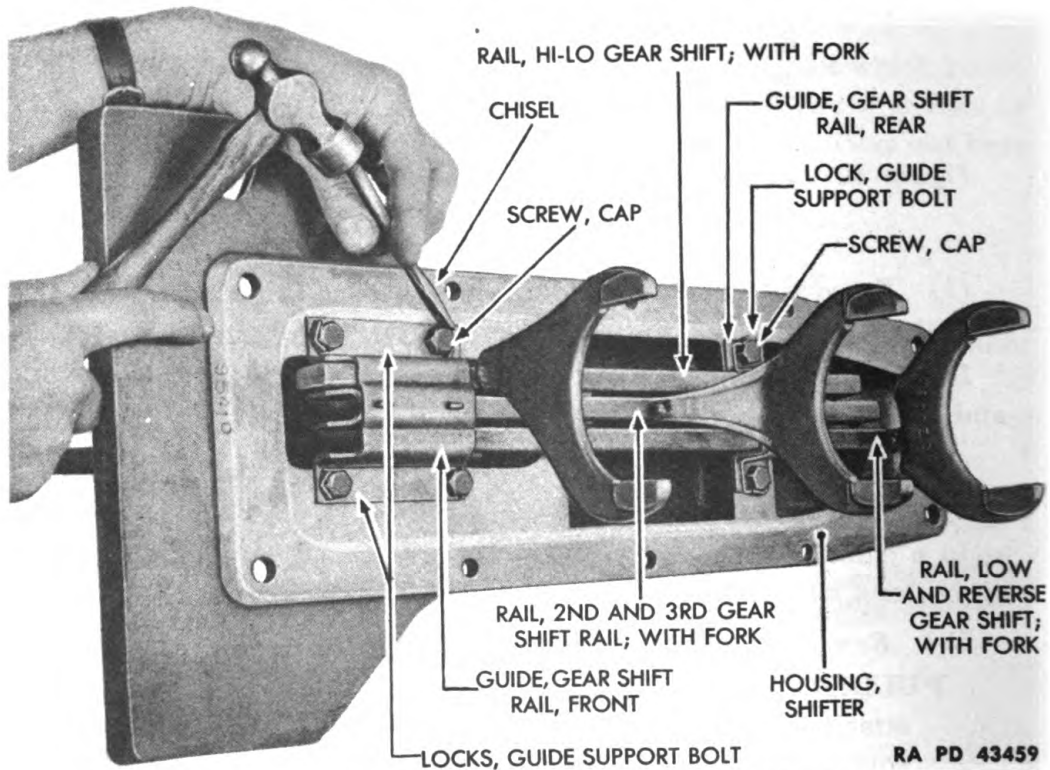

Figure 55 — Removal of Guide Support Bolt Locks from Shifter Housing

TRANSMISSION AND DRIVE BEVEL GEAR

2. Remove gear.
3. Remove Woodruff key.
4. Remove bearing pinion shaft spacer.

(1) *Remove First, Second, Third, and Fifth Speed Gear* (fig. 54).
 PRESS, arbor PULLER, gear OTC-938, with attachment OTC-952, or equivalent

Use same tools as in (k) 1 above, or arbor press. Remove Woodruff key.

(m) *Remove Reverse Gear* (fig. 54).
 PRESS, arbor PULLER, gear OTC-938, with attachment OTC-952, or equivalent

1. Use same tools as in (k) 1 above, or arbor press.
2. Remove Woodruff key.
3. Remove reverse gear spacer.

(n) *Remove Bevel Pinion Shaft Rear Bearing* (fig. 54).
 PULLER, gear OTC-938, with attachment OTC-952, or equivalent

Use same tools as in (k) 1 to remove bearing.

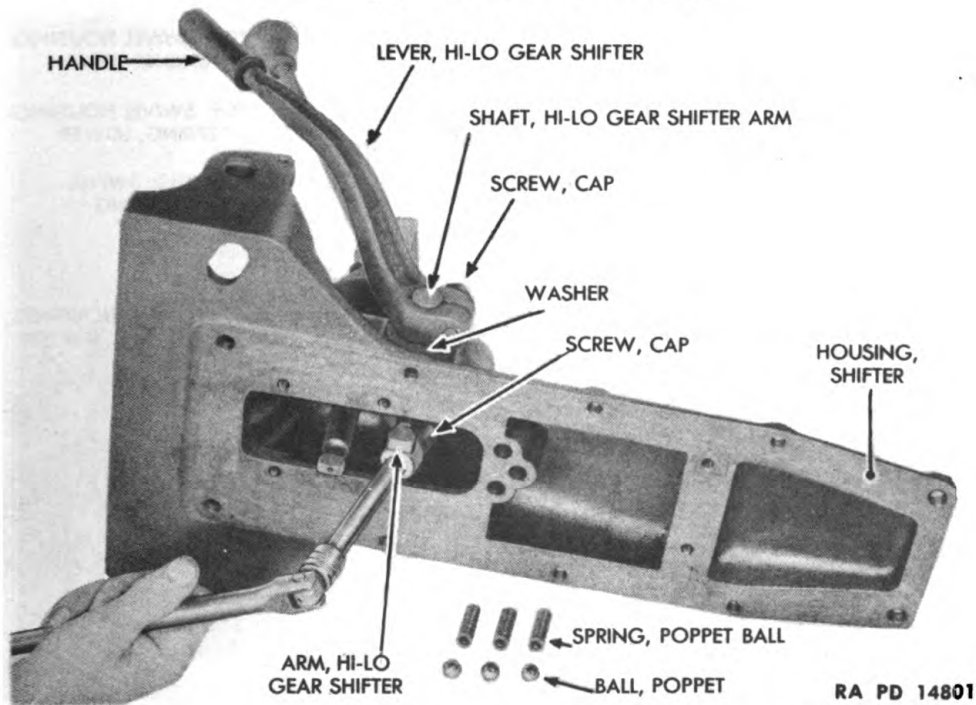

Figure 56 – Removal of Hi-Lo Gear Shifter Lever with Handle

**ORDNANCE MAINTENANCE — HEAVY TRACTOR MI (IHC TD-18) —
POWER TRAIN, TRACK FRAME ASSEMBLY, AND SEATS**

(o) *Remove Shifter Rails and Forks from Housing (figs. 55 and 56).*

CHISEL

WRENCH, socket, $\frac{9}{16}$ -in.

HAMMER

1. Use chisel and hammer to bend back guide support bolt locks.
2. Use $\frac{9}{16}$ -inch socket wrench to remove 6 nuts from cap screws securing rail guides to housing.
3. Remove front and rear gearshift rail guides.
4. Remove gearshift rails with forks and remove 3 poppet balls from housing.
5. Tip housing to remove 3 poppet ball springs.

(p) *Remove Hi-Lo Gear Shifter Lever with Handle (fig. 56).*

CHISEL

WRENCH, open-end, $\frac{3}{4}$ -in.

HAMMER

WRENCH, socket, $\frac{3}{4}$ -in.

PUNCH

1. Use $\frac{3}{4}$ -inch socket wrench to remove cap screw from shifter arm and shaft assembly.

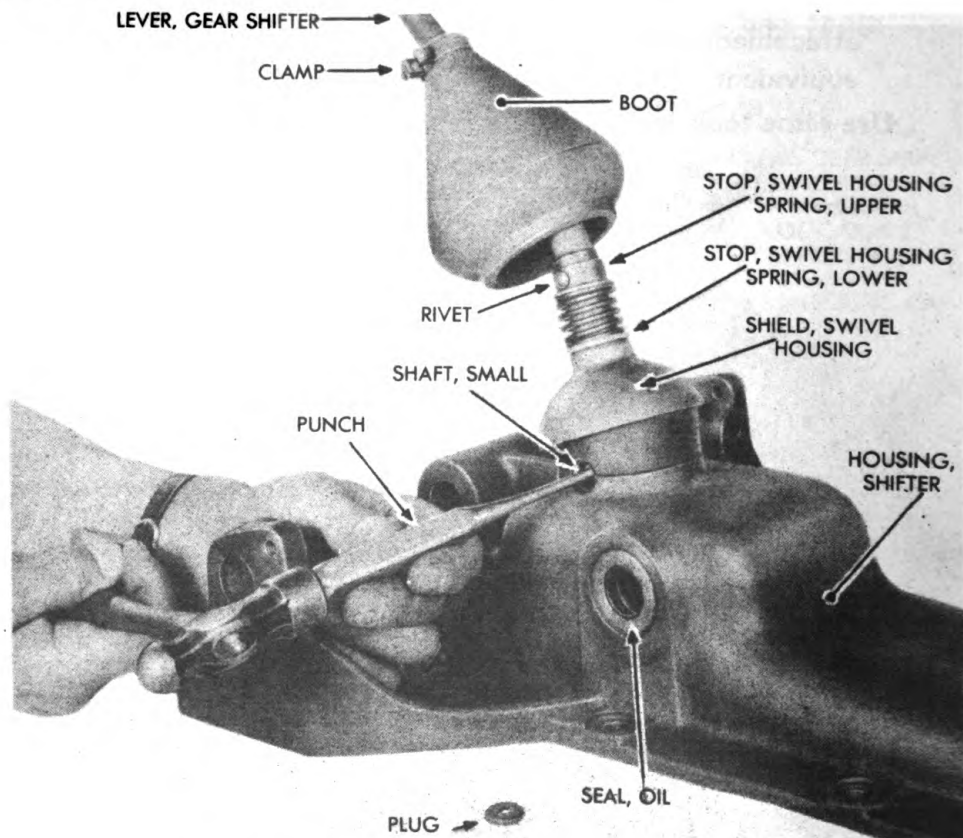

Figure 57 — Gear Shifter Lever Removal

RA PD 14837

TRANSMISSION AND DRIVE BEVEL GEAR

2. Remove Hi-Lo gear shifter arm from Hi-Lo gear shifter arm shaft. Remove Woodruff key.

3. Pull Hi-Lo gear shifter lever with shaft attached from the housing. Remove washer.

4. Use 3/4-inch open-end wrench to loosen cap screw which holds shifter lever to shaft. Use punch and hammer to remove shaft from Hi-Lo gear shifter lever with handle. Remove Woodruff key.

5. If handle is worn and should be replaced, use hammer and chisel to drive handle off Hi-Lo gear shifter lever.

(q) *Remove Gear Shifter Lever* (figs. 57 and 58).

**CHISEL
HAMMER**

**PUNCH
SCREWDRIVER**

1. Use screwdriver to loosen slotted screw in gear shifter boot clamp. Raise boot on lever.

2. Using a chisel and hammer, remove expansion plug which holds gear shifter lever swivel shaft in housing.

3. Use punch and hammer to drive out swivel shaft and expansion plug on opposite side of housing. Lift out gearshift lever assembly with large swivel shaft.

4. Push swivel housing shield against spring and push shaft from lever.

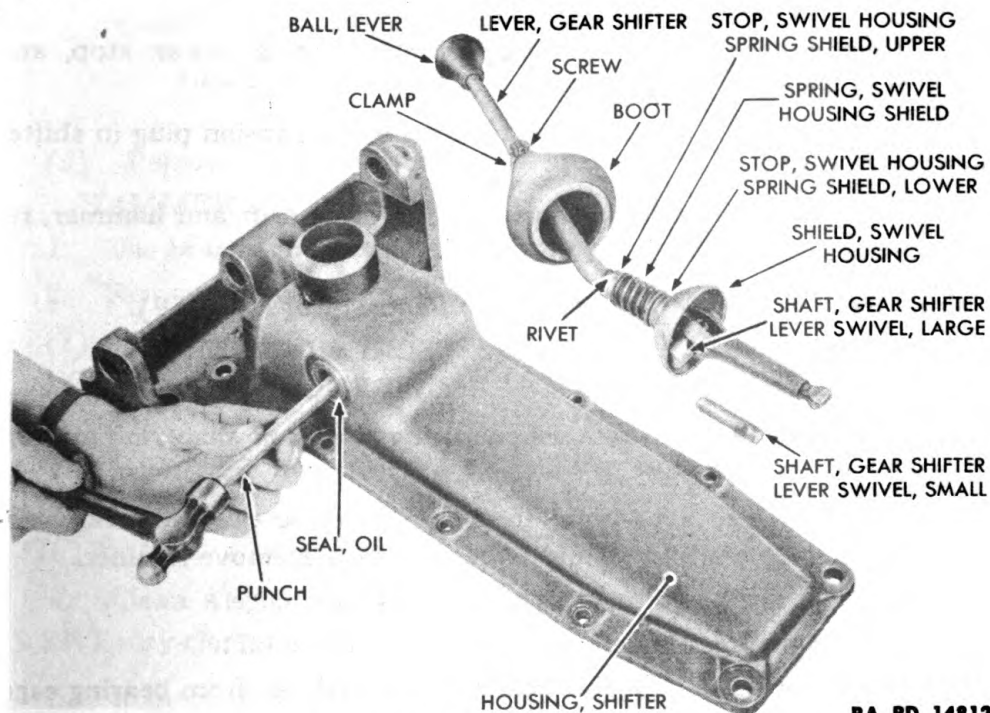

Figure 58 – Shifter Housing Plug Removal

ORDNANCE MAINTENANCE — HEAVY TRACTOR MI (IHC TD-18) —
POWER TRAIN, TRACK FRAME ASSEMBLY, AND SEATS

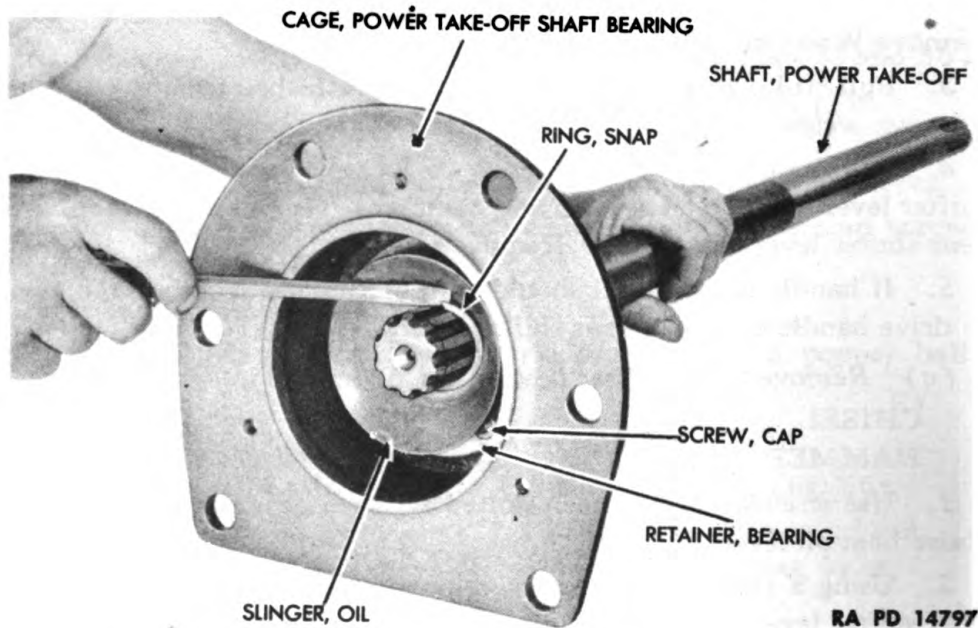

Figure 59 — Power Take-Off Shaft Bearing Cage Removal

5. If ball is worn and should be replaced, use chisel and hammer to remove ball from gearshift, lever.
6. Drive out rivet which secures upper stop to lever.
7. Remove boot with clamp, upper stop, spring, lower stop, and shield from lever.
8. Use brass drift and hammer to drive out expansion plug in shifter housing (fig. 58).
9. From opposite side of housing, using brass drift and hammer, remove oil seal from shifter housing.

(r) **Remove Power Take-off Shaft Bearing Cage (fig. 59).**

BAR, steel

SCREWDRIVER

PRESS, arbor

WRENCH, socket, $\frac{1}{8}$ -in.

1. Use screwdriver to remove snap ring. Take off snap ring and oil slinger.
2. Use $\frac{1}{8}$ -inch socket wrench to remove 4 cap screws and lock washers while holding bearing retainer to bearing cage. Remove retainer.
3. Pull out shaft with bearing through bearing cage.
4. Use arbor press to remove bearing (or drive off).
5. Use arbor press and steel bar to remove oil seal from bearing cage (or drive out).

TRANSMISSION AND DRIVE BEVEL GEAR

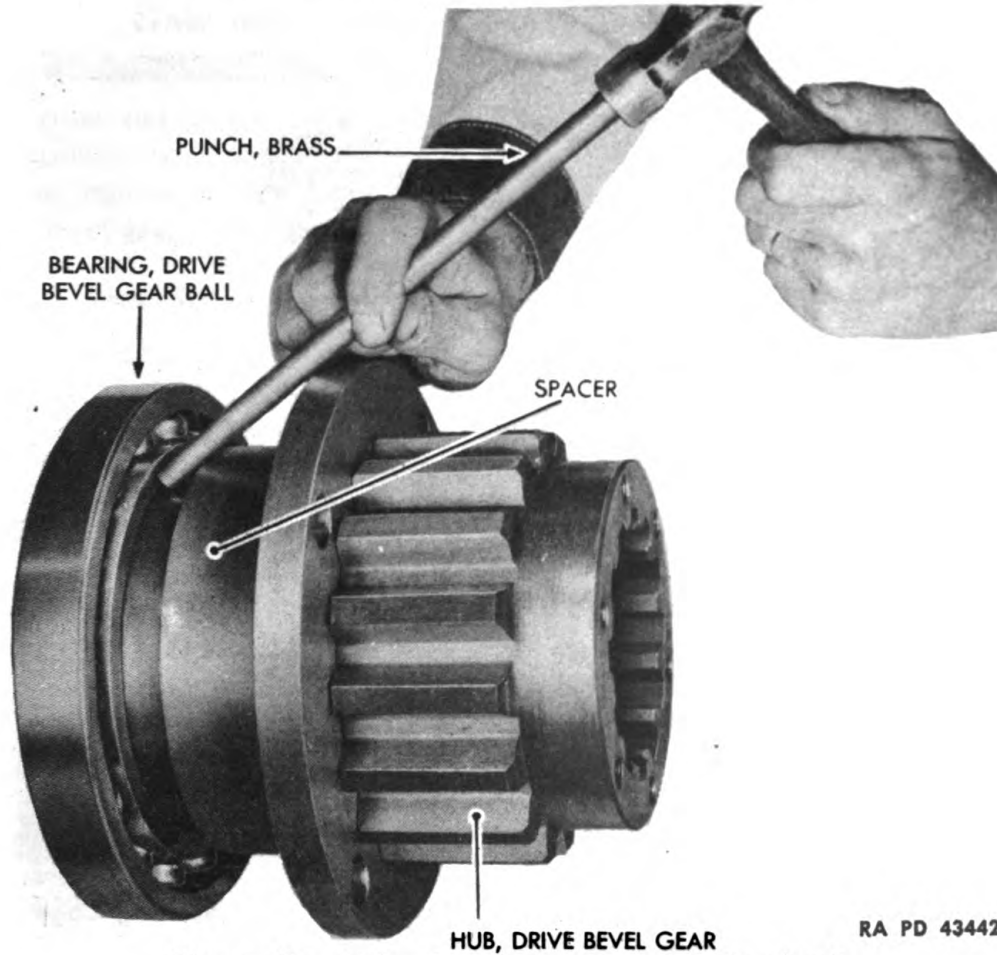

RA PD 43442

Figure 60 – Drive Bevel Gear Bearing Removal

(s) Remove Bearing from Drive Bevel Gear Hub (fig. 60).

HAMMER

PUNCH, brass

1. Use brass punch and hammer to drive bearing from hub.
2. Remove spacer from hub.

(t) Remove Drive Bevel Gear Bearing from Drive Bevel Gear Bearing Cage (fig. 61).

BAR, steel

PRESS, arbor

Use arbor press and steel bar to force out bearing.

37. PARTS, CLEANING, INSPECTION AND REPAIR.

a. Clean All Parts. Wash all gears, shafts, and other parts in **SOLVENT**, dry-cleaning.

b. Inspect Components. No part or subassembly should be installed unless it is either new, or completely rebuilt or repaired, unless inspection

**ORDNANCE MAINTENANCE – HEAVY TRACTOR MI (IHC TD-18) –
POWER TRAIN, TRACK FRAME ASSEMBLY, AND SEATS**

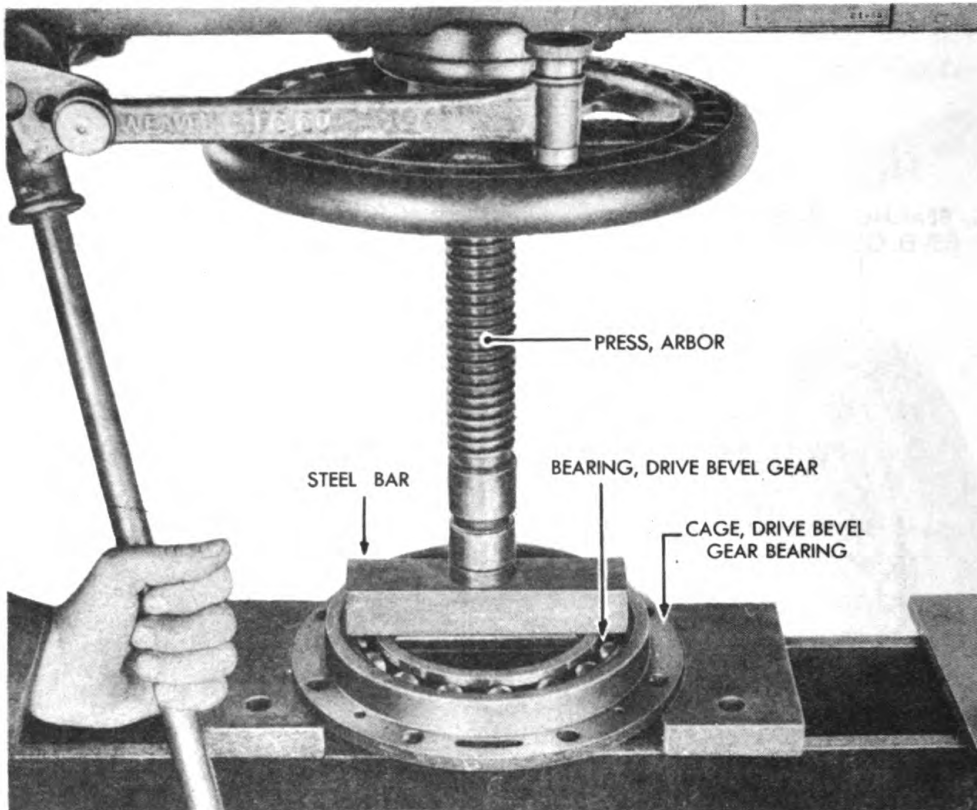

RA PD 65981

Figure 61 – Removal of Bearing from Drive Bevel Gear Bearing Cage

proves that it is in good operating condition. All defective parts should be replaced by new parts.

(1) **BEARINGS.** See that bearings fit snugly and that bearings are not loose in race or cage. If bearings are too loose it may be advisable to replace the bearing. Inspect for cracks, checking, and wear.

(2) **SPLINE SHAFT.** Inspect spline shaft to see if splines are noticeably notched where gears are located. If wear is excessive, the shaft should be replaced. If there are slight burrs that prevent gears from free movement they should be smoothed out.

(3) **GEARS.** Check gears for wear, and chipped or broken teeth.

(4) **SHIFTER RAILS.** Check notches in shifter rails. Balls should not seat all the way into notches. If necessary, replace rails, balls, and springs. Worn forks would allow too free movement; replace if necessary.

(5) **OIL SEALS.** New oil seals should be installed.

c. Repair. Repair consists of replacing defective parts with serviceable parts. When installing transmission and drive bevel gear, reference to the SNL G-101 must be made to be sure parts being installed are correct

TRANSMISSION AND DRIVE BEVEL GEAR

for the tractor. Several changes on installation have been made from time to time and certain changed parts are not interchangeable with parts originally used. Care must be exercised in adjusting bevel gear and pinion (par. 40) as the parts used in a particular tractor vary the adjustment of bevel gear.

38. ASSEMBLY.

a. Equipment.

BAR, steel	PRESS, arbor
BLOCK, wood	PUNCH
CHISEL	SCREWDRIVER
COMPOUND, joint and thread, cement type B	SLEEVE, steel
DISK, steel	TOOL, expansion plug
DRIFT, brass	WISE
HAMMER	WRENCH, box, $\frac{9}{16}$ -in.
HAMMER, rawhide	WRENCH, open-end, $\frac{3}{4}$ -in.
PLATE, steel (3)	WRENCH, socket, $\frac{9}{16}$ -in. (2)
PLIERS	WRENCH, socket, $\frac{3}{4}$ -in.
PLUG, $\frac{3}{4}$ -in. sq	WRENCH, socket, $\frac{3}{4}$ -in. sq

b. Procedure.

(1) INSTALL BEARING AND POWER TAKE-OFF SHAFT BUSHING IN SPLINE SHAFT AND INSTALL SPLINE SHAFT BEARING ON SHAFT (fig. 62).

BAR, steel	SCREWDRIVER
PRESS, arbor	SLEEVE, steel

Use arbor press and steel sleeve to install bearing (closed side away from splines of shaft). Use a steel bar and arbor press to install bushing, pressing it flush with end of spline shaft. Use screwdriver to install snap ring.

(2) INSTALL GEARS ON SPLINE SHAFT (fig. 51).

(a) Install spline shaft rear bearing retainer on shaft.

(b) Install reverse, first and third speed sliding gear (27 teeth) on spline shaft with grooved end away from bearing.

(c) Install second, fourth, fifth, and sixth sliding gear (33 and 44 teeth) with grooved end toward bearing end of shaft.

(d) Install Hi-Lo range sliding gear with grooved end toward bearing end of shaft.

(3) INSTALL REAR TRANSMISSION DRIVE SHAFT BEARING (fig. 49).

DRIFT, brass	HAMMER
--------------	--------

**ORDNANCE MAINTENANCE — HEAVY TRACTOR MI (IHC TD-18) —
POWER TRAIN, TRACK FRAME ASSEMBLY, AND SEATS**

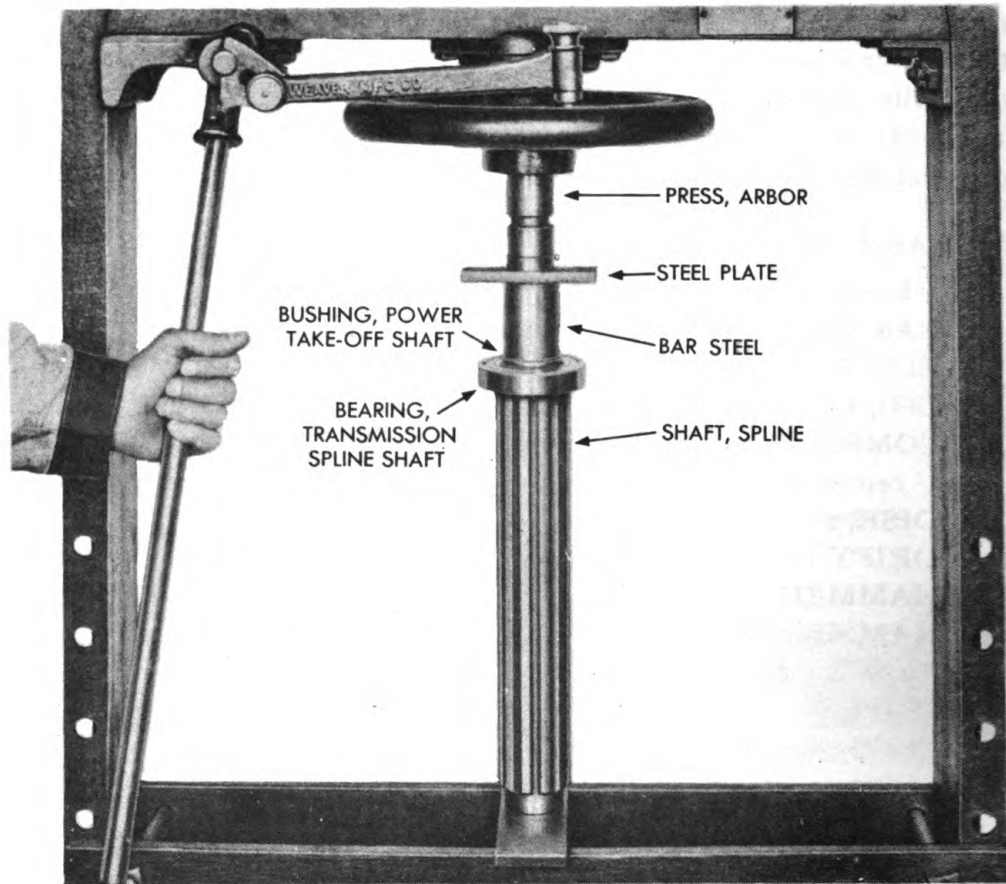

RA PD 65982

Figure 62 — Power Take-Off Bushing Installation

Tap bearing onto splined end of drive shaft and gear, using brass drift and hammer.

(4) **INSTALL TRANSMISSION DRIVE SHAFT AND GEAR IN END COVER** (fig. 48).

CHISEL
HAMMER
HAMMER, rawhide

PLUG, 3/4-in. sq
WRENCH, socket, 3/4-in.
WRENCH, socket, 3/4-in. sq

(a) Install transmission rear drive shaft bearing with shaft assembled in end cover, tapping bearing into position with a rawhide hammer.

(b) Install transmission drive shaft bearing spacer on shaft. Use a rawhide hammer to tap front transmission drive shaft bearing into end cover.

(c) Install oil seal in drive shaft bearing front retainer with lip of oil seal toward inside of end cover when retainer is assembled (fig. 63).

(d) Install retainer gasket and attach retainer to end cover. Secure 4 cap screws and lock washers with 3/4-inch socket wrench.

TRANSMISSION AND DRIVE BEVEL GEAR

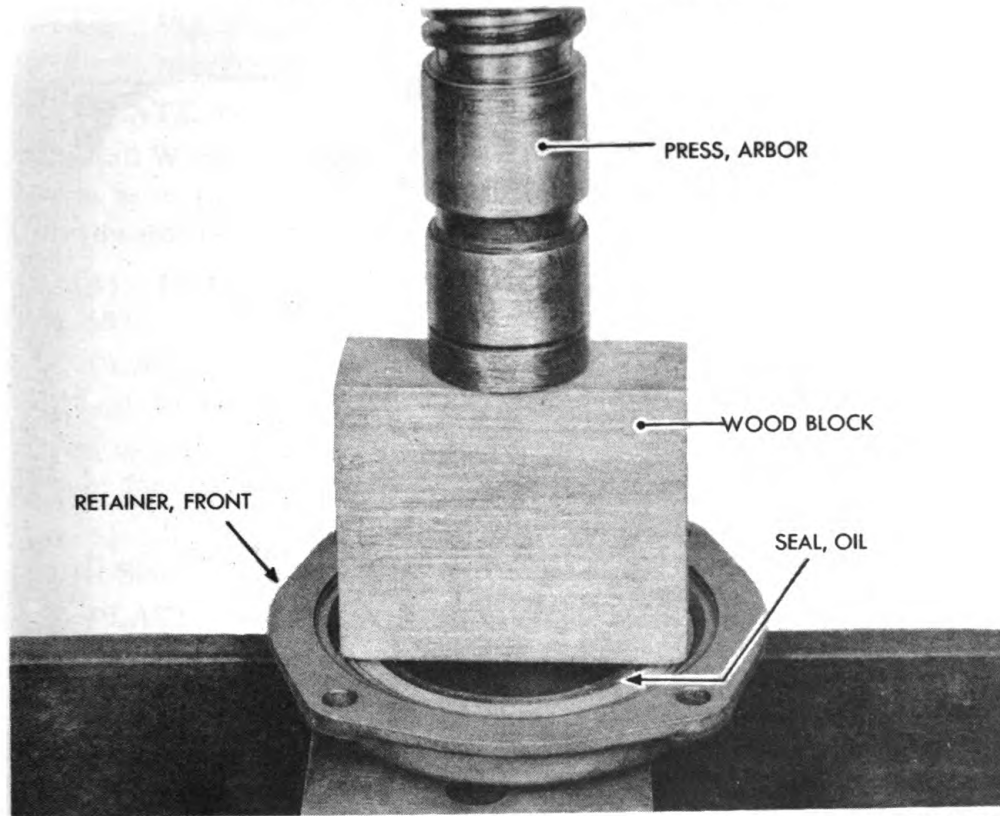

RA PD 65983

Figure 63 – Front Drive Shaft Bearing Retainer Oil Seal Installation

(e) Install driving flange on shaft, then install nut lock and nut on drive shaft, using $\frac{3}{4}$ -inch square plug and a $\frac{3}{4}$ -inch square socket wrench. Use chisel and hammer to bend lock into notches of nut.

(f) Tap transmission spline shaft bearing into drive shaft gear.

(5) **INSTALL OIL SCOOP ON IDLER SHAFT (fig. 52).**

PLIERS

WRENCH, box, $\frac{9}{16}$ -in.

Place oil scoop in position, finished surface toward reverse idler gear end of shaft, and secure with bolt and castellated nut, using a $\frac{9}{16}$ -inch box wrench to tighten. Install cotter pin with pliers. Install so that opening of scoop is on top side of shaft. Top side is determined by noting position of threaded hole in end of shaft. This hole is off center toward top side of shaft.

(6) **INSTALL BEARINGS IN REVERSE IDLER GEAR (fig. 64).**

PLATE, steel

PRESS, arbor

If bearings were removed, they must be replaced with new ones. Place reverse idler gear in arbor press with one reverse idler gear bearing in position. With a steel plate over bearing, press it into gear. In a similar manner, press other bearing into gear.

ORDNANCE MAINTENANCE — HEAVY TRACTOR MI (IHC TD-18) —
POWER TRAIN, TRACK FRAME ASSEMBLY, AND SEATS

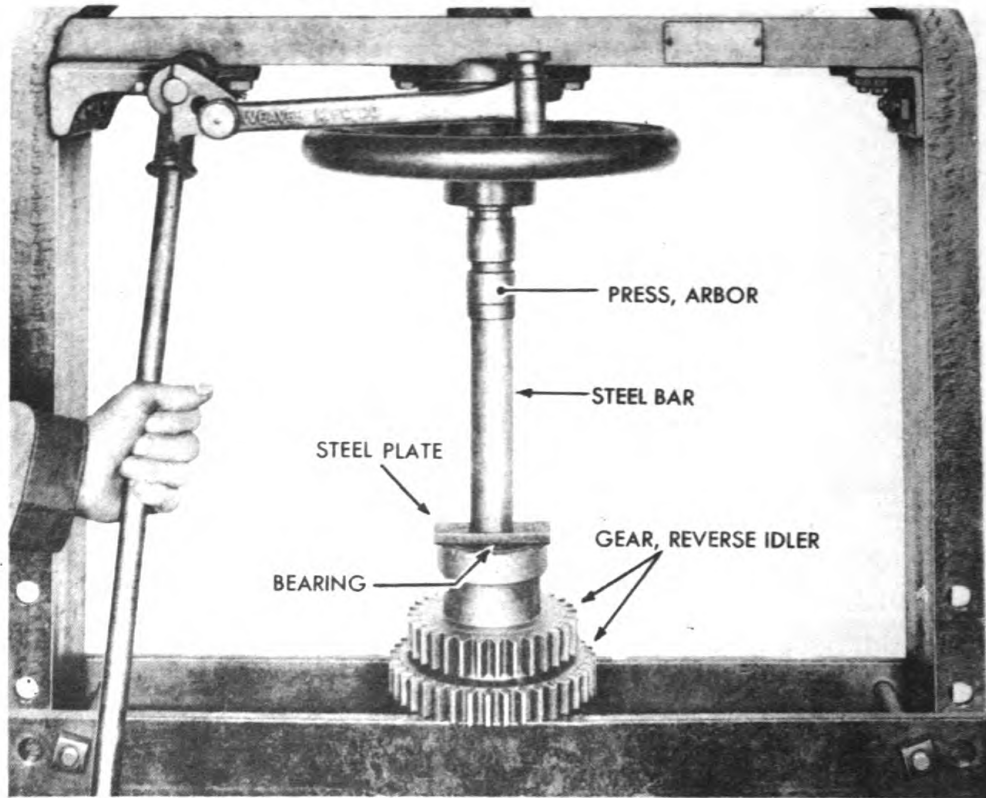

RA PD 65984

Figure 64 — Transmission Reverse Idler Gear Bearing Installation

- (7) **INSTALL REVERSE IDLER GEAR ON IDLER SHAFT** (fig. 52).
Install gear (31 and 38 teeth) on shaft with small gear toward oil scoop.
- (8) **INSTALL BALL BEARINGS IN HI-LO RANGE IDLER GEAR** (fig. 53).
PLATE, steel **PRESS, arbor**
Place front Hi-Lo range idler gear in position on gear and use an arbor press and steel plate to press bearing into gear. Turn gear over and, in a similar manner, install rear Hi-Lo range idler gear.
- (9) **INSTALL HI-LO RANGE IDLER GEAR ON IDLER SHAFT** (fig. 52).
This gear has 23 and 36 teeth and must be installed with small gear toward oil scoop.
- (10) **INSTALL HI-LO IDLER SHAFT RETAINER IN END COVER** (fig. 50).
Position retainer on cover so cap screw hole near center will be nearest to top of end cover when end cover is installed (fig. 86).
- (11) **INSTALL REAR BEVEL PINION AND SHAFT INNER BEARING RACE ON BEVEL PINION AND SHAFT** (fig. 54).
PLATE, steel (2) **PRESS, arbor**
Rest inner race of bearing on 2 steel plates on an arbor press. Insert shaft into bearing and press bearing into position against gear.

TRANSMISSION AND DRIVE BEVEL GEAR

(12) INSTALL REVERSE GEAR SPACER (BU, fig. 47).

(13) INSTALL REVERSE GEAR (fig. 65).

PLATE, steel (2)

PRESS, arbor

Install Woodruff key in bevel pinion shaft. Use arbor press and 2 steel plates as in (11) above to install reverse gear (40 teeth) with longer hub toward bevel pinion end.

(14) INSTALL FIRST, SECOND, THIRD, AND FIFTH SPEED GEAR (fig. 65).

PLATE, steel (2)

PRESS, arbor

Install Woodruff key in bevel pinion shaft. Use arbor press and 2 steel plates as in (11) above, to install gear. Larger gear (43 and 49 teeth) should face reverse idler gear.

(15) INSTALL BEVEL PINION SHAFT SPACER AND FOURTH AND SIXTH SPEED GEAR (fig. 65).

PLATE, steel (3)

PRESS, arbor

Install bevel pinion shaft spacer. Install Woodruff key in bevel pinion shaft. Then rest bevel pinion on arbor press and place fourth and sixth

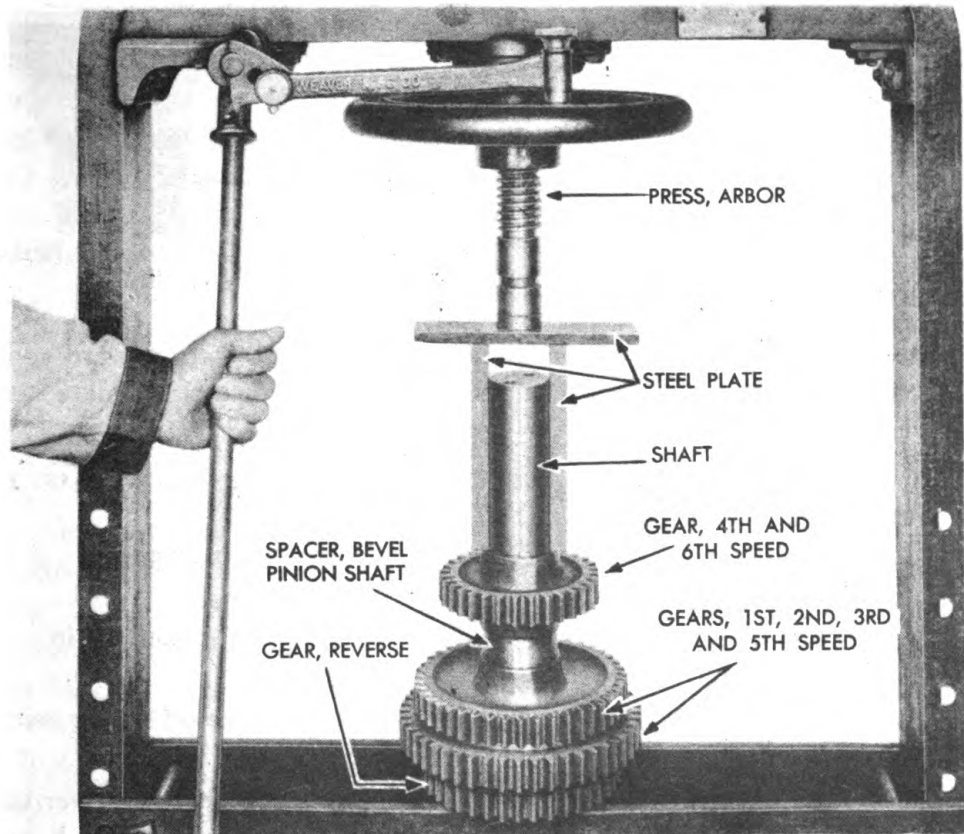
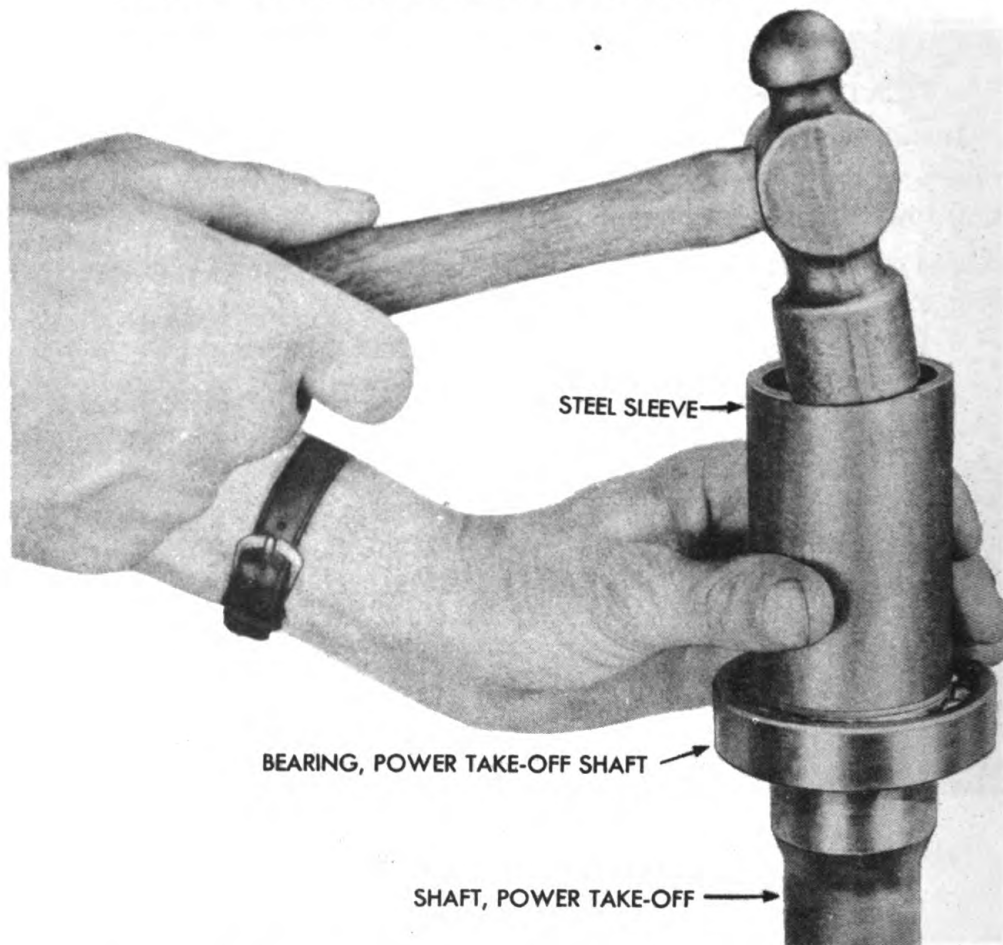

Figure 65 — Transmission 4th and 6th Speed Gear Installation

**ORDNANCE MAINTENANCE — HEAVY TRACTOR MI (IHC TD-18) —
POWER TRAIN, TRACK FRAME ASSEMBLY, AND SEATS**



RA PD 65986

Figure 66 — Power Take-Off Shaft Bearing Installation

speed gear (32 teeth) with rounded edges of gear teeth toward spacer. Place 2 steel plates vertically on sides of gear with a third plate across 2 vertical plates, and press gear against spacer.

(16) **INSTALL POWER TAKE-OFF SHAFT WITH BEARING IN END COVER (figs. 59 and 66).**

BAR, steel

HAMMER

HAMMER, rawhide

PRESS, arbor

SCREWDRIVER

SLEEVE, steel

WRENCH, socket, $\frac{9}{16}$ -in.

(a) Install power take-off bearing on power take-off shaft, using a steel sleeve and hammer to drive bearing into shaft (fig. 66).

(b) Use arbor press and a steel bar to install oil seal in power take-off bearing cage. Lip of oil seal must be toward small end of bearing cage.

TRANSMISSION AND DRIVE BEVEL GEAR

(c) Enter power take-off shaft with bearing through large opening of bearing cage. Use rawhide hammer to seat bearing against oil seal.

(d) Install bearing retainer gasket and bearing retainer in bearing cage. Use $\frac{9}{16}$ -inch socket wrench to secure 4 cap screws and lock washers.

(e) Install oil slinger and snap ring, using screwdriver to force on snap ring.

(17) **INSTALL GEAR SHIFTER LEVER ON SHIFTER HOUSING (fig. 58).**

COMPOUND, joint and thread, cement type B HAMMER	SCREWDRIVER TOOL, expansion plug
--	-------------------------------------

(a) Install swivel housing shield, lower swivel housing spring stop, swivel housing shield spring, and upper swivel housing spring stop on gear shifter lever.

(b) Attach rivet in upper stop and peen end with hammer.

(c) Install lever in housing with large (diameter) shaft in lever. To insert large shaft, press back shield. Lever must be positioned with bend away from narrow end of shifter housing.

(d) Install small (diameter) shaft in base of lever through hole in shifter housing and through hole in large shaft in lever.

(e) Install 2 expansion plugs at ends of shaft in shifter housing, using hammer and expansion plug seating tool.

(f) Install boot on lever and use a screwdriver to secure clamp which holds boot in position. Use joint and thread compound to coat the surface of the shifter housing which contacts the boot.

(g) Install lever ball on lever if it is to be replaced. Cement ball to lever with joint and thread compound.

(18) **INSTALL HI-LO GEAR SHIFTER LEVER (figs. 55 and 56).**

BAR, steel CHISEL COMPOUND, joint and thread, cement type B HAMMER	PUNCH VISE WRENCH, open-end, $\frac{3}{4}$ -in. WRENCH, socket, $\frac{9}{16}$ -in. WRENCH, socket, $\frac{3}{4}$ -in.
--	--

(a) Drive oil seal into side of shifter housing, using steel bar and hammer. Lip of seal must be toward outside of housing. **CAUTION:** Enter Hi-Lo gear shifter arm shaft through expansion plug hole opposite seal and through the oil seal. Enter end of shaft with keyway, nearest end first.

(b) Place Hi-Lo gear shifter arm on shaft inside shifter housing. Line up slot in arm with keyway in shaft and insert round key in slot. Install lock washer and cap screws, using $\frac{3}{4}$ -inch socket wrench.

**ORDNANCE MAINTENANCE — HEAVY TRACTOR MI (IHC TD-18) —
POWER TRAIN, TRACK FRAME ASSEMBLY, AND SEATS**

(c) Drive in expansion plug with hammer and with punch of the correct diameter.

(d) Attach plain washer on outside end of shaft and install Woodruff key. Then install Hi-Lo gear shifter lever. Use 3/4-inch open-end wrench to secure cap screw and lock washer which hold lever to shaft.

(e) Place shifter housing in vise. Insert springs in holes; then install poppet balls.

(f) Assemble rails with forks in proper order (fig. 55), in front and rear gear shift rail guides. Lift the assembled parts as a unit and place into position in shifter housing. Be sure ends of Hi-Lo gear shifter arm are engaged in notches on top side of shifter rails.

(g) Install guide support bolt locks and 6 cap screws into guides and shifter housing. Use 9/16-inch socket wrench to tighten cap screws. Use hammer and chisel to bend locks around cap screw heads.

(h) Install handle (if removed) on Hi-Lo gear shaft lever, cementing it to lever with joint and thread compound.

(19) **INSTALL BEVEL GEAR DRIVE BEARING IN LEFT DRIVE BEVEL GEAR BEARING CAGE (fig. 61).**

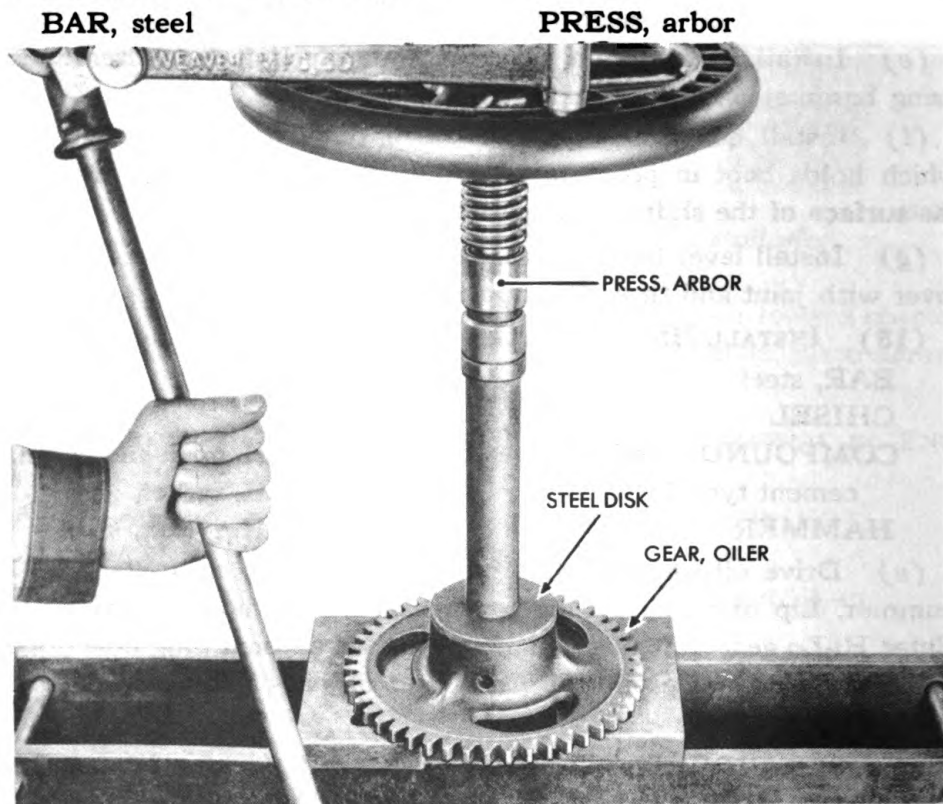

Figure 67 — Oiler Gear Bushing Installation RA PD 65987

TRANSMISSION AND DRIVE BEVEL GEAR

Place bearing cage in an arbor press with bearing in position on cage. Place a steel bar over bearing and press bearing into cage. The bearing has a wider inner race. Be sure that the flush side of the bearing is to the left when bearing and cage are installed in main frame. **NOTE:** Right drive bevel gear bearing is installed in process of drive bevel gear installation.

(20) INSTALL BUSHING IN OILER GEAR (fig. 67).**DISK**, steel**PRESS**, arbor

Place a steel disk or plate over bushing, with bushing in position on oiler gear. Use arbor press to press bushing into gear.

39. INSTALLATION.**a. Equipment.****CHAIN****WRENCH**, open-end, $\frac{9}{16}$ -in.**CHISEL****WRENCH**, open-end, $1\frac{1}{8}$ -in.**DRIFT****WRENCH**, open-end, $\frac{3}{4}$ -in.**HAMMER****WRENCH**, socket, $\frac{9}{16}$ -in.**HAMMER**, babbitt**WRENCH**, socket, $\frac{3}{4}$ -in.**HANDLE**, spinner**WRENCH**, socket, $1\frac{1}{8}$ -in.**HOIST****WRENCH**, socket, $1\frac{5}{16}$ -in.**PRESS**, arbor**WRENCH**, socket, $1\frac{1}{4}$ -in.**ROPE****WRENCH**, socket, $1\frac{7}{8}$ -in.**STUD**, $\frac{1}{2}$ -in. (2)**b. Procedure.****(1) INSTALL REAR SPLINE BEARING CAGE (fig. 43).****HAMMER**, soft**WRENCH**, open-end, $\frac{3}{4}$ -in.

Drive in place with soft hammer; use $\frac{3}{4}$ -inch open-end wrench to secure cap screws and lock washers.

(2) INSTALL BEVEL PINION AND SHAFT BEARING CAGE AND OUTER RACE, REAR, IN MAIN FRAME (fig. 43).**DRIFT****WRENCH**, open-end, $\frac{9}{16}$ -in.**HAMMER**, babbitt

Place bearing outer race, assembled in cage and retainer, in main frame. Use drift to position for cap screws. Drive in with babbitt hammer. Secure 3 cap screws with $\frac{9}{16}$ -inch open-end wrench.

(3) INSTALL BEVEL PINION AND SHAFT COMPLETE (fig. 42).**HAMMER**

(a) Lower into main frame, enter bevel pinion through rear opening to engage drive bevel gear. Use hammer to seat in position.

**ORDNANCE MAINTENANCE — HEAVY TRACTOR MI (IHC TD-18) —
POWER TRAIN, TRACK FRAME ASSEMBLY, AND SEATS**

(b) Install oiler gear, with long hub to rear of tractor, and sleeve on front end of bevel pinion shaft. Install front spacer (fig. 42).

(4) **INSTALL IDLER SHAFT COMPLETE** (fig. 41).

Lower into main frame, place thrust washer on shaft end, and position shaft end through hole in main frame.

(5) **INSTALL SPLINE SHAFT COMPLETE** (fig. 39).

WRENCH, open-end, $\frac{9}{16}$ -in.

Lower into main frame, being careful that gears mesh properly. Enter rear end of spline shaft through rear bearing cage. Install bearing retainer, using $\frac{9}{16}$ -inch open-end wrench for 3 cap screws and lock washers.

(6) **INSTALL HI-LO RANGE IDLER BEARING RETAINER** (fig. 40).

Force reverse idler gear ahead to install both halves of retainer with bolt, castellated nut and cotter pin. Push gear back in position against retainer.

(7) **INSTALL END COVER IN MAIN FRAME** (fig. 36).

STUD, $\frac{1}{2}$ -in. (2) **WRENCH**, socket, $\frac{3}{4}$ -in.

(a) Install gasket on end cover, using gasket shellac.

(b) Lower into position in main frame. Use two $\frac{1}{2}$ -inch studs as guides to secure end cover in position. Use care to mesh drive gear with Hi-Lo idler gear. Place idler shaft end in position in end cover; fit spline shaft end in drive shaft projecting through end cover; bevel pinion shaft projects into end cover.

(c) Insert end cover dowel pin and cap screws with lock washers. Tighten with $\frac{3}{4}$ -inch socket wrench.

(d) Install bevel pinion shaft bearing front retainer with gasket, washer, bearing, original shims, in end cover. Secure cap screws and lock washers with $\frac{3}{4}$ -inch socket wrench (fig. 33).

(8) **INSTALL DRIVE BEVEL GEAR.**

Install and adjust drive bevel gear following procedure in paragraph 40.

(9) **INSTALL ENGINE CLUTCH.**

Follow steps outlined in paragraph 30, omitting (1).

(10) **INSTALL ENGINE CLUTCH COVER** (fig. 32).

WRENCH, socket, $\frac{9}{16}$ -in.

Use a $\frac{9}{16}$ -inch socket wrench to secure 8 cap screws and lock washers which hold engine clutch cover to main frame, also 2 cap screws and lock washers which hold stop light switch to cover.

TRANSMISSION AND DRIVE BEVEL GEAR

(11) **INSTALL AIR CLEANER BODY ASSEMBLY (fig. 32).**

WRENCH, open-end, $\frac{3}{4}$ -in.

Use a $\frac{3}{4}$ -inch open-end wrench to secure 4 cap screws with lock washers which hold air cleaner body assembly to control housing and air cleaner top.

(12) **INSTALL POWER SHAFT BEARING CAGE, COMPLETE, AND POWER TAKE-OFF SHAFT (fig. 31).**

Place cage and shaft in position at rear of main frame; then push shaft into end of spline shaft and attach end cover of power take-off shaft over studs on main frame.

(13) **INSTALL POWER TAKE-OFF WITH LAYSHAFT ATTACHED (fig. 30).**

CHAIN

WRENCH, socket, $1\frac{1}{8}$ -in.

HOIST

WRENCH, socket, $1\frac{5}{8}$ -in.

ROPE

(a) Install new power take-off bearing cage gasket over studs at rear of main frame.

(b) Place chain or rope around power take-off with layshaft in position, so it can be lifted by means of a hoist to its normal position on tractor. Enter power take-off adapter over studs of main frame and power take-off shaft bearing cage. Also enter splined end of layshaft into winch drive shaft slip universal joint.

(c) Use $1\frac{1}{8}$ -inch socket wrench to secure nuts and lock washers on studs.

(d) Use a $1\frac{5}{8}$ -inch socket wrench to install cap screw and lock washer which hold support to power take-off bracket and left corner of main frame.

(14) **INSTALL BRACE AND BLOCK SUPPORT ASSEMBLY WITH PINTLE HOOK ATTACHED (fig. 30).**

CHAIN

WRENCH, open-end, $1\frac{1}{6}$ -in.

HANDLE, spinner

WRENCH, socket, $1\frac{7}{8}$ -in.

HOIST

(a) Place chain around assembly and use hoist to lift assembly into position. Use a $1\frac{7}{8}$ -inch socket wrench to secure 2 nuts and lock washers which hold brace and block support assembly to stay rods at left and right corners of main frame.

(b) Insert drawbar guide into position in drawbar guide brackets.

(c) Install bolts from bottom through brackets and guides. Use a $1\frac{7}{8}$ -inch socket and spinner handle wrench to attach and tighten 2 nuts and lock washers which secure brace and block support assembly to drawbar guide brackets. Hold boltheads with a $\frac{1}{6}$ -inch open-end wrench.

**ORDNANCE MAINTENANCE — HEAVY TRACTOR M1 (IHC TD-18) —
POWER TRAIN, TRACK FRAME ASSEMBLY, AND SEATS**

(d) Insert clevis pin through drawbar and drawbar guide.

(15) **INSTALL MAIN FRAME COVER, CLUTCH INSPECTION COVER AND STEERING CLUTCH RELEASE LEVERS, GEAR SHIFTER HOUSING WITH LEVERS ATTACHED, AND STEERING CLUTCH OPERATING RODS** (figs. 90, 91, and 92).

Follow procedure outlined in paragraph 56 b (10), (11), (12), and (13).

(16) **INSTALL SEAT, FENDERS, GROUSER BOXES, PACK CARRIER, DIESEL FUEL TANK AND FENDER SIDE SHEETS AS A UNIT** (figs. 81, 82, 83, and 84).

Follow procedure outlined in paragraph 56 b (20).

40. DRIVE BEVEL GEAR, ASSEMBLY AND ADJUSTMENT.

a. Equipment.

GAGE, 0.375-in.

WRENCH, open-end, 3/4-in.

GAGE, 0.625-in.

WRENCH, open-end, 1 1/8-in.

GAGE, long feeler

WRENCH, socket, 7/8-in.

INDICATOR, dial

WRENCH, socket, 1 5/8-in.

WRENCH, box, 1-in.

b. Procedure.

(1) **ASSEMBLE DRIVE BEVEL GEAR IN MAIN FRAME.**

WRENCH, box, 1-in.

WRENCH, socket, 7/8-in.

(a) Tap left bearing cage with bearing and gasket into position on main frame. Bearing has wider inner race and is assembled with flush side toward steering clutch.

(b) Attach left steering clutch bearing cap with several cap screws and tighten with a 7/8-inch socket wrench.

(c) Place bevel drive gear into compartment.

(d) Slide drive bevel gear hub into bevel gear and drive hub into left bearing, using a babbitt hammer.

(e) Slide bevel gear spacer over hub and attach bevel gear after inserting original shims between spacer and hub of gear. Place locks on spacer and secure with 4 cap screws, using a 1-inch box wrench. Do not lock cap screws, at this point.

(f) Assemble right bearing cage to main frame with gasket in place as in (a) above.

(g) Assemble right bearing to hub and bearing cage with flush side

TRANSMISSION AND DRIVE BEVEL GEAR

of bearing toward bevel gear and tap into place, using a babbitt hammer.

(h) Attach steering clutch coupling and bearing cage cap to right side. Install cap screw locks. Use a $\frac{3}{4}$ -inch open-end wrench to install 6 cap screws. Pull cap screws up securely. Do not lock.

(i) Remove left bearing cage cap, using a $\frac{7}{8}$ -inch socket wrench to remove 6 cap screws. Install steering clutch coupling to the hub, using a $\frac{3}{4}$ -inch open-end wrench to install 6 cap screws. Then fasten left bearing cage cap in place again, using a $\frac{7}{8}$ -inch socket wrench to install the 6 cap screws and lock washers.

(2) **CHECK CLEARANCE BETWEEN BEVEL PINION AND BEVEL GEAR HUB.**

GAGE, 0.625-in.

Place 0.625-inch gage between end of bevel pinion and hub of bevel gear. **NOTE:** Use 0.625-inch gage on tractor TDR3585 and up. On tractors TDR2215 to TDR3585, use 0.375-inch gage between end of pinion and smooth surface of bevel gear hub. On tractors TDR1659 to TDR2215, use 0.375-inch gage between end of bevel pinion and spacer.

(3) **ADJUST SHIMS AT BEARING CAGE IN TRANSMISSION FRONT COVER.**

To remove front bearing cage, follow procedure outlined in paragraph 35 b (9), (10), and (11). Install or remove shims between bearing cage and transmission cover until clearance has been adjusted. Each time shims are installed or removed, the cage must be completely assembled to end cover before checking clearance. As an extra check the red lead (or PRUSSIAN BLUE) method of determining tooth bearing of tooth contact can be used. When properly adjusted, the tooth bearing should be centered up and down on the tooth of the pinion.

(4) **CHECK BACKLASH OF DRIVE BEVEL GEAR (fig. 69).**

INDICATOR, dial

WRENCH, box, 1-in.

(a) Mount dial indicator on stand. Clamp stand to main frame and adjust stand so indicator contacts one of the drive bevel gear teeth.

(b) Move the gear gently back and forth to the extent of free play and note reading on indicator at each extreme. Backlash must be 0.014 inch.

(c) If backlash is not 0.014 inch, remove or insert shims between drive bevel gear and spacer (fig. 9). Remove 4 cap screws from spacer to install or remove shims, using 1-inch box wrench. Remove right bearing cage cap and loosen cap screws in coupling enough so spacer and bevel

**ORDNANCE MAINTENANCE – HEAVY TRACTOR M1 (IHC TD-18) –
POWER TRAIN, TRACK FRAME ASSEMBLY, AND SEATS**

gear can be spread apart to remove shims or insert shims. Removing shims decreases backlash and inserting shims increases backlash.

(5) ADJUST BEVEL GEAR DEFLECTION SCREW (fig. 70).

GAGE, long feeler

WRENCH, open-end, 1½-in.

Loosen lock nut on deflection screw and adjust deflection screw using 1½-inch open-end wrench to give 0.020-inch clearance between screw and bevel gear. Insert a long feeler gage between screw and bevel gear to check clearance.

(6) REMOVE RIGHT AND LEFT BEARING CAGE CAPS AND COUPLINGS AFTER SETTING THE BEVEL GEAR.

WRENCH, open-end, ¾-in.

WRENCH, socket, ½-in.

WRENCH, socket, 7/8-in.

(a) Remove right cage cap from the drive bevel gear bearing cage and main frame. Use a ½-inch socket wrench to remove nuts from studs. Then use a 7/8-inch socket wrench to remove 6 cap screws and lock washers which hold cage cap to bearing cage and main frame. Remove cage cap. In the same manner, remove left cage cap.

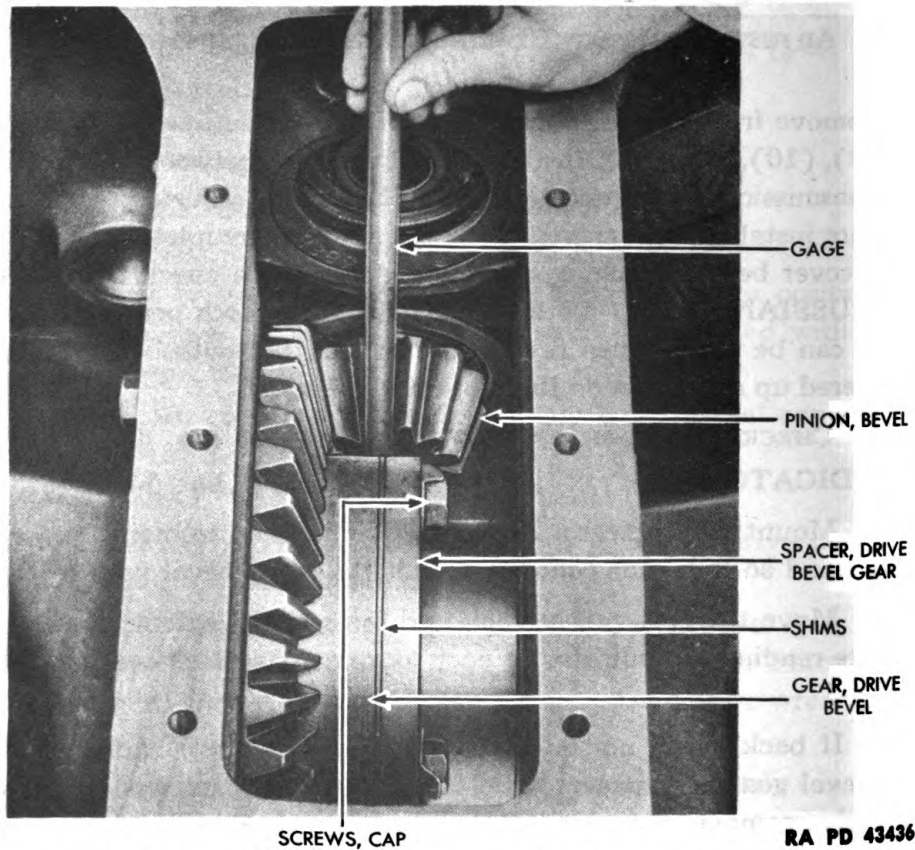

Figure 68 – Drive Bevel Gear and Pinion Clearance Check

TRANSMISSION AND DRIVE BEVEL GEAR

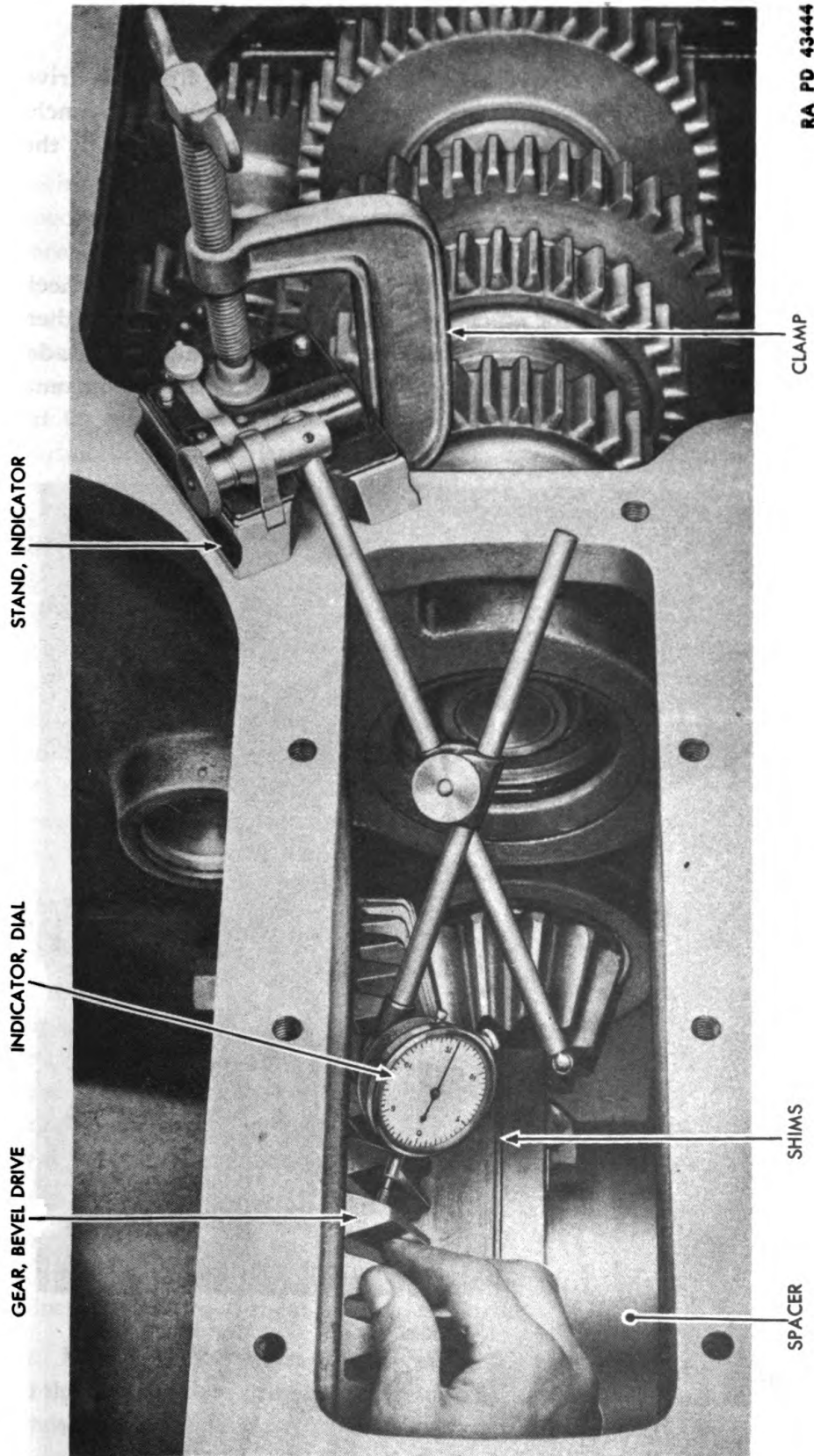

Figure 69 — Drive Bevel Gear Backlash Check

**ORDNANCE MAINTENANCE — HEAVY TRACTOR M1 (IHC TD-18) —
POWER TRAIN, TRACK FRAME ASSEMBLY, AND SEATS**

(b) Disconnect the right steering clutch shaft coupling from the drive bevel gear hub. Remove 6 cap screws using a 3/4-inch open-end wrench; then remove the coupling. Remove left steering clutch coupling in the same manner.

41. CHECK AFTER INSTALLATION.

a. After transmission and drive bevel gear have been installed, check operation through all gears for efficient shifting from one gear to another. Once installation is complete, no detailed inspections can be made. Therefore, it is of utmost importance that assembly, installation, and adjustment instructions as outlined in paragraphs 38, 39, and 40 be strictly followed.

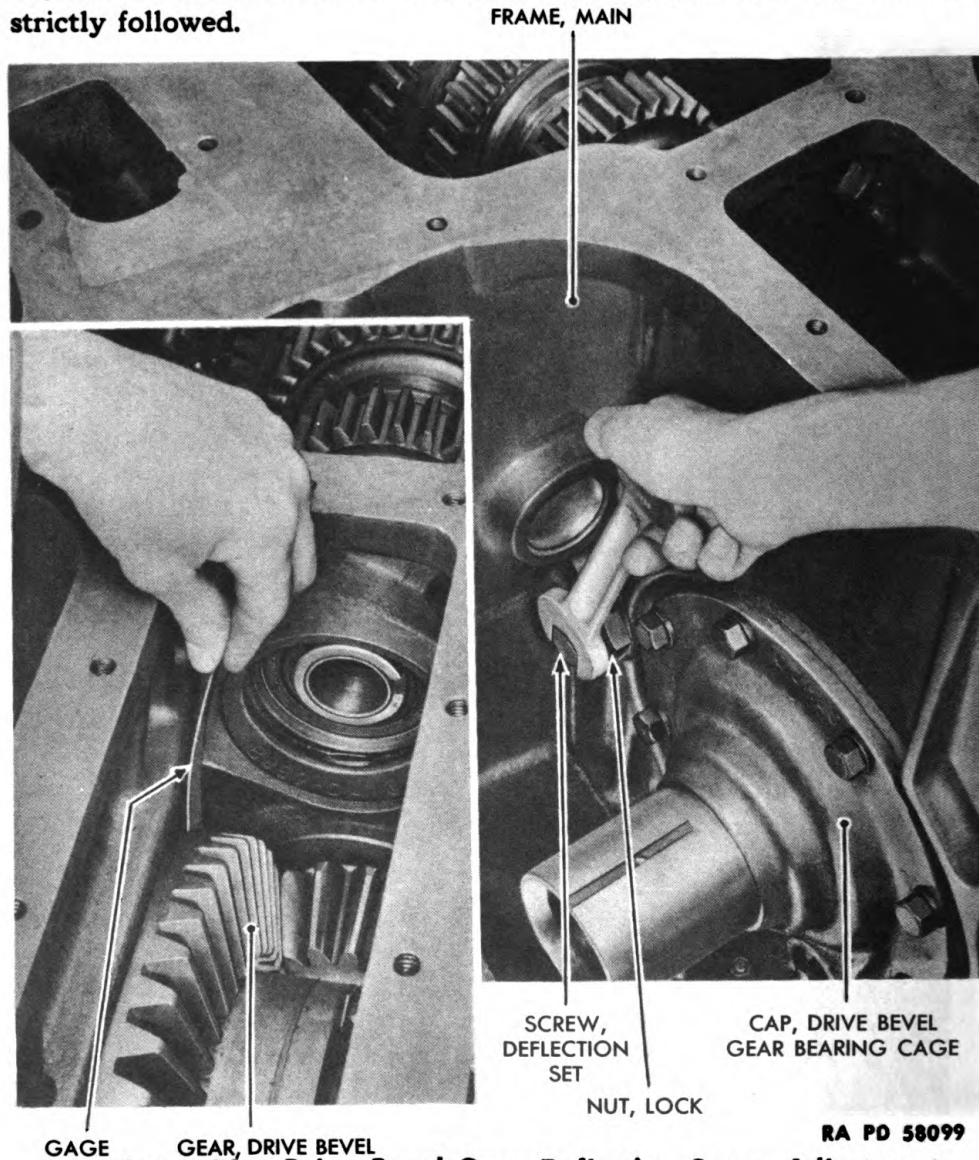

Figure 70 — Drive Bevel Gear Deflection Screw Adjustment

Section III

STEERING CLUTCHES AND BRAKES

	Paragraph
Steering clutches and brakes, construction and operation	42
Inspection of steering clutches and brakes in the vehicle	43
Allocation of maintenance duties by echelons, and trouble shooting	44
Steering brake relining	45
Steering brake removal	46
Steering brake disassembly	47
Steering brake parts, inspection	48
Steering brake assembly	49
Steering brake installation	50
Steering brake adjustment	51
Steering clutch removal	52
Steering clutch disassembly	53
Steering clutch parts, inspection	54
Steering clutch assembly	55
Steering clutch installation	56
Steering clutch control adjustment	57
Steering brake control removal	58
Steering brake control disassembly	59
Steering brake control parts, inspection	60
Steering brake control assembly	61
Steering brake control installation	62

42. STEERING CLUTCHES AND BRAKES, CONSTRUCTION AND OPERATION.

a. Each sprocket is connected to the drive bevel gear through a 15-inch multiple dry disk clutch of the spring-loaded type with manual release. These units are located in separate compartments, one on each side of bevel gear compartment at rear of main frame. They may be removed individually with their release mechanism without disturbing bevel pinion adjustment or sprocket drive assembly.

b. Adjustment of clutches may easily be made on control rods after lifting out seat cushions. Method of adjustment is outlined in paragraph 57. Hand control levers should have 4 inches free travel and should be 12 inches from hood sheet in forward position.

c. Pulling back on control lever compresses steering clutch springs and thereby releases pressure on friction and drive disks, which disengages clutch. Principle is same as disengaging a spring-loaded engine clutch.

**ORDNANCE MAINTENANCE — HEAVY TRACTOR M1 (IHC TD-18) —
POWER TRAIN, TRACK FRAME ASSEMBLY, AND SEATS**

d. A steering brake is provided for each steering clutch. Its purpose is to stop clutch drum from rotating after steering clutch has been disengaged. This locks one track and forms a pivot point for short turns. Brakes also may be used for parking purposes. Pedals for each brake are adjustable to suit operator. Each pedal may be locked in holding position. Brakes are simple and are very accessible, contracting on steering clutch drums. Bands may be relined after removing them through convenient holes in bottom of main frame. No other part of tractor need be disturbed.

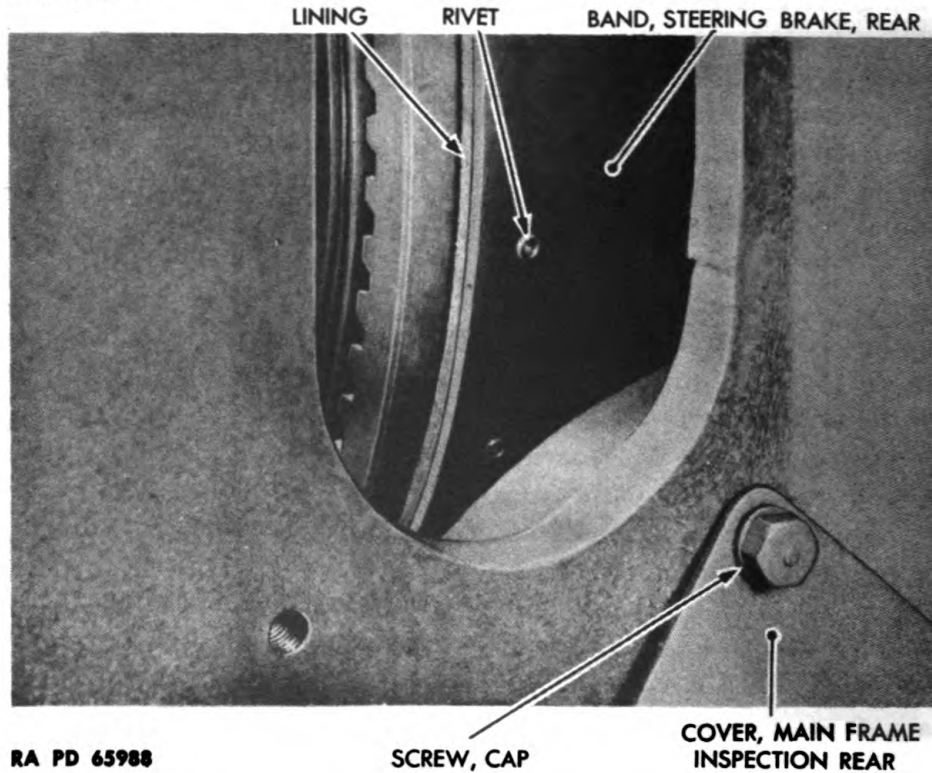

Figure 71 — Inspection of Steering Brakes in the Vehicle

43. INSPECTION OF STEERING CLUTCHES AND BRAKES IN THE VEHICLE.

a. Check Adjustment (pars. 51 and 57).

b. Check Steering Brake Bands for Wear (fig 71). Remove 3 cap screws and lock washers from each main frame rear inspection cover, and swing covers out of the way on fourth cap screw. Or remove 4 cap screws and lock washers and remove cover. Through openings, inspect thickness of brake band lining. Lining which is worn down to rivets should be replaced. Also, if adjustments, outlined in paragraph 51, fail

**ORDNANCE MAINTENANCE — HEAVY TRACTOR MI (IHC TD-18) —
POWER TRAIN, TRACK FRAME ASSEMBLY, AND SEATS**

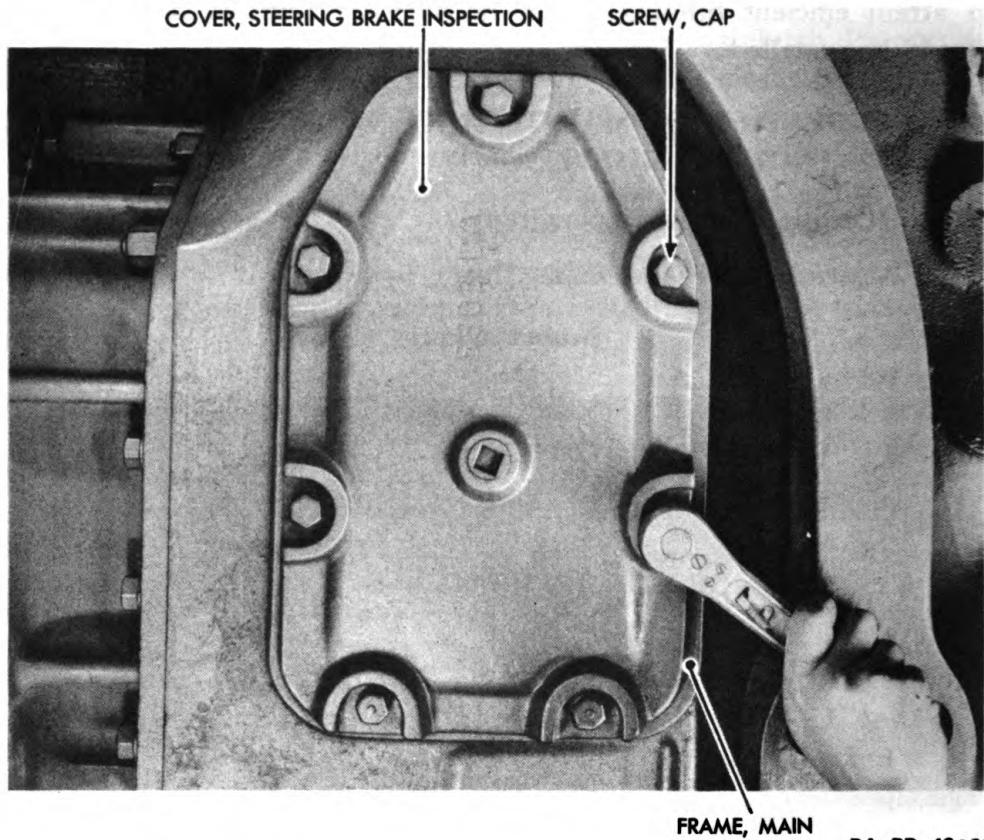

RA PD 43443

Figure 72 — Steering Brake Inspection Cover Removal

46. STEERING BRAKE REMOVAL.

a. Equipment.

CUTTERS, diagonal

PLIERS

SCREWDRIVER

WRENCH, open-end, 5/8-in.

WRENCH, open-end, 1-in.

WRENCH, socket, 3/4-in. (2)

b. Procedure.

(1) REMOVE STEERING BRAKE INSPECTION COVER (fig. 72).

WRENCH, socket, 3/4-in.

Use a 3/4-inch socket wrench to remove 7 cap screws and lock washers which hold cover to main frame at rear of bottom of frame. Remove cover.

(2) REMOVE STEERING BRAKE PIVOT SHAFT STUD (fig. 73).

WRENCH, socket, 3/4-in.

Use a 3/4-inch socket wrench to remove steering brake pivot shaft stud and lock washer. The stud holds pivot shaft to main frame.

STEERING CLUTCHES AND BRAKES

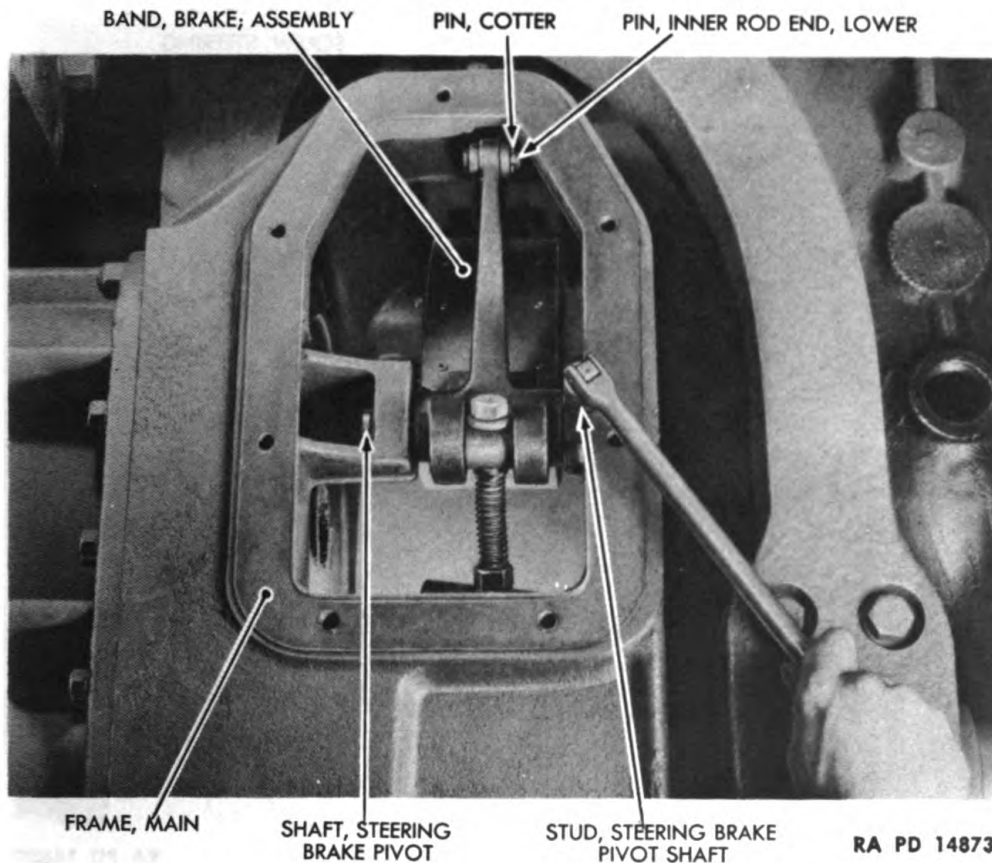

Figure 73 – Steering Brake Pivot Shaft Stud Removal

(3) REMOVE RETURN SPRING (figs. 74 and 78).

PLIERS

WRENCH, open-end, 1-in.

WRENCH, open-end, 5/8-in.

From underneath the main frame, use a 1-inch open-end wrench to loosen the lock nut on the steering brake band set screw. Then use a 5/8-inch open-end wrench to back out the set screw from the frame. This is necessary to facilitate removal of return spring; then, from inside the steering clutch compartment, use pliers to remove the return spring.

(4) REMOVE BRAKE BAND ASSEMBLY FROM MAIN FRAME (figs. 73 and 75).

CUTTERS, diagonal

SCREWDRIVER

Use diagonal cutters to remove cotter pin from end pin lower inner rod and remove pin. Then use a screwdriver to pry pivot shaft toward outside of tractor and lift out brake band assembly from bottom of main frame.

**ORDNANCE MAINTENANCE — HEAVY TRACTOR MI (IHC TD-18) —
POWER TRAIN, TRACK FRAME ASSEMBLY, AND SEATS**

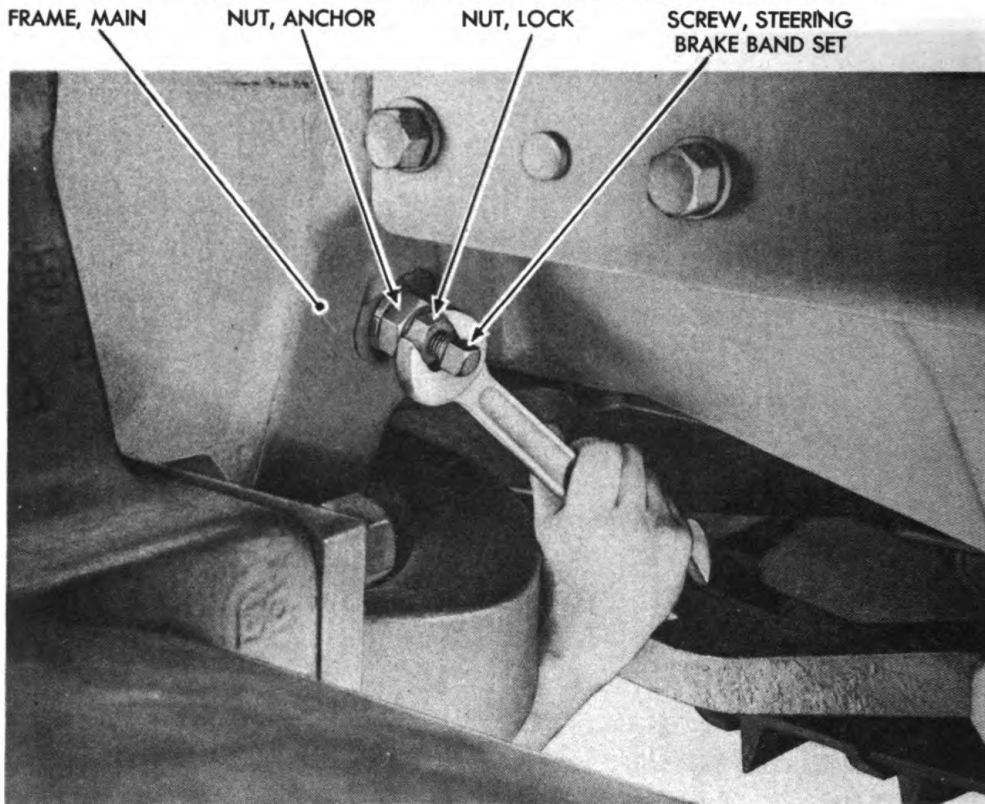

RA PD 14880

Figure 74 — Backing Up Steering Brake Band Set Screw

47. STEERING BRAKE DISASSEMBLY.

a. Equipment.

CUTTERS, diagonal
HAMMER
PUNCH

WRENCH, open-end, 7/8-in.
WRENCH, open-end, 1-in.

b. Procedure.

(1) **REMOVE STEERING BRAKE BAND ADJUSTING BOLT** (fig. 76).

WRENCH, open-end, 1-in.

Use a 1-inch open-end wrench to loosen lock nut on adjusting bolt. Use the same wrench to remove bolt. Also remove 2 flat washers; then, remove release spring and steering brake band adjusting pin.

(2) **REMOVE STEERING BRAKE PIVOT LEVER** (fig. 77).

CUTTERS, diagonal

Use diagonal cutters to remove cotter pin from steering brake band pivot joint pin; then remove pin and steering brake pivot lever.

(3) **REMOVE BUSHINGS FROM STEERING BRAKE BAND PIVOT LEVER** (fig. 77).

STEERING CLUTCHES AND BRAKES

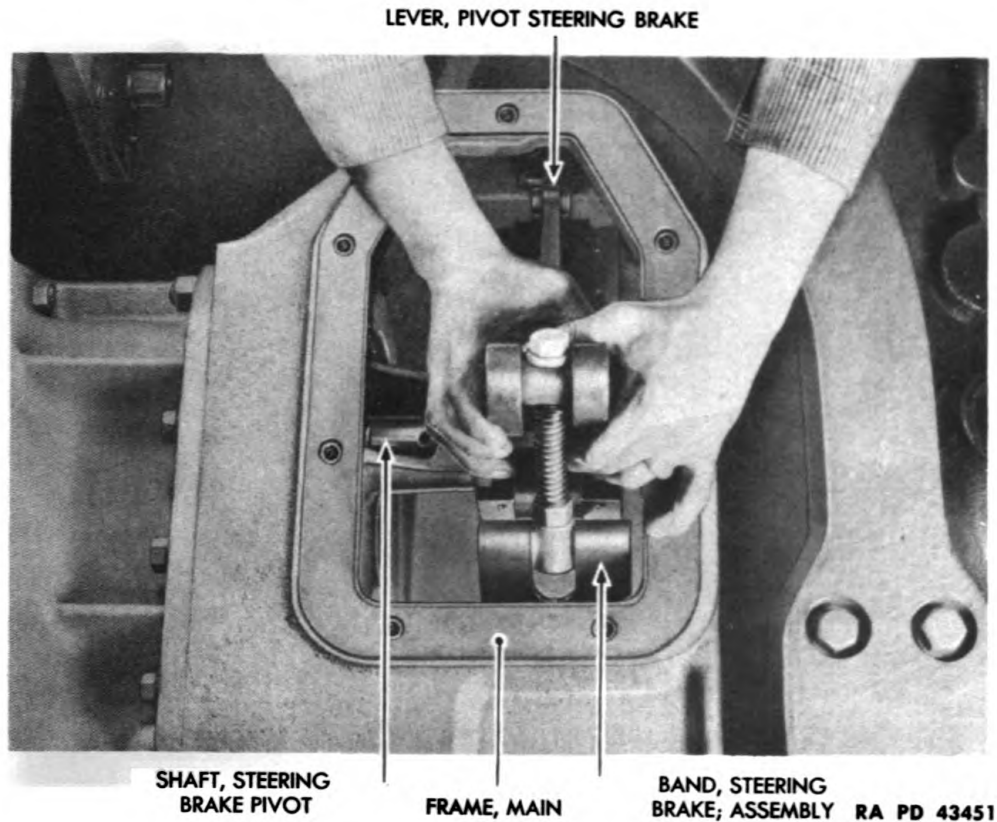

Figure 75 – Steering Brake Band Assembly Removal

CAUTION: Do not remove bushings unless they are worn to the extent that pin is loose when installed in lever.

HAMMER

PUNCH

If necessary to remove the 2 bushings, use a hammer and punch to drive them from the lever. Bushings which have been removed cannot be used again.

(4) REMOVE CENTER STEERING BRAKE BAND FROM FRONT STEERING BRAKE BAND (fig. 77).

CUTTERS, diagonal

Use diagonal cutters to remove cotter pin from steering brake band joint pin. Remove pin.

48. STEERING BRAKE PARTS, INSPECTION.

a. **Inspect Brake Band Lining.** Inspect lining on front, rear, and center steering brake bands. If lining is worn down to rivets, new lining should be installed as outlined in paragraph 45.

ORDNANCE MAINTENANCE — HEAVY TRACTOR MI (IHC TD-18) —
POWER TRAIN, TRACK FRAME ASSEMBLY, AND SEATS

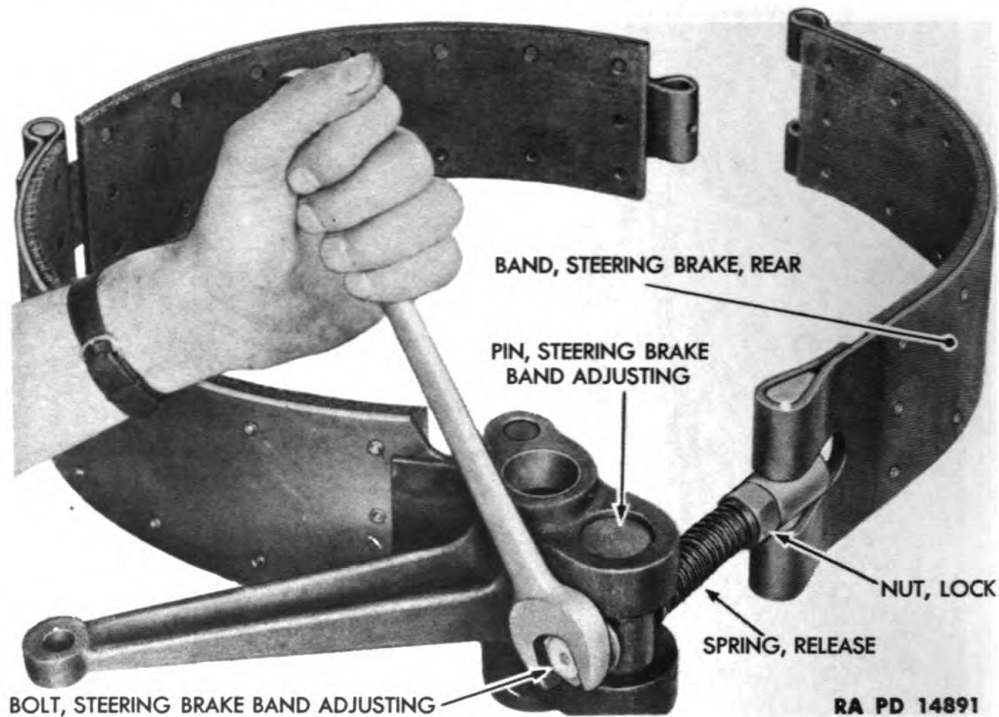

Figure 76 — Steering Brake Band Adjustment Bolt Removal

b. **Inspect Bands for Out of Round.** Lay front, rear, and center steering brake bands over drum and check for out of round. Distorted bands should be replaced.

49. STEERING BRAKE ASSEMBLY.

a. **Equipment.**

CUTTERS, diagonal
PRESS, arbor

SCREWDRIVER
WRENCH, open-end, 7/8-in.

b. **Procedure.**

(1) **ATTACH CENTER STEERING BRAKE BAND TO FRONT STEERING BRAKE BAND (fig. 77).**

CUTTERS, diagonal

SCREWDRIVER

Join center and front steering brake bands with joint pin. Use a screwdriver to line up cotter pin holes in pin with center band cotter pin holes. Use diagonal cutters to insert and lock cotter pin.

(2) **INSTALL BUSHINGS IN STEERING BRAKE PIVOT LEVER (fig. 77).**
PRESS, arbor

If bushings have been removed from lever, use an arbor press to press a new bushing into each side of lever.

STEERING CLUTCHES AND BRAKES

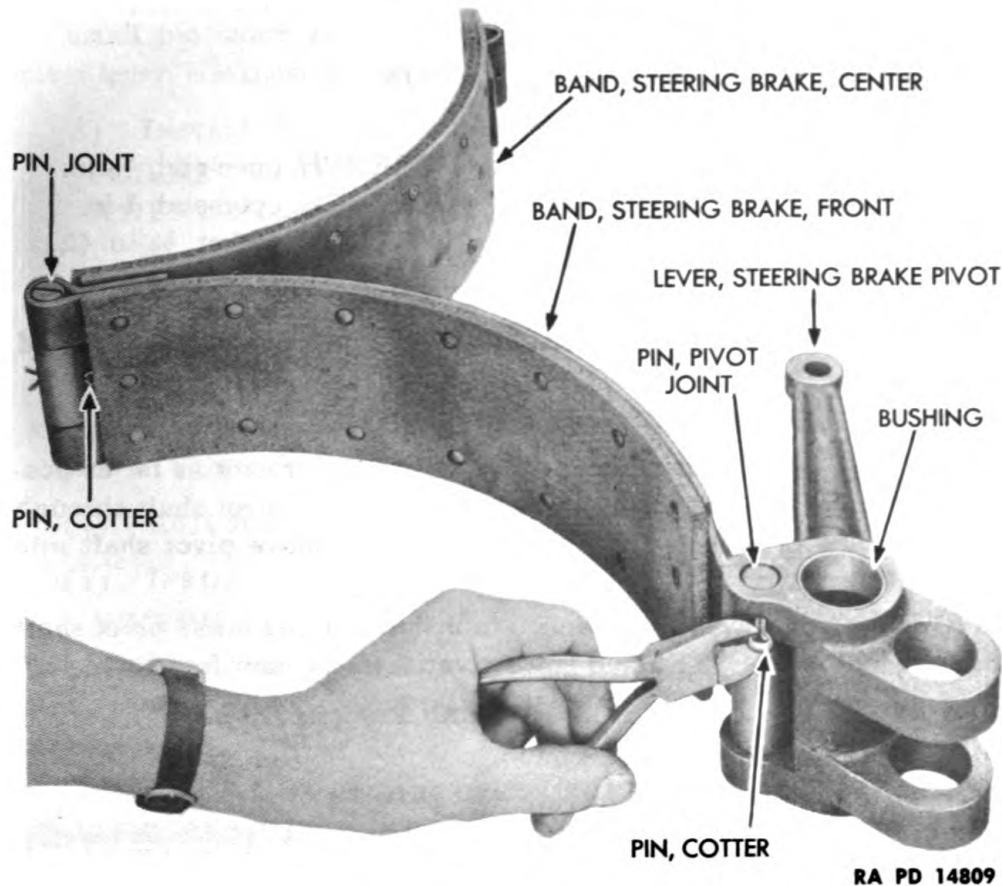

Figure 77 – Steering Brake Pivot Lever, Removal

(3) INSTALL STEERING BRAKE PIVOT LEVER (fig. 77).

CUTTERS, diagonal

Place lever in position on front steering brake band and insert pivot joint. Use diagonal cutters to install cotter pin which locks pivot joint pin to lever and band.

(4) INSTALL STEERING BRAKE BAND ADJUSTING BOLT (fig. 76).

WRENCH, open-end, $\frac{7}{8}$ -in.

(a) Install steering brake band adjusting pin in lever; then insert adjusting bolt and flat washer in adjusting pin. Place release spring on bolt and attach lock nut.

(b) Use a $\frac{7}{8}$ -inch open-end wrench to screw the bolt into rear steering brake band; then use the same wrench to secure lock nut against rear steering brake band.

**ORDNANCE MAINTENANCE — HEAVY TRACTOR MI (IHC TD-18) —
POWER TRAIN, TRACK FRAME ASSEMBLY, AND SEATS**

50. STEERING BRAKE INSTALLATION.

a. Equipment.

CUTTERS, diagonal

WRENCH, open-end, 5/8-in.

PLIERS

WRENCH, open-end, 1-in.

SCREWDRIVER

WRENCH, socket, 3/4-in. (2)

b. Procedure.

(1) POSITION BRAKE BAND ASSEMBLY IN MAIN FRAME (figs. 73 and 75).

SCREWDRIVER

WRENCH, socket, 3/4-in.

(a) With pivot shaft moved toward outside of tractor as far as possible, lift brake band assembly in position, and slide pivot shaft through steering brake pivot lever. Use a screwdriver to move pivot shaft into position in lever.

(b) Use a 3/4-inch socket wrench to install steering brake pivot shaft stud and lock washer. The stud holds pivot shaft to main frame.

(2) INSTALL LOWER INNER ROD END PIN (fig. 73).

CUTTERS, diagonal

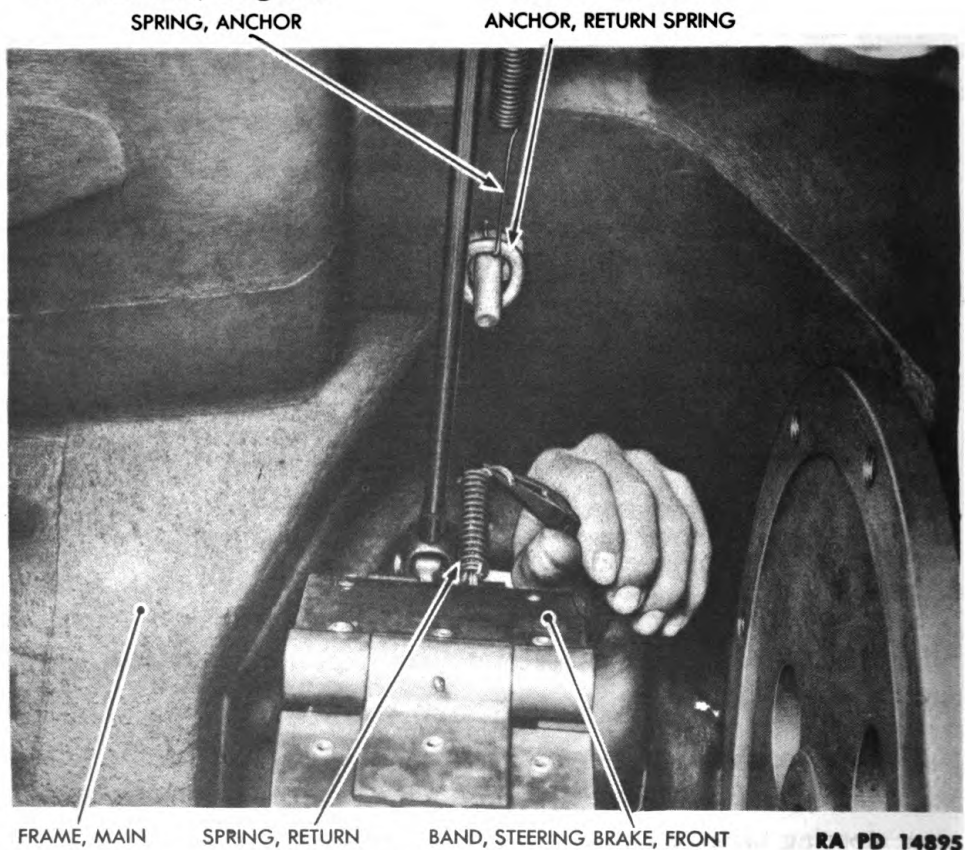

Figure 78 — Anchor Spring Installation

STEERING CLUTCHES AND BRAKES

Install pin which secures inner steering brake rod to steering brake pivot lever. Use diagonal cutters to install cotter pin in end pin.

(3) **INSTALL RETURN SPRING** (fig. 78).

PLIERS

WRENCH, open-end, 1-in.

WRENCH, open-end, $\frac{5}{8}$ -in.

(a) From underneath the main frame, reach through inspection cover opening and use pliers to attach return spring to front steering brake band and steering brake return spring anchor.

(b) From underneath the main frame, use a $\frac{5}{8}$ -inch open-end wrench to tighten steering brake band set screw. Then use a 1-inch open-end wrench to tighten lock nut on set screw.

(4) **ADJUST STEERING BRAKES.** Refer to paragraph 51.

(5) **INSTALL STEERING BRAKE INSPECTION COVER** (fig. 72).

WRENCH, socket, $\frac{3}{4}$ -in.

Lift the cover in position on bottom of rear of main frame and install 7 cap screws and lock washers. Tighten cap screws with a $\frac{3}{4}$ -inch socket wrench.

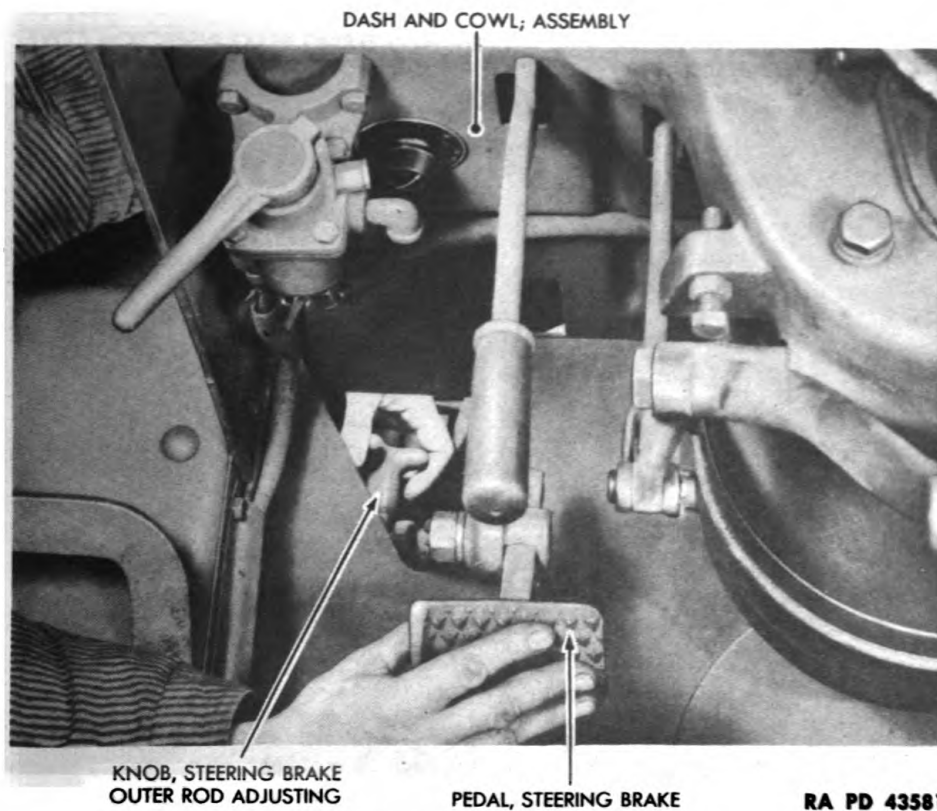

Figure 79 — Steering Brake Control, Adjustment

**ORDNANCE MAINTENANCE — HEAVY TRACTOR MI (IHC TD-18) —
POWER TRAIN, TRACK FRAME ASSEMBLY, AND SEATS**

51. STEERING BRAKE ADJUSTMENT.

a. Equipment.

WRENCH, open-end, 3/4-in.

WRENCH, open-end, 1-in.

WRENCH, open-end, 7/8-in.

WRENCH, socket, 3/4-in.

b. Procedure.

(1) **ADJUST STEERING BRAKE OUTER ROD ADJUSTING KNOB** (fig. 79).

By hand, from engine side of dash and cowl assembly or through opening in engine clutch cover, turn adjusting knob and at the same time operate the steering brake pedal by hand, until the free travel of 2 inches is attained. If knob turns all the way in, and desired steering brake action is not attained, it is necessary to take up steering clutch brake bands, as outlined in step (2) which follows.

(2) **ADJUST STEERING BRAKE BANDS** (fig. 80).

WRENCH, open-end, 3/4-in.

WRENCH, open-end, 1-in.

WRENCH, open-end, 7/8-in.

WRENCH, socket, 3/4-in.

(a) Move steering brake outer rod adjusting knob out as far as possible ((1) above).

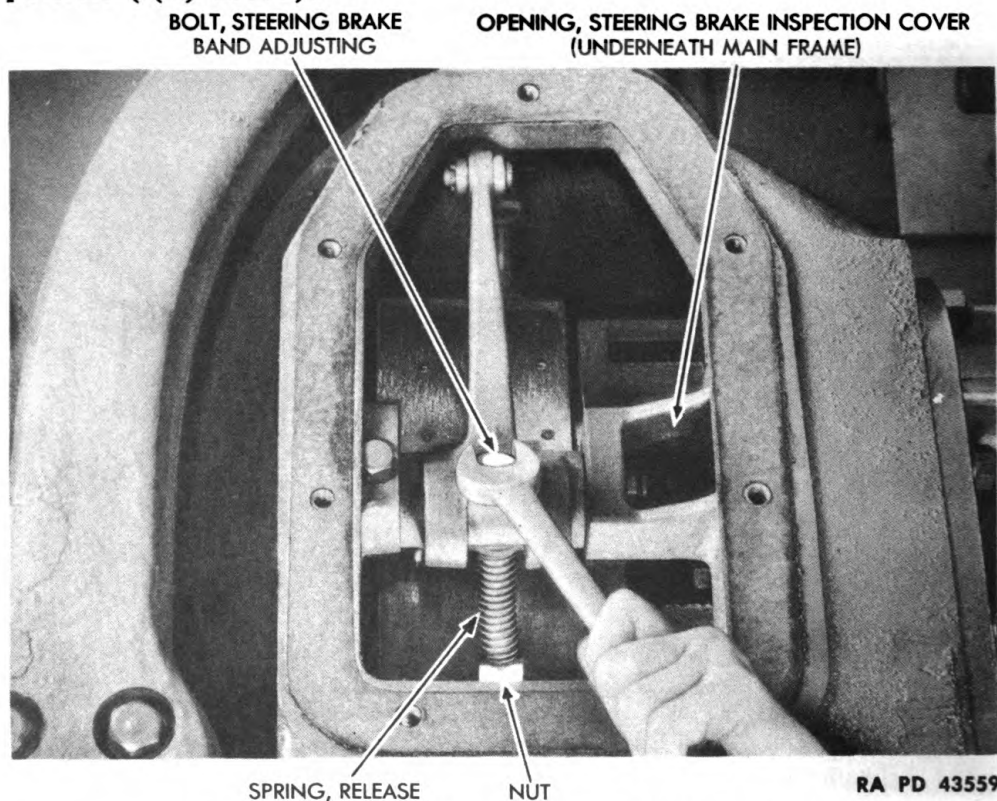

Figure 80 — Steering Brake Band Adjustment

STEERING CLUTCHES AND BRAKES

(b) Remove steering brake inspection cover, using a $\frac{3}{4}$ -inch socket wrench to remove 7 cap screws and lock washers which hold the cover to the main frame, below the steering brake to be adjusted.

(c) Through the inspection cover opening, use a 1-inch open-end wrench to loosen nut at top of release spring.

(d) Use a $\frac{7}{8}$ -inch open-end wrench to tighten the steering brake band adjusting bolt until desired adjustment is attained as in b (1) of this paragraph.

(e) Replace steering brake inspection cover on main frame. Use a $\frac{3}{4}$ -inch socket wrench to install 7 cap screws and lock washers.

(f) If necessary, repeat the adjustment outlined in (1) of this paragraph to attain desired steering brake pedal action.

(3) ADJUST OTHER STEERING BRAKE CONTROLS IN SAME MANNER (figs. 79 and 80).

52. STEERING CLUTCH REMOVAL.

a. Equipment.

BAR, long, steel	WRENCH, open-end, $\frac{1}{2}$ -in.
CHAIN (or rope)	WRENCH, open-end, $\frac{9}{16}$ -in. (2)
CORD	WRENCH, open-end, $\frac{5}{8}$ -in.
CUTTERS, diagonal	WRENCH, open-end, $\frac{3}{4}$ -in. (2)
HAMMER, rawhide	WRENCH, open-end, $\frac{7}{8}$ -in.
HOIST	WRENCH, open-end, 1-in.
NUT, $\frac{5}{8}$ -in.	WRENCH, open-end, $1\frac{1}{16}$ -in.
PLIERS	WRENCH, pipe
PUNCH	WRENCH, socket, $\frac{3}{4}$ -in. (2)
SCREWDRIVER	WRENCH, socket, $\frac{7}{8}$ -in.
SLING, rope	WRENCH, socket, $1\frac{1}{8}$ -in.
WRENCH, open-end, $\frac{7}{8}$ -in.	WRENCH, socket, $1\frac{7}{8}$ -in.

b. Procedure.

(1) REMOVE SEAT, FENDERS, GROUSER BOXES, PACK CARRIER, DIESEL FUEL TANK, AND FENDER SIDE SHEETS AS A UNIT (figs. 81, 82, 83, and 84).

HOIST	WRENCH, open-end, $\frac{3}{4}$ -in.
SLING, rope	WRENCH, pipe
WRENCH, open-end, $\frac{9}{16}$ -in. (2)	WRENCH, socket, $\frac{3}{4}$ -in. (2)

(a) Remove seat cushions.

(b) Remove batteries and battery bottom supports, following procedure outlined in paragraph 82 of TM 9-777 to remove batteries. To remove battery bottom supports, use a $\frac{3}{4}$ -inch open-end wrench. Re-

**ORDNANCE MAINTENANCE – HEAVY TRACTOR MI (IHC TD-18) –
POWER TRAIN, TRACK FRAME ASSEMBLY, AND SEATS**

move 4 cap screws and washers from each support and remove supports and 4 bottom spacers at each support.

(c) Remove 2 bolts, nuts, and lock washers which hold 2 cable clips to right fender side sheet TM 9-1777B. Also remove 2 bolts, nuts, and lock washers which hold 2 cable clips to left fender side sheet (fig. 84). Hold boltheads with one $\frac{9}{16}$ -inch open-end wrench while removing nuts with the other.

(d) Remove power take-off shifter hand lever rod. Disconnect yoke from power take-off shifter hand lever. Remove cotter pin from yoke pin using diagonal cutters; then lift out yoke pin. Remove cotter pin and rear yoke pin from rod and lift out rod.

(e) Disconnect winch clutch and brake control rods from winch shifter and brake levers. Use diagonal cutters to remove cotter pin from each end pin; then remove end pins which join yoke assemblies to levers. Lower winch and clutch brake control rods out of the way.

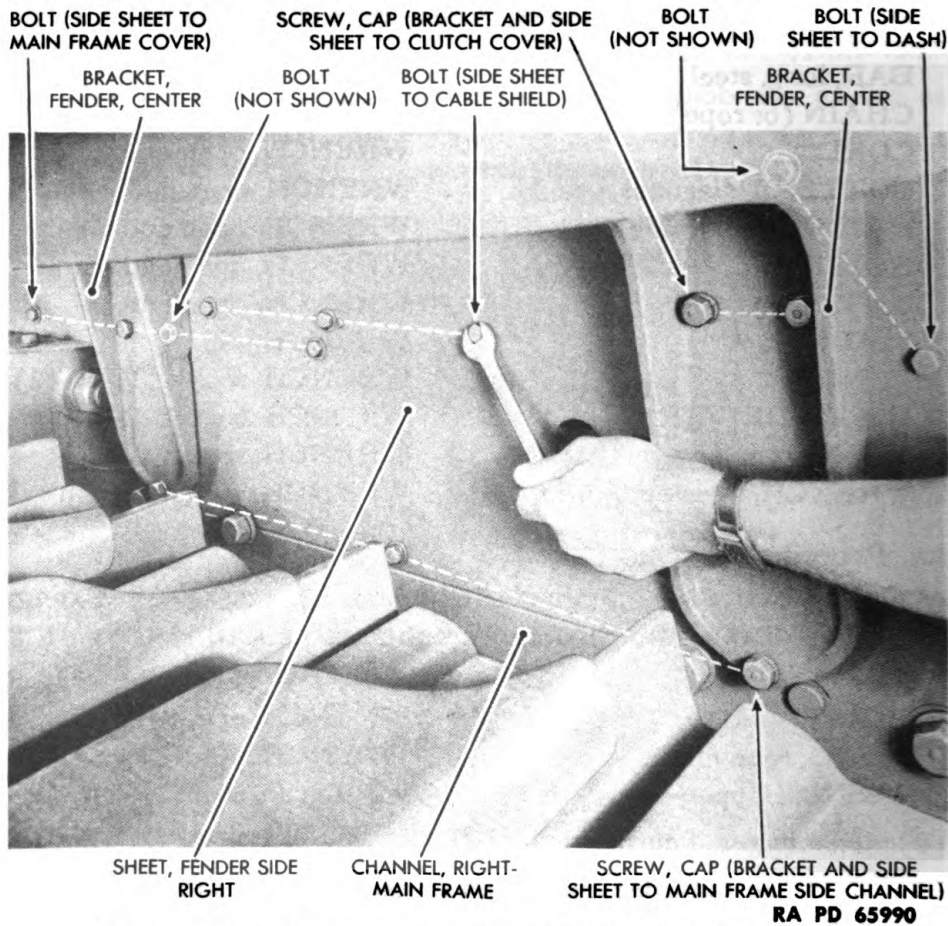

**Figure 81 – Disconnecting Right Fender Side Sheet from
Battery Cable Shield**

STEERING CLUTCHES AND BRAKES

(f) Disconnect right fender side sheet from battery cable shield by removing 3 bolts, lock washers, and nuts (fig. 81). Use two $\frac{9}{16}$ -inch open-end wrenches.

(g) Disconnect the right fender side sheet from main frame cover by removing 4 bolts, lock washers, and nuts (fig. 81). Two of these bolts are located in center fender bracket. Use two $\frac{9}{16}$ -inch open-end wrenches.

(h) Use two $\frac{9}{16}$ -inch open-end wrenches to disconnect right fender side sheet from dash and cowl assembly by removing 2 bolts, lock washers, and nuts (fig. 81). One of these bolts is located in top of side of front fender bracket.

(i) Disconnect right fender side sheet and front fender bracket from engine clutch cover by removing 2 cap screws and lock washers (fig. 81). Use a $\frac{3}{4}$ -inch socket wrench.

(j) Disconnect right fender side sheet from main frame right channel by removing 3 cap screws and lock washers (fig. 81). One cap screw is located in bottom of front fender bracket, another in bottom of center fender bracket. Both require a $\frac{3}{4}$ -inch socket wrench. The third cap screw also has a flat washer. Remove it with a $\frac{9}{16}$ -inch open-end wrench.

(k) Disconnect 2 dummy couplings from hose clippings; then remove hose couplings and pipes (fig. 82). Turn pipes with a pipe wrench.

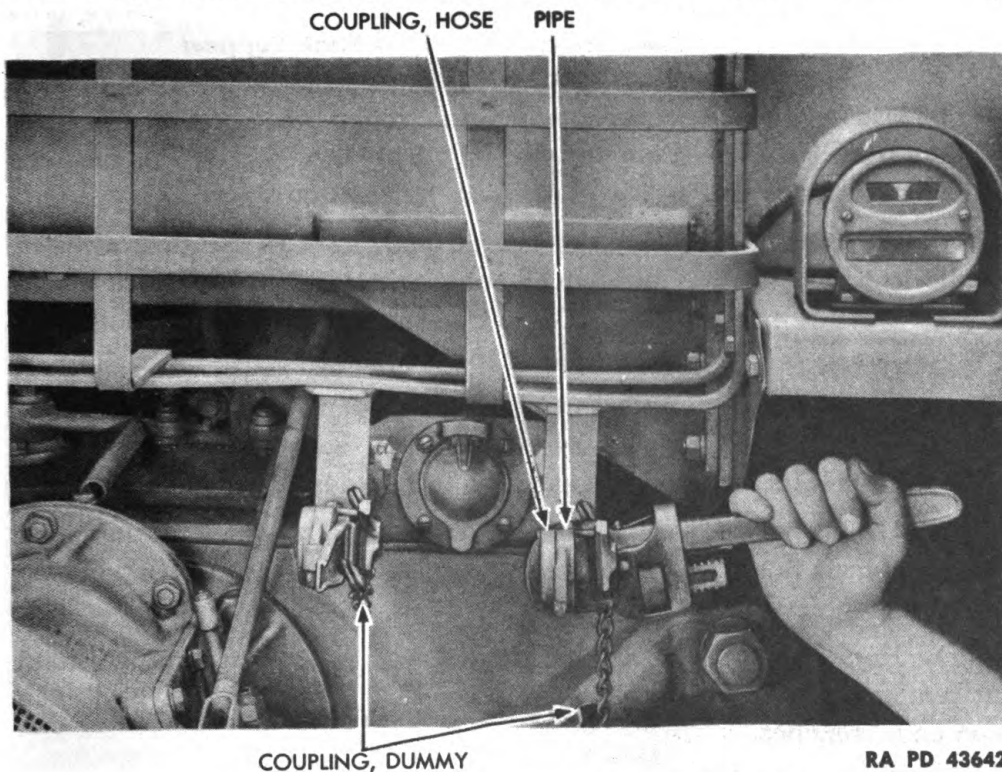
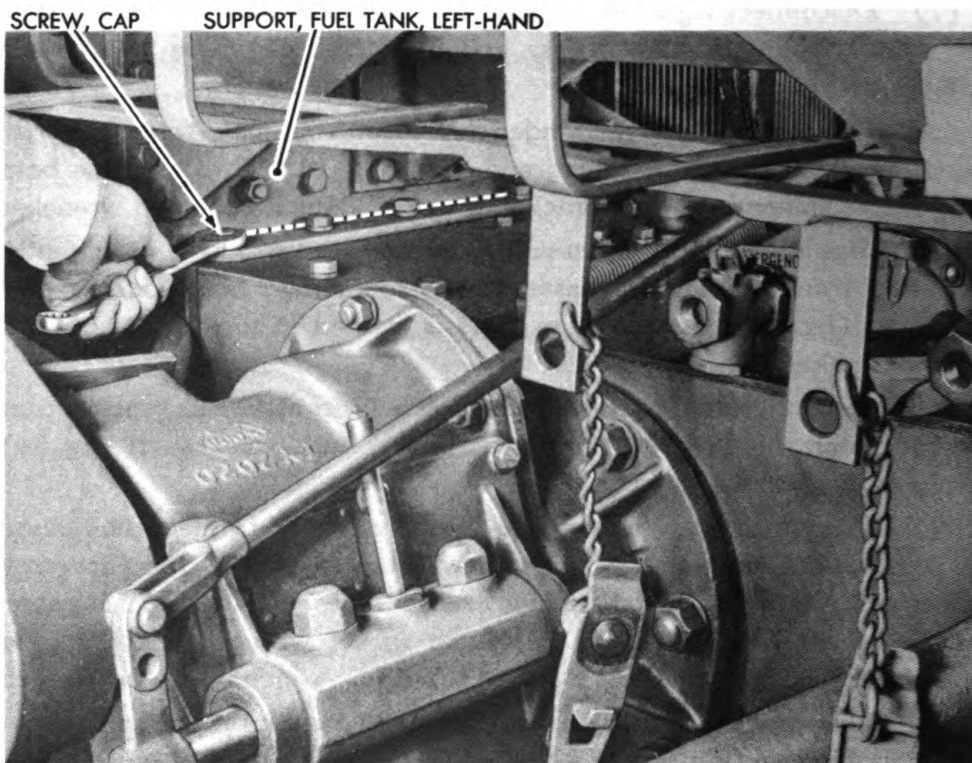

Figure 82 — Air Brake Hose Coupling and Pipe Removal

**ORDNANCE MAINTENANCE — HEAVY TRACTOR M1 (IHC TD-18) —
POWER TRAIN, TRACK FRAME ASSEMBLY, AND SEATS**



RA PD 14493

Figure 83 — Disconnecting Left Fuel Tank Support

(l) Use a $\frac{3}{4}$ -inch open-end wrench to remove 4 cap screws and lock washers from right fuel tank support (fig. 83). In a similar manner, remove 4 cap screws and lock washers from left fuel tank support.

(m) Remove winch drive shaft guard (par. 25 b (7)); then remove 2 bolts, lock washers, and nuts, which hold winch layshaft bearing housing in position. Use two $\frac{3}{4}$ -inch open-end wrenches. Remove housing and spacer; then lower layshaft and drive shaft.

(n) Remove 2 bolts, nuts, and lock washers which hold the left fender side sheet to the dash and cowl assembly. Use 2 open-end wrenches. One of these bolts is located in top of side of left front fender bracket (fig. 84).

(o) Use a $\frac{3}{4}$ -inch socket wrench to remove 2 cap screws and lock washers which hold left fender side sheet and front fender bracket to engine clutch cover (fig. 84).

(p) Remove 3 bolts, lock washers, flat washers, and nuts which hold left fender side sheet to air line cable shield (fig. 84). Use two $\frac{9}{16}$ -inch open-end wrenches.

(q) Disconnect left fender side sheet from main frame cover as in (g) above (fig. 81).

STEERING CLUTCHES AND BRAKES

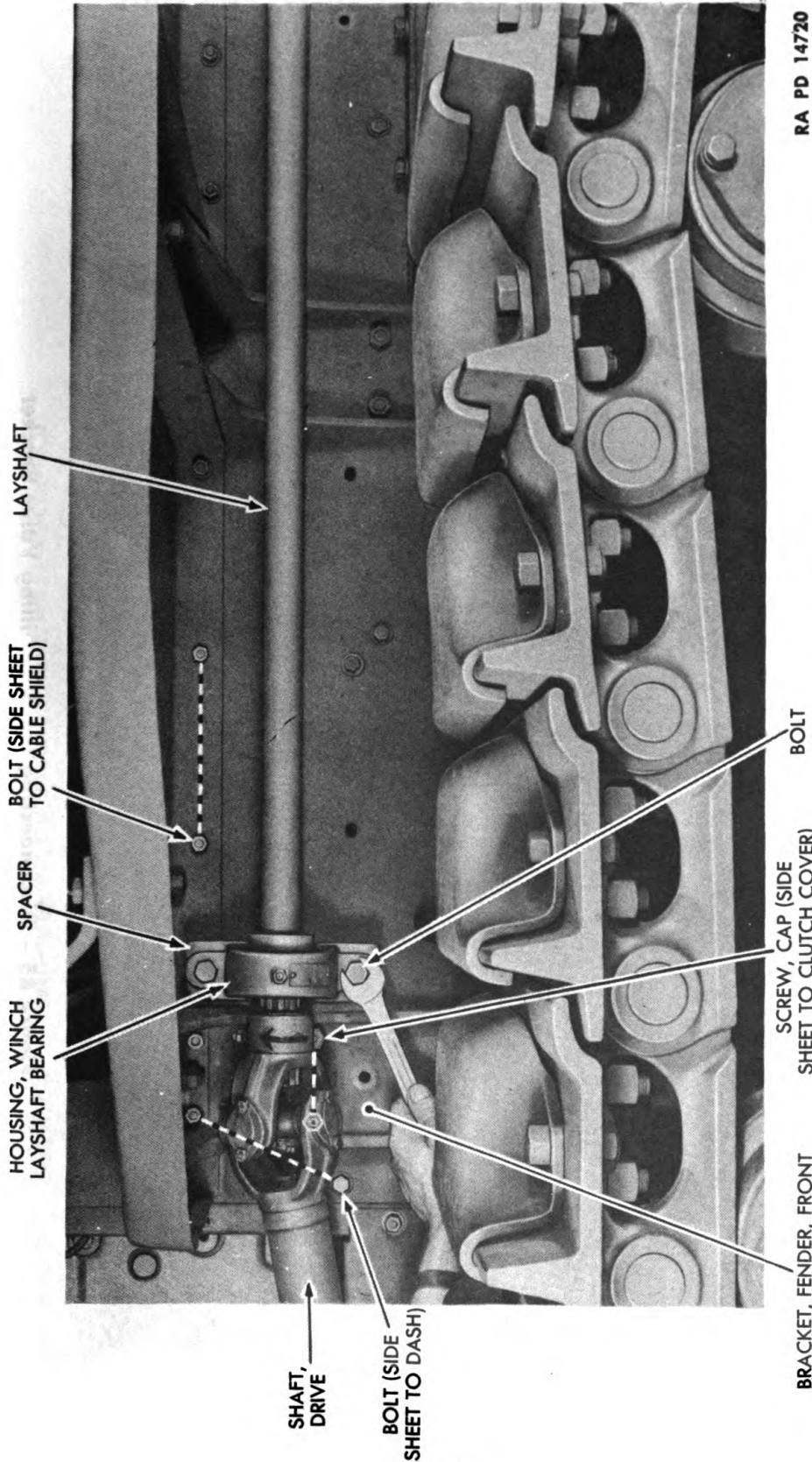
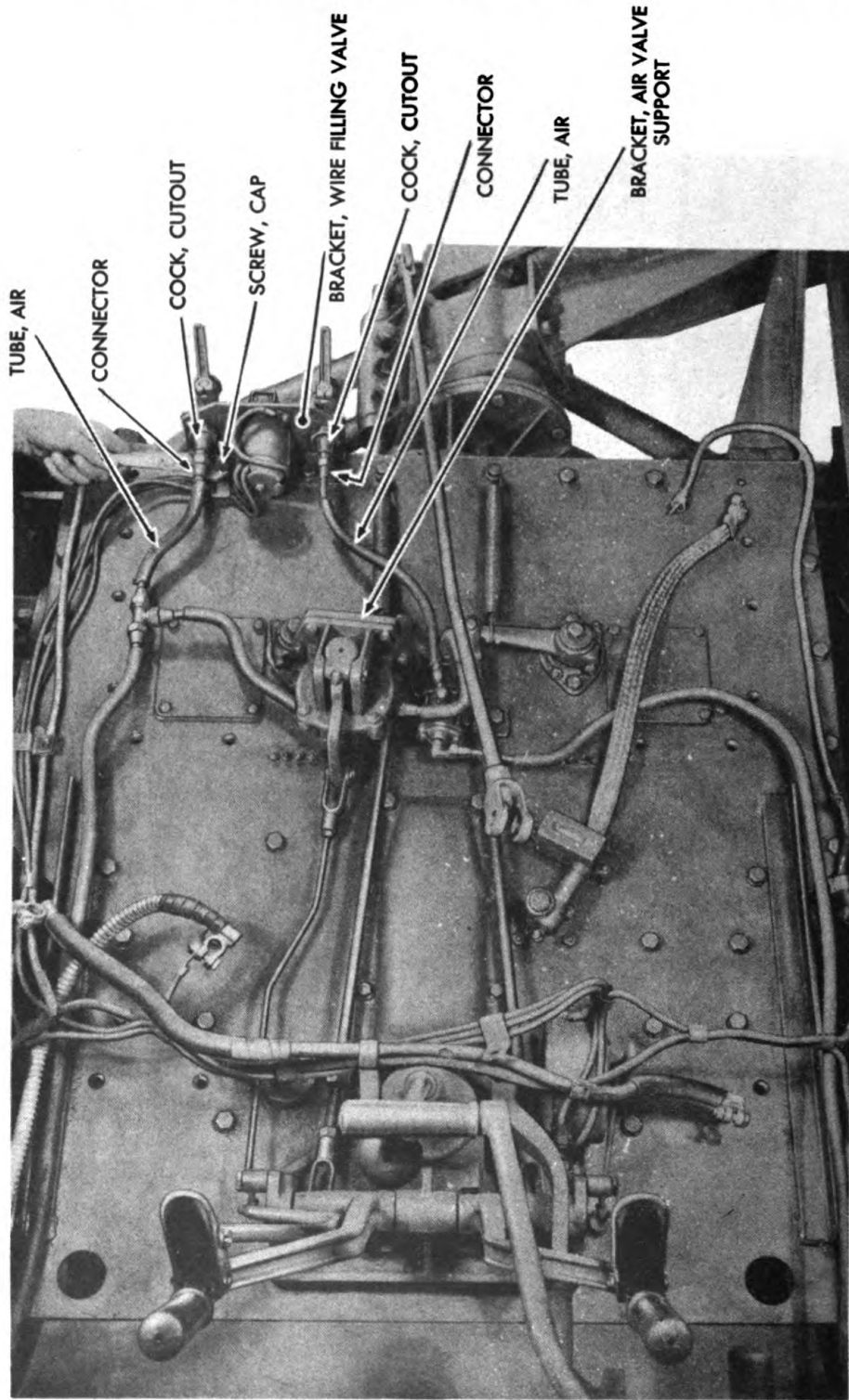

Figure 84 — Winch Layshaft Bearing Housing Removal

ORDNANCE MAINTENANCE – HEAVY TRACTOR MI (IHC TD-18) –
POWER TRAIN, TRACK FRAME ASSEMBLY, AND SEATS



RA PD 14661

Figure 85 – Disconnecting the Wire Filling Valve Bracket

STEERING CLUTCHES AND BRAKES

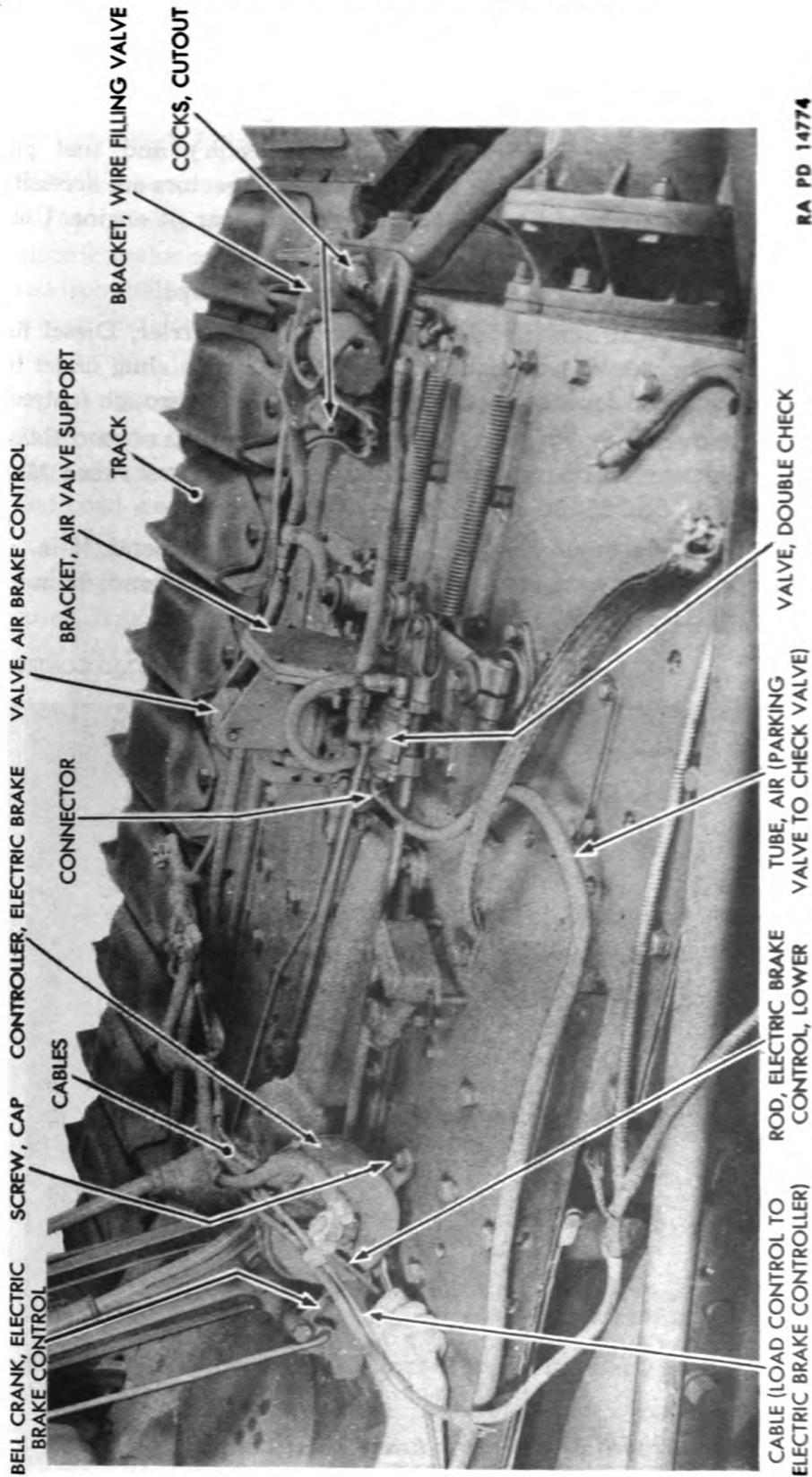

Figure 86 — Electric Brake Controller Disconnection

**ORDNANCE MAINTENANCE — HEAVY TRACTOR MI (IHC TD-18) —
POWER TRAIN, TRACK FRAME ASSEMBLY, AND SEATS**

(r) Disconnect left fender side sheet from main frame left channel as in (j) above (fig. 81).

(s) Disconnect the fuel return pipe (extension) and fuel pipe (extension) from fuel return pipe and fuel pipe. Connectors are accessible on engine side of dash and cowl assembly, at left rear of engine. Use a 5/8-inch open-end wrench.

(t) Remove cables from blackout tail and stop lamps.

(u) Lift out seat, fenders, grouser boxes, pack carrier, Diesel fuel tank, and fender side sheets, using a hoist. Place a rope sling under the Diesel fuel tank and fender support cross member and through footrests.

(2) REMOVE WIRE FILLING VALVE BRACKET AND ELECTRIC BRAKE COUPLING SOCKET ASSEMBLY WITH CONNECTING CABLES FROM MAIN FRAME COVER (figs. 85, 86, and 87).

CUTTERS, diagonal
WRENCH, open-end, 7/8-in.
WRENCH, open-end, 9/16-in.

WRENCH, open-end, 5/8-in.
WRENCH, open-end, 3/4-in.

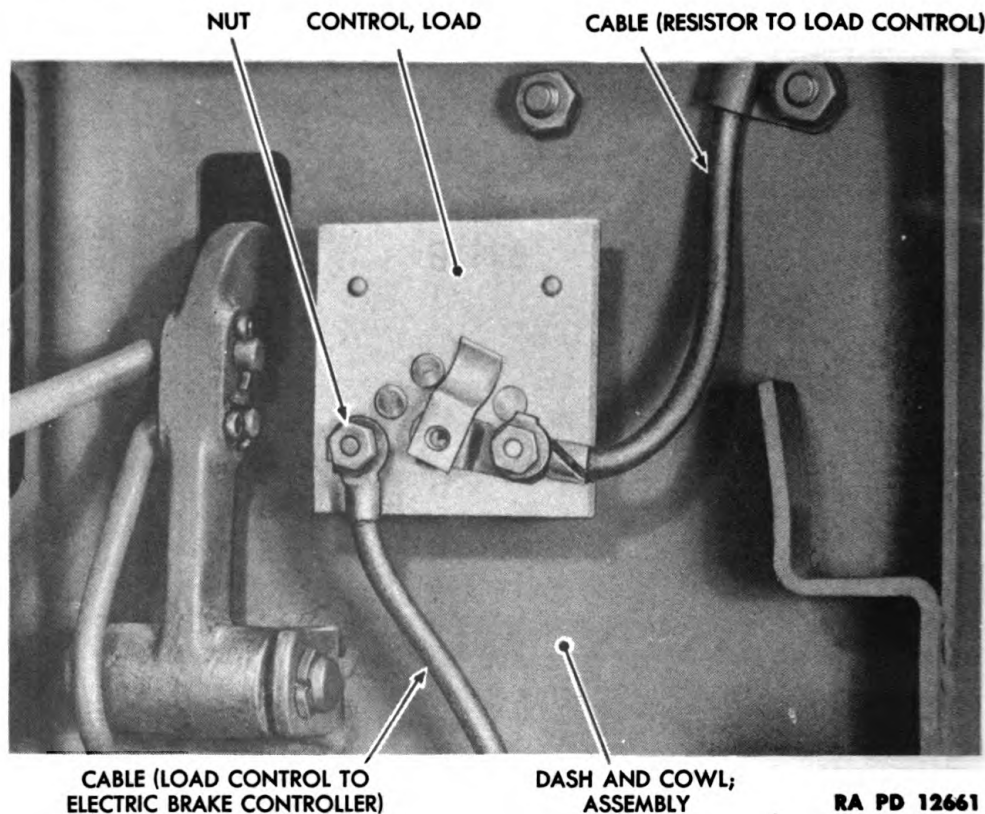

Figure 87 — Electric Brake Load Control

STEERING CLUTCHES AND BRAKES

(a) Disconnect wire filling valve bracket from main frame cover (fig. 86). Remove 2 cap screws and lock washers which hold bracket to main frame, using a 3/4-inch open-end wrench. Then remove 2 connectors which hold air tubes to cutout cocks, using a 5/8-inch open-end wrench.

(b) Using diagonal cutters, remove cotter pin which holds lower electric brake control rod to electric brake control bell crank and remove rod from bell crank. Then, using a 9/16-inch open-end wrench remove 2 cap screws and lock washers which hold electric brake controller to main frame cover (fig. 86).

(c) Using a 7/8-inch open-end wrench, remove nut which holds cable (load control to electric brake controller) to electric brake load control (fig. 87). Remove cable from load control and pull cable through dash and cowl assembly (fig. 86).

(d) Electric brake controller and wire filling valve bracket with cutout cocks and connecting cables can then be lifted from main frame cover. It is not necessary to disconnect cables. Lift connected parts and

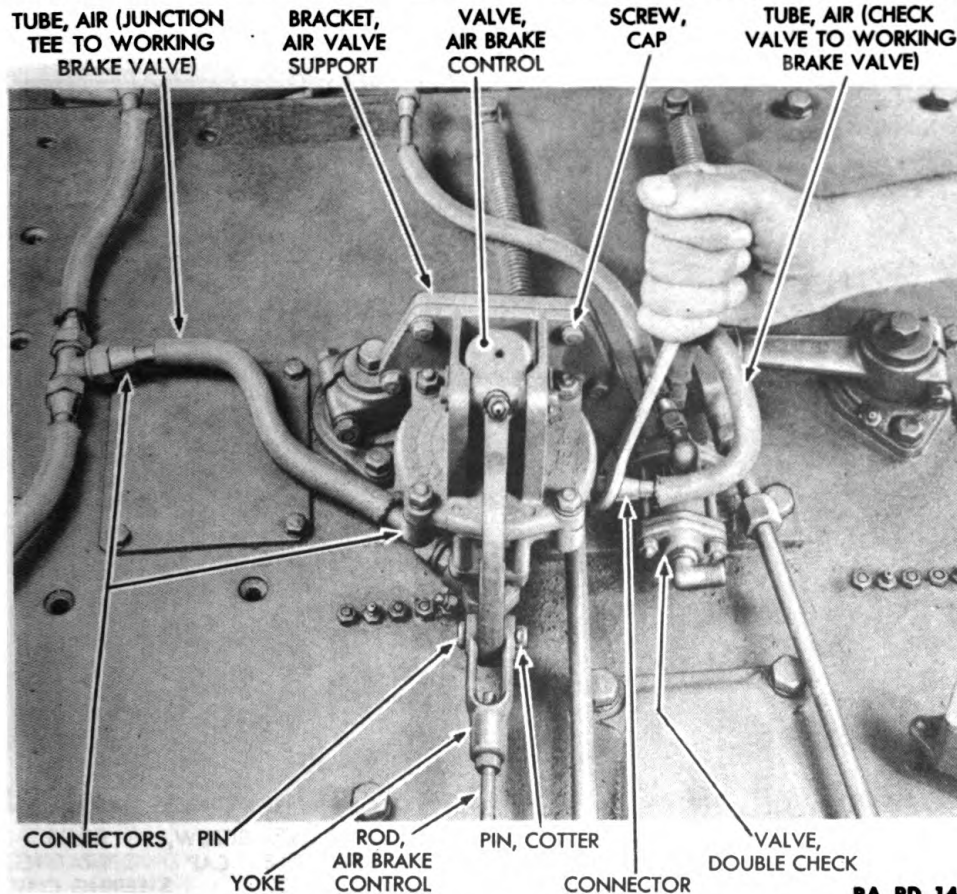

RA PD 14684

Figure 88 — Air Brake Control Valve Removal

STEERING CLUTCHES AND BRAKES

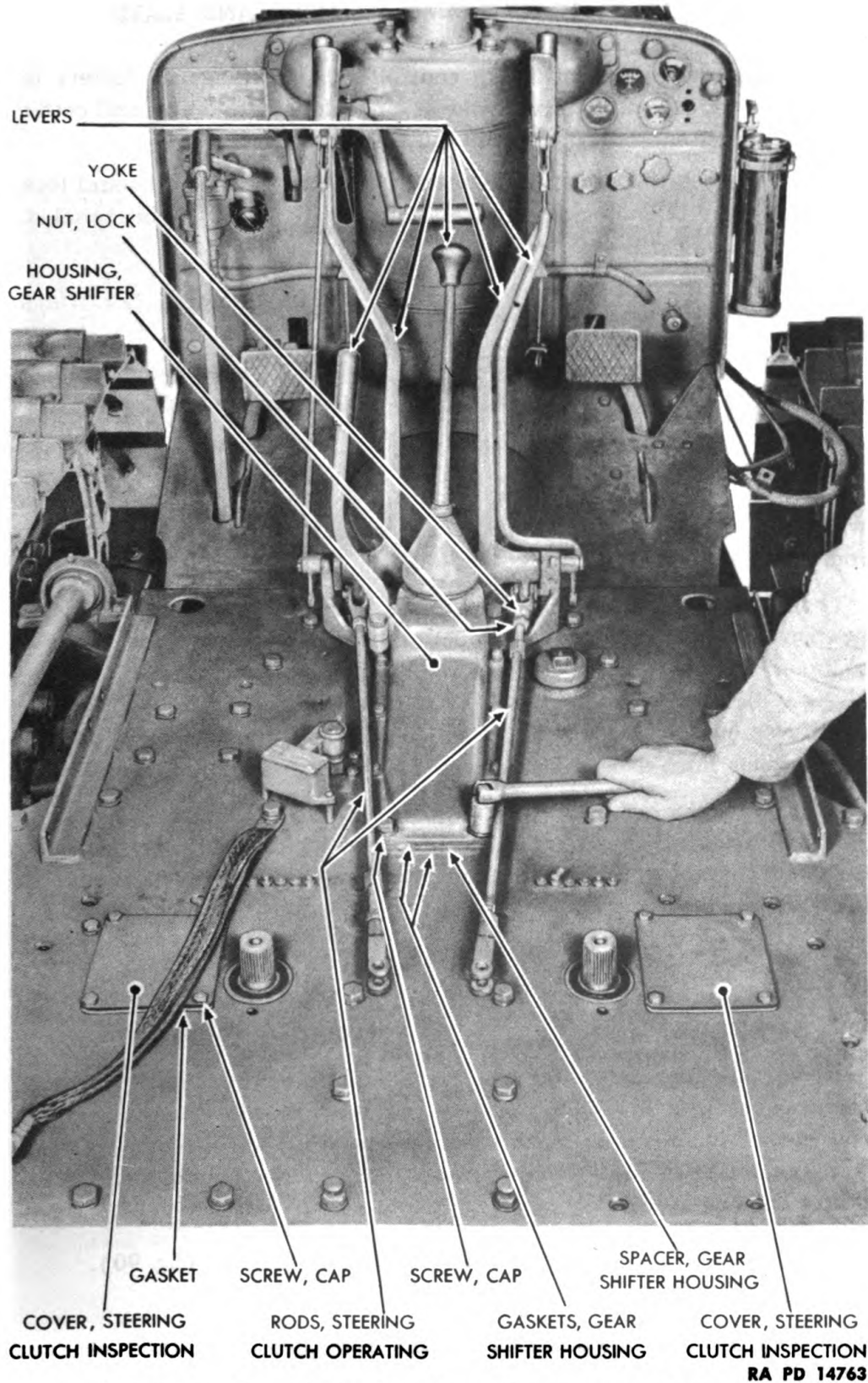

Figure 90 — Gear Shifter Housing with Levers Attached Removal

**ORDNANCE MAINTENANCE – HEAVY TRACTOR MI (IHC TD-18) –
POWER TRAIN, TRACK FRAME ASSEMBLY, AND SEATS**

(c) Remove lower air brake control rod. Use diagonal cutters to remove cotter pin and pin from yoke at air brake control valve and cotter pin from other end of rod; then lift out the rod.

(d) Use a 1/2-inch open-end wrench to remove 4 cap screws and lock washers which hold air brake control valve to air valve support bracket. Remove air brake control valve.

(5) REMOVE STEERING CLUTCH RELEASE LEVERS AND RETAINERS (fig. 89).

CUTTERS, diagonal

WRENCH, open-end, 5/8-in.

WRENCH, open-end, 9/16-in.

WRENCH, open-end, 3/4-in.

(a) Remove the 2 return springs.

(b) Using diagonal cutters, remove the cotter pin from each pin which holds each release lever in the yoke of steering clutch operating rod. Remove the pins.

(c) Using a 3/4-inch open-end wrench, remove 2 cap screws and lock washers which hold air valve support bracket and double check valve to main frame cover; then remove bracket and double check valve. Using a 9/16-inch open-end wrench, loosen bolt which holds levers to release forks. Remove the 2 levers and 2 felt retainers. Remove cap screw and lock washer from each release lever. Remove 2 release lever retaining washers.

(d) Remove 2 cap screws and lock washers which secure each retainer to main frame cover. Use a 5/8-inch open-end wrench to remove 2 retainers, felts, and spacers.

(6) REMOVE GEAR SHIFTER HOUSING WITH LEVERS ATTACHED (fig. 90).

WRENCH, open-end, 9/16-in.

WRENCH, open-end, 3/4-in.

Remove 10 cap screws and lock washers which secure housing to main frame cover. Use a 9/16-inch open-end wrench to remove 6 cap screws and 3/4-inch open-end wrench to remove 4 cap screws. Remove housing and levers with rail and forks attached. Also remove 2 gaskets and gear shifter housing spacer.

(7) REMOVE STEERING CLUTCH INSPECTION COVERS (fig. 90).

WRENCH, open-end, 1/2-in.

Remove 4 cap screws and lock washers from each cover; then remove the 2 covers and gaskets.

STEERING CLUTCHES AND BRAKES

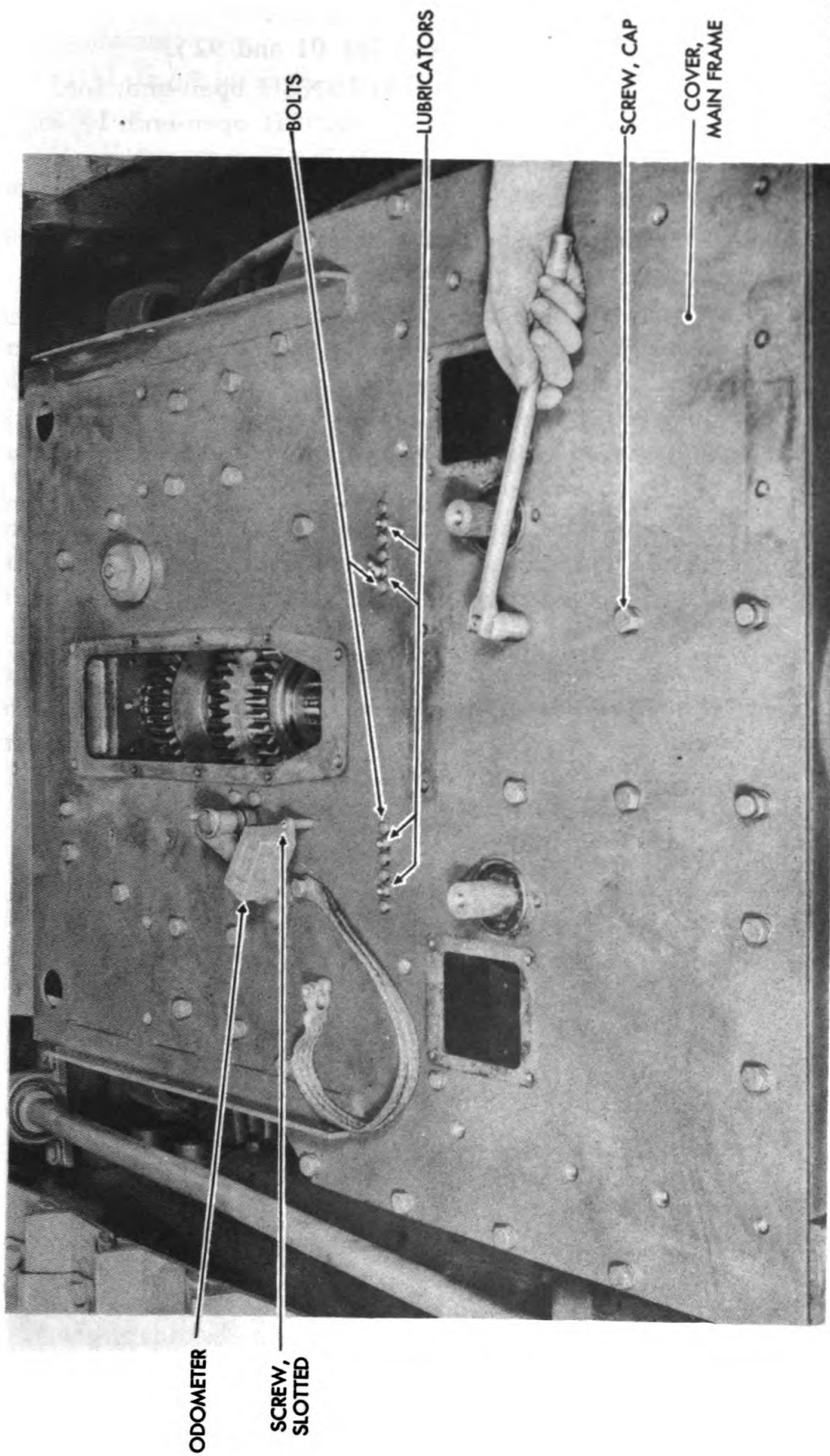

RA PD 14495

Figure 91 — Main Frame Cover Removal

**ORDNANCE MAINTENANCE — HEAVY TRACTOR MI (IHC TD-18) —
POWER TRAIN, TRACK FRAME ASSEMBLY, AND SEATS**

(8) REMOVE MAIN FRAME COVER (figs. 91 and 92).

NUT, 5/8-in.

SCREWDRIVER

WRENCH, open-end, 7/16-in.

WRENCH, open-end, 9/16-in.

WRENCH, open-end, 1-in.

WRENCH, open-end, 1 1/8-in.

WRENCH, socket, 3/4-in.

(a) Remove 32 cap screws and lock washers which secure main frame cover to main frame.

(b) Remove odometer. Use a screwdriver to remove 2 slotted screws and 2 spacers. Remove upper cover assembly and odometer head from main frame; then hold the odometer drive from underneath cover, while using a 9/16-inch open-end wrench to remove 4 cap screws and lock washers which hold odometer drive to main frame cover. Remove odometer drive.

(c) Remove 8 bolts, nuts, and lock washers which hold 4 lubricators in position in cover. Hold boltheads from underneath cover so bolts will not drop out when nuts are removed. Push lubricators through main frame cover.

(d) Remove frame cover dowel pins, if necessary. Place a 5/8-inch nut on pin and screw nut down as far as possible; then remove nut and place washers or a large nut over pin. Again attach a 5/8-inch nut and tighten

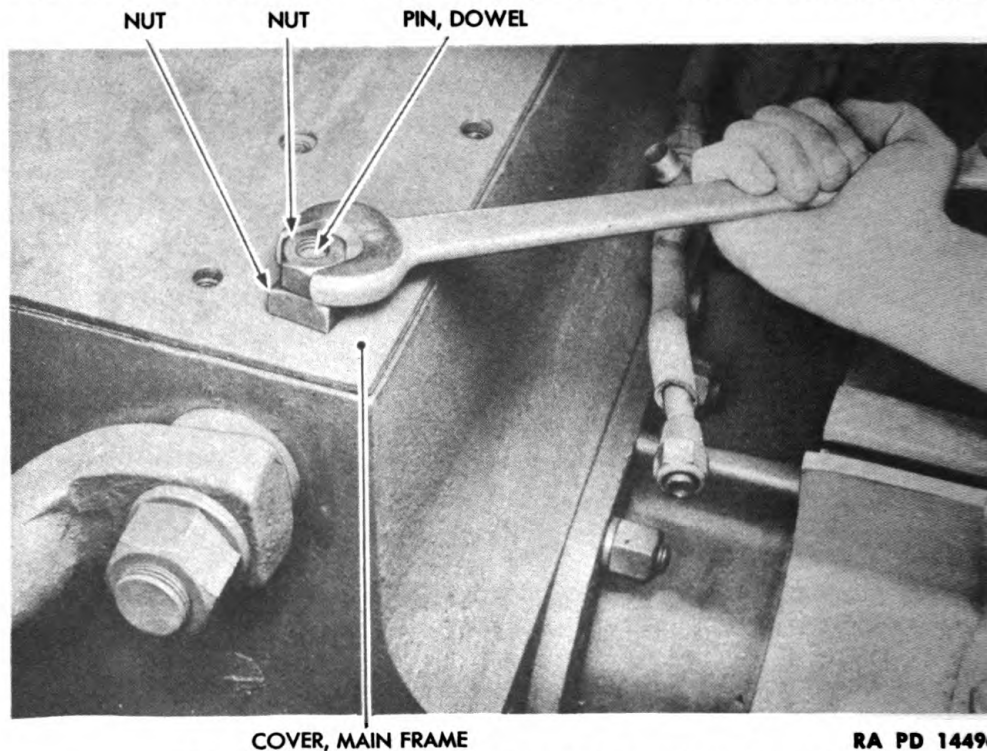

Figure 92 — Main Frame Cover Dowel Pin Removal

RA PD 14496

STEERING CLUTCHES AND BRAKES

until pin is removed. Remove second frame cover dowel pin in the same manner.

(e) Lift off main frame cover and remove main frame cover gasket (two men).

(f) Keep transmission and bevel gear compartments covered to keep out dirt.

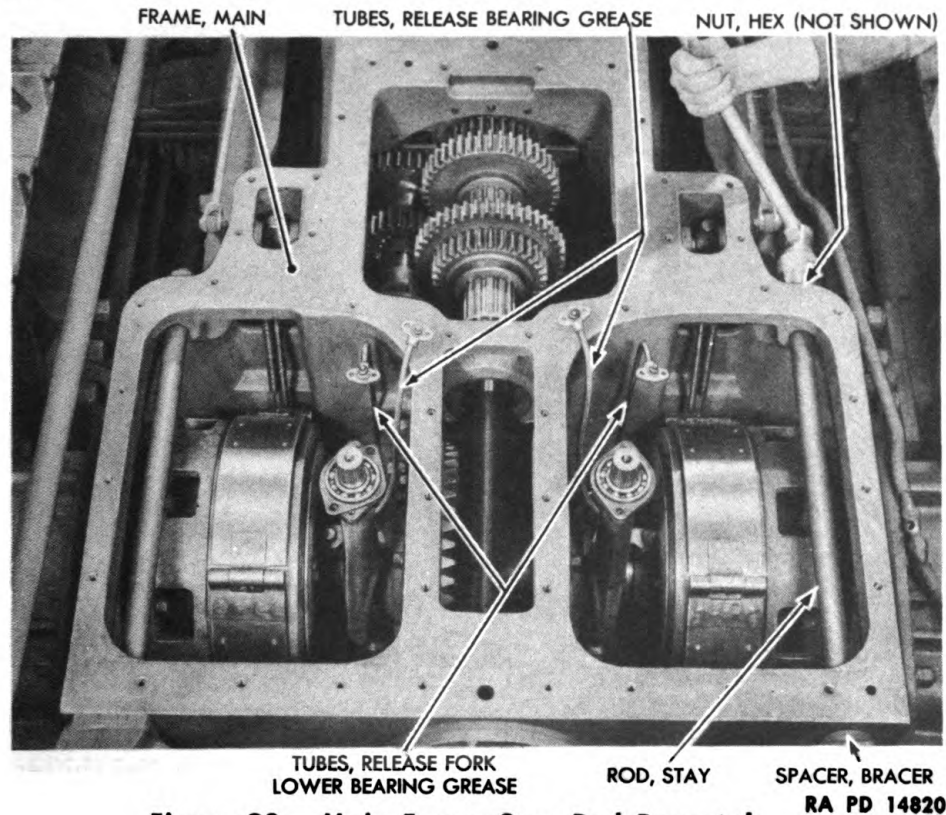

Figure 93 – Main Frame Stay Rod Removal

(9) REMOVE STAY RODS FROM MAIN FRAME (fig. 93).

HAMMER, rawhide

WRENCH, socket, 1 7/8-in.

Remove hexagonal nut and lock washer from forward end of stay rod. Tap rod loose and remove from rear of main frame. Also remove bracer spacer and second lock washer. **NOTE: Both stay rods can be removed from either end after power take-off is removed.**

(10) REMOVE GREASE TUBES (fig. 93).

WRENCH, open-end, 1/2-in.

WRENCH, open-end, 5/8-in.

Remove connectors from bearing cage cap and release collar. Lift out grease tubes.

(11) REMOVE RELEASE FORK (fig. 94).

CUTTERS, diagonal

**ORDNANCE MAINTENANCE — HEAVY TRACTOR MI (IHC TD-18) —
POWER TRAIN, TRACK FRAME ASSEMBLY, AND SEATS**

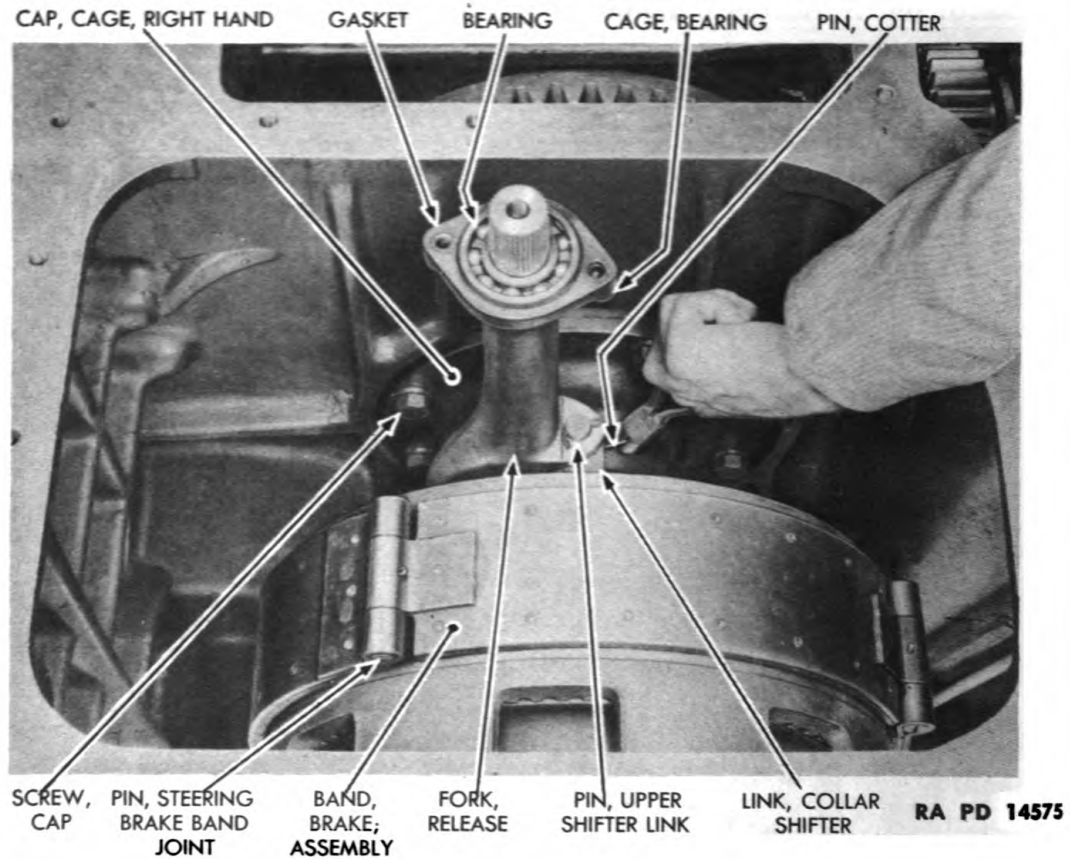

Figure 94 — Release Fork Removal

(a) Remove upper shifter link pin. Remove lower cotter pin from upper shifter link pin and lift out pin; then remove the collar shifter link. Remove upper cotter pin from lower shifter link pin and lift out pin. Remove the collar shifter link.

(b) Lift out release fork with bearing cage, oil seal, bearing, and gasket attached.

(12) REMOVE TOP STEERING BRAKE BAND JOINT PIN FROM BRAKE BAND ASSEMBLY (fig. 94).

PLIERS

PUNCH

Remove cotter pin and push out steering brake band joint pin. Fold back rear and center bands.

(13) DISCONNECT RIGHT DRIVE BEVEL GEAR BEARING CAGE CAP FROM DRIVE BEVEL GEAR BEARING CAGE AND MAIN FRAME (fig. 94).

SCREWDRIVER

WRENCH, socket, $\frac{1}{8}$ -in.

WRENCH, socket, $\frac{7}{8}$ -in.

Use a $\frac{7}{8}$ -inch socket wrench to remove 6 cap screws and lock washers and 2 nuts and lock washers which hold cage cap to bearing cage and main

STEERING CLUTCHES AND BRAKES

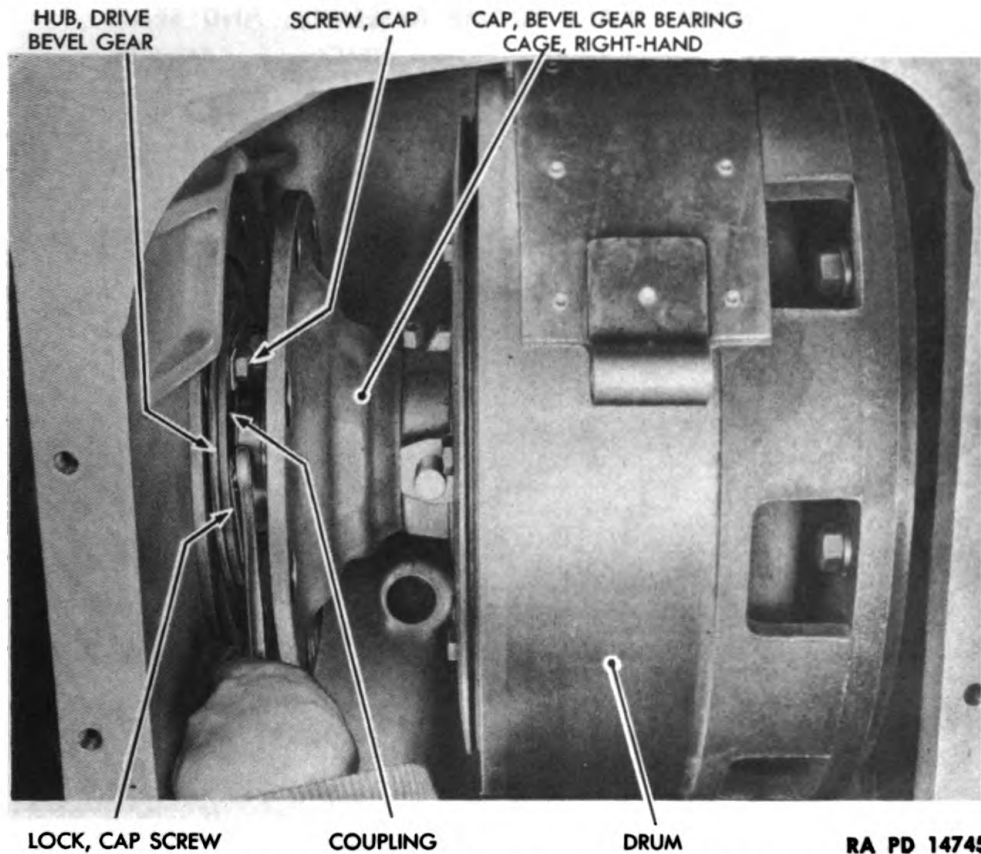

Figure 95 – Disconnecting Clutch Coupling from Bevel Drive Gear Hub

frame. Use a $\frac{1}{8}$ -inch socket wrench to remove nuts from studs. Pry cage cap loose.

(14) DISCONNECT STEERING CLUTCH SHAFT COUPLING FROM DRIVE BEVEL GEAR HUB (fig. 95).

SCREWDRIVER, long

WRENCH, open-end, $\frac{3}{4}$ -in.

Pry back cap screw locks. Then remove 6 cap screws and 3 cap screw locks. To provide access to all cap screws, it will be necessary to move the clutch drum, as outlined in (15) below. Pry the clutch coupling free from drive bevel gear hub.

(15) DISCONNECT DRUM FROM SPROCKET DRIVE PINION SHAFT (fig. 96).

BAR, long, steel
CORD

WRENCH, open-end, $\frac{7}{8}$ -in.

Tie forward end of brake band assembly so it will be out of the way. Remove 8 cap screws and lock washers which hold drum to pinion shaft, using a $\frac{7}{8}$ -inch open-end wrench. To gain access to all cap screws, after top cap screws are removed, place a long steel bar in one of the drum openings; then turn the drum until additional cap screws are

**ORDNANCE MAINTENANCE — HEAVY TRACTOR M1 (IHC TD-18) —
POWER TRAIN, TRACK FRAME ASSEMBLY, AND SEATS**

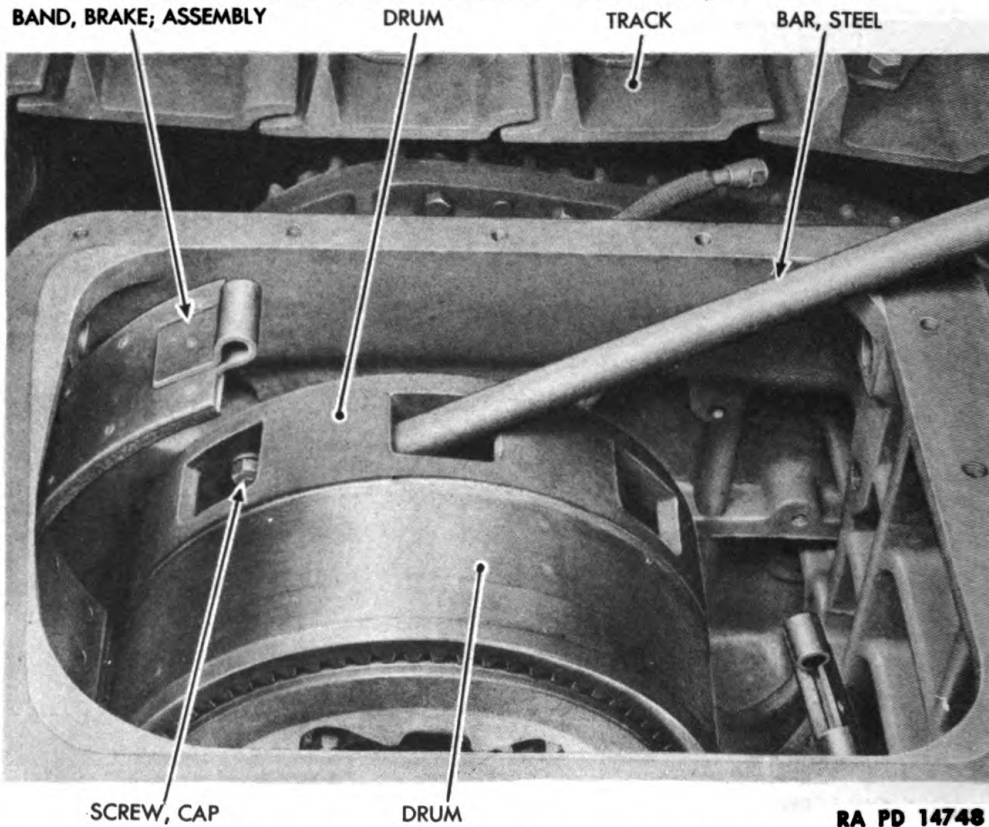

Figure 96 — Moving Drum for Access to Drum Cap Screws

accessible. **CAUTION:** The tractor will move slightly as the drum is rotated.

- (16) **LIFT OUT STEERING CLUTCH (fig. 97).**
CHAIN **ROPE**
HOIST

Place a chain or rope through openings on outer side of drum and under cage cap. Attach the hoist to chain or rope and lift out the clutch.

- (17) **REMOVE THE SECOND STEERING CLUTCH IN THE SAME MANNER.**

53. STEERING CLUTCH DISASSEMBLY.

a. Equipment.

BAR, steel
BOLT, 1/2-in. (3)
DRIFT, brass
HAMMER
HAMMER, rawhide
PLATE, steel
PRESS, arbor
PUNCH

VICE, copper
WRENCH, open-end, 7/8-in.
WRENCH, open-end, 9/8-in.
WRENCH, open-end, 3/4-in.
WRENCH, pipe
WRENCH, steering clutch pilot bearing retainer bolt, 50092D

STEERING CLUTCHES AND BRAKES

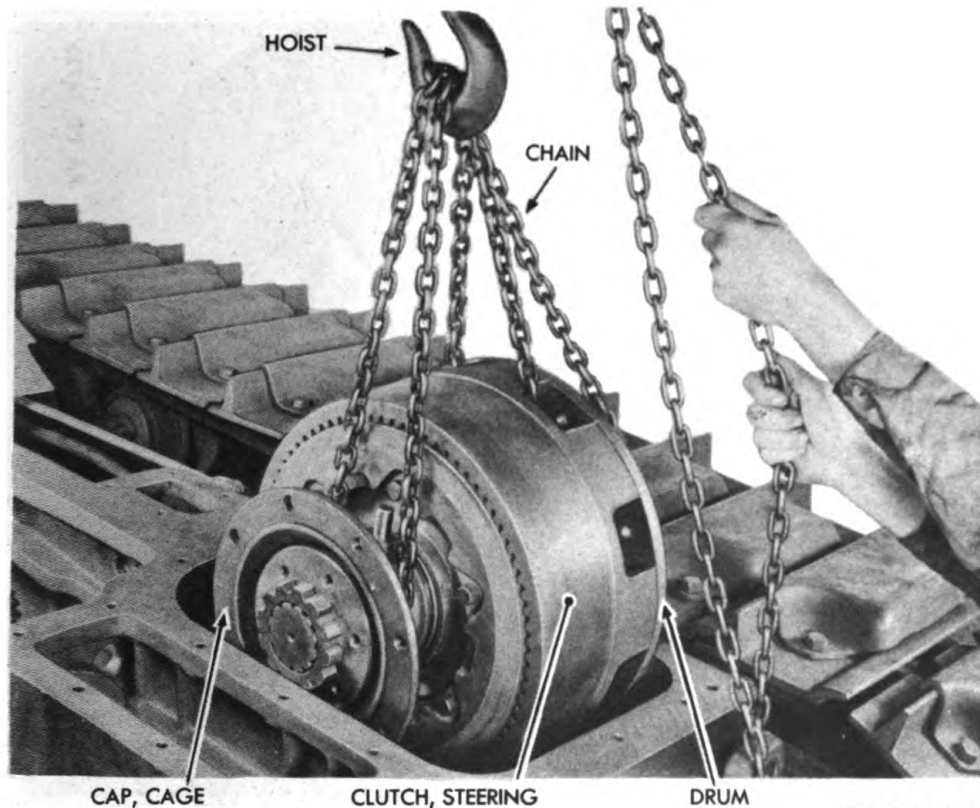

RA PD 14765

Figure 97 – Steering Clutch Removal

b. Procedure.

- (1) REMOVE GASKET FROM BEARING CAGE CAP.
- (2) LIFT OFF COUPLING (fig. 98).
- (3) REMOVE CAGE CAP, RELEASE COLLAR, BEARING, AND COLLAR KEY FROM SHAFT (fig. 98).

**HAMMER
PUNCH**

WRENCH, open-end, $\frac{9}{16}$ -in.

(a) Lift the parts from the shaft. If transmission grease leaks through coupling into clutch compartment in main frame, oil seal should be replaced. In such instances, use a hammer and punch to drive oil seal from cage cap. Otherwise do not remove oil seal.

(b) Use a $\frac{9}{16}$ -inch open-end wrench to remove 2 cap screws which hold release fork lower bearing cap to cage cap. Remove bearing cap.

- (4) COMPRESS STEERING CLUTCH SPRING (fig. 99).

BOLT, $\frac{1}{2}$ -in. (3)

WRENCH, open-end, $\frac{3}{4}$ -in.

Insert three $\frac{1}{2}$ -inch bolts into holes in pressure plate. Use a $\frac{3}{4}$ -inch

ORDNANCE MAINTENANCE — HEAVY TRACTOR MI (IHC TD-18) —
POWER TRAIN, TRACK FRAME ASSEMBLY, AND SEATS

RA PD 14723

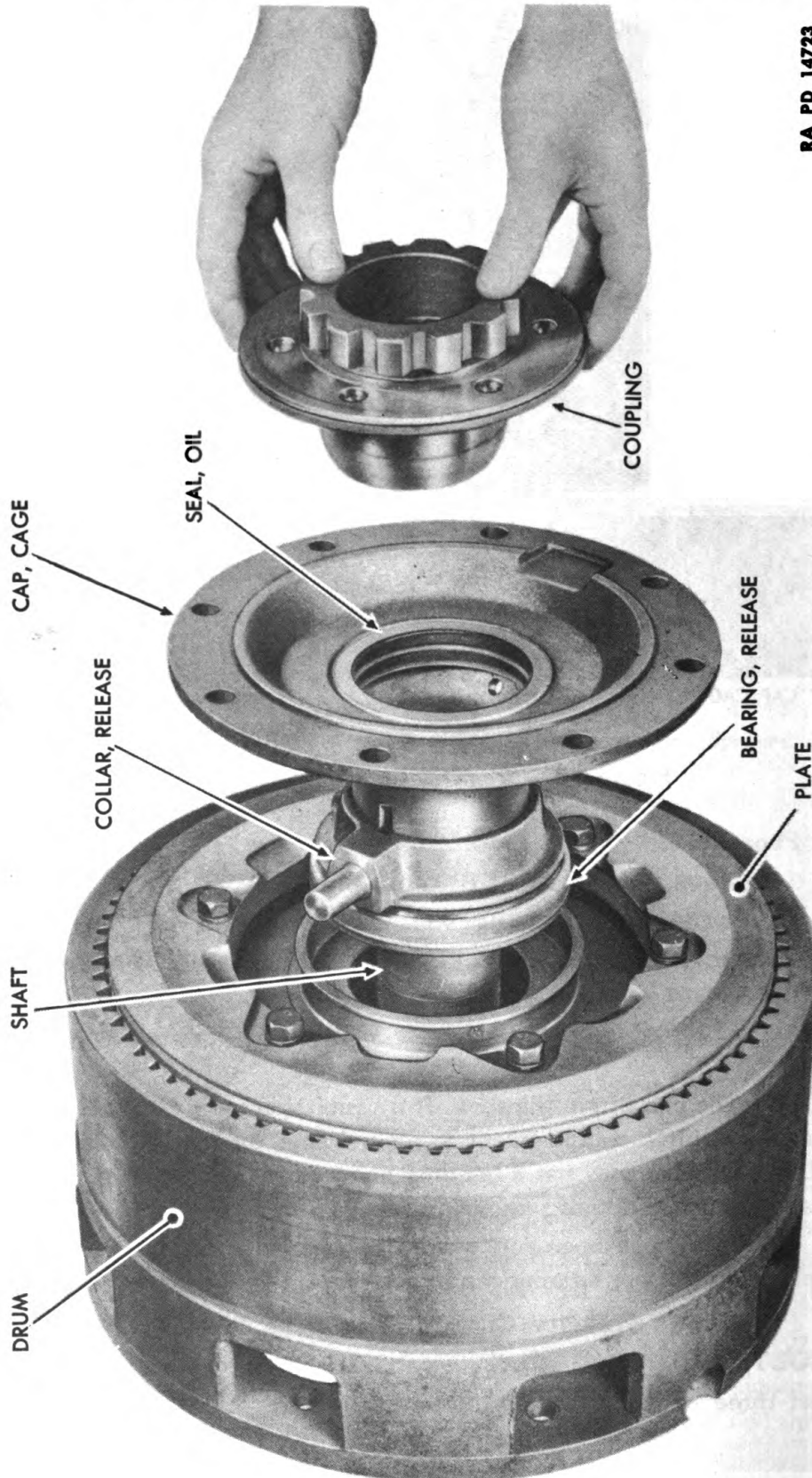
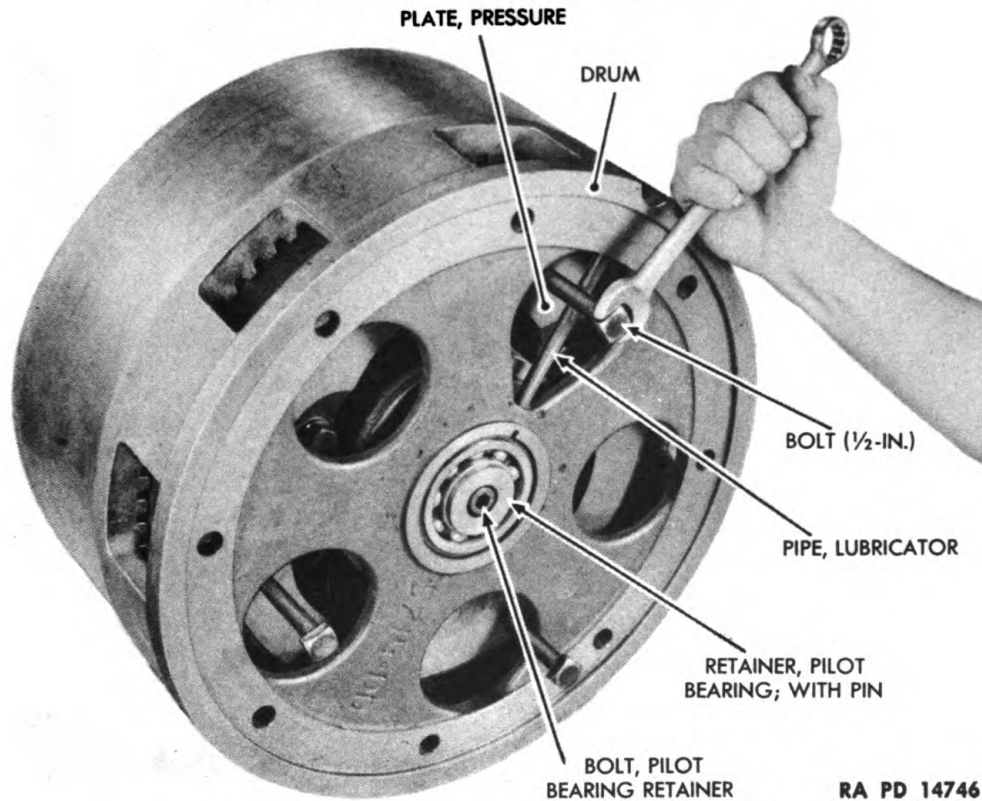

Figure 98 — Steering Clutch Coupling Removal

STEERING CLUTCHES AND BRAKES



RA PD 14746

Figure 99 – Compressing Steering Clutch

open-end wrench to screw the bolts into pressure plate against hub until spring is compressed.

(5) REMOVE PILOT BEARING RETAINER WITH PIN (fig. 99).

WRENCH, steering clutch pilot bearing retainer bolt, 50092D

Use steering clutch pilot bearing retainer bolt wrench 50092D to remove pilot bearing retainer bolt and lock washers; then remove pilot bearing retainer with pin.

(6) DRIVE OUT STEERING CLUTCH SHAFT (fig. 100).

DRIFT, brass **HAMMER**

Drive out shaft from drum, using a brass drift and a hammer.

(7) TAP OUT PILOT BEARING FROM DRUM (fig. 100).

DRIFT, brass **HAMMER**

Use a brass drift and a hammer to drive pilot bearing from drum.

(8) REMOVE LUBRICATOR PIPE AND LUBRICATOR (fig. 100).

WRENCH, open-end, $\frac{7}{16}$ -in. **WRENCH**, pipe

Remove lubricator, using a $\frac{7}{16}$ -inch open-end wrench. Use a pipe wrench to remove lubricator pipe.

ORDNANCE MAINTENANCE — HEAVY TRACTOR M1 (IHC TD-18) —
POWER TRAIN, TRACK FRAME ASSEMBLY, AND SEATS

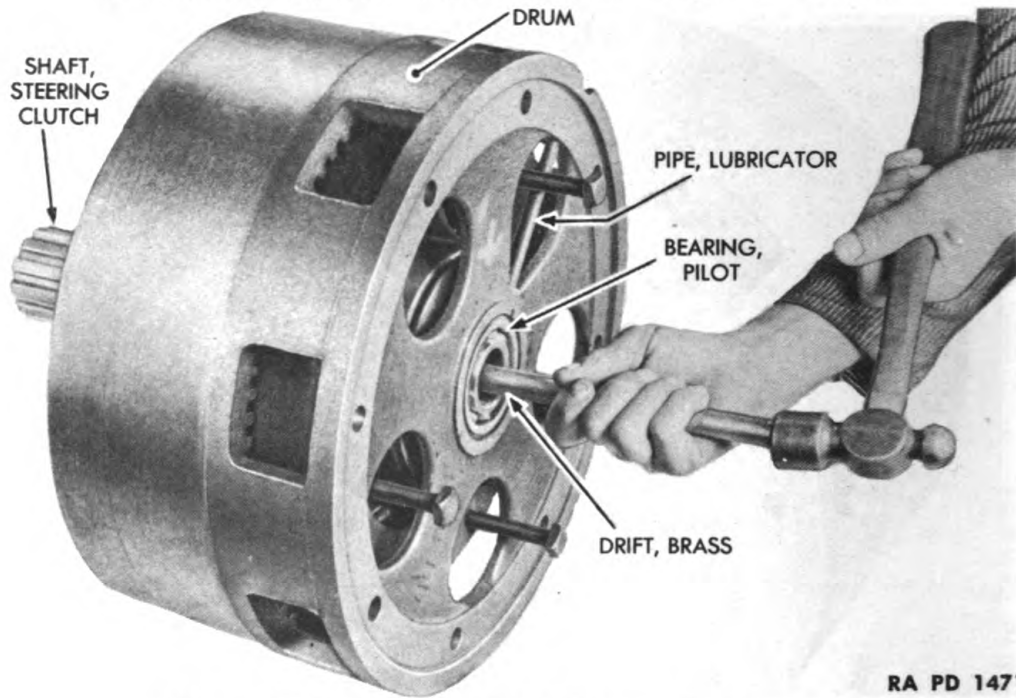

Figure 100 — Driving Out Steering Clutch Shaft

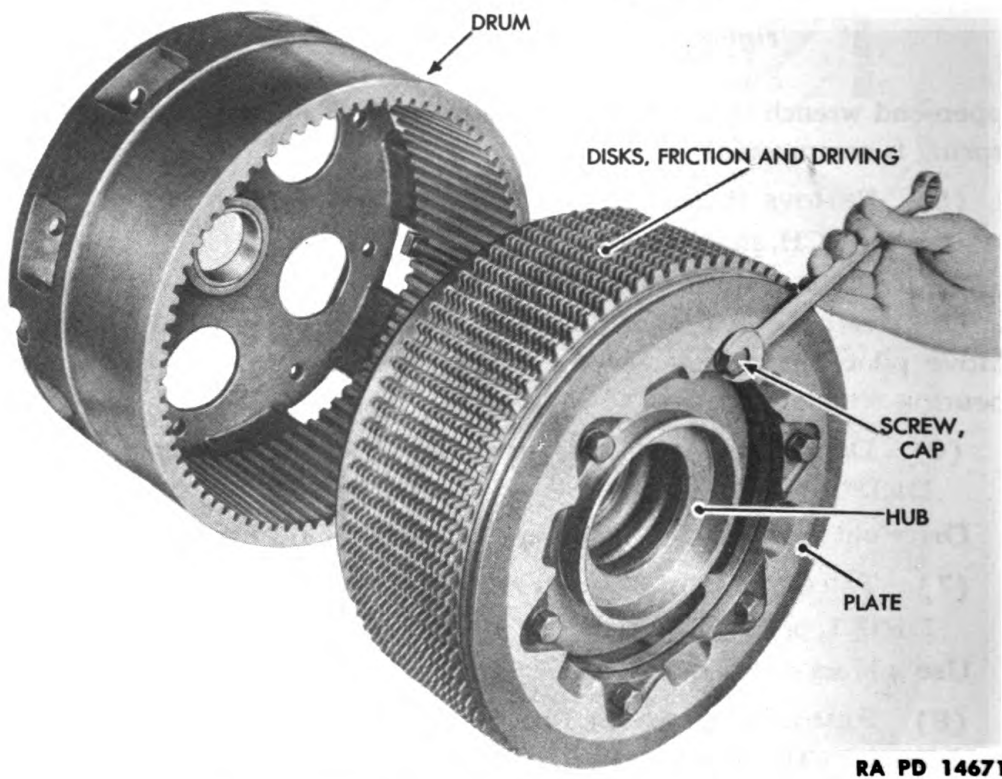

Figure 101 — Steering Clutch Plate Removal

STEERING CLUTCHES AND BRAKES

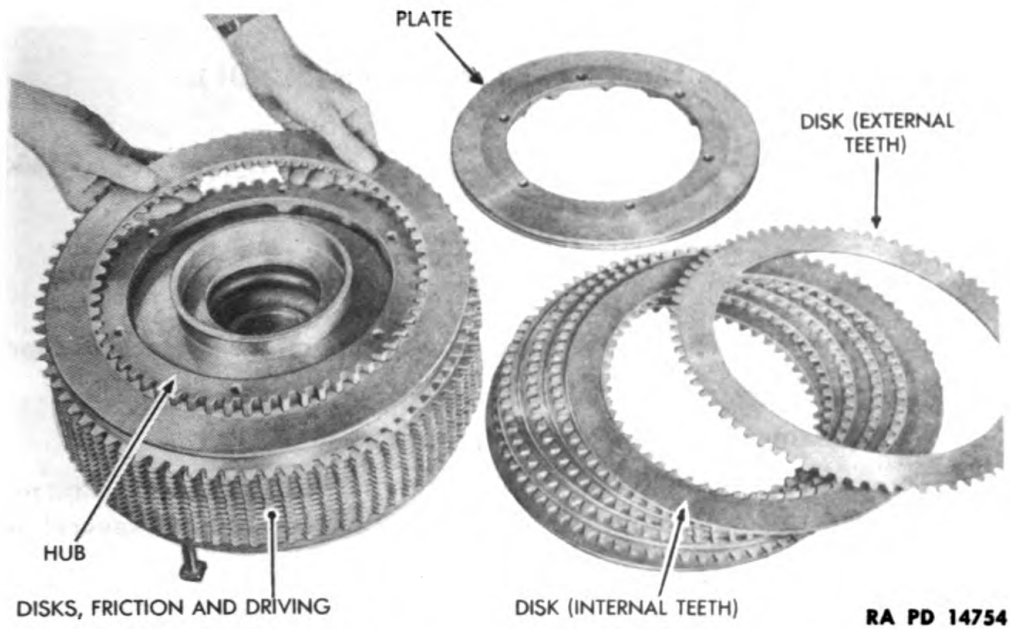

Figure 102 – Friction and Driving Disks Removal

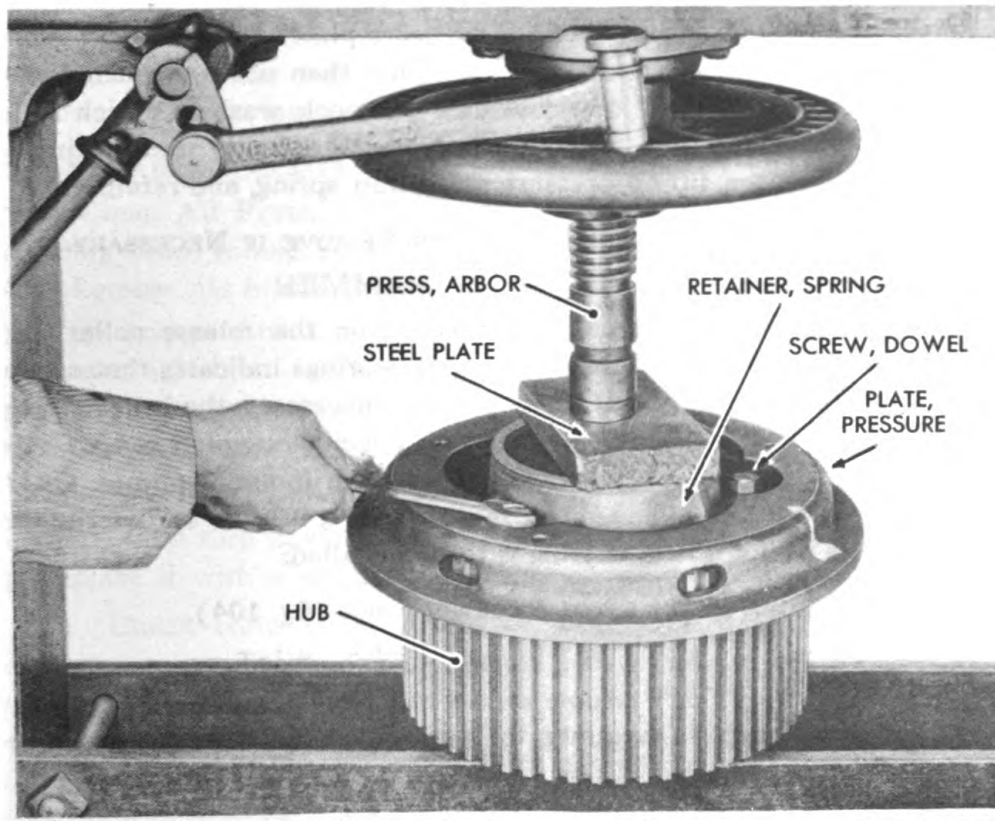

Figure 103 – Compressing Steering Clutch Spring and Removal of Retainer

**ORDNANCE MAINTENANCE — HEAVY TRACTOR MI (IHC TD-18) —
POWER TRAIN, TRACK FRAME ASSEMBLY, AND SEATS****(9) REMOVE FRICTION AND DRIVING DISKS (fig. 101).****HAMMER**

Lift drum from friction and driving disks. If necessary, tap or pry disks loose from drum with a hammer.

(10) REMOVE STEERING CLUTCH PLATE (figs. 101 and 102).**WRENCH, open-end, 3/4-in.**

Using a 3/4-inch open-end wrench, remove 6 cap screws and lock washers which hold steering clutch plate to hub. Remove plate.

(11) REMOVE FRICTION AND DRIVING DISKS (fig. 102).

Disks are assembled alternately with internal teeth and with external teeth. They may be removed from the hub one by one, or several at a time.

(12) COMPRESS STEERING CLUTCH SPRING (fig. 103).**BAR, steel****WRENCH, open-end, 3/4-in.****PRESS, arbor**

Place hub with spring retainer and pressure plate attached in an arbor press and press retainer and spring into hub; then use a 3/4-inch open-end wrench to remove 3 dowel screws and lock washers which hold pressure plate to retainer. Release arbor press gradually until spring is fully extended; then, lift off pressure plate, hub, spring, and retainer.

(13) INSPECT RELEASE BEARING AND REMOVE IF NECESSARY.**DRIFT, brass****HAMMER**

The release bearing should be inspected on the release collar and should not be removed unless looseness of bearings indicates that a new bearing should be installed. If replacement is necessary, the bearing may be driven off by placing release collar between jaws of a copper vise while the bearing is tapped off with a brass drift and hammer. **CAUTION:** Removal may damage bearing; therefore, it must be determined first whether or not a new bearing is to be installed.

(14) REMOVE PARTS FROM RELEASE FORK (fig. 104).**BAR, steel****PRESS, arbor****HAMMER, rawhide**

(a) Use a rawhide hammer to tap bearing cage from end of release fork.

(b) Tap lower bearing from other end of release fork.

(c) Use an arbor press and a steel bar to press bearing from bearing cage.

STEERING CLUTCHES AND BRAKES



Figure 104 - Release Fork Parts Removed

(d) Use an arbor press and a steel bar to press oil seal from bearing cage.

(15) REMOVE FELT, FELT RETAINER, AND SPACER FROM RETAINER.

NOTE: Retainer was removed before removing main frame cover in process of removing steering clutches from tractor (fig. 89).

54. STEERING CLUTCH PARTS, INSPECTION (fig. 105).

a. **Clean All Parts.** All parts of the disassembled steering clutch, including disks, should be washed in SOLVENT, dry-cleaning, until all oil and grease has been removed. Dry off parts with compressed air.

b. **Bearings.** Check pilot bearing and release bearing for rough and loose running, which is an indication of excessive wear. Replace bearings which are excessively worn.

c. Drum.

(1) Check surface of drum for scoring. If drum is scored, place it in a lathe and turn down not to exceed 0.015 inch. If it does not clean up, replace it with a serviceable drum.

(2) Check teeth inside drum for wear. Operation of disks may develop notches in drum teeth. Install a new drum if teeth are worn excessively. Remove small burrs with a stone.

d. **Disks.** Place disks one by one on a surface plate and check for warping. If disks are warped enough to permit a 0.005-inch feeler gage to be inserted between disk and surface plate, replace the disks.

e. **Hub.** Check hub teeth for wear from disks. Wear is indicated when notches have been worn in teeth. Replace hub if worn.

ORDNANCE MAINTENANCE — HEAVY TRACTOR MI (IHC TD-18) —
POWER TRAIN, TRACK FRAME ASSEMBLY, AND SEATS

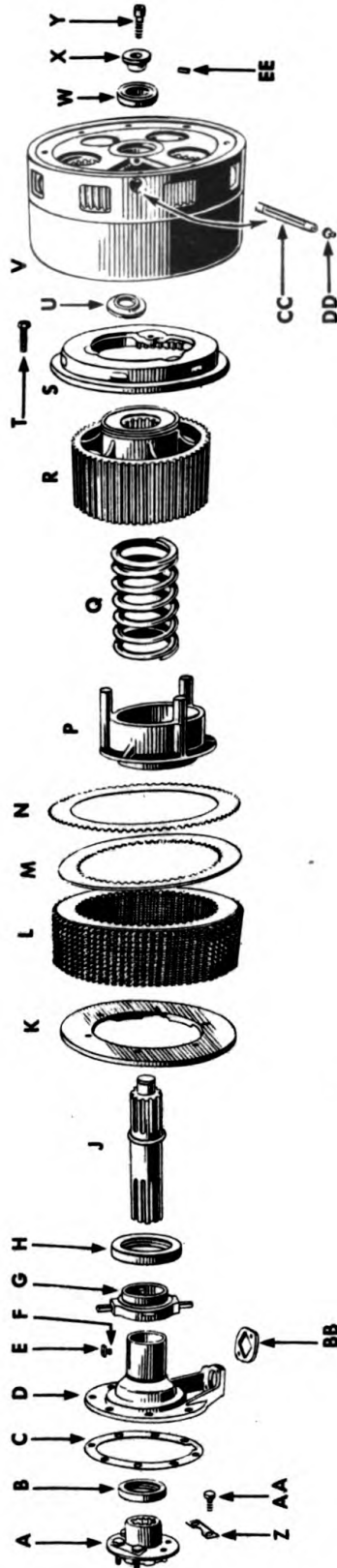

- A—COUPLING, SHAFT
- B—SEAL, OIL, SHAFT COUPLING
- C—GASKET, BEARING CAGE CAP, DRIVE BEVEL GEAR
- D—CAP, BEARING CAGE, DRIVE BEVEL GEAR
- E—PIN, COLLAR KEY, RELEASE
- F—KEY, COLLAR, RELEASE
- G—COLLAR, RELEASE
- H—BEARING, RELEASE THRUST
- J—SHAFT, CLUTCH
- K—PLATE, HUB
- L—COMPOSED OF "M" AND "N"
- M—DISK, FRICTION
- N—DISK, DRIVING
- P—RETAINER, PRESSURE SPRING
- Q—SPRING, PRESSURE
- R—HUB, STEERING CLUTCH
- S—PLATE, PRESSURE
- T—BOLT, DOWEL, PRESSURE PLATE
- U—SPACER, PILOT BEARING
- V—DRUM, CLUTCH
- W—BEARING, BALL, PILOT
- X—RETAINER, PILOT BEARING
- Y—BOLT, PILOT BEARING RETAINER
- Z—LOCK, BOLT
- AA—BOLT, COUPLING
- BB—CAP, LOWER BEARING, FORK
- CC—PIPE, LUBRICATOR
- DD—LUBRICATOR, STEERING CLUTCH PILOT BEARING
- EE—PIN, RETAINER, PILOT BEARING

RA PD 43544

Figure 105 — Steering Clutch Parts

STEERING CLUTCHES AND BRAKES

f. Shaft. If pilot bearing fits loose over end of shaft, replace shaft or bearing, or both. Also check for worn splines by placing coupling and hub on shaft and checking for loose fit.

g. Cage Cap and Release Collar. Check for loose fit release collar on cage cap. If looseness is present, replace either or both parts as is necessary to attain a tight fit.

h. Release Fork. Check fit of bearings on each end of release fork. If loose, replace fork or bearings, as required. Also check bearings for rough running, which is an indication of wear and need of replacement. Install new oil seal in a bearing cage.

i. Install New Felt. Install new felt in retainer which was removed from release fork and top of main frame cover when steering clutch was removed from tractor.

j. Spring. The free length of the pressure spring when new is $8\frac{3}{8}$ inches plus or minus $\frac{1}{16}$ -inch. Replace this spring if it has lost its strength or is defective.

55. STEERING CLUTCH ASSEMBLY.

a. Equipment.

BLOCK, steel	WRENCH, open-end, $\frac{9}{16}$ -in.
BLOCK, wood	WRENCH, open-end, $\frac{3}{4}$ -in.
BOLT, $\frac{1}{2}$ -in. (3)	WRENCH, steering clutch
HAMMER, rawhide	pilot bearing retainer bolt,
PLATE, steel	50092D
PRESS, arbor	

b. Procedure.

(1) INSTALL STEERING CLUTCH SPRING (fig. 103).

PLATE, steel	WRENCH, open-end, $\frac{3}{4}$ -in.
PRESS, arbor	

(a) Place spring in retainer; then place hub over retainer. Place both parts on an arbor press. Dowel screw holes in retainer must be opposite openings between hub spokes.

(b) Position steel plate over hub with dowel screw holes opposite dowel screw holes in retainer.

(c) Compress spring; then install and tighten 3 dowel screws and lock washers.

(2) COMPRESS STEERING CLUTCH SPRING WITH BOLTS (fig. 106).

BOLT, $\frac{1}{2}$ -in. (3)	WRENCH, open-end, $\frac{3}{4}$ -in.
------------------------------	--------------------------------------

Insert three $\frac{1}{2}$ -inch bolts into holes in pressure plate. Use a $\frac{3}{4}$ -inch open-end wrench to screw bolts against hub until spring is compressed sufficiently for installation of remaining parts.

ORDNANCE MAINTENANCE – HEAVY TRACTOR MI (IHC TD-18) –
POWER TRAIN, TRACK FRAME ASSEMBLY, AND SEATS

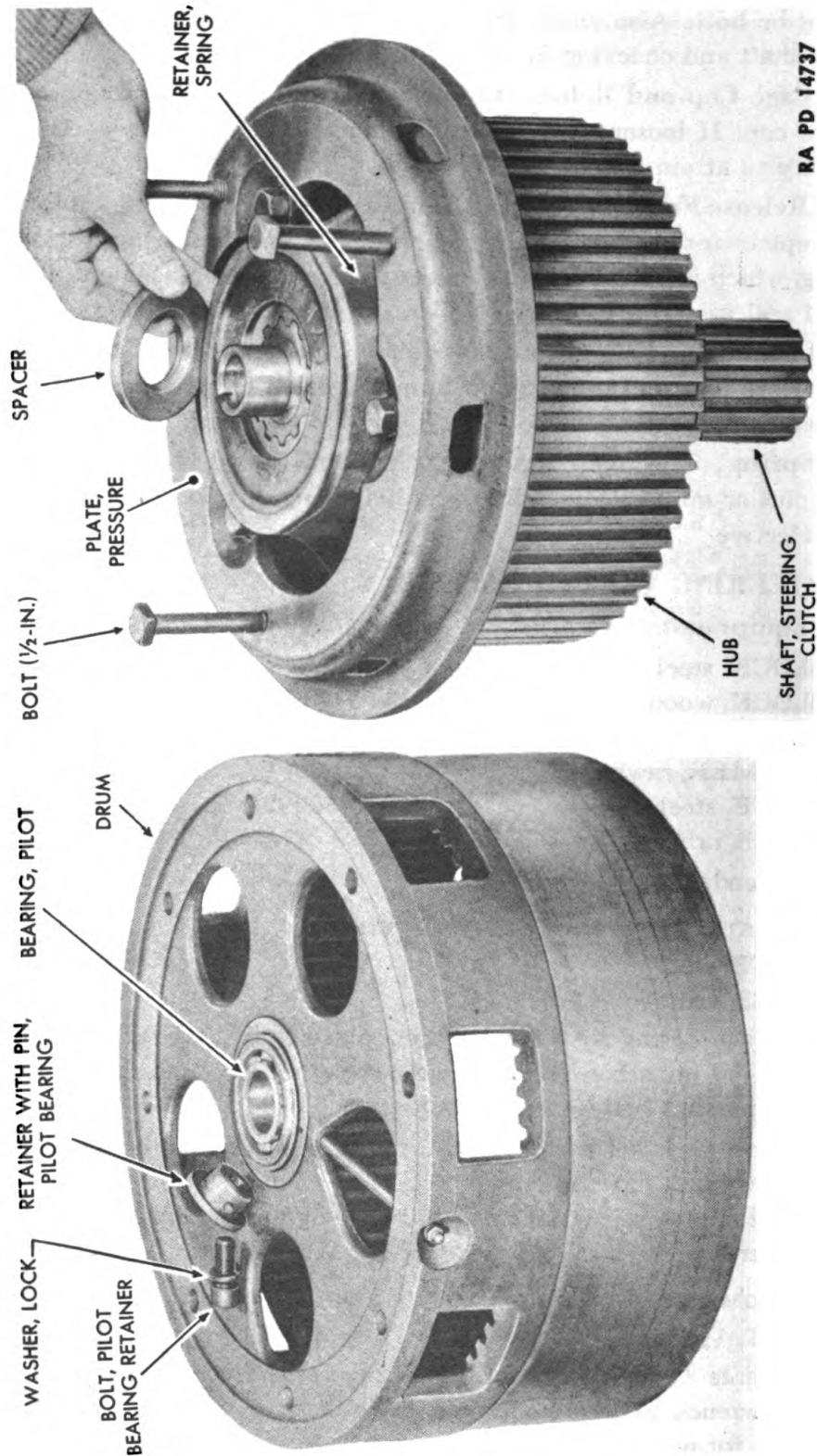

Figure 106 – Steering Clutch Shaft Installation

STEERING CLUTCHES AND BRAKES

(3) **INSTALL SHAFT AND DRUM (fig. 106).**

HAMMER, rawhide

WRENCH, steering clutch
pilot bearing retainer bolt,
50092D

(a) Enter shaft into hub and rest hub and attached parts on free end of shaft.

(b) Tap pilot bearing into drum from pressure plate end, using a rawhide hammer.

(c) Place spacer over end of shaft (pressure plate end) and lift drum over pressure plate, using a rawhide hammer to tap pilot bearing onto shaft.

(d) Place bearing retainer with pin into position in pilot bearing; then install and tighten pilot bearing retainer bolt and lock washer, using retainer bolt wrench 50092D.

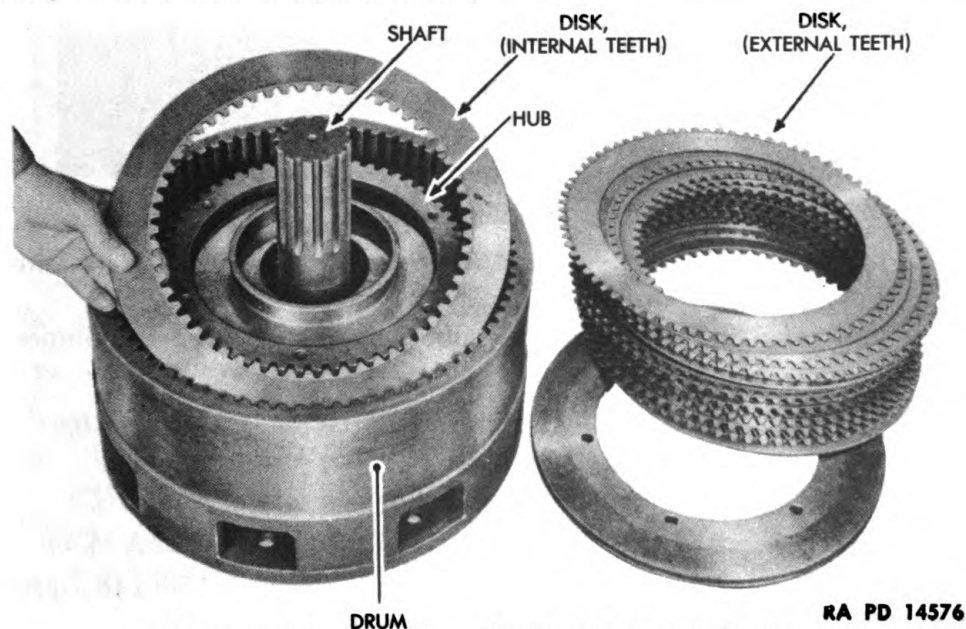

Figure 107 - Steering Clutch Disks Installation

(4) **INSTALL DISKS (fig. 107).**

Place disks in position over hub. The first disk to be installed should have the teeth on the hub side. Balance of disks should alternate with teeth on hub side and on drum side. There are 19 disks with teeth on the drum side, and 20 with teeth on the hub side.

(5) **INSTALL HUB PLATE.**

WRENCH, open-end, $\frac{3}{4}$ -in.

(a) Place the plate in position and secure it with 6 cap screws and lock washers. Tighten cap screws with a $\frac{3}{4}$ -inch open-end wrench.

ORDNANCE MAINTENANCE — HEAVY TRACTOR MI (IHC TD-18) —
POWER TRAIN, TRACK FRAME ASSEMBLY, AND SEATS

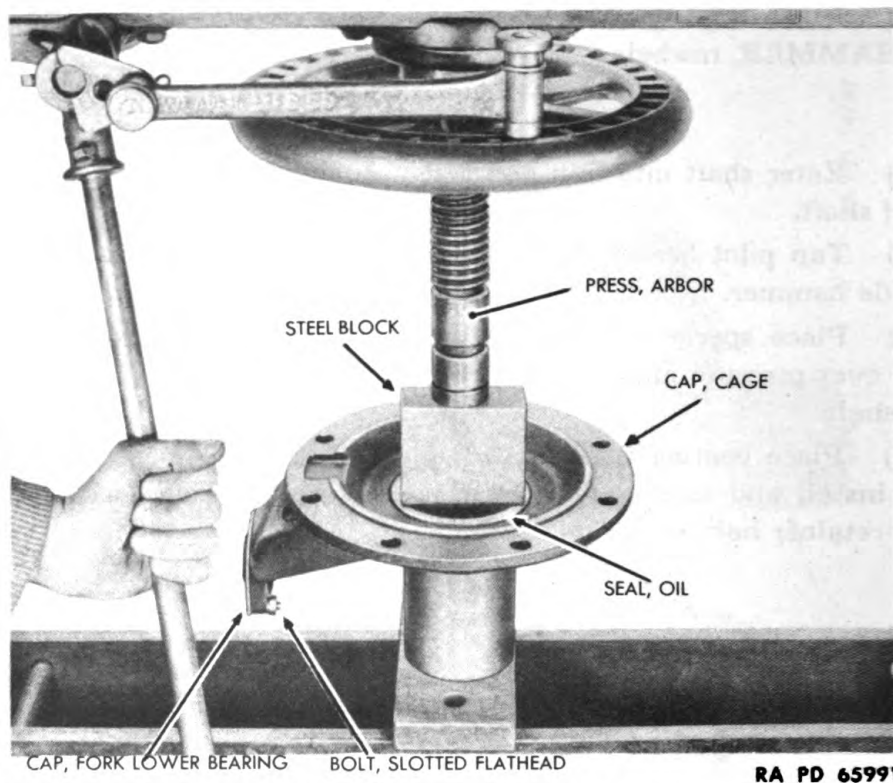

Figure 108 — Oil Seal in Drive Bevel Gear Bearing Cage Cap Installation

(b) Remove the three 1/2-inch bolts which were used to compress spring, using a 3/4-inch open-end wrench.

(6) **INSTALL OIL SEAL IN DRIVE BEVEL GEAR BEARING CAGE CAP** (fig. 108).

BLOCK, steel

PRESS, arbor

BLOCK, wood

WRENCH, open-end, 3/8-in.

(a) If a new oil seal is to be installed, press new seal into the inside of cage cap.

(b) Install release fork lower bearing cap to cage cap. Secure it with 2 slotted flathead bolts and lock washers, using a 3/8-inch open-end wrench.

(7) **INSTALL RELEASE COLLAR** (fig. 109).

PLATE, steel

PRESS, arbor

(a) Press release bearing into release collar, using a steel plate and an arbor press. Install collar key on cage cap sleeve and press release collar in position on cage cap.

(b) Place release collar in position on cage cap so that lubricating hole will face the front of tractor when steering clutch is installed.

STEERING CLUTCHES AND BRAKES

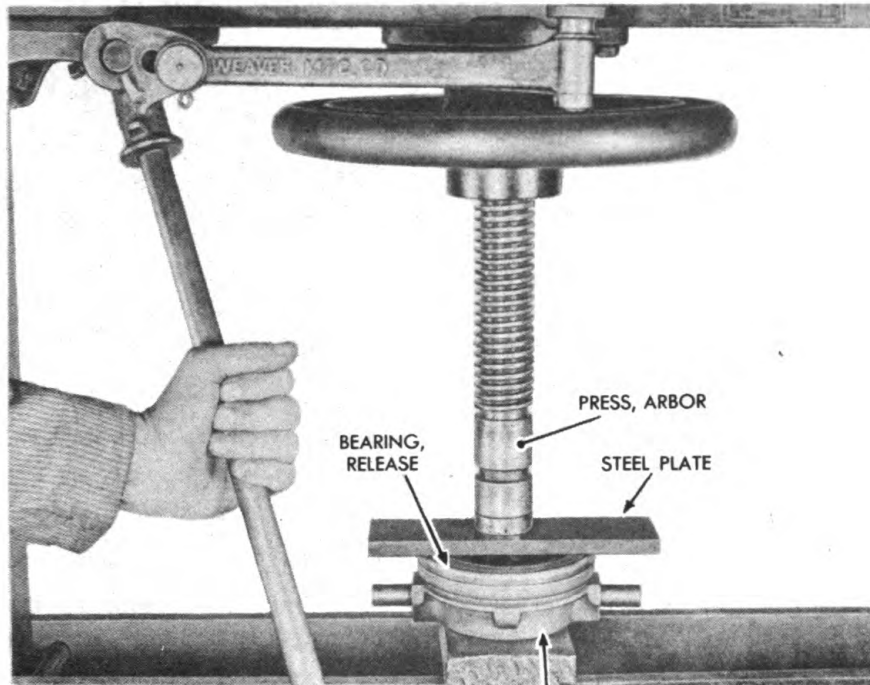

COLLAR, STEERING CLUTCH RELEASE THRUST RA PD 65992

Figure 109 – Release Bearing in Release Collar Installation

(8) **INSTALL RELEASE COLLAR AND CAGE CAP (fig. 98).**
Place release collar and cage cap over splined end of shaft.

56. STEERING CLUTCH INSTALLATION.

a. Equipment.

- BAR, pry
- CEMENT, gasket
- CHAIN
- CHISEL, cold
- CROWBAR
- CUTTERS, diagonal
- HAMMER
- HAMMER, babbitt
- HOIST
- PLIERS
- PUNCH
- ROPE
- SCREWDRIVER
- SHELLAC
- SLING, rope

- WRENCH, box, 7/8-in.
- WRENCH, open-end, 7/16-in.
- WRENCH, open-end, 1/2-in.
- WRENCH, open-end, 9/16-in.
- (2)
- WRENCH, open-end, 5/8-in.
- WRENCH, open-end, 3/4-in.
- (2)
- WRENCH, open-end, 7/8-in.
- WRENCH, pipe
- WRENCH, socket, 3/4-in.
- WRENCH, socket, 7/8-in.
- WRENCH, socket, 1 1/8-in.
- WRENCH, socket, 1 7/8-in.

b. Procedure.

**ORDNANCE MAINTENANCE — HEAVY TRACTOR MI (IHC TD-18) —
POWER TRAIN, TRACK FRAME ASSEMBLY, AND SEATS**

(1) **LIFT RIGHT STEERING CLUTCH INTO MAIN FRAME (fig. 97).**

CHAIN

ROPE

HOIST

SHELLAC

(a) Shellac a new bearing cage cap gasket to drive bevel gear bearing cage cap.

(b) Place a chain or rope around bearing cage cap and through openings in outer surface of drum; then use hoist to lift clutch into position in main frame.

(2) **ATTACH DRUM TO SPROCKET DRIVE PINION SHAFT (fig. 96).**

CROWBAR

WRENCH, box, 7/8-in.

PUNCH

Use a punch to aline cap screw holes in drum with holes in pinion shaft. Lubricator in drum must be in alinement with slot in hub of pinion shaft. Drum, however, will not fit on shaft unless slot in shaft and lubricator are alined. Install 8 cap screws and lock washers which hold drum to pinion shaft. Tighten cap screws with a 7/8-inch box wrench. Install as many cap screws as possible; then insert a crowbar in drum openings to turn drum for access to remaining cap screw holes. **NOTE:** Tractor will move when drum is turned.

(3) **INSTALL STEERING CLUTCH SHAFT COUPLING INTO DRIVE BEVEL GEAR HUB (figs. 95 and 110).**

BAR, pry

HAMMER

CHISEL, cold

WRENCH, open-end, 3/4-in.

CROWBAR

(a) Turn transmission gears by hand until coupling and drive bevel gear hub are in alinement; then use pry bars to push coupling from clutch assembly into drive bevel gear hub.

(b) Install 3 cap screw locks and 6 cap screws, using a 3/4-inch open-end wrench. Use crowbar in drum openings to turn clutch as is required to install all cap screws and locks. Use a cold chisel and hammer to pry locks over cap screw heads.

(4) **ATTACH RIGHT BEVEL GEAR BEARING CAGE CAP TO RIGHT DRIVE BEVEL GEAR BEARING CAGE (fig. 95).**

WRENCH, socket, 7/8-in.

WRENCH, socket, 1 1/8-in.

Slide bearing cage cap next to bearing cage and install 6 cap screws and lock washers, using a 7/8-inch socket wrench, and 2 nuts and lock washers, using a 1 1/8-inch socket wrench. Cap screws and bolts hold bearing cage cap to bearing cage and main frame.

**ORDNANCE MAINTENANCE — HEAVY TRACTOR MI (IHC TD-18) —
POWER TRAIN, TRACK FRAME ASSEMBLY, AND SEATS**

(6) **CONNECT STEERING CLUTCH BRAKE BANDS AROUND STEERING CLUTCH DRUM (fig. 94).**

CUTTERS, diagonal

Fold rear and center brake bands over drum. Install steering brake band joint pin which holds rear and center brake bands together. Use diagonal cutters to install and lock cotter pin in brake band and joint pin.

(7) **INSTALL RELEASE BEARING GREASE TUBES (fig. 93).**

WRENCH, open-end, 1/2-in. **WRENCH**, open-end, 5/8-in.

(a) Install release bearing grease tube, using a 5/8-inch open-end wrench to attach connector to release collar.

(b) Install release fork lower bearing grease tube. Using a 1/2-inch open-end wrench, attach connector to drive bevel gear bearing cage.

(8) **INSTALL LEFT STEERING CLUTCH.**

Follow same procedure outlined in the previous steps of this paragraph.

(9) **INSTALL STAY RODS IN MAIN FRAME (fig. 93).**

WRENCH, socket, 1 7/8-in.

(a) Install right stay rod into main frame from rear of frame. Also install bracer spacer and lock washer; then attach lock washer and hexagonal nut to forward end of stay rod, tightening nut with a 1 7/8-inch socket wrench.

(b) Install left stay rod in a similar manner, except that rod must be installed from forward end of frame.

(10) **INSTALL MAIN FRAME COVER (figs. 91 and 92).**

CEMENT, gasket

WRENCH, open-end, 7/16-in.

HAMMER, babbitt

WRENCH, open-end, 9/16-in.

SCREWDRIVER

WRENCH, open-end, 3/4-in.

SHELLAC

(a) Install frame cover dowel pins. Use a babbitt hammer to tap frame cover dowel pins in position in right rear corner of main frame and into main frame and the second dowel into main frame near engine clutch compartment.

(b) Be sure gasket surface on top of main frame is clean; then coat the surface with shellac or gasket cement and install new main frame cover gasket.

(c) Lift main frame cover into position on main frame, over the 2 dowel bolts.

STEERING CLUTCHES AND BRAKES

(d) Push the 4 lubricators located on the upper ends of the grease tubes through holes in main frame cover. Install 8 bolts, nuts, and lock washers which secure lubricators to cover.

(e) Install 32 cap screws and lock washers which secure main frame cover to main frame. One of these cap screws also holds battery ground cable to main frame (fig. 86). Use $\frac{3}{4}$ -inch open-end wrench.

(f) Install new odometer housing gasket on odometer drive housing. Install odometer. Place odometer upper cover assembly and odometer head in position on top of main frame, and hold remaining odometer parts in position from underneath main frame cover; then install 2 spacers and 2 slotted screws and 3 cap screws with lock washers. Tighten cap screws with a $\frac{9}{16}$ -inch open-end wrench and tighten slotted screws with a screwdriver.

(11) INSTALL STEERING CLUTCH INSPECTION COVERS (fig. 90).

WRENCH, open-end, $\frac{1}{2}$ -in.

(a) Install new steering clutch inspection cover gasket over each inspection cover opening.

(b) Install 2 steering clutch inspection covers, securing each cover to main frame with 4 cap screws and lock washers. Tighten cap screws with $\frac{1}{2}$ -inch open-end wrench.

(12) INSTALL STEERING CLUTCH RELEASE LEVERS AND RELEASE FORK UPPER BEARING RETAINERS (fig. 89).

WRENCH, open-end, $\frac{9}{16}$ -in.

WRENCH, open-end, $\frac{3}{4}$ -in.

WRENCH, open-end, $\frac{5}{8}$ -in.

(a) Install new upper bearing cage gasket on right release fork upper bearing retainer.

(b) Install release fork upper bearing retainer, securing it to main frame with 2 cap screws and lock washers. Tighten cap screws with a $\frac{5}{8}$ -inch open-end wrench.

(c) Install in order a new upper bearing felt, release lever spacer, and upper bearing felt retainer on release fork upper bearing retainer.

(d) Install steering clutch release lever on release fork (levers pointing toward each other). Install flat washer, lock washer, and cap screw. Tighten cap screw with $\frac{3}{4}$ -inch open-end wrench. Tighten bolt which holds lever to release fork, using a $\frac{9}{16}$ -inch open-end wrench.

(e) Install left steering clutch release lever and left release fork upper bearing retainer in the same manner.

(13) INSTALL GEAR SHIFTER HOUSING WITH LEVERS ATTACHED (fig. 90).

WRENCH, open-end, $\frac{9}{16}$ -in.

WRENCH, open-end, $\frac{3}{4}$ -in.

**ORDNANCE MAINTENANCE – HEAVY TRACTOR MI (IHC TD-18) –
POWER TRAIN, TRACK FRAME ASSEMBLY, AND SEATS**

- (a) Install new gear shifter housing gasket in position in main frame above transmission.
- (b) Place gear shifter housing spacer over gasket.
- (c) Install second gear shifter housing gasket in position on top of spacer.
- (d) Place gear shifter housing with levers attached in position on spacer and gasket. **NOTE:** Transmission gears must be in neutral position so spline shaft will rotate freely. Gear shifter lever must also be in neutral position. Be sure all shifter forks engage collars of their gears.
- (e) Install 4 cap screws and lock washers at corners of shifter housing securing housing to main frame. Tighten these cap screws with a $\frac{3}{4}$ -inch open-end wrench. Then install 6 additional cap screws and lock washers, using a $\frac{9}{16}$ -inch open-end wrench.

(14) INSTALL DOUBLE CHECK VALVE AND AIR VALVE SUPPORT BRACKET (fig. 89).

WRENCH, open-end, $\frac{3}{4}$ -in.

- (a) Place double check valve with air tubes attached and air valve support bracket in position on main frame cover. Right steering clutch operating rod must be entered through hole in bracket.
- (b) Secure bracket to main frame cover with 2 cap screws and lock washers. Tighten cap screws with $\frac{3}{4}$ -inch open-end wrench.

(15) CONNECT STEERING CLUTCH OPERATING RODS TO STEERING CLUTCH RELEASE LEVERS (fig. 89).

CUTTERS, diagonal

PLIERS

- (a) Install operating rod yoke pin in each operating rod yoke and steering clutch release lever. Use diagonal cutters to install and lock cotter pin in yoke pin.
- (b) Use pliers to attach 2 steering clutch release lever return springs. Attach each spring to the spring anchor at rear of main frame and to release lever.

(16) INSTALL AIR BRAKE CONTROL VALVE (fig. 88).

WRENCH, open-end, $\frac{1}{2}$ -in.

WRENCH, open-end, $\frac{7}{8}$ -in.

WRENCH, open-end, $\frac{5}{8}$ -in.

- (a) Place air brake control valve in position on air valve support bracket and secure it with 4 cap screws and lock washers, using a $\frac{1}{2}$ -inch open-end wrench.
- (b) Install air tube (junction tee to working brake valves), using a $\frac{7}{8}$ -inch open-end wrench to attach connector to valve and to junction tee.

STEERING CLUTCHES AND BRAKES

(c) Connect air tube (check valve to working brake valve) to air brake control valve, using a $\frac{5}{8}$ -inch open-end wrench to tighten connector.

(17) **ADJUST STEERING CLUTCH** (par. 57).

Lubricate pilot release and upper and lower fork bearings with **GREASE**, general purpose (seasonal grade), before adjusting.

(18) **INSTALL AIR TUBE (PARKING VALVE TO CHECK VALVE)** (fig. 86).

WRENCH, open-end, $\frac{5}{8}$ -in.

Connect air tube connectors to hand brake valve and double check valve. Use a $\frac{5}{8}$ -inch open-end wrench.

(19) **INSTALL WIRE-FILLING BRACKET AND ELECTRIC BRAKE CONTROLLER WITH CONNECTING CABLES TO MAIN FRAME COVER** (figs. 85, 86, and 87).

CUTTERS, diagonal

WRENCH, open-end, $\frac{3}{4}$ -in.

WRENCH, open-end, $\frac{7}{16}$ -in.

WRENCH, open-end, $\frac{7}{8}$ -in.

WRENCH, open-end, $\frac{9}{16}$ -in.

(a) Lift electric brake controller, wire-filling valve bracket, and connecting parts and cables, which have been moved out of the way at right side of engine, back in position on main frame cover.

(b) Push cable (load control to electric brake controller) through dash and cowl assembly and attach cable to electric load control (fig. 87). Install nut which holds cable to electric load control, using a $\frac{7}{16}$ -inch open-end wrench.

(c) Attach electric brake controller to main frame cover, using a $\frac{9}{16}$ -inch open-end wrench to install 2 cap screws and lock washers (fig. 86); then connect lower electric brake control rod to electric brake control bell crank. Use diagonal cutters to install cotter pin.

(d) Place wire-filling valve bracket in position on right rear corner of main frame cover and secure it with 2 cap screws and lock washers (fig. 85). Tighten cap screws with a $\frac{3}{4}$ -in. open-end wrench. Then use a $\frac{7}{8}$ -inch open-end wrench to attach air tube connectors to cutout cocks. Hold air cock with a wrench while installing connectors and tubes.

(20) **INSTALL SEAT, FENDERS, GROUSER BOXES, PACK CARRIER, DIESEL FUEL TANK, AND FENDER SIDE SHEETS AS A UNIT** (figs. 81, 82, 83, and 84).

CUTTERS, diagonal

WRENCH, open-end, $\frac{3}{4}$ -in.

HOIST

(2)

SLING, rope

WRENCH, pipe

WRENCH, open-end, $\frac{9}{16}$ -in. (2)

WRENCH, socket, $\frac{3}{4}$ -in.

WRENCH, open-end, $\frac{5}{8}$ -in.

**ORDNANCE MAINTENANCE — HEAVY TRACTOR MI (IHC TD-18) —
POWER TRAIN, TRACK FRAME ASSEMBLY, AND SEATS**

(a) Lift seat, fenders, grouser boxes, pack carrier, Diesel fuel tank, and fender side sheets into position on the tractor. Place a rope sling under the Diesel fuel tank and fender support cross member and through footrests; then attach a hoist to the sling to lift the assembled parts into position.

(b) Attach cables to blackout tail and stop lamps.

(c) Connect the fuel return pipe (extension) and fuel pipe (extension) to fuel return pipe and fuel pipe. Connectors are accessible on engine side of dash and cowl assembly at left rear of engine. Use a $\frac{5}{8}$ -inch open-end wrench to tighten connectors.

(d) Attach left fender side sheet to main frame left channel. Install 3 cap screws and lock washers (fig. 81). One cap screw is located in bottom of front fender bracket and another in bottom of center fender bracket. Both require a $\frac{3}{4}$ -inch open-end wrench. The third cap screw also has a flat washer, and requires a $\frac{9}{16}$ -inch open-end wrench.

(e) Install 3 bolts, lock washers, flat washers, and nuts which hold left fender side sheet to air line cable shield (fig. 81). Use two $\frac{9}{16}$ -inch open-end wrenches. Turn boltheads from outside fender side sheet with one wrench while holding nuts with the other.

(f) Install 2 cap screws and lock washers which hold left fender side sheet and left front fender bracket to engine clutch cover (fig. 84). Use a $\frac{3}{4}$ -inch socket wrench.

(g) Install 2 bolts, nuts, and lock washers which hold left fender side sheet to dash and cowl assembly. One of these bolts is located in top of side of left fender bracket. Use two $\frac{9}{16}$ -inch open-end wrenches. Hold nuts with one wrench while tightening boltheads with the other.

(h) Raise layshaft and drive shaft so bearing housing will be in position (fig. 84); then install 2 bolts, lock washers, and nuts which hold winch layshaft bearing housing in position. Also install 2 spacers. Hold boltheads with one $\frac{3}{4}$ -inch open-end wrench and tighten nuts with a similar wrench.

(i) Install winch drive shaft guard as outlined in paragraph 30 b (10).

(j) Connect left fender side sheet to main frame cover by installing 4 bolts, lock washers, and nuts (fig. 81). Use a $\frac{3}{4}$ -inch socket wrench to tighten boltheads and hold nuts with a $\frac{3}{4}$ -inch open-end wrench to install 2 of these bolts, located in center fender bracket. To install remaining 2 bolts, use two $\frac{9}{16}$ -inch open-end wrenches, holding boltheads with one wrench and tightening nuts with the other.

(k) Install 4 cap screws and lock washers in left fuel tank support (fig. 83). Use a $\frac{3}{4}$ -inch open-end wrench. In a similar manner, install 4 cap screws and lock washers in right fuel support.

STEERING CLUTCHES AND BRAKES

(l) Install hose couplings and pipes (fig. 82). Insert pipes through holes in pack carrier straps. Use a pipe wrench to install pipes in cutout cocks; then connect 2 dummy couplings to hose couplings.

(m) Connect right fender side sheet to main frame right channel, installing 3 cap screws and lock washers (fig. 81). Use a $\frac{3}{4}$ -inch open-end wrench to install one cap screw located in bottom of front fender bracket and another located in bottom of center fender bracket. The third cap screw also has a flat washer and requires a $\frac{9}{16}$ -inch open-end wrench.

(n) Attach right fender side sheet and front fender bracket to engine clutch cover by installing 2 cap screws and lock washers (fig. 81). Use a $\frac{3}{4}$ -inch socket wrench.

(o) Connect right fender side sheet to dash and cowl assembly, using two $\frac{9}{16}$ -inch open-end wrenches to install 2 bolts, lock washers, and nuts (fig. 81). One of these bolts is located in top side of front fender bracket.

(p) Connect right fender side sheet to main frame cover by installing 4 bolts, lock washers, and nuts (fig. 81). Use a $\frac{3}{4}$ -inch socket wrench to tighten boltheads and hold nuts with a $\frac{3}{4}$ -inch open-end wrench to install 2 of these bolts located in center fender bracket. To install remaining 2 bolts, use two $\frac{9}{16}$ -inch open-end wrenches, holding boltheads with one wrench and tightening nuts with the other.

(q) Raise winch and clutch brake control rods up into position. Install end pins which join yoke assemblies to winch shifter and brake lever. Use diagonal cutters to install and lock a cotter pin in each end pin.

(r) Install power take-off shifter hand lever rod. Place forward end of rod in position so it can be connected to support at center of front seat support. Install front yoke pin to front yoke to secure rod in position. Use diagonal cutters to install and loosen cotter pin to end of yoke. Connect rod to power take-off at rear by installing yoke pin. Use diagonal cutters to install and lock cotter pin in end of yoke pin.

(s) Install 2 bolts, nuts, and lock washers which hold 2 cable clips to right fender side sheet. Also install 2 bolts, nuts, and lock washers which hold 2 cable clips to left fender side sheet. Use two $\frac{9}{16}$ -inch open-end wrenches. Hold boltheads with one wrench and tighten nuts with the other.

(t) Install batteries and battery bottom supports. Follow procedure outlined in TM 9-777 to remove batteries. To remove battery bottom supports, place 4 right battery bottom spacers in position on main frame cover and place support in position over spacers. Install 4 flat washers and cap screws. Tighten cap screws with a $\frac{3}{4}$ -inch open-end wrench. Install left battery bottom support in the same manner.

(u) Place seat cushions in position on seats.

**ORDNANCE MAINTENANCE — HEAVY TRACTOR M1 (IHC TD-18) —
POWER TRAIN, TRACK FRAME ASSEMBLY, AND SEATS**

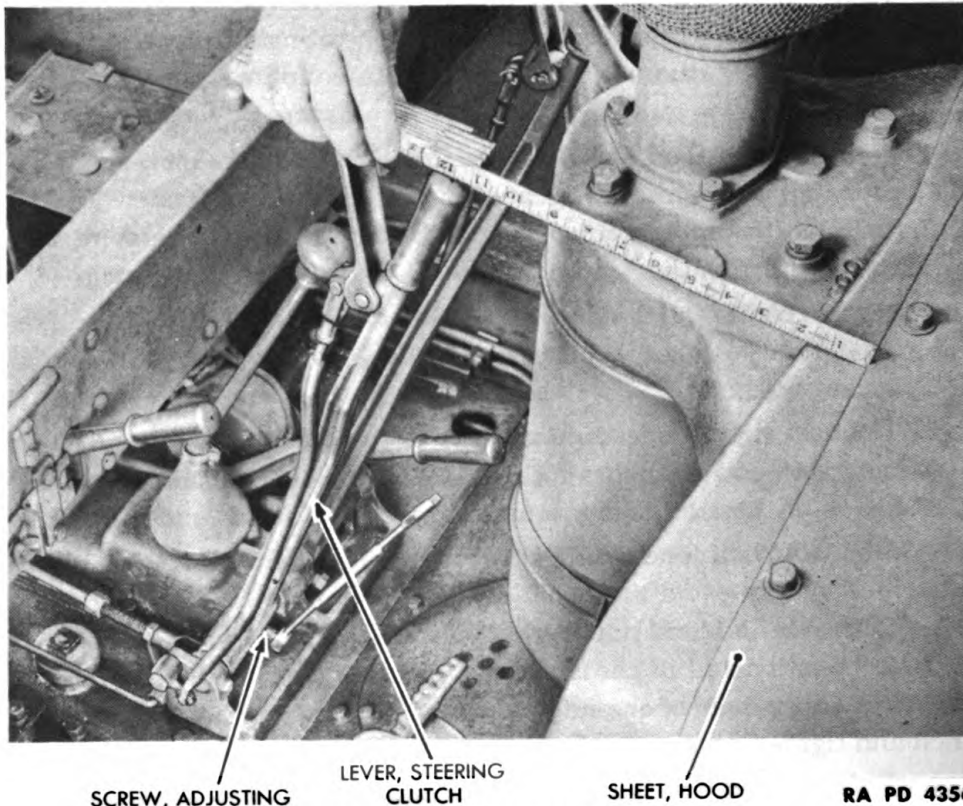

Figure 111 — Steering Clutch Lever Adjustment

57. STEERING CLUTCH CONTROL ADJUSTMENT.

a. Equipment.

RULER

WRENCH, open-end, $1\frac{3}{8}$ -in.

WRENCH, open-end, $\frac{3}{4}$ -in.

b. Procedure.

(1) ADJUSTMENT OF STEERING CLUTCH LEVER POSITION (fig. 111).

Steering clutch levers should be 12 inches from dash when in an extreme forward position. This adjustment is made as follows:

RULER

WRENCH, open-end, $\frac{3}{4}$ -in.

(a) Loosen lock nut on adjusting screw at base of steering clutch lever. Use a $\frac{3}{4}$ -inch open-end wrench.

(b) Adjust screw, using a $\frac{3}{4}$ -inch open-end wrench, until distance from top end of lever to dash measures 12 inches. To measure this, rest a ruler on top of lever and against rear end of hood sheet, which is alined with dash and cowl assembly.

(c) Tighten lock nut, using a $\frac{3}{4}$ -inch open-end wrench.

STEERING CLUTCHES AND BRAKES

(2) ADJUSTMENT OF STEERING CLUTCH OPERATING ROD (fig. 112).

The adjustment of steering clutch lever position outlined in (1) of this paragraph should be performed before adjusting steering clutch operating rods. With the lever in correct position, the clutch yoke must provide free-running clearance between yoke and bearing support.

RULER

WRENCH, open-end, $\frac{1\frac{3}{8}}$ -in.

(a) Use a $\frac{1\frac{3}{8}}$ -inch open-end wrench to loosen the lock nut at yoke at each end of operating rod.

(b) Use a $\frac{1\frac{3}{8}}$ -inch open-end wrench on nut which is welded to rod to turn rod to proper adjustment. Adjustment is correct when 4 inches of free travel is attained at the top end of the steering clutch lever, which can be measured by resting a ruler over end of lever and against end of hood sheet.

(c) Use a $\frac{1\frac{3}{8}}$ -inch open-end wrench to tighten lock nuts at yoke at each end of steering clutch operating rod.

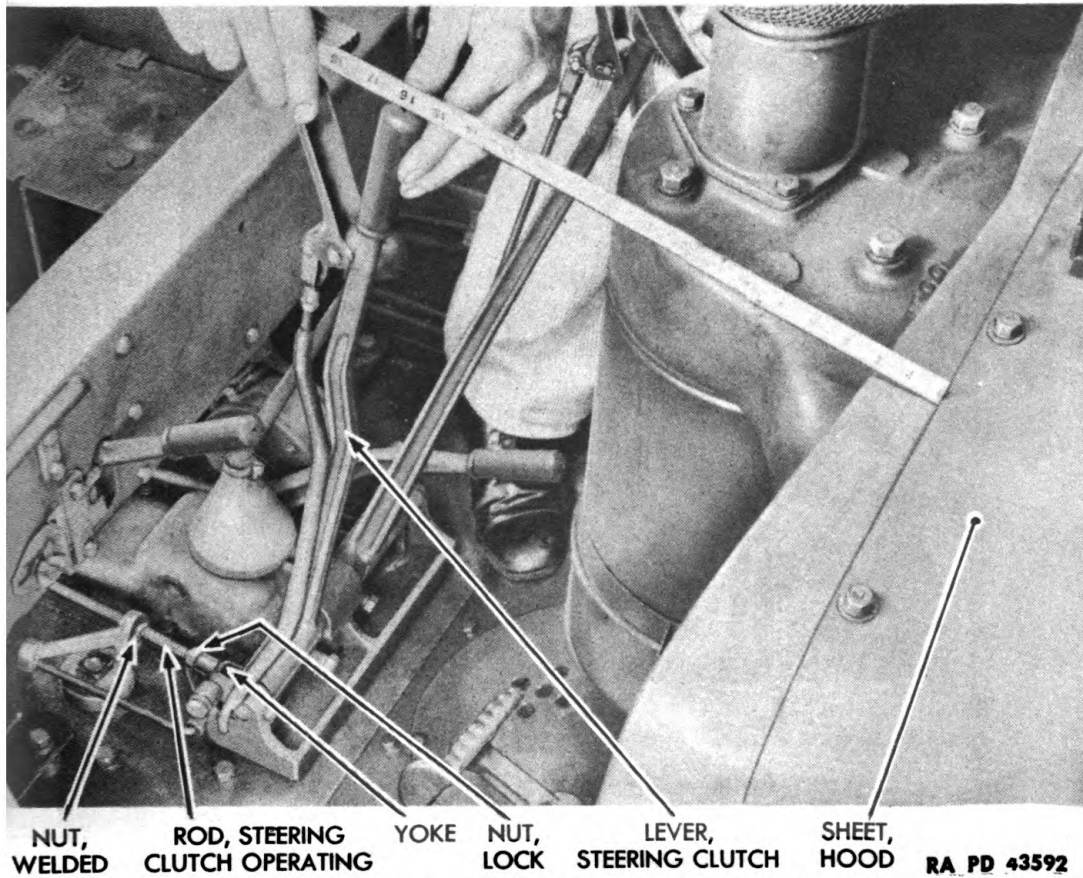
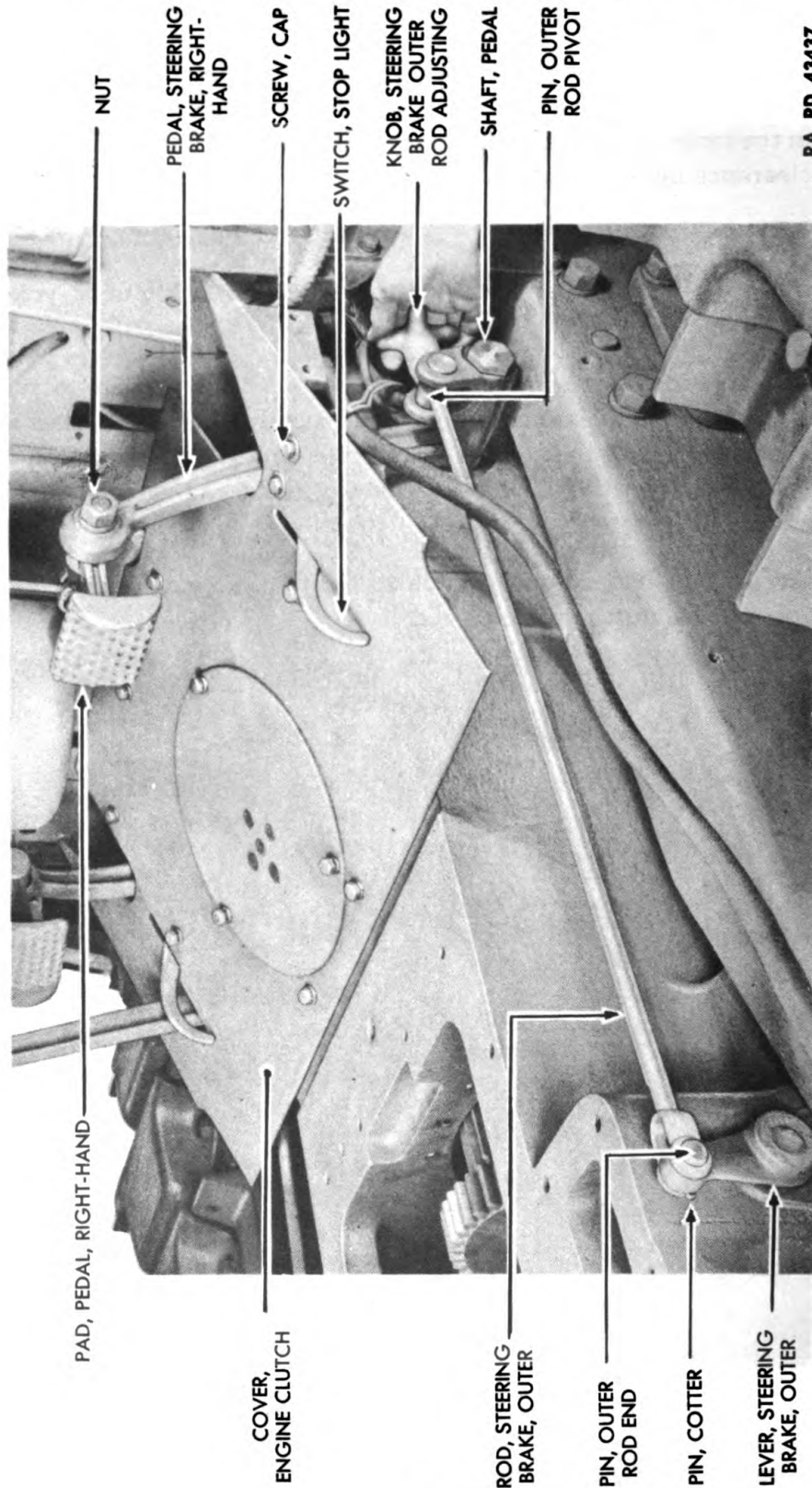

Figure 112 – Steering Clutch Operating Rod Adjustment

ORDNANCE MAINTENANCE — HEAVY TRACTOR MI (IHC TD-18) —
POWER TRAIN, TRACK FRAME ASSEMBLY, AND SEATS



RA PD 43437

Figure 113 — Steering Brake Outer Rod Adjusting Knob Removal

STEERING CLUTCHES AND BRAKES

58. STEERING BRAKE CONTROL REMOVAL.**a. Equipment.**

CUTTERS, diagonal

WRENCH, socket, $\frac{3}{4}$ -in. (2)

PLIERS

WRENCH, socket, $\frac{5}{8}$ -in.WRENCH, open-end, $\frac{1}{2}$ -in.WRENCH, socket, $1\frac{1}{2}$ -in.WRENCH, open-end, $1\frac{1}{8}$ -in.**b. Procedure.****(1) REMOVE MAIN FRAME COVER.**

This involves removing seat and fenders and other parts as outlined in paragraph 52 a through b (8). These steps also include removal of steering clutch controls. It is not necessary for steering brake bands or steering clutches to be removed, to remove steering brake controls.

(2) REMOVE STEERING BRAKE OUTER ROD ADJUSTING KNOB (fig. 113).

Unscrew and remove knob by hand. Move steering brake pedal forward until outer steering brake rod is removed from steering brake outer rod pivot pin.

(3) REMOVE OUTER STEERING BRAKE ROD (fig. 113).

CUTTERS, diagonal

Use diagonal cutters to remove cotter pin from steering brake outer rod end pin. Remove end pin and remove rod from outer steering brake lever.

(4) REMOVE RIGHT STEERING BRAKE PEDAL (fig. 113).WRENCH, open-end, $\frac{1}{2}$ -in.WRENCH, socket, $1\frac{1}{2}$ -in.WRENCH, open-end, $1\frac{1}{8}$ -in.

Using a $1\frac{1}{2}$ -inch socket wrench, remove pedal shaft; then remove right pedal pad, using a $1\frac{1}{8}$ -inch open-end wrench to remove nut so bolt can be removed and pedal pad taken off. Use a $\frac{1}{2}$ -inch open-end wrench to remove 2 cap screws and lock washers which hold stop light switch to engine clutch cover. Move stop light switch out of the way; then remove brake pedal through bottom of engine clutch cover.

(5) DISCONNECT INNER STEERING BRAKE LEVER FROM RIGHT OUTER STEERING BRAKE LEVER (fig. 114).

PLIERS

WRENCH, socket, $\frac{3}{4}$ -in.

Use a $\frac{3}{4}$ -inch socket wrench to remove the cap screw and lock washer which hold inner steering brake lever to right outer steering brake lever. Remove outer lever; then use pliers to remove steering brake band return spring from front steering brake band and from return spring anchor.

**ORDNANCE MAINTENANCE – HEAVY TRACTOR MI (IHC TD-18) –
POWER TRAIN, TRACK FRAME ASSEMBLY, AND SEATS**

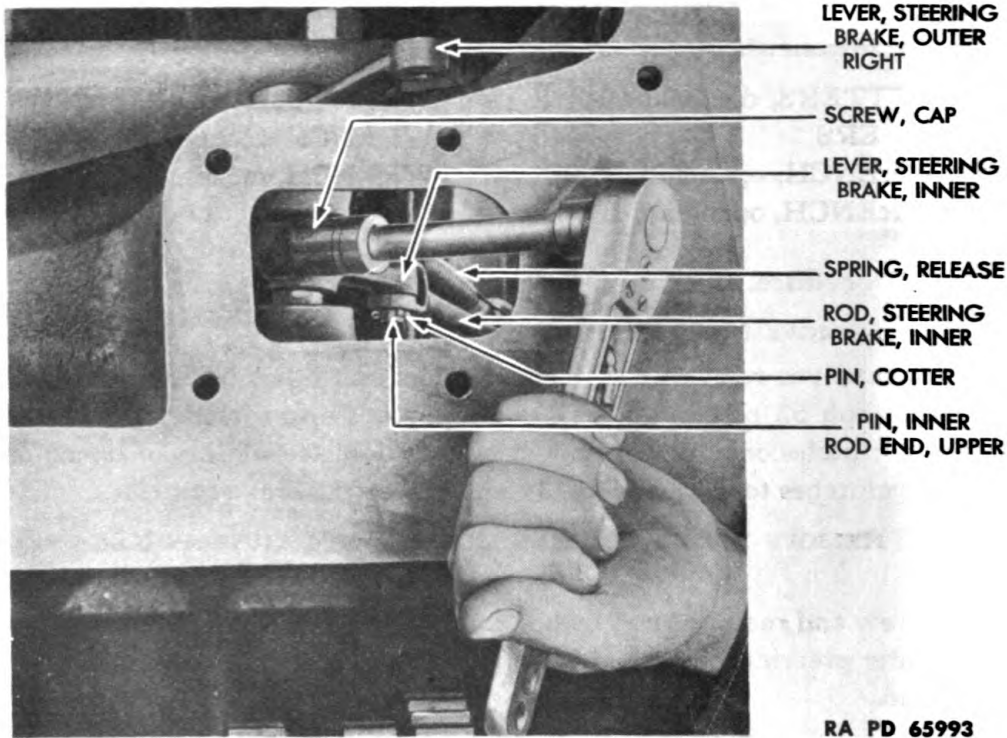

Figure 114 – Disconnecting Inner Steering Brake Lever from Outer Steering Brake Lever

(6) REMOVE INNER STEERING BRAKE ROD AND INNER STEERING BRAKE LEVER (figs. 73 and 114).

CUTTERS, diagonal

PLIERS

Use pliers to remove release spring. Use diagonal cutters to remove cotter pin from lower steering brake inner rod end pin; then remove end pin and lift out inner rod with inner steering brake lever.

(7) REMOVE STEERING BRAKE SET SCREW AND STEERING BRAKE RETURN SPRING ANCHOR (figs. 74 and 78).

WRENCH, socket, 5/8-in.

WRENCH, socket, 1 1/2-in.

(a) From underneath main frame (outside), use 5/8-inch socket wrench to remove steering brake band set screw with lock nut attached.

(b) At the same location use a 1 1/2-inch socket wrench to remove anchor nut. Steering brake return spring anchor can then be lifted out from inside main frame.

(8) REMOVE LEFT STEERING BRAKE CONTROLS.

Follow same procedure outlined in preceding steps of this paragraph.

STEERING CLUTCHES AND BRAKES

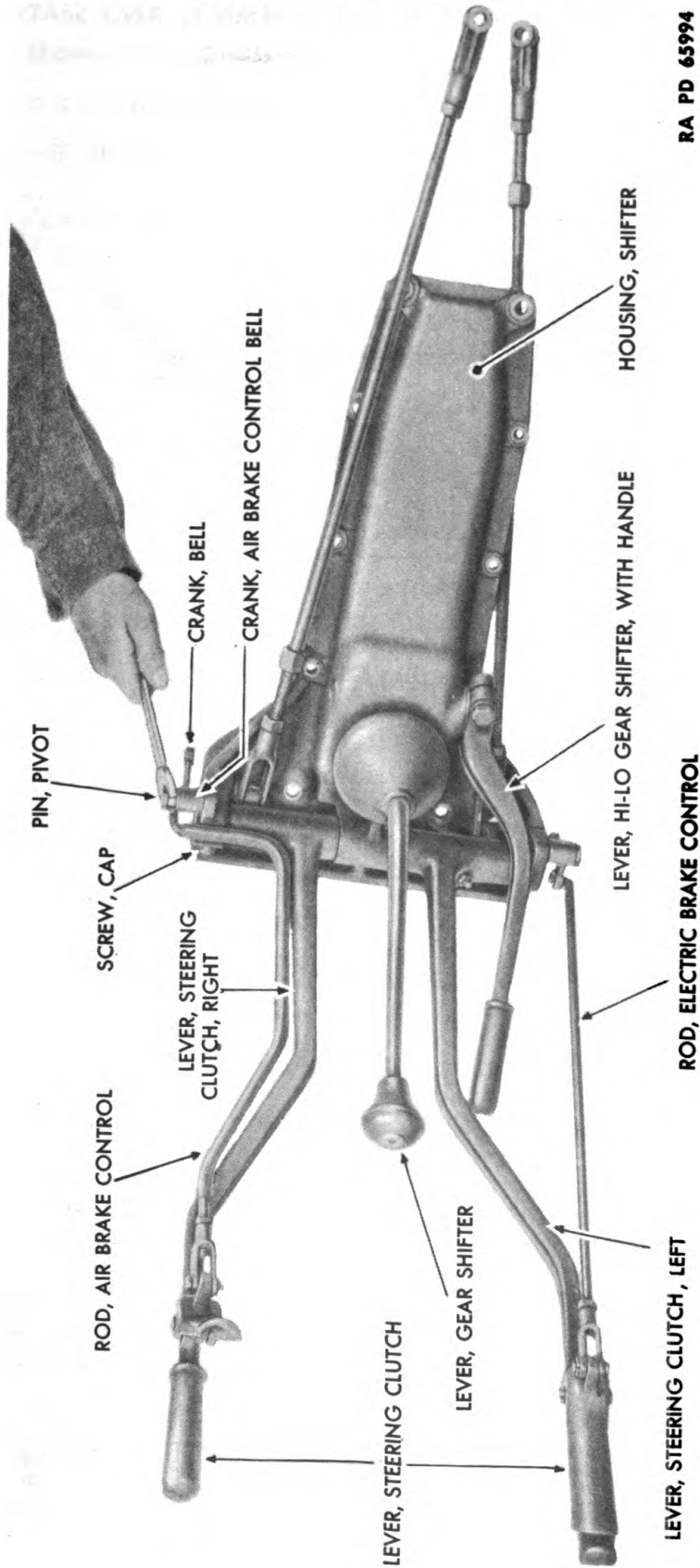

RA PD 65994

Figure 115 — Steering Clutch Lever Removal

**ORDNANCE MAINTENANCE — HEAVY TRACTOR MI (IHC TD-18) —
POWER TRAIN, TRACK FRAME ASSEMBLY, AND SEATS**

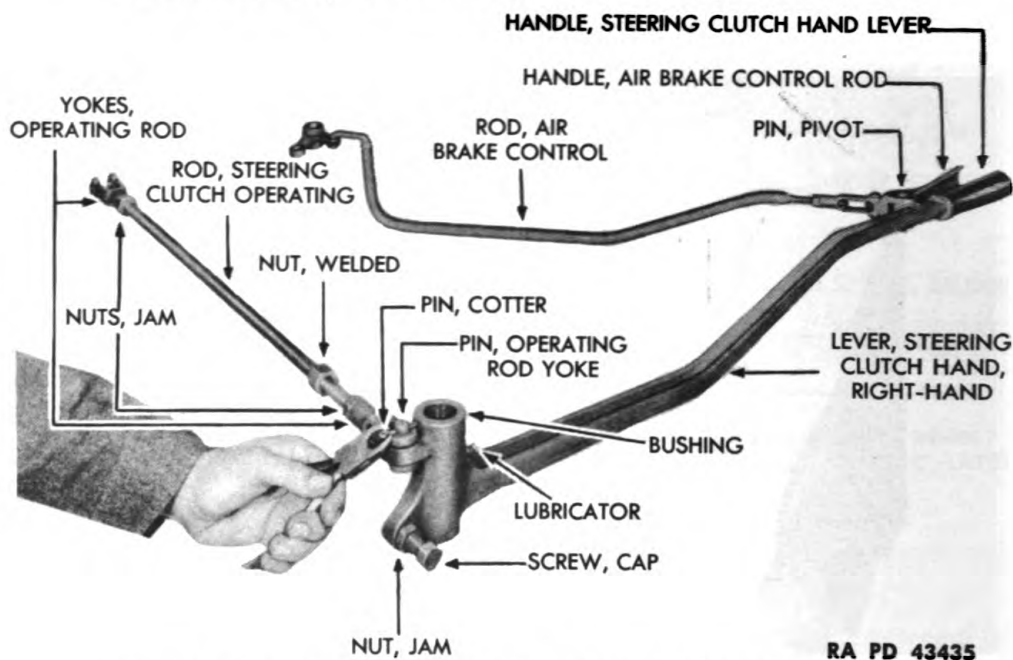

RA PD 43435

Figure 116 — Right Steering Clutch Lever Parts Removal

59. STEERING BRAKE CONTROL DISASSEMBLY.

a. Equipment.

CUTTERS, diagonal
DRIFT
HAMMER
PUNCH
SLEEVE, steel

WRENCH, open-end, 3/8-in.
WRENCH, open-end, 1/2-in.
WRENCH, open-end, 3/4-in.
WRENCH, open-end, 1 1/8-in.

b. Procedure.

(1) REMOVE STEERING CLUTCH CONTROLS FROM SHIFTER HOUSING (fig. 115).

DRIFT
HAMMER

WRENCH, open-end, 1/2-in.
WRENCH, open-end, 3/4-in.

(a) Use a 3/4-inch open-end wrench to remove pivot pin from bell crank at each end of steering clutch and hand lever shaft. Use a 1/2-inch open-end wrench to remove cap screw and lock washer which hold steering clutch and hand lever shaft to shifter housing.

(b) Use a hammer and drift to drive out steering clutch and hand lever shaft. Remove left and right steering clutch hand levers with air and electric brake control rods and handles attached.

STEERING CLUTCHES AND BRAKES

(2) REMOVE PARTS FROM RIGHT STEERING CLUTCH HAND LEVER (fig. 116).

CUTTERS, diagonal

HAMMER

PUNCH

WRENCH, open-end, $\frac{3}{8}$ -in.

WRENCH, open-end, $\frac{3}{4}$ -in.

WRENCH, open-end, $\frac{1}{2}$ -in.

(a) Remove steering clutch operating rod. Use diagonal cutters to remove cotter pin from operating rod yoke pin; then remove rod. Use a $\frac{1}{2}$ -inch open-end wrench to hold the welded nut and remove the 2 operating rod yokes, inserting a wrench handle between each yoke to unscrew it from the rod.

(b) Remove air brake control rod and handle. Use diagonal cutters to remove cotter pin from handle pivot pin; then remove pin.

(c) Use a $\frac{3}{4}$ -inch open-end wrench to loosen jam nut and to remove cap screw from right steering clutch hand lever.

(d) Inspect bushings in lever for excessive play when hand lever shaft is installed. If excessive play exists, use a hammer and punch to drive out the 2 bushings from lever.

(e) Use a $\frac{3}{8}$ -inch open-end wrench to remove lubricator from hand lever.

(f) If handle is loose or worn excessively, it should be removed so a new handle can be installed.

(3) SEPARATE INNER STEERING BRAKE LEVER FROM INNER STEERING BRAKE ROD (fig. 114).

CUTTERS, diagonal

Use diagonal cutters to remove cotter pin from upper inner rod end pin. Remove end pin, releasing inner rod and inner lever.

(4) REMOVE RIGHT STEERING BRAKE LEVER OUTER BUSHING (fig. 117).

HAMMER

PUNCH

SLEEVE, steel

(a) Remove felt.

(b) Use punch and hammer to drive out steering brake operating shaft plug.

(c) Drive out bushing, using a steel sleeve and hammer to drive it from main frame. **NOTE:** The remaining parts of steering clutch and brake controls are disassembled in the process of removal from tractor.

(5) REMOVE LEFT STEERING CLUTCH AND BRAKE CONTROLS.

Follow the procedure outlined in (2), (3), and (4) of this paragraph.

**ORDNANCE MAINTENANCE — HEAVY TRACTOR MI (IHC TD-18) —
POWER TRAIN, TRACK FRAME ASSEMBLY, AND SEATS**

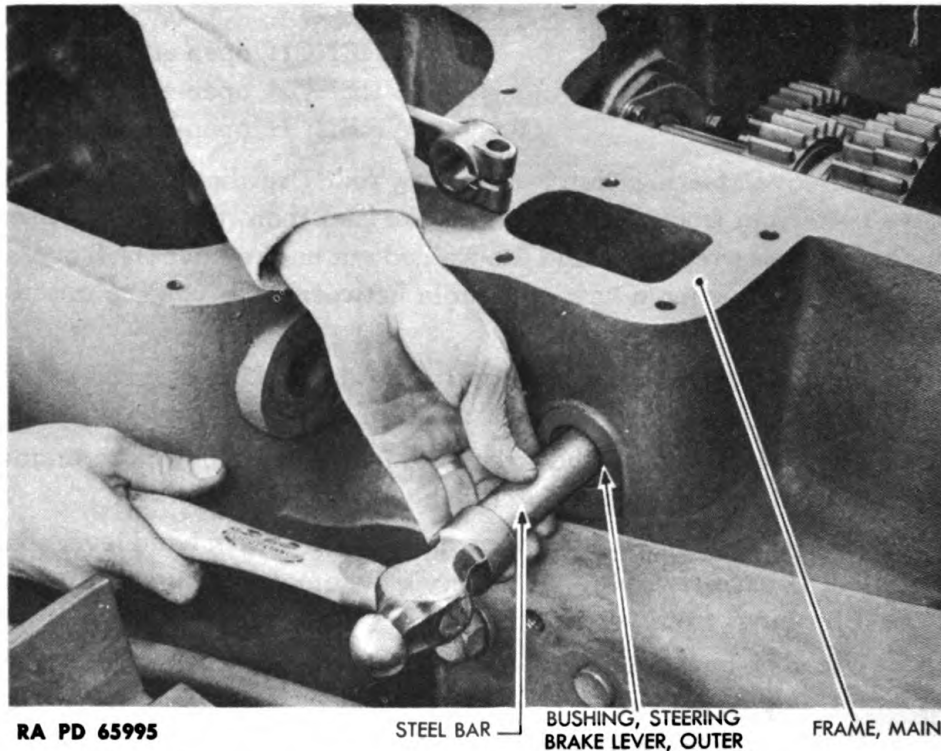

Figure 117 — Steering Brake Lever Outer Bushing Removal

60. STEERING BRAKE CONTROL PARTS, INSPECTION.

a. **Clean All Parts.** If necessary, use water to wash mud and dirt from exterior controls; then wash all parts thoroughly in SOLVENT, dry-cleaning.

b. **Inspect the Disassembled Parts.**

(1) **BUSHINGS.** Inspect bushings in hand levers by inserting hand lever shafts and checking for excessive play. Replace if bushing clearance is greater than 0.005 inch.

(2) **CHECK FOR BROKEN PARTS.** Inspect rods, bell cranks, and springs.

(3) **CHECK FOR DAMAGED THREADS ON RODS AND CAP SCREWS.**

(4) **CHECK FOR WORN PIVOT PINS, YOKE PINS, AND END PINS.** Replace pins where visible evidence of wear is noted.

(5) **CHECK TENSION OF SPRINGS.** Replace all springs which provide insufficient tension for efficient operation.

(6) **REPLACE ALL BROKEN OR WORN PARTS.**

STEERING CLUTCHES AND BRAKES

61. STEERING BRAKE CONTROL ASSEMBLY.

a. Equipment.

- | | |
|--|--------------------------------------|
| BAR, steel | PUNCH |
| COMPOUND, joint and thread,
cement type B | WRENCH, open-end, $\frac{3}{8}$ -in. |
| CUTTERS, diagonal | WRENCH, open-end, $\frac{1}{2}$ -in. |
| DRIFT | WRENCH, open-end, $\frac{3}{4}$ -in. |
| HAMMER | WRENCH, open-end, $\frac{1}{2}$ -in. |

b. Procedure.

(1) **INSTALL RIGHT STEERING BRAKE LEVER OUTER BUSHING** (fig. 117).

- | | |
|------------|--------|
| BAR, steel | HAMMER |
|------------|--------|

- (a) Place steel bar over bushing and drive bushing into main frame.
- (b) Use hammer to install new steering brake operating shaft plug on inside of frame.
- (c) Install new felt over bushing, on outside of main frame.

(2) **INSTALL LEFT STEERING BRAKE LEVER OUTER BUSHING** (fig. 117).

Follow procedure outlined in (1) of this paragraph.

(3) **ASSEMBLE INNER STEERING BRAKE LEVER TO INNER STEERING BRAKE ROD** (fig. 114).

- | |
|-------------------|
| CUTTERS, diagonal |
|-------------------|

Install upper inner rod end pin, joining inner rod and inner lever. Then use diagonal cutters to install cotter pin in end pin. The procedure is the same for right and left controls.

(4) **ASSEMBLE PARTS TO RIGHT STEERING CLUTCH HAND LEVER** (fig. 116).

- | | |
|--|--------------------------------------|
| BAR, steel | HAMMER |
| COMPOUND, joint and thread,
cement type B | WRENCH, open-end, $\frac{3}{8}$ -in. |
| CUTTERS, diagonal | WRENCH, open-end, $\frac{3}{4}$ -in. |
| | WRENCH, open-end, $\frac{1}{2}$ -in. |

- (a) If new bushings are to be installed in lever, use a steel bar and a hammer to drive a bushing into each side of the lever.
- (b) Use a $\frac{3}{8}$ -inch open-end wrench to install the lubricator on the lever.
- (c) Use a $\frac{3}{4}$ -inch open-end wrench to install the cap screw and jam nut at the bottom of the lever.

**ORDNANCE MAINTENANCE — HEAVY TRACTOR MI (IHC TD-18) —
POWER TRAIN, TRACK FRAME ASSEMBLY, AND SEATS**

(d) If a new lever handle is to be installed, use joint and thread compound to cement it in place.

(e) Install jam nuts on each end of steering clutch operating rod, using a $\frac{1}{8}$ -inch open-end wrench; then attach yoke to each end of rod, inserting a wrench handle in each yoke to turn it. Tighten jam nuts when yokes are in correct position. Refer to paragraph 57 for adjustment of the steering clutches.

(f) Attach operating rod to hand lever by inserting operating rod yoke pin through rod yoke and lever. Use diagonal cutters to install cotter pin in yoke pin.

(g) Attach air brake control rod and handle, inserting handle pivot pin through handle and steering clutch hand lever. Use diagonal cutters to install cotter pin in pivot pin.

(5) **ASSEMBLE PARTS TO LEFT STEERING CLUTCH HAND LEVER (fig. 116).**

Follow the procedure outlined in (4) of this paragraph.

(6) **ATTACH STEERING CLUTCH CONTROLS TO SHIFTER HOUSING (fig. 115).**

DRIFT

WRENCH, open-end, $\frac{1}{2}$ -in.

HAMMER

WRENCH, open-end, $\frac{3}{4}$ -in.

(a) Place left and right steering clutch hand levers, with air and electric brake control rods and handles attached, in position on the shifter housing; then use a hammer and drift to drive steering clutch and hand lever shaft into position.

(b) Install cap screw and lock washer which hold steering clutch and hand lever shaft to shifter housing, tightening cap screw with a $\frac{1}{2}$ -inch open-end wrench. Attach bell crank at each end of steering clutch and hand lever shaft by installing a pivot pin in bell crank and shifter housing. Tighten pivot pins with a $\frac{3}{4}$ -inch open-end wrench.

62. STEERING BRAKE CONTROL INSTALLATION.

a. Equipment.

CUTTERS, diagonal

WRENCH, open-end, $1\frac{1}{8}$ -in.

PLIERS

WRENCH, socket, $\frac{5}{8}$ -in.

WRENCH, open-end, $\frac{1}{2}$ -in.

WRENCH, socket, $\frac{3}{4}$ -in.

WRENCH, open-end, 1-in.

WRENCH, socket, $1\frac{1}{2}$ -in.

STEERING CLUTCHES AND BRAKES

b. Procedure.

(1) INSTALL BRAKE PEDAL AND STOP LIGHT SWITCH (fig. 113).

WRENCH, open-end, 1/2-in. WRENCH, socket, 1 1/2-in.

WRENCH, open-end, 1 1/8-in.

(a) Install brake pedal through bottom of engine clutch cover, installing pedal shaft and tightening it with a 1 1/2-inch socket wrench. Install right pedal pad, tightening bolt, lock washer, and nut with a 1 1/8-inch open-end wrench.

(b) Place stop light switch in position under engine clutch cover and secure it to cover with 2 cap screws and lock washers. Tighten cap screws with a 1/2-inch open-end wrench.

(2) INSTALL STEERING BRAKE SET SCREW AND STEERING BRAKE RETURN SPRING ANCHOR (figs. 74 and 78).

WRENCH, open-end, 1-in. WRENCH, socket, 1 1/2-in.

WRENCH, socket, 5/8-in.

(a) From inside main frame, place steering brake return spring anchor in position. From underneath main frame (outside), use a 1 1/2-inch socket wrench to install and tighten anchor nut.

(b) From underneath main frame (outside), install steering brake band set screw with lock nut attached, tightening the screw moderately with a 5/8-inch socket wrench and back off one half turn. Tighten lock nut with a 1-inch open-end wrench while holding the screw.

(3) INSTALL INNER STEERING BRAKE ROD AND INNER STEERING BRAKE LEVER (figs. 73 and 114).

CUTTERS, diagonal

PLIERS

(a) Place inner rod with inner steering brake lever attached in position in main frame. Install lower steering brake inner rod end pin in the inner steering brake rod and steering brake pivot lever. Use diagonal cutters to install cotter pin in end pin.

(b) Use pliers to install return spring to anchor and steering brake band. NOTE: If brake bands have been removed, place inner steering brake rod and inner steering brake lever in position and install return spring to anchor.

(4) INSTALL RIGHT OUTER STEERING BRAKE LEVER (fig. 114).

PLIERS

WRENCH, socket, 3/4-in.

Insert right outer steering brake lever into side of main frame and through inner steering brake lever; then install cap screw and lock washer which hold inner lever to outer lever. Tighten cap screw, using a 3/4-inch

**ORDNANCE MAINTENANCE – HEAVY TRACTOR MI (IHC TD-18) –
POWER TRAIN, TRACK FRAME ASSEMBLY, AND SEATS**

socket wrench. Use pliers to install release spring to anchor and to upper inner rod end pin.

(5) **INSTALL OUTER STEERING BRAKE ROD TO OUTER STEERING BRAKE LEVER (fig. 113).**

CUTTERS, diagonal

Use outer rod end pin to attach outer rod to outer lever. Using diagonal cutters, install cotter pin in end pin.

(6) **INSTALL OUTER ROD ADJUSTING KNOB (fig. 113).**

Move steering brake pedal forward until outer steering brake rod can be inserted in steering brake outer rod pivot pin. Pull brake pedal back and screw on knob by hand.

(7) **INSTALL LEFT STEERING BRAKE CONTROLS IN THE SAME MANNER ((1) through (6) of this par.).**

(8) **INSTALL MAIN FRAME COVER.**

This involves installation of steering clutch controls and seat, fenders, and other parts, as outlined in paragraph 56 b (10) to the end of the paragraph. If steering brake bands have been removed, they should be installed as outlined in paragraph 50. If steering clutches have been removed, they should be installed as outlined in paragraph 56.

Section IV

FINAL DRIVES AND SPROCKETS

	Paragraph
Construction and operation	63
Final drive and sprocket inspection	64
Trouble shooting and echelons of maintenance and repair	65
Sprocket removal	66
Sprocket installation	67
Final drive removal	68
Final drive disassembly	69
Final drive parts, inspection and lubrication	70
Final drive assembly	71
Final drive installation	72
Track frame pivot shaft replacement	73

63. CONSTRUCTION AND OPERATION.

a. The drive is from the steering clutches to the sprockets through one set of spur gears. Each sprocket drive pinion is mounted on 2 ball bearings. One drive pinion ball bearing is in the sprocket carrier and the other in the gear cover. The hub of each sprocket engages splines on the hub of each drive gear and each unit rotates on 2 ball bearings pressed on the pivot shaft. Labyrinth type dirt deflectors and self-adjusting type diaphragm seats are provided for each bearing. Entire sprocket assembly may be removed without disturbing steering clutches. If desired, sprocket drive gear with its pinion may be reversed to other side; they are interchangeable. Each set of spur gears of the final drive operate in an oil bath.

b. Sprockets are heat-treated steel castings, having 29 teeth. Weight of tractor is carried on 10 track rollers in track frame and is transmitted to track frame by equalizer spring and pivot shaft. No weight is carried by sprockets. Each sprocket is reversible. It may be removed from its hub, reversed and placed back on same side of tractor, thereby utilizing both sides of teeth. Removal may be made after taking off track, track frame, pivot bearing, pivot bracket, diaphragm seal, bearing retainer with bearing and lock nut on hub of driver gear.

64. FINAL DRIVE AND SPROCKET INSPECTION.

a. Final Drive.

(1) **GASKETS.** Check assembly for oil leaks which may occur at sprocket drive gear cover gasket or at other gaskets which will be indicated by oil leaks at outside of sprocket drive gear cover.

**ORDNANCE MAINTENANCE – HEAVY TRACTOR MI (IHC TD-18) –
POWER TRAIN, TRACK FRAME ASSEMBLY, AND SEATS**

(2) **SPROCKET DRIVE GEAR COVER.** Check for cracks in housing.

(3) **SPROCKET DRIVE CARRIER.** Check for cracks in housing. Check for loose bolts which secure carrier to sprocket drive gear cover.

(4) **SPROCKET SHIELD.** Check for dents and damage which prevent it from properly shielding sprocket. Replace if it cannot be dented out satisfactorily.

b. Sprockets. Examine sprockets for wear. Excessive wear is indicated if sprocket jumps track chain when track adjustment is in accord with procedure outlined in paragraph 112. A worn sprocket (if worn on one side of teeth only) may be reversed by removing sprocket as outlined in paragraph 66 and installing sprocket in reverse position as outlined in paragraph 67.

65. TROUBLE SHOOTING AND ECHELONS OF MAINTENANCE AND REPAIR

a. Trouble Shooting.

(1) **FAILURE OF SPROCKET TO DRIVE TRACK.** Refer to paragraph 19.

(2) **FAILURE OF FINAL DRIVE TO DRIVE SPROCKET.** Check operation of all elements of power train, including transmission and drive bevel gear, engine clutch, and steering clutches. If they are functioning properly, remove sprocket and final drive as outlined in paragraph 68 and inspect to locate inoperative part or parts.

b. Echelons of Maintenance and Repair.

(1) **DEFINITIONS.** Refer to paragraph 22.

	ECHELONS		
	2nd	3rd	4th
Final drive—repair or replace.....		X	
Sprocket—replace or adjust.....		X	

66. SPROCKET REMOVAL (fig. 118).

a. Equipment.

WRENCH, socket, $1\frac{5}{16}$ -in.

b. Procedure.

(1) **REMOVE TRACK.**

Refer to paragraph 106 b (1) and (2).

FINAL DRIVES AND SPROCKETS

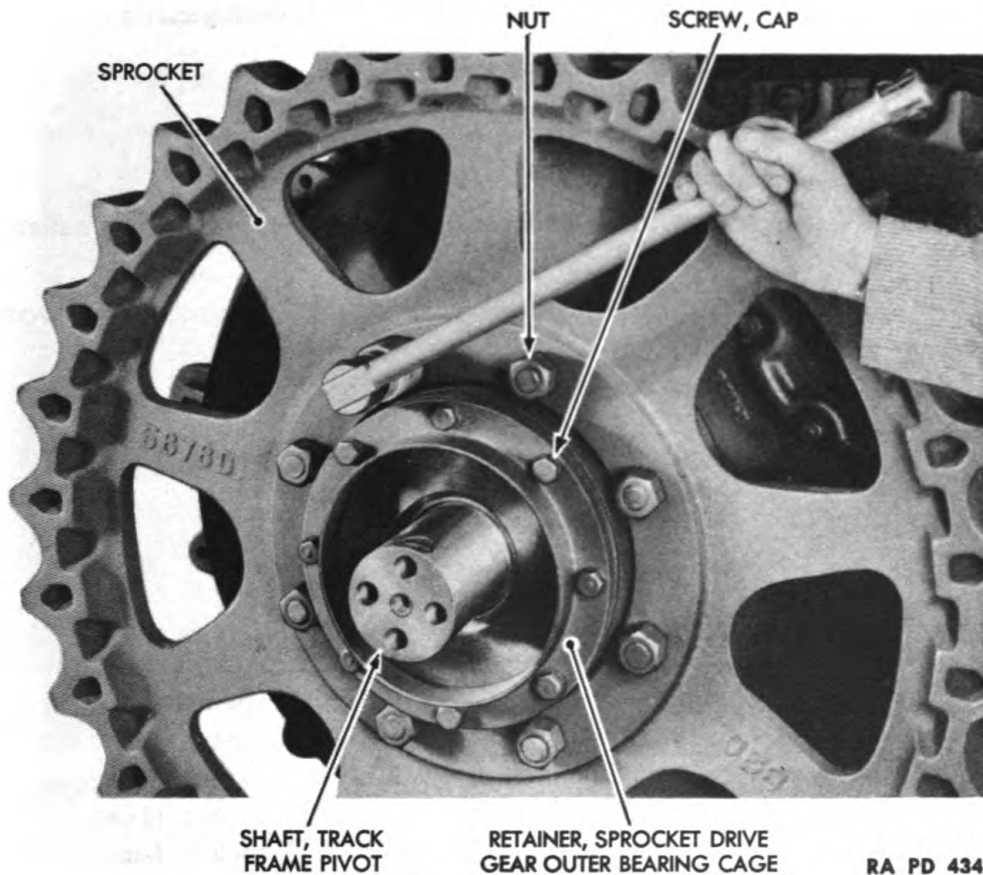

RA PD 43476

Figure 118 – Sprocket Removal**(2) REMOVE TRACK FRAME.**

Refer to paragraph 129 b (2) through (5).

(3) REMOVE PIVOT BEARING AND BRACKET.

Refer to paragraph 68 b (3).

(4) REMOVE SPROCKET (RIGHT).**WRENCH**, socket, $1\frac{5}{16}$ -in.Use a $1\frac{5}{16}$ -inch socket wrench to remove 8 cap screws with lock washers. Remove sprocket.**(5) REMOVE SPROCKET (LEFT).**

To remove left sprocket, follow procedure outlined in steps (1) (2) (3) and (4) above.

67. SPROCKET INSTALLATION (fig. 118).**a. Equipment.****WRENCH**, socket, $1\frac{5}{16}$ -in.

TM 9-1777C
67-68

**ORDNANCE MAINTENANCE — HEAVY TRACTOR MI (IHC TD-18) —
POWER TRAIN, TRACK FRAME ASSEMBLY, AND SEATS**

b. Procedure.

(1) INSTALL SPROCKET (RIGHT).

WRENCH, socket, $1\frac{5}{16}$ -in.

Use a $1\frac{5}{16}$ -inch socket wrench to install 8 cap screws with lock washers which secure sprocket to sprocket carrier.

(2) INSTALL TRACK FRAME PIVOT BEARING, BRACKET, AND PIVOT BEARING CAP.

Refer to paragraph 72 b (8) and (9).

(3) INSTALL TRACK FRAME ON TRACTOR.

Refer to paragraph 132 b (9).

68. FINAL DRIVE REMOVAL.

a. Equipment.

BLOCK, wood

CHISEL

HAMMER

SCREW, cap, $\frac{3}{8}$ -in. NC (3)

SCREW, cap, $\frac{1}{2}$ -in. NC (3)

WRENCH, socket, sprocket carrier nut, SE 1184-2, with iron bar

WRENCH, open-end, $\frac{9}{16}$ -in.

WRENCH, open-end, $\frac{3}{4}$ -in.

WRENCH, socket, $\frac{3}{4}$ -in.

WRENCH, socket, $\frac{7}{8}$ -in.

WRENCH, socket, $1\frac{1}{8}$ -in.

WRENCH, socket, 1-in.

b. Procedure.

(1) REMOVE TRACK FRAME.

Follow procedure outlined in paragraph 129 b (1) through (5).

(2) REMOVE TRACK FRAME PIVOT BEARING (figs. 119 and 183).

WRENCH, socket, $\frac{3}{4}$ -in.

WRENCH, socket, 1-in.

(a) Use 1-inch socket wrench to remove 4 cap screws with lock washers which hold track frame pivot bearing cap to track frame pivot bracket. Remove cap and gasket.

(b) Use $\frac{3}{4}$ -inch socket wrench to remove 4 cap screws and lock washers which secure pivot bearing to end of track frame pivot shaft.

(c) Remove pivot bearing, bracket, and track frame pivot oil seal packing.

(3) REMOVE TRACK FRAME PIVOT OIL SEAL DIRT DEFLECTOR.

WRENCH, socket, $\frac{3}{4}$ -in.

Use a $\frac{3}{4}$ -inch socket wrench to remove cap screws and lock washers. Then remove dirt deflector, retainer and gasket.

FINAL DRIVES AND SPROCKETS

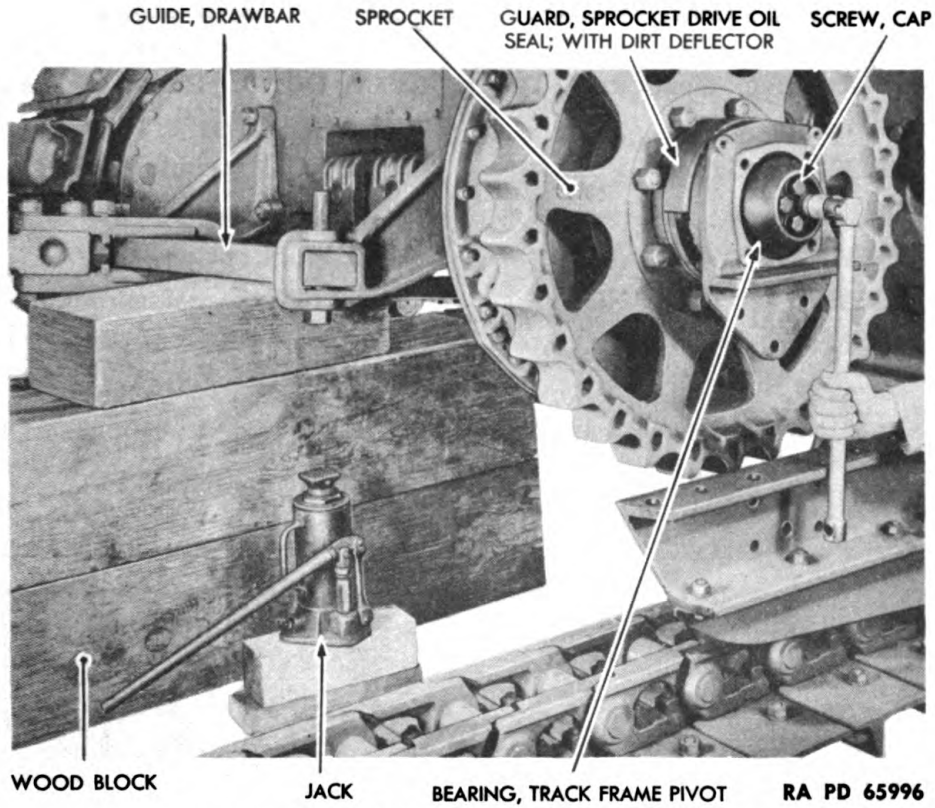

Figure 119 – Track Frame Pivot Bearing Removal

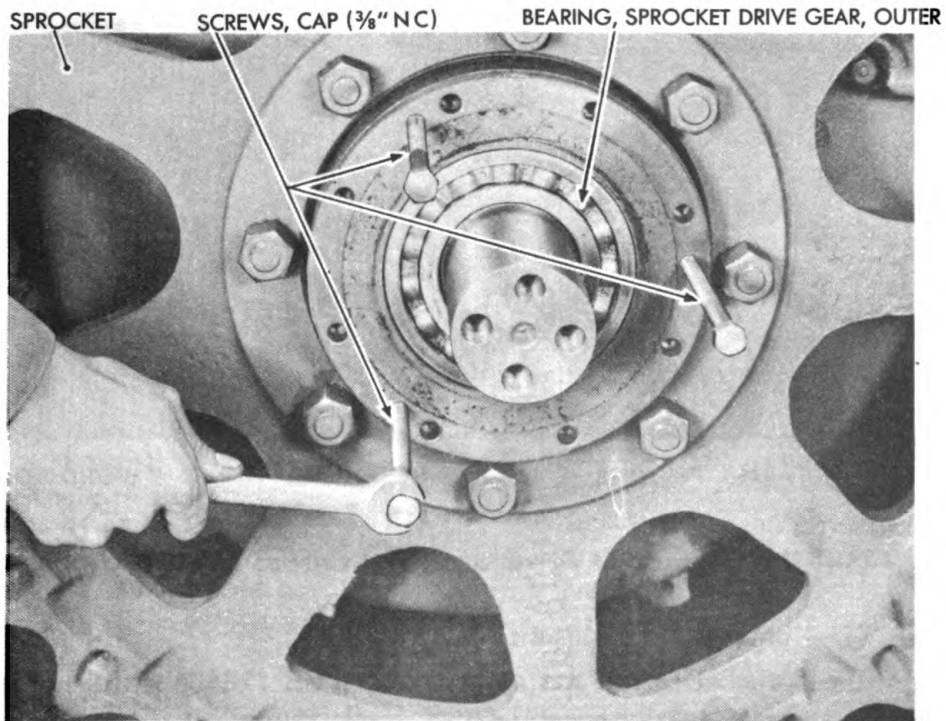

Figure 120 – Sprocket Drive Gear Outer Bearing Cage Removal

ORDNANCE MAINTENANCE — HEAVY TRACTOR MI (IHC TD-18) —
POWER TRAIN, TRACK FRAME ASSEMBLY, AND SEATS

(4) REMOVE SPROCKET DRIVE GEAR OUTER BEARING CAGE (fig. 120).

BLOCK, wood

CHISEL

HAMMER

SCREW, cap, $\frac{3}{8}$ -in. NC (3)

WRENCH, open-end, $\frac{9}{16}$ -in.

WRENCH, socket, $\frac{3}{4}$ -in.

WRENCH, socket, $\frac{7}{8}$ -in.

WRENCH, socket, 1-in.

WRENCH, socket, sprocket carrier nut, SE 1184-2, with iron bar

(a) Attach three $\frac{3}{8}$ -inch NC cap screws and use $\frac{9}{16}$ -inch open-end wrench to turn until bearing cage is freed.

(b) Remove bearing cage and gasket.

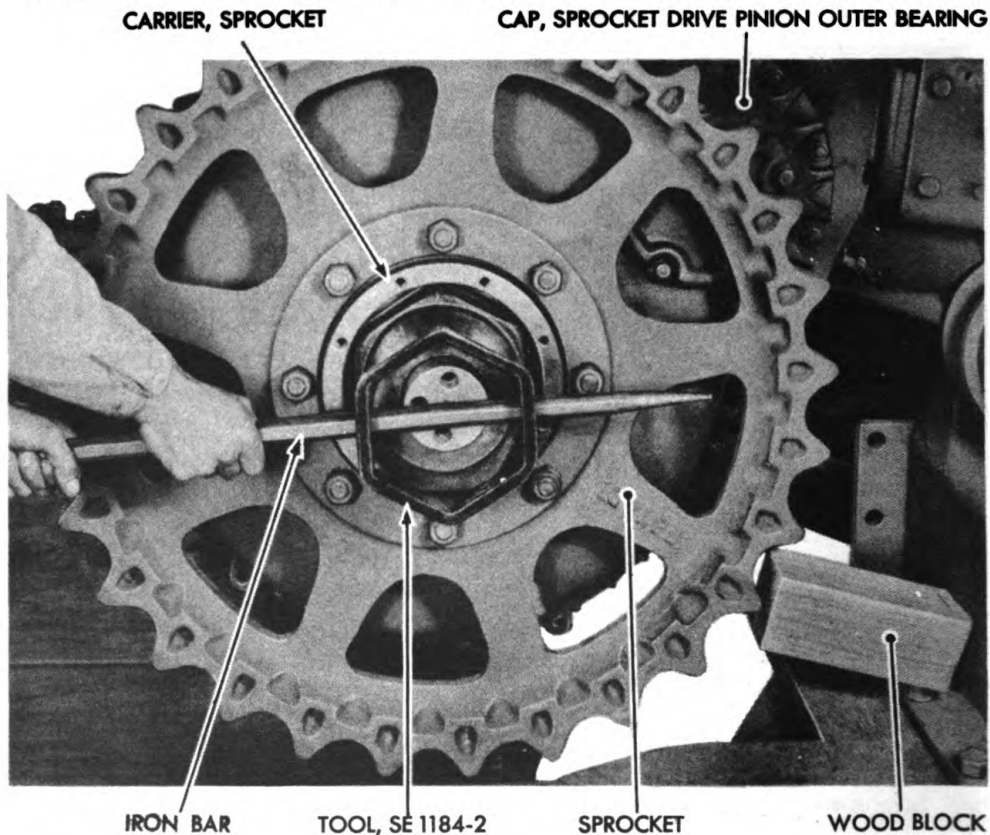

RA PD 65997

Figure 121 — Sprocket Drive Gear and Carrier Nut Removal

(c) Use hammer and chisel to bend up lock.

(d) Use sprocket carrier nut socket wrench SE 1184-2, with iron bar, to remove nut. Block sprocket against track frame with wood block.

(e) Remove nut and lock. Lift off sprocket. Pull out sprocket drive gear outer bearing spacer (long).

FINAL DRIVES AND SPROCKETS

(5) REMOVE SPROCKET DRIVE PINION OUTER BEARING CAP (fig. 121).

WRENCH, socket, $\frac{3}{4}$ -in.

Use $\frac{3}{4}$ -inch socket wrench to remove 6 cap screws with lock washers which hold cap to sprocket drive gear covers. Remove cap and gasket.

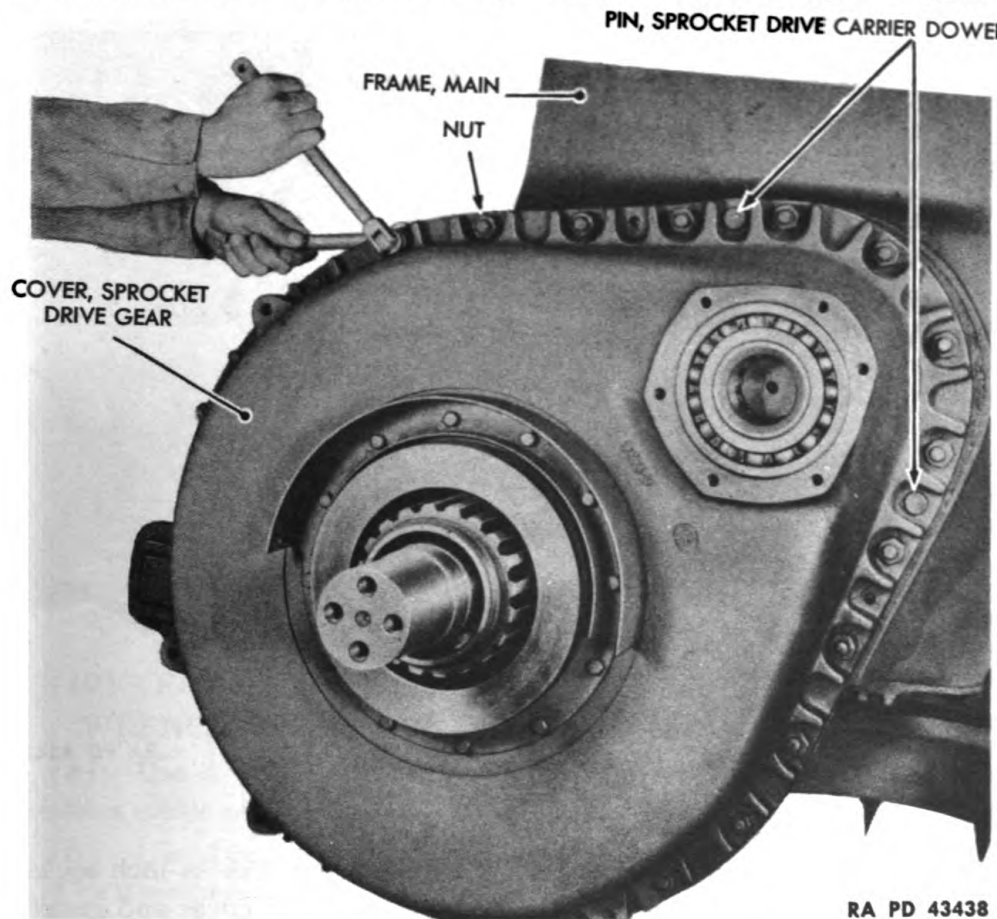

RA PD 43438

Figure 122 — Sprocket Drive Gear Cover Removal

(6) REMOVE SPROCKET DRIVE GEAR COVER (fig. 122).

SCREWS, cap, $\frac{1}{2}$ -in. NC (3)

WRENCH, socket, $\frac{7}{8}$ -in.

WRENCH, open-end, $\frac{3}{4}$ -in.

WRENCH, socket, $\frac{1}{8}$ -in.

WRENCH, socket, $\frac{3}{4}$ -in.

(a) Use $\frac{3}{4}$ -inch socket wrench to remove 14 cap screws with lock washers, which hold cover to sprocket drive carrier. Hold heads with a $\frac{3}{4}$ -inch open-end wrench.

(b) Use $\frac{1}{8}$ -inch socket wrench to remove 10 nuts and lock washers, which hold cover to sprocket drive carrier, using a $\frac{7}{8}$ -inch open-end wrench to hold heads.

ORDNANCE MAINTENANCE — HEAVY TRACTOR MI (IHC TD-18) —
POWER TRAIN, TRACK FRAME ASSEMBLY, AND SEATS

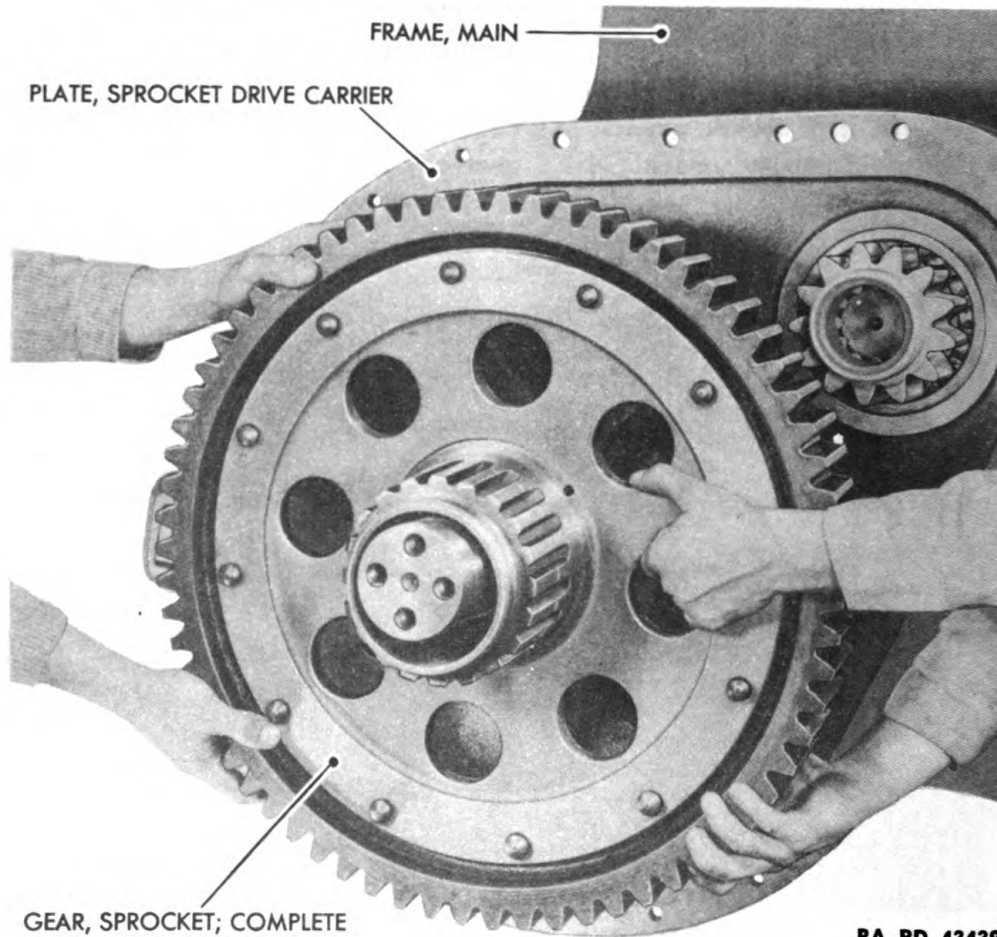

Figure 123 — Sprocket Gear Removal

(c) Insert three $\frac{1}{2}$ -inch NC cap screws in cover. Use $\frac{3}{4}$ -inch socket wrench to tighten cap screws to remove cover. Lift off cover and gasket.

(7) REMOVE SPROCKET DRIVE GEAR COMPLETE (fig. 123).

(a) Pull or force out gear. Two men are required to lift it off.

(b) Pull or force out sprocket drive pinion.

(8) REMOVE STEERING CLUTCHES (par. 52).

If it is necessary to remove the carrier plate, sprocket drive pinion shaft, or bearings, on the pinion shaft or in the carrier plate, perform this and the following steps.

(9) REMOVE SPROCKET DRIVE PINION SHAFT (fig. 124).

WRENCH, socket, $\frac{3}{4}$ -in.

Use a $\frac{3}{4}$ -inch socket wrench to remove 4 cap screws and lock washers which hold steering clutch support bearing retainer to carrier plate. Lift out shaft with attached parts.

FINAL DRIVES AND SPROCKETS

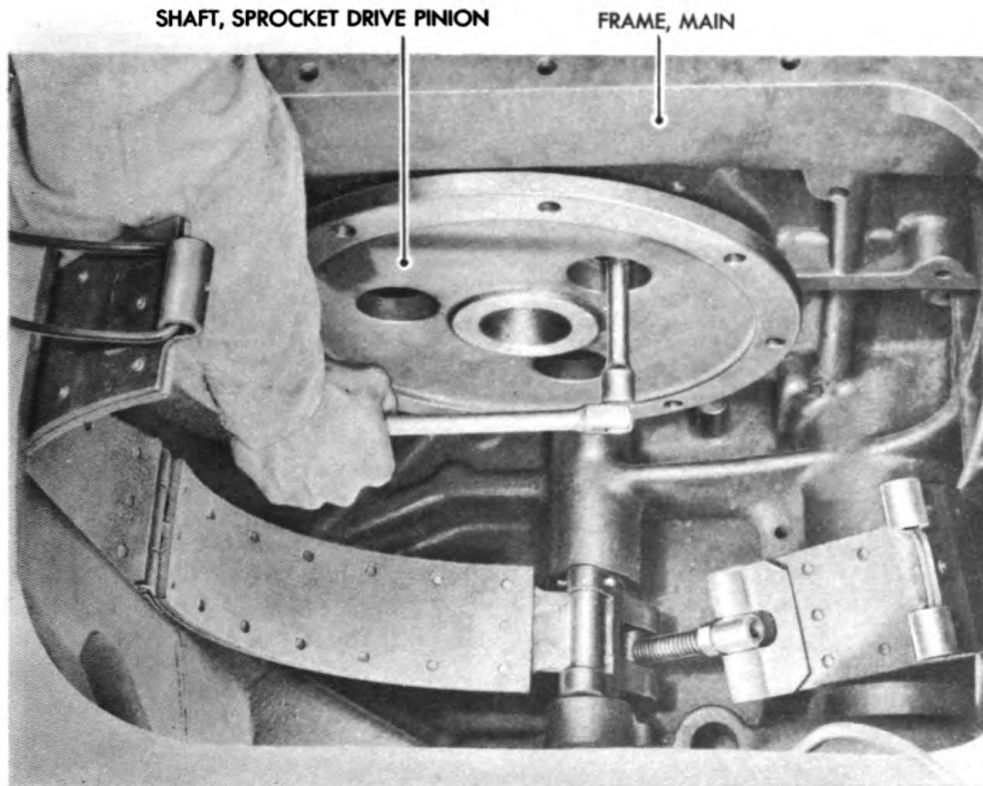

RA PD 43454

Figure 124 – Sprocket Drive Pinion Shaft Removal

(10) REMOVE SPROCKET DRIVE CARRIER PLATE (fig. 125).

WRENCH, socket, $\frac{7}{8}$ -in.

WRENCH, socket, 1-in.

(a) Use a $\frac{7}{8}$ -inch socket wrench to remove cap screws and lock washers inside of plate which hold carrier plate to main frame.

(b) Use 1-inch socket wrench to remove 8 nuts from cap screws and lock washers from studs on main frame around outside of plate, also cap screws with lock washers.

(c) Remove carrier plate and short spacer.

69. FINAL DRIVE DISASSEMBLY.

a. Equipment.

HAMMER

PLIERS

PRESS, arbor

PUNCH, brass

WRENCH, adjustable

WRENCH, box, $\frac{9}{16}$ -in.

WRENCH, open-end, $\frac{7}{16}$ -in.

WRENCH, socket, $\frac{7}{16}$ -in.

WRENCH, socket, $\frac{9}{16}$ -in.

b. Procedure.

(1) REMOVE SPROCKET DRIVE OIL SEAL (figs. 126 and 127).

WRENCH, box, $\frac{9}{16}$ -in.

WRENCH, socket, $\frac{7}{16}$ -in.

**ORDNANCE MAINTENANCE — HEAVY TRACTOR M1 (IHC TD-18) —
POWER TRAIN, TRACK FRAME ASSEMBLY, AND SEATS**

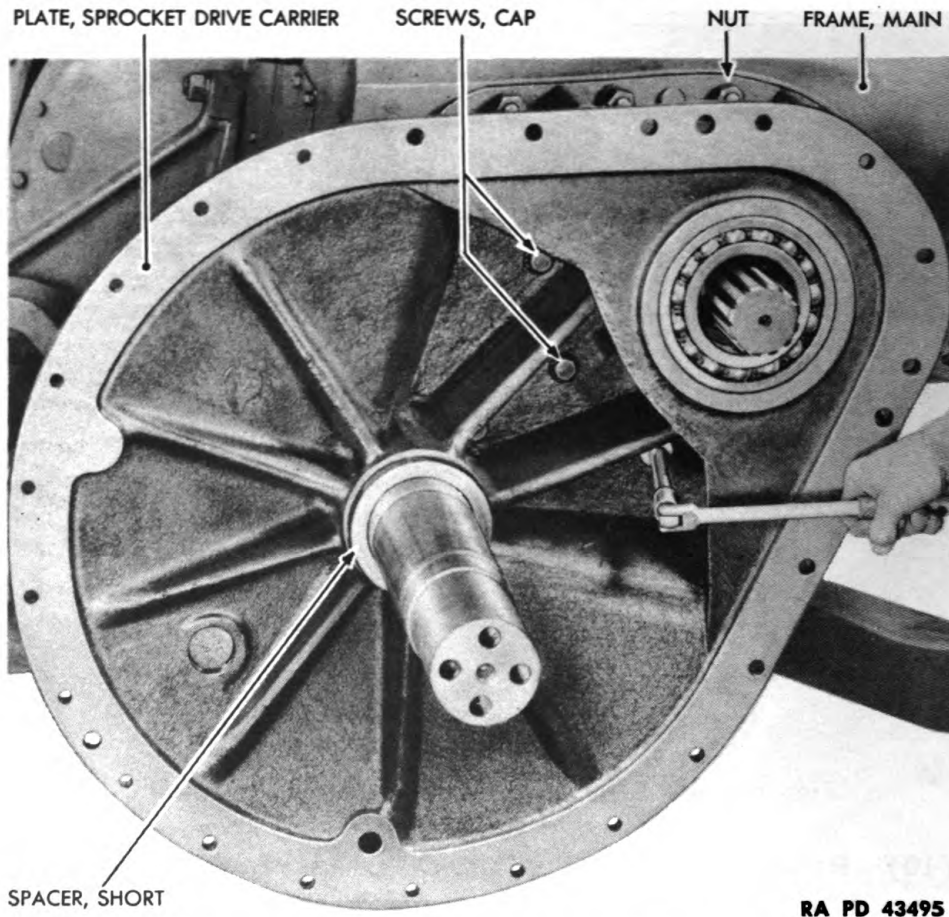

RA PD 43495

Figure 125 — Sprocket Drive Carrier Plate Removal

- (a) Use a $\frac{9}{16}$ -inch box wrench to remove 12 cap screws with lock washers which hold guard with dirt deflector to sprocket drive gear cover.
 - (b) Remove guard with oil seal and 6 springs.
 - (c) Use $\frac{7}{16}$ -inch socket wrench to remove 12 cap screws with lock washers which hold diaphragm retainer to sprocket drive oil seal pressure plate (fig. 127).
 - (d) Remove retainer, diaphragm, and pressure plate.
- (2) **DISASSEMBLE TRACK FRAME PIVOT BRACKET** (figs. 128 and 129).

HAMMER

PLIERS

PUNCH, brass

WRENCH, adjustable

WRENCH, box, $\frac{9}{16}$ -in.

WRENCH, open-end, $\frac{7}{16}$ -in.

WRENCH, socket, $\frac{9}{16}$ -in.

- (a) Use $\frac{9}{16}$ -inch socket wrench to remove 8 cap screws with lock washers which hold guard with dirt deflector to bracket.

FINAL DRIVES AND SPROCKETS

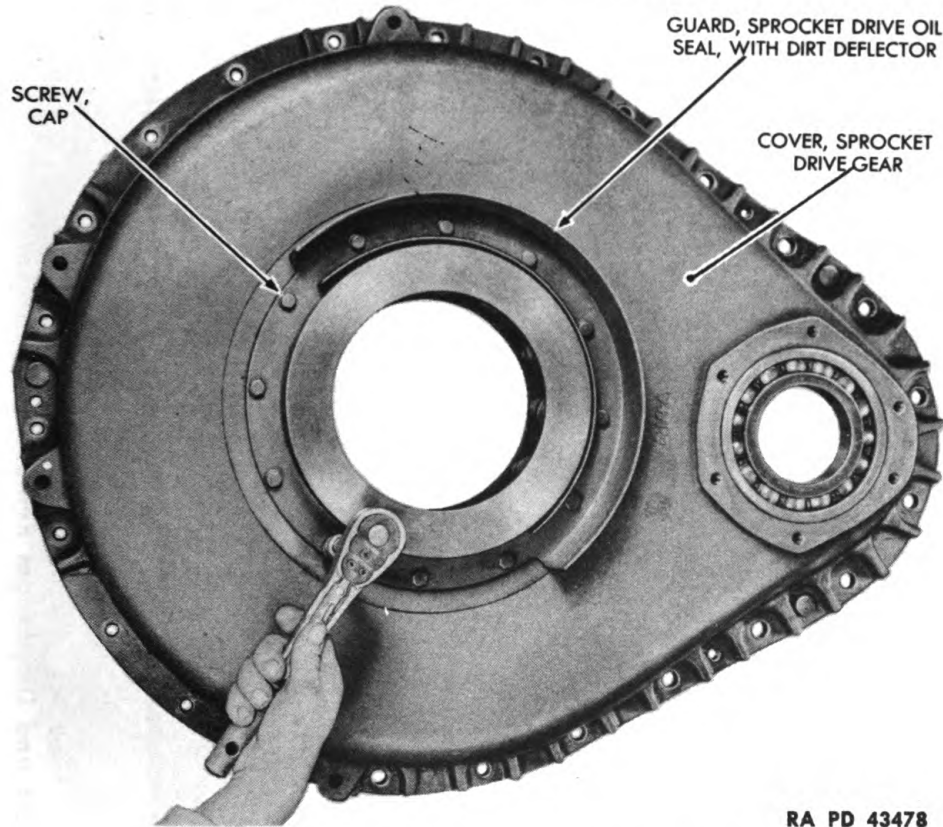

RA PD 43478

Figure 126 – Sprocket Drive Oil Seal Removal

(b) Remove guard with oil seal and 6 springs.

(c) Use $\frac{7}{16}$ -inch open-end wrench to remove 8 cap screws with lock washers which hold retainer to track frame pivot oil seal pressure plate (fig. 129).

(d) Remove retainer, diaphragm and pressure plate.

(3) REMOVE STEERING CLUTCH SUPPORT BEARING AND OIL SEAL (fig. 130).

HAMMER

WRENCH, adjustable

PLIERS

WRENCH, box, $\frac{9}{16}$ -in.

PUNCH, brass

(a) Use pliers to remove lock wire.

(b) Use $\frac{9}{16}$ -inch box wrench to remove 2 lock bolts which secure bearing nut.

(c) Use adjustable wrench to remove bearing nut.

(d) Remove bearing in cage with oil seal.

(e) Use brass punch and hammer to drive out bearing and oil seal.

ORDNANCE MAINTENANCE – HEAVY TRACTOR MI (IHC TD-18) –
POWER TRAIN, TRACK FRAME ASSEMBLY, AND SEATS

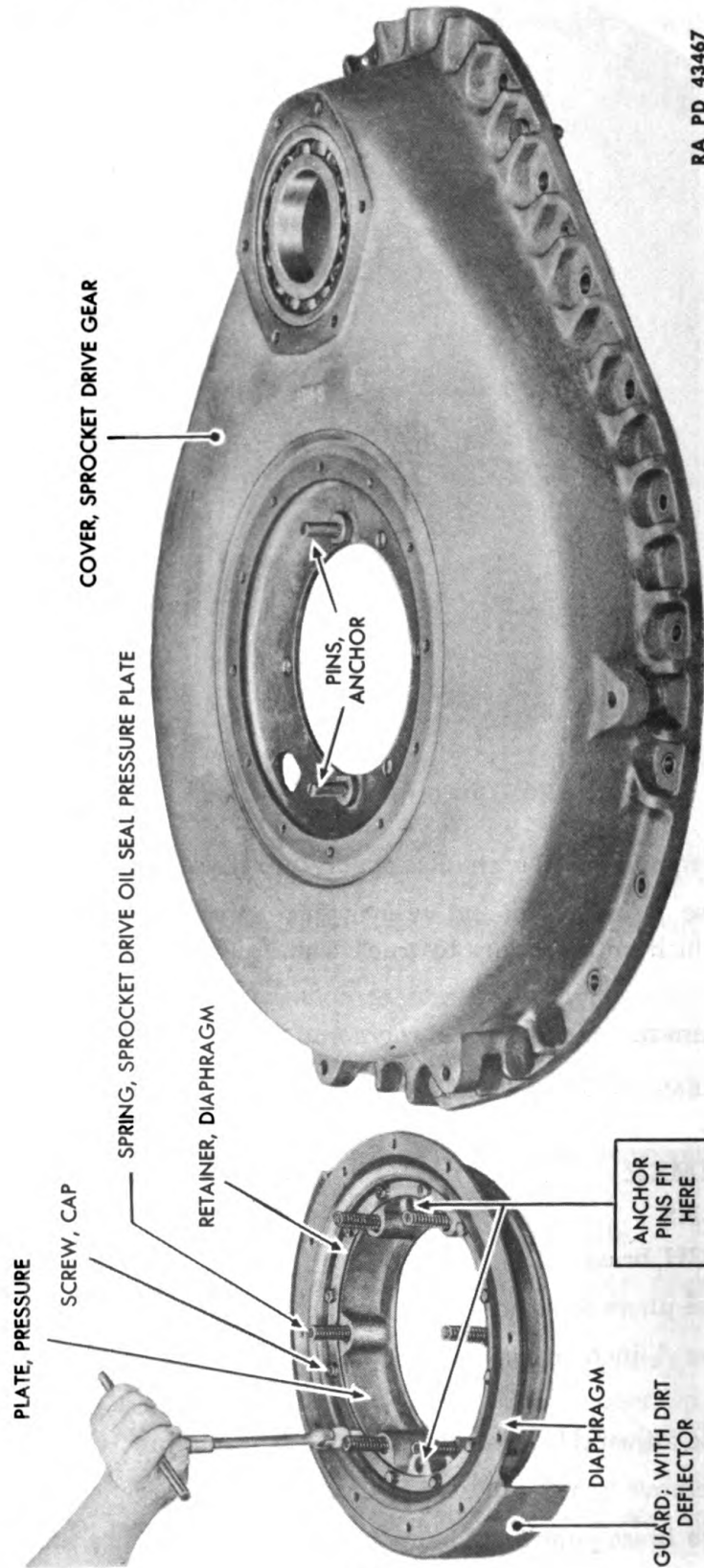

RA PD 43467

Figure 127 – Diaphragm Retainer and Diaphragm Removal

FINAL DRIVES AND SPROCKETS

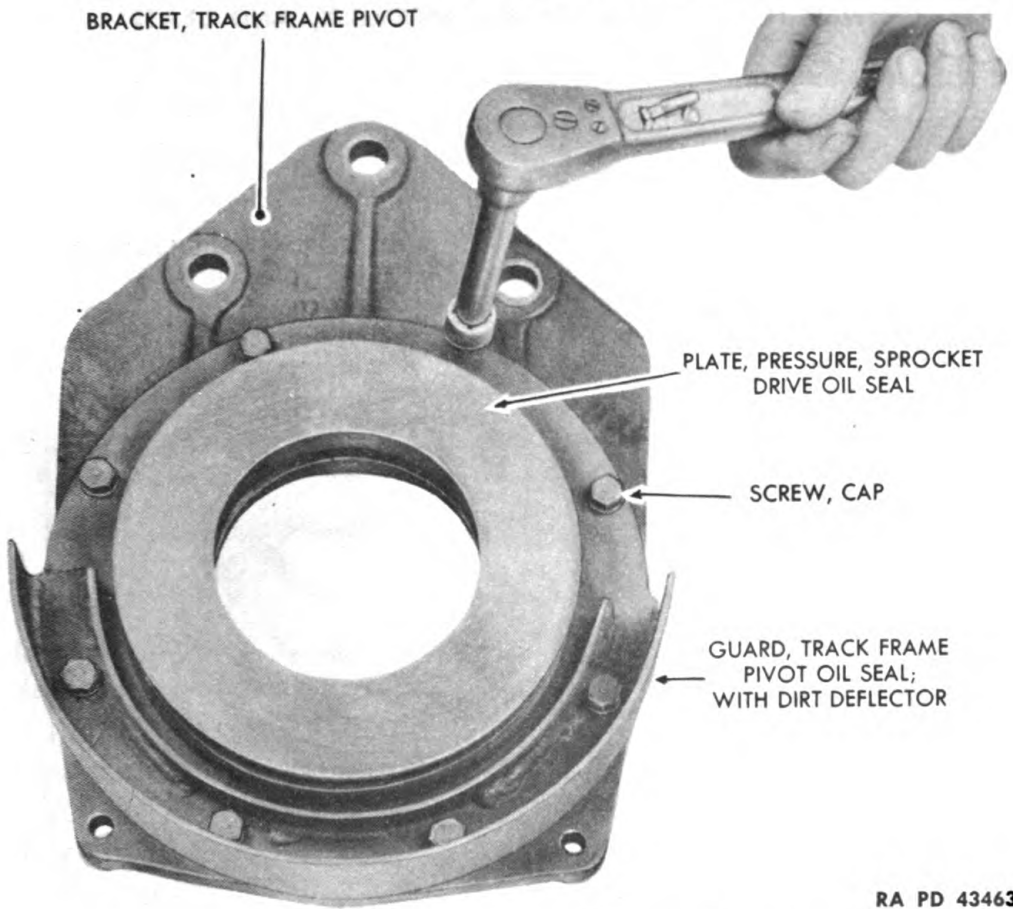

Figure 128 – Track Frame Pivot Bracket Disassembly

SPRING, TRACK FRAME PIVOT OIL SEAL PRESSURE PLATE

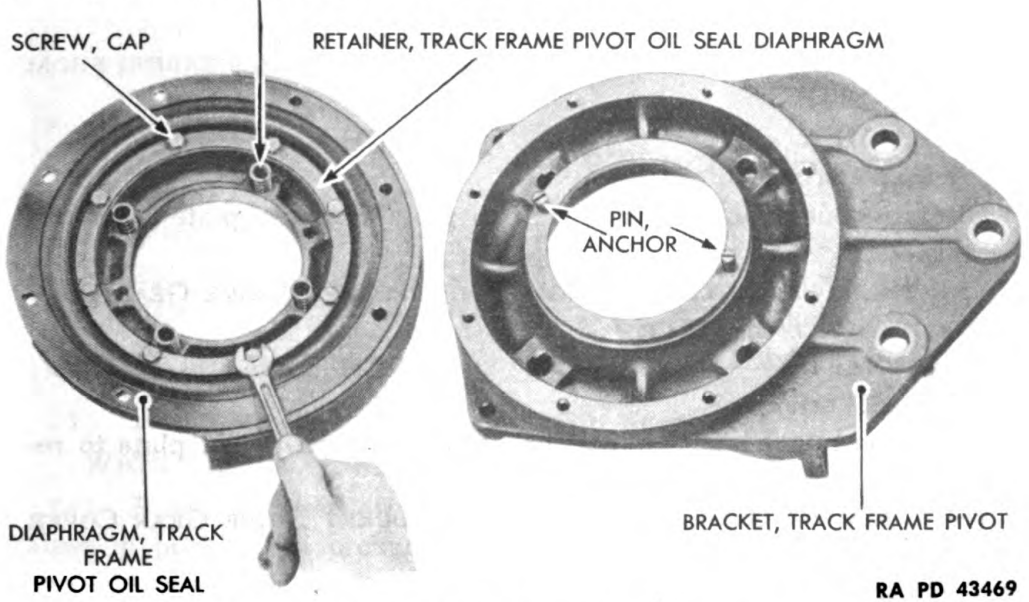

Figure 129 – Diaphragm Retainer and Diaphragm Removal

Generated on 2014-12-08 12:45 GMT / http://hdl.handle.net/2027/uc1.b3243976
Public Domain, Google-digitized / http://www.hathitrust.org/access_use#pd-google

ORDNANCE MAINTENANCE — HEAVY TRACTOR MI (IHC TD-18) —
POWER TRAIN, TRACK FRAME ASSEMBLY, AND SEATS

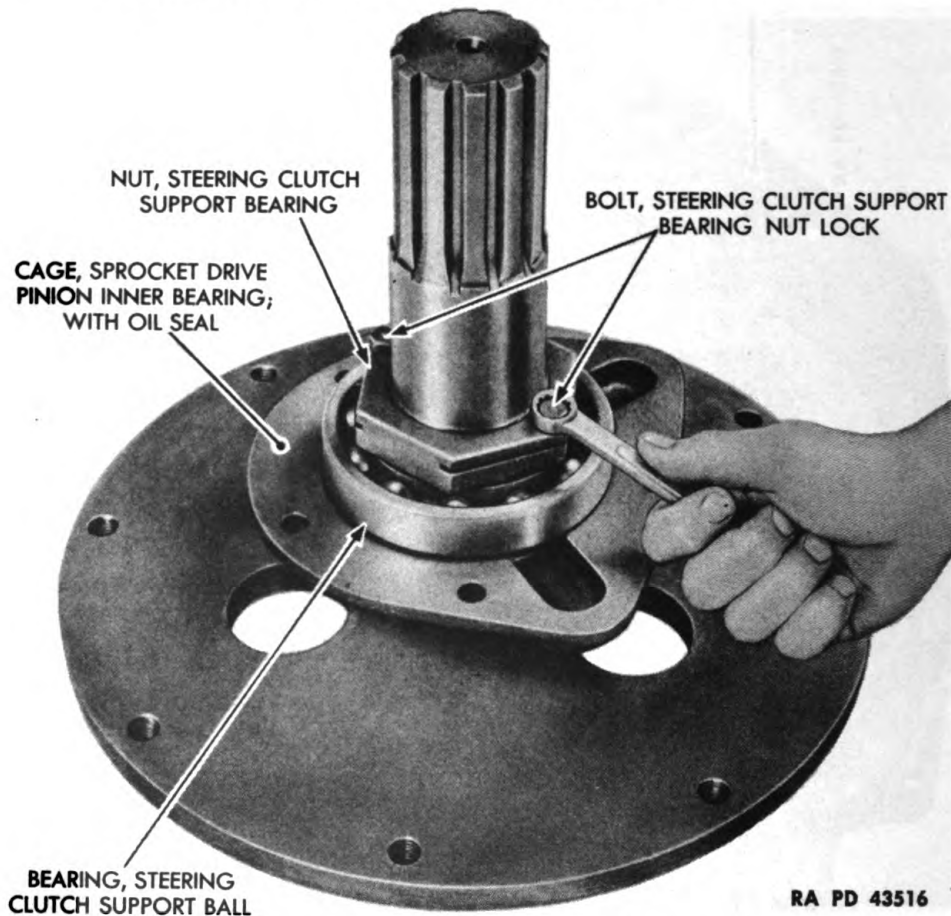

Figure 130 — Sprocket Drive Pinion Shaft Disassembly

(4) REMOVE SPROCKET DRIVE GEAR OUTER BALL BEARING FROM CAGE (fig. 120).

HAMMER

PUNCH, brass

PRESS, arbor

Use brass punch and hammer or arbor press with steel plate to remove bearing.

(5) REMOVE INNER BEARING FROM SPROCKET DRIVE GEAR COMPLETE (reverse of fig. 131).

HAMMER

PUNCH, brass

PRESS, arbor

Use brass punch and hammer or arbor press with steel plate to remove bearing.

(6) REMOVE BALL BEARING FROM SPROCKET DRIVE GEAR COVER (fig. 122).

HAMMER

PUNCH, brass

Use brass punch and hammer to drive out bearing.

FINAL DRIVES AND SPROCKETS

(7) REMOVE SPROCKET DRIVE PINION INNER BALL BEARING FROM SPROCKET DRIVE CARRIER (fig. 125).

HAMMER

PUNCH, brass

Use brass punch and hammer to drive out bearing.

70. FINAL DRIVE PARTS, INSPECTION AND LUBRICATION.

a. **Clean All Parts.** Wash all gears, shaft and other parts in SOLVENT, dry-cleaning. No part or subassembly should be installed unless it is either new, completely rebuilt, repaired or inspection proves that it is in good operating condition. All defective parts should be replaced with new parts.

b. **Inspect All Disassembled Parts.**

(1) **BEARINGS.** See that bearings fit snugly and that bearings are not loose in race or cage. If bearings are loose, replace the bearing. Inspect for cracks, checks and wear. Lubricate with OIL, lubricating, engine, SAE 30.

(2) **SHAFTS.** Inspect shafts for evidence of excessive wear. If grooved or otherwise damaged, install a new shaft.

(3) **GEARS.** Check gears for wear, chipped or broken teeth. Replace if necessary.

(4) **OIL SEALS.** When any oil seal has been removed, a new oil seal must be installed. Care should be taken in every case where oil seal is installed, so that lip is not damaged by improper installation. Replace packing if worn, also diaphragm.

71. FINAL DRIVE ASSEMBLY.

a. **Equipment.**

DRIFT, brass

HAMMER

PLIERS

PRESS, arbor

PUNCH, brass

WRENCH, adjustable

WRENCH, box, $\frac{9}{16}$ -in.

WRENCH, open-end, $\frac{7}{16}$ -in.

WRENCH, socket, $\frac{7}{16}$ -in.

WRENCH, socket, $\frac{9}{16}$ -in.

b. **Procedure.**

(1) **ASSEMBLE SPROCKET DRIVE OIL SEAL** (figs. 126 and 127).

WRENCH, box, $\frac{9}{16}$ -in.

WRENCH, socket, $\frac{7}{16}$ -in.

(a) Place sprocket drive oil seal diaphragm, and diaphragm retainer in position on pressure plate. Use a $\frac{7}{16}$ -inch socket wrench to install 12 cap screws with lock washers which hold retainer to pressure plate.

**ORDNANCE MAINTENANCE — HEAVY TRACTOR MI (IHC TD-18) —
POWER TRAIN, TRACK FRAME ASSEMBLY, AND SEATS**

(b) Install 6 springs in recesses of cover. Position pressure plate with guard upon cover as shown in figure 127. Use a $\frac{9}{16}$ -inch box wrench to secure 12 cap screws with lock washers which hold dust deflector unit to cover. When installed, dust deflector flange covers upper part of shaft opening.

(2) INSTALL TRACK FRAME PIVOT BRACKET (figs. 128 and 129).

WRENCH, open-end, $\frac{7}{16}$ -in. **WRENCH**, socket, $\frac{9}{16}$ -in.

(a) Install track frame pivot oil seal diaphragm, and diaphragm retainer on pressure plate. Use $\frac{7}{16}$ -inch open-end wrench to secure 8 cap screws with lock washers which hold retainer to pressure plate.

(b) Install 6 springs. Lift bracket over dirt deflector unit, being sure that dirt shield is opposite pointed side of bracket. Fit in place over anchor pins, taking care that springs remain in place. Use a $\frac{9}{16}$ -inch socket wrench to secure 8 cap screws with lock washers which hold oil seal unit to bracket.

(3) ASSEMBLE SPROCKET DRIVE PINION SHAFT (fig. 130).

HAMMER **WRENCH**, adjustable
PLIERS **WRENCH**, box, $\frac{9}{16}$ -in.
PUNCH, brass

(a) Use brass punch and hammer to install sprocket drive pinion oil seal and inner ball bearing in cage. Be sure that lip of oil seal faces steering clutch when cage is installed.

(b) Install bearing cage with oil seal on sprocket drive pinion shaft. Oil seal side of cage is toward plate on shaft end. Use adjustable wrench to secure large bearing nut.

(c) Install 2 lock bolts, using a $\frac{9}{16}$ -inch box wrench. Use pliers to secure with lock wire.

(4) ASSEMBLE OUTER SPROCKET DRIVE GEAR BALL BEARING IN CAGE (fig. 120).

HAMMER **PUNCH**, brass
PRESS, arbor

Use brass punch and hammer, or arbor press, to install bearing in cage.

(5) INSTALL INNER SPROCKET DRIVE GEAR BALL BEARING (fig. 131).

DRIFT, brass **HAMMER**

Install bearing in sprocket gear by tapping in place with brass drift and hammer.

FINAL DRIVES AND SPROCKETS

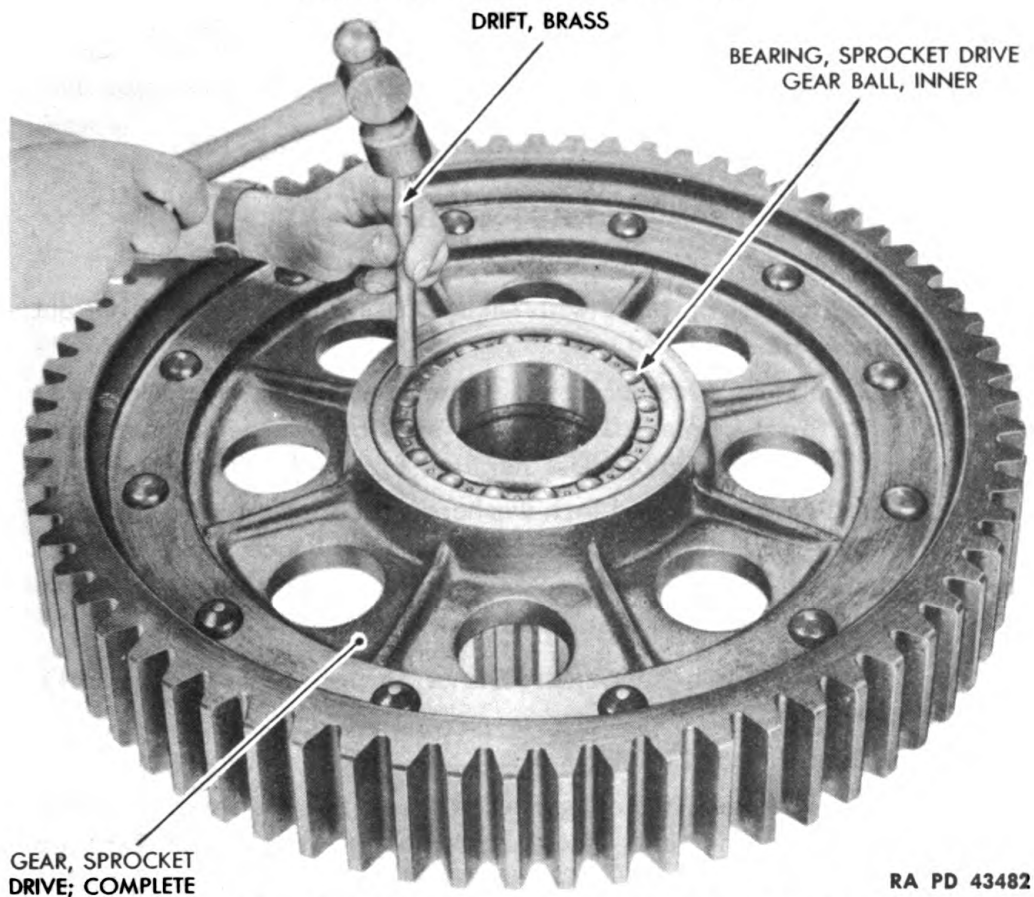

Figure 131 – Bearing in Sprocket Drive Gear; Complete Installation

(6) ASSEMBLE SPROCKET DRIVE PINION INNER BALL BEARING IN SPROCKET DRIVE CARRIER (fig. 125).

HAMMER

PUNCH, brass

Use a brass punch and hammer to install bearing in carrier.

72. FINAL DRIVE INSTALLATION.

a. Equipment.

BAR, iron

BLOCK, wood

CHISEL

DRIFTS, brass

HAMMER

HANDLE, spinner

PUNCH, brass

SHELLAC

SLEDGE

WRENCH, open-end, 3/4-in.

WRENCH, open-end, 7/8-in.

WRENCH, socket, 3/4-in.

WRENCH, socket, 7/8-in.

WRENCH, socket, 1 1/8-in.

WRENCH, socket, 1-in.

WRENCH, socket, sprocket carrier nut, SE 1184-2, with iron bar

**ORDNANCE MAINTENANCE – HEAVY TRACTOR MI (IHC TD-18) –
POWER TRAIN, TRACK FRAME ASSEMBLY, AND SEATS**

b. Procedure.

(1) INSTALL SPROCKET DRIVE CARRIER PLATE (fig. 125).

DRIFTS	WRENCH, socket, 7/8-in.
HAMMER	WRENCH, socket, 1-in.
SHELLAC	

(a) Install gasket on plate with shellac. Use a hammer to drive out 2 dowel pins in plate.

(b) Lift plate in position on main frame studs (2 men required) and use drifts to set in place. Install nuts and lock washers on studs of main frame, but do not tighten. Use hammer to install dowel pins.

(c) Install cap screws and lock washers, which secure inside of plate to main frame, using 7/8-inch socket wrench. Use 1-inch socket wrench to secure nuts on studs around outer rim of plate, also to secure cap screws with lock washers around outer rim.

(2) INSTALL RIGHT SPROCKET DRIVE PINION SHAFT (fig. 124).

DRIFTS	WRENCH, socket, 3/4-in.
SHELLAC	

If shaft was removed, install gasket with shellac on steering clutch support bearing retainer and place in position in main frame. Line up holes in steering clutch support bearing retainer with holes in sprocket drive carrier plate, using drifts. Oil troughs line up with oilholes in carrier plate. Use 3/4-inch socket wrench to secure 4 cap screws with lock washers which hold retainer to carrier plate.

(3) INSTALL SPROCKET DRIVE GEAR, COMPLETE, AND PINION (fig. 123).

BLOCK, wood	HAMMER
--------------------	---------------

(a) Insert short sprocket drive gear bearing spacer on track frame pivot shaft, then lift sprocket drive gear, complete, in place on shaft. Use wood block and hammer to seat gear.

(b) Install sprocket drive pinion with splines toward sprocket drive carrier plate. Use wood block and hammer to seat pinion.

(c) Install long sprocket drive gear spacer on track frame pivot shaft, pushing it inside the sprocket.

(4) INSTALL SPROCKET DRIVE GEAR COVER (fig. 122).

DRIFTS, brass	WRENCH, open-end, 7/8-in.
HAMMER	WRENCH, socket, 3/4-in.
SLEDGE	WRENCH, socket, 1 1/8-in.
WRENCH, open-end, 3/4-in.	

FINAL DRIVES AND SPROCKETS

(a) Use hammer to drive out 3 dowel pins. Lift cover in place (2 men required), and position by means of drifts. Use hammer to drive in dowels.

(b) Use $\frac{1}{8}$ -inch socket wrench to install the bolts and nuts with lock washers which secure cover to carrier plate. Use $\frac{7}{8}$ -inch open-end wrench to hold heads.

(c) Use $\frac{3}{4}$ -inch socket wrench to secure the remaining bolts and nuts with lock washers which hold cover to carrier plate.

(d) Use a hammer and brass drift to install the pinion outer bearing.

(5) INSTALL SPROCKET DRIVE PINION OUTER BEARING CAP (fig. 121).

SHELLAC

WRENCH, socket, $\frac{3}{4}$ -in.

Install gasket on cap with shellac, then install cap. Use $\frac{3}{4}$ -inch socket wrench to secure 6 cap screws with lock washers which hold cap to sprocket drive gear cover.

(6) INSTALL SPROCKET (fig. 121).

BAR, iron

WRENCH, socket, sprocket

CHISEL

carrier nut, SE 1184-2,

HAMMER

with iron bar

Lift sprocket in place on track frame pivot shaft (two men required). Install sprocket drive gear carrier nut lock and nut, using sprocket carrier and nut socket wrench SE 1184-2, with iron bar to tighten. Use chisel and hammer to bend lock on nut.

(7) INSTALL SPROCKET DRIVE GEAR OUTER BEARING CAGE (fig. 120).

DRIFTS

SHELLAC

HAMMER

WRENCH, socket, $\frac{3}{4}$ -in.

PUNCH, brass

(a) Install gasket on cage, using shellac. Use drifts to position cage inside of sprocket and over track frame pivot shaft, and drive in place with brass punch and hammer.

(b) Install gasket on sprocket drive gear outer bearing retainer, using shellac. Install retainer over pivot shaft against bearing cage, with machined side out.

(c) Install track frame pivot oil seal dirt deflector (fig. 119). Place deflector over pivot shaft and install, using drifts to line up holes in deflector, retainer and sprocket hub. Use $\frac{3}{4}$ -inch socket wrench to secure cap screws with lock washers which hold deflector to hub of sprocket.

**ORDNANCE MAINTENANCE — HEAVY TRACTOR MI (IHC TD-18) —
POWER TRAIN, TRACK FRAME ASSEMBLY, AND SEATS**

(8) **INSTALL TRACK FRAME PIVOT BEARING AND BRACKET** (figs. 119 and 183).

HAMMER **WRENCH**, socket, 3/4-in.

(a) Place packing over shaft and against retainer.

(b) Place bracket over track frame pivot shaft and install pivot bearing. Tap in with hammer. Secure bearing to track frame pivot shaft with 4 cap screws and lock washers, using 3/4-inch socket wrench.

(9) **INSTALL TRACK FRAME PIVOT BEARING CAP** (fig. 183).

HANDLE, spinner **WRENCH**, socket, 1-in.

(a) Install gasket on bracket.

(b) Use a 1-inch socket and spinner handle wrench to install 4 cap screws and lock washers to secure cap to bracket.

(10) **INSTALL TRACK FRAME.**

Follow procedure outlined in paragraph 132.

(11) **INSTALL LEFT FINAL DRIVE.**

Repeat procedure outlined in steps (1) through (10) above.

73. TRACK FRAME PIVOT SHAFT REPLACEMENT.

NOTE: Do not remove unless it is necessary to replace.

a. Equipment.

HAMMER	SLEDGE
LEAD , white	SOLVENT , dry-cleaning
PAPER , flint	WRENCH , box, 3/4-in.
PUNCH	WRENCH , socket, 1 1/2-in.
SCREWDRIVER	WRENCH , socket, 1 7/8-in.

b. Procedure.

(1) **REMOVE FINAL DRIVE.**

Follow procedure outlined in paragraph 68.

(2) **REMOVE DRAWBAR GUIDE BRACKETS.**

HAMMER	WRENCH , socket, 1 1/2-in.
PUNCH	WRENCH , socket, 1 7/8-in.

Use a 1 1/2-inch socket wrench to remove 3 nuts and lock washers which hold each bracket to main frame studs. Disconnect each bracket from brace and block assembly and guide by removing bolt nut and lock washer. Use a 1 7/8-inch socket wrench. Drive out bolt with hammer and punch. Remove brackets and guide.

FINAL DRIVES AND SPROCKETS

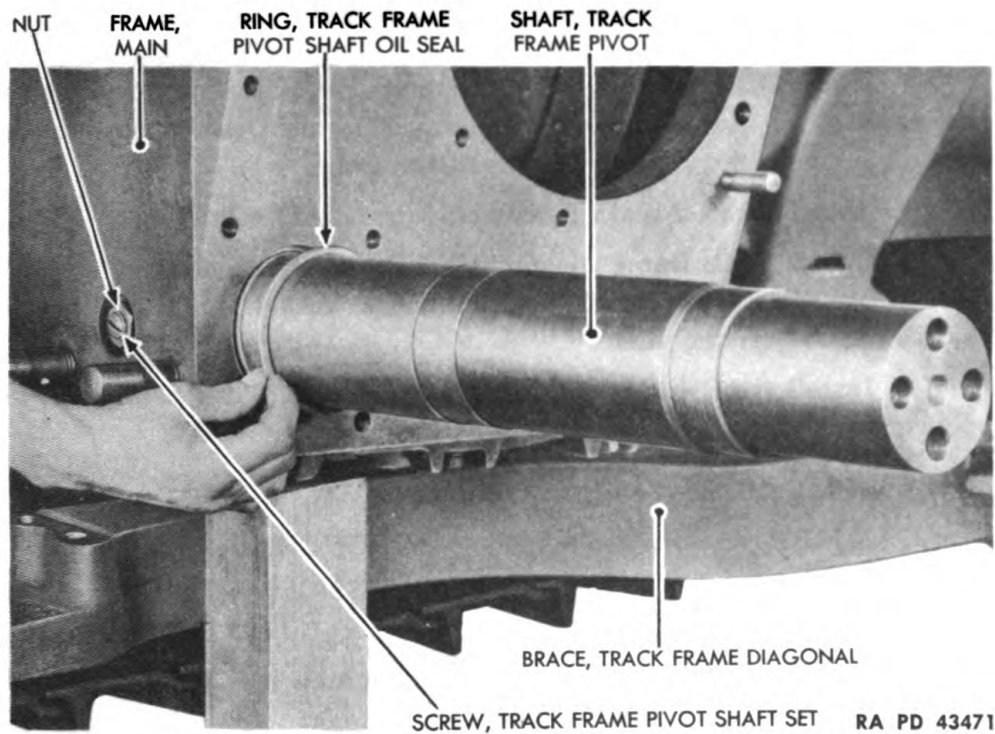

Figure 132 – Track Frame Pivot Shaft Oil Seal Ring Removal

(3) REMOVE TRACK FRAME PIVOT SHAFT (fig. 132).

PAPER, flint

SLEDGE

SCREWDRIVER

WRENCH, box, 3/4-in.

- (a) Use screwdriver to pry out track frame pivot shaft oil seal ring.
- (b) Remove track frame diagonal brace clamps and bearing sets. Use a 3/4-inch box wrench to remove bolts, lock washers, and nuts holding the 2 halves of each bearing together. Lift out track frame diagonal brass bearing bushings (split).

(c) Remove track frame pivot shaft set screws, using a 3/4-inch box wrench and screwdriver.

(d) Clean all exposed parts of pivot shaft.

(e) Drive out track frame pivot shaft. Use sledge and suitable drift.

(4) INSPECT TRACK FRAME PIVOT SHAFT.

SOLVENT, dry-cleaning.

Clean with SOLVENT, dry-cleaning. Check shaft for cracks and straightness. Replace it with a new shaft, if necessary.

(5) INSTALL TRACK FRAME PIVOT SHAFT (fig. 132).

HAMMER

SCREWDRIVER

LEAD, white

WRENCH, box, 3/4-in.

**ORDNANCE MAINTENANCE – HEAVY TRACTOR MI (IHC TD-18) –
POWER TRAIN, TRACK FRAME ASSEMBLY, AND SEATS**

(a) Insert shaft into main frame, being careful to line up set screw recesses in shaft with set screw holes in main frame. Use screwdriver and 3/4-inch box wrench to tighten set screws and nuts.

(b) Install new oil seal ring coated with LEAD, white.

(c) Install track frame diagonal brace bearings and bushings. Use 3/4-inch box wrench to install bolts with lock washers and nuts to hold the bearing halves together.

(d) Install track frame diagonal brace clamps. Turn bearing to receive clamp and then position clamp with open end down.

(6) INSTALL DRAWBAR GUIDE BRACKETS.

HAMMER

WRENCH, socket, 1 1/2-in.

PUNCH

WRENCH, socket, 1 7/8-in.

(a) Place bracket in position over main frame studs with guide in position. Use a 1 1/2-inch socket wrench to tighten the 3 nuts and lock washers which hold bracket to frame.

(b) Use a hammer and punch to drive bracket bolt through bracket and brace and block assembly. Install nut and lock washer, using a 1 7/8-inch socket wrench.

(c) Install other bracket in same manner.

(7) INSTALL FINAL DRIVE.

Follow procedure outlined in paragraph 72.

CHAPTER 5

TRACK FRAME ASSEMBLY

Section I

DESCRIPTION, INSPECTION, AND TROUBLE SHOOTING

	Paragraph
Description	74
Inspection	75
Allocation of maintenance duties by echelons, and trouble shooting	76

74. DESCRIPTION.

a. Front idler, track idlers, and track rollers are attached to heavy welded steel channel track frames. Each track is free to oscillate vertically independent of the other. Track frames are pivoted by a ball and socket on ends of pivot shaft. This feature does not permit leverage strains to be imposed on pivot shaft due to slight lateral movement of track frame. The weight of the forward part of the tractor is carried by an equalizer spring resting on track frames. Track spacing is maintained by a stabilizer at front. The stabilizer consists of heavy braces and brackets attached to main frame side channels. The stabilizing rollers are attached to the brackets. The rollers operate in roller guides which are bolted to track frame. Tracks are kept in vertical alinement by heavy steel diagonal braces which are bolted to track frames and pivot on replaceable bearings around pivot shaft. These braces in no way impede vertical movement.

75. INSPECTION.

a. **Clean All Parts.** Wash off dirt with water. Use SOLVENT, dry-cleaning, to remove oil and grease.

b. **Inspect All Parts.** Check for cracks, breakage, and similar damage. Replace any part with new part if old unit cannot be repaired. Track frame breaks may be welded but if frame is sprung or warped, it must be straightened or replaced by a new frame.

**ORDNANCE MAINTENANCE — HEAVY TRACTOR MI (IHC TD-18) —
POWER TRAIN, TRACK FRAME ASSEMBLY, AND SEATS**

**76. ALLOCATION OF MAINTENANCE DUTIES BY ECHELONS,
AND TROUBLE SHOOTING.**

a. Allocation of Maintenance Duties by Echelons.

(1) **DEFINITIONS.** Refer to paragraph 22.

TRACK FRAME ASSEMBLY	ECHELONS		
	2nd	3rd	4th
Roller frame guards—replace	x		
Roller frame guards—repair		x	
Stabilizer, crank and spring, assembly—repair and re- place		x	
Stabilizer, crank and spring, assembly—rebuild			x
Street plates—replace	x		
Track, assembly—replace		x	
Track, assembly—rebuild			x
Track idler—replace	x		
Track idler—repair		x	
Track idler—rebuild, weld, machine, aline			x
Track rail, assembly—repair or replace		x	
Track release—adjust	x		
Track release, assembly—repair		x	
Track release, assembly—rebuild			x
Track shoe, assembly—replace	x		
Track shoe plates—replace	x		
Track supporting roller, w/bracket, assembly—replace	x		
Track supporting roller, w/bracket, assembly—repair		x	
Track supporting roller, w/bracket, assembly—rebuild, weld, machine, aline			x
Truck wheel, assembly—replace	x		
Truck wheel, assembly—rebuild			x

b. Trouble Shooting. Refer to paragraph 15.

Section II

EQUALIZER SPRING

	Paragraph
Construction and operation	77
Removal	78
Disassembly	79
Parts, inspection	80
Assembly	81
Installation	82

77. CONSTRUCTION AND OPERATION.

a. The main frame and the parts and assemblies supported by the main frame are cushioned from shock and strain by an equalizer spring, located underneath the main frame near its center. The equalizer spring is attached to the frame by means of a lower frame pad which holds the spring in the center and secures it to the main frame with 4 dowel bolts and 6 cap screws. Each end of the equalizer spring rests on a guide pad which is housed in a track frame and equalizer spring guide. Each spring guide is secured to a track frame. The equalizer spring consists of 4 saddle-mounted leaves. Bumper pad brackets are secured to left- and right-hand main frame side channels, directly above the equalizer spring.

78. REMOVAL.

a. **Equipment.**

BLOCKS, wood	JACK, 10-ton
CROWBAR	WRENCH, socket, 1 $\frac{1}{8}$ -in.

b. **Procedure.**

(1) REMOVE RIGHT TRACK AND RIGHT TRACK FRAME WITH TRACK IDLERS, BOTTOM TRACK ROLLERS, FRONT IDLER, AND TRACK SPRINGS ATTACHED.

Follow procedure outlined in paragraph 129.

(2) REMOVE CRANKCASE GUARD.

Follow procedure outlined in TM 9-1777A.

(3) REMOVE LOWER EQUALIZER SPRING FRAME PAD (fig. 133).

BLOCK, wood	WRENCH, socket, 1 $\frac{1}{8}$ -in.
JACK, 10-ton	

(a) Place a jack and wooden block underneath end of equalizer spring and jack up spring.

ORDNANCE MAINTENANCE — HEAVY TRACTOR MI (IHC TD-18) —
POWER TRAIN, TRACK FRAME ASSEMBLY, AND SEATS

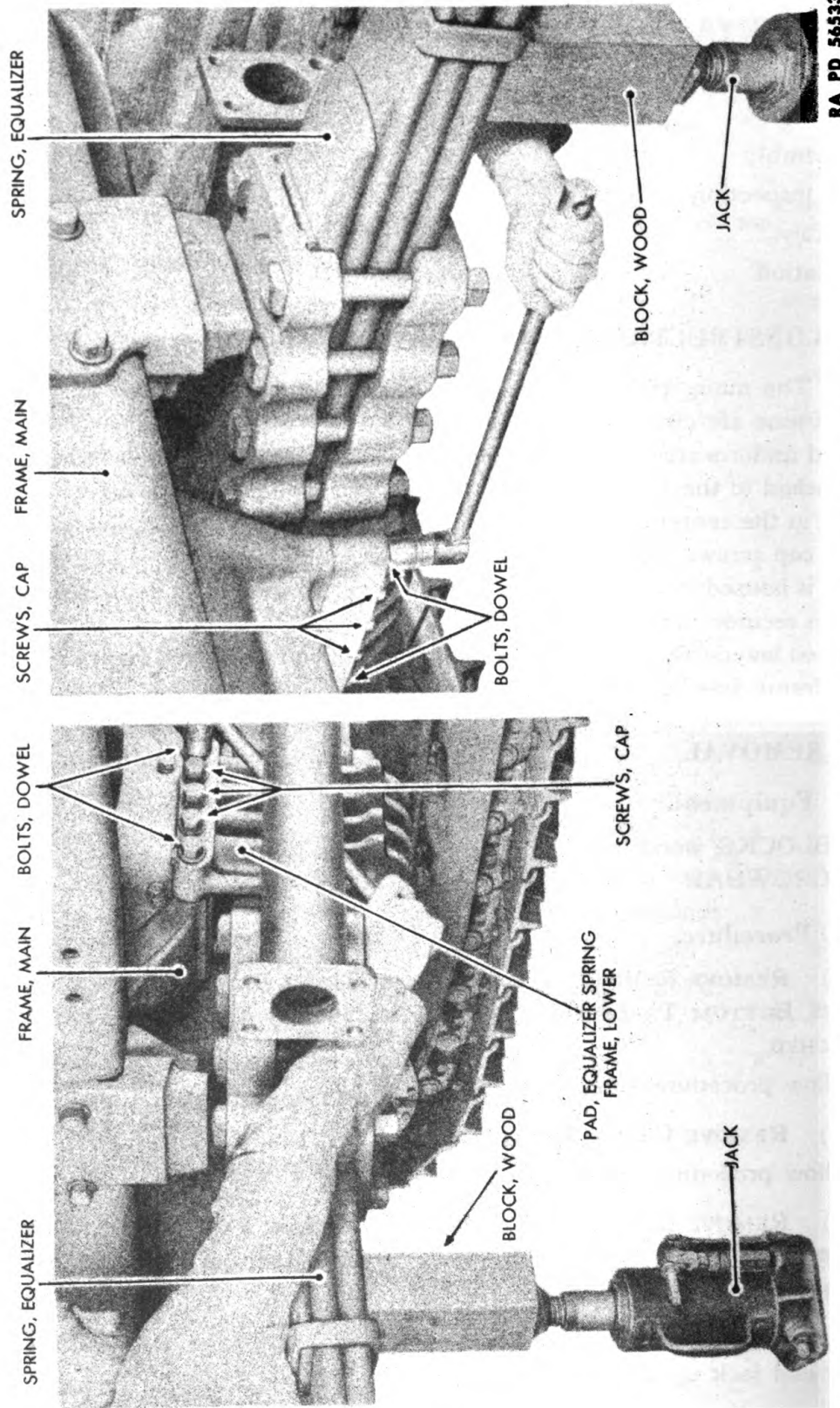

Figure 133 — Lower Equalizer Spring Frame Pad Removal

EQUALIZER SPRING

(b) Use 1½-inch socket wrench to remove 2 dowel bolts and lock washers and 3 cap screws and lock washers which hold top front of pad to main frame.

(c) Using a 1½-inch socket wrench, remove 2 dowel bolts and lock washers and 3 cap screws and lock washers which hold rear of pad to main frame.

(d) Remove lower equalizer spring frame pad.

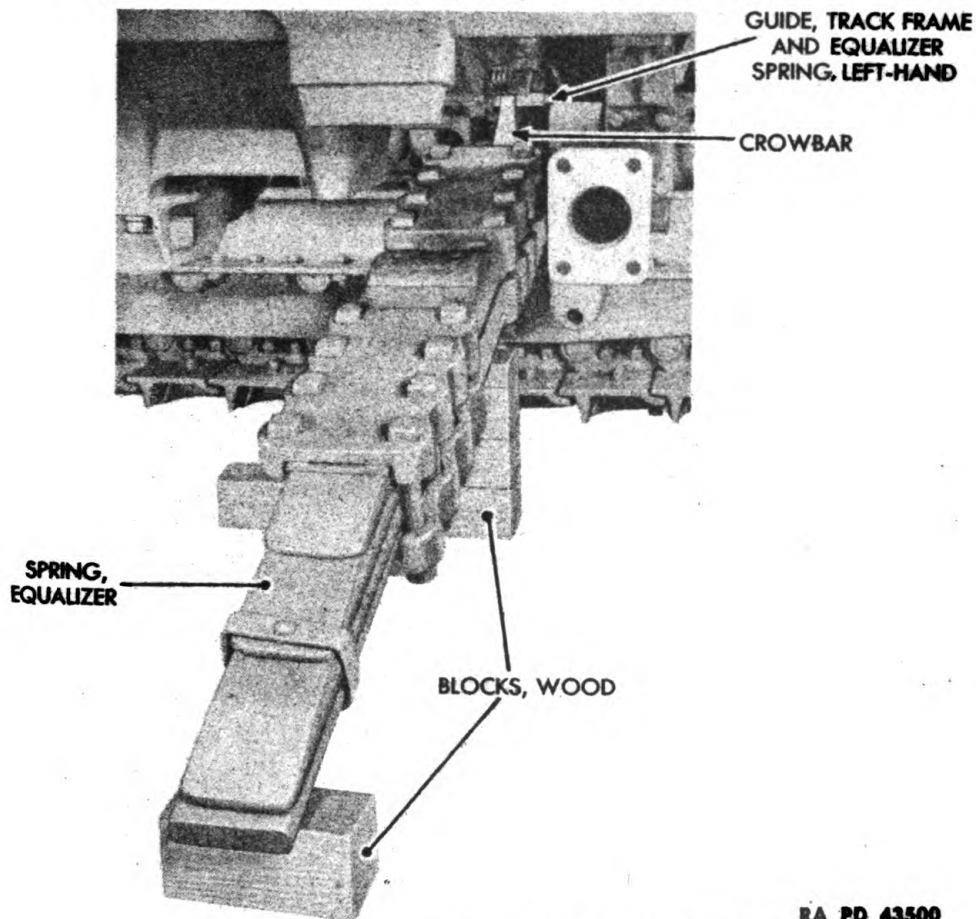

Figure 134 – Equalizer Spring Removal

(4) REMOVE EQUALIZER SPRING (fig. 134).

BLOCKS, wood
CROWBAR

JACK, 10-ton

Lower open end of spring on a jack. Lift out jack and continue to lower open end of spring on wooden blocks (2 men required). Place blocks under opposite end of spring and use crowbar to pry spring from left track frame and equalizer spring guide. Then remove spring from vehicle. **CAUTION:** Be sure sufficient manpower is used to handle spring safely.

**ORDNANCE MAINTENANCE — HEAVY TRACTOR MI (IHC TD-18) —
POWER TRAIN, TRACK FRAME ASSEMBLY, AND SEATS**

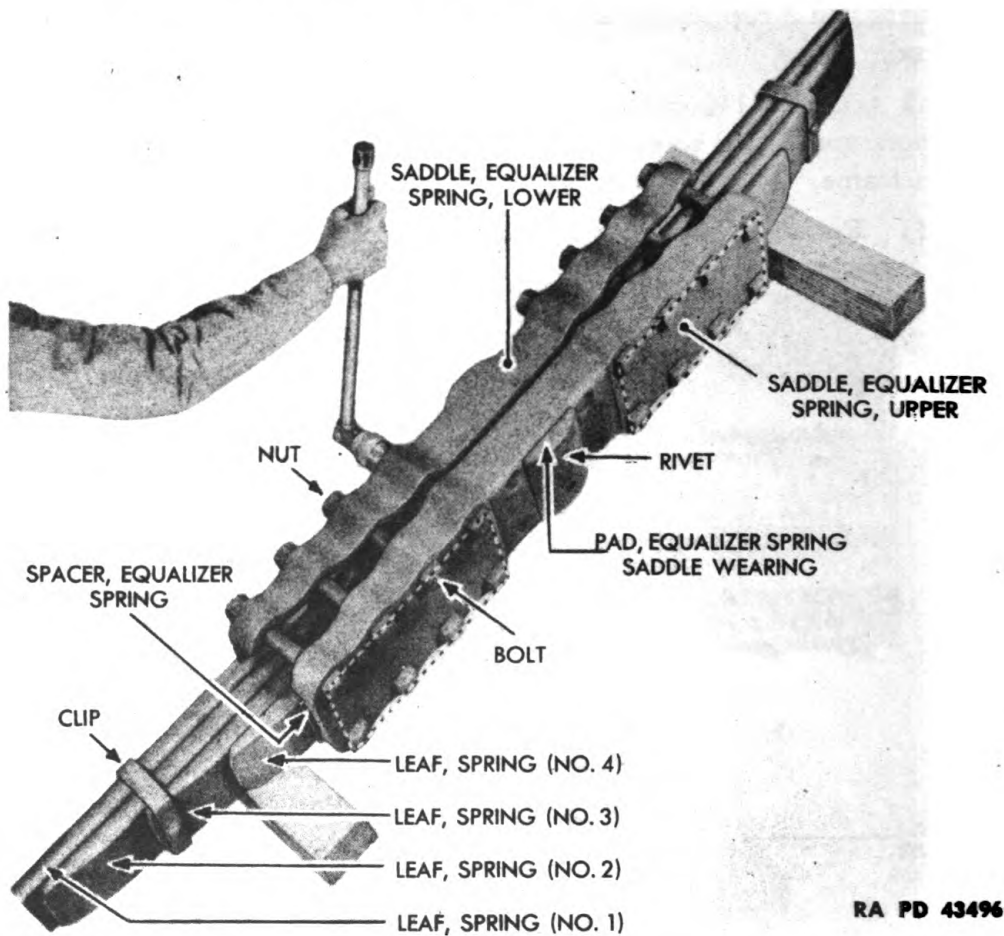

RA PD 43496

Figure 135 — Equalizer Spring Disassembly

79. DISASSEMBLY.

a. Equipment.

BAR, pry
CHISEL, cold
HACKSAW
HAMMER
PUNCH

SCREWDRIVER
WRENCH, open-end, 3/4-in.
WRENCH, open-end, 1 1/2-in.
WRENCH, socket, 7/8-in.
WRENCH, socket, 1 1/2-in.

b. Procedure.

(1) REMOVE UPPER AND LOWER EQUALIZER SPRING SADDLES (fig. 135).

PUNCH

WRENCH, socket, 1 1/2-in.

WRENCH, open-end, 1 1/2-in.

Remove 16 bolts and nuts which hold upper and lower spring saddles in position on spring leaves. Use a 1 1/2-inch socket wrench to remove nuts.

EQUALIZER SPRING

If necessary, hold bolt heads with a 1½-inch open-end wrench. Drive bolts from spring leaves with a punch. Then remove saddles. Remove equalizer spring spacer.

(2) REMOVE EQUALIZER SPRING SADDLE WEARING PAD (fig. 135).

NOTE: Normally it should not be necessary to remove wearing pad from upper spring saddle. However, if spring saddle is worn excessively, remove as follows:

**CHISEL, cold
HAMMER**

PUNCH

(a) Use a hammer and cold chisel to cut ends of 2 rivets which hold wearing pad to upper spring saddle.

(b) Use a punch and hammer to drive rivets from saddle, thus removing wearing pad.

(3) REMOVE EQUALIZER SPRING GUIDE PADS FROM EACH TRACK FRAME AND EQUALIZER SPRING GUIDE.

Pads may be lifted out of guides when track frame has been removed from tractor, which is necessary to remove equalizer spring.

(4) DISASSEMBLE SPRING LEAVES (fig. 135).

NOTE: Spring leaves should not be disassembled unless the spring leaf is broken and leaf replacements are necessary. To disassemble spring leaves, proceed as follows:

BAR, pry

PUNCH

HACKSAW

WRENCH, open-end, ¾-in.

(a) Use a ¾-inch open-end wrench to remove bolt which holds spring leaves together at center. Drive bolt from spring leaves with a punch.

(b) Remove No. 4 spring leaf.

(c) Spring leaves Nos. 1, 2, and 3 are held together by a clip riveted to each end of No. 3 leaf. If necessary to disassemble any of these leaves, use a hacksaw to cut clips at No. 1 leaf side. Pry clips apart with a pry bar until Nos. 1 and 2 leaves can be removed from clips. **NOTE:** In assembly, clips on No. 3 leaf are welded in position around Nos. 1 and 2 leaves.

(5) REMOVE EQUALIZER SPRING BUMPER PAD BRACKETS (fig. 136).

SCREWDRIVER

WRENCH, socket, 1½-in.

Use a 1½-inch socket wrench to remove 4 cap screws and lock washers which hold left bumper pad bracket to left main frame side channel. Then remove the bracket. In a similar manner, remove right bumper pad bracket. If necessary, use screwdriver to pry pads from brackets.

**ORDNANCE MAINTENANCE — HEAVY TRACTOR MI (IHC TD-18) —
POWER TRAIN, TRACK FRAME ASSEMBLY, AND SEATS**

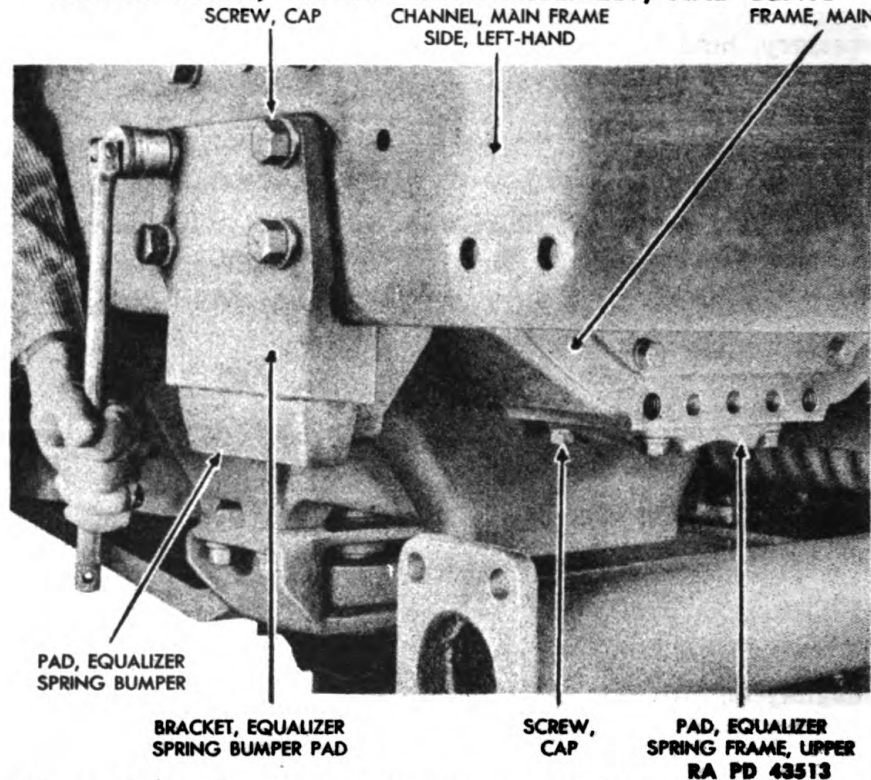

Figure 136 — Equalizer Spring Bumper Pad Bracket Removal

(6) REMOVE UPPER EQUALIZER SPRING FRAME PAD (fig. 136).

WRENCH, socket, 7/8-in.

Use a 7/8-inch socket wrench to remove 4 cap screws and lock washers which hold upper frame pad to main frame. Remove pad.

80. PARTS, INSPECTION.

a. Clean All Parts. If parts are covered with dirt, wash thoroughly in water. Then wash all parts in SOLVENT, dry-cleaning, to remove oil and grease. Keep SOLVENT, dry-cleaning, away from the rubber portion of the bumper pad.

b. Inspect All Parts.

(1) LEAVES AND SADDLES.

Inspect all leaves and upper and lower spring saddles for breaks and cracks. Replace broken leaves and saddles.

(2) BOLTS, NUTS AND CAP SCREWS.

Check for broken bolts and stripped threads. Replace broken or damaged parts.

EQUALIZER SPRING

(3) UPPER EQUALIZER SPRING FRAME PAD AND SADDLE WEARING PAD.

Inspect pad for excessive wear, which is indicated if pads are worn sufficiently for upper pad to rub against upper equalizer spring saddle. Replace worn pads.

(4) BUMPER PAD BRACKETS.

Broken brackets should be replaced. Inspect bumper pads for excessive wear, which is indicated if pad is worn sufficiently for spring to bump against bracket.

81. ASSEMBLY.

a. Equipment.

COMPOUND, cement, type B
CLAMP, "C" (2)
HAMMER
PUNCH
EQUIPMENT, welding, acetylene

WRENCH, open-end, $\frac{3}{4}$ -in.
WRENCH, open-end, $1\frac{1}{2}$ -in.
WRENCH, socket, $\frac{7}{8}$ -in.
WRENCH, socket, $1\frac{1}{2}$ -in.

b. Procedure.

(1) INSTALL UPPER EQUALIZER SPRING FRAME PAD (fig. 136).

WRENCH, socket, $\frac{7}{8}$ -in.

Place upper frame pad in position on bottom of main frame. Use a $\frac{7}{8}$ -inch socket wrench to install and tighten 4 cap screws and lock washers which hold pad to frame.

(2) INSTALL EQUALIZER SPRING BUMPER PAD BRACKETS (fig. 136).

COMPOUND, cement, type B WRENCH, socket, $1\frac{1}{2}$ -in.

(a) Install pads in brackets, cementing them in place with COMPOUND, cement, type B.

(b) Place bracket in position on main frame side channel, securing it with 4 cap screws and lock washers. Tighten cap screws with a $1\frac{1}{2}$ -inch socket wrench.

(c) In a similar manner, install other bracket.

(3) ASSEMBLE SPRING LEAVES (fig. 135).

CLAMP, "C" (2) WRENCH, open-end, $\frac{3}{4}$ -in.
EQUIPMENT, welding, acetylene

(a) Spring leaves Nos. 1, 2, and 3 are held together by a clip riveted to each end of No. 3 leaf. If these leaves have been disassembled, place

**ORDNANCE MAINTENANCE — HEAVY TRACTOR MI (IHC TD-18) —
POWER TRAIN, TRACK FRAME ASSEMBLY, AND SEATS**

them in position inside clips. Press each clip firmly against leaves, using 2 C-clamps. Then weld clip to No. 3 leaf at point where it was cut apart for removal.

(b) Place No. 4 spring leaf in position and install center bolt which holds all spring leaves together. Install and tighten hexagon nut to bolt, using $\frac{3}{4}$ -inch open-end wrench.

(4) INSTALL EQUALIZER SPRING GUIDE PADS IN EACH TRACK FRAME AND EQUALIZER SPRING GUIDE.

Pads may be installed by hand in spring guides.

**(5) INSTALL EQUALIZER SPRING SADDLE WEARING PAD (fig. 135).
HAMMER PUNCH**

If wearing pad has been removed, install wearing pad and rivet to upper spring saddle. Use a punch and hammer to lock rivet ends over saddle.

(6) INSTALL UPPER AND LOWER EQUALIZER SPRING SADDLES (fig. 135).

WRENCH, open-end, 1½-in. WRENCH, socket, 1½-in.

(a) Place equalizer spring spacer on No. 4 spring leaf.

(b) Place spring leaves between upper and lower spring saddles. Then install 16 bolts and nuts which hold upper and lower spring saddles in position on spring leaves. If necessary, hold boltheads with 1½-inch open-end wrench while tightening nuts with a 1½-inch socket wrench.

82. INSTALLATION.

a. Equipment.

**BLOCKS, wood
HOIST
JACK, 10-ton**

**WRENCH, socket, 1½-in.
WRENCH, socket, 1½-in.**

b. Procedure.

(1) LIFT LEFT END OF EQUALIZER SPRING INTO LEFT TRACK FRAME AND EQUALIZER SPRING GUIDE (fig. 134).

**BLOCKS, wood JACK
HOIST**

Slide equalizer spring under tractor and lift left end up until it can be inserted into left spring guide. Use a hoist, if available, to lift the end of the spring. Otherwise, 2 men are required to lift the end of the

EQUALIZER SPRING

spring onto wooden blocks until a jack can be placed underneath the spring to lift it sufficiently for installation in spring guide. After pushing left end of spring into left spring guide, lift right end of spring until equalizer spring can be pushed into position over equalizer spring guide pad in left spring guide. Use a hoist, if available, to lift right end of spring. Otherwise, 2 men are required to lift spring onto wooden blocks so a jack can be placed under the spring to lift it still higher. Leave right end of spring supported on hoist or jack so it is placed firmly into position with equalizer spring saddle wear pad in position against upper equalizer spring frame pad.

(2) **INSTALL LOWER EQUALIZER SPRING FRAME PAD (fig. 133).**

JACK, 10-ton

WRENCH, socket, 1½-in.

WRENCH, socket, 1⅛-in.

(a) Lift lower equalizer spring frame pad into position over equalizer spring and against main frame. Use a jack to hold pad in position.

(b) Use a 1½-inch socket wrench to install 4 dowel bolts and lock washers. A dowel bolt goes in each upper front corner and in each lower rear corner of pad and holds pad to main frame. Then install 3 cap screws and lock washers in upper front of pad and 3 cap screws and lock washers in lower rear of pad. Use a 1⅛-inch socket wrench. These 6 cap screws also hold pad and equalizer spring to main frame.

**ORDNANCE MAINTENANCE – HEAVY TRACTOR MI (IHC TD-18) –
POWER TRAIN, TRACK FRAME ASSEMBLY, AND SEATS**

Section III

TRACK IDLERS

	Paragraph
Description and operation	83
Removal	84
Disassembly	85
Parts, inspection	86
Assembly	87
Installation	88

83. DESCRIPTION AND OPERATION.

a. Upper section of track between sprocket and front idler is supported by 2 gray iron idlers with chilled outer faces (increasing their hardness). Idlers are mounted on track spring retainers extending upward from track frame. Idler revolves on heat-treated, replaceable steel shaft which is locked in bracket with a bolt. A felt washer and spring-loaded leather seal with lip turned toward center of tractor, are located in bracket and

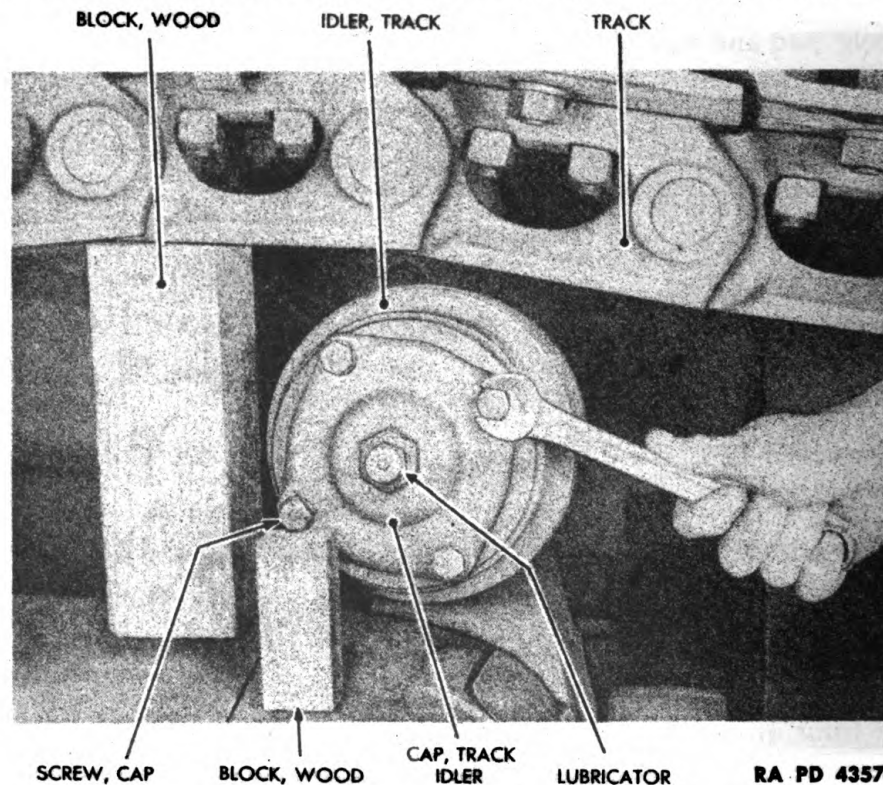

Figure 137 – Track Idler Removal

TRACK IDLERS

idler, respectively. Each idler may be removed without removing track chain.

84. REMOVAL.

a. Equipment.

BLOCK, wood

CHISEL

HAMMER

WRENCH, open-end, $\frac{3}{4}$ -in.

WRENCH, open-end, 1-in.

WRENCH, open-end, $1\frac{1}{8}$ -in.

WRENCH, socket, $\frac{3}{4}$ -in.

b. Procedure.

(1) RAISE TRACK ABOVE IDLER TO BE REMOVED (fig. 137).

BLOCK, wood

Wedge a wooden block between track spring guide and track, next to idler to be removed, until track is clear of flanges on idler.

(2) REMOVE TRACK IDLER CAP (fig. 137).

BLOCK, wood

WRENCH, socket, $\frac{3}{4}$ -in.

Place a small wooden block under 1 cap screw to keep idler from turning. Then use $\frac{3}{4}$ -inch socket wrench to remove 4 cap screws with lock washers which hold cap to track idler. Remove cap and track idler cap gasket.

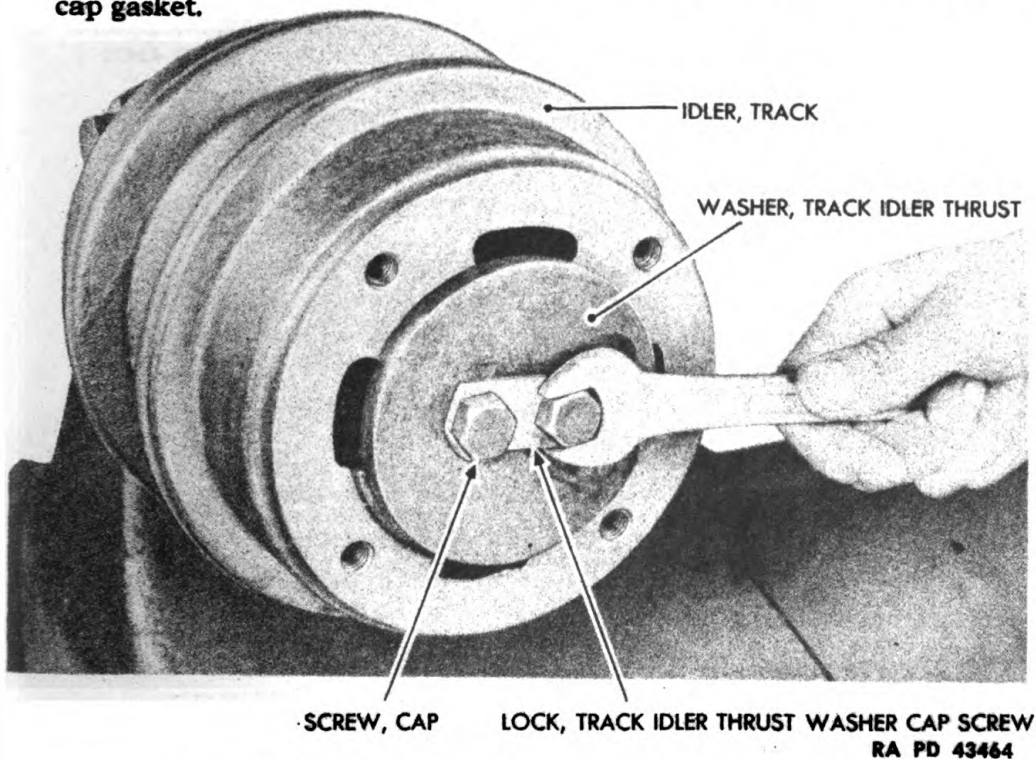
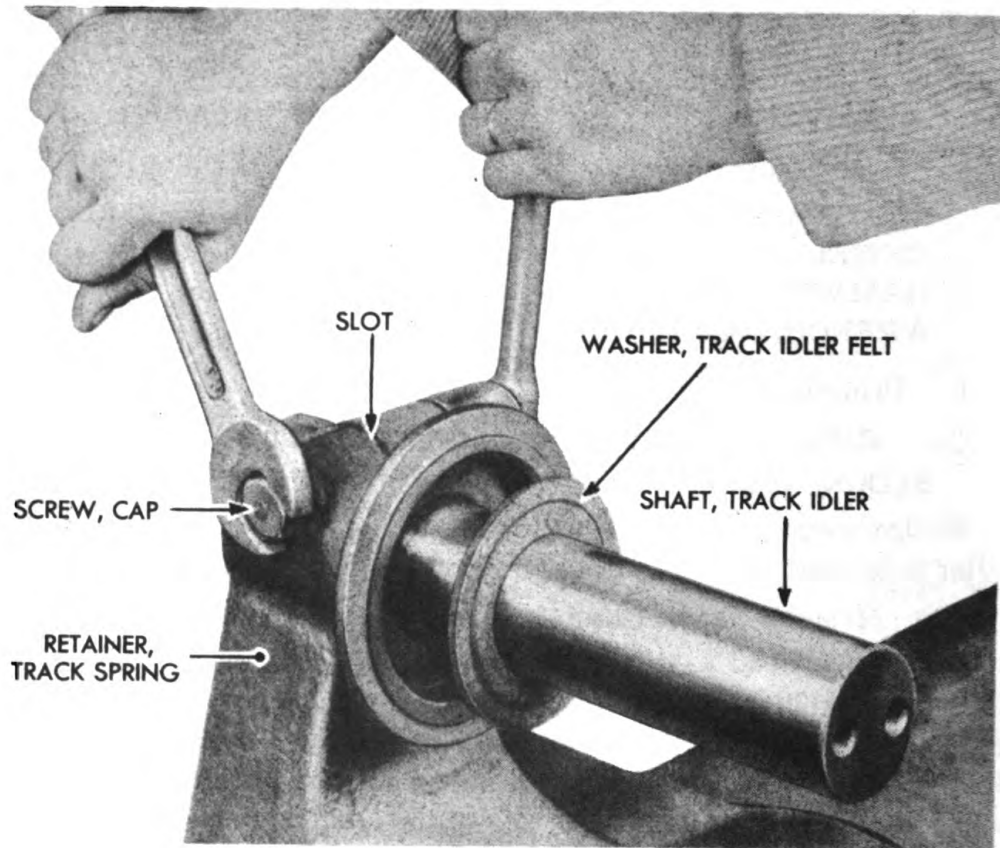

Figure 138 — Thrust Washer from Track Idler Removal

ORDNANCE MAINTENANCE — HEAVY TRACTOR MI (IHC TD-18) —
POWER TRAIN, TRACK FRAME ASSEMBLY, AND SEATS



RA PD 43472

Figure 139 — Track Idler Shaft Removal

- (3) REMOVE TRACK IDLER THRUST WASHER (fig. 138).

CHISEL
HAMMER

WRENCH, open-end, $\frac{3}{4}$ -in.

Bend back lock, using a hammer and chisel. Use a $\frac{3}{4}$ -inch open-end wrench to remove 2 cap screws in thrust washer. Remove thrust washer and track idler with oil seal and felt washer.

- (4) REMOVE TRACK IDLER SHAFT (fig. 139).

WRENCH, open-end, 1-in.

WRENCH, open-end, $1\frac{1}{8}$ -in.

(a) Use a $1\frac{1}{8}$ -inch open-end wrench to hold nut and a 1-inch open-end wrench to loosen bolt which secures shaft in housing on track spring retainer. Remove shaft.

(b) Remove felt washer from track spring retainer.

- (5) REMOVE OTHER TRACK IDLERS IN THE SAME MANNER.

TRACK IDLERS

85. DISASSEMBLY. Most parts of track idlers are removed in process of idler removal. Remaining parts are disassembled as follows:

a. Equipment.

HAMMER
PUNCH

WRENCH, box, $\frac{7}{8}$ -in.

b. Procedure.

(1) REMOVE TRACK IDLER FELT WASHER FROM IDLER.

(2) REMOVE OIL SEAL (if necessary).

HAMMER
PUNCH

Use a punch and hammer to remove oil seal from idler.

(3) REMOVE LUBRICATOR FROM CAP (fig. 137).

WRENCH, box, $\frac{7}{8}$ -in.

Use a $\frac{7}{8}$ -inch box wrench to remove lubricator.

86. PARTS, INSPECTION.

a. Clean All Parts. Wash all parts in SOLVENT, dry-cleaning.

b. Inspect All Parts.

(1) CHECK IDLER AND SHAFT FOR CRACKS AND WEAR WHICH MIGHT IMPAIR EFFICIENT OPERATION.

Replace if damaged.

(2) OIL SEAL.

Inspect lip and replace oil seal if lip shows break or wear, or if seal has been removed.

(3) FELT WASHER.

Install new felt washer.

(4) LUBRICATOR.

See that oil passage is clean.

87. ASSEMBLY.

a. Equipment.

CHISEL
HAMMER
PUNCH, brass

WRENCH, open-end, $\frac{3}{4}$ -in.
WRENCH, open-end, $\frac{7}{8}$ -in.

TM 9-1777C

87-88

ORDNANCE MAINTENANCE — HEAVY TRACTOR MI (IHC TD-18) — POWER TRAIN, TRACK FRAME ASSEMBLY, AND SEATS

b. Procedure.

(1) INSTALL NEW OIL SEAL.

HAMMER

PUNCH, brass

If oil seal has been removed, install new one with lip facing toward tractor when idler is installed. Use brass punch and hammer.

(2) INSTALL NEW FELT WASHER IN TRACK SPRING RETAINER (fig. 139).

Install shaft through front of idler.

(3) INSTALL THRUST WASHER AND CAP SCREWS WITH LOCK (fig. 138).

CHISEL

WRENCH, open-end, $\frac{3}{4}$ -in.

HAMMER

Place thrust washer in position on end of shaft. Insert 2 cap screws through lock and use $\frac{3}{4}$ -inch open-end wrench to tighten cap screws which hold washer to shaft. Use a chisel and hammer to bend up lock around cap screws.

(4) INSTALL SHAFT IN IDLER.

Enter shaft in idler from cap end of idler.

(5) INSTALL LUBRICATOR IN TRACK IDLER CAP (fig. 137).

WRENCH, open-end, $\frac{7}{8}$ -in.

Use a $\frac{7}{8}$ -inch open-end wrench. NOTE: Track idler cap must be installed after idler is installed.

(6) INSTALL IDLER CAP.

WRENCH, open-end, $\frac{3}{4}$ -in.

Place gasket and cap in position on idler and install 4 lock washers and cap screws ($\frac{3}{4}$ -in. open-end wrench).

(7) ASSEMBLE OTHER TRACK IDLERS.

Follow procedure outlined in steps (1) through (6) above.

88. INSTALLATION.

a. Equipment.

CHISEL

WRENCH, open-end, $1\frac{1}{8}$ -in.

WRENCH, open-end, 1-in.

TRACK IDLERS**b. Procedure.**

- (1) **INSTALL TRACK IDLER AND SHAFT** (fig. 139).

CHISEL

WRENCH, open-end, $1\frac{1}{8}$ -in.

WRENCH, open-end, 1-in.

Spread slot in track spring retainer with a chisel, to facilitate installation of shaft. Then enter shaft in housing with groove in alignment with boltholes in retainer. Be sure felt washer is in position in track spring retainer. Use $1\frac{1}{8}$ -inch open-end wrench to hold nut and 1-inch open-end wrench to secure bolt in housing on track spring retainer.

- (2) **LOWER TRACK ON IDLER.**

Remove wood block which has held track free of idler.

- (3) **LUBRICATE IDLER WITH LUBRICANT. GEAR.**

- (4) **INSTALL OTHER IDLERS.**

Follow procedure outlined in steps (1) and (2) above.

BOTTOM TRACK ROLLERS

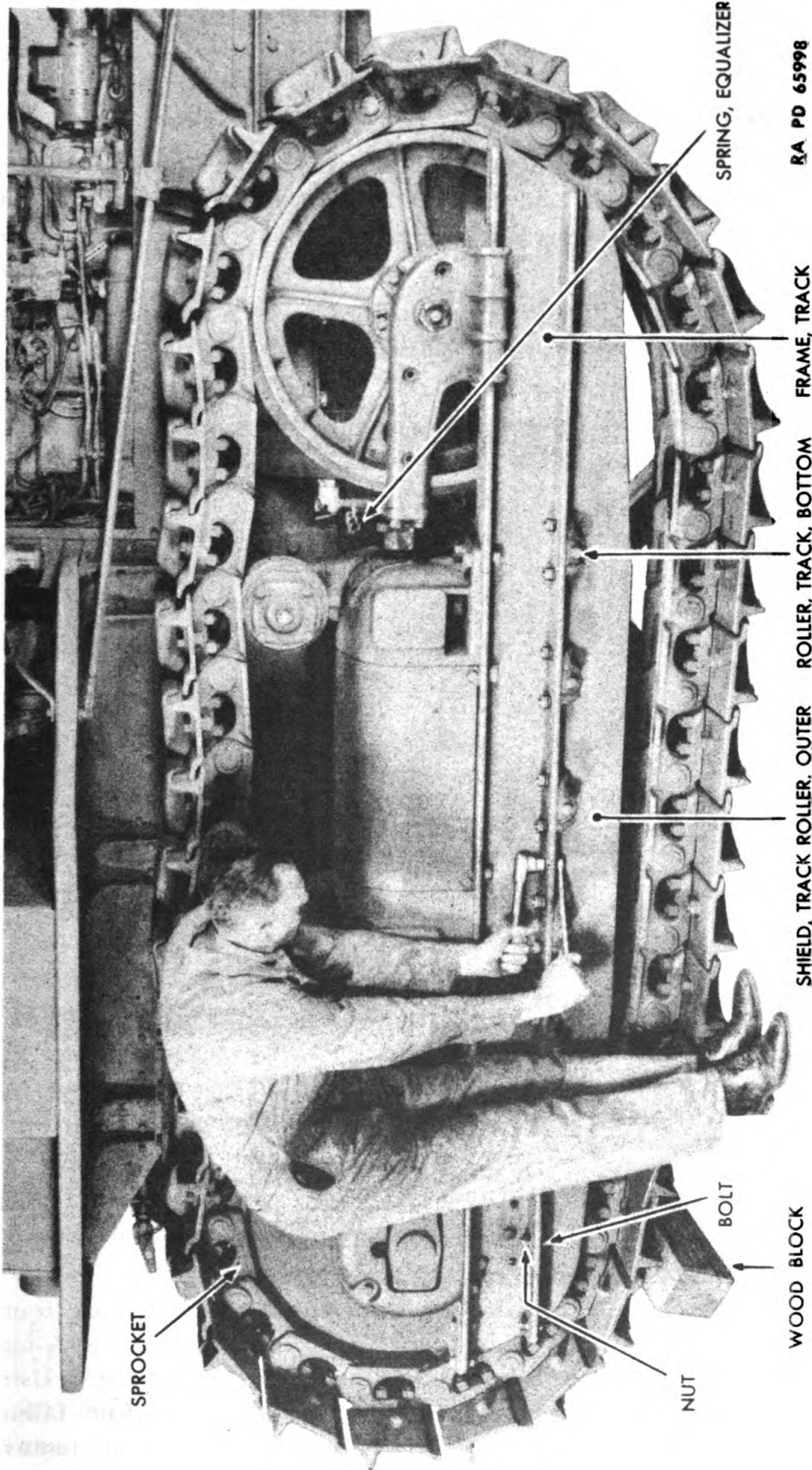

Figure 140 — Track Roller Shield Removal

**ORDNANCE MAINTENANCE — HEAVY TRACTOR M1 (IHC TD-18) —
POWER TRAIN, TRACK FRAME ASSEMBLY, AND SEATS**

(3) REMOVE TRACK ROLLER SHIELDS (fig. 140).

WRENCH, open-end, $\frac{7}{8}$ -in.

WRENCH, socket, 1-in.

(a) Remove 12 bolts, nuts and lock washers which hold outer track roller shield to track frame. Hold boltheads with a $\frac{7}{8}$ -inch open-end wrench and use a 1-inch socket wrench to remove nuts. Then lift off outer shield.

(b) In a similar manner, remove 8 bolts, nuts, and lock washers which hold inner shield to track frame.

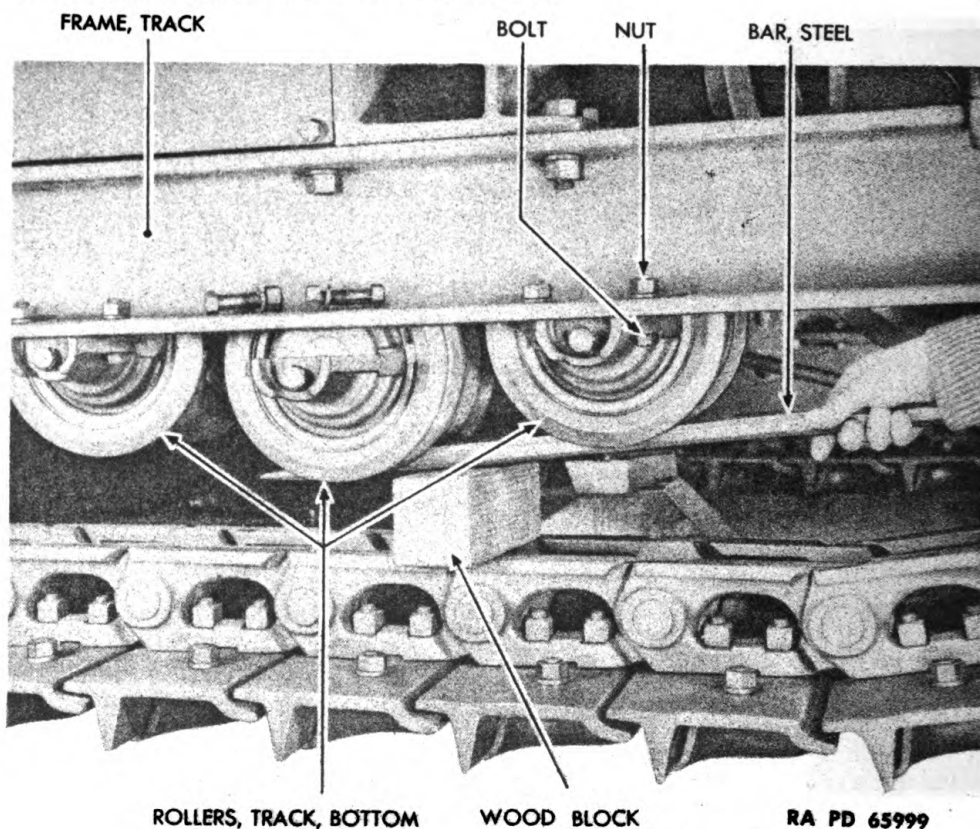

Figure 141 — Bottom Track Roller Removal

(4) REMOVE ROLLER (fig. 141).

BAR, iron

WRENCH, open-end, $\frac{7}{8}$ -in.

BLOCK, wood

WRENCH, socket, 1-in.

Remove 2 bolts, nuts and lock washers at each side of track frame which hold roller in position on frame. Hold boltheads with a $\frac{7}{8}$ -inch open-end wrench and remove nuts with a 1-inch socket wrench. Using a wooden block as a fulcrum, use an iron bar to keep roller from falling, once bolts are removed. Then lower roller from track frame and remove.

BOTTOM TRACK ROLLERS

- (5) REMOVE ADDITIONAL TRACK ROLLERS, AS REQUIRED.
Follow procedure outlined in steps (1) through (4) above.

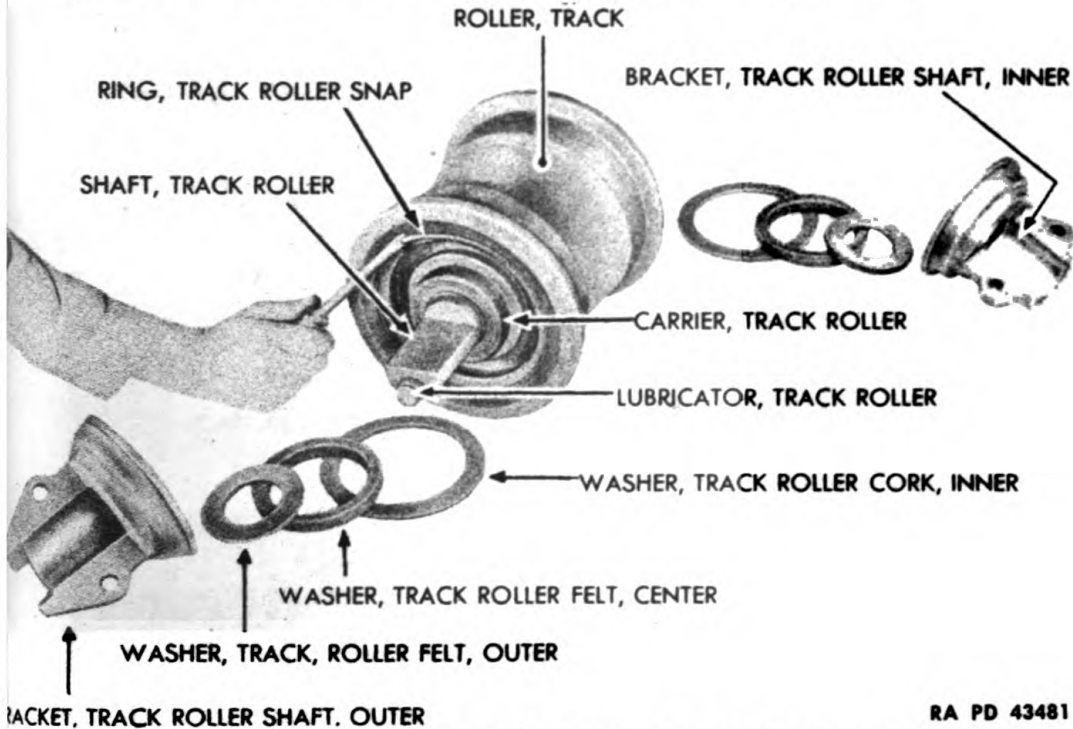

RA PD 43481

Figure 142 — Track Roller Carrier Snap Ring Removal

91. DISASSEMBLY.

a. Equipment.

BAR, pry
BAR, steel
CHISEL, cold
HAMMER
PAN

PRESS, arbor
SCREWDRIVER
WISE
WRENCH, open-end, 7/8-in.

b. Procedure.

- (1) REMOVE TRACK ROLLER SHAFT BRACKETS (fig. 142).
 - (a) Lift inner and outer brackets from ends of track roller shaft.
 - (b) Remove outer track roller felt washer and center track roller felt washer from each bracket.
 - (c) Remove inner track roller cork washer from each side of track roller.

**ORDNANCE MAINTENANCE – HEAVY TRACTOR M1 (IHC TD-18) –
POWER TRAIN, TRACK FRAME ASSEMBLY, AND SEATS**

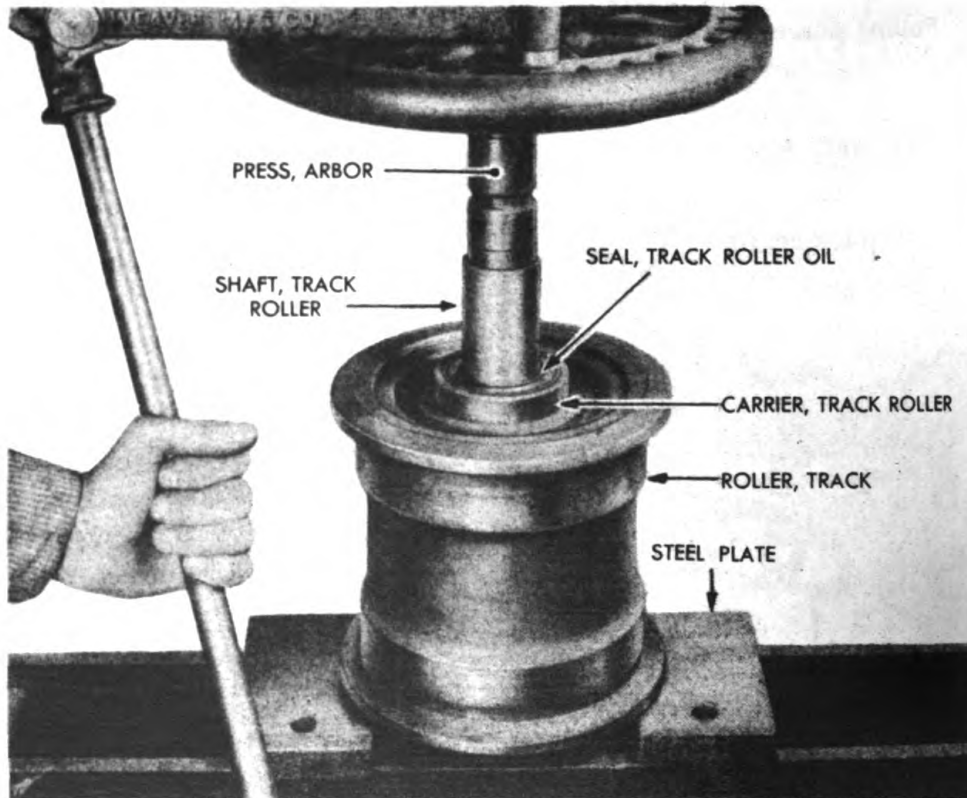

RA PD 66000

Figure 143 – Pressing Out Track Roller Carrier

**(2) REMOVE TRACK ROLLER CARRIER SNAP RINGS (fig. 142).
SCREWDRIVER**

Pry the snap ring at each end of roller loose with a screwdriver and remove the ring.

(3) PRESS OUT TRACK ROLLER CARRIER FROM ROLLER (fig. 143).

PAN

WRENCH, open-end, 7/8-in.

PRESS, arbor

(a) Place roller in arbor press with lubricator end of shaft down. Place a pan underneath roller in which oil can drain. Then remove track roller lubricator (fig. 142) from lower end of shaft, using a 7/8-inch open-end wrench.

(b) Press out one track roller carrier with bushings and oil seal. Place pressure on end of track roller shaft.

(c) Turn roller and shaft over in arbor press and exert pressure on end of shaft until second carrier on end of bushing and oil seal is removed.

(d) Remove track roller carrier thrust washer from each carrier.

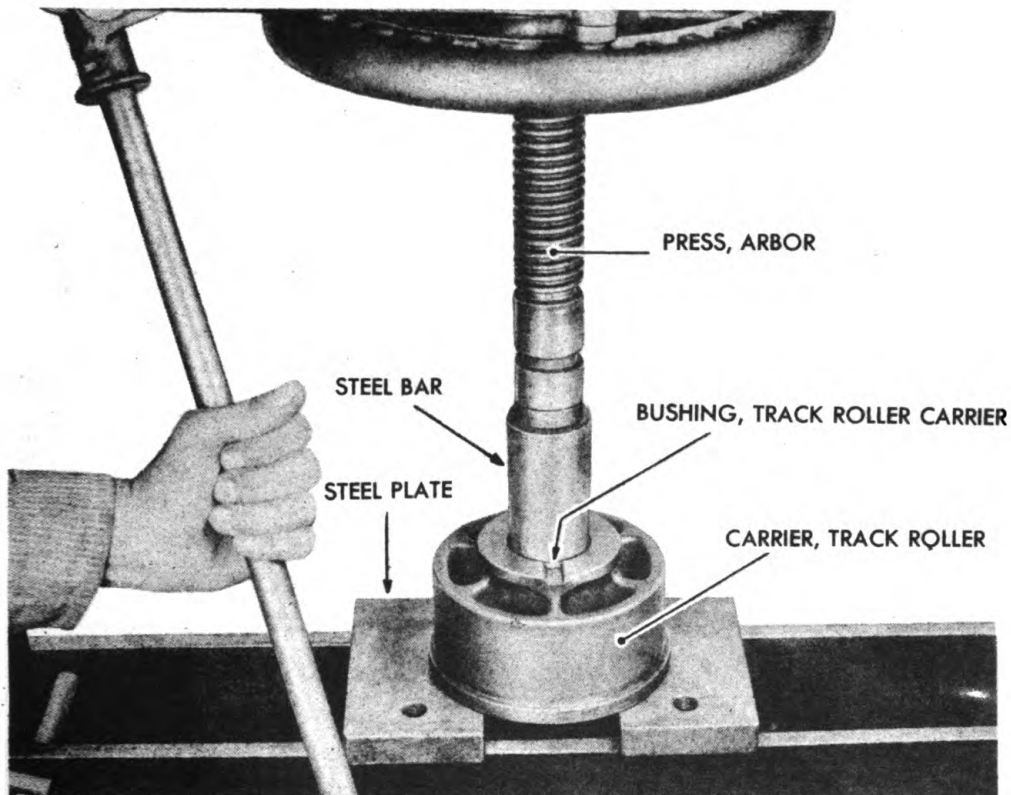
BOTTOM TRACK ROLLERS

RA PD 66001

Figure 144 – Pressing Bushings from Track Roller Carrier**(4) REMOVE TRACK ROLLER CARRIER BUSHINGS (fig. 144).**

BAR, pry

HAMMER

BAR, steel

PRESS, arbor

CHISEL, cold

(a) Place carriers with bushings back on shaft and check for excessive play. Do not remove bushings unless excessive play indicates the need for new bushings.

(b) Place carrier in an arbor press with oil seal down. Place a steel bar over top bushings and press out 2 bushings and oil seal.

(c) If bushings are not to be removed, remove oil seal by cutting it with a cold chisel and hammer and prying it out with a pry bar.

(5) REMOVE TRACK ROLLER OIL SCUPPER TRACK ROLLER SHAFT (fig. 145).

BAR, pry

VISE

Do not remove unless replacing old shaft. To remove, place oil scupper with shaft attached between copper jaws of a vise, grasping ends of shaft with hands and twist back and forth until oil scupper is loosened (scupper is not threaded). Alternately pry shaft from scupper, using a pry bar under flange of shaft, and twist shaft back and forth, until

ORDNANCE MAINTENANCE — HEAVY TRACTOR M1 (IHC TD-18) —
POWER TRAIN, TRACK FRAME ASSEMBLY, AND SEATS

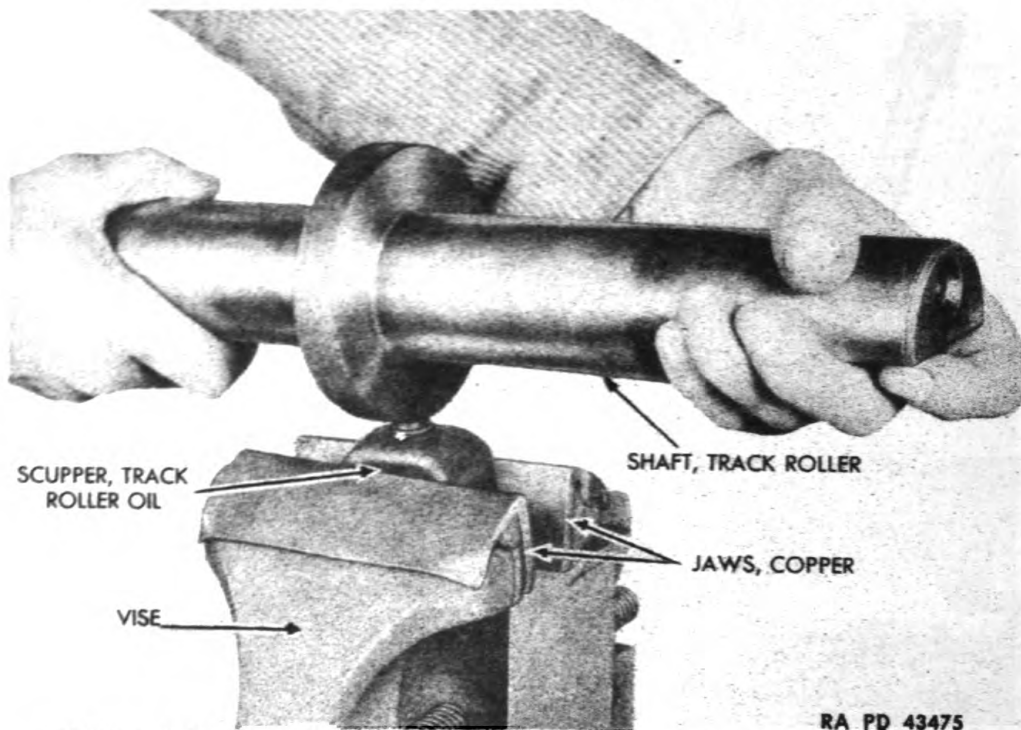

Figure 145 — Track Roller Oil Scupper from Track Roller Removal

shaft is pulled from scupper. CAUTION: Do not hammer oil scupper. It is cast iron and may break.

(6) DISASSEMBLE REMAINING TRACK ROLLERS.

Follow the above procedure.

92. PARTS, INSPECTION.

a. **Clean All Parts.** Wash oil and grease from all parts, using SOLVENT, dry-cleaning. Use compressed air to blow out oil passages of track roller shaft.

b. **Inspect Bottom Track Roller Parts.**

(1) **TRACK ROLLER SHAFT BRACKETS.** Inspect outer edge of each bracket for wear which may be caused if carrier thrust washers are worn. Inspect brackets for cracks or breakage. Install new brackets if any of these conditions are found.

(2) **OUTER TRACK ROLLER FELT WASHERS AND CENTER TRACK ROLLER FELT WASHERS.** Whenever a bottom track roller is disassembled, install new felt washers.

(3) **INNER TRACK ROLLER CORK WASHERS.** Install new washers whenever roller is disassembled.

BOTTOM TRACK ROLLERS

(4) **TRACK ROLLER CARRIER THRUST WASHERS.** If worn thin, or if roller has more than $\frac{1}{8}$ -inch end play on shaft, replace thrust washers.

(5) **TRACK ROLLER CARRIERS.** If a thrust washer has been worn thin, check the corresponding carrier for wear at point where thrust washer is placed on carrier. Check outside surface of each carrier for loose fit in roller, which may result if roller is worn. Install new carrier if these conditions exist.

(6) **TRACK ROLLER CARRIER BUSHINGS.** With bushings installed in each carrier, check bushings for loose fit on shaft. Install new bushings if clearance is greater than 0.012 inch. **CAUTION:** This inspection is outlined in paragraph 91, covering disassembly procedure to avoid unnecessary removal of bushings from carriers. When new bushings are used, use new thrust washers.

(7) **TRACK ROLLER OIL SEALS.** New oil seals must be installed whenever bottom track roller has been disassembled.

(8) **TRACK ROLLER SHAFT.** Inspect for grooves worn from carrier oil seals on bushings. Also check for looseness of shaft in carrier bushings when bushings are in good condition. Install a new shaft if any of these evidences of shaft wear are found.

(9) **TRACK ROLLER LUBRICATOR.** Install a new lubricator if lubricator leaks.

(10) **TRACK ROLLER OIL SCUPPER.** Replace if it fits loose in shaft or if broken.

(11) **TRACK ROLLER.** Inspect roller for worn flanges. Install new rollers if flanges are worn more than $\frac{1}{8}$ inch, or if inside bushings are worn more than 0.020 inch.

93. ASSEMBLY.

a. Equipment.

BAR, steel (3)	LEAD, white
BLOCK, wood	PLATE, steel
HAMMER	PRESS, arbor
HAMMER, rawhide	SLEEVE, steel

b. Procedure.

(1) **INSTALL TRACK ROLLER CARRIER BUSHINGS (fig. 144).**

BAR, steel	PRESS, arbor
------------	--------------

(a) Place carrier in arbor press, with one bushing in position, and use a steel bar over the bushing to press bushing into place. The bush-

**ORDNANCE MAINTENANCE – HEAVY TRACTOR MI (IHC TD-18) –
POWER TRAIN, TRACK FRAME ASSEMBLY, AND SEATS**

ing should be pressed into the carrier until its outer edge is flush with the lower countersunk edge of the carrier thrust washer surface.

(b) Turn carrier over in arbor press and again use a steel bar over second bushing to press second bushing into carrier until it rests against first bushing.

(c) Follow the same procedure to install 2 bushings in other carrier.

(2) INSTALL NEW TRACK ROLLER OIL SEALS.

BAR, steel

PRESS, arbor

Place oil seal in position on carrier with lip out. Place carrier in an arbor press with a steel bar over oil seal. Press oil seal into position. Follow same procedure to install oil seal in second carrier.

(3) INSTALL TRACK ROLLER OIL SCUPPER ON TRACK ROLLER SHAFT.

BLOCK, wood

HAMMER

Drive oil scupper into shaft, using wooden block and hammer. Position oil scupper with its trough at right angles with shaft. **CAUTION: Do not hit oil scupper directly with hammer. It is cast iron and may break.**

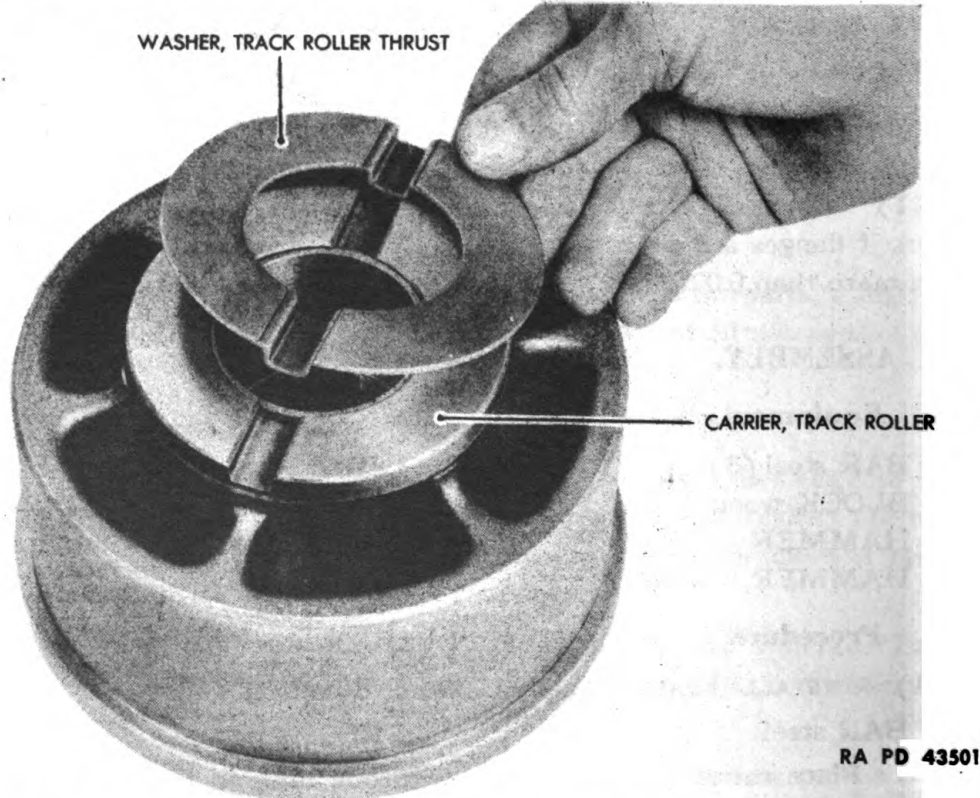

Figure 146 – Track Roller Carrier Thrust Washer Installation

BOTTOM TRACK ROLLERS

- (4) **INSTALL TRACK ROLLER CARRIER THRUST WASHERS (fig. 146).**

HAMMER, rawhide

Place thrust washer in position on each track roller carrier and tap washer into place, using a rawhide hammer.

- (5) **PLACE ONE TRACK ROLLER CARRIER INTO TRACK ROLLER.**

LEAD, white

PRESS, arbor

PLATE, steel

Coat outer surface of carrier with **LEAD**, white, to facilitate pressing carrier into roller and to prevent scoring. Then place roller and carrier in an arbor press, using a steel plate over carrier end with carrier in position on roller. Press carrier into roller.

- (6) **INSTALL TRACK ROLLER SHAFT.**

Insert track roller shaft into carrier bushings in roller with shaft flange resting against installed carrier.

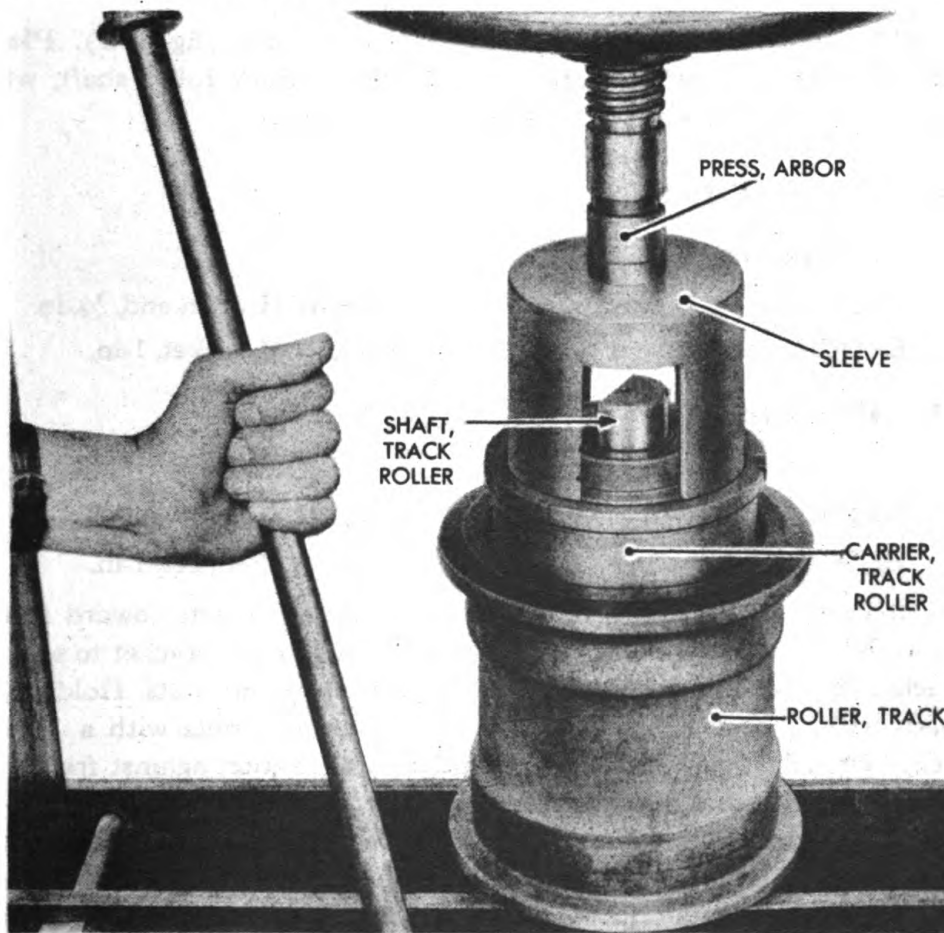

RA PD 43489

Figure 147 – Track Roller Carrier in Track Roller Installation

**ORDNANCE MAINTENANCE — HEAVY TRACTOR MI (IHC TD-18) —
POWER TRAIN, TRACK FRAME ASSEMBLY, AND SEATS**

(7) INSTALL SECOND TRACK ROLLER CARRIER (fig. 147).

PRESS, arbor

SLEEVE, steel

Place roller, with one carrier and shaft installed, in an arbor press. Position steel sleeve vertically in cork washer groove of second carrier, which should be in position on track roller. Press second carrier into roller.

(8) INSTALL SNAP RINGS (fig. 142). Install a snap ring into position in the groove in each end of roller.

(9) INSTALL NEW INNER TRACTOR CORK WASHERS (fig. 142). Place a new cork dasher in position on carrier at each end of roller.

(10) INSTALL OUTER TRACK ROLLER FELT WASHERS AND CENTER TRACK ROLLER FELT WASHERS (fig. 142). Soak new washer in lubricating oil to facilitate installation. Then install an outer felt washer and a center felt washer in each bracket.

(11) INSTALL TRACK ROLLER SHAFT BRACKETS (fig. 142). Place each bracket in position on roller, over end of track roller shaft, with flat surface of bracket alined with flat surface of shaft.

94. INSTALLATION.

a. Equipment.

BAR, steel

WRENCH, open-end, 7/8-in.

BLOCK, wood

WRENCH, socket, 1-in.

b. Procedure.

(1) INSTALL ROLLER (fig. 141).

BAR, steel

WRENCH, open-end, 7/8-in.

BLOCK, wood

WRENCH, socket, 1-in.

Lift roller in position with flat sides of shaft brackets toward track frame. Match boltholes and insert 2 bolts through each bracket to secure bracket to track frame. Then install lock washers and nuts. Hold bolt-heads with a 7/8-inch open-end wrench and tighten nuts with a 1-inch socket wrench. To facilitate lifting roller into position against frame, it is desirable to use a steel bar with wooden block as a fulcrum to hold roller in position against frame while bolts are being installed. **CAUTION:** Two of the 5 track rollers at each side of the track are double flange, and should be installed in the No. 2 and No. 4 positions from the front of the tractor.

BOTTOM TRACK ROLLERS**(2) INSTALL TRACK ROLLER SHIELDS (fig. 140).****WRENCH**, open-end, $\frac{7}{8}$ -in.**WRENCH**, socket, 1-in.

(a) Place outer track roller shield in position on the outside of the track frame and install 12 bolts, nuts and lock washers. Hold boltheads with a $\frac{7}{8}$ -inch open-end wrench and tighten nuts with a 1-inch socket wrench.

(b) In a similar manner install inner track roller shield, securing it to frame with 8 bolts, nuts and lock washers.

(3) LUBRICATE ROLLER WITH LUBRICANT, GEAR.**(4) ADJUST TRACK (fig. 140).**

Remove jack from under equalizer spring and from wooden block under track at rear. Then adjust track as outlined in paragraph 112.

ORDNANCE MAINTENANCE — HEAVY TRACTOR M1 (IHC TD-18) —
POWER TRAIN, TRACK FRAME ASSEMBLY, AND SEATS

Section V

FRONT IDLER

	Paragraph
Description and operation	95
Removal	96
Disassembly	97
Inspection	98
Assembly	99
Installation	100

95. DESCRIPTION AND OPERATION.

a. Front idler is of the open type of cast steel and is slide-mounted to the track frame. Over-all diameter of idler is 31¼ inches. All tension on track is adjustable at the idler sliding mount. Two heavy coil springs in tension release mechanism permit front idler to recoil under shock,

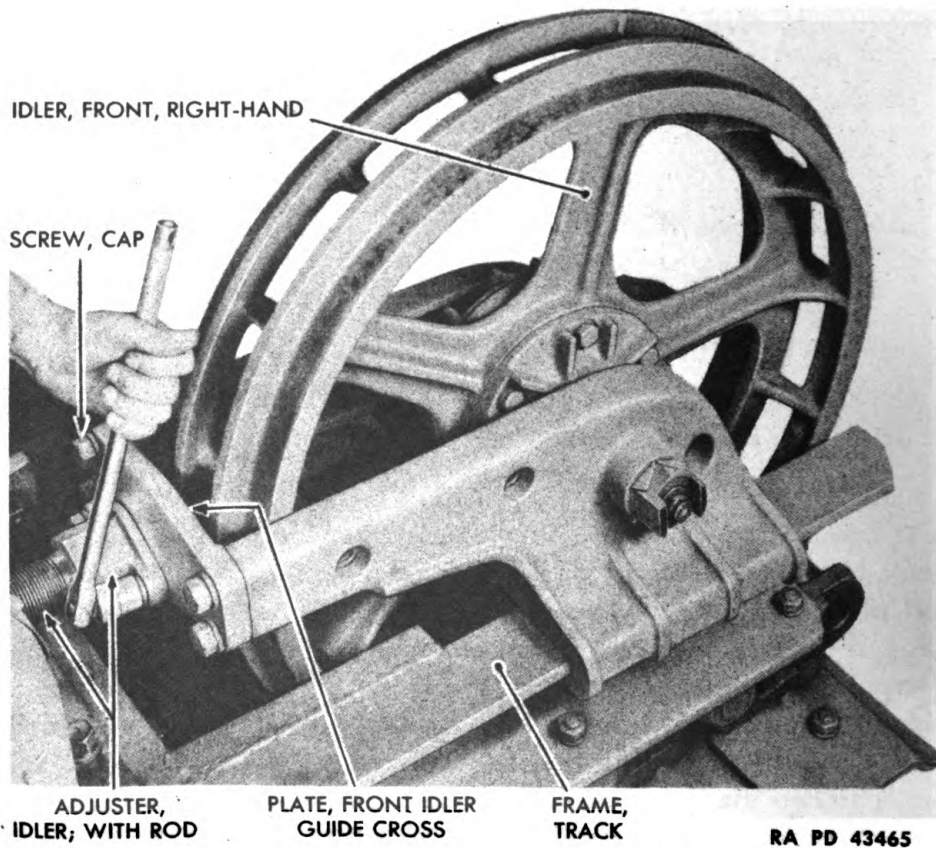

Figure 148 — Front Idler from Track Frame Removal

FRONT IDLER

but exert no tension on track when in normal operating position. Idler carrier is equipped with bronze bushings which rotate on a heat-treated steel shaft. Carriers are triple-sealed with dirt deflectors, felt washers and spring-loaded leather seal with their lips turned inward which prevents blowing out of these seals in case of excess lubrication. Service bushings as furnished are reamed to size.

96. REMOVAL

a. Equipment.

CHISEL

CROWBAR

HAMMER

WRENCH, adjustable

WRENCH, socket, $\frac{7}{8}$ -in.

WRENCH, socket, $2\frac{1}{4}$ -in.

b. Procedure.

(1) REMOVE TRACK (par. 107). NOTE: Track can be merely lifted free of idler and not completely removed from the tractor.

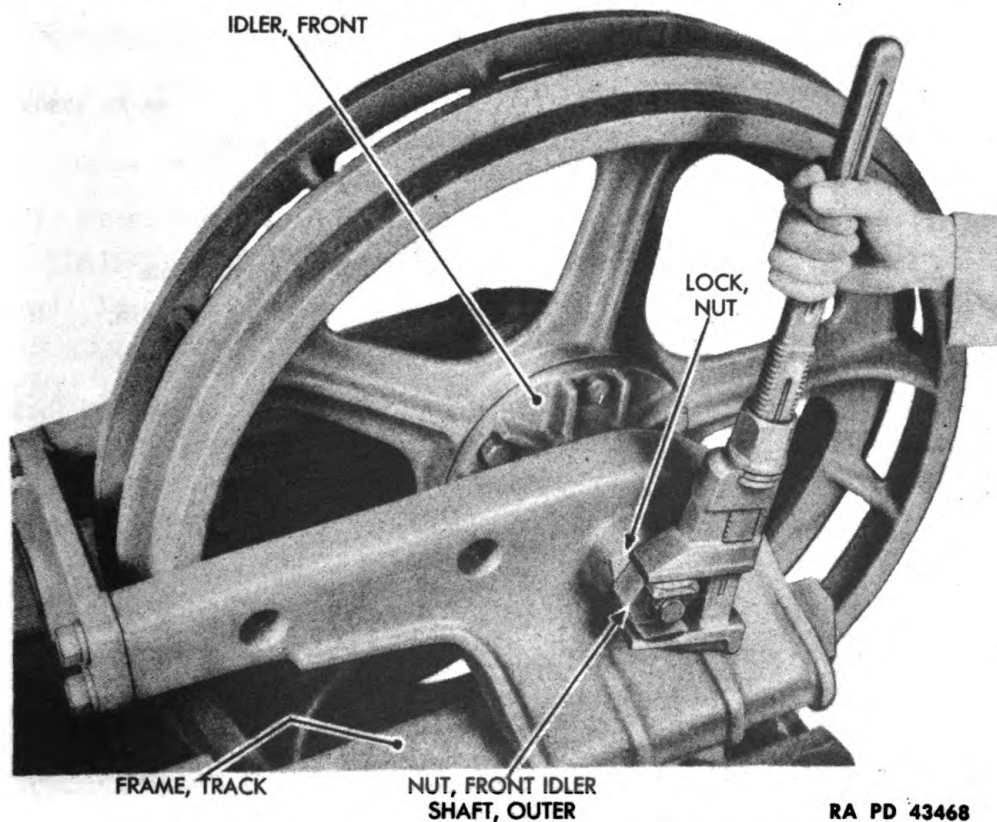

Figure 149 — Loosening Front Idler Shaft Nuts

ORDNANCE MAINTENANCE – HEAVY TRACTOR M1 (IHC TD-18) –
POWER TRAIN, TRACK FRAME ASSEMBLY, AND SEATS

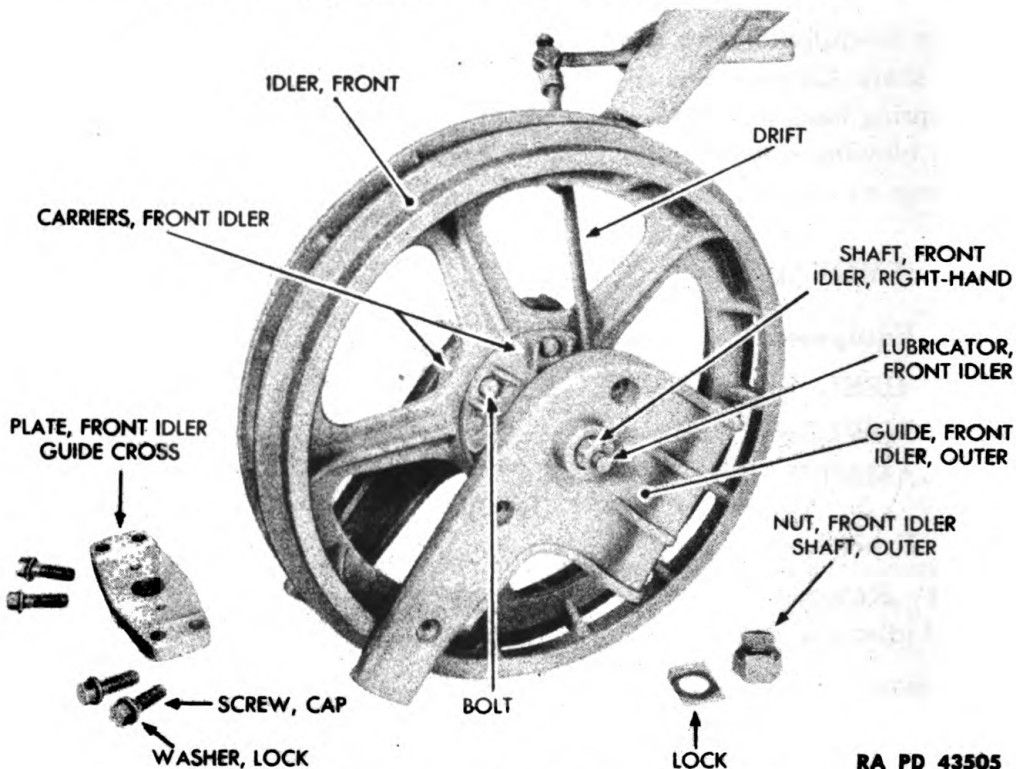

Figure 150 – Right Front Idler Disassembly

(2) REMOVE RIGHT FRONT IDLER (fig. 148).

CHISEL

CROWBAR

HAMMER

WRENCH, adjustable

WRENCH, socket, $\frac{7}{8}$ -in.

WRENCH, socket, $2\frac{1}{4}$ -in.

(a) Use a $\frac{7}{8}$ -inch socket wrench to remove 2 cap screws and lock washers which hold front idler adjuster with rod to front idler guide cross plate.

(b) Use a crowbar to force front idler to front end of track frame.

(c) After bending up nut locks on each end of shaft with chisel and hammer, use a $2\frac{1}{4}$ -inch socket wrench or an adjustable wrench to remove outer and inner nuts. **NOTE:** Nuts are loosened before removal of idler to facilitate removal of nuts later, since greater leverage with a wrench can be obtained before idler is removed from track frame.

(d) Lift front idler from track frame (two men required).

(3) REMOVE LEFT FRONT IDLER.

Follow the same procedure outlined for removal of right front idler (step (2) above).

FRONT IDLER

97. DISASSEMBLY.

a. Equipment.

- | | |
|-----------------|---------------------------|
| BAR, pry | PUNCH |
| BAR, steel | SCREWDRIVER |
| CHISEL, cold | WRENCH, adjustable |
| DRIFT | WRENCH, open-end, 7/8-in. |
| HAMMER | WRENCH, socket, 1-in. |
| HAMMER, rawhide | WRENCH, socket, 2 1/4-in. |
| PRESS, arbor | |

b. Procedure.

- (1) REMOVE RIGHT FRONT IDLER GUIDE CROSS PLATE (fig. 150).
WRENCH, socket, 1-in.

Use a 1-inch socket wrench to remove 4 nuts and lock washers from bolts which secure cross plate to front idler guides. Then lift off cross plate.

- (2) REMOVE INNER AND OUTER FRONT IDLER SHAFT NUTS (fig. 149).
WRENCH, adjustable WRENCH, socket, 2 1/4-in.

Use a 2 1/4-inch socket wrench, or adjustable wrench, to complete removal of nuts loosened during process of removing front idler. Lift off nuts and locks.

- (3) REMOVE RIGHT INNER AND OUTER FRONT IDLER GUIDES (fig. 150).
DRIFT HAMMER

(a) Insert a drift through spokes of idler and use a hammer to drive outer guide from front idler shaft. Remove front idler felt washer.

(b) In a similar manner, drive inner guide from shaft and remove felt washer.

- (4) REMOVE FRONT IDLER CARRIERS WITH BUSHINGS (fig. 150).
HAMMER, rawhide WRENCH, socket, 1-in.

Use a 1-inch socket wrench to remove 6 nuts and lock washers from bolts which hold each of the 2 carriers to front idler. Tap out bolts with a rawhide hammer. Then lift each carrier from shaft. CAUTION: While performing this operation, place idler over a pan or in a spot where oil, which will drain from idler when carriers are released, will not cause damage.

- (5) LIFT RIGHT FRONT IDLER SHAFT FROM FRONT IDLER (fig. 150).
HAMMER WRENCH, open-end, 7/8-in.
PUNCH

(a) Use a punch and hammer to drive front idler shaft key from shaft.

**ORDNANCE MAINTENANCE — HEAVY TRACTOR MI (IHC TD-18) —
POWER TRAIN, TRACK FRAME ASSEMBLY, AND SEATS**

(b) Use a 7/8-inch open-end wrench to remove front idler lubricator from shaft.

(6) REMOVE FRONT IDLER CARRIER GASKET FROM EACH CARRIER.

(7) REMOVE FRONT IDLER THRUST WASHER FROM EACH CARRIER.
SCREWDRIVER

Pry washer loose, using a screwdriver.

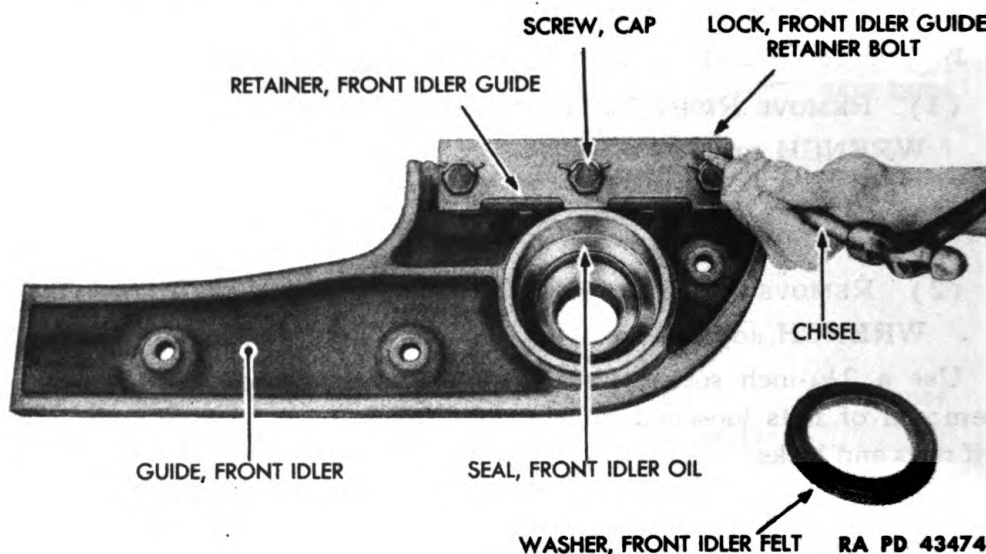

Figure 151 — Front Idler Guide Retainer Removal

(8) REMOVE CARRIER BUSHINGS.

BAR, steel

PRESS, arbor

Place carrier with bushings on shaft and check for excessive play. If play is excessive, bushings should be removed. Place the carrier in an arbor press with a steel bar in position over the bushings, and press the 2 bushings from each carrier.

(9) REMOVE FRONT IDLER GUIDE RETAINER FROM INNER AND OUTER IDLER GUIDES (fig. 151).

CHISEL, cold

WRENCH, open-end, 7/8-in.

HAMMER

(a) Use a cold chisel and hammer to drive front idler guide retainer bolt lock free from 3 cap screws which hold retainer to outer idler guide.

FRONT IDLER

(b) Use a $\frac{7}{8}$ -inch open-end wrench to remove 3 cap screws. Remove lock and retainer.

(c) Remove retainer from inner idler guide in the same manner.

(10) REMOVE FRONT IDLER OIL SEAL FROM INNER AND OUTER IDLER GUIDES (fig. 151).

BAR, pry

HAMMER

CHISEL, cold

Use a cold chisel and hammer to cut oil seal so it can be pried out of outer idler guide with a pry bar. Remove oil seal from inner guide in the same manner.

(11) DISASSEMBLE LEFT FRONT IDLER.

Follow the same procedure outlined in preceding steps of this paragraph for disassembly of right front idler.

98. INSPECTION.

a. **Clean All Parts.** Wash idler in water to remove mud and dirt. Then wash all parts in SOLVENT, dry-cleaning, to remove dirt, oil, and grease.

b. **Inspect All Parts.**

(1) IDLER.

Examine flange of idler for excessive wear and breaks. Replace idler if flanges are broken or worn.

(2) FRONT IDLER CARRIERS WITH BUSHINGS.

Check operation of carriers on shaft. Install new bushings, if worn in excess of a 0.009-inch clearance. Replace shaft if worn so that diameter is less than 2.230 inches.

(3) FRONT IDLER SHAFT.

(a) Use compressed air to blow out oilholes.

(b) Examine for visible evidence of wear, which is indicated by grooves around shaft. Install new shaft if old shaft is worn.

(4) FRONT IDLER THRUST WASHERS.

Examine the 2 washers and if they are worn thin, replace with new parts.

(5) INNER AND OUTER FRONT IDLER GUIDES.

Check guide and retainer for wear at points where guide rides on track frame. Install new guide and retainer if wear permits excessive movement on track frame.

FRONT IDLER**(5) INSTALL NEW FRONT IDLER CARRIER GASKETS.**

Place a gasket in position on each carrier.

(6) INSTALL RIGHT FRONT IDLER SHAFT IN RIGHT FRONT IDLER (fig. 150).

WRENCH, open-end, $\frac{7}{8}$ -in.

(a) Use a $\frac{7}{8}$ -inch open-end wrench to install front idler lubricator in end of front idler shaft.

(b) Place front idler shaft key in position on end of front idler shaft.

(c) Insert shaft in idler so key fits into keyway of shaft.

(7) INSTALL INNER AND OUTER CARRIERS WITH BUSHINGS (fig. 150).

WRENCH, open-end, 1-in.

Place carriers on ends of shaft with lubricator toward the outer carrier. Install 6 bolts, nuts, and lock washers which hold the 2 carriers to idlers. Tighten nuts with a 1-inch open-end wrench.

(8) INSTALL RIGHT INNER AND OUTER FRONT IDLER GUIDES (fig. 150).

HAMMER, rawhide

(a) Install a new felt washer in each guide.

(b) Use a rawhide hammer to drive guides onto shaft.

(9) INSTALL INNER AND OUTER FRONT IDLER SHAFT NUTS (fig. 150).

CHISEL

WRENCH, socket, $2\frac{1}{4}$ -in., or

HAMMER

WRENCH, adjustable

Install nut lock and nut on each end of shaft. Tighten nut with a $2\frac{1}{4}$ -inch socket wrench or adjustable wrench. Use a chisel and hammer to bend locks over nuts. **NOTE:** If nuts cannot be tightened sufficiently, they may be tightened further when idler is installed in track frame guide, where greater leverage can be obtained with wrench.

(10) INSTALL FRONT IDLER GUIDE CROSS PLATE (fig. 150).

WRENCH, socket, 1-in.

Place cross plate in position over ends of guides. Secure it to guides with 4 bolts, nuts, and lock washers. Tighten nuts, using a 1-inch socket wrench.

ORDNANCE MAINTENANCE — HEAVY TRACTOR M1 (IHC TD-18) —
POWER TRAIN, TRACK FRAME ASSEMBLY, AND SEATS

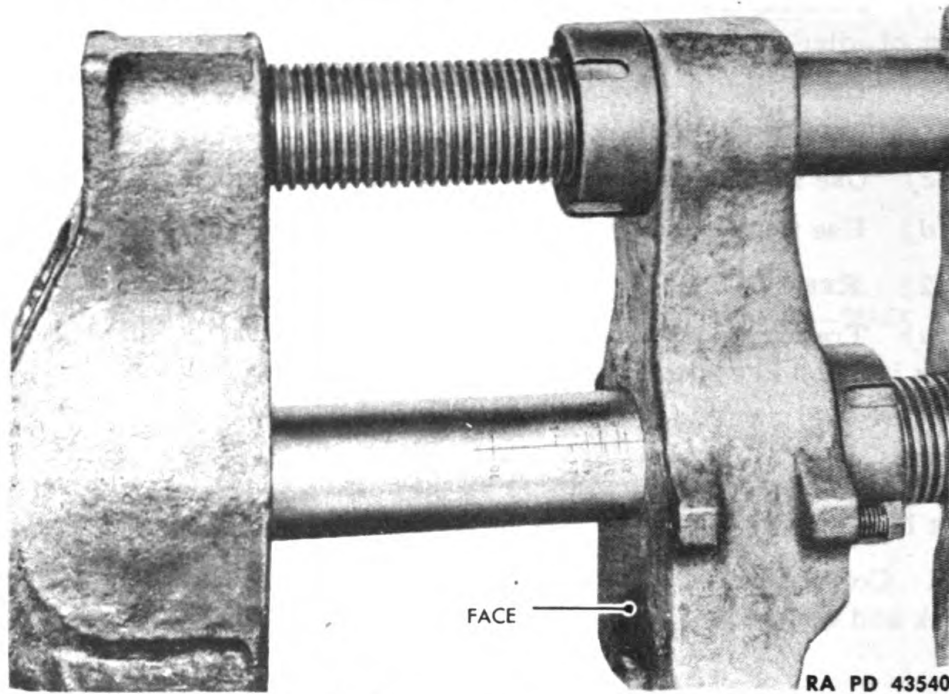

Figure 157 — Graduations on Lower Bar of Adjusting Head

107. DISASSEMBLY.

a. Equipment.

HOIST

PRESS, portable hydraulic pin
and bushing, SE-1026

ANGLE, front support,
SE-1026-56

ANGLE, rear support,
SE-1026-57

BUSHING, guide,
SE-1026-38

COLLAR, spacing,
SE-1026-42

HEAD, adjustable,
SE-1026-50

PIN, long alining,
SE-1026-45

PIN, short alining,
SE-1026-52

PLUG, bushing push,
SE-1026-39

ROD, extension, SE-1026-30

ROD, extension, SE-1026-35

ROD, push, SE-1026-21

ROD, push, SE-1026-22

ROD, push, SE-1026-25

ROD, push, SE-1026-26

SLEEVE, bushing, SE-1026-34

SLEEVE, pin, SE-1026-32

TRACK

b. Procedure.

- (1) REMOVE TRACK PLATES AND TRACK SHOES (par. 109).
- (2) BREAK TRACK INTO SHORTER LENGTHS (TO SUIT OPERATOR) (figs. 156, 157, and 158).

PRESS, portable hydraulic pin
and bushing, SE-1026

ANGLE, front support,
SE-1026-56

ROD, extension, SE-1026-30

ANGLE, rear support,
SE-1026-57

ROD, push, SE-1026-26

BUSHING, guide,
SE-1026-38

SLEEVE, pin, SE-1026-32

HEAD, adjustable,
SE-1026-50

(a) Install front support angle SE-1026-56 and rear support angle SE-1026-57 on adjustable head SE-1026-50 by using holes in angles (fig. 156).

(b) Adjust head so face will line up with mark on graduated scale marked "18." Move center part of head to make this adjustment.

(c) Assemble pin sleeve SE-1026-32 to outer end of head SE-1026-50. Place push rod SE-1026-26 through guide bushing SE-1026-38 and assemble push rod in head (fig. 157). Slide the guide bushing all the way forward to the hole in the inner end of the head and place 1/4-inch cotter key through compression bar, just in front of the piston and through the hole in the end of push rod. CAUTION: Never apply pressure before assembling guide bushing and 1/4-inch cotter pin.

(d) With push rod and track pin to be removed in alignment, screw in 2 wing-head screws at center of head to within 1/8-inch from bushing so that head will be self-aligning (fig. 158). Operate hand lever until piston reaches end of its travel. Return piston by releasing pressure and insert extension rod SE-1026-30 (1/4-inch cotter pin) behind push rod and finish driving out pin. Break track in convenient lengths for handling (usually 4 sections).

(3) PUSH PIN OUT OF FIRST LINK (WITH SHOES REMOVED) (fig. 159).

NOTE: When removing several or all pins from track begin from one end of the track chain and push all the track pins to be removed just enough to clear first link.

**ORDNANCE MAINTENANCE — HEAVY TRACTOR MI (IHC TD-18) —
POWER TRAIN, TRACK FRAME ASSEMBLY, AND SEATS**

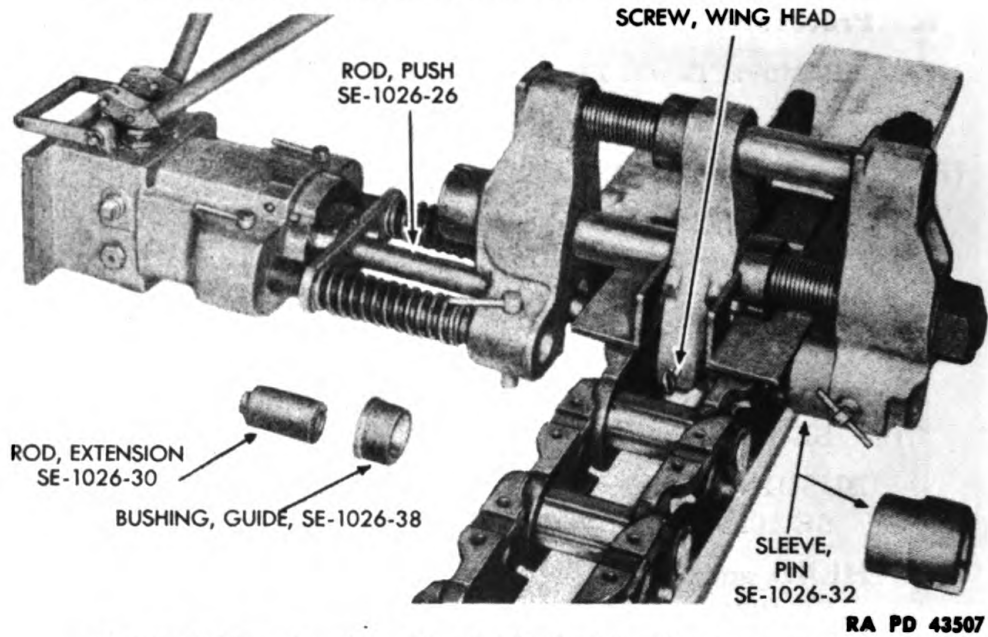

Figure 158 — Breaking Track Chain into Shorter Lengths

PRESS, portable hydraulic pin
and bushing, SE-1026

BUSHING, guide,
SE-1026-38

ROD, push, SE-1026-26

SLEEVE, pin, SE-1026-32

Follow procedure in step (2) of this paragraph with push rod SE-1026-26 and push rod guide bushing SE-1026-38 and pin sleeve SE-1026-32 to push pin until it is through the first link.

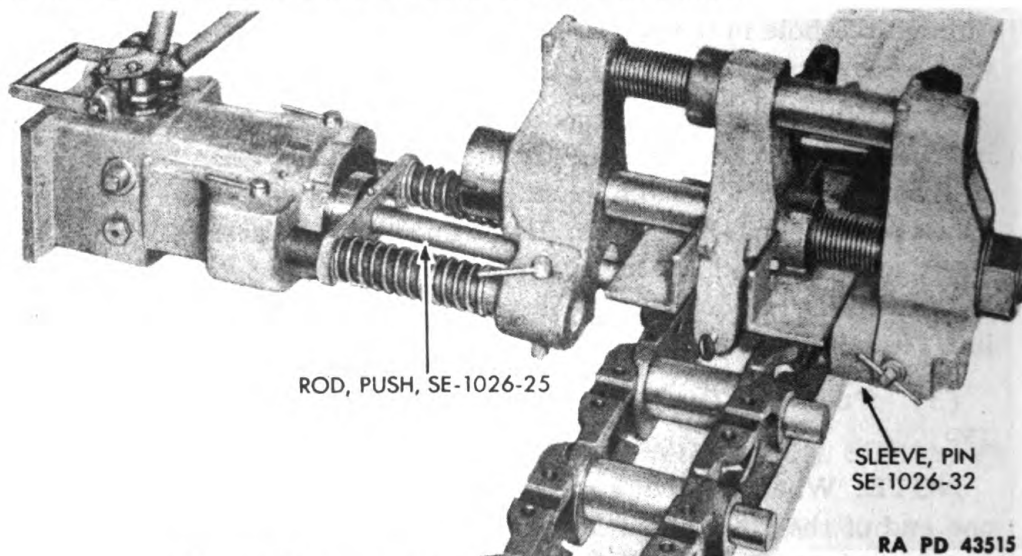

Figure 159 — Pushing Pin Just Out of First Link

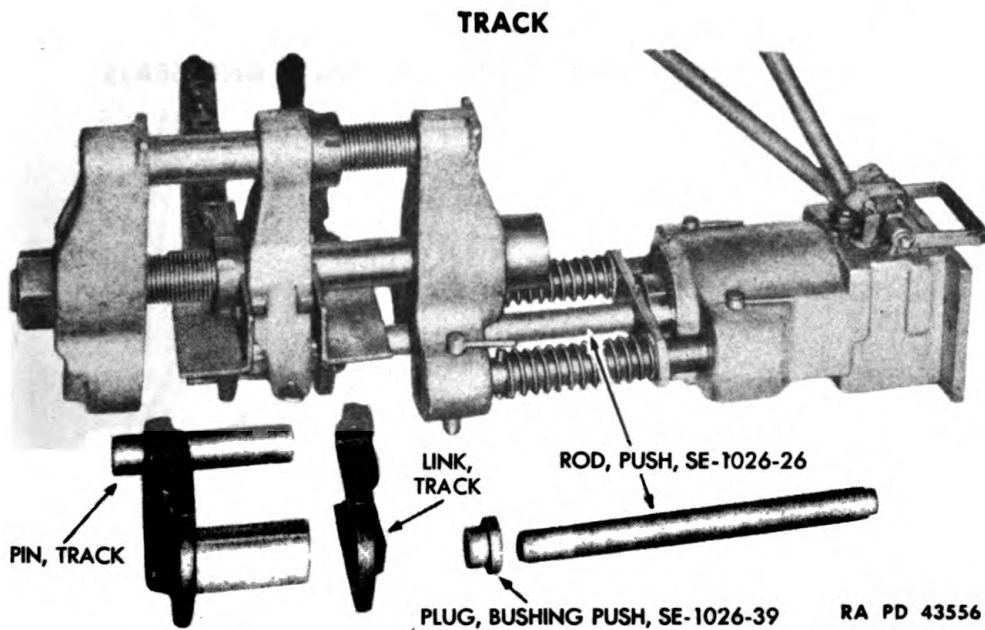

Figure 160 – Pushing Bushing Out of First Link

(4) PUSH BUSHING OUT OF FIRST LINK (WITH SHOES REMOVED)
(fig. 160).

PRESS, portable hydraulic pin
and bushing, SE-1026
BUSHING, guide,
SE-1026-38
PLUG, bushing push,
SE-1026-39

ROD, push, SE-1026-26

Place bushing push plug SE-1026-39 in end of bushing to be removed
and use push rod SE-1026-26 and guide bushing SE-1026-38 to push
out the bushing from the first link.

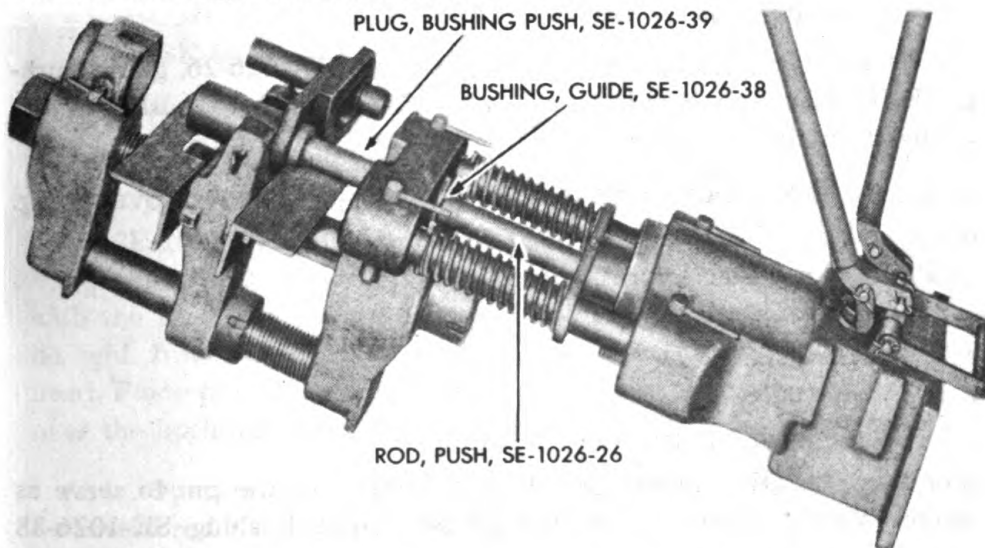
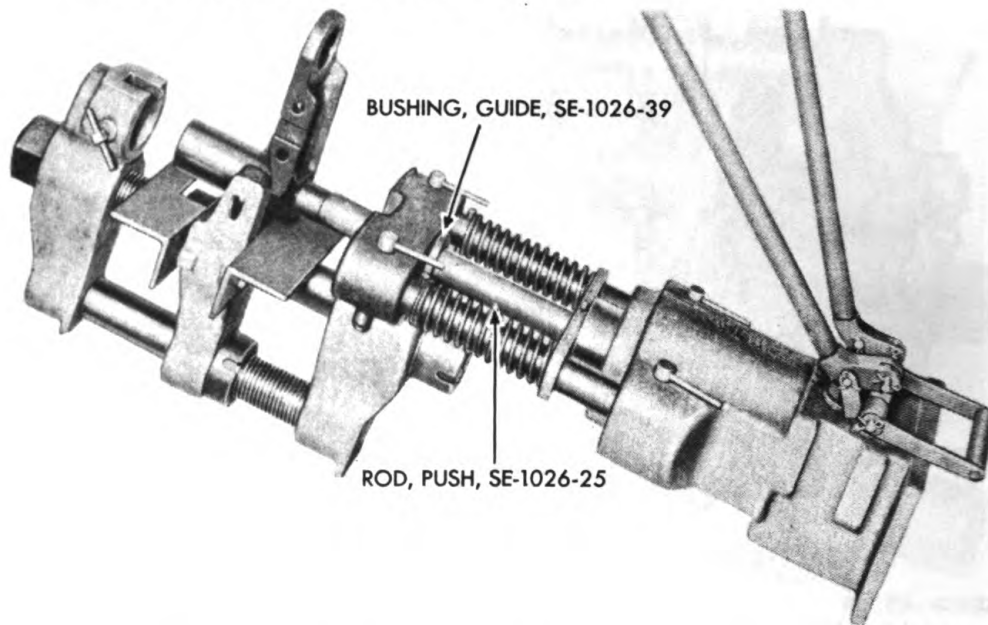

Figure 161 – Pushing Bushing Out of Second Link

RA PD 43508

ORDNANCE MAINTENANCE — HEAVY TRACTOR MI (IHC TD-18) —
POWER TRAIN, TRACK FRAME ASSEMBLY, AND SEATS



RA PD 43494

Figure 162 — Pushing Pin Out of Second Link

(5) PUSH BUSHING OUT OF SECOND LINK (WITH SHOES REMOVED)
(fig. 161).

PRESS, portable hydraulic pin
and bushing, SE-1026

BUSHING, guide,
SE-1026-38

ROD, push, SE-1026-26

PLUG, bushing push,
SE-1026-39

Invert head for this operation. Use push rod SE-1026-26, guide bushing SE-1026-38 and bushing push plug SE-1026-39 to push out the bushing from the second link.

(6) PUSH PIN OUT OF SECOND LINK (WITH SHOES REMOVED) (fig. 162).

PRESS, portable hydraulic pin
and bushing, SE-1026

BUSHING, guide,
SE-1026-38

ROD, push, SE-1026-25

For this operation place track link bushing over the pin to serve as a guide. With a push rod SE-1026-25 and guide bushing SE-1026-38 press pin out of second link.

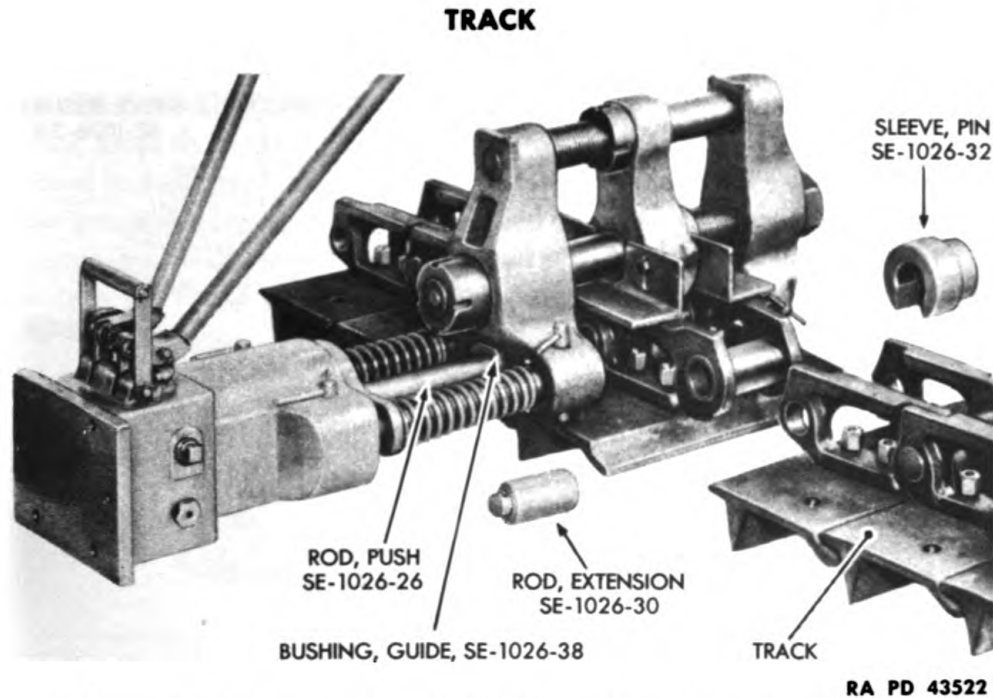

Figure 163 – Pushing Pin All the Way Out (Shoes Assembled)

(7) PUSH TRACK PIN ALL THE WAY OUT (WITH SHOES ASSEMBLED TO LINKS) (fig. 163).

PRESS, portable hydraulic pin and bushing, SE-1026

ANGLE, front support, SE-1026-56

ANGLE, rear support, SE-1026-57

BUSHING, guide, SE-1026-38

HEAD, adjustable, SE-1026-50

ROD, extension, SE-1026-30

ROD, push, SE-1026-26

SLEEVE, pin, SE-1026-32

(a) Remove the front support angle SE-1026-56 and rear support angle SE-1026-57 and fasten them to the adjustable head using the slots. Place the head SE-1026-50 over the track, lining up push rod opening with the track pins. Then tighten angle supports so this alignment will be held. Insert push rod SE-1026-26 and guide bushing SE-1026-38 in head. Place pin sleeve SE-1026-32 in outer end of head and place head over the bushing of the track pin to be removed.

(b) Operate press to end of piston travel. Release pressure. Insert extension rod SE-1026-30 and finish driving out track pin.

**ORDNANCE MAINTENANCE – HEAVY TRACTOR MI (IHC TD-18) –
POWER TRAIN, TRACK FRAME ASSEMBLY, AND SEATS**

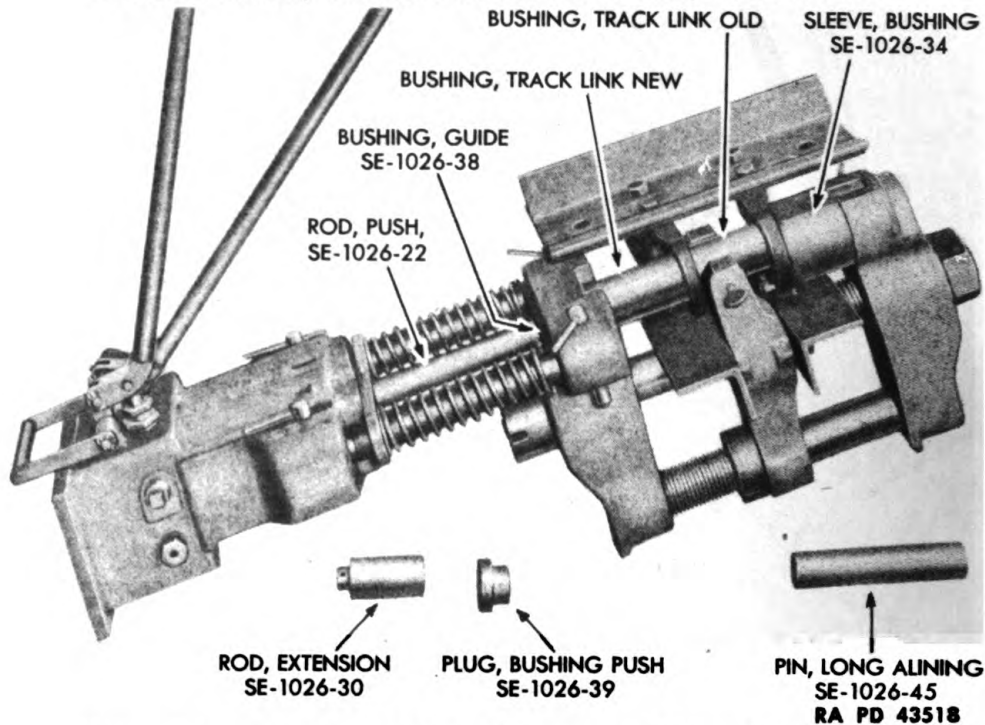

Figure 164 – Pushing Old Bushing Out and New Bushing in, in Same Operation (Shoes Assembled)

(8) PUSH OLD BUSHING OUT AND NEW BUSHING IN, IN SAME OPERATION (WITH SHOES ASSEMBLED TO LINKS) (fig. 164).

PRESS, portable hydraulic pin and bushing, SE-1026

BUSHING, guide, SE-1026-38

PIN, long alining, SE-1026-45

ROD, extension, SE-1026-30

ROD, push, SE-1026-22

SLEEVE, bushing, SE-1026-34

Invert head inside bushing sleeve SE-1026-34 in outer end of head. Place track shoe link bushing assembly in the head. Place long alining pin SE-1026-45 inside assembled track link bushing and new bushing to align both bushings. Place bushing push plug SE-1026-39 in end of new bushing, and with push rod SE-1026-22 and guide bushing SE-1026-38, drive out old bushing 4 inches. Release pressure on piston and insert extension rod SE-1026-30 to complete the operation.

108. INSPECTION.

a. **Clean All Parts.** The track should be washed or steam cleaned before removal.

TRACK

b. Inspect All Parts. Check all track link pins and track link bushings for loose fit as result of wear. Bushings and pins may be reversed as outlined in paragraph 109. Replace worn track links if the rails are worn to the point where the flanges of the front idler are contacting the track bushings. If the bushings and pins have been turned once, replace them with new parts. If the bushings and pins have not been turned, about 2/7 of the life of new pins and bushings can be obtained by installing the old pins and bushings at 180 degrees from their original position.

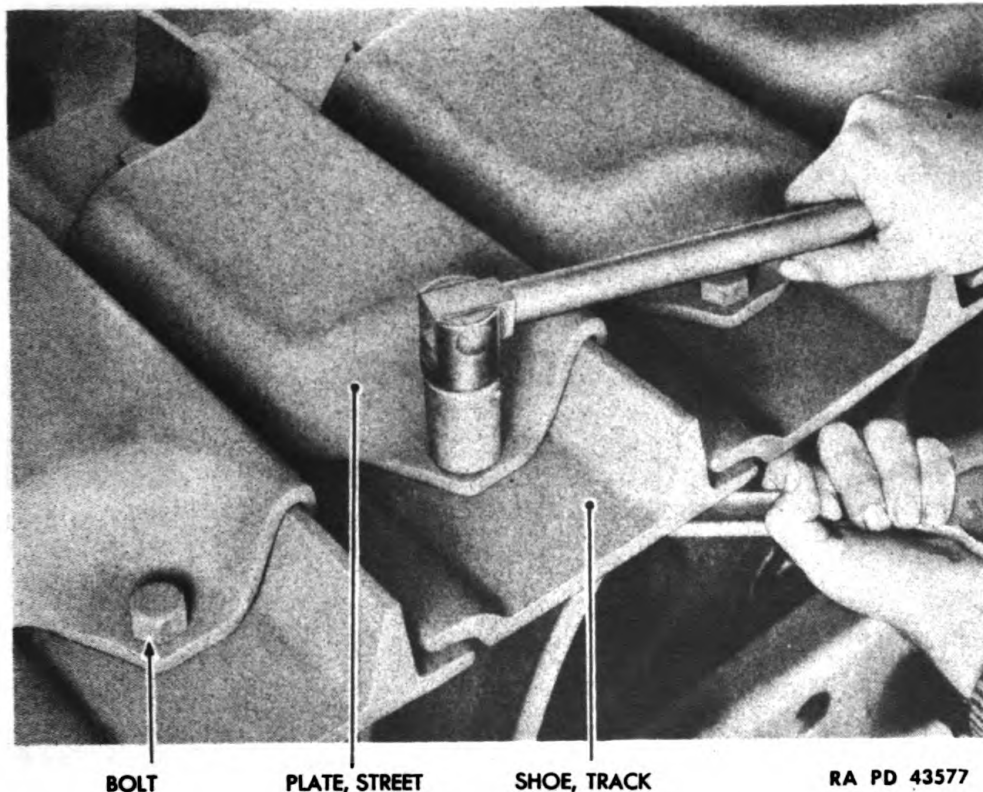

Figure 165 — Street Plate Removal

109. OVERHAUL.

NOTE: Worn street plates and track shoes can be replaced without removing the track from the vehicle (*a* and *b* below). Track pins and bushings can be reversed to obtain additional service from them, providing track is first removed (*b* (3)).

a. Equipment.

WRENCH, open-end, 1 1/8-in.

WRENCH, socket, 1-in.

WRENCH, socket, 7/8-in.

ORDNANCE MAINTENANCE — HEAVY TRACTOR MI (IHC TD-18) —
POWER TRAIN, TRACK FRAME ASSEMBLY, AND SEATS

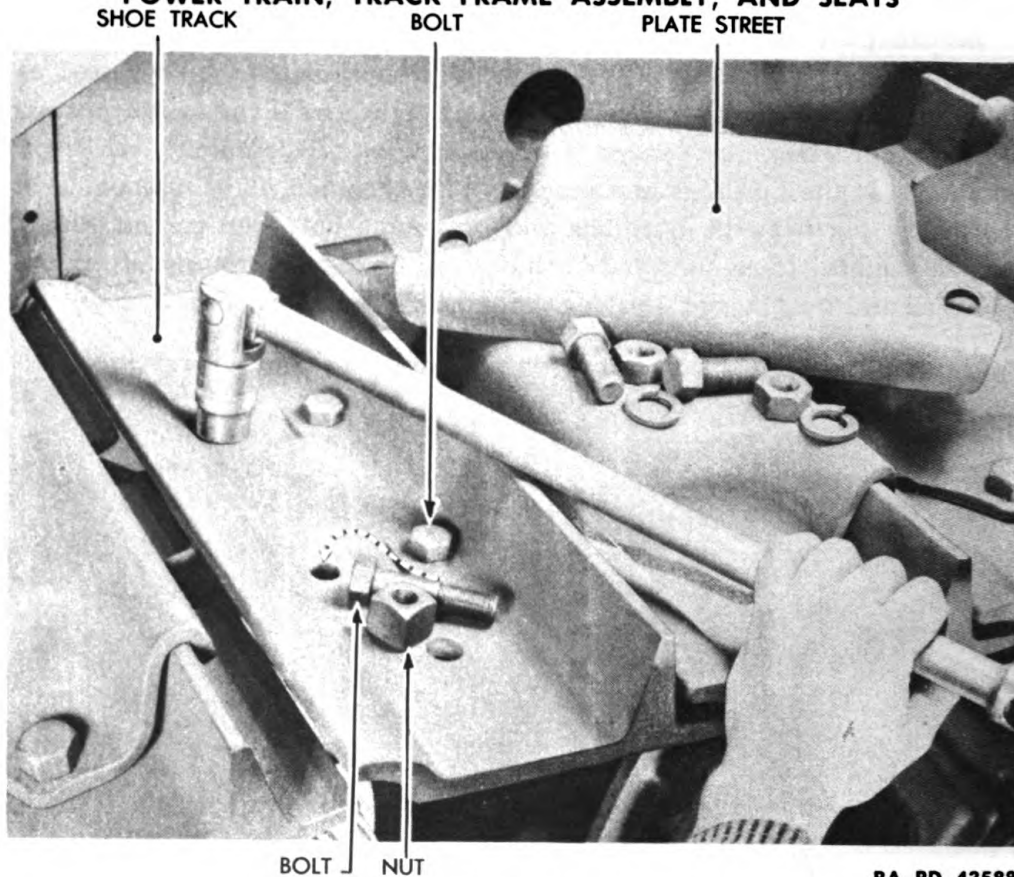

RA PD 43588

Figure 166 — Track Shoe Removal

b. Procedure.

(1) **TO REPLACE STREET PLATES.**

(a) *Remove Street Plate* (fig. 165).

WRENCH, open-end, 1 1/8-in.

WRENCH, socket, 1-in.

Remove the 2 bolts, nuts, and lock washers which hold street plate to track shoe. Hold nut from underneath shoe with a 1 1/8-inch open-end wrench while removing bolt from top of shoe with a 1-inch socket wrench.

(b) *Install Street Plate* (fig. 165).

WRENCH, open-end, 1 1/8-in.

WRENCH, socket, 1-in.

Insert 2 bolts through street plate and track shoe. Attach lock washers and nuts. Hold nuts with a 1 1/8-inch open-end wrench and tighten bolts with a 1-inch socket wrench.

(2) **TO REPLACE TRACK SHOES** (fig. 166).

(a) *Remove Street Plate if Street Plate is Installed* (fig. 165). Follow procedure outlined in step (1) above.

TRACK

(b) *Remove Track Shoe* (fig. 166).

WRENCH, socket, 7/8-in.

Use a 7/8-inch socket wrench on bolt heads to remove 4 bolts which hold track shoe to right and left links. It is not necessary to hold nuts to keep them from turning. Remove plate.

(c) *Install New Track Shoe* (fig. 166).

WRENCH, socket, 7/8-in.

Place shoe in position over right and left links. Install 4 bolts, washers, and nuts. Hold lock washer and nut underneath link while starting bolt through shoe and link by hand. Then use a 7/8-inch socket wrench on bolt heads to tighten.

(d) *Install Street Plate if Required* (fig. 165).

Follow procedure outlined in step (1) above.

(3) TO REVERSE TRACK PINS AND BUSHINGS.

(a) Worn pins and bushings in a track can be turned to obtain additional service from the track. In this way the worn surface is placed next to track shoe and unworn surface of bushing operates over the sprocket.

(b) Remove track from tractor (par. 106).

(c) Remove track shoes and street plates as outlined in steps (1) and (2) above.

(d) Press out track pins and bushings (par. 107).

(e) Turn bushings 180 degrees or one-half turn and install (par. 110).

(f) Turn pins one-half turn. By doing this, unworn surface of pin is operating against unworn surface in bushing. Install pins as outlined in paragraph 110.

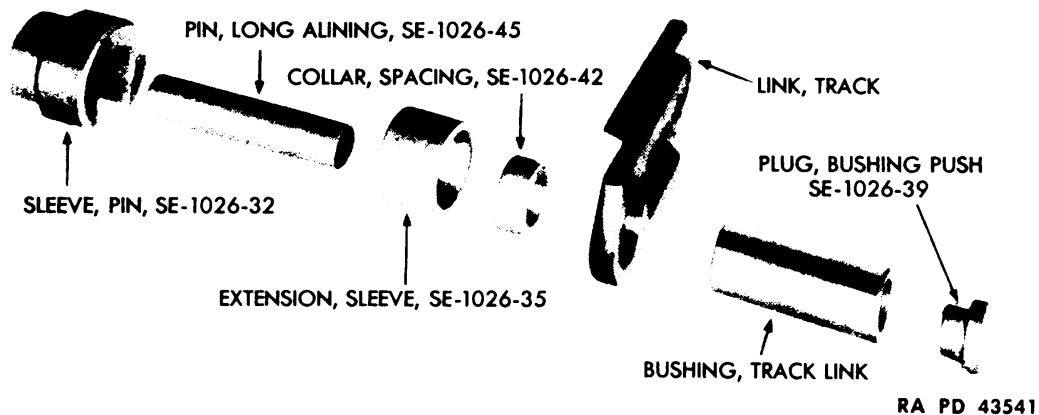

Figure 167 – Tools for Pushing Bushing into First Link Arrangement

ORDNANCE MAINTENANCE — HEAVY TRACTOR M1 (IHC TD-18) —
POWER TRAIN, TRACK FRAME ASSEMBLY, AND SEATS

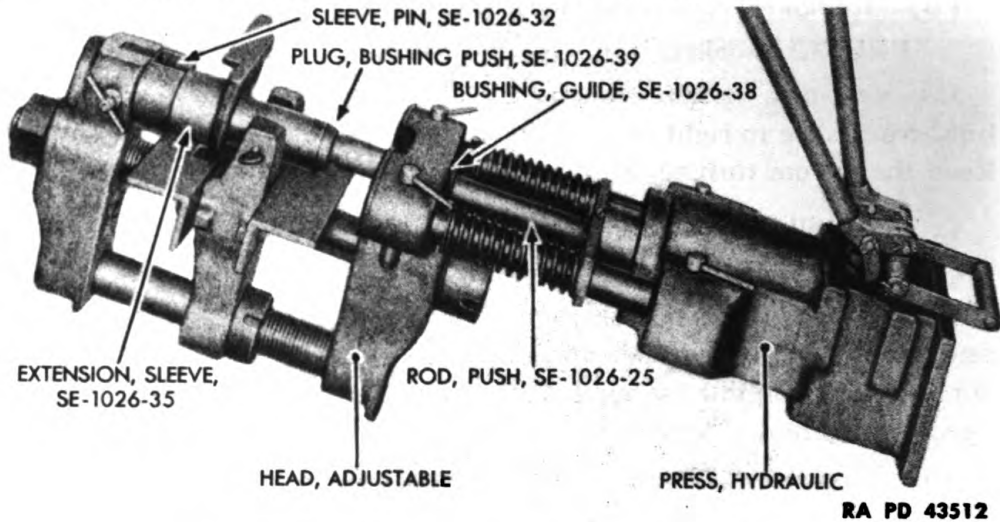

Figure 168 — Pushing Bushing into First Link

110. ASSEMBLY.

a. Equipment.

HAMMER

HAMMER, babbitt

HOIST

PRESS, portable hydraulic pin
and bushing SE-1026

BUSHING, guide,
SE-1026-38

COLLAR, spacing,
SE-1026-42

EXTENSION, sleeve,
SE-1026-35

HEAD, adjustable,
SE-1026-50

PIN, long alining,
SE-1026-45

PIN, short alining,
SE-1026-52

PLUG, bushing push,
SE-1026-39

ROD, extension, SE-1026-30

ROD, push, SE-1026-21

ROD, push, SE-1026-22

ROD, push, SE-1026-25

ROD, push, SE-1026-26

SLEEVE, bushing,
SE-1026-34

SLEEVE, pin, SE-1026-32

WRENCH, open-end, 1 1/8-in.

WRENCH, socket, 1-in.

WRENCH, torque tension

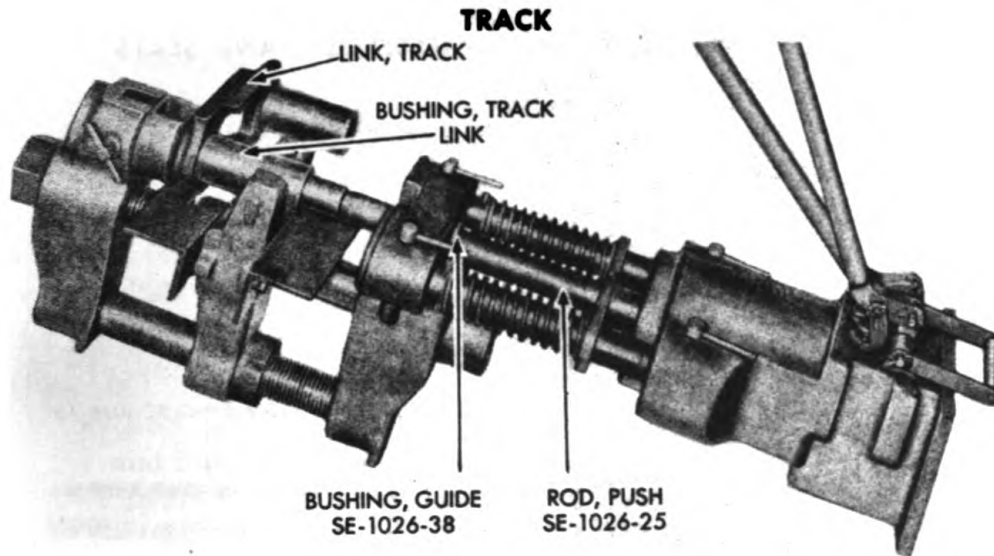

Figure 169 — Pushing Pin into First Link

RA PD 43568

b. Procedure.

- (1) **USE OF PORTABLE HYDRAULIC PIN AND BUSHING PRESS SE-1026.**
See paragraph 139 for description of portable hydraulic pin and bushing press, SE-1026.
- (2) **ASSEMBLE PINS AND BUSHINGS IN BOTH LINKS IN A SINGLE LINK UNIT (figs. 167 and 168).**

HAMMER, babbitt
PRESS, portable hydraulic pin and bushing, SE-1026
BUSHING, guide, SE-1026-38
COLLAR, spacing, SE-1026-42
EXTENSION, sleeve, SE-1026-35
HEAD, adjustable, SE-1026-50
PIN, long alining, SE-1026-45

PIN, short alining, SE-1026-52
PLUG, bushing push, SE-1026-39
ROD, push, SE-1026-25
SLEEVE, pin, SE-1026-32

(a) Push bushing into first link (fig. 168). Pin sleeve SE-1026-32 is placed in outer end of head. Long alining pin SE-1026-45 is placed through sleeve extension SE-1026-35 and spacing collar SE-1026-42 (which is placed inside sleeve extension for stopping travel of track bushing flush with face of link) and track bushing to aline track bushing with link. Bushing push plug SE-1026-39 is placed in end of bushing. With push rod SE-1026-25 and guide bushing SE-1026-38, press bushing into link.

ORDNANCE MAINTENANCE — HEAVY TRACTOR MI (IHC TD-18) —
POWER TRAIN, TRACK FRAME ASSEMBLY, AND SEATS

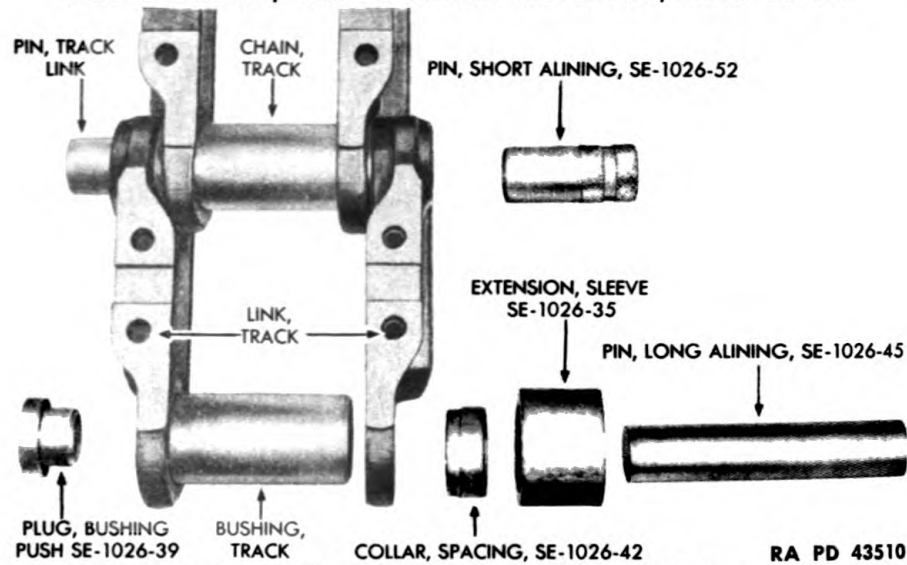

Figure 170 — Tools for Assembling Second Link Arrangement

(b) Push pin into first link (fig. 169). Start pin into link with babbitt hammer. Using track bushing as a guide and with push rod SE-1026-25 and guide bushing SE-1026-38 press pin into link, so that pin extends $1\frac{3}{8}$ inches beyond other side of link.

(c) Push bushing into second link and assemble section to track chain (figs. 170 and 171).

(d) Insert track pin of pin-link-bushing assembly into bushing of track chain. Insert short alining pin SE-1026-52 through link into bushing. Place long alining pin SE-1026-45 through sleeve extension SE-1026-35, spacing collar SE-1026-42, link and bushing to aline link to bushing (fig. 171).

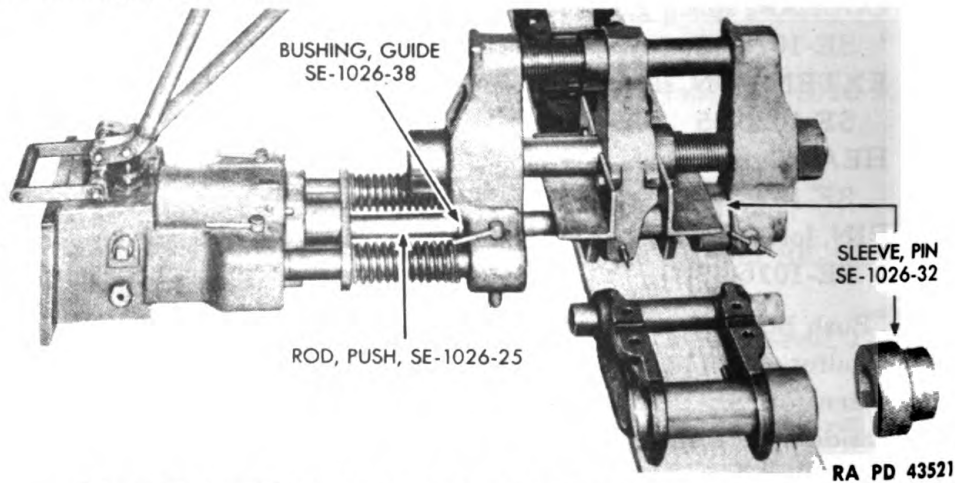

Figure 171 — Tools Used in Pushing Bushing into Second Link Assembled Position

TRACK

(e) Insert bushing push plug SE-1026-39 in other end of bushing. Place head in upright position, with push rod SE-1026-25, guide bushing SE-1026-38, and pin sleeve SE-1026-32 over bushing. With push rod SE-1026-25, against plug SE-1026-39, press bushing into link, keeping short alining pin SE-1026-52 in place to assure alinement between bushing and link.

(3) **INSTALLING SECOND LINK TO JOIN SECTIONS OF TRACK CHAIN** (fig. 172).

PRESS, portable hydraulic pin
and bushing, SE-1026

BUSHING, guide,
SE-1026-38

PIN, long alining,
SE-1026-47

ROD, extension, SE-1026-30

ROD, push, SE-1026-21

ROD, push, 1026-22

SLEEVE, pin, SE-1026-32

(a) Where several sections or all sections are to be assembled, the separate sections should first be handled as outlined in step (1) above. Then, work back on track to push track pin into second link of each section to assemble chain. Proceed as follows:

1. Assemble push rod SE-1026-22, guide bushing SE-1026-38, and pin sleeve SE-1026-32 into head and place head over bushing. Press in pin so that both ends extend equally beyond outside of links.

2. After pressing in first link, check spacing of track shoe bolt holes in links to see if any width adjustment of head is necessary before pressing in remaining pins.

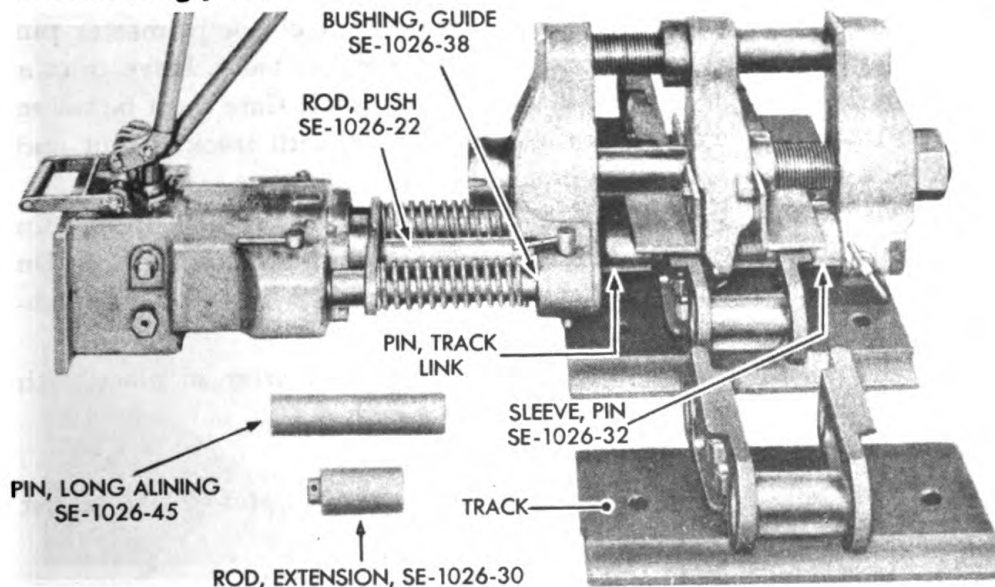

RA PD 43537

Figure 172 — Pushing Pin All the Way Through to Assemble Track Chain

**ORDNANCE MAINTENANCE — HEAVY TRACTOR MI (IHC TD-18) —
POWER TRAIN, TRACK FRAME ASSEMBLY, AND SEATS**

3. To assemble 2 lengths of track chain together, push track pin all the way in, using tools as in figure 172.

4. Place long alining pin SE-1026-45 through bushing and 2 links through which pin is to be driven. Place head with pin sleeve SE-1026-32 over bushing. Insert track pin into position shown. Install push rod SE-1026-21 and guide bushing SE-1026-38. Press pin in 4 inches, release pressure and insert extension rod SE-1026-38 behind push rod. Finish pressing in track pin.

111. INSTALLATION.

a. Equipment.

BAR, steel

BLOCK, wood, 8-in. x 8-in.

BOARD

HAMMER

SLEDGE

WRENCH, open-end, 1½-in.

WRENCH, socket, ⅞-in.

b. Procedure.

(1) INSTALL TRACK (fig. 155).

BAR, steel

BLOCK, wood, 8-in. x 8-in.

HAMMER

SLEDGE

(a) It is assumed that in removing old track, tractor has been driven backward on track.

(b) Place wood block, about 8 inches by 8 inches, under front track shoe of track to permit chain to follow curve of front idler and make it easier to install master link pin.

(c) Pick up rear end of track by inserting steel bar in master pin holes and engage bushings of first links in sprocket teeth. Have tractor driven slowly ahead and sprocket will pick up track. Care must be taken to guide track over track idlers and front idler until track is taut and master link is in place directly beneath front track idler.

(d) Use a steel bar to line up master link and bushing. Insert pin from inside of right track with flat sides matching flat sides of link. On the left track the pin is inserted from outside of track with flat sides matching flat side of link. Drive in with sledge.

(e) Insert new master link pin lock wire and drive in place with hammer, then use hammer to bend locking end.

(2) ADJUST TRACK TENSION (fig. 174).

Follow procedure outlined in paragraph 112 b (1) and (2), to adjust track tension.

(3) INSTALL OR REPLACE TRACK SHOES (fig. 166).

WRENCH, socket, ⅞-in.

TRACK

(a) Where track is installed on tractor, use a $\frac{7}{8}$ -inch socket wrench to secure each shoe to track with 4 bolts, lock washers, and nuts. Bolt heads must be toward outside of track. Move tractor as required, so shoes may be installed on upper side of track. Use a $\frac{7}{8}$ -inch socket wrench to tighten bolt heads. It is not necessary to hold nuts to keep them from turning.

(b) To install or replace shoes on removed track, turn track right side up. Then install or replace shoes as outlined in paragraph 109 b (2).

(4) INSTALL OR REPLACE STREET PLATES (fig. 165).

Follow procedure outlined in paragraph 109 h step (1).

112. ADJUSTMENT.

a. Equipment.

BLOCK, wood, approx. 1 ft high

RULE

STRAIGHTEDGE, 2-in. x 2-in. x 6 ft (or string)

WRENCH, open-end, $\frac{1}{8}$ -in.

WRENCH, open-end, 1-in.

WRENCH, open-end, $1\frac{1}{8}$ -in.

WRENCH, open-end, $2\frac{1}{4}$ -in. or adjustable wrench

WRENCH, socket, $\frac{7}{8}$ -in.

WRENCH, socket, $\frac{1}{8}$ -in.

WRENCH, socket, $2\frac{1}{4}$ -in.

ADJUSTER, FRONT IDLER, WITH ROD
BOLT, FRONT IDLER ADJUSTER LOCK (NOT SHOWN)
NUT
PLATE, FRONT IDLER GUIDE CROSS

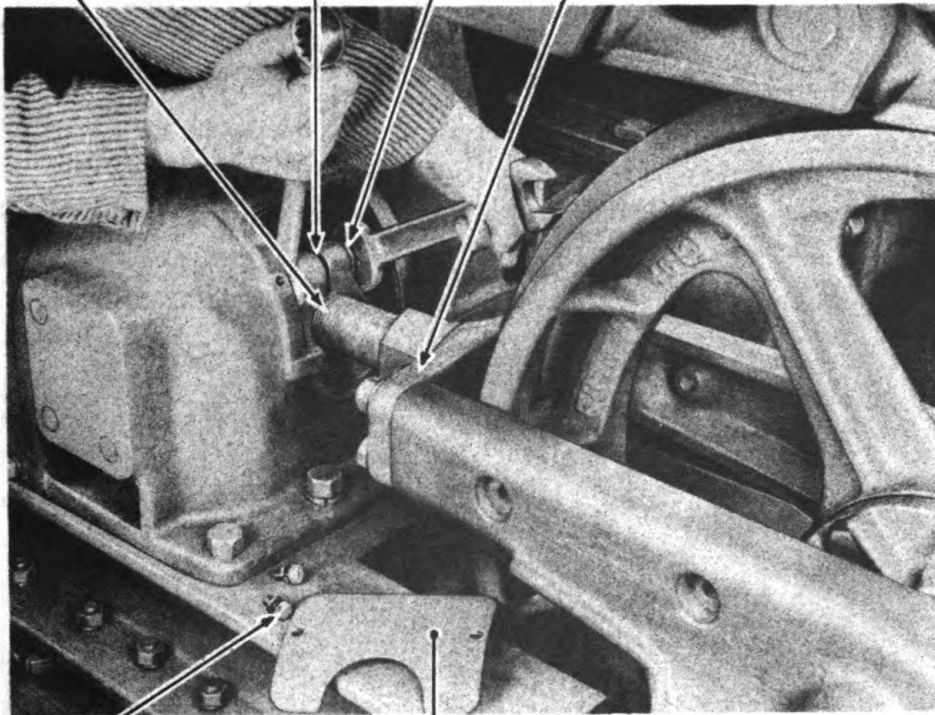

SCREW, CAP PLATE, TRACK FRAME AND EQUALIZER SPRING GUIDE COVER RA PD 43571

Figure 173 — Loosening Front Idler Adjuster Lock Bolt

ORDNANCE MAINTENANCE – HEAVY TRACTOR MI (IHC TD-18) –
POWER TRAIN, TRACK FRAME ASSEMBLY, AND SEATS

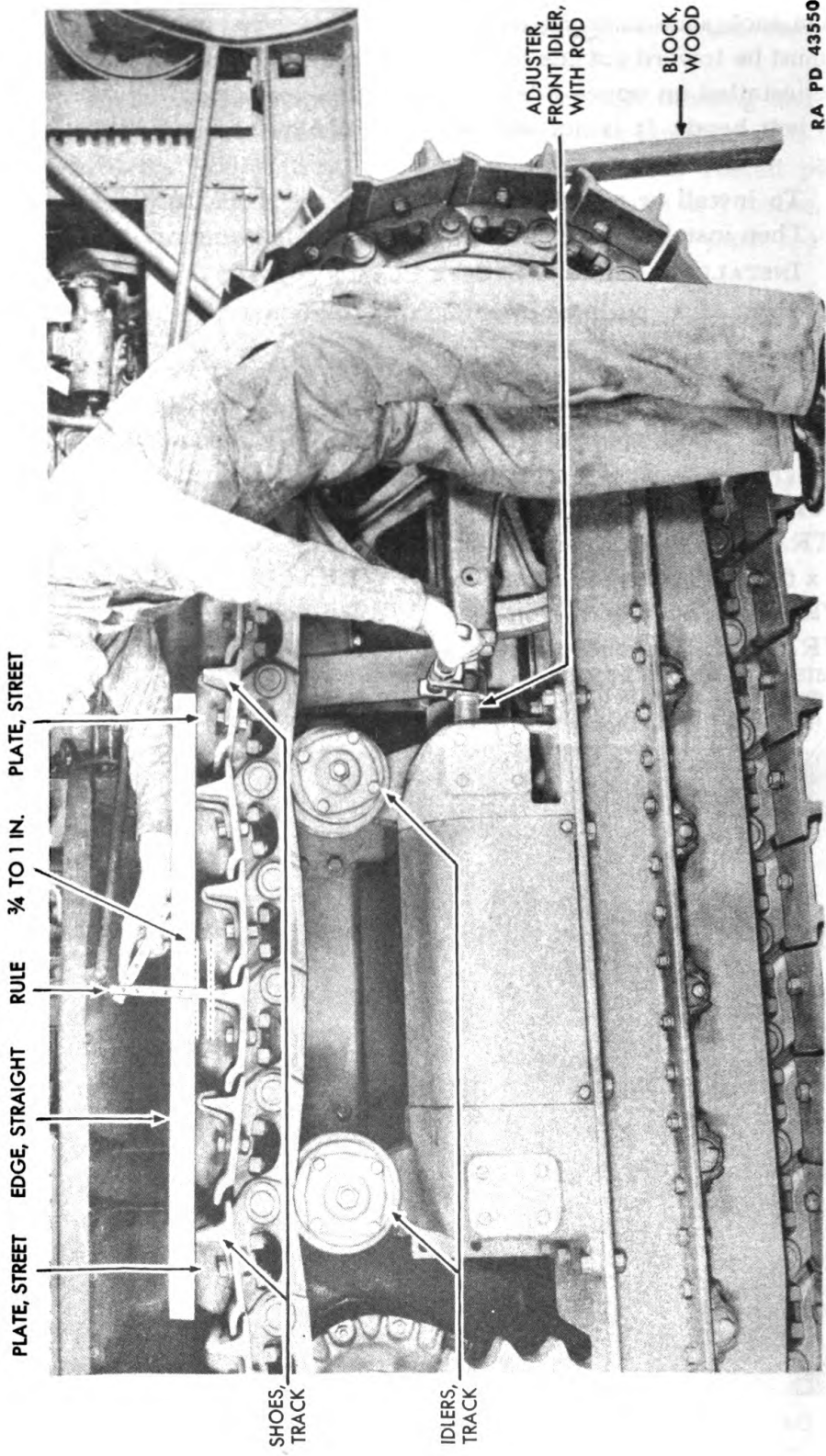

Figure 174 – Track Adjustment

TRACK

b. Procedure.

(1) ADJUSTMENT AFTER INSTALLING TRACK (figs. 173 and 174).

BLOCK, wood

WRENCH, open-end, 1 1/8-in.

STRAIGHTEDGE, 2-in. x 2-in.
x 6 ft (or string)WRENCH, open-end, 2 1/4-in.
or adjustable wrench

WRENCH, open-end, 9/16-in.

WRENCH, socket, 5/8-in.

WRENCH, open-end, 1-in.

(a) Check alinement of track by placing a straightedge, 6 feet long, on top of track grousers. If street plates are on shoes, lay straightedge at one side of street plates. When sag in track between top track idlers is less than 3/4-inch or more than 1-inch, an adjustment must be made.

(b) Use a 5/8-inch socket wrench to remove 2 cap screws with lock washers which secure front idler adjuster to front idler guide cross plate. Use a 9/16-inch open-end wrench to remove 2 cap screws and lock washers from track frame and equalizer spring guide cover plate. Loosen front idler adjuster lock bolt, holding bolt head with a 1-inch open-end wrench and loosening nut with a 1 1/8-inch open-end wrench.

(c) Place a wooden block about 1 foot high under the front track shoe lug. With the engine running, place tractor in low gear and engage clutch just enough so that sprocket drive tightens track along ground and on sprocket. Lock tractor brake, stop the engine and stand on top of track to pull it tight around front idler. All slack should now be in top part of track (fig. 174).

(d) Adjust alinement by using a 2 1/4-inch open-end or adjustable wrench to turn front idler adjuster with rod until proper tension is reached and check by straightedge (string may be used in place of straightedge).

(2) SECURE FRONT IDLER (figs. 173 and 174).

WRENCH, open-end, 9/16-in.

WRENCH, open-end, 2 1/4-in.

WRENCH, open-end, 1-in.

WRENCH, socket, 7/8-in.

WRENCH, open-end, 1 1/8-in.

(a) Using a 2 1/4-inch open-end wrench, turn front idler adjuster with rod until holes match with holes in front idler guide cross plate. Insert cap screws with lock washers and use a 7/8-inch socket wrench to tighten cap screws.

(b) Use a 1-inch open-end wrench to hold bolthead of locking bolt for front idler adjuster with rod and use a 1 1/8-inch open-end wrench to tighten nuts and adjusting rod.

(c) Use a 9/16-inch open-end wrench to secure 2 cap screws and lock washers in track frame and equalizer spring guide cover plate.

**ORDNANCE MAINTENANCE — HEAVY TRACTOR MI (IHC TD-18) —
POWER TRAIN, TRACK FRAME ASSEMBLY, AND SEATS**

Section VIII

TRACK FRAME DIAGONAL BRACE

	Paragraph
Construction and operation	113
Removal	114
Disassembly	115
Inspection	116
Assembly	117
Installation	118

113. CONSTRUCTION AND OPERATION.

Tracks are kept in vertical alinement by heavy steel diagonal braces which are bolted to track frames and pivot on replaceable bearings around pivot shaft. These braces in no way impede vertical movement. They form part of the stabilizer construction.

114. REMOVAL.

a. Equipment.

WRENCH, open-end, $\frac{3}{4}$ -in.

(2)

WRENCH, open-end, $1\frac{5}{16}$ -in.

WRENCH, socket, $\frac{7}{16}$ -in.

WRENCH, socket, 1-in.

b. Procedure.

(1) DISCONNECT RIGHT TRACK FRAME DIAGONAL BRACE CLAMP (fig. 181).

WRENCH, socket, 1-in.

Use a 1-inch socket wrench to remove 2 long and 2 short cap screws and lock washers which hold clamp to diagonal brace. Remove shims from clamp. This operation frees rear end of diagonal brace.

(2) REMOVE UPPER AND LOWER TRACK FRAME DIAGONAL BRACE BEARINGS (figs. 175 and 176).

WRENCH, open-end, $\frac{3}{4}$ -in. (2) WRENCH, socket, $\frac{7}{16}$ -in.

(a) Use a $\frac{7}{16}$ -inch socket wrench to remove lubricator from upper bearing.

(b) Use two $\frac{3}{4}$ -inch open-end wrenches to remove 2 bolts, lock washers, and nuts which hold upper and lower bearings together on track frame pivot shaft. Hold boltheads with one wrench and remove nuts with other. Remove upper and lower bearings from pivot shaft.

TRACK FRAME DIAGONAL BRACE

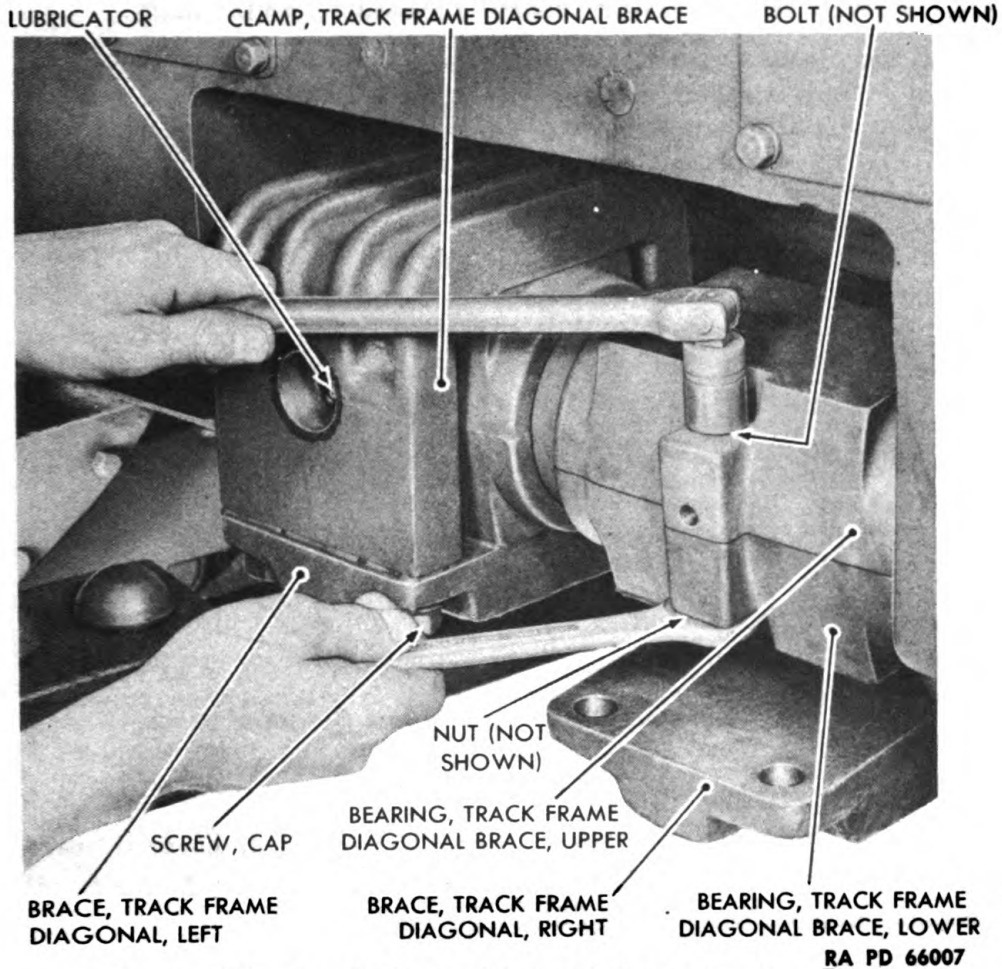

Figure 175 – Track Frame Diagonal Brace Bearings Removal

(c) Remove 2 track frame diagonal brace felts.

(d) Remove 2 track frame diagonal brace bushings from each bearing. **NOTE:** When diagonal brace only is to be removed, it is not necessary to perform this step.

(3) REMOVE RIGHT TRACK FRAME DIAGONAL BRACE.

WRENCH, open-end, $1\frac{5}{8}$ -in.

Use a $1\frac{5}{8}$ -inch open-end wrench to remove 6 nuts from studs to which diagonal brace is secured at rear track spring retainer (fig. 152). Remove lock washers and lift off diagonal brace.

(4) FOLLOW SAME PROCEDURE TO REMOVE LEFT TRACK FRAME DIAGONAL BRACE.

115. DISASSEMBLY.

a. All component parts of track frame diagonal braces are disassembled in the process of removal (par. 114).

**ORDNANCE MAINTENANCE — HEAVY TRACTOR M1 (IHC TD-18) —
POWER TRAIN, TRACK FRAME ASSEMBLY, AND SEATS**

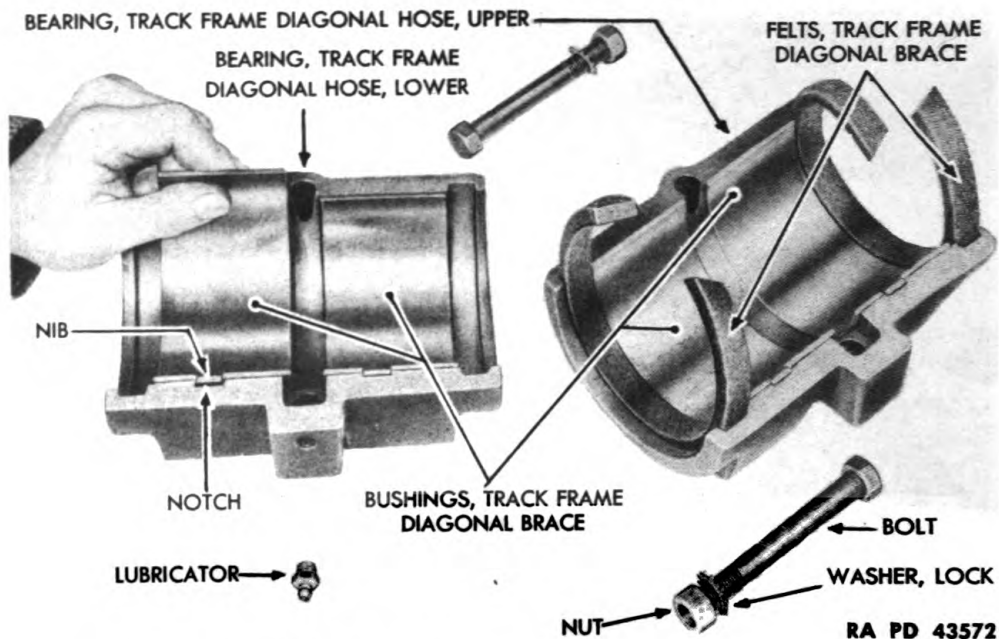

Figure 176 — Bushings from Track Frame Diagonal Brace Bearings Removal

116. INSPECTION.

a. **Clean All Parts.** Use water or steam to clean each diagonal brace to remove dirt. Use SOLVENT, dry-cleaning, to thoroughly wash all grease and oil from bearings and bushings.

b. **Inspect All Parts.**

(1) **DIAGONAL BRACES.** Bent or broken diagonal braces should be replaced with new parts.

(2) **BUSHINGS.** Inspect track frame diagonal brace bushings for loose movement on track frame pivot shaft, when bushings are installed in bearings and bearings are in position on shaft. Bushings should be replaced if excessive play is evident.

(3) **FELTS.** New felts should be installed whenever bearings are disassembled.

(4) **LUBRICATOR.** Inspect lubricator to see that it is not plugged.

117. ASSEMBLY.

a. Track frame diagonal brace parts are assembled in the process of installation, as outlined in paragraph 118.

118. INSTALLATION.

a. **Equipment.**

WRENCH, open-end, $\frac{3}{4}$ -in. (2)

WRENCH, socket, $\frac{7}{16}$ -in.

WRENCH, socket, 1-in.

WRENCH, socket, $1\frac{5}{16}$ -in.

TRACK FRAME DIAGONAL BRACE

b. Procedure.

(1) **INSTALL RIGHT UPPER AND LOWER TRACK FRAME DIAGONAL BRACE BEARINGS** (figs. 175 and 176). **NOTE:** If diagonal brace only has been removed, this step should be eliminated.

WRENCH, open-end, $\frac{3}{4}$ -in (2)

(a) By hand, place 2 diagonal brace bushings into position in each track from diagonal brace bearing, positioning bushings so nib fits into notch in bearing.

(b) Install new felts into position in lower bearing.

(c) Install upper and lower bearings in position on track frame pivot shaft. **CAUTION:** Do not install lubricator in upper bearing at this point. Bearings and clamp must be installed before lubricator is installed. Also exercise care to install bearing to which lubricator is attached in the upper position.

(d) Install 2 bolts, lock washers, and nuts which hold upper and lower bearings together on track frame pivot shaft. Hold boltheads with one $\frac{3}{4}$ -inch open-end wrench while tightening nuts with a similar wrench.

(2) **INSTALL TRACK FRAME DIAGONAL BRACE CLAMP** (fig. 175).

Position bearings so lubricator hole is down. Then place clamp over upper bearing with lubricator hole in line with hole in bearing. Tip bearing so clamp is on top.

(3) **INSTALL LUBRICATOR** (fig. 175).

WRENCH, socket, $\frac{7}{16}$ -in.

Use a $\frac{7}{16}$ -inch socket wrench to install lubricator in upper bearing.

(4) **INSTALL RIGHT TRACK FRAME DIAGONAL BRACE** (figs. 152 and 181).

WRENCH, socket, 1-in.

WRENCH, socket, $1\frac{5}{16}$ -in.

(a) Lift brace into position on rear track idler spring retainer studs. Install 6 lock washers and nuts, tightening them with a $1\frac{5}{16}$ -inch socket wrench.

(b) Secure rear end of diagonal brace to diagonal brace clamp. Insert short shims under clamp on one side, long shims under clamp on opposite side. Then install 2 long and 2 short cap screws with lock washers to secure diagonal brace to clamp. Tighten cap screws with a 1-inch socket wrench.

(5) **INSTALL LEFT DIAGONAL BRACE AND BEARINGS IN THE SAME MANNER.**

(6) **LUBRICATION.**

Lubricate the track frame diagonal braces with general purpose grease.

**ORDNANCE MAINTENANCE – HEAVY TRACTOR MI (IHC TD-18) –
POWER TRAIN, TRACK FRAME ASSEMBLY, AND SEATS**

Section IX

**TRACK FRAME GUIDE, BRACKET WITH ROLLER,
AND MAIN FRAME SIDE CHANNELS**

	Paragraph
Construction and operation	119
Track frame guide and bracket with roller removal.....	120
Track frame bracket with roller disassembly.....	121
Track frame guide and bracket with roller inspection.....	122
Track frame bracket with roller assembly.....	123
Track frame guide and bracket with roller installation.....	124
Main frame side channel removal.....	125
Main frame side channel inspection.....	126
Main frame side channel installation.....	127

119. CONSTRUCTION AND OPERATION.

a. The function of track frame guides is to keep the tracks parallel to each other. Track frame is connected to tractor by track frame diagonal braces for vertical alinement but these braces do not impede vertical movement. At all other points of contact between track frame and track or between track frame and tractor there is a measure of flexibility provided by ball and socket in track frame pivot bracket, and by track idlers, front idlers, equalizer spring and track frame guide rollers operating within track frame guides.

b. Track frame guides and brackets are of steel construction. The only moving parts are the two rollers mounted on brackets and operating within guides attached to track frame, and to track frame and equalizer spring guides. The track frame guide brackets are mounted on main frame side channels and are joined by a bracket brace. This forms part of the stabilizing construction.

c. Main frame side channels are rigid steel extensions of main frame to support engine, radiator, and winch.

**120. TRACK FRAME GUIDE AND BRACKET WITH ROLLER
REMOVAL.**

a. Equipment.

WRENCH, open-end, 1-in.

WRENCH, socket, 1 1/8-in.

**TRACK FRAME GUIDE, BRACKET WITH ROLLER, AND
MAIN FRAME SIDE CHANNELS**

b. Procedure.

(1) **REMOVE TRACK FRAME GUIDE ROLLER BRACKET (RIGHT)** (fig. 180).

WRENCH, open-end, 1-in.

WRENCH, socket, 1 1/8-in.

(a) Use a 1 1/8-inch socket wrench to remove 8 bolts and 2 cap screws which hold bracket to bracket brace and main frame side channel. Remove bolts, cap screws, and lock washers. Another man may be required to hold bolt and cap screw heads with 1-inch open-end wrench while nuts are being removed. Lift bracket with roller out of track frame guide.

(b) Remove left bracket with same procedure.

(2) **REMOVE TRACK FRAME GUIDE ROLLER BRACKET BRACE WITH FLANGES** (fig. 180).

Brace is detached when brackets are removed.

(3) **REMOVE TRACK FRAME GUIDE (RIGHT)** (fig. 152).

WRENCH, socket, 1 1/8-in.

(a) Use a 1 1/8-inch socket wrench to remove 2 cap screws and 2 bolts with lock washers which hold track frame guide to track frame and spring guide.

(b) Repeat procedure to remove left guide.

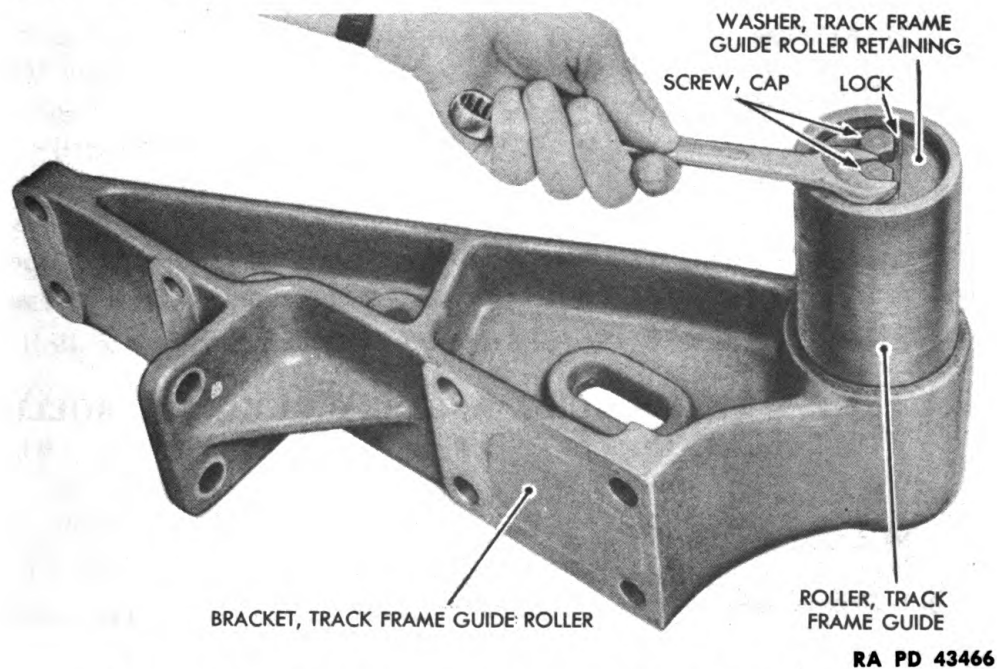

Figure 177 – Track Frame Roller from Bracket Removal

**TRACK FRAME GUIDE, BRACKET WITH ROLLER, AND
MAIN FRAME SIDE CHANNELS**

(a) Use 1 $\frac{1}{8}$ -inch socket wrench to install 4 cap screws with lock washers which hold guide to track frame and spring guide.

(b) Repeat to install other frame guide.

(2) **INSTALL TRACK FRAME GUIDE ROLLER BRACKET** (fig. 180).

WRENCH, socket, 1 $\frac{1}{8}$ -in.

(a) Place bracket in position with roller in guide. Use a 1 $\frac{1}{8}$ -inch socket wrench to secure bracket to main frame side channel, installing bolts and cap screws with lock washers.

(b) Repeat above operation to install other bracket.

(3) **INSTALL TRACK FRAME GUIDE ROLLER BRACKET BRACE** (fig. 180).

WRENCH, socket, 1 $\frac{1}{8}$ -in.

Lift brace in position with flanges matching faces on brackets. Insert cap screws with lock washers and secure with a 1 $\frac{1}{8}$ -inch socket wrench.

125. MAIN FRAME SIDE CHANNEL REMOVAL.

a. Equipment.

BAR

WRENCH, open-end, $\frac{3}{4}$ -in.

BLOCK, wood

WRENCH, open-end, $\frac{7}{8}$ -in.

HOIST

WRENCH, open-end, 1-in.

PLIERS

WRENCH, open-end, 1 $\frac{1}{16}$ -in.

SCREW, puller, $\frac{5}{8}$ x 2 $\frac{1}{2}$ -in.

WRENCH, socket, $\frac{9}{16}$ -in.

NC (2)

WRENCH, socket, $\frac{7}{8}$ -in.

SCREWDRIVER

WRENCH, socket, 1-in.

WRENCH, open-end, $\frac{9}{16}$ -in.

WRENCH, socket, 1 $\frac{1}{8}$ -in.

b. Procedure.

(1) **REMOVE SEAT, FENDERS, GROUSER BOXES, PACK CARRIER, DIESEL FUEL TANK AND FENDER SIDE SHEETS AS A UNIT.**

Follow procedure outlined in paragraph 52 h (1).

(2) **REMOVE THE WINCH.**

(a) *Remove Winch Drive Shaft Guard.*

WRENCH, open-end, $\frac{9}{16}$ -in.

WRENCH, open-end, $\frac{7}{8}$ -in.

WRENCH, open-end, $\frac{3}{4}$ -in.

WRENCH, socket, 1-in.

1. Remove 6 bolts, nuts, lock washers and flat washers, and 2 cap screws and lock washers which hold guard to left side sheet.

2. Remove cap screw and lock washer which hold guard to left frame channel.

ORDNANCE MAINTENANCE — HEAVY TRACTOR MI (IHC TD-18) —
POWER TRAIN, TRACK FRAME ASSEMBLY, AND SEATS

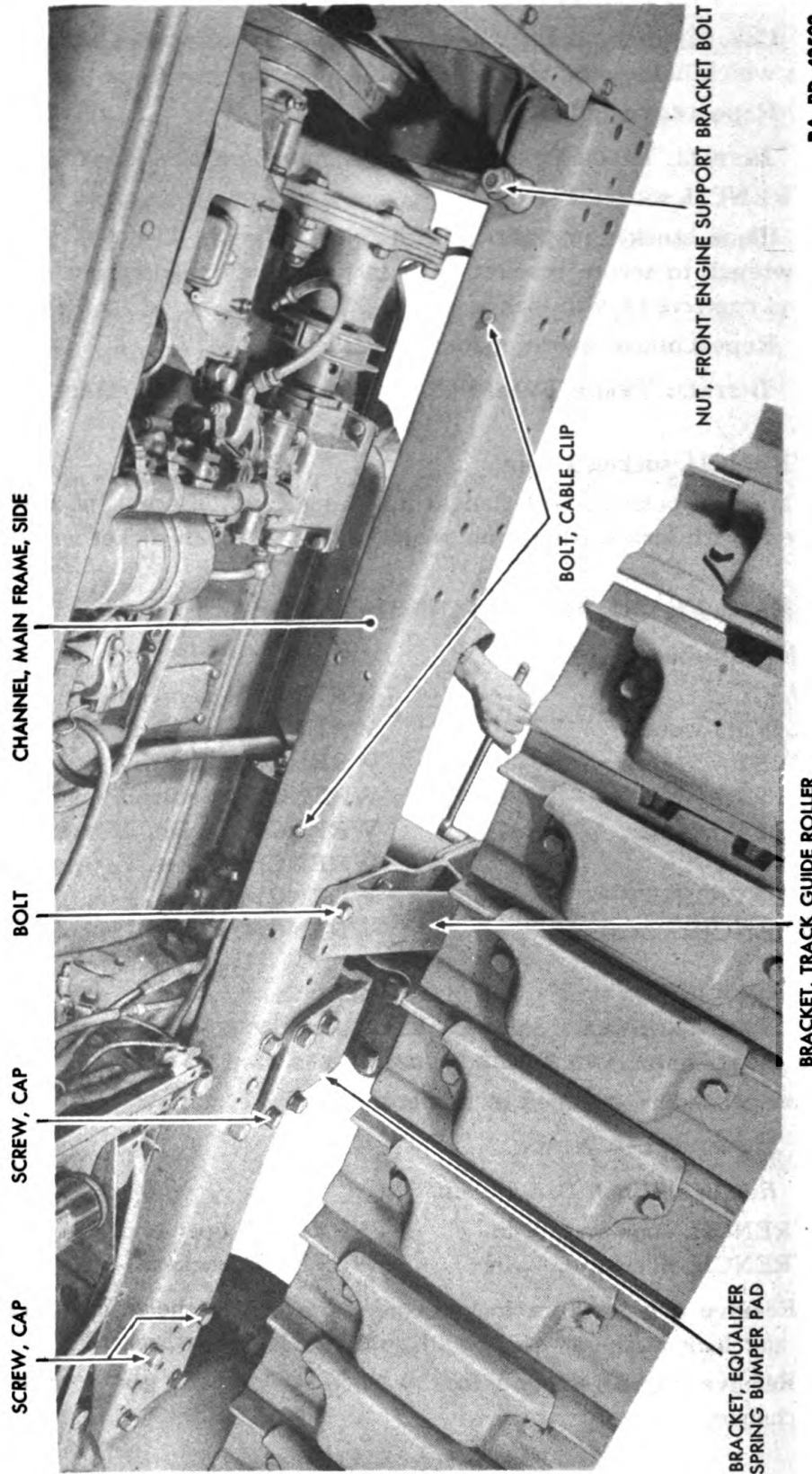

RA PD 43502

Figure 178 — Track Guide Roller Bracket and Equalizer Spring Bumper Pad Bracket Removal

**TRACK FRAME GUIDE, BRACKET WITH ROLLER, AND
MAIN FRAME SIDE CHANNELS**

3. Remove cap screw and lock washer which hold guard to the winch.

4. Remove bolt, spacer, lock washer and nut which hold winch guard to the left fender bracket.

5. Lift out guard.

(b) *Remove Winch Clutch Control Rod and Brake Control Rod.*

PLIERS

1. Disconnect rods from the long brake lever and long clutch lever. Remove rod end pins.

2. Disconnect clutch control rod and brake control rod from winch control levers. Remove pins, and then remove the rods.

(c) *Disconnect Blackout Marker Lamp Wire Terminals from Junction Block.*

SCREWDRIVER

Remove the screw which holds wire terminal of each lamp to the junction block, which is located under the hood sheet at the front end of the engine.

(d) *Attach Hoist to Winch.*

HOIST

Support weight of winch on a hoist so when winch has been disconnected from tractor, it can be lifted out and winch will not fall during subsequent steps.

(e) *Remove Winch from Vehicle.*

BAR

WRENCH, open-end, $1\frac{1}{8}$ -in.

HOIST

WRENCH, socket, 1-in.

1. The winch base is attached to each main frame side channel by 7 bolts, nuts, and lock washers, and by 4 cap screws and lock washers, which also hold the radiator to the main frame side channel. Use a 1-inch socket wrench with spinner handle on the bolts and cap screws when removing the bolts; hold bolt nuts from inside main frame side channels with a $1\frac{1}{8}$ -inch open-end wrench.

2. Pry the winch side channels free from the main frame side channels. Lift winch and radiator guard from vehicle. The winch drive shaft and universal joint will pull free from the winch layshaft.

(3) **REMOVE TRACK GUIDE ROLLER BRACKET (RIGHT) AND EQUALIZER SPRING BUMPER PAD BRACKET (RIGHT)** (fig. 178).

(a) Follow procedure outlined in paragraph 129 b (2), to remove track guide roller bracket.

ORDNANCE MAINTENANCE — HEAVY TRACTOR MI (IHC TD-18) —
POWER TRAIN, TRACK FRAME ASSEMBLY, AND SEATS

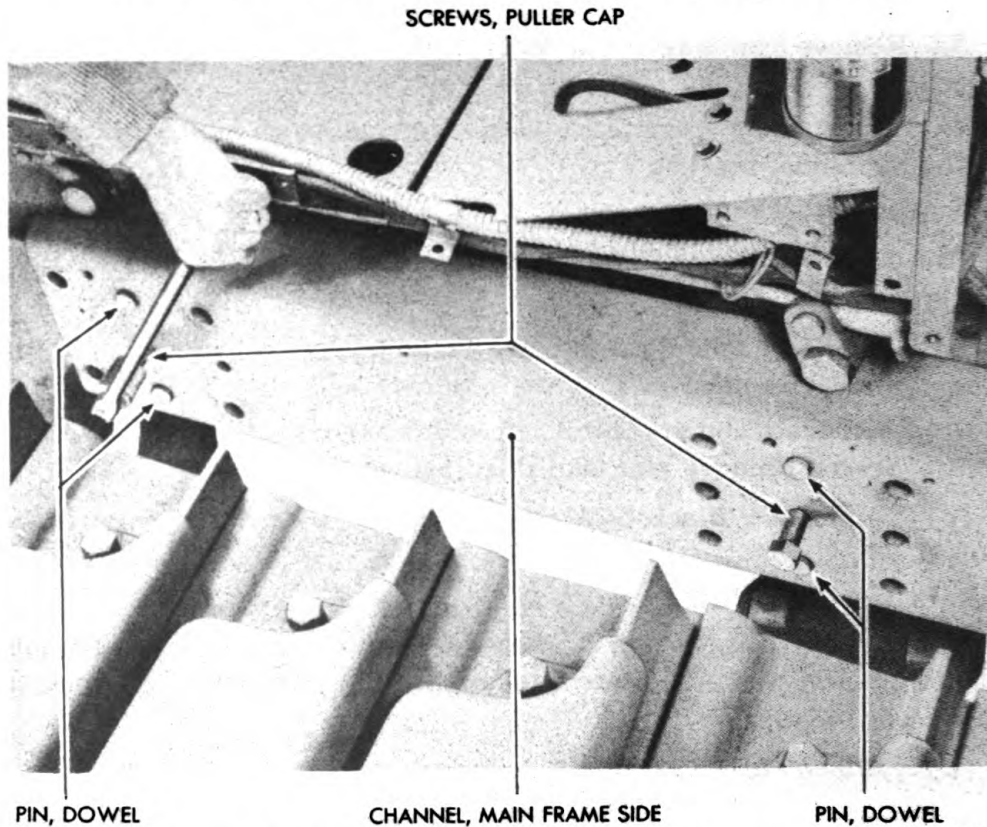

Figure 179 — Main Frame Side Channel Removal RA PD 43498

(b) To remove bumper pad bracket, follow procedure outlined in paragraph 79 b (5).

(4) REMOVE ENGINE SIDE SHEET (RIGHT) AND AIR RESERVOIR. Follow procedure outlined in TM 9-1777B.

(5) REMOVE MAIN FRAME SIDE CHANNEL (RIGHT) (fig. 179).

BLOCKS, wood

JACK

SCREW, puller, $\frac{5}{8}$ -in. x $2\frac{1}{2}$ -in.

NC (2)

WRENCH, open-end, 1-in.

WRENCH, socket, $\frac{9}{16}$ -in.

WRENCH, socket, $\frac{7}{8}$ -in.

WRENCH, socket, $1\frac{1}{8}$ -in.

(a) Use a $1\frac{1}{8}$ -inch socket wrench to remove 6 cap screws with lock washers which hold channel to main frame.

(b) Disconnect front engine support from main frame by holding nut with 1-inch open-end wrench and removing bolt with $\frac{7}{8}$ -inch socket wrench. Remove bolt, nut, lock washer, and shims. Support front end of tractor under radiator with wooden blocks or jack.

(c) Use a $\frac{9}{16}$ -inch socket wrench to remove 2 bolts with nuts and lock washers which hold cable clips to side channel.

**TRACK FRAME GUIDE, BRACKET WITH ROLLER, AND
MAIN FRAME SIDE CHANNELS**

(d) Attach 2 puller screws, $\frac{5}{8}$ -inch by 2 $\frac{1}{2}$ -inch NC, by using 1-inch open-end wrench to tighten into puller holes in channel. Turn until channel is removed from main frame.

(6) REMOVE MAIN FRAME SIDE CHANNEL (LEFT).

(a) Follow procedure outlined in step (3) of this paragraph to remove left brackets.

(b) Follow procedure outlined in TM 9-1777D to remove engine side sheet, left side.

(c) Repeat operations in steps b (5) (a), (b), and (d) of this paragraph to remove left channel.

126. MAIN FRAME SIDE CHANNEL INSPECTION.

a. Clean All Parts. Use SOLVENT, dry-cleaning.

b. Inspect All Parts. Check for cracks or breaks and replace with new part if advisable.

127. MAIN FRAME SIDE CHANNEL INSTALLATION.

a. Equipment.

HAMMER

WRENCH, open-end, $\frac{7}{8}$ -in.

WRENCH, socket, $\frac{9}{16}$ -in.

WRENCH, socket, 1-in.

WRENCH, socket, $1\frac{1}{8}$ -in.

b. Procedure.

(1) **INSTALL RIGHT CHANNEL** (fig. 178).

HAMMER

WRENCH, open-end, $\frac{7}{8}$ -in.

WRENCH, socket, $\frac{9}{16}$ -in.

WRENCH, socket, 1-in.

WRENCH, socket, $1\frac{1}{8}$ -in.

(a) Place channel in position at side of main frame and use hammer to drive in 4 dowel pins. Then use a $1\frac{1}{8}$ -inch socket wrench to install 6 cap screws with lock washers to secure channel to main frame.

(b) Install bolt, lock washer, nut, and shims (if any) in front engine support (right) to secure support to channel. Use $\frac{7}{8}$ -inch open-end wrench to hold bolthead and 1-inch socket wrench to tighten nut.

(c) Install 2 cable clips by inserting bolts to secure clips under flange of channel. Attach nuts and lock washers and use $\frac{9}{16}$ -inch socket wrench to tighten.

(d) Install air reservoir and engine side sheet (right) by following the procedure outlined in TM 9-1777D.

**ORDNANCE MAINTENANCE — HEAVY TRACTOR MI (IHC TD-18) —
POWER TRAIN, TRACK FRAME ASSEMBLY, AND SEATS**

(e) Install equalizer spring bumper pad bracket (right) as outlined in paragraph 31 b (2).

(f) Install track guide roller bracket (right) as outlined in paragraph 132 b (9) (b).

(g) Install seat, fenders, grouser boxes, pack carrier, Diesel fuel tank, and fender side sheets as outlined in paragraph 56 b (20).

(2) INSTALL LEFT CHANNEL.

(a) Repeat operations outlined in step (1) (a) and (b) of this paragraph to install left channel.

(b) Install engine side sheet (left). Follow procedure outlined in TM 9-1777D.

(c) Install equalizer spring bumper pad bracket as outlined in paragraph 81 b (2).

(d) Install track guide roller bracket as outlined in paragraph 132 b (9) (b).

(3) INSTALL THE WINCH.

Reverse procedure outlined in paragraph 125 b (2).

Section X

TRACK FRAME

	Paragraph
Construction	128
Removal	129
Inspection	130
Repair	131
Installation	132

128. CONSTRUCTION.

a. Track frames consist of U-shaped steel channels, the longer one outside in each case, with both channels joined across the top at two points by steel plates. Certain portions of the track frames are welded in place so that each track frame is a completely rigid unit. Track frame pivot bracket, front idler springs and retainer, in a housing which supports the two upper track idlers and the front idlers, are mounted on the upper side of each track frame. The housing consists of rear spring retainer, track frame and equalizer spring guide and track spring guard. A portion of this housing also supports the track frame diagonal brace. Equalizer spring ends rest on bumper pads within the housing. Track frame guides also are bolted both to spring guide and to track frame. On the under side of track frames are secured the five track rollers, also inner and outer track roller shields.

129. REMOVAL.

a. Equipment.

BLOCKS, wood	WRENCH, open-end, 1-in.
CROWBAR	WRENCH, open-end, 1 1/8-in.
HOIST	WRENCH, open-end, 1 1/8-in.
JACK	WRENCH, socket, 9/16-in.
ROLLER, pipe (2)	WRENCH, socket, 3/4-in.
SLING, rope, or hook	WRENCH, socket, 7/8-in.
WRENCH, box, 7/8-in.	WRENCH, socket, 1-in.
WRENCH, box, 1 1/8-in.	WRENCH, socket, 1 1/8-in.
WRENCH, open-end, 7/8-in.	

b. Procedure.

(1) REMOVE TRACK.

Follow procedure outlined in paragraph 106 c.

(2) REMOVE TRACK GUIDE ROLLER BRACKET (RIGHT) (fig. 180).

WRENCH, open-end, 1-in.	WRENCH, socket, 1 1/8-in.
-------------------------	---------------------------

ORDNANCE MAINTENANCE — HEAVY TRACTOR MI (IHC TD-18) —
POWER TRAIN, TRACK FRAME ASSEMBLY, AND SEATS

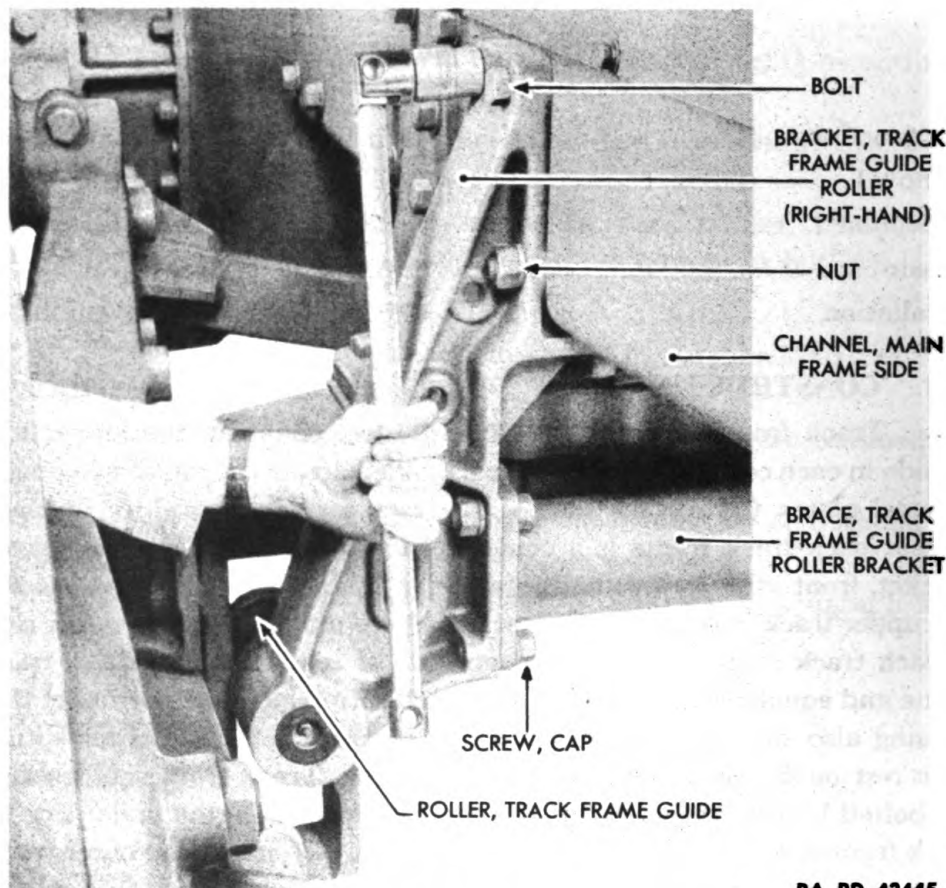

RA PD 43445

Figure 180 — Track Guide Bracket with Roller (Right) Removal

(a) Use 1 $\frac{1}{8}$ -inch socket wrench to remove 8 bolts and 2 cap screws which hold bracket to bracket brace and channel. Another man is required to hold boltheads, using 1-inch open-end wrench. Remove bolts, nuts, cap screws, and lock washers.

(b) Remove bracket.

(3) REMOVE TRACK FRAME DIAGONAL BRACE CLAMP (fig. 181).

WRENCH, open-end, 1-in.

Use a 1-inch open-end wrench to remove 2 long and 2 short cap screws which hold clamp to diagonal brace. Remove lock washers and 4 shims. **CAUTION:** Because of difficulty of alignment in installation of track frame, do not disconnect diagonal brace from rear track spring retainer at this point and do not leave it attached at the rear.

(4) REMOVE SPROCKET SHIELD WITH SUPPORTS (fig. 182).

WRENCH, box, $\frac{7}{8}$ -in.

WRENCH, socket, 1-in.

WRENCH, socket, $\frac{3}{4}$ -in.

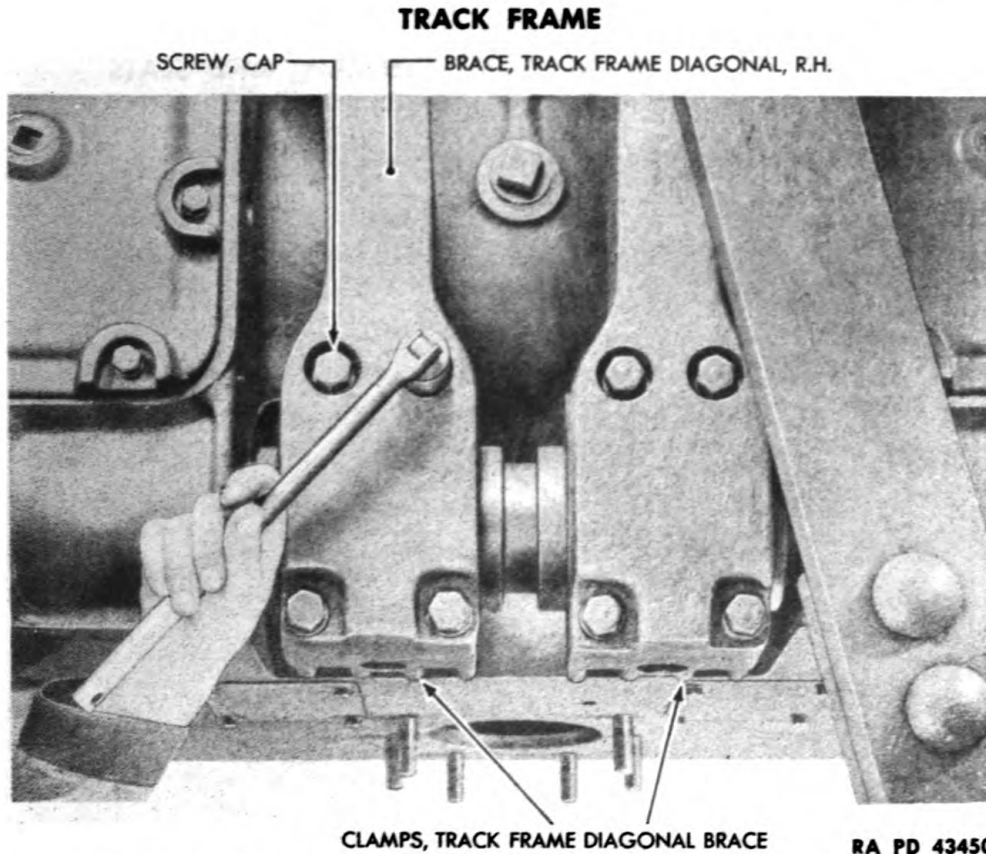

Figure 181 – Track Frame Diagonal Brace Clamp Removal

(a) Use $\frac{3}{4}$ -inch socket wrench to remove 2 cap screws with lock washers which hold shield to bracket.

(b) Use $\frac{7}{8}$ -inch box wrench to hold nut and a 1-inch socket wrench to remove 4 bolts with lock washers which hold shield to track frame.

(c) Remove shield.

(5) **DISCONNECT TRACK FRAME PIVOT BRACKET FROM TRACK FRAME** (fig. 183).

BLOCK, wood

WRENCH, socket, 1-in.

JACK

WRENCH, socket, $1\frac{1}{8}$ -in.

WRENCH, open-end, 1-in.

(a) Jack up tractor at drawbar guide. Insert wood blocks to support tractor under main frame at rear and under main frame side channels at front. Remove jack.

(b) Hold boltheads with 1-inch open-end wrench and use a $1\frac{1}{8}$ -inch socket wrench to remove 3 nuts and bolts with lock washers which hold bracket to frame; also 1-inch socket wrench to remove 2 bolts and nuts with lock washers.

(6) **REMOVE FRONT IDLERS FROM TRACK FRAME** (fig. 148).

CROWBAR

WRENCH, socket, $\frac{7}{8}$ -in.

**ORDNANCE MAINTENANCE — HEAVY TRACTOR MI (IHC TD-18) —
POWER TRAIN, TRACK FRAME ASSEMBLY, AND SEATS**

SCREW, CAP SHIELD, SPROCKET; WITH SUPPORTS

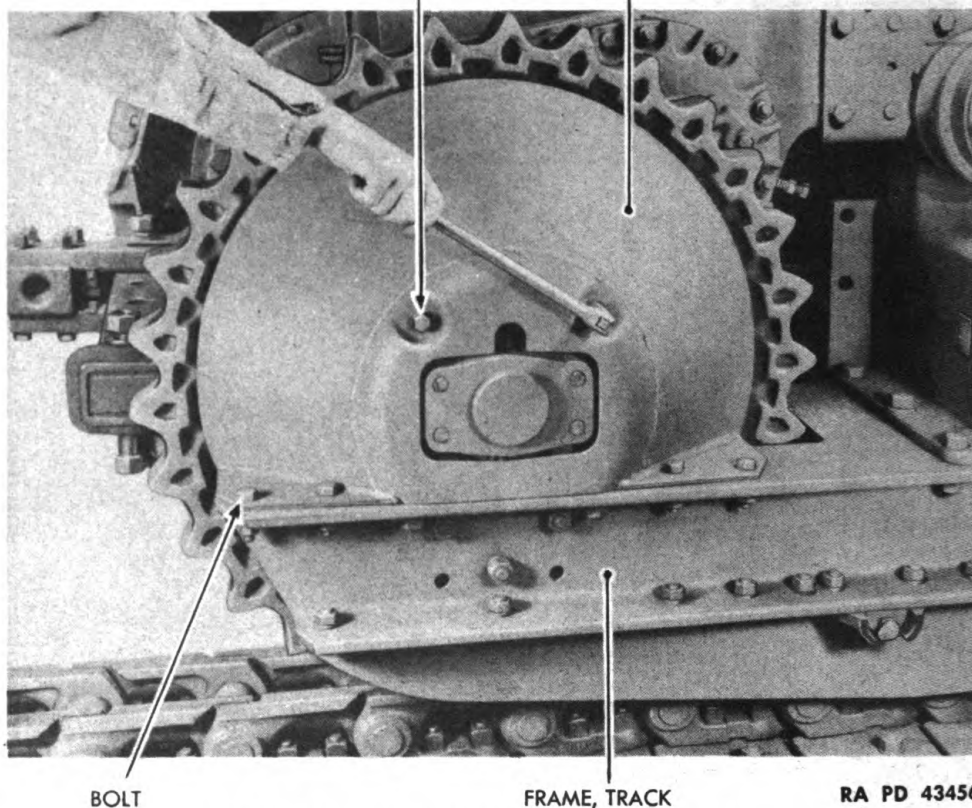

Figure 182 — Sprocket Shield with Supports Removal

(a) Use a $\frac{7}{8}$ -inch socket wrench to remove 2 cap screws with lock washers which hold each front idler adjuster with rod to front idler guide cross plate.

(b) Use a crowbar to force front idler to front end of track frame. Lift idler off track frame.

(7) REMOVE TRACK FRAME FROM TRACTOR (fig. 184).

CROWBAR

HOIST, or roller, pipe

Move track frame away from track and tractor by using hoist or pipe rollers and crowbar, leaving tractor supported on wood blocks.

(8) REMOVE TRACK FRAME DIAGONAL BRACES (fig. 152).

WRENCH, open-end, $1\frac{5}{16}$ -in.

Support diagonal brace while using a $1\frac{5}{16}$ -inch open-end wrench to remove nuts with lock washers on studs of rear track spring retainer. Repeat to remove diagonal brace on opposite side.

(9) REMOVE TRACK FRAME GUIDES (fig. 152).

WRENCH, box, $\frac{7}{8}$ -in.

WRENCH, socket, $1\frac{1}{8}$ -in.

TRACK FRAME

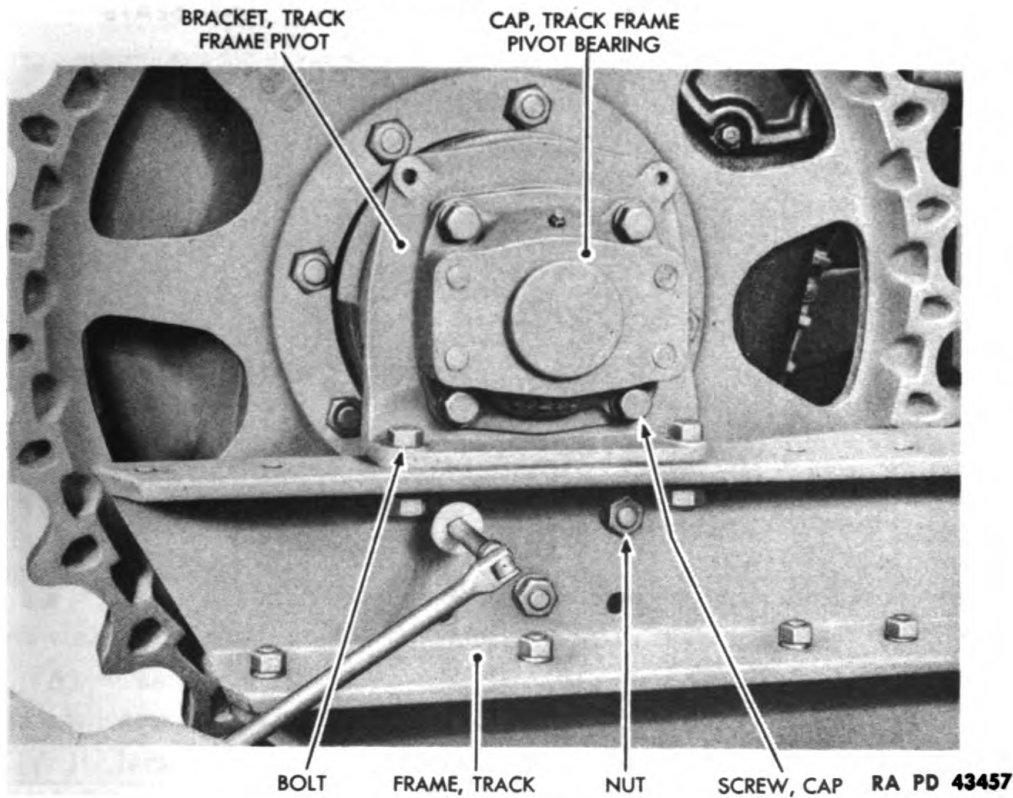

Figure 183 – Disconnecting Track Frame Pivot Bracket from Track Frame

(a) Remove 2 bolts with nuts and lock washers which secure track frame guide to flange on track frame and equalizer spring guide. Use 1 1/8-inch socket wrench with a 7/8-inch box wrench to hold bolt heads.

(b) Remove 2 cap screws with lock washers which hold track frame guide to boss on track frame, using a 1 1/8-inch socket wrench. Lift off track frame guide.

(10) REMOVE TRACK SPRING GUARD (RIGHT), AND TRACK FRAME, AND EQUALIZER SPRING GUIDE COVER PLATE (fig. 152).

WRENCH, socket, 9/16-in.

WRENCH, socket, 3/4-in.

(a) Use 9/16-inch socket wrench to remove 4 cap screws with lock washers which hold guard to rear track spring retainer and to track frame and equalizer spring guide. Lift off guard.

(b) Use 3/4-inch socket wrench to remove 2 cap screws with lock washers which hold cover plate to track frame and equalizer spring guide. Lift off cover plate.

(11) REMOVE FRONT IDLER ADJUSTER WITH ROD (fig. 153).

WRENCH, box, 1 1/8-in.

WRENCH, open-end, 1-in.

Turn rod by hand to unscrew and remove from front track spring retainer. If necessary, use 1 1/8-inch box wrench to loosen nut on bolt, in

**ORDNANCE MAINTENANCE – HEAVY TRACTOR MI (IHC TD-18) –
POWER TRAIN, TRACK FRAME ASSEMBLY, AND SEATS**

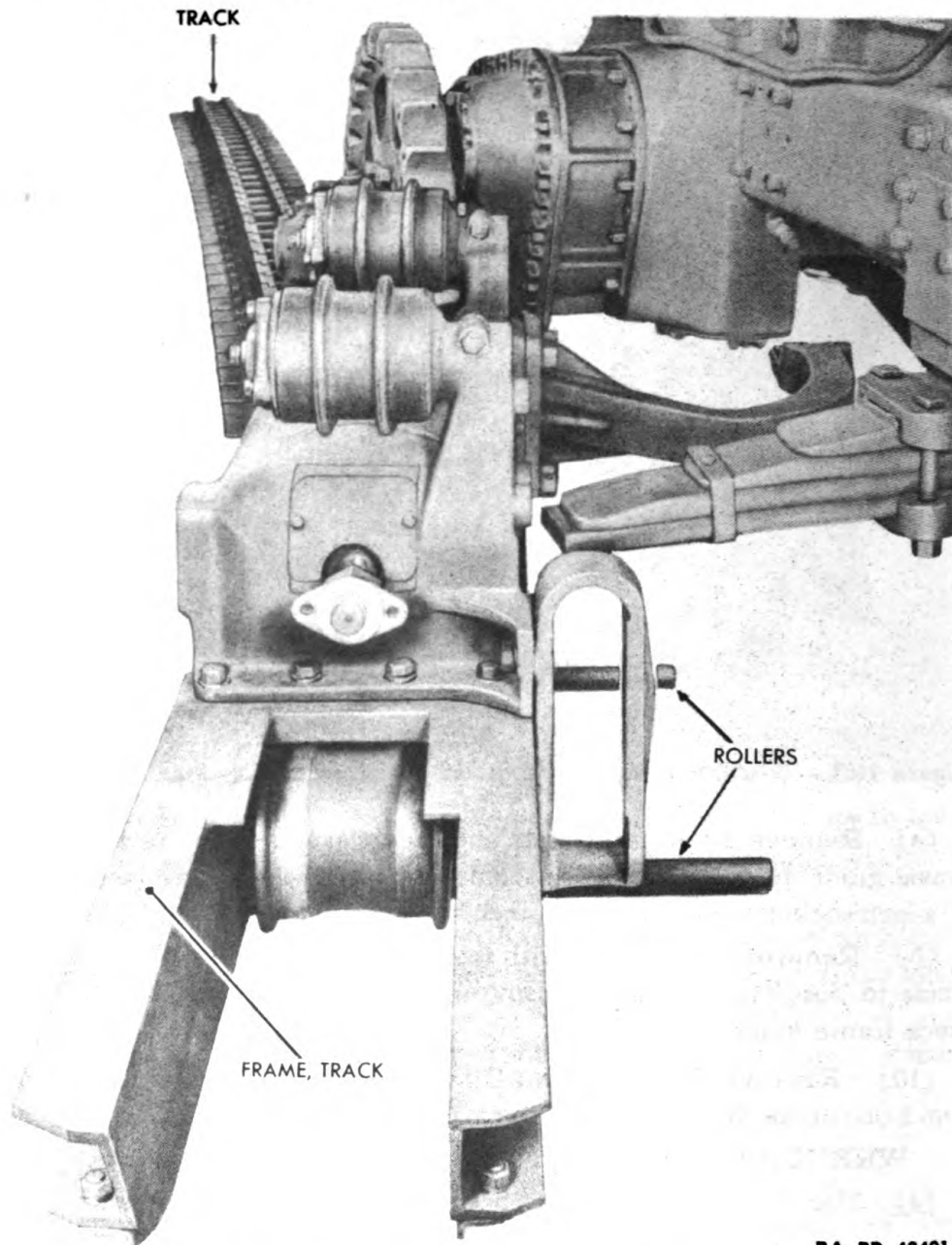

RA PD 43491

Figure 184 – Track Frame Removal

retainer which secures rod; also hold bolthead with 1-inch open-end wrench.

(12) REMOVE TRACK FRAME AND EQUALIZER SPRING GUIDE (RIGHT) (fig. 153).

JACK
ROLLER, pipe (2)

WRENCH, open-end, 1 1/8-in.
WRENCH, socket, 1 1/8-in.

TM 9-1777C
129-132

**ORDNANCE MAINTENANCE — HEAVY TRACTOR MI (IHC TD-18) —
POWER TRAIN, TRACK FRAME ASSEMBLY, AND SEATS**

(15) **REMOVE BOTTOM TRACK ROLLERS (RIGHT)** (fig. 141).

WRENCH, open-end, $\frac{7}{8}$ -in. **WRENCH**, socket, 1-in.

Use $\frac{7}{8}$ -inch open-end wrench to hold boltheads and 1-inch socket wrench to remove nuts with lock washers from 4 bolts which secure each track roller to track frame. Remove track rollers.

130. INSPECTION.

a. **Clean All Parts.** Wash off dirt with water. Use **SOLVENT**, dry-cleaning, to remove oil or grease.

b. **Inspect All Parts.** Check for cracks or breakage, especially at welded points. Also check to see if track frame is sprung out of alignment. Bent sheet metal should be bumped out.

131. REPAIR.

a. Should any cracks or breaks appear in the track frame, the only repair procedure to recondition is by welding (TM 9-850). If frame is bent or warped, it must be replaced by a new one.

132. INSTALLATION.

a. **Equipment.**

DRIFT	WRENCH , open-end, 1-in.
HOIST	WRENCH , open-end, $1\frac{5}{16}$ -in.
JACK	WRENCH , socket, $\frac{9}{16}$ -in.
PUNCH	WRENCH , socket, $\frac{3}{4}$ -in.
WRENCH , box, $\frac{7}{8}$ -in.	WRENCH , socket, 1-in.
WRENCH , box, $1\frac{1}{8}$ -in.	WRENCH , socket, $1\frac{1}{8}$ -in.
WRENCH , open-end, $\frac{7}{8}$ -in.	

b. **Procedure.**

(1) **INSTALL BOTTOM TRACK ROLLERS** (fig. 185).

PUNCH **WRENCH**, socket, 1-in.
WRENCH, open-end, $\frac{7}{8}$ -in.

Turn track frame (right) upside down. Install bottom track rollers with flat sides of track roller shaft brackets toward track frame. Use a punch to locate boltholes. Install 2 bolts with nuts and lock washers on each side of roller to secure shaft brackets to track frame, using $\frac{7}{8}$ -inch open-end wrench to hold boltheads and 1-inch socket wrench to tighten nuts. Install 5 bottom rollers on track frame, placing double-flanged rollers as No. 2 and No. 4 from front.

TRACK FRAME

- (2) INSTALL INNER AND OUTER TRACK ROLLER SHIELDS (fig. 185).

WRENCH, open-end, $\frac{7}{8}$ -in. WRENCH, socket, 1-in.

(a) Use a $\frac{7}{8}$ -inch open-end wrench to hold boltheads and 1-inch socket wrench to tighten nuts and lock washers on 8 bolts which hold inner shield to track frame.

(b) Repeat above operation to install 12 bolts with nuts and lock washers to secure outer shield to track frame.

- (3) INSTALL REAR TRACK SPRING RETAINER WITH SPRINGS INSTALLED (fig. 185).

DRIFT WRENCH, box, $1\frac{1}{8}$ -in.

(a) Turn track frame right side up.

(b) Lift retainer with track idler attached in position on track frame. Use a drift to locate boltholes and install 4 bolts with nuts and lock washers, using a $1\frac{1}{8}$ -inch box wrench to secure retainer to track frame.

(c) Use a $1\frac{1}{8}$ -inch box wrench to install 2 cap screws with lock washers which also hold retainer to track frame.

- (4) INSTALL TRACK FRAME AND EQUALIZER SPRING GUIDE (fig. 153).

DRIFT WRENCH, box, $1\frac{1}{8}$ -in.

(a) Lift guide with track idler attached in position on track frame. Use a drift to locate boltholes and install 4 bolts with nuts and lock washers. Secure spring guide to track frame with a $1\frac{1}{8}$ -inch box wrench.

(b) Install 4 cap screws with lock washers, which hold spring guide to track frame, using a $1\frac{1}{8}$ -inch box wrench.

- (5) INSTALL FRONT IDLER ADJUSTER WITH ROD (fig. 153).

Turn rod into threaded hole in end of front track spring retainer until most of rod is inside retainer.

- (6) INSTALL TRACK SPRING GUARD AND THE TRACK FRAME AND EQUALIZER SPRING GUIDE COVER PLATE (fig. 152).

WRENCH, socket, $\frac{9}{16}$ -in. WRENCH, socket, $\frac{3}{4}$ -in.

(a) Lift guard in place over springs and install 4 cap screws with lock washers which secure guard to rear track spring retainer and to track frame and equalizer spring guide. Use a $\frac{9}{16}$ -inch socket wrench.

(b) Place cover plate in position and install 2 cap screws with lock washers which secure cover plate to front of spring guide. Use $\frac{3}{4}$ -inch socket wrench to tighten cap screws.

- (7) INSTALL TRACK FRAME GUIDE (fig. 152).

WRENCH, box, $1\frac{1}{8}$ -in. WRENCH, socket, $1\frac{1}{8}$ -in.

**ORDNANCE MAINTENANCE — HEAVY TRACTOR MI (IHC TD-18) —
POWER TRAIN, TRACK FRAME ASSEMBLY, AND SEATS**

(a) Lift guide in position against track frame and equalizer spring guide and install 2 bolts with nuts and lock washers which secure guide to flange of spring guide. Use a 1 1/8-inch socket wrench.

(b) Install 2 cap screws with lock washers to secure frame guide to boss on track frame, using a 1 1/8-inch box wrench.

(8) INSTALL TRACK FRAME DIAGONAL BRACE (fig. 152).**HOIST****WRENCH, open-end, 1 5/16-in.**

Use hoist, if available, or lift brace in position on 6 studs of rear track spring retainer. Install nuts and lock washers, using a 1 5/16-inch open-end wrench to tighten nuts. **CAUTION:** This end of diagonal brace must be attached before other end is secured to brace clamps.

(9) INSTALL TRACK FRAME ON TRACTOR (figs. 180, 182, and 183).**HOIST****WRENCH, open-end, 1-in.****JACK****WRENCH, socket, 3/4-in.****PUNCH****WRENCH, socket, 1-in.****WRENCH, box, 7/8-in.****WRENCH, socket, 1 1/8-in.**

(a) Use a hoist, if available, or jack up track frame, remove wood blocks, and place pipe rollers under track frame. Insert guide pad in spring guide. Then skid unit in place at side of tractor, entering end of equalizer spring in opening in track frame and equalizer spring guide. End of equalizer spring must rest on guide pad.

(b) Install track guide roller bracket. Place a jack under front end of track frame for accurate alinement of bracket. Lift bracket in position with bracket roller in track frame guide. Install 6 bolts, lock washers, and nuts which hold bracket to main frame side channel. Line up bolt holes with a punch to install bolts. Top 2 bolts enter from outside of bracket, bottom 4 from inside of channel. Use a 1-inch socket wrench to hold bolt heads and a 1 1/8-inch socket wrench to tighten nuts.

(c) Secure bracket to track frame guide roller brace. Install 2 cap screws and lock washers which hold brace to bracket at bottom and 2 bolts, nuts, and lock washers which hold brace to bracket at top. Use a 1-inch open-end wrench to hold boltheads and tighten cap screws and a 1 1/8-inch socket wrench to remove nuts.

(d) Install track frame diagonal brace in clamp. Insert short shims under track frame diagonal brace clamp on one side and long shims on other side. Then secure brace to clamp with 2 long and 2 short cap screws with lock washers. Use a 1-inch open-end wrench to tighten cap screws. Raise or lower track as required, using a jack.

TRACK FRAME

(e) Connect track frame pivot bracket to track frame. Place a jack under drawbar guide and raise tractor to permit removal of wood blocks. Then lower tractor until bolts may be inserted to secure bracket to track frame. Use a 1-inch open-end wrench to hold boltheads and a 1 $\frac{1}{8}$ -inch socket wrench to tighten nuts and lock washers.

(f) Install sprocket shield with supports in place over sprocket and pivot bracket, using $\frac{3}{4}$ -inch socket wrench to tighten 2 cap screws with lock washers which secure shield to bracket. Using a $\frac{7}{8}$ -inch box wrench to hold boltheads, install 4 bolts, nuts, and lock washers which secure shield to track frame. Tighten nuts with a 1-inch socket wrench.

(10) INSTALL FRONT IDLER.

Follow procedure outlined in paragraph 100.

(11) Lubricate track from pivot and all other track pivots before adjusting. See lubrication guide in TM 9-777.

(12) INSTALL AND ADJUST TRACK.

Follow procedure outlined in paragraphs 111 and 112.

**ORDNANCE MAINTENANCE — HEAVY TRACTOR MI (IHC TD-18) —
 POWER TRAIN, TRACK FRAME ASSEMBLY, AND SEATS**

CHAPTER 6

METAL PARTS

	Paragraph
Maintenance and echelons of maintenance and repair.....	133
Seat and fender removal	134
Seat and fender inspection	135
Seat and fender installation	136

133. MAINTENANCE AND ECHELONS OF MAINTENANCE AND REPAIR.

a. Cleaning.

(1) All metal parts should be thoroughly cleaned before removal. Dirt and mud on metal parts may be steam-cleaned or washed off with water. Prevent water from contacting lubricated parts or other parts to which water would be harmful to the operation or life of the vehicle.

(2) Remove grease from metal parts by using SOLVENT, dry-cleaning.

(3) For detailed cleaning instructions and recommended cleaning agents, refer to TM 9-850.

b. Repair. Damaged sheet metal parts, such as the seat rear and side sheet, grouser boxes, and fenders, can frequently be “bumped out” by ordnance maintenance personnel.

c. Welding. Cracked and broken parts, such as sheet metal, brackets, and other non-moving supporting parts, often can be welded. See welding recommendations in TM 9-850.

d. Allocation of Maintenance Duties by Echelons.

(1) DEFINITIONS. Refer to paragraph 22.

(2) SHEET METAL PARTS.

	ECHELONS		
	2nd	3rd	4th
Sheet metal parts—repair		X	

134. SEAT AND FENDER REMOVAL.

a. Equipment.

CUTTERS, diagonal

WRENCH, open-end, $\frac{9}{16}$ -in. (2)

WRENCH, open-end, $\frac{5}{8}$ -in. (2)

WRENCH, open-end, $\frac{3}{4}$ -in. (2)

WRENCH, open-end, $\frac{1}{2}$ -in.

WRENCH, socket, $\frac{9}{16}$ -in.

WRENCH, socket, $\frac{3}{4}$ -in.

METAL PARTS

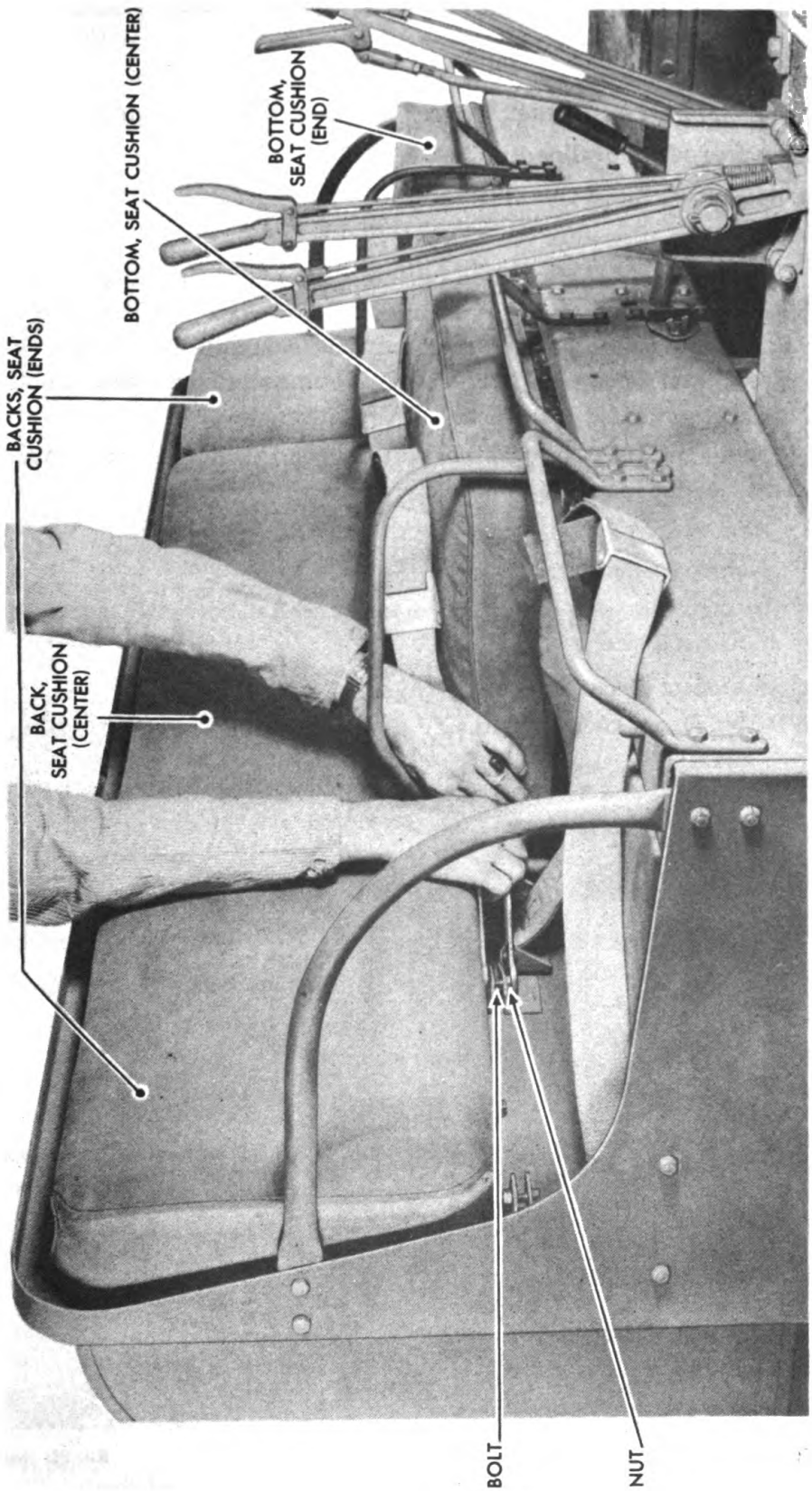

RA PD 14676

Figure 186 — Seat Cushion Back Removal

**ORDNANCE MAINTENANCE — HEAVY TRACTOR MI (IHC TD-18) —
POWER TRAIN, TRACK FRAME ASSEMBLY, AND SEATS**

b. Procedure.

(1) REMOVE THE DIESEL FUEL TANK AND PACK CARRIER.

Follow procedure outlined in TM 9-1777B.

(2) REMOVE SEAT CUSHIONS AND BACKS (fig. 186).

WRENCH, open-end, $\frac{9}{16}$ -in. (2)

(a) Lift out right seat cushion bottom (end). Then remove right seat cushion back (end). To do this, remove 2 bolts, lock washers, and nuts which hold the cushion back to rear seat and side sheet. Hold boltheads with one $\frac{9}{16}$ -inch open-end wrench while removing nuts with another. Then lift cushion back upward and lift it out.

(b) Remove left rear cushion bottom (end) and left side cushion back (end) as outlined in (a) above.

(c) Remove 2 tool box covers by hand.

(d) Remove rear seat support.

(e) In a similar manner, remove seat cushion bottom (center) and seat cushion back (center).

(3) REMOVE GROUSER BOXES (figs. 187 and 188).

WRENCH, open-end, $\frac{9}{16}$ -in. (2) WRENCH, open-end, $\frac{3}{4}$ -in. (2)

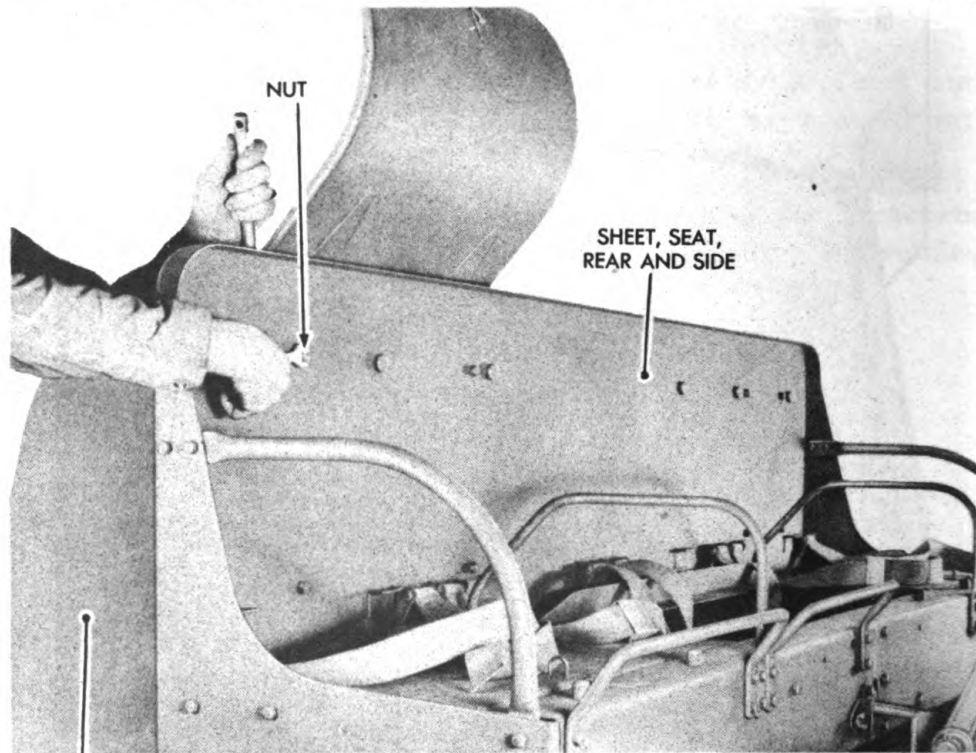

BOX, GROUSER

RA PD 14822

Figure 187 — Disconnecting Grouser Box from Seat Back

METAL PARTS

(a) Remove 4 bolts, lock washers, and nuts which hold right grouser box to rear seat and side sheet. Use two $\frac{9}{16}$ -inch open-end wrenches.

(b) Remove 8 bolts, lock washers, and nuts which hold the right grouser box to right fender. Four of these bolts are secured to right rear fender bracket and require the use of two $\frac{3}{4}$ -inch open-end wrenches. Use two $\frac{9}{16}$ -inch open-end wrenches on remaining bolts. Two others are secured to fender support cross member. Boltheads must be held from inside the grouser box while removing nuts from underneath fender. Lift grouser box from right fender.

(c) Similarly, remove left grouser box.

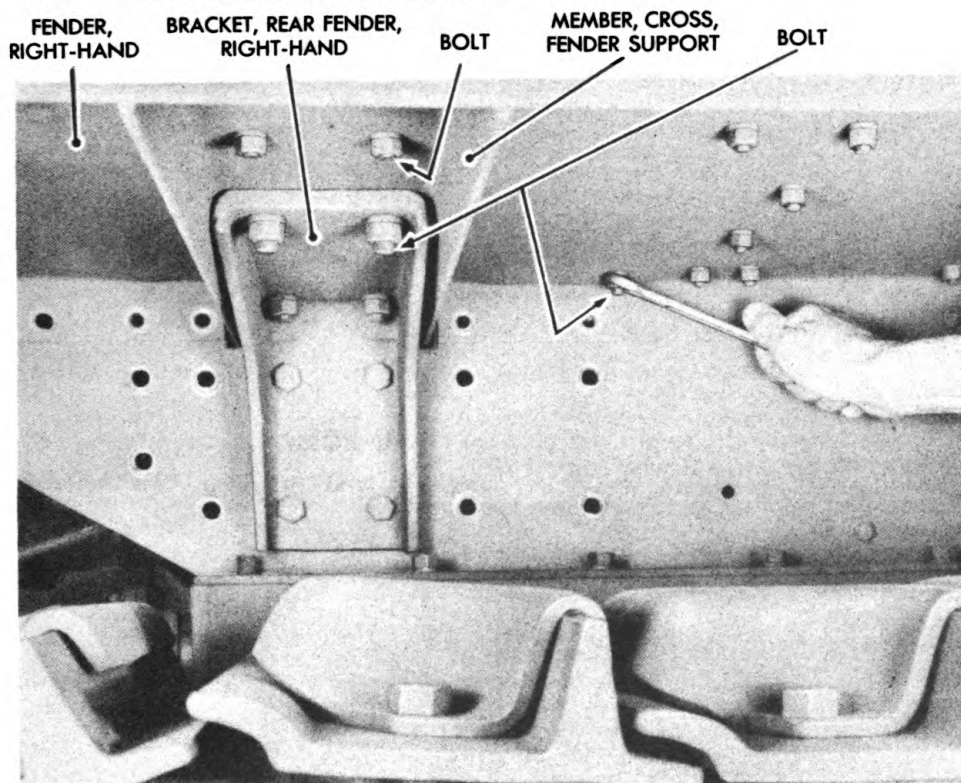

RA PD 14718

Figure 188 – Disconnecting Grouser Box from Fender

(4) REMOVE BOLTS WHICH HOLD SEAT TO RIGHT FENDER (fig. 189).

WRENCH, open-end, $\frac{9}{16}$ -in.(2) WRENCH, open-end, $\frac{3}{4}$ -in.(2)
WRENCH, open-end, $\frac{5}{8}$ -in.

Lift the tool box cover from the seat, above the right fender, and hold boltheads from turning, while a second mechanic removes the nuts and lock washers from 19 bolts which hold the seat to the right fender. Two bolts require the use of two $\frac{3}{4}$ -inch open-end wrenches; the balance, two $\frac{9}{16}$ -inch open-end wrenches.

ORDNANCE MAINTENANCE — HEAVY TRACTOR MI (IHC TD-18) —
POWER TRAIN, TRACK FRAME ASSEMBLY, AND SEATS

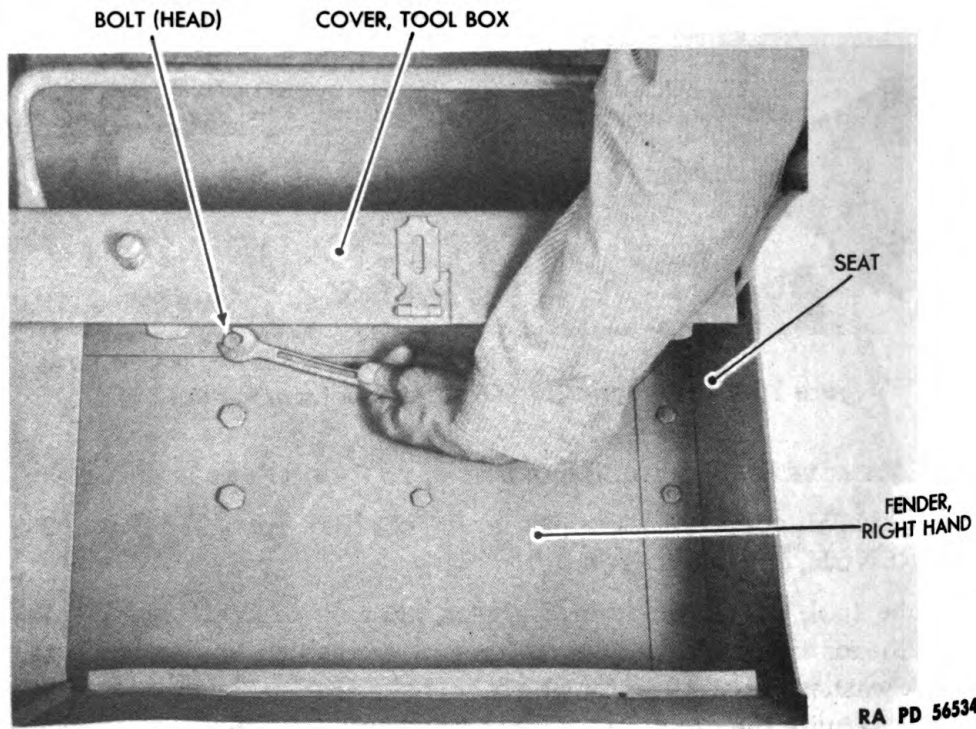
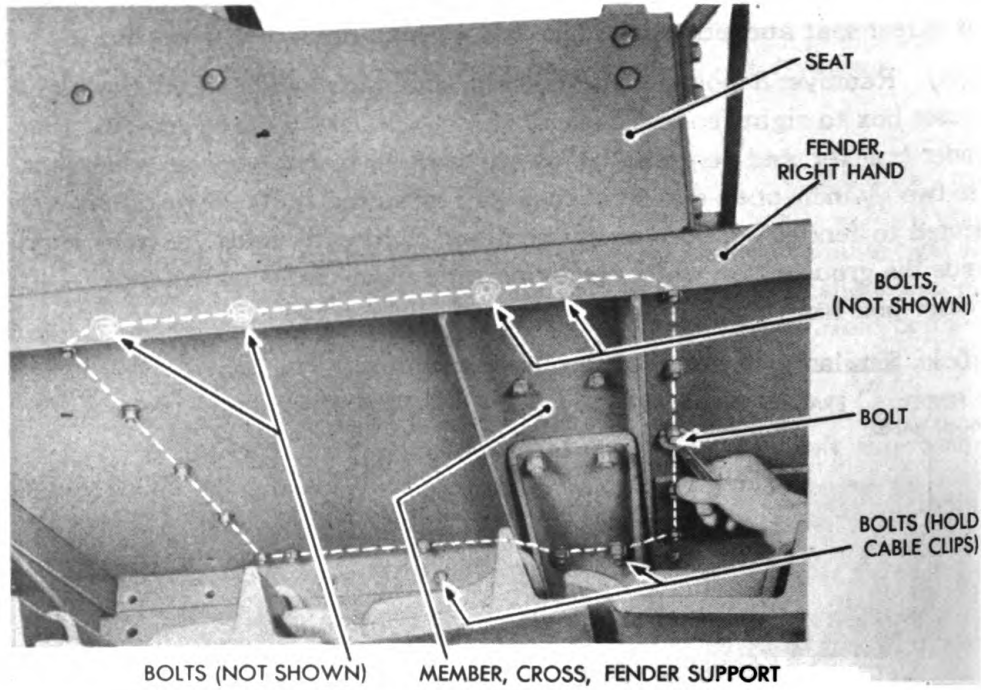

Figure 189 — Removing Bolts Which Hold Seat to Right Fender

**ORDNANCE MAINTENANCE — HEAVY TRACTOR M1 (IHC TD-18) —
POWER TRAIN, TRACK FRAME ASSEMBLY, AND SEATS**

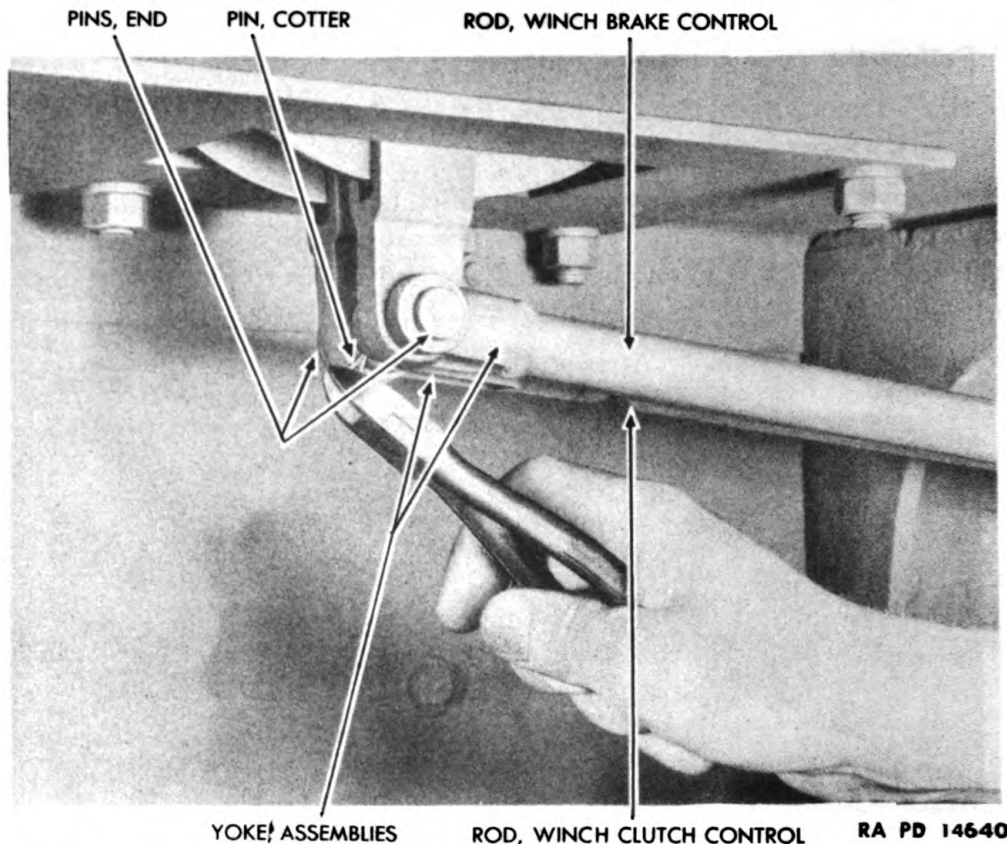

Figure 191 — Disconnecting Winch Clutch and Brake Control Rods from Winch Shifter and Brake Levers

(9) REMOVE BATTERIES AND SUPPORTS.

(a) Follow procedure outlined in TM 9-777 to remove batteries.

(b) Remove battery bottom supports, removing 4 cap screws, flat washers, and bottom spacers at each support. Use a 3/4-inch open-end wrench.

(10) DISCONNECT WINCH CLUTCH AND BRAKE CONTROL RODS FROM WINCH SHIFTER AND BRAKE LEVERS (fig. 191).

CUTTERS, diagonal

Use diagonal cutters to remove cotter pin from each end pin. Then remove end pins which join yoke assemblies to levers. Lower winch and clutch brake control rods out of the way.

(11) REMOVE RIGHT FENDER (fig. 192).

WRENCH, open-end, 9/16-in.

WRENCH, open-end, 1 1/8-in.

(2)

WRENCH, socket, 3/4-in.

WRENCH, open-end, 5/8-in.

METAL PARTS

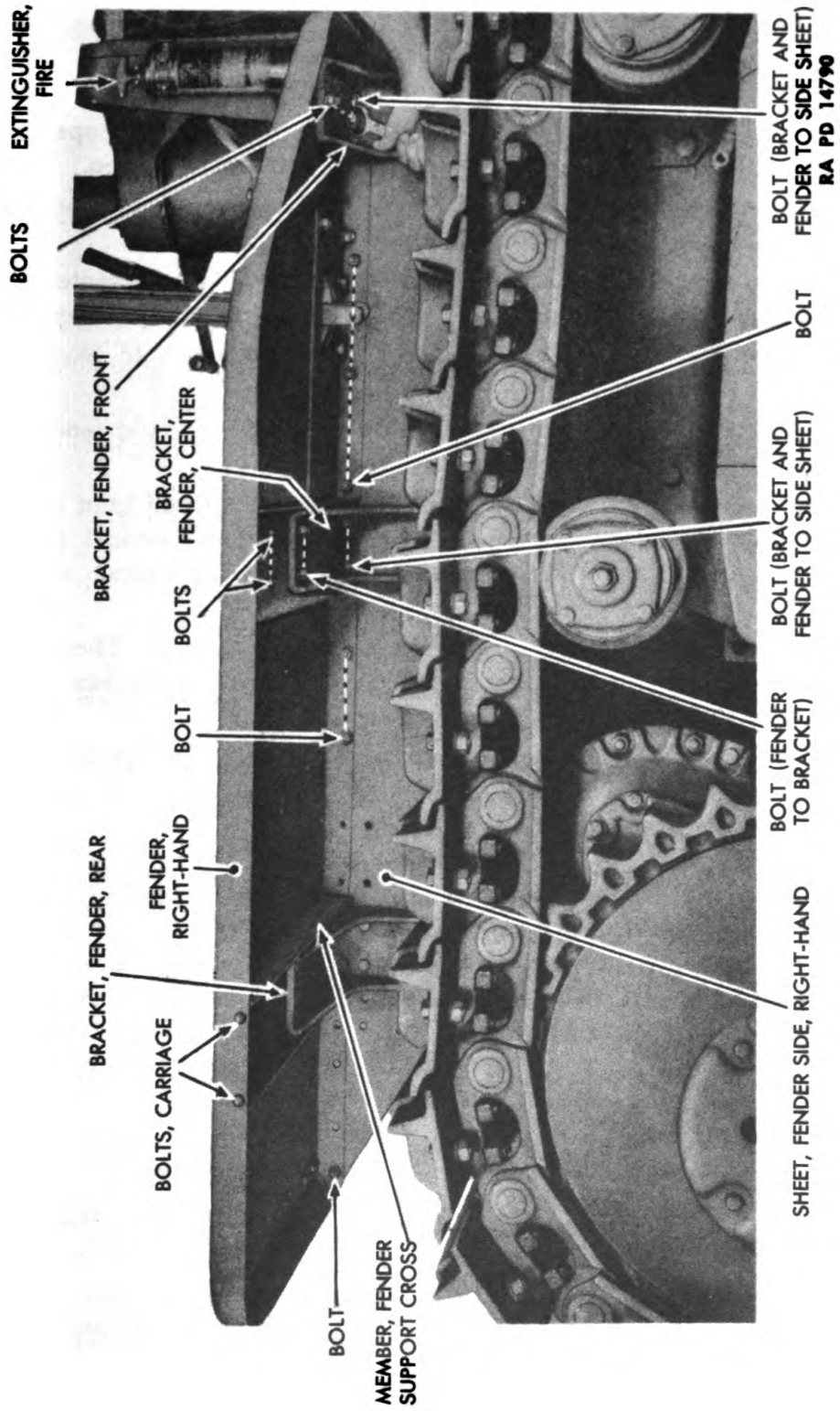

Figure 192 — Right Fender Removal

**ORDNANCE MAINTENANCE – HEAVY TRACTOR MI (IHC TD-18) –
POWER TRAIN, TRACK FRAME ASSEMBLY, AND SEATS**

(a) Remove 2 bolts, nuts, and lock washers which hold front fender bracket and fender to fender side sheet (two $\frac{9}{16}$ -in. open-end wrenches).

(b) Remove 2 bolts, nuts, and lock washers (two $\frac{9}{16}$ -in. open-end wrenches). These bolts hold fender to fender support extension.

(c) Remove 2 bolts, nuts, and lock washers which hold fender to center fender bracket (two $\frac{3}{4}$ -in. open-end wrenches).

(d) Remove 2 bolts, nuts, and lock washers which hold center fender bracket and fender to side sheet (two $\frac{9}{16}$ -in. open-end wrenches).

(e) Remove 2 bolts, nuts, and lock washers which hold fender to fender support cross member ($\frac{5}{8}$ -in. open-end wrench).

(f) Remove 6 bolts, nuts, and lock washers which hold fender to side sheet (two $\frac{9}{16}$ -in. open-end wrenches).

(g) Remove 3 cap screws and lock washers which hold front fender bracket to engine clutch cover and main frame right channel ($\frac{3}{4}$ -in. open-end wrench on 1 cap screw and a $\frac{3}{4}$ -in. socket wrench on the other 2).

(h) Remove cables from blackout tail and stop lamp. Then raise fender from the rear and slide it back from under fire extinguisher. The fender can then be lifted from the vehicle.

(i) Remove 2 carriage bolts, nuts, and lock washers which hold fender to front fender bracket ($\frac{1}{2}$ -in. open-end wrench). Remove bracket.

(12) REMOVE WINCH DRIVE SHAFT GUARD.

Follow procedure outlined in paragraph 125 b (2).

(13) REMOVE LEFT FENDER (fig. 192).

Follow procedure outlined in step (11) above. It is not necessary to remove left fender with front bracket attached, because there is no fire extinguisher on left side of tractor. Therefore, when removing left fender, step (11) (i) above should be performed first, and step (11) (g) above eliminated.

(14) REMOVE RIGHT FENDER BRACKETS AND FENDER SIDE SHEET (fig. 193).

WRENCH, open-end, $\frac{9}{16}$ -in.

WRENCH, socket, $\frac{9}{16}$ -in.

WRENCH, open-end, $\frac{3}{4}$ -in.

WRENCH, socket, $\frac{3}{4}$ -in.

(a) The right front fender bracket is removed with fender, as outlined in step (11) above. Bolts and cap screws which hold remaining right brackets and fender side sheet correspond to those identified on figure 193.

(b) Remove right center bracket from side sheet. Remove 1 cap screw and lock washer, using a $\frac{3}{4}$ -inch open-end wrench. Remove 2

**ORDNANCE MAINTENANCE — HEAVY TRACTOR MI (IHC TD-18) —
POWER TRAIN, TRACK FRAME ASSEMBLY, AND SEATS**

bolts, nuts, and lock washers, using a 3/4-inch open-end wrench to hold boltheads, and a 3/4-inch socket wrench to remove bolt nuts.

(c) Remove rear fender bracket from side sheet by removing 4 bolts, nuts, and lock washers.

(d) Remove 6 bolts, nuts, and lock washers and 1 cap screw and lock washer which hold the right fender side sheet to dash and cowl assembly, main frame right channel, main frame cover, and battery cable shield. Use two 1/8-inch open-end wrenches.

(e) Lift off the right fender side sheet.

(15) REMOVE LEFT FENDER BRACKETS AND FENDER SIDE SHEET (fig. 193).

WRENCH, open-end, 1/8-in.

WRENCH, socket, 1/8-in.

WRENCH, open-end, 3/4-in.

WRENCH, socket, 3/4-in.

(a) Remove 2 bolts, lock washers, and nuts which hold winch layshaft bearing housing in position. Use a 3/4-inch open-end wrench to hold nuts and remove bolts with a 3/4-inch socket wrench. Remove housing and spacer. Then lower layshaft and drive shaft.

(b) Remove 3 cap screws and lock washers which hold left front fender bracket to side sheet (3/4-in. socket wrench). Lift off bracket.

(c) Remove 2 bolts, nuts, and lock washers and 1 cap screw and

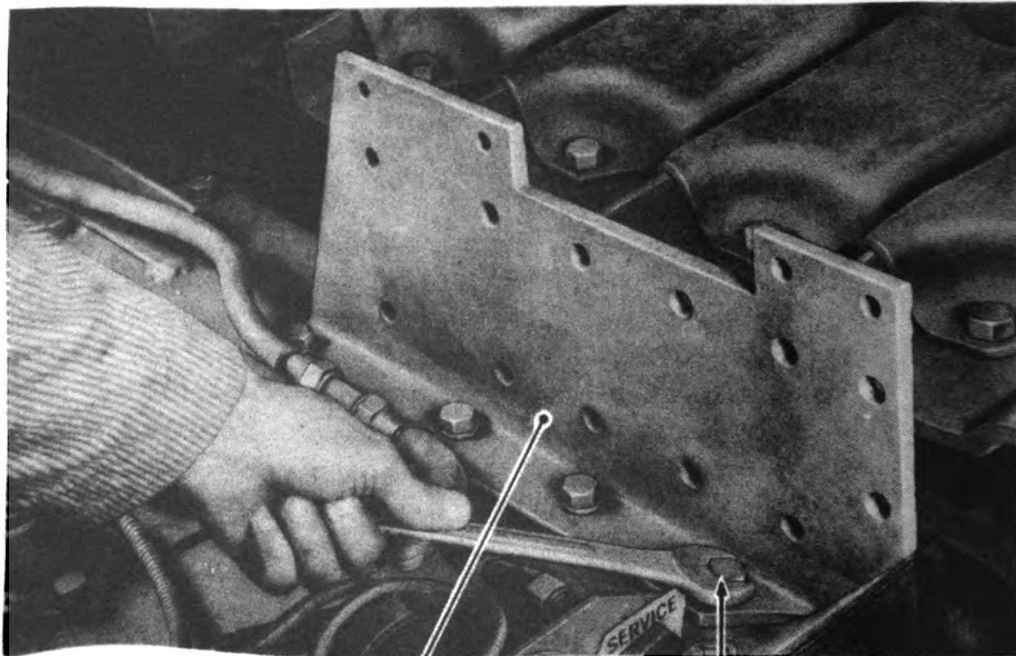

SUPPORT, FUEL TANK,
RIGHT

SCREW, CAP

RA PD 66009

Figure 194 — Right Fuel Tank Support Removal

METAL PARTS

lock washer which hold left center fender bracket to side sheet. Remove the bracket. Use a $\frac{1}{8}$ -inch open-end wrench to hold boltheads and a $\frac{1}{8}$ -inch socket wrench to remove nuts. Use a $\frac{3}{4}$ -inch socket wrench to remove cap screw.

(d) Remove 4 bolts, nuts, and lock washers which hold left rear fender bracket to side sheet. Hold nuts with a $\frac{3}{4}$ -inch open-end wrench and remove bolts with a $\frac{3}{4}$ -inch socket wrench. Lift off bracket.

(e) Remove 4 bolts, nuts, and lock washers which hold left side sheet to dash and cowl assembly, main frame cover, and main frame left side channel (two $\frac{1}{8}$ -in. open-end wrenches). Remove 3 additional bolts, nuts, and lock washers which hold fuel pipe clips to the side sheet. Use a $\frac{5}{8}$ -inch open-end wrench to disconnect connectors of fuel return and supply pipe at engine side of dash and cowl assembly. Then lift out fuel return and supply pipes (to Diesel fuel tank). Also remove 1 cap screw and lock washer which hold side sheet to main frame left side channel.

(f) Lift out left fender side sheet.

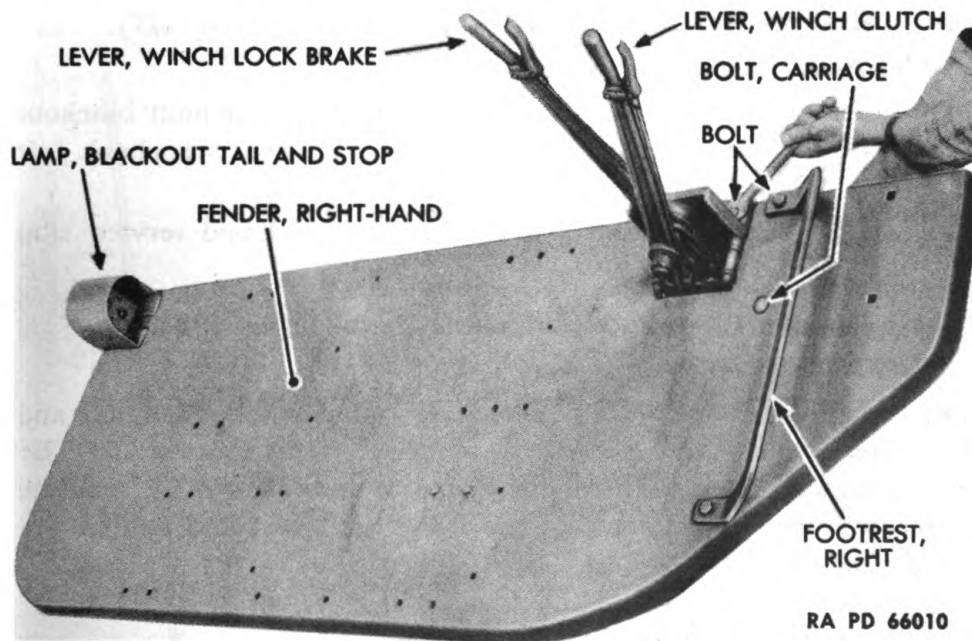

Figure 195 – Winch Shifter and Brake Lever Removal from Right Fender

(16) REMOVE FUEL TANK SUPPORTS (fig. 194).

WRENCH, open-end, $\frac{3}{4}$ -in.

(a) Remove 4 cap screws and lock washers which hold right fuel tank support to main frame cover and main frame ($\frac{3}{4}$ -in. open-end wrench). Remove support.

(b) Remove 4 cap screws and lock washers which hold left fuel

TM 9-1777C
134-135

**ORDNANCE MAINTENANCE — HEAVY TRACTOR MI (IHC TD-18) —
POWER TRAIN, TRACK FRAME ASSEMBLY, AND SEATS**

tank support to main frame cover and main frame ($\frac{3}{4}$ -in. open-end wrench).

(17) **REMOVE WINCH SHIFTER LEVER AND WINCH BRAKE LEVER FROM RIGHT FENDER** (fig. 195).

WRENCH, open-end, $\frac{3}{4}$ -in.

WRENCH, open-end, $\frac{1}{2}$ -in.

(2)

Use two $\frac{3}{4}$ -inch open-end wrenches to remove 2 bolts, nuts, and lock washers which hold levers to fender. Also remove 1 bolt, nut, and lock washer which holds footrest and right fender stiffener to fender and remove 1 carriage bolt which holds fender stiffener to fender ($\frac{1}{2}$ -in. open-end wrench).

(18) **REMOVE RIGHT FOOTREST** (fig. 195).

WRENCH, open-end, $\frac{3}{4}$ -in. (2)

Remove remaining bolt, nut, and lock washer which hold footrest to fender (two $\frac{3}{4}$ -in. open-end wrenches). Lift off the footrest.

(19) **REMOVE BLACKOUT TAIL AND STOP LAMPS** (fig. 195).

WRENCH, open-end, $\frac{9}{16}$ -in. (2)

(a) Remove 2 bolts, nuts, and lock washers which hold blackout tail and stop lamp to right fender (two $\frac{9}{16}$ -in. open-end wrenches). Lift off lamp.

(b) In the same manner, remove blackout tail and service stop lamp from left fender.

(20) **REMOVE LEFT FOOTREST FROM FENDER** (fig. 195).

WRENCH, open-end, $\frac{3}{4}$ -in. (2)

Use two $\frac{3}{4}$ -inch open-end wrenches to remove 2 bolts, nuts, and lock washers which hold footrest to fender. Lift off footrest. **NOTE:** Lot 1 tractors are equipped with one-man seat and fenders. To facilitate removal and installation, components of the lot 1 seat and fenders are illustrated in figure 196.

135. SEAT AND FENDER INSPECTION.

a. **Clean All Parts.** Wash all parts thoroughly with water. Steam-clean if facilities are available. Use **SOLVENT**, dry-cleaning to remove oil and grease.

b. **Inspect All Parts.**

(1) **BRACKETS.** Check all fender brackets for breaks or cracks. Weld damaged brackets, if possible. Otherwise, replace (par. 133).

METAL PARTS

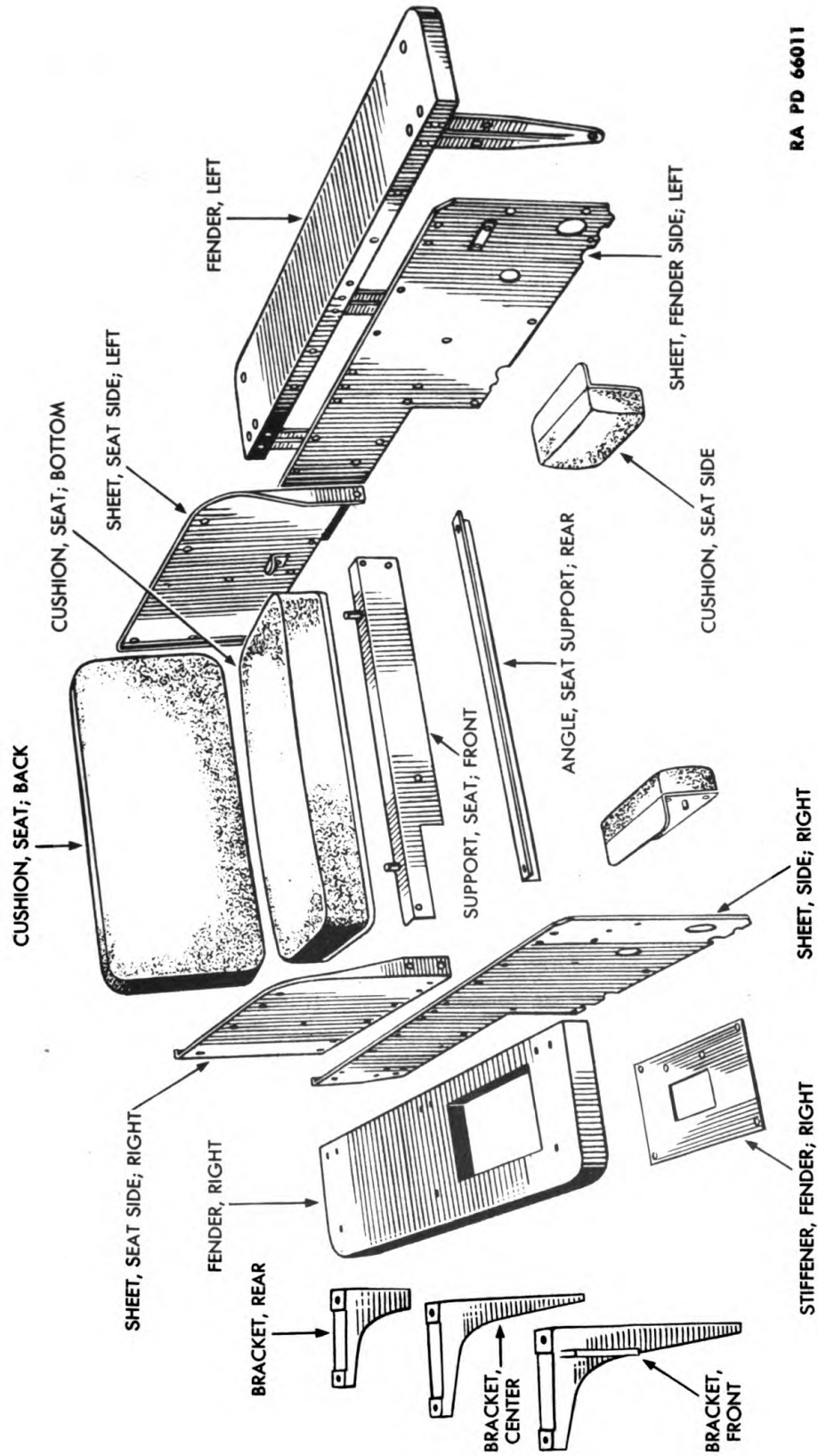

RA PD 66011

Figure 196 — Seat and Fenders (Lot 1) Parts

TM 9-1777C
135-136

**ORDNANCE MAINTENANCE — HEAVY TRACTOR MI (IHC TD-18) —
POWER TRAIN, TRACK FRAME ASSEMBLY, AND SEATS**

(2) **SHEET METAL.** Inspect fender, seat, grouser boxes, and other sheet metal for damage. Bump out and paint bent parts (par. 133).

(3) **FENDER SUPPORT CROSS MEMBER AND FENDER SUPPORT EXTENSION.** Inspect for breaks or cracks. Weld and straighten damaged parts, if possible.

(4) **BOLTS, CAP SCREWS, AND NUTS.** Inspect for damaged threads. Replace with new parts as required.

(5) **ARMRESTS, FOOTRESTS, AND HANDRAILS.** Check for bent parts. Straighten damaged parts or replace, if necessary.

(6) **PACK CARRIER.** If pack carrier has bent parts, they should be straightened.

(7) **DIESEL FUEL TANK.** Inspect fuel tank for leaks. Weld holes and cracks, if possible. Otherwise, install a new tank.

136. SEAT AND FENDER INSTALLATION.

a. Equipment.

BAR, steel	WRENCH, open-end, $\frac{5}{8}$ -in.
CHAIN	WRENCH, open-end, $\frac{3}{4}$ -in.
CUTTERS, diagonal	(2)
HOIST	WRENCH, open-end, $1\frac{3}{8}$ -in.
PLANK	WRENCH, open-end, $\frac{7}{8}$ -in.
PUNCHES, assembly	WRENCH, pipe
SLING, rope	WRENCH, socket, $\frac{9}{16}$ -in.
WRENCH, open-end, $\frac{9}{16}$ -in. (2)	WRENCH, socket, $\frac{3}{4}$ -in.

b. Procedure. Throughout the operations in this paragraph, bolt and cap screw holes of attaching parts should be placed in alignment by inserting and leaving one or more assembly punches into holes while initial bolts or cap screw are installed. **NOTE:** Lot 1 tractors are equipped with one-man seat and fenders. To install seat and fenders on lot 1 tractors, refer to figure 196. Procedure outlined here covers four-man seat and fenders, which are used on lots 2, 3, and 4.

(1) **ATTACH LEFT FOOTREST TO LEFT FENDER (fig. 195).**

WRENCH, open-end, $\frac{3}{4}$ in. (2)

Place footrest in position on fender and secure it to fender with 2 bolts, nuts, and lock washers. Tighten nuts with a $\frac{3}{4}$ -inch open-end wrench, while holding boltheads with another $\frac{3}{4}$ -inch open-end wrench.

(2) **ATTACH BLACKOUT TAIL AND STOP LAMPS TO FENDERS (fig. 195).**

WRENCH, open-end, $\frac{9}{16}$ -in. (2)

METAL PARTS

(a) Place blackout tail and stop lamp in position on left fender, securing it with 2 bolts, nuts, and lock washers. Tighten nuts with a $\frac{9}{16}$ -inch open-end wrench and hold boltheads with another $\frac{9}{16}$ -inch open-end wrench.

(b) In the same manner, install blackout tail and service stop lamp on right fender.

(3) INSTALL RIGHT FOOTREST.

WRENCH, open-end, $\frac{3}{4}$ -in. (2)

Place footrest in position on right fender and install bolt, nut, and lock washer which hold footrest to fender. Tighten nut with a $\frac{3}{4}$ -inch open-end wrench, holding boltheads with another $\frac{3}{4}$ -inch open-end wrench.

(4) INSTALL WINCH SHIFTER LEVER AND WINCH BRAKE LEVER ON RIGHT FENDER (fig. 195).

WRENCH, open-end, $\frac{3}{4}$ -in (2) WRENCH, open-end, $\frac{1}{2}$ -in.

Place levers in position on fender and install 1 bolt, nut, and lock washer which hold footrest and right fender stiffener to fender. Also install 1 carriage bolt which holds fender stiffener to fender. Tighten carriage bolt nut with a $\frac{1}{2}$ -inch open-end wrench and tighten the other bolt and nut, using a $\frac{3}{4}$ -inch open-end wrench to tighten the nut and another $\frac{3}{4}$ -inch open-end wrench to hold the bolthead. Then install 2 bolts, nuts, and lock washers which hold levers to fender. Use two $\frac{3}{4}$ -inch open-end wrenches, holding the boltheads with one while tightening nuts with other.

(5) INSTALL FENDER SUPPORT EXTENSION TO EACH FENDER (fig. 192).

WRENCH, open-end, $\frac{9}{16}$ -in. (2)

Install 2 bolts, nuts, and lock washers which secure each extension to fender, using two $\frac{9}{16}$ -inch open-end wrenches. Hold boltheads with 1 wrench and tighten nuts with other.

(6) INSTALL FUEL TANK SUPPORTS (fig. 194).

WRENCH, open-end, $\frac{3}{4}$ -in.

(a) Place fuel tank support in position against main frame cover in main frame. Install 4 cap screws and lock washers which hold left fuel tank support to main frame cover and main frame. Tighten cap screws with $\frac{3}{4}$ -inch open-end wrench.

(b) In a similar manner, install 4 cap screws and lock washers which hold right fuel tank support to main frame cover and main frame.

**ORDNANCE MAINTENANCE – HEAVY TRACTOR MI (IHC TD-18) –
POWER TRAIN, TRACK FRAME ASSEMBLY, AND SEATS**

(7) **INSTALL LEFT FENDER BRACKETS AND FENDER SIDE SHEET** (fig. 193).

WRENCH, open-end, $\frac{9}{16}$ -in. (2) **WRENCH**, open-end, $\frac{3}{4}$ -in. (2)
WRENCH, open-end, $\frac{5}{8}$ -in. **WRENCH**, socket, $\frac{3}{4}$ -in.

(a) Lift left fender side sheet into position at left side of main frame and main frame cover.

(b) Install top bolt, nut, and lock washer which hold side sheet to dash and cowl assembly, using two $\frac{9}{16}$ -inch open-end wrenches. Hold boltheads with 1 wrench while tightening nuts with the other. Install 2 bolts, nuts, and lock washers which hold side sheet to main frame cover, using two $\frac{9}{16}$ -inch open-end wrenches to hold boltheads and tighten nuts. Then install 1 cap screw and lock washer which hold side sheet to main frame side channel, using a $\frac{9}{16}$ -inch open-end wrench.

(c) Install fuel return and supply pipes. Place fuel pipes into position on left side of main frame cover, next to left fender side sheet, and insert pipes through dash and cowl assembly. Use a $\frac{5}{8}$ -inch open-end wrench to connect pipe connectors to pipes at engine. Install 3 fuel pipe clips which hold the return and supply pipes to left fender side sheet. Secure clamps with 3 bolts, nuts, and lock washers. Insert bolts from outside of fender side sheet, using two $\frac{9}{16}$ -inch open-end wrenches. Hold boltheads with one while tightening nuts with the other.

(d) Lift left rear fender bracket in position against side sheet. Install 4 bolts, nuts, and lock washers which hold left rear fender bracket to side sheet and left fuel tank support. Hold nuts with a $\frac{3}{4}$ -inch open-end wrench while tightening boltheads with a $\frac{3}{4}$ -inch socket wrench.

(e) Lift the left center fender bracket in position against side sheet. Then install 2 bolts, nuts, and lock washers which hold left center fender bracket to side sheet. Also install a cap screw which holds fender bracket to left main frame side channel. Tighten nuts with a $\frac{3}{4}$ -inch open-end wrench. Hold boltheads with another $\frac{3}{4}$ -inch open-end wrench.

(f) Lift the right front fender bracket in position against side sheet. Then install 3 cap screws and lock washers which hold right front fender bracket to side sheet main frame side channel and engine clutch cover. Tighten cap screws, using a $\frac{3}{4}$ -inch open-end wrench.

(g) Raise winch lower layshaft and drive shaft to a normal position. Then place winch layshaft bearing housing and spacer in position. Install 2 bolts, lock washers, and nuts which hold housing in place. Use two $\frac{3}{4}$ -inch open-end wrenches to tighten nuts and hold boltheads.

METAL PARTS

(8) **INSTALL RIGHT FENDER BRACKETS AND FENDER SIDE SHEET** (fig. 193).

WRENCH, open-end, $\frac{9}{16}$ -in. (2) **WRENCH**, socket, $\frac{3}{4}$ -in.
WRENCH, open-end, $\frac{3}{4}$ -in.

(a) Lift right fender side sheet in position against main frame and main frame cover.

(b) Install 1 bolt, nut, and lock washer which hold right fender side sheet to dash and cowl assembly, using two $\frac{9}{16}$ -inch open-end wrenches. Install 2 bolts, nuts, and lock washers which hold right fender side sheet to main frame cover. Use two $\frac{9}{16}$ -inch open-end wrenches. Use a $\frac{9}{16}$ -inch open-end wrench to install 1 cap screw and lock washer which hold side sheet to main frame side channel.

(c) Install battery cable shield over battery cable and air tube, securing it to right fender side sheet with 3 bolts, nuts, and lock washers. Use two $\frac{9}{16}$ -inch open-end wrenches to hold boltheads and tighten nuts.

(d) Lift right center fender bracket in position on side sheet. Secure it with 1 cap screw and lock washer and 2 bolts, nuts, and lock washers. Use a $\frac{3}{4}$ -inch open-end wrench to tighten cap screw and to hold bolt nuts while boltheads are tightened with a $\frac{3}{4}$ -inch socket wrench. Use another $\frac{3}{4}$ -inch open-end wrench to hold boltheads.

(e) The right front fender bracket is installed with fender as outlined in step (10) below. Bolts and cap screws which hold remaining right bracket to fender side sheet correspond to those identified in figure 193.

(9) **INSTALL FENDER SUPPORT CROSS MEMBER** (fig. 192).

Lift cross member into position over left and right rear fender brackets with boltholes in cross member and brackets in alinement.

(10) **INSTALL LEFT FENDER** (fig. 192).

Follow procedure outlined in step (11) below. It is not necessary to install left fender with front bracket attached, because there is no fire extinguisher on left side of tractor. Therefore, when installing left fender, step (11) (b) and (c) should be eliminated.

(11) **INSTALL RIGHT FENDER** (fig. 192).

WRENCH, open-end, $\frac{9}{16}$ -in. (2) **WRENCH**, open-end, $\frac{1\frac{1}{8}}$ -in.
WRENCH, open-end, $\frac{5}{8}$ -in. **WRENCH**, socket, $\frac{9}{16}$ -in.
WRENCH, open-end, $\frac{3}{4}$ -in. (2) **WRENCH**, socket, $\frac{3}{4}$ -in.

(a) Lift front fender bracket in position against fender and secure it to fender with 2 carriage bolts, nuts, and lock washers. Tighten bolt nuts, using a $\frac{1\frac{1}{8}}$ -inch open-end wrench.

(b) Lift fender with front fender bracket attached in position against

**ORDNANCE MAINTENANCE – HEAVY TRACTOR MI (IHC TD-18) –
POWER TRAIN, TRACK FRAME ASSEMBLY, AND SEATS**

main frame and main frame cover. Raise the fender at the rear and slide it in position under the fire extinguisher.

(c) Install 2 cap screws and lock washers which hold front fender bracket to engine clutch cover and 1 cap screw and lock washer which hold bracket to right main frame channel. Use a 3/4-inch open-end wrench to tighten cap screw and a 3/4-inch socket wrench to tighten the other 2.

(d) Install 6 bolts, nuts, and lock washers which hold fender to side sheet. Hold boltheads from inside with a 1/8-inch open-end wrench while tightening nuts with a 1/8-inch socket wrench.

(e) Attach cables to blackout tail and stop lamp.

(f) Install 2 bolts, nuts, and lock washers which hold fender to fender support cross member. Tighten bolt nuts with a 5/8-inch open-end wrench.

(g) Install 2 bolts, nuts, and lock washers which hold center fender bracket and fender to side sheet. Hold nuts from outside with a 1/8-inch open-end wrench. Tighten boltheads from inside, using another 1/8-inch open-end wrench.

(h) Install 2 bolts, nuts, and lock washers which hold fender to center fender bracket. Use two 3/4-inch open-end wrenches. Tighten nuts with 1 wrench and hold boltheads with the other.

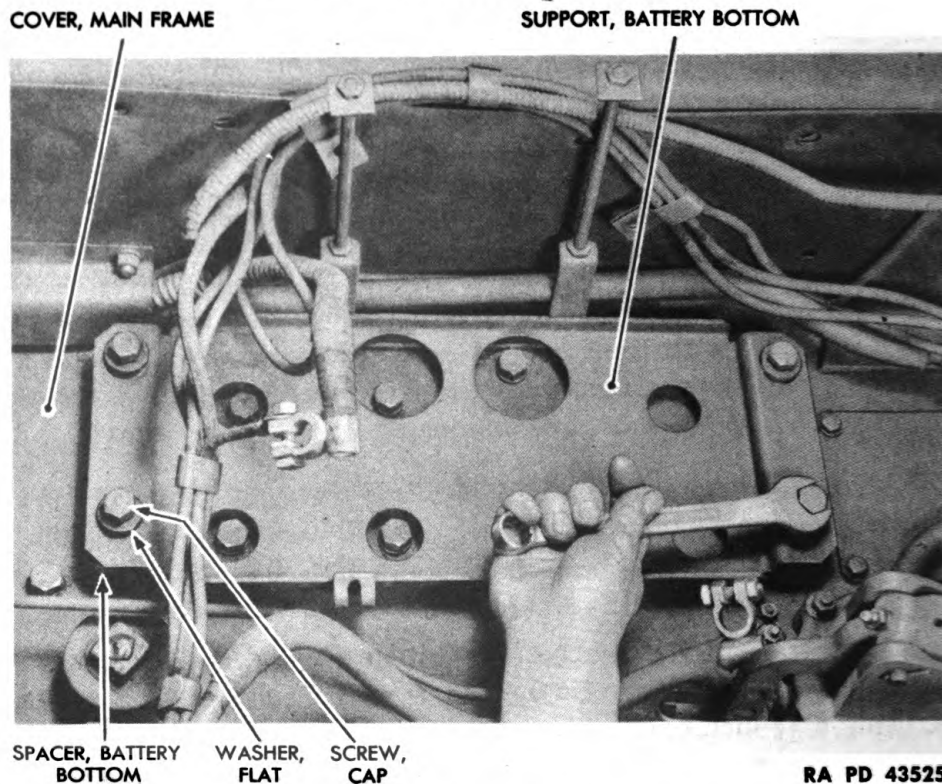

Figure 197 – Battery Bottom Support Installation

METAL PARTS

(i) Install 2 bolts, nuts, and lock washers which hold front fender bracket and fender to fender side sheet. Use two $\frac{9}{16}$ -inch open-end wrenches. Tighten boltheads with 1 wrench and hold nuts with another.

(12) INSTALL WINCH DRIVE SHAFT GUARD.

Follow procedure outlined in TM 9-1777 D.

(13) CONNECT WINCH AND CLUTCH BRAKE CONTROL RODS TO WINCH SHIFTER AND BRAKE LEVERS (fig. 191).

CUTTERS, diagonal

Raise winch and clutch brake control rods and install end pins which join yoke assemblies to levers. Insert cotter pin in end of each end pin and use diagonal cutters to lock cotter pins.

(14) INSTALL BATTERIES AND BATTERY BOTTOM SUPPORTS (fig. 197).

WRENCH, open-end, $\frac{3}{4}$ -in.

(a) Place right battery bottom support in position on main frame cover. Insert 4 battery bottom spacers into position under support and install 4 flat washers and cap screws. Use a $\frac{3}{4}$ -inch open-end wrench.

(b) Follow procedure outlined in TM 9-777 to install batteries.

(15) CONNECT THE FRONT POWER TAKE-OFF SHIFTER HAND LEVER TO ROD YOKE TO POWER TAKE-OFF SHIFTER HAND LEVER (fig. 190).

CUTTERS, diagonal

Connect the yoke to the lever. Install front power take-off shifter hand lever rod yoke pin. Place a cotter pin in end of yoke pin, locking it with diagonal cutters.

(16) LIFT SEAT INTO POSITION ON TRACTOR.

HOIST

ROPE, sling

The seat can be lifted into position by 2 men. Otherwise, a hoist with a rope sling placed around the seat should be used.

(17) CONNECT CABLES TO FRONT SEAT SUPPORT (fig. 190).

WRENCH, open-end, $\frac{9}{16}$ -in.

Use a $\frac{9}{16}$ -inch open-end wrench to install the bolt, nut, and lock washer which hold the cable clip and cables to front seat support at the left. Then use a $\frac{9}{16}$ -inch open-end wrench to install bolt, nut, and lock washer which hold 2 cable clips and cables to the front seat support at left.

(18) INSTALL BOLTS WHICH HOLD SEAT TO LEFT FENDER.

Follow the same procedure outlined in step (19) below.

**ORDNANCE MAINTENANCE – HEAVY TRACTOR MI (IHC TD-18) –
POWER TRAIN, TRACK FRAME ASSEMBLY, AND SEATS**

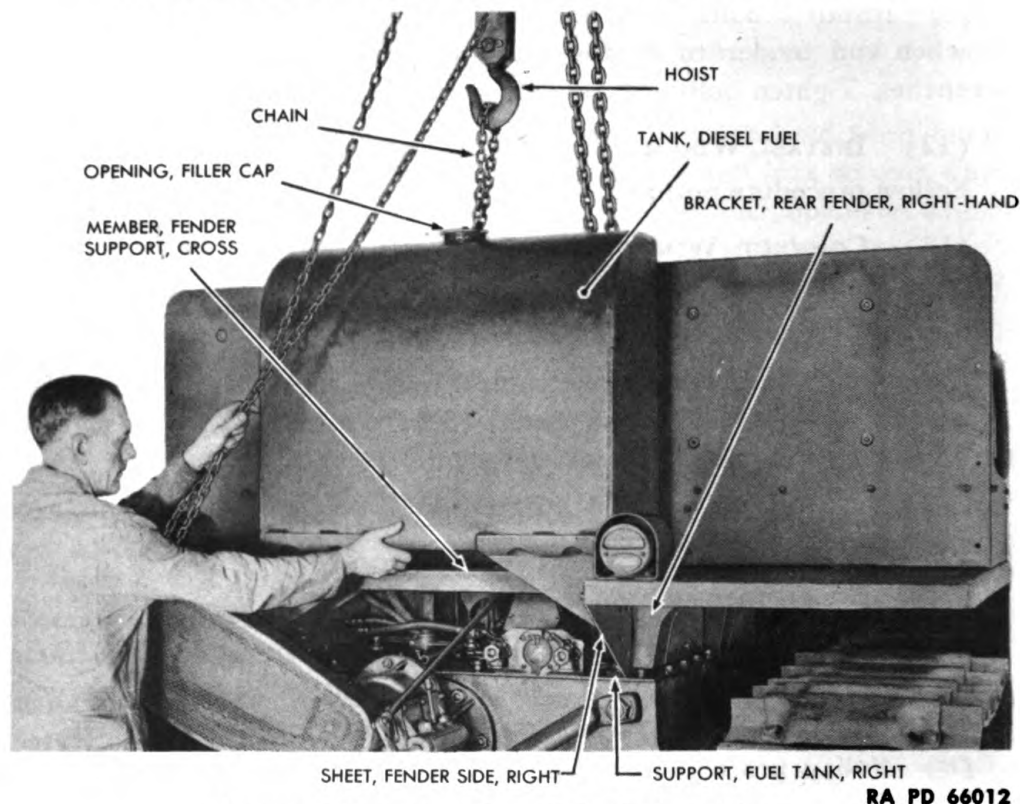

Figure 198 – Diesel Fuel Tank Installation

(19) INSTALL BOLTS, WHICH HOLD SEAT TO RIGHT FENDER (fig. 189).

WRENCH, open-end, $\frac{9}{16}$ -in. (2) WRENCH, open-end, $\frac{3}{4}$ -in. (2)
WRENCH, open-end, $\frac{5}{8}$ -in.

Lift the tool box from cover seat, above right fender. Install 19 bolts which hold seat to right fender. One mechanic should hold boltheads from turning, using a $\frac{9}{16}$ -inch open-end wrench while the second mechanic tightens the nuts and lock washers, using another $\frac{9}{16}$ -inch open-end wrench. Two of the 19 bolts require the use of two $\frac{3}{4}$ -inch open-end wrenches. Two bolts, located on outer end of left fender support cross member, are carriage bolts, which require the use of a $\frac{5}{8}$ -inch open-end wrench. Corresponding bolts on right fender are not carriage bolts, and require the use of two $\frac{9}{16}$ -inch open-end wrenches.

(20) INSTALL DIESEL FUEL TANK (fig. 198).

a. See TM 9-777.

(21) INSTALL PACK CARRIER (fig. 199).

a. See TM 9-777.

METAL PARTS



Figure 199 — Pack Carrier Installation

**ORDNANCE MAINTENANCE – HEAVY TRACTOR MI (IHC TD-18) –
POWER TRAIN, TRACK FRAME ASSEMBLY, AND SEATS**

(22) **INSTALL GROUSER BOXES** (figs. 187 and 188).

WRENCH, open-end, $\frac{1}{8}$ -in.(2) **WRENCH**, open-end, $\frac{3}{4}$ -in.(2)

(a) Use a $\frac{1}{8}$ -inch open-end wrench to install 4 cap screws and lock washers which secure right grouser chest to fuel tank and to pack carrier.

(b) Lift right grouser box in position on right fender. Install 8 bolts, lock washers, and nuts which hold the right grouser box to right fender. Four of these bolts are secured to right rear fender bracket and require the use of two $\frac{3}{4}$ -inch open-end wrenches. Remaining bolts require the use of two $\frac{1}{8}$ -inch open-end wrenches. Two of the bolts are secured to fender support cross member. Boltheads must be held from inside the grouser box while installing nuts from underneath fender.

(c) Install 4 bolts, lock washers, and nuts which hold right grouser box to seat rear and side sheet. Use two $\frac{1}{8}$ -inch open-end wrenches.

(d) In same manner, install left grouser box.

(23) **INSTALL SEAT CUSHIONS AND BACKS** (fig. 186).

WRENCH, open-end, $\frac{1}{8}$ -in.(2)

(a) Lift cushion back into position, sliding it upward as it is installed against seat back. Install 2 bolts, lock washers, and nuts which hold cushion back to seat rear and side sheet. Hold boltheads with one $\frac{1}{8}$ -inch open-end wrench while tightening nuts with another. Then place right seat cushion bottom (end) in position on seat.

(b) Install 2 tool box covers by hand.

(c) Lower rear seat support into position.

(d) Install left rear cushion bottom (end) and lift side cushion back (end) as outlined in (a) above.

(e) In a similar manner, install seat cushion bottom (center) on seat cushion back (center).

CHAPTER 7

FITS, TOLERANCES, AND SPECIAL TOOLS

Section 1

FITS AND TOLERANCES

	Paragraph
Fits and tolerances	137
Tension wrench table	138

137. FITS AND TOLERANCES.

a. All bushings and bearings furnished for the chassis are supplied, reamed to size. Wear tolerances are not available.

138. TENSION WRENCH TABLE.

Track shoe bolts	240-250 lb
-------------------------------	------------

ORDNANCE MAINTENANCE — HEAVY TRACTOR MI (IHC TD-18) —
POWER TRAIN, TRACK FRAME ASSEMBLY, AND SEATS

Section II

SPECIAL TOOLS

Special tools Paragraph
139

139. SPECIAL TOOLS.

a. **Sprocket Drive Carrier Nut Wrench.** The wrench illustrated in figure 200 is used with a round bar to remove the sprocket drive carrier nut.

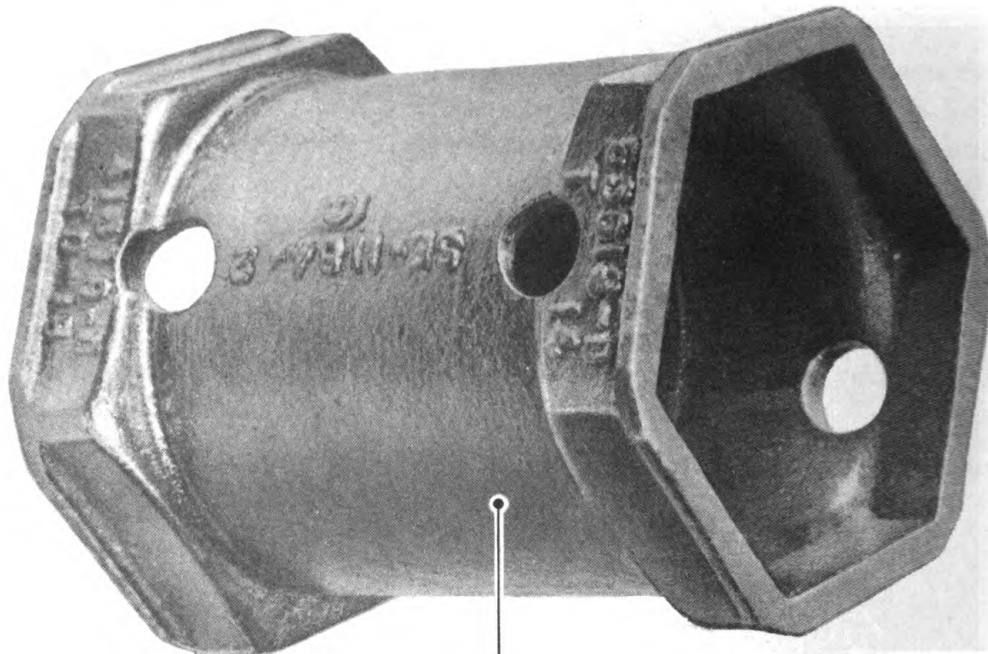

WRENCH, SPROCKET DRIVE CARRIER NUT—SE-1184-2

RA PD 43603

Figure 200 — Sprocket Drive Carrier Nut Wrench

SPECIAL TOOLS

b. Track Pin and Bushing Press with Adjustable Head (fig. 201). Press may be used to remove and replace track pins and bushings. Press unit SE-1026-1 and tools SE-1026-2, -4, -13, and -20 are packed in one box. Adjustable head SE-1026-50 and all tools covered by SE-1026-51 are packed in another box (fig. 188). This arrangement is helpful for quickly selecting tools required for each operation. Check list must be kept tacked to inside of box lid. After using press, replace tools in box. Check against list tacked on box lid to be sure all tools are replaced.

PRESS, portable hydraulic pin and bushing, complete with adjustable head, tools, and adapters.....SE-1026
WRENCH, sprocket drive carrier nut.....SE-1184-2

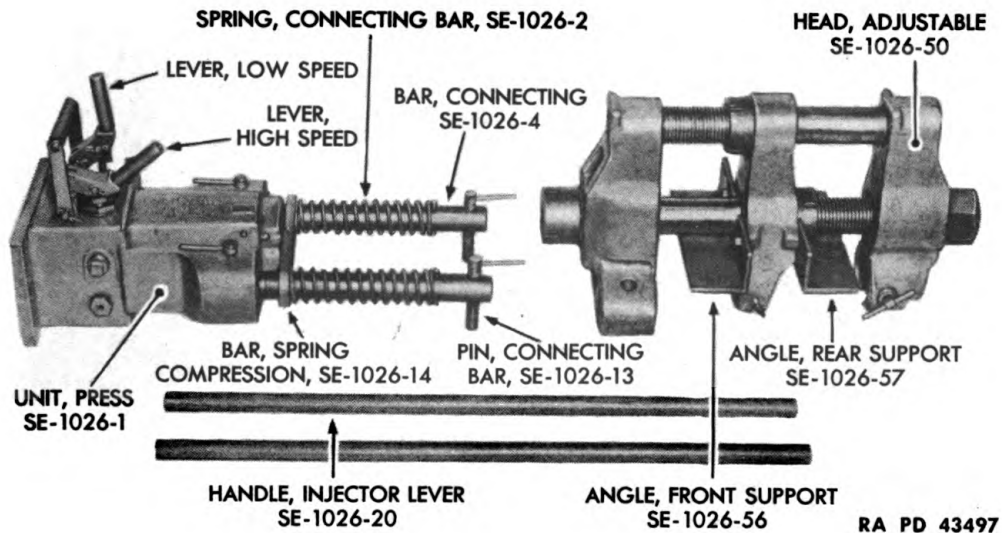
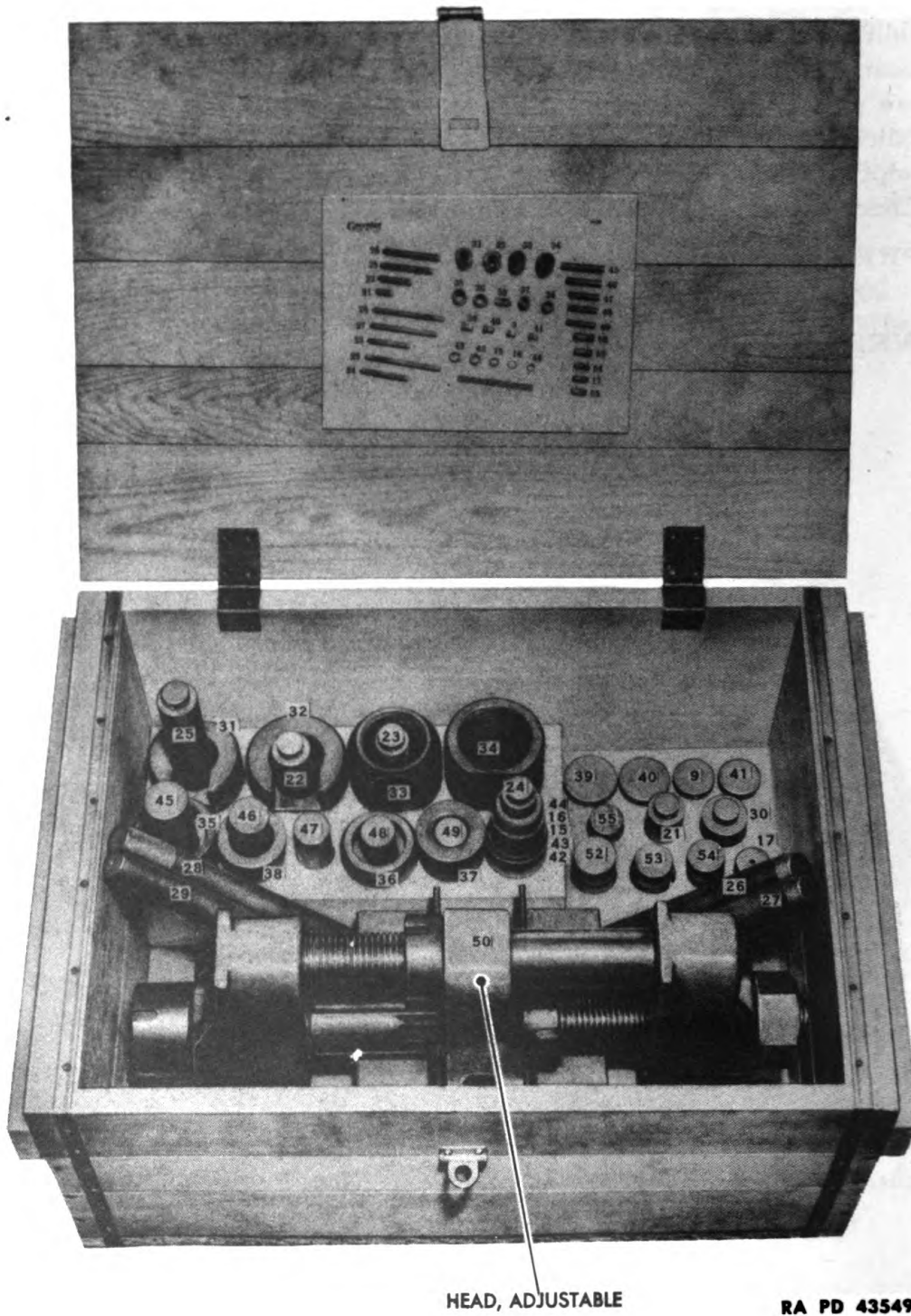

Figure 201 – Portable Hydraulic Track Pin and Bushing Press with Adjustable Head

**ORDNANCE MAINTENANCE – HEAVY TRACTOR MI (IHC TD-18) –
POWER TRAIN, TRACK FRAME ASSEMBLY, AND SEATS**



HEAD, ADJUSTABLE

RA PD 43549

Figure 202 – Box containing Adjustable Head and All Tools for SE-1026

SPECIAL TOOLS

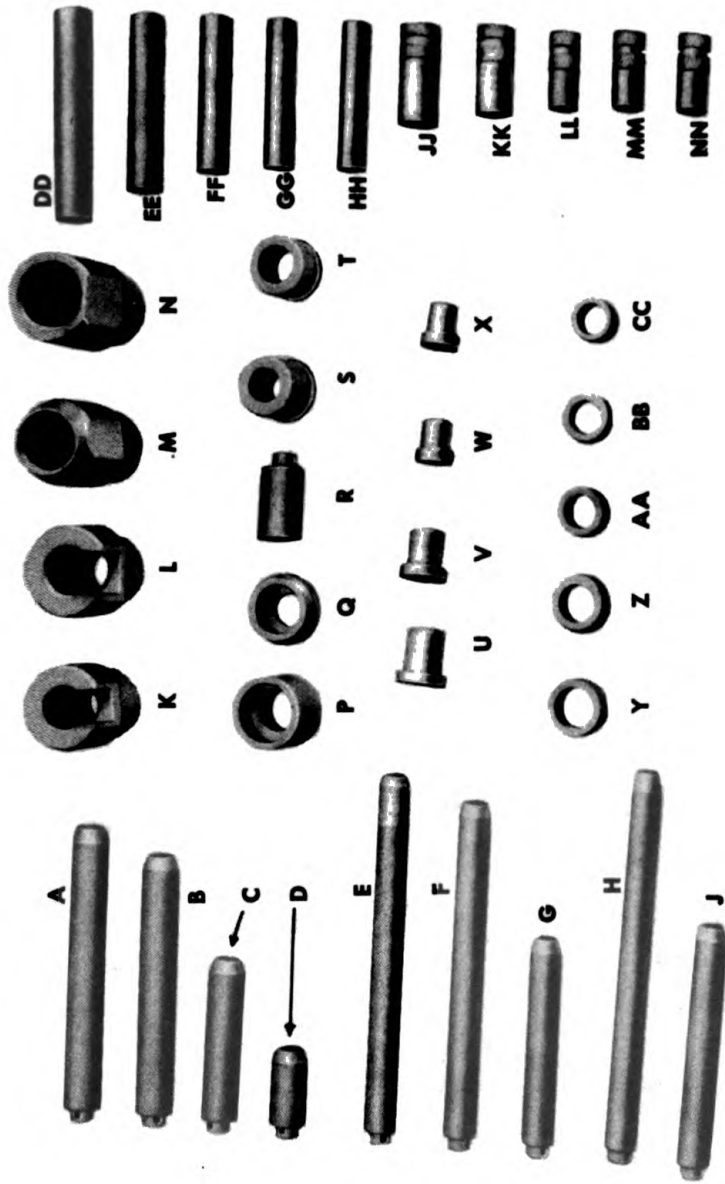

- A—ROD, PUSH, 12¾", SE-1026-26
- B—ROD, PUSH, 11¼", SE-1026-25
- C—ROD, PUSH, 7", SE-1026-22
- D—ROD, PUSH, 4½", SE-1026-21
- E—ROD, PUSH, 15", SE-1026-28
- F—ROD, PUSH, 14", SE-1026-27
- G—ROD, PUSH, 8½", SE-1026-23
- H—ROD, PUSH, 15½", SE-1026-29
- J—ROD, PUSH, 9¾", SE-1026-24
- K—SLEEVE, PIN, SE-1026-31
- L—SLEEVE, PIN, SE-1026-32
- M—SLEEVE, BUSHING, SE-1026-33
- N—SLEEVE, BUSHING, SE-1026-34
- P—SLEEVE, EXTENSION, SE-1026-35
- Q—SLEEVE, EXTENSION, SE-1026-36
- R—ROD, EXTENSION, 4", SE-1026-30
- S—BUSHING, GUIDE, SE-1026-37
- T—BUSHING, GUIDE, SE-1026-38
- U—PLUG, BUSHING, PUSH, SE-1026-39
- V—PLUG, BUSHING, PUSH, SE-1026-40
- W—PLUG, BUSHING, PUSH, SE-1026-9
- X—PLUG, BUSHING, PUSH, SE-1026-41
- Y—COLLAR, SPACING, SE-1026-42
- Z—COLLAR, SPACING, SE-1026-43
- AA—COLLAR, SPACING, SE-1026-15
- BB—COLLAR, SPACING, SE-1026-16
- CC—COLLAR, SPACING, SE-1026-44
- DD—PIN, LONG ALINING, SE-1026-45
- EE—PIN, LONG ALINING, SE-1026-46
- FF—PIN, LONG ALINING, SE-1026-47
- GG—PIN, LONG ALINING, SE-1026-48
- HH—PIN, LONG ALINING, SE-1026-49
- JJ—PIN, SHORT ALINING, SE-1026-52
- KK—PIN, SHORT ALINING, SE-1026-53
- LL—PIN, SHORT ALINING, SE-1026-54
- MM—PIN, SHORT ALINING, SE-1026-17
- NN—PIN, SHORT ALINING, SE-1026-55

RA PD 43570

Figure 203 — Parts for SE-1026 Portable Hydraulic Track Pin and Bushing Press with Adjustable Head

**ORDNANCE MAINTENANCE — HEAVY TRACTOR M1 (IHC TD-18) —
POWER TRAIN, TRACK FRAME ASSEMBLY, AND SEATS**

CHAPTER 8

REFERENCES

	Paragraph
Standard nomenclature list	140
Explanatory publications	141

140. STANDARD NOMENCLATURE LISTS.

- a. Cleaning, preserving and lubricating materials, recoil fluids, special oils and miscellaneous related items **SNL K-1**
- b. Tractor, ordnance, heavy, M1 (IHC-TD18) (Diesel) **SNL G-101**

Current standard nomenclature lists are as tabulated here. An up-to-date list of SNL's is maintained as the "Ordnance Publications for Supply Index" **OPSI**

141. EXPLANATORY PUBLICATIONS.

a. Automotive Materiel.

- Heavy tractor M1 (IHC-TD18)..... **TM 9-777**
- Military motor vehicles..... **AR 850-15**
- Motor transport **FM 25-10**
- Ordnance maintenance — Heavy tractor, M1 (IHC-TD18) Diesel engine accessories..... **TM 9-1777B**
- Ordnance maintenance — Heavy tractor, M1 (IHC-TD18) equipment **TM 9-1777D**
- Ordnance maintenance — Heavy tractor, M1 (IHC-TD18) Diesel engine..... **TM 9-1777A**

b. Care and Preservation.

- Cleaning, preserving, lubricating, and welding materials and similar items issued by the ordnance department **TM 9-850**
- Decontamination, 1941 **TC No. 38**
- Defense against chemical attack..... **FM 21-40**
- Detailed lubrication instructions for ordnance materiel **OFSB 6-Series**

REFERENCES

c. Inspection and Maintenance.

Echelon system of maintenance	TM 10-525
Fire prevention, safety precautions, accidents	TM 10-360
Motor transport inspections	TM 10-545
Ordnance maintenance procedure, materiel in- spection and repair	TM 9-1100

d. Miscellaneous.

Automotive electricity	TM 10-580
Diesel engines and fuels	TM 10-575
Electrical fundamentals	TM 1-455
List of training publications	FM 21-6
The internal combustion engine	TM 10-570

e. Shipment and Storage.

Loading of mechanized and motorized army equipment on open top railroad equipment — Association of American Railroads	
Storage of military motor vehicles	AR 850-18

f. Training Films and Film Strips.

Diesel engines	TF 9-159
Diesel engines and fuels	FS 10-37
Engine of the Diesel tractor	TF 9-171
Lubrication	FS 10-39
Power train of the Diesel tractor	TF 9-172
The electrical system of the Diesel tractor	TF 9-169
The fuel system of the Diesel tractor	TF 9-170
The track and suspension system of the Diesel tractor	TF 9-173

ORDNANCE MAINTENANCE — HEAVY TRACTOR MI (IHC TD-18) —
POWER TRAIN, TRACK FRAME ASSEMBLY, AND SEATS

INDEX

A	Page No.	C	Page No.
Adjustments:		Cage cap, checking.....	133
drive bevel gear.....	91-94	Channels, frame (See Main frame side channels)	
engine clutch	23, 47-48	Cleaning:	
steering brake	106-107	bottom track roller parts.....	204
steering clutch control.....	146-147	equalizer spring parts.....	188-189
track	243-245	final drive parts.....	173
Assembly:		front idler parts.....	215
bottom track rollers.....	205-208	front idler springs.....	222
drive bevel gear.....	90-91	gears, shafts and parts.....	77
engine clutch	40-43	main frame side channel.....	257
equalizer spring	189-190	track frame	266
final drives	173-175	track frame assembly.....	181
front idler	216-217	track frame diagonal brace.....	248
steering brake	102-103	track idler parts.....	195
steering brake control.....	155-156	tracks	234
steering clutch	133-137	steering brake control parts.....	154
track	238-242	steering clutch parts.....	131
track frame bracket with roller	252	Clutch return springs, inspection.....	23
track frame diagonal brace.....	248	Clutches (See Engine clutch and Steering clutches)	
track idlers	195-196	Construction:	
transmission and drive bevel gear	79-87	engine clutch	21
		equalizer spring	183
B		final drives	159
Backlash, drive bevel gear		steering clutches	95
checking.....	91-92	track	225
Backplate, inspection	23	track frame diagonal brace.....	246
Bearings, pilot and release, checking	131	track frame guide and bracket with roller	250
Belt in retainer, install new.....	133	track frames	15
Bevel gear, drive (See Drive bevel gear)		D	
Bottom track rollers		Definition of echelons and maintenance terms	21-22
assembly	205-208	Description:	
description and operation.....	198	bottom track rollers	198
disassembly	201-205	front idler	210-211
inspection	204-205	front idler springs	219
installation	208-209	power train	9-13
removal	198-201	sprockets	159
Brace (See Track frame diagonal brace)		track frame assembly	181
Brake band lining, inspection.....	101-102	track idlers	192-193
Brake disk with facing, inspection.....	23	transmission	49
Bracket with roller, track frame	252		

INDEX

D—Cont'd	Page No.	Page No.
Diagonal brace (See Track frame diagonal brace)		
Disassembly:		
bottom track rollers	201-205	
engine clutch	32-37	
equalizer spring	186-188	
final drives	167-173	
front idler	213-215	
steering brake	100-101	
steering brake control	152-153	
steering clutch	124-131	
track	228-234	
track frame bracket with roller.....	252	
track frame diagonal brace	247	
track idlers	195	
transmission and drive bevel gear	65-77	
Disks, checking	131	
Drive bevel gear		
assembly	79-87	
and adjustment	90-94	
cleaning, inspection, and repair..	77-79	
disassembly	65-77	
inspection in vehicle	51	
installation	87-90	
check after	94	
removal	51-64	
trouble shooting	18	
Drum, checking	131	
E		
Echelons, definition of	21-22	
(See also Maintenance)		
Engine clutch		
adjustment	47-48	
assembly	40-43	
construction and operation	21	
disassembly	32-37	
engine clutch facings, installation	39-40	
inspection in vehicle	22-23	
inspection of parts	37-39	
installation	43-47	
maintenance, allocation of by echelons	21-22	
removal	23-31	
trouble shooting	16-17	
Engine clutch facings, installation..	39-40	
Engine serial numbers	4	
Equalizer spring		
assembly	189-190	
construction and operation	183	
disassembly	186-188	
inspection	188-189	
installation	190-191	
removal	183-185	
F		
Fenders, use of	15	
(See also Seat and fender)		
Final drives		
assembly	173-175	
construction and operation	159	
disassembly	167-173	
echelons of maintenance and repair	160	
inspection	159	
inspection and lubrication	173	
installation	175-178	
removal	162-167	
sprockets (See Sprockets)		
track frame pivot shaft replacement	178-180	
trouble shooting	19, 160	
Fits and tolerances	293	
Frame, track (See Track frame and Track frame assembly)		
Front idler		
assembly	216-217	
description and operation ..	15, 210-211	
disassembly	213-215	
inspection	215	
installation	218	
removal	211-212	
Front idler springs		
description and operation	219	
inspection	222	
installation	223-224	
removal	219-222	
G		
Gaskets, oil leaks at	159	
Gear, drive bevel (See Drive bevel gear)		
Gears, trouble shooting	18	
Grouser boxes	15	
Guides, track frame (See Track frame guide and bracket with roller)		

TM 9-1777C

ORDNANCE MAINTENANCE — HEAVY TRACTOR MI (IHC TD-18) — POWER TRAIN, TRACK FRAME ASSEMBLY, AND SEATS

H	Page No.	Page No.	
Hi-Lo range gear and reverse shaft..	10, 49	track frame diagonal brace	248-249
Hi-Lo range lever	10	track frame guide and bracket with	
Hub, checking	131	roller	252-253
		track idlers	196-197
I		transmission and drive bevel gear	87-90
Idlers (See Front idler and Track		check after	94
idlers)		Interchangeable components	4
Inspection: (See also Inspection in			
vehicle)		L	
bottom track rollers	204-205	Low range gears	10
engine clutch parts	37-39	Lubrication:	
equalizer spring	188-189	final drives	173
final drives	159	transmission	49
front idler	215	Lubrication fittings	21
front idler springs	222		
main frame side channel	257	M	
seat and fender	282-284	Main frame side channel	
sprockets	160	inspection	253-257
steering brake control, disassembled		installation	257
parts	154	removal	257-258
steering brake parts	101-102	Maintenance	
steering clutch parts	131-133	definitions of echelons and terms	21-22
track	234-235	engine clutch	22
track frame assembly	181	final drives	160
track frame diagonal brace	248	metal parts	270
track frame guide and bracket with		sprocket	160
roller	252	steering clutches	97
track idlers	195	track frame assembly	182
transmission and drive bevel		transmission	49
gear	77-78	Metal parts	
Inspection in vehicle		maintenance	270
engine clutch	22-23	seat and fender	
steering clutches and brakes	96-97	inspection	282-284
transmission and drive bevel gear ..	51	installation	284-292
Installation:		removal	270-282
bottom track rollers	208-209		
engine clutch	43-47	N	
equalizer spring	190-191	Noisy gears	18
final drives	175-178	Numbers	
front idler	218	registration	3
front idler springs	223-224	serial	4
main frame side channel	257-258		
seat and fender	284-292	O	
sprockets	161-162	Oil leaks at gaskets	159
steering brake	104-105	Operation:	
steering brake control	156-158	bottom track rollers	198
steering clutch	137-145	engine clutch	21, 23
track	242-243	equalizer spring	183

INDEX

O—Cont'd	Page No.	Page No.
Operation—Cont'd		
final drives and sprockets	159	sprockets
front idler	210-211	steering brake
front idler springs	219	steering brake control
steering brake	96	steering clutch
steering clutches	95	track
track	225	track frame diagonal brace
track frame diagonal brace	246	track frame guide and bracket
track frame guide and bracket with		with roller
roller	250	track idlers
track idlers	192-193	transmissions and drive bevel
Overhaul of track	235-237	gear
		Repair
		defined
		transmission and drive bevel gear
		Replace defined
		Replacement of track frame pivot
		shaft
		S
		Seat and fender
		inspection
		installation
		removal
		Seats, provision for
		Serial numbers
		Service defined
		Shaft, checking
		Shifting
		transmission described
		transmission gears will not shift
		Slipping in steering clutches, cause
		and remedy
		Special tools
		Specifications:
		engine clutch
		steering brakes
		steering clutches
		Spring, equilizer (See Equilizer
		spring)
		Sprocket drive carrier nut wrench
		Sprockets
		description
		echelons of maintenance and repair
		fails to drive truck
		inspection
		installation
		removal
		trouble shooting

ORDNANCE MAINTENANCE — HEAVY TRACTOR MI (IHC TD-18) —
POWER TRAIN, TRACK FRAME ASSEMBLY, AND SEATS

S—Cont'd	Page No.		Page No.
Steering brake bands, checking for wear in	96-97	Track	
Steering brake control		adjustment	243-245
assembly	155-156	assembly	238-242
disassembly	152-153	construction and operation	225
inspection of disassembled parts.....	154	disassembly	228-234
installation	156-158	inspection	234-235
removal	149-150	installation	242-243
Steering brakes		overhaul	235-237
adjustment	106-107	removal	226-227
application	13	Track chain, trouble shooting	19
assembly	102-103	Track frame	
disassembly	100-101	construction	15, 259
inspection of parts	101-102	inspection and repair	266
installation	104-105	installation	266-269
operation and purpose of.....	96	removal	259-266
relining	97	Track frame assembly	
removal	98-99	description	181
specifications	9	inspection	181
trouble shooting	17-18	maintenance duties by echelons	182
will not hold, cause and remedy	18	trouble shooting	19
Steering clutch control, adjust-ment	146-147	Track frame bracket with roller	252
Steering clutches		Track frame diagonal brace	
assembly	133-137	assembly	248
construction and operation	95	construction and operation	246
disassembly	124-131	disassembly	247
disengaging	13	inspection	248
engaging and disengaging	10-13	installation	248-249
inspection of parts	131-133	removal	246-247
installation	137-145	Track frame guide and bracket with roller	
maintenance	97	construction and operation	250
removal	107-124	inspection	252
specifications	4	installation	252-253
trouble shooting	17-18	removal	250-251
Steering the vehicle	13	Track frame pivot shaft replacement	178-180
Stopping the vehicle	13	Track idlers	
Storage of street plates	15	assembly	195-196
		description and operation	192-193
		disassembly	195
		inspection	195
		installation	196-197
		removal	193-194
		Track pin and bushing press with adjustable head	295

T

Tension wrench table	293
Tolerances	293
Tool boxes, location	15
Tools, special	294-295
Torque capacity of engine clutch.....	21

INDEX

T—Cont'd	Page No.		Page No.
Track rollers, bottom (See Bottom track rollers)		Trouble shooting	
Transmission		drive bevel gear	18
assembly	79-87	engine clutch	16-17
cleaning, inspection, and repair..	77-79	final drive and sprockets	19, 160
description	49	gears	18
disassembly	65-77	scope of and facilities for	16
inspection in vehicle	51	sprockets	160
installation	87-90	steering clutches and brakes	17-18
check after	94	track chain	19
maintenance	49	track frame assembly	19
ranges	9	transmission	19-20
removal	51-64		
trouble shooting	19-20	W	
		Weight of vehicle, data on	15
		Welding metal parts	270
		Wrench, sprocket drive carrier nut..	294

[A.G. 062.11 (1-9-43)
0.0. 461/31184 0.0 (2-25-43)]

BY ORDER OF THE SECRETARY OF WAR:

G. C. MARSHALL,
Chief of Staff.

OFFICIAL:

J. A. ULIO,
Major General,
The Adjutant General.

DISTRIBUTION: R 9(2); IBn 9(1); IC 9(4),
(For explanation of symbols, see FM 21-6)