

TM5-1060

MHI
Copy 2

TM
5-1060
Feb 43

WAR DEPARTMENT MAINTENANCE MANUAL AND PARTS CATALOG

ROLLER, ROAD, TOWED TYPE, SHEEPS FOOT, 2 & 3 DRUM, IN-LINE

MODELS W2 & W3

R. G. LeTOURNEAU, INC.

PEORIA, ILL.

FEBRUARY 12, 1943

WARNING

SPARE PARTS can be supplied promptly and accurately only if positively identified by correct part number and correct part name.

FURNISH THIS INFORMATION ON ALL REQUISITIONS.

WITHOUT FAIL, on all requisitions, give name of machine, name of manufacturer, model or size, manufacturer's serial number of each machine and subassemblies attached to machine, and components and accessories for which spare parts are required.

List spare parts for only one make or kind of machine on each requisition.

Requisitions must be double spaced to provide room for office notations when necessary.

CPO JFR 304

WAR DEPARTMENT

LIBRARY

WASHINGTON, D. C.

TM5-1060, *Roller, Road*

ROLLER, ROAD, *Model 1060*

IN-LINE, MODEL

R. G. LaTOURNE

ATION AND GU

(AG 062.11

OTS CATALOG,

& 3 DRUM,

THE

INFORM-

41.)

I
AFF

OFFICIAL:

J. A. Ulio,

MAJOR GENERAL

THE ADJUTANT

TM5-1060

ROLLER, ROAD, TOWED TYPE,
SHEEPSFOOT, 2 AND 3 DRUM
IN-LINE
MODELS W2 AND W3

MANUFACTURED BY

R. G. LE TOURNEAU, INC.

PEORIA, ILL.

STOCKTON, CALIF.

(THIS BOOK COVERS ROLLERS SR-2199-W2B & UP)

(WAR DEPARTMENT PURCHASE ORDER C-2593)

INDEX

OPERATION SECTION

SECT. 1

	Page
Description of Sheep's Foot Roller	1
Operation	2
Safety Precautions	2
Functions of Sheep's Foot Roller	2
Connecting and Disconnecting Roller with Tractor	2
View showing points of lubrication and Adjustment that can be made by Operator	3
Specifications	3
Preparation for Initial Operation	4
Adding Ballast to Drums	4
Lubrication	5
Operation under Dusty, Muddy, Low Temperature and other abnormal conditions	6
Preparation for storage	6
Installing Additional drums	6

REPAIR SECTION

SECT. 2

	Page
Care of Sheep's Foot Roller	1
Adjustments	1, 2, 3 and 4
Disassembling	5 and 6
Overhauling and Repairing	7
Assembling	7
Table of Tolerances and Clearances of Bearings, and Adjustable parts	8

PARTS CATALOG

SECT. 3

	Page
Complete Roller Group	1
Drum Shaft Assembly (Exploded)	2
Universal Hitch Assembly	3

OPERATION SECTION

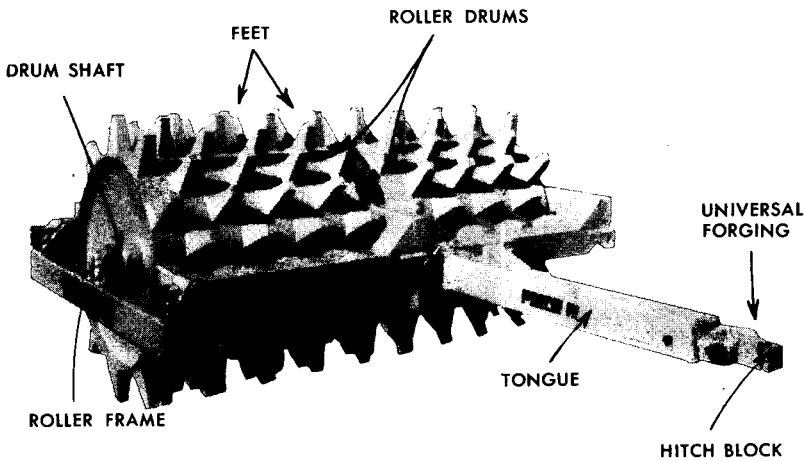

THE LETOURNEAU MODEL W-2 SHEEP'S FOOT ROLLER

LeTourneau Sheep's Foot Rollers offer the following features:

1. Full oscillating—equal distribution of tamping pressure on uneven ground contours.
2. Strong, non-kicking, pyramidal feet.
3. No kick-up, because they have no "toe" or "heel"—thus allowing the roller to operate forward or backward with equal ease and efficiency.
4. The long, pyramidal feet of heat treated alloy steel with thick soles are attached to drum with strong, heavy welds.
5. Pressure of one foot is distributed over 25 sq. in. of drum surface.
6. Easily assembled for use in two, three, four, five or seven sections to fit any size tractor. The two drum unit may be converted to any of the other size units by the purchase of additional drums. (Also additional tongue if used in tandem.)
7. Built from special analysis steel using boxbeam frames and standardized welding throughout.
8. Tapered roller bearings on drum shafts for minimum resistance to rolling.

LeTourneau's Sheep's Foot Rollers are widely used for compacting earth on highways, dams, levees, building foundations, etc. The Model W-2 Roller can be pulled by almost any size of Caterpillar Tractor.

OPERATING INSTRUCTIONS

LeTourneau Sheep's Foot Rollers are simple to operate, since they are merely pulled back and forth over the fill by the tractor.

It depends largely upon the job whether the roller should be continuously pulled forward over the fill or whether it should be repeatedly pulled forward and then reversed or "backed up" across the fill. Ordinarily the rollers are pulled forward over the fill if space permits turning.

If drums are used in tandem (one behind the other), the operator will have to use a certain amount of caution when backing up and when turning.

SAFETY PRECAUTIONS

Due to the few working parts and simplicity of design, there are few precautions or safety measures that need be taken, the principle precaution being to stay clear of the roller when it is moving, to prevent catching the clothing on one of the feet and thereby being pulled under the roller.

FUNCTIONS OF SHEEP'S FOOT ROLLER

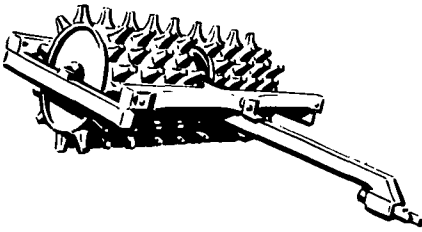

The functions of the Sheep's Foot Roller are simple. The drums turn forward when the roller is being pulled by the tractor, the tapered feet entering the ground, thus causing compaction. The individual drums oscillate independently to conform with the contour of the ground.

CONNECTING AND DISCONNECTING ROLLER WITH TRACTOR

To connect the Sheep's Foot Roller to the tractor, raise the tongue up to the level of the tractor drawbar. Back the tractor up, placing the Sheep's Foot Roller hitch block between the jaws of the tractor drawbar. Then insert the drawbar pin.

To disconnect the Sheep's Foot Roller from the tractor, reverse the above procedure.

**CUTAWAY VIEW OF SHEEP'S FOOT ROLLER,
SHOWING POINTS OF ADJUSTMENT
AND LUBRICATION WHICH CAN BE
TAKEN CARE OF BY OPERATOR**

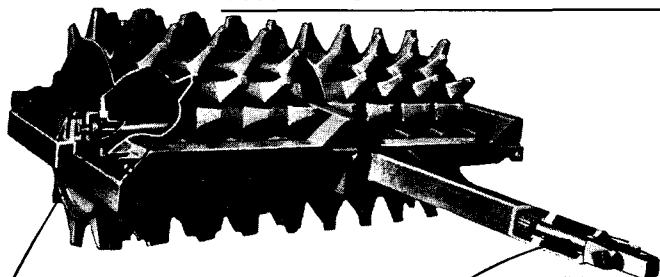

DRUM SHAFT BEARINGS
LUBRICATE EVERY 256 HRS
ADJUSTMENT — Made by
Maintenance and Repair Men.

UNIVERSAL FORGING
LUBRICATE EVERY 8 HOURS
ADJUSTMENT — Checked
every 64 hours, usually by
maintenance and repair men,
rather than operators.

SPECIFICATIONS

DRUM DIMENSIONS:

- Length 4'
- Diameter (less feet)..... 3' 6"
- Diameter (including feet)..... 4' 10"
- Space between Drums..... 8"

NUMBER OF FEET PER DRUM..... 88

OVERALL DIMENSIONS:

- Length 14' 7"
- Width 9' 7"
- Height 4' 10"

FOOT MATERIAL..... Heat Treated Alloy Steel

FOOT DIMENSIONS:

- Base (at drum)..... 5" x 5"
- Tamping Surface..... 2 1/4" x 2 1/4"
- Area of Foot Face..... 5-1/16 sq. in.
- Length (Drum to Tamping Surface)..... 8"

APPROXIMATE WEIGHT:

- Empty 6,040 lbs.
- *Loaded with water..... 10,240 lbs.
- *Loaded with saturated sand..... 13,440 lbs.

**COMPACTING PRESSURE PER SQUARE INCH
OF TAMPING SURFACE:**

- Empty 149 lbs.
- *Loaded with water..... 254 lbs.
- *Loaded with saturated sand..... 333 lbs.

*May be loaded with 2100 lbs. of water or 3700 lbs. of saturated sand per drum.

PREPARATION FOR INITIAL OPERATION

If the Roller arrives disassembled, first assemble the unit. (Refer to Assembling instructions on page 7 of the Repair Section). Check all points of adjustment and make any necessary corrections. Check all points of lubrication to determine if properly lubricated. After these points have been checked and any necessary changes made, the roller is ready to be placed in operation.

ADDING BALLAST TO DRUMS

Due to varying job conditions, etc., the required compaction per square inch varies on different jobs. Therefore the Sheep's Foot Roller Drums are designed so that ballast can be placed inside the drums to increase the weight.

Water is the most common form of ballast used in Sheep's Foot Rollers, although sand is quite often used. A mixture of water and sand (saturated sand) is also used at times to give more weight than can be obtained from either water or sand by themselves.

There is a pipe plug in each drum through which the ballast may be inserted. A larger opening is not provided since the drums must be sealed tight. When filling drums with sand, some users cut a small opening in the drum through which to insert the sand, and then weld the hole back up after the drums have been filled to the desired weight.

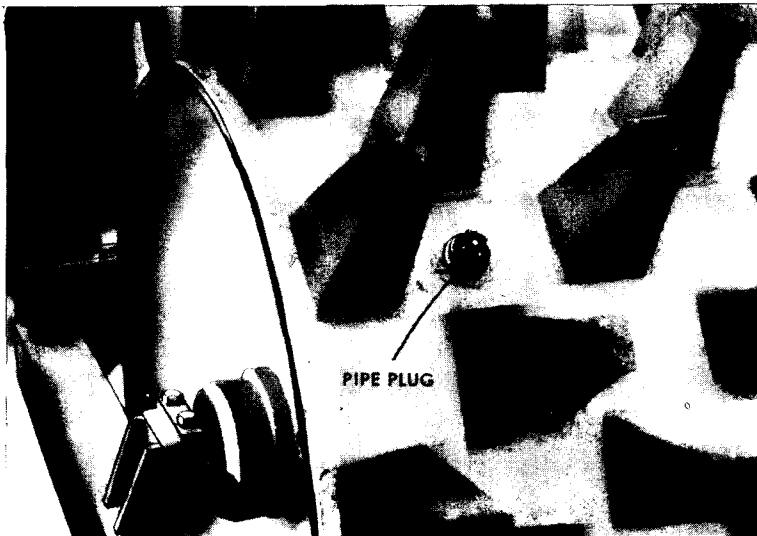

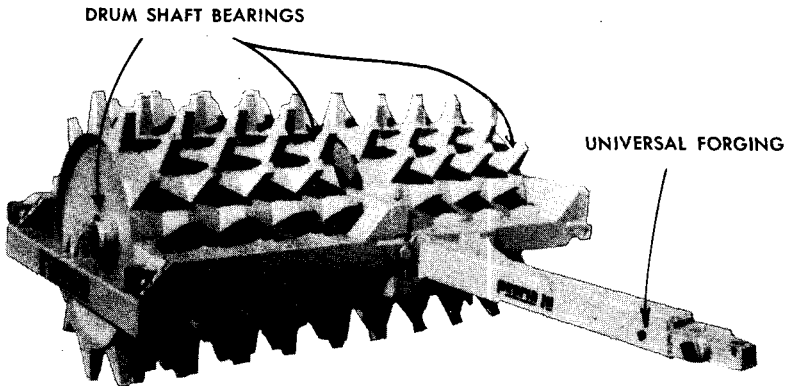

VIEW OF SHEEP'S FOOT ROLLER,
SHOWING POSITIONS OF GREASE FITTINGS

LUBRICATION

DRUM SHAFT BEARINGS

The drum shaft bearings receive lubrication through the button-head grease fittings on the hub caps.

Lubricate drum shaft bearings every 256 hours with WB #2 grease (in temperatures from +90°F. to 0°F.) using a conventional pressure grease gun. Pump grease into the fitting until excess grease is forced out around the hub oil seal. For lubrication instructions when operating in temperatures below 0°F. refer to Corps of Engineers Cold Weather Bulletin. In temperatures above +90°F. refer to High Temperature Bulletin.

UNIVERSAL FORGING

The universal forging receives lubrication through the button-head fitting in the side of the tongue.

Lubricate every 8 hours with CG #1 grease in temperatures from +90°F. to +32°F. and CG #0 grease in temperatures from +32°F. to 0°F., using a conventional pressure grease gun. Pump grease into the fitting until excess grease is forced out around the bushing in which the forging turns at the front of the tongue. For lubrication instructions when operating in temperatures below 0°F. refer to Corps of Engineers Cold Weather Bulletin. In temperatures above +90°F. refer to High Temperature Bulletin.

ADJUSTMENTS

All Sheep's Foot Roller adjustments are of a type which are ordinarily made by maintenance men. For adjustment instructions, refer to pages 2, 3 and 4 of the Repair Section.

OPERATION UNDER DUSTY, MUDDY, LOW TEMPERATURE AND OTHER ABNORMAL CONDITIONS

The usefulness of the Roller will be retarded only if the soil is too wet to compact or is frozen too hard for the feet to penetrate.

Slightly lighter lubricants should be used when operating in cold temperatures than those which are used when operating in warmer temperatures. (Refer to lubrication instructions on page 5 of the Operation Section.)

PREPARATION FOR STORAGE

Before placing the Roller in storage, follow the instructions below:

If water was used for ballast, drain the water from the drums through the pipe plug opening near the end of the drum.

Wash the roller clean of all dirt.

Lubricate all lubrication points.

If the Roller is to be stored in the open for a long period of time and the paint has been worn off the feet and drum, either paint the drums and feet or coat them with rust preventative or oil to prevent rust.

INSTALLING ADDITIONAL DRUMS

Additional drums may be easily added to the Sheep's Foot Roller.

To connect additional drums to the two drum unit, line the drums up end to end and secure them together with the hinge pins. Install the tongue in the center of the unit. If an odd number of drums are used it will be necessary to invert the tongue so that the line of pull will be from the center of the unit. (The construction of the tongue is such that the line of pull can be shifted by inverting the tongue.)

REPAIR SECTION

SECT. 2

REPAIR AND MAINTENANCE

The LeTourneau Sheep's Foot Roller is comparatively simple in design and has few working parts.

Therefore, few instructions are required to enable those in charge of maintenance to properly service the Roller.

CARE OF SHEEP'S FOOT ROLLER

Time spent on inspection and care of the Sheep's Foot Roller will be many times repaid in long life and trouble-free operation.

The Sheep's Foot Roller should be serviced as specified below at the intervals shown:

WHEN NEW SHEEP'S FOOT ROLLER IS DELIVERED:

Check all points of adjustment and make any necessary corrections.

Check all points of lubrication to determine if properly lubricated.

ONCE EVERY 8 HOURS

Grease universal forging.

ONCE EVERY 64 HOURS

Check universal forging adjustment.

ONCE EVERY 256 HOURS

Check drum shaft bearing adjustment.

Grease drum shaft bearings.

LUBRICATION

For lubrication instructions refer to page 5 of the Operation Section.

ADDING BALLAST TO DRUMS

Refer to page 4 of the Operation Section for instructions.

ADJUSTMENTS

There are two points of adjustment on the Sheep's Foot Roller, one being the drum shaft bearings and the other the universal forging. These adjustments should be made according to the instructions on the following pages.

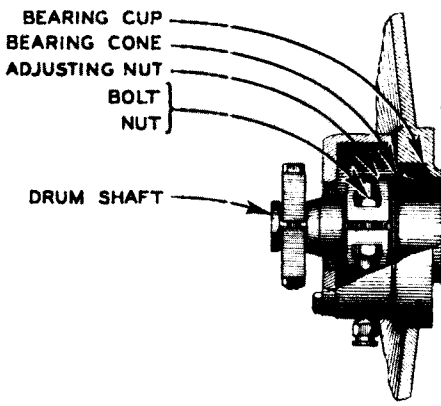

REPAIR

DRUM SHAFT BEARING ADJUSTMENT

Check the drum shaft bearing adjustment every 256 hours of operation.



Before checking the adjustment, it is necessary to first remove the hinge pins which connect the frames of the two drums.



To check the adjustment insert a pry bar between the frame and the end of the drum, and by prying back and forth, detect any end movement of the drum shaft. If movement is noticeable, the bearings are loose and an adjustment should be made.

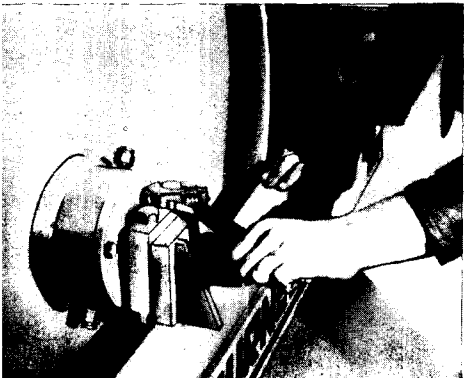

To make the adjustment, first remove the drum shaft clamp bolts at each end of the drum.

Raise one end of the frame above the hub cap, using a jack or hoist.

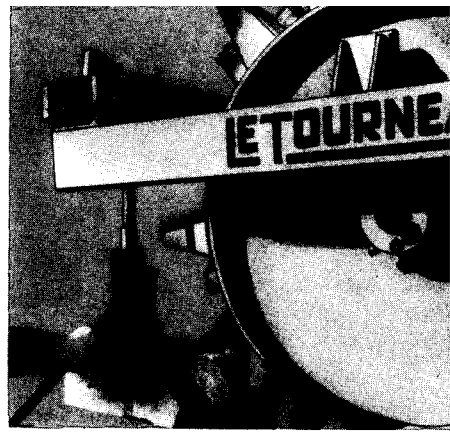

Remove the hub cap by removing the capscrews.



Loosen the adjusting nut clamp bolt to permit turning of the nut on the shaft.



Turn the adjusting nut on the shaft in a clockwise direction until all end play of the shaft is eliminated, but with no drag on the bearings. Lock the adjustment by tightening the adjusting nut clamp bolts. Then reinstall the hub cap, etc.

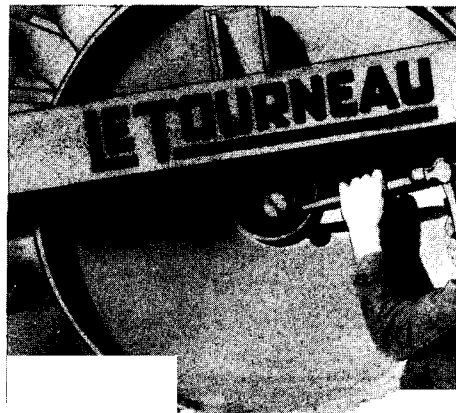

UNIVERSAL FORGING ADJUSTMENT

Check the universal forging for end play every 64 hours of operation. If Roller is disconnected from tractor, check end play by moving forging back and forth by hand. If Roller is hitched to tractor, drive tractor forward and backward while watching forging for end movement. If end movement is found, an adjustment should be made.

To make the adjustment, first remove inspection plate from side of tongue by removing capscrews. (Tongue disconnected from tractor and supported off the ground by a jack or blocks.)

Remove the cotter pin from the end of the forging and loosen the adjusting nut clamp bolts.

Insert a chisel in the slot in adjusting nut to keep nut from turning. Then insert a bar through hitch block and turn forging in a clockwise direction until all end play has been eliminated with the forging still left free to turn. Lock the adjustment by reinstalling cotter pin and tightening adjusting nut clamp bolts. Then reinstall inspection plate.

DISASSEMBLING

Disconnect the tongue by removing the bolts which secure the tongue to the frame.

Uncouple the frames by removing the hinge pins which connect the frames together.

Disconnect the frame from the drum shaft by removing the drum shaft clamp bolts.

Lift the frame off over the drum, using a hoist.

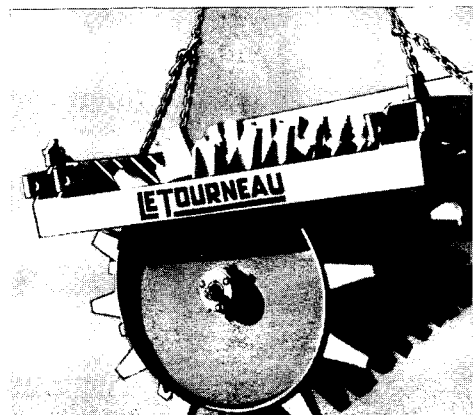
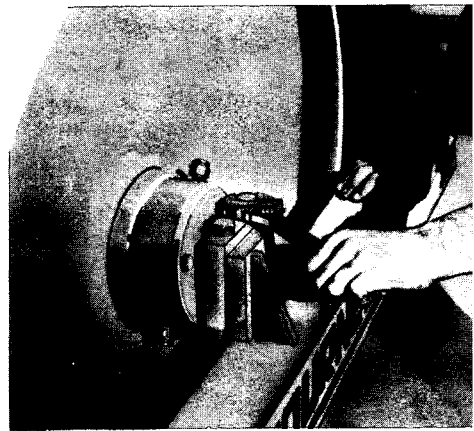
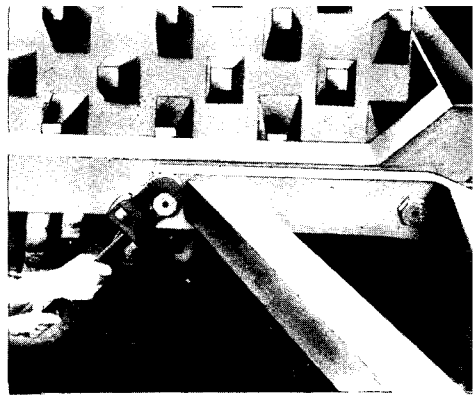

Remove the hub cap from each end of the drum by removing the cap-screws. Then remove grease seals from hub caps if they are to be replaced.

Remove the adjusting nuts at both ends of the drum. To remove an adjusting nut, loosen the adjusting nut clamp bolt. Then remove the adjusting nut by turning it off the end of the shaft.

Drive or pull the drum shaft out of the hub of the roller. One of the bearing cones will be forced off the end of the shaft during removal. The remaining bearing cone may be pulled off the drum shaft after the shaft has been removed. If the bearings are to be replaced, remove the bearing cups from the hub of the roller drum.

To remove universal forging, first remove inspection plate from side of tongue. Then remove cotter pin from end of forging and loosen adjusting nut clamp bolts. Insert a chisel in slot in adjusting nut to keep nut from turning. Then insert a bar through hitch block and turn forging counter-clockwise until adjusting nut is turned off end of forging. Pull forging out end of tongue. Remove adjusting nut through inspection hole.

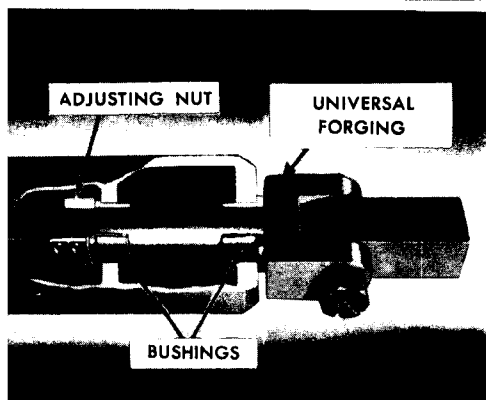
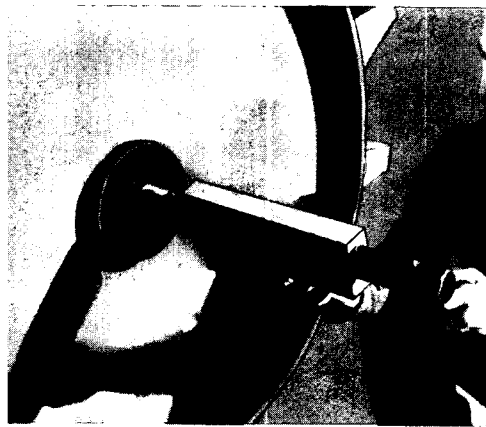
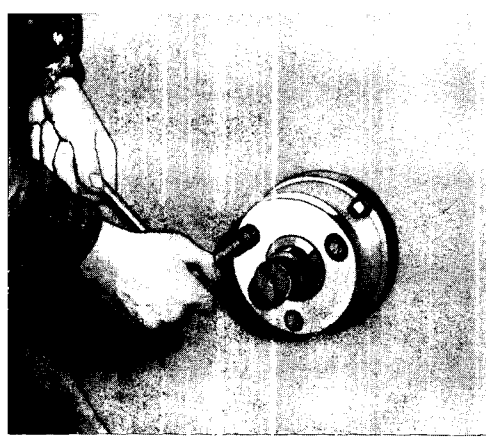

OVERHAULING AND REPAIRING

Other than replacing worn parts, practically the only repairs ever needed are welding repairs.

If any welded member of a LeTourneau Sheep's Foot Roller should start to crack or break through severe abuse, the Roller should be stopped immediately and the crack welded up and reinforced before the damage becomes serious.

REPLACING FEET—Should one of the feet be pulled off or become worn so badly through a long period of use that replacement is necessary, a replacement foot can be welded in its place without difficulty.

To do this, first "tack-weld" the foot in position on the drum, using the electric arc welding process. Hammer the foot down against the drum with a hammer, and then weld the foot solidly to the drum, along all four sides, using first a small hot stringer bead, and then a good strong 5·16" fillet weld. Weld along first one side of the foot and then the opposite side, rather than along adjoining sides.

The electric arc welding process can also be used for building up worn feet by placing weld metal on the top surface of each foot.

ASSEMBLING

To assemble a Sheep's Foot Roller, simply reverse the procedure outlined for disassembly.

During assembly, make all adjustments as outlined in the adjustment instructions on pages 2, 3, and 4 of the Repair Section.

Be sure bearings are free of grit, dirt, and other foreign particles before replacing.

When replacing bearing cones, also replace bearing cups, and vice-versa.

Lubricate Roller at all points of lubrication before placing it in operation.

Install the hub oil seals with the leather cupped outward, away from the grease chamber.

If the leather in an oil seal becomes dry, soak in kerosene until soft. Before installing the seal, rub the leather with some smooth round surface such as a hammer handle. This will seat the leather seal in place and round off the sharp edge, making possible quick and easy installation without danger of injury to the leather.

**TABLE OF TOLERANCES AND CLEARANCES OF
BEARINGS AND ADJUSTABLE PARTS**

Points of Adjustment	Correct Adjustment	Allowable Tolerance
Drum Shaft Bearings (Tapered Roller)	.000"	008" preload to .008" loose
Universal forging	Free turning with no end play	

PARTS CATALOG

SECT. 3

PREPARATION OF REQUISITIONS

SAMPLE COPY FOR USE IN THE PREPARATION OF REQUISITIONS

State PERIOD designation by use of one of the following terms:

- (1) "INITIAL"—first requisition of authorized allowances.
- (2) "REPLENISHMENT"—subsequent requisitions to maintain authorized allowances.
- (3) "SPECIAL"—requisitions for necessary repairs not covered by allowances.

Emergency requisitions sent by telephone, telegraph, or radio must always be confirmed immediately with requisition marked: "Confirming (state identifying data)"

Prepare a separate requisition for each different machine. Type "SPARE PARTS" in upper right hand corner of requisition form.

WAR DEPARTMENT
Q. M. C. Form No. 400
(Revised Apr. 6, 1941)

(SAMPLE)
REQUISITION

SPARE PARTS

To: Engineer Supply Officer, No. of Sheets 1 Sheet No. 1
Columbus Quartermaster Depot, Columbus, Ohio

Requisition No. E-531-3-43 Date August 14, 1942 Period Special

SHIP TO Engineer Property Officer, Pine Camp, New York

MARKED FOR: Engineer Supply Officer, 802nd Engr. Battalion, Pine Camp, N.Y.

Requisitioned By (show Signature, Rank, Organization, Destination. If different from "marks to" include address):

Robert E. Roe
Robert E. Roe,
Major, C.E.,
Engineer Property Officer

Approved:

John E. Doe
John E. Doe,
Col., C.E.,
Executive Officer

STOCK No.	ARTICLES	UNIT	ON HAND AND DUE	CONSUMED	REQUIRED	APPROVED
PARTS FOR <u>LeTOURNEAU SHEEP'S FOOT ROLLER, MODEL "W2", SERIAL NUMBER R-2000-W2B</u>						
Basis: <u>Repair of disabled equipment</u>						
Delivery is requested by <u>August 30, 1942</u>						
ROLLER GROUP						
D-1968	DRUM	ea	0	4	4	
D-1967	DRUM SHAFT	ea	0	4	4	
D-3227	FOOT	ea	0	4	4	
E-6301	FRAME	ea	0	4	4	
HITCH GROUP						
D-2815	NUT	ea	0	4	4	
D-2812	PIN	ea	0	4	4	
E-8230	BLOCK	ea	0	4	4	
H-2801	GASKET	ea	0	4	4	
NONEXPENDABLE ARTICLES SHOWN HAVE BEEN PLACED ON I & I REPORT (REPORT OF SURVEY, ETC.)						

Give complete shipping instructions. Special instructions for packing, marking, routing, etc. should be given at the end of the requisition.

State proper nomenclature of machine and make, model, serial number and registration number.

State basis or authority, and date delivery is required, immediately below description of machine.

State manufacturers' parts numbers and nomenclature descriptions accurately and completely. Do not use abbreviations.

Group parts required under group headings as shown in manufacturers' parts catalogs.

Double space between items.

Nonexpensible items must be accounted for

PREPARATION OF REQUISITIONS

A Sample requisition in the correct form for submission by the Engineer Property Officer is shown on the opposite page.

THIS SHALL BE FOLLOWED IN MAKING OUT REQUISITIONS.

In order to eliminate duplication of work, Property Officers may authorize organizations to prepare requisitions in final form, leaving requisition number space blank for completion by Property Officer.

THE FOLLOWING RULES WILL BE OBSERVED CAREFULLY IN PREPARING REQUISITIONS FOR SPARE PARTS:

- a. Prepare a separate requisition for each different machine.
- b. Type "SPARE PARTS" in upper right hand corner of requisition form.
- c. State PERIOD designation by use of one of the following terms:
 - (1) "INITIAL"—first requisition of authorized allowances.
 - (2) "REPLENISHMENT"—subsequent requisitions to maintain authorized allowances.
 - (3) "SPECIAL"—requisitions for necessary repairs not covered by allowances.
- d. Give complete shipping instructions.
- e. State proper nomenclature of machine, and make, model, serial number and registration number.
- f. State basis or authority, and date delivery is required, immediately below description of machine.
- g. Group parts required under group headings as shown in manufacturers' parts catalogs.
- h. State manufacturers' parts numbers and nomenclature descriptions accurately and completely. Do not use abbreviations.
- i. Double space between items.
- j. Emergency requisitions sent by telephone, telegraph, or radio must always be confirmed immediately with requisition marked: "Confirming (state identifying data)".
- k. Nonexpendable items must be accounted for.

MODEL W2 SHEEP FOOT ROLLER

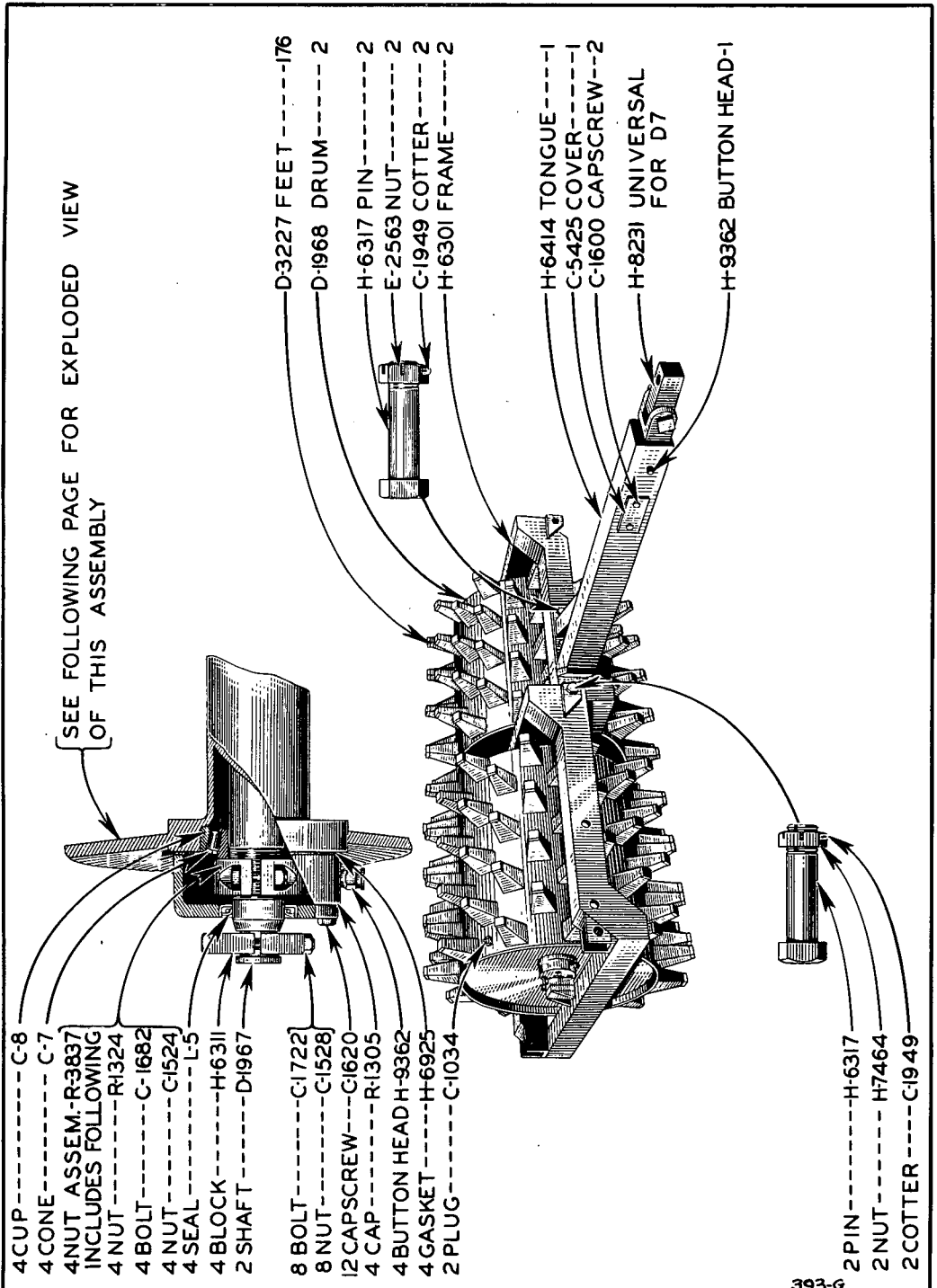

- 4CUP-----C-8
- 4CONE-----C-7
- 4NUT ASSEM.-R-3837
- INCLUDES FOLLOWING
- 4NUT-----R-1324
- 4BOLT-----C-1682
- 4NUT-----C-1524
- 4SEAL-----L-5
- 4BLOCK-----H-6311
- 2SHAFT-----D-1967

- 8BOLT-----C-1722
- 8NUT-----C-1528
- 12CAPSCREW---G-1620
- 4CAP-----R-1305
- 4BUTTON HEAD H-9362
- 4GASKET-----H-6925
- 2PLUG-----C-1034

- 2PIN-----H-6317
- 2NUT-----H-7464
- 2COTTER-----C-1949

- D-3227 FEET-----176
- D-1968 DRUM-----2
- H-6317 PIN-----2
- E-2563 NUT-----2
- C-1949 COTTER-----2
- H-6301 FRAME-----2
- H-6414 TONGUE-----1
- C-5425 COVER-----1
- C-1600 CAPSCREW--2
- H-8231 UNIVERSAL FOR D7
- H-9362 BUTTON HEAD-1

SEE FOLLOWING PAGE FOR EXPLODED VIEW OF THIS ASSEMBLY

SHEEP FOOT ROLLER GROUP

393-G

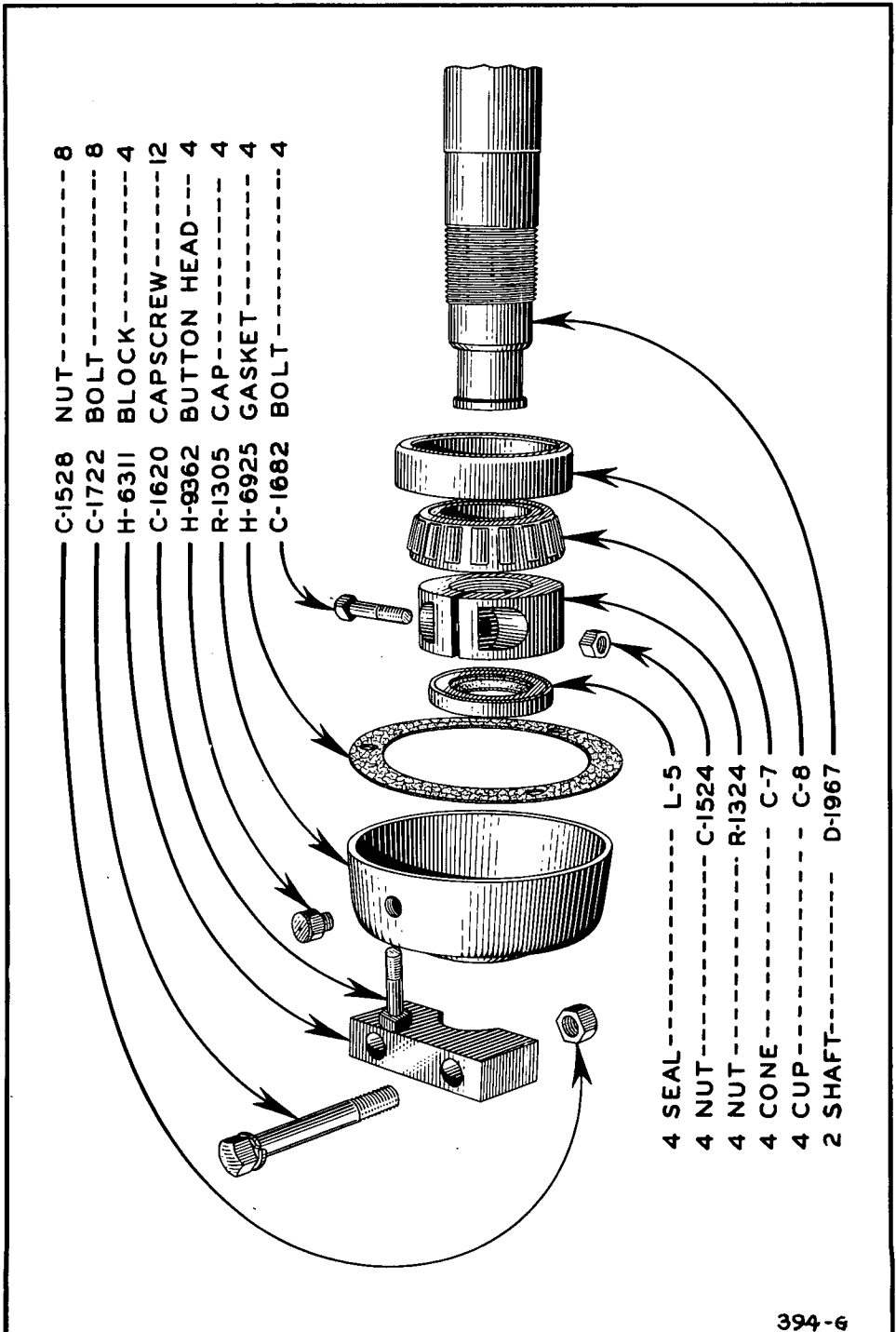

SHAFT GROUP-EXPLODED

394-6

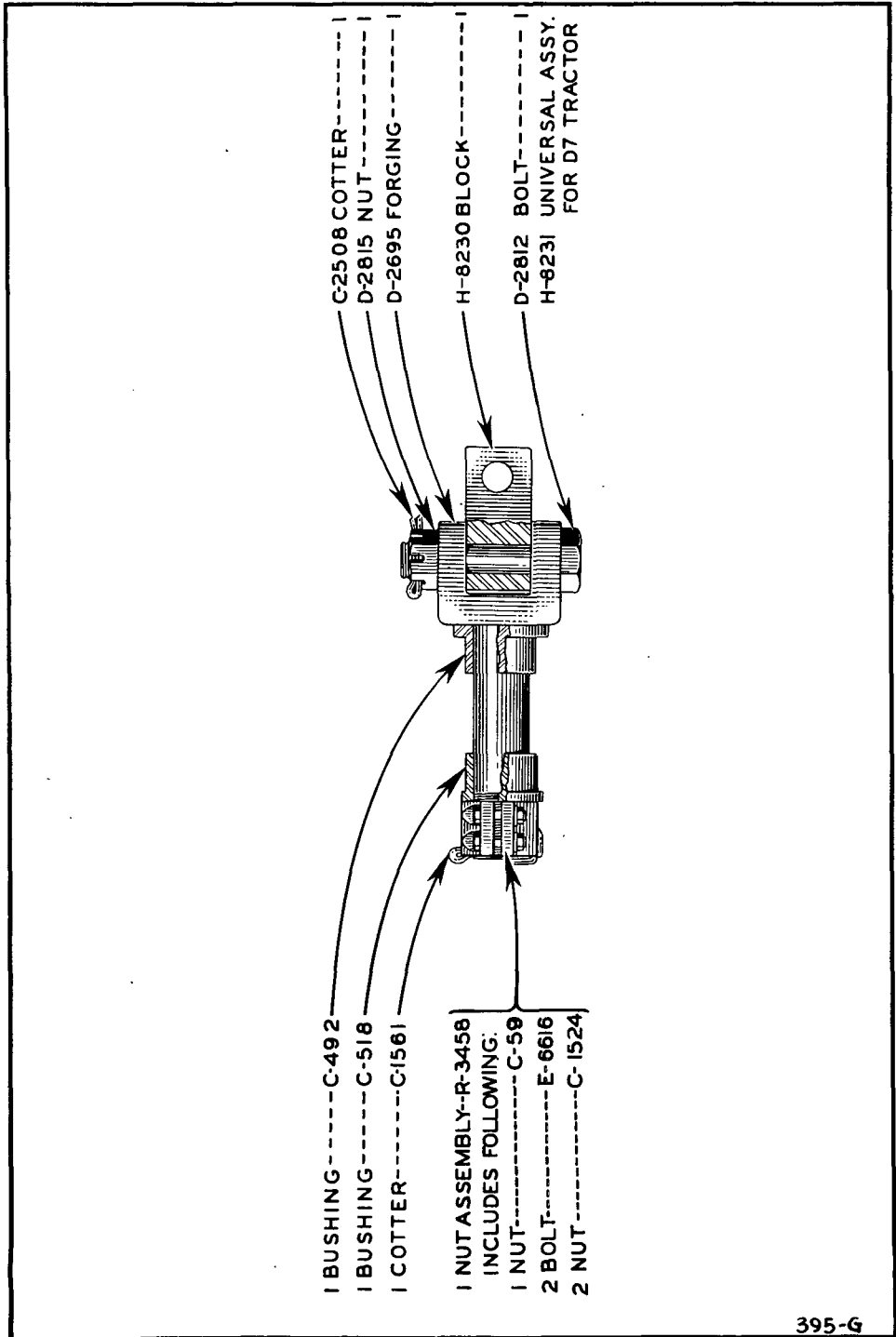

395-G

DRAWBAR UNIVERSAL GROUP

MODEL W2 SHEEP FOOT ROLLER

PART NUMBER	DESCRIPTION	PAGE	QTY.	WEIGHT Lbs. Oz.	Price Each
C-7	CONE—TIMKEN # 559.....	1, 2	4	2 10	4.56
C-8	CUP—TIMKEN # 552-A.....	1, 2	4	1 10	3.39
C-492	BUSHING.....	3	1	6 ..	6.15
C-518	BUSHING.....	3	1	4 4	6.11
C-1034	PLUG—1¼".....	1	2	.. 12	.17
C-1524	NUT—½" NF HEX.....	1, 3	403
C-1528	NUT—¾" NF HEX.....	1, 2	805
C-1561	COTTER—½" x 5".....	3	111
C-1600	CAPSCREW—¾" x ¾" NC.....	1	203
C-1620	CAPSCREW—½" x 3" NC.....	1, 2	1211
C-1722	CAPSCREW—¾" x 6" NF.....	1, 2	845
C-1949	COTTER—¼" x 3".....	1	401
C-2508	COTTER—5/16" x 3".....	3	101
C-5425	PLATE—INSPECTION.....	1	1	2 8	.56
D-1967	AXLE.....	1, 2	2	70 ..	29.50
D-1968	DRUM.....	1	2	1870 ..	411.75
D-2812	PIN.....	3	1	4 12	2.07
D-2815	NUT—1½" CASTELLATED NF.....	3	1	1 ..	.68
D-3227	FOOT—FOR DRUM.....	1	176	8 8	2.16
E-2563	NUT—1¾" SPECIAL HEX.....	1	2	1 ..	.78
H-6301	FRAME.....	1	2	900 ..	197.50
H-6311	BLOCK—CLAMP.....	1, 2	4	3 6	2.50
H-6317	PIN.....	1	4	7 8	3.80
H-6414	TONGUE STRUCTURE.....	1	1	300 ..	87.50
H-6925	GASKET.....	1, 2	415
H-7464	NUT—1¾" CASTELLATED.....	1	2	1 ..	.96
H-8230	BLOCK (FOR HITCH).....	1	1	17 4	8.45
H-8231	UNIVERSAL ASSEMBLY FOR D6 & D7.....	1	1	67 ..	41.20
H-9362	BUTTONHEAD—ALEMITE.....	1, 2, 3	5	.. 4	.33
R-1305	HUB CAP.....	1, 2	4	11 8	6.29
*R-3458	NUT ASSEMBLY.....	3	1	6 8	5.41
*R-3837	NUT ASSEMBLY.....	1	4	3 12	2.84
L-5	OIL SEAL # 35028.....	1, 2	4	.. 4	1.11
*R-3458	NUT ASSEMBLY—INCLUDES FOLLOWING:				
C-59	NUT.....	3	1
C-1524	NUT.....	3	2
E-6616	BOLT.....	3	2
*R-3837	NUT ASSEMBLY—INCLUDES FOLLOWING:				
R-1324	NUT.....	1, 2	4
C-1524	NUT.....	1, 2	4
C-1682	BOLT.....	1, 2	4

SPARE PARTS & PRICE LIST