

# TM 10-8340-242-13&P

---

## TECHNICAL MANUAL

OPERATOR'S AND FIELD MAINTENANCE MANUAL  
INCLUDING REPAIR PARTS AND SPECIAL TOOLS LIST

FOR

## STANDARD INTEGRATED COMMAND POST SYSTEM (SICPS), MEDIUM

NSN: 8340-01-516-0904 (GREEN)

NSN: 8340-01-516-0903 (TAN)



DISTRIBUTION STATEMENT A. - Approved for public release; distribution is unlimited.

---

HEADQUARTERS, DEPARTMENT OF THE ARMY

31 AUGUST 2010



## WARNING SUMMARY

This warning summary contains general safety warnings and hazardous materials warnings that must be understood and applied during operation and maintenance of this equipment. Failure to observe these precautions could result in serious injury or death to personnel. Also included are explanations of safety and hazardous materials icons used within the technical manual. For first aid treatments, refer to FM 4-25.11.

### EXPLANATION OF SAFETY WARNING ICONS



**BIOLOGICAL** – abstract symbol bug shows that a material may contain bacteria or viruses that present a danger to life or health.



**ELECTRICAL** – electrical wire to arm, with electricity symbol running through human body, shows that shock hazard is present.



**EYE PROTECTION** – person with goggles shows that the material will injure the eyes.



**FALLING PARTS** – arrow bouncing off human shoulder and head shows that falling parts present a danger to life or limb.



**FIRE** – flame shows that a material may ignite and cause burns.



**HEAVY OBJECT** – human figure stooping over heavy object shows physical injury potential from improper lifting technique.



**HEAVY OBJECTS** - heavy object on human figure shows that heavy parts present a danger to life or limb.



**MOVING PARTS** – hand with fingers caught between gears shows that the moving parts of the equipment present a danger to life or limb.



**SHARP OBJECT** – pointed object in hand shows that a sharp object presents a danger to limb.



**SUFFOCATION DANGER** – person with deflated lungs shows that there is a danger of an inability to breathe and a potential for suffocation.

#### EXPLANATION OF HAZARDOUS MATERIALS ICONS



**CHEMICAL** – drops of liquid on hand shows that the material will cause burns or irritation to human skin or tissue.



**POISON** – skull and crossbones shows that a material is poisonous or is a danger to life.

#### GENERAL SAFETY WARNINGS DESCRIPTION

##### WARNING



Lethal voltage is present when light set is connected to power source. Disconnect from power source before inspecting or repairing any electrical component. Electrical shock or death may result from failure to heed this warning.

##### WARNING



Lethal voltage is present when the power control system is connected to power source. Disconnect from power source before inspecting or repairing any electrical component. Electrical shock or death may result from failure to heed this warning.

**GENERAL SAFETY WARNINGS DESCRIPTION – CONTINUED**

**WARNING**



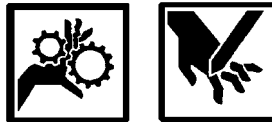
Lethal voltage is present when cables are connected to power control system. Ensure cables are disconnected from power source when working with cables or fixtures. Electrical shock or death may result from failure to heed this warning.

**WARNING**



Lethal voltage is present when the power distribution box is connected to power source. Disconnect from power source before making any repairs to the box. Serious injury or death to personnel may result from touching any component under power.

**WARNING**



Frame assembly hinges can pinch or crush hands and fingers. Keep hands and fingers away from frame assembly ridges and eaves.

**WARNING**



Two personnel are required to lift light set case to avoid injury to personnel.

**GENERAL SAFETY WARNINGS DESCRIPTION – CONTINUED**

**WARNING**



Assembled tent assembly is extremely heavy. Two soldiers should be placed at each arch leg to raise frame. Lift tent from correct squatting position, using legs. Back injury could result if lifted improperly.

**WARNING**



Do not lock handle toward diagonal brace. Arch may collapse causing injury to personnel or damage to equipment if improperly locked.

**WARNING**



Stakes, guylines, and frame feet must be used to prevent excessive movement of the extendable modular tents in high winds. Failure to stake and tie down the tent may result in injury to personnel or damage to equipment.

**WARNING**

All tent lines and frame feet must be staked down. Failure to stake and tie down tent may result in injury to personnel and damage to equipment.

**WARNING**

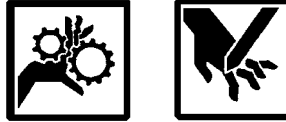
To eliminate the possibility of tripping, clear the fabric and guylines. Injury to personnel may result from falls.

**GENERAL SAFETY WARNINGS DESCRIPTION – CONTINUED**

**WARNING**

If the lights are in use, limit inspection of the individual lights to a visual inspection from the ground to avoid injuries from falls.

**WARNING**

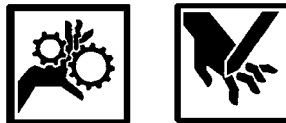


Frame hinge joints are capable of pinching or crushing hands or fingers. Use extreme caution when working near hinge joints during assembly of the frame.

**WARNING**

When end loading and unloading is required, LONG FORKS must be used. Serious injury to personnel may result from an imbalanced load.

**WARNING**



Use care when unfolding frame assemblies. Hands and fingers can be pinched when placed on hinge joints, causing serious and painful injuries to personnel.

**WARNING**

Do not apply the following fabric repair to a fabric panel of an erected SICPS Medium when it is located above working height. Strike, or lower the SICPS Medium, as described in WP 0005 00 to make repairs above normal working height. Serious injury to personnel may occur from falls.





**LIST OF EFFECTIVE PAGES / WORK PACKAGES**

NOTE: A vertical line in the outer margins of the page indicates the portion of text affected by the update. Updates to illustrations are indicated by miniature pointing hands. Updates to wiring diagrams are indicated by shaded areas.

**Date of issue for original and updated pages / work packages are:**

**Original ...31 AUGUST 2010**

**TOTAL NUMBER OF PAGES FOR FRONT AND REAR MATTER IS 20 AND TOTAL NUMBER OF WORK PACKAGES IS 57 CONSISTING OF THE FOLLOWING:**

<b>Page/WP No.</b>	<b>*Change No.</b>	<b>Page/WP No.</b>	<b>*Change No.</b>
Front Cover (1 page)	0	Chapter 5 Title Page	0
Warning	0	WP 0028 00 (2 pages)	0
i-x	0	WP 0029 00 (4 pages)	0
Chapter 1 Title Page	0	WP 0030 00 (4 pages)	0
WP 0001 00 (4 pages)	0	WP 0031 00 (8 pages)	0
WP 0002 00 (12 pages)	0	WP 0032 00 (4 pages)	0
WP 0003 00 (2 pages)	0	WP 0033 00 (4 pages)	0
Chapter 2 Title Page	0	WP 0034 00 (4 pages)	0
WP 0004 00 (4 pages)	0	WP 0035 00 (4 pages)	0
WP 0005 00 (48 pages)	0	WP 0036 00 (4 pages)	0
WP 0006 00 (4 pages)	0	WP 0037 00 (4 pages)	0
Chapter 3 Title Page	0	WP 0038 00 (4 pages)	0
WP 0007 00 (2 pages)	0	WP 0039 00 (4 pages)	0
WP 0008 00 (2 pages)	0	WP 0040 00 (4 pages)	0
WP 0009 00 (2 pages)	0	WP 0038 00 (4 pages)	0
Chapter 4 Title Page	0	WP 0041 00 (4 pages)	0
WP 0010 00 (2 pages)	0	WP 0042 00 (4 pages)	0
WP 0011 00 (2 pages)	0	WP 0043 00 (4 pages)	0
WP 0012 00 (26 pages)	0	WP 0044 00 (4 pages)	0
WP 0013 00 (2 pages)	0	WP 0045 00 (4 pages)	0
WP 0014 00 (2 pages)	0	WP 0046 00 (4 pages)	0
WP 0015 00 (4 pages)	0	WP 0047 00 (4 pages)	0
WP 0016 00 (2 pages)	0	WP 0048 00 (4 pages)	0
WP 0017 00 (2 pages)	0	WP 0049 00 (4 pages)	0
WP 0018 00 (2 pages)	0	WP 0050 00 (4 pages)	0
WP 0019 00 (4 pages)	0	WP 0051 00 (4 pages)	0
WP 0020 00 (2 pages)	0	WP 0052 00 (4 pages)	0
WP 0021 00 (6 pages)	0	WP 0053 00 (2 pages)	0
WP 0022 00 (2 pages)	0	WP 0054 00 (2 pages)	0
WP 0023 00 (2 pages)	0	WP 0055 00 (14 pages)	0
WP 0024 00 (8 pages)	0	WP 0056 00 (2 pages)	0
WP 0025 00 (2 pages)	0	WP 0057 00 (2 pages)	0
WP 0026 00 (2 pages)	0	Glossary (2 pages)	0
WP 0027 00 (6 pages)	0	Back Cover (1 page)	0

**\*Zero in this column indicates an original page or work package.**



**HEADQUARTERS,  
DEPARTMENT OF THE ARMY  
WASHINGTON, D.C., 31 AUGUST 2010**

**Technical Manual**

**OPERATOR'S AND FIELD MAINTENANCE MANUAL  
INCLUDING REPAIR PARTS AND SPECIAL TOOLS LIST**

**STANDARD INTEGRATED COMMAND  
POST SYSTEM (SICPS), MEDIUM**

**NSN: 8340-01-516-0904, GREEN**

**NSN: 8340-01-516-0903, TAN**

**REPORTING ERRORS AND RECOMMENDING IMPROVEMENTS**

You can help improve this manual. If you find any mistakes or if you know of a way to improve the procedures, please let us know. Mail your letter, DA Form 2028 (Recommended Changes to Publications and Blank Forms), directly to: TACOM Life Cycle Management Command, ATTN: AMSTA-LCL-MPP/TECH PUBS, 1 Rock Island Arsenal, Rock Island, IL 61299-7630. You may also send in your recommended changes via electronic mail or by fax. Our fax number is DSN 793-0726 and Commercial (309)782-0726. Our e-mail address is TACOMLCMC.DAForm2028@us.army.mil. A reply will be furnished to you.

**DISTRIBUTION STATEMENT A.** - Approved for public release; distribution is unlimited.

---

# TABLE OF CONTENTS

WP Sequence No.  
/Page No.

<b>How to Use This Manual</b>	<b>ix</b>
<b>Chapter 1 – Introductory Information</b>	
General Information .....	.0001
Equipment Description and Data .....	.0002
Figure 1. Power Distribution Box, Face .....	0002-3
Figure 2. Power Distribution Box, Bottom .....	0002-3
Figure 3. Convenience Outlet .....	0002-4
Figure 4. Power Panel Stand, Cables and Power Distribution Box .....	0002-4
Figure 5. Fluorescent Light Assembly .....	0002-4
Figure 6. End Cap On/Off Switch .....	0002-4
Figure 7. Field Table .....	0002-5
Figure 8. Sandwich Wall, Flat .....	0002-6
Figure 9. Sandwich Wall, Rolled .....	0002-6
Figure 10. Partially Attached Sandwich Wall .....	0002-7
Figure 11. Sandwich Wall Becket Laced .....	0002-7
Figure 12. Second Vestibule Frame Attached .....	0002-8
Figure 13. Sandwich Wall Door Opening, Laced .....	0002-8
Figure 14. Second Vestibule Frame, Attached .....	0002-9
Figure 15. Connecting the Sandwich Wall to Rigid Wall Shelter (RWS) Boot Wall .....	0002-9
Figure 16. Excess Fabric, Rolled and Buckled .....	0002-10
Figure 17. Boot Wall Installed .....	0002-10
Table 1. Equipment Data .....	0002-11
Table 2. Total System Equipment Data .....	0002-12
Table 3. Environmental Capabilities .....	0002-12
 Theory of Operation .....	 .0003
<b>Chapter 2 – Operator Instructions</b>	
Description and Use of Operator Controls and Indicators .....	.0004
Figure 1. Switches and Breakers .....	0004-1
Figure 2. Reset Buttons .....	0004-1
Figure 3. Fluorescent Light Assembly .....	0004-2
Figure 4. On/Off Switch .....	0004-2
Figure 5. Reset/Test Buttons on Convenience Outlet .....	0004-3

**TABLE OF CONTENTS – CONTINUED**

	<b>WP Sequence No. /Page No.</b>
Operation Under Usual Conditions .....	0005
Figure 1. Site Selection .....	0005-1
Figure 2. Arch Assembly .....	0005-3
Figure 3. Arch Assembly Components .....	0005-4
Figure 4. Upper Arch Assembly, Open .....	0005-4
Figure 5. Connecting Arch Assemblies .....	0005-5
Figure 6. Reflective Tape Alignment .....	0005-5
Figure 7. Connected Arch Assemblies, Flat .....	0005-5
Figure 8. Cable Header Assembly .....	0005-6
Figure 9. Arch Assemblies, Cable Attached .....	0005-7
Figure 10. Purlin Assembly Components .....	0005-7
Figure 11. End Fittings Locked Into Boss at Arches .....	0005-8
Figure 12. Placing Brace Stud in Arch Assembly Slot .....	0005-9
Figure 13. Locking Purlin Diagonal Brace .....	0005-9
Figure 14. Door Purlin .....	0005-10
Figure 15. Assembled Frame Assembly .....	0005-10
Figure 16. Insulated Roof Cap Liner .....	0005-11
Figure 17. Attaching Roof Cap Liner to Ridge .....	0005-11
Figure 18. Ridge Straps .....	0005-11
Figure 19. Attaching Straps .....	0005-12
Figure 20. Placing Fabric on Tent Frame Ridge .....	0005-13
Figure 21. Draping Fabric Over Frame .....	0005-13
Figure 22. Installed Fabric .....	0005-13
Figure 23. Placing Spindle Grommets on Ridge Spindles .....	0005-14
Figure 24. End Ridge Spindle .....	0005-14
Figure 25. Grommet On Spindle .....	0005-14
Figure 26. Hitch Clip Pin in Spindle .....	0005-15
Figure 27. Fabric Section Rolled to Eave .....	0005-15
Figure 28. After Attaching Endwall Sections .....	0005-15
Figure 29. Weaving Becket Lace Through First and Second Grommets .....	0005-16
Figure 30. Tying Off Becket Lace .....	0005-17
Figure 31. Installed Fabric .....	0005-17
Figure 32. Frame in Upright Position .....	0005-19
Figure 33. Securing Eave Purlin Straps .....	0005-19
Figure 34. Attaching Roof Cap Liner to Tent Frame at Eave .....	0005-20
Figure 35. Installing Light Assemblies .....	0005-21
Figure 36. Mating Two Lights Together .....	0005-21
Figure 37. Side Frame Assembly .....	0005-23
Figure 38. Sod Cloth Under Base Purlin .....	0005-23
Figure 39. Securing High Wind Lines .....	0005-24
Figure 40. 24 Foot Fabric Floor Section .....	0005-25
Figure 41. Unrolling Fabric Floor Inside Tent .....	0005-25
Figure 42. Mating Hook and Pile Fastener and Tape on the Side and End Walls .....	0005-26
Figure 43. Feeding Power Panel Stand Through Wall Liner Notch .....	0005-27
Figure 44. Position of Power Panel Stand .....	0005-27
Figure 45. Locking Power Panel Stand in Place .....	0005-27
Figure 46. Tent Doors .....	0005-29
Figure 47. Roof Vent Locations .....	0005-30

**TABLE OF CONTENTS – CONTINUED**

	<b>WP Sequence No. /Page No.</b>
Figure 48. Power Cable Floor Grid.....	0005-31
Figure 49. Electrical Sleeve Location .....	0005-31
Figure 50. ECU Sleeve Location .....	0005-32
Figure 51. Insulated Liner System (Side Wall, End Wall, and Roof Cap) .....	0005-32
Figure 52. Insulated Liner Folded and Placed on Transport Cover .....	0005-33
Figure 53. Electrical Assembly Layout .....	0005-34
Figure 54. Fluorescent Light Assembly .....	0005-35
Figure 55. Power Distribution System Components.....	0005-35
Figure 56. Cable Management System in the Floor in the Closed Position.....	0005-36
Figure 57. Cable Management System in the Floor in the Open Position .....	0005-36
Figure 58. Cable Management System in the Ceiling in the Closed Position.....	0005-36
Figure 59. Cable Management System in the Ceiling in the Open Position .....	0005-37
Figure 60. Cable Management System on the Roof Cap Liner .....	0005-37
Figure 61. Fabric Components Wrapped in Transport Bags.....	0005-37
Figure 62. Frame Components Wrapped in Transport Bags .....	0005-38
Figure 63. Identification Plate .....	0005-39
Figure 64. Caution on Power Distribution Box Cover.....	0005-39
Figure 65. Decals on the Face of the Power Distribution Box.....	0005-39
Figure 66. Decals on the Bottom of the Power Distribution Box .....	0005-40
Figure 67. Warning on Light Set.....	0005-40
Figure 68. Caution on Light Set.....	0005-40
Figure 69. Relamping Instructions on Light Set .....	0005-40
Figure 70. Tent Fabric Assembly and Transport Bag Identification Labels	
Table 1. Transport Bag Configuration. ....	0005-47
Operation Under Unusual Conditions .....	0006
 <b>Chapter 3 – Troubleshooting Procedures</b>	
Troubleshooting Index.....	0007
Troubleshooting Procedures, Operator Level.....	0008
Table 1. Troubleshooting Procedures, Operator Level. ....	0008-1
Troubleshooting Procedures, Unit Level.....	0009
Table 1. Troubleshooting Procedures, Unit Level .....	0009-1
 <b>Chapter 4 – Maintenance Instructions</b>	
Service Upon Receipt .....	0010
Table 1. SICPS Medium Inventory List .....	0010-2
Preventive Maintenance Checks and Services (PMCS), Introduction.....	0011
Preventive Maintenance Checks and Services (PMCS).....	0012

## TABLE OF CONTENTS – CONTINUED

	WP Sequence No. /Page No.
Table 1. PMCS Before Procedures .....	0012-1
Figure 1. Fabric Assembly .....	0012-1
Figure 2. Transport Bags .....	0012-3
Figure 3. Frame Components .....	0012-4
Figure 4. Power Distribution Components .....	0012-6
Figure 5. Convenience Outlets .....	0012-8
Figure 6. Light Assembly .....	0012-9
Figure 7. Field Table, Hinges and Braces .....	0012-10
Table 2. PMCS During Procedures .....	0012-11
Figure 8. Fabric Assembly .....	0012-11
Figure 9. Power Distribution Components .....	0012-13
Figure 10. Convenience Outlets .....	0012-15
Figure 11. Light Assembly .....	0012-16
Table 3. PMCS After Procedures .....	0012-17
Figure 12. Fabric Assembly .....	0012-17
Figure 13. Transport Bags .....	0012-19
Figure 14. Frame Components .....	0012-21
Figure 15. Power Distribution Components .....	0012-23
Figure 16. Convenience Outlets .....	0012-25
Figure 17. Light Assembly .....	0012-26
 Service .....	 0013
Arch Assembly, Inspect .....	0014
Figure 1. Upper Arch Assembly .....	0014-1
Figure 2. Lower Arch Assembly .....	0014-2
 Light Set Assembly, Repair .....	 0015
Figure 1. Light Set .....	0015-1
Figure 2. Light Switch .....	0015-1
Figure 3. End Cap .....	0015-1
Figure 4. End Cap Removed .....	0015-2
Figure 5. End Cap with Wires Disconnected .....	0015-2
Figure 6. EMI Shield .....	0015-2
Figure 7. Ground Wire .....	0015-3
Figure 8. Removing Bulb Socket Assembly .....	0015-3
Figure 9. Inner Tubing .....	0015-3
Figure 10. New Bulb .....	0015-4
 Cable Header Assembly, Inspect, Replace .....	 0016
Figure 1. Cable Header Assembly .....	0016-1
 Purlin Assembly, Inspect, Replace .....	 0017
Figure 1. Purlin Assembly (Folded for Transport) .....	0017-1
Figure 2. Purlin Assembly (Extended for Use) .....	0017-1

**TABLE OF CONTENTS – CONTINUED**

	<b>WP Sequence No. /Page No.</b>
Door Sill Assembly, Inspect, Replace .....	0018
Figure 1. Door Sill Assembly (Folded for Transport) .....	0018-1
Figure 2. Door Sill Assembly (Extended for Use).....	0018-1
Power Distribution Box, Inspect .....	0019
Figure 1. Outside of Power Distribution Box .....	0019-1
Figure 2. Circuit Breakers and Light Switches .....	0019-2
Figure 3. Duplex Receptacle .....	0019-2
Figure 4. Light Power Cable .....	0019-3
Figure 5. Receptacle Power Cable.....	0019-3
Arch Assembly, Repair, Replace .....	0020
Figure 1. Lower and Upper Arch Assemblies.....	0020-1
Tent Sections (Fabric), Repair .....	0021
Figure 1. Patch Placement .....	0021-1
Figure 2. Applying Patch .....	0021-2
Figure 3. Threading Needle.....	0021-4
Figure 4. Flat Stitch .....	0021-5
Figure 5. Round Stitch.....	0021-5
Figure 6. Overcast Stitch .....	0021-5
Figure 7. Backstitch .....	0021-6
Figure 8. Fishbone.....	0021-6
Quick Release Pin with Lanyard Assembly, Inspect, Replace .....	0022
Figure 1. Quick Release Pin with Lanyard .....	0022-1
Tent Sections (Fabric), Repair .....	0023
Figure 1. Hitting Top of Cutting Punch with Mallet .....	0023-1
Figure 2. Hitting Top of Setting Punch with Mallet .....	0023-2
Power Distribution Box, Repair .....	0024
Figure 1. Distribution Box – Back Plate.....	0024-1
Figure 2. Distribution Box – Back Plate Removed .....	0024-2
Figure 3. Circuit Breaker Retaining Nut.....	0024-2
Figure 4. Circuit Breaker.....	0024-2
Figure 5. Removing Screws and Washers .....	0024-3
Figure 6. Terminal Posts and Lugs.....	0024-3
Figure 7. Removing Screws .....	0024-4
Figure 8. Removing Receptacle Cover .....	0024-4
Figure 9. Removing Defective Receptacle .....	0024-5
Figure 10. Receptacle Cover Screws .....	0024-6
Figure 11. Mounting Plate .....	0024-6
Figure 12. Loosening Set Screws.....	0024-6
Figure 13. Removing Screws .....	0024-7



**TABLE OF CONTENTS – CONTINUED**

	<b>WP Sequence No. /Page No.</b>
Convenience Outlet, Repair.....	0025
Figure 1. Electrical Distribution System.....	0025-2
Tent Sections (Fabric), Repair .....	0026
Field Table, Repair.....	0027
Figure 1. Field Table (Upside Down).....	0027-1
Figure 2. Removing Rivet .....	0027-2
Figure 3. Inserting Rivet .....	0027-3
Figure 4. Leg Weldment and Braces.....	0027-4
Figure 5. Installing Braces.....	0027-5
 <b>Chapter 5 – Supporting Information</b>	
References.....	0028
Maintenance Allocation Chart (MAC), Introduction.....	0029
Maintenance Allocation Chart (MAC).....	0030
Table 1. MAC for Standard Integrated Post System (SICPS) Medium.....	0030-1
Table 1. Tools and Test Equipment for SICPS, Medium .....	0030-3
Table 1. Remarks for SICPS, Medium .....	0030-3
Repair Parts and Special Tools List (RPSTL), Introduction.....	0031
Group 0101 Tent Section (Fabric) – End Section.....	0032
Group 0102 Tent Section (Fabric) – Intermediate Section .....	0033
Group 0103 Tent Section (Fabric) – Sandwich Walls.....	0034
Group 0104 Tent Section (Fabric) – Insulated Liners/Plenum.....	0035
Group 0105 Tent Section (Fabric) – Floor .....	0036
Group 0106 – Tent Section (Fabric) – Vestibule Door.....	0037
Group 0201 Frame Section – Upper Arch Assembly.....	0038
Group 0202 Frame Section – Lower Arch Assembly.....	0039
Group 0203 Frame Section – Cable Header Assembly.....	0040
Group 0204 Frame Section – Purlin Assembly.....	0041
Group 0205 Frame Section – Threshold, Tent .....	0042
Group 0206 Frame Section – Vestibule Frame Assembly.....	0043
Group 0301 Power Control – Power Distribution Box.....	0044
Group 0302 Power Control – Cable Assemblies .....	0045
Group 0303 Power Control – Convenience Outlet .....	0046

**TABLE OF CONTENTS – CONTINUED**

	<b>WP Sequence No. /Page No.</b>
Group 0304 Power Control – Power Panel Stand Assembly.....	0047
Group 04 Light Set Assembly .....	0048
Group 05 Transport Bags.....	0049
Group 06 Tent Pins .....	0050
Group 07 Table, Field .....	0051
Group 99 Bulk Materials.....	0052
National Stock Number (NSN) Index .....	0053
Part Number (PN) Index.....	0054
Components of End Item (COEI) / Basic Issue Items (BII) Lists .....	0055
Table 1. Components of End Item (COEI) List.....	0055-2
Table 2. Basic Issue Items (BII) List.....	0055-14
Additional Authorization List (AAL) .....	0056
Table 1. Additional Authorization List (AAL).....	0056-2
Expendable and Durable Items List.....	0057
Table 1. Expendable and Durable Items List .....	0057-2
<b>Glossary</b> .....	Glossary -1

## HOW TO USE THIS MANUAL

This manual contains General Information, Operating Instructions, Operator Preventive Maintenance Checks and Services (PMCS), Maintenance and Repair Instructions, Maintenance Allocation Chart (MAC), Repair Parts and Special Tools List (RPSTL), and Supporting Information for the SICPS Medium.

Chapter 1 contains introductory information on the SICPS Medium.

Chapter 2 includes Operator Maintenance Instructions, and PMCS.

Chapter 3 includes Unit Maintenance Instructions.

Chapter 4 contains Direct Support Maintenance Instructions.

Chapter 5 concludes with the MAC, the RPSTL, References, and other supporting information.

Following Chapter 5 is a Glossary that includes several terms and definitions, which are listed in alphabetical order and used throughout the manual.

**Manual Organization and Page Numbering System.** The manual is divided into five major chapters that detail the topics mentioned above. Within each chapter are work packages (WP) covering a wide range of topics. Each work package is numbered sequentially starting at page 1. The work package has its own page-numbering scheme and is independent of the page numbering used by other work packages. Each page of a work package has a page number of the form XXXX -YY where XXXX is the work package number (e.g. 0010 is work package 10) and YY represents the number of the page within that work package. A page number such as 0010-1/(2 Blank) means that 1 page contains information but page 2 of that work package has been intentionally left blank.

**Finding Information.** The Table of Contents (TOC) permits the reader to find information in the manual quickly. The reader should start here first when looking for a specific topic. The table of contents lists the topics contained within each chapter and the Work Package Sequence Number where it can be found.

**Example:** If the reader was looking for instructions on “Service upon receipt”, which is an Operator Maintenance instruction, the table of contents indicates that Operator Maintenance information can be found in Chapter 2. Scanning down the listings for Chapter 2, “Service Upon Receipt” information can be found in WP 0004 00 (Work Package 4).



## **CHAPTER 1**

# **GENERAL INFORMATION, EQUIPMENT DESCRIPTION AND THEORY OF OPERATION FOR STANDARD INTEGRATED COMMAND POST SYSTEM (SICPS), MEDIUM**



---

**OPERATOR AND FIELD MAINTENANCE  
STANDARD INTEGRATED COMMAND POST SYSTEM (SICPS), MEDIUM  
NSN: 8340-01-516-0904, GREEN  
NSN: 8340-01-516-0903, TAN  
GENERAL INFORMATION**

---

## SCOPE

This technical manual contains instructions for the set-up, operation, take down, maintenance, and repair procedures for all components of the Standard Integrated Command Post System (SICPS), Medium.

Type of Manual: Operator and Field Maintenance Manual including Repair Parts and Special Tools List.

Model Number: No model number has been assigned at this time for the SICPS Medium.

Equipment Name: Standard Integrated Command Post System (SICPS), Medium.

Purpose of Equipment: The SICPS Medium tent provides environmental protection to support command, control, communications and intelligence (C3I) operations. The SICPS Medium tent is made of a lightweight frame assembly.

## MAINTENANCE, FORMS, RECORDS AND REPORTS

Department of the Army forms and procedures used for equipment maintenance will be those prescribed by (as applicable) DA PAM 750-8, The Army Maintenance Management System (TAMMS) Users Manual; DA PAM 738-751, or AR 700-138, Army Logistics Readiness and Sustainability.

## REPORTING EQUIPMENT IMPROVEMENT RECOMMENDATIONS (EIR)

If your shelter needs improvement, let us know. Send us an EIR. You, the user, are the only one who can tell us what you don't like about your equipment. Let us know why you don't like the design or performance. If you have Internet access, the easiest and fastest way to report problems or suggestions is to go to <https://aeeps.ria.army.mil/aeepspublic.cfm> (scroll down and choose the "Submit Quality Deficiency Report" bar). The Internet form lets you choose to submit an Equipment Improvement Recommendation (EIR), a product Quality Deficiency Report (PCDR or a Warranty Claim Action (WCA). You may also submit your information using an SF 368 (Product Quality Deficiency Report). You can send your SF 368 via e-mail, regular mail, or facsimile using the addresses/facsimile numbers specified in DA PAM 750-8, The Army Maintenance Management System (TAMMS) Users Manual. We will send you a reply.

## CORROSION PREVENTION AND CONTROL (CPC)

Corrosion Prevention and Control (CPC) of Army materiel is a continuing concern. It is important that any corrosion problems with this item be reported so that the problem can be corrected and improvements can be made to prevent the problem in future items.

Corrosion specifically occurs with metals. It is an electrochemical process that causes the degradation of metals. It is commonly caused by exposure to moisture, acids, bases, or salts. An example is the rusting of iron. Corrosion damage in metals can be seen, depending on the metal, as tarnishing, pitting, fogging, surface residue, and/or cracking.

Plastics, composites, and rubbers can also degrade. Degradation is caused by thermal (heat), oxidation (oxygen), salivation (solvents), or photolytic (light, typically UV) processes. The most common exposures are excessive heat or light. Damage from these processes will appear as cracking, softening, swelling, and/or breaking.

The form should be submitted to the address specified in DA PAM 750-8, The Army Maintenance Management System (TAMMS) Users Manual.

### **DESTRUCTION OF ARMY MATERIEL TO PREVENT ENEMY USE**

For procedures to destroy this equipment to prevent its use by the enemy refer to TM 750-244-2, Procedures for Destruction of Electronics Materiel to Prevent Enemy Use (Electronics Command).

### **PREPARATION FOR STORAGE OR SHIPMENT**

Refer to work package (WP) 0005, to prepare the SICPS Medium tent for storage or shipment.

Special Instructions for Administrative Storage: Placement of equipment in administrative storage should be for short periods of time when a shortage of maintenance resources exist. Items should be in mission readiness within 24 hours or within the requirements determined by the directing authority. Appropriate maintenance records will be kept during storage.

Before placing equipment in administrative storage, current maintenance services and Equipment Serviceability Criteria (ESC) evaluations should be completed, shortcomings and deficiencies should be corrected, and all Modification Work Orders (MWOs) should be applied.

Storage Site Selection. Inside storage is preferred for items selected for administrative storage. If inside storage is not available, trucks, vans, TRICONS or other containers may be used.

### **WARRANTY INFORMATION**

There are no warranty provisions for the Standard Integrated Command Post System (SICPS), Medium tent.

### **NOMENCLATURE CROSS-REFERENCE LIST**

<b>Common Name</b>	<b>Official Name</b>
Light Assembly	Light Set, Portable, Fluorescent, Type II
Liner	Insulated Liner
LME	Lightweight Maintenance Enclosure
MCPS	Modular Command Post System
MGPTS	Modular General Purpose Tent System
SICPS	Standard Integrated Command Post System
Table	Table Field, Folding Legs Metal
Door Sill Assembly	Threshold, Tent
TEMPER	Tent, Extendable, Modular, Personnel
TRICON	Triple Container
Convenience Outlets	Electrical Distribution System



**LIST OF ABBREVIATIONS/ACRONYMS**

<b>Abbreviation/Acronym</b>	<b>Name</b>
AAL	Additional Authorization List
AR	Army Regulation
BOI	Basis of Issue
C3I	Command, Control, Communications and Intelligence
CAGEC	Commercial and Government Entity Code
CBRN	Chemical, Biological, Radiological and Nuclear
CPC	Corrosion Prevention and Control
CU FT	Cubic Foot/Feet
DA	Department of the Army
DD	Department of Defense
DS2	Decontamination Solution (ready-to-use)
EA	Each
EC	Electronics Command
ECU	Environmental Control Unit
EIR	Equipment Improvement Report
EMI	Electromagnetic Interference
EMP	Electromagnetic Pulse
ESC	Equipment Serviceability Criteria
FGC	Functional Group Code
Ft	Foot
GFCI	Ground Fault Circuit Interrupter
HCI	Hardness Critical Item
Hz	Hertz
IAW	In Accordance With
In	Inch/Inches
KG	Kilograms
LAN	Local Area Network
LME	Lightweight Maintenance Enclosure
MAC	Maintenance Allocation Chart
MCPS	Modular Command Post System
MGPTS	Modular General Purpose Tent System
MOS	Military Occupational Specialty
mph	Miles Per Hour
MTOE	Modified Table of Organization and Equipment
MWO	Modification Work Order
NBC	Nuclear, Biological, Chemical
NHA	Next Higher Assembly
NIIN	National Item Identification Number
NSN	National Stock Number
P/N	Part Number
PAM	Pamphlet
PCDR	Product Quality Deficiency Report

Abbreviation/Acronym	Name
PMCS	Preventive Maintenance Checks and Services
RPSTL	Repair Parts and Special Tools List
RWS	Rigid Wall Shelter
SICPS	Standard Integrated Command Post System
SMR	Source, Maintenance and Recoverability
Sq Ft	Square Foot/Feet
SRA	Specialized Repair Activity
STB	Super Tropical Bleach
TAMMS	The Army Maintenance Management System
TB	Technical Bulletin
TMDE	Test, Measurement, and Diagnostic Equipment
TOC	Table of Contents
TRICON	Triple Container
U/M	Unit of Measure
U/I	Unit of Issue
UOC	Usable On Code
UUT	Unit Under Test
UV	Ultraviolet
V	Volt
VAC	Volts Alternating Current
V-agent	Vector Agent
WCA	Warranty Claim Action
WP	Work Package

## QUALITY OF MATERIAL

Material used for replacement, repair, or modification must meet the requirements of this manual. If quality of material requirements are not stated in this manual, the material must meet the requirements of the drawings, standards, specifications, or approved engineering change proposals applicable to the subject equipment.

## SAFETY, CARE, AND HANDLING

Always observe Warnings, Cautions, and Notes in the manual. They appear before appropriate procedures. Be sure you read and understand each of the Warnings, Cautions, and Notes. Failure to observe them may cause damage to yourself, others, or equipment.

## SUPPORTING INFORMATION FOR REPAIR PARTS, SPECIAL TOOLS, TMDE AND SUPPORT EQUIPMENT

**Common Tools and Equipment.** For authorized common tools and equipment, refer to the Modified Table of Organization and Equipment (MTOE) applicable to your unit.

**Special Tools.** Refer to WP 0030, Tool and Test Equipment Requirements, Maintenance Allocation Chart, for additional tool and equipment requirements.

**Repair Parts.** The repair parts required for unit level maintenance are listed and illustrated in WP 0031 through WP 0053, Unit and Direct Support Repair Parts and Special Tools List.

---

**OPERATOR AND FIELD MAINTENANCE  
STANDARD INTEGRATED COMMAND POST SYSTEM (SICPS), MEDIUM  
NSN: 8340-01-516-0904, GREEN  
NSN: 8340-01-516-0903, TAN  
EQUIPMENT DESCRIPTION AND DATA**

---

## **EQUIPMENT CHARACTERISTICS, CAPABILITIES, AND FEATURES**

The SICPS Medium tent is available in green and tan colors.

### **Characteristics.**

- Usable in a variety of climates.
- No special tool requirements to erect or strike.
- Deployed in forward battle areas.
- Provides blackout protection.
- Can be set up by MOS non-specific personnel.
- Internal power distribution box.
- Internal lighting.

### **Capabilities and Features.**

- Provides environmental protection for personnel and command and control.
- Accommodates external environmental control unit (ECU).
- May be used as a stand-alone structure or connected to a variety of tactical vehicles.
- Uses quick release fasteners throughout.
- Is made of water resistant, flame resistant, mildew resistant, polyester duck fabric.
- Can be heated or cooled through external sources.
- Designed for steady wind of 50 mph and gust of 65 mph.
- Side windows.
- Internal coated fabric liners for roof cap, side walls, and end walls.
- Can be complexed to other types of shelters.

## **LOCATION AND DESCRIPTION OF MAJOR COMPONENTS**

### **Tent Sections:**

**End Wall Tent Section.** The end section is "A" shaped and constructed of coated polyester fabric. A zippered operated door with inner screen is located in the center of the end section. Two large ECU duct openings are provided at the bottom left of the door. Two electrical sleeve duct openings are located on both sides of the door. A ventilator with weather flaps is located in the roof portion of the end section. The lower inside of the tent wall will provide a means to attach and secure the fabric floor.

**Intermediate Tent Section.** The intermediate section is 24 feet long and constructed of coated polyester fabric. The intermediate section connects to the end walls by using the standard becket lace system used in many military tent designs. The intermediate section includes one large window located in the center section at eye level on each side of the tent. Each window consists of a clear plastic panel and blackout flap. Both the plastic panel and the blackout flap can be rolled up and tied above the window opening. There are four standard sized doors operated by zippers. There are two doors per side, one on the left and one on the right, with a window located in the middle of each. The lower inside of the tent wall will provide a means to attach and secure the fabric floor.

**Roof Cap Insulated Liner.** The roof cap liner is one piece of insulated, quilted fabric, suspended under the roof of the tent. The roof cap liner includes the air distribution duct, light support straps, and additional straps for use in securing and separating power cables or local area network (LAN) cables. The roof cap liner is designed to be used at all times.

**End Wall Insulated Liner.** The end wall liner will attach to the roof cap liner and be compatible with all openings on the end wall to ensure compatibility. When ECU ducts or electrical sleeves are in use, flaps in the insulated liner will need to be secured open. When windows or doors are in use, the insulated liner can be opened and secured to the wall as well.

**Side Wall Insulated Liner.** The side wall liner will attach to the roof cap liner and be compatible with all openings on the end wall. Flaps will need to be opened when the ECU ducts or electrical sleeves are in use. When windows or doors are in use, the liners will be opened and secured to the wall.

**Floor.** The floor is a single 24-foot long fabric floor. The fabric floor attaches to the base of the walls of the tent. The floor contains a cable management system for organizing and containing power cables.

**Sandwich Wall.** A new short “sandwich wall” interfaces with standard Army vestibules and other sandwich walls by means of the standard becket lace system. The new vestibule sandwich wall also includes a piece of hook and pile fastener tape attached to the underside that connects the existing fielded Standard Integrated Command Post System (SICPS) rigid wall shelter (RWS) boot walls to the new SICPS Medium tent.

**End Wall Plenum.** The end wall plenum is constructed of a lightweight material. The plenum consists of a tubular horizontal body with an extension at one end. The horizontal body is a 24-foot long semi-circular shape and is approximately 3 feet wide. Both body section ends are capped with a removable plenum cover that is attached with hook and pile fastener tape. The 24-foot long body portion of the plenum contains openings that can be opened or closed to adjust the amount of conditioned air entering the tent. If the tent is extended in length, plenums can be connected together using the hook and pile fastener tape. A tubular extension approximately 12-inches in diameter is assembled and attached to the horizontal body plenum. Tie lines are provided at the open end of the end of the tubular extension to secure the plenum to the end wall air duct. The horizontal body of the plenum will be secured to the roof cap liner at all times.

**Side Entrance Plenum.** The side entrance plenum is constructed of the same material as the end wall plenum. The design allows the side wall extension plenum to connect to the horizontal body of the plenum in the roof cap liner when the tent is configured for the air ducts/ECUs entering from the side walls versus entering from the end walls.

**ECU and Electrical Sleeves.** ECU and electrical sleeves are built into fabric sections near ground level. The large ducts can be used to provide heating, cooling or ventilation, and the small duct can be used for external power cable access. The ducts can be closed using tie straps to make them weatherproof and light secure.

**Stovepipe Opening.** The stove pipe opening in the roof allows for passage of a four-inch diameter stovepipe. It has a protective cover that is secured with hook and pile fastener tape.

**Frame Sections.** The frame sections are composed of interchangeable major components: arch assembly, cable header assembly, purlin assembly, door sill purlin assembly, and frame sections cover assembly.

**Arch Assembly.** The arch assembly consists of two aluminum side arch assemblies and an aluminum roof arch assembly. The arch assembly can easily be folded into a closed “W” configuration for ease of handling and transporting. The fully extended arch assembly is 98 inches in length.

**Cable Header Assembly.** The cable header assembly is a coated, braided cable with an overall length of 98 inches. When in use, the cable header is attached, with hitch clip pins, to the arch assembly.

**Purlin Assembly.** The purlin assembly is made from tubular aluminum and is approximately 96-inches long and 1 ½-inches in diameter. The purlin assembly connects to other frame sections to stabilize the tent frame.

**Door Sill Purlin Assembly.** The door sill purlin assembly is constructed of the same material as the purlin assembly except that it has a four-foot long rotating door sill bolted to the center of the tubular section. Folding diagonal braces, which have a U-shaped cross section, are riveted to each of the purlins. At the end of each brace is a rotating brace stud and brace shackle. The brace stud and door sill end fitting lock into slots at the base of the arch.

**Tent Frame Covers.** Tent frame covers store major frame components in a heavyweight coated fabric with interior straps to secure the frame components and exterior straps that bind the assembly together and facilitate handling and transport.

**Transport Bags.** Fabric transport bags are required to transport the intermediate sections, end section walls, floors, sandwich wall, and insulated liners in the field. Frame transport bags are required to transport all frame components.

**Power Distribution Box.** Either a 120V or a 208V power control system is provided with the SICPS Medium tent. The power control system consists of a power distribution box, convenience outlets, extension cables -- in 103, 156, 173, and 408-inch lengths -- and a power panel stand. External power is provided to the power distribution box, which distributes and controls power to the lights and convenience outlets.



Figure 1. Power Distribution Box, Face.



Figure 2. Power Distribution Box, Bottom.



Figure 3. Convenience Outlet.



Figure 4. Power Panel Stand, Cables and Power Distribution Box.

**Light Assembly.** Each light assembly consists of one fluorescent bulb mounted in a reinforced plastic tube with a molded cap and cable assembly at each end. The cap with the male power cable contains the ON/OFF switch. A light filter is included with each light assembly.

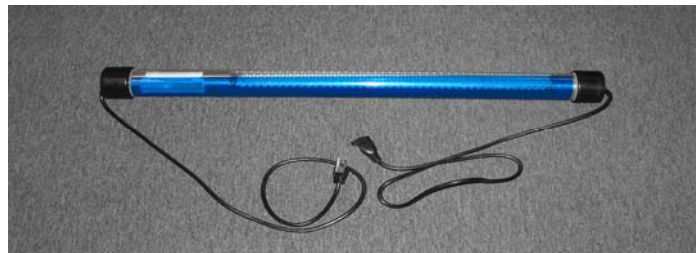


Figure 5. Fluorescent Light Assembly.



Figure 6. End Cap On/Off Switch.

**Field Table.** Six field table assemblies are included with the SICPS Medium tent. Folding legs allow the field table assembly to be stored in a minimum amount of space.



**Figure 7. Field Table.**

## **EQUIPMENT CONFIGURATION**

### **Sandwich Wall**

The new wall is approximately two feet in length. The wall includes the standard becket lace system with a weather seal flap found on the vestibule adapter and on the end and intermediate fabric sections.

The new sandwich wall can be used in any of four different ways:

1. As a short vestibule.
2. As a Blackout Entry/Exit Door. This will require two standard vestibule frame assemblies. All other uses will require only one vestibule frame assembly.
3. Connect existing SICPS RWS vehicle boot walls to the standard vestibule adapter located on either the end wall or intermediate tent sections of the SICPS Medium tent.
4. Allow the connection of any existing Modular Command Post System (MCPS) Small tent directly to any SICPS Medium tent, TEMPER or Modular General Purpose Tent System (MGPTS), in the Army today.

**Connecting the Sandwich Wall as a Short Vestibule or a Blackout Entry/Exit Door**

1. Lay out the sandwich wall on a flat surface.



**Figure 8. Sandwich Wall, Flat.**

2. Roll the C-shaped fabric up and tie off, exposing both becket lace ends.



**Figure 9. Sandwich Wall, Rolled.**



3. Attach the vestibule frame between any door opening and sandwich wall.



**Figure 10. Partially Attached Sandwich Wall**

4. Becket lace the sandwich wall door opening from the peak down.



**Figure 11. Sandwich Wall Becket Laced.**

5. Attach a second vestibule frame on the end of the sandwich wall.



**Figure 12. Second Vestibule Frame Attached.**

### **NOTE**

The entrance can be used as a blackout entry/exit door when a vestibule door is becket laced to the end of the sandwich wall.



**Figure 13. Sandwich Wall Door Opening, Laced.**

**Connecting the Sandwich Wall to an Existing Modular Command Post System (MCPS) Small**

1. Remove the vestibule door.

**NOTE**

This fabric section has the same dimensions as a MCPS Small Wall and will enable you to attach or “boot” to a MCPS Small.

2. Unroll the fabric on the inside of the sandwich wall.
3. Attach the sandwich wall to the roof cap and corresponding walls of the MCPS Small the same way you would for any MCPS Small wall.



**Figure 14. Second Vestibule Frame, Attached.**



**Figure 15. Connecting the Sandwich Wall to a Rigid Wall Shelter (RWS) Boot Wall.**

## NOTE

When connecting or booting to a RWS, the Sandwich Wall stays attached to the SICPS Medium tent door the same way.

4. Mate the command post end directly to the RWS opening.
5. Ensure the hook and pile fastener tape on the top edge is overlapped and the hook and pile fastener tape is attached together on the sides.
6. Roll and buckle the excess fabric.



**Figure 16. Excess Fabric, Rolled and Buckled.**



**Figure 17. Boot Wall Installed.**

**EQUIPMENT DATA**

Table 1 lists the weight, quantity, and total weight for the separate SICPS Medium components.

**Table 1. Equipment Data.**

<b>ITEM</b>	<b>WEIGHT LBS (KG)</b>	<b>QTY</b>	<b>TOTAL WEIGHT LBS (KG)</b>
<b>Frame Section</b>			
Upper Arch Assembly	11 (5.0)	4	44 (20.0)
Lower Arch Assembly	15 (6.8)	8	120 (54.4)
Cable Header Assembly	2 (0.9)	4	8 (3.6)
Door Sill Purlin	10 (4.5)	4	40 (18.1)
Purlin	5 (2.3)	11	55 (25.0)
Transport Bag	10 (4.5)	3	30 (13.6)
Vestibule Frame	8 (3.6)	7	56 (25.4)
Vestibule Transport Bag	12 (5.4)	1	12 (5.4)
<b>Fabric Section</b>			
End Section	53 (24.0)	2	106 (48.1)
24-foot Intermediate Section	232 (105.2)	1	232 (105.2)
Floor Section	72 (32.7)	1	72 (32.7)
Transport Bag	10 (4.5)	5	50 (22.7)
Sandwich Wall	24 (10.9)	6	144 (65.3)
Vestibule Door	8 (5.4)	1	8 (3.6)
<b>Insulated Liner</b>			
Roof Cap Liner	90 (40.8)	1	90 (40.8)
End Wall Liner	33 (15.0)	2	66 (30.0)
Side Wall Liner	44 (20.0)	2	88 (40.0)
<b>Electrical Components</b>			
Power Distribution Box	13 (5.9)	1	13 (5.9)
Power Panel Stand	10 (4.5)	1	10 (4.5)
Light Assembly	4.5 (2.0)	6	27 (12.3)
Light Cable (103 inches)	1 (0.5)	1	1 (0.5)

**Table 1. Equipment Data – Continued.**

ITEM	WEIGHT LBS (KG)	QTY	TOTAL WEIGHT LBS (KG)
<b>Electrical Components – cont.</b>			
Light Cable (103 inches)	1 (0.5)	1	1 (0.5)
Light Cable (173 inches)	1 (0.5)	1	1 (0.5)
Duplex Cables (156 inches)	2 (0.9)	2	4 (1.8)
Duplex Cables (254 inches)	2 (0.9)	2	4 (1.8)
Duplex Receptacle Sets	11 (5.0)	2	22 (10.0)
<b>Accessories</b>			
5-foot Tables	31 (14.1)	6	186 (84.4)
12-inch Steel Pins	1 (0.5)	12	12 (5.4)
24-inch Wooden Pins	1 (0.5)	16	16 (7.3)
Pin Container	4 (1.8)	1	4 (1.8)
12-lb Sledge Hammer	12 (5.4)	1	12 (5.4)

**Table 2. Total System Equipment Data.**

ITEM	TOTALS LBS (KG)
Total System Weight	1756 (787.61)
Total Volume Packed	113 cubic feet
Total Square Feet Deployed	480 square feet
Height at Eaves	10 ½ feet
Height at Ridge	6-feet 8-inches

**Table 3. Environmental Capabilities.**

Set-up Temperature	-50 to 120° F
Set-up Wind	25 mph maximum
Operate Temperature	-50 to 120° F
Operate Wind	55 mph steady state 65 mph gusts

---

**OPERATOR AND FIELD MAINTENANCE  
STANDARD INTEGRATED COMMAND POST SYSTEM (SICPS), MEDIUM  
NSN: 8340-01-516-0904, GREEN  
NSN: 8340-01-516-0903, TAN  
THEORY OF OPERATION**

---

## **GENERAL**

The SICPS Medium tent is designed for use in forward combat areas and has relatively few moving parts.

The SICPS Medium tent design permits complexing of multiple structures to accommodate a variety of operational requirements and uses. (Refer to WP 0002 for details on complexing multiple structures.)

The SICPS Medium tent is a frame-supported enclosure that can be erected without the use of special tools. A system of guyropes and tie-downs enhances the structure's stability in high winds.

The tent fabric is available in woodland green or desert tan. These colors provide camouflage and low visibility. The structure, when properly closed, is light secure and waterproof. Duct connectors incorporated into the side walls near ground level allow a heating or air conditioning duct attachment as required, or can be tied closed when not in use.

Windows on each side of the structure open for ventilation. A screen can be left in place, or the clear plastic section can be installed, using the hook and pile fasteners, to admit daylight. A fabric cover on the outside of each window can be rolled down and secured, using the hook and pile fasteners, to maintain light security.

The frame structure consists of components that are locked together using the attached quick release pins and turn-and-lock mechanisms. Components fold for storage. Transport covers are provided for storage and shipment purposes. The arch frame assemblies consist of upper arch and lower arch assemblies that lock together. The cable header assemblies provide lateral strength to the frame assemblies and are used on all frame assemblies. Purlins are used to space the arch frame assemblies 8 feet apart.

External electrical power is provided to the SICPS Medium tent through a power distribution box, which is mounted to a power panel stand and secured to the frame structure. The distribution box contains a switch to control the string of light assemblies that provide interior lighting. Electrical controls are found on the power distribution box for the power control system and on the light assembly as described in WP 0004. Ground fault protected convenience outlets are provided as well.

## **END OF WORK PACKAGE**





**CHAPTER 2**

**OPERATOR INSTRUCTIONS  
FOR  
STANDARD INTEGRATED COMMAND  
POST SYSTEM (SICPS), MEDIUM**



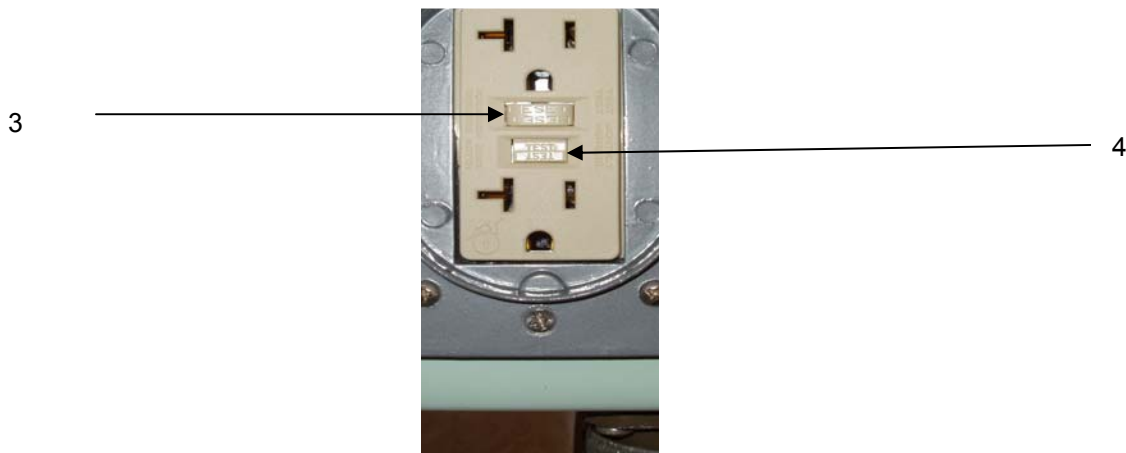
**OPERATOR AND FIELD MAINTENANCE  
STANDARD INTEGRATED COMMAND POST SYSTEM (SICPS), MEDIUM  
NSN: 8340-01-516-0904, GREEN  
NSN: 8340-01-516-0903, TAN  
DESCRIPTION AND USE OF OPERATOR CONTROLS AND INDICATORS**

**POWER DISTRIBUTION BOX CONTROLS**

Item	Control or Indicator	Function
1	ON/OFF Switch	Turns left or right bank electrical circuits ON or OFF.
2	Circuit Breakers	Provides overload or short circuit protection. Circuit is interrupted when breaker is out. Push to reset.
3	Reset Button	Used to reset the outlet after running a test.
4	Test Button	Used to ensure the outlet is properly functioning.



**Figure 1. Switches and Breakers.**



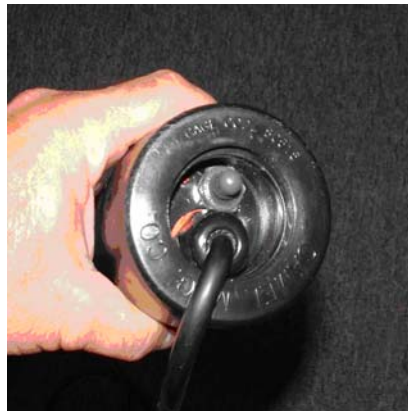
**Figure 2. Reset Buttons**

**LIGHT ASSEMBLY CONTROLS**

<b>Item</b>	<b>Control or Indicator</b>	<b>Function</b>
1	ON/OFF Switch	Turns bulb in light assembly ON or OFF.



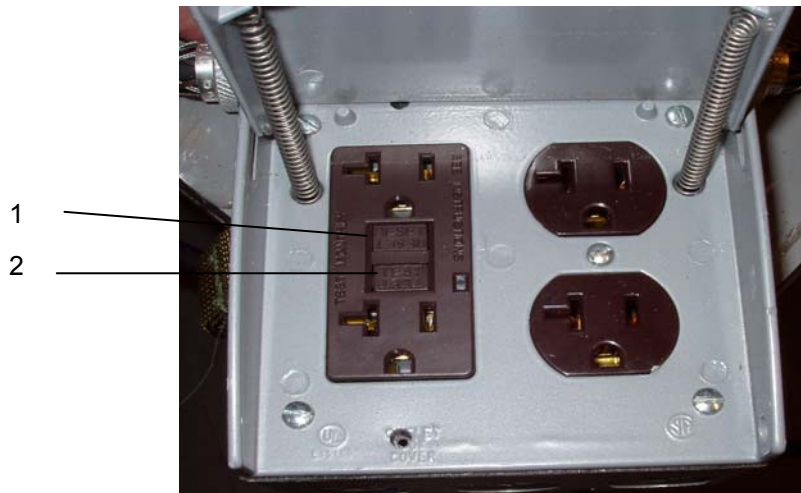
**Figure 3. Fluorescent Light Assembly.**



**Figure 4. On/Off Switch.**

**CONVENIENCE OUTLET CONTROLS**

Item	Control or Indicator	Function
1	Reset Button	Used to reset the outlet after running a test.
2	Test Button	Used to ensure the outlet is properly functioning.



**Figure 5. Reset/Test Buttons on Convenience Outlet.**



---

**OPERATOR AND FIELD MAINTENANCE  
STANDARD INTEGRATED COMMAND POST SYSTEM (SICPS), MEDIUM  
NSN: 8340-01-516-0904, GREEN  
NSN: 8340-01-516-0903, TAN  
OPERATION UNDER USUAL CONDITIONS**

---

**INITIAL SETUP****Tools and Special Tools**

N/A

**Equipment Condition**

N/A

**Materials/Parts**

N/A

**References**

N/A

---

**SITING REQUIREMENTS**

Site Selection. When selecting a site on which to set up the SICPS Medium tent:

1. The ground should be level, varying no more than three inches in ten feet of unprepared soil.
2. The site must be free of debris and clear of all rocks and underbrush.
3. The site should be firm and dry, away from any potential flood areas, as well as clear of trees that may create potential problems during high winds.
4. Ensure there is sufficient space to set up the SICPS Medium tent site. (The area needed to set up the SICPS Medium tent needs to be larger than the actual area the assembled tent will occupy. Approximately 50 feet by 50 feet of area is required.)
5. The area should be accessible to tactical vehicles. The tent should be set up in an area large enough to ensure there is enough room for vehicle connectivity.
6. If possible, the area should afford some protection from high winds.
7. If necessary, dig a drainage ditch around the area.



**Figure 1. Site Selection.**

## ASSEMBLY AND PREPARATION FOR USE

In preparation for assembly, place frame and fabric transport covers near the selected site. The initial task of erecting the SICPS Medium tent is to assemble the frame and fabric components in the order listed and detailed on the following pages.

### NOTE

Ensure the tent is erected in an area that allows room for vehicle connectivity.

#### Frame Assembly:

The frame assemblies are erected in three stages: kneeling, partially-erect, and erect. These stages permit the attachment of components without the aid of ladders. Both rigid and sectionalized arch assemblies are in use in the field. After initial assembly, the sectionalized arch assembly does not vary in function from the rigid arch assembly.

### WARNING



Four to eight personnel are required to assemble the SICPS Medium tent. Failure to do so may cause injury to personnel.

### WARNING

All tent lines and frame feet must always be staked down. Failure to do so may result in injury to personnel and damage to equipment.

### WARNING



Frame assembly hinges can pinch or crush hands and fingers. Keep hands and fingers away from frame assembly ridges and eaves.

### CAUTION

Do not twist or turn frame components when handling. Damage to equipment may result.



## CAUTION

Clear and level ground before installing floor. Sharp objects or depressions can damage tent floor.

## NOTE

Erect tent from top to bottom. Erect frame sequentially, end section towards opposite end section.

### Assemble the Tent Components as Follows:

1. Arch Assembly. Assemble one arch assembly as follows:
  - a. Remove upper arch assembly and lower arch assemblies from frame transport bag.
  - b. Ensure all quick release pins are disengaged.



Figure 2. Arch Assembly.

## CAUTION

Insert quick release pins towards inside of tent on end assemblies. Tent fabric may tear if inserted towards outside.

- c. Open upper arch assembly and align holes with holes in ridge gusset plate. Insert quick release pin. The lanyard of the quick release pin should not cross over the top of the upper arch assembly.



Figure 3. Arch Assembly Components.

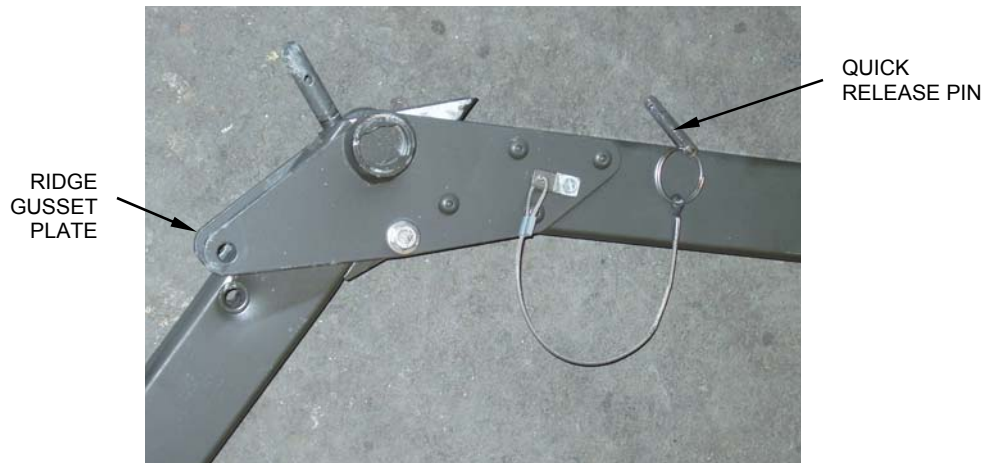


Figure 4. Upper Arch Assembly, Open.

- d. Connect upper arch and lower arch assemblies to form arch assembly. (Reflective tape should line up on top of the arch assembly to ensure the lower arch assembly is inserted properly.)

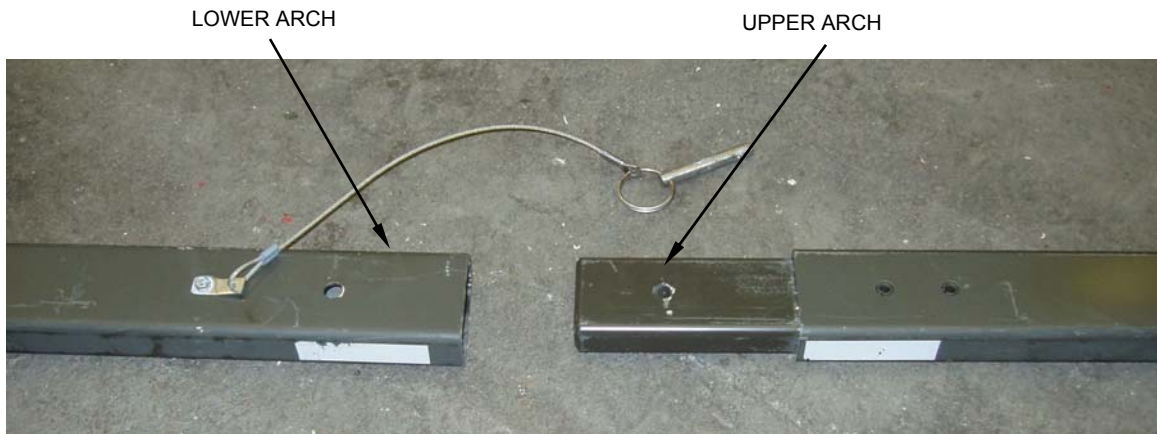


Figure 5. Connecting Arch Assemblies.

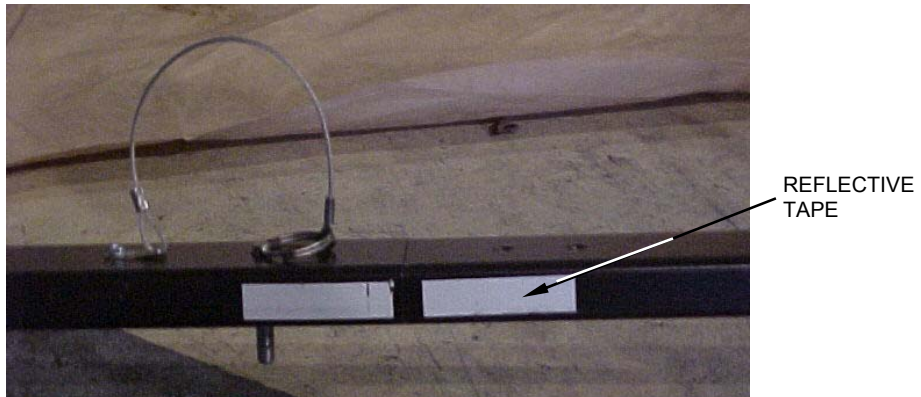


Figure 6. Reflective Tape Alignment.



Figure 7. Connected Arch Assemblies, Flat.

- e. Lay arch assembly flat on the ground.

**NOTE**

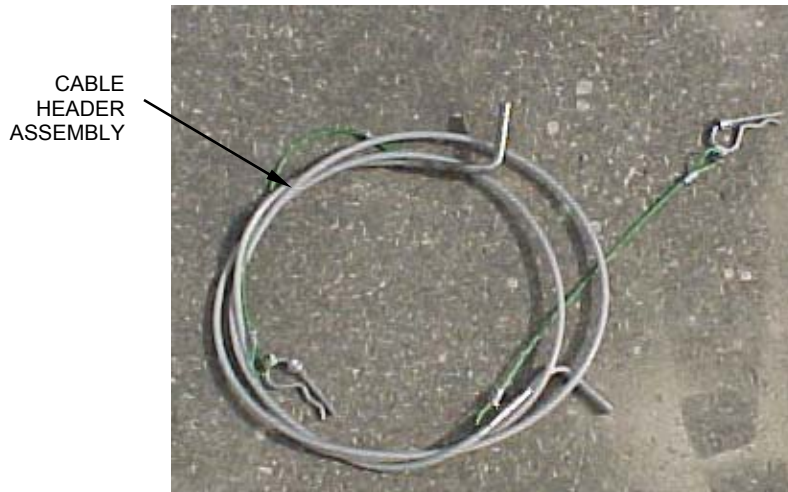
Arch assemblies should be spaced approximately 8 feet apart (purlin width) to ensure space for purlin.

- f. Repeat steps a. through f. for remaining arch assemblies.
2. Cable Header Assembly. Assemble one cable header assembly as follows:

**NOTE**

The cable header assembly will be pinned to the arch assembly between the ridge and eave.

- a. Identify the cable header assembly.



**Figure 8. Cable Header Assembly.**

- b. Align the arch assembly and cable header assembly.

**CAUTION**

Insert quick release pins towards inside of tent on end assemblies. Tent fabric may tear if inserted towards outside.

- c. Lift assembly off ground and insert quick release pin.

- d. Lay assembly on ground.



**Figure 9. Arch Assemblies, Cable Attached.**

- e. Repeat steps a. through d. for remaining arch assemblies.

- 3. Purlin Assembly. Assemble purlin assembly as follows:

**NOTE**

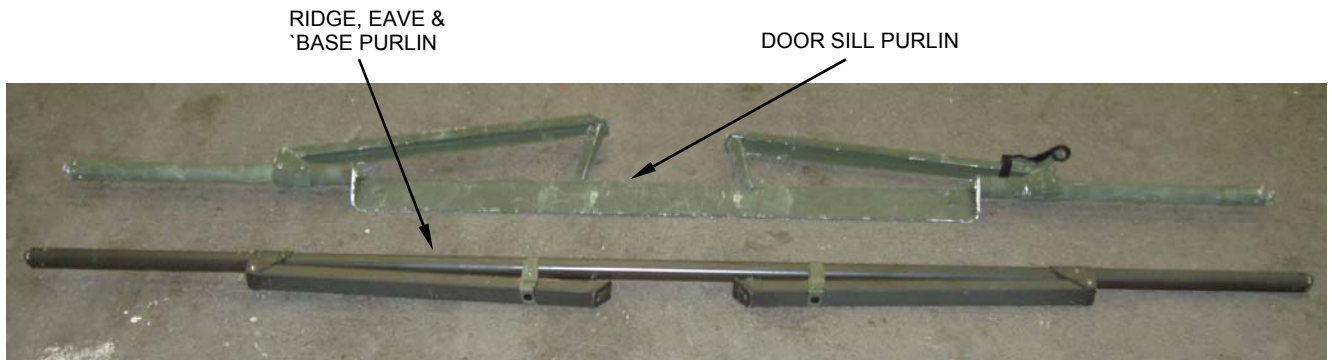
Purlins are used in either the ridge, eave, and/or base locations. Door sill purlins are used anywhere a door is located on the side of a tent. Installation procedures are identical.

Ensure the door sill purlin is used with the door section.

An 8-foot section of the frame will be completed with five purlins. To add sections, continue procedures until the required number of frame sections have been connected.

Alternate direction of ridge purlin diagonal braces for added support.

- a. Identify appropriate purlins for installation at ridge, eaves, and bases.



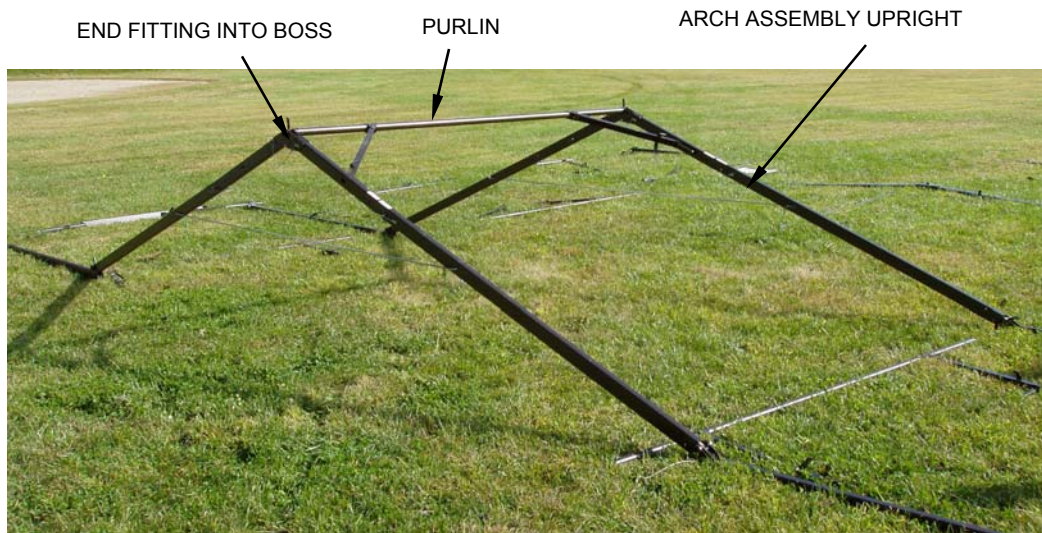
**Figure 10. Purlin Assembly Components.**

- b. Starting at the end arch, hold two arch assemblies upright, eight feet apart, in kneeling position.

### NOTE

Ensure arches are parallel.

- c. Install purlin at ridge.
- d. Identify the end fitting on each end of purlin.
- e. Place the end fitting in each arch assembly boss simultaneously.
- f. Unfasten retaining strap and rotate the purlin diagonal brace towards arch assembly.
- g. Rotate purlin 90 degrees so that end fittings lock into boss at each arch assembly.

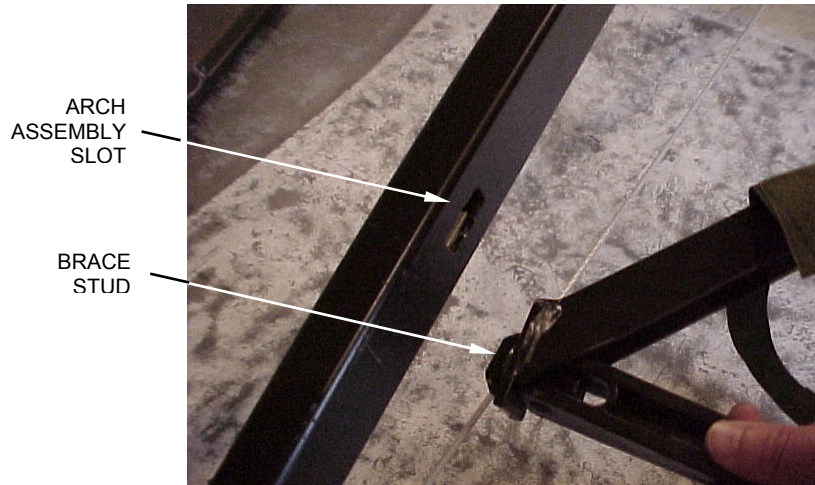


**Figure 11. End Fittings Locked Into Boss at Arches.**

### NOTE

The brace stud and brace shackle are located at the end of the purlin diagonal brace. The slot on the arch assembly is approximately two feet from the ridge.

- h. Holding the brace shackle, align and place brace stud in arch assembly slot located two feet from ridge.
- i. Rotate brace shackle 90 degrees to lock brace stud in place.



**Figure 12. Placing Brace Stud in Arch Assembly Slot.**

### **WARNING**

Do not lock brace shackle toward purlin diagonal brace. Arch assembly may collapse causing injury to personnel or damage to equipment if improperly locked.

- j. Lock purlin diagonal brace by pressing brace shackle towards arch assembly until it is secure.



**Figure 13. Locking Purlin Diagonal Brace.**

- k. Install purlin at the eave location using the same procedure as described above.

**WARNING**

Ensure the door sill purlin is used with door section. Door sills do not align with door openings if the wrong purlin is used. (There are two locations on each side of the tent at the bases.) Failure to use proper purlin may cause a tripping hazard to personnel.



**Figure 14. Door Purlin.**



**Figure 15. Assembled Frame Assembly.**

4. Insulated Roof Cap Liner. Attach insulated roof cap liner as follows:
  - a. Locate insulated roof cap liner.
  - b. Unfold liner so that ridge straps, with snap fasteners, face up towards the ridge of the tent frame.
  - c. Fold liner in half so that ridge straps align with the ridge purlin, thus, ensuring proper working space and less damage to liner material.



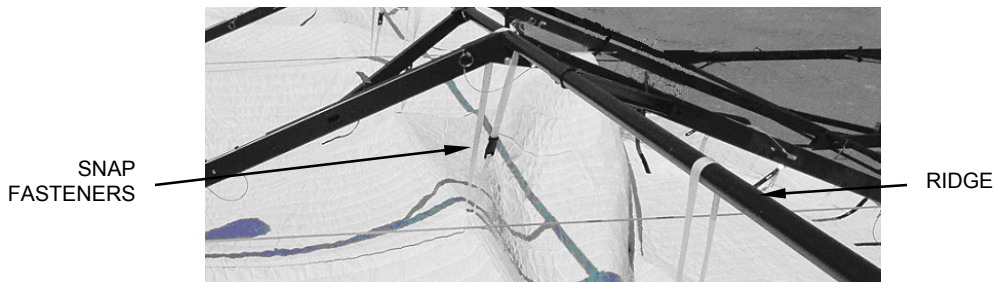
**NOTE**

At the cable headers, attach the straps so the cable header is contained within the strap when clipped. This helps ensure the roof cap liner accurately aligns to the tent frame.

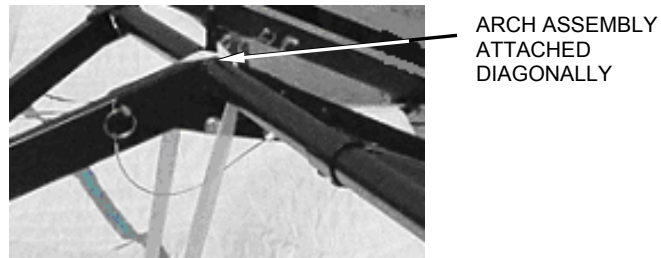
- d. Starting at the end section, pull the liner up at the straps and attach the roof cap liner to the ridge using the snap fasteners. Ensure the ridge straps located closest to the arch assemblies are attached diagonally over the purlin and arch assembly. Attach the remaining straps straight up and over the purlin.



**Figure 16. Insulated Roof Cap Liner.**



**Figure 17. Attaching Roof Cap Liner to Ridge.**



**Figure 18. Ridge Straps.**

**NOTE**

Do not over tighten straps at this time. All straps should be fastened first to ensure ease of attachment.

**NOTE**

Ensure roof cap liner straps are attached to the frame on the outside of the cable header and the light straps are attached within the cable header and around the arch assembly. This will ensure the liner is taut.

- e. On both sides of the tent, attach the roof cap liner to the tent frame, at the midpoint location, using the straps provided on the liner.
- f. Attach the light straps at the midpoint location using the straps provided on the liner.



**Figure 19. Attaching Straps.**

5. 24-Foot Fabric Section. Attach 24-foot fabric section as follows:
  - a. Locate the 24-foot fabric section.

**NOTE**

The stovepipe openings should all be placed on one side. Openings of the liner should be aligned.

- b. Determine the location of the stovepipe opening and align fabric section to match the stovepipe opening in the roof cap liner.

- c. Place the 24-foot fabric section on the tent frame ridge.



**Figure 20. Placing Fabric On Tent Frame Ridge.**

- d. Unfold fabric so the fabric drapes over each side of the tent frame at the ridge.



**Figure 21. Draping Fabric Over Frame.**



**Figure 22. Installed Fabric.**

- e. Place the large spindle grommets of the 24-foot fabric section on the ridge spindles.



**Figure 23. Placing Spindle Grommets on Ridge Spindles.**

- f. Insert quick release pins with lanyards into the center ridge spindles.

#### **NOTE**

Do not put quick release pins into end ridge spindles at this time. This step will occur after the end walls are put in place.



**Figure 24. End Ridge Spindle.**



**Figure 25. Grommet on Spindle.**



**Figure 26. Hitch Clip Pin in Spindle.**

- g. On both sides of the tent, pull the fabric section all the way out and then roll it up to the eave.



**Figure 27. Fabric Section Rolled to Eave.**

- h. Insert quick release pins with lanyards into the eave spindles.
6. Endwall. Attach endwall section as follows:
    - a. Identify endwall section.
    - b. Place endwall fabric grommets onto spindles.
    - c. Repeat steps a. and b. for other endwall.



**Figure 28. After Attaching Endwall Sections.**

7. Becket Lace the End Wall to the 24-Foot Fabric Section. At this point, lacing together of the ridge to the eave may be accomplished simultaneously. Begin all lacing from the ridge line and work to the eave. Becket lacing procedure is the same throughout the erection process and is accomplished as follows:

### CAUTION

Do not step on tent components. Material may be torn and dirt ground into material.

### NOTE

For easier lacing, place eave grommets with becket laces over eave spindles first.

- a. Place becket side eave grommet over eave spindle.
- b. Identify the first becket lace and becket grommet near the ridge.
- c. Insert first becket lace through first becket grommet and second becket lace through second becket grommet.



**Figure 29. Weaving Becket Lace Through First and Second Grommets.**

- d. Insert second becket lace through loop of first becket lace.
- e. Pull second becket lace tight away from ridge.
- f. Insert third becket lace through grommet and through loop of second becket lace.
- g. Pull third becket lace tight away from ridge.
- h. Continue lacing and close hook and pile weather flap until reaching last becket lace.
- i. Place remaining grommets over spindles.

- j. Upon reaching the last becket lace at the eave, insert next-to-last becket lace through loop of last becket lace.
- k. Pull the next-to-last becket lace back towards the ridge and tie off with half-hitch knot.



**Figure 30. Tying Off Becket Lace.**

- l. Complete lacing all sections up to the eave.



**Figure 31. Installed Fabric.**

**NOTE**

Do not lace any becket below the eave at this time.

8. Raise the frame to the partially-erect position. Raise one side of the frame as follows:

### WARNING

Ensure the side of the tent first raised is the side that is down wind. Failure to do so may cause problems with erecting the remaining portions of the tent (in high winds) and may cause serious injury to personnel.

### CAUTION

Avoid folding wall fabric into joints. Material may rip or tear if caught in a joint.

- a. Fold the 24-foot wall fabric onto the roof to expose eave gussets.
- b. Identify the quick release pin and ensure it is hanging free.
- c. Identify the locking hole in the lower arch assembly and ensure it is free of debris.

### WARNING



One or two soldiers should be placed at each arch leg to raise the frame. Lift the tent from correct squatting position, using your legs to avoid back injury.

### CAUTION

Tent frame must be raised uniformly to avoid twisting or turning. Damage to the frame can result if raised improperly.

- d. Step in next to the eave gusset.

### WARNING



Frame assembly hinges can pinch or crush hands and fingers. Keep hands and fingers away from frame assembly ridges and eaves.

- e. Place one hand on the lower arch assembly and one hand on the eave purlin outside the diagonal brace.
- f. Get in a stable squatting position.
- g. Lift frame straight up to shoulder height, dragging the lower leg assembly inward.





**Figure 32. Frame in Upright Position.**

- h. Place weight of the frame on the lower arch assembly foot.

### CAUTION

Insert quick release pins towards inside of tent on end assemblies. Tent fabric may tear if inserted towards outside.

- i. Align holes of eave gusset and lower leg assembly and install quick release pin.
- j. Attach remaining roof cap liner straps to eaves.
- k. Identify eave purlin straps on interior of the 24-foot fabric section.
- l. Secure eave purlin straps to frame at eave purlin using double D-ring strap assemblies.



**Figure 33. Securing Eave Purlin Straps.**

- m. Tent is now in a partially-erect stage.

9. Complete Attachment of Roof Cap Liner. Attach the roof cap liner to the tent frame, at the eave, using the suspension straps.



**Figure 34. Attaching Roof Cap Liner to Tent Frame at Eave.**

#### **NOTE**

The other side of the tent will be raised after installation of the lights.

10. While the frame is partially-erect, install the light assemblies as follows:

#### **NOTE**

Determine the tent end location for the power panel stand and power distribution box at this time. Ensure the male plug end of the light assembly is toward the power distribution box (which will be placed inside the tent later).

- a. Wrap light hanger strap around each end of the light on the inside of the rubber end caps.
- b. Pull the strap up through the D-ring and press down to engage the hook and pile fastener tape.

#### **CAUTION**

Do not connect more than six lights together. Loss of power may occur.

- c. Repeat steps a. and b. for additional lights.

#### **NOTE**

Attach two rows of lights by placing the cord between the plenum and the roof cap.

- d. Mate plug properly to the next light, ensuring reflecting surface faces up and lamp faces down.
- e. Using cable management system, secure the light straps.



**Figure 35. Installing Light Assemblies.**



**Figure 36. Mating Two Lights Together.**

11. Fully Erect the Frame. Raise the remaining side of the tent frame as follows:

### CAUTION

Avoid folding wall fabric into joints. Material may rip or tear if caught in joint.

- a. Fold wall fabric onto the roof to expose eave gussets.
- b. Place grommets on spindle and secure using hitch clip pins.
- c. Identify quick release pin and ensure it is hanging free.
- d. Identify the locking hole in the lower arch assembly and ensure it is free of debris.

### WARNING



One to two soldiers should be placed at each arch leg to raise frame. Lift tent from correct squatting position, using your legs to avoid back injury.

### CAUTION

Tent frame must be raised uniformly to avoid twisting or turning of the frame. Damage to frame can result.

- e. Step in next to the eave gusset.

**WARNING**

Frame assembly hinges can pinch or crush hands and fingers. Keep hands and fingers away from frame assembly ridges and eaves. Failure to do so may result in serious injury to personnel.

- f. Place one hand on the lower leg assembly and one hand on the eave purlin outside the diagonal brace.
- g. Get in a stable squatting position.
- h. Lift frame straight up to shoulder height, dragging lower leg assembly inward.
- i. Place weight of the frame on side arch assembly foot.

**CAUTION**

Insert quick release pins towards inside of tent on end assemblies. Tent fabric may tear if inserted towards outside.

- j. Align holes of eave gusset and lower leg assembly and install quick release pin.
- k. Identify purlin straps on interior of 24-foot intermediate fabric section.
- l. Secure purlin straps to frame at eave purlin using double D-ring strap assemblies.

**CAUTION**

Frame bases set more than 20 feet, 4 inches apart may cause end section fasteners to tear apart.

- m. Set frame bases 20 feet, 4 inches apart from the rivet on the center of the base purlin to the rivet on the center of the base purlin.



**Figure 37. Side Frame Assembly.**

### **CAUTION**

Use bow knots when tying all tie tapes to prevent tie tapes from becoming knotted and difficult to untie.

12. Complete Becket Lacing.
  - a. Complete lacing all remaining sections together.
  - b. Secure all weather seal flaps.
  - c. Pull sod cloth under base purlins and end wall sections.



**Figure 38. Sod Cloth Under Base Purlin.**

13. Secure purlin straps to the frame at the base purlin, using the double D-ring strap assemblies.
14. Stake the Tent. Secure the tent to the ground as follows:

### WARNING

Stakes and guylines must be used to prevent excessive movement of the tent, especially during high winds. Failure to stake and tie down the tent may result in damage to the equipment or serious injury to personnel.

- a. Place a 24-inch wooden stake approximately 8-feet from the side and ends of the tent and drive the stake(s) straight into the ground.
- b. Connect loop of eave extender guy line to the bottom notch of each wooden stake.
- c. Stake tent frame foot to ground using the 12-inch steel pins.
- d. Stake foot loops to ground.
- e. Tighten guylines.
- f. High wind lines are secured to the stake at the top notch.



**Figure 39. Securing High Wind Lines.**

15. Install the Single-Ply Fabric Floor.

### CAUTION

Clear and level ground before installing floor. Sharp objects or depressions can damage tent floor.

### NOTE

Always secure floor to the tent. This will help provide protection from the elements.

- a. Obtain the single-ply, 24-foot, fabric floor section.



**Figure 40. 24 Foot Fabric Floor Section.**

- b. Unwrap/unroll and spread out floor inside tent so it is flat and smooth, ensuring the black side is down.



**Figure 41. Unrolling Fabric Floor Inside Tent.**

- c. Starting in the corner and working in one direction, mate the pile fastener tape on the floor to the hook fastener tape on the side and end walls.



**Figure 42. Mating Hook and Pile Fastener and Tape on the Side and End Walls.**

16. Install Insulated Wall Liner.
  - a. Identify insulated liner section.
  - b. Unwrap insulated liner and unfold it inside tent.
  - c. Attach insulated liner to roof cap liner using the hook and pile fastener tape.
  - d. Using the black suspension straps, attach one corner of the wall liner to the arch assembly leg.
  - e. Walking between the insulated liner and tent fabric, working your way down from the far corner, secure the remaining black suspension straps to the arch assembly legs.
  - f. Repeat steps a. through e. for the remaining insulated liners.



17. While the frame is fully-erect, install the power panel stand as follows:
- As you come in the door, place the power panel stand at the left entrance side of the tent.
  - Feed the U-clamp of the power panel stand through notch in wall liner.



**Figure 43. Feeding Power Panel Stand Through Wall Liner Notch.**

- Place the U-clamp on the cable header assembly.



**Figure 44. Position of Power Panel Stand.**

- Extend the outer column of the stand to engage the frame header in the U-clamp.
- Step on the base plate to provide tension on the stand.
- Insert quick release pin to lock stand in place.



**Figure 45. Locking Power Panel Stand In Place.**

**NOTE**

Tuck base plate under hook and pile fastener tape. Stand should not move. If necessary, readjust the quick release pin for sufficient tension on the stand.

## 18. Install Power Distribution Box.

- a. Locate power distribution box.
- b. Install mounting bolt in rear of distribution box through keyhole slots in the power panel stand.

**WARNING**

Ensure that grounding has occurred at the power source before proceeding to connect electrical components. Failure to do so may cause serious injury or death to personnel.

## 19. Install Convenience Outlets.

**WARNING**

Lethal voltage is present when cables are connected to power control system. Ensure cables are disconnected from power source when working with cables or fixtures. Electrical shock or death may result from failure to heed this warning.

- a. Locate convenience outlets.
  - b. Lay out cables so that convenience outlets line up with arch assembly legs.
  - c. Secure power cables under cable management system, located in the floor, around the inside perimeter of the tent.
20. Connect electrical cables, convenience outlets, and light assemblies to the power distribution box as shown.

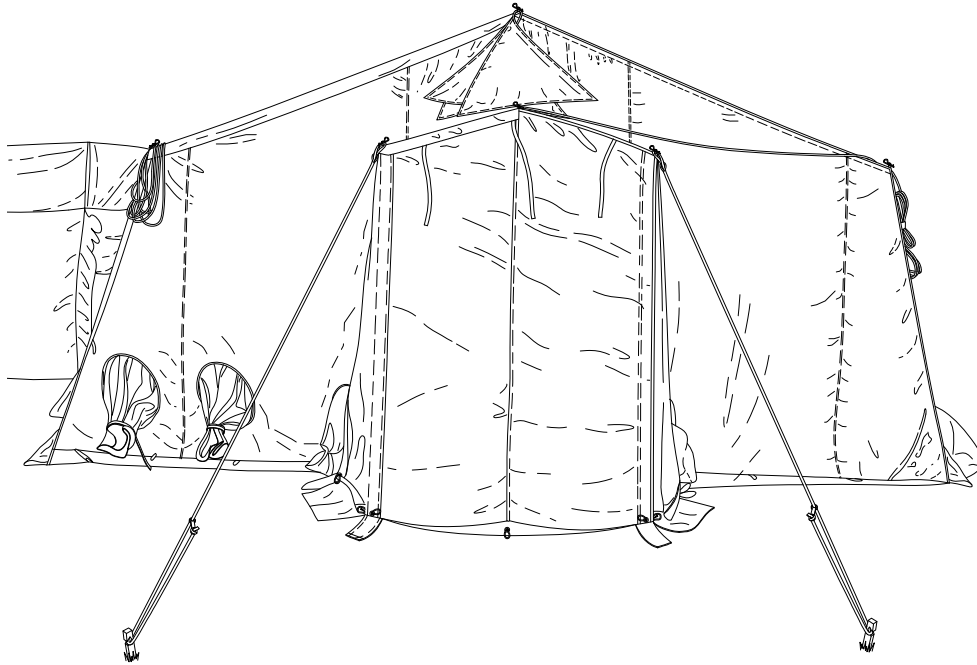
**OPERATING PROCEDURES****Operation in Blackout Conditions**

The new SICPS Medium tent provides a blackout capability to the naked eye for 300 meters and against night vision devices for 100 meters when all personnel doors, windows, electrical sleeves, environmental control unit ducts, stovepipe shield, and exterior weather seal flaps are closed and secured. For entry/exit purposes, the use of a standard vestibule with a vestibule fabric door or a new sandwich wall

with a vestibule fabric door is required. Enter into the vestibule area; then close the outer door before opening the inner door of the tent.

### Doors

Tent doors are located in the center of the end walls. A door may also be laced to the end of a vestibule. A door is opened by unzipping either side, rolling up, and tying with tie tapes. Inside the fabric outer door is a screened door that is fastened with hook and pile fastener on either side. The screen also may be rolled up and tied out of the way.



**Figure 46. Tent Doors.**

### Fabric, End Section (2 each)

Each end wall has two electrical sleeves (one on each side of the personnel door). The electrical sleeves possess the ability to be tied off when not in use or secured around the outside of the sleeve when electrical cables are used. The end wall provides a means to attach the 24-foot long, single-ply cable management fabric floor to the inside of the end wall.

### Fabric, Intermediate Section (24 foot) (1 each)

The 24-foot long intermediate section consists of two standard-sized personnel doors and one standard window on each side of one complete 24-foot intermediate section.

The new intermediate section is made in one 24-foot-long configuration, consisting of two personnel-sized door openings on each side of the tent for a total of four doors. Each door opening includes the standard vestibule adapter surrounding the door. A standard-sized window is located in between each door opening on both sides of the 24-foot section.

There are two standard-sized environmental control unit duct openings located approximately five feet on center from each other under each standard-sized window. Each ECU duct is approximately 18 inches in

diameter by 18 inches long, with the ability to be tied off when not in use or secured around the outside of the sleeve when ECU ducts are used.

Each intermediate section provides two electrical sleeves, one on each side of each personnel door for a total of eight electrical sleeves. The electrical sleeve is tied off when not in use or secured around the outside of the sleeve when electrical cables are used.

The intermediate section also provides a means to connect the floor directly to the inside wall. The 24-foot intermediate section interfaces with and is interoperable with the standard 8-foot long TEMPER tent sections used in the field today.

### **Windows of the 24-foot Fabric Section**

The windows are made in three layers: a rain flap on the outside, a clear plastic window in the middle, and a screen on the inside. The rain flaps and plastic windows are closed by hook and pile fasteners. The rain flap and the plastic window can each be held open with tie tapes. Each layer must be rolled up towards the inside to prevent rain from being trapped within the folds. To fully close the rain flap, the clear plastic window must first be rolled and secured.

### **Roof Vent**

The tent has a triangular vent at the peak of the tent, on the end wall, which may be tied open or closed.



**Figure 47. Roof Vent Location.**

### **Stovepipe Openings**

The stovepipe opening allows for passage of a 4-inch diameter stovepipe. When not in use, the weather flap must be secured with the hook and pile fastener tape.

### **Single-Ply Fabric Floor (24-foot) (1 each)**

The fabric floor is a single-ply, 24-foot long, fabric floor versus the standard 8-foot floor lengths now available in the TEMPER tent. The new floor design is compatible with the new intermediate section and/or insulated wall liner sections. The floor is secured to the intermediate section wall and to the end wall to create a closed seal. The design of the floor allows the floor to be secured to the tent wall when a door is not in use and arranged as to not pose a tripping hazard when a door is in use.

Additionally, the floor provides a means to secure power cables directly to the floor. The power cables are located on the topside of the floor in an open grid pattern. The size of the grid pattern creates a 9-grid pattern, every eight feet in length, and approximately every 6.5-feet in width.



Figure 48. Power Cable Floor Grid.

### Electrical Sleeves

The electrical sleeve is tied off when not in use or secured around the outside of the sleeve when electrical cables are used.



Figure 49. Electrical Sleeve Location.

### Environmental Control Unit (ECU) Sleeves

Each ECU duct is approximately 18 inches in diameter by 18-inches long, with the ability to be tied off when not in use or secured around the outside of the sleeve when ECU ducts are used.



**Figure 50. ECU Sleeve Location.**

### Plenum

The roof cap liner design includes a fully integrated air distribution system (i.e. plenum) that is detachable, if desired, by the user. The air distribution system plenum is capable of introducing air from the end by means of the ECU ducts located in the lower left outside corner of the end wall.



**Figure 51. Insulated Liner System (Side Wall, End Wall, and Roof Cap).**

One complete liner system is required for each SICPS Medium. The internal liner system is designed and developed in multiple components for ease of setup, strike, and packing. The insulated liner system is fabricated from an insulated material providing an approximate R-factor of three when used in conjunction with the tent itself. These insulated liners are used to assist field heaters and air conditioners at maintaining specific temperature ranges inside the SICPS Medium tent during operational use. The outer cover material of the insulated liner resists mildew and is flame resistant.



**Figure 52. Insulated Liner Folded and Placed on Transport Cover.**

### **Roof Cap Insulated Liner.**

The 24-foot long roof liner is suspended below the external roof fabric from eave to eave. The roof cap liner possesses the necessary quantity of connection points for supporting a minimum of six fluorescent lights in the roof. The roof design also includes a cable management system. The cable management system provides a means to manage and separate power cables from LAN lines (computer cables). The roof cap liner design includes a fully integrated air distribution system (i.e. plenum) that is detachable, if desired, by the user. The air distribution system plenum is capable of introducing air from the end by means of the ECU located in the lower left outside corner of the end wall. The roof cap liner provides a mechanism to hold in place the electrical power panel stand on diagonally opposing ends. The roof cap liner has a notch sewn in the fabric to accomplish this.

### **Side Wall Insulated Liner.**

There are two symmetrical side wall liners that can be installed/removed after the tent is initially erected halfway or in a fully erected position. Each sidewall liner is designed to allow the exterior doors, windows, ECU ducts and electrical sleeves to operate as intended when the insulated liner is in use.

### **End Wall Insulated Liner.**

There are two symmetrical end wall liners that can be installed and/or removed after the tent is erected. Each end wall liner is designed to allow the exterior door, ECU ducts, and electrical sleeves to operate as intended when the insulated liner is in use. The end wall liner has a mechanism to hold in place the power panel stand.

### **Sandwich Wall (6 each).**

The new sandwich wall may be used in any of four (4) different ways:

1. Connect existing SICPS RWS vehicle boot walls to the standard vestibule adapter located on either the end wall or intermediate tent sections of the SICPS Medium.
2. Allow the connection of any existing MCPS Small tent directly to any SICPS Medium, TEMPER or Modular General Purpose Tent System (MGPTS) in the Army today.
3. As a short vestibule.

4. As a Blackout Entry/Exit Door. This requires two standard vestibule frame assemblies. All other uses require only one vestibule frame assembly.

The new wall is approximately 2 feet in length. The wall includes the standard becket lace with weather seal flap system found on the vestibule adapter and on the end and intermediate fabric sections.

When the part of the sandwich wall that is used to connect to the MCPS Small to a RWS vehicle as boot wall is not used, it shall be provided with a means to secure the wall in a rolled up configuration on the underside of the new sandwich wall.

### Electrical Assembly

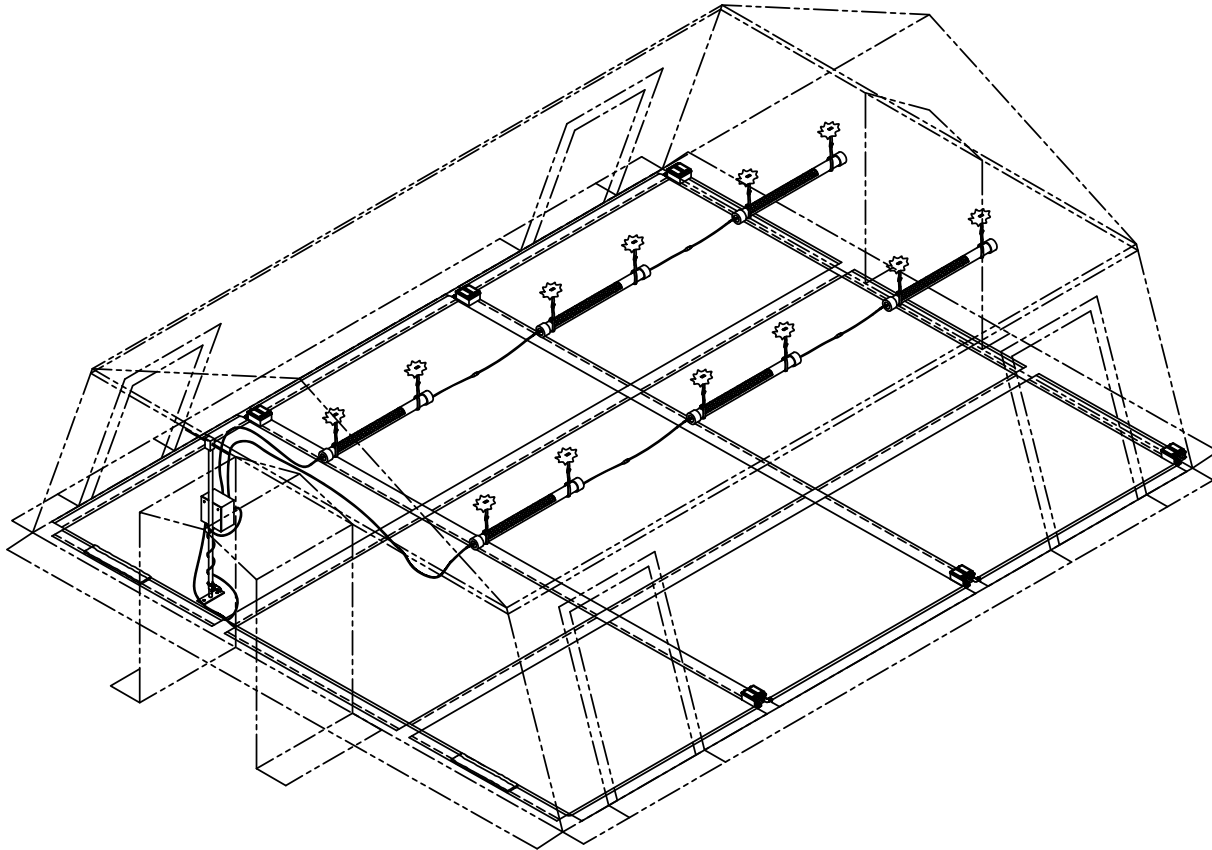
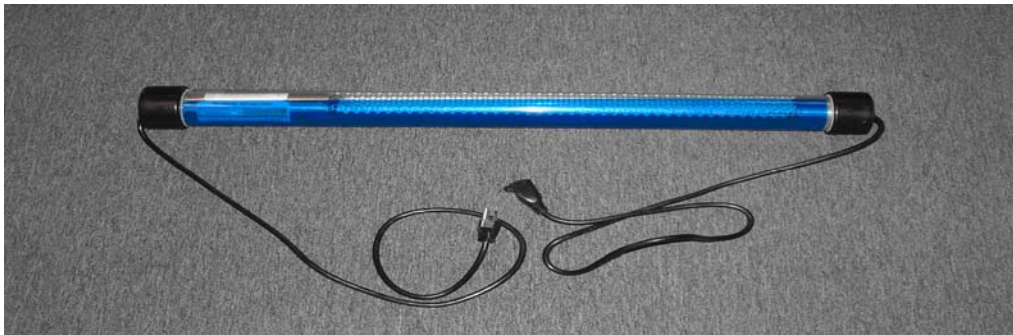


Figure 53. Electrical Assembly Layout.



**Lights (6 each)**

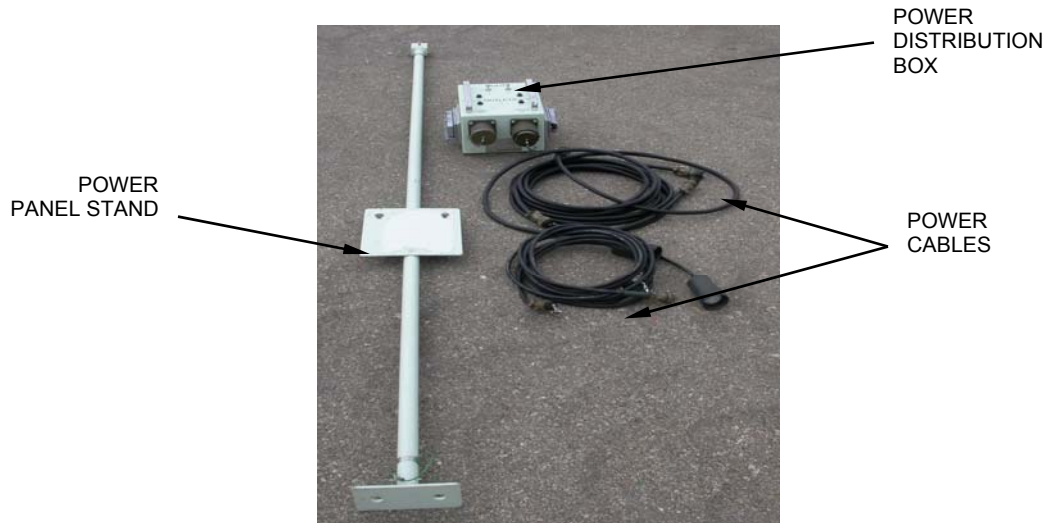
Six standard fluorescent lights will be required for each SICPS Medium tent.



**Figure 54. Fluorescent Light Assembly.**

**Power Distribution System (1 each)**

Each SICPS Medium tent requires a standard TEMPER tent power distribution box and a standard power panel stand to support the power distribution box. The SICPS Medium tent substitutes cable headers in lieu of headers for the same function. Additionally, the SICPS requires two rows of convenience outlets and applicable power cables, as well as power cables to attach the standard lights to the desired power distribution box.



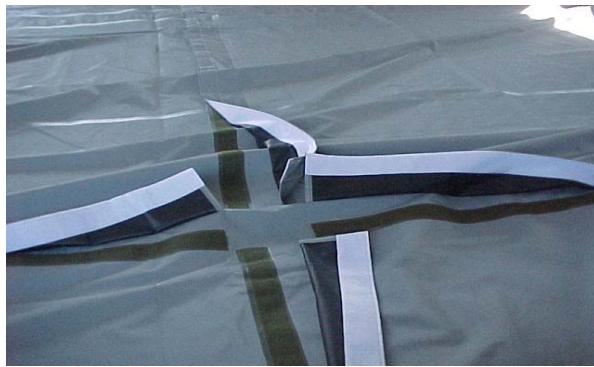
**Figure 55. Power Distribution System Components.**

### Cable Management Assembly

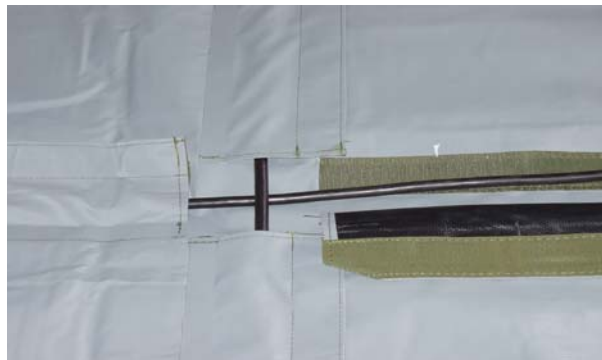
Cable management system in the floor is for the power cables. Cable management on the ceiling (insulated roof cap liner) is for LAN lines.



**Figure 56. Cable Management System in the Floor in the Closed Position.**



**Figure 57. Cable Management System in the Floor in the Open Position.**



**Figure 58. Cable Management System in the Ceiling in the Closed Position.**



**Figure 59. Cable Management System in the Ceiling in the Open Position.**



**Figure 60. Cable Management System on the Roof Cap Liner.**

#### **Fabric Transport Bags (7 each)**

Fabric transport bags will be required to transport the intermediate sections, end section walls, floors, sandwich wall, and insulated liners in the field.



**Figure 61. Fabric Components Wrapped in Transport Bags.**

**Frame Transport Bags (3 each)**

Frame transport bags will be required to transport all frame components.



**Figure 62. Frame Components Wrapped in Transport Bags.**

**Frame Components**

Sufficient tent frame components for assembling one 24-foot long modified TEMPER tent frame are required. Each 24-foot frame assembly consists of the following items and quantities: 4 standard upper arch assemblies, 8 lower arch assemblies, 11 purlins, 4 door sill purlins, and 4 cable header assemblies from the Army's Lightweight Maintenance Enclosure (LME) shall be used for the SICPS Medium tent. Modification to standard TEMPER frame is the rotating spindle at the eave location on each lower arch assembly.

**Vestibule Frames (7 total)**

Vestibule frames are provided with each of the six door openings per SICPS Medium tent. All vestibule frames are transported in frame transport bags.

**Vestibule Door (1 each)**

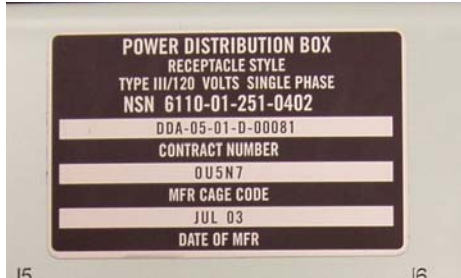
One vestibule door is required for each SICPS Medium tent. Vestibule doors are transported in appropriate transport bags containing the end wall or 24-foot intermediate section.

**Vestibule Bag (1 each)**

One vestibule bag is required to store vestibule frames and vestibule door.

**DECALS AND INSTRUCTION PLATES**

**Power Distribution Box.** The following WARNING, instruction, and identification labels are attached to the power distribution box:



**Figure 63. Identification Plate.**



**Figure 64. Caution on Power Distribution Box Cover.**



**Figure 65. Decals on the Face of the Power Distribution Box.**



Figure 66. Decals on the Bottom of the Power Distribution Box.

**Light Assembly.** The following combination identification, instruction, and CAUTION label is attached to each individual light:



Figure 67. Warning on Light Set.

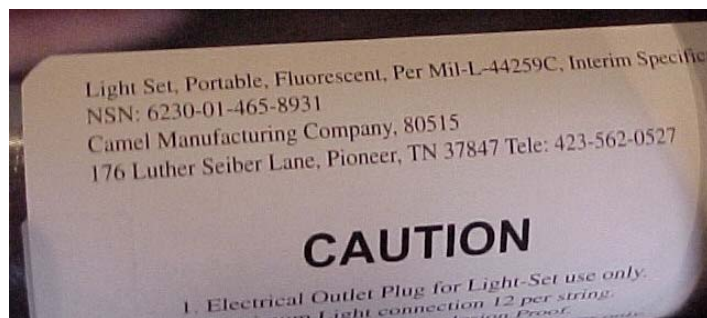


Figure 68. Caution on Light Set.

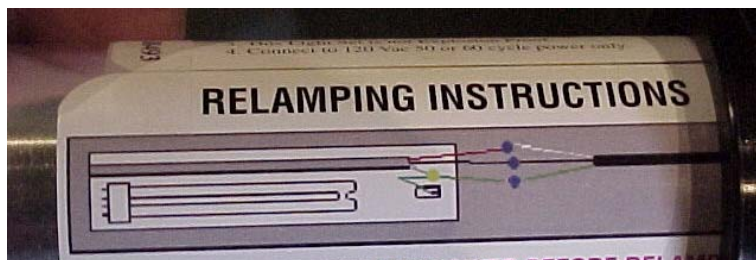


Figure 69. Relamping Instructions on Light Set.

- A CAUTION decal is found inside the cover of the light set storage container (not shown).
- Identification labels are found on the inside of each tent fabric assembly and transport bag.



**Figure 70. Tent Fabric Assembly and Transport Bag Identification Labels.**

- Transport bags are labeled on outside of bag.
- Labels show contents, loaded weight, and personnel lift requirements.

**PREPARATION FOR MOVEMENT**

To prepare the SICPS Medium tent for movement, clean and dry tent fabric sections and equipment, as described in WP 0013, and package the tent into transport bags following the procedures outlined on the following pages.

1. Turn off all power distribution box circuit breakers.

2. Disconnect external power supply at the source, then disconnect the external power supply cable (x) from the power distribution box.
3. Close personnel doors and windows on the SICPS Medium.
4. Ensure vehicle doors are unfastened.

Disassemble the MCPS Medium as follows:

#### **NOTE**

Fold fabric, label side out.

1. Ensure field tables are removed from inside of the tent.
2. Ensure the floor has been cleaned of all dirt and debris.
3. Locate the transport covers for the side wall and end wall liners.

#### **NOTE**

Ensure the black suspension straps are all unclashed before removing liners.

4. Remove side wall liners from tent frame. Fold liners and place in transport cover.
5. Remove end wall liners from tent frame. Fold liners and place in transport cover.
6. Unsnap suspension straps holding roof cap liner to eave of tent frame.
7. Remove double D-rings attaching roof cap liner to frame.
8. Disconnect power from power distribution box.
9. Remove convenience outlet from cable management system in the floor. Coil and prepare convenience outlets for storage.
10. Remove power distribution box from power panel stand.
11. Lift leg on power panel stand and pin it in the highest position.
12. Untie double D-rings securing floor to base purlins on tent frame.
13. Undo weather seal flaps at corners of tent and undo becket lacing up to eave.
14. Release guyline tension, except at each tent corner. Release tension on high wind lines and disconnect from wooden stakes.
15. Remove stakes and footstop tent pins.
16. Disconnect all the base purlin flaps.



17. Lower one side of the tent as follows:
- a. Ensure the windows and doors have been closed.
  - b. Remove lanyard pins from eave spindles.
  - c. Roll tent fabric up and place on top of the tent eave.

### WARNING



Frame assembly hinges can pinch or crush hands and fingers. Keep hands and fingers away from frame assembly ridges and eaves.

### CAUTION

Avoid folding end wall fabric into joints. Material may rip or tear if caught in joint.

- d. Place two soldiers at each arch on the side of the tent being lowered.
  - e. On command, remove the quick release pins, on eave gusset plate, holding the arches erect.
  - f. Ensure the tension has been relieved from the four corner ropes.
  - g. Standing clear of the tent, place one hand below the eave joint of the arch and one on the eave purlin. Swing out the side frame. Extra soldiers may assist in lowering the frame.
18. Remove light assemblies.

### CAUTION

Do not twist or turn frame components when handling. Damage to equipment may result.

### NOTE

If pin cannot be removed easily, loosen corner guylines and adjust the frame, then remove.

**WARNING**

Ensure power source has been disconnected. Failure to do so may cause injury to personnel.

- a. Ensure lights are turned off and disconnected from power source.
  - b. Unwrap light support strap around each end of light.
  - c. Repeat steps a. and b. for removal of additional lights.
19. Lower other side of the tent as follows:
- a. Ensure the windows and doors have been closed.
  - b. Remove lanyard pins from eave spindles.
  - c. Roll tent fabric up and place on top of the tent eave.

**WARNING**

Frame assembly hinges can pinch or crush hands and fingers. Keep hands and fingers away from frame assembly ridges and eaves.

**CAUTION**

Avoid folding end wall fabric into joints. Material may rip or tear if caught in joint.

- d. Place two soldiers at each arch on the side of the tent being lowered.
- e. On command, remove the quick release pins, on eave gusset plate, holding the arches erect.

**CAUTION**

Do not twist or turn frame components when handling. Damage to equipment may result.

**NOTE**

If pin cannot be removed easily, loosen corner guylines and adjust the frame, then remove.

- f. Ensure the tension has been relieved from the four corner ropes.

- g. Standing clear of the tent, place one hand below the eave joint of the arch and one on the eave purlin. Swing out the side frame. Extra soldiers may assist in lowering the frame.
20. Untie becket lacing on end walls.
  21. Remove end walls from tent frame.
  22. Fold end walls and place in appropriate transport bags.
  23. On both sides of the tent, roll the 24-foot fabric section up from the eave to the ridge.
  24. Remove the lanyard pins from the ridge spindles.
  25. Unclip the black suspension brackets holding the roof cap liner to the frame.
  26. With all six soldiers on the same side of the tent, lift the 24-foot fabric section up and off the ridge spindles and carry the fabric section off of the tent frame.
  27. In an area clear of debris, unroll the tent fabric and fold it, label side out.
  28. Unclip the roof cap liner from the ridge of the tent frame.
  29. Fold the roof cap liner and pack it into the appropriate transport bag.
  30. Remove the floor as follows:
    - a. Remove debris and clean insulated floor.
    - b. Fold floor.
    - c. Locate transport bag for floor and pack floor for shipment.
  31. Disassemble tent frame as follows:

### NOTE

Disassembly sequence is from base to ridge.

- a. Rotate purlin 90 degrees so that end fitting (x) unlocks from boss at arch assembly.
- b. Disconnect each purlin diagonal brace, fold and secure diagonal brace to purlin.

### WARNING



Position one soldier at each ridge arch to hold arch upright during frame disassembly. Failure to hold frame upright may allow frame to fall and cause injury to personnel.

- c. Rotate purlins and remove purlin from arch assembly.
- d. Remove cable header from arch assembly.

- e. Disassemble roof arch and side arch assembly and fold.
- f. Pack frame pieces in appropriate transport bag.
- g. Repeat steps a. through f. for remaining arch assemblies.

Table 1. Transport Bag Configuration.

Tent Cover - Fabric	
Item	Quantity
Sidewall liners	2

Tent Cover - Fabric	
Item	Quantity
Roof Liner	1
Plenum	1
Lights	6

Tent Cover - Fabric	
Item	Quantity
Floor	1
Sandwich Wall	6

Tent Cover - Fabric	
Item	Quantity
Intermediate Fabric Assembly	1

Tent Cover - Fabric	
Item	Quantity
Endwall Fabric Assembly	2

Tent Cover - Fabric	
Item	Quantity
Endwall Liner	2

Tent Frame Cover	
Item	Quantity
Arch Assembly	1
Cable Header Assembly	1
Purlin Assembly	3
Door Sill Purlin Assembly	2
Vestibule Frame Assembly	2

Tent Frame Cover	
Item	Quantity
Arch Assembly	1
Cable Header Assembly	1
Purlin Assembly	3
Door Sill Purlin Assembly	2
Vestibule Frame Assembly	2

Tent Pin Transport Bag	
Item	Quantity
Tent Pin, Steel, 12-inch	12
Tent Pin, Wood, 24-inch	16

Tent Frame Cover	
Item	Quantity
Vestibule Frame	7
Vestibule Door	1

Tent Frame Cover	
Item	Quantity
Purlin	5
Side Arch	4
Roof Arch	2
Cable Header	2

Tent Frame Cover	
Item	Quantity
Purlin	3
Side Arch	2
Roof Arch	1
Cable Header	1
Door Sill Purlin	2

END OF WORK PACKAGE



---

**OPERATOR AND FIELD MAINTENANCE  
STANDARD INTEGRATED COMMAND POST SYSTEM (SICPS), MEDIUM  
NSN: 8340-01-516-0904, GREEN  
NSN: 8340-01-516-0903, TAN  
OPERATION UNDER UNUSUAL CONDITIONS**

---

**INITIAL SETUP****Tools and Special Tools**

N/A

**Equipment Condition**

N/A

**Materials/Parts**

N/A

**References**

N/A

---

**GENERAL**

While it is not possible to prepare for all unusual conditions the SICPS Medium might be exposed, the following information should be helpful during unusual climatic conditions.

**UNUSUAL ENVIRONMENT/WEATHER****Operation in High Wind****WARNING**

All tent lines and frame feet must be staked down. Failure to stake and tie down tent may result in injury to personnel and damage to equipment.

1. Replace wooden stakes with ground anchor kit, if available (see AAL, WP 0055).
2. Close and fasten all windows and doors.
3. Frequently check all tent pins and lines.
4. Secure tentage by placing sandbags around base of tent.

**Operation in Wet Climate**

1. If heavy rain is expected or the SICPS Medium is going to be set up for a long period-of-time, dig a trench around the outside.
2. Tent lines may shrink from dampness, so keep tent lines loose enough to prevent tent pins from being pulled out of the ground.
3. Dry all SICPS Medium components before repacking.
4. Ensure leaks do not occur near the electrical distribution set of the light set. Disconnect power if leaks occur.

**Operation in Snow/Extreme Cold**

1. Inspect all roof vents for snow and ice accumulations. If accumulations exist, clear all snow and ice from roof vent.
2. Sweep snow using a snow rake.
3. Gently push up on the roof, from the inside of the SICPS Medium, to remove snow that may have piled up.
4. When erecting the SICPS Medium in snow conditions, gently stomp the snow down to provide a firm surface on which to set the tent up.

**WARNING**

All tent lines and frame feet must be staked down. Failure to stake and tie down tent may result in injury to personnel and damage to equipment.

**WARNING**

Stay alert to moisture conditions and adjust all guylines at tent slips, as required, before weight or shrinkage damages tent or injures personnel.

5. If ground is too frozen to drive steel tent pins, chop small holes to set them in. Fill holes with slush or water; allow holes to freeze and anchor pins.
6. On a daily basis, remove snow away from side of tent.

**Operation in Extreme Heat**

Roll up the end walls and window/roof section fabric to provide maximum ventilation.

1. Open weather flaps on both sides of the section to be opened.
2. Untie and disconnect becket lacing as high as eave purlin. Tie off becket lacing at eave.
3. Disconnect base purlin flaps from inside tent.
4. Open the entranceway door and tie back.
5. Fold and roll fabric underneath itself and towards top. Tie with tie tape.



## Operation in Soft Soil

### WARNING

If the soil is soft, additional stakes are required. Failure to properly stake the tent in soft soil may result in injury to personnel and damage to equipment.

1. Install an additional wooden stake at each guyrope location, six inches from the original stake.
2. Connect the guyrope to a third wooden stake, which should be placed horizontally behind the two stakes.
3. If necessary, add a fourth stake at each guyrope location.

## Operation with Damaged or Bent Purlins

A ridge or eave purlin that has been damaged or bent, but is still serviceable, should be moved to the lower part of the structure and used as a base purlin.

## INTERIM CHEMICAL, BIOLOGICAL, RADIOLOGICAL AND NUCLEAR (CBRN) DECONTAMINATION PROCEDURES

1. If chemical or biological contamination is expected, close all SICPS Medium openings, such as windows, doors, and stovepipe openings.

### NOTE

Perform unit level decontamination of the SICPS Medium only under supervision of unit NBC personnel.

2. If the SICPS Medium is set up, decontaminate the fabric around the entranceway area of nuclear, chemical, or biological contamination by applying STB slurry or brushing with hot, soapy water.
3. Prepare slurry by mixing approximately equal parts of water with STB. Use a swab or a broom to scrub slurry into fabric.
4. Remove slurry promptly with brush and liberal quantities of hot water and soap. Rinse with clear water.

### NOTE

STB slurry may leave a harmless, white, chalky residue. This is not a cause for concern.

5. Decontaminate the remaining sections of the SICPS Medium by natural methods. Expose the erected tent to the effects of weather and aeration for approximately two to three days.

### CAUTION

Heavy concentrations of DS2 are harmful to the SICPS Medium fabric. A fine spray mist is recommended. Do not scrub with mop or broom.

**NOTE**

DS2 will cause some change in fabric color.

6. Aeration is not effective against V-agents. If contaminated by V-agent, entire SICPS Medium must be decontaminated with DS2 slurry.
7. After completion of decontamination, NBC team needs to determine if tent is safe for use.

**EMERGENCY PROCEDURE**

If there is any evidence of smoke or heat in the electrical raceways, immediately shut down the power distribution box in the tent. Contact safety officer for further instruction.

**END OF WORK PACKAGE**

## **CHAPTER 3**

### **TROUBLESHOOTING PROCEDURES FOR STANDARD INTEGRATED COMMAND POST SYSTEM (SICPS), MEDIUM**



**OPERATOR AND FIELD MAINTENANCE  
STANDARD INTEGRATED COMMAND POST SYSTEM (SICPS), MEDIUM  
NSN: 8340-01-516-0904, GREEN  
NSN: 8340-01-516-0903, TAN  
TROUBLESHOOTING INDEX**

<u>Malfunction/Symptom</u>	<u>Troubleshooting Procedure</u>	<u>WP Reference</u>
<b>OPERATOR LEVEL PROCEDURES:</b>		
No Power to Electrical System	1	WP 0008
Convenience Outlets Inoperative	2	WP 0008
Lights Do Not Light	3	WP 0008
Tent Will Not Stay Taut	4	WP 0008
Tent Leaks	5	WP 0008
<b>UNIT LEVEL PROCEDURES:</b>		
Frame Assemblies Will Not Fit Together	1	WP 0009
Tent Leaks	2	WP 0009

**USE OF THE TROUBLESHOOTING PROCEDURES TABLE**

You should perform the tests/inspections and corrective actions in the step order listed.

**Malfunction.** Check for where or what the malfunction is.

**Test or Inspection.** Test or inspect the cause of the malfunction.

**Corrective Action.** Once the malfunction is determined, correct the situation.




**OPERATOR AND FIELD MAINTENANCE  
STANDARD INTEGRATED COMMAND POST SYSTEM (SICPS), MEDIUM  
NSN: 8340-01-516-0904, GREEN  
NSN: 8340-01-516-0903, TAN  
TROUBLESHOOTING PROCEDURES, OPERATOR LEVEL**

**GENERAL**

This table lists common malfunctions of the equipment and contains instructions for operator personnel diagnosing and correcting each malfunction. Perform the indicated steps in the order listed.

**Table 1. Troubleshooting Procedures, Operator Level.**

<b>MALFUNCTION</b>	<b>TEST OR INSPECTION</b>	<b>CORRECTIVE ACTION</b>
<p>1. No Power to Electrical System.</p>	<p>Step 1. Check security of connectors.</p> <p>Step 2. Check for overloaded sockets.</p> <p>Step 3. Check electrical distribution box for popped circuit breakers.</p>	<p>Tighten loose connections.</p> <p>Reset circuit breakers and unplug unnecessary equipment.</p> <p>Reset circuit breakers.</p> <p>If breakers continue to pop, turn power OFF, and notify unit maintenance.</p>
<p>2. Convenience Outlets Inoperative.</p>	<p align="center"><b>WARNING</b></p> <p align="center"></p> <p>Lethal voltage is present when the power distribution box is connected to a power source. Disconnect power before touching any wires in the power box.</p> <p>Step 1. If all power outlets are inoperative, check external power connection to distribution box.</p> <p>Step 2. Check power outlet circuit breakers.</p> <p>Step 3. Check GFCI test button.</p>	<p>Ensure an external power source (commercial or a generator providing 110VAC) is connected to distribution box.</p> <p>Reset power outlet circuit breakers.</p> <p>Reset test button.</p> <p>If condition persists or power outlet circuit breakers activate repeatedly, notify unit maintenance.</p>

**Table 1. Troubleshooting Procedures, Operator Level – Continued.**

<b>MALFUNCTION</b>	<b>TEST OR INSPECTION</b>	<b>CORRECTIVE ACTION</b>
<p>3. Lights Do Not Light.</p>	<p>Step 1. Check power source.</p> <p>Step 2. Ensure all electrical connectors are properly connected.</p> <p>Step 3. Check for burnt-out fluorescent lamp (lamp will be gray/black).</p> <p>Step 4. Check for proper operation of ON/OFF switch.</p>	<p>Select proper power source (110VAC 50/60HZ).</p> <p>Connect electrical connectors.</p> <p>Replace lamp as described in WP 0015.</p> <p>Replace entire light assembly if switch does not operate.</p>
<p>4. Tent Will Not Stay Taut.</p>	<p>Check tent lines, tent pins and tent line slips.</p>	<p>Anchor tent lines securely to pins. Replace tent pins or lines, if necessary. Tighten tent line slips.</p>
<p>5. Tent Leaks.</p>	<p>Ensure the windows are sealed, the stovepipe opening is closed, all weather flaps are sealed, and all hook and pile fasteners are secured.</p>	<p>Close stovepipe opening, seal weather flaps, and secure all hook and pile fasteners.</p> <p>Contact service level maintenance if leaks persist.</p>



**OPERATOR AND FIELD MAINTENANCE  
STANDARD INTEGRATED COMMAND POST SYSTEM (SICPS), MEDIUM  
NSN: 8340-01-516-0904, GREEN  
NSN: 8340-01-516-0903, TAN  
TROUBLESHOOTING PROCEDURES, UNIT LEVEL**

**GENERAL**

This table lists common malfunctions of the equipment and contains instructions for unit personnel diagnosing and correcting each malfunction. Perform the indicated steps in the order listed.

**Table 1. Troubleshooting Procedures, Unit Level.**

<b>MALFUNCTION</b>	<b>TEST OR INSPECTION</b>	<b>CORRECTIVE ACTION</b>
1. Frame Assemblies Will Not Fit Together.	Check for missing or bent frame components. Inspect for damaged fittings.	Replace any bent or missing frame component with a serviceable item from stock.
2. Tent Leaks.	Check for rips, tears, holes, or separating seams in the roof cap or wall fabric assemblies.	Repair any rips, tears, or holes not exceeding 6 inches in length as described in WP 0021. Refer more extensive damage to field support maintenance for repair.



## **CHAPTER 4**

### **MAINTENANCE INSTRUCTIONS FOR STANDARD INTEGRATED COMMAND POST SYSTEM (SICPS), MEDIUM**



---

**OPERATOR AND FIELD MAINTENANCE  
STANDARD INTEGRATED COMMAND POST SYSTEM (SICPS), MEDIUM  
NSN: 8340-01-516-0904, GREEN  
NSN: 8340-01-516-0903, TAN  
SERVICE UPON RECEIPT**

---

**INITIAL SETUP****Tools and Special Tools**

N/A

**Equipment Condition**

N/A

**Materials/Parts**

N/A

**References**

N/A

**SITING**

Select a level area and ensure there is sufficient space to set up and operate the SICPS Medium. The area should be clear of rocks and underbrush and accessible to tactical vehicles. Refer to WP 0005 for other siting requirements.

**SHELTER REQUIREMENTS**

If possible, the area should be sheltered from high winds.

**SERVICE UPON RECEIPT OF MATERIEL**

**Unpacking.** Upon receipt of equipment, check for damage. Report any damage to the carrier and your supervisor.

**CAUTION**

Unpack components carefully. Improper or hasty handling may result in damage to the SICPS Medium components and accessories.

**Shipping Material.** Save the shipping crate and any padding material for reuse and return shipment.

**Checking Unpacked Equipment.** Inspect the unpacked components for damage, completeness, and application of applicable Modification Work Orders (MWOs) as follows:

1. **Damage.** Check the equipment for damage incurred during shipment. Report any damage on SF 364, Report of Discrepancy. Also note damage on DA Form 2404, Equipment Inspection and Maintenance Worksheet, and initiate corrective maintenance procedures in accordance with this manual.
2. **Completeness.** Inspect the contents of the shipment against the packing slip to see if any items are missing (see WP 0054, Components of End Item). Report any discrepancies noted in accordance with instructions in DA PAM 738-751, Functional Users Manual for the Army Maintenance Management Systems. The equipment can be placed in service even if accessory or other parts/assemblies, that are not affecting proper functioning, are missing.
3. **Modifications.** Check DA PAM 25-30 to see if there is any MWO applicable to the SICPS Medium components you are unpacking. If an MWO is listed, check to see if it has been applied to the equipment. The MWO number will be shown on the case/bag near the equipment nomenclature. If a current MWO is listed in DA PAM 25-30, but there is no evidence that it has been applied to the equipment you are unpacking, note the discrepancy on DA Form 2404, Equipment Inspection and Maintenance Worksheet.

**Table 1. SICPS Medium Inventory List.**

<b>Section</b>	<b>Quantity</b>	<b>Item</b>
<b>Frame</b>		
	4	Upper Arch Assembly
	8	Lower Arch Assembly
	4	Cable Header Assembly
	4	Door Sill Purlin
	11	Purlin
	3	Transport Bag
	7	Vestibule Frame
	1	Vestibule Transport Bag
<b>Fabric</b>		
	2	End Section
	1	24-FT Intermediate Section
	1	Floor Section
	5	Transport Bag
	6	Sandwich Wall
	1	Vestibule Transport Bag
<b>Liner</b>		
	1	Roof Cap Liner
	2	End Wall Liner
	2	Side Wall Liner
<b>Electrical</b>		
	1	Power Panel Stand
	1	Power Distribution Box
	6	Lights (Double Fluorescent)
	1	Light Cable, 173-IN. Long
	1	Light Cable, 103-IN. Long
	2	Duplex Cables, 156-IN. Long
	2	Duplex Cables, 254-IN. Long
	2	Duplex Receptacle Sets
<b>Accessories</b>		
	6	5-FT. Tables
	12	12-IN. Steel Tent Pins
	16	24-IN. Wooden Tent Pins
	1	Tent Pin Container
	1	12-LB. Sledge Hammer

---

**OPERATOR AND FIELD MAINTENANCE  
STANDARD INTEGRATED COMMAND POST SYSTEM (SICPS), MEDIUM  
NSN: 8340-01-516-0904, GREEN  
NSN: 8340-01-516-0903, TAN  
PREVENTIVE MAINTENANCE CHECKS AND SERVICES (PMCS), INTRODUCTION**

---

**GENERAL**

The following paragraphs contain general information pertaining to unit and direct support maintenance procedures. WP 0012 lists preventive maintenance checks and services (PMCS).

Preventive Maintenance Checks and Services (PMCS) are performed to keep the tent in operating condition. The checks are used to find, correct, or report problems.

Pay attention to WARNING and CAUTION statements. A WARNING means someone could be hurt. A CAUTION means equipment could be damaged.

Before you begin operating the tent equipment, do Before PMCS.

During operation, do During PMCS.

After operation, do After PMCS.

Once a week do Weekly PMCS.

If you find something wrong when performing PMCS, fix it, if you can, using troubleshooting procedures and/or maintenance procedures.

The right-hand column of the PMCS table lists conditions that make the equipment not fully mission capable. Write up items not-fixed on DA Form 2404 for unit maintenance.

If tools required to perform PMCS are not listed in WP 0012 00, notify unit maintenance.

Recording Defects. All defects discovered during the inspection will be recorded using the applicable specifics in DA PAM 738-751, and TB 43-0002-43.

**END OF WORK PACKAGE**





**OPERATOR AND FIELD MAINTENANCE  
STANDARD INTEGRATED COMMAND POST SYSTEM (SICPS), MEDIUM  
NSN: 8340-01-516-0904, GREEN  
NSN: 8340-01-516-0903, TAN  
PREVENTIVE MAINTENANCE CHECKS AND SERVICES (PMCS)**

**INITIAL SETUP**

**Tools and Special Tools**

N/A

**Equipment Condition**

N/A

**Materials/Parts**

N/A

**References**

N/A

**Table 1. PMCS Before Procedures.**

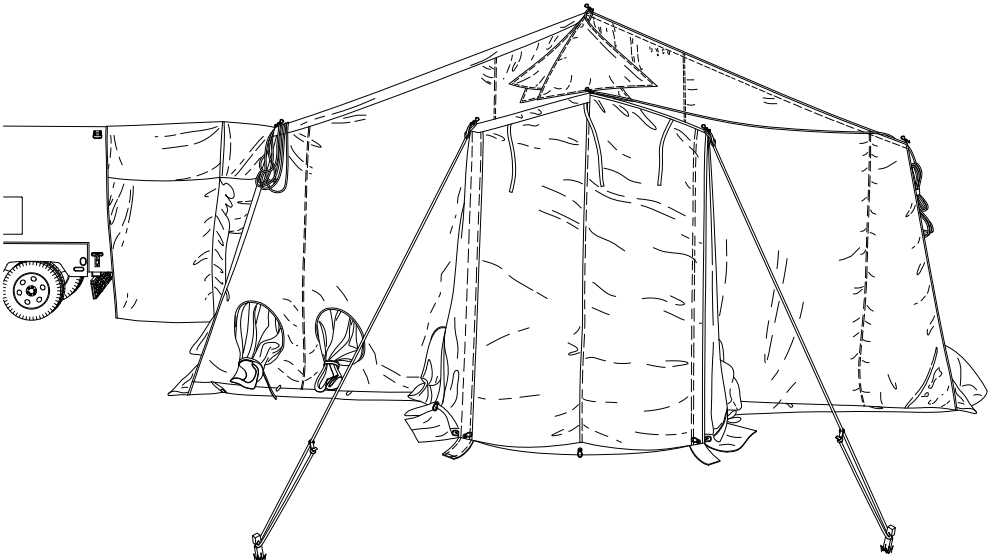
ITEM NO.	INTERVAL	ITEM TO BE CHECKED OR SERVICED	PROCEDURE	EQUIPMENT NOT READY/ AVAILABLE IF:
 <p align="center"><b>Figure 1. Fabric Assembly.</b></p>				
1	Before	Fabric Assembly (Roof, Walls)	<p>Check for tears, punctures, rips, and open seams that may have separated in walls, liners, and floor.</p> <p>Check for ripped or frayed web straps and missing hardware.</p> <p>Check window components for proper operation and condition of hook and pile fasteners. If window components are damaged, XXX.</p>	<p>Fabric ripped or torn. Separated seams or fabric punctures.</p> <p>Frayed or ripped straps. Missing hardware.</p> <p>Damaged window components.</p>

Table 1. PMCS Before Procedures – Continued.

ITEM NO.	INTERVAL	ITEM TO BE CHECKED OR SERVICED	PROCEDURE	EQUIPMENT NOT READY/ AVAILABLE IF:
			Inspect becket lace loops for fraying. Check for missing hitch clip pins.	Missing becket loops. Missing hitch clip pins.
2	Before	Grommets	Check for grommets that are torn away from or out of material.	Grommets are missing or torn away from material causing fabric to tear.
3	Before	Slide Fasteners	Check for smooth operation, missing teeth, and separated seams.	Slide fastener binds, does not open or close, or is torn away from fabric.
4	Before	Hook and Pile Fastener	Inspect hook and pile fasteners for proper alignment and cleanliness. Remove dirt by brushing fastener strips.	Fasteners do not hold when pressed together. Strips loose.
5	Before	Zippers	Check zipper for operation/movement.	Zipper does not move freely.
6	Before	Tent Lines	Inspect tent lines for cuts or fraying.	Tent lines are cut, frayed, or excessively worn.
7	Before	Tent Line Slips	Inspect for broken tent line slips.	Tent line slips broken or missing.
8	Before	Straps	Check interior and exterior straps for fraying or tears.	Straps loose or missing.
9	Before	Straps, Quick Disconnect	Check interior and exterior quick disconnect strap fasteners for tears, fraying, or broken hardware.	Straps loose or missing. Quick disconnect fasteners broken.
10	Before	Stakes	Ensure stakes are in good working condition.	Replace missing or unserviceable stakes.



Figure 2. Transport Bags.

Table 1. PMCS Before Procedures – Continued.

ITEM NO.	INTERVAL	ITEM TO BE CHECKED OR SERVICED	PROCEDURE	EQUIPMENT NOT READY/ AVAILABLE IF:
11	Before	Transport Bags	<p>Check frame and fabric transport bags and tent pin container for rips, tears, or splitting seams.</p> <p>Check strap assemblies for fraying or missing/broken hardware.</p> <p>Check carrying handles for excessive fraying.</p>	<p>Bags are ripped.</p> <p>Straps are loose. Missing/broken hardware.</p> <p>Handles ripped.</p>



Figure 3. Frame Components.

Table 1. PMCS Before Procedures – Continued.

ITEM NO.	INTERVAL	ITEM TO BE CHECKED OR SERVICED	PROCEDURE	EQUIPMENT NOT READY/ AVAILABLE IF:
12	Before	Frame Components	<p>Check condition of upper arch, lower arch, cable header, purlin, and tent threshold.</p> <p>Look for bends, cracks, or other damage. Check for free movement.</p> <p>Ensure quick release pins and hitch clip pins are present and in proper working order.</p> <p>Inspect binding strap assembly for fraying and presence of buckles.</p>	<p>Arch does not fold, locking tabs on purlin and door sill does not rotate and lock.</p> <p>Frame parts are bent or deformed.</p> <p>Quick release pins and hitch clip pins are missing or broken.</p>

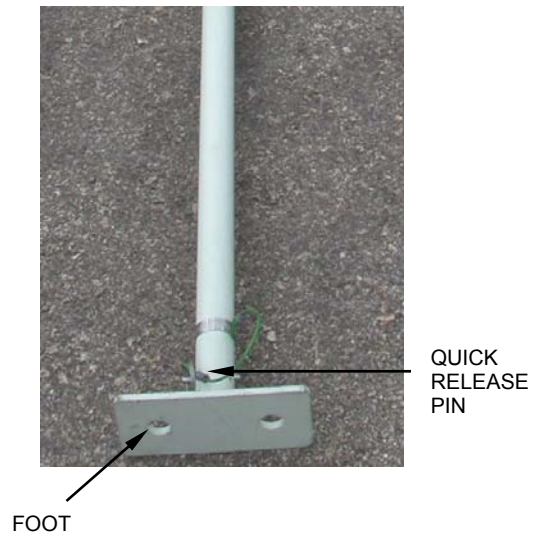
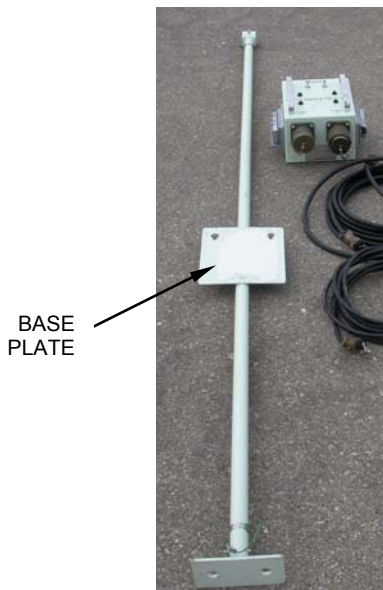
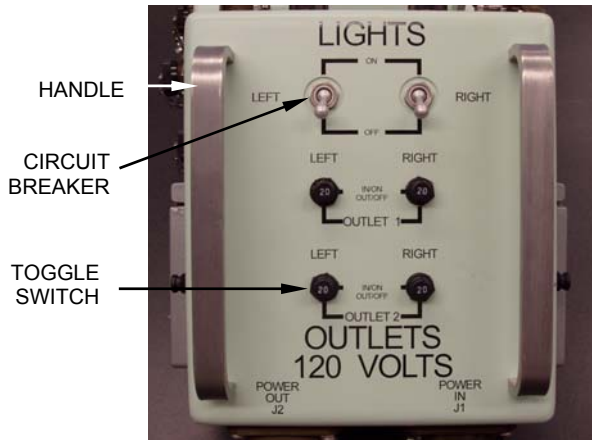


Figure 4. Power Distribution Components.

Table 1. PMCS Before Procedures – Continued.

ITEM NO.	INTERVAL	ITEM TO BE CHECKED OR SERVICED	PROCEDURE	EQUIPMENT NOT READY/ AVAILABLE IF:
13	Before	Cables	Check cable assembly for fraying and damage to swaged ends.	Cable assemblies frayed, damaged or missing.
14	Before	Handles	Check fittings (handles) for damage.	Cracked or broken fittings.
15	Before	Power Distribution Box and Power Panel Stand	<p>Check power distribution box for damage such as deformations, loose or missing hardware and corrosion.</p> <p>Check main panel, circuit breakers, and toggle switches for free and proper operation.</p> <p>Check for missing covers and dirt in electrical receptacles or plugs.</p> <p>Check cables for fraying and all assemblies for signs of shorts.</p> <p>Check power panel stand for security of base plate and foot.</p> <p>Ensure quick release pin is present and in proper condition.</p> <p>Ensure outer and inner tube move freely.</p>	<p>Circuit breakers and toggle switches do not operate.</p> <p>Covers missing.</p> <p>Cable frayed. Burn marks indicating shorts.</p> <p>Stand has damaged base plate or foot.</p> <p>Quick release pin is missing or not working.</p> <p>Tubes do not slide freely.</p>

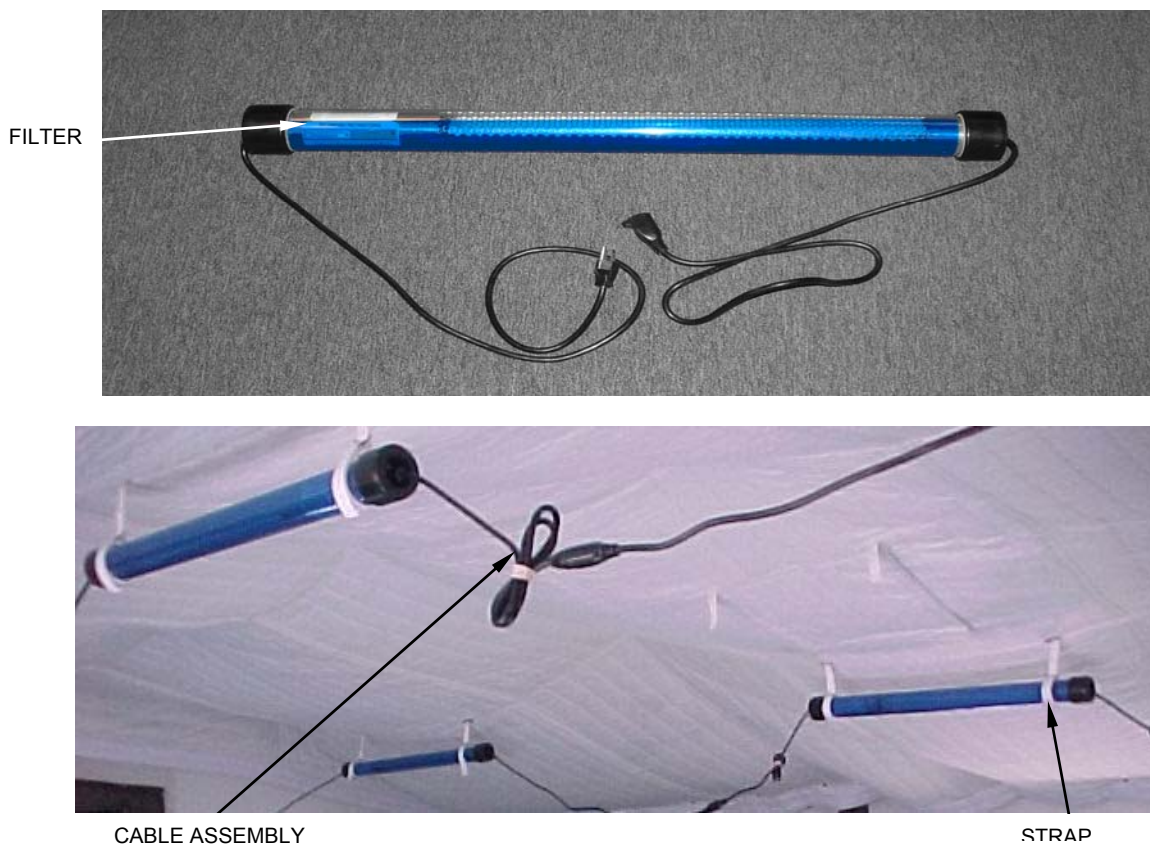


Figure 5. Convenience Outlets.

Table 1. PMCS Before Procedures – Continued.

ITEM NO.	INTERVAL	ITEM TO BE CHECKED OR SERVICED	PROCEDURE	EQUIPMENT NOT READY/ AVAILABLE IF:
16	Before	Convenience Outlets	Check for missing covers and dirt in electrical receptacles or plugs.  Check cables for fraying and all assemblies for signs of shorts.	Covers missing.  Cable frayed. Burn marks indicating shorts.





**Figure 6. Light Assembly.**

**WARNING**

Lethal voltage is present when light set is connected to power source. Disconnect from power source before inspecting or repairing any electrical component. Be careful not to contact electrical connections. Electrical shock or death may result from failure to heed this warning.

**Table 1. PMCS Before Procedures – Continued.**

ITEM NO.	INTERVAL	ITEM TO BE CHECKED OR SERVICED	PROCEDURE	EQUIPMENT NOT READY/ AVAILABLE IF:
17	Before	Light Assembly	Check lights for damage to end caps and plastic cover, missing parts, such as power cords, and presence of fluorescent bulbs.  Check cable assemblies for cracks, breaks, and fraying insulation.	Parts of light set missing or damaged.  Frayed insulation or broken plugs.
18	Before	Straps	Check straps for tear or fraying.	Broken, frayed, or missing straps.
19	Before	Filter	Check filter for tears or punctures.	Light escapes through area other than designated opening.

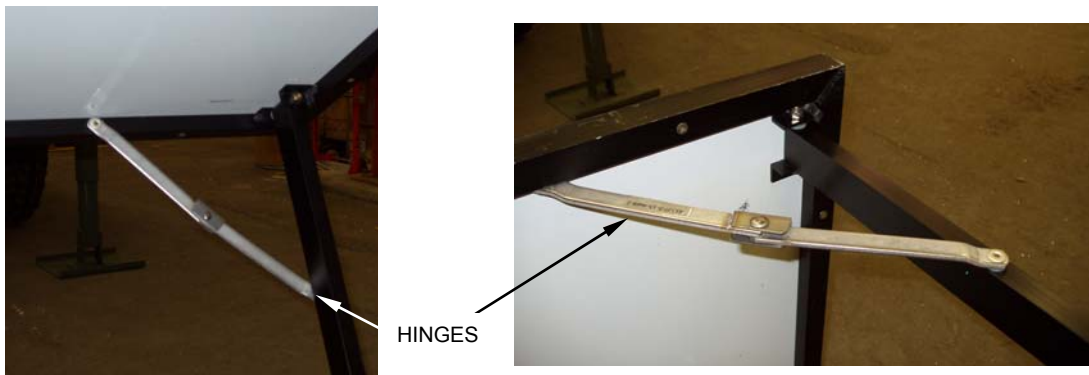


Figure 7. Field Table, Hinges and Braces.

Table 1. PMCS Before Procedures – Continued.

ITEM NO.	INTERVAL	ITEM TO BE CHECKED OR SERVICED	PROCEDURE	EQUIPMENT NOT READY/ AVAILABLE IF:
20	Before	Field Table	Check hinges for smooth operation.  Check for cracks or breaks in hinges and braces.	Table does not fold or open. Bent or broken hinges or braces.

Table 2. PMCS During Procedures.

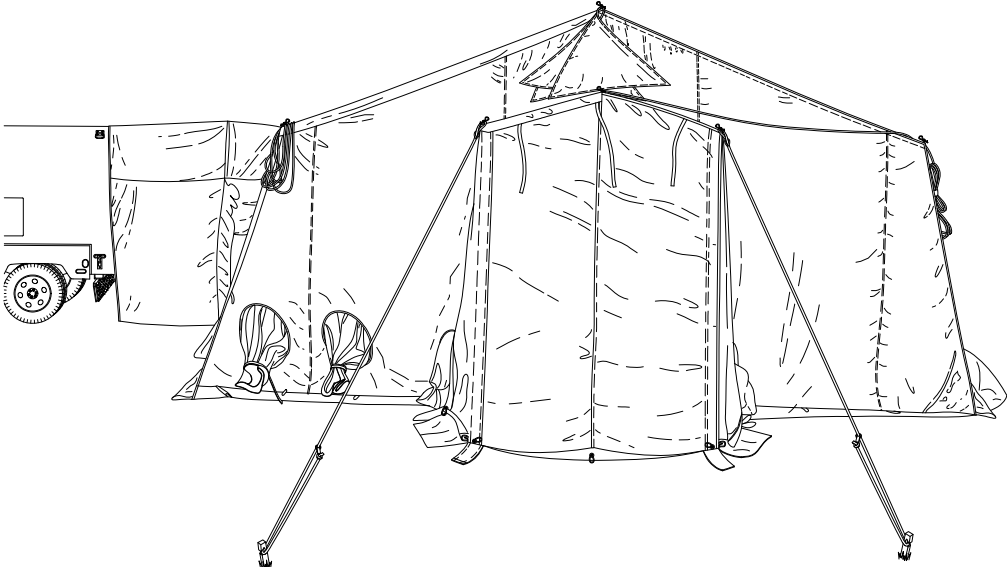
ITEM NO.	INTERVAL	ITEM TO BE CHECKED OR SERVICED	PROCEDURE	EQUIPMENT NOT READY/ AVAILABLE IF:
				
<p><b>Figure 8. Fabric Assembly.</b></p>				
1	During	Fabric Assembly (Roof, Wall)	Check for tears, punctures, rips, and seams that may have separated in walls, liners, and floor.	Fabric ripped or torn. Separated seams or fabric punctures.
2	During	Grommets	Check for grommets that are torn away from or out of material.	Grommets are missing or torn away from material, causing fabric to tear.
3	During	Slide Fasteners	Check for smooth operation, missing teeth, and separated seams.	Slide fastener binds, does not open or close, or is torn away from fabric.
4	During	Hook and Pile Fastener	Inspect hook and pile fasteners for proper alignment and cleanliness. Remove dirt by brushing fastener strips.	Fasteners do not hold when pressed together. Strips loose.
5	During	Tent Lines	Inspect tent lines for cuts or fraying.  Check for and tighten loose tent lines.	Tent lines are cut, frayed, or excessively worn.
6	During	Zippers	Check for proper operation.	Zipper does not move freely.
7	During	Tent Line Slips	Inspect for broken tent line slips.	Tent line slips broken or missing.
8	During	Straps	Check interior and exterior straps for fraying or tears.	Straps loose or missing.

Table 2. PMCS During Procedures – Continued.

<b>ITEM NO.</b>	<b>INTERVAL</b>	<b>ITEM TO BE CHECKED OR SERVICED</b>	<b>PROCEDURE</b>	<b>EQUIPMENT NOT READY/ AVAILABLE IF:</b>
9	During	Straps, Quick Disconnect	Check interior and exterior quick disconnect strap fasteners for tears, fraying, or broken hardware.	Straps loose or missing. Quick disconnect fasteners broken.
10	During	Stakes	Ensure stakes are in good working condition and are firmly in ground.	Stakes are missing or not serviceable.

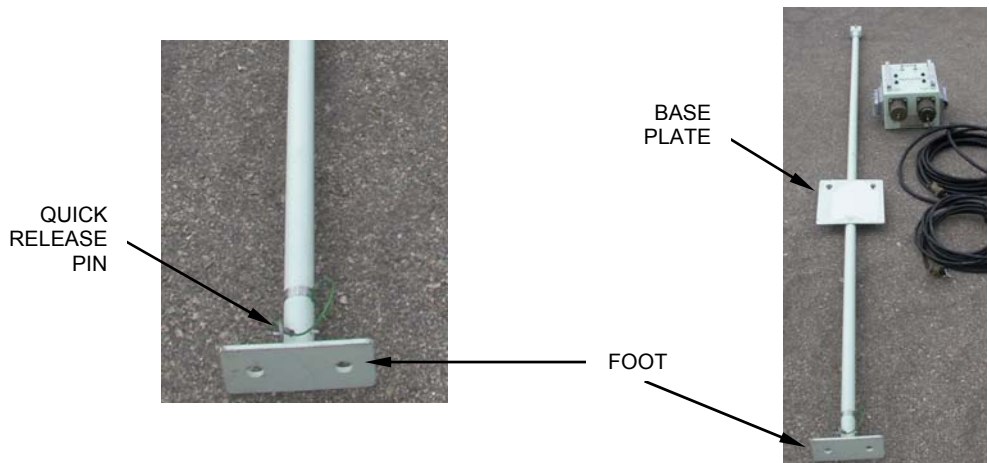
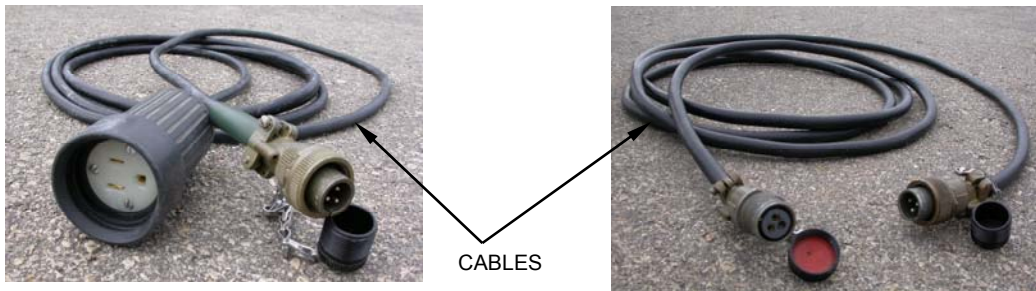


Figure 9. Power Distribution Components.

Table 2. PMCS During Procedures – Continued.

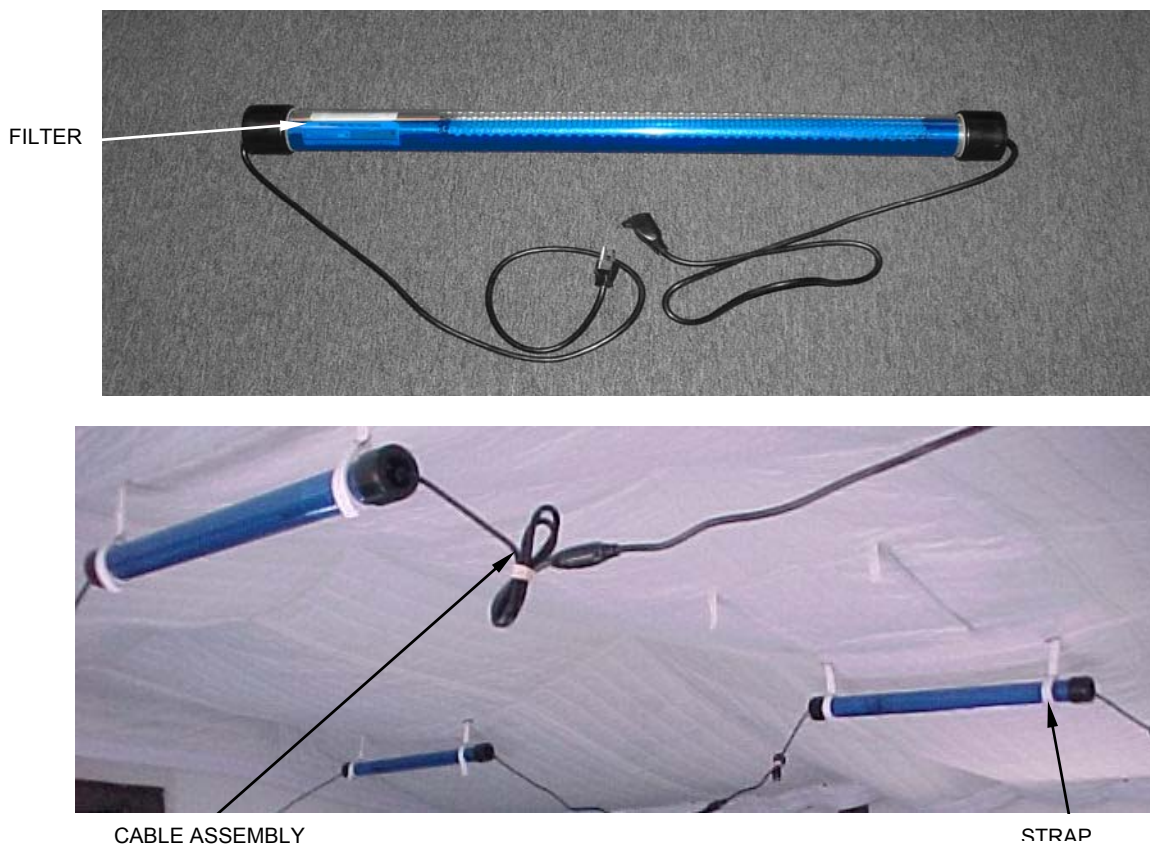
ITEM NO.	INTERVAL	ITEM TO BE CHECKED OR SERVICED	PROCEDURE	EQUIPMENT NOT READY/ AVAILABLE IF:
11	During	Power Distribution Box and Power Panel Stand	<p>Check power distribution box for damage, such as deformations, loose or missing hardware, and corrosion.</p> <p>Check main panel, circuit breakers, and toggle switches for proper operation.</p> <p>Check for missing covers and dirt in electrical receptacles or plugs.</p> <p>Check cables for fraying and all assemblies for signs of shorts.</p> <p>Check power panel stand for security of base plate and foot.</p> <p>Ensure quick release pin is present and in proper condition.</p> <p>Ensure outer and inner tubes move freely.</p>	<p>Circuit breakers and toggle switches do not operate. Cable frayed. Burn marks indicating shorts. Covers missing.</p> <p>Stand has damaged base plate or foot.</p> <p>Quick release pin is missing or not working. Tubes do not slide freely.</p>



Figure 10. Convenience Outlets.

Table 2. PMCS During Procedures – Continued.

ITEM NO.	INTERVAL	ITEM TO BE CHECKED OR SERVICED	PROCEDURE	EQUIPMENT NOT READY/ AVAILABLE IF:
12	During	Convenience Outlets	<p>Check for missing covers and dirt in electrical receptacles or plugs.</p> <p>Check cables for fraying and all assemblies for signs of shorts.</p>	<p>Covers missing.</p> <p>Cable frayed. Burn marks indicating shorts.</p>



**Figure 11. Light Assembly.**

**WARNING**

Lethal voltage is present when light set is connected to power source. Disconnect from power source before inspecting or repairing any electrical component. Be careful not to contact electrical connections. Electrical shock or death may result from failure to heed this warning.

**Table 2. PMCS During Procedures – Continued.**

ITEM NO.	INTERVAL	ITEM TO BE CHECKED OR SERVICED	PROCEDURE	EQUIPMENT NOT READY/ AVAILABLE IF:
13	During	Light Assembly	Check lights for damage to end caps and plastic cover, missing parts, such as power cords, and presence of fluorescent bulbs.  Check cable assemblies for cracks, breaks, and fraying insulation.	Parts of light set missing or damaged.  Frayed insulation or broken plugs.
14	During	Straps	Check straps for tear or fraying.	Broken, frayed, or missing straps.
15	During	Filter	Check filter for tears or punctures.	Light escapes through area other than designated opening.



Table 3. PMCS After Procedures.

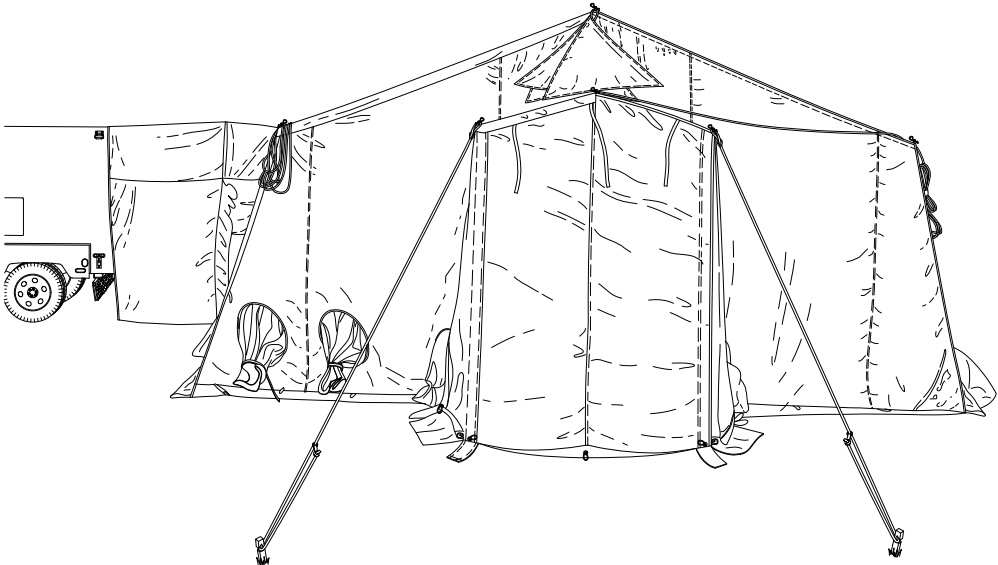
ITEM NO.	INTERVAL	ITEM TO BE CHECKED OR SERVICED	PROCEDURE	EQUIPMENT NOT READY/ AVAILABLE IF:
 <p data-bbox="651 919 1013 949"><b>Figure 12. Fabric Assembly.</b></p>				
1	After	Fabric Assembly (Roof, Wall)	Check for tears, punctures, rips, and seams that may have separated in walls, liners, and floor.	Fabric ripped or torn. Separated seams or fabric punctures.
2	After	Grommets	Check for grommets that are torn away from or out of material.	Grommets are missing or torn away from material causing fabric to tear.
3	After	Slide Fasteners	Check for smooth operation, missing teeth and separated seams.	Slide fastener binds, does not open or close, or is torn away from fabric.
4	After	Hook and Pile Fastener	Inspect hook and pile fasteners for proper alignment and cleanliness. Remove dirt by brushing fastener strips.	Fasteners do not hold when pressed together. Strips loose.
5	After	Zipper	Check for proper operation.	Zipper does not move freely.
6	After	Tent Lines	Inspect tent lines for cuts or fraying.	Tent lines are cut, frayed, or excessively worn.
7	After	Tent Line Slips	Inspect for broken tent line slips.	Tent line slips broken or missing.

Table 3. PMCS After Procedures – Continued.

ITEM NO.	INTERVAL	ITEM TO BE CHECKED OR SERVICED	PROCEDURE	EQUIPMENT NOT READY/ AVAILABLE IF:
8	After	Straps	Check interior and exterior straps for fraying or tears.	Straps loose or missing.
9	After	Straps, Quick Disconnect	Check interior and exterior quick disconnect strap fasteners for tears, fraying, or broken hardware.	Straps loose or missing. Quick disconnect fasteners broken.
10	After	Stakes	Ensure stakes are in good working condition.	Stakes are missing or not serviceable.



FRAME  
TRANSPORT BAG



TENT PINT CONTAINER TRANSPORT BAG



FABRIC TRANSPORT BAG



STRAP ASSEMBLY



CARRYING HANDLE

**Figure 13. Transport Bags.**

Table 3. PMCS After Procedures – Continued.

ITEM NO.	INTERVAL	ITEM TO BE CHECKED OR SERVICED	PROCEDURE	EQUIPMENT NOT READY/ AVAILABLE IF:
11	After	Transport Bags	Check frame and fabric transport bags and tent pin container for rips, tears, or splitting seams.  Check strap assemblies for fraying or missing/broken hardware.  Check carrying handles for excessive fraying.	Bags are ripped. Straps are loose. Broken hardware. Handles ripped.



Figure 14. Frame Components.

Table 3. PMCS After Procedures – Continued.

ITEM NO.	INTERVAL	ITEM TO BE CHECKED OR SERVICED	PROCEDURE	EQUIPMENT NOT READY/ AVAILABLE IF:
12	After	Frame Components	<p>Check condition of upper arch, cable header, lower arch, purlin, and tent threshold.</p> <p>Look for bends, cracks or other damage. Check for free movement.</p> <p>Ensure quick release pins and hitch clip pins are present and in proper working order.</p> <p>Inspect binding strap assembly for fraying and presence of buckles.</p>	<p>Sectional arch does not fold, locking tabs on purlin and door sill do not rotate and lock.</p> <p>Quick release pins and hitch clip pins are missing or broken.</p>

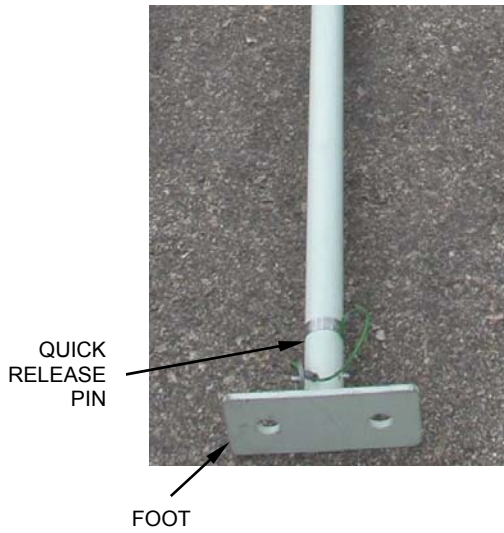
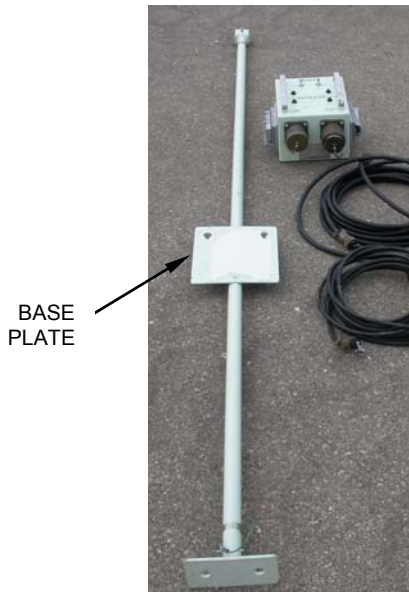


Figure 15. Power Distribution Components.

Table 3. PMCS After Procedures – Continued.

ITEM NO.	INTERVAL	ITEM TO BE CHECKED OR SERVICED	PROCEDURE	EQUIPMENT NOT READY/ AVAILABLE IF:
13	After	Cables	Check cable assemblies for frayed cables or damage to swaged ends.	Cable assemblies frayed, damaged or missing.
14	After	Handles	Check fittings (handles) for damage.	Cracked or broken fittings. Handles inoperable.
15	After	Power Distribution Box and Power Panel Stand	<p>Check power distribution box for damage to circuit breakers and toggle switches.</p> <p>Check for missing covers and dirt in electrical receptacles or plugs.</p> <p>Check cables for fraying and all assemblies for signs of shorts.</p> <p>Check power panel stand for security of base plate and foot.</p> <p>Ensure quick release pin is present and in proper condition.</p> <p>Ensure outer and inner tubes move freely.</p>	<p>Circuit breakers and toggle switches do not operate.</p> <p>Covers missing.</p> <p>Cable frayed. Burn marks indicating shorts.</p> <p>Stand has damaged base plate or foot.</p> <p>Quick release pin is missing or not working.</p> <p>Tubes do not slide freely.</p>

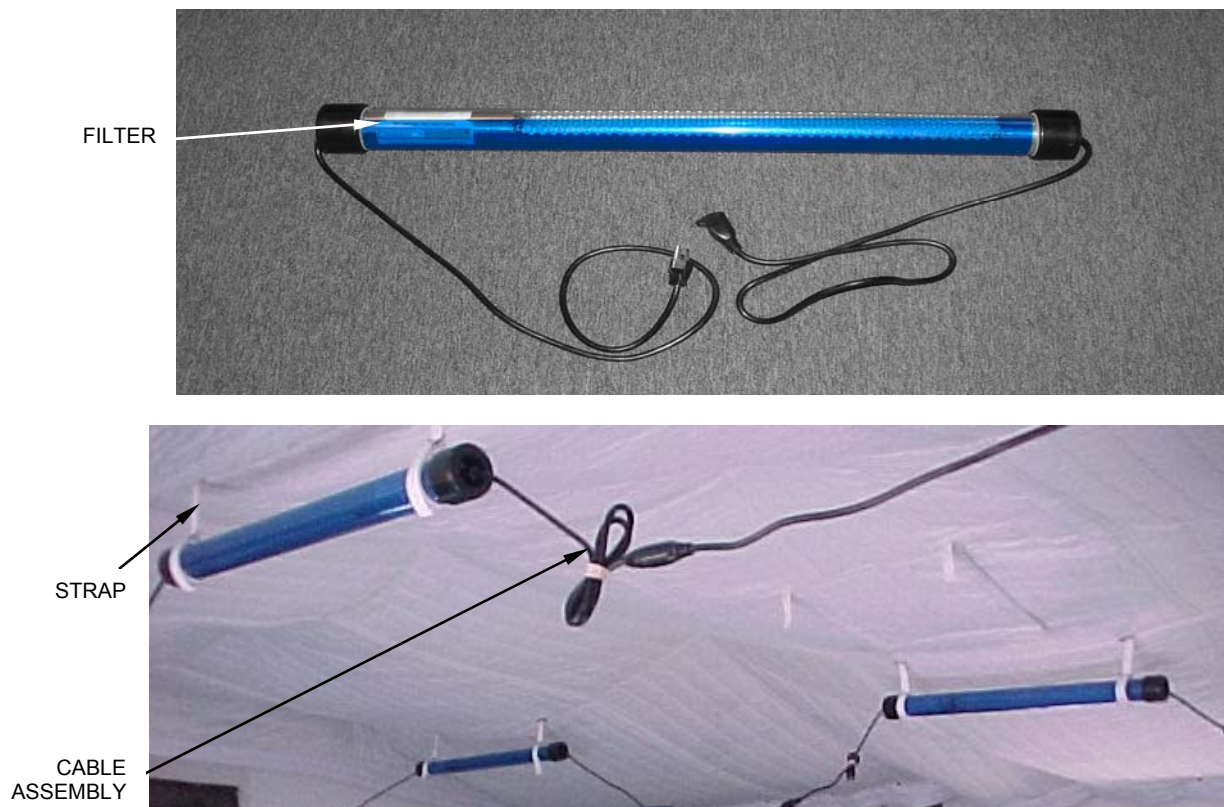




Figure 16. Convenience Outlets.

Table 3. PMCS After Procedures – Continued.

ITEM NO.	INTERVAL	ITEM TO BE CHECKED OR SERVICED	PROCEDURE	EQUIPMENT NOT READY/ AVAILABLE IF:
16	After	Convenience Outlets	Check for missing covers and dirt in electrical receptacles or plugs.  Check cables for fraying and all assemblies for signs of shorts.	Covers missing.  Cable frayed. Burn marks indicating shorts.



**Figure 17. Light Assembly.**

**WARNING**

Lethal voltage is present when light set is connected to power source. Disconnect from power source before inspecting or repairing any electrical component. Be careful not to contact electrical connections. Electrical shock or death may result from failure to heed this warning.

**Table 3. PMCS After Procedures – Continued.**

ITEM NO.	INTERVAL	ITEM TO BE CHECKED OR SERVICED	PROCEDURE	EQUIPMENT NOT READY/ AVAILABLE IF:
17	Before	Light Assembly	Check lights for damage to end caps and plastic cover, missing parts, such as power cords, and presence of fluorescent bulbs.  Check cable assemblies for cracks, breaks, and fraying insulation.	Parts of light set missing or damaged.  Frayed insulation or broken plugs.
18	Before	Straps	Check straps for tear or fraying.	Broken, frayed, or missing straps.
19	Before	Filter	Check filter for tears or punctures.	Light escapes through area other than designated opening.

---

**CREW MAINTENANCE  
STANDARD INTEGRATED COMMAND POST SYSTEM (SICPS), MEDIUM  
NSN: 8340-01-516-0904, GREEN  
NSN: 8340-01-516-0903, TAN  
SERVICE**

---

**INITIAL SETUP****Tools and Special Tools**

None Required

**Equipment Condition**

N/A

**Materials/Parts**

Brush, Scrub, w/o Handle (Item 1, WP 0057)

**References**

N/A

**CAUTION**

Failure to properly clean components of the SICPS Medium may cause material damage.

**GENERAL CLEANING**

Proper cleaning of the SICPS Medium components is an integral part of maintenance. It can help prevent possible problems in the future, so make it a habit to clean all SICPS Medium components whenever necessary.

1. Clean all SICPS Medium components with a brush and mild, soapy water.
2. Let fabric components air-dry.
3. Ensure components, especially fabric sections, are completely dry before being stored.

**ZIPPER CLEANING**

1. Using a mild detergent, water, and a soft bristle brush, clean the zipper and zipper slider.

**NOTE**

Rubbing the zipper with beeswax, after cleaning, will protect the zipper and will also reduce friction, force, wear, and tear and enhance the life of the zippers.

2. Rub the zipper with beeswax.

**FLOOR CLEANING**

1. Clean the tent floor by wiping it down with a mild soap (liquid hand soap) and lukewarm water solution.

**WARNING**

After cleaning, ensure the tent is completely dry, especially the heavier, double-stitched areas, such as the seams, before storing or mold and mildew are likely to grow.

2. Rinse thoroughly and dry completely.

**END OF WORK PACKAGE**

**CREW MAINTENANCE  
STANDARD INTEGRATED COMMAND POST SYSTEM (SICPS), MEDIUM  
NSN: 8340-01-516-0904, GREEN  
NSN: 8340-01-516-0903, TAN  
ARCH ASSEMBLY  
INSPECT**

**INITIAL SETUP**

**Tools and Special Tools**

None Required

**Equipment Condition**

N/A

**Materials/Parts**

None Required

**References**

N/A

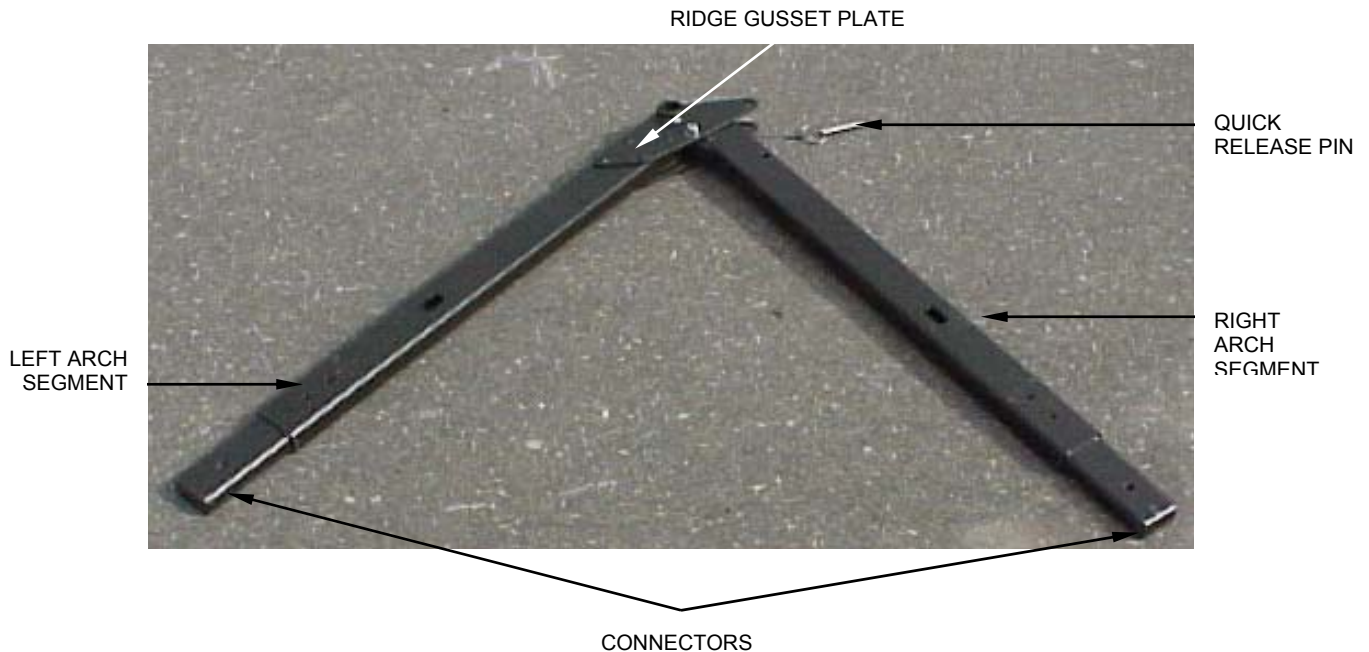
**INSPECT**

**WARNING**



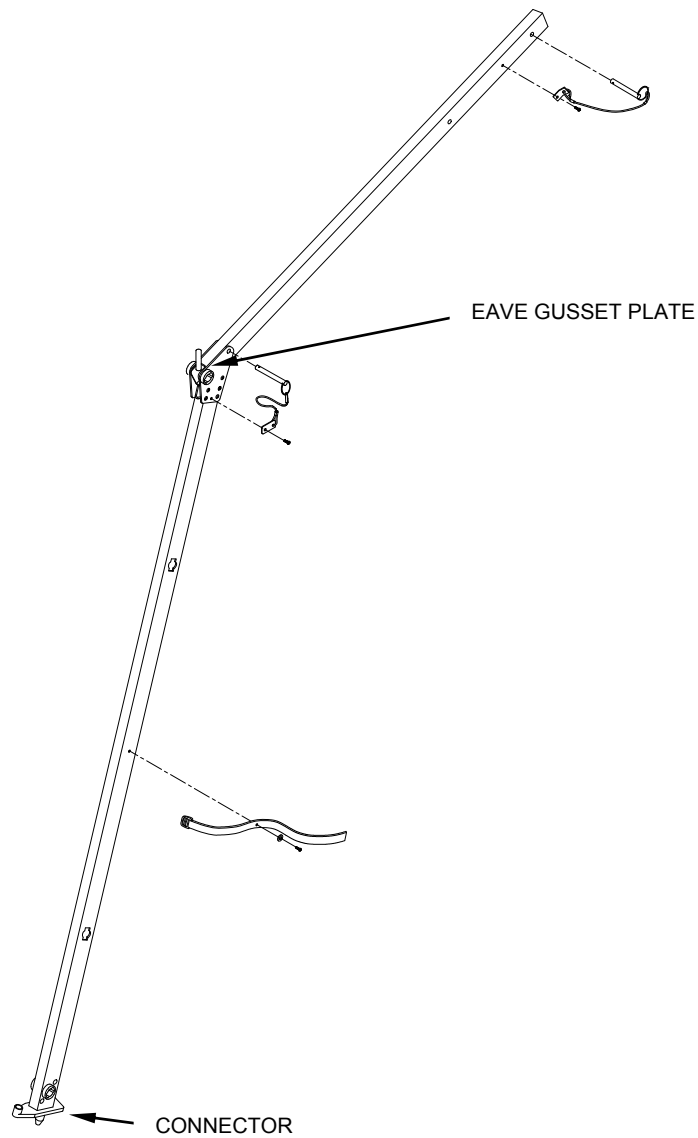
Use care when unfolding frame assemblies. Hands and fingers can be pinched when placed on hinge joints, causing painful injuries to personnel.

1. Unfold and inspect the upper arch assembly, left and right arch segments, for bends, damage to the connectors, cracks or deformations in the ridge gusset plate, and presence and proper functioning of the quick release pin and lanyard assembly.



**Figure 1. Upper Arch Assembly.**

2. Unfold and inspect the lower arch assembly eave arch segment and lower leg arch for bends, damage to the connector), cracks or deformations in the eave gusset plates, and presence and proper functioning of the quick release pin and lanyard assemblies (not shown).



**Figure 2. Lower Arch Assembly.**

**END OF WORK PACKAGE**

---

**CREW MAINTENANCE  
STANDARD INTEGRATED COMMAND POST SYSTEM (SICPS), MEDIUM  
NSN: 8340-01-516-0904, GREEN  
NSN: 8340-01-516-0903, TAN  
LIGHT SET ASSEMBLY  
REPAIR**

---

**INITIAL SETUP****Tools and Special Tools**

None Required

**Equipment Condition**

Light assembly turned off and disconnected.

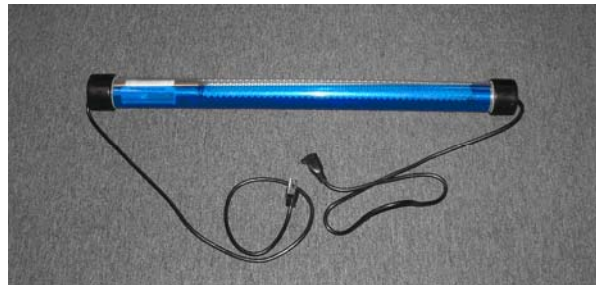
**Materials/Parts**

Bulb (Item 2, WP 0048)

**References**

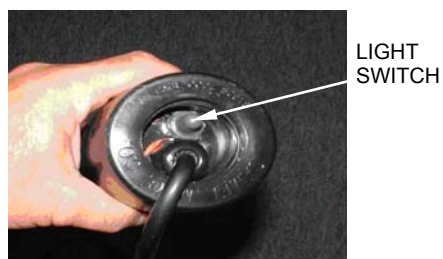
N/A

---

**REPAIR****Remove and Install Bulb**

**Figure 1. Light Set.**

1. Remove bulb.
  - a. Unscrew and remove end cap opposite to light switch end.

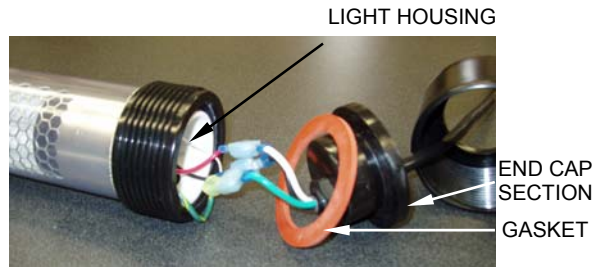


**Figure 2. Light Switch.**



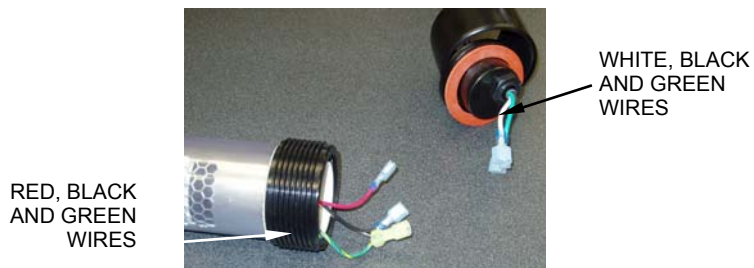
**Figure 3. End Cap.**

- b. Pull end cap section (with gasket) out of light housing.



**Figure 4. End Cap Removed.**

- c. Disconnect the white, black, and green wires from green, black and red wires.

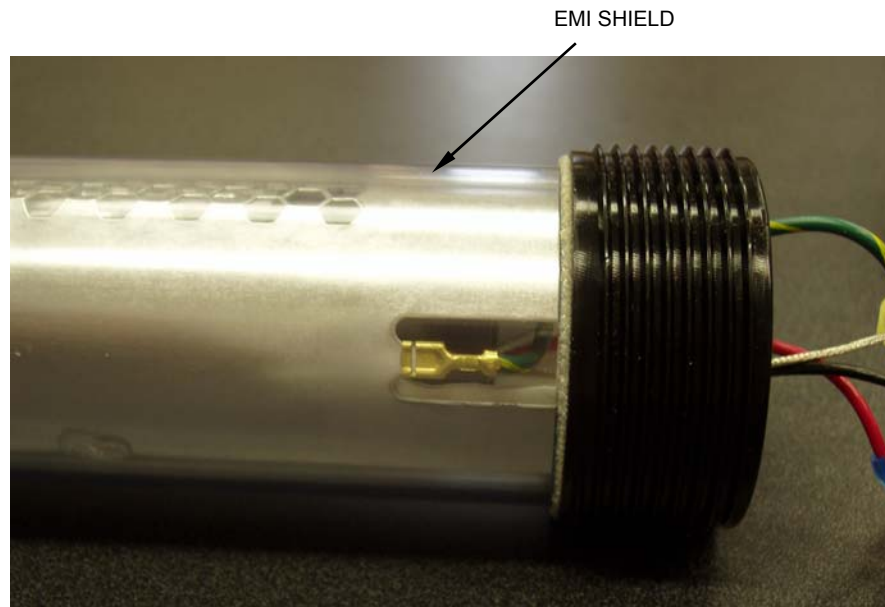


**Figure 5. End Cap With Wires Disconnected.**

**NOTE**

Gently pull EMI shield apart from light housing to allow easier removal of ground wire.

- d. Disconnect the ground wire (green/yellow) from the EMI shield.



**Figure 6. EMI Shield.**



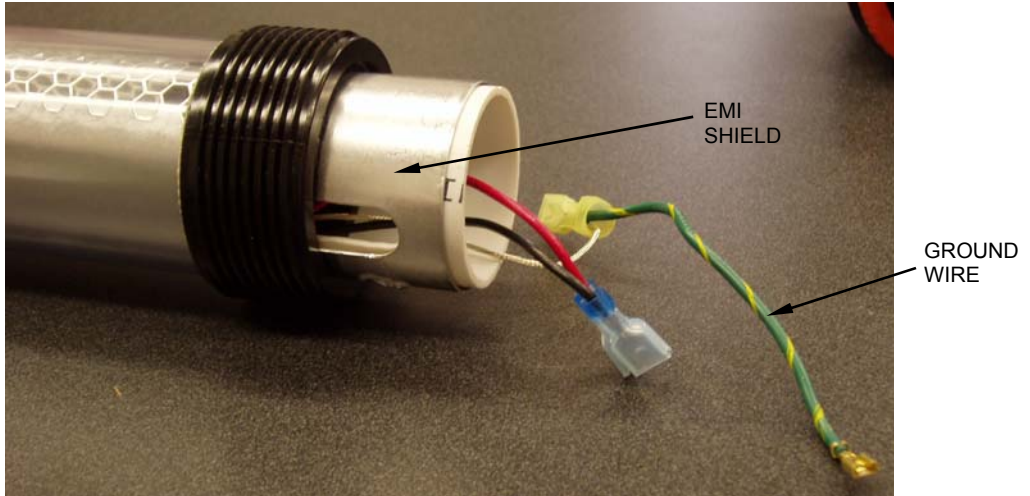


Figure 7. Ground Wire.

- e. Remove bulb socket assembly by pulling on wire hook.

BULB SOCKET ASSEMBLY

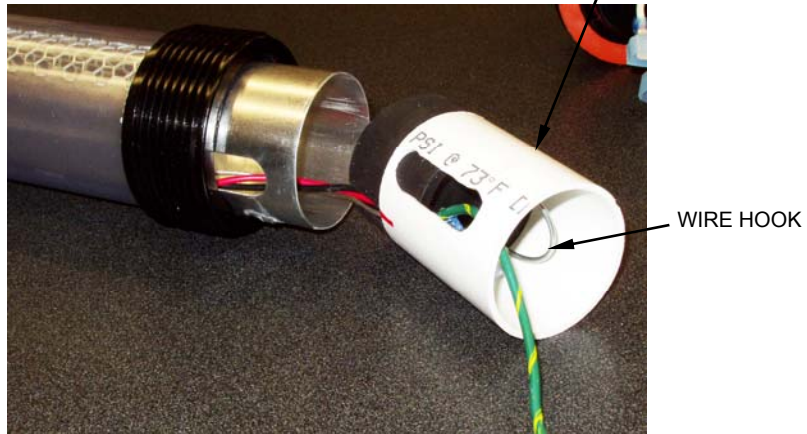


Figure 8. Removing Bulb Socket Assembly.

- f. Remove bulb from inner tubing.



Figure 9. Inner Tubing.

2. Install bulb.
  - a. Place new bulb in light assembly tubing. Ensure new bulb is inserted firmly in place.



**Figure 10. New Bulb.**

- b. Feed ground wire through slot in the bulb socket assembly and connect the ground wire to the EMI shield.
- c. Place the end cap section, with gasket, into the light housing.
- d. Reconnect the white, black, and green wires.
- e. Screw end cap onto light housing.
- f. Test for proper operation.

**END OF WORK PACKAGE**

**CREW MAINTENANCE  
STANDARD INTEGRATED COMMAND POST SYSTEM (SICPS), MEDIUM  
NSN: 8340-01-516-0904, GREEN  
NSN: 8340-01-516-0903, TAN  
CABLE HEADER ASSEMBLY  
INSPECT, REPLACE**

**INITIAL SETUP**

**Tools and Special Tools**

None Required

**Equipment Condition**

Cable Header Assembly Unpacked

**Materials/Parts**

None Required

**References**

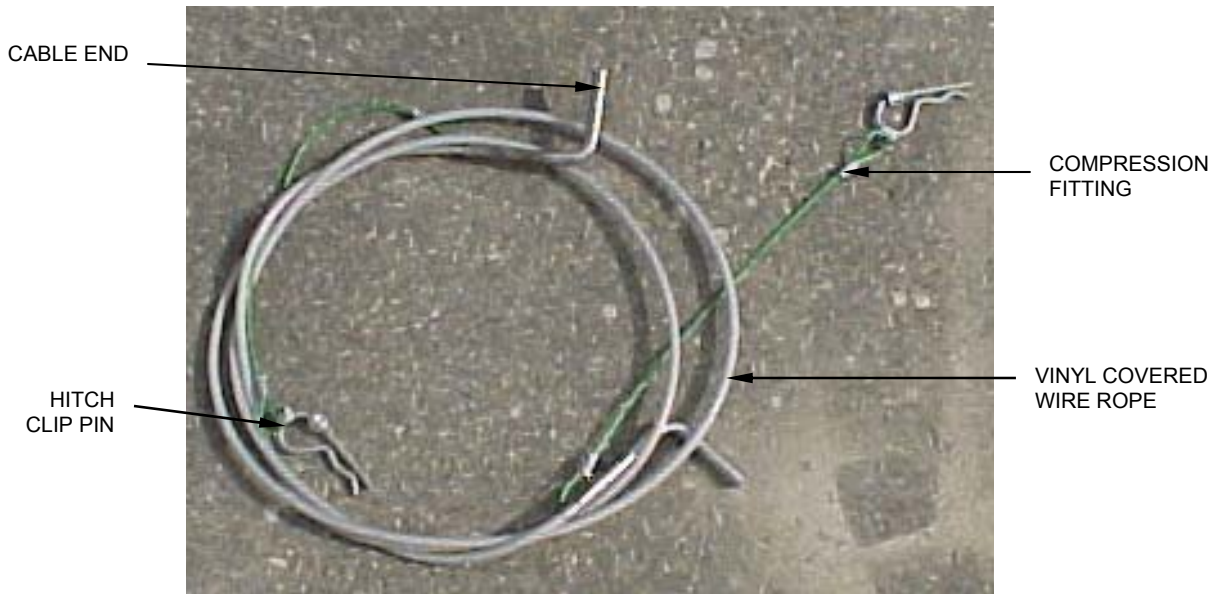
N/A

**GENERAL**

This procedure contains information and instructions to keep the SICPS Medium frame assembly in good working order by inspecting and replacing the entire cable header assembly.

**INSPECT**

Inspect the cable header assembly vinyl covered wire rope for fraying, secure attachment to the cable ends, presence of hitch clip pins, and security of compression fittings.



**Figure 1. Cable Header Assembly.**

**REPLACE**

If cable header assembly is damaged, bent, or has frayed wire, replace the entire cable header assembly with a serviceable item from stock.

**END OF WORK PACKAGE**



**CREW MAINTENANCE  
STANDARD INTEGRATED COMMAND POST SYSTEM (SICPS), MEDIUM  
NSN: 8340-01-516-0904, GREEN  
NSN: 8340-01-516-0903, TAN  
PURLIN ASSEMBLY  
INSPECT, REPLACE**

**INITIAL SETUP**

**Tools and Special Tools**

None Required

**Equipment Condition**

Purlin Assembly unpacked

**Materials/Parts**

None Required

**References**

N/A

**GENERAL**

This procedure contains information and instructions to keep the SICPS Medium frame assembly in good working order by inspecting and replacing the entire purlin assembly.

**INSPECT**

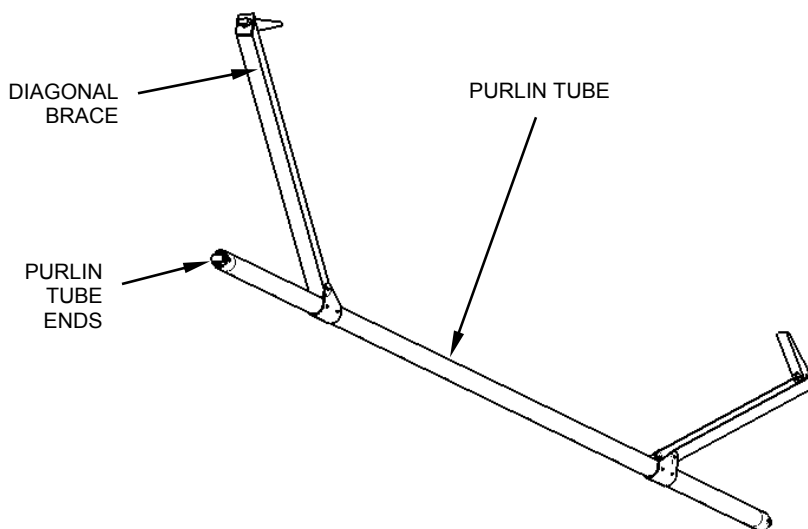
1. Inspect the purlin tube, retaining straps, and diagonal braces for bends and deformations.
2. Check the turn-and-lock mechanisms on purlin tube ends and braces for proper functioning.
3. Inspect retaining straps for fraying and hook and pile fasteners for serviceability.



PURLIN TUBE

**Figure 1. Purlin Assembly (Folded for Transport)**

RETAINING STRAP



**Figure 2. Purlin Assembly (Extended for Use)**

**REPLACE**

If any part of the purlin assembly is damaged to the extent that the purlin cannot be properly put in place, replace the entire purlin assembly with a serviceable item from stock.

**END OF WORK PACKAGE**

**CREW MAINTENANCE  
STANDARD INTEGRATED COMMAND POST SYSTEM (SICPS), MEDIUM  
NSN: 8340-01-516-0904, GREEN  
NSN: 8340-01-516-0903, TAN  
DOOR SILL ASSEMBLY  
INSPECT, REPLACE**

**INITIAL SETUP**

**Tools and Special Tools**

None Required

**Equipment Condition**

Door Sill Assembly unpacked

**Materials/Parts**

None Required

**References**

N/A

**GENERAL**

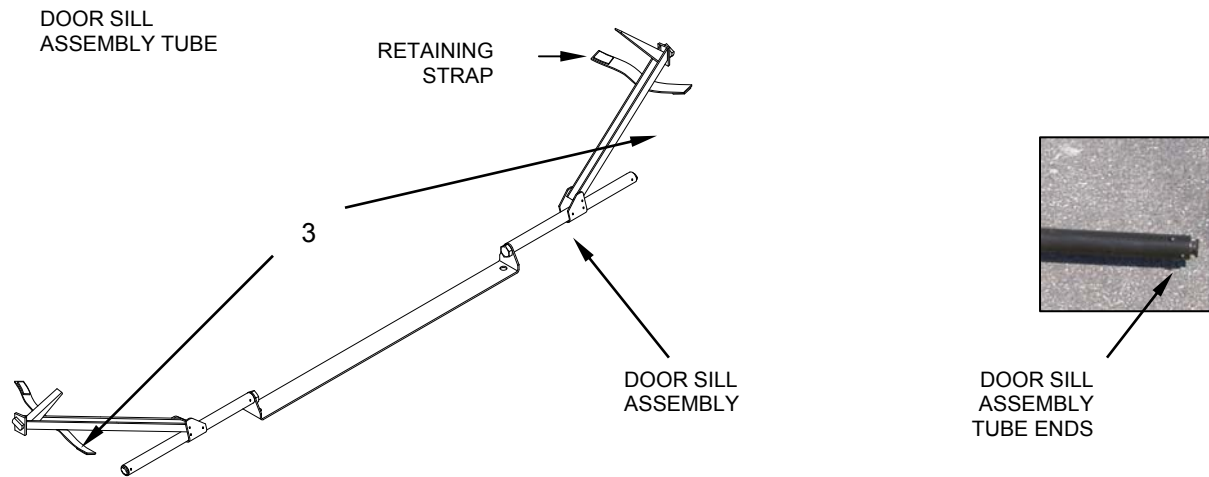
This procedure contains information and instructions to keep the SICPS Medium frame assembly in good working order by inspecting and replacing the entire door sill assembly.

**INSPECT**

1. Inspect the door sill assembly tube, retaining straps, and diagonal braces for bends and deformations.
2. Check the turn-and-lock mechanisms on the door sill assembly tube ends and braces for proper functioning.
3. Inspect retaining straps for fraying and hook and pile fasteners for serviceability.



**Figure 1. Door Sill Assembly (Folded for Transport).**



**Figure 2. Door Sill Assembly (Extended for Use)**

**REPLACE**

If any part of the door sill assembly is damaged to the extent that the door sill assembly cannot be properly put in place, replace the entire door sill assembly with a serviceable item from stock.

**END OF WORK PACKAGE**



**CREW MAINTENANCE  
STANDARD INTEGRATED COMMAND POST SYSTEM (SICPS), MEDIUM  
NSN: 8340-01-516-0904, GREEN  
NSN: 8340-01-516-0903, TAN  
POWER DISTRIBUTION BOX  
INSPECT**

**INITIAL SETUP**

**Tools and Special Tools**

None Required

**Equipment Condition**

N/A

**Materials/Parts**

None Required

**References**

N/A

**GENERAL**

This procedure contains information and instructions to keep the SICPS Medium power distribution box in good working order by inspecting the entire power distribution box.

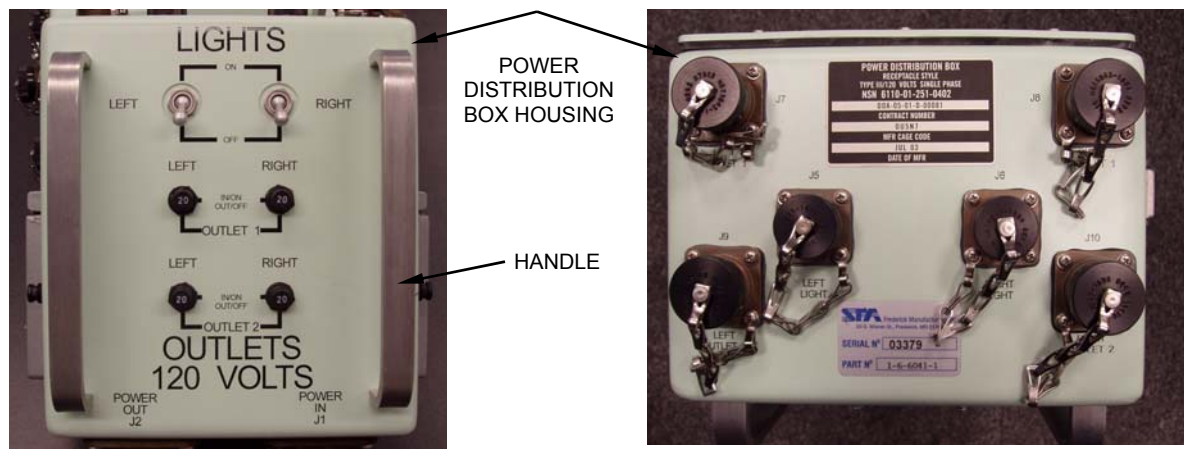
**WARNING**



Lethal voltage is present when the power distribution box is connected to a power source. Disconnect the power source before attempting any repairs to the box. Serious injury or death to personnel may result from touching any component under power.

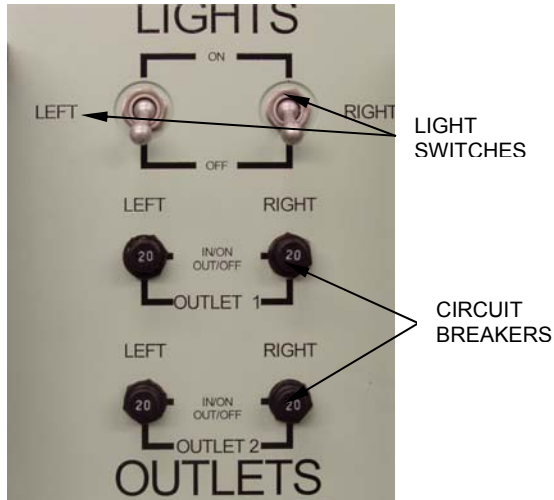
**INSPECT**

1. Inspect the power distribution box housing and handle for damage.
2. Visually inspect outside of power distribution box for cleanliness and corrosion.

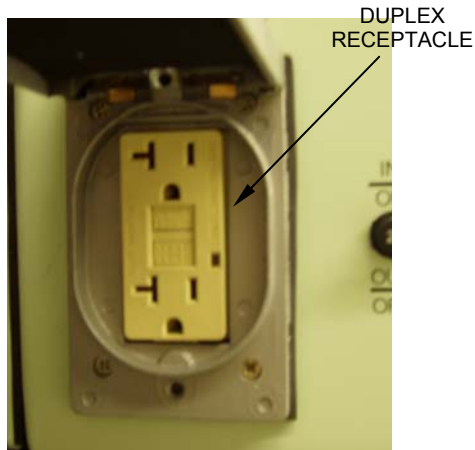


**Figure 1. Outside of Power Distribution Box.**

3. Notice condition of circuit breakers, power receptacles, and light switches. Refer a power distribution box with damaged or inoperative circuit breakers, receptacles, or light switch to higher level maintenance support.
4. Inspect the light power cables and the receptacle power cables for cuts or damaged ends. Refer defective cables to higher level maintenance support for replacement.



**Figure 2. Circuit Breakers and Light Switches.**



**Figure 3. Duplex Receptacle.**



Figure 4. Light Power Cable.



Figure 5. Receptacle Power Cable.

END OF WORK PACKAGE



---

**SERVICE MAINTENANCE**  
**STANDARD INTEGRATED COMMAND POST SYSTEM (SICPS), MEDIUM**  
**NSN: 8340-01-516-0904, GREEN**  
**NSN: 8340-01-516-0903, TAN**  
**ARCH ASSEMBLY**  
**REPAIR, REPLACE**

---

**INITIAL SETUP****Tools and Special Tools**

Tool Kit, General Mechanic's (Item 6, Table 2, WP 0030)

**Equipment Condition**

N/A

**Materials/Parts**

N/A

**References**

WP 0022

---

**REPAIR**

Repair to the arch assembly, both upper arch and lower arch, is limited to replacement of the quick release pin with lanyard. Refer to WP 0022 for detailed procedures.

**REPLACE**

1. If the upper arch assembly is damaged, bent, or will not unfold, replace the entire upper arch assembly with a serviceable item from stock.
2. If the lower arch assembly is damaged, bent, or will not unfold, replace the entire lower arch assembly.

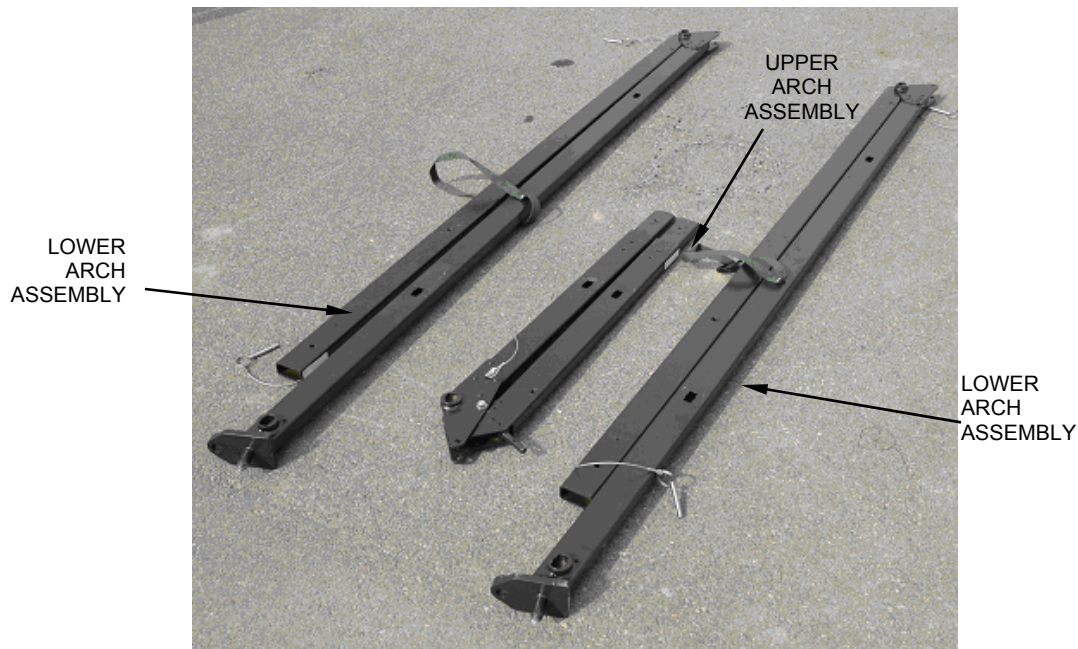


Figure 1. Lower and Upper Arch Assemblies.

**END OF WORK PACKAGE**



**SERVICE MAINTENANCE  
STANDARD INTEGRATED COMMAND POST SYSTEM (SICPS), MEDIUM  
NSN: 8340-01-516-0904, GREEN  
NSN: 8340-01-516-0903, TAN  
TENT SECTIONS (FABRIC)  
REPAIR**

**INITIAL SETUP**

**Tools and Special Tools**

- Brush, Paint (Item 1, Table 2, WP 0030)
- Repair Kit, Tentage (Item 3, Table 2, WP 0030)

**Materials/Parts**

- Denatured Alcohol (Item 3, WP 0057)
- Gloves, Latex-Nitrile (Item 5, WP 0057)
- K-Kote Seam Sealer (Item 8, WP 0057)
- Respirator, Air Filtering (Item 11, WP 0057)
- Wiping Rags (Item 17, WP 0057)

**Equipment Condition**

Although the fabric assemblies can be repaired while the tent is in use, it is recommended that the fabric be repaired when the tent is not in use, since repairs are easier when the fabric assemblies are separated. Refer to WP 0005 for striking instructions.

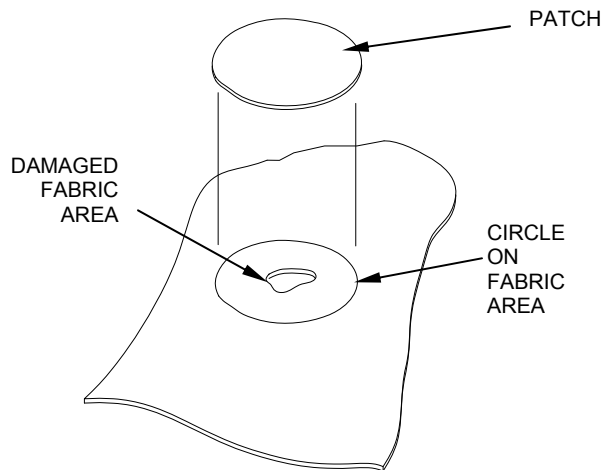
**References**

- FM 10-16; FM 21-11;
- FED-STD 595, FED-STD 751

**REPAIR**

**Miscellaneous Patches**

1. Apply miscellaneous patch as follows:
  - a. Obtain a clean, round patch from bulk material that is at least 1 inch larger, in all directions, than the damaged fabric area.



**Figure 1. Patch Placement.**

- b. Place the damaged fabric area on a flat surface or place a piece of softwood under the damaged fabric area.

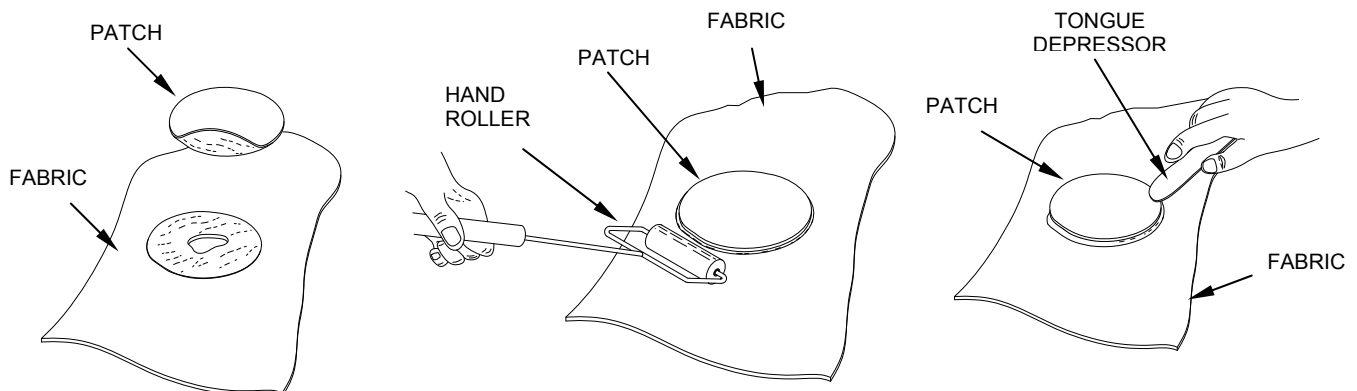
**Miscellaneous Patches – Continued.**

- c. Center patch over damaged fabric area. Draw a circle on fabric around patch, and then remove patch.
- d. Clean damaged fabric area inside circle.

**WARNING**

The adhesive has a high alcohol content and is highly flammable. Use only in well-ventilated areas, away from open flame. Do not smoke. In case of dizziness, leave area immediately and allow to ventilate. Failure to observe this warning may result in serious injury or death to personnel.

- e. Place patch facedown over circle. Coat patch evenly with adhesive, allowing adhesive to overlap onto fabric to form an adhesive circle. Remove patch and set aside with adhesive side up.
- f. Coat damaged fabric with adhesive inside circle. Allow adhesive on patch and adhesive circle to dry.
- g. Apply a second coat of adhesive to patch and inside of adhesive circle.
- h. Wait ten to fifteen minutes for adhesive to become tacky to touch.
- i. Center patch over circle, adhesive side down, and press the two sticky surfaces together.
- j. Using a hand roller, press excess adhesive and air bubbles from under patch. Roll first in one direction and then in the opposite direction.
- k. Using tongue depressor, apply a small amount of adhesive to edge of patch. Run tongue depressor around patch to seal and prevent fraying.
- l. Allow adhesive to dry.

**Figure 2. Applying Patch.**



**Miscellaneous Patches – Continued.**

2. Apply seam sealer to repaired areas as follows:

**WARNING**

Seam sealer and solvent are extremely flammable and the fumes toxic. Do not use seam sealer or solvent near an open flame. When using seam sealer and solvent, wear goggles and gloves. When indoors, wear a respirator or use sealer and solvent in an open, well-ventilated area away from sources of combustion. Severe injury or death may result from explosion or fire. Inhalation of fumes may cause toxic sickness.

**NOTE**

Tent may be erected or fabric assemblies may be removed and laid flat.

Do not use a foam brush. Use a bristle brush only.

Sealer may be applied to outside or inside of fabric assemblies.

Sealer should only be applied to new stitches, patches, etc., or those areas that have shown water leakage.

Two light coats of sealant are more effective than one thick coat. Do not use excessive amounts of sealer, as this does not increase effectiveness and will give the tent a poor appearance.

Do not leave original sealer container open, as sealer will thicken and become unusable. Limit the amount of time the container is open.

- a. The surface to be sealed should be cleaned as thoroughly as practical and completely dry before applying sealer.
- b. Pour a small amount of sealer into a clean container and immediately reseal the gallon container.
- c. Apply sealer to stitching or repair to be sealed, overlapping seam stitching or edges of repair by  $\frac{1}{2}$  inch.
- d. Allow first coat to dry to the touch.
- e. Apply a second coat as described in step c. above.

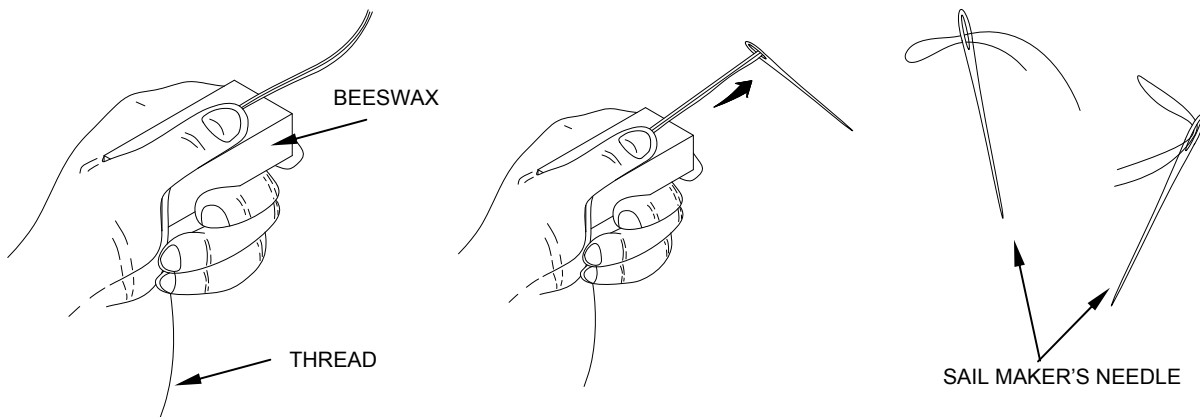
## Hand Stitching

1. Prepare needle and thread as follows:

### NOTE

If you use two-strand thread, you will need twice as much; if you use four-strand, you will need four times as much.

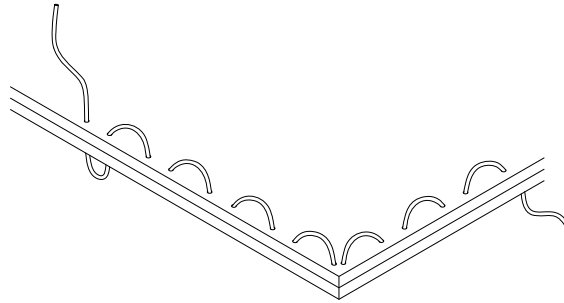
- a. Estimate the amount of thread required to complete stitching and cut thread to length.
- b. Wax the thread by pressing the thread between your thumb and the beeswax and by drawing the entire length of thread over the beeswax.
- c. Thread sail maker's needle with waxed thread to form a single, two or four-strand thread as follows:
  - (1) Fold one end of thread and push the loop through the eye of the needle.
  - (2) Two-Strand. To make a double-strand thread, pull the thread through the needle until the needle is at the midpoint of the single-thread strand.
  - (3) Four-Strand. To form four-strand thread, bend a length of thread in half and insert the loop end into the eye of the needle, pulling it through so that the eye is at the midpoint of the double strand of thread.
- d. Twist the strand together and re-wax the entire length of thread.
- e. Tie knot at far end of the single, two- or four-strand thread.



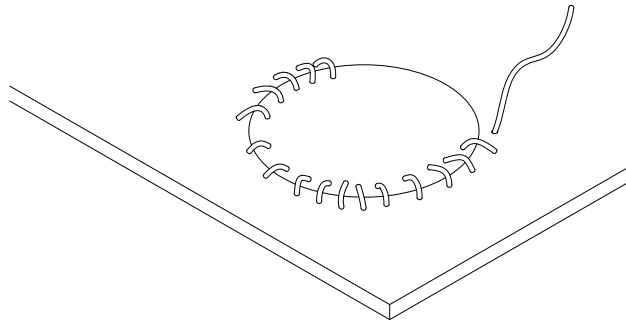
**Figure 3. Threading Needle.**

**Hand Stitching – Continued.**

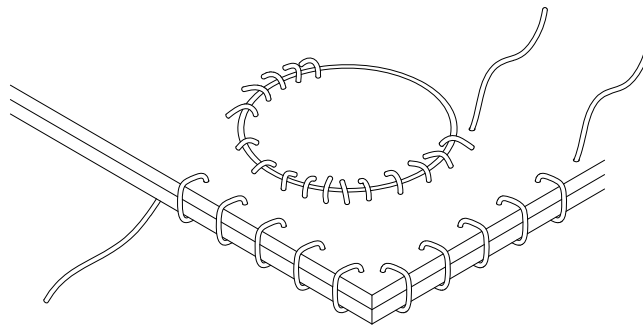
2. Hand Stitches. There are five common hand stitches used to mend fabric in different situations: flat, round, overcast, back and fishbone. Choose the one that most closely resembles the repair you are making.
- a. Flat Stitch. This stitch is used as a temporary fastening until machine repairs can be made. Pass the needle over and under an equal amount of material, each successively entering the material from the opposite side.

**Figure 4. Flat Stitch.**

- b. Round Stitch. This stitch is used to handwork grommets. Insert the materials at right angles to the edge of materials and bring around edge before making the next stitch.

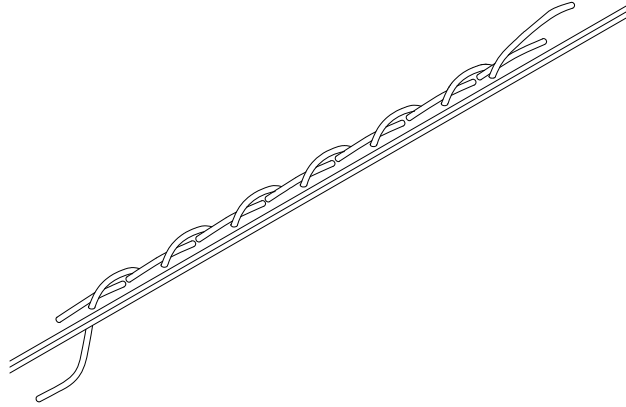
**Figure 5. Round Stitch.**

- c. Overcast Stitch. This stitch is used to apply a hand-sewn patch. Insert the needle through the material at an angle so that it comes out to one side and ahead of the point of insertion; bring the cord over to the original line of insertion before making the next stitch.

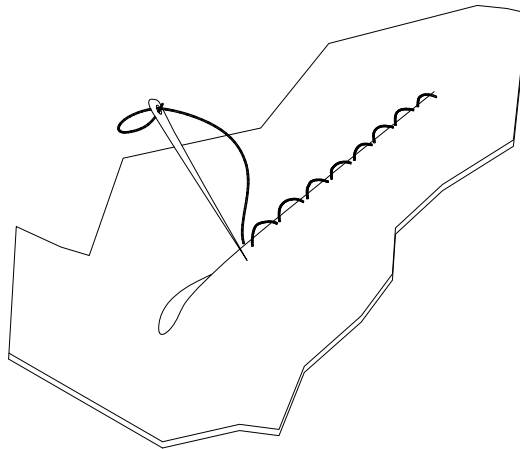
**Figure 6. Overcast Stitch.**

**Hand Stitching – Continued.**

- d. Backstitch. This stitch is used to secure an open seam. It is so named because the needle is always set back on half of a stitch length into the last stitch made. Make two small stitches in the same place to secure the cord ends. Continue by inserting the needle into the middle of the preceding stitch and bring it out on the same side of the material, one stitch length in advance of the preceding stitch.

**Figure 7. Backstitch.**

- e. Fishbone Stitch. This stitch is used to join edges of a tear; a patch can be applied. Insert needle between the two edges of material to be sewn together. Take a diagonal stitch from one side toward the other; bring the needle out between the two edges. Repeat this operation on the opposite side and continue alternating stitches from side to side. To keep the stitches uniform, hold the edges smoothly together. Make stitches firmly, but do not pull them tight enough to pucker the fabric.

**Figure 8. Fishbone.****END OF WORK PACKAGE**

---

**SERVICE MAINTENANCE**  
**STANDARD INTEGRATED COMMAND POST SYSTEM (SICPS), MEDIUM**  
**NSN: 8340-01-516-0904, GREEN**  
**NSN: 8340-01-516-0903, TAN**  
**QUICK RELEASE PIN WITH LANYARD ASSEMBLY**  
**INSPECT, REPLACE**

---

**INITIAL SETUP****Tools and Special Tools**

Tool Kit, General Mechanic's (Item 8, Table 2, WP 0030)

**Equipment Condition**

N/A

**Materials/Parts**

N/A

**References**

WP 0012

---

**INSPECT****WARNING**

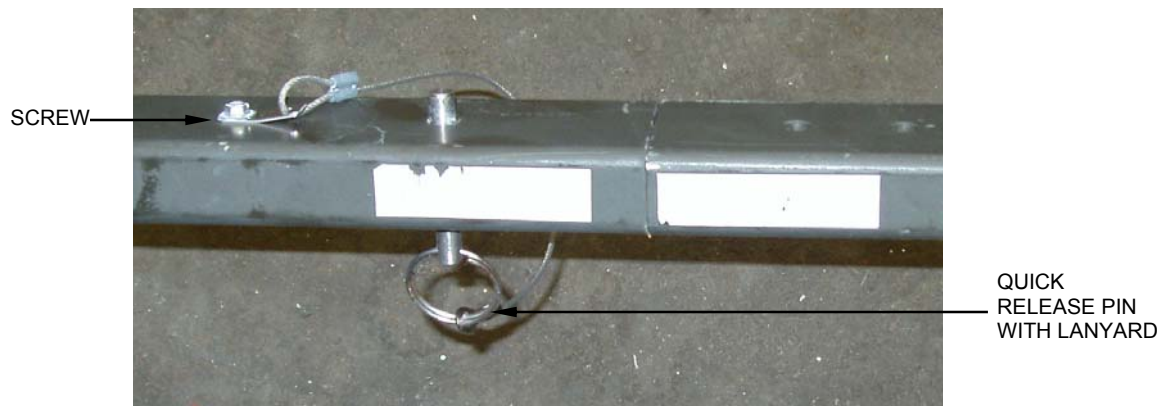
Use care when unfolding frame assemblies. Hands and fingers can be pinched when placed on hinge joints, causing painful injuries to personnel.

Inspect quick release pins with lanyard for damage as described in WP 0012.

**REPLACE**

If the quick release pin with lanyard is missing or damaged, replace it as follows:

1. Remove quick release pins with lanyard assembly.
  - a. Remove quick release pins with lanyard assembly from tent frame.
  - b. Remove screw holding quick release pin with lanyard assembly to frame section.



**Figure 1. Quick Release Pin with Lanyard.**

**REPLACE – Continued.**

2. Install new quick release pin with lanyard assembly.
  - a. Install screw through eye of quick release pin with lanyard assembly.
  - b. Install quick release pin into tent frame.

**END OF WORK PACKAGE**

---

**SERVICE MAINTENANCE  
STANDARD INTEGRATED COMMAND POST SYSTEM (SICPS), MEDIUM  
NSN: 8340-01-516-0904, GREEN  
NSN: 8340-01-516-0903, TAN  
TENT SECTIONS (FABRIC)  
REPAIR**

---

**INITIAL SETUP****Tools and Special Tools**

Repair Kit, Tentage (Item 3, Table 2, WP 0030)

**Equipment Condition**

SICPS Medium removed from service.

**Materials/Parts**

N/A

**References**WP 0021  
FM 10-16

---

**REMOVAL AND REPLACEMENT**

Remove and replace broken or missing grommet as follows:

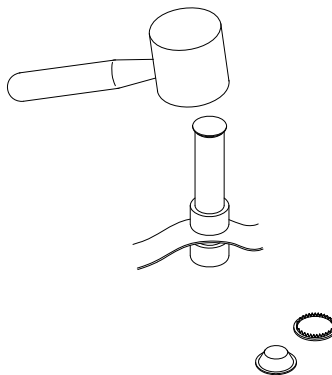
1. If still attached, cut the damaged grommet from fabric.

**NOTE**

If fabric repair is required, refer to WP 0021 for instructions.

A die inserted grommet consists of two brass parts: the male (barrel) is smooth and the female (washer) has spurs to grip the fabric.

2. Insert a grommet.
  - a. Position fabric face up on end grain surface of softwood lumber.
  - b. Using a size 5 cutting punch for a size 4 grommet (or a size 6 cutting punch for a size 5 grommet) and a rawhide mallet, cut a grommet hole in fabric by hitting top of cutting punch with rawhide mallet.



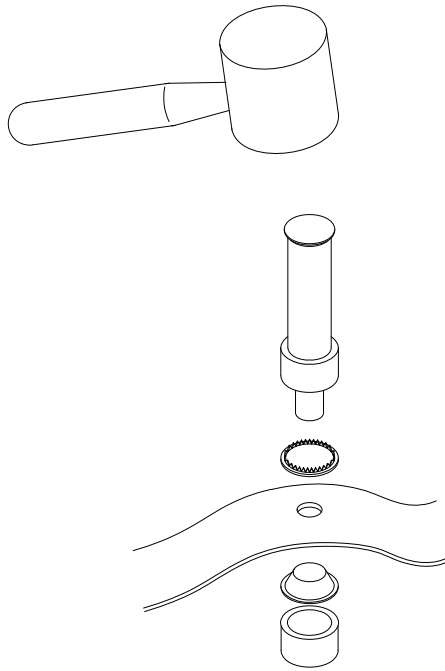
**Figure 1. Hitting Top of Cutting Punch with Mallet.**

**REPLACE – Continued.**

- c. Insert grommet barrel into hole of fabric from the underside.
- d. Place fabric and bottom (flat) part of grommet barrel on grommet die.
- e. Place the grommet washer spurs down over grommet barrel.
- f. Insert setting punch into grommet barrel and hold in place.
- g. Hit top of setting punch with rawhide mallet hard enough to clinch the parts to fabric without damaging grommet or fabric.

**NOTE**

When parts are clinched properly, the edge of the grommet barrel has a smooth roll.



**Figure 2. Hitting Top of Setting Punch with Mallet.**

**END OF WORK PACKAGE**



---

**FIELD MAINTENANCE  
STANDARD INTEGRATED COMMAND POST SYSTEM (SICPS), MEDIUM  
NSN: 8340-01-516-0904, GREEN  
NSN: 8340-01-516-0903, TAN  
POWER DISTRIBUTION BOX  
REPAIR**

---

**INITIAL SETUP****Tools and Special Tools**

Tool Kit, General Mechanic's (Item 6, Table 2  
WP 0030)

**Materials/Parts**

N/A

**Equipment Condition**

External electrical power disconnected;  
power control disconnected.

**References**

N/A

---

**REPAIR****Remove and Install Circuit Breaker (Toggle or Push-Pull)**

1. Remove circuit breaker.

**WARNING**

Lethal voltage is present when the power control system is connected to power source. Disconnect from power source before inspecting or repairing any electrical component. Electrical shock and death may result from failure to heed this warning.

- a. Disconnect electrical power from distribution box.
- b. Remove back plate (Figure 1) from distribution box (Figure 2).



**Figure 1. Distribution Box - Back Plate.**

**Remove and Install Circuit Breaker (Toggle or Push-Pull) – Continued.**

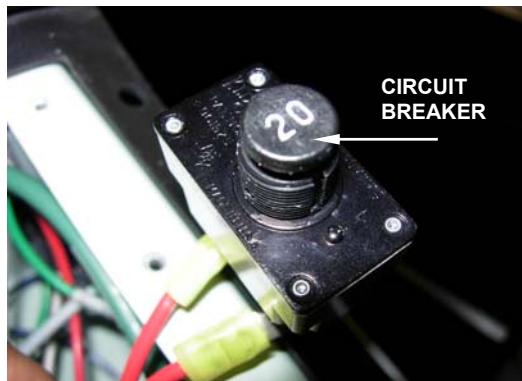


**Figure 2. Distribution Box - Back Plate Removed.**

- c. Remove circuit breaker retaining nut (Figure 3) to release circuit breaker (Figure 4) from the power distribution box.



**Figure 3. Circuit Breaker Retaining Nut.**

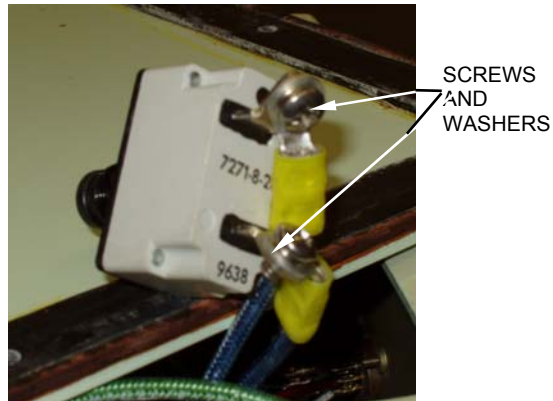


**Figure 4. Circuit Breaker.**

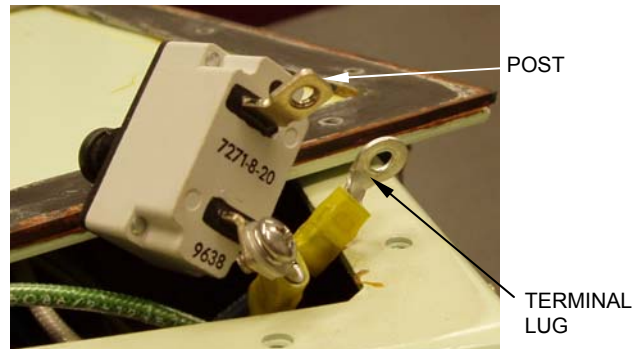
- d. Push circuit breaker in to release it from the power distribution box.

**Remove and Install Circuit Breaker (Toggle or Push-Pull) – Continued.**

- e. Remove screws and washers (Figure 5) from circuit breaker posts (Figure 6) and remove terminal lugs (Figure 6).



**Figure 5. Removing Screws and Washers.**



**Figure 6. Terminal Posts and Lugs.**

2. Install circuit breaker.
  - a. Install terminal lugs, washers, and screws on circuit breaker posts.
  - b. Place circuit breaker in proper position.
  - c. Install circuit breaker retaining nut and washer.
  - d. Install back plate.

## Remove and Install Cannon Connector (Receptacle) from Power Distribution Box

1. Remove defective receptacle connector with gasket.

### WARNING



Lethal voltage is present when the power control system is connected to power source. Disconnect from power source before inspecting or repairing any electrical component. Electrical shock and death may result from failure to heed this warning.

- a. Disconnect electrical power from power distribution box.
- b. Remove back plate from power distribution box (shown in Figures 1 and 2).
- c. Remove screws (Figure 7) and receptacle cover (Figure 8).

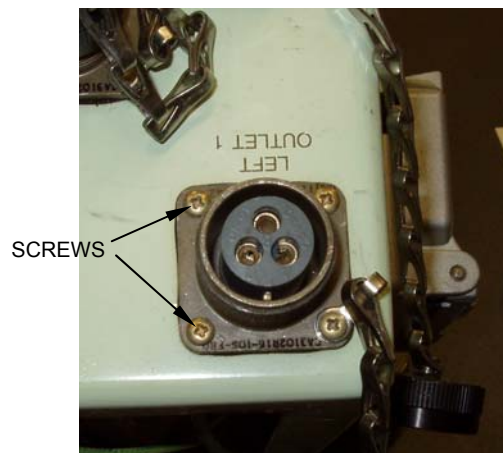


Figure 7. Removing Screws.

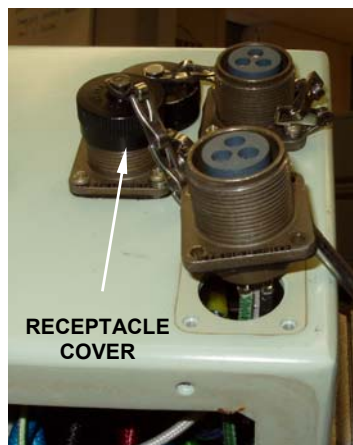
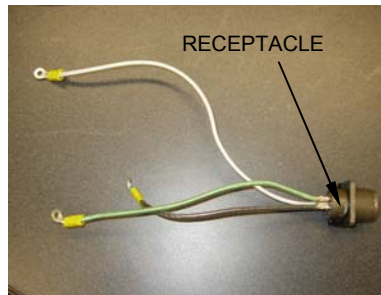


Figure 8. Removing Receptacle Cover.

- d. Remove nuts and washers from terminal block and circuit breaker terminal lug.
- e. Remove defective receptacle (Figure 9).



**Figure 9. Removing Defective Receptacle.**

2. Install receptacle connector with gasket.
  - a. Insert replacement receptacle connector with gasket into power distribution box.
  - b. Connect wires on receptacle connector to terminal block and circuit breaker terminal lug.
  - c. Install receptacle connector with gasket, receptacle cover, and screws.
  - d. Install back plate on power distribution box.
  - e. Connect electrical power and test for proper operation.

### **Remove and Install Duplex Receptacle from Power Distribution Box**

1. Remove duplex receptacle.

### **WARNING**



Lethal voltage is present when the power control system is connected to power source. Disconnect from power source before inspecting or repairing any electrical component. Electrical shock and death may result from failure to heed this warning.

- a. Disconnect electrical power from power distribution box.
- b. Remove back plate from power distribution box as shown in Figures 1 and 2.
- c. Remove screws (Figure 10) retaining receptacle cover with gasket and duplex receptacle to power distribution box mounting plate (Figure 11).



Figure 10. Receptacle Cover Screws.

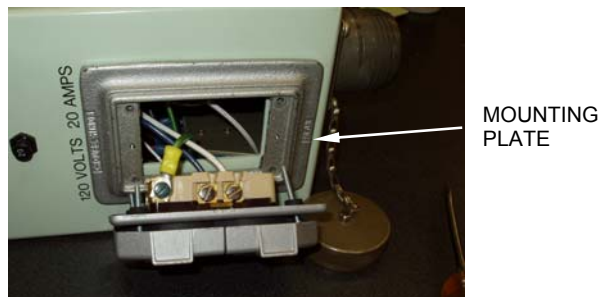


Figure 11. Mounting Plate.

- d. Remove screws (Figure 10) retaining receptacle cover with gasket and duplex receptacle to power distribution box mounting plate (Figure 11).
- e. Remove screws retaining duplex receptacle to receptacle cover with gasket.
- f. Loosen set screws and remove wires.

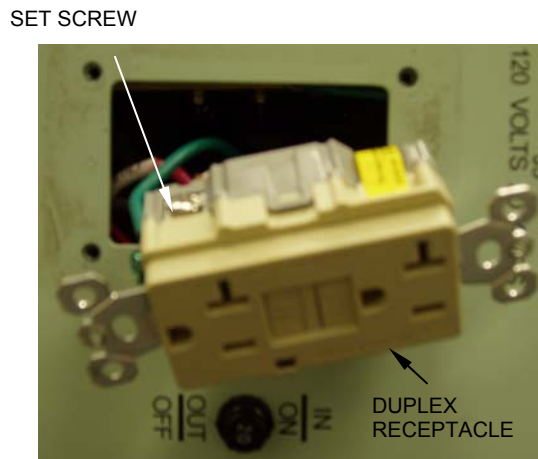
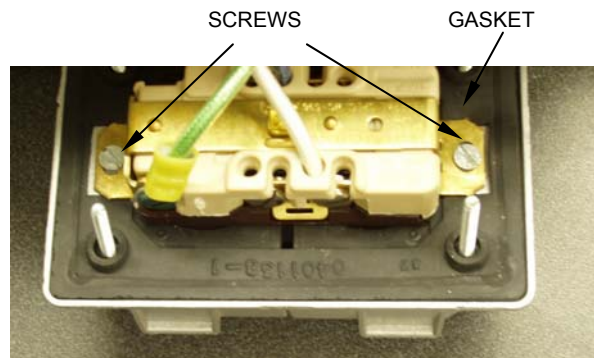


Figure 12. Loosening Set Screws.



**Figure 13. Removing Screws.**

2. Install duplex receptacle.
  - a. Install wires and tighten set screws.
  - b. Assemble duplex receptacle and cover with gasket; secure with screws.
  - c. If applicable, install screws in receptacle cover.
  - d. Install replacement duplex receptacle and receptacle cover with gasket onto the power distribution box.

**END OF WORK PACKAGE**





---

**FIELD MAINTENANCE  
STANDARD INTEGRATED COMMAND POST SYSTEM (SICPS), MEDIUM  
NSN: 8340-01-516-0904, GREEN  
NSN: 8340-01-516-0903, TAN  
CONVENIENCE OUTLET  
REPAIR**

---

**INITIAL SETUP****Tools and Special Tools**

Tool Kit, General Mechanic's (Item 6, Table 2,  
WP 0030)

**Materials/Parts**

N/A

**Equipment Condition**

External electrical power disconnected;  
power control disconnected.

**References**

N/A

---

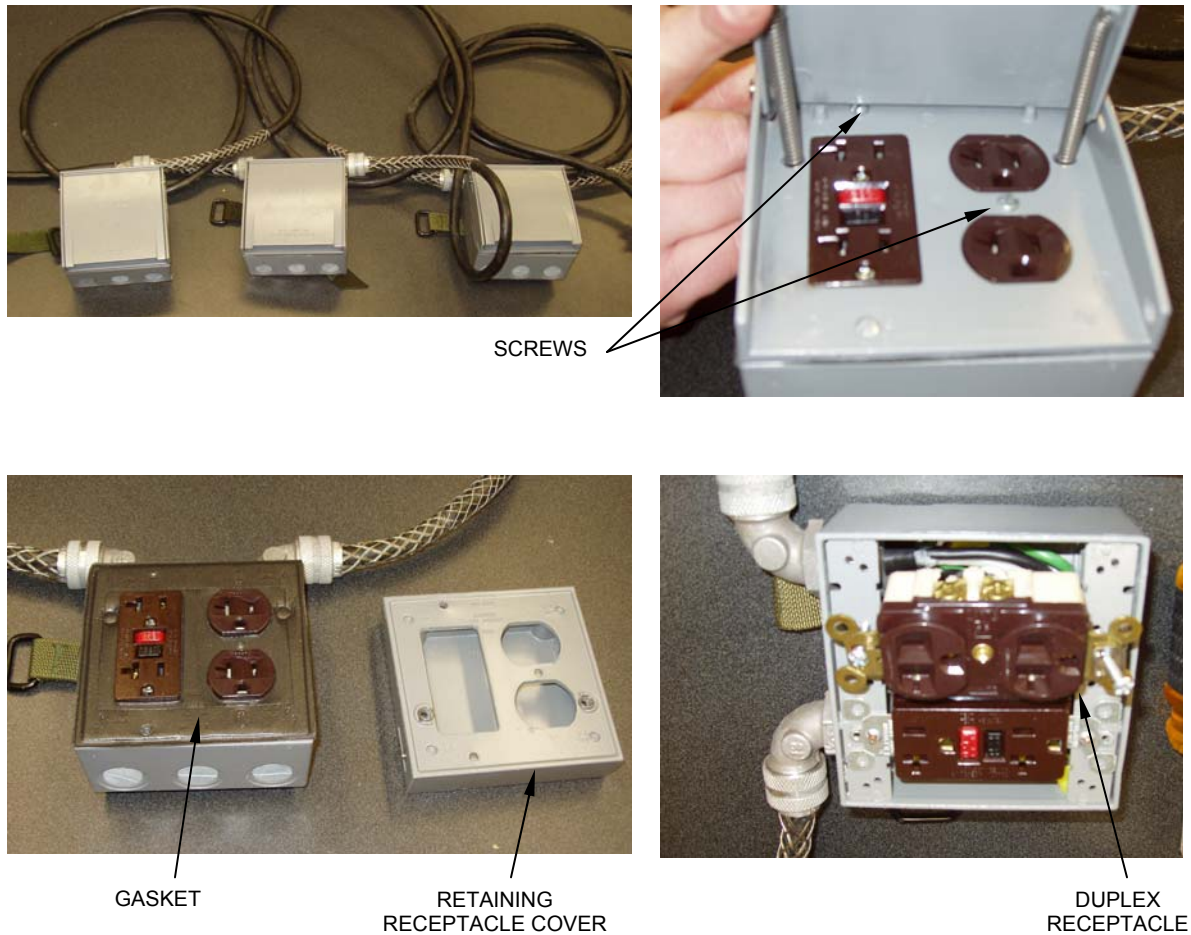
**REPAIR****Removal and Installation of Duplex Receptacle with Gasket from Convenience Outlet****WARNING**

Lethal voltage is present when the power control system is connected to power source. Disconnect from power source before inspecting or repairing any electrical component. Electrical shock and death may result from failure to heed this warning.

**NOTE**

The first convenience outlet box of the set contains the GFCI protected duplex outlet.

1. Remove duplex receptacle with gasket as follows:
  - a. Disconnect electrical power from power distribution box.
  - b. Remove screws, retaining receptacle cover, and gasket to convenience outlet box.
  - c. Remove screws retaining defective duplex receptacle to convenience outlet box.
  - d. Pull duplex receptacle out of convenience outlet box.
  - e. Loosen set screws and remove wires from duplex receptacle.

**REPAIR – Continued.****Figure 1. Electrical Distribution System.**

2. Install duplex receptacle with gasket as follows:
  - a. Attach wires to set screws of replacement duplex receptacle.
  - b. Place replacement duplex receptacle in the convenience outlet box.
  - c. Attach replacement duplex receptacle to convenience outlet box.
  - d. Install gasket and receptacle cover.
  - e. Connect electrical power and test for proper operation.

**END OF WORK PACKAGE**

---

**FIELD MAINTENANCE  
STANDARD INTEGRATED COMMAND POST SYSTEM (SICPS), MEDIUM  
NSN: 8340-01-516-0904, GREEN  
NSN: 8340-01-516-0903, TAN  
TENT SECTIONS (FABRIC)  
REPAIR**

---

**INITIAL SETUP****Tools and Special Tools**

Sewing Machine, Industrial (Item 5, Table 2,  
WP 0030)  
Repair Kit, Tentage (Item 3, Table 2, WP 0030)

**Equipment Condition**

N/A

**Materials/Parts**

N/A

**References**

FED-STD 595  
FED-STD 751;  
FM 10-16

---

**REPAIR****MACHINE STITCHING**

All stitch types, except bartacking, shall conform to FED-STD 751. Type 301 and 401 stitching requires 5-to-7 stitches per inch. Bartacking shall be  $\frac{1}{8}$  inch in width and free of thread breaks and loose stitching.

1. Thread Breaks. Thread breaks in stitching shall be overstitched no less than 1 inch at each break on stitch type 301 and not less than 1  $\frac{1}{2}$  inch at each break on stitch type 401. Thread breaks in type 401 may be overstitched with stitch type 301. Thread breaks noted during inspection must be repaired by overstitching the existing stitching, starting from a distance of 1 inch beyond the break. The ends of repair stitching are not required to be backstitched.
2. Stitching Ends. The ends of type 301 stitching shall be overstitched not less than 1 inch, except where ends are turned under in a hem or held down by other stitching. Where 301 stitching are performed automatically on stitch patterns such as box, box with cross-stitch, "W" stitching, or straight line tacking, at least three tying, overlapping, or back stitches shall be used to secure the ends of stitching.
3. Skipped Stitches. Two or more consecutively skipped stitches, occurring in type 301 stitching, shall be overstitched not less than 1 inch. Any skipped stitches in the 401 stitching shall be overstitched not less than 1  $\frac{1}{2}$  inches. Skipped stitches in 401 stitching may be overstitched with type 301 stitching. Skipped stitches noted during inspection shall be repaired, as specified for thread breaks, as described above.

**AUTOMATIC STITCHING**

Automatic stitching machines may be used to perform any of the required stitch patterns, provided the requirement of the stitch pattern, stitches per inch, size and type of thread are met and at least three or more overlapping, tying, or backstitches secure the ends of the stitching.

**END OF WORK PACKAGE**



**FIELD MAINTENANCE  
STANDARD INTEGRATED COMMAND POST SYSTEM (SICPS), MEDIUM  
NSN: 8340-01-516-0904, GREEN  
NSN: 8340-01-516-0903, TAN  
FIELD TABLE  
REPAIR**

**INITIAL SETUP****Tools and Special Tools**

Riveting Tool (Item 4, Table 2, WP 0030)  
Tool Kit, General Mechanic's (Item 6, Table 2, WP 0030)

**Equipment Condition**

On flat surface, upside down.

**Materials/Parts**

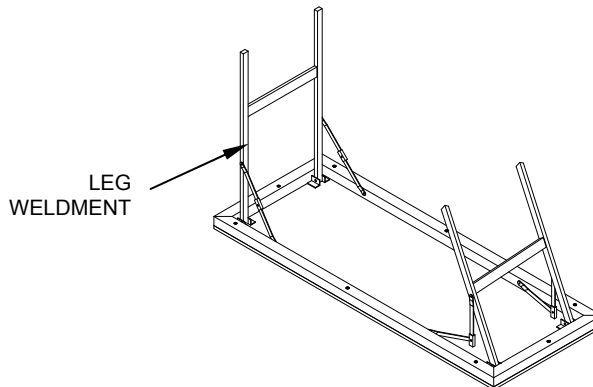
N/A

**References**

N/A

**REPAIR****Removal and Install of Leg Weldment**

1. Turn table upside down. Remove leg weldment as follows:



**Figure 1. Field Table (Upside Down).**

- a. Remove rivets holding braces to weldment as follows:

**CAUTION**

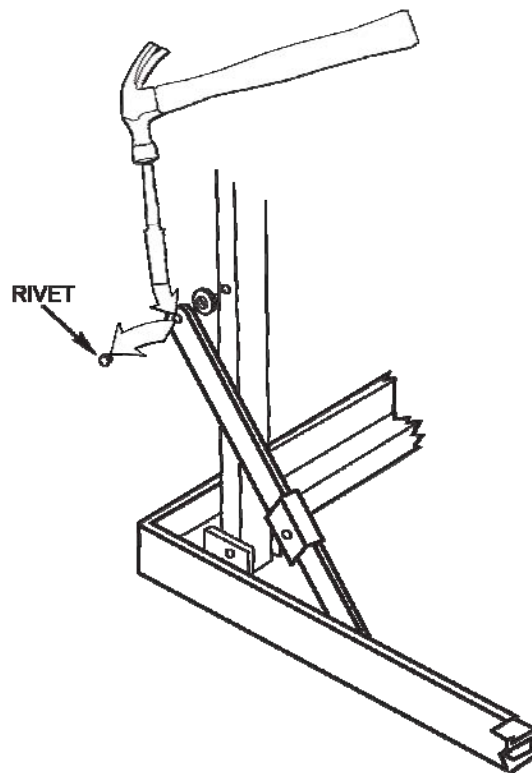
When removing rivets, be careful not to enlarge the rivet hole since this causes the use of a larger rivet for replacement.

**CAUTION**

Take care not to damage the surface of the brace(s) and table leg weldment(s) being repaired.

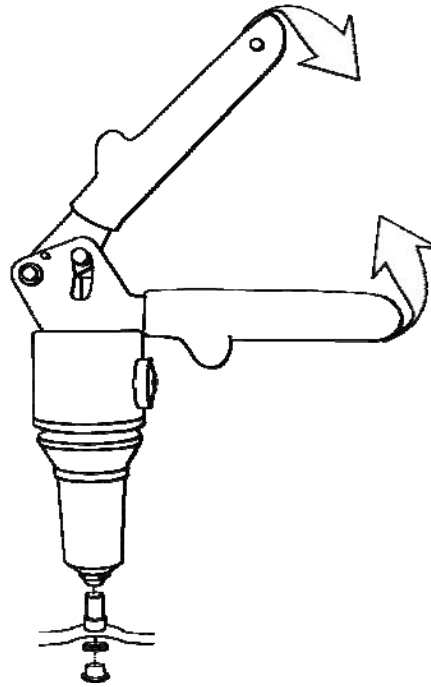
**CAUTION**

In order to prevent the corners from cutting grooves in the surface of the work, make sure the cutting edge of the chisel has a slight radius. In addition, always cut parallel to the plate edge.



**Figure 2. Removing Rivet.**

- 1) Cut off blind rivets using a cold chisel.
  - 2) Remove rivets.
- b. Remove screws, washers, nuts, and nylon washers holding the leg weldment to the table.
  - c. Remove leg weldment.
2. Install leg weldment as follows:
    - a. Align new leg weldment with bolt sleeve in top weldment.
    - b. Install screws, washers, nuts, and nylon washers, securing weldment to table.
    - c. Install blind rivets holding braces to weldment as follows:
      - 1) Obtain the correct rivet.



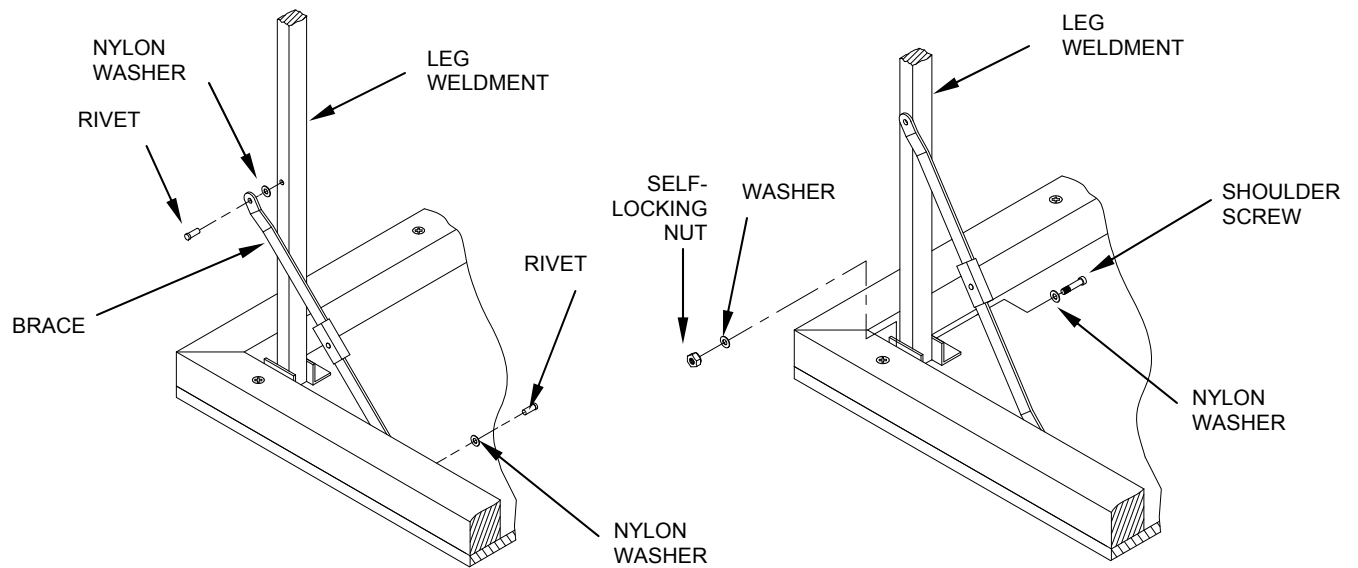
**Figure 3. Inserting Rivet.**

- 2) Insert the stem completely into the rivet gun.

**CAUTION**

To avoid causing damage, do not force rivet into hole in material.

- 3) Insert the rivet into the hole in the material being joined.
- 4) Keep the head of the rivet flat against the surface of the material while applying steady pulling pressure with the rivet gun to pull the rivet stem.
- 5) Once the rivet stem breaks free, ensure the rivet is seated properly and is not loose.
- 6) If the rivet is not seated properly or is loose, remove rivet as previously described and replace repeating steps 1) through 6).



**Figure 4. Leg Weldment and Braces.**

### Removal and Installation of Brace

1. Remove brace as follows:
  - a. Remove rivets holding brace to top weldment and leg weldment as follows:

#### CAUTION

When removing rivets, be careful not to enlarge the rivet hole since this causes the use of a larger rivet for replacement.

#### CAUTION

Take care not to damage the surface of the brace(s) and table leg weldment(s) being repaired.

#### CAUTION

In order to prevent the corners from cutting grooves in the surface of the work, make sure the cutting edge of the chisel has a slight radius. In addition, always cut parallel to the plate edge.

- 1) Cut off blind rivets using a cold chisel.
  - 2) Remove rivets.
- b. Remove brace.
2. Install brace as follows:
    - a. Align new brace with rivet holes in top weldment and leg weldment.
    - b. Install rivets as follows:
      - 1) Obtain the correct rivet.

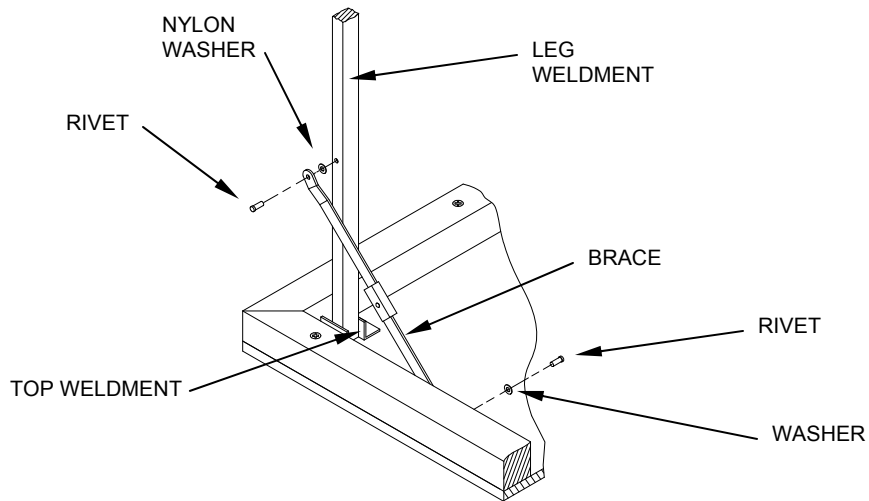


- 2) Insert the stem completely into the rivet gun.

### CAUTION

To avoid causing damage, do not force rivet into hole in material.

- 3) Insert the rivet into the hole in the material being joined.
- 4) Keep the head of the rivet flat against the surface of the material while applying steady pulling pressure with the rivet gun to pull the rivet stem.
- 5) Once the rivet stem breaks free, ensure the rivet is seated properly and is not loose.
- 6) If the rivet is not seated properly or is loose, remove rivet as previously described and replace repeating steps 1) through 6).



**Figure 5. Installing Braces.**

**END OF WORK PACKAGE**



## **CHAPTER 5**

### **SUPPORTING INFORMATION FOR STANDARD INTEGRATED COMMAND POST SYSTEM (SICPS), MEDIUM**



---

**OPERATOR AND FIELD MAINTENANCE  
STANDARD INTEGRATED COMMAND POST SYSTEM (SICPS), MEDIUM  
NSN: 8340-01-516-0904, GREEN  
NSN: 8340-01-516-0903, TAN  
REFERENCES**

---

This appendix lists all forms, technical manuals, and miscellaneous publications referenced, or to be used with this manual.

**PAMPHLETS**

DA PAM 25-30	Consolidated Index of Army Publications and Blank Forms
DA PAM 738-751	Functional Users Manual for The Army Maintenance Management System (Aviation) (TAMMS-A)

**FIELD MANUALS**

FM 3-11.3	Multiservice Tactics, Techniques, and Procedures for Chemical, Biological, Radiological, and Nuclear Contamination Avoidance
FM 3-11.4	Multiservice Tactics, Techniques, and Procedures for Nuclear, Biological, and Chemical (NBC) Protection
FM 3-11.5	Multiservice Tactics, Techniques, and Procedures for Chemical, Biological, Radiological, and Nuclear Decontamination
FM 3-97.6	Mountain Operations
FM 4-25.11	First Aid
FM 9-207	Operations and Maintenance of Ordnance Materiel in Cold Weather
FM 10-16	General Fabric Repair
FM 31-70	Basic Cold Weather Manual
FM 31-71	Northern Operations
FM 38-701	Packaging of Materiel - Packing

**ARMY REGULATIONS**

AR 25-52	Authorized Abbreviations, Brevity Codes, and Acronyms
AR 700-15	Packaging of Materiel
AR 70-38	Research, Development, Test, and Evaluation of Materiel for Extreme Climatic Conditions
AR 750-1	Army Materiel Maintenance Policy and Retail Maintenance Operation
AR 700-138	Army Logistics Readiness and Sustainability

**FORMS**

DA Form 2028	Recommended Changes to Equipment Technical Publications
DA Form 2404	Equipment Inspection and Maintenance Worksheet
DA Form 2408-9	Equipment Control Record
DA Form 2410	Component Removal and Repair/Overhaul Record
DA Form 2028	Recommended Changes to Publications and Blank Forms
SF 361	Discrepancy in Transportation Report
SF 362	U.S. Government Freight Loss/Damage Claim
SF 364	Report of Discrepancy (ROD)
SF 368	Product Quality Deficiency Report (PQDR)

**TECHNICAL MANUALS**

TC 9-510	Metal Body Repair and Related Operations
TM 10-8340-224-23P	Operator, Unit and Direct Support Maintenance Repair Parts and Special Tools List for Tent, Extendable, Modular Personnel (TEMPER)
TM 5-1080-200-13&P	Lightweight Camouflage Screen and Screen Support Systems
TM 750-244-2	Procedures for Destruction of Electronics Materiel to Prevent Enemy Use
TM 750-244-3	Procedures for Destruction of Equipment to Prevent Enemy Use

**FEDERAL STANDARDS**

FED-STD 595	Colors
FED-STD 751	Stitches, Seams and Stitching

**TECHNICAL BULLETINS**

TB 43-0002-43	Maintenance Expenditure Limits for FSC Group 16
---------------	---

**MISCELLANEOUS**

CTA 8-100	Army Medical Department Expendable/Durable Items
CTA 50-970	Expendable/Durable Items (Except Medical, Class V Repair Parts, and Heraldic Items)
<a href="http://www.dtic.mil/doctrine/dod_dictionary/">http://www.dtic.mil/doctrine/dod_dictionary/</a>	Dictionary of United States Army Terms

**END OF WORK PACKAGE**

---

**OPERATOR AND FIELD MAINTENANCE  
STANDARD INTEGRATED COMMAND POST SYSTEM (SICPS), MEDIUM  
NSN: 8340-01-516-0904, GREEN  
NSN: 8340-01-516-0903, TAN  
MAINTENANCE ALLOCATION CHART (MAC), INTRODUCTION**

---

## **MAINTENANCE ALLOCATION CHART (MAC)**

### **INTRODUCTION**

#### **The Army Maintenance System MAC**

This introduction provides a general explanation of all maintenance and repair functions authorized at the two maintenance levels under the Two-Level Maintenance System concept.

The MAC (immediately following the introduction) designates overall authority and responsibility for the performance of maintenance functions on the identified end item or component. The application of the maintenance functions to the end item or component shall be consistent with the capacities and capabilities of the designated maintenance levels, which are shown in the MAC in column (4) as:

Field – includes three subcolumns, Crew (C), Service (O), and Field (F).

Sustainment – includes two subcolumns, Below Depot (H) and Depot (D).

The maintenance to be performed below depot and in the field is described as follows:

1. Service maintenance. The responsibility of a using organization to perform maintenance on its assigned equipment. It normally consists of inspecting, servicing, lubricating, adjusting, and replacing parts, minor assemblies, and subassemblies. The replace function for this level of maintenance is indicated by the letter "O" in the third position of the SMR code. An "O" appearing in the fourth position of the SMR code indicates complete repair is possible at the service maintenance level.
2. Field maintenance. Maintenance accomplished on a component, accessory, assembly, subassembly, plug-in unit, or other portion either on the system or after it is removed. The replace function for this level of maintenance is indicated by the letter "F" appearing in the fourth position of the SMR code indicates complete repair is possible at the field maintenance level. Items are returned to the user after maintenance is performed at this level.
3. Below depot sustainment. Maintenance accomplished on a component, accessory, assembly, subassembly, plug-in unit, or other portion either on the system or after it is removed. The replace function for this level of maintenance is indicated by the letter "H" appearing in the third position in the SMR code. An "H" appearing in the fourth position of the SMR code indicates complete repair is possible at the below depot sustainment maintenance level. Items are returned to the supply system after maintenance is performed at this level.

The tools and test equipment requirements (immediately following the MAC) list the tools and test equipment (both special tools and common tool sets) required for each maintenance function as referenced from the MAC.

The remarks (immediately following the tools and test equipment requirements) contain supplemental instructions and explanatory notes for a particular maintenance function.

## Maintenance Functions

Maintenance functions will be limited to and defined as follows:

1. **Inspect.** To determine the serviceability of an item by comparing its physical, mechanical, and/or electrical characteristics with established standards through examination (e.g., by sight, sound, or feel). This includes scheduled inspection and gaugings and evaluation of cannon tubes.
2. **Test.** To verify serviceability by measuring the mechanical, pneumatic, hydraulic, or electrical characteristics of an item and comparing those characteristics with prescribed standards on a scheduled basis, i.e., load testing of lift devices and hydrostatic testing of pressure hoses.
3. **Service.** Operations required periodically to keep an item in proper operating condition; e.g., to clean (includes decontaminate, when required), to preserve, to drain, to paint, or to replenish fuel, lubricants, chemical fluids, or gases. This includes scheduled exercising and purging of recoil mechanisms. The following are examples of service functions:
  - a. **Unpack.** To remove from packing box for service or when required for the performance of maintenance operations.
  - b. **Repack.** To return item to packing box after service and other maintenance operations.
  - c. **Clean.** To rid the item of contamination.
  - d. **Touch up.** To spot paint scratched or blistered surfaces.
  - e. **Mark.** To restore obliterated identification.
4. **Adjust.** To maintain or regulate, within prescribed limits, by bringing into proper position, or by setting the operating characteristics to specified parameters.
5. **Align.** To adjust specified variable elements of an item to bring about optimum or desired performance.
6. **Calibrate.** To determine and cause corrections to be made or to be adjusted on instruments of test, measuring, and diagnostic equipment used in precision measurement. Consists of comparisons of two instruments, one of which is a certified standard of known accuracy, to detect and adjust any discrepancy in the accuracy of the instrument being compared.
7. **Remove/Install.** To remove and install the same item when required to perform service or other maintenance functions. Install may be the act of emplacing, seating, or fixing into position a spare, repair part, or module (component or assembly) in a manner to allow the proper functioning of an equipment or system.
8. **Paint (ammunition only).** To prepare and spray color coats of paint so that the ammunition can be identified and protected. The color indicating primary use is applied, preferably, to the entire exterior surface as the background color of the item. Other markings are to be repainted as original so as to retain proper ammunition identification.
9. **Replace.** To remove an unserviceable item and install a serviceable counterpart in its place. "Replace" is authorized by the MAC and assigned maintenance level is shown as the third position code of the Source, Maintenance and Recoverability (SMR) code.
10. **Repair.** The application of maintenance services, including fault location/troubleshooting, removal/installation, disassembly/assembly procedures and maintenance actions to identify troubles and restore serviceability to an item by correcting specific damage, fault, malfunction, or failure in a part, subassembly, module (component or assembly), end item, or system.



## NOTE

The following definitions are applicable to the “repair” maintenance function: Services. Inspect, test, service, adjust, align, calibrate, and/or replace.

**Fault location/troubleshooting.** The process of investigating and detecting the cause of equipment malfunctioning; the act of isolating a fault within a system or Unit Under Test (UUT).

**Disassembly/assembly.** The step-by-step breakdown (taking apart) of a spare/functional group coded item to the level of its least component, that is assigned an SMR code for the level of maintenance under consideration (i.e., identified as maintenance significant).

**Actions.** Welding, grinding, riveting, straightening, facing, machining, and/or resurfacing.

11. **Overhaul.** The maintenance effort (service/action) prescribed to restore an item to a completely serviceable/operational condition as required by maintenance standards in appropriate technical publications. Overhaul is normally the highest degree of maintenance performed by the Army. Overhaul does not normally return an item to like new condition.
12. **Rebuild.** Consists of those services/actions necessary for the restoration of unserviceable equipment to a like new condition in accordance with original manufacturing standards. Rebuild is the highest degree of material maintenance applied to Army equipment. The rebuild operation includes the act of returning to zero those age measurements (e.g., hours/miles) considered in classifying Army equipment/components.

### Explanation of Columns in the MAC

**Column (1) Group Number.** Column (1) lists Functional Group code (FGC) numbers, the purpose of which is to identify maintenance significant components, assemblies, subassemblies, and modules with the Next Higher Assembly (NHA).

**Column (2) Component/Assembly.** Column (2) contains the item names of components, assemblies, subassemblies, and modules for which maintenance is authorized.

**Column (3) Maintenance Function.** Column (3) lists the functions to be performed on the item listed in column (2). (For a detailed explanation of these functions, refer to “Maintenance Functions” outlined above.)

**Column (4) Maintenance Level.** Column (4) specifies each level of maintenance authorized to perform each function listed in column (3), by indicating work time required (expressed as manhours in whole hours or decimals) in the appropriate subcolumn. This work time figure represents the active time required to perform that maintenance function at the indicated level of maintenance. If the number or complexity of the tasks within the listed maintenance function varies at different maintenance levels, appropriate work time figures are to be shown for each level. The work time figure represents the average time required to restore an item (assembly, subassembly, component, module, end item, or system) to a serviceable condition under typical field operating conditions. This time includes preparation time (including any necessary disassembly/assembly time), troubleshooting/fault location time, and quality assurance time in addition to the time required to perform the specific tasks identified for the maintenance functions authorized in the MAC. The symbol designations for the various maintenance levels are as follows:

Field:

- C Crew maintenance
- O Service maintenance
- F Field maintenance

Sustainment:

- L Specialized Repair Activity (SRA)
- H Below depot maintenance
- D Depot maintenance

## NOTE

The "L" maintenance level is not included in column (4) of the MAC. Functions to this level of maintenance are identified by a work time figure in the "H" column of column (4), and an associated reference code is used in the REMARKS column (6). This code is keyed to the remarks and the SRA complete repair application is explained there.

Column (5) Tools and Equipment Reference Code. Column (5) specifies, by code, those common tool sets (not individual tools), common Test, Measurement, and Diagnostic Equipment (TMDE), special TMDE and special support equipment required to perform the designated function. Codes are keyed to the entries in the tools and test equipment table.

Column (6) Remarks Code. When applicable, this column contains a letter code, in alphabetical order, which is keyed to the remarks table entries.

### Explanation of Columns in the Tools and Test Equipment Requirements

Column (1) Tool or Test Equipment Reference Code. The tool and test equipment reference code correlates with a code used in column (5) of the MAC.

Column (2) Maintenance Level. The lowest level of maintenance authorized to use the tool or test equipment.

Column (3) Nomenclature. Name or identification of the tool or test equipment.

Column (4) National Stock Number (NSN). The NSN of the tool or test equipment.

Column (5) Tool Number. The manufacturer's part number.

### Explanation of Columns in the Remarks

Column (1) Remarks Code. The code recorded in column (6) of the MAC.

Column (2) Remarks. This column lists information pertinent to the maintenance function being performed as indicated in the MAC.

## END OF WORK PACKAGE

**OPERATOR AND FIELD MAINTENANCE  
STANDARD INTEGRATED COMMAND POST SYSTEM (SICPS), MEDIUM  
NSN: 8340-01-516-0904, GREEN  
NSN: 8340-01-516-0903, TAN  
MAINTENANCE ALLOCATION CHART (MAC)**

**Table 1. MAC for Standard Integrated Command Post System (SICPS), Medium.**

(1)  GROUP NUMBER	(2)  COMPONENT/ ASSEMBLY	(3)  MAINTENANCE FUNCTION	(4) MAINTENANCE LEVEL					(5)  TOOLS AND EQUIPMENT REFERENCE CODE	(6)  REMARKS CODE
			FIELD			SUSTAINMENT			
			CREW	SERVICE	FIELD	BELOW DEPOT	DEPOT		
			C	O	F	H	D		
00	Standard Integrated Command Post System (SICPS), Medium								
01	Tent Sections (Fabric)	Inspect Repair Replace Service	0.5  0.5	0.5 0.5	1.0			1, 2, 3, 5	A, B
0101	End Section	Repair Replace		0.5 0.5	0.5				
0102	Intermediate Section	Repair Replace		0.5 0.5	0.5				
0103	Sandwich Walls	Repair Replace		0.5 0.5	0.5				
0104	Insulated Liners /Plenum	Repair Replace		0.5 0.5	0.5				
0105	Floor	Repair Replace		0.5 0.5	0.5				
0106	Vestibule Door	Repair Replace		0.5 0.5	0.5				
02	Frame Sections	Inspect Repair Replace Service	0.5  0.5	0.5 0.5					A
0201	Upper Arch Assembly	Repair Replace		0.2 0.5				6	
0202	Lower Arch Assembly	Repair Replace		0.2 0.5				6	
0203	Cable Header Assembly	Repair Replace		0.2 0.5					

Table 1. MAC for Standard Integrated Command Post System (SICPS), Medium – Continued.

(1) GROUP NUMBER	(2) COMPONENT/ ASSEMBLY	(3) MAINTENANCE FUNCTION	(4) MAINTENANCE LEVEL					(5) TOOLS AND EQUIPMENT REFERENCE CODE	(6) REMARKS CODE
			FIELD			SUSTAINMENT			
			CREW	SERVICE	FIELD	BELOW DEPOT	DEPOT		
			C	O	F	H	D		
0204	Purlin Assembly	Repair Replace		0.2 0.5					
0205	Threshold, Tent	Repair Replace		0.2 0.5					
0206	Vestibule Frame Assembly	Repair Replace		0.5 0.5					
03	Power Control	Inspect Repair Replace	0.5	0.3 0.2	2.0			A	
0301	Power Distribution Box	Replace Repair		0.2 0.3	2.0		6		
0302	Cable Assemblies	Replace		0.2					
0303	Convenience Outlet	Repair Replace		0.3 0.2	1.0		6		
0304	Power Panel Stand Assembly	Repair Replace		0.5 0.1					
04	Light Set Assembly	Inspect Service Test Repair Replace	0.5 0.5 0.2 0.2		0.2 1.0			A	
05	Transport Bags	Inspect Service Repair Replace	0.1 0.1	0.5 0.1	0.5			A, B	
0501	Cover, Tent	Repair Replace	0.2	0.5	0.5				
0502	Cover, Tent Frame	Repair Replace	0.2	0.5	0.5				
0503	Container, Tent Pin	Repair Replace	0.2	0.5	0.5				
06	Tent Pins	Inspect Replace	0.1 0.1					A	
07	Table, Field	Inspect Repair Service Replace	0.1 0.2	0.5 0.2			4, 6	A	

**Table 2. Tools and Test Equipment for Standard Integrated Command Post System (SICPS), Medium.**

<b>TOOL OR TEST EQUIPMENT REFERENCE CODE</b>	<b>MAINTENANCE LEVEL</b>	<b>NOMENCLATURE</b>	<b>NATIONAL STOCK NUMBER</b>	<b>TOOL NUMBER</b>
1	O	Brush, Paint	8020-00-597-4761	
2	O	Hand Roller	5120-00-243-9401	
3	O	Repair Kit, Tentage	8340-00-262-5767	
4	F	Riveting Tool	5180-01-201-4978	
5	F	Sewing Machine, Industrial	3530-00-892-4631	
6	O	Tool Kit, General Mechanic's	5180-01-483-0249	

**Table 3. Remarks for Standard Integrated Command Post System (SICPS), Medium.**

<b>REMARKS CODE</b>	<b>REMARKS</b>
A	Inspect in accordance with PMCS.
B	Clean all fabric components with soapy water.

**END OF WORK PACKAGE**



---

**OPERATOR AND FIELD MAINTENANCE  
STANDARD INTEGRATED COMMAND POST SYSTEM (SICPS), MEDIUM  
NSN: 8340-01-516-0904, GREEN  
NSN: 8340-01-516-0903, TAN  
REPAIR PARTS AND SPECIAL TOOLS LIST (RPSTL), INTRODUCTION**

---

## INTRODUCTION

### SCOPE

This RPSTL lists and authorizes spares and repair parts; special tools; special test, measurement, and diagnostic equipment (TMDE); and other special support equipment required for performance of operator and field maintenance of the Standard Integrated Command Post System (SICPS), Medium. It authorizes the requisitioning, issue, and disposition of spares, repair parts, and special tools as indicated by the source, maintenance and recoverability (SMR) codes.

### GENERAL

In addition to the Introduction work package, this RPSTL is divided into the following work packages.

1. **Repair Parts List Work Packages.** Work packages containing lists of spares and repair parts authorized by this RPSTL for use in the performance of maintenance. These work packages also include parts which must be removed for replacement of the authorized parts. Parts lists are composed of functional groups in ascending alphanumeric sequence, with the parts in each group listed in ascending figure and item number sequence. Sending units, brackets, filters, and bolts are listed with the component they mount on. Bulk materials are listed by item name in FIG. BULK at the end of the work packages. Repair parts kits are listed separately in their own functional group and work package. Repair parts for reparable special tools are also listed in a separate work package. Items listed are shown on the associated illustrations.
2. **Special Tools List Work Packages.** Work packages containing lists of special tools, special TMDE, and special support equipment authorized by this RPSTL (as indicated by Basis of Issue (BOI) information in the DESCRIPTION AND USABLE ON CODE (UOC) column). Tools that are components of common tool sets and/or Class VII are not listed.
3. **Cross-Reference Indexes Work Packages.** There are two cross-reference indexes work packages in this RPSTL: the National Stock Number (NSN) Index work package and the Part Number (P/N) Index work package. The National Stock Number Index work package refers you to the figure and item number. The Part Number Index work package refers you to the figure and item number.

**EXPLANATION OF COLUMNS IN THE REPAIR PARTS LIST AND SPECIAL TOOLS LIST WORK PACKAGES**

ITEM NO. (Column (1)). Indicates the number used to identify items called out in the illustration.

SMR CODE (Column (2)). The SMR code containing supply/requisitioning information, maintenance level authorization criteria, and disposition instruction, as shown in the following breakout. This entry may be subdivided into 4 subentries, one for each service.

**TABLE 1. SMR Code Explanation.**

<u>Source Code</u> <u>XX</u>	<u>Maintenance Code</u> <u>XX</u>	<u>Recoverability Code</u> <u>X</u>
1 <sup>st</sup> two positions: How to get an item.	3 <sup>rd</sup> position: Who can install, replace, or use the item.	4 <sup>th</sup> position: Who can do a complete repair* on the item.
		5 <sup>th</sup> position: Who determines disposition action on unserviceable items.

\*Complete Repair: Maintenance capacity, capability, and authority to perform all corrective maintenance tasks of the "REPAIR" function in a use/user environment in order to restore serviceability to a failed item.

Source Code. The source code tells you how you get an item needed for maintenance, repair, or overhaul of an end item/equipment. Explanations of source codes follow:

<u>Source Code</u>	<u>Application/Explanation</u>
PA	
PB	
PC	<b>NOTE</b>
PD	Items coded PC are subject to deterioration.
PE	
PF	Stocked items; use the applicable NSN to requisition/request items with these source codes. They are authorized to the level indicated by the code entered in the third position of the SMR code.
PG	
PH	
PR	
PZ	
KD	Items with these codes are not to be requested/requisitioned individually. They are part of a kit which is authorized to the maintenance level indicated in the third position of the SMR code. The complete kit must be requisitioned and applied.
KF	
KB	



MO – Made at service/AMC level	Items with these codes are not to be requested/requisitioned individually. They must be made from bulk material which is identified by the part number in the DESCRIPTION AND USABLE ON CODE (UOC) column and listed in the bulk material group work package of the RPSTL. If the item is authorized to you by the third position code of the SMR code, but the source code indicates it is made at a higher level, order the item from the higher level of maintenance.
MF – Made at field/ASB level	
MH – Made at below depot, sustainment level	
ML – Made at SRA/TASMG	
MD – Made at depot	
MG – Navy only	
AO – Assembled by service/ACM level	Items with these codes are not to be requested/requisitioned individually. The parts that make up the assembled item must be requisitioned or fabricated and assembled at the level of maintenance indicated by the source code. If the third position of the SMR code authorizes you to replace the item, but the source code indicates the item is assembled at a higher level, order the item from the higher level of maintenance.
AF – Assembled by field/ASB level	
AH – Assembled by below depot sustainment level	
AL – Assembled by SRA/TASMG	
AD – Assembled by depot	
AG – Navy only	
XA	Do not requisition an “XA” coded item. Order the next higher assembly. (Refer to NOTE below.)
XB	If an item is not available from salvage, order it using the CAGEC and part number.
XC	Installation drawings, diagrams, instruction sheets, field service drawings; identified by manufacturer’s part number.
<b><u>Source Code</u></b>	<b><u>Application/Explanation</u></b>
XD	Item is not stocked. Order an XD-coded item through local purchase or normal supply channels using the CAGEC and part number given, if no NSN is available.

**NOTE**

Cannibalization or controlled exchange, when authorized, may be used as a source of supply for items with the above source codes except for those items source coded “XA” or those aircraft support items restricted by requirements of AR 750-1.

**Maintenance Code.** Maintenance codes tell you the level(s) of maintenance authorized to use and repair support items. The maintenance codes are entered in the third and fourth positions of the SMR code as follows:

**Third position.** The maintenance code entered in the third position tells you the lowest maintenance level authorized to remove, replace, and use an item. The maintenance code entered in the third position will indicate authorization to the following levels of maintenance:

<b>Maintenance Code</b>	<b><u>Application/Explanation</u></b>
O* -	Field (Service) level/AMC maintenance can remove, replace, and use the item.
F -	Field/ASB maintenance can remove, replace, and use the item.
H -	Below Depot Sustainment maintenance can remove, replace, and use the item.
L -	Specialized repair activity/TASMG can remove, replace, and use the item.
G -	Afloat and ashore intermediate maintenance can remove, replace, and use the item (Navy only)
K -	Contractor facility can remove, replace, and use the item.
Z -	Item is not authorized to be removed, replace, or used at any maintenance level.
D -	Depot can remove, replace, and use the item.

\*NOTE – Army may use C in the third position. However, for joint service publications, Army will use O.

Fourth position. The maintenance code entered in the fourth position tells you whether or not the item is to be repaired and identifies the lowest maintenance level with the capability to do complete repair (perform all authorized repair functions).

#### **NOTE**

Some limited repair may be done on the item at a lower level of maintenance, if authorized by the Maintenance Allocation Chart (MAC) and SMR codes.

<b>Maintenance Code</b>	<b><u>Application/Explanation</u></b>
O -	Field (Service)/AMC is the lowest level that can do complete repair of the item.
F -	Field/ASB is the lowest level that can do complete repair of the item.
H -	Below depot Sustainment is the lowest level that can do complete repair of the item.
L -	Specialized repair activity/TASMG (enter specialized repair activity or TASMG designator) is the lowest level that can do complete repair of the item.
D -	Depot is the lowest level that can do complete repair of the item.
G -	Both afloat and ashore intermediate levels are capable of complete repair of item. (Navy only)
K -	Complete repair is done at contractor facility.
Z -	Nonreparable. No repair is authorized.
B -	No repair is authorized. No parts or special tools are authorized for maintenance of "B" coded item. However, the item may be reconditioned by adjusting, lubricating, etc., at the user level.

Recoverability Code. Recoverability codes are assigned to items to indicate the disposition action on unserviceable items. The recoverability code is shown in the fifth position of the SMR code as follows:

<u>Recoverability Code</u>	<u>Application/Explanation</u>
Z -	Nonreparable item. When unserviceable, condemn and dispose of the item at the level of maintenance shown in the third position of the SMR code.
O -	Reparable item. When uneconomically repairable, condemn and dispose of the item at the service/AMC level.
F -	Reparable item. When uneconomically repairable, condemn and dispose of the item at the field level/ASB.
H -	Reparable item. When uneconomically repairable, condemn and dispose of the item at the below depot sustainment level.
D -	Reparable item. When beyond lower level repair capability, return to depot. Condemnation and disposal of item are not authorized below depot level.
L -	Reparable item. Condemnation and disposal not authorized below Specialized Repair Activity (SRA) or theater aviation sustainment maintenance group (TASMG).
A -	Item requires special handling or condemnation procedures because of specific reasons (such as precious metal content, high dollar value, critical material, or hazardous material). Refer to appropriate manuals/directives for specific instructions.
G -	Field level repairable item. Condemn and dispose at either afloat or ashore intermediate levels. (Navy only)
K -	Reparable item. Condemnation and disposal to be performed at contractor facility.

NSN (Column (3)). The NSN for the item is listed in this column.

CAGEC (Column (4)). The Commercial and Government Entity Code (CAGEC) is a five-digit code which is used to identify the manufacturer, distributor, or Government agency/activity that supplies the item.

PART NUMBER (Column (5)). Indicates the primary number used by the manufacturer (individual, company, firm, corporation, or Government activity), which controls the design and characteristics of the item by means of its engineering drawings, specifications, standards, and inspection requirements to identify an item or range of items.

#### NOTE

When you use an NSN to requisition an item, the item you receive may have a different part number from the number listed.

DESCRIPTION AND USABLE ON CODE (UOC) (Column (6)). This column includes the following information:

1. The Federal item name and, when repaired, a minimum description to identify the item.
2. P/Ns of bulk materials are referenced in this column in the line entry to be manufactured or fabricated.
3. Hardness Critical Item (HCI). A support item that provides the equipment with special protection from electromagnetic pulse (EMP) damage during a nuclear attack.

4. The statement END OF FIGURE appears just below the last item description in column (6) for a given figure in both the repair parts list and special tools list work packages.

QTY (Column (7)). The QTY (quantity per figure) column indicates the quantity of the item used in the breakout shown on the illustration/figure, which is prepared for a functional group, subfunctional group, or an assembly. A “V” appearing in this column instead of a quantity indicates that the quantity is variable and quantity may change from application to application.

**EXPLANATION OF CROSS-REFERENCE INDEXES WORK PACKAGES FORMAT AND COLUMNS**

1. National Stock Number (NSN) Index Work Package. NSN's in this index are listed in National Item Identification Number (NIIN) sequence.

STOCK NUMBER Column. This column lists the NSN in NIIN sequence. The NIIN consists of the last nine digits of the NSN. When using this column to locate an item, ignore the first four digits of the NSN. However, the complete NSN should be used when ordering items by stock number.

For example, if the NSN is 5385-01-574-1476, the NIIN is 01-574-1476.

FIG. Column. This column lists the number of the figure where the item is identified/located. The figures are in numerical order in the repair parts list and special tools list work packages.

ITEM Column. The item number identifies the item associated with the figure listed in the adjacent FIG. column. This item is also identified by the NSN listed on the same line.

2. Part Number (P/N) Index Work Package. Part Numbers in this index are listed in ascending alphanumeric sequence (vertical arrangement of letter and number combinations which places the first letter or digit of each group in order A through Z, followed by the numbers 0 through 9 and each following letter or digit in like order).

PART NUMBER Column. Indicates the part number assigned to the item.

FIG. Column. This column lists the number of the figure where the item is identified/located in the repair parts list or special tools list work package.

ITEM Column. The item number is the number assigned to the item as it appears in the figure referenced in the adjacent figure number column.

**SPECIAL INFORMATION**

UOC. The UOC appears in the lower left corner of the Description Column heading. Usable on codes are shown as “UOC:...” in the Description Column (justified left) on the first line under the applicable item/nomenclature. Uncoded items are applicable to all models. Identification of the UOCs used in the RPSTL are:

<u>Code</u>	<u>Used On</u>
FTX	Green, NSN: 8340-01-516-0904
FTY	Tan, NSN: 8340-01-516-0903

Fabrication Instructions. Bulk materials required to manufacture items are listed in the bulk material functional group of this RPSTL. Part numbers for bulk material are also referenced in the Description Column of the line item entry for the item to be manufactured/fabricated. Detailed fabrication instructions for items source coded to be manufactured or fabricated are found in the applicable maintenance work package.

Index Numbers. Items which have the word BULK in the figure column will have an index number shown in the item number column. This index number is a cross-reference between the NSN/ Part Number (P/N) Index work packages and the bulk material list in the repair parts list work package.

### **HOW TO LOCATE REPAIR PARTS**

#### 1. When NSNs or Part Numbers Are Not Known.

First. Using the table of contents, determine the assembly group to which the item belongs. This is necessary since the figures are prepared for assembly groups and subassembly groups, and lists are divided into the same groups.

Second. Find the figure covering the functional group or subfunctional group to which the item belongs.

Third. Identify the item on the figure and note the item number(s).

Fourth. Look in the repair parts list work packages for the figure and item numbers. The NSNs and part numbers are on the same line as the associate item numbers.

#### 2. When NSN Is Known.

First. If you have the NSN, look in the STOCK NUMBER column of the NSN index work package. The NSN is arranged in NIIN sequence. Note the figure and item number next to the NSN.

Second. Turn to the figure and locate the item number. Verify that the item is the one you are looking for.

#### 3. When Part Number Is Known.

First. If you have the part number and not the NSN, look in the PART NUMBER column of the part number index work package. Identify the figure and item number.

Second. Look up the item on the figure in the applicable repair parts list work package.

### **END OF WORK PACKAGE**



---

OPERATOR AND FIELD MAINTENANCE  
STANDARD INTEGRATED COMMAND POST SYSTEM (SICPS), MEDIUM  
END SECTION  
P/N 5-4-9709

REPAIR PARTS LIST

---

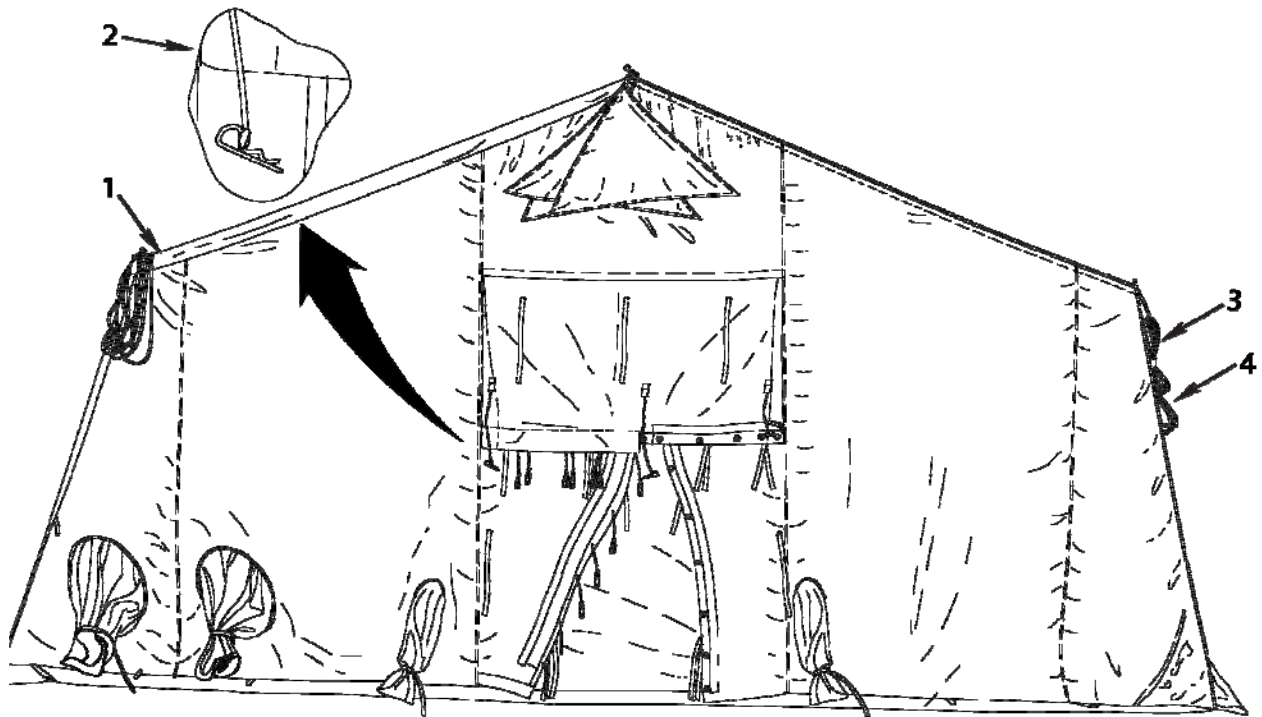


Figure 1. End Section.



(1) ITEM NO.	(2) SMR CODE	(3) NSN	(4) CAGEC	(5) PART NUMBER	(6) DESCRIPTION AND USABLE ON CODE (UOC)	(7) QTY
					GROUP 0101 END SECTION	
					FIG. 1 END SECTION	
1	PAOFF	8340-01-528-8212	81337	5-4-9709-1	Tent Section, End, Green UOC: FTX	2
1	PAOFF	8340-01-528-8211	81337	5-4-9709-2	Tent Section, End, Tan UOC: FTY	2
2	PAOZZ	8340-01-477-9709	81337	5-4-3342	.Hitch Clip Pin Assembly	4
3	PAOZZ	8340-00-205-2759	70167	23B28045-1	.Slip, Tent Line	2
4	MOOZZ		81337	5-4-9709-1-26	.Tent Line, Make From Part Number MIL-L-1709, Class G (Polyester) 3/8, Black, Cut 19' Long	2
					<b>END OF FIGURE</b>	



---

**OPERATOR AND FIELD MAINTENANCE  
STANDARD INTEGRATED COMMAND POST SYSTEM (SICPS), MEDIUM  
INTERMEDIATE SECTION  
P/N 5-4-9706**

**REPAIR PARTS LIST**

---

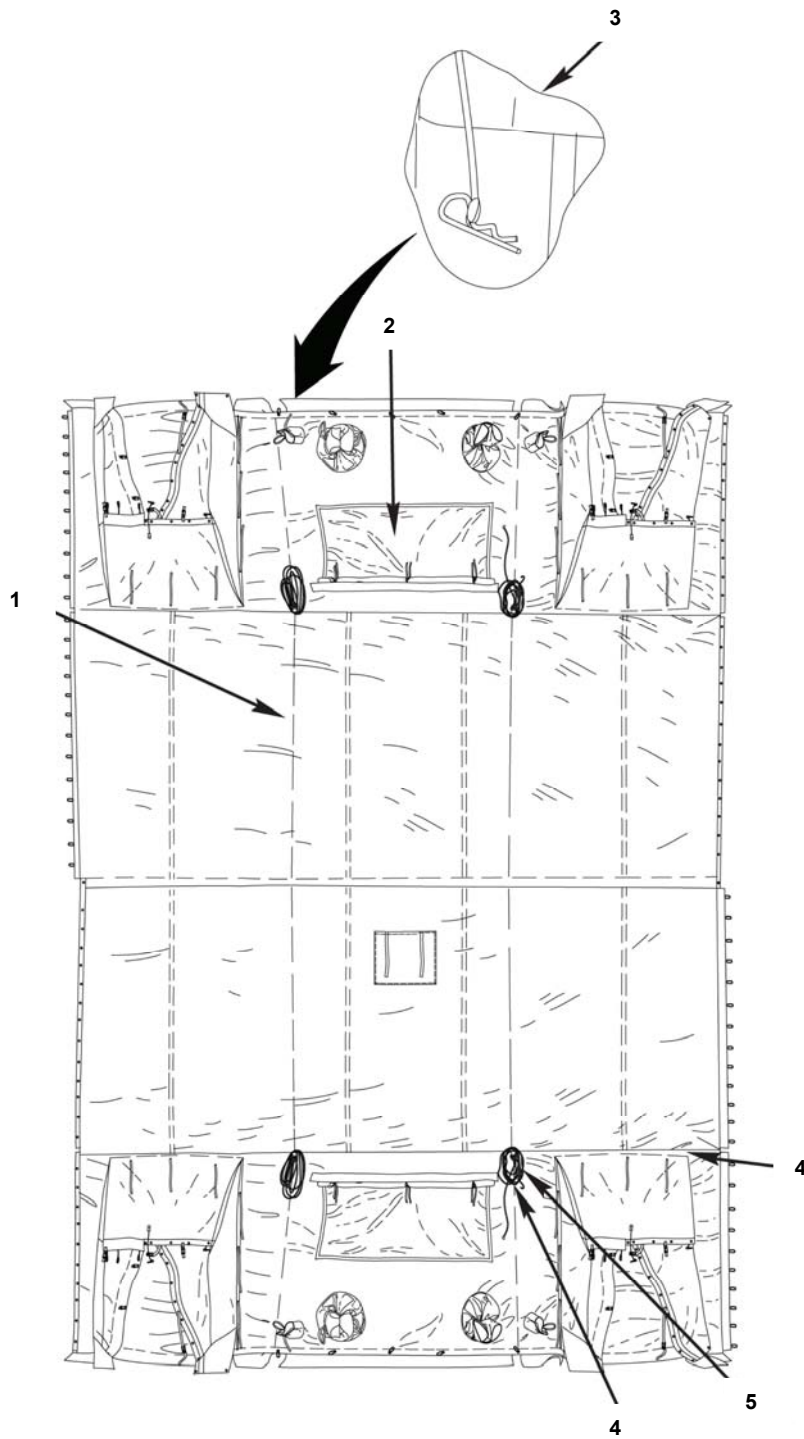


Figure 2. Intermediate Section.

(1) ITEM NO.	(2) SMR CODE	(3) NSN	(4) CAGEC	(5) PART NUMBER	(6) DESCRIPTION AND USABLE ON CODE (UOC)	(7) QTY
					GROUP 0102 INTERMEDIATE SECTION	
					FIG. 2. INTERMEDIATE SECTION	
1	PAOFF	8340-01-528-9296	81337	5-4-9706-1	Tent Section, Intermediate, Green UOC: FTX	1
1	PAOFF	8340-01-528-9297	81337	5-4-9706-2	Tent Section, Intermediate, Tan UOC: FTY	1
2	PAOZZ	8340-01-548-2266	81337	5-4-8727-1	.Fabric Section, Window Replaceable Glass Assembly, Green	2
2	PAOZZ	8340-01-548-2265	81337	5-4-8727-2	.Fabric Section, Window Replaceable Glass Assembly, Tan	2
3	PAOZZ	8340-01-477-9709	81337	5-4-3342	.Hitch Clip Pin Assembly	16
4	MOOZZ		81337	5-4-9706-1	.Tent Line, Make From Part Number MIL-L-1709, Class G (Polyester(3/8, black, Cut 19' Long	12
5	PAOZZ	8340-00-205-2759	70167	23B28045-1	.Slip, Tent Line	12
					<b>END OF FIGURE</b>	



---

**OPERATOR AND FIELD MAINTENANCE  
STANDARD INTEGRATED COMMAND POST SYSTEM (SICPS), MEDIUM  
SANDWICH WALLS  
P/N 5-4-9740**

**REPAIR PARTS LIST**

---

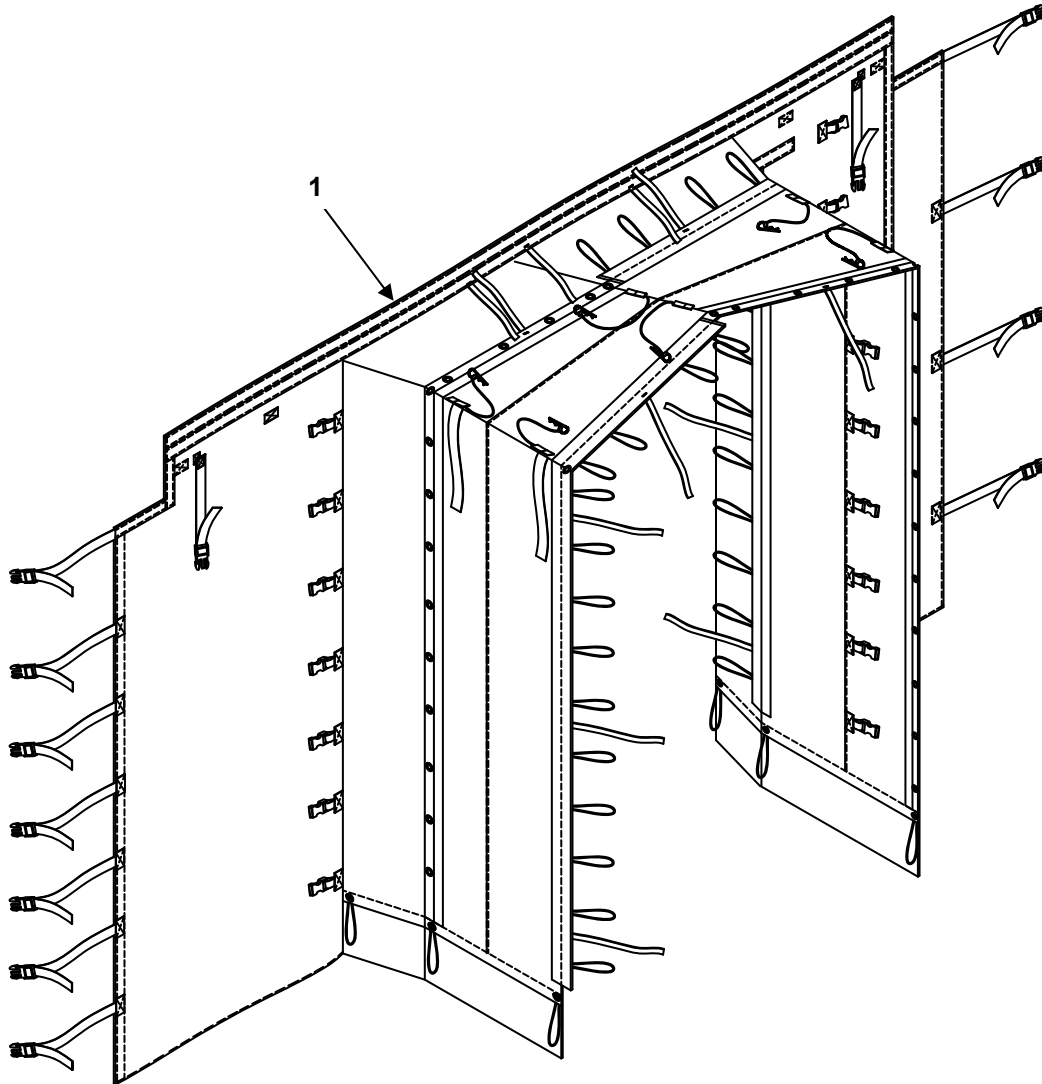


Figure 3. Sandwich Walls.



(1) ITEM NO.	(2) SMR CODE	(3) NSN	(4) CAGEC	(5) PART NUMBER	(6) DESCRIPTION AND USABLE ON CODE (UOC)	(7) QTY
					GROUP 0103 SANDWICH WALLS	
					FIG. 3. SANDWICH WALLS	
1	PAOFF	8340-01-529-0592	81337	5-4-9740-1	Wall, Sandwich, Green UOC: FTY	6
1	PAOFF	8340-01-529-0591	81337	5-4-9740-2	Wall, Sandwich, Tan UOC: FTX	6
					<b>END OF FIGURE</b>	



---

**OPERATOR AND FIELD MAINTENANCE  
STANDARD INTEGRATED COMMAND POST SYSTEM (SICPS), MEDIUM  
INSULATED LINERS/PLENUM  
P/N 5-4-9713**

**REPAIR PARTS LIST**

---

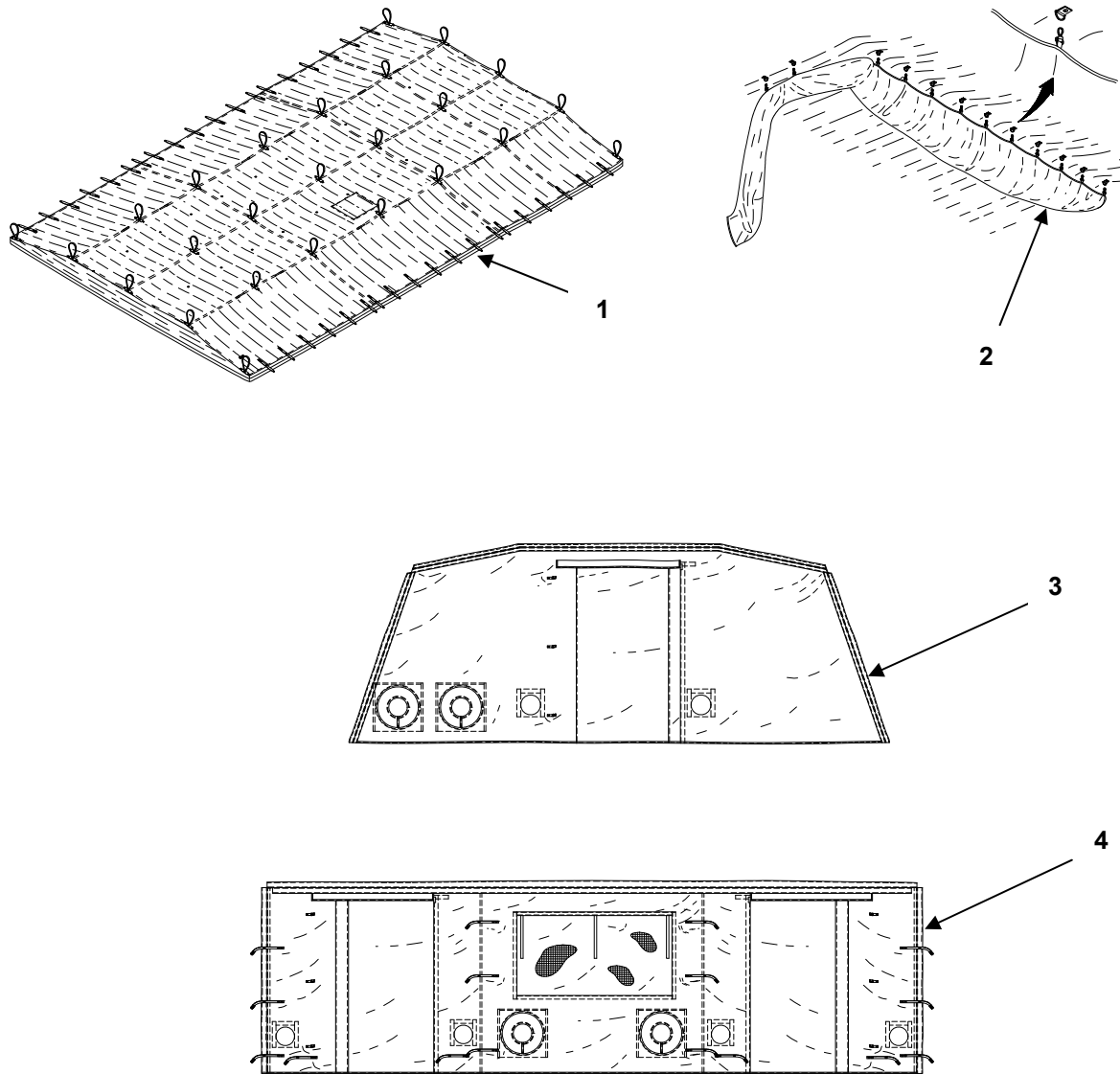


Figure 4. Insulated Liners/Plenum.

(1) ITEM NO.	(2) SMR CODE	(3) NSN	(4) CAGEC	(5) PART NUMBER	(6) DESCRIPTION AND USABLE ON CODE (UOC)	(7) QTY
					GROUP 0104 INSULATED LINERS/PLENUM	
					FIG. 4 INSULATED LINERS/PLENUM	
1	PAOFF	8340-01-528-9299	81337	5-4-9713-1	Tent Liner, Insulated, Roof Cap	1
2	PAOZZ	8340-01-528-9302	81337	5-4-9743-1	Plenum, Tent	1
3	PAOFF	8340-01-528-9300	81337	5-4-9715-1	Tent Liner, Insulated, End Wall	2
4	PAOFF	8340-01-528-9298	81337	5-4-9714-1	Tent, Insulated Side Wall	2
<b>END OF FIGURE</b>						



---

**OPERATOR AND FIELD MAINTENANCE  
STANDARD INTEGRATED COMMAND POST SYSTEM (SICPS), MEDIUM  
FLOOR  
P/N 5-4-9716-1**

**REPAIR PARTS LIST**

---

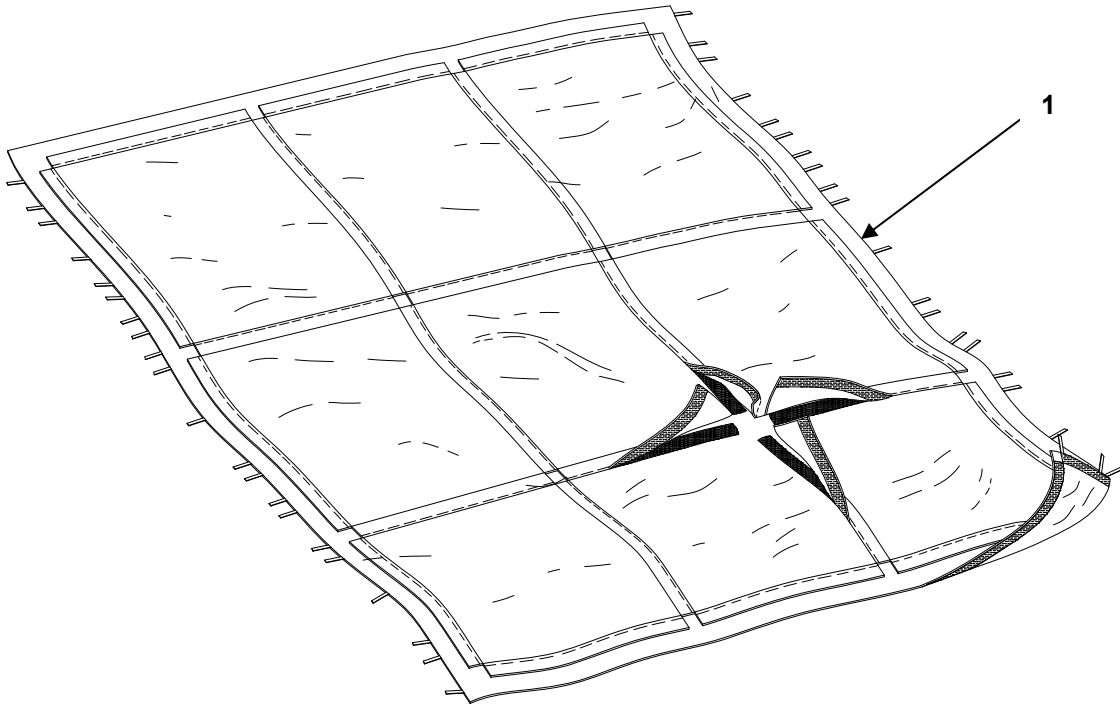


Figure 5. Floor.



(1) ITEM NO.	(2) SMR CODE	(3) NSN	(4) CAGEC	(5) PART NUMBER	(6) DESCRIPTION AND USABLE ON CODE (UOC)	(7) QTY
					GROUP 0105 FLOOR	
					FIG. 5 FLOOR	
1	PAOFF	8340-01-528-9301	81337	5-4-9716-1	Floor, Tent	1
					<b>END OF FIGURE</b>	



---

**OPERATOR AND FIELD MAINTENANCE  
STANDARD INTEGRATED COMMAND POST SYSTEM (SICPS), MEDIUM  
VESTIBULE DOOR  
P/N 5-4-3371**

**REPAIR PARTS LIST**

---

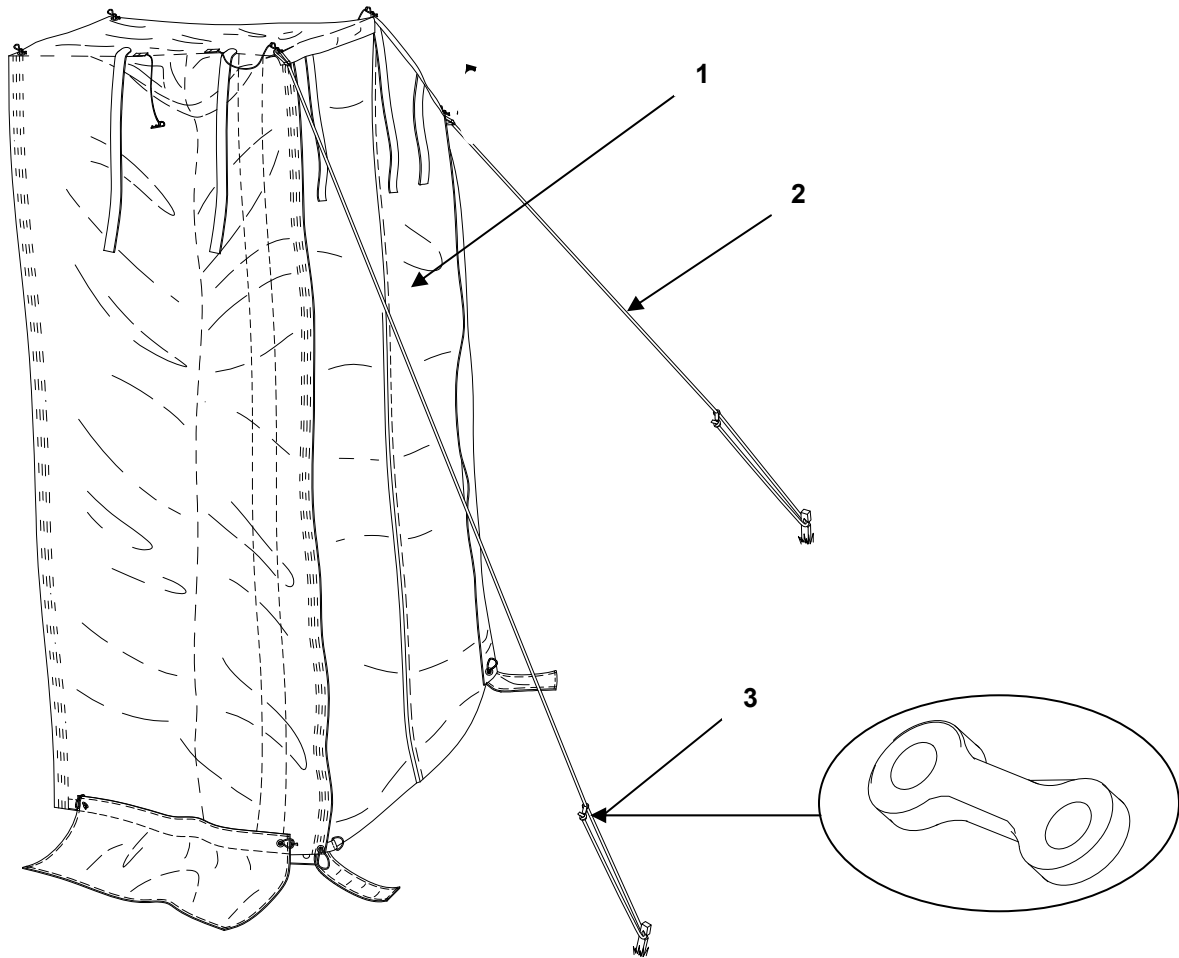


Figure 6. Vestibule Door.

(1) ITEM NO.	(2) SMR CODE	(3) NSN	(4) CAGEC	(5) PART NUMBER	(6) DESCRIPTION AND USABLE ON CODE (UOC)	(7) QTY
					GROUP 0106 VESTIBULE DOOR	
					FIG. 6 VESTIBULE DOOR	
1	PAOFF	8340-01-498-0217	81337	5-4-3371-1	Door, Tent, Green UOC: FTX	1
1	PAOFF	8340-01-498-0218	81337	5-4-3371-2	Door, Tent, Tan UOC: FTY	1
2	MOOZZ		81337	5-4-9706-1	.Tent Line, Make From Part Number MIL-L-1709, Class G (Polyester(3/8, black, Cut 19' Long	12
3	PAOZZ	8340-00-205-2759	70167	23B28045-1	.Slip, Tent Line	12
					<b>END OF FIGURE</b>	



---

**OPERATOR AND FIELD MAINTENANCE  
STANDARD INTEGRATED COMMAND POST SYSTEM (SICPS), MEDIUM  
UPPER ARCH ASSEMBLY  
P/N 5-4-7864-1**

**REPAIR PARTS LIST**

---

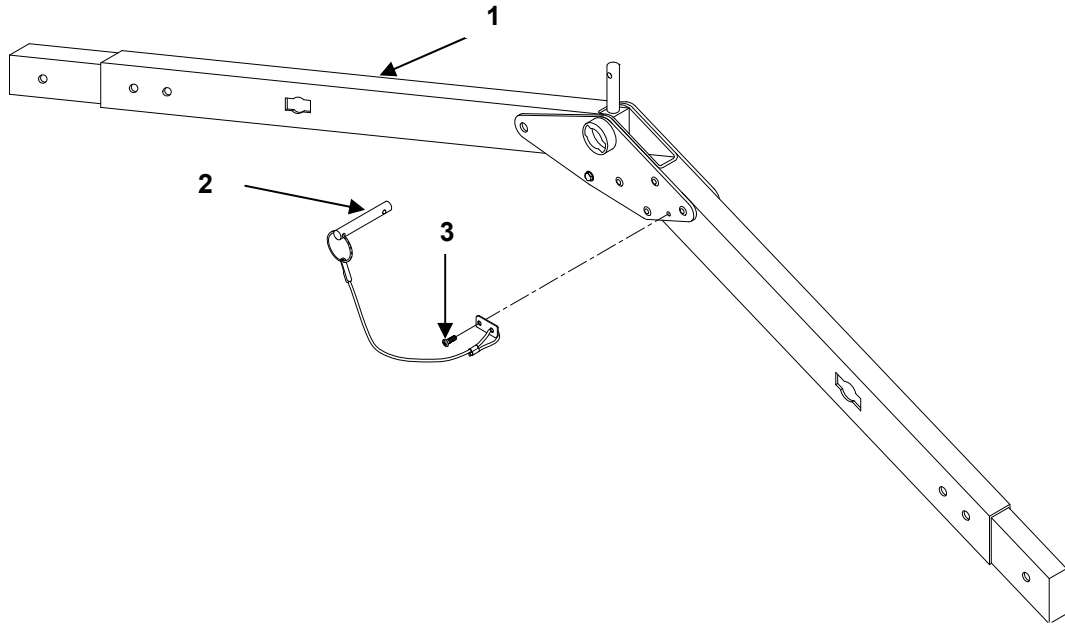


Figure 7. Upper Arch Assembly.



(1) ITEM NO.	(2) SMR CODE	(3) NSN	(4) CAGEC	(5) PART NUMBER	(6) DESCRIPTION AND USABLE ON CODE (UOC)	(7) QTY
					GROUP 0201 UPPER ARCH ASSEMBLY	
					FIG. 7 UPPER ARCH ASSEMBLY	
1	PAOOO	8340-01-475-8152	81337	5-4-7864-1	Arch, Tent Frame, Upper	4
2	PAOZZ	5315-01-260-6624	81337	5-4-4154	.Pin, Quick Release	1
3	PAOZZ	5305-00-637-4522	05047	ASME B.18.6.4	.Screw, Tapping	1
<b>END OF FIGURE</b>						



---

**OPERATOR AND FIELD MAINTENANCE  
STANDARD INTEGRATED COMMAND POST SYSTEM (SICPS), MEDIUM  
LOWER ARCH ASSEMBLY  
P/N 5-4-9721**

**REPAIR PARTS LIST**

---

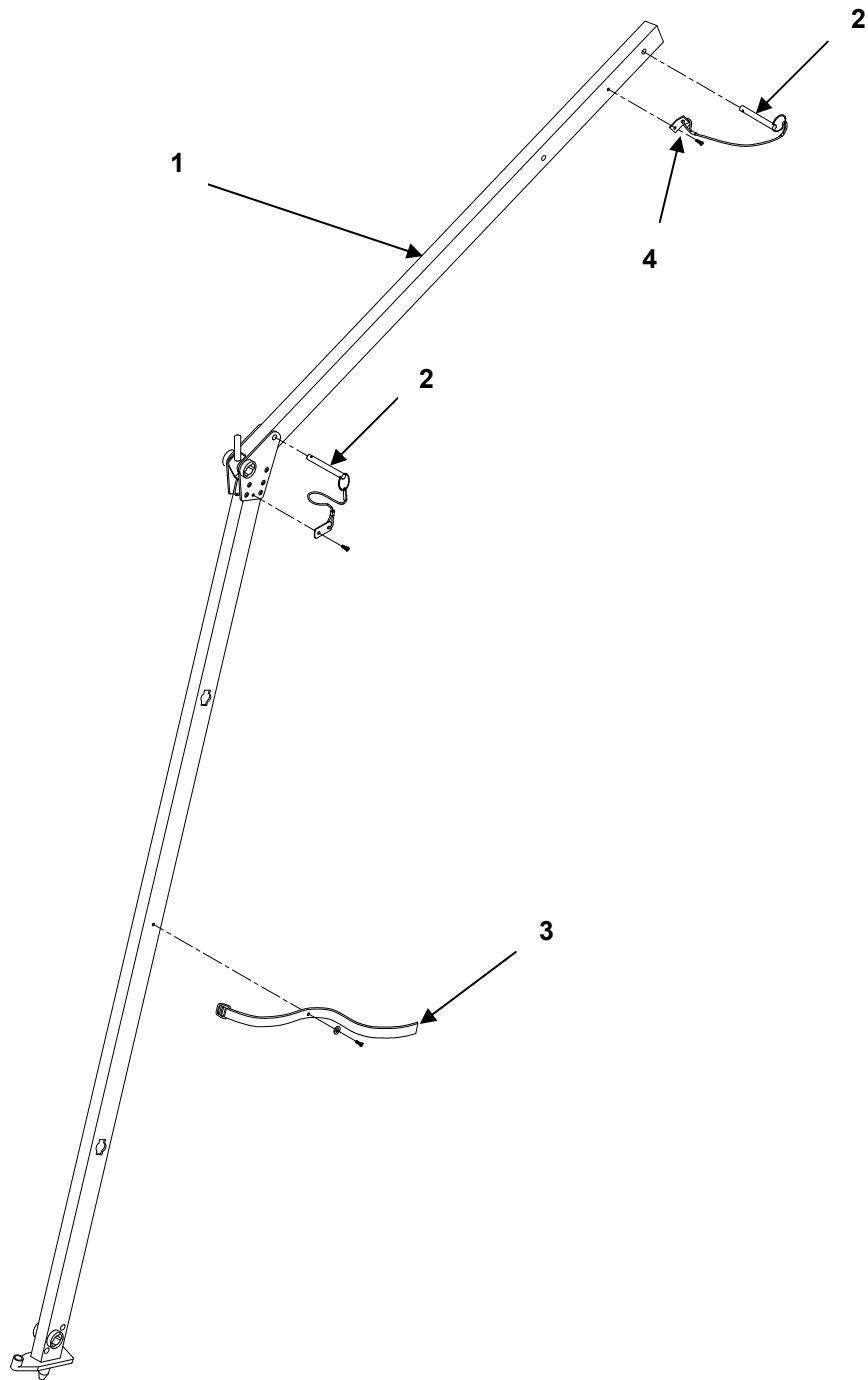


Figure 8. Lower Arch Assembly.

(1) ITEM NO.	(2) SMR CODE	(3) NSN	(4) CAGEC	(5) PART NUMBER	(6) DESCRIPTION AND USABLE ON CODE (UOC)	(7) QTY
					GROUP 0202 LOWER ARCH ASSEMBLY	
					FIG. 8 LOWER ARCH ASSEMBLY	
1	PAOOO	8340-01-528-8209	81337	5-4-9721-1	Arch, Tent Frame, Lower	8
2	PAOZZ	5315-01-260-6624	81337	5-4-4154	.Pin, Quick Release	2
3	PAOZZ	8340-01-186-2999	81337	5-4-3331	.Strap, Binding, Tent Frame	1
4	PAOZZ	5305-00-637-4522	05047	ASME B.18.6.4	.Screw, Tapping	1

**END OF FIGURE**



---

**OPERATOR AND FIELD MAINTENANCE  
STANDARD INTEGRATED COMMAND POST SYSTEM (SICPS), MEDIUM  
CABLE HEADER ASSEMBLY  
P/N 5-4-7889**

**REPAIR PARTS LIST**

---

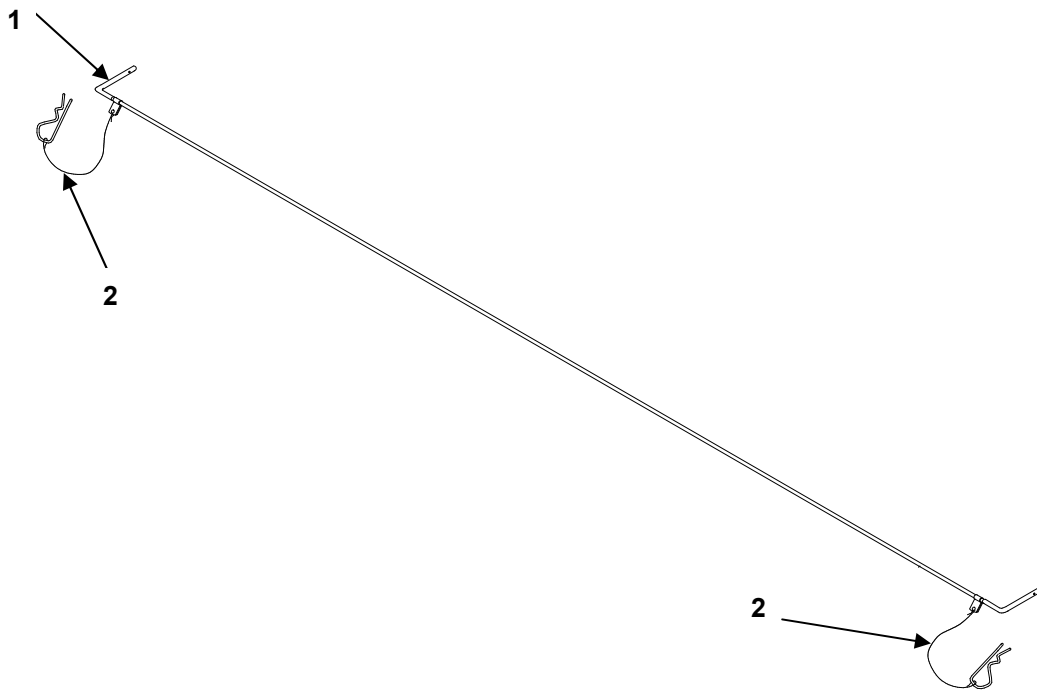


Figure 9. Cable Header Assembly.



(1) ITEM NO.	(2) SMR CODE	(3) NSN	(4) CAGEC	(5) PART NUMBER	(6) DESCRIPTION AND USABLE ON CODE (UOC)	(7) QTY
					GROUP 0203 CABLE HEADER ASSEMBLY	
					FIG. 9 CABLE HEADER ASSEMBLY	
1	PAOOO	8340-01-477-9657	81337	5-4-7889	Cable, Header, Assembly	4
2	PAOZZ	8340-01-477-9709	81337	5-4-3342	.Hitch Clip Pin Assembly	2
<b>END OF FIGURE</b>						



---

**OPERATOR AND FIELD MAINTENANCE  
STANDARD INTEGRATED COMMAND POST SYSTEM (SICPS), MEDIUM  
PURLIN ASSEMBLY  
P/N 5-4-3336**

**REPAIR PARTS LIST**

---

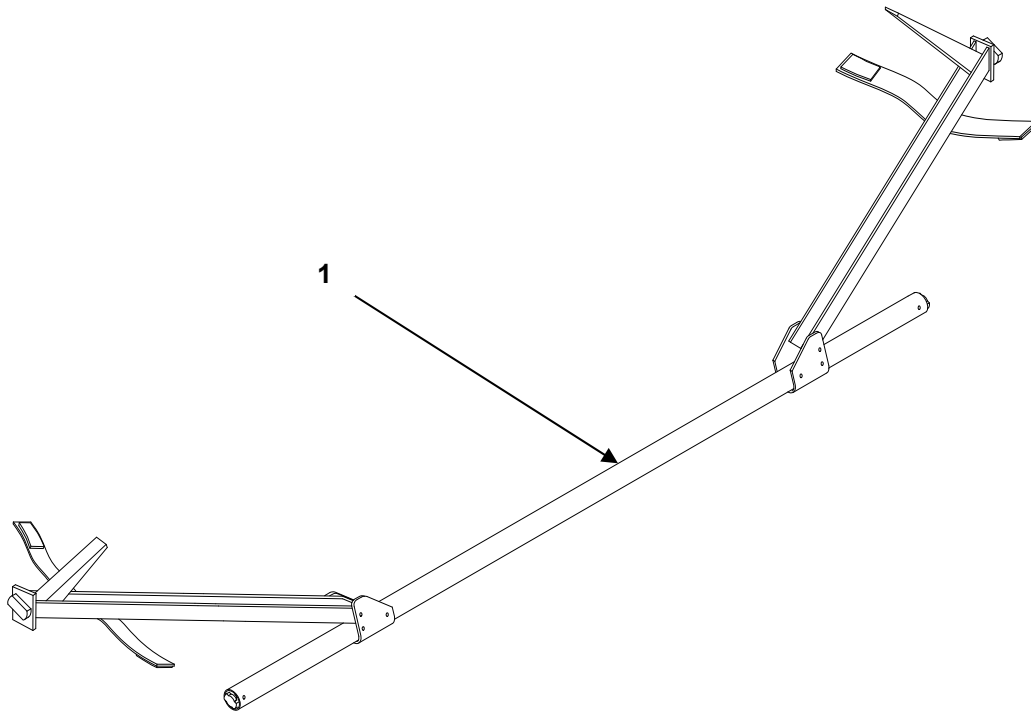


Figure 10. Purlin Assembly.

(1) ITEM NO.	(2) SMR CODE	(3) NSN	(4) CAGEC	(5) PART NUMBER	(6) DESCRIPTION AND USABLE ON CODE (UOC)	(7) QTY
					GROUP 0204 PURLIN ASSEMBLY	
					FIG. 10 PURLIN ASSEMBLY	
1	PAOZZ	8340-01-186-3005	81337	5-4-3336	Purlin, Tent	1

**END OF FIGURE**



---

**OPERATOR AND FIELD MAINTENANCE  
STANDARD INTEGRATED COMMAND POST SYSTEM (SICPS), MEDIUM  
THRESHOLD, TENT  
P/N 5-4-3337**

**REPAIR PARTS LIST**

---

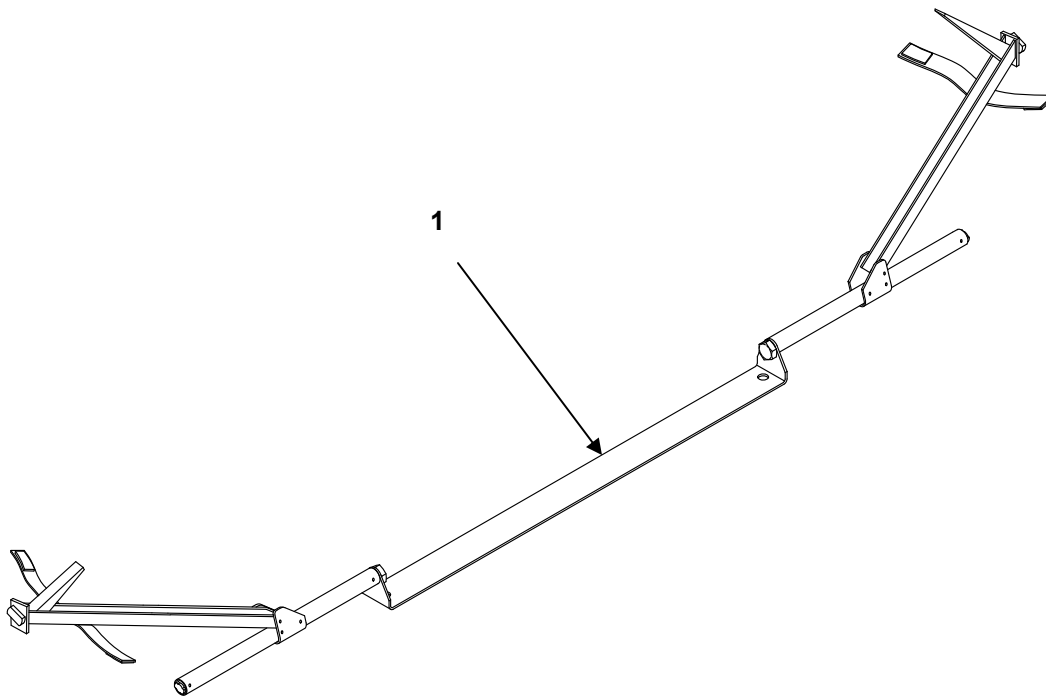


Figure 11. Tent Threshold.



(1) ITEM NO.	(2) SMR CODE	(3) NSN	(4) CAGEC	(5) PART NUMBER	(6) DESCRIPTION AND USABLE ON CODE (UOC)	(7) QTY
--------------------	--------------------	------------	--------------	-----------------------	---	------------

GROUP 0205  
THRESHOLD, TENT

FIG. 11 THRESHOLD, TENT

1	PAOOO	8340-01-186-3007	81337	5-4-3337	Threshold, Tent	4
---	-------	------------------	-------	----------	-----------------	---

**END OF FIGURE**



---

**OPERATOR AND FIELD MAINTENANCE  
STANDARD INTEGRATED COMMAND POST SYSTEM (SICPS), MEDIUM  
VESTIBULE FRAME ASSEMBLY  
P/N 5-4-3343**

**REPAIR PARTS LIST**

---

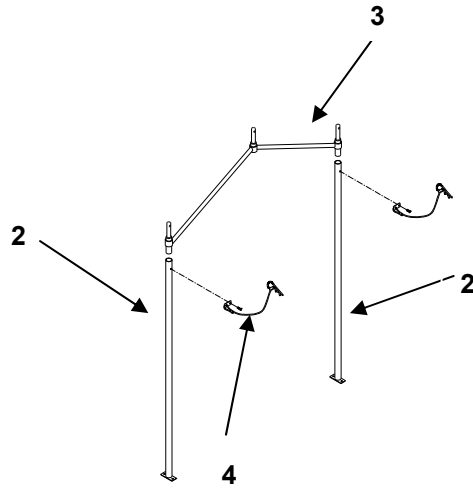
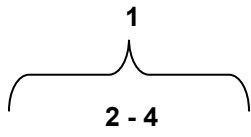


Figure 12. Vestibule Frame Assembly.

(1) ITEM NO.	(2) SMR CODE	(3) NSN	(4) CAGEC	(5) PART NUMBER	(6) DESCRIPTION AND USABLE ON CODE (UOC)	(7) QTY
					GROUP 0206 VESTIBULE FRAME ASSEMBLY	
					FIG. 12 VESTIBULE FRAME ASSEMBLY	
1	PAOOO	8340-01-186-3010	81337	5-4-3343	Frame Section, Tent	7
2	PAOZZ	8340-01-186-3011	81337	5-4-3344	.Door Post, Tent	2
3	PAOZZ	8340-01-186-3012	81337	5-4-3345	.Header, Tent Frame	1
4	PAOZZ	4010-01-241-3894	81337	5-4-3346	.Wire Rope Assembly, Single Leg	2
					<b>END OF FIGURE</b>	



---

**OPERATOR AND FIELD MAINTENANCE  
STANDARD INTEGRATED COMMAND POST SYSTEM (SICPS), MEDIUM  
POWER DISTRIBUTION BOX  
P/N 1-6-6041-1**

**REPAIR PARTS LIST**

---

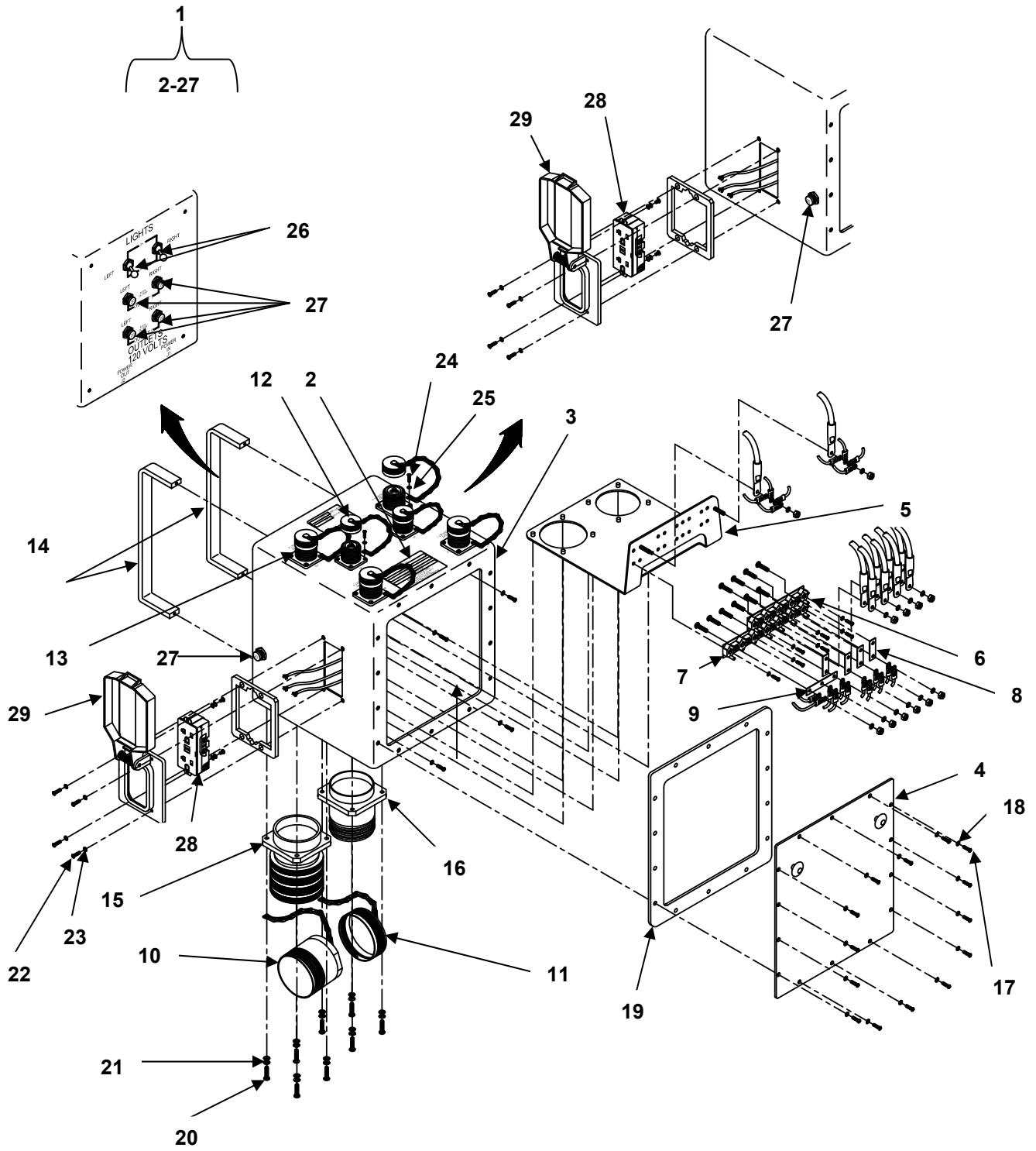


Figure 13. Power Distribution Box.



(1) ITEM NO.	(2) SMR CODE	(3) NSN	(4) CAGEC	(5) PART NUMBER	(6) DESCRIPTION AND USABLE ON CODE (UOC)	(7) QTY
					GROUP 0301 POWER DISTRIBUTION BOX	
					FIG. 13 POWER DISTRIBUTION BOX	
1	PAOFF	6110-01-251-0402	81337	1-6-6041-1	Distribution Box	1
2	XDFZZ		81337	1-6-7246-1	.Plate, Identification	1
3	XDFZZ		81337	1-6-7252-1	.Enclosure, Power Distribution Box, Type III/120V	1
4	XDFZZ		81337	1-6-7249	.Cover	1
5	XDFZZ		81337	1-6-7247-1	.Bracket, Mtg, Terminal Boards, Power Distribution Box	1
6	PAFZZ	5940-00-926-8120	96906	MS27212-6-4	.Terminal Board Assy, 4 POS, TB1	1
7	PAFZZ	5940-01-105-8085	96906	MS27212-6-6	.Terminal Board Assy, 6 POS, TB2	1
8	PAFZZ	6150-00-557-7653	81343	MS25226-4-2	.Link, Terminal, Connecting	4
9	PAFZZ	6150-00-557-7656	96906	MS25226-4-3	.Link, Terminal, Connecting	1
10	PAFZZ	5935-00-114-5781	96906	MS90564-3C	.Cover, Electrical, Connector W/Chain, J1	1
11	PAFZZ	5935-00-114-8061	96906	MS90563-3C	.Cover, Electrical Connector W/Chain, J2	1
12	PAFZZ	5935-01-181-6651	96906	MS25043- 14DA	.Cover, Electrical Connector W/Chain, J5,J6	2

(1) ITEM NO.	(2) SMR CODE	(3) NSN	(4) CAGEC	(5) PART NUMBER	(6) DESCRIPTION AND USABLE ON CODE (UOC)	(7) QTY
13	PAFZZ	5935-01-184-7188	96906	MS25043-16DA	.Cover, Electrical Connector W/Chain, J7-J10	4
14	XDFZZ		9W423	11495-A-0832	.Handle	2
15	PAFZZ	5935-00-114-8708	96906	MS90558C32 412P	.Connector, Receptacle, Electrical, J1	1
16	PAFZZ	5935-00-114-9740	96909	MS90555C32 412S	.Connector, Receptacle, Electrical, J2	1
17	PAFZZ	5305-00-054-6655	96906	MS51957-31	.Screw, Machine	14
18	PAFZZ	5310-00-480-3641	98905	MS15795-845	.Washer, Flat	14
19	XDFZZ		81337	1-6-6004	.Gasket	1
20	PAFZZ	5305-00-059-3663	80205	MS51958-67	.Screw, Machine	8
21	PAFZZ	5310-00-615-1556	80205	MS15795-846	.Washer, Flat	8
22	PAFZZ	5305-00-054-6656	96906	MS51957-32	.Screw, Machine	8
23	PAFZZ	5310-00-480-3641	98905	MS15795-845	.Washer, Flat	12
24	PAFZZ	5305-00-054-5649	96906	MS51957-15	.Screw, Machine	24
25	PAFZZ	5310-00-595-6211	80205	MS15795-803	.Washer, Flat	31
26	PAFZZ	5925-01-837-8964	96906	MS24509-A-10	.Circuit Breaker, 10 Amp	2
27	PAFZZ	5925-00-755-7906	82647	7271-8-20	.Circuit Breaker, 20 Amp	6
28	PAFZZ	5925-01-128-6284	74545	GP5352	.Interrupter, Ground Fault Receptacle 20 A	2
29	XDFZZ		0P0C9	WGFL100-CV	.Cover, Electrical	2

END OF FIGURE

---

**OPERATOR AND FIELD MAINTENANCE  
STANDARD INTEGRATED COMMAND POST SYSTEM (SICPS), MEDIUM  
CABLE ASSEMBLIES  
P/N 1-6-6043  
P/N 1-6-6044**

**REPAIR PARTS LIST**

---

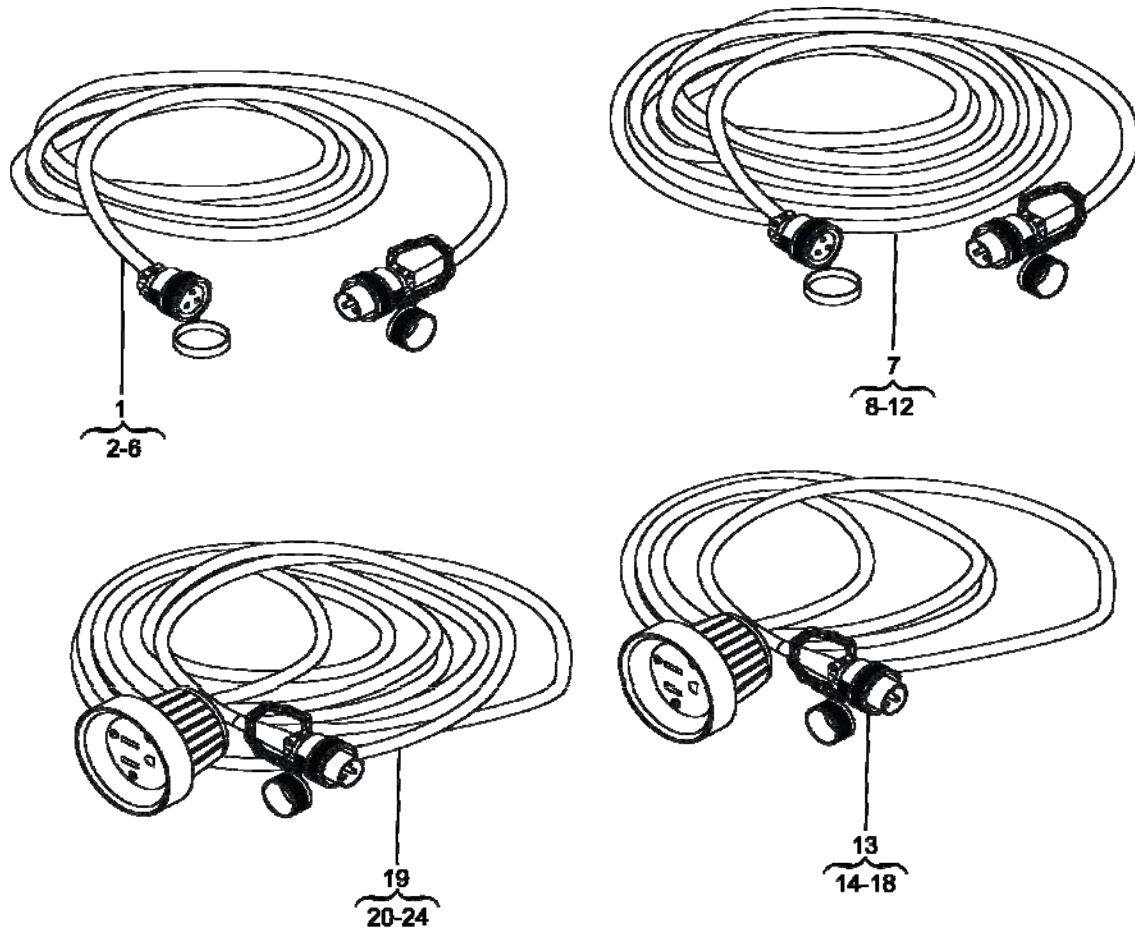


Figure 14. Cable Assemblies.

(1) ITEM NO.	(2) SMR CODE	(3) NSN	(4) CAGEC	(5) PART NUMBER	(6) DESCRIPTION AND USABLE ON CODE (UOC)	(7) QTY
					GROUP 0302 CABLE ASSEMBLIES	
					FIG. 14 CABLE ASSEMBLIES	
1	PAFFF	6150-01-353-5731	81337	1-6-6043-1	Cable Assembly, Special Purpose, 156-In.	2
2	XDFZZ		08718	CA3101E16- 10S-F80	.Connector Plug Electrical Cable Connector	1
3	PAFZZ	5935-01-184-7188	96906	MS25043- 16DA	.Cover , Electrical Connector	1
4	MFFZZ		81349	MIL-C-3432	Cable, Electrical (Make from Bulk NSN 6145-00-080-9821)	
5	XDFZZ		08718	CA06R16- 10P-F80	.Connector Plug Electrical Straight	1
6	PAFZZ	5935-01-189-3220	96906	MS25042- 16DA	.Cover Electrical Plug	1
7	PAFFF	6150-01-353-5732	81337	1-6-6043-2	Cable Assembly, Special Purpose, 254-In.	2
8	XDFZZ		08718	CA3101E16- 10S-F80	.Connector Plug Electrical Cable Connector	1
9	PAFZZ	5935-01-184-7188	96906	MS25043- 16DA	.Cover, Electrical Connector	1
10	MFFZZ		81349	MIL-C-3432	Cable, Electrical (Make from Bulk NSN 6145-00-080-9821)	
11	XDFZZ		08718	CA06R16-10- P-F80	.Connector Plug Electrical Straight	1
12	PAFZZ	5935-01-189-3220	96906	MS25042- 16DA	.Cover Electrical Plug	1
13	PAFFF	6150-01-354-5841	81337	1-6-6044-1	Cable Assembly, Special Purpose, Light 103-In.	1
14	PAFZZ	5935-00-458-6245	74545	HBL5269C	.Connector, Plug, Electrical	1
15	PAFZZ	5930-01-423-5769	74545	6018	.Boot, Dust and Moisture Seal	1

(1) ITEM NO.	(2) SMR CODE	(3) NSN	(4) CAGEC	(5) PART NUMBER	(6) DESCRIPTION AND USABLE ON CODE (UOC)	(7) QTY
16	MFFZZ		81349	MIL-C-3432	Cable, Electrical (Make from Bulk NSN 6145-00-080-9821)	
17	XDFZZ		08718	CA06R14S- 7P-F80	.Connector Electrical Plug Straight	1
18	PAFZZ	5935-01-175-8420	96906	MS25042- 14DA	.Cover Electrical Connector Plug	1
19	PAFFF	6150-01-354-5842	81337	1-6-6044-1	Cable Assembly, Special Purpose, Light 173-In.	1
20	PAFZZ	5935-00-458-6245	74545	HBL5269C	.Connector, Plug, Electrical	1
21	PAFZZ	5930-01-423-5769	74545	6018	.Boot, Dust and Moisture Seal	1
22	MFFZZ		81349	MIL-C-3432	Cable, Electrical (Make from Bulk NSN 6145-00-080-9821)	
23	XDFZZ		08718	CA06R14S- 7P-F80	.Connector Electrical Plug Straight	1
24	PAFZZ	5935-01-175-8420	96906	MS25042- 14DA	.Cover Electrical Connector Plug	1

**END OF FIGURE**

---

**OPERATOR AND FIELD MAINTENANCE  
STANDARD INTEGRATED COMMAND POST SYSTEM (SICPS), MEDIUM  
CONVENIENCE OUTLET  
P/N 9-1-0624-1**

**REPAIR PARTS LIST**

---

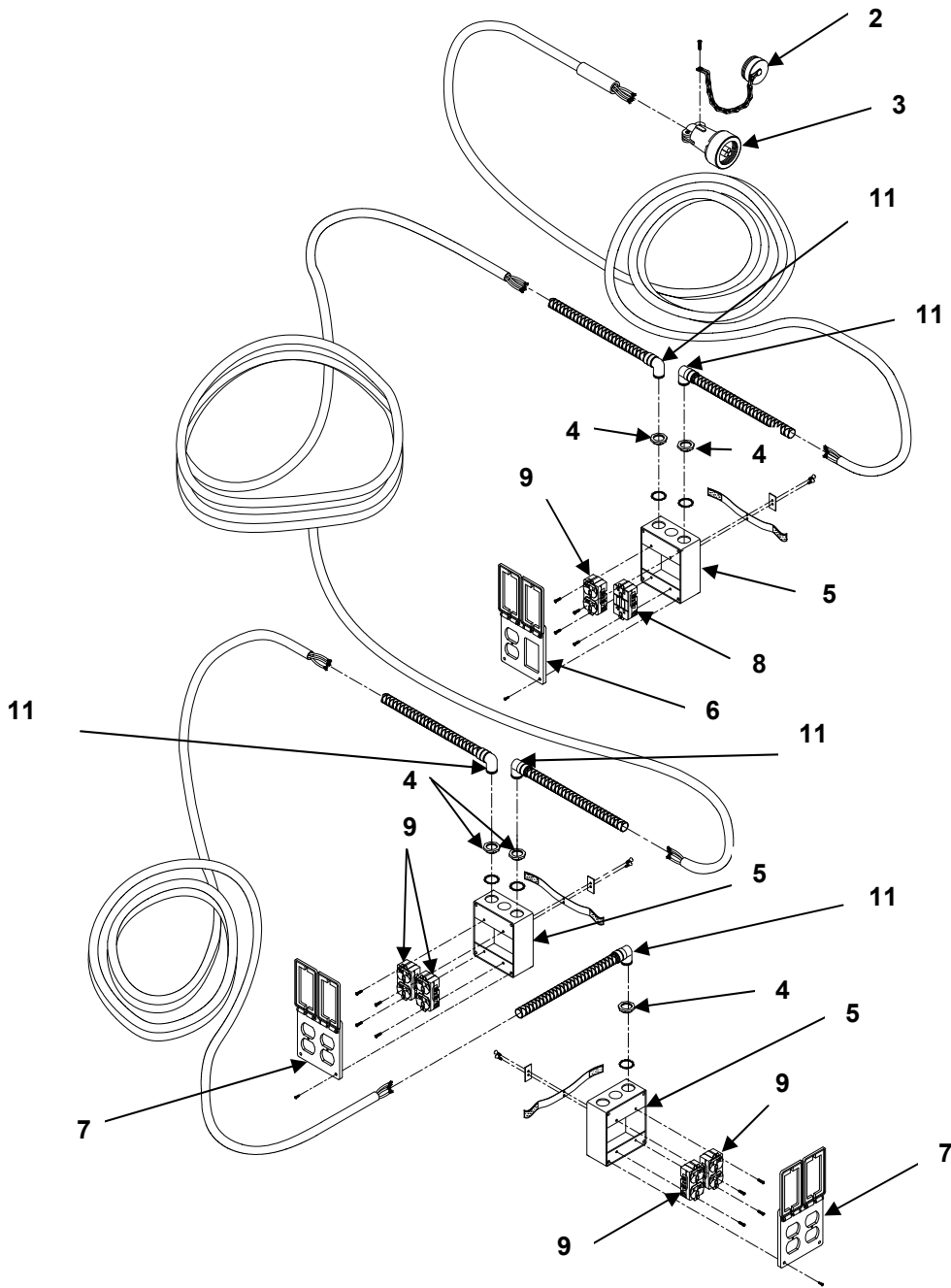


Figure 15. Convenience Outlet.



(1) ITEM NO.	(2) SMR CODE	(3) NSN	(4) CAGEC	(5) PART NUMBER	(6) DESCRIPTION AND USABLE ON CODE (UOC)	(7) QTY
					GROUP 0303 CONVENIENCE OUTLET	
					FIG. 15 CONVENIENCE OUTLET	
1	PAFZZ	6150-01-470-1916	81337	9-1-0624-1	Distribution System, Electrical	1
2	PAFZZ	5935-01-189-3220	96906	MS25042-16DA	.Plug Protection Cap	1
3	XDFZZ		71468	CA06R16-10PF80	.Connector	1
4	PAFZZ	5975-00-152-1075	28488	1002	.Conduit Locknut, 1/2"	5
5	XDFZZ		28488	5340-0	.Electrical Outlet Box	3
6	XDFZZ		31117	FGV-261V	.2 Gang Electrical Outlet Cover For Ground Fault and Standard Receptacle	1
7	XDFZZ		31117	FC-261V	.2 Gang Electrical Outlet Cover For Standard Receptacle	2
8	PAFZZ	5925-01-128-6284	74545	GF5352	.Interrupter, Ground Fault Receptacle 20A 125V 60HZ NEMA 5- 20R	1
9	PAFZZ	5935-01-058-9269	81348	WC596/40-2	.Duplex Receptacle	5
10	PAFZZ	8340-01-186-3033	81349	MIL-T-44243	.Velcro Strap Assembly	3
11	XDFZZ		81992	074-01-080	.Cord Grip, 1/2" NPT Thread Size, Grip Diameter 1/2"-5/8"	5
					<b>END OF FIGURE</b>	



---

**OPERATOR AND FIELD MAINTENANCE  
STANDARD INTEGRATED COMMAND POST SYSTEM (SICPS), MEDIUM  
POWER PANEL STAND ASSEMBLY  
P/N 1-6-6005**

**REPAIR PARTS LIST**

---

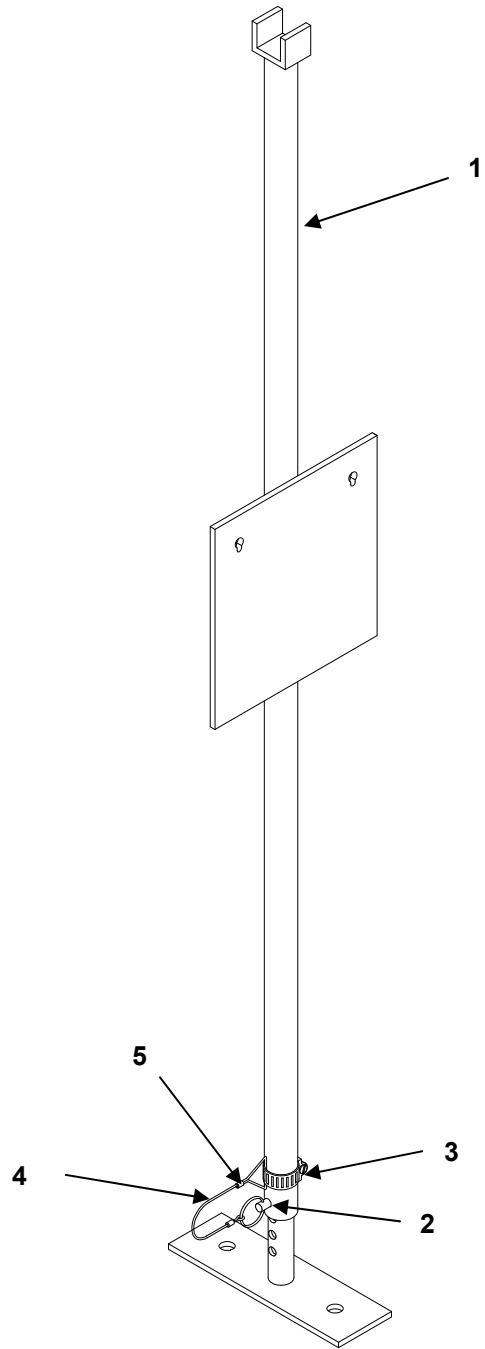


Figure 16. Power Panel Stand Assembly.

(1) ITEM NO.	(2) SMR CODE	(3) NSN	(4) CAGEC	(5) PART NUMBER	(6) DESCRIPTION AND USABLE ON CODE (UOC)	(7) QTY
					GROUP 0304 POWER PANEL STAND ASSEMBLY	
					FIG. 16 POWER PANEL STAND ASSEMBLY	
1	PAOOO	6110-01-242-6691	81337	1-6-6005	Stand, Distribution	1
2	XDOZZ		39428	98320A133	.Quick Release Pin 0.25 MIN OD X 1.25	1
3	PAOZZ	4730-00-908-3194	39428	5416K14	.Hose Clamp 0.5 MIN/1.25 MAX OD	1
4	MOOZZ		81349	M83420/4-001	.Rope, Wire Make from NSN 4010-00- 929-0041	1
5	PAOZZ	4030-01-021-6339	30003	2842687-3	.Swaging Sleeve, Wire Rope	1
					<b>END OF FIGURE</b>	



---

**OPERATOR AND FIELD MAINTENANCE  
STANDARD INTEGRATED COMMAND POST SYSTEM (SICPS), MEDIUM  
LIGHT SET ASSEMBLY  
P/N MIL-PRF-44259D-Type II**

**REPAIR PARTS LIST**

---

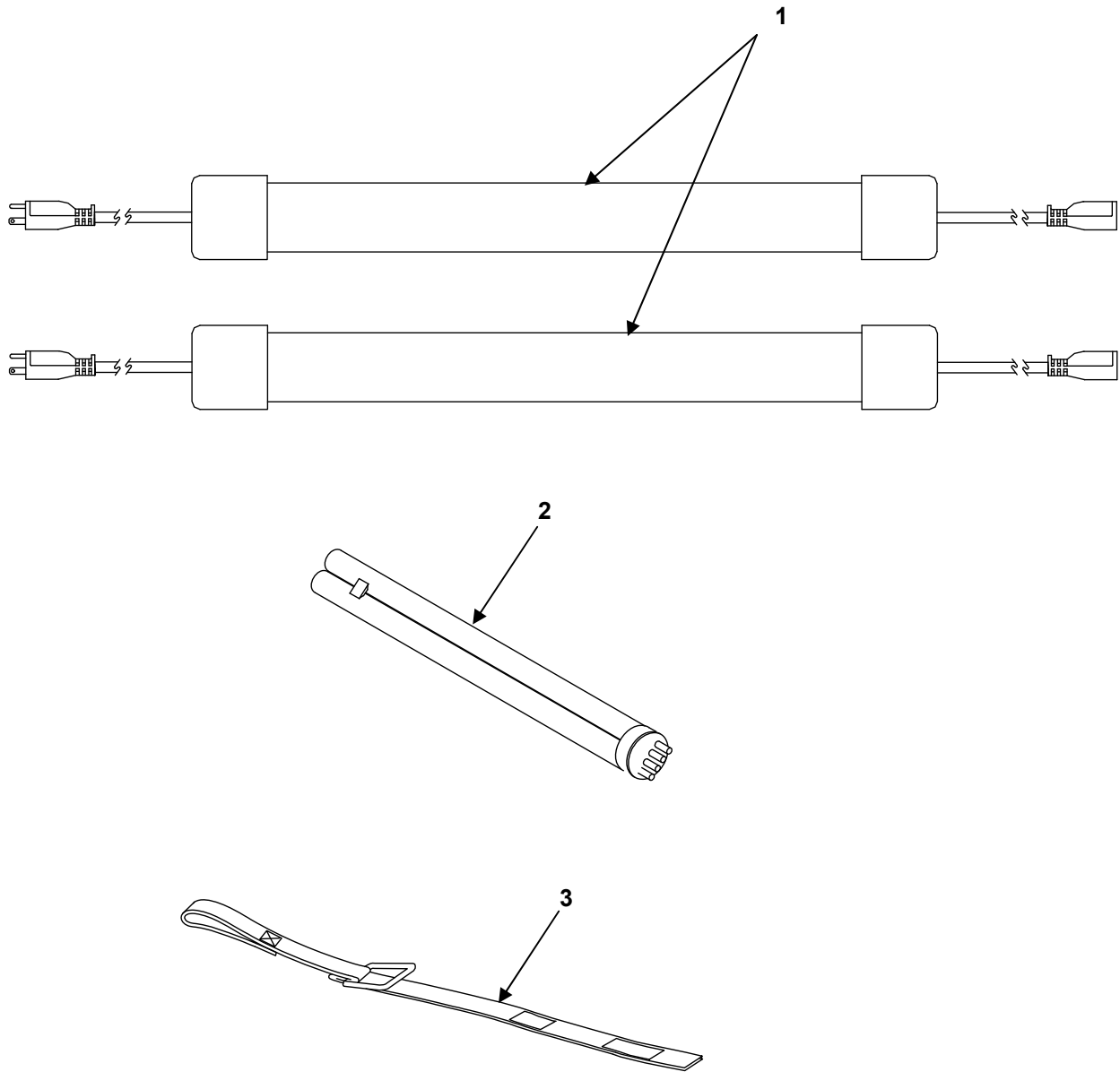


Figure 17. Light Set Assembly.



(1) ITEM NO.	(2) SMR CODE	(3) NSN	(4) CAGEC	(5) PART NUMBER	(6) DESCRIPTION AND USABLE ON CODE (UOC)	(7) QTY
					GROUP 04 LIGHT SET ASSEMBLY	
					FIG. 17 LIGHT SET ASSEMBLY	
1	PAOOO	6230-01-465-8931	81349	MIL-PRF-44259D Type II	Light Set, General Illumination	1
2	PAOZZ	6240-01-477-9718	80515	CMC-8185	.Bulb, 50 Watt, Double Tube, 4 Pin	1
3	PAOZZ	5340-01-475-8205	80515	CMC-7971	.Strap, Webbing	1
					<b>END OF FIGURE</b>	



---

**OPERATOR AND FIELD MAINTENANCE  
STANDARD INTEGRATED COMMAND POST SYSTEM (SICPS), MEDIUM  
TRANSPORT BAGS  
P/N 5-4-9757  
P/N 5-4-9751  
P/N 5-4-9758  
P/N 5-4-9759**

**REPAIR PARTS LIST**

---

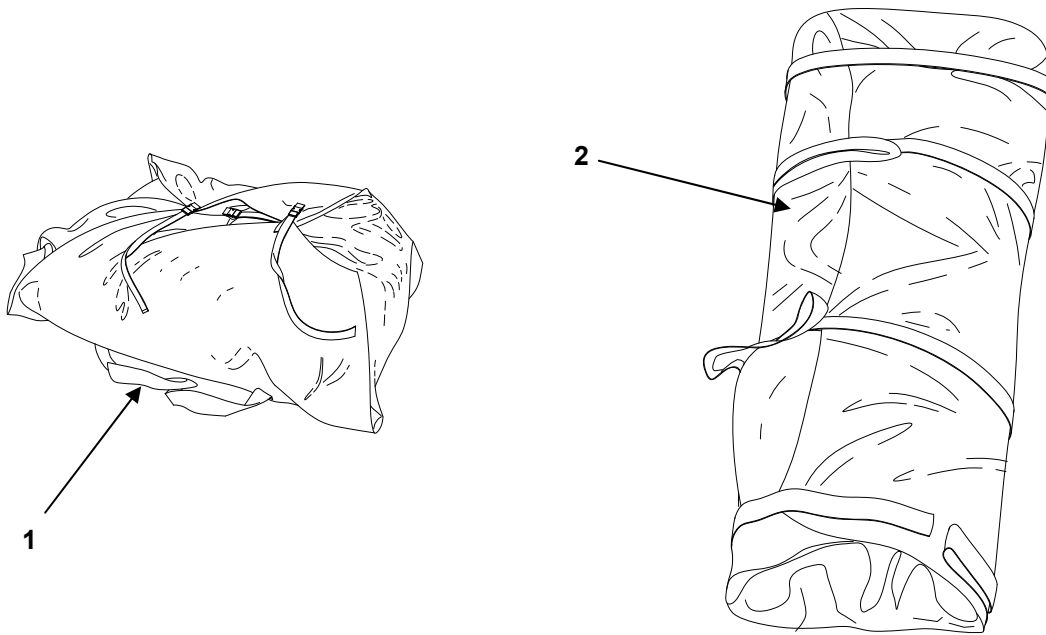


Figure 18. Transport Bags.

(1) ITEM NO.	(2) SMR CODE	(3) NSN	(4) CAGEC	(5) PART NUMBER	(6) DESCRIPTION AND USABLE ON CODE (UOC)	(7) QTY
					GROUP 05 TRANSPORT BAGS	
					FIG. 18 TRANSPORT BAGS	
1	PAOFF	8340-01-536-3677	81337	5-4-9757-1	Cover, Tent, Green, Content: 2 Each Sidewall Liners UOC: FTX	1
1	PAOFF	8340-01-536-3673	81337	5-4-9757-7	Cover, Tent, Tan, Content: 2 Each Sidewall Liners UOC: FTY	1
1	PAOFF	8340-01-536-3676	81337	5-4-9757-2	Cover, Tent, Green, Content: 1 Each Roof Liner, 1 Each Plenum, 6 Each Lights UOC: FTX	1
1	PAOFF	8340-01-536-5634	81337	5-4-9757-8	Cover, Tent, Tan, Content: 1 Each Roof Liner, 1 Each Plenum, 6 Each Lights UOC: FTY	1
1	PAOFF	8340-01-536-3675	81337	5-4-9757-3	Cover, Tent, Green, Content: 1 Each Floor, 6 Each Sandwich Wall UOC: FTX	1
1	PAOFF	8340-01-536-3678	81337	5-4-9757-9	Cover, Tent, Tan, Content: 1 Each Floor, 6 Each Sandwich Wall UOC: FTY	1
1	PAOFF	8340-01-536-3680	81337	5-4-9757-4	Cover, Tent, Green, Content: 1 Each Intermediate Fabric Assembly UOC: FTX	1
1	PAOFF	8340-01-536-3679	81337	5-4-9757-10	Cover, Tent, Tan, Content: 1 Each Intermediate Fabric Assembly UOC: FTY	1
1	PAOFF	8340-01-536-3674	81337	5-4-9757-5	Cover, Tent, Green, Content: 2 Each Endwall Fabric Assembly UOC: FTX	1
1	PAOFF	8340-01-536-3681	81337	5-4-9757-11	Cover, Tent, Tan, Content: 2 Each Endwall Fabric Assembly UOC: FTY	1

(1) ITEM NO.	(2) SMR CODE	(3) NSN	(4) CAGEC	(5) PART NUMBER	(6) DESCRIPTION AND USABLE ON CODE (UOC)	(7) QTY
1	PAOFF	8340-01-536-5635	81337	5-4-9757-6	Cover, Tent, Green, Content: 2 Each Endwall Liners UOC: FTX	1
1	PAOFF	8340-01-536-3682	81337	5-4-9757-12	Cover, Tent, Tan, Content: 2 Each Endwall Liners UOC: FTY	1
2	PAOFF	8340-01-536-3685	81337	5-4-9751-1	Cover, Tent Frame, Green, Content: 5 Each Purlin, 4 Each Side Arch, 2 Each Roof Arch, 2 Each Cable Header UOC: FTX	1
2	PAOFF	8340-01-536-3687	81337	5-4-9751-3	Cover, Tent Frame, Tan, Content: 5 Each Purlin, 4 Each Side Arch, 2 Each Roof Arch, 2 Each Cable Header UOC: FTY	1
2	PAOFF	8340-01-536-3684	81337	5-4-9751-2	Cover, Tent Frame, Green, Content: 3 Each Purlin, 2 Each Side Arch, 1 Each Roof Arch, 1 Each Cable Header, 2 Each Door Sill Purlin UOC: FTY	2
2	PAOFF	8340-01-536-3689	81337	5-4-9751-4	Cover, Tent Frame, Tan, Content: 3 Each Purlin, 2 Each Side Arch, 1 Each Roof Arch, 1 Each Cable Header, 2 Each Door Sill Purlin UOC: FTY	2
2	PAOFF	8340-01-536-3683	81337	5-4-9758-1	Cover, Tent Frame, Green, Content: 7 Each Vestibule Frames, 1 Each Vestibule Door UOC: FTX	1
2	PAOFF	8340-01-536-3686	81337	5-4-9758-2	Cover, Tent Frame, Tan, Content: 7 Each Vestibule Frames, 1 Each Vestibule Door UOC: FTY	1
3	PAOFF	8340-01-536-3688	81337	5-4-9759-1	Container, Tent Pin, Green, UOC: FTX	1
3	PAOFF	8340-01-536-3690	81337	5-4-9759-2	Container, Tent Pin, Tan, UOC: FTY	1

END OF FIGURE

---

OPERATOR AND FIELD MAINTENANCE  
STANDARD INTEGRATED COMMAND POST SYSTEM (SICPS), MEDIUM  
TENT PINS  
P/N 5-4-1  
P/N 5-4-791

REPAIR PARTS LIST

---

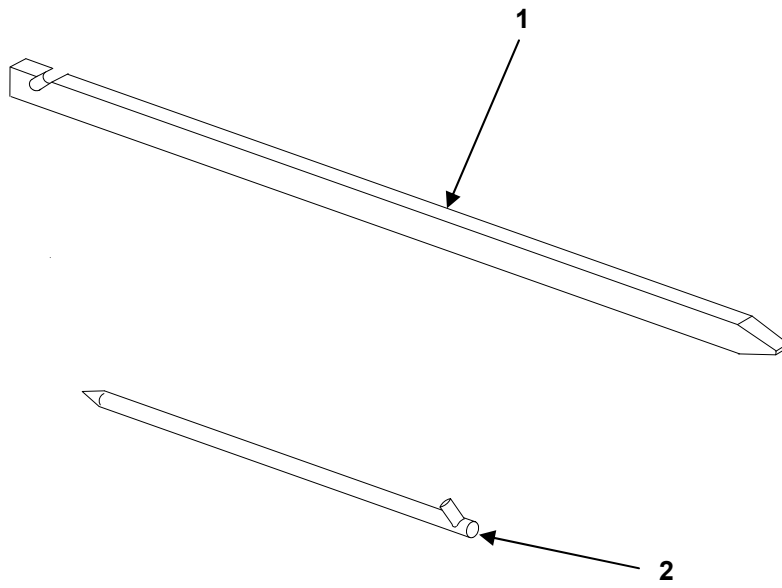


Figure 19. Tent Pins.



(1) ITEM NO.	(2) SMR CODE	(3) NSN	(4) CAGEC	(5) PART NUMBER	(6) DESCRIPTION AND USABLE ON CODE (UOC)	(7) QTY
					GROUP 06 TENT PINS	
					FIG. 19 TENT PINS	
1	PAOZZ	8340-00-261-9751	81337	5-4-1	Pin, Tent, 24"	16
2	PAOZZ	8340-00-823-7451	81337	5-4-791	Pin, Tent, Steel, 12"	12
					<b>END OF FIGURE</b>	



---

**OPERATOR AND FIELD MAINTENANCE  
STANDARD INTEGRATED COMMAND POST SYSTEM (SICPS), MEDIUM  
FIELD TABLE  
P/N 5-13-4661**

**REPAIR PARTS LIST**

---

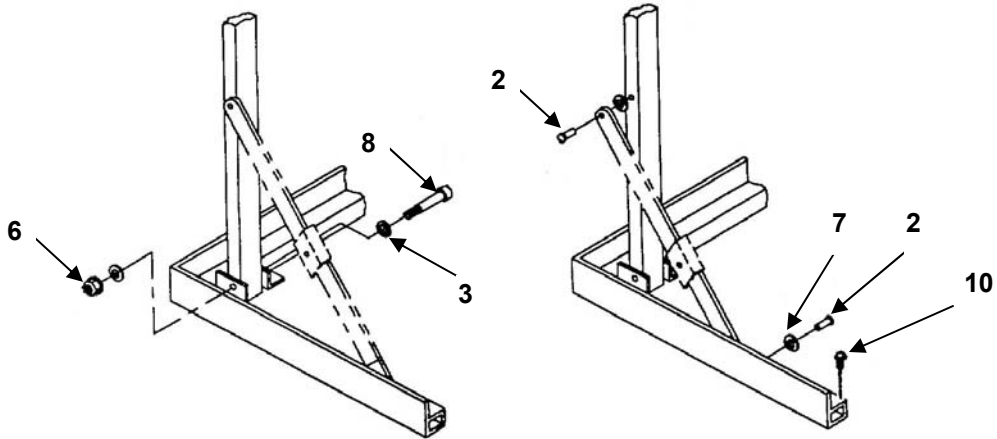
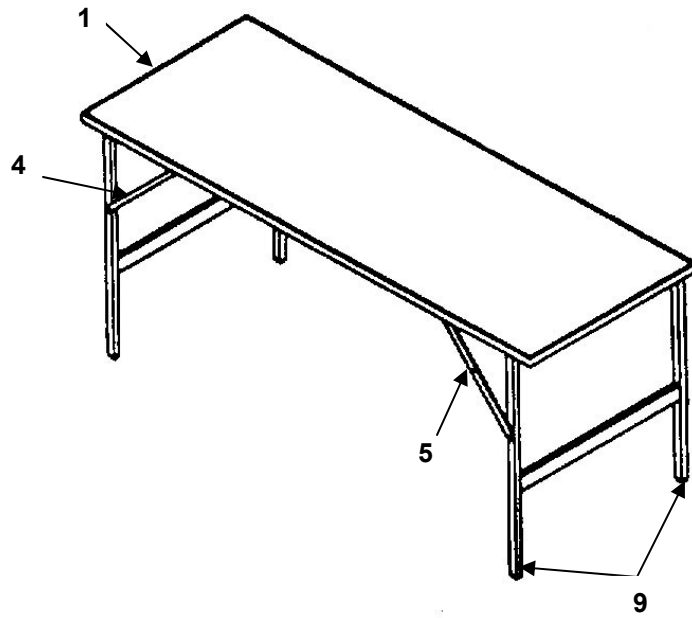


Figure 20. Field Table.

(1) ITEM NO.	(2) SMR CODE	(3) NSN	(4) CAGEC	(5) PART NUMBER	(6) DESCRIPTION AND USABLE ON CODE (UOC)	(7) QTY
					GROUP 07 FIELD TABLE	
					FIG. 20 FIELD TABLE	
1	PAOOO	8340-01-327-7685	81337	5-13-4661	TABLE, FOLDING, TENT	2
2	PAOZZ	5320-00-850-3256	07707	AD86BS	.RIVET, BLIND	8
3	PAOZZ	5310-00-533-9328	96906	MS51859-7	.WASHER, FLAT, NYLON	8
4	PAOZZ	5410-01-330-5146	81337	5-13-4668-1	.TABLE BRACE, LEG FIELD TABLE, RIGHT HAND BEND	2
5	PAOZZ	5410-01-331-7324	81337	5-13-4668-2	.BRACE, LEG, FIELD TABLE, LEFT HAND BEND	2
6	PAOZZ	5310-00-929-1807	81349	M45913/1-4CS3	.NUT, SELF-LOCKING, HEX	4
7	PAOZZ	5310-00-502-0106	1YGB8	2326-N-253	.WASHER, FLAT	8
8	PAOZZ	5305-00-935-2985	80205	MS51975-15	.SCREW, SHOULDER	4
9	PAOZZ	7195-01-328-1987	81337	5-13-4662-1	.LEG ASSEMBLY, WORK TABLE	2
10	PAOZZ	5305-00-115-9984	96906	MS35492-78	.SCREW, WOOD	14
<b>END OF FIGURE</b>						



**OPERATOR AND FIELD MAINTENANCE  
STANDARD INTEGRATED COMMAND POST SYSTEM (SICPS), MEDIUM**

**BULK MATERIALS LIST**

(1) ITEM NO.	(2) SMR CODE	(3) NSN	(4) CAGEC	(5) PART NUMBER	(6) DESCRIPTION AND USABLE ON CODE (UOC)	(7) QTY
GROUP 99 BULK MATERIAL						
1	MFFZZ	6145-01-134-2856	81349	MIL-C-3432	Cable, Electrical (Make from Bulk NSN 6145-00-080-9821)	
2	MOOZZ		81337	5-4-9709-1-26	Tent Line, Make From Part Number MIL-L-1709, Class G (Polyester) 3/8, Black,Cut 19' Long	
3	MOOZZ		81337	5-4-9706-1	Tent Line, Make From Part Number MIL-L-1709, Class G (Polyester) 3/8, black, Cut 19' Long	
4	MOOZZ	4010-00-929-0041	81349	M83420/4-001	Rope, Wire (Make from NSN 4010-00-929-0041)	

**END OF FIGURE**





**OPERATOR AND FIELD MAINTENANCE  
STANDARD INTEGRATED COMMAND POST SYSTEM (SICPS), MEDIUM  
NSN: 8340-01-516-0904, GREEN  
NSN: 8340-01-516-0903, TAN  
NATIONAL STOCK NUMBER (NSN) INDEX**

<b>NSN</b>	<b>Figure</b>	<b>Item</b>	<b>NSN</b>	<b>Figure</b>	<b>Item</b>
5305-00-054-5649	13	24	5925-01-128-6284	15	8
5305-00-054-6655	13	17	6145-01-134-2856	BULK	1
5305-00-054-6656	13	22	5935-01-175-8420	14	18
5305-00-059-3663	13	20	5935-01-181-6651	13	12
5935-00-114-5781	13	10	5935-01-184-7188	13	13
5935-00-114-8061	13	11	5935-01-184-7188	14	3
5935-00-114-8708	13	15	5935-01-184-7188	14	9
5935-00-114-9740	13	16	8340-01-186-2999	8	3
5305-00-115-9984	20	10	8340-01-186-3005	10	1
5972-00-152-1075	15	4	8340-01-186-3007	11	1
8340-00-205-2759	1	3	8340-01-186-3010	12	1
8340-00-205-2759	2	5	8340-01-186-3011	12	2
8340-00-205-2759	6	3	8340-01-186-3012	12	3
8340-00-261-9751	19	1	8340-01-186-3033	15	10
5935-00-458-6245	14	14	5935-01-189-3220	14	6
5935-00-458-6245	14	20	5935-01-189-3220	14	12
5310-00-480-3641	13	18	5935-01-189-3220	15	2
5310-00-480-3641	13	23	4010-01-241-3894	12	4
5310-00-502-0106	20	7	6110-01-242-6691	16	1
5310-00-533-9328	20	3	6110-01-251-0402	13	1
6150-00-557-7653	13	8	5315-01-260-6624	7	2
6150-00-557-7657	13	9	5315-01-260-6624	8	2
5310-00-595-6211	13	25	8340-01-327-7685	20	1
5310-00-615-1556	13	21	7195-01-328-1987	20	9
5305-00-637-4522	7	3	5410-01-330-5146	20	4
5305-00-637-4522	8	4	5410-01-331-7324	20	5
5925-00-755-7906	13	27	6150-01-353-5731	14	1
8340-00-823-7451	19	2	6150-01-353-5732	14	7
5320-00-850-3256	20	2	6150-01-354-5841	14	13
4730-00-908-3194	16	3	6150-01-354-5842	14	19
5940-00-926-8120	13	6	5930-01-423-5769	14	15
4010-00-929-0041	BULK	4	5930-01-423-5769	14	21
5310-00-929-1807	20	6	6230-01-465-8931	17	1
5305-00-935-2985	20	8	6150-01-470-1916	15	1
4030-01-021-6339	16	5	8340-01-475-8152	7	1
5935-01-058-9269	15	9	5340-01-475-8205	17	3
5940-01-105-8085	13	7			
5925-01-128-6284	13	28			

<b>NSN</b>	<b>Figure</b>	<b>Item</b>
8340- 01-477-9657	9	1
8340- 01-477-9709	1	2
8340- 01-477-9709	2	3
8340- 01-477-9709	9	2
6240- 01-477-9718	17	2
8340- 01-498-0217	6	1
8340- 01-498-0218	6	1
8340- 01-528-8209	8	1
8340- 01-528-8211	1	1
8340- 01-528-8212	1	1
8340- 01-528-9296	2	1
8340- 01-528-9297	2	1
8340- 01-528-9298	4	4
8340- 01-528-9299	4	1
8340- 01-528-9300	4	3
8340- 01-528-9301	5	1
8340- 01-528-9302	4	2
8340- 01-529-0591	3	1
8340- 01-529-0592	3	1
8340- 01-536-3673	18	1
8340- 01-536-3674	18	1
8340- 01-536-3675	18	1
8340- 01-536-3676	18	1
8340- 01-536-3677	18	1
8340- 01-536-3678	18	1
8340- 01-536-3679	18	1
8340- 01-536-3680	18	1
8340- 01-536-3681	18	1
8340- 01-536-3682	18	1
8340- 01-536-3683	18	2
8340- 01-536-3684	18	2
8340- 01-536-3685	18	2
8340- 01-536-3686	18	2
8340- 01-536-3687	18	2
8340- 01-536-3688	18	3
8340- 01-536-3689	18	2
8340- 01-536-3690	18	3
8340- 01-536-5634	18	1
8340- 01-536-5635	18	1
8340- 01-548-2265	2	2
8340- 01-548-2266	2	2
5925- 01-837-8964	13	26

**OPERATOR AND FIELD MAINTENANCE  
STANDARD INTEGRATED COMMAND POST SYSTEM (SICPS), MEDIUM  
NSN: 8340-01-516-0904, GREEN  
NSN: 8340-01-516-0903, TAN  
PART NUMBER INDEX**

<b>Part #</b>	<b>Figure</b>	<b>Item</b>	<b>Part #</b>	<b>Figure</b>	<b>Item</b>
074-01-080	15	11	5-4-8727-1	2	2
1-6-6004	13	19	5-4-8727-2	2	2
1-6-6005	16	1	5-4-9706-1	2	1
1-6-6041-1	13	1	5-4-9706-1	2	4
1-6-6043-1	14	1	5-4-9706-1	6	2
1-6-6043-2	14	7	5-4-9706-1	BULK	3
1-6-6044-1	14	13	5-4-9706-2	2	1
1-6-6044-1	14	19	5-4-9709-1	1	1
1-6-7246-1	13	2	5-4-9709-1-26	1	4
1-6-7247-1	13	5	5-4-9709-1-26	BULK	2
1-6-7249	13	4	5-4-9709-2	1	1
1-6-7252-1	13	3	5-4-9713-1	4	1
1002	15	4	5-4-9714-1	4	4
11495-A-0832	13	14	5-4-9715-1	4	3
2326-N-253	20	7	5-4-9716-1	5	1
23B28045-1	1	3	5-4-9721-1	8	1
23B28045-1	2	5	5-4-9740-1	3	1
23B28045-1	6	3	5-4-9740-2	3	1
2842687-3	16	5	5-4-9743-1	4	2
5-4-1	19	1	5-4-9751-1	18	2
5-4-3331	8	3	5-4-9751-2	18	2
5-4-3336	10	1	5-4-9751-3	18	2
5-4-3337	11	1	5-4-9751-4	18	2
5-4-3342	2	3	5-4-9757-1	18	1
5-4-3342	9	2	5-4-9757-10	18	1
5-4-3342-1	1	2	5-4-9757-11	18	1
5-4-3343	12	1	5-4-9757-12	18	1
5-4-3344	12	2	5-4-9757-2	18	1
5-4-3345	12	3	5-4-9757-3	18	1
5-4-3346	12	4	5-4-9757-4	18	1
5-4-3371-1	6	1	5-4-9757-5	18	1
5-4-3371-2	6	1	5-4-9757-6	18	1
5-4-4154	7	2	5-4-9757-7	18	1
5-4-4154	8	2	5-4-9757-8	18	1
5-4-7864-1	7	1	5-4-9757-9	18	1
5-4-7889	9	1	5-4-9758-1	18	2
5-4-791	19	2	5-4-9758-2	18	2

**OPERATOR AND FIELD MAINTENANCE  
STANDARD INTEGRATED COMMAND POST SYSTEM (SICPS), MEDIUM  
NSN: 8340-01-516-0904, GREEN  
NSN: 8340-01-516-0903, TAN  
PART NUMBER INDEX**

<b>Part #</b>	<b>Figure</b>	<b>Item</b>	<b>Part #</b>	<b>Figure</b>	<b>Item</b>
5-4-9759-1	18	3	MIL-C-3432	14	22
5-4-9759-2	18	3	MIL-C-3432	BULK	1
5-13-4662-1	20	9	MIL-PRF-44259D Type II	17	1
5-13-4668-1	20	4	MIL-T-44243	15	10
5-13-4668-2	20	5	MS15795-803	13	25
5340-0	15	5	MS15795-845	13	18
5416K14	16	3	MS15795-845	13	23
5935-01-175-8420	14	24	MS15795-846	13	21
6018	14	15	MS24509-A-10	13	26
6018	14	21	MS25042-14DA	14	18
7271-8-20	13	27	MS25042-16DA	14	6
9-1-0624-1	15	1	MS25042-16DA	14	12
98320A133	16	2	MS25042-16DA	15	2
AD86BS	20	2	MS25043-14DA	13	12
ASME B.18.6.4	7	3	MS25043-16DA	13	13
ASME B.18.6.4	8	4	MS25043-16DA	14	3
CA06R14S-7P-F80	14	17	MS25043-16DA	14	9
CA06R14S-7P-F80	14	23	MS25226-4-2	13	8
CA06R16-10PF80	15	3	MS25226-4-3	13	9
CA06R16-10P-F80	14	5	MS27212-6-4	13	6
CA06R16-10P-F80	14	11	MS27212-6-6	13	7
CA3101E16-10S-F80	14	2	MS35492-78	20	10
CA3101E16-10S-F80	14	8	MS51859-7	20	3
CMC-7971	17	3	MS51957-15	13	24
CMC-8185	17	2	MS51957-31	13	17
FC-261V	15	7	MS51957-32	13	22
FGV0-261V	15	6	MS51958-67	13	20
GF5352	15	8	MS51975-15	20	8
GP5352	13	28	MS90558C32412P	13	15
HBL5269C	14	14	MS90558C32412S	13	16
HBL5269C	14	20	MS90563-3C	13	11
M45913/1-4CS3	20	6	MS90564-3C	13	10
M83420/4-001	16	4	WC596/40-2	15	9
M83420/4-001	BULK	4	WGFL100-CV	13	29
MIL-C-3432	14	4			
MIL-C-3432	14	10			
MIL-C-3432	14	16			

---

**OPERATOR AND FIELD MAINTENANCE  
STANDARD INTEGRATED COMMAND POST SYSTEM (SICPS), MEDIUM  
NSN: 8340-01-516-0904, GREEN  
NSN: 8340-01-516-0903, TAN  
COMPONENTS OF END ITEM (COEI) AND BASIC ISSUE ITEMS (BII) LISTS**

---

**INTRODUCTION****Scope**

This work package lists COEI and BII for the SICPS, Medium to help you inventory items for safe and efficient operation of the equipment.

**General**

The COEI and BII information is divided into the following lists:

**Components of End Item (COEI).** This list is for information purposes only and is not authority to requisition replacements. These items are part of the Standard Integrated Command Post System (SICPS), Medium. As part of the end item, these items must be with the end item whenever it is issued or transferred between property accounts. Items of COEI are removed and separately packaged for transportation or shipment only when necessary. Illustrations are furnished to help you find and identify the items.

**Basic Issue Items (BII).** These essential items are required to place the Standard Integrated Command Post System (SICPS), Medium in operation, operate it, and to do emergency repairs. Although shipped separately packaged, BII must be with the Standard Integrated Command Post System (SICPS), Medium during operation and when it is transferred between property accounts. Listing these items is your authority to request/requisition them for replacement based on authorization of the end item by the TOE/MTOE. Illustrations are furnished to help you find and identify the items.

**Explanation of Columns in the COEI List and BII List**

Column (1) Illus Number. Gives you the number of the item illustrated.

Column (2) National Stock Number (NSN). Identifies the stock number of the item to be used for requisitioning purposes.

Column (3) Description, CAGEC, and Part Number. Identifies the Federal item name (in all capital letters) followed by a minimum description when needed. The stowage location of COEI and BII is also included in this column. The last line below the description is the CAGEC (Commercial and Government Entity Code) (in parentheses) and the part number.

Column (4) Usable On Code. When applicable, gives you a code if the item you need is not the same for different models of equipment. These codes are identified below:

<u>Code</u>	<u>Used On</u>
FTX	Green, NSN: 8340-01-516-0904
FTY	Tan, NSN: 8340-01-516-0903

Column (5) Unit of Issue (U/I). Indicates the physical measurement or count of the item as issued per the National Stock Number shown in column (2).

Column (6) Qty Rqr. Indicates the quantity required.

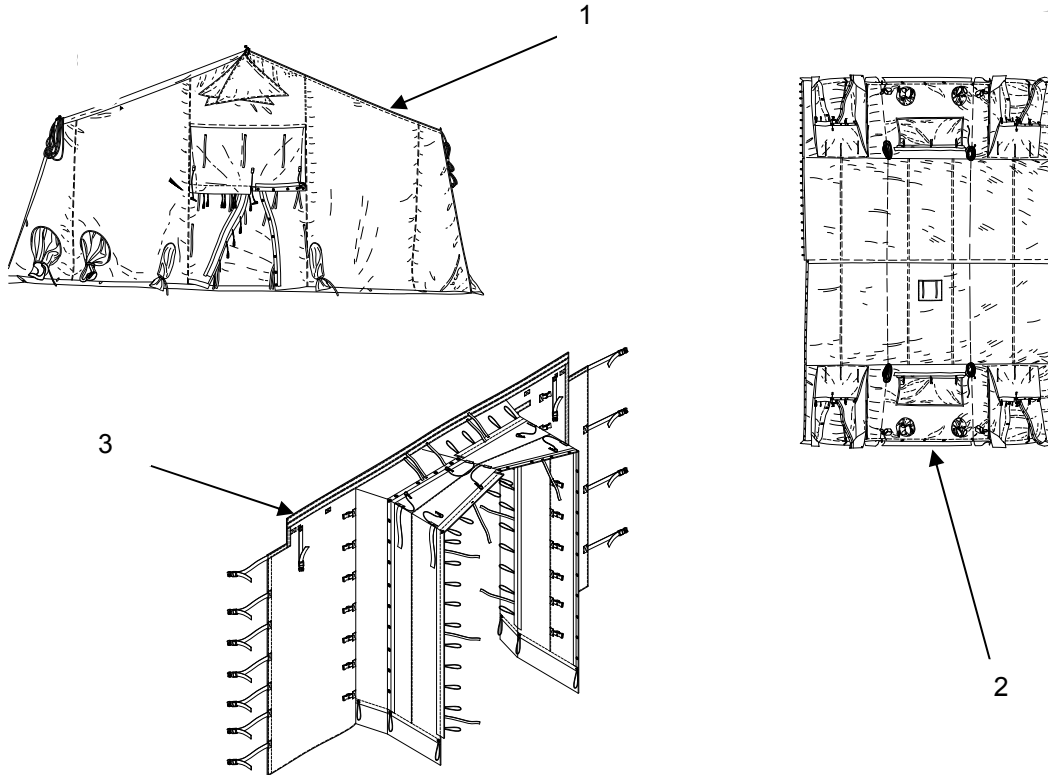


Table 1. Components of End Item List.

(1) ILLUS NUMBER	(2) NATIONAL STOCK NUMBER (NSN)	(3) DESCRIPTION, CAGEC, AND PART NUMBER	(4) USABLE ON CODE	(5) UNIT OF ISSUE (U/I)	(6) QTY RQR
1	8340-01-528-8212	TENT SECTION, END, GREEN 5-4-9709-1 (81337)	FTX	EA	2
1	8340-01-528-8211	TENT SECTION, END, TAN 5-4-9709-2 (81337)	FTY	EA	2
2	8340-01-528-9296	TENT SECTION, INTERMEDIATE, GREEN 5-4-9706-1 (81337)	FTX	EA	1
2	8340-01-528-9297	TENT SECTION, INTERMEDIATE, TAN 5-4-9706-2 (81337)	FTY	EA	1
3	8340-01-529-0592	WALL, SANDWICH, GREEN 5-4-9740-1 (81337)	FTX	EA	6
3	8340-01-529-0591	WALL, SANDWICH, TAN 5-4-9740-2 (81337)	FTY	EA	6

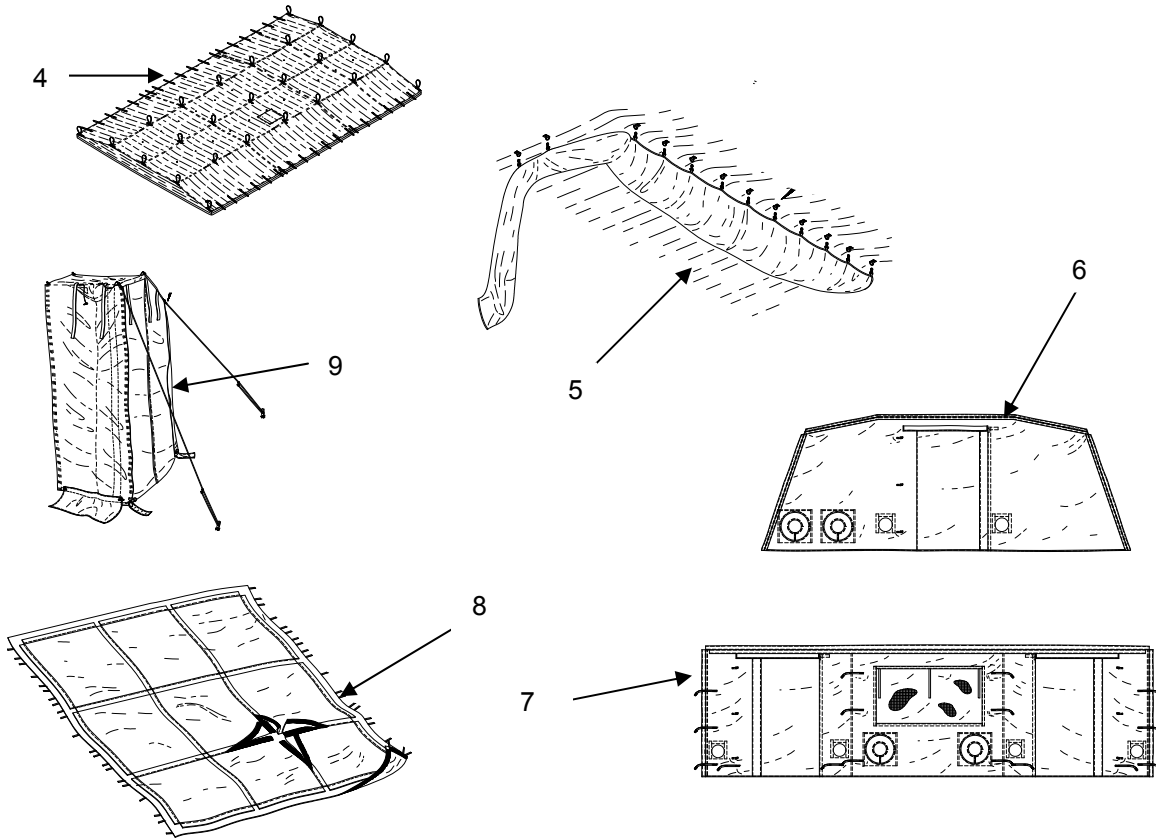


Table 1. Components of End Item List – Continued.

(1) ILLUS NUMBER	(2) NATIONAL STOCK NUMBER (NSN)	(3) DESCRIPTION, CAGEC, AND PART NUMBER	(4) USABLE ON CODE	(5) UNIT OF ISSUE (U/I)	(6) QTY RQR
4	8340-01-528-9299	TENT LINER, INSULATED, ROOF CAP 5-4-9713-1 (81337)		EA	1
5	8340-01-528-9302	PLENUM, TENT 5-4-9743-1 (81337)		EA	1
6	8340-01-528-9300	TENT LINER, INSULATED, END WALL 5-4-9715-1 (81337)		EA	2
7	8340-01-528-9298	TENT LINER, INSULATED, SIDE WALL 5-4-9714-1 (81337)		EA	2
8	8340-01-528-9301	FLOOR, TENT 5-4-9716-1 (81337)		EA	1
9	8340-01-498-0217	DOOR, TENT, GREEN 5-4-3371-1 (81337)	FTX	EA	1
9	8340-01-498-0218	DOOR, TENT, TAN 5-4-3371-1 (81337)	FTY	EA	1

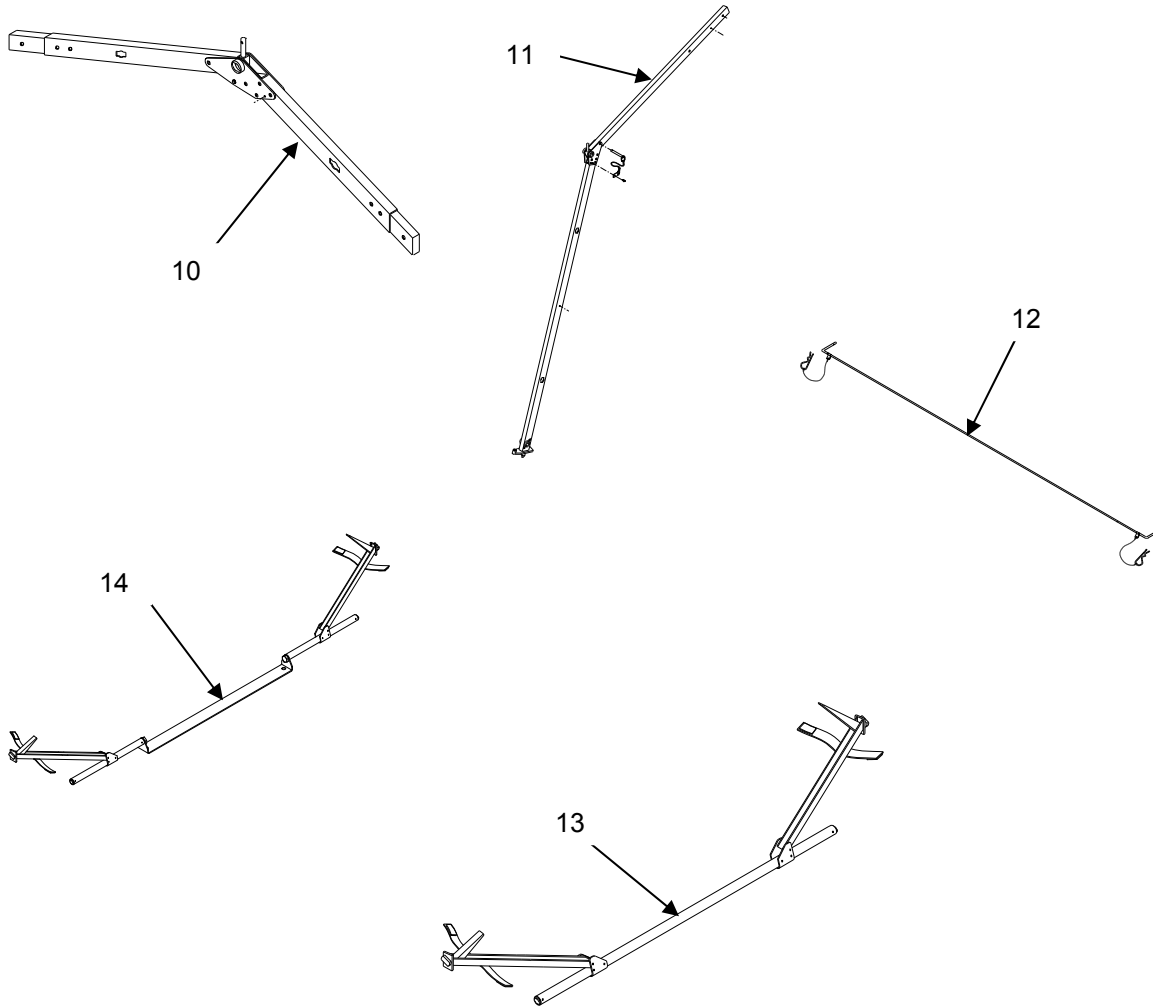


Table 1. Components of End Item List – Continued.

(1) ILLUS NUMBER	(2) NATIONAL STOCK NUMBER (NSN)	(3) DESCRIPTION, CAGEC, AND PART NUMBER	(4) USABLE ON CODE	(5) UNIT OF ISSUE (U/I)	(6) QTY RQR
10	8340-01-475-8152	ARCH, TENT FRAME, UPPER 5-4-7864-1 (81337)		EA	4
11	8340-01-528-8209	ARCH, TENT FRAME, LOWER 5-4-9721-1 (81337)		EA	8
12	8340-01-477-9657	CABLE, HEADER, ASSEMBLY 5-4-7889 (81337)		EA	4
13	8340-01-186-3005	PURLIN, TENT 5-4-3336 (81337)		EA	11
14	8340-01-186-3007	THRESHOLD, TENT 5-4-3337 (81337)		EA	4



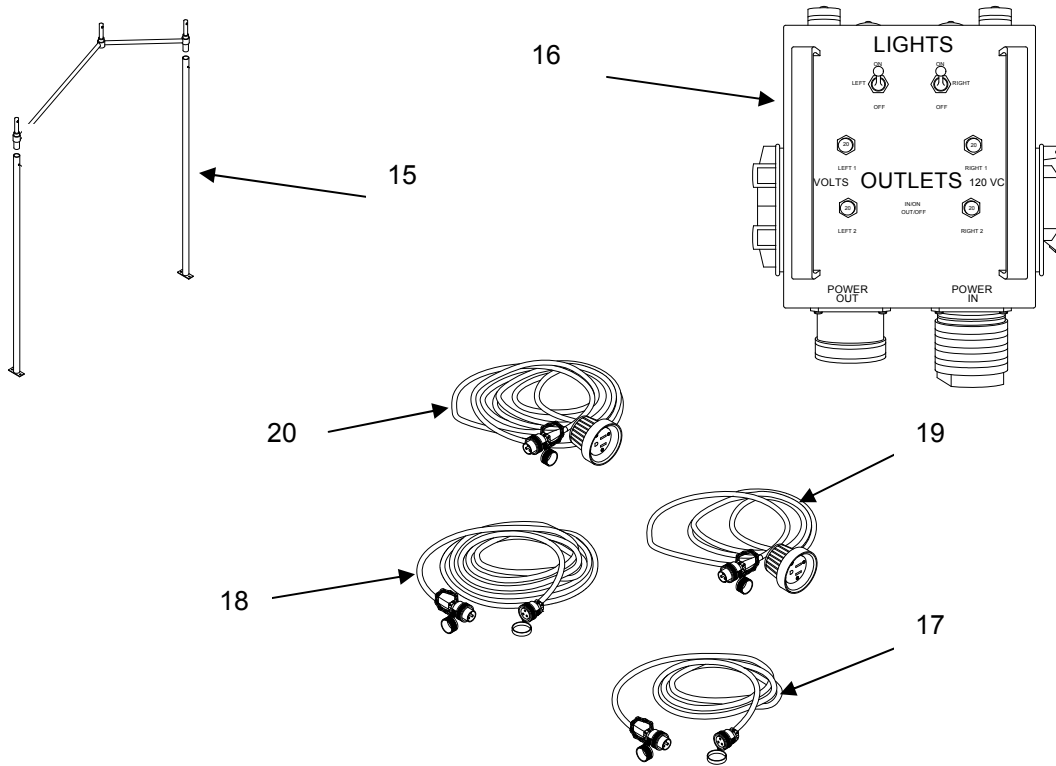


Table 1. Components of End Item List. – Continued.

(1) ILLUS NUMBER	(2) NATIONAL STOCK NUMBER (NSN)	(3) DESCRIPTION, CAGEC, AND PART NUMBER	(4) USABLE ON CODE	(5) UNIT OF ISSUE (U/I)	(6) QTY RQR
15	8340-01-186-3010	FRAME SECTION, TENT, VESTIBULE 5-4-3343 (81337)		EA	7
16	8340-01-251-0402	DISTRIBUTION BOX 1-6-6041-1 (81337)		EA	1
17	6150-01-353-5731	CABLE ASSEMBLY, SPECIAL PURPOSE, ELECTRICAL, 156 IN 1-6-6043-1 (81337)		EA	1
18	6150-01-353-5732	CABLE ASSEMBLY, SPECIAL PURPOSE, ELECTRICAL, 254 IN 1-6-6043-2 (81337)		EA	1
19	6150-01-354-5841	CABLE ASSEMBLY, SPECIAL PURPOSE, ELECTRICAL, LIGHT, 103 IN 1-6-6044-1 (81337)		EA	1
20	6150-01-354-5842	CABLE ASSEMBLY, SPECIAL PURPOSE, ELECTRICAL, LIGHT, 173 IN 1-6-6044-3 (81337)		EA	1

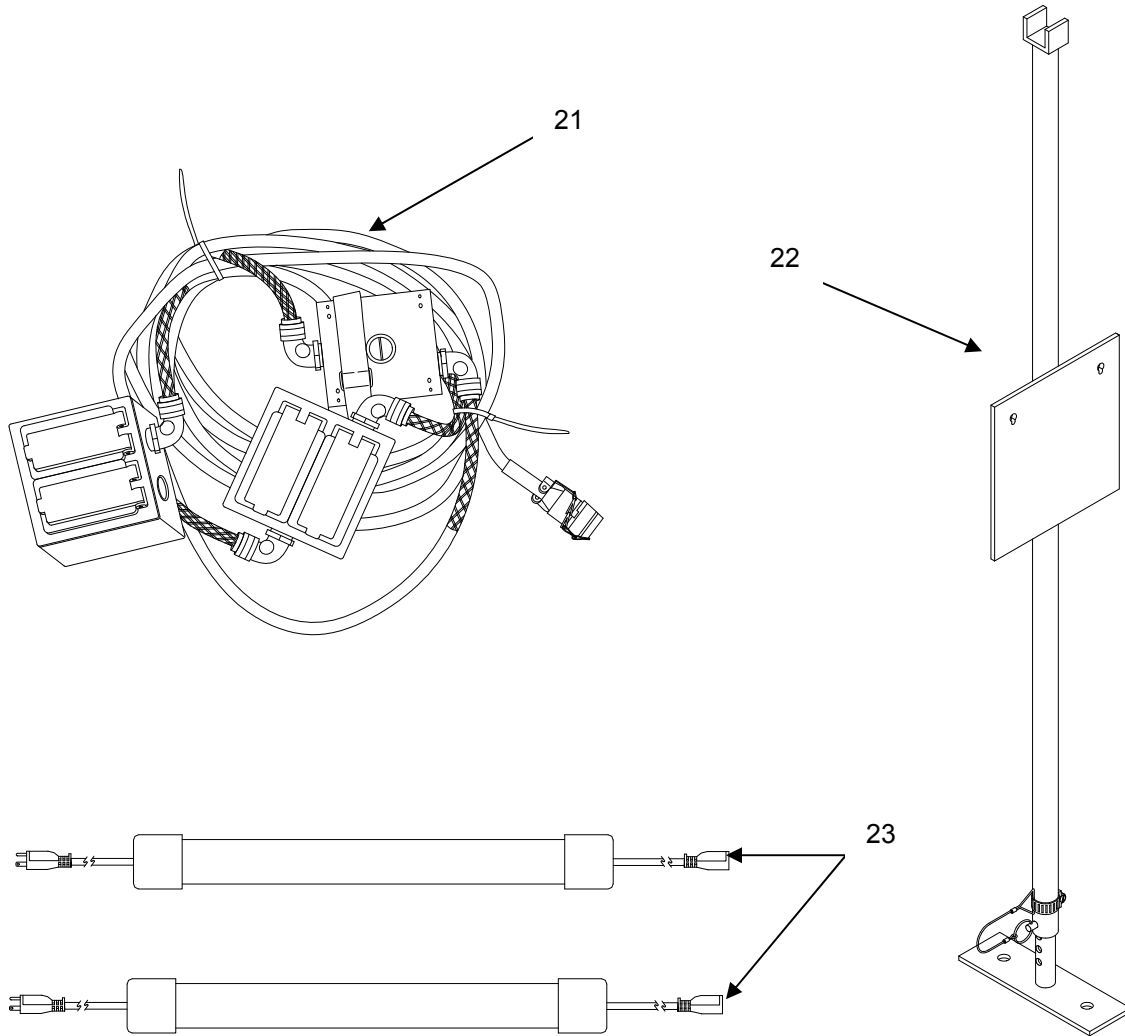


Table 1. Components of End Item List. – Continued.

(1) ILLUS NUMBER	(2) NATIONAL STOCK NUMBER (NSN)	(3) DESCRIPTION, CAGEC, AND PART NUMBER	(4) USABLE ON CODE	(5) UNIT OF ISSUE (U/I)	(6) QTY RQR
21	6150-01-470-1916	DISTRIBUTING SYSTEM, ELECTRICAL 9-1-0624-1 (81337)		EA	2
22	6110-01-242-6691	STAND, DISTRIBUTION 1-6-6005 (81337)		EA	1
23	6230-01-465-8931	LIGHT SET, GENERAL, ILLUMINATION MIL-PRF-4425PD (81349)		SE	3

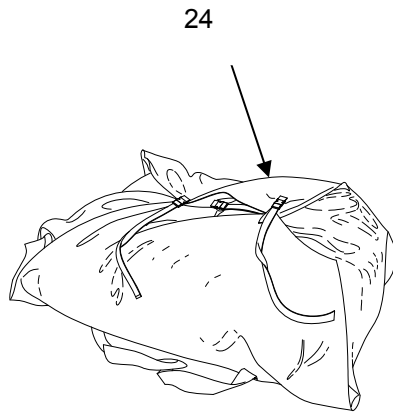


Table 1. Components of End Item List- Continued.

(1) ILLUS NUMBER	(2) NATIONAL STOCK NUMBER (NSN)	(3) DESCRIPTION, CAGEC, AND PART NUMBER	(4) USABLE ON CODE	(5) UNIT OF ISSUE (U/I)	(6) QTY RQR
24	8340-01-536-3677	COVER, TENT, GREEN, CONTENT: 2 EACH SIDEWALL LINERS	FTX	EA	1
24	8340-01-536-3673	5-4-9757-1 (81337) COVER, TENT, TAN, CONTENT: 2 EACH SIDEWALL LINERS	FTY	EA	1
24	8340-01-536-3676	5-4-9757-7 (81337) COVER, TENT, GREEN, CONTENT: 1 EACH ROOF LINER, 1 EACH PLENUM, 6 EACH LIGHTS 5-4-9757-2 (81337)	FTX	EA	1

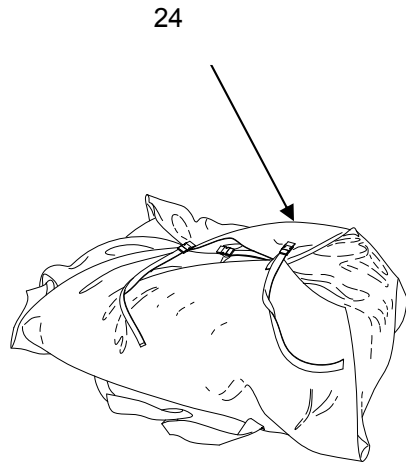


Table 1. Components of End Item Lists – Continued.

(1) ILLUS NUMBER	(2) NATIONAL STOCK NUMBER (NSN)	(3) DESCRIPTION, CAGEC, AND PART NUMBER	(4) USABLE ON CODE	(5) UNIT OF ISSUE (U/I)	(6) QTY RQR
24	8340-01-536-5634	COVER, TENT, TAN, CONTENT: 1 EACH ROOF LINER, 1 EACH PLENUM, 6 EACH LIGHTS 5-4-9757-8 (81337)	FTY	EA	1
24	8340-01-536-3675	COVER, TENT, GREEN, CONTENT: 1 EACH FLOOR, 6 EACH SANDWICH WALL 5-4-9757-3 (81337)	FTX	EA	1
24	8340-01-536-3678	COVER, TENT, TAN, CONTENT: 1 EACH FLOOR, 6 EACH SANDWICH WALL 5-4-9757-9 (81337)	FTY	EA	1

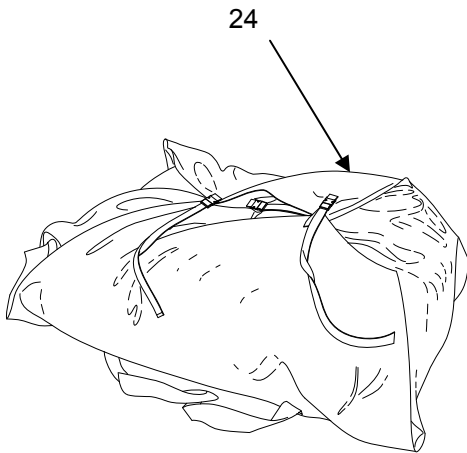


Table 1. Components of End Item Lists – Continued.

(1) ILLUS NUMBER	(2) NATIONAL STOCK NUMBER (NSN)	(3) DESCRIPTION, CAGEC, AND PART NUMBER	(4) USABLE ON CODE	(5) UNIT OF ISSUE (U/I)	(6) QTY RQR
24	8340-01-536-3680	COVER, TENT, GREEN, CONTENT: 1 EACH INTERMEDIATE FABRIC ASSEMBLY 5-5-9757-4 (81337)	FTX	EA	1
24	8340-01-536-3679	COVER, TENT, TAN, CONTENT: 1 EACH INTERMEDIATE FABRIC ASSEMBLY 5-4-9757-10 (81337)	FTY	EA	1
24	8340-01-536-3674	COVER, TENT, GREEN, CONTENT: 2 EACH ENDWALL FABRIC ASSEMBLY 5-4-9757-5 (81337)	FTX	EA	1

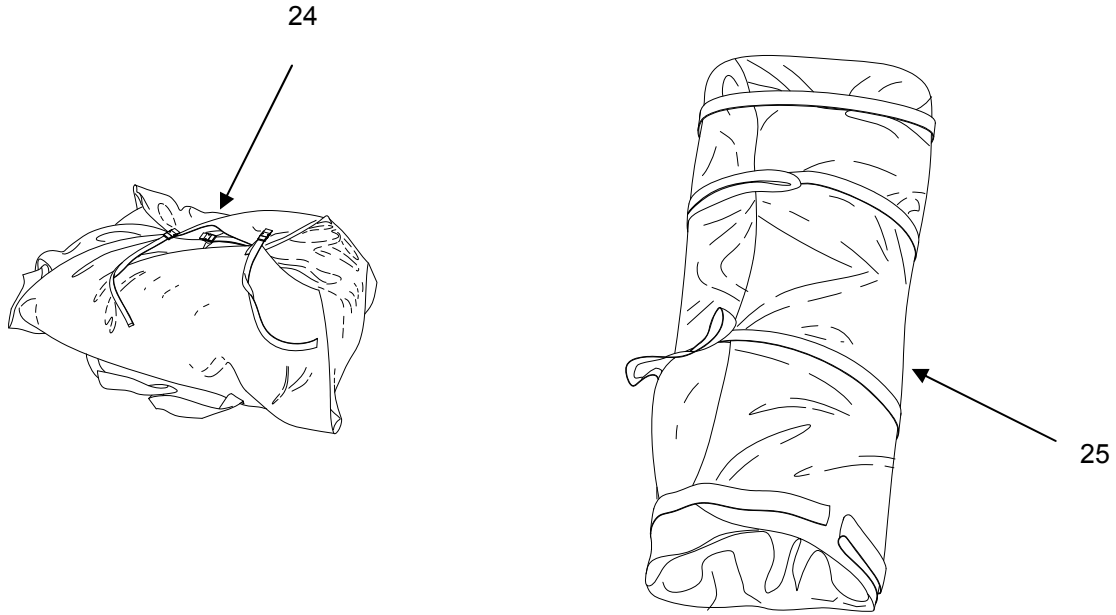


Table 1. Components of End Item Lists – Continued.

(1) ILLUS NUMBER	(2) NATIONAL STOCK NUMBER (NSN)	(3) DESCRIPTION, CAGEC, AND PART NUMBER	(4) USABLE ON CODE	(5) UNIT OF ISSUE (U/I)	(6) QTY RQR
24	8340-01-536-3681	COVER, TENT, TAN, CONTENT: 2 EACH ENDWALL FABRIC ASSEMBLY 5-4-9757-11 (81337)	FTY	EA	1
24	8340-01-536-5635	COVER, TENT, GREEN, CONTENT: 2 EACH ENDWALL LINERS 5-4-9757-6 (81337)	FTX	EA	1
24	8340-01-536-3682	COVER, TENT, TAN, CONTENT: 2 EACH ENDWALL LINERS 5-4-9757-12 (81337)	FTY	EA	1
25	8340-01-536-3685	COVER, TENT FRAME, GREEN, CONTENT: 5 EACH PURLIN, 4 EACH SIDE ARCH, 2 EACH ROOF ARCH, 2 EACH CABLE HEADER 5-4-9751-1 (81337)	FTX	EA	1

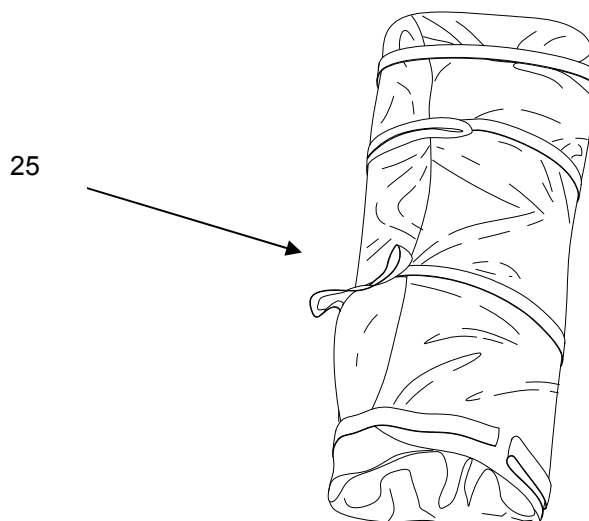


Table 1. Components of End Item Lists – Continued.

(1) ILLUS NUMBER	(2) NATIONAL STOCK NUMBER (NSN)	(3) DESCRIPTION, CAGEC, AND PART NUMBER	(4) USABLE ON CODE	(5) UNIT OF ISSUE (U/I)	(6) QTY RQR
25	8340-01-536-3687	COVER, TENT FRAME, TAN, CONTENT: 5 EACH PURLIN, 4 EACH SIDE ARCH, 2 EACH ROOF ARCH, 2 EACH CABLE HEADER	FTY	EA	1
25	8340-01-536-3684	5-4-9751-1 (81337) COVER, TENT FRAME, GREEN, CONTENT: 3 EACH PURLIN, 2 EACH SIDE ARCH, 1 EACH ROOF ARCH, 1 EACH CABLE HEADER, 2 EACH DOOR SILL PURLIN	FTX	EA	1
25	8340-01-536-3689	5-4-9751-2 (81337) COVER, TENT FRAME, TAN, CONTENT: 3 EACH PURLIN, 2 EACH SIDE ARCH, 1 EACH ROOF ARCH, 1 EACH CABLE HEADER, 2 EACH DOOR SILL PURLIN 5-4-9751-4 (81337)	FTY	EA	1

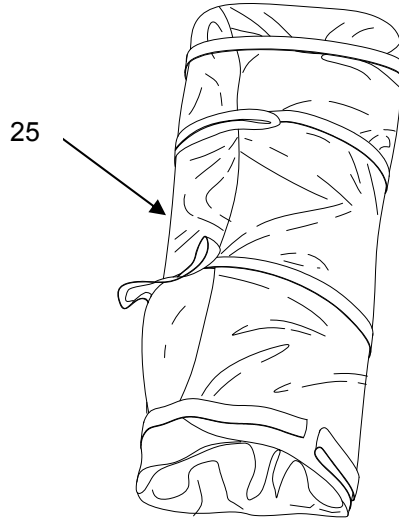
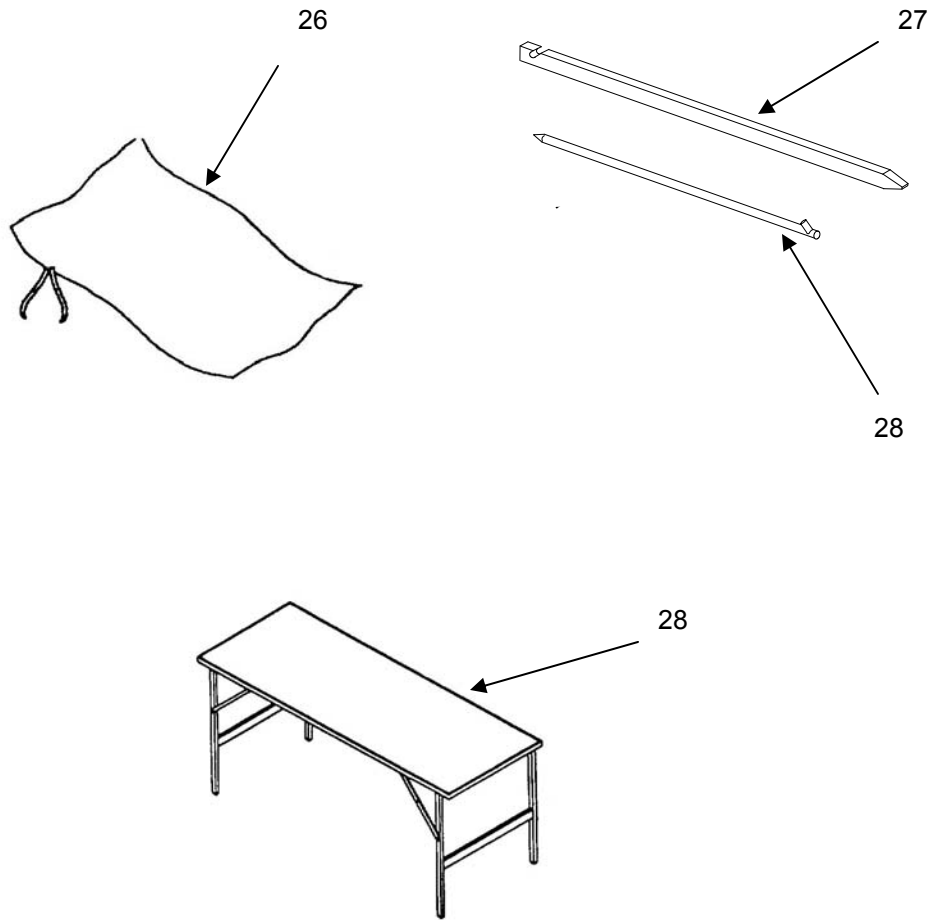


Table 1. Components of End Item Lists – Continued.

(1) ILLUS NUMBER	(2) NATIONAL STOCK NUMBER (NSN)	(3) DESCRIPTION, CAGEC, AND PART NUMBER	(4) USABLE ON CODE	(5) UNIT OF ISSUE (U/I)	(6) QTY RQR
25	8340-01-536-3683	COVER, TENT FRAME, TAN, CONTENT: 3 EACH PURLIN, 2 EACH SIDE ARCH, 1 EACH ROOF ARCH, 1 EACH CABLE HEADER, 2 EACH DOOR SILL PURLIN 5-4-9758-1 (81337)	FTX	EA	1
25	8340-01-536-3686	COVER, TENT FRAME, TAN, CONTENT: 7 EACH VESTIBULE FRAMES, 1 EACH VESTIBULE DOOR 5-4-9758-2 (81337)	FTY	EA	1





(1) ILLUS NUMBER	(2) NATIONAL STOCK NUMBER (NSN)	(3) DESCRIPTION, CAGEC, AND PART NUMBER	(4) USABLE ON CODE	(5) UNIT OF ISSUE (U/I)	(6) QTY RQR
26	8340-01-536-3688	CONTAINER, TENT PIN, GREEN 5-4-9759-1 (81337)	FTX	EA	1
26	8340-01-536-3690	CONTAINER, TENT PIN, TAN 5-4-9759-2 (81337)	FTY	EA	1
27	8340-00-261-9751	PIN, TENT, WOOD, 24" 5-4-1 (81337)		EA	16
28	8340-00-823-7451	PIN, TENT, STEEL, 12" 5-4-791 (81337)		EA	12
29	8340-01-327-7685	TABLE, FOLDING, TENT 5-13-4661 (81337)		EA	6

**Table 2. Basic Issue Items (BII) List.****NOTE**

There are no applicable BII Items in this technical manual.

END OF WORK PACKAGE

---

**OPERATOR AND FIELD MAINTENANCE  
STANDARD INTEGRATED COMMAND POST SYSTEM (SICPS), MEDIUM  
NSN: 8340-01-516-0904, GREEN  
NSN: 8340-01-516-0903, TAN  
ADDITIONAL AUTHORIZATION LIST (AAL)**

---

**INTRODUCTION****Scope**

This work package lists additional items you are authorized for the support of the SICPS, Medium.

**General**

This list identifies items that do not have to accompany the SICPS, Medium and that do not have to be turned in with it. These items are all authorized to you by CTA, MTOE, TDA, or JTA.

**Explanation of Columns in the AAL**

Column (1) National Stock Number (NSN). Identifies the stock number of the item to be used for requisitioning purposes.

Column (2) Description, Commercial and Government Entity Code (CAGEC), and Part Number (P/N). Identifies the Federal item name (in all capital letters) followed by a minimum description when needed. The last line below the description is the CAGEC (in parentheses) and the part number.

Column (3) Usable On Code. When applicable, gives you a code if the item you need is not the same for different models of equipment. These codes are identified below:

<b><u>Code</u></b>	<b><u>Used On</u></b>
FTX	Green, NSN: 8340-01-516-0904
FTY	Tan, NSN: 8340-01-516-0903

Column (4) Unit of Issue (U/I). Indicates the physical measurement or count of the item as issued per the National Stock Number shown in column (1).

Column (5) Qty Recm. Indicates the quantity recommended.

Table 1. Additional Authorization List.

(1) NATIONAL STOCK NUMBER (NSN)	(2) DESCRIPTION, COMMERCIAL AND GOVERNMENT ENTITY CODE (CAGEC), AND PART NUMBER (P/N)	(3) Usable On Code	(4) UNIT OF ISSUE (U/I)	(5) QTY RECM
8340-00-951-6423	Ground Anchor Kit (81337)		EA	
8340-00-951-6423	Ground Anchor Kit (81337)		EA	
5120-00-926-7116	Mallet, Wood		EA	
8340-00-261-7451	Pin, Tent, Metal, Type II (12-In. Long) (81337)		EA	
8340-01-475-8229	Repair Kit, Tentage CMC-8159 (80515)		EA	
5120-00-900-6098	Sledge Hammer, 12 LB, Fiberglass Handle		EA	
	Rake, Snow (62840) 89-416		EA	
8340-00-262-5767	Tentage Repair Kit (81337) 8340-90-CL-POL		EA	

---

**OPERATOR AND FIELD MAINTENANCE  
STANDARD INTEGRATED COMMAND POST SYSTEM (SICPS), MEDIUM  
NSN: 8340-01-516-0904, GREEN  
NSN: 8340-01-516-0903, TAN  
EXPENDABLE AND DURABLE ITEMS LIST**

---

## INTRODUCTION

### Scope

This work package lists expendable and durable items that you will need to operate and maintain the Standard Integrated Command Post System (SICPS), Medium. This list is for information only and is not authority to requisition the listed items. These items are authorized to you by CTA 50-970, Expendable/Durable Items (Except Medical, Class V Repair Parts, and Heraldic Items), or CTA 8-100, Army Medical Department Expendable/Durable Items.

### Explanation of Columns in the Expendable/Durable Items List

Column (1) Item No. This number is assigned to the entry in the list and is referenced in the narrative instructions to identify the item (e.g., Use brake fluid (WP 0098, item 5)).

Column (2) Level. This column identifies the lowest level of maintenance that requires the listed item (C = Operator/Crew, O = Unit/AMC, F = Direct Support/ASB).

Column (3) National Stock Number (NSN). This is the NSN assigned to the item which you can use to requisition it.

Column (4) Item Name, Description, Part Number/(CAGEC). This column provides the other information you need to identify the item. The last line below the description is the part number and the Commercial and Government Entity Code (CAGEC) (in parentheses).

Column (5) U/I. Unit of Issue (U/I) code shows the physical measurement or count of an item, such as gallon, dozen, gross, etc.

Table 1. Expendable and Durable Items List.

(1) ITEM NO.	(2) LEVEL	(3) NATIONAL STOCK NUMBER (NSN)	(4) ITEM NAME, DESCRIPTION PART NUMBER/(CAGEC)	(5) U/I UNIT OF ISSUE
1	C	7920-00-240-7174	Brush, Scrub, w/o Handle	EA
2	O	8020-00-597-4761	Brush, Varnish	EA
3	O	6810-00-782-2686	Denatured Alcohol	Gal
4	O	4240-01-204-2827	Filter, Cartridge (55799) 464023	EA
5	O		Gloves, Latex-Nitrile (55799) 695456 Sz 8 to 8 ½ (55799) 695457 Sz 9 to 9 ½ (55799) 695458 Sz 10 to 10 ½	Pr
6	O		Goggles, Chemical Splash	
7	F	5970-00-431-8599	Insulation, Sleeving	Ft
8	O	8030-01-350-4984	K-Kote Seam Sealer (0R6N1) 83-234C	Gal
9	C	9150-00-999-7548	Lubricant, Stick Form	EA
10	O		Rake, Snow (62840) 89-416	EA
11	O	4240-01-315-1864 4240-01-315-1863 4240-01-311-9013	Respirator, Air Filtering (55799) 479529 Sz Small (55799) 479528 Sz Medium (55799) 479530 Sz Large	EA
12	C	7930-00-965-4868	Soap, Toilet, Cake, Hand	Box
13	F	3439-00-223-2538	Solder, 50/10/50 Lead	
14	O	5440-00-227-1592	Step Ladder, 4-Foot, Wooden, with Bucket Shelf	EA
15	F	5970-00-644-3167	Tape, Electrical Insulation, ¾-inch width	EA
16	O	5210-00-221-1882	Tape, Measure 100-Foot	EA
17	O	7920-00-205-1711	Wiping Rags	Bale

---

**OPERATOR AND FIELD MAINTENANCE  
STANDARD INTEGRATED COMMAND POST SYSTEM (SICPS), MEDIUM  
NSN: 8340-01-516-0904, GREEN  
NSN: 8340-01-516-0903, TAN  
GLOSSARY**

---

<b>TERM</b>	<b>DEFINITION</b>
Becket	A loop of rope designed to catch another loop or eye.
Becket Lacing	A lacing procedure used to join the fabric panels together. The procedure requires aligning the sewn in grommets of one fabric panel with the sewn-in becket laces of another panel. Each lace is pulled through the corresponding grommet as well as the preceding lace loop. Becket lacing is a strong but flexible method of attachment that helps mitigate the effects of wind and load stress on the fabric panels.
Boss	A hub or receptacle for a fitting.
Cable Header	These are used to provide lateral rigidity to the frame upper arch assembly.
Door Header	The door headers are used to suspend the vehicle access doors and incorporate a curtain mechanism.
Eave	The lower ridgeline where the wall and roof meet.
Erect Position	The elevated tent position.
Fastener Tape	Hook and pile, zipperless cloth fastening tape.
Kneeling Position	Arch assemblies joined; neither side raised.
Partially Erect	Partially elevated ten position; one side raised.
Purlin	A horizontal member of the frame that connects the arch frame assemblies together and provides structural stability.
R-Factor	Rating of insulation values.
Ridge	The line of intersection at the peak of both roofs.
Siders	The sider assemblies enhance structural stability of the frame arch assemblies.
Slide Fastener	A zipper.

<b>TERM</b>	<b>DEFINITION</b>
Slurry	A mixture of water and subtropical bleach for use in NBC decontamination procedures.
Spindle	A tapered rod which receives grommets.
Telescopic	Tubular poles (i.e., frame legs) that slide inside each other to become longer or shorter.
VAC	Volts alternating current used to measure electrical potential.



## ***These are the instructions for sending an electronic 2028***

The following format must be used if submitting an electronic 2028. The subject line must be exactly the same and all fields must be included; however only the following fields are mandatory: 1, 3, 4, 5, 6, 7, 8, 9, 10, 13, 15, 16, 17, and 27.

From: "Whomever" <whomever@avma27.army.mil>  
To: TACOMLCMC.DAForm2028@us.army.mil

Subject: DA Form 2028

1. From: Joe Smith
2. Unit: home
3. Address: 4300 Park
4. City: Hometown
5. St: MO
6. Zip: 77777
7. Date Sent: 19-OCT-93
8. Pub no: 55-2840-229-23
9. Pub Title: TM
10. Publication Date: 04-JUL-85
11. Change Number: 7
12. Submitter Rank: MSG
13. Submitter FName: Joe
14. Submitter MName: T
15. Submitter LName: Smith
16. Submitter Phone: 123-123-1234
17. Problem: 1
18. Page: 2
19. Paragraph: 3
20. Line: 4
21. NSN: 5
22. Reference: 6
23. Figure: 7
24. Table: 8
25. Item: 9
26. Total: 123
27. Text:

This is the text for the problem below line 27.



<b>RECOMMENDED CHANGES TO PUBLICATIONS AND BLANK FORMS</b> For use of this form, see AR 25-30; the proponent agency is ODISC4.						Use Part II (reverse) for Repair Parts and Special Tool Lists (RPSTL) and Supply Catalogs/Supply Manuals (SC/SM).	DATE 21 October 2003
<b>TO:</b> (Forward to proponent of publication or form) (Include ZIP Code) US ARMY TACOM LIFE CYCLE MANAGEMENT COMMAND ATTN: AMSTA-LCL-MPP/TECHPUBS 1 Rock Island Arsenal ROCK ISLAND, IL 61299-7360						<b>FROM:</b> (Activity and location) (Include ZIP Code)  PFC JANE DOE Co A 3 <sup>RD</sup> Engineer Br. Ft Leonard Wood, MO 63108	
<b>PART I - ALL PUBLICATIONS (EXCEPT RPSTL AND SC/SM) AND BLANK FORMS</b>							
PUBLICATION/FORM NUMBER TM 10-1670-296-20&P						DATE 30 October 2002	TITLE Unit Manual for Ancillary Equipment for Low Velocity Air Drop Systems
ITEM NO.	PAGE NO.	PARA-GRAPH	LINE NO. *	FIGURE NO.	TABLE NO.	RECOMMENDED CHANGES AND REASON (Provide exact wording of recommended changes, if possible).	
	0036 00-2				1	<p><i>In Table 1, Sewing Machine Code Symbols, the second sewing machine code symbol should be MDZZ not MD22</i></p> <p><i>Change the manual to show Sewing Machine, Industrial: Zig-Zag; 308 stitch; medium-duty; NSN 3530-01-181-1421 as a MDZZ code symbol.</i></p>	
<i>*Reference to line numbers within the paragraph or subparagraph.</i>							
TYPED NAME, GRADE OR TITLE  Jane Doe, PFC				TELEPHONE EXCHANGE/AUTOVON, PLUS EXTENSION (508) 233-4141 DSN 256-4141		SIGNATURE  Jane Doe <i>Jane Doe</i>	

<b>TO:</b> <i>(Forward direct to addressee listed in publication)</i> US ARMY TACOM LIFE CYCLE MANAGEMENT COMMAND ATTN: AMSTA-LCL-MPP/TEHPUBS 1 Rock Island Arsenal ROCK ISLAND, IL 61299-7360	<b>FROM:</b> <i>(Activity and location) (Include ZIP Code)</i> PFC JANE DOE Co A 3 <sup>RD</sup> Engineer Br. Ft Leonard Wood, MO 63108	<b>DATE</b> 21 October 2003
---	--	--------------------------------

**PART II – REPAIR PARTS AND SPECIAL TOOL LISTS AND SUPPLY CATALOGS/SUPPLY MANUALS**

PUBLICATION NUMBER TM 10-1670-296-20&P	DATE 30 October 2002	TITLE Unit Manual for Ancillary Equipment for Low Velocity Air Drop Systems
---	-------------------------	--

PAGE NO.	COLM NO.	LINE NO.	NATIONAL STOCK NUMBER	REFERENCE NO.	FIGURE NO.	ITEM NO.	TOTAL NO. OF MAJOR ITEMS SUPPORTED	RECOMMENDED ACTION
0066 00-					4			<i>Callout 16 in figure 4 is pointed to a <u>D-Ring</u>. In the Repair Part List key for Figure 4, item 16 is called a <u>Snap Hook</u>. Please correct one or the other.</i>

**PART III – REMARKS** *(Any general remarks or recommendations, or suggestions for improvement of publications and blank forms. Additional blank sheets may be used if more space is needed.)*

--

TYPED NAME, GRADE OR TITLE	TELEPHONE EXCHANGE/AUTOVON, PLUS EXTENSION	SIGNATURE
----------------------------	--	-----------

<b>RECOMMENDED CHANGES TO PUBLICATIONS AND BLANK FORMS</b>  For use of this form, see AR 25-30; the proponent agency is ODISC4.	Use Part II (reverse) for Repair Parts and Special Tool Lists (RPSTL) and Supply Catalogs/Supply Manuals (SC/SM).	DATE
---	---	------

<b>TO:</b> (Forward to proponent of publication or form) (Include ZIP Code) US ARMY TACOM LIFE CYCLE MANAGEMENT COMMAND ATTN: AMSTA-LCL-MPP/TECHPUBS 1 Rock Island Arsenal ROCK ISLAND, IL 61299-7360	<b>FROM:</b> (Activity and location) (Include ZIP Code)
---	---

**PART I – ALL PUBLICATIONS (EXCEPT RPSTL AND SC/SM) AND BLANK FORMS**

PUBLICATION/FORM NUMBER TM 10-8340-242-13&P	DATE 31 AUGUST 2010	TITLE Maintenance Manual for Standard Integrated Command Post System (SICPS), Medium
--	------------------------	---

ITEM NO.	PAGE NO.	PARA-GRAPH	LINE NO. *	FIGURE NO.	TABLE NO.	RECOMMENDED CHANGES AND REASON <i>(Provide exact wording of recommended changes, if possible).</i>
----------	----------	------------	------------	------------	-----------	---

--	--	--	--	--	--	--

*\*Reference to line numbers within the paragraph or subparagraph.*

TYPED NAME, GRADE OR TITLE	TELEPHONE EXCHANGE/AUTOVON, PLUS EXTENSION	SIGNATURE
----------------------------	--	-----------

<b>TO:</b> (Forward to proponent of publication or form) (Include ZIP Code) US ARMY TACOM LIFE CYCLE MANAGEMENT COMMAND ATTN: AMSTA-LCL-MPP/TECHPUBS 1 Rock Island Arsenal ROCK ISLAND, IL 61299-7360	<b>FROM:</b> (Activity and location) (Include ZIP Code)	<b>DATE</b>
---	---	-------------

**PART II – REPAIR PARTS AND SPECIAL TOOL LISTS AND SUPPLY CATALOGS/SUPPLY MANUALS**

<b>PUBLICATION NUMBER</b> TM 10-8340-242-13&P	<b>DATE</b> 31 AUGUST 2010	<b>TITLE</b> Maintenance Manual for Standard Integrated Command Post System (SICPS), Medium
--	-------------------------------	--

PAGE NO.	COLM NO.	LINE NO.	NATIONAL STOCK NUMBER	REFERENCE NO.	FIGURE NO.	ITEM NO.	TOTAL NO. OF MAJOR ITEMS SUPPORTED	RECOMMENDED ACTION

**PART III – REMARKS**

*(Any general remarks or recommendations, or suggestions for improvement of publications and blank forms. Additional blank sheets may be used if more space is needed.)*

TYPED NAME, GRADE OR TITLE	TELEPHONE EXCHANGE/AUTOVON, PLUS EXTENSION	SIGNATURE
----------------------------	--	-----------



<b>TO:</b> <i>(Forward to proponent of publication or form) (Include ZIP Code)</i> US ARMY TACOM LIFE CYCLE MANAGEMENT COMMAND ATTN: AMSTA-LCL-MPP/TECHPUBS 1 Rock Island Arsenal ROCK ISLAND, IL 61299-7360	<b>FROM:</b> <i>(Activity and location) (Include ZIP Code)</i>	<b>DATE</b>
--	--	-------------

**PART II – REPAIR PARTS AND SPECIAL TOOL LISTS AND SUPPLY CATALOGS/SUPPLY MANUALS**

<b>PUBLICATION NUMBER</b> TM 10-8340-242-13&P	<b>DATE</b> 31 AUGUST 2010	<b>TITLE</b> Maintenance Manual for Standard Integrated Command Post System (SICPS), Medium
--	-------------------------------	--

PAGE NO.	COLM NO.	LINE NO.	NATIONAL STOCK NUMBER	REFERENCE NO.	FIGURE NO.	ITEM NO.	TOTAL NO. OF MAJOR ITEMS SUPPORTED	RECOMMENDED ACTION

**PART III – REMARKS**

*(Any general remarks or recommendations, or suggestions for improvement of publications and blank forms. Additional blank sheets may be used if more space is needed.)*


TYPED NAME, GRADE OR TITLE	TELEPHONE EXCHANGE/AUTOVON, PLUS EXTENSION	SIGNATURE
----------------------------	--	-----------



By Order of the Secretary of the Army:

GEORGE W. CASEY, JR.  
*General, United States Army*  
*Chief of Staff*

Official:

  
JOYCE E. MORROW  
*Administrative Assistant to the*  
*Secretary of the Army*  
1023710

**DISTRIBUTION:**

This publication is produced in electronic media only.



# The Metric System and Equivalents

## Linear Measure

1 centimeter = 10 millimeters = .39 inch  
 1 decimeter = 10 centimeters = 3.94 inches  
 1 meter = 10 decimeters = 39.37 inches  
 1 dekameter = 10 meters = 32.8 feet  
 1 hectometer = 10 dekameters = 328.08 feet  
 1 kilometer = 10 hectometers = 3,280.8 feet

## Weights

1 centigram = 10 milligrams = .15 grain  
 1 decigram = 10 centigrams = 1.54 grains  
 1 gram = 10 decigrams = .035 ounce  
 1 dekagram = 10 grams = .35 ounce  
 1 hectogram = 10 dekagrams = 3.52 ounces  
 1 kilogram = 10 hectograms = 2.2 pounds  
 1 quintal = 100 kilograms = 220.46 pounds  
 1 metric ton = 10 quintals = 1.1 short tons

## Liquid Measure

1 centiliter = 10 milliliters = .34 fl. ounce  
 1 deciliter = 10 centiliters = 3.38 fl. ounces  
 1 liter = 10 deciliters = 33.81 fl. ounces  
 1 dekaliter = 10 liters = 2.64 gallons  
 1 hectoliter = 10 dekaliters = 26.42 gallons  
 1 kiloliter = 10 hectoliters = 264.18 gallons

## Square Measure

1 sq. centimeter = 100 sq. millimeters = .155 sq. inch  
 1 sq. decimeter = 100 sq. centimeters = 15.5 sq. inches  
 1 sq. meter (centare) = 100 sq. decimeters = 10.76 sq. feet  
 1 sq. dekameter (are) = 100 sq. meters = 1,076.4 sq. feet  
 1 sq. hectometer (hectare) = 100 sq. dekameters = 2.47 acres  
 1 sq. kilometer = 100 sq. hectometers = .386 sq. mile

## Cubic Measure

1 cu. centimeter = 1000 cu. millimeters = .06 cu. inch  
 1 cu. decimeter = 1000 cu. centimeters = 61.02 cu. inches  
 1 cu. meter = 1000 cu. decimeters = 35.31 feet

## Approximate Conversion Factors

<i>To change</i>	<i>To</i>	<i>Multiply by</i>	<i>To change</i>	<i>To</i>	<i>Multiply by</i>
inches	centimeters	2.540	ounce-inches	newton-meters	.007062
feet	meters	.305	centimeters	inches	.394
yards	meters	.914	meters	feet	3.280
miles	kilometers	1.609	meters	yards	1.094
square inches	square centimeters	6.451	kilometers	miles	.621
square feet	square meters	.093	square centimeters	square inches	.155
square yards	square meters	.836	square meters	square feet	10.764
square miles	square kilometers	2.590	square meters	square yards	1.196
acres	square hectometers	.405	square kilometers	square miles	.386
cubic feet	cubic meters	.028	square hectometers	acres	2.471
cubic yards	cubic meters	.765	cubic meters	cubic feet	35.315
fluid ounces	milliliters	29.573	cubic meters	cubic yards	1.308
pints	liters	.473	milliliters	fluid ounces	.034
quarts	liters	.946	liters	pints	2.113
gallons	liters	3.785	liters	quarts	1.057
ounces	grams	28.349	liters	gallons	.264
pounds	kilograms	.454	grams	ounces	.035
short tons	metric tons	.907	kilograms	pounds	2.205
pound-feet	newton-meters	1.356	metric tons	short tons	1.102
pound-inches	newton-meters	.11296			

## Temperature (Exact)

  °F Fahrenheit temperature  $\times \frac{5}{9}$  (after subtracting 32) = Celsius temperature   °C

**PIN: 086548-000**