

old
U113
TM
1941

TM 9-1548

U.S. WAR DEPARTMENT
U.S. Dept of Army
TECHNICAL MANUAL
ORDNANCE MAINTENANCE
**PANORAMIC TELESCOPE M1 AND
TELESCOPE MOUNT M3**
October 15, 1941



U 113
12

TM 9-1548

1-2

TM 9:1548
1941

TECHNICAL MANUAL }
No. 9-1548 }

WAR DEPARTMENT,
WASHINGTON, October 15, 1941.



ORDNANCE MAINTENANCE

PANORAMIC TELESCOPE M1 AND TELESCOPE
MOUNT M3

Prepared under direction of the
Chief of Ordnance

	Paragraph
General.....	1
Description.....	2
Operation.....	3
Inspection.....	4
Maintenance and repair.....	5
Care and preservation.....	6
	Page
APPENDIX. List of references.....	18

1. **General.**—*a. Purpose.*—This manual is published primarily for the information and guidance of ordnance maintenance personnel.

b. Scope.—This manual supplements the Technical Manuals which are prepared for the using arm. It contains descriptive matter and illustrations sufficient to provide a general working knowledge of the equipment and detailed instructions for inspection, maintenance, and repair by ordnance maintenance personnel.

c. References.—The appendix lists the Technical Manuals and Standard Nomenclature Lists for the equipment described herein.

2. **Description.**—*a. General.*—The panoramic telescope M1 and the telescope mount M3 constitute the aiming device for the 75-mm pack howitzer carriage M1. The telescope is attached to and remains integral with the telescope mount. The mount is secured to the left side of the howitzer carriage and moves in elevation and deflection with the howitzer. The telescope provides the mechanism for setting the deflection angles while the mount supplies the elevation, angle of site, and cross leveling mechanisms.

b. Panoramic telescope M1 (figs. 1, 2, and 3).—(1) The panoramic telescope M1 is the sighting medium for the 75-mm pack howitzer. The optical elements are so arranged that the line of sight can be directed by means of the azimuth mechanism through any desired angle in the horizontal plane. In addition, provision is also made for raising or lowering the line of sight through a limited vertical angle so that the aiming point can be kept within the field of view.

M558665

(2) The panoramic telescope is secured to the telescope mount by means of four screws (two of A31379A and two of A31379B) passing through drilled holes in the flange of the azimuth worm housing (C2534) and elbow retaining plate (B10212, fig. 3) of the telescope and the housing (C44372, fig. 5) of the mount. Two of these screws (A31379B) also secure the cross level bracket (B16892) to the mount. The panoramic telescope is of the fixed focus type and has the following optical characteristics:

Power.....	3X
Field of view.....	12°12'
Diameter of exit pupil.....	0.15 inch
Apparent field of view.....	36°36'
Effective focal length of objective.....	2.362 inches
Effective focal length of eyepiece.....	0.784 inch

(a) The azimuth worm mechanism (sec. B-B, fig. 2) rotates the telescope rotating head (C44393) 360° in a horizontal plane. The azimuth scale, attached to the lower part of the rotating head, is graduated in 100-mil steps, every four being numbered from 0 to 32 in two consecutive semicircles. The azimuth micrometer, secured to the azimuth worm knob (A37677) rotates with the azimuth worm (A37674). The micrometer is graduated around its circumference into 100 equal spaces numbered from 0 to 100, each space representing an angle of 1 mil. The azimuth worm throwout lever (A30865) when rotated and held against the action of the torsion spring (A30867) disengages the azimuth worm from the teeth of the worm gear permitting free rotation of the rotating head.

(b) The elevating worm mechanism of rotating head (C44393, sec. A-A, fig. 3) elevates or depresses the line of sight. The worm shaft of the elevating mechanism is provided with a series of stop rings (A49929) and (A49930) which prevent the worm from being damaged by excessive turning. The elevation micrometer (A37665) is secured to the elevating knob (A30923) and is marked with a zero line which indicates the normal position of the line of sight. A line is marked on the open sight side of the rotating head to be used with the zero line on the body of the rotating head when setting the elevation micrometer to indicate the normal position of the line of sight. An open sight (A30834, sec. C-C, fig. 2) attached to the rotating head cover (A37671) is used to obtain preliminary direction of sight.

(c) The eyepiece assembly (C44495, sec. A-A, fig. 3) is inclined at an angle of 25° from the horizontal. The eyepiece is fitted with a soft rubber eyeshield (A39125, fig. 3) which protects the observer's

eye from shocks and stray light. The reticle (A37950, fig. 3) is inscribed with a vertical and a horizontal line, the intersection of which indicates the optical axis of the telescope. A window (A35616) is fitted into the eyepiece adapter (B16947) opposite the edge of the reticle and admits light for night illumination of the lines. The eyepiece can be rotated about the vertical axis of the telescope. Such rotation of the eyepiece does not change the direction of the line of sight.

*c. Telescope mount M3 (for 75-mm pack howitzer carriage M1).—*The telescope mount M3 (figs. 4, 5, and 6) is of the azimuth-compensating type, automatically applying the necessary corrections in azimuth and elevation for trunnion cant.

(1) The elevating mechanism is contained in the elevating worm housing (C44372, fig. 5) and activated by rotating the elevating worm knob (A31357). An elevation scale (A36351, fig. 4) and associated micrometer are provided. The elevating scale is graduated in 100-mil intervals and the micrometer in 1-mil intervals. The elevating knob is secured to the range drum (B16895, sec. A-A-A-A-A-A, fig. 5) which carries a continuous range scale graduated in yards. The range drum is marked to indicate the type of ammunition. As the range drum rotates with the elevating worm knob the helical groove in its surface moves the pointer (A36352, fig. 6), thereby indicating the range corresponding to the elevation angle.

(2) The angle of site mechanism is contained in the upper part of the elevating worm housing (C44372, fig. 5). Rotation of the angle of site micrometer knob (A32087) which is attached to the angle of site worm (A36353) elevates or depresses the line of sight. The angle of site scale (A36350, fig. 6) and associated micrometer (A32096, fig. 5) indicate the angle of site in mils. The 300-mil setting on the angle of site scale corresponds to the zero angle of site. The angle of site level vial attached to the angle of site gear segment (B16513, fig. 6) provides the means for determining a horizontal datum plane for the line of sight.

(3) The cross level worm mechanism is contained in the cross level worm housing (C44371, sec. A-A-A-A-A-A, fig. 5). When the cross level worm knob is rotated, the mount tilts about the mount bracket (B16783, fig. 6). The cross leveled position is indicated on the cross level vial (A31308, fig. 5), which is located over the eyepiece of the telescope when set in the telescope mount.

(4) The telescope mount M3 is held in position on the gun cradle by means of support (B16782, fig. 6). The mount bracket (B16783, fig. 6) slides on the support and positions the mount in azimuth by

means of a key and keyway. The lug and notch located on the lower end of the support are used for properly positioning the support on the gun cradle.

d. Accessories.—A spare sight chest M6 for 75-mm pack howitzer M1 is furnished with this equipment. It consists of a rectangular-shaped wooden box with a properly positioned socket. A cap is attached to the lid for firmly holding the sight when the lid is screwed down tight.

3. Operation.—The panoramic telescope M1 and telescope mount M3 may be used either for direct or indirect fire.

a. Direct fire.—(1) Cross level the mount by turning the cross level knob (A36349, fig. 6) until the bubble in the cross level vial (A31308) is centered.

(2) Rotate the telescope elevating knob (A30923, fig. 3) so that the index on the rotating head of the panoramic telescope indicates zero and the zero indication on the elevation micrometer (A37665) is opposite its index. These settings should remain undisturbed during the operation of direct fire.

(3) Set in the desired lateral deflection on the azimuth scale (A37668) and on the azimuth micrometer (A30870, sec. B-B, fig. 2), by turning the azimuth knob (A37677). Large deflections may be set in by use of the throwout lever (A30865, fig. 2). Set the angle of site to normal and set the elevation on the elevation scale and micrometer.

(4) Traverse and elevate the gun carriage until the point of intersection of the cross lines in the telescope falls on the target, keeping the bubble of the cross level vial centered at all times by means of the cross level knob.

b. Indirect fire.—(1) Cross level the mount by turning the cross level knob (A36349, fig. 6) until the bubble in the cross level vial (A31308) is centered.

(2) Set off the azimuth of the target, with respect to the aiming point, on the azimuth scale (A37668) and micrometer (A30870) of the panoramic telescope. Large settings may be set in the instrument by means of the throwout lever. Set the angle of site and the elevation on their respective scales and micrometers. Traverse and elevate the gun carriage until the vertical line in the telescope reticle falls on the aiming point and the angle of site bubble is centered, keeping the bubble in the cross level vial centered at all times by means of its knob.

(3) It may be necessary to rotate the elevating knob (A30923) on the panoramic telescope in order to bring the aiming point within the

vertical field of view. This procedure is permissible in indirect fire only as, due to the fact that the telescope axis is kept vertical, the azimuth correction is not affected.

4. Inspection.—Inspection is for the purpose of determining the condition of the matériel, whether repairs or adjustments are required, and the remedies necessary to insure serviceability and proper functioning. The following list will serve as a guide:

Parts to be inspected

Points to be observed

a. External screws, knobs, clamping screws, and nuts.

a. Examine the equipment as a whole for loose and missing parts such as screws, nuts, and knobs.

b. Level vials.

b. See that the angle of site and cross level vials are not broken and that they are secure in their housings.

c. Azimuth worm mechanism.

c. Operate the azimuth worm knob in one direction and then in another so that the telescope is traversed 360° in each direction. Observe any sticking or binding in the mechanism.

d. Elevating mechanisms.

d. Operate the elevating knob (A31357) of the mount and the elevating knob (A30923) of the telescope to the limit of their travel in each direction. Observe any sticking or binding in the mechanisms.

e. Angle of site mechanism.

e. Operate the angle of site knob (A32087) of the mount to the limit of its motion in each direction. Observe any sticking or binding in the mechanism.

f. Backlash in azimuth mechanism.

f. Sight on a vertical line by turning the azimuth knob (A37677, fig. 2) in one direction. Record the readings of the azimuth scale and micrometer. Turn the knob in same direction several more turns and then turn the knob in the opposite direction until the vertical line of the reticle again coincides with the line originally sighted upon. Again record the readings of the indexes on

Parts to be inspected

g. Backlash in angle of site mechanism.

h. Backlash in telescope mount elevating mechanism.

Points to be observed

the azimuth scale and micrometer. The difference between the initial and final readings is the backlash. If it exceeds 2 mils, replacement of the wearing parts is necessary by personnel qualified to disassemble optical instruments. The backlash should not exceed 1 mil after repair.

g. Center the bubble in the angle of site level vial by turning the micrometer knob (A32087, fig. 5) in one direction. Record the readings of the indexes on the angle of site scale and associated micrometer. Turn the knob in the same direction several more turns. Then center the bubble again by turning the angle of site knob in the opposite direction. Again record the readings of the indexes on the angle of site scale and associated micrometer. The difference between the initial and final readings is the backlash. If it exceeds 2 mils, adjustment might be made by means of plug (A34654) or cap (A37913) and socket (A32119) which are each secured by locking screws. If adjustment by this means cannot reduce the backlash to 1 mil, replacement of the wearing parts will be necessary to attain this value.

h. Sight on a distant horizontal line by turning the elevating knob (A31357, fig. 5) in one direction. Record the readings of the indexes on the elevation scale (A36351, fig. 4) and elevation micrometer on the range drum (B16895). Turn the elevating knob several turns farther in the same direction. Then sight

*Parts to be inspected**Points to be observed*

on the same line originally sighted upon by turning the elevating knob in the opposite direction. Again record the readings of the indexes on the elevation scale and associated micrometer. The difference between the initial and final readings is the backlash. If it exceeds 2 mils, adjustment might be made by means of plug (A31378) or cap (A32117) and socket (A32122) which are each secured by locking screws. If adjustment by this means cannot reduce the back lash to 1 mil, replacement of the wearing parts will be necessary to attain this value.

i. Alinement of elevation scale and angle of site level.

i. With the support (B16782, fig. 6) of the telescope mount vertical and the flat surface of the elevating worm housing (C44372, fig. 5), which supports the telescope, horizontal, set the elevation scale and associated micrometer to zero. Center the angle of site bubble by means of the micrometer knob (A32087). Then the angle of site index line should coincide with the "3" graduation of the angle of site scale, and the index on the associated micrometer should coincide with zero. Failure to coincide may be due to the elevation scale and associated micrometer out of adjustment or the angle of site scale micrometer, and angle of site level vial out of alinement. Adjustment of these parts is described in paragraph 4*i*.

5. Maintenance and repair.—*a. Tools.*—An optical repair kit containing the necessary tools, fixtures, cements, oils, etc., for use with this equipment is furnished to ordnance maintenance companies. A complete list of the items comprising the kit is contained in a blue-

print which is fastened to the cover of the chest. Every item in the kit is designated by a number equivalent to the compartment number. Most of the items such as screw drivers, etc., require no description as their uses are self-explanatory. The collimating telescope No. 90 (15-17-7) which is furnished with the kit is an ordinary nonerecting type. It is adjusted for parallax by focusing the eyepiece on the cross wires and then removing parallax by focusing the objective, temporarily loosening the drawtube clamping screw in the side of the telescope for the purpose. The magnifying power of the collimating telescope is 9.78X; the field of view is 4°20'.

b. Disassembly and assembly.—The assembled and sectioned views show the location of the various parts and the means by which they are held in place. These figures should be carefully studied before attempting any assembling or disassembling operations. Optical instruments should not be disassembled to an extent that would expose or disturb the optical elements unless carried out by personnel who have the training and equipment necessary for the work.

(1) *To disassemble angle of site worm (A36353, fig. 5).*—(a) Remove the angle of site knob (A32087) by unscrewing the associated nut (A32112). Lift off the angle of site micrometer (A32096).

(b) Remove the micrometer adapter (A32125) by first extracting the associated pin (BFCX1B).

(c) Remove the worm plug (A34654), worm plunger (A34100), and spring. Loosen the cap screw (BCUX1CC) and the socket screw (A34658, fig. 4). Unscrew the ball cap (A37913).

(d) Extract the angle of site worm (A36353) together with the ball socket (A32119) from the housing (C44372).

(2) *To disassemble elevating worm (A37493, fig. 5).*—(a) Remove the elevating knob (A31357) by removing the three flathead screws (BCLX3DG).

(b) Extract the range drum (B16895) from the adapter (A37489). Slide the range drum support (A37490) about an inch to the right on the worm shaft by first driving out the support pin (BFCX1L).

(c) Unscrew the plunger plug (A31378) and remove the plunger (A31363) and associated spring.

(d) Loosen the headless screw (BCUX1CC) and then unscrew the worm ball cap (A32117).

(e) Loosen the cone point screw (A34659, fig. 4) and the clamp screw (A37437, fig. 5), and then remove the elevating worm (A37493) together with the ball socket (A32122).

(3) *To replace cross level vial (A31308, sec. C-C, fig. 5).*—(a) Remove the plugs (A34055) on the ends of the level vial by remov-

ing the pin (BFDX1AK) from each. Remove the level tube pin (BFDX1AD), loosen each of the four level vial adjusting screws (BCUX2CB), and extract the level tube from the level bracket (B16892).

(b) Remove the level vial and old packing from the level tube. Wrap the ends of new level vial with paper to suit tube and locate in level vial tube with white paper backing and calcined gypsum (plaster of paris) setting. When reassembling, the adjusting screws should be tight before any of the pins or plugs are replaced.

(4) *To assemble various parts.*—The procedure to be followed for reassembling is the reverse order for disassembling. When reassembling worm shafts fitted with socket and cap bearings, adjust the cap to provide a snug fit on the ball so that there is neither end play nor excessive friction.

(5) *Lubrication when assembling.*—Before assembling, clean all parts with solvent, dry cleaning, dry with a clean cloth, and then apply a light film of grease, special, low temperature.

c. Adjustments.—The adjustments of the panoramic telescope M1 and the telescope mount M3 can be verified by following the procedure given in paragraph 4i.

(1) The adjustment of the telescope elevation micrometer is accomplished by temporarily loosening the three flathead screws (BCLX3CT) at the top of the elevating worm knob (A30923, fig. 3) and rotating the micrometer (A37665) as required while holding the knob stationary.

(2) To adjust the telescope azimuth micrometer (A30870, sec. B-B, fig. 2). Rotate the azimuth micrometer the desired amount by first loosening the azimuth micrometer nut (A30871). Then tighten the nut.

(3) To adjust the telescope azimuth scale (A37668, fig. 3). Loosen the four flathead screws (BCLX3CT), sec. C-C, fig. 2), which clamp ring (A30918) over the scale and shift the azimuth scale the desired amount. Then tighten the four screws.

(4) To adjust the angle of site scale (A36350, fig. 6). Loosen the two screws (BCOX3CC, fig. 4) and shift the scale the desired amount. Then tighten the screws.

(5) To adjust the angle of site micrometer (A32096, sec. A-A-A-A-A, fig. 5). Loosen the micrometer nut (A32112). Hold the angle of site knob with one hand and with the other hand turn the micrometer until the desired indication is opposite the index. Then tighten the micrometer nut.

(6) To adjust the elevation scale (A36351, fig. 4). Loosen the two roundhead screws (BCOX3CC) by which the scale is fastened to the elevating worm housing and shift the scale until the desired indication is opposite the index. Then tighten the screws.

(7) To adjust the range drum (B16895, sec. A-A-A-A-A-A, fig. 5), containing the elevation micrometer. Loosen the three flathead screws (BCLX3DG). Hold the elevating knob (A31357) with one hand and with the other hand turn the drum (B16895) until the desired indication on the micrometer is opposite its index. Then tighten the screws.

(8) To adjust the angle of site level vial (A31314, fig. 4). (This adjustment will ordinarily be necessary only when the angle of site scale adjustment is inadequate.) Remove the plug (A34057) by removing the associated pin (BFDX1AG). Access can now be had to the four level vial adjusting screws (BCUX2CB) which will be found in the recess for the plug. Arrangement of these screws is such that a small lateral as well as vertical adjustment is permitted. When adjusting, as one screw is backed out, the opposite one should be screwed in.

6. Care and preservation.—a. Handling.—(1) This equipment contains delicate mechanisms and accurately arranged optical parts and should be handled gently to avoid all unnecessary shocks, etc., which will eventually render the instrument unserviceable.

(2) When disengaging the azimuth worm from the worm wheel, care should be taken to rotate the throwout lever far enough to prevent the worm from scraping over the teeth of the worm wheel. Any scraping of the teeth will eventually damage the teeth, causing inaccurate readings.

(3) Stops are provided limiting the motions of the angle of site, mount elevating, telescope elevating, and cross leveling mechanisms. Avoid any attempt to operate the mechanisms past these stops.

(4) Keep the angle of site and cross level vials covered with the covers provided when the levels are not being used.

(5) The telescope mount should be clamped to the support in the lower position when not in use.

(6) The support clamping screw, bracket retaining screw, and other screws should be kept tight at all times to insure proper functioning of equipment.

(7) All oil that seeps from the bearings should be removed to prevent the accumulation of dust and grit.

(8) The rubber eyeshield should be washed periodically in lukewarm water and then dried with a clean cloth.

TELESCOPE M1 AND MOUNT M3

b. Optical parts.—(1) To obtain satisfactory vision it is necessary that the exposed surfaces of the lenses and other optical parts be kept clean and dry. This will help prevent corrosion and etching of the surface of the glass, which greatly interfere with the good optical qualities of the instrument.

(2) Under no conditions will polishing liquids, pastes, or abrasives be used for polishing lenses and windows.

(3) For cleaning optical glass use only paper, lens, tissue (Fed. Spec. No. U-U-P-313). To remove dust, brush the glass lightly with a clean camel's-hair brush and rap the brush against a hard body in order to knock out the small particles of dust that cling to the hairs. Repeat this operation until all dust is removed.

(4) Moisture due to condensation may collect on the optical parts of the instrument when the temperature of the parts is lower than that of the surrounding air. This moisture may be removed by the application of gentle warmth. Heat from strongly concentrated sources should never be applied direct as it may cause unequal expansion of parts, resulting in breakage of optical elements or inaccuracies in observation.

(5) Exercise particular care to keep optical parts free from oil or grease. Do not wipe the lenses or windows with the fingers. To remove oil or grease from optical surfaces, apply alcohol, ethyl, lightly with a clean camel's-hair brush and rub gently with clean paper, lens, tissue. If alcohol is not available, breathe heavily on the glass and wipe off with clean paper, lens, tissue. Repeat this operation several times until clean.

c. Lubrication.—(1) The interior moving parts of the panoramic telescope M1 are lubricated when assembled. No additional lubrication in the field is necessary.

(2) The telescope mount M3 is lubricated when assembled and requires additional lubrication as follows:

(a) The angle of site worm (A36353) should be oiled sparingly in the oil cup provided.

(b) At periodic intervals the threads of the bracket retaining screw (A37147) and the threads of the clamp screw (A37437) should be lubricated with oil.

(3) The authorized lubricants to be used are—

(a) Oil, lubricating, for aircraft instruments and machine guns (U. S. A. Spec. No. 2-27).

(b) Grease, special, low temperature, where grease is required.

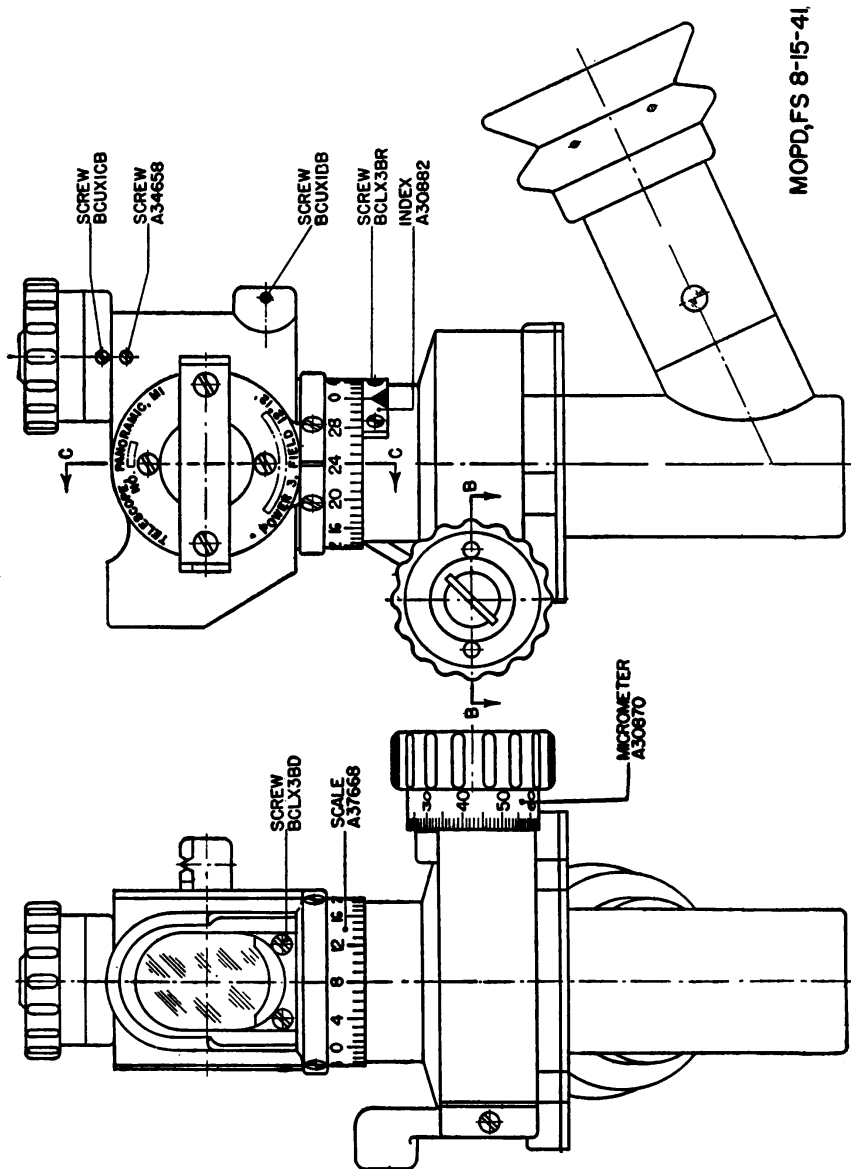
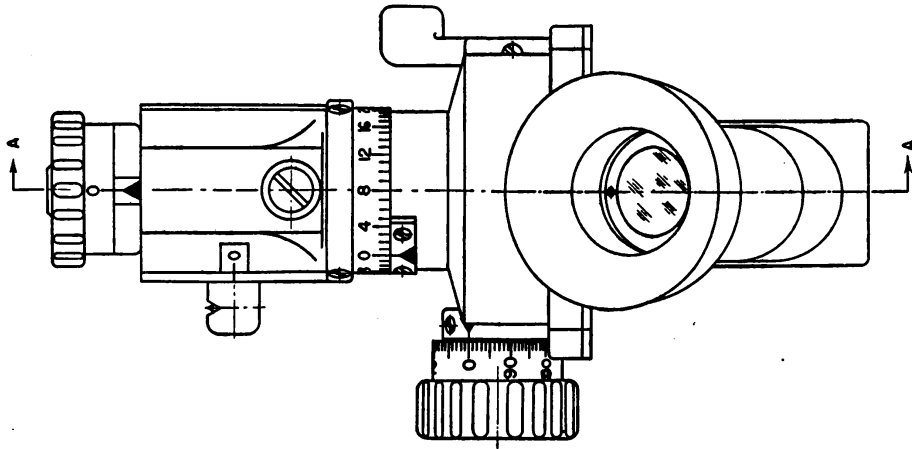

FIGURE 1.—Panoramic telescope M1—assembled views.

TELESCOPE M1 AND MOUNT M3

TM 9-1548
6

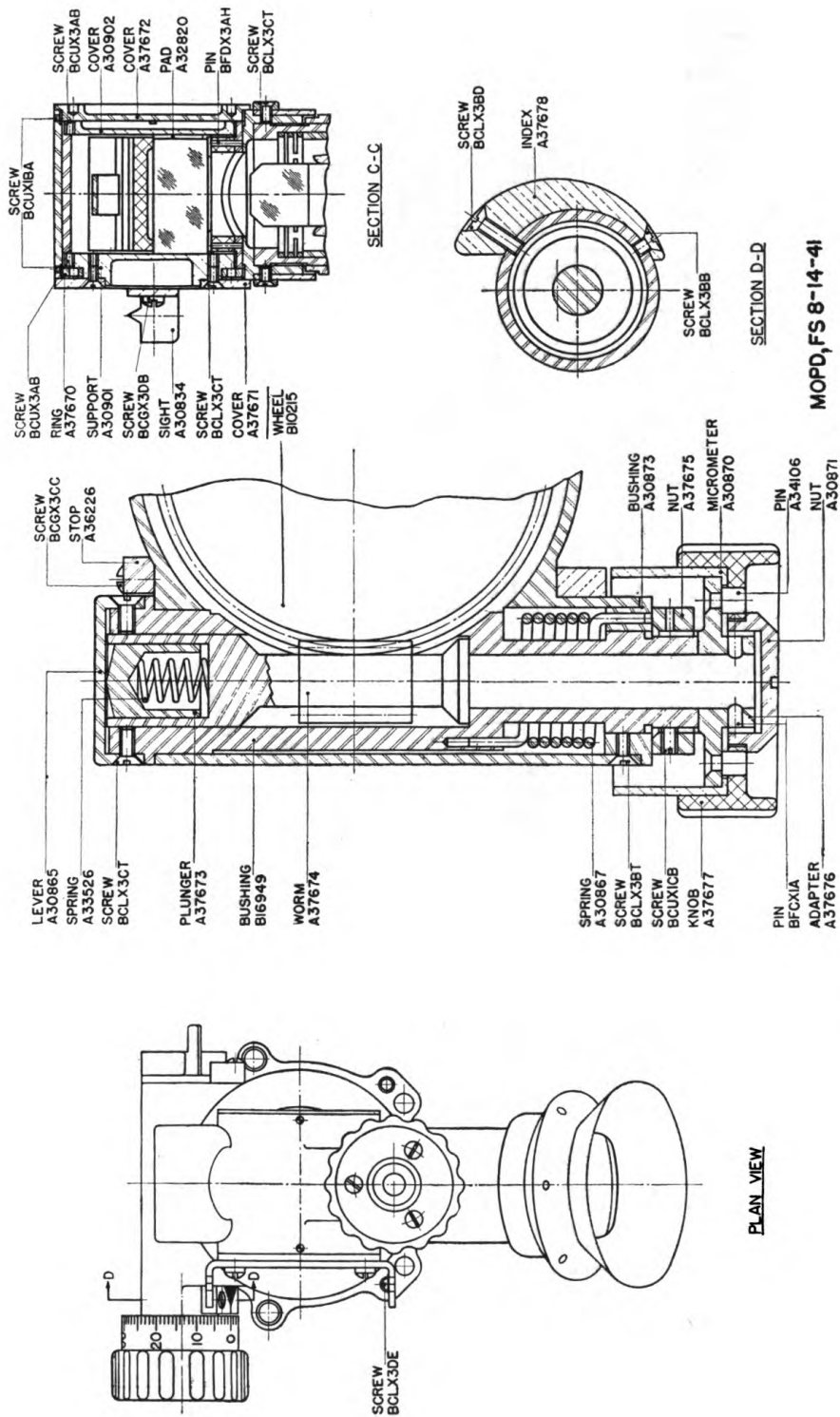
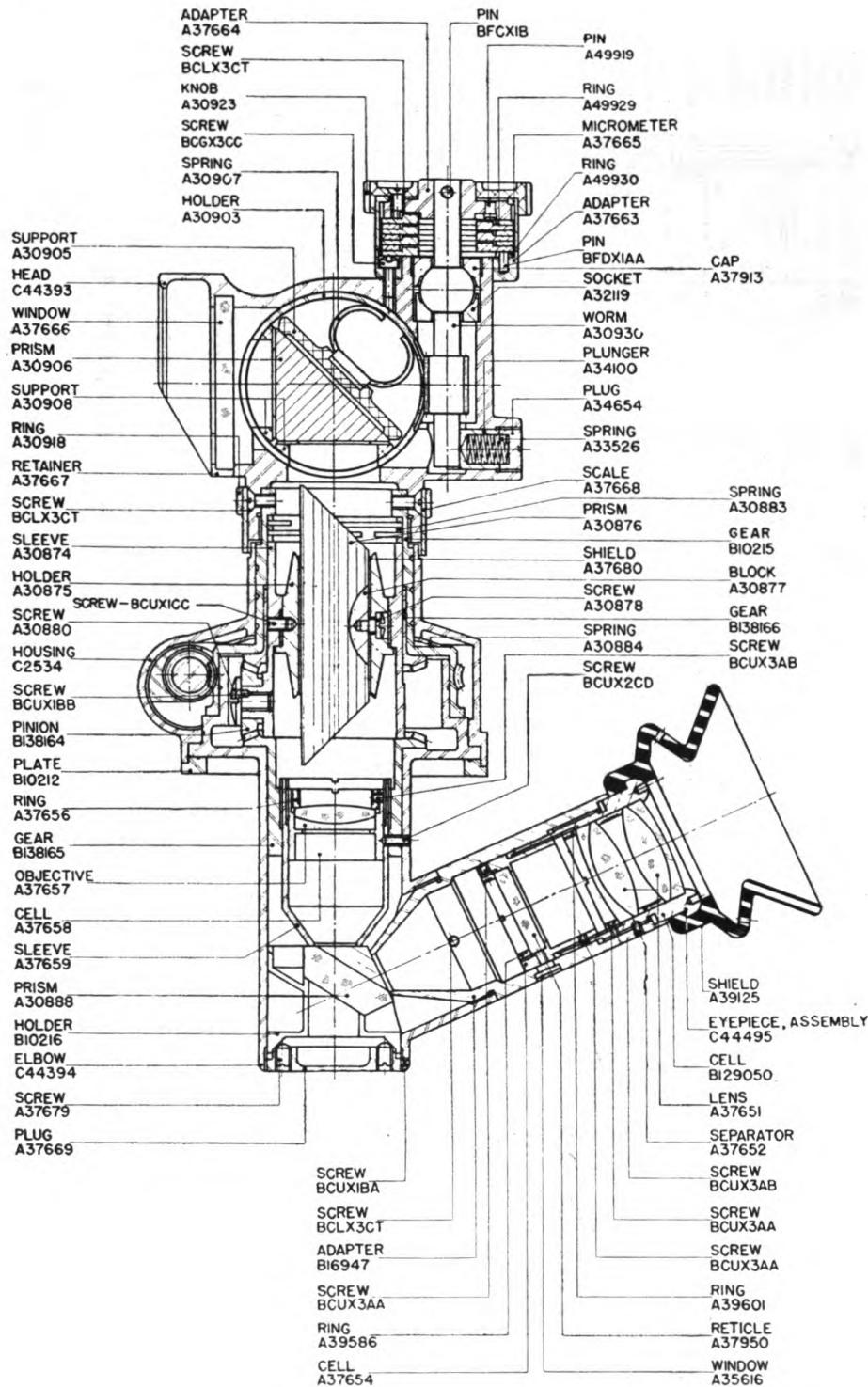

FIGURE 2.—Panoramic telescope M1—plan and sectioned views.

ORDNANCE DEPARTMENT



SECTION A-A

FR A. 316-1

FIGURE 3.—Panoramic telescope M1—sectioned view.

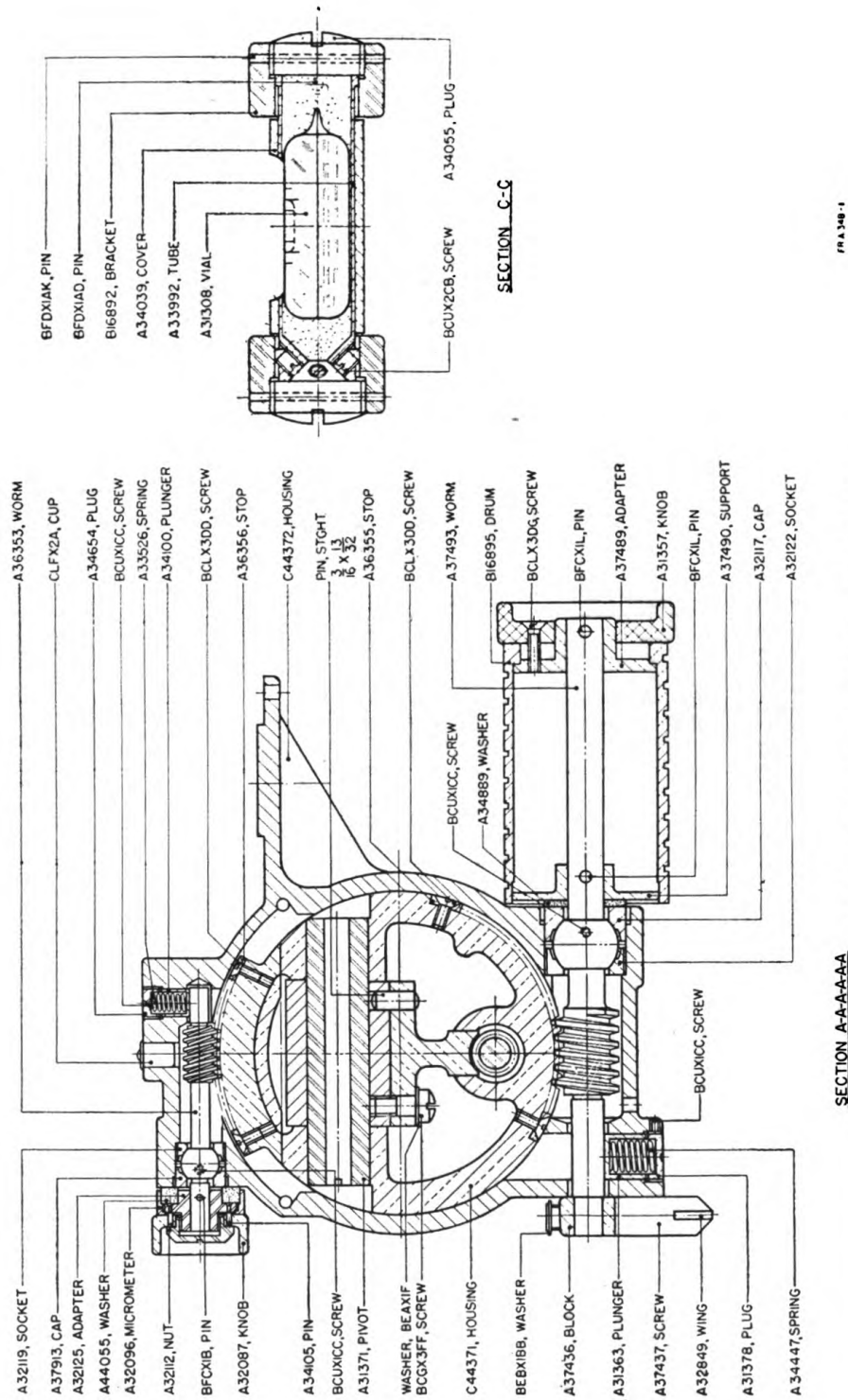
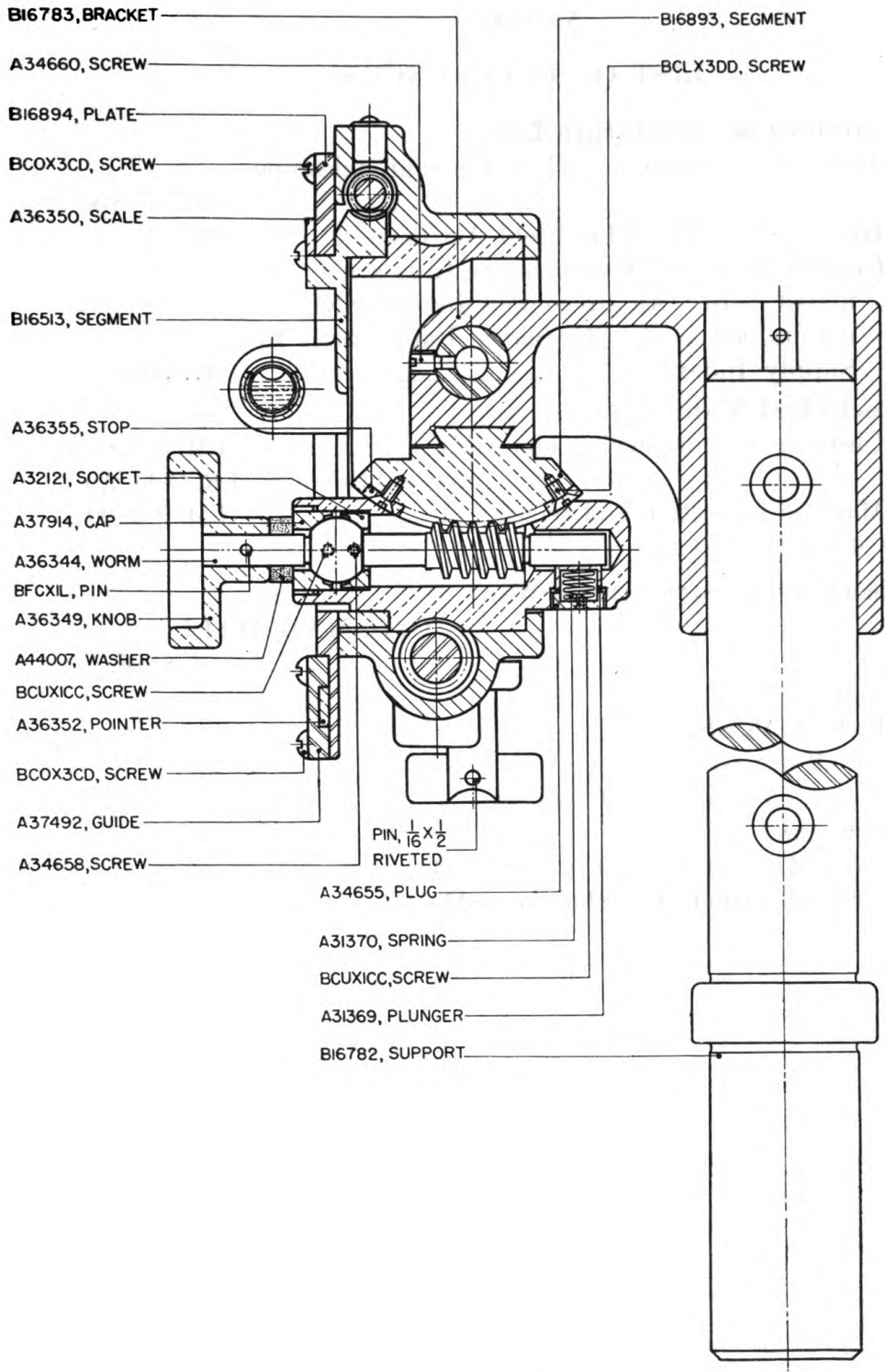

FIGURE 5.—Telescope mount M8—sectioned views.

TELESCOPE M1 AND MOUNT M3



SECTION B-B

FIGURE 6.—Telescope mount M3.

FR. A. 349-1

APPENDIX

LIST OF REFERENCES

1. Standard Nomenclature Lists.

- Telescope, panoramic, M1 and mount, telescope,
M3..... SNL F-106
Kit, repair, optical, for Field Artillery..... SNL F-21
Current Standard Nomenclature Lists are as tab-
ulated here. An up-to-date list of SNL's is
maintained as the "Ordnance Publications for
Supply Index"..... (OPSI)

2. Technical Manuals.

- Cleaning and preserving materials..... TM 9-850
(now published as TR 1395-A)
Matériel inspection and repair..... TM 9-1100
[A. G. 062.11 (8-12-41).]

BY ORDER OF THE SECRETARY OF WAR:

G. C. MARSHALL,
Chief of Staff.

OFFICIAL:

E. S. ADAMS,
Major General,
The Adjutant General.

DISTRIBUTION:

B 6 (2) ; IR 6 (2) ; IBn 9 (2) ; IC 9 (4).
(For explanation of symbols see FM 21-6.)

