

ADVANCE COPY FOR USE IN  
ORDNANCE OFFICE ONLY.  
REGULAR DISTRIBUTION WILL  
BE MADE BY YOUR LOCAL  
ADJUTANT GENERAL OR  
POST ADJUTANT.

2113  
12  
TM  
1943

**TM 9-1539**

24<sup>US</sup> 5. Dept of Army  
**WAR DEPARTMENT**  
**TECHNICAL MANUAL**

**ORDNANCE MAINTENANCE**  
**TELESCOPE MOUNT M35**  
**AND TELESCOPE M31**

(for 6-inch Barbette Carriage M1, 8-inch Barbette Carriage M1, and  
16-inch Barbette Carriage M4)

**5 AUGUST 1943**



**FOR ORDNANCE PERSONNEL ONLY**

TECHNICAL MANUAL  
No. 9-1539

U113  
12  
TM 9:1539  
1943  
★ ★

TM 9-1539  
WAR DEPARTMENT  
Washington, 5 August 1943

# ORDNANCE MAINTENANCE

## TELESCOPE MOUNT M35 AND TELESCOPE M31

(for 6-inch Barbette Carriage M1, 8-inch Barbette Carriage M1, and  
16-inch Barbette Carriage M4)

---

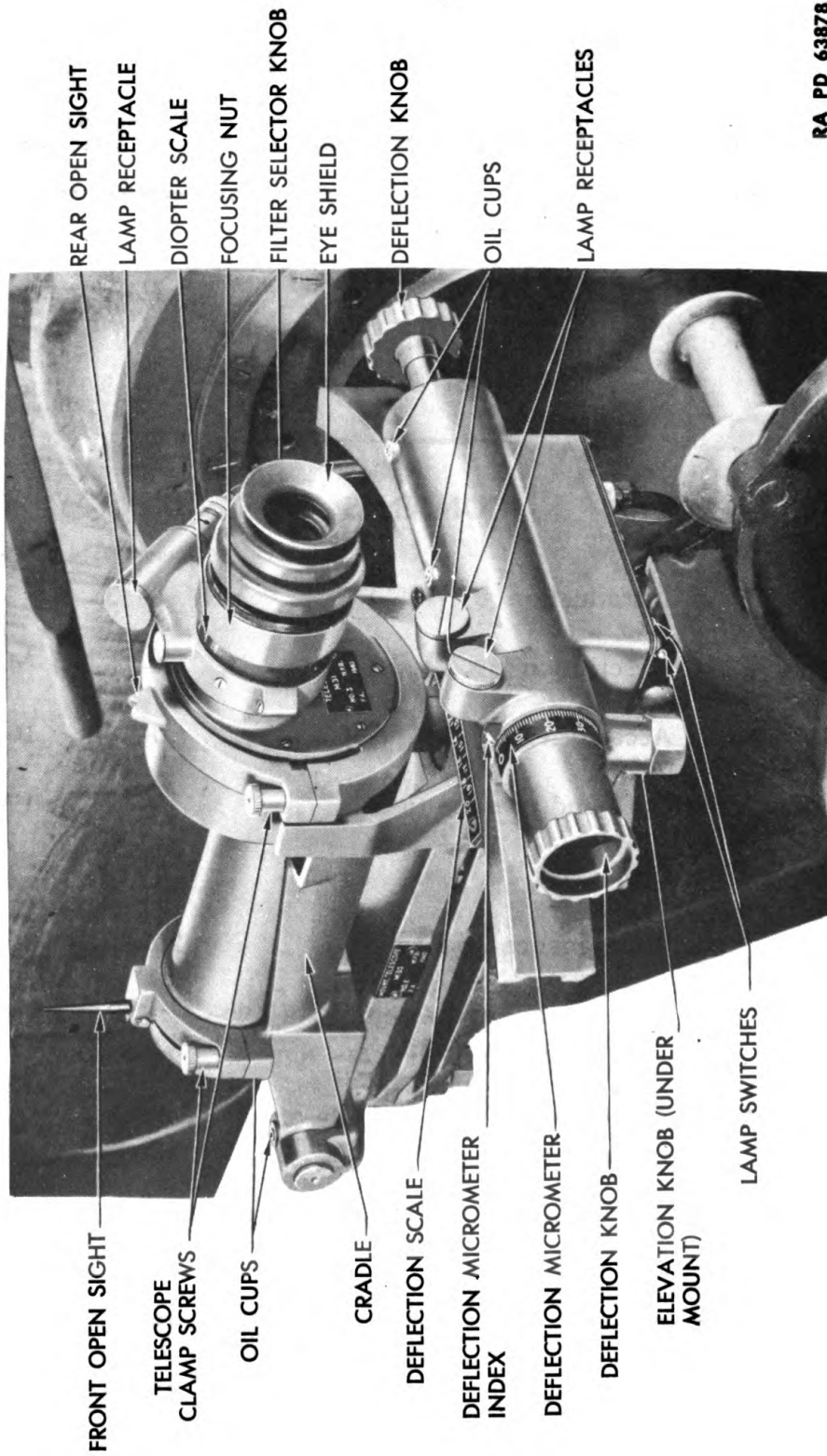
Prepared under direction of the  
Chief of Ordnance

---

### CONTENTS

SECTION		Paragraphs	Pages
I.	Introduction .....	1- 3	3
II.	Description .....	4- 5	4-15
III.	Accessories .....	6- 8	16-18
IV.	Care and preservation .....	9-11	19-21
V.	Inspection .....	12-19	22-29
VI.	Maintenance and repair .....	20-30	30-36
VII.	Disassembly and assembly of tele- scope mount M35 .....	31-37	37-49
VIII.	Disassembly and assembly of tele- scope M31 .....	38-46	50-65
IX.	Assembling telescope mount M35 to gun carriage .....	47-48	66-67
X.	Painting .....	49-50	68
XI.	References .....	51-52	69-70
INDEX	.....		71-73

ORDNANCE MAINTENANCE—TELESCOPE MOUNT M35 AND TELESCOPE M31



RA PD 63878

Figure 1—Telescope Mount M35 and Telescope M31

**Section I**

**INTRODUCTION**

	Paragraph
Scope .....	1
Characteristics .....	2
Application .....	3

**1. SCOPE.**

a. This manual is published for the information and guidance of ordnance maintenance personnel. It contains detailed instructions for inspection, disassembly, assembly, maintenance, and repair of the Telescope Mount M35 and Telescope M31 supplementary to those in the Field Manuals and Technical Manuals prepared for the using arms. Additional descriptive matter and illustrations are included to aid in providing a complete working knowledge of the materiel.

**2. CHARACTERISTICS.**

a. The Telescope Mount M35 and Telescope M31 are used for aiming in azimuth. The Telescope Mount M35 (fig. 1) has deflection and elevation motions. Deflection is read on a deflection scale and micrometer, but there is no provision for reading elevation, as none is required for the type of fire in which this telescope and telescope mount are used. The Telescope M31 fits into the cradle of the telescope mount and is secured therein by two cradle clamps. Two open sights, one on the top of each cradle clamp, may be used initially for rapid approximate aiming (fig. 2). Built-in illuminating devices are provided for the deflection scale and micrometer, and for the telescope reticle.

**3. APPLICATION.**

a. The Telescope Mount M35 and Telescope M31 are used on the 6-inch Barbette Carriage M1, the 8-inch Barbette Carriage M1, and the 16-inch Barbette Carriage M4.

**ORDNANCE MAINTENANCE—TELESCOPE MOUNT M35 AND TELESCOPE M31**

**Section II**

**DESCRIPTION**

	Paragraph
Telescope mount M35 .....	4
Telescope M31 .....	5

**4. TELESCOPE MOUNT M35.**

**a. Description.** The major parts of Telescope Mount M35 are the carriage or mounting bracket, the support, deflection worm housing, gear segment, elevation mechanism, cradle, and electrical wiring (figs. 2 and 3). The mounting brackets D29310 for 8-inch barbette carriage and D42614 for 16-inch barbette carriage are telescope mount items. The carriage bracket D42464 for 6-inch barbette carriage is a carriage item. It supports the indicator and drive as well as the telescope mount proper. Information for the bracket to be used on the 90-mm antiaircraft gun mount will be furnished when available.

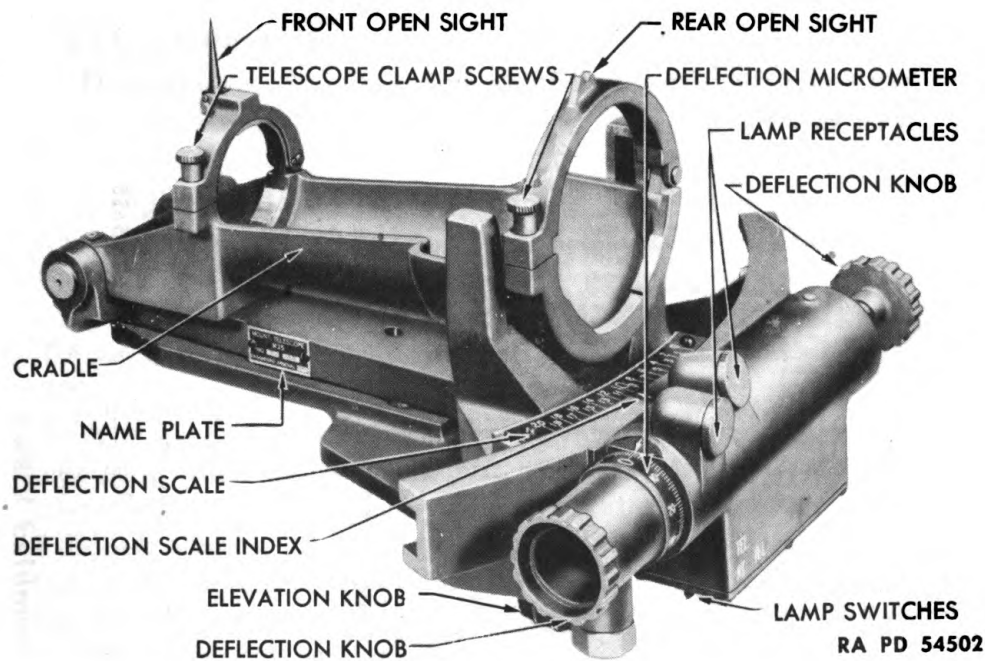
**b. Support.** The support D45717 is fastened to the carriage or bracket D29310. Method of fastening is shown in figure 4, section A-A and figure 5, section E-E.

**c. Deflection Worm Housing** (figs. 5, 16, and 31). The deflection worm housing D45718 is fastened on the rear of the support. It contains the deflection worm C56515 assembled in the upper portion (fig. 5, section C-C) and the terminal block assembly B174794 and cover A179432 (fig. 6) assembled in the lower portion. The two bolts A203535 (fig. 4, section A-A) which fasten the deflection worm housing to the support are also a means of adjusting the deflection worm, as explained in paragraph 23. The deflection worm carries a micrometer A179429 secured by the left-hand deflection knob A179428 (fig. 5, section C-C). The micrometer is calibrated directly in hundredths of degrees, and provides the fine reading for use in conjunction with the deflection scale B138937. The deflection scale, mounted on the gear segment, is calibrated from 0 to 20 degrees in 1-degree intervals. Normal deflection setting (line of sight parallel to axis of gun bore) is 10.00 degrees.

**d. Gear Segment.** The gear segment D29312 pivots about a vertical stud at the front end (fig. 4). At the rear of the gear segment, gear teeth cut in the arc engage the deflection worm (fig. 5, section C-C). A seat for the elevation mechanism is formed in the gear segment. Cradle guides are an integral part of the gear segment.

**e. Elevation Screw.** The elevation screw A179415 is threaded

## DESCRIPTION



**Figure 2—Telescope Mount M35**

through a ball A179440 seated in the rear of the gear segment. The ball is held in position by ball cap A179439 (fig. 4). A dowel pin BFDX1CE in the ball cap prevents horizontal rotation of the ball, so that the ball acts as a nut for the elevation screw. The ball head of the elevation screw seats in a socket A179416 assembled in the cradle, and is secured in position by cap A179417. An elevating knob A314010 on the bottom of the elevation screw is turned to raise or lower the cradle.

f. **Cradle.** The cradle D29311 is secured to the gear segment at the front end by a horizontal pin upon which it rotates when it is elevated or depressed by the elevation screw A179415 (fig. 4).

g. **Electrical Wiring.** A terminal block assembly B174794, in a well in the lower portion of the deflection worm housing (fig. 6), is the connection between the outside power source and the socket A178646 for the extension cable and the two toggle switches. A flexible tube A179435 passing through a housing assembly in the lower front face of the deflection worm housing at the right-hand side carries the wires from outside power source to terminal block. The socket for the extension cable and the two toggle switches is assembled in the deflection worm housing cover A179432 (fig. 6). One switch operates the built-in electric lamps on top of the housing and the other switch operates the electric lamp assembled in the telescope lamp bracket (fig. 5, section D-D and fig. 7, section B-B).

ORDNANCE MAINTENANCE—TELESCOPE MOUNT M35 AND TELESCOPE M31

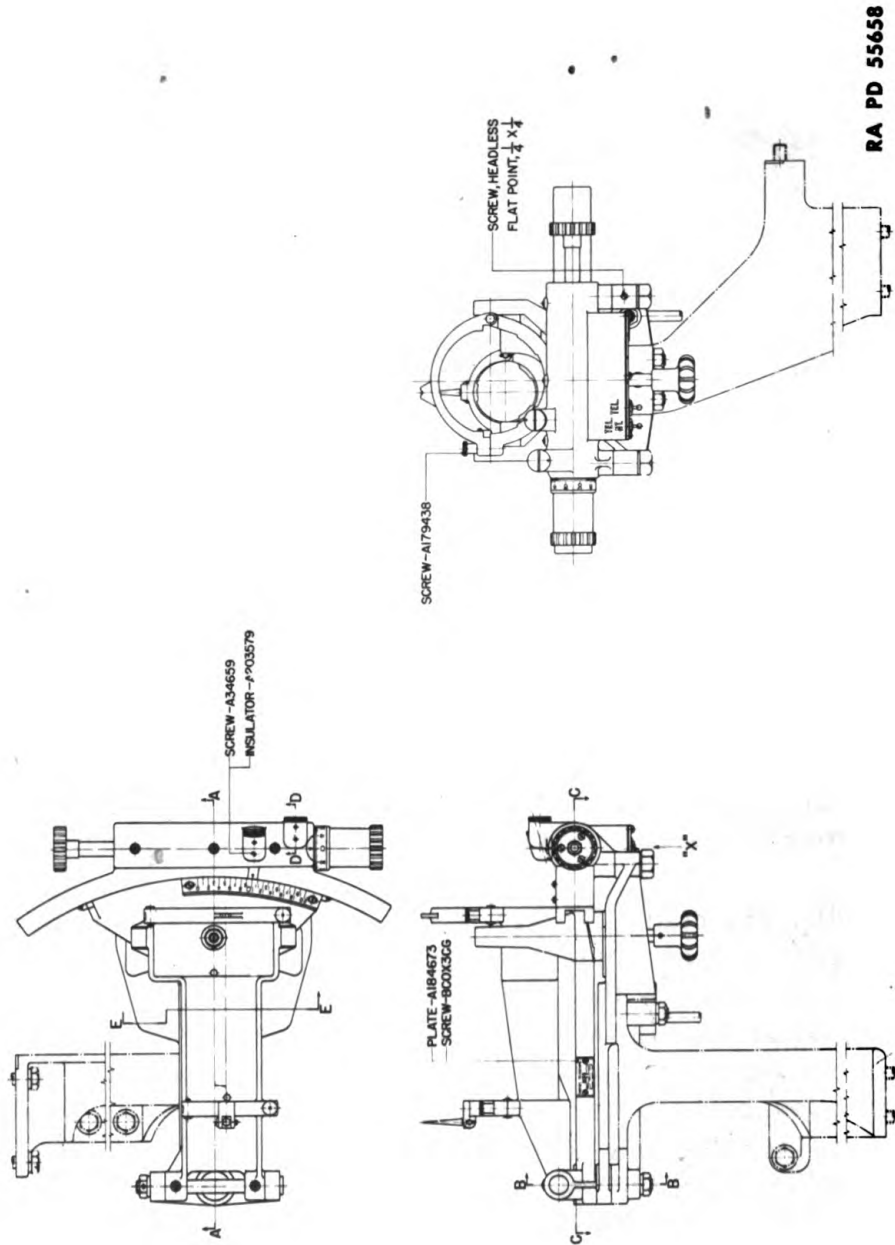


Figure 3—Telescope Mount M35—Assembled Views

**DESCRIPTION****5. TELESCOPE M31.**

**a. Description.** The major parts of Telescope M31 are the eyepiece adapter assembly and the telescope body (figs. 8 and 35). The optical system for the telescope is shown in figure 9.

**b. Eyepiece Adapter Assembly.**

(1) The eyepiece adapter assembly consists of the eyepiece adapter C69961, to which is assembled the eyepiece assembly C69964, focusing nut B138053, reticle assembly B137993, lamp bracket assembly C69963, and ray filter assembly B137994, (fig. 7, section B-B and fig. 10).

(2) The eyepiece assembly is moved inward or outward by turning the focusing nut. The focusing nut carries a diopter scale B138047 which registers the particular eye correction for an individual observer. The diopter scale is graduated from 0 to plus 3 and minus 3 diopters. At 0 diopter, the telescope is in sharp focus for an observer with normal vision. The observer can prefocus the telescope by using the diopter scale if he knows his own eye correction.

(3) The reticle pattern as seen through the telescope eyepiece consists of intersecting horizontal and vertical wires mounted on a clover leaf reticle B137931 (fig. 7, section B-B). The reticle is illuminated through windows in the top and right side of the eyepiece adapter by a lamp in the lamp bracket assembly.

(4) The lamp bracket assembly C69963 consists of two reflectors A39691, the lamp A35189, and an adjustable shutter A39678 assembled in the bracket C69760. The shutter controls the illumination and is operated by turning plug A39679.

(5) The ray filter assembly B137994 is for use under varying conditions of haze and glare. It consists of an amber and neutral filter and a clear disk mounted in a filter holder B137238 so that any one of the filters can be placed into the optical path. The filter holder is operated by turning the filter selector knob A48730 to the indicated filter on plate A49878. The desired filter is held in position by detent action of a ball and spring assembled in the eyepiece adapter (fig.10).

**c. Telescope Body.**

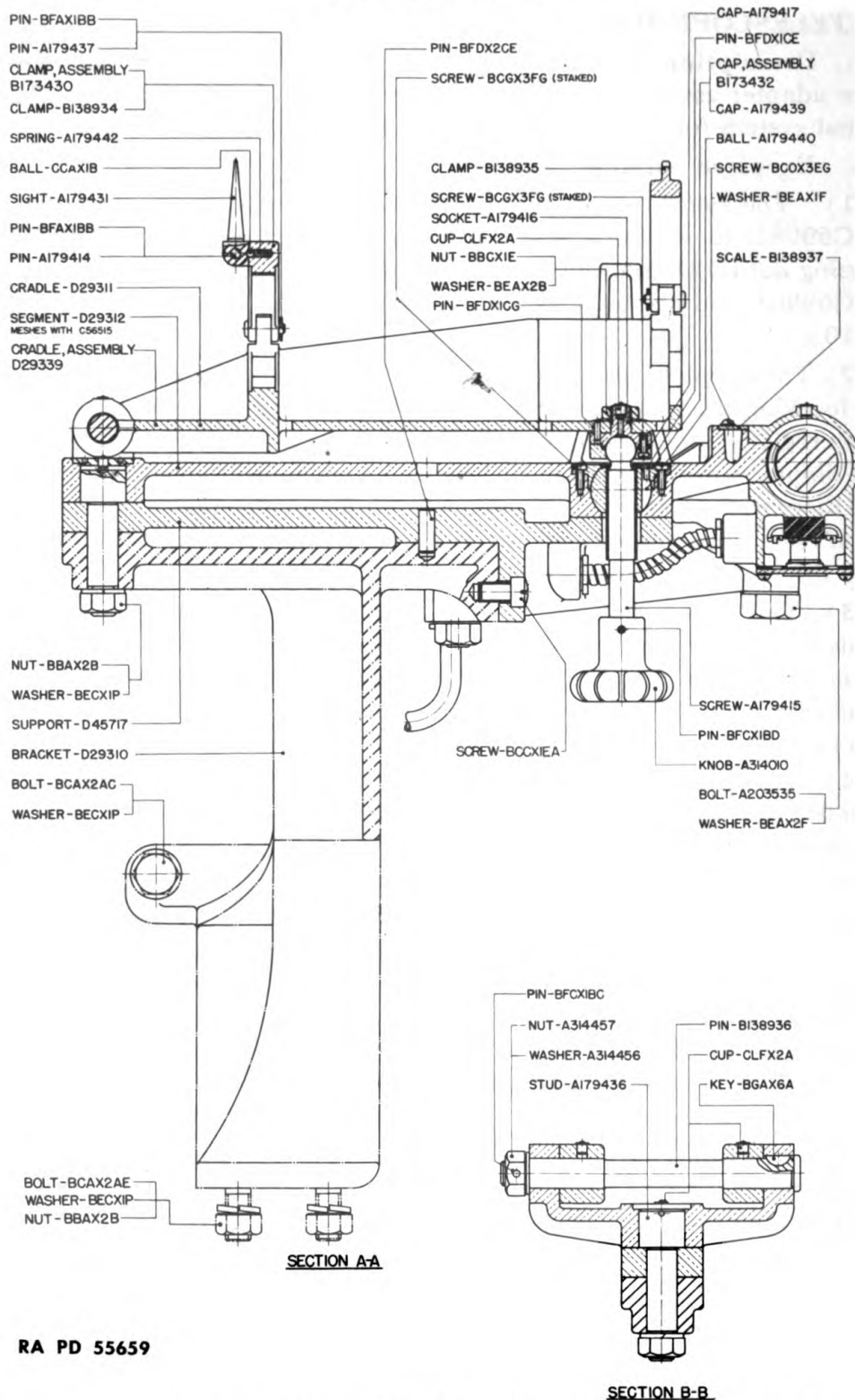
(1) The telescope body D29343 contains the abbe prism assembly B137995 and the objective assembly B137992 (fig. 7, section C-C and fig. 10).

(2) The abbe prism assembly is supported on a raised seat integral with the telescope body and is held in position by a pad A48691 and spring B137239. The direction of the ray of light through the prisms is shown in figure 11.

(3) The objective assembly screws into the telescope body and is held in position by headless screw BCUX1CC (fig. 10).



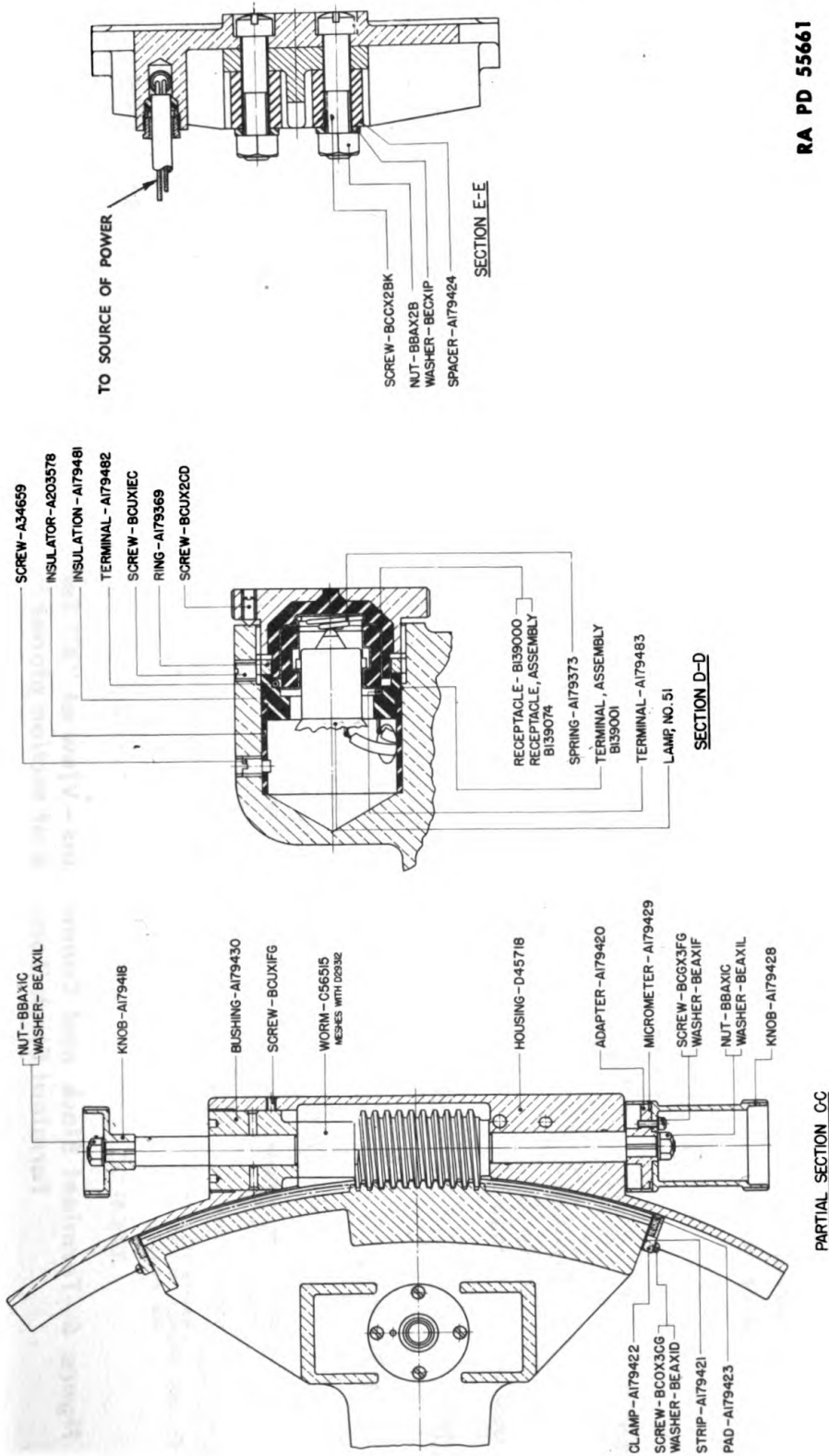
**ORDNANCE MAINTENANCE—TELESCOPE MOUNT M35 AND TELESCOPE M31**



RA PD 55659

**Figure 4—Telescope Mount M35—Sectional Views Through Planes A-A and B-B (Location of section planes is shown in fig. 3)**

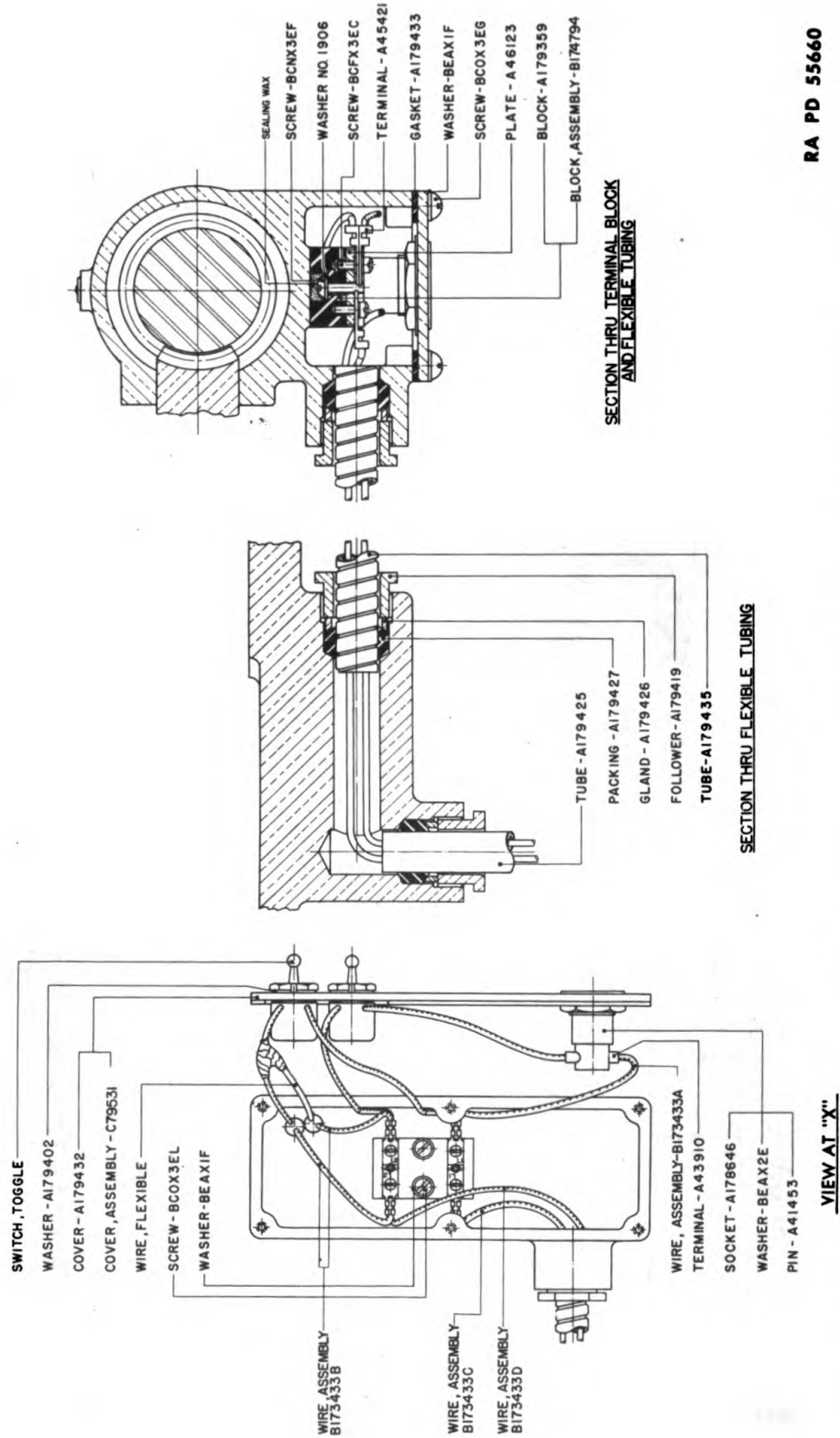
DESCRIPTION



RA PD 55661

Figure 5—Telescope Mount M35—Sectional Views Through Planes C-C, D-D, and E-E  
 (Location of section planes is shown in fig. 3)

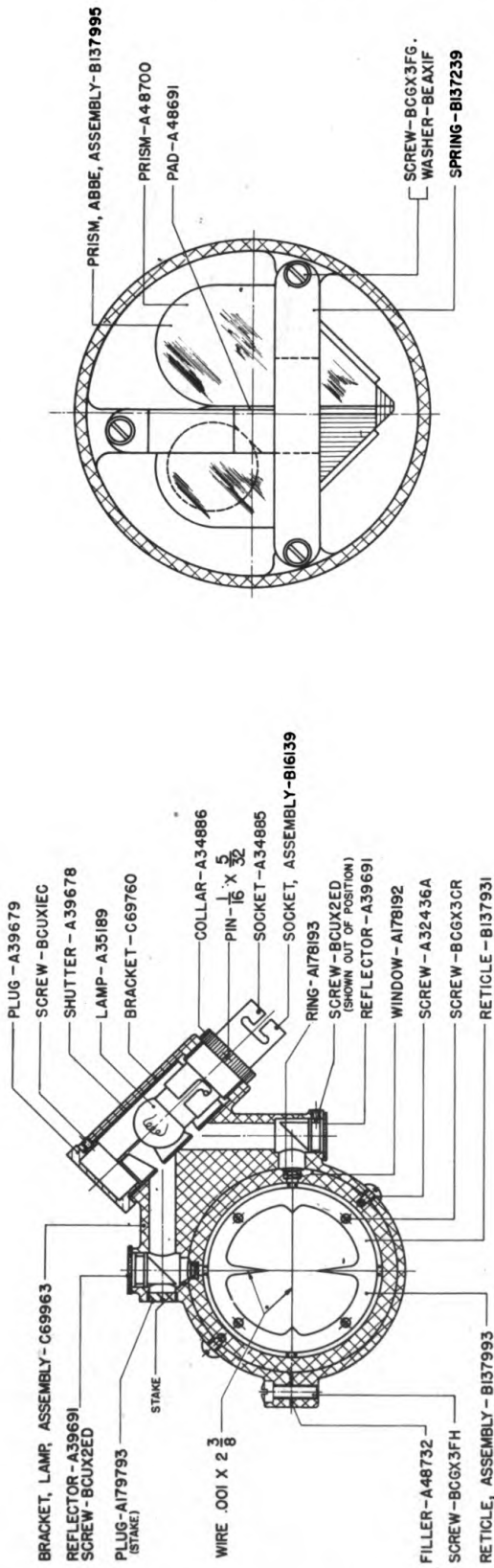
ORDNANCE MAINTENANCE—TELESCOPE MOUNT M35 AND  
TELESCOPE M31



RA PD 55660

Figure 6—Terminal Block and Connections—View at "X" Section Through Flexible Tubing and Terminal Block (Location of section planes is shown in fig. 3)

DESCRIPTION



RA PD 55666

SECTION C-C

SECTION B-B

Figure 7 - Lamp Bracket Assembly - Section Through B-B and C-C  
 (Location of section planes is shown in fig. 8)

TM 9-1539  
5

ORDNANCE MAINTENANCE—TELESCOPE MOUNT M35 AND  
TELESCOPE M31

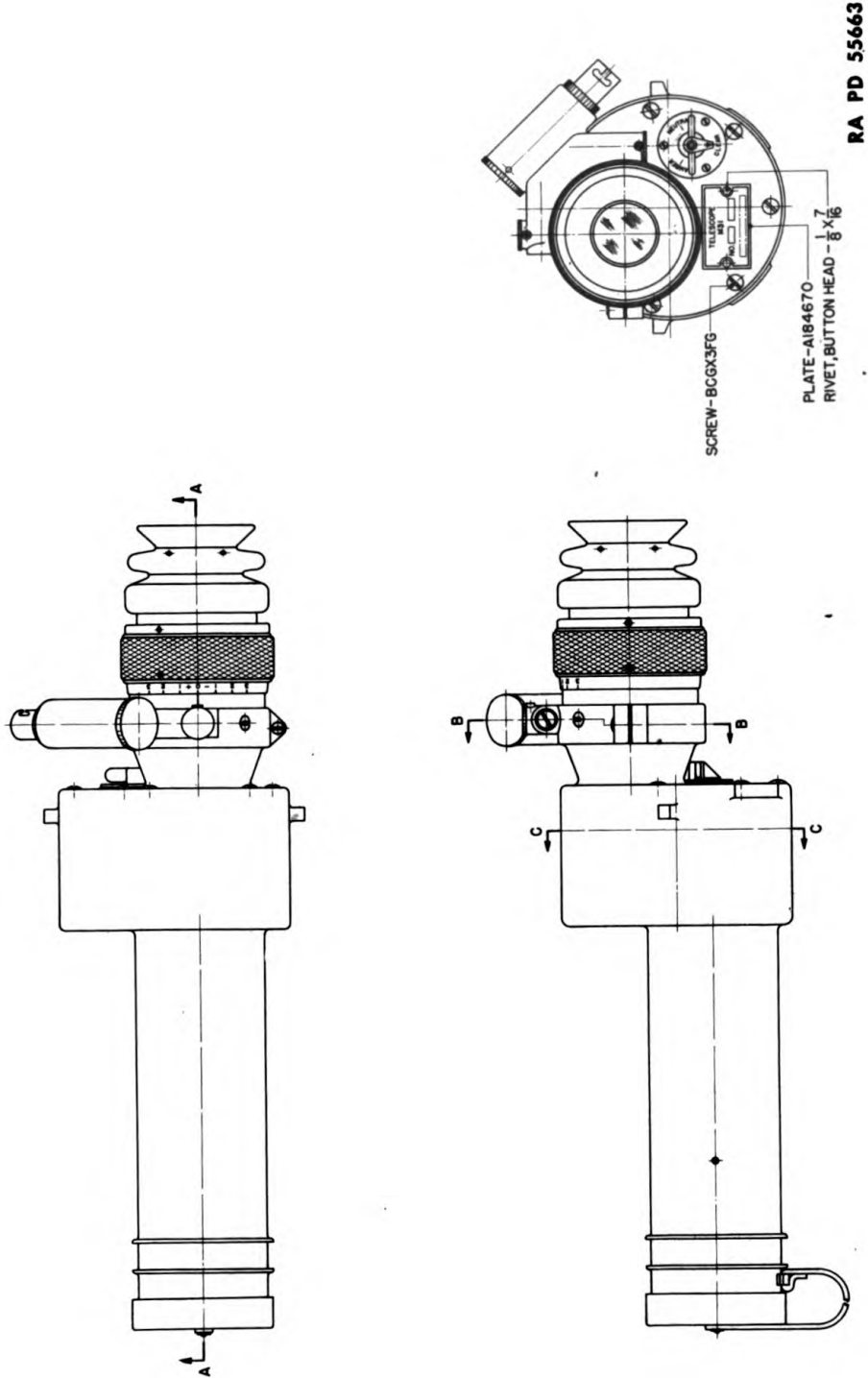
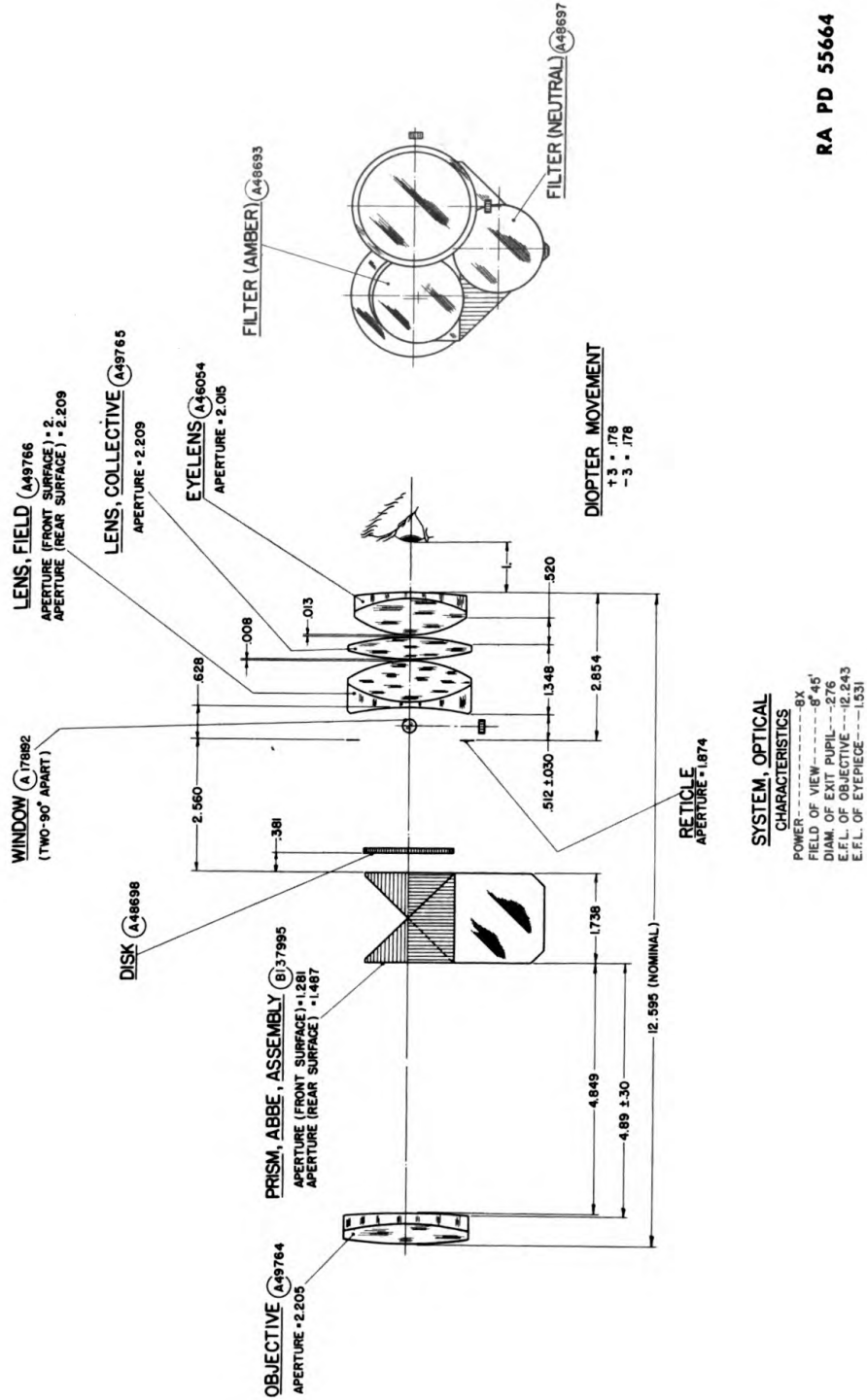


Figure 8—Telescope M31—Assembled Views

DESCRIPTION



RA PD 55664

Figure 9 — Optical System — Telescope M31

ORDNANCE MAINTENANCE—TELESCOPE MOUNT M35 AND TELESCOPE M31

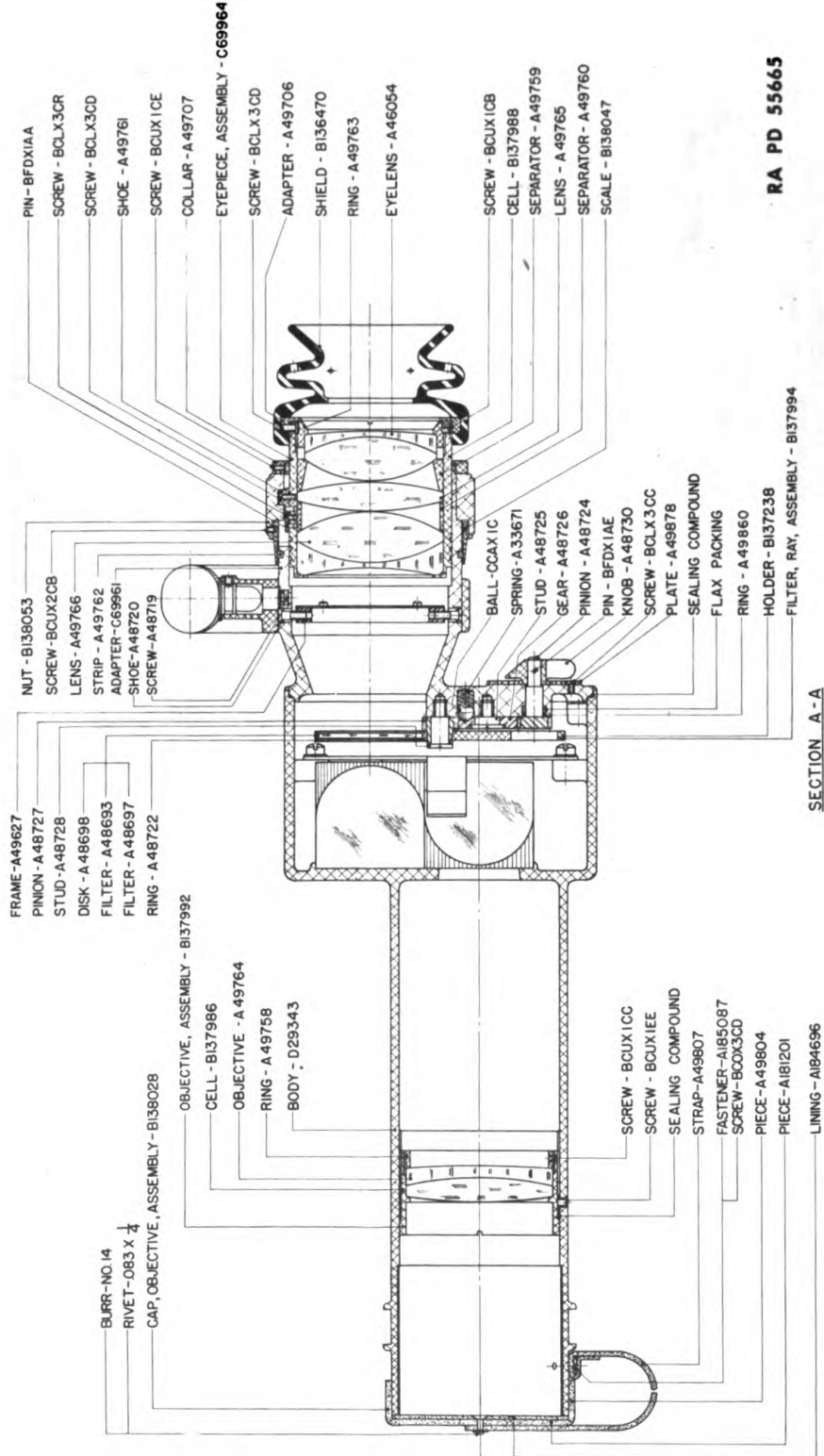
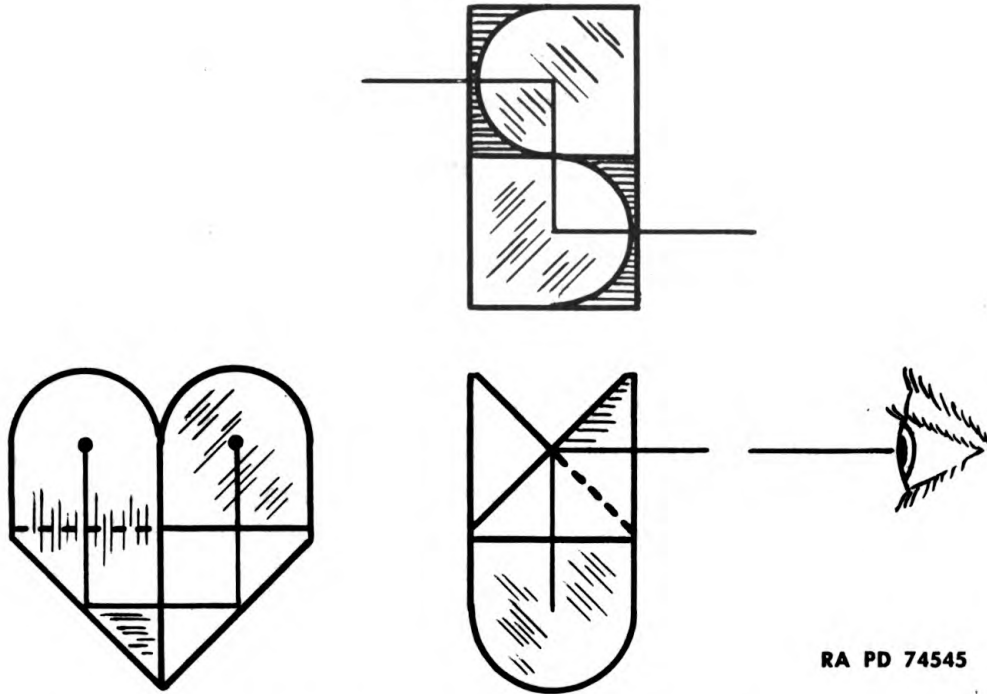


Figure 10—Telescope M31—Sectional View Through Plane A-A (Location of section plane is shown in fig. 8)

**DESCRIPTION**



RA PD 74545

**Figure 11—Direction of Ray of Light Through Abbe Prisms**

**d. Optical Characteristics.**

Power .....	8X
Field of view .....	8 deg 45 min
Diameter of exit pupil .....	0.276 in.
Effective focal length of objective .....	12.243 in.
Effective focal length of eyepiece .....	1.531 in.
Eye distance (eyelens to pupil) .....	1.000 in.



**ORDNANCE MAINTENANCE—TELESCOPE MOUNT M35 AND  
TELESCOPE M31**

**Section III**

**ACCESSORIES**

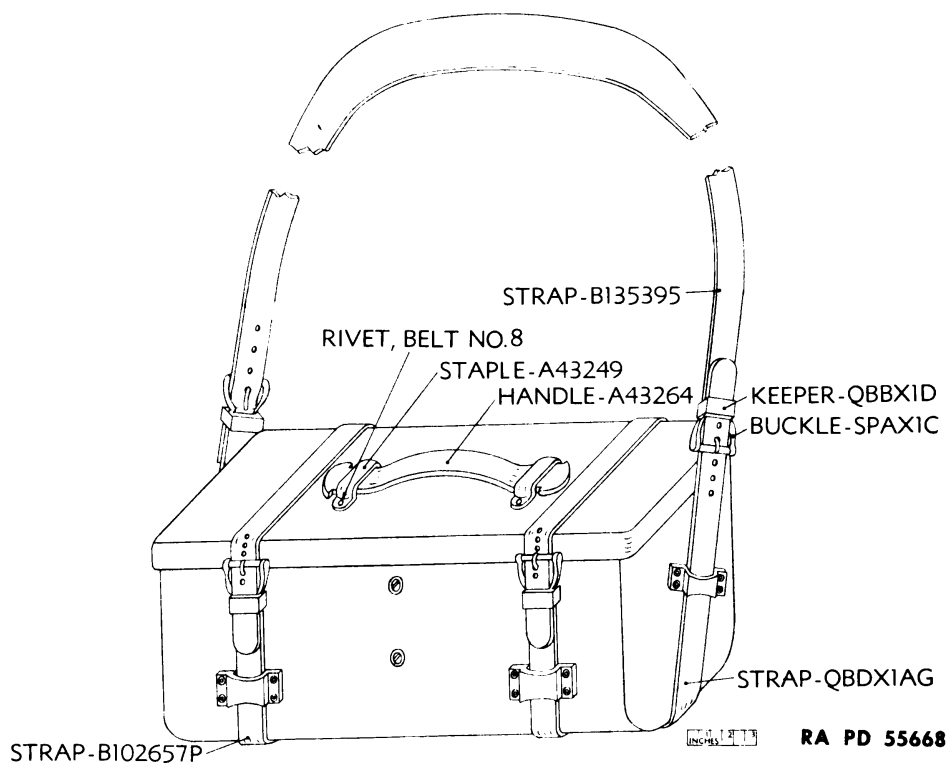
	Paragraph
Carrying case M16 (for telescope M31) .....	6
Cover for telescope mount M35 .....	7
Electrical equipment .....	8

**6. CARRYING CASE M16 (FOR TELESCOPE M31).**

a. A leather case (fig. 12) is provided for Telescope M31 and the electrical equipment. The case has two leather straps and buckles for securing the cover. A leather handle on top of the cover and leather straps fastened to the ends of the case afford means of carrying by either hand or shoulder.

**7. COVER FOR TELESCOPE MOUNT M35.**

a. A cotton duck cover (fig. 13) with two zipper fasteners is furnished for the telescope mount.



**Figure 12—Carrying Case M16 (For Telescope M31)**

ACCESSORIES

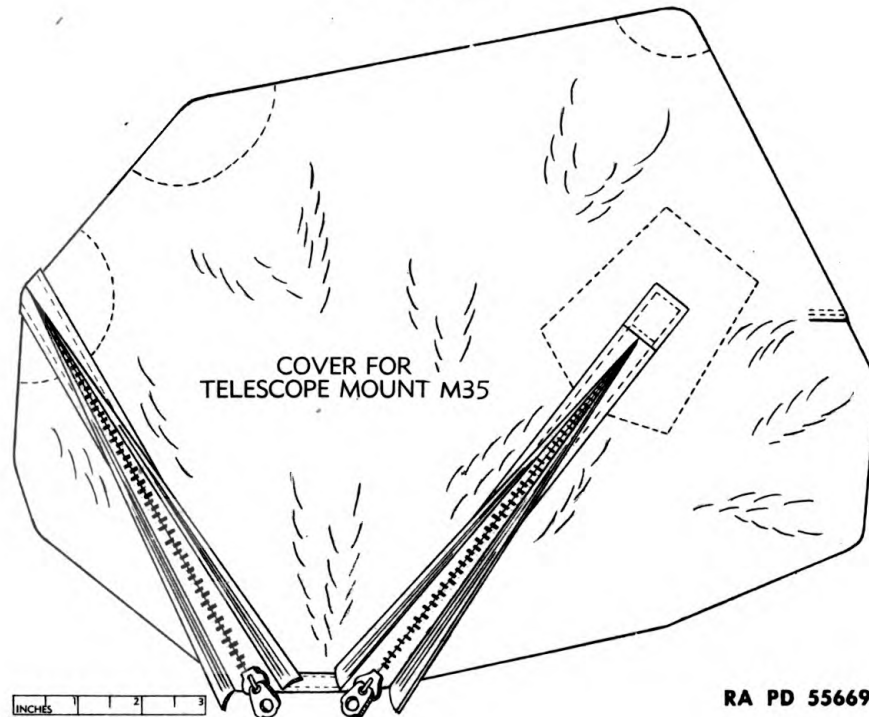


Figure 13—Cover for Telescope Mount M35

8. ELECTRICAL EQUIPMENT.

a. **Trouble Lamp.** A trouble lamp B135896 (fig. 14) is a part of the electrical equipment. This has a 3-candlepower, 6- to 8-volt, double contact lamp (No. 64), a lamp guard, a handle, approximately 9 feet of cable, and a plug for plugging into the socket A178646 on the under side of the deflection worm housing.

b. **Extension Cable and Plug Assembly.** A two-conductor cable, 20 inches long, with plugs (fig. 15) is provided for transmitting power to the lamp in the telescope lamp bracket. This cable plugs into the socket A178646 on the under side of the deflection worm housing and socket A34885 on the telescope lamp bracket.

c. **Jeweler's Screwdriver.** One jeweler's screwdriver (0.07-inch blade width) is furnished for use in removing the headless screws in the lamp receptacles.

ORDNANCE MAINTENANCE—TELESCOPE MOUNT M35 AND  
TELESCOPE M31

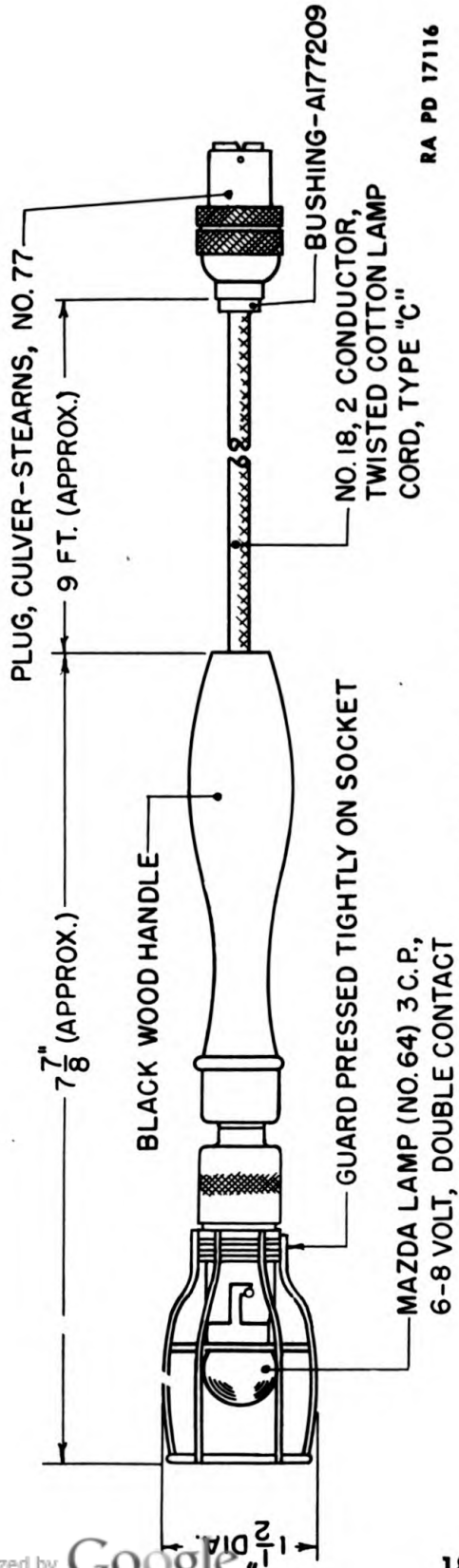


Figure 14—Trouble Lamp

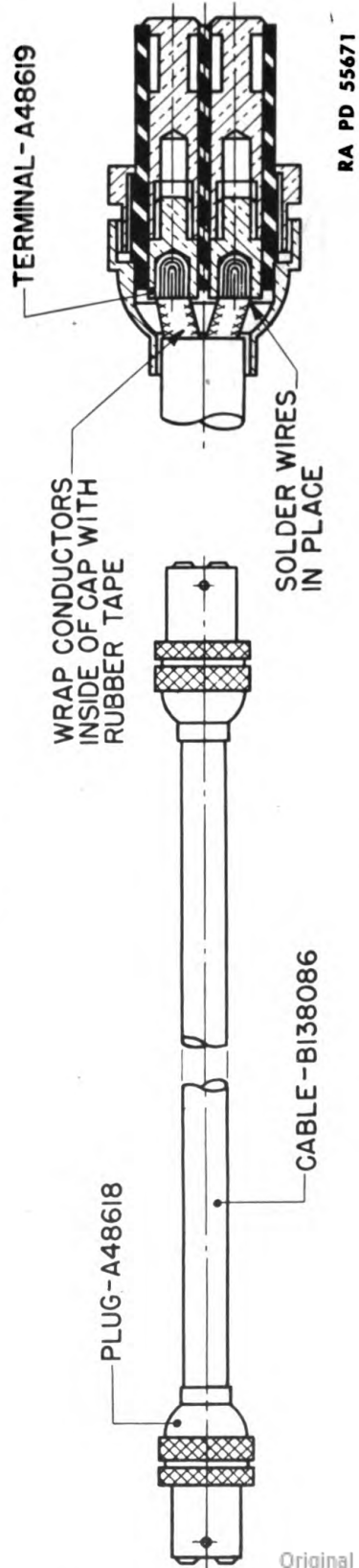


Figure 15—Extension Cable

**Section IV**

**CARE AND PRESERVATION**

	Paragraph
Cleaning and preserving materials . . . . .	9
Care in handling . . . . .	10
Lubrication . . . . .	11

**9. CLEANING AND PRESERVING MATERIALS.**

**a. Materials Used for Cleaning.**

ALCOHOL, ethyl, grade 1 (for cleaning optical parts)

BRUSH, artist, camel's-hair, rd.

BULB, air

PAPER, lens, tissue

SOAP, liquid, lens cleaning (for cleaning optical parts)

SOLVENT, dry-cleaning (for cleaning metal components)

**b. Authorized Lubricants.**

GREASE, lubricating, special (for all lubrication where grease is required)

OIL, lubricating, for aircraft instruments and machine guns (for all lubrication where oil is required)

**10. CARE IN HANDLING.**

**a. General.**

(1) Keep the telescope mount and telescope as dry as possible. If the telescope becomes wet, dry it carefully before placing in its carrying case.

(2) Keep the objective cap in place whenever the telescope is not in use. During idle periods, store the telescope in the carrying case and keep the telescope mount protected from dust and moisture with the cover.

**b. Optical Parts.**

(1) The exposed surfaces of the lenses and other parts should be kept clean and dry. Under no circumstances will polishing pastes or abrasives be used for polishing lenses. To remove oil or grease from optical surfaces, apply SOAP, liquid, lens cleaning, or ALCOHOL, ethyl, grade 1, with a tuft of PAPER, lens, tissue, and rub gently; use ALCOHOL, ethyl, grade 1, to remove wax or gum. Rinse with water at room temperature. Then clean and dry with PAPER, lens, tissue. CAUTION: ALCOHOL, ethyl, grade 1, should be used sparingly and should not be allowed to run in between lens and lens mounting. To clean extremely dirty or dusty lenses, use BRUSH, artist, camel's-hair, wetted with either SOAP, liquid, lens

TM 9-1539  
10-11

### ORDNANCE MAINTENANCE—TELESCOPE MOUNT M35 AND TELESCOPE M31

cleaning, or ALCOHOL, ethyl, grade 1, as required. Then rinse, clean, and dry with PAPER, lens, tissue. If these cleaning liquids are not available, breathe heavily on the glass and wipe off with clean lens tissue; repeat until clean. Before assembling optical parts, use the air bulb provided to blow out all particles of dirt from lens and prism seats.

(2) Moisture may condense on the optical parts of the telescope. This moisture, if not excessive, can be removed by placing the telescope in a warm place. Heat from strongly concentrated sources should not be applied directly to the telescope.

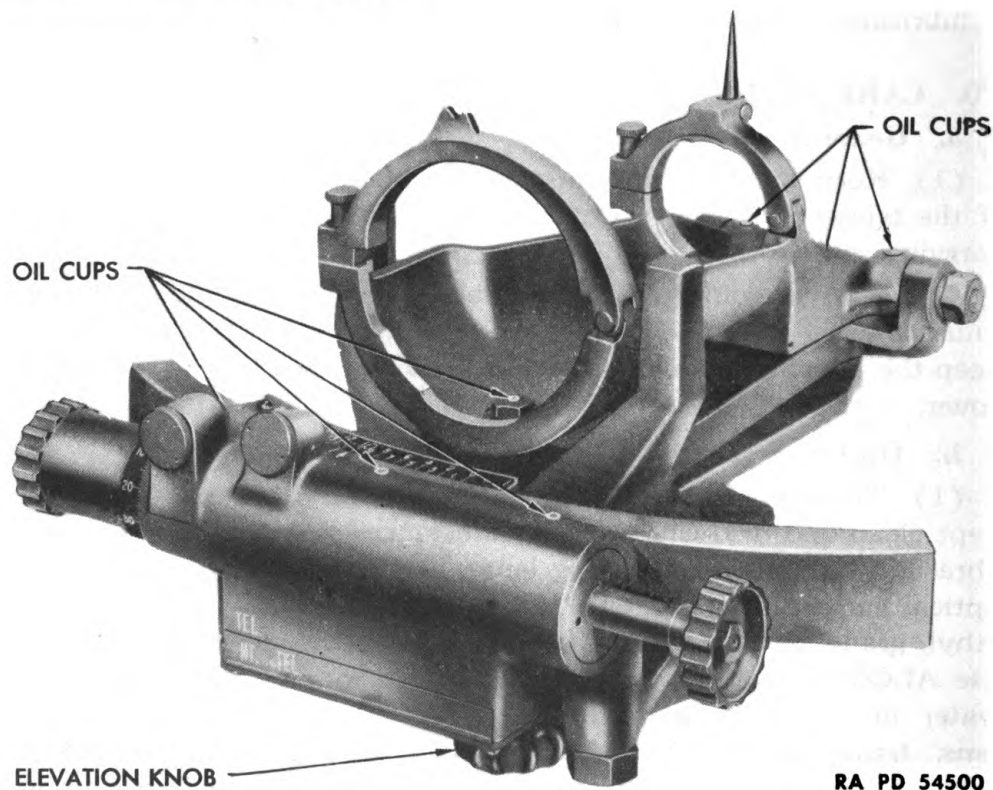
c. **Metal Parts.** Avoid nicking or scratching of the locating surfaces. Keep a light film of oil on these surfaces to prevent corrosion.

#### 11. LUBRICATION.

a. **Precaution.** Avoid getting oil or grease on the glass of the optical parts.

b. **Oil.** Where lubrication with oil is indicated, use OIL, lubricating, for aircraft instruments and machine guns.

c. **Grease.** Where lubrication with grease is indicated, use GREASE, lubricating, special.



**Figure 16—Telescope Mount M35—Oil Cups**

## CARE AND PRESERVATION

**d. Application.** It is important that lubrication be applied carefully and effectively. Do *not* apply lubricants excessively. Any excess should be wiped off immediately with PAPER, lens, tissue, or clean lintless CLOTH, wiping, cotton. Before applying lubricant, oil fittings and bearing surfaces should be wiped clean with PAPER, lens, tissue, or clean lintless cloth. After applying lubricant to the fittings, operate the telescope mount through its entire range and then wipe off any excess. When lubrication has been completed, the telescope mount should be allowed to stand for several hours and then excess lubricant which has leaked out should be removed. When the telescope mount is idle for protracted periods, it should be operated at regular intervals to spread the lubricant.

**e. Bearing Surfaces.** The bearing surface of the cradle guides and the bearing surface of the gear segment with the support should be lightly greased. Elevate the cradle and turn the gear segment through its range and wipe off any excess lubricant with PAPER, lens, tissue, or clean lintless CLOTH, wiping, cotton. Where sandy and windy conditions prevail, resulting in excessive accumulation of grit on these surfaces, it may be advisable to clean the surfaces of all grease and operate them dry.

**f. Oil Cups.** The location of the oil cups on the telescope mount is shown in figure 16.

**g. Gear Segment Pads.** Keep the gear segment pads pliable by occasionally applying a few drops of oil (fig. 5, section C-C).

**ORDNANCE MAINTENANCE—TELESCOPE MOUNT M35 AND  
TELESCOPE M31**

**Section V**

**INSPECTION**

	<b>Paragraph</b>
Purpose .....	12
Tolerances .....	13
Inspection requirements .....	14
Tools for inspection and repair .....	15
Facilities needed for inspection .....	16
Basic inspection of telescope mount M35 .....	17
Basic inspection of telescope M31 .....	18
Action to be taken .....	19

**12. PURPOSE.**

a. Inspection is vital. Thorough systematic inspection at regular intervals is the best insurance against an unexpected breakdown at the critical moment when maximum performance is absolutely necessary.

b. Inspection is for the purpose of determining the condition of the instrument, whether repairs or adjustments are required, and the action necessary to place the instrument in serviceable condition.

c. The basic inspection is a preliminary search to determine the condition of the instrument and to locate basic faults. Proper disposition of the instrument can then be made and necessary action taken or recommended. Inspection forms (O. O. F. 7228 and O. O. F. 7229, fig. 17) are provided for recording the results of the inspection. Instructions concerning the entries to be made are printed on the back of the forms.

d. The detailed inspection and correction described in the maintenance and repair section of this manual are performed by the instrument repairman. With these instructions, he puts the instrument in serviceable condition. The procedure may vary with each instrument, depending on the faults indicated by the basic inspection. Inspection forms and methods used in connection with the detailed inspection are described in Technical Manual No. 9-2602, "Instruction Guide: Instrument Repairman."

**13. TOLERANCES.**

a. Tolerances, or allowable errors, are specified where necessary to indicate the degree of accuracy required in performing certain adjustments. In general, an instrument is considered unserviceable if the error in any part exceeds the specified tolerances. However, it





**ORDNANCE MAINTENANCE—TELESCOPE MOUNT M35 AND  
TELESCOPE M31**

**14. INSPECTION REQUIREMENTS.**

a. The Telescope Mount M35 should be checked for:

- (1) Name plate data.
- (2) Completeness.
- (3) Appearance.
- (4) Condition of paint.
- (5) Condition of oil fittings.
- (6) Condition of machined locating surfaces.
- (7) Action of telescope cradle clamps.
- (8) Action of front sight.
- (9) Binding or play in telescope guides.
- (10) Backlash in deflection mechanism.
- (11) Backlash or binding in the elevation mechanism.
- (12) Deflection scale and micrometer readings.
- (13) Legibility of scales.
- (14) Condition of electrical components.

b. The Telescope M31 should be checked for:

- (1) Name plate data.
- (2) Completeness.
- (3) Appearance.
- (4) Condition of paint.
- (5) Condition of eyeshield.
- (6) Action of focusing nut.
- (7) Diopter scale reading for proper focus (use collimating telescope).
- (8) Condition of horizontal and vertical reticle wires.
- (9) Condition of adjustable light shutter in lamp bracket.
- (10) Reticle wires should be truly horizontal and vertical.
- (11) Condition of filters and their operation.
- (12) Condition of optics.
- (13) Parallax.
- (14) Condition of locating surfaces.
- (15) Condition of electrical components.

**15. TOOLS FOR INSPECTION AND REPAIR.**

a. The tools required for inspection and repair are an adjustable open-end wrench to fit nuts up to 1¼ inches, and the tools included in the Instrument Repair Kit M4.

b. The collimating telescope furnished with the kit is a small pre-focused telescope of cylindrical shape. Optical adjustment can be made more accurately with the collimating telescope than with the unaided eye, as it not only makes it easier to see the adjustment but also eliminates the error introduced by the repairman's eyes. The

## INSPECTION

collimating telescope does not require adjustment in use and must not be disassembled by the using arms.

### 16. FACILITIES NEEDED FOR INSPECTION.

- a. Sturdy work bench, affording clear vision to the front.
- b. Sensitive spirit level.
- c. Collimating telescope.
- d. V-blocks for telescope.

### 17. BASIC INSPECTION OF TELESCOPE MOUNT M35.

a. **General.** Record name and serial number from plate. Examine the telescope mount for completeness, appearance, condition of paint, and for bent or broken parts.

b. **Oil Fittings.** Oil fittings should be undamaged. See figure 16 for location of oil cups.

c. **Gear Segment Bearing Surfaces.** Machined locating surfaces on the gear segment should be smooth and clean. See that the two felt pads at ends of gear segment arc contact the exposed surface of the housing arc.

#### d. Worn Cradle Guides.

(1) With telescope clamped in the cradle, sight on a well defined distant point. Rock the cradle in the guides to determine play. The vertical cross wire should not move off the point in either direction more than the width of the vertical cross wire. If movement exceeds this, it will be necessary to replace the gear segment or cradle. See paragraph 22 b for further inspection and replacement.

(2) Raise and lower the cradle to determine if binding exists. See paragraph 22 b for adjustment for binding.

e. **Backlash in Deflection Mechanism.** Backlash in the deflection mechanism is determined in the following manner:

(1) Select a sharply defined distant aiming point. Turn the telescope so that it points 4 or 5 degrees to the *left* of the aiming point. Then, using the deflection knob, bring the telescope directly onto the aiming point, being careful not to overpass it. When the vertical cross wire is exactly on the aiming point, read the deflection micrometer.

(2) Repeat the operation starting with the telescope 4 or 5 degrees to the *right* of the aiming point. Bring the vertical cross wire back directly onto the aiming point again, being careful not to overpass the aiming point. Again read the deflection micrometer.

(3) If the two readings of the deflection micrometer are the same,

**TM 9-1539**

**17-18**

**ORDNANCE MAINTENANCE—TELESCOPE MOUNT M35 AND  
TELESCOPE M31**

there is no backlash in the deflection mechanism. If there is a difference in the two micrometer readings, there is backlash in the deflection mechanism. The amount of this difference is the measure of the backlash. A tolerance of one graduation or (0.01 degree) is permissible. Anything over this must be eliminated by adjustment of the deflection worm as described in paragraph 23. Before making this adjustment, repeat the operation described above to make sure there has been no slippage while the telescope was being aimed.

**f. Binding or Backlash in Elevation Mechanism.** Check the motion of the elevation mechanism for binding or backlash by turning the elevating knob to the limits of motion in each direction. If binding or backlash occurs, it will be necessary to disassemble the elevation mechanism in order to determine just what adjustments or repairs will be required. For disassembly, see paragraph 34.

**g. Inspection for Defective Electrical Components.** Connect the wiring to the source of power, operate switches, and check lighting for defective lights or wiring. If a light is out, the lamp may be burned out. If a light flickers, there may be a loose connection.

**18. BASIC INSPECTION OF TELESCOPE M31.**

**a. General.** Record the serial number from the name plate. Examine the telescope for completeness, appearance, condition of paint, and for broken or bent parts. Looking through the telescope observe whether there is fogging or dust which would indicate a break in the sealing at some part of the telescope.

**b. Action of Cradle Clamps.** See that the telescope is securely held in position in the cradle when the clamping screws are tightened firmly. Note the action of clamps and clamping screws.

**c. Condition of Eyeshield.** Check the appearance and general condition.

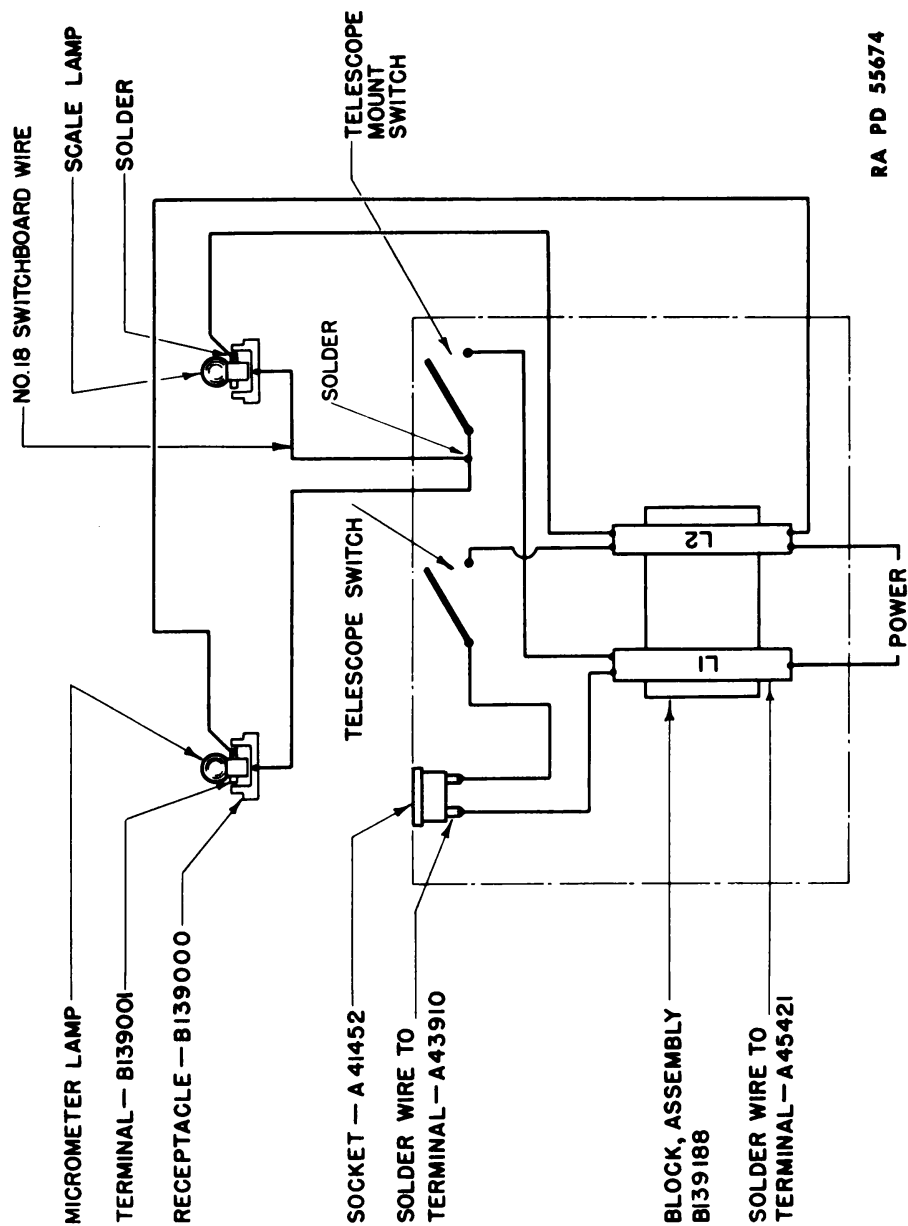
**d. Condition of Optical System.** Examine the optical elements for signs of breakage, dirt, grease, moisture, and deterioration of adhesive balsam in the compound lenses. The image should appear sharp and clear, and the reticle should be in sharp focus.

**e. Illumination.**

(1) Plug in the cable between the telescope and housing sockets. With source of power connected, operate switches and check lighting for defective lights or wiring.

(2) Place the cap on the telescope objective. With the lamp bracket light on and light shutter fully open, observe through the eyepiece the illumination on the reticle cross wires. If the cross wires remain dark or very faintly illuminated, a further inspection of the reflectors at the top and right-hand side is necessary. For disassembly

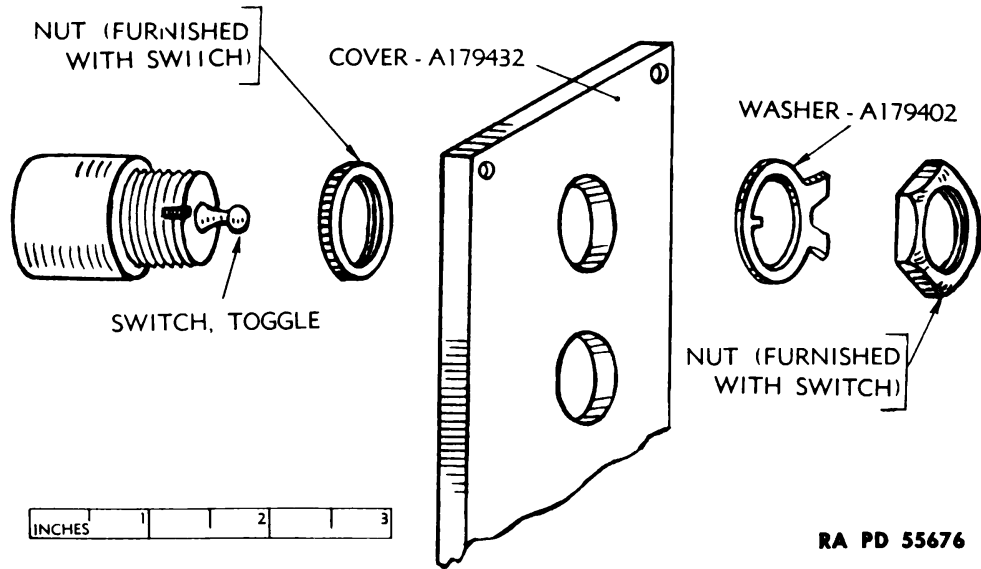
INSPECTION



RA PD 55674

Figure 18 - Wiring Diagram

**ORDNANCE MAINTENANCE—TELESCOPE MOUNT M35 AND TELESCOPE M31**

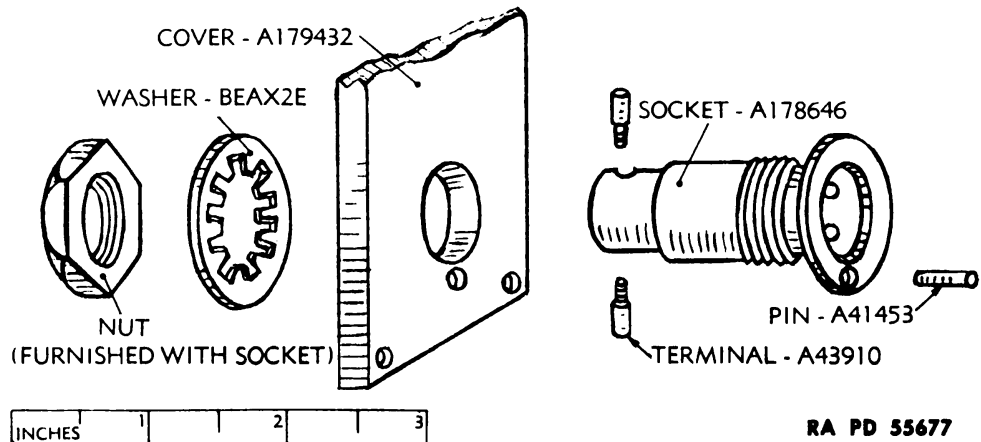


**Figure 19—Toggle Switch Assembly—Exploded View**

and assembly of reflectors, see paragraph 41. Turn the plug A39679 at the top of the lamp housing to operate the light shutter (fig. 7). If the shutter does not regulate the illumination or does not operate smoothly, disassembly will be necessary in order to make repairs.

**f. Verticality of Reticle.** With the telescope in clamped position in the cradle, sight on a plumb line in the field of view. The vertical wire of the reticle should coincide with the plumb line. If adjustment is necessary, see paragraph 24 b.

**g. Action of Ray Filters.** Turn the filter selector knob A48730



**Figure 20—Socket Assembly in Deflection Worm Housing Cover—Exploded View**

## INSPECTION

and check the ray filters to see that the corresponding filter to the one registered on the plate appears fully in view when looking through the telescope. See that the detent operates properly to retain the ray filters in position. Check for damaged or broken filters, and smooth motion of the gear assembly. For detailed inspection, see paragraph 27.

**h. Setting of Diopter Scale.** Check the diopter scale to see that it reads zero when the eyepiece is sharply focused on the reticle. Use the collimating telescope. If reading exceeds a half diopter, adjustment will be necessary as described in paragraph 25.

**i. Parallax.** Check the focusing of the objective by directing the telescope on an object about 150 yards or more distant. The object should remain stationary in the field of view while the observer moves his eye from side to side or up and down across the eyepiece. For adjustment see paragraph 26.

### 19. ACTION TO BE TAKEN.

**a.** If the telescope mount and telescope are found defective, they must be repaired or adjusted to render them serviceable. Defects noted and action to be taken must be entered on the inspection form. The action to be taken will be governed by the facilities available. If the facilities of the section do not permit satisfactory accomplishments of the repair or adjustments, the unserviceable instrument will be passed on to a higher maintenance echelon; replacement items should then be issued to the using arms.

ORDNANCE MAINTENANCE—TELESCOPE MOUNT M35 AND  
TELESCOPE M31

Section VI

MAINTENANCE AND REPAIR

	Paragraph
Precautions .....	20
Facilities for making repairs .....	21
Backlash or binding in elevation mechanism .....	22
Backlash or binding in deflection mechanism .....	23
Reticle repair and alinement .....	24
Diopter scale setting .....	25
Elimination of parallax .....	26
Ray filter assembly .....	27
Abbe prism assembly .....	28
Electrical repairs .....	29
Instructions for soldering .....	30

**20. PRECAUTIONS.**

a. The following operations may be performed only by qualified personnel.

b. To preserve the parts of the instrument, it is necessary to exercise care and close attention during disassembly, cleaning, and adjustment. The extent of disassembly for any certain repair job is determined by the repairman when he makes his detailed inspection.

c. Defective parts should be replaced from stock. Replacement of components is easily accomplished for the most part, since the components are all standardized and available as replacements. Parts should be marked before disassembly to indicate original settings.

**21. FACILITIES FOR MAKING REPAIRS.**

a. **Mechanical Repairs.** The Instrument Repair Kit M4 and two adjustable open-end wrenches to fit nuts up to 1¼ inches are required.

b. **Electrical Repairs.** A soldering iron, solder (tin-lead, grade A), and soldering paste are required for making electrical repairs.

**22. BACKLASH OR BINDING IN ELEVATION MECHANISM.**

**a. Inspection.**

(1) Binding in the elevation mechanism may be due to several causes. Inspect the cradle guides to see they are not bent. Look for dirt and insufficient lubrication in the elevation mechanism. See that the elevation screw is not bent or the threads damaged. Turn the elevating knob to determine whether the binding is in the cap assembly in the gear segment or in the cap and socket assembly at the head of the elevation screw.

## MAINTENANCE AND REPAIR

(2) Backlash in the elevation mechanism may be due to worn threads on the elevation screw or looseness at the ball surfaces. Turn the elevating knob to determine whether the play is in the cap assembly in the gear segment or in the cap and socket assembly at the head of the elevation screw. Make sure nut BBCX1E, which secures the cradle to the socket, is tight.

### b. Bent or Worn Cradle Guides.

(1) Excessive play between the cradle and guides will require replacement with either a new cradle or gear segment.

(2) If binding exists between guides and cradle, scrape enough metal from bearing surface of guides to permit free movement of cradle without side play.

### c. Repair and Adjustment of Cap and Socket.

(1) If binding or play exists at the head of the elevation screw, remove the cradle from the socket A179416 as described in paragraph 34 a.

(2) Observe the straight pin BFDX1CG for wear. Replace if worn.

(3) Remove the elevation screw and cap and socket as described in paragraph 34 b, c, and d.

(4) To eliminate play, remove some of the metal from the cap where it seats on the socket, or to eliminate binding, shim the seat. Reassemble and check the motion. If satisfactory, stake the four clamping screws.

### d. Repair and Adjustment of Cap Assembly.

(1) If the ball, when moved through its forward and backward limits, binds or is loose, remove the four clamping screws BCGX3FG from the ball cap and remove the ball cap from the gear segment.

(2) To repair, remove some of the metal from the ball cap where it seats in the gear segment to eliminate play, or shim the seat to eliminate binding. Reassemble and check the motion. If satisfactory, stake the four clamping screws.

## 23. BACKLASH OR BINDING IN DEFLECTION MECHANISM.

a. **Elimination of Backlash or Binding in Deflection Worm Bearing.** To eliminate backlash or binding in the deflection worm bearing, loosen the headless locking screw BCUX1FG in the rear face of the deflection worm housing at the right-hand side (fig. 5, section C-C and fig. 31). Screw the bushing A179430 up tight and then back off just enough to permit free rotation of the deflection worm without end play. Tighten the headless locking screw to retain the adjustment and recheck the worm gear motion.

b. **Elimination of Backlash or Binding Between the Deflection Worm and Gear Segment.** To eliminate backlash or binding be-



**ORDNANCE MAINTENANCE—TELESCOPE MOUNT M35 AND  
TELESCOPE M31**

tween the deflection worm and gear segment, adjust the deflection worm as described below.

(1) Loosen the headless adjusting screw in the rear face of the support at the right-hand side (figs. 3 and 30). Loosen the two bolts A203535 which secure the deflection worm housing to the support, a half turn. (The left-hand bolt has a very close fit in the support, while the right-hand bolt has a comparatively loose fit. This construction permits a limited rotation about the left-hand bolt.)

(2) Tap the right-hand end of the deflection worm housing away from the gear segment. Tighten the headless adjusting screw until a distinct resistance to motion is felt. *Do not force the adjusting screw.* Try the action of the deflection worm. If the deflection worm operates stiffly, back off the adjusting screw very gradually until the worm motion is smooth. Do not loosen the adjusting screw more than the amount necessary to obtain smooth motion, as loosening the screw past the critical point will introduce backlash. If uniform smooth motion cannot be obtained by the above adjustment, the deflection worm is probably bent or the worm teeth are damaged and the worm will have to be replaced.

(3) Tighten the two bolts A203535 slightly and operate the deflection worm again to determine if the adjustment is retained. Repeat the above operation, if necessary, until smooth worm motion is obtained. Tighten the two bolts A203535 at the same time to firmness.

**24. RETICLE REPAIR AND ALINEMENT.**

**a. Replacement of Cross Wires.**

(1) Remove the clover leaf reticle as described in paragraph 42.

(2) Unsolder the ends of the cross wires from the grooves in the clover leaf reticle and remove all solder from the grooves. Solder one end of a piece of 0.001-inch nichrome or platinum wire, furnished with the instrument repair kit, in one of the grooves. Stretch the wire to the opposite groove with enough tension to hold the wire taut, and solder. Use just enough solder to hold securely. Be sure that no part of the wire or solder extends beyond the rim of the reticle frame. Replace the clover leaf reticle on the reticle frame in accordance with the scribed marks. Replace the reticle assembly in the eyepiece adapter as described in paragraph 42 and check for reticle alinement and collimation as described in paragraph 18 f and subparagraph b (3), below.

**b. Adjustment of Reticle.**

(1) Remove the lamp bracket from the telescope as described in paragraph 40 in order to expose the four positioning screws A48719 (figs. 10 and 39).

(2) To adjust the cross wires of the reticle for true horizontal and vertical position, secure the telescope in the cradle and sight on a

## MAINTENANCE AND REPAIR

plumb line. If the vertical wire does not coincide with the plumb line, loosen one of the vertical and one of the horizontal positioning screws. Rotate the reticle frame to bring the vertical wire to coincidence with the plumb line. Tighten the positioning screws and check alinement.

(3) To adjust the reticle for collimation alinement, it will be necessary to remove the lamp bracket as described in paragraph 40, in order to expose the four positioning screws. Place the telescope in V-blocks and sight on a clearly defined distant reference point. Rotate the telescope while in this position. If collimation is correct, the reticle center will not move off the reference point. If collimation is out of alinement, the reticle center will follow a circular path through the reference point while the telescope is rotated. If this occurs, shift the reticle frame horizontally or vertically by means of the four positioning screws A48719 (fig. 10). Repeat the centering operation with the target until satisfactory adjustment is obtained. Tighten the four positioning screws.

### 25. DIOPTER SCALE SETTING.

a. **Description.** The diopter scale should register zero when the reticle cross wires are brought into sharp focus with the eyepiece by the aid of the collimating telescope. If diopter scale registers more than a half diopter plus or minus, adjustment will be necessary.

b. **Adjustment.** Loosen one of the headless screws BCUX2CB in the focusing nut B138053 (figs. 10 and 36) and turn the diopter scale to bring the zero graduation in register with the index. Tighten the headless screw. After adjusting, turn the diopter scale to the limits of motion in each direction to see that it registers plus 3 and minus 3 diopters. If the diopter scale is limited by the stop at either end so that it cannot be brought into register at either plus 3 or minus 3 diopters, incorrect assembly of the component parts in the eyepiece cell is indicated. Disassemble the eyepiece cell as described in paragraph 39 and reassemble correctly (figs. 9 and 10).

### 26. ELIMINATION OF PARALLAX.

a. **Precaution.** Always check for parallax any time an optical element has been removed or replaced. Parallax will occur if the clover leaf side of the reticle is not lying in the focal plane of the objective.

b. **Adjustment.** To correct for parallax, direct the telescope on an object about 150 yards distant. Remove the headless screw BCUX1EE (figs. 10 and 44) which locks the objective cell and screw the objective cell in or out ( $2\frac{1}{2}$ -inch spanner wrench), to obtain sharpest definition of the object. Assuming that the eyepiece has been correctly focused on the reticle, the objective position which provides sharpest definition will also be the position for minimum parallax.

**TM 9-1539**

**26-29**

**ORDNANCE MAINTENANCE—TELESCOPE MOUNT M35 AND  
TELESCOPE M31**

Check results with the collimating telescope. When sharpest focus has been obtained, tighten the headless screw to retain the adjustment.

**27. RAY FILTER ASSEMBLY.**

**a. Detent Action.** The filters are held in position through detent action of ball CCAX1C and spring A33671 assembled in the eyepiece adapter. If a filter does not remain in position, remove the ball and spring as described in paragraph 43, and inspect the ball and spring. Note cleanliness of seating surfaces. Repairs will be determined by results of the inspection.

**b. Gear Matching.** The filter indicated on the filter plate A49878 by the filter selector knob A48730 should appear fully in the line of sight, if the gears of the ray filter assembly are correctly matched. If a corresponding filter does not fully appear in the line of sight, disassemble the gears as described in paragraph 43 and match the gears correctly.

**c. Filter Replacement.** Each filter is secured in the filter holder B137238 by a retaining ring A48722 which in turn is secured by spinning over the edge of the filter holder. To replace a filter, work the metal away from the retaining ring with a burnishing tool. Remove the retaining ring and broken parts of the filter. Use the air bulb to remove all fine particles. Insert new filter and replace the retaining ring. Spin over the edge of the filter holder with the burnishing tool to secure the ring.

**28. ABBE PRISM ASSEMBLY.**

**a. Seating of Prisms.** See that the prisms are fully seated in their support, that the pad A48691 is in place, and that the spring B137239 has sufficient tension to hold the prisms securely in position (figs. 7 and 43). For disassembly see paragraph 44.

**29. ELECTRICAL REPAIRS.**

**a. Location of Defects in Electrical Components.** Refer to wiring diagram (fig. 18).

**b. Lamp Replacement (Deflection Scale and Micrometer).** Burning out of lamps will probably be the chief electrical trouble. Replacement of the deflection scale and micrometer lamps is made as follows:

(1) Loosen headless screw BCUX2CD in lamp receptacle. Unscrew the receptacle, which is part of the lamp socket (fig. 7, section B-B, and fig. 34).

(2) Press the lamp inward and give it a quarter turn counter-

## MAINTENANCE AND REPAIR

clockwise to clear the bayonet type socket. Examine the lamp to see if it is burned out or broken.

### c. Lamp Replacement (Telescope Lamp Bracket).

(1) Remove the extension cable from the lamp bracket socket A34885 and unscrew the socket assembly B16139 from the lamp bracket C69760.

(2) Remove the lamp A35189 for inspection as described above.

### d. Switch Replacement.

(1) Remove the cover A179432 from under side of deflection worm housing (fig. 6, view at "X," and fig. 19).

(2) Remove the nut and washer from the toggle switch, so the switch can be released from the cover.

(3) Unsolder the wires from the switch terminal lugs.

(4) Install new switch and solder the wires to the terminal lugs.

(5) Fasten new switch in place, test the circuit, and if all right, replace the cover.

### e. Socket Replacement.

(1) To replace deflection worm housing socket A178646, remove the cover from bottom of deflection worm housing (par. 36 b).

(2) Unsolder the terminals, and unscrew them from the socket.

(3) Remove the nut that fastens the socket to cover. The socket can now be withdrawn through the cover and a new one inserted (fig. 6, view at "X," and fig. 20).

(4) When replacing the socket, make sure that the positioning pin in the socket lines up with the hole in the cover.

(5) To replace the lamp bracket socket A34885, unscrew the collar A34886 and remove the socket assembly B16139 (fig. 7, section B-B, and fig. 37). Drive the pin out of the collar to release the socket.

## 30. INSTRUCTIONS FOR SOLDERING.

a. Thoroughly clean or scrape the surfaces to be soldered. Copper and brass will show a bright surface when properly cleaned.

b. Use rosin flux, either in paste form or in self-contained core form in which some solders are furnished. When using paste, dab a very small amount of the paste on the cleaned surfaces. Flux in self-contained cores needs no special application, as it will flow properly when the soldering iron is applied.

c. The solder is intended primarily to provide electrical contact, and is not intended to withstand mechanical strain. Where possible, wrap the wire around the terminal device. Where two wires are to be soldered, first twist them together to obtain a mechanically strong joint.

**ORDNANCE MAINTENANCE—TELESCOPE MOUNT M35 AND  
TELESCOPE M31**

d. Heat the joint with the point of a hot soldering iron, and flow the solder smoothly into the joint. Remove the soldering iron and allow the joint to cool. A good joint should show a thin continuous film of solder, with no lumps or excess of solder. If too much solder has been applied, reheat the joint with the soldering iron and allow the excess to flow onto the iron.

e. In order to separate soldered parts, apply a hot soldering iron to the joint until the solder flows; then pull the parts away from each other.

Section VII

DISASSEMBLY AND ASSEMBLY OF TELESCOPE MOUNT M35

	Paragraph
Cradle removal .....	31
Cradle disassembly and assembly .....	32
Gear segment disassembly and assembly .....	33
Elevation mechanism disassembly and assembly .....	34
Deflection worm housing removal .....	35
Deflection worm housing disassembly and assembly .....	36
Telescope mount M35 assembly .....	37

**31. CRADLE REMOVAL.**

**a. Front Bearing.**

(1) Remove the taper pin BFCX1BC from nut A314457 at the right-hand side of the front horizontal pivot pin B138936 (fig. 21). Remove the nut and washer from the front horizontal pivot pin.

(2) Remove the front horizontal pivot pin being careful not to lose the Woodruff key BGAX6A in the head end of the pin.

**b. Elevation Screw Socket.** Remove the nut BBCX1E and washer BEAX2B from the elevation screw socket A179416 at rear end of cradle (fig. 22). Pry the cradle from the elevation screw socket until it clears the locating pin BFDX1CG and lift the cradle from the gear segment.

**32. CRADLE DISASSEMBLY AND ASSEMBLY.**

**a. Cradle Clamp Removal.**

(1) Unscrew the two thumbscrews A179438 on the left-hand side of cradle clamps (fig. 23). This releases thumbscrew from cradle.

(2) Remove cotter pins BFAX1BB from two pivot pins A179437 on right-hand side and remove pivot pins. Remove cradle clamps.

**b. Front Clamp Disassembly.**

(1) Remove cotter pin BFAX1BB from front sight pivot pin A179414 and remove the pin (fig. 24).

(2) In removing front sight A179431, be careful not to lose the front sight detent ball CCAX1B and spring A179442 assembled in the cradle clamp.

**c. Thumbscrew Removal.** Re-engage the threads of the thumbscrew with those in the clamp and remove thumbscrew from clamp.

**d. Assembly.** Apply a light film of GREASE, lubricating, special, to the front sight detent ball and spring, cradle clamp pivots, and the threads of the cradle clamp thumbscrews before assembly. Assembly is the reverse of disassembly.

ORDNANCE MAINTENANCE—TELESCOPE MOUNT M35 AND  
TELESCOPE M31

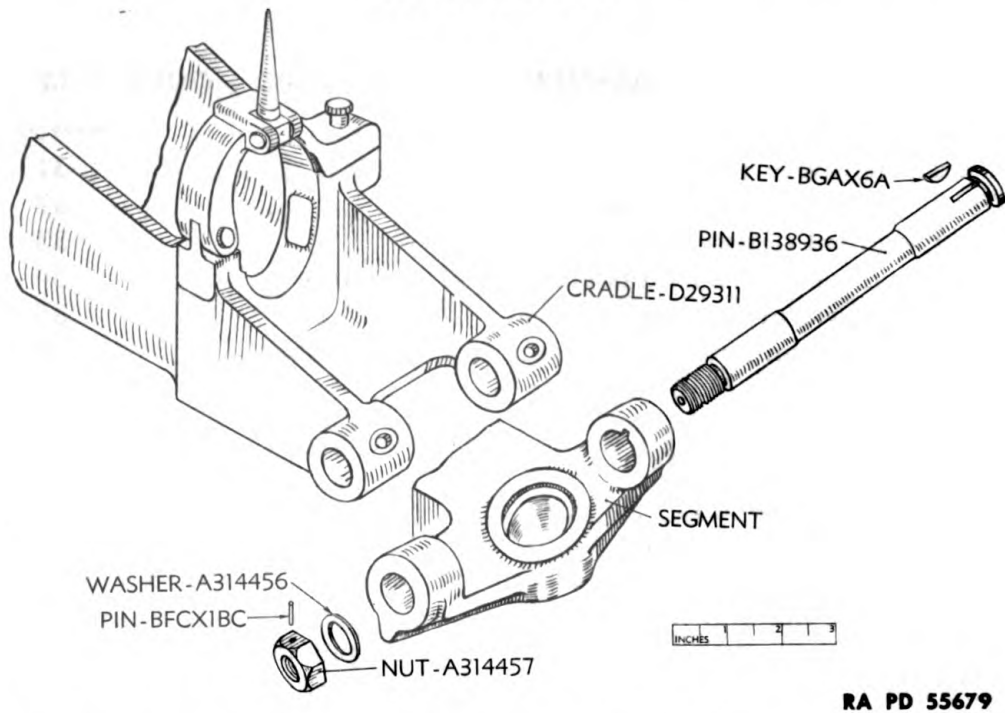


Figure 21—Cradle and Gear Segment Assembly at Front End Exploded View

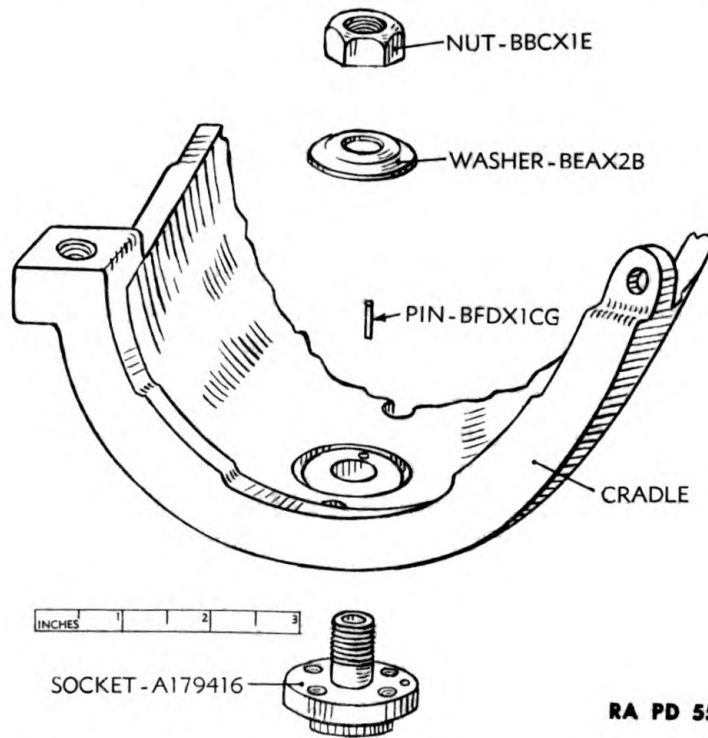
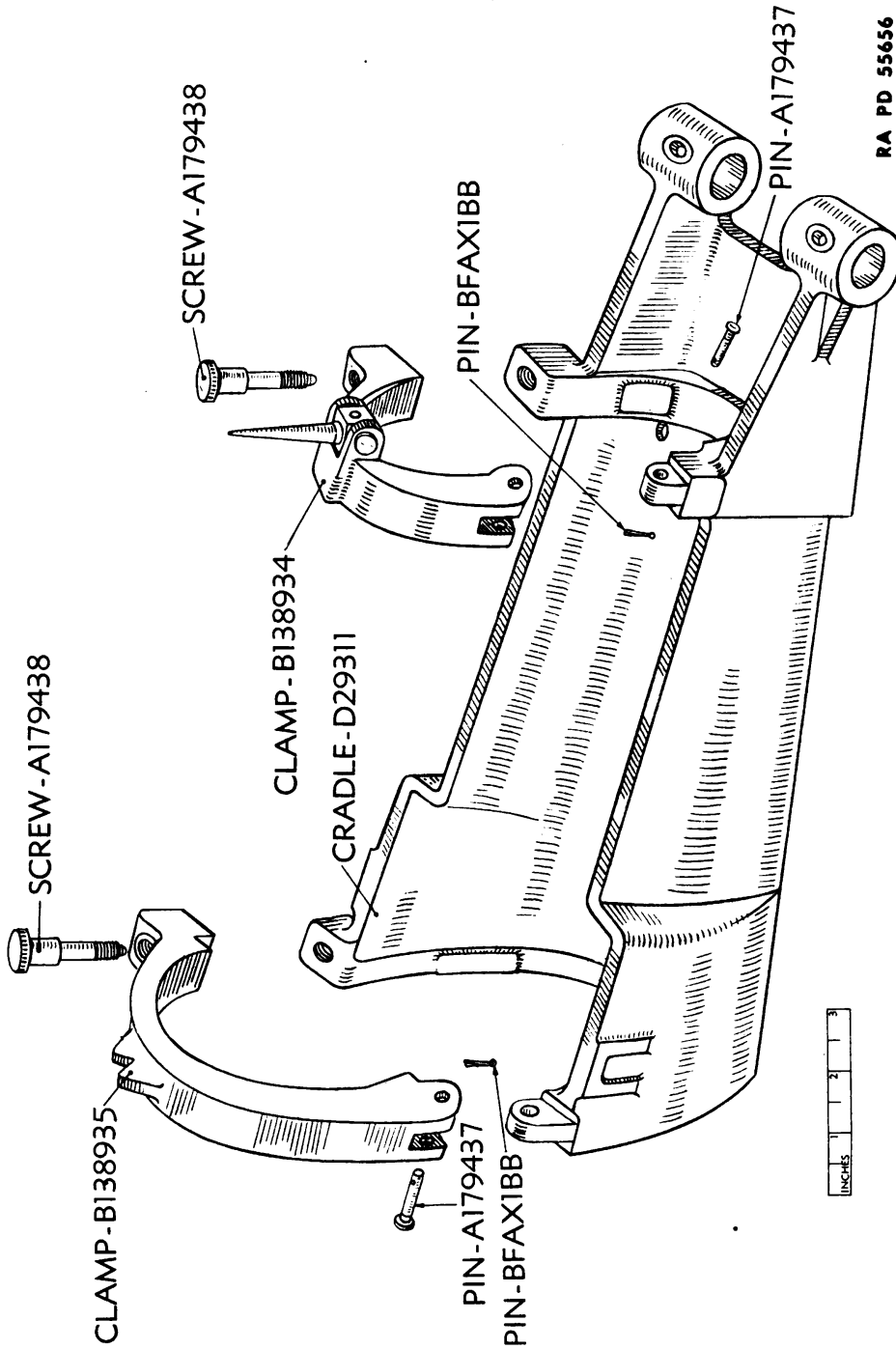


Figure 22—Cradle and Elevation Screw Socket Assembly—Exploded View

DISASSEMBLY AND ASSEMBLY OF TELESCOPE MOUNT M35

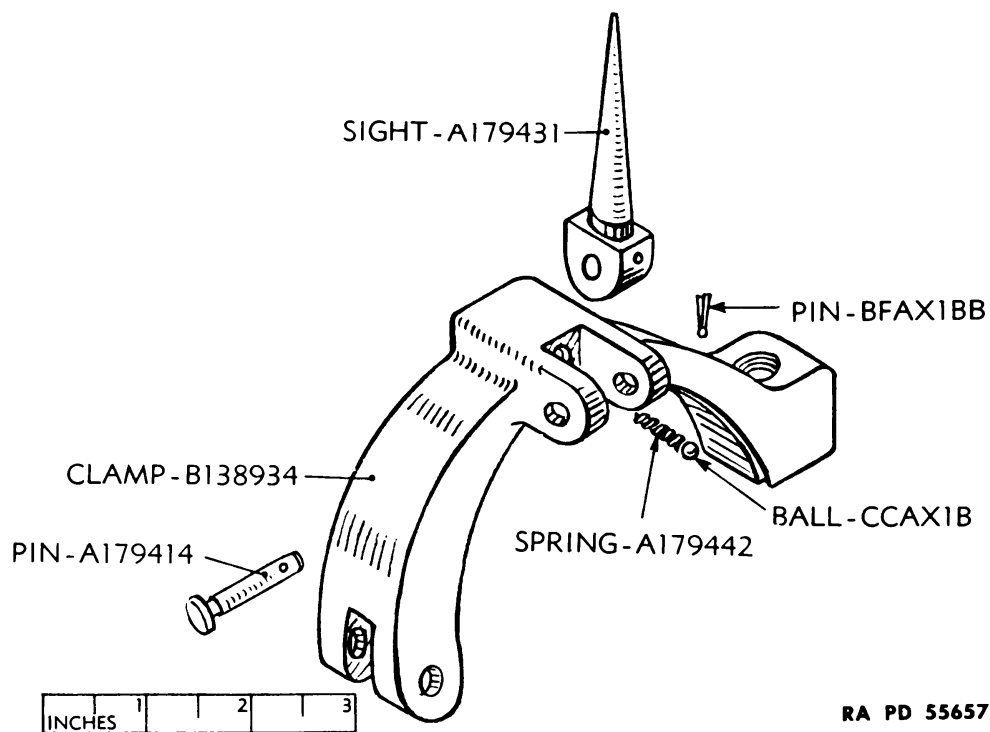


RA PD 55656

Figure 23—Cradle and Clamp Assembly—Exploded View



**ORDNANCE MAINTENANCE—TELESCOPE MOUNT M35 AND  
TELESCOPE M31**



**Figure 24—Front Clamp Assembly—Exploded View**

**33. GEAR SEGMENT DISASSEMBLY AND ASSEMBLY.**

a. **Front Bearing Removal.** Having removed the cradle (as described in par. 31) remove nut BBAX2B and washer BECX1P from lower end of front stud A179436 (fig. 25), and lift out the stud.

b. **Elevation Screw Removal.** Remove the elevation screw as described in paragraph 34 c.

c. **Gear Segment Removal.** Slide gear segment D29312 forward to disengage deflection worm and remove gear segment from support.

**d. Gear Segment Disassembly.**

(1) To remove the oil pads assembled at the ends of the arc of the gear segment, remove the two roundhead screws BCOX3CG and washers BEAX1D (fig. 5, section C-C and fig. 32).

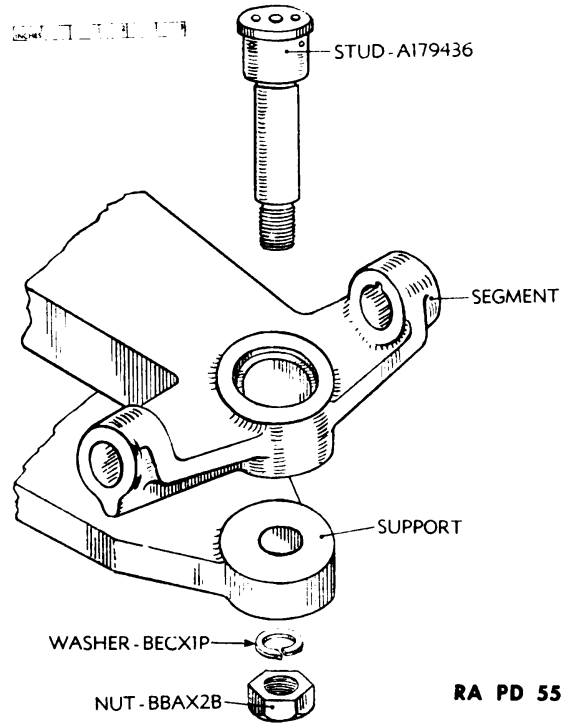
(2) To remove the deflection scale, remove the two roundhead screws, BCOX3EG and washers BEAX1F at the rear and left-hand side of the gear segment.

e. **Assembly.** Apply GREASE, lubricating, special, if required by conditions (par. 11 e). Assembly is the reverse of disassembly.

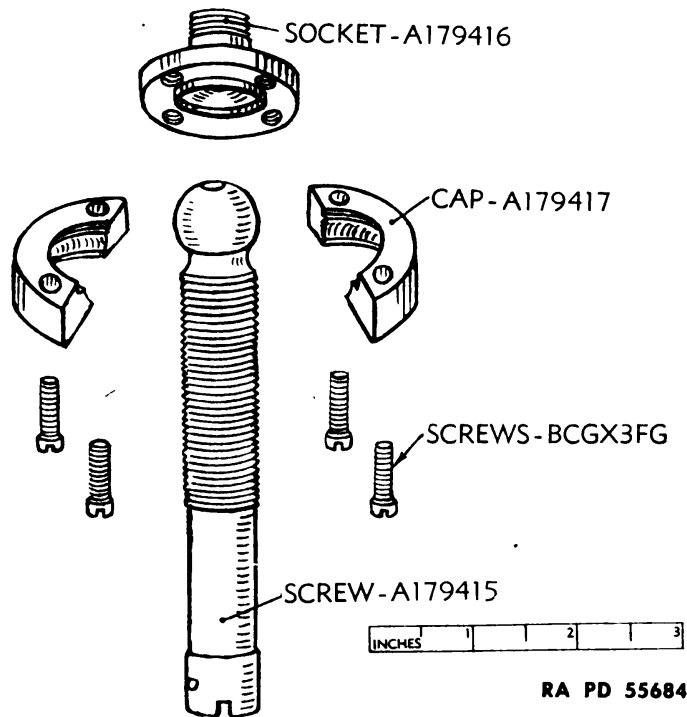
**34. ELEVATION MECHANISM DISASSEMBLY AND ASSEMBLY.**

a. **Cradle Removal.** Release the cradle from the elevation screw

**DISASSEMBLY AND ASSEMBLY OF TELESCOPE MOUNT M35**

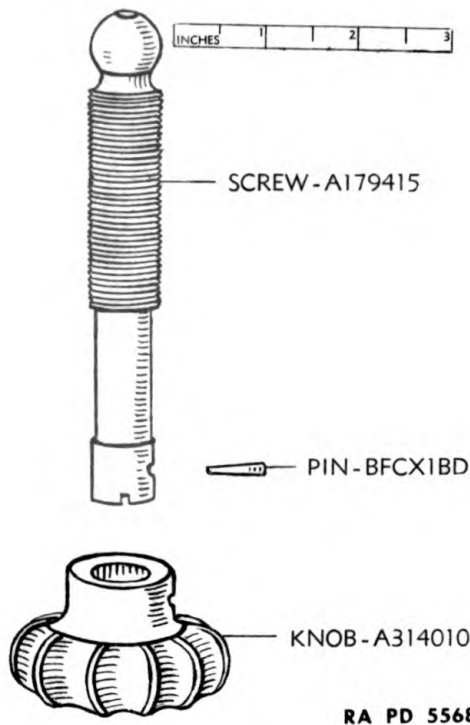


**Figure 25—Gear Segment and Support—Assembly at Front End—Exploded View**

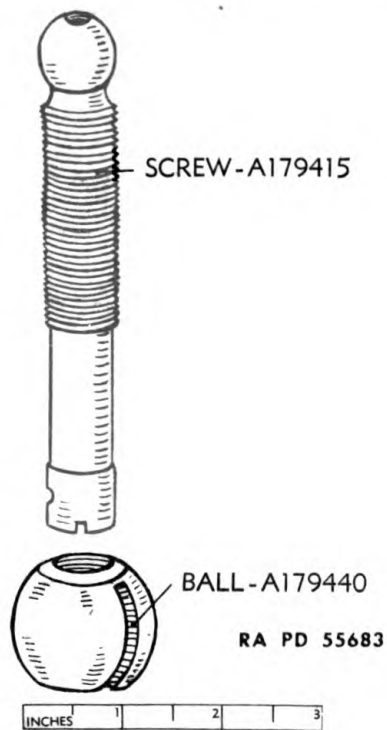


**Figure 26—Elevation Screw, Cap, and Socket Assembly—Exploded View**

**ORDNANCE MAINTENANCE—TELESCOPE MOUNT M35 AND  
TELESCOPE M31**



**Figure 27—Elevating Knob and Elevation Screw—Exploded View**



**Figure 28—Elevation Screw and Ball**

**DISASSEMBLY AND ASSEMBLY OF TELESCOPE MOUNT M35**

socket A179416 as described in paragraph 31 h.

**b. Elevating Knob Removal.** Drive out the taper pin BFCX1BD from the elevating knob A314010 and remove the knob from the elevation screw (fig. 27).

**c. Elevation Screw Removal.** Turn the elevation screw A179415 with a screwdriver, small enough to clear the threads in the ball, until the threads are disengaged from the ball A179440, removing the elevation screw through the top of the ball (fig. 28).

**d. Elevation Screw Socket and Cap Removal.** Remove the four screws BCGX3FG from cap A179417 (fig. 26), and remove elevation screw socket and cap from head of elevation screw A179415.

**e. Cap Assembly Removal.** Remove the four screws BCGX3FG from the cap A179439 (fig. 4), and lift the cap and ball out of the seat in the gear segment.

**f. Assembly.** Apply a light film of GREASE, lubricating, special, to the threads and ball head surface of the elevation screw and the ball and to the seating surfaces in the gear segment before assembly. Assembly is the reverse of disassembly.

**35. DEFLECTION WORM HOUSING REMOVAL.****a. Electrical Connections.**

(1) Remove the extension cable from the socket A178646 in the under side of the deflection worm housing.

(2) Drop cover A179432 from under side of deflection worm housing, and remove outside power source terminals from terminal block as described in paragraph 36 b and c.

(3) Remove follower A179419 and gland A179426, and pull out the flexible tubing from the deflection worm housing (figs. 6 and 29).

**b. Deflection Worm Housing Removal.** Loosen the headless adjusting screw in the support at right-hand side and remove the two bolts A203535 and washers BEAX2F from under side of the deflection worm housing (fig. 30). Remove the housing.

**36. DEFLECTION WORM HOUSING DISASSEMBLY AND ASSEMBLY.****a. Deflection Worm Removal.**

(1) The deflection worm is removed through the right-hand side of the deflection worm housing (fig. 31). If the deflection worm is to be removed from the deflection worm housing while the telescope mount is completely assembled, it will be necessary to remove the oil pad assembly at the left-hand end of the arc of the gear segment (par. 33 d), and then turn the deflection worm off the gear segment so that it will clear the teeth of the gear segment.

(2) Remove the three screws BCGX3FG in the cupped end of the

ORDNANCE MAINTENANCE—TELESCOPE MOUNT M35 AND  
TELESCOPE M31

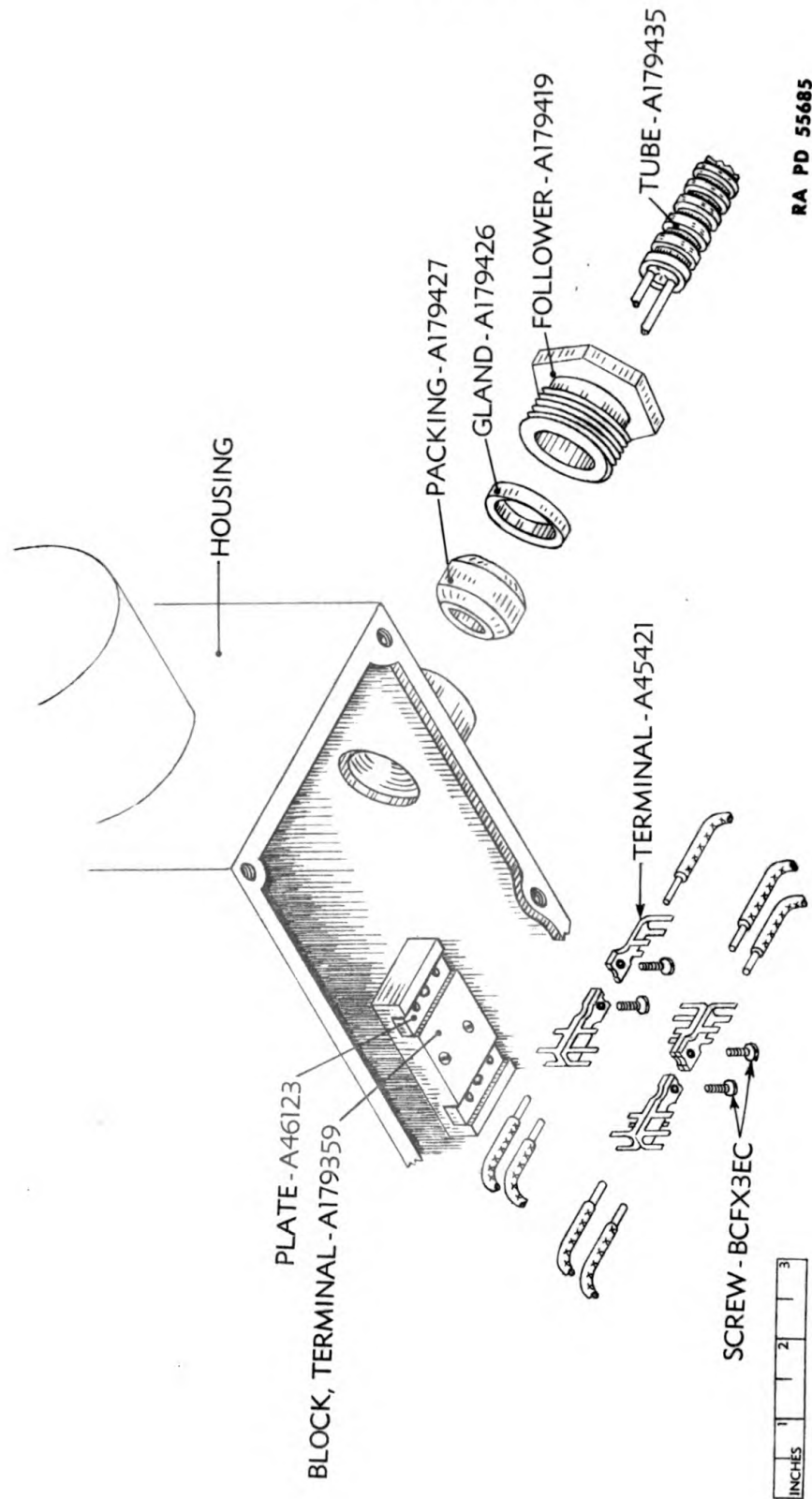


Figure 29—Terminal Block Connections—Exploded View

DISASSEMBLY AND ASSEMBLY OF TELESCOPE MOUNT M35

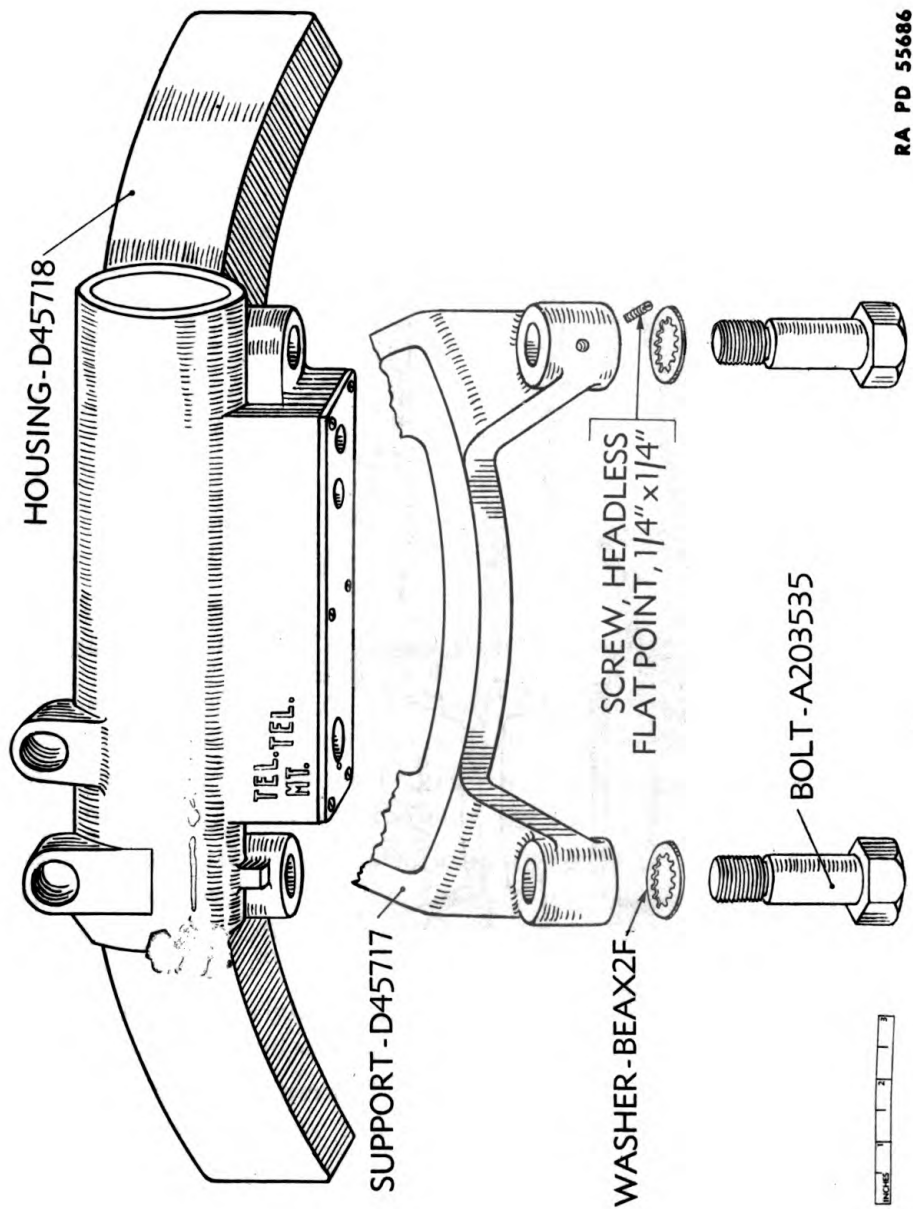


Figure 30—Deflection Worm Housing and Support Assembly—Exploded View

ORDNANCE MAINTENANCE—TELESCOPE MOUNT M35 AND  
TELESCOPE M31

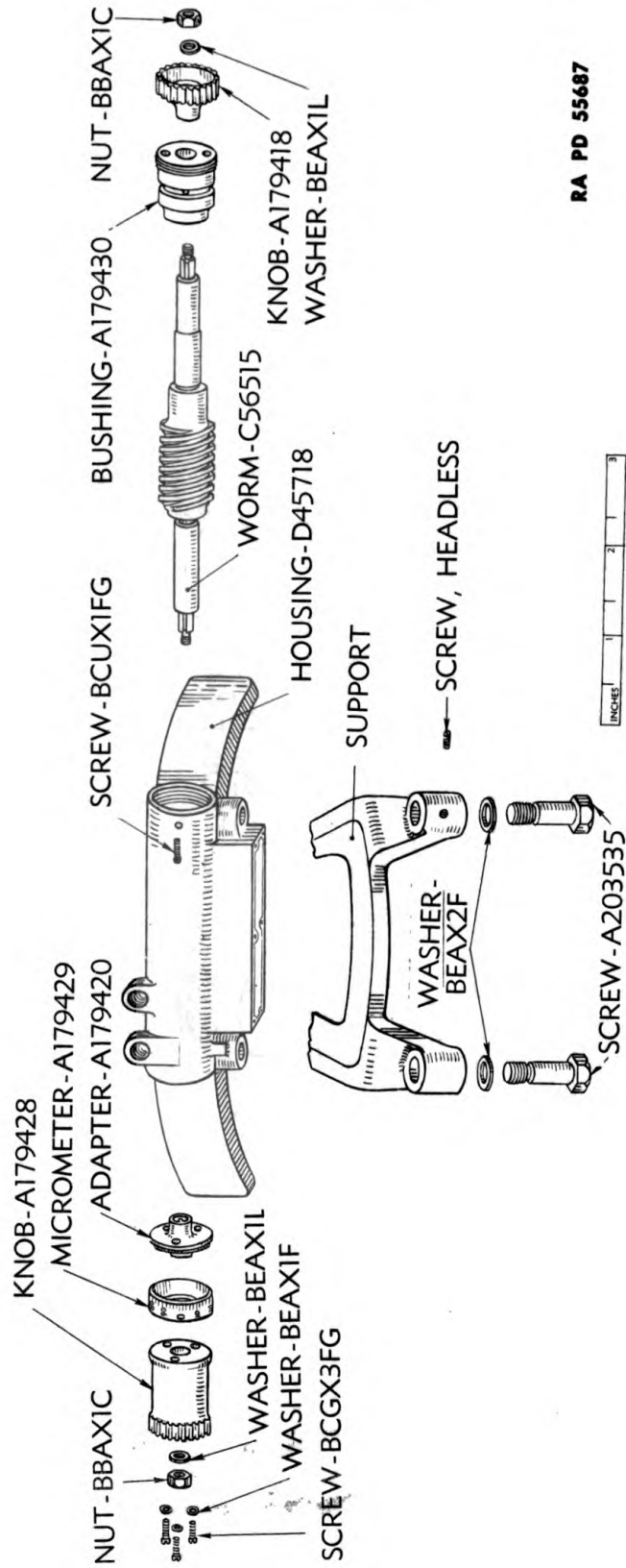
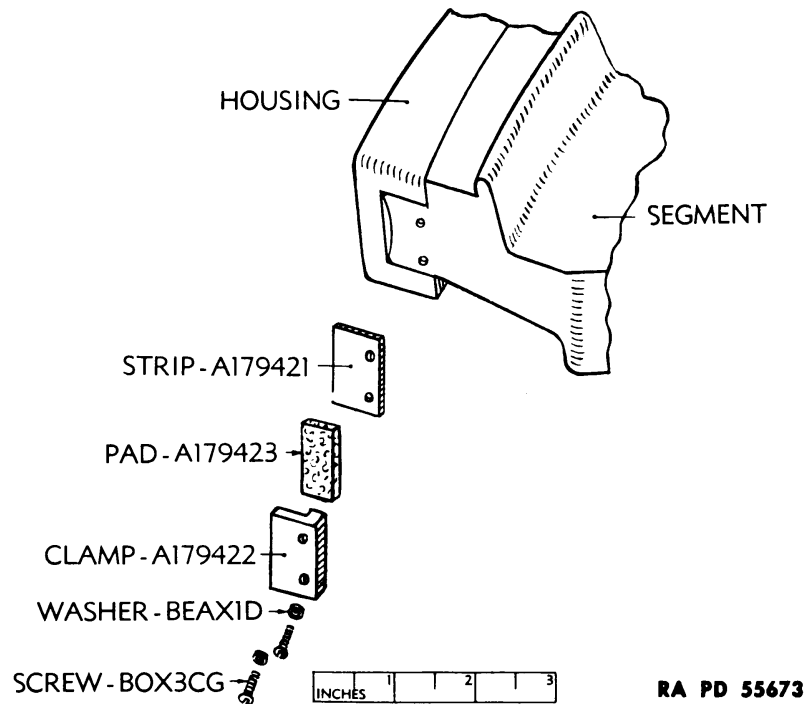


Figure 31—Deflection Worm Assembly—Exploded View

## DISASSEMBLY AND ASSEMBLY OF TELESCOPE MOUNT M35



**Figure 32—Gear Segment Pad Assembly—Exploded View**

left-hand deflecting knob A179428. Remove clamping nut BBAX1C and washer BEAX1L from the deflection worm C56515. The left-hand deflecting knob, micrometer A179429, and adapter A179420 may now be removed (fig. 5, section C-C and fig. 31).

(3) Loosen the headless locking screw BCUX1FG in rear face of the deflection worm housing D45718 on right-hand side. Unscrew bushing A179430 from the deflection worm housing and remove the deflection worm.

(4) To remove right-hand deflecting knob A179418, remove clamping nut BBAX1C and washer BEAX1L, and slide knob off worm.

**b. Deflection Worm Housing Cover Removal.**

(1) Remove the six roundhead screws BCOX3EG and washers BEAX1F from under side of deflection worm housing (fig. 33). The deflection worm housing cover A179402 may now be lowered from the housing. Protect gasket A179433 against damage.

(2) Remove terminals from light switches, and extension cable socket as described under repairs in paragraph 29 d and e.

**c. Electrical Component Removal.**

(1) The lower part of the deflection worm housing contains the electrical connections (figs. 6 and 29). To remove the terminals, unscrew the four terminal screws BCFX3EC.



ORDNANCE MAINTENANCE—TELESCOPE MOUNT M35 AND  
TELESCOPE M31

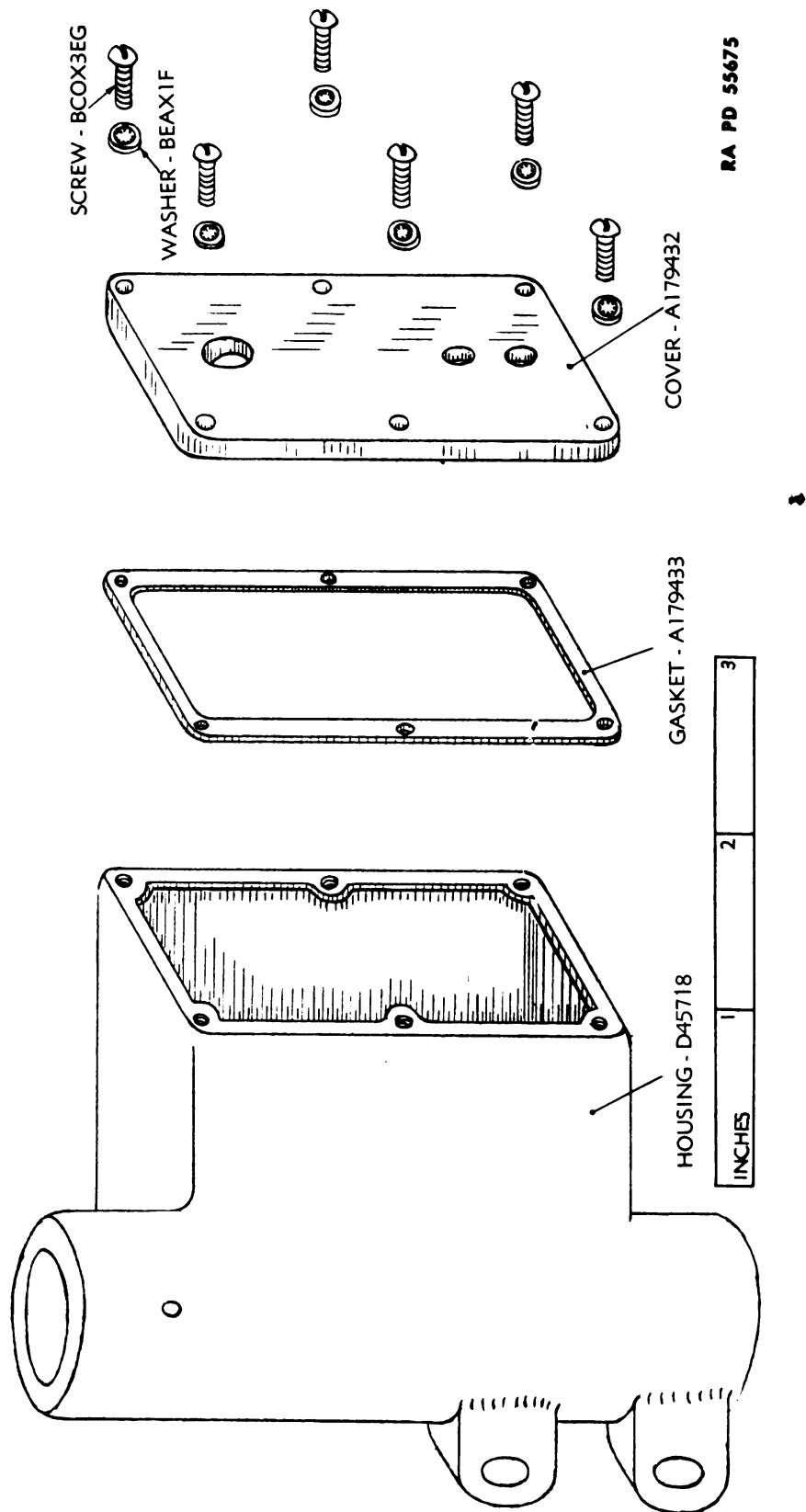
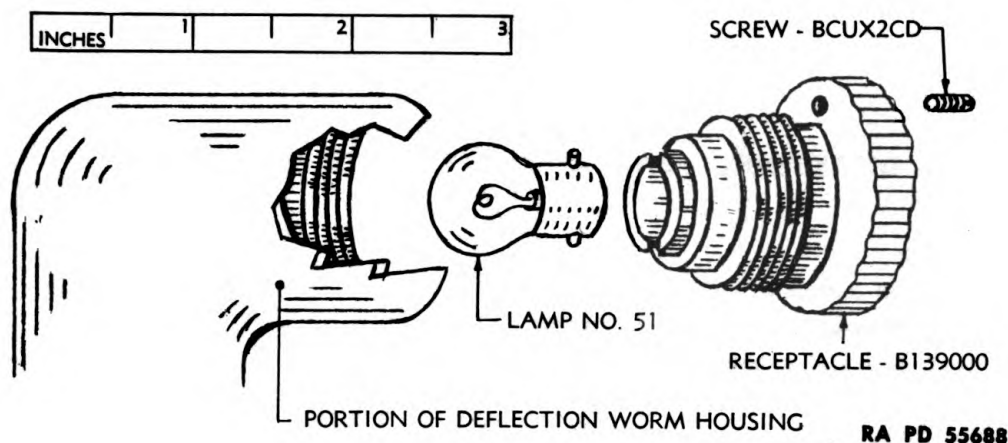


Figure 33—Deflection Worm Housing Cover—Exploded View

**DISASSEMBLY AND ASSEMBLY OF TELESCOPE MOUNT M35**



**Figure 34—Removal of Lamp from Deflection Worm Housing**

(2) The lamps in the deflection worm housing are removed as described in paragraph 29 h.

**d. Assembly.**

(1) Pack the deflection worm thread with **GREASE**, lubricating, special, before assembly. Assembly is the reverse of disassembly.

(2) If gear segment is being installed with oil pads assembled, be careful not to damage oil pad assembly when engaging rear end of gear segment with arc of deflection worm housing.

(3) When assembling the deflection worm housing onto the support, be careful not to force the bolt A203535 into the support at the left-hand side. The bolt has a very close fit in the support, and if forced, the surfaces are liable to become damaged and thereby affect the adjustment of the deflection worm.

**37. TELESCOPE MOUNT M35 ASSEMBLY.**

**a. Assembly** is performed in the reverse order of disassembly. Precautions to be taken in assembly are noted in several of the descriptions of disassembly and assembly of parts. Necessary adjustments are performed as indicated in section VI.

**b. All metal parts** which have been removed from the telescope mount should be carefully cleaned in **SOLVENT**, dry-cleaning, and allowed to dry in the air before reassembly.

**c. Inspection After Assembly.** After assembly inspect telescope mount to see requirements given in paragraph 14 a are met.

**d. Sealing After Assembly.** After assembly is complete, plug the exposed recesses above the various adjusting screws with cement, sealing or plugging, of the same color as the telescope mount. Smooth the cement to hide the openings as completely as possible. Paint over the openings and flush screws in accordance with instructions in section X.

ORDNANCE MAINTENANCE—TELESCOPE MOUNT M35 AND  
TELESCOPE M31

Section VIII

DISASSEMBLY AND ASSEMBLY OF TELESCOPE M31

	Paragraph
General .....	38
Eyepiece assembly disassembly and assembly .....	39
Lamp bracket assembly removal .....	40
Lamp bracket assembly disassembly and assembly .....	41
Reticle assembly disassembly and assembly .....	42
Ray filter assembly disassembly and assembly .....	43
Abbe prism assembly disassembly and assembly .....	44
Objective assembly disassembly and assembly .....	45
Telescope M31 assembly .....	46

**38. GENERAL.**

a. **Marking and Tagging Parts.** To insure correct positioning in the instrument on assembly, all optical elements and metal components should be carefully marked or tagged as they are disassembled. If parts are not so marked or tagged, difficulty may be encountered in the final adjustment. Reference marks should be scribed when deemed advisable. An indelible pencil or diamond may be used for marking on unpolished surfaces of optical elements. Metal components may be scribed, marked, or tagged. To prevent reversal of removed parts, a "v" may be marked on the removed parts with the point of the letter directed towards the objective end of the telescope.

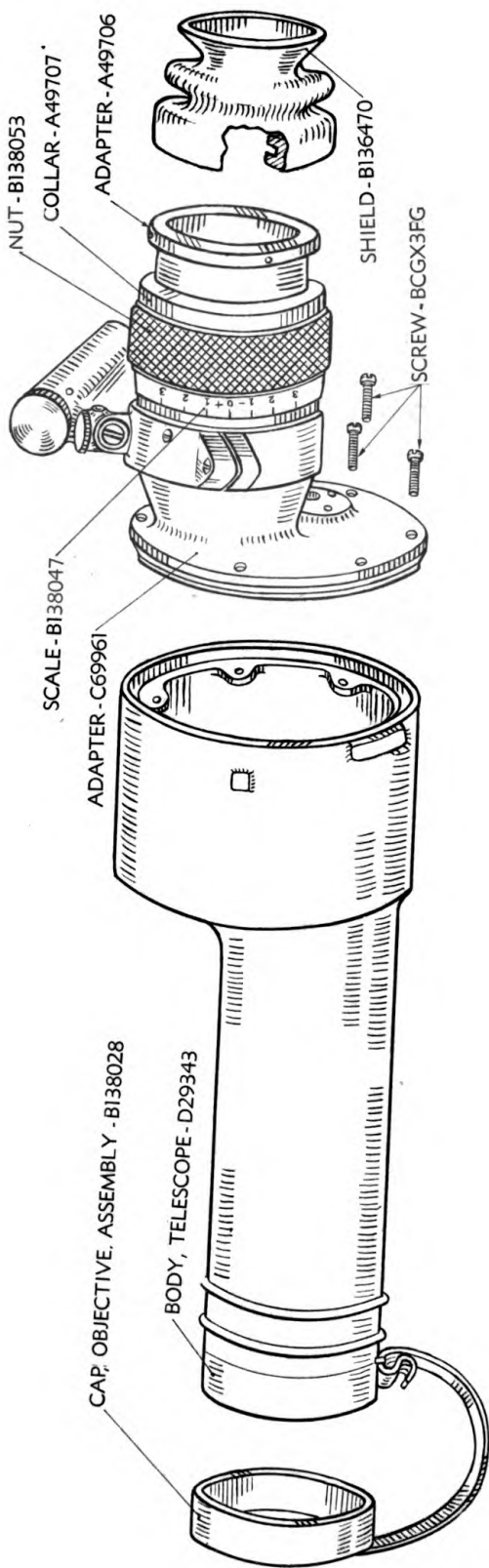
b. **Replacements.** Defective parts should be replaced from stock. Replacement of defective optical elements must be carefully checked as replacement of even one optical element may change the optical characteristics of the telescope and render readjustment necessary. Replacement of metal components is easily accomplished since the components are all standardized and available as replacements. Keep in mind, however, that the replacement of certain mechanical components which affect optical dimensions, such as the reticle cell, may cause parallax and affect the final adjustment of the telescope.

**39. EYEPIECE ASSEMBLY DISASSEMBLY AND ASSEMBLY.**

a. **Removal.**

(1) Turn the focusing nut B138053 so that the eyepiece lens cell B137988 extends outward as far as possible. Slip the eyeshield B136470 over the shoulder of the eyeshield adapter A49706 (figs. 35 and 36).

**DISASSEMBLY AND ASSEMBLY OF TELESCOPE M31**



RA PD 55662

**Figure 35—Telescope Body and Eyepiece Adapter Assembly—Exploded View**

ORDNANCE MAINTENANCE—TELESCOPE MOUNT M35 AND  
TELESCOPE M31

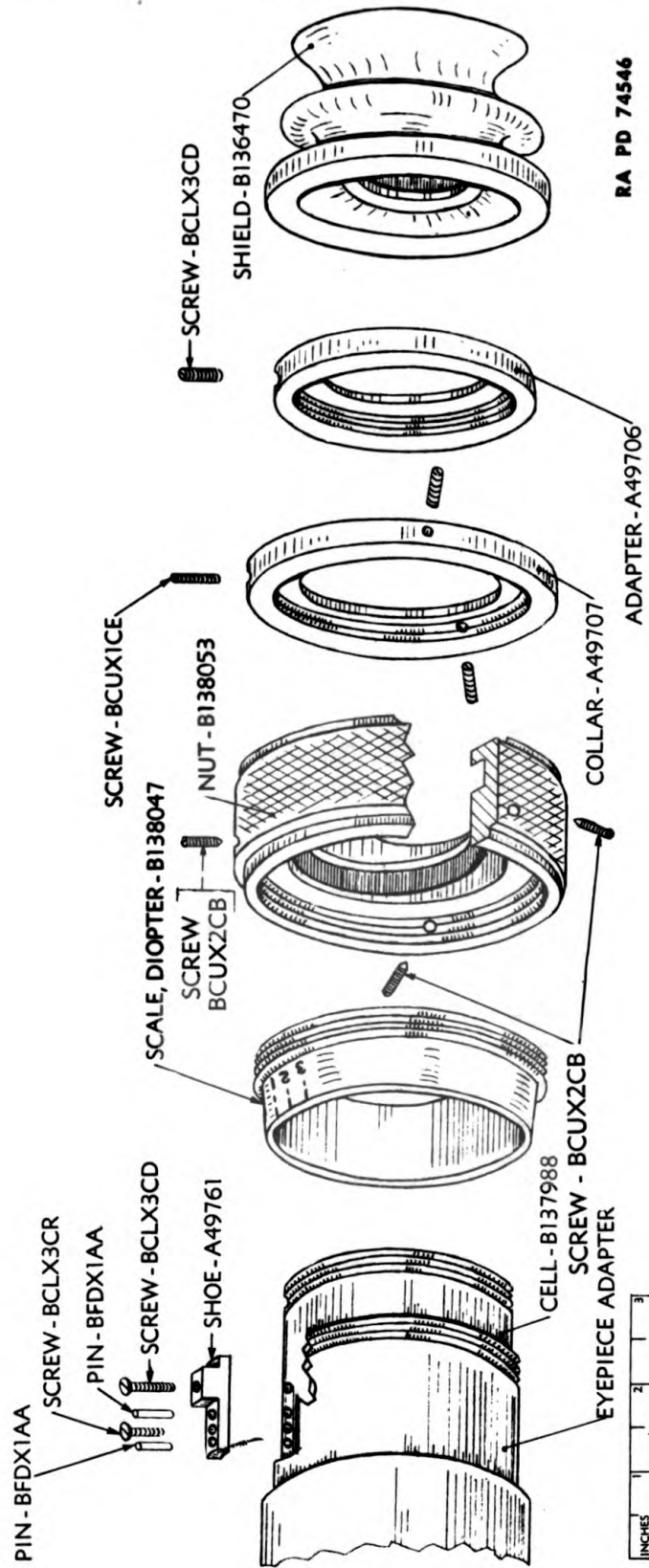


Figure 36—Focusing Nut and Eyepiece Cell Assembly—Exploded View

**DISASSEMBLY AND ASSEMBLY OF TELESCOPE M31**

(2) Remove the headless screw BCLX3CD from the eyeshield adapter and unscrew the eyeshield adapter from the eyepiece lens cell.

(3) Remove the three headless screws BCUX1CE from the focusing nut retaining collar A49707 and unscrew the collar from the eyepiece adapter C69961.

(4) Now turn the focusing nut backward off the shoe A49761 and remove it from the eyepiece adapter (fig. 36).

(5) To remove the shoe from the eyepiece lens cell, remove the two screws BCLX3CR and BCLX3CD from the top of the shoe. The two straight pins BFDX1AA remaining in the shoe have a drive fit and care should be used in removing them. If the shoe is gently pried upwards a little at a time at both ends, the shoe can gradually be released. When the shoe is removed draw the eyepiece assembly C69964 out through the end of the eyepiece adapter.

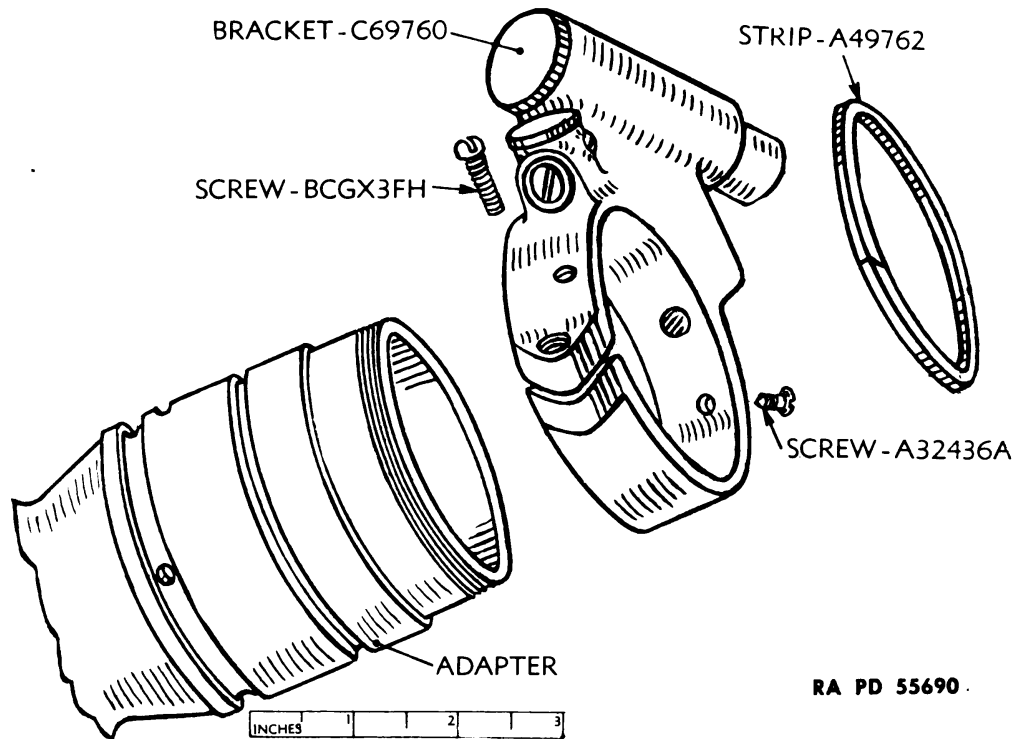
**h. Disassembly.** Loosen the headless screw BCUX1CB and remove the retaining ring A49763 from the eyepiece lens cell B137988 (fig. 10). Be careful when removing the retaining ring to see that the eyelens A46054 rides out on the ring to prevent slipping. Scribe a reference point at some convenient place on the eyepiece lens cell and mark a corresponding point on each lens and separator as they are extracted from the cell. It is important that the component parts of the eyepiece assembly go back into their original positions when assembling. Carefully remove the eyelens A46054 and wrap in clean PAPER, lens, tissue; store in a safe place to prevent possible damage or breakage. Follow the same procedure when removing the separator A49759, the collective lens A49765, the separator A49760, and the field lens A49766.

**c. Assembly.**

(1) Before assembling the eyepiece assembly, remove all dust from the interior of the eyepiece lens cell with the air bulb. See that the lenses and separators are clean. For care in handling optical parts, see paragraph 10 h. Assemble each lens and separator in the reverse order of disassembly making sure each part is assembled in the original position according to the reference marks. See that all components are fully seated. The retaining ring should be drawn up to firmness and secured by the headless screw BCUX1CB.

(2) Before inserting the eyepiece assembly in the eyepiece adapter, pack the three grease grooves on the outside of the eyepiece lens cell level full, but no more, with GREASE, lubricating, special. Be careful not to get any grease on the surface of eyepiece lens cell forward of the front groove. Insert the eyepiece lens cell in the eyepiece adapter and slide forward to limit of motion. Wipe off any excess grease that may

**ORDNANCE MAINTENANCE—TELESCOPE MOUNT M35 AND  
TELESCOPE M31**



**Figure 37—Lamp Bracket—Removal**

have collected on the rear of the eyepiece adapter. Apply a light film of **GREASE**, lubricating, special, to the internal thread and outer sides of the focusing nut and the focusing nut shoe.

**40. LAMP BRACKET ASSEMBLY REMOVAL.**

**a. Partial Removal.**

(1) This type removal is performed when it is desired to obtain access to the parts underneath the lamp bracket without further disassembling the telescope or eyepiece parts.

(2) Remove the two roundhead screws A32436A from the bracket C69760, and loosen the clamping screw BCGX3FH (fig. 7, section B-B and fig. 37). Slide the lamp bracket assembly C69963 forward on the eyepiece adapter C69961 to expose the four reticle positioning screws A48719, and the two illumination windows A178192.

**b. Complete Removal.**

(1) This type removal is performed when it is necessary to disassemble the lamp bracket assembly completely.

(2) Remove the eyeshield B136470, the eyeshield adapter A49706, and the focusing nut B138053 (subpar. a, above).

(3) Cut the felt strip A49762 and remove from the groove of the eyepiece adapter.

(4) Unscrew the two roundhead screws A32436A and clamping

DISASSEMBLY AND ASSEMBLY OF TELESCOPE M31

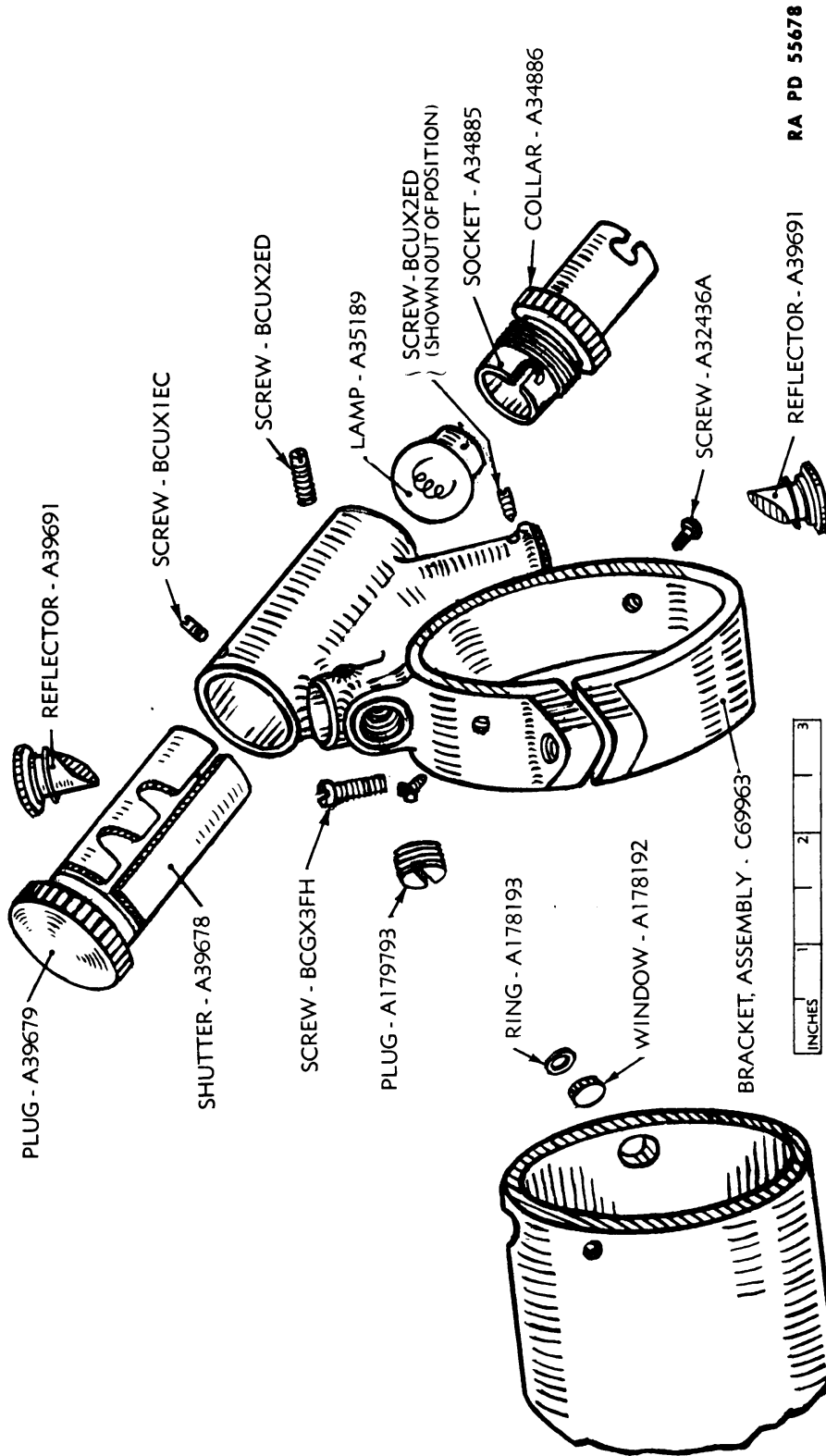
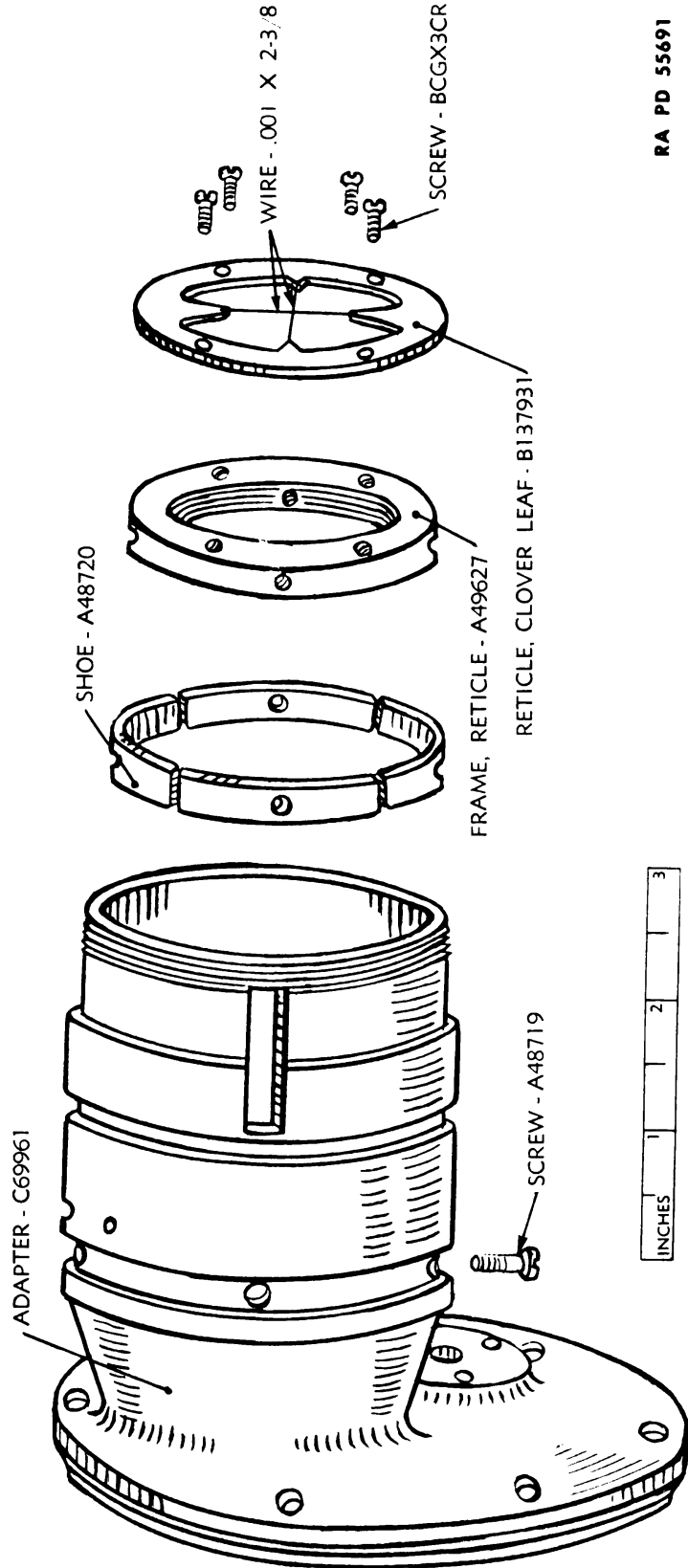


Figure 38—Lamp Bracket Assembly—Exploded View



ORDNANCE MAINTENANCE—TELESCOPE MOUNT M35 AND  
TELESCOPE M31

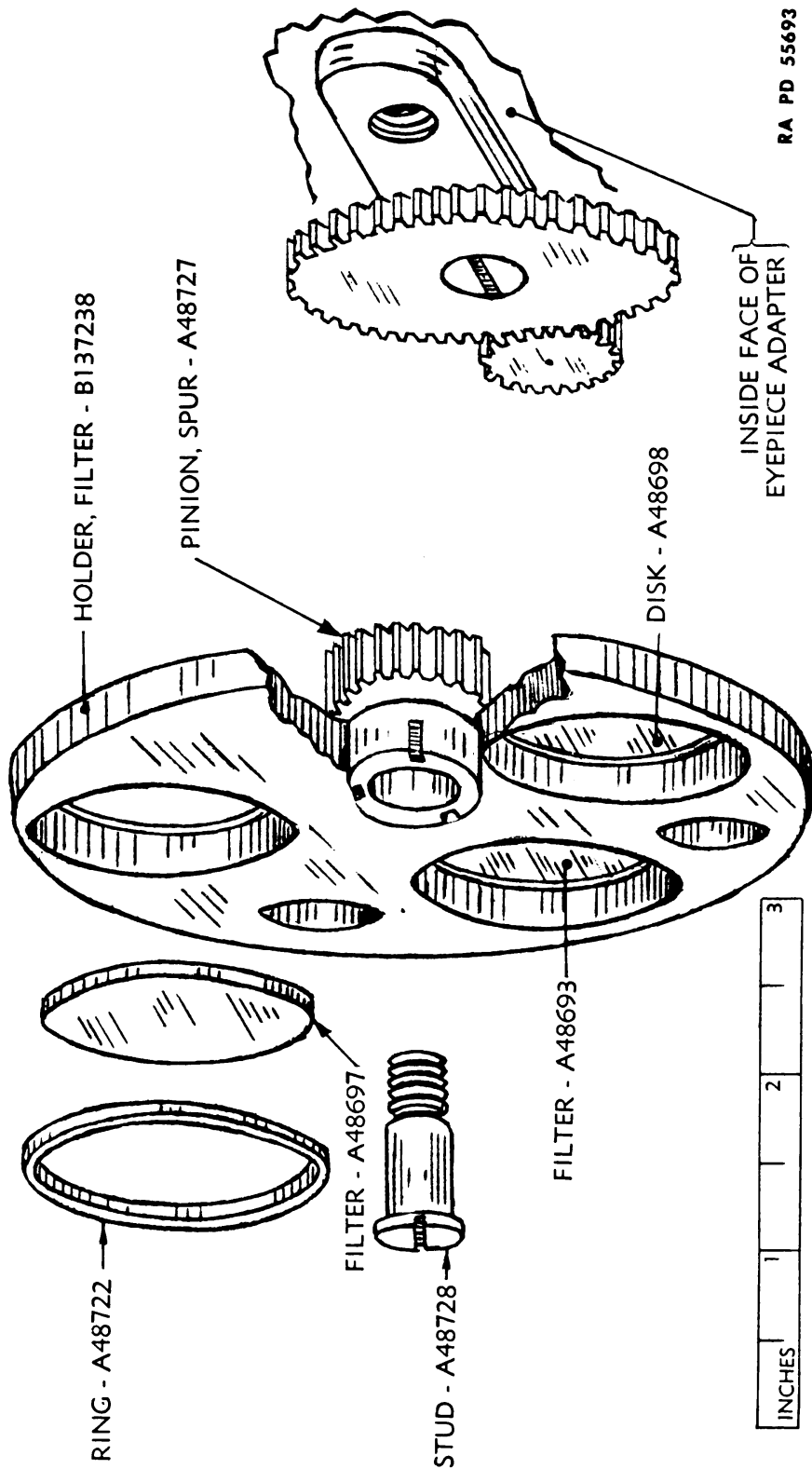


RA PD 55691

Figure 39 — Reticle Assembly — Exploded View

TM 9-1539  
40

**DISASSEMBLY AND ASSEMBLY OF TELESCOPE M31**



**Figure 40—Ray Filter Assembly—Exploded View**

**TM 9-1539**

**40-42**

**ORDNANCE MAINTENANCE—TELESCOPE MOUNT M35 AND  
TELESCOPE M31**

screw BCGX3FH (fig. 37). Remove the lamp bracket assembly from the eyepiece adapter.

**41. LAMP BRACKET ASSEMBLY DISASSEMBLY AND ASSEMBLY.**

**a. Light Shutter Removal.** Loosen the headless screw BCUX1EC from the light shutter plug A39679 at top of lamp bracket. Remove the light shutter plug and light shutter A39678 as a unit. The light shutter is sweated to the light shutter plug (fig. 7, section B-B and fig. 38).

**b. Reflector Removal.** Remove the positioning screw BCUX2ED, and unscrew the reflector A39691 from the lamp bracket. When assembling, be sure to see that each reflector is positioned and secured in the lamp bracket so the 45-degree face fully deflects the light from lamp A35189 onto the reticle.

**c. Socket Assembly Removal.** Unscrew the socket collar A34886 and remove the socket assembly.

**d. Lamp Removal.** Remove the lamp as described in paragraph 29 c.

**e. Assembly.** Assembly is the reverse of disassembly. After assembling the lamp bracket to the eyepiece adapter, fit a new felt strip A49762 in the groove of the telescope adapter and glue together the two beveled ends with VARNISH, shellac. After the glue or shellac is dry, apply one or two drops of OIL, lubricating, for aircraft instruments and machine guns.

**42. RETICLE ASSEMBLY DISASSEMBLY AND ASSEMBLY.**

**a. Exposing the Positioning Screws.** Remove the eyepiece assembly C69964, as described in paragraph 39, and the lamp bracket assembly C69963, as described in paragraph 40.

**b. Marking Parts.** Scribe corresponding marks on the eyepiece adapter and reticle assembly to assure same position when assembling.

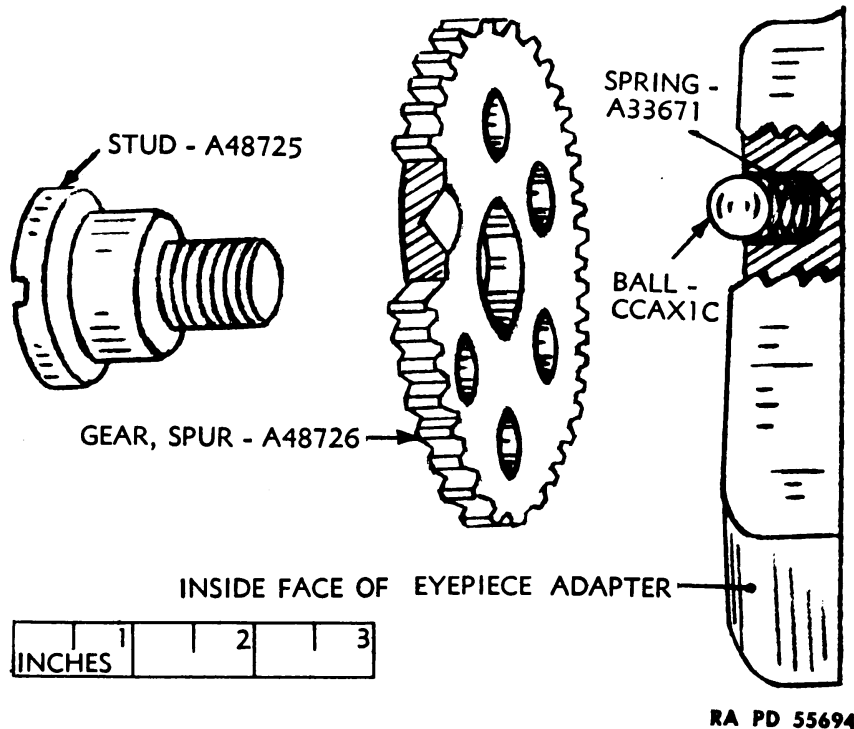
**c. Removal.** Remove the four positioning screws A48719, and four shoes A48720 (fig. 39). Support the reticle at the edges with the hook drawing tool (in instrument repair kit) so as not to damage the cross wires, and remove the reticle and frame from the eyepiece adapter.

**d. Clover Leaf Reticle Removal.** Remove the four screws BCGX3CR from the clover leaf reticle B137931 and remove the clover leaf reticle from the reticle frame A49627 (fig. 39).

**e. Cross Wires, Removal.** Unsolder the ends of the cross wires from the grooves in the clover leaf reticle and remove all solder from the grooves.

**f. Assembly.** Assembly is the reverse of disassembly.

## DISASSEMBLY AND ASSEMBLY OF TELESCOPE M31



**Figure 41—Spur Gear Assembly—Exploded View**

#### 43. RAY FILTER ASSEMBLY DISASSEMBLY AND ASSEMBLY.

**a. Eyepiece Adapter Removal.** Since the ray filter assembly B137994 is mounted on the inside face of the eyepiece adapter C69961 (figs. 10, 35 and 40), it will be necessary to remove the eyepiece adapter from the telescope body D29343 in order to remove the ray filter. Remove the six fillister-head screws BCGX3FG. Pry the eyepiece adapter loose from the telescope body carefully, as the sealing compound in the joint will tend to hold the two parts together.

**b. Marking Gear Teeth.** Before removal of the separate gears, scribe a mark across the matching teeth to assure the same tooth engagement when reassembling.

**c. Ray Filter Removal.** Unscrew the pinion stud A48728 (fig. 40). Remove the filter holder B137238 and spur pinion A48727 as a unit from the eyepiece adapter. The spur pinion should not be removed from the filter holder as it is staked in place and cannot be removed without destroying the parts.

**d. Filter Removal.** For replacement of filter, see paragraph 27 c.

**e. Spur Gear Removal.**

(1) Unscrew spur gear stud A48725 (fig. 41), and remove spur gear A48726.

(2) Remove ball CCAX1C and spring A33671 assembled in the eyepiece adapter C69961.

ORDNANCE MAINTENANCE—TELESCOPE MOUNT M35 AND  
TELESCOPE M31

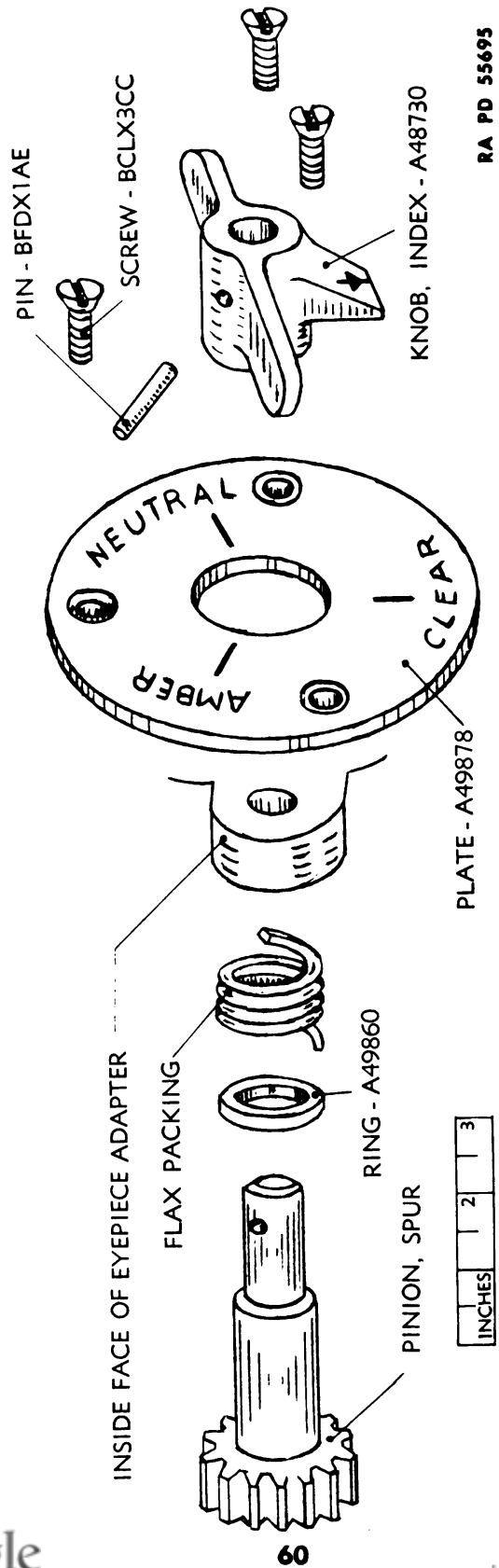
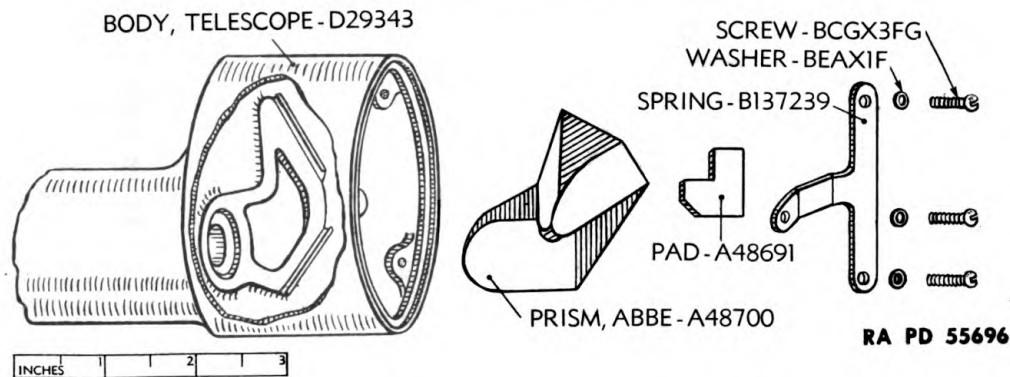


Figure 42—Spur Pinion and Filter Selector Knob Assembly—Exploded View

**DISASSEMBLY AND ASSEMBLY OF TELESCOPE M31**



**Figure 43—Abbe Prisms and Seat Assembly—Exploded View**

**f. Spur Pinion Removal.**

- (1) Drive out straight pin BFDX1AE from the filter selector knob A48730 (fig. 42), and remove the knob.
- (2) Remove the spur pinion A48724, being careful not to lose the packing ring A49860. Remove the flax packing.

**g. Assembly.**

- (1) When assembling the separate gears, be sure to match gear teeth according to the scribed markings on the teeth so the filter seen through the eyepiece will be correctly indicated by the filter selector knob on filter plate A49879.
- (2) Before assembling the ray filter assembly in the telescope, clean away all the old sealing compound in the joint. Apply new cement, sealing or plugging, being careful not to use an excessive amount, as the cement is likely to be worked into the telescope body when engaging the two parts. Keep the sealing cement below the inner edge of the telescope body joint to prevent this.

**44. ABBE PRISM ASSEMBLY DISASSEMBLY AND ASSEMBLY.**

**a. Disassembly.** Remove the three fillister-head screws BCGX3FG and washers from the retaining spring B137239 (fig. 43). Remove the retaining spring and pad A48691. Remove the prism assembly carefully from its seat. Wrap the prism in clean PAPER, lens, tissue, and store in a safe place until assembly.

**b. Assembly.** Before assembly, use the air bulb to remove all dust from prism seats. Be sure the prism faces are clean. See that the prism is fully seated before assembling the pad and retaining spring.

**45. OBJECTIVE ASSEMBLY DISASSEMBLY AND ASSEMBLY.**

**a. Removal.** Loosen the headless screw BCUX1EE in the under side of the telescope body D29343 (fig. 44), and unscrew the objective assembly B137992, using a spanner wrench (2½ inch span). It may be necessary to exert some force in starting the objective assembly due

ORDNANCE MAINTENANCE—TELESCOPE MOUNT M35 AND  
TELESCOPE M31

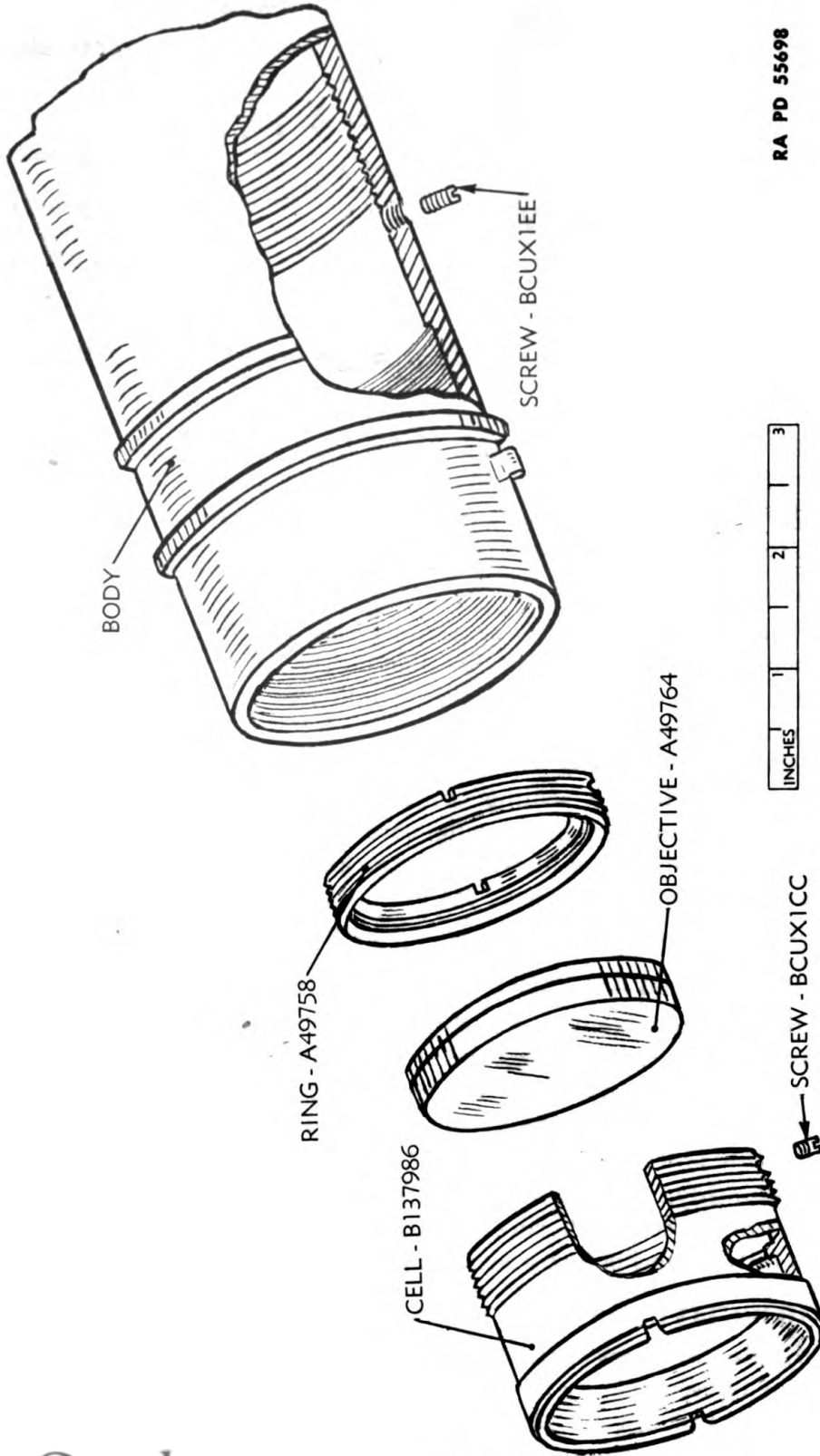


Figure 44—Objective Assembly—Exploded View

**DISASSEMBLY AND ASSEMBLY OF TELESCOPE M31**

to the sealing cement between the objective cell B137986 and the telescope body. Remove the objective assembly carefully from the telescope.

**b. Disassembly.** Unscrew the headless screw BCUX1CC in the objective cell B137986 (fig. 44). Unscrew the retaining ring A49758. Remove the objective from the cell. Mark the edge of the objective A49764 to insure correct positioning on assembly. Wrap the objective in clean PAPER, lens, tissue, and store in a safe place to prevent possible damage or breakage.

**c. Assembly.**

(1) Before assembling, remove all dust from the interior of the objective cell with the air bulb and see that the objective is clean. Replace the objective in its original position in the objective cell in accordance with the reference marks, making sure the objective is fully seated. Insert the retaining ring and draw up to firmness and secure with the headless screw BCUX1CC.

(2) Before assembling the objective assembly in the telescope body, clean away all old sealing cement from the objective cell and telescope body. Use the air bulb to remove all fine particles. Fill the external space around the objective cell with new CEMENT, sealing or plugging, and assemble in the telescope body. Adjust for parallax (par. 26) and when the adjustment is satisfactory tighten the headless locking screw BCUX1EE.

**46. TELESCOPE M31 ASSEMBLY.**

**a. Assembly of the telescope is performed in the reverse order of disassembly. Precautions to be taken in reassembly are noted in several of the descriptions of the disassembly and assembly of parts. Necessary adjustments are performed as indicated in section VI.**

**b. All metal parts from which optics have been removed, should be carefully cleaned in SOLVENT, dry-cleaning, and allowed to dry in the air before assembling.**

**c. Optical parts should be cleaned as described in paragraph 10.**

**d. Inspection After Assembly.** After assembly, inspect the telescope to see that it meets the requirements of paragraph 14 b.

**e. Sealing After Assembly.** After assembly is complete, plug the exposed recesses above the various adjusting screws with CEMENT, sealing or plugging, of the same color as the telescope. Smooth the cement to hide the openings as completely as possible. Paint over the openings and screw heads in accordance with instructions in section X.



**ORDNANCE MAINTENANCE—TELESCOPE MOUNT M35 AND TELESCOPE M31**

**Section IX**

**ASSEMBLING TELESCOPE MOUNT M35 TO GUN CARRIAGE**

	Paragraph
Assembly of telescope mount M35 to carriage or mounting bracket .....	47
Disassembly of telescope mount M35 from carriage or mounting bracket .....	48

**47. ASSEMBLY OF TELESCOPE MOUNT M35 TO CARRIAGE OR MOUNTING BRACKET.**

**a. Preparation.** Clean the mating surfaces between the support and the carriage of mounting bracket. Surfaces should be clean and smooth. Smooth any burred edges with a fine file. Grease the mating surfaces lightly.

**b. Straight Pin.** Drive the straight pin BFDX2CE into position in the hole in the upper surface of the bracket, towards the rear (fig. 4, section A-A). Be careful, while driving the straight pin, not to upset or bur the head. If any burs are produced, smooth them with a fine file.

**c. Front Bearing.**

(1) With the front stud A179436 assembled in the telescope mount, and with nut BBAX2B and washer BECX1P removed, place the telescope mount over the bracket and enter the front stud in its hole in the bracket.

(2) Lower the telescope mount until the hole in the support engages the straight pin. Press the telescope mount downward with the hands onto the straight pin as far as it will go. (It can be drawn up tight later on by the nuts on the front stud and the two rear fillister-head clamping screws.) Place the washer and nut on the front stud.

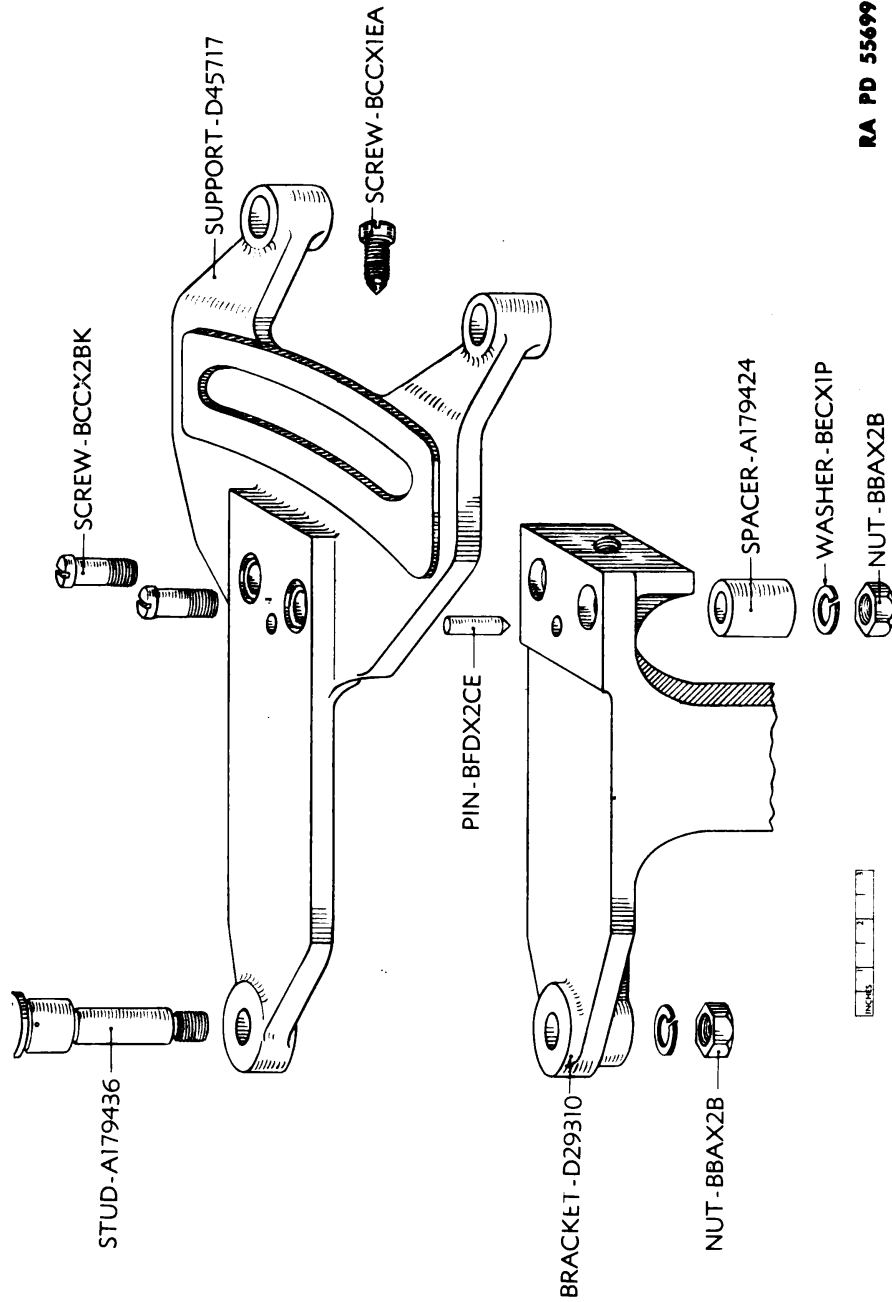
**d. Rear Clamping Screws.** Insert the two fillister-head clamping screws BCCX2BK through the support and bracket. Place the two spacers A179424, washers BECX1P, and nuts BBAX2B on the fillister-head clamping screws. To secure full contact between the surface of the support and the bracket, draw up evenly and tightly the two rear clamping nuts and front stud nut.

**e. Rear Screw.** Screw in the fillister-head screw BCCX1EA in the rear face of the support and tighten.

**f. Electrical Connections.** Connect electrical terminals to source of power.

**g. Bore Sighting.** The gun must be bore sighted by the using arm each time the telescope mount is replaced.

DISASSEMBLY AND ASSEMBLY OF TELESCOPE M31



RA PD 55699

Figure 45—Support and Bracket Assembly—Exploded View

ORDNANCE MAINTENANCE—TELESCOPE MOUNT M35 AND  
TELESCOPE M31

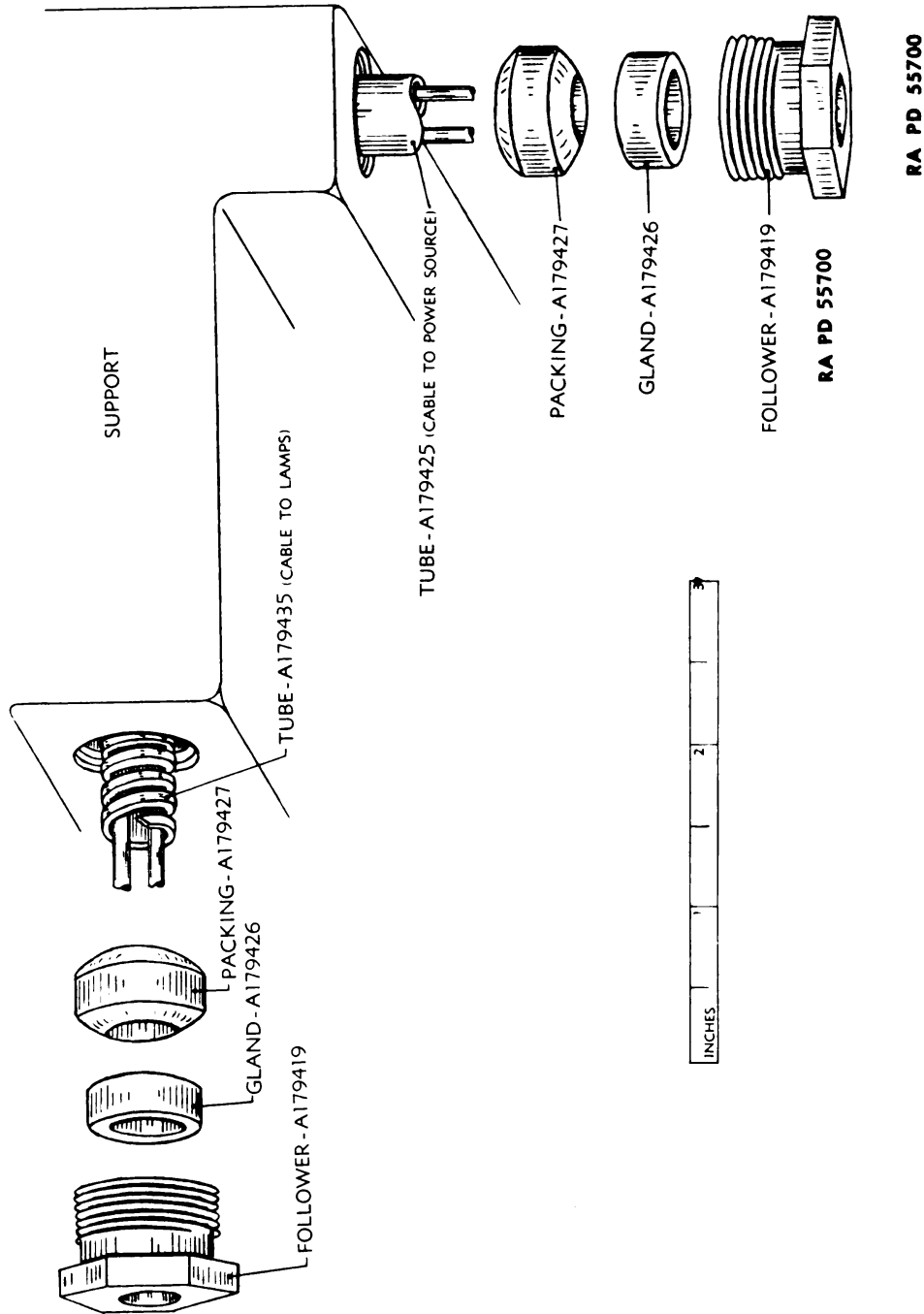


Figure 46—Power Source Assembly—Exploded View

**ASSEMBLING TELESCOPE MOUNT M35 TO GUN CARRIAGE****48. DISASSEMBLY OF TELESCOPE MOUNT M35 FROM CARRIAGE OR MOUNTING BRACKET.**

**a. Preparation.** Disconnect the outside cable from source of power as described in paragraph 36 **b** and **c**. Remove the extension cable between the telescope lamp bracket socket A34885 and the deflection worm housing socket A178646. Remove the telescope from the cradle.

**b. Removal of Telescope Mount From Bracket.** The telescope mount is disassembled from the carriage or mounting bracket in the reverse order of assembly as described in paragraph 47. The straight pin BFDX2CE has a drive fit in both the support and bracket, and is the last bond to be broken before removal of the telescope mount. Pry the support upwards gradually until the straight pin is released. Then lift the telescope mount further so the front stud clears the bracket and remove.

**TM 9-1539  
49-50**

**ORDNANCE MAINTENANCE—TELESCOPE MOUNT M35 AND  
TELESCOPE M31**

**Section X**

**PAINTING**

	<b>Paragraph</b>
Touch-up painting .....	49
Over-all painting .....	50

**49. TOUCH-UP PAINTING.**

a. Small scratches or worn spots, as well as unavoidable blemishes caused by assembly or adjusting operations, should be touched up with an air-drying enamel of a practical color match of the original finish.

**50. OVER-ALL PAINTING.**

**a. General.**

(1) Occasionally instruments are received at the arsenals for repairs which malfunction because excessive enamel has entered bearings and bearing surfaces. The effect of enamel or paint on bearing surfaces and in bearings is obvious.

(2) In order to eliminate the conditions described above, the painting of fire control instruments by the using arms is prohibited.

(3) The painting of instruments, when done by ordnance personnel, must be supervised by someone who is familiar with the functioning of the instruments, and who is in a position to caution against the application of enamel to bearing surfaces, machined locating surfaces, etc. The paint to be required will be governed by the instrument to be serviced.

**b. Preparing for Painting.**

(1) All surfaces to be painted must be dry and free of dirt, oil, grease, and rust. For cleaning use SOLVENT, dry-cleaning, and rinse with hot water. Dry in an air stream. It must be remembered that frequent washing of metal components in the same batch of solvent will soon render it unfit for further use, since it easily becomes saturated with grease, oil, and dirt. The solvent must be changed frequently.

(2) Remove loose enamel around marred parts by rubbing those parts with PAPER, flint, No. 1. Dust off all loose sand and enamel flakes, and clean as described above.

c. **Painting.** Apply the enamel with a brush or spray gun. Exercise care to avoid splashing or spraying enamel on parts which are not to be painted. Finished colors must match authorized or prescribed hues. Minor deviations of pigment proportions are permissible, if necessary to match colors. The exterior parts will be universally painted with ENAMEL, synthetic, olive-drab, lusterless.

**Section XI**

**REFERENCES**

	Paragraph
Standard nomenclature lists .....	51
Explanatory publications .....	52

**51. STANDARD NOMENCLATURE LISTS.**

Cleaning, preserving and lubricating materials; recoil fluids, special oils, and miscellaneous related items .....	SNL K-1
Kit, repair instrument, M4 .....	SNL F-206
Mount, telescope, M35 (for 6-in., 8-in., 16-in. barbette carriages and 90-mm A. A. gun mount T2E1) .....	SNL F-234
Soldering, brazing and welding materials, gases and related items .....	SNL K-2
Telescope, M31 (for 6-in., 8-in., 16-in. barbette carriages and 90-mm A. A. gun mount T2E1) ..	SNL F-234
Truck, 2½-ton, 6 x 6, instrument repair, M10 (load B) .....	SNL G-141
Current standard nomenclature lists are as tabulated here. An up-to-date list of SNL's is maintained as the "Ordnance Publications for Supply Index" .....	OPSI

**52. EXPLANATORY PUBLICATIONS.**

Chemical decontamination materials and equipment .....	TM 3-220
Cleaning, preserving, lubricating, and welding materials and similar items issued by the Ordnance Department .....	TM 9-850
Defense against chemical attack .....	FM 21-40
Instruction guide: Instrument repairman .....	TM 9-2602
Maintenance of materiel in the hands of troops .....	OFSB 4-1
Sighting and fire control instruments—lubrication—general .....	OFSB 6-9
6-inch seacoast materiel: Guns M1903A2 and M1905A2; barbette carriage M1 .....	TM 9-428

**TM 9-1539**  
**52**

**ORDNANCE MAINTENANCE—TELESCOPE MOUNT M35 AND  
TELESCOPE M31**

8-inch seacoast materiel: Gun Mk. V1 mod. 3A2;  
barbette carriage M1 . . . . . TM 9-442

16-inch seacoast gun materiel: Gun Mk. II M1;  
barbette carriage M4 . . . . . TM 9-471

90-mm gun M1 and 90-mm antiaircraft gun  
mount T2E1 . . . . . TM 9-371

**ORDNANCE MAINTENANCE—TELESCOPE MOUNT M35 AND TELESCOPE M31**

<b>E</b>	Page No.	<b>E</b>	Page No.
Electrical components, removal	47-49	tolerances	22-23
Electrical equipment used with telescope	17	tools for inspection and repair	24-25
Electrical repairs	34-35	Instructions for soldering	35-36
Electrical wiring, description	5	<b>L</b>	
Elevating knot, removal	43	Lamp bracket assembly	
Elevating mechanism		assembly and disassembly	58
assembly	43	removal	54-58
backlash or binding in	30-31	Light shutter, removal	58
disassembly	40-43	<b>M</b>	
inspection, basic	26	Maintenance and repair	
Elevation screw		abbe prism assembly	34
description	4-5	backlash or binding	
removal	40	deflection mechanism	31-32
Elevation screw socket and cap, removal	42	elevation mechanism	30-31
Eyepiece adapter assembly		diopter scale setting	33
description	7	electrical repairs	34-35
removal	59	elimination of parallax	33-34
Eyepiece assembly		facilities for making repairs	30
assembly	53-54	instructions for soldering	35-36
disassembly	53	precautions	30
removal	50-53	ray filter assembly	34
<b>F</b>		reticle repair and alinement	32-33
Facilities needed for inspection	25	Metal parts, care and preservation	20
Front bearing		Mount, telescope, M35	
assembly	64	assembling to carriage or mounting bracket	64
removal	40	assembly	49
<b>G</b>		characteristics	3
Gear segment		description	4-5
assembly	40	disassembling from carriage or mounting bracket	67
description	4	inspection, basic	25-26
disassembly	40	<b>O</b>	
elimination of backlash or binding	31-32	Objective assembly	
removal	40	assembly and disassembly	63
Gear segment pads, lubrication	21	removal	61-63
<b>I</b>		Oil fittings, inspection	25
Inspection		Optical characteristics of telescope	15
action to be taken	29	Optical parts, care and preservation	19-20
basic inspection		Over-all painting	68
telescope M31	26-29	<b>P</b>	
telescope mount M35	25-26	Painting, touch-up and over-all	68
facilities needed for inspection	25	Parallax	
inspection requirements	24	elimination of	33-34
mount	49	inspection for	29
purpose	22		



INDEX

<b>P—Cont'd</b>	<b>Page No.</b>	<b>T</b>	<b>Page No.</b>
Partial removal of lamp bracket assembly .....	54	Telescope lamp bracket, replacement .....	35
<b>Precautions</b>		<b>Telescope M31</b>	
elimination of parallax.....	33	assembly .....	63
lubrication of optical parts....	20	characteristics .....	3
		description	
		eyepiece adapter assembly... ..	7
		optical characteristics .....	15
		telescope body .....	7
		disassembly .....	50-63
		inspection, basic .....	26-29
		<b>Thumbscrew, removal .....</b>	<b>37</b>
		<b>Tools for inspection and repair.</b>	<b>24-25</b>
		<b>Touch-up painting .....</b>	<b>68</b>
		<b>W</b>	
		<b>Worn cradle guides</b>	
		basic inspection .....	25
		maintenance and repair.....	31

[ A.G. 300.7 (19 Jun 43)  
O.O. 461/42808 R.A. (5 Aug 43) ]

BY ORDER OF THE SECRETARY OF WAR:

G. C. MARSHALL,  
*Chief of Staff.*

OFFICIAL:

J. A. ULIO,  
*Major General,  
The Adjutant General.*

DISTRIBUTION: R 9(4); Bn 9(2); C 9(8)

(For explanation of symbols, see FM 21-6)

