

*Support*

# No. 21

**RESTRICTED**

## SIGNAL CORPS

## TECHNICAL

# INFORMATION LETTER

## *AUGUST · 1943*

**ARMY SERVICE FORCES · OFFICE OF THE CHIEF SIGNAL OFFICER**

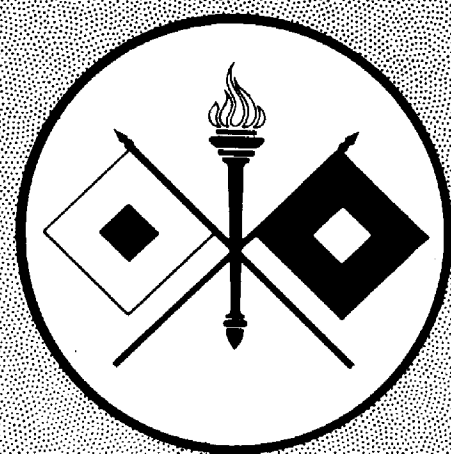

DECLASSIFIED  
 Authority E.O. 10501  
 By fc NARA Date 1/25/11

# SIGNAL CORPS TECHNICAL INFORMATION LETTER

Number 21

• August 1943

## **RESTRICTED**

This document contains information affecting the national defense of the United States within the meaning of the Espionage Act (U.S.C. 50:31, 32). The transmission of this document or the revelation of its contents in any manner to any unauthorized person is prohibited.

WAR DEPARTMENT • ARMY SERVICE FORCES  
OFFICE OF THE CHIEF SIGNAL OFFICER  
EXECUTIVE OFFICE • SPECIAL ACTIVITIES BRANCH

# SCTIL

## *PURPOSE*

Signal Corps Technical Information Letter (SCTIL) is issued monthly for the purpose of keeping officers in charge of field activities informed on the newest training methods, operational procedures, equipment under development, standardization or procurement, and providing other pertinent information as coordinated in the Office of the Chief Signal Officer.

## *SOURCE OF MATERIAL*

This Letter is compiled largely from information available in the divisions and branches of the Office of the Chief Signal Officer. All Signal Corps training centers and other agencies are invited to submit items of general interest. Such items should reach the Office of the Chief Signal Officer (SPSAY) not later than the 15th of each month for inclusion in the Letter of the following month.

## *DISTRIBUTION*

Distribution of the Letter is made to army, corps, and division signal officers; commanding officers of signal companies and battalions; service command and department signal officers; post, camp, and depot signal officers; the signal officers of bases and task forces; Signal Corps inspection zones, procurement districts, training centers and laboratories; directors of Signal Corps ROTC units; signal officers of Army Air Forces and Army Ground Forces headquarters and major commands; overseas headquarters; units of the Office of the Chief Signal Officer and of Headquarters, Army Service Forces.

If any such activity is not receiving the letter or is receiving too few or too many copies for its present needs, a memorandum addressed to the Chief Signal Officer (SPSAY), Washington, will rectify the condition.

\*\*\*\*\*

This Letter is for information only. Requisitions for new types of equipment should not be submitted on the basis of data contained in this Letter.

# TABLE OF CONTENTS

COMBAT COURSE CONSTRUCTION . . . . .	5
NEWEST LIST OF VACUUM TUBE TYPES . . . . .	8
VISUAL TRAINING AIDS	
Demonstrator of V-T Characteristic Curves . . . . .	9
Simplex and Phantom Circuits Demonstrator . . . . .	13
Vacuum Tube Operation Demonstrator. . . . .	15
OPERATING TESTS OF THE SCR-299 WITH DOUBLET ANTENNA. . . . .	21
SIGNAL CORPS PHOTOGRAPHERS IN TUNISIA. . . . .	25
"THE SIGNAL MUST GET THROUGH" - - - . . . . .	28
"HANDBOOK FOR RADAR OFFICERS". . . . .	29
FUNDAMENTALS OF CARRIER COMMUNICATIONS . . . . .	30
IMPROVISED BRIDLE RING . . . . .	37
SIGNAL CORPS WANTS 1-10 KW USED TRANSMITTERS . . . . .	38
OCSigO LIBRARY . . . . .	39
EQUIPMENT NOTES	
Equipment Coordination . . . . .	40
Directives Forwarded to the Signal Corps Board . . . . .	40
Signal Corps Board Reports Approved by the Chief Signal Officer. . . . .	40
Ground Signal . . . . .	44
Telephone Kits Now Available for Radio Set SCR-551-T1 and SCR-551-T2 . . . . .	46
Radio Receiver Outputs Are Modified for Headset HS-30-( ). . . . .	46
Report on Captured Enemy Equipment . . . . .	48
Standardisation of Crystal Units . . . . .	50
Two-Piece Power Unit . . . . .	52
MILITARY TRAINING	
Responsibility for Supervision of Installations . . . . .	53
Films on Proper Use of Tools. . . . .	53
Film Strips on Radio Set SCR-284. . . . .	53
Publications. . . . .	54
Reduced Quotas Lead to Changes in OCS Curriculum. . . . .	54
Engine and Chassis Laboratory in Officers' School . . . . .	55
Restoration of Damaged Lines. . . . .	58
Training Civilian Technicians for Airborne Radio and Radar. . . . .	59
SHOULD INSTRUCTORS PREVIEW TRAINING FILMS? . . . . .	62
NEW MESSAGE CENTER NUMBER SHEET. . . . .	63
PROCUREMENT	
New Device Promises to Improve Mica Situation . . . . .	64
Phenolic Resins . . . . .	65
Electronic Tubes Present Material Problems. . . . .	66
IDENTIFICATION SIGN FOR BLACKOUTS. . . . .	67
MILITARY INTELLIGENCE	
Radio Communication for German 105-MM Gun Battery . . . . .	68
Axis Smoke Codes and Signals. . . . .	69
MILITARY ORGANIZATION	
Transferred . . . . .	70
Disbanded . . . . .	70
Reorganized . . . . .	70
Redesignated. . . . .	71
Reassigned. . . . .	71
Permanent Changes of Station. . . . .	71
Activations . . . . .	71
MILITARY PERSONNEL	
WAAG Personnel on Duty with the Signal Corps. . . . .	72
WAACs or WACs?. . . . .	73
New Signal Corps Officer Replacement Sub-Pool . . . . .	73
Army Specialized Training Program . . . . .	73
Freeze on Appointments from Civilian Life . . . . .	74
Signal Corps Enlisted Personnel . . . . .	74
Temporary Suspension of Promotions. . . . .	74
Officer Promotions. . . . .	75





FIELD MESSAGE CENTER IN  
OPERATION DURING WAR GAMES  
IN TAHOE NATIONAL FOREST  
FOR CAMP KOHLER TRAINEES

# COMBAT COURSE CONSTRUCTION

In response to lessons learned in initial engagements of American troops, combat conditioning courses in training centers are constantly being stiffened to simulate the noise, confusion, hardships and dangers of actual battle. The experience of the Eastern Signal Corps Replacement Training Center in creating a training area to meet these requisites may be of value to other units that are working on this aspect of training.

The ESCRTC course is laid out in a circular arrangement so that no time is lost in moving groups from one place to another. Local terrain, chosen for its variety of features -- ridges, hills, thick and light woods, open areas, draws, marshes, streams and valleys -- offers positions for many typical field fortifications and obstacles.

The company is divided into the same squads that have been used during preliminary extended order training. Each squad begins at a different phase of the combat course so that the instant the 7 o'clock cannon is fired, all men move forward simultaneously.

## Variety of Obstacles

The soldier encounters mustard gas, simulated both as to appearance and odor. He must quickly don his mask and choose a safe path through the wood and brush. And when the squad leader says "Remove and replace mask," the man who fails to test for gas is tabbed as a casualty.

Snipers at an enemy observation post fire blank ammunition as the squad attacks, and the officer in charge keeps a record of the men who expose themselves to this fire in approaching the position. The squad crosses a cable bridge and on the far side encounters a vast barbed-wire entanglement. The barbed wire, as shown in Figure 4, is constructed with just enough clearance for a man to creep and crawl beneath it for about 100 yards.

As the squad moves along, machine gun and rifle fire suddenly break out overhead, encouraging the soldier to hug the ground even more tightly than he is being forced to do by the barbed wire.

Other forms of opposition commonly encountered in the field -- anti-tank guns, paratroopers, machine gun nests, and enemy bivouacs -- are dealt with in turn. Firecrackers, blanks and nitro-starch explosions furnish characteristic battle noises.

After each phase is completed, an enthusiastic, trained umpire gives the squad an on-the-spot critique of individual and collective performances.

To impress the dangers of booby traps as strongly as possible upon the



FIG. 1 - LOOKING DOWN A STREET OF THE SIMULATED BATTLE-FRONT VILLAGE..

neophyte soldier, an old house (Figure 3) in the training area has been filled with begged and borrowed furniture. At each point where intelligence reports indicate that booby traps are actually being encountered, a specially constructed device awaits the unwary soldier. Forewarned by a sign on the door which reads: "When the bell rings, St. Peter says hello," the man who

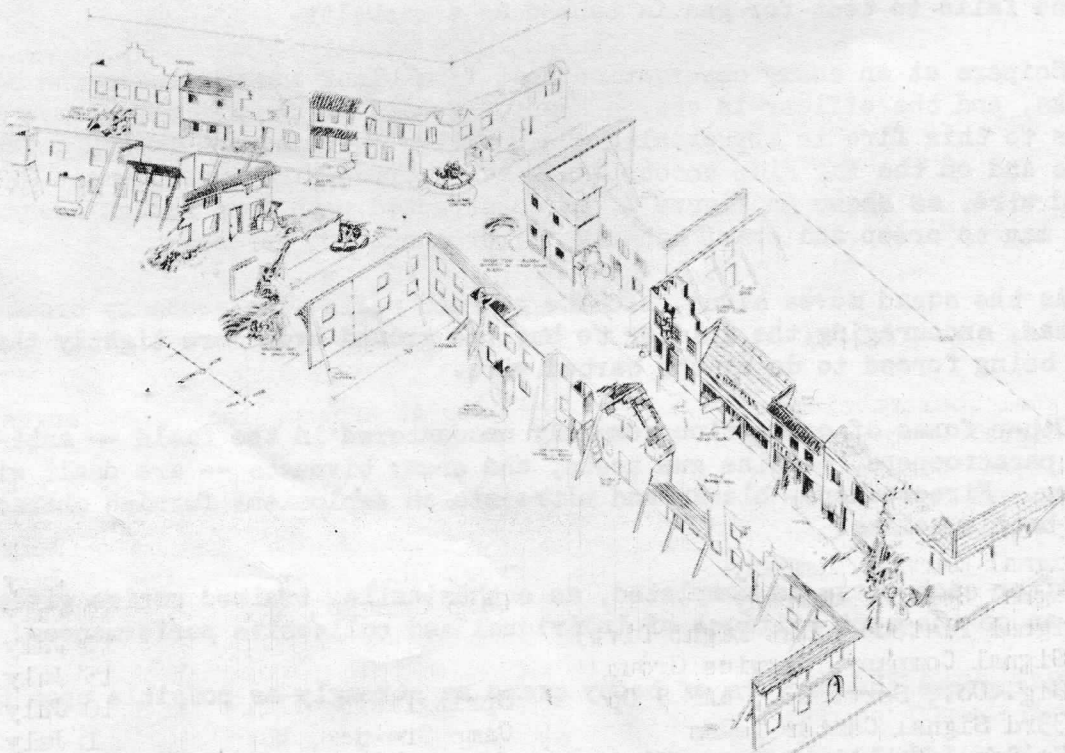

FIG. 2 - A SKETCH OF THE NAZI VILLAGE SHOWING SOME OF THE CONSTRUCTION DETAILS.



sits lazily on the rocking chair, or snatches a Nazi pistol or rifle as a souvenir, or reaches into the icebox to see if the Boche left any beer behind, will be reminded by the clattering of a gong that the next time he moves before looking he may be a dead soldier.

### Nazi Territory

Most elaborate of all the installations, however, is the German village. As shown in Figures 1 and 2, the village consists of a long street with an intersection about midway through it. The village was designed by the Visual Aids Section of Plans and Training.

After considerable research at the post library to provide accuracy of architectural detail, the task of securing the material and the labor began. A search was made for nearby condemned property and, in one case, an entire two-story house was wrecked and the material removed to the combat course. Local lumber and brick yards cooperated by selling second-hand material at extremely reasonable figures. Ersatz cement binder was devised, but it proved necessary to spend money for the red, white, green and black paint used. Soldier labor provided the necessary manpower, under the supervision of company mechanics and the Training Aids Section, while the Post Engineer supplied Civil Service employees for bricklaying. Altogether the planning and construction of the village required about five weeks.

As the squad approaches the village street, the men encounter sand-bagged machine gun emplacements, each of which is manned by cadreman and must be overcome. The village itself

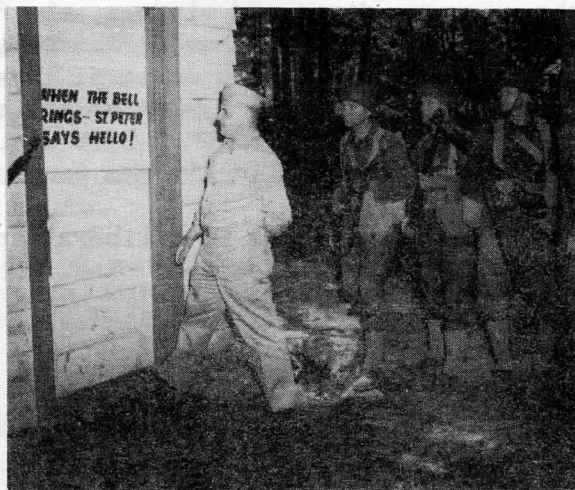

FIG.3- ESCRTC COMMANDING GENERAL EDGAR L. CLEWELL CONTEMPLATES THE "BOOBY-TRAP HOUSE" WHERE EVERY PIECE OF FURNITURE REPRESENTS A POTENTIAL HAZARD.



FIG.4- HE HAS TO KEEP FLAT! A TOUCH OF THE WIRE CAUSES THE TELL-TALE CAN (EXTREME RIGHT) TO RATTLE.

gives the appearance of having undergone a recent shelling, with battered walls, toppled telegraph poles and numerous shell holes. The squad leader deploys his men along both sides of the street; then, as soldiers twist past the numerous doors and windows, the "Germans" hidden behind second-story windows open fire on them. Platforms with ladders have been built at appropriate places for these snipers. Controlled from a room at the end of the street which commands a view of the entire area, explosive charges are detonated in the shell holes. Dirt and debris from the blast hit the soldiers, and they automatically hit the ground.

Here, too, there is a liberal sprinkling of booby traps, not to teach the soldier to be afraid of them, but to remind him always to be alert in looking for them.

### Other Conditioning Factors

The ESCRTC combat conditioning course is four miles long. Having received his "K" ration in the morning, the soldier is kept in action for thirteen successive hours, eating his meals and husbanding his one canteen of water as he proceeds from phase to phase.

The company breaks camp before dawn the following morning and marches eight miles to the next bivouac area.

To accommodate approximately 250 soldiers at one time, a number of the fifteen different phases have been designed to employ defending squads as well as attackers, and by this means one of the most important aspects of genuine combat is achieved: Uninterrupted action in the face of constantly changing problems.

The continued success of the combat course depends, it is believed, upon constant policing and maintenance of present installations, and the creation of simple, practical obstacles to correspond with new zones and new lessons of battle.

## NEWEST LIST OF VACUUM TUBE TYPES

A new and comprehensive list of approximately 1,200 vacuum tube types, arranged by commercial numbers but also including the Signal Corps and any other existing numbers for each tube, has been prepared by the Research and Development Division, OCSigO. In addition to listing as completely as possible all tubes employed in Signal Corps equipment or carried in Signal Corps depots, this 8-page folder describes the latest tube numbering practice, including the Joint Army-Navy tube designation system which will replace the old VT system of designations.

Copies of this folder, "Correlation of Signal Corps Vacuum Tube Types," are obtainable from the above Division.

# VISUAL TRAINING AIDS

## DEMONSTRATOR OF V-T CHARACTERISTIC CURVES

In past issues of the Technical Information Letter, several of the visual training aids employed in the Southern Signal Corps School have been described. These aids are used to augment lectures and class room study in both radio and preliminary Radar training. This article will describe another such training aid that is used in teaching the fundamental theory and operation of vacuum tubes as circuit elements.

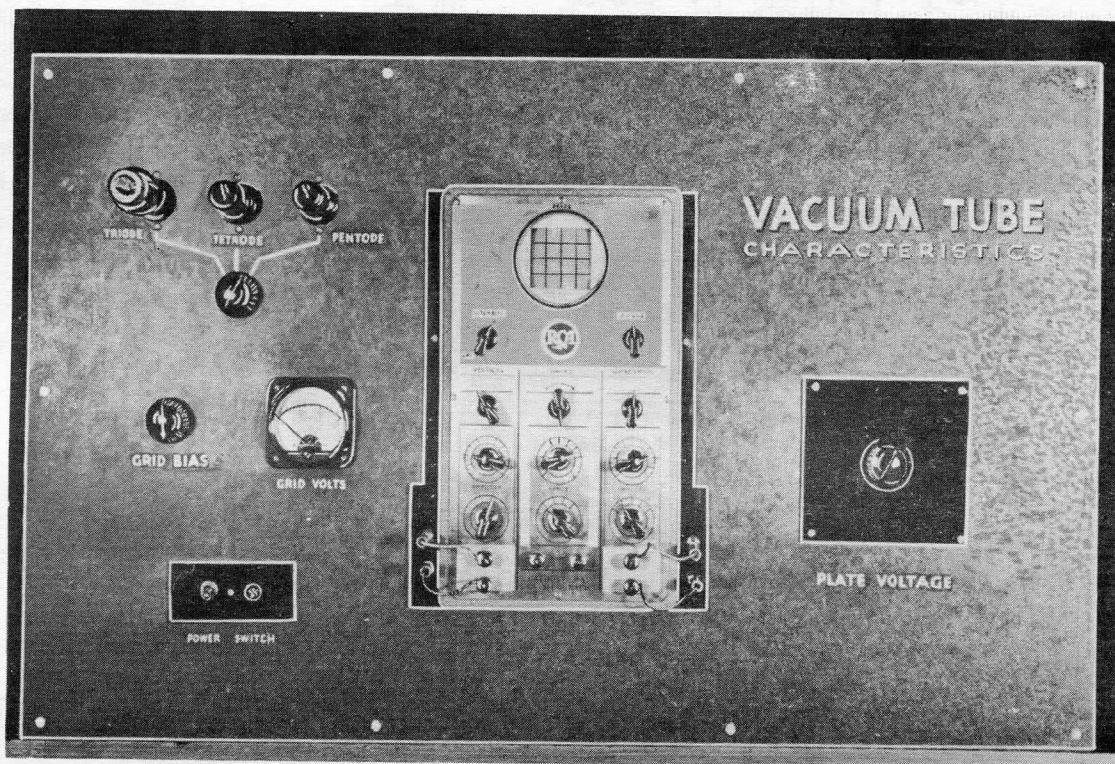

FIG. 1- FRONT VIEW OF DEMONSTRATOR USED AT THE SOUTHERN SIGNAL CORPS SCHOOL FOR SHOWING CHARACTERISTIC CURVES OF VACUUM TUBES.

The purpose of this visual teaching aid, a front view of which is shown in Figure 1, is to illustrate to the student the  $I_p$ - $E_p$  characteristic curves of different types of tubes and also to show the student what effect a change of bias or plate voltage will have on these characteristic curves.

Referring again to Figure 1, it can be readily seen that simplicity in the arrangement of parts has been sought. Because of the relatively large size of some of the circuit components, the demonstrator measures approxi-

mately 4 feet in length by 3 feet in height by 2½ feet in depth.

Located on the front panel are three vacuum tubes, a switch for choosing the particular type of tube it is desired to test, a commercial cathode-ray oscilloscope (RCA 155A), controls for varying the bias and plate voltages applied to the tube under test, and a voltmeter for measuring the value of fixed grid bias applied to this tube. An a-c line switch, together with its associated pilot light, also appears on this panel.

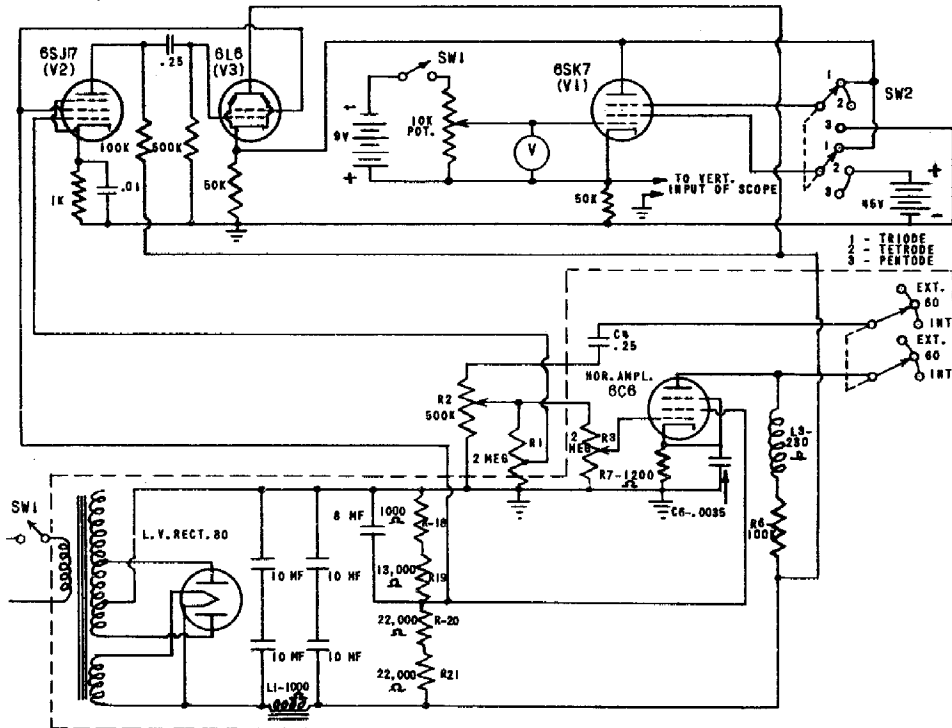

FIG. 2- SCHEMATIC DIAGRAM OF THE DEMONSTRATOR.

Located between the screen of the cathode-ray tube and the front panel of the oscilloscope are two cardboard scales. The vertical scale (Y axis) represents relative values of plate current and the horizontal scale (X axis) represents relative values of plate voltage. The zero points of both scales are at the lower left of the scope screen and during operation of this unit the various oscilloscope controls are so adjusted that all images seen on the screen start at this zero point.

An explanation regarding the three tubes appearing on the front panel is necessary at this point. Two of these tubes are not employed during the actual operation of the demonstrator. The filaments of these tubes are lit but they are not connected into the circuit. Out of the three tubes shown, the middle tube, a 6SK7, is the only one which is active. The elements of this tube are connected to a wafer switch (shown beneath the tubes in Figure



1), which permits the 6SK7 to be connected as a triode, a tetrode, or a pentode. The other tubes are merely placed on the front panel so as to indicate the position of the switch with the particular type of tube being tested.

In the interest of economy, this demonstrator was primarily designed to use as few parts as necessary and still accomplish the desired results. To meet this requirement, certain voltages which are necessary for the operation of the demonstrator are obtained directly from the commercial oscilloscope, the only additional voltage sources being a 45-volt battery and a 9-volt battery.

The complete schematic diagram of this demonstrator, utilizing three separate tubes, is shown in Figure 2. The tube V1 (a 6SK7) is the tube the characteristic curves of which are observed on the oscilloscope screen. V2 (a 6SJ7) is operated as a high-gain amplifier for the saw-tooth voltage obtained at the output of the sweep generator in the RCA oscilloscope. The output of V2 is fed into the cathode-follower stage (V3), which employs a type 6L6 tube. Tubes V2 and V3 have been placed inside the oscilloscope cabinet. Briefly, the function performed by each of these tubes is as follows:

The linear change in plate voltage required by V1 is obtained from the saw-tooth generator (an 884) in the oscilloscope and fed to the grid of tube V2 where it is amplified; the output of V2 is coupled to the grid of tube V3

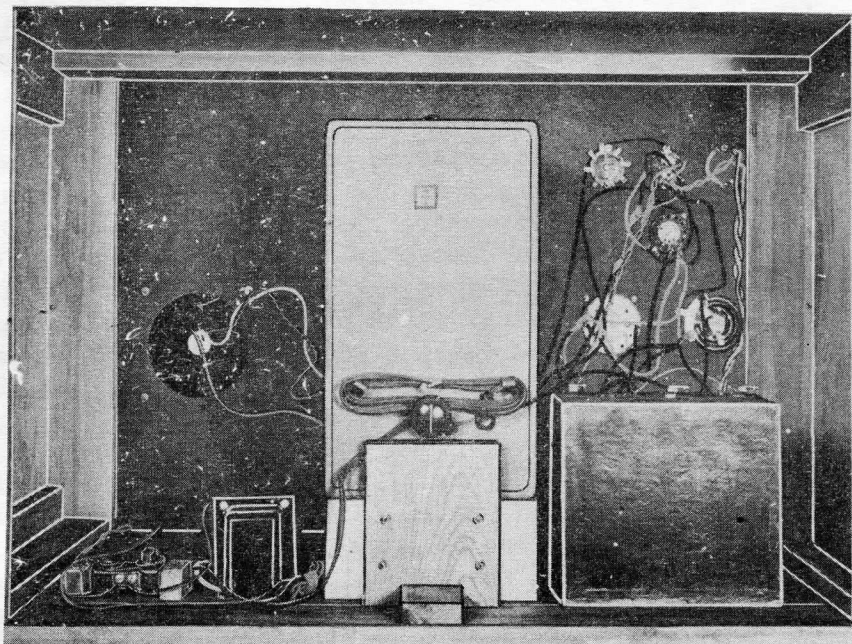

FIG. 3- REAR VIEW OF DEMONSTRATOR SHOWING PLACEMENT OF COMPONENTS.



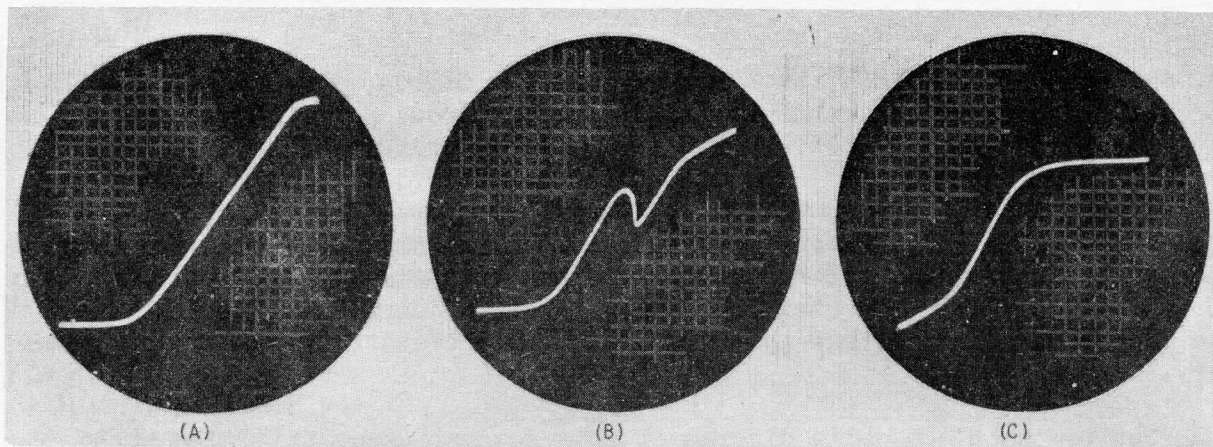

FIG. 4- CHARACTERISTIC CURVES SHOWN ON THE OSCILLOSCOPE SCREEN FOR (A) TRIODE, (B) TETRODE, AND (C) PENTODE.

by means of a 0.25-mf coupling condenser. This tube is used as a cathode follower and its cathode resistor serves as a plate load for V1. Through the use of tubes V2 and V3, the low-voltage output of the saw-tooth generator is amplified and applied as an operating plate voltage to tube V1. The output of V1 is taken from its cathode circuit and applied to the vertical-deflection plates of the oscilloscope.

The same saw-tooth voltage that is applied to the input of V2 is also used as a sweep voltage for the oscilloscope. The plate and screen voltages required by tubes V2 and V3 are obtained from the output of the low-voltage power supply in the oscilloscope. The filament voltage for V1, V2, and V3 is obtained from a separate filament transformer, not shown in Figure 2.

That portion of the schematic diagram of Figure 2 which is enclosed by the dotted line is a partial circuit of the oscilloscope. It was necessary to replace the 0.5-megohm potentiometer, the horizontal GAIN control in the scope, with one having a value of 2 megohms. This is identified as R3 in Figure 2. This change was necessary so that the parallel combination of R1 and R3 will approximate the original value of resistance which was 0.5 megohm. Another change in the scope was the addition of a 0.5 megohm potentiometer, R2. The back of the scope cabinet was drilled to accommodate this potentiometer, which may be seen in Figure 3, a rear view of the demonstrator.

The PLATE VOLTAGE control, Figure 1, is a 2-megohm potentiometer, R1 in Figure 2, and this can be seen to the left of the scope in Figure 3. The GRID BIAS potentiometer has a value of 10,000 ohms and is seen at the extreme right of Figure 3. The meter in the grid circuit should be a 0 to 10 d-c voltmeter. The connection for the 115-volt a-c input and the filament transformer are shown in the left foreground of Figure 3. On the right of the scope is the 45-volt battery which hides the 9-volt battery and the POWER SWITCH SW1. Note in Figure 2 that this double-pole single-throw switch not

only controls the 115-volt a-c line, but also opens the line between the 9-volt battery and the 10,000 ohm-potentiometer in the grid circuit of V1. This prevents the potentiometer from placing a drain on the 9-volt battery when the demonstrator is not in use.

The characteristic curve for a particular type tube is obtained in the following manner. With the demonstrator turned on, set the wafer switch to the desired tube type. Adjust the horizontal and vertical GAIN controls of the oscilloscope so as to limit the amplitude and position of the observed image. By varying the GRID BIAS and PLATE VOLTAGE controls, it is possible to obtain curves representing a variety of conditions. However, unless it is desired to show some unusual operation, these controls are normally set so as to demonstrate typical characteristic curves most commonly encountered.

Some Ip-Ep characteristic curves that are obtainable from this unit are shown in Figure 4. In Figure 4(A) the wafer switch, SW2, is thrown to the TRIODE position and this typical triode characteristic curve is obtained.

In Figure 4(B) the familiar tetrode Ip-Ep curve is shown. This curve was obtained with the wafer switch set to the TETRODE position. Note the dip in plate current which is common in such tubes.

The last oscilloscope pattern, Figure 4(C), represents the tube V1 operating as a true pentode. The smooth bend in the knee of this curve and the leveling off of the plate current past this point, allows the instructor a means of comparing visually the action of a pentode with that of a tetrode.

Like other training aids employed at the Southern Signal Corps School, this demonstrator board is conspicuously wall-mounted in one of the laboratories where the students study the practical aspects of the "hows" and "whys" of vacuum-tube operation. A good knowledge of vacuum-tube operation is one of the essential "musts" for all students attending this school and by the use of this visual aid, the instructor is able more readily to instill in the students' minds the actions of different type of vacuum tubes.

#### SIMPLEX AND PHANTOM CIRCUITS DEMONSTRATOR

A new type of "instruction board" has been developed and is being used by the Officers' School of the Eastern Signal Corps Training Center, Fort Monmouth, N. J. The purpose of this device is to demonstrate visually the current flow caused by the mutual interference of telephone and telegraph signals on phantom or simplexed phantom circuits, as a result of various types of trouble on the physical circuits. This visual demonstration helps to overcome difficulties experienced when the subject is explained on a theoretical basis.

The device as shown in the accompanying photograph consists of a plywood board or panel 5½ feet wide by 3 feet high. On this board are mounted 2 Switchboards BD-9, 6 Coils C-161, 2 Telegraph Sets TG-5-A, 6 Lamp Sockets (6-

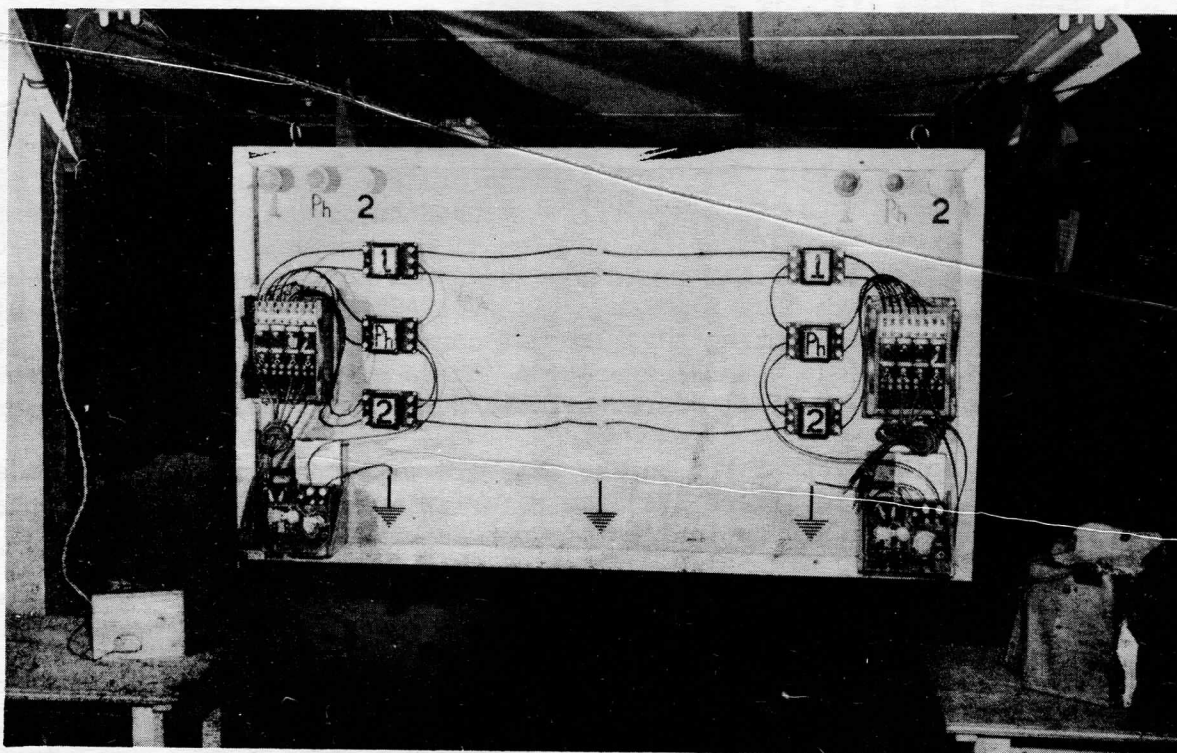

"INSTRUCTION BOARD" USED TO DEMONSTRATE EFFECT OF VARIOUS LINE TROUBLES UPON OPERATION OF TELEPHONE AND TELEGRAPH EQUIPMENT.

volt) with lamps and colored reflectors. Other items needed are a transformer to step down the supply from 120 volts to 6 volts (shown on table at left), and a Telephone EE-8-A (at right).

Two circuits are connected through the repeating coils to the Switchboards BD-9. Ringing current from the generator of the EE-8-A at one switchboard causes the shutter to fall on the drop connected to that line on the other end.

The connections from the night-alarm contacts on three drops are brought out to the back of the board. Each pair of contacts is connected in series with a light and the power source (the secondary of the transformer). Thus, when the shutter falls, the corresponding lamp on the board lights. Each of the two physical and phantom circuits has a light of a distinctive color. These lights are plainly visible to every student officer in the classroom. The bells on the TG-5-A have been so adjusted that one rings and the other "buzzes," thus enabling the class to determine which is operating.

The use of this device simplifies instruction by enabling the student officers to visualize the results caused by various troubles on the line, such as shorts, opens, grounds, cross-connections, etc. This is done by observing the effect which each trouble has upon the operation of the equipment. Troubles are introduced at the binding posts located at the center of the line.



## VACUUM TUBE OPERATION DEMONSTRATOR

The Enlisted School, Eastern Signal Corps Schools, Fort Monmouth, N. J., has developed a vacuum tube demonstrator as a visual aid in the teaching of vacuum-tube operation. Since vacuum tubes are ordinarily operated at audio and radio frequencies, and the actions of these frequencies are too rapid to follow by the use of meters, it was necessary to devise a mechanical source of very low frequency voltages. This generator source of voltages was to be used as the input signal for a simple vacuum tube amplifying circuit. The alternations had to be slow enough to follow visually, but at the same time it was necessary for them to have all the characteristics of a sine wave, because circuits are explained in terms of such waves. In addition to the varying voltage, a visual sine wave was needed, synchronized with the voltage so that points along the sine wave might be identified with the change in voltage.

The demonstrator developed meets the need for a low-frequency alternating current, accompanied by a picture of this action occurring in sine wave form. The demonstrator uses a low-frequency "oscillator" as a source of voltage, while a sine wave cut out in the panel with a series of lights behind it indicates the various voltages produced. A zero center meter is

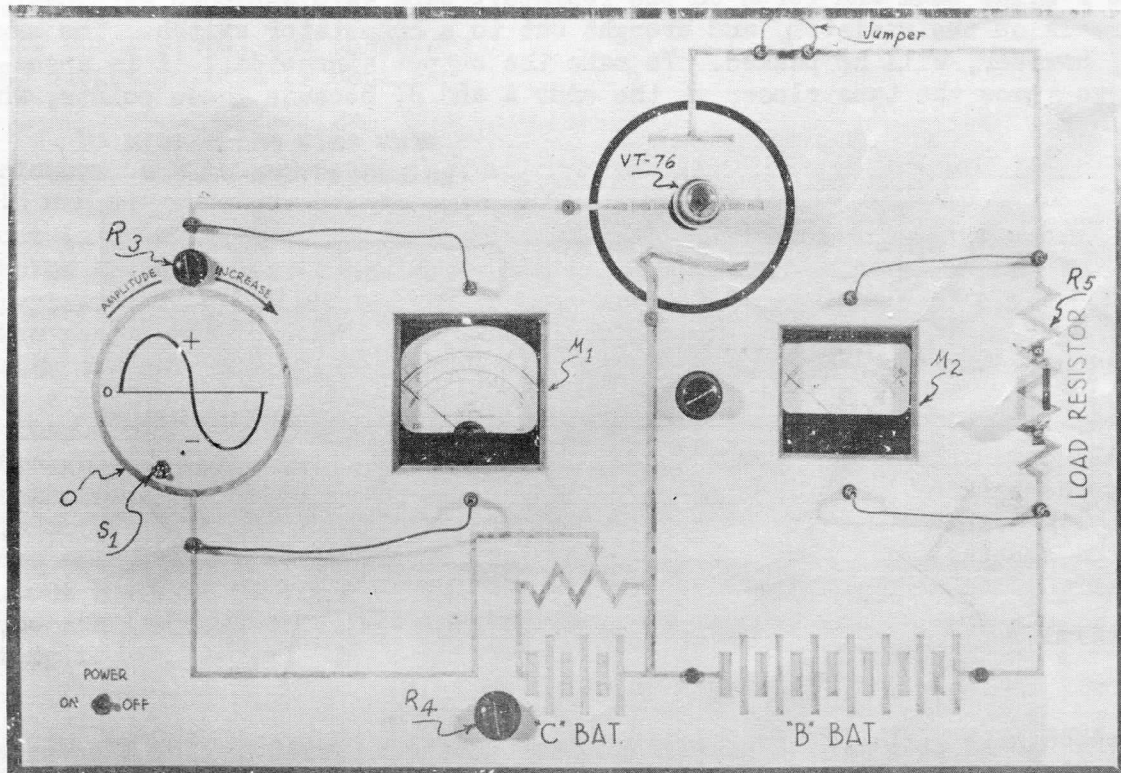

FIG. 1- THE V.T. DEMONSTRATOR.

placed across the oscillator output to show exactly what value of voltage is obtained at any instant. Another d-c voltmeter is placed in the plate circuit to show the corresponding rise and fall of voltage there. The action takes place very slowly, and can be followed by the eye.

As shown in Figure 1, the parts making up the demonstrator are mounted on the front panel. The tube VT-76, bias control  $R_4$  and amplitude control  $R_3$  are mounted on the front, along with clips in the plate side for interchanging load resistances. (See Figures 1 and 2.) Meters V1 and V2 appear through cut-outs in the panel, with their scales showing. A schematic diagram is traced on the panel; the actual wiring is behind the panel.

The mechanical oscillator depends on the potentiometer principle, as illustrated in Figure 3. If a center-tapped resistor A-B is connected across a d-c voltage source and P is variable along the resistor, from A to B, it is possible to develop variable voltage between X and Y. As P approaches the center point, the output voltage decreases; beyond the tap it again increases, this time in the opposite polarity. This provides a means of getting an output voltage which changes in both polarity and magnitude. The output will look as represented in Figure 4.

The same resultant voltage could be obtained if, instead of making the point P slide back and forth on the resistor, taps were attached at close intervals on the resistor, and brought out to a commutator switch. The waveform, however, will be peaked. To make the output sinusoidal, it is necessary to space the taps closer at the ends A and B, because these points, which

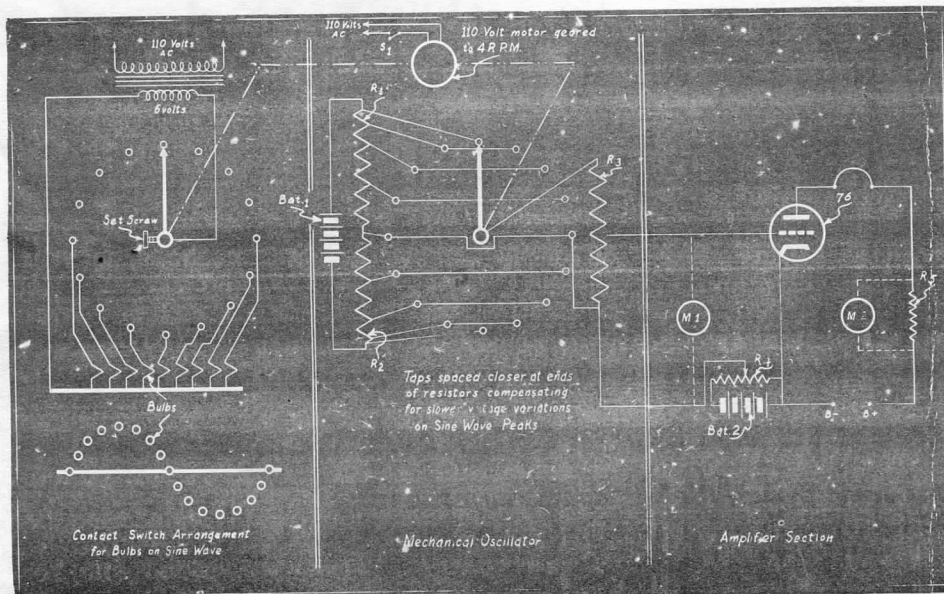

FIG. 2- SCHEMATIC DIAGRAM OF THE V.T. DEMONSTRATOR.

are maximum and minimum output, undergo the least change in value in a sine wave. Therefore, when the taps have been spaced correctly on either side of the resistor, the result is an accurate sine wave.

This arrangement of contacts and spacing is used in the mechanical oscillator in the vacuum-tube demonstrator. The taps are made by soldering leads to two 5,000-ohm wire wound resistors. An a-c motor, geared down to 4 R.P.M., is used to drive the wiper contacts on the commutator.

The switch  $S_1$  starts and stops the motor. Because of the use of the commutator to vary the voltages, the wiper will still make contact when the motor stops, and therefore an output voltage is obtained.

To create the sine wave picture, a slit corresponding in shape to a sine wave is cut out in the panel. A series of bulbs (each in a separate compartment) is arranged behind the panel along the wave. One side of each bulb is connected to a common lead, while the other contact on each bulb is brought out to contacts on the commutator. This commutator is not to be confused with the one mentioned above which produces the voltage input. The two are similar, however, and are mounted in tandem.

A step-down transformer supplies the voltage for the bulbs.

In order to synchronize the sine picture with the output voltages, the wiper  $M$  (Figure 6) is mounted on the same drive shaft that is used to turn the oscillator wiper. Accurate setting is made possible by means of a set-screw. If the oscillator commutator stops at a certain place, the bulb representing that wave value will stay lighted.

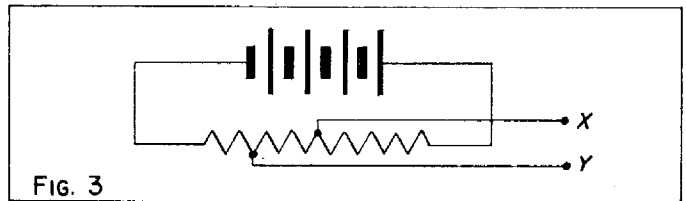

FIG. 3

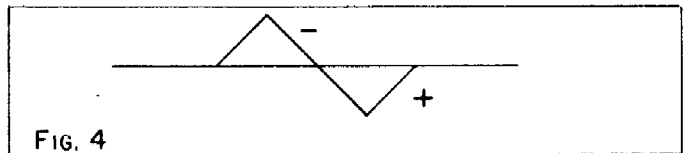

FIG. 4

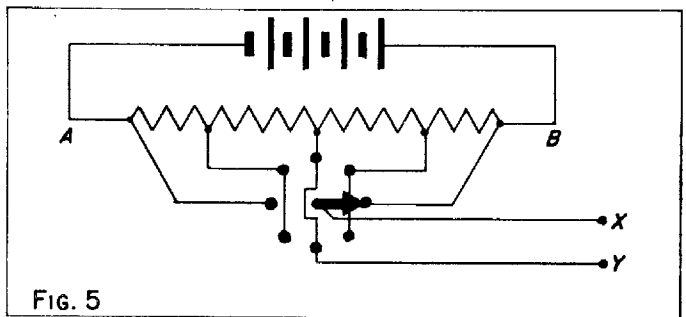

FIG. 5

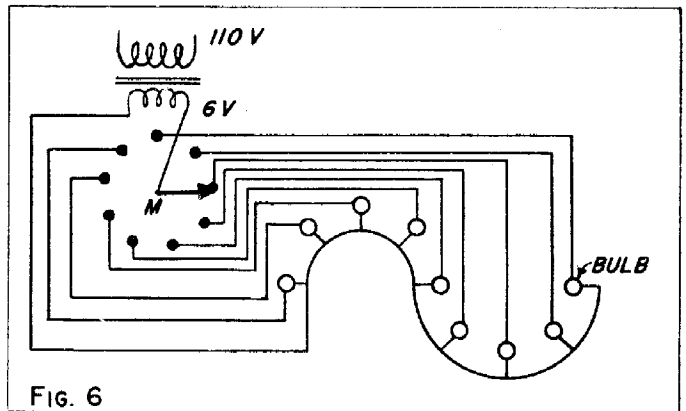

FIG. 6



$R_3$  (Figure 1) is a variable resistor connected across the output of the oscillator. Its purpose is to regulate the amplitude of input signal voltage. It is not critical, 15,000 ohms being the value used in this demonstrator.

Figure 1 shows the front panel of the demonstrator. In this picture, O represents the mechanical oscillator which turns out four electrically perfect sine waves per minute.  $S_1$  is the control switch which makes it possible to stop or start the voltage wave and the lighted sine wave at any point. When it is stopped at a certain value, the voltage will remain fixed, while the light wave also is stopped and shows at what place along the sine wave this voltage is obtained. Suppose, for example, that the peak voltage from the oscillator is 2 volts, and it is desired to see what effect is obtained at 1 volt input. In this case, the switch is opened at the proper instant. The oscillator will stop halfway up to a peak, and, at the same time, the light bulbs will stop at  $45^\circ$ , or halfway to the sine wave peak. Then at this static value of input, the observer can study the rest of the circuit, noting the amount of bias, the plate voltage, and the output obtained for this one particular point along the sine wave.

The peak output voltage of the oscillator can be adjusted to meet different input voltage needs of the circuit.  $R_3$  (Figure 1) is a variable resistor which controls the output of the oscillator, making it continuously

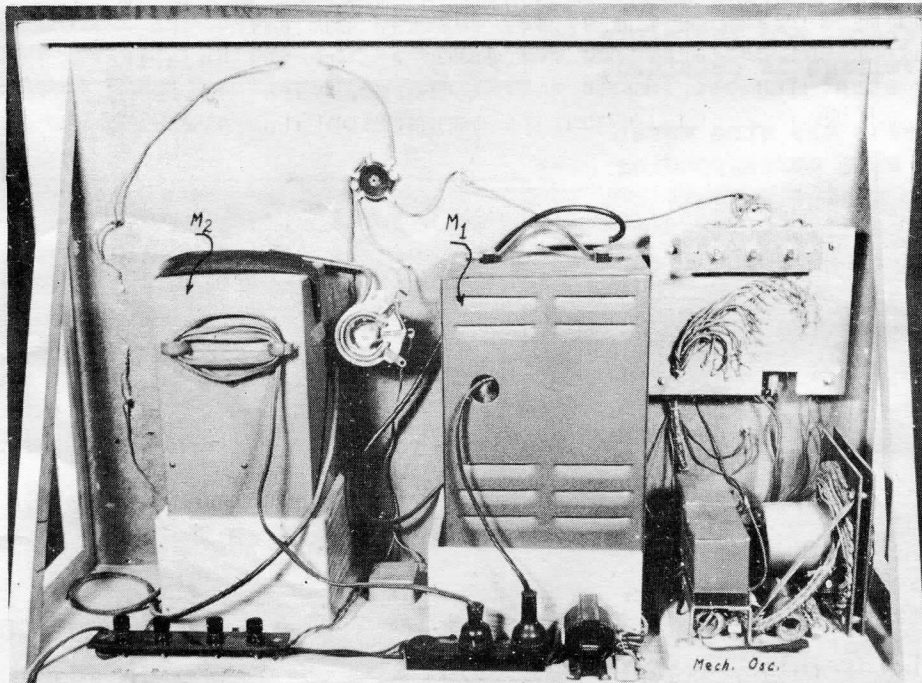

FIG. 7- REAR VIEW OF THE V.T. DEMONSTRATOR.

variable over a wide range.

$M_1$ , which is connected across the oscillator, serves two functions. It records the value of voltage from the source, and, at the same time, shows the polarity of this voltage.

The bias is made adjustable by  $R_4$ , which has a wide enough range in conjunction with a bias battery to permit changes of bias for any class of operation.

$M_2$ , mounted to the right, is a d-c voltmeter connected across the load in the plate circuit of the tube. Any voltage developed across the load due to plate current flow is indicated by this meter.

The jumper, shown at the top of Figure 1, is in series with the plate of the tube. Because it is removable, it is possible to insert a plate milliammeter in the plate circuit, and thereby to read plate current changes directly.

The schematic diagram of the vacuum tube demonstrator shows a d-c plate voltage supply. This voltage is obtained from a Variac controlled power pack. Thus plate voltage is made adjustable.

In summary, then, the demonstrator is comprised of a low-frequency oscillator; a synchronized picture of a sine wave; a meter for measuring the value and the polarity of the slow input wave, together with other conditions, such as variable bias and load; and a meter for showing what happens in the plate circuit.

It is possible, with this equipment, to demonstrate various classes of tube operation. Classes of tube operation are established on the basis of the proportion of the input signal cycle through which plate current flows. The demonstrator can be adjusted so that plate current will flow for any desired portion of the input signal cycle. This is accomplished by varying the following factors:

1. The amplitude of the signal.
2. The amount of bias on the grid.
3. The plate potential.

#### Class A

The equipment has been turned on. The input signal is set at zero, at any of the three points where the sine wave approaches its axis; that is, at 0, 180°, or 360° on the cut-out. This is done by  $S_1$ , which is opened at any of these points. The bias on the tube and the plate voltage are then adjusted so that plate current flows for all portions of the cycle. Proper manipulation of  $R_4$  and the B voltage will result in this effect. For class A operation, the plate current will vary linearly. Variations in the readings of  $M_1$  and  $M_2$  will permit verification of this.



Class B

The input signal, with the lights showing the wave, will again be stopped at zero, this time preferably at the start of the cycle. The bias is adjusted by  $R_4$  until cut off; in other words, until no current flows. The oscillator is again started. Plate current will flow during the first half of the input cycle, because the addition of the signal has overcome the bias on the tube; but, for the second or negative half of the cycle, the grid is made still more negative, and no current flows. This flow of plate current with the positive half of the input cycle, and no output at zero signal, demonstrates class B. It will also be noticed that more input signal is required than for class A to obtain appreciable plate current variation.

Class C

In this class, bias is increased beyond cut-off, and plate current flows for less than half of the input cycle. It is necessary, therefore, to stop the wave at some point along the positive half cycle, that is beyond zero. The bias is increased, so that even with a somewhat positive input there is no plate current flow. At this point, if the oscillator is again started, and there is a larger positive input voltage on the grid, plate current begins to flow, but is limited to the most positive values of input. The amplitude of the input signal has to be increased at the same time. This shows that class C operation calls for more driving voltage.

Sometimes more pertinent information can be gained by stopping the input cycle at any prearranged point. This can be done by opening  $S_1$ . The motor drive stops, the bulbs stay lighted at the chosen place, the input voltmeter reads that value of input, and meter  $M_2$  shows what is happening in the plate circuit. Then  $S_1$  can again be closed, and the cycle resumed.

There are other uses for this demonstrator.  $M_2$  shows the voltage developed across  $R_5$ . By inserting a plate current milliammeter, as explained above, it is possible to compare plate current and developed voltage. In this manner it can be seen that the plate output voltage is the result of plate current and that the voltage produced is directly proportional to the current.

The out-of-phase relationship between grid and plate voltages can also be demonstrated.  $M_2$  is connected across the plate and cathode, and the oscillator is started. When the grid voltage is a maximum positive, there will be most current drawn through the load  $R_5$ . Hence, there will be a large voltage drop across the load; since this drop is subtracted from the plate voltage, it results in lower plate potential on the plate for an increase in grid voltage and vice versa. The voltages are in direct opposition and are, therefore,  $180^\circ$  out of phase.

Variations from the usual classes, which are termed class AB or class AB 1, can be likewise shown by making proper adjustments on the demonstrator. The instructor can make use of these adjustments for the needs of the lecture.

# OPERATING TESTS OF THE SCR-299 WITH DOUBLET ANTENNA

An article on the use of half-wave doublet antennas with Radio Set SCR-299-( ) appeared in the No. 20 Signal Corps Technical Information Letter, July 1943. The information contained therein was the result of considerable experimentation by the Camp Coles Signal Laboratory, and it is believed that a resume of the tests which established the final findings will be of interest.

## PURPOSE OF TESTS

The purpose of these tests was to investigate the possibility of using a doublet antenna with Radio Set SCR-299-( ) without making extensive changes in final tank coils of Radio Transmitter BC-610-( ) or Antenna Tuning Unit BC-729-( ).

## PROCEDURE

1. The transmitter used in these tests was Transmitter BC-610-A, part of Radio Set SCR-299-A in Truck K-51.
2. The antenna proper consisted of a half wave 240-foot horizontal doublet, each half made in 5-foot, 10-foot and 20-foot sections separated by insulators across each of which was provided a jumper. Jumpers were disconnected to give shorter lengths of antenna resonating at various frequencies from 2 to 8 megacycles.
3. Determination of the fundamental frequency for a half-wave was computed by using the formula, 
$$\frac{468}{\text{frequency in Mc}} = \text{length of antenna in feet.}$$
4. The antenna was suspended between two 35-foot metal masts, the center being supported by a 35-foot wooden mast to prevent sagging due to the weight of the transmission line.
5. An 0-5 RF ammeter was inserted in series with each junction of the transmission line to the center of the antenna to observe a balanced current condition for determining proper half-wave operation.
6. Transmission lines of the following types were tried:

- 30-foot open wire 400 ohm line;
- 30-foot open wire 600 ohm line;
- 30-foot - twisted pair;
- 50-foot - copolene coaxial line.

7. Methods of coupling tried with the above mentioned transmission lines were as follows:

a. Connection of transmission line across secondary of RF transformer in the Antenna Tuning Unit BC-729-A.

b. Connection of transmission line directly to link coil of final amplifier output of Transmitter BC-610-A.

c. Connection in such a manner as to place the variable inductance loading coil L-6 in the Antenna Tuning Unit BC-729-A in series with one side of the transmission line to the link output of the Radio Transmitter BC-610-A. Refer to Figure 1.

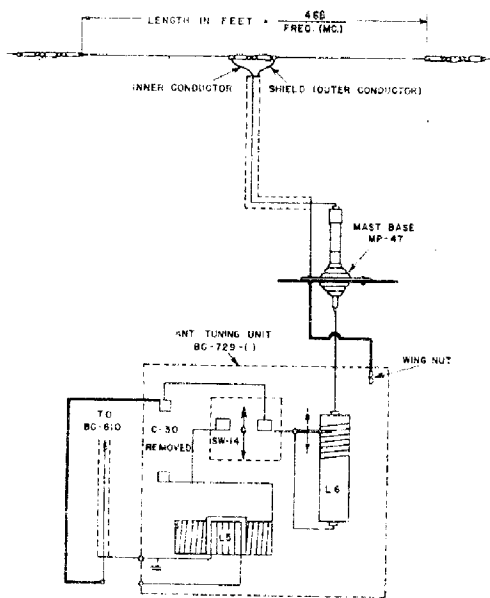

DISCONNECT CENTER CONDUCTOR OF COAX. CABLE FROM TERMINAL MARKED "X". USING JUMPER CONNECT CENTER CONDUCTOR TO TERMINAL MARKED "Y" ON VACUUM CONDENSER MOUNTING. REMOVE VACUUM CONDENSER C-30.

OPEN SWITCH SW-14 AND LEAVE IT IN THIS POSITION.

CONNECT GROUND JUMPER FROM CORNER OF TUNING UNIT BC-729 TO BOLT IN MP-47 MOUNTING, USE THE SAME BOLT TO CONNECT SHIELD OF COAX. FEEDER ON OUTSIDE OF TRUCK.

CONNECT CENTER CONDUCTOR OF COAX. FEEDER TO THE TOP OF MP-47.

8. In each case the transmission line was fed through the vehicle, one lead to the top of Mast Base MP-47 and the other lead to a flange bolt on the Mast Base MP-47.

9. No changes were made in Radio Transmitter BC-610-A.

10. Tests were then conducted comparing the standard whip antenna to the half-wave horizontal doublet, using copolene cable for a transmission line. (EO-1 cable was not available). Radio Set SCR-299-A was taken to Wilkes Barre, Pennsylvania, a distance of 120 miles airline, and signal strength readings were taken by Camp Coles Signal Laboratory Communication Station WIAM-18 using a Hallicrafter SX28 radio receiver and an output meter.

RESULTS

Different Transmission Lines

1. Thirty-foot open wire transmission lines of either 400 ohms or 600 ohms acted as a Marconi antenna and results were unsatisfactory.
2. The thirty-foot twisted pair of No. 14 gauge rubber-covered wire, when used as a transmission line, afforded doublet operation, but line losses rendered its use unsatisfactory.
3. The fifty feet of copolene cable as a transmission line gave satisfactory doublet operation with low line losses.
4. No difficulty was encountered in loading of the Radio Transmitter BC-610-A on any frequency using either a twisted pair or copolene cable connected as illustrated in Figure 1. The results shown in Figure 2 were accomplished using copolene cable as a transmission line.

FREQUENCY	METER # 1	METER # 2	PLATE CURRENT	ANTENNA LENGTH	VARIABLE INDUCTANCE "L6" # OF TURNS SHORTED INDICATED ON COUNTER
KILOCYCLES	R.F. AMPS	R.F. AMPS	MILLIAMPS	FEET	
7 8 0 0	3.5	3.5	2 8 0	6 0	5 4 . 0
6 3 4 0	3.3	3.2 5	2 9 0	7 0	4 9 . 8
5 6 4 0	3.0	3.0	2 8 0	8 0	5 4 . 3
5 1 0 0	3.0	3.0	2 8 0	9 0	5 4 . 3
4 6 4 0	3.1	3.1	2 9 0	1 0 0	5 2 . 3
4 2 2 0	3.2 5	3.2 5	2 8 0	1 1 0	5 4 . 3
3 8 0 0	3.3	3.2 5	2 8 0	1 2 0	5 3 . 3
3 4 4 0	3.3	3.2	2 8 0	1 4 0	5 3 . 6
2 9 4 0	3.5	3.5	2 9 0	1 8 0	5 9 . 7
2 3 4 0	3.1	3.2	2 8 5	2 0 0	5 7 . 8
1 9 5 0	3.0	3.1	2 9 0	2 4 0	5 6 . 0

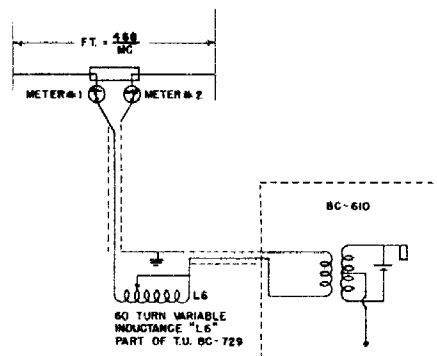

Different Coupling Methods

1. Transmission line connected directly to the link output of Radio Transmitter BC-610-A afforded no means of controlling coupling, and resulted in excessive loading of the final amplifier in the Radio Transmitter BC-610-A.
2. Transmission line connected to secondary of RF transformer in Tuning Unit BC-729-A with the loading coil L-6 out of the circuit resulted in slight loading of the final amplifier in Radio Transmitter BC-610-A.
3. Transmission line connected as shown in Figure 1, provided a means of controlling the loading of the final RF amplifier. This system proved satisfactory and the antenna functioned as a doublet with balanced current in each feeder. No extensive changes or extra parts are required.

Coaxial-fed (Copolene) Doublet Versus the Standard Whip

<u>Time</u>	<u>Frequency</u>	<u>Type Antenna Used</u>	<u>Meter Reading</u>
9:55 a.m.	3440 kcs.	Doublet Co-ax.	25 mW.
9:55 a.m.	3440 kcs.	Whip	7 mW.
10:10 a.m.	3900 kcs.	Doublet Co-ax.	50 mW.
10:10 a.m.	3900 kcs.	Whip	15 mW.
10:20 a.m.	4220 kcs.	Doublet Co-ax.	35 mW.
10:20 a.m.	4220 kcs.	Whip	10 mW.
10:30 a.m.	4640 kcs.	Doublet Co-ax.	300 mW.
10:30 a.m.	4640 kcs.	Whip	35 mW.
11:25 a.m.	5100 kcs.	Whip	30 mW.
11:25 a.m.	5100 kcs.	Doublet Co-ax.	300 mW.
11:30 a.m.	5640 kcs.	Doublet Co-ax.	700 mW.
11:30 a.m.	5640 kcs.	Whip	200 mW.
11:45 a.m.	5640 kcs.	Doublet Co-ax.	1000 mW.
11:45 a.m.	5640 kcs.	Whip	400 mW.

Permissible Variation from Cut Frequency

The transmitter was operated at the frequency for which the antenna was cut (4220 kc.) plus 100 kc. and minus 100 kc. No change in signal strength was noted. The transmitter frequency was then shifted 200 kc. higher than the frequency for which the antenna was cut and a marked difference in signal strength was noted. Readings were less than half that taken on 4320 kc. and 4120 kc. It would appear that a deviation of more than 100 kc. either side of the frequency for which the antenna is cut is impractical.

## CONCLUSION

The doublet antenna in every case proved to be at least three times better in signal strength than the standard whip.

Changes in the Antenna Tuning Unit BC-729-A are trivial and can be made in the field.

The doublet antenna may also be used with Radio Set SCR-299-B, SCR-299-C and SCR-299-D with the same slight modification of Antenna Tuning Unit BC-729-( ).

The doublet possesses directional characteristics and should be operated at right angles to the receiving station for best results.

Any length of transmission line can be used, but should be kept as short as possible.

In an emergency any twisted pair can be substituted for a transmission line, providing the insulation is reasonably good for the frequencies used.

## SIG. C. PHOTOGRAPHERS IN TUNISIA

Following is an informative letter received by the Army Pictorial Service from a photographic officer in Tunisia, indicating something of the problems of our photographers:

"In reply to your letter, I can truthfully say that it was the first pertinent information that we have received on any of our work since arriving here on D day. We were handicapped just after the initial landing, with faulty cameras and lenses. This took nearly two months to rectify, as all of our three-inch lenses failed to function properly on the 16 MM jobs, so we had to send the cameras and lenses to London to be repaired. Some of those lenses and cameras have just returned to us, six months later. However, we have managed to test strip most of the cameras we now have in our possession and know that they are O. K.

"Another little headache we ran into was the different lighting conditions, which proved rather interesting for Kodachrome. Although the meter reading was accurate, the actinic light rays here are altogether different from those in the States, making a predominance of red and pinkish reflected light on everything. This undoubtedly accounted for the under exposure. Then when we changed sections of country, a different type of terrain and light faced us. This time it was open country, desert sun, and rough rugged mountains, dirty black and brown in color. The reflected light was terrific; so was the heat.

"When we first came up to this section, it was the beginning of the rainy season, and what a problem we had in trying to keep our film dry ... and with nothing to use except our heads. We had to sleep on the ground, wet and damp ground, mud, rocks, and, if we were lucky, we got under a pine tree. Our three-quarter ton weapons carrier with our waterproof box saved our film, until the boards began to swell and the film began to sweat. About that time the rain stopped and everything was normal again. The boys have learned a lot, the hard way, and, after carefully coaching them on exposures and story telling pictures, I think a definite improvement will be noted.

"You spoke of continuity. That is something that will have to be argued and reargued, particularly when it comes to a battle scene. Let's take a tank battle for example. Our tanks are in front of us, and, if we are lucky to have a high spot, all the better. The enemy is 5,000 yards away. You have to use glasses to see him. Our tanks spread out and we have just got that sequence with our trusty little one-inch lens. We move forward so as to get our close-up with our one-inch lens, when all hell cuts loose and we have to duck for cover. We can't see Jerry at all now, nor can we see our own tanks. The dust is terrific. Our tanks are scattered and so well camouflaged behind hills and waddis that it is impossible to see him while they slug it out with the enemy. That is the reason why we are lucky

to even get the long shot of a tank battle, first because of the terrain and it has been mostly level where tanks fight ... or our one-inch lenses could not pick up the tanks so far away.

"This war is not being fought by any of the so-called modern warfare methods. Just plain cowboy-and-Indjun fighting is the type we have to use over here. The infantry doesn't charge en masse. One man moves here, one over there. They fall and blend with the terrain. We are lucky to get more than three soldiers in a 4x5 camera.

"The boys have stuck their necks out plenty to follow the continuity and in most cases have been fired upon by machine guns, infantry, and by the inevitable 88's until everyone of them have what we call up here at the front "Eighty-eight-itis." You don't see them, you don't hear them, then Whoosh, there they are right in the middle of your area, and everybody has to duck ... but duck good.

"We are handicapped by the lack of long focal length lenses and, until this is rectified, I can see no hope of getting a continuity satisfactory to the War Department of any battle scenes. All of our shots are bonafide and strictly G.I. The war correspondents are equipped with long focal length lenses and aren't getting the pictures that we are because we usually meet them on the way back when we come in from the front. However, they are following us up now and are getting some shots with their berthas that should be good. I have had three cameras shot out of my men's hands to date; one Eyemo, one cine-Kodak Special and one Contax.

"I am enclosing a clipping that appeared in the Army newspaper over here about one of my boys receiving the Silver Star for gallantry in action. These boys aren't afraid to get pictures and their conduct has been of the highest but long focal lenses would certainly help the situation. Then the continuity could be gotten without any trouble. We have just completed a training film for the Corps of Engineers on mines and booby traps and I think it will save thousands of lives, it's that good. It was made by one of the best men I have. He had to travel over all of Tunisia to get his shots, even as far as Enfidaville, Sousse, Sfax, Gabes, Gafsa, Haidra and Souk El Kemis.

"We aren't as smart as the British in this war as yet, but are learning fast. Everything we have had to do here has been contrary to our training. The Signal Corps has had to train men over here to detect mines. They never told us about that back in the States, so we just learn the hard way. We know so little about Booby traps that we don't touch them but let the British do it instead. We are fighting a well trained machine with soldiers of three years' experience and, let me tell you, they know all the tricks. It is taking us a little while to get on to them.

"When I was first sent up here, only one unit was here and three men of another unit. With the four men I had and these eight men, I had twelve men to cover a 148-mile front. So I had to resort to means contrary

to all training and organization, to cover this front by holding my men in a pool at Corps Headquarters, where I kept abreast of the current maneuvers and battles thru the cooperation of G-3, G-2 and the General Staff, shooting one still man and one cameraman out in a jeep to that hot spot where most of the action was taking place.

"We ran the wheels off of the lone peep I had until I managed to pick up two more. These vehicles are the only vehicles for photographers to use. Panels are too much of a target and a carryall is out of the question altogether. I have been using the weacoibs carruer as a supply base and using the jeeps or peeps for photographic assignments.

"This two-man idea has proven to be the solution to all our problems, and as a safety factor, perfect, because the strafings have been plentiful and not so far apart. A driver is unnecessary at the front, while a mechanic is — to keep the vehicles in running shape. We confiscated a shot up panel job and made a portable lab out of it, but this later proved to be unsatisfactory, due to lack of a power unit (we managed for one, however) and due to the fact that two of the men were caught in it during an air raid, just missing death by inches when a plane strafed it. We had been using it at the front, so I pulled it back to Corps Headquarters for safety. Now the lab is with me at Corps Headquarters.

"I have Lieutenant \_\_\_\_\_ and his five men at the northern part of this section, Lieutenant \_\_\_\_\_ in the central sector, and I have three men with an armored division. I keep five men in a pool to shoot out to any area where the action is hot and for use for G-2 work, which has been plenty — terrain shots, information shots on captured materiel and captured mines, etc. These are the only prints made at the front, as the rest of the negatives have to go back to Algiers for processing and disposition to the War Department.

"A little trick that we were using when we first came in on D day to get more footage and to have our close-ups and long shots available, was the taping together, one on top of the other, of two 16MM mag. loading Filmos, the three-inch lens on the top camera, the one-inch on the bottom. This gave us 100 ft. of film, instead of 50, at the same time our three-inch and one-inch lens were all set for what might happen. I wish that I had the time and the place to put all that we have learned over here in actual combat conditions on paper so that the training of the photographers back in the states would take a different slant instead of the peacetime tactics and training they are now using. It's so very different it's amazing. We expect this deal here in this section to be over with shortly. We have learned a lot about fighting and are profiting by our first mistakes."



# "THE SIGNAL MUST GET THROUGH" \_ \_ \_

- - - might well be the caption for the home-made key shown below. It is one of a number made by the 98th Signal Company, Camp Breckinridge, Ky., for code-practice training in the Division Signal School. Fabricated of wood and miscellaneous bits of hardware, its high point of design is a poker chip for a "button."

It isn't a stunt, this key. They were installed at each position of the code-practice table (right) to meet the lack of GI keys.

Another improvisation is the practice "blinker light" shown at right, below. This is simply a 40-watt lamp enclosed within a painted gallon jar. It too is operated by means of one of the trick keys.

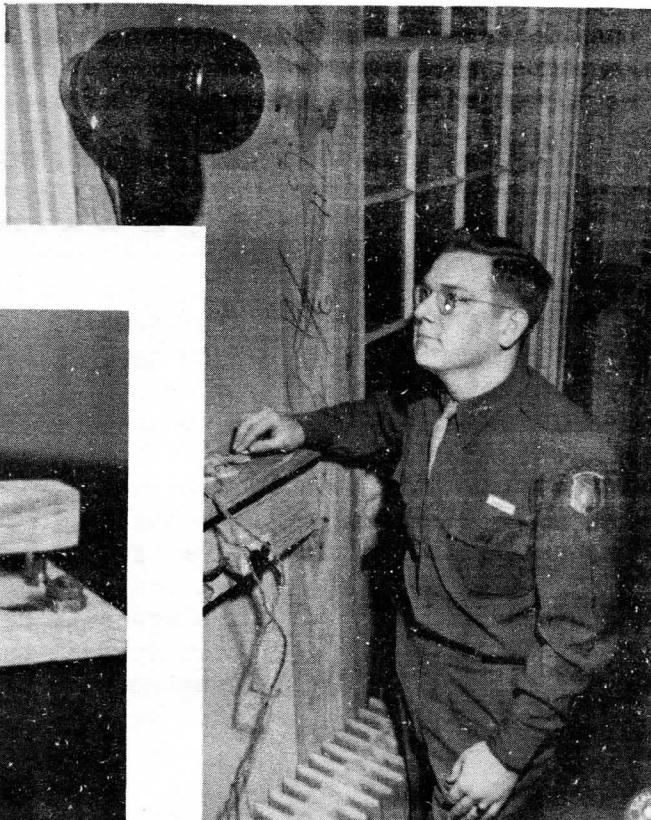
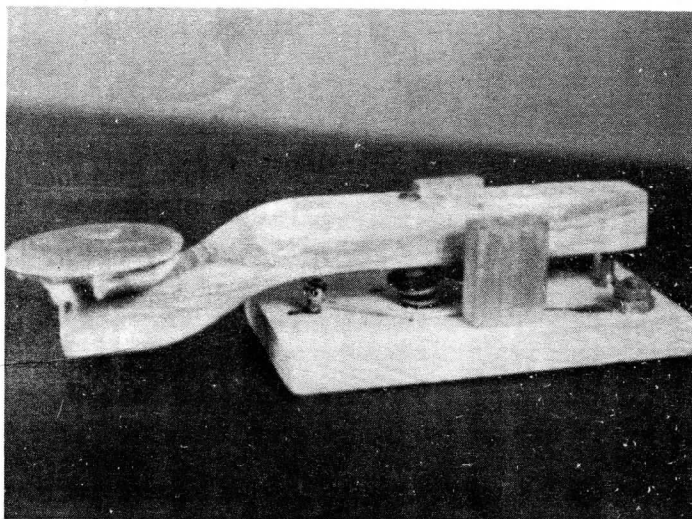
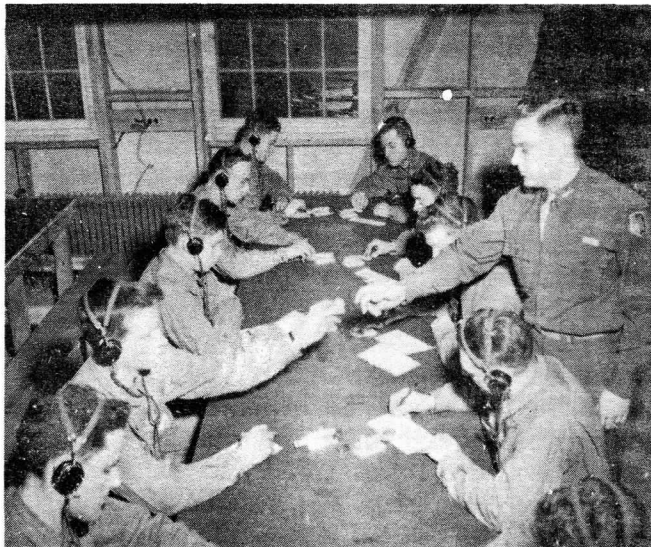

# "HANDBOOK FOR RADAR OFFICERS"

Published at the Southern Signal Corps School, Camp Murphy, the 400-page book of the above title provides a comprehensive library of information and reference, not alone for radar officers but for every officer in a position of command and particularly those in isolated commands. Its scope is indicated by the following Table of Contents:

Page	Page
<b>MESS MANAGEMENT</b>	<b>MESSENGER COMMUNICATION</b>
Methods of Cooking Food . . . . . 1	Personnel . . . . . 166
The Field Ration System . . . . . 3	Message Center . . . . . 170
Daily Ration Strength Reporting Form . . . . . 8	Message Center Procedures . . . . . 174
Vitamin Chart . . . . . 15	Message Center Set-ups for Divisions and Higher Units . . . . . 179
<b>COMPANY ADMINISTRATION</b>	<b>MAP READING</b>
The Detachment Morning Report . . . . . 21	Maps in General . . . . . 181
The Daily Sick Report . . . . . 23	Orientation of Equipment by Means of a Compass . . . . . 188
The Daily Roster . . . . . 24	
<b>MILITARY RECORDS</b>	<b>CAMOUFLAGE AND CONCEALMENT</b>
Types of Changes . . . . . 28	Military Manuals . . . . . 192
Company Finance . . . . . 41	Camouflage . . . . . 194
Check List for Company Commanders . . . . . 50	Erection of Flat-Tops . . . . . 207
Basic Records . . . . . 52	Garnishing Camouflage Nets . . . . . 211
Duty Rosters . . . . . 53	Rules for Camouflage . . . . . 214
General Rules for Keeping the Sick Report . . . . . 55	
Organization Property . . . . . 57	<b>DEFENSE AGAINST CHEMICAL WARFARE</b>
Accounting for Property on T/BA . . . . . 59	Classification of Gases . . . . . 215
Acct'g for Post, Camp or Station Property . . . . . 67	Shelters . . . . . 223
Property Adjustments . . . . . 69	
Reference Texts . . . . . 71	<b>MOTOR TRANSPORT</b>
Signal Supply . . . . . 75	Duties of the Primary Parties . . . . . 227
Radar Supply Line Organization . . . . . 80	Requirements for Efficient Operation . . . . . 238
Emergency Procurement . . . . . 81	Roads, Improved and Unimproved . . . . . 256
Catalog . . . . . 86	Stripes . . . . . 260
Statement of Charges . . . . . 89	
Report and Requisition Forms . . . . . 90	<b>DEMOLITIONS</b>
Table of Organization . . . . . 97	Explosives . . . . . 270
Duties of a Platoon Commander . . . . . 103	Use in Aircraft Warning Service . . . . . 274
Standard Radar Operation Procedure . . . . . 106	
Log Sheets . . . . . 114	<b>ARMAMENTS FOR A.W. UNITS</b>
Interference Report Form . . . . . 119	Tactical Employment of the Different Weapons . . . . . 287
<b>MILITARY SANITATION AND FIRST AID</b>	Care of Firearms in General . . . . . 288
Types of Services . . . . . 126	U.S. Rifle, Caliber .30 M 1903 . . . . . 290
Caring for Injuries . . . . . 124	U.S. Machine, Caliber .30 M . . . . . 294
<b>AGENCIES OF SIGNAL COMMUNICATION</b>	Automatic Pistol, Caliber .45 M 1911 and M 1911 Al . . . . . 297K
Information, Divisions, etc. . . . . 129	Thompson Submachine Gun Caliber .45 M 1928 Al. 297W
Pigeon Communication . . . . . 132	Browning Machine Gun, Caliber .50, M2, Water Cooled With Anti-Aircraft Mount. 297KG
<b>RADIO COMMUNICATION</b>	<b>ORDERS</b>
Sound Communication . . . . . 134	Outline Orders, Section I . . . . . 298
Radio Communication, Section I . . . . . 135	Forms for Orders . . . . . 304
Radio Communication, Section II . . . . . 139	Combat Orders, Section II . . . . . 317
Radio Communication, Section III . . . . . 141	Types of Combat Orders . . . . . 329
<b>WIRE COMMUNICATION</b>	<b>MILITARY LAW</b>
Divisions . . . . . 142	Powers Authorized by 102th Article of War. 354
Classification of Wire Circuits . . . . . 143	Authorization of Court Martial Charges . . . . . 365
Field Telegraph Sets and Stations . . . . . 146	Notes on Court Martial Practice . . . . . 374
Symbols for Wire Installation . . . . . 147,152	Example for Drafting Charges and Specifications . . . . . 384
Army Corps Wire Nets . . . . . 148	App'd Solution to Hypothetical Situation . . . . . 386
Division Radio Nets . . . . . 151	Articles of War . . . . . 388
Cryptographic Security . . . . . 155	
Military Cryptography . . . . . 160	
Use of Cipher Device M-94 . . . . . 164	

The "Handbook for Radar Officers" is 8-inch by 10½-inch manual size and is illustrated. The Commandant of the Southern Signal Corps School has expressed willingness to provide an individual copy to any organization down to battalions having real need for it for reference purposes.

# FUNDAMENTALS OF CARRIER COMMUNICATIONS

Carrier telephone and telegraph equipment is being made available for both tactical and fixed-plant military communications. Some of the extended applications will be described in forthcoming issues of this publication. Preliminary to this, however, it is felt that there will be interest among Signal Corps officers in a discussion of the fundamental principles of carrier equipment operation. It is therefore the purpose of this article, prepared by Communications Engineering Branch, Army Communications Service, to present such a discussion. Effort has been made to present the subject in a semi-technical fashion. Those desiring a more complete treatment of the theories involved are referred to "Principles of Electricity applied to Telephone and Telegraph," published by the Long Lines Department of the American Telephone and Telegraph Company, and available in the OCSigO Library.

The principles involved in carrier current transmission on land wires are similar to those involved in radio transmission, in that in both methods of communication intelligence is transmitted by a "carrier" wave which has been modulated by a voice wave or by the opening and closing of a telegraph key. Wire transmission using carrier currents was until recently limited to relatively low frequencies. Now, with the commercial use of the coaxial cable over fairly long routes, wire transmission is carried on at what were previously considered radio frequencies.

Carrier current operation is not new. It is interesting to note that in 1910-11 Major Squier, later Major General Squier, ninth Chief Signal Officer of the Army, conducted experiments with and obtained patents for a carrier channel operating over a short length of cable. Early experiments were considerably hampered by the absence of a suitable generator of high frequencies. The advent of the three element vacuum tube with its properties of generating, amplifying, and rectifying alternating voltages of various frequencies gave great impetus to the work on carrier current transmission. Successful operation of carrier current equipment was accomplished before World War I.

The term "carrier circuit" is generally used to indicate that the circuit is operating at a frequency above the normal voice range. It has been found that for intelligible transmission of speech the telephone circuit need transmit only those frequencies between about 200-3000 cycles per second which are generally referred to as "voice frequencies." It was found that telephone circuits will satisfactorily transmit currents of frequencies well above the normal voice range (200-3000). If use is made of those higher frequencies, therefore, there obviously is a possibility of increasing the message carrying capacity of the line wires. Additional circuits obtained by use of frequencies above the voice frequencies are called carrier channels.

The number of carrier channels that can be operated simultaneously on the same circuit depends on the type of line conductors and the frequency band

which is required by each channel. This band width per channel may vary from about 170 cycles for carrier telegraph to about 3000 cycles or more for carrier telephone systems. In commercial practice the number of channels per system varies from the single channel carrier system to the carrier system which operates on coaxial cable and is designed to transmit nearly 500 messages simultaneously. The more commonly used are the 3 and 12 channel telephone and 12 and 18 channel telegraph systems. The Signal Corps has at this time adopted only the single and 3 channel carrier telephone systems and a modified 12 channel carrier telegraph systems.

### Operation of the Carrier Circuit

A simplified carrier system of one channel is shown in Figure 1. To avoid confusion reference to carrier channels will mean channels over and above the voice channel; that is, a 3 channel carrier system provides for the normal voice channel plus 3 carrier circuits or a total of 4 telephone circuits.

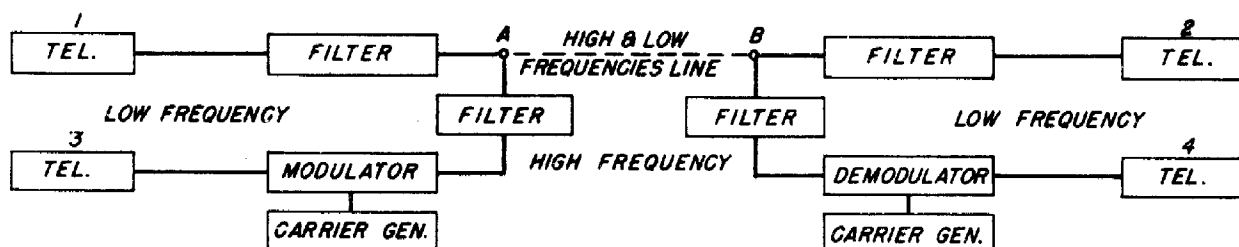

FIG. 1- SIMPLIFIED DIAGRAM OF SINGLE CHANNEL CARRIER SYSTEM

Referring to Figure 1, it is seen that telephones 1 and 2 are connected directly by line A-B. Telephones 3 and 4 are also connected by line A-B, but through a modulator and demodulator. For simplicity, operation of the carrier circuit is assumed from telephone 3 to 4 only; actually a modulator and demodulator would be used at both ends, thereby providing two-way operation. The function of the modulator is to "lift" the voice current from telephone 3 above the frequency range of the current from telephone 1 and "place" it on the carrier current from the carrier generator. The actual process that takes place in the modulator and demodulator will be explained later in this article.

At point A there appears the voice frequency current from telephone 1 and the current from telephone 3 which has been "shifted" into a higher frequency range. The filters prevent the high frequency currents from telephone 3 entering the circuit of telephone 1 and the low frequency currents from telephone 1 entering the circuit of telephone 3. Currents from both phones are transmitted over the line simultaneously. The message from telephone 3 is "carried" by the carrier current over the line facilities. At point B the currents are directed into the proper circuits by the filters; the low frequency current from telephone 1 flowing directly into telephone 2 without change, while the current from telephone 3 (on the carrier wave) enters the

demodulator. Here it is "lifted" off the carrier wave and restored to its original position in the frequency spectrum. (200-3000 cycles.) Insofar as the subscribers are concerned, there is no difference between talking from telephones 1 to 2 or from telephones 3 to 4. If a second carrier channel is added, the third voice currents would be "lifted" above the first carrier channel and this would be continued for each additional channel added. In the following, the steps involved are considered in some detail.

Modulation

Modulation is defined as "to vary or inflect for the sake of expression." Intelligible speech is produced by modulating, with the lips and throat, the air waves produced by vibration of the vocal chords. Modulation as applied to carrier telephone and radio may be defined as the process whereby currents at voice frequency are impressed upon a carrier current of higher frequency. The carrier current is a single frequency constant amplitude wave while the voice current wave is practically always complex; that is, of varying amplitude and containing frequencies ranging from approximately 200 to 3000 cycles. Practically speaking, the carrier current wave is varied or moulded to assume the configuration of the voice wave. The voice wave and unmodulated carrier are shown by Figure 2 (a) and (b) respectively. The modulated carrier wave or the carrier wave after the voice has been superimposed on it is shown in Figure 2 (c).

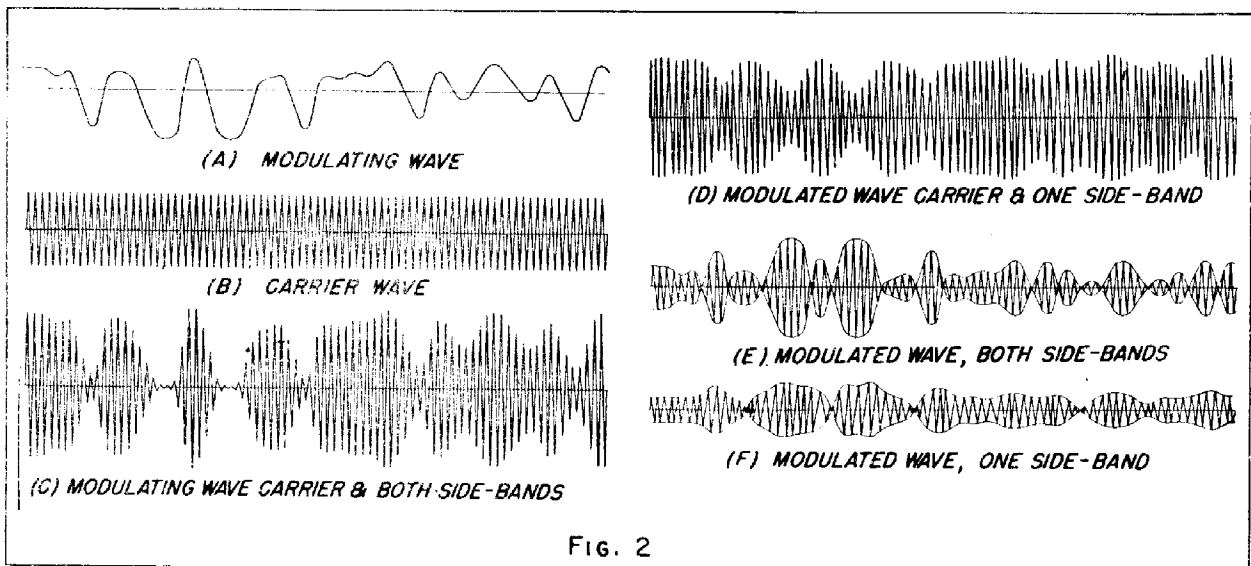

FIG. 2

Modulation may be accomplished by use of vacuum tubes or other types of rectifying devices. In radio circuits vacuum tubes are commonly used while in recent wire carrier equipment the vacuum tube has generally been replaced by the varistor (copper oxide rectifier) in the modulator and demodulator circuits.

Vacuum Tube Modulator

In the vacuum tube modulator the carrier and voice voltages are impressed on the grid circuit as shown in Figure 3. The grid bias is made sufficiently negative to force the steady plate current down to the lower bend of the plate current-grid voltage characteristic curve, as shown in Figure 3 (b). Under that condition the tube acts as a rectifier or modulator since negative swings of the alternating signal voltages cause relatively small changes in plate current compared to the corresponding positive swings. The output currents in the plate circuit are, therefore, somewhat distorted compared to the input voltages in the grid circuit, due to the non-linear relation that exists between grid voltage and plate current under these conditions of operation. Actually the modulating properties of the tube result from the interaction between applied voltages (voice and carrier) which this non-linear relation introduces.

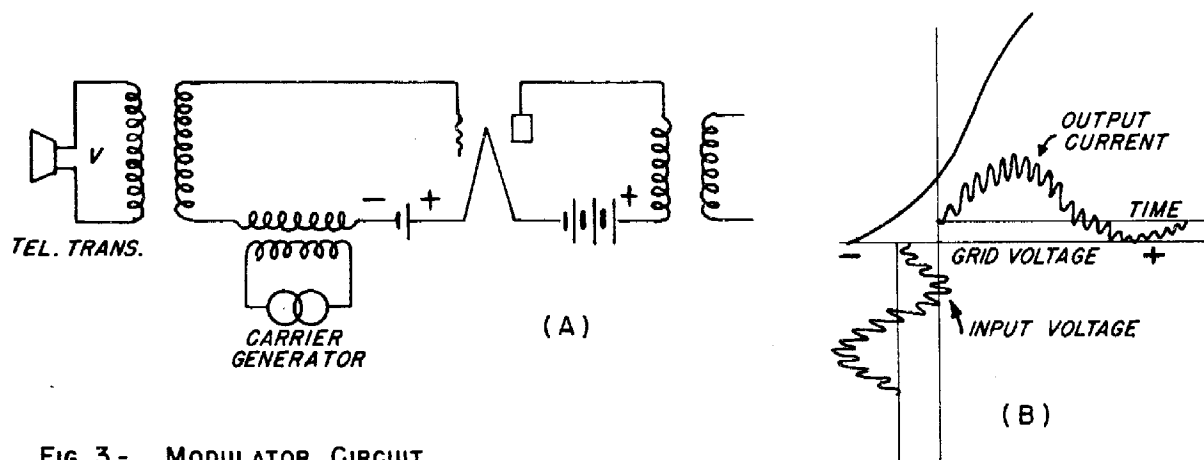

FIG. 3 - MODULATOR CIRCUIT

Referring to Figure 2 (c) it is seen that the output or modulated carrier current wave is rather complex and its envelope resembles the original voice wave. It is generally known that any complex wave may be resolved into component sine waves, consisting of a base or fundamental frequency and various harmonics or multiples of the fundamental. It must be kept in mind that the voice current that is modulating or mixing with the carrier is composed of component frequencies which in this discussion have been assumed to be between 200-3000 cycles per second. Therefore, each component frequency interacts with or modulates the carrier wave independently of all other frequencies and the modulated carrier wave shown in Figure 2 (c) is the result of the carrier Figure 2 (b) being modulated by all of these frequencies simultaneously. Note that the envelope of the modulated wave follows the variations of the voice wave Figure 2 (a).

When two alternating voltages are applied to a vacuum tube operating as a modulator, the output current will contain frequencies other than those of the applied voltages. If the output wave is analyzed mathematically by Fourier's Theorem or by laboratory methods, it will be found that it contains the following frequencies. Letting  $V$  represent the voice frequency (or frequencies) and  $C$  the carrier frequency, the frequencies present will be:

## CARRIER COMMUNICATIONS

### Frequencies in Grid Circuit

V  
C

### Frequencies in Plate Circuit

V Voice Frequency  
C Carrier Frequency  
2V Twice Voice Frequency  
2C Twice Carrier Frequency  
C+V Sum of Carrier & Voice  
C-V Difference between carrier and voice.

For example, if a 1000 cycle voice wave is assumed to be modulating a 10,000 cycle carrier wave, the following frequencies will be present in the output circuit of the demodulator.

### Grid Circuit

1,000  
10,000

### Plate Circuit

1,000  
10,000  
2,000  
20,000  
11,000  
9,000

It should be observed that with a complex voice wave, as has been assumed, the terms  $C - V$  or  $C + V$  mean the carrier frequency minus or plus each component frequency of the voice. Therefore,  $C - V$  is a band of frequencies as is also  $C + V$ . These two components of the modulated wave are known as the "side bands," the term  $C + V$  representing the upper side band and  $C - V$  the lower side band. If  $V$  is 200-3000 cycles and  $C$  is 10,000 cycles, then  $C + V$  will be the frequency band 10,200-13,000 and  $C - V$  will be the frequency band 9800-7000 cycles per second. Note particularly that both side bands contain the term  $V$  which means that both have the same frequency range as the original voice although in a different position in the frequency spectrum. This is equivalent to saying that either side band contains all the intelligence contained in the voice wave before modulation.

### Single Side-band Transmission

It was stated earlier in this article that the purpose of the carrier equipment is to accomplish transmission of additional messages over the line circuit at frequencies above the voice-frequency range. Therefore, the voice frequency currents in the modulator output are not transmitted over the line wires. Also the unmodulated carrier in the modulator output contains no signal intelligence and for the present discussion has no value. However, a current of the same frequency as the carrier current in the modulator will be needed for demodulation as explained later. The multiples of voice and carrier currents ( $2C$  and  $2V$ ) can likewise be eliminated. Therefore, if all frequencies in the modulator output current, except those contained in either side band, were eliminated (by filtering) before transmitting the output current over the line, the elements of the original speech would be preserved.

The choice of which side band is transmitted is determined by design considerations.

An important consideration in connection with transmitting only one side band is that the frequency space required for the other side band is made available for other channels. If both side bands are transmitted, the frequency width required per channel is more than twice that of the original voice and the frequency band required for the entire carrier system is thereby reduced by using single side band transmission. Figure 4 illustrates graphically the "raising" of the voice band into another part of the frequency spectrum by modulation and the frequency band required for transmission of single and both side bands.

An apparent exception to this practice is in the single channel carrier system where both side bands are transmitted over the line. In this case, the lower side band is used for transmission in one direction and the upper side band for transmission in the opposite. However, since in either direction only one side band is transmitted, this is also single side-band operation.

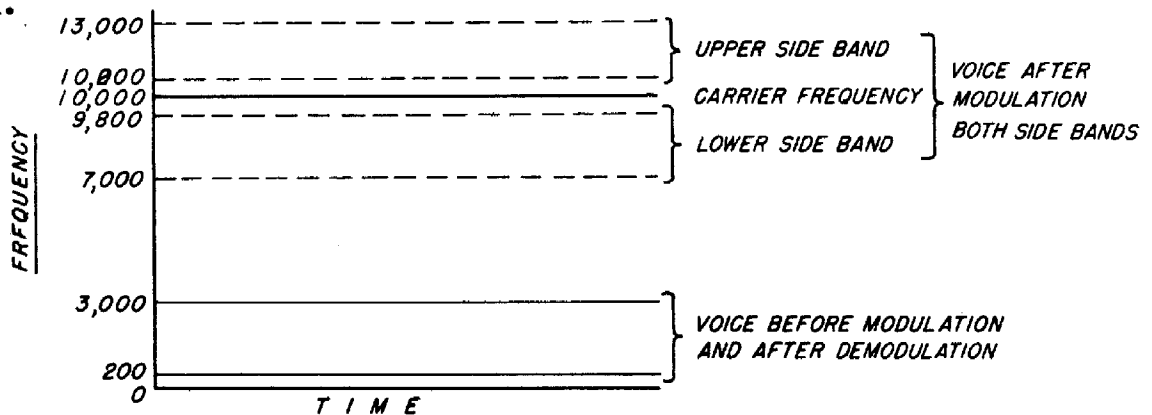

FIG. 4 - FREQUENCY CHANGES DURING MODULATION AND DEMODULATION

Transmission of Carrier Current

Although demodulation (restoring the voice currents to their original frequencies) will be covered later, it may be stated here that a carrier current of the same frequency is needed at the distant terminal to react with the side band to produce the original voice currents. The carrier current from the modulator may be transmitted over the line (it was shown that unmodulated carrier current (C) was present in the output of the modulator) or it may be generated locally, that is, at the distant terminal or demodulator.

Referring to Figure 2, it is readily seen that the energy contained in the wave consisting of the carrier and one side band (d) is considerably larger than the energy in the wave containing one side band only (f). Since the cost of vacuum tube equipment is affected by the energy to be transmitted, considerable saving may be realized by eliminating the large amount of energy contained in the unmodulated carrier. The amplitude of the carrier wave applied to the modulator is kept large compared with the voice wave in order





It will be noted that the voice currents have now been restored to their original position of 200-3000 cycles and their transmission at carrier frequency is no longer of importance. It is necessary now only to remove all frequencies in the modulator output circuit other than the original voice frequencies. This is readily accomplished by use of a low pass filter which passes only the currents up to about 3000 cycles and excludes all frequencies above that value. After demodulation the voice currents are the same as the original currents which entered the modulator from the telephone.

Summarizing, we find that the voice currents of 200-3000 cycles were by modulation "lifted up" above the normal voice range and placed on a carrier current of 10,000 cycles, transmitted over the line wires in the frequency range 7000-9800 cycles (lower side band) and by demodulation or remodulation "lifted off" the carrier and restored to their original position in the frequency spectrum.

This treatment of the fundamentals of carrier systems will be concluded next month with a discussion of carrier suppression, filters, 2- and 4-wire systems, etc.

## IMPROVISED BRIDLE RING

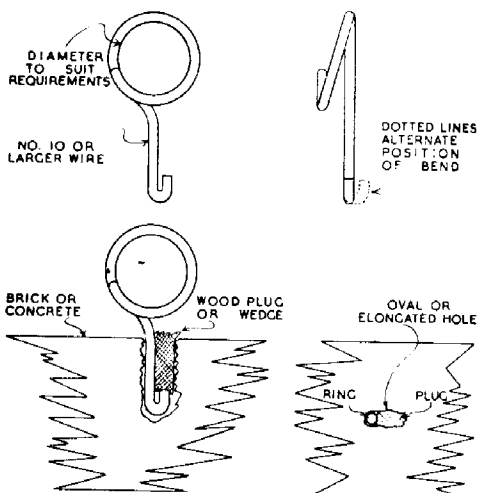

An installation recently was made by the 904th Signal Depot Company, Avn., which required that wires be placed along a brick wall of a new building. Since difficulty was encountered in using standard bridle rings, this organization improvised a ring of somewhat different design which proved to be simple to make and to install.

In the event that other organizations may encounter similar difficulties, details of the improvised ring are presented below. This ring offers an advantage over standard type rings PF-73, -74, -75, and -76, with anchors, under certain conditions where soft masonry is encountered.

# SIGNAL CORPS

## WANTS

### 1-10 KW USED TRANSMITTERS

The Signal Corps would like broadcast station owners who have broadcast transmitters of from 1 kw to 10 kw for sale to forward details to its Philadelphia Depot where a register of such equipment is to be maintained. The purpose of this record is to enable the Signal Corps to quickly initiate purchase of such equipments as the need arises. These needs are rather extensive and frequent inasmuch as the Signal Corps not only serves as the procurement agency for radio equipment for all branches of the Army, but on occasion for our allies and for other government departments.

This situation is here being brought to the attention of readers with the request that information be passed along to any likely prospects with whom they may be in contact.

Information on equipment available for sale should be forwarded to the Emergency Purchase Section, Philadelphia Signal Corps Procurement District, 5000 Wissahickon Avenue, Philadelphia, Pennsylvania.

# O.C. SIG. O. LIBRARY

Following are a few of the books added to the collection in the Signal Corps Reference Library, 4C340, Pentagon Building, during the last month.

- The Military Cipher of Commandant Bazeries; An Essay in Decrypting by Rosario Candela. Cardanus, 1938. 137 p. Z104.B35.
- X-ray Crystallography by M.J. Buerger. Wiley, 1942. 531 p. QD945.B8.
- Fundamentals of Electricity by W.H. Johnson and L.V. Newkirk. Macmillan, 1943. 212 p. QC523.J65.
- Alternating-current Circuits by J.M. Bryant and others. 3d ed. McGraw, 1939. 522 p. TK1141.B75.
- Fundamental Principles of Electric and Magnetic Circuits by F.A. Fish. 3d ed. McGraw, 1940. 229 p. TK146.F5.
- The Performance and Design of Alternating Current Machines by M.G. Say and E. N. Pink. London, Pitman, 1942. 552 p. TK2711.S3.
- Practical Electric Metering by M.F. Smalley and others. Wiley, 1940. 228 p. TK301.P7.
- Applied Electronics, Massachusetts Institute of Technology. Dept. of Electrical Engineering. Wiley, 1943. 772 p. TK161.M3.
- Electronics by Jacob Millman and Samuel Seely. McGraw, 1941. 721 p. QC721.M73.
- Fluorescent Chemicals and Their Applications by J.A. DeMent. Chemical Pub. Co., 1942. 240 p. QC477.D4.
- Graphs, How to Make and Use Them by Herbert Arkin and R.R. Colton. Rev. Harper, 1940. 236 p. QA90.A7.
- Practical Knots and Splices by K.E. Cahoon. U.S. Naval Institute, 1942. 69 p. VM533.C3.
- Manual of Meteorology by W.N. Shaw and Elaine Austin. Cambridge, Eng., University Press, 1942. 4v. QC861.S5.
- A Dictionary of Metals and Their Alloys by F.J. Camm, ed. Brooklyn, Chemical Pub. Co., 1940. 245 p. REF TN609.C3.
- Photography, Its Science and Practice by J.R. Roebuck and H.C. Staehle. Appleton, 1942. 283 p. TR200.R56.
- Kodak Reference Handbook. Eastman Kodak Co., 1941. 1v. REF TR150.E3.
- The Making and Moulding of Plastics by L.M.T. Bell. 2d Rev. Impression. Chemical Pub. Co., 1938. 242 p. TP986.A5.
- Radio in Airmanship by J.E. Fechet and Others. National Aeronautics Council, 1942. 124 p. TL695.F4.
- Radio Goes to War by C.J. Rolo. Putnam, 1942. 293 p. D798.R6.
- Everybody's Radio Manual; How to Build and Repair Radio Receivers. Popular Science, 1942. 256 p. TK6550.P6.
- Short-wave Manual by F.J. Camm, ed. 1st Am. Ed. Chemical Pub. Co., 1942. 213 p. TK6563.C31.
- Mass Spectra and Isotopes by F.W. Aston. Longmans, 1942. 276 p. QD466.A8.
- Substitutes; A Handbook of Substitutes and Alternatives for Chemicals, Metals, Fibers and Other Commercial Products by Harry Bennett. Chemical Pub. Co., 1943. 225 p. TPL49.B44.
- Handbook of Technical Instruction for Wireless Telegraphists by H.M. Dowsett and L.E.G. Walker. 7th ed. London, Iliffe, 1942. 654 p. TK5741.D57.
- Television Standards and Practice; Selected Papers from the Proceedings of the National Television System Committee and Its Panels. Ed. by D.C. Fink. McGraw, 1943. 405 p. TK6630.N38.
- Weather Prediction by R.M. Lester. Chemical Pub. Co., 1940. 256 p. QC995.L4.
- What You Should Know About the Signal Corps by H.M. Davis and F.G. Fassett. Norton, 1943. 214 p. UG573.D3.

RESTRICTED

# EQUIPMENT NOTES

## EQUIPMENT COORDINATION

### DIRECTIVES FORWARDED TO THE SIGNAL CORPS BOARD

<u>Date</u>	<u>No.</u>	<u>Subject</u>
6 July 1943	536	Earth Boring Equipment for Tactical Use.
7 July 1943	537	Investigation of Lineman's Safety Straps.
7 July 1943	538	Study of Tactical Employment of Wire Communication during North African Operations.

### SIGNAL CORPS BOARD REPORTS APPROVED BY THE CHIEF SIGNAL OFFICER

Signal Corps Board Case No. 521 - Rain Repellent Clothing.  
Approved 16 June 1943.

The Signal Corps Board was directed to test articles of newly developed rain repellent clothing including Raincoat with Parka Hood; Rainshirt, Knee Length; Poncho, Synthetic Resin; Raincoat, Synthetic Resin, and Raincoat, G.I.; to determine the suitability of designs and materials for use by Signal Corps troops.

The Case deals entirely with tests of the impervious type of rain repellent clothing, which is rendered repellent against wind and rain by reason of impregnation of base fabric material with vulcanized natural rubber, vulcanized synthetic rubber, polymerized plastic, or oxidized oils.

The items tested were development models proposed as substitutes for Raincoats, Rubberized. A shortage of rubber limits the procurement of this item. Reports from the field indicate that the present issues of Raincoats, Synthetic, Resin-Coated and Raincoats, Oil Treated, are less satisfactory than Raincoats, Rubberized.

The Signal Corps Board recommended that:

1. The Signal Corps representatives to the Quartermaster Technical Committee be instructed to disapprove standardization of Raincoat, with Parka Hood; Rainshirt, Knee Length; Poncho, Synthetic, Resin-Coated; Raincoat, Synthetic, Resin-Coated, Test Model.

## EQUIPMENT

2. The Quartermaster General be notified that the Signal Corps recommends that development be continued in the direction of producing:

a. A raincoat material which does not soak up water on its exterior surface.

b. A raincoat design embodying greater shoulder freedom at armpit (construction similar to G.I. field jacket); new collar construction to permit water-tightness at throat (use of a drawstring or strap arrangement suggested); protection against the entrance of water into the pockets, or if this is not feasible, small drainage eyelets at bottom of raincoat pockets to permit collected water to drain down outside of coat; and greater strength of buttons and buttonholes.

Signal Corps Board Case No. 522 - Methods of Tying Field Wire.  
Approved 25 June 1943.

Reports from observers in the field indicated that unsatisfactory service had been obtained from Field Wire W-110-B under certain conditions. It appeared that methods of installation and support of this wire might have been at fault.

The Signal Corps Board was requested to study methods of tying field wire employed by the Army, with a view toward recommending the most suitable methods of making field wire ties involving the use of Wires W-110-B, W-130 and development type a long range tactical, "Wire W-143."

The Signal Corps Board sent observers to the Officers' and Enlisted Men's Schools at Fort Monmouth to note methods of instruction in wire tying. Experimental ties were also subjected to laboratory and field tests under various conditions of heat, moisture and strain.

The Board concluded that the present methods of tying Wire W-130 are satisfactory. However, under certain conditions of heavy strain, temperatures of above 100 degrees F., and continued exposure to the elements, present methods of tying Wire W-110-B are not satisfactory.

The recommendations in this case are that:

1. No change be made in existing training literature concerning methods of tying Wire W-130.

2. Using the information contained in Inclosure No. 1 as a guide, a training circular be prepared and disseminated to troops which shall include instructions for the preparation of the Basket Hitch from single strands of scrap lengths of Wire W-110-B, and for its use as:

a. An aerial tie for Wire W-110-B under conditions of extreme heat, long spans, heavy wind or sleet loading;



## EQUIPMENT

b. As an aerial and ground tie for larger field wires and for field cables.

3. The Signal Troops Division be directed to institute training in the use of the Basket Hitch for Wire W-110-B and larger field wires, and for field cables as soon as practicable; and to include the instructions contained in the training circular in the next revision of FM 24-5, "Signal Communication."

Signal Corps Board Case No. 516 - Service Test of Wire W-143-T5 and Wire W-143-T6. Approved 28 June 1943.

The use of two pairs of either Wire W-143-T5 or Wire W-143-T6 is possible as a substitute for a single spiral-four facility. The Signal Corps Board was directed to supervise a service test to determine their suitability as a supplement to long range, carrier frequency Cable WC-548 (Spiral-Four).

Wire W-143-T5 consists of a duplex rubber insulated pair, utilizing stranded copper conductors equivalent to No. 15 A.W.G. The parallel pair is shielded with paper backed foil and covered with a weatherproof cotton braid. Wire W-143-T6 is similar to Wire W-143-T5 except the conductors are of solid 15 A.W.G. copper.

Wire W-143-T5 and Wire W-143-T6 were tested by the 930th Signal Battalion in collaboration with representatives of the Signal Corps Board, Eatontown Signal Laboratory, and Bell Telephone Laboratories.

One circuit of each wire was laid between Keystone Army Air Field and Williston, Florida, a total distance of 79 miles. A thirty-mile section was placed underground by means of Cable Plow LC-61, six miles were aerial construction, and forty-three miles were laid on the surface of the ground.

The wires were tested with reference to their ability to serve as a substitute for Cable Assemblies CC-358 (Spiral-Four) and as long range tactical lines.

The recommendations of the Signal Corps Board are as follows:

1. No further consideration be given to the military employment of Wire W-143-T6 at the present time.
2. Wire W-143-T5, procured in accordance with present specification, be recorded Wire W-143-(Long Range Tactical Wire).
3. Wire W-143 be standardized as Required Type, Adopted Type, Standard Article.
4. The proposed Military Characteristics for Connector for Wire W-143, appended to the report as Inclosure No. 1, be adopted.

## EQUIPMENT

5. The Signal Corps Ground Signal Service be directed to:
  - a. Develop a Connector for Wire W-143 in accordance with the adopted military characteristics.
  - b. Continue development of a carrier loading coil system suitable for permanent installation in Wire W-143 at the factory.
  - c. Investigate the possibility of eliminating the web between conductors.
  - d. Add a suitable equalizer to Parts Lists for Telephone Terminal CF-1, Repeater CF-3 and similar equipment, and add instructions for the use of the equalizer in appropriate Instruction Books.
6. Wire W-143, procured to meet immediate requirements, be supplied in 5/8-mile lengths on standard Reel DR-5 with a factory made midsection transposition splice at the 5/16-mile point but without permanently installed voice or carrier loading coils, and without permanently installed end connectors.
7. Nonloaded "Wire W-143" be employed as an alternate carrier facility to Spiral-4 Cable only where necessary.
8. The methods of splicing Wire W-143 appended to the report as Inclosure No. 2 be approved.
9. Pending the availability of a suitable Connector for Wire W-143, voice loading be applied as required, utilizing Coil C-334 spliced into the circuit at 5/8-mile intervals.
10. Pending the availability of a suitable connector for Wire W-143, test points be provided at a maximum interval of five miles, utilizing Terminal Strip TM-184 housed in improvised weatherproof shelters.
11. The Military Training Branch be directed to publish a Technical Manual entitled "Long Range Tactical Wire," using the following as a guide:  
Section
  - I - General. (Including purpose and scope, related manuals, description of Wire W-143, and use of Reel DR-5).
  - II - General Transmission Considerations (including field of use, electrical characteristics, circuit facilities, general telephone and telegraph transmission capabilities, allowable circuit lengths, carrier frequency use, voice frequency use, methods of loading for carrier and voice operation, and use as an alternate carrier facility on Spiral-4 Cable).

## EQUIPMENT

---

- III - Advanced Planning of Construction and Routing; Guiding principles.
- IV - Survey to Aid Specific Planning and Marking the Route.
- V - Construction on the Ground Surface.
- VI - Buried Construction.
- VII - Aerial Construction of Lines. (See recommendations in Signal Corps Board Case No. 522 entitled "Methods of Tying Field Wire".)
- VIII - Maintenance of Wire Lines (including methods of splicing, use of tension bridges and equipment for maintenance teams).
- IX - Electrical Testing and Fault Locating. (See approved Signal Corps Board Case No. 507 entitled "Investigation of Fault Location Equipment".)
- X - Recovery of Wire.
- XI - Repair of Recovered Wire.

Signal Corps Board Case No. 525 - Frequency Calibrator BC-1166-( ).

Approved 2 July 1943.

During the early part of 1942 it appeared that the requirements for Frequency Meter Set SCR-211, used in the calibration of Signal Corps radio sets, could not be met by the manufacturers. It was therefore considered necessary to develop a substitute equipment, composed of less critical materials, and capable of being produced in large numbers within a limited period of time.

Frequency Calibrator BC-1166-( ) was developed as a possible supplement. It is less accurate than Frequency Meter Set SCR-211 and also less convenient in use. It produces extremely accurate test frequencies at fixed points separated by 500 kc, 100 kc and 10 kc throughout the frequency spectrum instead of continuously variable test frequencies. The calibrator is further simplified by the omission of equipment for monitoring the radiation from other sources, such as a transmitter, it being presumed that receivers will always be available which will permit the calibrator to be used to accurately calibrate transmitters.

Six models of Frequency Calibrator BC-1166-( ) were obtained from Camp Coles Laboratory and tested by the Signal Corps Board.

The maximum frequency variation over an ambient temperature range of minus 20° C. to plus 50° C. was 500 cycles at a frequency of 5,000 kc, an accuracy of .01%. At 1,000 kc, room temperature, an average frequency devia-

## EQUIPMENT

tion from that indicated by a secondary standard was observed to be 50 cycles. The instrument was slightly less accurate with the KC INTERVAL switch in the 10 kc position than when in the 500 kc and 100 kc positions.

The signal output level on all frequencies from 100 kc to 5,000 kc was sufficient for realignment or calibration of receivers.

The Frequency Calibrator BC-1166-( ) was found to be less convenient in use than Frequency Meter SCR-211-( ) because it requires the counting of harmonics and interpolation between observed readings if a frequency not a multiple of 10 kc is required.

The approved recommendations are that:

1. Communication Coordination Division be directed to initiate action to recommend classification of Frequency Calibrator BC-1166-( ) as a "Substitute Standard Article."
2. The Signal Corps Ground Signal Service be directed to continue development of auxiliary power supply equipment for this unit.

Signal Corps Board Case No. 503, Part E - Development of Methods for Use of Cable Assembly CC-358, Part E - Location and Repair of Trouble. Approved 2 July 1943.

The Signal Corps Board in Case No. 503 was directed to develop methods of handling, installing and recovering Spiral-Four Cable. Part E of this case consists of a study of the material submitted by the Bell Telephone Laboratories as Section VIII, Physical Maintenance of Spiral-Four Cable Lines and Section IX, Electrical Testing and Fault Locating, of a preliminary Technical Manual 11-369, Spiral-Four Cable.

The material presented was checked and tested in the installation, operation, and recovery of a 103-mile Spiral-Four Cable carrier facility between Dunnellen and Keystone Army Air Fields, in the vicinity of Gainesville, Fla.

The experience gained in the Florida operations indicated the need for revision of the preliminary manual. This was accomplished for Sections I to VII, inclusive, in the approval of the reports of the Signal Corps Board in Case No. 503, Part D, on 11 May 1943. The approval of Part E completes the Technical Manual 11-369 which is now in the hands of the publishers.

The approved recommendation is as follows: that the material contained in Inclosure No. 1, appended to the report, be published and distributed as Sections VIII and IX of the complete Technical Manual 11-369, Spiral-Four Cable, at the earliest practicable date.

Signal Corps Board Case No. 532 - Confidential. Approved 9 July 1943.

**GROUND SIGNAL**

TELEPHONE KITS NOW AVAILABLE  
FOR RADIO SET SCR-551-T1 and SCR-551-T2

Telephone modification kits have been prepared by the Laboratory for the several hundred each Radio Set SCR-551-T1 (Direction Finding) and SCR-551-T2 which were issued without telephone facilities for the operator. These sets were procured without this feature and issued to Army Air Forces units because of urgent need for this kind of equipment. There were no telephone facilities originally included because at the time that the sets were designed it was not known how to avoid distortion of the radiation pattern due to the vertical telephone line necessary to reach the operator's position in the tower. The purpose of including the kits is to provide facilities for rapid transmission by telephone of direction-finder bearings without giving rise to the errors ordinarily associated with telephone lines in the vicinity of direction finders.

This kit consists of:

- |                                  |                             |
|----------------------------------|-----------------------------|
| 1 Slip Ring Assembly             | 1 Vertical Telephone Line   |
| 2 Control Spring Assemblies      | (15 feet long)              |
| 1 Junction Box                   | 1 Chest Set TD-1            |
| 1 Cable Support                  | 1 Headset HS-19             |
| 1 Junction Box Support (consists | 2 Battery BA-30             |
| of 3 pieces of pine wood)        | 1 Set of Bolts and Nuts     |
| 1 Telephone EE-8-A               | 4 Instruction Books         |
| 1 Telephone Box (to hold EE-8-A) | 1 Chest to hold everything. |

These kits have been constructed on the basis of one for each SCR-551-T1 and SCR-551-T2 and may be obtained by requisition from Storage and Issue Agency, Controlled Items Section, OCSigO. It is necessary to include the serial number of the set on the requisition.

RADIO RECEIVER OUTPUTS ARE MODIFIED  
FOR HEADSET HS-30-( )

Headset HS-30-( ), the new all-purpose, high-efficiency headset for use by ground forces, has an impedance of 256 ohms. Most ground radio sets have, on the other hand, output impedances of 4000 ohms, to match older types of headsets and high impedance loud speakers.

It is at present possible to use HS-30-( ) with such outputs by employing a Cord CD-605, or a Cord CD-604 plus Cord CD-307-A, for both the CD-604 and the CD-605 contain a Transformer C-410, which has a high-impedance primary and a 250 ohm secondary. (See circuit "A" herewith.)

# EQUIPMENT

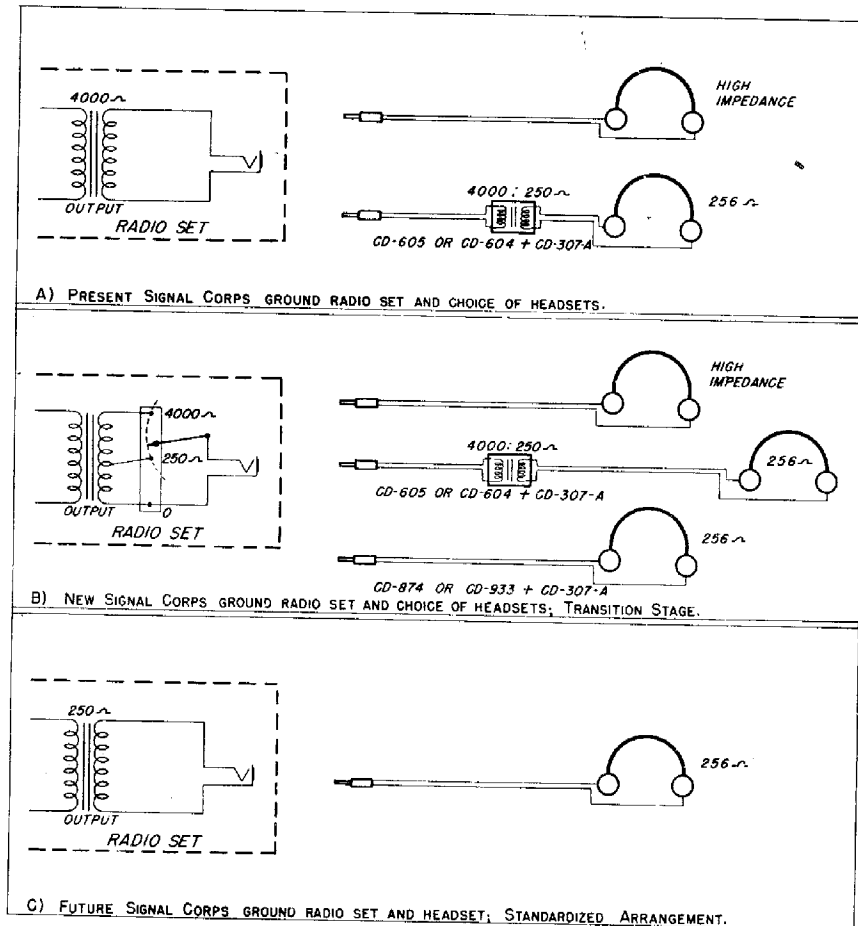

A change has been authorized in Receiver BC-312, BC-314, BC-342 and BC-344 (as manufactured by Farnsworth Radio and Television Corps.) to provide both 250 ohm and 4000 ohm taps on the output transformers, to obviate the need for cords containing additional matching transformers. Leads from the taps in the new output transformers will be brought to a terminal strip inside the set, and it will be possible to connect either impedance to the phone jack. A reversible plate, lettered 250 OHMS on one side and 4000 OHMS on the other will be located near the phone jack or jacks, and the exposed side will indicate which tap is connected. If a change in output impedance becomes necessary, the set can be opened, the change made, and the indicator plate turned to indicate the impedance provided. This arrangement is illustrated at "B" in the accompanying circuit drawing.

Information as to the serial numbers of the sets containing this modification, and nomenclatures of other sets which will include the same modification, or those which will provide only 250 ohm impedance output, will be released in the near future. Fort Monmouth Signal Laboratory has expressed the opinion that sets with the optional 250 ohm and 4000 ohm impedance outputs will be ready for distribution within the next few months. Eventually, it is planned to supply all ground signal equipment with the 250 ohm impedance output only as shown at "C". Loud-speakers with 250 ohms impedance will also then be procured for use with such sets.



## REPORT ON CAPTURED ENEMY EQUIPMENT

Successful advances into enemy territory have resulted in our forces obtaining a number of enemy radio and wire equipments for analysis and study. To facilitate the coordination of these investigations and to provide a source of technical information, the Captured Equipment Test Section was activated as part of Test and Maintenance Equipment Branch, Camp Coles Signal Laboratory. This section is to act as a clearing house for all work of this type being carried on by the Signal Corps Ground Signal Service.

The following items of German equipment have been received at Camp Coles Signal Laboratory or Fort Monmouth Signal Laboratory: tank transmitter type 10 W.S.C. and receiver type UKWEe, tank transmitter power supply 12 volts, 4000 ohm receiver, spare transmitting tubes types RL-12P35 and RV-12P4000, hand-microphone, battery for pack sets, dynamotors types EUa and U20a3 (for tank receiver), a torn FuF pack transceiver and certain other items. Metallurgical and mechanical tests have been started on five of these. Frequency stability tests have been completed by Radio Communication Branch, Camp Coles Signal Laboratory on the German tank transmitter type 10 W.S.C. and receiver type UKWEe.

The Battery Development Section at Fort Monmouth Signal Laboratory investigated the physical, chemical, and electrical characteristics of the following three types of batteries: A German battery type Sa-2B-38, a German Rulag miniature storage battery with dry electrolyte, and a 1.65 volt Japanese dry battery. The chemical components of the Rulag Battery for radiosonde

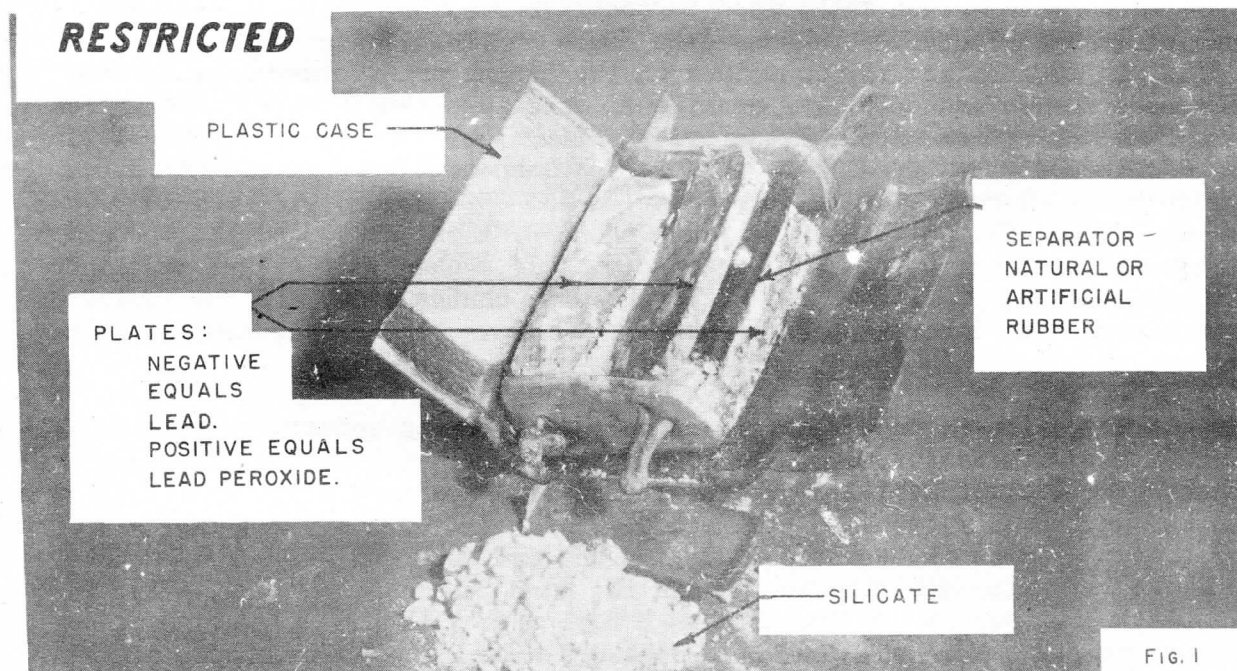

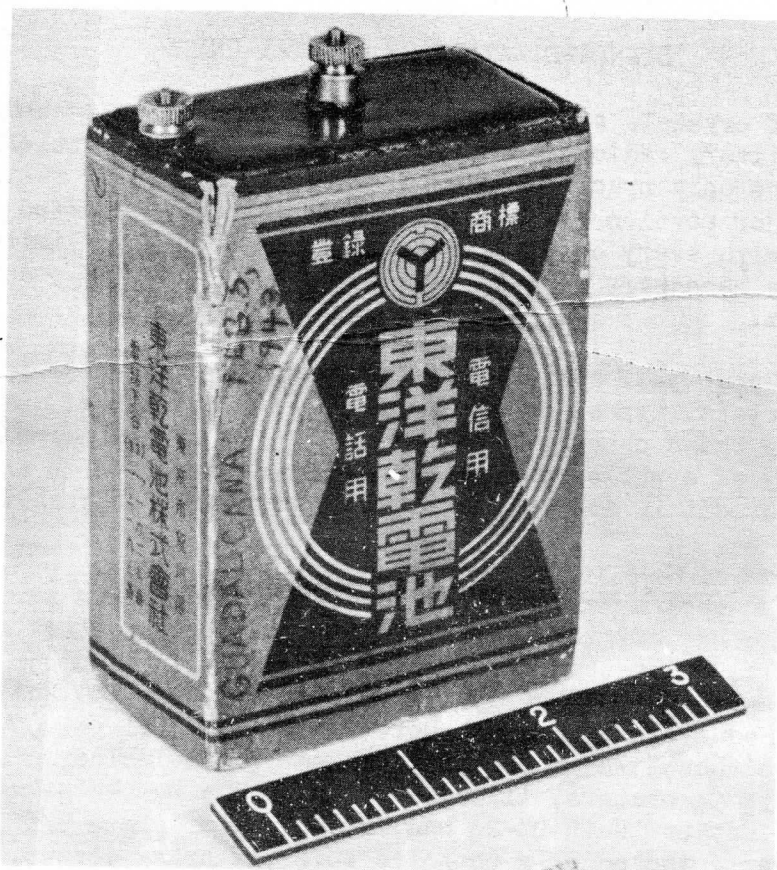

FIG. 2

equipment were determined as illustrated in the photograph, Figure 1. This battery seemed to show no unusual chemical or physical features and is very similar to the American lead-acid batteries utilizing some form of siliceous material as an absorbent for the sulphuric acid electrolyte. However, all these German batteries seem to be made of ersatz material.

Figure 2 shows an exterior view of a captured Japanese primary battery. Investigations of this showed it to exceed the Signal Corps specifications for the corresponding BA-15-A. This is thought to be due to the use of square bobbins (instead of the cylindrical type used in the BA-15-A) allowing more active material to be placed into the square shaped bobbin. The tests likewise indicated a relatively high percentage of iron and a low percentage of total chlorides although large percentages of iron in the mix are usually considered to be detrimental to the life of the batteries. The manganese dioxide used was found to be very active.

Investigations have been started on a German quartz crystal resonator or calibrating crystal by the Crystal Branch, CCSL. Tests have been completed on the electrical capabilities.

In the course of time, further investigations will probably bring to light many interesting and valuable points on the mechanical and electrical features of the enemy's equipment.

## EQUIPMENT

### STANDARDIZATION OF CRYSTAL UNITS

Millions of crystals are needed this year to equip the hundreds of thousands of military radio sets spread over the world's battlefields. Crystal quartz is the only practical piezoelectric material for making these crystals and the major portion of this raw quartz is being imported from Brazil. As is the case with every critical material, the supply is limited and accordingly it becomes necessary to make as many crystal units as possible from the available quartz.

During the past year considerable progress has been made in the standardization of crystal types and the reduction in the size of quartz oscillator plates. Many of these changes have been initiated by the Signal Corps. The crystal industry as a whole has been extremely cooperative in these developments and much credit is due to the manufacturers for the results now in effect.

The Signal Corps' crystal program has also resulted in saving considerable amounts of other critical materials by the development of smaller and simpler holders. An outstanding example of economy in a number of critical materials is the replacement of Crystal Unit DC-12-A, a 200 kc. calibrating crystal, by its equivalent, Crystal Unit DC-24. Crystal Unit DC-12-A had an oscillator plate about  $5/8$ " x 1", and 54 other parts including an aluminum cover, 9 steatite insulators, 11 brass screws and a number of machined brass parts. The new Crystal Unit DC-24 has an oscillator plate  $3/8$ " x  $3/8$ ", and only 13 other parts including a phenolic cover, 2 brass screws, a neoprene gasket, 2 pins and 4 short pieces of wire. The simplicity of the new crystals as compared with the older design is strikingly illustrated in the accompanying photograph. When the savings of critical materials effected in one crystal are multiplied by 100,000, the importance of these conservation steps becomes apparent.

One of the outstanding accomplishments of standardization and reduction of oscillator plate size has been in the crystals for the ultra high frequency sets used by the Army Air Force. The recently developed Crystal Unit CR-1A/AR is replacing Crystal Unit DC-11, DC-16 and DC-26. DC-11 has plates  $3/4$ " x  $3/4$ ". The new Crystal Unit CR-1 has three size plates: 0.4" x 0.5", 0.5" x 0.5" and 0.6" x 0.5", the larger sizes being necessary for the lower frequencies. The CR-1A/AR holder is much smaller than the DC-11 holders, and since millions of these crystals are needed, it is evident that the new design will result in the saving of great quantities of critical materials.

It is reported that one manufacturer is using quartz which heretofore was scrap from the production of larger blanks, to supply  $3/8$ " x  $1/2$ " blanks to another manufacturer who uses them in the production of plated type crystals. Utilization of this otherwise waste quartz is possible because of the small size of the blanks required. This is just one example of how the manufacturers are doing their part to utilize every possible bit of quartz which is available.

# EQUIPMENT

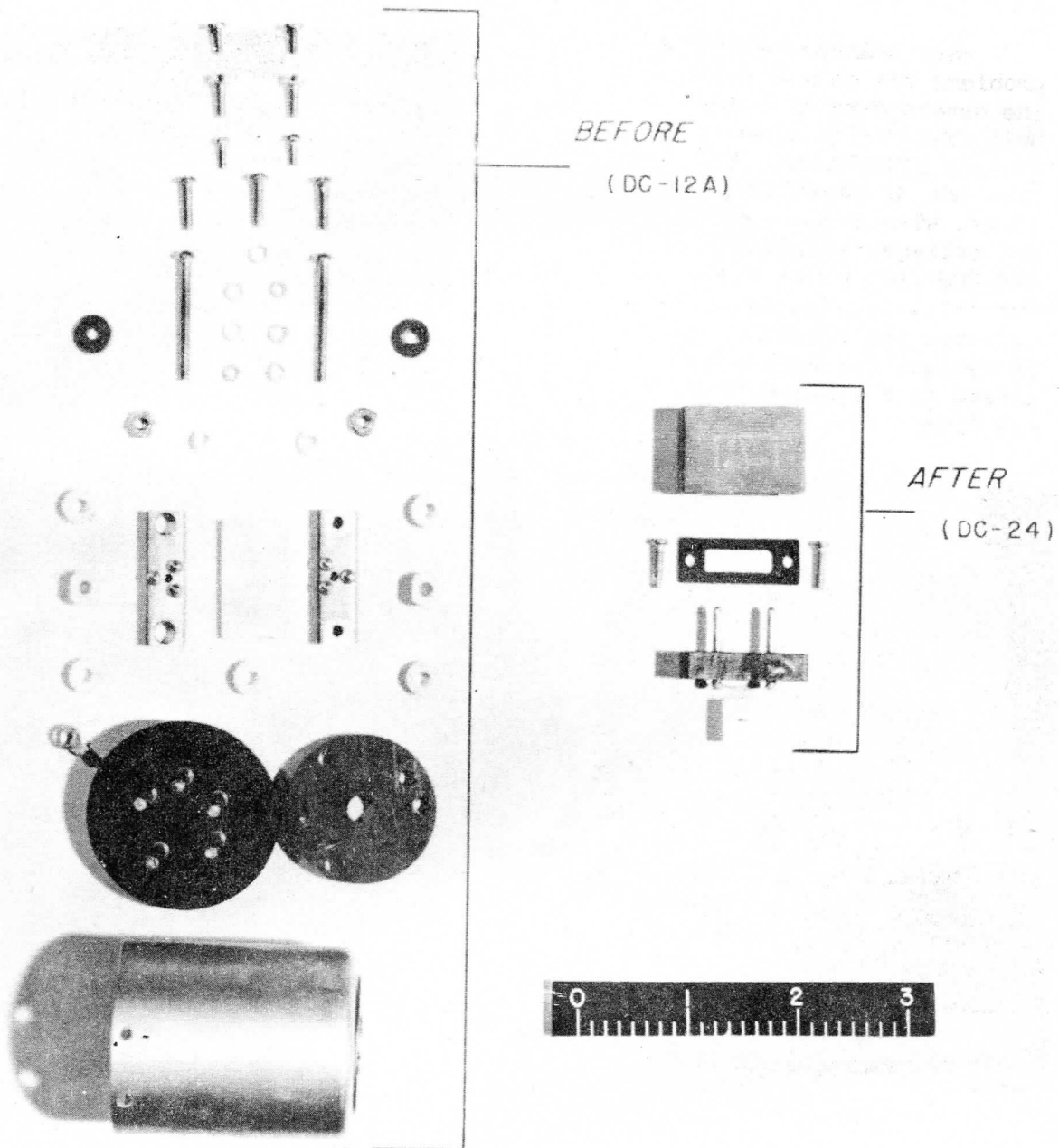

The ultimate aim of the Signal Corps is to standardize on three or possibly four types of crystals for all radio sets. The saving of critical materials and the reduction of manufacturing effort, with its attendant economy in manpower, make the Signal Corps crystal program a worthwhile contribution to the war effort.

**RESTRICTED**



## EQUIPMENT

### TWO-PIECE POWER UNIT

Many transportation problems are solved with the development of Power Unit PE-182-( ), soon to go into production. The unit has a capacity of 10 kw, with 3-phase output voltages of 120/208 and 208/416, with 4 wires for utilizing single phase current. The frequency is 60 cycles. The engine employed is a standard Willys "jeep" model.

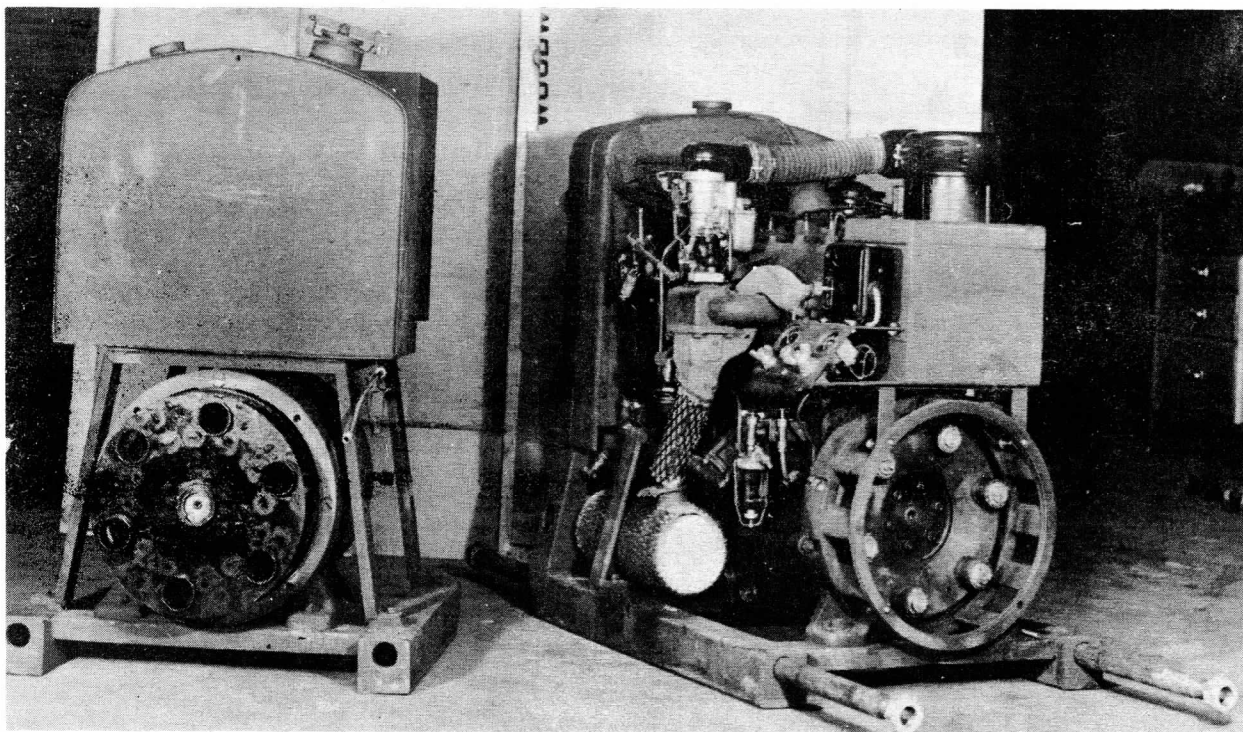
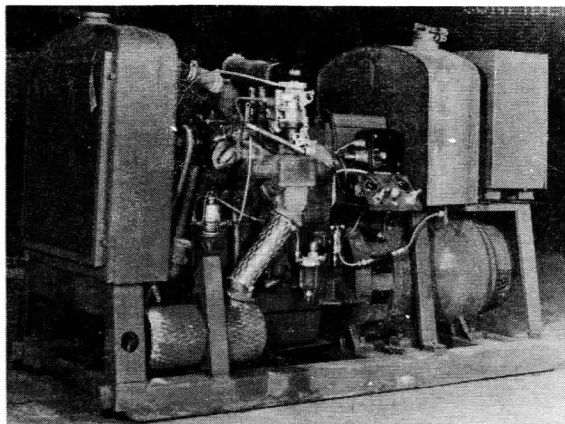

POWER UNIT PE-182-( ) SEPARATED INTO ITS TWO COMPONENT UNITS TO FACILITATE TRANSPORTATION. AT TOP, ASSEMBLED AND READY FOR OPERATION.

The unique feature of this power unit is that the generator and engine are mounted on separate bases for easier portability, and can be screwed together upon arrival at their destination. It was designed for air-transportable use, but may be used in other applications where an output of this order is necessary, but where the transportation of large units is a problem. It is contemplated that the unit will be issued only with Radio Set SCR-682-( ).

# MILITARY TRAINING

## RESPONSIBILITY FOR SUPERVISION OF INSTALLATIONS

In accordance with AR 170-10, all Army Service Forces training activities at Class I and Class II installations are placed under complete control of the commanding general of the service command, except for the promulgation of training doctrine, establishment of student quotas, and preparation of training programs.

The Central Signal Corps Training Center, Camp Crowder, Missouri, and the Western Signal Corps Training Center, Camp Kohler, California, which were previously under the control of the Chief Signal Officer, are, therefore, now under complete control of the commanding general of the service commands, except for those training activities mentioned above. The Eastern Signal Corps Training Center, Fort Monmouth, New Jersey, and the Southern Signal Corps School, Camp Murphy, Florida. (Class IV installations), are still directly under control of the Chief Signal Officer.

## FILMS ON PROPER USE OF TOOLS

Films dealing with the correct use of tools have been added to the numerous visual aids available. Given to the Army by the Floum Tool Company of Los Angeles, California, the films demonstrate the correct use of common tools and illustrate difficulties arising from incorrect practices. It is believed that in some instances these films may have specific application and fill a definite need.

They have been assigned official WD training film numbers in the nine series as follows:

TF 9-2026 - Wrenches	TF 9-2029 - Hammers
TF 9-2027 - Pliers and Screwdrivers	TF 9-2030 - Punches, Drifts and Bars
TF 9-2028 - Chisels	TF 9-2031 - Hacksaws

## FILM STRIPS ON RADIO SET SCR-284

The latest film strips produced by the Signal Corps include a series of three on the Radio Set SCR-284. This series was completed with the release of FS 11-19. The following is a brief resume of the subject material contained in each film strip:

FS 11-17, Radio Set SCR-284, Part I, Description. - Gives a com-



## MILITARY TRAINING

plete description of the set showing typical installations, capabilities, component parts, accessories for field installation, safety measures and precautions.

FS 11-18, Radio Set SCR-284, Part II, Installation. - Depicts the steps required for ground installation, the steps required to install the set in a command truck and several views of installation in various vehicles.

FS 11-19, Radio Set SCR-284, Part III, Operation. - Deals with processes required to tune the transmitter and receiver to an assigned frequency, the function of both a net control station and a subordinate station and certain operation tips.

Illustrated Instructor's Reference Books are planned for each of these three film strips.

### PUBLICATIONS

The following new technical manuals of particular interest to the Signal Corps have been published since FM 21-6 was issued and may be obtained through regular Adjutant General channels:

- FM 1-46, Fighter Radiotelephone Procedures and Code, 15 May 1943.
- FM 24-11, Combined Operating Signals, 17 January, 1943.
- TM 11-235, Radio Sets SCR-536-A, SCR-536-B, and SCR-536-C, 14 May 1943.
- TM 11-403, Identification Equipment PH-385, 12 May 1943.
- TM 11-404, Photographic Darkroom Equipment (Processing Equipment PH-395), 29 May 1943.
- TM 11-405, Photographic Darkroom Equipment (Processing Equipment PH-406), 12 May 1943.
- TM 11-447, Keyer TG-10-J (Automatic, 60 cycles) and Keyers TG-10-A, TG-10-B, TG-10-C, TG-10-D, TG-10-F, 15 May 1943.
- TM 11-454, The Radio Operator, 12 May 1943.
- TM 11-459, Instructions for Learning International Morse Characters, 2 June 1943.
- Cl, TM 11-615A, Radio Set SCR-609-A and Radio Set SCR-610-A, 20 May 1943.

### REDUCED QUOTAS LEAD TO CHANGES IN OCS CURRICULUM

A number of important changes, occasioned by lowered quotas and the consequent selection of candidates with a better knowledge of basic technical subjects, have been made in the curriculum of the Signal Corps Officer Candidate School at Fort Monmouth, N. J.

## MILITARY TRAINING

Basic Mathematics and Elements of Electricity have been dropped from the basic course, since all candidates from the ROTC and Electronic Training Group who are now entering the school have this basic knowledge. The time saved will be devoted to practical radio and wire work and to the technique of signal communication. This measure will tend to offset the ROTC and ETG candidates' lack of field experience.

Basic Signal Communication (Radio) and Basic Signal Communication (Wire) have been dropped from the intermediate course and added to the basic subjects with a substantial increase in the hours of instruction. In addition, the two days formerly devoted to the reduced distance command post exercise, which employs field wire, radio, and message center techniques, have been switched to the basic course. The courses in Organization, Tactics, and Signal Communication of Larger Units, II, and Tactics and Technique of Signal Communication, I, have been expanded to utilize the time that has been made available in the intermediate course.

In the advanced course, the two-day field exercise has been modified considerably. The division, division rear, and three combat teams installation maneuver has been replaced by a command post exercise of a corps and two divisions in three successive positions. This change enables a smaller number of candidates to install and operate more extensive message centers and wire and radio nets, and to lay the longer trunks required for higher units.

### ENGINE AND CHASSIS LABORATORY IN OFFICERS' SCHOOL

An engine and chassis laboratory plays a vital part in the 6-week motors course given at the Officers' School, Eastern Signal Corps Schools, Fort Monmouth, N. J. The work in this laboratory, consisting of mechanical operations on component units and assemblies of various types of military vehicles, covers the last two weeks of the course after the student officers have been given instruction in vehicular operation and maintenance and the formation and conduct of motor movements.

The aim throughout the course is not to make motor mechanics of the officer students; but rather to aid the students to better understand the problems confronting enlisted personnel engaged in motor transport activities in the field, and to enable them to explain both the HOW and WHY of preventive maintenance and proper operation.

The organization of the training in the engine and chassis laboratory involved three general problems: scope of instruction, procurement of supplies and sequence of material to be covered.

The basic requirement was to cover the work on vehicle assemblies in 76 hours in a building approximately 40 feet by 40 feet. The available time is devoted to the assembly and disassembly of certain vehicle components, trouble shooting on internal combustion engines in operation, and first eche-

lon maintenance of vehicles of the signal motor pool under simulated field conditions. All of this work is performed by the officer student under the supervision and guidance of qualified instructors, many of whom are either graduates of the Holabird Ordnance Motor Base or have had extensive civilian motor transport experience.

Since the students were to work with actual parts, it was necessary to secure the full cooperation of supply officers of the higher echelons. Each officer student, however, must determine the source of all parts and supplies from which they would be procured under actual field conditions.

In planning the engine laboratory, it was decided to provide a row of engines without such external units as the starter, carburetor, generator, distributor and the like. These engines are torn down and reassembled in order to familiarize the student with their nomenclature and principles of construction. The precision characteristics of internal combustion engines are emphasized but detailed adjustments are not stressed, since this knowledge is not essential to the duties the officers will perform in the Signal Corps. Various assemblies, such as axles, steering columns, transfer cases, transmissions, differentials, etc., are mounted on wooden frames and benches to facilitate disassembly and reassembly by the students under the supervision of the instructor staff.

After completing the work on dead engines and the various assemblies, the student works on engines in operation. This work is probably the most interesting since it gives the student experience in shooting trouble and tuning up actual operating mechanisms. Various types of artificial troubles are introduced into the engines by the instructors to be cleared by the students. To terminate the course, the student spends some time working on vehicles of the school motor pool under actual field conditions in the capacity of a driver responsible for the maintenance of his vehicle. This phase includes lubrication, tire rotation, and similar duties to give him a better understanding of the problems which will confront the drivers he will eventually control as an officer. Throughout all phases of the course, problems of planning and organizing instructional material are emphasized in order to prepare the officer-student for his later duties as an instructor of motor transport personnel in a tactical unit.

One of the major problems encountered in starting the course was the difficulty of securing parts and assemblies. Since all available new parts are urgently needed to supply units in active theaters, salvaged parts were used. These were obtained from local supply and salvage officers, and, through the Second Service Command, from the salvage and reclamation units at Fort Dix, N. J., the automotive center for this locality. The parts and assemblies used had been surveyed or declared unfit for use. Frequent replacement of such parts is necessary but they are entirely satisfactory for training purposes.

The successful development of the engine and chassis laboratory resulted from the sustained efforts of officers who were ingenious, aggressive, original, and willing to do a lot of dirty work.

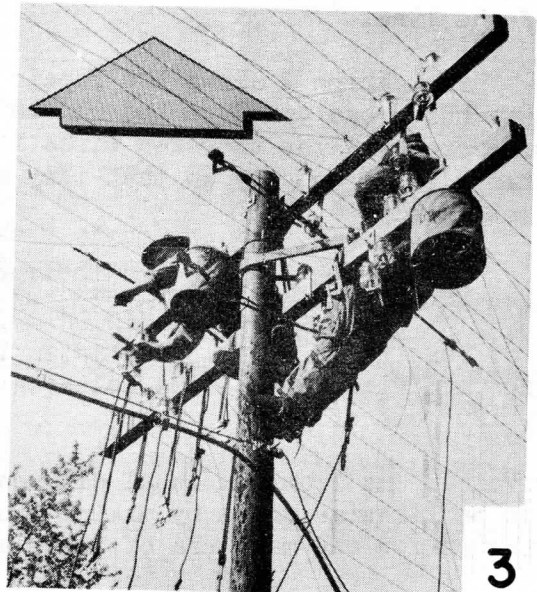
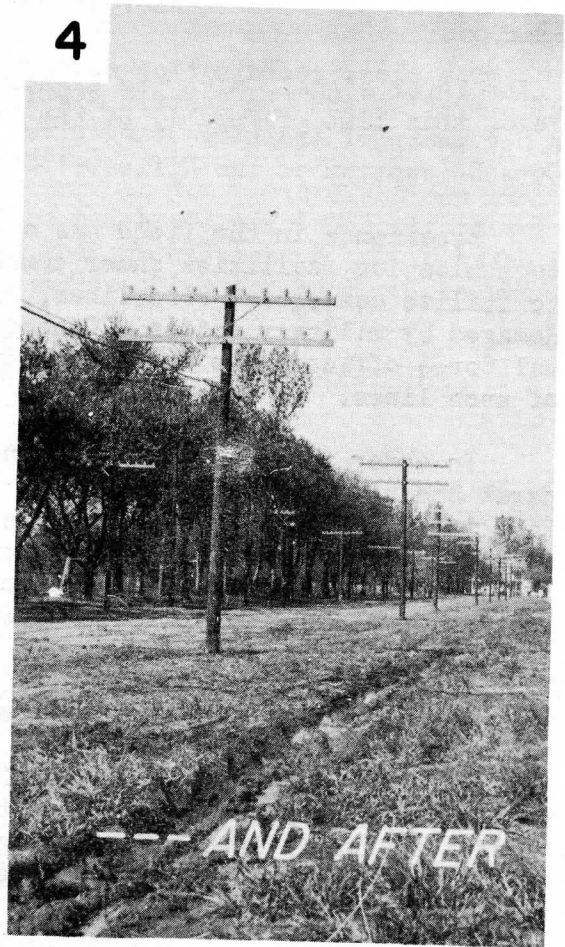

RESTORATION OF DAMAGED LINES

The close coordination existing between Signal Corps units in theaters of operation and the Eastern Signal Corps Training Center is demonstrated by a new phase of training being given to student officers in the Long Lines Outside section of the Officers' School.

Experience in the field has shown that the problem of providing adequate communication facilities under combat conditions frequently makes it desirable to utilize commercial wire lines, even though they may have been seriously damaged by military action. Consequently, there is a pressing need for Signal Corps officers who are competent to plan and supervise rapid restoration of such lines.

In order to meet this need, the Long Lines Outside section of the Officers' School now devotes a part of its regularly scheduled time to instruction in restoration of lines. This phase of the course consists of a demonstration conducted by the instructors. On the basis of this, the students later undertake various practical activities, working in crews under the direction of student officers-in-charge.

The demonstration is given in the LLO area on a line which has been demolished in such a way that it appears to have been destroyed with explosive violence. While the line is being repaired by the instructors, the demonstration is described to the class by the Senior Instructor, who analyzes the methods being employed to restore the line to service in minimum time. Speed of restoration is stressed as being more important in this situation than quality of workmanship. The photographs opposite show the broken line in several stages of repair.

Photograph 1 shows the demolished section of the line before any repair work has been done on it. Note the broken pole, the broken cross arm dangling in the wires, and the broken wires twisted among the remaining good wires of the line.

Photograph 2 shows the repair crew clearing the broken pole top and its attached cross arm from the remaining unbroken wires. This is done first in order to have the unbroken wires free as soon as possible. These wires are then cleared quickly so that they can be used to form working circuits almost immediately.

Photograph 3 shows two instructors replacing broken wires at an adjacent pole in such a way that working circuits are established as each successive pair is replaced. If this procedure is followed, some communication can be established within a very few minutes after the arrival of the crew at the break.

Photograph 4 shows the restored line with all circuits back in service.

After the students have received a week of field training, they are required to restore service on broken lines along the Fort Monmouth-Fort Dix

## MILITARY TRAINING

pole line. This work is done under the supervision of student officers who are acting as officers-in-charge of construction crews on the day chosen.

After nightfall, the instructor in charge of field work notifies each OIC that a break has been reported at a designated point on the line and that he is to take his crew and make the necessary repairs. There are previously set up breaks for each crew. The repair work is done entirely under black-out conditions, and each crew is graded on the speed with which it restores the circuit to service. The supervising instructor keeps a log in which he records the time required to establish communication and to complete the restoration job.

### TRAINING CIVILIAN TECHNICIANS FOR AIRBORNE RADIO AND RADAR

In December 1941, less than two weeks after our entry into the war, the Signal Corps called together in Washington representatives from service commands, Signal Corps supply depots, and Signal Corps laboratories for a conference on civilian training within the Signal Corps to meet war-time requirements. At this conference steps were taken to inaugurate training programs in maintenance of ground radio equipment and ground radar equipment. This training was undertaken by the signal officers of the various service commands and by certain of the signal depots, including those at Philadelphia, Lexington and Chicago. No concerted effort was made at this conference to provide a training program for civilian employees destined for duty with airborne radar or with development in connection with aircraft radio equipment.

In January 1942, the Aircraft Radio Laboratory established the Aircraft Radio Engineering School in a portion of the laboratory building for the instruction of a limited number of technicians for immediate duty in the few activities where the Signal Corps had airborne radar equipment in operation. As aviation radar equipment became standardized and maintenance demands increased, contracts for instruction of civilian employees of the Signal Corps in the maintenance of aviation radar equipment were placed with a number of leading radio companies who were then engaged in production of airborne radar equipment. This activity was transferred in June 1942 to the Signal Aircraft Maintenance Section, Wright Field, Dayton, Ohio, and it has been the means of arranging for the technical and maintenance education of thousands of civilian employees for duty within the United States.

The Aircraft Radio Engineering School, which pioneered in the instruction of airborne radar, soon expanded to one of the floors of a building occupied by the Signal Corps in Dayton, Ohio, and has continued to pioneer in the teaching of all types of aviation radio and radar equipment which are new to the Signal Corps or are not being taught on a quantity basis at contract schools conducted by the Signal Aircraft Maintenance Section. In addition, this school has been the source of aviation radio instruction for Army Air



## MILITARY TRAINING

Forces civilian inspectors, certain enlisted personnel from the Army Air Forces, and civilian personnel from the Aircraft Radio Laboratory itself. The Aircraft Radio Engineering School is the only known activity in the War Department that is qualified at this time to teach all types of aviation radio and radar equipment. It enjoys this distinction by virtue of close contact with the development divisions of the Aircraft Radio Laboratory where all types of new equipment are available for study by the school instructors.



PRACTICAL STUDY OF REGULAR SIGNAL CORPS EQUIPMENT IS A PART OF THE 8-WEEK GRADUATE TRAINING COURSE AT THE AIRCRAFT RADIO ENGINEERING SCHOOL, DAYTON.

The December 1941 Conference, although it did provide a basis for ground radio training of radio technicians, repairmen, etc., did not provide a course which might be suitable for the instruction of personnel for electrical engineering duty at the Aircraft Radio Laboratory (the development laboratory of the Signal Corps for aviation radio equipment). The Civilian Training Section of the Office of the Chief Signal Officer authorized the Aircraft Radio Laboratory to prepare a training course outline to meet the individual requirements of the Laboratory and, in February 1942, this course was completed and approved. Entitled "Under Engineer, Trainee (Aircraft Radio)," it provides for instruction of civilian employees at engineering colleges and universities for a period of 24 weeks (six 8-hour work days per week) under

## MILITARY TRAINING

ESMWT (Engineering, Science, Management, War Training Plan), the college or university being reimbursed for tuition costs by the U.S. Office of Education.

The first classes were opened in four Ohio universities in April 1942. These classes were composed of men but, as time went on, with the change in the Selective Service Act to a minimum of 18 years of age, it was found desirable to eliminate from consideration for training any male students other than those exempt from Selective Service by reason of physical disabilities. The Aircraft Radio Laboratory was one of the first activities to enroll women trainees for study in the field of electrical engineering and the young women who have graduated from this course and are on duty at the laboratory have justified the basis of their selection. They have proven to be capable of assisting professional and project engineers in technical duties and have demonstrated an ability to progress in this line of endeavor which has exceeded expectations.

The requirements for entrance to Under Engineer Trainee Schools have been maintained at a high level and where it has been found impossible to recruit young women for enrollment in schools in a certain locality, these schools have been dropped and new schools taken on in localities where there is a source of adequate training personnel. As a result, schools have been discontinued at universities in the Ohio area and new schools opened in mid-western colleges, such as Missouri, Kansas, and Oklahoma.

The course of 24 weeks is divided into three 8-week periods, embracing the following subjects:

- Term I - Algebra, Trigonometry, Slide Rule, Principles of Electricity, Electrical Laboratory, Materials of Engineering, Drafting, Shop.
- Term II - Principles of Alternating Currents, Electrical Laboratory, Electronics, Electronics Laboratory, Elementary Communication and Radio, Mechanics, Shop.
- Term III - Radio Principles and Practice, Radio Laboratory, DC and AC Machinery, Machinery Laboratory, Shop Practice, Transmission Lines and Radio Antenna, Specifications and Tests.

After successful completion of the course, the students are transferred to Dayton, Ohio, and assigned to approximately eight weeks' additional instruction at the Aircraft Radio Engineering School. Here they enjoy their first contact with Signal Corps radio equipment and put into practical use the theory which they have acquired at the college training school. Students completing this course have proven of inestimable worth to the Aircraft Radio Laboratory in its development activities.

Through training such as that described above, exacting technical requirements have been met and competent and qualified civilian personnel has been made available for duty.

## SHOULD INSTRUCTORS PREVIEW TRAINING FILMS ?

Important evidence on the value of film previews has been received from the Visual Aids Coordinator at Camp Callan, California. A careful record was kept of the instructors who attended film previews. Later, all instructors borrowing films were asked to answer four questions regarding the use they made of each film. The following table shows the differences between the use of films that were previewed and those that were not.

	Preview			No Preview		
	Yes	No	No Answer	Yes	No	No Answer
1. Was a quiz given after showing the film?	73%	26%	1%	39%	59%	2%
2. Was a discussion held <u>before</u> showing the film?	68%	32%		12%	88%	1%
3. Was a discussion held <u>after</u> showing the film?	89%	11%		51%	48%	1%
4. Was the film suited to the purpose for which it was used?	97%	2%	1%	98%	1%	1%

The replies to Question 1 show that 73% of the previewed films were followed by a quiz, while 39% of the films not previewed were accompanied by a quiz. Similarly, in Question 2, a discussion preceded the showing of 68% of the previewed films and only 12% of the non-previewed pictures. For discussions after the film, Question 3, the percentages are 89 and 51, respectively. The differences in Question 4 are negligible. The high percentages, however, probably reflect the favorable regard that instructors have for training films in general.

The results of this little study point to the conclusion that the previewing of films leads to a more active and significantly better use of training films in instruction.

# NEW MESSAGE CENTER NUMBER SHEET

W. D., Sig. C. Form 244

WAR DEPARTMENT  
SIGNAL CORPS, U. S. ARMY

## NUMBER SHEET

(UNIT)								(ORGANIZATION)								(DATE)	
NO.	PREC	TG	TT	RAD	MSGR	FROM	TO	NO.	PREC	TG	TT	RAD	MSGR	FROM	TO		
1								51									
2								52									
3								53									
4								54									
5								55									
6								56									
7								57									
8								58									
9								59									
10								60									
11								61									
12																	
13																	
14																	
								95									
								96									
37								97									
48								98									
49								99									
50								100									

/ Indicates number has been used.  
X Indicates message has been delivered.

16-0000-1

(DATE)

Concurrence of the Army Air Forces and the Army Ground Forces recently has been obtained in the adoption of a new message center number sheet to replace the present Signal Corps Form 159. The latter will continue to be used, however, until the supply is exhausted. The new form, designated War Department Signal Corps Form No. 244, a reduced-size draft of which is shown above, was adopted as a result of recommendations from the field as coordinated by the Communication Coordination Branch. Its primary purpose is to indicate, by simple clerical markings, the weight imposed on each agency and to permit better balancing of traffic loads of using organizations.

Only a minimum amount of message data should be recorded on this form. Such additional data as may be required can be obtained by an inspection of the message center files. However, it was recognized that the needs of message centers vary and space has been provided on the form for the entry of fairly complete message data when desired. In order to provide message center personnel employing the form for the first time with a guide to its use, printed instructions will be furnished with each pad of forms.

RESTRICTED

# PROCUREMENT

## NEW DEVICE PROMISES TO IMPROVE MICA SITUATION

The mica situation has been a subject of great interest to the Signal Corps for a period of several months. Although the Resources Branch of the Procurement and Distribution Service has been encouraging a broad program of conservation by means of substitution of alternates throughout this time, and has been instrumental in replacing a number of mica applications, the reduction of stock piles has steadily increased. In the face of this constant depletion is the rather paradoxical fact that there is much additional mica which might be used, if some means were found to overcome the prejudice against stains which threaten to be iron, and frequently are, but which often turn out to be harmless vegetable compounds.

Inspection of mica heretofore has been by the century-old visual methods used in India (India has for many years been substantially the sole source of high-grade mica for capacitors), which though suitable for the old fashioned uses is hopelessly inadequate in the modern, more stringent applications at radio frequency. A discouraging experience which further disqualifies the traditional visual inspection is that occasionally after mica has been carefully selected and then flown all the way back to this country it is found to be worthless. Again, some heavily stained mica frequently makes capacitors which are on a par with those made of the best "clear." Obviously some other test, which will more nearly predict the performance of the mica when made into a capacitor, is needed.

With this idea in mind and at the instigation of the War Production Board, the Bell Laboratories have developed a so-called "Q Meter" which gauges the quality of mica test samples in terms of the "Q" (or its reciprocal, which is the power factor). Such a meter gives an approximation of the quality of the mica sample under actual operating conditions and is prophetic of the manner in which it will actually perform when made into a capacitor.

Preliminary tests have shown excellent correlation between the indicated quality of samples and capacitors built therefrom, on extreme grades of good and bad mica, but less correlation on intermediate grades in which the final capacitor might be either better or worse than predicted by the meter. Such departure from correlation in the middle grades might be due more to irregularities in manufacture than to shortcomings in the meter; irregularities which are swamped out by either extremely good or bad samples.

While many such tests were made by Bell Laboratories, the Fort Monmouth Signal Laboratories are running a thorough set of confirmation tests.

At present writing it is possible to say that the meter employed in these new tests is a self-contained, battery-operated portable instrument for use either in the field or laboratory. The mica sample is inserted between

plates provided and preliminary null adjustments made, after which the meter becomes direct reading, in terms of power factor or its reciprocal, "Q," at 1000 KC.

The results of tests, thus far, confirm the opinion that there is much domestic mica that may be used. However, the selection and grading required are of such proportions that processing facilities must be set up, hence it will require time for the capacitor manufacturers to put domestic mica into very extensive use.

One immediate application of the meter, however, lies in the preselection of mica at foreign mines to eliminate the waste of flying worthless mica back to this country.

### PHENOLIC RESINS

For the past ten years the magic story of phenolic resins, together with other plastics, has been spread across the columns of the daily press, magazines, and scientific journals. Radio, clock and vanity cases, plastic knives and forks, handbags, ornaments, jewelry, toilet articles, buttons, textiles, hosiery, and countless other household and garment uses followed in the wake of their development and increased knowledge of fabrication.

With the advent of phenolic resins every branch of the electrical industry came into possession of a new and highly adaptable material. The use of porcelain and clay insulators, vulcanized rubber and many metal parts soon found substitutions in plastics. Before Pearl Harbor, there was scarcely an electrical gadget on the counters of the dime stores that did not involve the use of plastic material.

As a result of laboratory development and engineering adaptation, plastics have today made possible the building of storage cells that give both range and security to the modern submarine. Someone once said that "the national consumption of phenolic resins during the last decade is in direct ratio and indicative of the economic progress and the cultural development of a nation."

One of the first organizations to avail itself of the magic of phenolic plastics was the Signal Corps.

Favored by high di-electric value, imperviousness to moisture, resistance to solvents, plastics had been incorporated in hundreds of items of Signal Corps equipment, even prior to Pearl Harbor. Extended use by the Signal Corps had greatly improved the military characteristics of practically all items of air and wire communications. Thus did phenolics contribute to the recognized superiority of equipment and to the readiness with which the Signal Corps responded to its task.



With the coming of war, however, phenolics took to the air! Air Corps glider and trainer requirements for technical plywood for plane construction, plus other military applications of this proven sturdy material processed from phenolic resins, added to the requirements of practically every other branch of the service, brought an order -- "Be prepared to cut Signal Corps requirements for phenolics \_\_\_\_\_ pounds." This came at a time when the tempo of requirements for radio, radar, and field communication equipment of all kinds was at a crescendo.

The Resources Branch went into a huddle with R & D, Facilities, and the Laboratories. The problem was posed. All went quickly to the task: first, to bring in plans for expanded production; and, second, to comb the nation's resources for an acceptable substitute material.

All agreed that there should be no sacrifice of the benefits that attended the use of phenolic resins in Signal Corps equipment. The question of retooling necessary in the development of substitutes was made a subject of intensive study. Precautions were taken to insure against any letdown in production schedules.

Report is now made that worthwhile objectives have been attained. New production has been brought in. Should disaster be met within any one of these phenolic plants, the substitutes are known and readied for use. When notice was served that substitution for, or drastic cut in, phenolic resins in Signal Corps equipment might be necessary, there was the "proverbial gripe." But, phenolics or no phenolics, the Signal Corps will "Get the Message Through."

#### ELECTRONIC TUBES PRESENT MATERIAL PROBLEMS

The vast procurement program for communication equipments, with the concurrent demand on facilities for the manufacture of electronic tubes, brought with it several material problems. These have led to extensive research by commercial and government laboratories in an effort to conserve certain special critical and strategic materials, and to develop sources of substitute materials both for use in electronic tubes and for uses in competing end-use requirements. Three of these special materials -- tungsten, molybdenum and tantalum -- have been classified as most critical from the standpoint of fabricated material supply, with tantalum suffering a shortage in natural resources of ore as well. Each of these special materials was placed under complete allocation in 1942 and it was urgently recommended to the services and commercial interests that conservation and substitution measures be initiated.

Molybdenum sheet was first employed as a substitute for tantalum sheet, but, as this material became even more critical than tantalum sheet, the tube manufacturers turned to the use of graphite wherever possible. Various means of using graphite have been employed in order to provide the desirable degassing effect of tantalum at high temperatures. The principal objection to graphite anodes is that the exhaust time cycle is considerably increased.

Carbonized nickel and nickel steel anodes have likewise been successfully employed and approved in several tube types. Pure copper of oxygen-free, high-conductivity type has supplanted tantalum for anodes in certain special-purpose types, and a process has been developed for sealing copper anodes to hard glass (Nonax) for water-cooled and forced air-cooled type tubes. Nickel-plated copper, nickel-plated steel, and copper-clad nickel have been successfully employed as alternates for tungsten and molybdenum support rods for the internal structures of the tubes. The use of Kovar, a nickel, cobalt, manganese, iron alloy for sealing to hard glass, as a substitute for tungsten lead-ins, will be increased upon the completion of a current expansion by the War Production Board in the source of supply.

An industry-wide salvage program has been undertaken which has resulted in decreasing material requests for tungsten, tantalum and molybdenum. In addition to salvaging their own rejects, the tube manufacturers are preparing to salvage a selected list of tubes that have failed in military field service, and to utilize component parts in the fabrication of new tubes. Where miscellaneous pieces cannot be salvaged in this manner, they will be shipped to steel manufacturers for replacing ferro-tungsten and ferro-molybdenum in steel, thereby effecting a saving in the ore supply which can be diverted to the manufacture of the pure metallic tungsten and molybdenum.

It is considered that the full effect of the actions outlined above will be to alleviate to a large degree the current material shortages until such time as expansions now in progress may be brought into full production.

## IDENTIFICATION SIGN FOR BLACKOUTS

From Signal Officer, Headquarters 38th Infantry Division, Camp Livingston, La., comes the following:

This organization has experimented with the identification sign described in page 55, Signal Corps Technical Information Letter No. 17, April 1943, and has made some modifications which are deemed worthy of your attention.

In place of using a single sheet of glass, we are using two sheets with a sheet of ordinary brown wrapping paper between. By the use of dark paint the entire glass is then made opaque except for the desired lettering which is left unpainted. A reflector from an unserviceable flashlight is bent oval-shaped and helps to diffuse the light from the light source. The sign is not visible over 150 yards and can be read at approximately 100 feet.

# MILITARY INTELLIGENCE

## RADIO COMMUNICATION FOR GERMAN 105-MM GUN BATTERY

Recent information gathered from German sources refers to the radio facilities that are part of the equipment of these batteries. The equipment consists of two 30-watt transmitters, one mounted on an armored reconnaissance car, the other on a truck when on the march, or near battery headquarters while stationary. In addition a battery has at least three portable transceivers known as "Fritzs." This is a two-man outfit; one carries the transceiver, the other, the accessories, batteries, and antenna. Each radio set has two microphones, throat and mouth, with the latter generally preferred. The "Fritzs" radio set is not a "walkie-talkie" but must be set up for operation. It has a range of about 5.5 miles. The battery also has direction-finding equipment.

### Tactical Use of the Radio Equipment

The two 30-watt sets are only used when on the march. Then the armored reconnaissance car is sent out ahead and keeps in contact with the battery by radio. When in stationary position, it is stated that the 30-watt equipment was not used and that no radio net existed among the various batteries, communication being limited to wire telephone circuits.

Two advanced observation posts are set up by each battery. The forward advanced post is equipped with telephone and radio, the radio being used only as a standby. The forward observation post reports directly to the battery, and only in emergencies will it communicate with the other observer. Direction-finding equipment is theoretically to be used to locate enemy stations, but was also used in the Libyan desert by the observers to orient themselves in case they got lost or detached from their battery. Under ordinary circumstances, so it appeared, the direction-finding device was little used.

### Use of Codes

Codes are used by the observers. The radio-station call signs and frequencies are changed every four hours. The call signs are made up of letters and numbers. The signal operation instructions concerning call signs and frequencies are issued every three days. No authenticators are used. It is thought that changing call signs and frequencies every four hours is sufficient signal security. All messages transmitted to the battery headquarters and all orders to observers are sent in a prearranged code. All points in view of the observer, and the area in general, have previously been mapped and designated points given code numbers. As a result, the observer gives all

## MILITARY INTELLIGENCE

points mentioned in a report in code. Reference was here made to the fact that the sending of false messages by enemy troops either to the observer or to battery headquarters would be difficult. Only fire commands are given in the clear; otherwise, code is strictly used. The only exception to this is the case where the officer originating the message signs a statement that he wants it sent in the clear.

The statement was made that considerable trouble was experienced because the German radio equipment was not watertight. It was felt the British equipment was superior to the German in this respect. It usually took three days to get a set back when it was sent in for repairs. Other than the equipment getting waterlogged, no troubles were encountered.

### AXIS SMOKE CODES AND SIGNALS

From a South African source comes a memorandum on Italian smoke signals for communication with aircraft, stated as applicable to German troops as well. The main advantages of smoke were given to be:

Safe and easy handling;  
With good visibility it can be seen at 2,000 feet;  
Produces dense concentrations for at least 30 seconds.

Five basic colors used are orange, violet, red, green, and white. By using the five colors in various pair combinations, a total of twelve distinct and useful signals can be made. These are as follows:

#### Own Troops

Orange	Own troops are here
Orange and red	We are isolated - enemy is behind us
Orange and green	Continue your active support
Green	We are advancing - we are attacking - increase the radius of your action.

#### Enemy Troops

Red	Enemy is attacking
Red and green	Enemy attacking our right flank
Red and white	Enemy attacking our left flank

#### Tanks

Violet	Enemy tanks in front of us
Violet and red	Enemy tanks behind us
Violet and green	Enemy tanks on our right
Violet and white	Enemy tanks on our left
Violet and orange	Own tanks going into action.

# MILITARY ORGANIZATION

The 214th Signal Depot Company, affiliated with the Western Electric Co., begins active military duty 15 August as directed by the Commanding General, Second Service Command, and concurrently is to be organized at Camp Crowder, Mo., by the Commanding General, Second Army. The authorized strength is five officers, four warrant officers, and 182 enlisted men.

The 805th Signal Service Company (less detachments) was reorganized by the Commanding General, Second Service Command, on 10 July, at the Bell Telephone Laboratories, New York City, with an authorized strength of 75 officers and 165 enlisted men.

## TRANSFERRED

The 76th Signal Company, from Fort George G. Meade, Md., to A.P. Hill Military Reservation, Va., for a temporary change of station. A new permanent station will be announced.

One 1-KW Fixed Radio Station Team and one 300-Watt Fixed Radio Station Team, 2 July, from the 848th Signal Training Battalion, Camp Crowder, Mo., to the newly activated 974th Signal Service Company, Camp Crowder.

## DISBANDED

The 15th Signal Radio Installation Team (Type A), 10 July, at Miami, Florida. Personnel and equipment were transferred to the Southeast Sector, Army Communications Service.

## REORGANIZED

The 690th Signal Aircraft Warning Company, 25 June, without change of station or assignment. The authorized strength is eight officers, three warrant officers and 131 enlisted men, including two officers and 11 enlisted men, attached medical.

The 762nd Signal Aircraft Warning Company, 1 July, with an authorized strength of 17 officers, five warrant officers and 380 enlisted men, including two officers and 21 enlisted men, attached medical.

The 551st Signal Aircraft Warning Battalion, 10 July, without change of station or assignment. The authorized strength is 37 officers, 10 warrant officers, and 634 enlisted men, including four officers and 38 enlisted men, attached medical.

# MILITARY ORGANIZATION

## REDESIGNATED

The 669th Signal Aircraft Warning Siting and Testing Company was reorganized, 20 July, and redesignated as the 669th Signal Aircraft Warning Company. Concurrently, the 659th Signal Aircraft Warning Siting and Testing Company was disbanded, and all personnel and equipment were transferred to the 669th SAW Company, Western Defense Command.

The 110th Signal Company has been redesignated as the 110th Signal Platoon, effective 15 July 1943.

## REASSIGNED

The following units were relieved of their present assignments and assigned to the VII Corps, effective 16 July: 69th Signal Company (from XV Corps), Camp Shelby, Miss.; 87th Signal Company (from III Corps), Camp McCain, Miss.; 99th Signal Company (from XV Corps), Camp Van Dorn, Miss.

The 659th and 669th Signal Aircraft Warning Siting and Testing Companies are relieved from their present assignments and reassigned to the Western Defense Command.

## PERMANENT CHANGES OF STATION

<u>Organization</u>	<u>From</u>	<u>To</u>
81st Signal Company	Camp Rucker, Ala.	Desert Training Center
246th Signal Operation Company	Camp Crowder, Mo.	Camp Ellis, Ill.
Hq. and Hq. Company, XI Corps	Chicago, Ill.	Fort Riley, Kan.

## ACTIVATIONS

<u>Organization</u>	<u>Place</u>	<u>Date</u>
42nd Signal Construction Bn.	Camp Atterbury, Ind.	August
1361st Signal Company, Wing	Pinedale, Calif.	1 August
1362nd Signal Company, Wing	Pinedale, Calif.	1 August
1363rd Signal Company, Wing	Pinedale, Calif.	1 August
984th Signal Service Company	Fort Dix, N. J.	July
985th Signal Service Company	Fort Dix, N. J.	July
974th Signal Service Company	Camp Crowder, Mo.	10 July
571st Signal Platoon (71st Light Div.)	-	10 July
1125th Signal Company, Service Group	-	15 July
1157th Sig. Co., Serv. Gp., AAF S Dp	Springfield, Ill.	10 July
1st to 33rd Signal Center Teams	Camp Crowder, Mo.	1 July
Hq and Hq Sqn., 6th Air Defense Wing	Boston, Mass.	15 June

24-44037ABCD

RESTRICTED

# MILITARY PERSONNEL

## WAAC PERSONNEL ON DUTY WITH THE SIGNAL CORPS

### Fort Monmouth, New Jersey

On the 9th of July, 1943, 325 WAACs were reported as being on duty at Fort Monmouth, New Jersey. This WAAC unit has now been designated as the WAAC Detachment, Eastern Signal Corps Training Center, and personnel has been assigned as follows: 94 are being used in Administration of the 15th Signal Battalion, 67 in the 803d Signal Battalion, 69 in the Post QM, 19 in the Station Hospital, 15 in Special Services, 5 as Chaplains' Assistants, 6 in the Photographic Laboratory, 2 in the Post Exchange, 6 in the Post Headquarters, 9 in the School Headquarters, 1 in the Training Center Headquarters, 8 in the Motor Pool, and 24 as overhead.

### War Department Signal Center

A total of 35 WAAC auxiliaries are already on duty at the War Department Signal Center, 31 being assigned as teletypewriter operators and 4 as code clerks.

In connection with this group of WAACs there is a story:

The first group of auxiliaries to report to the Signal Center was composed of four code clerks. They arrived at a time when the morale of the entire Signal Center was at an extremely low ebb, due mainly to the pressure of work, and the fact that the personnel on duty was becoming discouraged. When the trim, uniformed auxiliaries walked in, they were immediately assigned to their duties, with a few brief instructions given to them regarding the work they were to do and the part the Signal Center played in the war effort. The girls took off their hats and sat down, tackling their machines with that well-known determination to Get the Message Through.

As the officers tell it now, within an hour after the arrival of the WAACs, a subtle change took place in the organization. The completed work was beginning to stack up beside the WAACs. They were serious about the whole thing and were evidently doing their level best — and it was good. Gradually the output of the other employees began to rise — they weren't going to be outdone by the WAACs! And by the end of the day, the records showed an amazing increase in production. From that day on, there has been a steady improvement in both morale and efficiency in the War Department Signal Center, and a friendly camaraderie between the WAACs and the regular personnel of that organization exists. Maybe it was the competition — or maybe it was the uniform! Whatever it was, the officers of the Signal Center say that they've got to hand it to the WAACs!



## MILITARY PERSONNEL

### WAACs OR WACs?

Although the newspapers and the newsreels are using the abbreviation WAC for the Women's Army Corps, as a result of the final approval of the law creating the Women's Army Corps as a component of the AUS, the Women's Army Auxiliary Corps still exists, and will continue to be referred to as the WAAC until the former law creating the Women's Army Auxiliary Corps expires as of 30 September 1943. In the meantime, all present WAAC officers and auxiliaries must decide whether or not they want to become members of the WAC, and physical examinations are required for all WAACs who have not had a satisfactory examination since 1 March 1943. Physical standards have been modified to permit a minimum height of 58 inches, a minimum weight of 100 pounds, and a minimum vision of 20/400, if correctible to 20/40.

On the 1st of July, 1943, it was stated that recruiting would temporarily continue in the WAAC, using the same forms and processes as formerly, with the age limits from twenty-one to forty-five. However, new AUS forms and instructions for recruiting will be issued to permit enlistment of women between the ages of twenty and fifty.

WAAC officers are to be converted to AUS status at the time of transfer of all WAAC personnel — which may be any time between the first and the thirtieth of September 1943. The Director of the Women's Auxiliary Corps can now be called Colonel Oveta Culp Hobby, WAC, but according to the latest news from WAAC Headquarters, she is the only bona fide WAC in existence. So in spite of the newspapers, they're still WAACs!

### NEW SIGNAL CORPS OFFICER REPLACEMENT SUB-POOL

A Signal Corps Officer Replacement Sub-Pool was established at the Fourth Service Command, Atlanta, Georgia, to provide for a maximum of 25 officers who will be assigned to various duties for a period of 90 to 120 days, which will furnish them with background and experience to fit them for staff duties. After sufficient on-the-job training to qualify them for assignment as staff officers, they will be made available for suitable assignments. Some may be retained by the Fourth Service Command itself in allotted positions, if necessary. This plan is similar to that now in effect in the Western Defense Command, whereby a small number of carefully chosen men are given such training and assigned according to the best interests of the service.

### ARMY SPECIALIZED TRAINING PROGRAM

In accordance with the request by Army Service Forces, revised 1944 requirements for the Army Specialized Training Program for Signal Corps personnel have been submitted by Military Personnel Branch. Inasmuch as there is no troop basis at the present time, the figures for replacement could not be

## MILITARY PERSONNEL

too definite in character. Approximately 12,000 Signal Corps participants in the ASTP were requested, broken down into four categories representing the courses which pertain to Signal Corps duties. Two basic courses appropriate to the Signal Corps were the Communications Courses, BE-4, for communications specialists, and the Combustion Engine Courses, BE-3, for motor transport personnel. Advanced courses were the Electrical Engineering, EE-1 Course, for more specialized communications training, and the Foreign Area and Language Studies, 705 Course, for linguistic specialists.

### FREEZE ON APPOINTMENTS FROM CIVILIAN LIFE

Around the first of July decision was reached to discontinue all procurement of Signal Corps officers from civilian life, with the exception of those secured through the affiliated plan, for a tentative period of three months. This move was made in order to take stock of the over-all situation pertaining to Signal Corps officer strength, and availability of officers for Signal Corps duty. Until further notice, only affiliated applications will be submitted to the Military Personnel Branch, OCSigO. All other applications will be discontinued, and remain as they were at the time the suspension order was received.

### SIGNAL CORPS ENLISTED PERSONNEL

With the approval of ASF, Military Personnel Branch will call all civil service and non-civil service enlisted reservists to active duty by 30 September 1943. A total of 6,600 of these reservists will be earmarked for and assigned to the Army Air Forces. The intake of the Signal Corps Replacement Training Centers during the period 5 July 1943 to 30 September 1943 will be such that all enlisted reservists, less the number earmarked for the AAF, will be called to active duty and sent to the Signal Corps Replacement Training Centers. Revised quotas to the service commands are being issued as a result of this decision.

### TEMPORARY SUSPENSION OF PROMOTIONS

All promotions to the grades of Major, Lieutenant Colonel and Colonel have been temporarily suspended by the Chief Signal Officer pending a clarification of the status of bulk allotments for installations under the jurisdiction of the Chief Signal Officer. Promotions to the grades of Lieutenant Colonel and Colonel have been further restricted with the publication of War Department Circular 157, dated 9 July 1943, which states that the time in grade required for eligibility for promotion to these grades has been extended from a minimum of six months to a minimum of nine months for the grade of Lieutenant Colonel, and from a minimum of six months to a minimum of twelve months in grade for promotion to Colonel.

## MILITARY PERSONNEL

Also stipulation is made that all officers recommended for promotion to these grades must have served in, and demonstrated their fitness for the position for which promotion is recommended during a period of not less than three months. Each headquarters forwarding a recommendation for promotion to Lieutenant Colonel or Colonel must also specifically state in their indorsement that there are no officers in similar grades located in Signal Corps pools under their jurisdiction who could fill the position for which recommendation is made.

All recommendations for promotions to Lieutenant Colonel and Colonel in the future, as soon as the present suspension is lifted, will be forwarded by the Signal Corps to the War Department through Headquarters, Army Service Forces.

### OFFICER PROMOTIONS

The following promotions have occurred among Signal Corps personnel from reports received during the period of 18 June 1943 to 15 July 1943:

#### Major General (Temporary)

Harrison, William H.

#### Promoted to Lt. Col. RA (Permanent)

Clendenen, Clarence C.  
Corput, Rex Van Den, Jr.  
Gillette, Edward C., Jr.

Horn, Tyree R.  
Lanahan, Francis H., Jr.  
Link, Eugene M.

Meade, Frank C.  
Renno, James G.  
Tully, Terence J.

#### Lt. Col. to Col. (Temporary)

Gillette, Edward C., Jr.

#### Major to Lt. Col. (Temporary)

Brumbaugh, John Clark  
Case, Bernard  
Haller, George Louis  
Hotchkiss, Edwin Lyman  
Kahler, George Everett  
Kelsey, John Eugene  
Kleinknight, Luster Ray  
Kullback, Solomon  
LaBrum, John Harry  
Luth, Louis Henry

Needham, John Addison  
Richmond, Lawrence Palmer  
Russell, John Howard  
Simms, Preston Wolbert  
Slack, James Edward  
Soeurt, William John  
Stadtler, George James, Jr.  
Tetley, Wilfred Henry  
Watts, William Walter  
Wilde, Helm George

RESTRICTED

## MILITARY PERSONNEL

### Promoted Major RA (Permanent)

March, Kenneth F.  
Larew, Walter Byron

### Captain to Major (Temporary)

Atwell, Robert Brown	Lambert, Joseph S.
Baker, William Prescott	Lanham, Clyde Buford
Baldwin, Clarence Truman	Lischer, Ludwig Frederick
Ballinger, Lowell Harlan	Long, Wayne Eggleston
Belden, Harry Joseph	Mann, Robert Neville
Bottum, Edward Lee	Massa, Ernest Alred
Botzum, John Robert	McDowell, Jouett Shearer
Boynton, Edward Palen	McEvilly, Martin John
Byrnes, Francis Clair	McNeal, Tilton Donald
Case, Stanley Rae	Minnick, Adrian Eugene
Chrisley, William Henry	Morrison, Lorraine Geiberson
Craddock, John Martin	Niccolini, Mario Edward
Crawford, Kelsey Alexander	Olin, Stanley Carlyle
Crosby, Joseph Franklin	Parrish, Emmett Albritton
Cyng, Alexander Aloysius	Peterson, Lawrence Joy
Deady, William Walter	Peterson, Lawrence LeRoy
Dibble, Edward Fitzgerald	Pettit, Dorn Leroy
Dillow, Joseph Clinton	Poutre, Clifford Algy
Downs, Walter Wellman	Renz, John Emerson
Dinger, Clarence Harrison	Riggs, Clarence Bonnett
Edgerton, William Franklin	Robinson, Bernard Cone
Fauth, Paul Frederick	Rohling, Arthur Henry
Fortune, William Brooks	Ryder, Elwood Frank
Gantt, Richard Rayburn	Saibara, Robert
Germain, Louis Vincent	Scheppach, Maximilian
Gibbs, Charles Woodrow	Stevens, Earl Maynard
Gilman, Turner Wright	Stice, Marc Andrew
Greenfield, Edward Teeter	Tenley, Ercla D.
Haraden, Elmer Eugene	Tuxworth, Frank Edward, Jr.
Healy, Joseph Jeremiah	Van Haaften, Edward Clarence
Herrlein, Wesley Rhinehardt	Vanko, Joseph August
Holbrook, Paul Everett	Vogel, John Franklin
Huff, Patrick D.	Wadsworth, James Alred
Ivey, Albert James	Watson, Tom Allen
Kibbe, Stewart Henry	Wetterauer, Donald Guthery
Kramer, Frederick John	Whitehead, Joseph Edgar
Kuhn, Todd Arden	Whitham, Strayer Earle
	Young, William Morris