

*46d* *4113*  
*2*  
*Tm*  
*1943*

**TM5-1212**

*U.S. Dept. of Army*

**WAR DEPARTMENT**  
*Technical Manual*  
**MAINTENANCE MANUAL  
AND PARTS CATALOG**

**SCRAPER, ROAD, TOWED TYPE, CABLE  
OPERATED, TYPE IV, MODEL LP**

**R. G. LeTOURNEAU, INC.**

**PEORIA, ILL.**

**JULY 3, 1943**

TM5-1212

War Department

TM5-1212, Maintenance Manual and Parts Catalog,  
Scraper, Road, Towed Type, Cable Operated, 12  
Cu. Yd., Type IV, Model LP published by the  
R. G. LeTourneau, Inc., is furnished for the  
information and guidance of all concerned.  
(AG 300.7 (7/9/43) PC (C), June 10, 1941.)

G. C. MARSHALL  
Chief of Staff

Official:

J. A. ULIO,  
Major General,  
The Adjutant General

**TM5-1212**

**SCRAPER, ROAD, TOWED TYPE,  
CABLE OPERATED, 12 CU.YD.  
TYPE IV, MODEL LP**

MANUFACTURED BY

**R. G. LE TOURNEAU, INC.**

PEORIA, ILL.

STOCKTON, CALIF.

(EFFECTIVE WITH SERIAL No. S-11915-LPD & UP)







U113  
TMC 1943  
★ ★

# TABLE OF CONTENTS

Description of Scraper.....Preface

## OPERATION SECTION

SECT. 1

Connecting Scraper to Tractor..... 2  
Controlling Scraper with Power Control Unit..... 3  
The Operating Cycle (Functions)..... 4  
Operation.....6 thru 15  
Safety Precautions.....16  
Preparation for Initial Operation.....16  
Specifications.....17  
Points of Lubrication and Adjustment that  
can be taken care of by Operator.....18  
Tire Inflation and Maintenance.....19  
Lubrication.....20 thru 22  
Cable.....23  
Cable Threading.....24 thru 27  
Changing Blades and Ground Plates.....28  
Operation under Dusty, Muddy, Low Temperature  
and Other Abnormal Conditions.....30  
Preparation for Storage.....30 thru 32

## REPAIR SECTION

SECT. 2

Care of Scraper..... 1  
Adjustments.....2 thru 6  
Removing and Installing Tires..... 7  
Disassembling.....8 thru 13  
Overhauling and Repairing.....14  
Re-Assembling.....15  
Table of Clearances and Tolerances of  
Bearings and Adjustable Parts.....15  
Trouble Shooter's Guide.....16

## PARTS CATALOG

SECT. 3

Cable Requirements and Threading Instructions.....1 and 2  
Main Body Assembly and Sub-Assemblies.. .3 thru 7  
Cantilever Yoke Group and Sub-Assemblies.....8 thru 10  
Apron Group.....11  
Tailgate Group and Sub-Assemblies.....12 and 13  
Pushbeam Group and Sub-Assemblies.....14 and 15  
Front Axle Assembly and Sub-Assemblies.....16 thru 18  
Rear Hitch and Spiral Sheave Group.....19 thru 21  
Wheel Assemblies.....22 thru 25  
Spare Parts and Price List.....26 thru 28

# I N D E X

Adjustments .....	2 thru 6	(Repair Section)
Apron Group (Parts Illustrations).....	11	(Parts Catalog)
Assembling .....	15	(Repair Section)
Cable .....	23	(Operation Section)
Cable Requirements.....	1 and 2	(Parts Catalog)
Cable Threading .....	24 thru 27	(Operation Section)
Care of Scraper.....	1	(Repair Section)
Care of Tires.....	19	(Operation Section)
Changing Blades.....	28	(Operation Section)
Changing Ground Plates.....	29	(Operation Section)
Controlling Scraper with Power Control Unit..	3	(Operation Section)
Connecting Scraper to Tractor.....	2	(Operation Section)
Description of Scraper.....		Preface
Disassembling .....	8 thru 13	(Repair Section)
Front Axle Group		
(Parts Illustrations).....	16 thru 18	(Parts Catalog)
Functions of Scraper.....	4	(Operation Section)
Lubrication .....	20 thru 22	(Operation Section)
Main Body Group		
(Parts Illustrations).....	3 thru 7	(Parts Catalog)
Operation .....	6 thru 15	(Operation Section)
Operating Cycle.....	4	(Operation Section)
Operation under Dusty, Muddy, Low Tempera- ture or other Abnormal Conditions.....	30	(Operation Section)
Overhauling and Repairing.....	14	(Repair Section)
Points of Lubrication and Adjustment that can be taken care of by Operators.....	18	(Operation Section)
Preparation for Initial Operation.....	16	(Operation Section)
Preparation for Storage.....	30 thru 32	(Operation Section)
Pushbeam Group (Parts Illustration)..	14 and 15	(Parts Catalog)
Re-Assembling .....	15	(Repair Section)
Rear Hitch and Spiral Sheave Group		
(Parts Illustrations) .....	19 thru 21	(Parts Catalog)
Removing and Installing Tires.....	7	(Repair Section)
Safety Precautions .....	16	(Operation Section)
Spare Parts and Price List.....	26 thru 28	(Parts Catalog)
Specifications .....	17	(Operation Section)
Table of Clearances and Tolerances of Bearings and Adjustable Parts.....	15	(Repair Section)
Tailgate Group (Parts Illustrations)..	12 and 13	(Parts Catalog)
Tire Inflation .....	19	(Operation Section)
Trouble Shooter's Guide.....	16	(Repair Section)
Wheel Assemblies		
(Parts Illustrations) .....	22 thru 25	(Parts Catalog)
Yoke Group (Parts Illustrations).....	8 thru 10	(Parts Catalog)

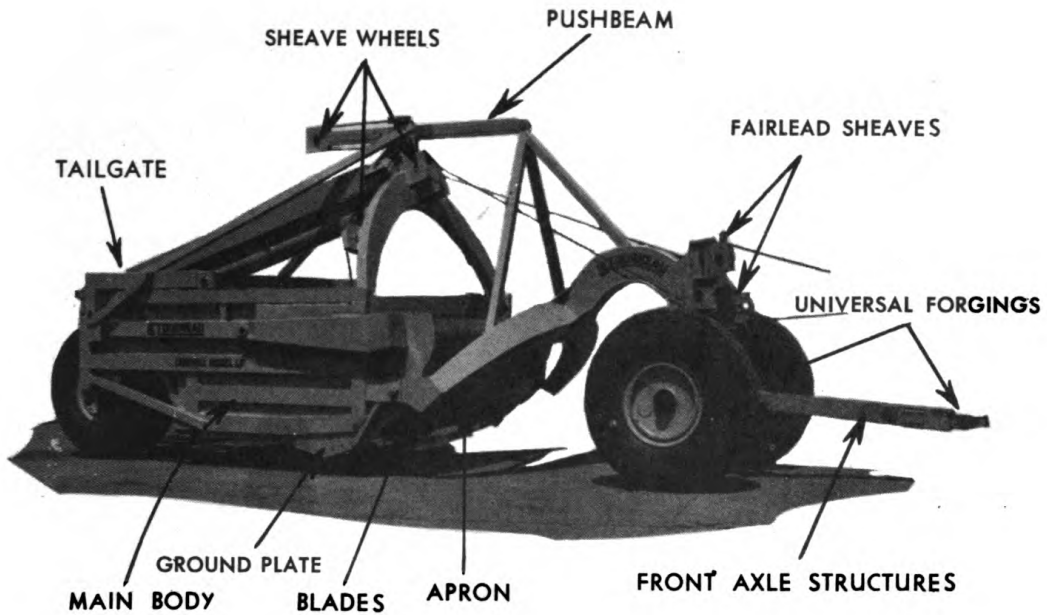

## THE LETOURNEAU MODEL LP CARRYALL SCRAPER

Designed for use behind either the Caterpillar D8 Tractor or the D7 Tractor (if a pusher tractor is used), the LeTourneau Model LP Carryall Scraper is a self-loading, hauling, and spreading unit rated at 15 cubic yards heaped capacity. The Scraper is cable controlled by means of the LeTourneau Power Control Unit on the rear of the tractor. This places quick, positive control of the Scraper in the hands of the tractor operator.

The Model LP Scraper embodies the same good features found in other LeTourneau Scrapers. Large, low pressure pneumatic tires provide ample flotation. High apron lift permits loading of large boulders and clears all material in unloading. The sliding tailgate provides positive ejection of all material. Sheaves and cables are out of the dirt, which gives longer cable life. Electrically arc welded alloy steel construction gives maximum strength at a minimum of weight. Like other LeTourneau Scrapers, the Model LP is built to stand up under the toughest of job conditions, and if properly operated and maintained, it should give an almost unlimited amount of trouble-free operation.

## PRINCIPAL PARTS OF CARRYALL SCRAPER

**FRONT AXLE STRUCTURE**—Structure at front of Scraper consisting of tongue and horizontal axle beam.

**YOKE**—The arched member connecting front axle structure with main body structure. Arched construction provides clearance for wheels when turning.

**MAIN BODY STRUCTURE**—Main structure of Scraper, consisting of bowl, into which dirt is loaded; springpipe, which extends at an angle above the bowl and which houses the tailgate return springs; and arched A-frame, which adds rigidity and supports front end of springpipe.

**APRON**—Structure hinged to main body which can be raised and lowered to provide an opening at the front of the bowl through which dirt can enter. Apron holds part of the dirt when bowl is filled.

**TAILGATE**—Structural member which rolls either to the front or to the rear inside the main body structure to eject the dirt and which serves as the rear end of the bowl.

**PUSHBEAM**—The beam which is hinged at the top of the yoke structure and which extends back through the sheave housing at the top of the main body structure. The pushbeam assists in raising and lowering the front of the bowl and blade.

**REAR HITCH**—The structural member at rear of main body structure which can be used as a hitch if desired and which supports pusher block used for pusher loading.

**UNIVERSAL FORGINGS**—Forged parts which are free to turn in steel bushings in the front axle structure and yoke and which, when coupled with another universal forging or hitch block, serve as a universal coupling.

**SHEAVE WHEELS**—Grooved wheels over which cable passes.

**SPIRAL SHEAVE WHEEL**—Spiral reduction wheel at rear of main body to which springpipe cable and spiral sheave-to-tailgate cable are attached, that assists in compressing tailgate return springs when tailgate is pulled ahead, and vice-versa.

**FAIRLEAD SHEAVES**—The two sheave wheels at the front of the yoke which are free to pivot either to the right or left to cause perfect cable alignment when turning.

**BLADES**—The replaceable cutting edges at the front of the main body which, when pulled through the ground causes dirt to be loaded into the Scraper bowl.

**GROUND PLATES**—The replaceable blade-like plates which are bolted to the sides of the main body structure at the lower corners to serve as wear strips.

**PUSHER BLOCK**—The block at the rear of the Scraper which serves as a contact point for the Dozer bowl of a pusher tractor to bear against when pusher loading.

## OPERATING TERMS

**THE CUT**—Place where Scrapers are loading.

**THE FILL**—Place where Scrapers are unloading.

**FINISHING**—Leveling or smoothing the surface of a finished cut, fill, slope, or other plot of ground.

**PUSHER LOADING**—Loading dirt into a Scraper when the pulling tractor is being assisted by another tractor pushing from the rear.



SECT. 1

# OPERATION SECTION







## **OPERATION SECTION**

The efficiency of the Carryall Scraper is more dependent on the ability and skill of the operator than on any one other thing. For this reason, it is hoped that every operator will recognize the importance of his services, and will operate the scraper to the best of his ability at all times.

The operating instructions in this book are brief, and are intended only to familiarize the operator with the accepted methods of operation and the procedure to be used in doing the more common types of Scraper work, as practiced by skilled operators with years of experience.

These instructions should help the new operator in becoming more efficient at his work.

It should be kept in mind, however, that an operator cannot become skilled by reading a book, but can attain skill only through actual operating experience.

On the following pages will be found not only the recommended operating procedures, but also instructions covering the points of maintenance that can be taken care of by the operator.



## CONNECTING SCRAPER TO TRACTOR

To connect a Scraper to a tractor, it is usually not necessary to thread the cable through the Scraper, because when uncoupled from the tractor, the cable is usually disconnected from the Power Control Unit on the rear of the tractor and left threaded through the Scraper. If the cable is not threaded through the Scraper, the cable threading instructions on page 24 of the Operation Section should be followed.

With the cable threaded through the Scraper, back the tractor up to the Scraper tongue and thread the hoist cable thru the double deck sheave assembly and onto the Power Control Unit right hand cable drum. (Refer to Power Control Unit Manual.) Likewise, the dump cable should be threaded thru the double deck sheaves and onto the left cable drum. Since the tongue is too heavy to lift by hand, a cable socket is welded to the side of the tongue so that it can be raised mechanically by the Power Control Unit.



To raise the tongue, pull a few feet of slack in the right cable and loop it down through the cable socket on the side of the tongue as illustrated, and insert the cable wedge from the bottom side. Tap the wedge into place. Then raise the tongue so that the hitch block is even with the tractor drawbar by engaging the Power Control Unit right hand clutch.

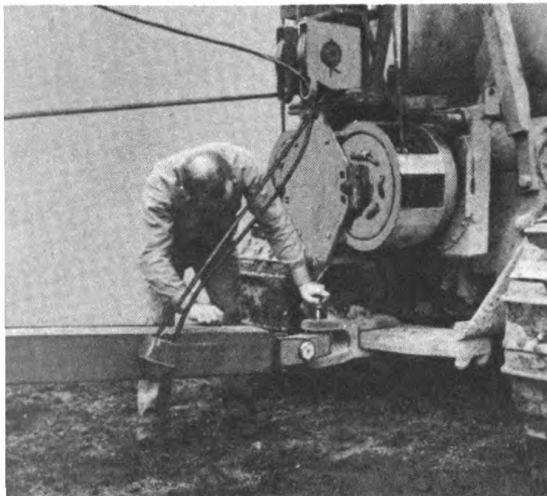

After the tongue is raised up even with the tractor drawbar, back the tractor up, positioning the Scraper hitch block between the jaws of the tractor drawbar, and insert the drawbar pin.

Remove the cable wedge from the cable socket on the side of the tongue, and take up slack cable. Keep the wedge in the tractor tool box or some safe place where it can be readily found.

## OPERATION

CONTROLLING SCRAPER WITH  
POWER CONTROL UNIT

The Scraper is controlled by means of the Power Control Unit on the rear of the tractor.

The right control lever (viewed from Scraper to tractor) controls the raising and lowering of the bowl. Moving the lever toward the center of the tractor (to the left) engages the hoist clutch and raises the Scraper bowl. Returning the lever to neutral position applies the brake to the cable drum and holds the bowl in the raised position.

Moving the right lever away from the center of the tractor (to the right) releases the brake from the cable drum and allows the bowl to lower. Returning the lever to neutral position applies the brake to the cable drum and holds the bowl at the level to which it was lowered.

The left control lever of the Power Control Unit controls the apron and tailgate. Moving the lever toward the center of the tractor (to the right) engages the dump clutch and raises the apron. When the apron is raised to its full height, the tailgate is then pulled forward and the tailgate return springs inside the springpipe are compressed. Returning the control lever to neutral position applies the brake to the cable drum and holds the apron and tailgate in the position desired.

Moving the control lever away from the center of the tractor (to the left) releases the brake from the cable drum, allowing the tailgate return springs to return the tailgate to its original position at the rear of the Scraper bowl, and also permits the apron to lower.

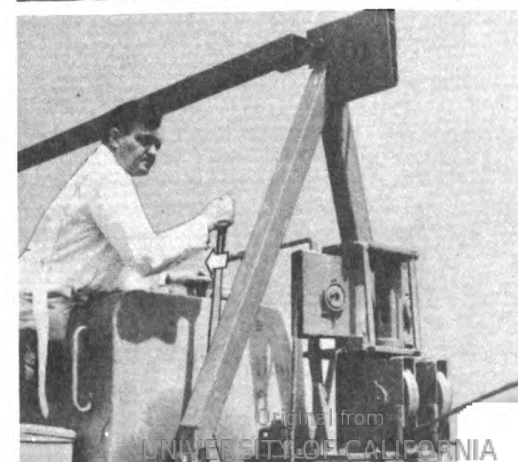
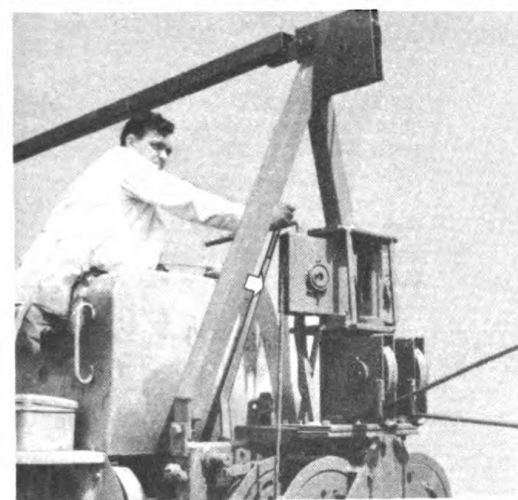
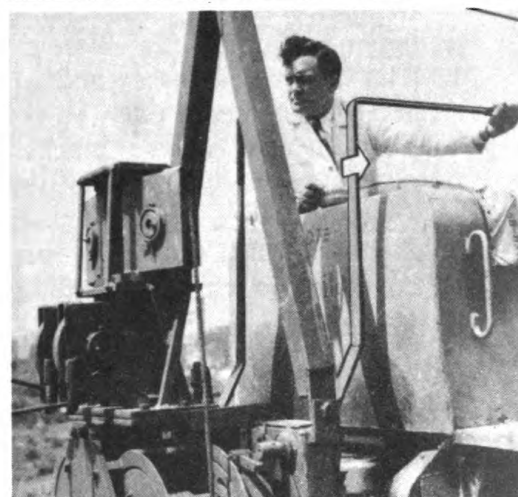

## THE OPERATING CYCLE

The operating cycle of the Carryall Scraper includes the operations of loading, hauling, unloading or spreading, and returning to the cut, as illustrated below.

The power for each of these operations is supplied by the tractor. The tractor pulls the Scraper blade through the ground when loading, tows the Scraper when traveling, and provides the power for unloading.

The Power Control Unit, in controlling the working parts of the Scraper, either spools or unspools the cable on or off the cable drums, depending upon the movement of the control levers by the operator. The control cables extend to the various working parts of the Scraper and actuate these parts to perform the necessary functions. The cables pass through sheave blocks at various points on the Scraper. This multiplies the line pull delivered by the Power Control Unit many times at some points, depending on the number of sheave wheels used in the sheave blocks, thus providing the large amount of power needed for operations such as unloading.

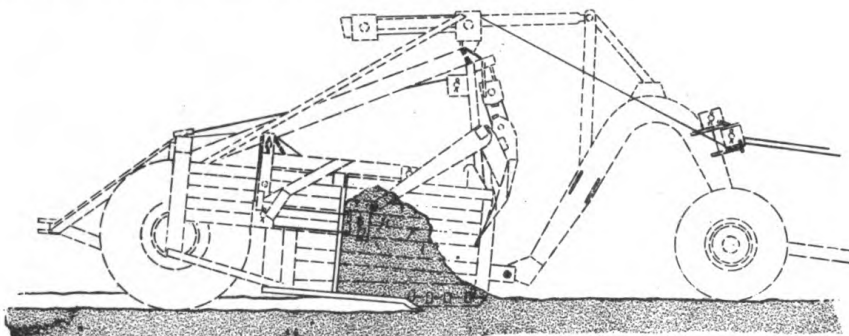

1. To load the scraper, enter the cut with the tailgate at the extreme rear of the bowl and with the apron raised four to eight inches above the cutting edge. Release the hoist brake and lower the blade into the ground to the desired depth. As the tractor pulls forward, the Scraper blade cuts into the ground and the dirt is forced up into the scraper bowl.

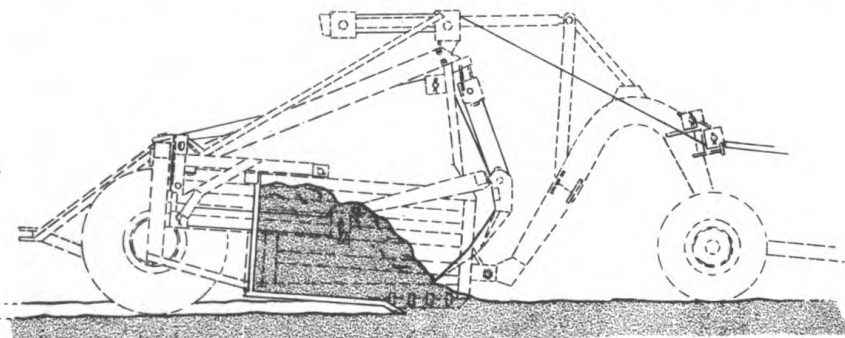

2. As the bowl is being filled, the material will roll back against the tailgate and forward against the apron, thereby assisting in closing the apron. When the bowl is filled, release the Power Control Unit dump brake to close the apron, and at the same time engage the hoist clutch and raise the bowl one or two inches above the surface of the ground.



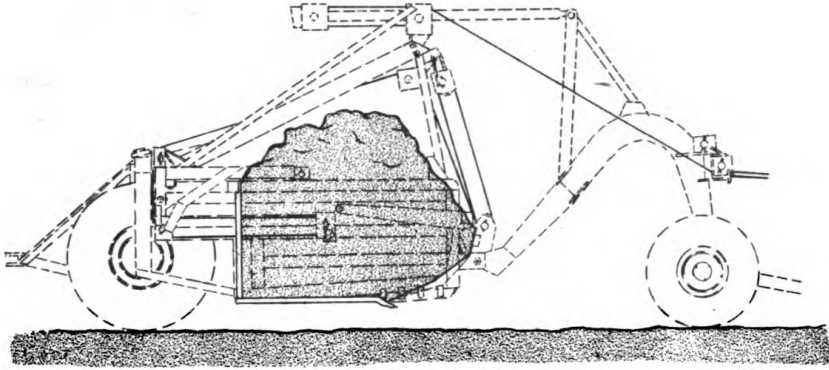

3. After pulling the Scraper ahead a few feet, spreading the material which was in front of the blade, raise the bowl to the desired traveling position and proceed to the fill, carrying the bowl comparatively close to the ground.

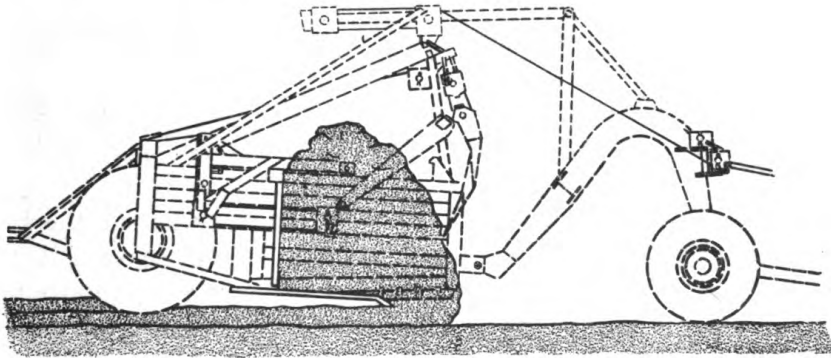

4. Upon arriving at the fill, raise or lower the blade to the desired depth of spread. Raise the apron to its full height by engaging the dump clutch, allowing the dirt to fall out. Shake any sticky material from the back of the apron by releasing the brake, dropping the apron about twelve inches and then immediately engaging the clutch to raise the apron again. Repeat this procedure in sticky material if necessary.

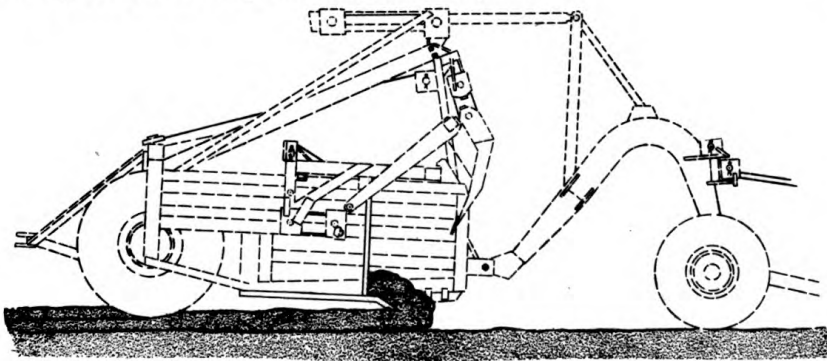

5. After the dirt has fallen out with the apron raised, re-engage the power control unit dump clutch, thereby pulling the tailgate forward to eject the remainder of the load. Pull the tailgate forward approximately 12" at a time and then allow it to return a few inches before pulling it forward again. When the bowl is completely emptied, release the Power Control Unit dump brake, allowing the tailgate return springs inside the springpipe to return the tailgate to its rear position and also lowering the apron about six or eight inches. The Scraper is now in traveling position.

APRON RAISED 6 TO 12 INCHES

TAILGATE AT REAR



## OPERATION

### LOADING

To load the bowl of the Scraper and fully utilize its capacity, enter the cut with the tailgate in the extreme rear position and with the apron raised approximately 6 to 12 inches.

Move forward and lower the blade into the ground, allowing it to penetrate to the desired depth. Keep the apron low, leaving an open-

ing just large enough for the dirt to enter, but not so low as to cause the dirt to bank up in front of the blade. Loading is normally done in low gear.

As the unit moves forward, loading the dirt into the bowl, the material will fall forward against the apron as well as back against the tailgate.

When the Scraper is loaded, lower the apron and raise the blade an inch or two above the surface of the ground. Travel several feet before raising the blade to a higher position. This will spread the loose material in front of the blade and thereby leave the cut smooth to pull in and out of.

All operators like to obtain as large a load as possible, but in some materials it sometimes takes as much time to get the last yard of dirt as it does to get an average load. On short hauls it is not profitable to take this extra time to get the last yard of dirt. However, on long hauls, it often pays to take the extra time and effort to obtain the added yardage because on long hauls the extra loading time is such a small percentage of the total cycle time.

If possible, arrange the work so that the Scraper can be loaded down hill and in the direction of travel to the fill.

RAISE BLADE 1" OR 2" ABOVE SURFACE OF GROUND



CORRECT

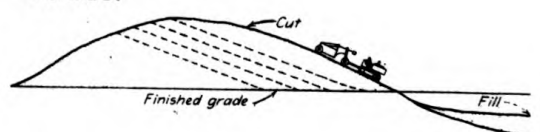

INCORRECT

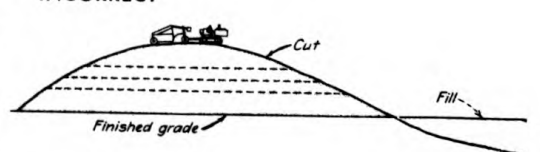

## TRAVELING TO THE FILL

Traveling to the fill with a loaded Scraper is usually done with the tractor in the highest gear possible without over-loading the tractor engine. The bowl of the Scraper should be carried fairly close to the ground, but high enough to clear any objects on the haul road without having to continually raise and lower the bowl. Carrying the bowl

close to the ground prevents danger of upsetting the Scraper, particularly when traveling over rough haul roads. It also prevents traveling with the pushbeam stops together which might cause breakage of the hoist cable or upsetting the Scraper when making a short turn to the left. Provide at least 6 inches of clearance between the pushbeam stops at all times when traveling.

When turning sharply on extremely rough ground, the operator should be careful not to cramp the front axle structure beyond reasonable limits, in order to avoid the danger of damaging the tires by bringing them into contact with the yoke.

When there is a choice of two or more routes for traveling from the cut to the fill—one a short steep route that would require traveling in low gear and the other a long gradual incline that would allow traveling in fourth or fifth gear, with each route ending at the same place and taking approximately the same time, the shorter route should normally be taken, even though it requires traveling steep inclines in low gear. The reason for this is that the maintenance cost on tracks, rollers, bearings, etc., is higher while traveling at high speed than at low speed. Several factors should be considered in making the choice, however, such as traveling time, condition of haul roads, wear on equipment, etc.

ALWAYS ALLOW AT LEAST 6" CLEARANCE BETWEEN  
PUSHBEAM STOPS WHEN TRAVELING

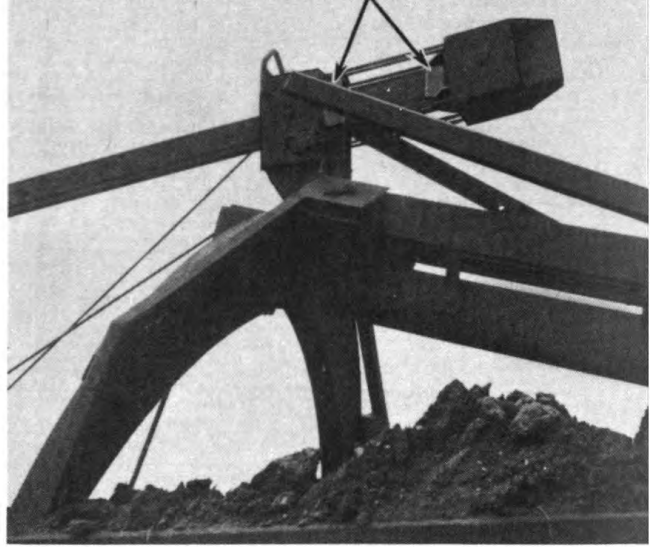

APRON RAISED TO FULL HEIGHT  
TO PERMIT DIRT TO FALL OUT



## OPERATION

### UNLOADING OR SPREADING

Spreading is usually done in the highest gear possible. This, of course, is dependant upon material and conditions.

Upon arriving at the fill with the loaded Scraper, either raise or lower the bowl as is required to give the desired thickness of spread. Then engage the Power Control Unit left clutch, raising the apron to its full height, allowing the dirt in the apron

to fall out. When the apron reaches its full height, disengage the clutch and release the brake, allowing the apron to drop about twelve inches. Then immediately engage the clutch and raise the apron again. If operating in sticky material, it may be necessary to repeat this operation once or twice to dislodge the dirt from the back side of the apron. After the dirt has fallen out of the apron, re-engage the clutch and bring the tailgate forward about twelve inches at a time, letting it move back a few inches after each forward movement, until the bowl is empty. If possible, stop the forward movement of the tailgate just before the tailgate sliding sheave housing above the springpipe reaches its stop block at the rear of the channel in which it slides.

If starting a new spread, the blade should be lowered slightly as the rear wheels come up onto the dirt that is ejected, in order to maintain an even depth of spread.

The operator should be careful not to force the load out too

rapidly, as this causes unnecessary strain on the tailgate and cable. Also, it may cause the dirt to stack up in front of the blade, thereby adding additional draft on the tractor. As the tailgate nears its forward position and the load decreases, it is advisable to use less pressure on the control lever, unless the pressure is actually required to pull the tailgate forward. By exerting less pressure as the tailgate nears its forward position, the

TAILGATE PULLED FORWARD TO EMPTY SCRAPER

SMOOTH SPREAD





clutch would slip rather than the cable breaking, in event the tailgate should accidentally be brought so far forward that the tailgate sliding sheave strikes against the stop block at the rear of the channel above the springpipe. Remember, however, that the clutch should not be allowed to slip during operation unless this extreme forward position is reached, and in this case it is done only to prevent cable breakage. The operator should always disengage the clutch immediately whenever the tailgate sliding sheave strikes the stop block.

When the Scraper is completely emptied, return the tailgate to its rear position and lower the apron. Then raise the bowl to the desired traveling position and return to the cut. The operator should at no time return to the cut with the apron raised and the tailgate in the extreme forward position, because cable breakage would occur when turning or when traveling over unlevel ground.

### RETURNING TO THE CUT

Returning to the cut is usually done in as high a gear as possible.

When returning, the bowl should be carried comparatively close to the ground, but high enough to clear any rocks and obstructions in the path of travel without repeated raising and lowering of the bowl. Carrying the bowl low to the ground prevents up-setting.

Always allow at least 6" clearance between the pushbeam stops. This will prevent cable breakage when traveling over rough, un-level ground and when turning.

It is sometimes advisable to smooth up the haul road with the empty Scraper by dragging the blade on the ground. With the apron raised and the tailgate within approximately 8" of the extreme forward position, an action similar to that of a 'Dozer or grader is obtained. The tailgate should never be in the extreme forward position during this operation, or cable breakage might occur when traveling over unlevel ground and when turning.





PULL TAILGATE AHEAD  
APPROX. 12" AT A TIME

DON'T SPREAD TOO THIN



## OPERATION

### HANDLING SPECIAL MATERIALS Wet or Sticky Material

When operating in wet or sticky material, difficulty may be experienced in unloading or spreading unless certain precautions are observed.

When unloading, do not try to make too thin a spread. Keep the bowl high enough to allow the material to pass under the Scraper. Material not having enough room to pass under the Scraper will roll up inside the bowl into a solid

mass that will be difficult for the tailgate to eject.

Do not try to force the load out too fast, as that too will cause the material to roll up in front, and might result in cable breakage.

For best results in wet or sticky material, bring the tailgate forward about twelve inches at a time. After each forward movement, permit the tailgate to return approximately six inches, allowing the material inside the bowl to settle back and loosen up. Repeat this operation until the bowl is emptied.

### Loose Sand

Because of the tendency of loose sand to float ahead in front of the blade rather than entering the bowl when loading, the following procedure should be used when loading loose sand.

Start to load with the apron raised 6 to 12 inches and with the tailgate in the rear position. Move forward with the blade in the ground, loading in the conventional manner. When the bowl has become approximately half filled, lower the apron into the pile of sand that will have stacked up in front of the blade and then raise the bowl approximately 2 inches. Then, while moving forward, release the hoist brake, permitting the bowl to drop about 3 or 4 inches. This will force more sand up into the bowl. By repeating this operation, the Scraper can usually be fully loaded.

The above method of raising and lowering the bowl to obtain a load is sometimes referred to as "pumping in a load". When lowering the bowl in this operation, do not leave the hoist brake released long enough to allow the cable to become slack on the drum as that would cause unnecessary cable wear and possible breakage.

In unloading loose sand, make the spread as thin as possible. This will give better compaction and will make traveling over the fill easier.

RAISE AND LOWER BLADE TO PUMP IN LOAD

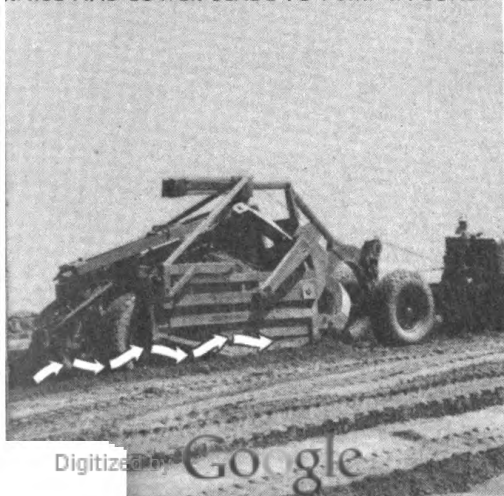

## Gravel

When loading gravel, it may be necessary to follow a procedure similar to that for loading loose sand in order to obtain a full load. However, little difficulty should be experienced except occasional failure of the apron to completely close, due to interference by large stones, resulting in a partial loss of the load.

If encountered, this difficulty may be overcome by backing the Scraper up a few inches and at the same time lowering the apron and raising the bowl. As the bowl is raised, the apron will usually drop into the completely closed, carrying position.

## Large Rocks and Stumps

Rocks and stumps that are too large for the tractor and Scraper to pass over can be loaded into the Scraper easily by proper handling of the Scraper as follows:

With the apron raised and the tailgate in the rear position, move forward with the tractor and Scraper, heading the tractor straight toward the rock or stump. Just before the tractor reaches the object, turn sharply either to the right or to the left, and start to move past the object along either side. When the front wheels of the Scraper have moved up alongside the object, turn the tractor sharply toward the rock or stump and at the same time lower the blade to the ground. By turning the Scraper in this manner, the front wheels will pass around the object but the blade will swing in behind it. At this point, turn the tractor back into its original direction of travel and, with the rock or stump between the front wheels and the blade, pull forward, loading the object into the bowl of the Scraper.

It is sometimes necessary to load a little dirt into the Scraper after the object is loaded in order to push the object far enough into the bowl to allow the apron to close.

To unload the rock or stump, use the regular unloading procedure. If, in unloading, a large rock should be tilted up inside the bowl so that it will not pass under the apron, it is necessary to return the tailgate to the rear to allow the rock to settle back to its flat position before pulling the tailgate ahead again. After the object has fallen out, turn the tractor and back up so that neither the front wheels nor the front axle structure will hit the object when pulling away.

BACK UP WHILE LOWERING APRON  
AND RAISING BLADE



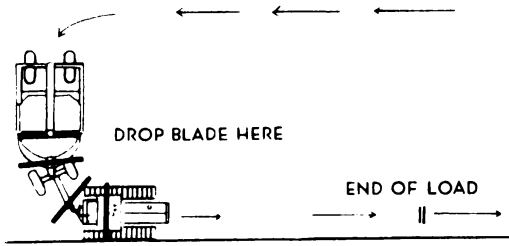

## DOING SPECIAL JOBS

### Making Side Hill Cuts

In starting a side hill cut with a Carryall Scraper, approach the slope stakes from the lower side of the slope and at a right angle to the row of slope stakes. When the front of the tractor reaches the line of stakes, swing the tractor around parallel to the slope stakes and at the same time lower the Scraper blade into the ground. As

the tractor moves forward, the Scraper will also turn parallel to the row of slope stakes and the side of the blade nearest the stakes will cut into the hill. By repeating this operation, there will soon be a level bank on which to start loading and loading can then be done in the conventional manner.

Always keep a side-hill cut low next to the bank and high on the outside. The result will be a neat, easily controlled slope with a minimum of finishing necessary.

To make the side of the cut slope down at the desired angle, follow the procedure of "stepping" in away from the bank or slope with each successive depth of cut, as is outlined in the following instructions for making through-hill cuts. Also, if finishing the slope with a Scraper, perform the finishing operation as the work progresses as per the instructions on the following page.

### Making Through-Hill Cuts

In making through-hill cuts, always keep the cut low next to the slopes or sides of the cut and high in the center. This will help maintain a better slope and also make the loads larger and more uniform.

Plan the work so that the sides of the cut slope down at the desired angle. This can be done by "stepping" in away from the bank or slope with each successive depth of cut, just enough to cause the slope to taper down at the desired angle. The slope can be finished by Carryall Scraper, or by other accepted methods of back-sloping. If finishing with a Scraper, the slope should be finished as the cut progresses, or, in other words, the newly cut part of the slope should be finished each time that the unfinished part reaches a width or height equal to or nearly equal to the width of the Scraper blade. (Refer to Finishing instructions on the following page.)

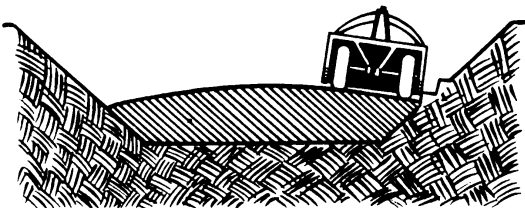

## Building A Fill

In building a fill, it is highly essential to keep the outside or shoulders of the fill higher than the center. This prevents the Scraper from sliding over the shoulder while dumping close to the edge and also helps make the sides of the fill slope at the correct angle as the fill is built up.

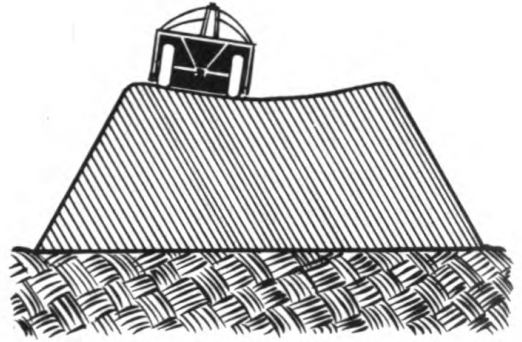

When the shoulders have reached grade level, the center can be filled quickly just before final leveling and finishing. Also, before closing down the job for the night or for any period of time, fill in the low center for better drainage in event it should rain.

## Finishing

Carryall Scrapers are often used for leveling or finishing airports, roads, building sites, etc.

**LEVEL GROUND**—For preliminary finishing where it is necessary to skim off dirt in some spots and fill at others, the Scraper can be operated in somewhat the normal manner, picking up part of a load at one spot and spreading it at another. For final finishing, however, the tailgate should be brought forward to within approximately 8" of its extreme forward position and the Scraper then used similar to a Dozer or grader. Keep the rear tires inflated to equal air pressures or the blade will cut low on one side.

**SLOPES**—Slopes that are not too steep can be finished with a Scraper without difficulty. For best results and greater safety, the slope should be finished as the work progresses. In other words, each time that the Scraper has cut the slope down far enough to cause the unfinished part of the slope to equal the approximate width of the Scraper blade, it should then be used to finish the unfinished part by running one tractor track and one side of the Scraper up onto the slope with the other track and wheels running along the bottom of the slope. Then, with the tailgate pulled forward to within approximately 8" of its extreme front position the Scraper can travel along the side of the slope, skimming off the surplus dirt, thus finishing the slope as you go.

When finishing, do not attempt to load the bowl on a slope or the dirt will fall to the low side of the bowl, causing that side of the blade to cut deeper than the other and as a result dig a ditch in the slope.

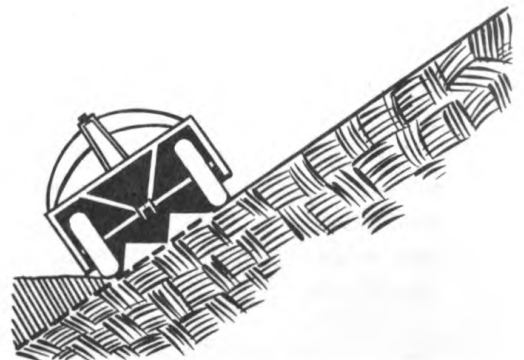

## BOOSTING PRODUCTION

### Pusher Loading

Equipped with a pusher block on the rear, the Carryall Scraper can be pusher loaded by an Angledozer or Bulldozer in order to increase production.

By using a pusher tractor when loading, larger loads can be obtained and the loading time can be decreased. Also, because less effort is required by the pulling tractor, pusher loading lengthens tractor life.

The Scraper operator should load the Scraper in the normal manner when being assisted by a pusher tractor. It is highly important that he keep the tractor and Scraper moving in a straight line in order to prevent the unit from jack-knifing.

The pulling tractor should be operated at wide open throttle when loading. The speed of the pushing tractor should be synchronized with that of the pulling tractor so that it moves along with the Scraper, assisting in loading. If the motor of the pulling tractor should start to lug down, the pushing tractor should apply full power to prevent the pulling tractor from stalling.

The operator of the pusher tractor should ease the 'Dozer bowl up to the pusher block on the rear of the Scraper when making contact to start pushing.

Extreme care should be used to prevent the 'Dozer blade from contacting the rear tires of the Scraper and possibly cutting them. The pusher tractor should travel straight with the Scraper and pulling tractor to assist in keeping the unit travelling in a straight line.

### Using The Rooter

The loading efficiency of Carryall Scrapers in hard materials can be greatly increased by using a Rooter to break up the material.

LeTourneau Rooters can tear through such materials as decomposed shale, decomposed granite, tough clay, boulder strewn ground, black top, etc., all of which can be easily loaded into a Scraper if properly rooted.

LeTourneau Rooters are equipped with either three or five teeth as standard.

The fewer the teeth the deeper the penetration can be in tough ground and the larger the breakage will be; and vice-versa, with more teeth the shallower the penetration and the more pulverizing the action will be.

For best Scraper loading the material should not be broken up too fine. Therefore, it is often advisable to remove one or more shanks from the Rooter to prevent fine breakage. This is dependent, of course, upon job conditions, type of material, etc.

When rooting in a side-hill or through-hill cut, always root parallel with and close to the slope and work away from the slope. This allows the Scrapers to maintain proper slopes as the work progresses. Plan the work to avoid congestion and interference of the Scrapers with the Rooter.



### Eliminating Turns

Wherever possible, plan the work to eliminate all unnecessary turns. By so doing, an accumulated saving of turning time in the course of a day's work will result in several additional yards of material being moved.

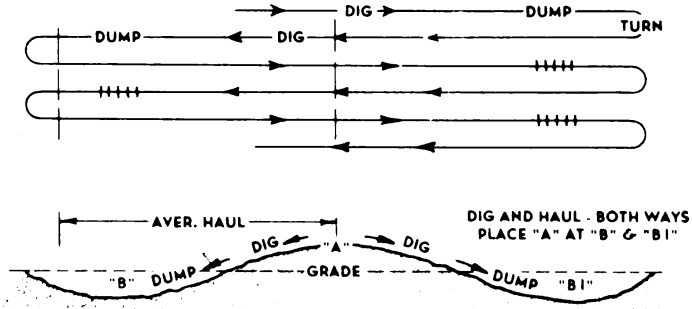

Many jobs can be laid out so that there is a fill on each side of the cut or a cut on each side of the fill. With a job lay-out of the type illustrated above or the figure 8 loading and hauling cycle can be used to great advantage.

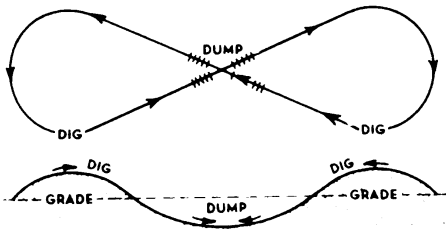

In the first example, load going down the hill and continue with the load to the fill. When unloaded, turn and come back to the hill and this time load going down the opposite side of the hill, continuing on to the second fill, etc., as diagrammed.

The figure 8 lay-out is very effective where there are two cuts on either side of the fill.

By using either method, only two turns are required while two full loads are delivered, whereas normally two turns are required for each load.

On jobs where there are a series of cuts and fills, a lay-out of the type illustrated below can be used.

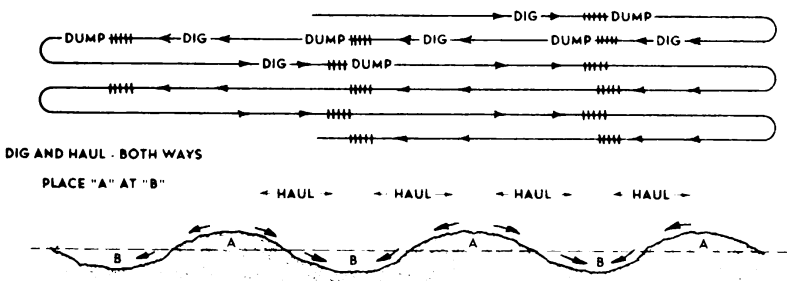

## SAFETY PRECAUTIONS

As with all heavy equipment, reasonable precautions must be taken when working around the Carryall Scraper. Listed below are safety precautions which should be observed.

1. When changing blades or working underneath the Scraper, always block up under the bowl to prevent it from dropping in event someone should accidentally release the Power Control Unit hoist brake. Likewise, do not work under the apron when in the raised position without first placing blocks between the apron arms and Scraper sides to prevent the apron from dropping.

2. Do not work behind the tailgate when it is pulled forward without first blocking it in the forward position.

3. Keep the hands free from the cable and sheaves while the unit is in operation.

4. Use gloves when handling cable.

5. When traveling down a steep hill, always be ready to drop the blade to the ground to serve as a brake in event the Scraper should start to jack-knife or get out of control.

6. Do not leave Scraper with blade in raised position.

7. Do not use weak, frayed, cable.

8. When replacing springpipe cable or tailgate return springs, use care to avoid being injured in any manner by the springs, which have considerable pressure behind them when under compression.

## PREPARATION FOR INITIAL OPERATION

If the Scraper arrives partially disassembled, it is first necessary to assemble the unit. (Refer to assembling instructions on page 14 of the Repair Section.)

After the Scraper has been completely assembled, thread the cable through the sheave housings as outlined in the cable threading diagram on page 23 of the Operation Section.

Check all points of lubrication to determine if properly lubricated.

Check cable alignment to determine whether it is fouling at any point.

Check tire pressures.

Check universal forgings which connect yoke with tongue. Make sure they are installed with beveled edge to the front and heavy side down, as illustrated on page 14 of the Repair Section.

Raise and lower apron and also pull tailgate forward and allow it to return to the rear position, checking for free movement.

When the Scraper has been thoroughly checked and any necessary corrections made, it is ready to be placed in operation.

## SPECIFICATIONS

<b>MODEL</b>	.....LP
	For use with tractor model.....Caterpillar D8 or D7
<b>CAPACITY</b>	
	Struck, cubic yards.....12.1
	Heaped, cubic yards.....15
<b>BOWL</b>	
	Height of sides.....4' 4 <sup>3</sup> / <sub>4</sub> "
	Dimensions of bottom.....4' 11" x 8' 6"
	Type of bottom.....Double
<b>OVERALL MEASUREMENTS</b>	
	Length .....32' 2"
	Width .....10' 2"
	Height, blade on ground.....10' 11"
<b>CUTTING EDGE</b>	
	Length .....8' 6"
	Dimensions:
	Center section.....7 <sup>7</sup> / <sub>8</sub> " x 16" x 56"
	Each tip.....3 <sup>3</sup> / <sub>4</sub> " x 13" x 23"
	Type.....Reversible, hard surfaced
<b>WHEELS</b>	
	Axles.....Front: Stub—Rear: Supported both ends
	Tires .....4 (18x24) 12 ply front, 16 ply rear
	OR 6 (14x20) 16 ply
	Bearings.....Tapered roller
<b>CABLE REQUIREMENTS (Type: 6 x 19 Preformed Tournarope)</b>	
	Dump Cable (size 1 <sup>1</sup> / <sub>2</sub> " ).....130'
	(furnished in storage reel).....500'
	Tailgate Forward Cable (size 7 <sup>7</sup> / <sub>8</sub> " ).....51'
	Apron Lift Cable (size 7 <sup>7</sup> / <sub>8</sub> " ).....14 <sup>1</sup> / <sub>2</sub> '
	Hoist Cable (size 1 <sup>1</sup> / <sub>2</sub> " ).....125'
	Springpipe Cable (size 5 <sup>5</sup> / <sub>8</sub> " ).....17'
	Spiral Sheave-to-tailgate cable (size 5 <sup>5</sup> / <sub>8</sub> " ).....13 <sup>1</sup> / <sub>2</sub> '
<b>GENERAL SPECIFICATIONS</b>	
	Wheelbase .....20'
	Maximum ground clearance at rear of bowl.....18"
	Maximum ground clearance at front axle.....24"
	Width required for non-stop turn.....25'
	Type of ejection.....Forward, Positive, Mechanical
	Lift of front apron.....48 <sup>1</sup> / <sub>4</sub> "
	Maximum depth of spread.....21"
	Maximum depth of cut.....8"
<b>APPROXIMATE SHIPPING WEIGHT</b>	
	19,700 lbs.....4 (18 x 24) Tires
	19,000 lbs.....6 (14 x 20) Tires

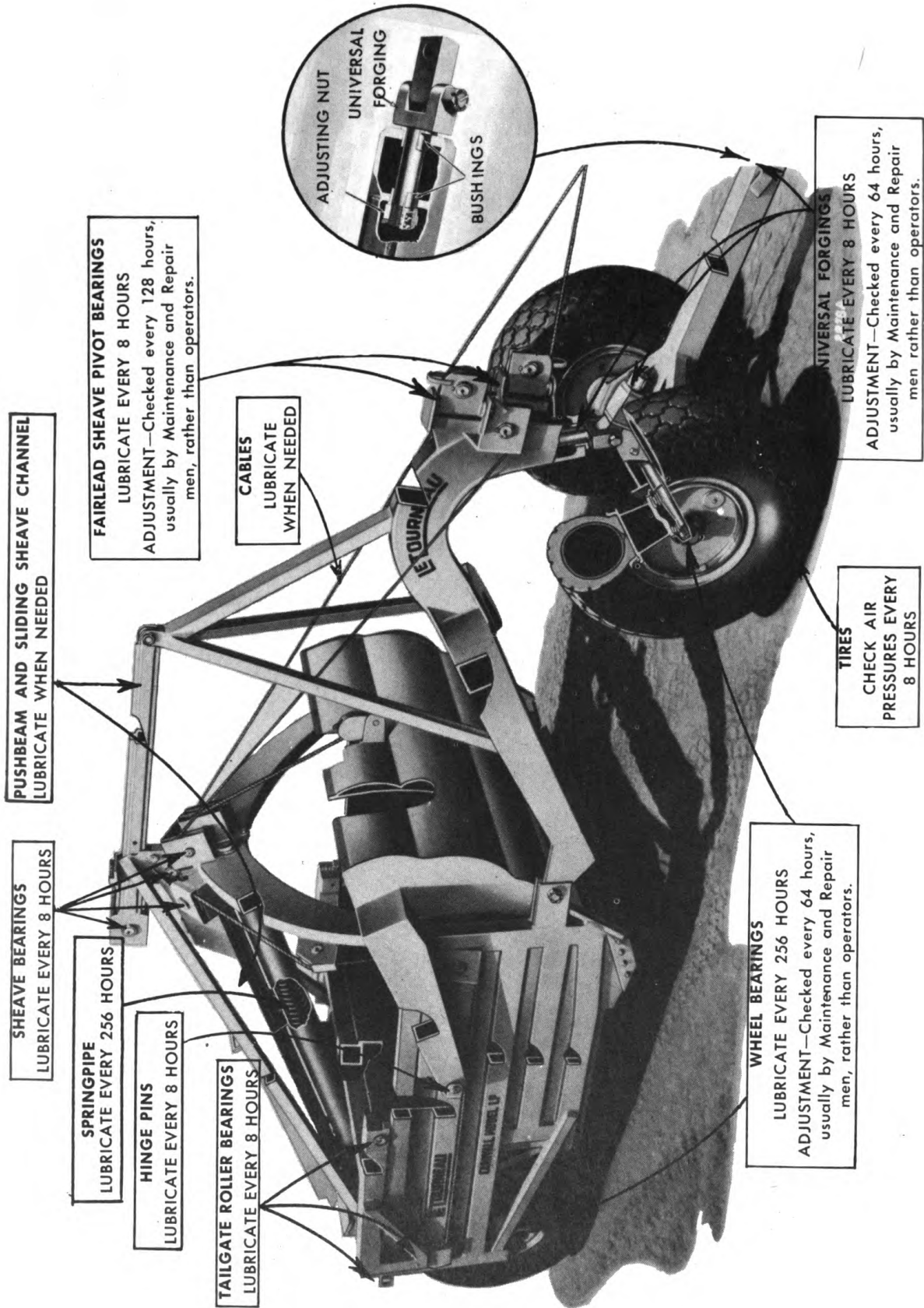

**PUSHBEAM AND SLIDING SHEAVE CHANNEL**  
LUBRICATE WHEN NEEDED

**FAIRLEAD SHEAVE PIVOT BEARINGS**  
LUBRICATE EVERY 8 HOURS  
ADJUSTMENT—Checked every 128 hours, usually by Maintenance and Repair men, rather than operators.

**CABLES**  
LUBRICATE WHEN NEEDED

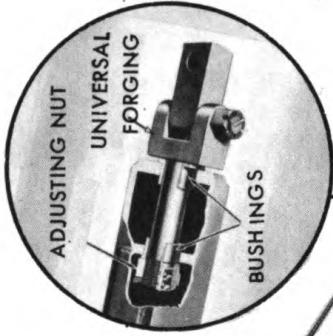

**ADJUSTING NUT**  
**UNIVERSAL FORGING**  
**BUSHINGS**

**UNIVERSAL FORGINGS**  
LUBRICATE EVERY 8 HOURS  
ADJUSTMENT—Checked every 64 hours, usually by Maintenance and Repair men rather than operators.

**TIRES**  
CHECK AIR PRESSURES EVERY 8 HOURS

**SHEAVE BEARINGS**  
LUBRICATE EVERY 8 HOURS

**SPRINGPIPE**  
LUBRICATE EVERY 256 HOURS

**HINGE PINS**  
LUBRICATE EVERY 8 HOURS

**TAILGATE ROLLER BEARINGS**  
LUBRICATE EVERY 8 HOURS

**WHEEL BEARINGS**  
LUBRICATE EVERY 256 HOURS  
ADJUSTMENT—Checked every 64 hours, usually by Maintenance and Repair men, rather than operators.



## TIRE INFLATION

Keep the tires correctly inflated at all times.

Check tire pressures every eight hours of operation if possible—never when tires are hot. “Bleeding” tires (reducing pressures to recommended levels when they are hot) is not recommended. If done, this would later result in under-inflation when tires cool off, which might be destructful.

The following table gives the recommended pressures for the various tire combinations used on the Model LP Scraper.

Quantity	<i>Tires</i>	<i>Air Pressures</i>	
	Size	Front	Rear
4	18 x 24 (12 ply front, 16 ply rear)	30 lbs.	40 lbs.
6	14 x 20 (16 ply )	55 lbs.	50 lbs.

Always inflate dual tires to equal pressures and avoid the use of unmatched duals wherever possible. To cause the scraper to cut level, it is important that the rear tires (singles or duals) on both sides of the scraper be inflated to equal pressures.

In mud or extreme soft underfoot conditions which tend to bog down or immobilize equipment, front and rear tires could be reduced as much as ten pounds but never below a minimum pressure of 25 lbs. Should pressures be reduced below 25 lbs. slippage on the rim might occur and damage to the tubes result.

If pressures are thus reduced for operation in soft conditions, they should be brought back up to the recommended pressures listed above and kept there as soon as that need is over.

## CARE AND MAINTENANCE OF TIRES

Maintenance of roads and patrolling to throw off large boulders, etc., pay big dividends in production and in tire conservation.

Where Scrapers are working in scarified or blasted material, avoid striking sharp stones with front tires, and depend on the Scraper blade and bowl to protect the back tires.

Where a grader is not patrolling regularly, occasionally drop the Scraper blade and drag the road on the return trip, as the road becomes littered with sharp stones and spillage from the Scraper.

Repair at once any deep injuries which penetrate to the cord body of the tire, allowing dirt and water to enter. Single small cuts which do not gap or bulge, but leave only a hair line opening, will cause no damage. However, when a cut shows any sign of a gap or bulge, it should be repaired.

Knock out rocks or wood from between dual tires, as they cause failures that seldom are repairable.

Keep oil off tires as much as possible. Oil causes very rapid deterioration.

When pusher loading Scrapers with a Bulldozer or Angledozer, don't allow 'dozer blade to gouge rear tires.

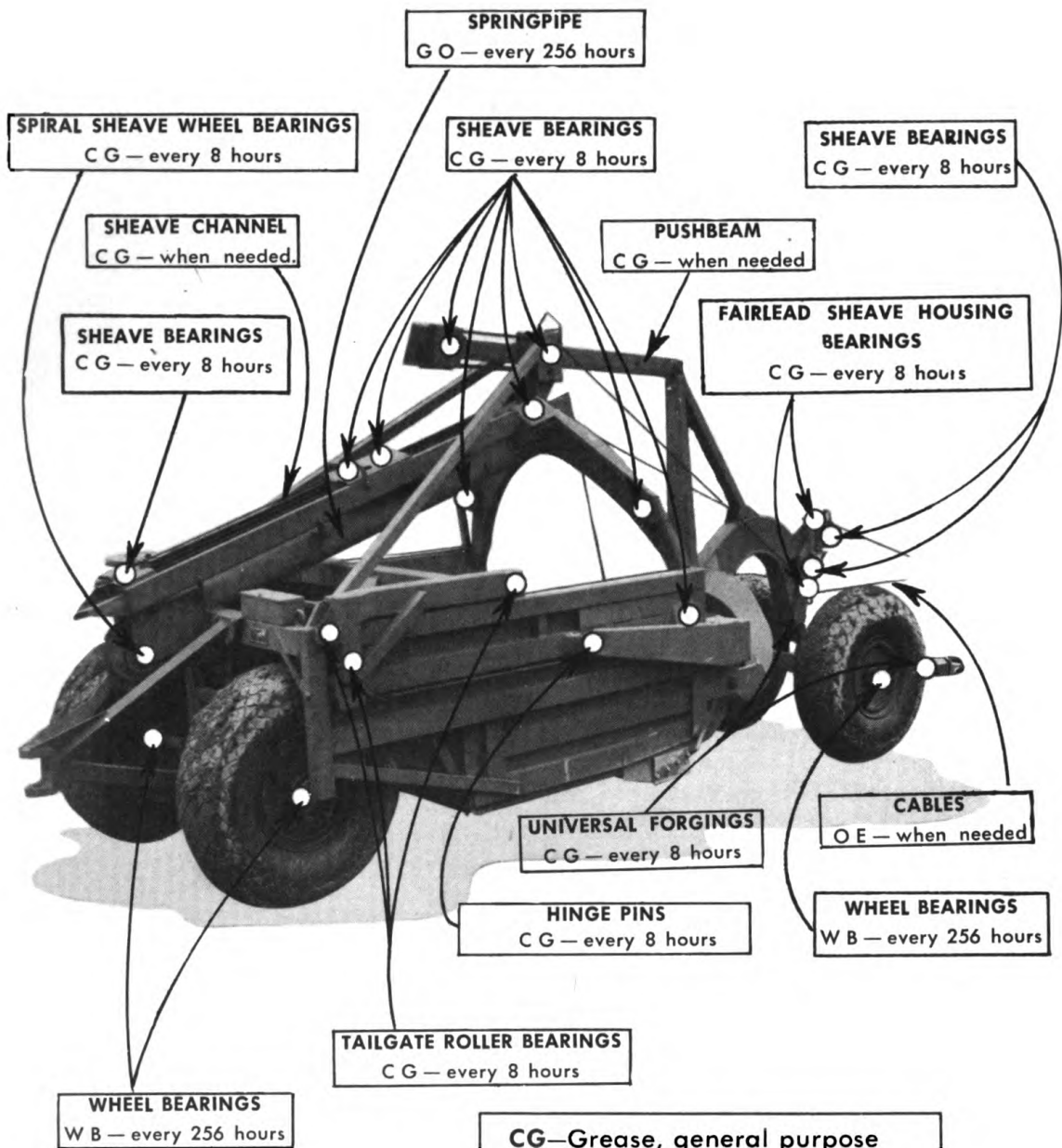

**CG—Grease, general purpose**

No. 1 (+90° F. to +32° F.)

No. 0 (+32° F. to 0° F.)

**WB—Grease, general purpose**

No. 2 (+90° F. to 0° F.)

**GO—Lubricant, gear universal**

SAE 90 (+90° F. to +32° F.)

SAE 80 (+32° F. to 0° F.)

**OE—Oil, engine**

SAE 30 (+90° F. to +32° F.)

SAE 10 (+32° F. to 0° F.)

**NOTE:** For recommendations in temperatures above +90° F. refer to Engineer Field Service Bulletin L-1000-E. In temperatures below 0° F. refer to Engineer Field Service Bulletin L-1000-D.

## LUBRICATION

### Sheave Bearings

The roller bearings in the sheave wheels receive lubrication through the grease fittings in the ends of the sheave pins. Insert one or two shots of the recommended grease through the grease fittings every 8 hours of operation, using a conventional pressure grease gun. This will force out a small amount of grease at the sheave hub, removing any dirt or grit that may have worked in at this point.

Use CG-1 (grease, general purpose, No. 1) in temperatures from +90° F. to +32° F. and CG-0 (grease, general purpose, No. 0) in temperatures from +32° F. to 0° F. When operating in temperatures above +90° F., refer to Engineer Field Service Bulletin L-1000-E. In temperatures below 0° F., refer to Engineer Field Service Bulletin L-1000-D.

### Fairlead Sheave Housing Bearings

The tapered roller bearings at the top and bottom of the fairlead sheaves on which the sheave housings pivot receive lubrication through the grease fittings located at the upper and lower ends of the housings.

Lubricate every 8 hours of operation, using the same grease and the same procedure as is recommended for sheave bearings.

### Tailgate Roller Bearings

The bearings in the tailgate rollers receive lubrication through the grease fittings in the ends of the roller pins.

Lubricate every 8 hours of operation, using the same grease and the same procedure as is recommended for sheave bearings.

### Spiral Sheave Wheel Bearings

The bearings in the spiral sheave wheel at the rear of the Scraper receive lubrication through the grease fitting on the side of the spiral wheel.

Lubricate every 8 hours of operation, using the same procedure as is recommended for sheave bearings.

### Wheel Bearings

The wheel bearings receive lubrication through the grease fittings located on the wheel hub caps. Lubricate the wheel bearings every 256 hours of operation, using a conventional type pressure grease gun. Pump grease through the grease fittings until lubricant is forced out around the wheel hub oil seals. (The oil seals should be installed with the leathers cupped outward.)

Use WB-2 (grease, general purpose, No. 2) in temperatures from +90° F. to 0° F. When operating in temperatures above +90° F., refer to Engineer Field Service Bulletin L-1000-E. When operating in temperatures below 0° F., refer to Engineer Field Service Bulletin L-1000-D.

## Universal Forgings

The universal forgings at the front and rear of the tongue and in the bottom of the yoke receive lubrication through the grease fittings in the side of the tongue and yoke.

Lubricate every 8 hours of operation, using a conventional type pressure grease gun. Pump one or two shots of grease through the fittings, forcing out a small amount of grease at the bushings in which the forgings pivot, removing any dirt or grit that may have worked in at this point.

Use the same grease as is used in the sheave bearings.

## Hinge Pins

Hinge pins requiring lubrication are lubricated through the grease fittings in the ends of the pins.

Lubricate every 8 hours of operation, using the same grease and the same procedure as is recommended for sheave bearings.

## Springpipe Lubrication

Lubricate the inside of the springpipe every 256 hours of operation.

To lubricate the spring pipe, remove the cover plate from the upper end of the pipe and pour in approximately one quart of GO-80 or GO-90 so that it will work down the lower side of the pipe where the springs are moving back and forth.

## Pushbeam and Sheave Channel Lubrication

Apply CG-0 or CG-1 grease whenever needed to the sides of the pushbeam and also to the sheave channel above the spring pipe in which the apron and tailgate sheaves slide. There should be some grease on the sides of the pushbeam and on the sheave channel at all times.

## Cable Lubrication

Coat the cable (wire rope) sparingly with OE-10 or OE-30 at infrequent intervals to serve as a rust preventative. If the Power Control Unit that is used to operate the Scraper is equipped with woven clutch and brake facings, do not coat that portion of the cable which wraps onto the cable drums, because of the danger of oil getting on the facings and causing clutch and brake slippage.

The cable should not be lubricated in extreme dusty conditions,

the cable should be capped



## CABLE

LeTourneau Carryall Scrapers are designed for use with Tournarope or other high quality wire rope meeting the following specifications: *6 x 19 wire rope of Warrington construction with strand center, preformed Langlay, and made from improved plow steel. It should be internally lubricated during the manufacturing process.* (Different cable of equal construction can be used without harmful results.)

For sizes of cable (diameter and length) refer to the Parts Catalog. Do not use larger diameter cable than that specified in the Parts Catalog or damage to the equipment may result. If smaller cable than specified is used, frequent cable breakage may occur.

### CARE OF CABLE

Proper care and treatment of cable is very important and will pay big dividends in the way of longer cable life. Listed below are a few helpful suggestions along this line.

- (1) Use the recommended sizes of cable, as the design of the sheave wheels vary somewhat for cables having different diameters.
- (2) Check cables every 8 hours of operation for excessive wear, kinks, etc., which might result in cable breakage or failure.

The dump cable normally wears faster than the other cables. To obtain maximum life from this cable, it is necessary to occasionally cut off the end of the cable that wraps onto the cable drum and to feed through enough cable from the spare cable reel to replace that which was cut off. If in checking the cable at the above interval, it is found that the part that wraps onto the cable drum has become frayed with possibly one or more of the six main strands broken, it is then necessary to cut off the bad portion back to the point where the cable is not damaged.

Due to difference in operators, job conditions, etc., the time intervals at which this cable must be cut off varies considerably.

- (3) When installing new cables on the Power Control Unit cable drums, make sure the cables reeve evenly onto the drum. Do not permit the cable to criss-cross or stack up on the drum.
- (4) Replace sheave wheels having badly worn cable grooves, especially those having a rope lay impression worn into them.
- (5) Always make sure that the sheave wheels and tailgate rollers are turning and that none are broken, because if either of these are not functioning properly, the cable will wear extremely fast.
- (6) Do not cause cable to become kinked by allowing an excessive amount of slack in the cables.
- (7) Unless operating in dusty conditions, lubricating the cable will normally add to cable life. Apply O.E. (S.A.E. #10 or #30) oil on the cable with a paint brush when needed.

## CABLE THREADING

The following cable threading instructions, together with the accompanying cable threading diagram, give complete information needed for threading the cables through the Scraper.

### HOIST CABLE

(Cable extending from Power Control Unit right cable drum to hoist sheaves on pushbeam.)

- From right drum of Power Control Unit, cable enters the top of fairlead sheave housing ..... B
- Then down and around the sheave in housing..... C
- Cable then extends up and enters the outside sheave on top of A-frame in housing ..... I
- Cable then goes back and enters the outside sheave in pushbeam housing..... K
- Then forward to the center sheave in housing..... I
- Then back to the inside sheave in housing..... K
- Then forward to the inside sheave in housing..... I
- Then back and around sheave in housing..... L
- Then forward and enter inside sheave in housing..... H
- Then back to the inside sheave in pushbeam housing..... J
- Then forward to the outside sheave in housing..... H
- Then back to the outside sheave in housing..... J
- Then forward and anchor cable at cable wedge on the side of housing..... H

### APRON LIFT CABLE

(Cable extending from apron sliding sheave above springpipe to apron)

- The apron lift cable is first anchored in sliding sheave housing F (located in channel above springpipe at cable wedge..... V
- Then cable goes up and over sheave in housing..... G
- Then down and anchor cable at apron cable wedge..... D
- IMPORTANT:**—Raise apron to make sure that sheave housing F strikes stop block at front of sheave housing P before apron strikes against top of arched A-frame. If apron strikes A-frame, let out on cable at Wedge V or D enough to prevent apron from striking A-frame when in extreme raised position.

### DUMP CABLE

(Cable extending from Power Control Unit left cable drum to sliding sheave housings above springpipe.)

- From cable spool at rear of Scraper, unspool approximately 130 feet of cable, leaving extra cable wrapped on reel.
- Take end of cable and extend from left to right around top sheave in sliding sheave housing..... T (located above springpipe)
- Then back and around top sheave in housing..... P
- Then forward and around center sheave in housing..... T
- Then back and around the second sheave from the top in housing..... P
- Then forward and around the bottom sheave in housing..... T
- Then back through housing P and around the sheave in housing..... Q
- Then forward and around the top sheave in housing..... F
- Then back and around the second sheave from the bottom in housing..... P
- Then forward and around the bottom sheave in housing..... F
- Then back and around the bottom sheave in housing..... P
- Then forward and over sheave E at top of A-frame.
- Then down and enter the top sheave on left side of yoke and down and around fairlead sheave..... A
- Then forward and through the Power Control Unit double-deck sheaves and onto the Power Control Unit left cable drum. Place two wraps of cable on drum.
- With tailgate in rear position and apron lowered, take slack out of cable and anchor cable at cable wedge S on rear sheave housing..... P
- Spool excess cable onto cable spool and tighten the wing bolt to keep cable spool from turning.

OPERATION SECTION

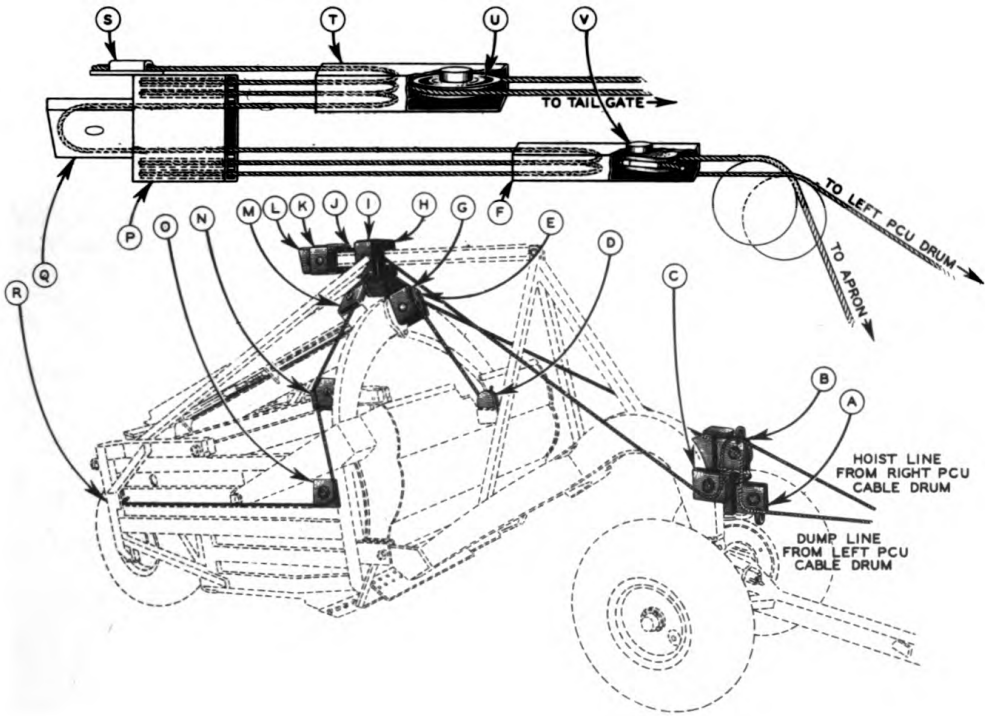

LEFT & RIGHT DETERMINED BY STANDING IN REAR & LOOKING FORWARD

**TAILGATE FORWARD CABLE**

(Cable extending from tailgate sliding sheave above springpipe to either side of tailgate.)

- Tailgate forward cable is anchored to cable wedge..... R
- Then forward and around sheave in housing..... O
- Then up and around lower A-frame sheave..... N
- Then up and enter at top of A-frame sheave..... M
- Then back to sheave housing T (located above springpipe) and around equalizer sheave ..... U

The cable is then carried down around the sheaves on the opposite side of Scraper in the manner just described and then anchored to the left side of the tailgate at a cable wedge corresponding with wedge..... R

**IMPORTANT:**—Pull tailgate ahead to make sure that the tailgate moves to the front of the Scraper and also that sheave housing T strikes against stop block on front of sheave housing P before tailgate roller arms strike against structural members at front of Scraper side sheets near A-frame. If tailgate roller arms strike structural members at front of side sheets, let out on cable at cable wedge—R, enough to prevent tailgate from striking when pulled into extreme forward position. If tailgate does not move to front of Scraper bowl, take up cable at wedge..... R

REPLACING SPRINGPIPE CABLE

If the springpipe cable breaks, it can be replaced by the following procedure:

First pull through several feet of slack on the dump cable above springpipe and pull the tailgate sliding sheave to the top of sliding sheave channel by hand. Then pry tailgate to its extreme rear position, using a bar.

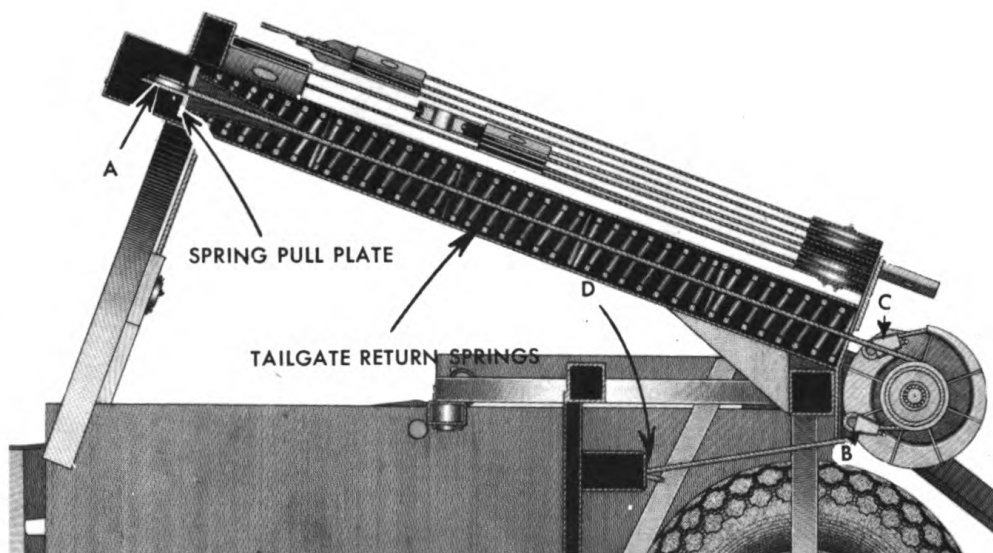

Remove the two 1 1/4" pipe plugs located on the sides of the springpipe near the upper end. Insert a pry bar through one of pipe plug holes and part way through springpipe to hold tailgate return springs in a slightly compressed condition, keeping them from coming out end of springpipe when performing the following step.

Disconnect apron lift cable from apron and place one end of a 4"x4"x72" block against apron lift sheave at front of springpipe and other end against the A-frame at top of yoke where pushbeam hinges, and then lower the bowl. By doing this, the spring pressure is relieved from the capscrews which hold the sheave housing plate to the springpipe, and the capscrews can then be removed without them binding, and without danger to the workman.

After the capscrews have been removed, raise the Scraper bowl, relieving spring pressure from the 72" block and also from the sheave housing plate, permitting both the block and plate to be removed. Now remove the old springpipe cable and insert new cable through spring pull plate and down through springpipe, rotating cable to prevent it from catching on springs. Fasten upper end of cable to spring pull plate with cable wedge (A). Then go to rear of Scraper and extend remaining end of new cable out through hole at bottom of springpipe.

Then, with the Scraper bowl in the raised position, place the 72" block against the spring pull plate and yoke A Frame where the pushbeam hinges, and gradually lower Scraper bowl, at the same time removing the bar from pipe plug hole in the side of springpipe, thereby compressing springs until the distance between

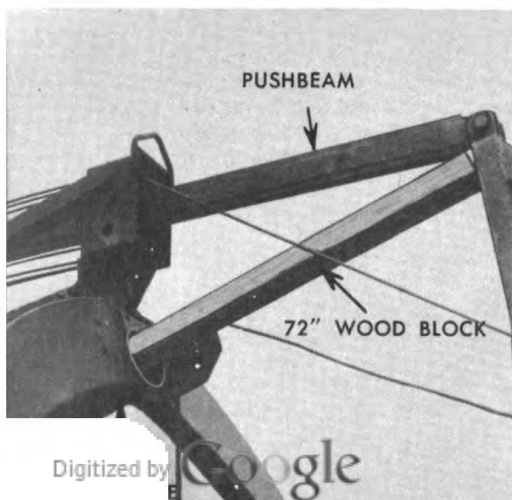



cable wedge (A) and the end of springpipe is approximately 23". With the tailgate in the extreme rear position, take all the slack out of spiral sheave-to-tailgate cable and wrap the springpipe cable ½ wrap on the drum on the left side of the spiral sheave and dead-end it at cable wedge (B), with all the slack taken out of the cable by hand.

Raise the Scraper bowl, releasing the spring pressure from the 72" block and transferring it onto the cable. Remove the 72" block. With the apron lowered and the tailgate in the rear position, there should be a distance of approximately 14" to 16" between cable wedge (A) and end of springpipe. Re-install the sheave housing plate, apron lift cable and pipe plugs to complete the cable replacement.



If after a long period of operation, the spring tension should decrease enough to permit the tailgate to move forward before the apron raises or if the spring tension should not be great enough to return the tailgate all the way to the rear, the above mentioned 14" to 16" distance between cable wedge (A) and the end of the springpipe should be increased to give additional spring tension.

To do this, compress the tailgate return springs by use of the 72" block as outlined above, leaving a slightly greater distance than the above 23 inches between cable wedge (A) and the end of the springpipe. Then pry the tailgate to the rear, as outlined above, and increase the spring tension by taking up enough slack springpipe cable at wedge (B) to give the desired spring tension, and retighten the wedge.

**NOTE:** Never attempt to increase the spring tension by taking up on the spiral sheave-to-tailgate cable as this would change the timing of the spiral sheave.

#### REPLACING SPIRAL SHEAVE-TO-TAILGATE CABLE

If the spiral sheave-to-tailgate cable breaks, it can be replaced by the following procedure.

Remove the old cable from the spiral sheave and tailgate. Then rotate spiral sheave wheel by hand, taking all slack out of springpipe cable. Anchor the new cable at spiral sheave with wedge (C). Place one wrap of cable around the spiral sheave wheel. Then, with all the slack taken out of cable, anchor the remaining end to the tailgate with wedge (D).

Remove the two 1¼" pipe plugs located on either side of springpipe near the upper end. Then pull tailgate forward with Power Control Unit enough to allow a bar to be inserted ahead of the spring pull plate, through the two pipe plug holes in the spring pipe.

Then with the bar in place, release Power Control Unit dump brake slowly until spring pull plate presses against bar. The bar will now hold the springs in a compressed condition. Then pry the tailgate to its extreme rear position.

Remove cable wedge (D) from the tailgate and take all slack out of spiral sheave-to-tailgate cable, leaving 2" distance between the end of the groove and cable as illustrated. (This 2" dimension will decrease to approximately 1½" after completing following step when cable is under tension.) Re-install cable wedge (D) and pull tailgate forward with Power Control Unit. Then remove pry bar from springpipe. Check for 1½" dimension between cable and groove on spiral sheave, and if correct, replace pipe plugs.

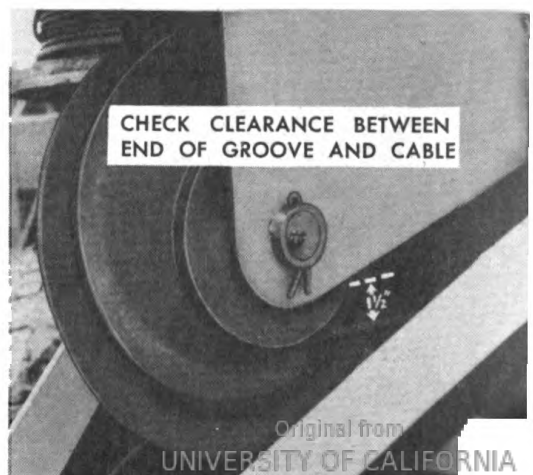

## BLADES

The Scraper is equipped with a 3 piece offset blade as standard. Each of the three sections of blade is self sharpening and is reversible.

The off-set center section makes possible easier loading. The self sharpening feature is brought about by the hard-facing metal welded along the edges of the blades. With the blades correctly installed, the hard-facing metal along the front edge of the blade is on the top side, as illustrated. Because the softer heel of the blade wears away more rapidly than the hard-faced top side, the blade will grow sharper with use.

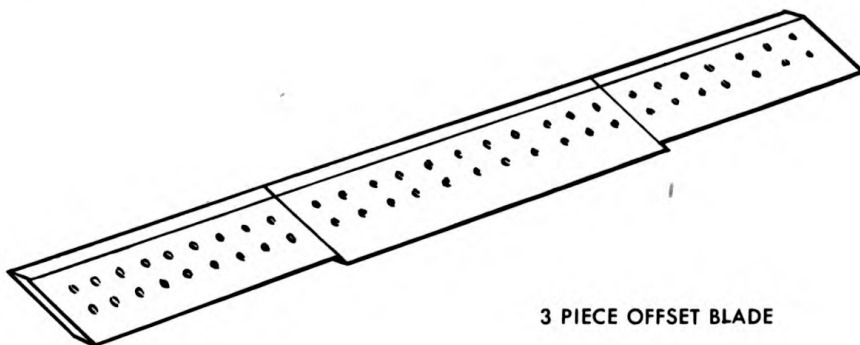

3 PIECE OFFSET BLADE

By being hard-faced along both edges, the blades are reversible. Therefore, when a blade has become worn along one edge, it can be reversed rather than replaced, and the blades will therefore last approximately twice as long as blades that are non-reversible.

In addition to the 3 piece off-set blade, a one piece straight blade is also available for use on jobs where fine finishing is to be done with the Scraper. This blade also is self-sharpening and reversible. Although finishing can be done with the three piece off-set blade, it can normally be done more efficiently with this straight blade.

## CHANGING BLADES

The Scraper blades should be changed before they wear back into the blade base. When worn back to the point where they should be changed, the procedure below should be followed.

Hoist the Scraper bowl to its full height and place blocks under the bowl to prevent it from dropping in case some one should acci-



dentally release the power control unit hoist brake. The apron should likewise be raised to its full height and blocks placed between the apron arms and side sheets to keep it from dropping in case the brake on the dump cable is accidentally released. Then, using the blade wrench, remove the bolts that secure the blades to the blade base. If the blades have not already been reversed, they can be used again by turning them over and wearing them along the other edge. If reversing the end blades, it is necessary not only to turn them over but also to move them from one side of the Scraper to the other.

After laying the blades in place, the use of a round drift punch will be very helpful in lining up the holes. Re-install the blade bolts, tightening them down evenly and making sure they are all tight.

When installing new blades instead of reversing worn ones, the same procedure as outlined above should be used.

When installing blades, make sure that they are turned with the beveled edges positioned as illustrated.

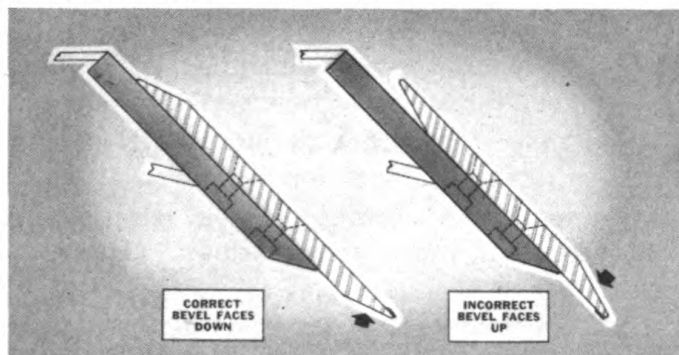

### CHANGING GROUND PLATES

The Scraper ground plates should be changed before they wear back into the base to which they are bolted. When they have worn to the point where it is necessary to change them, the procedure outlined below should be followed.

First, block the apron arms and bowl in the raised position as when changing blades.

Remove bolts which secure ground plates to Scraper side sheets. If the ground plates have not already been reversed, they can be used again by turning them over and wearing them along the other edge.

If reversing a ground plate, turn it over and end for end. After reversing, insert the bolts and draw them up tight.

Use the same procedure when installing new ground plates.

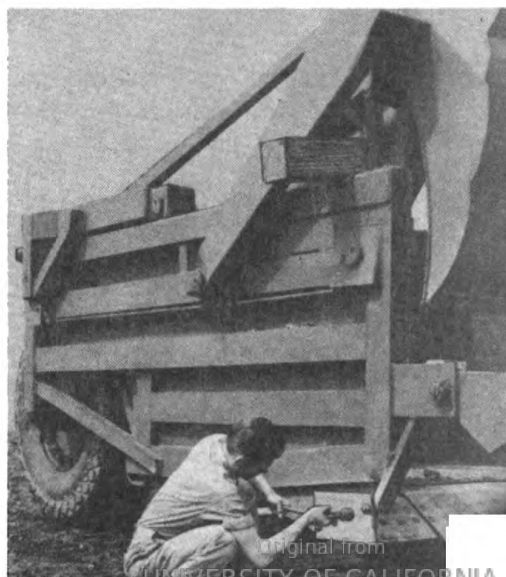

## OPERATION UNDER DUSTY, MUDDY, LOW TEMPERATURE AND OTHER ABNORMAL CONDITIONS

When operating in extreme dusty conditions, it is very important that the Scraper be thoroughly lubricated at the specified intervals. (Refer to lubrication instructions.) Unless this is done, fine particles of dirt and grit will work into the bearings and working parts of the Scraper. By lubricating regularly, the dust and dirt that accumulates around the bearings is forced out and away from the bearings by the new grease.

Watering or oiling haul roads is often resorted to in order to keep the dust down.

When working in muddy conditions, it is important that the mud be kept out of the sheaves. In some muddy conditions, it may be necessary to stop the Scraper once or twice a shift and clean the mud out of the Scraper bowl, as the mud will gather on the bottom and sides of the bowl, making it hard for the tailgate to come fully ahead, and in some cases breaking the cable.

For instructions for loading and unloading in wet, sticky material, refer to page 10 of the operation section.

When operating in cold weather, the use of a Rooter may be necessary in order to break up the frozen top soil ahead of the Scraper.

Use lighter greases when operating in cold temperatures than those used when operating in warm temperatures. (Refer to lubrication instructions.)

Be sure there is no dirt left in the bowl at the end of the shift in cold weather, as it will be frozen tight by morning, and it would then be necessary to thaw it out before the load could be ejected. When shutting down for the night, lower the bowl onto planks rather than onto the ground to prevent the Scraper bottom from freezing tight to the ground.

### PREPARATION FOR STORAGE

When the Scraper is shut down for a long period or put in storage for an indefinite length of time, it is recommended that the procedure below be followed.

Inspect all working parts and if necessary, repair or replace any that are in bad condition.

Clean the Scraper free of all dirt. Paint the Scraper if needed.

Lubricate all points of lubrication.

Coat the cable with OE (SAE 10 or 30).

Lower the blade onto planks or blocks and raise each wheel, placing blocks under axles.

Deflate some of the air from the tires.

For further instructions, refer to Tentative Technical Manual, TM5-9715, published by Engineer Field Maintenance Office, P. O. Box 1679, Columbus, Ohio.



## PACKING FOR EXPORT SHIPMENT

To pack the Scraper for export shipment first remove the wheels and axles, yoke, front axle structure, pushbeam, and rear hitch from the scraper main body structure. (Refer to disassembling instructions on Page 8 of the Repair Section). Then proceed as follows:

1. Attach hoist to scraper yoke with  $\frac{1}{3}$  of sling chain anchored on one side of pushbeam A-frame and  $\frac{2}{3}$  of sling chain anchored to end of yoke arm as illustrated. Raise the yoke until it tips and then lower it to the floor. This procedure will ease the yoke over on its side without danger of yoke swinging.

2. Disconnect sling chain and then reattach chain to yoke as illustrated. This will give yoke necessary balance to get it under Scraper A-frame. Then hoist the yoke into the scraper body.

3. After pushbeam A-frame is on the inside of apron, lower the yoke and attach three sling chains, one to the end of each of the yoke arms and the other to universal forging at front of yoke. Then raise the yoke and set pushbeam A-frame on  $\frac{3}{4}$ " board at Point (A). Pushbeam A-frame should be centered at the middle of the bowl, along the top edge of the scraper blade. Place a 2" block on apron arm at point (B) and lower yoke, at the same time crowding it tight against the A-frame, and securely wire it in place.

4. Remove the axles from both rear wheels and lower the wheels into Scraper bowl and position them parallel with and tight against the side of the bowl. Then lower the front wheels into bowl and position them tight against the rear wheels as illustrated. Securely wire each wheel in place, placing several thicknesses of burlap between the wires and tires to keep from cutting the rubber.

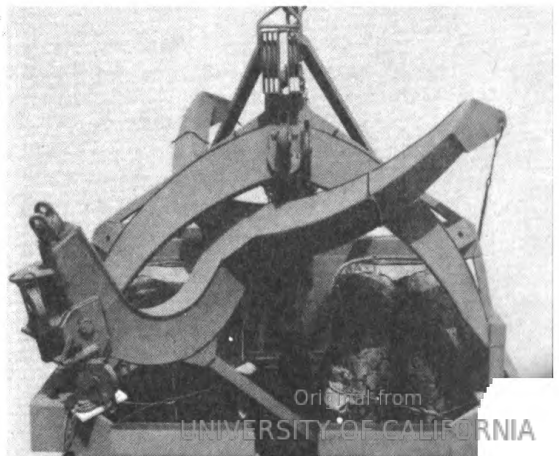
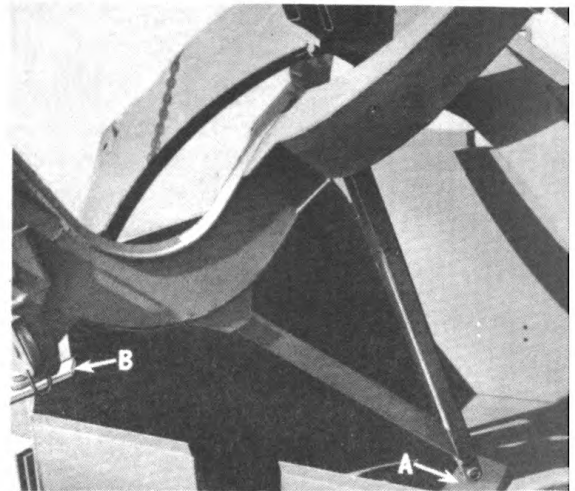
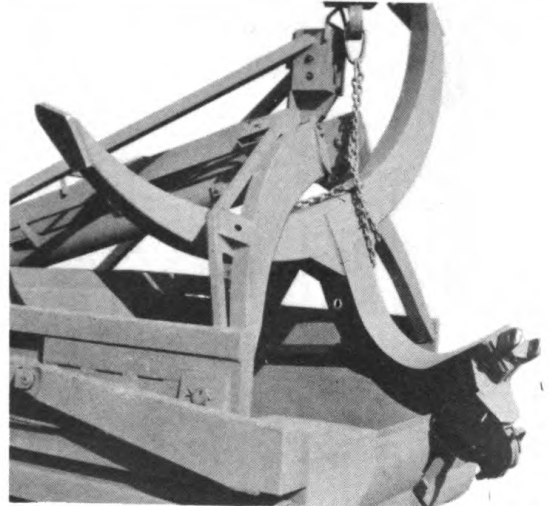
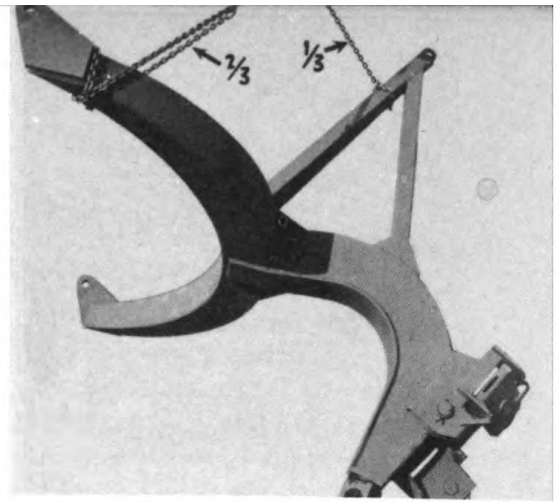



## OPERATION

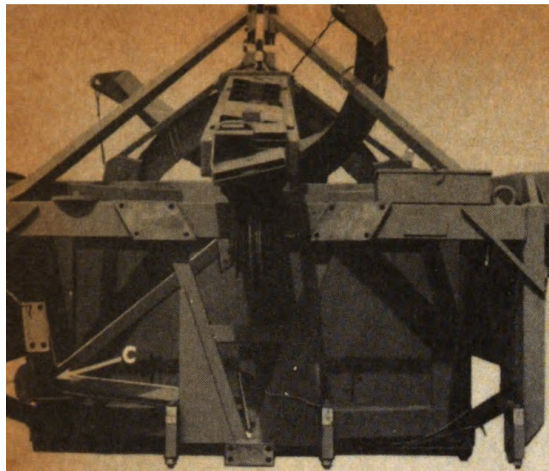

5. Position rear hitch structure (c) between axle support braces and tailgate as illustrated, and wire it to tailgate and axle support braces.

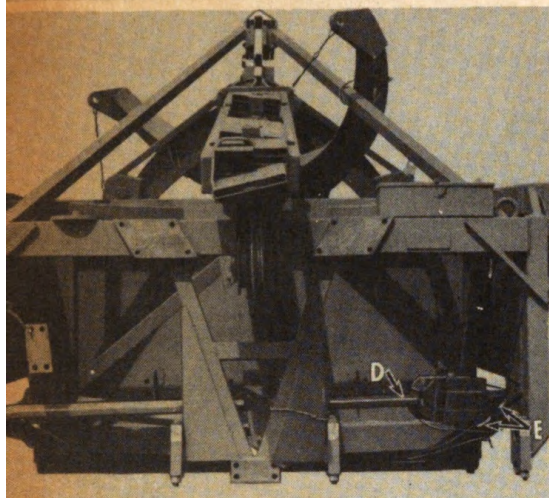

6. Position pushbeam (D) across rear of scraper body with sheave housing head resting on blocks (E) as illustrated and other end wired securely to axle support block.

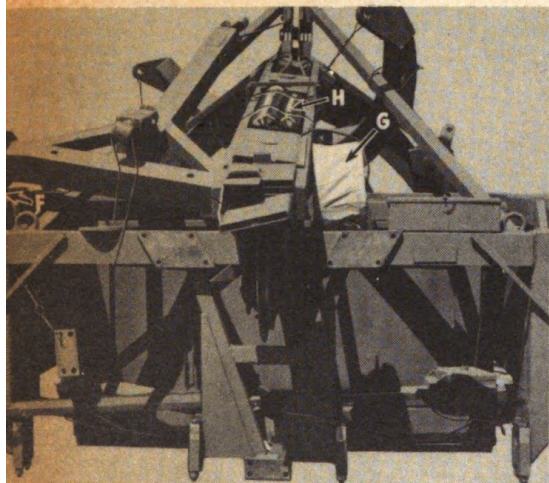

7. Raise front axle structure with a hoist, placing it on top of tailgate as illustrated, with a  $\frac{3}{4}$ " thick board (F) under axle beam. With tongue placed on top of angling brace as illustrated, securely wire it in place. Place cable spool (G) between tailgate and rear body structure and wire it securely to sliding sheave channel. Then wrap rear axles in waterproof paper and also in burlap and place them in the sliding sheave channel as shown at (H) and wire them in place.

If in shipment, the Scrapers are to be stacked one on top of another, a strong wood or steel frame should be constructed on top of the scraper bowl in order to protect the springpipe, sliding sheave channel, etc., and in order to serve as a platform on which to stack other Scrapers. The bowl of the Scraper serves as the bottom of the package.

To assemble the Scraper after it reaches its point of destination, unpack the various parts and assemble as outlined in the Assembling instructions on page 15 of the Repair Section.



# REPAIR SECTION

SECT. 2







## REPAIR AND MAINTENANCE

The instructions on the pages which follow give complete information needed for correctly servicing and repairing the Carryall Scraper. It has been prepared to be of assistance to Maintenance and Repair men in keeping the Scraper running and in good condition.

### CARE OF SCRAPER

Time spent on inspection and care of the Scraper will be many times repaid in long life and trouble-free operation.

The Scraper should be serviced as specified below at the intervals shown:

#### ONCE EVERY 8 HOURS

- Lubricate sheave bearings.
- Lubricate fairlead sheave pivot bearings.
- Lubricate spiral sheave wheel bearings.
- Lubricate tailgate roller bearings.
- Lubricate hinge pins.
- Lubricate universal forgings.
- Check tire pressure.
- Check cables.

#### ONCE EVERY 64 HOURS

- Check wheel bearing adjustment.
- Check universal forging adjustment.

#### ONCE EVERY 128 HOURS

- Check fairlead sheave bearing adjustment.

#### ONCE EVERY 256 HOURS

- Lubricate wheel bearings.
- Lubricate springpipe.

#### WHEN NEEDED

- Lubricate cable.
- Lubricate Pushbeam and Sliding Sheave Channels.

### LUBRICATION

For lubrication instructions, refer to page 21 of the Operation Section.

### TIRE INFLATION

Refer to instructions on page 19 of the Operation Section.

### CHANGING BLADES

Refer to instructions on page 28 of the Operation Section.

### CHANGING GROUND PLATES

Refer to instructions on page 29 of the Operation Section.

### CABLE THREADING

Refer to instructions on page 24 of the Operation Section.

LOWER BOWL AND BACK UP  
TO RAISE FRONT WHEELS

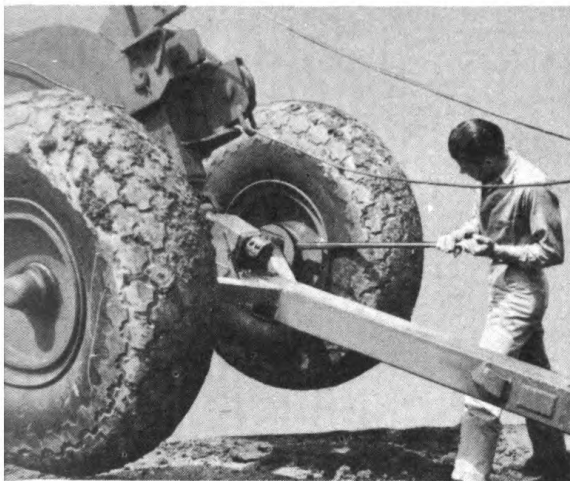
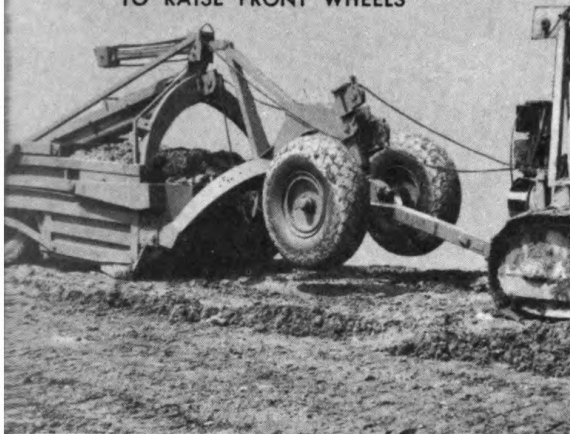

## WHEEL BEARING ADJUSTMENT

### Checking Adjustment

Check the wheel bearings for looseness every 64 hours of operation.

**FRONT WHEELS**—To check the front wheel bearings, first raise the wheels off the ground. To do this, load the Scraper bowl and lower the blade to the ground. Release the brake from the Power Control Unit hoist drum and then back up slowly, thereby raising the front wheels off the ground. When the wheels are raised to the desired height, lock the tractor brake to hold the wheels in this position.

Insert a pry bar between the wheel and axle housing. Pry back and forth with the bar, noticing any movement of the wheel on the axle. If there is perceptible movement, the bearings are loose and an adjustment should be made as outlined on the following page.

**REAR WHEELS**—To check the rear wheel bearings, first raise the wheels off the ground. To raise either wheel, raise the bowl and place a block under the bowl just back of the balance point. Then lower the Scraper bowl. This will tip the front of the Scraper forward, raising the rear wheel.

Insert a pry bar between the wheel and body structure. Pry back and forth with the bar, noticing any movement of the wheel on the axle. If there is perceptible movement, the bearings are loose and an adjustment should be made, as outlined on the following page.

## Making Adjustment

**FRONT WHEELS**—To adjust the front wheel bearings, first remove hub cap by removing capscrews.

Remove cotter pin from end of axle and loosen the adjusting nut clamp bolt.

Start the wheel rotating slowly. While rotating, turn adjusting nut in a clockwise direction until wheel binds heavily. Then relieve binding by backing off adjusting nut  $\frac{1}{8}$  turn minimum and not more than  $\frac{1}{4}$  turn. Lock adjustment by re-inserting cotter pin and tightening adjusting nut clamp bolt. Check adjustment by rotating wheel, making certain that it is free rolling without perceptible end play. If adjustment is correct, re-install hub cap.

**REAR WHEELS**—Each rear wheel is equipped with two adjusting nuts, one on each side of the wheel. However, only one of these adjusting nuts needs to be tightened in making the adjustment, and since the adjusting nut on the inner side of the wheel is easier to reach, it is normally used.

To make the adjustment, follow the same procedure as is used for front wheel bearings. The only difference is that no cotter pins are used in the adjusting nuts in the rear wheels.

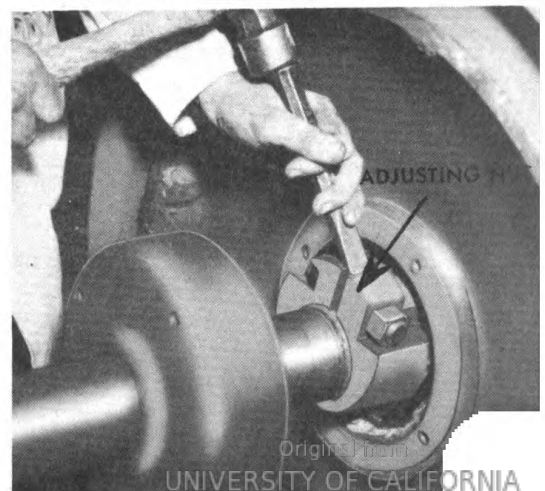
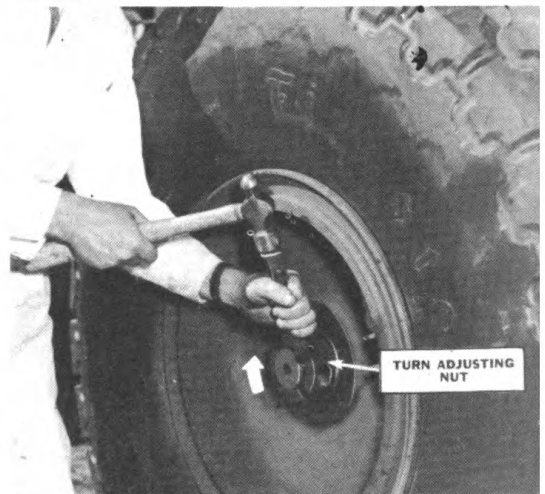
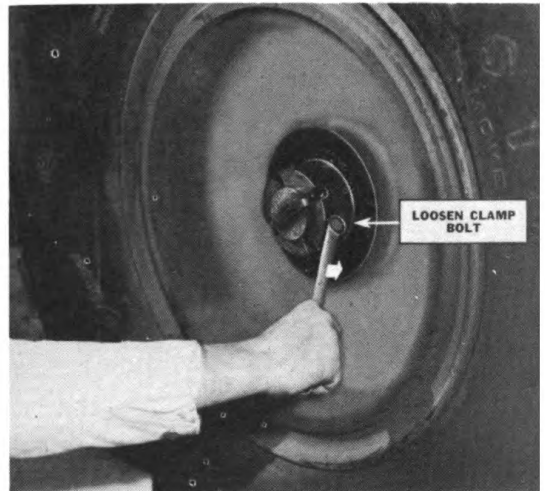

## UNIVERSAL FORGING ADJUSTMENT

Check the three universal forgings for end play every 64 hours of operation.

The procedures for checking and making the adjustment on each of the forgings are as follows:

**DRAWBAR UNIVERSAL FORGING**—If Scraper is disconnected from tractor, check end play by moving forging back and forth by hand. If Scraper is hitched to tractor, drive tractor forward and backward while watching forging for end movement. If end movement is found, an adjustment should be made.

To make adjustment, first remove inspection plate from side of tongue by removing capscrews. (Tongue disconnected from tractor and supported off the ground by a jack or block.)

Remove cotter pin from end of forging and loosen adjusting nut clamp bolts.

Insert a chisel in slot in adjusting nut to keep nut from turning. Then insert a bar through hitch block and turn forging in a clockwise direction until all end play has been eliminated with forging still left free to turn. Lock the adjustment by re-installing cotter pin and tightening adjusting nut clamp bolts. Then re-install inspection plate.



**AXLE UNIVERSAL FORGING**

—Check universal forging on top of front axle structure for end play by driving tractor forward and backward while watching forging for end movement in housing. If end movement is found, an adjustment should be made. To make adjustment, remove cotter pin and loosen adjusting nut clamp bolts. Then turn adjusting nut clockwise until all end play has been eliminated with forging still left free to turn. Lock adjustment by re-inserting cotter pin and tightening adjusting nut clamp bolts.

**YOKE UNIVERSAL FORGING**

—To check yoke universal forging for looseness, first lower Scraper blade to ground and then insert a pry bar between forging and bottom of yoke and pry up and down with pry bar. If noticeable end movement of forging is found, an adjustment should be made.

To make adjustment, first remove bolt connecting axle universal forging with yoke universal forging. In doing this, it is first necessary to wrap a hoist chain around top of yoke and raise yoke only enough to relieve bolt of weight. Then remove bolt and hoist yoke, enough to raise yoke forging free from axle forging, and then make the adjustment, eliminating all end play but leaving forging free to turn, using the same procedure as is used for adjusting drawbar universal forging described on opposite page.

After adjustment has been completed, lower the yoke and re-insert the bolt connecting the axle forging and yoke forging. **IMPORTANT**—In installing the bolt, make certain thick side of axle forging is on bottom and that beveled side of yoke forging faces the front. Otherwise the forgings may bind when traveling across ditches or at other times when axle structure and yoke are at extreme angles, possibly resulting in damage to forgings, tongue or yoke.

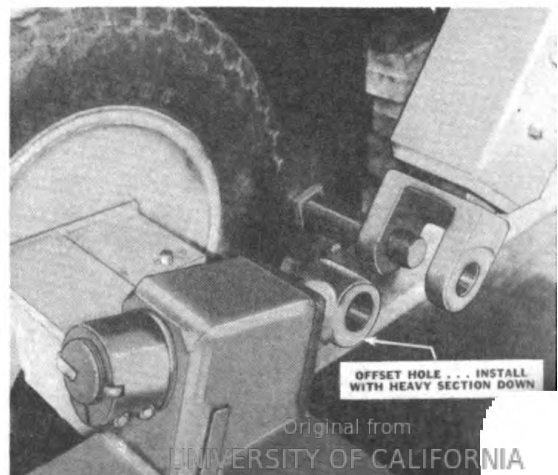
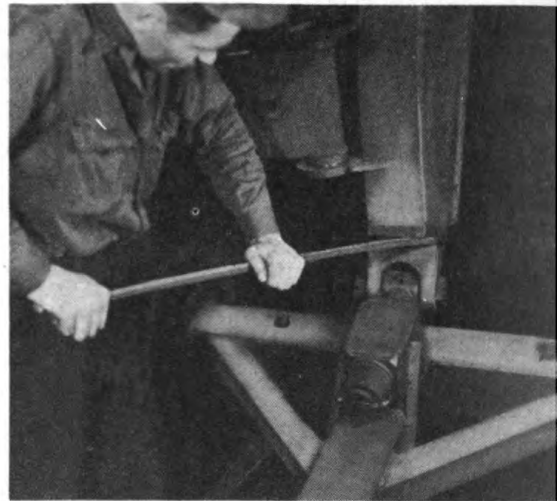
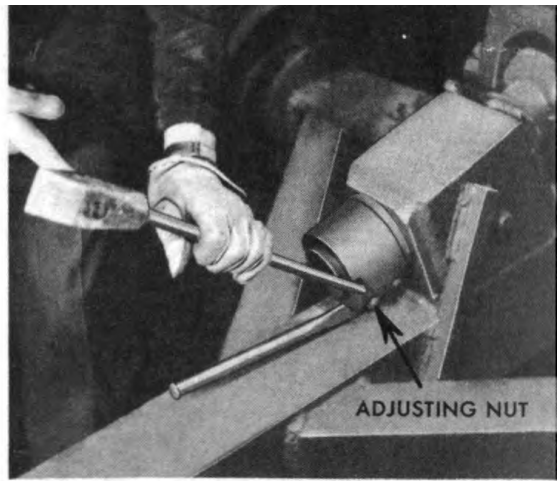



## FAIRLEAD SHEAVE HOUSING BEARING ADJUSTMENT

Check the fairlead sheave housing bearings for looseness every 128 hours of operation.

To check the adjustment, insert a pry bar between the bottom of the sheave housing and the bracket in which it is held. Then, by prying up and down with the bar, detect any end movement of the housing in the bracket. If end movement is noticeable, an adjustment should be made.

To make the adjustment, first loosen the clamp bolt from the sheave bracket.

Turn the adjusting nut at the upper end of the housing in a clockwise direction until all up and down movement of the sheave housing in the bracket is eliminated and until a slight drag is felt when turning the sheave housing to either side by hand. Lock the adjustment by tightening the clamp bolt.

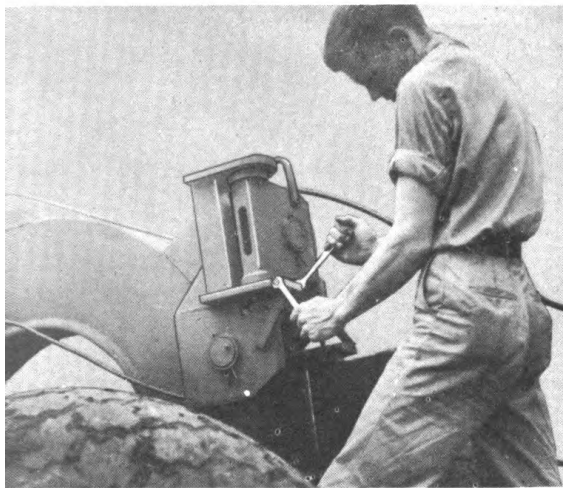
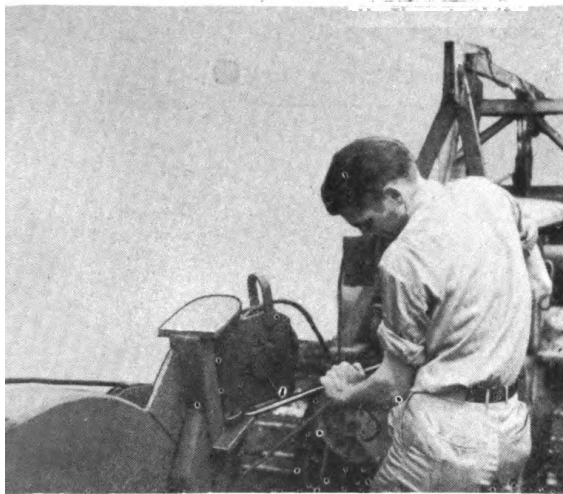
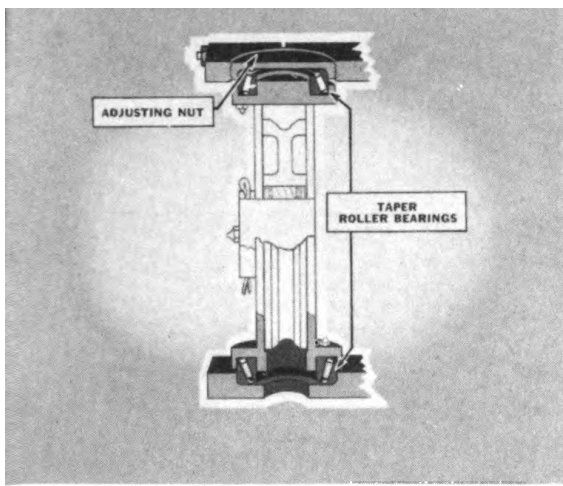

## REMOVING AND INSTALLING TIRES

To remove the rear tires, it is necessary that the wheels and axles first be removed from the Scraper. To remove the front tires, it is not absolutely necessary that the wheels first be removed. However, due to the large size and weight of the tires, it is usually advisable to also remove the front wheels before changing the tires. (For instructions covering the removal of either the front or rear wheels from the Scraper, refer to Disassembling Instructions on page 8 of the Repair Section.)

To remove a tire, first let all the air out of the tire. Insert a small pry bar in the slot in the locking ring. Then, while prying up on the locking ring, use a sledge hammer to drive the sliding ring toward the center of the rim. This will release the locking ring, and both the locking ring and sliding ring can then be removed from the wheel.

If available, place a round valve cap on the valve stem. Push the valve stem through the rim, into the tire. Then insert a bar between the tire and the retainer ring on the side of the tire opposite the locking ring, and pry the tire off the wheel.

Before re-installing a tire on the wheel inspect the wheel rim for rust. If rust is present, remove the rust with a wire brush and if time permits, paint the rim and allow it to dry.

To install a tire, reverse the procedure described above for removing a tire. Be careful not to pinch the inner tube with the bar. Insert only enough air in the inner tube to hold it in place. Be sure the valve stem is in the center of the hole in the rim before installing the sliding ring and locking ring. Then install the sliding ring and locking ring and inflate the tires to the correct pressures. (Refer to tire inflator instructions on page 19 of the Operation Section.)



TO RAISE FRONT WHEELS  
LOWER BOWL AND BACK UP



## REPAIR

### DISASSEMBLING

#### Removing and Disassembling Wheels

**FRONT WHEELS** — To remove the front wheels, first raise the wheels off the ground. To do this, first load the Scraper bowl and lower the blade to the ground. Release the brake from the power control unit hoist drum and then back up slowly, thereby raising the front wheels off the ground. When the wheels are raised to the desired height, lock the tractor brake to hold the wheels in this position. Also place blocks under the axle structure.

The wheels can be removed and disassembled either with or without the axles removed from the front axle structure. First remove hub cap by removing capscrews.

Remove cotter pin from end of axle and loosen adjusting nut clamp bolt. Then remove bearing adjusting nut by backing it off over threads on end of axle.

Remove oil seal retainer plate from opposite side of wheel by removing capscrews.



Remove wheel from axle. To do this, first remove outer bearing cone. It may be necessary to jar outer bearing loose from axle by striking against back side of wheel (if axle is not removed from front axle structure) or against outer end of axle (if axle is removed from front axle structure). The inner bearing cone can then be pulled off the axle. If the bearings are to be replaced, remove bearing cups from wheel hub.

**REAR WHEELS**—To remove the rear wheels, first raise the wheels off the ground. To do this, raise the blade and place a block under the bowl just back of the balance point. Then lower the Scraper bowl. This will tip the front of the Scraper forward, raising the rear wheel.

Remove the wheel and axle assembly from the Scraper by removing the clamp blocks from the ends of the axle.

To disassemble the axle from the wheel, first remove the hub caps from both sides of the wheel. Remove the clamp bolt from the outer adjusting nut. Then drive against the axle from the outer end, forcing the outer bearing cone off the axle. Remove the axle from the wheel hub. The remaining bearing cone and adjusting nut can be removed from the axle and the bearing cups removed from the wheel hub, if desired.

## SCRAPER WHEEL ASSEMBLY

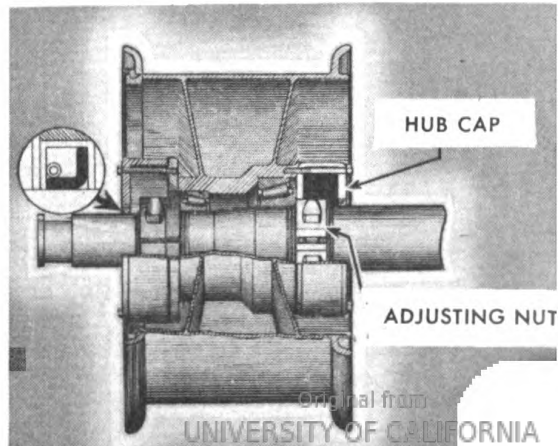
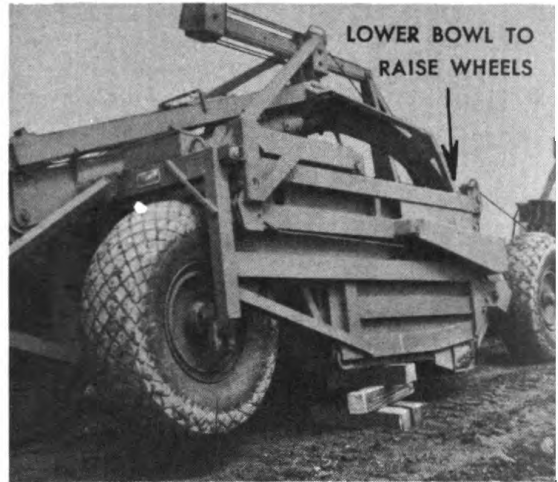
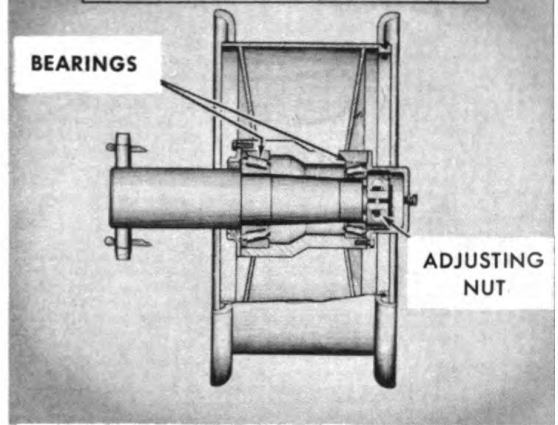

### Removing Universal Forgings

**DRAWBAR UNIVERSAL FORGING**—To remove the universal forging at the front of the tongue, first remove inspection plate from side of tongue. Then remove cotter pin from the end of the forging and loosen adjusting nut clamp bolt.

Insert a chisel in slot in adjusting nut to keep the nut from turning. Insert a bar through hitch block and turn forging counter-clockwise until forging is turned out of the adjusting nut. Then pull forging out of end of tongue. Remove adjusting nut from inspection hole.

### AXLE UNIVERSAL FORGING

To remove the universal forging from the housing at the rear of the tongue, first remove cotter pin from end of forging, release adjusting nut clamp bolts, and turn adjusting nut off end of forging. Then remove bolt which connects tongue forging with yoke forging. In doing this, it is necessary to connect a hoist chain around top of yoke and raise yoke only enough to relieve the bolt of weight. After removing bolt, pull universal forging out of housing.

**YOKE UNIVERSAL FORGING**—To remove the yoke forging, first remove the bolt connecting the yoke forging with the axle forging as outlined above. Raise the front of the yoke high enough to free the yoke forging from the axle forging. Then remove the inspection plate from the side of the yoke, loosen the adjusting nut capscrews and remove the cotter pin, and then remove the forging in the same manner as outlined above for removing the drawbar universal forging.

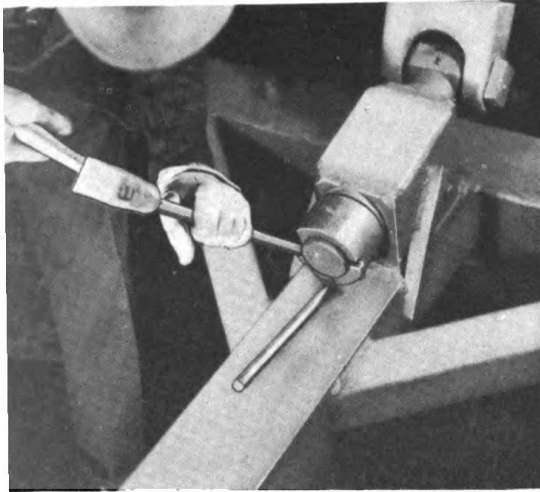
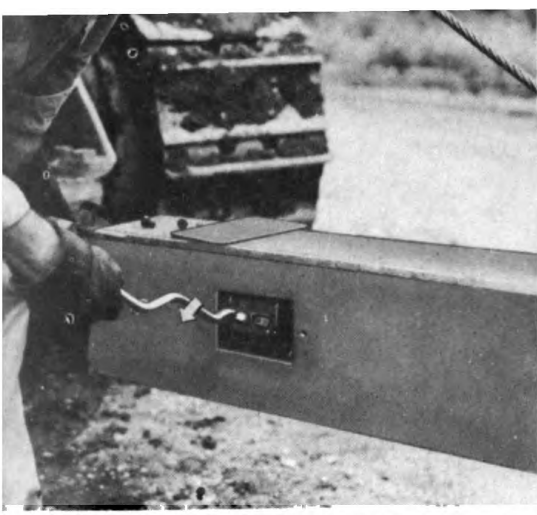



### Removing Sheave Wheels, Bearings, Pins, Etc.

To remove the sheave wheels, bearings, pins, etc., first remove cotter pin from end of the sheave pin, pull sheave pin out the side of the sheave housing and then remove sheave wheel from sheave housing.

Then remove dust seals from hub of sheave wheel and slide sheave bearing out of hub.

### Removing Tailgate Rollers, Bearings, Pins, Etc.

To remove the tailgate rollers, bearings, pins, etc., first remove cotter pin or lock pin from end of roller pin. Pull roller pin out the side of the roller housing and remove roller, raising tailgate arm if necessary.

Then remove dust seals from hub of roller and slide bearing out of hub.

Before removing the large rollers at the rear of the tailgate, it is first necessary to pull the tailgate ahead to the point where the rollers line up with the round holes in the sides of the Scraper bowl provided for the purpose of removing these rollers.

### Removing Fairlead Sheave Housings and Bearings

To remove either of the fairlead sheave housings, first release the clamp bolt and remove the adjusting nut from the bracket in which the sheave housing pivots. Then remove the housing from the bracket by raising (or lowering) and tilting it in the bracket. The bearing cones can then be removed from the sheave housing and the bearing cups removed from the bracket and adjusting nut.

### Removing Rear Hitch

To remove the rear hitch, simply remove the bolts which secure the hitch to the rear of the main body structure.

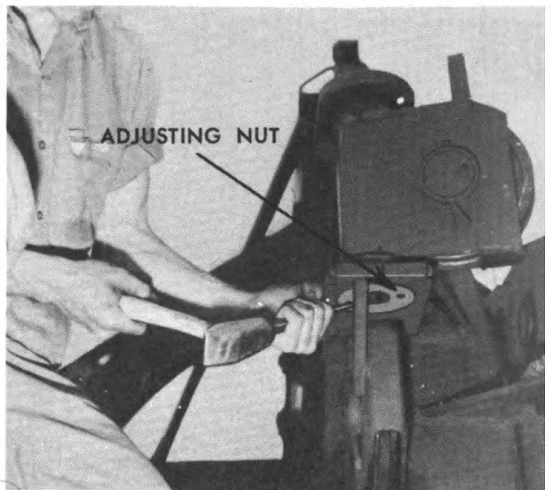
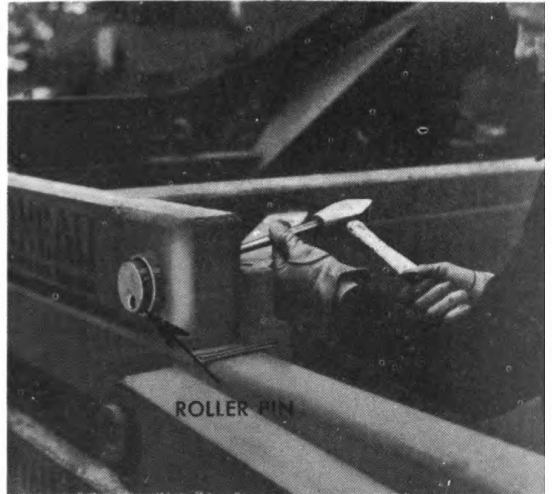

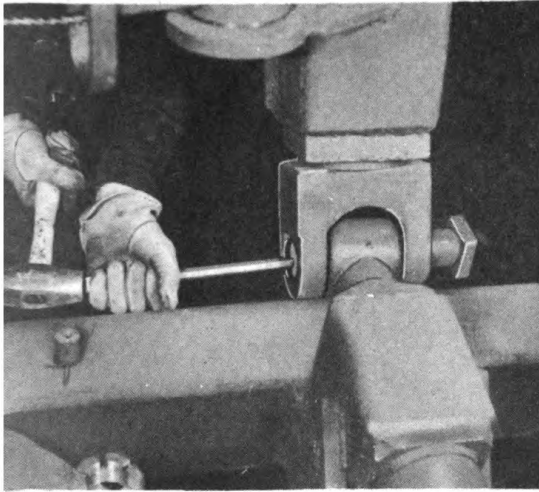
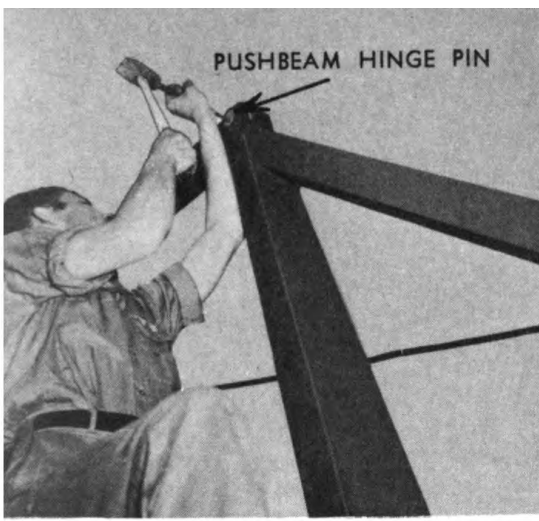

### Removing Pushbeam

To remove the pushbeam, first lower the Scraper onto blocks. Remove hoist cable from pushbeam and then remove pushbeam hinge pin by first removing cotter pin and then driving pin out of pushbeam. The pushbeam is now free to be removed from the Scraper by sliding it to the rear through the upper sheave housing at the top of the arched "A" frame.

### Removing Front Axle Structure (tongue)

To remove the front axle structure, lower the blade onto blocks. Remove cotter pin and castellated nut from end of bolt which connects yoke with tongue. Connect a hoist chain around the upper arch of yoke and raise front of yoke only enough to free bolt. Then drive bolt out of Universal Forgings. Move the front axle structure away from yoke and lower front of yoke onto blocks.

### Removing Yoke Structure

To remove the yoke structure from the Scraper, remove front axle structure and pushbeam. Also raise apron enough to clear head of yoke hinge pin and block apron in this position.

Connect a hoist chain around the upper arch of the yoke and raise yoke only enough to remove weight from yoke hinge pins. Remove cotter pins and castellated nuts from end of hinge pins and then remove pins. Then remove yoke from main body structure with a hoist.

### Removing Apron

To remove the apron, first remove the apron cable, and wrap a hoist chain around the front of each apron arm. Then remove the apron hinge pins by first removing the lock screws from the head of each pin and then driving out the hinge pins. The apron is now free to be hoisted out of the scraper.

### Removing Tailgate Return Springs From Springpipe

When removing the tailgate return springs from inside the springpipe, it is first necessary to compress the springs by placing a 4" x 4" x 72" block against the spring pull plate and the "A" frame at the top of the yoke, as was done in replacing the springpipe cable (see page 26 of the Operation Section). Remove from the spiral sheave the cable wedge that secures the springpipe cable to the spiral sheave. Then, with the scraper bowl lowered, the 72" block in place, and the dead end cable wedge removed from the spiral sheave wheel, gradually raise the scraper bowl, thereby permitting all of the spring tension to be released. The springs can then be removed from the upper end of the springpipe.

### Removing Tailgate

Tailgates in Carryall Scrapers are very seldom removed. However, this can be done, as is outlined below.

To remove the tailgate, first disconnect the spiral sheave-to-tailgate cable at the cable wedge on the rear of the tailgate. In doing this, it is necessary to relieve the cable of tension by pulling tailgate forward a short distance and then inserting a bar through the pipe plug holes in the sides of the spring pipe. Then release the Power Control Unit brake for the dump cable, moving the control lever into lock-out position. Due to the bar being inserted through the upper end of the spring pipe, the springs cannot return the tailgate to the rear, so it is necessary to pry it a short distance to the rear, using a bar. The spiral sheave-to-tailgate cable can then be disconnected from the back side of the tailgate by removing the cable wedge.

Pull the tailgate forward to the position where the large rollers at the rear of the tailgate are in line with the corresponding holes in the sides of the Scraper. Then remove these large tailgate rollers and pins. Pull the tailgate to the front of the bowl and then remove the cable wedges which secure the cable to both sides of the tailgate. Tie hoist chains to both sides of the tailgate, straddling the spring pipe. Then hoist the tailgate up under the spring pipe as high as possible and while hoisted, move the left side of the tailgate to the rear and the right side forward. Block up tailgate in this position and untie hoist chain from right side of tailgate. Now pass hoist chain under spring pipe and again hook chain to right side of tailgate, leaving some slack in chain so that when tailgate is hoisted, the left side is hoisted first. Now hoist tailgate out of body, continuing to turn tailgate sideways while hoisting.

## OVERHAULING AND REPAIRING

Other than inspection and replacement of worn sheaves, rollers, bearings, universal forgings, hitch blocks, oil seals, pins and other parts, practically the only type of repairs ever required on LeTourneau Carryall Scrapers are welding repairs.

If any welded member of a Carryall Scraper should crack or start to break through severe abuse, the Scraper should be stopped immediately and the crack welded up and reinforced before the damage becomes serious.

Only alloy steel should be used in reinforcing LeTourneau Scrapers and coated arc electrodes used in welding. When welding the heat (amperage) should be high enough to make a good strong weld, but not so high as to cause the alloy qualities of the steel to be burned up.

STEEL REINFORCING BARS

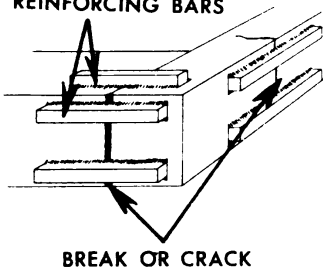

BREAK OR CRACK

To correctly repair a break in a weld or a crack appearing on a boxbeam, first "V" out the old weld or crack and re-weld, filling the V'd out section with weld metal, flush with the surface of the boxbeam. Then reinforce the point of failure by placing steel bars across the break or crack as illustrated, welding them along both sides but leaving both ends unwelded.

If, after a long period of operation, the blade base should become worn back through the bolt holes as a result of neglect to change the blades, a new blade base can be installed without difficulty if the procedure below is followed.

First, cut the worn blade base from one end to the other along the top edges of the bolt holes, as illustrated.

After having trimmed the old blade base, the new blade base may be laid on top of the old one, with the top edge flush with the scraper bottom. Clamp it in position with "C" clamps. Then weld it to the old blade base along both the top and the bottom edges, as illustrated.

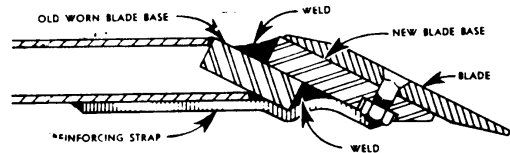
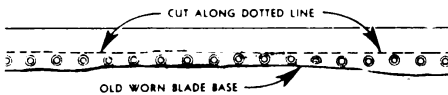

Install new blade base reinforcing ribs between the old ones, letting them extend down onto the new blade base. It will be necessary to heat and bend the new reinforcing ribs to make them fit down around the old blade base and up against the new one.

**RE-ASSEMBLING**

The instructions for re-assembling a Carryall Scraper are the reverse of those for disassembling.

When re-assembling, keep all bearings and working parts free of dirt, grit, or other foreign matter. Do not replace bearing cups without also replacing bearing cones, and vice-versa.

Soak in oil any oil seals in which the leather has become dry and hard before installing. Also, rub oil seal leathers with some smooth round object such as a hammer handle. This will cause the leathers to be properly seated when installed on the axle. It also makes possible quick and easy installation. When installing oil seals in place, use uniform pressure all around to avoid distorting and breaking the seal cage. *The wheel hub oil seals should be installed with leather cupped outward, away from the grease chamber.*

Dust seals are straight on one side and beveled on the other. When installing dust seals in sheave wheel hubs or in tailgate rollers, make sure the seals are turned so that the bevel faces the side of the sheave from which the pin is inserted. Avoid pushing the pin against the straight side of the leather during installation, because such action would probably injure the leather.

During assembly, make all adjustments as outlined on pages 2 thru 6 of the Repair Section.

Lubricate all points of lubrication before placing the Scraper in operation. (Refer to instructions on page 24 of Operation Section.)

When connecting axle universal forging with yoke universal forging, make sure beveled side of yoke forging faces the front and that thick side of axle forging is on bottom. (See illustration at bottom of page 5, Repair Section.)

**TABLE OF CLEARANCES AND TOLERANCES OF BEARINGS AND ADJUSTABLE PARTS**

POINT OF ADJUSTMENT	CORRECT ADJUSTMENT	ALLOWABLE TOLERANCE
Wheel Bearings	.000"	.008" loose to .008" tight
Fairlead Sheave Housing Pivot Bearings	.001" tight	.000" to .002" tight
Sheave Bearings	Non-adjustable	.....
Tailgate Roller Bearings	Non-adjustable	.....
Universal Forgings	Free turning without end play	.....



# TROUBLE SHOOTER'S GUIDE

## EXCESSIVE CABLE BREAKAGE

CAUSE	REMEDY
<i>Tailgate forward cable too short</i> causing tailgate arms to strike vertical braces on top of side sheets before tailgate sliding sheave strikes stop block, possibly resulting in bottom of tailgate kicking up.	Correctly adjust or replace cable. (Refer to cable threading instructions on Page 25 of Operation Section.)
<i>Tailgate forward cable too long</i> , preventing tailgate from coming forward far enough to eject all the load.	Correctly adjust or replace cable. (Refer to cable threading instructions on Page 25 of Operation Section.)
<i>Apron lift cable too short</i> , causing apron to strike arched A-Frame when in raised position.	Correctly adjust or replace apron lift cable. (Refer to cable threading instructions on Page 24 of Operation Section.)
<i>Failure of operator to release Power Control Unit clutch when pushbeam stops or tailgate sliding sheave stops are brought together.</i>	Promptly release Power Control Unit clutch when pushbeam stops or tailgate stops have been pulled together.
<i>Traveling over unlevel ground or turning with either the pushbeam stops or tailgate sliding sheave stops together.</i>	Allow clearance at these points when traveling. (Refer to instructions on Pages 7 and 9 of Operation Section.)

## BEARING FAILURES

CAUSE	REMEDY
<i>Bearings improperly lubricated.</i>	Lubricate at specified intervals and with recommended lubricants. (Refer to Page 21 of Operation Section.)
<i>Bearings incorrectly adjusted.</i>	Correctly adjust bearings. (Refer to Pages 2, 3, and 6 of Repair Section.)
<i>Oil seals or dust seals failed</i> , permitting dirt or other foreign matter to enter bearings.	Replace oil seals or dust seals.

## SCRAPER CUTTING LOWER ON ONE SIDE THAN ON OTHER

CAUSE	REMEDY
<i>Unequal air pressures in rear tires.</i>	Check air pressures and inflate to equal pressures. (Refer to Page 19 of Operation Section.)
<i>The use of tires of unequal diameters on rear of Scraper</i> , such as a new tire on one side and worn tire on other, or a larger size tire on one side than on other.	Install tires having equal diameters.

For troubles related to the functions of structural parts, such as failure of the tailgate to return to its rear position, check for points of binding, incorrect spring tension resulting from the spiral sheave wheel being improperly timed, etc.

# PARTS CATALOG

## WARNING

SPARE PARTS can be supplied promptly and accurately only if positively identified by correct part number and correct part name.

FURNISH THIS INFORMATION ON ALL REQUISITIONS. WITHOUT FAIL, on all requisitions, give name of machine, name of manufacturer, model or size, manufacturer's serial number of each machine and subassemblies attached to machine, and components and accessories for which spare parts are required.

List spare parts for only one make or kind of machine on each requisition.

Requisitions must be double spaced to provide room for office notations when necessary.

SECT. 3







# PREPARATION OF REQUISITIONS

## SAMPLE COPY FOR USE IN THE PREPARATION OF REQUISITIONS

State PERIOD designation by use of one of the following terms:

- (1) "INITIAL" — first requisition of authorized allowances.
- (2) "REPLENISHMENT" — subsequent requisitions to maintain authorized allowances.
- (3) "SPECIAL"—requisitions for necessary repairs not covered by allowances.

Type 'SPARE PARTS' in upper right hand corner of requisition.

Give complete shipping instructions. Special instructions for packing, marking, routing, etc., should be given at the end of the requisition.

State proper nomenclature of machine, and make, model, serial number and registration number.

Prepare a separate requisition for each different machine.

State basis or authority and date delivery is required, immediately below description of machine.

Double space between items.

Group parts required under group headings as shown in manufacturers' parts catalogs (Technical Manuals).

State manufacturers' parts numbers and nomenclature descriptions accurately and completely. Do not use abbreviations.

WAR DEPARTMENT Q. M. C. Form No. 400 Revised Apr. 6, 1931		SAMPLE REQUISITION		SPARE PARTS			
To: <u>Engineer Supply Officer,</u>		No. of Sheets <u>1</u>		Sheet No. <u>1</u>			
Columbus Army Service Forces Depot, COLUMBUS, OHIO		Date <u>July 3, 1943</u>		Period <u>Replenishment</u>			
Requisition No. <u>E-531-3-44</u>		SHIP TO <u>Engineer Property Officer, Pine Camp, New York</u>		MARKED FOR: <u>Supply Officer, 802nd Engineer Battalion, Pine Camp, N.Y.</u>			
REQUISITIONED BY (show Signature, Rank, Organization, Destination. If different from "SHIP TO" include address):		Approved For the Commanding Officer					
Robert E. Roe Major, C.E. Engineer Property Officer		John E. Doe Col., C.E. Executive Officer					
MFG. No.	NOMENCLATURE AND UNIT	AUTHORIZED OR MAXIMUM LEVEL	ON HAND	DUE IN	REQUIRED	APPROVED	
PARTS FOR CARRYALL SCRAPER, LeTOURNEAU MODEL LP							
SERIAL NO. S-10000-LPD AND UP							
Basis: To complete second echelon Delivery requested by August 15, 1943							
BODY GROUP							
H-1001	BLADE, Right	ea.	2	1	0	1	
H-1003	BLADE, Left	ea.	2	1	0	1	
H-220	BOTTOM STRUCTURE	ea.	2	1	0	1	
H-1771	HOUSING, Sliding Sheave	ea.	2	1	0	1	
TAILGATE GROUP							
C-131	ROLLER, Main Tailgate	ea.	2	1	0	1	
C-133	ROLLER, Side Thrust	ea.	2	1	0	1	
C-177	BEARING, Hyatt #RA 212	ea.	2	1	0	1	
FRONT AXLE GROUP							
F-2825	TONGUE STRUCTURE	ea.	2	1	0	1	
D-2899	UNIVERSAL ASSEMBLY	ea.	2	1	0	1	
R-3408	NUT ASSEMBLY	ea.	2	1	0	1	

\*Nonexpendable items such as tools must be accounted for, when requisitioned, by a statement that they have been placed on REPORT OF SURVEY or STATEMENT OF CHARGES.

Emergency requisitions sent by telephone, telegraph, or radio must always be confirmed immediately with requisition marked: "Confirming (state identifying data)."



# PREPARATION OF REQUISITIONS

A Sample requisition in the correct form for submission by the Engineer Property Officer is shown on the opposite page.

## THIS SHALL BE FOLLOWED IN MAKING OUT REQUISITIONS.

In order to eliminate duplication of work, Property Officers may authorize organizations to prepare requisitions in final form, leaving requisition number space blank for completion by Property Officer.

## THE FOLLOWING RULES WILL BE OBSERVED CAREFULLY IN PREPARING REQUISITIONS FOR SPARE PARTS:

- a. Prepare a separate requisition for each different machine.
- b. Type "SPARE PARTS" in upper right hand corner of requisition form.
- c. State PERIOD designation by use of one of the following terms:
  - (1) "INITIAL"—first requisition of authorized allowances.
  - (2) "REPLENISHMENT"—subsequent requisitions to maintain authorized allowances.
  - (3) "SPECIAL"—requisitions for necessary repairs not covered by allowances.
- d. Give complete shipping instructions.
- e. State proper nomenclature of machine, and make, model, serial number and registration number.
- f. State basis or authority, and date delivery is required, immediately below description of machine.
- g. Group parts required under group headings as shown in manufacturers' parts catalogs.
- h. State manufacturers' parts numbers and nomenclature descriptions accurately and completely. Do not use abbreviations.
- i. Double space between items.
- j. Emergency requisitions sent by telephone, telegraph, or radio must always be confirmed immediately with requisition marked: "Confirming (state identifying data)".
- k. Nonexpendable items must be accounted for.





# MODEL LP CARRYALL

## TAILGATE TO SPIRAL SHEAVE CABLE

H-9543  $\frac{5}{8}$ x6x19=13'6" Long

## TAILGATE FORWARD CABLE

H-9544  $\frac{7}{8}$ x6x19=51' Long

## SPRING PIPE CABLE

H-9545  $\frac{5}{8}$ x6x19=17' Long

## HOIST LINE CABLE

H-9682  $\frac{1}{2}$ x6x19 = 125' Long

## DUMP CABLE

R-931  $\frac{1}{2}$  x 6 x 19 = 130' Long

D-3883  $\frac{1}{2}$  x 6 x 19 = 500' Spool

## SLIDING SHEAVE TO APRON

R-932  $\frac{7}{8}$  x 6 x 19 = 14'6" Long

**(SEE OPERATIONS SECTION FOR CABLE THREADING INSTRUCTIONS.) CABLE THREADING DIAGRAM ALSO SHOWN IN OPERATIONS SECTION.**

516-G

**CABLE LENGTH**

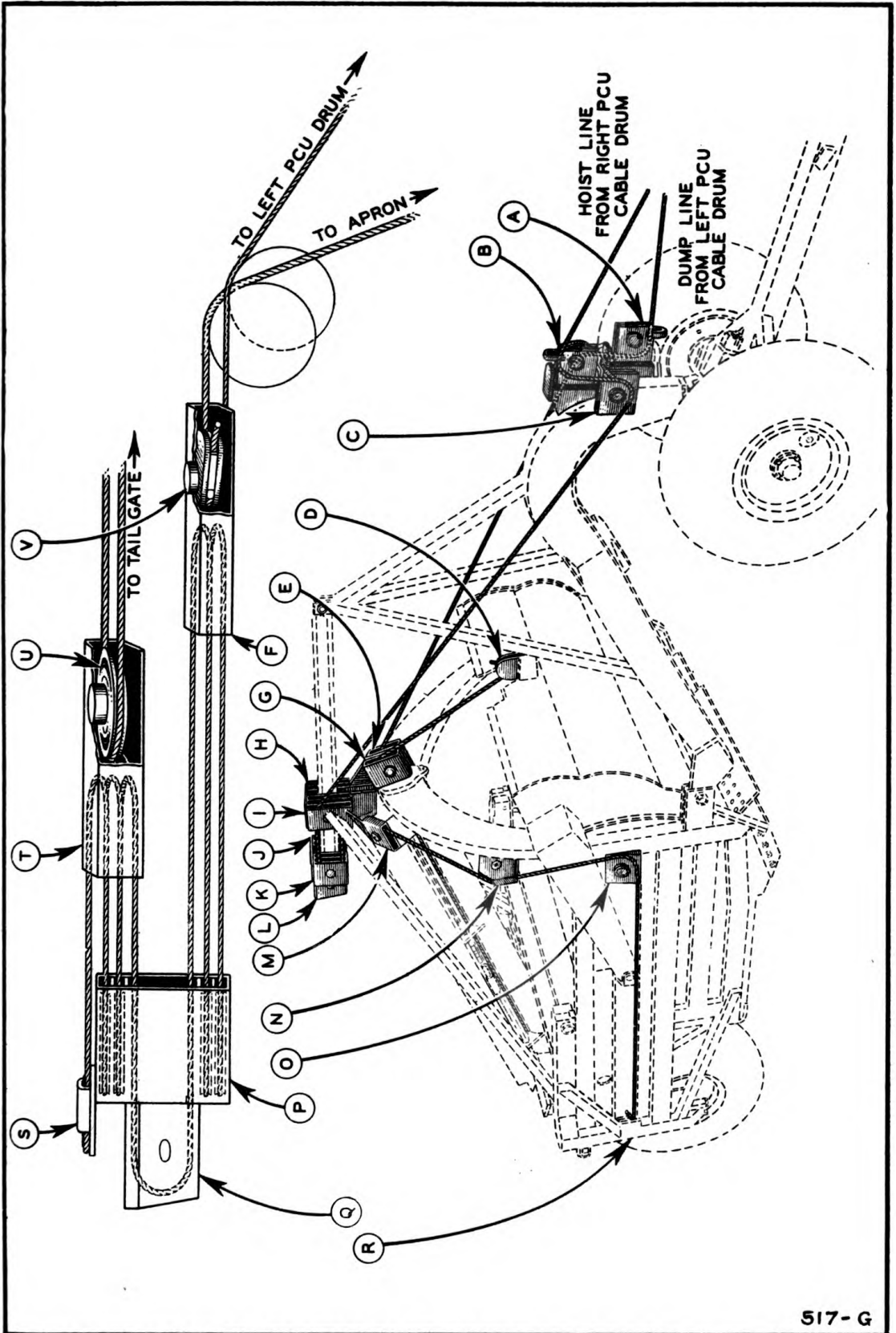

517-G

CABLE THREADING DIAGRAM





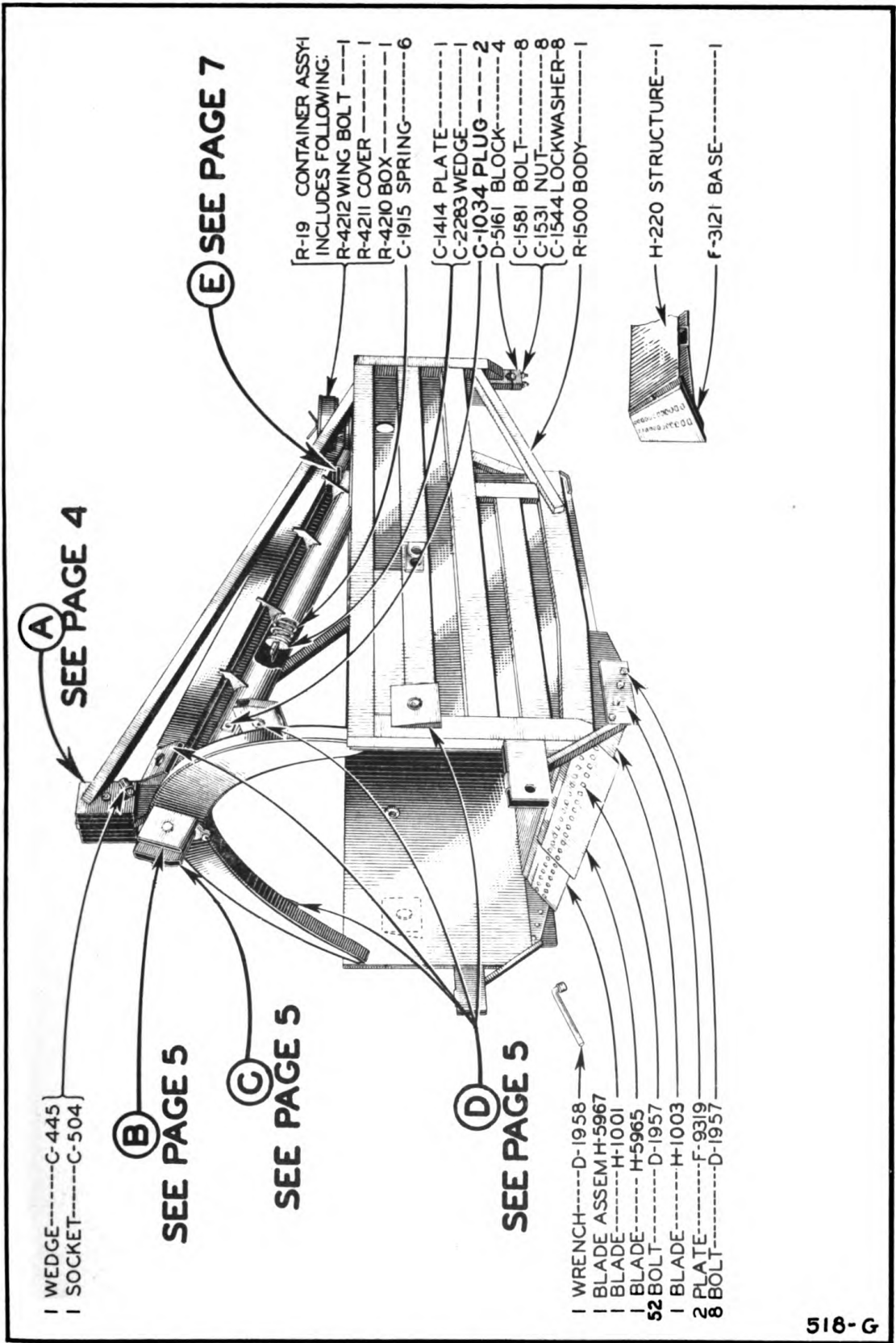

518-G

MAIN BODY ASSEMBLY



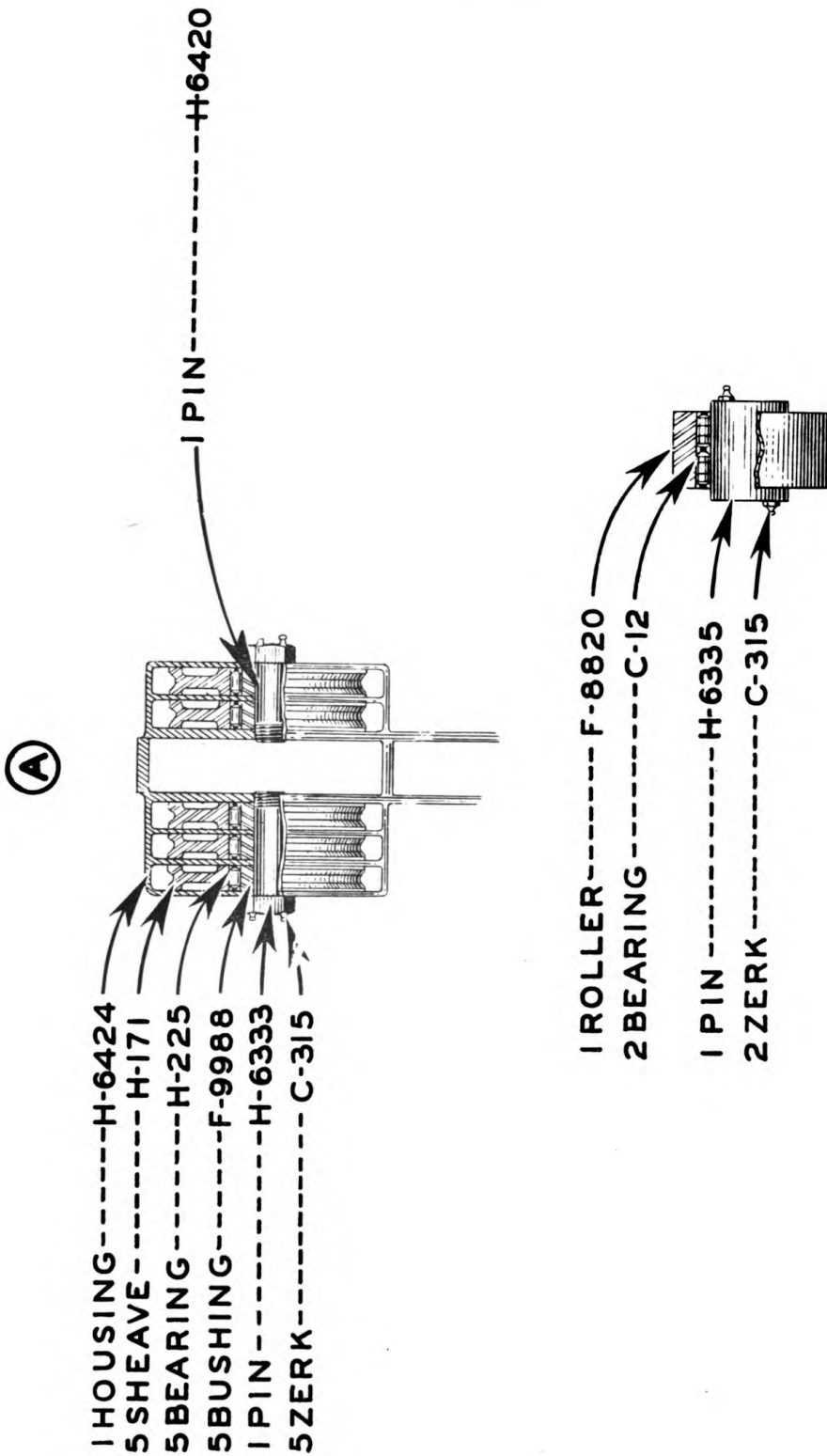

519-G

MAIN BODY SUB ASSEMBLIES





- 1 SHEAVE ----- H-171
- 1 BEARING ----- H-225
- 1 BUSHING ----- F-9988
- 1 PIN ----- F-9991
- 1 NUT ----- F-9989
- 1 ZERK ----- C-315

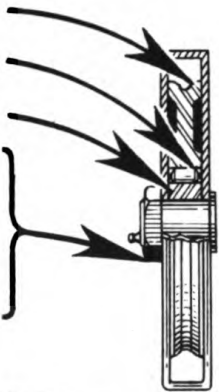

(B)

- 1 HOUSING ----- H-271
- 1 SHEAVE ----- F-7269
- 1 BEARING ----- C-177
- 1 COTTER ----- C-1051
- 1 PIN ----- C-138
- 1 ZERK ----- C-1596
- 3 CAPSCREW ----- H-1111
- 3 LOCKWASHER --- C-1544

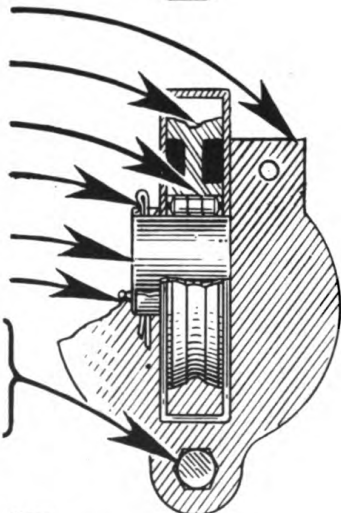

(C)

- 6 SHEAVE ----- F-7269
- 6 BEARING ----- C-177
- 6 COTTER ----- C-1051
- 4 PIN ----- C-138
- 6 ZERK ----- C-315

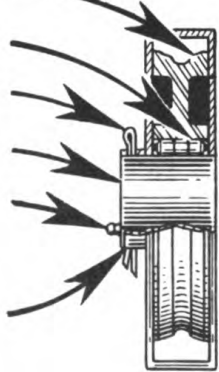

(D)

- 2 PIN ----- F-5027
- FOR SIDE SHEET HOUSING

520-G

MAIN BODY SUB ASSEMBLIES



SLIDING SHEAVE ASSEMBLIES

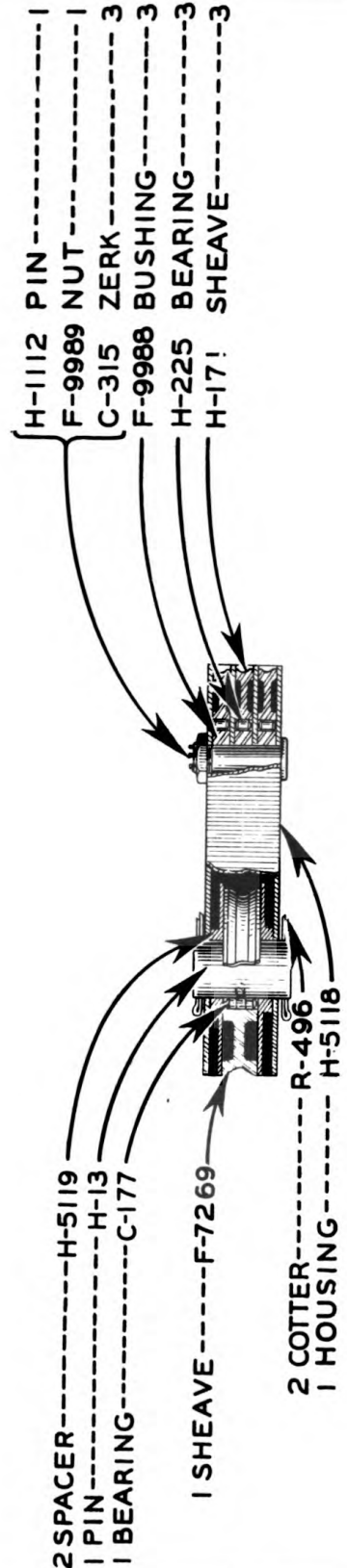
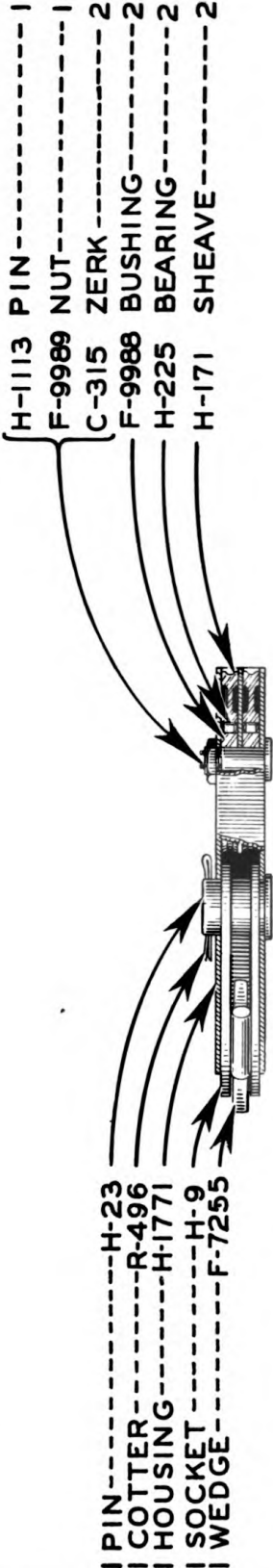

MAIN BODY SUB ASSEMBLIES

521-G





(E)

- H-2084 CAPSCREW-----2
- H-5288 BUMPER-----1
- C-315 ZERK-----2
- C-503 SOCKET-----1
- C-502 WEDGE-----1
- F-9991 PIN-----1
- F-9989 NUT-----1
- C-315 ZERK-----1
- H-171 SHEAVE-----5
- H-225 BEARING-----5
- F-9988 BUSHING-----5
- H-272 SPACER-----1
- H-273 SPACER-----1
- H-6427 PIN-----1
- F-9989 NUT-----1
- C-315 ZERK-----2

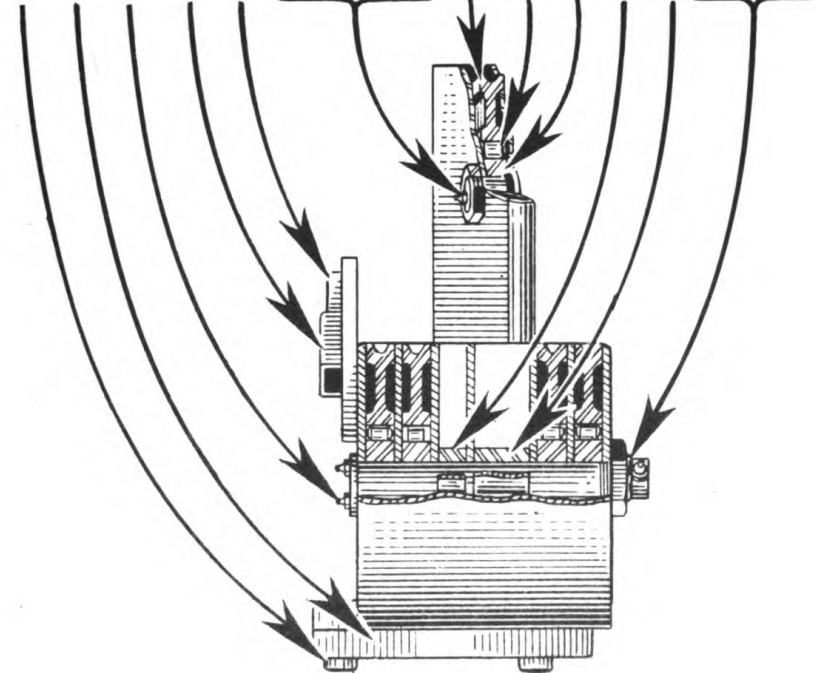

522-G

MAIN BODY SUB ASSEMBLIES



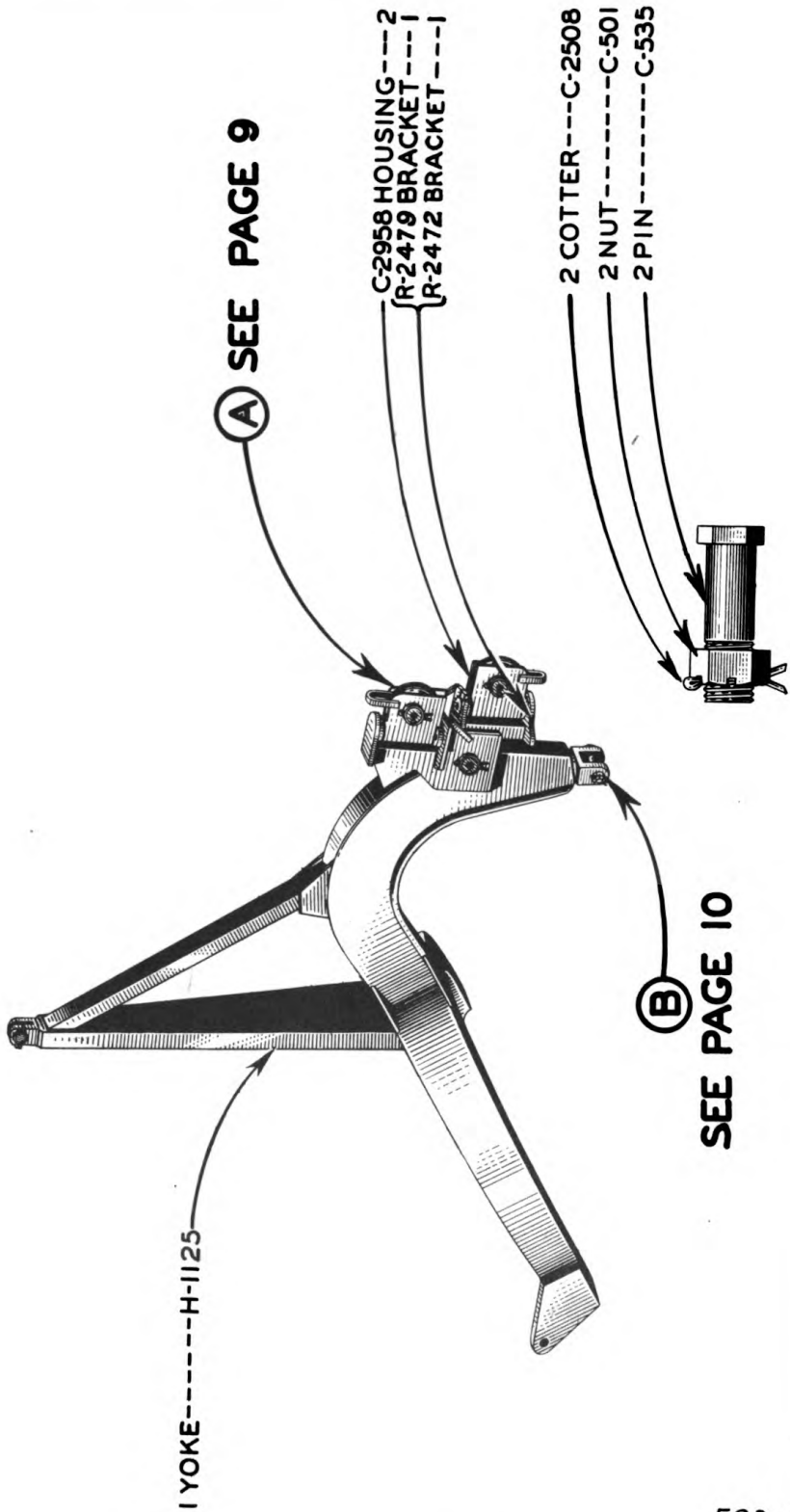

523-G

CANTILEVER YOKE



(A)

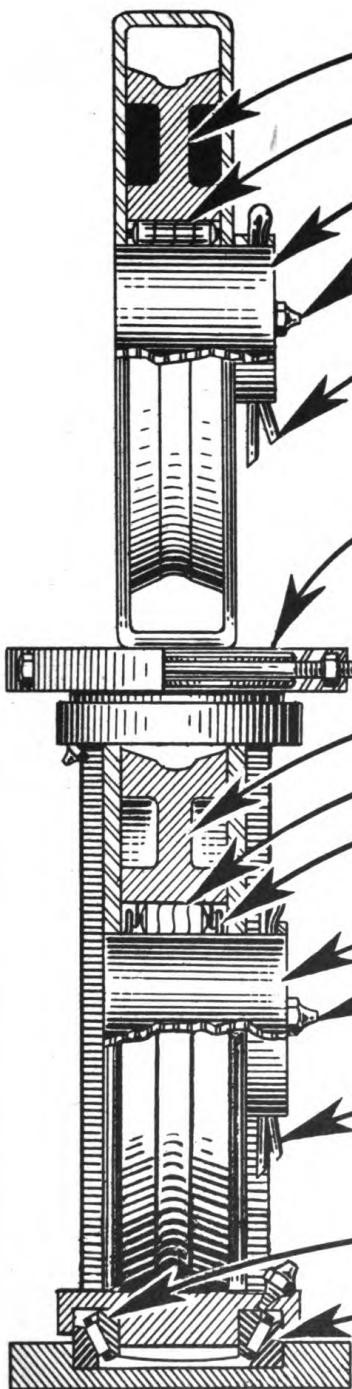

- C-172 SHEAVE----2
- G-175 BEARING---2
- C-174 PIN-----2
- C-315 ZERK-----2
- G-1051 COTTER----2
- C-498 NUT-----2
- { H-6906 BOLT ----- 1
- { H-7536 BOLT ----- 1
- { C-5783 NUT ----- 2
- C-137 SHEAVE ----2
- C-175 BEARING---2
- L-323 SEAL-----4
- C-138 PIN-----2
- C-315 ZERK-----6
- C-1051 COTTER----2
- C-16 CONE-----4
- C-1 CUP-----4

524-G

YOKE SUB ASSEMBLY





(B)

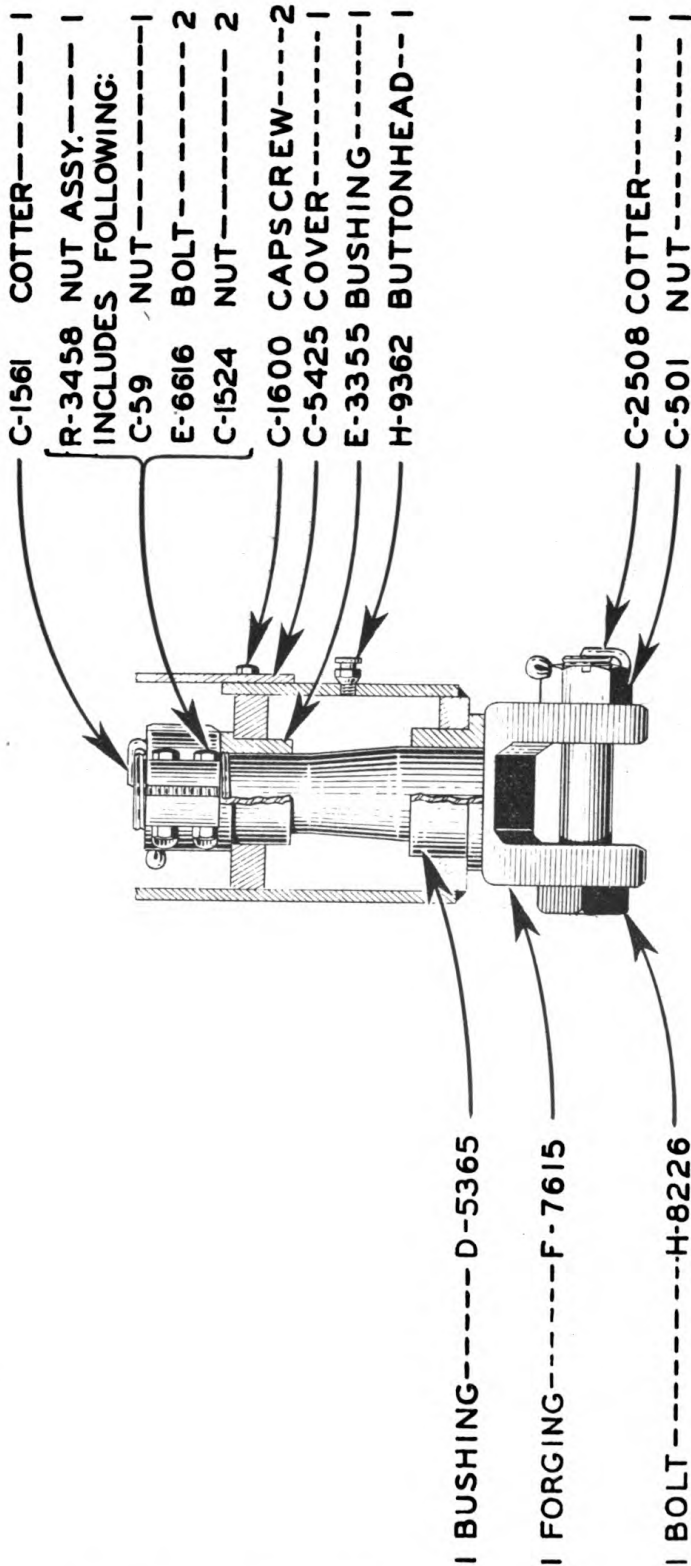

YOKE SUB ASSEMBLY

525-G



D-2889 LOCKWASHER--6  
C-1612 CAPSCREW--6  
F-1230 PIN-----2  
C-315 ZERK-----2

F-7255 WEDGE-----1  
F-7860 HINGE-----1  
C-2508 COTTER-----1  
F-8448 PIN-----1

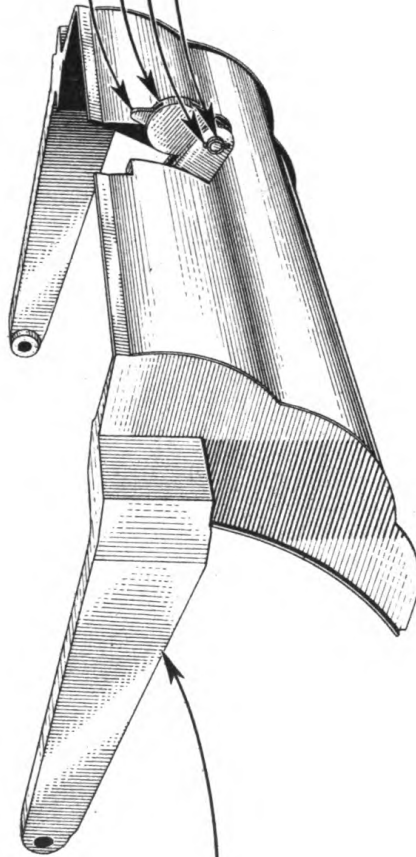

1 APRON-----H-290

526-G

APRON GROUP





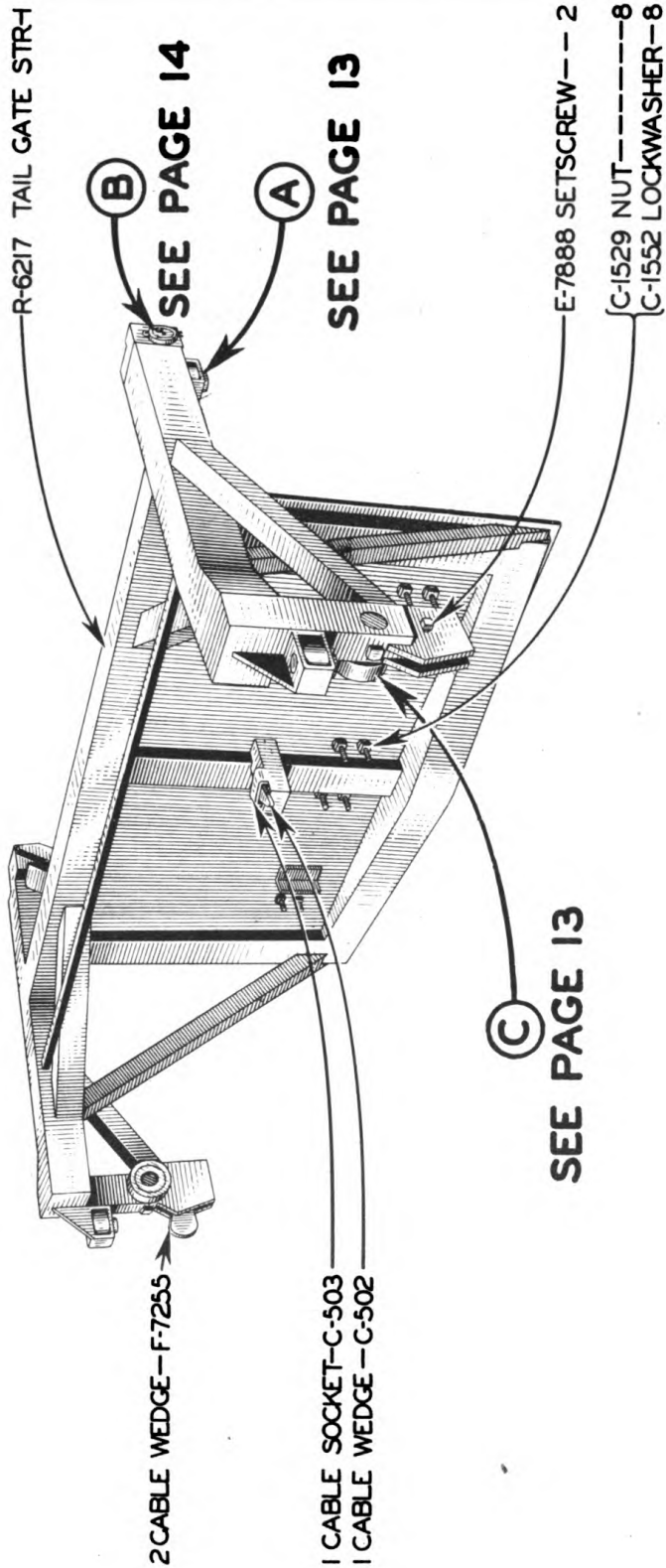

TAILGATE GROUP

527-G



(A)

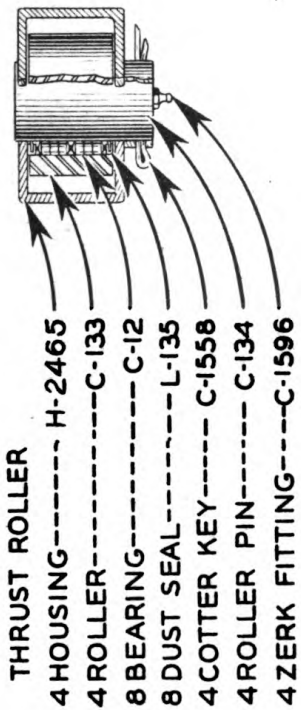

- THRUST ROLLER
- 4 HOUSING----- H-2465
- 4 ROLLER-----C-133
- 8 BEARING-----C-12
- 8 DUST SEAL-----L-135
- 4 COTTER KEY----- C-1558
- 4 ROLLER PIN----- C-134
- 4 ZERK FITTING-----C-1596

(B)

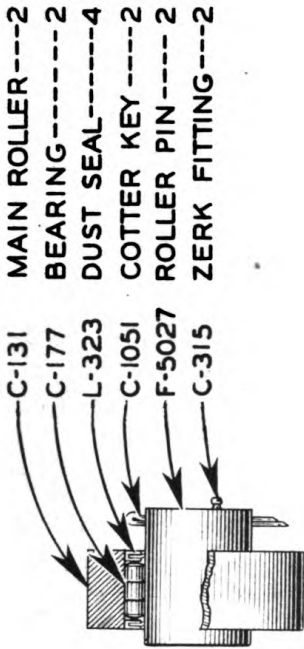

- C-131
- C-177
- L-323
- C-1051
- F-5027
- C-315
- MAIN ROLLER-----2
- BEARING-----2
- DUST SEAL-----4
- COTTER KEY-----2
- ROLLER PIN-----2
- ZERK FITTING-----2

(C)

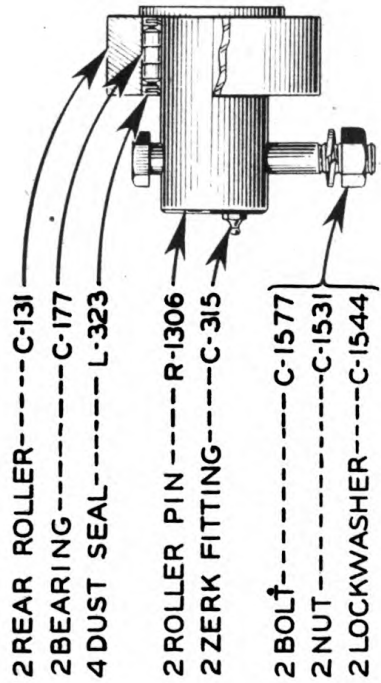

- 2 REAR ROLLER-----C-131
- 2 BEARING-----C-177
- 4 DUST SEAL-----L-323
- 2 ROLLER PIN-----R-1306
- 2 ZERK FITTING-----C-315
- 2 BOLT-----C-1577
- 2 NUT-----C-1531
- 2 LOCKWASHER-----C-1544

528-G

TAILGATE SUB ASSEMBLIES



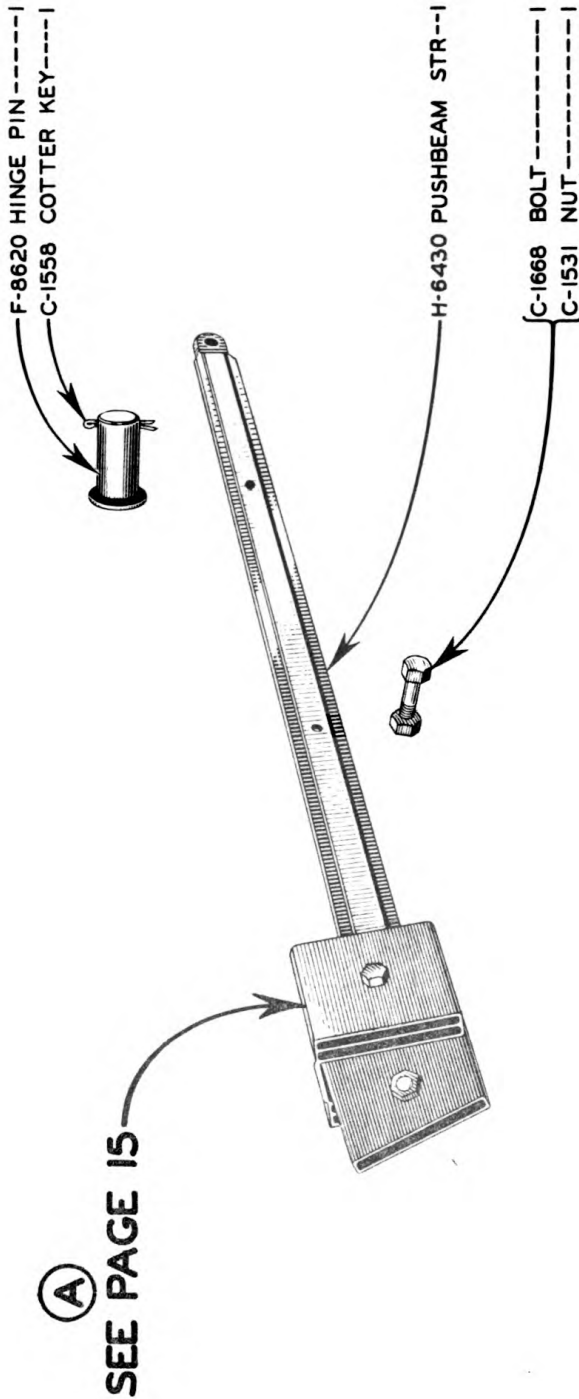

529-G

PUSHBEAM GROUP





(A)

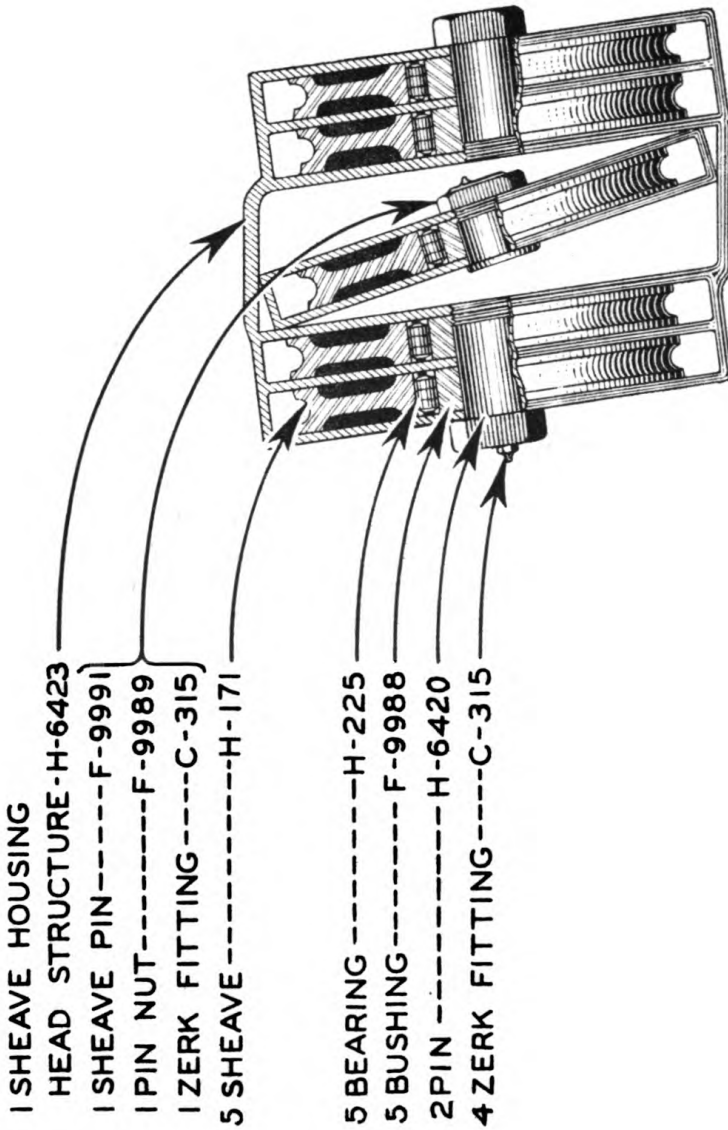

530 - G

PUSHBEAM SUB ASSEMBLY

ALWAYS GIVE MACHINE NUMBER WHEN ORDERING PARTS



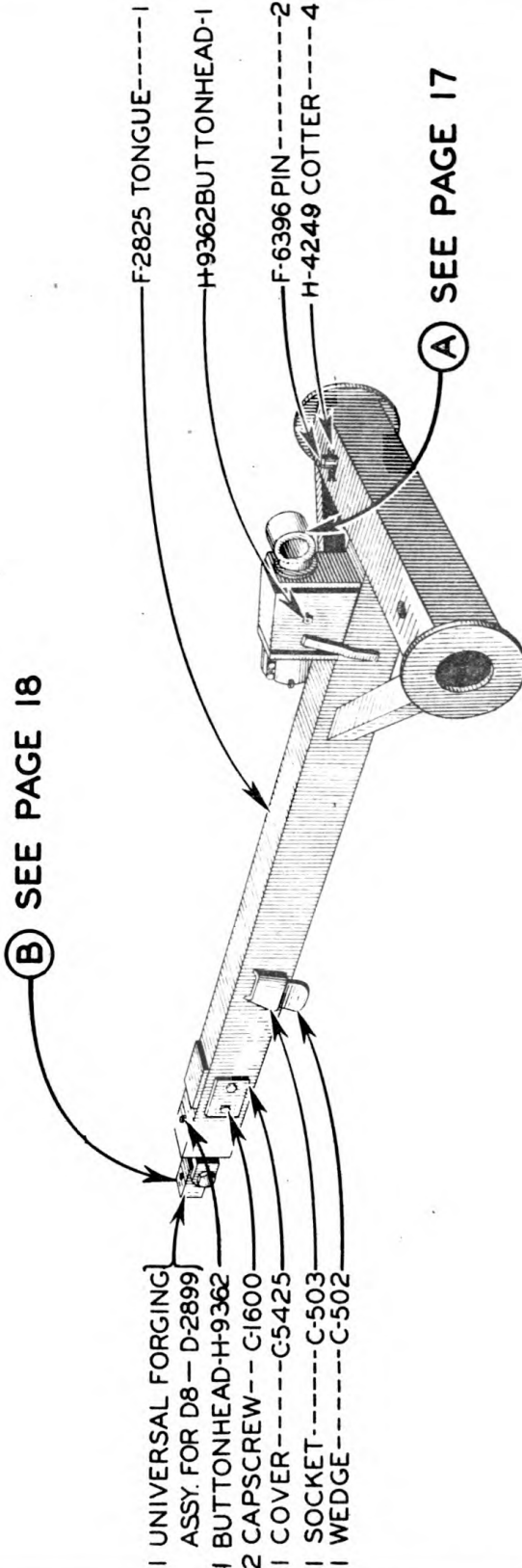

531-G

FRONT AXLE ASSEMBLY





(A)

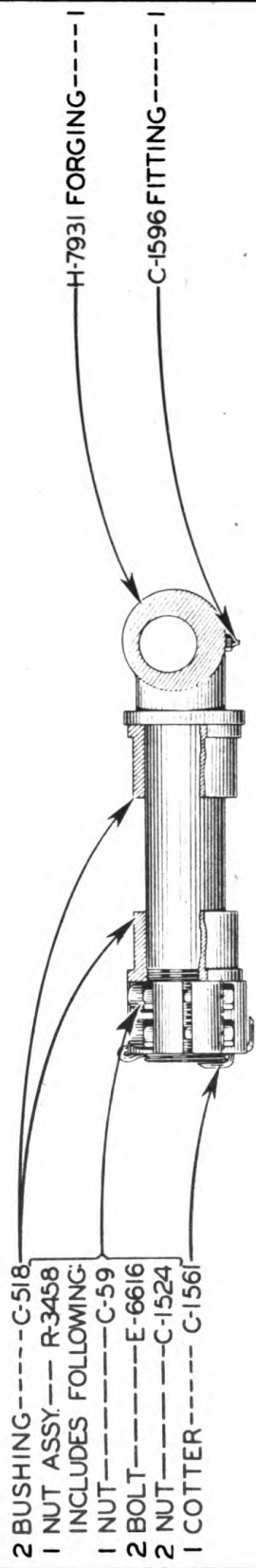

- 2 BUSHING-----C-518
- 1 NUT ASSY---- R-3458
- INCLUDES FOLLOWING:
- 1 NUT-----C-59
- 2 BOLT-----E-6616
- 2 NUT-----C-1524
- 1 COTTER----- C-1561

- H-7931 FORGING-----I
- C-1596 FITTING-----I

532-G

FRONT AXLE SUB ASSEMBLY



(B)

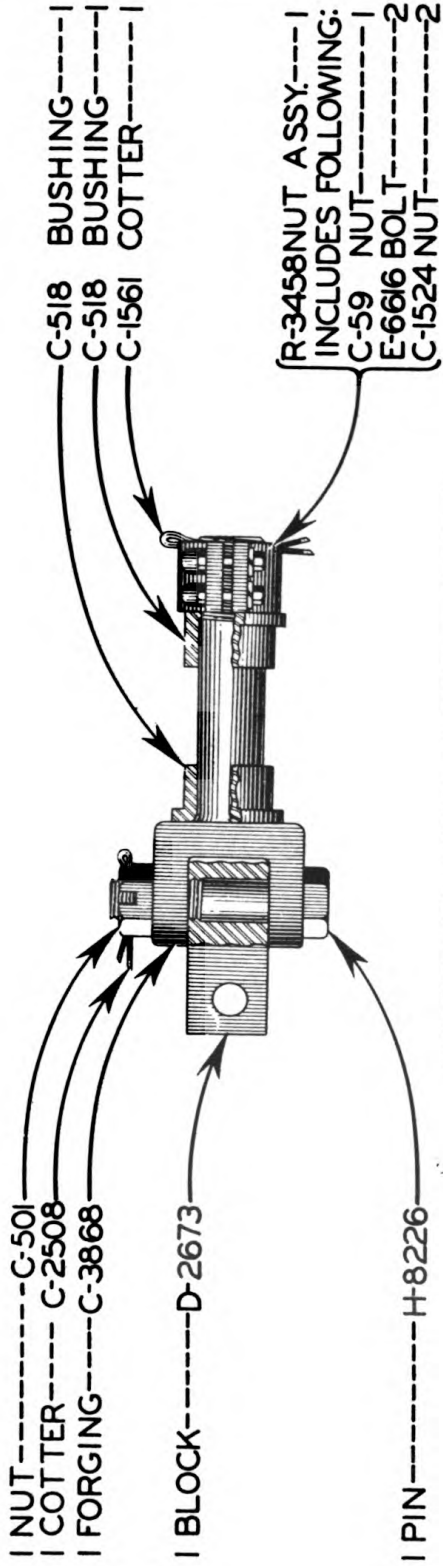

UNIVERSAL ASSY. FOR D8---D-2899

533-G

UNIVERSAL ASSEMBLY



D-1784 CAPSCREW---8  
C-1544 LOCKWASHER8

E-3909 BOLT-----4  
C-1531 NUT-----4  
C-1544 LOCKWASHER4

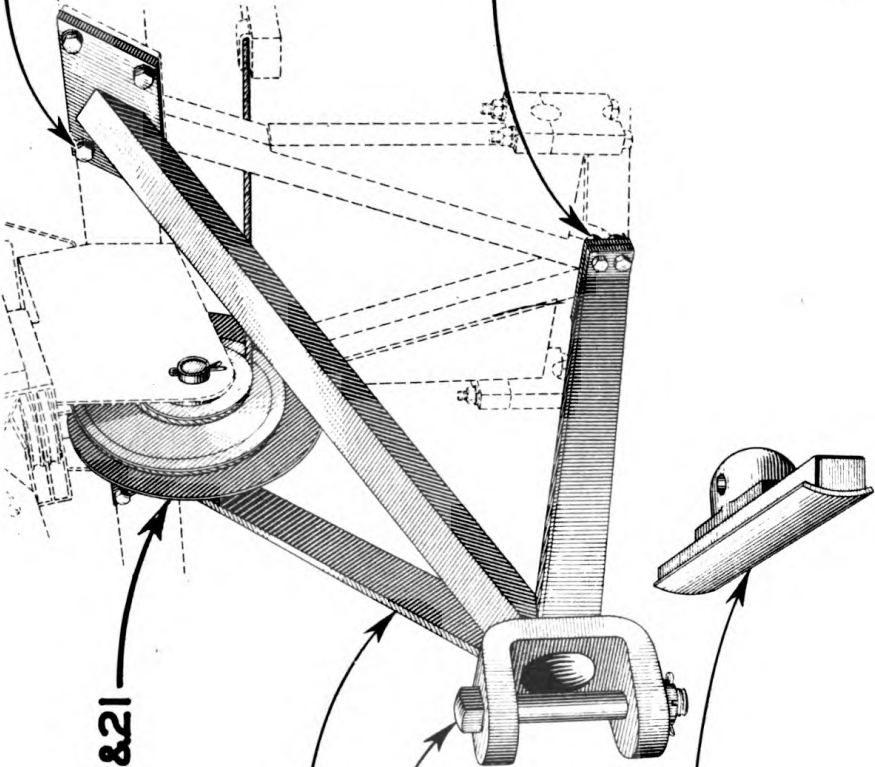

**(A)**  
**SEE PAGES 20 & 21**

HITCH-----H-270

BOLT-----F-3551  
NUT-----C-501  
COTTER-----C-2508

BAR-----R-1203

534 - G

**REAR HITCH & SPIRAL SHEAVE GROUP**







(A)

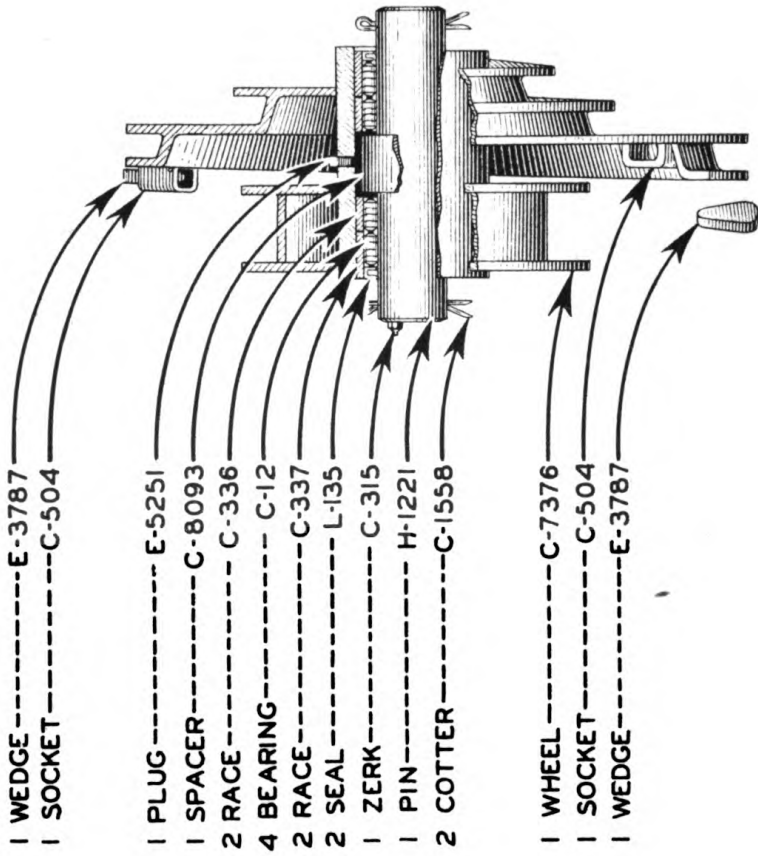

- 1 WEDGE-----E-3787
- 1 SOCKET-----C-504
  
- 1 PLUG-----E-5251
- 1 SPACER-----C-8093
- 2 RACE-----C-336
- 4 BEARING-----C-12
- 2 RACE-----C-337
- 2 SEAL-----L-135
- 1 ZERK-----C-315
- 1 PIN-----H-1221
- 2 COTTER-----C-1558
  
- 1 WHEEL-----C-7376
- 1 SOCKET-----C-504
- 1 WEDGE-----E-3787

535-G

**SPIRAL SHEAVE ASSEMBLY**

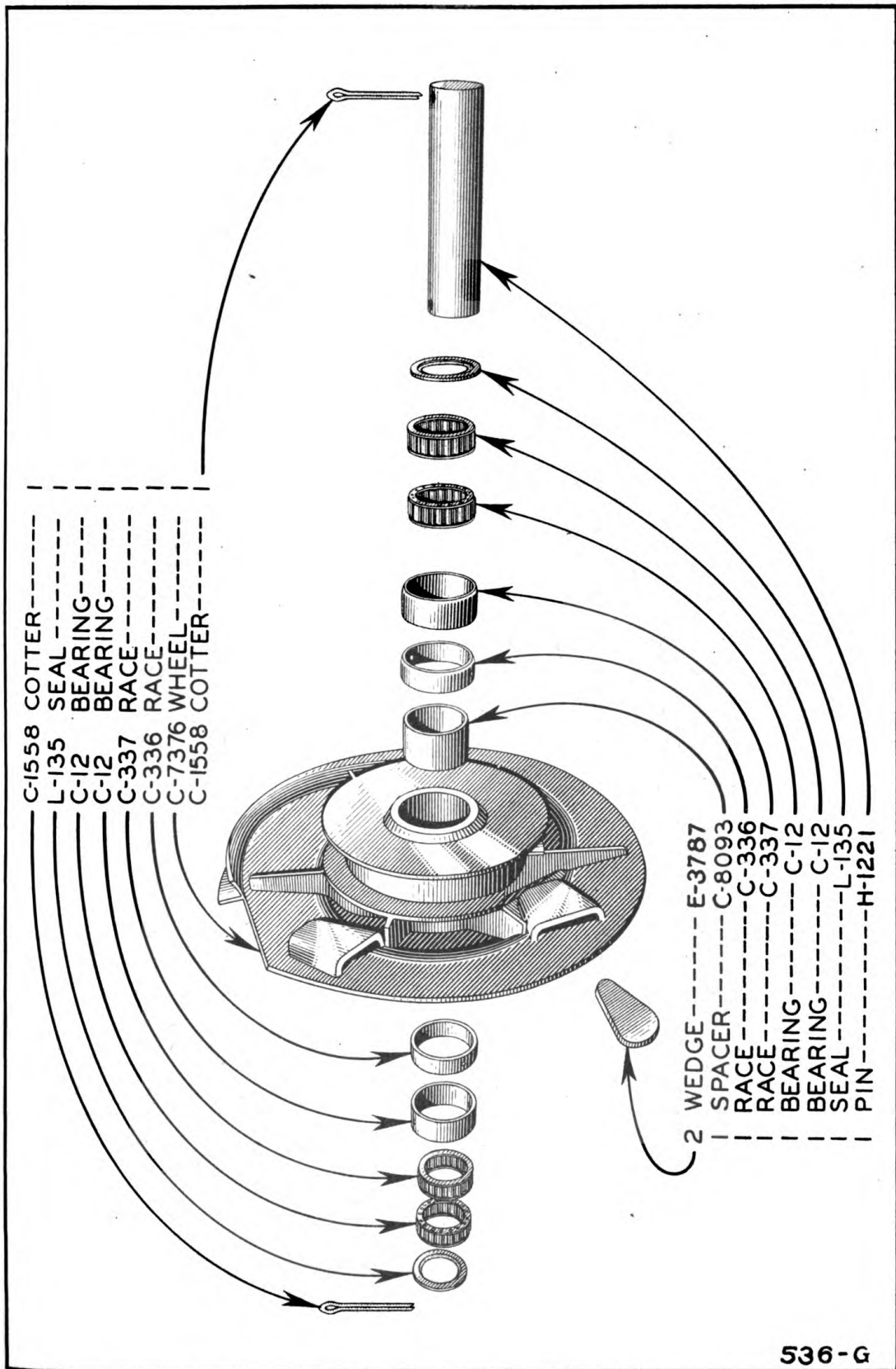

536-G

**SPIRAL SHEAVE-EXPLODED**







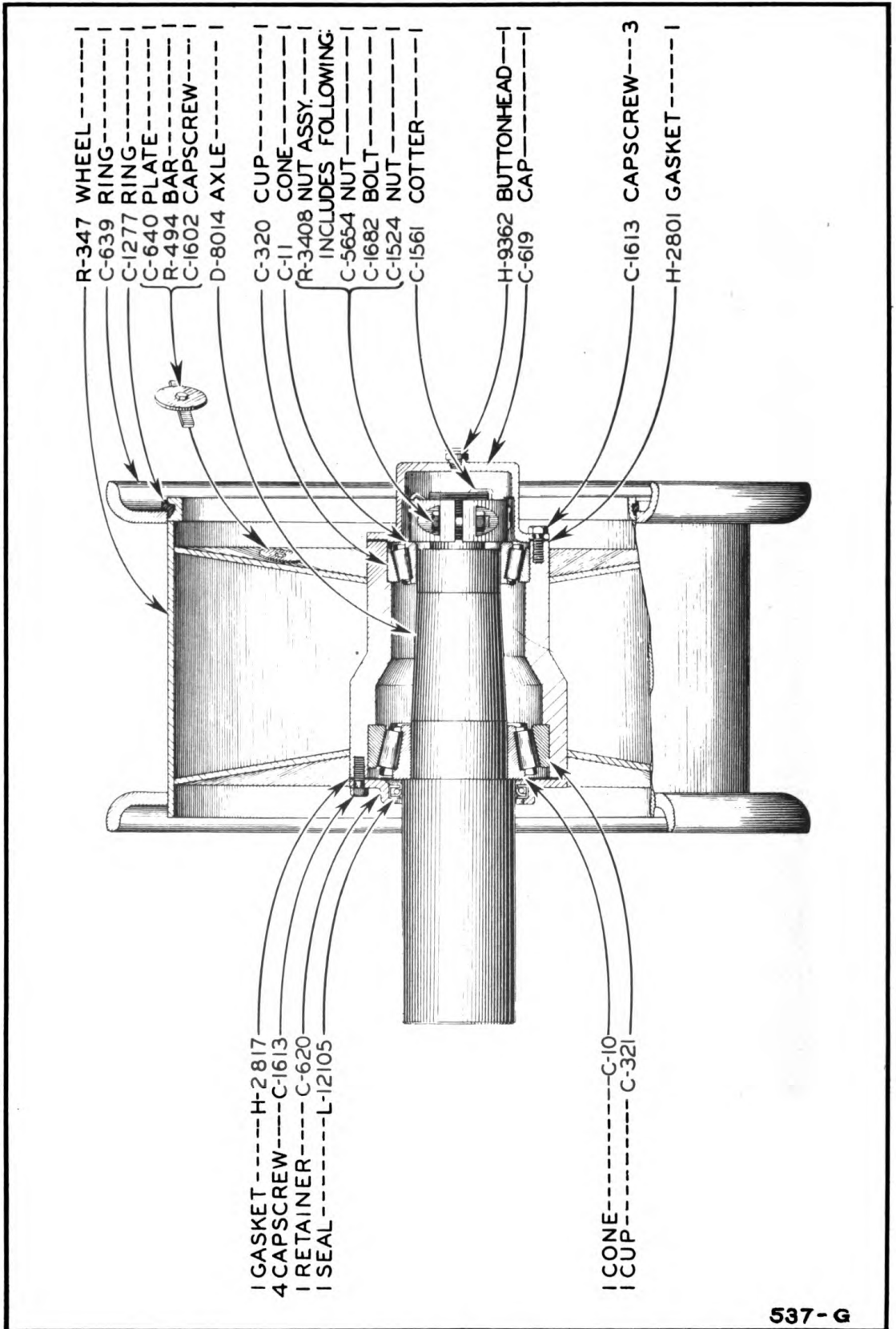

537-G

18 X 24 SGL. FRONT WHEEL

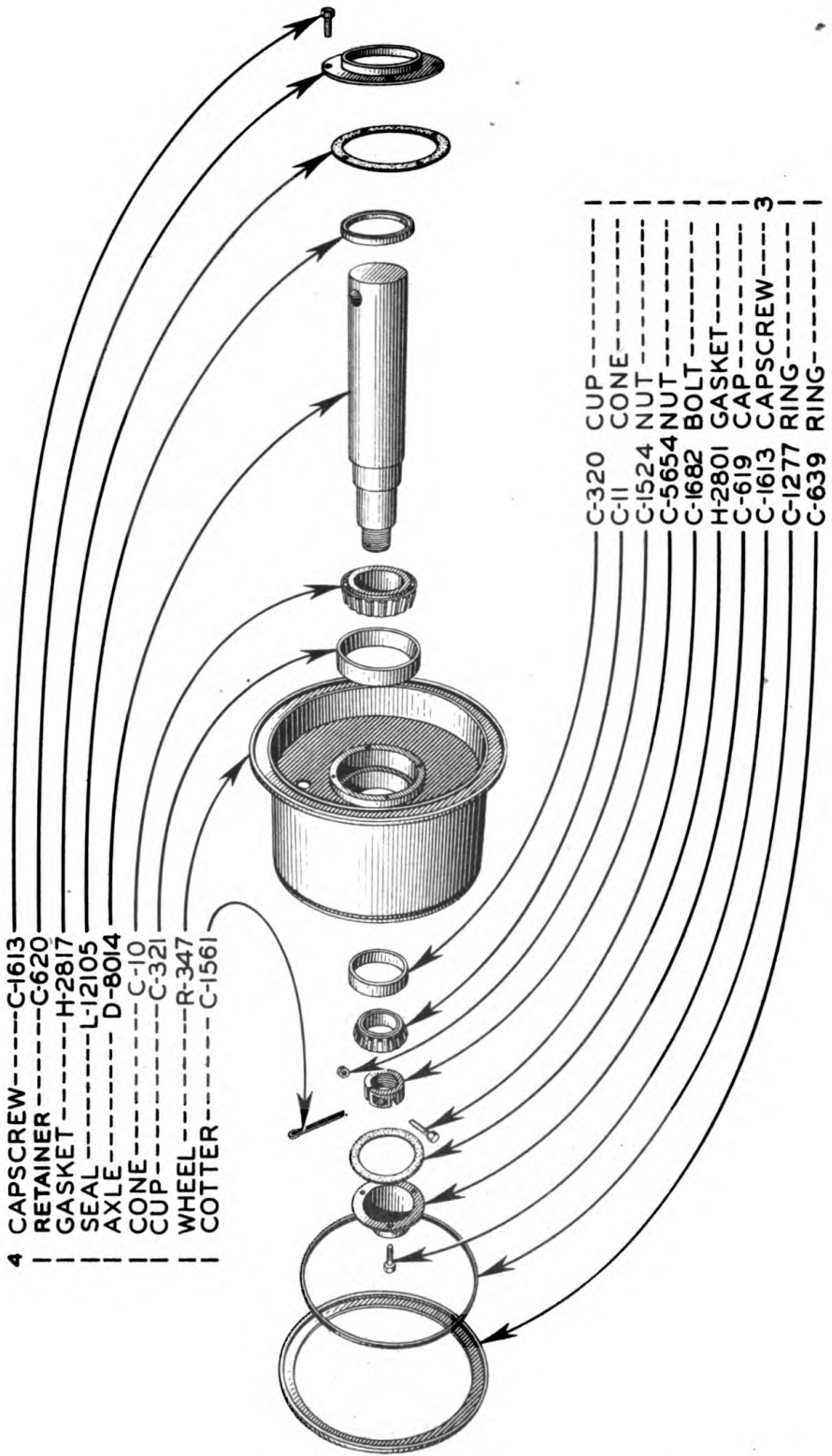

538-G

18 X 24 SGL. FRONT WHEEL-EXPLODED





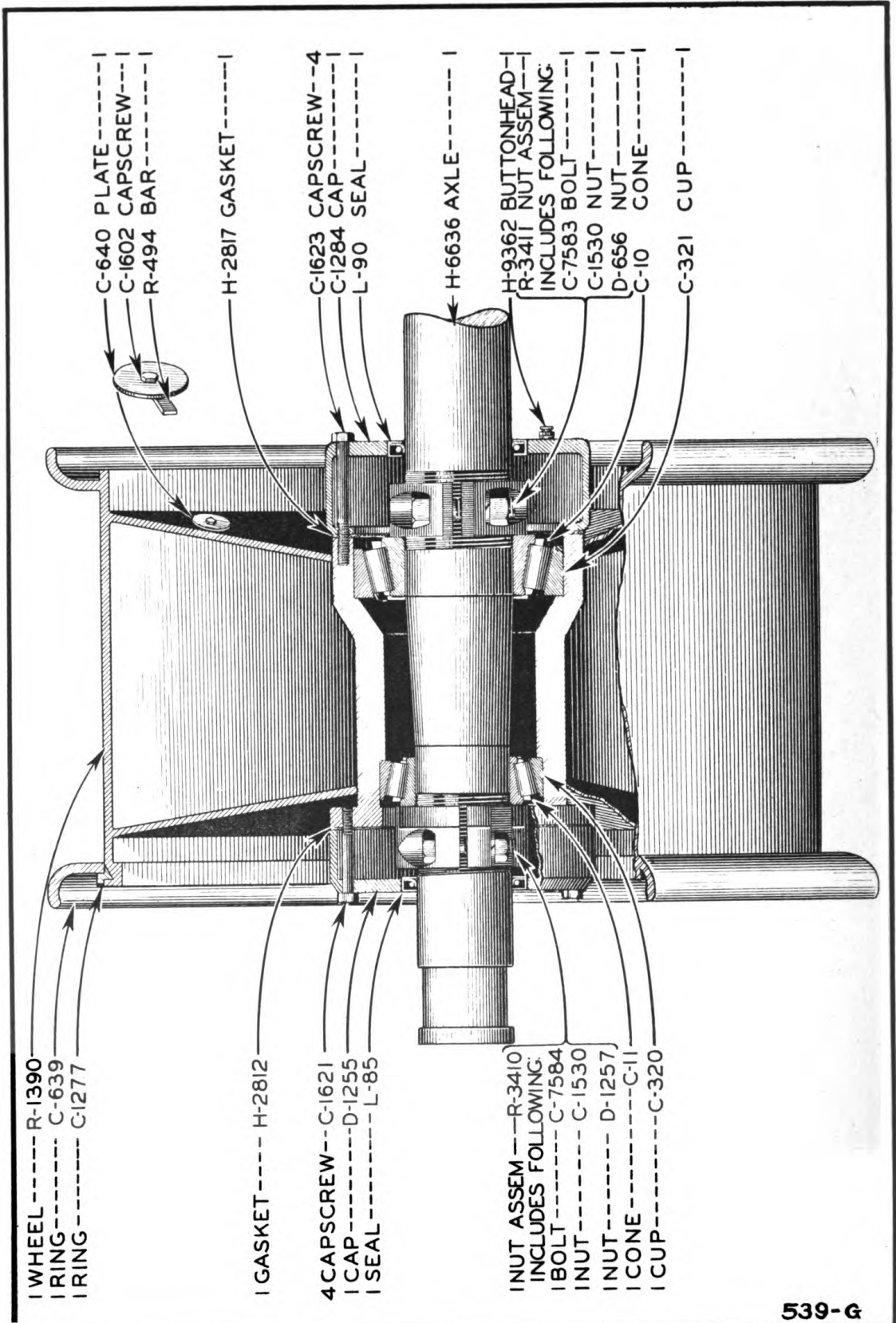

539-G

18X24 SGL. REAR WHEEL

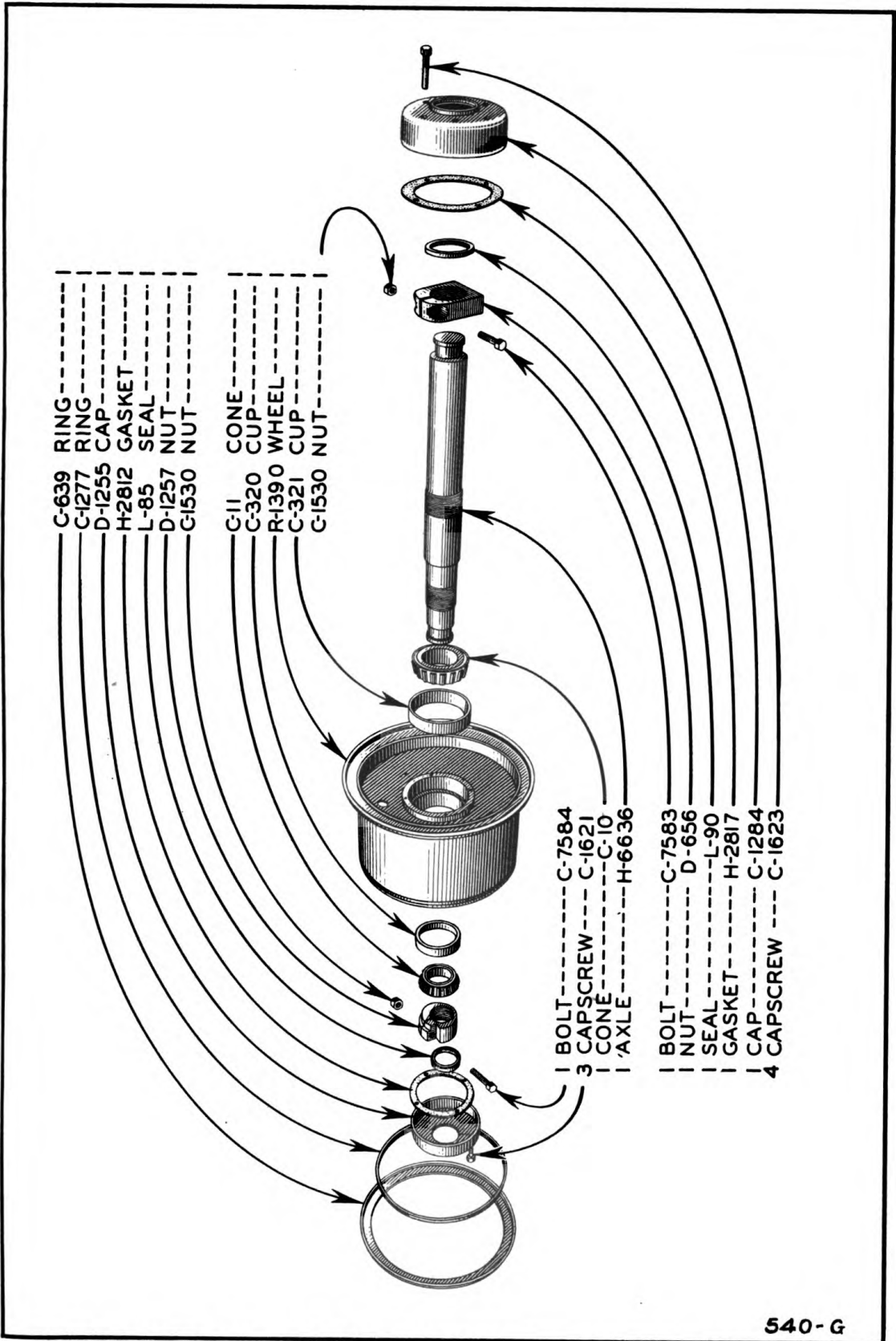

540-G

18X24 SGL. REAR WHEEL-EXPLODED





(WITH 4 OF 18 x 24, 12 AND 16 PLY TIRES, WITH TR-14M TUBE VALVE STEM)

PART No.	DESCRIPTION	Page	Qty.	WEIGHT		Price Each
				Lbs.	Oz.	
C-1	CUP—TIMKEN #3720 .....	9	4	..	12	\$1.20
C-10	CONE—TIMKEN #861 .....	22,23,24,25	4	9	2	17.19
C-11	CONE—TIMKEN #749 .....	22,23,24,25	4	4	8	8.19
C-12	BEARING—HYATT #RA-208 .....	4,13,20,21	14	..	8	1.78
C-131	ROLLER—MAIN TAILGATE .....	13	4	10	8	5.21
C-133	ROLLER—SIDE THRUST .....	13	4	4	4	2.96
C-134	PIN—FOR THRUST ROLLER .....	13	4	3	8	2.09
C-137	SHEAVE WHEEL .....	9	2	15	..	5.28
C-138	PIN .....	5, 9	6	6	..	2.65
C-172	SHEAVE WHEEL .....	9	2	12	..	5.20
C-174	PIN .....	9	2	5	..	2.38
C-175	BEARING—HYATT #RA-212 .....	9	4	1	8	2.38
C-177	BEARING—HYATT #RAW-212 .....	5, 6	12	2	..	2.70
		4,5,6,7,9,11,				
C-315	ZERK— $\frac{1}{8}$ " STRAIGHT .....	13,15,20	44	..	..	.06
C-320	CUP—TIMKEN #742 .....	22,23,24,25	4	2	8	4.09
C-321	CUP—TIMKEN #854 .....	22,23,24,25	4	6	..	10.58
C-336	RACE—HYATT #OR-208 .....	20, 21	2	..	8	1.23
C-337	RACE—HYATT #WOR-208 .....	20, 21	2	..	12	1.35
C-445	WEDGE—SMALL .....	3	1	..	8	.38
C-498	NUT—BEARING ADJUSTING .....	9	2	2	..	3.30
C-501	BOLT .....	8,10,18,19	5	1	14	1.05
C-502	WEDGE—LARGE .....	7, 12, 16	3	3	4	1.03
C-503	SOCKET—LARGE .....	7, 12, 16	3	2	8	1.31
C-504	SOCKET—SMALL .....	3, 20	3	1	4	.68
C-518	BUSHING .....	17, 18	4	4	4	6.11
C-535	BOLT .....	8	2	5	8	2.79
C-619	CAP—HUB .....	22, 23	2	9	..	6.23
C-620	RETAINER .....	22, 23	2	4	8	1.86
C-639	RING—SLIDING .....	22,23,24,25	4	40	..	8.58
C-640	PLATE—INSPECTION .....	22,23,24,25	4	1	..	.78
C-1034	PLUG— $\frac{1}{4}$ " PIPE .....	3	2	..	12	.17
C-1051	COTTER— $\frac{3}{8}$ " x 5" .....	5, 9, 13	13	..	4	.06
C-1277	RING—LOCKING .....	22,23,24,25	4	5	8	3.04
C-1284	CAP—HUB .....	22,23,24,25	2	15	..	6.38
C-1414	PULL PLATE .....	3	1	30	..	8.38
C-1529	NUT— $\frac{7}{8}$ " NC HEX .....	12	8	..	..	.08
C-1531	NUT—1" NC HEX .....	3,13,14,19	15	..	..	.11
C-1544	LOCKWASHER—1" .....	3,5,13,19	25	..	..	.07
C-1552	WASHER— $\frac{7}{8}$ " CUT .....	12	8	..	..	.01
C-1558	COTTER— $\frac{3}{8}$ " x 3 $\frac{1}{2}$ " .....	13,14,20,21	7	..	..	.05
		10,17,18				
C-1561	COTTER— $\frac{1}{2}$ " x 5" .....	22,23	5	..	8	.11
C-1577	BOLT—1" x 6 $\frac{1}{2}$ " MACHINE .....	13	2	3	..	.48
C-1581	BOLT—1" x 11" MACHINE .....	3	8	3	2	.62
C-1596	ZERK—60° .....	5, 13, 17	6	..	..	.10
C-1600	CAPSCREW— $\frac{3}{8}$ " x $\frac{1}{2}$ " NC .....	10, 16	4	..	..	.03
C-1602	CAPSCREW— $\frac{3}{8}$ " x 1" NC .....	22,23,24,25	4	..	..	.03
C-1612	CAPSCREW— $\frac{1}{2}$ " x 1" NC .....	11	6	..	..	.05
C-1613	CAPSCREW— $\frac{1}{2}$ " x 1 $\frac{1}{4}$ " NC .....	22, 23	14	..	..	.06
C-1621	CAPSCREW— $\frac{1}{2}$ " x 3 $\frac{1}{4}$ " NC .....	24, 25	8	..	4	.11
C-1623	CAPSCREW— $\frac{1}{2}$ " x 3 $\frac{3}{4}$ " NC .....	24, 25	8	..	4	.12
C-1668	CAPSCREW—1" x 3" NC .....	14	1	1	..	.47
C-1915	SPRING .....	3	6	50	..	13.50
C-2283	WEDGE .....	3	1	..	12	.38
		8,10,11,				
C-2508	COTTER— $\frac{5}{16}$ " x 3" .....	18,19	6	..	..	.01
C-2958	HOUSING .....	8	2	17	..	11.18
C-3868	FORGING .....	18	1	48	..	30.10
C-5425	PLATE—INSPECTION .....	10, 16	2	2	8	.56

541-6

## SPARE PARTS & PRICE LIST



PART No.	DESCRIPTION	Page	Qty.	WEIGHT		Price Each
				Lbs.	Oz.	
C-5783	NUT-7/16" NF HEX.....	9	2	..	..	.03
C-7376	SPIRAL SHEAVE WHEEL STRUCTURE.....	20, 21	1	67	..	30.55
C-8093	SPACER .....	20, 21	1	12	..	.53
D-1255	CAP-FOR HUB.....	24, 25	2	14	12	6.37
D-1784	CAPSCREW-1" x 2 1/4" NC.....	19	8	..	12	.42
D-1957	PLOWBOLT-7/8" x 2 1/4" -#3 HEAD.....	3	68	..	8	.16
D-1958	SOCKET WRENCH.....	3	1	3	..	3.83
D-2673	HITCH BLOCK-FOR D8.....	18	1	27	..	9.93
D-2889	LOCKWASHER-1/2" SHAKEPROOF.....	11	6	..	..	.01
*D-2899	UNIVERSAL ASSEMBLY FOR D8.....	16, 18	1	88	..	45.92
D-5365	BUSHING .....	10	1	6	..	6.90
D-8014	AXLE-FRONT .....	22, 23	2	97	..	39.93
E-3355	BUSHING .....	10	1	4	8	6.11
E-3787	WEDGE .....	20, 21	2	..	12	.53
E-3909	CAPSCREW-1" x 3 1/4" NC.....	19	4	1	..	.51
E-5251	PLUG-1/8" PIPE .....	21	1	..	..	.05
E-7888	SETSCREW-5/8" x 1 1/4".....	12	2	..	..	.13
F-1230	PIN-APRON HINGE.....	11	2	12	..	7.80
F-2825	TONGUE STRUCTURE .....	16	1	570	..	175.75
F-3121	BASE-FOR BLADE.....	3	1	425	..	100.00
F-3551	BOLT-2" x 13/8".....	19	1	12	8	6.56
F-5027	PIN .....	5, 13	4	7	..	4.18
F-6396	PIN-AXLE RETAINER .....	16	2	4	8	2.86
F-7255	WEDGE .....	6, 11, 12	2	5	12	1.57
F-7269	SHEAVE WHEEL .....	5, 6	8	15	..	5.28
F-7615	FORGING .....	10	1	66	..	44.15
F-7860	HINGED SOCKET.....	11	1	18	8	6.72
F-8448	PIN-HINGE .....	11	1	2	..	1.30
F-8620	PIN-PUSHBEAM HINGE.....	14	1	3	12	3.34
F-8820	ROLLER .....	4	1	3	4	3.03
F-9319	RUNNER RAIL.....	3	2	24	..	5.35
F-9988	BUSHING .....	4, 5, 6, 7	21	1	8	2.29
F-9989	HALF-NUT-1 1/2" NF.....	5, 6, 7	3	..	8	.52
F-9991	PIN .....	5, 7, 15	3	1	8	2.04
H-9	HINGED SOCKET .....	6	1	18	8	6.71
H-13	PIN-HINGE .....	6	1	8	12	5.47
H-23	PIN-HINGE .....	6	1	6	4	3.91
H-171	WHEEL-SHEAVE .....	4, 5, 6, 7, 8	20	6	8	4.01
H-220	BOTTOM STRUCTURE.....	3	1	1540	..	398.50
H-225	BEARING-SPECIAL HYATT #RA-212.....	4, 5, 6, 7, 8	20	1	4	2.38
H-270	REAR HITCH.....	19	1	281	..	89.53
H-271	SHEAVE HOUSING .....	5	1	31	..	10.28
H-272	SPACER (SMALL).....	7	1	..	4	.31
H-273	SPACER (LARGE).....	7	1	..	8	.47
H-290	APRON STRUCTURE.....	11	1	1480	..	477.00
H-1001	BLADE-RIGHT .....	3	1	51	..	10.30
H-1003	BLADE-LEFT .....	3	1	51	..	10.30
H-1111	CAPSCREW-1" x 1 1/2" NF.....	5	3	..	10	.37
H-1112	PIN .....	6	1	2	..	3.30
H-1113	PIN .....	6	1	1	8	2.79
H-1125	YOKE STRUCTURE.....	8	1	1500	..	487.50
H-1221	PIN-SPIRAL SHEAVE.....	20, 21	1	7	4	5.93
H-1771	HOUSING-SLIDING SHEAVE.....	6	1	60	..	20.25
H-2084	CAPSCREW-3/4" x 1" NC ALLENHEAD.....	7	2	..	4	.31
H-2465	ROLLER HOUSING-SMALL.....	13	4	4	8	1.76
H-2801	GASKET .....	22, 23	4	..	..	.15
H-2812	GASKET .....	24, 25	4	..	..	.20
H-2817	GASKET .....	22, 23, 24, 25	8	..	..	.20
H-4249	COTTER-5/16" x 2".....	16	4	..	..	.01

542-G

SPARE PARTS AND PRICE LIST



PART No.	DESCRIPTION	Page	Qty.	WEIGHT		Price Each
				Lbs.	Oz.	
H-5118	HOUSING—SLIDING .....	6	1	76	..	26.40
H-5119	SPACER .....	6	2	9	8	3.00
H-5288	BUMPER PLATE .....	7	1	9	..	3.45
H-5965	BLADE—CENTER—7/16" x 16" x 56".....	3	1	186	..	36.15
H-5967	BLADE ASSY. (INCLUDED H-5965, H-1001, H-1003)	3	1	288	..	56.75
H-6333	PIN .....	4	1	2	4	4.05
H-6335	PIN—PUSHBEAM ROLLER.....	4	1	2	4	3.03
H-6420	PIN .....	4, 15	3	1	8	3.05
H-6423	HOUSING STRUCTURE.....	15	1	133	..	42.35
H-6424	HOUSING—FOR A-FRAME.....	4	1	133	..	42.35
H-6427	PIN—FOR GANG HOUSING.....	7	1	4	12	6.13
H-6430	PUSHBEAM STRUCTURE.....	14	1	270	..	86.75
H-6636	AXLE—FOR REAR WHEELS.....	24, 25	2	110	..	42.50
H-6906	CAPSCREW—7/16" x 5½" NF.....	9	1	..	6	.11
H-7536	CAPSCREW—7/16" x 5" NF.....	9	1	..	6	.11
H-7931	FORGING .....	17	1	39	..	20.40
H-8226	PIN .....	10, 18	2	9	..	4.73
H-9362	BUTTONHEAD GREASE FITTING.....	10,16,22,24	7	..	4	.33
*R-19	CABLE CONTAINER ASSEMBLY.....	3	1	37	..	10.00
R-347	WHEEL STRUCTURE—18 x 24 SINGLE.....	22,23	2	264	..	60.85
R-494	BAR .....	22,23,24,25	4	1	..	.35
R-496	COTTER—5/16" x 4".....	6	3	..	..	.04
R-1203	PUSHER BAR.....	19	1	150	..	37.50
R-1306	PIN .....	13	2	11	..	6.78
R-1390	WHEEL STRUCTURE—18 x 24—SGL. REAR .....	24,25	2	240	..	64.36
R-1500	.....	3	1	6700	..	2152.00
R-2472	BRACKET .....	8	1	47	..	13.93
R-2479	BRACKET .....	8	1	47	..	13.93
*R-3408	AXLE NUT ASSEMBLY.....	22	2	3	12	2.84
*R-3410	AXLE NUT ASSEMBLY.....	24	2	9	4	4.49
*R-3411	AXLE NUT ASSEMBLY.....	24	2	8	..	4.45
*R-3458	AXLE NUT ASSEMBLY.....	10, 17, 18	3	6	8	5.41
R-6217	TAILGATE STRUCTURE.....	12	1	1600	..	515.00
L-85	SEAL—# 42534 .....	24, 25	2	..	5	1.36
L-90	SEAL—SPECIAL .....	24, 25	2	..	6	1.51
L-135	SEAL—SPECIAL .....	13, 20, 21	10	..	1	.30
L-323	SEAL—SPECIAL .....	9, 13	12	..	2	.50
L-12105	SEAL—# 575422 .....	22, 23	2	..	8	2.11
*D-2899	UNIVERSAL ASSEMBLY (INCLUDES FOLLOWING):			88	..	45.92
C-3868	FORGING .....			48	..	30.10
D-2673	BLOCK .....			27	..	9.93
C-501	NUT .....			1	14	1.05
H-8226	PIN .....			9	..	4.73
C-2508	COTTER—5/16" x 3".....					.01
*R-19	CABLE CONTAINER ASSEMBLY (INCLUDES FOLLOWING):					
R-4210	BOX .....			20	..	6.80
R-4211	COVER .....			10	10	1.69
R-4212	WING BOLT .....			6	7	1.51
*R-3408	NUT ASSEMBLY (INCLUDES FOLLOWING):					
C-5654	NUT .....			3	12	2.84
C-1682	BOLT—½" x 2¼" NF.....					.08
C-1524	NUT—½" NF HEX.....					.03
*R-3410	NUT ASSEMBLY (INCLUDES FOLLOWING):					
D-1257	NUT .....			9	4	4.49
C-7584	BOLT—¾" x 3½" NF.....				12	.33
C-1530	NUT—¾" NF HEX.....					.08

543-G

## SPARE PARTS & PRICE LIST





PART No.	DESCRIPTION	Page	Qty.	WEIGHT		Price Each
				Lbs.	Oz.	
*R-3411	NUT ASSEMBLY (INCLUDES FOLLOWING):					
D-656	NUT .....			8	..	4.45
C-7583	BOLT— $\frac{7}{8}$ " x 3" NF.....				12	.36
C-1530	NUT— $\frac{7}{8}$ " NF HEX.....					.08
*R-3458	NUT ASSEMBLY (INCLUDES FOLLOWING):					
C-59	NUT .....			6	8	5.41
E-6616	BOLT— $\frac{1}{2}$ " x 3" NF.....					.10
C-1524	NUT— $\frac{1}{2}$ " NF HEX.....					.03

544-G

SPARE PARTS & PRICE LIST



