

TECHNICAL MANUAL

**OPERATOR, UNIT, DIRECT SUPPORT AND GENERAL
SUPPORT MAINTENANCE MANUAL
(INCLUDING REPAIR PARTS AND
SPECIAL TOOLS LISTS)**

**POWER UNIT
PU-495A/G (NSN 6115-00-394-9575)
AND
PU-495B/G (NSN 6115-01-134-0165)
MEP-007A 100 KW 60 HZ
OR
MEP-007B 100 KW 60 HZ
GENERATOR SET
M353 2-WHEEL, 2-TIRE
MODIFIED TRAILER**

Approved for public release, distribution is unlimited.

***This manual supersedes Chapter 7 of TM 5-6115-594-14&P, 25 September 1984.**

**HEADQUARTERS, DEPARTMENT OF THE ARMY
10 MAY 1990**



**SAFETY STEPS TO FOLLOW IF SOMEONE
IS THE VICTIM OF ELECTRICAL SHOCK**

DO NOT TRY TO PULL OR GRAB THE INDIVIDUAL

IF POSSIBLE, TURN OFF THE ELECTRICAL POWER

**IF YOU CANNOT TURN OFF THE ELECTRICAL
POWER, PULL, PUSH OR LIFT THE PERSON TO
SAFETY USING A DRY WOODEN POLE OR A DRY
ROPE OR SOME OTHER INSULATING MATERIAL**

SEND FOR HELP AS SOON AS POSSIBLE

**AFTER THE INJURED PERSON IS FREE OF
CONTACT WITH THE SOURCE OF ELECTRICAL
SHOCK, MOVE THE PERSON A SHORT DISTANCE
AWAY AND IMMEDIATELY START ARTIFICIAL
RESUSCITATION**

WARNING

All specific cautions and warnings contained in this manual shall be strictly adhered to. Otherwise, severe injury, death and/or damage to the equipment may result.

HIGH VOLTAGE

is produced when this power unit is in operation.

DEATH

or severe burns may result if personnel fail to observe safety precautions. Do not operate this power unit until the ground terminal stud has been connected to a suitable ground. Disconnect the battery ground cable on the generator set before removing and installing components on the engine or in the electrical control panel system. Remove all rings, watches, and other jewelry when performing maintenance on this equipment. Loose fitting clothing should be secured to prevent it catching moving parts. Do not attempt to service or otherwise make any adjustments, connections or reconnections of wires or cables until generator set is shut down and completely de-energized.

DANGEROUS GASES

Batteries generate explosive gas during charging therefore, utilize extreme caution. Do not smoke, or use open flame in the vicinity of the generator set when servicing batteries.

Exhaust discharge contains noxious and deadly fumes. Do not operate power unit generator sets in enclosed areas unless exhaust discharge is properly vented to the outside.

To avoid sparking between filler nozzle and fuel tank, always maintain metal to metal contact between filler nozzle and fuel tank when filling generator set fuel tank.

Do not smoke or use open flame in the vicinity of the power unit while refueling generator sets.

LIQUIDS UNDER HIGH PRESSURE

are generated as a result of operation of the power unit generator set. Do not expose any part of the body to a high pressure leak in the fuel injection system.

NOISE

Operating noise level of the generator set can cause hearing damage. Ear protectors, as recommended by the medical or safety officer, must be worn when working near this power unit.

WARNING

Clean parts in a well-ventilated area. Avoid inhalation of solvent fumes and prolonged exposure of skin to cleaning solvent. Wash exposed skin thoroughly. Dry cleaning solvent (PD-680) used to clean parts is potentially dangerous to personnel and property. Do not use near open flame or excessive heat. Flash point of solvent is 100°F to 138°F (38°C to 59°C).

C1

CHANGE

NO. 1

HEADQUARTERS
DEPARTMENT OF THE ARMY
WASHINGTON, D.C., 30 May 1997

**Operator, Unit, Direct Support and General Support
Maintenance Manual (Including Repair Parts and Special Tools Lists)**

**POWER UNIT PU-495A/G (NSN 6115-00-394-9575) AND
PU-495B/G (NSN 6115-01-134-0165) MEP-007A 100 KW 60 HZ OR
MEP-007B 100 KW 60 HZ GENERATOR SET
M353 2-WHEEL, 2-TIRE MODIFIED TRAILER**

DISTRIBUTION STATEMENT A: Approved for public release; distribution is unlimited

TM 9-6115-646-14&P, 10 May 1990, is changed as follows:

1. Remove and insert pages as indicated below. New or changed text material is indicated by a vertical bar in the margin. An illustration change is indicated by a miniature pointing hand.

<i>Remove pages</i>	<i>Insert pages</i>
i and ii	i and ii
1-1 and 1-2	1-1 and 1-2
3-5 and 3-6	3-5 and 3-6
4-9 through 4-12	4-9 through 4-12
B-1 and B-2	B-1 and B-2

2. Retain this sheet in front of manual for reference purposes.

By Order of the Secretary of the Army:

DENNIS J. REIMER
General, United States Army
Chief of Staff

Official:

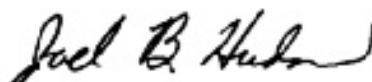

JOEL B. HUDSON

*Administrative Assistant to the
Secretary of the Army*

03268

DISTRIBUTION:

To be distributed in accordance with DA Form 12-25-E, block no. 4026, requirements for TM 9-6115-646-14&P.

**Operator, Unit, Direct Support and General Support
Maintenance Manual (Including Repair Parts and Special Tools Lists)**

**POWER UNIT PU-495A/G (NSN 6115-00-394-9575) AND
PU-495B/G (NSN 6115-01-134-0165) MEP-007A 100 KW 60 HZ OR
MEP-007B 100 KW 60 HZ GENERATOR SET
M353 2-WHEEL, 2-TIRE MODIFIED TRAILER**

REPORTING ERRORS AND RECOMMENDING IMPROVEMENTS

You can help improve this manual. If you find any mistakes, or if you know of a way to improve these procedures, please let us know. Mail your letter or DA Form 2028 (Recommended Changes to Publications and Blank Forms), or DA Form 2028-2 located in the back of this manual directly to: Commander, US Army Aviation and Troop Command, ATTN: AMSAT-I-MP, 4300 Goodfellow Blvd., St. Louis, MO 63120-1798. You may also submit your recommended changes by E-mail directly to <mpmt%avma28@st-louis-emh7.army.mil>. A reply will be furnished directly to you. Instructions for sending an electronic 2028 may be found at the back of this manual immediately preceding the hard copy 2028.

DISTRIBUTION STATEMENT A: Approved for public release; distribution is unlimited

TABLE OF CONTENTS

		PAGE
CHAPTER 1	INTRODUCTION	
Section I	General	1-1
Section II	Description and Data.....	1-2
CHAPTER 2	OPERATING INSTRUCTIONS	
Section I	Operating Procedures	2-1
Section II	Operation of Auxiliary Equipment.....	2-1
Section III	Operation Under Unusual Conditions	2-1
CHAPTER 3	OPERATOR/CREW MAINTENANCE INSTRUCTIONS	
Section I	Consumable Operating and Maintenance Supplies.....	3-1
Section II	Lubrication Instructions	3-1
Section III	Preventive Maintenance Checks and Services (PMCS).....	3-1
Section IV	Troubleshooting	3-21
Section V	Operator/Crew Maintenance.....	3-21

*This manual supersedes Chapter 7 of TM 5-6115-594-14&P dated 25 September 1984.

CHAPTER 4	UNIT MAINTENANCE	
Section I	Service Upon Receipt of Equipment	4-1
Section II	Movement to a New Worksite	4-6
Section III	Repair Parts, Special Tools, Special Test, Measurement and Diagnostic Equipment (TMDE)	4-7
Section IV	Lubrication Instructions	4-7
Section V	Preventive Maintenance Checks and Services.....	4-8
Section VII	Troubleshooting	4-12
Section VIII	Radio Interference Suppression	4-12
Section IX	Maintenance of Power Unit Trailer.....	4-12
CHAPTER 5	DIRECT AND GENERAL SUPPORT MAINTENANCE INSTRUCTIONS	
Section I	Introduction	5-1
Section II	Maintenance of Power Unit Trailer.....	5-1
Section III	Generator Set.....	5-3
CHAPTER 6	TEST AND INSPECTION AFTER REPAIR	
Section I	General Requirements	6-1
Section II	Inspection.....	6-1
Section III	Operational Tests.....	6-1
APPENDIX A	REFERENCES.....	A-1
APPENDIX B	COMPONENTS OF END ITEM AND BASIC ISSUE ITEMS LISTS.....	B-1
APPENDIX C	MAINTENANCE ALLOCATION CHART.....	C-1
APPENDIX D	UNIT, DIRECT SUPPORT, GENERAL SUPPORT AND DEPOT MAINTENANCE REPAIR PARTS AND SPECIAL TOOLS LIST.....	D-1

LIST OF ILLUSTRATIONS

Figure	Title	Page
1-1	Power Unit, Curbside Front, Three-Quarter View	1-3
1-2	Power Unit, Roadside Rear, Three-Quarter View	1-3
4-1	Power Unit Packed for Shipment	4-2
4-2	Unpacking Power Unit	4-3
4-3	Installing Power Unit	4-4
4-4	External Fuel Line Connection	4-6
4-5	Accessory Stowage Chest Replacement	4-13
4-6	Fire Extinguisher Bracket Replacement	4-14
4-7	Front Step Replacement	4-15
4-8	Rear Step Replacement	4-17
4-9	Front Platform/Plate Replacement	4-18
4-10	Cover Plate Replacement	4-20
5-1	Accessory Stowage Chest Repair	5-2
5-2	Power Unit Markings	5-3
5-3	Generator Set Replacement	5-4
	Components of End Item	B-2
	Basic Issue Items	B-3
D-1	Generator Set	D-8
D-2	Trailer	D-11
D-3	Accessory Box	D-16
D-4	Front Steps	D-18
D-5	Rear Steps	D-20
D-6	Data Plates and Reflectors	D-22

LIST OF TABLES

Number	Title	Page
3-1	Consumable Operating and Maintenance Supplies	3-1
3-2	Operator/Crew Preventive Maintenance Checks and Services (PMCS)	3-4
4-1	Unit Preventive Maintenance Checks and Services (PMCS)	4-9

CHAPTER 1 INTRODUCTION

SECTION I. GENERAL

1-1. Scope. This manual is for your use in operating and maintaining the Power Unit, PU-495A/G and PU-495B/G. The PU-495A/G and PU-495B/G are mobile power units used to supply power to any system or equipment requiring up to 100 KW of 50/60 Hz input operating power. In addition to operating instructions and operator, unit, direct support and general support maintenance procedures, this manual contains a Repair Parts and Special Tools List for the power units. Throughout this manual, the designation PU-495 is used when referring to both the PU-495A/G and PU-495B/G power units. The A/G and BIG suffixes are used when the information discussed is applicable to only one model power unit.

1-2. Maintenance Forms and Records. Maintenance forms and records used by Army personnel are prescribed by DA Pam 738-750.

1-3. Reporting of Errors. Reporting of errors and omissions and recommendations for improvement of this publication by the individual user is encouraged. Reports should be submitted on a DA Form 2028 directly to: Commander, US Army Aviation and Troop Command, ATTN: AMSAT-I-MT, 4300 Goodfellow Boulevard, St. Louis, MO 63120-1798..

1-4. Reporting Equipment Improvement Recommendations (EIR). EIR's will be prepared using SF 368, Product Quality Deficiency Report. Instructions for preparing EIR's are provided in DA PAM 738-750, The Army Maintenance Management System. EIR's should be mailed directly to: Commander, US Army Aviation and Troop Support Command, ATTN: AMSAT-I-MDO, 4300 Goodfellow Boulevard, St. Louis, MO 63120-1798.

1-5. Levels of Maintenance Accomplishment. Army users shall refer to the Maintenance Allocation Chart (MAC) for tasks and levels of maintenance to be performed.

1-6. Destruction of Army Materiel. Destruction of Army materiel to prevent enemy use shall be in accordance with TM 750-244-3.

1-7. Administrative Storage.

a. Placement of equipment in administrative storage should be for short periods of time when a shortage of maintenance effort exists. Items should be in mission readiness within 24 hours or within the time factors as determined by the directing authority. During the storage period appropriate maintenance records will be kept

b. Army equipment placed in administrative storage will have preventive maintenance performed in accordance with the PMCS tables before storage. When equipment is removed from storage, PMCS will be performed to assure operational readiness.

c. Storage site selection. Inside storage is preferred for items selected for administrative storage. If inside storage is not available, trucks, vans, conex containers and other containers may be used.

1-8. Preparation for Shipment and Storage. Refer to TB 740-97-2.

Section II. DESCRIPTION AND DATA

1-9. **Description.** Power Unit PU-495 (figures 1-1 and 1-2) is made up of one Tactical Utility Generator Set, DOD Model MEP-007 mounted on a modified M353 trailer. The generator set is a liquid-cooled, diesel engine-driven unit with a load capacity of 100 KW at 50/60 Hz. The trailer is a two-wheeled, single-tired unit with a 3-1/2-ton carrying capacity. Modifications to the basic trailer provide stowage for the accessories and all equipment necessary for mobile operation. Steps mounted on each corner of the trailer, and cover plates on the sides and front frame rails, provide a work platform for the operator and maintenance personnel when servicing the generator set.

1-10. **Tabulated Data.** The tabulated data provides operator and unit level personnel with the dimensions and weights for Power Unit PU-495. These specifications are computed from the combined dimensions and weights of the generator set and trailer as modified for use with the power unit. Specifications of the individual components can be found in their respective technical publications. For additional information concerning Generator Set, DOD Model MEP-007A, refer to TM 5-6115-457-12 and -34. For additional information concerning Generator Set, DOD Model M EP-007B, refer to TM 5-6115-600-12 and -34. For additional information on the M353 trailer, refer to TM 9-2330-247-14&P. The tabulated data also includes the location and content of all data plates unique to the power unit.

a. Identification and Instruction Plates.

(1) *Identification plate.*

(a) *Location.* This plate is located on the front roadside frame between the trailer body and the drawbar ring.

(b) *Content.*

US		US
POWER UNIT		POWER UNIT
PU-495A/G	or	PU-495B/G
KW 100		KW 100
HERTZ 50/60		HERTZ 50/60
NSN 6115-00-394-9575		NSN 6115-01-134-0165

(2) *Instruction plate.*

(a) *Location.* This plate is located near the ground stud on the front, roadside corner of the trailer body.

(b) *Content.*

GROUND TERMINAL

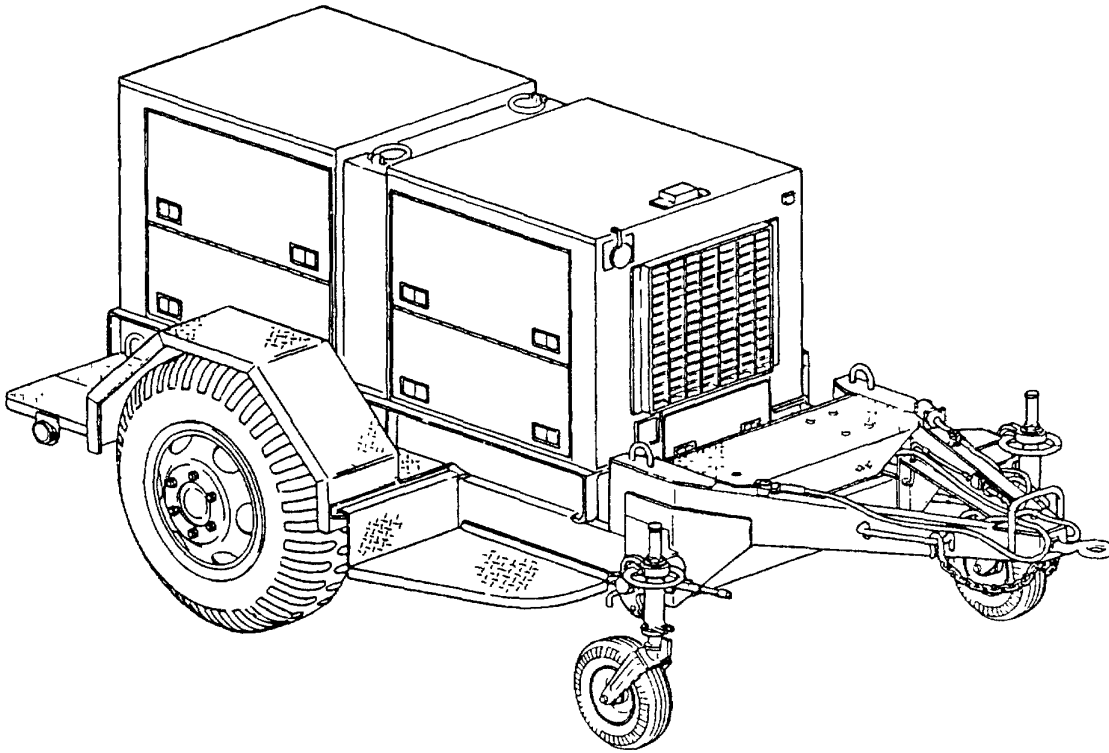

4882 001

Figure 1-1. Power Unit, Curbside Front, Three-Quarter View.

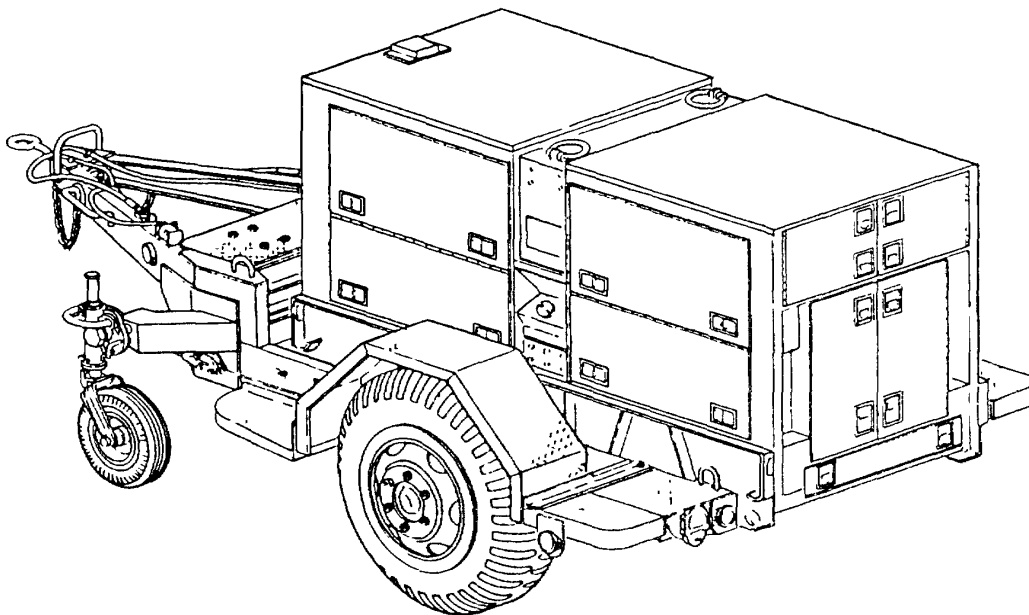

4882-002

Figure 1-2. Power Unit, Roadside Rear, Three-Quarter View.

b. Tabulated Data for Power Unit.

Overall Length	186 in (472.4 cm)
Overall Width	95 7/8 in (218.1 cm)
Overall Height	84 1/4 in (214.0 cm)
Net Weight (empty)	6680 lb (4337 kg)
Net Weight (filled)	7500 lb (3405 kg)
Shipping Weight	8400 lb (3813 kg)
Cubage	T.B.S.

1-11. **Differences Between Models.** The PU-495A/G and PU-495B/G differ from each other only in regard to the model generator set utilized by each. The PU-495A/G is equipped with an MEP-007A generator set whereas the PU-495B/G uses model MEP-007B generator set. The only difference between generator set models is the installation of different diesel engines. The performance of both engines is similar and therefore there is no significant difference in specifications between generator sets or power unit models.

CHAPTER 2**OPERATING INSTRUCTIONS****Section I. OPERATING PROCEDURES**

2-1. **Operating Procedures.** Before the power unit generator can be turned on and operated, the power unit must be towed to a worksite and installed. Installation instructions are provided in paragraph 4-2. Instructions for dismantling the power unit for movement are given in paragraph 4-3. Detailed prestarting, startup, operating and shutdown procedures for the generator set can be found on the "Operating Instructions" data plate located inside the left hand control cubicle door at the rear of the power unit, and in the generator set technical manuals TM 5-6115-457-12 or TM 5-6115-600-12, as applicable.

WARNING

Do not operate generator set until it is properly grounded (paragraph 4-2, b). Serious injury or death by electrocution can result from operating an ungrounded generator set.

Operating noise level of generator can cause hearing damage. Ear protectors, as recommended by medical or safety officer, must be worn when working near power unit.

Section II. OPERATION OF AUXILIARY EQUIPMENT

2-2. **Operation of Auxiliary Equipment.** There is no auxiliary equipment supplied with the power unit.

Section III. OPERATION UNDER UNUSUAL CONDITIONS

2-3. **Operation Under Unusual Conditions.** When operating the power unit under unusual conditions such as extremes in temperature or difficult terrain, there are steps that must be taken to protect the equipment.

- a. Refer to TM 5-6115-457-12 or TM 5-6115-600-12, as applicable, for special procedures when operating the generator set under unusual conditions.
- b. Refer to TM 9-2330-247-14&P for special procedures when operating the trailer under unusual conditions.

2-1/(2-2 blank)

CHAPTER 3

OPERATOR/CREW MAINTENANCE INSTRUCTIONS

Section I. CONSUMABLE OPERATING AND MAINTENANCE SUPPLIES

3-1. **Consumable Supplies.** Consumable supplies used in the maintenance and operation of the power unit are listed in Table 3-1.

Table 3-1. Consumable Operating and Maintenance Supplies

(1) Component application	(2) National stock number	(3) Description	(4) Qty required for initial operation	(5) Qty required 8 hours operation	(6) Notes
General Cleaning	6850-00-664-5685	Solvent, Drycleaning, PD-680	1 quart	As required	
Accessory Stowage Chest	9150-00-186-6681	Oil, Lubricating, OE/HDO-30	1 quart	As required	
	9150-00-402-4478	Oil, Lubricating, OEA	1 quart	As required	

Section II. LUBRICATION INSTRUCTIONS

3-2. **General.** Detailed instructions for the lubrication of the major components of the power unit are contained in the applicable Lubrication Orders (LO's). Refer to DA Pam 25-30 to ensure the latest editions of the LO's are used.

3-3. **Generator Lubrication.** Refer to TM 5-6115-457-12 or TM 5-6115-600-12, as applicable, for generator set Lubrication Order.

3-4. **Trailer Lubrication.** There are no operator/crew lubrication requirements for the power unit trailer.

Section III. PREVENTIVE MAINTENANCE CHECKS AND SERVICES (PMCS)

NOTE

The PMCS chart in this section contains all necessary Operator/Crew preventive maintenance checks and services for this equipment.

3-5. **General.** The preventive maintenance checks and services listed in Table 3-2 are grouped according to stages of equipment operation or time intervals. Using the following as a guide, do the checks and services at the intervals shown.

- a. Before you operate, perform your before (B) PMCS. Observe all CAUTIONS and WARNINGS.
- b. While you operate, perform your during (D) PMCS. Observe all CAUTIONS and WARNINGS.
- c. After you operate, be sure to perform your after (A) PMCS.
- d. Do (W) PMCS weekly.
- e. Do (M) PMCS monthly.
- f. If equipment falls to operate, refer to Section IV Troubleshooting. If the problem cannot be corrected, see paragraph 3-8, Reporting Deficiencies.

3-6. **Purpose of PMCS Table.** The purpose of the PMCS table is to provide a systematic method of inspecting and servicing the equipment. In this way, small defects can be detected early before they become a major problem causing the equipment to fail to complete its mission. The PMCS table is arranged with the individual PMCS procedures listed in sequence under assigned intervals. The most logical time (before, during, or after operation) to perform each procedure determines the interval to which it is assigned. Make a habit of doing the checks and services in the same order each time and anything wrong will be seen quickly. See paragraph 3-7 for an explanation of the columns in table 3-2.

3-7. **Explanation of Columns.** The following is a list of the PMCS table column headings with a description of the information found in each column.

- a. Item No. This column shows the sequence in which the checks and services are to be performed, and is used to identify the equipment area on the Equipment Inspection and Maintenance Worksheet, DA Form 2404.
- b. Interval. This column shows when each check is to be done.
- c. Item to be Inspected. This column identifies the general area or specific part where the check or service is to be done.
- d. Procedures. This column lists the checks or services to be done and explains how to do them.
- e. Equipment s Not Ready/Available If. This column lists conditions that make the equipment unavailable for use because it is unable to perform its mission or because it would represent a safety hazard. Do not accept or operate equipment with a condition in the "Equipment Is Not Ready/Available If" column.

3-8. **Reporting Deficiencies.** If you discover any problem with the equipment during PMCS or while operating it that you are unable to correct, it must be reported. Refer to DA Pam 738-750 and report the deficiency using the proper forms.

3-9. **Special Instructions.** Preventive maintenance is not limited to performing the checks and services listed in the PMCS table. Covering unused receptacles, stowing unused equipment and other routine procedures such as equipment inventory, cleaning components, and touch-up painting are not listed in the PMCS table. " These are things you should do any time you see they need to be done. If a routine check is listed in the PMCS table it is because other operators have reported problems with this item. Take along tools and cleaning cloths needed to perform the required checks and services. Use the information in the following paragraphs to help you identify problems at any time.

a. Routine Inspections. Use the following information to help identify potential problems before and during checks and services

WARNING

Drycleaning solvent PD-680 is both toxic and flammable. Wear safety goggles and gloves and use in a well-ventilated area. Avoid prolonged breathing of vapors and avoid skin contact. Do not use near open flame or excessive heat. Flash point of solvent is 100°F to 138°F (38°C to 59°C) if you become dizzy while using PD-680, get fresh air immediately and get medical aid. If PD-680 contacts eyes, flush with water and get medical aid immediately.

- (1) Keep it clean. Dirt, grease, and oil get in the way and may cover up a serious problem. Use drycleaning solvent PD-680, to clean metal surfaces. Use soap and water to clean rubber or plastic parts and material.
- (2) Bolts, nuts, and screws. Check them all to make sure they're not loose, missing, bent, or broken. Don't try to check them all with a tool, but look for chipped paint, bare metal, or rust around bolt heads. If you find one loose, tighten it or report it to unit maintenance.
- (3) Welds. Look for loose or chipped paint, rust, or gaps where parts are welded together. If a broken weld is found, report it to higher level of maintenance.
- (4) Electrical wires, connectors, terminals and receptacles. Look for cracked or broken insulation, bare wires, and loose or broken connectors. Tighten loose connectors and make sure the wires are in good condition. Examine terminals and receptacles for serviceability.
- (5) Hoses and fluid lines. Look for wear, damage, and leaks. Make sure clamps and fittings are tight. Wet spots and stains around a fitting or connector can mean a leak. If a leak comes from a loose connector, tighten it. If something is broken or worn out, report it to unit maintenance.

b. Leakage Definitions. It is necessary for you to know how fluid leakage affects the status of your equipment. The following are definitions of the types/classes of leakage you need to know to be able to determine the status of your equipment. Learn and be familiar with them. When in doubt, NOTIFY YOUR SUPERVISOR!

Leakage Definitions:

Class I	Seepage of fluid (as indicated by wetness or discoloration) not great enough to form drops.
Class II	Leakage of fluid great enough to form drops but not enough to cause drops to drip from item being checked/inspected.
Class III	Leakage of fluid great enough to form drops that fall from the item being checked/inspected.

CAUTION

Equipment operation is allowable with minor leakage (Class I or II) of any fluid except fuel. Of course, consideration must be given to the fluid capacity in the item being checked/inspected. When in doubt, notify your supervisor.

When operating with Class I or II leaks, continue to check fluid level more often than required in the PMCS. Parts without fluid will stop working and/or cause equipment damage.

Class III leaks should be reported to your supervisor or unit maintenance

NOTE

If the equipment must be kept in continuous operation, check and service only those items that can be checked and serviced without disturbing operation. Make the complete checks and services when the equipment can be shut down.

Within designated interval, these checks are to be performed in the order listed.

Table 3-2. Operator/Crew Preventive Maintenance Checks and Services (PMCS).

B - Before

D - During

A - After

W - Weekly

M - Monthly

Item no.	Interval				Item to be inspected. Procedure: check for and have repaired, filled, or adjusted as needed	Equipment is not ready/available if:
	B	D	A	W		
					<p style="text-align: center;"><u>WARNING</u></p> <p>Before performing any maintenance that requires climbing on or under trailer, set trailer handbrakes and chock wheels. Injury to personnel could result from trailer suddenly rolling or tipping.</p> <p style="text-align: center;">NOTE</p> <p>Perform weekly as well as before PMCS if you are the assigned operator but have not operated the equipment since the last weekly inspection, or if you are operating the equipment for the first time.</p> <p style="text-align: center;">3-4</p>	

Table 3-2. Operator/Crew Preventive Maintenance Checks and Services (PMCS) (cont).

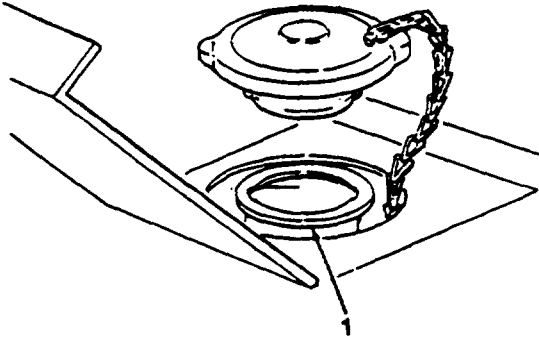
Item No.	Interval					Item To Be Inspected Procedure:	Equipment Is Not Ready/Available If:
	B	D	A	W	M		
1	•					<p>GENERATOR SET EXTERIOR</p> <p>a. Check on, around, and beneath generator set for fuel or oil and coolant leaks.</p> <p>b. Check that generator set ground is properly installed and grounding connections are tight.</p> <p>c. Manually open and close radiator louver doors to check for proper operation.</p>	<p>A Class III coolant or lubrication oil leak or any class fuel leak is detected.</p> <p>Generator set ground wire is not properly installed.</p> <p>Louver doors do not operate correctly.</p>
2	•					<p>COOLANT</p> <p>Check coolant level. Coolant should be two inches below overflow in radiator filler neck (1).</p>  <p style="text-align: right;">4882-003</p>	<p>Coolant level is below recommended level.</p>

Change 1 3-5

Table 3-2. Operator/Crew Preventive Maintenance Checks and Services (PMCS) (cont).

Item No.	Interval					Item To Be Inspected Procedure:	Equipment Is Not Ready/Available If:
	B	D	A	W	M		
3	•					<p>FUEL GAGE</p> <p>Check fuel gage (2) for sufficient fuel for continuous operation.</p>  <p>FUEL LEVEL</p> <p>4882-004</p>	
4	•					<p>ENGINE OIL LEVEL</p> <p>Check oil filler dipstick (3) for proper oil level. Add oil as required.</p>  <p>4882-005</p>	Engine oil level is at or below ADD mark.

Table 3-2. Operator/Crew Preventative Maintenance Checks and Services (PMCS) (cont.)

		B - Before	D - During	A - After	W - Weekly	M - Monthly	
ITEM NO	INTERVAL					ITEM TO BE INSPECTED PROCEDURE: Check for and have repaired, filled, or adjusted as needed	Equipment is Not Ready/Available If:
	B	D	A	W	M		
5	•						<p>ACCESSORIES</p> <p>Check that the following accessories are not missing.</p> <p>a. Sledge hammer</p> <p>b. Fire extinguisher</p> <p>c. Slide hammer</p> <p>d. Ground rods</p> <p>e. Fuel drum adapter</p> <p>Fire extinguisher is missing.</p> <p>Ground rods are missing.</p>
6	•						<p>BRACKETS</p> <p>Check fire extinguisher and fuel can mounting brackets for loose hardware and broken fittings.</p>
7	•						<p>TIRES</p> <p>a. Check for cuts, foreign objects, or unusual tread wear. Remove any stones from between the treads.</p> <p>b. Check tires (4) for damage or low pressure. Correct pressure is:</p> <p>Highway 70 psi (482.65 kPa) Cross-country 50 psi (344.75 kPa) Mud, snow, or sand 15 psi (103.4 kPa).</p> <p>One tire is flat, missing, or unserviceable.</p>

Table 3-2. Operator/Crew Preventative Maintenance Checks and Services (PMCS) (cont.)

ITEM NO	INTERVAL					ITEM TO BE INSPECTED PROCEDURE: Check for and have repaired, filled, or adjusted as needed	Equipment is Not Ready/Available If:
	B	D	A	W	M		
8	•					<p>WHEELS</p> <p>Check for wheel damage and loose or missing stud nuts (5).</p>  <p style="text-align: right;">4882-006</p>	<p>One wheel is damaged One stud nut is loose or missing.</p>
9	•					<p>LUNETTE</p> <p>Check lunette (6) for Insecure mounting and obvious damage.</p>	<p>Lunette Is loose, bent or cracked.</p>
10	•					<p>SAFETY CHAINS</p> <p>Check safety chains (7) for Insecure mounting and obvious damage.</p>  <p style="text-align: right;">4882-007</p> <p style="text-align: right;">4882-007</p>	<p>Safety chains are missing or damaged.</p>

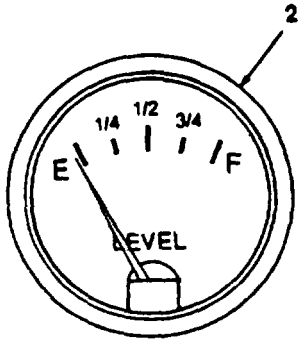
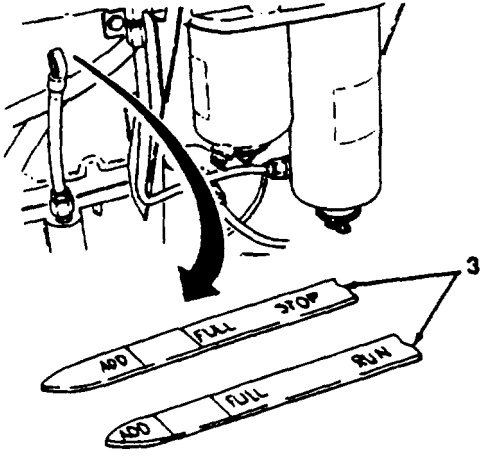
Table 3-2. Operator/Crew Preventative Maintenance Checks and Services (PMCS) (cont.)

ITEM NO	INTERVAL					ITEM TO BE INSPECTED PROCEDURE: Check for and have repaired, filled, or adjusted as needed	Equipment is Not Ready/Available If:
	B	D	A	W	M		
11	•					<p>INTERVEHICULAR CABLE</p> <p>Inspect cable (8) to insure it is in good condition and all connectors (9) are correctly assembled and secured in mounting clips (10).</p>  <p>4882-008</p>	

4882-00E

Table 3-2. Operator/Crew Preventative Maintenance Checks and Services (PMCS) (cont.)

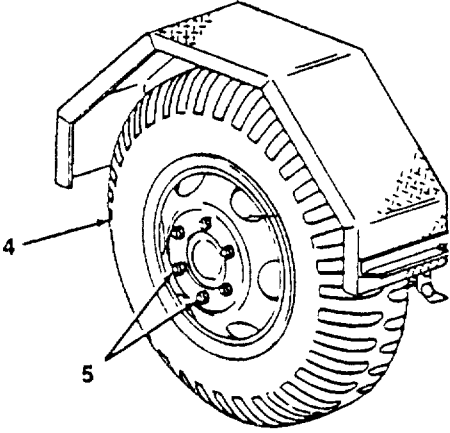
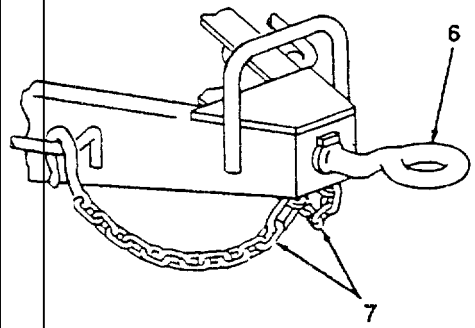
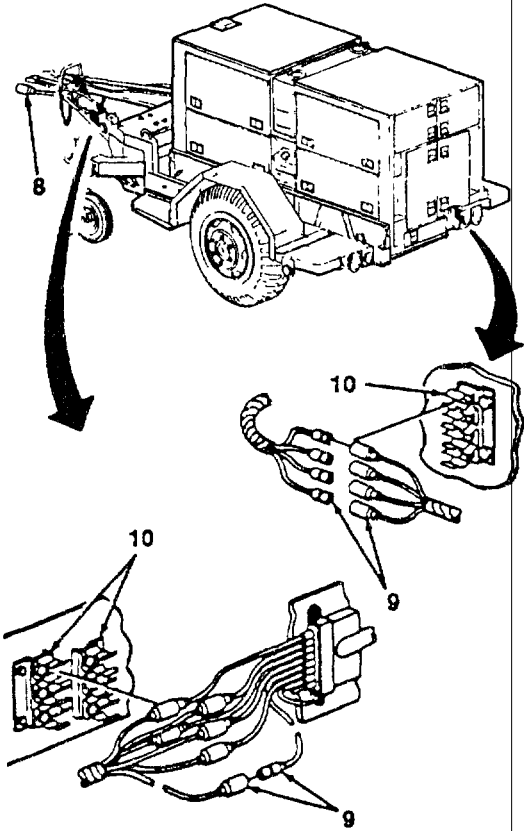
ITEM NO	INTERVAL					ITEM TO BE INSPECTED PROCEDURE: Check for and have repaired, filled, or adjusted as needed	Equipment is Not Ready/Available If:
	B	D	A	W	M		
12	•					<p>AIR HOSES, FITTINGS AND BRAKE AIR CHAMBER</p> <p>Check air hoses (11), fittings (12) and brake air chamber (13) for signs of damage or leaks.</p>	Damage or leaks are detected.
13				•		<p>AIR FILTER</p> <p>Remove pipe plug (14) from bottom of air filter (15), drain filter and reinstall plug.</p>  <p style="text-align: right;">4882-010 4882-010</p>	
14	•					<p>REFLECTORS</p> <p>Check for damaged or missing reflectors.</p> <p style="text-align: center;">3-10</p>	

Table 3-2. Operator/Crew Preventative Maintenance Checks and Services (PMCS) (cont.)

ITEM NO	INTERVAL					ITEM TO BE INSPECTED PROCEDURE: Check for and have repaired, filled, or adjusted as needed	Equipment is Not Ready/Available If:
	B	D	A	W	M		
15	•					<p>HYDRAULIC HOSES, FITTINGS AND MASTER CYLINDER</p> <p>Check brake system hoses (16) and fittings (17) and master cylinder (18), and check under vehicle for signs of brake fluid leaks.</p>  <p style="text-align: right;">4882-011</p>	A class III brake fluid leak is detected Hoses are broken or worn.
16		•				<p>SWIVEL CASTERS</p> <p>Check condition of swivel casters (19) and tires (20) Correct pressure for caster tires is 65 psi (448.18 kPa).</p>  <p style="text-align: right;">4882-012</p> <p style="text-align: center;">3-11</p>	There Is Indication that swivel caster may collapse.

Table 3-2. Operator/Crew Preventative Maintenance Checks and Services (PMCS) (cont.)

ITEM NO	INTERVAL					ITEM TO BE INSPECTED PROCEDURE: Check for and have repaired, filled, or adjusted as needed	Equipment is Not Ready/Available If:
	B	D	A	W	M		
17	•					<p>LIGHTS</p> <p>a. With inter-vehicular cable connected to towing vehicle, operate vehicle light switch through all settings and check lights (21).</p> <p style="text-align: center;">NOTE</p> <p>An assistant is required while checking brake lights</p> <p>b. Step on brake pedal and check brake lights (21)</p> <div style="text-align: center;">  </div> <p style="text-align: right;">4882-013</p>	<p>Lights are not functioning properly</p> <p>Brake lights are not functioning properly</p>
18		•				<p>BRAKE SYSTEM</p> <p>Test brake system by hooking trailer to towing vehicle and applying brakes. operate</p>	<p>Service brakes fall to</p>
19		•				<p>TRAILER OPERATION</p> <p>a. Be alert for any unusual noises while towing trailer Stop and investigate any unusual noises.</p> <p>b. Ensure that trailer is tracking/following correctly behind towing vehicle with no side pull</p>	<p>Trailer is not tracking/following correctly</p>

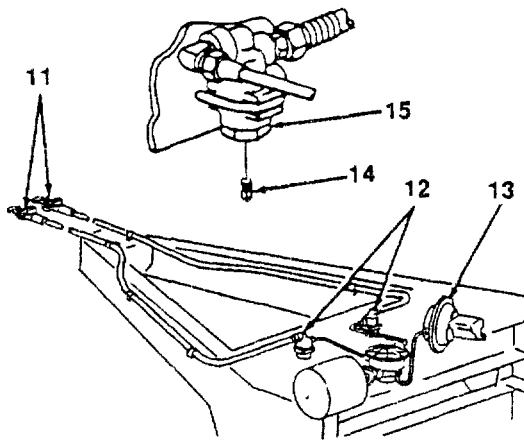
Table 3-2. Operator/Crew Preventative Maintenance Checks and Services (PMCS) (cont.)

ITEM NO	INTERVAL					ITEM TO BE INSPECTED PROCEDURE: Check for and have repaired, filled, or adjusted as needed	Equipment is Not Ready/Available If:
	B	D	A	W	M		
20		•				<p>GENERATOR SET GAGES AND INSTRUMENTS</p> <p>a. Check that air cleaner condition indicator (22) does not indicate a clogged air cleaner Press-to-test</p> <p>b. Check that battery charging ammeter (23) is in green area during normal operation.</p> <div style="text-align: center;">  <p>AIR CLEANER CONDITION</p> <p>BATTERY CHG AMMETER</p> </div> <p style="text-align: right;">4882-014</p> <p style="text-align: center;">4882-014</p> <p>c. Check that frequency meter (24) indicates 60 Hz (red line) when generator is operating under load.</p> <p>d. Check that kilowatt meter (25) reading does not exceed 100% during 60 Hz operation or 83.3% during 50 Hz operation.</p> <div style="text-align: center;">  <p>24</p> <p>25</p> </div> <p style="text-align: right;">4882-015</p>	<p>Light remains on during operation</p> <p>Battery indicator not in green area</p> <p>Correct frequency cannot be maintained</p>

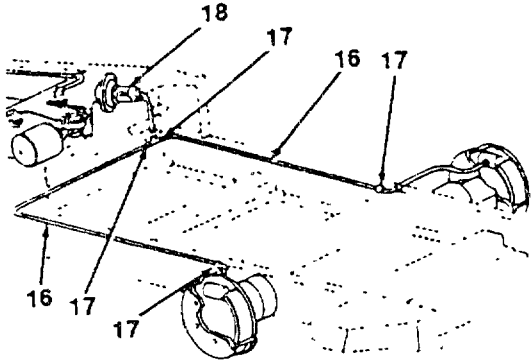
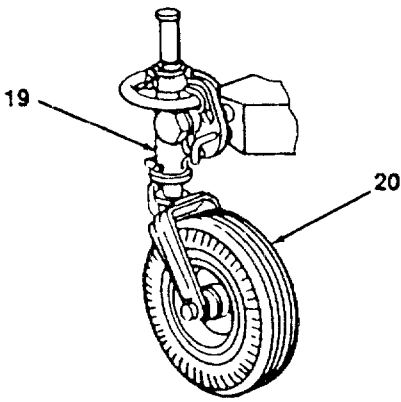
Table 3-2. Operator/Crew Preventative Maintenance Checks and Services (PMCS) (cont.)

ITEM NO	INTERVAL					ITEM TO BE INSPECTED PROCEDURE: Check for and have repaired, filled, or adjusted as needed	Equipment is Not Ready/Available If:
	B	D	A	W	M		
20		•				<p>GENERATOR SET GAGES AND INSTRUMENTS (cont.)</p> <p>e. Check that A.C. ammeter (26) reading does not exceed 100% of rated current or more than 5% load difference between phases</p> <p>f. Check that A C voltmeter (27) indicates desired output voltage as determined by load connections and amps-volts selector switch</p> <div style="text-align: center;">  <p>4882-016</p> </div> <p>g. Check engine oil pressure gage (28) for 40 to 60 psi indication</p> <p>h. Check coolant temperature gage (29) for 180 to 200°F (76.7° to 93.3°C) indication</p> <div style="text-align: center;">  <p>4882-017</p> </div> <p>3-14</p>	<p>No Indication when load is applied</p> <p>Desired voltage cannot be obtained and maintained</p> <p>Oil pressure drops below 15 ± 3 psi</p> <p>Temperature exceeds 200°F (93.3°C)</p>

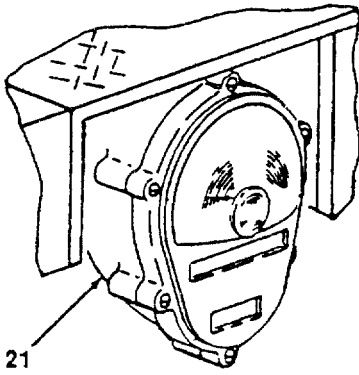
Table 3-2. Operator/Crew Preventative Maintenance Checks and Services (PMCS) (cont.)

ITEM NO	INTERVAL					ITEM TO BE INSPECTED PROCEDURE: Check for and have repaired, filled, or adjusted as needed	Equipment is Not Ready/Available If:
	B	D	A	W	M		
20		•				<p>GENERATOR SET GAGES AND INSTRUMENTS (cont.)</p> <p>i. Check that all lights on FAULT INDICATOR panel (30) are out during operation. Check bulb operation with TEST or RESET switch on panel. All bulbs should be lit when switch is in TEST or RESET position.</p>  <p style="text-align: right;">4885-018</p>	<p>Fault light will not go out when switch is set to TEST or RESET position, then</p>
21		•				<p>AIR RESERVOIR</p> <p>a. Visually inspect air reservoir (31) for damage or leaks.</p> <p style="text-align: center;">WARNING</p> <p>Airstream from open draincock could cause eye injury. Wear protective goggles when working with air under pressure. Failure to do so could result in eye injury.</p> <p>b. Open draincock (32) to drain accumulated moisture.</p> <p style="text-align: center;">3-15</p>	

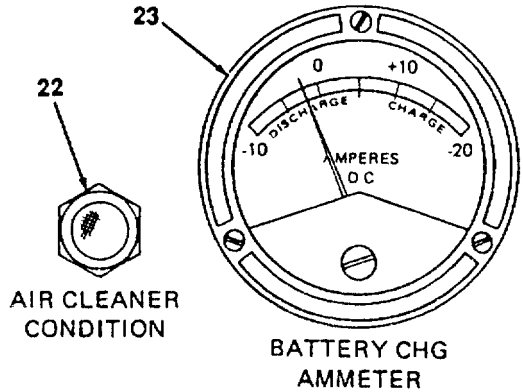
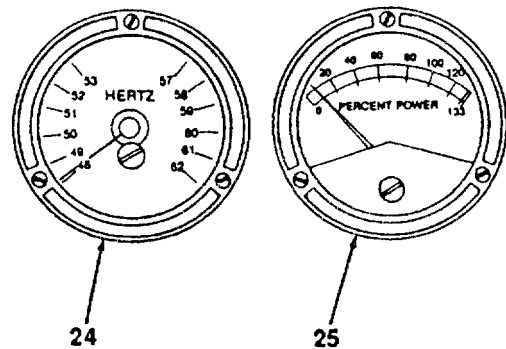
Table 3-2. Operator/Crew Preventative Maintenance Checks and Services (PMCS) (cont.)

ITEM NO	INTERVAL					ITEM TO BE INSPECTED PROCEDURE: Check for and have repaired, filled, or adjusted as needed	Equipment is Not Ready/Available If:
	B	D	A	W	M		
21			•			<p>AIR RESERVOIR (cont.)</p> <p>c. Close draincock (32) before operation.</p>  <p style="text-align: right;">4882-009</p>	
22			•			<p>FUEL TANK</p> <p style="text-align: center;">WARNING</p> <p>Do not smoke or use open flame in the vicinity of the power unit while refueling generator set</p> <p>a. Fill set tank upon completion of operation</p> <p style="text-align: center;">NOTE</p> <p>Fuel system temperature must be above freezing when draining water and sediment</p> <p>b. Remove drain cap (33), open drain (34) and drain water and sediment from fuel tank into a suitable container. Allow to drain until fuel runs clean</p> <p style="text-align: center;">3-16</p>	

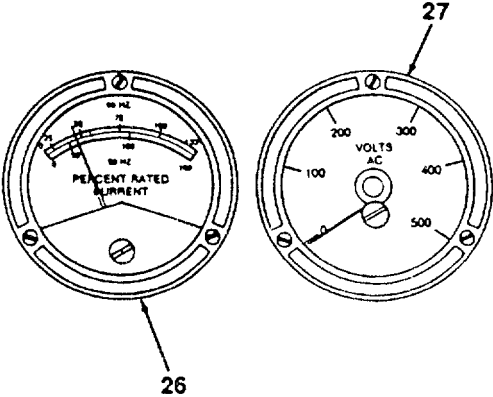
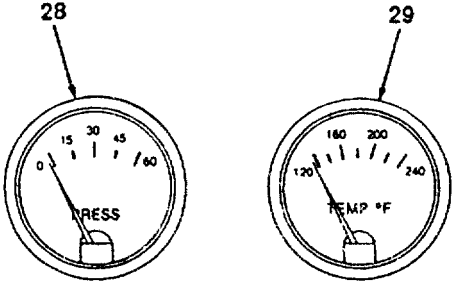
Table 3-2. Operator/Crew Preventative Maintenance Checks and Services (PMCS) (cont.)

ITEM NO	INTERVAL					ITEM TO BE INSPECTED PROCEDURE: Check for and have repaired, filled, or adjusted as needed	Equipment is Not Ready/Available If:
	B	D	A	W	M		
22			•			<p>FUEL TANK (cont.)</p>  <p>4882-019</p>	
23			•			<p>DAY TANK</p> <p>Remove drain cap (35) and open drain (36) and drain water and sediment from fuel tank Into a suitable container Allow to drain until fuel runs clean</p>  <p>4882-020</p>	

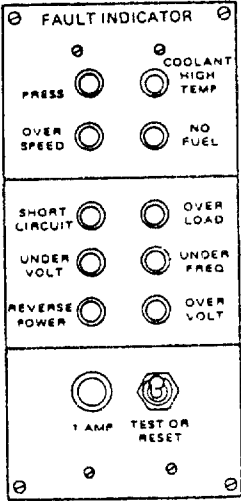
Table 3-2. Operator/Crew Preventative Maintenance Checks and Services (PMCS) (cont.)

ITEM NO	INTERVAL					ITEM TO BE INSPECTED PROCEDURE: Check for and have repaired, filled, or adjusted as needed	Equipment is Not Ready/Available If:
	B	D	A	W	M		
24			•			<p>FUEL STRAINER AND FILTERS</p> <p>Drain water and sediment from strainer (37), primary (38) and secondary (39) filters into a suitable container Allow to drain until fuel runs clean</p>  <p style="text-align: right;">4882-021</p>	
25		•				<p>BATTLE SHORT INDICATOR LIGHT</p> <p>Push in on lens housing Light (40) should illuminate If not, replace bulb</p>	
26		•				<p>CIRCUIT BREAKER INDICATOR LIGHT</p> <p>Push In on lens housing Light (41) should illuminate If not, replace bulb</p>  <p style="text-align: right;">4882-022</p>	

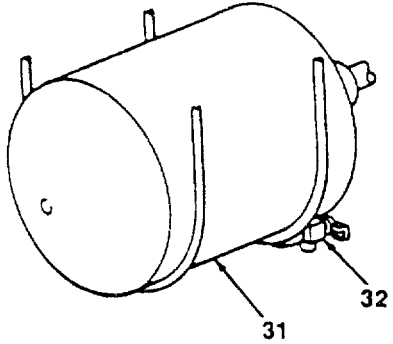
Table 3-2. Operator/Crew Preventative Maintenance Checks and Services (PMCS) (cont.)

ITEM NO	INTERVAL					ITEM TO BE INSPECTED PROCEDURE: Check for and have repaired, filled, or adjusted as needed	Equipment is Not Ready/Available If:
	B	D	A	W	M		
27			•			<p>BRAKE DRUMS AND HUBS</p> <p>WARNING A defect in the operation of the brakes or hub can cause these parts to get hot enough to cause serious burns. Use extreme caution when attempting to detect heat in this area.</p> <p>Feel drums (42) and hubs (43) for overheating or binding.</p>  <p>4882-023</p>	Brakes or hub are dragging
28	•					<p>HANDBRAKES</p> <p>With trailer hooked to towing vehicle, set handbrakes (44). Move trailer slightly to see if handbrakes hold wheels. Adjust as required.</p>  <p>4882-024</p>	Handbrakes cannot be adjusted

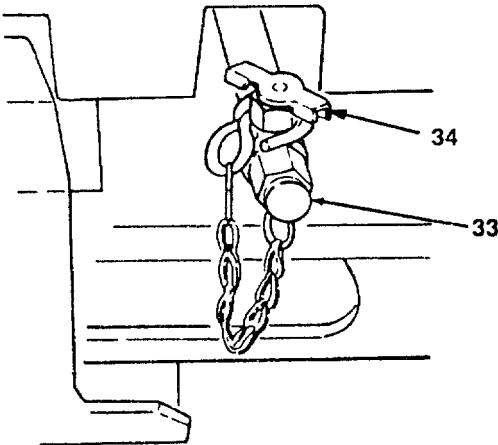
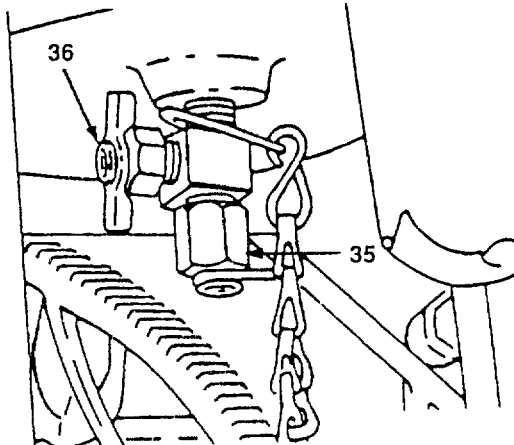
Table 3-2. Operator/Crew Preventative Maintenance Checks and Services (PMCS) (cont.)

ITEM NO	INTERVAL					ITEM TO BE INSPECTED PROCEDURE: Check for and have repaired, filled, or adjusted as needed	Equipment is Not Ready/Available If:
	B	D	A	W	M		
29				•		<p>BATTERIES</p> <p>Check battery (45) electrolyte level should be about 3/4 Inch above top of plates Add water If level is low Use clean water (distilled water If available)</p>  <p style="text-align: right;">4882-025</p>	
30						<ul style="list-style-type: none"> • FIRE EXTINGUISHER <ul style="list-style-type: none"> a. Inspect seal for damage b. Inspect gage to see If extinguisher needs recharging c. Weigh fire extinguisher (See paragraph 3-11) 	
31						<ul style="list-style-type: none"> • TRAILER FRAME <p>Inspect entire chassis frame for damage, cracks, and broken welds</p>	<p>Frame is obviously broken or cracked</p>

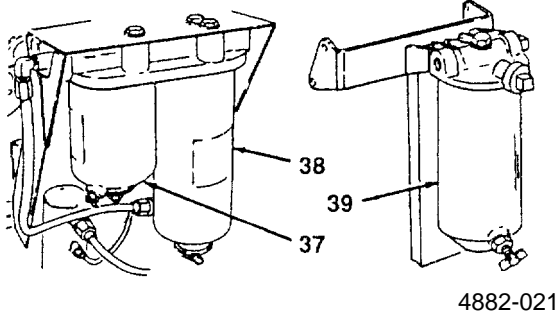
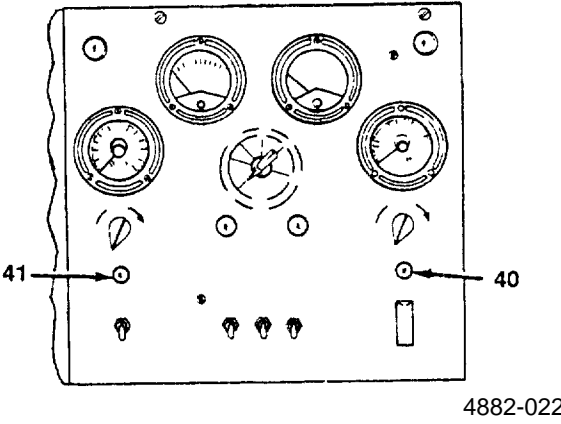
Section IV. TROUBLESHOOTING

3-10. **Power Plant Troubleshooting.** There are no troubleshooting procedures authorized at operator level for the power unit end Item Troubleshooting procedures for the Individual generator set and trailer are contained in their respective technical manuals referenced below

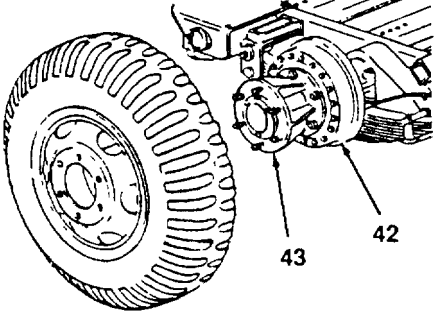
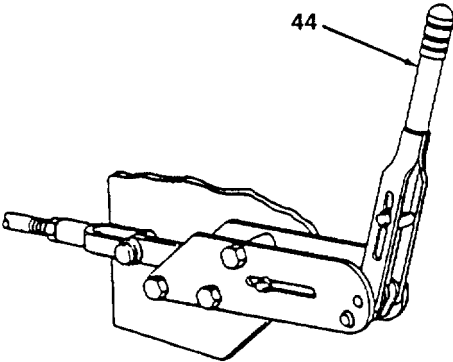
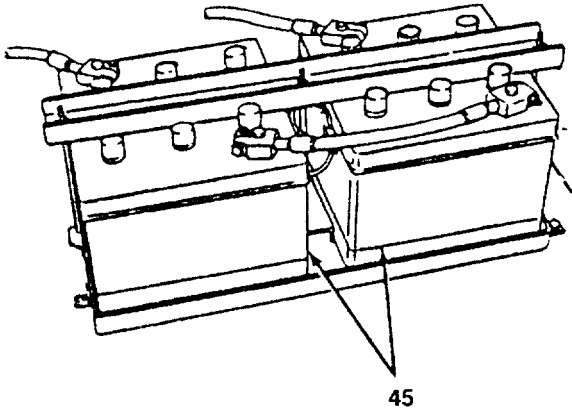
a. Generator Set Troubleshooting. Refer to TM 5-6115-457-12 or TM 5-6115-600-12, as applicable, for generator set troubleshooting procedures.

b. Trailer Troubleshooting. Refer to TM 9-2330-247-14&P for troubleshooting procedures applicable to the trailer.

Section V. OPERATOR/CREW MAINTENANCE

3-11. **Fire Extinguisher Maintenance.** The PU-495 Power Unit is equipped with two 5 lb. CO₂ fire extinguisher. Maintenance is limited to weighing the fire extinguisher monthly to insure that it is sufficiently charged. Fully charged, the fire extinguisher weighs 13 lb. Send the unit to specialized activity for recharging if it weighs 12.5 lb. or less.

CAUTION

Do not attempt to verify readiness of a fire extinguisher by partially discharging unit. Any discharge of contents will require refilling.

3-21/(3-22 blank)

CHAPTER 4

UNIT MAINTENANCE

Section I. SERVICE UPON RECEIPT OF EQUIPMENT

4-1. **Inspecting and Servicing Equipment.** The power unit is unpacked, inspected, and serviced as described in the following paragraphs. Unpacked equipment must be checked against the Equipment Packing List to insure completeness. Discrepancies must be reported in accordance with instructions in DA Pam 738-750.

a. *Unpacking Power Unit.* (See figures 4-1 and 4-2.) The generator set is packed in place on the trailer frame. Before beginning the unpacking procedure, locate, remove, and save the waterproof envelope marked Depreservation Guide.

WARNING

The steel banding used in packaging of power unit has sharp edges. Care should be taken when cutting and handling banding to avoid injury to personnel.

- (1) Remove steel banding around plywood box covering generator set and drop plywood cover from beneath generator set.
- (2) Remove lag screws securing plywood box cover over generator set and lift box off generator.
- (3) Remove wooden wedges and spacers from around generator set base.
- (4) Remove and save package of technical manuals secured to barrier material covering generator.
- (5) Remove barrier material from generator set.
- (6) Remove packaged fire extinguisher from within generator set enclosure. Unpack and secure fire extinguisher in bracket on rear curbside step.
- (7) Remove steel banding around accessory box, unpack, and inventory contents.
- (8) Refer to DA Form 2258, Depreservation Guide for Vehicles and Equipment, packed with power unit and follow instructions given for putting unit into service.
- (9) Stow all authorized accessories in the accessory box.

b. *Inspection and Servicing of Generator Set.* Refer to Service Upon Receipt of Materiel in TM 5-6115-457-12 or TM 5-6115-600-12, as applicable, for initial inspection and servicing procedures.

c. *Inspection and Servicing of Trailer.* Refer to Service Upon Receipt of Materiel in TM 9-2330-247-14&P for initial inspection and servicing procedures.

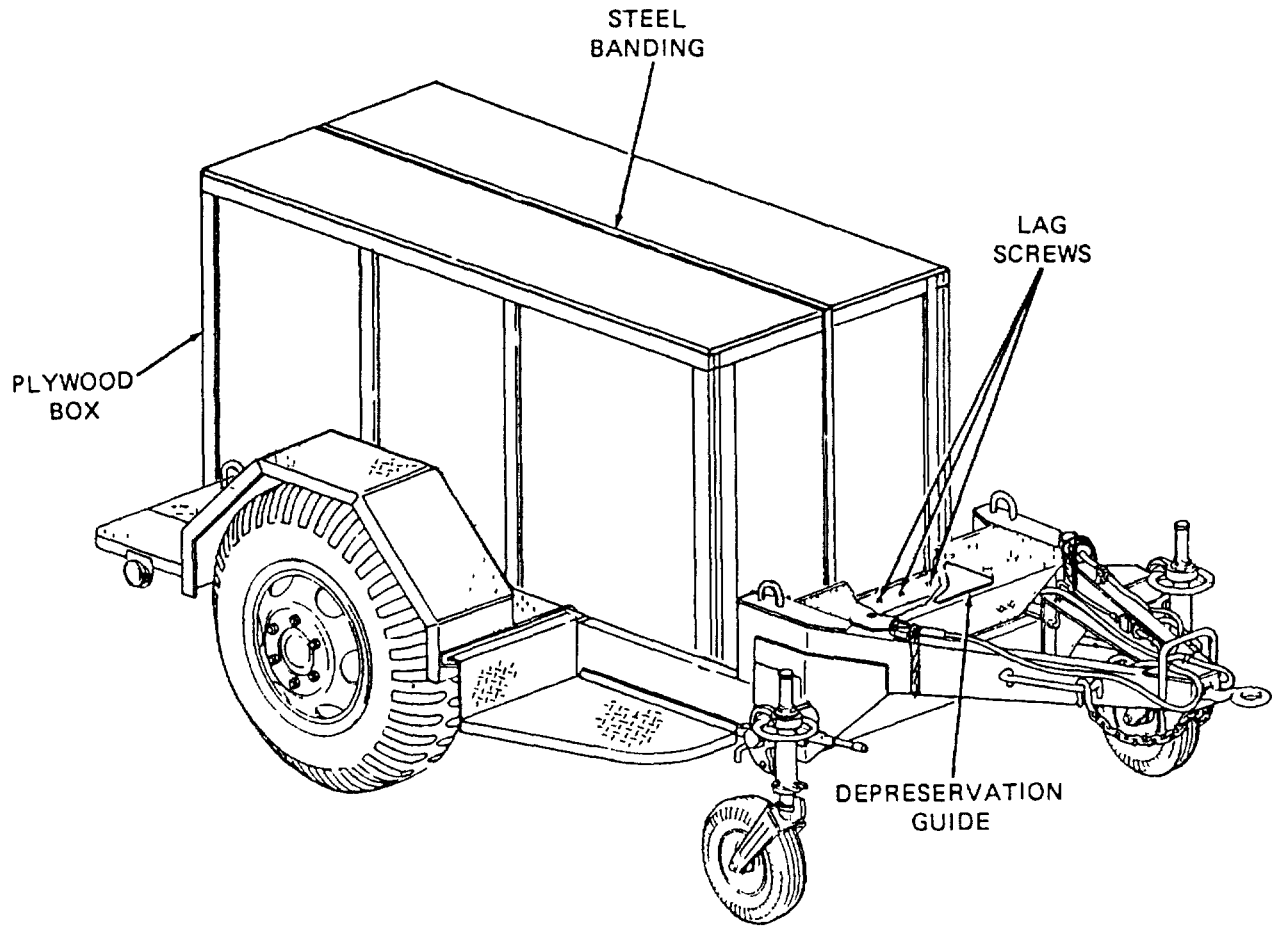

4882-026

4882-026

Figure 4-1. Power Unit Packed for Shipment.

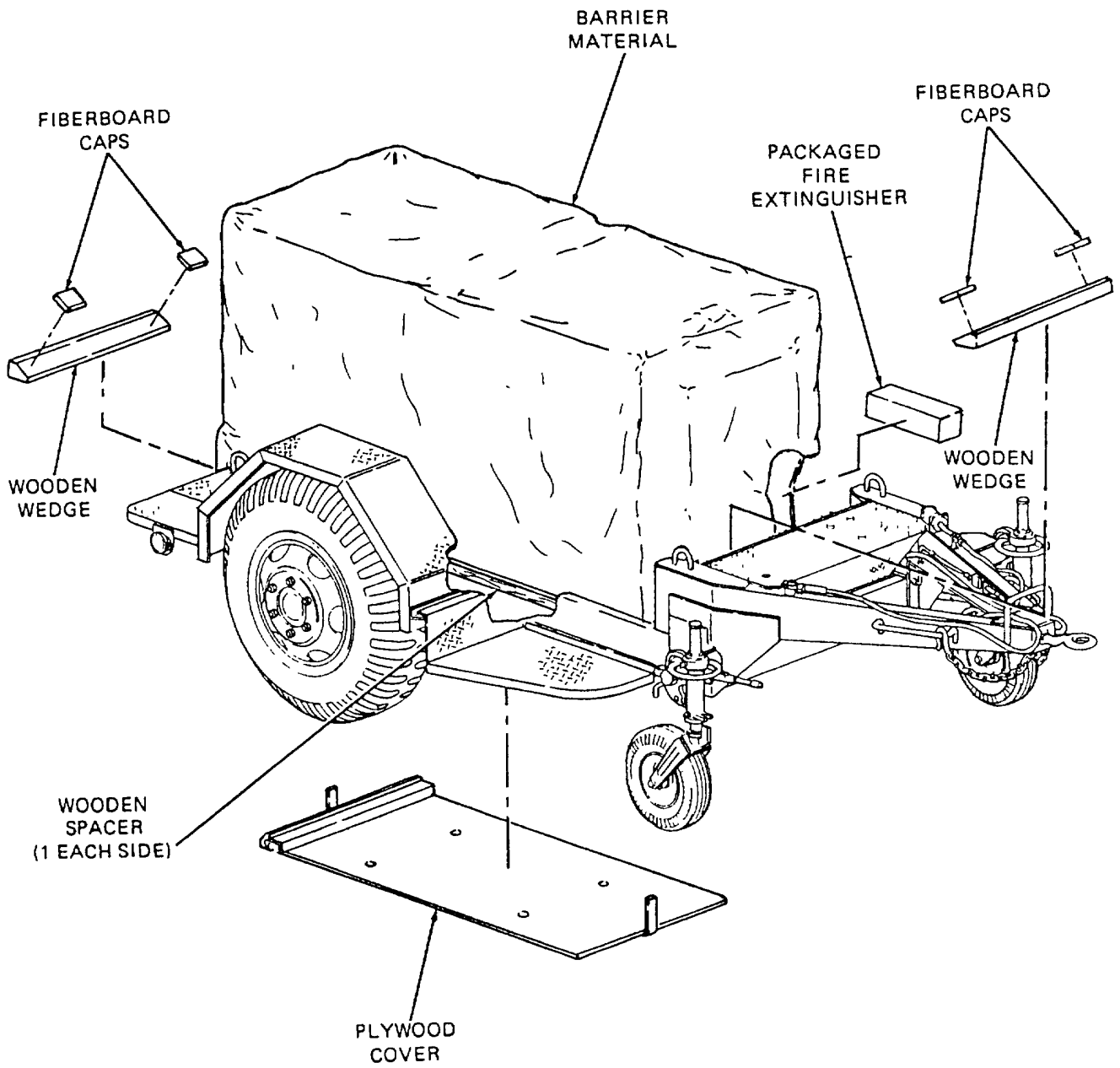

4882-027
4882-027

Figure 4-2. Unpacking Power Unit.

4-2. Installation. (See figure 4-3) Installation of the power unit at a worksite involves positioning the trailer and grounding the power unit.

a. *Positioning Power Unit.* Position the power unit on the work-site as follows

- (1) Select an area as level as possible to install power unit and position trailer
- (2) Set trailer handbrakes and lower swivel casters
- (3) Level trailer by turning handwheel on either or both swivel casters
- (4) Chock trailer wheels

CAUTION

Remove fire extinguishers from power unit when generator set is in operation This will insure that, in the event of fire, the extinguisher will remain accessible

- (5) Locate fire extinguisher on ground away from power unit

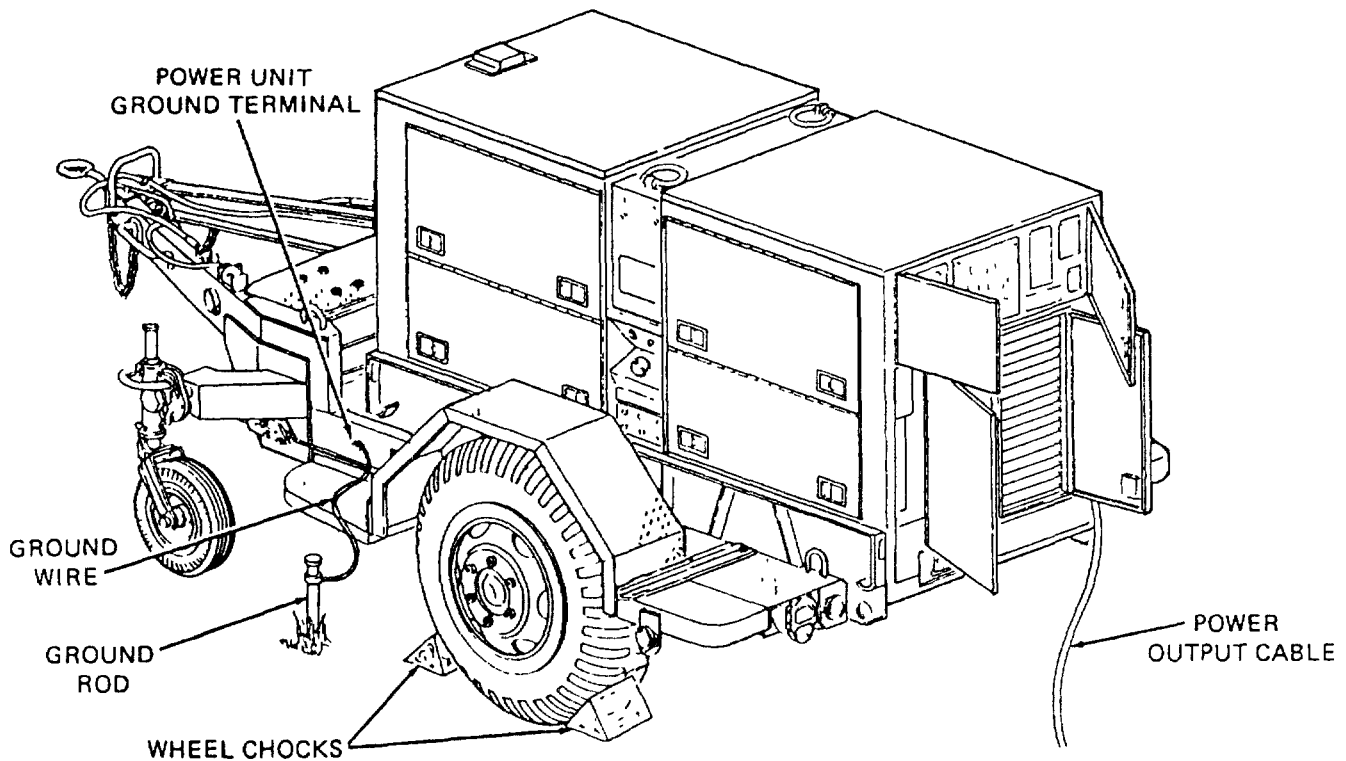

4882 028

Figure 4-3. Installing Power Unit.

WARNING

Do not operate generator set until power unit is properly grounded (paragraph 4-2, b.) Serious Injury or death by electrocution can result from operating an ungrounded power unit

CAUTION

To avoid damage to equipment, make certain of voltage, frequency, and phase requirements of load being connected to generator set.

- (6) Connect power unit to system or equipment to be powered Refer to TM 5-6115-457-12 or TM 5-6115-600-12, as applicable, and generator set load terminal board data plate Data plate is located on Inside of generator enclosure door near load terminals
- (7) Close all doors on generator set enclosure except control panel doors and the two doors Immediately below the control panel
 - b Grounding. Check that generator set is grounded to GROUND TERMINAL stud on trailer frame Using ground wire supplied with power unit, connect power unit GROUND TERMINAL to a suitable ground as described below The following sources of good ground are listed In order of preference

NOTE

As a substitute for the supplied ground wire, any copper wire of a least No 6 AWG may be used

- (1) Underground water system Ground power unit to one of the accessible pipes In an underground water system Make certain underground pipe is made of metal and there is no insulation, such as a water meter, between ground wire and the earth
- (2) Ground rod Drive ground rod a minimum of eight feet Into earth and saturate area around hole with salt water A ground rod must have a minimum diameter of 5/8-inch, If solid, or 3/4-inch If pipe

NOTE

It may be necessary to saturate the area around ground rod with water If soil conditions are dry

- (3) Ground plate. Ground power unit to a metal plate buried four feet deep Ground plate should cover a minimum area of nine square feet.
 - c External Fuel Line Connection (See figure 4-4) The power unit generator set can be fueled from an external source such as a five-gallon fuel can or 55 gallon drum This eliminates the need for frequent refilling of the generator's fuel tank during long intervals of operation
 - (1) Remove fuel can adapter and fuel pickup tube from storage locations on power unit and assemble by threading pickup tube Into adapter

- (2) Thread one end of auxiliary fuel line onto fuel can adapter fitting and tighten
- (3) Connect free end of auxiliary fuel line to FUEL SUPPLY INLET connection This connection is located next to the fuel filler above the trailer roadside fender
- (4) Insert fuel can adapter In external fuel source and secure by pressing down on lever
- (5) Set FUEL SELECTOR valve above fuel filler, to AUXILIARY position

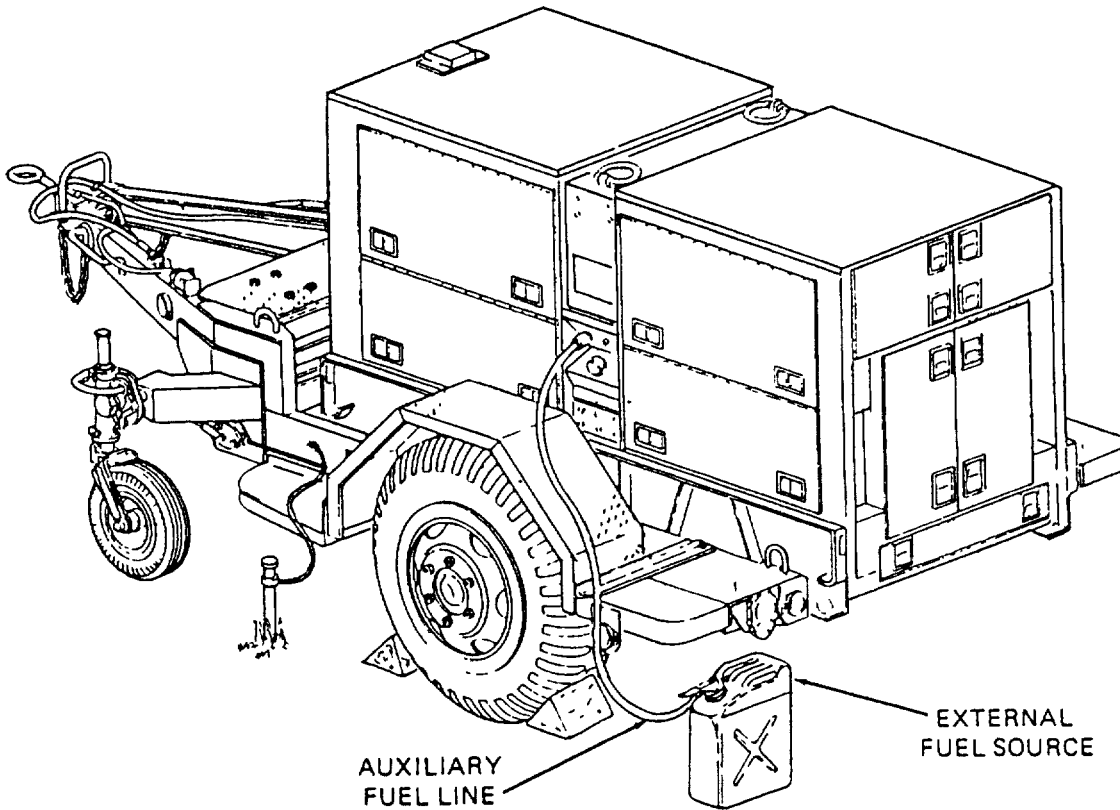

4882-029

Figure 4-4. External Fuel Line Connection.
Section II. MOVEMENT TO A NEW WORKSITE

4-3. Dismantling for Movement. Because the power unit is designed to be mobile, a minimum amount of effort is required to relocate to a new worksite Procedures are as follows

- a Disconnect power unit from system or equipment being powered
- b Disconnect ground cable from source of ground and from power unit GROUND TERMINAL Roll up cable and store In accessory stowage chest
- c Using slide hammer, remove ground rod Disassemble, clean, and stow ground rod In accessory stowage chest
- d Disconnect power unit from external fuel source, If applicable

- e Stow any remaining authorized equipment In accessory stowage chest
- f Secure fire extinguisher In mounting bracket
- g Close and secure all doors on generator set enclosure
- h Remove wheel chocks
- I Attach power unit to towing vehicle. Refer to TM 9-2330-247-14&P
- j Raise swivel casters to travel position and release trailer handbrakes

4-4. **Reinstallation After Movement.** After movement to a new worksite, Install power unit in accordance with paragraph 4-2.

Section III. REPAIR PARTS, SPECIAL TOOLS, SPECIAL TEST, MEASUREMENT AND DIAGNOSTIC EQUIPMENT (TMDE)

4-5 . **Tools and Equipment.** There are no special tools or equipment required to maintain the PU-495 power unit

4-6 **Maintenance Repair Parts.** Repair parts and equipment for maintenance of this power unit are listed and Illustrated in the repair parts and special tools list in Appendix D of this manual

Section IV. LUBRICATION INSTRUCTIONS

4-7. **General.** Detailed instructions for the lubrication of the major components of the power unit are contained in the applicable Lubrication Orders (LO's) Refer to DA Pam 25-30 to ensure that the latest editions of the L O 's are used This section contains lubrication instructions that are not included in the Lubrication Orders

4-8. **Generator Lubrication.** Refer to TM 5-6115-457-12 or TM 5-6115-600-12, as applicable, for generator set Lubrication Order

4-9. **Trailer Assembly Lubrication.**

- a Trailer Lubrication Refer to TM 9-2330-247-14&P for trailer Lubrication Order.
- b Accessory Stowage Chest The accessory stowage chest is a modification to the standard M353 trailer and, as such, does not appear in the associated L O. Lubricate the accessory stowage chest semiannually as follows:

WARNING

Clean parts in a well-ventilated area Avoid inhalation of solvent fumes and prolonged exposure of skin to cleaning solvent Wash exposed skin thoroughly Dry cleaning solvent (PD-680) used to clean parts is potentially dangerous to personnel and property Do not smoke or use near open flame or excessive heat Flash point of solvent is 100°F to 138°F (380C to 590C)

- (1) Using PD-680, or equivalent, clean area to be lubricated
- (2) Apply OE lubricating oil along entire length of accessory stowage chest hinge and to pivot points on latch assemblies

Section V. PREVENTIVE MAINTENANCE CHECKS AND SERVICES

NOTE

The PMCS chart in this section contains all necessary unit preventive maintenance checks and services for this equipment

4-10. **General.** The trailer assembly and generator set must be inspected and serviced systematically to insure that the power unit is ready for operation at all times. Inspection will allow defects to be discovered and corrected before they result in serious damage or failure. Table 4-1 contains a tabulated list of preventive maintenance checks and services to be performed by unit maintenance personnel. All of the unit PMCS on the trailer is scheduled to be performed semiannually or annually. Unit PMCS on the generator set is scheduled monthly or on a per-hours-of-operation basis. The running time meter on the control panel is used to determine the operating time of the generator set. Using the following as a guide, do the checks and services at the intervals shown. Observe all CAUTIONS and WARNINGS.

- a. For PMCS performed on an operating time basis, perform your hourly (H) PMCS as close as possible to the time intervals indicated.

NOTE

For units in continuous operation, perform PMCS before starting operation. If continuous operation will extend service interval past that which is shown:

- b. Perform your monthly (M) PMCS every month or 100 hours of generator set operating time.
- c. Do your semiannual (S) PMCS once every six months.
- d. If you discover a problem with the equipment, refer to Section VI, Troubleshooting. If you cannot correct the problem, refer to paragraph 4-12, Reporting Deficiencies.

4-11. **Explanation of Columns.** The following is a list of the PMCS table column headings with a description of the information found in each column:

- a. Item No. This column shows the sequence in which to do the checks and services, and is used to identify the equipment area on the Equipment Inspection and Maintenance Worksheet, DA Form 2404.
- b. Interval. This column shows when each check is to be done.
- c. Item to be Inspected. This column identifies the general area or specific part where the check or service is to be done.
- d. Procedures. This column lists the checks or service you have to do and explains how to do them.

4-12. **Reporting Deficiencies.** If you discover any problem with the equipment during PMCS that you are unable to correct, it must be reported. Refer to DA Pam 738-750 and report the deficiency using the proper forms.

Table 4-1. Unit Preventive Maintenance Checks and Services (PMCS).

Item No.	H-Hours of operation (As Indicated)			M - Monthly (100 hours)	S-Semiannually (500 hours)	Item to be Inspected.	Procedures
	H	M	S				
1		•				Generator Set Exterior	<p style="text-align: center;">WARNING</p> <p>Before performing any maintenance that requires climbing on or under trailer, set trailer handbrakes and chock wheels. Injury to personnel could result from trailer suddenly rolling or tipping.</p> <p>Inspect generator set for fuel and oil leaks, loose or missing components and hardware, and unusual wear or deterioration.</p> <p style="text-align: center;">NOTE</p> <p>Fuel system must be above freezing temperature when draining water and sediment from strainer, filters, and tank.</p> <p>Open drains on fuel strainer, and primary and secondary fuel filters. Drain water and sediment into a suitable container. Allow to drain until fuel runs clean.</p> <p>Open drains on main fuel tank and day tank. Drain water and sediment into a suitable container. Allow to drain until fuel runs clean.</p> <p>Clean or replace, as necessary, fuel strainer in bottom of fuel pump.</p> <p>Perform a hydrometer test on batteries every 100 hours. Refer to TM 5-6115-457-12 or TM 5-6115-600-12 for test procedures.</p>
2		•				Fuel Strainer and Filters	
3		•				Fuel Tanks	
4			•			Fuel Pumps	
5		•				Batteries	

Table 4-1. Unit Preventive Maintenance Checks and Services (PMCS) (cont).

Item No.	H-Hours of operation (As Indicated)			M - Monthly (100 hours)	S-Semiannually (500 hours)
	Interval			Item to be Inspected.	Procedures
	H	M	S		
6		•		V-Belts	Inspect for worn, frayed, oil soaked, or cracked belts. Check adjustment. Proper adjustment for fan belt is a deflection of 1/2 inch with application of 12-14 lb pressure midway between fan and accessory drive pulley.
7		•		Fuel Filters	Replace filter elements after every 100 hours of operation.
8	300			Fuel Strainers	Clean fuel strainer.
9	300			Lubricating Oil and Filters	Change lubricating oil and filter. (Refer to L.O.)
10	300			Breather and Breather Tube	Inspect for damage. Clean breather and tube at oil change interval.
11	AR			Air Cleaner	Clean air cleaner element whenever necessary as indicated by air filter condition indicator light.
12			•	Taillights	Replace any broken or cracked lenses or defective bulbs.
13			•	Intervehicular Cable	Check for cuts, breaks, frayed wires, or damaged plug.
14			•	Lunette	Check security of mounting. Inspect ring for excessive wear.
15			•	Safety Chains	Inspect for broken links or missing chain(s).
16			•	Reflectors	Replace any cracked, broken, or missing reflectors.
17			•	Data Plates and Markings	Make sure data plates are legible and securely mounted. Replace illegible data plates.
18			•	Swivel Casters	Inspect swivel caster wheels and struts for bent or broken parts.

Table 4-1. Unit Preventive Maintenance Checks and Services (PMCS) (cont).

Item No.	H-Hours of operation (As Indicated)			M - Monthly (100 hours)	S-Semiannually (500 hours)		
	Interval					Item to be Inspected.	Procedures
	H	M	S				
19			•	Suspension Assemblies	a. Inspect shackles, bearings, pins, leaf springs and spring eyes for damage or broken parts. b. Inspect mounting brackets for cracks or loose or missing hardware.		
20			•	Axle	a. Check for damaged axle tube. b. Check for loose or missing U-bolts or nuts.		
21			•	Wheels and Tires	a. Check serviceability of tires as indicated in TM 9-2610-220-14. b. Tighten wheel stud nuts to 450 to 500 ft-lb (611 to 678 N-m).		
22			•	Brakes	a. Inspect brake linings for wear. Replace if brake shoe lining is less than 1/8-inch (3.2 mm) thick. b. Inspect brake adjusting screw, retaining screw, retaining pins, springs, and clips for corrosion and wear. c. Inspect hydraulic wheel cylinders for leaks. d. Adjust brakes.		
23			•	Wheel Bearings	Clean and repack wheel bearings.		
24			•	Hydraulic Brake Hoses and Fittings	Inspect for dents, cracks, loose connections and leaks.		
25			•	Air Hoses and Fittings	Inspect for dents, cracks, loose connections and leaks.		
26			•	Brake Master Cylinder	Check fluid level. Fill to 1/2 inch from top.		
27			•	Trailer - Road Test	Perform road test paying special attention to items that were repaired or adjusted, in accordance with TM 9-2330-247-14&P.		

Section VI. TROUBLESHOOTING

4-13. **Power Unit Troubleshooting.** There are no troubleshooting procedures authorized at unit level for the power unit end item. Troubleshooting procedures for the individual generator set and trailer are contained in their respective technical manuals referenced below.

a. Generator Set Troubleshooting. Refer to TM 5-6115-457-12 or TM 5-6115-600-12, as applicable, for generator set troubleshooting procedures.

b. Trailer Troubleshooting. Refer to TM 9-2330-247-14&P for troubleshooting procedures applicable to the trailer.

Section VII. RADIO INTERFERENCE SUPPRESSION

4-14. **General Methods Used to Attain Proper Suppression.** Essentially, suppression is attained by providing a low resistance path to ground for stray currents. The methods used include shielding ignition and high-frequency wires, grounding the frame with bonding straps, and using filtering systems.

4-15. **Radio Interference Suppression Components.** All component parts on the power unit end item, whose primary or secondary function is radio interference suppression, are on the generator set. Refer to TM 5-6115-457-12 or TM 5-6115-600-12, as applicable for location of radio interference suppression components.

Section VIII. MAINTENANCE OF POWER UNIT TRAILER

4-16. **General.** This section of the manual contains unit level maintenance procedures for components of the M353 trailer added when the trailer is used as part of the PU-495 power unit. These components are not covered in the overall trailer maintenance manual. For all other unit maintenance procedures on the trailer, refer to TM 9-2330-247-14&P. When power unit has been painted in camouflage, replacement parts must be painted to match authorized patterns and colors as specified in TB 43-0147. Application of camouflage paint shall be done in accordance with MIL-C-53072.

WARNING

Before performing any maintenance that requires climbing on or under trailer, set trailer handbrakes and chock both wheels. Injury to personnel could result from trailer suddenly rolling or tipping.

4-17. **Accessory Stowage Chest Replacement.** (See figure 4-5.) The accessory stowage chest and associated bracket are mounted to the trailer in front of the generator. The chest and bracket are secured with the same hardware and must be removed and installed as a unit.

a. Removal.

- (1) Remove three screws (1, figure 4-5), three flat washers (2), and three nuts (3) securing accessory stowage chest (4) to plate (5).
- (2) Remove two screws (6), two flat washers (7), and two nuts (8) securing accessory stowage chest (4) to bracket (9) and separate chest and bracket.

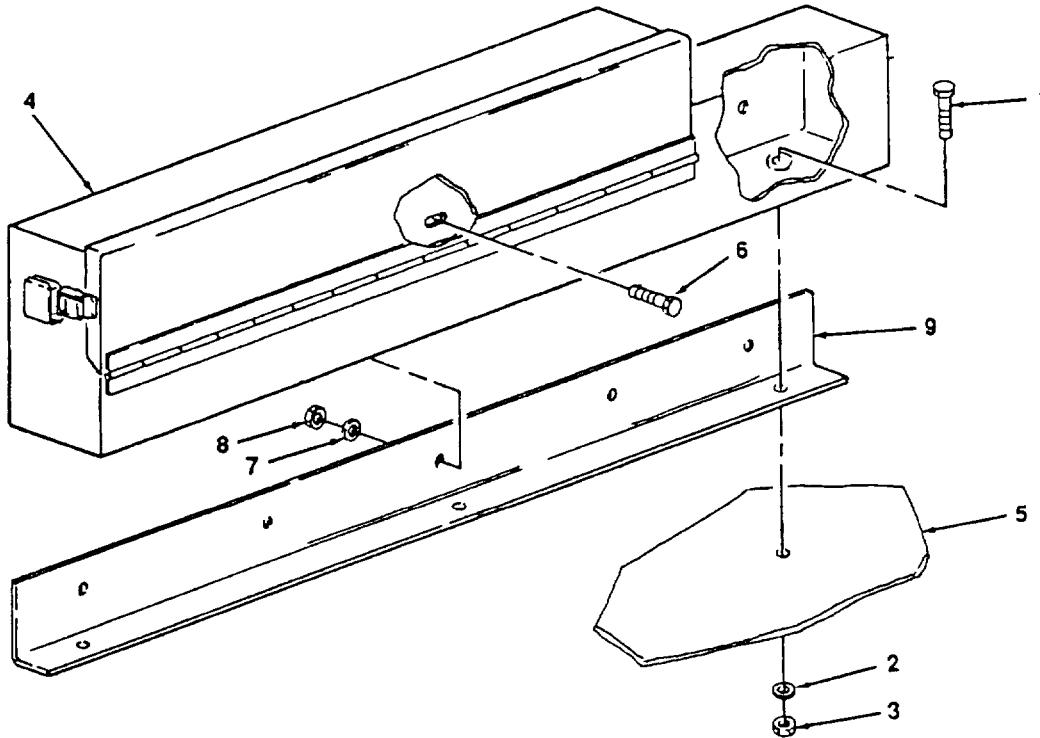

4882-033

Figure 4-5. Accessory Stowage Chest Replacement

b. Installation.

- (1) Aline holes in accessory stowage chest (4) with holes in bracket (9) and install two screws (6), two flat washers (7), and two nuts (8)
- (2) Position accessory stowage chest (4) on plate (5) and install three screws (1), three flat washers (2), and three nuts (3)

4-18 **Fire Extinguisher Bracket Replacement.** (See figure 4-6) The fire extinguisher supplied with the power unit is carried in a bracket mounted on the curbside rear corner of the trailer

a. Removal

- (1) Remove four screws (1, figure 4-6), four flat washers (2), and four nuts (3) securing bracket (4) to trailer (5)
- (2) Remove bracket (4) from trailer (5)

b. Installation.

- (1) Position fire extinguisher bracket (4) on trailer (5)
- (2) Insert four screws (1) down through bracket (4) and trailer (5).

- (3) Install one flat washer (2) and one nut (3) on each screw (1) Tighten hardware to secure bracket (4)

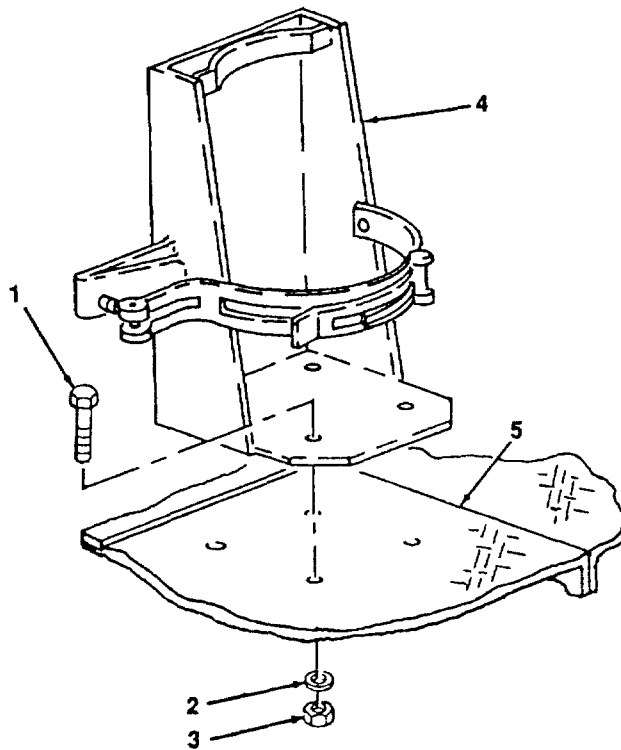

4882-034

Figure 4-6. Fire Extinguisher Bracket Replacement

4-19 **Front Step Replacement.** (See figure 4-7) The roadside and curbside front steps are symmetrical, and replacement procedures are the same for both

aRemoval.

- (1) Remove four screws (1, figure 4-7), eight flat washers (2) and four nuts (3) securing front step (4) to trailer frame (5)
- (2) Remove three screws (6), six flat washers (7) and three nuts (8) securing front step (4) to fender bracket (9)
- (3) Remove two screws (10), four flat washers (11) and two nuts (12) securing front step (4) to support (13)
- (4) Lift front step (4) off of fender bracket (9) and support (13)

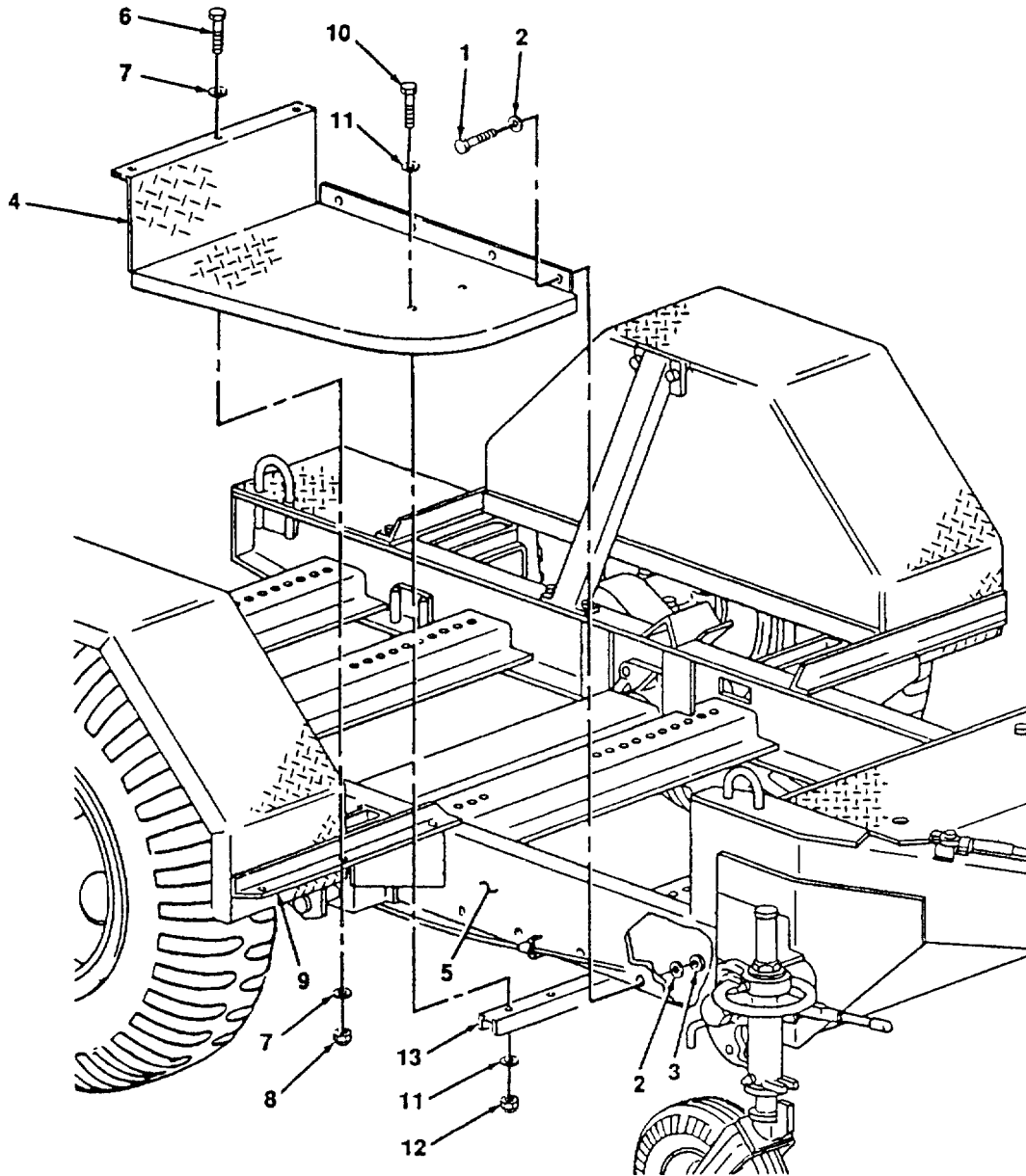

4882-035

Figure 4-7. Front Step Replacement

Installation

- (1) Position front step (4) on top of fender bracket (9) and support (13) taking care to align all mounting holes
- (2) Install, but do not tighten, two screws (10), four flat washers (11), and two nuts (12) securing front step (4) to support (13)

- (3) Install, but do not tighten, three screws (6), six flat washers (7) and three nuts (8) securing front step (4) to fender bracket (9)
- (4) Install, but do not tighten, four screws (1), eight flat washers (2), and four nuts (3) securing front step (4) to trailer frame (5)
- (5) After all hardware is installed, tighten hardware to secure front step (4) to trailer

4-20 **Rear Step Replacement.** (See figure 4-8) The roadside and curbside rear steps are symmetrical, and replacement procedures are the same for both

a. Removal.

- (1) Remove four screws (1, figure 4-8), eight flat washers (2) and four nuts (3) securing rear step (4) to trailer frame (5)
- (2) Remove three screws (6), six flat washers (7), and three nuts (8) securing rear step (4) to fender bracket (9)

NOTE

When replacing rear step, remove and retain reflector and associated screws for installation on new rear step

- (3) Remove two screws (10) and reflector (11)

b. Installation.

- (1) Position rear step (4) on trailer frame (5) and install, but do not tighten, four screws (1), eight flat washers (2), and four nuts (3)
- (2) Install, but do not tighten, three screws (6), six flat washers (7), and three nuts (8) securing rear step (4) to fender bracket (9)
- (3) After all hardware is installed, tighten hardware to secure rear step (4) to trailer

NOTE

If installing new rear step, reinstall reflector retained during removal procedure

- (4) Position reflector (11) on rear step (4) and install two screws (10)

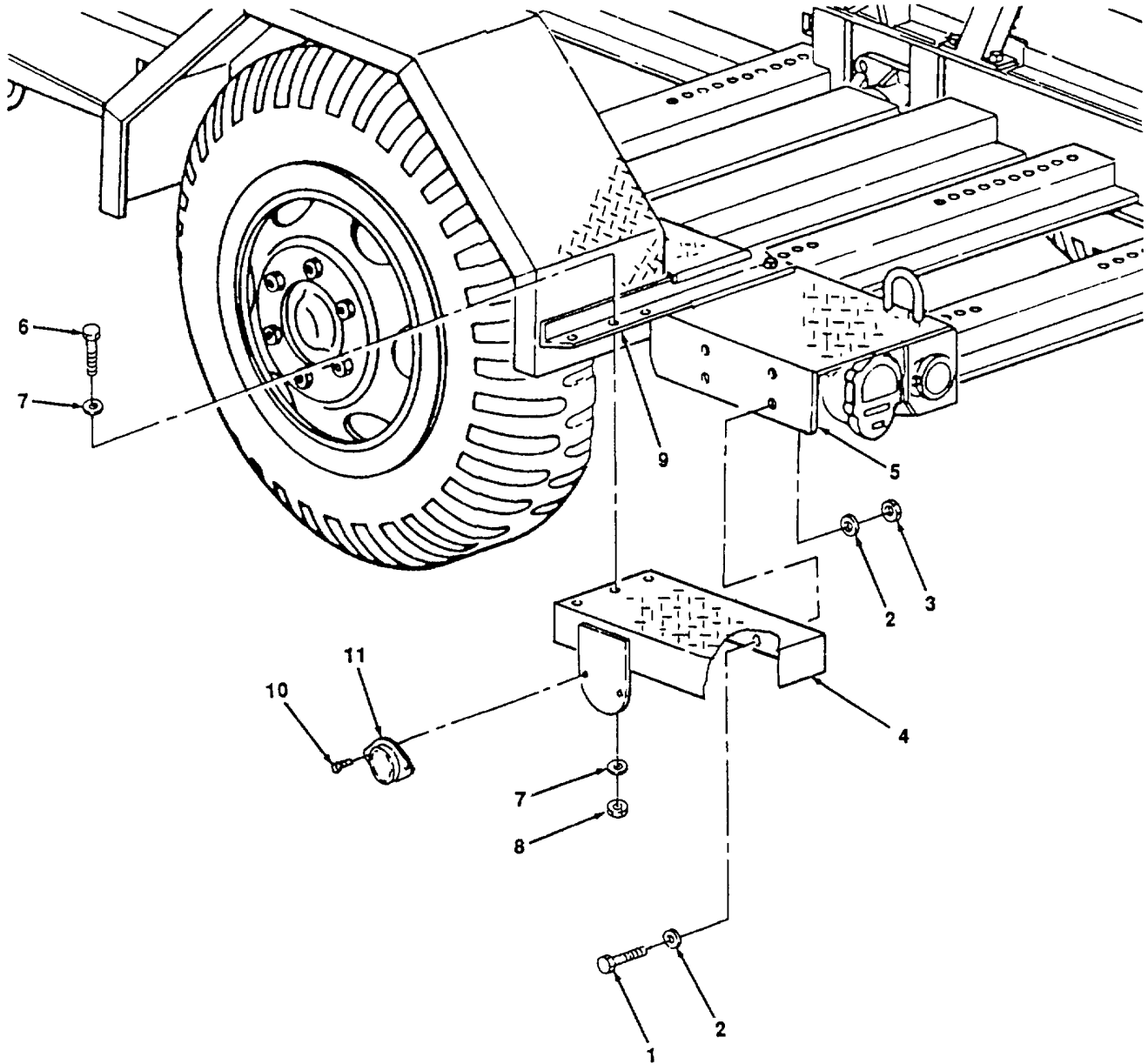

4882-036

Figure 4-8. Rear Step Replacement

4-21 Front Platform/Plate Replacement. (See figure 4-9) The front platform/plate is secured to the trailer crossmembers directly in front of the generator set. In addition to providing personnel access to the front of the generator set, the plate also provides a mounting point for the accessory storage chest and the hammer bracket.

- a Removal.
 - (1) Remove accessory storage chest and bracket from plate. See paragraph 4-17.

- (2) Remove eight screws (1), sixteen flat washers (2), and eight nuts (3) securing plate (4) to trailer frame (5) and front step support (6).
- (3) Lift plate (4) and spacer (7) off of trailer

NOTE

When replacing plate, remove and retain hammer bracket, clip, and associated hardware for installation on new plate

- (4) Remove two screws (8), two flat washers (9), two nuts (10) and hammer bracket (11)
- (5) Remove screw (12), flat washer (13), nut (14) and clip (15)

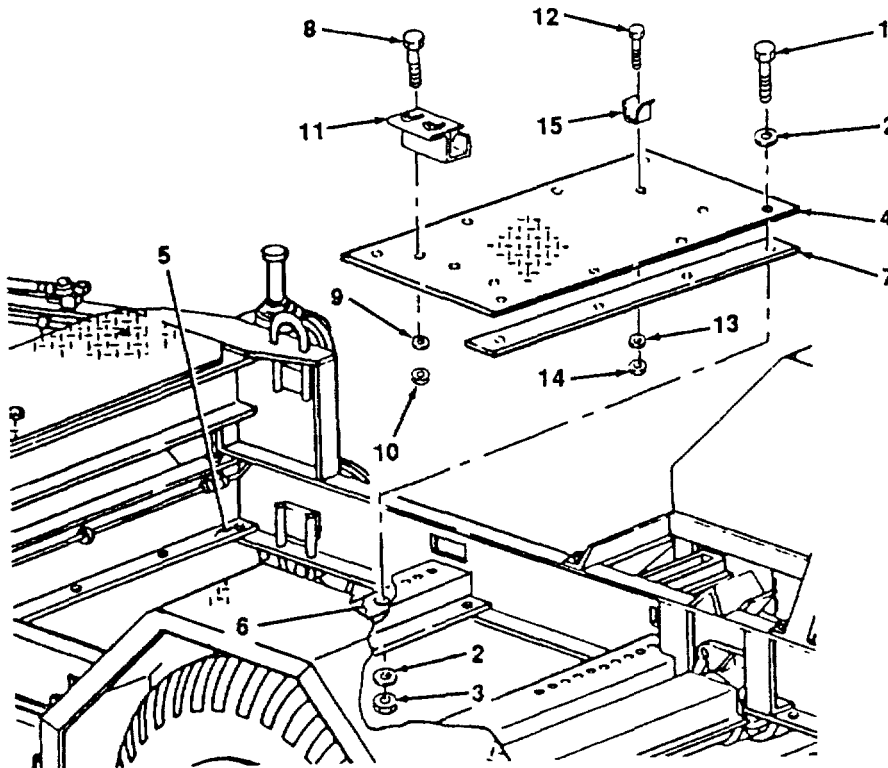

4882-037

Figure 4-9. Front Platform/Plate Replacement

b Installation

NOTE

If Installing a new plate, reinstall hammer bracket and clip retained during removal procedure (steps 1 and 2) If reinstalling original plate, go to step 3

- (1) Position clip (15) on plate (4) and install screw (12), flat washer (13) and nut (14)

- (2) Position hammer bracket (11) on plate (4) and install two screws (8), two flat washers (9), and two nuts (10)
- (3) Position plate (4) on trailer with spacer (7) between plate and front step support (6)
- (4) Install eight screws (1), sixteen flat washers (2) and eight nuts (3)
- (5) Install accessory stowage chest and bracket on plate See paragraph 4-17

4-22 Cover Plate Replacement. (See figure 4-10) The cover plates are mounted on either side of the trailer to provide personnel access to the generator set. The roadside and curbside cover plates are symmetrical and replacement procedures are the same for both.

a Removal.

- (1) Remove six screws (1, figure 4-10), twelve flat washers (2), and six nuts (3) securing cover plate (4) to fender bracket (5).
- (2) Remove six screws (6), twelve flat washers (7), and six nuts (8) securing cover plate (4) to trailer frame (9)
- (3) Lift cover plate (4) off trailer frame (9) and slide plate out from under fender brace (10)

b Installation

- (1) Slide cover plate (4) under fender brace (10) and position plate on trailer frame (9)
- (2) Install six screws (6), twelve flat washers (7), and six nuts (8) securing cover plate (4) to trailer frame (9) and tighten
- (3) Install six screws (1), twelve flat washers (2), and six nuts (3) securing cover plate (4) to fender bracket (5) and tighten

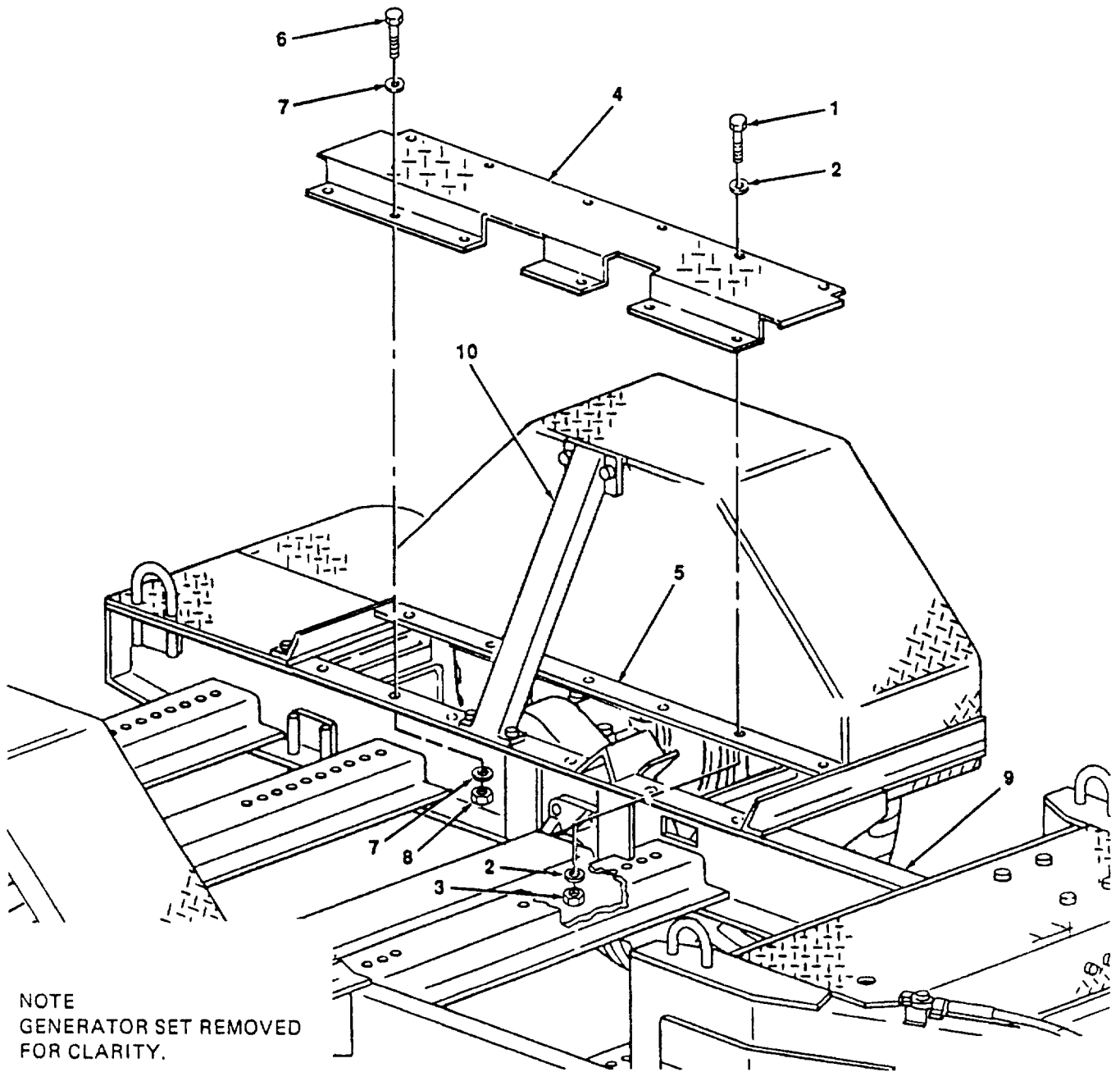

NOTE
GENERATOR SET REMOVED
FOR CLARITY.

4882-038

Figure 4-10. Cover Plate Replacement
4-20

CHAPTER 5

DIRECT SUPPORT AND GENERAL SUPPORT
MAINTENANCE INSTRUCTIONS

Section I. INTRODUCTION

5-1 **General.** This chapter contains Direct Support and General Support level maintenance procedures for components of the M353 trailer added when the trailer is used as part of the PU-495 power unit. These components are not covered in the overall trailer maintenance manual. For all other direct and general support maintenance procedures on the trailer, refer to TM 9-2330-247-14&P. For direct and general support maintenance procedures on the generator set, refer to TM 5-6115-457-34 or TM 5-6115-600-34, as applicable.

WARNING

Before performing any maintenance that requires climbing on or under trailer, set trailer handbrakes and chock wheels. Injury to personnel could result from trailer suddenly rolling or tipping.

Section II. MAINTENANCE OF POWER UNIT TRAILER

5-2 **Step and Cover Plate Repair.** Repair of the front and rear steps and the front and side cover plates is limited to straightening, welding and repainting. If required, repaint in accordance with MIL-T-704, Type F, Color Green, No 383 of MIL-C-46168. If power unit is painted in camouflage, refer to paragraph 5-4, Marking.

5-3 **Accessory Stowage Chest Repair.** (See figure 5-1.) The accessory stowage chest is repaired by replacing the latch and strike assemblies. The chest itself may be straightened, welded and repainted. If required, repaint in accordance with MIL-T-704, Type F, Color Green, No 383 of MIL-C-46168. If power unit is painted in camouflage, refer to paragraph 5-4, Marking. Replace latch and strike assemblies as follows:

- a Grind off or drill out solid rivets (1, figure 5-1) securing latch and strike assembly (2) to accessory box (3)
- b Position new latch and strike assembly (2) on accessory box (3) and secure with solid rivets (1)
- c Touch up with paint as required

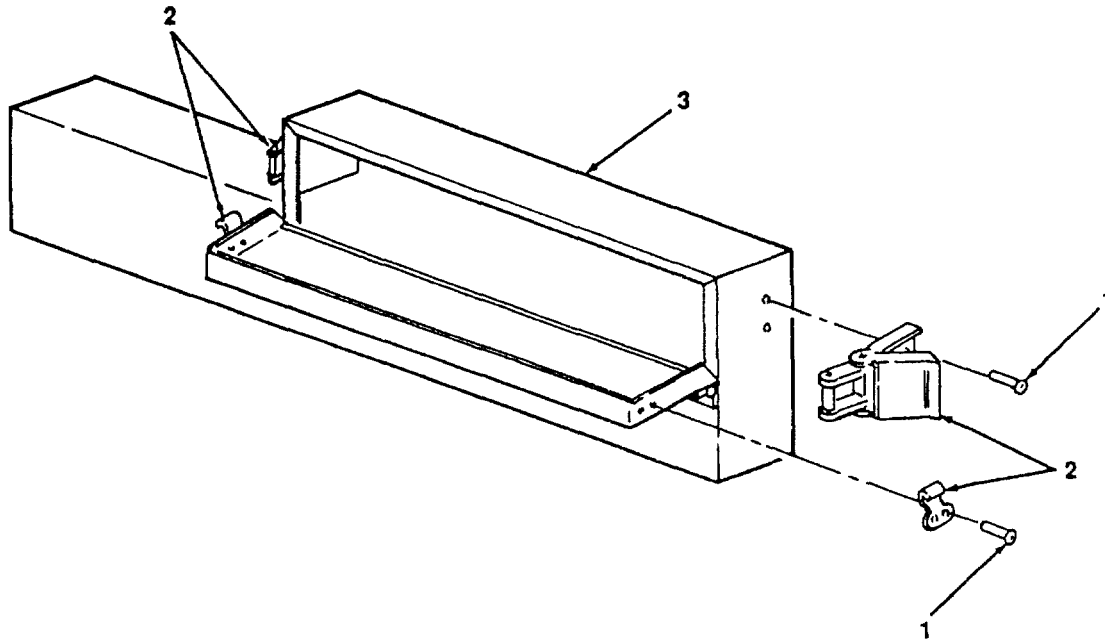

4882 039

Figure 5-1. Accessory Stowage Chest Repair

5-4. **Marking.** (See figure 5-2) The power unit four-digit registration number, preceded by the prefix "VE" and the words "U S ARMY", is marked in four places on the power unit trailer. Marking is done in accordance with MIL-STD-642. On the fender, over each wheel, "T P 30/50 PSI" is marked in 1 00 + .12 Inch high characters in accordance with MIL-STD-130. In addition, on each swivel caster strut, "T P 65 PSI" is marked in 1 00 + 12 Inch high characters. Figure 5-2 shows the approximate location of markings on the power unit. If required, touch-up painting of the base color shall be done in accordance with MIL-T-704, Type F, Color Green, No 383 of MIL-C-46168. When the power unit has been previously painted in camouflage, any touch-up painting following repairs must match authorized patterns and colors as specified in TB 43-0147. Application of camouflage paint shall be done in accordance with MIL-C-53072.

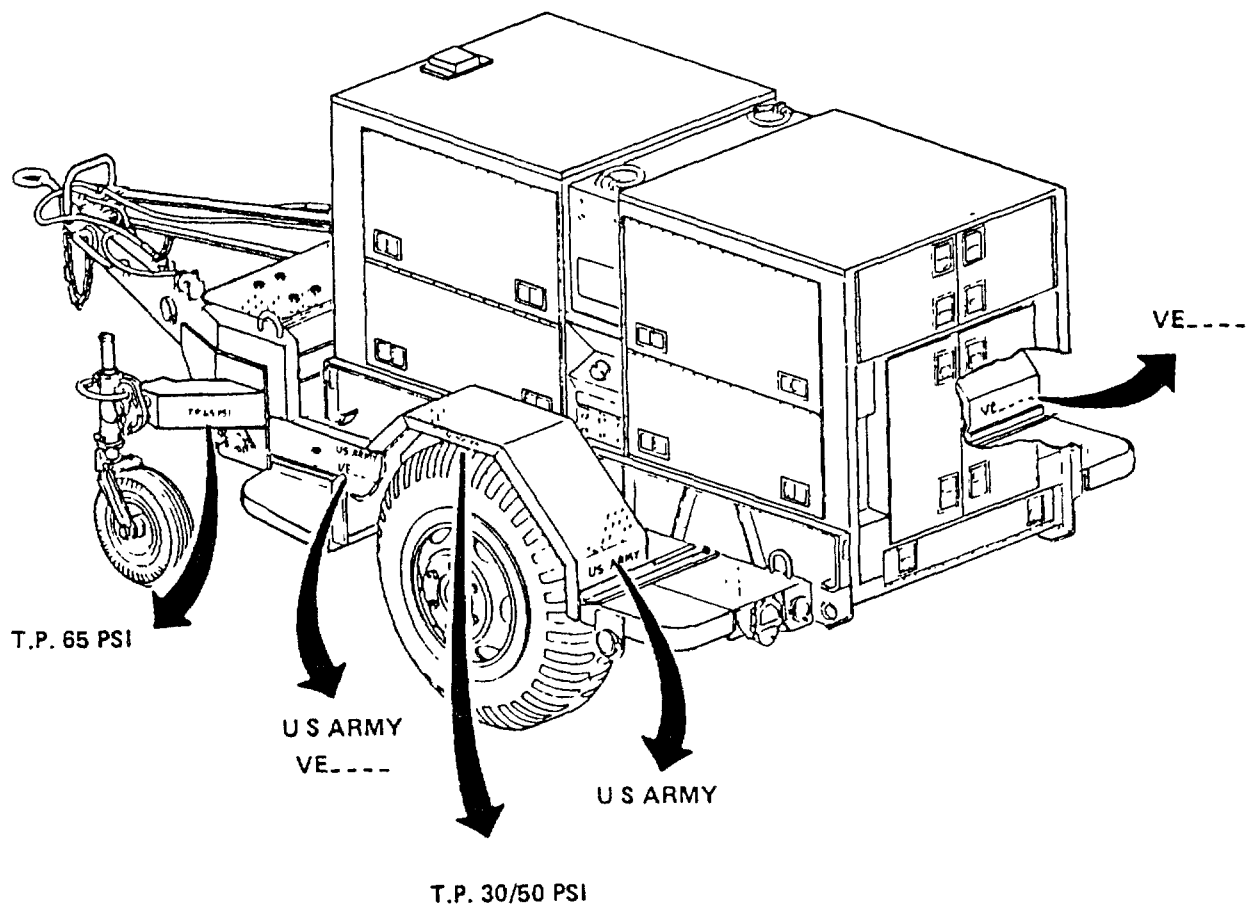

Figure 5-2. Power Unit Markings

4882-030

Section III. GENERATOR SET

5-5. Generator Set Replacement. (See figure 5-3)

a Removal

- (1) Disconnect ground wire (1, figure 5-3) from generator set (2) to GROUND TERMINAL stud (3) on trailer (4)

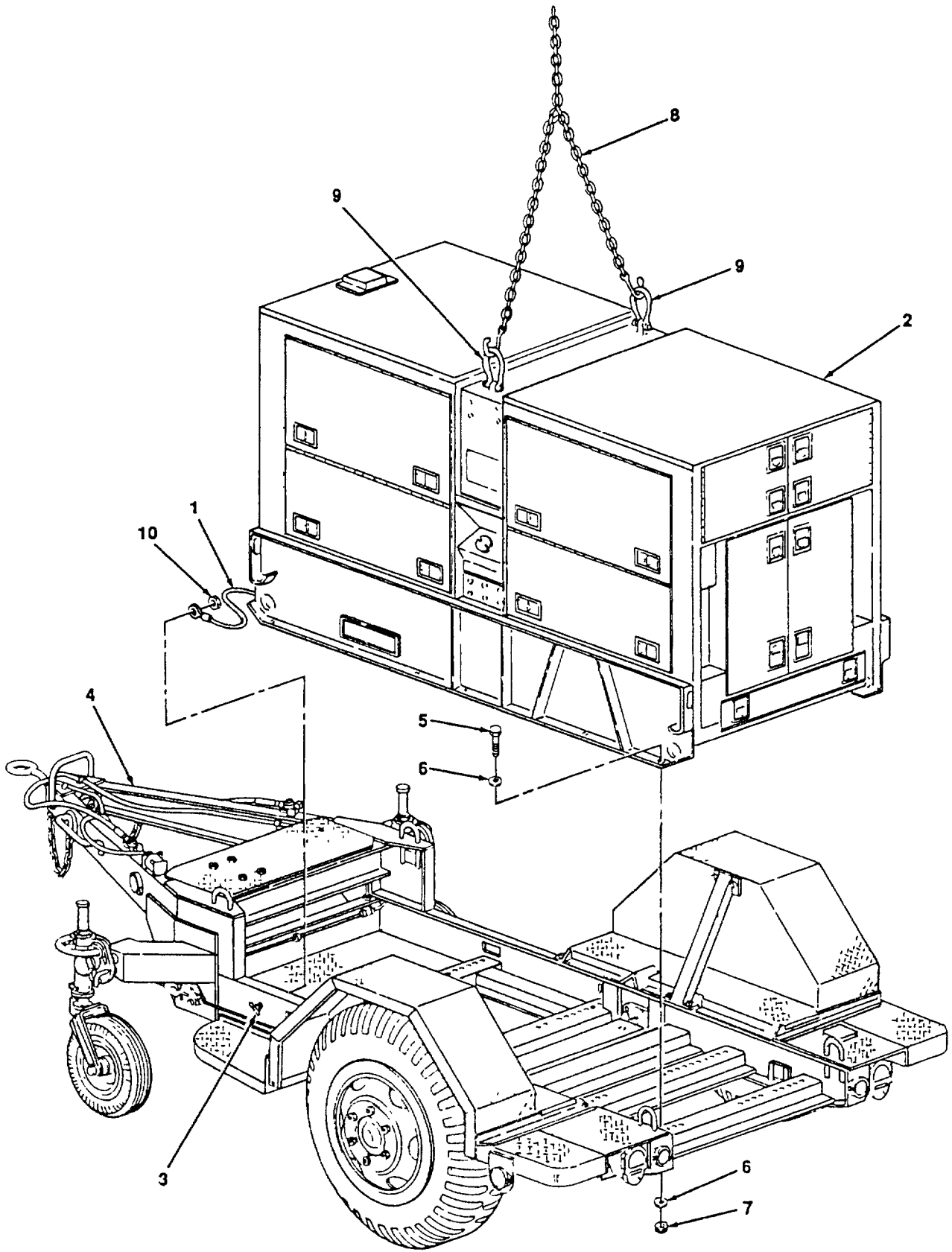

4882-040

Figure 5-3. Generator Set Replacement
5-4

- (2) Remove 12 screws (5), 24 flat washers (6), and 12 nuts (7) securing generator set (2) to trailer (4)

WARNING

When lifting generator set, use lifting equipment with a minimum lifting capacity of 10, 000 lb. Do not stand under generator while it is being lifted Do not permit generator set to swing Failure to observe these precautions can cause injury to personnel or damage to equipment

- (3) Attach lifting equipment with a minimum lifting capacity of 10, 000 lb. (8) to both lifting eyes (9) on top of generator set (2) and lift generator set off of trailer (4)

b. Installation.

WARNING

When lifting generator set, use lifting equipment with a minimum lifting capacity of 10, 000 lb. Do not stand under generator while it is being lifted Do not permit generator set to swing Failure to observe these precautions can cause injury to personnel or damage to equipment

- (1) Attach lifting equipment with a minimum lifting capacity of 10, 000 lb. (8) to lifting eyes (9) on top edges of generator set (2) and lift generator set
- (2) Position trailer (4) under generator set (2) and slowly lower generator set onto trailer while aligning mounting holes
- (3) Install 12 screws (5), 24 flat washers (6), and 12 nuts (7) securing generator set (2) to trailer (4) and tighten
- (4) Install generator set ground wire (1) on trailer GROUND TERMINAL stud (3) and secure using hardware (10) provided

5-5/(5-6 blank)

CHAPTER 6

TEST AND INSPECTION AFTER REPAIR

Section I. GENERAL REQUIREMENTS

6-1. General Requirements. The activity performing the repair is responsible for the performance of all applicable tests and inspections specified in the technical manuals referenced below. Activities performing maintenance on any component of the power unit must perform those tests and inspections required by the applicable component or system repair instruction.

Section II. INSPECTION

6-2. Generator Set Inspections. Refer to TM 5-6115-457-12 and -34, or TM 5-6115-600-12 and -34, as applicable, for inspections required following repair of the generator set.

6-3. Trailer Inspections. Refer to TM 9-2330-247-14&P for inspections required following repair of the trailer.

Section III. OPERATIONAL TESTS

6-4. Generator Set Operational Tests. Refer to TM 5-6115-457-12 and -34, or TM 5-6115-600-12 and -34, as applicable, for operational tests required to verify satisfactory performance of the generator set.

6-5. Trailer Operational Tests. Refer to TM 9-2330-247-14&P for operational tests required to verify satisfactory performance of the trailer.

6-1/(6-2 blank)

APPENDIX A

REFERENCES

A-1. Scope. This appendix lists all pamphlets, forms, technical manuals, specifications and miscellaneous publications referenced in this manual

A-2. Forms and Records.

Supply Policy below the Wholesale Level	AR 700-2
Recommended Changes to Publications and Blank Forms	DA Form 2028
Depreservation Guide for Vehicles and Equipment	DA Form 2258
Equipment Inspection and Maintenance Worksheet	DA Form 2404
Maintenance Request.....	DA Form 2407
Consolidated Index of Army Publications.....	DA PAM 25-30
The Army Maintenance Management System (TAMMS).....	DA PAM 738-750
Product Quality Deficiency Report	SF 368

A-3. Military Specifications.

Chemical Agent Resistant Aliphatic Polyurethane Coating.....	MIL-C-46168
Identification Marking of U S Military Property.....	MIL-STD-130
Identification Marking of Combat and Tactical Transport.....	MIL-STD-642
Treatment and Painting of Material	MIL-T-704

A-4. Technical Manuals.

Operator and Organizational Maintenance Manual Generator Set, Diesel Engine Driven, Tactical Skid MTD 100 Kw, 3 Phase, 4 Wire, 120/208 and 240/416V (DOD Model MEP-007A), Utility Class, 50/60 Hz (NSN 6115-00-133-9101), (Model MEP-106A) Precise Class, 50/60 Hz (6115-00-133-9102), (Model MEP-116A) Precise Class, 400 Kw (6115-00-133-9103) Including Optional Kits (Model MEP-007AWF) Winterization Kit, Fuel Burning (6115-00-463-9082), (MEP-007AWE) Winterization Kit, Electric (6115-00-463-9084), (Model MEP-007ALM) Dummy Load Kit (6115-00-463-9086) and (Model MEP-007AWM) Wheel Mounting Kit (6115-00-463-9089)	TM 5-6115-457-12
Organizational, Intermediate (Field) (Direct Support and General Support) and Depot Maintenance Repair Parts and Special Tools List Generator Set, Diesel Engine Driven, Tactical, Skid MTD, 100 Kw, 3 Phase, 4 Wire, 120/208 and 240/416 V, DOD Models MEP-007A Utility Class, 50/60 HZ (NSN 6115-00-133-9101), MEP-106A, Precise Class, 50/60 HZ (6115-00-133-9102) and MEP-116A, Precise Class, 400 Hz (6115-00-133-9103), Including Optional Kits DOD Models MEP-007AWF, Winterization Kit, Fuel Burning, (6115-00-463-9082), MEP-007AWE, Winterization Kit, Electric (6115-00-463-9084), MEP-007ALM, Dummy Load Kit (6115-00-463-9086) and MEP-007AWM, Wheel Mounting Kit (6115-00-643-9089).....	TM 5-6115-457-24P

Intermediate (Field) (Direct and General Support) and Depot Level Maintenance Manual Generator Set, Diesel Engine Driven, Tactical, Skid MTD 100 Kw, 3 Phase, 4 Wire, 120/208 and 240/416V (DOD Model MEP-007A), Utility Class, 50/60 Hz (NSN 6115-00-133-9101), (Model MEP-106A) Precise Class, 50/60 Hz (6115-00-133-9102); (Model MEP-1 16A) Precise Class, 400 Kw (6115-00-133-9103) Including Optional Kits (Model MEP-007AWF) Winterization Kit, Fuel Burning (6115-00-463-9082), (MEP-007AWE) Winterization Kit, Electric (6115-00-463-9084), (Model MEP-007ALM) Wheel Mounting Kit (6115-00-463-9089)TM 5-6115-457-34

Operator's and Organizational Maintenance Manual for Generator Set, Diesel Engine Driven, Tactical Skid MTD, 100 KW, 3 Phase, 4 Wire, 120/208 and 240/416V (DOD Model MEP-007B) Utility Class 50/60 Hz (NSN 6115-01-036-6374) including Optional Kits, DOD Model MEP-007BWF Winterization Kit, Fuel Burning, and MEP-007BWE Winterization Kit, Electric..... TM 5-6115-600-12

Organizational, Intermediate (Field) (Direct and General Support) and Depot Maintenance Repair Parts and Special Tools List for Generator Set, Diesel Engine Driven, 100 KW, 3 Phase, 4 Wire, 120/208 and 240/416V (DOD Model MEP-007B), Utility Class, 50/60 Hz (NSN 6115-01-036-6374) Including Optional Kits, DOD Model MEP-007BWE Winterization Kit, Electric TM 5-6115-600-24P

Intermediate (Field) (Direct and General Support) and Depot Maintenance Manual for Generator Set, Diesel Engine Driven, 100 KW, 3 Phase, 4 Wire, 120/208 and 240/416V (DOD Model MEP-007B), Utility Class, 50/60 Hz (NSN 6115-01-036-6374) Including Optional Kits, DOD Model MEP-007BWF, Winterization Kit, Fuel Burning and MEP-007BWE, Winterization Kit, Electric TM 5-6115-600-34

Operator's, Organizational, Direct Support and General Support Maintenance Including Repair Parts and Special Tools List for Chassis, Trailer, General' Purpose, 3 1/2-Ton, 2-Wheel, M353 (NSN 2330-00-542-2831) TM 9-2330-247-14&P

Organizational Direct Support, and General Support Care Maintenance and Repair of Pneumatic Tires and Inner Tubes TM 9-2610-200-24

A-5. Technical Bulletins.

Preservation of USAMECOM Mechanical Equipment for Shipment and Storage TB 740-97-2

APPENDIX B COMPONENTS OF END ITEM AND BASIC ISSUE ITEMS LISTS

Section I. INTRODUCTION

B-1. **Scope.** This appendix lists components of end item and basic issue items for the power unit to help you inventory items required for safe and efficient operation.

B-2. **General.** The Components of End Item and Basic Issue Items lists are divided into the following sections:

a. Section II. Components of End Item. This listing is for informational purposes only, and is not authority to requisition replacements. These items are part of the end item, but are removed and separately packaged for transportation or shipment. As part of the end item, these items must be with the end item whenever it is issued or transferred between property accounts. Illustrations are furnished to assist you in identifying the items.

b. Section III. Basic Issue Items. These are the minimum essential items required to place the power unit in operation, to operate it, and to perform emergency repairs. Although shipped separately packaged, BII must be with the power unit during operation and whenever it is transferred between property accounts. The illustrations will assist you with hard-to-identify items. This manual is your authority to request/requisition BII, based on TOE/MTOE authorization of the end item.

B-3. **Explanation of Columns.** The following provides an explanation of columns found in the tabular listings:

a. Column (1). Illustration Number (Illus No.). This column indicates the number assigned to the item.

b. Column (2). National Stock Number. Indicates the National stock number assigned to the item.

c. Column (3). Description. Indicates the federal item name and, if required, a minimum description to identify and locate the item. The last line for each item indicates the FSCM (in parentheses) followed by the part number. If item needed differed for different models of this equipment, the model would be shown under the "Usable on Code" heading in this column. The Usable on Code is not applicable for this equipment.

d. Column (4). Unit of Measure (U/M). Indicates the measure used in performing the actual operational/maintenance function. This measure is expressed by a two-character alphabetical abbreviation (eg, ea, in, pr).

e. Column (5). Quantity Required (QtY Req'd). Indicates the quantity of the item authorized to be used with/on the equipment.

Section II. COMPONENTS OF END ITEM

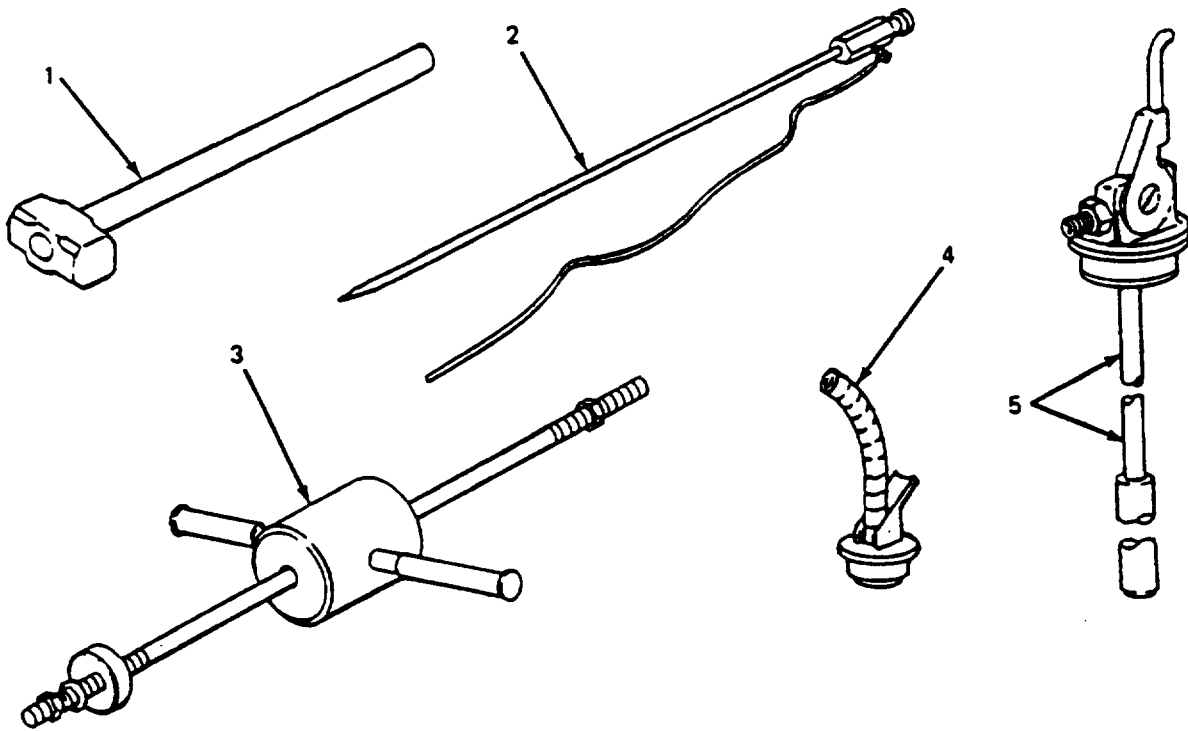

4882-031

(1) Illus. no.	(2) National stock number	(3) Description, FSCM And part number	Usable on code	(4) U/M	(5) Qty req'd
1	5120-00-243-2957	Hammer, Hand, Engineers 8 lb (3.6 kg) (81348) GGG-H-86		ea	1
2	5975-00-878-3791	Rod, Ground, Driven, Sectional 9 ft (2.7 m) (81349) MIL-R-11461		ea	1
3	5120-01-013-1676	Hammer, Slide (97403) 13226E7741		ea	1
4	7240-00-177-6154	Spout, Can, Flexible (81349) MIL-S-1285		ea	1
5	2910-00-066-1235	Adapter Assy, Fuel Drum (97403) 13214E7541		ea	1

Section III. BASIC ISSUE ITEMS

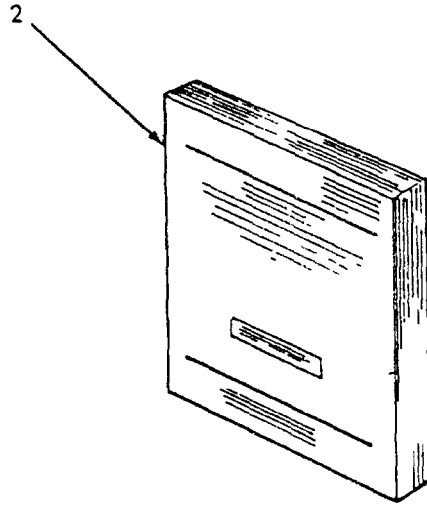
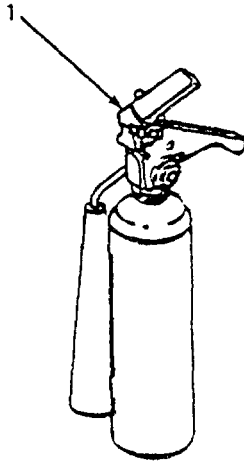

4882 032

4882-032

(1) ILLUS NUMBER	(2) NATIONAL STOCK NUMBER	(3) DESCRIPTION, CAGEC and Part Number	(4) Usable On Code U/M	(5) QTY Req.
1	4210-00-270-4512	Extinguisher, Fire, Hand, 5 lb. (2 3 kg) (81348) O-E-910	ea	1
2		Manual, Technical TM 9-6115-646-14&P	ea	1

B-3/(B-4 blank)

APPENDIX C

MAINTENANCE ALLOCATION CHART

Section I. INTRODUCTION

C-1. General.

a. This section provides a general explanation of all maintenance and repair functions authorized at various maintenance levels.

b. Section II designates overall responsibility for the performance of maintenance functions on the identified end item or component. The implementation of the maintenance functions upon the end item or component will be consistent with the assigned maintenance functions.

c. Section III lists the tools and test equipment required for each maintenance function as referenced from Section II.

d. Section IV contains supplemental instructions, explanatory notes and/or illustrations required for a particular maintenance function.

C-2. Explanation of Columns in Section II.

a. Group Number. Column 1. The assembly group is a numerical group assigned to each assembly in a top down breakdown sequence. The applicable assembly groups are listed on the MAC in disassembly sequence beginning with the first assembly removed in a top down disassembly sequence.

b. Assembly Group. Column 2 This column contains a brief description of the components of each assembly group.

c. Maintenance Functions. Column 3. This column lists the various maintenance functions (A through K) and indicates the lowest maintenance category authorized to perform these functions. The symbol designations for the various maintenance categories are as follows.

- C - Operator or crew
- O - Unit maintenance
- F - Direct support maintenance
- H - General support maintenance
- D - Depot maintenance

The maintenance functions are defined as follows:

A - Inspect. To determine serviceability of an item by comparing its physical, mechanical, and electrical characteristics with established standards.

B - Test. To verify serviceability and to detect electrical or mechanical failure by use of test equipment.

C - Service. To clean, to preserve, to charge, and to add fuel, lubricants, cooling agents, and air if it is desired that elements, such as painting and lubricating, be defined separately, they may be so listed.

D - Adjust. To rectify to the extent necessary to bring into proper operating range.

E - Align. To adjust specified variable elements of an item to bring to optimum performance.

F - Calibrate. To determine the corrections to be made in the readings of instruments or test equipment used in precise measurement Consists of the comparison of two instruments, one of which is a certified standard of known accuracy, to detect and adjust any discrepancy in the accuracy of the instrument being compared with the certified standard.

G - Install. To set up for use In an operational environment such as emplacement, site, or vehicle.

H - Replace. To replace unserviceable items with serviceable like items.

I - Repair. Those maintenance operations necessary to restore an item to serviceable condition through correction of material damage to a specific failure Repair may be accomplished at each category of maintenance.

J - Overhaul. Normally, the highest degree of maintenance performed by the Army in order to minimize time work in process is consistent with quality and economy of operation It consists of that maintenance necessary to restore an item to completely serviceable condition as prescribed by maintenance standard in technical publications for each item of equipment Overhaul normally does not return an item to like new, zero mileage, or zero hour condition.

K - Rebuild. The highest degree of material maintenance. It consists of restoring equipment as nearly as possible to new conditions in accordance with original manufacturing standards Rebuild is performed only when required by operational considerations or other paramount factors and then only at the depot maintenance category Rebuild reduces to zero the hours or miles of the equipment, or component thereof, has been in use.

d. Symbols. The uppercase letter placed in the appropriate column indicates the lowest level at which that particular maintenance function IS to be performed.

e. Tools and Equipment Column 4. This column is provided for referencing by code, the special tools and test equipment, (Section III) required to perform the maintenance functions (Section II).

f. Remarks. Column 5 This column is provided for referencing by code, the remarks (Section IV) pertinent to the maintenance functions.

C-3. Explanation of Columns in Section III. Section III, Tools, Test, and Support Equipment Requirements is not applicable.

C-4. Explanation of Columns in Section IV. Section IV, Remarks, is not applicable.

Section II. MAINTENANCE ALLOCATION CHART

(1) Group No.	(2) Assembly group	(3) Maintenance functions											(4) Tools and equipment	(5) Remarks	
		A	B	C	D	E	F	G	H	I	J	K			
		Inspect	Test	Service	Adjust	Align	Calibrate	Install	Replace	Repair	Overhaul	Rebuild			
01	GENERATOR SET	C 0.2		C 2.0					F 3.0						See TM 5-6115-457-12, -34 or TM 6115-600-12, -34, as applicable, for generator set maintenance
02	ACCESSORIES Sledge Hammer	C 0.1							C 0.1						
	Fire Extinguisher	C 0.1							C 0.1						
	Slide Hammer	C 0.1							C 0.1						
	Ground Rods	C 0.1							C 0.1						
03	TRAILER ASSEMBLY	C 0.5	O 1.0	C 0.5											See TM 9-2330-247-14&P for trailer maintenance
	Accessory Storage Chest								O 0.5	F 2.0					
	Fire Extinguisher Brackets	C 0.1							O 0.5						
	Steps/Platforms	C 0.1							O 1.0	F 2.0					
	Cover Plates								O 1.0	F 2.0					
	Reflectors	C 0.1							O 0.5						
	Data Plates								F 0.2						
	Lighting	C 0.1	O 0.3						O 1.0	O 0.5					
	Bracket	C 0.1		O 0.2					O 0.5	F 0.5					
		C-3/(C-4 blank)													

APPENDIX D

UNIT, DIRECT SUPPORT AND GENERAL SUPPORT
AND DEPOT MAINTENANCE REPAIR PARTS
AND SPECIAL TOOLS LIST

Section I. INTRODUCTION

- D-1. Scope.** This manual lists repair parts and special tools required for the performance of unit, direct support, general support and depot maintenance of the power unit.
- D-2. General.** The Repair Parts and Special Tools List is divided into the following sections.
- a. *Repair Parts - Section II.* A list of repair parts authorized for the performance of maintenance at the unit, direct support, general support and depot level in figure and item number sequence.
 - b. *Special Tools, Test and Support Equipment - Section III* A list of special tools, test and support equipment authorized for the performance of maintenance at the unit, direct support, general support and depot level.
 - c. *National Stock Number and Reference Number Index - Section IV.* A list of National stock numbers in numerical sequence, followed by a list of reference numbers appearing in all the listings, in alphanumeric sequence, cross-referenced to the illustration figure number and item number.
 - d. *Reference Designator Index - Section V.* The reference Designator Column includes all assigned reference designators arranged first in alphabetical order, second in numerical order. Opposite each symbol is listed the figure and item number of the part in Section II and the reference number.
- D-3. Explanation of Columns.** The following provides an explanation of columns in the tabular lists in Sections II and III.
- a. *Illustrations. (Column 1).* This column is divided as follows.
 - (1) *Figure number.* Indicates the figure number of the illustration on which the item is shown.
 - (2) *Item number.* Indicates the number used to identify the item on the illustration.

b. Source, Maintenance, and Recoverability Codes (SMR). (Column 2).

(1) *Source codes.*

GENERAL: Source Codes are assigned to support items to indicate the manner of acquiring support items for maintenance, repair, or overhaul of end items Source codes are entered in the first and second positions of the Uniform SMR Code format as follows:

Code	Definition
PA	Item procured and stocked for anticipated or known usage.
PB	Item procured and stocked for insurance purposes because essentially dictates that a minimum quantity be available in the supply systems.
PC	Item procured and stocked and which otherwise would be coded PA except that it is deteriorative in nature.
PD	Support item, excluding support equipment, procured for initial issue or outfitting and stocked only for subsequent or additional initial issues or outfittings Not subject to automatic replenishment.
PE	Support equipment procured and stocked for initial issue or outfittings to specified maintenance repair activities.
PF	Support equipment which will not be stocked but which will be centrally procured on demand.
PG	Item procured and stocked to provide for sustained support for the life of the equipment it is applied to an item peculiar to the equipment which because of probable discontinuance or shutdown of production facilities would prove uneconomical to reproduce at a later time.
KD	An item of depot overhaul/repair kit and not purchased separately Depot kit defined as a kit that provides items required at the time of overhaul or repair.
KF	An item of maintenance kit and not purchased separately Maintenance kit defined as a kit that provides an item that can be replaced at unit, direct support or general support levels of maintenance.
KB	Item included in both a depot overhaul/repair kit and a maintenance kit.
MO	Item to be manufactured or fabricated at unit level.

Code	Definition
MF	Item to be manufactured or fabricated at general support maintenance levels.
MD	Item to be manufactured or fabricated at depot maintenance level.
AO	Item to be assembled at unit level.
AF	Item to be assembled at direct support maintenance levels.
AH	Item to be assembled at general support maintenance levels.
AD	Item to be assembled at depot maintenance level.
XA	Item is not procured or stocked because the requirements for the item will result in the replacement of the next higher assembly.
XB	Item is not procured or stocked. If not available through salvage, requisition.
XC	Installation drawing, diagram, instruction sheet, field service drawing, that is identified by manufacturer's part number.
XD	A support item that is not stocked. When required, item will be procured through normal supply channels.

(2) *Maintenance codes:* GENERAL Maintenance Codes are assigned to indicate the levels of maintenance authorized to USE and REPAIR support items. The Maintenance Codes are in the third and fourth position of the Uniform SMR Code Format.

(a) *Use (third position).* The Maintenance Code entered in the third position indicates the lowest level maintenance level authorized to remove, replace, and use the support item. The Maintenance Code entered in the third position indicates one of the following levels of maintenance.

Code	Application/Explanation
O	Support item is removed, replaced, used at the unit level of maintenance.
F	Support item is removed, replaced, used at direct support levels.
H	Support item is removed, replaced, used general support levels.

Code	Definition
D	Support items that are removed, replaced, used at depot only. Depot, Mobile Depot and Specialized Repair Activity

(b) *Repair (fourth position)*. The maintenance code entered in the fourth position indicates whether the item is to be repaired and identifies the lowest maintenance level with the capability to perform complete repair (i.e., all authorized maintenance functions).

Code	Application/Explanation
O	The lowest maintenance level capable of complete repair of the support item is the unit level
F	The lowest maintenance level capable of complete repair of the support item is direct support level
H	The lowest maintenance level capable of complete repair of the support item is general support level

Code	Definition
D	The lowest maintenance level capable of complete repair of the support item is the depot level Depot, Mobile Depot, and Specialized Repair Activity

Code	Application/Explanation
L	Repair restricted to designated Specialized Repair Activity
Z	Non-reparable No repair is authorized
B	No repair is authorized The item may be reconditioned by adjusting, lubricating, etc., at the user level No parts or special tools are procured for the maintenance of this item

(3) *Recoverability codes*- GENERAL Recoverability Codes are assigned to support items to indicate the disposition action on unserviceable items The recoverability code is entered in the fifth position of the uniform SMR Code Format as follows:

Recoverability Codes	Definition
Z	Non-reparable item When unserviceable, condemn and dispose at the level indicated in column 3.
O	Reparable item When uneconomically repairable, condemn and dispose at unit level.
F	Reparable item When uneconomically repairable, condemn and dispose at direct support level.
H	Reparable item When uneconomically repairable, condemn and dispose at general support level.

Recoverability Codes	Definition
D	Reparable item When beyond lower level repair capability, return to depot Condemnation and disposal not authorized below depot level
L	Reparable item Repair, condemnation and disposal not authorized below depot/Specialized Repair Activity level
A	Item requires special handling or condemnation procedure because of specific reasons (i e , precious metal content, high-dollar value, critical material or hazardous material) Refer to appropriate manuals/directives for specific instructions

c. National Stock Number (Column 4). Indicates the National Stock Number assigned to the item and will be used for requisitioning purposes.

d. Description (Column 5). Indicates the Federal item name and any additional descriptions of the item required The abbreviation "w/e" when used as a part of the nomenclature, indicates that the National Stock Number includes all armament, equipment, accessories and repair parts issued with the item A part number or other reference number is followed by the applicable five digit Federal Supply Code for Manufacturer in parentheses if two reference numbers and Federal Supply Codes for Manufacturer are listed, the first listing refers to the Department of Defense Drawing Number, the second listing refers to the actual part manufacturer items that are included in kits and sets are listed below the name of the kit or set with the quantity of each item in the kit or set indicated in the quantity incorporated in unit column.

e. Unit of Measure (U/M) (Column 6). Indicates the standard of the basic quantity of the listed item as used in performing the actual maintenance function This measure is expressed by a two-character alphabetical abbreviation (e. g., ea., in., pr. etc.) When the unit of measure differs from the unit of issue, the lowest unit of issue that will satisfy the required units of measure will be requisitioned.

f. Quantity Incorporated in Unit (Column 7). Indicates the quantity of the item used in the assembly group A "V" appearing in this column in lieu of a quantity indicates that a definite quantity cannot be indicated (e g , shims, spacers, etc.).

D-4. Special Information.

a. Identification of Usable On Codes for this manual is not applicable.

b. Army unit maintenance personnel will extract the items which they require from Section II, 3rd or 4th position of column 2 of the direct and general support RPSTL Parts which are manufactured or assembled at a higher level than that authorized to install the part are indicated by the use of higher level code in the source column.

c. Stockage Information. Army stockage is demand based in accordance with AR 710-2 Repair parts listed in this publication represent those authorized for use at indicated maintenance levels and will be requisitioned on an as-required basis until stockage is justified in accordance with AR 710-2.

d. In the parts list, some items are indented to show that they are a component of the item under which they are indented.

D-5. How to Locate Repair Parts.

a. When National Stock Number or Reference Number is Unknown:

- (1) Using the table of contents, determine the functional group, i.e., batteries and related parts, exhaust and breather pipes, within which the repair part belongs This is necessary since illustrations are prepared for functional groups.
- (2) Find the illustration covering the functional group to which the repair part belongs.
- (3) Identify the repair part on the illustration and note the illustration figure and item number of the repair part.
- (4) Using the Repair Parts Listing, find the figure and item number noted on the illustration.

b. When National Stock Number or Reference Number is Known:

- (1) Using the Index of National Stock Numbers and Reference Numbers, find the pertinent national stock number or reference number This index is in ascending NSN sequence followed by a list of reference numbers in alphanumeric sequence, cross-referenced to the illustration figure number and item number.
- (2) After finding the figure and item number, locate the figure and item number in the repair parts list.

D-6. Use of the Reference Designator Index Section. This Section (Section V) is used when the reference designator is known or identified by other technical manuals supporting this equipment The reference number is given in this section if description or location is desired, note the figure and item number Turn to Section II to the noted figure and item number The location of the part and description is given in this listing.

D-7. Abbreviations.

Abbreviations	Explanation
Not Applicable	

D-8. Federal Supply Codes for Manufacturers.

Code	Manufacturer
Not Applicable	

D-9. Recommendation for Maintenance Publication Improvements. Report of errors, omissions, and recommendations for improving this publication by the individual user is encouraged. Reports should be submitted as follows Army DA Form 2028, directly to Commander, US Army Troop Support Command, ATTN AMSTR-MCTS, 4300 Goodfellow Boulevard, St. Louis, MO 63120-1798.

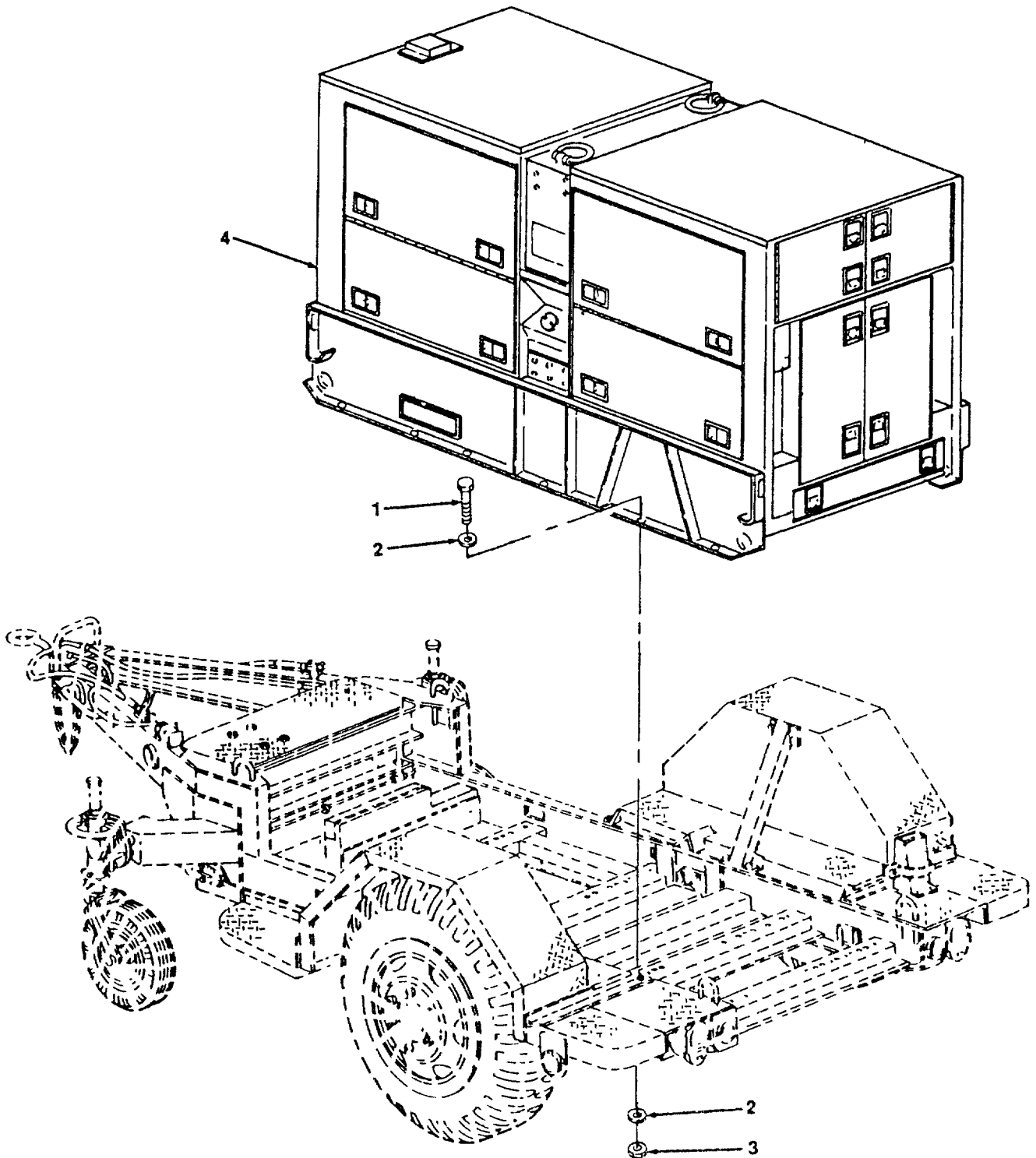
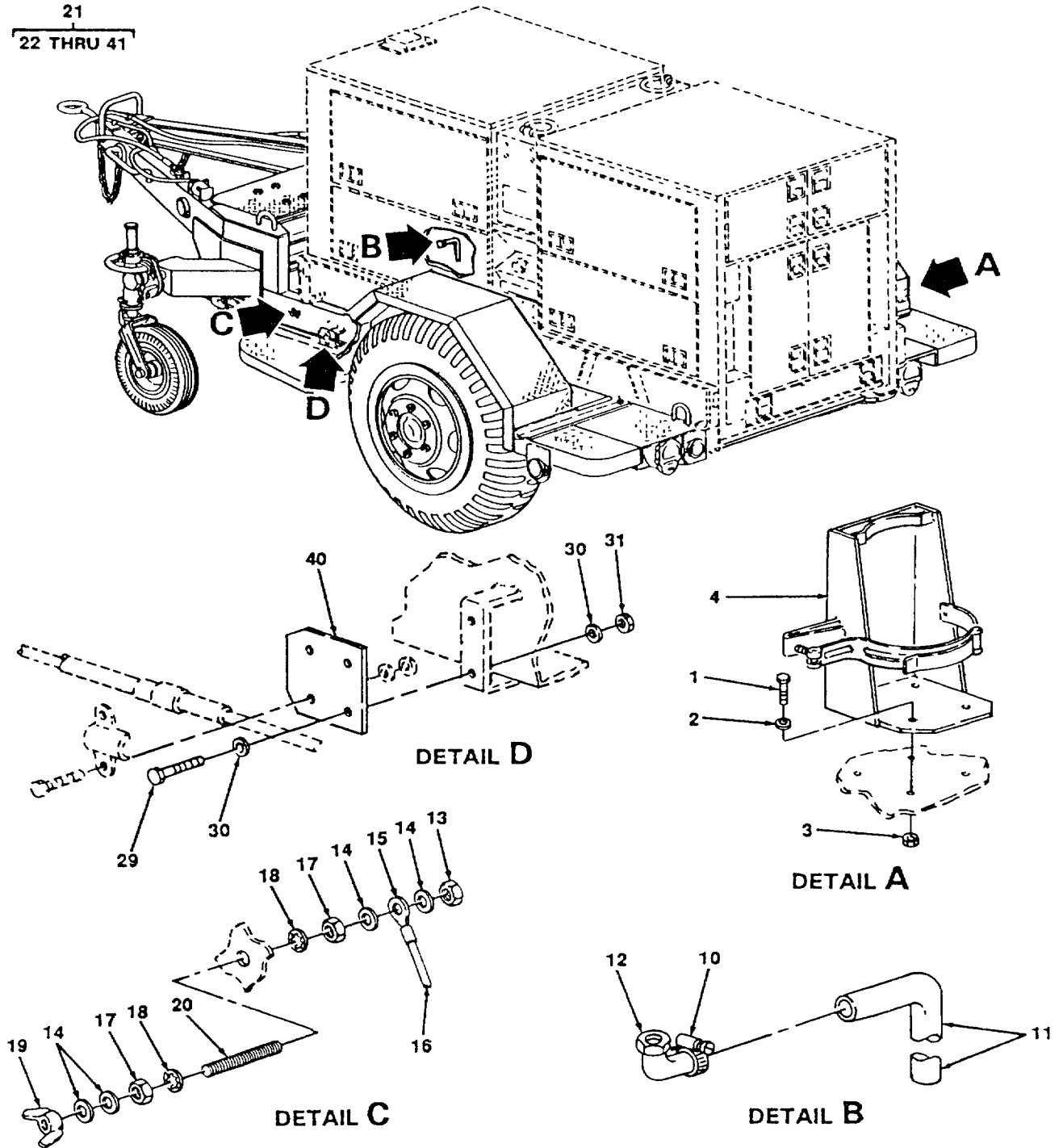

Figure D-1. Generator Set

D-8/(D-7 Blank)

(1) ILLUS- TRATION		(2) SMR CODE				(3) USMC		(4)	(5) DESCRIPTION	(6)	(7) QTY	(8) USMC
a FIG NO.	b ITEM NO.	a ARMY	b AIR FORCE	c NAVY	d USMC	a SSI	b REPL FACTOR	NATIONAL STOCK NUMBER	USABLE ON CODE & MFR CODE	U/M	INC IN UNIT	QTY PER EQUIP
									Group 01 - GENERATOR SET			
D-1	1	PAFZZ						5305-00-724-7222	SCREW, CAP MS90728 164 96906	EA	12	
D-1	2	PAFZZ						5310-00-828-8803	WASHER, FLAT MS27183-21 96906	EA	24	
D-1	3	PAFZZ						5310-00-269-4044	NUT, SELF-LOCKING MS51922-49 96906	EA	12	
D-1	4	PAFFO						6115-00-133-9101	GENERATOR SET, MEP-007A (USED ON PU-495A/G) MIL-G-52884/11 81349	EA	1	
D 1	4	PAFFD						6115-01 036-6374	GENERATOR SET, MEP-007B (USED ON PU 495B/G) MIL-G-52884/11 81349	EA	1	
D-9/(D-10 blank)												

21
22 THRU 41



4882-042 1

Figure D-2. Trailer (Sheet 1 of 2)

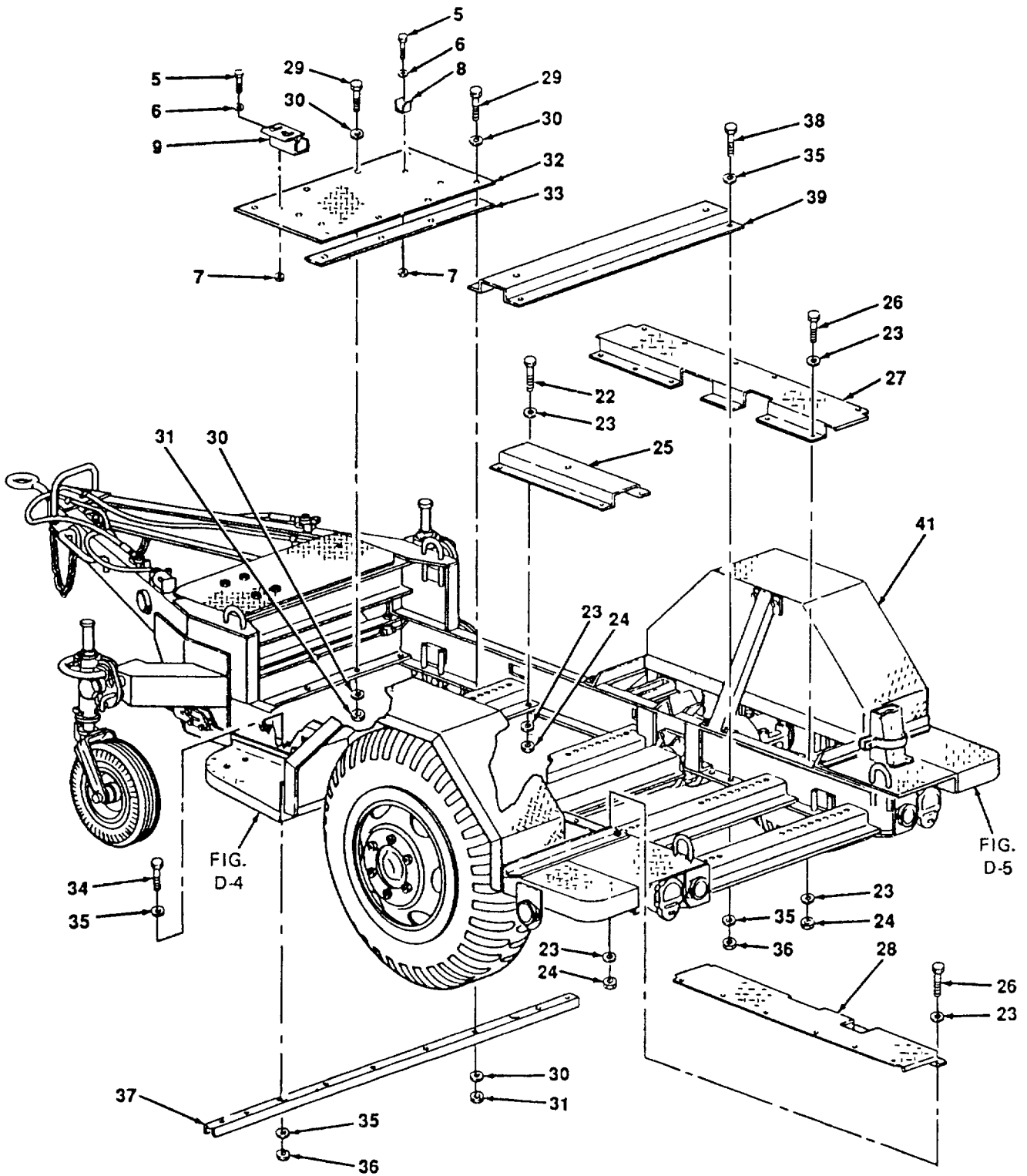

Figure D-2. Trailer (Sheet 2 of 2)

4882 042 2

(1) ILLUSTRATION		(2) SMR CODE				(3) USMC		(4)	(5) DESCRIPTION	(6)	(7) QTY	(8) USMC	
a FIG NO.	b ITEM NO.	a ARMY	b AIR FORCE	c NAVY	d USMC	a SSI	b REPL FACTOR	NATIONAL STOCK NUMBER	REF NUMBER & MFR CODE	USABLE ON CODE	U/M	INC IN UNIT	QTY PER EQUIP
									Group 03- TRAILERASSEMBLY				
D-2	1	PAOZZ						5305-00-269-3209	SCREW, CAP MS90725-58	96906	EA	4	
D-2	2	PAOZZ						5310-00 080-6004	WASHER, FLAT MS27183-14	96906	EA	4	
D-2	3	PAOZZ						5310-00-087-4652	NUT, SELF-LOCKING MS51922-17	96906	EA	4	
D-2	4	XBOZZ						4210-00-223-4857	BRACKET, FIRE EXTINGUISHER 13214E1235	97403	EA	1	
D-2	5	PAOZZ						5305-00-068-0502	SCREW, CAP MS90725-6	96906	EA	3	
D-2	6	PAOZZ						5310-00-809 4058	WASH4R, FLAT MS27183 10	96906	EA	3	
D-2	7	PAOZZ						5310-00 088-1251	NUT, SELF-LOCKING MS51922-1	96906	EA	3	
D-2	8	XBOZZ						5340 00-914-2578	CLIP, SPRING 13214E1213-1	97403	EA	1	
D-2	9	XBOZZ						5340-00-999-6277	BRACKET ASSY 13214E1214	97403	EA	1	
D-2	10	PAOZZ						4730-00-908-3194	CLAMP, HOSE MS35842-11	96906	EA	1	
D-2	11	PAOZZ							HOSE MIL-H 6000	81349	EA	1	
D-2	12	PAOZZ						4730-00 809-9703	ELBOW, PIPE TO HOSE MS24519 9	96906	EA	1	
D-2	13	PAOZZ						5310-00-584-7995	NUT, PLAIN, HEX MS16203-27	96906	EA	1	
D-2	14	PAOZZ						5310-01-004-9129	WASHER, FLAT AN961-616S	81352	EA	4	
D-2	14	PAOZZ						5310-00-187-2413	WASHER, FLAT AN961-616T	81352	EA	4	
D-2	15	PAOZZ						5940 00-115-4992	TERMINAL, LUG, CRIMP MS20659-110	96906	EA	3	
D-2	16	PAOZZ							WIRE, NO 6AWG QQ-W-343	81348	FT	AR	
D-2	17	PAOZZ						5310-01 026-5824	NUT, PLAIN, HEX MS16203-39	96906	EA	2	
D-2	18	PAOZZ						5310 00-913 9776	LOCKWASHER, EXTERNAL TOOTH MS35335 91	96906	EA	2	
D-2	19	PAOZZ						5310 00 543-4717	NUT, WING MS35425-28	96906	EA	1	
D-2	20	PAOZZ						5307-00-722-9437	STUD 13214E1223	97403	EA	1	

(1) ILLUS- TRATION		(2) SMR CODE				(3) USMC		(4)	(5) DESCRIPTION	(6)	(7)	(8)
a	b	a	b	c	d	a	b	NATIONAL STOCK NUMBER	USABLE ON CODE	U/M	INC IN UNIT	QTY PER EQUIP
FIG NO.	ITEM NO.	ARMY	AIR FORCE	NAVY	USMC	SSI	REPL FACTOR	REF NUMBER & MFR CODE				
								Group03- TRAILERASSEMBLY(Cont)				
D-2	21	XBFZZ						TRAILER 13220E6330	97403	EA	1	
D-2	22	PAOZZ						5305-00-068-0510 . SCREW, CAP MS90728-60	96906	EA	8	
D-2	23	PADZZ						5310-00-080-6004 . WASHER, FLAT MS27183-14	96906	EA	64	
D-2	24	PAOZZ						5310-00-087-4652 . NUT, SELF-LOCKING MS51922-17	96906	EA	32	
D-2	25	XBDZZ						. BOLSTER 13221E4796	97403	EA	2	
D-2	26	PAOZZ						5340-00-006-6574 . SCREW, CAP MS90725-60	96906	EA	24	
D-2	27	XBOZZ						. PLATE, COVER, CURBSIDE 13221E4798	97403	EA	1	
D-2	28	XBOZZ						. PLATE, COVER, ROADSIDE 13221E4797	97403	EA	1	
D-2	29	PAOZZ						5306 00-225-8499 . SCREW, CAP MS90725-34	96906	EA	12	
D-2	30	PAOZZ						5310-00-081-4219 . WASHER, FLAT MS27183-1296906		EA	24	
D-2	31	PAOZZ						5310 00-984-3806 . NUT, SELF-LOCKING MS51922 9	96906	EA	12	
D-2	32	XBOZZ						. PLATE 13214E1322	97403	EA	1	
D-2	33	XBOZZ						. SPACER 13214E1323	97403	EA	1	
D-2	34	XDOZZ						. SCREW, CAP MS90725-111	96906	EA	2	
D-2	35	PAOZZ						5310-00 809-5998 . WASHER, FLAT MS27183-18	96906	EA	12	
D-2	36	PAOZZ						5310 00-225-6993 . NUT, SELF-LOCKING MS51922-3396906		EA	6	
D-2	37	XBOZZ						. SUPPORT 13214E1318	97403	EA	1	
D-2	38	PAOZZ						5305 00-225 3841 . SCREW, CAP MS90128-1-11	96906	EA	4	
D-2	39	XBOZZ						. BOLSTER 13221E4795	97403	EA	1	
D-2	40	XBOZZ						. BRACKET 13221E4792	97403	EA	2	
D-2	41	XBHHH						. CHASSIS 13220E6331	97403	EA	1	
D-14/(D-15 blank)												

4
5 AND 6

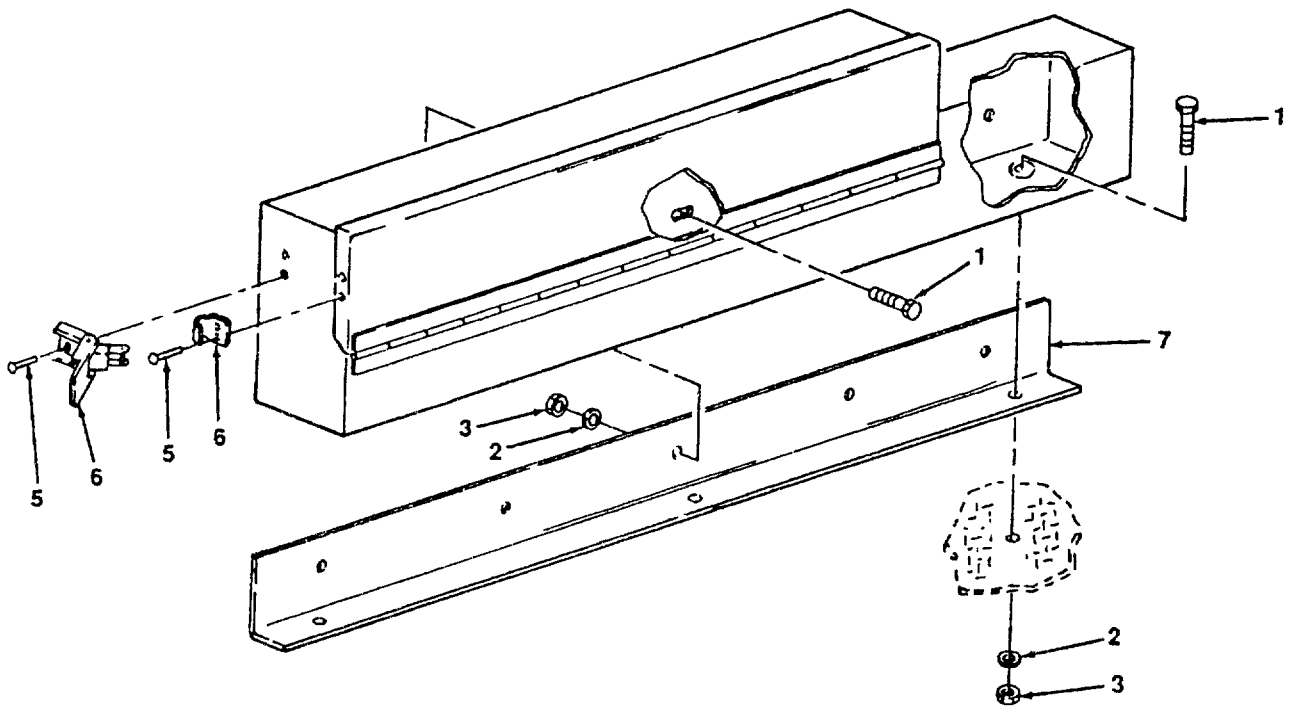
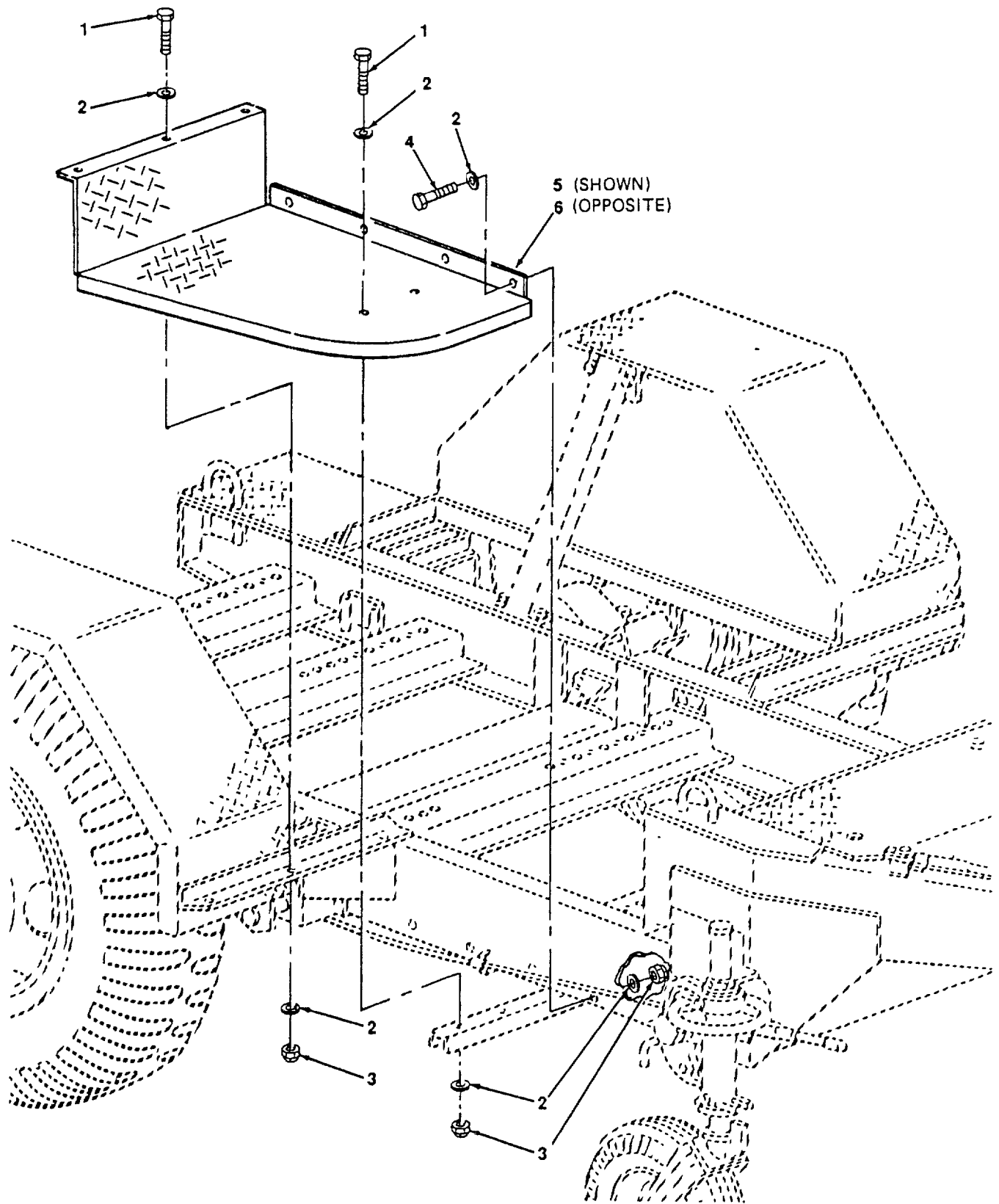

Figure D-3. Accessory Storage Chest

4882-043

(1) ILLUS- TRATION		(2) SMR CODE				(3) USMC		(4)	(5) DESCRIPTION	(6)	(7) QTY	(8) USMC	
a FIG NO.	b ITEM NO.	a ARMY	b AIR FORCE	c NAVY	d USMC	a SSI	b REPL FACTOR	NATIONAL STOCK NUMBER	REF NUMBER & MFR CODE	USABLE ON CODE	U/M	INC IN UNIT	QTY PER EQUIP
D-3	1	PAOZZ						5306-0W-225-8498	03 - Accessory Stowage Chest SCREW, CAP MS90725-33	96906	EA	5	
D-3	2	PAOZZ						5310-00-081 4219	WASHER FLAT 1527183-12	96906	EA	5	
D-3	3	PAOZZ						5310 00-984 3806	NUT, SELF LOCKING MS51922-9	96906	EA	5	
D-3	4	XBOOO						6115-00 705-4604	CHEST, ACCESSORY STOWAGE 13214E12739	7403	EA	1	
D-3	5	PAOZZ							RIVET, SOLID MS35744-1	96906	EA	8	
D-3	6	PAOZZ						5340 00-975-2126	LATCH AND STRIKE ASSY MS18015-1	96906	EA	2	
D-3	7	XBOZZ							BRACKET 13214E1329	97403	EA	1	



4882-044

Figure D-4. Front Steps
D-18

(1) ILLUS- TRATION		(2) SMR CODE				(3) USMC		(4)	(5) DESCRIPTION		(6)	(7)	(8)
a	b	a	b	c	d	a	b	NATIONAL STOCK NUMBER	REF NUMBER & MFR CODE	USABLE ON CODE	U/M	INC IN UNIT	QTY PER EQUIP
FIG NO.	ITEM NO.	ARMY	AIR FORCE	NAVY	USMC	SSI	REPL FACTOR						
D-4	1	PAOZZ						5340 00-006-6574	03 - Front Steps SCREW, CAP MS90725-60	96906	EA	10	
D-4	2	PAOZZ						5310 00 080-6004	WASHER, FLAT MS27183 -14	96906	EA	36	
D-4	3	PAOZZ						5310-00 087-4652	NUT, SELF-LOCKINUG MS51922-17	96906	EA	18	
D-4	4	PAOZZ							SCREW, CAP MS90728-60	96906	EA	8	
D-4	5	XBOZZ							STEP, FRONT, CURBSIDE 13221E4790	97403	EA	1	
D-4	6	XBOZZ							STEP, FRONT, ROADSIDE 13221E4791	97403	EA	1	

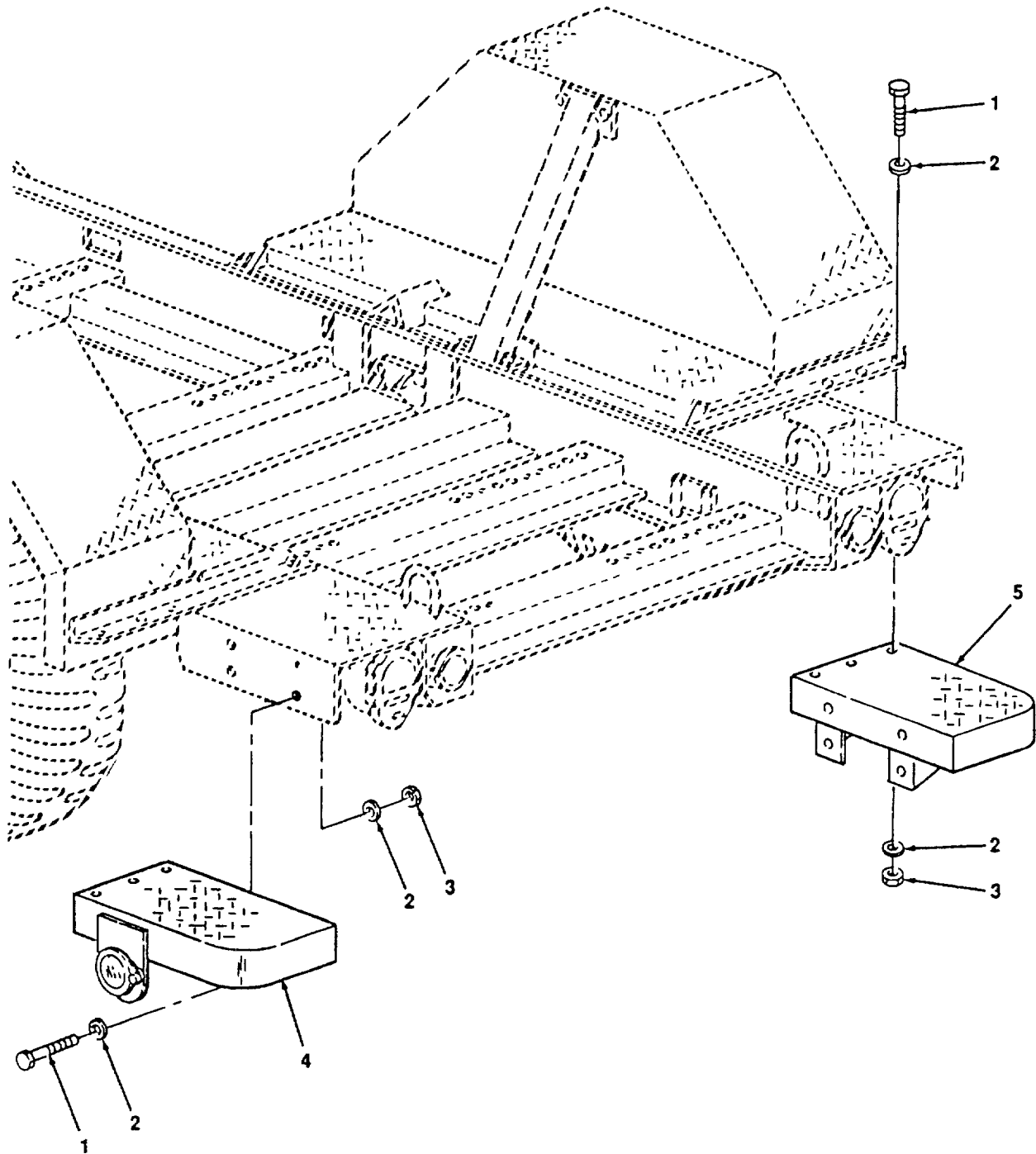

Figure D-5. Rear Steps

(1) ILLUS- TRATION		(2) SMR CODE				(3) USMC		(4)	(5) DESCRIPTION			(6)	(7)	(8)
a	b	a	b	c	d	a	b	NATIONAL STOCK NUMBER	REF NUMBER & MFR CODE	USABLE ON CODE	U/M	INC IN UNIT	QTY PER EQUIP	
FIG NO.	ITEM NO.	ARMY	AIR FORCE	NAVY	USMC	SSI	REPL FACTOR							
D-5	1	PAOZZ						5340-00-006 6574	03 - Rear Steps SCREW, CAP MS90725-60	98906	EA	14		
D-5	2	PAOZZ						5310-00-080-6004	WASHER, FLAT MS27183-14	96906	EA	28		
D-5	3	PAOZZ						5310-00 087 4652	NUT, SELF-LOCKING MS51922-17	96906	EA	14		
D-5	4	XBOZZ							STEP, REAR, ROADSIDE 13221E4794	97403	EA	1		
D-5	5	XBOZZ							STEP, REAR, CURBSIDE 13221E4793	97403	EA	1		
D-21														

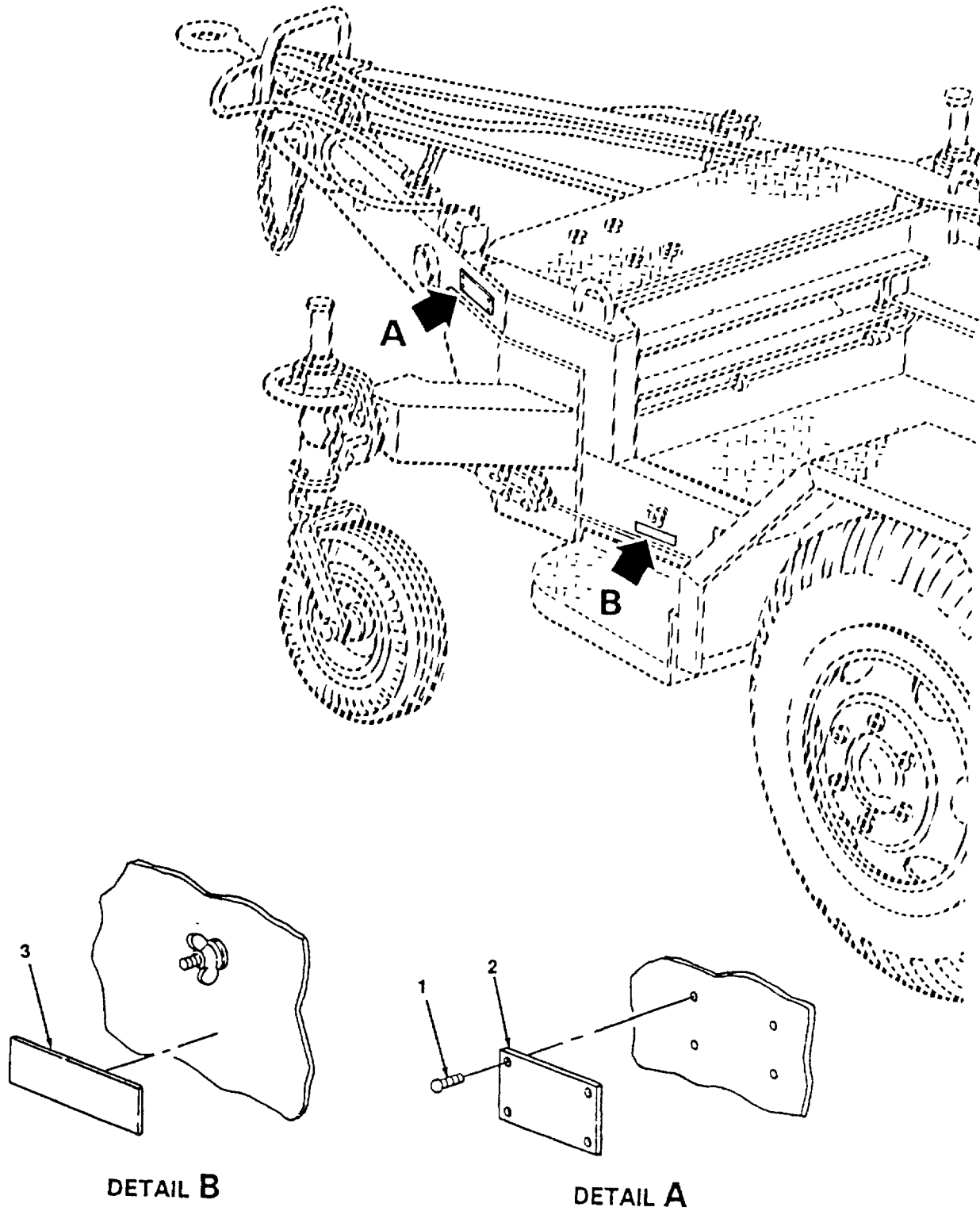

Figure D-6. Data Plates and Reflectors

(1) ILLUS- TRATION		(2) SMR CODE				(3) USMC		(4)	(5) DESCRIPTION		(6)	(7)	(8)
a	b	a	b	c	d	a	b	NATIONAL STOCK NUMBER	USABLE ON CODE	U/M	INC IN UNIT	QTY PER EQUIP	
FIG NO.	ITEM NO.	ARMY	AIR FORCE	NAVY	USMC	SSI	REPL FACTOR		REF NUMBER & MFR CODE				
D-6	1	PAFZZ						5305-00-175-3230	03 - Data Plates SCREW, DRIVE MS21318-14 96906	EA	4		
D-6	2	XBFZZ							PLATE, IDENTIFICATION 13216E7604-42 97403	EA	1		
D-6	3	XBFZZ							PLATE, IDENTIFICATION 13205E4918 97403	EA	1		

Section III. SPECIAL TOOLS, TEST AND SUPPORT EQUIPMENT

Not Applicable

Section IV. NATIONAL STOCK NUMBER AND REFERENCE NUMBER INDEX

NSN	Figure No.	Item No.	NSN	Figure No.	Item No.
4210-00-223-4857	D-2	4	5310-00-187-2413	D-2	14
4730-00-809-9703	D-2	12	5310-00-225-6993	D-2	36
4730-00-908-3194	D-2	10	5310-00-269-4044	D-1	3
5305-00-068-0502	D-2	5	5310-00-543-4717	D-2	19
5305-00-068-0510	D-2	22	5310-00-584-7995	D-2	13
5305-00-175-3230	D-6	1	5310-00-809-4058	D-2	6
5305-00-225-3841	D-2	38	5310-00-809-5998	D-2	35
5305-00-269-3209	D-2	1	5310-00-828-8803	D-1	2
5305-00-724-7222	D-1	1	5310-00-913-9776	D-2	18
5306-00-225-8498	D-3	1	5310-00-984-3806	D-2	31
5306-00-225-8499	D-2	29		D-3	3
5307-00-722-9437	D-2	20	5310-01-004-9129	D-2	14
5310-00-080-6004	D-2	2	5310-01-026-5824	D-2	17
	D-2	23	5340-00-006-6574	D-2	26
	D-4	2		D-4	1
	D-5	2		D-5	1
5310-00-081-4219	D-2	30	5340-00-914-2578	D-2	8
	D-3	2	5340-00-975-2126	D-3	6
5310-00-087-4652	D-2	3	5940-00-115-4992	D-2	15
	D-2	24	5940-00-999-6277	D-2	9
	D-4	3	6115-01-036-6374	D-1	4
	D-5	3	6115-00-133-9101	D-1	4
5310-00-088-1251	D-2	7	6115-00-705-4604	D-3	4

Section IV. NATIONAL STOCK NUMBER AND REFERENCE NUMBER INDEX (cont)

Reference Number	FSCM	Fig No.	Item No.	Reference Number	FSCM	Fig No.	Item No.
AN961-616S	81352	D-2	14	MS90725-33	96906	D-3	1
AN961-616T	81352	D-2	14	MS90725-111	96906	D-2	34
QQ-W-343	81348	D-2	16	MS90725-34	96906	D-2	29
MEP-007A	81349	D-1	4	MS90725-58	96906	D-2	1
MEP-007B	81349	D-1	4	MS90725-6	96906	D-2	5
MIL-H-6000	81349	D-2	11	MS90725-60	96906	D-2	26
MS16203-27	96906	D-2	13			D-4	1
MS1 6203-39	96906	D-2	17			D-5	1
MS18015-1	96906	D-3	6	MS90728-111	96906	D-2	38
MS20659-110	96906	D-2	15	MS90728-164	96906	D-1	1
MS21318-14	96906	D-6	1	MS90728-60	96906	D-2	22
MS24519-9	96906	D-2	12	13205E4918	97403	D-6	3
MS27183-10	96906	D-2	6	13214E1213-1	97403	D-2	8
MS27183-12	96906	D-2	30	13214E1214	97403	D-2	9
		D-3	2	13214E1223	97403	D-2	20
MS27183-14	96906	D-2	2	13214E1235	97403	D-2	4
		D-2	23	13214E1273	97403	D-3	4
		D-4	2	13214E1318	97403	D-2	37
		D-5	2	13214E1322	97403	D-2	32
MS27183-18	96906	D-2	35	13214E1323	97403	D-2	33
MS27183-21	96906	D-1	2	13214E1329	97403	D-3	7
MS35335-91	96906	D-2	18	13216E7604-42	97403	D-6	2
MS35425-28	96906	D-2	19	13220E6330	97403	D-2	21
MS35744-1	96906	D-3	5	13220E6331	97403	D-2	41
MS35842-11	96906	D-2	10	13221E4790	97403	D-4	4
MS51922-1	96906	D-2	7	13221 E4791	97403	D-4	5
MS51922-17	96906	D-2	3	13221 E4792	97403	D-2	40
		D-2	24	13221E4793	97403	D-5	5
		D-4	3	13221E4794	97403	D-5	4
		D-5	3	13221E4795	97403	D-2	39
MS51922-33	96906	D-2	36	13221E4796	97403	D-2	25
MS51922-49	96906	D-1	3	13221E4797	97403	D-2	28
MS51922-9	96906	D-2	31	13221E4798	97403	D-2	27
		D-3	3				

Section V. REFERENCE DESIGNATOR INDEX

Not Applicable

D-25/(D-26 blank)

By Order of the Secretary of the Army:

CARL E. VUONO
General, United States Army
Chief of Staff

Official:

WILLIAM J. MEEHAN, II
Brigadier General, United States Army
The Adjutant General

DISTRIBUTION:

To be distributed in accordance with DA Form 12-25A, Organizational, Unit, Direct Support and General Support Maintenance Requirements for Generator Set, Diesel Engine Driven, Trailer Mounted, 1 (TM 5-6115-594 series)

The Metric System and Equivalents

Linear Measure

1 centimeter = 10 millimeters = .39 inch
 1 decimeter = 10 centimeters = 3.94 inches
 1 meter = 10 decimeters = 39.37 inches
 1 dekameter = 10 meters = 32.8 feet
 1 hectometer = 10 dekameters = 328.08 feet
 1 kilometer = 10 hectometers = 3,280.8 feet

Weights

1 centigram = 10 milligrams = .15 grain
 1 decigram = 10 centigrams = 1.54 grains
 1 gram = 10 decigrams = .035 ounce
 1 dekagram = 10 grams = .35 ounce
 1 hectogram = 10 dekagrams = 3.52 ounces
 1 kilogram = 10 hectograms = 2.2 pounds
 1 quintal = 100 kilograms = 220.46 pounds
 1 metric ton = 10 quintals = 1.1 short tons

Liquid Measure

1 centiliter = 10 milliliters = .34 fl. ounce
 1 deciliter = 10 centiliters = 3.38 fl. ounces
 1 liter = 10 deciliters = 33.81 fl. ounces
 1 dekaliter = 10 liters = 2.64 gallons
 1 hectoliter = 10 dekaliters = 26.42 gallons
 1 kiloliter = 10 hectoliters = 264.18 gallons

Square Measure

1 sq. centimeter = 100 sq. millimeters = .155 sq. inch
 1 sq. decimeter = 100 sq. centimeters = 15.5 sq. inches
 1 sq. meter (centare) = 100 sq. decimeters = 10.76 sq. feet
 1 sq. dekameter (are) = 100 sq. meters = 1,076.4 sq. feet
 1 sq. hectometer (hectare) = 100 sq. dekameters = 2.47 acres
 1 sq. kilometer = 100 sq. hectometers = .386 sq. mile

Cubic Measure

1 cu. centimeter = 1000 cu. millimeters = .06 cu. inch
 1 cu. decimeter = 1000 cu. centimeters = 61.02 cu. inches
 1 cu. meter = 1000 cu. decimeters = 35.31 cu. feet

Approximate Conversion Factors

To change	To	Multiply by	To change	To	Multiply by
inches	centimeters	2.540	ounce-inches	newton-meters	.007062
feet	meters	.305	centimeters	inches	.394
yards	meters	.914	meters	feet	3.280
miles	kilometers	1.609	meters	yards	1.094
square inches	square centimeters	6.451	kilometers	miles	.621
square feet	square meters	.093	square centimeters	square inches	.155
square yards	square meters	.836	square meters	square feet	10.764
square miles	square kilometers	2.590	square meters	square yards	1.196
acres	square hectometers	.405	square kilometers	square miles	.386
cubic feet	cubic meters	.028	square hectometers	acres	2.471
cubic yards	cubic meters	.765	cubic meters	cubic feet	35.315
fluid ounces	milliliters	29.573	cubic meters	cubic yards	1.308
pints	liters	.473	milliliters	fluid ounces	.034
quarts	liters	.946	liters	pints	2.113
gallons	liters	3.785	liters	quarts	1.057
ounces	grams	28.349	liters	gallons	.264
pounds	kilograms	.454	grams	ounces	.035
short tons	metric tons	.907	kilograms	pounds	2.205
pound-feet	newton-meters	1.356	metric tons	short tons	1.102
pound-inches	newton-meters	.11296			

Temperature (Exact)

°F	Fahrenheit temperature	5/9 (after subtracting 32)	Celsius temperature	°C
----	------------------------	----------------------------	---------------------	----

These are the instructions for sending an electronic 2028

The following format must be used if submitting an electronic 2028. The subject line must be exactly the same and all fields must be included; however only the following fields are mandatory: 1, 3, 4, 5, 6, 7, 8, 9, 10, 13, 15, 16, 17, and 27.

From: "Whomever" <whomever@avma27.army.mil>
To: mpmtYoavma28@st-louis-emh7.army.mil

Subject: DA Form 2028

1. **From:** Joe Smith
2. **Unit:** home
3. **Address:** 4300 Park
4. **City:** Hometown
5. **St:** MO
6. **Zip:** 77777
7. **Date Sent:** 19-OCT-93
8. **Pub no:** 55-2840-229-23
9. **Pub Title:** TM
10. **Publication Date:** 04-JUL-85
11. **Change Number:** 7
12. **Submitter Rank:** MSG
13. **Submitter FName:** Joe
14. **Submitter MName:** T
15. **Submitter LName:** Smith
16. **Submitter Phone:** 123-123-1234
17. **Problem:** 1
18. **Page:** 2
19. **Paragraph:** 3
20. **Line:** 4
21. **NSN:** 5
22. **Reference:** 6
23. **Figure:** 7
24. **Table:** 8
25. **Item:** 9
26. **Total:** 123
27. **Text:**

This is the text for the problem below line 27.

RECOMMENDED CHANGES TO EQUIPMENT TECHNICAL PUBLICATIONS



SOMETHING WRONG WITH THIS PUBLICATION?

THEN... JOT DOWN THE DOPE ABOUT IT ON THIS FORM, CAREFULLY TEAR IT OUT, FOLD IT AND DROP IT IN THE MAIL!

FROM: (PRINT YOUR UNIT'S COMPLETE ADDRESS)

DATE SENT

PUBLICATION NUMBER

PUBLICATION DATE

PUBLICATION TITLE

BE EXACT... PIN-POINT WHERE IT IS

PAGE NO.	PARA. GRAPH	FIGURE NO.	TABLE NO.

IN THIS SPACE TELL WHAT IS WRONG AND WHAT SHOULD BE DONE ABOUT IT:

TEAR ALONG PERFORATED LINE

PRINTED NAME, GRADE OR TITLE, AND TELEPHONE NUMBER

SIGN HERE:

DA FORM 2028-2
1 JUL 79

PREVIOUS EDITIONS
• ARE OBSOLETE.

P.S.—IF YOUR OUTFIT WANTS TO KNOW ABOUT YOUR RECOMMENDATION MAKE A CARBON COPY OF THIS AND GIVE IT TO YOUR HEADQUARTERS.

PIN: 067744-001