

U 113  
12  
TM  
1944

# TM 11-947

WAR DEPARTMENT TECHNICAL MANUAL

U.S. Dept. of Army



## POWER UNIT

### PE-210

**RESTRICTED. DISSEMINATION OF RESTRICTED MATTER.**  
The information contained in restricted documents and the essential characteristics of restricted materiel may be given to any person known to be in the service of the United States and to persons of undoubted loyalty and discretion who are cooperating in Government work, but will not be communicated to the public or to the press except by authorized military public relations agencies. (See also par. 28, AR 380-5, 15 Mar 1944.)

WAR DEPARTMENT

29 AUGUST 1944

# POWER UNIT

## PE-210



WAR DEPARTMENT

29 AUGUST 1944

---

**RESTRICTED.** *DISSEMINATION OF RESTRICTED MATTER.*  
The information contained in restricted documents and the essential characteristics of restricted materiel may be given to any person known to be in the service of the United States and to persons of undoubted loyalty and discretion who are cooperating in Government work, but will not be communicated to the public or to the press except by authorized military public relations agencies. (See also par. 28, AR 380-5, 15 Mar 1944.)

---

WAR DEPARTMENT  
WASHINGTON 25, D. C., 29 AUGUST 1944.

TM 11-947, Power Unit PE-210, is published for the information and guidance of all concerned.

A. G. 300.7 (9 May 44).

BY ORDER OF THE SECRETARY OF WAR:

G. C. MARSHALL,  
*Chief of Staff.*

OFFICIAL:

J. A. ULIO,  
*Major General,  
The Adjutant General.*

DISTRIBUTION:

I C 11 (5).  
(For explanation of symbols see FM 21-6.)

# TABLE OF CONTENTS

U113

.2

TM11-947

1944

Paragraph Page

<b>SECTION I. Description.</b>		
General -----	1	1
Components -----	2	1
Weights and dimensions -----	3	3
<b>II. Installation and operation.</b>		
Installation -----	4	4
Preparation for use -----	5	5
Operation -----	6	6
<b>III. Functioning of parts.</b>		
Generator theory -----	7	11
Two-cycle engine principle -----	8	13
Electric governor operating principle -----	9	15
<b>IV. Maintenance.</b>		
General -----	10	17
Engine -----	11	17
Generator -----	12	33
Lubrication -----	13	35
Disassembly -----	14	35
Reassembly -----	15	38
Trouble chart -----	16	39
Moistureproofing and Fungi- proofing -----	17	42
<b>V. Supplementary data.</b>		
Maintenance parts list -----	18	45

M574752

III

# LIST OF ILLUSTRATIONS

<i>Fig. No.</i>	<i>Title</i>	<i>Page</i>
1	Power Unit PE-210, front view -----	vii
2	Power Unit PE-210, rear view -----	viii
3	Power Unit PE-210, connected to storage battery for starting -----	8
4	Six-volt storage batteries connected in series for recharging -----	9
5	Generator theory, permanent magnet -----	12
6	Generator theory, electromagnet -----	12
7	Generator armature and field windings -----	12
8	Principle of two-cycle engine -----	14
9	Spark plug -----	17
10	Test for spark output -----	18
11	Magneto point adjustment -----	20
12	Magneto timing -----	22
13	Magneto cable positioned in backplate -----	24
14	Carburetor float assembly -----	28
15	Electric governor assembly -----	30
16	Carbon removal, exhaust ports -----	31
17	Carbon removal, intake ports -----	32
18	Dressing commutator -----	34
19	Brush removal -----	36
20	Exploded parts view of Power Unit PE-210 -----	53
21	Frame, tool box, base, fuel tank, and canvas cover --	54
22	Carburetor parts -----	55
23	Carburetor float parts -----	56
24	Electric governor parts -----	57
25	Generator assembly -----	58
26	Magneto stator-plate assembly -----	59
27	Magneto assembly -----	60
28	Schematic wiring diagram, generator -----	61
29	Schematic wiring diagram, control box -----	62
30	Meter box, wiring diagram -----	63
31	Cross-section drawing of Generator GN-52 -----	64
32	Rear view of Power Unit PE-210 in cross-section --	66
33	Top view of Power Unit PE-210 in cross-section ----	67
34	Side view of Power Unit PE-210 in cross-section --	68
35	Tools -----	69
36	War Department Lubrication Order No. 3054 -----	70
37	Masking details -----	71

## DESTRUCTION NOTICE

**WHY—** To prevent the enemy from using or salvaging this equipment for his benefit.

**WHEN—**When ordered by your commander.

- HOW—**
1. Smash—Use sledges, axes, handaxes, pickaxes, hammers, crowbars, heavy tools.
  2. Cut—Use axes, handaxes, machetes.
  3. Burn—Use gasoline, kerosene, oil, flame throwers, incendiary grenades.
  4. Explosives—Use firearms, grenades, TNT.
  5. Disposal—Bury in slit trenches, fox holes, other holes. Throw in streams. Scatter.

### USE ANYTHING IMMEDIATELY AVAILABLE FOR DESTRUCTION OF THIS EQUIPMENT.

- WHAT—**
1. Smash—Cylinder head, cylinder, spark plug, magneto, carburetor, generator, and gas tank.
  2. Cut—All connecting wires and cables.
  3. Burn—Instruction books, canvas cover, shipping case, fuel and oil.
  4. Bury or scatter—Any or all of above pieces after breaking.

## DESTROY EVERYTHING

## **SAFETY NOTICE**

**This equipment uses high voltages which are dangerous and may be fatal if contacted by operating personnel. Observe all precautions and safety regulations. If Power Unit PE-210 is operated within a building, make certain that all exhaust connections are gas-tight and that room is well ventilated. Carbon monoxide, contained in exhaust gases, is tasteless, odorless, and a deadly poison. Stop the unit before attempting to work on it and before removing the gasoline tank filler cap. Do not spill gasoline on a hot engine.**

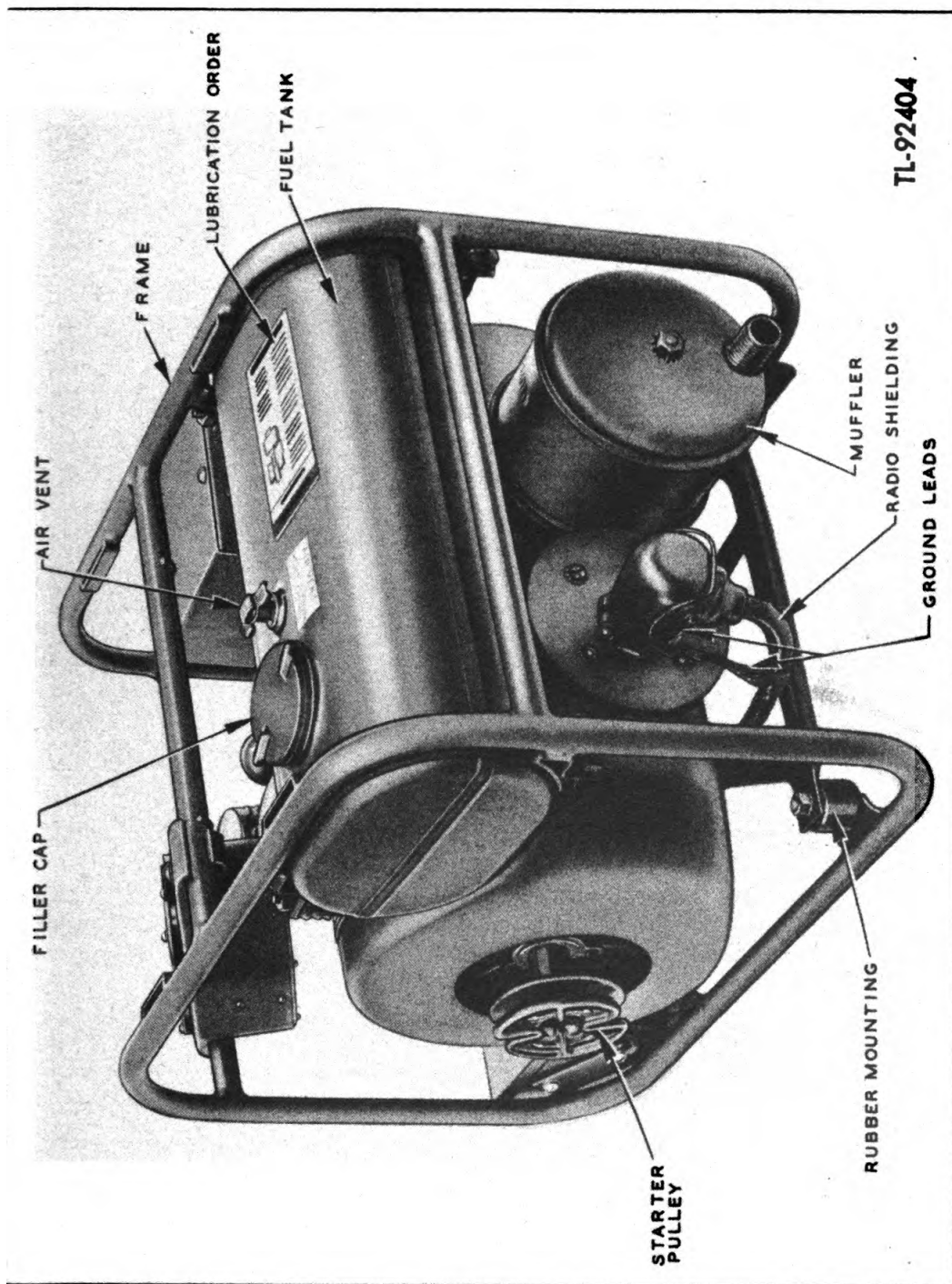

Figure 1. Power Unit PE-210, front view



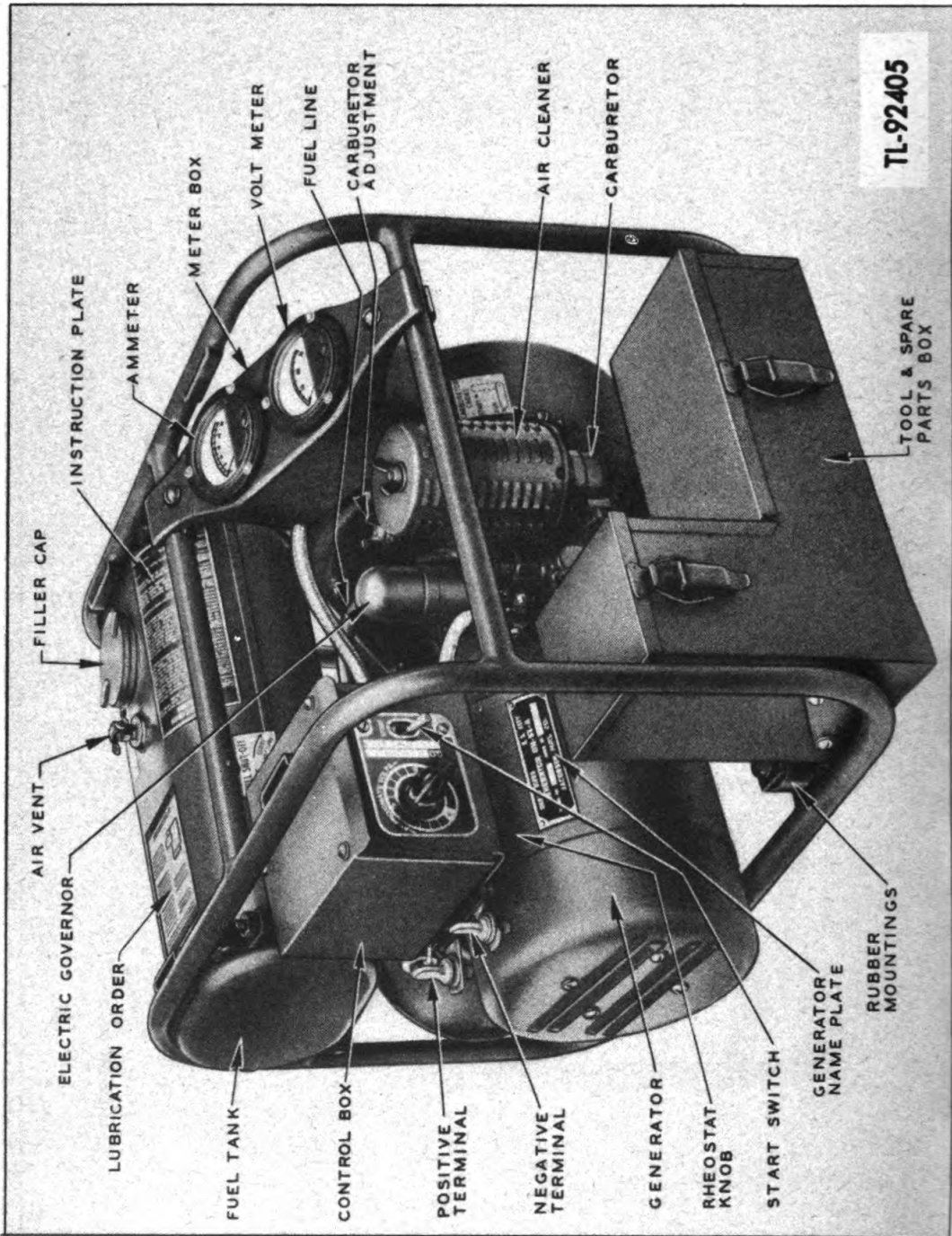

Figure 2. Power Unit PE-210, rear view

## SECTION I

# DESCRIPTION

---

### 1. GENERAL.

a. Power Unit PE-210 is a compact, light-weight, electric generator set, consisting of a gasoline engine GE-12-B and a direct-current generator GN-52. It has a nominal rating of 450 watts and is designed to deliver 30 amperes direct current, with voltage variable from 6 to 22 volts. It may be started manually or by connecting to a storage battery of 12- or 18-volt capacity. The unit is used principally for charging storage batteries. It may also be incorporated as an aid in starting larger units in sub-zero temperatures.

b. Engine GE-12-B is a single-cylinder, air-cooled, two-cycle gasoline engine which develops one hp at 3,000 rpm.

c. Generator GN-52 is a direct-current machine and is coupled directly to the engine crankshaft by means of a female spline coupling which matches the splined extension on the crankshaft. Mounted on the generator is a control box which is used in controlling the output and is provided with a switch for starting the engine when connected to a battery.

d. The complete power unit is contained in an open frame of tubular construction. It is mounted on four rubber shock mountings which hold the unit securely in place when being transported and also serve to absorb vibrations when the equipment is in operation. A metal box for tools and spare parts is attached to the tubular frame assembly. The net weight of the complete power unit, ready for field service, is approximately 61 pounds, with the fuel tank empty.

### 2. COMPONENTS.

a. **Engine.** Engine GE-12-B is a single-cylinder, two-cycle, air-cooled unit, with a 2-inch bore, a 1½-inch stroke, and a piston displacement of 4.72 inches. It is designed to operate satisfactorily on 80-octane field gasoline, or 100-octane aviation gasoline, commercial gasolines with an octane rating as low as 62, and will run

approximately 7½ hours at full load on a single filling of the fuel tank. The fuel tank capacity is 1 gallon.

**b. Generator.** (1) Generator GN-52 is a 450-watt, 30-ampere, 15-volt, direct-current, shunt-wound, compensated, open, 4-pole machine. The generator voltage can be regulated in the range of 6 to 22 volts full load by dual control of engine speed and shunt field through the rheostat adjusting knob on the control box. Rotation of armature is counterclockwise, viewed from commutator end.

(2) Mounted on the generator is a control box containing a rheostat, a starting switch, and a reverse-current relay or cut-out. The rheostat controls the engine speed and generator voltage to allow charging of 6- to 18-volt storage batteries. The rheostat dial is marked to show the approximate position of the control knob when charging batteries of the voltages just mentioned. An (0- to 50-amp) ammeter and (0- to 30-volt) voltmeter are located on the tubular frame. The ammeter will indicate the amount of current going into a battery; the voltmeter will show the battery voltage when the unit is stopped and the charging voltage when the unit is running.

(3) The starting switch, when held in the ON position, allows the battery current to be sent through the generator, converting it to a motor for rotating the engine to start it.

(4) The reverse-current relay or cut-out closes the charging circuit when the generator voltage rises sufficiently to send current to the battery. It also opens the charging circuit when the engine stops for lack of fuel or other reasons and prevents battery drain through the generator.

**CAUTION: The rheostat should not be set lower than the voltage of the connected battery. Otherwise, the cut-out relay will not function.**

**c. Magneto.** Ignition is supplied by a high-tension flywheel-type magneto. This consists of a rotor (moving member) and a stator plate (stationary member) mounted directly on the engine crankcase.

**d. Carburetor.** The carburetor is of the float-feed type. Fuel is supplied to it directly from the gasoline tank through the fuel line.

**e. Air Cleaner.** The air cleaner is of the replaceable dry-car-

tridge type. Its function is to prevent the air which enters the carburetor from drawing dust and dirt into the engine.

**f. Governor.** The governor is of the electric solenoid type and is actuated by generator voltage. The solenoid is mounted on the carburetor, and the plunger or armature is connected to the carburetor throttle shaft by a link and lever arrangement. The electric current from the generator produces a magnetic pull on the plunger, moving it against the action of a small spring, and thus controls the carburetor throttle valve movement. This, in turn, varies the engine speed to obtain substantially constant voltage under generator load variations.

**g. Canvas Cover.** A canvas cover is furnished for protecting the power unit from dampness, dust, or dirt when not in use. A carrying handle, furnished with the cover, may be attached to the top crossbar of the tubular frame for lifting and transporting the unit.

### 3. WEIGHTS AND DIMENSIONS.

TABLE I

Unit	Height (in.)	Width (in.)	Length (in.)	Weight (lb.)
Power Unit PE-210 .....	12-13/16	13-3/4	17-3/4	61
Engine GE-12-B (complete)..	12-13/16	13-3/4	17-3/4	35 lb 8 oz
Generator (less control box)..	5	7-1/4	8	20
Control box .....	3-1/2	4	4-1/2	3
Meter box assembly .....	2-1/4	3-1/4	9-3/4	2 lb 8 oz
Engine only .....	5	7-1/4	8	6 lb 4 oz

## SECTION II

# INSTALLATION AND OPERATION

---

### 4. INSTALLATION.

a. As soon as the equipment has been removed from its shipping case, inspect it for any damage that might have occurred during shipment. If any items are found unserviceable, report this fact immediately and procure replacements.

b. Remove the unit from the wooden sub-base by unscrewing the nuts on the under side of the base from the four hold-down hooks which hold the unit in place.

c. The engine has been processed in accordance with Signal Corps Spec. No. 72-0-1. Before setting up the equipment for operation, note carefully the instructions contained on each tag attached to the unit, and proceed as follows:

(1) Remove the blank washers between the air cleaner cartridge and air cleaner base.

(2) Remove the pipe cap from the exhaust outlet on the muffler.

(3) Open the drain cock located on the under side of the engine crankcase. Turn the engine over a few times to clean out the crankcase thoroughly. Close the drain cock.

(4) If a silica-gel plug is found in the spark plug hole, remove it and insert the spark plug.

(5) Remove the paper wrapping from the air cleaner cartridge.

d. Install the unit on a dry, level surface in a clean and accessible location. Place it in such a position that free air circulation is obtained, and make sure the exhaust from the muffler is carried away from operating personnel.

**WARNING: CARBON MONOXIDE, CONTAINED IN EXHAUST GASES, IS TASTELESS, ODORLESS, AND A DEADLY POISON.**

e. If the unit is installed indoors, make certain that all exhaust

connections are gas-tight and that the room is well ventilated. Place the unit near a door or window and connect one end of a suitable length of flexible exhaust tubing to the threaded muffler outlet, and extend the other end of the tubing outside the building. Avoid bending the tubing wherever possible. Where the distance from the power unit to the outside of the building is less than 10 feet, a piece of tubing with a 1-inch internal diameter may be used. For distances over 10 feet, use tubing with a 1½-inch internal diameter.

## 5. PREPARATION FOR USE.

a. **General.** Power Unit PE-210 is intended to furnish power principally for charging storage batteries, and is designed to deliver 30 amperes, direct current at from 6 to 22 volts. The unit should not be overloaded more than 10 percent above its current rating (30 amps) except for short periods. Do not operate continuously at any overload in high ambient temperature. At voltages above 15, the current output may be reduced due to engine power limitation.

**CAUTION:** If the unit is used to charge batteries while operating a radio set, adjust the rheostat knob on the control box so the voltage will not exceed 7 volts when connected to a 6-volt battery, and 14 volts when connected to a 12-volt battery. Failure to observe this precaution may damage the radio equipment through excess voltage.

b. **Engine.** Never run the engine with gasoline only. Use a mixture of oil and gasoline in accordance with the following instructions:

**NOTE:** If available, use unleaded and undyed gasoline, covered by U. S. Army Spec. No. 2-116 and straight mineral oil, SAE 10, Spec. No. NS2110. See War Department Lubrication Order attached to the unit.

- (1) Use a separate container to mix the fuel and oil.
- (2) **Fill the tank with thoroughly mixed gasoline and oil, proportioned 16 parts gasoline to 1 part oil.**
- (3) Use the measure on the gasoline tank cap for the oil. Two full measures of oil are required for 1 gallon of gasoline, or one-half measure per quart of gasoline.

To avoid loss of oil from the measuring cap, hold a finger over

the vent hole located in the side of the tube. DO NOT PLUG THIS HOLE.

## 6. OPERATION.

**a. Starting.** (1) Check to make sure the magneto high-tension wire is attached to the spark plug.

(2) Open the air vent on fuel tank and open the fuel line shut-off.

(3) Check the gasoline in the fuel tank; then proceed as follows :

(a) Turn the carburetor adjustment-knob extension so the adjustment is at the No. 5 position. The number should line up with the fin on the carburetor just below it.

(b) Move the choke lever to the vertical position.

(c) Stand behind the unit. Slip the knotted end of the starter rope into the notch on the starter pulley and wind it around clockwise (to the right).

(d) Pull the rope up sharply to the rear, steadying the unit with the left hand on the loop frame. Repeat until engine starts. If the engine does not start on the fourth or fifth cranking, refer to paragraph 16.

(e) Then move the choke lever to the horizontal position. When the engine is warm, adjust the carburetor so the engine runs smoothly. Under load, it may be necessary to make a slight compensating adjustment on the needle valve.

**CAUTION: Except in cases of extreme emergency, under low temperature conditions, always operate the equipment without load for a warm-up period of ten minutes before applying load.**

(4) For subsequent starting, the carburetor needle valve will not have to be disturbed. Merely use the choke as described in the starting instructions. This does not apply, however, where climatic condition are extremely cold. In that case, the needle valve should be opened fully for starting.

**b. Starting from a Storage Battery.** In starting the engine from a storage battery, the same directions covering position of carburetor adjustment knob, position of choke lever, and other instructions contained in paragraph 6 a, should be followed, with one exception; that being, when starting a warm engine, do not place the choke lever in vertical position. Set it to intermediate

position or do not use if unnecessary. For connecting wires and use of start switch (fig. 3) for electrically starting the engine, follow these directions:

- (1) Connect an insulated wire of 12 gauge or heavier, from the positive terminal on the battery to the terminal on the control box marked (+).
- (2) Connect an identical wire from the negative terminal on the battery to the terminal on the control box marked (—).
- (3) Note the voltmeter reading. If the leads are connected properly, the voltmeter will indicate the battery voltage. If improperly connected, the voltmeter pointer will swing off scale to the left. Reverse the connections if the voltmeter reading is not correct.
- (4) The unit is now ready to start. Lift up the start switch on the control box and hold it there until the engine starts; then release the switch and make running adjustments as instructed.

**IMPORTANT: If engine does not start in 20 to 30 seconds or sooner, something is wrong and the trouble chart, paragraph 16, should be consulted. In the event the unit is hooked up properly and yet the engine will not revolve, the battery is too weak and needs recharging. Start the unit manually for the charging operation.**

(5) In the event a charged 12- or 18-volt battery fails to turn the engine over and yet the generator charges normally, the trouble may be in the control-box wiring. Check the wiring (fig. 29) or the diagram in the control-box cover. Pay special attention to the red and yellow leads connecting to the terminals above the start switch. If these leads are improperly connected (interchanged), the generator will charge normally, but no current will be supplied to the field when the switch is moved up to the start position.

**c. Charging Storage Batteries.** Power Unit PE-210 is capable of charging 6-, 12-, and 18-volt storage batteries. Three 6-volt batteries only, connected in series (fig. 4), can be charged simultaneously. To connect up the unit for the charging operation, follow the same procedure as outlined in paragraph 6 b, except the charging rheostat on the control box should be set to the approximate location on the dial conforming with the voltage of the battery to be charged before starting the engine. Turning the rheostat to the right (clockwise) increases the charging rate; turning it to the left (counterclockwise), decreases the charging rate.



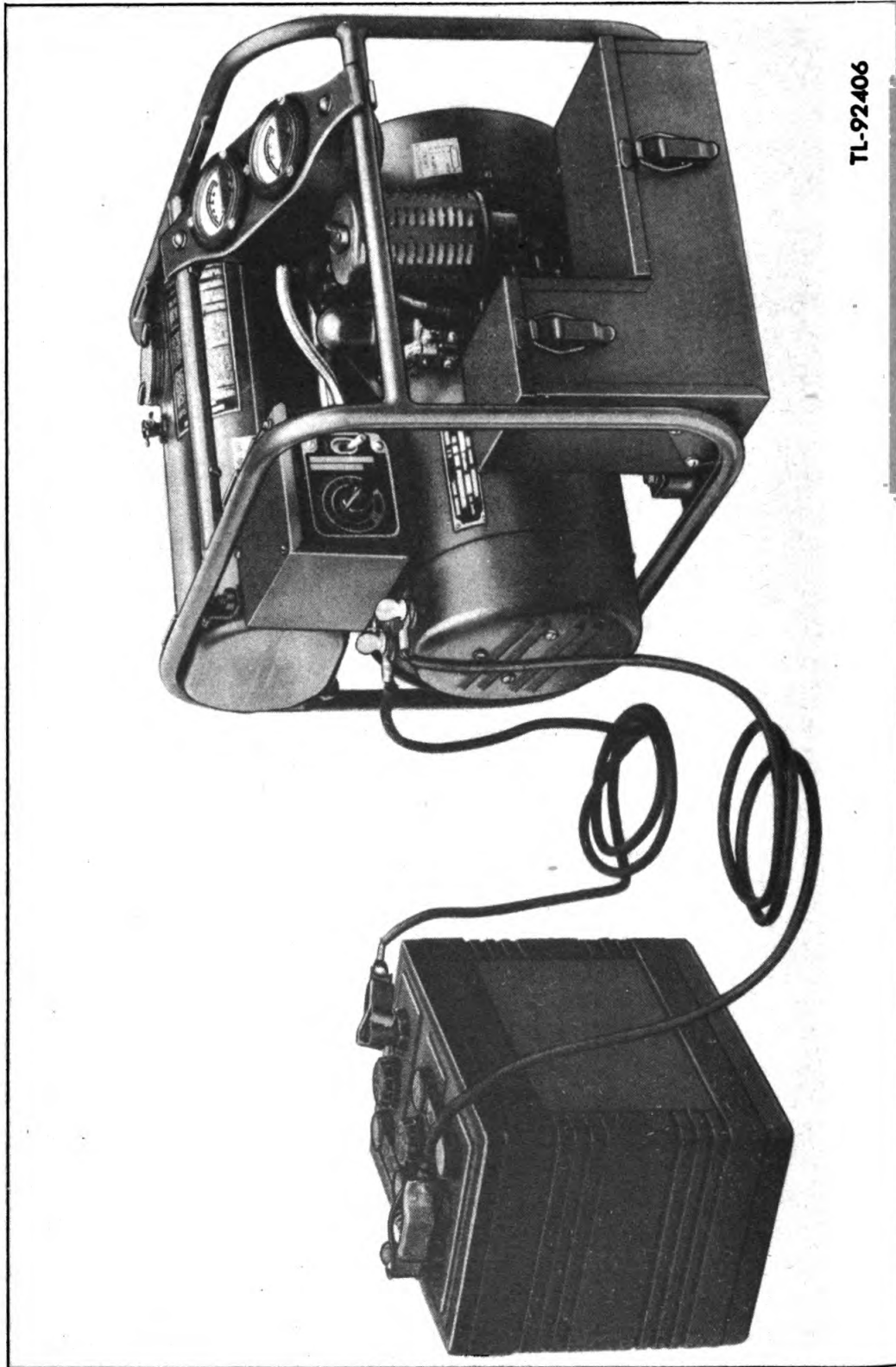
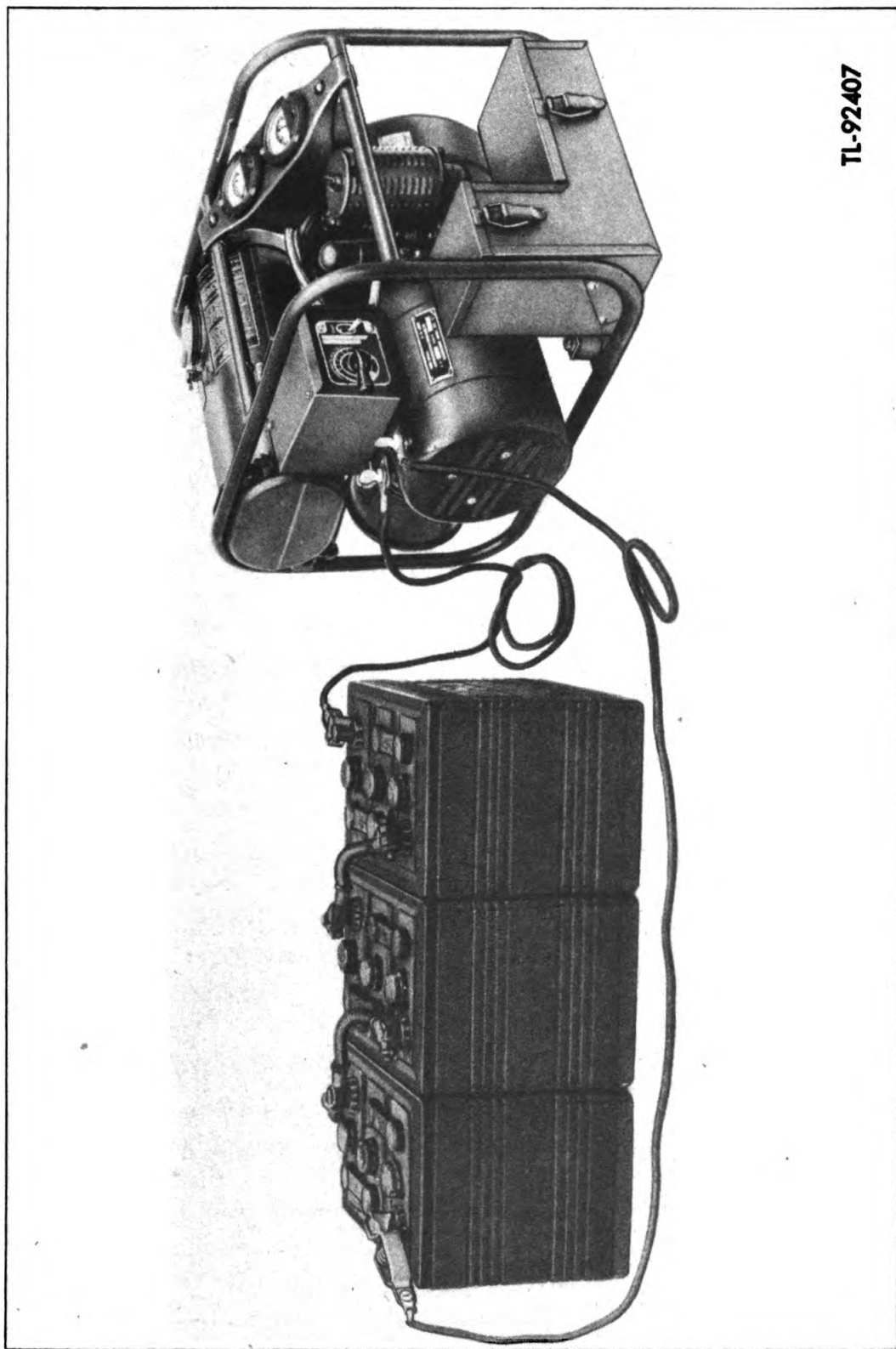

Figure 3. Power Unit PE-210, connected to storage battery for starting



**Figure 4. Six-volt storage batteries connected in series for recharging**

**d. Generator Precautions.** Be sure the generator is not overloaded. This will cause overheating and destroy the windings. However, an overload of 10 amperes beyond the rated output (30 amperes) for a period not to exceed 5 or 10 minutes, is permissible.

(1) A short-circuiting generator will cause the engine throttle to open wide and the engine to overspeed.

(2) When charging 18-volt batteries, limit the charging rate to 20 amperes to avoid overloading the engine.

(3) As an aid to starting larger units at sub-freezing temperatures, this unit may be used to increase battery output by connecting leads to battery terminals. This may be done without removing the battery from its normal position. Turn control knob clockwise for increased voltage output to compensate for increased internal battery resistance due to low temperature. Power Unit PE-210 may be operated during the starting operation.

**e. Flooded Engine.** Choking the engine too much when starting will flood it. This is particularly true when starting a warm engine. To overcome a flooded condition, proceed as follows:

(1) Open the drain cock underneath the crankcase and crank the engine over a few times.

(2) When drained, close the drain cock before cranking.

(3) Remove and dry the spark plug before again attempting to start the unit.

**f. Stopping.** To stop the engine, press down on the throttle shaft lever until the unit stops.

**NOTE: ALWAYS CLOSE THE FUEL LINE SHUT-OFF AND AIR VENT WHEN TRANSPORTING EQUIPMENT.**

**g. When Engine Fails to Start.** If, at any time, the engine should fail to start, check the following possibilities:

(1) Make sure there is at least 1 inch of gasoline in the fuel tank.

(2) Make sure the air vent on the fuel tank is open.

(3) Remove the spark plug. Lay it on the motor base with the body of the plug grounded on the engine and the high-tension wire connected, and spin the engine to check the spark. Do not permit the terminal of the plug to contact the engine. If no spark occurs at the points, clean out the spark plug or replace it with a new one. The spark plug points should have a gap of 0.035 inch.

(4) A weak spark may be the trouble. This is generally due to improper point adjustment. Check point opening and adjustment as outlined in paragraph 11b.

## SECTION III

### FUNCTIONING OF PARTS

---

#### 7. GENERATOR THEORY.

a. Figure 5 shows a permanent bar magnet, with lines of flux leaving the north pole and entering the south pole. If a wire is moved past the pole of the magnet at right angles to the pole as shown, a voltage will be induced in the wires. The amount of this voltage depends on three things: strength of the magnet, length of wire cutting the lines of flux, and speed of movement of wire.

b. The stronger the magnet, the greater the density of the lines of flux; the faster the wire is moved, the greater will be the voltage induced in it per unit of length. This is the simple, fundamental principle of operation of any generator, either direct-current or alternating-current.

c. In practice, an electromagnet (fig. 6) is used instead of a permanent magnet. The reason for this is that the strength of an electromagnet can be varied at will by the number of turns of wire wound on it and by the amount of current supplied through this wire.

d. In an actual generator, the field poles serve as electromagnets. The armature winding acts the same as the wire shown moving by the end of the magnet (figs. 5 and 6). This movement is spoken of as cutting the lines of flux of the magnet. This motion induces a voltage in the armature winding which is connected to the armature commutator. The carbon brushes mounted in brush-holders serve to pick up this voltage from the armature as it rotates, and wires from the brushes make the voltage available at the terminals of the generator.

e. Once the field poles are magnetized, they retain some of the magnetism (called residual magnetism) even though there is no current in the field winding when the generator is not running. When the armature starts to rotate, the armature windings pass through, or cut, the field flux of the residual magnetism. This generates a small amount of voltage in the armature. This action keeps increasing as the armature comes up to speed until the full rated output of the generator is reached.

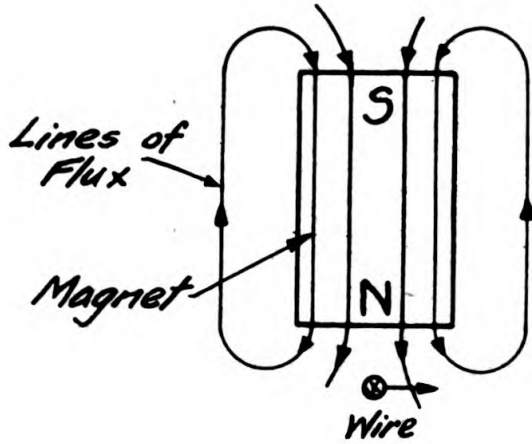

TL-92340

Figure 5. Generator theory, permanent magnet

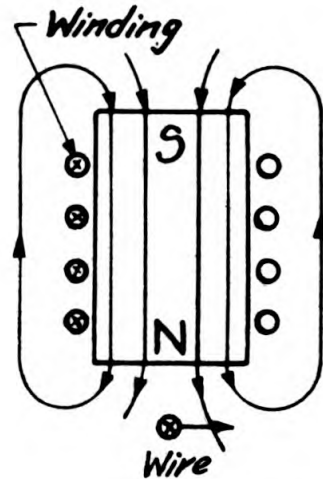

TL-92311

Figure 6. Generator theory, electromagnet

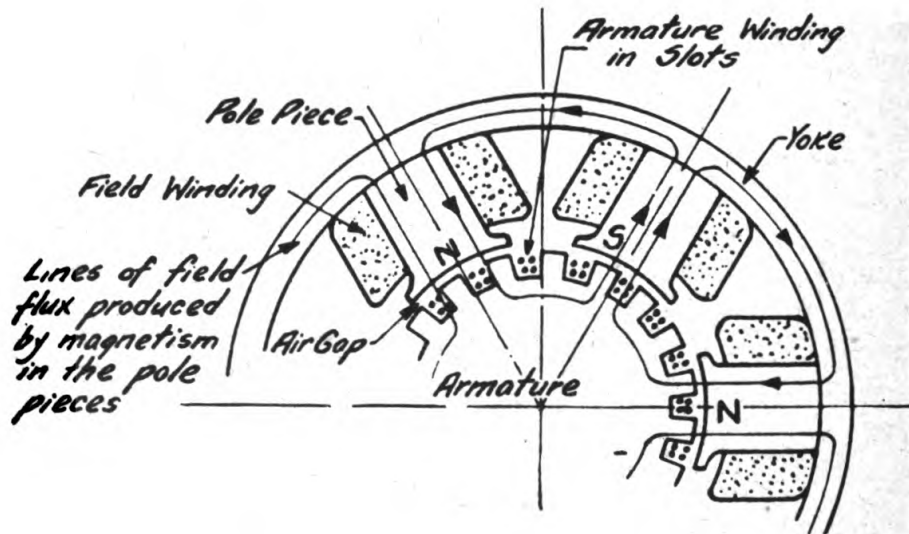

TL-92276

Figure 7. Generator armature and field windings

f. Figure 7 shows the principal parts of a generator and illustrates the function of the armature and field windings. The lines of field flux pass from a north pole through the air gap between the armature and field pole, through the armature, back through the air gap into the south pole, and through the yoke back to the starting point. As the armature rotates, the armature windings cut through these lines of flux, thereby generating a voltage in the armature windings.

g. This field flux is greater during operation of the generator, but is present in a small amount even when the generator is stopped because of the residual magnetism which remains in the pole pieces.

h. In summarizing the difference between a direct-current generator and an alternating-current generator, the current flow in a d-c unit is constant and unidirectional; while in an alternating-current generator, the current starts at zero, increases to a maximum value in the positive direction, decreases to zero, increases to a maximum value in the negative direction, decreases to zero again, and repeats this cycle a number of times each second, depending on the frequency for which the generator is designed. For example, this occurs 60 times per second in a 60-cycle generator.

## 8. TWO-CYCLE ENGINE PRINCIPLE.

a. As shown in figure 8 (1), the piston, on its up stroke (compression), draws a charge of fuel into the crankcase through a reed valve attached to the rear of the carburetor. At the same time, a charge previously drawn into the crankcase and by-passed into the combustion chamber is compressed above the piston.

b. The charge in the combustion chamber is ignited when the piston is  $\frac{1}{8}$  inch from top dead center (fig. 8 (2)). The expansion of the burning gases forces the piston down on its power stroke. The descending piston compresses the charge previously drawn into the crankcase.

c. Near the bottom of its downward (power) stroke (fig. 8 (3)), the piston uncovers the exhaust ports, releasing the exhaust gases. At almost the same moment, the piston uncovers the intake ports, permitting the fuel charge compressed in the crankcase to rush through into the combustion chamber.

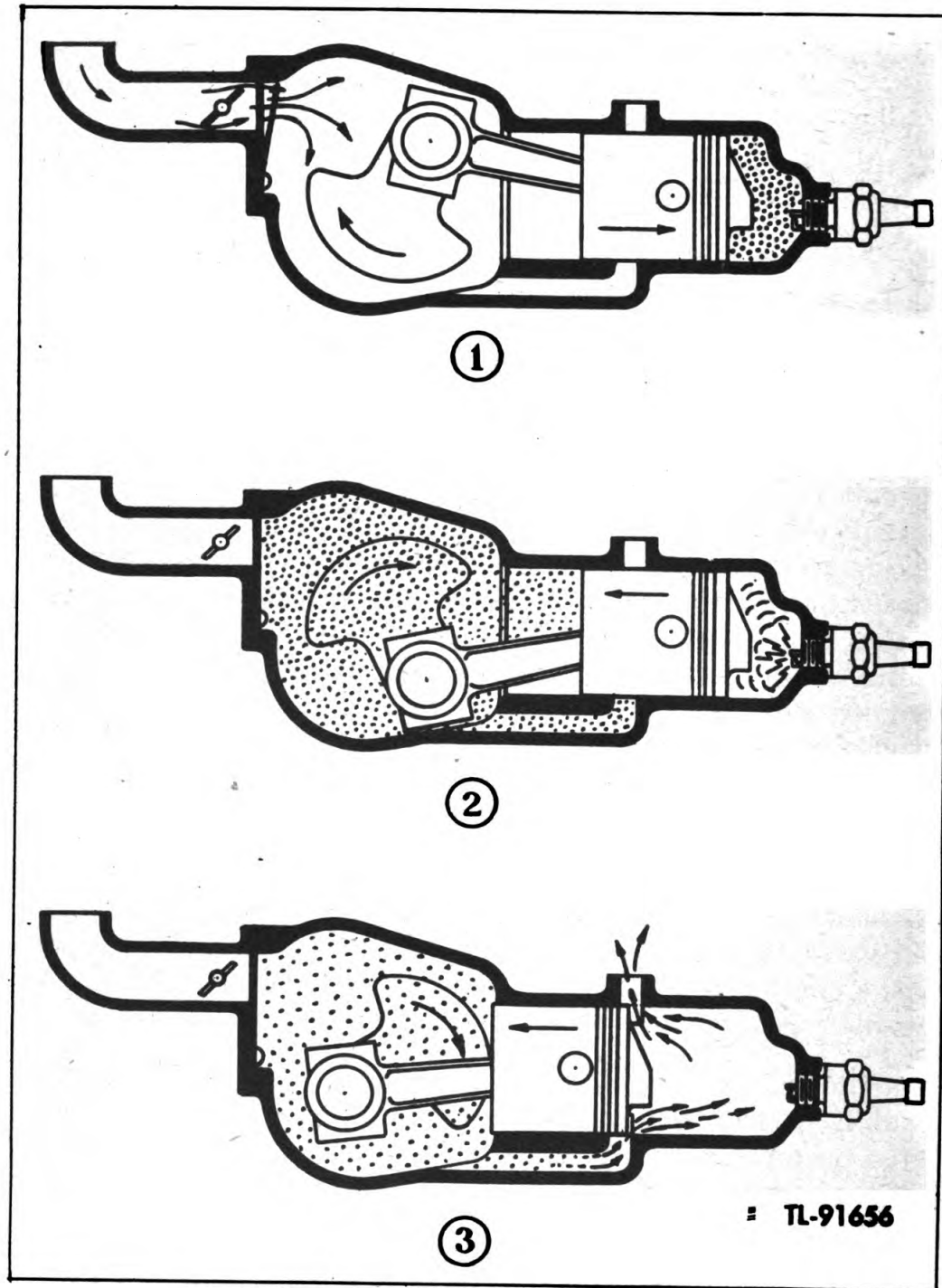

Figure 8. Principle of two-cycle engine

d. One power stroke is accomplished for every revolution of the crankshaft, or two strokes (one up and one down) of the piston.

**NOTE:** For a complete explanation of internal combustion engines, carburetion, and ignition systems, see the following manuals:

- (1) TM 10-570, The Internal Combustion Engine.
- (2) TM 10-550, Fuels and Carburetion.
- (3) TM 10-580, Automotive Electricity.

## 9. ELECTRIC GOVERNOR OPERATING PRINCIPLE.

a. Mounted above the carburetor is a small solenoid type electric governor. Its function is to control the engine speed and, in so doing, control the generator voltage to charge batteries of various voltages. A small rheostat in the control box provides the means of adjusting generator voltage by changing both the engine speed and the generator field resistance.

b. The solenoid is made up of copper wire wound on a hollow tube, a plunger or armature inside of the tube, a link and lever connecting the plunger to the carburetor shaft, and a spring to position the plunger in response to the magnetic pull of the solenoid.

c. A portion of the electric current from the generator is supplied to the solenoid. This current produces a downward pull on the plunger, which tends to position it in the center of the tube. The downward movement of the plunger closes the carburetor throttle by means of the connecting link and lever. The small tension spring, attached to the top of the plunger, balances the solenoid pull and tends to position the engine throttle so that the correct engine speed to produce the proper voltage is obtained.

d. The wiring diagram (fig. 29) shows that one lead of both the governor and voltage coil of the reverse-current relay is connected to one side (upper) of the generator. The other leads of both are connected to the right end of the 12-ohm rheostat. The arm of the rheostat is connected to the other side (lower) of the generator. Thus, both the governor and reverse-current relay are subjected to a definite fraction of the generator voltage, depending on the position of the arm of the potentiometer. For example, with the arm in the extreme position to the right on the diagram (full



counterclockwise position of the control knob on the control box), full generator voltage is supplied to the governor and relay and both will close at approximately 6 volts. When the control knob is moved in the clockwise direction, a smaller fraction of the generated voltage is supplied to the governor and relay. However, as approximately 6 volts are required by the governor for any control knob position, it is apparent that the engine speed and generator voltage must increase with the clockwise movement of the control knob in order to supply this required governor voltage.

## SECTION IV MAINTENANCE

---

**NOTE:** Unsatisfactory performance of this equipment will be reported on W. D., A. G. O. Form No. 468. If form is not available, see TM 38-250.

### 10. GENERAL.

This section deals mainly with points of inspection and adjustment that can be performed in the field. To insure satisfactory operation of the equipment, follow directions thoroughly.

### 11. ENGINE.

Engine troubles usually are: fails to start, hard to start, runs and stops, overheats, and loss of power. When the engine fails to operate, and there is fuel in the gasoline tank, check the spark plug, ignition, and carburetor in the order named. Install a new spark plug first to see if this corrects the difficulty. If it does not, leave the new plug in while checking further.

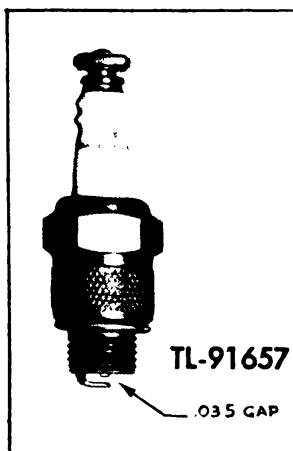

Figure 9. Spark plug

**a. Spark Plug.** (1) If the engine fails to start, starts hard, or misses, the spark plug may be damaged or dirty, or points may be in need of adjustment.

(a) Remove the spark plug from the cylinder head and shield, first disconnecting the magneto high-tension wire from the plug, and the ground lead from the shield.

(b) Then reattach the high-tension wire to the spark plug and lay the body of the plug on the muffler (par. 6g).

(c) Spin motor to check spark.

(d) If no spark occurs at the spark plug points, clean out plug or regap to 0.035 inch (fig. 9).

(2) Always use a Champion J5 spark plug or one in equivalent heat range. Whenever the plug is removed, make certain the

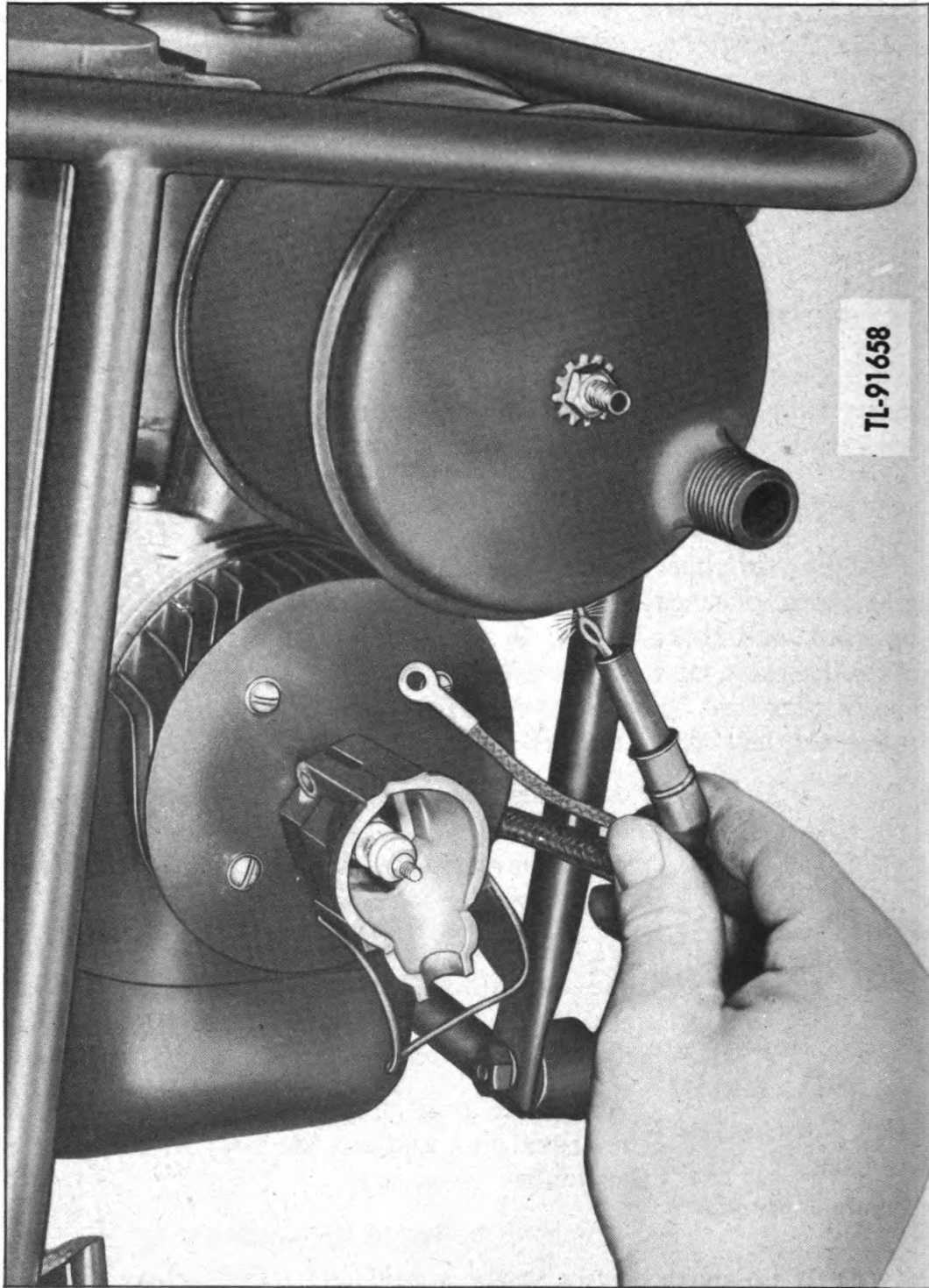

Figure 10. *Test for spark output*

gasket is on it before reinstalling. It is extremely important, when the plug is dirty, to thoroughly scrape out all carbon, brownish lead deposits, and loose particles.

(3) If the spark plug is removed and the points are found to be wet, it is an indication that the engine is being operated with too rich a fuel mixture, or the ratio of gasoline to oil is not correct.

**b. Magneto.** (1) If there is an indication that the magneto is causing trouble, test the magneto before attempting to repair it. If the engine refuses to start after it is determined that the spark plug is all right, check the magneto by removing the high-tension wire from the spark plug and hold the end of the wire about 3/16 inch away from a point on the engine (fig. 10). When the engine is cranked in the usual manner, a properly performing magneto will have a spark output strong enough to jump the prescribed gap.

(2) If the spark produced will not meet the above test, it is very likely the breaker points require adjustment and should be gapped to 0.020-inch opening. The only adjustable part of the magneto is the breaker plate, which provides adjustment for the breaker points.

(3) To adjust the breaker points, proceed as follows:

(a) Remove the spark plug shield and spark plug.

(b) Then take off the magneto flywheel housing.

(c) Unscrew the starter pulley from the crankshaft.

(d) Screw on the flywheel removal tool supplied with the equipment and tap the tool on the end to loosen the flywheel. At the same time, pull on the flywheel in the direction of removal to take advantage of any crankshaft end play.

(e) Remove the flywheel to provide access to the points.

(f) Next, turn the engine clockwise (to the right) by hand until the breaker points are fully open.

(g) Check the opening (fig. 11) with feeler gauge. Correct opening is 0.020 inch.

**NOTE:** Although contact points remain open during the entire travel of the cam from the breaking edge, being closed only while the flat section of the cam is passing the breaker arm fiber, the cam must be positioned so the breaker arm fiber rests on the highest point of the cam when gauging the point opening.

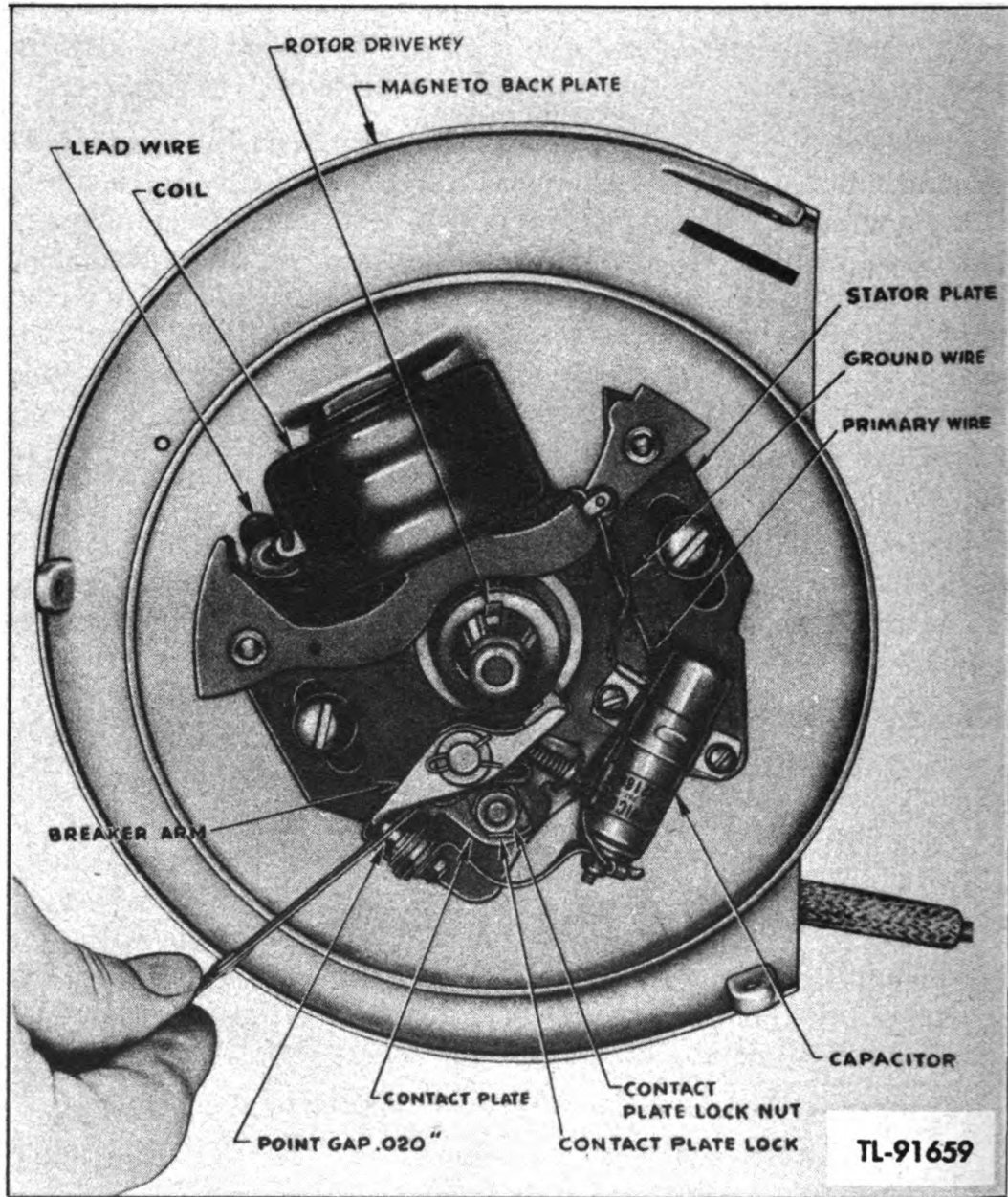

Figure 11. Magneto point adjustment

(4) If the points need resetting, bend down the contact plate lock (fig. 11), loosen the locknut which holds the breaker plate in position, and move the plate up or down as necessary to obtain the proper point opening. After the setting is accomplished, be sure to tighten the locknut and bend the ear of the plate lock against the flat of the locknut so it cannot loosen up.

(5) The breaker-plate setting should be made only in the manner prescribed. At no time should the fixed contact on the plate be loosened or the breaker arm bent to provide adjustment.

(6) The moving contact is integral with the breaker arm. In replacing the breaker arm, make certain the breaker-arm bushing is in place. If either one of the contact points needs replacing, change both of them at the same time to insure satisfactory operation.

(7) The breaker-arm bearing is packed with a cam lubricant at the time of assembly and should not require additional lubrication. A small amount of this lubricant is also packed on the breaker-arm cam wiper and wipes off on the cam surface, providing permanent lubrication between these rubbing surfaces.

(8) Uneven or pitted points may be restored to a true even condition by using the point cleaner furnished with the equipment. Be sure to remove all dust particles after servicing the points. If the points are in need of extensive dressing, replace them.

**c. To time magneto.** If, for any reason, the magneto assembly is removed from the engine, follow these directions for proper timing (see fig. 11):

(1) Check the point opening as outlined in subparagraph **b** (3).

(2) Remove the cylinder head baffle, then the spark plug shield and the spark plug.

(3) Turn the crankshaft in direction of engine rotation (to the right) until the piston reaches top dead center.

(4) Insert the small narrow rod furnished with equipment through the spark plug hole in the cylinder head until it touches top of piston.

(5) The lower edge of recess on the rod should then be flush with the top of spark plug hole.

(6) Then withdraw the rod.

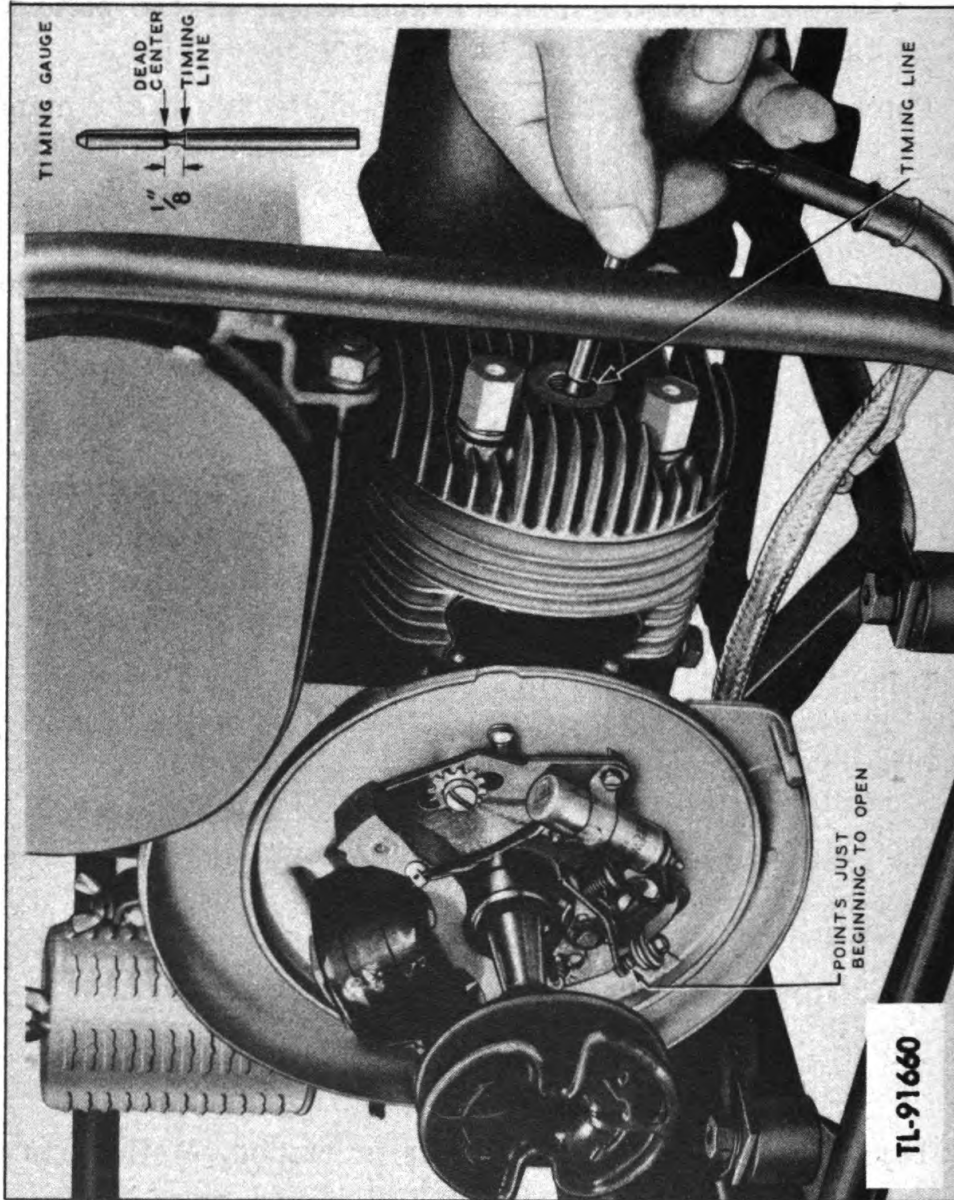

Figure 12. Magneto timing

(7) Turn the engine in the opposite direction of rotation (to the left) about one quarter turn.

(8) Insert the rod again through the spark plug hole until it touches the top of the piston. Then turn the engine in the direction of rotation (to the right) until the top edge of recess is flush with the top of the spark plug hole.

(9) Move the stator plate until the points just begin to break. Tighten the plate by means of two screws which lock it in place.

(10) Recheck to determine if the piston is  $\frac{1}{8}$  inch from top dead center when the magneto points just begin to break. If the setting is exactly as described, the timing is then set so a spark occurs when the piston is  $\frac{1}{8}$  inch from top dead center.

**d. Replacing High-tension Wire.** A chafed or broken magneto high-tension cable can cause continuous or intermittent misfiring of the engine. Should the cable require replacement, follow these instructions to change:

(1) Remove the ground lead screw from the spark plug shield cap.

(2) Press down the spring retainer and take off the cap.

(3) Remove the ground lead from the magneto cable shielding to the spark plug shield body.

(4) Remove cable lead from spark plug.

(5) Remove the magneto flywheel housing, then the starter pulley.

(6) Screw the flywheel removal tool onto the crankshaft. Tap the removal tool on the end until the magneto flywheel loosens up. At the same time, pull on the flywheel in the direction of removal to take advantage of any crankshaft end play. Remove the flywheel.

(7) Unfasten the wire end of the magneto cable from around the bracket in the coil. Loosen the screw and locknut at the back side of the magneto backplate (fig. 13) and withdraw the cable assembly.



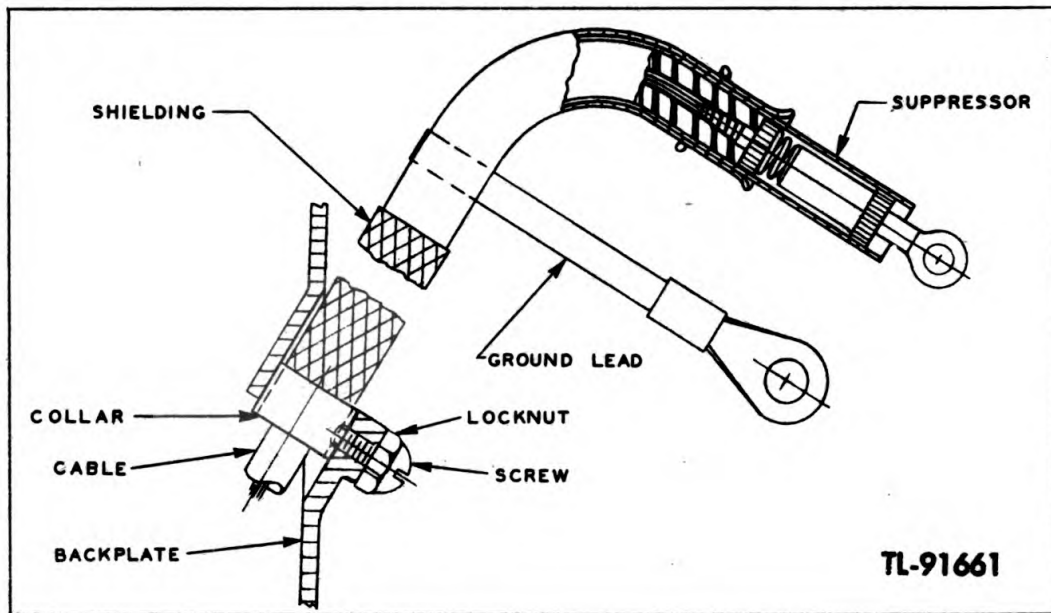

Figure 13. Magneto cable positioned in backplate

(8) Unscrew the suppressor from the cable and withdraw the cable from the shielding assembly.

(9) Install a new cable in the shielding, first being sure the cable insulation is stripped back  $\frac{1}{2}$  inch at one end. Twist the wire strands together.

(10) Insert the shielding through the opening in the magneto backplate so the collar is about flush with the boss (fig. 13).

(11) Tighten the small screw and locknut.

(12) Insert the wire end of the cable through the bracket on the coil. Bend the strands around so the cable cannot work out.

(13) Bring the cable and shield assembly forward between the cylinder and magneto backplate. Screw on the suppressor.

(14) Install the assembly on the spark plug and replace the cap and ground leads.

(15) Reassemble the flywheel, starter pulley, and flywheel housing.

**e. Capacitor.** If no spark, or a weak spark, occurs after adjusting the magneto breaker points, the trouble may be in the capacitor. If it is necessary to change this part, proceed as follows:

(1) Remove the flywheel housing and unscrew the starter pulley.

(2) Install the flywheel removal tool and tap it until the magneto flywheel loosens up. Remove the flywheel.

(3) Unfasten the black lead wire from the coil to the end of the capacitor, and unfasten the ground wire located in the clamp attached to the bracket which holds the capacitor in place.

(4) Remove the clamp and install a new capacitor.

(5) Replace all parts removed by reversing the above procedure.

**f. Coil.** If the spark from the magneto remains weak, or there is no output after adjusting the points and installing a new capacitor, replace the complete stator plate. Follow this procedure:

(1) Remove the flywheel housing and unscrew the starter pulley.

(2) Install the flywheel removal tool and tap it until the flywheel loosens up. Remove the flywheel.

(3) Unfasten the end of the high tension cable from the bracket in the coil.

(4) Remove screws holding stator plate in place and take off plate assembly.

(5) Install new stator plate, retune the engine as described in subparagraph c. Attach the high tension wire to coil making sure the wire is twisted around the bracket so it cannot loosen up.

(6) Install flywheel, starter pulley and flywheel housing.

**g. Magnet.** Integrally cast in the rim of the magneto rotor is the magnetic unit, which concentrates a powerful magnetic field within a small volume of iron. By virtue of its ability to retain indefinitely this high-magnetic concentration, the unit is able to provide the magneto with high-spark output throughout its entire life. Therefore, no trouble should be experienced with the magnet.

**h. Magneto Lubrication.** The magneto should require no lubrication for a long period of service. For cam lubrication, apply a little grease to the cam wiper after approximately 200 hours of operation. Do not use oil or a fluid lubricant, as either can get on the breaker points and short them out.

**i. Carburetor.** (1) The carburetor needle valve is correctly positioned with the adjustment knob at the time of assembly and should require no attention for some time. However, if the valve should, for any reason, require removal for replacement, follow these instructions:

- (a) Remove the adjustment knob extension.
  - (b) Hold the adjustment knob with one hand, loosen the acorn nut on top of the knob with a wrench or pair of pliers and remove it.
  - (c) Take off the spring and unscrew the valve by turning it in a counterclockwise direction (to the left).
  - (d) When reassembling the valve to carburetor, turn it in a clockwise direction (to the right) in the seat as far as it will go. **Do not tighten it up hard against the seat as damage might occur to the seat and valve.**
  - (e) With the valve in its seat as far as it will go, turn it back about one-eighth turn from this closed position.
  - (f) Replace the spring and valve adjustment knob, with the knob against the left-hand side of the stop. Screw on the acorn nut and tighten it, making sure the valve does not move while this is being done.
- (2) If the engine is hard to start, idles improperly, or will not keep running, first check the fuel mixture for the proper ratio of oil to gasoline; then check the exhaust and intake port holes for carbon accumulation (subpar. 1 below).
- (3) Should there be no restriction due to carbon and the carburetor is properly adjusted and the spark plug and magneto points are correctly set, follow these directions:
- (a) Remove the air cleaner and one screw from each side of the carburetor bowl.
  - (b) Remove the air valve and examine it to determine whether small particles of foreign matter are preventing the valve from seating.
  - (c) Clean out the valve if necessary. If the valve is bent or otherwise damaged, replace the assembly.
- (4) If the air check valve is functioning properly, the trouble may be with the reed valve which is attached to the back side of the carburetor. To check this valve, proceed as follows:
- (a) Remove the air cleaner and disconnect the fuel line from the carburetor float bowl.
  - (b) Then take out the two bottom screws that lead from the control box to the electric governor.

(c) Remove the four screws holding the carburetor to the crankcase.

(d) The valve must seat fully. If it is bent, straighten it or replace it. Remove any obstructions found under the valve.

(e) In reattaching the carburetor, make sure all connections are tight to prevent air leakage.

**IMPORTANT: The carburetor reed valve is concaved about 0.002 inch. In order that it will function properly, it is necessary, if the valve is removed or replaced, that the concaved side seats against the back of the carburetor.**

(5) If the engine floods easily when starting and is not over-choked, or if it is not possible to adjust the carburetor for satisfactory engine performance, the difficulty may be caused by a faulty float needle valve, needle valve seat, or float cork. If any of these mentioned parts are not functioning properly, the level of the fuel in the float bowl will be too high, permitting the fuel to flow into the air bleed chamber. Figure 14 shows the position of parts constituting the float assembly. To determine if the needle valve and seat are seating properly and the float levers are not bent too high or too low, the distance from the lower lever to the face of the float bowl where the gasket is located should measure  $13/32$  inch, as shown in figure 14.

(6) If a new float is installed, make certain it moves up and down freely on the float bowl pin.

(7) The needle valve seat is replaceable by unscrewing it from the float bowl cover.

**j. Air Cleaner.** The air cleaner serves to prevent dust and grit from entering the engine and causing wear to moving parts. If the equipment is operated under extremely severe and dusty conditions, remove the cover and brush the dirt accumulation from the filter element every 32 hours. When operating conditions are normal, clean the element every 64 hours. Examine the filter element periodically to see that no openings are present to permit entry of foreign matter. **Do not dip filter element in oil.**

**k. Electric governor.** (1) No adjustments should be necessary to the governor (fig. 15) unless the plunger return spring is replaced, as it is correctly set for the requirements of the unit at the factory.

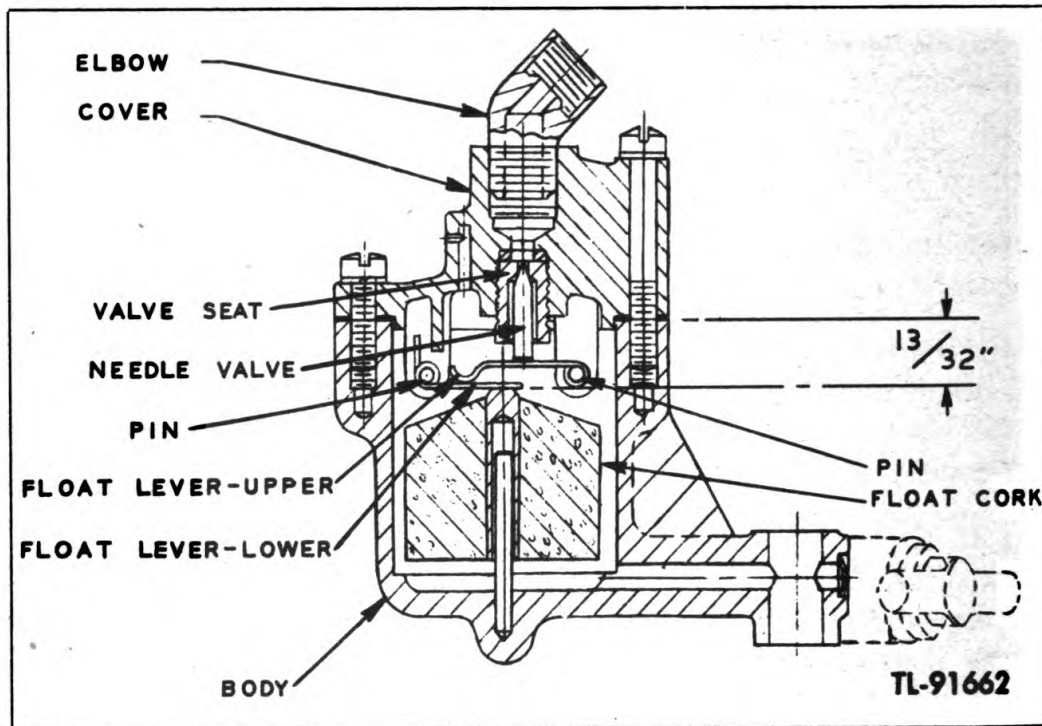

Figure 14. Carburetor float assembly

(2) To install a new governor spring, proceed as follows:

(a) Disconnect the wires at the terminal block on the side of the governor housing.

(b) Disconnect the fuel line at the carburetor.

(c) Remove the carburetor and solenoid as a unit by removing the four screws holding the carburetor to the engine.

(d) Remove the solenoid top cover and release the wire connector by bending the connector up and loosening the screw in the upper spring support.

(e) Remove the two screws holding the electric governor to the carburetor. Lift the assembly straight up until clear of the plunger. Loosen the throttle lever retaining screw and slide the plunger off of carburetor throttle shaft.

(f) With a small punch, drive out the upper brass pin in the plunger and remove the spring.

(g) Insert the large end of the new spring in the plunger and install the brass pin in the plunger engaging the lower spring loop. Lightly peen the pin ends to secure them and file them flush with the plunger surface.

(h) Assemble the plunger to the carburetor throttle shaft. Slide the governor assembly over the plunger and reattach complete unit to the carburetor. Connect the spring support so that the spring loop is about  $\frac{3}{8}$  inch from the support. This setting may have to be changed after the engine is running to obtain the proper voltage.

(i) Note the position of the plunger when the throttle is closed. The top of the plunger should be approximately flush with the top of the solenoid tube. If it is not, the throttle lever should be moved on the throttle shaft for correct positioning. After the plunger is properly set tighten the lock screw in the lever.

(j) Check the plunger linkage and the throttle shaft to see that all parts are working freely and not binding.

(k) Reassemble the governor and carburetor to the engine. Make a final adjustment for speed and voltage after the engine has been warmed up and running evenly. To increase the voltage, extend the spring by drawing the wire link upward in the upper spring support.

(l) Proper governor spring tension is important, but adjustment is not critical to accomplish. Insufficient tension results in failure of the reverse-current relay to close when the engine is started. The engine merely idles, and the ammeter will show no charge, regardless of the control knob position. A quick counterclockwise movement of the control knob will cause the relay to close even with insufficient spring tension.

(m) To set governor spring tension, start the engine manually or by means of a 12-volt storage battery. After the engine is warmed up, disconnect the 12-volt battery if used and connect a 6-volt battery to the control-box leads. Turn the control knob to the extreme counterclockwise position and adjust the governor spring tension at the upper support to obtain a charging rate of approximately 5 to 10 amperes. When the spring is properly positioned, be sure to tighten the screw which locks it in place.

**l. Carbon Removal.** Make a check of the engine exhaust and intake port holes about every 24 operating hours to make sure no carbon has built up at these points. Carbon deposits in the exhaust and intake port holes restrict the scavenging of exhaust gases from the cylinder and reduce power output. To remove carbon, follow these instructions:

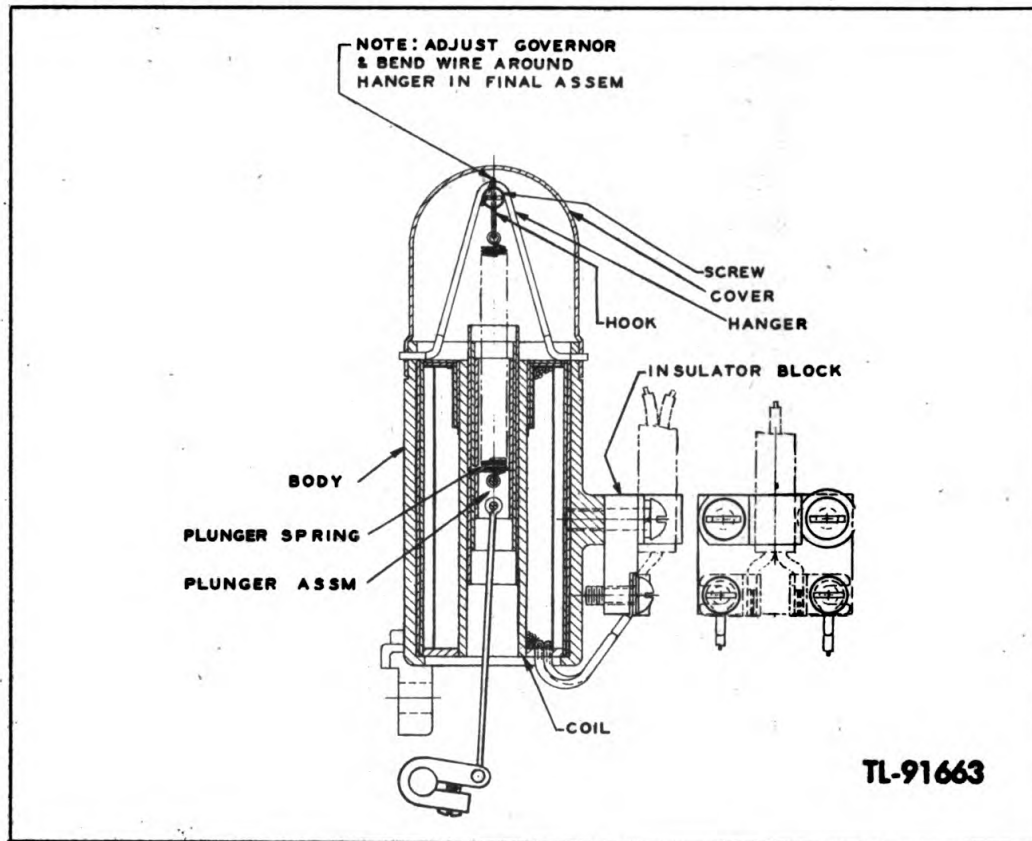

Figure 15. *Electric governor assembly*

(1) **Exhaust ports.** To clean out the exhaust port holes (fig. 16), remove the muffler. Turn the engine over by hand until the piston reaches bottom dead center. Clean out the port openings, using the combination screwdriver and socket wrench furnished with the equipment or a small screwdriver ground down to fit. Turn the engine over several times to permit carbon chips an opportunity to pass out of the engine before reinstalling the muffler.

(2) **Intake ports.** Access to the intake port holes (fig. 17), for cleaning, is attained by removing the spark plug shield, spark plug, cylinder-head baffle, and cylinder head. Turn the engine over until the piston is on bottom dead center. The openings can then be cleaned out, using the same tool as for the exhaust ports. Be sure no chips remain in the cylinder, as they will foul up the spark plug in starting. To facilitate reaching the intake port openings, remove the muffler.

**m. Muffler.** Disassemble and clean the muffler every 250 operating hours.

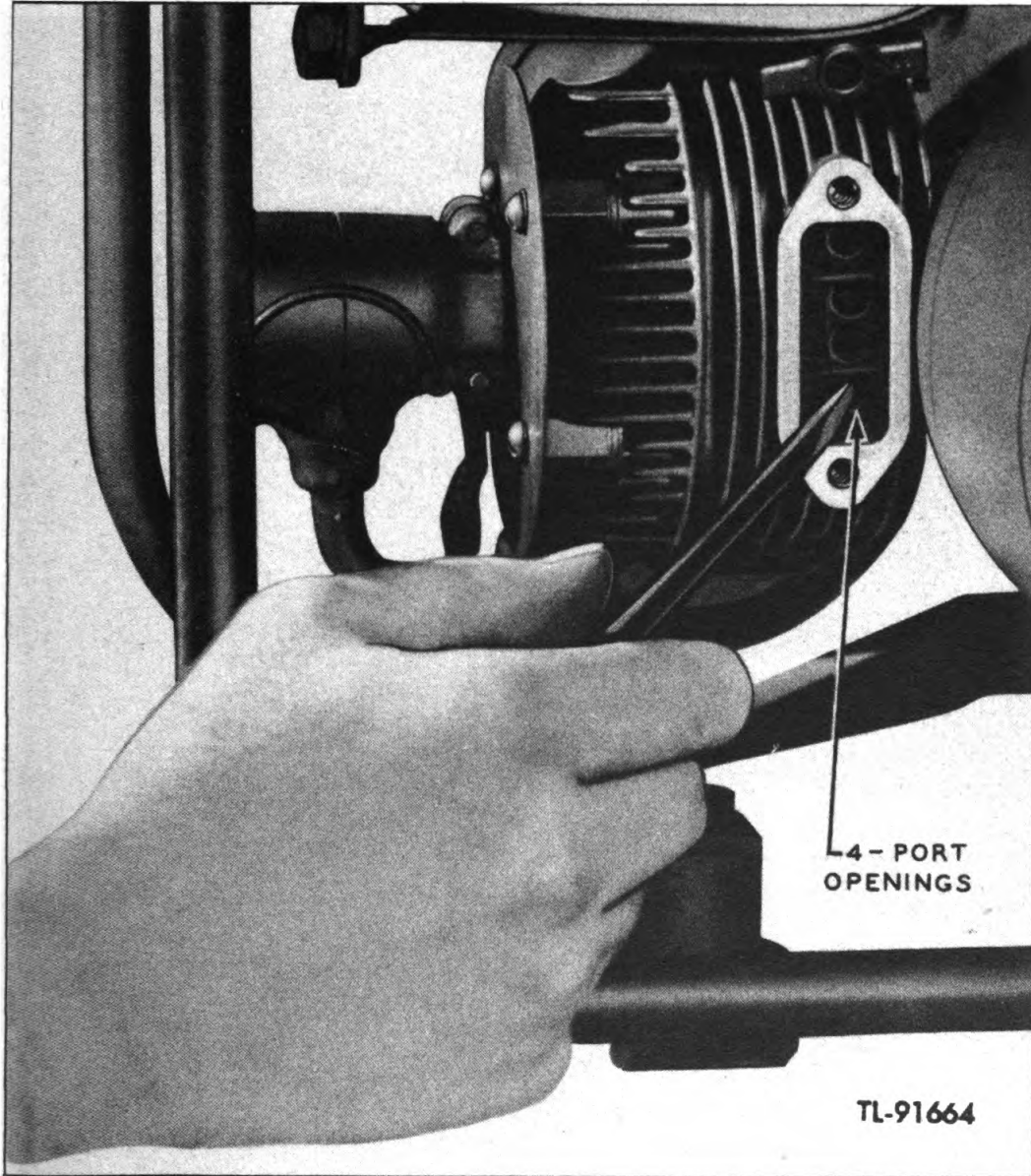

Figure 16. Carbon removal, exhaust ports



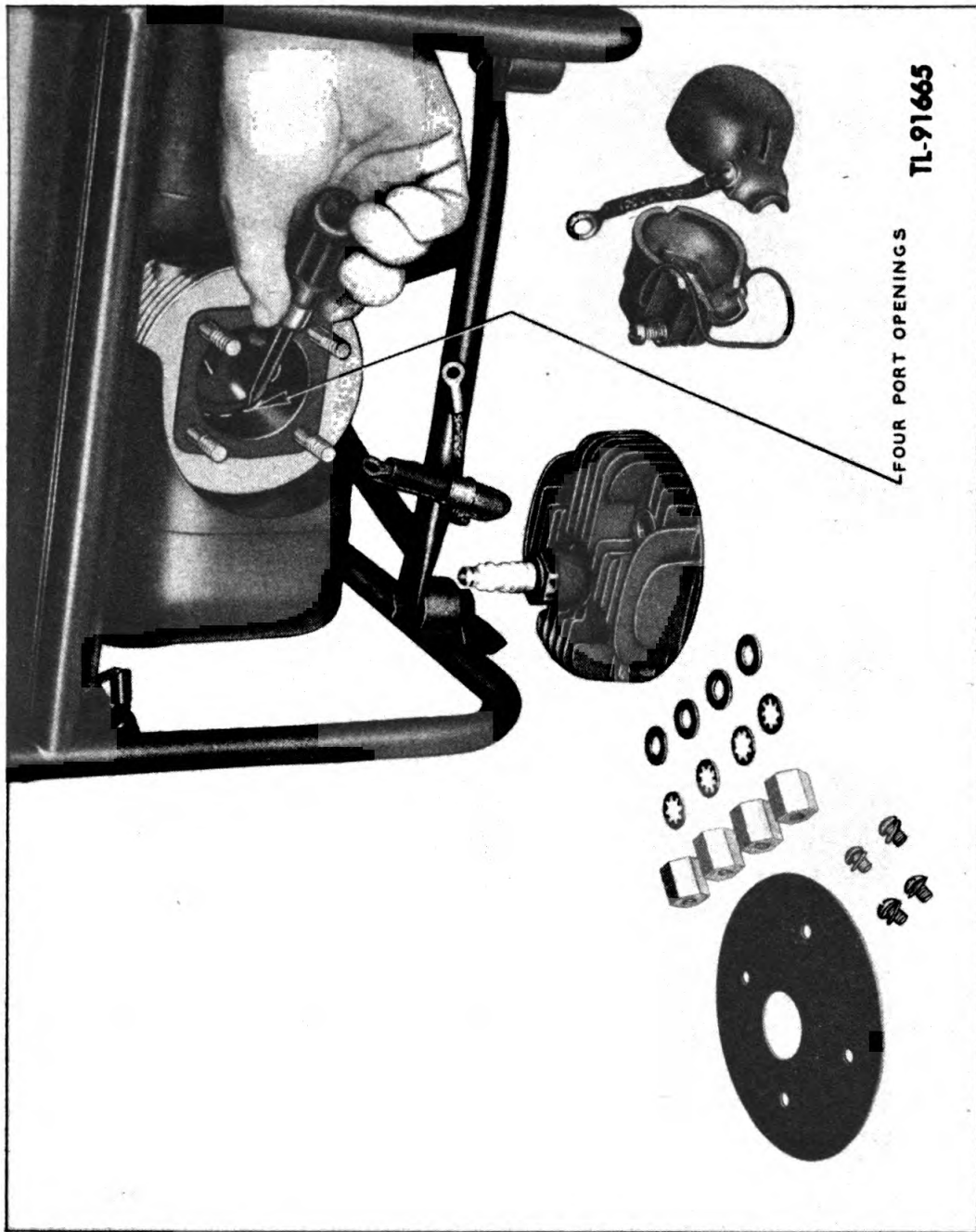

Figure 17. Carbon removal, intake ports

## 12. GENERATOR.

The generator of Power Unit PE-210 requires very little attention with the exception of occasional brush replacements and examination of the commutator to make sure there is a good electrical contact between it and the brushes. Oil, grease, or dirt affects the output of the generator and causes sparking at the brushes. The generator may be inspected by removing the end cover which is fastened in place by four screws on the outboard end.

**a. To Clean Commutator.** Access to the commutator is possible by removing the four screws which hold the end cover in place, then removing the cover. To clean the commutator (fig. 18), use a piece of wood or other flat nonmetallic object, about the same width ( $\frac{1}{2}$  inch) as the #00 sandpaper furnished with the equipment. With the armature rotating, place the strip of sandpaper on the object in use and hold it on the commutator exactly as shown in figure 18. Stop the unit and, with a small brush or pointed stick, remove dust or carbon from between the bars of the commutator.

**b. To Replace Worn Brushes.** Remove the generator cover as outlined in the preceding paragraph. Loosen the terminal end of the brush pigtailed by loosening the screw in the top of the brushholder and slipping the terminal from under the screw head. The brush pressure arm, which applies spring pressure to the brush, may be lifted by inserting a hooked instrument or stiff wire (fig. 19) through the hole in the bent-up ear directly over the top of the brush. With the brush pressure arm lifted, the brush may be removed by pulling on its pigtail wire.

**c. To Install Brushes.** Reverse the above procedure, being careful the brushes seat firmly against the commutator and move freely in the holders. New brushes should be fitted to have 100 percent effective surface contacting the commutator. This is accomplished by the use of #00 sandpaper the exact width of the commutator. Wrap the strip around the commutator with the sanded side out. Dress the brushes by turning the armature slowly in a clockwise direction (to the right). After dressing, be sure to blow any carbon dust out of generator.

**d. To Remove Armature.** The armature cannot be removed through the outboard end of the generator because the fan is larger in diameter than the bore. The generator must, therefore, be removed from the engine. Follow these directions:

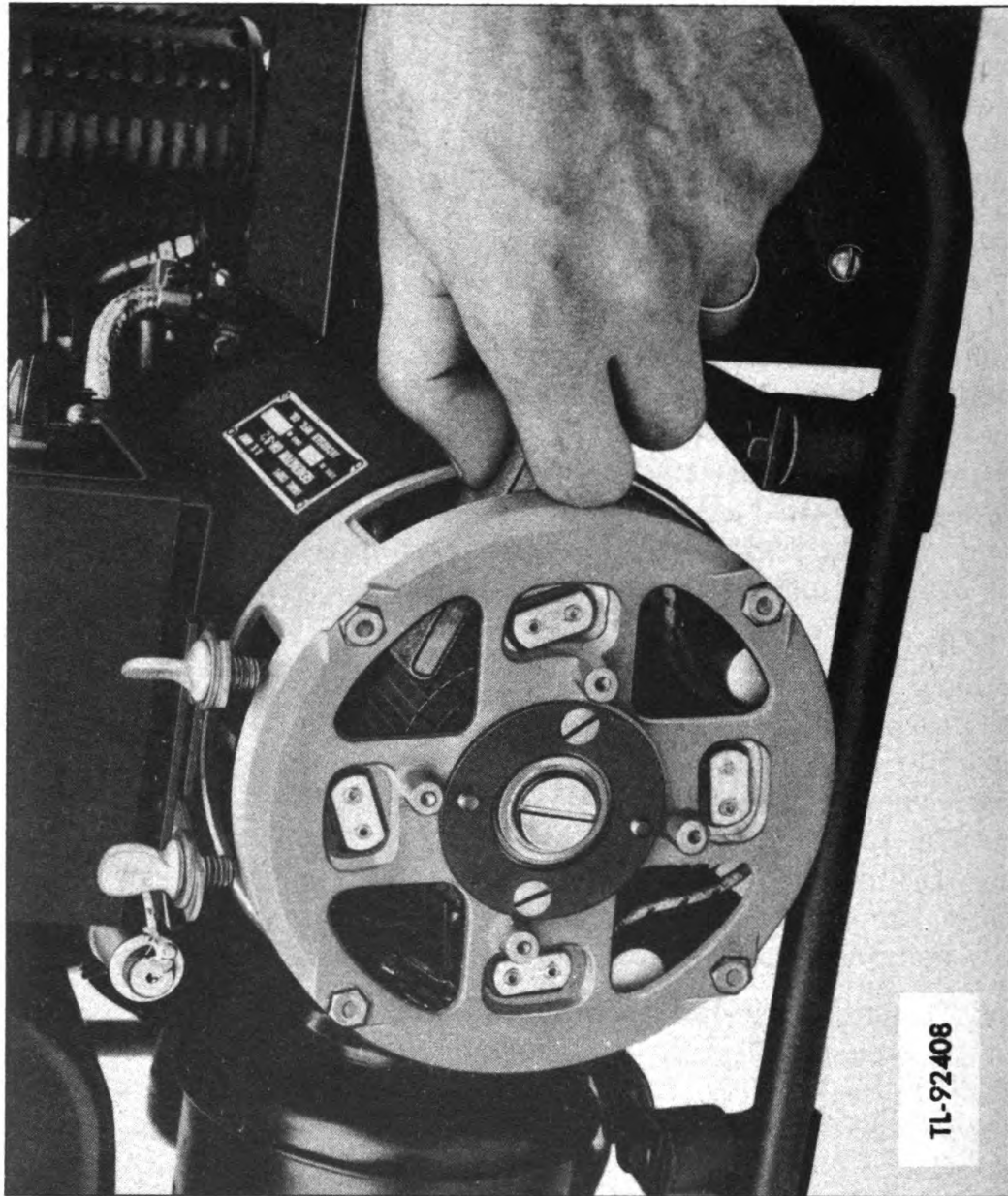

Figure 18. Dressing commutator

- (1) Disconnect the control box lead wire from the insulating block on the electric governor. Remove the three cap screws which fasten the generator to the engine crankcase adapter.
- (2) With a block of wood or soft hammer, tap the generator on the inner end bell until it disengages from the engine crankshaft.
- (3) After the generator has been removed from the engine, remove the cover from the commutator end. Remove the lock and holding nuts from the engine end of the generator through bolts, and remove the bolts by using a screwdriver at the commutator end.
- (4) Remove the engine end bell. Remove the brushes as described in subparagraph b above. Remove the screw at the commutator end of the armature and withdraw the armature toward the engine end of the generator. To replace the armature, proceed in reverse order. Be sure to have the armature in place before installing brushes.

### 13. LUBRICATION.

a. Power Unit PE-210 requires no lubrication other than the oil mixed with the gasoline for the engine (par. 5b) and occasional lubrication of the magneto cam with grease, applied sparingly. Do not use a fluid lubricant.

b. The generator has only one bearing, which is of the completely sealed ball type, and requires no lubrication. In case of failure, it should be replaced, since it cannot be relubricated.

### 14. DISASSEMBLY.

a. **Engine.** (1) To disassemble the engine for major repairs, first remove it from the tubular frame. This is accomplished by first disconnecting the fuel line at carburetor. Then remove the nut and washers from each stud holding the engine base to the rubber shock mountings. Next, remove the engine from its mounting base by taking out the four bolts holding it in place.

(2) Next, remove the generator from the engine. This is done by first disconnecting the lead wire from the control box at the governor. Then unscrew the three hex-head cap screws from the back side of the bearing adapter. Tap the generator until it disengages from the engine crankshaft.



Figure 19. Brush removal

(3) For complete dismantling of engine, follow these instructions:

(a) Remove the spark plug shield, spark plug, and cylinder-head baffle.

(b) Next remove the magneto housing. Then unscrew the starter pulley. Screw the flywheel removal tool onto the crankshaft and tap it on the end until the flywheel loosens up on the taper.

(c) Remove the stator plate. Take out the screw from the brass tube on the back side of the magneto backplate and withdraw the magneto-cam ground-brush and its spring assembly. Remove the backplate.

(d) Take off the air cleaner and remove the screws holding the carburetor to the crankcase. Remove the carburetor and solenoid as one unit.

(e) Remove the nuts holding the cylinder head to the cylinder. Slip the cylinder head from the studs. Then remove four nuts from the crankcase studs and pull off the cylinder.

(f) Removal of the piston and connecting rod assembly is accomplished by removing the two cap screws from the connecting rod cap through the opening in the crankcase where the carburetor is attached.

(g) Remove the screws which hold the crankcase bearing adapter to the crankcase. To remove the adapter from the crankcase, screw the flywheel removal tool onto the crankshaft and tap it on the end until the adapter comes out of the crankcase. Next, remove the connecting rod and crankshaft.

(h) The piston is removed from the connecting rod by straightening out the bulge in the cotter pin, then pulling the pin out, using a pair of pliers. Take a small punch and tap the piston pin from the piston.

(4) When reinstalling the piston to the connecting rod, use a new cotter pin. Be sure to spread the center of the cotter pin with a sharp V-shaped tool after it is in place. The piston pin should be a light tap fit in the piston. If the piston pin is loose, it will shear the cotter pin, which, in turn, will permit side movement of the pin to the extent that it will contact and cut grooves in the cylinder liner.

(5) Should the connecting rod ever become loose on the crankshaft pin and require taking up, file the connecting rod bearing

cap. The connecting rod bearing should be fitted to the crankshaft with about 0.003-inch clearance between the connecting rod and crank pin, or so there is absolutely no bind, and some slack is perceptible when assembled dry. This bearing should be fitted before the crankshaft is installed in the crankcase.

(6) In reassembling the piston and connecting rod assembly to the crankshaft, be sure the hump or intake side of the piston is on the same side as the intake port holes in the cylinder (fig. 34). This is the side opposite to that to which the muffler is attached.

(7) Piston rings should make contact with the cylinder wall all around its circumference. Replace the rings if the ring end gap exceeds 0.030 inch when the piston rings are in the cylinder. If the rings are stuck tightly in the piston-ring grooves, try to remove them without breaking. Should the end gap not exceed 0.030 inch, use the old rings again. Transpose the rings by installing the bottom ring in the top groove, the top ring in the bottom groove. Before installing new piston rings or the old ones, be sure the piston-ring grooves are clean and free of carbon. The end gap of new rings should be approximately 0.010 inch. Side clearance in grooves for new rings should be 0.002 to 0.003 inch.

(8) To break in new piston rings, run the engine 1 hour on no load, then not over half a load until good compression develops.

(9) While the engine is disassembled, remove all carbon and lead deposits from exhaust and intake ports, as well as from top of the piston and cylinder head. Be sure all gaskets are in good condition, or replace them with new ones before the unit is reassembled.

**b. Generator.** If it is necessary to dismantle the generator, the same procedure is followed in removal from the engine and disassembly as outlined in paragraph 12d.

**c. Control Box.** If the control box should develop trouble, replace the complete unit rather than attempt any service on it. Repairs should be made only at a source equipped to handle electrical units.

## 15. REASSEMBLY.

To reassemble the engine and generator, reverse the sequence for the disassembly of each component.

## 16. TROUBLE CHART.

SYMPTOM	POSSIBLE CAUSE	CHECK	REMEDY
<b>a. Engine.</b> Fails to start or hard to start.	No fuel in tank.	Fuel tank.	Fill.
	Fuel line shut-off not open.	Shut-off valve.	Open.
	Air vent not open.	Air vent.	Open.
	Defective spark plug.	Spark plug.	Replace.
	Carbon across spark plug points.	Spark plug.	Clean.
	Spark plug gap too wide.	Spark plug.	Adjust to 0.035 in.
	Obstruction under carburetor air valve.	Carburetor air valve.	Remove (par. 11 i (3)).
	Obstruction under carburetor reed valve.	Carburetor reed valve.	Remove (par. 11 i (4)).
	Wet spark plug.	Spark plug.	Dry.
	Water or dirt in fuel.	Fuel tank.	Drain, clean, and refill.
	Carburetor nozzle clogged.	Carburetor nozzle.	Clean out.
	Cylinder port holes plugged.	Cylinder port holes.	Clean out (par. 11 l).
	Muffler plugged.	Muffler.	Clean out.
	Magneto points out of adjustment.	Magneto points.	Adjust gap to 0.020 in. (par. 11 b).
	Broken magneto cable.	Magneto cable.	Replace (par. 11 d).
Defective capacitor.	Magneto.	Replace (par. 11 e).	
Defective coil.	Magneto.	Replace (par. 11 f).	
Engine flooded.	Crankcase.	Open and drain (par. 11 i (5)).	
<b>Engine overheats and lacks power.</b>	Incorrect fuel mixture.	Fuel tank.	Drain and refill.
	Cylinder port holes partially plugged.	Cylinder port holes.	Clean out (par. 11 l).



SYMPTOM	POSSIBLE CAUSE	CHECK	REMEDY
	Improper ignition timing.	Ignition timing.	Retime (par. 11 c).
	Carburetor needle valve not properly adjusted.	Needle valve adjusting knob.	Reset (par 11 i).
	Piston and cylinder head carbonized.	Cylinder and piston head.	Clean.
	Wrong type spark plug.	Spark plug.	Use Champion J5 or equivalent.
	Low compression.	Compression.	Replace or free up piston rings.
Engine misfires.	Carburetor choke lever not in running position.	Choke lever.	Move to horizontal position.
	Chafed or broken magneto high-tension cable.	Magneto cable.	Replace.
	Carburetor needle valve not properly adjusted.	Needle valve adjusting knob.	Reset (par. 11 i).
Excessive smoke from exhaust.	Incorrect ratio of oil to gas in fuel.	Fuel.	Replace with correct mixture (par. 5 b).
	Too rich a mixture in carburetor.	Carburetor adjusting knob.	Reset (par. 11 i).
Poor cylinder compression.	Loose cylinder head.	Cylinder head nuts and gasket.	Replace gasket or tighten cylinder-head nuts.
	Worn or stuck piston rings.	Piston rings.	Replace or free up.
	Loose spark plug.	Spark plug.	Tighten.
Poor crankcase compression.	Faulty gasket on crankcase head.	Crankcase gasket.	Replace.
	Faulty carburetor gasket.	Carburetor gasket.	Replace.
b. Generator. Arcing at brushes.	Dirty commutator.	Commutator.	Clean (par. 12 a).
	Worn out brushes.	Brushes.	Replace (par. 12 b).
	Brushes stuck in holders.	Brushes.	Free up.

SYMPTOM	POSSIBLE CAUSE	CHECK	REMEDY
	Brushes not properly seated.	Brushes.	See paragraph 12 c.
Fails to generate voltage.	Brushes stuck in holders.	Brushes.	Free up.
	Brushes not properly seated.	Brushes.	See paragraphs 12 b and c.
	Dirty commutator.	Commutator.	Clean (par. 12 a).
	Defective armature.	Armature.	Replace (par. 12 d).
	Defective capacitor.	Capacitor.	Replace.
Fails to deliver rated output (450 watts).	Engine not up to speed.	Engine speed.	Turn knob on control box.
	Engine lacks power.	Engine.	See trouble chart covering engine.
	Worn out brushes.	Brushes.	Replace (par. 12 b).
	Brushes not properly seated.	Brushes.	Reseat (par. 12 c).
	Defective capacitors.	Capacitors.	Replace.
Noisy radio reception.	Defective generator and control-box capacitors.	Capacitors.	Replace.
	Loose spark plug shield.	Spark plug shield.	Tighten.
	Defective magneto cable shielding.	Magneto cable shielding.	Replace.

## 17. MOISTUREPROOFING AND FUNGIPROOFING (fig. 37).

a. **General.** The operation of Signal Corps equipment in tropical areas where temperature and relative humidity are extremely high requires special attention. The following items represent problems which may be encountered in operation:

- (1) Resistors, capacitors, coils, chokes, transformer windings, etc., fail.
- (2) Electrolytic action takes place in resistors, coils, chokes, transformer windings, etc., causing eventual break-down.
- (3) Hook-up wire and cable insulation break down. Fungus growth accelerates deterioration.
- (4) Moisture forms electrical leakage paths on terminal boards and insulating strips causing flash-overs.
- (5) Moisture provides leakage paths between battery terminals.

b. **Treatment.** A moistureproofing and fungiproofing treatment has been devised which, if properly applied, provides a reasonable degree of protection against fungus growth, insects, corrosion, salt spray, and moisture. The treatment involves the use of a moisture- and fungi-resistant varnish applied with a spray gun or brush. Refer to TB SIG 13, Moistureproofing and Fungiproofing Signal Corps Equipment, for a detailed description of the varnish-spray method of moistureproofing and fungiproofing.

**CAUTION:** Varnish spray may have a toxic effect if inhaled. To avoid inhaling spray, use respirator if available; otherwise, fasten cheesecloth or other cloth material over nose and mouth.

### c. Step-by-step Instructions for Treating Power Unit PE-210.

#### (1) Preparation.

(a) Make all repairs and adjustments necessary for proper operation of the equipment.

(b) Clean all dirt, dust, rust, fungus, oil, grease, etc., from the equipment to be processed.

#### (2) Disassembly.

(a) Remove the three screws that hold the cover to the control box and remove the cover. Set the cover to one side to be treated.

(b) Remove eight leads from the relay inside of the control box, remove the two mounting bolts that hold the relay and remove the relay from the control box.

(c) Remove the four screws that hold the cover on the relay and remove the cover. Set the relay cover to one side to be treated.

(d) Remove the binding post screws from the binding posts inside of the relay.

(e) Slip the heavy wire coil from over the voltage coil and set it aside to be treated.

(f) Remove the paper from the inside of the relay cover.

(g) Remove the two bolts from the clamps that hold the meter case to the frame and remove the meter case.

(h) Turn the meter case bottom side up and remove the bottom cover. The inside of this case is to be treated.

### (3) Masking.

(a) Mask all soldering lugs on the ends of wires that have been disconnected and mask all terminals from which wires have been removed.

(b) Mask the back of the rheostat inside of the control box with paper and masking tape.

(c) Mask the contacts on the starting switch and mask the adjustable resistor on the inside of the control box.

(d) Mask the armature guide in the relay case (fig. 37).

(e) Mask the opening in the end of the solenoid coil as shown in figure 37.

(f) Mask the binding posts and loose terminal lugs on the under side of the relay. Make sure that all of the parts indicated in figure 37 have been masked.

(4) **Drying.** Use infra-red lamps to dry out components for 2 to 3 hours at 160°F.

### (5) Varnishing.

(a) Spray the inside of the control box and the control box wiring.

(b) Spray the inner sides of the control box cover, the inside of the meter case and the inside of the relay cover.

(c) Spray the heavy wire current coil and the voltage coil of the relay.

(d) Apply moistureproofing and fungiproofing varnish around the edges of the meter glasses where they join the case. Apply varnish to the zero adjusting screws on both meters. These applications must be carefully made with a suitable brush.

**(6) Reassembly.**

(a) Remove all masking tape.

(b) Reassemble all disassembled parts of the equipment and check the operation.

**(7) Marking.** Mark MFP and the date of treatment in a conspicuous place on the unit.

**Example:** MFP — 8 June 1944.

**SECTION V  
SUPPLEMENTARY DATA**

**18. MAINTENANCE PARTS LIST FOR POWER UNIT PE-210.**

Ref. Figure	Signal Corps Stock No.	Name of Part and Description	Quan. per Unit	Run-ning Spares	Orgn. Stock	3rd Ech.	4th Ech.	5th Ech.	Depot Stock
1, 2	3H1912B	ENGINE GE-12-B: Jacobsen model J100; 1-cylinder, 2-cycle, 2" bore, 1½"-stroke, 3,000-rpm; Jacobsen A2468.	1				*		
36	6D10113-54	LUBRICATION ORDER No. 3054.	1				*		
14, 20, 22, 23	3H1912B/F1	<b>Carburetor Group</b> CARBURETOR AND CARBURETOR FLOAT BOWL ASSEMBLY WITH AIR CLEANER: Jacobsen A2552; consists of 1 carburetor (Tillotsen model B-7A), aluminum die-cast body, air-metering valve in bowl, 3-stage choke lever, reed valve; and 1 carburetor float-bowl assembly, consisting of the body, die-cast cover and needle valve seat and valve.	1				*		

\* Indicates stock available.

Ref. Figure	Signal Corps Stock No.	Name of Part and Description	Quan. per Unit	Run-ning Spares	Orgn. Stock	3rd Ech.	4th Ech.	5th Ech.	Depot Stock
20	3H1912B/E10	<p align="center"><b>Engine Group</b></p> <p><b>BASIC ENGINE ASSEMBLY:</b> includes 1 cylinder head, 1 cylinder-head gasket, 1 cylinder, 1 cylinder-base gasket, 1 piston assembly with 3 rings and piston pin, 1 connecting rod assembly, 1 crankshaft with bearings, 2 oil seals, 1 crankcase, and 1 kit of running spare parts; Jacobsen A2553.</p>	1				*		
20	3H4600-214/AP	<p><b>KIT:</b> running spare parts; consisting of:                      6 ea rings, piston; Jacobsen 2359B.                      2 ea needle and seat assembly, carburetor float; Jacobsen A2550.                      1 ea gasket, cylinder mounting; Jacobsen 03322.                      1 ea gasket, carburetor; Jacobsen 04060.                      1 ea gasket, crankcase head; Jacobsen 04377.                      1 ea gasket, fan housing plate; Jacobsen 04378.                      1 ea gasket, muffler mounting; Jacobsen 05218.                      1 ea gasket, air-cleaner mounting; Jacobsen 05225.</p>							

• Indicates stock available.

Ref. Figure	Signal Corps Stock No.	Name of Part and Description	Quan. per Unit	Run-ning Spares	Orgn. Stock	3rd Ech.	4th Ech.	5th Ech.	Depot Stock
26, 27		<p>1 ea gasket, intake passage cover; Jacobsen 05819.</p> <p>1 ea gasket, exhaust flange; Jacobsen 05821.</p> <p>1 ea gasket, filler cap; Jacobsen 05871.</p> <p>1 ea gasket, float bowl cover; Tillotson 07198.</p> <p>2 ea gasket, float bowl mounting; Jacobsen 05879.</p> <p>2 ea breaker plate and arm assembly, consisting of: breaker arm, pilot bushing, fiber make-and-break shoe, breaker-plate tungston point with nut and washer; Wico X5112.</p> <p>3 ea capacitor, magneto, 18 mf; Wico X2186.</p> <p>10 ea spark plugs; Champion J-5.</p> <p>1 ea rope, starting, with grip; Jacobsen A2170.</p> <p>2 ea valve, carburetor reed; Jacobsen 04049A.</p> <p>1 ea cable assembly, spark plug, with suppressor; Jacobsen A2283.</p> <p>1 ea shield assembly, spark plug, with radio shielding; Jacobsen A2549.</p>							



Ref. Figure	Signal Corps Stock No.	Name of Part and Description	Quan. per Unit	Run-ning Spares	Orgn. Stock	3rd Ech.	4th Ech.	5th Ech.	Depot Stock
		4 ea gaskets, cylinder head; Jacobsen 04371A. 10 ea gasket, exhaust flange; Jacobsen 05821. 1 ea spline and pin assembly, female; EM&S 49 and EM&S 50. 1 ea spring, governor plunger return; Jacobsen 05900. 4 ea nuts, cylinder-head mounting; Jacobsen 05863. 4 ea lockwashers, cylinder-head mounting; 5/16". 4 ea screws, cylinder-head cover; 10-24 x 5/16". 4 ea lockwashers, cylinder-head cover mounting; Jacobsen C2569ZP. 4 ea screws, exhaust flange; Jacobsen C102ZP. 4 ea washers, exhaust flange; Jacobsen C2571ZP. 4 ea screws, shroud. 4 ea washers, shroud.	1	*			*		
	3H1912B/L15	Fuel Line Group LINE: fuel, with fittings; Jacobsen A2329.	1				*		

\* Indicates stock available.

Ref. Figure	Signal Corps Stock No.	Name of Part and Description	Quan. per Unit	Run-ning Spares	Orgn. Stock	3rd Ech.	4th Ech.	5th Ech.	Depot Stock
24	3H1912B/G60	<b>Governor Group</b> GOVERNOR ASSEMBLY: electric; complete; Jacobsen A2342.	1				*		
26, 27	3H2699-9	<b>Ignition Group</b> MAGNETO ASSEMBLY: complete; Wico FW1653; Jacobsen A2125.	1				*		
20	3H1912B/M15	<b>Muffler Group</b> MUFFLER ASSEMBLY: includes body, head, stud, nut, and washer; Jacobsen A2332.	1				*		
25	3H2351A/B10	<b>Generator Group</b> BEARING: ball; generator; single-row; double-seal; New Departure 88502.	1				*		
25	3H2352/B5	BRUSH: generator; carbon; over-all dimensions $\frac{7}{8}$ " x $\frac{3}{8}$ " x $\frac{1}{4}$ "; has No. 14 cable-covered lead with brass spade terminal clip $\frac{1}{2}$ " x $\frac{3}{8}$ "; National Carbon No. 549.	4	*			*		
	3DA500-217	CAPACITOR: fixed, paper foil; 0.5 mf, 150 v dc + 0.1 mf — 0.05 mf; hermetically sealed, oil-impregnated; 2 for generator; Gudeman Mfg Co. type 7266.	2	*			*		

Ref. Figure	Signal Corps Stock No.	Name of Part and Description	Quan. per Unit	Run-ning Spares	Orgn. Stock	3rd Ech.	4th Ech.	5th Ech.	Depot Stock
25	3DA500-239	CAPACITOR: fixed; paper foil; .5 mf; 150 v dc, + .01, .05 mf, hermetically sealed, oil-impregnated; 3" lead with Stak-On terminal; for control box. Gudeman Mfg Co. type 7278.	1	*			*		
	3H2352	GENERATOR GN-52: model G1, serial 2; 30 amp dc; 15 v dc; 450 w dc; 3600 rpm; Jacobsen A2231.	1				*		
	3H4600-210/B1	Control Group CONTROL BOX ASSEMBLY: voltage; over-all dimensions 4-1/16" long x 4 3/8" wide x 3-15/32" high; has 1 + and 1 — terminal with thumbscrews, start switch lever, rheostat control knob, range 0-18 volts marking, 3-hole ventilating louvres in rear; Square D model J1301 No. 2314-S1-G1; Jacobsen A2380.							
30	3F1796	METER BOX ASSEMBLY: Jacobsen A2533 consisting of No. 12 cast aluminum box 9 1/2" long x 2-29/32" wide, each end tapers to a 1 1/4" width; with a 9/64" hole drilled in center 1 1/4" from outside edge on each end; each end is curved to fit 1/2" round pipe held in place by detachable bolted	1				*		

Ref. Figure	Signal Corps Stock No.	Name of Part and Description	Quan. per Unit	Run-ning Spares	Orgn. Stock	3rd Ech.	4th Ech.	5th Ech.	Depot Stock
		clamp; meter housing compartment 5 1/2" long x 2-29/32" wide x 2 1/4" deep with rounded ends; inspection plate on bottom of box is held in place by four 6—32 machine screws 2 1/2" apart on each side; shielded cable protruding from lower rear left side is 9" long and is connected to terminals with 1/4"—20 machine screws.	1				*		
	3F8030-20	VOLTMETER: dc, 0-30-v; Triplett model No. 221-T; 2% accuracy; flush mounting; 30 scale divisions; round bakelite housing; flange diameter 2-11/16"; body diameter 2-5/32"; body depth 1-27/32"; three mounting holes 120° apart; hole diameter 0.144"; mounting screws 6—32.							
21	3H4600-214/C5	Miscellaneous Group CANVAS COVER AND HANDLE ASSEMBLY: Jacobsen A2377.	1				*		
35	6Q27460	Tool Kit Group KIT: tool; Jacobsen A2463 consisting of the following: 2 ea cleaners, breaker point; Jacobsen C6064.	*	*			*		

\* Indicates stock available.

Ref. Figure	Signal Corps Stock No.	Name of Part and Description	Quan. per Unit	Run-ning Spares	Orgn. Stock	3rd Ech.	4th Ech.	5th Ech.	Depot Stock
	6Q45231-1	1 ea gauge, double end feeler; Jacobsen 05372.		*			*		
	6R4780-6.5	1 ea pliers; Jacobsen 05370.		*			*		
	6R7395-2	1 ea puller, flywheel; Jacobsen 05250.		*			*		
	6R55522-16	1 ea wrench, open end, 1/2" x 11/16"; Jacobsen 05254.		*			*		
	6R55514-12	1 ea wrench, open end, 3/8" x 7/16"; Jacobsen 05252.		*			*		
	6R55516-18.2	1 ea wrench, open end, 1/2" x 9/16"; Jacobsen 05371.		*			*		
	6R55510-14.1	1 ea wrench, hex. box end, 5/16" x 7/16"; Jacobsen 06126.		*			*		
	6R15430	1 ea screwdriver, small; Jacobsen C4830.		*			*		
	6Q45684	1 ea gauge, spark timing; Jacobsen 06134.		*			*		
	6R55496	1 ea wrench, No. 10 Allen set screw; Jacobsen C5472.		*			*		
	6Z7500-00	6 pcs No. 00 sandpaper, 1/2" x 6", Jacobsen 05256.		*			*		

• Indicates stock available.

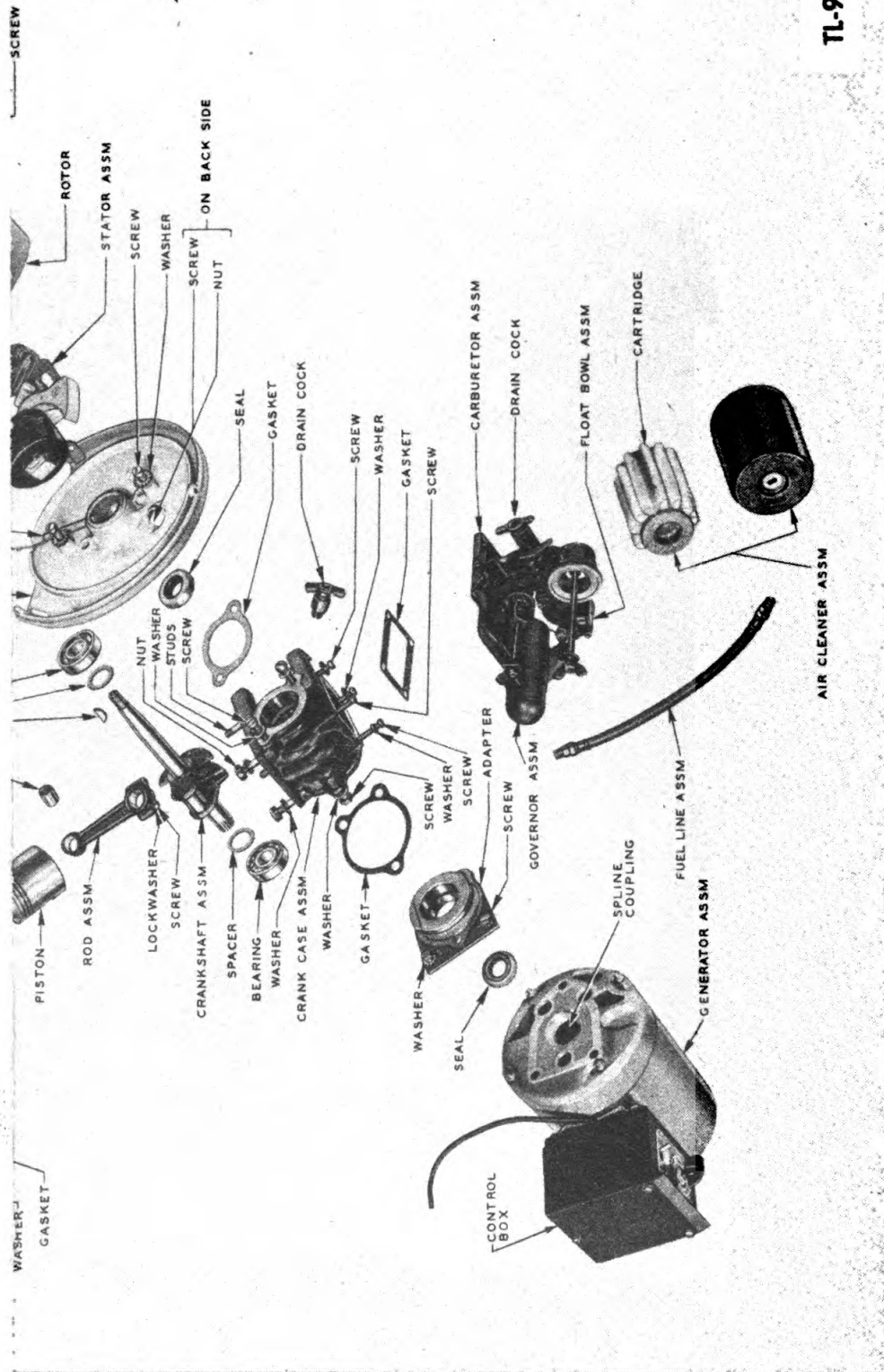

8 view of Power Unit PE-210

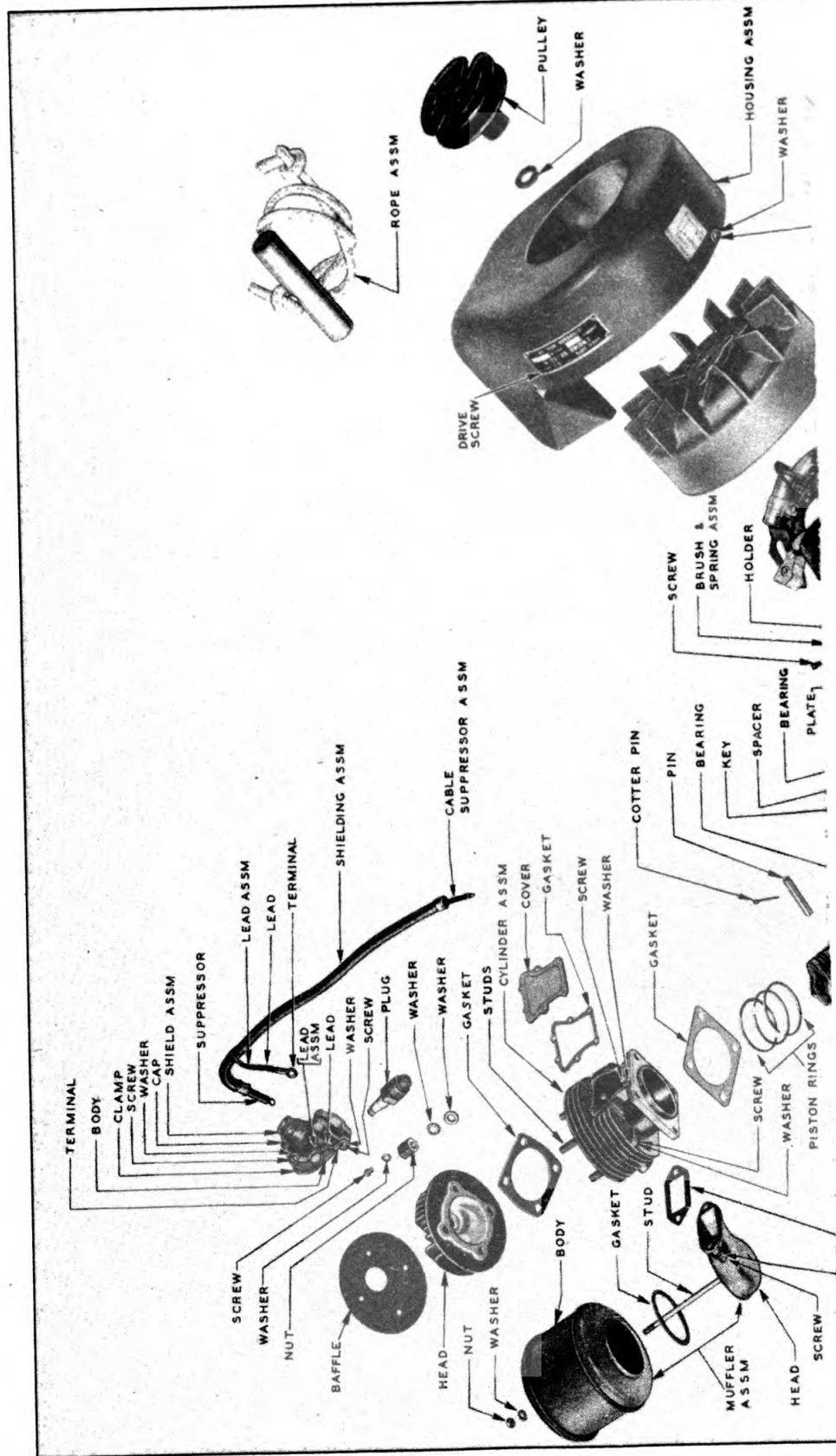

Figure 20. Exploded part

Generated on 2015-10-29 12:31 GMT / http://hdl.handle.net/2027/uc1.b3243898  
 Public Domain, Google-digitized / http://www.hathitrust.org/access\_use#pd-google

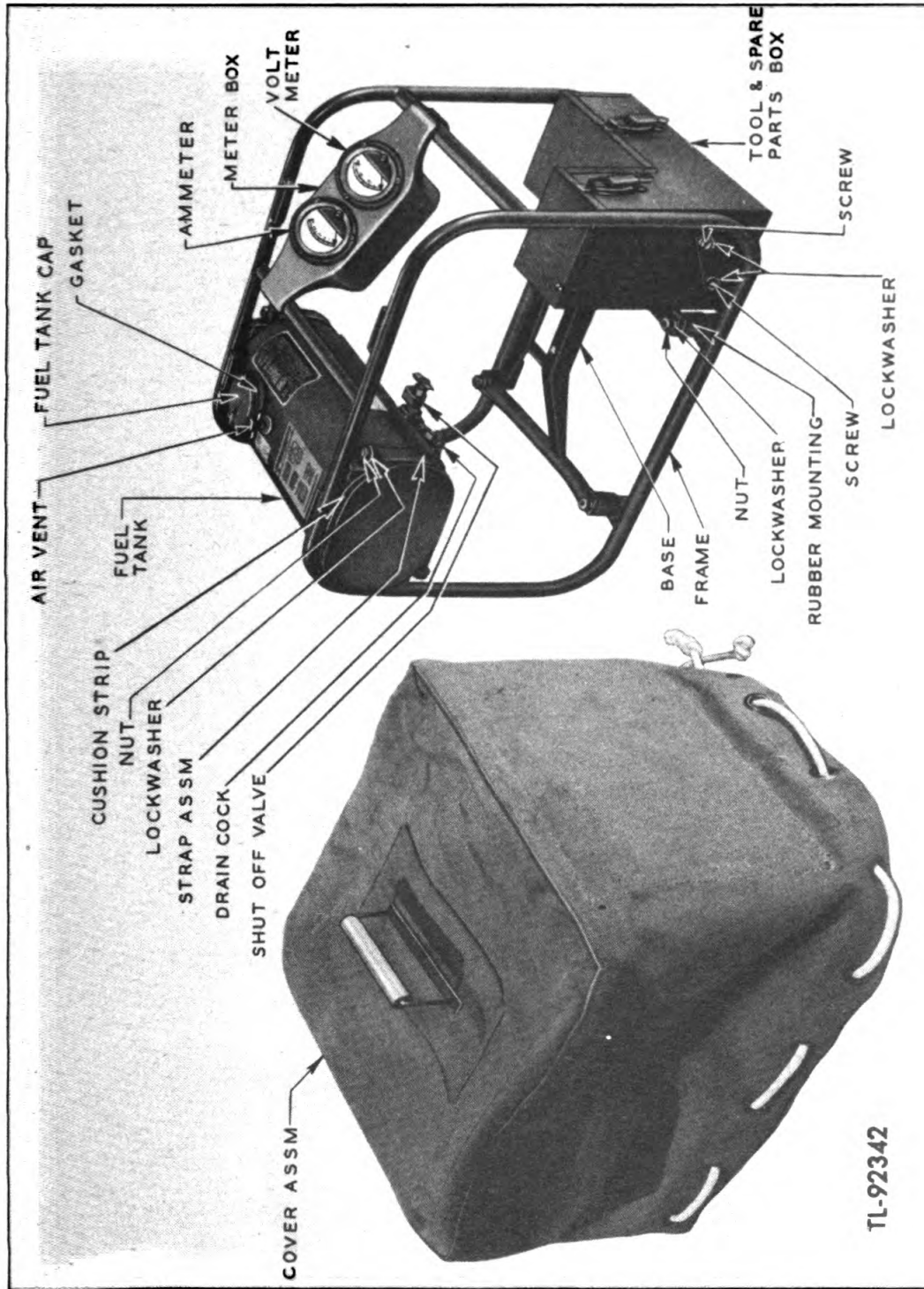
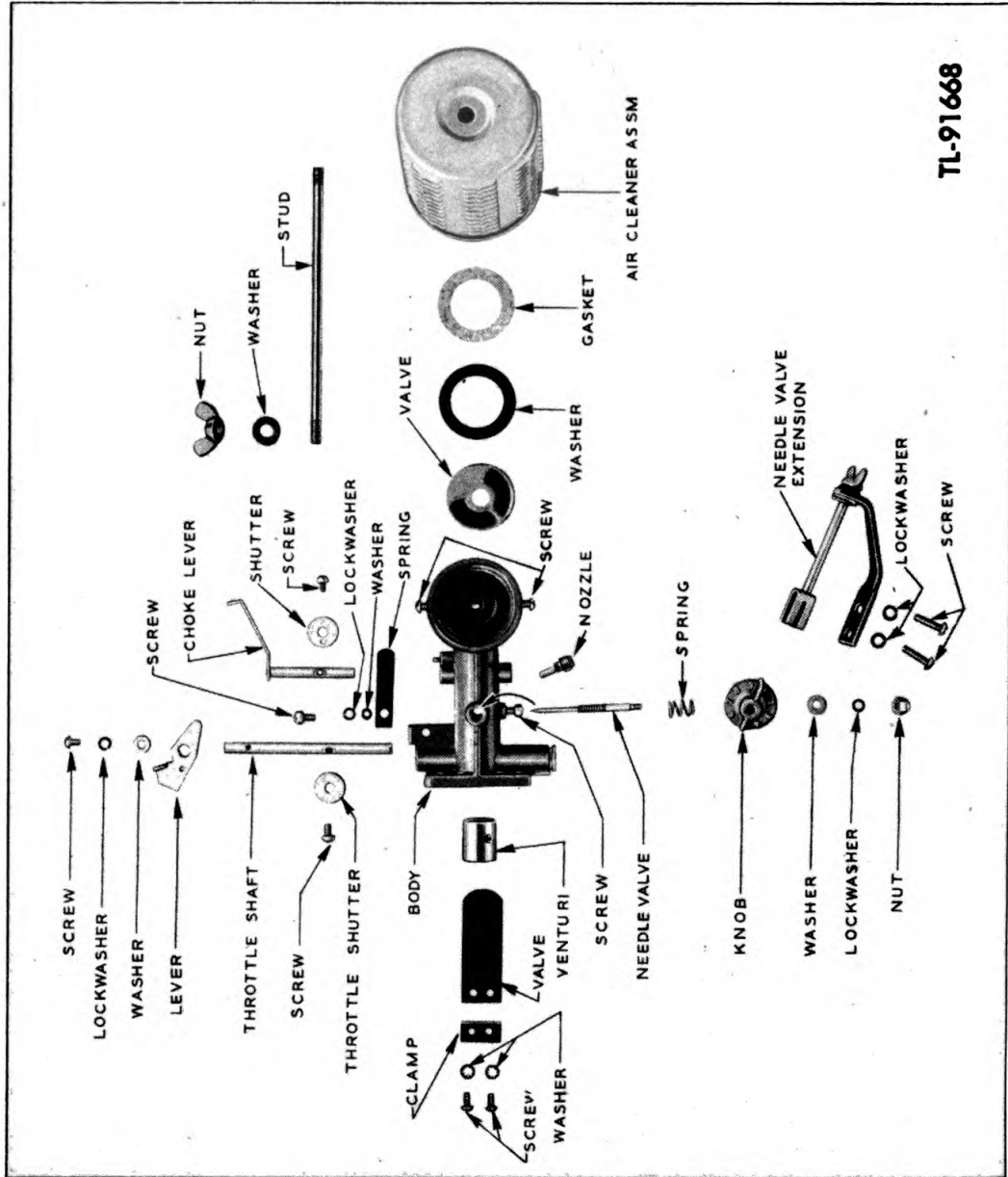

Figure 21. Frame, tool box, base, fuel tank, and canvas cover





TL-91668

Figure 22. Carburetor parts

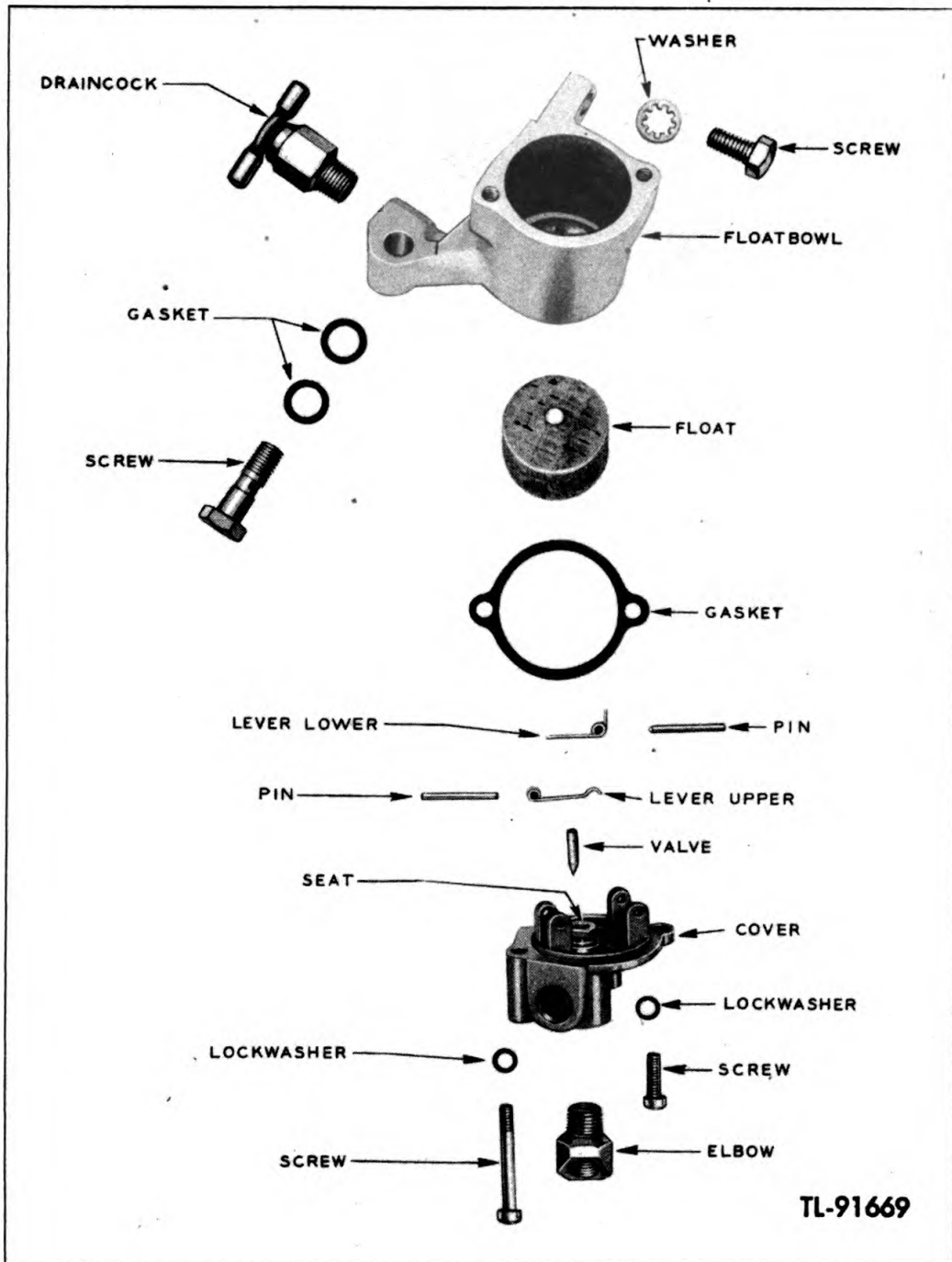

Figure 23. Carburetor float parts

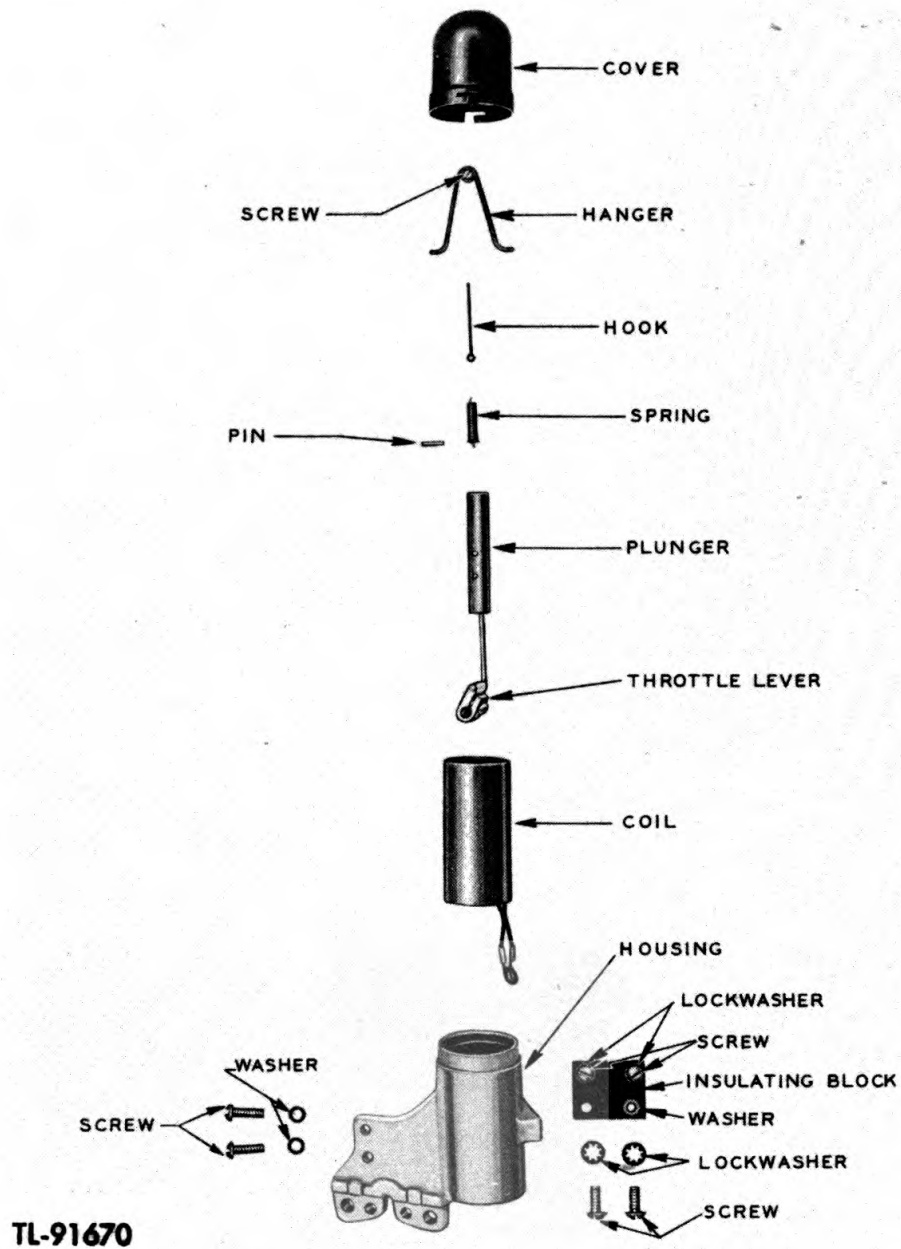

Figure 24. Electric governor parts

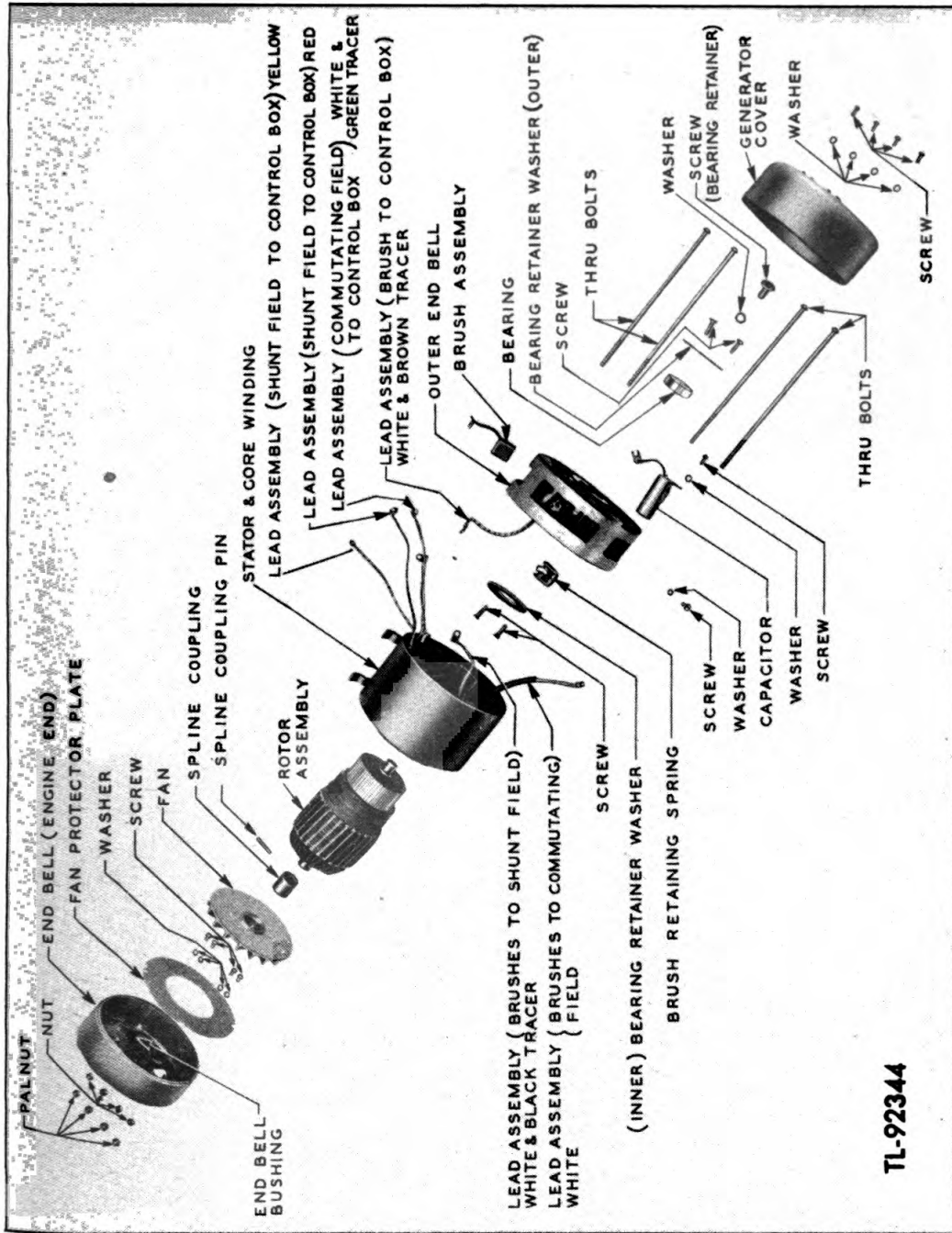

Figure 25. Generator assembly

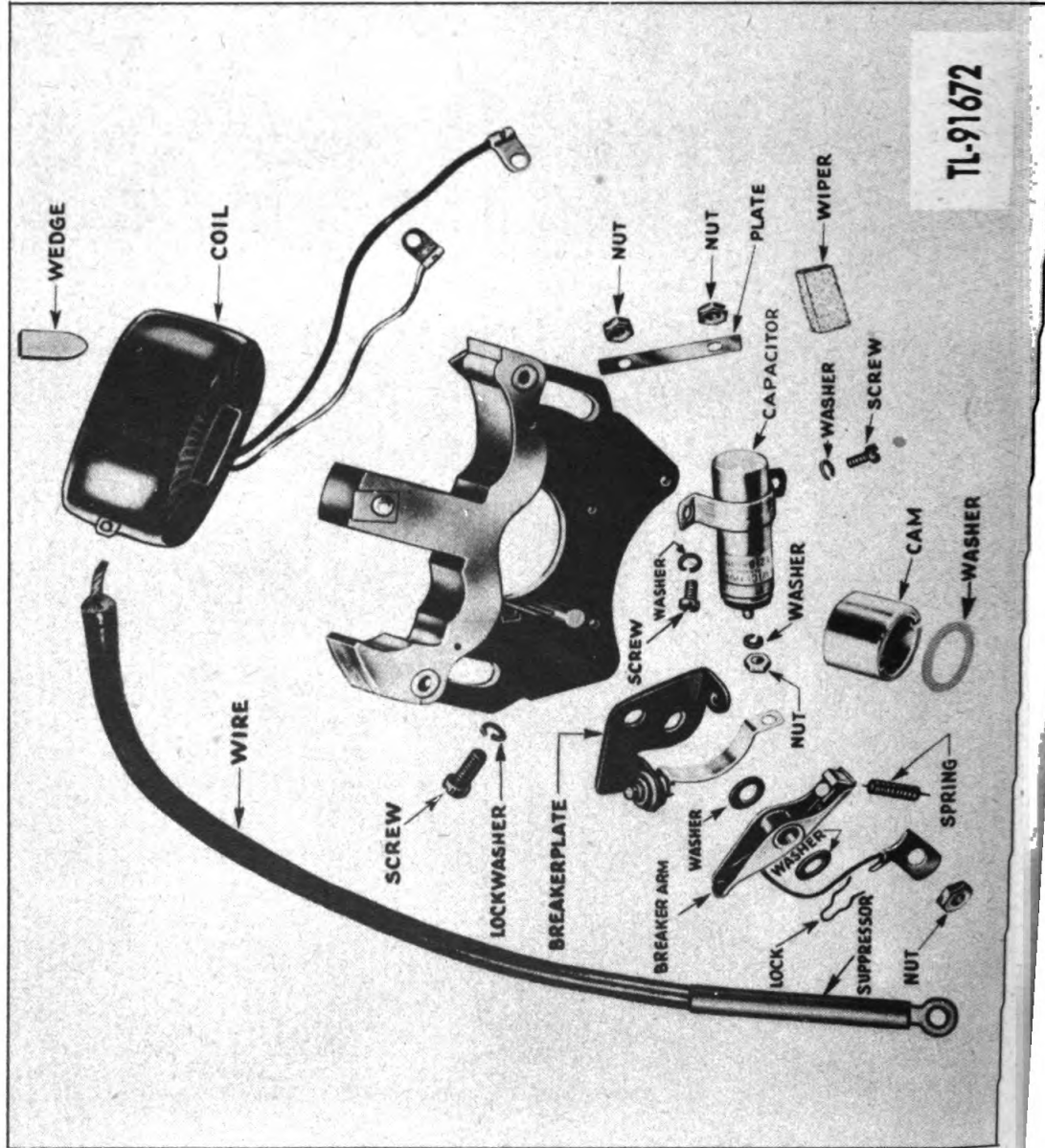

Figure 26. Magneto stator-plate assembly

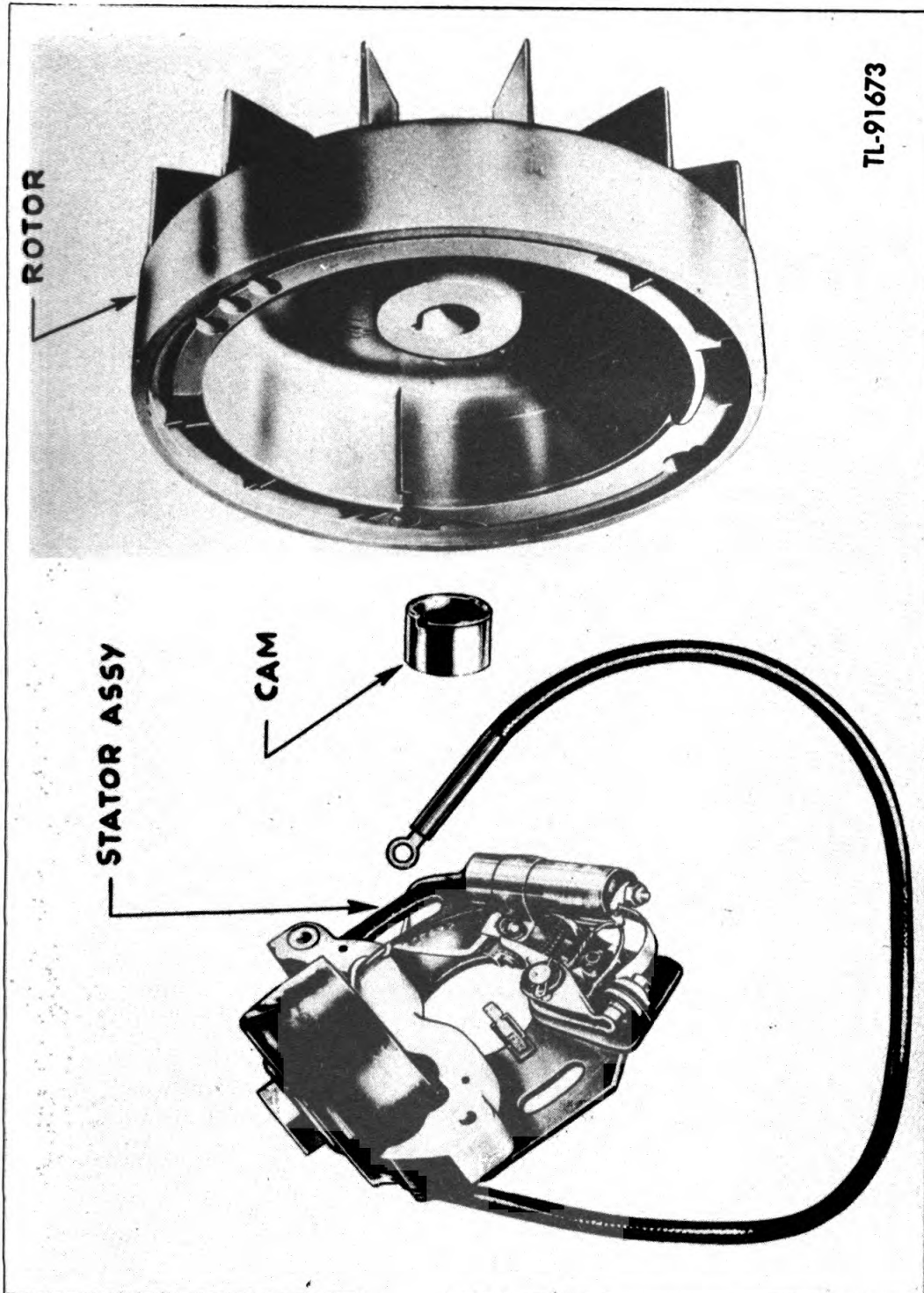

Figure 27. Magneto assembly

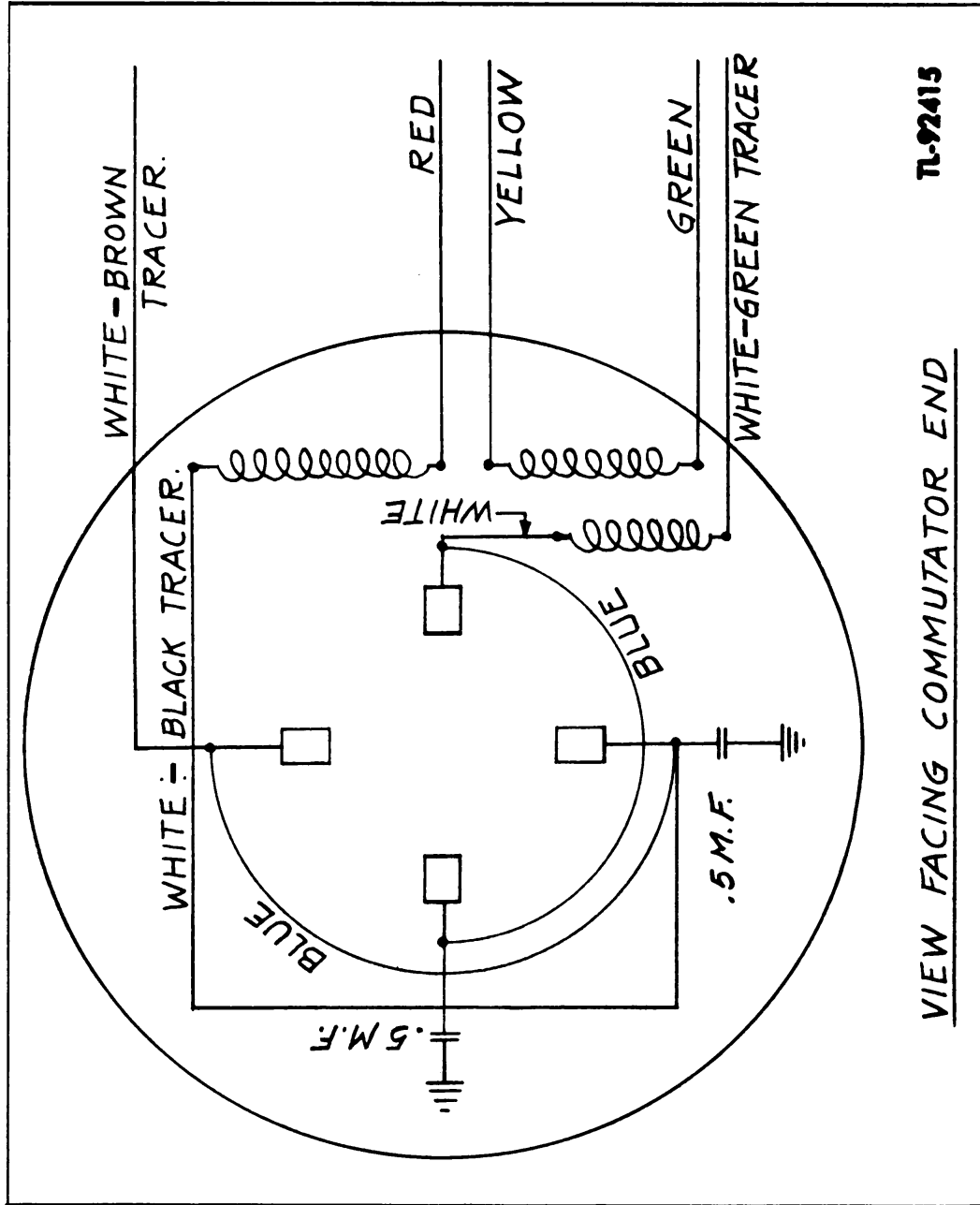

Figure 28. Schematic wiring diagram, generator

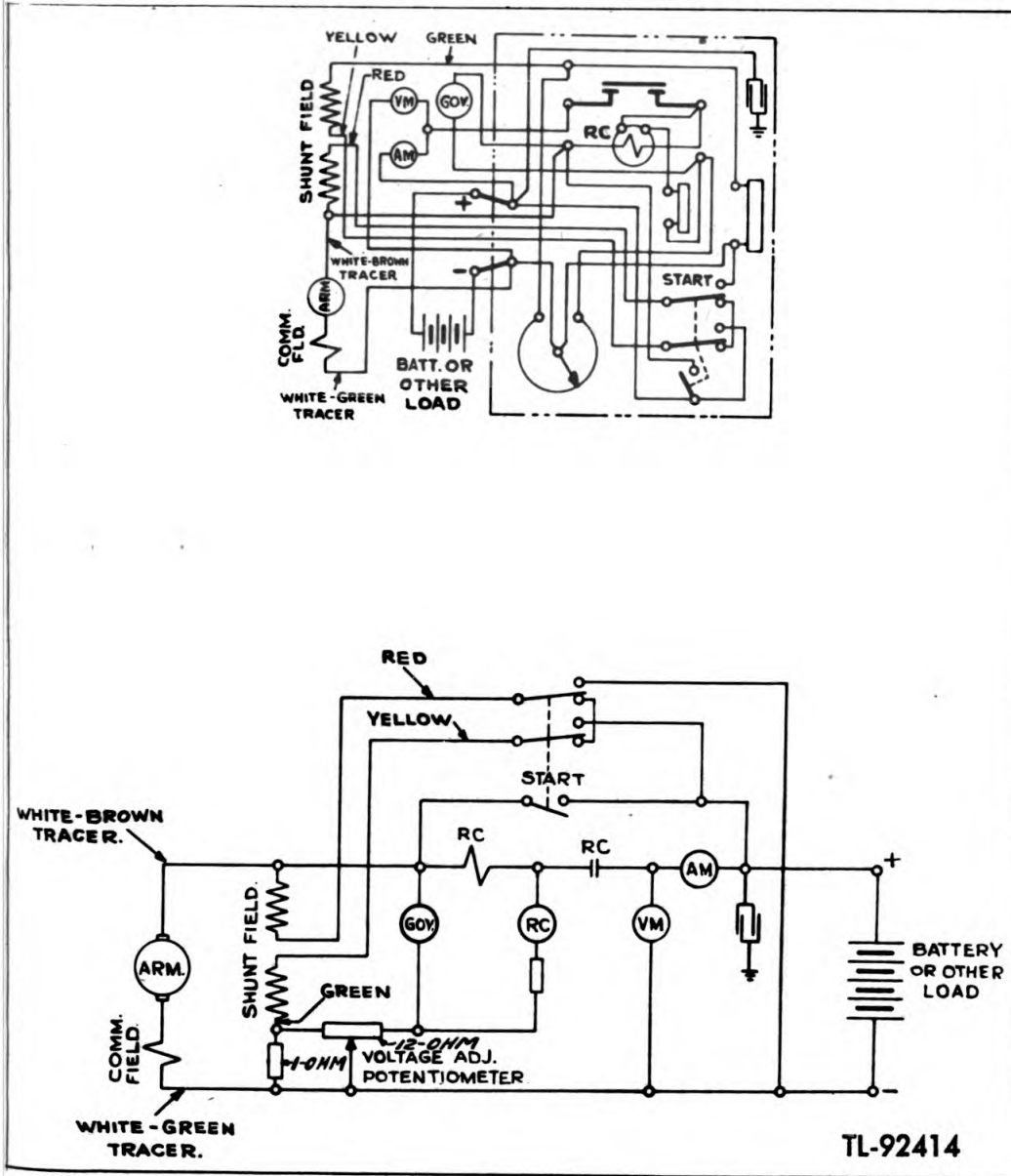
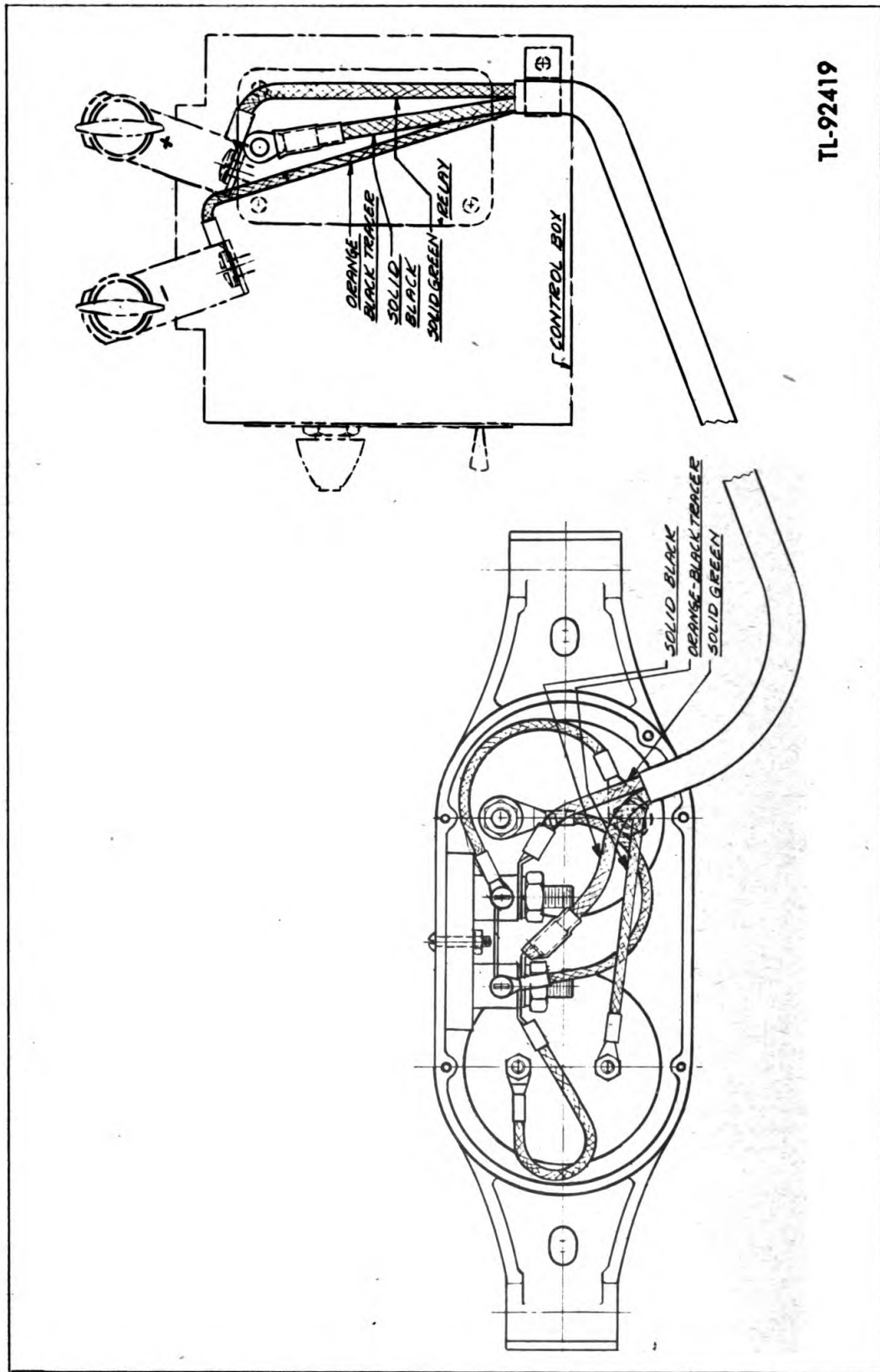

Figure 29. Schematic wiring diagram, control box





TL-92419

Figure 30. Meter box, wiring diagram

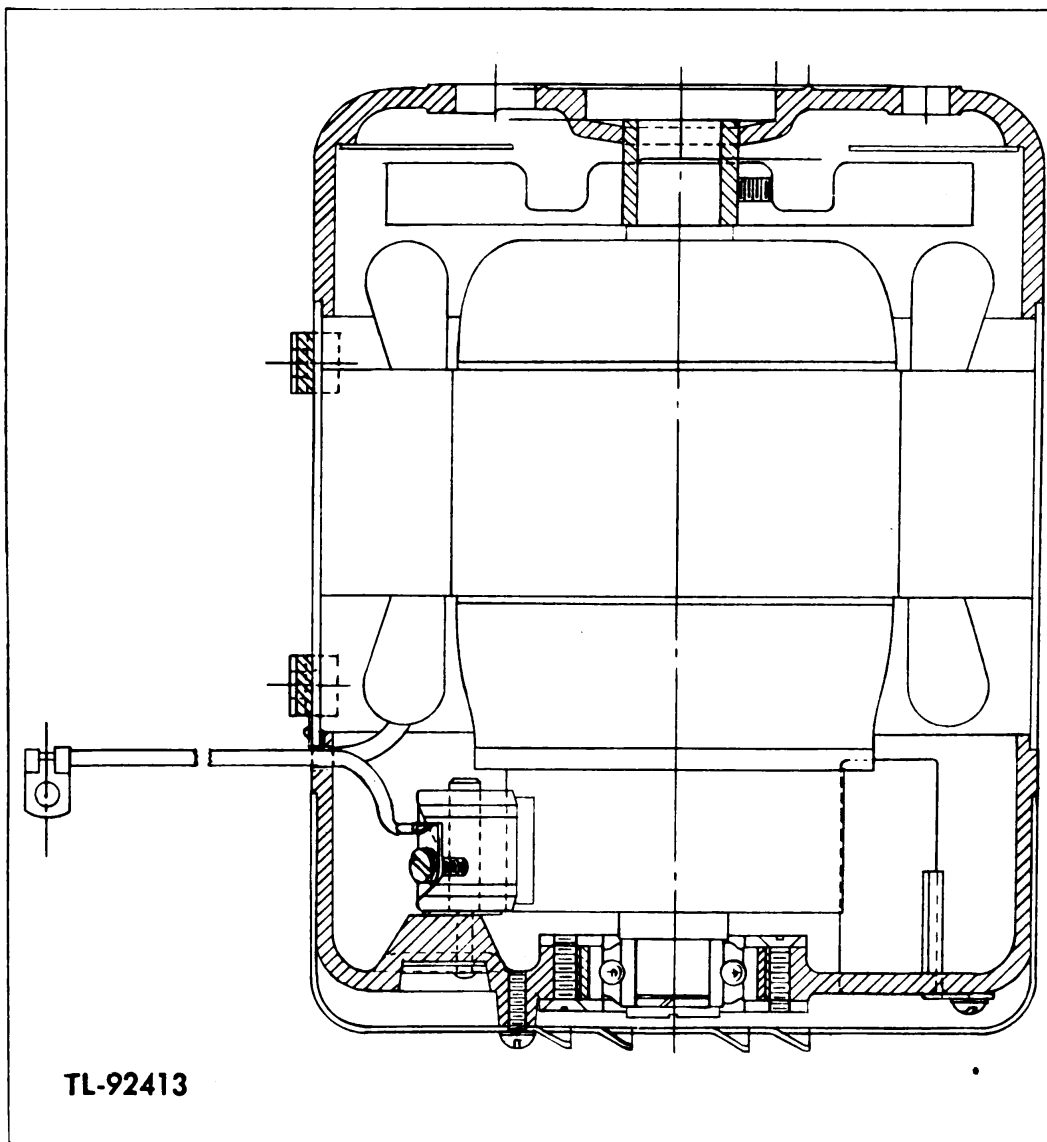
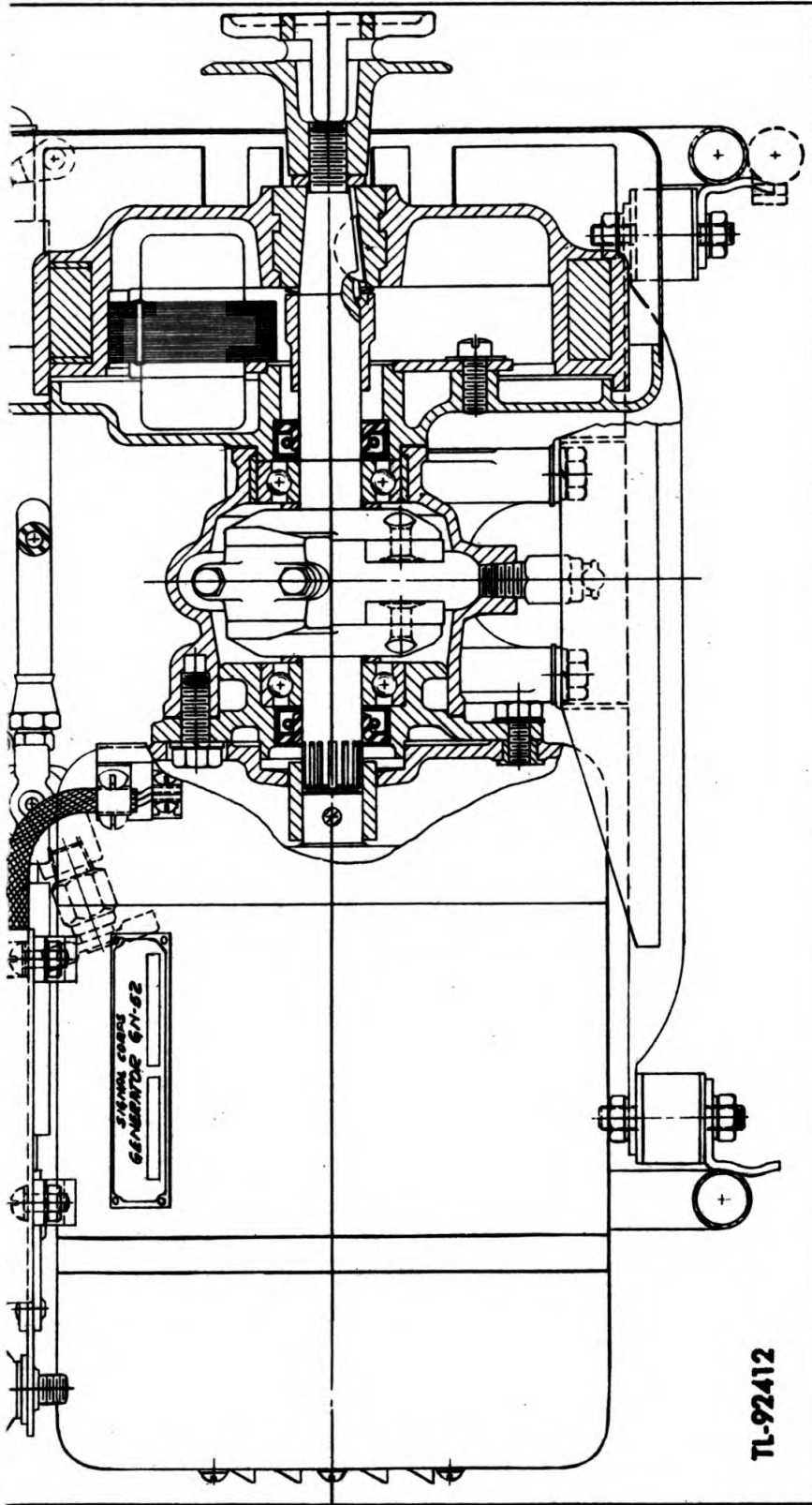

Figure 31. Cross-section drawing of Generator GN-52

Generated on 2015-10-29 12:38 GMT / http://hdl.handle.net/2027/uc1.b3243898  
Public Domain, Google-digitized / http://www.hathitrust.org/access\_use#pd-google



over Unit PE-210 in cross-section

TL-92412

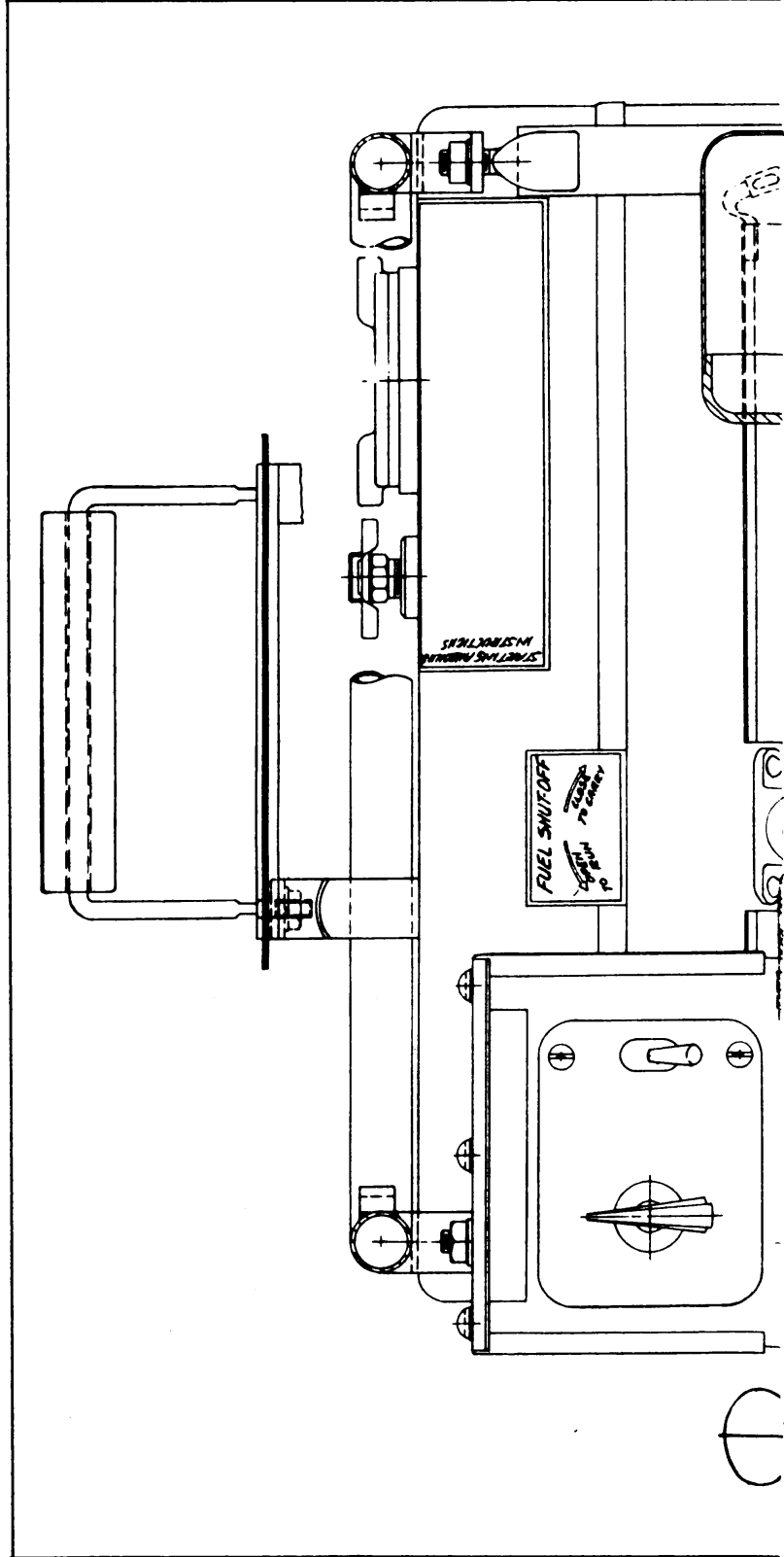
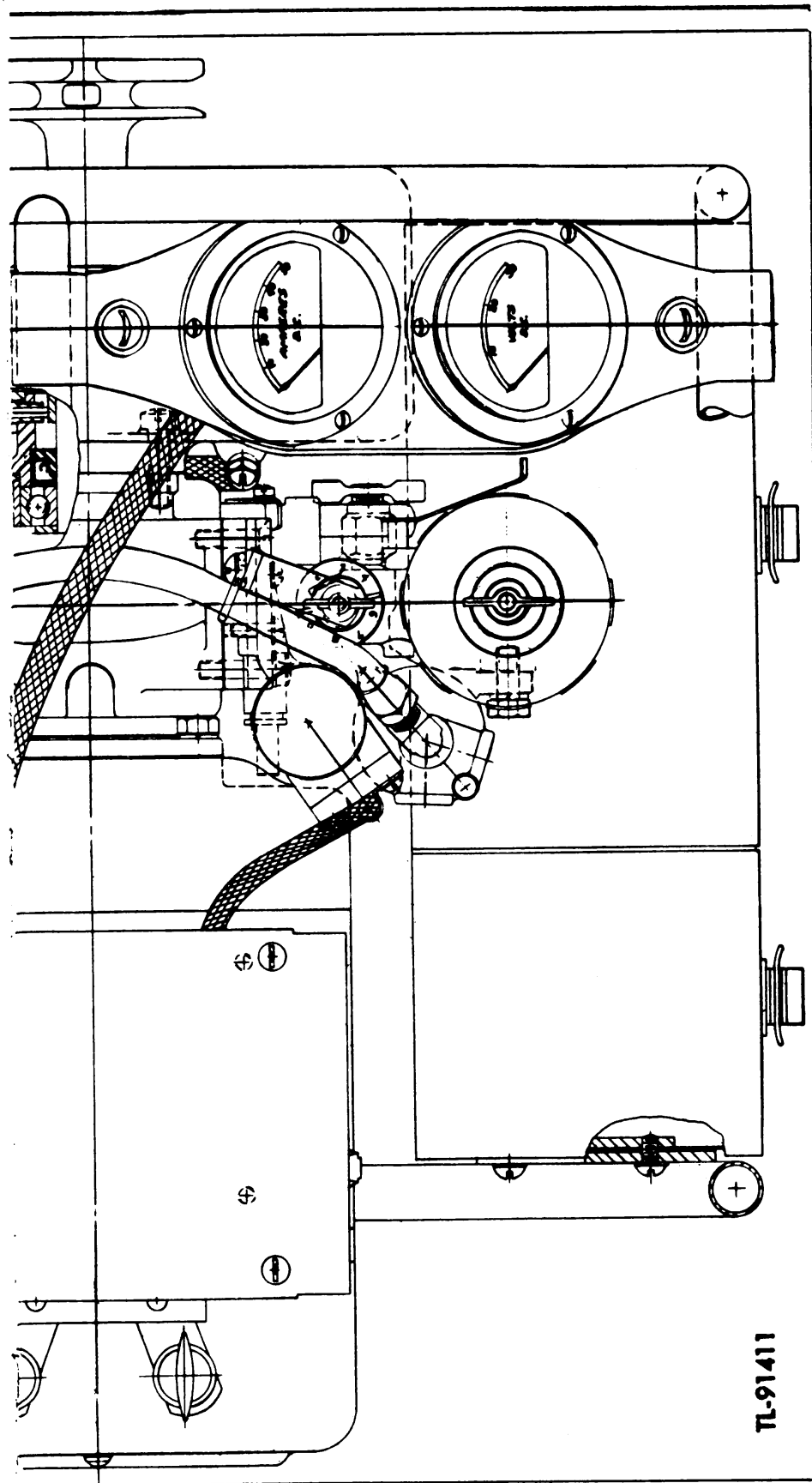

Figure 32. Rear view of P.



er Unit PE-210 in cross-section

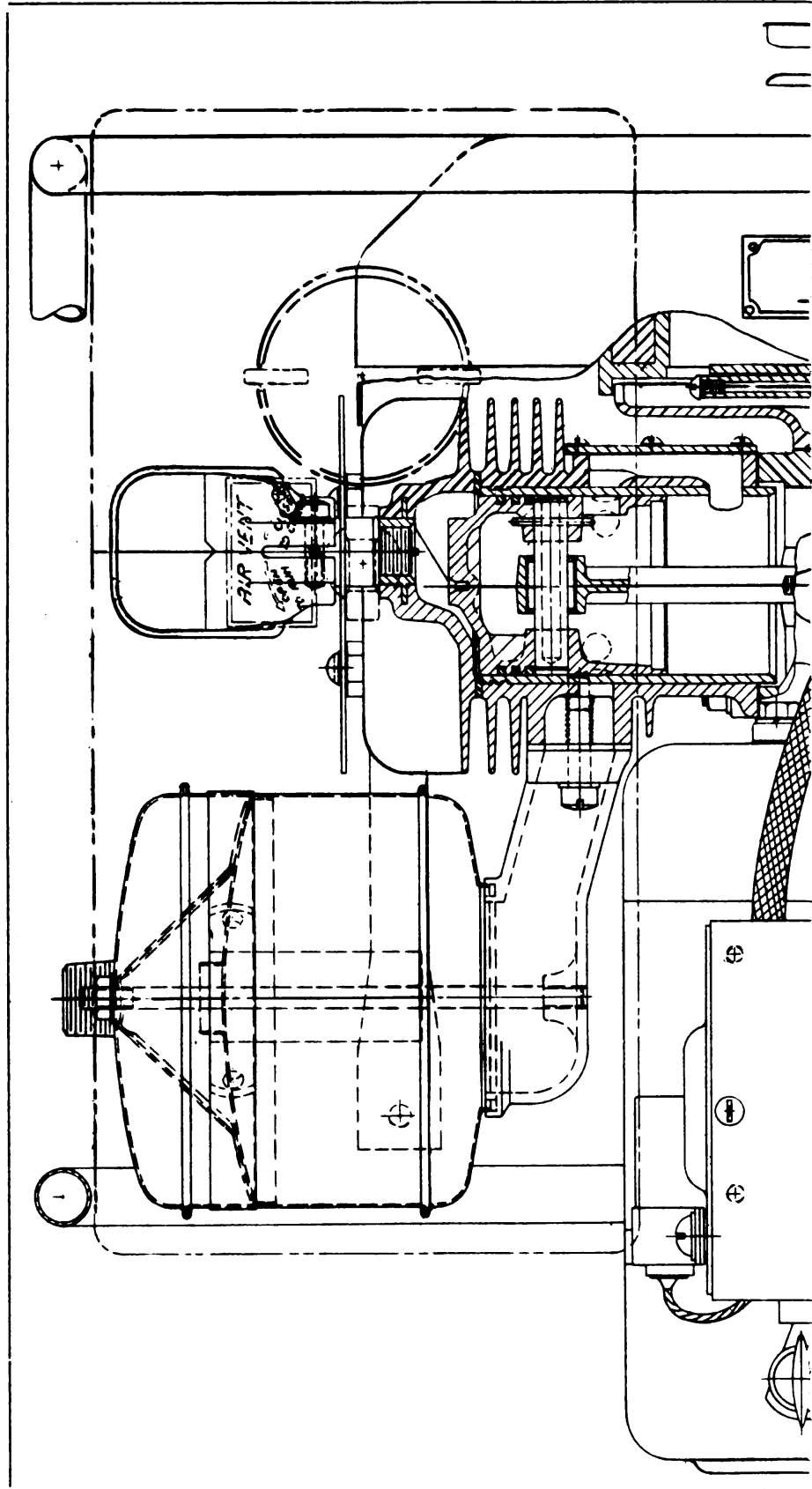
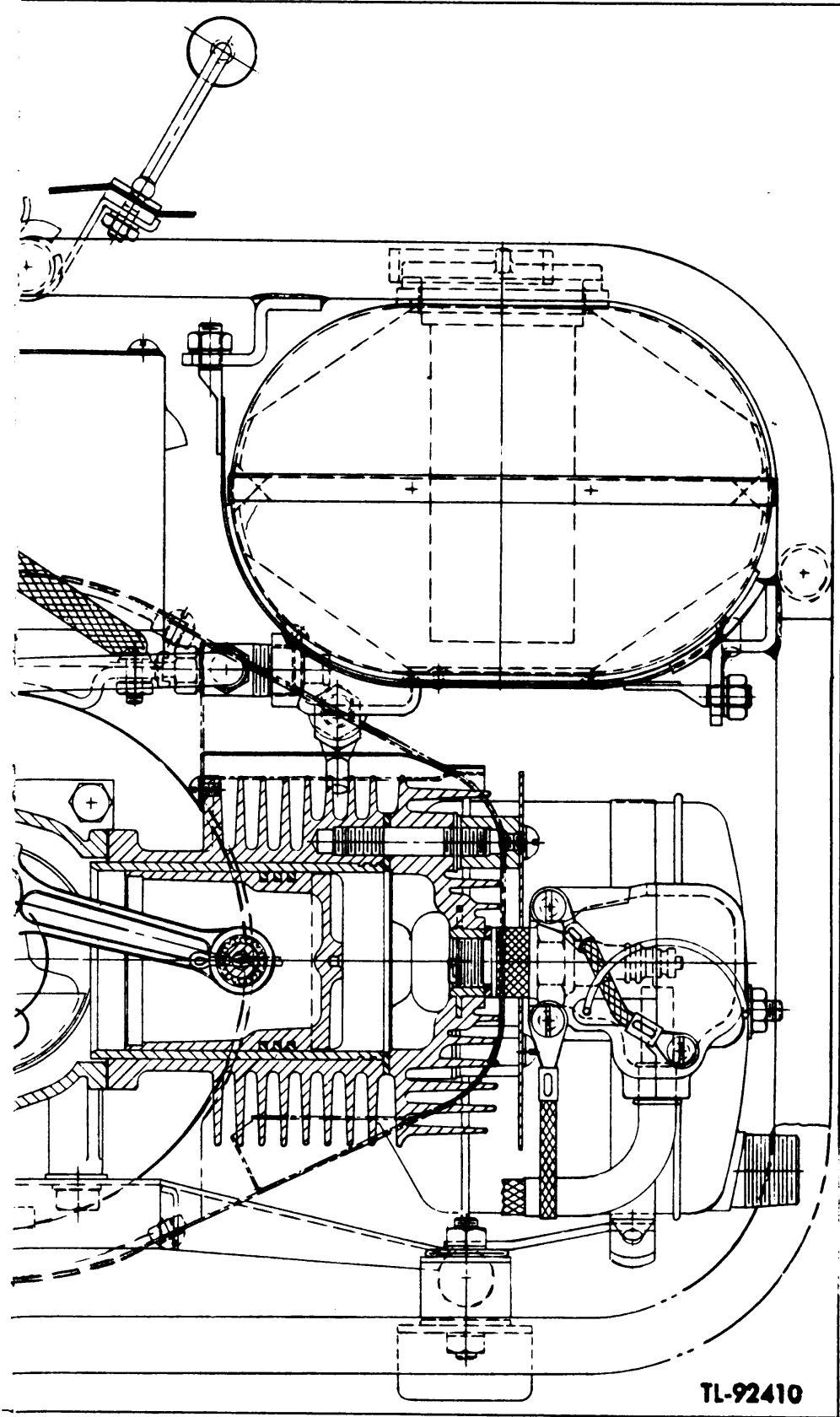

Figure 33. Top view of Pow



er Unit PE-210 in cross-section

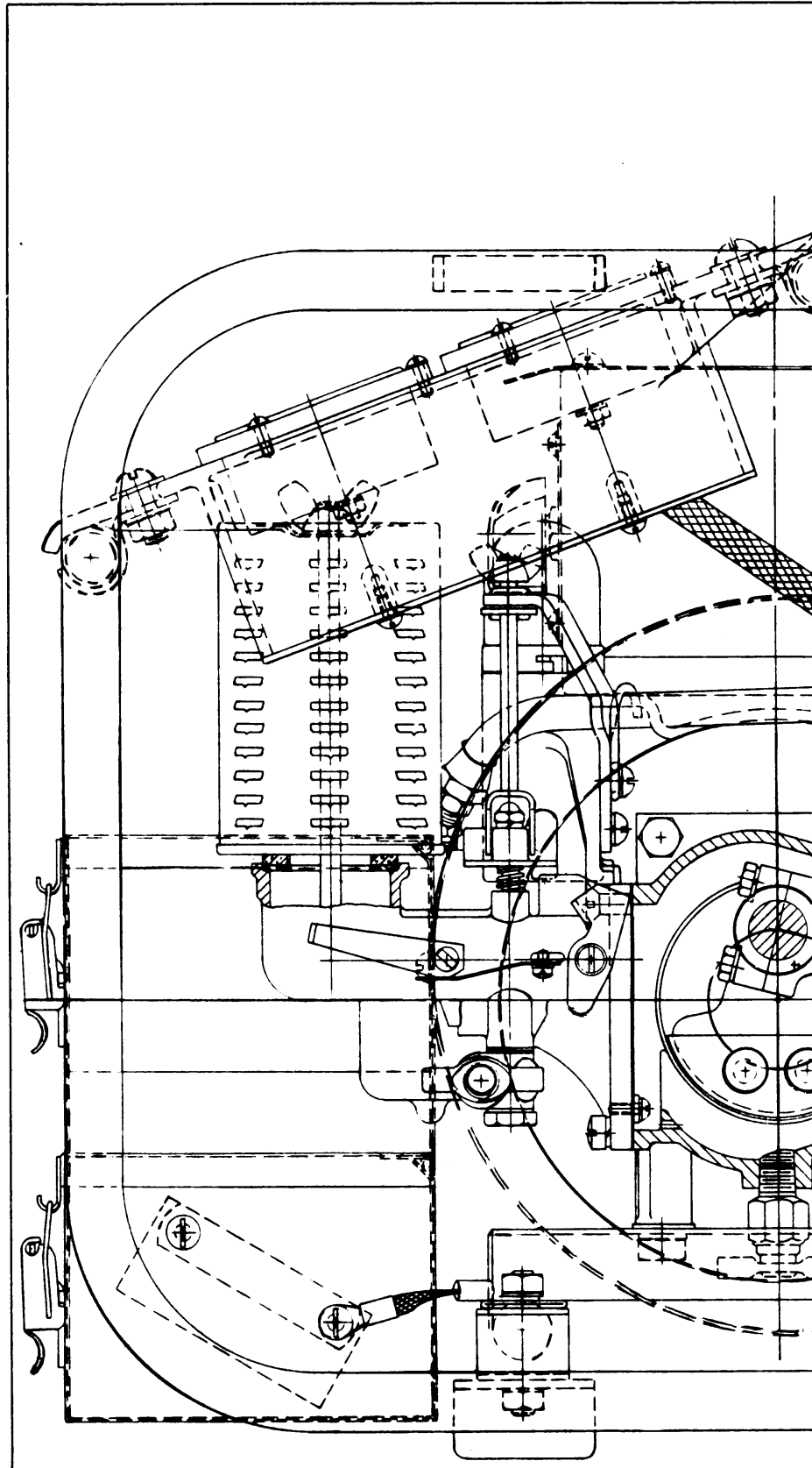

Figure 34. Side view of

Original from  
UNIVERSITY OF CALIFORNIA



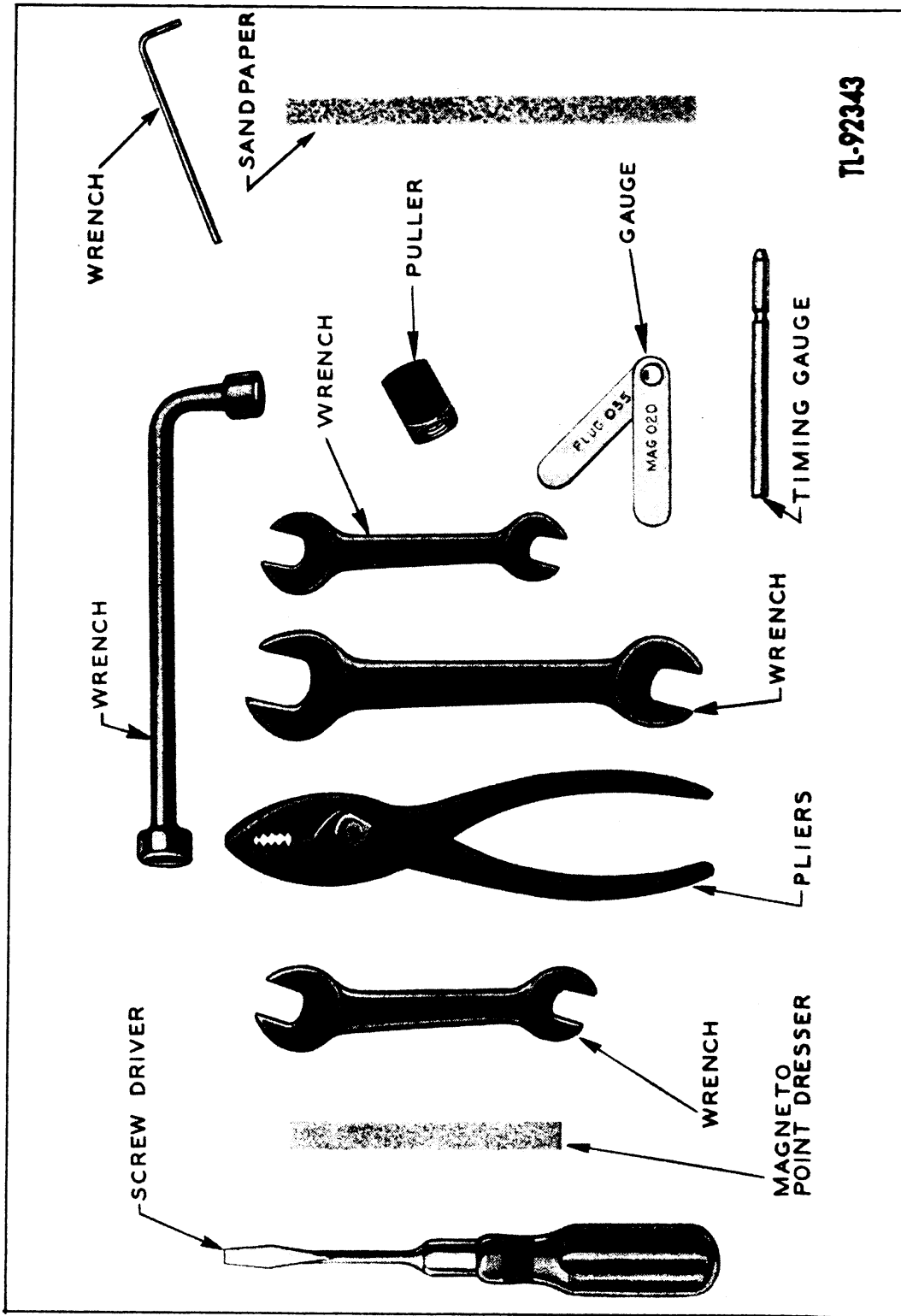
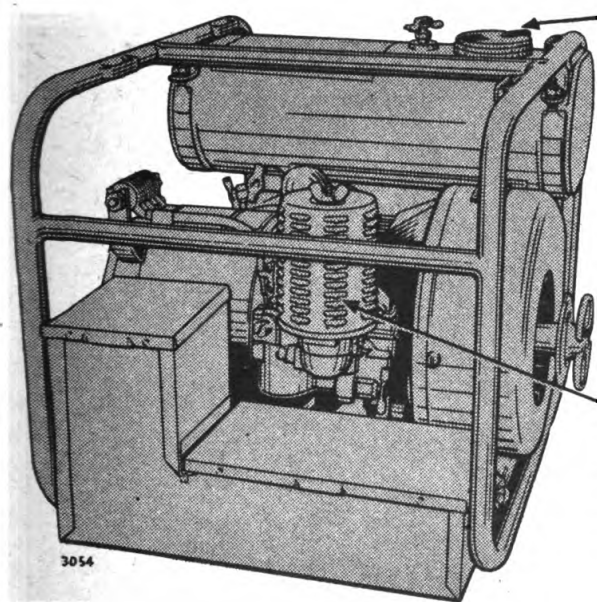

Figure 35. Tools

**WAR DEPARTMENT LUBRICATION ORDER No. 3054**

WAR DEPARTMENT, WASHINGTON 25, D. C., 4 MAY 1944

**POWER UNITS PE-210 & PE-214-B****Fuel Tank**

Fuel mixture—1 part oil to 16 parts gasoline. Oil measure is attached to fuel tank cap. Use 2 full measures of OE to each 1 gallon of gasoline. Mix oil and gasoline thoroughly before pouring into fuel tank. Open fuel tank air vent cock before operating. Every 256 hours, flush fuel tank, clean fuel tank outlet screen and fuel line. **CAUTION:** Do not use gasoline only. Capacity approx. 1 gal.

**Air Cleaner**

Every 64 hours, remove cover and brush dirt accumulations from filter element. Renew filter element when clogged or damaged.

**KEY**

**OE—OIL, engine, SAE 10. All air temperatures.**

**HOURS**—Reduce hours under severe operating conditions.

**DO NOT LUBRICATE**—Generator End Bearing.

**LUBRICATED BY MAINTENANCE PERSONNEL**—Magneto Breaker Cam.

**REFERENCE**—Technical Manual TM 11-947 for Power Unit PE-210; Technical Manual TM 11-945 for Power Unit PE-214-B.

**Requisition LUBRICATION ORDER** from Philadelphia Signal Depot, or Utah ASF Depot, Ogden, Utah by Signal Corps Stock No. 6D10113-54

**No. 3054**

*Copy of this Lubrication Order will remain with the equipment at all times. Instructions contained therein are mandatory and supersede all conflicting lubrication instructions dated prior to 4 May 1944.*

BY ORDER OF THE SECRETARY OF WAR:

G. C. MARSHALL,  
Chief of Staff.

OFFICIAL:

J. A. ULIO,  
Major General,  
The Adjutant General.

TL-92416

Figure 36. War Department Lubrication Order No. 3054

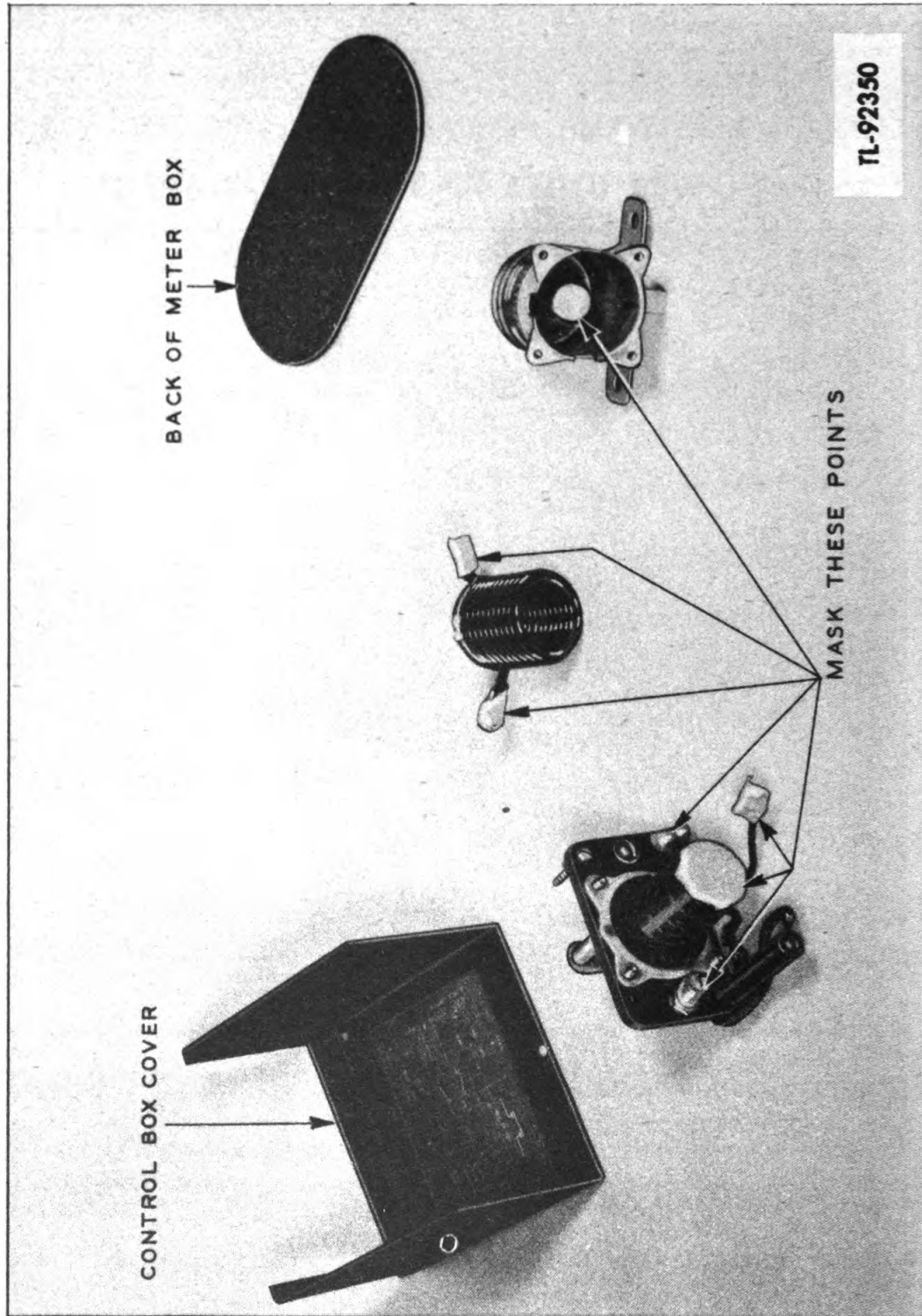

Figure 37. Masking details

