This is a reproduction of a library book that was digitized by Google as part of an ongoing effort to preserve the information in books and make it universally accessible.

Google™ books

<https://books.google.com>



35:9-981

TM 9-981

WAR DEPARTMENT

TECHNICAL MANUAL



MILITARY PYROTECHNICS

May 30, 1942



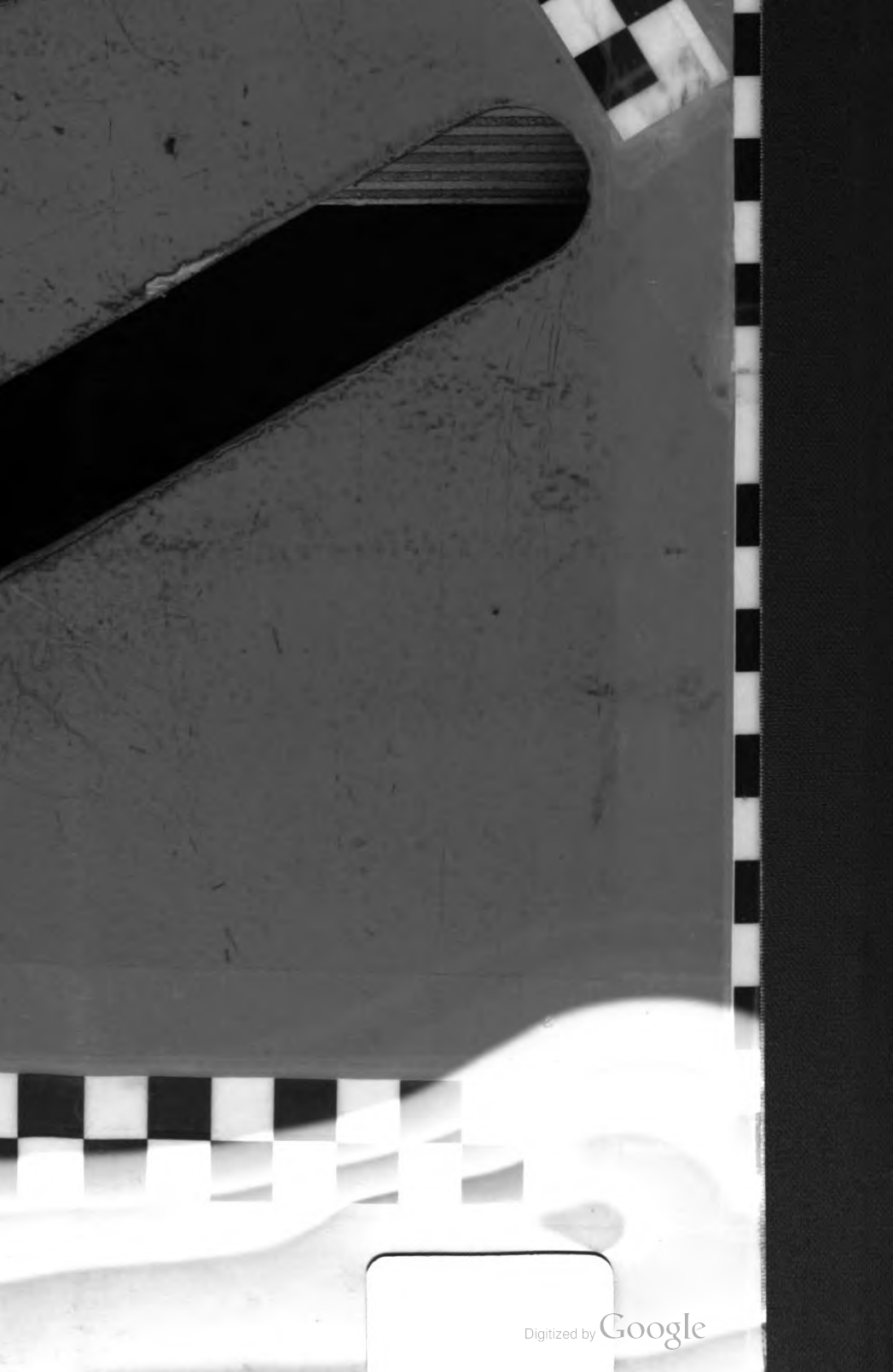

W1.35:9-981

TM 9-981

WAR DEPARTMENT

TECHNICAL MANUAL



MILITARY PYROTECHNICS

May 30, 1942



TECHNICAL MANUAL

MILITARY PYROTECHNICS

CHANGES
No. 1

WAR DEPARTMENT
WASHINGTON, OCT 8 1942

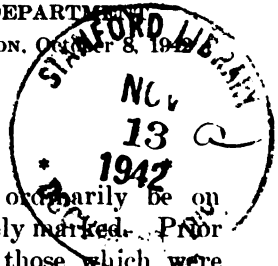

TM 9-981, May 30, 1942, is changed as follows:

13. Care, handling, and preservation.

q. Repacking and storage.—Pyrotechnics will ordinarily be on hand * * * original packings and appropriately marked. Prior to repacking, components will be inspected and those which were originally sealed will be **resealed**. Such ammunition should * * * kept at a minimum.

[A. G. 062.11 (8-14-42).] (C 1, Oct. 8, 1942.)

21. Distinguishability.

Distance of distinguishability, average weather conditions

Type	Candlepower	Day (miles)	Night (miles)
Red star parachute	10,000	0.57	2

[A. G. 062.11 (8-14-42).] (C 1, Oct. 8, 1942.)

23. Packing data.—* * *

TABLE II.—Packing data

Item	Inner container		Packing box					
	Number of rounds	Type	Total rounds	Type	Dimensions (inches)	Square feet	Cubic feet	Weight (pounds)
Signal, aircraft:	*	*	*	*	*	*	*	*
Red star, cluster, M14.	12	Carton	60	W ⁴	24 $\frac{3}{8}$ x 14 $\frac{1}{16}$ x 11 $\frac{1}{2}$.	2.4	2.3	69
Green star, blinker, parachute, M16.	12	do.	60	W ⁴	24 $\frac{3}{8}$ x 14 $\frac{1}{16}$ x 11 $\frac{1}{2}$.	2.4	2.3	61

[A. G. 062.11 (8-14-42).] (C 1, Oct. 8, 1942.)
485003°—42

25. Flare, aircraft, parachute, M26 (with fuze, flare, mechanical time, M111).—*a. Data.*

* * * * *

[A. G. 062.11 (8-14-42).] (C 1, Oct. 8, 1942.)

29½ (added). **Bomb photoflash, M46, unfuzed** (adapted for nose fuze M111).—*a. General.*—This bomb (fig. 9½) is similar in function to the M23A1 except that it is adapted for a time fuze which permits its use for high altitude photography. The fuze is the same model as that used for flare, aircraft, parachute, M26 (par. 25). The bomb is 48.39 inches in length and 8 inches in diameter. It weighs 51.9 pounds as released, including a 25-pound charge of flashlight powder. It is issued unfuzed but with fins and suspension bands assembled. The complete round consists of—

Bomb, photoflash, M46, unfuzed, adapted for nose fuze M111.

Fuze, flare, mechanical time, M111.

Wire, arming, assembly, piece mark 82-3-234GB.

b. Fuzing.—To fuze the bomb proceed as follows:

(1) Remove fuze hole plug and inspect cavity and threads to be sure they are clean and free of foreign material.

(2) Unseal fuze can, remove fuze from packings and inspect it to see that it is not corroded or otherwise unserviceable.

(3) Screw fuze into bomb, hand tight.

(4) Set fuze by loosening thumbscrew and rotating the head until the desired number of seconds is indicated by the marker. Tighten thumbscrew.

(5) Thread arming wire through forward suspension lug, then inner hole of the fuze arming pin, and finally through inner holes of the vane stop. Slip on a safety clip until it just touches the vane. Cut off any excess arming wire, leaving no more than 2 to 3 inches protruding beyond the clip when the bomb is installed in the airplane. Remove all kinks and burs. Remove shipping wire and safety pin.

c. Unfuzing.—If the bomb is not used, it will be unfuzed and returned to storage by reversing the steps in *b* above.

d. Care and precaution in handling.—See paragraphs 13, 25, and 29.

[A. G. 062.11 (8-14-42).] (C 1, Oct. 8, 1942.)

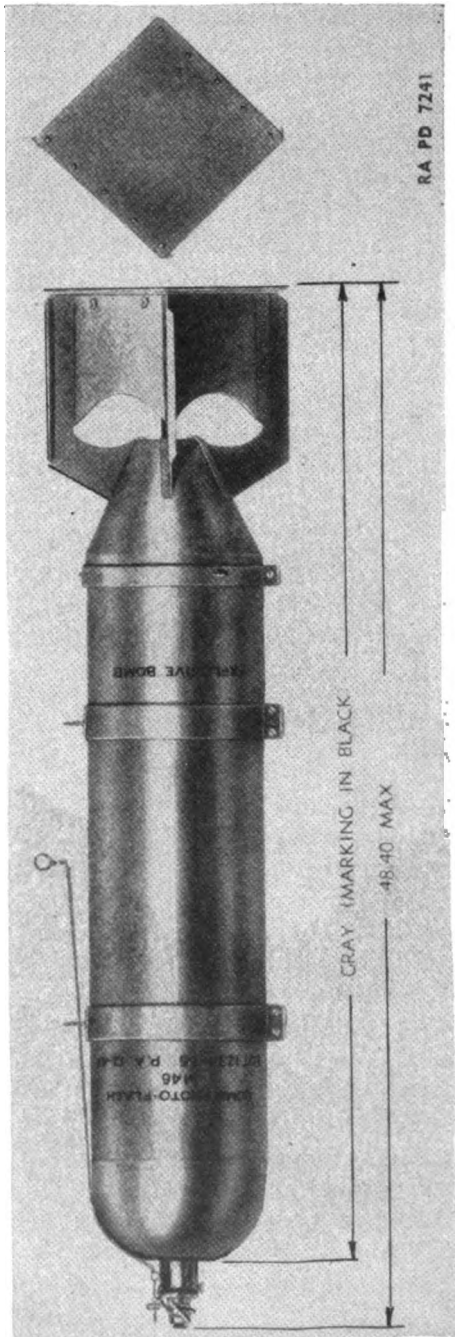

Figure 9 1/4.—Bomb, photoflash, M46.

[A. G. 002.11 (8-14-42).] (C 1, Oct. 8, 1942.)

30. General.—*a.* Aircraft signals (figs. 10 and 10½) are designed to be fired from pistol, pyrotechnic, M2 or M8, and discharger, pyrotechnic, M5. Any of these signals may be fired in the pyrotechnic pistol M8. The pyrotechnic pistol M2 can be used to fire only the AN-M11, and AN-M28 to AN-M36 signals (fig. 10), which are assembled in an aluminum case 1.58 inches in diameter. The pyrotechnic discharger M5 can be used to fire only the AN-M37 to AN-M45 signals which are assembled in a shotgun-type shell, 1.54 inches in diameter and 3.85 inches in length. The signals are identified by the markings on the side and on the identification top (closing wad).

b. Components for signals for use in pistol, pyrotechnic, M2.

* * * * *
 [A. G. 062.11 (8-14-42).] (C 1, Oct. 8, 1942.)

31. Signals, aircraft (for pistol, pyrotechnic, M2).

* * * * *
 [A. G. 062.11 (8-14-42).] (C 1, Oct. 8, 1942.)

31½ (added). Signals, aircraft, double star, and single star, AN-M37 to AN-M45.—*a. Signals, aircraft, double star, AN-M37 to AN-M42.*—(1) *General.*—These signals (fig. 10½) are assembled in a shotgun-type shell of cartridge paper with a brass head. The signal cartridge is 3.85 inches in length by 1.537 inches in diameter. They are designed for use in the breech loading projector, pyrotechnic, M8, or the six-round discharger, pyrotechnic, M5. When it is fired, the propelling charge ignites and projects two freely falling stars of the same or different colors which burn for 7 to 13 seconds. The colors and intensity of the stars are as follows:

- Red—25,000 candlepower minimum.
- Yellow—20,000 candlepower minimum.
- Green—12,000 candlepower minimum.

- (2) *Models.*—The following signals are provided:
- Signal, aircraft, double star, red-red, AN-M37.
 - Signal, aircraft, double star, yellow-yellow, AN-M38.
 - Signal, aircraft, double star, green-green, AN-M39.
 - Signal, aircraft, double star, red-yellow, AN-M40.
 - Signal, aircraft, double star, red-green, AN-M41.
 - Signal, aircraft, double star, yellow-green, AN-M42.

b. Signals, aircraft, single star, AN-M43-45.—(1) *General.*—These signals are similar to those described above except that each cartridge produces one star instead of two. The cartridge is the same size and is for use in the same projectors. The stars have the same burning time and intensity.

MILITARY PYROTECHNICS

(2) *Models.*—The following signals are provided:

Signal, aircraft, single star, red, AN-M43.

Signal, aircraft, single star, yellow, AN-M44.

Signal, aircraft, single star, green, AN-M45.

c. Marking.—The cartridge case is natural color, marked in black with the type and model of signal, the ordnance insignia, lot number, manufacturer's symbol, and date of loading. Around the case of double star signals two $\frac{1}{4}$ -inch bands are marked, each the color of one of the stars. The color of each of the stars is also marked on one-half of the identification top and the name of the color is stenciled thereon in black. Single star signals are similarly marked except that the single band around the case is $\frac{1}{2}$ inch wide and the identification top is solid color.

d. Packing.—Double star and single star signals of this type are packed 12 per carton, 12 cartons per box, $28\frac{1}{8}$ by $13\frac{1}{16}$ by $12\frac{1}{32}$ inches. The weight of the box with signals is as follows:

Signal, aircraft, double star, red-red, AN-M37—87.5 pounds.

Signal, aircraft, double star, yellow-yellow, AN-M38—87.5 pounds.

Signal, aircraft, double star, green-green, AN-M39—98.3 pounds.

Signal, aircraft, double star, red-yellow, AN-M40—87.5 pounds.

Signal, aircraft, double star, red-green, AN-M41—92.9 pounds.

Signal, aircraft, double star, yellow-green, AN-M42—92.9 pounds.

Signal, aircraft, single star, red, AN-M43—75.8 pounds.

Signal, aircraft, single star, yellow, AN-M44—74.6 pounds.

Signal, aircraft, single star, green, AN-M45—83.4 pounds.

[A. G. 062.11 (8-14-42).] (C 1, Oct. 8, 1942.)

36. General.—Flares are used by troops on the ground to provide illumination for airplane landings at emergency landing fields or in case of power failure at airports. **Illuminating shell are provided for illumination of targets and objectives, or other tactical use.**

[A. G. 062.11 (8-14-42).] (C 1, Oct. 8, 1942.)

$37\frac{1}{2}$ (added). Shell, illuminating, 60-mm, M83, with fuze, time (fixed), M65.—*a. General.*—This pyrotechnic item is provided for the illumination by ground troops of objectives not within range of other flares. It consists of a shell for the 60-mm mortar which contains a flare candle and a parachute and is equipped with a time fuze which ignites the flare and expels the assembly 14 seconds after firing.

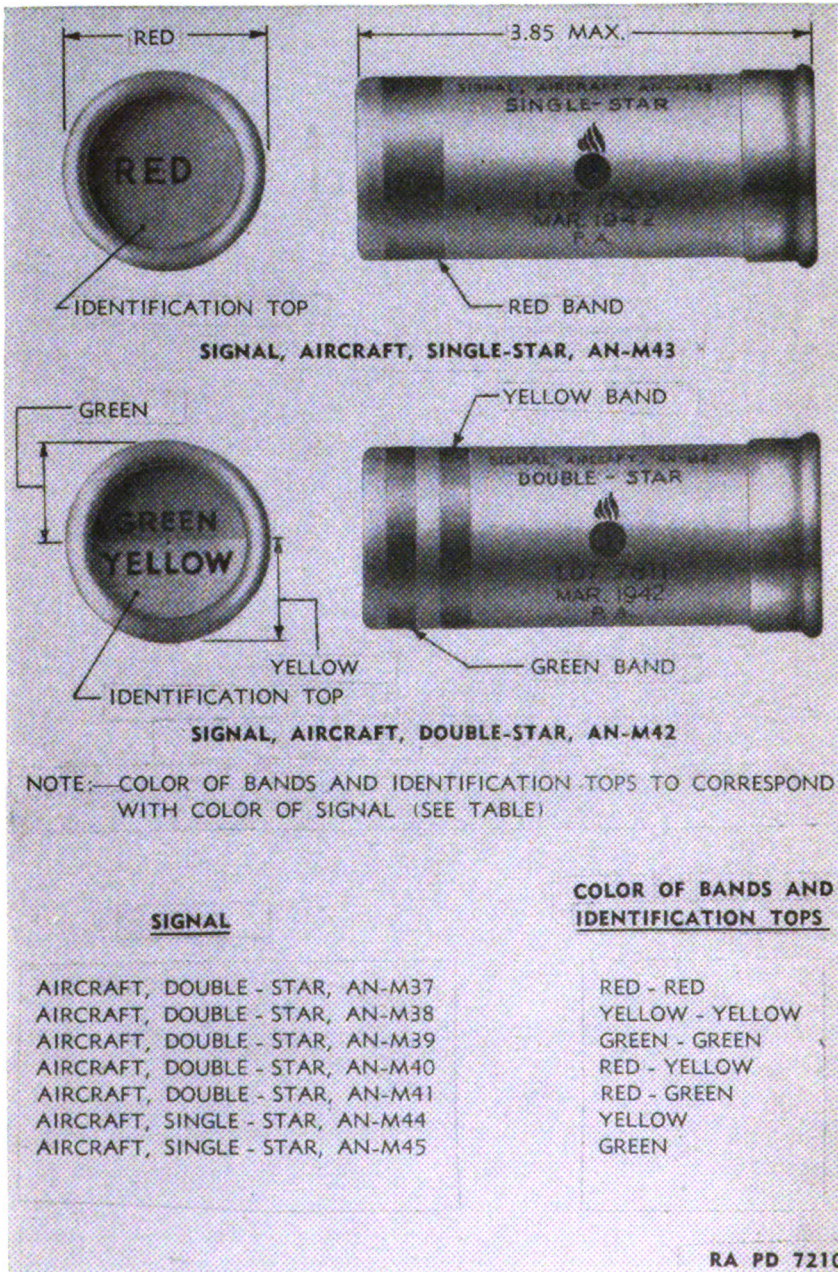

Figure 10½.—Aircraft signals (cartridge type).

[A. G. 062.11 (8-14-42).] (C 1, Oct. 8, 1942.)

b. Description.—This illuminating shell (fig. 12½) is 14.25 inches over-all in length and 2.33 inches in diameter. It weighs 3.7 pounds as fired. At the fuze end there is a ring which is provided for ease in extracting the safety pin. (This pin will be removed just before firing and at no other time.) Nested in the fins of the tail are four propellant increments in the form of bundles of square powder flakes. The hollow tail contains the ignition charge, which is held in place by the primer assembly. Sixteen ventholes allow escape of the propelling and igniting gases from the ignition charge.

c. Function.—The safety pin is removed from the fuze and the shell inserted fin first into the muzzle of the mortar and the loader's hands promptly removed. The shell slides by gravity down the mortar tube and the primer strikes the fixed firing pin, igniting the cartridge. The propelling charge burns, projecting the shell. At the instant of firing, a set-back element in the fuze acts to ignite the powder time train, which burns for 14 seconds and then ignites a black powder expelling charge which, in turn, ignites the candle and expels the candle and parachute assembly from the base of the shell body. The candle burns for a minimum of 25 seconds with a light of 110,000 candlepower, dropping meanwhile at a rate of approximately 10 feet per second.

NOTE.—The ballistic properties of this round are markedly different from those of service shell for the 60-mm mortar and the shell will not illuminate the target of HE shell fired with the same zone and elevation.

d. Precautions.—In addition to the precautions listed in paragraph 13, the following will be observed (see also FM 23-85):

(1) The safety pin in the fuze will be removed just before firing and at no other time. If the round is not fired or if the primer misfires and the round is removed from the mortar, the pin will be replaced.

(2) The shear wire which appears just below the safety pin in the nose of the fuze should not be disturbed. This is a fine wire which passes through the fuze and has its ends twisted together on the outside. If this wire is broken or missing, the round should not be used.

e. Painting and marking.—In common with other pyrotechnics this shell is painted gray and marked in black with the type and model of shell, mortar from which fired, filler, and lot number. The fuze is stamped on the flange with the type and model, manufacturer's symbol, lot number and date of loading. The complete round is packed one per fiber container, six such containers per outer container, three outer containers—18 rounds in all—per bundle. (See also SNL R-4.)

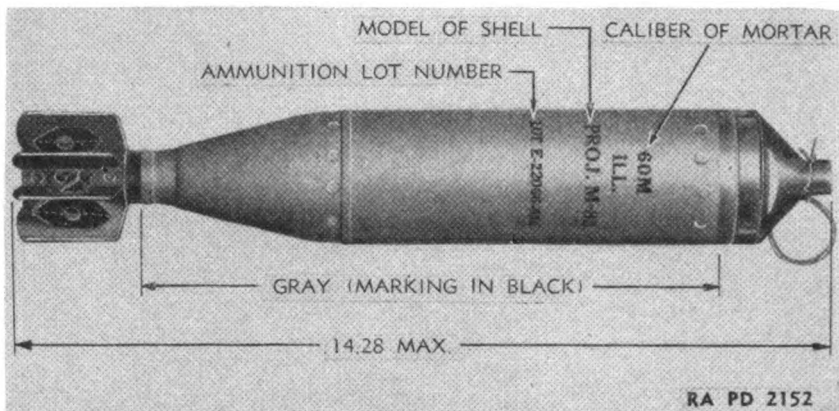

Figure 12 1/2.—Shell, illuminating, 60-mm, with fuze, time, fixed, M65.

[A. G. 062.11 (8-14-42).] (C 1, Oct. 8, 1942.)

38. Signals, ground.

* * * * *

b. *Operation.*—Operation is similar * * * to an altitude of 600 feet. The fuze is designed to burn 5.5 seconds—permitting the case to attain maximum altitude—before igniting the signal and expelling the signal assembly from the case.

c. *Types.*

* * * * *

(8) Signal, ground, range indicating, parachute, M47 (fig. 13 1/2), produces two stars supported by a parachute and separated by an interval of 72 feet. It functions at a height of 500 feet and burns for approximately 30 seconds, each star producing a white light of 3,800 candlepower. The range from observer to the signal may be computed from the angular interval between the stars.

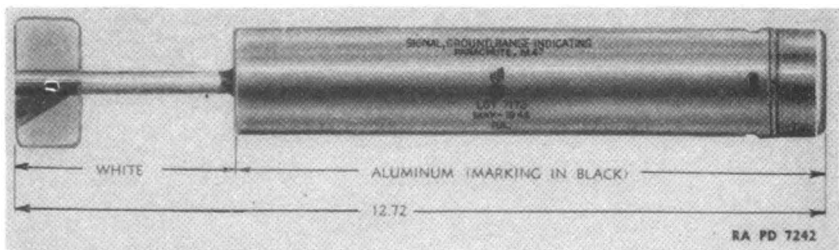

Figure 13 1/2.—Signal, ground, range indicating, parachute, M47.

[A. G. 062.11 (8-14-42).] (C 1, Oct. 8, 1942.)

d. Rescinded.

* * * * *

f. *Marking.*—Ground signals are identified by the marking on the packing and on the item itself.

(1) Rescinded.

(2) Rescinded.

* * * * *

[A. G. 062.11 (8-14-42).] (C 1, Oct. 8, 1942)

39. Lights, signal, Very, Mk. II.—*a. General.*—These signals resemble shotgun shells in appearance and are designed to be fired from the pistol, Very, 10-gage, Mk. III (fig. 14) or **M5**. Each cartridge produces a single star which, on firing, ignites almost immediately, burning as it rises to a height of 200 feet.

* * * * *

[A. G. 062.11 (8-14-42).] (C 1, Oct. 8, 1942.)

BY ORDER OF THE SECRETARY OF WAR:

G. C. MARSHALL,
Chief of Staff.

OFFICIAL:

J. A. ULIO,
Major General,
The Adjutant General.

MILITARY PYROTECHNICS

CHAPTER 1. General.	
SECTION I. Introduction	Paragraphs 1
II. General discussion.....	2-15
III. Visibility.....	16-19
IV. Tables of pyrotechnic data.....	20-23
CHAPTER 2. Aircraft types.	
SECTION I. Flares	24-28
II. Photoflash bombs.....	29
III. Signals.....	30-35
CHAPTER 3. Ground types.	
SECTION I. Flares	36-37
II. Signals.....	38-39
APPENDIX. List of references	Page 42
INDEX	44

CHAPTER 1

GENERAL

SECTION I. Introduction	Paragraphs 1
II. General discussion.....	2-15
III. Visibility.....	16-19
IV. Tables of pyrotechnic data.....	20-23

SECTION I

INTRODUCTION

Scope	Paragraph 1
--------------------	----------------

1. **Scope.**—*a.* This manual is published for the information and guidance of the using arms and services.

b. This manual provides information of a technical nature regarding the identification, properties, care, and use of military pyrotechnics.

SECTION II

GENERAL DISCUSSION

	Paragraph
General.....	2
Nomenclature.....	3
Classification.....	4
Pyrotechnic compositions.....	5
Identification.....	6
Model.....	7
Ammunition lot number.....	8
Ammunition data card.....	9
Painting and marking.....	10
Priority of issue.....	11
Expiration date.....	12
Care, handling, and preservation.....	13
Packing and marking for shipment.....	14
Field report of accidents.....	15

2. General.—*a.* The term pyrotechnics as used herein will be understood to mean military pyrotechnics (fig. 1). Pyrotechnics are modifications of fireworks designed to produce a brilliant light for illumination or colored lights and smokes for signaling. Some types of pyrotechnics are projected from or used on the ground; others are released or fired from airplanes.

b. Signaling may involve sending messages—

- (1) From aircraft to other aircraft or to ground units.
- (2) From ground troops to other ground units or to aircraft.

c. Illumination may be necessary for—

- (1) Reconnaissance.
- (2) Observation.
- (3) Bombardment.
- (4) Landing of airplanes and of parachute troops.

3. Nomenclature.—*a. General.*—Standard nomenclature is established in order that each item supplied by the Ordnance Department may be identified specifically by name. The nomenclature of pyrotechnic items is published in Standard Nomenclature Lists (SNL's) of group S. For all purposes of record, except as noted in *b* below, the use of this nomenclature is mandatory. Standard nomenclature will be used for specific items in this manual.

b. Ammunition identification code (A. I. C.).—To facilitate reporting, requisitioning, and record-keeping in the field, each complete round and each item of issue is assigned a 5-character code symbol. These symbols and information concerning their use may be found in the SNL's, OFSB 3-14, and FM 9-6.

4. Classification.—*a.* According to use, pyrotechnics are classified as—

(1) Aircraft types—for use from aircraft.

(2) Ground types—for use on the ground.

b. They are further classified according to purpose as—

(1) Illuminants, which provide light for an appreciable time; flares, or an instantaneous flash for night photography; and photo-flash bombs.

(2) Signals, which produce lights of various colors and arrangements for the conveyance of messages.

c. Any of the above types when provided with parachutes are known as parachute types.

5. Pyrotechnic compositions.—*a.* Pyrotechnic compositions consist of a mixture of chemical elements and compounds. On burning they produce illumination which ranges in intensity from the “dark fire” used as an element of blinker signals to the brilliant flash of photoflash bombs. Standard pyrotechnic compositions, in general, consist of compounds to provide oxygen for burning, such as chlorates and nitrates; aluminum or magnesium for fuel; salts of barium, copper, or strontium for color, and agents such as asphalt and paraffin for binding and waterproofing.

b. Pyrotechnics generally function by means of an igniter train similar to the explosive train. In general, ignition is initiated by a primer mixture and intensified by a “first-fire composition” which properly ignites the luminous candle.

6. Identification.—*a.* Each pyrotechnic item is completely identified by the painting and marking (which includes the ammunition lot number) and the accompanying data card. The marking includes all information necessary for the intelligent handling, storage, and use of the item. It is placed on all containers and, where the size of the item permits, on the item itself.

b. In addition to the standard markings, varieties of one type of signal carry, as a means of identification among themselves, additional marking as follows:

(1) Aircraft signals are distinguished by the color and embossing on the identification top (outer wad). (See par. 31 and fig. 10.)

(2) Standard ground signals are distinguished by the color and embossing on the fin. Older signals are distinguished by the color and embossing on the identification top. (See par. 38 and fig. 13.)

(3) Very signals are distinguished by the color and shape of the outer wad. (See par. 39 and fig. 14.)

7. Model.—To distinguish a particular design, a model designation is assigned at the time the model is classified as an adopted type. This model designation becomes an essential part of the standard nomenclature and is included in the marking on the item. Prior to July 1, 1925, it was the practice to assign mark numbers. The word "Mark," abbreviated "Mk.," was followed by a roman numeral, for example: light, signal, Very, Mk. II, 10-gage. The first modification of a model was indicated by the addition of MI to the mark number, the second by MII, etc. The present system of model designations consists of the letter M followed by an arabic numeral. Modifications are indicated by adding the letter A and appropriate arabic numerals. Thus M8A1 indicates the first modification of an item for which the original model designation was M8. Certain items have been adopted for use by both Army and Navy. These are designated by the letters AN preceding the mark or model number.

8. Ammunition lot number.—When ammunition is manufactured, an ammunition lot number, which becomes an essential part of the marking, is assigned in accordance with pertinent specifications. This lot number is stamped or marked on every item of ammunition unless the item is too small, on all packing containers, and on the accompanying ammunition data card. It is required for all purposes of record, including reports on condition, functioning, and accidents in which the ammunition is involved. To provide for the most uniform functioning, all of the components in any one lot are manufactured under as nearly identical conditions as practicable. Thus, for example, when one ammunition lot of signal, ground, white star, parachute, M17, is manufactured, all required components such as the primer, propelling charge, illuminant candle, etc., are from only one lot of each of these components.

9. Ammunition data card.—A 5- by 8-inch card, known as an ammunition data card, is packed in each packing box with the ammunition, or in each fiber container. When required, assembling and firing instructions are printed on the reverse side of the card.

10. Painting and marking.—*a. Painting.*—Ammunition is painted to prevent rust and to provide, by the color, a ready means of identification as to type. Pyrotechnics, except those which have an outer covering or case of aluminum, are painted gray and marked in black. Other chemical ammunition is also painted gray; but markings and bands—red, green, purple, or yellow—indicate the kind of chemical filler and serve to distinguish between other types of chemical ammunition and pyrotechnics.

b. Marking.—Pyrotechnics are marked in such a way as to provide positive identification for all purposes. Each item is marked to show the type and model, ammunition lot number, manufacturer's initials or symbol, date of manufacture, and, where required, limiting date for use.

c. Overage flares assigned to training will have a blue band approximately 2 inches wide painted around the body immediately below the label. The flares may also be stenciled "For training use only." Those assigned to use as substitutes for airport flares will be stenciled "Substitute for flare, airport, M13."

d. For the information of those installing pyrotechnics in airplanes, the word "Front" is stenciled on the front of the case and the location of suspension bands is indicated by black bands painted on the case.

11. Priority of issue.—Subject to special instructions from the Chief of Ordnance, ammunition of appropriate type and model will be used in the following order: limited standard, substitute standard, standard. Within this rule, ammunition which has had the longest or least favorable storage will be used first. Among lots of equal age, priority will be given to the smallest lot. Further information will be found in OFSB 3-1 and 3-9 and in AR 775-10.

12. Expiration date.—Some pyrotechnics deteriorate in storage. The serviceable life of these items is indicated in the marking. When the serviceable life has expired, pyrotechnics which are otherwise serviceable will be assigned to training or other use as prescribed in OFSB 3-9.

13. Care, handling, and preservation.—Pyrotechnics contain material of an intrinsically hazardous nature. Special precautions for certain pyrotechnics are prescribed in chapters 2 and 3. In general, the following regulations will be observed:

a. Moisture.—The functioning of pyrotechnics is affected by moisture. Pyrotechnics are packed in moisture-proof and hermetically sealed containers. The seals of such packings should not be broken until just before the item is to be used. If pyrotechnics are exposed to moisture, they should be segregated from all other material until an examination has been made to make sure that they are serviceable and not dangerous. Containers which show signs of dampness or moisture will be opened and if there is any evidence of moisture on the pyrotechnics they will be destroyed by authorized and experienced personnel.

b. Handling.—(1) Besides the hazardous pyrotechnic compositions, pyrotechnics are composed of sensitive elements, such as fuzes, fric-

tion compositions, and primers. Disassembly of pyrotechnics or components is prohibited. Pyrotechnics should be handled with care and protected against shock; boxes should not be dropped or thrown. Boxes containing signal cartridges, which are discharged by percussion primers, should be placed flat with top up. Protective or safety devices should not be removed until just before use. Care should be exercised to avoid damage to fiber cases and parachute pull-out cords.

(2) Pyrotechnics, especially the type which are projected, should be so handled as to avoid denting or deforming the barrel or case. Pyrotechnics which are seriously dented or deformed will not be used.

c. Storage.—Pyrotechnics should be stored in a dry, well-ventilated place, out of the direct rays of the sun, and protected against excessive or variable temperatures. Pyrotechnics should not be stored with other kinds of ammunition, except with small-arms ammunition. When storage space is limited, pyrotechnics, except photoflash bombs, may be stored with burning type chemical ammunition (group D) provided that the total quantity of pyrotechnic, chemical, and explosive material in the magazine does not exceed 1,000 pounds. Photoflash bombs will not be stored with other types of ammunition except that under conditions of limited storage space they may be stored in one magazine with small-arms ammunition, provided the total amount of explosives and flashlight powder does not exceed 1,000 pounds. Red and green light pyrotechnics contain compositions which may explode under certain conditions and hence should be stored separately if practicable. Certain pyrotechnics deteriorate in storage and have an expiration date on the containers. Care should be taken to observe the directions for disposal of this material at the time indicated as prescribed in OFSB 3-9. Smoking will not be permitted in places where pyrotechnics are stored. Matches or flame or spark-producing articles will not be permitted in magazines and only approved lights will be used. Precautions should be taken to prevent fires and adequate fire-fighting apparatus should be available.

d. Fires.—(1) Pyrotechnics such as photoflash bombs and high burst ranging signals explode when heated, but most types burn with an intense heat and without serious explosions. Water should not be used to combat fires involving material containing magnesium.

(2) The incendiary effect of pyrotechnic material should be kept in mind in using such material in the vicinity of dry brush and grass.

e. Serviceability.—Pyrotechnics and components will be maintained in serviceable condition. Those pyrotechnics whose service-

ability is uncertain will be tested. Length of serviceable life of pyrotechnics is discussed in paragraph 12.

f. Toxicity.—Pyrotechnic material is poisonous to men and animals if taken internally.

g. Recoil.—Because of its powerful recoil, the pistol should be held with both hands in discharging the flare, aircraft, parachute, M9.

h. Duds.—During maneuvers over terrain other than military reservations, the location of dud flares and photoflash bombs will be observed and reported. The duds will be sought out and destroyed as soon as possible by authorized and experienced personnel. Duds of photoflash bombs are especially dangerous and should be destroyed in place by detonation as provided in TM 9-1900. Painful burns, serious injury, or property damage may result if inexperienced persons handle duds, especially photoflash bomb duds.

i. Safe altitudes and distances.—Flares not entirely burned out and cool when they land are liable to ignite combustible material. Safe altitudes and distances are dependent upon the burning time, dropping rate, and drift of the flare. Such factors will be considered in determining minimum altitudes and distances of release. Released safe, flares possibly, and photoflash bombs probably, will function on impact. Signals also are a potential fire hazard in case the parachute fails to support the signal properly. In tests and in peacetime maneuvers, if fire is to be avoided, pyrotechnics will not be used over terrain covered with dry vegetation or other inflammable material unless adequate fire protection is available.

j. Before and during firing.—(1) Pyrotechnics should be inspected to locate any defective units. Pyrotechnics should be kept clean. Any foreign substance, such as dirt, sand, mud, or grease, will be carefully removed before pyrotechnics are stored or used.

(2) Pyrotechnics to be fired should be stored in small amounts away from the firing point, either to the right or the left, but not directly behind the firing point. They should be placed so as to minimize the possibility of ignition or explosion in case of accident during firing. Smoking will be prohibited wherever pyrotechnics are piled and only approved lights will be used in their vicinity. When firing pyrotechnics, extreme care should be taken to fire them in such a manner that burning material or burned-out signals will not fall on the firer or other personnel, or into boxes of pyrotechnics or other ammunition. Care should also be exercised when firing through trees or obstructions.

k. Misfire.—In case of a misfire or hangfire, aircraft signals and flares, aircraft, M9, will be disposed of by releasing the flare from

the pistol. This is done by depressing the thumb release on the left-hand side of the breech of the pistol, which is held outside the airplane muzzle downward.

l. Renovation.—The only pyrotechnics which are reconditioned or renovated are those which are issued in metal cases. Such work will be done in accordance with specific instructions for the Chief of Ordnance.

m. Photoflash bombs.—Photoflash bombs must be handled with special care at all times. The flashlight powder used in such bombs is as hazardous as black powder. Photoflash bombs which have been damaged will be destroyed by authorized and experienced personnel in accordance with the provisions of TM 9-1900.

n. Fuzes.—Fuzes should be examined for any deterioration, such as heavy rust or corrosion, which might impair proper functioning. Only serviceable fuzes will be used.

o. Suspension lugs.—Suspension lugs should be examined for any damage which might weaken the lug or its attachment to the body of the pyrotechnic. Lugs for horizontal suspension should be gaged to assure proper center distance and alinement.

p. Fuzing.—Fuzing and unfuzing will be done at a safe distance from magazines.

q. Repacking and storage.—Pyrotechnics will ordinarily be on hand only in sufficient quantities to meet immediate requirements. Any assembled complete rounds in excess of such requirements will be restored to their original packings and appropriately marked. Prior to repacking, components will be inspected and those which were originally sealed will be released. Such ammunition should be used first in subsequent firings in order that the stock of opened packings may be kept at a minimum.

14. Packing and marking for shipment.—*a.* Pyrotechnics are packed and marked in accordance with pertinent specifications and drawings. Packings are designed to withstand all conditions ordinarily encountered in handling, storage, and transportation and to comply with Interstate Commerce Commission regulations. Due consideration is given in packing to prevent the entrance of moisture. Packing and marking data are given in paragraph 23 of this manual, SNL S-1 and S-4, and under the specific items described herein.

b. Pyrotechnics are packed in metal-lined or unlined, nailed or wire-bound wooden boxes. Those in unlined boxes are placed in inner containers consisting of sealed corrugated board cartons, cylindrical fiber containers, or metal containers. The cartons are dipped in paraffin to protect the contents from moisture. All containers are

MILITARY PYROTECHNICS

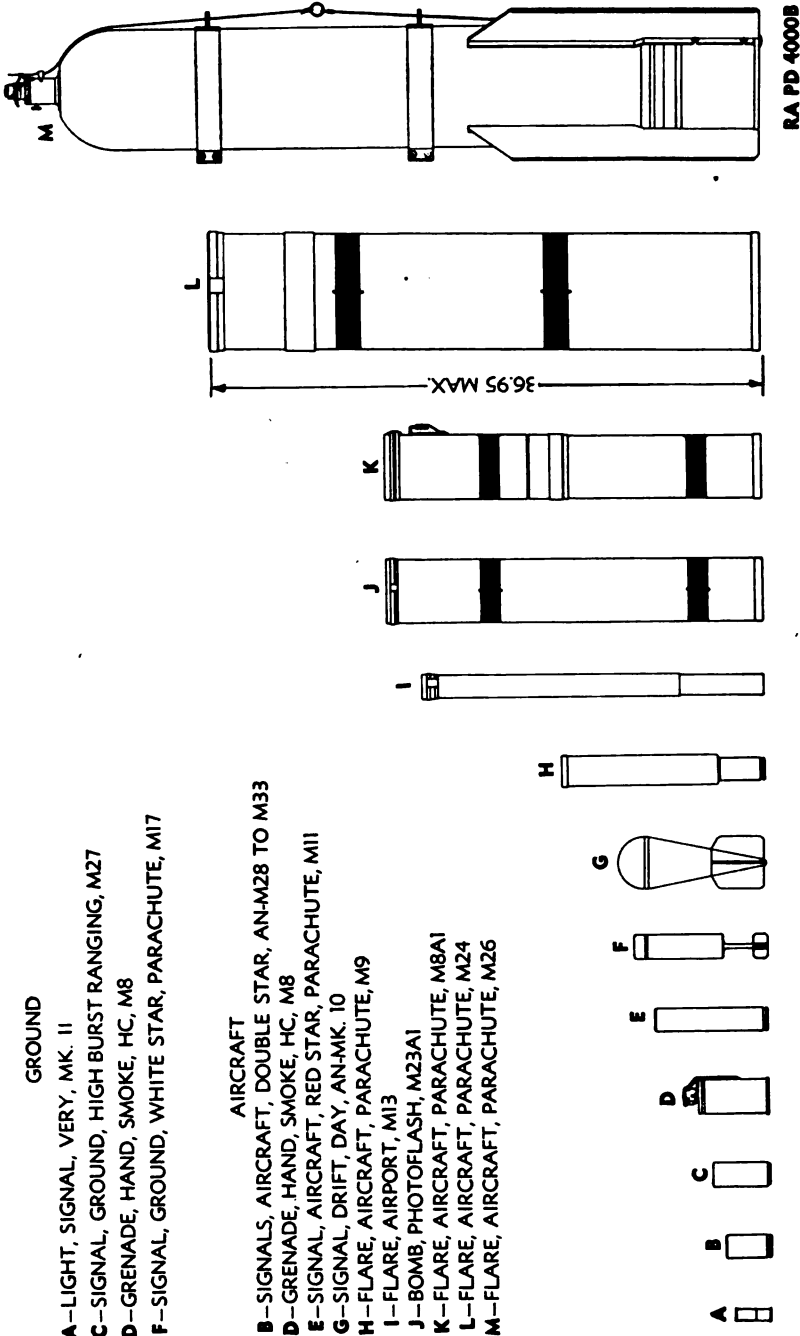

GROUND

- A - LIGHT, SIGNAL, VERY, MK. II
- B - SIGNAL, GROUND, HIGH BURST RANGING, M27
- C - GRENADE, HAND, SMOKE, HC, M8
- D - SIGNAL, GROUND, WHITE STAR, PARACHUTE, M17

AIRCRAFT

- B - SIGNALS, AIRCRAFT, DOUBLE STAR, AN-M28 TO M33
- D - GRENADE, HAND, SMOKE, HC, M8
- E - SIGNAL, AIRCRAFT, RED STAR, PARACHUTE, M11
- G - SIGNAL, DRIFT, DAY, AN-MK. 10
- H - FLARE, AIRCRAFT, PARACHUTE, M9
- I - FLARE, AIRPORT, M13
- J - BOMB, PHOTOFLASH, M23A1
- K - FLARE, AIRCRAFT, PARACHUTE, M8A1
- L - FLARE, AIRCRAFT, PARACHUTE, M24
- M - FLARE, AIRCRAFT, PARACHUTE, M26

FIGURE 1.—Types of military pyrotechnics.



STAR



CLUSTER

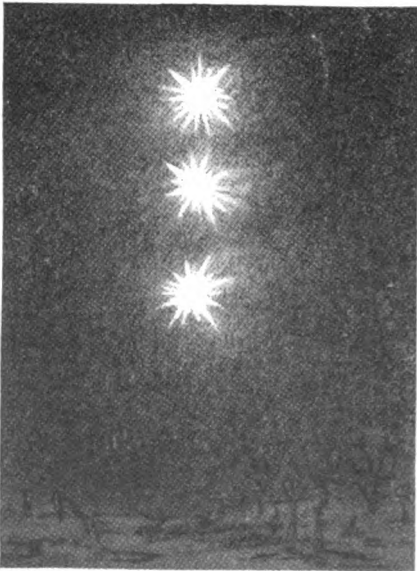

CHAIN

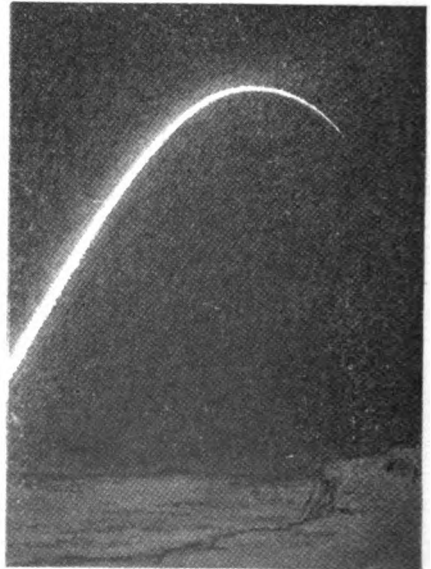

VERY

FIGURE 2.—Types of pyrotechnic signals.

RA PD 5317

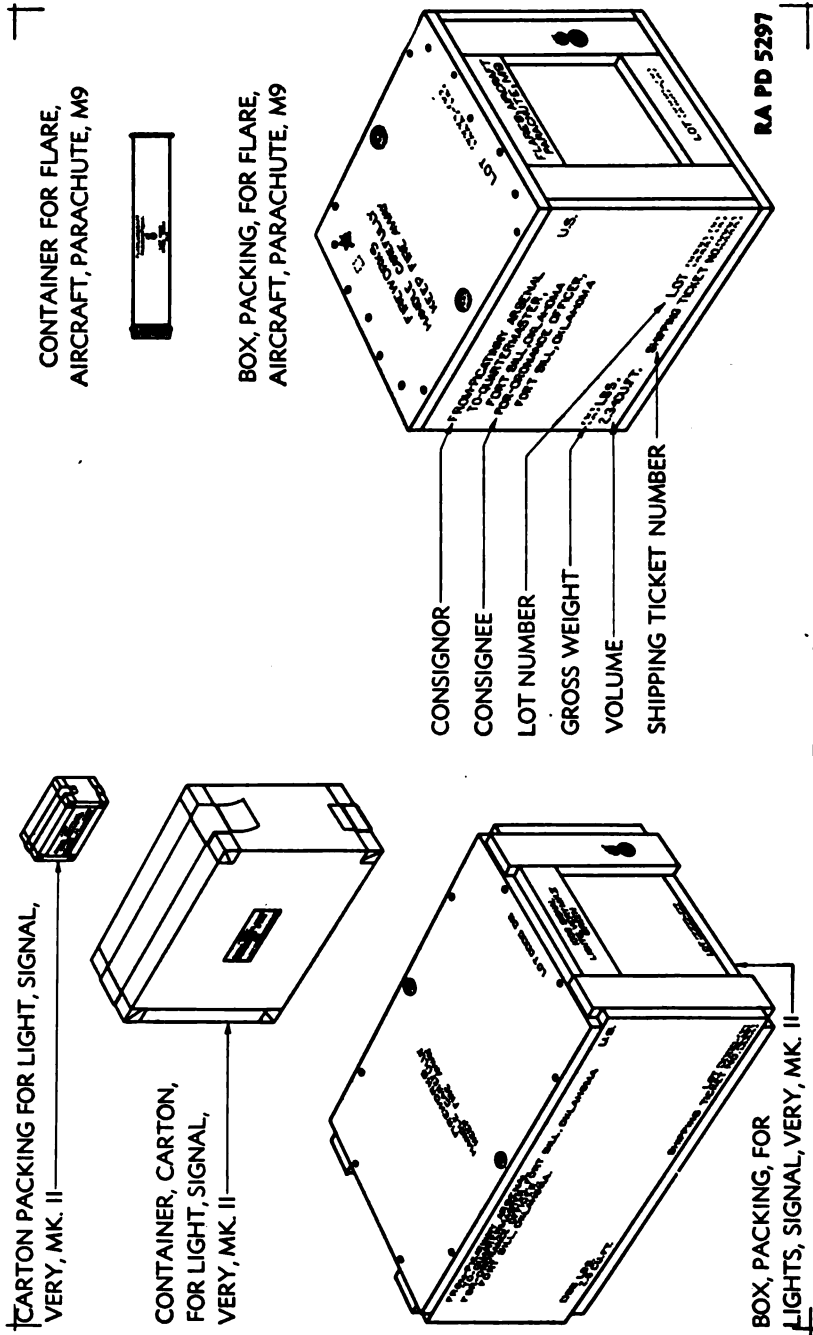

FIGURE 3.—Typical packings and markings.

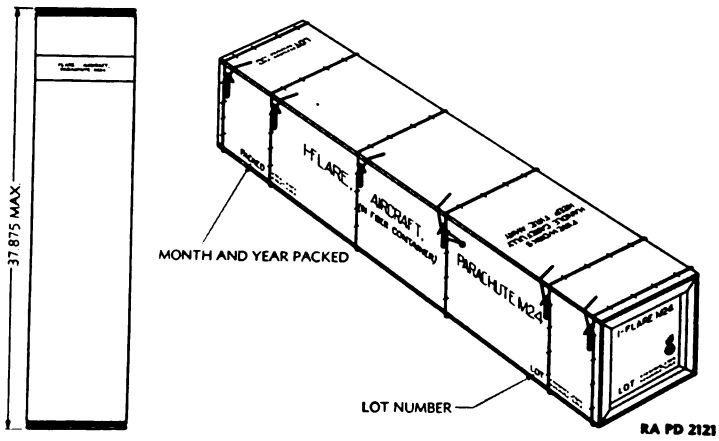
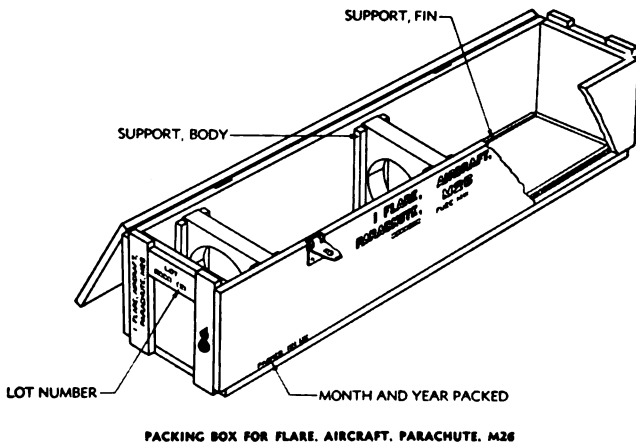

FIGURE 4.—Typical packings and markings.

labeled or marked to show the type or kind, lot number, quantity, and limiting date for use, if any. Typical packings and marking thereon are illustrated in figures 3 and 4.

c. Marking includes all information required—

(1) For complete identification of contents.

(2) By the Interstate Commerce Commission for shipping, including addresses of consignor and consignee and shipping designation of the contents.

(3) For intelligent handling, storage, and use.

d. Pyrotechnics are marked as **FIREWORKS** for shipment, with the exception of photoflash bombs which are marked with the words **EXPLOSIVE BOMB**.

e. Cartons for signals are colored yellow, red, white, or green, dependent upon the type of signal.

15. **Field report of accidents.**—Any serious malfunctions of pyrotechnics must be promptly reported to the ordnance officer, under whose supervision the material is maintained and issued (par. 7, AR 45-30).

SECTION III

VISIBILITY

	Paragraph
General	16
Variation due to design	17
Variation due to position	18
Variation due to atmospheric conditions	19

16. **General.**—a. The principal factors controlling the effectiveness of pyrotechnics are design, position, and atmospheric conditions.

b. Factors of design include candlepower, color, and degree of separation of the parts of a composite signal (blinker, cluster, or chain).

c. Factors of position include height at which the flare or signal functions, distance of observer from signal, distance of flare from objective to be illuminated, background, and relative position of flare, objective, and observer.

d. Atmospheric conditions include clarity of atmosphere, time (day or night), presence of haze, fog, dust, rain, or snow, and the color and brightness of the sky.

e. Tables of visibility, distinguishability, and distances will be found in section IV.

17. **Variation due to design.**—a. *Candlepower.*—The visibility of signals and illuminating power of flares depends primarily on the candlepower of the pyrotechnic candle. Although there are minor

variations due to composition and density, there is a limit to the amount of light produced by a given weight of candle. Thus a short, thick candle will give greater illumination for a shorter time than a long thin candle of the same weight, which will burn for a longer time with less brilliance.

b. Color.—(1) Variation in the visibility of signals due to color is due to two factors:

(a) The greater sensitivity of the eye to colors in the middle of the spectrum, that is, to yellow and its neighbors green and orange.

(b) The greater ability of the longer light waves (reds and yellows) to penetrate haze and fog.

(2) Color and texture of an objective control the amount of light reflected by it and, consequently, its visibility. For example, barren ground, such as an airport, reflects three or four times as much light as woods or deep water and needs less illumination.

c. Type.—A light can be seen much farther than its pattern can be distinguished. At ranges of 2 miles or more the various parts of such signals as chains or clusters blend into each other, giving the impression of a single spot of light. In addition, most colors fade or otherwise change at long range. Consequently, signals are apt to be misunderstood at greater distances than 1,500 yards in the day-time or 2 miles at night.

18. Variation due to position.—*a. Distance.*—Light varies inversely as the square of the distance. That is, a source of illumination will shed on a unit area one-fourth as much light at 2 feet as it will at 1 foot.

b. Relative position.—(1) The closer a flare is to an objective, the greater will be the illumination and, hence, the greater the visibility, provided the flare is not so close to the line of vision as to blind the observer by its glare.

(2) A flare above and behind the observer illuminates nearby objects well but is useless for long-range observation.

(3) A flare midway between the observer and objective loses effectiveness due to the distance its light must travel to the objective and back to the observer.

(4) A flare placed behind the objective and almost in the line of vision is useful in silhouetting the objective, especially when the atmosphere is slightly hazy.

c. Background.—Backgrounds which offer contrast in color or brightness increase visibility; noncontrasting backgrounds materially reduce it.

d. Angle of observation.—Although light is diffused in all directions from an unpolished object, the maximum amount of light is reflected according to the same principle as that of a mirror: The angle at which the light leaves the reflecting surface is equal to the angle at which it strikes; this angle of observation will consequently give maximum visibility.

19. Variation due to atmospheric conditions.—Particles of dust, moisture, or smoke in the air materially reduce visibility. All colors are affected, but the reds and yellows less so than the greens and blues. Heavy fog, snow, or rain will totally obscure the light from pyrotechnics at distances so short as to make their use impractical. Sky background and direction alter color and distinctiveness materially, for example, looking toward the sun.

SECTION IV

TABLES OF PYROTECHNIC DATA

Relative visibility.....	Paragraph 20
Distinguishability.....	21
Authorized rounds.....	22
Packing data.....	23

20. Relative visibility.—*a.* The following table will serve as a guide in the use of pyrotechnics. This table is based on a fixed distance. Variation due to distance should be calculated by use of the inverse square law.

b. Candlepower of colored light necessary for visibility at 5,000 yards:

	Red	Amber	White	Green
Night, clear.....	1.0	2.0	2.5	2.8
Night, rain, light.....	1.2	2.1	3.0	3.2
Night, overcast and haze.....	3.2	4.1	3.1	5.9
Night, rain, heavy.....	8.9	33.5	132.0	33.5
Night, snow, light.....	222.0	835.0	1,556.0	567.0
Day, overcast and haze.....	2,000.0	2,111.0	3,222.0	4,000.0
Day, clear.....	4,778.0	7,556.0	11,111.0	10,000.0

21. Distinguishability.—The following table indicates the distances at which, under average weather conditions, the various types of signals may be recognized. Signals may be seen at greater distances but, due to the tendency of colors to change with distance and the tendency of several lights to merge into one, reliable recognition of

the type of signal should not be expected at distances notably greater than those given in the table.

Distance of distinguishability, average weather conditions

Type	Candlepower	Day (miles)	Night (miles)
White star parachute.....	30,000	2.5	7-10
Red cluster.....	5 x 1500	0.57	2
Red chain.....	3 x 160	0.57	2
Red star parachute.....	10,000	0.75	2

22. Authorized rounds.—Table I lists the pyrotechnic items currently authorized, together with pertinent data.

TABLE I.—Authorized rounds

Nomenclature	Delay ¹ time (seconds)	Burning time (seconds)	Rate ² of fall (ft./sec.)	Candle- power (thou- sands)	Weight (pounds)	Length (inches)	Diameter (inches)
Flare, aircraft, parachute:							
M9.....	2.5	60	7.0	60	1.91	13.8	2.06
M8.....	3.0	180	8.0	260	18.00	26.41	4.25
M8A1.....	3.0	180	8.0	350	17.60	25.50	4.25
M24.....	5.0	195	11.6	800	47.00	37.00	8.12
M26.....	5.0	195	11.6	800	52.50	50.00	8.00
Flare, airport, M13.....		180		40	2.30	23.00	1.75
Grenade, hand, smoke, HC,							
M8.....	3.0	210	Free	Smoke	1.78	5.70	2.57
Signal, drift, M25.....	3.0	60		do	1.70	16.00	2.44
Bomb, photoflash, M23.....	15.0	.16	Free	150,000	10.50	25.40	4.25
Signal, aircraft:							
White star, parachute, M10.....	2.5	30	6.0	20	.61	7.69	1.58
Red star, parachute, M11.....	2.5	30	6.0	20	.59	7.69	1.58
Red star, cluster M14.....	2.5	9.00	Free	4.0 each	.71	7.69	1.58
White star, blinker, para- chute, M15.....	2.5	44	6	10.0	.58	7.69	1.58
Green star, blinker, para- chute, M16.....	2.5	51	6	1.5	.58	7.69	1.58
Double star:							
Red-red, AN-M28.....	0	7	Free	9.0-9.0	.31	3.02	1.56
Yellow-yellow, AN-M29.....	0	7	Free	2.0-2.0	.31	3.02	1.56
Green-green, AN-M30.....	0	7	Free	6.0-6.0	.34	3.02	1.56
Red-yellow-AN-M31.....	0	7	Free	9.0-2.0	.31	3.02	1.56
Red-green, AN-M32.....	0	7	Free	9.0-6.0	.32	3.02	1.56
Green-yellow, AN-M33.....	0	7	Free	6.0-2.0	.32	3.02	1.56
Single star:							
Red, AN-M34.....	0	7	Free	9.0	.24	3.02	1.56
Yellow, AN-M35.....	0	7	Free	2.0	.24	3.02	1.56
Green, AN-M36.....	0	7	Free	6.0	.25	3.02	1.56

See footnotes at end of table.

Nomenclature	Delay time (seconds)	Burning time (seconds)	Rate of fall (ft./sec.)	Candlepower (thousands)	Weight (pounds)	Length (inches)	Diameter (inches)
Signal, drift:							
Day, AN-Mk. I.....	0	-----	Free	-----	-----	-----	-----
Night, AN-Mk. IV.....	0	-----	Free	-----	-----	-----	-----
Signal, ground:							
White star, parachute, M5.	3.5	25	7	35.0	.7	5.8	1.63
Red star, cluster, M6.....	3.5	.5	Free	5.0	.70	5.8	1.63
Red chain, parachute, M7..	3.5	25	7	.5	.57	5.8	1.63
White star, parachute, M17..	5.5	25	7	20.0	.68	9.0	1.63
White star, cluster, M18...	5.5	6	Free	18.0 each	.74	9.0	1.63
Green star, parachute, M19.	5.5	25	7	5.0	.66	9.0	1.63
Green star, cluster, M20...	5.5	5	Free	7.0 each	.74	9.0	1.63
Amber star, parachute, M21.	5.5	25	7	4.0	.64	9.0	1.63
Amber star, cluster, M22...	5.5	5	7	2.0 each	.71	9.0	1.63
High burst ranging, M27...	5.0	Inst.	Free	Smoke	.42	3.82	1.63
Light, signal, Very:							
Red star, Mk. II.....	(9)	7	-----	.3	.06	2.43	.875
White star, Mk. II.....	(9)	6	-----	.25	.06	2.43	.875
Green star, Mk. II.....	(9)	5	-----	.6	.06	2.43	.875

- 1 Between release and full function.
- 2 In still air.
- 3 Substitute flare composition gives minimum of 575,000 candlepower.
- 4 After impact on water.
- 5 Five periods of 5.5 seconds each separated by 4 seconds dark.
- 6 Five periods of light of 7 seconds each separated by 4 seconds dark.
- 7 To give 400 feet rise.
- 8 To give 600 feet rise.
- 9 To give 200 feet rise; no delay, burns on rise.

23. Packing data.—Table II gives the standard packing for each item authorized.

TABLE II.—Packing data

Item	Inner container		Packing box					
	Number of rounds	Type	Total rounds	Type	Dimensions (inches)	Square feet	Cubic feet	Weight (pounds)
Band, suspension for M8, M8A1, or M23.	-----	None.....	20	WB 1.	28½ x 6¾ x 6¾	1.2	0.6	11
Bomb, photoflash, M23A1 1	1	Fiber.....	1	WB 2.	28½ x 6¾ x 6¾	1.1	0.5	17
Flare, aircraft, parachute:								
M8 1	1	do.....	2	W 4.	30½ x 12¼ x 7¾	2.7	1.7	53
M8 or M8A1 1	1	do.....	1	WB 1	28½ x 6¾ x 6¾	1.2	0.6	27
M9.....	1	Metal.....	25	W 4.	17¼ x 15½ x 15½	1.8	2.3	84
M24.....	1	Fiber.....	1	WB 2	43 x 9¾ x 9¾	2.8	2.2	62
M26 1	-----	None.....	1	ML 1.	52½ x 12½ x 13¾	4.4	4.8	105

See footnotes at end of table.

TABLE II.—Packing data—Continued

Item	Inner container		Packing box					
	Number of rounds	Type	Total rounds	Type	Dimensions (inches)	Square feet	Cubic feet	Weight (pounds)
Flare, airport, M13.....	6	Carton...	36	W ⁴	26 ¹ / ₁₆ x 14 ¹ / ₁₆ x 15 ¹ / ₁₆ ...	2.8	3.6	119
Fuze, nose, mechanical time, M111.	1	Metal...	50	W ⁴	16 ¹ / ₁₆ x 15 ¹ / ₁₆ x 11 ¹ / ₁₆ ...	1.8	1.7	74
Grenade, hand, smoke, HC, M8, with hand grenade ignition, fuze M200A1.	1	Fiber...	25	W ⁴	18 ¹ / ₂ x 16 ¹ / ₁₆ x 8 ² / ₁₆ ...	2.0	1.6	70
Signal, aircraft:								
White star, parachute, M10.	12	Carton...	60	W ⁴	23 ³ / ₄ x 13 ³ / ₄ x 9 ³ / ₄	2.3	1.9	54
Red star, parachute, M11.	12	do.....	60	W ⁴	24 ⁵ / ₁₆ x 14 ⁵ / ₁₆ x 11 ⁵ / ₁₆ ...	2.4	2.3	61
Red star, parachute, M11.	12	do.....	60	W ⁴	24 ⁵ / ₁₆ x 14 ⁵ / ₁₆ x 11 ⁵ / ₁₆ ...	2.4	2.3	60
Red star, cluster, M14.....	12	do.....	60	W ⁴	24 ⁵ / ₁₆ x 14 ⁵ / ₁₆ x 11 ⁵ / ₁₆ ...	2.4	2.3	61
White star, blinker, parachute, M15.	12	do.....	60	W ⁴	24 ⁵ / ₁₆ x 14 ⁵ / ₁₆ x 11 ⁵ / ₁₆ ...	2.4	2.3	61
Green star, blinker, parachute, M16.	12	do.....	60	W ⁴	24 ⁵ / ₁₆ x 14 ⁵ / ₁₆ x 11 ⁵ / ₁₆ ...	2.4	2.3	71
Double star, M28, M29, M30, M31, M32, M33.	6	do.....	72	W ⁴				
Single star, M34, M35, M36.	6	do.....	72	W ⁴				
Signal, drift, M25.....	6	do.....	24	W ⁴	20 ¹ / ₂ x 18 ¹ / ₁₆ x 13 ¹ / ₁₆ ...	2.6	3.0	71
Signal, ground:								
Whitestar, parachute, M6.	6	do.....	30	W ⁴	23 ¹ / ₁₆ x 9 ⁵ / ₁₆ x 8 ⁵ / ₁₆	1.5	1.0	34
Red star, cluster, M6.....	6	do.....	30	W ⁴	23 ¹ / ₁₆ x 9 ⁵ / ₁₆ x 8 ⁵ / ₁₆	1.5	1.0	34
Red chain, parachute, M7.	6	do.....	30	W ⁴	23 ¹ / ₁₆ x 9 ⁵ / ₁₆ x 8 ⁵ / ₁₆	1.5	1.0	30
White star, parachute, M17.	1	Fiber...	50	W ⁴	23 ¹ / ₁₆ x 11 ¹ / ₁₆ x 12 ² / ₁₆ ...	1.8	2.0	64
White star, cluster, M18...	1	do.....	50	W ⁴	23 ¹ / ₁₆ x 11 ¹ / ₁₆ x 12 ² / ₁₆ ...	1.8	2.0	67
Green star, parachute, M19.	1	do.....	50	W ⁴	23 ¹ / ₁₆ x 11 ¹ / ₁₆ x 12 ² / ₁₆ ...	1.8	2.0	63
Green star, cluster, M20...	1	do.....	50	W ⁴	23 ¹ / ₁₆ x 11 ¹ / ₁₆ x 12 ² / ₁₆ ...	1.8	2.0	67
Amber star, parachute, M21.	1	do.....	50	W ⁴	23 ¹ / ₁₆ x 11 ¹ / ₁₆ x 12 ² / ₁₆ ...	1.8	2.0	62
Amber star, cluster, M22...	1	do.....	50	W ⁴	23 ¹ / ₁₆ x 11 ¹ / ₁₆ x 12 ² / ₁₆ ...	1.8	2.0	65
High burst ranging, M27...	2	do.....	100	W ⁴	23 ¹ / ₁₆ x 12 ² / ₁₆ x 9 ³ / ₁₆	1.6	1.7	71
Light, signal, Very:								
Mk. II, all types.....		None	250	ML ⁵	10 ¹ / ₈ x 9 x 17 ¹ / ₂63	.92	31
Mk. II, all types.....	10	Carton...	1,000	ML ⁵	24 x 15 ³ / ₁₆ x 12 ³ / ₁₆	2.5	2.6	100

¹ Packed without suspension bands.

² With or without fuze. Weight without fuze, 104 pounds.

³ Wire-bound.

⁴ Wooden.

⁵ Metal-lined.

CHAPTER 2

AIRCRAFT TYPES

	Paragraphs
SECTION I. Flares	24-28
II. Photoflash bombs	29
III. Signals	30-35

SECTION I

FLARES

	Paragraph
General	24
Flare, aircraft, parachute, M26	25
Flare, aircraft, parachute, M24	26
Flare, aircraft, parachute, M8A1 and M8	27
Flare, aircraft, M9	28

24. General.—*a.* Flares for aircraft use are designed to provide illumination for reconnaissance, observation, bombardment, and landing. Details of design vary with the purpose of the flare, but all flares have certain characteristics in common.

b. All flares produce a white or yellowish light of high intensity for an appreciable length of time ranging from 60,000 candlepower for 1 minute to 1,000,000 candlepower for 3.5 minutes or longer.

c. All flares are parachute-supported to retard their dropping speed and make additional time available for illuminating purposes.

d. All flares have some form of delayed ignition to insure their clearing the plane before starting to burn. The method usually employed is the use of the cut-off action of a short cord—attached to parachute cable or shock absorber—to pull ignition wires through a block of flame composition. The flame is then carried by quickmatch to the primer, first fire, and illuminant composition of the candle.

e. Flares designed for use below the plane, such as those intended for bombardment, are provided with shades to shield the glare from the bombardier.

f. Flares designed for release from launching tubes or racks are equipped with a hangwire assembly which is attached to the arming pawl of the tube or rack. When the flare is released armed, the hangwire remains attached to the plane and pulls out the parachute or stabilizing sleeve. A section of soft metal tear wire enables the flare to break free.

g. Flares designed for release from racks or launching tubes may be released armed or unarmed. If released unarmed, they will not function in the air but may ignite on impact. This possibility must be kept in mind in releasing flares unarmed over friendly territory.

h. Flares equipped with hangwire are shipped with the hangwire in a hangwire container in the base of the flare case. The case is closed with a shipping cover which is sealed by means of a strip of tape or a soft metal tear strip. The tape or tear strip is torn off and the shipping cover removed when the flare is installed in the plane. If the flare is removed from the plane and returned to storage, the shipping cover will be replaced and sealed with tape.

i. Pyrotechnic compositions are subject to deterioration with time. Although some mixtures become more sensitive, most pyrotechnics become more difficult to ignite and hence less dependable. Such pyrotechnics are marked with an expiration date of serviceable life at which time they are withdrawn from service and assigned to another use, such as training. These flares are identified by a 2-inch blue band painted around the flare case. Further information will be found in OFSB 3-9.

25. Flare, aircraft, parachute, M26 (with fuze, nose, mechanical time, MIII).—*a. Date.*—This flare (fig. 5) is designed to provide illumination for night bombardment. It is a parachute-supported type with a shaded candle. The flare is designed to burn with a minimum of 800,000 candlepower for 3 to 3.5 minutes. (A substitute composition may be used which gives a light of 575,000 candlepower minimum. The data card will bear the information as to which composition has been used.) The time fuze permits its use for high altitude bombardment, as the fuze may be set to function a certain number of seconds after it is released. It may be made to function at 3,000 feet when released from aircraft at any altitude between 5,500 and 25,000 feet. When the parachute opens at the time of fuze functioning, it retards the dropping rate to approximately 11.6 feet per second. The flare may be released from a plane traveling at any speed up to 200 miles per hour. It may be released only from horizontal racks.

b. Description.—The flare case is cylindrical with the nose rounded and tail finned. It is 50 inches long and 8 inches in diameter. It weighs 53 pounds including a 1-pound fuze. It is equipped with two suspension lugs, the rear lug being located above the center of gravity of the flare. A shipping cover with a handle attached closes the tail end of the body and is sealed by a strip of tape.

c. Installation and operation.—(1) *Fuzing.*—Unscrew the fuze hole plug, screw the fuze in by hand, and seat it by hand force. Set the

fuze to the desired time by loosening the thumbscrew, rotating the body of the fuze until the desired number of seconds is indicated opposite the marker, then tightening the thumbscrew. A table showing the time setting of the fuze and other data is published as BT Flare-A-1.

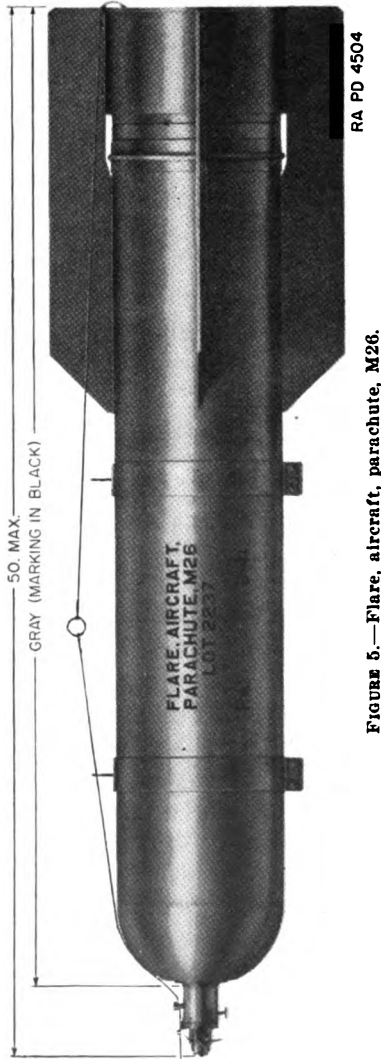

(2) *Arming-wire-hangwire.*—The cover is removed from the base of the flare and the outer end of the arming-wire-hangwire assembly is drawn from the hangwire container, taking care not to pull out the

attached end of the hangwire. The hangwire is brought around the vane stiffener to the suspension side of the flare and the arming wire threaded through first the forward suspension lug, then the inner hole in the arming pin of the fuze, then the inner holes in the vane stop. After this has been done, and not before, the safety cotter pin is removed from the arming pin and the shipping wire from the vane stop. (If it is necessary to unfuze a flare, the shipping wire and safety pin will be replaced before the arming wire is removed or the fuze unseated.) The flare is then installed in the plane, and the ring of the arming-wire-hangwire assembly attached to the arming pawl of the rack.

(3) *Operation.*—The flare may be released safe or armed. If released safe, it may function on impact. If released armed, the flare functions in the following steps:

(a) The movement downward withdraws the arming wire from the fuze, allowing the vane to rotate to arm the fuze and, at the same time, allowing the arming pin to be ejected, thus starting the time mechanism.

(b) When the flare has dropped the length of the hangwire, the latter breaks the seal wire and pulls out the hangwire container, which drops free. Meanwhile the tear wire, which is attached to the hangwire near its end, pulls out the tear-wire cord which, in turn, pulls out the stabilizing sleeve and its shrouds. A short length of cord attached to the shrouds removes the lock of the cover releasing cup.

(c) When the flare has dropped the combined length of the hangwire, tear wire, tear-wire cord, sleeve, and shrouds, its momentum breaks the tear wire, allowing the flare to drop. It is stabilized in flight by its fins and sleeve. The arming vane on the fuze rotates to arm the fuze approximately 6 seconds after release.

(d) At the time set, the fuze functions to push out the cover releasing cup. This releases the detachable cover to which the sleeve shrouds are attached, allowing the sleeve and cover assembly to separate from the flare and, by means of the parachute pull-out cord, pull out the parachute.

(e) The parachute opens and retards the fall of the flare with a jerk which—

1. Breaks the parachute pull-out cord, allowing the sleeve assembly to fall separately.
2. Pulls the ignition wires through the igniting mixture, thus starting the ignition train of igniter, quickmatch, primer, first fire, and candle, which reaches full ignition in approximately 3 seconds.
3. Pulls the flare assembly out of the case, which drops free.

(f) As the candle ignites it expels the rib retainer, allowing the rib springs to open the shade.

(g) The flare burns for 3 to 3.5 minutes with a light of at least 800,000 candlepower while dropping at an average speed of 11.6 feet per second.

d. Care and precautions in handling.—(1) In addition to the general precautions given in paragraphs 13 and 24, the following precautions will be observed:

(2) Fuzes will be handled with care at all times. They will be assembled to and disassembled from the flare as directed in *c* above, with particular attention to keeping the seal wire and safety pin in place until after the arming wire is inserted. The seal wire and safety pin will be replaced before removing the arming wire if the fuze is disassembled from the flare.

(3) In assembling the arming-wire-hangwire and in installing the flare in the plane, care will be taken not to pull so strongly on the hangwire as to loosen or remove the hangwire container.

(4) If the fuze is disassembled from the flare, care will be taken to replace the fuze hole plug, to replace and reseal the shipping cover on the flare, and to repack and reseal flare and fuze in the original containers.

e. Packing and marking.—Flare, aircraft, parachute, M26, is packed, one to a sealed metal-lined wooden box, with or without a fuze in a fuze can. Fuze, nose, time, mechanical, M111, when shipped separately, is packed one in a metal container, 50 such containers to the wooden box. Further information on packing and marking will be found in paragraphs 10, 14, and 23.

26. Flare, aircraft, parachute, M24.—This flare (fig. 6) is substitute standard for night observation and bombardment. Its illuminant, shade, and parachute assembly are similar to those of the M26 described above. It is not equipped with a time fuze; the hangwire acts directly to pull the parachute from the flare case and thus function the flare, which reaches full illumination 5 seconds after release from the plane. Candlepower and burning time are essentially the same as those of the M26. Dropping rate is 11.6 feet per second. This flare is designed for release from planes flying at an altitude of 2,500 to 3,000 feet at speeds not greater than 200 miles per hour. For installation in the plane and precautions to be observed see paragraphs 13 and 24. The flare, aircraft, parachute, M24, is 37 inches long by 8 inches in diameter. It weighs 47 pounds. This flare is packed one to a carton, one such carton to the box. Further information on packing and marking will be found in paragraphs 10, 14, and 23.

27. Flare, aircraft, parachute, M8A1 and M8.—*a. M8A1.*— This flare (fig. 7) is designed for use in emergency night landings. The candle is unshaded and burns with a yellowish light of 350,000 candlepower for 3 minutes. Its average dropping rate while burning is approximately 8 feet per second. This flare may be released from hori-

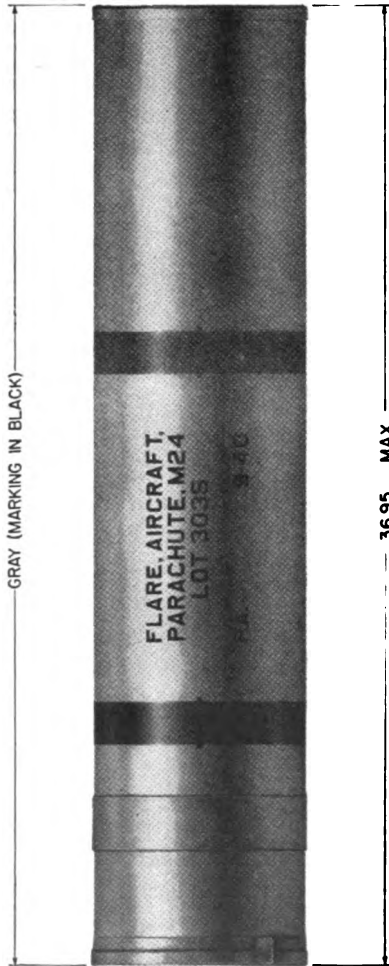

RA PD 4005A

FIGURE 6.—Flare, aircraft, parachute, M24.

zontal or vertical flare racks. When installed in horizontal racks, the suspension bands, which are shipped separately, must be first attached. The M8A1 operates in a manner similar to the M24, reaching full ignition approximately 5 seconds after release from the plane. It may be released from planes flying at speeds not in excess of 200 miles per hour.

The flare, aircraft, parachute, M8A1 is 25.5 inches long by 4.25 inches in diameter and weighs approximately 18 pounds. It is packed without suspension bands in individual fiber containers, one such container to the wire-bound box. Further information on packing and marking will be found in paragraphs 10, 14, and 23.

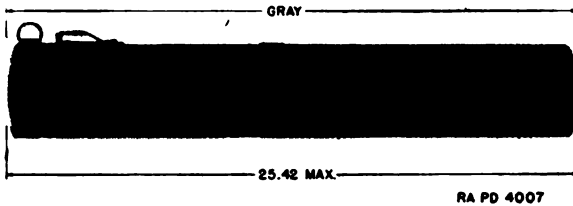
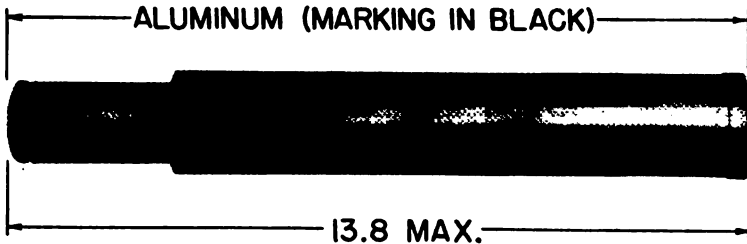

FIGURE 7.—Flare, aircraft, parachute, M8A1.

b. Flare, aircraft, parachute, M8.—This flare is an earlier model of the M8A1 and differs from the standard M8A1 only in that the candle burns with a white light of approximately 250,000 candlepower and the parachute assembly is designed for release of the flare from a plane flying at speeds between 85 and 165 miles per hour.

28. Flare, aircraft, parachute, M9.—This flare (fig. 8) was developed to satisfy the requirement for a small parachute flare for reconnaissance. The complete round is supplied in cartridge form de-



RA PD 4006A
FIGURE 8.—Flare, aircraft, parachute, M9.

signed for projection from the pistol, pyrotechnic, M2 (fig. 10), similarly to aircraft signals, described in paragraph 31. When the flare is discharged, the fuze burns for 2.5 seconds before igniting the expelling charge which ignites the flare and expels the flare and parachute from the case. The flare burns with a white light of 60,000 candlepower for 1 minute while dropping at an average rate of 7 feet per second. The flare cartridge is 13.8 inches long by approximately 2 inches in diameter and weighs about 1.9 pounds. Although the pistol is designed for operation by one hand, in discharging the flare, air-

craft, parachute, M9, the use of both hands is recommended because of the powerful recoil. The signals designed for use with this pistol may be discharged from a grounded plane but the flare, aircraft, parachute, M9, should not be so used. These flares are packed in individual metal containers, 25 such containers per box. Further information on packing and marking will be found in paragraphs 10, 14, and 23.

SECTION II

PHOTOFLASH BOMBS

Bomb, photoflash, M23A1-----

Paragraph
29

29. Bomb, photoflash, M23A1.—a. General.—Photoflash bombs are designed to provide a light of high intensity and short duration for night photography. In function they are strictly pyrotechnic but are designated bombs because of their explosive effect. They consist of a charge of flashlight powder and a means of ignition.

b. Description.—Bomb, photoflash, M23A1 (fig. 9), is in the shape of a cylinder 25.4 inches long and 4.25 inches in diameter. Its weight is 10.6 pounds, of which 7.75 is flashlight powder charge. The front end (FRONT is marked on the case for the information of persons attaching suspension bands and installing bomb in rack) contains the hangwire assembly and hangwire container. It is closed by a shipping cover sealed with adhesive tape.

c. Installation and operation.—The sealing tape is pulled off and the shipping cover removed. The swivel loop of the hangwire is drawn out and attached to the arming pawl of the rack or launching tube. When the bomb is released, the hangwire remains attached to the arming pawl. As the bomb drops, the hangwire pulls the igniter wires through the flame composition of the fuze and pulls out the hangwire container, allowing both hangwire container and bomb to fall free. The delay element burns for 15 seconds before igniting the charge. The charge produces a light of 150,000,000 candlepower for 0.16 second.

d. Care and precautions in handling.—In addition to the precautions given in paragraph 13 and on the label of the bomb itself, the following precautions will be observed:

(1) A photoflash bomb which is dropped safe, or whose fuze fails to function, may detonate on impact. Any that do not will be sought out and destroyed in place by authorized and experienced personnel.

(2) Because of the brilliance of the flash, it is detrimental to vision to watch the explosion of photoflash bombs, even at distances prescribed as safe from bomb fragments.

MILITARY PYROTECHNICS

e. *Packing and marking.*—(1) Bomb, photoflash, M23A1, is packed in individual fiber containers, one such container per wire-bound box.



RA PD 3997A

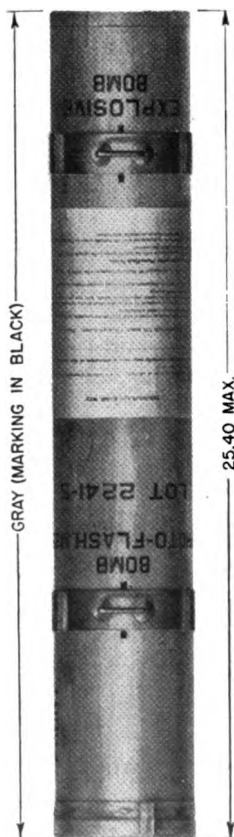

FIGURE 9.—Bomb, photoflash, M23A1.

(2) The bomb is marked to indicate the position of suspension bands, to indicate the front, and with regulations information as to type, model, and lot. The label also carries instructions as to storage and handling.

(3) Further information on packing and marking will be found in paragraphs 10, 14, and 23.

f. Bomb, photoflash, M23.—The M23 is an earlier model with which it is necessary to use an adapter as a means of allowing the bomb to clear the plane by 100 feet before functioning.

SECTION III

SIGNALS

	Paragraph
General.....	30
Signals, aircraft.....	31
Grenade, hand, smoke, HC, M8.....	32
Signal, drift, M25.....	33
Signal, drift, day, AN-Mk. I.....	34
Signal, drift, night, AN-Mk. IV.....	35

30. General.—*a.* Aircraft signals (fig. 10) are designed to be fired from the pistol, pyrotechnic, M2. They are all of the same size and shape: cylindrical, 7.69 inches in length by 1.58 inches in diameter, and identified by the marking on the side and on the identification top.

b. Components.—The signal is assembled in a removable barrel (for the pyrotechnic pistol, see *c* below) in which are assembled the primer, the propelling charge, and the signal case. The signal case contains a delay fuze, an expelling charge, and the signal. The signal consists of an illuminant assembly with or without a parachute, depending upon the type.

c. Pistol, pyrotechnic, M2.—The pistol is designed to load, cock, fire, and eject by one hand wearing a heavy glove. It consists of receiver, grip, and double action firing mechanism. It is operated as follows:

(1) The receiver is pushed down over the primer end of the removable barrel of the signal until the locking stud engages the groove of the barrel.

(2) The signal is withdrawn from the rack and aimed outside the plane—45° to the rear and 45° up.

(3) The pistol is cocked and fired by one continuous pull on the trigger.

(4) The pistol is pointed downward and the releasing tab depressed, allowing the empty barrel—or a misfired signal—to drop clear.

d. Signal operation.—Firing the pistol initiates the operation of the signal, which occurs in the following steps:

(1) The primer ignites the propelling charge which ignites the fuze and propels the signal case outward.

(2) The fuze burns approximately 2.5 seconds and then ignites the expelling charge.

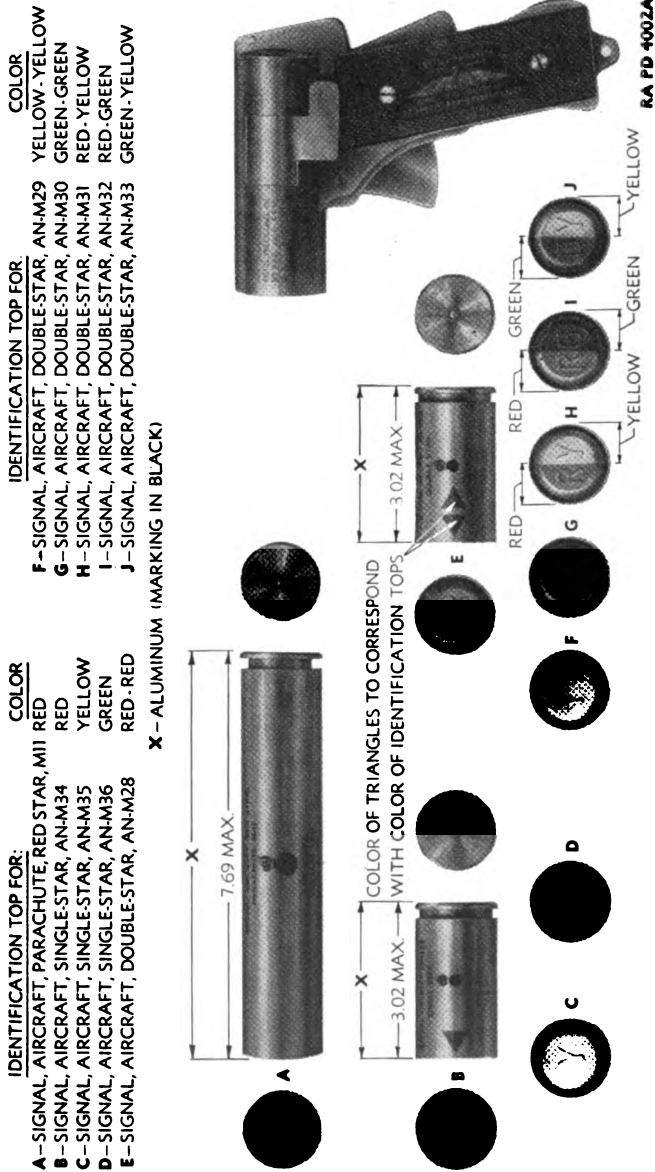

FIGURE 10.—Aircraft signals and pistol.

(3) The expelling charge ignites the candle and expels the signal assembly from the case.

(4) The signal burns, producing effect according to its type.

(5) In the case of double star and single star signals, the illuminant assembly is projected and ignited directly from the barrel. There is no delay.

31. Signals, aircraft.—a. Types.—(1) Signal, aircraft, red star, parachute, M11, is parachute-supported, dropping at a rate of approximately 6 feet per second. It burns for approximately 30 seconds with a red light of 20,000 candlepower. This signal is authorized for firing from a grounded plane as a distress signal.

(2) Signal, aircraft, double star, red-red, AN-M28, produces two freely falling stars which burn simultaneously for 7 seconds, each producing a red light of 9,000 candlepower.

(3) Signal, aircraft, double star, yellow-yellow, AN-M29, produces two freely falling stars which burn simultaneously for 7 seconds, each producing a yellow light of 2,000 candlepower.

(4) Signal, aircraft, double star, green-green, AN-M30, produces two freely falling stars which burn simultaneously for 7 seconds, each producing a green light of 6,000 candlepower.

(5) Signal, aircraft, double star, red-yellow, AN-M31, produces two freely falling stars which burn simultaneously for 7 seconds. One burns with a red light of 9,000 candlepower, the other with a yellow light of 2,000 candlepower.

(6) Signal, aircraft, double star, red-green, AN-M32, produces two freely falling stars which burn simultaneously for 7 seconds. One burns with a red light of 9,000 candlepower, the other with a green light of 6,000 candlepower.

(7) Signal, aircraft, double star, green-yellow, AN-M33, produces two freely falling stars which burn simultaneously for 7 seconds. One burns with a green light of 6,000 candlepower, the other with a yellow light of 2,000 candlepower.

(8) Signal, aircraft, single star, red, AN-M34, produces one freely falling star which burns for 7 seconds with a red light of 9,000 candlepower.

(9) Signal, aircraft, single star, yellow, AN-M35, produces one freely falling star which burns for 7 seconds with a yellow light of 2,000 candlepower.

(10) Signal, aircraft, single star, green, AN-M36, produces one freely falling star which burns for 7 seconds with a green light of 6,000 candlepower.

(11) Signal, aircraft, white star, parachute, M10, is limited stand-

ard. It is parachute-supported, dropping at an average rate of 6 feet per second. It produces light of approximately 20,000 candlepower for 30 seconds.

(12) Signal, aircraft, red star, cluster, M14, is limited standard. It contains five freely falling stars which burn simultaneously for approximately 9 seconds, each producing a red light of 4,000 candlepower.

(13) Signal, aircraft, white star, blinker, M15, is limited standard. It is parachute-supported, dropping at a rate of approximately 6 feet per second. It burns for approximately 44 seconds, producing a white light of 10,000 candlepower for 5.5 seconds, and a dark period for 4 seconds, alternately for a total of five periods of light.

(14) Signal, aircraft, green star, blinker, M16, is limited standard. It operates in the same manner as the white star, blinker, M15, except that, in the light periods, it produces a green light of 1,500 candlepower for 7 seconds.

b. Care and precautions in handling.—In addition to the general precautions given in paragraph 13, the following will be observed:

(1) Signal cartridges will be guarded against a blow on the primer, as such a blow may discharge the propellant and ignite the signal.

(2) Signals, aircraft, and flares, aircraft, parachute, M9, will be examined on installation in planes. Those with dented, deformed, or cracked barrels, or with loose identification tops will not be used.

c. Packing and marking.—(1) *Marking.*—Aircraft signals are identified by the marking on the packings and on the item itself. In addition to the usual marking as to type, color, lot number, etc., the identification top or closing cap is painted the color of the signal and embossed—for identification in the dark—as follows:

RP	Red star, Parachute, M11
RS	Red star, cluster, M14
WB	White star, Blinker, parachute, M15
GB	Green star, Blinker, parachute, M16
WP	White star, Parachute, M10
RG	Double star, Red-Green, AN-M32
GY	Double star, Green-Yellow, AN-M33
RY	Double star, Red-Yellow, AN-M31
RR	Double star, Red-Red, AN-M28
YY	Double star, Yellow-Yellow, AN-M29
GG	Double star, Green-Green, AN-M30
R	Single star, Red, AN-M34
G	Single star, Green, AN-M36
Y	Single star, Yellow, AN-M35

(2) *Packing*.—Standard aircraft signals are packed 6 to a carton, 12 cartons to a box; limited standard signals are packed 12 to a carton, 5 such cartons to a wooden box. Further information will be found in paragraphs 10, 14, and 23.

32. Grenade, hand, smoke, HC, MS.—This item (fig. 11) is standard as an emergency smoke signal. It is in the shape of a cylinder approximately 5 inches long and 2.5 inches in diameter. A fuze

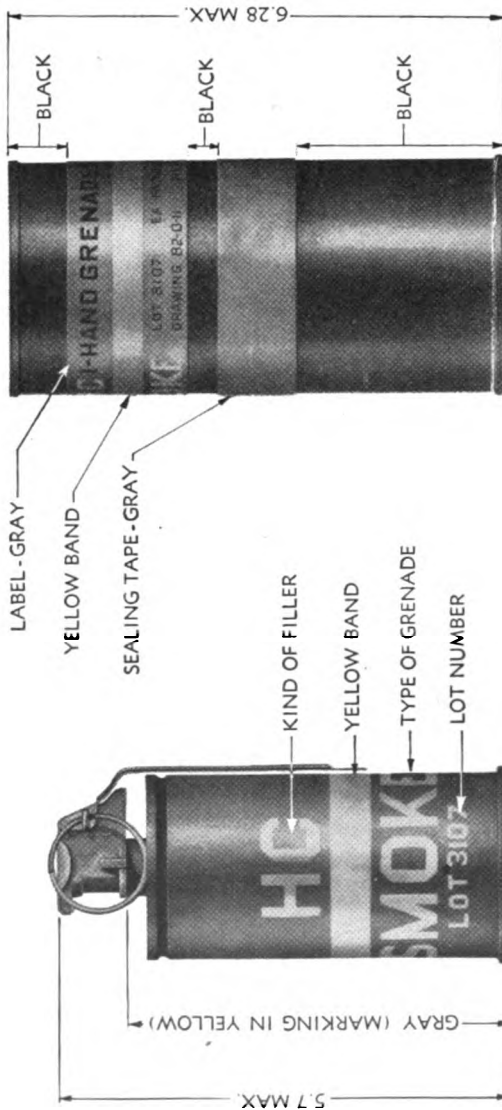

RA PD 7206

FIGURE 11.—Grenade, hand, smoke, HC, MS, and fiber container.

with a safety lever and pin protrudes approximately three-fourths of an inch from the head end. To operate, the grenade is grasped with one hand which, at the same time, holds the safety lever in position. The ring and cotter pin are removed with the other hand and the grenade is thrown. The production of smoke starts 2 seconds after the release of the lever and reaches full volume in 3 seconds. The evolution of smoke continues for 3.5 minutes. The smoke is harmless to personnel or matériel but Army Regulations forbid the discharge of this type of grenade closer than 20 feet to personnel because of the occurrence of an occasional flashing grenade. These grenades are packed in moisture-resistant fiber containers, 25 such containers to the box. They are painted gray and marked, in yellow, with one band, the symbol of the filler, HC, and the word SMOKE. Further information on packing and marking will be found in paragraphs 10, 14, and 23.

33. Signal, drift, M25.—This limited standard signal is used as an aid to navigation over water by providing a stationary reference point for determination of the drift of the airplane. It is in the shape of a cylinder 16 inches long by 2.44 inches in diameter. The signal is released from the plane by hand and drops to the water, stabilized in fall by fins. On impact, the nose fuze functions to ignite a delay pellet which burns for 2 seconds before igniting the charge, thus allowing the signal to bob to the surface before functioning. The signal will not function on impact with solid ground. The charge burns to produce a 6-inch flame and a column of smoke. This signal should not be released from an altitude lower than 500 feet as it may not have sufficient speed to operate the fuze, nor should it be released at altitudes higher than 16,000 feet as the point of origin of the smoke column becomes indeterminate due to distance. The signal, drift, M25, is packed 6 to a carton, 4 such cartons in a wooden box. Further information on packing and marking will be found in paragraphs 10, 14, and 23.

34. Signal, drift, day, AN-Mk. I.—This signal consists of a streamlined paper shell containing a metallic powder. When the signal is dropped in water the shell breaks, allowing the metallic powder to form a slick on the surface, which may be used as a reference point for air navigation. The shell is a waterproof paper, $\frac{1}{16}$ inch thick. The nose is of hemispherical shape, $3\frac{1}{2}$ inches in diameter, and the body tapers over its 10-inch length to a blunt point. The cone of the tail has four paper fins formed integral with it, which tend to stabilize the flight of the signal. Because the paper shell is fragile these signals should be handled with care to prevent their destruction.

35. Signal, drift, night, AN-Mk. IV.—This signal is torpedo-shaped and consists of a bronze hemispherical nose, a wood body tapered at the rear, and an aluminum alloy tail fin assembly. It is designed to float in water in a vertical position with the nose submerged. The wooden body is hollow and contains the first fire composition and the pyrotechnic pellet. The fuze functions when the signal strikes the water surface and ignites the first fire composition, which in turn ignites the pyrotechnic pellet. It burns out of the tail and projects a flame which may be used as a reference point for air navigation at night.

CHAPTER 3

GROUND TYPES

	Paragraphs
SECTION I. Flares	36-37
II. Signals	38-39

SECTION I

FLARES

	Paragraph
General	36
Flare, airport, M13	37

36. General.—Flares are used by troops on the ground to provide illumination for airplane landings at emergency landing fields or in case of power failure at airports. No flares are currently authorized for other purposes.

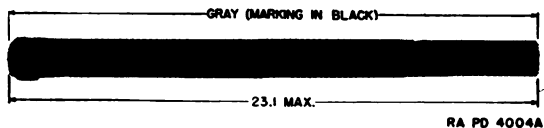

FIGURE 12.—Flare, airport, M13.

37. Flare, airport, M13.—*a.* This flare (fig. 12) is in the form of a cylinder 23 inches long by 1.75 inches in diameter. The cover is sealed on the top with a strip of adhesive tape which should not be removed until just before the flare is to be used. On the opposite end, a 7-inch handle is formed by a hollow chipboard tube. This hollow tube may also be slipped over a straight or hinged rod stuck into the ground to serve as a support. The flare is ignited by a pull on a lanyard attached to the loop of the igniting wire, and burns for 3 minutes with a light of 40,000 candlepower. Flare, airport, M13, is packed 6 to a carton and 6 such cartons to a wooden box. Further information on packing and marking will be found in paragraphs 10, 14, and 23.

b. Airport flares may be used on the stand, floodlight flare, A1, with brackets for flare, airport, M13, and flare, aircraft, M8 or M8A1. The procedure is as follows:

- (1) With the stand in horizontal position, the appropriate bracket is attached to the stand.
- (2) The flare is clamped securely to the bracket.

(3) The shipping cover is removed and the lanyard attached to the loop of the ignition wire (to the parachute cable in the case of the substitute M8).

(4) The stand is raised vertically and secured.

(5) A sharp pull on the lanyard ignites the flare.

c. When overage M8 or M8A1 flares are available as substitutes for the M13, they will be prepared in the following manner:

(1) The sealing strip and shipping cover are removed and the parachute gently withdrawn from the case, taking care that no pull is exerted on the parachute cable.

(2) The shrouds and tie cord are cut close to the spool and the spool cleared.

(3) The cable is coiled in the parachute case and the shipping cover replaced and sealed with tape.

(4) The flare body is stenciled with **SUBSTITUTE FOR FLARE, AIRPORT, M13.**

d. In using this flare, it should be borne in mind that all burning pyrotechnics drip to some extent. The firer should not stand under the burning flare and, when it is necessary to use the flare over dry vegetation, adequate care should be exercised to avoid fire.

SECTION II

SIGNALS

Signals, ground.....	Paragraph 38
Lights, signal, Very, Mk. II.....	39

38. Signals, ground.—a. General.—Ground signals are designed to be fired from the projector, pyrotechnic, M1A1, M3, or M4 (fig. 13). They are similar in construction to the aircraft signals described in paragraph 31, except that the signal case closing top carries a tail and fin assembly to improve flight characteristics. The fin is marked by painting and embossing for identification as described in *f* below.

b. Operation.—Operation is similar to that for aircraft signals except that the signal case is projected from the fixed barrel of the projector instead of from an individual removable barrel as is the case with aircraft signals. The signal is fired by the impact of the signal primer with the firing pin of the projector. In the case of projector, pyrotechnic, M1, the firing pin is operated by a pull on the lanyard. In the case of projector, pyrotechnic, M3 or M4, the projector is struck smartly on the ground, thus driving the signal primer against a fixed firing pin. The signal is projected fin first. It reverses itself in flight at approximately 100 feet and continues to

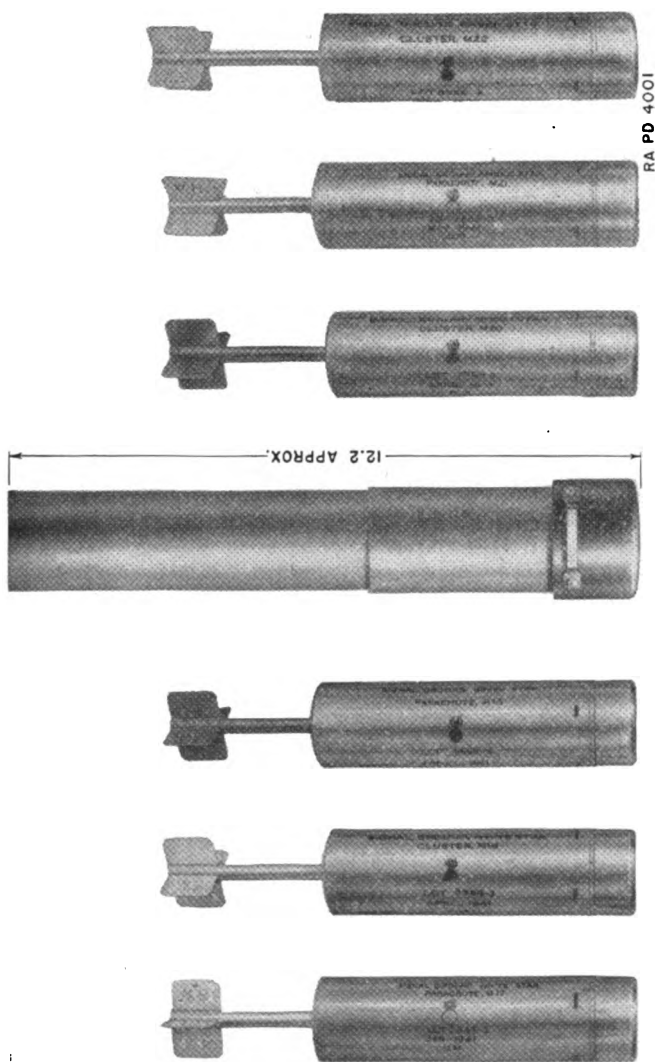

FIGURE 13.—Ground signals and projector.

rise to an altitude of 600 feet. The fuze is designed to burn 5.5 seconds—permitting the case to attain maximum altitude—before igniting the signal and expelling the signal assembly from the case. (The limited standard signals M5, M6, and M7 (see *d* below) rise only 400 feet.)

c. Standard types.—(1) Signal, ground, white star, parachute, M17, is parachute-supported, falling at an average rate of 7 feet per second. It burns for 20 to 30 seconds, producing a white light of 20,000 candlepower.

(2) Signal, ground, white star, cluster, M18, produces a group of five freely falling stars which burn simultaneously for approximately 5.5 seconds, each producing a white light of 18,000 candlepower.

(3) Signal, ground, green star, parachute, M19, is parachute-supported, falling at an average rate of 7 feet per second. It produces a green light of approximately 5,000 candlepower for 20 to 30 seconds.

(4) Signal, ground, green star, cluster, M20, produces a group of five freely falling stars which burn simultaneously for approximately 5.5 seconds, each producing a green light of approximately 7,000 candlepower.

(5) Signal, ground, amber star, parachute, M21, is parachute-supported, falling at an average rate of 7 feet per second. It produces a yellow light of 4,000 candlepower for 20 to 30 seconds.

(6) Signal, ground, amber star, cluster, M22, produces a group of five freely falling stars which burn simultaneously for 5.5 seconds, each producing an amber light of 2,000 candlepower.

(7) Signal, ground, high burst ranging, M27, produces a smoke puff at the top of its rise. This signal is used to simulate the high burst of artillery shell. It is fired from the M1A1 projector and rises to an altitude of approximately 550 feet. Cover or other protection from the fragments of the signal case should be available.

d. Limited standard types.—The following signals differ from those described above in that they have no stabilizing fin on the signal case and are designed to function at a height of 400 feet:

(1) Signal, ground, white star, parachute, M5, is parachute-supported, falling at an average rate of 7 feet per second. It burns for 20 to 30 seconds, producing a white light of 35,000 candlepower.

(2) Signal, ground, red star, cluster, M6, produces a group of five freely falling stars which burn simultaneously for 5.5 seconds, each producing a red light of 1,000 candlepower.

(3) Signal, ground, red chain, parachute, M7, is parachute-supported, falling at an average rate of 7 feet per second. It consists

of three stars, suspended at intervals of 3 feet on an asbestos cable, which burn simultaneously for 20 to 30 seconds, each producing a red light of 160-candlepower.

e. Care and precautions in handling.—In addition to the general precautions given in paragraph 13, the following special precautions will be observed:

(1) The primer will be carefully guarded against blows from a sharp instrument. Such blows may fire the propelling charge and ignite the signal.

(2) Signals with deformed, dented, or cracked cases and bent or deformed fin assemblies will not be used.

(3) Care will be exercised in firing the signal to keep all parts of the person below the muzzle of the projector.

f. Marking.—Ground signals are identified by the marking on the packing and on the item itself.

(1) Standard ground signals have the fin painted to match the color of the signal and stamped—for identification in the dark—as follows:

WP White star, Parachute, M17
 WS White Star, cluster, M18
 GP Green star, Parachute, M19
 GS Green Star, cluster, M20
 AP Amber star, Parachute, M21
 AS Amber Star, cluster, M22

(2) The limited standard signals have an identification top painted the color of the signal and embossed as follows:

WP White star, Parachute, M5
 RS Red Star, cluster, M6
 RC Red Chain, parachute, M7

g. Packing.—Ground signals are packed in individual cartons, 25 such cartons to the box. Further information on packing and marking will be found in paragraphs 10, 14, and 23.

39. Lights, signal, Very, Mk. II.—*a. General.*—These signals resemble shotgun shells in appearance and are designed to be fired from the pistol, Very, 10-gage, Mk. III (fig. 14). Each cartridge produces a single star which, on firing, ignites almost immediately, burning as it rises to a height of 200 feet.

b. Types.—(1) Light, signal, Very, Mk. II, red star, burns for 7 seconds with a red light of 300 candlepower. The closing wad is corrugated.

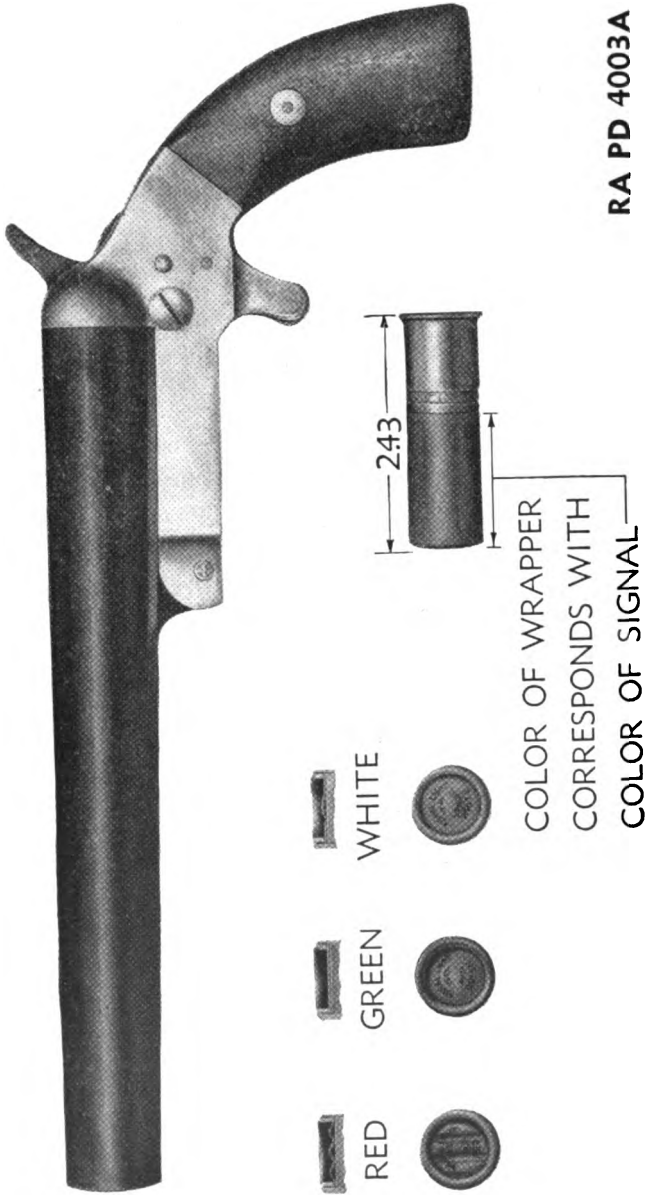

RA PD 4003A

COLOR OF WRAPPER
CORRESPONDS WITH
COLOR OF SIGNAL

FIGURE 14.—Very lights and pistol.

(2) Light, signal, Very, Mk. II, white star, burns for 6 seconds with a white light of 250 candlepower. The closing wad has a small cone in the center.

(3) Light, signal, Very, Mk. II, green star, burns for 5 seconds with a green light of 600 candlepower. The closing wad is smooth.

c. Marking.—Very lights are identified by the marking on the items and on the packings. In addition the closing wad is shaped as noted above for identification by touch in the dark.

d. Packing.—Very lights are packed 250 per metal-lined box (old packing); and 10 per carton, 25 cartons per carton container, and 4 carton containers (1,000 rounds) per metal-lined box (new packing). Further information on packing and marking will be found in paragraphs 10, 14, and 23.

APPENDIX

LIST OF REFERENCES

1. Standard Nomenclature Lists.

a. Bombs and grenades.

Aircraft bombs (including photoflash bombs)----- SNL S-1

Ammunition instruction material, grenades, pyrotechnics, and aircraft bombs----- SNL S-5

Grenades (including grenade, hand, smoke, HC, M8)----- SNL S-3

b. Cleaning, preserving, and lubricating materials. SNL K-1*c. Pistols.*

Pistol, pyrotechnic, M2----- SNL B-18

Pistol, Very, 10-gage, Mk. III----- SNL B-23

d. Projectors.

Projector and support, signal, ground, M1----- SNL B-19

Projector, signal, ground, M3 and M4----- SNL B-24

e. Pyrotechnics, military, all types----- SNL S-4

Current Standard Nomenclature Lists are as tabulated here. An up-to-date list of SNL's is maintained as the "Ordnance Publications for Supply Index" (OPSI).

f. Bombing table for flare, aircraft, parachute, M26, BT Flare-A-1.

Firing tables and trajectory charts----- SNL F-69

2. Explanatory publications.

a. Ammunition.

Ammunition, general----- TM 9-1900

Ammunition, general----- OFSB 3-1

Ammunition, nomenclature and shipping names----- OFSB 3-12

Ammunition identification code----- OFSB 3-14

Qualification in arms and ammunition training allowances----- AR 775-10

Range regulations for firing ammunition in time of peace----- AR 750-10

b. Cleaning, preserving, lubricating, and welding materials----- TM 9-850*c. Miscellaneous.*

Interstate Commerce Commission regulations.

Ordnance field service in time of peace----- AR 45-30

MILITARY PYROTECHNICS

Ordnance safety manual.....	OO 7224
Table of Basic Allowances (T/BA).	
<i>d. Pyrotechnic material.</i>	
Aircraft armament and pyrotechnics.....	TM 1-409
Bomb racks, tow target equipment, and flare racks..	TM 1-500
Military pyrotechnics.....	OFSB 3-9
<i>e. Signals.</i>	
Signal communication.....	FM 1-45
Signal communication.....	FM 24-5
<i>f. Transportation.</i>	
Marking shipments.....	U. S. Army Spec. 100-2
Transportation by water of explosives, inflammables, and chemical warfare materials.....	AR 30-1270

INDEX

	Paragraph	Page
Accidents, field report of	15	13
Aircraft flares	24-28, 37	19, 35
M8 and M8A1	27, 37	24, 35
M9	28	25
M24	26	23
M26	25	20
Misfire	13	5
Aircraft signals	30-35	28
Drift signals	33-35	33
Grenade, hand, smoke, HC, M8	32	32
Misfire	13	5
Pistol, pyrotechnic, M2	30	28
Aircraft types of pyrotechnics	24-35	19
Flares	24-28	19
Photoflash bombs	29	26
Signals	30-35	28
Airport flares	37	35
Altitudes, safe	13	5
Ammunition data card	7	4
Ammunition Identification Code	3	2
Ammunition lot number	8	4
Atmospheric conditions	19	15
Bombs, photoflash, M23 and M23A1	29	26
Candlepower	20	15
Care, handling, and preservation	13	5
Data card, ammunition	9	4
Deterioration in storage	13	5
Disassembly	13	5
Distance, safe	13	5
Drift signals	33-35	33
Duds	13	5
Expiration date	12	5
Fires	13	5
Firing precautions	13	5
Flare, aircraft, parachute:		
M8	27, 37	24, 35
M8A1	27, 37	24, 35
M9	13, 28	5, 25
M24	26	23
M26	25	20
Flare, airport, M13	37	35

INDEX

	Paragraph	Page
Flares:		
Aircraft	24-28	19
Ground	36, 37	35
Fuze, nose, M111.....	25	20
Fuzes.....	13, 25	5, 20
Grenade, hand, smoke, HC, M8.....	32	32
Ground flares.....	36, 37	35
Ground signals.....	38, 39	36, 39
Handling.....	13	5
Hangfire.....	13	5
Hangwire assembly.....	24	19
Identification.....	6	3
Illumination, when necessary.....	2	2
Light, signal, Very, Mk. II.....	39	39
Limited standard signals.....	38	36
Lot number, ammunition.....	8	4
Markings of pyrotechnics.....	6-10, 14, 24, 29, 31, 38	3, 8, 19, 26, 30, 36
Misfire.....	13	5
Model designations.....	8	4
Moisture, effect of.....	13	5
Nomenclature.....	3	2
Packing.....	14, 23	8, 17
Painting.....	10	4
Photoflash bombs.....	13, 14, 29	5, 8, 26
Pistol, pyrotechnic, M2.....	13, 30	5, 28
Pistol, Very, 10-gage, Mk. III.....	39	39
Projector, pyrotechnic, M1A1, M3, or M4.....	38	36
Pyrotechnic compositions.....	5	3
Recoil (pistol).....	7	4
Renovation.....	13	5
Repacking and storage.....	13	5
Serviceability.....	13	5
Shipment, packing and marking for.....	14	8
Signal cartridges, care of.....	13	5
Signal, drift:		
M25.....	33	33
Day, AN-Mk. I.....	34	33
Night, AN-Mk. IV.....	35	34
Signaling, when necessary.....	2	2
Signals:		
Aircraft.....	30-35	28
Ground.....	38, 39	36, 39

INDEX

	Paragraph	Page
Stand, floodlight flare, A1.....	37	35
Storage.....	13	5
Substitutes, marking.....	10	4
Suspension lugs.....	13	5
Toxicity.....	13	5
Training flares, marking.....	24	19
Very lights (signals).....	39	39
Visibility.....	16-19	13

[A. G. 062.11 (1-6-42.)

BY ORDER OF THE SECRETARY OF WAR:

G. C. MARSHALL,
Chief of Staff.

OFFICIAL:

J. A. ULIO,
Major General,
The Adjutant General.

DISTRIBUTION :

D (2) ; R and H 1, 7(5), 17(2) ; IBn 1, 6, 7(3), 9, 17(2) ; IC 2, 6, 7, 17(2), 9(4).

(For explanation of symbols see FM 21-6.)



Stanford University Libraries



3 6105 113 796 374

