

62 ULL3
JM
1941

TM 9-1535

U.S. Army
WAR DEPARTMENT

TECHNICAL MANUAL

ORDNANCE MAINTENANCE

**SIGHTS, M4, M3 (FOR 60-MM AND 81-MM
MORTAR MATÉRIEL); SIGHTS, M2A3,
M2A1, M2 (FOR 81-MM MORTAR
MATÉRIEL)**

September 12, 1941



U 113

12

TM 9-1535

TM 9-1535
1941

TECHNICAL MANUAL }
No. 9-1535 }



WAR DEPARTMENT,
WASHINGTON, September 12, 1941.

ORDNANCE MAINTENANCE

SIGHTS, M4, M3 (FOR 60-MM AND 81-MM MORTAR
MATÉRIEL); SIGHTS M2A3, M2A1, M2 (FOR 81-MM
MORTAR MATÉRIEL)

Prepared under direction of the
Chief of Ordnance

SECTION I. General.	Paragraph
Purpose	1
Scope	2
References	3
II. Description and operation.	
General	4
Sight, M4	5
Sight, M3 (Brandt)	6
Sight, M2A3	7
Sight, M2A1	8
Sight, M2	9
Operation	10
Field test and adjustment	11
III. Sight, M4.	
Inspection	12
Tools for maintenance and repair	13
Disassembly and assembly	14
Adjustments	15
IV. Sight, M2A3.	
Inspection	16
Tools for maintenance and repair	17
Disassembly and assembly	18
Adjustments	19
V. Sight, M2A1.	
General	20
VI. Care and preservation.	
Method	21
APPENDIX. List of references	Page 24

108061°—41—1

M558675

SECTION I
GENERAL

Purpose	-----	Paragraph	1
Scope	-----		2
References	-----		3

1. **Purpose.**—This manual is published primarily for the information and guidance of ordnance maintenance personnel.

2. **Scope.**—This manual supplements the Technical Manuals which are prepared for the using arm. It contains general descriptive matter and detailed instructions for maintenance and repair of the sights by ordnance personnel. Figures which accompany the manual show the placement and method of fastening of each of the component parts of the sights described.

3. **References.**—The appendix lists all Standard Nomenclature Lists and other publications pertaining to these sights.

SECTION II

DESCRIPTION AND OPERATION

General	-----	Paragraph	4
Sight, M4	-----		5
Sight, M3 (Brandt)	-----		6
Sight, M2A3	-----		7
Sight, M2A1	-----		8
Sight, M2	-----		9
Operation	-----		10
Field test and adjustment	-----		11

4. **General.**—The several sights applicable to the 60-mm and 81-mm mortars are generally similar to each other but differ considerably in application and design. Each sight includes a collimator, elevating and lateral deflection mechanisms, longitudinal level, and cross level, all supported by a bracket with a dovetailed base which fits in a slot in the mortar yoke and latches in place. The levels when centered indicate that the elevation and deflection angles, respectively, are measured in true vertical and horizontal planes. The longitudinal level also provides a datum line for elevation settings. When the sight is level, the collimator establishes a vertical line in the field of view, the line of sight with a “normal” lateral deflection setting being parallel to the plane of fire. The collimator is pivoted so that it may be moved in elevation as required to bring the aiming point into the field of view; this motion has no effect on

elevation indications. The principal features of each sight are described in succeeding paragraphs.

5. Sight, M4.—This sight (fig. 1) is standard for use with the mortar, 60-mm, M2, and the mortar, 81-mm, M1. Elevation in degrees is indicated on the elevation scale, graduated in 10° steps, supplemented by a micrometer graduated in $\frac{1}{4}^\circ$ steps. Elevation motion is from 40° to 90° . Deflection in mils is indicated on the deflection micrometer which is graduated in 5-mil steps. Directions of motion for left and right deflections are indicated by the letters "L" and "R" and arrows near the index. Deflection motion is 150 mils in either direction, and a zero indication corresponds to normal setting (line of sight parallel to plane of fire). The collimator and open sight have vertical reference lines and may be placed as desired in elevation. With the collimator moved to the extreme rear and elevation set at 40° , the elevation of the overhead portion of the open sight is 2° below the axis of the mortar tube, a feature of service in determining the approximate minimum elevation for clearing nearby objects.

6. Sight, M3 (Brandt).—This sight was formerly furnished with the mortar, 60-mm, M1 (Brandt). It is of French manufacture and differs from the sight, M4, principally in that metric dimensions have been used in the design. No open sight is included. The collimator, however, has a horizontal cross line which may be used for determining approximate minimum elevation, using the procedure given for the sight, M4. The normal deflection indicated on the micrometer (line of sight parallel to the plane of fire) is 150 mils. Direction for left (increasing readings) or right (decreasing readings) deflections, respectively, are indicated by inscription "aug" and "dim" and arrows near the index. Except for the features mentioned above, the information given for the sight, M4, is applicable to the sight, M3, as well.

7. Sight, M2A3.—This sight (fig. 2) is limited standard for use with the mortar, 81-mm, M1. Elevation in mils is indicated on the associated scale, graduated in 100-mil steps, supplemented by the micrometer graduated in 2-mil steps. Deflection in mils is indicated on the associated scale, graduated in 200-mil steps and supplemented by the micrometer graduated in 2 mil steps. The coarse and fine deflection motions are separate. The former, which is unlimited, is actuated by pushing up on the head nut and turning the head to give the desired indication; releasing the head nut causes the teeth in the collar and body to engage, locking the collar. The latter is actuated by turning the micrometer knob. The value of the deflec-

tion setting is the sum of the two readings. The normal position (line of sight parallel to the plane of fire) corresponds to an indication of 3,300 mils (32 on the scale, 100 on the micrometer). Readings above 3,300 mils correspond to left deflections; below 3,300 mils to right deflections. An open sight, not movable in elevation, is provided near the longitudinal level. The collimator contains a reticle with a vertical line and may be moved without limit in elevation. An auxiliary collimator is also provided, alined in fixed relation to the bore and containing a reticle with a horizontal line which may be used for the determination of the approximate minimum elevation for clearance of nearby objects. Both collimators have arrows to indicate the proper relative direction of the line of sight.

8. **Sight, M2A1.**—This sight is limited standard for use with the 81-mm mortar, M1. It is similar to the sight, M2A3, except that a somewhat less rugged elevating mechanism is employed. The elevation scale is graduated in 100-mil steps and the elevation micrometer in 10-mil steps.

9. **Sight, M2.**—This sight, the original French design for use with the mortar, 81-mm, M1, is similar to the sights, M2A3 and M2A1. The elevation scale is graduated in 1° steps and the elevation micrometer in 1/2° steps.

10. **Operation.**—*a.* Remove the sight from the carrying case and insert the dovetailed base of the bracket in the slot of the mortar yoke. When the sight is fully inserted, the latch will snap into place, securing the sight in position. Check to see that the sight is firmly seated, latched, and free from lost motion.

b. Set the elevation and lateral deflection to the desired values. Range elevation data are obtainable from the pertinent firing table.

c. The angular units employed in elevation and the “normal” deflection (line of sight parallel to plane of fire) settings are tabulated below for the various sights:

Sight	Normal deflection (mils)	Angular units (elevation)	Mortar matériel
M4.....	0	Degrees.....	60-mm, M2, and 81-mm, M1.
M3.....	150	Degrees.....	
M2A3.....	3,300	Mils.....	81-mm, M1.
M2A1.....	3,300	Degrees.....	81-mm, M1.
M2.....	3,300	Degrees.....	81-mm, M1.

d. Operate the elevating and cross leveling mechanisms of the mount until the levels are both centered, simultaneously traversing the mount until the vertical line of the collimator falls on the target or aiming point. The mortar is then properly aimed in direction and laid in elevation.

e. To remove the sight for traveling, depress the latch to release the bracket, withdraw the sight, and place it in the carrying case provided.

11. Field test and adjustment.—Proper alignment of the levels, pivots, and collimator is accomplished when the sight is assembled. No facilities are ordinarily available for verification in the field and no adjustment by the using arm is permitted.

SECTION III

SIGHT, M4

	Paragraph
Inspection.....	12
Tools for maintenance and repair.....	13
Disassembly and assembly.....	14
Adjustments	15

12. Inspection.—Inspection is for the purpose of determining the condition of the sight, whether repairs or adjustments are required, and the remedies necessary to insure serviceability and proper functioning. The listing below will serve as a general guide for inspection. Refer to figures 3 and 4 for location of parts.

<i>Parts to be inspected</i>	<i>Points to be observed</i>
<i>a.</i> Exposed mechanical parts.	<i>a.</i> Observe general appearance, functioning of latch, and any bent or missing parts. Scale and micrometer graduations and index lines should be clear and legible.
<i>b.</i> Level vials.	<i>b.</i> See that the longitudinal and cross level vials are not broken and that they are secure in their housings.
<i>c.</i> Elevating motion.	<i>c.</i> Operate elevating worm knob through complete range of motion. Elevating worm should operate with a smooth, restrained motion. A positive stop should be felt at the scale limits. There should be no perceptible backlash between body, D29390, and bracket, D29391 (fig. 4).
<i>d.</i> Deflection motion.	<i>d.</i> Operate deflection screw through complete range of motion (somewhat less than one complete turn). Screw should

*Parts to be inspected**Points to be observed*

- operate with a smooth, restrained motion. A positive stop should be felt at the scale limits. There should be no perceptible backlash between body, D29390, and body head, C69996 (fig. 4).
- e.* Collimator assembly. *e.* The collimator reticle should appear in sharp focus of the eyelens when viewed through the collimating telescope, and should be free from parallax. Plane of sight of the open sight should be parallel to plane of sight of the collimator within approximately 5 mils. Mounting of collimator parts should be firm. Collimator tube bracket, B138176, should operate smoothly, with sufficient friction to prevent accidental movement.
- f.* Locating surface. *f.* The flat back surface of the bracket dovetail forms the locating surface of the sight. This surface must be smooth, clean, and free from any imperfections which would impair the accuracy of the sight in its normal mounting.
- g.* Alinement. *g.* Verify the sight adjustments according to the procedure given in paragraph 9.

13. Tools for maintenance and repair.—An optical repair kit containing the necessary tools and materials for use with these sights is furnished to ordnance maintenance companies. Every item in the kit is designated by a number equivalent to the compartment number in the kit tool chest. A complete list of the items comprising the kit is contained in a blueprint which is fastened in the cover of the chest. The collimating telescope, No. 90, which is furnished with the kit, is an ordinary nonerecting type. It is adjusted for parallax by the usual means of focusing the eyepiece on the cross wires and then removing parallax by focusing the objective, temporarily loosening the drawtube clamping screw in the side of the telescope for the purpose. The magnifying power of the collimating telescope is 9.78X; the field of view is 4°20'.

14. Disassembly and assembly.—*a. Collimator.*—To replace collimator assembly, remove nut, A49985, and screw, A49984 (fig. 4).

Collimator assembly may then be removed and replaced as a unit. Adjust fit of collimator bracket on body head to give a smooth, restrained motion. Stake nut to screw when satisfactory adjustment has been obtained.

b. Latch.—To replace latch, C56411, or latch torsion spring, A43139, drive out latch pin, A43135, and withdraw parts. Clean and lubricate parts before reassembling. Stake latch pin securely at both ends when reassembling.

c. Elevating worm.—To remove elevating worm, B138171, (fig. 4, sec. A-A), first remove elevating worm knob, A49972, and micrometer, B138173, secured by nut, A49970. Remove headless screw, A49976, which secures bushing, A49975. Unscrew bushing and remove elevating worm with bushing attached. Clean and lubricate parts before reassembling. Assemble in reverse order of disassembly. Adjust elevation micrometer as described in paragraph 15.

d. Worm gear torsion spring.—To replace worm gear torsion spring, A49977 (fig. 4, sec. B-B), remove elevating worm, B138171, as in *c* above. Remove large worm gear retaining screw, A49979, secured by headless locking screw, A49976. Withdraw worm gear, B138172, and body, D29390, from bracket, D29391. Torsion spring and related parts are then accessible for replacement. Inspect stop screw, A49990, and replace if necessary. Clean and lubricate all parts before reassembling. The worm gear has three keyways, evenly spaced, which permit a choice of surfaces in reassembling. However, unless the worm gear teeth show excessive wear, the worm gear should be replaced in its original relation. Worm gear retaining screw should be tightened to provide a snug fit without excessive friction.

e. Head torsion spring.—To replace head torsion spring, A49980 (fig. 4, sec. B-B), remove collimator assembly as in *a* above. Remove body, D29390, from bracket, D29391, as in *c* above. Drive out straight pin, BFDX1AE, which secures pivot, A49981, and unscrew pivot. Head, C69996, may then be removed, exposing torsion spring. Clean and lubricate parts before reassembling. Assemble in reverse order of disassembly.

f. Deflection screw.—To replace deflection screw, C69997 (fig. 4, sec. C-C), remove headless locking screw, BCUX1EE, and retaining screw, A49986. Disengage deflection screw from eccentric pin, A49982, and remove deflection screw. Inspect stop pin and replace if necessary. Inspect friction washers, A49987 and A49988, and replace if necessary. Clean and lubricate parts before reassembling. Assemble in reverse order of disassembly.

g. Level vial.—To replace level vial, A31308 (fig. 4, sec. D-D-D and E-E), remove plug, A49989, at each end of level vial cavity. Clean out broken glass and old packing. Center new level vial in level vial opening. Adjust as described in paragraph 15. Pack with calcined gypsum (plaster of paris) which has been mixed to medium consistency. Allow the plaster to become thoroughly dry, then replace plugs and stake the threads.

15. Adjustments.—*a.* The sight socket in the yoke of the mortar is so constructed that when the mortar is cross-leveled and inclined at 45° , the axis and the flat surface of the socket are vertical and parallel to the vertical plane passing through the axis of the bore of the mortar.

b. The sight, when placed in its socket with the mortar leveled and inclined as mentioned above, is in adjustment when the line of sight is parallel with the vertical plane passing through the axis of the bore of the mortar, and when the bubbles in the levels are centered, with the sight set at 45° elevation, as shown in figures 3 and 4.

c. By construction, the axis of the pivot about which the head rotates, the line on the reticle of the collimator, and the wire of the open sight are parallel with the flat back surface of the dovetailed portion of the bracket. The line of sight through the collimator and open sights has also been adjusted to be parallel with the flat back surface of the bracket when the zero on the deflection scale registers opposite the index. Therefore, the line of sight should be parallel to the vertical plane passing through the axis of the bore of the mortar. The cross level vial is positioned so that its bubble is centered when the flat surface of the bracket is vertical.

d. Adjustment for the deflection mechanism is provided and may be accomplished as follows:

(1) Clamp the flat surface of the bracket against a long flat surface and sight along the surface at a distant object. Rotate the deflection knob until the line of sight of the collimator sight falls on the same object and note the reading on the deflection scale. If the zero on the deflection scale does not register opposite its index, adjustment is required.

(2) To adjust the deflection mechanism, rotate the deflection knob until the zero on the deflection scale registers opposite its index. Back out one of the adjusting screws, A49983, in the front of the head a slight amount. Tighten the other screw, repeating the procedure until the line of sight falls on the object. When the adjustment has been properly made, both screws must be tightened.

e. No adjustment is provided for the collimator sight and open sight with relation to the head other than the manual motion for raising or lowering the line of sight for sighting on an aiming point.

f. Adjustment for the elevation mechanism is provided and should be made when the elevation micrometer does not register within the limits of $\frac{1}{4}^\circ$ with the index when the mortar and sight are adjusted as described in *b* above. Adjustment of the elevation mechanism is accomplished as follows:

(1) Cross-level the mortar by means of the cross level and with a gunner's quadrant placed against the flat surfaces near the muzzle of the mortar, set the mortar accurately to an elevation of 60° (1,067 mils). Turn the elevating knob of the sight until the bubble in the longitudinal level is centered and note the readings of the elevation scale and elevation micrometer. If the 60° graduation on the elevation scale and the zero graduation on the elevation micrometer are not opposite their respective indexes, proceed as follows: Without disturbing the setting of the mortar and sight, hold the elevating knob and loosen the nut in the end of the knob and slip the micrometer until the zero graduation is opposite its index. Then tighten the nut.

(2) No adjustment is provided for the elevation scale or its index. If the 10° graduations on the elevation scale are out of registration with the index to such an extent that confusion is experienced when making settings on the elevation micrometer, it will then be necessary to make an adjustment so that the 10° graduations register opposite or closer to the index when the zero on the micrometer is opposite its index. This adjustment should be accomplished as follows: With the mortar leveled and inclined as described in (1) above, turn the elevating knob until the 60° graduation of the elevation scale registers opposite its index and adjust the elevation micrometer to have the zero graduation register opposite its index. Remove the plugs in the ends of the longitudinal level housing and repack the level vial until its bubble is centered. Allow the plaster to become thoroughly dry, then replace plugs and stake the threads.

g. No adjustment is provided for the cross level vial. When replacement or adjustment becomes necessary, proceed as follows: Clamp the flat back surfaces of the bracket against a vertical plate. Remove the plugs in the ends of the cross level housing and repack the level vial until its bubble is centered. Allow the plaster to become thoroughly dry, then replace plugs and stake the threads.

h. The adjustments described above should not be attempted in the field except by trained maintenance personnel.

SECTION IV

SIGHT, M2A3

	Paragraph
Inspection	16
Tools for maintenance and repair.....	17
Disassembly and assembly.....	18
Adjustments.....	19

16. Inspection.—Inspection is for the purpose of determining the condition of the sight, whether repairs or adjustments are required, and the remedies necessary to insure serviceability and proper functioning. The listing below will serve as a general guide for inspection. Refer to figures 5, 6, and 7 for location of parts.

- | <i>Parts to be inspected</i> | <i>Points to be observed</i> |
|---|--|
| <p><i>a.</i> Exposed mechanical parts.</p> | <p><i>a.</i> Observe general appearance, functioning of latch, and any bent or missing parts. Scale and micrometer graduations and index lines should be clear and legible.</p> |
| <p><i>b.</i> Level vials.</p> | <p><i>b.</i> See that the longitudinal and cross level vials are not broken and that they are secure in their housings.</p> |
| <p><i>c.</i> Elevating motion.</p> | <p><i>c.</i> Operate elevating worm knob through complete range of motion. Elevating worm should operate smoothly, without irregularities, undue looseness, or friction. A positive stop should be felt at the scale limits. There should be no perceptible backlash between body, D28815, and bracket, D28814 (fig. 6).</p> |
| <p><i>d.</i> Deflection motion (coarse).</p> | <p><i>d.</i> The teeth of the collar, C56512, and body, D28688, should fit together without play at any azimuth setting.</p> |
| <p><i>e.</i> Deflection motion (fine).</p> | <p><i>e.</i> Azimuth micrometer screw, A43147, should operate with a smooth, restrained motion. A positive stop should be felt at the scale limits. There should be no perceptible backlash between head, C56410, and collar, C56412.</p> |
| <p><i>f.</i> Azimuth collimator assembly.</p> | <p><i>f.</i> The collimator reticle should appear in sharp focus of the eyelens when viewed through the collimating telescope and should be free from parallax. Plane of</p> |

*Parts to be inspected**Points to be observed*

sight of the open sight (V-grooves on longitudinal level) should be parallel to plane of sight of the collimator within approximately 5 mils. Collimator mounting should be firm. Collimator adapter, A43149, should operate smoothly, with sufficient friction to prevent accidental movement.

g. Elevation collimator assembly.

g. The collimator reticle should appear in sharp focus of the eyelens when viewed through the collimating telescope and should be free from parallax. Mounting of collimator parts should be firm.

h. Locating surface.

h. The flat back surface of the bracket dovetail forms the locating surface of the sight. This surface must be smooth, clean, and free from any imperfections which would impair the accuracy of the sight in its normal mounting.

i. Alinement.

i. Verify the sight adjustments according to the procedure given in paragraph 19.

17. Tools for maintenance and repair.—The optical repair kit for use with this sight is described in paragraph 13.

18. Disassembly and assembly.—*a. Azimuth collimator.*—To replace azimuth collimator assembly, remove adapter retaining nut, A43134, and remove adapter, A43149. Screws which secure collimator are then accessible. When replacing adapter, adjust adapter retaining nut on friction washer, A43133, to give a smooth, restrained motion. Stake threads when satisfactory adjustment has been obtained.

b. Latch.—To replace latch, C56411, or latch torsion spring, A43139, drive out latch pin, A43135, and withdraw parts. Clean and lubricate parts before reassembling. Stake latch pin securely at both ends when reassembling.

c. Elevating worm.—To remove elevating worm, B135276 (fig. 6, sec. B-B), first remove elevating worm knob, A46821, and elevation micrometer, B135277. Remove worm plunger plug, A31378B, with spring, A34447, and plunger, A31363. Unscrew ball cap, A46819, secured by screw, BCUX1FD. Remove worm with ball socket, A32124. Clean and lubricate parts before reassembling. Assemble in reverse order of disassembly. Adjust elevation micrometer as described in paragraph 19.

d. Head.—To remove head, C56410, drive out straight pin, 0.0635 by $\frac{7}{8}$, which secures head nut, A43142, and remove head nut. Lift collar and head out of body. Inspect springs and replace if necessary. Clean and lubricate parts before reassembling. Assemble in reverse order of disassembly.

e. Level vial.—To replace level vial, A31332 (fig. 7), remove plug, A43336, at each end of level vial cavity. Loosen adjusting screws, BCUX2CB, in end of level vial tube, A43337, and remove tube. Clean out broken glass and old packing. Seat new level vial in tube with graduations centered in level vial opening. Pack with calcined gypsum (plaster of paris) which has been mixed to medium consistency. Allow the plaster to become thoroughly dry, then replace tube in holder and adjust as described in paragraph 19*i*. Replace plugs.

19. Adjustments.—*a.* The sight, M2A3, is in adjustment when the vertical line in the collimator is parallel to the vertical plane passing through the axis of the bore of the mortar, and the bubble in the level vial of the longitudinal level is centered, with the mortar inclined 800 mils (45°).

b. By construction, the axis about which the head rotates is parallel to the flat back surface on the dovetailed portion of the bracket. The cross level is adjusted so that the bubble in the level vial is centered when the surface is vertical.

c. With the level bubbles centered as described above, the azimuth scale index should register opposite the "32" graduation on the azimuth scale; the azimuth micrometer index should register opposite the normal graduation on the azimuth micrometer (indicated by a small 100 and a large red 0); the elevation scale index should register against the 8 (800-mil) graduation on the elevation scale; and the elevation micrometer index should register opposite a zero graduation on the elevation micrometer.

d. To adjust the sight, cross level the mortar and set the mortar at 800 mils (45°) elevation by means of a gunner's quadrant placed on the flat surface provided at the muzzle of the mortar barrel. Rotate the elevating knob until the bubble of the longitudinal level is centered. Note the position of the elevation scale index with respect to the "8" graduation on the elevation scale, and the position of the elevation micrometer index with respect to the "0" graduation on the elevation micrometer. If the indexes are not in precise coincidence with their respective graduations, loosen the two clamping screws, BCOX3DE, on the elevation scale index, and the three clamping screws, BCGX3DE, on the elevation knob. Slip the index and micrometer to obtain coincidence, then tighten the screws.

e. The line of sight through the azimuth collimator is adjusted parallel with the flat back surface of the dovetailed portion of the bracket at the time the sight is assembled, with the azimuth index registering 32 and micrometer set at 100 or normal position. This adjustment will not be attempted in the field unless adequate facilities are available to collimate the line of sight with the flat surfaces mentioned, when the method explained in *f* and *g* below may be used.

f. The micrometer screw, A43147, has an axial movement corresponding to 200 mils; half the motion being in, or decreasing, and the other half out, or increasing. With the screw set at the midposition of the motion, loosen the three screws, BCLX3DD, in the end of the knob, and slip the azimuth micrometer until the normal graduation (indicated by the numerals 100 and the large red 0) is opposite the index. Then tighten the screws.

g. Loosen the locking screw, BCUX1CB, which locks the adjusting screw, A43141, and by means of the screw driver slot move the adjusting screw to the position where the line of sight is parallel to the flat back surface of the bracket, which by construction is parallel to the axis of the bore of the mortar. Then tighten the locking screw.

h. The cross level and longitudinal level are likewise adjusted at assembly with reference to the vertical axis and flat back surfaces of the dovetailed portion of the bracket. Adjustment in the field will not be attempted unless adequate facilities are available.

i. If adjustment of the levels is necessary, remove the plugs, A43336. Then by means of the four small screws, BCUX2CB (fig. 7), in the end of the level tube, make the necessary adjustment and replace the plugs. Take care that all four screws are tight and that the plugs bear firmly against the end of the level tubes.

j. No adjustment is provided for the auxiliary collimator, as the proper relation of its line of sight is fixed at the time of assembling the sight.

SECTION V

SIGHT, M2A1

General.....	Paragraph 20
--------------	-----------------

20. General.—This sight is generally similar to the sight, M2A3. For maintenance operations refer to section IV. Assembled and sectioned views of the sight, M2A1, are shown in figures 8 to 10, inclusive.

SECTION VI

CARE AND PRESERVATION

Method..... Paragraph 21

21. Method.—*a.* Exercise care to prevent denting of the bearing surfaces of the dovetailed portion of the bracket.

b. Do not attempt to force mechanisms beyond the limits of their motions which are indicated by the scales.

c. In sights of the M2A3 type, avoid scraping the teeth of the body and collar over each other. Before turning the head, lift it sufficiently to insure that the teeth will clear.

d. Lubricate the accessible moving parts occasionally with oil, lubricating, for aircraft instruments and machine guns. Wipe off any excess lubricant that seeps from the moving parts. Keep the sight free of dust and grit.

e. Keep the lenses and windows of the collimators clean. Do not wipe them with the fingers or an oily cloth. To remove dust, brush the glass lightly with a camel's-hair brush, then rap the brush against a hard body to knock out dust particles. Continue until all dust is removed. For wiping glass surfaces, use only lens tissue paper specially intended for cleaning optical glass (Paper, tissue; Fed. Spec. No. VVP 313). Use of cleaning cloths in the field is not permitted. To remove oil or grease from optical surfaces, apply alcohol, ethyl, with a clean camel's-hair brush and wipe dry with paper, tissue. In the absence of alcohol, breathe heavily on the surface and wipe dry with paper, tissue.

f. Remove sight from its socket on the mortar yoke during the process of "firing in" of the mortar in service practice.

g. When not in use, keep the sight in its carrying case.

SIGHTS FOR 60-MM AND 81-MM

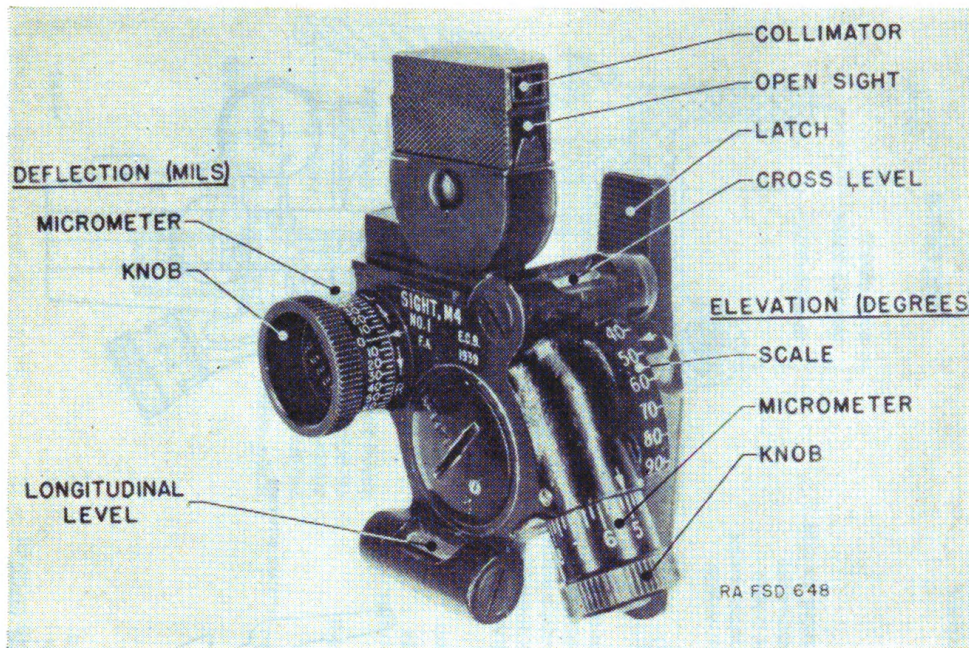

FIGURE 1.—Sight, M4.

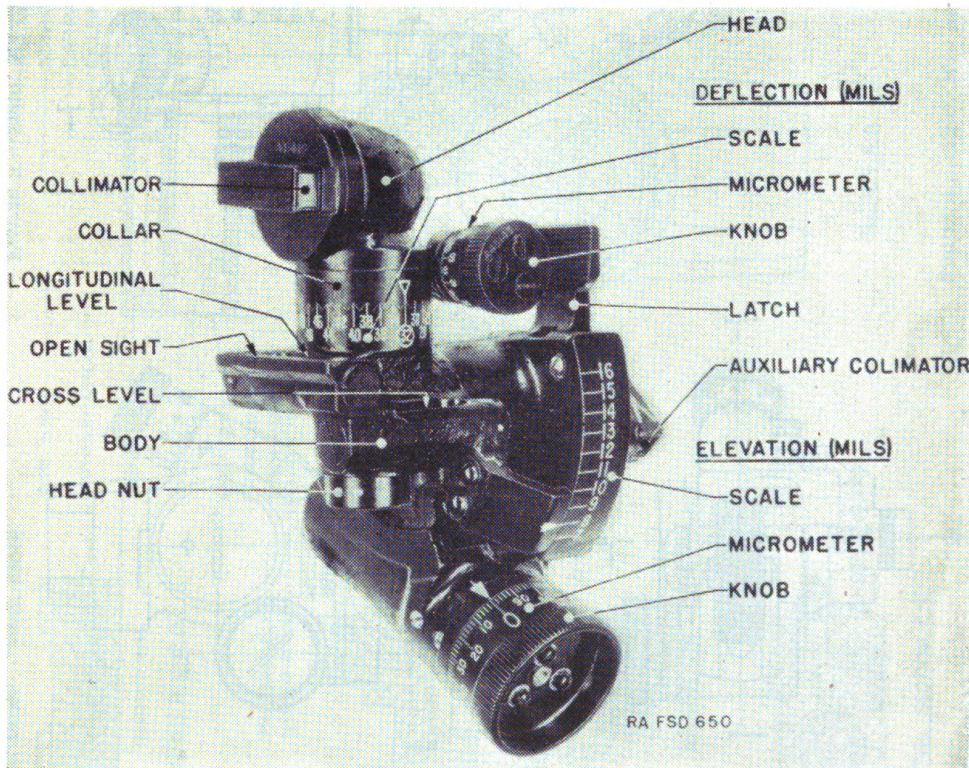

FIGURE 2.—Sight, M2A3.

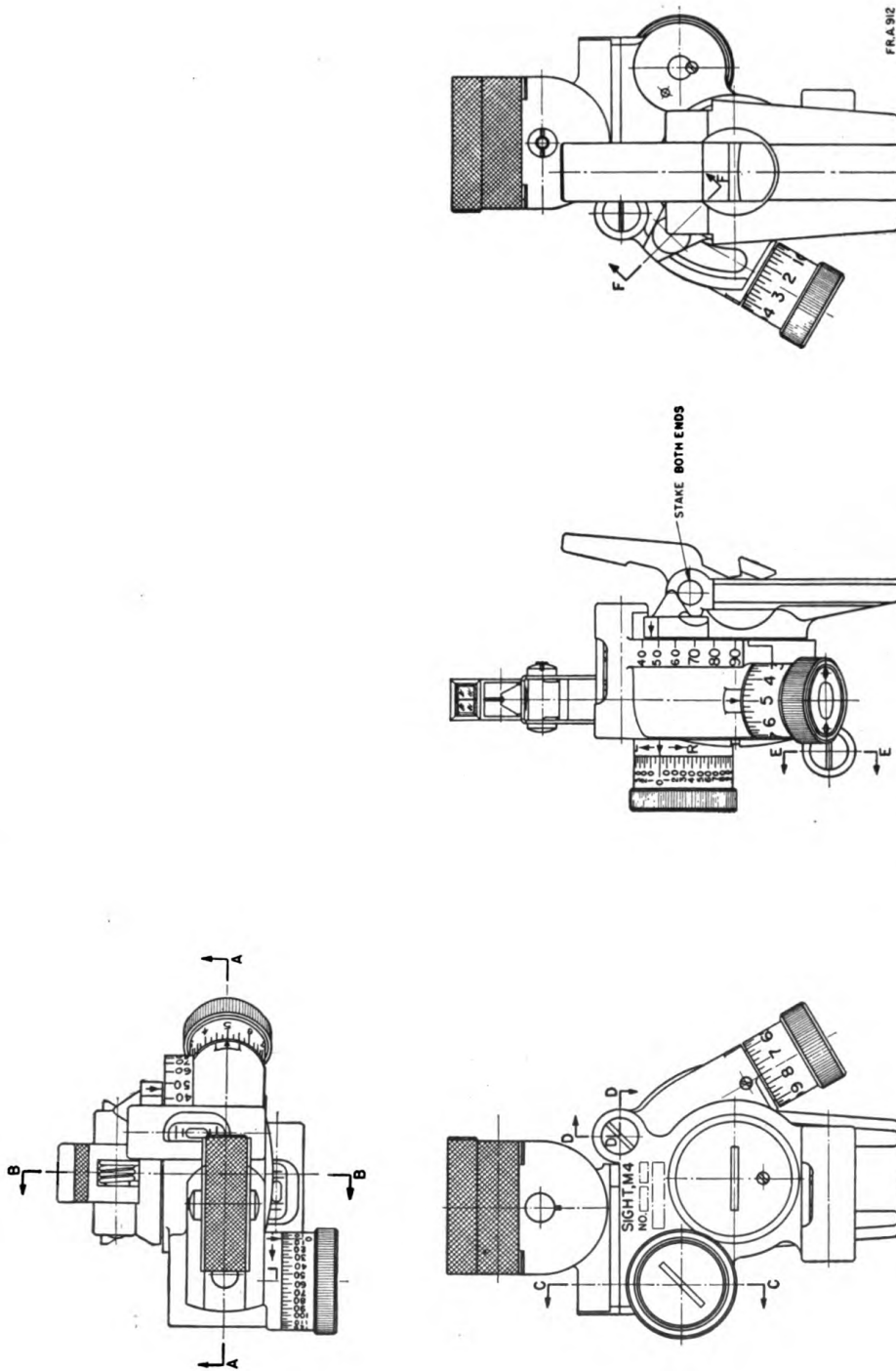

FIGURE 3.—Sight, M4—assembled views.

SIGHTS FOR 60-MM AND 81-MM

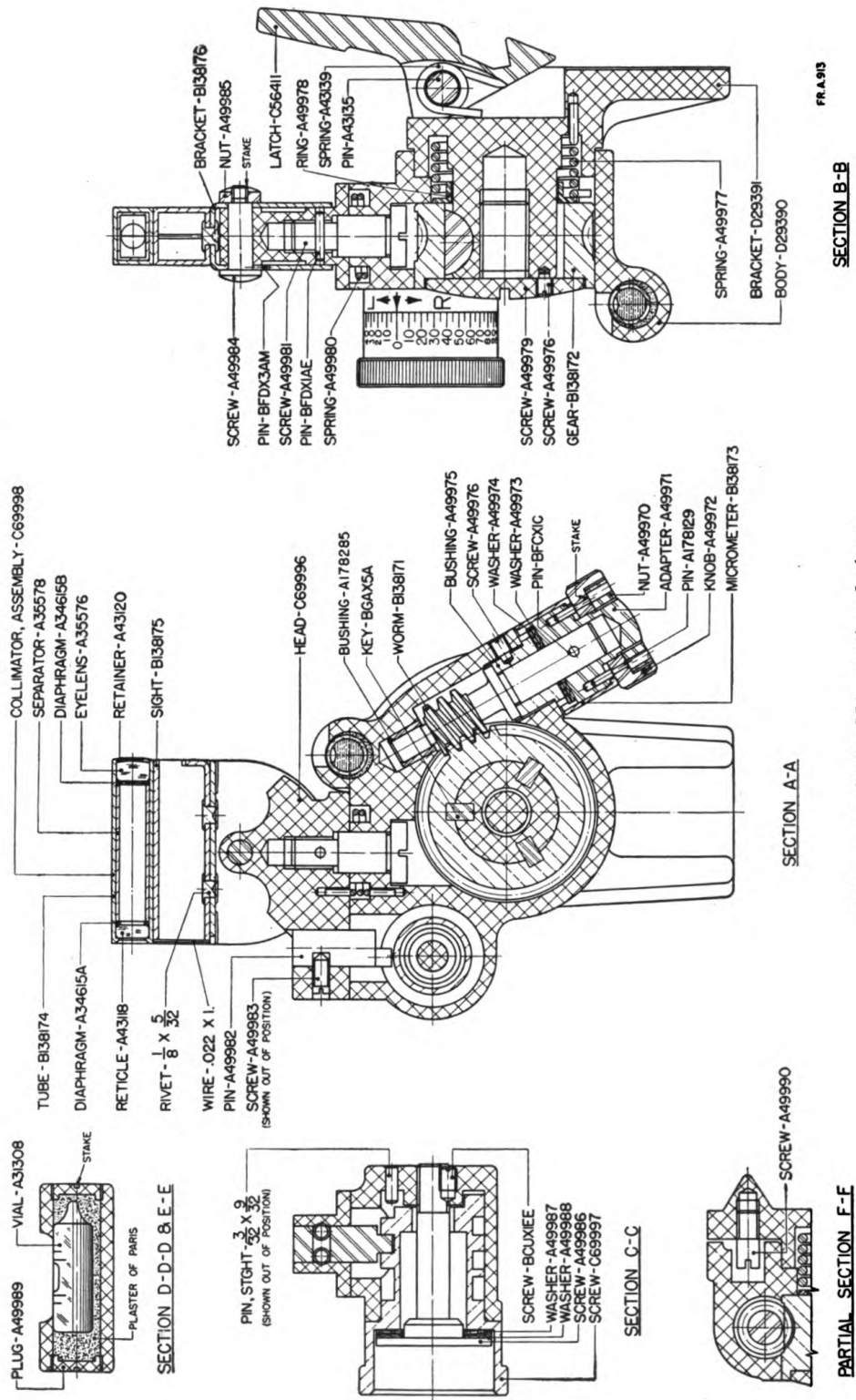

Figure 4.—Sight, M4—sectioned views.

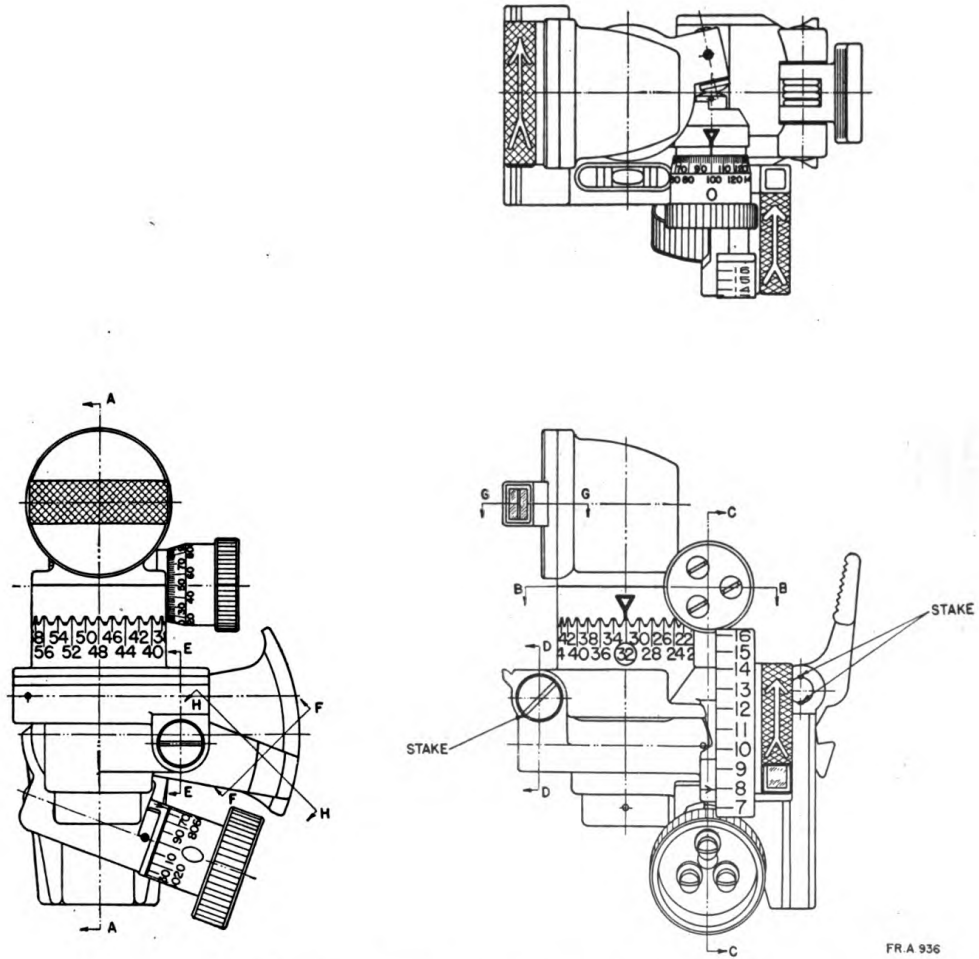

FIGURE 5.—Sight, M2A3—assembled views.

SIGHTS FOR 60-MM AND 81-MM

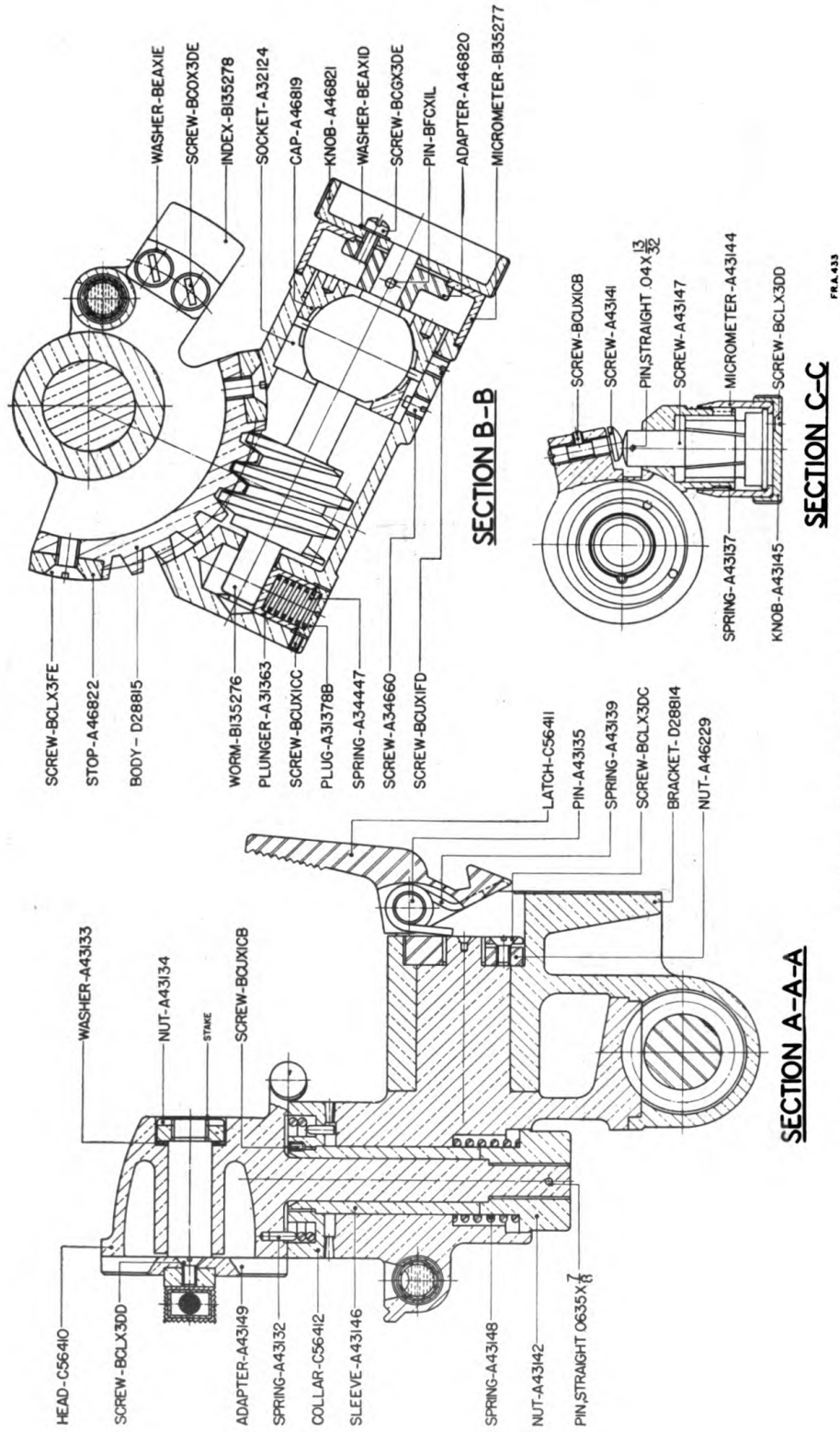
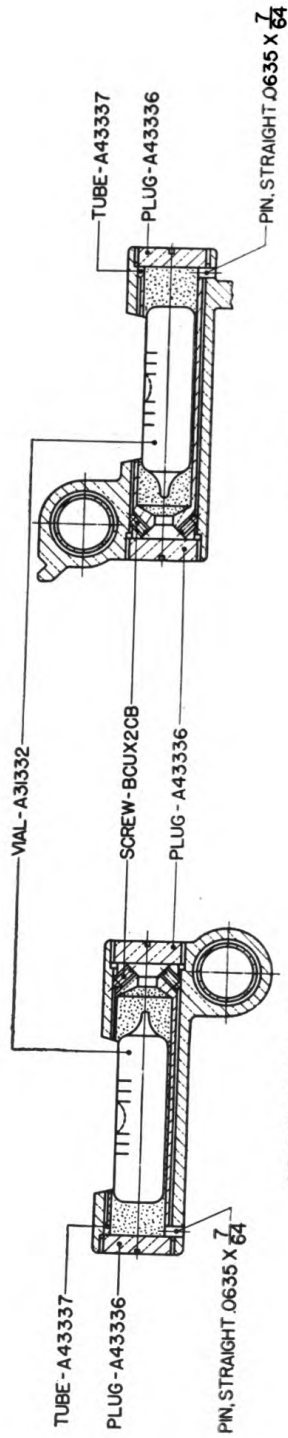

FIGURE 6.—Sight, M2A3—sectioned views.

FRA.433



SECTION E-E

SECTION D-D

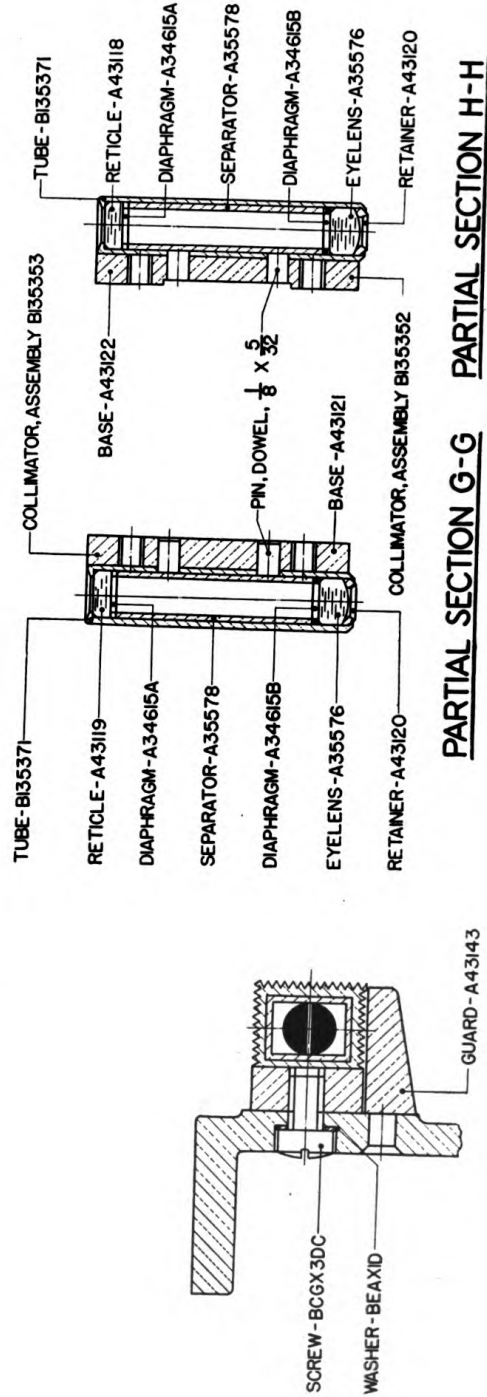

FRA 434

FIGURE 7.—Sight, M2A3—sectioned views.

SIGHTS FOR 60-MM AND 81-MM

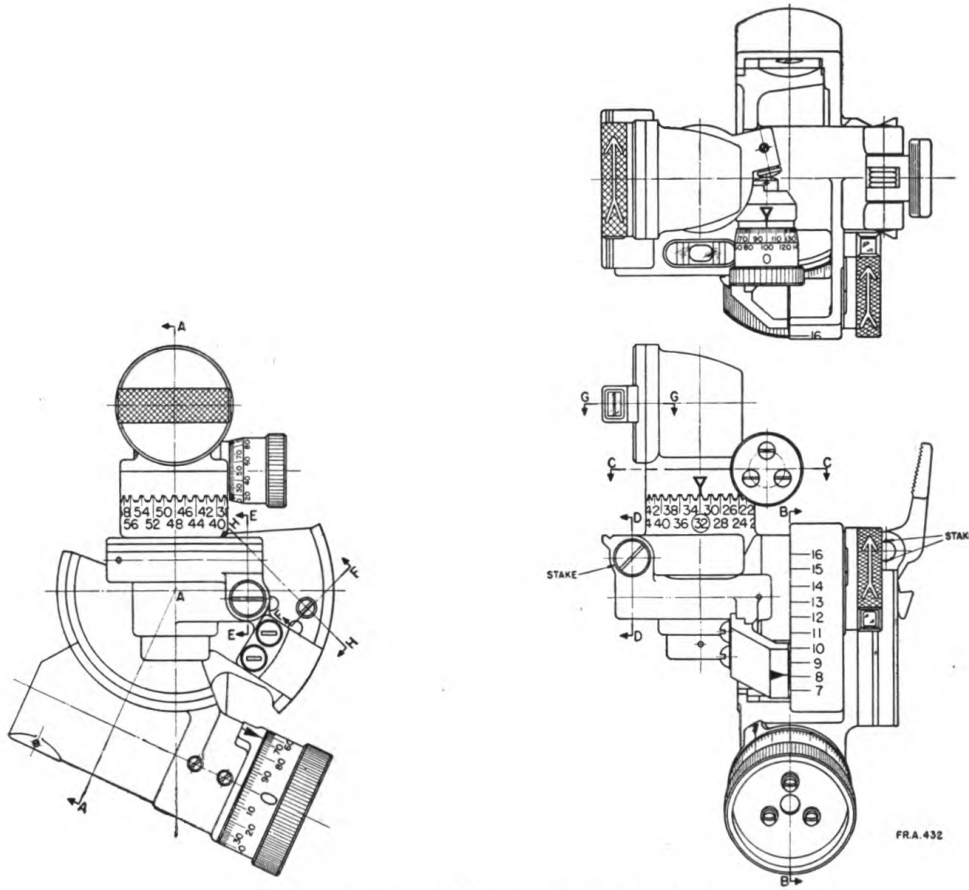

FIGURE 8.—Sight, M2A1—assembled views.

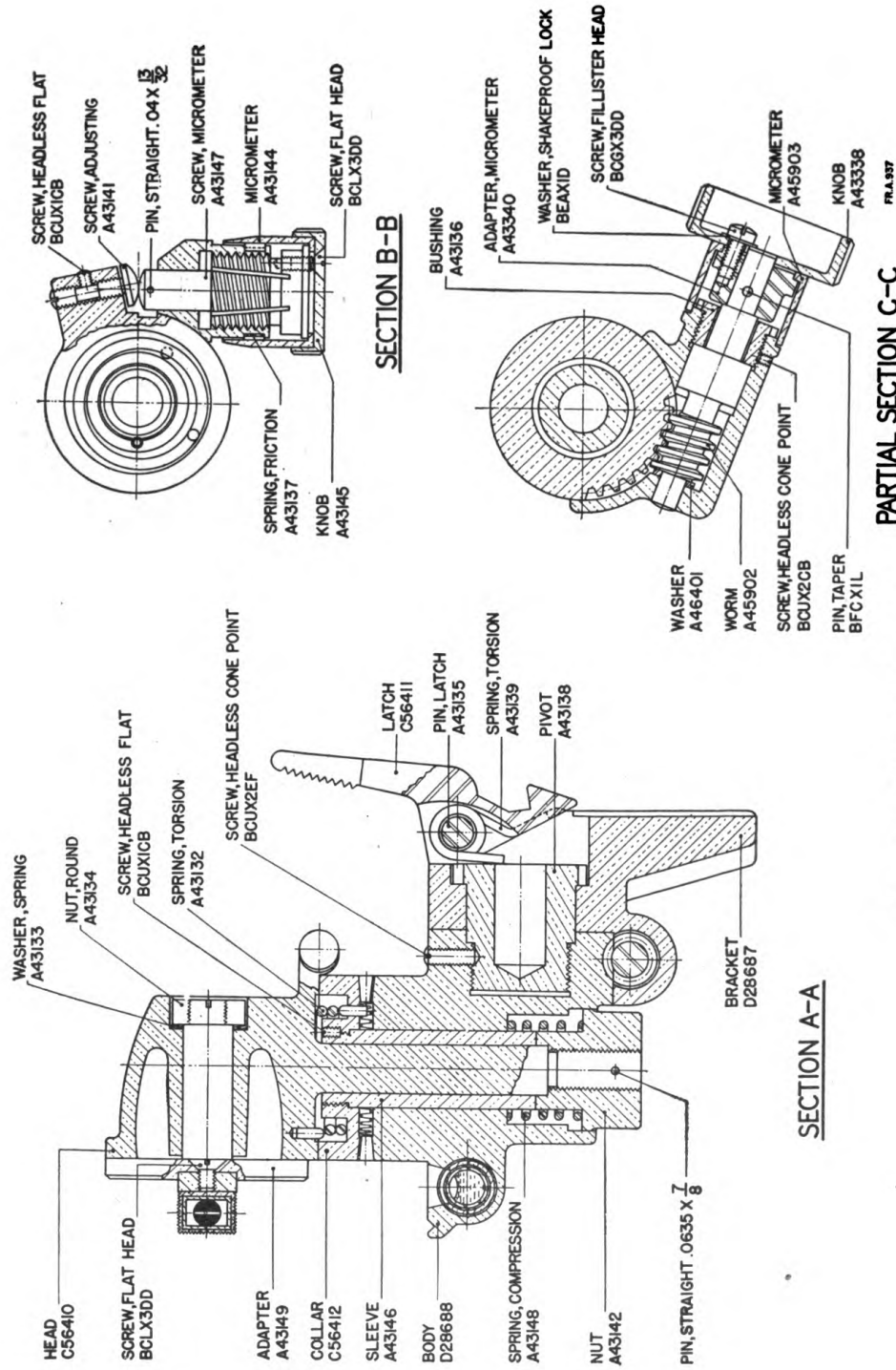

FIGURE 9.—Sight, M2A1—sectioned views.

SIGHTS FOR 60-MM AND 81-MM

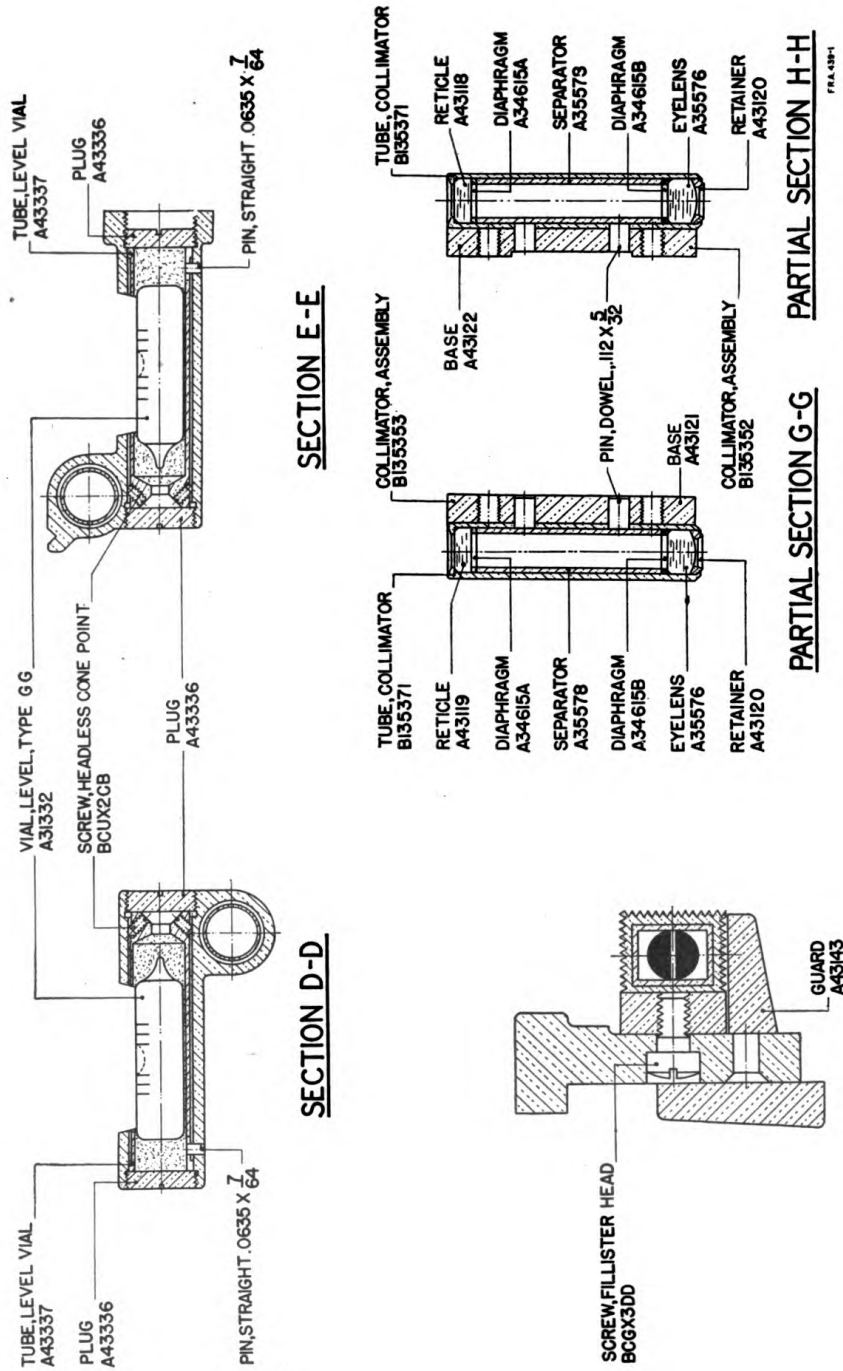

FIGURE 10.—Sight, M2A1—sectioned views.

APPENDIX

LIST OF REFERENCES

1. **Standard Nomenclature Lists.**

- Sights, M2A1, M2A3, M3----- SNL F-148
- Sight, M3----- SNL F-175
- Cleaning, preserving, and lubricating materials, re-
coil fluids, special oils and similar items of issue. SNL K-1
- Current Standard Nomenclature Lists are as tabu-
lated here. An up-to-date list of SNL's is main-
tained as the "Ordnance Publications for Supply
Index" ----- (OPSI)

2. **Technical Manuals.**

- Cleaning, preserving, lubricating, and welding ma-
terials and similar items issued by the Ordnance
Department----- TM 9-850
(now published as TR 1395-A)

3. **Field Manuals.**

- Mortar, 60-mm, M2----- FM 23-85
 - Mortar, 81-mm, M1----- FM 23-90
- [A. G. 062.11 (7-22-41).]

BY ORDER OF THE SECRETARY OF WAR:

G. C. MARSHALL,
Chief of Staff.

OFFICIAL:

E. S. ADAMS,
Major General,
The Adjutant General.

DISTRIBUTION:

D 2, 7, 17 (2); B 2, 7, 17 (3); R 2, 7, 17 (5); Bn 9 (2); IC 9 (4).
(For explanation of symbols see FM 21-6.)

